

DOCUMENT RESUME

ED 376 301

CE 067 564

AUTHOR Sorensen, Mary K.; And Others  
 TITLE Integrated Technical Curriculum. Curriculum Developed for Project Second Chance II: Tech Reading, Tech Science, Tech Math, Automotive.  
 INSTITUTION Milwaukee Area Technical Coll., Wis.  
 SPONS AGENCY Wisconsin State Board of Vocational, Technical, and Adult Education, Madison.  
 PUB DATE Jun 93  
 NOTE 215p.; Some faint type in "Automotive Component".  
 PUB TYPE Guides - Classroom Use - Teaching Guides (For Teacher) (052)

EDRS PRICE MF01/PC09 Plus Postage.  
 DESCRIPTORS Adult Education; \*Auto Mechanics; Behavioral Objectives; Competence; Competency Based Education; \*Content Area Reading; Electronic Equipment; Engines; Equipment Utilization; Instrumentation; \*Integrated Curriculum; Learning Activities; Lesson Plans; \*Mathematics Skills; Physical Sciences; Power Technology; Reading Skills; \*Remedial Reading; Skill Development; Technical Institutes; Two Year Colleges; \*Vocational Education

ABSTRACT

This integrated technical curriculum is designed to enroll and retain adult high school noncompleters in occupational programs by providing them with the remedial and content-area reading instruction needed for success in an automotive program. The following topics are covered in the four units: (1) skills for reading technical materials (basics of technical reading; using, understanding, and studying technical books; building technical vocabulary; and general study and test-taking skills for technical material); (2) applied mathematics for automotive students (whole numbers, decimal numbers, fractions, percentages, tables and graphs, and measurement and computer skills); (3) physical science for automotive students (measurement, chemistry, energy and force, electricity and magnetism, and machines); and (4) automotive tune-up (safety, engine design, compression testing, spark plug servicing, distributors, electronic ignition, engine analyzers, secondary wires, battery servicing, automotive air pollution, legislated automotive emission standards, and emission control/testing). Each component contains some or all of the following: course objectives, course outline, lesson plans for each course session, learning activities/exercises, and transparency masters. (MN)

\*\*\*\*\*  
 \* Reproductions supplied by EDRS are the best that can be made \*  
 \* from the original document. \*  
 \*\*\*\*\*

01950295

09-956-150-613  
Curriculum developed for Project  
Second Chance II:

- Tech Reading
- Tech Science
- Tech Math
- Automotive

ED 376 301

# INTEGRATED TECHNICAL CURRICULUM

CE 027564

U.S. DEPARTMENT OF EDUCATION  
EDUCATIONAL RESOURCES INFORMATION  
CENTER (ERIC)

- This document has been reproduced as received from the person or organization originating it.
- Minor corrections have been made to improve readability.
- Points of view or opinions stated in this document do not necessarily represent official OEI position or policy.

"PERMISSION TO REPRODUCE THIS  
MATERIAL HAS BEEN GRANTED BY

*E. C. Miller*

TO THE EDUCATIONAL RESOURCES  
INFORMATION CENTER (ERIC)"

BEST COPY AVAILABLE

# INTEGRATED TECHNICAL CURRICULUM

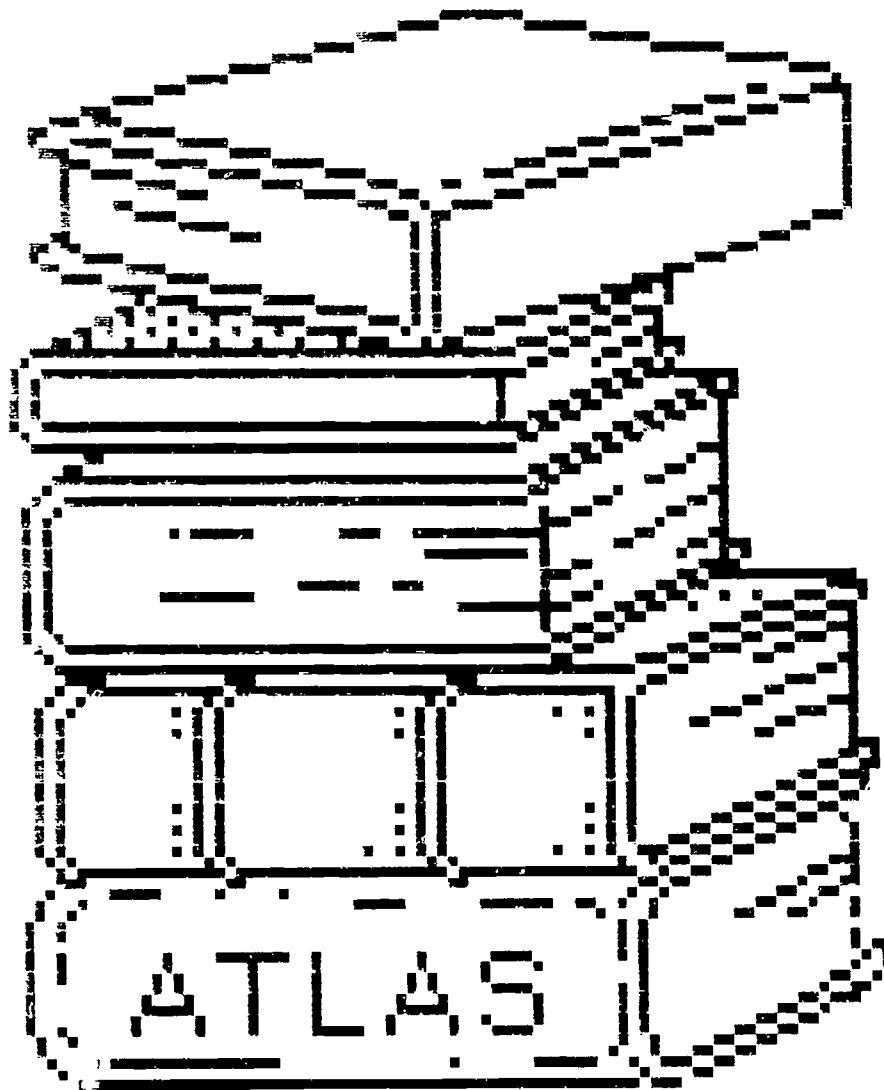

## READING COMPONENT

Integrated Technical Curriculum  
Reading Component

How To Read Technical Materials

Developed by  
Mary K. Sorensen

Milwaukee Area Technical College  
Adult High School

June, 1993

TEXTBOOK :  
READING TECHNICAL BOOKS  
by  
ANNE EISENBERG  
PUBLISHER - PRENTICE HALL

SUPPLEMENTARY MATERIALS  
for course

HOW TO READ TECHNICAL MATERIALS

1. SRA GRAPHS STUDY SKILLS
2. STRATEGIC LEARNING IN THE  
CONTENT AREA/WISCONSIN DPI
3. CURRICULUM PLANNING IN  
READING/WISCONSIN DPI

## Reading Technical Material Course Objectives

### Unit I

#### Basics of Technical Reading

1. To distinguish between definitions and statements that are not definitions
2. To locate definitions of terms in longer selections and to be able to use this information to answer questions
3. To note how entire chapters may be based on definitions of terms
4. To use the ability to identify terms to help remember textbook information
5. To develop the ability to use classification - listing patterns to help understand and remember technical information
6. To recognize typical words and punctuation that signal classifications and lists as they are used in technical writing
7. To answer questions based on text in classification - listing patterns
8. To write out the main ideas of passages
9. To answer questions based on your understanding of main ideas
10. To understand the supporting points of the main ideas

### Unit II

#### Using and Understanding a Technical Book

1. To understand line graphs, circle graphs, and bar graphs as well as tables, diagrams, and charts
2. To identify direct and inverse proportions in line graphs
3. To identify dependent and independent variables in line graphs
4. To use the captions, labels, and directional arrows to match the information in the illustration with the words in the text
5. To use graphs to make comparisons between variables
6. To use tables to make comparisons between variables
7. To test your understanding of certain ideas by making simple drawings that illustrate the ideas

### Unit III

#### Studying a Technical Book

1. To build prior knowledge concerning the chapter contents
2. To preview the chapters by turning the titles of chapter sections into questions that information in the section will answer
3. To create an overview of the chapter by using section headings, italic and boldface type and picture captions to make simple lists of how the information in the section will be divided
4. To use introductory material to predict the content of the chapter to follow

5. To "boil down" the chapter information to a minimum while showing the relationship of ideas that are major to those that are minor
6. To use marginal notations to summarize important points
7. To master a set of abbreviations to use on terms encountered in technical books

Unit IV

Building Technical Vocabulary

1. To understand the precision of technical words
2. To use the etymology of technical words to help fix their meanings in your mind
3. To build your knowledge of roots and root words
4. To develop a broad technical vocabulary - flash cards etc.

Unit V

General Study Skills and Test Taking Skills for Technical Material

1. To strike a balance between listening to understand and writing to remember when taking notes. Listen first, write second
2. To use a two-column note taking system
3. To develop test taking strategies for multiple choice, short answer, and open book tests

## Reading Technical Material Course Outline

### Goal:

The student will develop a pair of basic skills: how to "shake" all the information needed out of a technical textbook and how to organize this information so that he/she will be able to remember it.

### Course Competencies:

The student will achieve the following competencies:

- I. **Distinguish between definitions and examples**
  - A. Technical terms
    1. Terms that have different meanings than they do in everyday life
    2. Terms used with more precision
    3. Terms frequently confused
  - B. Identifying definitions
  - C. Definition vs. example
  - D. Use of examples
    1. idea vs. example
    2. abstract ideas/concrete examples
- II. **Use classification - listing patterns to help understand and remember technical information**
  - A. Recognize typical words - punctuation that signal classification and lists
  - B. Uses of lists
- III. **Write out the main idea of passages**
  - A. What point is author making
  - B. What point do examples illustrate
  - C. What is the point of contrast
  - D. Understand supporting points
- IV. **Understand line, circle, and bar graphs, tables, diagrams and charts**
  - A. Direct and inverse proportion in line graphs
  - B. Dependent and independent variables in line graphs
  - C. Use of captions, labels, directional arrows
  - D. Understanding illustrations
- V. **Study technical books and material**
  - A. Prior Knowledge
  - B. Previewing
  - C. Overviews
  - D. Strategic Organizers
  - E. Prediction
  - F. Relationships of ideas
  - G. Marginal notes
  - H. Technical abbreviations



**VI. Build Technical Vocabulary**

- A. Precision of technical words
- B. Etymology of technical words
- C. Roots - root words
- D. Development of broad technical words

**VII. Develop general study skills and test taking skills**

- A. Listening to understand
- B. Writing to remember
- C. Two column notetaking
- D. Test taking strategies

Integrated Technical Curriculum Science Component

How to Read Technical Materials

Instructional Units and Time Frame\*

Unit	Days (Suggested Number)
Basics of Technical Reading	5
Using and Understanding a Technical Book	15
Studying Technical Book	9
Building a Technical Vocabulary	4
Test Taking Skills for Technical Material	4
End of Course	
Review	1
Exam	1
Grades	1

\* The time frame is a 40 day quarter with classes meeting for 1 hr 55 min daily.

## Session One

### Introduce Basics of Technical Reading

#### Technical Books - difficult to read

1. whole new vocabulary
2. familiar words often have entirely different technical meanings
3. illustrations highly specialized
4. technical books  
saturated with ideas  
dense with abstract ideas

Discuss what they expect to learn and would like to learn and what the course will cover. Any mismatches?

Discuss text and how it will be used

#### Introduce Chapter I - Definition of terms

1. Three kinds of technical terms
2. Identifying definitions
3. Definition vs. example
4. Expanding definitions

Read together and discuss pps. 1-9

Define in notebook

matter	solid	cohesion
volume	liquid	
weight	water	
inertia	air	
mass	pressure	

Terms may be adjusted to complement the particular technical course with which this reading course is learned (i.e. automotive, welding, electrical technology etc.)

Discuss Flash card technique

## Session Two

Cover together Ex 1.1, 1.2, 1.3, 1.4, and 1.5 in text pps. 11 and 12

Complete Exercise 1.6 or 1.7 in notebook pps. 13 and 14

Here a longer selection from some aspect of the automotive curriculum will be substituted for Ex. 1.8 p. 17 on simple computers. The students will be asked to try out what they have learned about definitions of terms on this piece of reading.

### Session Three

Discuss the use of examples - give some automotive examples

Read together Chapter 2 pps. 17-23

#### Ideas vs. examples

1. different
2. examples clarify ideas
3. examples function s a bridge from concrete to abstract

Ideas clarified by examples each student to think of one

Do Ex. 2.1, 2.2,2.3, together pps 21-23

Each student to do either parts 1 or 2 or 3 of exercise 2.4 pps. 24-25

Model the reading of Exercise 2.6 p. 26-27

## Session Four

Read together and discuss the comprehension strategies that must be used to adequately understand Exercise 2.7 Law of Inertia pps. 27-28 and Exercise 2.8 Force and Motion pps. 28-32

### Discuss

- Prior Knowledge
- Previewing
- Definitions - how learn
- Strategic Organizers

What can we as students use to take these abstract words on the page and create visual pictures in our minds which will aid us in remembering?

How can we remember better?

Session Five

Review of automotive terms

List:

Test:

Sample of automotive reading that must be read

1. examples listed
2. what ideas do these examples illustrate
3. define all of the terms needed to make the meaning clear
4. in your own words how do you plan to remember this material

## Session Six

### Introduce Chapter 4 - Classification and Listing

Try memorization exercise p. 45 what does this show about memorization?

How can you increase your ability to understand and remember information?

Can you take clear notes? Classification in the core of all note-taking systems

Good students must learn to read for classification patterns and then use these patterns to take notes.

Read together and discuss pps. 46-50

1. How can students distinguish between the subject of a list and the items within the list
2. What words and punctuation signal classifications and lists
3. Can you take simple notes or use strategic organizers?

Do Exercise 4.1 together and then do Exercise 4.2 in your notebook pps. 50-52

NEW SHEET (each session goes on new sheet)



## Session Seven

A good technical reader must learn to recognize classification patterns and to take simple notes when paragraphs are organized as classifications and lists.

Do Exercises 4.3, 4.4, and 4.5 together pps. 52-54.

Do Ex 4.9 or Exercise 4.10 to be handed in as quiz grade pps. 57-58

Discuss and model the taking of simple notes from three passages of automotive reading where the author is listing information

## Session Eight

Progress Test - combining the skills of definition example and classification to enhance comprehension

As you read the automotive example given you 1) Identify all new terms by underlining the terms and definition 2) Think about the examples used and try to visualize (see them in your mind) 3) Take simple notes

### Introduce Chapter 7 Writing Out Main Ideas

How does an author develop ideas? Is it any different in automotive manuals? key point?

Read and discuss pps. 107-112

## Session Nine

Discuss the "ways" in which a good reader "boils down" the main idea

Give examples of main ideas which are:

1. a definition
2. a listing
3. a similarity or difference (comparison-contrast) between two factors
4. a cause-effect explanation

Do Exercises 7.1, 7.2, 7.3, and 7.4 pps. 112-115 together

Do Exercise 7.9 in your notebook

## Session Ten

Model the reading and thinking processes needed to comprehend  
Exercise 7.10 pps. 122-123

After reading and taking simple notes to aid comprehension,  
answer Question 1-3 on p. 125

### Progress Test:

From a longer piece of automotive reading, choose one or two  
pages where it is difficult to understand the information from  
reading through it quickly, take simple notes

1. write out each main idea
2. list the supporting details or examples below each main idea

Be sure to "boil down" all information

## Session Eleven

### Introduce Chapter Eight Using Illustrations

Technical books explain their ideas in two ways. Unlike many texts, which use only words technical books use words and illustrations.

The author of a technical book expects you to go back and forth from the word to the picture until the point is clear

The reader must study each illustration and match it up with the main ideas expressed.

Illustrations are a valuable source of information. There are many ways to study illustrations and to use them to understand and remember information.

**Line Drawings** - most common form of illustration. Called figures or diagrams

Discuss and read pps. 132 and 133

Do Charts and diagrams  
Floor Plan of a House

Refining Sugar

# Floor Plan of a House

- |                       |                  |
|-----------------------|------------------|
| 1. Living room        | 19. Freezer      |
| 2. Dining area        | 20. Oven         |
| 3. Kitchen            | 21. Front door   |
| 4. Bedroom 1          | 22. Garage doors |
| 5. Bedroom 2          | 23. Driveway     |
| 6. Bedroom 3          |                  |
| 7. Bath               |                  |
| 8. Stairs to basement |                  |
| 9. Hall               |                  |
| 10. Garage            |                  |
| 11. Garden            |                  |
| 12. Patio             |                  |
| 13. Covered walk      |                  |
| 14. Chimney           |                  |
| 15. Fireplace         |                  |
| 16. Dishwasher        |                  |
| 17. Sink              |                  |
| 18. Refrigerator      |                  |

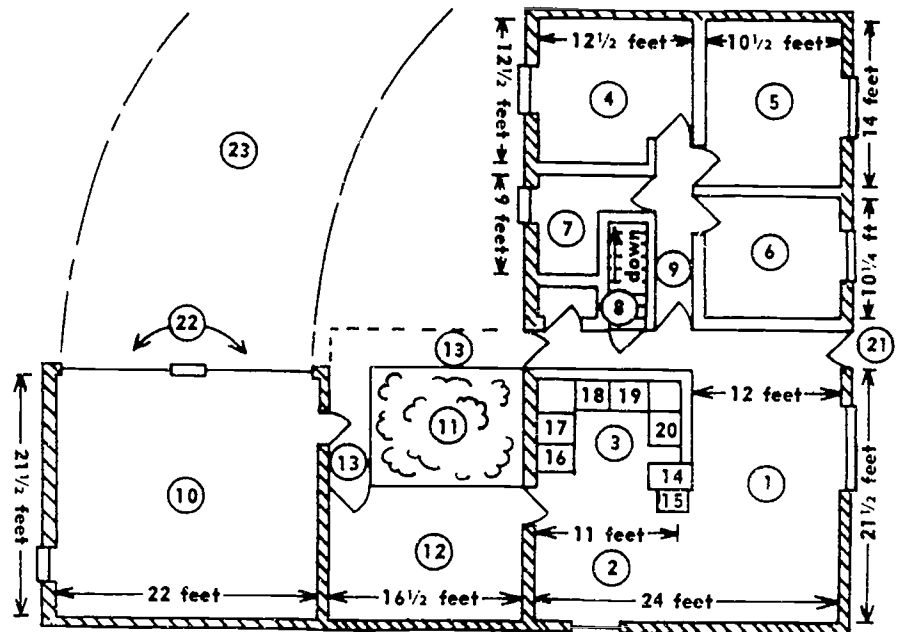

Number your paper from 1 to 15. For 1 to 7, read each sentence and fill in the blank to make the sentence complete. For 8 to 15, choose the best answer for the question. Write its letter on your answer paper. Look at the diagram first. Then read *all* the answers before you decide which one is best.

- This diagram shows the \_\_\_\_\_ of a house.
- You can find the garden of this house at the place numbered \_\_\_\_\_.
- The place numbered 10 on the diagram is \_\_\_\_\_.
- The garden separates the \_\_\_\_\_ from the kitchen.
- How many doors open onto the patio? \_\_\_\_\_
- The patio is \_\_\_\_\_ feet long.
- There are \_\_\_\_\_ bedrooms in the house.
- You can tell from the diagram that the freezer is in the A. garage B. basement C. kitchen D. hall
- The stairs shown in the diagram lead A. to the attic B. to the basement C. from the bath to the hall D. from the kitchen to the patio
- How many doors open into the bath? A. two B. three C. four D. one
- The combined width of bedrooms 1 and 2 is A. 23 feet B. 21 feet C.  $16\frac{1}{2}$  feet D.  $12\frac{1}{2}$  feet
- The outside walls of this house will be built of A. wood B. brick C. stone D. You can't tell from the diagram.
- After putting a car in the garage, you would probably go into the house through A. the front door B. the garden C. the door leading to the basement D. either the door from the covered walk or the door from the patio

- |                       |                  |
|-----------------------|------------------|
| 1. Living room        | 19. Freezer      |
| 2. Dining area        | 20. Oven         |
| 3. Kitchen            | 21. Front door   |
| 4. Bedroom 1          | 22. Garage doors |
| 5. Bedroom 2          | 23. Driveway     |
| 6. Bedroom 3          |                  |
| 7. Bath               |                  |
| 8. Stairs to basement |                  |
| 9. Hall               |                  |
| 10. Garage            |                  |
| 11. Garden            |                  |
| 12. Patio             |                  |
| 13. Covered walk      |                  |
| 14. Chimney           |                  |
| 15. Fireplace         |                  |
| 16. Dishwasher        |                  |
| 17. Sink              |                  |
| 18. Refrigerator      |                  |

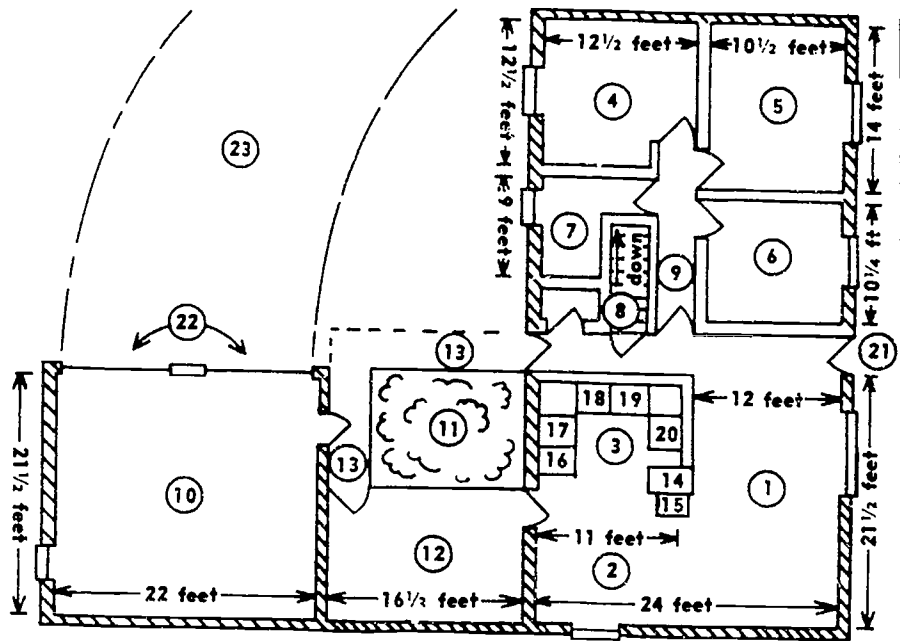

14. If you walked from the kitchen to the bath, you would have to walk through A. the living room, the hall, and a bedroom B. the dining area, the hall, and a bedroom C. the dining area, the living room, and a bedroom D. the dining area, the living room, and the hall

15. You can tell from the plan that this house A. has two floors B. has one floor and a basement C. has a garage for three cars D. is built on a hillside

Copyright © 1961 by Science Research Associates, Inc. All rights reserved. Printed in the United States of America.

# Refining Sugar

Number your paper from 1 to 15. For 1 to 7, read each sentence and fill in the blank to make the sentence complete. For 8 to 15, choose the best answer for the question. Write its letter on your answer paper. Look at the chart first. Then read *all* the answers before you decide which one is best.

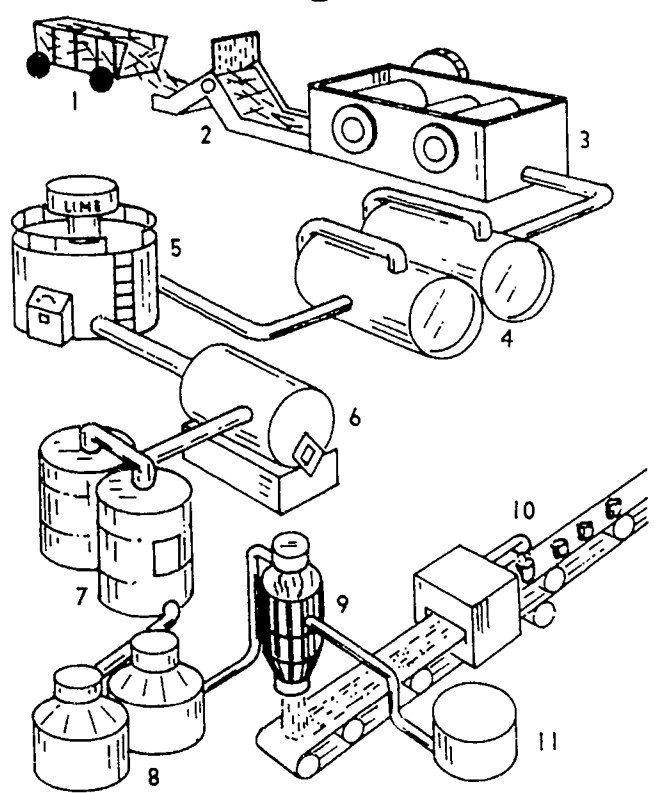

1. The main purpose of this chart is to show how \_\_\_\_\_ is made from \_\_\_\_\_.
2. According to the chart, only the \_\_\_\_\_ are used to make sugar.
3. The sugar cane is brought to the sugar mill by \_\_\_\_\_.
4. After the crystals are separated from the molasses, raw sugar is put into \_\_\_\_\_.
5. Before the sugar cane is pressed it is \_\_\_\_\_.
6. You can tell from the chart that sugar is made from the \_\_\_\_\_ of the sugar-cane stalks.
7. According to the chart, the two products made from sugar cane are \_\_\_\_\_ and \_\_\_\_\_.
8. You can tell from the chart that lime is added to the juice to **A.** make it taste better **B.** help make impurities settle **C.** make the juice thicker **D.** help form sugar crystals
9. The sugar-cane juice is heated the second time to remove **A.** water **B.** lime **C.** impurities **D.** crystals
10. After the juice is pressed from the stalks it is first **A.** washed **B.** filtered **C.** heated **D.** spun

1. Sugar cane stalks brought from fields
2. Stalks washed
3. Juice pressed from stalks
4. Juice heated
5. Impurities settled out
6. Juice filtered
7. Some water removed to form heavy sirup
8. Sirup heated to remove all water and form sugar crystals
9. Crystals separated from molasses by spinning
10. Raw sugar put into bags
11. Molasses stored

11. After all the water is taken out of the juice, what is left is **A.** molasses **B.** raw sugar **C.** a mixture of molasses and sugar **D.** sugar crystals
12. The raw sugar and the molasses are separated by **A.** filtering the sirup **B.** washing the crys-



tals C. heating the molasses D. spinning the sugar and molasses

13. Between the pressing of the stalks and the separation of sugar crystals from molasses there are A. five steps B. four steps C. six steps D. seven steps
14. You can guess from the name *raw sugar* that A. it must be cooked before it can be used B. it will be refined still more before it is used C. it is ready to be used the way it is D. sugar is used when it is raw
15. You can be sure from the chart that sugar-cane juice A. contains a great deal of lime B. is very thick when it is pressed C. does not contain much molasses D. contains a great deal of water

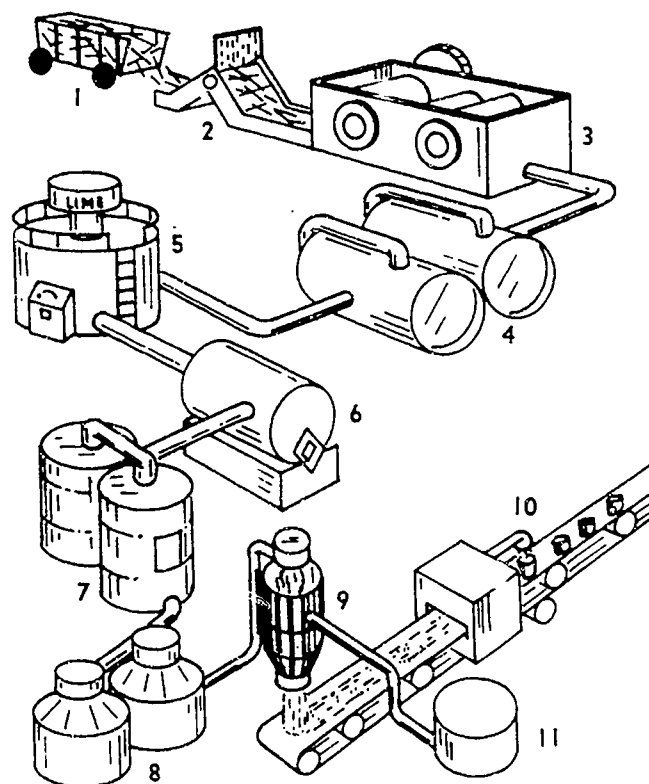

1. Sugar cane stalks brought from fields
2. Stalks washed
3. Juice pressed from stalks
4. Juice heated
5. Impurities settled out
6. Juice filtered
7. Some water removed to form heavy sirup
8. Sirup heated to remove all water and form sugar crystals
9. Crystals separated from molasses by spinning
10. Raw sugar put into bags
11. Molasses stored

**Session Twelve**

Model reading and discuss how to extract information from two  
more diagrams

Use two automotive diagrams or other sample provided

# Manufacture of Nylon

Number your paper from 1 to 15. For 1 to 7, read each sentence and fill in the blank to make the sentence complete. For 8 to 15, choose the best answer for the question. Write its letter on your answer paper. Look at the chart first. Then read *all* the answers before you decide which one is best.

- The purpose of this chart is to show how \_\_\_\_\_ is made.
- \_\_\_\_\_ different raw materials are used to make the kind of yarn shown on this chart.
- Before the nylon salt goes to the storage tank, \_\_\_\_\_ is added.
- The last step in making the finished yarn is \_\_\_\_\_.
- Before the nylon salt enters the pressure cooker it goes through the \_\_\_\_\_.
- As the nylon comes out of the melt chamber it is cooled by \_\_\_\_\_.
- Just before the nylon falls into the hopper of the melt chamber it goes through \_\_\_\_\_.
- You can tell from the chart that water is used in making nylon A. once B. twice C. three times D. four times
- During the manufacture of nylon, cooling takes place A. twice B. once C. after each step D. after it is spun
- The chart shows that the chipper is a machine that A. cools the nylon B. cuts the nylon into small pieces C. heats the nylon D. makes the nylon into a ribbon

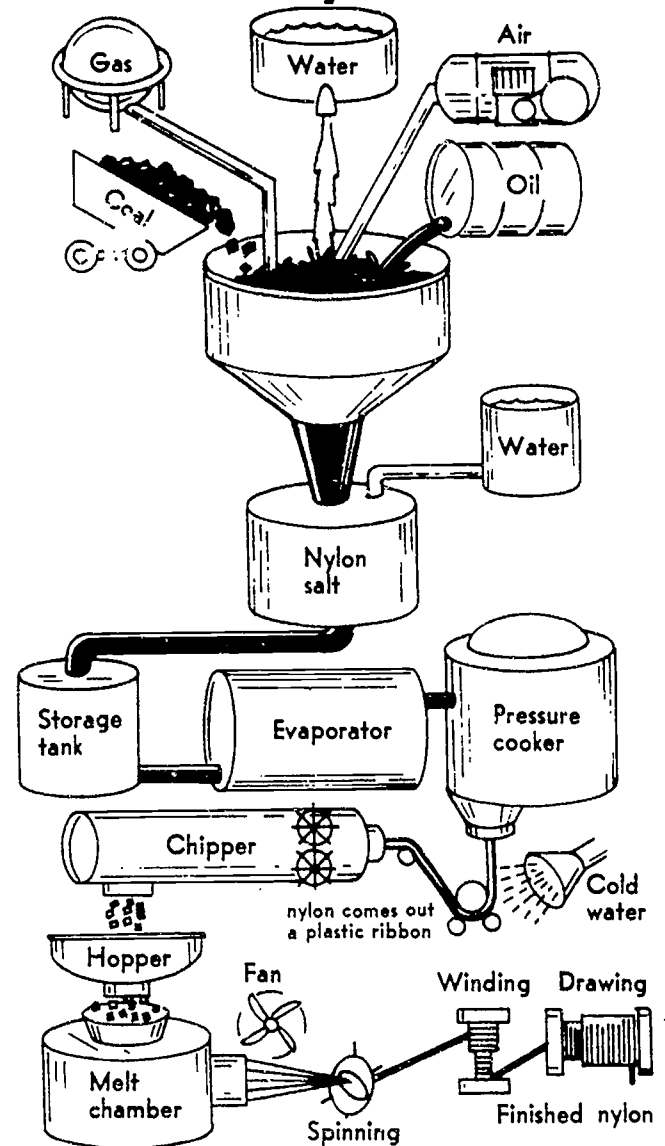

- In the storage tank you would expect to find A. oil and coal B. nylon salt and gas C. nylon salt and water D. gas and coal
- You can tell from the chart that nylon yarn is A. found ready to use in mines B. made from animal fibers C. made from plant fibers D. made from several natural resources

13. You can tell from the chart that nylon yarn could not be made without **A.** heat **B.** air **C.** coal **D.** all of the above
14. You can tell that the purpose of the spinning machine is to **A.** pull the nylon from the melt chamber **B.** twist several strands into one **C.** stretch the nylon yarn **D.** make the nylon into cloth
15. After the nylon leaves the melt chamber, it must be **A.** chipped, cooled, and cooked **B.** cooked, cooled, and spun **C.** spun, wound, and drawn **D.** spun, melted again, and drawn

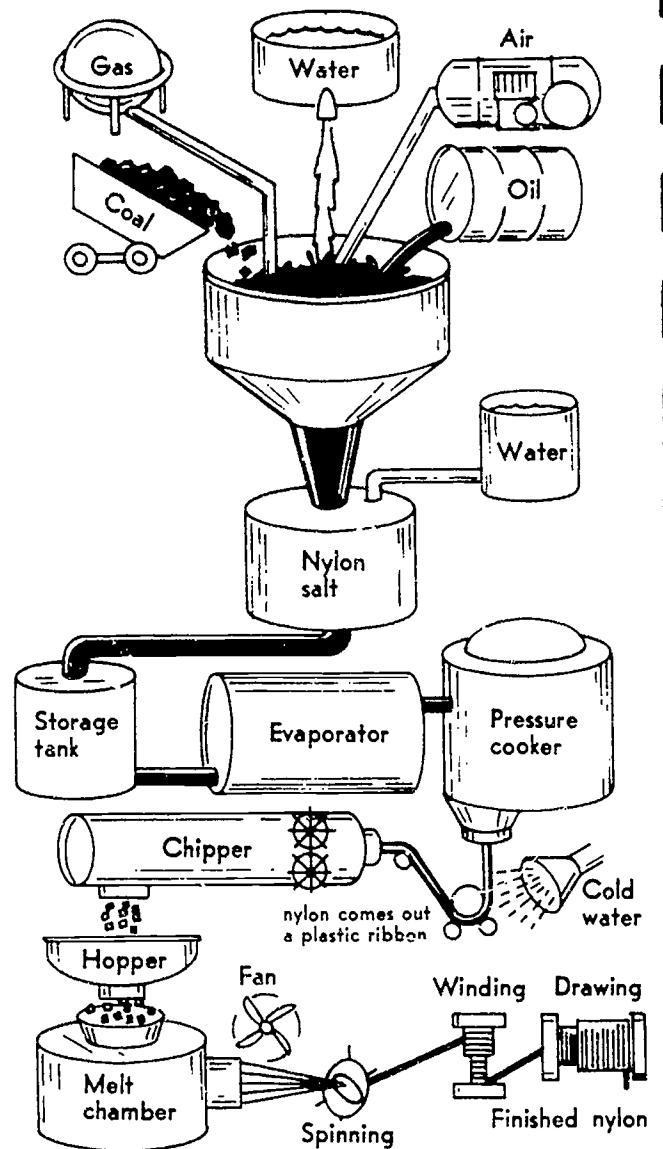

# How Water Is Purified

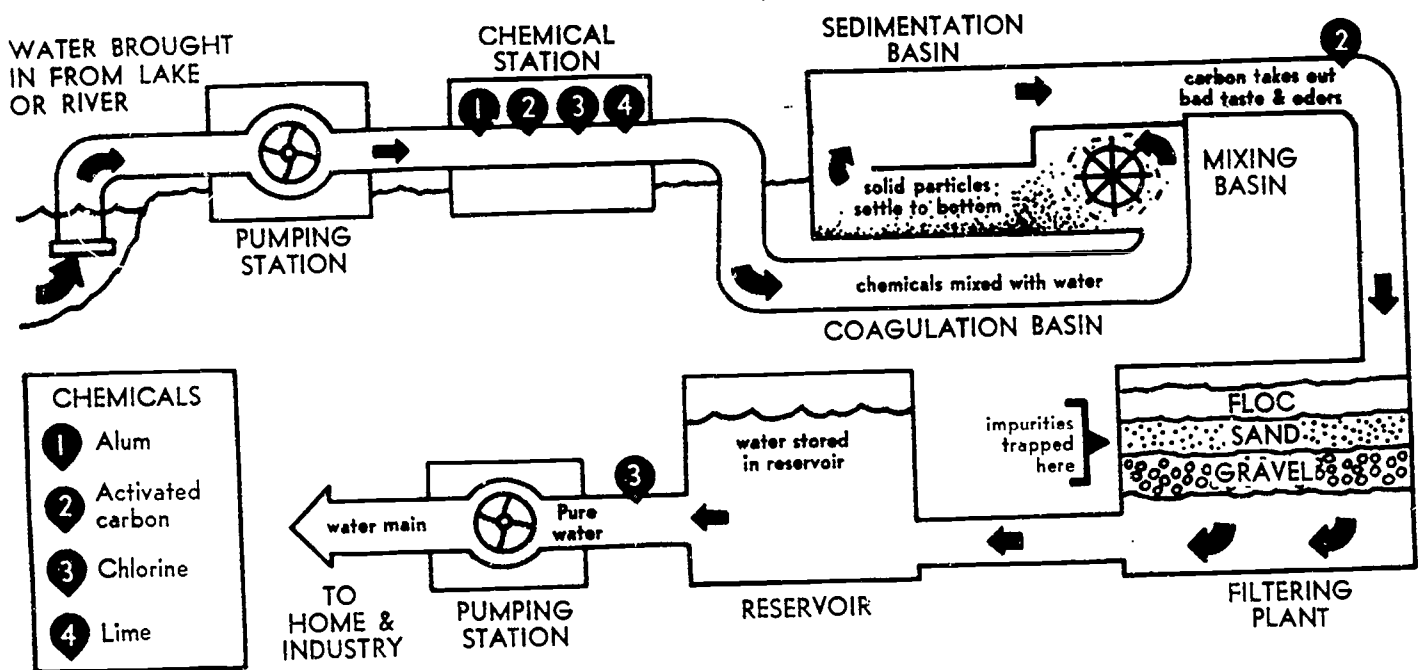

Number your paper from 1 to 15. For 1 to 8, read each sentence and fill in the blank to make the sentence complete. For 9 to 15, choose the best answer for the question. Write its letter on your answer paper. Look at the chart first. Then read *all* the answers before you decide which one is best.

1. This chart shows the process by which water is \_\_\_\_\_ before it is used.
2. The arrows show the direction the \_\_\_\_\_ takes as it flows through the plant.
3. The legend shows the kinds of \_\_\_\_\_ that are put into the water.
4. \_\_\_\_\_ different chemicals are added to the water.
5. After bad odors have been taken out, the chart shows that the water flows through \_\_\_\_\_, \_\_\_\_\_, and \_\_\_\_\_ in the filtering plant.
6. After the water is purified, it is stored in a \_\_\_\_\_ before it is pumped to homes and industries.
7. The last chemical added to the water is \_\_\_\_\_.
8. Lime is added to the water at the \_\_\_\_\_ station.
9. The first step in the process of purifying water is A. bringing the water into the plant from a lake or river B. adding chemicals to the water C. pumping the water through the water mains D. filtering the water through sand and gravel
10. How many different chemicals are added to the water at the chemical station? A. three B. five C. four D. six
11. The chemical added between the sedimentation basin and the filtering plant is A. lime B. alum C. chlorine D. activated carbon

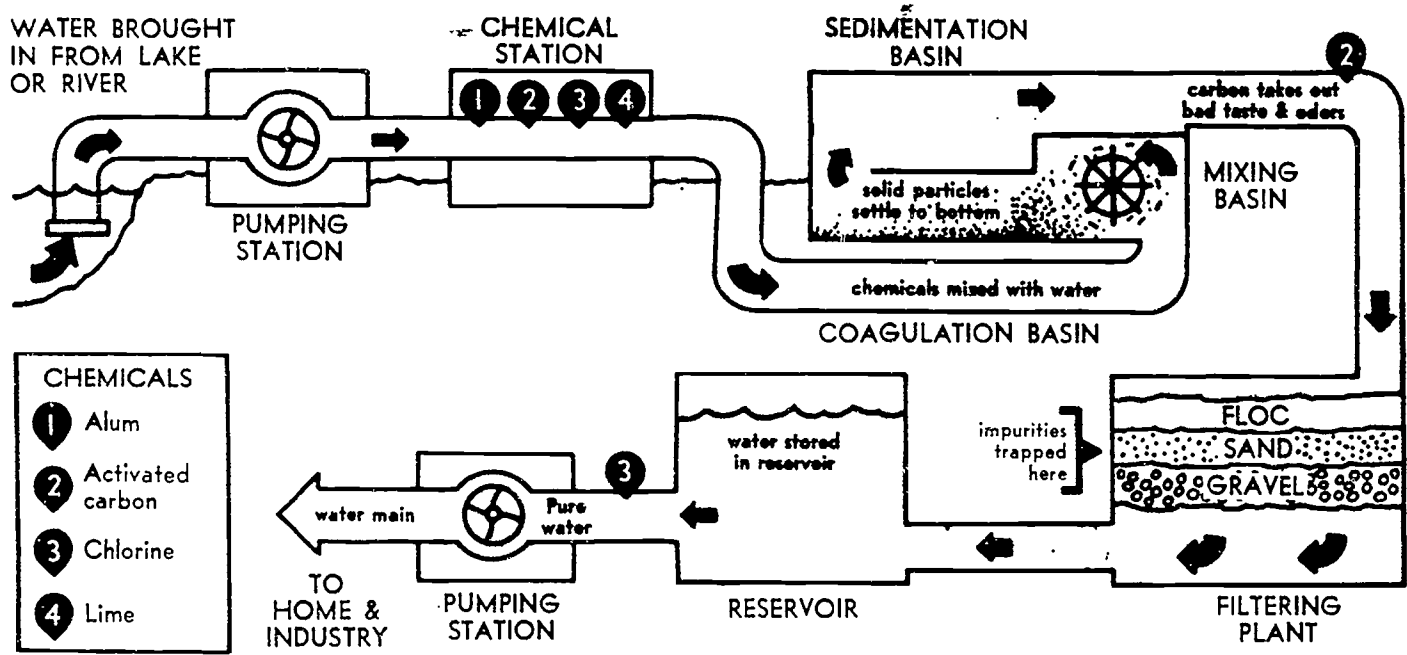

12. The purpose of the floc, sand, and gravel is  
 A. to trap impurities B. to hold back the flow of water C. to mix chemicals with the water D. to remove bad odors
13. After the water goes through the filtering plant, it flows into the  
 A. pumping station B. chemical station C. reservoir D. mixing basin
14. The last pumping station shown on the chart pumps water  
 A. into the chemical station

- B. to homes and factories C. out of the sedimentation basin D. into the reservoir
15. The purpose of adding activated carbon to the water is  
 A. to make the water clear B. to remove bad odors C. to cause the water to filter through the sand more easily D. to trap impurities

Copyright © 1961 by Science Research Associates, Inc. All rights reserved. Printed in the United States of America.

## Session Thirteen

Discuss graphs pps. 133-140

Line graph is used to show a relationship between variables  
see figures 8.3, 8.4, 8.5 pps. 134-135

Discuss independent variable  
dependent variable  
pps. 135 bottom - 138

Discuss direct proportion  
inverse proportion  
pps. 138-139

Do Line Graph (Rockets Launched by the Air Force) for  
practice or an automotive line graph if there is one available

## Rockets Launched by the Air Force

Number your paper from 1 to 20. Read the sentences on the card. If a sentence is true, write *True* on your answer paper. If it is false, write *False* on your paper. If you write *False*, tell why the sentence is false. You must look at the graph to find your answers.

1. This graph shows how many rockets were launched by the Air Force over a period of 12 months.
2. The vertical scale is divided into units of one rocket.
3. The horizontal scale is divided into units of one year.
4. The horizontal grid lines show units of 5 rockets.
5. You can tell from the graph that no more than 15 rockets were launched in any one month.
6. A bar shows how the number of rocket launchings changed from month to month.
7. Five rockets were launched in January.
8. Twice as many rockets were launched in May as were launched in January.
9. Half as many rockets were launched in April as were launched in August.
10. Nine rockets were launched in November.
11. More rockets were launched in September than in any other month.
12. A total of 128 rockets were launched in all the months shown.

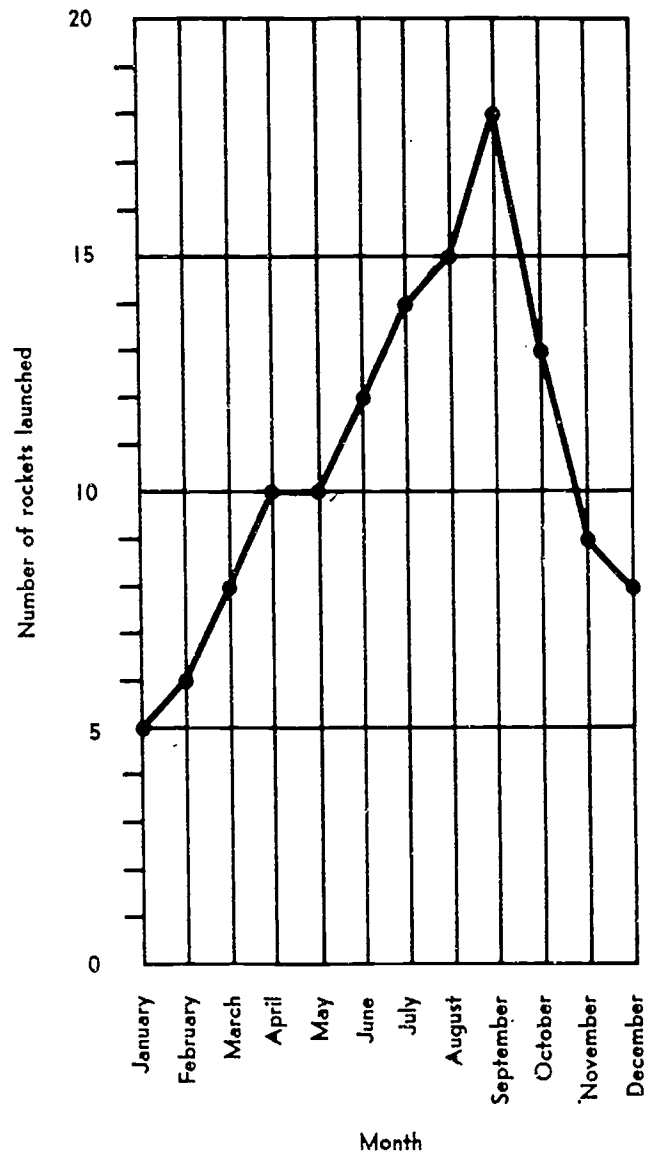

13. This graph could not show more than 20 rocket launchings for any one month.
14. September was the only month in which more rockets were launched than were launched in October.
15. More than 11 rockets were launched in only two of the months.



16. Three more rockets were launched in August than were launched in June.
17. Seventeen rockets were launched in November and December together.
18. The same number of rockets were launched in March as were launched in December.
19. You can tell from the graph that the Air Force had trouble with rocket launchings in January and February.
20. The graph shows fewer rocket launchings each month from September through December.

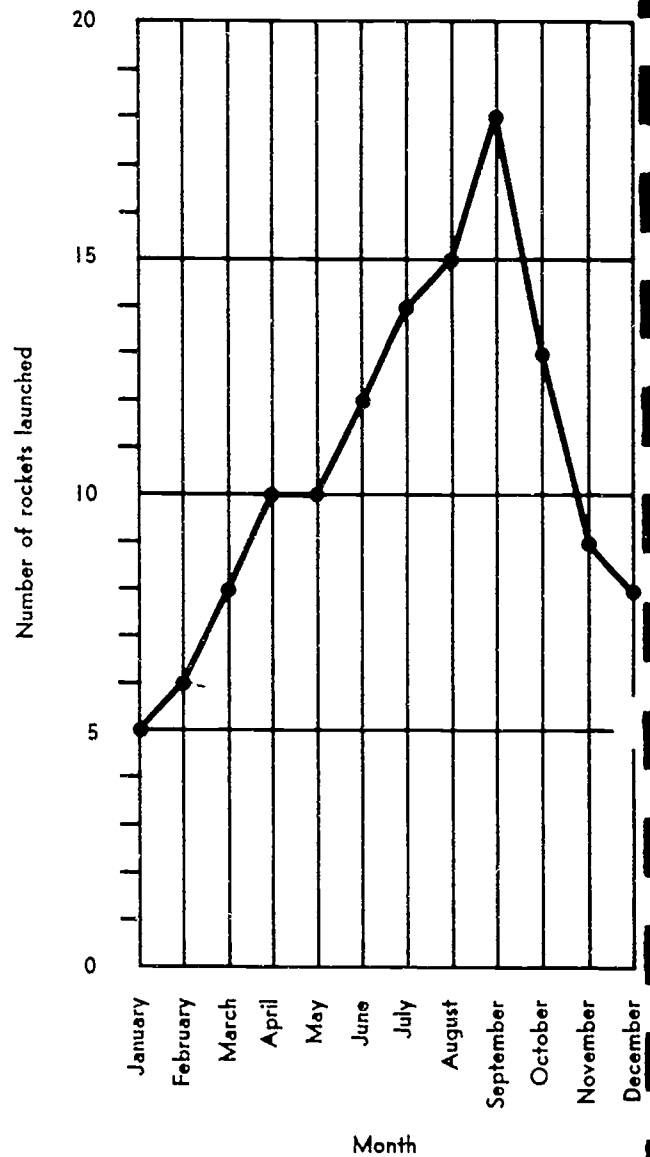

**Session Fourteen**

**Discuss Circle Graphs and Bar Graphs pps. 139-140**

**Use Visuals A through D as examples, discussion and practice**

**Do for practice in your notebook  
Circle graph (Snowfall in New York City)**

**Bar Graph (Morning Traffic)**

# American Global Trade: Part I

**I. U.S. Trade Balance, 1990**  
(billions of U.S. dollars)

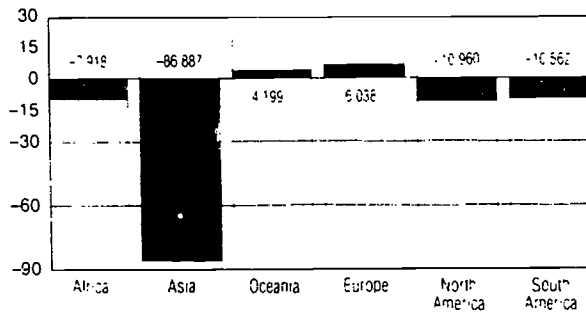

Source: U.S. Bureau of the Census, Highlights of the U.S. Export and Import Trade

**II. U.S. Trade Balance with Germany and Japan, 1980-1990**  
(billions of U.S. dollars)

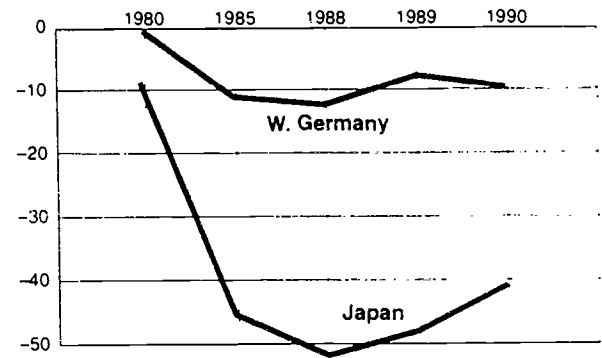

Source: U.S. Bureau of the Census, Highlights of the U.S. Export and Import Trade

**III. Share of U.S. Export, 1980 and 1990**  
(percentage)

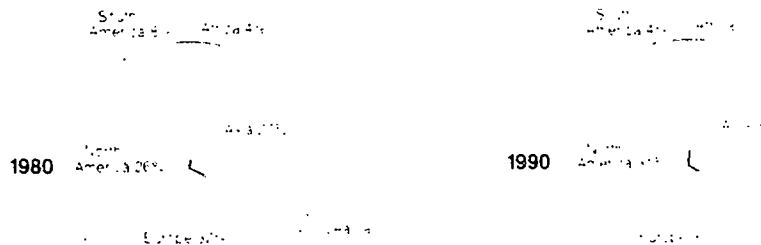

**IV. U.S. Balance of Trade with EC Nations, 1990**

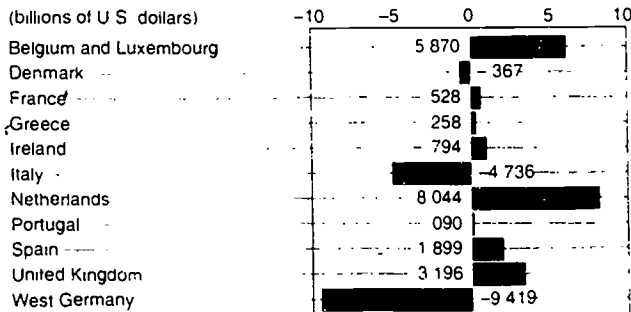

Source: U.S. Bureau of the Census, Highlights of the U.S. Export and Import Trade

**V. U.S. Trade Balance with the European Community**

The U.S. Surplus with the EC Soars

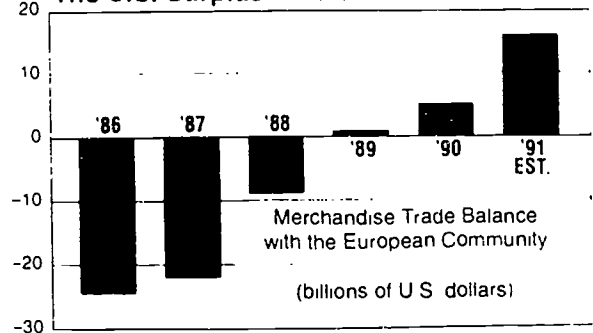

Source: U.S. Bureau of the Census, Highlights of the U.S. Export and Import Trade

Reprinted by permission from FORTUNE Magazine © 1990 Time Inc. All rights reserved.

## VISUAL A

## Vocabulary

---

**Balance of trade:** balance between imports and exports of one nation

**Capital:** accumulated goods

**Competitiveness:** the ability of one entity to operate efficiently and productively in relation to other similar entities

**Direct investment:** buying stock, real estate and other assets in another country

**Export:** the sale of goods to other nations

**Four dragons:** rising Asian markets – South Korea, Taiwan, Singapore and Hong Kong

**Free trade:** the international movement of goods without any restriction

**GATT (General Agreement on Tariffs and Trade):** the world's free trade organization, established in 1947

**GNP (Gross National Product):** value of a nation's total output of goods and services

**Import:** the purchase of goods from other nations

**MNCs (Multinational Corporations):** firms with headquarters in one nation and their business operations in one or more foreign nations

**NAFTA (North American Free Trade Association):** free trade zone among the United States, Canada and Mexico

**NICs (Newly industrializing Countries):** less developed nations with advancement in manufactured products

**Protectionism:** limitation of imports into the country through tariffs and non-tariff barriers

**Recession:** decline in national business activity

**Tariff:** a tax that importers pay on goods purchased abroad

**Trade deficit:** the excess of imports over exports of one nation

# A Closer Look at North American Trade

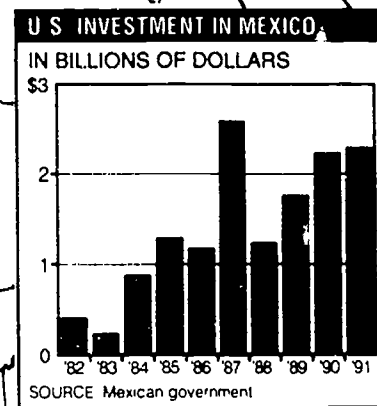
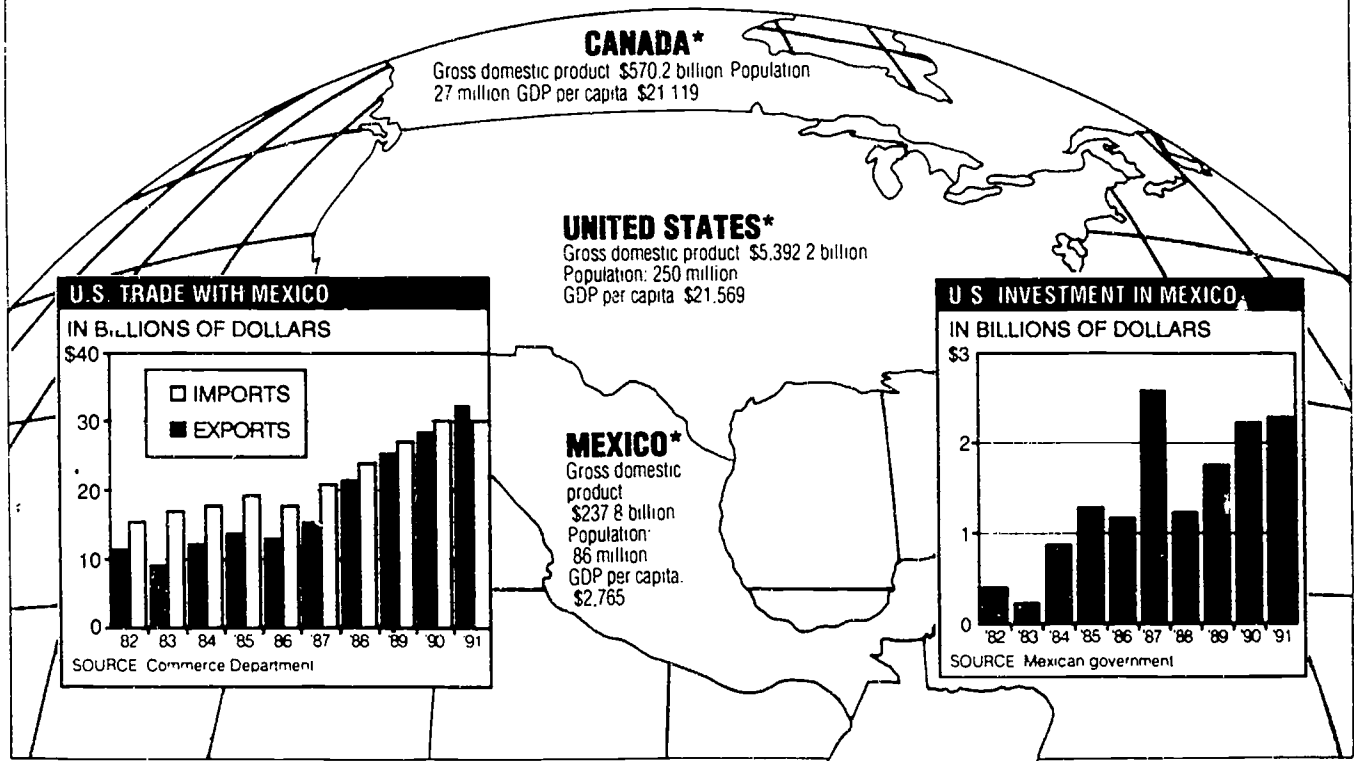
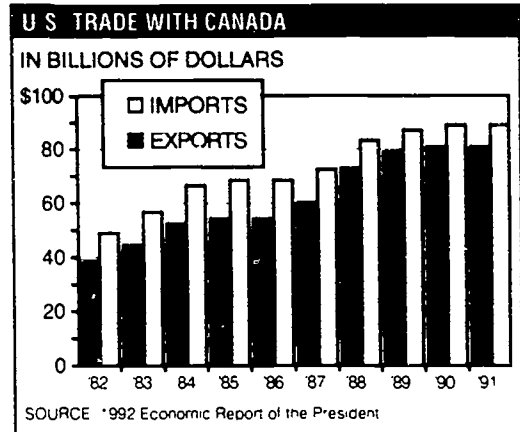
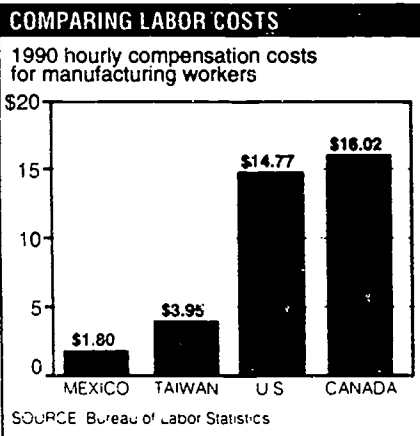

© 1992 The Washington Post Co. Reprinted with permission

## VISUAL C

# American Global Trade: Part II

## I. U.S. Export and Import of Selected Commodities, 1989

In millions of dollars. Includes nonmonetary gold. Exports are f.a.s. (free alongside ship) transaction value basis; imports are customs value basis

### DOMESTIC EXPORTS

SELECTED COMMODITIES	Total	WESTERN HEMISPHERE		WESTERN EUROPE				ASIA
		Canada	Mexico	United Kingdom	West Germany	France	Italy	Japan
Total	350,017	74,977	24,117	19,643	16,069	10,919	6,529	42,764
Food and live animals	19,724	1,903	1,990	469	384	371	338	7,238
Crude materials, excluding fuels	26,627	2,288	1,493	798	1,255	445	906	7,233
Mineral fuels and related materials	9,823	1,678	712	259	102	334	632	1,510
Manufactured goods	276,359	68,977	19,759	18,029	14,089	9,741	4,967	25,283
Machinery	139,994	15,634	8,327	8,579	5,690	5,093	1,969	8,467
Transport equipment	50,517	17,560	2,486	2,982	3,017	1,262	639	2,993
Clothing								
Footwear								

### GENERAL IMPORTS

Total	WESTERN HEMISPHERE		WESTERN EUROPE				ASIA
	Canada	Mexico	United Kingdom	West Germany	France	Italy	Japan
472,926	88,210	27,186	18,242	24,834	13,029	11,946	93,586
20,685	3,521	2,391	164	273	150	218	290
15,370	7,983	627	162	160	116	103	178
52,649	7,770	4,299	1,663	105	154	333	140
379,597	68,269	19,596	15,638	24,105	11,721	10,847	92,924
126,758	11,490	9,739	5,478	8,770	3,626	2,380	43,959
79,003	27,640	2,437	2,375	6,200	2,401	975	29,439
24,559	260	592	219	120	196	899	228
8,393	55	170	34	31	56	816	7

Source: U.S. Bureau of the Census, copied from Statistical Abstract of the U.S., 1991

## II. Developing Nations' Share of U.S. Exports

Poor Countries, Good Customers

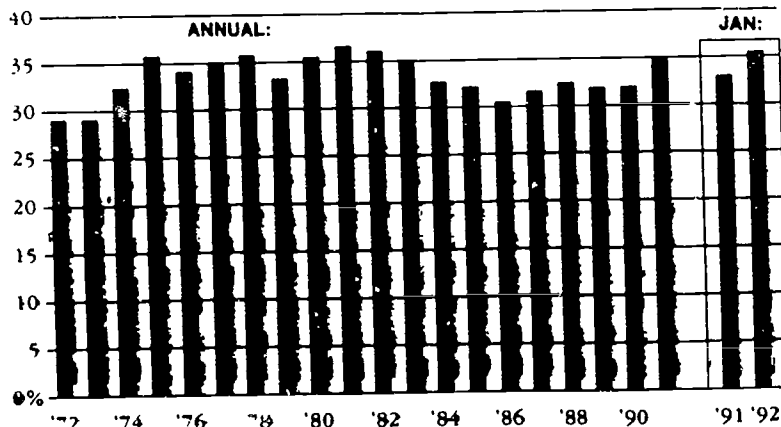

Source: Commerce Department © 1992 by The New York Times Co. Reprinted by permission.

## III. U.S. Exports to 20 Latin American Countries

(billions of U.S. dollars)

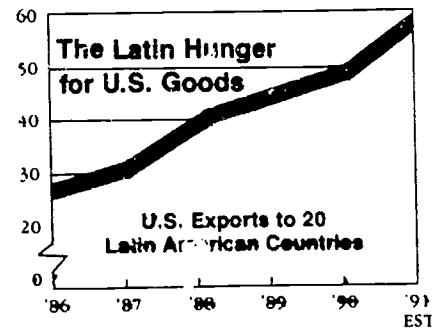

Data: U.S. Census Bureau, BW Estimate  
Reprinted from February 10, 1992, issue of Business Week by special permission. Copyright © 1992 by McGraw-Hill, Inc.

## VISUAL B

# How Competitive Are American Industries?

## I. U.S. Industries Compared to Japan and Europe

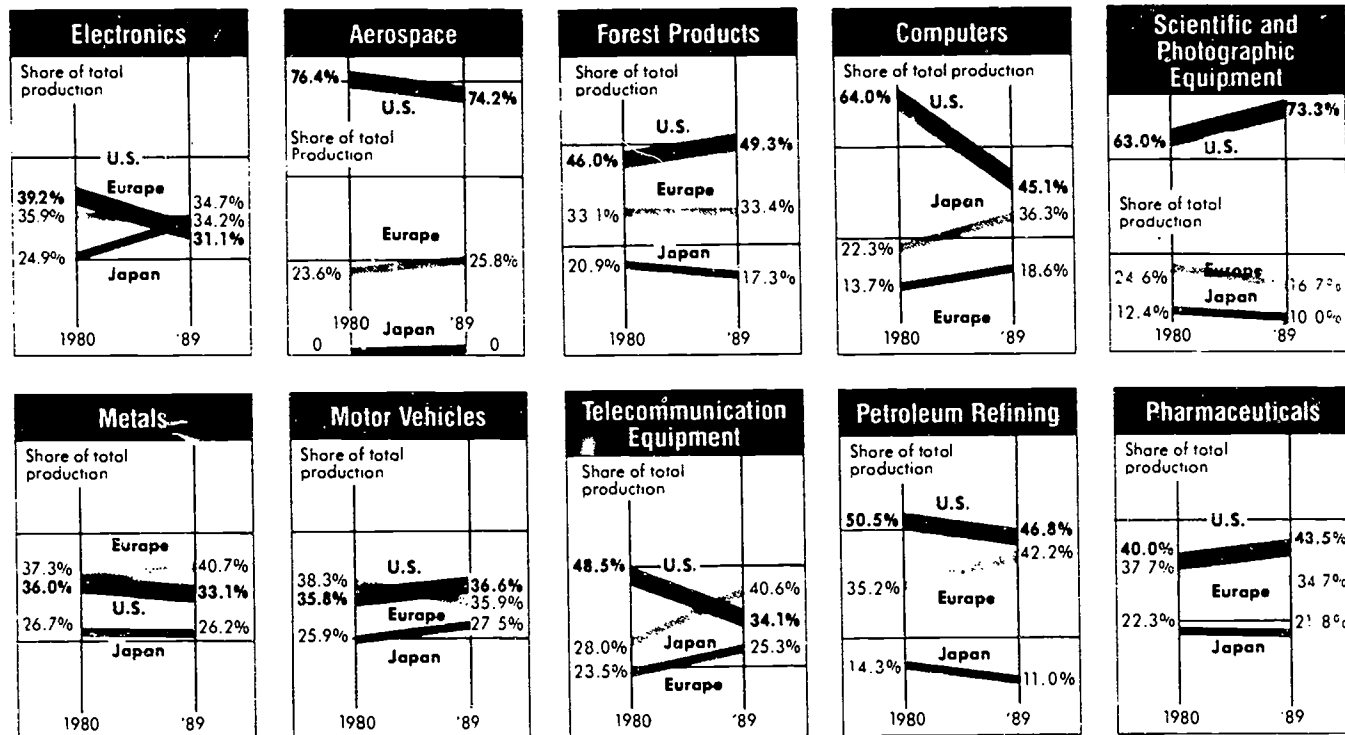

Reprinted by permission from FORTUNE Magazine © 1992 Time Inc. All rights reserved

## II. U.S. Share of World Export

(percent)

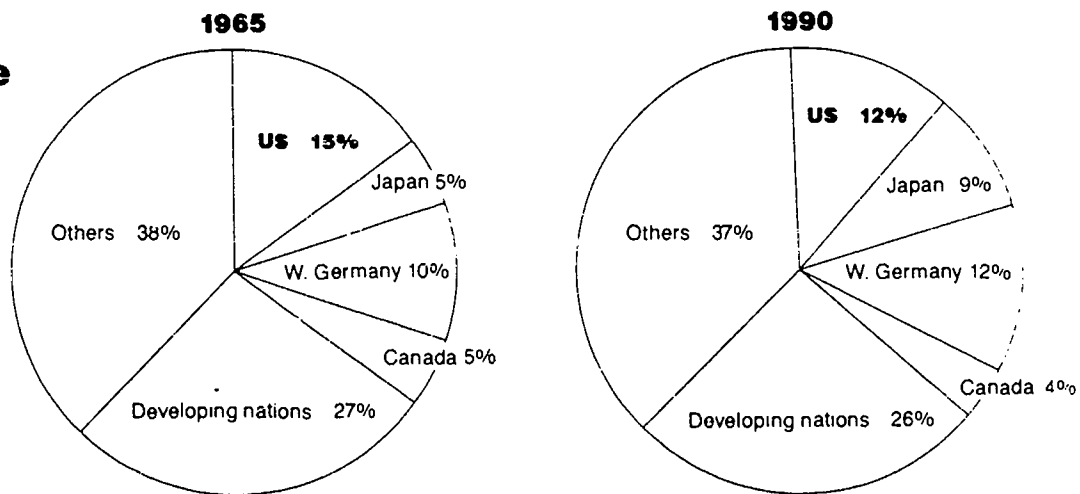

Source: IMF, International Financial Statistics Yearbook, 1991

## VISUAL D

# Is the U.S. in Decline?

## I. Myths and Facts about American Decline

**Myth:** The United States can't get rid of its trade deficit.

**Fact:** The first quarter merchandise trade deficit was about \$11 billion. But if services like consulting and air travel are added in and exports are adjusted for undercounting, the United States had an estimated \$3 billion surplus.

**Myth:** U.S. productivity is growing slowly.

**Fact:** By some estimates U.S. productivity is 15 percent higher than Japan's and is growing just as quickly. Productivity in services may be rising far more rapidly than official statistics report.

**Myth:** America is losing its financial clout.

**Fact:** U.S. investment banks underwrite more than two thirds of the world's securities. While U.S. banks aren't the biggest anymore, they're still among the most profitable.

Newsweek, June 8, 1992

## III. Foreign Direct Investment

Percent of host-country GDP

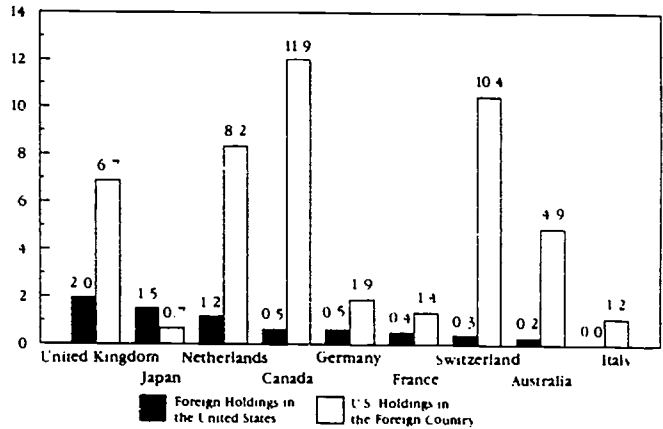

Note: Japan data based on GNP. German output is for former West Germany.  
 Source: Department of Commerce and Organization for Economic Cooperation and Development.  
 Economic Report of the President Transmitted to the Congress, Feb., 1992 (U.S. Govt. Printing office)

II.



Reprinted by permission: Tribune Media Services.

by Locher for the Chicago Tribune

## VISUAL E

40



# Snowfall in New York City

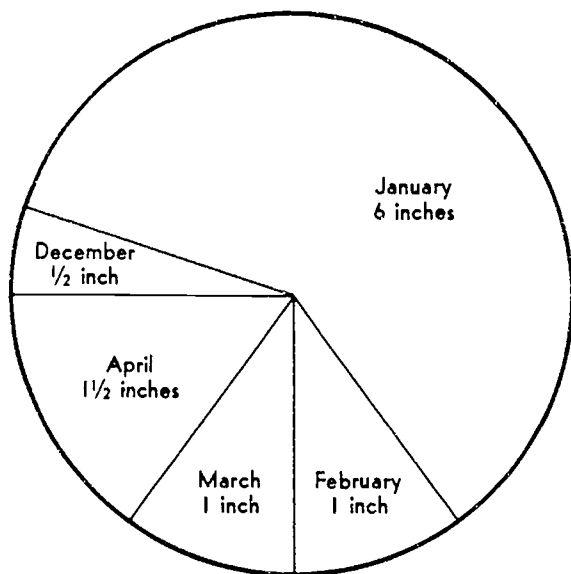

Winter of 1940-41

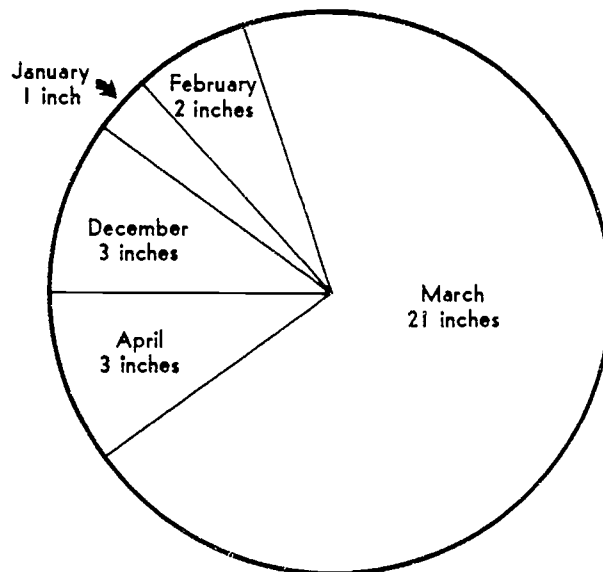

Winter of 1955-56

Number your paper from 1 to 20. Read the questions below. After each question are several answers. Look at the graph to see which answer is correct. Then write its letter on your paper after the number of the question. Be sure to read *all* the answers before you decide which one is correct.

- The name of the city in which the snow fell is shown
  - in each part of each graph
  - only in the graph at the left
  - in the title
  - in the subtitles
- How many winters are shown in each circle graph?
  - two
  - three
  - four
  - one
- You can find the years that are compared
  - in each part of the graph
  - in the title
  - in the subtitle below each graph
  - in none of these
- The amount of snowfall was measured in
  - yards
  - tons
  - feet
  - inches
- The months in which snow fell were
  - January, February, March, and April
  - January, February, March, April, and May
  - December, January, February, and March
  - December, January, February, March, and April
- In the graph on the left the month of December is in the year
  - 1941
  - 1940
  - 1955
  - 1956
- In the graph on the right the month of March is in the year
  - 1941
  - 1942
  - 1955
  - 1956
- How many inches of snow fell in April 1956?
  - 1 1/2
  - 3
  - 2
  - 1
- In 1955-56 almost three-fourths of the total number of inches of snow fell in
  - January
  - March
  - April
  - May
- In 1940-41 the greatest amount of snow fell in
  - April
  - February
  - January
  - March
- The total snowfall in 1940-41 was
  - 6 inches
  - 7 inches
  - 8 inches
  - 10 inches

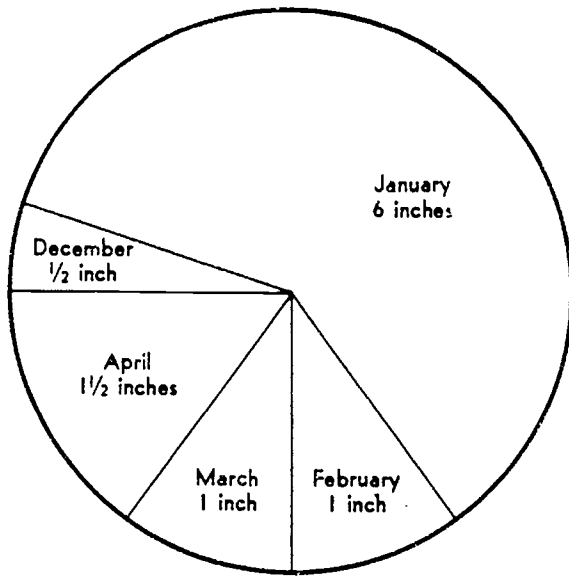

Winter of 1940-41

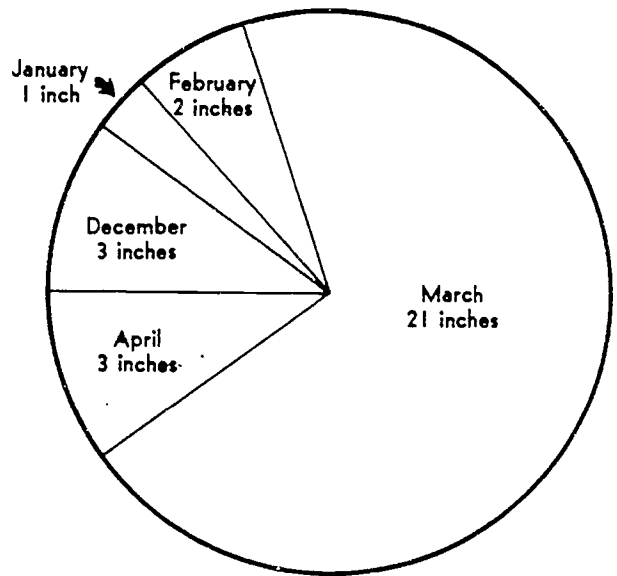

Winter of 1955-56

12. The total snowfall in 1940-41 was A. one-third the total snowfall in 1955-56 B. two times as great as the total snowfall in 1955-56 C. one-half the total snowfall in 1955-56 D. three times as great as the total snowfall in 1955-56
13. In February 1941 it snowed exactly one-half as much as in A. March 1942 B. December 1941 C. December 1955 D. February 1956
14. The amount of snow in December 1940 plus the amount in April 1941 equals A. one-half the total snowfall in the winter of 1940-41 B. one-fifth the total snowfall in the winter of 1940-41 C. one-fourth the total snowfall in the winter of 1940-41 D. one-tenth the total snowfall in the winter of 1940-41
15. About how much more snow fell in April 1956 than in April 1941? A. 1 inch B. 1 1/2 inches C. 3 inches D. 2 inches
16. In 1940-41 the same amount of snow fell in March as in A. February B. January C. December D. April
17. It snowed twenty-one times as much in one month in 1956 as it did in the same month in 1941. That month was A. March B. April C. December D. January
18. The amount of snow that fell in April 1956 was what part of the total snowfall for that winter? A. one-half B. one-tenth C. one-third D. one-fourth
19. The least amount of snowfall in any one month during the two winters was A. 1 inch B. 2 inches C. 1/2 inch D. 1 1/2 inches
20. Twice as much snow fell in February 1956 as in A. January 1956 B. April 1956 C. December 1955 D. March 1956

Copyright © 1961 by Science Research Associates, Inc. All rights reserved. Printed in the United States of America.

# Warrensburg High School Band

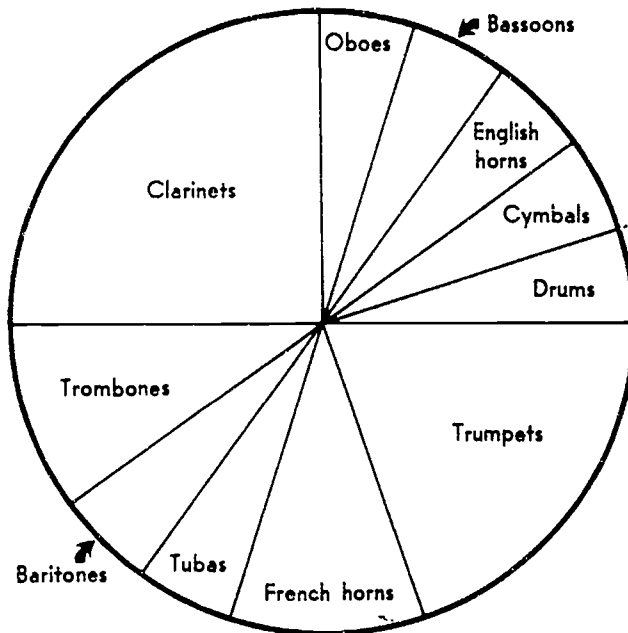

Number your paper from 1 to 20. Read the sentences on the card. If a sentence is true, write *True* on your answer paper. If it is false, write *False* on your paper. If you write *False*, tell why the sentence is false. You must look at the graph to find your answers.

- The graph is a picture graph.
- The title tells you that the graph is about a symphony orchestra.
- The names of different kinds of musical instruments are shown in the graph.
- The whole graph stands for all the instruments in the band.
- Each part of the graph stands for two instruments.
- The Warrensburg High School Band has twelve kinds of instruments.
- The band has more clarinets than any other kind of instrument.
- Trumpets make up the second-largest group of instruments in the band.
- You can tell that the band has the same number of oboes and bassoons.
- There are more cymbals in the band than there are drums.
- There are more trombones than baritones.
- The graph shows that the band has about twice as many French horns as English horns.
- There are about half as many French horns as trumpets.
- About one-fourth of all the instruments are clarinets.
- About one-half of the band is made up of clarinets, oboes, bassoons, English horns, cymbals, and drums.

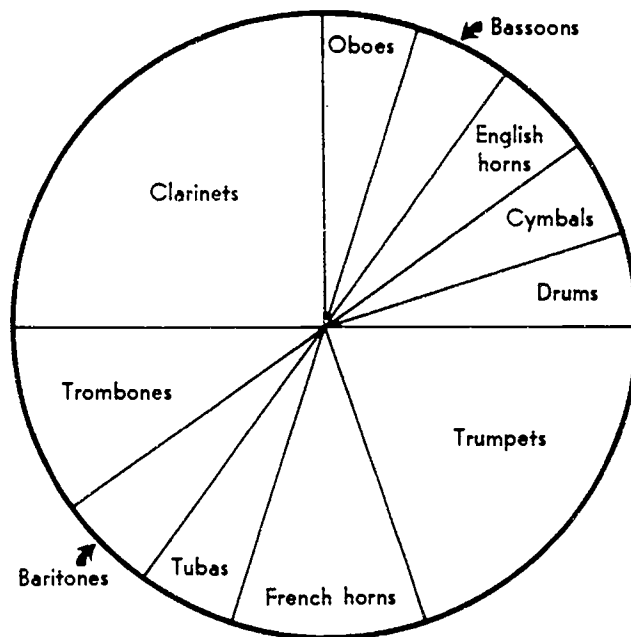

16. The graph shows that Warrensburg High School has a large band.
17. There are more English horns in the band than bassoons.
18. Trombones make up a larger part of the band than do French horns.
19. Trombones, baritones, tubas, French horns and trumpets make up about one-half of the band.
20. There are about as many baritones and tubas together as there are French horns.

Copyright © 1961 by Science Research Associates, Inc. All rights reserved.  
Printed in the United States of America.

# Morning Traffic on Main Street

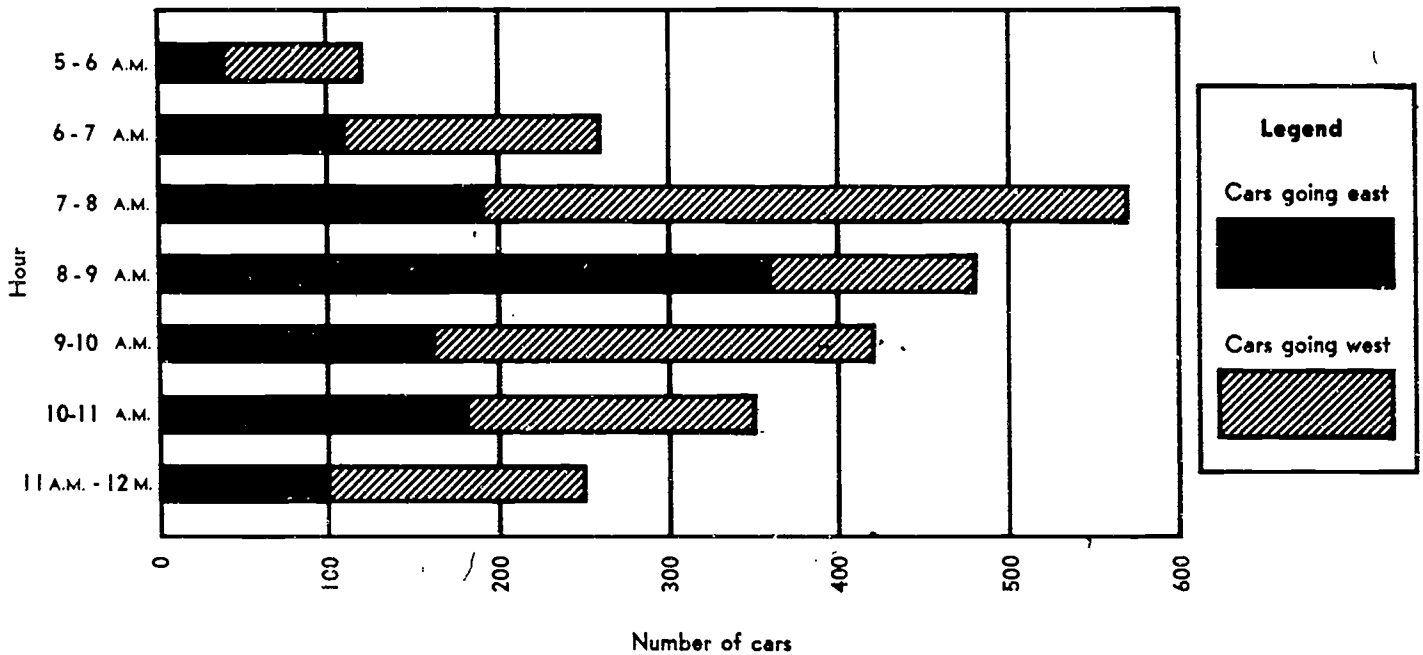

Number your paper from 1 to 20. Read each sentence below. Fill in the blank to make the sentence complete. Look at the graph to find your answer.

- The graph shows the number of cars traveling on Main Street for \_\_\_\_\_ hours.
- On the horizontal axis, the scale is divided into units of \_\_\_\_\_.
- From the legend you know that the part of each bar with slanting lines shows the cars going \_\_\_\_\_.
- The solid part of each bar shows how many cars went \_\_\_\_\_.
- Between 7 A.M. and 8 A.M. about \_\_\_\_\_ cars traveled east.
- One hundred cars traveled east during the hour from \_\_\_\_\_ to \_\_\_\_\_.
- The largest number of cars to travel on Main Street during any hour was about \_\_\_\_\_.
- More cars traveled west during the hour from \_\_\_\_\_ to \_\_\_\_\_ than during any other hour.
- The fewest cars traveled on Main Street from \_\_\_\_\_ to \_\_\_\_\_.
- A total of about 350 cars traveled in both directions on Main Street between \_\_\_\_\_ and \_\_\_\_\_.
- A total of about \_\_\_\_\_ cars traveled Main Street during the hour from 9 A.M. to 10 A.M.
- At least 400 cars traveled on Main Street during \_\_\_\_\_ different hours.
- More cars traveled east during the hour from \_\_\_\_\_ to \_\_\_\_\_ than during any other hour.
- The total number of cars traveling Main Street from 5 A.M. to 6 A.M. is about equal to \_\_\_\_\_.

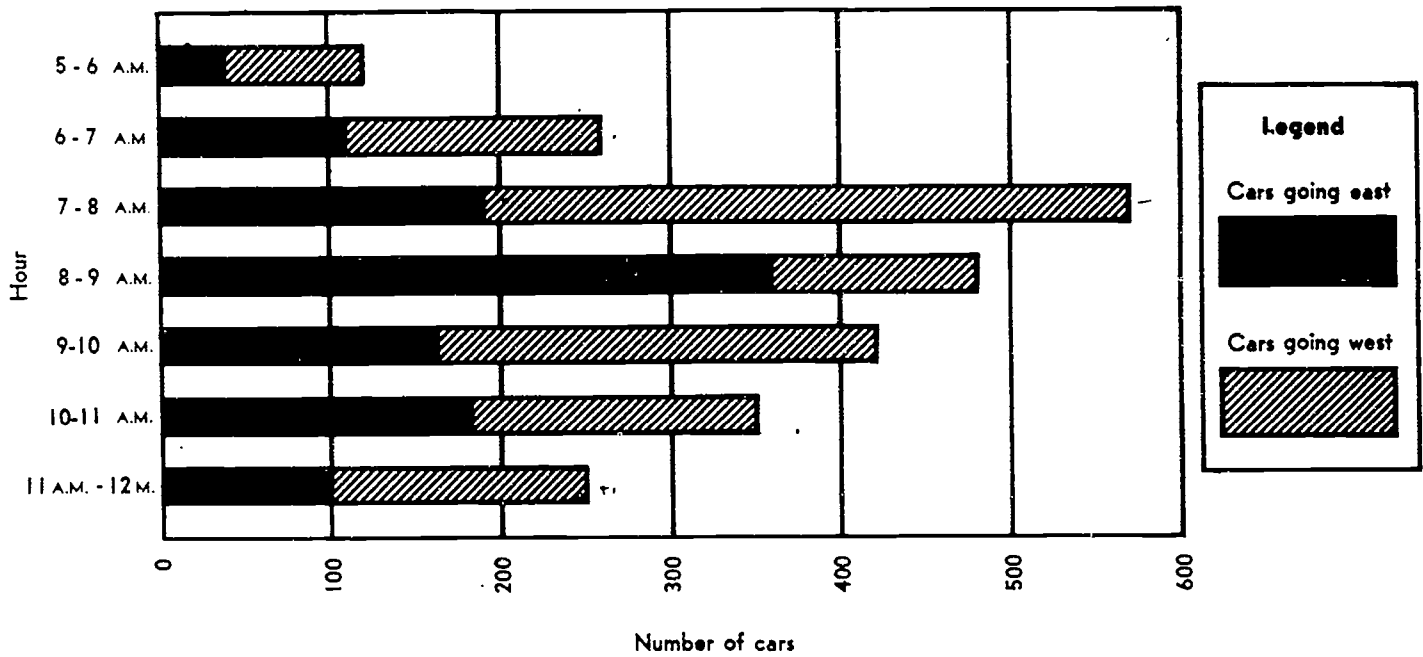

- the number of cars going west from \_\_\_\_\_ to \_\_\_\_\_.
15. About 150 cars were going west during \_\_\_\_\_ different hours of the morning.
  16. About the same number of cars went east as went west during the hour from \_\_\_\_\_ to \_\_\_\_\_.
  17. About \_\_\_\_\_ cars traveled west on Main Street between 5 A.M. and 6 A.M.
  18. At least 150 cars traveled east during \_\_\_\_\_ different hours.
  19. More than 200 cars traveled west during \_\_\_\_\_ different hours.
  20. More cars were going west than were going east during \_\_\_\_\_ different hours.

Copyright © 1961 by Science Research Associates, Inc. All rights reserved.  
 Printed in the United States of America.

**Session Fifteen**

Discuss Tables pps. 140-141 compact storage spots capable of holding great amounts of data

1. Title
2. Stub column
3. Field columns
4. Headings

Do Table (Great Inventions and Scientific Discoveries) for practice or an automotive table if available

# Great Inventions and Scientific Discoveries

Invention or discovery	Inventor or discoverer	Date	Nation
Airplane	Langley	1896	United States
Balloon	Montgolfier	1783	France
Bicycle	MacMillan	1842	Scotland
Cement	Aspdin	1845	England
Ice-making machine	Gorrie	1851	United States
Lightning rod	Franklin	1752	United States
Power loom	Cartwright	1785	England
Piano	Cristofori	1709	Italy
Radar	Taylor & Young	1922	United States
X ray	Roentgen	1895	Germany

Number your paper from 1 to 20. Read the sentences on the card. If a sentence is true, write *True* on your answer paper. If it is false, write *False* on your paper. If you write *False*, tell why the sentence is false. You must look at the table to find your answers.

- This table lists some of the world's great inventions and scientific discoveries.
- You can tell from the table the country in which each man did his work.
- You can tell from the table which of the inventions or discoveries is the most important.
- The table lists the birth date of each man.
- The airplane was invented by Montgolfier.
- An Italian invented the piano.
- The bicycle and cement were invented within a few years of one another.
- The most recent invention listed in the table is radar.
- Cartwright invented the power loom in England.
- The ice-making machine was invented by a man who lived in England.
- The X ray was discovered one year before the airplane was invented.
- The lightning rod was invented before the piano was invented.
- Radar is the only invention listed on which two men worked.
- The power loom was invented sixty years after cement was invented.
- Langley, Montgolfier, and MacMillan all helped to improve transportation.



Invention or discovery	Inventor or discoverer	Date	Nation
Airplane	Langley	1896	United States
Balloon	Montgolfier	1783	France
Bicycle	MacMillan	1842	Scotland
Cement	Aspdin	1845	England
Ice-making machine	Gorrie	1851	United States
Lightning rod	Franklin	1752	United States
Power loom	Cartwright	1785	England
Piano	Cristofori	1709	Italy
Radar	Taylor & Young	1922	United States
X ray	Roentgen	1895	Germany

16. More of the inventors listed lived in England than in Germany.
17. In this table, the United States has five times as many inventors and discoverers as Italy.
18. The earliest invention listed was made 213 years before the latest invention listed.
19. More of the inventions and discoveries listed in this table were made before 1800 than were made after 1800.
20. The table shows that important inventions have been made by people from many countries.

*Copyright © 1961 by Science Research Associates, Inc. All rights reserved.  
Printed in the United States of America.*

**Session Sixteen**

Discuss Block Diagrams p. 141 and picture graphs

Do Picture Graph (Fred's Newspaper Sale for practice or an automotive picture graph if available

Discuss Captions, labels, arrows, and other parts of the illustration pps. 142-144

# Fred's Newspaper Sales

Number your paper from 1 to 25. Read the sentences on the card. If a sentence is true, write *True* on your answer paper. If it is false, write *False* on your paper. If you write *False*, tell why the sentence is false. You must look at the graph to find your answers.

1. From the title and the legend you know that the graph will show the number of newspapers Fred sold.
2. The vertical axis shows the days in June when Fred sold papers.
3. The purpose of the graph is to show Fred's sales on each day from May 7 through May 16.
4. The graph compares the number of papers Fred sold with the number he couldn't sell.
5. The legend shows two kinds of symbols.
6. Each symbol in the graph stands for 10 newspapers sold.
7. Fred's sales for twelve days are shown in the graph.
8. On May 7 Fred sold 50 newspapers.
9. On May 10 only 10 newspapers were sold.
10. People bought 40 newspapers from Fred on May 12.
11. On May 11 Fred sold 30 more newspapers than on May 8.
12. Fred sold twice as many newspapers on May 8 as on May 10.

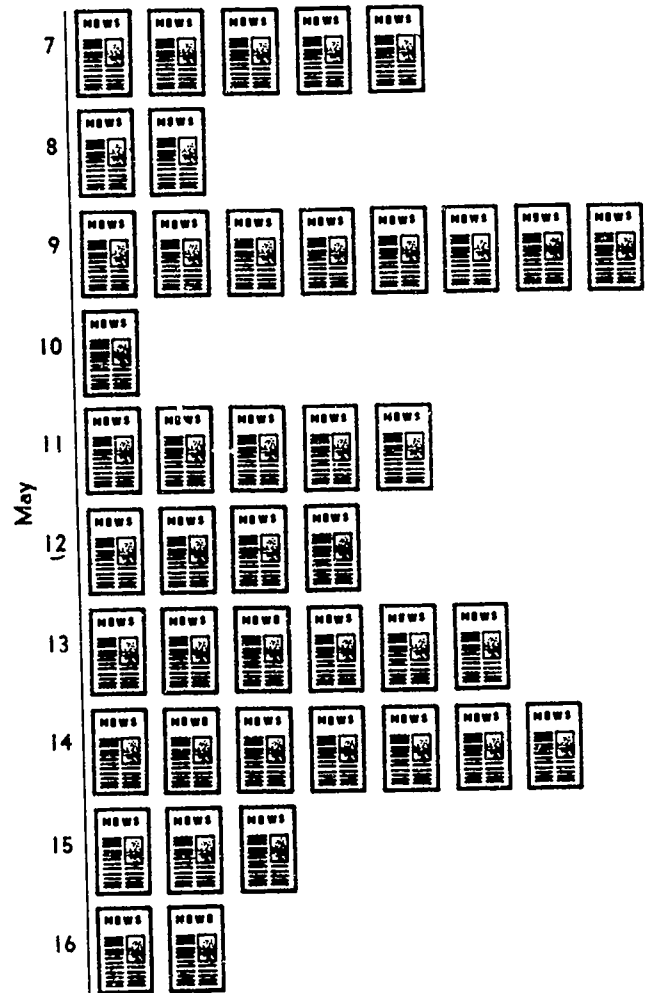

**Legend**



= 10 newspapers sold

13. Three newspapers were sold on May 15.
14. The most newspapers were sold on May 9.
15. The fewest newspapers were sold on May 8.
16. On May 7 and on May 13 Fred sold the same number of newspapers.

17. On May 11 fewer than 40 newspapers were sold.
18. Fred sold 10 more newspapers on May 15 than on May 16.
19. On May 8 and again on May 16, Fred sold 20 newspapers.
20. The graph shows that Fred sold a total of 430 newspapers during ten days.

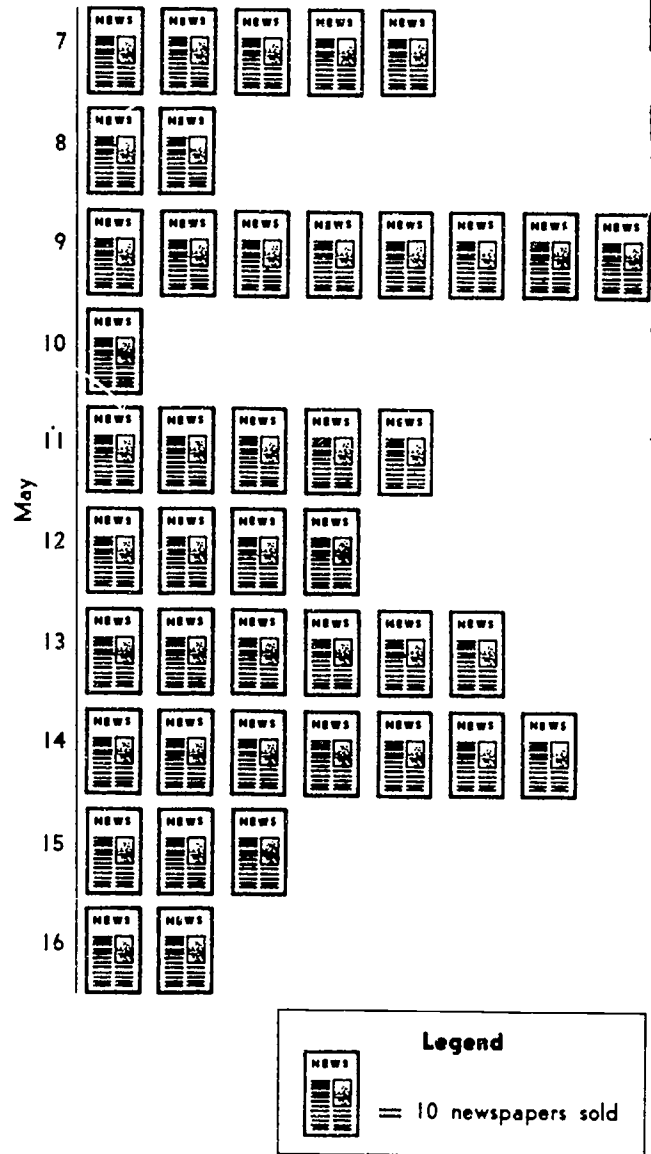

## Session Seventeen

Illustrations in technical books are not decorations. They are usually at the core of the explanations; therefore the good technical reader must be able to use

1. all parts of the illustration
2. match the information in the illustration with the words in the text
3. understand the relationships between the variables shown

Do Exercises 8.1, 8.2, 8.3, and 8.4 together in class pps. 144-147

Do Exercise 8.5 in your notebook and 8.7 (automotive) in your notebook

**Session Eighteen**

Discuss and model the reading and thinking skills used to complete Exercises 8.8, 8.9, and 8.10 pps. 152-155

**Progress Test - Engine Cycles**

Complete Exercise 8.11 on engine cycles as a progress test

**Session Nineteen**

· Complete Exercise 8.12 together

Test your understanding of difficult ideas by drawing an illustration or making a graph of your own using any of the information in Exercises 8.13, 8.14, 8.15, or 8.16.

Use only one

**Session Twenty**

**Midterm**

**Progress Test - using automotive diagrams, graphs and charts**



## Session Twenty-one

Introduce how to use and study a technical book

Discuss prior knowledge

Discuss Before, During, and After Reading Strategies - see handout

Discuss Previewing 0 Preview Chapter 9 pps. 162-168

Read and discuss pps. 162-168

1. learn to combine quick reading with slow reading - scan until you find what you want than read more slowly
2. Use titles subtitles, illustrations, captions etc. as part of overview

## Procedure

**Before Reading.** Develop questions that help students think about what they already know and how it relates to the material to be read. Students can make predictions on their own (On My Own).

**During Reading.** Develop questions that will guide the students' reading. These questions should enhance the sense of the story content and should follow the structure of the text. Some of these questions will be from the *right there* category, but *think and search* questions should dominate because these questions require integrating information to make inferences and should lead to the asking of *author and me* questions (Right There, Think and Search, Author and Me).

**After Reading.** Develop questions that require student to think about their knowledge as it pertains to the text (Author and Me, On My Own).

Figure 9 presents a graphic illustration of the four types of QARs which can be used for overheads or bulletin boards to help students remember the key differences.

Figure 9

In the Book	In My Head
<p><b>Right There:</b> The answer is in the text and easy to find. The words used to develop the question and to answer the question are <b>RIGHT THERE</b> in the same sentence.</p>	<p><b>Author and You:</b> The answer is not in the text. You need to think about what you already know, what information the author provided in the text, and how it fits together.</p>
<p><b>Think and Search (Putting together):</b> The answer is in the story but you need to put together different parts of the story to find the answer. Words for the question and for the answer are not found in the same sentence. They come from different parts of the text.</p>	<p><b>On My Own:</b> The answer is not in the text. You can even answer the question without reading the story. You need to use your own experiences.</p>

Adapted from T. E. Raphael

## Textbook Assessment

Title: \_\_\_\_\_

Author: \_\_\_\_\_

Publisher: \_\_\_\_\_

Copyright: \_\_\_\_\_

This checklist is designed to help you evaluate the considerateness of the textbook you are using or considering purchasing for your class. A considerate text helps students learn. An inconsiderate text places roadblocks in their path.

As you evaluate the textbook consider students' background knowledge. You may want to ask students to help evaluate the text.

Using the following scale, evaluate how well the text meets the criteria listed.

Inconsiderate					Considerate
1	2	3	4	5	

### Look at the whole book.

- \_\_\_\_\_ Does the overall content of the text reflect what you feel are the important concepts in your course?
- \_\_\_\_\_ Is the content up to date and relevant to your students?
- \_\_\_\_\_ Does the book contain helpful organizational features such as a table of contents, index, glossary, and appendices?
- \_\_\_\_\_ Is the book clearly organized?

### Look at each chapter.

- \_\_\_\_\_ Is a helpful introduction provided for each chapter?
- \_\_\_\_\_ Is sufficient background knowledge provided so that students can link new knowledge with information previously learned?
- \_\_\_\_\_ Is there a clearly recognizable organizational pattern for each chapter?
- \_\_\_\_\_ Is the organizational pattern signaled by headings, transition words, bold print, italics or other indicators?
- \_\_\_\_\_ Do the questions and activities draw attention to the organizational pattern of the chapter?
- \_\_\_\_\_ Do the questions encourage thoughtful responses?
- \_\_\_\_\_ Does the text suggest activities for students to practice using new concepts?
- \_\_\_\_\_ Do the pictures, graphic aids, and supplementary information clearly relate to the important concepts of the chapter?
- \_\_\_\_\_ Are there summaries that clarify the organization?

**Examine the way the book is written.**

- Does the textbook use clear, readable language?
- Is the level of vocabulary appropriate for the background of your students?
- Does the text introduce new vocabulary clearly using direct definitions or examples?
- Is the vocabulary density (i.e., percentage of difficult words) appropriate for your students?
- Are the assumptions about prior knowledge of the content appropriate for your students?
- Does the text clearly explain new concepts using concrete examples that link the concepts to what students already know?
- Is the level of sentence complexity appropriate for your students?
- Does the text use active verbs and personal pronouns such as "you," "we," and "us" to involve the students in the content?
- Does the text clearly link pronouns to referents and place subjects and verbs near the beginning of sentences?
- Does the text stick to the topic and avoid irrelevant details?
- Does the text relate content to students' lives?
- Does the text provide positive models for both sexes and for different ethnic or cultural groups?

**Look at the teacher's manual.**

- Does the teacher's manual provide introductory activities that build on students' background and motivate them to read?
- Does the teacher's manual provide guidance in helping students recognize organizational patterns?
- Does the teacher's manual provide follow-up activities that help students integrate new knowledge into existing frameworks?

**Look at supplementary materials.**

- Do supplementary materials, such as texts, worksheets, or computer programs, support the concepts presented in the text?
- Are supplementary materials motivating and interesting?

**Weaknesses**

On which items was the book rated lowest?

What are the weaknesses of this text?

What can you do in class to compensate for the weaknesses of this text?

**Strengths**

On which items was the book rated highest?

What are the strengths of this text?

What can you do in class to take advantage of the strengths of this text?

# "Bookworm" Map

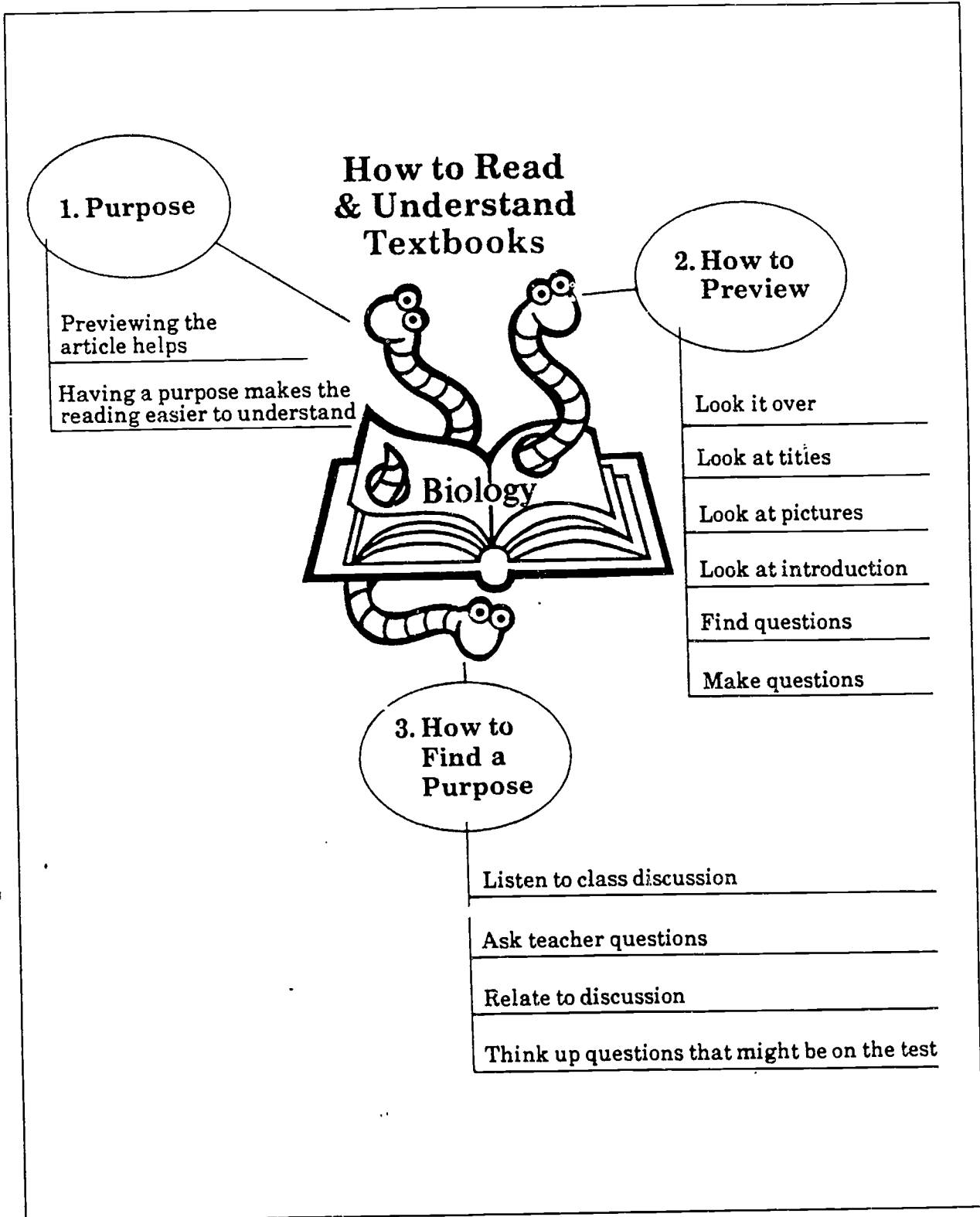

## Semantic Mapping

### *Description*

Semantic mapping is a strategy for activating background knowledge about a topic or for encouraging vocabulary development.

Semantic maps (sometimes called conceptual maps or webbing) display words, ideas, or concepts in categories and indicate how words relate to one another or how they go together (figure 7). Such maps are valuable for students to link previous or old knowledge and words to a new idea or words and to see the relationships among words on the map (Johnson and Pearson).

Students are often helped by visualizing information learned from text. Semantic mapping is a successful method for helping students to see how information can be related. This information can include vocabulary concepts, main ideas and supporting details, or topics. Creating a semantic map has the advantage of total student involvement. Students are active participants in the process of developing visual maps of the concepts. Mapping can be an alternative to note taking or outlining. It forces students to read for key words and supporting ideas.

### *Procedure*

1. Select a vocabulary concept or identify the major point of a reading and write it out on the board, or in the center of a piece of paper, and circle it.
2. Determine secondary categories or related words and write them around the central idea or word. Connect them with lines.
3. Identify supportive details and connect them to the secondary categories they support.
4. Be creative. Encourage students to use words, pictures, phrases, circles, squares, colors, whatever they feel best portray the concepts.
5. Discuss the ideas contained in the semantic map, and compare maps made by different students.
6. Use the maps both as prereading activities to activate prior knowledge and as a means of review and reinforcement. You can also use maps as a prewriting activity with main points on the map becoming topic sentences in paragraphs, and details becoming supportive sentences.

## Structured Overview

### *Description*

A structured overview is a graphic depiction of the important vocabulary and concepts of a reading assignment or content unit. The overview, constructed so that important relationships between vocabulary and concepts can be clearly shown, serves to systematically introduce upcoming technical vocabulary and provides a mechanism permitting teachers to analyze what is important in the new material. The strategy is used initially as a readiness activity before the students encounter the new material and thus serves as a form of advance organizer. It may also be used periodically during the course of the unit to reinforce concepts and learning of vocabulary. New words or terms may be added to the diagram to make concepts clearer and to aid in the assimilation of new material. The structured overview thus provides a framework for students to learn the new material and master key vocabulary and for teachers to set lesson priorities and direct their teaching.

### *Procedure*

1. Analyze the vocabulary of the learning task and list all words that relate to the major concepts you want the student to understand. Ask yourself which concepts are most central to the learning of the new material and then decide which vocabulary is necessary to understanding these concepts. Often difficult words which appear in a reading can be ignored because they do not directly relate to major concepts.
2. Arrange the list of words until you have a diagram (see figure 6) which shows the interrelationships with the relevant concepts.
3. Add vocabulary concepts which you believe are already understood by the students in order to relate the known with the new.
4. Evaluate the overview. Are the major relationships clear? Can the overview be simplified and still effectively communicate the important relationships?
5. When introducing the learning task, display the diagram and explain briefly to the students why you arranged the words as you did. Encourage the students to supply as much information as possible.
6. During the course of the learning task, relate new information to the structured overview as it seems appropriate.

*Adapted from Cyrus F. Smith.*

## Know-Want to Learn-Learn Interactive Strategy (K-W-L)

### *Description*

In the K-W-L "reading to learn" process, elementary students learn how to learn from texts. This process involves students in three cognitive steps: assessing what we know, what we want to find out, and what we learned. Through a process of brainstorming, students call up what they know about a topic. Questions are raised about what we want to find out and are recorded. Teachers may ask students to find general categories of information by charting what they already know and by predicting how they think the text will be organized. After reading, students record what was learned and discuss questions that may not have been answered. Appendix F has a sample worksheet that is used to record the information.

### *Procedure*

**Discuss.** Before students read, discuss with them what they already know about the topic of the article to be read. As students volunteer information, list on the board what they already know. An example of this would be an article on black widow spiders. Students might volunteer information about spiders, poison, hour-glass shaped markings, and spiders eating their mates.

**Categorize.** Ask students to find information that is related-pieces that are on the same topic or category. You may want to give them an example such as what black widows eat, where they live, or their mating habits. Then ask students to find other information that can be chunked.

**Anticipated Structure.** Ask students to think about the categories of information they would expect an article on this topic to cover. For example, explain that the article on spiders should include information about how that animal looks, what it eats, what enemies it has, and how it produces and raises offspring. List the expected categories on the board as students volunteer them.

**Question.** Ask students to use their own worksheets and write down any questions that have come to their minds as they read the article.

**Learn.** Suggest to students that as they read the article, they jot down answers to their questions on their worksheet. (Some may prefer to do this upon completion of the reading.)

**Reflect.** When students have completed the article and their worksheets, discuss what they learned from reading. Review their questions to find any that have not been dealt with satisfactorily. Suggest ways students could continue their search for information.

*Adapted from Donna Ogle*



**Session Twenty-two**

Do together Exercise 9.1 pps. 169-172 Modeling the reading and  
comprehension strategies use

Answer questions 1-5 pps 171-172

Discuss Semantic Mapping  
Structured Overview  
K-W-L Strategy

**Session Twenty-three**

Do Together Exercise 9.2 pps 172-175. Make a simple outline that shows how the information is organized

**Progress Test**

Using a longer piece of automotive reading, make a list or simple outline showing the organization of the chapter. Write five key questions that the chapter should answer

## Texts Containing Only One Major Element or Idea and Supporting Information

**Description.** Descriptive frames and categories depend somewhat on the nature of what is being described. For example, description in literature focuses on characters, places, and objects. In such descriptions, readers must identify what is being described and its attributes. In geography, regions are usually described using such categories as land, people, and government. Descriptive texts are sometimes referred to as list or collection structures because the attributes may be described in any order.

### Descriptive Graphic Structures

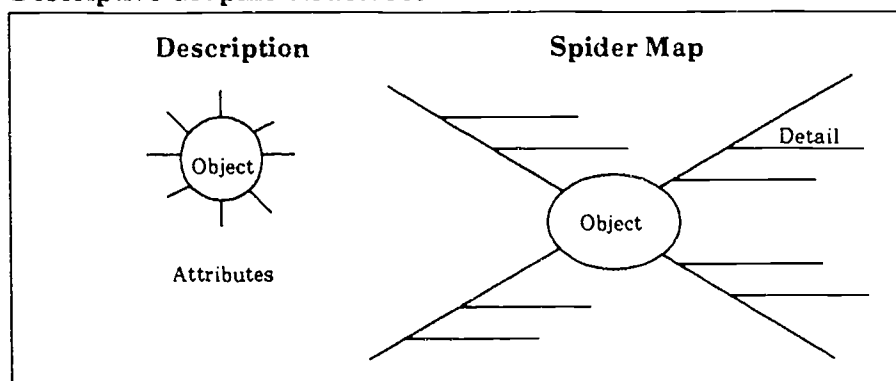

### Signal Words

also	further	moreover
and	furthermore	too
besides	in addition	

### Frame Questions

What is it?
Where can it be found?
What does it look like?
What are its attributes?

**Proposition/Support.** Proposition/support is a very common paragraph structure. In its most simple form, it is a statement plus information supporting the statement. Frame categories for a theme paragraph, for example, include the statement of the theme, elaboration and interpretation of the theme, and supporting information, such as examples, quotes, and data. Proposition/support paragraphs often have both major and minor supporting ideas.

This structure is sometimes difficult to identify because it uses few easily recognizable signal words.

### Frame Questions

What is the conclusion?  
What are the arguments for the conclusion?  
What are the premises that support the conclusion?

**Concept/Definition.** To understand a concept, it is important to know what it is, what category it belongs to, and its critical attributes. Readers also must connect new concepts with what they already know by using examples, analogies, or comparisons.

### Concept/Definition Graphic Structures

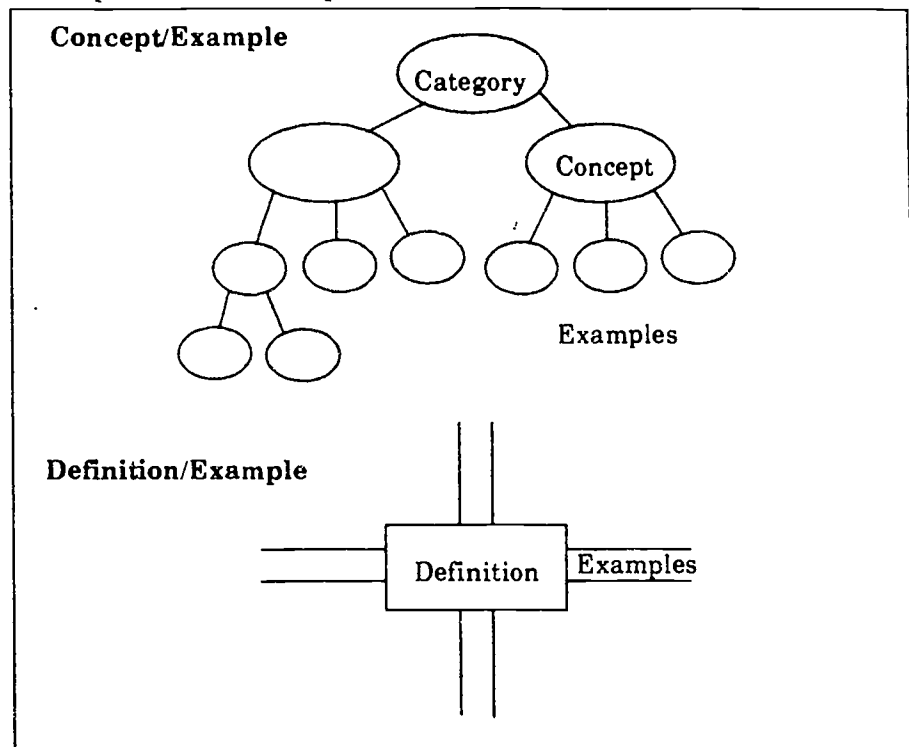

### Signal Words

for example	specifically	as	which is
e.g.	for instance	such as	like

### Frame Questions

What is the concept?  
What category does it belong to?  
What are its critical attributes?  
How does it work?  
What does it do?  
What are its functions?  
What are examples of it?  
What are not examples of it?

## Texts Describing a Sequence

**Sequence Texts.** An important task when reading sequence texts is understanding and predicting the correct sequence of events. Events in sequential structures may be in chronological order or some other logical order. Typical sequential texts are steps in a procedure (e.g., how milk is pasteurized) and stages of development (e.g., the life cycle of primates). Literature and history texts involve flashbacks and forecasts.

To understand sequential texts, readers should identify the object, procedure, or initiating event; describe the stages, steps, or series of events that follow, showing how one leads to another; and describe the final outcome.

### Sequential Text Graphic Structures

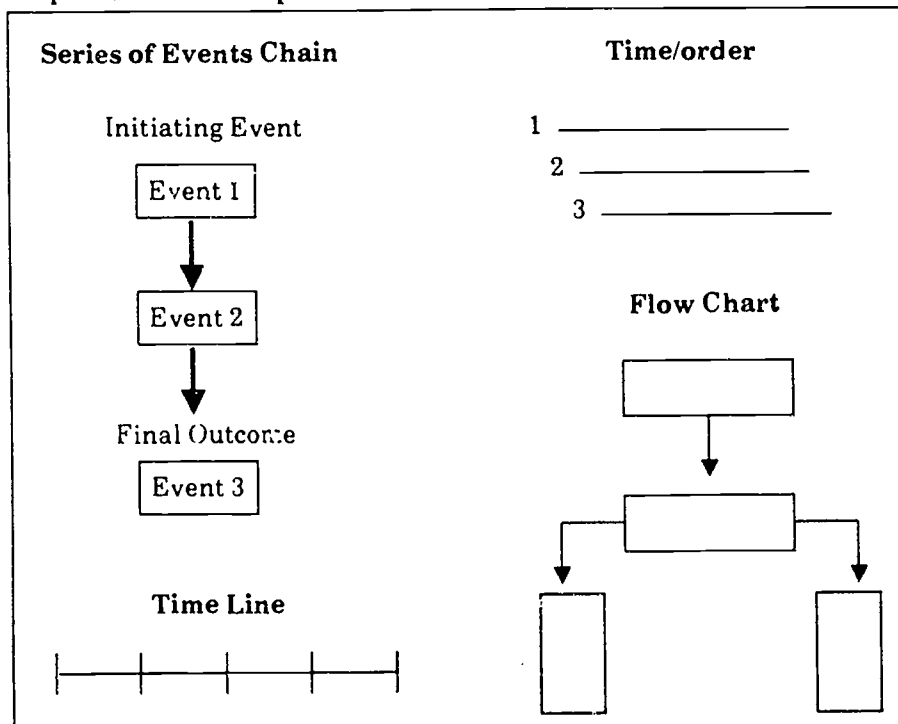

### Signal Words

finally	second	then	to begin with
first	next	last	later
afterwards	meanwhile	now	previously
before	subsequently	presently	ultimately

### Frame Questions

What is the subject or object?  
 How did it begin?  
 What are the steps/stages?  
 What is the outcome?

## Session Twenty-four

Discuss systems to remember important information.

What works for you?

Discuss graphic organizers

1. descriptive
2. content/definition
3. sequential text

Read and discuss pps. 176-182

Underlining

Numbers

Boxes

Marginal notes

Practice this technique using a piece of automotive reading

## Session Twenty-five

Continue to discuss underlining, notes, and diagram as well as symbols

common markings underline main points

underline main points

box key words

Condense - "boil down" language

Do together modeling the thinking and comprehension strategies used Exercises 10.1, 10.2, 10.3 and 10.4 pps. 185-188

In your notebook do an overview of the two sections in Exercises 10.5 and 10.6 pps. 188-192

## Session Twenty-six

Continue working on Exercises 10.5 and 10.6 pps. 188-192 by underlining and using margin notes to indicate major points sub-categories, and important explanations

If all of the above does not allow your to master the material then you must do some final note-taking

Discuss the simple system for informal notetaking on p. 194

Using informal notetaking or outlining on the section on automotive design on p. 194

How does outlining differ from note-taking from graphic organizers

"Boil down" the information to a minimum



**Session Twenty-seven**

Read and discuss abbreviating your notes pps. 198-201

Study the abbreviations or symbols most commonly used so you can speed up your notetaking

Together do Exercises 11.1 and 11.2 pps. 203-205

In your notebook Do Exercise 11.3 pps. 205-206

**Session Twenty -eight**

Read together and take study notes on Exercise 11.4 pps 206-208

In your notebook do either Exercise 11.5 or 11.6 underlining the important points and taking study notes on the selection

**Session Twenty-nine**

**Progress Test**

Using a long piece of automotive writing

1. underline the key points
2. all margin notes

Then take notes on the passage

## **Session Thirty**

### **Introduce Building Technical Vocabulary Skills**

#### **Discuss**

- 1. Word meaning**
- 2. Prior Knowledge - vocabulary**
- 3. Acquiring new vocabulary**
- 4. Selecting words to learn**
- 5. Using "clues" to develop the meanings of words we do not know  
- see handouts**

**Discuss and model context clues**

---

## Introduction

*Students of all ages  
would benefit from a  
renewed instructional  
focus on the more  
complex comprehension  
skills and strategies.  
-Reading Report Card  
(1985)*

Underlying the framework found in this section of the guide is the understanding that reading comprehension involves a merging of reader, text, and context that goes far beyond merely processing the meaning of a string of decoded words and that reading comprehension is greater than the sum of its parts. To get meaning or gain information from a given text, readers use different skills and strategies necessary for comprehending or remembering. The skills and strategies, highlighted within the framework, are components of an effective reading program and need to be emphasized in K-12 instruction. Each component is described in this section with a consideration of *why* the component is important, *what* it involves, and *how* it can be taught and its effectiveness measured. Scope and sequence charts are included for each component. Each of these components should be considered within the framework for the development of strategic behavior which was described in the preceding section.

---

## Word Meaning

### *Why Is Word Meaning Important?*

Word meaning is a necessary yet limited factor in reading comprehension. A strong meaning vocabulary is necessary for comprehending text. However, it does not insure comprehension. In order for comprehension to occur, the reader must analyze the words, recognize the interrelationships among them, and derive meaning from the unique combinations used by authors. Word meaning represents a strong underlying conceptual network of knowledge that supports reading comprehension.

### *What Should Be Considered In Teaching Vocabulary?*

First, the goal of reading instruction is comprehension; vocabulary growth is of value only as it serves to further reading comprehension. A reader can read a selection not knowing the meaning of every word and yet comprehend the selection if such words are not crucial to the information and ideas in the selection. Second, incidental learning through everyday experiences accounts for a substantial amount of vocabulary knowledge. Third, words are learned and retained when used frequently in reading, writing, and speaking and when connections are made between the new words and prior knowledge. Fourth, the greater the prior knowledge students have of the meanings of related words under study, the easier the new words are to learn and retain over the long term.

Prior knowledge makes such a strong impact on learning that it is important to describe some of its patterns.

**Oral/Aural Vocabulary.** These are words in the students' speaking/listening vocabulary that they cannot yet read. Once students can decode these words they usually know their meanings. The knowledge possessed by Emergent and Beginning Readers is based primarily on experiences from natural language settings. The language experience approach uses the natural language as the basis for beginning reading instruction. Commercial publishers of beginning reading materials also attempt to choose words familiar to students.

*Meaning is constructed as readers link what they read to what they know.*

**New Word Labels for Known Meanings.** These words are also referred to as synonyms. The student may know the meaning of a word such as car and then learn a new label, automobile, for the same meaning. This experience is common to Emergent, Beginning Reading and Reading for Consolidation stages.

**New Meanings for Known Words.** Referred to as multiple meaning words, these words are already known to students. However, the meaning is for one situation and needs to be expanded to include meanings for other contexts. Multiple meaning words are particularly problematic in content-area reading where a familiar word suddenly assumes a different meaning. Therefore, these words should receive particular emphasis beginning with the Reading for Consolidation stage.

**New Words, Easily Learned.** These words are not in students' oral nor reading vocabulary. Students do not know their meanings, but meanings can easily be built because students have related background knowledge which can be used in instruction to connect the known with the unknown.

**New Words, Difficult to Learn.** These words also are not in students' oral nor reading vocabulary. Students don't know meanings, and because they have limited or no background knowledge on the topic, they have difficulty developing meanings.

As students progress into the Reading for Consolidation and the stages that follow, they read more about new topics with specialized vocabulary and complex concepts. As a result more new words fall in the new words, easily learned, and difficult to learn categories.

### *How Can Teachers Help Students To Acquire New Vocabulary?*

The following categories of words are not mutually exclusive. Often a word can fall into several categories depending on its use in a given text. However, this categorization is useful in focusing attention on the function of words in text.

*... attempts to improve comprehension are more likely to be productive if consideration is given to the components of the comprehension process and the abilities and knowledge required to perform these processes and the instructional procedures used to promote the abilities and teach the knowledge.*  
-Isabel Beck (1983)

**High frequency words** occur so often in print that they are essential to fluent reading, particularly in the beginning stages. These words need to be recognized at sight.

**Text - critical words** are absolutely necessary to understand a particular selection. Technical vocabulary and words representing specific concepts are included in this category.

**Structural words** consist of root words and prefixes or suffixes, which change the meanings of the words.

**General vocabulary** includes the remaining words in a text not specified by the above, including synonyms, antonyms, homographs, and homophones.

Each of these categories is important at each of the development stages. However, the degree of emphasis may differ. During Emergent and Beginning Reading stages, students learn the high frequency words so that both pronunciation and meaning become automatic. Technical vocabulary, a subset of text critical words, becomes a more direct concern beginning with the Reading for Consolidation stage. It is at this stage in elementary schools that most students acquire textbooks in several different fields.

### *How Should Words Be Selected?*

Upon preview of the reading selection, the teacher should select those words that are necessary for comprehension and then determine how well the students need to know the words. The gist of the meaning may be sufficient, or a fully developed conceptual meaning may be necessary. The following recommendations suggest ways to proceed.

- Teach words central to the important ideas in the selection.
- Teach only the words students do not already know.
- Expect students to develop meaning during reading if there is a good context.
- Teach a few words well (five or less) so that students retain them over a long term.

Before instruction begins, the classroom teacher needs to determine the extent of students' vocabulary knowledge, more specifically their knowledge of words related to the topics under study. The following informal procedures are easiest to employ.

- Observe oral language usage during discussions and listen for students' knowledge of words and meanings central to the topic.
- Pretest the key terms that will appear in a new unit of instruction.
- Encourage the students to tell what they already know about the concept.
- Ask the question, "What can you tell me about this word?", instead of requiring its use in a sentence.

## *How Can Teachers Help Students Acquire Strategies for Developing Word Meanings?*

Throughout instruction teachers need to encourage students to develop strategies for determining word meanings. It is the teachers' role to consistently guide students to use available clues to develop word meanings on their own and, thus, move toward independence as readers. Instruction should guide students to

- read a paragraph, perhaps a single sentence;
- ask themselves if they understand what they read;
- determine which specific words hinder understanding;
- consider how to develop meanings for problem words;
- look for possible clues to meaning in surrounding text;
- think of who might be asked for help in developing meanings.

It is important to stress that students be guided to develop strategies for figuring out meanings themselves. Students might find it helpful to use the sample bookmark included below. A sample poster for guiding independent use of strategies is included in Appendix B.



- ❖ Does it make sense? If not,
- ❖ What word don't I know?
- ❖ How can I find out?
- ❖ What clues? Who can help?

Teachers should model first the use of context clues, then other strategies when the surrounding text is not helpful. The use of a dictionary should be encouraged for students at Reading to Learn the New stage and beyond. Dictionaries are ineffective with young children since definitions are often far removed from their experiences.



**Session Thirty-one**

Read together and discuss pps. 33-39

How do we use etymology - What is it?

How do we use the dictionary - Discuss and model dictionary  
use

Session Thirty - two

Analyze the following automotive words:

What is the etymology?

Are they in the dictionary?

If not where can we find them?

Who can help us?

Together Do Exercise 3.5 and 3.6 pps. 42-43 Can we do it without a dictionary?

List: Automotive words

**Session Thirty-three**

**Progress Test**

Using a longer piece of automotive writing

1. underline the words you do not know
2. Pick out fifteen of these words
3. Write each word down - look it up or try to "predict" its meaning from its etymology and context clues

## Session Thirty-four

### Introduce Test - taking skills

#### I. Control Test Anxiety (caused by pressure , past experiences, and fear of failure

- A. Help yourself - learn how to relax and control your anxiety
- B. Don't have low expectations - studying does bring results. Use all the "remembering techniques your have practiced in this course
- C. Improve your concentration by learning basic self-discipline techniques
- D. Learn in the way that's best for you
- E. Create your own learning aids flash cards marginal notes, simple outlines

#### II. Learn good test taking skills

##### A. Short-answer exams

- 1. Budget your time - estimate how much time you have to answer each question
- 2. Do easiest questions first - don't dwell on any particular question
- 3. Answer each question - write what you do know even if you don't know the complete answer
- 4. Use the full time allowed

##### B. Essay exams

- 1. Read all questions first - underline by words
- 2. Start with the easiest question - organize your thoughts in simple outline and then draft your answer
- 3. Be realistic - answers should be logical and clear but do not have to be masterpieces. Be short, simple and concise
- 4. Answer more difficult questions last

##### C. Objective exams, multiple choice, matching

- 1. Solve in the order given - don't get hung up on the tough questions. Leave them and move on. Return if time allows
- 2. Reach each choice carefully - select the answer that's most correct
- 3. Think as you read - be sure you understand what's being asked - make an educated guess

4. Try to finish if timed. Be sure to finish if not timed

III How do you deal with pressure? How do you beat test anxiety?

## Session Thirty-five

Introduce How to Study and Academic Survival Skills

### I. Why study

- A. studying is planned learning
- B. Helps you achieve your goals

### II. Your Attitude

- A. Studying is planned learning
- B. Do you want to learn

### III Positive Thinking - make learning a game

### IV. Plan your studying - see handouts

### V. Review main points of simple notetaking, outlining, strategic organizer's

## Session Thirty-six

Introduce The Language of Math before you "do" a math problem you first have to read it. Math starts with reading

Three strategies that will help you with almost any math problem

1. Make a Picture of the facts you know in the problem
2. State the label to be used in the answer. In other words what are you looking for? Dollars and cents? Hours? Feet? Miles per hour? Gallons?
3. Use your own words to state what you have to do to solve this problem?

Practice on the problems and stating them in your own words

### Session Thirty-Seven

Review of all we have learned about reading charts, graphs, diagrams etc.

### Session Thirty-eight

Practical exam in the automotive area - reading whatever is necessary to diagnose automotive problems (automotive teacher to supply the reading problems?)

### Session Thirty-nine

Reading exam on the skills have acquired this semester student must be able to interpret all diagrams.

### Session Forty

Exams returned  
Final grade



INTEGRATED TECHNICAL

CURRICULUM

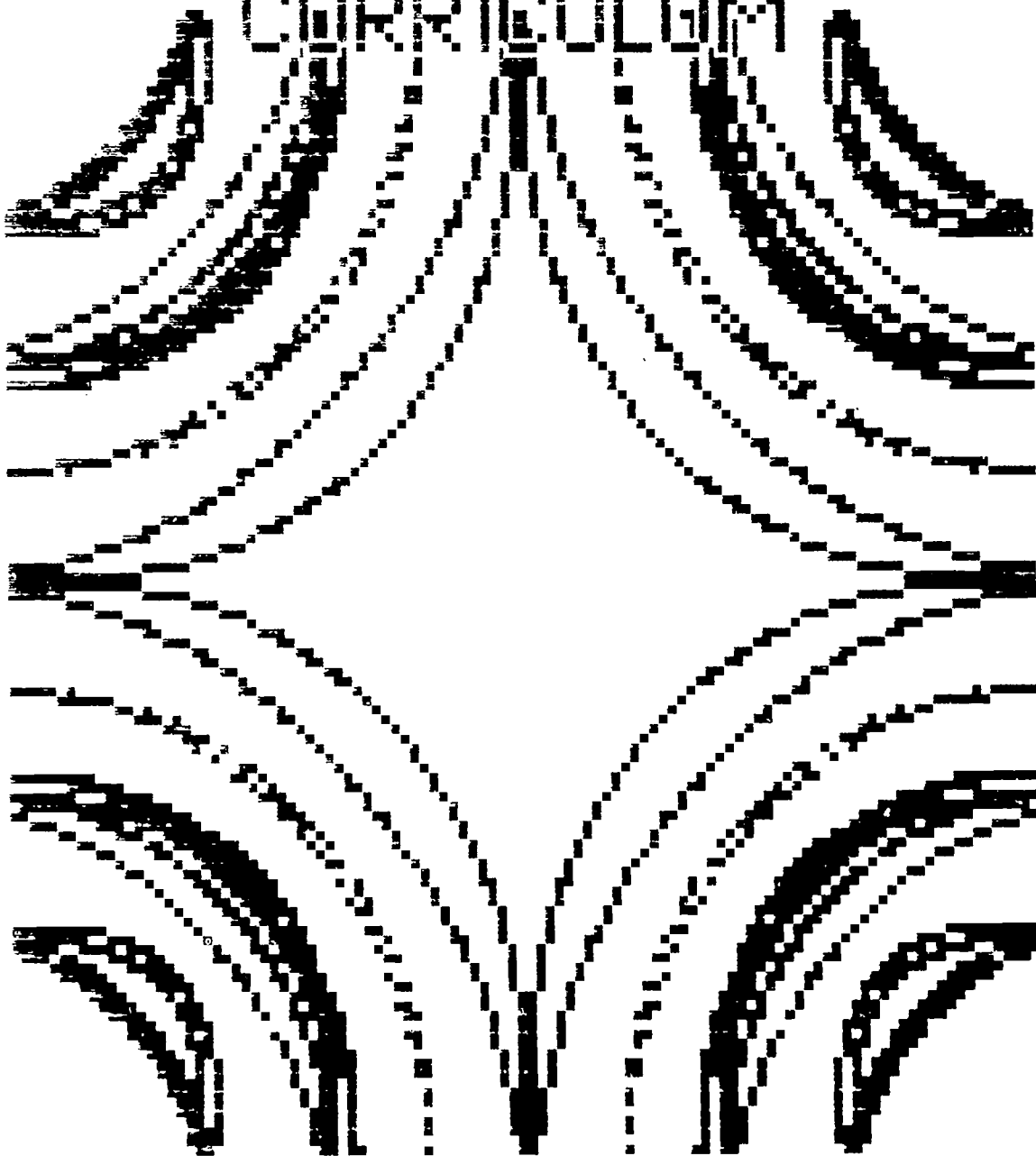

MATH COMPONENT

*Integrated Technical Curriculum*

*Math Component*

*Applied Math - Automotive*

*Developed By*

*Geri Weber  
Milwaukee Area Technical College  
Adult High School*

*June, 1993*

*SUGGESTED TEXTBOOK*

Mastering Essential Mathematics Skills, Third Edition,  
Itzkowitz and Richards, Glencoe (Division of Macmillan), 1988.

*SUGGESTED REFERENCE MATERIALS*

1. Applied Mathematics, Phagan, Goodheart-Willcox Co., 1992.
2. Mitchell Automechanics, Second Edition, Prentice Hall.

## APPLIED MATH - AUTOMOTIVE

### GENERAL OBJECTIVES

1. To obtain a functional knowledge of basic mathematical operations with whole numbers, fractions, and decimals.
2. To understand the forms and relationships associated with whole numbers, fractions, decimals, and percents with special emphasis toward automotive applications.
3. To understand and use tables and graphs with special emphasis toward automotive applications.
4. To understand and find measurements of geometric shapes common to automotive work.
5. To develop a computer competency on computers used in the automotive shop.

## COURSE OUTLINE

### INSTRUCTIONAL UNITS AND COMPETENCIES

1. Whole Numbers
  1. Identify natural, whole, and integer numbers
  2. Identify place values in whole numbers
  3. Add, subtract, multiply, and divide whole numbers with a calculator
  4. Round and estimate whole numbers
  5. Applications to automotive field
2. Decimal Numbers
  1. Identify place values in decimal numbers
  2. Add, subtract, multiply, and divide decimal numbers with a calculator
  3. Applications to automotive field
3. Fractions
  1. Identify the parts of a fraction
  2. Change fractions to different forms
  3. Change between fraction and decimal forms
  4. Place fractions in order according to size
  5. Add, subtract, multiply, and divide fractions
  6. Identify and use ratios
  7. Applications to automotive field
4. Percentage
  1. Define percentage
  2. Change between percent, decimal, and fraction forms
  3. Application to automotive field
5. Using tables and graphs
  1. Read and do calculations from a schedule
  2. Read and do calculations from charts with zones
  3. Read and do calculations from bar graphs
  4. Read and do calculations from line graphs
  5. Read and do calculations from circle graphs
  6. Using automotive charts and graphs
6. Finding measurements and Computer skills
  1. Measure angles with a protractor
  2. Find area and perimeter of various geometric shapes
  3. Understand parts and formulas of circles
  4. Find volume of squares and rectangles
  5. Learn computer terminology
  6. Gain skill in using a computerized manual on automotive repair (Mitchell on Demand)
  7. Find and print out appropriate diagrams and information using Mitchell on Demand

# Integrated Technical Curriculum - Math Component

## Applied Math - Automotive

### Instructional Units and Time Frame

UNIT	DAYS (Suggested Number)
1. Whole Numbers	6
2. Decimal Numbers	5
3. Fractions	7
4. Percentage	6
5. Using tables and graphs	6
6. Finding measurements and Computer Skills	7
End of course	
Review	1
Final exam	1
Final interviews	1

The time frame is a 40 day quarter with classes meeting for 1 hour 55 minutes daily.

## SUGGESTIONS REGARDING HOMEWORK AND TESTING

### HOMEWORK

I believe that many students learn by patterns. That is intelligent and good. However, I believe that, in addition, the student will benefit greatly if he/she can discriminate and discern what to do when seeing a mixture of problems. Therefore, I propose that first a student is presented with a number of problems so that he/she can first see the pattern for completing a set of problems. Then I propose that the student be given a mixture of problems from all previous lessons.

TECHNIQUES: I allow students to make up all homework up until testing.

### TESTING

A similar approach is taken with testing. I suggest that each test include a significant mix of problems from previous tests. For example, the second test may be half old and half new. The third test may be a quarter from the first test, a quarter from the second, and half from the new. I think a good approach is to keep half of the test over the new material.

POSITIVE ASPECTS: This approach gives the students a reason to correct old tests and learn from their mistakes, since these same problems will reappear. (I give credit for correcting exams.) Another benefit is that I do not need to give make-up tests. In addition, I can drop one exam with no guilt because all material is constantly be retested. However, I make it clear that only one exam can be missed. I will have to give a fail because I do not have enough information to give a grade.

## QUIZZES

I think it is a good teaching method to give a quiz every day over the previous night's homework. I always have a question and answer time before the quiz in order to work out any problems the student might have had. An added advantage is that the student who missed the previous day has a chance to "catch on" to what we did. I believe this eliminates a lot of students, who catch on quickly, from having to come see me during office hours and frees that time for those who need more individual help.



DAY 1  
(Introduction, Groups of Numbers)  
(Rounding and Writing of Whole Numbers)

1. Introduce why we need numbers and why there is math phobia.
2. Explain the grouping of numbers.

Suggestion:

Numbers come in lots of forms. We don't want to not understand a number's value just because it is in a form we don't recognize. Let's first look at how numbers are named in certain groups.

NAMES OF GROUPS OF NUMBERS:

Counting numbers: Ask a child to count! Where do they begin? With the number 1, then 2, 3, etc. (Recap: 1,2,3,4,5,...forever)

Whole numbers: See the oh in the word whole! Looks just like a zero, too! This group of numbers includes the 0 with the counting numbers.  
(Recap: 0,1,2,3,...forever)

Integers: Integers have "jerks" in them who are negative types. Hear the jerks as you say in-ta-jerks? This group of numbers include -1, -2, -3 etc, with all the whole numbers. (Recap: ..., -3, -2, -1, 0, 1, 2, 3...)

Fractions (Chapter 2) are made up of two integers divided by a fraction bar. You can place any integer you want in the top part or numerator and you can put any integer EXCEPT ZERO in the denominator or bottom part. By definition, you may NEVER divide by zero. To remember this, see the zero as a balloon and there are demons in the denominator who will burst the balloon, which causes the fraction to fall apart. (Note that you can manipulate any of the counting or whole numbers into integer form by simply placing a fraction bar under the number and placing a "1" under it for the denominator.)

Decimals (Chapter 3) and percentages (Chapter 4) are just different forms of fractions.

3. Explain place value of whole numbers, translating between numbers and words
4. Explain rounding

HOMEWORK: MEMS: pg 3-8

Temperature  
°F

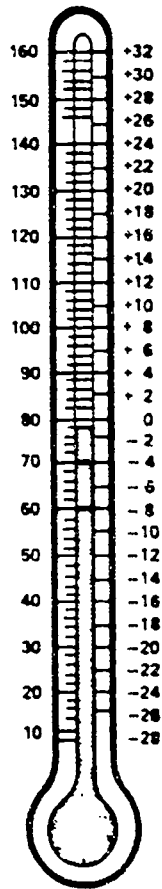

Gravity  
points to  
add or subtract

Use this table to convert Fahrenheit degrees (F°) directly to Celsius degrees (C°) and vice versa. Conversions can be made by substituting a known Fahrenheit (F°) or Celsius (C°) temperature figure in either of the following formulas.

$$F^{\circ} = \frac{C^{\circ} \times 9}{5} + 32$$

$$C^{\circ} = \frac{F^{\circ} - 32}{9} \times 5$$

F°	C°	F°	C°	F°	C°	F°	C°	F°	C°
-160	-107	340	171	840	449	1340	727	1840	1004
-140	-96	360	182	860	460	1360	738	1860	1016
-120	-84	380	193	880	471	1380	749	1880	1027
-100	-73	400	204	900	482	1400	760	1900	1038
-80	-62	420	216	920	493	1420	771	1920	1049
-60	-51	440	227	940	504	1440	782	1940	1060
-40	-40	460	238	960	516	1460	793	1960	1071
-20	-29	480	249	980	527	1480	804	1980	1082
0	-18	500	260	1000	538	1500	816	2000	1093
20	-7	520	271	1020	549	1520	827	2020	1104
40	4	540	282	1040	560	1540	838	2040	1116
60	16	560	293	1060	571	1560	849	2060	1127
80	27	580	304	1080	582	1580	860	2080	1138
100	38	600	316	1100	593	1600	871	2100	1149
120	49	620	327	1120	604	1620	882	2120	1160
140	60	640	338	1140	616	1640	893	2140	1171
160	71	660	349	1160	627	1660	904	2160	1182
180	82	680	360	1180	638	1680	916	2180	1193
200	93	700	371	1200	649	1700	927	2200	1204
220	104	720	382	1220	660	1720	938	2220	1216
240	116	740	393	1240	671	1740	949	2240	1227
260	127	760	404	1260	682	1760	960	2260	1238
280	138	780	416	1280	693	1780	971	2280	1249
300	149	800	427	1300	704	1800	982	2300	1260
320	160	820	438	1320	716	1820	993	2320	1271

DAY 2  
(Adding and Subtracting Whole Numbers)

1. Explain addition and subtraction of whole numbers using a calculator

HOMEWORK: (MEMS: pg 9-10,33-34,37-40)  
MEMS: pg 11-12 for those who wish to do more.

Homework should consist of problems from the previous day's assignments, too. (See the suggestions regarding homework and testing at the beginning of the course instructions.) I think an extra worksheet of 3 problems of rounding, 3 of writing whole numbers from words into numerals, 3 of numerals into words, 5 adding, and 5 subtracting would be a good mix to assign. Be sure to include up to columns of five numbers and three numbers added together.

DAY 3  
(Multiplying Whole Numbers)

1. Explain multiplication of whole numbers using a calculator

(MEMS: pg 11-18)

HOMEWORK: Homework might consist of 3 rounding, 3 of writing whole numbers from words into numerals, 3 of numerals into words, 3 adding, 3 subtracting, and 5 multiplying.

DAY 4  
(Dividing Whole Numbers)

1. Explain division of whole numbers using a calculator  
(MEMS: pg 19-20,41-42)

HOMEWORK: Homework might consist of 3 rounding, 3 of writing whole numbers from words into numerals, 3 of numerals into words, 3 adding, 3 subtracting, and 3 multiplying, 5 division.

DAY 5  
(Application to Automotive Field)

1. Explain odd and even numbers

ODD VERSUS EVEN

Odd numbers are whole numbers, beginning with "1" and then skipping the next number. Next is "3", skip the next number, etc. (Recap: 1,3,5,7,9,...)

Even numbers follow the same procedure of skipping every other whole number, but this time you begin with zero. (Recap: 0,2,4,6,...)

2. Use of odd and even numbers in the engine cylinder diagrams  
(See attached diagrams)

3. Explain use of tolerance and range in automotive:

TOLERANCE AND RANGE

A engine might have an idle speed tolerance of  $650 \pm 25$ . This would mean that in order to get the range or the maximum and minimum amount allowed, you would take 650 plus 25 and get 675, then 650 minus 25 to get 625. This give you a range of acceptable values from 625 to 675.

A tolerance of  $-1 \text{ mm} \pm 3 \text{ mm}$  means a range of  $-4 \text{ mm}$  to  $+2 \text{ mm}$ .

4. Integers in temperature: Fahrenheit and Centigrade scales. See attached chart.

Printed for: Milwaukee Area Tech. College 1020 N. 7th Street Milwaukee WI

Copyright 1992, Mitchell International, All Rights Reserved.  
Fri Jun 04 09:53:39 1993

1990 Buick Century ENGINE PERFORMANCE C - V6 TUNE-UP SPECS

Fig. 1 3.1L (VIN T & V) Firing Order & Timing Marks

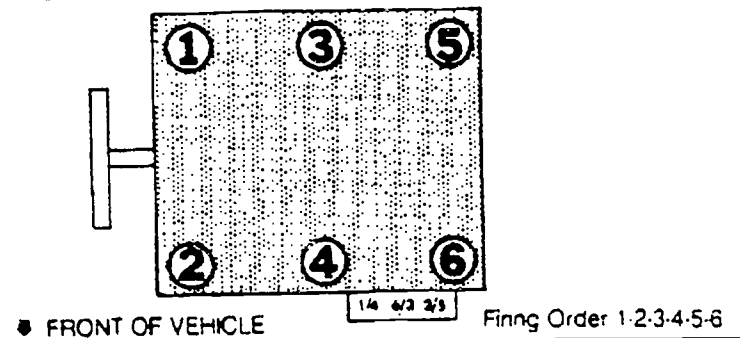

Printed for: Milwaukee Area Tech. College 1020 N. 7th Street Milwaukee WI

Copyright 1992, Mitchell International, All Rights Reserved.  
Fri Jun 04 09:55:30 1993

1990 Geo Storm ENGINE PERFORMANCE C - TUNE-UP SPECS

Fig. 1 Firing Order & Distributor Rotation

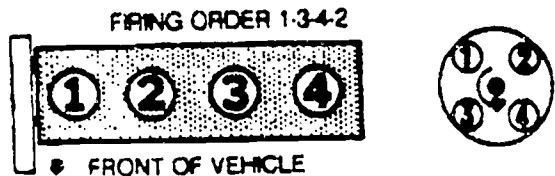



1990 Cadillac Brougham ENGINE PERFORMANCE C - V8 TUNE-UP SPECS

Fig. 1 4.5L (VIN 3) Firing Order & Timing Marks

● FRONT OF VEHICLE (FWD ONLY)

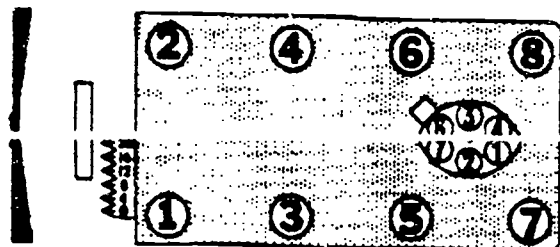

Firing Order 1-8-4-3-6-5-7-2

● FRONT OF VEHICLE (RWD ONLY)

1990 Ford Bronco ENGINE PERFORMANCE C - TUNE-UP SPECS

Fig. 2 5.0 Firing Order & Timing Marks

● FRONT OF VEHICLE

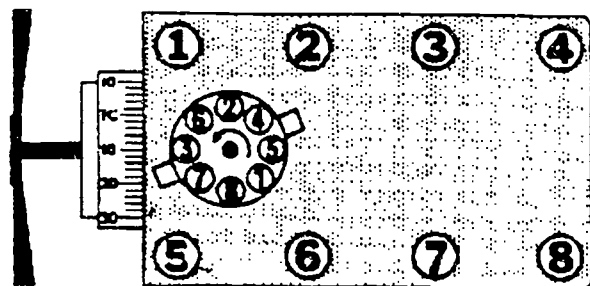

FIRING ORDER 1-5-4-2-6-3-7-8

BEST COPY AVAILABLE

DAY 6  
(Review for Exam)

Suggestion: Use old quizzes and MEMS: pg 29-31

DAY 7  
(Exam and Decimal Notation)

1. Give exam first hour.
2. Explain decimal place values (MEMS: pg 21-22)
3. Show applications of where decimal understanding is needed in the automotive shop.

It is very important to stress thousandths place here. Most of the decimals and gauges in automotive are to thousandths place. A number like .020 is read 20 thousandths rather than 2 hundredths. This is to show the user that the accuracy of the machine or gauge is to thousandths.

Example: A piece might need to measure to a minimum of 0.850

There is a need to discuss:

- Is 0.850 OK? - Yes
- Is 0.849 OK? - Yes
- Is 0.851 OK? - No
- Is 0.085, 8.50, etc.

This is a good place to learn how to read the gauges that are in decimal notation and have increments. There are brake lathe gauges that are read in mm and have four units between a whole number. (Review of whole numbers) and there is also a gauge reading inches that have five increments between numbers like .020 and .030

Other automotive applications: see attached sheets.

Refer to chart: student should be able to read and understand the plastigage reading of .0015

ENGINE SPEED

1 RPM  
METER

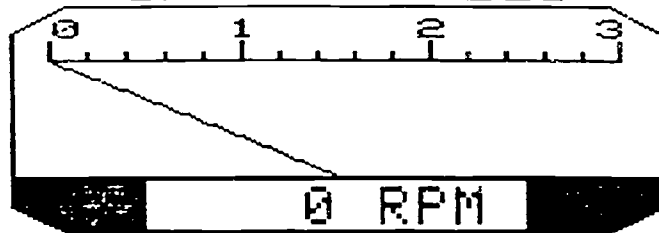

OFF  
TIMING  
+ .0°

INLET  
.0°

CO2  
.00

HC PPM  
0

PRESSURE  
.2 PSI

CO2  
.0

CO2  
.0

ENGINE TEMP  
0° F

PRINT

CONTINUE

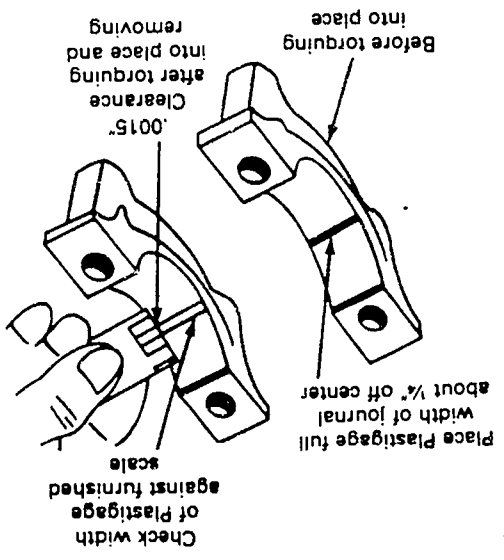

**Metric system  
of linear measurement**

	Symbol	Length (in.)
Meter	m	39.37
Decimeter	dm	3.937
Centimeter	cm	0.3937
Millimeter	mm	0.03937
Microrometer	$\mu\text{m}$	0.003937
Nanometer	nm	0.0003937

**English-Metric Conversion Chart**

To Convert	To:	Multiply by:
<b>Length</b>		
Millimeters	Inches	0.03937
Inches	Millimeters	25.4
Meters	Feet	3.28084
Feet	Meters	0.3048
Kilometers	Miles	0.62137
Miles	Kilometers	1.60935
<b>Area</b>		
Square centimeters	Square inches	0.155
Square inches	Square centimeters	6.45159
<b>Volume</b>		
Cubic centimeters	Cubic inches	0.06103
Cubic inches	Cubic centimeters	16.38703
Liters	Cubic inches	61.025
Cubic inches	Liters	0.01639
Liters	Quarts	1.05672
Quarts	Liters	0.94633
Liters	Pints	2.11344
Pints	Liters	0.47317
Liters	Ounces	33.81497
Ounces	Liters	0.02957
<b>Weight</b>		
Grams	Ounces	0.03527
Ounces	Grams	28.34953
Kilograms	Pounds	2.20462
Pounds	Kilograms	0.45359
<b>Work</b>		
Centimeter-kilograms	Inch-pounds	0.8676
Inch-pounds	Centimeter-kilograms	1.15262
Meter-kilograms	Foot-pounds	7.23301
Foot-pounds	Newton-meters	1.3558
<b>Pressure</b>		
Kilograms/square centimeter	Pounds/square inch	14.22334
Pounds/square inch	Kilograms/square centimeter	0.07031
Bar	Pounds/square inch	14.504
Pounds/square inch	Bar	0.06895
Atmosphere	Pounds/square inch	14.695
Pounds/square inch	Atmosphere	0.06805
<b>Temperature</b>		
Celsius degrees	Fahrenheit degrees	$(^{\circ}\text{C} \times \frac{9}{5} + 32)$
Fahrenheit degrees	Celsius degrees	$(^{\circ}\text{F} - 32) \times \frac{5}{9}$

DAY 8  
(Decimal Addition and Subtraction)

1. Time to correct exam from previous day. The student may work alone, but is encouraged to work in groups to learn what they missed on their test. I am also there to show them how to work in groups or direct the correction procedure. This is a very new concept to them and they "feel" like they are cheating rather than learning. They are to hand in all problems missed in entirety. Their job is to prove to me that they now know how to do the missed problems. This is in opposition to my philosophy for the exam. I give full credit for answers on tests that have NOT shown steps or how they did it. I believe different people think and learn differently and showing steps is definitely logical or left-brained. Thus, I am penalizing the right-brained thinking techniques. However, for the corrections, I need to know if there thinking is on track. It doesn't have to follow logical sequence, but rather show how they got there. It is also permissible for them to tell me and I mark an initialled OK on their correction paper.

Grading of corrected exam: When I grade the exam itself, I only circled or somehow indicate WHERE the mistake occurred. When I grade the corrections, if they miss it again, I now show how and work it out for them. These corrections are stapled to their exam for future review. I add on half of the corrected points back to the text grade. However, I have a top limit of seven points. I simply chose this number of a reasonable one to me.

2. Explain addition and subtraction of decimals using a calculator

(MEMS: pg 43-44)

HOMEWORK: Homework might consist of 3 rounding, 3 of writing whole numbers from words into numerals, 3 of numerals into words, 3 adding, 3 subtracting, and 3 multiplying, 3 division of whole numbers, 5 adding and 5 subtracting decimal numbers.

DAY 9  
(Multiplication and Division of Decimals)

1. Explain multiplication and division using a calculator  
(MEMS: pg 23-26)

HOMEWORK: Homework might consist of 2 rounding, 2 of writing whole numbers from words into numerals, 2 of numerals into words, 2 adding, 2 subtracting, and 2 multiplying, 2 division of whole numbers, 3 adding and 3 subtracting, 5 multiplying and 5 dividing decimal numbers.



DAY 10  
(Addition, Subtraction, Multiplication, and Division of  
Decimals)

1. Continuation of Day 5 (MEMS: pg 43-46,49-54)

HOMEWORK: Homework might consist of 2 rounding, 2 of writing whole numbers from words into numerals, 2 of numerals into words, 2 adding, 2 subtracting, and 2 multiplying, 2 division of whole numbers, 3 adding and 3 subtracting, 3 multiplying and 3 dividing decimal numbers.

DAY 11  
(Review)

1. Use Exam 1
2. Use old quizzes
3. Use MEMS: pg 55-60

DAY 12  
(Exam and Fraction Parts)

1. Exam first hour.
2. Define numerator, denominator, mixed fraction, improper, proper

Suggestion: Use a circle, divide in half, then show a fourth, up to sixteenths (common fractions in automotive). Then show with a rectangular shape.

HOMEWORK:

DAY 13  
(Forms of fractions)

1. Correct exams.
2. Explain equivalent fractions. Suggestion: Use attached sheet titled EQUIVALENT FRACTIONS

Suggestion: Bring in US Customary wrenches and sockets to examine and measure so as to see labeling of tools.

3. Explain reducing fractions. (Phagan: pg 30)

HOMEWORK: Homework might consist of 1 rounding, 1 of writing whole numbers from words into numerals, 1 of numerals into words, 1 adding, 1 subtracting, and 2 multiplying, 2 division of whole numbers, 2 adding, 2 subtracting, 2 multiplying and 2 dividing decimal numbers, 5 reducing fractions.

DAY 14  
(Changing fractions to decimals)

1. Explain how to change the different forms of fractions to decimal equivalents using a calculator.

MEMS: pg 65-68

Automotive applications:

1. Balancing tires:  $1/4$ ,  $1/2$ ,  $3/4$ ,  $1\ 3/4$ , etc. ounce weight. The trays and weights are usually not in sync. The tray may be in decimal, while the weights themselves are in fractions. The reverse situation exists, too.
2. To adjust a carburetor: turn "in"  $1/4$  of a turn means turn clockwise. Auto instructor says students will just turn and have no idea how much  $1/4$  is. See attached diagram.
3. Know  $1/2$  of some number, estimate. Students can't do in their heads.

HOMEWORK: Homework might consist of 1 rounding, 1 of writing whole numbers from words into numerals, 1 of numerals into words, 1 adding, 1 subtracting, and 1 multiplying, 1 division of whole numbers, 1 adding, 1 subtracting, 1 multiplying and 1 dividing decimal numbers, 3 reducing fractions, 5 changing fractions to decimals.

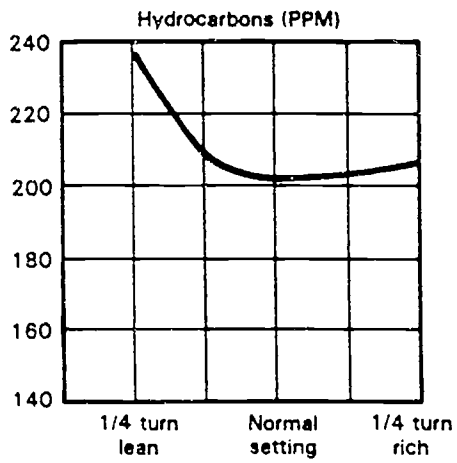
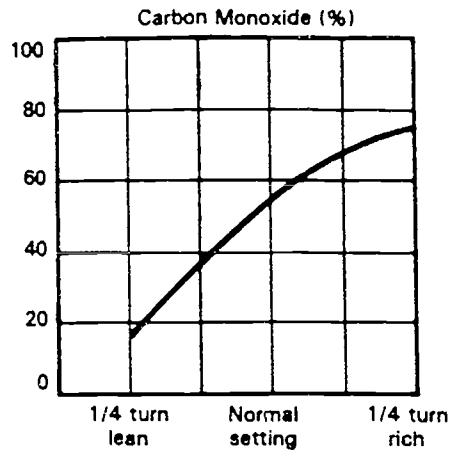

### Decimal and Metric Equivalents

Fractions	Decimal In.	Metric mm.	Fractions	Decimal In.	Metric mm.
1/64	015625	397	33/64	.515625	13.097
1/32	03125	.794	17/32	.53125	13.494
3/64	.046875	1.191	35/64	.546875	13.891
1/16	0625	1.588	9/16	.5625	14.288
5/64	078125	1.984	37/64	.578125	14.684
3/32	09375	2.381	19/32	.59375	15.081
7/64	109375	2.778	39/64	.609375	15.478
1/8	125	3.175	5/8	.625	15.875
9/64	.140625	3.572	41/64	.640625	16.272
5/32	15625	3.969	21/32	.65625	16.669
11/64	171875	4.366	43/64	.671875	17.066
3/16	.1875	4.763	11/16	.6875	17.463
13/64	203125	5.159	45/64	.703125	17.859
7/32	21875	5.556	23/32	.71875	18.256
15/64	234375	5.953	47/64	.734375	18.653
1/4	250	6.35	3/4	.750	19.05
17/64	265625	6.747	49/64	.765625	19.447
9/32	28125	7.144	25/32	.78125	19.844
19/64	296875	7.54	51/64	.796875	20.241
5/16	3125	7.938	13/16	.8125	20.638
21/64	328125	8.334	53/64	.828125	21.034
11/32	34375	8.731	27/32	.84375	21.431
23/64	359375	9.128	55/64	.859375	21.828
3/8	375	9.525	7/8	.875	22.225
25/64	390625	9.922	57/64	.890625	22.622
13/32	40625	10.319	29/32	.90625	23.019
27/64	421875	10.716	59/64	.921875	23.416
7/16	4375	11.113	15/16	.9375	23.813
29/64	453125	11.509	61/64	.953125	24.209
15/32	46875	11.906	31/32	.96875	24.606
31/64	484375	12.303	63/64	.984375	25.003
1/2	500	12.7	1	1.00	25.4

DAY 15  
(Order of fractions)

1. Explain size of fractions and comparison of small to large or vice versa. Suggestion: use tools from shop

HOMEWORK: Homework might consist of 1 rounding, 1 of writing whole numbers from words into numerals, 1 of numerals into words, 1 adding, 1 subtracting, and 1 multiplying, 1 division of whole numbers, 1 adding, 1 subtracting, 1 multiplying and 1 dividing decimal numbers, 3 reducing fractions, 3 changing fractions to decimals, 5 ordering of fractions.



DAY 16  
(Multiplication of fractions)

1. Explain rules for multiplication, cancelling, and reducing of answer.

MENS: pg 115,116

HOMEWORK: Homework might consist of 1 rounding, 1 of writing whole numbers from words into numerals, 1 of numerals into words, 1 adding, 1 subtracting, and 1 multiplying, 1 division of whole numbers, 1 adding, 1 subtracting, 1 multiplying and 1 dividing decimal numbers, 3 reducing fractions, 3 changing fractions to decimals, 3 ordering of fractions, 5 multiplication of fractions.

DAY 17  
(Division of fractions)

1. Explain rules for division of fractions.  
MEMS: pg 113,114

HOMEWORK: Homework might consist of 1 rounding, 1 of writing whole numbers from words into numerals, 1 of numerals into words, 1 adding, 1 subtracting, and 1 multiplying, 1 division of whole numbers, 1 adding, 1 subtracting, 1 multiplying and 1 dividing decimal numbers, 3 reducing fractions, 3 changing fractions to decimals, 3 ordering of fractions, 3 multiplication of fractions, 5 division of fractions.

DAY 18  
(Review for exam)

1. Use last two exams for review
2. Use old quizzes
3. MEMS: pg 79-80, 1-9; 81-90, A-D; 127-128; 131-132

DAY 20

(Addition and Subtraction of fractions with different denominators)

1. Correct exams.
2. Explain how to add and subtract fractions with different denominators  
(Include how to find LCD)  
MEMS: pg 119-122, 125,126

HOMEWORK: Homework might consist of 1 rounding, 1 of writing whole numbers from words into numerals, 1 of numerals into words, 1 adding, 1 subtracting, and 1 multiplying, 1 division of whole numbers, 1 adding, 1 subtracting, 1 multiplying and 1 dividing decimal numbers, 1 reducing fractions, 1 changing fractions to decimals, 1 ordering of fractions, 1 multiplication of fractions, 1 division of fractions, 5 adding fractions with same denominator, and 5 fractions with differing denominators.

DAY 19  
(Exam, Addition and subtraction of fractions with same  
denominators)

1. Exam
2. Explain addition and subtraction of fractions with the  
same denominators MEMS: pg 117-118

DAY 21  
(Ratios)

1. Explain meaning of ratio and use in automotive fields  
Suggestion: P of I, Unit 5, pg 139: Different ways to say)
  - A. Gear ratio: See diagram and perhaps bring cardboard display
  - B. Cylinder compression of air to gas (Ex. 14.7:1)  
See attached diagram .

Automotive uses:

1. Exhaust analyzer: 220 ppm HC means 220 parts per million of hydrocarbons. Need to discuss what would be a pass or fail.
2. 7:1 concentration of a liquid. Idea: Use small cup and make a mixture of 7 cups clear water to 1 cup colored water. Then do reverse.

HOMEWORK: Homework might consist of 1 rounding, 1 of writing whole numbers from words into numerals, 1 of numerals into words, 1 adding, 1 subtracting, and 1 multiplying, 1 division of whole numbers, 1 adding, 1 subtracting, 1 multiplying and 1 dividing decimal numbers, 1 reducing fractions, 1 changing fractions to decimals, 1 ordering of fractions, 1 multiplication of fractions, 1 division of fractions, 3 adding fractions with same denominator, and 3 fractions with differing denominators, 5 ratio problems.

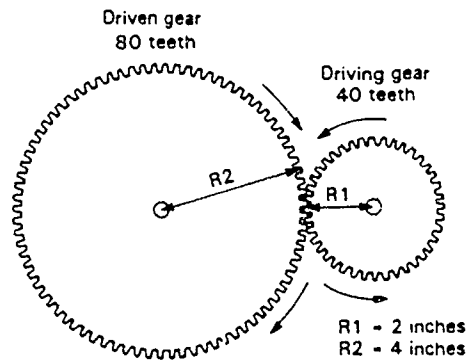

Torque multiplication factor = 2 times  
 Gear ratio = 2:1

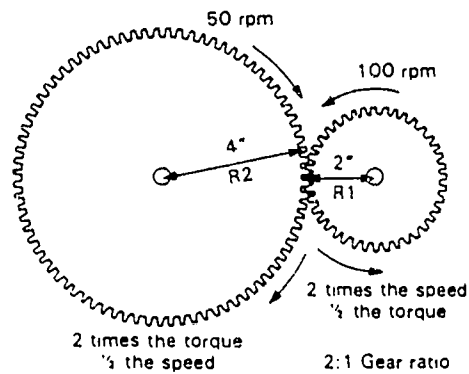

2 times the torque  
 1/2 the speed

2:1 Gear ratio

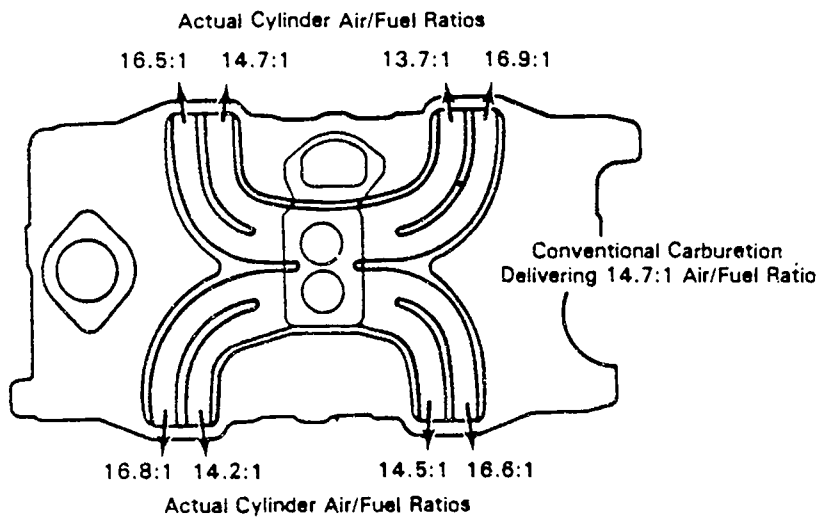



DAY 22

(Percent, Changing forms: decimal, %)

1. Explain meaning of percent
2. Change decimals to percent form
3. Change percents to decimal form
4. Explain meaning of greater than 100%

Reference: Phagan, pg 46,7

(MEMS: pg 181-182,189-190)

HOMEWORK: Homework might consist of 1 rounding, 1 of writing whole numbers from words into numerals, 1 of numerals into words, 1 adding, 1 subtracting, and 1 multiplying, 1 division of whole numbers, 1 adding, 1 subtracting, 1 multiplying and 1 dividing decimal numbers, 1 reducing fractions, 1 changing fractions to decimals, 1 ordering of fractions, 1 multiplication of fractions, 1 division of fractions, 2 adding fractions with same denominator, and 2 fractions with differing denominators, 2 ratio problems, 5 or more percent problems.

**Specific  
gravity and battery charge**

Charge (%)	Specific gravity range at 80°F
100	1260-1280
75	1240-1260
50	1200-1240
25	1170-1200
10	1140-1170

DAY 23  
(Using percents in Automotive)

1. Percent tolerance (Reference: Phagan pg 48, problems pg 49)
2. Have students mix a percent of antifreeze (Use colored water)
3. Compression test: Look at readings of cylinders  
    Lowest cylinder must be 70% of highest  
    (Percents could be 70 to 80%)  
    See chart.
4. Cylinder leakage test: Each cylinder must have a 20% or less leakage
5. Accuracy of CO testing: Car must test less than or equal to 1.20% permissible Carbon Monoxide. Student needs to know .012 (decimal form) and instructor of automotive will probably tell student that a good testing will be another % less before the student tells the owner of the car to go for the emission's testing.

HOMEWORK: Homework might consist of 1 rounding, 1 of writing whole numbers from words into numerals, 1 of numerals into words, 1 adding, 1 subtracting, and 1 multiplying, 1 division of whole numbers, 1 adding, 1 subtracting, 1 multiplying and 1 dividing decimal numbers, 1 reducing fractions, 1 changing fractions to decimals, 1 ordering of fractions, 1 multiplication of fractions, 1 division of fractions, 1 adding fractions with same denominator, and 1 fractions with differing denominators, 2 ratio problems, 3 or more percent problems, and 3-5 percents in the automotive field.

## CRANKING TEST

CYL#	1	5	4	2	6	3	7	8
COMP. %	87	81	93	93	100	93	93	81
CRANKING VOLTS	10.18 VOLTS							
CRANKING CURRENT	222.0 AMPS							
CRANKING VACUUM	.0 INCHES							
CRANKING SPEED	186 RPM							
CRANKING DWELL	21.6 DEGREES							
COIL INPUT VOLTS	8.8 VOLTS							
HYDROCARBONS	0 PPM							

DAY 24  
(Review)

1. Review old tests
2. Review old quizzes
3. Review new material MEMS: pg 127-132

DAY 25  
(Exam and Charts)

1. Exam
2. Chart reading and problem from it  
MEMS: pg 155-158

DAY 26  
(Reading charts)

1. Correct exam
2. Charts  
MEMS: pg 159-162

HOMEWORK: Homework might consist of 1 rounding, 1 of writing whole numbers from words into numerals, 1 of numerals into words, 1 adding, 1 subtracting, and 1 multiplying, 1 division of whole numbers, 1 adding, 1 subtracting, 1 multiplying and 1 dividing decimal numbers, 1 reducing fractions, 1 changing fractions to decimals, 1 ordering of fractions, 1 multiplication of fractions, 1 division of fractions, 1 adding fractions with same denominator, and 1 fractions with differing denominators, 1 ratio problems, 2 or more percent problems, and 2 percents in the automotive field.

DAY 27  
(Reading and Calculating from Charts)

MEMS: pg 163-163

HOMEWORK: Homework might consist of 1 rounding, 1 of writing whole numbers from words into numerals, 1 of numerals into words, 1 adding, 1 subtracting, and 1 multiplying, 1 division of whole numbers, 1 adding, 1 subtracting, 1 multiplying and 1 dividing decimal numbers, 1 reducing fractions, 1 changing fractions to decimals, 1 ordering of fractions, 1 multiplication of fractions, 1 division of fractions, 1 adding fractions with same denominator, and 1 fractions with differing denominators, 1 ratio problems, 1 or more percent problems, and 1 percent in the automotive field.



DAY 28  
(Reading and Calculating from Charts)

MEMS: pg 169-174

HOMEWORK: Homework might consist of 1 rounding, 1 of writing whole numbers from words into numerals, 1 of numerals into words, 1 adding, 1 subtracting, and 1 multiplying, 1 division of whole numbers, 1 adding, 1 subtracting, 1 multiplying and 1 dividing decimal numbers, 1 reducing fractions, 1 changing fractions to decimals, 1 ordering of fractions, 1 multiplication of fractions, 1 division of fractions, 1 adding fractions with same denominator, and 1 fractions with differing denominators, 1 ratio problems, 1 or more percent problems, and 1 percent in the automotive field.

DAY 29  
(Reading and Interpreting Automotive Charts)

See charts following.

HOMEWORK: Homework might consist of 1 rounding, 1 of writing whole numbers from words into numerals, 1 of numerals into words, 1 adding, 1 subtracting, and 1 multiplying, 1 division of whole numbers, 1 adding, 1 subtracting, 1 multiplying and 1 dividing decimal numbers, 1 reducing fractions, 1 changing fractions to decimals, 1 ordering of fractions, 1 multiplication of fractions, 1 division of fractions, 1 adding fractions with same denominator, and 1 fractions with differing denominators, 1 ratio problems, 1 or more percent problems, and 1 percent in the automotive field.

NOTES FOR AUTOMOTIVE CHARTS  
USING THE BEAR ACE

CHART 1: This chart is a printout of a car that is idling. Notice that the pressure has a number. The computer is so sensitive that it may not give zero readings.

CHART 2: The test will give a reading of each individual cylinder of the carburetor. The -47 means that there was a drop or loss of 47 rpm. The chart shows the information with the numbers and as a bar graph.

CHART 3: Here we view the burn time in milliseconds. That means that it took 1 1/2 millionths of a second for this to occur. Other information is in KV or kilovolts or 1000 volts. The 10 KV would be 10,000 volts.

CHART 4: The eighth cylinder has been disconnected. Notice that the bar graph shows that cylinder eight is definitely different from the others.

CHART 5: Again the eighth cylinder has been disconnected. Notice that it doesn't show up on the bar graph and the +1 on the chart.

CHART 6: Again the eighth cylinder is disconnected. Notice how the numbers for the eighth cylinder differ from the other cylinders.

CHART 7: Notice the readings of the compression percent. Here the computer has done the percentages for the tester and the results can be seen that all the cylinders are within range and the car would pass the test.

ENGINE SPEED

1 RPM  
METER

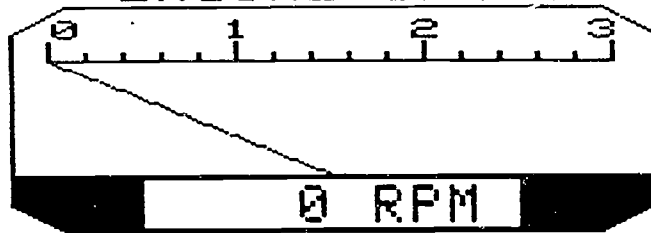

6 OFF  
TIMING  
+ .0°

8 DWELL  
.0°

4 CO %  
.00

7 HC PPM  
0

9 PRESSURE  
.2 PSI

5 O2 %  
.0

8 CO2 %  
.0

ENG TEMP  
0° F

PRINT

CONTINUE

CYL#	△RPM
1	- 47
5	- 31
4	- 44
2	- 46
6	- 39
3	- 43
7	- 44
8	- 37

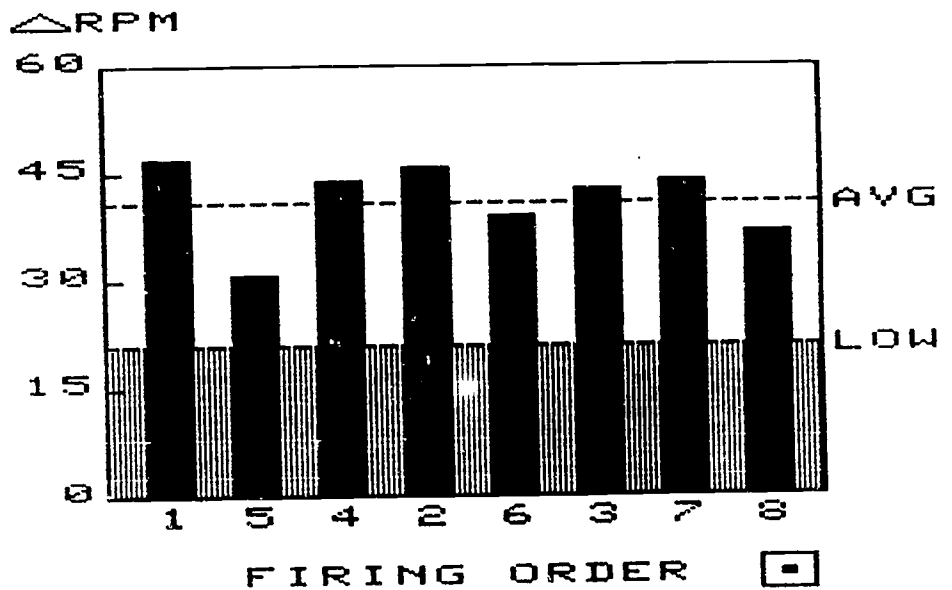

CONTINUE REPEAT PRINT

CYL #	BURN TIME (MS)	BURN KV	AVG KV	△ KV	SNAP KV	CKT GAP KV
1	1.5	2.4	10	7	13	5
5	1.0	2.3	10	3	14	6
4	1.5	2.5	10	5	14	6
2	1.6	2.5	9	3	13	6
6	1.5	2.5	10	3	14	5
3	1.5	2.7	12	4	18	6
7	1.7	2.0	9	4	12	4
8	1.6	2.6	11	3	14	5

CONTINUE

REPEAT

PRINT

■

1090 RPM

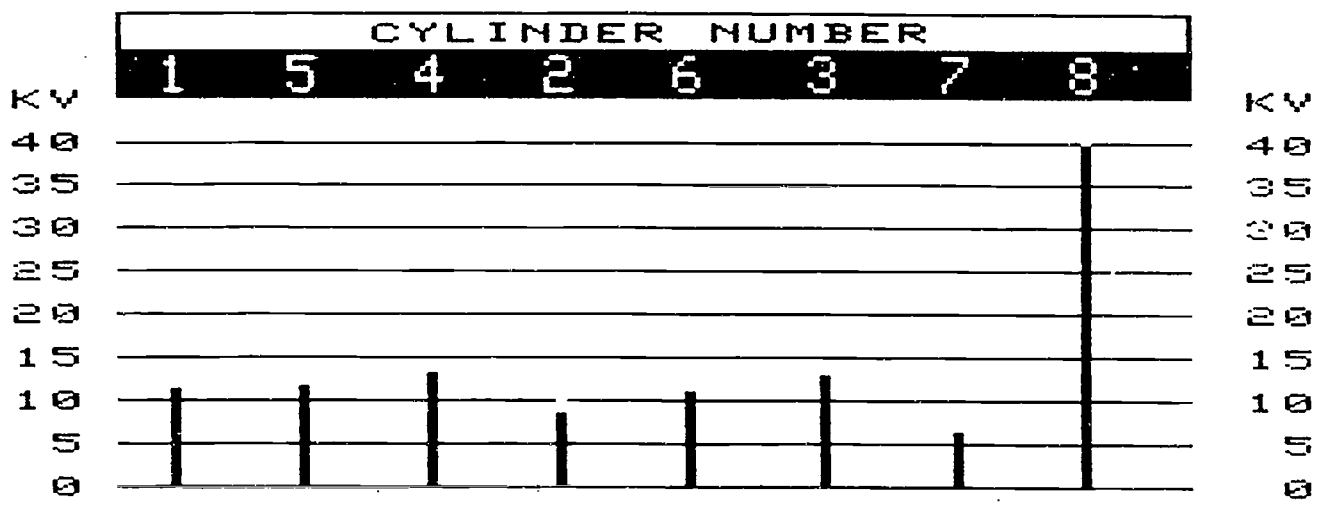

CYL#	△RPM
1	- 61
5	- 45
4	- 52
2	- 44
6	- 49
3	- 48
7	- 51
8	+ 1

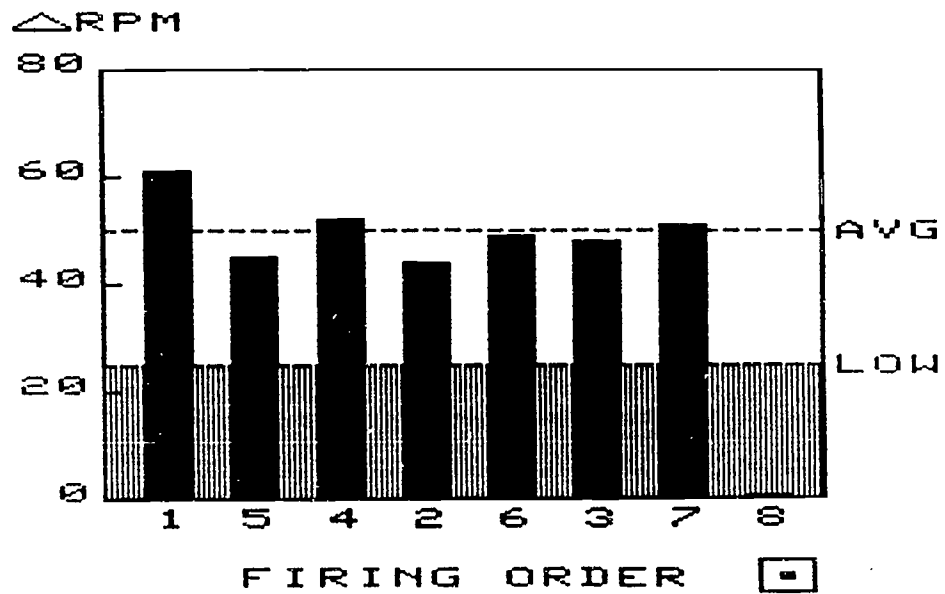

CONTINUE     REPEAT     PRINT



CYL #	BURN TIME (MS)	BURN KV	AVG KV	▷ KV	SNAP KV	CKT GAP KV
1	1.1	20.0	12	3	13	6
5	1.5	20.5	9	4	17	6
4	1.4	20.6	14	6	21	6
2	1.4	20.4	11	6	15	5
6	1.4	20.6	10	5	14	6
3	1.3	20.9	16	2	18	6
7	1.0	20.2	9	5	14	5
0	.0	4.3	45	0	40	40

CONTINUE

REPEAT

PRINT

□

## CRANKING TEST

CYL#	1	5	4	2	6	3	7	8
COMP. %	87	81	93	93	100	93	93	81
CRANKING VOLTS	10.18 VOLTS							
CRANKING CURRENT	222.0 AMPS							
CRANKING VACUUM	.0 INCHES							
CRANKING SPEED	186 RPM							
CRANKING DWELL	21.6 DEGREES							
COIL INPUT VOLTS	8.8 VOLTS							
HYDROCARBONS	0 PPM							

CONTINUE

REPEAT

PRINT

-

DAY 30  
(Review)

1. Review old tests
2. Review old quizzes

MEMS: pg 195-196

DAY 31  
(Exam and Angles)

1. Exam
2. Measure various angles with a protractor.
3. See relationship with degrees on shop diagrams.

DAY 32

(Area and perimeter of geometric shapes)

1. Find area and perimeter of triangles
2. Find area and perimeter of squares and rectangles

MEMS: pg 277-278

HOMEWORK: Homework might consist of 1 rounding, 1 of writing whole numbers from words into numerals, 1 of numerals into words, 1 adding, 1 subtracting, and 1 multiplying, 1 division of whole numbers, 1 adding, 1 subtracting, 1 multiplying and 1 dividing decimal numbers, 1 reducing fractions, 1 changing fractions to decimals, 1 ordering of fractions, 1 multiplication of fractions, 1 division of fractions, 1 adding fractions with same denominator, 1 fraction with differing denominators, 1 ratio problem, 1 or more percent problems, 1 percent in the automotive field, 1 angle measurement, 1 each of area of triangle and a rectangle, and 1 each of the perimeter of a triangle and a rectangle.

DAY 33  
(Circles)

1. Explain diameter, radius, circumference, and area
2. There are many places in automotive where the student will need to understand 90, 180, 270 and 360 degrees. This needs to be stressed.
3. Explain  $CID = \pi \times \text{Radius squared} \times \text{Length of Stroke} \times \# \text{ Cylinders}$   
(Cubic Inch Displacement)

MEMS: pg 289-292

HOMEWORK: Homework might consist of 1 rounding, 1 of writing whole numbers from words into numerals, 1 of numerals into words, 1 adding, 1 subtracting, and 1 multiplying, 1 division of whole numbers, 1 adding, 1 subtracting, 1 multiplying and 1 dividing decimal numbers, 1 reducing fractions, 1 changing fractions to decimals, 1 ordering of fractions, 1 multiplication of fractions, 1 division of fractions, 1 adding fractions with same denominator, 1 fraction with differing denominators, 1 ratio problem, 1 or more percent problems, 1 percent in the automotive field, 1 angle measurement, 1 each of area of triangle and a rectangle, and 1 each of the perimeter of a triangle and a rectangle, and 3 circle problems.

DAY 34  
(Volume of square and rectangles)

1. Explain the volume and cubic units
2. Have make different sized boxes from same half sheet of paper and discuss different volumes

MEMS: pg 293-296

HOMEWORK: Homework might consist of 1 rounding, 1 of writing whole numbers from words into numerals, 1 of numerals into words, 1 adding, 1 subtracting, and 1 multiplying, 1 division of whole numbers, 1 adding, 1 subtracting, 1 multiplying and 1 dividing decimal numbers, 1 reducing fractions, 1 changing fractions to decimals, 1 ordering of fractions, 1 multiplication of fractions, 1 division of fractions, 1 adding fractions with same denominator, 1 fraction with differing denominators, 1 ratio problem, 1 or more percent problems, 1 percent in the automotive field, 1 angle measurement, 1 each of area of triangle and a rectangle, and 1 each of the perimeter of a triangle and a rectangle, 2 circle problems, and 2 volume problems.

DAY 35  
(Mitchell on Demand)

1. Explain basic terminology of computer. Include user-friendly, input, output, printout
2. Explain use of discs, how to load, menus
3. Practice printing a diagram
4. Practice locating and printing a specific piece of information or diagram

Example: Find and print out the diagram of the configuration of the tune-up specifications for a 1990 Ford Bronco.



NOTES FOR MENUS  
MITCHELL ON DEMAND

MENU 1: The Mitchell on Demand that is used in MATC's automotive shop only displays the first two selections. Therefore, the student only needs to choose between Import and Domestic cars and trucks. Use the up and down arrow keys to go up and down the list. Then press the Enter key to make the choice. The computer knows when it is its turn to do something when the user presses the Enter key. (Example of user-friendly) Notice the choices at the bottom of the screen. For example, if the user wishes to quit, press the F10 key at the top of the keyboard.

MENU 2: Now, the user is to choose the year of the car or truck. Again, the user should use the up and down arrow keys to go up or down the list of years and the right arrow key will go to the column at the right. Notice that at the top of the screen is [YEAR] [MAKE] in brackets. This indicates that these choices are not yet made, but are forthcoming. Notice that at the bottom left of the screen is ON-DEMAND DOMESTIC. This shows that the user previously chose domestic cars and trucks. In order to choose the desired year, the user should again press the Enter key. On the screen, the user is choosing 1989.

MENU 3: Note that at the top of the screen, is 1989 [MAKE]. This indicates that the user has chosen 1989 for the year, but is still to choose the make of the car or truck. If the user wishes to choose and different year, notice the F1 circled at the left of YEAR on the left of the screen. By pressing F1, the user can go back to the previous screen instead of starting all over. This time the user is choosing Dodge.

MENU 4: Notice that at the top of the screen is 1989 Dodge [MODEL]. This means the user has already chosen 1989 for the year and Dodge for the make. The model in brackets shows what this menu is for. If the user should decide to choose a different make of car, the user would press F2 to go back to that menu, but if the year is wrong, F1 would go back to that menu. Again at the bottom left of the screen, the computer shows that the user had chosen domestic cars and trucks. This time notice the PgDn choice included at the bottom of the screen. That indicates that there are more selections of models on another screen. PgUp would then get you back to the previous screen. The F9 choice gets the user to a table of contents that show what is included in each section.

MENU 5: Notice that this is just another level deeper in the domestic car and truck path. Now the user is to choose the section of information needed about the vehicle. The user chose electrical.

MENU 6: Still, the user gets to make another choice. These menus continue until the computer has enough information to get the user to the proper place in the manual.

PRODUCT SELECTION			
IMPORT CARS AND TRUCKS			
DOMESTIC CARS AND TRUCKS			
ESTIMATING			
MAINTENANCE			

STAT [F2]	CD [F6]			HELP [F9]	EXIT [F10]
-----------	---------	--	--	-----------	------------

Fig. 4 - PRODUCT SELECTION Screen

Select 1989.

[YEAR] [MAKE]

YEAR >>>>>>>>>>

1983	1991
1984	
1985	
1986	
1987	
1988	
1989	
1990	

ON-DEMAND DOMESTIC

PROD [F6]   HELP [F9] EXIT [F18]

Select DODGE.

1989 [MAKE]

F1 YEAR  
MAKE >>>>>>>>>>

Buick	GMC
Cadillac	Jeep
Chevrolet	Lincoln
Chrysler	Mercury
<b>Dodge</b>	Oldsmobile
Eagle	Plymouth
Ford	Pontiac
GEO	

ON-DEMAND DOMESTIC

PROD [F6] [ ] [ ] HELP [F9] EXIT [F10]

Fig. 6 - MAKE (Manufacturer) Selection Screen

## Select COLT.

1989 Dodge [MODEL]

(F1) YEAR  
(F2) MAKE  
MODEL >>>>>>>>

Aries	Dynasty
Caravan/Mini Ram Van	Lancer
<b>Colt</b>	Omni
Colt Vista	Pickup
Conquest	Raider
Dakota	Ram Charger
Daytona	Ram Van/Ram Wagon
Diplomat	Ram-50 Pickup

ON-DEMAND DOMESTIC

PgDn HELP [F9] EXIT [F10]

Fig. 7 - MODEL Selection Screen

The status line or path (across the top of the screen) displays the year, make and model selected. Now you are asked to select the type of information you need at the SECTION screen. Sometimes there may be more than one screen full of section selections. When this is the case, the PgDn selection will appear. If you need information from a section not on the screen, select PgDn to access the next screen for more choices. Use PgUp to get back to the first screen. The HELP [F9] key describes what included in each section. If you are unsure which section to choose, the TABLE OF CONTENTS can help.

Select **ELECTRICAL**.

**NOTE:** If you are using the keyboard, use the Page Up or Page Down keys on the keyboard.

1989 Dodge Colt [SECTION]

F1 YEAR  
F2 MAKE  
F3 MODEL  
SECTION ▶▶▶▶

TABLE OF CONTENTS	ENGINE COOLING
ACCESSORIES & EQUIPMENT	ENGINE PERFORMANCE
AIR CONDITIONING & HEAT	ENGINES
BRAKES	FUEL SYSTEMS
CLUTCHES	MAINTENANCE
DRIVE AXLES	STEERING
ELEC COMPONENT LOCATION	SUSPENSION
<b>ELECTRICAL</b>	TECHNICAL BULLETINS

ON-DEMAND DOMESTIC

INDX [F6]    PgDn    HELP [F9]    EXIT [F10]

Fig. 8 - SECTION Selection Screen

Select ALTERNATOR - MITSUBISHI.

1989 Dodge Colt ELECTRICAL [TITLE]	
(F1) YEAR	ALTERNATOR - MITSUBISHI
(F2) MAKE	STARTER - MITSUBISHI
(F3) MODEL	
(F4) SECTION	
TITLE >>>>>>>>	
ON-DEMAND DOMESTIC	PRINT [F7] <input type="text"/> <input type="text"/> HELP [F9] EXIT [F10]

Fig. 9 - TITLE Selection Screen

DAY 36  
(Review)

1. Review old exams
2. Review quizzes
3. Review new material



DAY 37  
(Exam)

DAY 38  
(Review for final)

DAY 39  
(Final Exam)

This leaves a last day in order to have exit interviews with each student, discussing their final exams and final grades. This last day also gives flexibility for the instructor to use an extra day on an area that need more attention. Another place that an extra day could be obtained is to review for the final on day 37, eliminating day 38.

# INTEGRATED TECHNICAL CURRICULUM

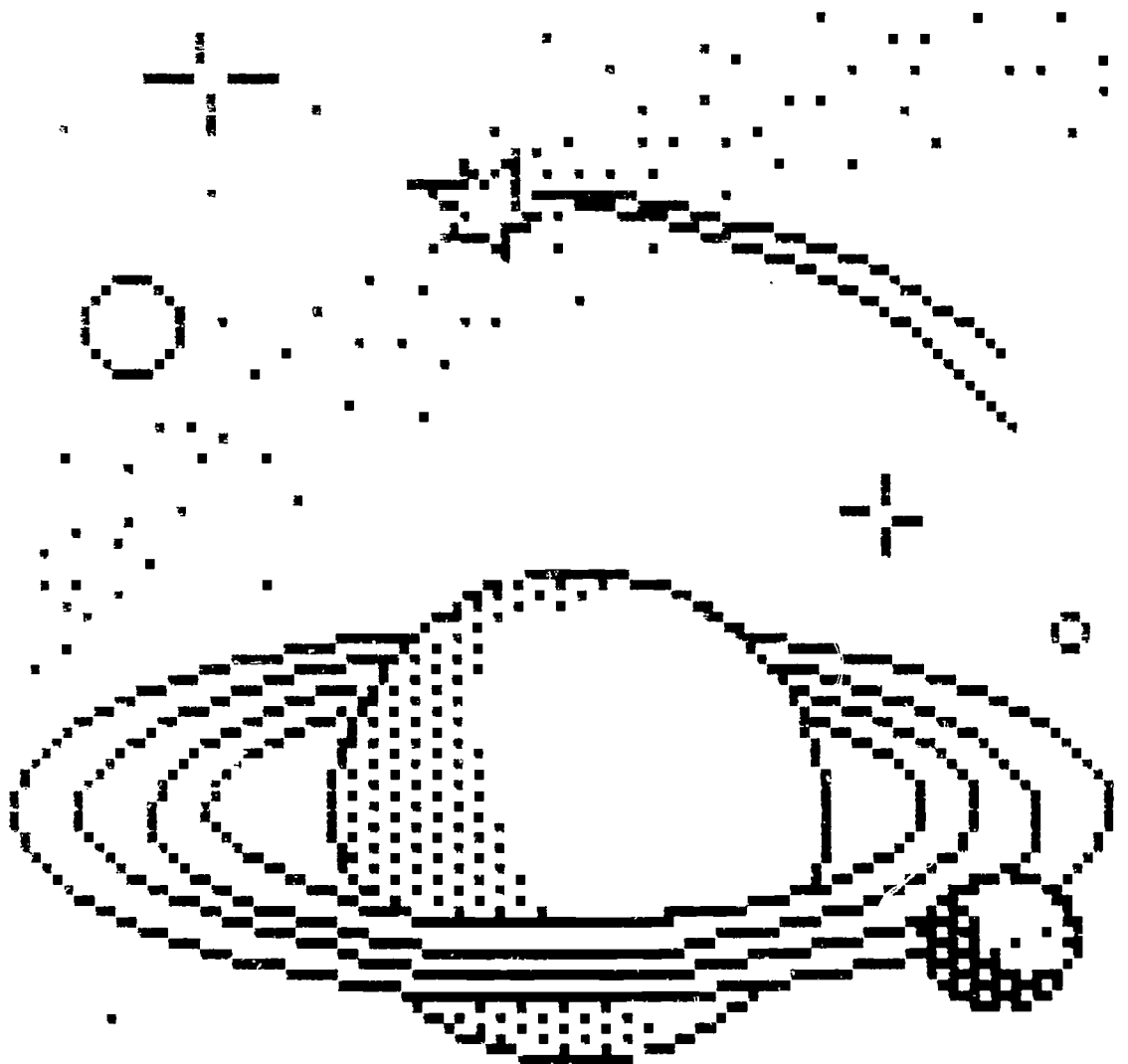

## SCIENCE COMPONENT

Integrated Technical Curriculum  
Science Component

Physical Science for Automotive Students

Developed by  
Norrine E. Nolan

Milwaukee Area Technical College  
Adult High School

June, 1993

## Integrated Technical Curriculum Science Component

### Physical Science for Automotive Students

As of this writing, a textbook has not been determined.

Assignments, quizzes, tests, labs, etc. will be up to the discretion of the instructor and determined when and if a textbook is chosen.

#### References:

Mitchell Automechanics, 2nd edition, Prentice Hall.

Life Science Library: Energy.

Life Science Library: Machines.

Principles of Technology, Units 1 - 6, Center for Occupational Research and Development.

Workbook for Automotive Mechanics, McGraw-Hill, Inc.

Any physical science, general science, physics, and/or chemistry text.

## **Integrated Technical Curriculum Science Component**

### **Physical Science for Automotive Students**

#### **General Objectives**

1. To obtain a functional knowledge of basic scientific concepts and principles.
2. To provide an understanding of basic scientific concepts and principles and the mathematics associated with them.
3. To identify workplace applications for these scientific concepts and principles.

Integrated Technical Curriculum Science Component  
Physical Science for Automotive Students

Course Outline

Instructional Units and Competencies

<u>Instructional Unit</u>	<u>Competency</u>
1. Measurement	<ol style="list-style-type: none"><li>1. Identify the basic units of measurement for length, weight (mass), volume (capacity), and temperature for the US Customary (English) system.</li><li>2. Work with the US Customary System.</li><li>3. Identify comparable units of measurement to the US Customary System within the Metric system.</li><li>4. Work with the metric system.</li><li>5. Compare, contrast, and convert between US Customary System and Metric System.</li></ol>
2. Chemistry	
A. Matter	<ol style="list-style-type: none"><li>1. Define the term matter.</li><li>2. Describe the three states of matter.</li><li>3. List examples of the physical and chemical properties of matter.</li><li>4. Describe and list examples of physical and chemical changes.</li><li>5. Compare and contrast elements, compounds, and mixtures.</li></ol>
B. Atoms	<ol style="list-style-type: none"><li>1. Describe the properties of atoms, neutrons, protons, and electrons and tell where they are located in an atom.</li><li>2. Compare and contrast elements and atoms.</li><li>3. Compare and contrast compounds and molecules.</li><li>4. Relate the atomic theory to chemical changes.</li></ol>
3. Energy and Force	<ol style="list-style-type: none"><li>1. Explain the concept of energy.</li><li>2. Define kinetic energy.</li><li>3. Define potential energy.</li><li>4. Name and describe six forms of energy.</li><li>5. Describe how one form of energy can be transformed into another form of energy.</li><li>6. Explain the law of conservation of energy.</li></ol>

<u>Instructional Unit</u>	<u>Competency</u>
Energy and Force (continued)	7. Define and describe properties and effects of heat energy. 8. Understand the effects of pressure. 9. Explain a vacuum. 10. Compare heat and temperature.
4. Electricity and Magnetism	1. Describe how electric charges are formed. 2. Describe how an electric current can be made to flow through an electric circuit. 3. Discuss volts, amperes, and ohms. 4. Describe the difference between series and parallel circuits. 5. Explain the theory of magnetism. 6. Describe electromagnetism.
5. Machines	1. Define tool and machine. 2. Define the terms force, work, rate, resistance, energy, and power. 3. Know the four basic machine systems (mechanical, fluid, electrical, and thermal). 4. Understand the relationships of the four basic machine systems and their applications to the appropriate technology.

Integrated Technical Curriculum Science Component

Physical Science for Automotive Students

Instructional Units and Time Frame\*

Unit	Days (Suggested Number)
Measurement	6
Chemistry	7
Energy	6
Electricity	7
Machines	11
End of Course	
Review	1
Exam	1
Grades	1

\* The time frame is a 40 day quarter with classes meeting for 1 hr 55 min daily.



Physical Science for Automotive Students

MEASUREMENT UNIT

**Objective:** To learn and apply the basic units of measurement in the Metric and United States Customary (English) Systems for length, weight (mass), volume (capacity), and temperature.

**Materials:** Various instruments of measurement in both metric and US customary: meter stick, graduated cylinder, measuring cup, measuring beaker, thermometer, etc.

Everyday comparison items: 2 liter &  $\frac{1}{2}$  gallon bottles; 1 liter & 1 quart bottles; 1 oz, 1 lb, 1 g, & 1 kg weights; thermometer, etc.

Automotive measurement tools: metric and US Customary wrenches, ratchets, & sockets; voltmeter, ammeter, ohmmeter, and/or multimeter; etc.

**Student Handouts:** US Customary Units of Measure  
Metric Units of Measure  
Metric/US Customary Conversion  
English-Metric Conversion Chart

**Optional:** Videos - Reading a Ruler (2 videos, 1989)  
1. The Customary System (12 min)  
2. The Metric System (11 min)  
VCR and monitor

<b>Method:</b>	Lecture/Discussion	Demonstration/Modeling
	Optional: Videos	Hands on/Lab
	Assign problems	Quizzes/Test

**Automotive topics:** Besides general topics of measurement, the following specific material must be covered and related to the automobile.

- Comparison of sizes on tools, such as sockets and wrenches.
- Meaning and importance of the prefix milli as applied to millimeters in tools and millivolts (mv) and milliohms (mo).
- Meaning and importance of the prefix kilo as applied to kilovolts (kV), kilohms (ko), and kilowatts (kW).
- cubic in (cu in or in<sup>3</sup>) = liters.  
(In Ford V8 engine, 5 l = 302 cu in.)
- Spark plug gapping.
- Freezing and boiling points in °F and °C.
- Raising and lowering the freezing and boiling points through chemicals and pressure. Include both °F and °C.
- Other Automotive related topics.

**Time Frame:** This will be a 5 - 6 day unit that includes at least one day with students working hands on in a lab.

**Daily Topics:** Daily assignments to be determined.

**Categories of Measurement:**

Length - distance.

US Customary - inch, foot, yard, rod, mile.

Metric - centimeter, meter, kilometer.

Area - 2 dimensional measurement of a region.

US Customary - square inch, square foot, acre.

Metric - square centimeter, square meter, square kilometer.

Volume (dry) - 3-dimensional measurement of space

US Customary - cubic inch, cubic foot.

Metric - cubic centimeter, cubic meter.

Volume (liquid) - Capacity - measure of what is contained within an object.

US Customary - ounce, cup, pint, quart, gallon.

Metric - milliliter, liter, kiloliter.

Weight or mass - measure of how heavy something is.

US Customary - ounce, pound, ton.

Metric - milligram, gram, kilogram.

Temperature - Measurement of how hot or cold.

US Customary - Fahrenheit degrees.

Metric - Centigrade or Celsius degrees.

- Day 1:**
- Orientation. Help the student to be comfortable in their new environment. Go through the course syllabus thoroughly so students know what material will be covered and what will be expected of them.
  - Idea of measurement.
  - Units in the US customary system.
  - Video: The Customary System.
  - Using appropriate tools, demonstrate the units.
  - Staying within the US Customary System, demonstrate the relationship between units.
  - Students work on problems in this system.
  
  - Units in the metric system.
  - Video: The Metric System.
  - Using appropriate tools, demonstrate the units.
  - Staying within the Metric System, demonstrate the relationship between units.
  - Students work on problems within the Metric System.
  - Assign problems working with both systems but not converting from one system to another.

- Day 2: - Comparison of the US Customary and Metric Systems of measurement.
- Compare and contrast units with measurement devices.
  - Use the liter & quart and the 2 liter &  $\frac{1}{2}$  gallon bottles to experiment to see which are larger.
  - Compare and contrast units using the metric and US Customary tools.
  - Assign problems working with converting between the two systems.

Day 3: - Lab (to be determined).

Day 4: - Work with both systems and conversion between the systems with information that is specific to the automobile.

- Suggestions:

1. The specifications call for the spark plugs to be gapped at 0.035 inches. Determine the metric equivalent.

$$\text{(Use } 1 \text{ in} = 2.54 \text{ cm} = 25.4 \text{ mm)}$$

$$\text{(} 0.035 \times 25.4 = 0.889 \text{ mm)}$$

2. The decal on the engine air cleaner states that the engine has a displacement of 225 cubic inches. You know that in the metric system the engine size is measured in liters. Find the engine size in liters.

$$\text{(Use } 1 \text{ l} = \text{approximately } 61 \text{ cu in)}$$

$$\text{(} 225/61 = 3.7 \text{ l)}$$

3. The horsepower of the engine you are tuning is given as 105 hp at 3,600 rpm. In the metric system, power is measured in kilowatts. Change horsepower to kilowatts.

$$\text{(Use } \text{hp} \times 0.746 = \text{kW)}$$

$$\text{(} 105 \times 0.746 = 78.3 \text{ kW)}$$

- Assign problems that are automobile specific.

Day 5: - Review.

Day 6: - Test.

## US CUSTOMARY (ENGLISH) UNITS OF MEASURE

### Length

1 foot (ft or ') = 12 inches (in or ")  
1 yard (yd) = 3 ft = 36 in  
1 rod (rd) =  $5\frac{1}{2}$  or 5.5 yd = 198 in  
1 mile (mi) = 320 rd = 1,760 yd = 5,280 ft = 63,360 in

### Area

1 square foot (sq ft or ft<sup>2</sup>) = 144 square inches (sq in or in<sup>2</sup>)  
1 square yard (sq yd or yd<sup>2</sup>) = 9 ft<sup>2</sup>  
1 acre = 43, 560 yd<sup>2</sup>  
1 square mile (sq mi or mi<sup>2</sup>) = 640 acres

### Weight

1 pound (lb) = 16 ounces (oz)  
1 ton = 2,000 lb = 32,000 oz

### Volume (Capacity)- Liquid

1 cup = 8 fluid ounces (fl oz)  
1 pint (pt) = 2 cups = 16 fl oz  
1 quart (qt) = 2 pts = 4 cups = 32 fl oz  
1 gallon (gal) = 4 qts = 8 pts = 32 cups = 128 fl oz

### Volume (Capacity)- Dry

1 tablespoon (T or tblsp) = 3 teaspoons (t or tsp)  
1 cup = 8 T  
1 pint (pt) = 2 cups  
1 quart (qt) = 2 pts = 4 cups  
1 peck = 8 qts  
1 bushel (bu) = 4 pecks = 32 qts

### Capacity

1 cubic foot (cu ft or ft<sup>3</sup>) = 1,728 cubic inches (cu in or in<sup>3</sup>)  
1 cubic yard (cu yd or yd<sup>3</sup>) = 27 cu ft  
1 gallon (gal) = 231 cu in  
1 cu ft = 7.48 gal

### Temperature- Fahrenheit (°F)

Boiling Point of H<sub>2</sub>O = 212°F

Freezing Point of H<sub>2</sub>O = 32°F

## METRIC UNITS OF MEASURE

Unit of LENGTH = METER = m

Unit of WEIGHT (MASS) = GRAM = g

Unit of VOLUME (CAPACITY) = LITER = l

Unit of TEMPERATURE = CELSIUS or CENTIGRADE = °C

### Prefixes

	↑			↓
Divide		\$1,000,000	mega (M) = 1,000,000	Multiply
by 10		\$1,000	kilo (k) = 1000	by 10
or		\$100	hecto (h) = 100	or
move		\$10	deka (da) = 10	move
decimal		\$1	no prefix; just unit name	decimal
point		dime	deci (d) = .1 or 1/10	point
left		cent	centi (c) = .01 or 1/100	right
		mill	mill (m) = .001 or 1/1000	
		micro	micro (μ) = .000001 or 1/1,000,000	

### Metric Weights and Measures

#### Length

1 km = 10 hm = 1000 m  
 1 hm = 10 dam = 100 m  
 1 dam = 10 m  
 1 m = 10 dm  
 1 dm = 10 cm = .1 m  
 1 cm = 10 mm = .01 m

1 mm = 1000 μm = .000001 m

#### Weight (Mass)

1 Mg = 1000 kg = 1,000,000 g  
 (1000 kg is a metric ton)

1 kg = 10 hg = 1000 g  
 1 hg = 10 dag = 100 g  
 1 dag = 10 g  
 1 g = 10 dg  
 1 dg = 10 cg = .1 g  
 1 cg = 10 mg = .01 g

#### Volume (Capacity)

1 Ml = 1000 kl = 1,000,000 l

1 kl = 10 hl = 1000 l  
 1 hl = 10 dal = 100 l  
 1 dal = 10 l  
 1 l = 10 dl  
 1 dl = 10 cl = .1 l  
 1 cl = 10 ml = .01 l

#### Area

1 are (a) = 100 sq m (m<sup>2</sup>)  
 1 hectare (ha) = 10,000 m<sup>2</sup>  
 1 sq km (km<sup>2</sup>) = 1,000,000 m<sup>2</sup>  
 1 m<sup>2</sup> = 100 sq dm (dm<sup>2</sup>)  
 1 dm<sup>2</sup> = 100 sq cm (cm<sup>2</sup>)  
 1 cm<sup>2</sup> = 100 sq mm (mm<sup>2</sup>)

#### Temperature

1 ml = 1 cubic cm (cc or cm<sup>3</sup>)  
 1000 cc or cm<sup>3</sup> = 1000 l

Boiling Point of H<sub>2</sub>O = 100°C  
 Freezing Point of H<sub>2</sub>O = 0°C

## METRIC/US CUSTOMARY CONVERSION

### Length

English	Metric
1 in	= 2.54 cm = 25.4 mm
1 ft	= 30.5 cm = 305 mm
1 yd	= 91.4 cm = 914 mm
1 mi	= 1610 m
1 mi	= 1.61 km
0.0394 in	= 1 mm
0.394 in	= 1 cm
39.4 in	= 1 m
3.28 ft	= 1 m
1.09 yd	= 1 m
0.621 mi	= 1 km

### Weight

English	Metric
1 oz	= 28.3 g
1 lb	= 454 g
1 lb	= 0.454 kg
0.0353 oz	= 1 g
0.0022 lb	= 1 g
2.2 lb	= 1 kg

### Volume (Capacity)

English	Metric
1 cu in	= 16.39 cc
1 cu ft	= 28.317 cc
1 cu yd	= 0.7646 cu m
0.06 cu in	= 1 cc
35.3 cu ft	= 1 cu m
1 l	= 1.06 qt
1 l	= 33.8 oz
2 l	= 2.12 qt

### Temperature

English	Metric
32°F	= 0°C
212°F	= 100°C

### Temperature Conversion Formulas

$$^{\circ}\text{F} = 9/5^{\circ}\text{C} + 32^{\circ} \text{ or } \frac{9x^{\circ}\text{C} + 32^{\circ}}{5}$$

$$^{\circ}\text{C} = 5/9(^{\circ}\text{F} - 32^{\circ}) \text{ or } \frac{5x(^{\circ}\text{F} - 32^{\circ})}{9}$$

### Area

English	Metric
1 in <sup>2</sup>	= 6.4 cm <sup>2</sup>
1 ft <sup>2</sup>	= 929 cm <sup>2</sup>
1 yd <sup>2</sup>	= 8361 cm <sup>2</sup>
1 acre	= 4047 m <sup>2</sup>
1 mi <sup>2</sup>	= 2.59 km <sup>2</sup>
10.76 ft <sup>2</sup>	= 1 m <sup>2</sup>
1,350 in <sup>2</sup>	= 1 m <sup>2</sup>
1.196 yd <sup>2</sup>	= 1 m <sup>2</sup>
0.155 in <sup>2</sup>	= 1 cm <sup>2</sup>
247.1 acres	= 1 km <sup>2</sup>
0.386 mi <sup>2</sup>	= 1 km <sup>2</sup>

### English-Metric Conversion Chart

To Convert	To:	Multiply by:
<b>Length</b>		
Millimeters	Inches	0.03937
Inches	Millimeters	25.4
Meters	Feet	3.28084
Feet	Meters	0.3048
Kilometers	Miles	0.62137
Miles	Kilometers	1.60935
<b>Area</b>		
Square centimeters	Square inches	0.155
Square inches	Square centimeters	6.45159
<b>Volume</b>		
Cubic centimeters	Cubic inches	0.06103
Cubic inches	Cubic centimeters	16.38703
Liters	Cubic inches	61.025
Cubic inches	Liters	0.01639
Liters	Quarts	1.05672
Quarts	Liters	0.94633
Liters	Pints	2.11344
Pints	Liters	0.47317
Liters	Ounces	33.81497
Ounces	Liters	0.02957
<b>Weight</b>		
Grams	Ounces	0.03527
Ounces	Grams	28.34953
Kilograms	Pounds	2.20462
Pounds	Kilograms	0.45359
<b>Work</b>		
Centimeter-kilograms	Inch-pounds	0.8676
Inch-pounds	Centimeter-kilograms	1.15262
Meter-kilograms	Foot-pounds	7.23301
Foot-pounds	Newton-meters	1.3558
<b>Pressure</b>		
Kilograms/square centimeter	Pounds/square inch	14.22334
Pounds/square inch	Kilograms/square centimeter	0.07031
Bar	Pounds/square inch	14.504
Pounds/square inch	Bar	0.06895
Atmosphere	Pounds/square inch	14.695
Pounds/square inch	Atmosphere	0.06805
<b>Temperature</b>		
Celsius degrees	Fahrenheit degrees	$(^{\circ}\text{C} \times \frac{9}{5} + 32)$
Fahrenheit degrees	Celsius degrees	$(^{\circ}\text{F} - 32) \times \frac{5}{9}$

## Conversion Factors

### Length

1 in = 2.54 cm  
 1 cm = 0.394 in  
 1 ft = 30.5 cm  
 1 m = 39.4 in = 3.281 ft  
 1 km = 0.621 mi  
 1 mi = 5280 ft = 1.609 km  
 1 light-year =  $9.461 \times 10^{15}$  m

### Mass

1 lb = 453.6 g (where  $g = 9.80$  m/sec<sup>2</sup>)  
 1 k = 2.205 lb (where  $g = 9.80$  m/sec<sup>2</sup>)  
 1 atomic mass unit (amu) =  $1.66061 \times 10^{-27}$  kg

### Volume

1 liter = 1.057 quarts  
 1 in<sup>3</sup> = 16.4 cm<sup>3</sup>  
 1 gallon = 3.786 liter  
 1 ft<sup>3</sup> =  $2.832 \times 10^2$  m<sup>3</sup>

### Energy

1 cal = 4.184 J  
 1 J = 0.738 ft · lb = 0.239 cal  
 1 ft · lb = 1.356 J  
 1 Btu = 252 cal = 778 ft · lb  
 1 Kw·hr =  $3.60 \times 10^6$  J = 860 kcal  
 1 hp = 550. ft · lb/sec = 746 w  
 1 w = 0.738 ft · lb/sec  
 1 Btu/hr = 0.293 w  
 Absolute zero (OK) = -273.15°C  
 1 J =  $6.24 \times 10^{18}$  eV  
 1 eV =  $1.6022 \times 10^{-19}$  J

### Speed

1 km/hr = 0.278 m/sec = 0.621 mi/hr  
 1 m/sec = 3.60 km/hr = 2.237 mi/hr = 3.281 ft/sec  
 1 mi/hr = 1.61 km/hr = 0.447 m/sec = 1.47 ft/sec  
 1 ft/sec = 0.305 m/sec = 0.682 mi/hr = 1.47 ft/sec

### Force

1 N = 0.2248 lb  
 1 lb = 4.448 N

### Pressure

1 atm = 1.013 bar =  $1.013 \times 10^5 \frac{\text{N}}{\text{m}^2} = 14.7 \frac{\text{lb}}{\text{in}^2}$   
 1 lb/in<sup>2</sup> =  $6.90 \times 10^3$  N/m<sup>2</sup>

## Metric Prefixes

Prefix	Symbol	Meaning
Giga-	G	1,000,000,000 times the unit
Mega-	M	1,000,000 times the unit
Kilo-	k	1,000 times the unit
Hecto-	h	100 times the unit
Deka-	da	10 times the unit
Base Unit		
Deci-	d	0.1 of the unit
Centi-	c	0.01 of the unit
Milli-	m	0.001 of the unit
Micro-	μ	0.000001 of the unit
Nano-	n	0.000000001 of the unit

## Physical Constants

Quantity	Approximate Value
Gravity	$g = 9.80$ m/sec <sup>2</sup>
Gravitational law constant	$G = 6.67 \times 10^{-11}$
Earth radius (mean)	$6.38 \times 10^6$ m
Earth mass	$5.98 \times 10^{24}$ kg
Earth-sun distance (mean)	$1.50 \times 10^{11}$ m
Earth-moon distance (mean)	$3.84 \times 10^8$ m
Fundamental charge	$e = 1.60 \times 10^{-19}$ C
Coulomb law constant	$k = 9.00 \times 10^9$ N · m <sup>2</sup> /C <sup>2</sup>
Electron rest mass	$9.11 \times 10^{-31}$ kg
Proton rest mass	$1.6726 \times 10^{-27}$ kg
Neutron rest mass	$1.6750 \times 10^{-27}$ kg
Bohr radius	$5.29 \times 10^{-11}$ m
Avogadro's number	$6.02 \times 10^{23}$ /mol
Planck's constant	$6.62 \times 10^{-34}$ J · sec
Speed of light (vacuum)	$3.00 \times 10^8$ m/sec
Pi	$\pi = 3.1415926536$



Physical Science for Automotive Students

CHEMISTRY UNIT

**Objective:** To learn basic matter, chemistry, and atomic terminology, concepts, and principles.

**Materials:** Various examples of appropriate, common chemicals.

**Student Handouts:** Periodic Table of the Elements  
other appropriate handouts

**Demonstration materials:** H<sub>2</sub>O, ice, beaker, solid, balance, graduated cylinder, bunsen burner, etc.

**Optional:** During the Chemistry Unit, there are a number of videos, films, and film strips in room 680 or through the AV department that may be used. (VCR/monitor and/or film and/or filmstrip projector needed.)

**Method:** Lecture/Discussion  
Demonstration/Modeling  
Assignments

**Optional:** Video  
Hands on/Lab  
Quizzes/Test(s)

**Automotive topics:** Besides general topics of chemistry, the following specific material must be covered and related to the automobile:

- States and properties of matter.
- Safety with handling of chemicals.
- Acids and Bases.
- Freezing and boiling points. Include °F & °C.
- Water. Water expands when freezes and could crack engine block, cylinder head, or radiator.
- Effects of chemicals, especially antifreeze (ethylene glycol) on the freezing and boiling points. Include °F & °C. (50%-70% solution)
- Atmospheric/Barometric Pressure.
- Effects of pressure on the freezing and boiling points. Include °F & °C.
- Vacuum.
- Solutions and % of mixtures.
- Air/gasoline mixture. (Perfect fuel mixture-air:gasoline = 14.7:1)
- Specific elements and compounds:

Oxygen- O <sub>2</sub>	Hydrogen- H <sub>2</sub>
Carbon- C	Water- H <sub>2</sub> O
Carbon Dioxide- CO <sub>2</sub>	Carbon Monoxide- CO
Nitrogen- N <sub>2</sub>	Nitrogen compounds
Sulfur compounds	Hydrocarbons
- Emission gases of automobiles. Guidelines to pass the emission test for your automobile. Gases tested for are CO which must be ≤ 1.20%, prefer to be about 1.0% and Hydrocarbons which must be ≤ 220 parts per million (ppm).
- Other appropriate topics as necessary.

**Time Frame:** This will be a 6 - 7 day unit that includes at least one day with students working hands on in a lab.

**Daily Topics:** Daily assignments to be determined

- Day 7: - Matter.  
- States and properties of matter. (Demonstration)  
- Elements, compounds, mixtures.  
- Physical changes.
- Day 8: - Atomic theory.  
- Chemical changes and reactions.  
- Chemical equations.  
- Elements and compounds.
- Day 9: - Safety with handling of chemicals.  
- Acids and Bases.  
- Specific properties of H<sub>2</sub>O.  
- Solutions and % in mixtures.  
- Freezing and Boiling points. Include °F & °C.  
- Chemical effects on freezing and boiling points.  
Include °F & °C.
- Day 10: - Lab (to be determined).
- Day 11: - Elements, compounds, mixtures, and solutions that are specific to the automobile.  
- Automobile emissions and standards.
- Day 12: - Review.
- Day 13: - Test.

IA												IIIA					IVA	VA	VIA	VIIA		
1 H 1.01											5 B 10.8	6 C 12.0	7 N 14.0	8 O 16.0	9 F 19.0							
3 Li 6.94	4 Be 9.01											13 Al 27.0	14 Si 28.1	15 P 31.0	16 S 32.1	17 Cl 35.5						
11 Na 23.0	12 Mg 24.3	IIIB	IVB	VB	VIB	VII B	VIII B			IB	IIB											
19 K 39.1	20 Ca 40.1	21 Sc 45.0	22 Ti 47.9	23 V 50.9	24 Cr 52.0	25 Mn 54.9	26 Fe 55.8	27 Co 58.9	28 Ni 58.7	29 Cu 63.5	30 Zn 65.4	31 Ga 69.7	32 Ge 72.6	33 As 74.9	34 Se 79.0	35 Br 79.9						
37 Rb 85.5	38 Sr 87.6	39 Y 88.9	40 Zr 91.2	41 Nb 92.9	42 Mo 95.9	43 Tc 98.9	44 Ru 101.1	45 Rh 102.9	46 Pd 106.4	47 Ag 107.9	48 Cd 112.4	49 In 114.8	50 Sn (222)	51 Sb 121.8	52 Te 127.6	53 I 126.9						
55 Cs 132.9	56 Ba 137.3	57 La 138.9	72 Hf 168.5	73 Ta 180.9	74 W 183.9	75 Re 186.2	76 Os 190.2	77 Ir 192.2	78 Pt 195.1	79 Au 197.0	80 Hg 200.6	81 Tl 204.4	82 Pb 207.2	83 Bi 209.0	84 Po (210)	85 At (210)						
87 Fr (223)	88 Ra 226.0	89 Ac (227)	104 (261)	105 (262)	106 (263)	107 (262)	108 (265)	109 (267)														

1	—	Atomic number
H	—	Symbol
1.01	—	Atomic weight (rounded value)

58 Ce 140.1	59 Pr 140.9	60 Nd 144.2	61 Pm (145)	62 Sm 150.4	63 Eu 152.0	64 Gd 157.3	65 Tb 158.9	66 Dy 162.5	67 Ho 164.9	68 Er 167.3	69 Tm 168.9	70 Yb 173.0
90 Th 232.0	91 Pa (231)	92 U 238.0	93 Np (237)	94 Pu (244)	95 Am (243)	96 Cm (247)	97 Bk (247)	98 Cf (251)	99 Es (252)	100 Fm (257)	101 Md (258)	102 No (259)

( ) represents an isotope

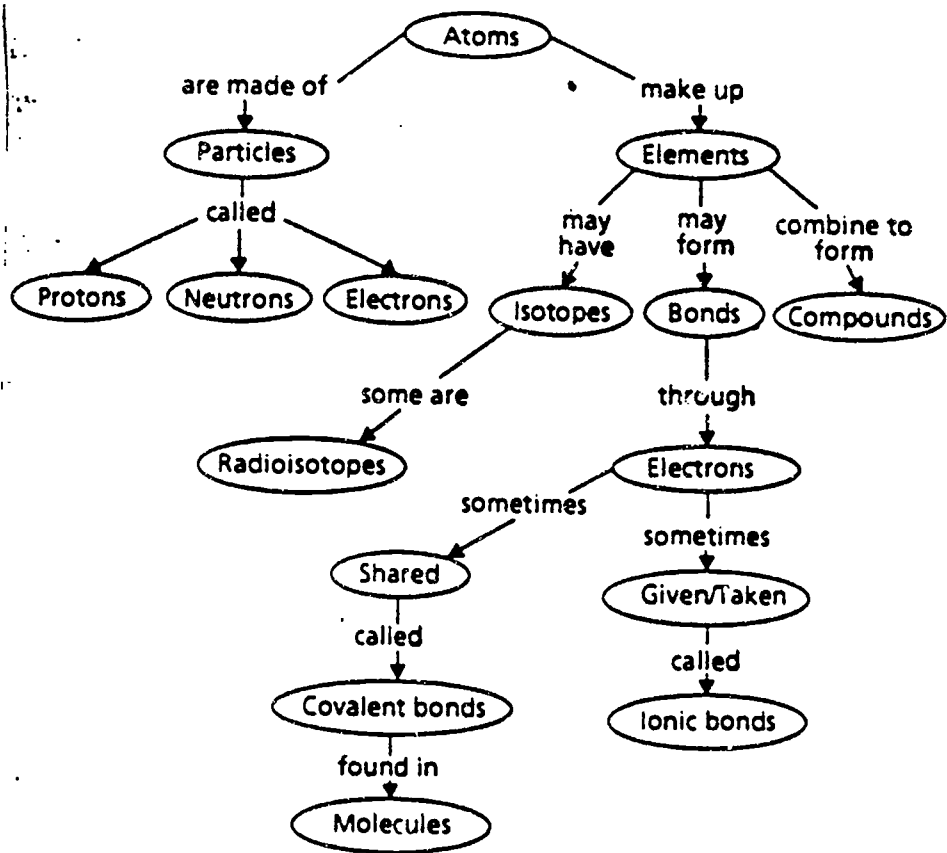

# The MINI page

Especially for  
kids and their  
families

By BETTY DEBNAM

Tuesday, November 5, 1991 MILWAUKEE SENT

What Chemistry Is All About

## Itty-Bitty Atoms

from The Mini Page by Betty Debnam © 1991 Universal Press

THAT'S 100,000,000  
ATOMS!

### Atoms

Atoms are teeny-weeny. You could fit 100 million on the tip of your little finger!



They are so small that no one has ever seen an atom all by itself.

Atoms are what chemistry is all about.

Chemistry is the study of substances and what they are made of. All substances are made of atoms.

However, you can see lots of atoms when they are together. In all of nature, there are more than 100 types of atoms.

Each type is called an element.

### Symbols for atoms

Chemists use symbols to stand for atoms or elements.

They often use the first letter as the symbol.

O is the symbol for oxygen. When elements begin with the same letter, the second letter is added.

Ne is the symbol for neon.

Most of the names are based on Greek or Roman words.

Some are old words that we do not

use. Pb is the symbol for lead. It stands

### When atoms join

When atoms join together, they make molecules.

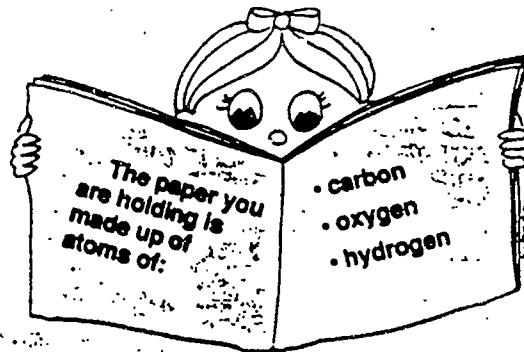

When these atoms attach to each other, they make a chemical molecule called cellulose.

### Atoms all around

Hydrogen and oxygen in water

Oxygen

Calcium in milk



You eat, drink and breathe atoms. You are quite a mixture of atoms and molecules. Your body is a wonderful chemical plant.

### What chemists do

Chemists work with atoms and study how they interact with each other.

Chemists also study substances to discover which atoms they are made up of.



### Atoms and you

Your body is made up of atoms.

Your hair and fingernails are made up of atoms of

- carbon
- hydrogen
- oxygen
- nitrogen
- sulfur

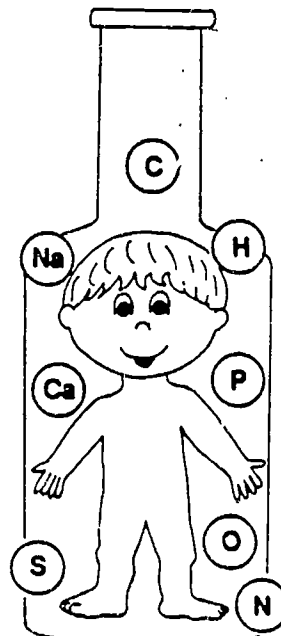

These atoms make a molecule called protein.

Your skin is made of atoms of

- carbon • hydrogen

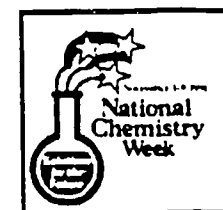
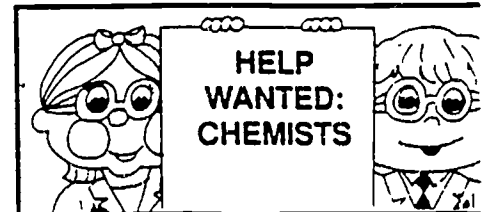

The week of Nov. National Chemistry Week.

One purpose of the week is to encourage kids to become chemists.

Much of our country's future depends on the

new products that well-trained chemists develop.

National Chemistry Week is sponsored by the

# Organizing Atoms

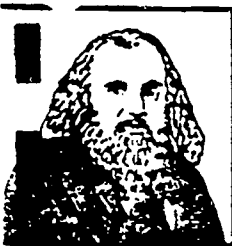

## The inventor

In 1834, a Russian scientist and college professor, Dmitry Mendeleev (Duh-MEE-tree Mend-del-LAY-uv), figured out an important table, or chart.

Mendeleev discovered that certain atoms or elements always behaved the

same way when they came in contact with certain other atoms or elements.

He found that he could group them together according to how they behaved when compared with each other.

His interest in cards helped him invent the chart. He wrote symbols for the elements on cards and spread them out.

Today, no chemist would be without the periodic table!

The periodic table is a list of all of the elements arranged in rows and columns.

All of the elements in the vertical columns (up and down) are alike in some ways.



All of the elements in the horizontal rows (left to right) are about the same size.



## How chemists use the table

Chemistry is the study of how elements or atoms interact with each other.

By using the periodic table, a chemist can tell:



- if one substance will mix with another substance.

How much of a substance to mix together to get another substance.



- what will happen when they do mix.

BEST COPY AVAILABLE



Photo by Dave Stepanek, courtesy BP Research

A chemist checks out her periodic table. You will find these charts on display in most chemistry labs. Many chemists have the table in their computers.

1 H																	2 He
3 Li	4 Be											5 B	6 C	7 N	8 O	9 F	10 Ne
11 Na	12 Mg											13 Al	14 Si	15 P	16 S	17 Cl	18 Ar
19 K	20 Ca	21 Sc	22 Ti	23 V	24 Cr	25 Mn	26 Fe	27 Co	28 Ni	29 Cu	30 Zn	31 Ga	32 Ge	33 As	34 Se	35 Br	36 Kr
37 Rb	38 Sr	39 Y	40 Zr	41 Nb	42 Mo	43 Tc	44 Ru	45 Rh	46 Pd	47 Ag	48 Cd	49 In	50 Sn	51 Sb	52 Te	53 I	54 Xe
55 Cs	56 Ba	57 La	72 Hf	73 Ta	74 W	75 Re	76 Os	77 Ir	78 Pt	79 Au	80 Hg	81 Tl	82 Pb	83 Bi	84 Po	85 At	86 Rn
87 Fr	88 Ra	89 Ac	104 Unq	105 Unp	106 Unh	107 Uns											

## The periodic table

The numbers at the top are called the atomic numbers. The letters are symbols for the chemicals. The tables have other elements and numbers, but we left them cut to save space.

Most of the elements in the periodic table are metals.

The bold line divides the metals from the non-metals.

Here are some everyday things and some of the elements from which they are made. Can you find them on the periodic table? We have given the item, the chemical and the symbol.

<p><b>Table salt</b> • sodium: Na • chlorine: Cl</p>	<p><b>Water</b> • hydrogen: H</p>	<p><b>SUGAR</b> • carbon: C • hydrogen: H</p>	<p><b>Chalk</b> • calcium: Ca • carbon: C</p>	<p><b>Knives, forks, spoons</b> • iron: Fe</p>
<p><b>Glass</b> • silicon: Si • oxygen: O</p>	<p><b>Matches</b> • sulfur: S</p>	<p><b>Pencil points</b> • carbon: C</p>	<p><b>TOOTHPASTE</b> • fluorine: F</p>	<p><b>Coins from ...</b> • nickel: Ni</p>

Physical Science for Automotive Students

ENERGY/FORCE UNIT

**Objective:** To develop a basic understanding of the scientific concepts of energy and force and the principles associated with them.

**Materials:** Student Handouts:

Demonstration materials:

Optional: During the Energy/Force Unit, there are a number of videos, films, and film strips in room 680 or through the AV department that may be used. (VCR and monitor, film projector, and/or film strip projector are needed.)

**Method:** Lecture/Discussion  
Demonstration/Modeling  
Assignments

Optional: Video  
Hands on/Lab  
Quizzes/Test(s)

**Automotive topics:** Besides general topics of energy and force, the following specific material must be covered and related to the automobile:

- Use and transfer of energy within an automobile.
- Potential and kinetic energy as they relate to the automobile.
- Compressed air; air pressure measured in PSI and its effects.
- Vacuum.
- Oil pressure; spring pressure.
- Other Automotive related topics.

**Time Frame:** This will be a 6 - 7 day unit that includes at least one day with students working hands on in a lab.

**Daily Topics:** Daily assignments to be determined.

- Day 14:** - Energy.  
- Six forms of energy: mechanical, chemical, heat, electric, electromagnetic, and nuclear.  
- Hands on activity or assignment: Kinds of energy used.
- Day 15:** - Transferring of energy from one form to another.  
- Law of conservation of energy.  
- Force.  
- Vacuum.  
- Oil pressure; spring pressure.
- Day 16:** - Heat energy.  
- Matter and heat.  
- Heat and temperature.  
- Energy and force topics specifically related to the automobile.
- Day 17:** - Lab (to be determined).
- Day 18:** - Review.
- Day 19:** - Test.



Physical Science for Automotive Students

ELECTRICITY/MAGNETISM UNIT

**Objective:** To develop a basic understanding of the scientific concepts of electricity and magnetism and the principles associated with them.

**Materials:** Student Handouts:

Demonstration materials: series circuit; parallel circuit; batteries; automobile battery; voltmeter, ammeter, ohmmeter, and/or multimeter; magnets; etc.

Optional: During the Electricity Unit, there are a number of videos, films, and film strips in room 680 or through the AV department that may be used. (VCR and monitor, film projector, and/or film strip projector are needed.)

**Method:** Lecture/Discussion  
Demonstration/Modeling  
Assignments

Optional: Video  
Hands on/Lab  
Quizzes/Test(s)

**Automotive topics:** Besides general topics of electricity and magnetism, the following specific material must be covered and related to the automobile:

- Use and transfer of electricity and magnetism within an automobile.
- Voltage, amperage, and resistance.
- Application of Ohm's Law to the various electrical circuits and components.
- Series, parallel, and series-parallel circuits.
- Magnetism and its application to the automobile.
- Use of ammeter, voltmeter, ohmmeter, and digital VOM.
- Lead acid-storage battery.
- - & + posts; - post grounded to car; do not touch + post with other metal; do not lay metal across the battery.
- Battery boils as charged.
- Battery has acid; explosive.
- Reinforce idea of kilovolts.
- Generator..
- Other Automotive related topics.

**Time Frame:** This will be a 5 - 6 day unit that includes at least one day with students working hands on in a lab.

**Daily Topics:** Daily assignments to be determined.

- Day 20: - Electricity overview.  
- Sources and formation of electricity.  
- Static electricity  
- Demonstrate static electricity.  
- Electron theory.
- Day 21: - Automobile battery.  
- Electricity transfer to other forms of energy.  
- Magnetism and electricity.  
- Demonstrate magnetism.
- Day 22: - Circuits.  
- Demonstrate series and parallel circuits.
- Day 23: - Lab (to be determined).
- Day 24: - Electrical and magnetic topics specifically related to the automobile.
- Day 25: - Review.
- Day 26: - Test.

Physical Science for Automotive Students

MACHINE UNIT

**Objective:** To develop a basic understanding of the scientific concepts of machines and the principles associated with them.

**Materials:** Student Handouts:

Demonstration materials: simple machines such as pulleys, levers, inclined plane, gears etc; 4 stroke engine; etc.

Optional: During the Machine Unit, there are a number of videos, films, and film strips in room 680 or through the AV department that may be used. (VCR and monitor, film projector, and/or film strip projector are needed.)

**Method:** Lecture/Discussion  
Demonstration/Modeling  
Assignments

Optional: Video  
Hands on/Lab  
Quizzes/Test(s)

**Automotive topics:** Besides general topics of electricity and magnetism, the following specific material must be covered and related to the automobile:

- 4 stroke engine.
- The breakdown of the automobile into individual machines.
- How the individual machines work independently and together.
- Other Automotive related topics.

**Time Frame:** This will be a 10 - 11 day unit that includes at least one day with students working hands on in a lab.

**Daily Topics:** Daily assignments to be determined.

Day 27: - Machine overview.  
- Machines are tools.  
- Simple machines.

Day 28: - Lab on simple machines.

Day 29: - Introduce the four energy systems:  
Mechanical.  
Fluid.  
Electrical.  
Thermal.

- Day 30: - Force.  
- Force as related to the four energy systems.  
- Work.  
- Work as related to the four energy systems.
- Day 31: - Rate  
- Rate as related to the four energy systems.  
- Resistance.  
- Resistance as related to the four energy systems.
- Day 32: - Energy.  
- Energy as related to the four energy systems.  
- Power.  
- Power as related to the four energy systems.
- Day 33: - The interrelationships of the four energy systems with the concepts of force, work, rate, resistance, energy, and power.
- Day 34: - Lab to be determined.
- Day 35: - Relate the above topics to the automobile.  
- Gear ratios.  
- Crank shaft.  
- 4 Stroke Engine.  
- Piston down- in (suck).  
- Piston up- compression (squeeze).  
- Piston down- expand (bang). POWER  
- Piston up- exhaust (blow).
- Day 36: - Review.
- Day 37: - Test.

# INTEGRATED TECHNICAL CURRICULUM

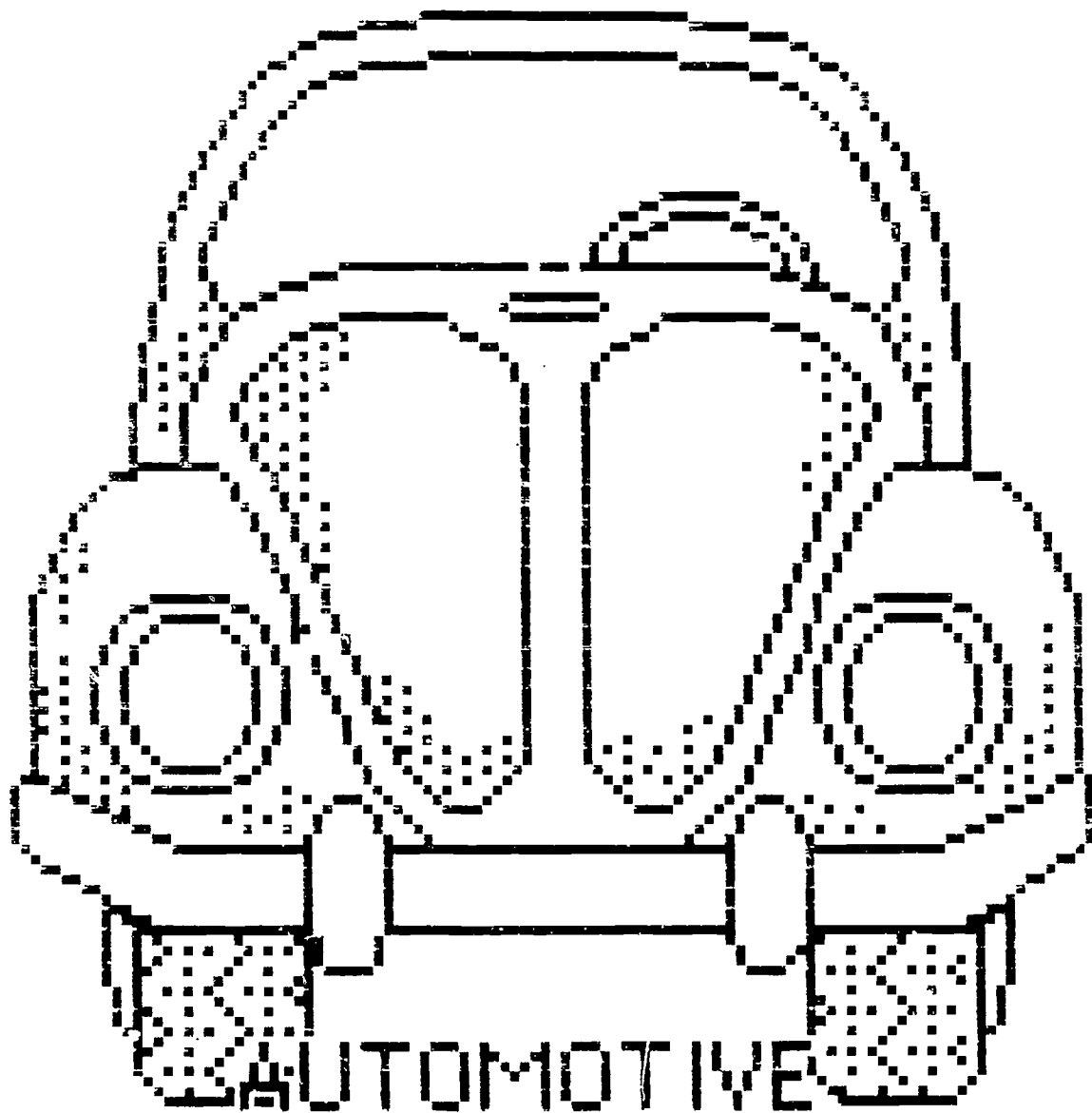

AUTOMOTIVES  
COMPONENT

Integrated Technical Curriculum  
Automotive Tune-Up

Developed By  
Lawrence J. Uebelher  
Milwaukee Area Technical College  
High School Relations  
June, 1993

BEST COPY AVAILABLE

## Integrated Technical Curriculum

### Automotive Tune-Up

#### General Objectives

1. To obtain a functional knowledge of basic (mechanical) engine, ignition and emission control theory.
2. To demonstrate the procedures required for testing (mechanical) engine condition, ignition systems and various emission controls on today's automobiles.
3. To repeatedly perform objectives on customer vehicles to obtain a reasonable amount of automaticity regarding basic maintenance, testing and repair procedures used in the automotive tune-up industry.

BEST COPY AVAILABLE

Integrated Technical Curriculum  
Automotive Tune-Up

Course Outline

UNIT NO.	INSTRUCTIONAL UNIT	SPECIFIC OBJECTIVES
1	Orientation and Safety	<ol style="list-style-type: none"><li>1. Describe the grading and attendance policies of this shop.</li><li>2. Describe the practicality of Material Safety Data Sheets.</li><li>3. Follow the proper handling and safety precautions when using tools and equipment.</li><li>4. Develop an understanding of where tools and equipment are located.</li></ol>
2	Engine Design	<ol style="list-style-type: none"><li>1. Describe the four-stroke cycle theory of operation.</li><li>2. Demonstrate the ability to position a given cylinder (cut-a-way engine) on a particular stroke.</li><li>3. Describe diesel engine theory of operation.</li></ol>
3	Compression Testing	<ol style="list-style-type: none"><li>1. Use a compression gauge and interpret the readings.</li><li>2. Use a cylinder leakage tester and interpret the readings.</li></ol>
4	Spark Plug Servicing	<ol style="list-style-type: none"><li>1. Inspect, gap and replace plugs.</li><li>2. Describe common cylinder arrangements.</li><li>3. Describe what is meant by firing order.</li></ol>
5	Distributors	<ol style="list-style-type: none"><li>1. Remove a distributor (crank over engine) and properly reinstall to achieve a smooth idling engine.</li></ol>
6	Electronic Ignition	<ol style="list-style-type: none"><li>1. Identify the basic components of the primary ignition.</li><li>2. Identify the basic components of the secondary ignition.</li><li>3. Describe the operation of the primary and secondary ignition as it pertains to spark development.</li></ol>



UNIT NO.	INSTRUCTIONAL UNIT	SPECIFIC OBJECTIVES
7	Engine Analyzer	<ol style="list-style-type: none"> <li>1. Enter specifications and hook-up an engine analyzer.</li> <li>2. Perform a cylinder performance test and interpret the readings.</li> <li>3. Identify basic ignition patterns and develop skills to recognize problem areas.</li> </ol>
8	Secondary Wires	<ol style="list-style-type: none"> <li>1. Use an ohm meter to measure secondary wire resistance.</li> <li>2. Repair a secondary wire if appropriate.</li> <li>3. Replace secondary wire sets.</li> </ol>
9	Battery Servicing	<ol style="list-style-type: none"> <li>1. Clean and replace battery terminals as needed.</li> <li>2. Safely charge a battery.</li> <li>3. Perform an automatic battery test and interpret the readings.</li> </ol>
10	Automotive Air Pollution	<ol style="list-style-type: none"> <li>1. Describe the different types of automotive air pollution.</li> <li>2. Explain the sources of automotive air pollution.</li> </ol>
11	Legislated Automotive Emission Standards	<ol style="list-style-type: none"> <li>1. Describe the application of federal standards to today's cars.</li> <li>2. Describe the application of various state standards to today's cars.</li> </ol>
12	Emission Controls	<ol style="list-style-type: none"> <li>1. Describe the operation of crankcase emission controls.</li> <li>2. Describe the operation of evaporative emission controls.</li> <li>3. Describe the operation of exhaust system emission controls.</li> <li>4. Develop an understanding of the interaction between emission controls and the automobiles on-board computer.</li> </ol>
13	Emission Testing	<ol style="list-style-type: none"> <li>1. Correctly use and maintain a four gas analyzer.</li> <li>2. Interpret the readings from a four gas analyzer.</li> <li>3. Develop an understanding of the procedures followed to set-up vehicles to meet state emission standards.</li> </ol>

BEST COPY AVAILABLE

Integrated Technical Curriculum  
Automotive Tune-Up

Instructional Units and Time Frame\*

UNIT NO.	INSTRUCTIONAL UNIT	DAYS
1	Orientation and Safety	2
2	Engine Design	2
3	Compression Testing	2
4	Spark Plug Servicing	1
5	Distributors	2
6	Electronic Ignition	2
7	Engine Analyzer	4
8	Secondary Wires	2
9	Battery Servicing	1
10	Automotive Air Pollution	1
11	Legislated Automotive Emission Standards	1
12	Emission Controls	4
13	Emission Testing	3
		27
	Reinforcing Shop Time.....	3
	Review of Theory & Shop Objectives....	2
	Exam: Written and Performance.....	2
	Make-Up (exam), clean shop & grades....	1
		40

\* Each quarter consist of 40 days; each having two 55 minute periods.

BEST COPY AVAILABLE

#### DAY 1 - Orientation

1. Help the students to be comfortable in their new environment. Go through the course syllabus thoroughly so students know what materials will be covered and how they will be graded.
2. Discuss the attendance policy, course completion card requirements and remind them of the MATC Code of Conduct.
3. Explain the purpose of Material Safety Data Sheets and show students where the MSDS are located and how to use the text.

#### DAY 2 - Safety & Tour

1. Demonstrate how to properly use a fire extinguisher and the shop exhaust ventilation system. Discuss the precautions used when working with compressed air and electrical tools/equipment.
2. Demonstrate the proper use of hydraulic floor jacks and jack stands.
3. Discuss and demonstrate proper hand and specialty tool identification and usage.
4. Shop tour highlighting daily use items such as safety glasses, shop coats, floor dry, drop lights, overhead door operation, brooms, etc.

#### DAY 3 - Engine Design

1. Lecture/discussion covering basic engine nomenclature and 4-stroke theory. The 4-stroke work sheets can be used as hand-outs and the four cylinder cutaway engine makes the ideal visual aid.

#### DAY 4 - Engine Design (continued)

1. Start class by having students participate in some type of game where they are challenged to properly position a given cylinder (cutaway engine) on a certain stroke.
  - a) students could design game
  - b) students could challenge one another
  - c) score and reward possibilities, etc.
2. Conclude lesson on engine design by explaining the basic differences between a 4-stroke gasoline engine and a 4-stroke diesel engine.

The four strokes of a four stroke combustion engine are: INTAKE, COMPRESSION, POWER, and EXHAUST. In order for an engine to run and deliver power the four strokes must be in the correct order.

First is the INTAKE stroke. On this stroke the piston is going \_\_\_\_\_ in the cylinder. This creates a low pressure in the cylinder. Outside of the engine is a higher pressure (atmospheric pressure). As the piston goes down the intake valve opens, allowing the high pressure to rush into the \_\_\_\_\_. The air must first go through the carburetor before entering the cylinder. As it does, it attracts fuel from the bowl of the carburetor. This is how the cylinder is filled with the needed air/fuel mixture for combustion.

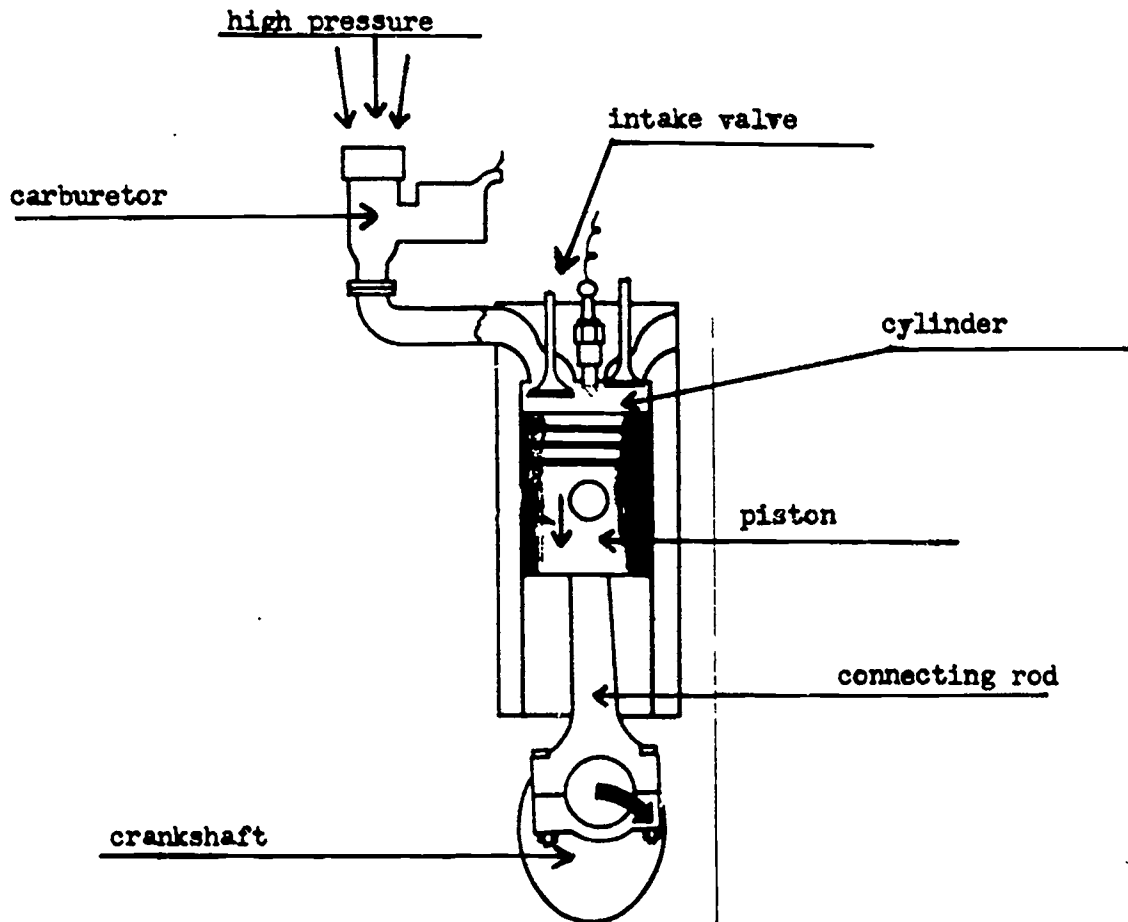

Next comes the \_\_\_\_\_ stroke. Now the valves in the cylinder must be closed. The piston goes up in the \_\_\_\_\_ and compresses the air/fuel mixture. This is done so that when the air/fuel is ignited it will deliver a great deal of power as it burns.

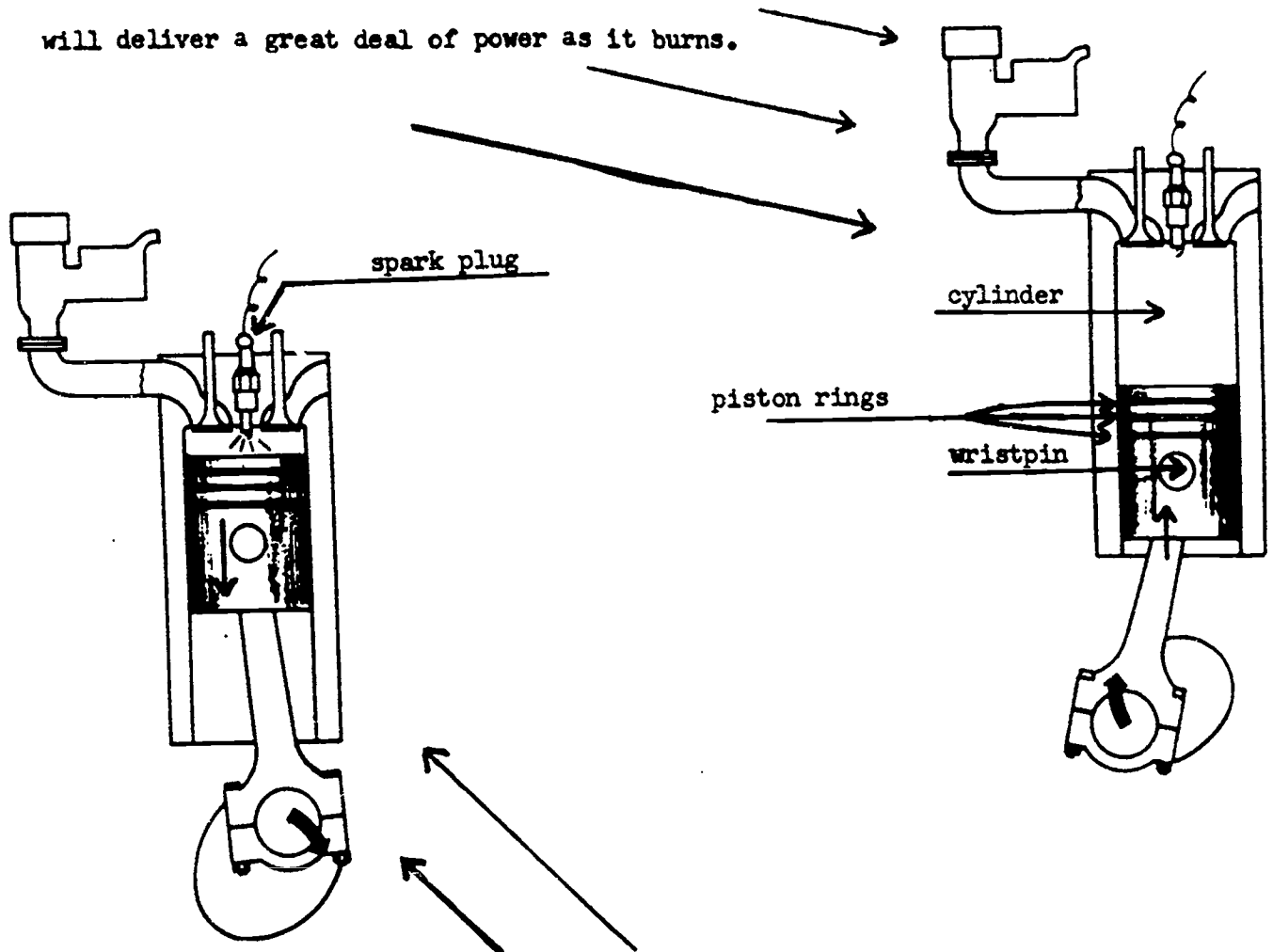

Now it is time for the POWER stroke. Again both valves must stay closed. A spark from the spark plug ignites the air/fuel mixture causing it to burn very quickly. The burning of the air/fuel mixture pushes the \_\_\_\_\_ down in the cylinder. By now you have noticed that the piston is connected to the crankshaft. As the piston is pushed down on the \_\_\_\_\_ stroke the crankshaft rotates. This rotating motion is what we use to spin the lawn mower blade, turn the motorcycle tire, etc.

The last of the four strokes is the EXHAUST stroke. After the air/fuel mixture is burned, the cylinder is full of exhaust. Now the piston goes \_\_\_\_\_ the cylinder pushing the exhaust. The exhaust valve must \_\_\_\_\_ to allow the exhaust to be pushed out of the cylinder. This is done to clear the cylinder so that the engine will continue to run by starting all over with the \_\_\_\_\_ stroke.

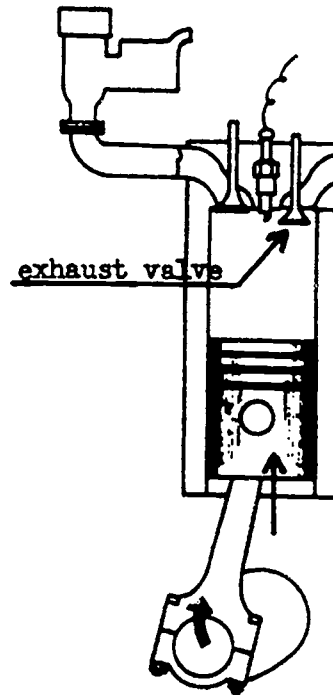

Self-check:

1. \_\_\_\_\_
2. \_\_\_\_\_
3. \_\_\_\_\_
4. \_\_\_\_\_
5. \_\_\_\_\_
6. \_\_\_\_\_
7. \_\_\_\_\_
8. \_\_\_\_\_
9. \_\_\_\_\_
10. \_\_\_\_\_

In the spaces at the left,  
 identify the matching numbered  
 parts from the picture shown at  
 the right.

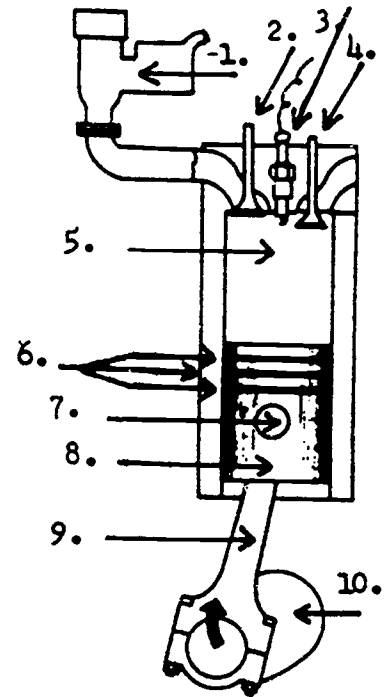

Name the four strokes in the proper order:

11. \_\_\_\_\_
12. \_\_\_\_\_
13. \_\_\_\_\_
14. \_\_\_\_\_

True or False:

15. Both valves must stay closed during the exhaust stroke. \_\_\_\_\_
16. Check your answers with the bottom of the page, if they are all correct, see your instructor for questions regarding the classroom cut-away engine. If you made any mistakes, review the material as needed and correct your answers before seeing your instructor on the cut-away model.

Name: \_\_\_\_\_

Date: \_\_\_\_\_

### Four-Stroke Theory

1. Name the four strokes (IN ORDER) of a four-stroke cycle engine.  
\_\_\_\_\_, \_\_\_\_\_, \_\_\_\_\_ & \_\_\_\_\_
2. The air/fuel mixture in most of today's cars is ignited by the \_\_\_\_\_.
3. On the \_\_\_\_\_ stroke the piston is moving \_\_\_\_\_, the intake valve is \_\_\_\_\_, the exhaust valve is \_\_\_\_\_, and the air/fuel mixture has just been ignited.
4. The following compression readings are noted: 130 - 125 - 55 - 125
  - a) Mechanic "A" says the engine passes the compression test
  - b) Mechanic "B" says the engine fails the compression test
  - c) Both mechanics are correct
  - d) Neither mechanic is correct
5. When performing a cylinder leakage test: Mechanic "A" says for an engine to pass the test, all cylinders should read 20% or less leakage...Mechanic "B" says the test should be done on a well warmed engine.
  - a) Mechanic "A" is correct
  - b) Mechanic "B" is correct
  - c) Both mechanics are correct
  - d) Neither mechanic is correct
6. On the \_\_\_\_\_ stroke the piston goes \_\_\_\_\_, the intake valve is \_\_\_\_\_ and the exhaust valve is open.
7. The piston is connected to the \_\_\_\_\_ by the connecting rod.
8. After replacing the spark plugs on a customer car you notice a loud bang from the exhaust when trying to start the car: Mechanic "A" says you probably crossed one or more spark plug wires...Mechanic "B" says you might have gapped the new plugs incorrectly.
  - a) Mechanic "A" is correct
  - b) Mechanic "B" is correct
  - c) Both mechanics are correct
  - d) Neither mechanic is correct
9. The air/fuel mixture is compressed prior to ignition in order to develop maximum \_\_\_\_\_.
10. In order to pass a compression test: the engine's lowest cylinder must read at least \_\_\_\_\_% (percent) of the highest cylinder.



#### DAY 5 - Compression Testing

Equipment: compression gauges - necessary hand tools -  
operational test engines/cars

1. Explain the theory behind compression testing.
2. Demonstrate a compression test emphasizing the individual steps which make-up a complete test.
3. Explain how to properly interpret test results....lowest must be 70% of highest.
4. Remainder of time set aside for students to perform compression testing in the shop.

#### DAY 6 - Cylinder Leakage Testing

Equipment: cylinder leakage testers - necessary hand tools -  
operational test engines/cars

1. Explain the theory behind cylinder leakage testing.
2. Demonstrate a leakage test emphasizing equipment set-up, calibration and the individual steps required to make-up a complete test.
3. Explain how to properly interpret test results....20% or less to pass and where to listen for excessive leakage to aid in diagnosing.
4. Remainder of time for students to perform cylinder leakage testing.

#### DAY 7 - Spark Plug Servicing

Equipment: necessary hand tools - plug gapping tools -  
variety of used and new plugs - engines/cars

1. 4-stroke quiz
2. Lecture/discussion/show-and-tell focusing on various cylinder arrangements, the definition of "firing order" and examples of same.
3. Demonstrate how to inspect, gap and replace spark plugs (without damaging spark plug wires).
4. Students to perform spark plug servicing.

BEST COPY AVAILABLE

### DAY 8 - Shop/Hands-On

1. This is the first of eight shop days set aside for students to become more proficient in performing shop objectives. This is valuable time during which the students can apply and transfer the daily lessons and objectives that they have been exposed to.
2. On this shop day it is suggested that customer/student cars be scheduled for compression testing, cylinder leakage testing and spark plug servicing.

### DAY 9 - Distributors

Equipment: necessary hand tools - shop lights - operational engines/cars that have distributors

1. Demonstrate the easiest method of removing and reinstalling a distributor.
2. Show the relationship between the distributor rotor location and the distributor cap spark plug wire terminals.
3. Demonstrate what can go wrong when reinstalling a distributor...loud exhaust bang and possible backfire/flame out of carburetor.
4. Explain/review the importance of the relationship between when the spark occurs and what stroke the cylinder is on (4-stroke theory).
5. Demonstrate the procedure followed to reinstall a distributor once the engine has been cranked over (or rebuilt) with the distributor out.
6. Students to use remainder of time to perform distributor R & R both the easy way and in the manner needed once the engine has been cranked over.

### DAY 10 - Distributors (cont.)

Equipment: necessary hand tools - shop lights - operational engines/cars that have distributors

1. Review of demonstration (as needed) removing the distributor, cranking engine and properly reinstalling the distributor.
2. Students to perform distributor R & R.

## DAY 11 - Electronic Ignition

Show and Tell: resistor - ignition switch - distributors - module - pick up coil - trigger unit - coil - distributor cap and rotor - etc.

1. Lecture/discussion where the job of the primary ignition is defined and explained in detail. Primary components are shown and identified.
2. The job of the secondary ignition is defined and explained in detail. Secondary components are shown and identified.
3. Students are asked to locate and identify various ignition components on test engines and cars; working up from the most obvious to the well hidden systems (to present a challenge).

## DAY 12 - Electronic Ignition (cont.)

Show and Tell: functional electronic ignition distributor - volt meter - engine analyzer

1. Lecture, carefully explaining how the primary and secondary components working together produce spark to ignite the air/fuel mixture.
2. Demonstration of primary on/off signal being produced, using a distributor and volt meter.
3. Demonstration showing the intensity of secondary voltage being developed.
  - a) using insulated pliers show secondary voltage jumping a half inch gap to ground
  - b) using an engine analyzer show same voltage jump on screen/CRT

Note: Concluding the class by using the engine analyzer is an "appetizer" for the next lesson (Engine Analyzer).

## DAY 13 - Shop/Hands-On

1. Customer and student cars are scheduled to expose students to different manufacturers and models.
2. At this point students are asked to further recognize and identify ignition components.
3. Again students are asked to demonstrate objectives such as spark plug replacement, compression testing and cylinder leakage testing in order to continue their growth in using shop tools and equipment.
4. Students should be starting to demonstrate the ability to be somewhat self-sufficient in the shop...comfortable with the simplest of tasks.

DAY 14 - Engine Analyzer

Equipment: engine analyzer (Bear "Ace") - test engines/cars

1. Basic familiarization of Bear "Ace" power control panel and switches.
2. Demonstrate how to "enter specifications" into engine analyzer using micro floppy disc.
  - a) explain/show the easiest method of determining the year and engine size of vehicle
  - b) show the students where to find the emission labels
  - c) introduce students to the importance of the vehicle identification number (VIN)
3. Demonstrate how the analyzer is "hooked-up" to the car. Build a simple but solid foundation for analyzer use showing basic leads used and how to check your set-up on the analyzer.
  - a) battery leads
  - b) vacuum lead
  - c) primary leads and adapters
  - d) secondary lead and variations
  - e) #1 lead
4. After the demonstration students are split into groups to "enter specs"...."hook-up"....and check "set-up" of the analyzer on a variety of engines/cars.
5. Finish class with one simple, to the point demonstration of how to perform a cylinder performance test.

DAY 15 - Engine Analyzer (cont.)

Equipment: engine analyzer - engines/cars

1. Review and discussion regarding entering specifications, hooking-up the analyzer and checking the set-up screen.
2. A more detailed discussion/lecture making students comfortable with the "Master Menu" and the "Service Tests" menu.
3. Demonstrate another cylinder performance test (one done previous day) and explain how to interpret test results.
4. Students in shop entering specifications, hooking-up analyzer, checking set-up screen, performing cylinder performance test and explaining test results on a variety of engines/cars.

DAY 16 - Engine Analyzer (cont.)

Equipment: engine analyzers -- engines/cars

1. Lecture defining ignition patterns.
  - a) parade pattern showing voltage in kilovolts
  - b) raster pattern showing time in milliseconds
2. Describe the practicality of "seeing" secondary voltage requirements.
  - a) show a variety (on board) of good and bad parade patterns and explain how to interpret
  - b) with students helping...demonstrate various good and bad parade patterns using the engine analyzers and shop engines/cars
3. Describe the practicality of "seeing" secondary ignition time requirements.
  - a) on the board identify the three sections of a raster pattern
  - b) on the board show good and bad patterns and explain how to interpret them
  - c) with students helping...demonstrate good and bad raster patterns using the engine analyzers on shop engines/cars

DAY 17 - Engine Analyzer (cont.)

1. Review/discussion of parade and raster ignition patterns .
2. Review/discussion of Electronic Ignition operational theory and the correlation with ignition pattern interpretation.
3. Ignition Quiz

DAY 18 and 19 - Shop/Hands-On

1. Customer and student cars are scheduled for diagnostic testing of the mechanical engine and ignition systems.
2. Emphasis is placed on engine analyzer use:
  - a) entering specifications
  - b) hook-up and set-up
  - c) cylinder performance testing and interpretation
  - d) ignition pattern interpretation
3. Students will perform objectives as spark plug replacement, compression testing and leakage testing depending on the results of engine analyzer testing.
4. By this point students should have developed a respectable degree of automaticity regarding basic analyzer hook-up and testing procedures.

DAY 20 - Secondary Wires

Equipment: engine analyzer (ohm meter) - high impedance  
digital volt/ohm meter (hand held) - Information  
Center - ignition components

1. Discuss the theory behind using an ohm meter.
2. Demonstrate using an ohm meter to check various ignition components.
  - a) secondary wire resistance (approx. 5,000 ohms ft.)
  - b) coil resistance (primary and secondary)
  - c) pick-up coil resistance
3. Demonstrate the proper method of repairing damaged secondary wires.....  
common place if students expect to be changing spark plugs since terminals do separate from wires.
4. Demonstrate how to use the Information Center for looking up firing order, cylinder arrangements, distributor secondary terminal identification and resistance values of various ignition components.
  - a) power switch - warm up period - proper care and handling
  - b) finding "Mitchell On-Demand" in opening menu and entering the "repair" section (F1)
  - c) entering vehicle information
  - d) various menus/tables of contents
  - e) using the printer

DAY 21 - Secondary Wires (cont.)

Equipment: engine analyzer (ohm meter) - high impedance  
digital volt/ohm meter (hand held) - Information  
Center - engines/cars

1. Students apply and transfer the information covered in the previous days lessons while working in the shop.
2. Students are asked to use an ohm meter in diagnosing the condition of secondary wires.
3. Students are to demonstrate the proper way to repair secondary wires when applicable.
4. Students are asked to replace secondary wire sets with the aid of the information center.
  - a) it is appropriate to have some engines and cars that already have the secondary wires off
  - b) ask students to show the print-out used to aid in rewiring

BEST COPY AVAILABLE

## DAY 22 - Battery Servicing

Equipment: vehicles with batteries - battery charger - engine analyzer - necessary hand tools

1. Demonstrate the proper method of cleaning battery terminals.
  - a) negative off first and on last
  - b) tool usage....puller - spreader - cleaner
  - c) safety precautions
  - d) computer memory saver
2. Demonstrate how to charge a battery safely....this is an appropriate time for discussion on how to safely "jump start" an automobile.
3. Discuss the theory and demonstrate an automatic battery test using the engine analyzer or similar equipment.
  - a) define Cold Cranking Amps....the amount of amps the battery can deliver for thirty seconds at zero degrees and still maintain a voltage of 7.2 volts
  - b) explain why the battery temperature is needed
  - c) explain the importance of zeroing the amp meter and entering the correct CCA rating
  - d) demonstrate the test procedure
4. Students are to clean battery terminals and perform an automatic battery test (interpreting the results).

## DAY 23 - Shop/Hands-On

1. Secondary Wires and Battery Quiz
2. Customer and student cars are scheduled for service emphasizing repair of the secondary wiring and battery service.
3. Students are urged to use the engine analyzer to interpret ignition patterns.
  - a) based on results, students will follow through using the ohm meter to diagnose problems detected
  - b) students will repair and replace secondary wires
4. Students should perform battery servicing and testing.
5. Remember, students will constantly repeat previous lessons such as compression testing, spark plug replacement, cylinder performance testing, information center use, cleaning battery terminals, etc. on customer vehicles. This is a very necessary part of the program that ensures retention and some degree of automaticity of course objectives.

## DAY 24 - Automotive Air Pollution

Equipment: four-gas exhaust analyzer - customer cars

1. Lecture describing the three major by-products of an internal combustion engine that are pollutants.
  - a) carbon monoxide (CO) - very poisonous - colorless, tasteless and odorless gas - a by-product of incomplete combustion - equal parts carbon & oxygen
  - b) hydrocarbons (HC) - gasoline and diesel fuels are hydrocarbons (containing hydrogen and carbon) - major component in photochemical smog (smog) - no engine 100% efficient and all produce some HC
  - c) oxides of nitrogen (NOx) - produced with heat and pressure of combustion - second major component in smog
2. Describe other sources of air pollution that an automobile engine emits.
  - a) crankcase fumes
  - b) fuel evaporation
3. Describe various engine conditions and explain the effects on the levels of the above mentioned by-products/pollutants.
4. Demonstrate (using a four-gas exhaust analyzer) actual cause and affect of pollution using engines and cars set-up with various problems.
  - a) ask for student assistance and suggestions
  - b) misadjusted carburetor....vacuum leaks
  - c) secondary ignition failure....EXPERIMENT

## DAY 25 - Legislated Automotive Emission Standards

1. Lecture describing the authority of the United States Environmental Protection Agency (USEPA).
  - a) tampering....individual \$2,500 - repair shop \$2,500 per incident - dealers \$25,000
2. Lecture describing the application of Wisconsin state law....the Wisconsin Vehicle Inspection Program.
  - a) registration renewal requirements
  - b) over-view of seven point visual inspection (1/93)
  - c) engine exchange policy (1/93)
  - d) transfer of title/change of ownership (1/93)

Note: The instructor must keep up with current law....Getting on the mailing list to receive the WVIP's quarterly flyer, The Analyzer, is the simplest way to stay current. It should also be mentioned that the next four classes will be spent identifying emission components and how to inspect and test them. Approximately 1/3 to 1/2 of each day will be spent on show & tell, with the remainder of time set aside for students to demonstrate the ability to describe and perform that days emission related lesson. It is advisable that the instructor be certain to have



enough customer cars on hand to expose students to various designs and makes. Again, students will have some shop time to perform previous objectives. This is when the students start to put together individual objectives building towards learning how to perform a tune-up on today's automobiles.

#### Day 26 - Emission Controls

Equipment: customer and student cars

1. Identify the components that make-up the positive crankcase ventilation (PCV) system.
  - a) PCV valve, hose and grommet
  - b) breather filter, hose and grommet
  - c) sealed dipstick tube and oil filler cap
2. Explain how the PCV system operates.
3. Demonstrate how to properly inspect the operation of the PCV system.
  - a) rpm drop and vacuum check
  - b) free check valve and visual inspection
4. Students to identify components of and check operation of customer PCV systems.
5. Identify the components of the evaporative emission control system.
  - a) sealed gas cap and gas tank restrictor
  - b) vapor canister and hoses
6. Demonstrate a visual inspection of evaporative emission controls.
7. Students to identify components of and visually inspect evaporative emission controls on customer cars.

#### DAY 27 - Emission Controls (cont.)

Equipment: customer and student cars

1. Identify for students the components that make up the exhaust system emission controls.
  - a) catalytic converter
  - b) exhaust gas recirculation valve (EGR)
  - c) air injection reactor system (AIR system): pump - check valve - diverter valve - exhaust tubes
  - d) sealed, thermostatically controlled air cleaner
2. Describe the operation of and demonstrate a visual inspection of a catalytic converter.
3. Describe the operation and theory behind the EGR valve.

4. Demonstrate how to test the EGR system.
  - a) visual inspection
  - b) inspection of intake manifold passages
  - c) valve operation (vacuum supply)
5. Students to identify components of and inspect customer catalytic converters and EGR systems.

DAY 28 - Emission Controls (cont.)

Equipment: customer and student cars

1. Lecture describing the theory behind and the operation of the Air Injection Reactor system.
  - a) oxygen added to the manifold
  - b) pump - check valve - diverter valve (vacuum or electric) - exhaust tubes
2. Demonstration showing a visual and operational inspection of the AIR system.
3. Demonstration using exhaust analyzer on customer car showing the emission levels with operational AIR system and one that has been disconnected.
4. Students to identify components of and perform visual inspection of customer AIR systems.

DAY 29 - Emission Controls (cont.)

Equipment: customer and student cars

1. Discussion/lecture explaining the importance of a sealed thermostatically controlled air cleaner.
  - a) dirt
  - b) air/fuel temperature vs. performance
2. Identify and demonstrate how to inspect a thermostatically controlled air cleaner (visual and physical inspection).
3. Students to identify components of and inspect (visual and physical) customer air cleaner assemblies.
4. Review: It is time to review the causes of automotive pollution, the legislation of automotive emissions and to identify once again the various emission control systems. These systems are; Positive Crankcase Ventilation, Evaporative Emission Control, Exhaust Gas Emission, Air Injection Reaction and Sealed Thermostatically Controlled air cleaner systems. Students should be able to identify components, describe system operation and inspection procedures as outlined above.

## DAY 10 - Shop/Hands-On

1. Emission Quiz
2. After the quiz, students will have shop time to work on objectives. Students are now starting to look at the overall picture of engine condition, ignition systems, emission controls and tune-up procedures. It is interesting/rewarding to hear their comments as they open the hoods and test various customer cars. Although knowing the individual objectives they have been taught is important...it is equally important to see that they realize how these objectives, when put together in a practical diagnostic approach, are the makings of a tune-up.

## DAY 11 - Shop/Hands (cont.)

Equipment: vehicle with various computer controlled emission controls

1. Start the day with a discussion that explains the manner in which the on-board computer controls some emission controls. Identify how to recognize such a vehicle.
  - a) EGR system
  - b) AIR system
  - c) evaporative controls
2. Proceed with a continuation of the previous day's shop activities.
3. At the end of shop ask the class as a whole how they are doing. Being informal, remind them (show on the board) how far they have traveled in the last six weeks.
  - a) 4-stroke theory...ignition theory...analyzer theory...emission controls theory
  - b) spark plug replacement...compression testing...cylinder leakage testing...distributor R & R...engine analyzer use...repairing secondary wires...battery servicing...emission controls servicing

## DAY 12 - Emission Testing

Equipment: 4-gas exhaust analyzer - shop engines/cars

1. Demonstrate how to use an exhaust analyzer.
  - a) warm-up period
  - b) calibration of analyzer (leak check, electrical and gas calibration)
  - c) demonstration of emission test
2. Demonstrate how to maintain an exhaust analyzer.
  - a) after test procedures (pump on)
  - b) sample probe location
  - c) filter inspection and replacement

3. Students to demonstrate the correct procedures to calibrate, maintain and perform an emission test using an exhaust analyzer.

#### DAY 33 - Emission Testing (cont.)

Equipment: 4-gas analyzer - shop engines/cars

1. Lecture describing/identifying the four gases.
  - a) hydrocarbons and carbon monoxide (review from lesson on emission controls)
  - b) oxygen(O<sub>2</sub>) - measured in percent by volume - combines with materials to release heat energy - needed for combustion and catalytic converter
  - c) carbon dioxide(CO<sub>2</sub>) - measured in percent by volume - a result of burning hydrocarbons with proper amount of oxygen - a non-toxic byproduct of combustion - in soda water
2. Explanation of basic 4-gas exhaust analyzer interpretation.
  - a) guidelines for converter equipped cars  
CO (0 - 0.75%)      HC (0 - 150ppm)  
CO<sub>2</sub> (1 - 4%)      CO<sub>2</sub> (7 - 15%)
  - b) HC high with CO low....suspect a lean mixture
  - c) HC high with CO high....suspect a rich mixture
  - d) CO<sub>2</sub> low....suspect an exhaust leak or tester mal-function
  - e) CO<sub>2</sub> high....possible lean misfire
3. Students to perform emission tests and interpret the results.
4. Demonstrate the Wisconsin 7-point Visual Emission Equipment Inspection.
  - a) PCV visual
  - b) AIR visual
  - c) vapor canister visual
  - d) EGR visual
  - e) catalytic converter visual
  - f) fuel filler restrictor visual
  - g) fuel cap visual

#### DAY 34 - Shop/Hands-On

Equipment: customer and student cars

1. Emphasis is placed on inspecting cars for the state emission test.
2. Cars that failed the inspection are to be diagnosed as to the reason for failure.
3. Repairs are to be performed (within customer cost and time restrictions) to meet state standards.

### DAY 15 - Shop/Hands-On

1. Continuation of the previous day.
2. A reminder that students are now applying and transferring knowledge that they have accumulated since the first days of the quarter. They should understand basic engine, ignition and emission control theory. They should be able to apply this theory and use a variety of shop equipment to test/inspect these systems on today's automobiles. Students should be comfortable in this shop!

### DAY 16 & 17 - Review

1. All quizzes are returned and discussion is open for any questions pertaining to theory.
2. Once all students are comfortable (prepared for written exam) a simple reminder is given informing students of all the shop objectives that have been covered since the start of the quarter. Students are also reminded that their shop/practical exam is made up of several (instructor discretion) of these objectives.
3. Remainder of time to be used by students either reviewing for shop exam or working on customer cars to further develop their level of automaticity.

### DAY 18 - Written Exam and Shop Exam

1. I use a written exam that is a review or work sheet developed from the quizzes given during the quarter....give written exam.
2. Start of shop exam.
  - a) test stations set-up for various shop objectives (instructor discretion)
  - b) all equipment must be in good working order
  - c) a time frame (10-15-20 minutes....instructor discretion) is determined for all objectives/test stations (easiest if the time frame remains constant throughout the exam)

### DAY 19 - Shop Exam (cont.)

1. Completion of the shop exam.

### DAY 20 - Last Day of the quarter/grade day.

1. Make-up any exams that a student may have missed due to extenuating circumstances.
2. Clean the shop and award quarterly grades to the students.

# Resources in Vocational Education (RIVE)

---

AN ID State; Proposal ST W FY 93 FS CD Curriculum Development  
NO GN: 09-956-150-63 CD AL PI W193CD06  
TI Project Second Chance II

PD

Phone (414) 278-6309

ON Milwaukee Area Technical College

AD 700 W. State Street Milwaukee, WI 53233

OT 07 Community/Junior College or Technical Institute

SA

DT 01Jul92; 30Jun93

FF 93; 47404

TD

0

P

DN

E 09 Adult

Contact WI1

TP 08 Student

James Halloran

PP 03 Adult Education

P 04 Curriculum Guide

Date Recd 9/29/94

AB This project is designed to enroll and retain adult high school non-completers in occupational programs. As part of the project, a remedial Integrated Technical Curriculum will be developed.