

AUTHOR Bodomo, Adams B.
 TITLE Complex Predicates and Event Structure: An Integrated Analysis of Serial Verb Constructions in the Mabia Languages of West Africa. Working Papers in Linguistics No. 20.
 INSTITUTION Trondheim Univ. (Norway). Dept. of Linguistics.
 REPORT NO ISSN-0802-3956
 PUB DATE 93
 NOTE 148p.; Thesis, University of Trondheim, Norway. Map on page 110 may not reproduce well.
 PUB TYPE Dissertations/Theses - Undetermined (040)

EDRS PRICE MF01/PC06 Plus Postage.
 DESCRIPTORS *African Languages; Foreign Countries; *Grammar; *Language Patterns; Language Research; Language Variation; *Semantics; Structural Analysis (Linguistics); *Syntax; Uncommonly Taught Languages; *Verbs
 IDENTIFIERS Africa (West); Dagari

ABSTRACT

An integrated analysis of the syntax and semantics of serial verb constructions (SVCs) in a group of West African languages is presented. With data from Dagaaare and closest relatives, a structural definition for SVCs is developed (two or more lexical verbs that share grammatical categories within a clause), establishing SVCs as complex predicates. Based on syntactic theories, a formal phrase structure is adapted for representation of SVCs, interpreting each as a product of a series of VP adjunctions. Within this new, non-derivational, pro-expansionary approach to grammar, several principles are developed to license grammatical information flow and verbal ordering priority. Based on semantic theories, a functional account of SVCs is developed: that the actions represented by the verbs in the SVC together express a single, complex event. A new model of event structure for all constructional transitions is proposed, and it is illustrated how two types of these transitions, West African SVCs and Scandinavian small clause constructions (SCCs), conform to this proposed event structure. Further, SVCs and SCCs are used to propose a parameter of variation between serializing and non-serializing languages. A survey of the general structure of the Mabia languages is also presented. (MSE)

 * Reproductions supplied by EDRS are the best that can be made *
 * from the original document. *

ED 373 534

"PERMISSION TO REPRODUCE THIS
MATERIAL HAS BEEN GRANTED BY

Adams B.
Bodomo

TO THE EDUCATIONAL RESOURCES
INFORMATION CENTER (ERIC)."

U. S. DEPARTMENT OF EDUCATION
Office of Educational Research and Improvement
EDUCATIONAL RESOURCES INFORMATION
CENTER (ERIC)

This document has been reproduced as
received from the person or organization
originating it.

Minor changes have been made to improve
reproduction quality.

• Points of view or opinions stated in this docu-
ment do not necessarily represent official
OERI position or policy.

FL022094

BEST COPY AVAILABLE

COMPLEX PREDICATES AND EVENT STRUCTURE:

**An Integrated Analysis of Serial Verb Constructions
in the Mabia Languages of West Africa.**

by

Adams B. Bodomo

A Thesis Submitted to
the Department of Linguistics,
University of Trondheim, Norway
for the Award of the Degree of
Candidatus Philologiae (Cand. Philol.)

Spring Semester, 1993.

Abstract

This thesis presents an integrated analysis of the Syntax and Semantics of Serial Verb Constructions (SVCs) in a group of West African Languages. With data from Dagaare and its closest relatives, a structural description for SVCs is established. An SVC consists of two or more lexical verbs which share grammatical categories within a clause. This establishes SVCs as complex predicates.

Based on the syntactic theories of Chomsky (1981) and Hellan (1991), a formal X-bar phrase structure is adapted for the representation of SVCs. This approach interprets each SVC as a product of a series of VP adjunctions. This is compatible with the theoretical views of Hellan (1993) which considers sentential production as the incremental building up of larger and larger constructs from minimal signs. Within this new, non-derivational, pro-expansionary approach to grammar, several principles, including Corporate Theta Assignment, Valence Sensitive Ordering and Temporal Precedence, are developed to licence grammatical information flow and verbal ordering priority in SVCs. In parts of the thesis, the present approach is compared to earlier approaches such as Awoyale (1988), Baker (1989) and Lefebvre (1991).

Based on the semantic theories of Hellan and Dimitrova-Vulchanova (1993), a functional account of SVCs is developed. We defend the view that the actions represented by the verbs in the SVC together express a single, complex event. We propose a novel model of event structure for all constructional transitions and show how two types of these transitions, West African SVCs and Scandinavian small clause constructions (SCCs) conform to this proposed event structure. Further, we use SVCs and SCCs to propose a parameter of variation between serialising and non-serialising languages based on the type of word categories that are used to express secondary predications in these languages.

A survey of the general structure of the Mabia languages, including Dagaare, Dagbane, Gurenne, Kusaal, Mampruli and Moore, and some sociolinguistic information on Northern Ghana, which is the research area, are also presented.

Acknowledgements

Writing these acknowledgements is like giving a speech at the end of a wonderful reception full of warmth and hospitality. I must say that I have enjoyed every bit of my study period for the last three years at the Department of Linguistics, which might best be called the Home for International Linguists. To all my teachers, my fellow students and everybody at the Department of Linguistics who helped to create this most congenial academic and social setting to complete this work, I say: 'Tusen takk!'

Doing research work may be compared to a journey into the world of the unknown. One person has been my constant guide. As my supervisor, Lars Hellan did not only put all available research facilities at my disposal, he has also helped me shape most of the ideas expressed in this thesis. In the last few weeks, like a good coach, Lars did give me 'drills' in the art of thesis writing. For that and for all the patience, the time and the good ideas he had for me, he would be my choice for the World's 1993 Best Supervisor Award.

In the course of this research, I got help from so many individuals and organisations, distributed across three continents. I thank the Norwegian Research Council for supporting me financially for the past two years with a scholarship under its programme: 'International Studies in the Humanities'.

During my fieldwork in Africa, I got assistance from so many people that it is impossible to mention everybody here. I am very grateful to all of them. In particular, I thank members of staff of the relevant departments at the University of Ghana, Accra and the Université de Ouagadougou, Burkina Faso for the discussions I had with them. I am grateful to the Ghana Institute of Linguistics, Literacy and Bible Translation (GILLBT) at Tamale, especially its Director and my personal friend, Grace Agyekum, for putting their research facilities at my disposal. The staff of the Tamale Institute of Cross Cultural Studies (TICCS), the Tamale Catholic Guest House, the GBC Ura-Radio Station at Bolgatanga and the Institute of Adult Education at Wa deserve thanks, especially for enduring my lengthy interviews. Special thanks go to the Abugri and Tia families of Nalerigu and the Abdulai Vulcaniser family of Tamale.

Back in Europe, I have had the benefit of lengthy communications by electronic mail on my research topic with Marc van Oostendorp and Felix Ameka in the Netherlands and Chris Collins and Mary Dalrymple in the U.S. A. I thank them all for the ideas and the many papers they sent me.

I thank members of the Ghanaian Community in Trondheim, some of who helped me in so many ways including serving as informants to cross-check my data from the field. Thanks to Assibi Amidu, Adam Abugri, Paul Opoku-Mensah, Kofi Agyekum and the 'Okyeame' electronic mail network, I stayed in constant touch with Ghanaian affairs and the outside world in the last weeks of the thesis write-up. I am particularly grateful to James Essegbey who, for many months, had to serve as testing grounds for some of the ideas developed in this work and for proof-reading this work at short notice. Thanks to Sjur Moshagen for having always helped me on the computer and especially for salvaging me from an eleventh-hour computer trouble shooting.

But most of all, I am deeply grateful to members of the 'home front'. Mary and the children have provided me with immeasurable support throughout all this period. I have not been able to satisfactorily answer Nuo's questions why 'grown ups' go to school even at week-end. As for Vilaa, I have had to sneak away from her, for she kept protesting my departures. I promise that, with this book in my hands, things will now begin to normalise.

Table of Contents

Abstract	i
Acknowledgements	ii
Table of Contents	iii
Introductory remarks	1
1. The Data and Research Area.....	1
2. The Phenomenon.....	1
3. The Approach and Theoretical Framework.....	2
4. The Organisation of the Thesis.....	3
Chapter 1: An Introduction To Mabia Syntax	5
1.0. Introduction	5
1.1. Mabia Morpho-Syntactic Structure.	5
1.1.1. The Noun Phrase in Mabia	7
1.1.2. Noun phrase structure	8
1.1.3. Noun class system	10
1.2. The Verb Phrase.	11
1.2.1. A note on the term AUX in Mabia	12
1.2.2. The preverbal particles.	13
1.2.2.1. Time depth and tense particles.....	14
1.2.2.2. Polarity and tense particles.....	14
1.2.2.3. Modality and Aspect particles.....	15
1.2.2.4. Aspectual suffixes.....	15
1.2.3. The Main verb.....	15
1.2.4. The 'postverbal' particle:.....	19
1.3. A Two-Level X-Bar Syntax For Mabia.	20
1.3.1. The framework:.....	20
1.3.2. From the lexicon to phrase structure.	21
1.3.3. Establishing a TAM system.....	23
1.3.3.1. The TAM elements.....	23
1.3.3.2. The position and function of <i>lá</i> in TAMP.....	26
1.3.3.3. Constraints on <i>lá</i> movement.....	28
1.3.4. Adjunction and double object clusters in Dagaare.....	30

1.3.4.1. Adjunction.....	30
1.3.4.2. Double object clusters.	31
1.4. Conclusion.....	33
Chapter 2: SVCs: Presentation, Proposed Analysis And Earlier Approaches.....	35
2.0. Introduction.....	35
2.1. Part One: A Presentation Of SVCs.....	35
2.1.1. The Concept and its Geographical Distribution.....	35
2.1.1.1. The Concept.....	35
2.1.1.2. Geographical distribution.....	37
2.1.2. Constraints on Serialisation in Mabia.....	38
2.1.2.1. The Subjecthood constraint.	39
2.1.2.2. TAMP constraints.....	39
2.1.2.2.1. Tense particle constraint.....	40
2.1.2.2.2. Aspectual affix constraint.....	41
2.1.2.2.3. The Modality Constraint.....	42
2.1.2.2.4. The Polarity constraint.....	42
2.1.2.3. The Connector Constraint.....	44
2.1.2.4. The Object Constraint.....	47
2.1.2.5. The Predicate Constraint.....	49
2.1.3. Conclusion for Part One.....	50
2.2. Part Two: The Present Account.....	51
2.2.1. A Two-level X-bar Syntax.....	52
2.2.1.1. The Interpretation of a complex predicate.....	52
2.2.1.2. SVCs at Surface Structure.....	53
2.2.2. Corporate Theta Role Assignment.....	55
2.2.2.1. Serial Verbs, Adverbials and Double Object Clusters.....	57
2.2.2.1.1. Serial Verb Adverbials.....	58
2.2.2.1.2. Serial Verb Object Clustering.....	59
2.2.2.2. Extending the Database.....	60
2.2.2.2.1. Dagbane/Mampruli.....	60
2.2.2.2.2. Moore.....	61
2.2.2.3. Looking beyond Mabia.....	62
2.2.2.3.1. Ewe.....	63
2.2.2.3.2. Thai.....	64
2.3. Part Three: Other Approaches.....	64
2.3.1. A Summary of the Approaches.....	65
2.3.2. Lefebvre (1991).....	65
2.3.3. Baker (1989).....	67
2.3.4. Comparing the Approaches.....	69
2.3.4.1. Sranan.....	71
2.3.4.2. Fon.....	72
2.4. Conclusion.....	73

Chapter 3: An Integrated Account Of SVCs.....	74
3.0 Introduction	74
3.1 Outline Of The Integrated Account.....	74
3.2 The Analysis.....	77
3.2.1 Grammatical Functional Referents	77
3.2.2 Valence Sensitive Verb Ordering.....	81
3.2.3 Corporate Theta Assignment and NP Arguments.....	82
3.2.4 Temporal Sequence.....	84
3.2.4.1 A Principle of Temporal Precedence for Verb Order.....	85
3.3 Gestalt Theory And Event Structure	88
3.3.1 The Temporal or Aspectual Dimension.....	90
3.3.2 The Transition dimension:	91
3.3.2.1 Constructional transitions.....	92
3.3.2.2 A Model of Event Structure.....	95
3.3.2.2.1 The root.....	96
3.3.2.2.2 Inception.....	97
3.3.2.2.3 Resultative.....	97
3.3.2.3 SVCs in West African languages.	98
3.3.2.4 SCCs in Scandinavian	100
3.3.2.5 Parametric Variation between SVCs and SCCs.....	101
3.4 Conclusion.....	102
 Concluding Remarks.....	 104
1. The Status of the Syntactic String.....	104
2. SVCs and Eventhood	106
3. SVCs and Clausehood	106
4. Verb Order	106
5. Parametrisation	107
 Appendix I: Language, History And Culture In Northern Ghana:.....	 109
1.1. Introduction	109
1.2. Geographical distribution.....	109
1.3. Linguistic classification of Northern Ghana.....	111
1.3.1. The Nomenclature for Classifying African Languages	111
1.3.2. The Meaning of Mabia.....	112
1.3.3. Genetic Relationship.....	113
1.3.4. The Classification of Mabia Languages	115

1.3.5. Typological Relation	116
1.4. Historical and Cultural Affinities of Speakers.....	118
1.5. Sociolinguistic Information for the Various Languages.....	123
1.5.1. The Grusi group.....	123
1.5.2. The Guang group.....	123
1.5.3. The Gurma group.....	123
1.5.4. The Mabia group.....	124
1.6. Conclusion.....	125
References.....	127

Introductory remarks

The main aims of this thesis are i. to develop an integrated structural account of the concept of *Serialisation* as it occurs in a group of West African languages, and ii. to show how this grammatical concept is used by speakers to express events as they occur in real world situations. The purpose of these introductory remarks is to present the research area, to give a general idea of the linguistic phenomenon we are investigating, to introduce our approach, and to outline the contents of each chapter.

1. The Data and Research Area

The data forming the basis of our analysis come mainly from a group of West African languages. As with many language groupings in Africa and other parts of the world, there is not a commonly accepted cover name to refer to them. They have been variously referred to as Mole- or Moore-Dagbane languages, Western Oti-Volta languages, etc. I have proposed to call them Mabia¹ languages in this thesis. Genetically, the Mabia languages are members of the Gur or Voltaic language group which, in turn, belongs to the Niger-Congo language family, one of four families in Africa. The Mabia languages cover large parts of Northern Ghana, Burkina Faso and some adjoining parts of Northern Togo and the Ivory Coast (see map in Appendix I). The data collected for this thesis come from six of the main languages, viz Dagaare, Dagbane, Gurenne, Kusaal, Mampruli and Moore. Most of the fieldwork was concentrated in Northern Ghana and especially on Dagaare, which is my native language. This is reflected by the preponderance of data from this language throughout the analysis.

2. The Phenomenon

The term *serialisation* is used, among others, in the linguistic literature to refer to constructions involving two or more verbs within what is probably a single clause. The following Dagaare construction in (1) will serve as our first example of the phenomenon:

- (1) *Deri da zo gaa wuo la ta'ŋma wa ku ma*
Dery past run go collect a.m shea fruits come give me

¹ This term denotes sibling relationship in most of these languages. It is built out of the lexical items: 'ma' = mother and 'bia'/'bie'/'biiga' = child. Refer to Appendix II for a further explanation of the linguistic use of the term being proposed in this thesis.

'Dery ran there and collected shea fruits for me'

In the above construction, there are as many as five lexical verbs within what is presumably a single clausal construction. We provide a more technical and detailed description later on in the text. In some of these constructions all these verbs may refer to just a single event or a series of tightly related events.

This and many other constructions involving verbs occurring in a series within the same clause in these languages is often termed, generally, *Serialisation*. Since it involves verbs, it is sometimes termed *Verb Serialisation*. The various verbs may then be described as *Serial Verbs*, *Consecutive Verbs*, *Sequential Verbs* or even *Split Verbs*, depending on the way one conceives of their occurrence relationship.

The term *Serial Verb Construction* (SVC) seems to have gained currency over the others as many experts would now prefer to emphasise the characteristics of the construction as a whole. While not ignoring most of the other terms, this is the term that is favoured in the present work. We shall use the term *Serialisation* as the general, superordinate phenomenon; reserving SVC for a specific kind of it. SVCs in our usage would refer to the kind of *Serialisation*, whose verbs and other grammatical categories are more syntactically cohesive and which express a single, albeit, complex event or at least a semantically, tightly related series of events.

The above construction already indicates a difference in lexicalisation strategies between what we may call 'serialising languages' such as Dagaare, Akan and Ewe on the one hand, and 'non-serialising languages' such as English, French and Norwegian, on the other. This difference is by no means trivial and has triggered a number of experts on Syntax and Semantics of Natural Languages to discuss the exact nature of these constructions and why it is that speakers of these languages express concepts the way they do. For instance, one may want to know if these lexicalisation differences merely indicate different linguistic strategies for expressing the same concepts and can therefore be accounted for by simple universal parameters or they constitute radically different ways of conceptualising the world because of the different linguistic and cultural orientations of the speakers. While we do not intend to go into the specifics of these issues, our accounts of the syntax and semantics of the SVCs may bear some relevance to these wider issues.

3. The Approach and Theoretical Framework

In an attempt to realise the objectives set for this work we have assumed the thesis that, structurally, SVCs are complex predicates and that, functionally, speakers of the languages investigated use these complex predicates to express complex events. Considering SVCs as complex predicates is a position that has been pursued by some earlier works. In this work, we confirm this position with new evidence and, more importantly, use it as a point of departure to establish the functional parameter of our thesis: that speakers use these complex predicates to express complex events, i.e., a tightly related group of acts constituting one cohesive happening.

The anti-thesis may then be that the different verbs in serialised entities represent separate events. We have considered this possibility of multi-event serialisation. We have recognised in our data a small number of serialised constructions that, structurally and functionally, do not seem to conform with our thesis of single eventhood. This small group may well be candidates in support of the anti-thesis of multi-eventhood. We leave this open for investigation.

The greater majority of our data do, however, support our stated position which we demonstrate throughout the thesis by describing and accounting for the structure of SVCs and then by developing a model of event structure to show how the SVC structure patterns into this.

The formal frameworks for representing the objectives of this thesis are the syntactic and semantic theories of Hellan (1991) and Hellan and Dimitrova-Vulchanova (1993). The former is a version of the Government and Binding (GB) theory of grammar posited in Chomsky (1981) while the latter is a new conceptually-based semantic theory. Within these frameworks we assume a grammar design where we consider our data to be simultaneously accessible to all levels of our grammatical representation, including the lexicon.

4. The Organisation of the Thesis

This thesis, comprising three chapters, is organised as follows: In Chapter 1, we present briefly general features of the structure of Mabia. We cover mainly canonical declarative sentences of the group, with emphasis on the Verb Phrase. There is very little published material on the syntax of these languages. Yet it is necessary to have an idea of the general structure of these languages in order to gain an understanding of the SVC data to be discussed.

In Chapter 2, we present the phenomenon of SVCs, describing as systematically as possible, its grammatical structures as they pertain to the Mabia data. This description establishes the SVC as a complex predicate. We then provide our initial analysis of the phenomenon, showing how it is formally represented on our chosen phrase structure and how grammatical information is processed on these structures. We then situate this initial analysis in the literature by comparing it to earlier approaches.

Chapter 3 implements the analysis sketched earlier. Several conditions are outlined and brought together to build an integrated account of SVCs. Following this, we then develop a novel model of event structure and show how our account of SVC structure fits functionally into this event structure. In the concluding remarks we indicate how far this research has addressed some of the basic questions about the syntactic and semantic phenomenon of serialisation.

There is an appendix which contains a sociolinguistic introduction to the research area.

Chapter 1: An Introduction To Mabia Syntax

1.0. Introduction

In this chapter, we present briefly the syntactic structure of the Mabia languages and give a formalisation of this structure in the GB theory of generative grammar, using the version that is known as the two-level X-bar system (Hellan 1991).

There exists no comprehensive publication on the syntax of Mabia and other Gur languages (Naden 1989). Yet some knowledge of the salient features or their syntax is essential for a comprehension of the phenomenon of verb serialisation. We shall concentrate on only the canonical declarative sentence, especially the Verb Phase as this is the part of the sentence that concerns us most.

The chapter is divided into three major sections. In section 1.1, we describe the nominal phrase briefly. In section 1.2, our description of the general structure of the Mabia sentence focus on the verb phrase. This is done with particular reference to data from Dagaare. Section 1.3 contains our proposal for a formalisation of some of the construction types in this language group.

1.1. Mabia Morpho-Syntactic Structure.

Most of the earlier descriptions (e.g. Bendor-Samuel 1971, Naden 1988) of the canonical simple declarative sentence in this group recognise the following sequence: A nominal phrase usually precedes the verb phrase, functioning as the subject of the sentence. Another nominal phrase follows the verb phrase functioning as the object, in the case of transitive verbs.

This sequence suggests that in terms of word order parameter these languages are basically SVO in their syntactic structure. Of course, as we shall see later, adverbial phrases and other particles make the basic structure more complex than it looks at first. The following sentences in (1) from Dagaare, Dagbane, Gurenne, Kusaal, Mampruli and Moore will illustrate this basic structure.

- (1a) *Deri nyu la kuo* : Dagaare
- S V O
- Dery drink a.m water
- 'Dery drank water'



- (1b) *Nindoo ŋmε la Nimpaga* : Dagbane
 S V O
 Nindoo beat a.m Nimpaga
 'Nindoo beat Nimpaga'
- (1c) *Aduku yin ŋmi ma* : Gurenne
 S V O
 Aduku fut beat me
 'Aduku will beat me'
- (1d) *Seidu yiis kugra* : Kusaal
 S V O
 Seidu remove stone+a.m
 'Seidu removed the stone'
- (1e) *Wuni piisi la taama* : Mampruli
 S V O
 Wuni pick a.m sheafruits
 'Wuni picked sheafruits'
- (1f) *Wirdaogo paba la mi* : Moore
 S V O
 Wirdaogo beat a.m me
 'Wirdaogo beat me'

After confirming this basic word order, Bendor-Samuel (ibid) lists some of the clause types that may occur in these languages as intransitive, transitive, ditransitive, directive, stative, equative, demonstrative etc. Naden (ibid) on his part indicates the types of sentences that may occur in the languages by looking at the kind of functions that sentences of a language may perform. In the process he lists a lot of sentences as evoking event, patient, benefactive, state etc.

We shall not attempt to spell out all these sentence types. What we intend to show here is that a more constraining way of looking at the structure and types of sentences in Mabia is to look at the argument structure and the inherent semantic properties of each of the verbs taking part in the sentence, with this basic word order parameter in mind.. This will be

demonstrated more substantially with the sentence structure in Dagaare in section 1.3, but the two examples here will illustrate the point already.

(2) *O ŋmɛ ma la*
 S/he beat me a.m.
 'S/he has beaten me'

(3) *O kù ma lá gan*
 S/he gave me a.m book
 'S/he has given me a book'

By the nature of the verb 'beat' in (2) we have a transitive sentence because the verb's argument structure, as shown in (4), is basically transitive,

(4) *ŋmɛ*, V:agent, patient.

taking the two arguments 's/he' and 'me'. At the same time the semantic nature of the verb tells us that the direct object of 'beat' is the patient of the sentence, thereby making the sentence perform a patient role as Naden would want to have it.

In the same way the argument structure of the verb 'give' from the lexicon, represented in (5), tells us that it is a triadic or a ditransitive verb.

(5) *kù*, V: agent, theme, benefactive.

As a result our sentence will be ditransitive. Also by its semantic nature we get the indirect object 'me' as the benefactor of the action of giving.

By the foregoing explanation, rather than listing a myriad of sentences to illustrate the various types we simplify issues by recognising the fact that sentence types are the projection into the syntactic level of the argument structure and semantic properties of the individual verbs participating in the constructions. This is in line with the Projection Principle as posited in Chomsky (1981). We shall come back to these issues of formalisation but for now let us present the facts of the nominal and verbal phrases in Mabia, in general, and Dagaare, in particular.

1.1.1. *The Noun Phrase in Mabia*

Two morpho-syntactic issues are important in talking about the Maba Noun phrase:

- a) the structural positions in which the elements forming this phrase occur (syntax) and
- b) the nominal class systems in these languages (morphology)

We shall consider, first, the noun phrase structure.

1.1.2. Noun phrase structure

According to Bendor-Samuel (1971), the Gur noun phrase structure is quite simple, consisting either of a noun followed by a numeral or a noun followed by an demonstrative but rarely of a noun followed by an adjective and never a noun followed by a string of adjectives. He says little about items that precede, mentioning only that possessive pronouns precede the noun.

Angkaaraba (1980) however gives a much more comprehensive structure of the Dagaare noun phrase, suggesting that the noun phrase structure in this language group may be much more complex than that thought by Bendor-Samuel (ibid). The diagram below in (8) shows the complexity of the Dagaare noun phrase. According to this diagram the head noun can be followed by adjectives, quantifiers, demonstratives, intensifiers and locative markers. On the other hand, it can be preceded by modifiers, another noun phrase and articles. Indeed, contrary to Bendor-Samuel's observation that Gur languages never exhibit a string of adjectives after the head noun, this actually happens in Dagaare according to this study. The following construction (6) from Angkaaraba (ibid) illustrates this and all the other structures in the diagram:

(6)

A n bie nga sukuuligan bil zi wog sunni ata ama zaa paa puo
 the my child this school book small red long good-prural three these all intensifier among
 'Among all these three small red long good school books of this my child'

'Gan' is the head noun. It is followed by as many as four adjectives. In fact there is no motivation why Angkaaraba (ibid) sets only a maximum of four adjectives to follow the head; we can have more than that as shown below in (7).

(7)

a gan bil zi wog baal sunni na
 the book small red long slender good+pl those
 'Those small, red, long, slender, good books'

(8)

6	4	2	0	1	2				3	4	6	7	8		10
					.2	.4	.6	.8					.2	.4	
Art	np	nm	NH	(pl)	Adj	Adj	Adj	Adj	(pl)	Q	D	(pl)	int	int	loc

Key: Art - Article; np - nominal phrase; nm- noun modifier; NH; Noun Head; pl - plural;
Adj - Adjective; Q - Quantifier; D - Demonstrative; int - intensifier; loc - locative.

Even numbers show slots where major constituents of the nominal phrase occur while odd numbers indicate affixes of the preceding item.

Of course the argument about whether strings of adjectives can or can never follow a noun head in Mabia is partly also an argument about whether we consider nouns and adjectives to form one or more than one word. This issue can be clarified when we look at the following data from Dagaare and Mampruli in (9) and (10) respectively.

(9a) *yiri, yie; zie; kpoŋ*
house houses red big

but

(9b) *yizie*
house+red
'red house'

(9c) *yiziri*
house+red+pl
'red houses'

(9d) *yizikpoŋ*
house+red+big
'Red big house'

(9d) *yizikponni*
house+red+big+pl
'Red big houses'

(10a) *gbaŋŋu; bila; gyia*
book small red

but

(10b) *gbaŋbilligyia*
book+small+red

'small red book'

- (10c) *gba ŋbiligyisi*
 book+small+red+pl
 'small red books'

In both Dagaare and Mampruli, as can be seen from the data, only the stem of the noun is available when the noun takes on one or more adjectives. Indeed adjectives also lose part of their endings when they combine with a following adjective. The noun and adjective(s) can be seen as forming one word. This observation is buttressed by the fact that the plural of the whole complex appears at the end of the last adjective.

Looking at these constructions in Dagaare and Mampruli as single words would probably be the only way to defend Bendor-Samuel's assertion that a noun (word) is never followed by a string of adjectives (as separate words ?) in Gur.

Even then the data do not dispute the fact that a noun or its stem is followed by adjectives or adjectival stems. The data from Dagaare and Mampruli therefore confirm the fact that the structure of the nominal phrase in Mabilia is much more complex than observed by earlier works.

1.1.3. Noun class system

Another important aspect of the nominal phrase in Mabilia and indeed the whole of the Gur language family is the occurrence of a system of noun classes. In some languages nouns can be put into classes depending on the way they form the singular and plural forms of nouns. In other languages the noun classes are set up based on a system of concord operating between the nouns and any substituting pronouns, numerals and other quantifiers (Bendor-Samuel 1971). In many languages, however, the two criteria are congruous, thereby giving a straightforward classification.¹

¹ The following two tables illustrate examples of noun class systems in Gurenne and Dagaare. The Gurenne one illustrates noun classification based on a system of concord between nouns and their qualifiers while the Dagaare table illustrates the second option i.e. classification based on the singular and plural forms of nouns.

Noun class system in Gurenne:

Class 1: a/ba e.g. 'nɛra ayɛma' (one person) but 'nɛreba batan' (three people)

Class 2: de/a e.g. 'yɛnɛ deyɛma' (one tooth) but 'yɛna atan' (three teeth)

1.2. The Verb Phrase.

Class 3:ka/se e.g 'zuna kayema' (one fly) but 'zununhe setan' (three flies)

Class 4: ko/to e.g 'koyema' (one leaf) but 'koynto totan' (three leaves)

Class 5: bo/- e.g 'dahoyema' (one "pito") but ???????

Class 6: bo/i e.g 'nahoyema' (one cow) but 'nli kan' (three cows)

Noun class system in Dagaare:

Class 1: E / rI	Singular: -E	Plural: -rI
	bie - child	biiri - children
	tie - tree	tiiri - trees
Class 2:O/ bO	Singular: -O or a	Plural: -bO or ba
	poɔɔ - woman/wife	poɔbo - women/wives
	doɔ - man	doɔbo - men
Class 3: O/rI	Singular: O	Plural: rI
	duo - pig	dori - pigs
	dɔɔ - 'dawadawa'	dɔri - 'dawadawas'
Class 4:rU/rI	Singular: rU	Plural: rI
	piɔɔ -sheep	piiri - sheep
Class 5: φ/rI	Singular: φ	Plural: rI
	nu - hand	nuuri - hands
Class 6: rI/E	Singular: rI	Plural: E
	ti - spoon	tie - spoons
	miri - rope	mie - ropes
Cl. 7: -nv/nv	Singular: nasal(lised) syllable	Plural: nasal(lised) syllable
	kpaɑŋv	kpinni
	kpiɔɔ	kpiini
Class 8: a/I	Singular: (la)a or (ra)a	Plural: (I)I or (r)I
	gbiŋgbilaa - drying spot	gbiŋgbilli - drying spots
	poɔsaraa - young girl	poɔsaari - young girls

For more information on noun class systems in this language group, especially the Dagaare language, see Bodomo (in preparation).

The verb phrase in Mabia and other Gur languages is said to have the following general structure:

preverbal particles - the main verb - postverbal particle

We shall first discuss the preverbal particles. This will be followed by the structure of the main verb and the discussion on the verb phrase will end with the postverbal particle, where we will suggest that the particle that has been treated as postverbal is indeed preverbal at D-structure, appearing only as postverbal after movement rules. Before this, it will be useful to discuss the use of the term 'auxiliary verb' in the Mabia languages.

1.2.1. A note on the term AUX in Mabia .

Earlier linguists of the group (e.g. Bendor-Samuel 1971) report of 'auxiliary verbs' in some of the languages occurring between the preverbal particles and the main verb. In this work, we argue against the use of the term as there is a tendency to confuse the concept of auxiliary verbs as can be found in Indo-European languages and the phenomenon of verb serialisation where different lexical verbs may occur together without any being auxiliary to the other. My arguments are based on the fact that there exists a number of particles, as will be shown in section 1.2.2, which perform the temporal, modal and aspectual functions normally performed by those verbs in the Indo-European languages called auxiliary verbs.

In fact, the lexicalisation strategies that are available in serialising languages for expressing conceptual properties such as tense, aspect, mood, and polarity are rather complex. On the one hand, in Indo-European languages like English, French and Norwegian most of the items that are described as auxiliary like 'to be' 'to have' and 'to be able to' (English); 'etre', 'avoir' and 'pouvoir' (French) and 'å være' and 'å ha' (Norwegian) are themselves lexical verbs, i.e. they can stand independently in a simple sentence and they can themselves inflect for tense and aspect.

On the other hand, the linguistic items in Dagaare and other Mabia languages that carry tense and aspect are not lexical verbs. They can never stand on their own behaving like 'to be', 'etre' and 'å være' as is the case in English, French and Norwegian respectively. They may therefore be auxiliaries but certainly not auxiliary verbs. Muysken (1981) has also observed this grammatical difference between Indo-European languages and Creoles such as Sranan, Saramaccan and Krio.

From all indications then the (auxiliary) particles that help verbs to express tense, aspect and mood in serialising languages are substantially different from the auxiliary verbs of Indo-European. And the best thing to do in any formal analysis of the verb phrase in these languages will be to assign them to a node of their own; one which will replace the AUX node as is often postulated for Indo-European languages.

1.2.2. *The preverbal particles.*

Many have recognised the presence of preverbal particles in the Mabia verb phrase, though not all may have realised the crucial functions they perform. Bendor-Samuel (1971) recognises that virtually all the Gur languages have these particles occurring optionally before the verb. He even lists as many as 30 such particles in Dagbane. Dong (1981), on his part, lists as many as 15 such particles for Dagaare. In the diagram below we try to list the major particles occurring in two of these languages, Dagbane and Dagaare, before we begin to discuss their temporal and aspectual functions.

(11)

Tense, Aspect, Modal Particles	Dagbane	Dagaare
today (also once upon a time)	də	da
one day away	sa	zaa
two or more days away	daa	daar
habitual	yi	maŋ
still, not yet	na	naŋ
actually	siri	svrvŋ
once again, as usual	yaa	yaa
suddenly, just	dii	diε
nonfuture negative	bə	ba
future affix	nə	na
future negative	ku	kvŋ
imperative subjunctive negative	də	ta
again	lah	là

Having now listed the particles we will look at their functions. One thing about these particles is that it is very difficult to separate them into temporal, aspectual, modality and polarity particles. Some of the particles as

can be seen in (11) express, for instance, tense or time depth and polarity while others express mood and polarity. Dakubu (1989) has also recognised the same problem with respect to the particles of Dagaare.

1.2.2.1. Time depth and tense particles.

One difference between Mabia and Indo-European languages or even between them and the Kwa languages is their ability to express not just tense but also time depth by the use of these particles. The particles 'dɔ' and 'da' both express an action which has taken place within the last 24 hours i.e before yesterday in both Dagaare and Dagbane. There is, however, an additional meaning in Dagaare as it can also express an action that happened some time ago. This is illustrated in (12).

- (12) *Kɔŋ da lee la*
 Hunger past fall a.m
 'There was famine some time ago'

In this sense it can be said to express the neutral past without marking the gradations mentioned.

The particles 'sa' and 'zaa' in Dagbane and Dagaare as can be seen above express events which took place a day away (and even in the case of Dagbane a day still to come, according to Bendor-Samuel *ibid*). The particles 'daa' and 'daar' express actions which took place two or more days ago but again in Dagbane it can also express an action still to take place two days from now. I shall discuss the rest of the tense particles under polarity below.

1.2.2.2. Polarity and tense particles.

Again the relationship between polarity and tense is so tight in these languages that one has single individual particles which can express a positive or negative action in the past and a positive or negative action in the future. The following Dagaare sentences in (13) illustrate the point.

- (13a) *N da gaa la wɛ*
 I past go a.m farm
 'I went to the farm'
- (13b) *N na gaa la wɛ*
 I fut+pos go a.m farm
 'I will go to the farm'
- (13c) *N ba gaa wɛ*

- I past+neg go farm
 'I did not go to the farm'
 (13d) *N kʊŋ gaa wie*
 I fut+neg go farm
 'I will not go to the farm'

The particle '*na*', for instance, is not just a particle about future tense but is as much a particle about positivity of the action.

On the other hand, its counterpart in (c) which is '*kʊ*' is not simply negating an action, it is also indicating the tense (future in this case) in which the action is conceived of by the speaker.

1.2.2.3. Modality and Aspect particles.

Particles such as '*maŋ*', '*diɛ*', '*ta*', and '*la*' as can be seen from the table above express modality, aspectual features and even some features of polarity as is the case with the imperative subjunctive negative marker '*ta*'.

1.2.2.4. Aspectual suffixes.

Apart from these particles there are also some 'suffixes' to the verb expressing perfective and imperfective aspects in these languages. Indeed with respect to these, the verb in Mabilia has, at least, three forms as shown with the Dagaare verb '*to go home*' below in (14):

- (14a) *kul* - dictionary form
 (14b) *kulee* - perfective aspect
 (14c) *kulo* - imperfective aspect

From all the above, it can be seen that these particles and the affixes mentioned form a very cohesive structural and functional group and any formal representation ought to consider this cohesiveness and the possibility of their forming a functional projection. These will, in fact, be treated as independent 'functional heads' in the formalism to be suggested in section 3.

1.2.3. The Main verb.

As can be seen from the above two-tier inflectional morphology of the Dagaare verb '*to go home*', the basic system of the Mabilia verb is often labelled as aspect - the perfective and imperfective aspect. It may also be called, according to Bendor-Samuel (1971) event and process, punctiliar and linear,

etc. In this basic system, the speaker sees the action as either completed or not yet completed. This is irrespective of whether the action is viewed as being in the past or not, as is shown in the following Dagaare sentences:

- (15a) *O da kulee la*
 S/he past go home+perf a.m
 'S/he went home'
- (15b) *O da kulo la*
 S/he past go home+imperf. a.m
 'S/he was going home'
- (15c) *O kulo la*
 S/he go home+imperf. a.m
 'S/he is going home'

In languages like Dagbane and Mampruli there is, in addition to this basic inflectional system, another inflectional positive imperative suffix '-*ma*' added to the verb. This is illustrated in (16a):

- (16a) *Isima*
 Get up+imp
 'Get up'
- (16b) *O isiya*
 S/he get up a.m
- (16c) *O kyamya*
 S/he walk+a.m
 'S/he has gone'
- (16d) *O kyεŋεŋ* : Dagaare
 S/he walk+a.m
 'S/he has walked'

Further still there are other verbal suffixes, '-*ya*' in Dagbane and Mampruli and '-*ŋ*' in Dagaare, which serve to affirm or emphasise the verbal action. This is also shown above in (16b - d). In Dagaare and, possibly, in Mampruli and Dagbane these affirmative affixes are in complementary distribution with the so-called postverbal '*lá*' which will be discussed in the next section.

An interesting aspect of the Mabilia verbal system is that verbs can be classified into pairs or even several classes of oppositions depending on derivational processes such as causativity, transitivity, reversivity and many others. The table below in (17) is an attempt to illustrate this with a number of Dagaare verbs :

(17)

1	kʋ - kill	kpi - die
2	ɔɔ - make fall	le - fall
3	gaali - put to sleep	gaŋi - sleep
4	zigli - seat	ziŋi - sit
5	tuuli - make drink	nyu - drink
6	su - feed (put in mouth)	di - eat
7	siŋi - cause to wake up	iri - wake up (from sleep)
8	yagli - hang	yagi - take off
9	ʋɔgli - put on (hat)	ʋɔgi - remove(hat)
10	úú - bury	únni - exhume
11	leŋ - tie	lori - untie
12	nyogli - hold loosely	nyɔgi - hold
13	sɔgli - to hide	sɔɔ - to be black
14	yieli - sing, say repeatedly	yeli - say, speak

The pairs of oppositions from 1 up to 7 seem to illustrate causativity oppositions with the members to the left being the causatives. This opposition proves to be important for verb serialisation in terms of predicate constraints.

While illustrating causativity the pairs from 1 - 4 also illustrate transitivity, with the pairs to the left being the transitive verbs while those to the right are the intransitives.

Pairs from 8 - 11 illustrate the reversivity opposition, while pair 12 may illustrate what may be called the releasive opposition. Pair 14 seems to illustrate the repetitive opposition between the two members.

In addition to these oppositions one may also find other oppositions. One good example is the polarity opposition between the following Mampruli verbs:

mi - to know *zi* - to not know

This is illustrated in the following sentences where 'zi' is an inherent negative verb:

(18a) *N mi*
I know
'I know'

(18b) *N ba mi*
I neg know
'I don't know'

(18c) *N zi*
I not+know
'I don't know'

(18d) **N bi zi*
I neg not+know
'I don't know'

Now, a glance at the table of oppositions will show that derivational affixation is not a very developed phenomenon in Dagaare and by extension other Mabia languages, certainly not as developed as the derivational systems of Bantu (Amidu 1992) and Fulfulde (Fargeli 1993). From the table in (17), there is only one consistent suffix '-li' between the pairs of oppositions. One cannot, however, say that it is any particular derivational suffix as the pairs of words in which it occurs cut across several derivational classes. In this regard, there are no regular sequences of derivational affixes. As can be seen, the rest of the morphological changes in these oppositions do not involve affixation but rather internal vowel changes as in pairs 1 and 2 on the table.

This near lack of derivational morphology with respect to the verb is not surprising in such languages where verb serialisation is very productive. Within African languages there seems to be an interesting relation between verb serialisation and verbal extensions; the two possibly have complementary functions. If this observation is correct, it is my strong belief that languages with a rich verb serialisation system will necessarily have a poor verb derivational system and vice versa. This is an interesting comparative research agenda, at least, within African linguistics. More

interesting still is Baker's (1991) suggestion that verb serialisation and verb extensions can be explained by the same grammatical principles.

1.2.4. The 'postverbal' particle:

Both Bendor-Samuel(1971) and Dong (1981) recognise that the particle 'lá' occurs postverbally in Dagaare. The same has been recognised for other Gur languages. In Dagaare, Moore, Kusaal and Mampruli this particle serves to mark affirmation or even emphasis of particular aspects of the sentence.

Distributionally, 'lá' , in all cases, is in complementary distribution with the negative polarity particles, as one would expect of an affirming particle. This is illustrated below in (19) where (19a) and (19b) are grammatical but (19c) is ungrammatical because of the violation of the complementarity condition.

(19a) O na kul la
 S/he fut+pos go home a.m
 'S/he will not go home'

(19b) O kvŋ kul.
 S/he fut+neg go home
 'S/he will not go home'

(19c) *O kvŋ kul la
 S/he fut+neg go home a.m
 'S/he will not go home'

It seems then from this analysis that, apart from being an affirming or an emphatic particle, 'lá' may as well be a positivity particle. This speculation is confirmed when we realise the fact that 'lá' has a cliticised version '-ŋ' whose distribution is much the same as that of 'lá', except that as a clitic it gets incorporated into its host. Now, this cliticised version behaves much like the aspectual suffixes which are treated as preverbal particles even though they are apparently part of the verb system. The cliticised version like the aspectual suffixes is part of the preverbal particles. In that case then, 'lá' is arguably also a preverbal particle.

In the formal representation suggested in this work I will thus treat it as belonging to the group of preverbal particles, all of which will be seen as belonging to one functional projection.

1.3. A Two-Level X-Bar Syntax For Mabia.

In this part of the chapter we consider issues about how to best represent in a formal way the facts of the sentence structure of the Mabia languages that we presented in the last section. Our attention will be focused more on formalising the structure of the VP as this concerns us most in this thesis.

1.3.1. The framework:

The grammatical framework used here is called a 'two-level X-bar system' developed in Hellan (1991). It is essentially a version of the Government and Binding (GB) theory of grammar developed in works such as Chomsky (1981, 1986) and Hellan (1988). The theory owes its name to the fact that it assumes only two levels of syntactic projection whereas the standard theory assumes three levels. The following configuration types in (20) and (21) will illustrate the basic difference between the two versions:

(20a)

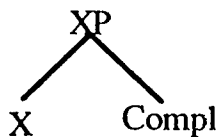

(20b)

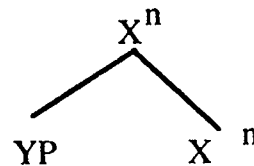

(21)

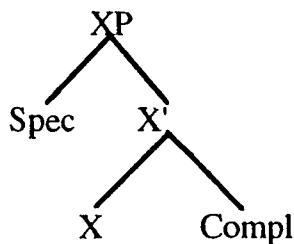

The only configuration types found in the two-level system are those in (20), with (20a) being the head-complement configuration and (20b) being the adjunction configuration. In (21), which is the standard GB representation, there is an intermediate projection, X' between the maximal projection XP and the zero level projection or the lexical word, X or X⁰ but it could also have the configuration in (20b) above as adjunction.

interesting still is Baker's (1991) suggestion that verb serialisation and verb extensions can be explained by the same grammatical principles.

1.2.4. The 'postverbal' particle:

Both Bendor-Samuel(1971) and Dong (1981) recognise that the particle '*lá*' occurs postverbally in Dagaare. The same has been recognised for other Gur languages. In Dagaare, Moore, Kusaal and Mampruli this particle serves to mark affirmation or even emphasis of particular aspects of the sentence.

Distributionally, '*lá*' , in all cases, is in complementary distribution with the negative polarity particles, as one would expect of an affirming particle. This is illustrated below in (19) where (19a) and (19b) are grammatical but (19c) is ungrammatical because of the violation of the complementarity condition.

(19a) *O na kul la*
 S/he fut+pos go home a.m
 'S/he will not go home'

(19b) *O kuv̄ŋ kul*
 S/he fut+neg go home
 'S/he will not go home'

(19c) **O kuv̄ŋ kul la*
 S/he fut+neg go home a.m
 'S/he will not go home'

It seems then from this analysis that, apart from being an affirming or an emphatic particle, '*lá*' may as well be a positivity particle. This speculation is confirmed when we realise the fact that '*lá*' has a cliticised version '-ŋ' whose distribution is much the same as that of '*lá*', except that as a clitic it gets incorporated into its host. Now, this cliticised version behaves much like the aspectual suffixes which are treated as preverbal particles even though they are apparently part of the verb system. The cliticised version like the aspectual suffixes is part of the preverbal particles. In that case then, '*lá*' is arguably also a preverbal particle.

In the formal representation suggested in this work I will thus treat it as belonging to the group of preverbal particles, all of which will be seen as belonging to one functional projection.

1.3. A Two-Level X-Bar Syntax For Mabia.

In this part of the chapter we consider issues about how to best represent in a formal way the facts of the sentence structure of the Mabia languages that we presented in the last section. Our attention will be focused more on formalising the structure of the VP as this concerns us most in this thesis.

1.3.1. The framework:

The grammatical framework used here is called a 'two-level X-bar system' developed in Hellan (1991). It is essentially a version of the Government and Binding (GB) theory of grammar developed in works such as Chomsky (1981, 1986) and Hellan (1988). The theory owes its name to the fact that it assumes only two levels of syntactic projection whereas the standard theory assumes three levels. The following configuration types in (20) and (21) will illustrate the basic difference between the two versions:

(20a)

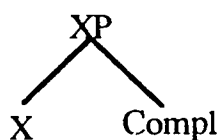

(20b)

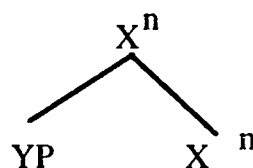

(21)

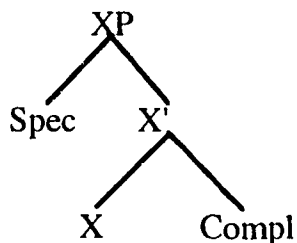

The only configuration types found in the two-level system are those in (20), with (20a) being the head-complement configuration and (20b) being the adjunction configuration. In (21), which is the standard GB representation, there is an intermediate projection, X' between the maximal projection XP and the zero level projection or the lexical word, X or X⁰ but it could also have the configuration in (20b) above as adjunction.

The theory being presented here is essentially binary branching in nature, thereby giving us very well-structured configurations. Another attractive aspect of the theory is that it is formally economical since we can do without one more level X-bar. This is remarkably advantageous in an era where economy is crucial in issues of grammatical design (Chomsky 1992).

One consequence of these configurations is that while the two versions have a uniform way of treating complements, they differ in the way adjuncts and specifiers are represented. In fact, the present version treats subjects and other specifiers either as heads of functional projections or as adjuncts based on a number of arguments (e.g. both respecting the island constraints (Ross 1967)). In our application of the theory to Mabia syntax we will assume the latter treatment.

1.3.2. *From the lexicon to phrase structure.*

We mentioned in section 2 that a more constraining way of approaching sentence structure is not to catalogue sentence types but to consider all syntactic constructions in the language as properties of their lexical heads, especially the verbs. Argument structure, then, and subcategorisation frames, which are presented in the lexical entries within the lexicon, decide the phrase structure of sentences. This is in line with the projection principle, one of the most fundamental principles of GB and all lexicalist theories of generative grammar. This principle is defined below in (22), according to Chomsky (1981).

(22) The projection principle:

Suppose α is a lexical category and β is a position of argument type.

a. If β is an immediate constituent of a one-bar level projection of α at some syntactic level, then α θ -marks β in α '.

b. If α θ -marks β as a lexical property, then α θ -marks β at all syntactic levels.

This principle then stipulates that the argument structure or the complementation properties of heads must be projected on to all levels of the syntax.

Consider the lexical representation of the following Dagaare verbs:

(23a) *ɲmɛ*, V, <NP>, (Agent, Theme)

'beat'

(23b) *Gbir*, V, (Agent)

- 'sleep'
- (23c) *Ku*, V, <NP,NP>, (Agent, Theme, Benefactor)
- 'give'

In this representation we have both the argument structure (with the external argument underlined) and the subcategorisation frame for each individual verb which shows how the internal argument will be realised in the syntax.

Now, applying the projection principle and our SVO word order parameter (a reason why GB is also called the principles and parameters approach) we get the following phrase structure representations at D-structure for the above lexical entries for Dagaare.

(24a)

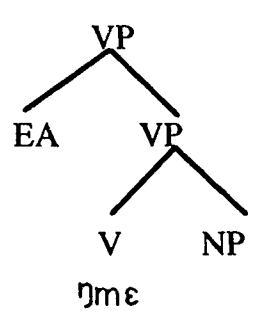

(24b)

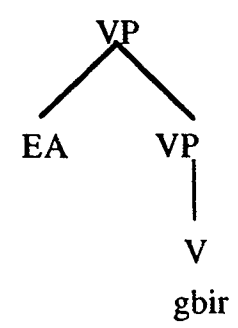

(24c)

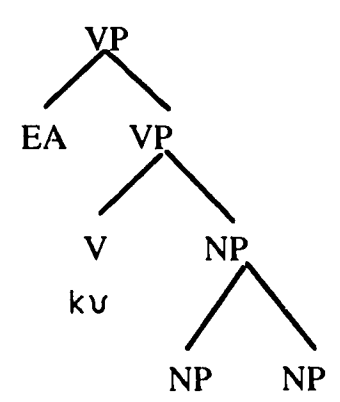

The EA in each of the X-bar projections stands for the external argument of the verb, functioning as agent or subject and appearing canonically to the left of the verb, since we are dealing with an SVO language. Where there are complements (direct internal arguments) these appear canonically to the right

of the verb and, following our X-bar configurations in (20), are in a sisterhood relationship with the lexical verb, V, which acts as the head of the maximal projection, VP. We here postpone the way the double objects are represented to a latter part of the formalisation process. As can be seen, the subcategorisation frames also show up in the syntax, realising the theme and benefactor roles of the verb's argument structure. By all intents and purposes then, the argument structure of these verbs are projected into the syntax within the framework of the two-level X-bar. Hence the projection principle is satisfied, and we can already see the contours of the different sentence types - intransitive, transitive and ditransitive - according to which verbs we are dealing with.

Having projected argument structure into the syntax we still need further grammatical and lexical instantiations to achieve full sentences of the language. In particular, we haven't accounted for the preverbal and postverbal particles of the verb phrase that we described in section 1.2.

1.3.3. Establishing a TAM system.

1.3.3.1. The TAM elements.

We saw in section 1.2.2 that the particles that express tense, aspect, modality, polarity and other systems are both structurally and functionally prominent in the Mabia verb phrase, playing similar roles as the auxiliary verbs in Indo-European languages. The normal treatment for this functional category of auxiliary verbs within GB literature is to assign them to a separate projection in the syntax. This is usually named AUX (for auxiliary verbs) or INFL or simply I (for Inflection). Rather than being part of the verb in the lexicon, AUX then gets into the verb constellation only after the argument structure has been projected into the syntax.

We, here, assume basically the same algorithm but since our preverbal particles are neither auxiliary verbs nor inflections in the same way as in English or French, the terminologies AUX or I are inappropriate for the Mabia languages. We, instead, replace these with TAM, standing for the temporal, aspectual, modal and all the other functions (including polarity) performed by this node. The TAM projection (TAMP) of Mabia has basically similar functions as the I projection (IP) of other languages, even though they are structurally different. TAMP then is a collective name describing the projections that will be headed by the various functional particles. Included in this collective designation are projections such as TP headed by temporal particles, AP, headed by aspectual particles etc.

We illustrate the representation of TAMP with the sentence in (25a) at D-structure as follows in (25b):

- (25a) *O da ba maŋ ŋmiɛɛ ma*
 S/he past neg. hab. beat+imperf. me
 'S/he was not always beating me'

(25b)

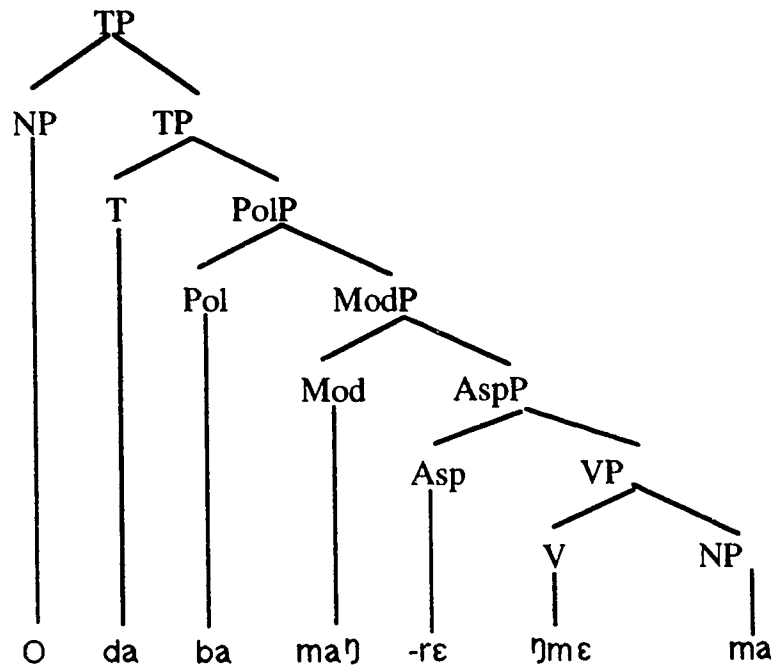

The first observation about the diagram in (25b) is that it responds to the two-level configurations as in (20) there being no intermediate level between the maximal projections and the lexical or zero level. We have about four maximal TAM (TP, PolP, ModP, and AspP) projections headed by a temporal node (T), a polarity node (P), a modal node (M) and an aspectual node (A) respectively: a TAMP is a label we put on whichever of these projections serves as the root of a given clause.

An important formal gain we achieve in using the two-level, rather than the three-level, approach lies in the way we treat TAMP. Our approach to the representation of TAMP is a direct consequence of the way auxiliary verbs are handled in the two-level system. The following diagram (26) exemplifies the way auxiliary verbs are handled in Hellan (1991)

(26)

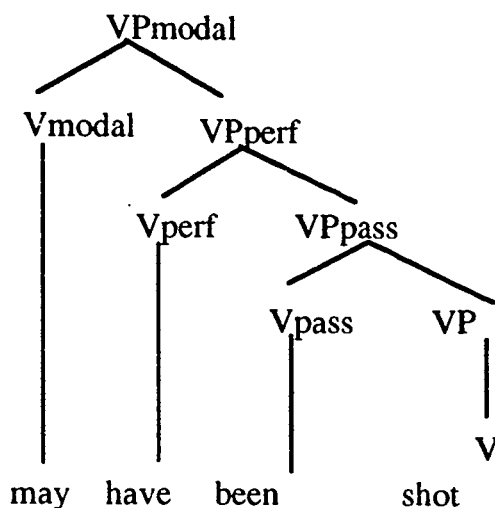

In this constellation, rather than treating auxiliary verbs as specifiers, they are 'most naturally construed as heads of their own verbal projection, with the projection of the verb following as the complement'

We follow basically the same line of formalisation and claim that each of the TAM elements are heads of their own projections with the preceding TAM as its complement and in the case of the last TAM element (here A) with VP as its complement. The requirements that these particles be in a certain kind of sequence, (in this case T, P, M, A...), can be regarded as instances of government, just as the obligatory sequential arrangements for auxiliary verbs are construed as instances of government in Hellan(1991).

There is, however, one issue to resolve in looking at the various TAMP nodes as heads. This involves A i.e. the aspectual suffixes such as '-re' above. Aspectual features, though functionally belonging to TAMP, are structurally part of the verb stem at surface structure. The representation of (25a) at surface structure is shown below in (27), where the aspectual particle and the verb become one lexical item (with internal vowel changes).

(27)

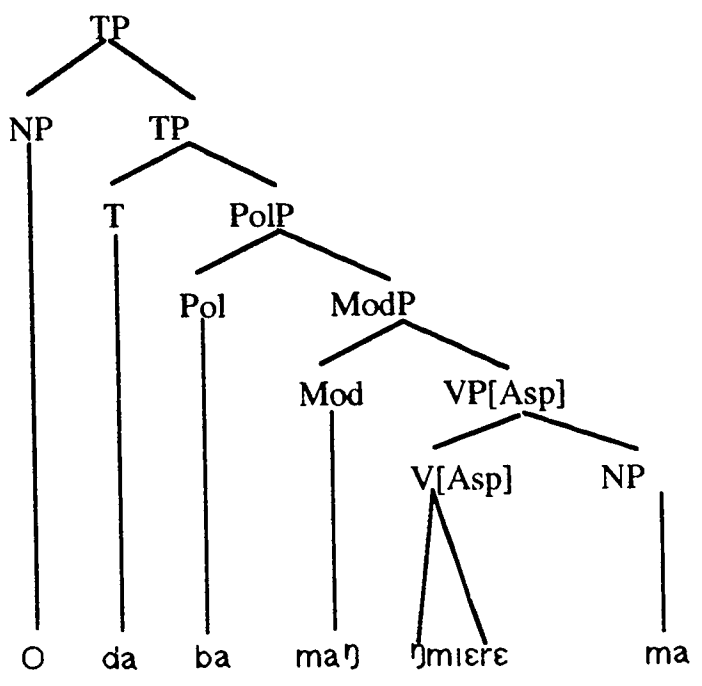

This observation then gives us the following configuration where the aspectual particle would be incorporated into the verb as it moves to that position. In this constellation, then, the V category above will take dominance over the aspectual projection.

Another aspect of the two-level approach is the interpretation of subjects as adjuncts of VP (rather than specifiers) following works such as Manzini (1988). One motivation for this comparison is the fact that both obey the island constraints of Ross(1967), one advantage being that the subject will act as the sister of its case assigner, such as the governing verb in Accusative with Inflection (Acl). In our analysis, we can reinterpret subjects, not as adjuncts of VP, but of TAMP. By this reinterpretation, the above advantage will not be available to us but we will not lose anything either since we can still have predication and theta-roles assignment, following the presupposition by this theory that predication and theta roles can be transmitted through auxiliary verbs (and in our case through the TAM particles).

1.3.3.2. The position and function of /á in TAMP.

The last issue is to account for '/á ' as part of TAMP. We noted earlier on that in Dagaare '/á ' has a very close functional relationship with some of the TAM particles and suffixes. In particular, it is in complementary distribution with negative particles, meaning that functionally, it can be placed on the

positive side of the polarity grid. For instance, as shown in (28) below our example sentence cannot occur with 'lá', that is why (28b) is ungrammatical but its positive counterpart in (28c) is grammatical.

(28a) O da ba maŋ ŋmiεε ma
S/he past neg. hab. beat+imperf. me
'S/he was not always beating me'

(28b) * O da ba maŋ ŋmiεε ma la
S/he past neg. hab. beat+imperf. me a.m.
'S/he was not always beating me'

(28c) O da maŋ ŋmiεε ma la
S/he past hab. beat+imperf. me a.m.
'S/he was always beating me'

Our claim in this formalisation is that at D-structure *lá* occupies the polarity node as shown below in (29):

(29)

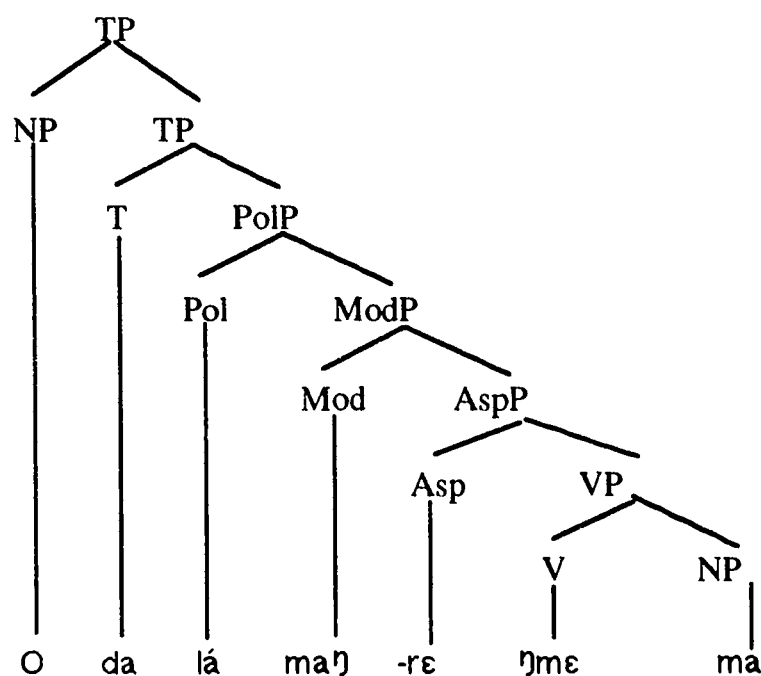

Note that this affirmative or polarity particle is not the same as the repetitive particle *là* shown on the chart in (11). Note also that in line with treating

subjects as adjuncts and not specifiers we replace the spec node with an NP such that structurally our subject position is now simply defined as <NP TAMP>. Like IP, TAMP is transparent to theta role assignment, permitting both internal and external theta roles to reach the appropriate NPs. Returning to the formalisation of *lá*, it will then occur postverbally in the s-structure representation after movement rules have applied.

1.3.3.3. Constraints on *lá* movement.

One difference between the polarity/affirmative particle movement and aspectual suffix movement lies in their landing sites. While the latter's landing site is quite straightforward: incorporating with the verb stem, that of '*lá*' needs some amount of explanation.

One clear constraint is that it never occurs after adjuncts postverbally, confirming our prediction that '*lá*' is essentially a verbal element. It therefore tries as much as possible to be in the maximal projection of VP even when it moves out of PolP. This constraint is illustrated in (30) where (30b) is ungrammatical following the illicit post-adjunct occurrence. (30c) shows that the cliticised form '-ŋ' of '*lá*' follows exactly the same pattern as its full form in terms of landing sites.

- (30a) *Bayuo da gbiree la vilaa*
 Bayuo past sleep+perf a.m good
 'Bayuo slept well'
- (30b) **Bayuo da gbiree vilaa la*
- (30c) *Bayuo da gbireeŋ vilaa*

A further tendency of '*la*' to be as close as possible to the verb (or to even get incorporated into the verb), is demonstrated with the occurrence of full NP complement clusters. It occurs before all full NP complements (31a), but never intervenes (31b) nor comes after them (31f). A pronominal complement in the cluster must however intervene between the verb and '*lá*' as shown in (31c), rendering (31e) ungrammatical. In this case '-ŋ' which is the affixal/cliticised form of '*lá*' will get attached to the indirect object pronoun as shown in (31d).

- (31a) *O da ko la Deri a gan*
 S/he past give a.m Dery def. book
 'S/he gave Dery the book'

- (31b) *O da ko Dəri la a gan
S/he past give Dery a.m def. book
'S/he gave Dery the book'
- (31c) O da ko ma la a gan
S/he past give me a.m def. book
'S/he gave me the book'
- (31d) O da ko maŋ a gan
- (31e) *O da ko la ma a gan
- (31f) *O da ko ma a gan la //

Finally, an important constraint on landing sites, after take off from Pol, is rather pragmatic. Pragmatically, 'lá' serves to affirm either the rheme or the theme (which have syntactic equivalents as subject and object respectively and semantic equivalents as agent and theme or even actor and action). When it affirms the rheme at canonical subject position it may never even move at all. It moves however when it affirms a left dislocated item and the landing site is preverbally in a position we call CP. If however it affirms the theme (including predicates and their complements) its landing site is postverbally in the VP. As shown below in (32) there is no movement because it affirms the rheme, which is in a canonical subject position.

- (32a) Bader la kpi
Spider a.m die+perf
'Spider died'

(32b)

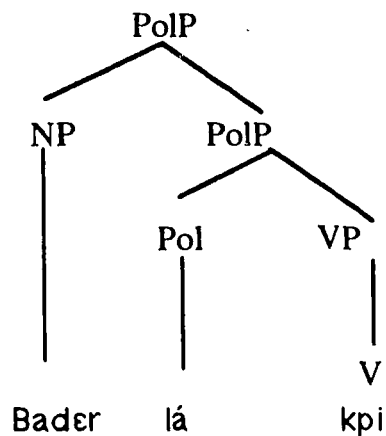

However in (33) below there is movement to the postverbal position because it is the theme that is being affirmed here, as shown by the underlined verb.

- (33a) *Bader kpie la*
 Spider die+perf a.m.
 'Spider died'

(33b)

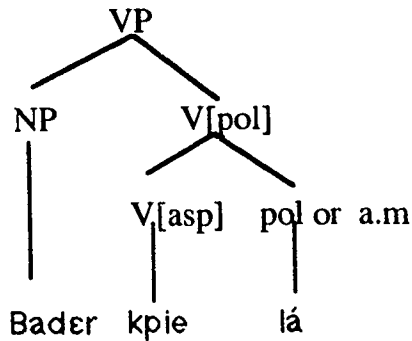

Again these figures show that our formalism is able to handle this grammatical and pragmatic relationship very well.

The TAM projection has now been established. We have in the process explained the nature of our formalism and shown how we can already use it to analyse aspects of the verb phrase in Dagaare. We shall spend the last part showing briefly how we can extend our formalism to handle issues like adjunction and double object constructions.

1.3.4. *Adjunction and double object clusters in Dagaare*

1.3.4.1. Adjunction

We touched briefly on the issue of adjunction in talking about the interpretation of subjects as adjuncts in this theory. We did not however consider the representation of non subject adjuncts which are represented canonically (i.e, when they are not left dislocated) at the end of the sentence in Dagaare. This is exemplified below in (34a).

- (34a) *Bayuo da gbir la seŋ puɔ*
 Bayuo past sleep+perf a.m bed loc.
 'Bayuo slept in bed'

We stated earlier that the verb 'sleep' projects the following argument structure repeated below:

(23b) *Gbir*, V, (Agent)

We claimed further that from the argument structure of verbs we could simply represent all the canonical sentence types. According to the projection principle, however, only one argument will be projected into the syntax. How are we then to account for the locative expression, the place adjunct, in our example sentence?

We could simply say that, like TAM features, adjunction is instantiated at D-structure and after movement rules we get the following diagram in (34b). As will be seen below, however, the two-level system has a better explanatory way of accounting for adjunction and double object clusters.

(34b)

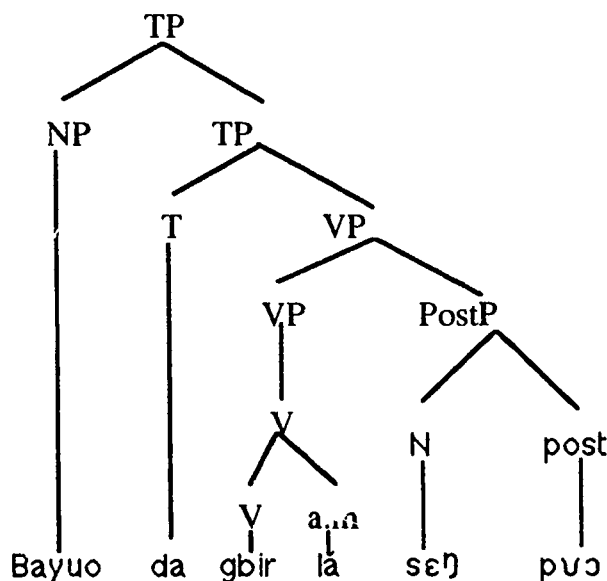

The projection, 'postP' stands for what I call 'postpositional projection'. This can be compared with PP (prepositional projection) of other languages. It has been necessary to make this adjustment for Dagaare because of the extensive use of postpositions, rather than prepositions for expressing adjunction, especially locative expressions. With this configuration, we account for both intransitive sentences and adverbial constructions in Dagaare.

1.3.4.2. Double object clusters.

The double object cluster descriptively illustrates cases of ditransitive constructions. Again our theory proves very much capable of handling this construction. This construction type is illustrated below in (35), with 'a gan' being the direct object and 'Dery' being the indirect.

- (35a) *O* *da* *ko* *la* *Deri* *a* *gan*
 S/he past give a.m Dery def. book
 'S/he gave Dery the book'

(35b)

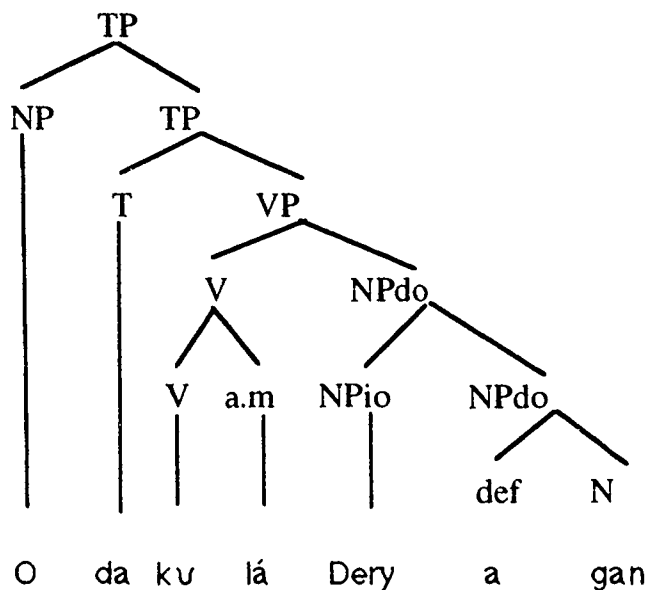

As mentioned earlier on in section 3.3.1, TAM elements are transparent to theta role assignment, so here the verb 'kill' can easily distribute its internal and external theta roles to the appropriate NPs 'O' and 'a gan' through the various TAMP particles, 'da' and 'lá' even when they move.

What we have however not accounted for is how government effect gets to the direct object. In other words how do we know which of the NPs in such a cluster is the complement and which the adjunct? (With regard to establishing an adjunct the configuration [vp VP PostP] in (34b) is also important. A theory should have means of predicting which daughter nodes are adjoined and which are complements. These questions have been well addressed in the framework of the 'group analysis' (Hellan 1988) and in the two-level framework under consideration here (Hellan 1991). To put it briefly the account has the underlying principles in (36) and (37) below.

- (36) Given two phrasal daughters A and B and their mother node M, if B and M do the same type of service, then A is recessive.
- (37) Given two phrasal daughters A and B, if A represents a function F and B represents the argument to F, and argument and value of F are of different types, then B is recessive.

Recessivity here is interpreted to mean adjunction. In the configurations below in (38), extracted from (34b) and (35b), the VP mother and daughter nodes in (41a) certainly do the same type of service while the NPdo mother and daughter nodes in (38b) do the same type of service. According to (36) then PostP and NPio are the recessives, i.e they are adjuncts in (38a) and (38b) respectively.

(38a)

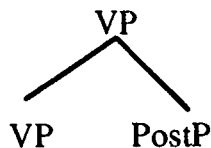

(38b)

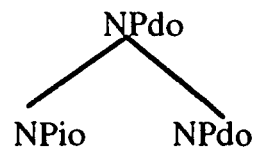

Principle (37) further confirms (38b). Since NPdo represents the direct object function, NPio will represent the argument and thereby end up being recessive i.e being the adjunct.

As pointed out in Hellan (1991), if we remove the word 'phrasal' in (37) this principle can equally account for head-complement configurations. In my opinion then we may not need a separate definition for government in this framework. Based on these principles and many of the mechanisms we have seen within this theory and the way it handles Dagaare data we can say that the two-level system has more explanatory power, and at the same time is more economical, than the three-level system.

1.4. Conclusion

In this chapter, an attempt has been made to summarise the facts of the nominal and verbal phrases of Dagaare and the other major languages in the Mabia language group. Certainly, there still remains a lot to be explored in the

nominal and verbal phrases of these languages but the most salient feature, first with respect to the nominal phrase of the group, is the noun class system. Nouns can be categorised into classes based on a pronoun concord system and/or the way they form their singular and plural forms. Secondly, with regard to the verb phrase, we found out that most of the functions are expressed by preverbal particles. We conclude then that these particles should form a prominent functional group in the verb phrase in these languages.

With the facts of the sentence at hand, we then set off to formalise the verb phrase, as this is the part of the sentence that concerns us most in this work. Our chosen model of formalisation is the two-level X-bar system as espoused in Hellan (1991), a choice based on the fact that it is both more explanatory and formally more economical (e.g we could do without one more bar) than a three-level X-bar system. The most important aspect of the formalisation was the establishment of TAMP to cater for the important role performed by the particles of the verb phrase. We conclude that functionally this is the most important aspect of the verb phrase in Mabilia.

Concerning the coverage of data we concentrated on only the canonical declarative sentence of the Dagaare language during the formalisation process. However, based on the facts presented earlier, we conclude that, just with minor adjustments, the structure of the verb phrase in the other languages of the group like Dagbane, Gurenne and Moore conform to that of Dagaare.

Not all syntactic constructions were covered. On the one hand, it would be interesting to attempt accounting for verbless sentences (or what Dakubu 1989 designates as minor sentences in Dagaare) since our basic idea is that it is the argument structure of verbs that are projected into the syntax. On the other hand, one would like to see how the theory could be extended to account for complex constructions including hypotactic and paratactic constructions. These would include, for instance, coordination, wh-constructions, ergativity and topicalisation.

In the next chapter, the grammatical facts of one type of complex constructions, SVCs, which forms the topic of the thesis, will be presented and accounted for.

Chapter 2: SVCs: Presentation, Proposed Analysis And Earlier Approaches

2.0. Introduction

This chapter is divided into three parts. In part one, the grammatical phenomenon of Serial Verb Constructions (SVCs) is introduced. A descriptive overview is then presented showing the major characteristics of the SVC data to be used throughout the thesis, especially with reference to Dagaare and other Mabia language data.

This paves the way for issues of analysis and formalisation to be discussed in part two. We present our initial account here. First, we propose ways for a formal representation SVCs on X-bar trees, following Hellan (1991). We then propose a quite novel way of theta role assignment, which we term corporate theta assignment.

Part three concludes this chapter with a comparison of our new proposals with those of earlier approaches such as Baker (1989) and Lefebvre (1991).

2.1. Part One: A Presentation Of SVCs

In this part we present a descriptive overview of the phenomenon of Serial Verb Constructions (SVCs) as it occurs in Dagaare and other Mabia languages of West Africa. We begin with a general introduction of the concept, explaining the terms that have been used for it, giving a brief history of its analysis, and stating the geographical distribution of the phenomenon among languages of the world. Following this we begin to describe the phenomenon. With examples from the Mabia and other languages of West Africa we state systematically most, if not all, of the issues that go to explain the facts of the phenomenon, distinguishing it from other similar syntactic constructions. When all the constraints are applied we arrive at a usefully restrictive and well-defined view of the phenomenon.

2.1.1. The Concept and its Geographical Distribution

2.1.1.1. The Concept

Ever since Christaller observed the presence of Serial Verb Constructions (SVCs) in his (1875) pedagogical grammar of the Akan language, the phenomenon has grown to become one of the most topical issues in African linguistics. Together with concepts like ideophones and vowel harmony, SVCs constitute a core topic in the structural analysis of a great number of African

languages. Indeed, it has been described as "perhaps the most interesting of the grammatical phenomena from a general typological point of view" in these languages (Stewart 1971). When we talk of serial verb constructions we generally refer to a grammatical concept involving a series of different verbs and their arguments occurring within the borders of what seems to be a monoclausal construction. The following Dagaare, Akan and Yoruba sentences in (1), (2) and (3) respectively illustrate the concept.

- (1a) *Ayuo da di la a bie zigi*
 Ayuo past take a.m def. child seat
 'Ayuo seated the child'
- (1b) **Ayuo da di la a bie da zigi*
 Ayuo past take a.m def. child past seat
 'Ayuo seated the child'
- (2a) *Kofi tɔɔ nsuo numvi*
 Kofi buy+past water drink+past
 'Kofi bought water and drank it'
- (2b) **Kofi tɔɔ nsuo numvi nu*
 Kofi bought water drank it
 'Kofi bought water and drank it'
- (3a) *Olu gbe aso wo*
 Olu took dress wore
 'Olu put on some clothes'
- (3b) **Olu gbe aso Olu wo aso*
 Olu took dress Olu wore dress
 'Olu put on some clothes'

All the sentences above involve two different lexical verbs. They seem to share close grammatical relations. An obvious one is temporal markers. Both verbs must 'share' or be within the scope of one temporal marker for those languages that have these markers. This is exemplified in (1a) for Dagaare. Sentence (1b) is ungrammatical because there is an undesirable copy of the past tense marker.

Another fact within these constructions is that even though the V2's - 'zigli', 'numui' and 'wo' are two place predicates, they do not have direct object NPs coming after them. That is why (2b) and (3b) are ungrammatical. On the contrary, these V2's must share a direct object with V1. In (1), 'take' and 'seat' share the object 'child'. In (2) 'buy' and 'drink' share 'water'. So the postverbal object pronoun in (2b) which is co-referential with 'water' is unnecessary, making the sentence ungrammatical. As will be addressed later, this object constraint raises serious problems for the Projection Principle (Chomsky 1981) and its counterparts in most other grammatical theories.

A third fact about the SVCs above is that the various verbs are in the scope of one structural subject. In other words, they share a single subject. So, (3b) is ungrammatical not only because of the undesirable occurrence of a post V2 object but also because of the extra occurrence of subject NP, Olu, before the V2.

The surface configuration in (4) (from Awoyale 1988) is indicative of SVCs

(4) NP INFL/AUX [_{VP} V' V' ...]

The heads under the various V's therefore seem to share just one subject NP and one INFL/Aux node. The whole construction then is seen as a single clause.

These are just some of the grammatical characterisations of the concept of SVCs. We must however mention that not all serialising languages manifest the same kind of grammatical constraints, nor do all kinds of serialisation have the same characteristics. In section 2.1.2, we outline constraints peculiar to the kind of serialisation within the Mabia languages that will constitute our data in this thesis.

2.1.1.2. Geographical distribution

The phenomenon has been observed in four main language areas of the world. The first group involves West African languages, especially of the Kwa and Gur sub-groups. So far, most of the major accounts are done with material from Kwa languages such as Akan, Ewe and Yoruba, and it is one of the aims of this thesis to contribute to the debate with data from a group of languages within the Gur language family.

The next major language group where SVCs have been observed is African-Caribbean creoles. These languages are spoken mainly in the Caribbean islands but they have some striking typological similarities with the languages of West Africa, one of them being, of course, SVCs.

The languages of South East Asia constitute the third group of serialising languages. The concept has been observed in languages such as Chinese (Li 1991), Khmer (Schiller 1990) and Thai (in this work).

The fourth group includes Oceanic, i.e the Pacific and Papuan languages such as Kallam and Alambak.

Of late, attempts, such as Pullum (1990), have been made to glean the concept in traditionally non-serialising languages such as English. The argument is often made that deictic serialisation, a kind of SVC involving a directional verb at the beginning as shown in (5) occurs in American English.

(5a) Go get it

However, this is very unproductive in the language. More over, the two verbs in this often cited example cannot share NP subjects and Aux nodes as shown in (5b) and (5c)

(5b) *I go get it

(5c) *I will go get it

In our opinion therefore serialisation does not occur in English or any of the Indo-European languages, at least, in the same productive way as it occurs in the languages mentioned above¹. In this thesis, the term 'serialising languages' will be used to refer to such languages while 'non-serialising languages' will refer to all other languages even if such languages may have the restrictive case of deictic serialisation.

Having now delineated the concept let us see how it manifests itself in some languages of West Africa.

2.1.2. Constraints on Serialisation in Mabia

¹Scandinavian constructions such as :

Ta og kaste stein

take and throw stone

'Take a stone and throw it'

and

Gå og kjøpe billett

Go and buy ticket

'Go and buy a ticket'

may have a semantics which is similar to that of some types of serial verb constructions.

In this section we discuss in greater detail the characteristics of SVCs, some of which were outlined in section 2.1.1. We claim that with just five grammatical categories SUBJECT, OBJECT, TAMP, PREDICATE and CONNECTOR², we are able to describe most of the intricate structural and semantic properties of SVCs that we saw previously in a straight -forward way. Our discussion will have in mind the SVCs as they occur in the Mabia languages under consideration here.

2.1.2.1. The Subjecthood constraint.

The constraint here revolves around the grammatical category SUBJECT. In section 2.1.1.1, it was mentioned that the various verbs share the same subject. This is so in most of the SVCs of the Mabia languages. We term this condition on SVCs in Mabia as the 'subject sameness constraint', defined in (6).

(6) Subject sameness constraint:

A construction c satisfies the subject sameness constraint iff all the lexical verbs in c share the same structural subject

This structural subject usually serves as the external argument, both singularly and jointly, to all the verbs in the series. This is illustrated in (7) below where 'Ayuo' serves as the external argument for as many as four verbs viz: *zo*, *gaa*, *wuo*, and *di* i.e if each verb were to head a clause by itself, 'Ayuo' could be subject in all of the clauses with a semantic function similar to what she is understood to have relative to each verb in (7).

(7) *Ayuo da zo gaa wuo la haani di*
 Ayuo past run go collect a.m blackberries eat
 'Ayuo ran & went & collected blackberries & ate them'

Of course this constraint in itself does not distinguish SVCs from all other constructions. What it does is to distinguish SVCs from constructions such as canonical coordination and subordination where different arguments can act as the subject.

2.1.2.2. TAMP constraints

²Dalrymple (1990) and other analyses within the LFG framework have used a similar approach to characterise anaphoric binding

It has been established in Chapter 1 that one of the most important functional categories in the Mabia sentence is the TAMP node which contains temporal, aspectual, modality and polarity markers within the VP much more like the IP or AUX category in other languages. The constraints here revolve around the TAMP node. All the verbs must be within the scope of one single TAMP node. We state this constraint as in (8)

(8) The TAMP constraint:

For any construction c to pass as an SVC, all the different verbs in c must be in the scope of one TAMP node.

We shall consider the various items under this node in the various languages to illustrate the constraints in this filter.

2.1.2.2.1. Tense particle constraint

Mabia languages express tense not by the use of auxiliary verbs as, for instance, Romance and Germanic languages do, but by the use of preverbal temporal particles. A list of these particles has already been provided in Chapter 1. All the verbs in a Mabia SVC must be within the scope of just one particle. This has already been illustrated with the Dagaare SVC in (1). We further illustrate this constraint with the following Mampruli and Moore structures in (9) and (10) respectively.

(9a) *O da dug la sinkaafa ŋmɔbi*
 He past boil a.m rice eat
 'He boiled some rice and ate it'

(9b) **O da dug la sinkaafa da ŋmɔbi*
 He past boil a.m rice past eat
 'He boiled some rice and ate it'

(10a) *O sa duka mui di*
 He yesterday boil rice eat
 'Yesterday he boiled some rice and ate it'

(10b) **O sa duka mui na di*
 He yesterday boil rice fut eat
 'Yesterday, he boiled some rice and ate it'

In (9a) and (10a) the constructions are acceptable because the verbs share the temporal markers 'da' and 'sa' respectively. Their counterparts in (9b) and (10b) are, however, unacceptable because each verb seems to have its own temporal particle. Further still, in the case of (10b) while V1 is in the scope of a present tense particle, V2 is in the scope of a future tense particle.

2.1.2.2.2. Aspectual affix constraint

Aspectual suffixes form a very important constraint within Mabilia SVCs. In these languages verbs are either in a perfective or an imperfective aspect, where the action is regarded as completed or not completed respectively. The constraint here is that verbs in an SVC must be in the same aspect.

Consider the following Dagaare sentences in (11). In (11a) all the verbs are in the perfective aspect. The actions within this time period are considered complete.

- (11a) *Ba zo gaa di la bundiri*
 They ran went eat a.m food
 'They ran there and ate food'

In (11b) on the other hand the actions are considered not complete at the time of conceptualisation. They are ongoing, whether repetitively or habitually.

- (11b) *Ba zoro gere dire la bundiri*
 They running going eating a.m food
 'They run there and eat food (repeatedly)'

In (12), however, the two verbs are not in the same aspect. They are not having uniform aspectual suffixes and do not therefore respect the aspectual affix constraint. That is why the sentences are ungrammatical.

- (12a) **Ba zo gere la*
 They ran going a.m
 'They ran there'

- (12b) **Ba zoro gaa la*
 They running went a.m
 'They ran there'

It is, however, possible for some constructions in Dagaare to violate the aspectual affix constraint of SVCs and yet remain grammatical. This is illustrated by (13).

- (13) *Ba zo gaa dire la*
 They ran went eating a.m.
 ' They ran there and they are now eating'

These constructions share a lot of grammatical features with SVCs but they have different semantics. Unlike SVCs, the actions encoded by the verbs in these constructions are not conceptually cohesive. They are performed at different time periods and are not therefore within the same event. In short, they do not share the eventhood constraint (to be explained subsequently) of the constructions discussed in this thesis. They are therefore not SVCs or at best they are only a different type of verb serialisation in Dagaare.

2.1.2.2.3. The Modality Constraint

Verbs within an SVCs must also be in the scope of just one modality particle. This is illustrated in (14)

- (14a) *Te maŋ zoro gɛrɛ la*
 We always running going a.m
 ' We are always running there'
- (14b) **Te maŋ zoro maŋ gɛrɛ la*
 We always running always going a.m
 ' We are always running there'

In (14a) both verbs share the modality particle, thereby obeying the TAMP constraint with respect to modality but in (14b) they do not. The second verb is in the scope of a copy of the modality particle and is therefore ungrammatical. It is important to specify here that in this and other examples, by the expression 'be in the scope of X' we mean 'syntactically c-commanded by X', as opposed to the weaker case, where all verbs are semantically in the scope of the same marker, which could however be repeated syntactically.

2.1.2.2.4. The Polarity constraint

Consider the following Norwegian and Dagaare declarative sentences in (15) and (16) respectively:

- (15a) *Kåre elsker Kari*
 Kåre love+3.pers.pres. Kari
 'Kåre loves Kari'
- (15b) *Kåre elsker ikke Kari*
 Kåre loves not Kari
 'Kåre does not love Kari'

While the negative declarative sentence in (15b) is appropriately marked with a negative polarity particle, in (15a) the absence of a polarity particle shows that the sentence is a positive declarative sentence. In the Dagaare constructions, on the other hand, all declarative sentences must be marked for polarity. This is illustrated in (16a) where the sentence is marked for positivity with the particle, 'la' and in (16b) where it is marked for negativity with the particle, 'ba'.

- (16a) *Dorsaa buɔɔ la Pogsaa*
 Dorsaa loves a.m Pogsaa
 'Dorsaa loves Pogsaa'
- (16b) *Dorsaa ba buɔɔ Pogsaa*
 Dorsaa not loves Pogsaa
 'Dorsaa does not love Pogsaa'

Once this grammatical difference is explained we can now illustrate clearly the polarity constraint. All the verbs within the SVC must be within the scope of just a single polarity marker, whether positive or negative. Consider the following positive and negative Dagaare declarative sentences in (17) and (18) respectively.

- (17a) *Pogsaa di la a bie zigi*
 Pogsaa take a.m the child seat
 'Pogsaa seated the child'
- (17b) ** Pogsaa di la a bie zigi la*
 Pogsaa take a.m the child seat a.m
 'Pogsaa seated the child'
- (18a) *Bayɔɔ ba kyir kuɔ waar Ayɔɔ*

Bayor not pour water wet Ayor
'Bayor did not pour water on Ayor'

- (18b) * Bayɔɔ ba kyirkɔɔ ba waar Ayɔɔ
Bayor not pour water not wet Ayor
'Bayor did not pour water on Ayor'

The (a) sentences are acceptable while the (b) ones are not. This is because in the former both verbs share or are in the scope of the polarity particle while in the latter they are not. Hence, here too the polarity constraint must be passed before the sentence is grammatical.

Together these TAMP constraints illustrated in this section explain one of the major differences between serialisation in the Mabia language group and that of other groups such as the Kwa where SVCs in languages such as Akan and Ewe may not have a single TAMP (or in their case AUX) node .

2.1.2.3. The Connector Constraint

The use of the term 'connector' here is meant to include any linguistic item that connects or conjoins two predicate items in various degrees, be it coordination, subjunction or complementation.

The connector constraint can be stated in (19) as follows:

- (19) The connector constraint:
If a construction c is a well-formed SVC, then there exists no connector y such that y intervenes between the row of verbs in c

This constraint underlies one of the most important distinctive characteristics on SVCs in the Mabia languages. There is a tendency in the literature to classify SVCs into 'coordinating' and 'subordinating' SVCs (e.g Sebba 1987; Schiller 1990) or 'linking' and 'modifying' SVCs (Bamgbose) solely based on their surface structures. Still, in an attempt to conform to this 'bi-modular' division, SVCs have often been interpreted as 'coordinations with conjunctions suppressed' (Bamgbose 1974) or as 'embedded purpose or result clauses with complementizers suppressed' (Awobuluyi 1973).

However, it looks as if this distinction is not possible or at least difficult to make in the Mabia SVCs. On the contrary there seems to be a systematic difference in interpretation between SVCs (without connectors) and coordinated

constructions on the one hand and subordinated constructions on the other. We illustrate here how the native speakers conceive of constructions with or without conjunctions. We do this with examples from three Mabia languages, Dagaare, Moore and Mampruli. Schiller (1991) cites the following Moore example (20) as a case of coordinating serial verb construction, the reason being that an optional conjunction is inserted. In fact his syntactic description of this type of serial verb constructions is that they are coordinate structures with null conjunctions, reminding us of the above treatment of SVCs (Bangbose 1974) as coordinations with conjunctions suppressed.

- (20) *a iku suuga n wag nɛmɔda*
 S/he took knife CM cut meat
 'He cut the meat with a knife'

What is important to note is that a closer elicitation of field work material shows that, at least, in the Mabia languages there is a direct relationship between the presence or absence of surface conjunctions and the way the sentences are conceived of in the minds of native speakers. The absence of conjunctions or other connectors more than often made the speakers to interpret the actions underlying the various verbs as more tightly related. On the other hand, however, the actions were regarded as more loosely related with the presence of connectors in the constructions. Consider the following Dagaare, Moore and Mampruli constructions in (21), (22) and (23) respectively:

- (21a) *O di la suɔ ŋmaa nɛn ɔɔ*
 S/he take a.m knife cut meat eat
 'He cut meat with a knife and ate it'
- (21b) *O di la suɔ, a ŋmaa nɛn, a ɔɔ*
 S/he take a.m knife, and cut meat and eat
 'He took a knife, cut meat, and then ate it'
- (21c) *Bayuo ŋmɛ la Ayuo ɔɔ*
 Bayuo beat a.m Ayuo fall
 'Bayuo knocked Ayuo down'
- (21d) ?*Bayuo ŋmɛ la Ayuo, a ɔɔ*
 Bayuo beat a.m Ayuo and fell

'Bayuo knocked Ayuo and fell ner'

- (22a) *I ti tigis taaman n di*
Let us pick sheafruits and eat
'Lets us and go collect sheafruits and then eat them'
- (22b) *O sa duka mui di*
S/he yesterday boiled rice ate
'Yesterday he boiled some rice and ate it.'
- (22c) * *O sa duka mui n di*
S/he yesterday boiled rice and ate
'Yesterday he boiled some rice and ate it.'
- (23a) *O dug la sinkaafa ŋmɔbi*
S/he boiled a.m rice ate
'S/he boiled rice and it '
- (23b) *O dug la sinkaafa n ŋmɔbi*
S/he boiled a.m rice and ate
'S/he boiled rice and then ate it'

There is an almost consistent interpretation among native speakers of the various languages that the actions evoked by those constructions (21 - 23) without a conjunction in them are more tightly related than actions evoked by those with a conjunction. In other words, in the examples without conjunctions the speaker intends to conceive of the actions s/he expresses through these verbs as a single event while those expressed with the conjunction would preferably be treated as being separate, sequential events.

What is more, it is not always the case that in such constructions in the various Mabia languages, one has the option of leaving out the conjunction. In the Dagaare examples in (21) the c. example is grammatical while the d. is awkward because of the insertion of the conjunction. The case is even clearer in Mampruli examples below in (24) where some speakers discard (24a) outright (even though some only doubt it, saying it depends on the context). Majority of speakers however had no problem with the acceptability of the conjoined counterpart in (24b).

- (24a) * (?) *M ba da la kparigu ti ma*
 My father buy a.m shirt give me
 'My father bought a shirt for me'
- (24b) *M ba da la kparigu n ti ma*
 My father buy a.m shirt and give me
 'My father bought a shirt for me'

It would seem to me then that Schiller's attempt to use conjunction optionality fails to distinguish his so called coordinate constructions from other types of SVCs. Indeed his own analysis in which he talks of the 'unsunderability condition', defined below in (25),

- (25) The unsunderability condition:
No conjunctive particle can appear in , or be inserted between , the serialised constituents without altering the meaning of the sentence.

contradicts this position and instead lends support to the importance of our connector constraint in distinguishing between SVC proper and other types of apparent verb serialisation .

The connector constraint seems then to be an important one as it enables us to distinguish between SVC proper and those serial constructions with what may be called the serialising connective³. It is also an important constraint as it helps elucidate the important view of serialisation as expressing one unitary event.

2.1.2.4. The Object Constraint

The object constraint is one of the most discussed in the literature. For Baker (1989) it is not only possible for verbs in the serial construction to share objects, it is even necessary if certain principles within the GB framework that he writes in must be satisfied.

We take a similar position and state our object sharing constraint as follows in (26):

- (26) The object sharing constraint:
-

³ Ameka (personal communication) reports of cases in Oceanic languages (and probably other languages ?) where some types of 'serial' constructions may be said to have elements which may indeed be interpreted as 'connectives', thus his use of the term 'serialising connectives'.

For a construction c to be a well-formed SVC, if there are two or more polyadic verbs, then all these must share the syntactic realisation of their direct internal arguments,

Consider the following Dagaare sentences in (27). The verb 'kV' is a dyadic verb. It is represented as such in the lexicon where its argument structure must show both Agent and Theme or external and internal arguments.

However, in (27a) where this lexical argument structure is violated ('kV' does not seem to have an object), the sentence is acceptable. It is rather not acceptable where it is respected. A closer look will show that the object sharing constraint has been violated and that every thing falls in place when it is respected, because 'kV' will be assigned an object by sharing Ayuo with the verb 'ŋmε'.

(27a) *Bayuo ŋmε la Ayuo kV*
 Bayuo beat a.m. Ayuo kill
 Bayuo beat Ayuo to death

(27b) * *Bayuo ŋmε la Ayuo kV Ayuo*
 Bayuo beat a.m Ayuo kill Ayuo
 'Bayuo beat Ayuo to death'

(27c) * *Bayuo ŋmε la Ayuo kV o*
 Bayuo beat a.m Ayuo kill her
 Bayuo beat Ayuo to death

Sebba (1987) differentiates between coordinating serialisation and subordinating serialisation on the basis of whether the object is shared or not. The following Sranan constructions in (28) illustrate this differentiation.

(28a) *Kofi naki Amba kiri en* : 'coordinating SVC'
 'Kofi struck Amba and killed her'

(28b) *Kofi naki Amba kiri* : 'subordinating SVC'
 'Kofi struck Amba dead'

However this distinction is not possible in Mabia as the above constructions in (27) indicate. When the object sharing constraint as stated above is not followed then the sentence is ungrammatical.

Evidence supporting this constraint comes from Chinese according to Chang (1990:292). She gives a good treatment of this constraint with examples from Chinese. According to her when nouns refer to the same thing one of them can and tends to be deleted for the sake of economy. That is why in her opinion it is clumsy and redundant to repeat the second noun *cai* in (29) if we are to give it the second reading in (29a), what she calls the 'subordinate and temporal sequence' reading.

(29a) *Ta zhong cai mai4 cai*
 He plant vegetable sell vegetable
 'He plants vegetables and sells vegetables'
 'He plants vegetables to sell'

(29b) *Ta zhong cai | mai4 e |*
 He plant vegetable sell
 'He plants vegetables to sell'

Like the preceding constraints, the object constraint also helps to give verb serialisation a distinctive characteristics.

2.1.2.5. The Predicate Constraint

This is by far the most controversial aspect of verb serialisation and addresses one of the major issues mentioned above: how verb order is determined in the clause, if at all it is a single clause, and the importance of this for the meaning of the SVC. We state our predicate constraint as follows in (30), which we claim captures some very important restrictions making useful distinctions between SVCs and similar constructions.

(30) The predicate constraint:
A construction c is an SVC if two or more different finite verbs occur monoclausally, selecting each other in such a way that together they express a single event.

By insisting on the fact that it should be different verbs that follow each other in the clause, we eliminate the following reduplicated constructions in (31).

(31a) *O da tuur tuur la taŋma*
 S/he PAST pick pick a.m sheafruits
 "S/he picked sheafruits (many times/a lot)"

- (31b) *O da di di la taŋma*
 S/he past eat eat a.m sheafruits
 S/he ate sheafruits (many times/a lot)

These constructions are often employed in serialising languages to express emphasis or repetition of the action.

It is important to note in passing however that reduplication can even occur in serialisation as shown below in (32):

- (32) *O da tuur tuur la taŋma di di*
 S/he past pick pick a.m sheafruits eat eat
 S/he picked and ate sheafruits (many times/ a lot).

In the example above the verbs 'pick' and 'eat' are both serialised and reduplicated.

By insisting on the finite nature of verbs this constraint also distinguishes between SVCs and infinitival constructions of non-serialising languages. Further still it prevents SVCs from being interpreted as adverbial, prepositional or adjectival predicates (Lord 73) or even pseudocomplementation (Seuren 1990), at least syntactically because these verbs have full inflections and tonal changes where these inflections are not observable.

These facts of SVCs as being distinct from infinitival constructions of non-serialising languages, etc. together with facts originating from TAMP and other constraints go to show that SVCs are monoclausal. The issues of verb ordering and of NP placement are taken up more comprehensively in the accounts of SVCs proposed in the next two chapters.

2.1.3. Conclusion for Part One

In this part, the grammatical concept of verb serialisation has been introduced. It has been shown to be a productive grammatical phenomenon, especially in the languages of West Africa but also in other parts of the world such as the languages of South East Asia, the creole languages of the Caribbean islands and the Oceanic languages.

After giving a brief indication of the grammatical features of SVCs in section 2.1.1, we set off in section 2.1.2 to describe the grammatical features of SVCs in the Mabia languages of West Africa more closely. Based on five grammatical categories - Subject, TAMP, Connector, Object and Predicate - we were able to develop five constraints to show how the various categories in the

SVC are patterned together. Having explained all the constraints built around the five grammatical functional categories, we can summarise them as follows in (33).:

(33) A construction *c* is an SVC iff:

all the different lexical verbs in c share the same structural subject and are in the scope of a single TAMP node with no connector y such that y intervenes between the row of verbs in c. All these different verbs, if polyadic, must share their direct internal arguments and must, in-addition, occur monoclausally, selecting each other in such a way that together they express a single event.

In other words, a construction *c* is an SVC iff it satisfies.

the subject sameness constraint,
the TAMP constraint,
the connector constraint,
the object constraint and
the predicate constraint.

Based on these constraints we now conclude that, syntactically, SVCs are constructions in which two or more verbs share arguments and temporal particles without intervening connectors.

We also gave indications of their semantic properties of expressing single, albeit complex events. We shall maintain throughout our thesis that the various verbs in the SVC together form a single semantic unit - a complex predicate. Functionally this semantic unit expresses single events in real world situations.

In the next part of this chapter and in Chapter 3, we take these syntactic and semantic issues of SVCs into more detail. We develop accounts for the syntactic issues described and concentrate more on the eventhood of SVC, proposing a model of event structure.

2.2. Part Two: The Present Account.

Having given a descriptive overview of Serial Verb Constructions (SVCs) in Part One, we shall in this part introduce our initial account of the structure of SVCs. Our approach assumes the thesis that the various verbs in an SVC form a complex predicate and that functionally, this complex predicate expresses just one (complex) event in real world situations. Further, we assume a grammar

design in which our data, the serial constructions, have simultaneous access to all levels of representation in the grammar. Complex predicate formation therefore involves an interaction of all levels of the grammar. This simultaneous accessibility of information at all levels enables us to concentrate on analysing SVCs at surface structure without recourse to any derivational mechanisms. In terms of formal X-bar representation, we adopt a two-level X-bar formalism, following Hellan (1991).

2.2.1. A Two-level X-bar Syntax

Characteristics of the two-level approach, employed in Chapter 1, include the following: Unlike the standard GB version, it has only two X-bar levels as the name indicates. Further, it has essentially binary branching configurations, indeed only two types, as shown below in (34). The figure in (34a) is indicative of complementation while that in (34b) is adjunction.

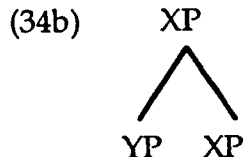
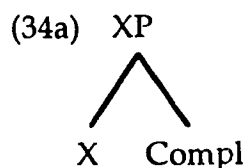

We shall maintain these configurations as our approach to phrase structure, giving specific explanations later as we adapt them to suit the structure of SVCs.

2.2.1.1. The Interpretation of a complex predicate.

We recall here the basic structure of the particular type of SVCs we discuss in this work. Consider the Dagaare sentence below in (35), which contains two lexical verbs.

- (35) *Ayuo da di lá a bie zigi*
 Ayuo past take a.m def child seat
 'Ayuo seated the child'

Both have the NP 'Ayuo' as subject, NP 'a bie' as object and share or are in the scope of the grammatical particles 'da' and 'lá'. All this conforms with the constraints on serialisation we established for the Mabia languages in part one. These are summarised below in (36).

- (36) Constraints on serialisation in Mabia:
 i. **The subject sameness constraint:** All the verbs in an SVC must share a single structural subject or its referent thereof.

- ii. **The TAMP constraint:** In an SVC there is only a single TAM node.
- iii. **The connector constraint:** There is an absence of conjunctions or complementizers within the string of verbs.
- iv. **The object sharing constraint:** Dyadic verbs must share direct internal arguments.
- v. **The Predicate constraint:** Verbs expressing the same type of event occur together

From the above we could just summarise that SVCs are constructions composed of two or more verbs sharing arguments and other grammatical properties within the borders of a single clause. This is what we call a complex predicate (a complex predicate being defined, generally, as two or more predicates sharing a common subject and within the same clause) .

The normal interpretation of the sentence (35) for most native speakers of Dagaare is that the actions represented by the two verbs in the sentence are so tightly and intimately related that they can be regarded as constituting a single event⁴ (where a single event can roughly be defined as a unitary event taking place in time and space). This is in line with our discussion about the eventhood of SVCs in part one. Functionally, then, these constructions express a unitary semantic entity, an event.

Having now recalled the basic structure and functions of our data which form the basis of our thesis we move on to illustrate how these complex predicates may be represented at surface syntactic structure within the phrase structure assumed above.

2.2.1.2. SVCs at Surface Structure.

In line with our approach to the formal representation of SVCs where we assume a simultaneous interaction of all levels of the grammar, we shall go ahead to consider the basic SVC strings at surface structure without any recourse to a derivational interpretation of this structure. To illustrate how SVCs are handled within our assumed phrase structure, consider the following quite lengthy Dagaare SVC and its structural representation in (37).

- (37a) O da zo wa ŋmɛ la a boi pur baar.
 inception root resultative
 S/he past run come kick a.m the ball burst finish
 'S/he has finished coming to kick the ball flat'

⁴Event originates from the Latin verb: 'evenire', meaning 'to happen'

(37b)

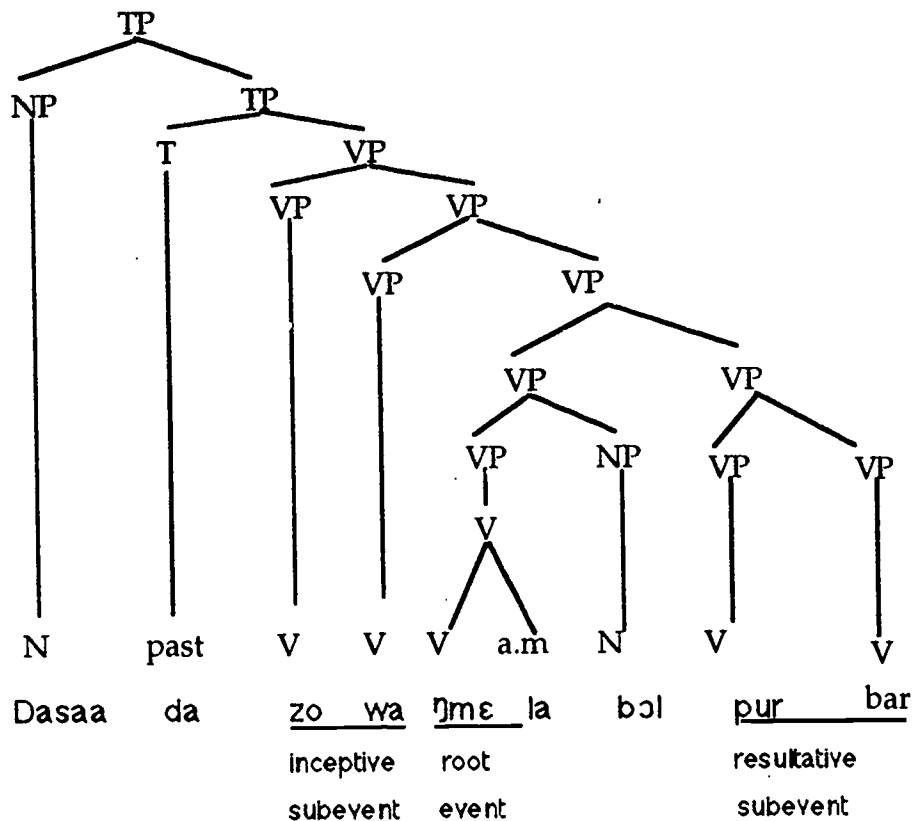

(37c)

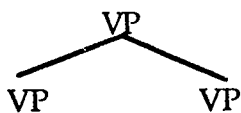

The diagram (37b) shows how as many as five verbs within an SVC can be structurally represented with the two-level X-bar approach. In addition, we show how each of the verbs (or groups of verbs) functionally express various parts of a complex event (to be explained in Chapter 3). The configuration of these tree structures was explained in chapter 1. We do, however, need to show how they accommodate SVCs. The basic characteristics include the following: They are essentially binary branching, (as can be seen, unlike the Baker and the Lefebvre diagrams to be seen in part three, there is no intermediate X-bar level, X': we do with just two projection levels i.e. single V's projecting into just one maximal projection, VP). Of course, each of the VP projections are iterative. The TAMP we mentioned is also present at this level with two of its items, the past tense marker 'da' and the affirmative marker (a.m) 'lá'.

Constraints on 'la' distribution still hold, as discussed in chapter 1. In addition to that, we can add the following stipulations on how it is distributed in a multi-verbal configuration. In a group of monadic, dyadic and triadic verbs, 'la' occurs after the first dyadic verb as shown above (it comes after 'ŋmε'). The second stipulation is that, with only monadic verbs it comes after all the verbs in the construction.

The configuration in (37c), which is a recurrent constellation throughout (37b), is our adaptation of the adjunction construction in (34b) to accommodate the iterative nature of SVCs. In our SVC representation, each time we come up to a new V, we treat it as a VP *adjoined* to the earlier VP. In taking such an approach, we provide our answer to one of the basic questions often posed in the literature on SVCs (e.g. Larson 1991. p186): whether serialisation structure is basically coordination, adjunction or complementation. Our main reason to let each V of an SVC be dominated by its own VP is that any V in a sequence, subject to the principle of corporate theta role assignment, to be mentioned shortly below, can have an NP complement. Hence structurally speaking, the 'cells' of an SVC are VPs.

2.2.2. Corporate Theta Role Assignment.

Having shown how our data can be represented on our chosen phrase structure, we now begin to show how grammatical information may be processed on the trees. In particular, we consider theta role assignment. An SVC being a complex predicate, syntactic information is therefore processed with respect to the various verbs as if they were a single lexical item. For instance, they will perform theta role assignment, in part, as if they were a single verb. The following principle can be posited to cater for this state of affairs:

(38) The principle of corporate theta role assignment:

Partners in a complex predicate select competent members in a syntactically appropriate environment to perform theta role assignment on behalf of the complex.

This statement needs an explanation. The first criterion for selecting a member to perform a theta assignment job on behalf of the group is that the member must be 'competent' to do it. Consider the following Dagaare construction:

(39) Ayuo kyεŋ gaa da lá nen ɔɔ
 Ayuo walk go buy a.m. meat eat

'Ayuo went (by walking) & bought meat & ate it'

In this sentence, all of the four verbs can release an 'agent' role, however only two, 'buy' and 'eat', can discharge a 'theme' role. To illustrate the 'competence criterion', in negotiating who will do agent role assignment all the verbs will be considered. But on the issue of 'theme' assignment only 'buy' and 'eat' are competent and so only they will be considered.

The second criterion is that the delegate member must be in the 'appropriate' syntactic environment. By this is meant that it must be as near as possible to the NP to be licensed (and in fact, there is a tendency on the part of NPs to be as near as possible to their thematic benefactors). An environment is appropriate also only if no word order parameter is contravened. To illustrate the above, all the four verbs need to discharge an 'agent' role on the NP 'Ayuo' but only 'walk' can do it with the least minimum cost as it is the one that is nearest it. So all the members in the complex 'agree' on 'walk' as the representative agent assigner. For the business of theme assignment, of the two competent members for the job, 'buy' is in the more appropriate environment as it is reasonably near to the NP 'meat' and as it assigns the theme role rightwards on to the NP. (The verb 'sell' would undesirably assign 'theme' leftwards).

Hence, to do theta role assignment on behalf of the group, a member must:

- i. be inherently competent to do it and
- ii. be able to do it with minimum cost.

In effect, then, the principle of corporate theta role assignment can be regarded as a minimalist concern in grammar construction (Chomsky 1992) for it ensures an optimal use of linguistic resources. In order for (38) to serve as an operative principle, one additional requirement is needed, implicit in what we have now said, namely that of all potentially competent role assigners, the first one is the one to be chosen. With this stipulation, the distribution of NPs follows from the corporate principle in the way just illustrated.

Having now explained the principle of corporate theta role assignment as formulated in (38) with (39) above, we begin to demonstrate theta role assignment on our phrase structure diagrams. The diagram in (40) then illustrates our proposal to theta role assignment.

(40)

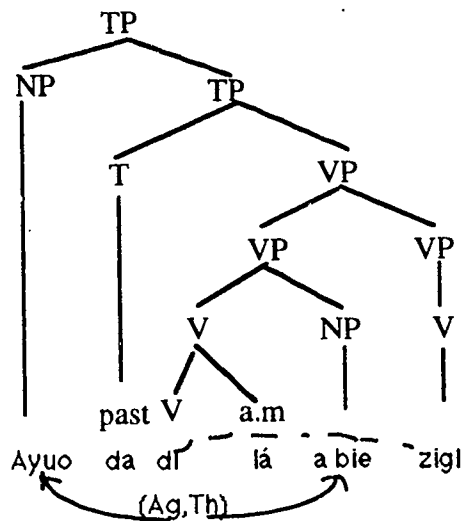

The dotted line linking the two lexical verbs represents the circumstance that we are dealing with a single complex predicate which manifests itself discontinuously at the syntactic level, with the common maximal projection of the two verbs making up this complex predicate being the topmost VP.

The presence of the dotted line, though not part of the analytical machinery, always sets the scene for corporate theta role assignment by reflecting the complex predicate. Applying the principle in (38), the two lexical verbs will 'decide', as illustrated above, which of them is in a syntactically appropriate position to do canonical theta role assignment. This happens to be the verb 'take' in this diagram. So it takes up this assignment on behalf of the whole complex and assigns agent and theme roles to the appropriate NPs in the configuration. The arrows in the above diagram illustrate this clearly.

Through this account, the complementation properties of the two lexical verbs are satisfied *in a single operation* and both 'take' and 'seat' license agent and theme NPs at this level of the grammar. Through conceiving the complex as a single theta assigner, the projection principle as posited in Chomsky (1981) - (see part three) would be well adhered to. Furthermore, in our proposal, the theta criterion (also in part three) would be adhered to since each of the NP arguments bears one and only one theta role, and each of the agent and theme roles is assigned to one and only one NP argument.

To further extend the theoretical point, we apply our new techniques of SVC representation to serial constructions with adverbials and more than one object.

2.2.2.1. Serial Verbs, Adverbials and Double Object Clusters.

So far, our data has accounted for SVCs involving up to only one internal argument, i.e. cases of intransitive and monotransitive serialisation. In this section we extend our data to examine cases in which adjuncts and more than one internal argument may be part of the SVC.

2.2.2.1.1. Serial Verb Adverbials.

Consider the Dagaare data below in (41). In (41a) we have a case of SVCs involving two intransitive verbs, followed by a locative expression. This involves a classical case of Serial Verb Adverbials (SVA), even though SVAs can occur with transitive verbs. Unlike objects, locative expressions cannot intervene between the verbs. This makes (41b) ungrammatical. Their canonical position then is post verbal, as shown in (41a).

(41a) *Bayuo da gbir gaŋ lá a seŋ puɔ*
 Bayuo past sleep lie a.m art mat loc.
 'Bayuo lay asleep inside the mat'

(41b) **Bayuo da gbir lá a seŋ puɔ gaŋ*
 Bayuo past sleep a.m art mat loc. lie
 'Bayuo lay asleep inside the mat'

(41c)

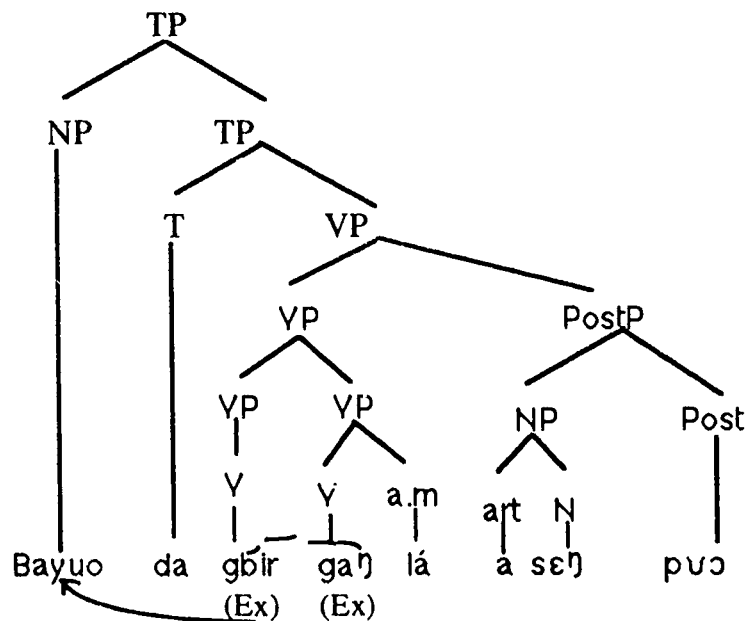

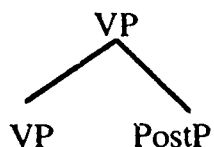

The diagram in (41c) shows how we can represent SVAs on our two-level formalism. Corporate theta role assignment is indicated as usual, showing how the two verbs share or theta mark the same subject NP. While it could also be argued that theta role assignment occurs inside PostP with the postposition theta marking its complement NP, what is left unaccounted for is the adverbial relation existing between the PostP and the VP. One possibility is to simply state that since the verbs are intransitives the PostP cannot form part of their argument structure, as such there could only be some kind of relation such as adverbial between them. This does not however define properly an adverbial relation between the two projections.

As was observed in chapter 1, the two-level X-bar system has a ready-made mechanism for handling adverbials and adjunction, in general, and this could apply to explain the SVA facts under consideration here. The principle in (36) of chapter 1, restated below as (42) is one of two principles developed in Hellan (1991) to handle in a more predictive way cases of adjunction.

- (42) Given two phrasal daughters A and B and their mother node M, if B and M do the same type of service, then A is recessive.

The diagram above in (41d) extracted from (41c) will illustrate this principle. If the PostP, the daughter VP and the mother VP are unified respectively with the variables A, B and M, then PostP will come out as the recessive phrasal daughter, since the mother and daughter VPs do the same type of work. Recessivity indicates adjunction or adverbiality, in our particular case. Through this principle, the theory then explains unequivocally that PostP is a case of adverbial in this serial construction.

2.2.2.1.2. Serial Verb Object Clustering.

Consider (43):

- (43a) *O da di lá a gan ku Deri*
 S/he past take a.m art. book give Dery

'S/he took a book and gave it to Dery'

- (43b) *O da dī lá kú Dery a gan
 S/he past take a.m give Dery art. book
 'S/he took a book and gave it to Dery'

(43c)

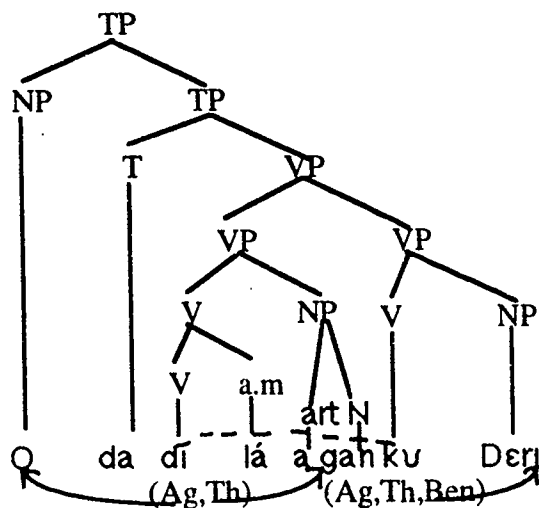

As will be shown, the pattern in Serial Verb Object Clustering (SVOC) is adequately handled by the principle of corporate theta role assignment. The sentence in (43a) illustrates an SVOC in Dagaare and is formalised in (43c). Indeed the objects do not really cluster as in the non-serial counterpart shown in chapter 1, thus (43b) is ungrammatical. The verb 'give' actually intervenes between the objects. The construction is still comparable to cases of actual object clustering if we realise that 'give' is a triadic verb and has the NP, 'the book' as its direct object and the NP 'Dery' as its indirect object, where the direct object is shared with the verb 'take', thereby confirming the object sharing hypothesis, while 'give' releases a benefactive role on behalf of the complex.

This analysis can also account for similar structures in other Mabia languages as can be shown in the Dagbane/Mampruli and Moore examples below.

2.2.2.2. Extending the Database

So far, illustrations of the two-level X-bar representation and the corporate theta assignment technique have been done with only Dagaare data. We now extend this to other languages.

2.2.2.2.1. Dagbane/Mampruli.

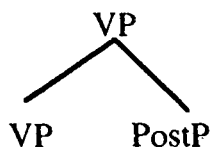

The diagram in (41c) shows how we can represent SVAs on our two-level formalism. Corporate theta role assignment is indicated as usual, showing how the two verbs share or theta mark the same subject NP. While it could also be argued that theta role assignment occurs inside PostP with the postposition theta marking its complement NP, what is left unaccounted for is the adverbial relation existing between the PostP and the VP. One possibility is to simply state that since the verbs are intransitives the PostP cannot form part of their argument structure, as such there could only be some kind of relation such as adverbial between them. This does not however define properly an adverbial relation between the two projections.

As was observed in chapter 1, the two-level X-bar system has a ready-made mechanism for handling adverbials and adjunction, in general, and this could apply to explain the SVA facts under consideration here. The principle in (36) of chapter 1, restated below as (42) is one of two principles developed in Hellan (1991) to handle in a more predictive way cases of adjunction.

- (42) Given two phrasal daughters A and B and their mother node M, if B and M do the same type of service, then A is recessive.

The diagram above in (41d) extracted from (41c) will illustrate this principle. If the PostP, the daughter VP and the mother VP are unified respectively with the variables A, B and M, then PostP will come out as the recessive phrasal daughter, since the mother and daughter VPs do the same type of work. Recessivity indicates adjunction or adverbiality, in our particular case. Through this principle, the theory then explains unequivocally that PostP is a case of adverbial in this serial construction.

2.2.2.1.2. Serial Verb Object Clustering.

Consider (43):

- (43a) *O da di lá a gan ku Deri*
 S/he past take a.m art. book give Dery

'S/he took a book and gave it to Dery'

- (43b) *O da dī lá kú Dery a gan
 S/he past take a.m give Dery art. book
 'S/he took a book and gave it to Dery'

(43c)

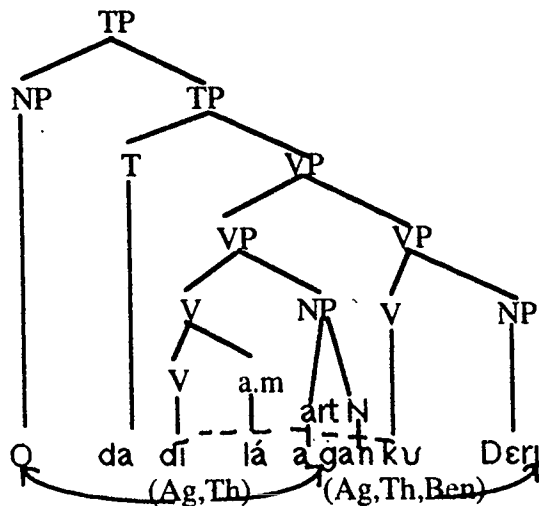

As will be shown, the pattern in Serial Verb Object Clustering (SVOC) is adequately handled by the principle of corporate theta role assignment. The sentence in (43a) illustrates an SVOC in Dagaare and is formalised in (43c). Indeed the objects do not really cluster as in the non-serial counterpart shown in chapter 1, thus (43b) is ungrammatical. The verb 'give' actually intervenes between the objects. The construction is still comparable to cases of actual object clustering if we realise that 'give' is a triadic verb and has the NP, 'the book' as its direct object and the NP 'Dery' as its indirect object, where the direct object is shared with the verb 'take', thereby confirming the object sharing hypothesis, while 'give' releases a benefactive role on behalf of the complex.

This analysis can also account for similar structures in other Maba languages as can be shown in the Dagbane/Mampruli and Moore examples below.

2.2.2.2. Extending the Database

So far, illustrations of the two-level X-bar representation and the corporate theta assignment technique have been done with only Dagaare data. We now extend this to other languages.

2.2.2.2.1. Dagbane/Mampruli.

- (44a) *O da zaŋ la kpargu yi*
 S/he past take a.m shirt wear
 'S/he took a shirt and wore it'

(44b)

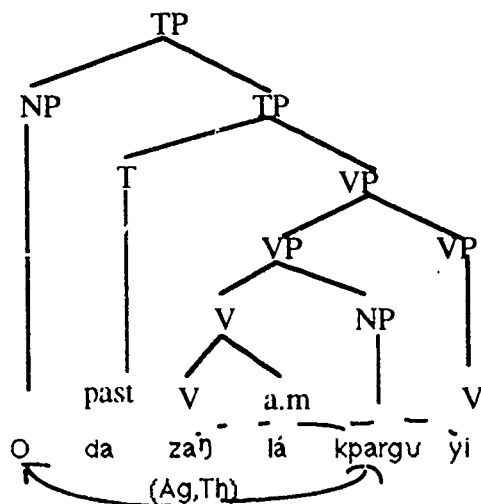

In the Dagbane / Mampruli example, the heads 'take' and 'wear' again form a complex predicate 'take wear' and this is indicated by the dotted line. Again, since the first head is in a more convenient theta assignment position as far as the word order parameter of this language group, among other issues, is concerned, it is 'take' which performs theta role assignment for the complex in accordance with the corporate theta role assignment principle.

2.2.2.2.2. Moore.

- (45a) *O sa duka mui di*
 S/he yesterday boil+am rice eat
 'Yesterday he boiled some rice and ate it.'

(45b)

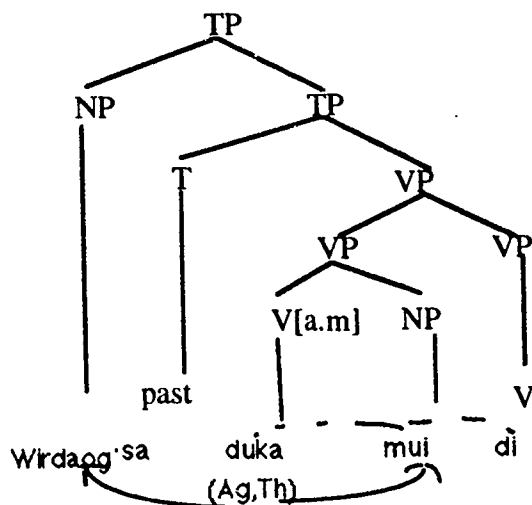

The Moore data in (45) need a bit of explanation. It must be pointed out that, unlike the Dagaare and Dagbane/Mampruli data, the polarity particle or the affirmative marker is incorporated into the verb following a possible head to head movement involving Pol and VP. The V takes dominance over the a.m in this projection. Furthermore the tense particle 'sa' can also be interpreted as a time depth particle. The action is not only specified as occurring in the past but as occurring a day away. This aspect of temporal specifications involving time depth by the use of verbal particles and not adverbials seems to be a unique feature in Mabia.

These factual specifications of the data aside, the design formalisms are as straight forward as in the Dagaare and Dagbane/Mampruli examples above, in the sense that 'boil' and 'eat' are interpreted as a complex predicate with the attendant corporate theta role assignment.

The formal power of our formalism is further enhanced when we recall the fact that it handles very well most of the constraints on SVCs in Mabia that we set in part one. For instance, the principle of corporate theta role assignment can be said to illustrate very much the subject and object constraints. The complex predicate which subsumes both verbs ensures that they theta mark the same agent and theme NPs which in this case are in canonical subject and object positions.

2.2.2.3. Looking beyond Mabia.

In this subsection, we extend our database beyond the Mabia language group in order to test our theory on other serialising languages. We will consider

SVCs from Ewe, a Gbe language within the Kwa language family of West Africa and Thai, a South-East Asian language.

2.2.2.3.1. Ewe

Ewe and other Kwa languages, unlike the Mabia, do not always have a single TAMP node. As pointed out by Ameka (personal communication), there must be two nodes because the verbs in the series may only share semantic temporal reference but not formal temporal reference. For instance, in the sentence in (46) below

- (46) *Ama le te ɔa ge a-ɔu*
 Ama be:pres yam cook ingr fut-eat
 'Ama is going to cook yam and eat'

the verb 'ɔa' is in the prospective aspect while the second verb is in the future, so what they share is the future time reference, but not formal temporal reference.

It is also true however that in some Ewe SVCs the verbs share both semantic and formal temporal reference, as shown by the construction in (47a), the difference between this and Mabia sentences still being that the temporal marker in the Ewe data, is copied on to all the verbs in the series.

We claim that by relaxing the TAMP constraints imposed on Mabia in the light of the above peculiarities for Ewe, our formalism applies normally to Ewe SVCs as with Mabia SVCs.

- (47a) *Komi afo Ami afu anyi*
 Komi fut+beat Ami fut+fall ground
 'Komi will knock Ami down'

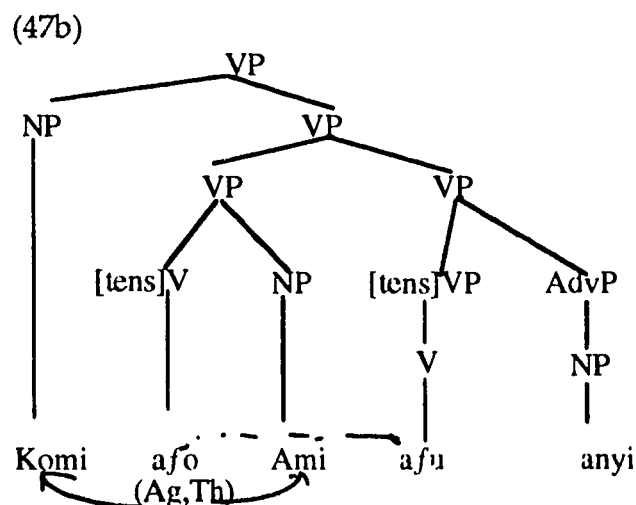

This is illustrated in (47) above, where the tense marker 'a' gets incorporated into the V's by movement rules. Once this is explained, all that is left to be done is corporate theta role assignment, ensuring that the complementation properties of both verbs get instantiated at this level.

2.2.2.3.2. Thai

Finally, we apply our formalism to the South East Asian language, Thai, a genetically unrelated language to the serialising languages of Africa and the Carribeans. Our example sentence is shown below in (48a)

- (48a) *Pranom au man-farang ma ni*
 Pranom bring potatoes come here
 "Pranom brought potatoes here"
- (48b)

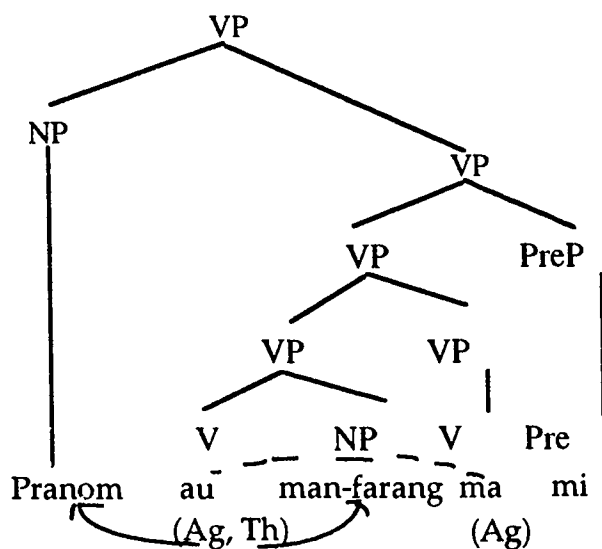

Again, as was observed in Sranan above, there seems to be little or no inflectional morphology in Thai. We do not therefore need a TAMP node in this diagram. This observation aside, the verbs 'au' and 'ma' are shown to form a complex predicate and therefore theta mark corporately as was indicated in earlier examples.

This last example shows that it is possible to extend our analysis to account for SVCs in South-East Asian languages like Thai and Chinese even though they are genetically unrelated to West African languages.

2.3. Part Three: Other Approaches

The above approach to the structure of SVCs has both similarities and differences with respect to some earlier approaches such as Baker (1989) and Lefebvre (1991). We present some of these earlier analyses of SVCs. Six groups

are listed but we discuss the two mentioned quite extensively, comparing them with the one outlined in this work. This then enables us to situate our work within the literature.

2.3.1. *A Summary of the Approaches.*

Within Generative Grammar, there exist about six main attempts to account for the structure of SVCs. These are succinctly listed as follows:

- i. The constituent deletion approach (transformational generativist) which assumes that SVCs are abstracted from two or more clauses by the deletion of repeated constituents. This approach is represented by works such as Awobuluyi (1973) and Bamgbosi (1973, 1974).
- ii. The base-generated approach which believes that SVCs are a result of VP-iterated PS rules. Examples of such works are Schachter (1974) and Jansen, Koopman, and Muysken (1978).
- iii. The complex predicate or lexical approach with the idea that two verbs could combine in the lexicon to form a single discontinuous complex predicate. This line of thinking is represented by Déchaine (1986) and Lefebvre (1991).
- iv. The empty category approach (e.g Carstens (1988)) which claims that there is an empty NP that satisfies the argument structure conditions of subsequent verbs.
- v. The across-the-board representation posited by Craig and Hale (1988) which apparently recouches the old idea that SVCs are a result of conjunction reduction.
- vi. The double-headed VP or object sharing approach represented by Baker (1989).

We now proceed to discuss Lefebvre (1991) and Baker (1989):

2.3.2. *Lefebvre (1991)*

Lefebvre (1991) together with works such as Déchaine (1986) and Lefebvre (1986, 1987,) pursue the main idea that SVCs 'are derived complex predicates which are formed prior to D-structure by means of operations on the lexical conceptual structure (LCS) of verbs.'

With data from causative SVCs (what she terms 'take' serial verb constructions) in the Fon language, Lefebvre claims that the process of serialisation originates from the lexicon. The resulting complex predicate is then projected onto the syntax as a bi-headed VP. One of the example sentences she uses is shown below 11. (49):

(49)

Kòkú *só* *àsǒ* *yì/wá* *àxì*
Koku take crab go/come market
Koku brought (direction away/ towards speaker) the crab to the
market.

According to Lefebvre, the LCS of (49) will then be represented as follows in (50):

(50)

a. *só*: [x cause [y undergo change of location]]

b. *yì/wá*: [y undergo change of location
away from/towards speaker to location z]

c. *só- yì/wá*: [x cause [y undergo change of location
away from/towards speaker to location z]]

The verbs *só* and *yì/wá* will receive the LCS as shown in (50a) and (50b) respectively. To Lefebvre, a certain process (which she fails to mention) 'conflates' the LCS to form the complex lexical predicate in (50c). This complex predicate then projects into the syntax as a bi-headed VP in an essentially complementation configuration (as shown in (51)).

(51)

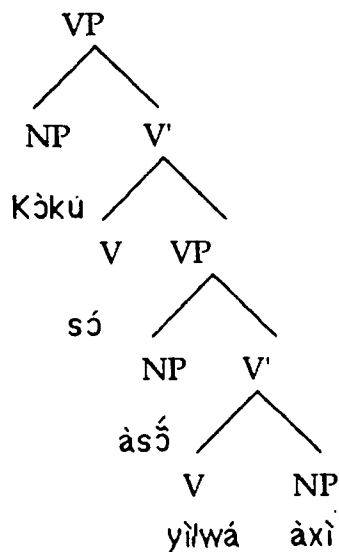

The following X-bar theory (52) would permit such a configuration.

(52)

a. $XP \rightarrow \text{Spec}X' X'$ b. $X' \rightarrow X YP$

From the above, we see that this is a three-level X-bar representation while ours, as has been seen, is one bar less. A further difference is that Lefebvre does not seem to account for how theta role assignment is executed in her approach but, like Baker's approach below, our analysis clearly indicated this⁵.

2.3.3. *Baker (1989)*

While the foregoing account considers the issue of SVCs to be a product of the lexicon, Baker (1989, 1991) together with works such as Awoyale (1988) and Hale (1991) consider it to be post-lexical. To them it is a product of the syntax (and possibly, other post-lexical levels).

The structural characteristics of the SVCs that we saw earlier in this chapter threaten the entirety of the theta-theory, especially the Projection Principle (PP) and the theta criterion. Naturally, therefore, most analyses within the GB framework, including Baker (1989) are concerned with analysing SVCs in the light of the problems posed by the threat to the theta theory. Most of the SVCs we have seen so far, exemplified by (53) from Sranan below,

- (53) *Kofi naki Amba kiri* (taken from Baker (ibid))
 Kofi hit Amba kill
 'Kofi struck Amba dead'

seem to violate the Projection Principle (Chomsky 1981), stated as in (54)

- (54) The projection principle
 Suppose α is a lexical category and β is a position of argument type.
 a. If β is an immediate constituent of a one-bar level projection of α at some syntactic level, then α θ -marks β in α' .
 b. If α θ -marks β as a lexical property, then α θ -marks β at all syntactic levels.

According to Baker, the V2, *kiri*, in the above example is a transitive verb but there is no argument following it in the surface structure. The object seems to be 'deleted' at this level by identity with the object of V1, from the point of view of old-fashioned transformational grammar. This means then that the

⁵One can however object, at least, to her representation of the LCS of 'go/come'. It may be that both x and y undergo change of location away from or towards speaker to location z.

complementation properties of such verbs are not represented at all the levels of the syntax of SVCs, thereby violating the PP as stated above.

To solve this problem, Baker (1989) proposes that double-headed VPs be allowed in serialising languages, thereby making it possible for both verbs to 'share' the single object NPs in each of the constructions. Figure (55) below (also taken from Baker(ibid)) illustrates the principles for this approach with the Sranan sentence in (53). The VP and higher V', as can be seen, are projections of both verbs, 'naki' and 'kiri'. The arrows indicate theta-role assignments. According to the standard conditions on theta-role assignment (stated in Chomsky(1986)) 'naki' directly theta-marks 'Amba' with a theme role while 'kiri' indirectly or "predicationally" theta-marks 'Amba', also with a theme role. Quoting Williams (1984), Baker again claims that the two verbs can theta-mark 'Kofi' by the fact that the external (agent) theta-roles of the verbs percolate to their maximal projections, which is the VP, thereby being assigned to the subject. In this way, according to Baker, the lexical theta-role-assigning properties of both verbs are satisfied in this structure, and the PP would then be obeyed.

(55)

S

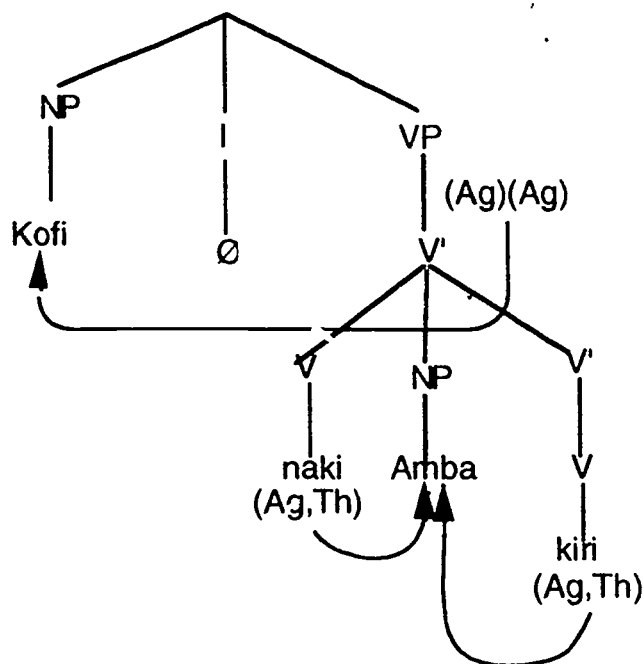

The conclusions behind such an approach are that X' theory is extended in such a way that serialising languages allow V's to embed within V' to form a double-headed construction. Finally, he claims that these conclusions may have some consequences on what kind of verbs may combine in an SVC, their linear order and the structural positions of their argument NPs. This is shown in (56):

(56)

- a. Each verb may or may not θ -mark the subject of the whole serial VP.
- b. For each other argument a in the SVC:
 - i. a must be θ -marked by all the verbs that follow it.
 - ii. a must be θ -marked by the verb that immediately precedes it.
 - iii. a is not θ -marked by any verb that precedes it other than as in (ii).
- c. For each verb in the SVC, the arguments of that verb must appear in the following hierarchical order:
Agent>Instrument>Patient/Theme>Goal/Location. (Baker 1989:p550)

Baker's proposals certainly constitute an important contribution to the discussion on SVCs and offers us a lot of good premises to build upon. There may, however, be a number of objections to this approach. We address some of these issues in the framework of the our chosen approach.

2.3.4. Comparing the Approaches

One possible way of accounting for theta role assignment is to follow Baker's approach. This is illustrated with the Dagaare sentence represented in our formalism in (57). We therefore say that the agent role of both verbs is assigned

by percolation up to the first VP projection which will then do the assignment. As for the theme role, while the first verb will theta mark canonically, as shown, the second verb will have to theta mark "predicationally". In this way, according to Baker, the complementation properties of both verbs will be met and the projection principle would have been obeyed.

- (57a) *Ayuo da di la bie zigl*
 Ayuo past take a.m child seat
 'Ayuo seated the child'

(57b)

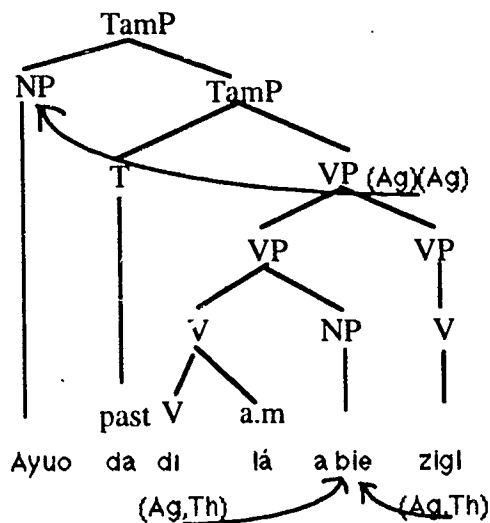

This approach is what is often termed the object sharing approach. Two objections, among others, can be raised against this approach as follows:

If we observe the diagram carefully we will notice that each of the NP arguments gets two roles, two Agents in the case of Kofi and two Theme roles in the case of Amba. This, in effect, contravenes the theta criterion, stated in (58), in its classical reading.

(58) Theta Criterion:

'Each Argument bears one and only one θ -role, and each θ -role is assigned to one and only one Argument' (Chomsky 1981).

Baker tries to bail himself out by saying that recent versions of the theta criterion allow an NP to receive more than one theta role of the same type. We believe that this is a weaker interpretation of the theta criterion.

The second problem to be observed here is that because of the different strategies employed by Baker to enable the two verbs achieve theta role assignment we have a case in which the two verbs have different directions of theta role assignment. One would expect that an SVO language like Dagaare should assign the theme role rightwards but this is not so with the verb 'z•gl'. As things stand now, even though Baker calls it theta role assignment by "predication", the thematic assignment in (57) looks like a direct thematic assignment on a passive construction, which is not the case here. This, we believe, is not too elegant a treatment of theta role assignment.

How does our approach solve these problems? Through our demonstrated account, the complementation properties of the two lexical verbs are satisfied *in a single operation* and both 'take' and 'seat' license agent and theme NPs at this level of the grammar. In this way, the projection principle would be well adhered to. Furthermore, in our proposal, the theta criterion would be strongly adhered to since each of the NP arguments bears one and only one theta role, as opposed to Baker's analysis, and each of the agent and theme roles is assigned to one and only one NP argument.

2.3.4.1. Sranan.

A natural way to show how different our approach is from Baker's is to reanalyse his own data as shown below in (59) from Sranan (a Carribean creole).

(59a) *Kofi naki Amba kiri* (taken from Baker (ibid))
 Kofi hit Amba kill
 'Kofi struck Amba dead'

(59b)

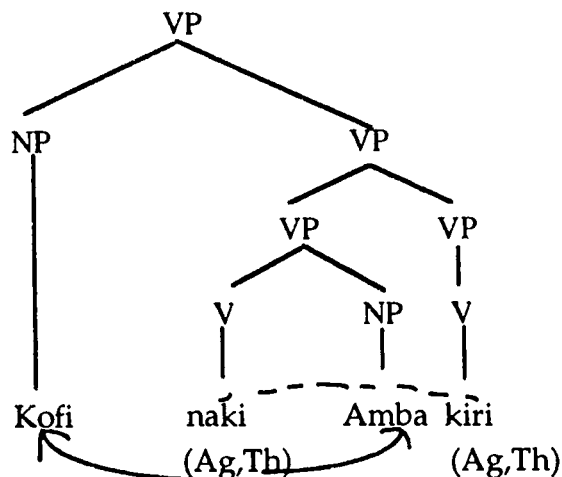

As this language has little or even no inflectional morphology, we don't need a TAM projection for our representation. Besides this specification, the representation falls into place clearly if we look at earlier representational specifications of the theory. Both verbs must release agent and theme roles. But since they are corporate partners doing business together, they democratically decide on which of them is in a better syntactic position to do the theta assignment business on behalf of the whole complex. In this case, it is 'naki' which releases these thematic roles, as shown above by the arrows, in a single operation. Needless to say, the grammatical principles are all adhered to: the projection principle is obeyed and the theta criterion is respected in its strongest interpretation.

2.3.4.2. Fon

The next language group we consider is Fon which is a Gbe language. Here, we, among others, hope to illustrate the similarities and differences that were said to exist between Lefebvre's approach and the present one by considering a similar sentence (60) as analysed by Lefebvre in Fon.

- (60a) *Kòkú sọ àsó wá àxí*
 Koku take crab come market
 'Koku brought the crab to the market.'

(60b)

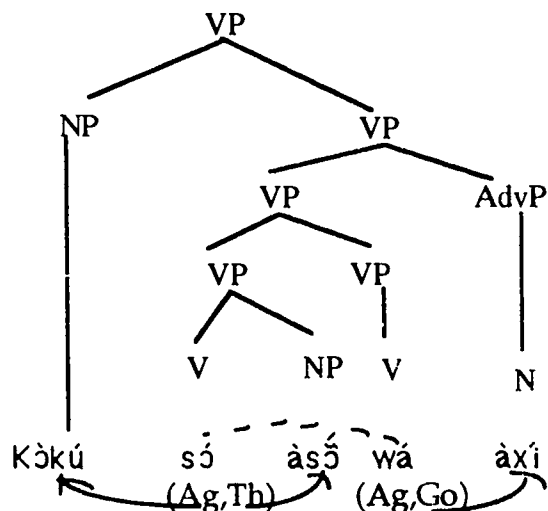

Both approaches assume an essentially binary tree branching configuration for representing our data. This makes the representation more structured than in Baker's. However, unlike both Lefebvre and Baker who

assume a three level X-bar system, the present approach, as can be seen in this and other trees, assumes a two-level approach.

In terms of syntactic operations, Lefebvre is not explicit on how issues such as theta role assignment take place. In our representation of the example diagram however, this is clearly shown (60b). We agree with Lefebvre that 'take' and 'come' form a complex predicate, 'take come' (though in the case of Lefebvre, it is by the corflation of their PAS). This projects discontinuously into the syntax.

As usual, corporate theta role assignment takes place as has been described previously. The verb, 'come', in addition to releasing an agent role, releases a goal role on behalf of the group. In this way the thematic requirements of all the verbs are met.

2.4. Conclusion

This chapter, divided into three parts, has been largely concerned with giving a straightforward description of our data and presenting our initial account of the phenomenon of SVCs.

Part one mainly discussed the structure of SVCs in Mabia with respect to five grammatical notions : Subject, Object, Connector, TAMP and Predicate and showed SVCs to be highly structure sharing constructions. Following this, we conclude that SVCs are indeed complex predicates.

We then set off to lay the foundations for an account of these characteristics in part two. We introduced our phrase structure formalism and showed how our data could be formally represented on these. Also with data from Dagaare and languages as diverse as Ewe, Thai and Sranan, we indicated how lexical information can be processed, especially through the principle of corporate theta role assignment. We conclude that because of stipulations such as the corporate theta role assignment, our formalism is capable of indicating information flow in the syntax without sacrificing general principles within GB.

We also gave a brief presentation of earlier approaches to the analysis of SVCs and showed how our proposals compare with these.

The account of corporate theta assignment that has been presented in this chapter is still a bit more metaphorical. The constraints on complex predicate formation presented in (36) still can be sharpened with respect to their implementation. In the next chapter, we take up these and other issues such as verb order and the eventhood of SVCs. We abstract out a 'functional' aspect of S-structure and define checking rules applicable to this representation.

Chapter 3: An Integrated Account Of SVCs

3.0 Introduction

In this final chapter we collate the ideas that were presented in previous chapters to develop and implement an integrated representational account of the structural characteristics of SVCs in Dagaare and other Mabia languages. This is based on our approach to SVCs as complex predicates which functionally express a single event. As mentioned in Chapter 2, we assume a representational grammar design in which SVCs, as our data, have simultaneous access to all levels of the grammar, from which information can be drawn in the course of our analysis.

This chapter is organised as follows: In section 3.1, we give an outline of the account. This will facilitate an understanding of its basic assumption, components and methodology. Section 3.2 is the core of this representational analysis. The account is systematically developed through various stages. Illustrations are made mainly with SVC data from Dagaare. In section 3.3, we begin the other main theme of the chapter: a gestalt analytical interpretation of SVCs. After summarising the main tenets of the theory we concentrate on the conceptual level where we give an analysis of 'constructional transitions'. This results in the proposal of a model of event structure for the two main types of these constructions. Section 3.4 concludes the chapter.

3.1 Outline Of The Integrated Account

We offer first an outline of this integrated account before we begin to demonstrate it with data from the various Mabia languages. The account consists of an assumption and a methodology involving the satisfaction of a series of well-formedness conditions. First the assumption.

We assume that the set of conditions applying to an SVC has simultaneous access to all levels of the grammatical representation. What this means is that from the surface structure construction available to us we can look into, for instance, the lexicon where we can extract argument structure information about the verbs that are manifest in the construction. This assumption is essentially non-derivational in nature. With it we do not have to worry about specifying where the process of complex predicate formation begins in our grammar.

We also specify clearly a methodology for this account and this involves a series of conditions or constraints to account for the well-formedness of SVCs.

The diagram in (1) gives us a sketch of the various conditions to be described below.

(1)

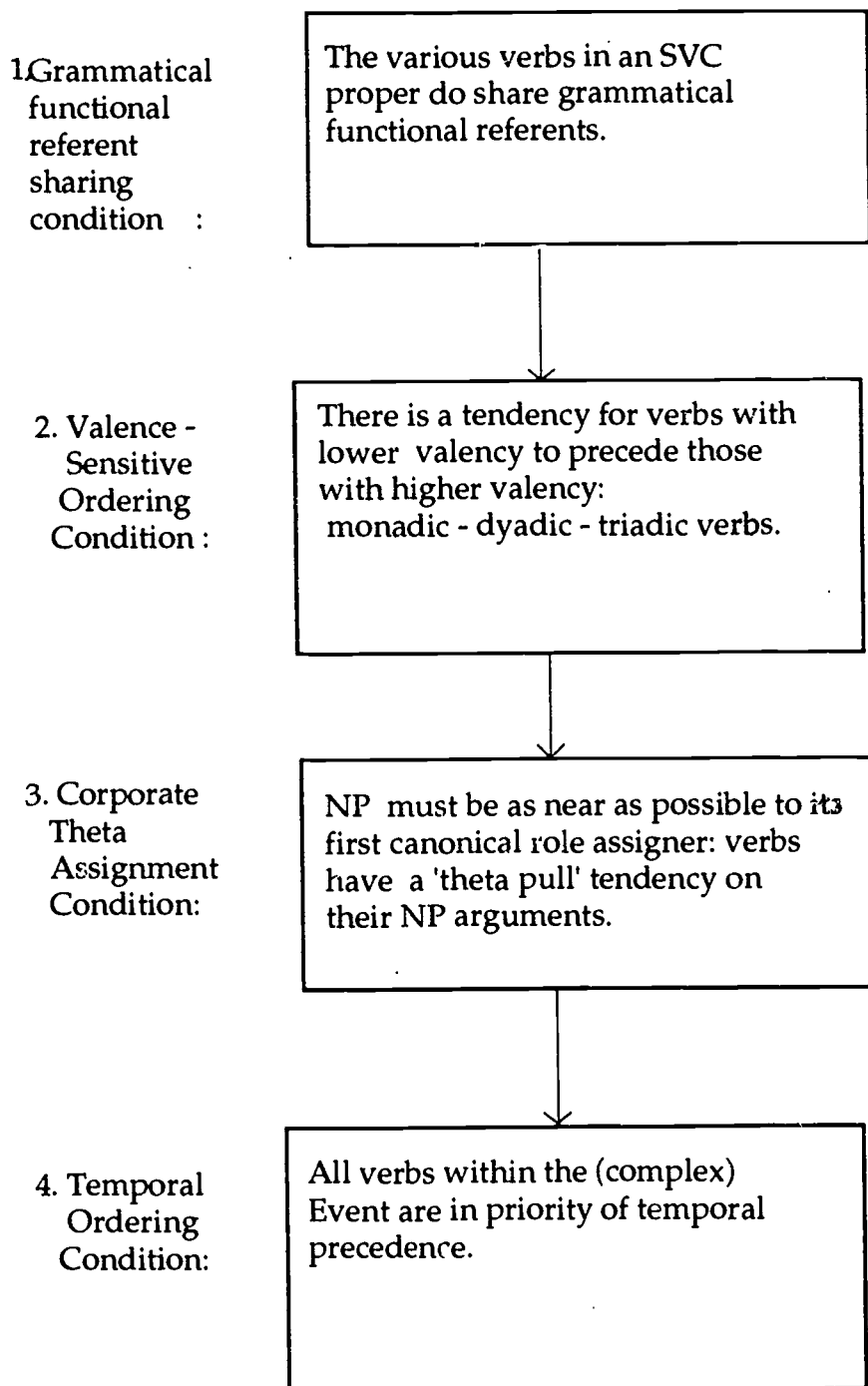

These four main conditions, to be implemented in the course of our account, can be explained as follows:

i. The Grammatical Functional Referent Sharing Condition.

This condition basically summarises most of the constraints on SVC complex predicate formation that were outlined in Chapter 2. Since the integrated approach being developed here is essentially an acceptance device, what this first condition for the acceptance of a construction as an SVC in the language does is to check if the referents of the grammatical NP arguments of the verbs within each particular potential SVC construction at surface structure are identical. This concerns mainly the grammatical functions SUBJECT and OBJECT. It is with these two categories that we shall illustrate this constraint.

ii. The Valence-Sensitive Sequential Ordering Condition.

The previous condition involved grammatical functional referent sharing. This by itself does not specify precedence rules. The present condition specifies the syntactic precedence rules of the verbs in the SVC. The constraint here simply requires that, canonically, verbs in the surface SVC construction must be arranged in increasing order of valency from left to right. So, in the canonical case, we should have monadic verbs first, to be followed by dyadic verbs and finally the triadic verbs, if there are any. This is summed up in the requirement that the rightmost verbs ought to be verbs with the most inclusive roles. This will be further explained as we begin to demonstrate with the data. Notice however that this syntactic sequential arrangement constraint can be overridden by the semantic-conceptual constraint of temporal natural sequence to be stated in section 3.2.4.1 below.

iii. Corporate Theta Assignment Condition.

This condition basically summarises ideas developed in Chapter 2. Predictably then, it is built around the principle of Corporate theta role assignment. This is an economy/efficiency principle which ensures that NPs are rearranged in the clause in such a way that the most 'competent' verb, namely the first, performs theta role assignment at the least cost on behalf of the others. In other words, each NP occurs in the canonical assignment position for its role, relative to the first verb assigning that role.

iv. The Temporal Precedence Condition.

Through this condition, we attempt to account for the semantic-conceptual properties of the SVC .i.e the semantic well-formedness of the construction. Verbs occurring together in an SVC (i.e verbs forming a complex predicate) express various components of the same event and there is a certain kind of

temporal natural sequence in which such verbs occur. Below we will show that the complex event that is translated by this complex verbal predicate has a well-defined structure. We are then in a position to define 'cognitive packaging' (Givon 1991) aspects of SVCs i.e how all these verbs are packaged into expressing one single, albeit complex event. In our demonstration of these concepts we use some aspect of the conceptual structure of the Gestalt theory to account for this event structure. An account of the conceptual structure shows how conceptually 'tightly related' these verbs are.

3.2 The Analysis

Consider the well-formed string in Dagaare as shown in (2):

- (2) *O da nyɔg la a bie di ku ma*
 He past hold a.m the child take give me
 'He held & took the child for me'

It is quite difficult to give a translation of longer SVCs like the above into non-serialising languages without using a conjunction. Hence we have to use two clauses to translate one clause. In the source language however the verbal predicates are so tightly related that we may say that the three verbs form a complex verb as follows : *nyɔg-di-ku* . The various verbs can be said to act together to express various components of a single event and not different events. These conceptual issues will be taken up at a later stage of the representation. But for now we investigate and implement the mechanisms governing this intricate rearrangement. The first step to this representational problem is to investigate what constraints the grammatical functions impose the SVC construction. We shall concentrate on two categories, SUBJECT and OBJECT.

3.2.1 Grammatical Functional Referents

This constraint can simply be stated as being that the various verbs in an SVC proper do share or are in the scope of one grammatical functional referent. The constraint is anticipated by the following general definition of SVC arrived at in Chapter 2, repeated below as (3):

- (3) A construction *c* is an SVC iff:

all the different lexical verbs in c share the same structural subject and are in the scope of a single TAMP node with no connector y such that y intervenes between the row of verbs in c. All these different verbs, if polyadic, must share their direct internal arguments and must, in addition, occur monoclausally, selecting each other in such a way that together they express a single event.

More precisely, what this constraint requires is that the same individual(s) or actor(s) must perform the acts represented by the various verbs. And in most cases it is the same object referents that are acted upon. We illustrate the constraint with the following quite lengthy Dagaare SVC construction in (4a)

- (4a) *Ayuo da zo gaa wuo la haani di*
 Ayuo past run go collect a.m blackberries eat
 'Ayuo ran and went and collect blackberries and ate them'

(4b)

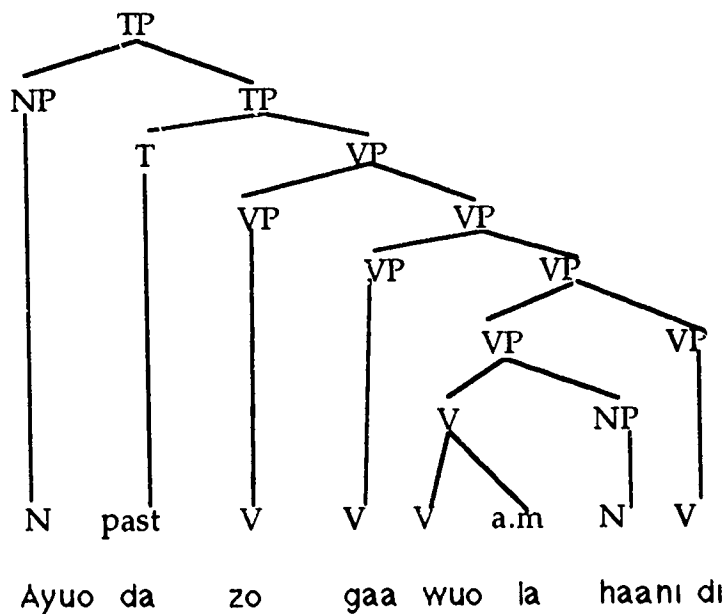

'Ayuo' = same subject referent for all verbs

'Haani' = same object referent for all dyadic verbs

So, same actor, same thing acted upon in one time period, etc (in one event).

The diagram configurationally defines the NP, Ayuo, as the subject (all the verbs are dominated by TP and TP is in sisterhood relationship with NP: <NP, TP>),

and the other NP, *haani*, as a complement of the verb 'wuo'. It is also shared by the verb 'di' as a complement. So the two NPs are really subjects and objects respectively of all the verbs. We also insist that the act of running there and collecting and eating the berries must be performed by the referential entities in real world situations. For instance, if a group of people ran there and it was only Ayuo who ate the berries, this cannot be expressed by a serial verb construction proper. This is illustrated in the following Dagaare constructions in (5)

- (a) *Ba zo gaa wuo la haani di*
 They ran went collected a.m berries ate
 'They ran there & collected berries & ate them'
- (5b) **Ba zo gaa wuo la haani Ayuo di*
 They ran went collected a.m berries Ayuo ate
 'They ran there & collected berries & Ayuo ate them'
- (5c) *Ba zo gaa wuo la haani ka Ayuo di*
 They ran went collected a.m berries conj. Ayuo ate
 'They ran there & collected berries and Ayuo ate them'

In (5a) it is considered that the individuals were the people who took part in all the acts constituting the event. So it is well expressed as an SVC. In (5b), we have an instance of what may be called 'split subject referent'. The individuals ran there and picked berries but it was Ayuo who ate the berries. This is clearly a case of separate events. This construction violates the subject referent constraint and cannot therefore be represented as the one event serialisation we are discussing.

Now, let us consider violations of the requirement that object referents be shared. It may sometimes happen that some constructions (which are also serial verbs) obey the subject referent constraint but yet cannot qualify as single event serialisation. One group of these is what may be called instrumental serialisation, which we consider an instance of VP serialisation. Consider the following Dagaare construction in (6)

- (6) *Bayuo da di la suɔ ŋmaa Ayuo*
 Bayuo past take a.m knife cut Ayuo
 'Bayuo took a knife and cut Ayuo'

The two verbs in (6), while sharing the same subject, do not share the same object referents. We may say here too that we have a case of 'split object referent'. Intuitively, these constructions do not seem to have the same conceptual cohesion as cases in which we have the object sharing referents. We may then say that the actions are indeed more loosely knit than those evoked by proper SVCs. Claims of single eventhood in these constructions is much less substantial than in other SVCs discussed. Their eventhood may be said to be mid-way between separate events represented by coordinations and the single events of proper SVCs. It may be that they represent separate but tightly related events.

This suspicion of loose eventhood is supported by what happens in other forms of serialisation. This involves constructions whose structures are like the SVCs discussed in this work but whose semantics are quite different. Consider the following constructions in (7a).

(7a) *John da daa la a bie loo*
 John past push a.m. the child fell
 'John 'felled' the child by pushing it' i.e John pushed down the child

(7b) **? John da daa la a bie le*
 John past push a.m the child fall
 'John pushed the child & and it fell'
 or
 'John pushed the child & fell'

(7c) *John da daa la a bie a le*
 John past push a.m the child conj fall
 'John pushed the child and then fell'

In (7a) both constraints described above are met as both verbs share subject and object. This is a normal one event SVC, indeed a typical case of the SVCs described in this thesis. In (7b), if we are to give it the SVC interpretation involving subject sharing as above (i.e John pushing the child down), the sentence would be ungrammatical.

However, there is a case of mixed acceptance among speakers if it is given the second reading: John knocked the child and fell. This is different from the clear single eventhood SVC reading in (7a). Indeed, this unclear 'coordinate'

reading in (7b) is finally clearly accepted as we introduce a conjunction in (7c). The hedging acceptability in (7b) may have been due to the fact that we were trying unsuccessfully to superimpose a single eventhood reading on a (veiled) coordinated construction. We therefore see this kind of serialisation as an instance of veiled coordination.

There is a third case of serialisation which has a different semantics than the single eventhood serialisation. These constructions are those that do not obey the constraints on aspectual marking discussed in chapter 2. These are illustrated in (8).

- (8) *O* *da* *ziŋ* *dire* *la*
 S/he past sit+perf eat+imperf a.m
 'S/he sat (while) eating'

Proper, one event, serialisation must obey all TAMP constraints, including the aspectual ones. However, this type of serialisation which we call an instance of pseudocomplementation¹, does not obey it. It is about the clearest to show that such types of serialisation do not only express multi-events², they also show that these separate events are conceived aspectually in a different perspective.

These evidences from the three types of multi-event serialisation - instrumental serialisation, veiled coordination and pseudocomplementation - show that the grammatical functional referent sharing condition is pertinent for implementing single event SVCs, both in terms of their syntax and their semantics.

3.2.2 Valence Sensitive Verb Ordering

Accounting for verb order has been one of the most problematic issues in attempts at analysing the structure of SVCs (Baker 1989, Lefebvre 1991 and Awoyale 1988). The main idea behind the Valence-Sensitive Ordering Condition is that there is a tendency for verbs with lower valency to precede those with higher valency. With this condition, we want to find an ordering of some sort for verbs in the SVC based on the number of their argument structures. It would seem that in most serial constructions triadic verbs occur right-most. They are preceded by dyadic and finally monadic verbs. Consider the following Dagbane and Dagaare constructions in (9) and (10) respectively:

¹ Seuren (1990) describes a pseudocomplement as a suppositious sentential complement foisted on the syntax of a verb which either does not require such a complement semantically, or, if it does, does not allow for it on grounds of lexico-grammatical restrictions
 e.g John went fishing

² Ameka (personal communication) suggests that such serialisation types are cases of multi-event serialisation.

- (9) O da zaŋ la kpargu ti ma
 S/he past take a.m shirt give me
 Ag V1 V2
 'S/he took a shirt for me'

- (10a) O da zo wa di la suɔ ku ma
 S/he past run come take a.m knife give me
 Ag V1 V2 V3 V4
 'S/he came and picked a knife for me'

In (9) a dyadic verb precedes a triadic. This conforms to the valency-sensitive ordering condition. In (10a) we have as many as four verbs two monadic, two dyadic and one triadic. As predicted by the Valency condition, the triadic verb comes right-most. This is preceded by the dyadic. Finally the two monadic verbs follow leftwards.

Those were the canonical cases. It looks as if some verbs do not obey this condition. That is the case with the grammatical construction in (10b).

- (10b) O da di la suɔ zo wa ku ma
 S/he past take a.m knife run come give me
 'S/he took a knife & brought it to me by running'

We have exactly the same verbs as in (10a), the only difference being that the order is changed. We now have a case in which the two monadic verbs come after the dyadic verb in contravention of the Valency condition. Moreover, we cannot explain the ordering priority between the monadic verbs with the valency condition. With these two problems, it will look as if there are some other issues determining verb order which can override the Valency condition. We illustrate this with the Temporal ordering condition in section 3.2.4.2

3.2.3 Corporate Theta Assignment and NP Arguments.

The principle of Corporate Theta Role Assignment (CTRA), as developed in chapter 2, is an economy/efficiency principle that ensures that NP arguments are rearranged in an SVC in such a way that the most competent verb(s) perform theta role assignment at the very least syntactic cost on behalf of all the others. This principle, stated in chapter 2, is repeated below as (11).

- (11) The principle of corporate theta role assignment:
Partners in a complex predicate do select competent members in a

syntactically appropriate environment to perform theta role assignment on behalf of the complex.

To repeat the metaphor in Chapter 2, this syntactic unit, the SVC or complex predicate can be said to be, metaphorically, a business firm. The overriding concern of most business firms is to maximise profits and minimise losses as much as possible. This is a corporate concern. As a consequence of this concern, management tries to negotiate and select as much as possible only the most competent personnel who can carry out assignments on behalf of all the other people in the firm with minimum resources or cost of production. In the CTRA business, the verbs are the personnel, the business is to discharge theta roles on NPs with minimum linguistic resources.

To illustrate the CTRA constraints we shall draw on an example from chapter 2. Consider the following in (12)

(12a) O da di lá a gan ku Deri

S/he past take a.m art. book give Dery
'S/he took a book and gave it to Dery'

(12b) *O da di lá ku Deri a gan

S/he past take a.m give Dery art. book
'S/he took a book and gave it to Dery'

(12c)

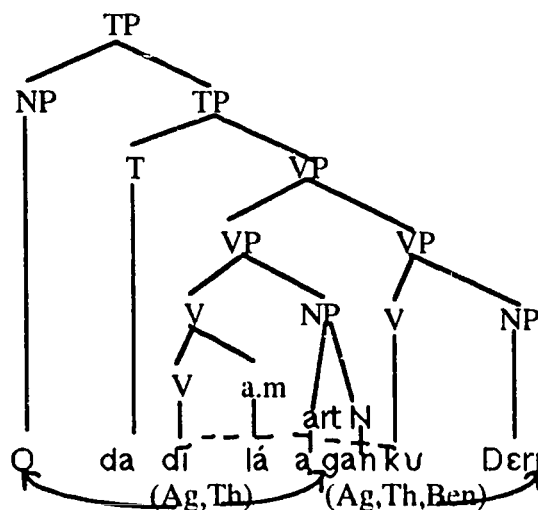

In the above example, we have two verbs in the SVC, one dyadic and the other triadic. Against these two verbs are three NP arguments. All these lie in the boundary of a single syntactic unit, the SVC. Each verb has its own area of

competence in terms of theta role discharge. All the NPs are in dire need of appropriate theta roles. The scene is thus set for CTRA. How is this done?

We start with the Agent assignment. Both verbs are capable of assigning Agent role. The verb ' *di* ' comes first, and so should assign the role. The canonical position for Agent assignment relative to ' *di* ' is preceding it, hence the Agent NP will occur first in the sequence. The position of 'O' the Agent in (12) is thus confirmed. The dotted line shows that we are dealing with a complex predicate and the various verbs in the unit are partners in CTRA.

Now, let's see how Theme role assignment is negotiated. The direct object, ' *a gan* ' needs a Theme role. Again both verbs are capable of doing this job, and so it is again the first of the two, ' *di* ' that will assign the role. Dagaare is an SVO language, and as such, canonical theta role assignment for themes should be from left to right. Any decision to theta mark the theme role from right to left will have to be accompanied by extra rule stipulations (see Baker 1989). This will be the more costly option and we don't want that. On the basis of this economy concern, the verb *di* is thus again the more appropriate candidate to do theme role assignment within the unit and so the location of ' *a gan* ' is confirmed.

The only NP occurrence not yet licensed in *Deri*. It needs a benefactive role. So we start all over with competence considerations. Here things are more straight. It turns out that only *ku* is competent to do the benefactive role assignment. In any case it is the closer of the two verbs to the NP in question and with ' *Deri* ' following it, ' *Deri* ' is in an acceptable position for receiving the role.

It would therefore seem that, indeed, NPs have a tendency to be in the most appropriate position to receive the right kind of theta role. In other words there is a certain kind of magnetic pull on NPs to be as near as possible to their role benefactors.

We can therefore say that whenever all the options are patiently exhausted and CTRA is successful, the sentence is a properly formed SVC, otherwise we are dealing with an ungrammatical SVC.

In (12b) the theme role would not be economically administered. The verb *ku* would be forced to 'trek' a longer distance to discharge the role on *a gan* than *di* would have done as in (12a). The CTRA test/constraint is not properly adhered to and the sentence is out.

The CTRA principle then serves an important test in ascertaining precedence rules between verbs and their NP arguments. This is complemented by the Valence-Sensitive Conditions that were discussed earlier.

3.2.4 Temporal Sequence

The Temporal ordering Condition is another attempt at further constraining verb order in the SVC. It states that all verbs within the (complex) event are in priority of temporal precedence. This is formalised in (14).

It has been widely assumed in the linguistic literature (e.g. Givon 1991) that there is a correlation between the cognitive packaging i.e the 'event' and the grammatical packaging i.e the 'proposition', 'sentence' or 'clause'. The cognitively motivated principle underlying this basic assumption, as stated in (13), is termed the 'Distance Principle'

- (13) The temporal-physical distance between chunks of linguistically-coded information correlates directly with the conceptual distance between them.

On the basis of the principle, Clausehood and Eventhood can be seen to match on a one to one basis. The SVC, which is assumed to be formed within a single clause, can then be said to represent a single event.

What has however not been adequately addressed in the literature, to the best of our knowledge, is just what constitutes a single event. What are the components of a single - albeit complex - event and which of these components do the various verbs of any given SVC translate? Before tackling these various aspects of the correlation between grammar and cognition, we shall formulate a temporal precedence principle to account for verb order in an SVC.

3.2.4.1 A Principle of Temporal Precedence for Verb Order

Assuming the Distance principle as stated above and with motivation from the SVC data in Dagaare and its closest relatives we state the principle in (14).

- (14) The Principle of Temporal Precedence (PTP):
 Let S = SVC and E= Event,
 Let v1 and v2 = Verbs in S and e1 and e2 = parts of E
 Suppose S is a grammatical encoding of E and
 v1 and v2 encode e1 and e2 respectively,
 If e1 temporally precedes e2
 Then v1 must structurally precede v2 .

This principle then forms the basis of the test for the right verb order at this component of the representational analysis. Faced with any two or more verbs within a single clause i.e an SVC, the question to ask oneself is: Which of these

encodes an action that precedes all the actions encoded by the other verb(s) ? The verb that answers the question positively is placed before all others. The questioning procedure is repeated until all the verbs in the SVC are exhausted. According to the PTP, the result will predict the grammatically correct ordering of any SVC in any of the Mabilia languages and presumably all SVO languages.

This notion of temporal precedence for parts of an event even has a pragmatic appeal. According to Thorstein Fretheim (personal communication) temporal precedence may be a plausible pragmatic explanation of verb order in an SVC because iconicity with regard to temporal sequence and linear ordering is universal and does not just depend on the syntax and semantics of the particular languages(s). As such, temporal precedence of verbs which form part of a single action may be thought of in terms of the pragmatic notion of generalised conversational implicature. We shall however not pursue this pragmatic issue further. We shall instead draw examples from Dagaare to demonstrate the PTP. Consider the following Dagaare structures in (15)

(15a) *O da moŋ la saa u di biŋ bar ku ma*
 S/he past make a.m food take put leave give me
 'S/he made food & left it there for me'

(15b) * *O da moŋ la saa u di bar ku biŋ ma*
 S/he past make a.m food take leave give put me
 'S/he made food & left it there for me'

(15c) *O da moŋ la saa u di wa ku ma*
 S/he past make a.m food take come give me
 'S/he made food & brought it to me'

In (15) there are 5 verbs encoding the notions of 'cooking food', 'taking it', 'putting it', 'leaving it there' and 'allowing someone to have it'. These are all different parts of, not just a simple event but, a complex though single event of 'cooking food for the benefit of someone'. With these various notions of 'cooking', 'taking', 'putting', 'leaving' and 'giving' there must be some kind of precedence relation. The answer to the question of which notion precedes which in this case will look like this: 'cooking something' will precede 'taking it' and 'taking it' will precede 'putting it' and 'putting it' will precede 'leaving it there' and 'leaving it there' will precede the purpose of 'allowing someone to have it'. If so, then according to PTP the verbs of cooking, taking, putting, leaving and giving must

follow each other in that order. With this principle then we have accounted for the verb order in the serial construction.

Now, consider (15b). We have the same verbs as in (15a) but this time the order of the last three verbs has changed. As a result we have an ungrammatical construction. It is important at this moment to notice that the valency constraints were unable to account for this ungrammaticality of the constructions. We indicated then that we had to look elsewhere for solutions. Can the PTP help us? The observation was made above that the notion of 'putting something down' precedes 'leaving it there' while 'leaving it there' precedes 'allowing someone to have it'. As such, verbs encoding these cognitive notions must follow this order. However, a look at the last three verbs in (15b) shows that they do not follow this order: 'leaving it there' cannot precede 'putting it down' in this context and 'allowing someone to have it' cannot precede 'putting it down'. With this we can explain in a principled way why the sentence is ungrammatical. Rearranging it according to our PTP will produce a correct sentence in the language. Unlike the valency condition, these temporal sequential stipulations based on PTP can account for verb positioning even among a group of verbs with the same arity.

There was a second case in which the valency condition could not explain in a principled way why some constructions violated the monadic - dyadic - triadic sequence and yet were acceptable in the language. Consider (15c). We have a monadic verb *wa* right in the middle of polyadic verbs. But according to PTP, 'cooking food' precedes 'taking it' and 'taking it' precedes 'bringing it' while 'bringing it' precedes 'giving it'. The verbs as they stand in the construction obey these constraints. As such PTP predicts the sentence as grammatical while valency rules predict it as ungrammatical. In such cases PTP acts as an *overriding* rule. It is important to note that this cognitive -conceptual principle takes precedence over some other conditions of our theory.

We now give an example in (16) to illustrate a minor condition which supplements or probably, in a way, overrides PTP in turn.

- (16) *O da zo wa di la suɔ ku ma*
 S/he past run come take a.m knife give me
 Ag V1 V2 V3 V4
 ' S/he ran here & took the knife for me'

Since 'wa' is not obviously an agentive verb, in this sentence, the Agent sharing would have been more 'prototypical' if 'wa'³ were not there and we got:

³Some people may not consider 'wa' as an agentive verb.

(16b) *O da zo di la suɔ ku ma
 S/he past run take a.m knife give me
 Ag V1 V2 V3

This sentence is bad because we haven't got the appropriate verbs to express all parts of the event (the inceptive part, in this case, which must occur first - refer to section 3.3.2.2.2). To satisfy this, the temporal sequence conditions have to be overridden and the 'wu' introduced to complete the inceptive part of the event structure: one cannot just 'run' and 'take' one must 'run go' or 'run come' in order to 'take'. The cognitive notion of 'movement to' must precede 'taking' in this case. We may call this principle the '*Principle of Exhaustive Phasing*' - that all phases of a complex event be expressed with this principle in mind.

We now move forward to propose an analysis of the structure of an event.

3.3 Gestalt Theory And Event Structure

Analyses throughout this thesis and works such as Givon(1991) and Li(1991) have shown that eventhood plays an important role in the definition and the functional analysis of serialisation. Yet, as regretted above, little has been done in the linguistic literature to provide an analysis of the structure of 'event', particularly complex events. Such an analysis would provide us with a mechanism for studying in a more principled way how the various aspects of a complex predicate are used to represent different parts the complex event.

We shall in this section of the thesis use data from Serial Verbs in West Africa languages and Small Clauses in Norwegian to propose a model of Event Structure. This will be in the framework of the Gestalt Theory (GT), a new grammatical theory presented in works such as Hellan and Dimitrova-Vulchanova (1993) and Tonne (1993).⁴ In this analysis we shall mainly be

⁴ 'Gestalt' is the German word for 'whole forms' or 'patterns' and is used in this sense to refer to conceptual entities and how the mind models these entities. The term 'Gestalt' is reminiscent of the Gestalt Theory of psychology which was interested in a 'holistic' approach to concepts, arguing that the whole is different from the sum of its parts and that something is essentially missing when only just the parts of an entity are examined. However, far from concerning itself with all kinds of conceptual entities, or gestalts, the present work, as a linguistic theory, focuses on what is called the 'propositional gestalt' or gestalts as they pertain to sentences or linguistic

constructions. The gestalt of a given sentence would then be "the idealised model of reality which any piece of reality has to match in the relevant respects in order to count as being referred to by the sentence." In this sense then, gestalt refers to a conceptual representation of the sentence but it may also refer to syntactic aspects of the sentence. Gestalt, then, is a relevant feature in terms of the syntactic-semantic interface relationships within a given sentence (Hellan & D-M 1993). The term then translates quite appropriately the basic concern of the theory: to pay a much closer attention on the interface relationships between the syntactic and the conceptual levels.

Now, there are different ways of conceptualising any reality and by extension different ways of expressing the same reality in natural language. As an example, we can express the same reality of hitting John in the following two ways:

He knocked John on the head

He knocked the head of John

These sentences then represent two (propositional) gestalts, two ways of modelling one 'situation-in-the-world' by the mind.

The variations representing this or any other conceptual entity may even be more substantial from language to language. One of the avowed aims of GT then is to study how this representational variation occurs from language to language. This concern of searching linguistic variation is parallel to the idea of searching language universals in other generative theories of grammar.

In addition to this idea of modelling different gestalt types in languages of the world, a further idea is to describe various aspects of each conceptual entity (gestalt) in a fine way. This may be termed the 'finer-grained' categorisation approach. It is common in some current semantic theories to categorise the various participants in a conceptual or grammatical entity as actor or agent, acted upon or theme etc. etc. without outlining their inner characterisations. GT would prefer to go a step further. Through its binary feature mechanism it is able to categorise in a finer way the various participants in the gestalt.

GT proposes various levels of analysis including, of course, conceptual and syntactic levels. So far, it is the conceptual level which is most developed.

A sentence in every natural language is supposed to evoke a certain mental image in the minds of speakers and hearers. The conceptual level within the Gestalt theory is the place where such conceptual information about the propositional gestalt is represented. The basic conceptual category at this level is called *image* and is supposed to emphasise this mental aspect of the syntactic construction. Outside the mind, and into the referential world, the conceptual notion of image would then correspond to a situation-in-the-world as evoked by the sentence, the gestalt (Hellan 1993).

There are three main dimensions of the overriding notion at this level, the image:

concerned with how the theory contributes to the analysis of event structure in 'constructionally expressed transitions' such as SVCs and Small Clause Constructions (SCCs). As such, we shall only mention certain parts of the temporal or aspectual dimension and then focus specifically on aspects of the transitional dimension of the conceptual structure.

3.3.1 *The Temporal or Aspectual Dimension*

The Temporal or Aspectual dimension of an image deals with how the image is conceived within a time scale. An important parameter for distinguishing between images is punctual/non-punctual (durative) parameter. This dichotomy indicates whether 'the whole image is mapped onto one (idealised) point in the temporal dimension, or is distributed onto a time interval'. The former case would be a punctual image while the latter would be non-punctual. Punctual images are necessarily dynamic but non-punctual images are either dynamic (when changes are occurring) or static. Punctual images can either be differentiated or monotonic. Examples of punctual verbs include the Dagaare verbs 'tɪɛ' (kick), 'pur' (burst) and 'fal' (slap) while verbs such as 'tɪɛr' (ponder) and 'mʊʊr' (suck) would be durative.

There is, however, a much more pertinent aspectual distinction with particular reference to the concept of serialisation in this work. Each SVC is either complete or incomplete and we prefer to use the terms perfective versus imperfective respectively. Consider the following Dagaare constructions in (17):

(17a) *Ba da zoro gɛɛ ɔɔɔ la*
 They past running going chewing a.m
 'They were running there and eating'

(17b) *Ba da zo gaa ɔɔɛ la*
 They past run go chew a.m
 'They run there and ate'

(17c) **Ba da zo gɛɛ ɔɔɛ la*
 They past run going chew a.m

but

(17d) *Ba da zo gaa ɔɔɔ la*
 They past run go chewing a.m
 'They run there and were eating'

the argument direction, the temporal dimension and the transitional dimension. The reader may contact the references mentioned for more information on the basic tenets and structure of the theory.

As has already been illustrated with TAMP constraints in chapter 2, all the verbs in the series must be either in the imperfective aspect (17a) or in the perfective (17b) but not a mixture (17c). This is the case with SVCs proper i.e those that express a single event as we have demonstrated throughout. In (17c) the construction should express a single event. That is why the mixture of aspectual markers renders it ungrammatical for it will be inconceivable to have earlier parts of the events as in progress while a later part would be already complete.

However, the construction in (17d) has this mixture of aspectual markers and yet is acceptable in Dagaare. This needs explanation, for though it has the structure of single event SVCs, it has a different semantics. The normal interpretation of the actions conveyed by the expression would be in terms of a sequential happening rather than the tightly related interpretations that have been explained throughout this work.⁵ The other important notion within the temporal dimension besides punctuality is *telicity*. 'For an image I to be telic means that if some event E is modelled by I, then no subpart of E can count as being modelled by I, nor can any extension of E' (Hellan and D-M 1993). The opposite case would be *atelic*.

Having now discussed the Temporal and Aspectual Structure of GT we move on to the transitional dimension specifically.

3.3.2 The Transition dimension:

The issue of transition is an important consideration in describing the image which is a mental encoding of a situation in the world or an event. Earlier characterisations of image within the spatial domain are often concentrated on movement, in the sense of traversal of path (e.g. Gruber 1965, and Talmy 1987). It is clear, however, that there are other issues here.

One contribution by GT in this respect is the notion of transition. According to this notion 'themes' or 'figures' do not only move along or traverse a path, they also serve as pivots to a certain change which defines images of its own. These new images are then the transition dimension of the change.

We suggest here that this way of perceiving things within GT is an important contribution to a principled explanation of the mental representation

⁵These construction types seem to have a very close semantic interpretation with Scandinavian constructions such as the Norwegian sentence below:

Jeg satte og spiste
I sat and ate
'I sat down eating'

of complex situations or what I term complex events. The mental representation of these complex events are, of course, complex images.

Within GT a transition may be either complete or incomplete. A completed transition always ends in what is called the result, constituting an image all by itself.

3.3.2.1 Constructional transitions

There are two major types of transitions depending on the linguistic rendition of this complex image. These are the verb inherent transitions and the constructional transitions (CT). In this analysis we shall concentrate on this latter type with data from SVCs and SCCs

In our representation of the transition dimension we see it as a sequence of images. This sequence is tied together by a pivotal or focal participant. This focal participant has been called in various ways such as undifferentiated (Tenny 1987) or monotonous (Tonne 1993) but we shall maintain the term *focal participant* to emphasise the spotlight position it occupies in this mental image, the transition.

(18) Definition of focal participant:

In any complex image, where there are two participants x, y
if x is
i. syntactically more persistent, i.e non-deletable and
ii. intuitively more affected by the relations
then x is the focal participant.

Y would then be the engendering participant in this case.

Consider the following Dagaare constructions in (19)

(19) *Bayuo ŋmε la Ayuo lɔɔ*
Bayuo beat a.m Ayuo fall
' Bayuo knocked Ayuo down'

(20) *Kåre sparket Kari ned*
Kåre kicked Kari down
' Kåre kicked Kari down'

In (19) 'Ayuo' is the more syntactically persistent because, among others, 'Ayuo' must survive in most transformations in order to keep the meaning more or less

intact. This is the case in the following imperative, nominalised and left dislocated constructions in (21a), (21b) and (21c) respectively

(21a) *ŋmɛ Ayuo ɪɔɔ*

Beat Ayuo fall

'Knock Ayuo down'

(21b) *A Ayuo ŋmɛ ɪɔɔv*

The Ayuo beat falling

'The knocking down of Ayuo'

(21c) *Ayuo la ka ba ŋmɛ ɪɔɔ*

Ayuo a.m that they beat fall

'It is Ayuo that they knocked down'

In the same way 'Ayuo' is the more affected of the two as far as the effect of 'beating' and 'falling' is concerned.

In the Norwegian small clause example in (20), for instance, Kari is the more syntactically persistent participant since it must be retained in the following imperative, passive and left dislocated transformations in (22a), (22b) and (22c) respectively in order to retain a greater amount of the original meaning.

(22a) *Spark Kari ned*

Kick Kari down

'Kick Kari down'

(22b) *Kari ble sparket ned*

Kari became knocked down

'Kari was knocked down'

(22c) *Det var Kari som ble sparket ned.*

It was Kari who became knocked down

'It was Kari that was knocked down'

Just as in (19) Kari is the more affected of the act of kicking down in this case. As a result 'Ayuo' and 'Kari' are the focal participants in (19) and (20) while 'Bayuo' and 'Kåre' are the engendering participants.

From the above, an engendering participant may then be defined simply as the author, causer or the source of a complex image.

The two cases can be compared to a photographer and the objects focused on by the lens of the photographer. Metaphorically, engendering participants are photographers while focal participants are those being photographed i.e in the spotlight of the photographers camera.

Having defined the nature of participants we give more characterisations of the constructional transition as a whole. It is clear from the above descriptions that there is always a resultant quite clearly stated in CTs. Even in aspectually incomplete CTs there is a (potential) result as in (23) and (24)

(23) *Bayuo ŋmierε la Ayuo loɔɔɔ*
 Bayuo beating a.m Ayuo falling
 ' Bayuo is knocking Ayuo down'

(24) *Kâre sparker Kari ned.*
 Kâre kicking Kari down
 ' Kâre is kicking Kari down'

Since there is always a resultant image in a constructional transition, there must be some causal or some engendering element in these constructions. We call such 'antecedents' the causal image. Below in (25) is a graphical representation of a constructional transition.

(25)

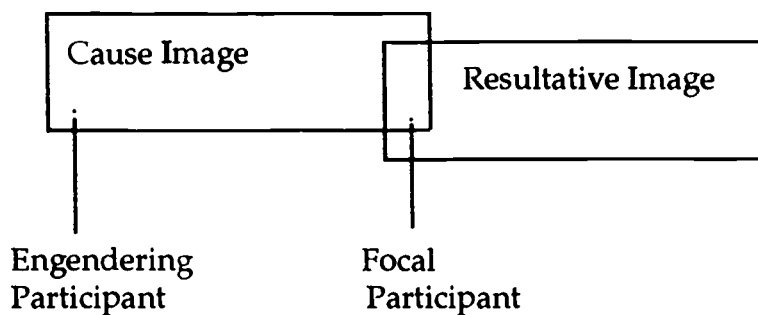

Further still, we shall now draw on the various criterial specifications we have been building at this conceptual structure description of the GT to analyse a

constructional transition as in (26) using the gamut of binary features from these criterial specifications.⁶

- (26a) *Bayuo ŋmɛ la Ayuo loɔ*
 Bayuo knocked a.m Ayuo make fall
 ' Bayuo knocked Ayuo down'

(26b)

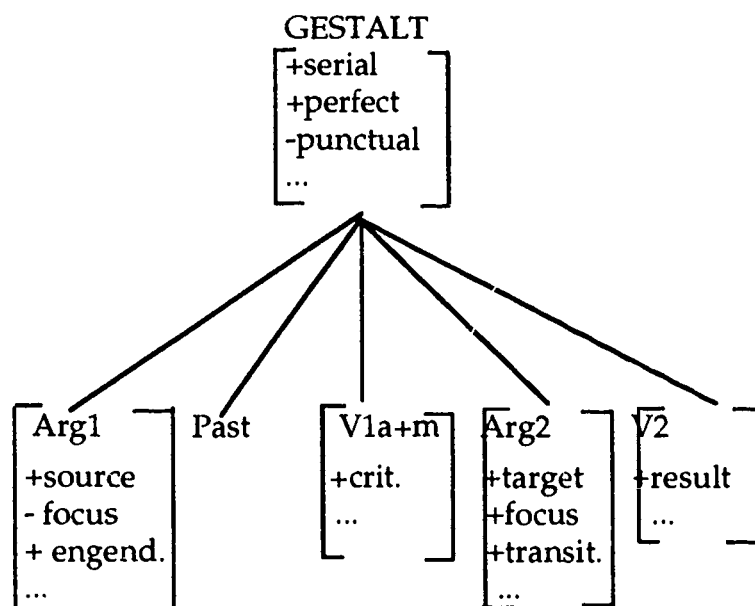

3.3.2.2 A Model of Event Structure

After this quite extensive analysis of the conceptual notion of image (which is the mental rendition of event in the referential world) offered within the framework of GT, it is now possible to propose, in a quite straight forward manner, a model of event structure.

From the characterisation we have given about an image it looks as if we can describe an event as some coherent well defined act(s) or happening(s) occurring or likely to occur within a specified temporal period and spatial location in a real world and conceived of in a uniform aspectual angle.

This rough definition of the concept shows that when we are talking about an event we refer to a cognitively well-defined unit which has temporal, spatial and

⁶This representation here is based on a tentative representation of constructional transitions in Hellan and D-V. (1993: p.35). In this monograph too one can find a definition of the binary features used. We have renamed some of the features but an entirely new feature we add here is [\pm serial]. In a way it is this feature we have been accounting for in this thesis: what it is that makes a construction as being +serial or -serial.

aspectual ramifications. There is unity of time, unity of space and unity of manner.

In a complex event therefore even though there may be two or more acts or happenings these must conform to the constraints of unity of time, unity of space and unity of manner. Any mental and linguistic expressions, images and clauses, that are attempts to instantiate an event must also necessarily respond to the above constraints (That is why temporal and aspectual constraints are important in SVCs - indeed an evidence that they encode single, albeit complex images and events).

A good way to accounting for the structure of sentences and the images that encode events is to have a working model of the notion 'event'. Based on West African SVCs and Scandinavian SCCs we propose below a universal general working model of (complex) event structure.

There are three main parts of any event in the world: one obligatory, the other two optional. For complex events at least one of the optional parts must be realised syntactically or conceptually. The diagram in (27) is our proposal for event structure.⁷

(27)

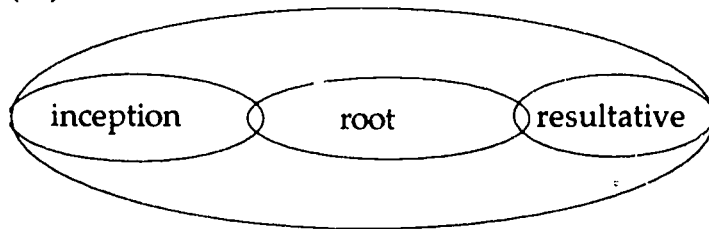

3.3.2.2.1 The root

This is the core, the most latent part of the event, comparable to the epicentre of a volcano. It must always occur and it is the purpose for which any other parts of an event exist. This is the part of the event in which the focal participant comes into the limelight. To illustrate, consider the construction in (28)

(28)

root: *Ayuo zigl la a bie*
 Ayuo seated a.m the child
 'Ayuo seated the child'

⁷ See Grimshaw (1990: 26) for brief indication of how event structure could be sketched.

Here, there is just one act, the act of seating a child. So, it is clear that this is the root of the event, as there are no other competing candidates. The focal participant is in the limelight of the act of seating. It is the one that undergoes the action or on which the effect of the action falls. Simple events always have only this part expressed by verbal predicates in canonically serialised constructions.

3.3.2.2.2 Inception

In real world situations, some acts/actions are not independent. They occur as preparatory steps towards a major act. These are connected together and are better seen as constituting a single, cohesive event.

But it sometimes happens that the expression of these facts of the event varies from language to language. For instance, in serialising languages, in expressing the event of cutting something with a knife not only is that act of cutting expressed with verbal predicates, the acts preceding the cutting are also expressed with verbal predicates, namely, that of grabbing/taking the knife to perform the major act. In the same vein the event of going out could include what acts immediately preceded the going out. If one were seated just before going out, one would have to get up. This act could be encoded in an SVC as one event, though this could be encoded as two events in non serialising languages with the presence of a coordinating conjunction. To consider the case of our example sentence above, if the child were lying down for example the event of seating the child would have to be started off by first lifting/taking the child. This would be expressed as in (29).

- (29) inception-root : *Ayuo di la a bie zigi*
 Ayuo took a.m the child seated
 ' Ayuo seated the child'

We term this preliminary act an inceptive act or an inception. This act constitutes the inceptive stage of the event. It is in expressing this that we would see one of the major differences between SVCs and SCCs.

3.3.2.2.3 Resultative

The third component of the complex event is what we term resultative. While some acts within an event may be said to be inceptive or constituting an inception of the root act of the event, others may also be said to be terminative, durative, locative, causative or, in short, resultative. They represent the result, the purpose or the consequences of the major act of the event. To take the going

out example, one may get up, go out for the purpose of buying something in the shop. This purpose will be expressed by an adjacent verbal predicate. To illustrate with our example sentence, the event of seating a child may be completed by adding a terminative predicate to show the end point of the event. This is shown in (30)

- (30) inception-root-result: *Ayuo di la a bie zigi bar*
 Ayuo take a.m. the child seat leave
 'Ayuo has seated the child there'

The above then constitute our proposed model of event structure. In the next section we illustrate with more examples from SVCs in West African languages and also from SCCs in Scandinavian, particularly, Norwegian.

3.3.2.3 SVCs in West African languages.

SVCs illustrate clearly this proposed event structure. All SVCs have at least two of the three components explicitly expressed by verbal predicates. The following constructional transitions from the West African languages, Dagbane, Akan and Yoruba in (31), (32) and (33) respectively illustrate various aspects of the model.

The first two, Dagbane and Akan illustrate the inception - root sequence. In (31) we want to express the event of wearing a shirt and not taking a shirt. However, in wearing a shirt we may have to take it up from somewhere. The act of taking initiates the whole event process.

- (31) *O zaŋ la kpargu yi*
 S/he took a.m shirt wore
 S/he took a shirt and wore it

The same is true of the Akan case. The purpose of buying the water is to drink, so in effect, we are concentrating on the fact that water is drunk and that is the root of the event. But preceding this root is the act of buying which seems to initiate the whole process.

- (32) *Kofi tɔɔ nsuo numu*
 Kofi buy water drink
 Kofi bought water and drank it

Here, there is just one act, the act of seating a child. So, it is clear that this is the root of the event, as there are no other competing candidates. The focal participant is in the limelight of the act of seating. It is the one that undergoes the action or on which the effect of the action falls. Simple events always have only this part expressed by verbal predicates in canonically serialised constructions.

3.3.2.2.2 Inception

In real world situations, some acts/actions are not independent. They occur as preparatory steps towards a major act. These are connected together and are better seen as constituting a single, cohesive event.

But it sometimes happens that the expression of these facts of the event varies from language to language. For instance, in serialising languages, in expressing the event of cutting something with a knife not only is that act of cutting expressed with verbal predicates, the acts preceding the cutting are also expressed with verbal predicates, namely, that of grabbing/taking the knife to perform the major act. In the same vein the event of going out could include what acts immediately preceded the going out. If one were seated just before going out, one would have to get up. This act could be encoded in an SVC as one event, though this could be encoded as two events in non serialising languages with the presence of a coordinating conjunction. To consider the case of our example sentence above, if the child were lying down for example the event of seating the child would have to be started off by first lifting/taking the child. This would be expressed as in (29).

- (29) inception-root : *Ayuo di la a bie zigi*
 Ayuo took a.m the child seated
 ' Ayuo seated the child'

We term this preliminary act an inceptive act or an inception. This act constitutes the inceptive stage of the event. It is in expressing this that we would see one of the major differences between SVCs and SCCs.

3.3.2.2.3 Resultative

The third component of the complex event is what we term resultative. While some acts within an event may be said to be inceptive or constituting an inception of the root act of the event, others may also be said to be terminative, durative, locative, causative or, in short, resultative. They represent the result, the purpose or the consequences of the major act of the event. To take the going

out example, one may get up, go out for the purpose of buying something in the shop. This purpose will be expressed by an adjacent verbal predicate. To illustrate with our example sentence, the event of seating a child may be completed by adding a terminative predicate to show the end point of the event. This is shown in (30)

- (30) inception-root-result: *Ayuo di la a bie zigi bar*
 Ayuo take a.m. the child seat leave
 'Ayuo has seated the child there'

The above then constitute our proposed model of event structure. In the next section we illustrate with more examples from SVCs in West African languages and also from SCCs in Scandinavian, particularly, Norwegian.

3.3.2.3 SVCs in West African languages.

SVCs illustrate clearly this proposed event structure. All SVCs have at least two of the three components explicitly expressed by verbal predicates. The following constructional transitions from the West African languages, Dagbane, Akan and Yoruba in (31), (32) and (33) respectively illustrate various aspects of the model.

The first two, Dagbane and Akan illustrate the inception - root sequence. In (31) we want to express the event of wearing a shirt and not taking a shirt. However, in wearing a shirt we may have to take it up from somewhere. The act of taking initiates the whole event process.

- (31) *O zaŋ la kpargu yi*
 S/he took a.m shirt wore
 S/he took a shirt and wore it

The same is true of the Akan case. The purpose of buying the water is to drink, so in effect, we are concentrating on the fact that water is drunk and that is the root of the event. But preceding this root is the act of buying which seems to initiate the whole process.

- (32) *Kofi tɔɔ nsuo numvi*
 Kofi buy water drink
 Kofi bought water and drank it

The Yoruba construction in (33) however has a different sequence. It is root - resultative. This is because ,intuitively, the main issue here is eating the yam. And that is the focus of the whole event. The inception portion of the event is not expressed. It is rather the resultative portion that is. Here the resultative component illustrates a finality aspect of the event.

(33) *Olu je isu tan*
 Olu eat yam finish
 'Olu finished eating the yam'

I shall further illustrate more complex cases in the following Dagaare constructions. Two important points ought to be noted in this direction. The first is that there is a changing role for the verbal predicates from construction to construction. A verb might be expressing root in one case and inception or resultative in the other. It is not that particular verbs express particular components of the event structure at all times, even though it might be possible to narrow down the ranges. The second point is that more than one verb can express either inception or resultative.

Consider the following Dagaare constructions in (34). In (34a) only one verbal predicate is expressed, so automatically we have the root component and no inceptive and resultative component of the model. This makes it a simple and not a complex event.

(34a) *O da zoe la*
 root
 S/he past run a.m
 'S/he ran'

In (34b) we have two verbal predicates and therefore a complex construction. The act of coming is the root and the act of running which was the root in (34a) is now simply expressing the means , the inceptive component of the model.

(34b) *O da zo waε la*
 incep. root
 S/he past run come a.m
 'S/he ran here'

The construction in (34c) illustrates the case where more than one verbal predicate can express a component of the model. The act of coming which was in root in the previous construction is now demoted into the inceptive stage of the

event and expresses this together with the act of running. It is then the act of kicking the ball which is the root of the event.

- (34c) O da zo wa ŋmε la a bɔl
- incep. root
- S/he past run come kick a.m the ball
- ' S/he ran here and kicked the ball'

In (34d), the act of kicking is still in the root position. There is an act of bursting which expresses a resultative function in the event.

- (34d) O da zo wa ŋmε la a bɔl pur
- incep. root resul.
- S/he past run come kick a.m the ball burst
- ' S/he came & kicked the ball flat'

This terminative predicate is supplied in (34e).

- (34e) O da zo wa ŋmε la a bɔl pur baar.
- inception root resultative
- S/he past run come kick a.m the ball burst finish
- ' S/he has finished coming to kick the ball flat'

The above explanation has served to show that the model proposed can account for longer constructions than the two or three verb constructions we have seen so far.

3.3.2.4 SCCs in Scandinavian

The next group of constructional transitions to consider are the resultative Small Clause Constructions (SCCs) in Scandinavian. They have mainly two predicates and as opposed to SVCs, SCCs have a non-verbal predicate as their second and final predicates. Further still, they do not seem to express any inceptive component, at least not by means of a verbal predicate. All these are illustrated in the Norwegian expressions in (35) and (36). In (35) 'slo' is the root and 'ned' is the resultative' with Sigrid and Sigurd being the focal and causal (engendering) participants respectively.



- (35) *Sigurd slo Sigrid ned*
 Sigurd hit+PAST Sigrid down
 'Sigurd knocked Sigrid down'

The same is true for (36). The verb 'sparket' expresses the root and 'flat' the resultative component. 'Gøran' is the causal participant while 'ballen' is the focal participant. The 'aux' marker in this SCC, like the TAMP particles in SVCs, does not express any part of the event model. It only serves to denote the temporal and aspectual dimensions of the event.

- (36). *Gøran har sparket ballen flat*
 Gøran kick+PAST ball+DEF flat
 'Gøran kicked the ball flat'

3.3.2.5 Parametric Variation between SVCs and SCCs

The above shows that it is possible to establish a parametric variation between SVCs and SCCs, (which may be called sharing gestalts because of the way the various predicates share grammatical features) without compromising the model of event structure proposed.

The differences between the two types of constructional transitions is quite systematic. Structurally, the SVCs have more than one verb while SCCs have only one verbal predicate. Functionally, the SVCs have a tendency to express the inceptive stage of the event and even does so by the use of verbal predicates while the SCCs may not even express inception at all. More pertinently, SVCs express the resultative stage of the event with verbal predicates while SCCs systematically do that with other word categories.

At this point, as has been suggested in Bodomo (1992), it can be said that the world's languages divide into two main types of constructional transitions (or gestalts): SCCs and SVCs, and the claim is that in the expression of sharing gestalts in causative constructions of the format in (37):

- (37) $S \rightarrow NP + VP [NP XP]$

the XP of non-serialising languages like Norwegian, English and French is essentially [-V] while that of serialising languages like Dagaare, Akan and Yoruba is essentially [+V]. This parametric variation has been illustrated to the best of our ability with the two types of constructional transitions in West African and Scandinavian languages.

3.4 Conclusion

This last chapter of the thesis may be regarded as the implementational part of our account of Verb Serialisation but it has also broadened the discussion to more complex phenomena than were treated in Chapter 2. It has dealt mainly with developing and implementing this integrated account of Serial Verb Constructions in Dagaare and other Mabia languages of West Africa. The account comprises four main conditions. Our methodology involved demonstrating how each of these conditions work by testing it with various kinds of serialising and non-serialising data, especially in Dagaare.

The first condition involved Grammatical Functional Reference. With several constructions, we showed that the verbs in the SVCs we describe in this work share the SUBJECT and OBJECT referents. They therefore conform to this Grammatical Functional Referent Condition. These types of serialisation are those we describe as expressing single, albeit, complex events. On the other hand, other kinds of serialisation such as Instrumental SVCs, Veiled Coordinations and Pseudocomplementations do not conform fully to the grammatical functional referent conditions. It turns out that they are the kinds of serialisation which functionally express multiple events. This condition is therefore important in delineating our data structurally and functionally from other similar kinds of constructions.

The second condition is the Valence-Sensitive Ordering Condition. It ensures that in canonical cases we have the following order of priority for verbs in the SVC: monadic verbs-dyadic verbs-triadic verbs. It was noticed however, that in some non-canonical cases, this Valency condition can be overridden by the Temporal Ordering condition.

The third condition involves the principle of Corporate Theta Role Assignment. It was developed to account for the positioning of arguments vis a vis their governing verbal predicates. It is an economy principle which ensures that verbs and their NP arguments distribute information among each other in the most efficient manner.

The last major condition is the Temporal Ordering Condition. This is expressed by the Principle of Temporal Precedence that was developed. This provides the basis for constraints ensuring that verbs are structurally ordered according to temporal precedence. The principle is powerful enough to override the Valence condition. Functionally, then, this principle ensures that irrespective of the structural constraints, verbs that are needed to express the various components of the event are well arranged. This is necessarily supplemented by

the minor principle of Exhaustive Phasing which ensures that all verbs needed to express all parts of the complex event are brought into the construction.

These conditions are structured in such a way that all SVCs coming out of them are accounted for at some point. That is why we refer to the account as integrated. This is further enhanced by the fact that the constructions are assumed to be simultaneously accessible to all levels of the grammar.

The last section of the chapter was spent looking at aspects of the Gestalt Theory (GT) of grammar and how they relate to a conceptual analysis of SVCs. Different dimensions of the conceptual level of GT were discussed before using the theory as a tool to analyse and propose a model of event structure for SVCs. According to our model there are three main parts of an event: the inceptive stage, the root stage and the resultative stage. While using GT as a tool for our analysis we also hope that we have contributed to an understanding of the nature of constructional transitions within this theory. This was illustrated with data from SVCs in West African languages and SCCs in Scandinavian languages.

With respect to coverage of data, motivation for the account came mostly from the Dagaare language and occasionally from other Mabilia languages. We do, however, conclude that because of the flexibility and integrated nature of the account, data from other languages can also be accounted for with minimum accommodation.

Concluding Remarks

The foregoing chapters have presented a structural and functional account of serialisation, one of the most pertinent and most discussed¹ structural features in Mabia and most other languages of West Africa. In these concluding remarks, I mention some of the main issues often discussed in the healthy linguistic debate provided by SVCs and then point out how the present analysis has tried to address them.

1. The Status of the Syntactic String

Naturally, the first issue concerns the structure of the string, particularly, the underlying form of verb serialisation. What type of phrase structure configuration best represents the serial structures? As Larson (1991) suggests there are basically three ways: coordination, complementation and adjunction. These three configurations are summarised below in (1)

(1a) Coordination:

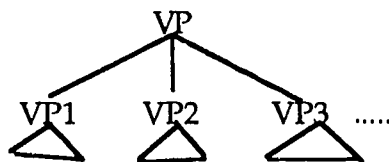

(1b) Complementation:

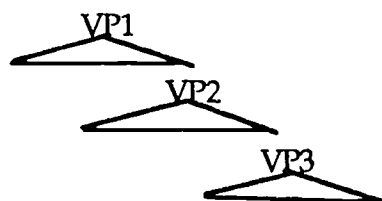

(1c) Adjunction:

¹ As early as 1973, Welmers (1973:366-380) indicated the concern for SVCs in the following way: 'Serialisation has attracted the attention of a number of graduate students in linguistics in recent years..... All of the writers agree that perhaps an adequate description is impossible within the frameworks of (the then) current grammatical models. None of the writers has been entirely satisfied with his own treatment of the subject...'

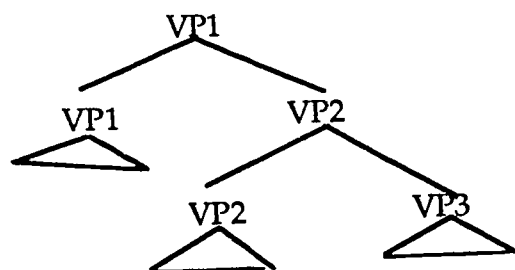

The first, the coordinate representation, considers serialisation to be basically a product of VP conjunctions. All the three verbs of the Dagaare SVC in (2), according to coordination analysis, are seen to be structurally a par, representing a '... series of successive predications of the matrix subject' (Larson, 1991:187).

- (2) *Bader zo kul waε la*
 Bader ran go home come a.m.
 'Bader came home by running'

In fact, SVCs have been described by Bamgbosi (1974) as coordinations with conjunctions suppressed. Other works that have analysed SVCs this way include Schachter (1974a, 1974b), Lord (1974) and Collins (1987).

The second configuration looks at SVC as basically constituting a series of embedded verbal complements. Here, preceding verbs are regarded as having selectional restrictions on each other. At least one work, Awobuluyi (1973) has described SVCs as constituting embedded purpose or result clauses with complementizers suppressed. Lefebvre (1991) also belongs to this group that sees SVCs as a complementation structure involving VPs.

The third group considers SVCs to be a product of adjunction: subsequent VPs are simply adjoined to the preceding VP. This is clearly the position we take. Successive VPs are considered as being adjoined or merged (footnote, Bodomo, forthcoming, explores formal aspects of this merger) to the first VP. There is syntactic motivation for this in our data. The successive VPs in the SVCs we account for have no independent TAMP markers. They are seen more as adjunct(ion)s, than as coordinations or complementations. This approach to the structure of SVCs is compatible with a new approach to grammar which considers the 'production' dimension of grammar as an "incremental building up of larger and larger constructs, with lexical objects called 'minimal signs' as the first steps" (Hellan 1993: 1). In our approach, the view that the successive VPs are adjunctions is only syntactic; it does not generalise into the semantics. In the

semantics, an adjoined verb may indeed be central to the event expressed by the entire SVC. This has been demonstrated in the relevant parts of the thesis.

2. SVCs and Eventhood

Another issue in the literature on SVCs is whether the set of verbs in the SVC together express a single event or they do in fact express separate events. We see this aspect of the debate as addressing a very important functional aspect of SVCs. To answer the question, we think that we need to have a clear picture of both the structure of SVCs and of (complex) events. We believe, however, that there has been no serious attempt in the literature at modelling a precise structure for complex events. (note however Talmy (1985) and Grimshaw (1990)). It has been the main aim of this thesis to offer models of both SVC and event structure. Based on these analyses, we conclude that for most of our SVC data, the gamut of verbs in the serial construction together express a single, albeit, complex event. We, however, leave open the possibility that some types of SVCs, such as instrumental serialisation, veiled coordination and pseudocomplementation, may indeed be cases of multi-event serialisation.

3. SVCs and Clausehood

Are SVCs monoclausal or multiclausal? This question addresses the extent to which we can say that the various verbs within an SVC are within the borders of one clause. Once again, this discussion borders on what a clause is. A clause is often described with the notion of verb finiteness. Each clause would then be composed of just a finite verb. Finiteness may be a hazy feature in most serialising languages which have a very reduced verbal morphology. Our response to this question, which is less direct than in the other cases described above, is to establish SVCs as complex predicates. We then emphasise the semantic aspects of a clause, considering it as constituting a predicate or a series of predicates, in which case it is a complex clause. A complex clause is an expanded form of a single clause and not separate clauses. In this way, then, we may conclude that our approach in this thesis favours the interpretation of SVCs as complex monoclausal constructions.

4. Verb Order

Another issue has been how to account for verb order in the SVC. Baker (1989), for instance, uses thematic assignment principles to account for verb order. We approach this issue from an integrated perspective. Two conditions within our integrated approach are postulated to account for verb order. The

Valence Sensitive Verb Ordering Condition is built on the observation that there is a tendency for lower valency verbs to precede higher valency ones. This condition by itself is not enough, as there are non-canonical cases where monadic verbs come after dyadic ones. The Principle of Temporal Precedence translates the idea that, faced with any two verbs, the one whose action has a temporal precedence over the other's action also has a sequential precedence over it. The case of a dyadic verb coming before a monadic verb will be acceptable only if the action of the dyadic verb temporarily precedes that of the monadic verb. This is how our approach addresses the quite thorny issue of verb order in SVCs.

5. Parametrisation

This issue is an inquiry into language universals. The basic questions are, why is it that some languages serialise and others do not? Can we abstract a basic parameter accounting systematically for this difference in grammatical structure across languages of the world? Suggestions here are among the most inconclusive in the whole serialisation debate. In our attempt to address this issue, we build upon a suggestion by Larson (1991) which tries to draw a parallel between SVCs and secondary predication constructions in English. Larson suggests the structures in (3) and (4) for English secondary predication and SVCs respectively:

(3) [V' V (NP) { NP/PP/AP}]
* VP

(4) [V' V (NP) { NP/PP/AP}]
*NP

What this suggests in such constructions is that there is a systematic difference in what categories can express secondary predication between serialising and nonserialisation languages across the world.

Based on this and following Bodomo (1992), I draw data from Scandinavian small clauses (SCCs) and West African SVCs to propose the following: the world's languages divide into two main types of constructional transitions (or *gestalts*), SCCs and SVCs, and the claim is that in the expression of sharing *gestalts* in causative constructions of the format in (5):

(5) S → NP + VP [NP XP]

the XP of non-serialising languages like Norwegian, English and French is essentially non-VP while that of serialising languages like Dagaare Akan and Yoruba is essentially VP . This is our proposal for a serialisation parameter, but it is subject to further cross-linguistic investigation.

The above conclusions constitute our contributions to this unending debate on one of the most challenging grammatical structures, not just in the Mbia languages of West African, but across many other languages of the world. To conclude this thesis, I shall go back home to Mbialand and borrow some authentic idiomatic concluding remarks that are used at the end of a discourse across these languages. They translate roughly as: ' I am done ! '

Dagaare: *N nuor yele baare la !* - My mouth's speech is finished!

Mampruli: *N noor naaya !* - My mouth is finished!

Appendix I: Language, History And Culture In Northern Ghana: A Sociolinguistic Introduction to the Mabia Languages

1.1. Introduction

In this appendix, we offer an introduction to the geographical, historical and cultural environments in which the Mabia languages, which have been our object of study, find themselves. We shall concentrate on the Ghana side of our research area and make occasional reference to Burkina Faso, where, Moore, the largest Mabia language is mostly situated. We first provide a geographical description of the area and show how the languages are distributed in it. Next we give a linguistic classification of the languages of the region, both in terms of genetic and typological features of these languages. There exist four main groups of languages in Northern Ghana: the Mabia, the Grusi, the Gurma and the Guang languages. While making quite regular reference to the other groups, we shall necessarily concentrate more on the Mabia languages as it is they which constitute our topic. In any case, it is this group which is the most widespread in the region and as much as 80% of the population of Northern Ghana speak the Mabia languages. Following this classification we then attempt to draw some historical and cultural affinities that exist or may have existed between these people, making occasional comparisons with other groups of people at the national level. Finally we give some sociolinguistic information pertaining to the area and especially to the major individual languages.

1.2. Geographical distribution

The Mabia languages are spoken in an area which covers the greater part of Northern Ghana and almost the whole of the Republic of Burkina Faso. This area of Africa is bordered to the South by the Forest belt and to the North by the Sahara desert. The area thus delimited is what has often been termed the savannah belt of the West African region. The Northern Ghana part of the region is approx. between latitudes 8 and 11 degrees N of the equator and longitudes 1 and 3 degrees W. A language map of Ghana, including the Ghana part of the area being described, is shown in (1).

(1)

LANGUAGE MAP OF GHANA

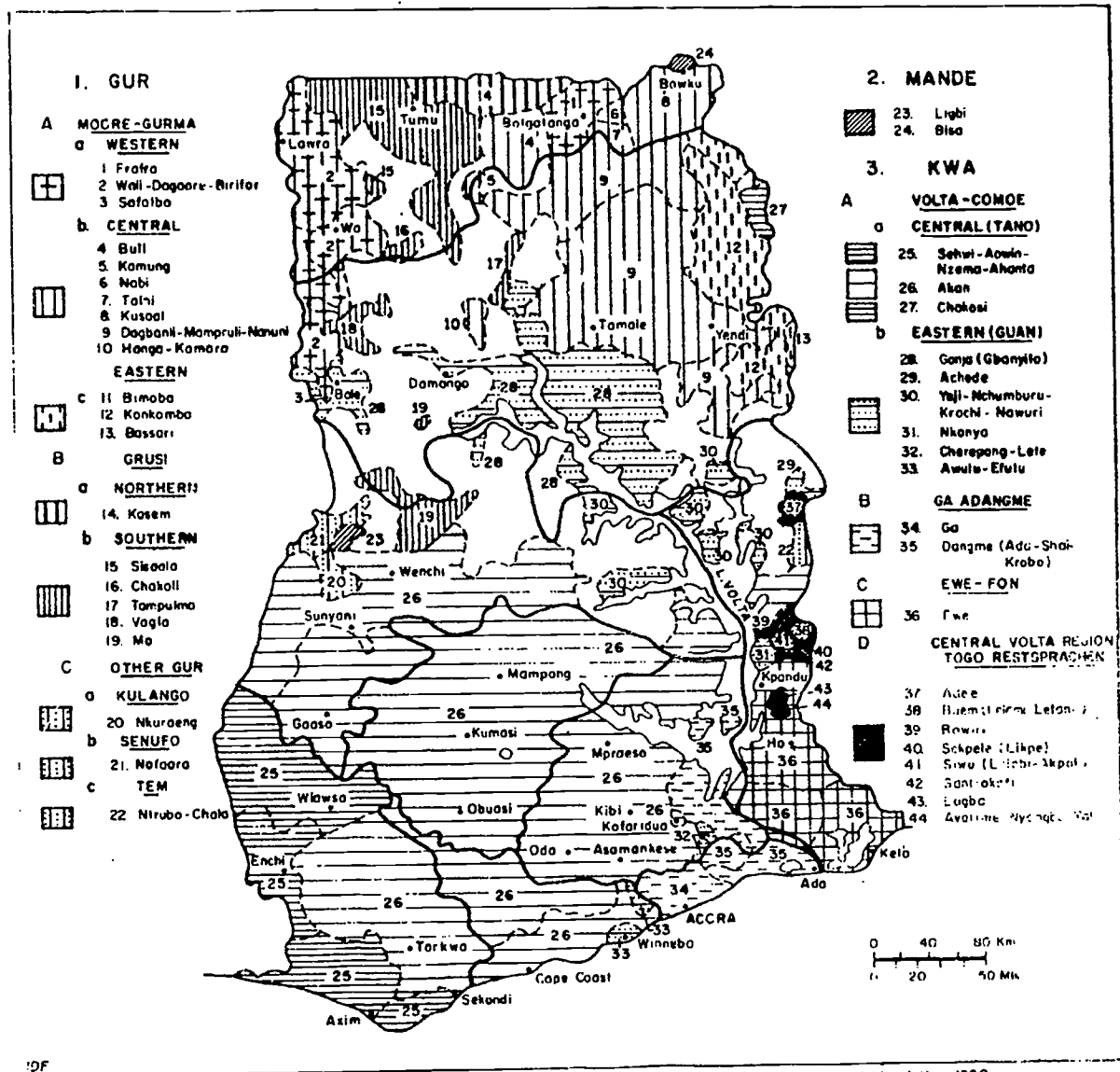

Adapted from Map of Ghana Languages by Language Centre, Legon and Ghana Institute of Linguistics, 1980

There are two main seasons, one wet and one dry, the former from April to October and the latter the rest of the year. Temperatures hardly fall below 20 degrees C and can sometimes exceed 40 degrees, except during the cold, dry harmattan winds around November and February, when the nights can be relatively cold. This area, mid way between the forest and the desert area of West Africa, is comparatively less well-known by the outside world because, as Naden (1989) puts it, it '...was cut off from direct contact with the early European traders by the forest belt and its peoples, was separated from the Saharan trade routes by the Fulani-Mali-Songhai states.... the area where Gur languages are spoken is still somewhat of a backwater.'

On the other hand, however, the region constitutes a unique climatic and social environment in West Africa which could be of great interest for linguistic

and cultural studies . Barker (1986) in a 'preliminary report' has shown both the diversities and uniqueness of peoples, languages and religions in this part of Ghana. This was however preceded by anthropological works such as Goody (1967 and 1972) and Drukner (1975) which, true to the anthropological method of participant observation, concentrated on only individual communities and not the whole region.

Not only is it a unique climatic, linguistic and cultural zone, it has also been historically regarded as a unique political and administrative zone. As Bening (1990) documents, separate administrative and especially educational policies were sometimes made for the Northern Territories, as the region was known then. It became known as Northern Ghana at independence of the whole country in 1957 and since then it has continued to be seen more or less as a composite administrative area in the country. Today, Northern Ghana comprises three of the country's ten administrative regions, Northern region with administrative seat at Tamale, the Upper east Region, with its seat at Bolgatanga and the Upper West Region with its seat at Wa.

1.3. Linguistic classification of Northern Ghana.

In classifying languages, two main methods are often used. One is genetic or historical and the other is typological. We give a brief classification of the Mabia languages using both. But before doing this we explain the nomenclature for classifying African languages and then the term 'Mabia'.

1.3.1. The Nomenclature for Classifying African Languages

In the classification of African languages, efforts have been made over the years to give appropriate cover names for groups of languages. Earlier researchers have taken a number of approaches to this linguistic nomenclature.

One method is to name groups of languages after the physical geographical features around which they are located. This is especially so with river names. Hence the largest language family in Africa is termed Niger-Congo. By calling a group of languages Niger-Congo or Oti-Volta it would mean that all these occur between the Niger and Congo rivers or between the Oti and Volta rivers or within their basins. Besides rivers, groups of languages are also named after mountain and desert names etc. Hence, we have Nilo-Saharan and Adamawa languages.

Another is the use of specific language names or features as cover names for groups of languages. Languages may be named after some sound and syllable regularities. For instance, the terms 'Kwa' and 'Gur' are used to refer to branches of the Niger-Congo family because the syllables 'kwa' and 'gur' are

thought to occur quite frequently in these languages. As an example, many personal names begin with 'kwa' in languages such as Twi and Ewe. And some language names such as 'gurma', 'gurenne' and 'gursi' begin with syllables resembling 'Gur'. So they are termed as such. Sometimes too, some prominent language names are chosen to represent a whole group. Thus we have Moore-Gurma, Moore-Dagbane or Aja-Fon.

Cardinal points are often used in conjunction with these two main methods to designate groups of languages. Hence, we may have Western Oti-Volta, Eastern Kwa, etc.

In recent times, however, as the linguistic picture became clearer, and people became more and more aware of the cultural and political affinities between groups of people who speak the same languages, language planning activities included refining this nomenclature and giving more meaningful cover names to some of these languages. Terms such as Bantu, Akan, Gbe and Guang which are a mixture of ethnographic and linguistic designations are used to describe groups of languages in East and West Africa. The term 'Akan', for instance, was used to describe a group of Kwa languages only in the 1950's (Dolphyne (1988)). 'Gbe' has also been proposed (e.g. Capo 1978) for languages such as Ewe and Fon. With this quite later development of the nomenclature of classifying African languages in mind, we now explain the term, Mabia.

1.3.2. The Meaning of Mabia

'Mabia' is a term that is in frequent use among speakers of most, if not all, of the languages I have studied in this work. It is used to designate a sibling relationship and, by extension, also a fraternal relationship between two interlocutors. It is composed of two lexical items: 'ma' = mother and 'bia' (bie or biiga) = child. Now, in the genetic classification of languages, sibling relationship is an important criterion for classifying languages into families and groups. Languages descending from a common (hypothetical) ancestor are said to be in sisterhood relationship. The languages I have studied are 'sisters'; they are more closely related to each other than to any other group of languages in the world. This has been indicated in a number of comparative historical analyses (e.g. Swadesh et al (1966), Bendor-Samuel (1971) and Manessy (1977)). They therefore belong to a common (hypothetical) ancestor. I have found it necessary to look for an authentic terminology that is more or less common to all these languages which captures this theoretical point of view in the field of diachronic linguistics. The term Mabia is, in my view, more authentic and more appropriate than the term Western Oti-Volta which has been used to describe these languages (see diagram in (2)). It is also more inclusive than the other

alternative, Moore-(Mole-) Dagomba, which is a bit confusing and which has already even been dropped in some more recent classifications (Manessy, 1977, 1981).

1.3.3. Genetic Relationship

With this explanation of the term 'Mabia', we can now use the diagram in (2) to explain the genetic relationship between these languages and with other African languages.

(2) (see next page for figure)

(2)

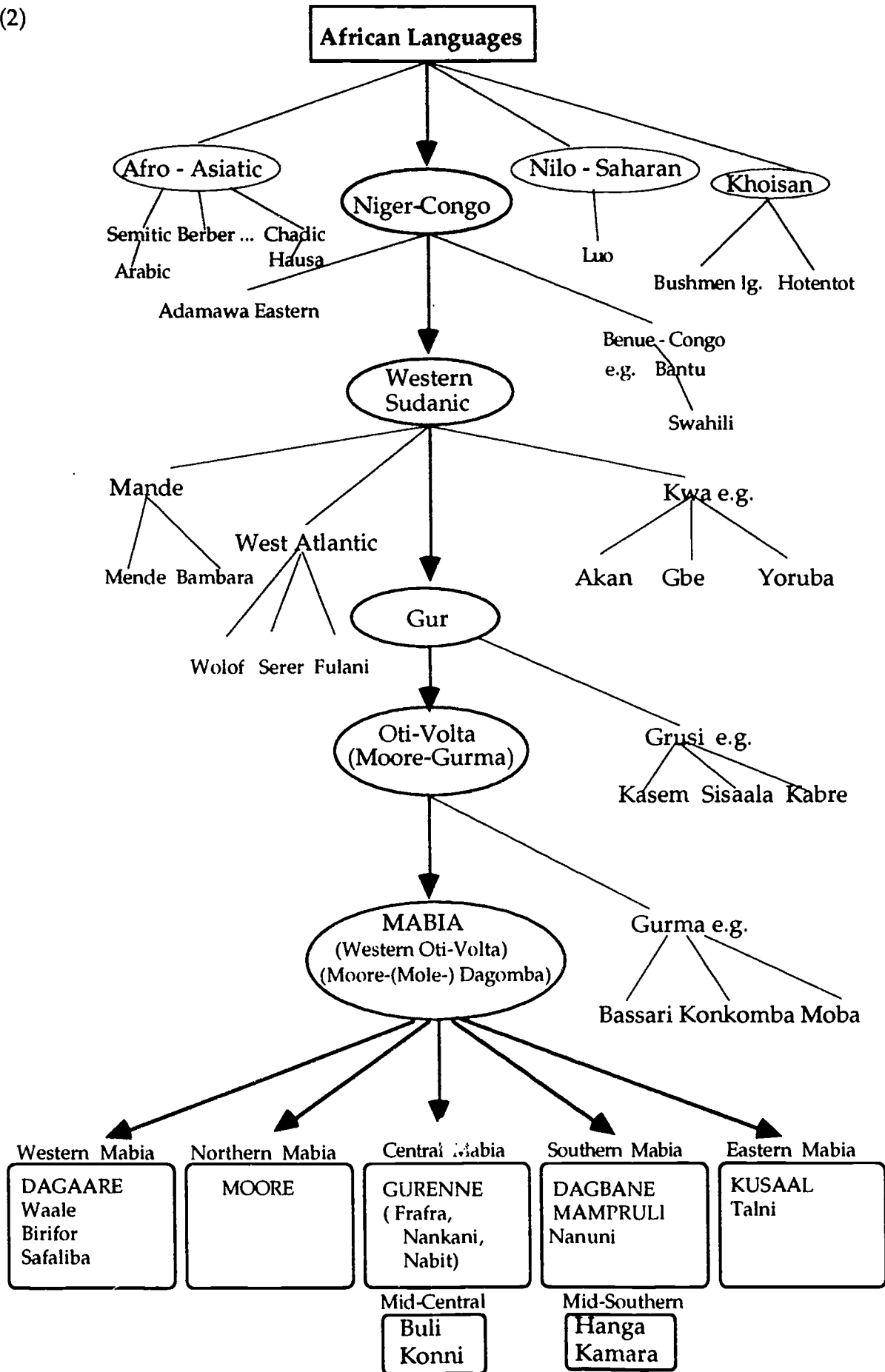

As the figure shows, each African language belongs to one of four linguistic families, Afro-Asiatic, Niger-Congo, Nilo-Saharan and Khoisan. I have indicated major languages in the other three families that do not concern us here. By far, the Niger-Congo language family is the largest. It has some of the most widespread languages in Africa, such as Swahili. The branch that concerns us most is the Western Sudanic branch. This branch in turn has four major groups, Mande, West Atlantic, Gur and Kwa. Prominent languages in these groups include Mende, Bambara (Mande), Wolof, Serer, Fulani or Fulfulde (West Atlantic) and Akan, Gbe, Yoruba (Kwa). Most of the languages in Ghana are members of the Gur and Kwa groups. Gur, in its turn, is composed of subgroups such as Oti-Volta and Grusi. Most of the languages in Northern Ghana and Burkina Faso belong to these two subgroups within Gur, which is sometimes called Voltaic, especially by French speaking scholars. Prominent languages within the Grusi subgroup include Kasem, Sisaala and Kabre. There are two important subgroups within Oti-Volta. The Gurma subgroup includes languages such as Bassari, Konkomba and Moba. The other subgroup, the Western Oti-Volta or Moore-(Mole-) Dagomba, is the one that concerns us in this thesis. This is the group that we rename as Mabia.

1.3.4. The Classification of Mabia Languages

The Mabia languages can be divided into five main groups: The languages within most of these groups are more or less mutually intelligible. Major languages within each group which we investigated are written in capitals. Western Mabia, which includes Dagaare, Waale, Birifor and Safaliba, is geographically located to the western end of the research area, i.e. Northern Ghana and parts of Burkina Faso. Northern Mabia, which includes just Moore and all its dialectal forms, is found mostly in Burkina Faso. Central Mabia is located approximately in the middle of the research area. There is one cover name for this group, Gurenne, which includes Frafra, Nankani and Nabit. This group has a subdivision which is Mid-Central Mabia. The two languages in this subgroup, Buli and Konni, though geographically close to Gurenne, are linguistically a bit distinct from Gurenne and some other Mabia languages. Indeed, there is some amount of controversy as to whether this group belongs to the Mabia group or the Grusi group. I will certainly put it in the Mabia group because of more lexical similarities with Mabia than with Grusi, a position that seems to have been confirmed by the lexicostatistics of Swadesh et al. (1966). Southern Mabia, comprising Dagbane, Mampruli and Nanuni, is geographically located to the south of the research area. As with the previous group, Southern

Mabia has a subdivision, Mid-Southern Mabia (Hanga-Kamara). Hanga and Kamara, though also occurring to the south, are quite linguistically different from, say, Dagbane. Eastern Mabia, which is the fifth group, is composed of Kusaal and Talni.

This attempt at classifying the Mabia languages does not suggest in any way that there are clear boundaries. Most of these languages do, in fact, form a continuum and speech variation is rather gradual. It is sometimes difficult to say whether Mampruli is more related to Dagbane or to Kusaal. Moving from Dagbane through Mampruli to Kusaal, we observe more of a continuum than discrete variation. A similar situation has been observed for Birifor, Waale and Dagaare in Bodomo (1989).

Data for this present work came mostly from the following which are the major languages and which also represent the major subgroups of Mabia languages: DAGAARE, DAGBANE, GURENNE, KUSAAL, MAMPRULI and MOORE. We give more, sociolinguistic, information below for these and other languages.

1.3.5. Typological Relation

Within the area of typological classification, linguists try to outline a number of regular types of phonological, morphological and syntactic features in natural languages and then see how a particular language or group of languages may be grouped according to these types of grammatical features. Naden (1989) provides an excellent summary of the grammatical features of Mabia and other Gur languages. This follows Manessy (e.g. 1975, 1979, 1981). Most of what will be said about these languages also reflect general African language features.

Phonologically, these languages are marked by a preponderance of consonants and a scarcity of vowel phonemes when compared to Indo-European languages like English, French and Norwegian. Following Manessy (1979), (3) and (4) are modified forms of the proto-Mabia and other Central Gur consonantal and vocalic systems, respectively.

(3)

Labial	Alveolar	Palatal	Velar	Labiov.
m	n	ɲ	ŋ	ɲm
p	t	c	k	kp
b	d		g	gb
f	s			

y	j	
	y	w

(4)

i	u
ɪ	ʊ
e	o
a	

The synchronic consonantal and vocalic systems of the individual Mabia languages are then built on these proto-systems, resembling them more or less.

One typological phonological feature is the issue of double articulations for some consonants. These include the three labio-velar features, as shown above. There are hardly any such features with respect to Indo-European languages. But again, this is a general African language feature, even though it is conspicuously absent in languages such as Akan. According to Naden (1980) these labio-velar obstruents and the velar ones are partially complementary as in the alternate causative/non-causative forms of the verbs die 'kʊ' / 'kpi' in Dagaare and Mampruli. Regular allophones often involve /d/ and /r/, /g/ and /ʒ/ across the various languages. There may also be limited cases of free variation between /h/ and /z/ as in the Dagaare word for 'all', 'haa' /'zaa'.

With respect to vowels, there is the typological feature of vowel harmony. This feature does not only distinguish between some of these languages and Indo-European languages, it also divides these languages into harmonising and non-harmonising languages. For instance, one difference between Western Mabia languages like Dagaare and Waale and the rest of the group is that these exhibit the system of vowel harmony based on advanced tongue root (Bodomo 1986) while the other members of the group do not seem to do this. It may, however, be possible to abstract a proto-form of vowel harmony for all these languages.

Front rounded vowels, as can be found in French and Norwegian, and back rounded vowels are absent in these languages, except when phonetically realised in some environments.

Syllabic nasality is a typological feature in these languages. These are usually realised as pronouns and particles such as the Dagaare third person pronoun /N/ as in 'm ba' (my father), 'n zu' (my head) and the particle, '-ŋ', which is the cliticised form of the polarity marker, 'la',

Mabia languages are typologically tone languages. They have primarily two tonal systems with cases of downstep in some of the languages. These tones serve to express both lexical and grammatical oppositions as in Dagaare verbs, *dá /dà*, meaning: push (many things) / buy, and as in the declarative and hortative readings of the pronouns e.g. *ù kul la yiri / ú kul yiri* - He went home /He should go home.

In terms of syllable structure, we may say that Mabia languages usually manifest open syllables. Naden (1989) mentions that both CV and CVC syllables can be reconstructed, but I think that, in cases of closed syllables, it is usually possible to reconstruct a final syllable. Thus, the Dagaare verb 'to leave', may be written either as '*bar*' or '*bari*'. There are indeed dialectal differences with respect to these two forms.

Morphological and syntactic characteristics for the Mabia languages have already been discussed in Chapter 1. The most important typological feature for these languages is the system of noun classes. Noun class manifestation is a common feature for Niger-Congo languages but while most of these languages use a prefixal pattern, Mabia and other Gur languages use a system of class suffixes. These are typically based on singular/plural alternations. Most nouns exist in three forms: the root, the singular and the plural. For instance, the Dagaare word for woman/wife '*pɔg-*' (root), '*pɔga*' (singular), '*pɔgba*' (plural). In this case the singular/plural affixes are '*-a*' / '*-ba*'. All words which behave like this would be categorised into one class.

Another important typological difference is with respect to verb morphology. In most of these languages there is a regular form of marking perfective and imperfective aspect by some suffixes on the verbs. These suffixes regularly respond to the vowel harmony feature for languages that have this. Again, this and other verbal systems have been discussed in Chapter 1.

Syntactic characteristics have also been discussed but the most important typological feature, with respect to the syntax, is the SVO parameter. Other syntactic typological characteristics include serialisation, which is the subject of this thesis.

1.4. Historical and Cultural Affinities of Speakers

The above presentation has touched on theoretical issues within genetic and typological classifications to show that these languages are quite closely related. But are there any cultural and historical affinities between the people who speak these languages?

Manessy (1979), Dakubu (1985) and Naden (1988) have all used linguistic methods to help throw some light on the historical and cultural affinities existing, or that have existed, between the speakers of the Mabia languages and also between these people and their neighbours. As Naden (1988) has indicated, there is an almost lack of written documentation of the history of this region and 'the primary source for the history of these peoples is therefore the living oral language data obtainable in this century.' (Naden 1988:205). Linguistics may therefore be one of the most important areas of study that can establish the historical and cultural relationships between the speakers of Mabia languages.

The study of migration patterns can often establish a historical link between a group or groups of people. Linguistics can help here in two ways. Based on the geographical distribution of these languages and on the analysis of living oral language, linguists have suggested two possible areas of origins for these people. Dakubu (1985:3) suggests that the cradle of present-day Gur speaking people is centred west of Ghana around present-day Bobo-Dioulasso in Burkina Faso. This is based '... on the general principle that the area of maximum linguistic differentiation is likely to be the area of oldest settlement, and adding to this the general principle that most people don't move further than they have to.' This is what I term the 'western' hypothesis, according to which present-day Mabia language speakers are supposed to have originated from the West of Northern Ghana. This hypothesis seems to be supported even by present-day migratory trends. The Birifors and other groups are still crossing the international boundary and moving into Northern Ghana in search of better farm lands, etc. Fulanis are also crossing the boundary and moving into as far as North-eastern Ghana. Naden (1988), on his part, suggests that the Mabia speaking populations originate from the east of Northern Ghana. This argument is based on the fact that the most closely related groups of the Niger-Congo family, Gur, Kwa and Benue-Congo meet in the general area of central Nigeria. This 'eastern' hypothesis seems to be supported by a current legend in Northern Ghana according to which most of the centralised states (Mamprusi, Dagomba and Mossi) recognise a common ancestor, Naa Gbewaa. Naa Gbewaa is supposed to have moved from an area in the North-East of Ghana (probably, Fada N'gourma) 'into North-East Ghana (Pusiga) and thence southwards and westwards (Gambaga- Nalerigu, Old Yendi - near Diare north of Tamale, Bimbilla) and finally northwards (the Mossi empire having roots in Nalerigu)' (Naden (1988:227).

An important reasoning in all this is that the geographical separation of people speaking related languages and the juxtaposition of those speaking

dissimilar languages is a good argument for some significant group movement. The main assumption here is of course that a language cannot move without its speakers. This seems to be very important for explaining the relationship between speakers of Western Mabia, Northern Mabia and those in the centre, east and south of the research area. For instance, the geographical neighbours of Dagaare and Waale are not their closest linguistic neighbours. These Mabia languages are separated from other Mabia languages to the east such as Gurenne, Mamprusi and Dagbane by Grusi languages such Sissala, Kasem, Tampulma and Vagla. Likewise, Sissala and Kasem separate Dagaare from Moore. One interpretation for this distribution is that some kind of movement has taken place involving Western and Northern Mabia speakers. They may have moved away from other Mabia speakers and then crossed the Grusi speaking areas to settle in their present homeland. The other interpretation is that, it is the Grusi speakers who may have pushed into a homogenous Mabia speaking area. It would seem to us that Mabia movement from their relatives in the North eastern part of the research area is the more plausible one and this is supported by works such as St. John-Parsons (1959), Tuurey (1987) and Herbert (1985), some of which are recorded versions of legends of migration.

A second way in which linguistics can help in establishing historical links between groups of people is to give indications of the periods of time these migrations took place. Based on the glottochronology of Swadesh et al (1966), Dakubu (1985) has suggested that the ancestors of present-day Mabia and other central Gur speakers separated from each other about 7 centuries ago. Based on the same study, we also suggest here that Dagaare separated from Moore, Gurenne, Mampruli, Kusaal and Dagbane about 5, 6, 7, 7 and 8 centuries ago in that order. Moore separated from Mampruli, Kusaal, Gurenne and Dagbane about 5, 6, 6 and 6 centuries ago in that order. By contrast, a language like Mampruli separated from Dagbane and Kusaal only 2 centuries ago. Based on the assumption that a language cannot move without its speakers, we may say that these are also approximate dates the people separated from each other and that before that they were living together in a common linguistic and cultural set-up. These linguistic deductions are supported by oral historical evidences of separation due to chieftaincy disputes, family quarrels, the search for better farmland, etc.¹.

Are there also cultural affinities between these people and between them and their neighbours? Despite the fact that there may be more or less synchronic

¹ of the 'Zirli ku Kufogo' evidence and how these groups of peoples trace to a common ancestor Naa Gbewaa

cultural differences (due to factors such foreign religious influences and local ecological variation) between groups of the Mabia speakers, once a historical relationship of sort has been established between any groups of people, it is also plausible and even possible to establish normative and material cultural relationships between these groups of people. A vast amount of information about the systems of inheritance, traditional political organisations and belief systems can be extracted from oral language texts such as legends, stories, (praise)-songs and the general periodical and everyday activities of the people of Northern Ghana. This, in itself, constitutes an important research agenda, as indicated by Naden (*ibid*: 237).²

As regards the system of inheritance, for instance, most, if not all, the Mabia peoples are essentially patrilineal. Besides observing this in present day life, this can be deduced from oral language texts as enumerated above. This is one main difference between the populations of Northern Ghana and the largest ethnic group in Ghana, the Akan. There are, however, other groups in the South, such as the Ga-Dangme- and Ewe-speaking populations which also have a patrilineal system of inheritance.

There are a number of similarities and differences between the populations of northern Ghana and that of the south with respect to traditional political organisation. Both parts of the country have experienced the creation of centralised states between the eleventh and the fifteenth centuries to the end of the nineteenth centuries. These include the kingdoms of the Mamprusi, Mossi and Dagomba, all of which are Mabia speakers, and later the Gonja and Ashanti kingdoms. One interesting difference within Mabia itself is that, of the six languages investigated, speakers of three of these mentioned above have a history of centralised states while speakers of the other three, Dagaare, Gurenne and Kusaal, do not seem to have this and are often referred to as being traditionally 'acephalous' (e.g. Goody). If these people have a common origin, why then the difference in this cultural political system? This is a question that merits further investigation. But for now, the following observation can be made: Legends of migration often show that the 'acephalous' Mabia mostly refer to the 'centralised' Mabia locations as the origin of their migration. The reasons for most of these migrations are often due to chieftaincy disputes, family quarrels and other forms of dissent. It would seem to me that the 'acephalous' Mabia were indeed part of these centralised political systems but had to move away because of a dissidence of some sort. With this dissidence in mind at their new locations,

² This introduction is written partly with the aim of presenting the area to potential researchers, and in that sense constitutes an open invitation.

these populations may have reorganised themselves in favour of a more decentralised political system. The political functions of chiefs was very much reduced or scraped altogether. In place of this, they had a 'Tindana', literally, owner of the land. Because each group may have arrived at slightly different stages, each major settlement has a 'Tindana' who has delegates in nearby clan settlements. The functions of the 'Tindana' are limited to cultural and religious performances with the political functions invariably curtailed from community to community. The 'Tindana' cannot normally take major political decisions, like taking in new settlers, without a meeting of delegates and elders³. While each major settlement may have their 'Tindana', because the clan system within this culture transcends settlements, there are tight political relations between most if not all the settlements in Dagao (home of the Dagaaba), for example, and in times of outside intervention, most settlements quickly rally to the aid of their kin. There is political and cultural cohesion. From this description, it is therefore misleading, in my opinion, to refer to such communities as 'acephalous' or even 'stateless'. I would therefore suggest here that, rather than being acephalous, before the advent of colonialism, which re-instituted chieftaincy of some sort to facilitate uniform indirect rule, these communities were already practising early versions of what is known today as political decentralisation. Political decentralisation is now a national developmental goal for most governments in present-day Africa.

However, this pertinent cultural parametric difference between these groups of people in Northern Ghana is becoming less and less pertinent as most communities are now under a paramountcy of some sort.

One interesting difference between Northern and Southern Ghanaian chieftaincy is with respect to the designation of the title of a chief. While that of the North is called a skin, that of the South is a stool.

Another interesting difference between North and South is the traditional costume. While Northern Ghanaian traditional dress is a smock, that of the south is a cloth, usually worn around the shoulder and under the arm. It is a woven fabric called 'kente'. However, this difference too is narrowing as these two costumes are now becoming more and more national and people from different parts of the country may be seen wearing them.

The above is only just a sketch of some of the cultural and historical affinities existing among Mabia speakers and between these and other groups

³ Evidence for this kind of parliamentary convention is in my village Kogri, called '*tiepar*' - literally, under the tree.

both in Northern and Southern Ghana. We hope, however, that this will provide a global cultural picture of the area.

1.5. Sociolinguistic Information for the Various Languages.

In this section, we list the major languages and show the areas of use for each of them in the region. The indigenous languages in the region may be divided into four main groups as follows:

1.5.1. The Grusi group

This group includes languages such as Kasem, Sisaala, Chakali, Tampulma, Vagla and Mo. Kasem and Sisaala are the most prominent in the group in terms of L1 speakers and general language planning policies.

Kasem is spoken around towns such as Navrongo, Chana, Paga and into Burkina Faso. In 1984, it was spoken by about 120, 000 L1 speakers (Barker, 1986). Kasem is one of the first literary languages of Northern Ghana, having benefited from early missionary activities. It is one of the languages selected and supported by the government for educational purposes and is already being taught at the Ajumako School of Ghanaian Languages, now part of the University College of Winneba. Most Nankane speakers in the Kassena-Nankane district also speak Kasem.

Sissala is spoken around the towns of Tumu, Gwellu and Lambussie, all in the Upper West Region. It is spoken by about 100,000 people.

1.5.2. The Guang group

Members of this group include Gonja, Achode, Nchumburu, Krachi and Nawuri. These languages are sparsely distributed around areas in the Northern Region and also in parts of the Brong-Ahafo and Volta Regions which are adjacent to Northern Ghana.

Gonja is the most prominent in this group, concentrating in towns such as Bole and Salaga and with L1 speakers numbering up to 150, 000 in 1984. Gonja is also one of the languages being promoted by the government for educational purposes. Most people in the Guang group in Northern Ghana use Gonja as a second language.

1.5.3. The Gurma group

This group includes Konkomba, Bimoba and Bassari, found at the North-eastern border with Togo i.e. the eastern sides of the Upper-East and Northern regions.

Konkomba is more prominent in this group with speakers numbering up to 250 000. Baker (1986) reports that up to 50% of Konkombas speak Dagbane as a second language in their homeland i.e. around Saboba and Zabzugu. The language is taught in primary schools and there are many literacy programmes in it.

1.5.4. The Mabia group

This is the group we have been studying in this thesis. It includes Dagbane, Dagaare, Gurenne, Kusaal, Mampruli, Buli, Koma, Nabdam, Talni, Hanga and Kamara. This group, extrapolating from 1960 figures, constitutes 80% of the population of Northern Ghana and approx. 15% of the national population. Dagbane, Dagaare and Gurenne are prominent languages, each of them numbering up to or more than half a million speakers. The largest language of the group is, however, Moore, spoken mostly in Burkina Faso by about 5 million people.

Dagbane has a large number of L1 speakers, numbering more than 500, 000 and many L2 speakers. Indeed, it is a trade language in and around Tamale. In terms of official language policies, Dagbane is the most important language in the region, especially that it is the language of Tamale, the fourth largest town in Ghana and the largest in our research area. So far, it is the only Northern Ghanaian language broadcast from the national radio and television network in Accra, the Capital of Ghana. At one time in the history of the region, 'Dagbani was adopted as the literary language of the Northern Territories in 1930...' (Bening 1990:60), but by 1933, this idea was abandoned because of a number of sociolinguistic problems. Today it is a major language of education and literacy in Dagbon, home of the Dagomba. It is taught in various undergraduate programmes at the University of Ghana and now at the University College of Winneba.

Dagaare is spoken in the Northwestern Ghana, around towns like Wa, Jirapa, Lawra and Nandom. L1 speakers number up to half a million with probably a similar number in Burkina Faso. Like Kasem, it benefited from early missionary activities and is one of the most literary languages in the region. It is taught in primary and secondary schools in Dagaao, home of the Dagaaba, and even in some schools in the Northern Region. Like Dagbane, it is taught at undergraduate programmes in the University of Ghana and now at the University College of Winneba. It is one of the six languages that is being broadcast over the Ura FM radio at Bolgatanga.

Gurenne (Frafra, Nankanne and Nabit) has a large number of L1 speakers, numbering about 450, 000. It is the language of Bolgatanga, one of the

cosmopolitan towns in the research area. It is broadcast over the GBC FM station at Bolgatanga, a very powerful and influential station for the people.

Other languages of the group used as important literacy languages covering large numbers of people are Kusaal, spoken by about 250,000 people around Bawku and Mampruli, spoken by about 100,000 L1 speakers around towns such as Gambaga and Nalerigu. Waale (about 100,000 L1 speakers) is also an important trade language in the Upper West Region and parts of Northern region. Buli, with about 65,000 speakers in and around Sandema, also has some literacy programmes running in it.

To sum up, most of these languages are being used for educational purposes in the communities. Some of them serve wider communities than their traditional areas. There are some mass communication programmes in seven of these languages at present; Dagbane, on national radio and television, Dagaare, Gurenne, Kusaal, Kasem, Sisaala and Buli on local FM radio in the area.

Hausa is often erroneously thought by many people in Ghana to be an effective lingua franca in the area but this is not true. It may have been some time ago but now, in the face of serious attempts at educational and mass communication in all these indigenous languages, awareness is being raised about the importance of the mother tongue. Besides, some of the indigenous languages like Dagbane, Gurenne and Dagaare-Waale are beginning to replace Hausa as a lingua franca in their respective areas. A non indigenous language which is, however, widely used in the area is English, the official language of Ghana.

1.6. Conclusion

The above survey is an attempt to introduce our research area and to provide basic data and information about Northern Ghana for the general public and especially for potential researchers knowing little about Ghana and, particularly, the area. No attempt has been made to exhaust any of the topics touched on as each may constitute a research topic all by itself. I should like to conclude by mentioning some resident research organisations in the area. In the area of linguistics and literacy, the Ghana Institute of Linguistics, Literacy and (Bible) Translation (GILLBT), which is a branch of the Summer Institute of Linguistics (SIL), is an important contact organisation in Northern Ghana. Its headquarters is at Tamale. Basic information about the languages and cultures of the region can be found in their library. They also run literacy programmes in many languages. The Tamale Institute of Cross Cultural Studies (TICCS) should be of special interest to anthropologically-oriented research. The Catholic

Diocesan printing houses and bookshops in the various regional capitals may also be important places to get information from. The recent opening of Ghana's fourth university, The University of Development Studies (UDS), in the region, marks an important milestone for research activities in the area.

References

- Amidu, A. (1992) 'Some Observations on Derivational Affixes in Kiswahili Predicate Items', Seminar Paper, Dept. of Linguistics, University of Trondheim.
- Angkaaraba, J. (1980) "The Nominal Phrase in Dagaari" Long Essay, Department of Linguistics, University of Ghana, Accra.
- Awobuluyi, O. (1973) 'The Modifying Serial Constructions: A Critique,' *Studies in African Linguistics* 4, 87-110.
- Awoyale, Y. (1988) 'Complex Predicates and Verb Serialisation,' ms., University of Ilorin and MIT, Cambridge, Massachusetts.
- Baker, Mark (1989): 'Object Sharing and Projection in Serial Verb Constructions,' *Linguistic Inquiry* 20, 513-553.
- Baker, Mark (1991) 'On the Relationship of Serialisation to Verb Extensions.' In *Serial Verbs: Grammatical, Comparative and Cognitive Approaches*. Studies in The Sciences of Language Series 8. ed. by C.Lefebvre, Amsterdam/Philadelphia: John Benjamins.
- Bamgbose, A.(1973) 'The Modifying Serial Constructions: A Reply,' *Studies in African Linguistics* 4, 207-217.
- Bamgbose, A.(1974) 'On Serial Verbs and Verbal Status,' *Journal of West African Languages* 9, 17-48.
- Barker, P. (1986) *Peoples, Languages and Religion in Northern Ghana*. Ghana Evangelical Committee, Accra.
- Bendor-Samuel, T. (1971) "Niger Congo, Gur" in *Current Trends in Linguistics* vol. 7, ed. Sebeok et. al. Mouton
- Bening R, B. (1990) *A History of Education in Northern Ghana : 1907 - 1976*. Ghana Universities Press, Accra.
- Bodomo, A. (1986) 'Vowel Harmony in Dagaare', Seminar Paper, Department of Linguistics, University of Ghana, Accra.
- Bodomo, A. B. (1989) A Study of Dialect Variation in Dagaare, M.A. Project, Department of Linguistics, University of Ghana, Accra
- Bodomo, A. B. (1992) A Unification-Based Grammar of Serial Verb Constructions. In *Proceedings of the 1991 Scandinavian Conference in Computational Linguistics*, Bergen, Norway

- Bodomo, A. B. (forthcoming) Unification and Verb Serialisation.
- Bodomo, A.B. (forthcoming) 'Sharing gestalts among Scandinavian and West African: A case of parametric variation ?
- Bodomo, A. B. (in preparation) The Noun Class System of Dagaare: A Phonology-Morphology Interface.
- Capo, H (1978) 'Please, call me MIDOGBE'. ms Dept of Linguistics, University of Ghana, Accra, Ghana.
- Carstens, V. (1988) ' Yoruba Serial Verbs,' paper presented at 2nd Niger-Congo Syntax and Semantics Workshop, MIT, Cambridge, Massachusetts, April 1988.
- Chang (1990) 'On Serial Verbs in Mandarin Chinese: VV Compounds and Co-Verbial Phrases' in *When Verbs Collide: Papers from the 1990 Ohio State Mini Conference on Serial Verbs. Working Papers in Linguistics No. 39.* (ed) Joseph B. D and Zwicky A. M.
- Chomsky, Noam (1981): *Lectures on Government and Binding*, Foris, Dordrecht.
- Chomsky, Noam (1986): *Barriers*, MIT Press, Cambridge, Massachusetts.
- Chomsky, Noam (1992) ' A Minimalist Program for Linguistic Theory', *MIT Occasional Papers in Linguistics*, 1
- Christaller, J. G. (1875) *A Grammar of the Asante and Fante Language called Tshi.* Basel: Basel Evangelical Missionary Society
- Craig, C. and K. Hale (1988) ' Verb sequencing Constructions in Macro-Chibchan,' paper presented at 2nd Niger-Congo Syntax and Semantics Workshop, MIT, Cambridge, Massachusetts, April 1988.
- Dakubu, M. E. K., (1985) "The Peopling of North-Western Ghana", Accra.
- Dakubu, M. E. K., (1989) 'The Dagaare Verbal Phrase', ms Department of Linguistics, University of Ghana, Accra.
- Dalrymple, M. E. (1990) *Syntactic Constraints on Anaphoric Binding* Doctoral dissertation, Stanford University.
- Déchainé, R.-M (1986) *Opérations sur les structures d'argument: Le cas des constructions sérielles en haitien*, Master's thesis, Université du Québec à Montréal.
- Dolphyne, F. A. and Kropp-Dakubu, M. E. (1988) 'The Volta-Comoe Languages' in *The Languages of Ghana* . ed Kropp-Dakubu, M. E.

- Dong, D.A. (1981) 'The Verb Phrase in Dagaare ', Long Essay, Language Centre, University of Ghana, Accra.
- Drukner, B. S. (1975) *Ritual Aspect of Mamprusi Kingship*. Leiden: Afrika-Studiecentrum, Cambridge: African Studies Centre.
- Fargeli, O. T. (1993) *Verbal Derivations in Fulfulde*, Thesis, University of Trondheim.
- Givon, T (1991) 'Some Substantive Issues Concerning Verb Serialisation: Grammatical vs Cognitive Packaging.' In *Serial Verbs: Grammatical, Comparative and Cognitive Approaches*. Studies in The Sciences of Language Series 8. ed. by C.Lefebvre, Amsterdam/Philadelphia: John Benjamins.
- Goody, J. (1967) The Social Organisation of the LoWiili, IAS, London.
- Goody, J. (1972) The Myth of the Bagre, OLAS, Oxford.
- Grimshaw (1990) *Argument Structure*. , MIT Press, Cambridge, Mass.
- Gruber, (1965) *Studies in Lexical Relations*, Doctoral dissertation, MIT, Cambridge.
- Hale, K.(1991) 'Misumalpan Verb Sequencing Constructions' In *Serial Verbs: Grammatical, Comparative and Cognitive Approaches*. Studies in The Sciences of Language Series 8. ed. by C.Lefebvre, Amsterdam/Philadelphia: John Benjamins.
- Hellan, L. (1988) *Anaphora in Norwegian and Theory of Grammar*. Foris, Dordrecht
- Hellan, L. (1991) A two-level X-bar system, *Lingua* 84 239-257. North-Holland
- Hellan, L. (1993) *Minimal Signs and Grammar*, ms, Dept of Linguistics, University of Trondheim.
- Hellan, L. and Dimitrova-Vulchanova, M. (1993) *The Gestalt Framework* (monograph),
- Herbert, J. (1985) Esquisse d'une Monographie Historique du Pays Dagara. Diebougou.
- Jansen, B., H. Koopman, and Muysken (1978) 'Serial Verbs in the Creole Languages,' *Amsterdam Creole Studies* 2, 125-159.

Joseph B. D and Zwicky A. M (1990) ed. When Verbs Collide: Papers from the 1990 Ohio State Mini Conference on Serial Verbs. Working Papers in Linguistics No. 39.

Larson, R. K.(1991) 'Some Issues in Verb Serialisation' In *Serial Verbs: Grammatical, Comparative and Cognitive Approaches*. Studies in The Sciences of Language Series 8. ed. by C.Lefebvre, Amsterdam/Philadelphia.

Lefebvre, C. (1986) 'Serial Verbs in Fon: a lexical account' In Rapport de Recherche -Haiti, (ed) J. Kaye and C. Lefebvre. Universite du Quebec a Montreal

Lefebvre, C. (1987) " 'PRENDRE' + 'ALLER' = APPORTER: la formation de predicats complexes en Fon" Presented at the 8th International Conference of Linguistics, Paris.

Lefebvre, C. (1991)'Take Serial Verb Constructions: Please,'In *Serial Verbs: Grammatical, Comparative and Cognitive Approaches*. Studies in The Sciences of Language Series 8. ed. by C.Lefebvre, Amsterdam/Philadelphia: John Benjamins.

Lefebvre, Claire ed.(1991) *Serial Verbs: Grammatical, Comparative and Cognitive Approaches*. Studies in The Sciences of Language Series 8. Amsterdam/Philadelphia.

Li, Y () 'On Deriving Serial Verb Constructions.' In *Serial Verbs: Grammatical, Comparative and Cognitive Approaches*. Studies in The Sciences of Language Series 8. ed. by C.Lefebvre, Amsterdam/Philadelphia: John Benjamins.

Lord, C. (1973) 'Serial Verbs in Transition.' *Studies in African Linguistics* 4. 269 - 296.

Manessy, G. (1975) *Les Langues Oti/Volta*. Paris: SELAF.

Manessy, G. (1977) 'Linguistique historique et traditions ethniques: Les peuples voltaiques dans l'est de la boucle du Niger', in: *Zur Sprachgeschichte und Ethnohistorie in Afrika*, ed. by Mohlig et al Berlin.

Manessy, G. (1978) *Le kirma, le tyurama, et les langues voltaiques centrales*. AuU 61: 82 - 119.

Manessy, G. (1979) *Contribution a la classification des geneologique des langues voltaiques (le groupe proto-central)*. Paris: SELAF

- Manessy, G. (1981) 'Les langues voltaïques ' in: *Les langues dans le monde ancien et moderne* , ed. by Jean Perrot: Paris: CNRS
- Manzini, R. (1988) 'Constituent structure and locality'. In: A. Cardinaletti, G. Cinque, G. Giusti (eds), *Constituent Structure* . Dordrecht: Foris
- Muysken, P. (1981) 'Quechua Word Structure' In Heny, ed., *Binding and Filtering*, pp. 279 - 327. MIT Press, Cambridge.
- Naden, A. (1980) ' Review of Manessy 1975' *Journal of African Languages and Linguistics* 2, 2: 156 - 159.
- Naden, A. (1988) 'Language, History, and Legend in Northern Ghana', *Sprache und Geschichte in Afrika* 9 205 - 246
- Naden, A. (1989) 'Gur' in Bendor-Samuel ed *Niger-Congo*, Lanham, MD. : Universities Press of America.
- Pullum, G. K. (1990) 'Constraints on Intransitive Quasi-Serial Verb Constructions in Modern Colloquial English' in *When Verbs Collide: Papers from the 1990 Ohio State Mini Conference on Serial Verbs*. Working Papers in Linguistics No. 39. (ed) Joseph B. D and Zwicky A. M.
- Ross, J. R. (1967) *Constraints on variables in syntax*. Doctoral dissertation, MIT, Cambridge, MA.
- Schachter, P. (1974) ' A non-Transformational Account of Serial Verbs' *Studies in African Linguistics*, supplement 5, 253-270
- Schacter, P. (1974) 'A Non-Transformational Account of Serial Verbs', *Studies in African Linguistics* , supplement 5, 253-270.
- Schiller (1990) 'On the Definition and Distribution of Serial Verb Constructions' in *When Verbs Collide: Papers from the 1990 Ohio State Mini Conference on Serial Verbs*. Working Papers in Linguistics No. 39. (ed) Joseph B. D and Zwicky A. M.
- Schiller (1991) *An Autolexical Account of Subordinating Serial Verb Constructions*. Doctoral dissertation, Ohio State University.
- Sebba, M. (1987) *The Syntax of Serial Verbs : An Investigation into Serialization in Sranan and other Languages*. Amsterdam: Benjamins
- Seuren (1990) 'Serial Verb Constructions' in *When Verbs Collide: Papers from the 1990 Ohio State Mini Conference on Serial Verbs*. Working Papers in Linguistics No. 39. (ed) Joseph B. D and Zwicky A. M.

- St. John-Parsons, Donald (1958) *Legends for Northern Ghana*. London: Longmans & Accra: SPC
- Stewart, J. M. (1971) 'Niger - Congo, Kwa' In *Current Trends in Linguistics*, vol. 7 ed T. Sebeok. Mouton: Paris
- Swadesh et al. (1966) "A Preliminary Glottochronology of the Gur Languages", in Journal of West African languages vol.3.2.
- Talmy, L. (1987) 'Lexicalization patterns: semantic structure in lexical forms' in Shopen, T. (ed): *Language Typology and syntactic description* , III. Cambridge University Press.
- Tenny, C. (1987) *Grammaticalizing Aspect and Affectedness* . Doctoral dissertation, MIT.
- Tonne, I. (1993) *Scales and Participants*, Working Papers in Linguistics No. 15, University of Trondheim
- Tuurey, G. (1987) Introduction to the Mole-speaking Community, Catholic Press, Wa.
- Welmers, Wm. E. (1973): *African Language Structures*. Berkeley: University of California Press
- Williams, E (1984) 'Grammatical Relations,' *Linguistic Inquiry* 15, 639-673

ISSN 0802-3956

148