

DOCUMENT RESUME

ED 364 536

SP 034 904

AUTHOR Allen, Michael G.; Sheppard, Ronnie L.  
 TITLE Teacher Advisory Programs in Georgia: A Handbook of Ideas and Activities.  
 PUB DATE 92  
 NOTE 115p.  
 PUB TYPE Guides - Classroom Use - Teaching Guides (For Teacher) (052)

EDRS PRICE MF01/PC05 Plus Postage.  
 DESCRIPTORS \*Adolescent Development; Elementary School Students; Elementary School Teachers; \*Group Guidance; Intermediate Grades; Junior High Schools; Junior High School Students; \*Learning Activities; \*Middle Schools; Program Design; Program Development; Program Implementation; \*School Counseling; Secondary School Teachers; Student Attitudes; Student Behavior; \*Teacher Student Relationship; Teaching Models

IDENTIFIERS Advisory Approach; Georgia; \*Teacher Advisors

ABSTRACT

An important component of sound middle school education is a commitment to providing coordinated advising and counseling services in the school setting. This handbook describes how middle school professionals can develop small group advisory support for each student. Known variously as home-base, advisor-advisee, or teacher advisory (TA) programs, the concept is designed to lend concrete support to students experiencing the changes inherent in early adolescence. The publication, organized into four sections, provides a description of the TA process. Section 1 "A Georgia Model of Teacher Advisory Programs" discusses the characteristics of TA programs focusing on the following topics: (1) why have a TA program? (2) what are the goals of TA programs? (3) how are TA groups formed? (4) when do TA groups meet? (5) where do TA groups meet? (6) how do TA groups get started? (7) what does the teacher advisor really do? (8) what results accrue from TA programs? and (9) the do's and don'ts of TA programs. Section 2 "Teacher Advisory Programs in Georgia" presents concrete examples of activities and ideas from the field; section 3 offers resources for TA programs; section 4 requests teacher's ideas for future TA program guides. An appendix lists schools that contributed advisory program ideas. (LL)

\*\*\*\*\*  
 \* Reproductions supplied by EDRS are the best that can be made \*  
 \* from the original document. \*  
 \*\*\*\*\*

# TEACHER ADVISORY PROGRAMS IN GEORGIA

## A Handbook of Ideas and Activities



U.S. DEPARTMENT OF EDUCATION  
Office of Educational Research and Improvement  
EDUCATIONAL RESOURCES INFORMATION  
CENTER (ERIC)

- This document has been reproduced as received from the person or organization originating it.
- Minor changes have been made to improve reproduction quality.
- Points of view or opinions stated in this document do not necessarily represent official OERI position or policy.

"PERMISSION TO REPRODUCE THIS  
MATERIAL HAS BEEN GRANTED BY

*M. G. Allen*  
\_\_\_\_\_

**Michael G. Allen**

**Ronnie L. Sheppard**

TO THE EDUCATIONAL RESOURCES  
INFORMATION CENTER (ERIC)."

58034904

## DEDICATION

To the early adolescents and their teachers who populate the middle grades throughout the great state of Georgia. May they continue to meet and grow through first-rate Teacher Advisory Programs. And may we all remember that there is no finer calling in this life than total commitment of a teacher to the academic and social-emotional well being of early adolescents.

Michael G. Allen

Ronnie L. Sheppard

Copyright 1992 by Michael G. Allen and Ronnie L. Sheppard.  
All rights reserved. No part of this publication may be reproduced or transmitted in any form or by any means without permission in writing from the authors with the following exceptions:

The purchase of this book entitles the buyer to reproduce materials for classroom use.

Reproduction for use beyond that teacher's class or team is strictly prohibited.

Imagining Systems Specialists  
Donna Colson  
Julie Mizell  
Tina Southwell

Printed in the United States

\$10.00

ii 3

BEST COPY AVAILABLE

## TABLE OF CONTENTS

<b>FOREWORD</b>	iv
<b>Section 1. A Georgia Model of Teacher Advisory Programs</b>	1
<b>Introduction</b>	1
A. Why Have A Teacher Advisory Program?	2
B. What Are the Goals of Teacher Advisory Programs?	2
C. How Are Teacher Advisory Programs Formed?	3
D. When Do Teacher Advisory Groups Meet?	3
E. Where Do Teacher Advisory Groups Meet?	3
F. How Do Teacher Advisory Groups Get Started?	4
G. What Does the Teacher Advisory Really Do?	4
H. What Results Accrue From Teacher Advisory Programs	4
I. Teacher Advisory Programs: Do's and Don'ts	5
<b>Section 2. Teacher Advisory Programs in Georgia: Examples From the Field</b>	7
<b>Section 3. Resources for Teacher Advisory Programs</b>	105
<b>Section 4. You Can Become Part of Volume 2</b>	107
<b>Appendix A.</b>	108
Schools That Contributed Advisory Activities	108
<b>About the Authors</b>	111

## FOREWORD

Change is the only constant in life today. How many times have we all heard this stated? Commentators constantly cry "Wolf" as they outline the manifold pressures on and problems challenging early adolescents in the final decade of the 20th Century.

Report after report presents volumes of data to substantiate the reality that these youth need significant adult support to survive the time period. A recent report (Turning Points, 1989) stresses the importance of providing small group advisory support for each student in the middle school. This publication is about how middle school professionals can develop such support groups.

Known variously as home-base, advisory-advisee, or teacher advisory programs, the concept is designed to lend concrete support to students experiencing the changes inherent in early adolescence. In addition to answering "why", "how", "what", "when", "where", questions, the publication provides readers with concrete examples of teacher advisory programs currently functioning in middle schools throughout Georgia.

These are exciting times in Georgia's middle schools. With clear commitments to improving the educational experience of young adolescents comes the challenge to develop or otherwise redesign extant programs to meet their myriad needs. Teacher advisory programs are an essential vehicle for addressing far-reaching social-emotional problems while providing each youngster with a small group support system that is clearly necessary today.

Readers are invited to share successful TA programs that may be in place in their middle grades schools. There is a reporting form at the end of this publication for sharing this important information. Each person who submits TA materials will be credited with the submission.

Michael G. Allen

Ronnie L. Sheppard

# SECTION 1

## A Georgia Model of Teacher Advisory Programs

### Introduction

A recent publication (Johnston, 1990) paints a chilling picture of the "new American family" and related changes this important institution of society has experienced in recent decades.

Data on current household composition, childbirth and family relationships offer a dramatically different view of the family than exists in the minds of most Americans. That schools today are challenged by significant demographic and value shifts in families whose children they are required to educate is axiomatic.

It is a "new day" in the United States, and the changes in recent years lie at the heart of many of the problems faced by public education. Among the many "solutions" offered by educators and others, the middle school represents a conscious attempt to positively influence the lives of early adolescents. As "an educational response to the needs and characteristics of [early adolescents] it deals with the full range of intellectual and developmental needs" (This We Believe, 1982, 1992).

In a recent report (Turning Points, 1989) data regarding the impact of modern life on early adolescents is presented. Even a cursory review of the challenges that face young adolescents today reveals a pressure-packed, stress-inducing day-to-day reality. The middle school remains the single major social institution, beyond the immediate family, capable of moderating the impact of our changed social situation on these young people.

An important component of sound middle level education is the clear commitment to providing coordinated advising and counseling services in the school setting. The usual response to such a need--employing one or more guidance counselors--is insufficient to meet the growing social-emotional needs of early adolescents.

Every middle school student "needs an adult who knows him or her well and is in a position to give individual attention" (This We Believe, 1992). Home-base, advisor-advisee or teacher advisory programs are the principal means of providing early adolescents regular and recurring opportunities to interact with both caring adults and a small group of peers.

What follows is a description of the Teacher Advisory process. The characteristics of TA are discussed in a question-answer format.

**A. Why Have A Teacher Advisory Program?**

Middle schools exist not simply to provide academic work in the core subjects. They are responsible for providing appropriate and necessary support for both the cognitive and affective needs of early adolescents. Well-developed teacher advisory programs provide this necessary support.

There is no single "best" way to begin teacher advisory programs. Beyond the basics--one teacher and a small group of students meeting on a regular basis--the options are almost limitless. What follows is a detailed description of the "what, how, when, and where" of teacher advisory program development.

**B. What Are The Goals of Teacher Advisory Programs?**

Middle grades schools are designed to promote both the academic and social-emotional development of early adolescents. The notion that these schools should play an important role in students' personal development is an accepted part of the middle school concept.

Goals of any educational program are neither static nor absolute. As conditions change, so, too, must goals. Teacher advisory programs do, however, share certain common goals. They include assisting young adolescents in becoming self-possessed, positive and successful in both life and learning.

All TA programs should promote student success in school, improve communication between student, school and family, and provide a nurturing experience for each student in the school setting. Finally, TA programs generally result in improved school climate, bonding between students and between students and teachers.

TA programs are practical responses to the expectation that "Each early adolescent needs an adult who teaches him or her well and is in a position to give individual attention" (This We Believe, 1992, pp. 12-13).

**C. How Are Teacher Advisory Groups Formed?**

Groups may be composed of students from one grade level or they may be multi-age grouped. In some advisory programs, students are randomly placed in groups by the administrator or counselor. Occasionally, advisory groups are formed according to their first period class or homeroom. In situations in which teams exist, teacher teams may divide their students into groups. In schools that have a diverse population, advisory groups are often formed by taking the population and balancing each advisory group using the following variables: sex, achievement scores, and race. In this situation, each group is similar in structure, with a balance between race, sex, and developmental levels.

**D. When Do Teacher Advisory Groups Meet?**

As is the case in many schools, schedules for teacher advisory vary depending on the grade configuration, size of the school, and school organization. For the most part, advisory groups meet at a regularly scheduled time during the day when the advisor and advisees can get together. An alternative would be to schedule an advisory period two or three times a week. Whatever the schedule developed, advisory programs need meet regularly to promote intra-group communication. Depending on the function of the advisory program, the placement of the time during the day may vary from the first part of the day, middle of the day, or at the end of the day. Decisions about the organization of an advisory program should be based on the goals of the program.

**E. Where Do Teacher Advisory Groups Meet?**

Advisory groups meet throughout the school building in order to reflect a community atmosphere. One plan is to organize grade level advisory groups located in the building where these grades are located. Another plan is to form advisory groups in each team. These meetings can take place in the rooms used by the various teams. In some schools, multi-age grouping exists, thus plans can be made to assign advisory groups in various locations of the buildings. As schools



plan their advisory programs, they need to keep in mind that if advisory groups utilize the entire building then the program is perceived as a school effort and one that is recognized as being a central part of the school curriculum.

#### **F. How Do Teacher Advisory Groups Get Started?**

A successful advisory program begins with a clearly defined purpose. An organizational plan is determined based on the purpose of the program in each individual school. Substantial staff development is needed prior to implementation to provide a direction and purpose for the advisory program, as well as administrative support. Attempts should be made to develop an advisory curriculum that includes regular activities, as well as special activities, that are school based. Advisory experiences should be varied--study skills, interpersonal relationships, career planning, citizenship education, and other experiences that balance the emphasis on the affective and cognitive domains. Advisory programs must evolve from the needs of the students. Advisory experiences should be coordinated-- perhaps by an advisory committee--across grade levels in order to prevent duplication and assure that the advisory program addresses needs at varied developmental levels.

#### **G. What Does the Teacher Advisory Really Do?**

Teacher advisors complement the school guidance program by providing students with daily interaction with an adult. Teacher advisors provide an environment and activities that foster acceptance, assist students in setting personal goals, develop interpersonal relationships, provide experiences in critical thinking and problem solving, develop communication skills, build self-esteem, accept responsibility, help students become good citizens, and provide opportunities for meaningful dialogue. Teacher advisors should establish a rapport in order to get to know students on a personal level. They promote communication between home and school and plan activities that will assist students in growing socially, emotionally, and intellectually. The teacher advisor serves as a caring adult and plays a major role in a school.

#### **H. What Results Accrue From Teacher Advisory Programs?**

Teacher advisory programs result in a school that provides opportunities for

students to cope with personal conflict, discuss their strengths, become accepting of themselves as growing individuals, and strategies to interact with others. Such a climate leads to more students being involved in their own learning, confidence in facing the rapid changes they are experiencing, and skills needed to become successful in their own development. Advisory programs provide opportunities for students to become active members in their school and community, thus becoming more confident in facing challenges they encounter. Students develop a sense of personal worth, enabling them to set personal goals. The most successful teacher advisory programs establish a school climate that is cooperative and built on trust.

### **I. Teacher Advisory Programs: Do's and Don'ts**

While each effort to develop and sustain on-going TA programs is unique there are a number of "Do's and Don'ts" that will assure greater success. Adapted from James (1986) they focus on the process of initiating TA programs and on expanding and improving TA in your school.

#### **1. The DO'S of TA Programming**

- a. DO assess the need for a TA program in your school with colleagues before developing such a program.
- b. DO arrange a total staff meeting to discuss the importance and implications of your findings.
- c. DO ask for volunteers to serve on a Steering Committee for further study of options before initiating a TA program.
- d. DO secure administrative approval for your initial plans.
- e. DO expand your Steering Committee to include students, parents, and school support staff.
- f. DO gather information about functioning TA's from other schools involved in such a program.
- g. DO develop a set of recommendations for development of a TA program.
- h. DO arrange for specific staff development prior to implementing a TA program.
- i. DO designate a program coordinator.
- j. DO design a calendar of themes, topics, and activities that are meaningful to both advisors and students.
- k. DO keep administrators and parents informed of progress.

- l. DO plan continuing evaluation of the TA program.
- m. DO give advisors the latitude to "do their own thing" within reason.
- n. DO recognize publicly events sponsored and conducted by various TA groups.
- o. DO look for opportunities to interface TA activities with other aspects of the school experience.
- p. DO remain flexible.

## 2. The DON'T of TA Programming

- a. DON'T expect the program development process to be free of conflict.
- b. DON'T try to solve all the social-emotional problems extant in the school through TA programs and activities.
- c. DON'T get frustrated. Developing first-rate TA programs is difficult.
- d. DON'T copy another school's program. Develop your own.
- e. DON'T succumb to arguments that relegate TA programs to a secondary status in the overall school program.
- f. DON'T forget to follow through on appropriate staff development as an important component of TA program development.

# SECTION 2

## Teacher Advisory Programs in Georgia: Examples From The Field

The authors extend a hearty THANK YOU to teachers who contributed TA program descriptions to this publication. Your willingness to spend quality TA time with early adolescents makes a real difference in the lives of these young people beyond measure.

This section presents contributors' descriptions of TA programs existing in many of Georgia's middle grades schools. We reproduced each contribution faithfully, in spite of the fact that several ideas/suggestions/descriptions of activities may already be copyrighted. It is impossible to determine the principal source of a number of the activities. The authors acknowledge the possibility of already copyrighted material in this publication, though have made every effort to secure the original source of each.

Readers are reminded that they may contribute to a Volume Two by submitting their ideas for TA programming which are in practice in their middle grades classrooms. The form for submission is found at the end of this publication.

# FIND SOMEONE WHO...

\*\*\*Each member of the group takes turns getting other members to sign his/her sheet.  
A person can only sign your sheet twice.

Is wearing tennis shoes \_\_\_\_\_

Has brown eyes \_\_\_\_\_

Enjoys watching sports on TV \_\_\_\_\_

Has two brothers \_\_\_\_\_

Has a cat \_\_\_\_\_

Has a first name that begins with the same letter as yours \_\_\_\_\_

Went to the beach this summer \_\_\_\_\_

Loves ice cream \_\_\_\_\_

Has a parent who went to school in Buford \_\_\_\_\_

Likes to read \_\_\_\_\_

Is the youngest person in their family \_\_\_\_\_

Listens to the same radio station that you do \_\_\_\_\_

Likes the Georgia Bulldogs \_\_\_\_\_

Was born in the same month as you were \_\_\_\_\_

Went to Six Flags this summer \_\_\_\_\_

Was not born in Georgia \_\_\_\_\_

Likes the same TV show that you do \_\_\_\_\_

*Mitzi Pearson  
Buford Middle School  
Buford, Georgia*

## Silhouettes

Students form pairs and draw each other's silhouette. After each student cuts out his/her silhouette, each student in the class is given a day. On that day, all students in the class must write one positive comment about that person on a small piece of paper. These are then glued onto the silhouette and all are laminated.

*Cynthia Quick  
Burke County Middle School  
Waynesboro, Georgia*

.....

## Role Playing

Settle a dispute by effectively attacking the problem and not the person. Students play roles of feuding students and mediator.

## Journal

Instead of fighting physically or verbally, put their feelings and aggressions into the written word. A means of calming down or working out their feelings in a nonaggressive method.

## Drama

Let the students get into groups and make up their own plays. Everyone has to be involved and participate in some way.

*Burke County Middle School  
Waynesboro, Georgia*

.....

## Developing Social Skills

Have students work cooperatively in small cooperative learning groups to improvise situations of their daily lives. Then have students act out their situations. Allow them to volunteer.

*Joyce Herrington Kelley  
Burke County Middle School  
Waynesboro, Georgia*

.....

## Current Events Exercise

Use reproducible pages from Current Events Magazine to inform students about events taking place in the world around them.

*Jon Vinson  
Burke County Middle School  
Waynesboro, Georgia*



**MAKE YOUR VERY OWN NAME POSTER, ALL ABOUT YOU!!!!**

What are your preferences, your favorite people, places and things? Make a terrific poster for your room, your parents, your grandparents, Open House, or to share with your classmates!

Practice printing your name in big, FAT letters that fill up a whole page. When you are satisfied with your lettering, print your name on a large piece of butcher paper or poster board, for example; any size is fine, the bigger, the better. Fill in the letters with ideas, drawings, photographs, and other things that interest you personally. Give your poster added eye appeal by using crayons, markers, magazine pictures, colored chalk, and more. Have fun and enjoy yourself!

**HERE ARE SOME POSSIBLE TOPICS TO SHAPE YOUR IMAGINATION!**

- |                 |                            |                     |                  |                  |
|-----------------|----------------------------|---------------------|------------------|------------------|
| Friends         | Things that make you happy | Sports              | Colors           | Sounds I like    |
| Pets            | Movies                     | I laugh when...     | School subjects  | IF I could BE... |
| Favorite places | Songs                      | Books I've enjoyed  | Exciting moments | DO...HAVE        |
| Foods I like    | I'm good at                | Things I like to do | When I grow up.. | anything at      |
| TV shows        |                            |                     |                  | all....          |

*Pamela Franklin  
Burke County Middle School  
Waynesboro, Georgia*

# KNOW YOUR SCHOOL

1. If I am late for school in the morning, what shall I do? \_\_\_\_\_
2. How many times can I be late to school before some action is taken? \_\_\_\_\_
3. What will happen if I am late to class between periods? \_\_\_\_\_
4. Does my school have rules about the way I dress? \_\_\_\_\_
5. If I am absent from school, do I have to explain why? \_\_\_\_\_
6. If I have to leave school early to go to the dentist, what arrangements do I make with the school? \_\_\_\_\_
7. Does my school have a list of things I am not permitted to bring to school? \_\_\_\_\_
8. If I lose a book that is issued to me, what happens? \_\_\_\_\_
9. If I destroy or write in a book, what will happen? \_\_\_\_\_
10. What is the penalty for smoking in school? \_\_\_\_\_
11. For what problems I have in school can I be given detention? \_\_\_\_\_
12. What will I do during the time I spend in detention? \_\_\_\_\_
13. What are the rules covering my behavior while I am at school? \_\_\_\_\_
14. What is a hall pass? When do I need one? \_\_\_\_\_
15. Will I have a locker? What can I use my locker for? \_\_\_\_\_
16. If I ride the bus, what rules cover my behavior? \_\_\_\_\_
17. Under what circumstances would my parents receive a progress report? \_\_\_\_\_
18. When I eat lunch in the cafeteria or the snack bar, what am I expected to do with my lunch litter, utensils, and tray? \_\_\_\_\_
19. Where can I buy schools supplies at school? \_\_\_\_\_
20. If I am ill at school and want to go home, how can I arrange to go? \_\_\_\_\_
21. Where is the "Lost and Found"? \_\_\_\_\_
22. How can I get a library pass? \_\_\_\_\_



23. If I am late returning the library books I checked out, what do I do? \_\_\_\_\_

24. How can I make an appointment with a guidance counselor? \_\_\_\_\_

This activity is great to conduct with students during the first month of school. Not only will it help them open up and discuss, but it will orient them to the school and its rules.

*James A. Zoll  
Crabapple Middle School  
Roswell, Georgia*



## **YOUR STRENGTHS**

**HOW TO PLAY:** See Attached Sheet. This activity needs to be done a little later in the school year, after the group has become a little more familiar with one another. It is good to emphasize that it is always easier to think negative things about ourselves than positive. Other people, however, usually can think of positive things. This is also a good lesson in peer relations. Point out that alot of people feel free to make fun of others, but have a hard time saying positive things.

### **PROCEDURE:**

1. Sit in a circle with others.
2. Fold a piece of paper in half lengthwise. Put your name at the top of each side.
3. List your good qualities and the things you like about yourself on the left side.
4. Pass the paper to the person on your right. The person on your right list the good qualities he/she sees in you on the right side.
5. Keep passing the papers until yours returns to you. Compare the two sides.

### **WRAP UP:**

Follow-up activities -- Discuss the following questions:

- Do people see me the same way I see myself?
- How do I let others see more of my strengths?

*James A. Zoll  
Crabapple Middle School  
Roswell, Georgia*

# TAP ACTIVITIES FOR JANUARY

Topic: Interpersonal and Communication Skills

Objectives:

- 1) Students will understand how communication skills affect the way in which people interact with one another
- 2) Students will understand the value of developing positive interpersonal relationships
- 3) Students will learn communication skills and conflict resolution skills

Activity #1: Communication Problems - (Jan. 3rd - Thursday)

Review TAP rules

**Purpose:** To help students recognize common problems in interpersonal communications.

**Voting Exercise:** Read aloud the following questions that deal with communication. After each question is read, students will take a position by a show of hands. Those who wish to answer in the affirmative raise their hands. Those who choose to answer negatively point their thumbs down. Those who are undecided fold their arms. Those who want to pass simply take no action at all. Discussion is tabled until the teacher has completed the entire list. Voting provides a simple and rapid means by which every student in the class can make a public affirmation on a variety of value issues. The teacher votes, too, but he/she does not make value judgments concerning the answers of the students. Suggested questions dealing with communications are:

**How Many of You:**

Find it difficult to listen to people sometimes?

Feel free to discuss sex with your peers?

Have a communication problem with your parents?

Feel frightened when you speak in a large group?

Have a friend to discuss problems with?

Feel your parents lack understanding of your problems?

Wish you could communicate better?

Think a communication unit might improve your ability to understand other people?

Would like to understand your parents better?

Would like to communicate better with the opposite sex?

Discuss.

Activity #2: More Communication Problems (Jan. 8th - Tuesday)

Read "Letter From A Boy." Discuss the communication problem. Leading questions might be:

What was the problem?

How could it have been resolved?

How would you deal with the same problem?

What do you think the parents' viewpoint is?

Activity #3: Saying What You Mean (Jan. 10th - Thursday)

Students pair up and sit back-to-back on the floor. With paper and pencil, one student in each pair draws a simple picture like the one below using squares, circles, triangles, or other simple geometric forms.

While the partners are still seated back-to-back, the artist must give the other partner directions that will allow him or her to duplicate the picture: "In the middle of the page, draw one circle one inch in diameter," and so on. Once the picture is duplicated, compare it to the original. Reverse roles.

Debrief. Discuss the difficulty of conveying exactly what one means. If it is hard to describe circles and squares, think how hard it must be to communicate about drugs, music, sex, love, or happiness.

Activity #4: Non-Verbal Communication (Jan. 15th - Tuesday)

Give each student a non-verbal situation card (do not show to each other).

Using body movements and facial expressions only, have student enact the situation. Have remaining students respond and "actor" convey what he or she was trying to communicate. Discuss how body movement and facial expressions influence communication.

## LETTER FROM A BOY

"It is too late for us because the damage has been done, and our child has a record . . . but maybe if we share this letter it will help other parents. Thank you very, very much."

Parents of a child

Dear Folks:

Thank you for everything, but I am going to Chicago and try to start some kind of new life.

You asked me why I did those things and why I gave you so much trouble, and the answer is easy for me to give you, but I am wondering if you will understand.

Remember when I was about six or seven and I used to want you to just listen to me? Remember all the nice things you gave me for Christmas and my birthday and I was real happy with the things for about a week at the time I got the things, but the rest of the time during the year, I really didn't want presents. I just wanted all the time for you to listen to me like I was somebody who felt things too, because I remember even when I was young, I felt things. But you said you were busy.

Mom, you are a wonderful cook and you had everything so clean and you were so tired so much from doing all those things that made you busy, but you know something Mom? I would have liked crackers and peanut butter just as well -- if you had only sat down with me a little while during the day and said to me: "Tell me all about it so I can maybe help you understand."

And when Donna came I couldn't understand why everyone made so much fuss because I didn't think it was my fault that her hair is curly and her teeth so white, and she doesn't have to wear glasses with such thick lenses. Her grades were better, too, weren't they?

If Donna ever has children, I hope you will tell her to just pay some attention to the one that doesn't smile very much because that one will really be crying inside. And when she's about to bake six dozen cookies to make sure first that the kids don't want to tell her about a dream or a hope or something, because thoughts are important too to small kids even though they don't have so many words to use when they tell about what they have inside them.

I think that all the kids who are doing so many things that the grownups are tearing their hair out worrying about are really looking for somebody that I will have to listen a few minutes and who really and truly will treat them as they would a grownup who might be useful to them. You know -- polite to them. If you folks had ever said to me: "Pardon me" when you interrupted me, I'd have dropped dead. If anybody asks you where I am, tell them I have gone looking for somebody with time because I've got a lot of things I want to talk about.

Love to all,

Reprinted from the KANSAS CITY STAR, Kansas City, Missouri.

**Activity #5: Respect for the differences in People are Important (Jan. 17th - Thursday)**

Ask the class to look at a group of six pictures of people's faces (collected by the teacher). Students can write a brief characterization of each person (include what they think he or she does for a living) based upon their impressions of the person from the photograph.

If possible, actual biographical information should be available for each person pictured so, after the exercise, students can compare the character sketches they produced with the person's actual biography. Try to include a few surprises (e.g., a "grandmother" type who is a nuclear physicist). How accurate were the students' impressions? How much information is needed about someone to tell what kind of person he or she really is? How often do we make false judgments based on appearances?

**Activity #6: Stereotyping Male/Female Roles (Jan. 22nd - Tuesday)**

Ask students to put an "M" by each job they think of as a male occupation, and an "F" by the ones they would classify as female:

doctor	coal miner	typist
nurse	electrician	plumber
pilot	elementary school teacher	soldier
hair stylist	prison warden	telephone operator
bus driver	homemaker	

Now, through discussion, determine how the majority of people classified each and why. For example, if most people classified doctor as "M" was it because there are more male doctors or because they feel men are better suited to be doctors than women are? Has the class stereotyped sex roles? Do they think stereotyping should be prevented, and if so how could they personally help prevent it?

**Activity #7: Exploring Expectations of Others (Jan. 24th - Thursday)**

Have students complete these questions. Discuss answers. See if anyone changes their answers after discussion.

Should You?

(Circle one answer for each question)

Should you date? Yes No Don't Know

Should there be a certain age to begin dating? Yes No Don't Know

Should parents have a say about whether their teenage children date or not? Yes No Don't Know

Would you be upset if you wanted to date but were not allowed to? Yes No Don't Know

Should you be upset if you want to date but don't get asked?	Yes No Don't Know
Should a girl ask a boy for a date?	Yes No Don't Know
Should boys and girls do things in groups rather than date?	Yes No Don't Know
Should a girl ask a boy to do something with her (not a date)?	Yes No Don't Know
Should you compete with others for someone's attention?	Yes No Don't Know
Should a parent or another adult be present when boys and girls get together at someone's house?	Yes No Don't Know
Should a parent or another adult be present when boys and girls get together for a public dance or party?	Yes No Don't Know

**Activity #8: Boy/Girl Relationships (Jan.29th - Tuesday)**

Ask the girls in your class: "What do you believe makes a girl attractive to a guy?" Put their "beliefs" on the board. Then ask the boys: "What makes a guy attractive to a girl?" Put their statements at the other end of the board. (Leave room beside each list for the last part of this activity.) Discuss with both the girls and the boys:

Do any of your "beliefs" keep you from really being yourself? (Do you pretend that you couldn't care less about someone when in reality you want that person to like you!)

Are you willing to do things you don't want to do just to please the person you want to like you? (Note: Discuss a range of examples here -- from simple issues, like pretending an interest in sports or a type of music to more complicated issues that could involve personal risks, such as trying drugs or sex. Discuss the difference between deciding to let the other person have his way because you truly want to please him, and giving in because you're scared he won't like you if you don't.)

To conclude this activity, ask the guys in the class: "What makes a girl attractive to you?" Put their comments on the board beside the earlier statements the girls made about what they believe makes them attractive. How do the two "lists" compare? Are there any surprises? Do the guys want girls to be "themselves?" Now ask the girls: "What makes a guy attractive to you?" Make the same comparison with the boys' earlier list.

**Activity #9: Conflict Resolution (Jan. 31st - Thursday)**

During TAP, make a poster for your room with the following six steps for "Handling Disagreements." The six steps are:

- One: Figure out what the disagreement is about.  
Two: Listen to the other person to find out why you think the way he or she does.  
Three: Kindly and honestly tell the other person why you think the way you do.  
Four: Research both opinions.  
Five: Decide together what you should do.  
Six: Do what you have both decided to do.

If you have time, here is a fun puzzle to try.

First, unscramble these words:

1. OTHUS                    -----
2. DIDECE                 -----
3. KOWR                    ----
4. VOSEMI                 -----
5. LEPOEP                 -----
6. REGAE                    -----
7. YLAP                     ----
8. VENRE                    -----

Second, write down all the letters that appear in boxes:

-----

Third, when you unscramble this word, you will be able to complete this sentence:

It's okay to \_\_\_\_\_.

*Pam Bachman  
Dawson County Middle School  
Dawsonville, Georgia*

## **SPORTS**

During schoolwide picnic for lunch, grade levels divide into homebase groups. PE Dept. starts play and arranges rotation of game teams every ten minutes.

Door can be used for any group or to show other ideas from group such as: "Best gift I got", "Favorite Book", "Favorite Lunch", or "Pets".

## **CREATING "ABOUT ME POSTERS"**

The idea and general guidelines for the poster are discussed with the group: can use photographs, drawings, or magazine pictures to show family and interests/hobbies.

Variations can come with different themes, such as family sports favorites, favorite music, favorite food, etc. and graffiti for sayings used.

## **COMMUNITY PROJECTS**

Teacher and students share experiments and helping in the community. Group decides on project for them and makes plans to do it. This can be long or short term.

Much variety because there are many areas of the community. We have concentrated on nursing homes and homeless shelters.

## **GREETINGS**

As students arrive, greet each one personally. Inquire how things are going. Welcome them back if they have been absent. Inquire about their progress of make-up work. Ask about extracurricular activities. Check on illnesses. Offer sympathy when needed. Remind them of upcoming events. Give them a pat on the back when appropriate.

## **FAREWELLS**

As students exit the classroom from the homebase period, encourage each one to smile. I make comments such as "Have a (wonderful, marvelous, fabulous, stupendous, etc.) day! Can say something more personal if there is a try-out, test, project due, presentation for that student on that day.



## DOOR DECORATION TO INTRODUCE GROUP TO SCHOOL

Beginning the second week of school, the homebase group (teacher and students) discuss what they feel best introduces them to others. They have information about each other from "get acquainted" games. The group decides on theme for door and divides jobs to accomplish the task.

Door can be used for any new group or to show other ideas from the group such as: "Best gift I got", "Favorite Book", "Favorite Team", "Favorite Lunch", or "Pets".

*Rebecca McDaniel  
East Cobb Middle School  
Marietta, Georgia*

.....

## SNOWFLAKES — ACCEPTING OURSELVES AND OTHERS

Provide students with positive descriptive words that could be used to describe people. Give students 1 sheet of white paper. Have them fold and cut them to form snowflakes. Have students draw a name and instruct them to write the name on the snowflakes and 5-10 positive attributes of that person. Collect snowflakes and share them with group.

*Anne Carroll  
E.T. Booth Middle School  
Woodstock, Georgia*

.....

## LOOKING AT ME

- Student writes 4 positive things about self.
- Student writes 3 things he or she would like to improve about self.
- Write how you see yourself as a person.
- Draw a picture of your self.

*Lois Wilson  
E.T. Booth Middle School  
Woodstock, Georgia*

## NAME GAME

Using a large piece of cloth, divide students into (2) groups. Place each group on either side of cloth. Hold cloth between groups. One person from each group sits close to either side of cloth. When cloth drops then first person to name the person they see wins. The team that "wins" get the loser on their side of cloth. Team with most people "wins".

*Alane Devaney  
E.T. Booth Middle School  
Woodstock, Georgia*

.....

## SHOW YOUR UNIQUENESS & ORIGINALITY

Have students put their thumbprints on a piece of white paper. They can put more than one print if desired. You explain to the students that all their prints are different & unique. No one else has a print like theirs. Then circulate markers, crayons etc. & have them make a picture out of their print. Display these somewhere.

*Helen Tate  
E.T. Booth Middle School  
Woodstock, Georgia*

.....

## OPERATION DEAR ABBY

Write letters to servicemen and women during the Christmas holidays. Students can tell about everything that is going on for the holidays at school, poem, etc.

*Lisa Long  
E.T. Booth Middle School  
Woodstock, Georgia*

.....

## SMOKEFREE AMERICA AD CONTEST

1. Each advisement class brainstorms on reasons not to smoke.
2. Make a list on butcher paper and post in each room.
3. Students create their own ads telling the truth about smoking - its addictive, unattractive, and unhealthy.
4. Ads will be posted in the team area.

*Lori Como  
E.T. Booth Middle School  
Woodstock, Georgia*

# THREE PERSON DRAWING

(An activity to cultivate cooperation)

HOW TO PLAY: Arrange students into groups of three: Without talking take turns drawing a group picture. Do not decide beforehand what the picture will be. Each person should draw a line about 1" in length. It can be curved, straight, crooked, etc. Students should try and transmit their ideas through the shape of the line. Allow 10 - 15 minutes to complete the drawing.

*Sauder Garcia  
E.T. Booth Middle School  
Woodstock, Georgia*

.....

## A SIMPLE IDEA MAKES MILLIONS

(Lesson in creativity/inventions/brain-storming/becoming an entrepreneur)

HOW TO PLAY: Present samples of cockleburs to class. Ask students to try to identify what everyday item we now have come from the idea of cockleburs.

*Joyce Hutchins  
E.T. Booth Middle School  
Woodstock, Georgia*

## ***FAILURE IS AN OPPORTUNITY TO BEGIN AGAIN MORE INTELLIGENTLY.***

**Henry Ford**

Competent people are aware of what they do well; they understand the importance of positive risk-taking; they know how to learn from their mistakes; and they take responsibility for their experiences in life. The activities in this chapter are designed to teach you students how to be competent people.

Students need opportunities to focus on what they do well. Unfortunately, we frequently teach them to do the opposite. Consider this typical question and response: "How did you do in school today, Jane?" "Oh, I blew it. I got twenty wrong in math, and I missed fifteen on the chemistry test." Jane's response is not surprising. She has been conditioned to look at what she does wrong rather than at what she does right.

Conditioning students to focus on their mistakes creates young people who are afraid to take risks — afraid to try something new because they might fail. Rather than teaching students to avoid mistakes, we need to encourage them to learn from their mistakes. Rather than teaching students to concentrate on what they do wrong, we need to encourage them to focus on what they do right. Students who understand the importance of positive risk-taking are more likely to become competent, contributing members of society.

We also need to teach students to take responsibility for their learning and for their performance in the classroom. Competent learners are not born; they are made! The activities in this chapter teach your students the skills they need to "own" their own competence as learners.

Finally there is no greater gift we can give to our students than teaching them to have the Winner's Circle attitude which says, "Yes, I can!" People with this attitude know how to *create* powerful, positive, productive lives. This chapter will give you the wrapping you need to give that gift to your students in a manner which will be eagerly accepted by them and which will teach them an important truth about life: **LIFE IS NOT A SPECTATOR SPORT!**

## THROW AWAY THE FAILURE

**TIME NEEDED:** 5 to 10 minutes

---

**THE LESSON:** This activity teaches students to become powerful, positive risk-takers by encouraging them to throw away their failures and to keep their lessons.

---

### TEACHER'S FIRST WORDS:

[Quickly pair students, and then say,] *"Turn to your partner and share your answer to this question: 'Why do some people fail in getting what they want in life?'* [Give the partners about thirty seconds to interact. Then ask for class shares and put their answers on the board. They probably will not come up with the answer you are going to suggest, but if they do, that is great!] *After acknowledging their answers say, "The number one reason people fail is because of FEAR OF FAILURE!"* [Write this on the board in large letters.]

*"How would you like to learn a technique that very few people know — in fact, a technique that only truly successful people know? Using this technique will guarantee that FEAR OF FAILURE will not prevent you from getting what you want in life."*

### THE PROCESS:

1. Ask students to take out a piece of notebook paper and tear it in half. Tell students that **NO ONE** is going to see what they are about to write down on one of the half sheets of paper.
2. Ask students to think of a time when they failed — a time when things did not turn out the way they had hoped.
  - a. The failure might be something they did not do and wish they would have done. Clarify that it makes no difference what kind of failure they call to mind. Maybe they will remember something that happened in the third grade; perhaps they forgot to put the garbage out yesterday, and they are now grounded for a week!

- b. Using one of the half sheets of paper, the students is to take thirty seconds to jot down a word or two or a short phrase — just to bring the memory back. There is no need to write out all the details of the incident.
3. After students have finished writing down the failure, tell them to think about what they learned from it. Explain to students that we always learn something from our failures, even if it is, *"I'm never going to do that again!"* Say to them, *"Maybe you learned to get up earlier in order to get to class on time. Maybe you learned to leave a note by your bedroom door to remind you to put the garbage out."* (Give them about thirty seconds to describe the lesson in a few words or short phrases using the OTHER half sheet of paper.)
4. Ask students to pick up the piece of paper on which they have written the failure.
5. Holding a half sheet of paper up in front of you and crumbling it into a ball as you speak, say to the students, *"Now do this to your failure. Hold on to it because on the count of three, you are going to have a fantasy come true! You are going to get to throw something at the teacher! But not until I say, 'Go!'"* [Then cover your eyes and say,] *"One, two, three, go!"* [If you prefer, have your students throw their failures into a waste paper basket in the middle of the room.]
6. Next ask the students, *"What is the message here? What do successful people do with their failures in life? THROW THEM AWAY! What do they keep? THE LESSON!"*
7. Explain to the students that most of us have been trained to believe there is something awful and unforgiving about failing. We respond to it by saying, *"Boy, I'm never going to do that again!"* We may even get to the point of avoiding certain things in life we might want to do because we are afraid we will fail.
8. Write the following statement on the board: *"It is okay to fail; it is not okay to give up!"* Tell students that this is a powerful life attitude which all successful people hold. Suggest that from this day forward when something does not work out the way they had expected, they can step back and say, *"Well, that didn't work. How can I do it differently next time?"*
9. Suggest that students start seeing the *"lesson"* in the failure as a *"gift."* It is a gift because it is something they might not have learned any other way.

Acknowledge that they might not be willing to accept the gift immediately; after all, sometimes we need to allow ourselves to experience the hurt or anger for a while before we can be truly open to the lesson/gift. This is fine, but it is important to look for the gift at some point because it is always there, and they will not want to miss it!

10. Suggest to students that they go out of their way to take positive risks and begin learning from mistakes they might make. A positive risk for a secondary student might be going up to someone at a dance and asking him for a dance. Even if the student is turned down, the risk-taker has grown by going through and surviving an experience which may have been a bit embarrassing. (If you wish, students can brainstorm examples of positive risks at this point and you can record them on the board.)
11. Using an overhead or a handout, share the information about Abraham Lincoln which clearly illustrates all the failures he survived. Then tell students about Walt Disney. Disney went bankrupt five times and had a number of nervous breakdowns. These are not what we call success stories in our society! Point out that what is important is that these successful people did not see themselves as failures. When things did not work out the way they wanted them to, they did not give up:

*“It is okay to fail; it is not okay to give up.”*

12. Convey to the students that there are times when we may want to stop going in a particular direction or going after a certain goal. This may look to other people as though we are giving up when in fact we are intentionally changing directions. We may be the only ones who know whether we are giving up or changing directions. As long as we are always looking and moving forward, we are not giving up. After all, changing directions, in itself, involves a risk.
13. As a final wrap up of the main message in this activity, share the information on the “losing” and “winning” decision making models from the overhead master included with this lesson.

#### **STUDENT REACTIONS:**

This concept will be new for most students, but you will quickly see the wheels begin to turn. Understandably, they are fascinated by the message; after all, they have spent anywhere from seven to twelve years in a school system that has told them again and again that failure brings shame. Through this activity students become encouraged to begin taking “positive” risks, now that they realize there is no shame in failure; there is only growth from the lessons learned.

**PURPOSE:**

**One of business' biggest complaints is that we are sending them brilliant 4.0's who refuse to take risks. Can you image what kind of a world we would create if we graduated students who were willing to take positive risks, who did not fear failure, and who knew that anything that looked like failure would bring with it a valuable "gift"? I am very proud that I have taught this concept to my students, and I know you will be, too. It is a powerful life attitude that will serve them well for the rest of their lives!**



**IT IS**

***OKAY***

**TO FAIL;**

**IT IS NOT**

***OKAY***

**TO GIVE UP!**

## **ABRAHAM LINCOLN**

- 31 - FAILED IN BUSINESS**
- 32 - DEFEATED FOR THE HOUSE**
- 34 - FAILED IN BUSINESS**
- 36 - NERVOUS BREAKDOWN**
- 38 - LOST AN ELECTION**
- 43 - LOST CONGRESSIONAL RACE**
- 46 - RAN FOR OFFICE AND LOST**
- 48 - RAN FOR OFFICE AND LOST**
- 55 - LOST SENATE RACE**
- 56 - UNSUCCESSFUL IN HIS BID FOR VICE  
PRESIDENCY**
- 58 - LOST SENATE RACE**
- 60 - BECAME  
PRESIDENT  
OF THE  
UNITED STATES  
OF AMERICA!**

### LOSING DECISION-MAKING MODEL

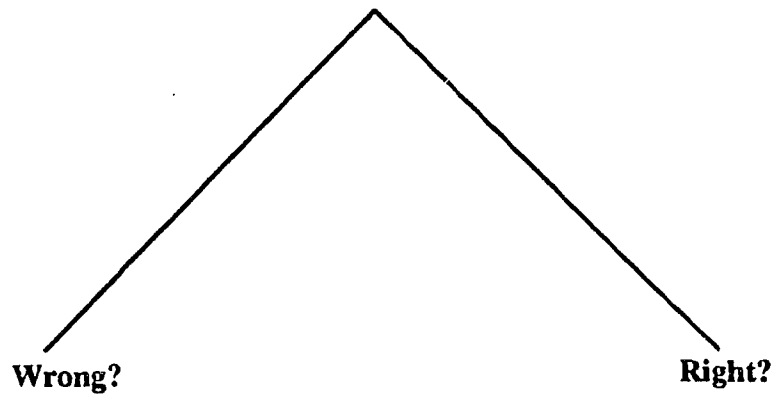

The person using the "losing" decision-making model says, "Oh no. I have a decision to make. It is either going to be right or wrong. What should I do?"

### WINNING DECISION-MAKING MODEL

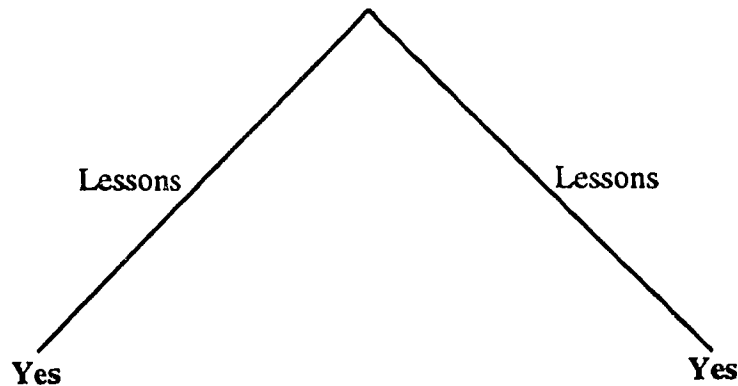

The person using the "winning" decision-making model says, "You know what? Either I am going to get exactly where I want to go and learn valuable lessons along the way, or I am going to get someplace else, AND learn valuable lessons along the way."

*Justina Ingram  
E.T. Booth Middle School  
Woodstock, Georgia*

# THE HANDSHAKE

**TIME NEEDED:** 30 to 40 seconds each use; approximately 3 minutes the first time you explain it.

---

**THE LESSON:** In this activity the teacher shakes every student's hand each day for the express purpose of letting the students know that the teacher cares about them and that the teacher is glad the students are in his or her class.

---

## TEACHER'S FIRST WORDS:

[Introduce this activity by standing at the door and shaking hands with each student as he or she enters the room. When class starts, say:]

*"I need your help! There is something I would like you to do for me this year that would help me to be a better teacher for you. I am what is called a 'content person.' What that means is sometimes I get so involved in teaching my content, I forget that I am teaching that content to 180 plus students. It would really help me to remember that I am dealing with people and not content if I had physical contact and eye contact with each of you every day.*

*"I am asking that you please seek me out when you come in the room each day, shake my hand and say, 'Hello,' so that we have eye contact, OR gently touch me on the shoulder and say, 'Hello.' If you are not feeling well, I recommend we not shake hands so that we do not pass germs around. Just touch me on the shoulder in that case, and say 'Hello' so that we will have eye contact."*

## THE PROCESS:

1. After the first time you use this activity, it is not necessary to be standing at the door every day to shake students' hands. While some students will come to you before class starts to shake your hand, you will soon discover which ones will go directly to their seats waiting for you to approach them.

2. When not feeling well, wear a glove so as to avoid passing germs to students. (My students hated the glove! "*Aren't you feeling better, yet, Ms. LaMeres?*")
3. After the first day, I recommend you make a point of saying the student's name as you shake his or her hand. This is a great way to learn names quickly, a task that used to take me weeks before I started using the "*handshake*" activity.

#### **OTHER POSSIBILITIES:**

Wait until students are seated each day, and then go around the room shaking hands with each one. It only takes approximately 36 seconds to shake hands with 36 students. That is not much time invested for such a powerful connection.

Every once in a while, ask the students to give you a "*business*" handshake. Explain that a business handshake means the inside of their thumb and forefinger go all the way up to the inside of the other person's thumb and forefinger, and the grip is nice and firm. (I believe this is an extremely powerful life skill to teach young people.)

If you teach physical education, have 50 or more students and must walk around with a clipboard in one hand and a pen or pencil in the other for taking roll, here is a suggestion: Ask a student to walk along with you. Let the student mark the attendance record according to your instructions as you walk up and down the rows shaking hands with each of your students.

If you do now wish to shake students' hands every day, then do so on Mondays and Fridays, or on Mondays and Fridays, beginning and ending the week that way. I personally enjoyed making the connections every day. (Read the "*Student Reaction*" and "*Purpose*" sections to understand why.)

#### **STUDENT REACTIONS:**

I realize that you will have to experience first hand the connections created between you and your students before you can fully appreciate the power of shaking students' hands. All I can tell you is that I get cards and letters from teachers who are using the handshake with their students, and these teachers use the same terminology every time: "*The handshake is the magic!*"

In some districts teachers have told me that, for fear of lawsuits, they have been warned against touching students. My response to that advice is — if you are in education, and you do not know how to touch kids safely, then get out! This is a people profession, and people need to be touched. No one is offended by a handshake or a touch on the shoulder.

I have had teachers ask what they should do if a student says, "*Don't touch me!*" Very few questions in life have one right answer, but this is one of them: **THEN DON'T TOUCH THEM!** Of course we want to honor their right not to be touched.

What about students from various ethnic backgrounds where eye contact is rude if not taboo? While I do not want to ask to do something that goes against their cultural heritage, I do explain to students that the eye contact part of this activity is an extremely important one. I further explain that giving eye contact is a powerful communication skill in many situations, such as when they are looking for a job. Therefore, I recommend they practice eye contact so as to learn to be comfortable enough to use it when it will serve them well.

#### **PURPOSE:**

This activity is the single most transformational activity you will find in this book. I guarantee you that if you are willing to go outside your comfort zone enough to use the handshake activity with your students, the payoff will be well worth your risk.

Shaking hands with students creates an experience whereby for a few seconds every day, Johnny Logan is reminded that you are a human being (not someone to terrorize for the period), and you are reminded that Johnny Logan is a human being in spite of his actions that sometimes suggest otherwise. Students who were climbing the walls in other teachers' classrooms were only going half-way up the wall in mine. Johnny Logan didn't need to act out. Ms. LaMeres touched him today; she looked into the "*windows of his soul.*" This may sound corny, but it is absolutely true!

*Nancy Coffey  
E. T. Booth Middle School  
Woodstock, Georgia*

# STANDING OVATIONS

**TIME NEEDED:** 15 to 20 seconds

**THE LESSON:** This activity teaches students that it is important to honor one another simply because they exist.

## TEACHER'S FIRST WORDS:

*"I believe we are all born inherently worthy. 'Inherently' means it is not something we have earned. It is something we own simply because we are here on Earth. In this classroom we are going to acknowledge that inherent worthiness. I need a volunteer to help me demonstrate how we will do that."*

[When the volunteer comes to the front of the room, ask him or her to keep eye contact with the group during this next activity and to graciously accept what is about to happen.]

Next, say to the students, *"On the count of three we are going to give Ernie Pomin, our volunteer, a standing ovation. We are going to hoot and holler and yell Ernie's name, and let him know that he deserves our recognition just because he exists! One, two, three, everybody UP!"* [Let students applaud for about 15 to 20 seconds.]

## THE PROCESS:

1. Give a 3 x 5 card to each student. Ask each students to put his or her name on a card, and then collect the cards.
2. The next day and every day thereafter, the minute the bell rings, pull one of the 3 x 5 cards and call that student to the front of the room for a standing ovation.
  - a. The students will scream and shout for about 15 seconds, and then you can begin class on a very upbeat note.
  - b. Put that particular student's card at the bottom of the stack, and it will work its way back up to the top many times throughout the year.
  - c. Make sure you put your name in the stack, too!

The Winner's Circle: Yes, I Can





### OTHER POSSIBILITIES:

- \* Pull a card at the end of the class period instead of at the beginning. You could also pull a card at the beginning and at the end.
- \* If you do not wish to do this every day, do it on Mondays and/or on Fridays only. Start and/or end the week with this powerful and positive message to students.

### STUDENT REACTIONS:

Admittedly, this activity requires some genuine risking on the part of teachers who are, understandably, concerned about student reactions. Let me address several of these concerns. Some teachers ask, "What if students 'boo' each other." When I, myself, was contemplating using this activity, I was sure I knew exactly who would do the booing in my classes and who would be booed. As usual, my assumptions were wrong. If you use the information in the "Teacher's First Words" section, I know you will have a similar experience. Never were any of my students booed.

Teachers also ask, "What if a student begins to edge toward his or her seat before the standing ovation is finished?" Smiling cheerfully say, "Wait a minute; we're not finished yet!" Make sure you keep a big smile on your face. This activity is not meant to be an unpleasant experience, and students do feel more comfortable with this recognition as the year progresses.

"What if a student refuses to go up in front of the class altogether?" Pull another card! When you have a chance, talk to the student in private to see if you can uncover the problem. Let the student know you will never force him or her to receive a standing ovation, but encourage the students to take the positive risk when he or she is willing. As more and more fellow students are seen not only surviving, but beaming from the ovations, the reluctant student will eventually risk experiencing it, too.

Teachers also wonder about the reactions of their colleagues. "What if that standing ovations disrupt my colleagues next door, and they complain about it?" Just tell them to shut up! No, No, just kidding; do not do that! The fact is, if you do this activity during the first or last thirty seconds of your class period, you are not going to destroy anyone's lesson plan. It does not hurt, however, to be proactive. Explain to your colleagues what you plan to do and what the benefits are for the students. Perhaps they will risk trying the activity in their own classrooms!

The human need to be kind to one another shines through in this activity. One of the wonderful benefits of doing self-esteeming lessons in your classroom is getting to see a side of students you may not have seen before, and it is a beautiful side!

**PURPOSE:**

The major purpose of this activity is to help students discover and acknowledge their inherent worthiness. While students do deserve recognition for doing well on assignments, I recommend you use this activity only for the purpose suggested here, and that is to give them recognition **JUST FOR BEING!**

As you continue to use standing ovations in your class, a number of additional benefits will emerge. One of them is that the shy students have an opportunity to stand up in front of the class and survive! Another benefit is that your students will get to class on time. A case in point: One day early in the semester, I pulled a card and said, Julie Sanders to the front of the room for a standing ovation! "Oh, Julie isn't here today?" (I pulled another card.) "Brock Wheeler to the front of the room for a standing ovation!" Meanwhile, Julie came running into the classroom late — too late. She quickly learned that her card had been pulled and that she missed it. Julie eventually got her standing ovation, albeit some time later in the semester. Her card had not been thrown out; it had simply gone to the bottom of the stack. Getting to class on time, however, became very important to Julie — and to other students like her. Besides demonstrating that we all want and need recognition, this activity clearly shows that we all want to be there the day our card gets pulled!

*E. T. Booth Middle School  
Woodstock, Georgia*

# HOMEMADE KITE

**SUPPLIES:** Amount will vary according to the number being made.

plastic garbage bags (see custodian)

permanent markers

thin dowl rods - • - (craft shop) 36" - cut in half

colored survey tape (hardware/builders store)

kite string (discount store/drug)

thin paper plates

masking tape

mailing tape

hole punch

Cut kite body out of plastic bag.

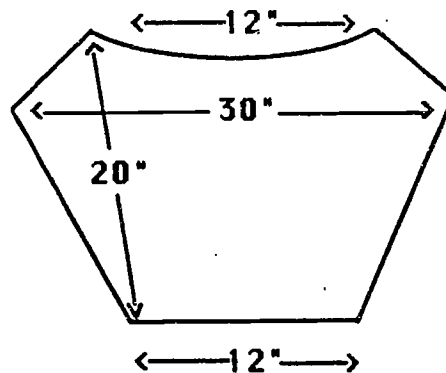

Students use markers to draw/design on kite.

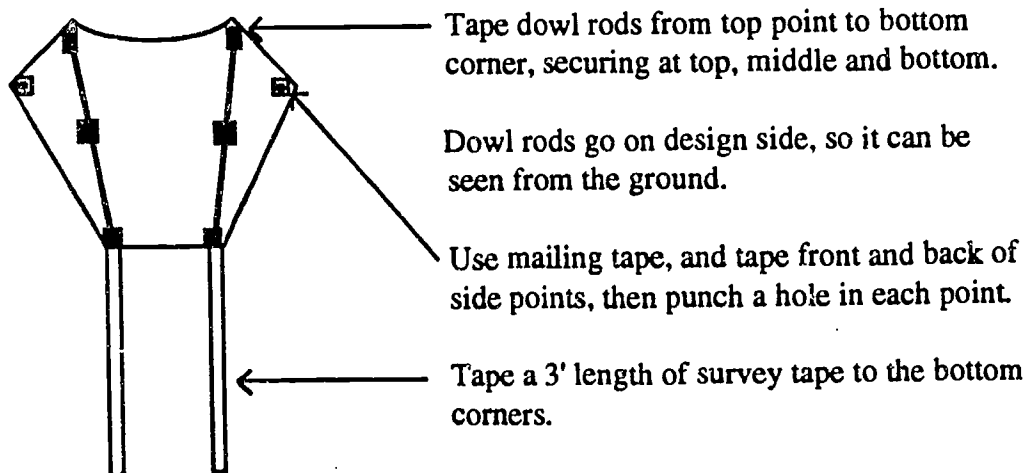

Roll a thin 9" paper plate to wind kite string on.

Tape secure. Tape end of string to center of roll. Roll on 66 yards of string.

Students should work with a partner - one person measures the string and the other winds the string.

Take a 8' piece of string and make a mark midway on string. Secure each end of the string thru the side holes.

Tie the end of the string from paper plate onto 8' string at the mark.

Wait for a strong wind, then the fun begins!

GOOD LUCK —

*Donna Mau.  
E. T. Booth Middle School  
Woodstock, Georgia*

# I AM UNIQUE BECAUSE . . .

**HOW TO PLAY:** Provide each student with a 3 x 5 card. Ask each student to think of one thing about them or herself that is different from everyone else in the room. This should be something that the student would like for the other class members to know about him or her. Allow two or three minutes for the students to select and write the unique item on the 3 x 5 card. Place all of the cards in a bag. Shake up the bag. Draw slips out of the bag and read one at a time. Ask the students to guess whom the card belongs to. Discuss with the class that we are all alike and different. Several circles can be made with fewer students to share.

*John Spindler  
Executive Director of Middle  
Schools for Fulton County  
Atlanta, Georgia*

# How Well Do You Know Your Parents?

Directions: This fun-quiz is designed for you to see just how well you really know your parents. Predict how you think they will answer these questions, then interview them when you get home today. This activity could provide an excellent way to get to see another side of your parents! Have fun!!

You may use this with your father or mother. You may substitute "father" for the word "mother" if you'd like for the questions below.

1. Which does your mother dislike the most? Cleaning up the dishes after dinner, ironing clothes, or cleaning her bathroom?
2. If your mother went on a trip to a foreign city, where would she head first? Museum, restaurant, or shopping district?
3. On vacation would she prefer.....a luxury resort, rustic mountain cabin, or resting at home?
4. What kind of salad dressing would she order in a restaurant? Ranch, oil and vinegar, or Italian?
5. When she watches T.V., she would choose ....a soap opera, old movie, or sports show?
6. Name the high school your mother attended. \_\_\_\_\_
7. How many rings does your mother usually wear? none, one, two, three, or four?
8. Did your mom have a pet when she was a child? What kind of pet?
9. Which do you think would be the hardest for your mom to do? Stand on her head, rewire a lamp, or add a quart of oil to the car? \_\_\_\_\_
10. What was your mom's first full-time job? \_\_\_\_\_

*Barbara Seaton  
Haynes Bridge Middle School  
Alpharetta, Georgia*

# END OF THE CALENDAR YEAR

It's nearing the end of this calendar year already!! This activity is for you to reflect on things you've learned this year, to remember exciting events, and to realize how much you've changed.

1. The funniest thing that happened this year was when \_\_\_\_\_  
\_\_\_\_\_
2. One thing that I did not expect to happen in this grade was \_\_\_\_\_  
\_\_\_\_\_
3. My favorite movie this year was \_\_\_\_\_  
\_\_\_\_\_
4. I was very embarrassed when \_\_\_\_\_  
\_\_\_\_\_
5. A very special time I had with my mom (or dad) was when we \_\_\_\_\_  
\_\_\_\_\_
6. My favorite song this year was \_\_\_\_\_  
\_\_\_\_\_
7. I was really worried when \_\_\_\_\_  
\_\_\_\_\_
8. My friends were really surprised when I \_\_\_\_\_  
\_\_\_\_\_
9. A very sad time this year was when \_\_\_\_\_  
\_\_\_\_\_
10. I was really scared when \_\_\_\_\_  
\_\_\_\_\_
11. \_\_\_\_\_ really made me so mad!
12. The way I have changed the most since last January is \_\_\_\_\_  
\_\_\_\_\_

*Barbara Seaton  
Haynes Bridge Middle School  
Alpharetta, Georgia*

# ASSERTIVENESS VS. AGGRESSIVENESS

**DIRECTIONS:** Read the short explanation presented below that explains the difference between assertive and aggressive behaviors. Read to the students the 10 statements below and have them label them as either aggressive or assertive. A short discussion could follow.

---

**Assertiveness:** Assertiveness can be viewed as expressing one's thoughts and feelings honestly and forthrightly without putting others down. It can clarify a situation and allow for a possible solution without hurt feelings.

**Aggressiveness:** Aggressiveness is accusing, striking out, blaming, and putting others down. It almost always creates anger or defensiveness, which denies any constructive outcome. It severs relationships and causes hurt feelings.

---

Read the following ten statements and have the students decide whether they are "aggressive or assertive" statements. The answers are provided. Please point out to the students that much depends on their tone of voice and body language. If you have time, you may want to ask the students to reword the "aggressively" stated ones into "assertively" stated ones.

1. You're always picking on me! (aggressive)
2. If you and Dad weren't such slobs, I wouldn't be either. (aggressive)
3. I feel threatened when you watch over my shoulder when I am typing. (assertive)
4. You'll do what I say and you'll do it now! (aggressive)
5. I will be leaving at 10:00 and if your homework is done, you may go with me. (assertive)
6. Mrs. Johnson, when you give an assignment, it would be helpful to me if you would write it on the board. Sometimes I'm not sure if I am hearing the correct page numbers. (assertive)
7. That's too much work! You're crazy if you think I'm going to do it! (aggressive)
8. When I see you talk and laugh with Meredith at lunch, sometimes I feel hurt because I think you are laughing at me. (assertive)
9. It makes me upset when you and Dad argue in front of me. (assertive)
10. You're a snob! You're friends with me in the neighborhood but won't speak to me at school! (aggressive)

*Barbara Seaton  
Haynes Bridge Middle School  
Alpharetta, Georgia*



# Our Family Relationships

## HUMOR

We never laugh and joke together

Our home is full of fun and laughter.

## TRUST

We can never trust each other.

We can always trust each other.

## SECURITY

I don't ever feel secure with my parents.

I always feel secure with my parents.

## HONESTY

We are not up front with our thoughts and feelings.

We tell each other our real feelings.

## RESPECT

We do not treat each other the way we want to be treated.

We treat each other the way we want to be treated.

## AFFECTION

We do not show affection to each other.

We often show affection to each other.

## DELIGHT

We are not delighted by each other.

We are often amazed and delighted by each other.

## PATIENCE

Our parents are never patient with us.

Our parents are always patient with us.

**DIRECTIONS:** Take a quick inventory of your family's relationship qualities. Place an "X" on the line where your family would score in each of the above eight categories. We will then discuss the scores and come up with ideas in dealing with them.

*Barbara Seaton  
Haynes Bridge Middle School  
Alpharetta, Georgia*

# Making Assertive Statements

TOPIC: Making Assertive Statements

**DIRECTIONS:** Explain that using the word "I" instead of "YOU" could help a listener be less defensive. Read the example of an I-message presented below to the students. Then have the students make up their own I-messages using the nine situations presented below for practice. A short discussion could follow.

Use the form:

"When you \_\_\_\_\_, (offending behavior)  
it makes me feel \_\_\_\_\_ (feeling word) because  
\_\_\_\_\_." (effect of behavior)

**FOR EXAMPLE:** "When you play the stereo so loudly, it makes me feel angry because I can't read my book."

Challenge the students to think up some I-messages for each of the following situations. If you have time, you can think up some possible situations here at school where they could use I-messages to get their feelings across (being assertive) but not appearing aggressive.

1. Just after Judy's mother finished cleaning, Judy and her friends sat in front of the T.V. eating potato chips and pretzels.
2. Mr. Cooper surprises his class with a math quiz today and some of the students had been absent the last few days with the flu.
3. Mrs. Smiley compares her son, who is an average student, with his sister, who get straight A's.
4. Your friend keeps telling you, "If you'd just try harder, I know you could be our team pitcher. You just aren't trying hard enough."
5. Jean goes to dance lessons, scouts, and her church group meetings. Now her mom wants her to start taking piano lessons. Jean feels frustrated and overwhelmed.
6. Jerry's friends call him "chicken" because he won't smoke with them.
7. Mrs. Coat's dog chases the kids in the neighborhood when they go past her yard. Today, he caused your little sister to fall down and skin her knee.
8. When Tom spent the night with Mike, he was upset when they went to the video store. Mike was pressuring Tom to pick out an "R-rated" movie, even though they knew that Tom's parents would have objected to it. Mike said, "Come on, Tom, your mom will never know." What could Tom say to Mike? Tom does not want to check out the movie.

9. Sandy is upset because her father yells at the dinner table every night.
10. Ray feels pressured by his friends to drink wine coolers at parties.

*Barbara Seaton  
Haynes Bridge Middle School  
Alpharetta, Georgia*



## School Pride

The object is to role play an Oprah Winfrey or Phil Donahue-type show. You will need to assign one student to role play the talk show host(ess). Then decide on your panelists. Possible panelists that the students can portray might be: teacher, student, principal, administrator, and/or parent.

One session will need to be devoted to planning the show. You might want to consider adding commercials, making up cheers, etc. Students will also need to brainstorm questions to ask the panelists.

The second session will be the talk show. The theme of the show is to discuss school pride.....why Haynes Bridge Middle School is the BEST! The host will have the questions written on note cards to ask the different panelists. Possible questions might be:  
1. What is school pride? 2. Does it show school pride to put graffiti on the bathroom walls? 3. Litter on the grounds? 4. Leaving a mess in the cafeteria? 5. What are the great things about our school?

*Barbara Seaton  
Haynes Bridge Middle School  
Alpharetta, Georgia*

# MY SCHOOL

STUDENT SUPPORT ACTIVITY (WEEK 1 OF 4)

DATE \_\_\_\_\_

DISCUSSION: How well do you know your school?

ACTIVITY: Help students answer the following questions?

1. If I need to ask about a schedule change, where will I go?
2. If I have to leave school early, where do I go to make arrangements?
3. When I am absent, to whom do I give the note explaining the absence?
4. If I want to check out books, how can I use the Media Center? When can I use the Media Center?
5. If I need medical attention, where do I go?
6. What times does the building open? Where can I enter the building? When can I go to my locker?
7. If I need to make a telephone call, where is the telephone? When can I use it?
8. If another student is bugging me, who can help me?
9. If I am having trouble with one of my teachers, who can help me solve the problem?
10. For what offenses can I be suspended?
11. How can I make an appointment to see the guidance counselor?
12. If my locker doesn't work, how can I get it fixed?
13. If I lost a book, my gym clothes, or any personal equipment, where will I look for it?
14. If I have lost a library book, where can I pay for it?
15. If I have to take special medication, how can I arrange to get out of class?
16. If I lost my lunch money, what can I do?
17. If my favorite cousin comes to visit, can I bring him to school?

# MY SCHOOL

STUDENT SUPPORT ACTIVITY (WEEK 2 of 4)

DATE \_\_\_\_\_

**DISCUSSION:** It is important to be familiar with all aspects of our school.

How much do you know about your faculty?

What are some advantages of getting to know your teachers?

**ACTIVITY:** Have students write at least 2 questions they would like to ask in a faculty survey. (ex. What is your favorite sport? What is your favorite radio station/TV program? etc.)

**HOMEROOM TEACHERS:** Collect and compile questions and place in Carolyn Gabo's mailbox by Friday. These will be used as part of the activity for week 4.

**SUGGESTION:** Use the results of the student activity for week 2 as a discussion topic for week 4.

Have SST committee or a member select 8-10 questions and write up a short faculty survey. Give to faculty to answer and return the next day. Compile results for the discussion and activity for week 4.

STUDENT SUPPORT ACTIVITY (WEEK 3 of 4)

DATE \_\_\_\_\_

**DISCUSSION:** Read or have a student read "The Legacy of Haynes Bridge M.S."

**ACTIVITIES:** The Time and Place Machine

- A. List at least three things that make Haynes Bridge M.S. different from any place else in the world.
  
  
  
  
  
  
  
  
  
  
- B. If you were to be a "Rip Van Winkle", what aspects of Haynes Bridge Middle School do you think you would find the same 20 years from now? Why?

- C. Is there anything in Haynes Bridge M.S. that you would find exactly the same if you went back in time 20 years? How about something that was there then, but in a different form (the wood in your pencil might have come from a tree growing there 20 years ago).

### **The Legacy of Haynes Bridge Middle School**

Anything that has a history can be traced to its original beginnings. This is certainly true of Haynes Bridge Middle School which has roots that are short and long.

Because of the continuing rapid population growth in North Fulton County, several new schools were needed. Haynes Bridge was opened in the fall of 1983 for grades six and seven from Dolvin, Alpharetta, Kimball Bridge, and Northwestern Elementary Schools, and grade eight from Milton High School. It is located at 10665 Haynes Bridge Road in Alpharetta, Georgia, and is one mile east of Georgia 400.

The school has been under the leadership of two principals - Larry Land from 1983 to 1986 and Gayle Giles since 1986. The administration has increased from a principal and two assistants to a principal and three assistants. The staff has grown from sixty-two to over one hundred. Student enrollment began at 700 and now stands in excess of 1300. The facilities have expanded from the original building to the addition of seven portable trailers. A new building wing housing fourteen classrooms and several resource rooms was added this year.

Haynes Bridge Middle School is constructed on a thirty acre tract and contains 76,000 square feet. The property was once a 240 acre plantation owned by Richard Luther Haynes, Jr. It was then in Milton County which was created in 1857 and was later merged with Fulton County. After Richard Haynes' death in 1894, the property was divided and sold with one section now being Haynes Bridge Middle School.

The area surrounding the school continues to grow, and in the 1990-91 school year Haynes Bridge will provide facilities for the new middle school that is in construction on Taylor Road.

Haynes Bridge's challenge is to provide every student with the opportunity for social, emotional, creative, physical, and intellectual growth, and embodies the epitome of success through the efforts of dedicated individuals working together for the attainment of common goals.

As growth and achievement follow its pattern, history continues to unfold.

# MY SCHOOL

STUDENT SUPPORT ACTIVITY (WEEK 4 OF 4)

DATE \_\_\_\_\_

DISCUSSION: Faculty Survey Results

ACTIVITIES:

1. Ask students selected questions from the survey before giving the faculty results. Point out that students might be surprised at the similarities between their responses and the teachers', showing that teachers are "human" too.
2. Give results of faculty survey.

Did you find similarities between yourself and the faculty?

Do you have a different opinion of school teachers and administrators?

New students might be asked if they see any real differences between our teachers and those of their previous school.

*Barbara Seaton  
Haynes Bridge Middle School  
Alpharetta, Georgia*

# ROLE PLAYING FAMILY SITUATIONS

Directions: Choose students to role play one or two of the situations presented below. (You may only have time for one.) The student is to pretend that he/she is the parent and to role play how they would react to these situations below. After the role playing, ask the class if they agreed to the reaction presented. They may offer their own opinions on how they think a parent should react and why. They want to share some incidences that have happened in their lives and how their own parents reacted to them.

- Situation #1 Wendy came home 2 hours after she was supposed to be home after a party.
- Situation #2 Jessica didn't finish her math homework before her favorite T.V. show came on.
- Situation #3 Hal cut art class at school.
- Situation #4 Carol didn't get the lead part in the school play.
- Situation #5 Tom wants to see an "R-rated" video movie at Jeff's house when he spends the night with him on Saturday night.
- Situation #6 Jennifer get too many phone calls at night from her friends and she has a hard time concentrating on her homework.

*Barbara Seaton  
Haynes Bridge Middle School  
Alpharetta, Georgia*



# NAME TAB

Write name on front of card. Decorate with things that represent you -- ie. tennis racket, football, dancer.

Inside card, where only student can see, write the following: 3 things I am great at or do well; 3 things I value (ideals); One person I respect most; My favorite place to be.

## STUDY SKILLS/WORK HABITS

### OBJECTIVES:

1. To identify specific behaviors which develop good work and study habits.
2. To organize time more effectively with regard to task completion.
3. To examine one's current use of time.
4. To make a slide/tape presentation of good study skills/work habits.

TARGET GROUP: Ages 9 to 12; 6 - 10 children per group

TIME REQUIREMENT: 45 minutes per session; 6 sessions

### SESSION #1

Name Game

Group Discussion Time: My strengths are . . .

My weaknesses are . . .

### FOLLOWING DIRECTIONS/LISTENING ACTIVITY:

The group of students structure a runway of chairs or people, wide enough for a person to walk the length. Litter the runway with books and pencils. The group then selects one person who is to be blindfolded to be the pilot. Another person is to play the part of the control tower. He can station himself anywhere he desires for maximum visibility. A storm has hit - lightning has knocked out the transmitter of the plane, although the receiver is still working. The pilot can send, but can't receive, messages. The control tower must help the pilot land the plane without damage by sending directions over the radio. If the pilot brushes against any object on the runway, the plane sustains damage. Total incidents of damage are recorded for each pilot.

Compare, through discussion, how piloting a plane without being able to see or ask directions is like trying to succeed in academics without good study skills and work habits. Allow the pilots to express their frustrations at feeling lost and doomed to failure.

Repeat the exercise several times without the blindfold and with two-way communication between pilot and control tower. Discuss the differences in rate of success (absence of damage), pilot's feelings, need of outside support, etc.

Reinforce the essential need of good study skills and work habits for the student who is attempting to pilot his way through school. Point out that following directions and listening are two essential skills.

### SESSION #2

Name Game

Group Discussion Time: If my teacher could change one thing about me, it would be . . .

### TEST ACTIVITY:

The study will take a "test" given by the counselor.

Name \_\_\_\_\_

**DIRECTIONS:** Read all the questions on the page before you begin answering them.

1. What is your full name?
2. What is your address?
3. When was the last time you ate chicken?
4. What is the capital of Georgia?
5. When is your birthday?
6. What is your favorite song?
7. Who is the president of the U.S.?
8. Do not do questions 1-7. Sign your name at the bottom of the paper. Put your pencil down. Turn your paper over. Sit quietly and see how many others followed the directions.

*Barbara Lyon  
Hulcomb Bridge Middle School  
Alpharetta, Georgia*

# GROWTH CHART

Each student takes off shoes and stands in front of a sheet of butcher paper the teacher has attached to a wall, bulletin board, or chalk board. The teacher marks the student's height and puts student's name under the line. This activity is done at the beginning of the school year. Each time, a different color of ink is used -- blue at the beginning of school, red after Christmas, and black at the end of the year.

*Carol Irwin  
Lowndes Middle School  
Valdosta, Georgia*



## " I "

Students browse through magazines, newspapers, etc. and select and clip pictures, or words that reveal things about their lives. They use these to prepare a collage. Students may write a brief description of their lives.

# LET'S TALK

**HOW TO PLAY:** Choose a topic to discuss (Ex. Do you believe in the death penalty?) Hand a ball of string (twine) to one student and have him give his or her opinion on the topic. When he finishes with how he feels, he holds the end of the string in his hand and throws the ball to the one wishing to speak (hands are raised if they wish to talk). Students may speak as much as they please, but only when holding the string. String is thrown back and forth with each person speaking holding on to the string.

*Jeanette Woolfolk  
Lowndes Middle School  
Valdosta, Georgia*

## **RANDOM RAP**

Students list topics relating to current events, school, parents, peers, etc. The teacher then selects 1 topic and all students are encouraged to share their ideas on the topic.

## **STUDENT SCHOOL BROCHURE**

Students are asked to design a brochure for the upcoming 6, 7, or 8 grade students. They design an interesting cover, discuss guidelines for behavior and include activities such as intramurals, dances, and special events. Schedules may also be included.

## **DEAR PEERS**

Students use a format similar to letters written to Dear Abby. They write out concerns in question form and then place in the shoe box. Each group of 4 students has a box. Then they must exchange boxes and write solutions on the back of the card. The original owners of the box can then read the solutions.

*Susan Faith Jones  
McClesky Middle School  
Marietta, Georgia*

.....

## **GETTING TO KNOW THE GROUP**

Place students in small groups of 3-4. Supply each group with a large piece of white poster board. Ask the students to look for four ways in which they all have something in common. They should then draw pictures in the center to depict this. Also, students should identify four ways in which they are unique. These characteristics should be depicted in a corner. The teacher should rotate and make herself a member of each group.

*Pamela Paul  
McKendree Elementary School  
Lawrenceville, Georgia*

# PERSONAL COAT OF ARMS

Distribute "Coat of Arms" activity sheet. The Personal Coat of Arms is a well-known method of visually displaying one's values to others.

Have students write or draw the answers to various questions in each section of the shield. Questions can vary from individual to individual or from group to group below. Sample questions are given below.

1. Show one thing you are successful in.
2. Show things you do to make other people happy.
3. Show what you want to be when you grow up.
4. Draw a picture that best describes your last name.
5. What is your greatest achievement in life?
6. What is most important to you in your life?
7. What makes you the happiest in life?
8. What is one thing that makes you proud of your family?
9. Show your favorite pastime after school.
10. Show your favorite season of the year and what you do during that season that is fun.
11. What are your favorite things to look at?
12. What makes you jealous of others?

*Pat Kohn  
Otwell Middle School  
Cummings, Georgia*

ACTIVITY SHEET: COAT OF ARMS

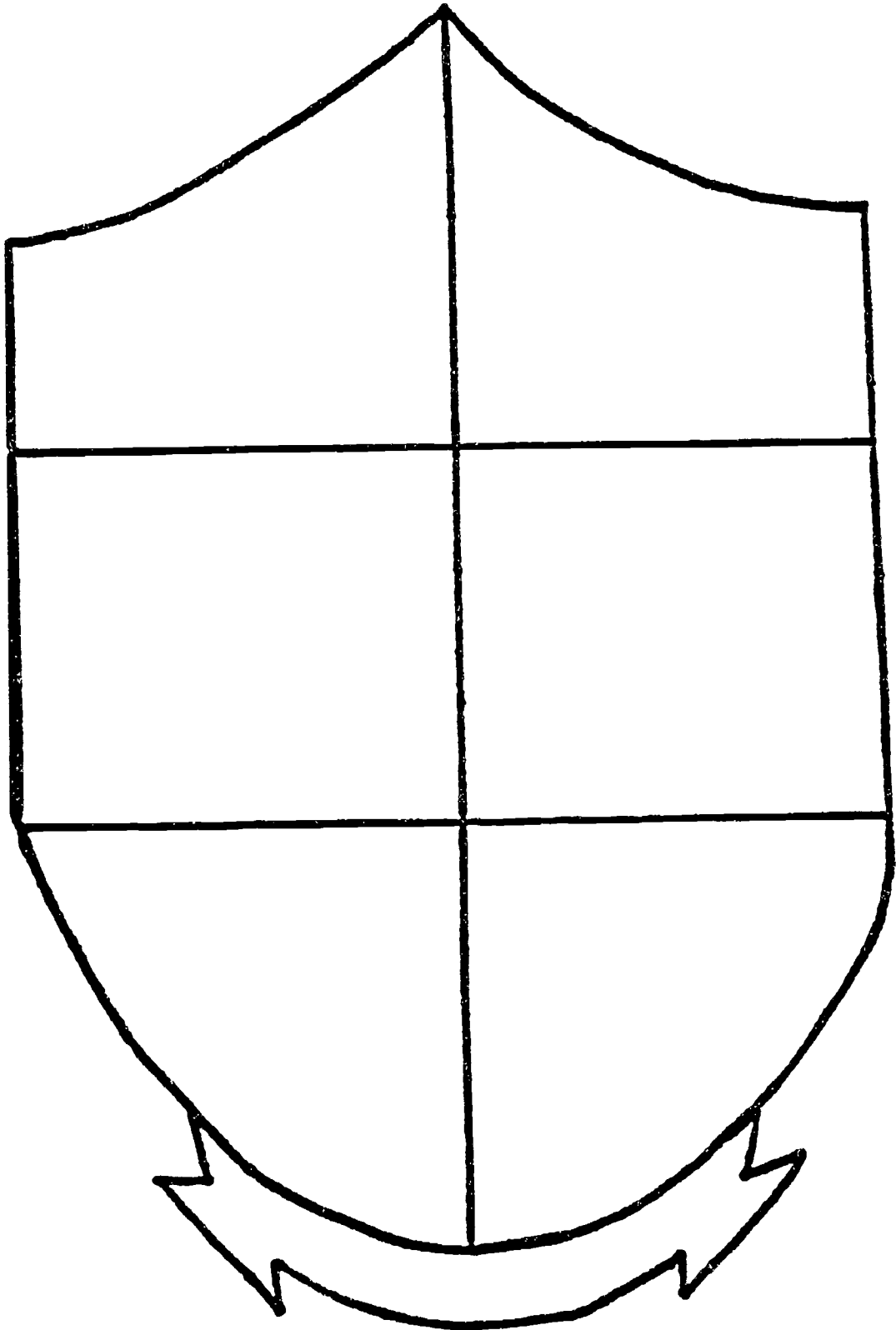

# FRIENDSHIP BOOK

Tell the students that you are going to take their ideas of friendship and put them into a book. Each student receives an activity sheet and responds individually to each section. The sections may be decorated by the students. Two pages are done for the groups. The remaining pages are blank so the group can insert their own ideas.

The pages are then cut and collated into a book. A cover may be made which says:

Friendship is ...

by

(Name of group)

(Date)

## WRAP UP:

Allow time for the groups to share their "Friendship is ..." books if they wish.

*Pat Kohn  
Otwell Middle School  
Cummings, Georgia*

**ACTIVITY SHEET: FRIENDSHIP BOOK**

... a caring thing

... when you have a friend



# BELONGING

The advisor begins the activity by giving a brief explanation of "non-verbal" behavior. Then she/he explains that she/he is going to place a colored dot on the forehead of each person. The colored dots represent a group that they are going to join.

Explain the following rules of the game:

- a. No talking
- b. Students must use non-verbal behavior to discover the color of their dot and to form a group with those who have dots of the same color.

The advisor begins the "no-talking" time and goes around and places the dots on the forehead of each student (without them seeing the color). The advisor selects one student (preferably one who is popular and accepted by others in the group) to get the yellow dot. Then she/he instructs the students to form a group (using non-verbal behavior) with those who have the same color dot. (Allow enough time for all groups to be formed.)

WRAP UP: After all groups have been formed, the student with the yellow dot will be left out of the group. Ask this student to relate his feelings about being "left out". Then involve the total group in a discussion on how it feels to be excluded. (What can we do to include others? Do new students feel this way?) Finally discuss the non-verbal behaviors students used to let others know that they were included or excluded. (Try to get students to relate these behaviors to situations which occur daily around the campus and to discuss ways that they can avoid some of the negatives.)

*Pat Kohn  
Orwell Middle School  
Cummings, Georgia*

# IF I WERE RULER OF THE WORLD

## PROCEDURE:

### First Session:

Allow students to complete the statements.

Provide opportunities for the students to share their statements with the class.

### Second Session:

Divide the class into groups of three.

Ask the students to choose five of the statements and give them 15 minutes to agree on the sentence completions.

After 15 minutes, allow groups time to share their decisions and give their decision-making process.

## WRAP UP:

Have students separately or in groups write a story describing the world they have created.

Some may be read aloud or posted around the room.

# THE TIME I GOOFED

With the class assembled in a large circle, ask the students to share the time they make a mistake. Use the following questions to help students to deal with their feelings:

- a. How did you feel at the time?
- b. How did the people around you feel?
- c. What did you say?
- d. What did you do?
- e. Are mistakes always bad?
- f. Can they be good? When?
- g. Can a mistake be funny?
- h. Does everyone make mistakes?

## WRAP UP:

To bring closure to the activity, the advisor should summarize student comments during the discussion and remind students that everyone makes mistakes. It is important that we learn from our mistakes so as not to repeat them.

## ACTIVITY SHEET: THE TIME I GOOFED

### DIRECTIONS:

Before beginning the circle discussion, jot down your answers to the following questions. This will lead to a richer discussion.

The time I goofed was when...

Now answer the following questions about that time.

- a. How did you feel at the time?
- b. How did the people around you feel?
- c. What did you say?
- d. What did you do?
- e. Are mistakes always bad?
- f. Can they be good? When?
- g. Can a mistake be funny?
- h. Does everyone make mistakes?

*Pat Kohn  
Otwell Middle School  
Cumming, Georgia*

# "I AM UNIQUE BECAUSE..."

Provide each student with a slip of paper.

Ask each student to think of one thing about himself that is different from everyone else in the room. This should be something that the student would like for the other class members to know about him.

Allow two or three minutes for the student to select and write the unique item on the slip of paper.

Place all of the slips in a bag. Shake up the bag.

Draw slips out of the bag and read one at a time.

Usually, two or more students write down the same item. This helps reassure students that they are normal and other people have some of the same experiences. Also, the students who do select unique items realize that they are unique as individuals.

Discuss with the class that we are all alike and different.

## **WRAP UP:**

Ask some of the following questions to generate student discussion.

- a. Have you ever thought that you were the only person in the whole world who had a particular problem?
- b. How does being different in some ways from every other person make you feel? Why?
- c. Is being like others in some way important? Why?
- d. Is being different from others in some way important?

*Pat Kohn  
Oswell Middle School  
Cumming, Georgia*

# ACCEPTING YOURSELF MEANS HAVING HIGH SELF-ESTEEM

## MOTIVATION:

Explain objective to students, discuss self-esteem, and relate activity to the real-life experiences and situations of students. This will be more meaningful if the teacher will share personal examples from his/her own life. Students are to recognize characteristics that can be changed and those that cannot be changed.

## ADVISEMENT PROCEDURE:

1. The teacher will read the following description of self-esteem to students. Students will complete and discuss RAP Sheet #1.

"Self-esteem is defined as your self-image, the thoughts and feelings that you have about yourself. These thoughts and feelings can be positive or negative. If you have more positive thoughts about yourself, then you have higher self-esteem. Your self-esteem is constantly developing. This development is affected by the feedback you get from others, as well as by the way you feel about yourself. Feeling good about yourself does not mean that you are conceited. In fact, those people who go around bragging about themselves and making fun of others actually have low self-esteem. They try to hide their faults by acting as if they're more important than everyone else. People with high self-esteem do have faults, but they also recognize their strengths.

"To rate your self-esteem, complete RAP Sheet #1 'Self-Esteem Inventory'."

(Teacher Note: Announce after students have completed questionnaire that if the number of "yes's" was eight or more, then the student's self-esteem is high.)

2. A. Ask students to make a list of all the characteristics of themselves that they can think of in five (5) minutes. The guideline is to list only characteristics that influence their opinions of themselves. In other words, don't list factual characteristics such as age, color of hair, etc., unless there are feelings -- positive or negative -- about those characteristics.
- B. The next step is to ask students to mark each characteristic on their list with "G" for good point and "B" for bad point. Then, students privately count the number of "G's" and "B's" and note which one outweighs the other in students' self-esteem. Ask students to complete these sentences at the bottom of the lists:

I see myself as .....

I learned that I .....

- C. Divide the class into small groups (4 - 5 students) to share information of their choice from their lists. Set the climate for discussion by pointing out that all of us have characteristics we do not like about ourselves. Sometimes other people do not see those characteristics as "faults." When we see that other people have some of the same "faults" we have, and that those "faults" don't seem nearly as critical as we once believed them to be, we are better able to accept ourselves totally.

**CLOSURE:**

Ask students to verbalize what they have learned about personal characteristics that affect their self-images and to give feedback to the advisor.

**OPTIONAL ACTIVITIES:**

Ask students to identify characteristics on their lists that are changeable and that they would genuinely like to change. Help students develop personal programs that can be reached within reasonable time frames. Students with similar programs may wish to work together. Suggest that students explore the school library to see what is available for them to read on the subjects of "Self-concept" and "Self-awareness."

ACTIVITY #5 ..... GRADE: NINTH  
 RAP SHEET #1

SELF-ESTEEM INVENTORY

I FEEL I .....

- CHECK ONE -

		YES	NO
1)	Am not easily discouraged		
2)	Get along well with most people		
3)	Have abilities in many areas		
4)	Would change my looks if I could		
5)	Have a short attention span		
6)	Am competitive with others		
7)	Try to please others rather than myself		
8)	Am a person who listens and comprehends well		
9)	Have a confused life		
10)	"Freeze up" under pressure		
11)	Am shy when I meet new people		
12)	Blame myself when things go wrong		
13)	Am a reliable person		
14)	Give in easily to peer pressure		
15)	Am an inportant person		
16)	Am usually satisfied with my appearance		

Linda Fountain  
 Peachtree Junior High School  
 Atlanta, Georgia

## STUDENT SUPPORT GROUPS

Students who have particular needs are placed in groups where the team teachers (one of them) serve as facilitators. These groups could be new student groups, academic problem groups, low self-esteem groups. In addition, teams meet with students in small conferences.

*Ketus Cawthon  
Perry Middle School  
Perry, Georgia*



## NEW STUDENT BUDDY

1. A new student enters and is assigned to an advisee/advisor group. On return, a buddy is assigned to help that student for several days.
2. New student also has that one teacher he/she could go to if lost or needs help.

## GOOD NEWS LETTER

Teachers send home Good News letters each nine weeks and in between grading periods. Make sure one goes out for every child during the year.

A Good News letter is sent to a child whose behavior is not all that "great". Check the students doing one good thing. Send a letter home.

*Linda Booth  
Putnam County Middle School  
Eatonton, Georgia*





As we approach each new year, we often pledge to make it better in some way. Many people make New Year's resolutions for some sort of personal change.

1. List 5 things you would like to do or achieve this year.

1. \_\_\_\_\_
2. \_\_\_\_\_
3. \_\_\_\_\_
4. \_\_\_\_\_
5. \_\_\_\_\_

2. What are some changes you would have to make in yourself to achieve these?

1. \_\_\_\_\_
2. \_\_\_\_\_
3. \_\_\_\_\_
4. \_\_\_\_\_
5. \_\_\_\_\_

Write 1 or 2 New Year's resolutions on the back.

Sandy Springs Middle School  
Atlanta, Georgia

# DID I CATCH YOUR NAME?

**HOW TO PLAY:** Students arrange desks in circle. Hold up ball and say to students, "I'd like each of you to pass this ball gently to someone else in the circle. Say your name and describe something about yourself after you catch it." After everyone has had a chance, each person introduces the person to his/her left to the group including the characteristics that person shares. Select topics to tell about yourself: favorite activity, something good that happened in the last 2 days, something you did that you feel good about, a time when you helped someone.

*Lucy Seabolt  
South Hall Middle School  
Gainesville, Georgia*



# WHY DID I GET THAT "D" LAST WEEK?

- TEACHER**
- Hand out a copy of the activity sheet to each student (page OT-3a).
  - Discuss grades and how students are responsible for their own.
  - Organize students in small groups.

- STUDENTS**
- Fill in responses on the activity sheet.
  - Discuss responses in small groups.

**NOTE:** This activity can be used as a pretest.

## Discussion/Follow Up

- In a large circle, discuss:
  - How can you improve your study habits?
  - Which skill would you agree to work on for the next week?
  - Is there any way you can help others in the class improve their study skills?

## Evaluation

Was the activity successful \_\_\_\_\_ yes \_\_\_\_\_ no

Why? \_\_\_\_\_

Did students enjoy the activity? \_\_\_\_\_ yes \_\_\_\_\_ no

Why? \_\_\_\_\_

Comments/Changes for improvement: \_\_\_\_\_

\_\_\_\_\_

**Organizing Time 3  
Seventh Grade**

**WHY DID I GET THAT GRADE LAST WEEK?**

Directions: Place a check in the box which gives your best answer.

	Always	Usually	Sometimes	Rarely
1. There is a special quiet place at home where I study.	_____	_____	_____	_____
2. My papers are clean and neat.	_____	_____	_____	_____
3. I have my school work organized in a notebook or folder.	_____	_____	_____	_____
4. I ask questions when I don't understand something in class.	_____	_____	_____	_____
5. I finish my school work on time.	_____	_____	_____	_____
6. I listen carefully to oral directions the teacher gives.	_____	_____	_____	_____
7. I always read the directions before starting an assignment.	_____	_____	_____	_____
8. When I study with friends, I do the work and then socialize.	_____	_____	_____	_____
9. I have a place where I write down all homework assignments.	_____	_____	_____	_____
10. I come to class prepared with pencil and paper.	_____	_____	_____	_____

*Janis Carey  
Staley Middle School  
Americus, Georgia*

# WISH UPON A STAR

Teacher - Distribute stars.

- Ask students of all the wishes, hopes and dreams they would like to come true within the next year.

Student - Place their wishes, hopes and dreams on the stars. (GOLD ADVISOR DOES THE SAME.)

- Each student discusses at least one of their wishes, hopes and dreams.
- Make a "star studded" display using the students' stars.
- Ask the students if they have ever had a hope or dream come true. Explain.

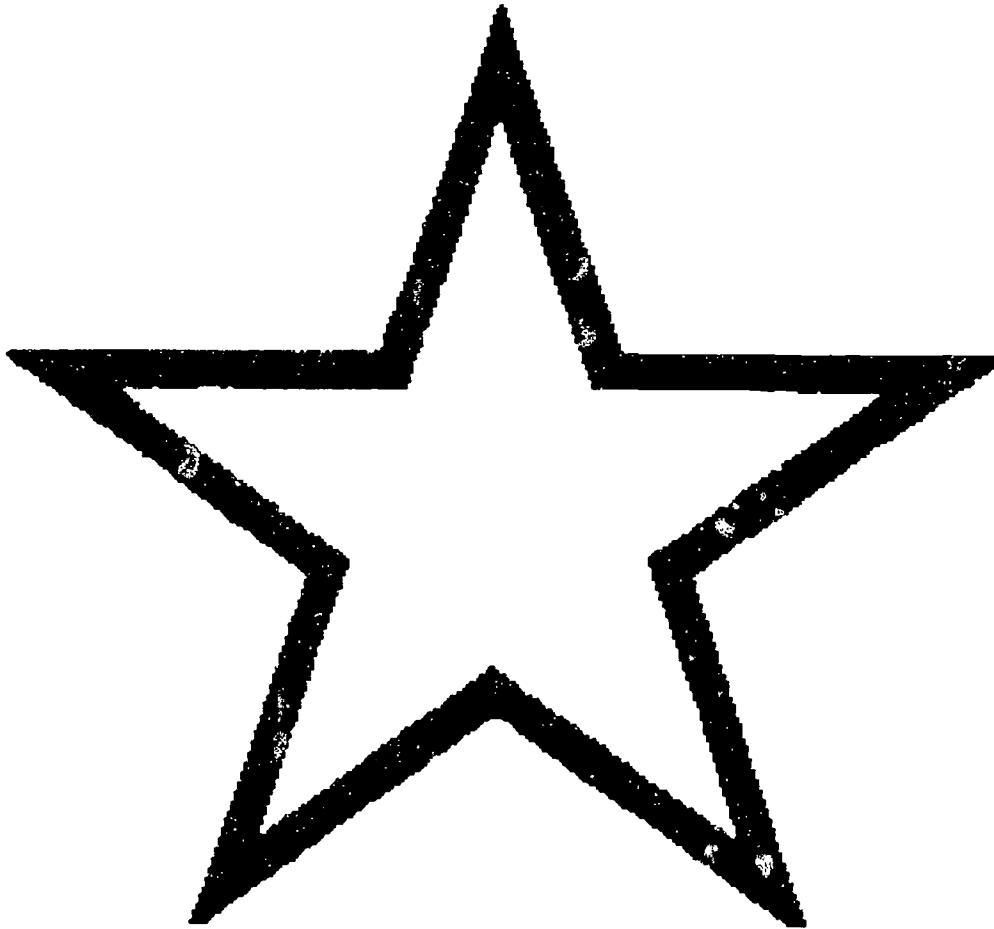

*Janis Carey  
Staley Middle School  
Americus, Georgia*

# NAME-O

Unit/Grade	Activity Title	Activity #
Orientation 7	NAME-O	0-1

## Goal

To learn other students' names (played like Bingo)

Time Needed	Material Needed	Grouping Structure
1 session	<ul style="list-style-type: none"> <li>- pen/pencil</li> <li>- copies of page 0-1a</li> <li>- 10 to 15 "chips" per student (small squares of poster board)</li> <li>- Slips of paper with each student's or VIP's name</li> </ul>	- large group

## Preparation

- MAKE COPIES OF PAGE 0-1a
- Cut out enough chips for each student
- Write each name to be used on separate slips of paper

## Procedures

- STUDENTS** - Individually write their own names on the board for an introduction.
- TEACHER** - Introduce rules of NAME-O Game (played just like Bingo).  
 - Add additional names of VIP's (principal, teachers, counselor, custodians) on board until number totals 24.
- STUDENTS** - Copy names from board on NAME-O Card in random order.
- TEACHER** - Place all name slips in box.  
 - Call names from box as they are drawn.
- STUDENTS** - Cover the names with chips as they are called (first student with 5 squares filled vertically, horizontally, or diagonally wins NAME-O Game).

NAME-O may be played several times in one session (prizes optional).

## Discussion/Follow Up

- Ask students to identify 2-3 students by name.

## Evaluation

Was the activity successful?  Yes  No

Why? \_\_\_\_\_

Did students enjoy the activity?  Yes  No

Why? \_\_\_\_\_

Comments for improvement: \_\_\_\_\_

*Janis Carey  
Staley Middle School  
Americus, Georgia*

N A M E - O

		Free Space!		

# I'M THUMB-BODY

Unit/Grade	Activity Title	Activity #
Self-Esteem 8	I'm "Thumb-body"	SE-2

## Goal

To help students become aware of their uniqueness

Time Needed	Material Needed	Grouping Structure
	<ul style="list-style-type: none"> <li>- Ink pad</li> <li>- Manilla paper</li> <li>- Scissors</li> <li>- 3 X 5 cards</li> <li>- Chalkboard/chalk</li> </ul>	

## Preparation

- Get the above materials.

## Procedures

- TEACHER**
- Discuss what it means to be unique. How is everybody special?
  - List ways students are unique on the board.
  - Give students manilla paper, ink pad and 3 X 5 cards.

- STUDENTS**
- Mark thumb print on manilla paper.
  - Study your thumb print carefully observing its uniqueness.
  - Write sentence on a 3 X 5 cards, I'm unique because ....

- TEACHER**
- Collect all thumbprints and sentences and shuffle them.
  - Identify their thumbprints and handwriting.
  - Encourage students to draw pictures on their thumbprint.
  - Display all thumbprints on a bulletin board entitled, "I'm Thumb-body"
  - Select three or four students to summarize the session.

## Discussion/Follow Up

- Say, "Each of you is unique." There has never been anyone like you and there never will be again. Is that good or bad? Do you agree?
- How did you know your thumbprint? Your handwriting? What is unique or different about it?

## Evaluation

Was the activity successful?  Yes  No

Why? \_\_\_\_\_

Did students enjoy the activity?  Yes  No

Why? \_\_\_\_\_

Comments for improvement: \_\_\_\_\_

*Janis Carey  
Staley Middle School  
Americus, Georgia*

# I'M A GOOD EGG

Teacher - Discuss his/her own good qualities. Then teacher will instruct students to think of qualities they most admire in themselves.

Student - Write these qualities on a precut egg. Eggs may be decorated in some way. Students will share positive qualities with the class. See if any students have any positive qualities in common. Once eggs are decorated they may be displayed.

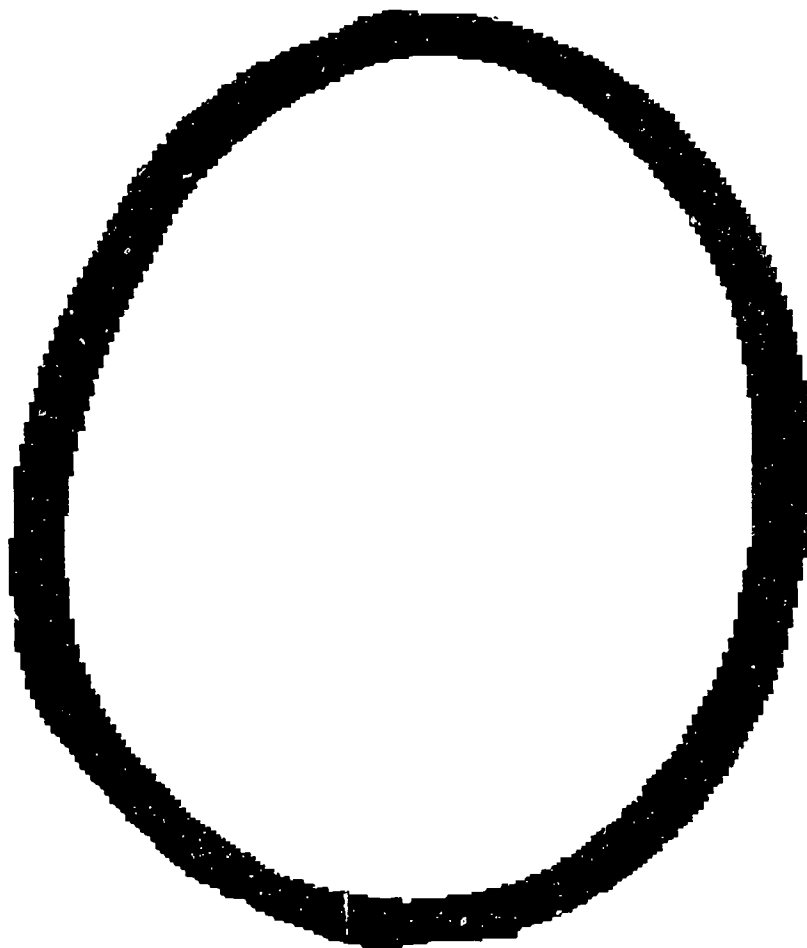

*Janis Carey  
Staley Middle School  
Americus, Georgia*



# HOW DO YOU FEEL?

- TEACHER**
- Ask students to brainstorm a list of pleasant and unpleasant "feeling words".
  - Write the words on the board.
  - Ask students the questions from the "How Do You Feel?" sheet and have them use the list on the chalkboard to answer.

- STUDENTS**
- Think of feeling words and and share with class.
  - Answer "How Do You Feel?" questions orally.

- TEACHER**
- Ask students to create their own "How Do You Feel?" questions.

- STUDENTS**
- Write original "How Do You Feel?" questions and share them with the class.

## Discussion/Follow Up

- Ask students to discuss the "How Do You Feel?" questions with a significant person in their life.
- Have students develop their own list of "How Do You Feel?" questions.
- Have students write their responses in their notebook.

## Evaluation

Was the activity successful? \_\_\_\_\_ Yes \_\_\_\_\_ No  
Why? \_\_\_\_\_

Did students enjoy the activity? \_\_\_\_\_ Yes \_\_\_\_\_ No  
Why? \_\_\_\_\_

Comments/Changes for improvement? \_\_\_\_\_  
\_\_\_\_\_

Positive Relationships 4  
Seventh Grade

"HOW DO YOU FEEL?"

How do you feel when . . .

1. ... people yell at you?
2. ... you sit down to your favorite meal?
3. ... you are the last one chosen for a game?
4. ... someone tells you that you have done something very well?
5. ... someone doesn't do what they said they would do?
6. ... you get a gift you didn't expect to get?
7. ... you do not have to get up on Saturday morning to go to school?
8. ... someone says, "I know you can do better?"
9. ... you do poorly on a test?
10. ... no one speaks to you?



PR-4a

*"A cheerful friend is like a sunny day."*

*Janis Carey  
Staley Middle School  
Americus, Georgia*

# RUDOLPH, THE RED-NOSED REINDEER

- 1) Sing the song together as a group.
- 2) Discuss what has happened in the song. How is this song like being in the real world?
- 3) Ask - Who has made fun of someone because he/she was different? (No names) Have you ever laughed when someone else made fun of another person? Why?

Have you ever felt like Rudolph? When - How?

After Rudolph guided the sleigh, the other reindeer treated him differently. How do you feel about this? Was Rudolph any different then?

Do you disapprove of ostracizing or making fun of others? Have you ever made this known? How?

Who do you feel more like? Why? (This could be written)

- a. Rudolph before guiding the sleigh.  
Rudolph after guiding the sleigh.
- b. The reindeer before Rudolph guided the sleigh.  
The reindeer after Rudolph guided the sleigh.

Optional: How is Santa Claus like your teacher or counselor in this case?

- 4) Summarize the session in your own words.
- 5) Adjourn when the bell sounds.

*Diane Shuler  
Tubman Middle School  
Augusta, Georgia*

# HIGH SCHOOL CURRICULUM REQUIREMENTS FOR GENERAL EDUCATION DIPLOMA

The number of units\* required for high school graduation are shown in the following table:

English	4.0 units**
Mathematics	2.0
Science	2.0
Math/Science	1.0
Social Studies	3.0
U.S. History	1.0
World History	1.0
Citizenship	.5
Principles of	.5
Economics/or	
Business/or Free	
Enterprise	
Health/Safety	.5
Physical Education	1.0***
Computer Technology/or	1.0
Fine Arts/or Vocational/ or ROTC	
Foreign language	0.0****
Vocational	0.0
Electives	7.5

\*Students earn one-half (.5) unit for successfully completing (a grade of "D" or better) one course, meeting five periods per week for one semester (a semester is 2 nine- weeks).

\*\*To earn 1 unit in a subject, students must pass both semester classes (one year is 2 semesters or 4 nine weeks). Some classes last only one semester (.5 unit). Other classes last 2 semesters (1 unit).

\*\*\*Some courses such as marching band and ROTC may be substituted for one semester (.5 unit) of Physical Education, but the credit is still given for PE.

\*\*\*\*Foreign language is only required for students who are trying to earn a college preparatory seal for their diploma. Foreign language is not required for a general high school diploma.

# HIGH SCHOOL GRADUATION REQUIREMENTS

## DIRECTIONS:

A. EVERY PERSON IN YOUR GROUP COMPLETES ONE OF THESE QUESTIONNAIRES. USING THE ATTACHED INFORMATION SHEET (HIGH SCHOOL CURRICULUM REQUIREMENTS - GENERAL)

B. PUT THE LETTER OF THE CORRECT ANSWER IN THE BLANK.

- \_\_\_\_\_ 1. How long does it take to earn one (1) unit of credit? a) 1 nine weeks b) 2 nine weeks c) 1 semester d) 1 school year.
- \_\_\_\_\_ 2. A semester of study is a) 1 nine weeks b) 2 nine weeks c) 3 nine weeks d) 1 school year.
- \_\_\_\_\_ 3. A full course load in high school is how many classes per day? a) 6 b) 5 c) 4 d) 3.
- \_\_\_\_\_ 4. How many units of English are required to graduate from high school? a) 6 b) 5 c) 4 d) 3.
- \_\_\_\_\_ 5. How many years of English are required to graduate from high school? a) 6 b) 5 c) 4 d) 3.
- \_\_\_\_\_ 6. How many social studies units are required to graduate from high school? a) 6 b) 5 c) 4 d) 3
- \_\_\_\_\_ 7. How many math and science (combined) units are required to graduate from high school? a) 6 b) 5 c) 4 d) 3
- \_\_\_\_\_ 8. How many units of a foreign language are required to graduate from high school? a) 3 b) 2 c) 1 d) 0
- \_\_\_\_\_ 9. How many physical education units are required? a) 3 b) 2 c) 1 d) 0
- \_\_\_\_\_ 10. How many total units are required to graduate from high school in Georgia? a) 24 b) 23 c) 22 d) 21

When every group has completed answering the question, your teacher will tell you the correct answer.

Write below any questions you have about this activity and save it. Mrs. Lange will be meeting with you soon to discuss high school graduation requirements in more detail, especially for students who plan to attend college or technical school. Those students have different diploma requirements. The above questions covered general diploma requirements.

I need to know \_\_\_\_\_

# HOMEROOM GUIDANCE

## 8TH GRADE ACTIVITY 2

### HIGH SCHOOL CURRICULUM REQUIREMENTS

**GOAL:** TO HELP STUDENTS BEGIN TO PLAN THEIR HIGH SCHOOL PROGRAMS OF STUDY

**OBJECTIVES:** STUDENTS WILL LEARN THE SPECIFIC CURRICULUM REQUIREMENTS AROUND WHICH THEY MUST PLAN THEIR HIGH SCHOOL PROGRAMS

**MATERIALS:**

1. WORKSHEET: "HIGH SCHOOL GRADUATION REQUIREMENTS"
2. WORKSHEET: "HIGH SCHOOL CURRICULUM REQUIREMENTS FOR GENERAL EDUCATION DIPLOMA"

**ACTIVITIES:**

5 mins.            1. Introduce activity by asking if anyone knows any of the high school graduation requirements of the state of Georgia. (Answer: a. Must earn a certain number of units of credit by passing a certain number of specified courses - don't tell class how many; that is in their group activity. b. Must pass the Georgia Basic Skills Test which they take for the first time in the 10th grade. Tell them that their 8th grade CRT is a practice version of the Basic Skills Test.)

20 mins.            2. Divide class into groups; hand out worksheets. Have them answer questions on page 1 by using information on page 2. Every person in the group should complete a worksheet.

5 mins.            3. Read answers to page 1:

1. d
2. b
3. a
4. c
5. c
6. b
7. b
8. d
9. c
10. c

5 mins.            4. Tell students to write questions they have on the bottom of their worksheet and to hold it until Mrs. Lange meets with them during the next couple of weeks to further discuss high school graduation requirements and program planning.

5 mins.            5. Closure: ask volunteers to summarize requirements for the general education diploma.

*Karen Lange  
Wilder Middle School  
Savannah, Georgia*

## MY PERSONAL TIME-MANAGEMENT SCHEDULE

Directions: Write in your daily activities and the time you perform each activity. Start with the time you get up in the morning and end with the time you go to bed at night.

TIME	ACTIVITY
	Get up.
	Go to bed.

I \_\_\_\_\_ will follow this time-management schedule beginning immediately.

Adapted from Bread and Butterflies, p. 36.

*Wilder Middle School  
Homeroom Guidance Handbook  
Savannah, Georgia*



# Goal-Setting

Directions: Complete as directed.

1. Here is a list of career fields used in the CHOICES program. (CHOICES is the computer career program used in the public schools in Chatham County). What career field(s) are you at this time interested in?
- 

1. Executives, Administrators and Managers
2. Engineers and Architects
3. Computer and Mathematical Scientists
4. Natural Scientists
5. Social Scientists/Workers, Religious Workers, Lawyers
6. Teachers and Counselors
7. Medical Doctors and Other Health Specialists
8. Nurses, Dieticians, Therapists, and Physicians Assistants
9. Writers, Artists, Entertainers, and Athletes
10. Health Technologists and Technicians
11. Technologists and Technicians, Except Health
12. Marketing and Sales Occupations
13. Clerical Occupations
14. Service Occupations
15. Farming and Agriculture Occupations
16. Forestry and Logging Occupations
17. Fishers and Hunters
18. Mechanics and Repairers
19. Construction, Mining and Drilling Occupations
20. Production Occupations
21. Machine Operators
22. Transportation and Material Moving Occupations

2. What school subjects do you think you need to be good in to eventually perform in these fields? (You can always look up job requirements in the media center later if you are not sure) Field(s) refers to answer to number 1.

- 1.
- 2.
- 3.
- 4.
- 5.

3. In this career field, will you work inside, outside or partly inside and out?
-

4. Of the following choices, up to what level (CHOICES, 1983) do you want to go in school? \_\_\_\_\_

1. Up to grade 8
2. Grade 8
3. Grade 9
4. Grade 10
5. Grade 11
6. Grade 12
7. Grade 13
8. Less than 1 year after high school
9. 1 year community college/vocational/technical/trade school
10. 1 year university
11. 2 years community college/vocational/technical/trade school
12. 2 years university
13. 3 years community college/vocational/technical/trade school
14. 3 years university
15. Complete undergraduate degree
16. Professional or graduate degree

Now that you have chosen a level of school to work towards, please sign the following statement committing yourself to begin working towards this educational goal immediately.

I \_\_\_\_\_ agree to work toward my  
goal of completing \_\_\_\_\_  
level chosen in #4

*Wilder Middle School  
Homeroom Guidance Handbook  
Savannah, Georgia*

## WHAT ARE MY STRENGTHS?

Complete.

Circle a number according to this scale:

- 1      excellent
- 2      above average
- 3      average
- 4      below average
- 5      very weak

1. How would you rate your ability to:
- |   |   |   |   |   |   |
|---|---|---|---|---|---|
| Catch on or understand instructions?      | 1 | 2 | 3 | 4 | 5 |
| Reason and make judgments?                | 1 | 2 | 3 | 4 | 5 |
| Recognize and solve problems by yourself? | 1 | 2 | 3 | 4 | 5 |
| Learn new subjects quickly and easily?    | 1 | 2 | 3 | 4 | 5 |
| Work out underlying reasons for things?   | 1 | 2 | 3 | 4 | 5 |

(Choices, 1983, p. 26)

2. What school subjects do you make passing grades in?
3. What school subjects do you make D's or failing grades in?
4. What conclusions can you draw from your answers in numbers 2 and 3?
5. Are there exercises that you can do to become better in your weaknesses?

Name \_\_\_\_\_ Date \_\_\_\_\_

*Wilder Middle School  
Homeroom Guidance Handbook  
Savannah, Georgia*

## WHAT ARE MY STRENGTHS?

Complete.

1. What is a memorable decision you had to make?
2. What did you decide?
3. Why are decisions sometimes hard to make?
4. The following steps to making a decision may be useful:
  - A. Identify the problem.
  - B. List possible choices.
  - C. Consider the pros and cons of each, thinking about what is important to you.
  - D. Make decision.

*(Bread and Butterflies, p. 26)*

5. Apply the steps in number 4 to a choice between doing homework at a time your favorite TV show is on? (Distractions such as TV should not be present when you are doing your homework).

Name \_\_\_\_\_ Date \_\_\_\_\_

*Wilder Middle School  
Homeroom Guidance Handbook  
Savannah, Georgia*

## "HOW DO I USE MY TIME?"

I. Answer the following questions (BE HONEST - no one else is going to see this):

1. What do you do in homeroom on most days? \_\_\_\_\_  
\_\_\_\_\_

2. If a teacher gives you free time in class, what do you usually do? \_\_\_\_\_  
\_\_\_\_\_

3. What do you do between classes? \_\_\_\_\_  
\_\_\_\_\_

4. What do you do during the following time periods after school?

2pm - 3pm: \_\_\_\_\_

3pm - 4pm: \_\_\_\_\_

4pm - 5pm: \_\_\_\_\_

5pm - 6pm: \_\_\_\_\_

6pm - 7pm: \_\_\_\_\_

7pm - 8pm: \_\_\_\_\_

8pm - 9pm: \_\_\_\_\_

9pm: YOU SHOULD BE IN BED!

5. List 2 ways you use time well in school. \_\_\_\_\_  
\_\_\_\_\_

6. List 2 ways you waste time well in school. \_\_\_\_\_  
\_\_\_\_\_

7. List 2 ways you use time well at home. \_\_\_\_\_  
\_\_\_\_\_

8. List 2 ways you waste time at home. \_\_\_\_\_  
\_\_\_\_\_

9. How did your use of time affect your marks on your Academic Status Report (ASR or mid-nine-weeks progress report)?

\_\_\_\_\_

II. List 5 ways you can improve your grades by changing the ways you use your time, at home and at school:

1. \_\_\_\_\_

2. \_\_\_\_\_

3. \_\_\_\_\_

4. \_\_\_\_\_

5. \_\_\_\_\_

III. (VOLUNTARY) If you wish, make a pledge to yourself that you are going to try to improve your grades by using your time more wisely.

I, \_\_\_\_\_, am going to try to make better use of my time so that I can succeed in school and in life.

\_\_\_\_\_  
Signature

Activity 1 - Seventh grade

*Wilder Middle School  
Homeroom Guidance Handbook  
Savannah, Georgia*

# "MY GOALS FOR NOW AND LATER"

name \_\_\_\_\_

date \_\_\_\_\_

homeroom \_\_\_\_\_

I. A goal is the thing for which you are working. For example, if you have a job cutting lawns, your goal is probably to earn some money (unless you just like to cut lawns).

A. When people go to school, they seem to be more successful if they set specific goals to work toward such as making a certain grade in a class.

1. List two short-term goals you have for school right NOW:

\_\_\_\_\_  
\_\_\_\_\_

2. List two long-term goals you have for school for LATER this school year:

\_\_\_\_\_  
\_\_\_\_\_

B. Because school is only one part of your life, you should have some goals for your life outside of school. For instance, you might be saving money to be yourself something important - like a new outfit.

1. List two short-term goals you have for yourself for NOW:

\_\_\_\_\_  
\_\_\_\_\_

2. List two long-term goals you for yourself for LATER:

\_\_\_\_\_  
\_\_\_\_\_

II. This section is voluntary. You do not have to do it if you do not want to. Sign below if you want to make a commitment (promise) to yourself about trying to reach the goals you have set for yourself:

I, \_\_\_\_\_, promise myself that I will try to the best of my ability to reach the goals I have set for myself.

\_\_\_\_\_  
signature

\_\_\_\_\_  
date

*Wilder Middle School  
Homeroom Guidance Handbook  
Savannah, Georgia*

## "WHY CAN'T I DO BOTH?"

**Scene:** Tina, Marie, and Tonya are good friends. They are in the 8th grade. Tina is trying to make a very big decision and has asked her friends for help.

**Tina:** I don't care what my mother says. She won't know about it until it's too late to do anything.

**Marie:** Tina, you must be out of your mind, girl. Nobody would try to fail a grade just so she can be in the same school with her boyfriend!

**Tonya:** Besides, Tina, you have always made some of the best grades of anyone I know. You couldn't fail if you tried.

**Tina:** Yes, I can. I haven't turned in my science notebook yet. I'll make an "F" for sure if I don't turn it in by tomorrow. And don't you know that will be my third "F" this year. Joey doesn't like smart girls, he says, so I haven't tried very much on my school work this year.

**Marie:** But, Tina, your science notebook is perfect. I borrowed it to get the notes I missed last week.

**Tina:** Yeah, it is complete. I did it just in case I changed my mind about Joey. But I don't think I could stand being in another school next year with him here with all those girls chasing him all the time.

**Tonya:** Tina, my cousin did something like that 2 years ago. But she was in high school. She didn't graduate on purpose so she and her boyfriend could graduate at the same time.

**Tina:** Well, if I don't turn in my notebook tomorrow, that will be it - I will fail.

**Marie:** Does Joey know that you are thinking about failing for him?

**Tina:** Yeah, I told him. He said what I did in school was my business, but I know he will be glad to have me here next year.

**Tonya:** Did he tell you that?

**Tina:** No, but I just know he doesn't want me to go to high school without him.



Discuss the following questions and decide on one answer from your group:

1. What choice does Tina have to make? \_\_\_\_\_  
\_\_\_\_\_
2. What advice did her friends give her? \_\_\_\_\_  
\_\_\_\_\_
3. What advice would you give to Tina? \_\_\_\_\_  
\_\_\_\_\_
4. Do you think Tina has any goals for school? \_\_\_\_\_  
If so, what are they? \_\_\_\_\_  
\_\_\_\_\_
5. What do Tina's goals for her life outside of school seem to be? \_\_\_\_\_  
\_\_\_\_\_
6. What should Tina do (about her goals) before she makes a final decision about whether or not to fail the grade? \_\_\_\_\_  
\_\_\_\_\_
7. Think of a different situation which requires you to think about your goals before making a choice. \_\_\_\_\_  
\_\_\_\_\_

*Wilder Middle School  
Homeroom Guidance Handbook  
Savannah, Georgia*

## "WHO DOES HE THINK HE IS?"

Johnny (age 14), Carl (age 14), and Chris (age 13) are in the 8th grade at Simpson Middle School. Terry (age 13) and Richard (age 13) are in the 7th grade there. They have been hanging out together for about 3 years, at home and in school (between classes and at lunch).

Last week, Johnny won 4 tickets to a concert. He invited Carl, Chris, and Terry to go with him. Richard's feelings were hurt, but he didn't say anything. In fact, when his uncle gave him \$10.00, Richard invited Johnny to go to the movies with him, with Richard paying. Johnny went to the movies with Richard but talked Richard into seeing a different movie than the one Richard had planned to see. Richard really wanted to see the first one, but he agreed to see Johnny's choice.

The next day at lunch, Terry's class was late coming in, so Johnny had invited a new boy, Jackie, to sit with them. When Terry finally got there, Johnny told Richard to move to another table so Terry could sit in his seat. Richard said he didn't want to, but Carl and Chris told him to go ahead and move, after Richard had given Carl half of his hamburger. So Richard moved.

Questions: discuss with your group and come up with one answer per question.

1. Who was the group's leader? \_\_\_\_\_
2. Does every group have a leader? yes or no Why or why not? \_\_\_\_\_  
\_\_\_\_\_
3. What happens when a group has a very strong leader? \_\_\_\_\_  
\_\_\_\_\_
4. What happens when a group has a weak leader, or no leader? \_\_\_\_\_  
\_\_\_\_\_
5. Does the group you are in right now have a leader? yes or no If so, who is it? \_\_\_\_\_  
\_\_\_\_\_
6. There are several roles in every group: usually, there is a leader; then there are some active members (they participate in the group's activity and help make decisions) and some passive members (they participate in the group very little and do not help make decisions very often). Which kind of roles did the following play in their group:
  - a. Richard - active or passive?
  - b. Carl - active or passive?
  - c. Chris - active or passive?

7. Would you say Richard's behavior was good (constructive) or bad (destructive) for the group? \_\_\_\_\_  
\_\_\_\_\_

8. Would you Richard's behavior was constructive or destructive for himself? \_\_\_\_\_  
\_\_\_\_\_

Activity 3 - Seventh grade

*Wilder Middle School  
Homeroom Guidance Handbook  
Savannah, Georgia*

## "HOW DO I SEE MYSELF IN A GROUP?"

Everyone plays a different roles in groups. Some people are leaders, some are followers. Some are active (they help the group reach its goals); some are passitve (they don't help too much, they are just there). Almost all leaders are active. Followers can be active or passive.

Write your opinions about the following ideas:

1. Think about the last group activity you participated in.
  - a. Who was the leader? \_\_\_\_\_
  - b. What roles did you play: leader \_\_\_\_\_ or follower \_\_\_\_\_  
active \_\_\_\_\_ or passive \_\_\_\_\_
2. If you have ever been the leader of a group, why do you suppose you were the leader? \_\_\_\_\_
3. If you have never been a leader, why so you think that is so? \_\_\_\_\_  
\_\_\_\_\_  
\_\_\_\_\_
4. Have you ever done anything (good or bad) with a group that you would not have done alone? yes \_\_\_\_\_ no \_\_\_\_\_ (you don't have to tell what it is).
5. Why do you think people will do things with a group that they are afraid to do alone? \_\_\_\_\_  
\_\_\_\_\_
6. Give an example of something bad that a person will do with a group, but will not usually do alone? \_\_\_\_\_  
\_\_\_\_\_
7. Give an example of something good that a person will do with a group, but will not usually do alone? \_\_\_\_\_  
\_\_\_\_\_
8. Do you think that a person who has never been the leader of any group should be the leader of a group? yes or no? Why or why not? \_\_\_\_\_  
\_\_\_\_\_
9. Do you think a person can be taught to be a leader? yes or no?
10. If you are not usually the leader of a group, would you like to be leader sometimes? yes or no? Why? \_\_\_\_\_  
\_\_\_\_\_

*Wilder Middle School  
Homeroom Guidance Handbook  
Savannah, Georgia*

## DECISION-MAKING

Please complete.

1. What is a memorable decision you made this school year?
  
  2. Why was this a hard decision?
  
  3. How did you arrive at the choice you made?
  
  4. The following steps to making a decision may be useful:
    - A. Identifying the problem.
    - B. List possible choices.
    - C. Consider the pros and cons of each, thinking about what is important to you.
    - D. Make decision.
- (Bread and Butterflies, p. 36)
5. Apply the steps in number 4 to a problem where the choices are going to summer school to take a failed subject or going on a family trip.

Activity 6 - Seventh Grade

*Wilder Middle School  
Homeroom Guidance Handbook  
Statesboro, Georgia*

## "BUT I THOUGHT THIS WEEK HAD 8 DAYS IN IT"

Paul, student

Marsha, student

Monday morning, social studies class

Paul: Why is he talking about that test again? It's not until Friday.

Marsha: Joel asked him about something that might be on it.

Paul: That figures. I bet Joel has already started studying for it!

Marsha: I think he is trying to be sure that he has everything in his notebook so he can study.

Paul: Boy, I have really got to study for this one or I am in deep trouble. If I fail this nine weeks, I will have to go to summer school. I need to get the notes I missed when I was out last week.

Marsha: Paul, I told you that you could borrow my notebook over the weekend, but you never asked me for it.

Paul: Well, I knew I wouldn't have time to use it. I had to work after school Friday and all day Saturday. And Tina, my girlfriend, gave a party for her cousin's birthday, so I had to go to that Sunday night. Can I borrow your notebook Wednesday night? I don't have to work then.

Marsha: No, I'll need to use it to study Wednesday night. But you can borrow it tonight or tomorrow. I won't be using it then, because I have to finish my book report for English.

Paul: Why do you have to finish that now. It's not due until next Wednesday?

Marsha: Paul, it's due this Wednesday, the 12th!

Paul: Oh, NO! Is this Wednesday the 12th? I haven't even gotten a book to read yet. Well, I guess I'll go to the library at lunch. I can read the book tonight and write the report tomorrow night.

Marsha: So you won't be needing my social studies notebook tonight then?

Paul: Listen, Marsha, you do your book report tonight and study social studies tomorrow night so could use your notebook Wednesday night, right?

That sounds like pretty good planning, doesn't it?

Marsha: It's nice of you to plan my time for me, Paul. But I have already planned it. I have planned to spend tonight and tomorrow night on my book report and Wednesday and Thursday nights studying social studies.

Paul: Well, thanks for nothing. Some friend you are.

Questions: discuss with your group and come up with one answer per question:

1. Paul has a problem. What is it? \_\_\_\_\_  
\_\_\_\_\_

2. Paul has a lot of things going on in his life. Do you think he is trying to do too much? yes or no Why or Why not? \_\_\_\_\_  
\_\_\_\_\_

3. What are 2 choices Paul has for ways to solve his problem? \_\_\_\_\_  
\_\_\_\_\_

4. What would be the consequences of each choice? (What would happen as a result of each choice?) \_\_\_\_\_  
\_\_\_\_\_  
\_\_\_\_\_

5. Using your time well is called "effective time-management." Paul is not doing well in school because of ineffective time-management (not using his time well). Suggest some ways Paul could be successful in school and still have time for a job and a girl-friend.  
\_\_\_\_\_  
\_\_\_\_\_  
\_\_\_\_\_

*Wilder Middle School  
Homeroom Guidance Handbook  
Statesboro, Georgia*

## "It's Later Than You Think"

Jason is in the 10th grade. He is talking with this advisor, Mrs. Knowittall, about classes for the 11th grade. He has to sign up for his classes tomorrow and he tells Mrs. Knowittall that he will just take whatever classes his friend Raymond is taking.

Mrs. K: Jason, have you talked to your parents about this?

Jason: Well, not really. It doesn't matter what I take, Mrs. K., just so I am getting the credits I need to graduate. I know I need an English, social studies, and a math or science class. You just sign me up for the classes you think would be best for me. You know me well.

Mrs. K.: I can't do that Jason. I can't make these decisions for you. What are you planning to do after you graduate?

Jason: I don't know yet. That's 2 years away. I have plenty of time to worry about that.

Mrs. K.: Oh, no, you don't. You better start worrying about it right now. Which classes you take in high school may very well determine what you do after high school.

Jason: Huh? What difference does it make as long as I graduate?

Mrs. K.: Well, Jason, suppose you decide you want to go to college. If you don't take 2 years of foreign language and algebra you won't be eligible for admission to any colleges in Georgia. I see here on your records that you took Spanish in the 9th grade, but not in the 10th. You will need another year of Spanish to be eligible for college.

Jason: Aw - I don't like Spanish. I don't want to take any more foreign language. I know how to speak English and that's foreign to some people.

Mrs. K.: Very funny. Well, Jason, I can see that you are not ready to sign up for your classes. Tomorrow is the deadline so you need to go home and talk to your parents about this.

Questions: discuss with your group and come up for one answer to each question:

1. What is Jason's goal? \_\_\_\_\_

2. What else does Mrs. Knowittall think Jason needs to have for a goal? \_\_\_\_\_

\_\_\_\_\_



3. What are two choices Jason has to make before tomorrow? \_\_\_\_\_

---

---

4. What would be one consequence of each choice named in #3? \_\_\_\_\_

---

---

5. Can Jason set a goal for the future without making some choices now? \_\_\_\_\_  
Why or why not? \_\_\_\_\_

---

6. Besides knowing which classes to take in school, what are some of the other reasons it important to have a goal for the future? \_\_\_\_\_ is \_\_\_\_\_

---

7. In setting a goal (for what he is going to do when he graduates from high school), what are some of the things Jason should find out about jobs he is interested in? \_\_\_\_\_

---

---

8. What are some sources of information about jobs? \_\_\_\_\_

---

---

9. If Jason has not decided by the time he must sign up for classes tomorrow what he is going to do after high school, what would you recommend he do about his classes?

---

---

*Wilder Middle School  
Homeroom Guidance Handbook  
Statesboro, Georgia*

# "You Said GOAL? I Thought You Said Gold!"

Short term goals are those goals you hope to reach soon. Long term goals are those you look for in the future. In thinking about your educational goals, we will say that short term refers to this school year and long term refers to what you plan to do after high school.

1. What is your educational goal for this school year? \_\_\_\_\_  
\_\_\_\_\_

2. Will your first nine-weeks' report card help you make that goal? \_\_\_\_\_  
\_\_\_\_\_

3. If not, what do you need to do differently to help you reach that goal? \_\_\_\_\_  
\_\_\_\_\_  
\_\_\_\_\_

4. You need to start thinking about a long-term educational goal for yourself, because at the end of the 8th grade, you have to make some decisions about the classes you are going to take in high school. In settings that long-term goal, you need to think about occupational areas (jobs) that might interest you.

a. Give one reason for each of the following telling why it would be important to consider this item when choosing a job to work toward.

(1) amount of education required \_\_\_\_\_  
\_\_\_\_\_

(2) hobbies, interest \_\_\_\_\_  
\_\_\_\_\_

(3) favorite school subject \_\_\_\_\_  
\_\_\_\_\_

(4) amount of salary paid \_\_\_\_\_  
\_\_\_\_\_

(5) job location, environment \_\_\_\_\_  
\_\_\_\_\_

b. List 3 things you would like to do outside of school (hobbies, interest): \_\_\_\_\_  
\_\_\_\_\_  
\_\_\_\_\_

c. List any jobs which you have thought about for yourself (for the future): \_\_\_\_\_  
\_\_\_\_\_  
\_\_\_\_\_

d. Do the jobs in "c" fit the interests you put in "b"? \_\_\_\_\_  
(You are lucky if they do.)

e. Think about the following items. Put a check next to any which would be important to you in a job?

- |  |   |
|--|---|
| <input type="checkbox"/> work with people      | <input type="checkbox"/> make decisions for yourself    |
| <input type="checkbox"/> work alone            | <input type="checkbox"/> have others make decisions     |
| <input type="checkbox"/> work with machinery   | <input type="checkbox"/> help people                    |
| <input type="checkbox"/> work in an office     | <input type="checkbox"/> make things                    |
| <input type="checkbox"/> be your own boss      | <input type="checkbox"/> do a variety of tasks          |
| <input type="checkbox"/> work for someone else | <input type="checkbox"/> do the same thing most of time |
| <input type="checkbox"/> give directions       |   |
| <input type="checkbox"/> take directions       |   |

\*(adapted from Savannah-Chatham Public Schools Middle School Career Planning Program)

f. The items in "e" are only a few of the kinds of things you need to be thinking about in setting a long-term educational/career goal. Do the items you checked in "e" fit the jobs you put in "c"? \_\_\_\_\_

g. List anything else you think is important to consider when trying to decide on a job for the future: \_\_\_\_\_  
\_\_\_\_\_  
\_\_\_\_\_

*Wilder Middle School  
Homeroom Guidance Handbook  
Statesboro, Georgia*

# "WHO AM I"

The following is a list of personality characteristics. Everyone has some of these characteristics. Use this list to answer the questions which follow:

1. Adventurous, tries new things
2. Aggressive, pushy
3. Assertive, stands up for what is right
4. Boring, always saying and doing the same thing
5. Competitive, wants to win
6. Considerate, thinks of other's feelings
7. Courageous, brave
8. Courteous, polite
9. Covetous, interested in finding answers
10. Curious, interested in finding answers
11. Independent, solves own problems
12. Insensitive, does not consider feelings of others
13. Intellectual, interested in learning about new things
14. Obedient, always follow rules
15. Outgoing, friendly
16. Persistent, keeps trying
17. Popular, well-liked
18. Physically strong, strong body
19. Quarrelsome, always arguing
20. Reserved, quiet personality
21. Sense of humor
22. Sincere, means what is said
23. Timid, shy, does not make friends easily
24. Thorough, tries to do all parts of a task well
25. Versatile, good at many things

1. List 5 characteristics from the list which your teachers would say you possess?  
1) \_\_\_\_\_ 2) \_\_\_\_\_ 3) \_\_\_\_\_  
4) \_\_\_\_\_ 5) \_\_\_\_\_
2. List 5 characteristics from the list which your friends would say you possess?  
1) \_\_\_\_\_ 2) \_\_\_\_\_ 3) \_\_\_\_\_  
4) \_\_\_\_\_ 5) \_\_\_\_\_
3. List 5 characteristics from the list which you would want your teachers to think you possess?  
1) \_\_\_\_\_ 2) \_\_\_\_\_ 3) \_\_\_\_\_  
4) \_\_\_\_\_ 5) \_\_\_\_\_

4. List 5 characteristics from the list which you would want your friends to think you possess?

1) \_\_\_\_\_ 2) \_\_\_\_\_ 3) \_\_\_\_\_  
4) \_\_\_\_\_ 5) \_\_\_\_\_

5. Most people's answers to #3 and #4 will be different. Why do you suppose that people want their teachers to think about them differently than their friends?

\_\_\_\_\_  
\_\_\_\_\_

6. If your answers to #3 and #4 were different, why do you suppose you want teachers and your friends to think different things about you? \_\_\_\_\_

\_\_\_\_\_  
\_\_\_\_\_

7. List 5 characteristics from the list which you would NOT want your friends to think you possess?

1) \_\_\_\_\_ 2) \_\_\_\_\_ 3) \_\_\_\_\_  
4) \_\_\_\_\_ 5) \_\_\_\_\_

8. What can you do to change any personality characteristics that you have the you don't want to have? \_\_\_\_\_

\_\_\_\_\_  
\_\_\_\_\_

*Wilder Middle School  
Homeroom Guidance Handbook  
Statesboro, Georgia*

## SECTION 3

### Resources for Teacher Advisory Programs

An Agenda for Excellence at the Middle Level. (1985). Reston, VA: National Association of Secondary School Principals.

Bergmann, S. and J. Baxter. (1983). "Building a Guidance Program and Advisory Concept for Early Adolescents." NASSP Bulletin. 1983, 67, 49-55.

Canfield, J. and H.C. Wells. 100 Ways to Enhance Self-Concept in the Classroom. (1976). Englewood Cliffs, NJ: Prentice-Hall, Inc.

Casteel, J.D. and R.J. Stahl. Values Clarification in the Classroom: A Primer. (1975). Glenview, IL: Scott, Foresman and Co.

Caught in the Middle: Educational Reform for Young Adolescents in California's Public Schools. (1988). Sacramento, CA: Department of Education.

Chase, L. The Other Side of the Report Card. (1976). California: Goodyear.

Chesler, M. and R. Fox. Role-Playing Methods in the Classroom. (1966). Chicago, IL: SRA, Inc.

Cisek, J. and A. George. Finding Solutions: Learning How to Deal With Life's Problems and Decisions. (1983). Chicago, IL: Life Skills Training Associates.

Cole, Claire. "Guidance in the Middle School: Everyone's Responsibility." Virginia Personnel and Guidance Journal. 1981, 9, 19-23.

Dareh, John and Thomas Pautsch. "A Successful Teacher Advisor Program." Middle School Journal. (May 1983). 3, 12.

Feshbach, N.D. et al. Learning to Care: Classroom Activities for Social and Affective Development. (1983). Glenview, IL: Scott, Foresman and Co.

Finch, M.B. and R.B. Dunn. Teachers Advising Students. A Successful Program. (1984). Spectrum.

Gill, Jim and Jo Ellen Reed. "The 'Experts' Comment on Advisor-Advisee Programs." Middle School Journal. (May, 1990). 31-33.

Gram, R.K. and P.M. Guest. Activities for Developing Positive Self-Awareness. (1977). St. Louis, MO: Milliken Publishing Co.

Hoversten, C., N. Doda, and J. Lounsbury. (1991). Treasure Chest: A Teacher Advisory Source Book. Columbus, Ohio: National Middle School Association.

- James, Michael. (1986). Advisor-Advisee Programs: Why, What and How. Columbus, OH: National Middle School Association.
- Johnston, J. Howard. (1990). The New American Family and the School. Columbus, OH: National Middle School Association.
- Lipham, J.M. and J.C. Daresh. (1980). Teacher-Advisor Programs. In Klausmeier, H.J., J.M. Lapham and J.C. Daresh.
- The Renewal and Improvement of Secondary Education: Concepts and Practices. Madison, WI: Research and Development Center for Individualized Schooling.
- Mills, Helene. "A Participative Program for Developing An Advisor-Advisee Program." Middle School Journal. (August 1985) 6-7.
- Mitchell, J.J. (1974). Human Life: The Early Adolescent Years. Toronto: Holt, Rinehart, Winston.
- One TA To Grow Please. ed. Carol Spencer. Vermont Association for Middle Level Education. 1990.
- Raths, Louis, Mark Harmin, and Sidney Simon. (1978) Values and Teaching: Working With Values in the Classroom. 2nd. edition. Columbus, OH: Charles E. Merrill Publishing Co.
- Shaftel, F. and G. Shaftel. (1982). Role-Playing in the Curriculum. Englewood Cliffs, NJ: Prentice-Hall, Inc.
- Silverstein, S. (1964). The Giving Tree. New York, NY: Harper and Row.
- Silverstein, S. (1974). Where the Sidewalk Ends. New York, NY: Harper and Row.
- Simon, Sidney, L. Howe and H. Kirschenbaum. (1972). Values Clarification. New York, NY: Hart Publishing Co.
- This We Believe. (1982, 1992). Columbus, OH: National Middle School Association.
- Thornburg, H. (1978). The Bubblegum Years: Sticking With Kids From 9-13. Tucson, AZ: H.E.L.P. Books.
- Turning Points, Inc. (1989). Report of the Task Force on Education of Young Adolescents. New York, NY: Carnegie Corporation.

# SECTION 4

## You Can Become Part of Volume II

Please take a few moments to send some of your ideas for Teacher Advisory programs. Feel free to photocopy this sheet and distribute it to colleagues. Follow the format for reporting your ideas. Send to: Michael G. Allen, L.B. 8134, Department of Middle Grades, Georgia Southern University, Statesboro, GA 30460-8134.

ACTIVITY NAME:

HOW TO PLAY:

VARIATIONS:

PROBLEMS AND PITFALLS:

SUPPLIES NEEDED:

RESULTS:

ORIGINAL SOURCE:

Contributed by:

Name:

Home Address:

Phone #:

School:



# APPENDIX A

## Schools That Contributed Advisory Program Ideas

### **Buford Middle School**

2200 Highway 13  
Buford, GA 30518  
Mitzi Pearson

### **Burke County Middle School**

P.O. Box 849 Park Dr.  
Waynesboro, GA 30830  
Pamela L. Franklin  
Joyce Herrington Kelley  
Cynthia Quick  
Jon Vinson

### **Crabapple Middle School**

10700 Crabapple Rd.  
Roswell, GA 30075  
James A. Zoll

### **Dawson County Middle School**

P.O. Box 688  
Dawsonville, GA 30534  
Pam Bachman

### **East Cobb Middle School**

380 Holt Rd.  
Marietta, GA 30068  
Rebecca McDaniel

### **E. T. Booth Middle School**

1899 Eagle Dr.  
Woodstock, GA 30188  
Anne Carroll  
Lois Wilson  
Alane DeVaney  
Helen Tate  
Lisa Long  
Lori Como  
Sandra Garcia  
Joyce Hutchins

**Fulton County School Board**  
1302 Highland Bluff, N.W.  
Atlanta, GA 30339  
John Spindler

**Haynes Bridge Middle School**  
10665 Haynes Bridge Rd.  
Alpharetta, GA 30202  
Barbara Seaton

**Holcomb Bridge Middle School**  
2700 Holcomb Bridge Rd.  
Alpharetta, GA 30202  
Barbara Lyon

**Lowndes County Middle School**  
506 Copeland Rd.  
Valdosta, GA 31601  
Carol Irwin  
Jeanette Woolfolk

**McClesky Middle School**  
4080 Maybreeze Rd.  
Marietta, GA 30066  
Susan Faith Jones

**McKendree Elementary School**  
1600 Riverside Parkway  
Lawrenceville, GA 30243  
Pamela Paul

**Otwell Middle School**  
135 Elm St.  
Cumming, GA 30130  
Pat Kohn

**Peachtree Junior High School**  
4664 N. Peachtree Road  
Atlanta, GA 30338  
Linda Fountain

**Perry Middle School**  
Sunshine Avenue  
Perry, GA 31069  
Ketus Cawthon

**Putnam County Middle School**

314 S. Washington St.

Eatonton, GA 31024

Linda Booth

**Sandy Springs Middle School**

227 Sandy Springs Place

Atlanta, GA 30328

**South Hall Middle School**

3215 Poplar Springs Place

Gainesville, GA 30503

Lucy Seabolt

**Staley Middle School**

915 N. Lee St.

Americus, GA 31709

Janis Casey

**Tubman Middle School**

1740 Walton Way

Augusta, GA 30904

Diane Shuler

**Wilder Middle School**

1300 E. 66th St.

Savannah, GA 31404

Karen Lange

## ABOUT THE AUTHORS

Michael G. Allen has been actively involved in middle level education for twenty-six years. A native Vermonter, he earned degrees in the field of education including the B.S. in Education (Castleton State College), M.A.T. in history (Saint Michael's College), and Ed.D. in social studies education (University of Maine at Orono).

Mike taught middle grades social studies in Vermont, and California, and in several teacher education programs in Vermont, Maine and North Carolina. Before returning to higher education in 1990, he served as Director of Curriculum and Instruction for a large school district in Vermont. He has published articles, reviews, and monographs in the fields of middle school education, social studies and special education.

Currently, Mike serves as an Associate Professor of Middle Grades and Secondary Education at Georgia Southern University. He also served as the Director of Publications for the New England League of Middle Schools from 1987-1991.

Ronnie L. Sheppard has been involved in middle grades teacher education in Georgia for the past sixteen years. Prior to coming to Georgia, he taught middle grades language arts in Texas. He earned his B.S. in English Education from Baylor University and his M.Ed. and Ed.D. in Elementary Education from North Texas State University.

Ronnie has served on the Publications Committee of the National Middle School Association and has published articles, reviews and monographs in middle level education, reading, and language arts.

Ronnie currently serves as a Professor and Head of the Department of Middle Grades and Secondary Education at Georgia Southern University. He also serves as Editor of *Becoming*, the official state journal of the Georgia Middle School Association and Georgia Association of Middle School Principals.