

DOCUMENT RESUME

ED 363 353

IR 054 707

AUTHOR Fischer, Barbara H.  
 TITLE Catch the Wave. Adventures with Paddington Reading Club. 1989 Summer Reading Program: Information, Activities, Ideas.  
 INSTITUTION Virginia State Library and Archives, Richmond.  
 PUB DATE 89  
 NOTE 127p.  
 PUB TYPE Guides - Non-Classroom Use (055) -- Reference Materials - Bibliographies (131) -- Tests/Evaluation Instruments (160)

EDRS PRICE MF01/PC06 Plus Postage.  
 DESCRIPTORS Age Differences; Childrens Libraries; \*Childrens Literature; Elementary Secondary Education; Instructional Materials; \*Library Services; Public Libraries; \*Reading Programs; \*Resource Materials; State Libraries; \*Summer Programs; Workbooks

IDENTIFIERS Paddington Books; \*Virginia

ABSTRACT

Information, activities, and ideas for implementing two summer reading programs are presented. For young readers, the "Adventures with Paddington Reading Club" program of the American Library Association (ALA), drawing on the popular character from children's fiction, is introduced; and materials are included for its use in local libraries. For older readers and teenagers, the "Catch the Wave" program from UPSTART is described. Bookmarks, stickers, posters, reading logs, and certificates for these programs are included, along with the manuals developed by ALA and the Virginia State Library and Archives. Multiple illustrations that can be copied are included. A resource bibliography lists 57 sources for librarians and program leaders. (SLD)

\*\*\*\*\*  
 \* Reproductions supplied by EDRS are the best that can be made \*  
 \* from the original document. \*  
 \*\*\*\*\*

ED 363 353

U. S. DEPARTMENT OF EDUCATION  
Office of Educational Research and Improvement  
EDUCATIONAL RESOURCES INFORMATION  
CENTER (ERIC)

- This document has been reproduced as received from the person or organization originating it.
- Minor changes have been made to improve reproduction quality.
- Points of view or opinions stated in this document do not necessarily represent official OERI position or policy.



Adventures With  
Paddington™  
Reading Club



1989 Summer Reading Program  
INFORMATION  
ACTIVITIES  
IDEAS

from the  
Virginia State Library and Archives  
Public Library Development Division

Barbara H. Fischer  
Children's/Youth Services Consultant

"PERMISSION TO REPRODUCE THIS  
MATERIAL HAS BEEN GRANTED BY

John C. Tyson

**BEST COPY AVAILABLE**

TO THE EDUCATIONAL RESOURCES  
INFORMATION CENTER (ERIC)."

Virginia State Library and Archives  
11 th. Street at Capitol Square  
Richmond, Virginia

Thank you to the many librarians across Virginia who contributed ideas and suggestions for this manual, to Charles W. Fischer for design assistance, and to the staff of the Public Library Development Division of the Virginia State Library and Archives.

The 1989 Virginia Summer Reading Program is partially supported with Library Services and Construction Act (LSCA) Title III funds administered by the Virginia State Library and Archives.

BEST COPY AVAILABLE

3

Dear Colleagues,

Once again the summer reading program is fast approaching. It provides the public library in every community the opportunity to showcase its services, resources and activities for children and families. Soon across Virginia youngsters will become involved in library planned activities and events, they will listen to stories, read tens of thousands of books and they will discover the pleasures of the world of literature.

For young readers and the read-to-me set materials from the American Library Association's "Adventures With Paddington Reading Club" invite exploration. Appealing to older readers and teenagers are materials from UPSTART's "Catch the Wave" program. Bookmarks, stickers, posters, reading logs and certificates along with manuals from ALA and the Virginia State Library & Archives are provided by the Virginia State Library and Archives. These resources combined with the innovative and creative programs of Virginia's librarians make the library an exciting center for summer reading.

Through the summer reading program the public library reaches thousands of children who seldom use the public library at any other time. For these children as well as for those who are regular library users the summer reading program provides an opportunity to pursue one's personal curiosity, to seek answers and to discover the myriad ways through which ideas are expressed. In so doing their lives are enriched, their world expanded and their understanding of self and others is increased.

Reading program registration, attendance at programs and library circulation provide concrete outputs for this component of library service. Yet, the full impact of the program on the lives of young participants cannot be measured. It can, however, be observed in the eyes of children as they enjoy a program or when a child enthusiastically describes a story just completed or when families return to the library to check out books. These library experiences make lasting impressions. They open doors to lifelong learning.

Best wishes for an exciting, successful and rewarding summer reading program.

*Barbara*

Barbara H. Fischer  
Children's/ Youth Services Consultant

## **SUMMER READING PROGRAM GOALS**

- To promote public library services for children and young people.
- To provide activities for children and young people which promote library use.
- To provide opportunities for children to develop and maintain vital reading skills.
- To encourage parents to read to their children.

## **THE READING PROGRAM**

The annual summer reading program is a tremendous undertaking for a library. It requires careful planning and coordination as well as cooperation from all concerned. Because of the numbers of youngsters involved, it may be necessary to enlist the aid of volunteers to assist with various aspects of the program and its associated activities and events. Parents and grandparents, members of the Friends of the Library or other community organizations and teenagers can be solicited to assist. Teens especially enjoy participating in programs which they present to younger children.

As an experiment, materials for two reading programs have been chosen for use this summer. The program guides serve as resources for programs, activities, crafts and special events. In order to expand the scope of the program you may wish to expand the themes to include other bears, teddy bears, sea life and creatures and summer activities. Both themes lend themselves to activities and displays related to travel.

## **READING LOGS**

The reading logs for each program have been designed to encourage use not only in the summer but throughout the year. Each contains a game which can be played independently or by a group of children. Solutions for the reading log games are included in this publication.

The reading logs include spaces for listing the books that a child reads during the program. This booklet contains additional log lists should you need to reproduce them.

Some libraries prefer to track the number of hours read rather than the number of books. The Paddington Reading log includes space for this. Also, included in this booklet are additional individual reading time logs which may be reproduced as necessary with either the Paddington program or the Catch the Wave program.

## **REGISTRATION**

Individual libraries determine the rules and regulations for their summer reading program. Some may set a limited period for registration while others elect to register youngsters throughout the summer.

Build success for each child into the summer's experience. Permit the young read-to-me children to participate through registration and the recording of books which have been shared with them by parents and care providers. Through these experiences do they gain an awareness of the power of language and story to enthrall.

No age limit is set for participants in the program. Young children whose parents read to them are eligible as are older teens. Generally, however, most libraries find that the program appeals to children between the ages of 3 and 12. Depending on space, staffing in a library or a particular activity it may be necessary to limit the number of children who may attend an event. Whenever possible try to schedule additional sessions to accommodate demand.

For some children the successful completion of 5 or 10 books is as positive an accomplishment as the completion of 50, 60 or 100 books is for others. Encourage each child who participates to set a personal realistic reading goal based on interest and ability rather than competition. Likewise, encourage youngsters to read widely rather than to only read an arbitrarily determined number of books in the shortest possible time. Certificates awarded for personal accomplishment have greater meaning for the individual.

In order to gather information about the summer reading program, a sample registration card is included. Its use will help determine not only the numbers of children who participate but also the numbers of children who complete the program at each location. At the end of the summer an analysis of the registration cards can also provide information on which to base decisions about future programs.

Reading Goal \_\_\_\_\_

Name \_\_\_\_\_

Address \_\_\_\_\_ Zip \_\_\_\_\_

Phone \_\_\_\_\_ Age \_\_\_\_\_

School \_\_\_\_\_ Grade entering \_\_\_\_\_

Completed goal yes \_\_\_\_\_ no \_\_\_\_\_

Library \_\_\_\_\_

## PROMOTION

Promote the summer reading program through all available means. School and class visits, end of year newsletters from teachers and librarians, the PTA or parent support group, church newsletters and bulletins may be willing to provide space. Print, radio and television news medias should be contacted. Flyers, brochures and bookmarks distributed through the library's traditional channels are also effective means to promote the program and its activities. The ALA produced Program Guide for the "Adventures with Paddington Reading Club" contains a variety of sample releases which can be easily adapted for use by your library to promote the entire program as well as individual events. A few promotional suggestions for the "Catch the Wave" program may be found in the VSL&A manual.

You may wish to utilize the Best Gift Promotion spot created and produced by the American Library Association in conjunction with your promotion campaign.

## **INCENTIVES**

Incentives not only initially promote the program they help to keep children reading throughout the summer. When incentives are discussed with prospective donors, especially fast food merchants, request that they distribute a bookmark or flyer about the library's program to their consumers. In this way prospective participants may be reached and another avenue of promotion is accessed.

When merchant coupons are used, request the donor provide the library with information regarding the redemption rate. This will provide some indication of the economic impact of the program and the level of financial support provided by a merchant.

## **EVENTS INVOLVING FOOD**

Reading program finale events, holidays, and other special events have a festive nature. On such occasions it is appropriate to provide refreshments. However, when food is to be served at a library sponsored event, be sure to make arrangements with the library director and check with the local health department. Care in the preparation and storage of foods should be taken. When possible alert parents to what the menu will include so that allergic reactions can be avoided.

Ease of preparation and storage should also be taken into consideration when planning an event involving food. Estimate the number of children to be served and the amount of actual serving time. When possible plan several serving areas, especially when large groups of children are involved.

Enlist the assistance of adult and teen volunteers. Their help can be invaluable, especially when 'spreadables' are involved.

Have on hand an abundance of utensils, napkins and disposable cups. Both damp and dry paper towels also come in handy.

To facilitate cleanup, provide several large trash containers.

## **FILMS**

Films are available to support summer programming. Film and Video Services plans to have additional Paddington Bear materials in both 16 mm and video format available for the summer. Contact Film and Video Services at the Virginia State Library and Archives for information. **Phone: 800/ 336-5266.**

# Adventures With Paddington™ Reading Club

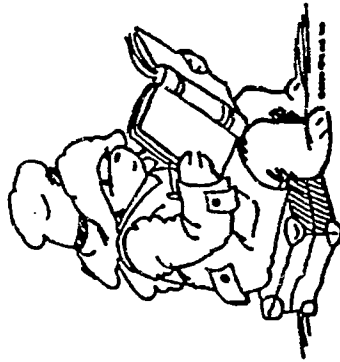

## 1989 Summer Reading Program Reading Log

Name: \_\_\_\_\_

Reading Hours					
week 1	week 2	week 3	week 4	week 5	week 6

Sponsored cooperatively by your local library and the  
Virginia State Library and Archives

Books I Have Read

1. \_\_\_\_\_
2. \_\_\_\_\_
3. \_\_\_\_\_
4. \_\_\_\_\_
5. \_\_\_\_\_
6. \_\_\_\_\_
7. \_\_\_\_\_
8. \_\_\_\_\_
9. \_\_\_\_\_
10. \_\_\_\_\_
11. \_\_\_\_\_
12. \_\_\_\_\_
13. \_\_\_\_\_
14. \_\_\_\_\_
15. \_\_\_\_\_

Books I Have Read

16. \_\_\_\_\_
17. \_\_\_\_\_
18. \_\_\_\_\_
19. \_\_\_\_\_
20. \_\_\_\_\_
21. \_\_\_\_\_
22. \_\_\_\_\_
23. \_\_\_\_\_
24. \_\_\_\_\_
25. \_\_\_\_\_
26. \_\_\_\_\_
27. \_\_\_\_\_
28. \_\_\_\_\_
29. \_\_\_\_\_
30. \_\_\_\_\_







### PADDINGTON'S ADVENTURES

- Use small buttons for playing pieces.
- A roll of the dice determines the number of spaces moved.
- Players must correctly answer the question or perform the action in the space where they land or lose a turn.

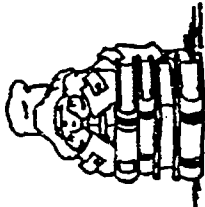
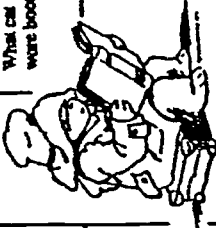
### READING ACHIEVEMENTS

				
START	In what city does Paddington Bear live?	Who is Paddington's favorite food?	Whose cupboard was bare?	FINISH
What is Paddington's favorite food?	Hop on one foot 3 times.	What three was it when the news ran down the clock?	Loss a turn.	Who would not let three billy goats across a bridge?
Why did Jack and Jill go up the hill?	What cat went booo?	Flap your arms and crow.	Who did Cinderella lose at the ball?	What did Cinderella lose at the ball?
Who tried to catch the three little pigs?	Croak like a frog and hop about 2 spaces.	Howl at the moon.	Crypt... Paddington accidentally bumped into Mr. Curry. Go back 3 spaces.	

14.	28.
13.	27.
12.	26.
11.	25.
10.	24.
9.	23.
8.	22.
7.	21.
6.	20.
5.	19.
4.	18.
3.	17.
2.	16.
1.	15.

Books I Have Read

# 1989 Summer Reading Program

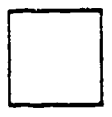
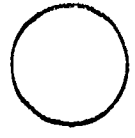

Name: \_\_\_\_\_

# FLOTILLA FUN

The wind has changed and the boats must shift direction. By moving only 3 boats, can you help the flotilla maintain its triangle formation but with the point of the triangle at the bottom?

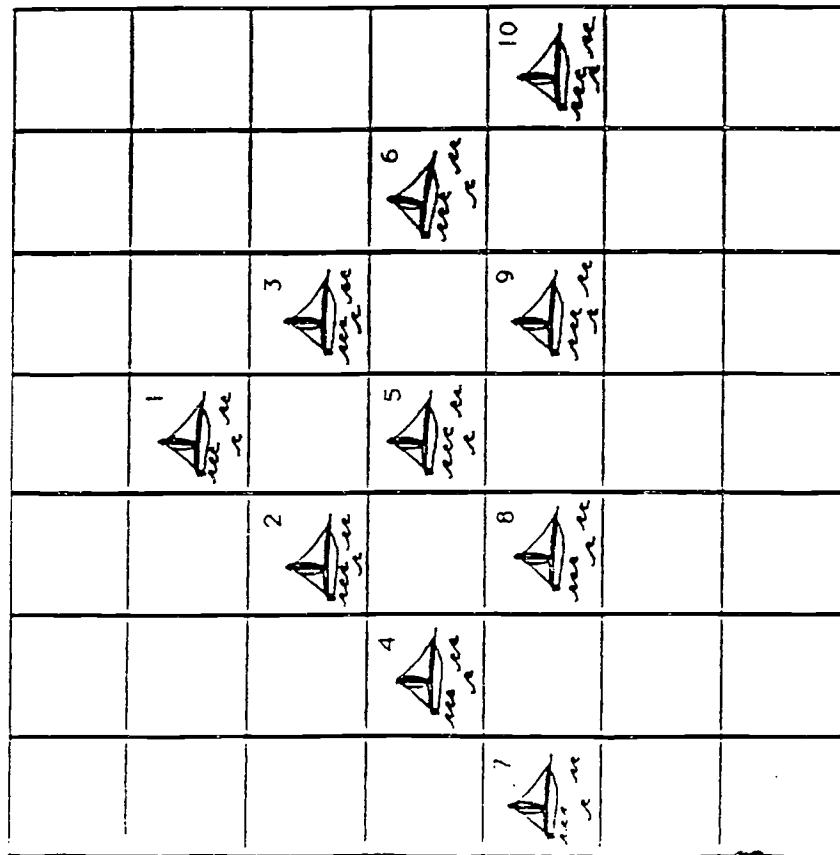

# CATCH THE WORD

The following words are included in this word search game. How many can you locate?

- Beach
- Lighthouse
- Pier
- Seaweed
- Sun
- Beachball
- Miami
- Sailboat
- Shark
- Surfboard
- Fish
- Mermaid
- Sand
- Shell
- Swim
- Jetty
- Palmtree
- Sea
- Starfish
- Tent
- Wave

Words may be found forward or backward, horizontal, vertical, diagonal or wave shaped.

H I E Q U W E N M B X Z Z O P T T E Y I L L M O J Q  
 E T F R E B S T B Q W D F R J L I L P L O H M Y P  
 B S M L K E U Y U T S A A J W R S I M U T Y S S O O  
 A I G G H A O N E A M K E L K J M O F S Y O H T S U  
 R H G T N C H N M O K O T S S E R Q W F Y S U T D C  
 R G K R M H T B P O L C X V A A G M B N F K L O T Q Y  
 B R M Q V Z A G N A I A E D R A O B F R U S M O O R H  
 N E N Q Z L I E H S D F B B H Y T T R E Q Y Y T T S  
 K J D R E L L E H S D F B B H Y T T R E Q Y Y T T S  
 I M U T R A L M T A D Y I V Q A R R Q F T Y U J I C I D  
 L O I P A L M A I K K P O J W H B Y N I K M H V R J O  
 O R Y Z A O A I D P O T R A E Q V A S T I D R Y U I L Y  
 L T N X S A O U O I R V J E T I Y Q D I G Y U I L Y  
 U U Q O P I S U J K E I S D O I H K L M H U D T Q M L Q

We the undersigned do hereby award this

# Certificate of Achievement

to

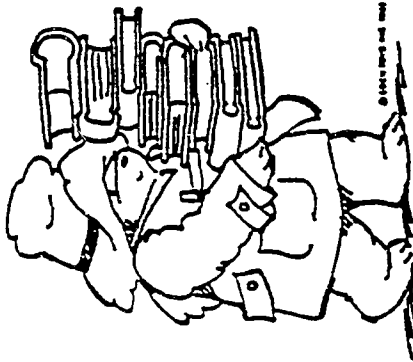

for participation in the  
**Adventures With  
Paddington™  
Reading Club**

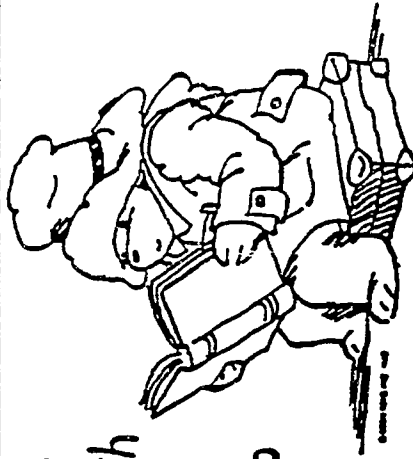

at

Library

*Ella Gaines Yates*  
Ella Gaines Yates  
State Librarian of Virginia

Librarian

*Gerald L. Baliles*  
Gerald L. Baliles  
Governor of the Commonwealth of Virginia

Sponsored cooperatively by your local library and the Virginia State Library and Archives

## Just a reminder . . .

The Paddington clip art may be used only in conjunction with the 1989 Summer Reading Program.

When using the clip art, the copyright notice must be clearly visible and permanently affixed.

The Paddington artwork itself must not be altered in any way.

Locally produced items which use the Paddington artwork must be provided FREE -- NOT SOLD.

Thank you.



© EDEN TOYS, INC. 1989

## PARENT NOTE

These tags may be reproduced and given to the parents of reading program participants. Or, should you desire, they may be cut out and strung with bright colored yarn for each child to take home.

### Please look after this READER

Make this an enjoyable reading summer for your family and help your child develop and maintain vital reading skills.

- Register for the Summer Reading Program at your local library.
- Help your child set a personal reading goal for the summer.
- Visit the library often to check out books and other materials to enjoy.
- Plan a time to read every day.
- Keep a list of the books which are read.
- Attend programs and activities at the library.

### Please look after this READER

Make this an enjoyable reading summer for your family and help your child develop and maintain vital reading skills.

- Register for the Summer Reading Program at your local library.
- Help your child set a personal reading goal for the summer.
- Visit the library often to check out books and other materials to enjoy.
- Plan a time to read every day.
- Keep a list of the books which are read.
- Attend programs and activities at the library.

## LIBRARY READER RECOGNITION

For each participating child, make a stack of books similar to the one carried by Paddington to which may be added additional books (or stacks) for a specified number of books read.

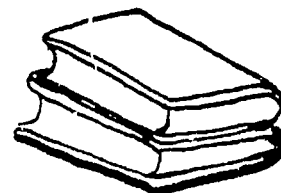
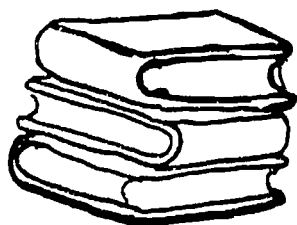

**GAMES  
and  
ACTIVITIES**



## COSTUMES

Large grocery sacks make wonderful costumes for young children. Cut a circle in the bottom of the sack for the child's head and a circle in each narrow side for arms. The sacks can be decorated to represent bears, story book characters or with designs of the child's choosing.

Use your costumes to act out a story.

### Suggestions

The Gingerbread Boy

The Little Red Hen

The Tale of Peter Rabbit

The Three Bears

The Three Billy Goats Gruff

The Three Little Pigs

The Three Wishes

# CRITTERS

Use your imagination to create a variety of bears, animals, and assorted critters using 'Leggs eggs', plastic eggs or basic oval shapes.

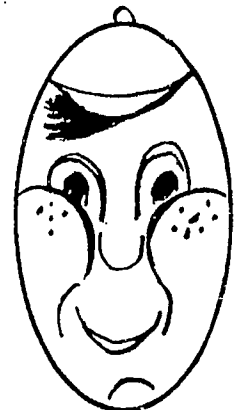
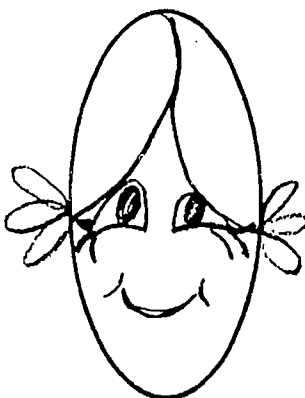
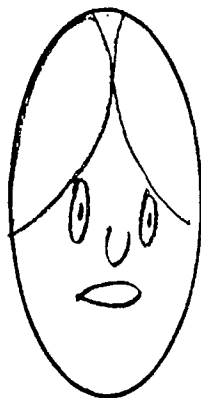
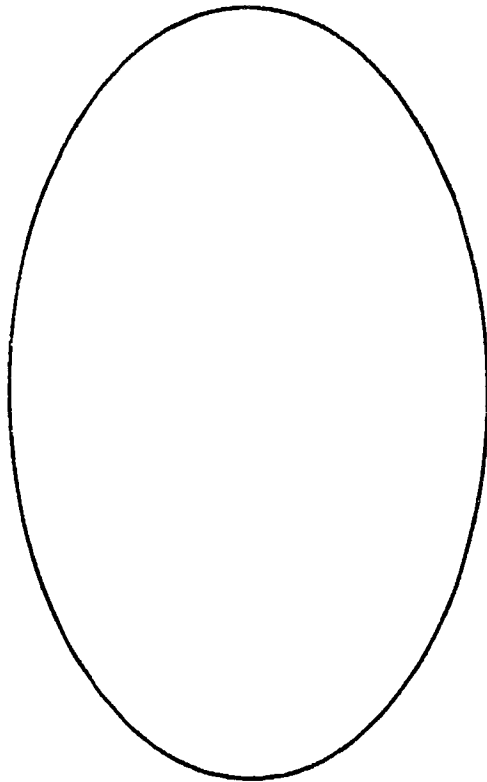
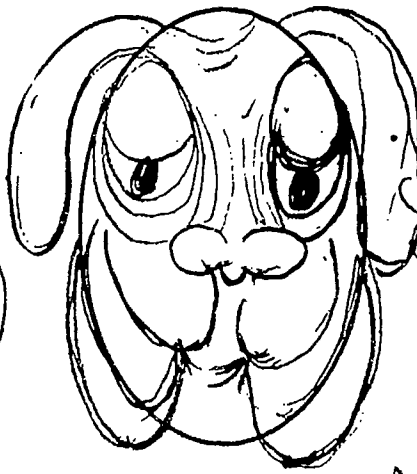
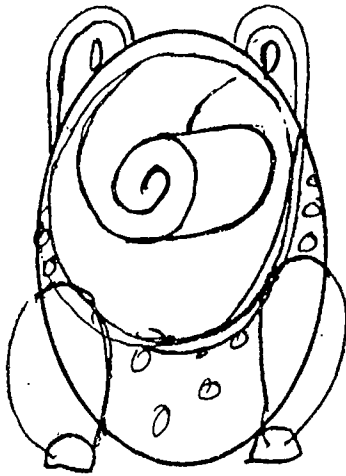

## FUN PHRASES

Complete these words and phrases with the word **BEAR** or its homophone, **BARE**.

1. \_\_\_\_\_ in mind. (Remember)
2. Un\_\_\_\_\_able. (Can't stand it)
3. \_\_\_\_\_ up. (Withstand)
4. \_\_\_\_\_ necessities. (Absolute minimum)
5. \_\_\_\_\_ facts. (A simple truth)
6. \_\_\_\_\_ claws. (A sweet pastry)
7. \_\_\_\_\_ witness. (To testify)
8. \_\_\_\_\_ back. ((Riding a horse without a saddle)
9. \_\_\_\_\_er of bad news. (A person who brings sad messages)
10. Thread\_\_\_\_\_. (Worn out)
11. \_\_\_\_\_ skin rug. (Fuzzy floor covering)
12. \_\_\_\_\_ your soul. (Be completely honest)
13. \_\_\_\_\_ foot. (Without shoes)

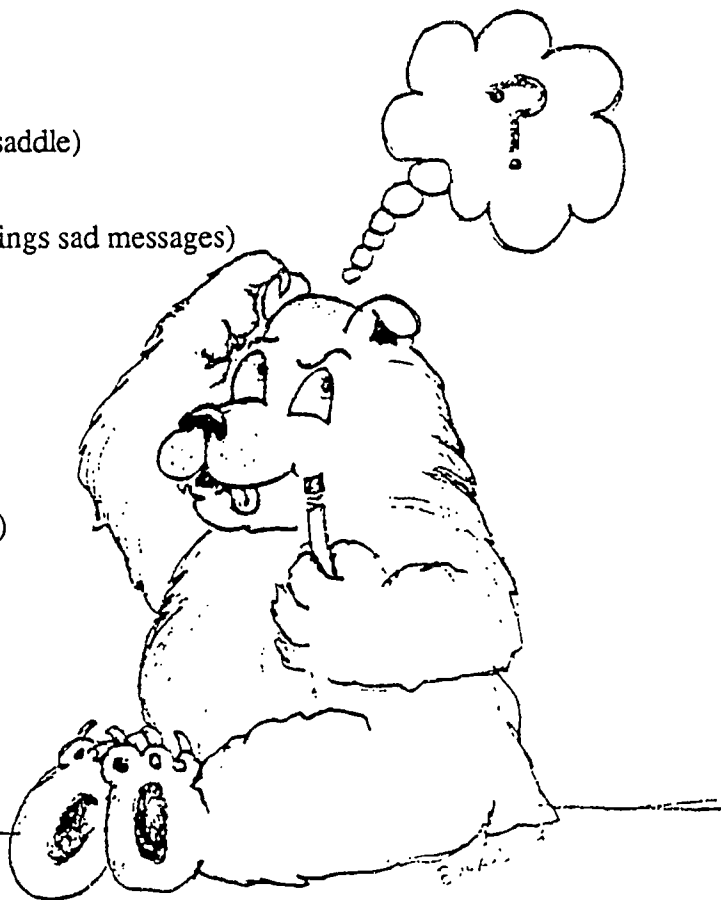

## GUESSING GAME

Children of all ages enjoy estimating and guessing how many items are in a container.

Fill a large container with any of the following:

Jelly Beans

Gummi Bears

Teddy Grahams (tm Nabisco) You may wish to mix several flavors in the jar.

(For fun try having one large jar and one or more smaller jars.)

Provide simple entry forms. (Example)

Name \_\_\_\_\_

Age \_\_\_\_\_

I think there are \_\_\_\_\_ in the container.

A child may guess once each library visit.

Group entries into age groupings if you wish and award small prizes in each category.

# I SPY - Scavenger Hunt

Recommended ages 7 - adult.

"I Spy " is a game which develops powers of observation. It calls for sharp eyes and quick minds since it's easy to overlook something which is in plain sight. Though perhaps best played by a small group (5 - 10) of children, it is suitable for larger groups.

## RULES

- Players may not touch or move any item in the playing area.
- A player should not indicate the location of any item to another player.

## TO PLAY

- Gather 20 to 50 items for the game in a large box.
- Make a list of the items and provide each player with a copy of the list and a pencil.
- Designate a playing area and "hide" each item in sight within the area before the players arrive. If older children and/or adults are playing, it is permissible to "hide" decoy items - items which do not appear on the list.
- Try to be certain that only one of any item is in the playing area. In disputed cases the ruling of the leader or game director is final.
- Set a time limit for playing the game. Each player is to hunt independently for the items and should mark them off the list as found. Remind players not to move items.
- When time is called all players return to the starting area and the leader determines the winners.

## PRIZES

- Prizes may be awarded for the most items "found" in the designated time. Call out each item and ask a player to locate it and return it to the box.
- Prizes may also be given for the fewest number of items located.

## SUGGESTED ITEMS

pencil	calendar	plastic glass
toothpick	spoon	matchbook
cork	doll	paper clip
piece of string	bar of soap	rubber band
spool	thimble	bobby pin
safety pin	needle	staple
candy wrapper	nut	cassette box
barrette	duck decoy	date due card
shell	cardboard tube	penny
bow	postage stamp	box
apple	card	straw
cookie cutter	nail	brush
ticket stub	ball	top
library card	light bulb	teddy bear
magnet	mint	bulb (plant)
pen	flower	crayon
key	book	battery
bell	candle	candy kiss
greeting card	diskette	rock
raisin	ruler	mirror

Can you draw 3 straight  
 lines to help Paddington create  
 6 rooms in this house with each room containing  
 a jar of marmalade, a loaf of bread and a cup of hot chocolate?

A B C D E F G H I J K L M N O P

1 2 3 4 5 6 7 8 9 10 11 12 13 14 15 16 17 18 19 20 21

22 23 24 25 26 27 28 29 30 31 32 33 34 35 36 37 38 39 40 41 42

Q R S T U V W X Y Z AA BB CC DD EE

## IN TITLES

This selection contains **20** book titles. How many of them can you locate? How many of the books have you read?

Using additional titles, continue this story or make up one of your own. You may wish to add your own illustrations.

When Amelia Bedelia first saw the cat in the hat he was talking to a bear called Paddington and some other friends.

"Come join us," invited Paddington. "We are planning a party for fox and his friends. Old Mother West Wind said we could have everyone over to her house on Kneeknock Rise. There we can hid in a dark, dark room and shout our 'surprises' when fox arrives.

"Hugh Pine is going to bring some green eggs and ham," announced Ramona. "We must have plenty of ice for Mr. Popper's penguins and for the cold drinks," she said. "Frog and Toad together have promised to show us how to eat fried worms."

"May I bring my father's dragon?" asked Dominic. "I know he will keep his dragonwings from knocking anything over."

"Let's play the Egypt game," requested a girl called Al. "It is fun and will really make this a freaky Friday."

## MY ADVENTURES WITH PADDINGTON

Write a short story about an adventure you might have with Paddington Bear and a character from another story.

### EXAMPLES

When Paddington and I met Robin Hood

An encounter with Chicken Little

Paddington and I visit the Three Bears



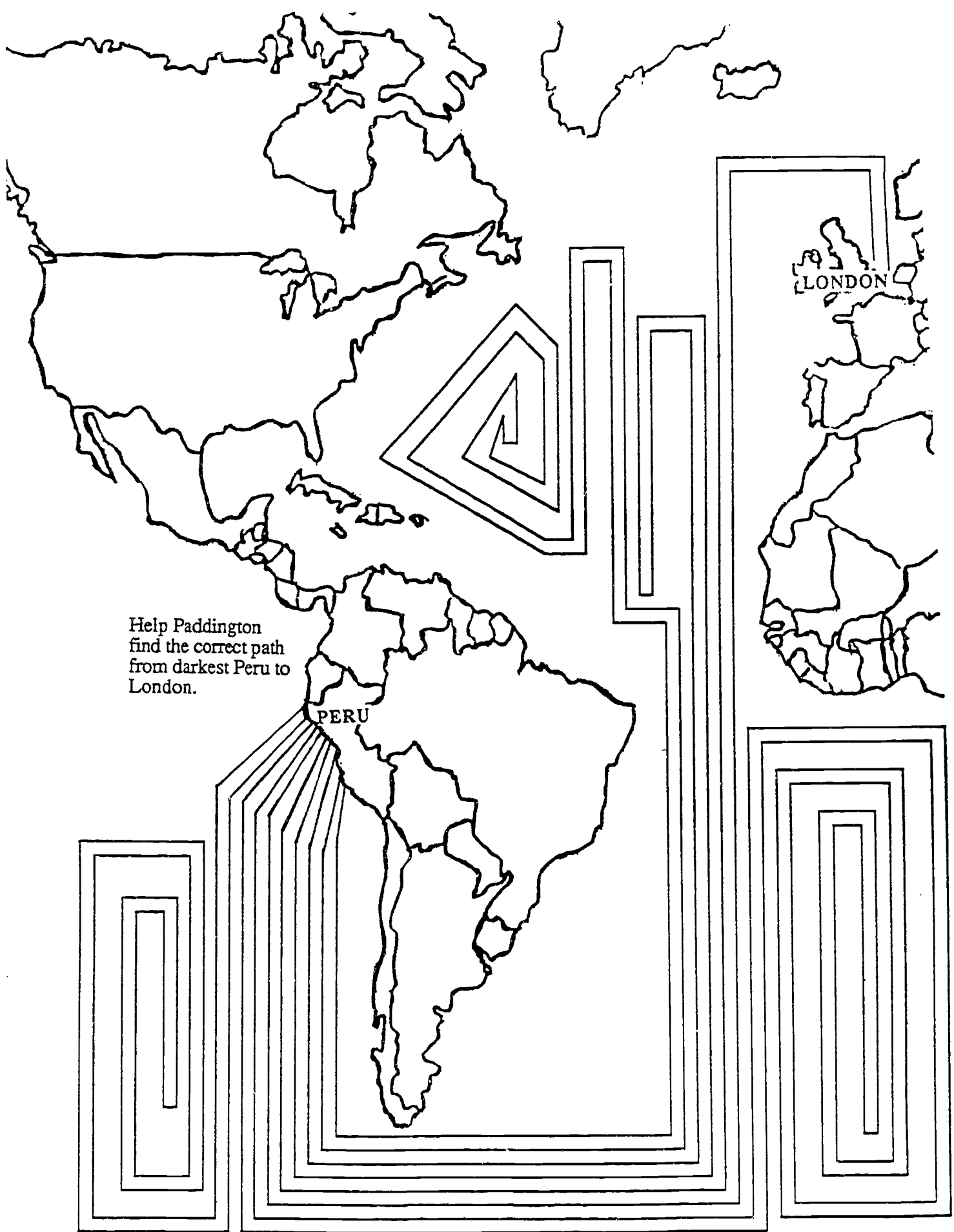

# PERU

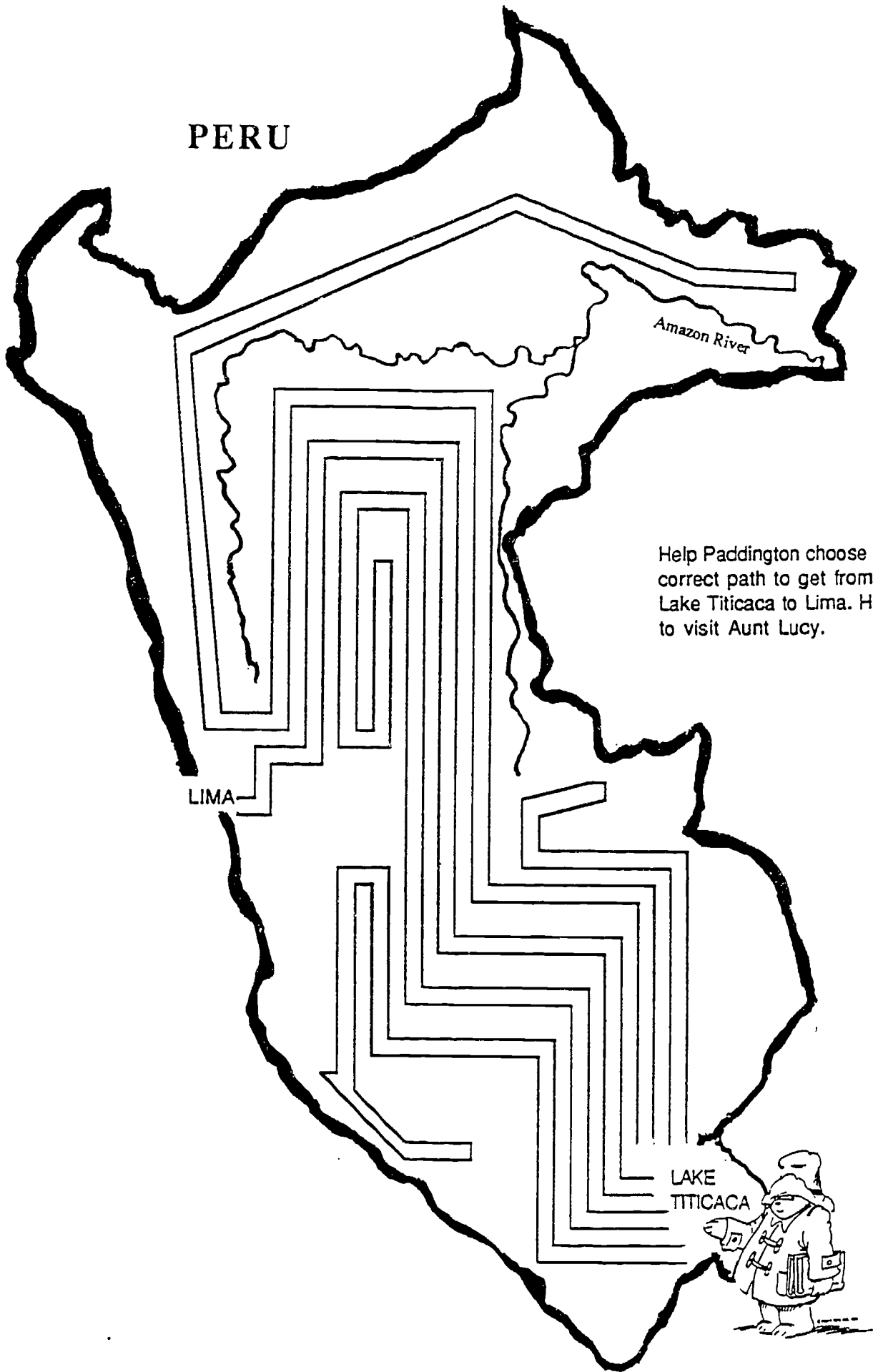

Help Paddington choose the correct path to get from Lake Titicaca to Lima. He wants to visit Aunt Lucy.

LIMA

LAKE  
TITICACA



## PADDINGTON PENCIL TOPPERS

To create simple pencil toppers for reading club participants reproduce these patterns on cover weight paper or card stock. Cut out, punch holes where indicated by the black circles and thread onto a standard pencil.



## PENCIL TOPPERS

Simple pencil toppers for reading club participants may be made by reproducing these patterns on cover weight paper or card stock. Cut out, punch holes where indicated by the black circles and thread onto a standard pencil. You may add an illustration or children may create their own designs.

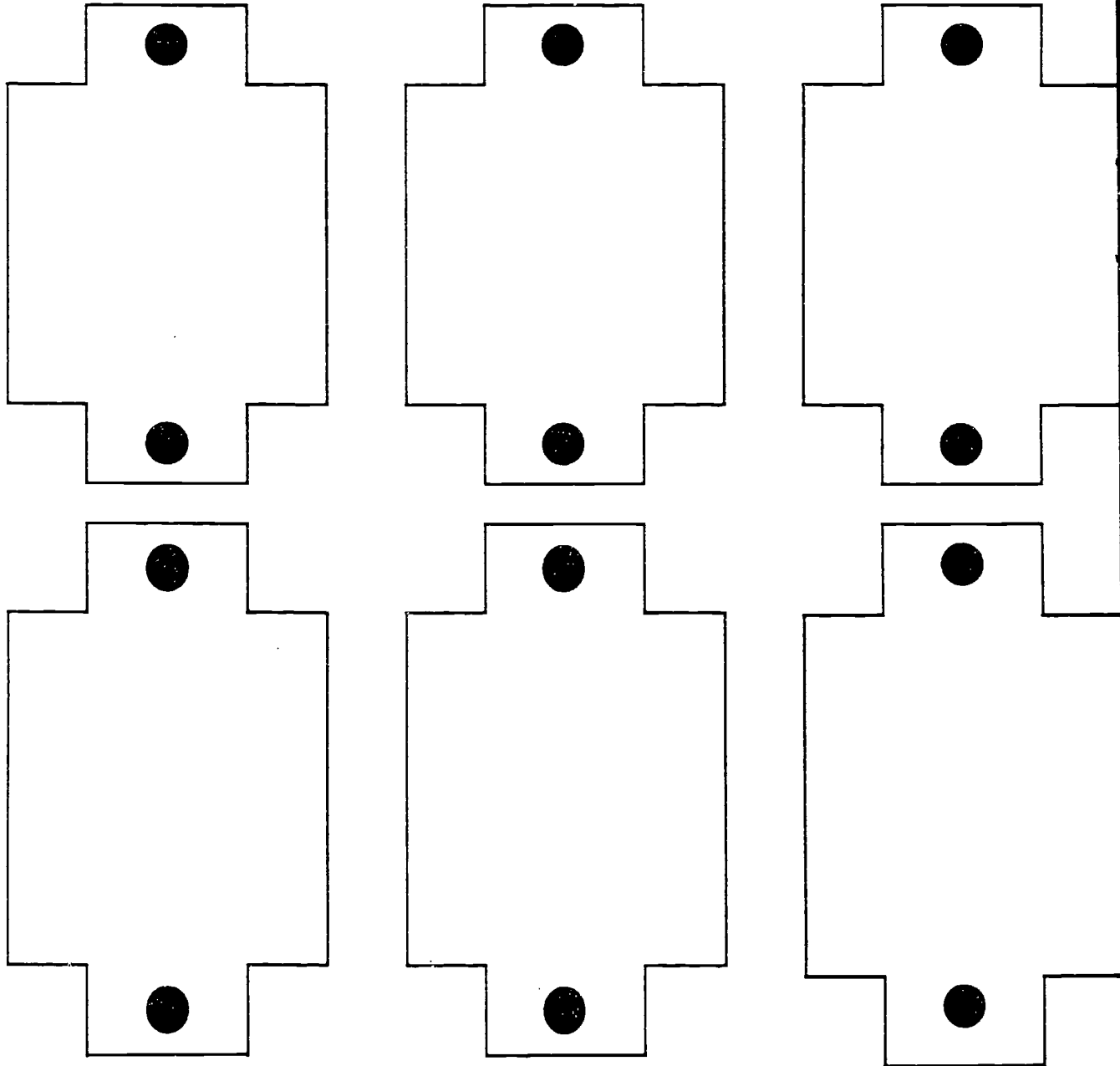

## PAW PRINTS

Since paws may be difficult to obtain for this activity, fingers are a ready substitute.

An almost unlimited array of creatures can be created with ordinary stamp pads or poster paints, felt tip markers and fingers. Experiment with the use of fingertips, the side of a finger and thumbs.

Be certain to use non-toxic inks. Clean up with soap and water.

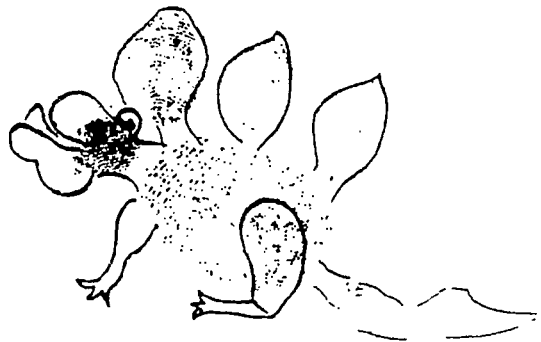
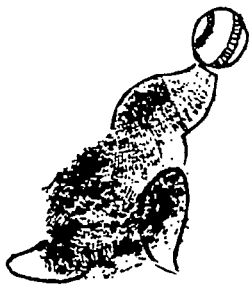

## STICKY SANDWICH

(a variation of the traditional game of  
"Pin the Tail On the Donkey")

Enlarge Paddington onto a large bulletin board or other display area. Make paper "marmalade sandwiches" for each participant. Write the participant's name on his/her sandwich. Place the starting line several feet away from the Paddington display. Use masking or transparent tape to affix the "sandwiches to the display. Each child may have at least one turn to place his or her sandwich in or near Paddington's hand. Blindfold each child in turn and spin him/her around before releasing in the direction of the display. The child whose "sandwich" is nearest Paddington's hand is the winner.

Prizes might include small jars of marmalade, gummi bears or a box of bear cookies.

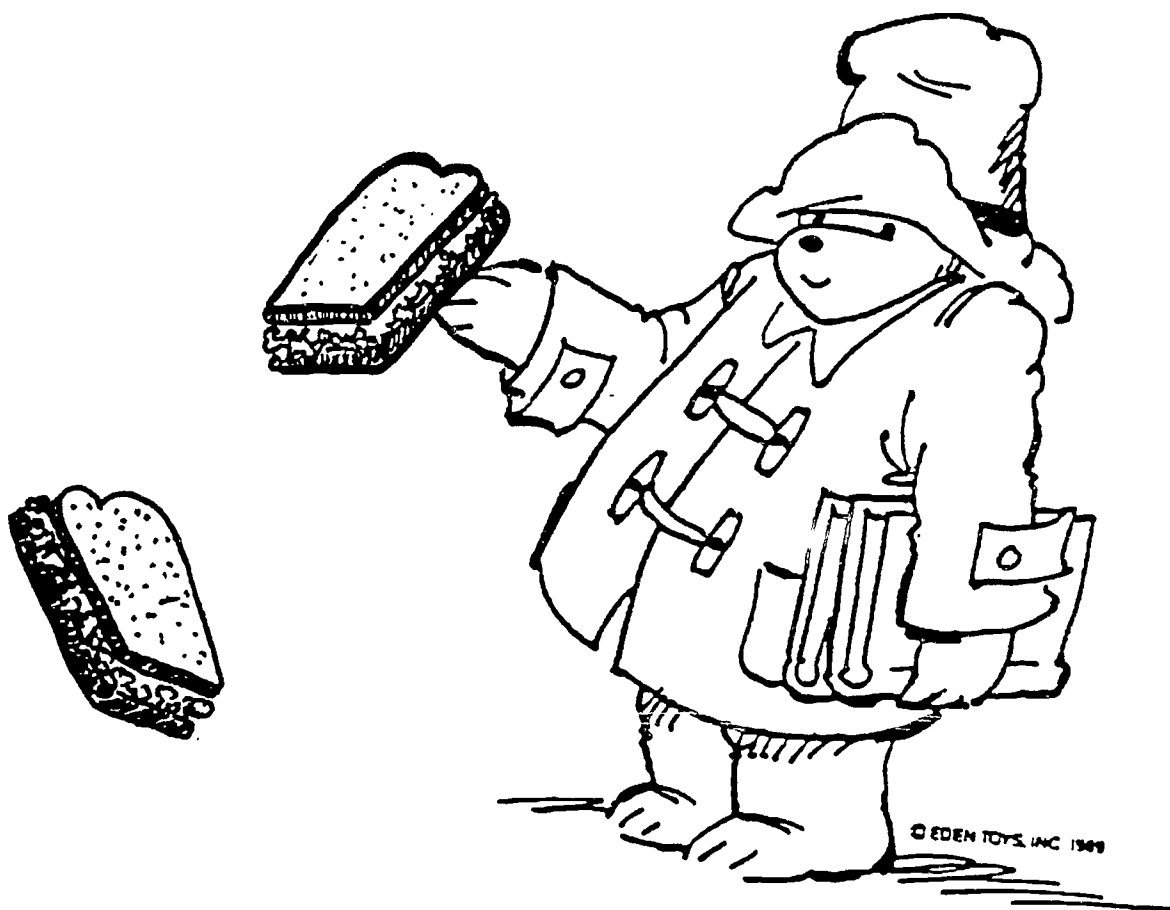



© EDEN TOYS, INC 1989

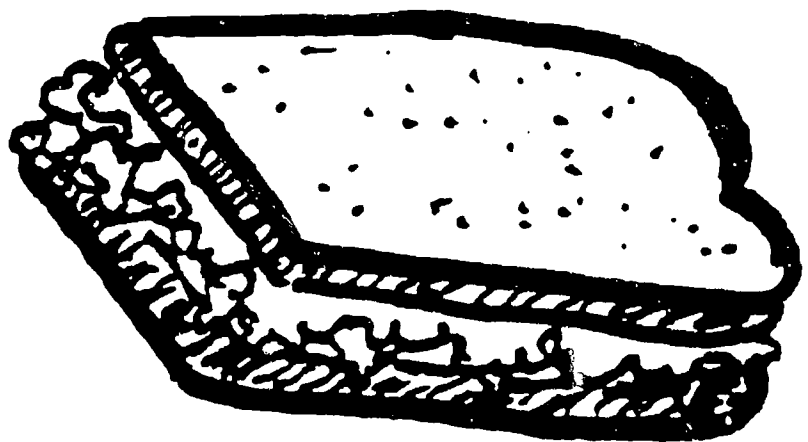
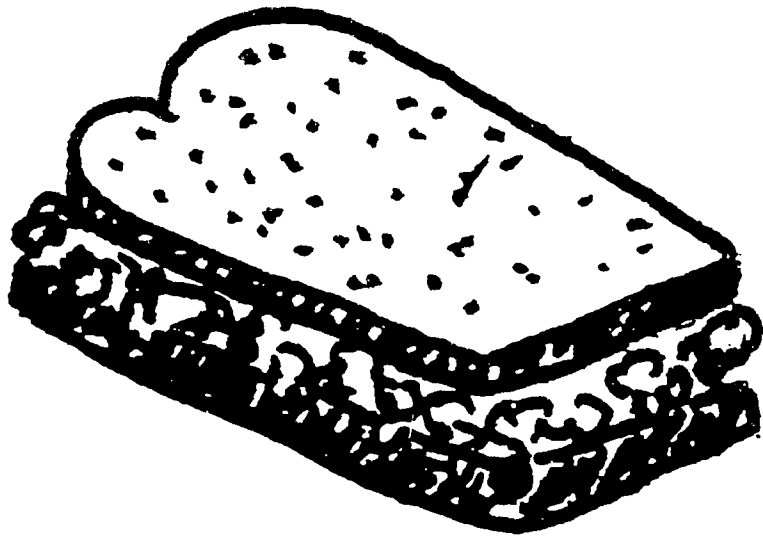
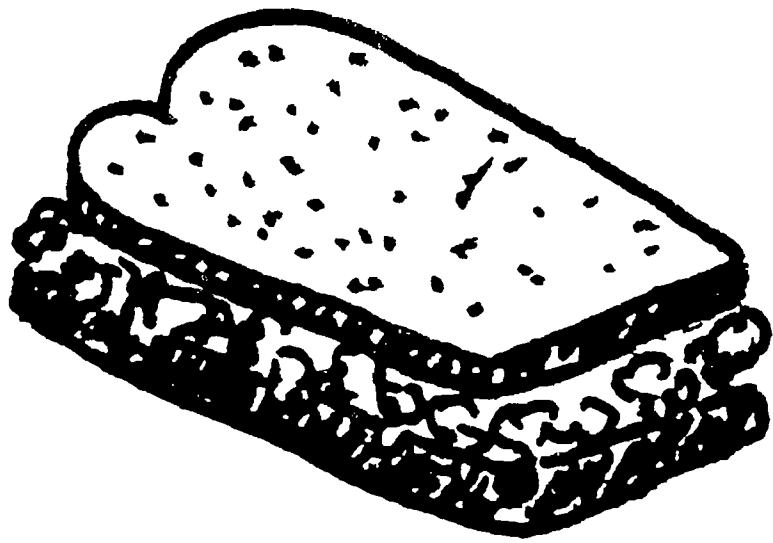



# SUMMER WINDYS

Create colorful banners from construction paper triangles and strips of crepe or wrapping paper. Attach lengths of string so that when the child runs with the "windy" it will float freely along behind.

Miniature "windys" may be created and attached to pencils or straws.

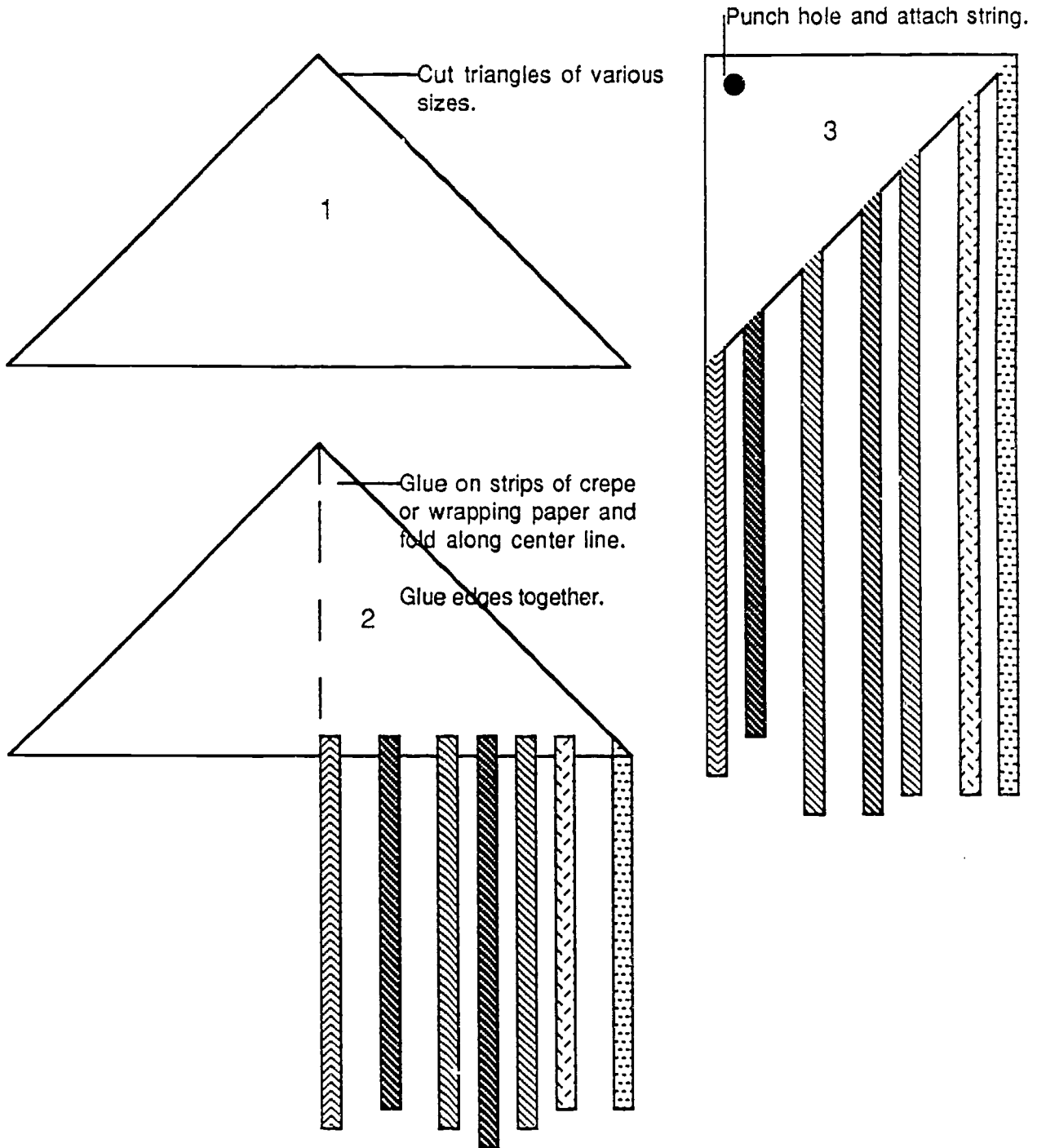

# ANOTHER WINDY

1 Provide each child with a piece of plain construction paper. It may be decorated if desired.

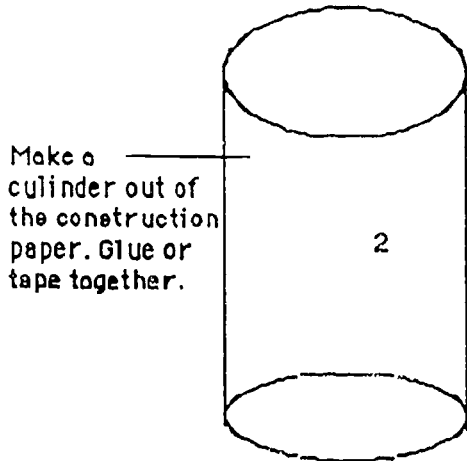

Make a cylinder out of the construction paper. Glue or tape together.

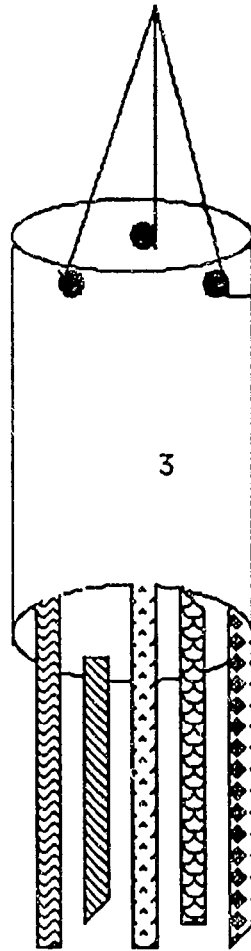

Punch three holes as shown by the dots. Attach string and hang. It may be held by the child when running it will flow in the breeze.

Glue on streamers of crepe or wrapping paper.

## TEDDY BEAR'S PICNIC

Invite children to bring their favorite teddy bear to this event.

Consider holding this event in the evening as a family outing.

Plan an alternate date if it is to be an outside event.

### SUGGESTED MENU

**Tasty Mix:** nuts, raisins, cheerios, chocolate chips and dried fruit bits

**Marmalade sandwiches:** quartered English muffins spread with marmalade

**Fresh fruit:** apples, bananas, fresh pineapple, strawberries, melon all cut into serving pieces

**Party sandwiches:** fruit breads spread with cream cheese  
peanut butter sandwich fingers  
graham crackers topped with honey and sprinkled with coconut

**Fresh veggies:** carrot sticks, celery sticks, cherry tomatoes, cucumbers, broccoli, cauliflower, green pepper and other crunchies. (These may be more popular with the adults than the children).

**Ants on a log:** Celery stuffed with peanut butter and topped with a few raisins or currants

**Assorted cookies**

**Drink:** Ice cold honey sweetened lemonade.

### ACTIVITIES

Plan stories, fingerplays, songs and games appropriate to the age group. The story and song "Teddy Bear's Picnic" will fit nicely with the theme.

### ALTERNATE

Make arrangements with the park or local recreation department for a field trip. Issue invitations through the children's services desk. Have the participants bring their own lunch in a sack decorated like a bear. Take along a few extra lunches as a safety precaution. The library should provide the drinks.

## ELEGANT 'UN-BAKED ELASTIC'

Paddington's 'baked elastic' was a disaster! This recipe for 'un-baked elastic' however, is quite tasty and festive. Some very 'creative' decorating will occur, so keep a camera handy.

Cookie decorating is great fun for groups of all sizes. Be certain that there are enough adults or older youth to assist the younger ones.

Spread the work area with plastic table cloths or drop cloths for easy clean up.

You will need

- marshmallow cream or prepared icing in one or more colors
- enough graham crackers or plain sugar cookies for each participant to have several
- a variety of toppings in small styrofoam bowls or individual nut cups
  - sugar sprinkles
  - colored coconut
  - chopped nuts
  - cheerios
  - tiny chocolate chips
  - raisins or dried fruit bits
  - etc...
- small plastic spoons
- plastic knives or popsicle sticks for spreading
- paper plates for each participant's creative work area
- small plastic bags

Provide each child with a paper plate work area, one cookie at a time for decorating and a personal spreader (knife or popsicle stick).

Place icing or marshmallow cream on the cookie and let the participants select toppings.

HINT: Keep plenty of damp sponges or paper towels handy for sticky hands.

**FOUR BEARS**  
**A PUPPET PLAY**  
(based on the story "Why the Bear is Stumpy Tailed")  
By Barbara H. Fischer  
Children's/ Youth Services Consultant

**Characters:**

Narrator - this can be a person or a puppet.  
Granny Bear  
Baby Bear  
Mama Bear  
Papa Bear  
Bear with long tail attached with velcro so can be removed  
Fox

**Props:**

basket for Mama Bear  
fish for Fox and for Papa Bear

**Scenes:**

Scene 1 - Outside the Bear family cottage in the woods  
Scene 2 - The edge of the forest in winter time  
Scene 3 - The frozen pond (this can be the same as scene two)  
Scene 4 - Outside the Bear Family cottage

Narrator: Once upon a time, in a small cottage in the woods, there lived a family of bears. There was Papa Bear, Mama Bear, Baby Bear and Granny Bear.

Granny: "My, my. Summer is hot and fretful this year."

Baby Bear: "What's fretful, Granny?"

Granny: "Well, it's like a storm is a-brewin'. Not really a rain storm but not quiet and peaceful like I prefer."

Papa Bear: "It's a time to be alert, to ..."

Mama Bear: (finishing Papa Bear's sentence) ... "be careful."

Granny: "I think today Baby Bear and I will visit Farmer Weston's field. The corn he planted should be tasty."

Mama Bear: "I'll check on how the berries on the hill are doing."

Papa Bear: "I'll visit the pond. This just might be the day that 'Old Whopper' gets caught."

Baby Bear: "Papa, what's an 'old whopper'?"

Granny: "Hasn't your Papa told you about that old fish, Baby Bear?"

Baby Bear: "No mam! What about 'Old Whopper', Papa?"

Papa Bear: "Well, Baby Bear, 'Old Whopper' is probably the oldest and biggest fish that ever was. Why, he's been in that pond since the days when bears had long, long tails. Why, I bet 'Old Whopper' is still a-laughin' over that.

Baby Bear: "I never knew that bears had long, long tails! When was that, Papa?"

Papa Bear: "Ask your Granny to tell you the story. She's the best teller of tales around." (Papa Bear exits.)

Mama Bear: "Yes indeed, Granny can tell a fine tale. And the 'Old Whopper' tale is a fine one for a hot, hot day." (She picks up her berry basket and exits.)

Granny Bear: "Come along, Baby Bear. I'll tell you that tale on the way over to Farmer Weston's field. It happened in the coldest part of the winter when there was snow everywhere and the pond was frozen."

Baby Bear: "Brrr... it makes me shiver just to think about it."

Granny: "Now, in the long, long ago times all bears had beautiful long tails. There was one bear who was just unbearable about how beautiful and furry his was. He was always brushing it and boasting about it being the most beautiful tail in the entire world. Well, on this particular day old fox decided to play a trick on old bear.

(Granny and Baby Bear exit.)

Narrator: Granny continued her story as they walked along. It seemed almost real to Baby Bear. He could practically see what happened.

**Scene changes to outside in winter.**

Bear: (brushing his long bushy tail). "My what a mess. This winter weather is such a bother." There now! Just look at this bushy tail. It is lovely now that it's been brushed."

Fox enters carrying a fish,

Fox: "Hi there, Bear. What's that you are doing?"

Bear: (shows Fox his tail) "Just making myself presentable."

Bear notices the fish that Fox is carrying.

"And what do you have there? It looks like a fine fish."

Fox: "It is a fine fish. It will taste mighty good on a cold winter day like this."

Bear: "Where did you get it?"

Fox: "Well, Bear, I went fishing for it."

Bear: (amazed) "Fishing? Where? Everything is frozen solid."

Fox: (smugly) "Well not if you know how to fish."

Bear: "Just what do you mean by that?"

Fox: "Just what I said. You have to know how to fish when the pond is frozen."

Bear: "Could I have a taste of that fish, Fox?"

Fox: "No, absolutely not. But, I could tell you how to get one of your own."

Bear: (demanding to know) "How?"

Fox: "Well, go down to the pond and look carefully through the ice. If you look closely you'll see fish swimming way down deep. Cut yourself a hole in the ice and drop the end of your tail into the water. When you feel a pinch pull your tail out right away. In no time you'll have caught yourself a fine fat fish. The more fish you want the longer you have to leave your tail in the water."

Bear: "I could never do that. My lovely tail would be ruined."

Fox: "Then you will just have to do without any delicious fish."

Bear: "Are you sure that's all? Well ... (looks at Fox's fish) ... Allright, I'll do it and I'll catch the biggest fish there is in that pond."

Fox: "You do that Bear." Well, I must be off. Enjoy your fish." (Fox exits.)

Bear: (hurries off stage and immediately returns - now at the pond)

"Well, well well. (peering down) Would you look at that. Fish are indeed swimming there. One is a whopper! Now, Fox said to cut a hole. (pantomimes action) and to drop my tail into the water. ( Bear calls into the hole) Hey there you old whopper, tonight you'll be my supper. Brrr... it's cold! Ouch! a pinch. That must mean there's a fish. But, that was just a little nibble, I'll wait a while for a larger bite.

Bear settles himself on the ice and waits.

"O! another nibble. Well, I'm so hungry that I'll wait a while longer. Then I know I'll catch that old whopper. My, my, he will taste mighty good."

Bear continues to wait,

"Gracious the sun is starting to go down. Ouch! That wasn't just a nibble that was a bite. I must have caught that old whopper at last. Now, I'll just pull out my catch and be off to supper.

Bear tries to stand up but his tail is frozen in the ice.

"P u l l .. .., P u l l .. (tries again to pull tail out)

Bear gives a gigantic pull.

"**P U L L.**" (he is finally free but minus his tail.

Bear exits crying about his loss.

Narrator: When bear pulled himself out of the ice his tail was caught fast.

**Scene changes back to summer with Granny and Baby Bear entering.**

Granny: "And ever since that time bears have had short short tails."

Baby Bear: " What happened to Bear's tail?"

Granny: "Well, it's said that 'Old Whopper' wears it as a beard."

Mama Bear enters with basket of berries.

Baby Bear: "Granny says that 'Old Whopper' wears a beard.

Mama Bear: (laughing...) "Perhaps he does. Why don't you ask your father?"

Papa Bear enters with fish.

Baby Bear: "Papa, did you catch 'Old Whopper?'"

Papa Bear: "No, Baby Bear, I didn't. But I saw him."

Baby Bear: "Does he have a beard?"

Papa Bear: "Well, I suppose you could call his whiskers a beard." He's a smart old catfish he is." Now, suppose we all pitch in and help get supper ready."

Narrator: That evening the bears had a delicious dinner. And, whenever Baby Bear went fishing he always looked for 'Old Whopper.'



## SIMPLE SACK PUPPETS

Color bear, cut out and glue to flap of a small paper sack. Color mouth section, cut out and glue underneath top flap of sack.

Place your hand inside the sack to make the puppet talk.

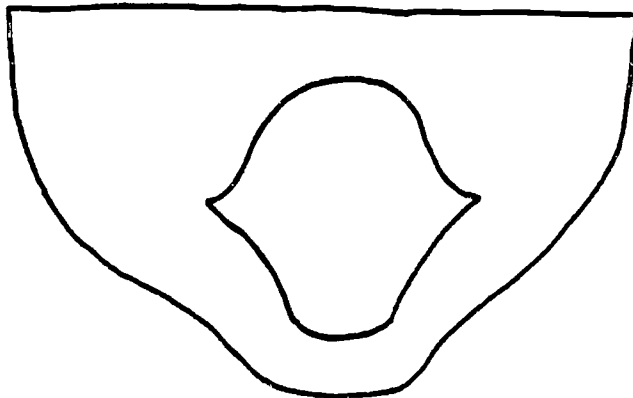
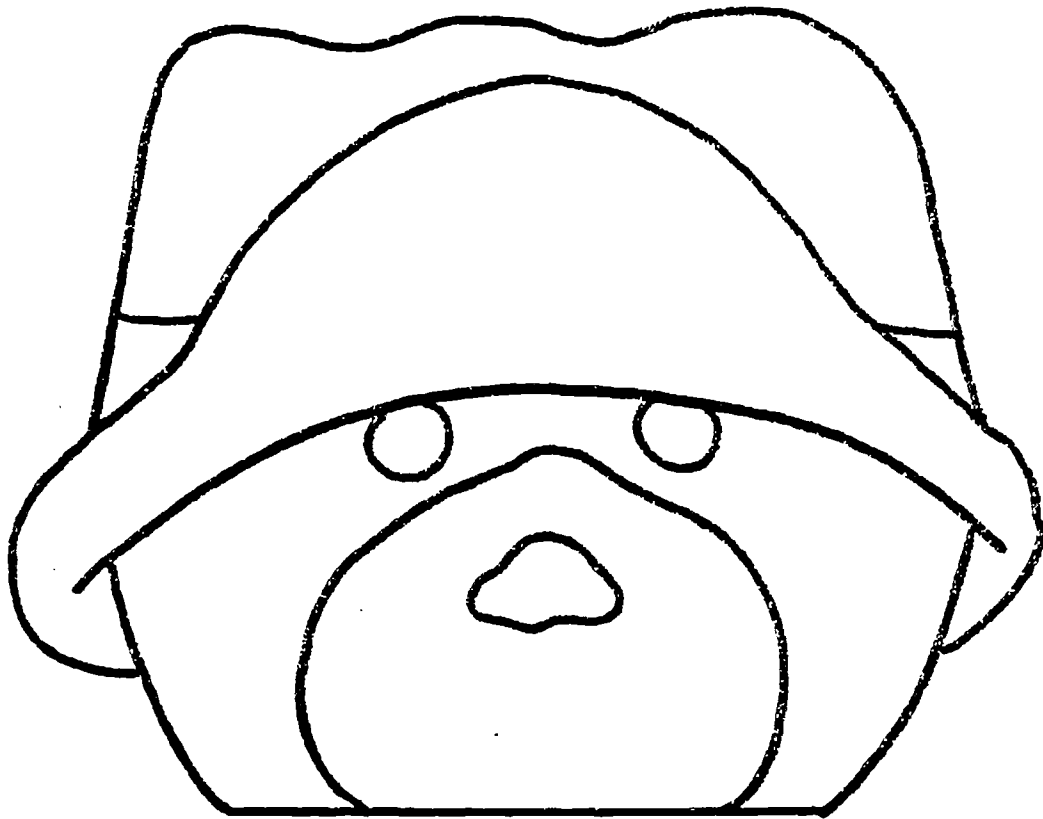

1989 Summer Reading Program

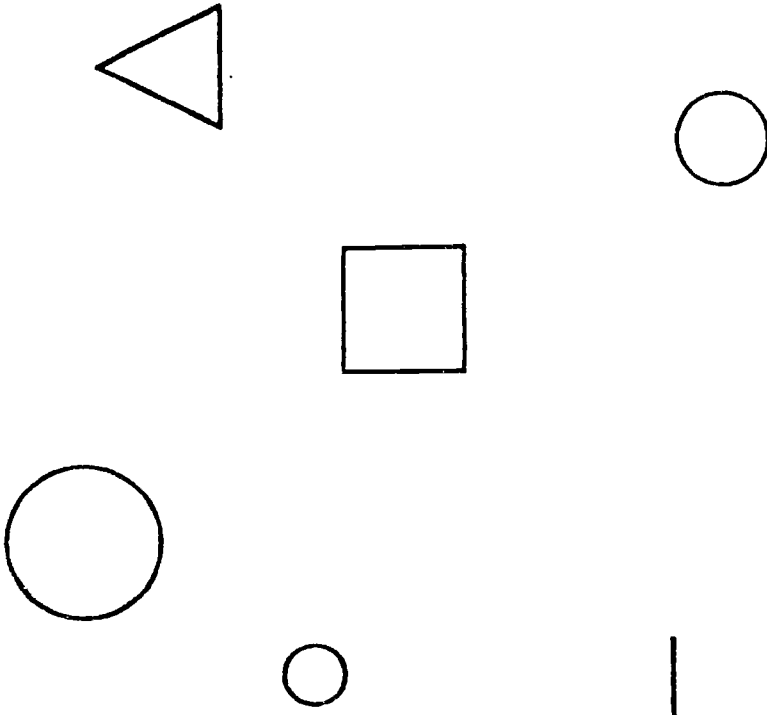
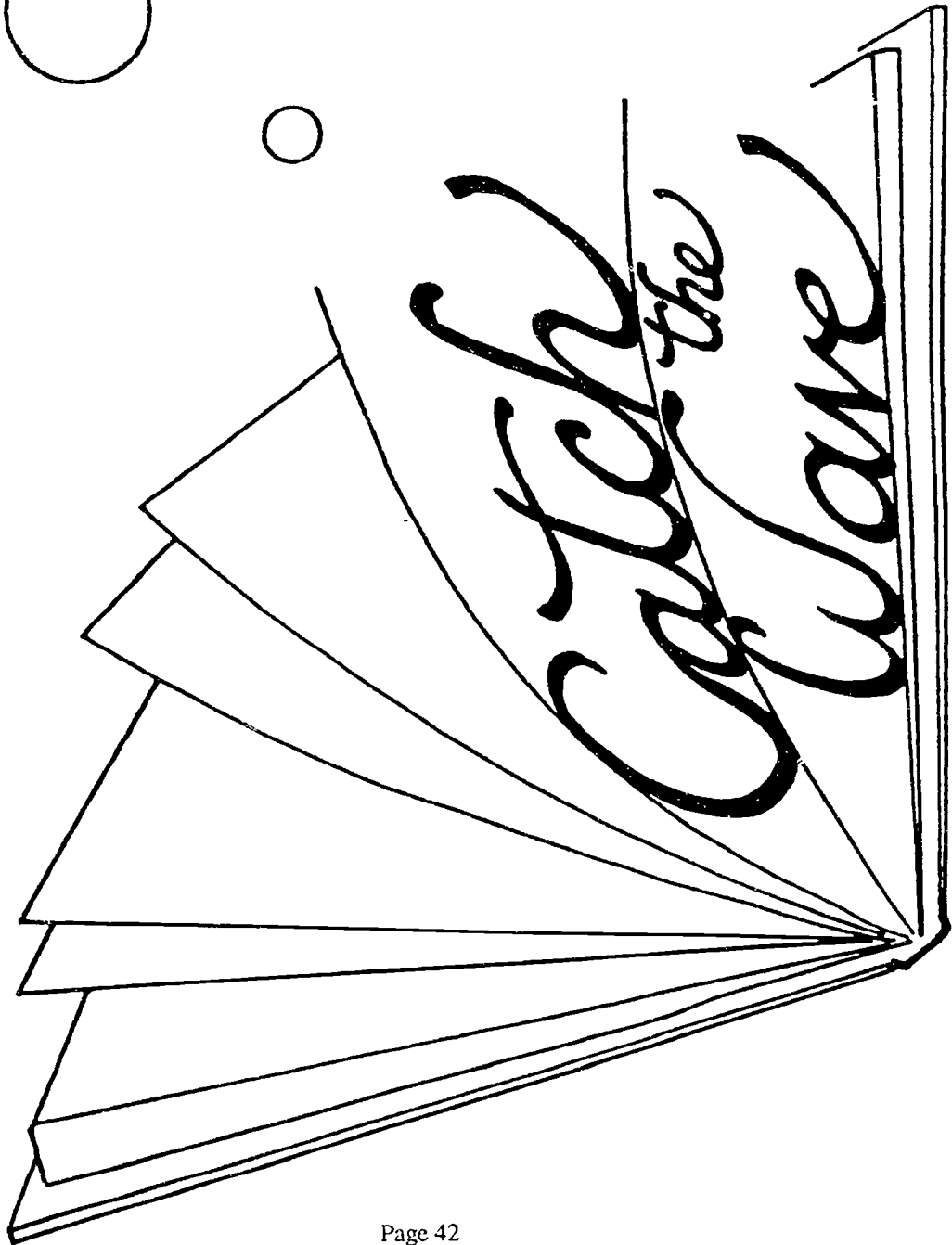

## PUBLICITY

### ALL PRESS RELEASES MUST INCLUDE

**Contact:** (Your name, phone)

**Date:**

### FOR IMMEDIATE RELEASE

Promote the summer program through all available channels - especially those available through the schools.

You may be able to enlist the assistance of a high school journalism or media production class for an extra credit project - particularly popular near the end of the year when it can influence a final grade.

Invite teens to help create a special summer 'rap' for airing over local radio stations.

### EXAMPLE:

Hey there, you with nothin' to do  
Readin's fine and will give you a clue  
To mystery, romance and travel too  
The library's just the place for you.

Catch the wave for summer fun  
Don't let 'em tell you it can't be done  
You're a leader, you're the one  
Come on, read your way to summer fun,

Catch the wave and read today  
A book a day will keep the dull away  
Before you know it you can say  
"I caught the wave today! Say hey!"

### SAMPLE PSA:

Hey there, kid with nothin' to do  
Readin's fine and will give you a clue  
To mystery, romance and travel too  
The library's just the place for you.  
Call \_\_\_\_\_ Library for  
information about summer programs for ages \_\_\_\_\_ .  
Phone: \_\_\_\_\_

## PRESS RELEASE FOR SPECIAL EVENT

### LIBRARY SPONSORS ( name of event)

The \_\_\_\_\_ Library will sponsor (or present) a  
\_\_\_\_\_ (event) on \_\_\_\_\_ (day and date)  
at \_\_\_\_\_ (time) for ages \_\_\_\_\_.

Brief 1 - 2 sentence description of the event or program.

This event is held in conjunction with the \_\_\_\_\_ Library's  
1989 "Catch the Wave" Summer Reading Program and is sponsored (or  
underwritten) by \_\_\_\_\_ (list of community  
contributors).

For additional information about \_\_\_\_\_ (event) call  
\_\_\_\_\_.

## DISPLAYS

Let your imagination be your guide as you create displays based on the theme. Beg, borrow or make decorations. Use bold colors.

### **Beach scene**

Turn the young adult reading area into a beach scene. Beach towels, deck or beach chairs, etc... will help to create the appropriate atmosphere. A beach umbrella can be held in place with breko blocks. Drape beach towels over the blocks to disguise them. Paper palm trees on the walls and book cases will complete the scene. You may be able to borrow items from a department store for display - check library policy relating to this so the library will not be held liable should the items be damaged.

### **Waves**

Create a sea scene with several large waves of construction paper. Participants may create their own surfboards (set a design size limit) to place on the display.

### **Neptune's domain**

Hang nets, shells and sea creatures around the area. Make sea creatures from construction paper and decorate with markers or temptra. Hang from ceiling with fishing line.

## IN TITLES

This diary entry includes **30** different book titles. How many of them can you locate? How many of the books have you read?

Using titles of books you have read, try creating a story of your own. Challenge your friends to locate them in your story.

*Dear Diary . . .*

*Today was an unusual day. As I hurried home from gymnastics Tex, the moonlight man, was sitting on his porch singing his bad man ballad - I will call it Georgie's Blues. Apparently he thought he was a child of the owl because he punctuated the haunting melody with raucous hoots which, like a dogsong, went on forever!! For a moment I felt like we were going backwards - captives in time. Though I knew I had to be home before dark, I stood riveted in one spot. Old Mrs. Lillian Wald of Henry Street was out early flying one of her exotic night kites. "Sweet whispers, Brother Rush," she said as she glided by. Some people say that was the code she used during the war to signal the return was safe. "The cheese stands alone, the cheese stands alone," she chanted. "I am the cheese and the cheese stands alone." Her eyes glowed like tiger eyes. She seemed lost in her own private unknown memories and was crossing beyond the divide of reality into fantasy. I felt ensnared in a wrinkle in time. "Good evening, Princess Ashley," she murmured, staring past me as though I didn't exist. "Just as long as we're together everything will be just fine," When I spoke it seemed to bring her back to reality. "Oh, hello Kim/Kimi. I'm sorry, I was so lost in my own thoughts I didn't see you there. My you are growing up to be quite a beauty. You should enter a pageant." That's all she said. Then, suddenly she was gone. "Remember me to Harold Square," she called as she disappeared into her house. A strange unexplained energy lingered in the air. The rest of the way home I wondered if there really was a difference in one's perceptions in summer light.*

*Well, so much for the magical adventures of the pretty pearl. That's all for now. If I don't win the chocolate war I'm having with myself it's going to be one fat summer.*

## NEPTUNE'S BOUNTY (A Guessing Game)

Fill a large fishbowl or other container with a variety of sea shells or fish-shaped crackers. Permit reading program participants to place a guess about how many are in the container each time they visit the library or for reading a designated number of books.

Sample entry form

NAME \_\_\_\_\_

ADDRESS \_\_\_\_\_

PHONE \_\_\_\_\_

AGE \_\_\_\_\_

The container or other prizes may be awarded to the participant who correctly guesses or has the closest guess to the actual number of items.

The Pepperidge Farms company produces an assortment of tiny fish-shaped crackers which are generally found in the cracker or cookie section of the grocery store.

## **SAND CASTLES**

(An outdoor activity)

Secure small bags of children's play sand from a local store if it is not otherwise readily available. Select an area of the grounds which cannot be damaged by the addition of quantities of sand. Participants should bring their own building tools: small cans, hand trowels, small buckets, etc... You may wish to provide a few plastic spoons, knives and forks for detail work.

Provide each participant with a designated area covered with a plastic drop cloth. Open each bag of sand and dampen it thoroughly with water. A ready source of water should be available for additional dampening and clean up. Participants are to create a sand castle using the available sand within a time limit.

Prizes may be awarded to the 'most creative' as well as for other categories which you devise.

## **'SAND' PAINTING**

(Use colored granulated sugar in place of sand)

Food coloring added to plain granulated sugar will create pastel to vibrant colors depending on the amount of coloring added.

Provide a work area for each participant, a work surface of cardboard or construction paper. Place several bowls of colored sugar on each table along with a container of Elmer's, or other white glue, thinned with a little water. Provide several 1/2" or smaller brushes.

The glue brushed lightly on the 'sand' painting area before the sugar is added will secure the painting to the surface. It will be necessary to work quickly to apply the sugar before the surface is completely dry.

### **ALTERNATE:**

Use large sugar cookies and plain icing as the 'painting surface'. For fun and contrast add some colored coconut to the activity.

(Add a few drops of food coloring to coconut and mix well.)



## YACHT RACES

This event is sure to spark the ingenuity of young inventors and model makers.

You will need a large child's wading pool, a stop watch to time the races and prizes for the winners and/or losers.

Invite teens to create their own small craft for entry into this event. Set specification limits on the size of each entry. Have categories for battery operated and self propelled craft. You may also wish to designate age level categories for entries. Each entry must have a name.

Place entries on display at the library for several days before the races.

You may be able to arrange for publicity about young "inventors" at work building their entries to generate interest prior to the event.

Be sure to have available several titles about building model boats.

On the day of the race fill the pool with water, designate starting and finishing points, permit only two boats in the pool at any one time and time each entry as it cruises across the pool. Depending on the number of entries, it may be necessary to have the races run in several pools with a final race to determine the winner.

Log the time of each race on a chart.

Award "silver trophies" (foil covered toy boats) to the winners.

Sample entry form:

Name \_\_\_\_\_

Address \_\_\_\_\_

Age \_\_\_\_\_

Name of craft \_\_\_\_\_

Primary construction material \_\_\_\_\_

Method of propulsion \_\_\_\_\_

## BIBLIOGRAPHIES

## RESOURCE BIBLIOGRAPHY

- Abisch, Roz.           The Make It, Play It, Show Time Book. Walker, 1977.
- ALA.                    "Latchkey Children" In the Public Library: A Position Paper. American Library Association, 1988.
- Alkema, Chester Jay. Puppet Making. Sterling, 1971.
- Amery, Heather.       The Know How Book of Action Toys. Sterling, 1976.
- Anderson, Paul S.     Storytelling With the Flannel Board; Book Two. T. S. Denison & Company, Inc., 1970.
- Baeckler, Virginia.   Go, Pep, and Pop!; 250 Tested Ideas for Lively Libraries. Unabashed Librarian, 1976.
- Bauer, Caroline.      Celebrations: Read Aloud Holiday and Theme Book Programs. H. W. Wilson Company, 1985.
- \_\_\_\_\_.                 Handbook For Storytellers. American Library Association, 1977.
- \_\_\_\_\_.                 Presenting Reader's Theater: Plays and Poems To Read Aloud. H. W. Wilson Company, 1987.
- \_\_\_\_\_.                 This Way To Books. H. W. Wilson Company, 1983.
- Bodart, Joni.          Booktalk! H. W. Wilson Company, 1980.
- Broad, Laura.         The Playgroup Handbook. St. Martin's Press, 1974.
- Burns, Marilyn.        Good Times: Every Kid's Book of Things To Do. Bantam, 1979.
- Carlson, Bernice.     Funny-Bone Dramatics. Abingdon, 1974.
- \_\_\_\_\_.                 Let's Pretend It Happened To You. Abingdon, 1973.
- \_\_\_\_\_.                 Listen! and Help Tell the Story. Abingdon, 1965.
- Champlin, Connie.    Storytelling With Puppets. American Library Association, 1985.
- Civardi, Anne.        The Know How Book of Action Games. Corwin, 1976.
- Cole, Ann.             I Saw a Purple Cow. Little, Brown & Company, 1972.
- \_\_\_\_\_.                 Purple Cow to the Rescue. Little, 1982.
- Croft, Doreen J.      An Activities Handbook for Teachers of Young Children. 2nd. ed. Houghton Mifflin, 1975.
- Doray, Maya B.        See What I Can Do! A Book of Creative Movement. Prentice-Hall, 1973

- Dorian, Margery. Telling Stories Through Movement. Fearon-Pitman Publishers, Inc., 1974.
- Emberley, Ed. Ed Emberley's Great Thumbprint Drawing Book. Little, 1977.
- \_\_\_\_\_. Ed Emberley's Picture Pie: A Book of Circle Art. Little, 1984.
- Engler, Larry. Making Puppets Come Alive. Taplinger Publishing Company, 1973.
- Fiarotta, Phyllis. Be What You Want To Be. Workman, 1977.
- Forgan, Harry W. The Reading Corner: Ideas, Games and Activities for Individualizing Reading. Scott Foresman, 1977.
- Garvey, Mona. Library Displays; Their Purpose, Construction and Use. H. W. Wilson Company, 1969.
- Glazer, Tom. Do Your Ears Hang Low? Doubleday, 1980.
- Graves, Ginny. Ginny Graves' Discovery Stuff: Twelve Months of Creative Art Ideas. Discovery Stuff, 1977.
- Grayson, Marion. Let's Do Fingerplays. Luce, 1972.
- Gregson, Bob. The Incredible Indoor Games Book. Pitman Learning, 1982.
- Haas, Carolyn. Backyard Vacation. Little, 1980.
- Liu, Sarah. Games Without Losers: Learning Games and Independent Activities for Elementary Classrooms. Incentive Publication, 1975.
- Liebold, Louise. Fireworks, Brass Bands and Elephants: Promotional Events With Flair For Libraries and Other Nonprofit Organizations. Oryx Press, 1986.
- Lowndes, Betty. Movement and Creative Drama for Children. Plays, Inc., 1971.
- Marzollo, Jean. Learning Through Play. Harper, 1976.
- Matterson, Elizabeth. Games for the Very Young. American Heritage Press, 1969.
- Never A Dull Moment. Schoken Books, 1983.
- Nichols, Judy. Storytimes for Two-Year-Olds. American Library Association, 1987.
- Polette, Nancy. Activities With Folktales and Fairy Tales. Book Lures, 1979.
- \_\_\_\_\_. Celebrating With Books. Scarecrow, 1977.
- \_\_\_\_\_. E Is For Everybody. Scarecrow, 1976.

- Robinson, Jeri.           Activities for Anyone, Anytime, Anywhere. Little, 1983.
- Ross, Laura.             Puppet Shows Using Poems and Stories. Lothrop, Lee and Shepard, 1970.
- Sierra, Judy.            The Flannel Board Storytelling Book. H. W. Wilson Company, 1987.
- Simons, Robin.         Recyclopedia: Games, Science Equipment and Crafts Made From Recycled Materials. Houghton-Mifflin, 1976.
- Taetzsch, Sandra.      Pre-School Games and Activities. Fearon, 1974.
- Thomson, Neil.         Fairground Games To Make and Play. Lippincott, 1978.
- Thomson, Ruth.         Exciting Things To Make With Paper. Lippincott, 1977.
- Toole, Amy L.          Off to a Good Start: 464 Readiness Activities for Reading, Math, Social Studies and Science. Walker, 1983.
- Wallick, Clair H.      Looking for Ideas?; A Display Manual for Libraries and Bookstores. Scarecrow, 1970.

**IN TITLES BIBLIOGRAPHY**  
**(For younger readers)**

Amelia Bedelia	Peggy Parish	Harper
A Bear Called Paddington	Michael Bond	Houghton
The Cat In the Hat	Dr. Seuss	Random
Dominic	William Steig	Farrar
Dragonwings	Laurence Yep	Harper
The Egypt Game	Zilpha Keatley Snyder	Atheneum
Fox and His Friends	Edward Marshall	Dial
Freaky Friday	Mary Rogers	Harper
Frog and Toad Together	Arnold Lobel	Harper
A Girl Called Al	Constance C. Greene	Viking
Green Eggs and Ham	Dr. Seuss	Random
How To Eat Fried Worms	Thomas Rockwell	Watts
Hugh Pine	Jan Willem Van de Wetering	Houghton
In a Dark, Dark Room	Alvin Schwartz	Harper
Kneeknock Rise	Natalie Babbitt	Farrar
Mr. Popper's Penguins	Richard Atwater	Little
My Father's Dragon	Ruth Gannett	Random
Old Mother West Wind	Thornton Burgess	Little
Ramona	Beverly Cleary	Morrow
Surprises	Lee Bennett Hopkins	Harper

**IN TITLES BIBLIOGRAPHY**  
(For older readers)

Bad Man Ballad	Scott R. Sanders	Bradbury
Beauty	Robin McKinley	Harper
Beyond the Divide	Kathryn Laskey	Macmillan
Captives In Time	Malcolm Bosse	Delacorte
Child of the Owl	Laurence Yep	Harper
The Chocolate War	Robert Cormier	Pantheon
Crossing	Gary Paulsen	Orchard
Dear Diary	Jeanne Betancourt	Avon
Dogsong	Gary Paulsen	Bradbury
Forever	Judy Blume	Bradbury
Going Backwards	Norma Klein	Scholastic
Princess Ashley	Richard Peck	Delacorte
Home Before Dark	Ellen Bridges	Knopf
I Am the Cheese	Robert Cormier	Pantheon
I Will Call It Georgie's Blues	Suzanne Newton	Viking
In Summer Light	Zibby Oneal	Viking
Just As Long As We're Together	Judy Blume	Orchard
Kim/Kimi	Hadley Irwin	McElderry
Lillian Wald of Henry Street	Beatrice Siegel	Macmillan
The Magical Adventures of the Pretty Pearl	Virginia Hamilton	Harper
The Moonlight Man	Paula Fox	Bradbury
Night Kites	M. E. Kerr	Harper
One Fat Summer	Robert Lipsite	Harper
Pageant	Kathryn Laskey	Four Winds
Remember Me to Harold Square	Paula Danziger	Delacorte
The Return	Sonia Levitin	Atheneum
Sweet Whispers, Brother Rush	Virginia Hamilton	Philomel
Tex	S. E. Hinton	Delacorte
Tiger Eyes	Judy Blume	Bradbury
A Wrinkle in Time	Madeline L'Engle	Farrar

## SOLUTIONS



# ANSWER KEY

## PADDINGTON'S ADVENTURES



- Use small buttons for playing pieces.
- A roll of the dice determines the number of spaces moved.
- Players must correctly answer the question or perform the action in the space where they land or lose a turn.

START	Suck your thumb until your next turn.	Hop on one foot 3 times.	In what city does Paddington Bear live?	
What is Paddington's favorite food?		What time was it when the mouse ran down the clock?	Neigh like a horse and gallop ahead 3 spaces.	
Who tried to catch the three little pigs?	Flap your arms and crow.		What cat wore boots?	
		Who would not let three billy goats across a bridge?		
	Croak like a frog and hop ahead 2 spaces.	Howl at the moon.	Oops... Paddington accidentally bonaped into Mr. Curry. Go back 3 spaces.	What did Cinderella lose at the ball?
				Whose cupboard was bare?
				Loss a turn.

## PADDINGTON'S ADVENTURES (Answer Key)

What is Paddington's favorite food?  
MARMALADE SANDWICHES

Why did Jack and Jill go up the hill?  
TO FETCH A PAIL OF WATER

Who tried to catch the three little pigs?  
THE WOLF

What time was it when the mouse ran down the clock?  
ONE O'CLOCK

In what city does Paddington Bear live?  
LONDON

What cat wore boots? PUSS IN BOOTS

What did Cinderella lose at the ball?  
HER SLIPPER

Who would not let three billy goats across a bridge?  
THE TROLL

Whose cupboard was bare?  
OLD MOTHER HUBBARD'S

			1							
		2			3					
				4		5				
							6			
								7		
									8	
										9
										10

## FLOTILLA FUN

The wind has changed and the boats must shift direction. By moving only 3 boats, can you help the flotilla maintain its triangle formation but with the point of the triangle at the bottom?

## SOLUTION

Move ship number 1 down four spaces.  
Move ships 7 and 10 up two spaces.

# SOLUTION

Can you draw 3 straight lines to help Paddington create 6 rooms in this house with each room containing a jar of marmalade, a loaf of bread and a cup of hot chocolate?

A line from 2 to 36,  
a line from 15 to H and  
a line from T to P.

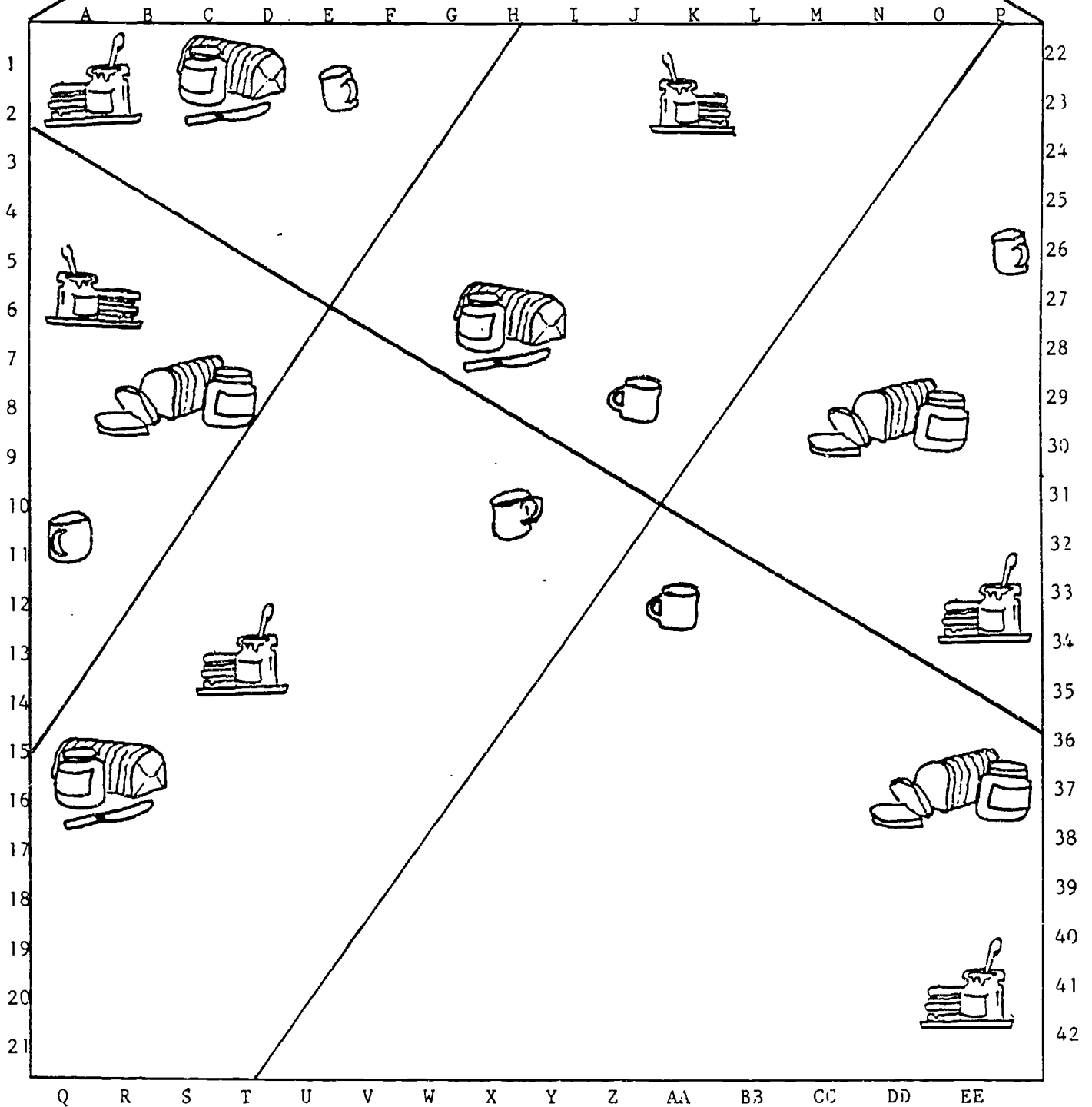

## FUN PHRASES

Complete these words and phrases with the word BEAR or its homophone, BARE.

1. \_\_\_\_\_ in mind. (Remember)
2. Un\_\_\_\_\_ able. (Can't stand it)
3. \_\_\_\_\_ up. (Withstand)
4. \_\_\_\_\_ necessities. (Absolute minimum)
5. \_\_\_\_\_ facts. (A simple truth)
6. \_\_\_\_\_ claws. (A sweet pastry)
7. \_\_\_\_\_ witness. (To testify)
8. \_\_\_\_\_ back. ((Riding a horse without a saddle)
9. \_\_\_\_\_ er of bad news. (A person who brings sad messages)
10. Thread\_\_\_\_\_. (Worn out)
11. \_\_\_\_\_ skin rug. (Fuzzy floor covering)
12. \_\_\_\_\_ your soul. (Be completely honest)
13. \_\_\_\_\_ foot. (Without shoes)

### SOLUTION

1. Bear in mind
2. Unbearable
3. Bear up
4. Bare necessities
5. Bare facts
6. Bear claws
7. Bear witness
8. Bare back
9. Bearer of bad news
10. Threadbare
11. Bearskin rug
12. Bare your soul
13. Barefoot

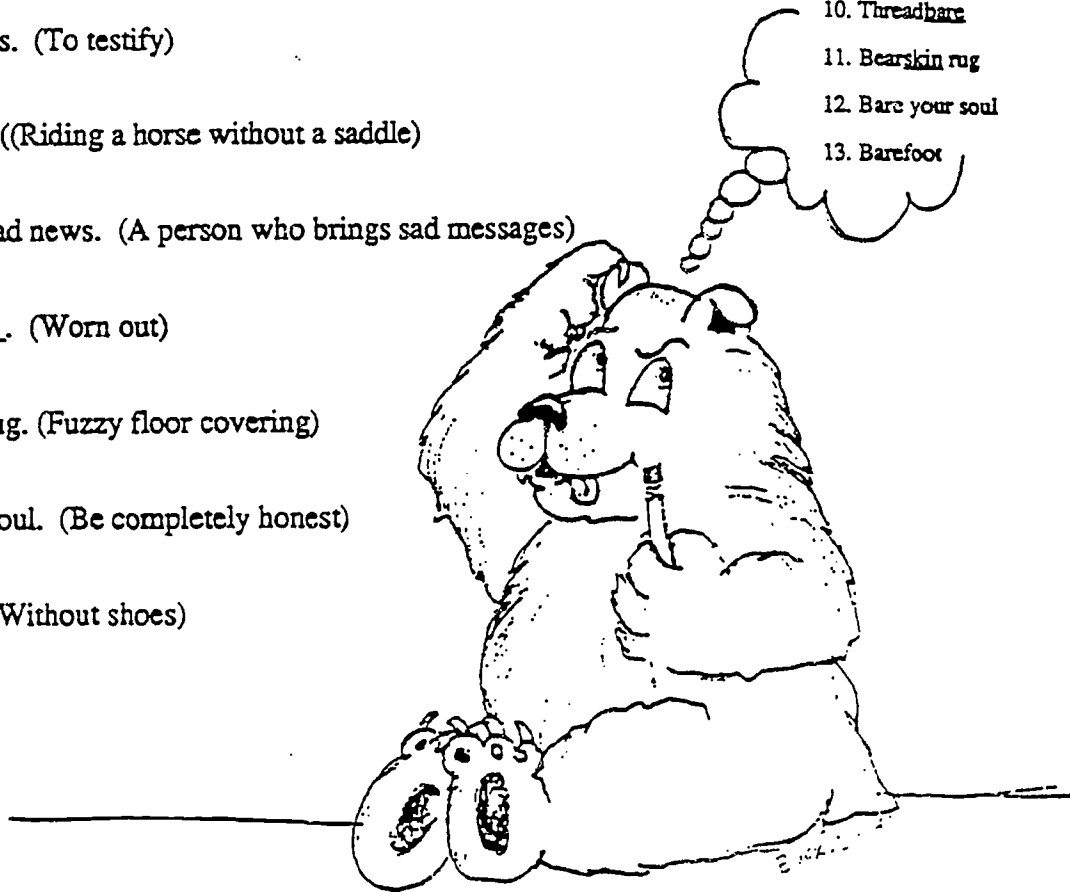

## IN TITLES (Solution)

This selection contains **20** book titles. How many of them can you locate? How many of the books have you read?

Using additional titles, continue this story or make up one of your own. You may wish to add your own illustrations.

When **Amelia Bedelia** first saw **the cat in the hat** he was talking to a **bear called Paddington** and some other friends.

"Come join us," invited Paddington. "We are planning a party for **fox and his friends**. **Old Mother West Wind** said we could have everyone over to her house on **Kneeknock Rise**. There we can hid in a **dark, dark room** and shout our '**surprises**' when fox arrives.

"**Hugh Pine** is going to bring some **green eggs and ham**," announced **Ramona**. "We must have plenty of ice for **Mr. Popper's penguins** and for the cold drinks," she said. "**Frog and Toad together** have promised to show us **how to eat fried worms**."

"May I bring **my father's dragon**?" asked **Dominic**. "I know he will keep his **dragonwings** from knocking anything over."

"Let's play **the Egypt game**," requested a **girl called Al**. "It is fun and will really make this a **freaky Friday**."

## IN TITLES SOLUTION

(For older readers)

This diary entry includes **30** different book titles. How many of them can you locate?  
How many of the books have you read?

Using titles of books you have read, try creating a story of your own. Challenge your friends to locate them in your story.

**Dear Diary . . .**

Today was an unusual day. As I hurried home from gymnastics **Tex, the moonlight man**, was sitting on his porch singing his **bad man ballad - I will call it Georgie's Blues**. Apparently he thought he was a **child of the owl** because he punctuated the haunting melody with raucous hoots which, like a **dogsong**, went on **forever!!** For a moment I felt like we were **going backwards - captives in time**. Though I knew I had to be **home before dark**, I stood riveted in one spot. Old Mrs. **Lillian Wald of Henry Street** was out early flying one of her exotic **night kites**. "**Sweet whispers, Brother Rush**," she said as she glided by. Some people said that was the code she used during the war to signal **the return** was safe. "The cheese stands alone, the cheese stands alone," she chanted. "**I am the cheese** and the cheese stands alone." Her eyes glowed like **tiger eyes**. She seemed lost in her own private unknown memories and was **crossing beyond the divide** of reality into fantasy. I felt ensnared in a **wrinkle in time**. "Good evening, **Princess Ashley**," she murmured, staring past me as though I didn't exist. "**Just as long as we're together** everything will be just fine," When I spoke it seemed to bring her back to reality. "Oh, hello **Kim/Kimi**. I'm sorry, I was so lost in my own thoughts I didn't see you there. My you are growing up to be quite a **beauty**. You should enter a **pageant**." That's all she said. Then, suddenly she was gone. "**Remember me to Harold Square**," she called as she disappeared into her house. A strange unexplained energy lingered in the air. The rest of the way home I wondered if there really was a difference in one's perceptions **in summer light**.

Well, so much for **the magical adventures of the pretty pearl**. That's all for now. If I don't win **the chocolate war** I'm having with myself it's going to be **one fat summer**.

# CATCH THE WORD

The following words are included in this word search game. How many can you locate?

- |          |           |           |       |            |
|----------|-----------|-----------|-------|------------|
| Beach    | Beachball | Fish      | Jetty | Lighthouse |
| Miami    | Mermaid   | Palmtree  | Pier  | Sailboat   |
| Sand     | Sea       | Seaweed   | Shark | Shell      |
| Starfish | Sun       | Surfboard | Swim  | Tent       |
| Wave     |           |           |       |            |

H	E	B	A	R	R	B	N	K	K	I	L	O	P	L	H	Q
I	T	S	I	H	G	R	E	V	J	M	O	R	T	T	Y	U
E	F	M	G	G	K	M	N	L	D	U	I	Y	H	N	U	Q
Q	R	L	G	T	R	Q	Q	W	R	T	P	Z	Y	X	B	O
U	E	K	H	N	M	V	Z	Z	E	R	R	A	A	S	M	P
W	B	E	A	C	H	B	A	L	L	V	L	O	D	S	A	O
E	S	U	O	H	T	H	G	I	L	M	M	A	I	N	U	S
N	S	Y	N	N	M	P	N	M	E	B	T	A	I	D	Q	U
M	T	U	E	M	V	O	A	G	H	G	R	D	K	P	T	J
B	B	T	A	O	B	L	I	A	S	B	E	Y	K	O	T	K
X	Q	S	M	K	E	C	A	S	D	R	E	I	P	T	R	E
Z	W	A	K	O	A	X	E	V	F	Y	G	V	O	R	V	I
Z	D	A	E	T	C	V	D	O	B	A	Q	Q	J	A	J	S
O	F	J	L	S	H	A	R	K	B	S	E	A	W	E	E	D
P	R	W	K	S	V	A	A	B	H	A	E	R	H	Q	T	O
T	J	R	J	E	B	G	O	N	Y	S	T	R	B	V	T	T
T	L	S	M	R	V	M	B	Z	T	V	I	Q	Y	A	Y	N
E	I	L	M	O	Q	T	B	F	A	T	R	K	F	N	S	K
Y	L	P	M	F	W	M	N	R	V	R	E	I	T	I	T	L
I	L	P	U	S	F	A	F	U	U	E	V	T	Y	K	D	M
L	L	O	T	Y	O	S	M	L	M	G	Y	C	U	J	N	T
L	M	O	H	S	H	U	H	O	O	H	Y	O	B	I	V	Y
O	J	M	S	T	T	V	T	O	M	T	S	C	C	R	U	I
J	Y	P	O	S	D	F	Q	R	E	T	Y	U	I	J	I	L
Q	P	O	U	C	V	Y	H	F	S	E	R	D	O	T	Y	Q

# CATCH THE WORD

## (Solution)

The following words are included in this word search game. How many can you locate?

Beach	Beachball	Fish	Jetty	Lighthouse	
Miami	Mermaid	Palmtree	Pier	Sailboat	
Sand	Sea	Seaweed	Shark	Shell	
Starfish	Sun	Surfboard	Swim	Tent	Wave

Words may be found forward or backward, horizontal, vertical, diagonal or wave shaped.

```

                P
                A
                L
                S
    E   B   E   A   C   H   B   A   L   L   M   A   I   N   D   U   S
        S   U   O   H   T   H   G   I   L   R   T   I   D
            E   N
            T   E   O   B   L   I   A   S   R   E   I   P   E
            A   E   A   C   D   K   S   E   A   W   A   V   J   E   D
                S   H   A   R   K   S   E   A   W   E   J   E   T   T   Y
                    M   O   B   A   T   I   F
                        I   M   F   R   U   S
                            W   S   A   I   M
                                S   S   H
    
```



# PERU SOLUTION

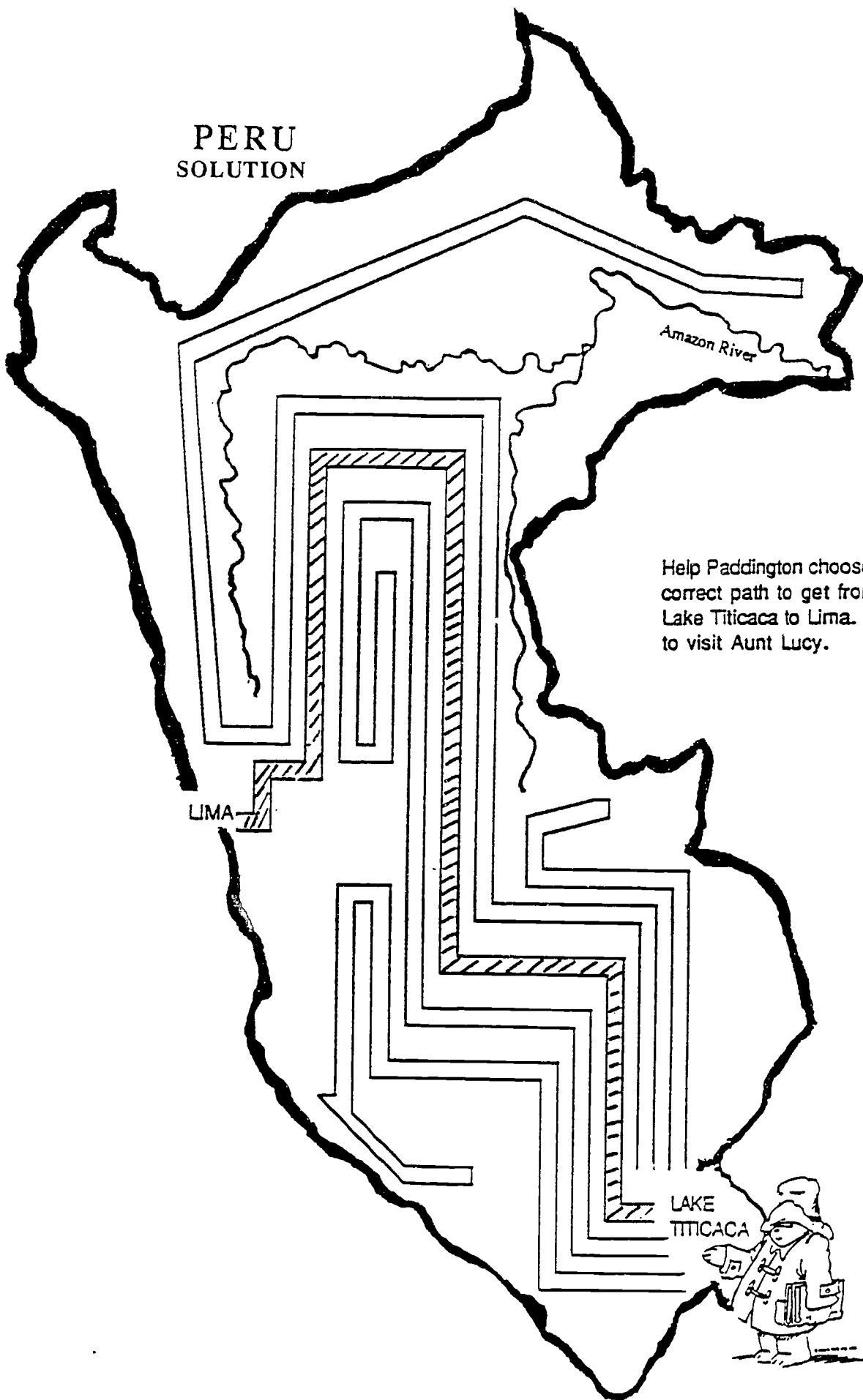

Help Paddington choose the correct path to get from Lake Titicaca to Lima. He wants to visit Aunt Lucy.

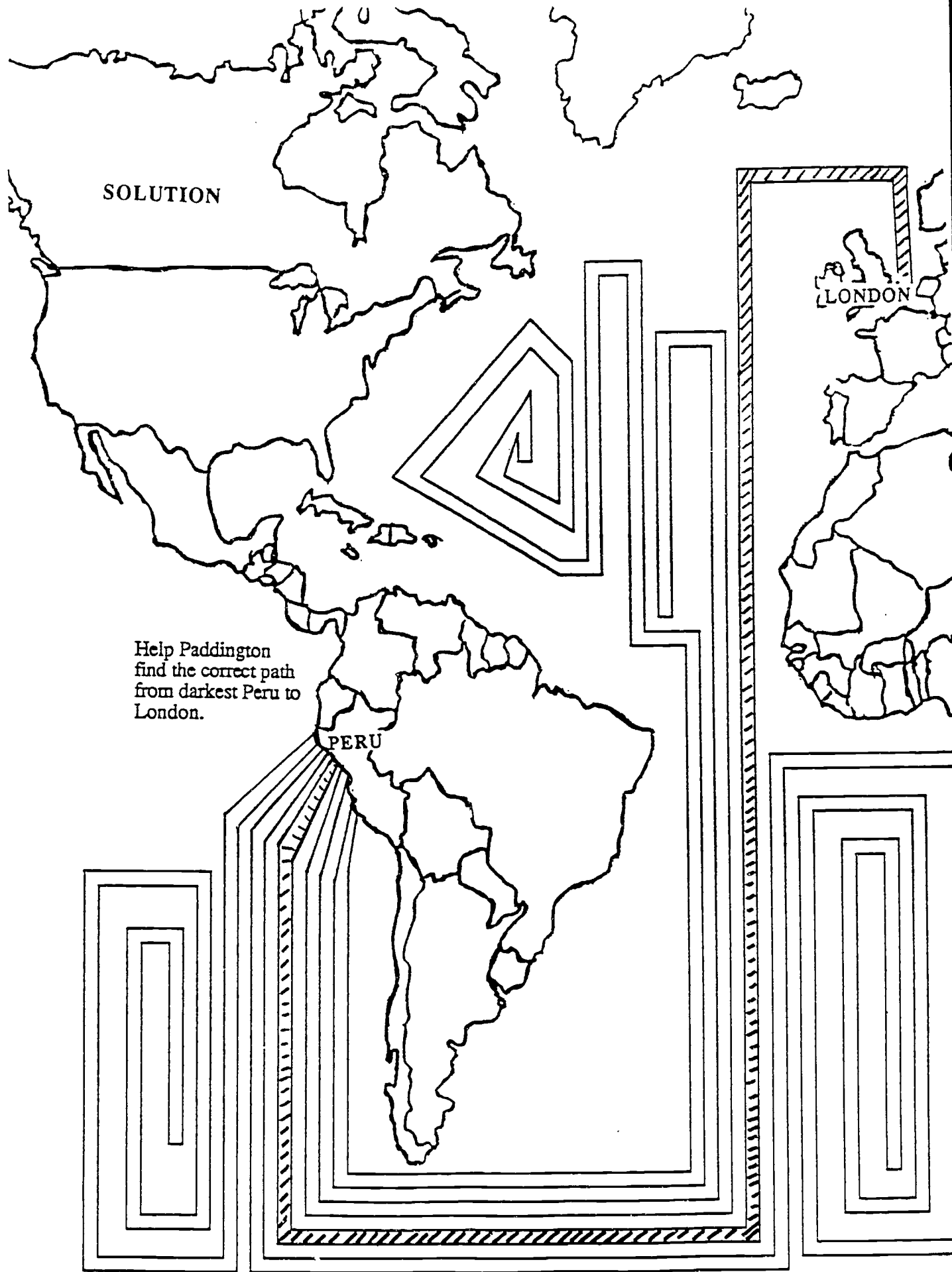

## FORMATS

## PADDINGTON PENCIL TOPPERS

To create simple pencil toppers for reading club participants reproduce these patterns on cover weight paper or card stock. Cut out, punch holes where indicated by the black circles and thread onto a standard pencil.

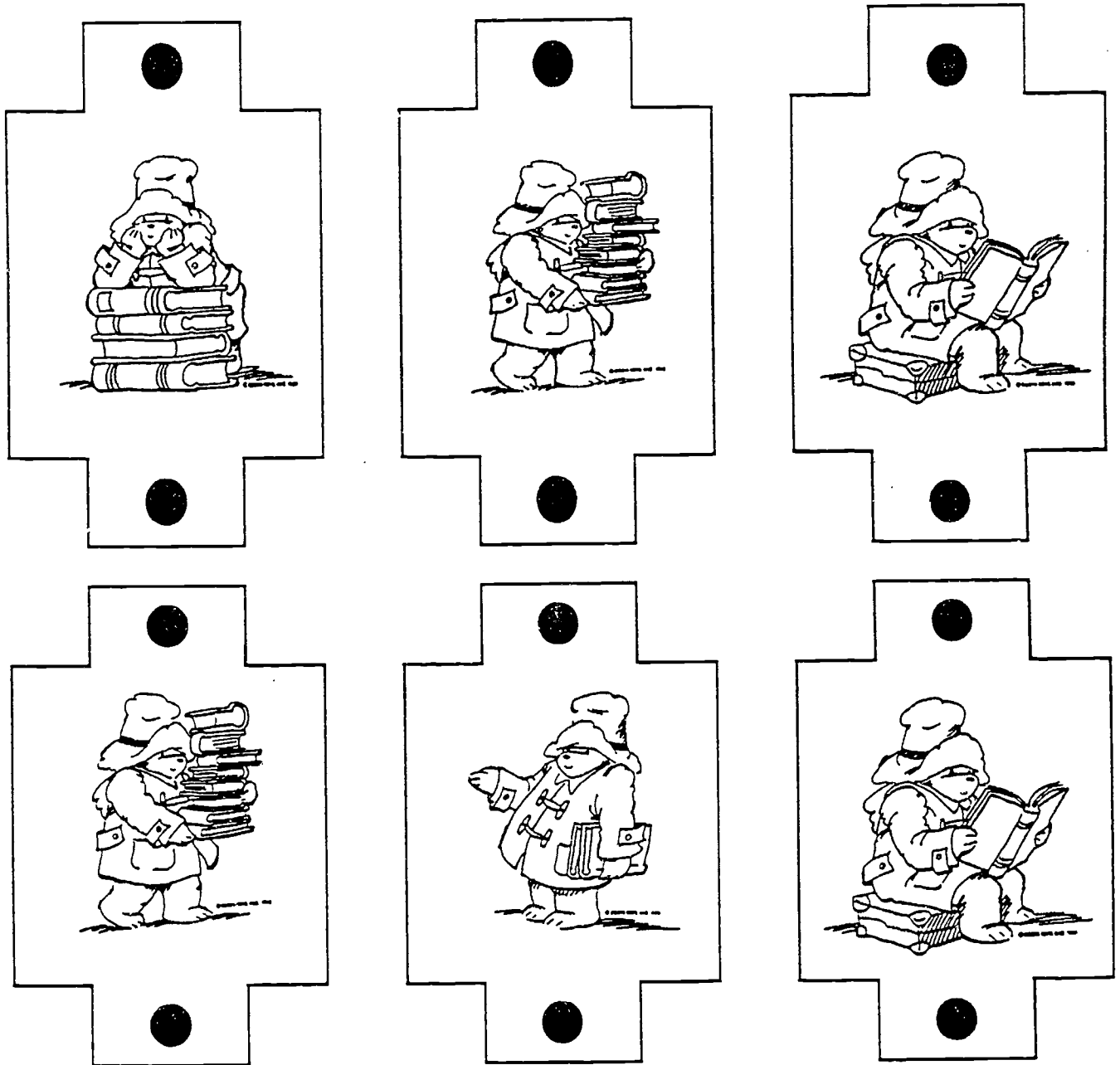

## PENCIL TOPPERS

Simple pencil toppers for reading club participants may be made by reproducing these patterns on cover weight paper or card stock. Cut out, punch holes where indicated by the black circles and thread onto a standard pencil. You may add an illustration or children may create their own designs.

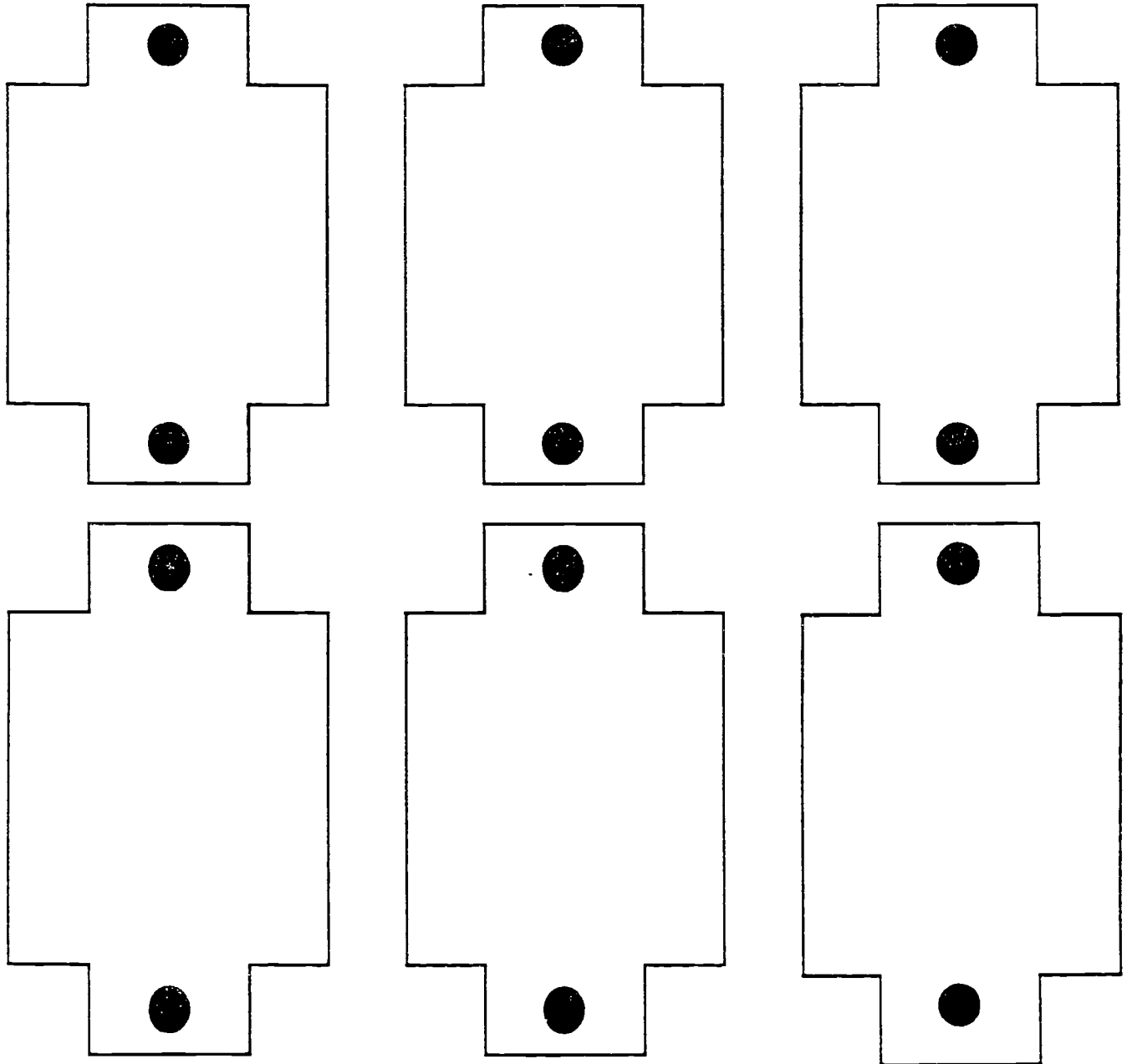

## MORE BOOKS I HAVE READ

- 1 \_\_\_\_\_
- 2 \_\_\_\_\_
- 3 \_\_\_\_\_
- 4 \_\_\_\_\_
- 5 \_\_\_\_\_
- 6 \_\_\_\_\_
- 7 \_\_\_\_\_
- 8 \_\_\_\_\_
- 9 \_\_\_\_\_
- 10 \_\_\_\_\_

## MORE BOOKS I HAVE READ

- 1 \_\_\_\_\_
- 2 \_\_\_\_\_
- 3 \_\_\_\_\_
- 4 \_\_\_\_\_
- 5 \_\_\_\_\_
- 6 \_\_\_\_\_
- 7 \_\_\_\_\_
- 8 \_\_\_\_\_
- 9 \_\_\_\_\_
- 10 \_\_\_\_\_

## MORE BOOKS I HAVE READ

- 1 \_\_\_\_\_
- 2 \_\_\_\_\_
- 3 \_\_\_\_\_
- 4 \_\_\_\_\_
- 5 \_\_\_\_\_
- 6 \_\_\_\_\_
- 7 \_\_\_\_\_
- 8 \_\_\_\_\_
- 9 \_\_\_\_\_
- 10 \_\_\_\_\_

**PERSONAL READING HOURS LOG**

NAME	SUN	MON	TUES	WED	THURS	FRI	SAT

NAME	SUN	MON	TUES	WED	THURS	FRI	SAT
		78					

# TAGS

Blank tags in several sizes are included for your use. They can be used as notes, announcements or as recognition awards for participants.

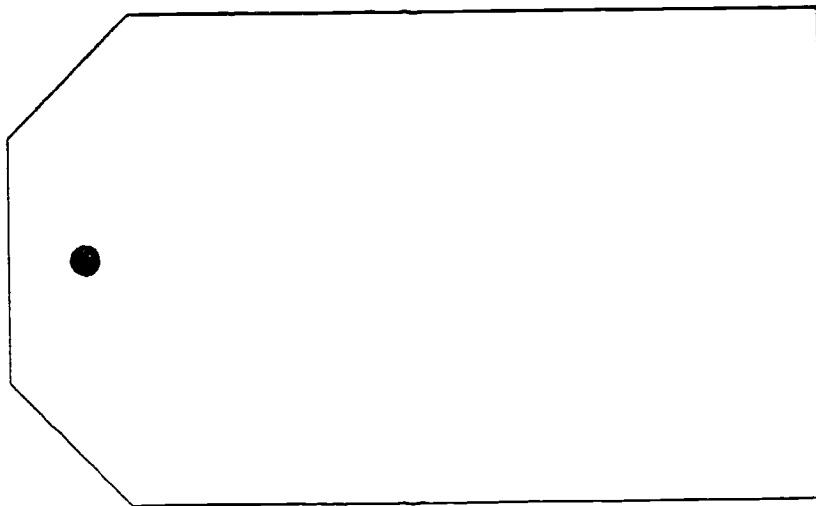
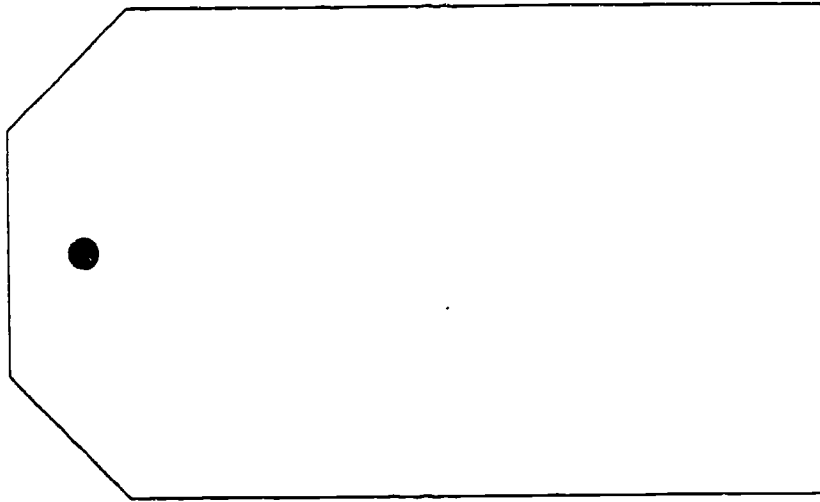



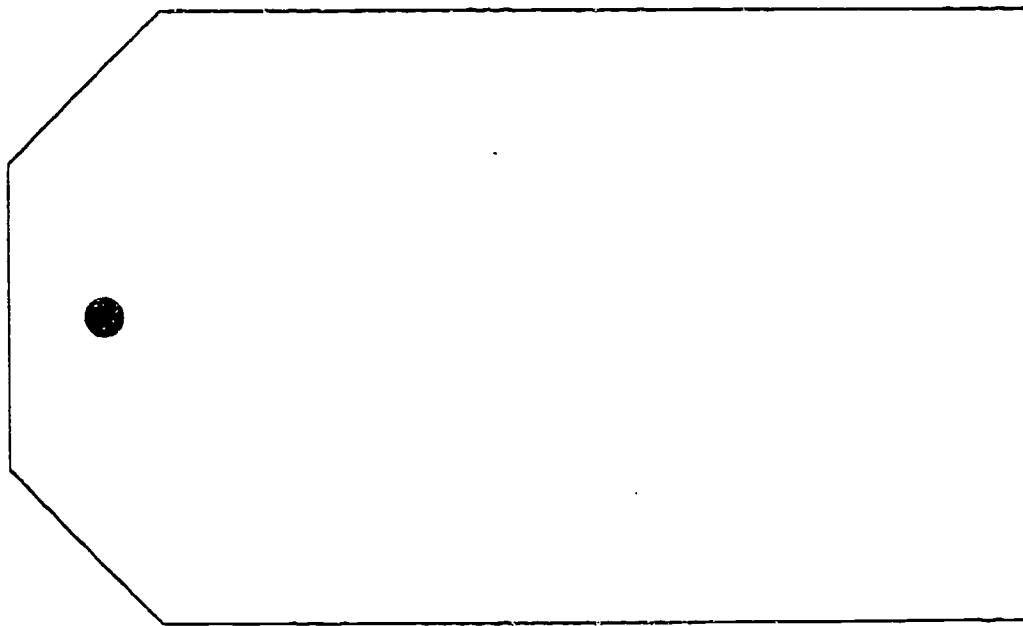
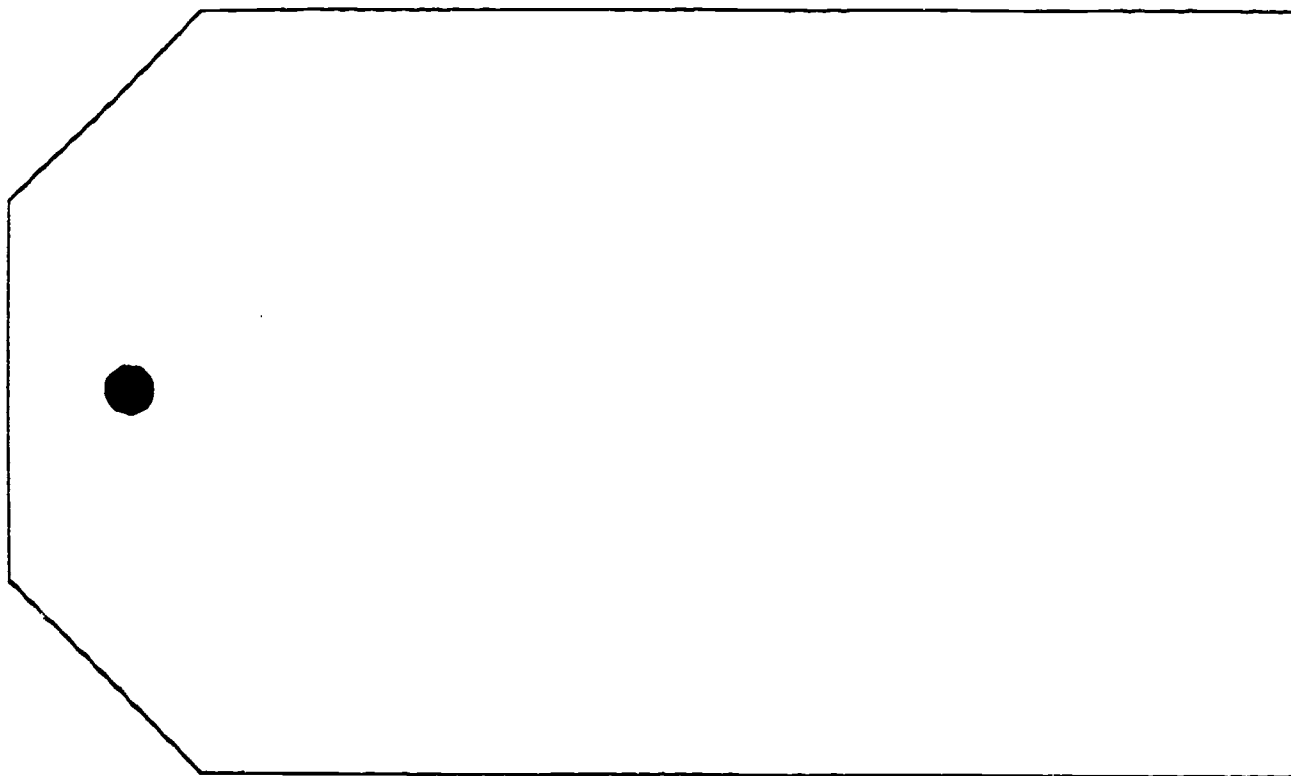

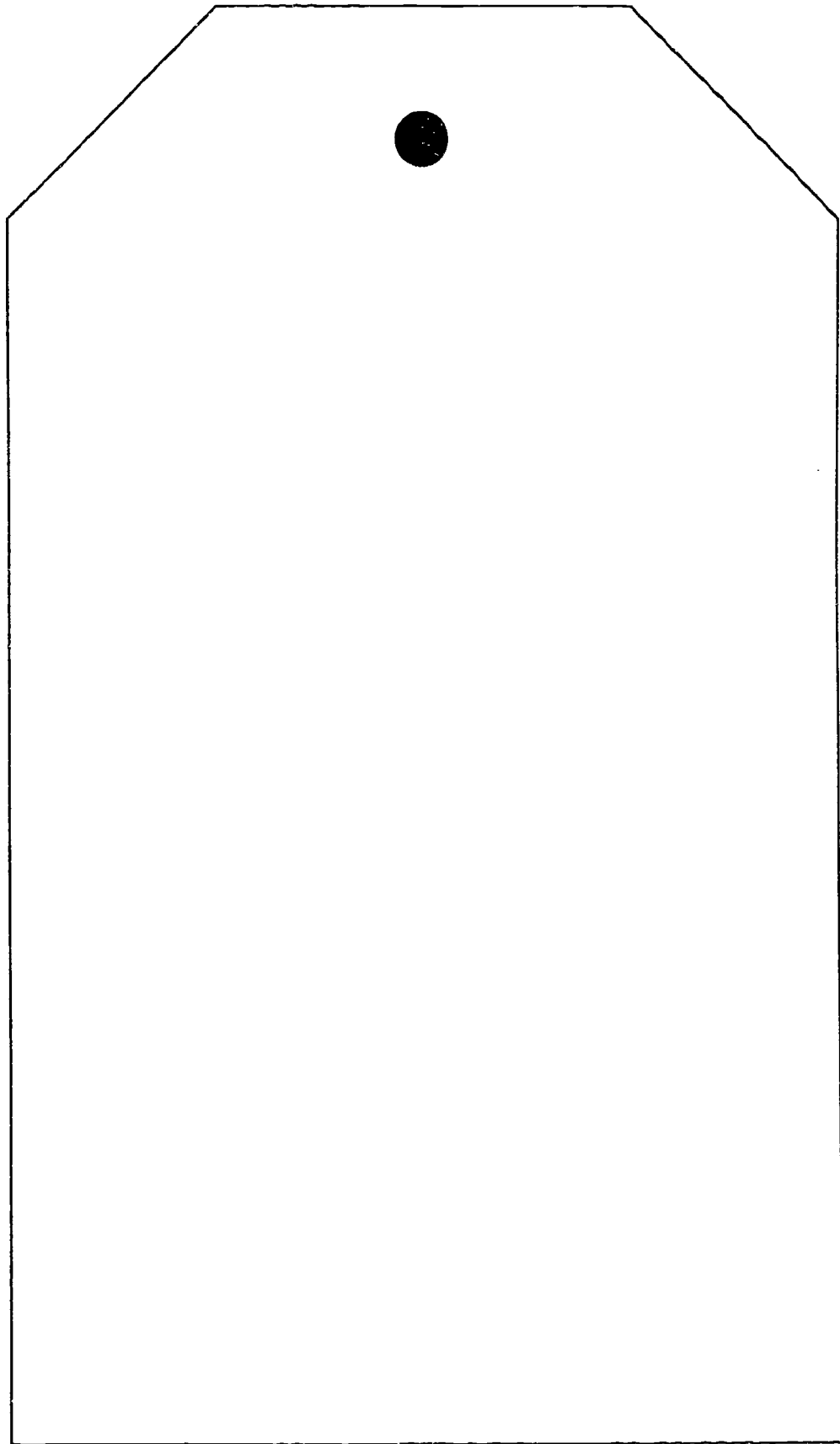

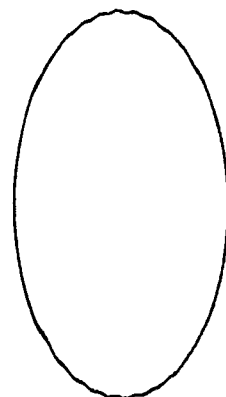
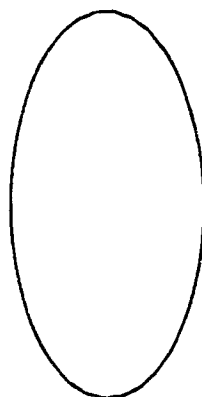
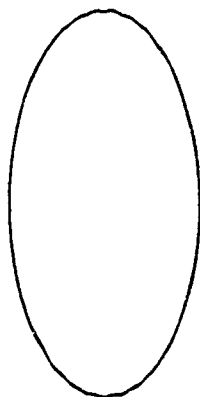
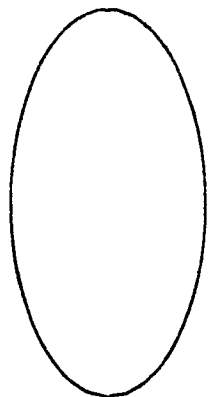
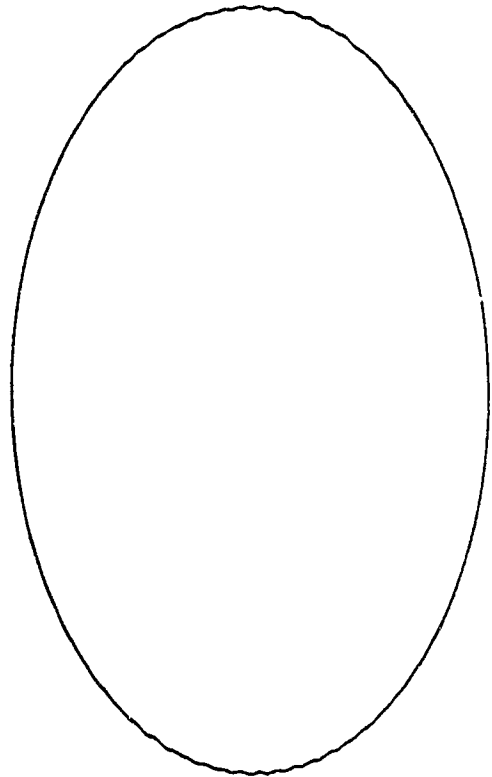
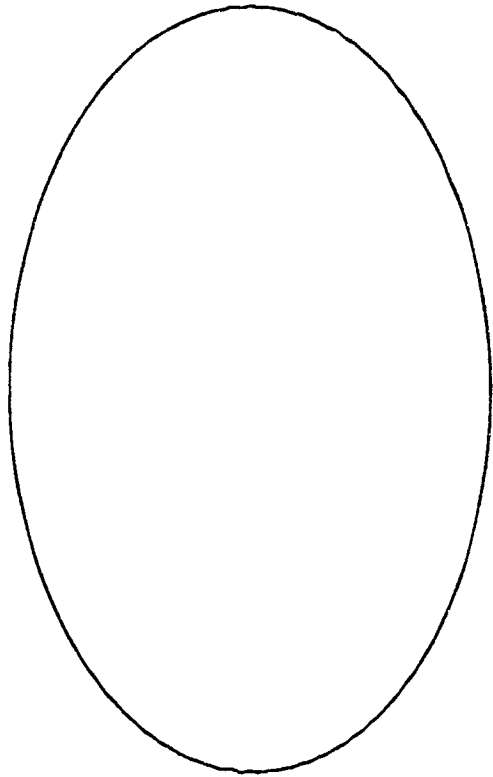
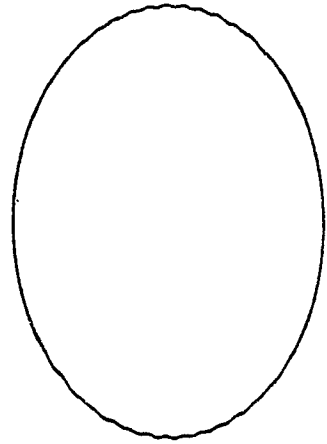
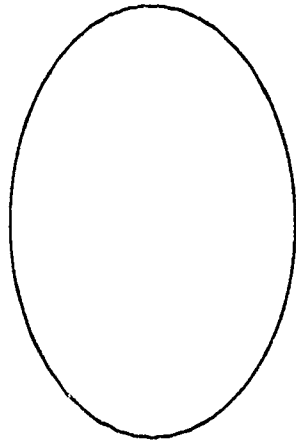
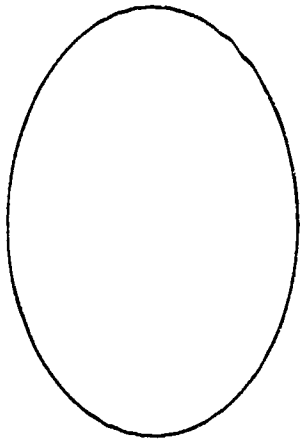

Books are



BEAR-y  
Special!

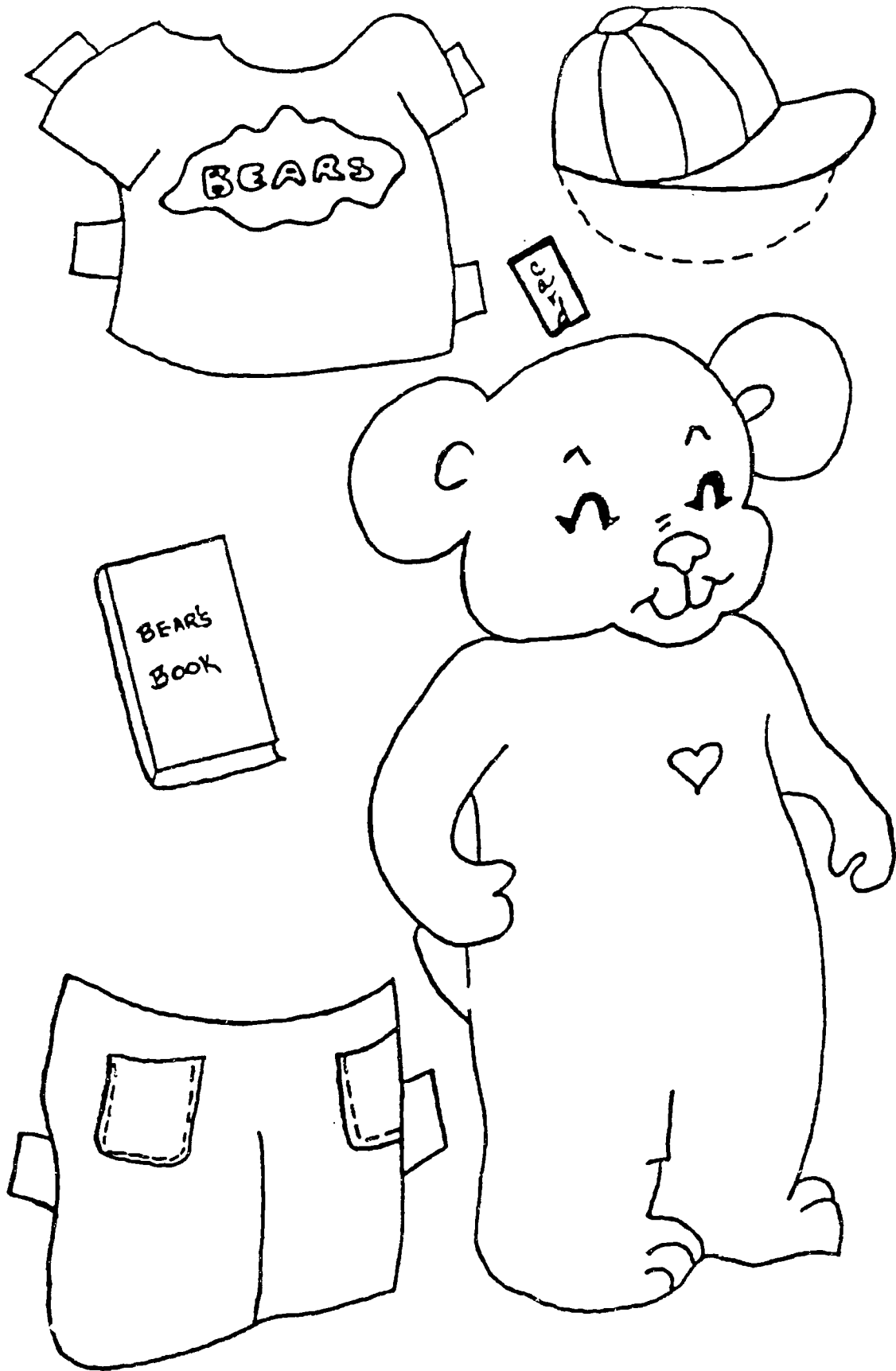

COLOR AND CUT OUT TEDDY'S CLOTHES  
DRESS HIM TO GO TO THE LIBRARY

# PERU

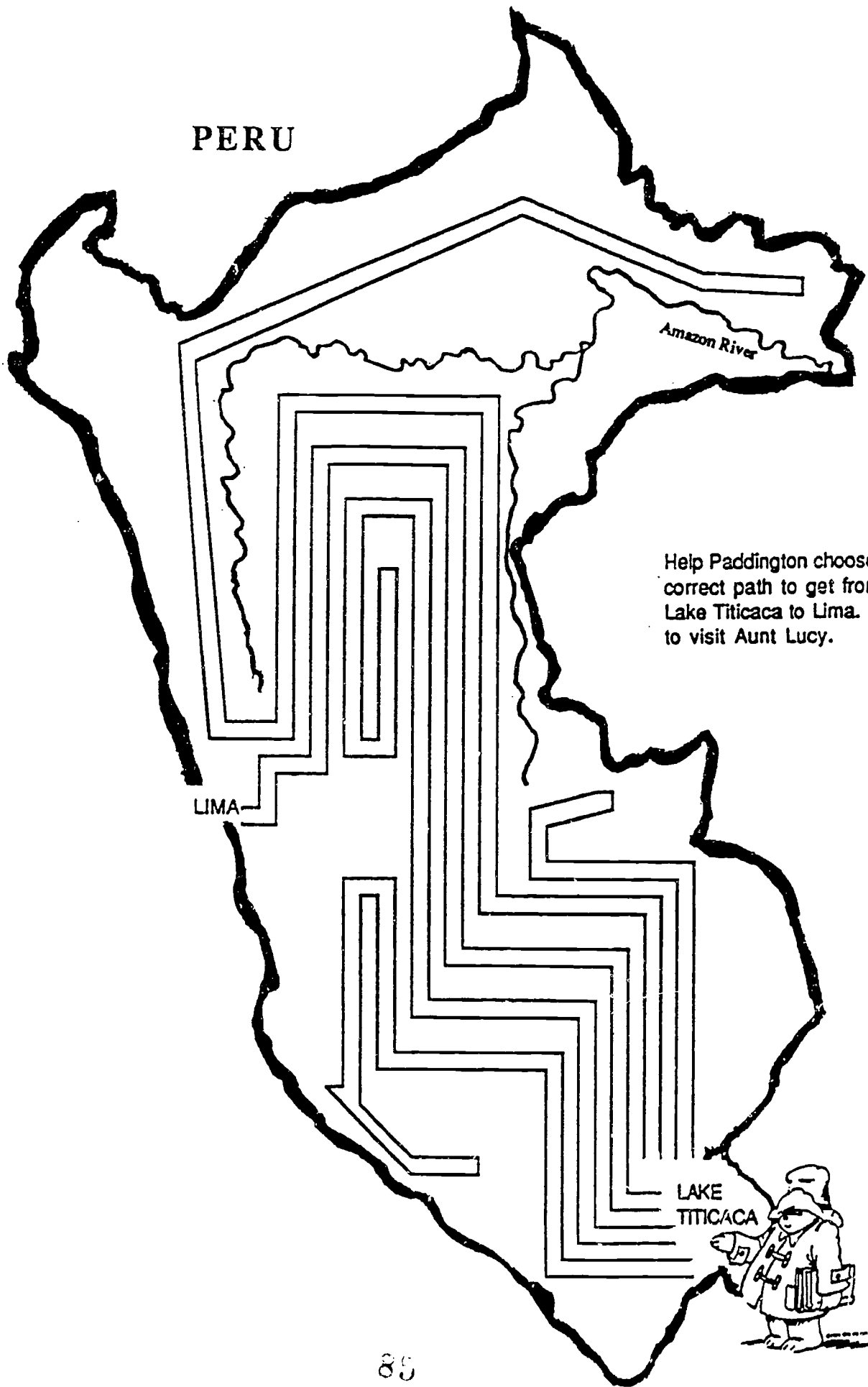

Help Paddington choose the correct path to get from Lake Titicaca to Lima. He wants to visit Aunt Lucy.

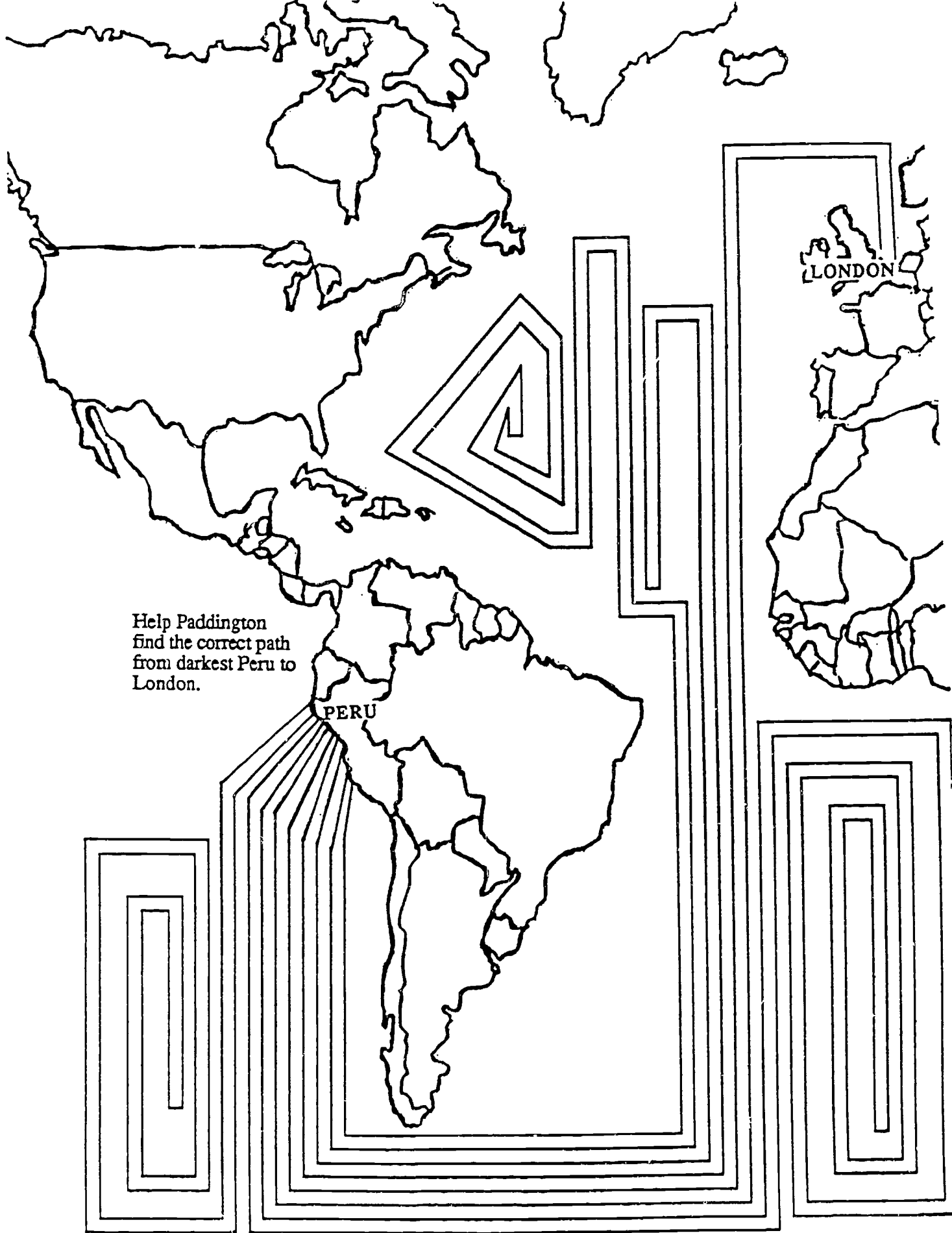

Help Paddington  
find the correct path  
from darkest Peru to  
London.

PERU

LONDON

## Just a reminder . . .

The Paddington clip art may be used only in conjunction with the 1989 Summer Reading Program.

When using the clip art, the copyright notice must be clearly visible and permanently affixed.

The Paddington artwork itself must not be altered in any way.

Locally produced items which use the Paddington artwork must be provided FREE -- NOT SOLD.

Thank you.



© EDEN TOYS, INC. 1989



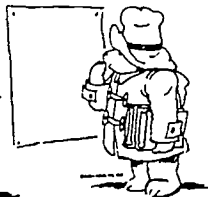

Adventures With  
Paddington  
Reading Club



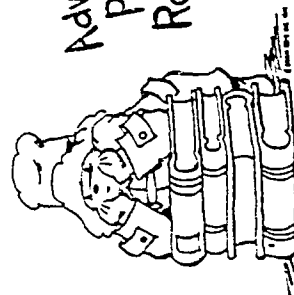
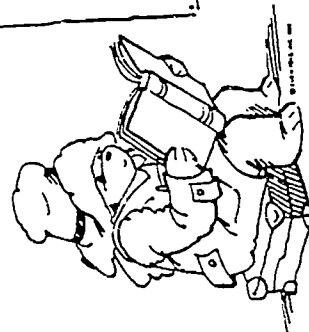
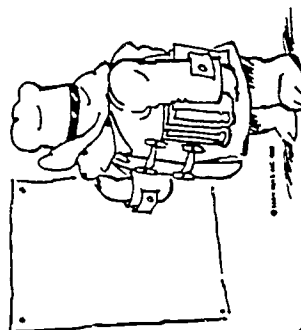
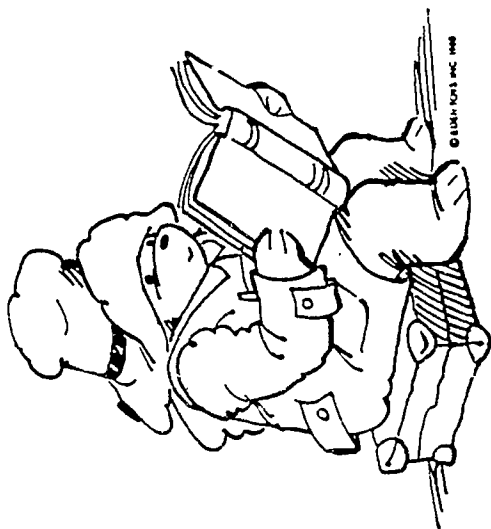
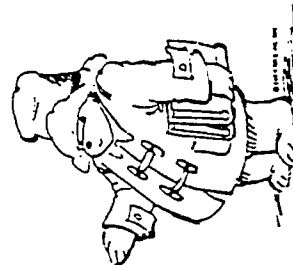
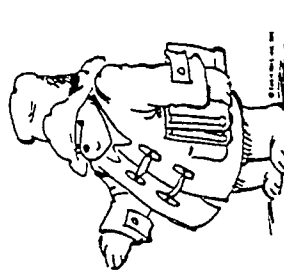
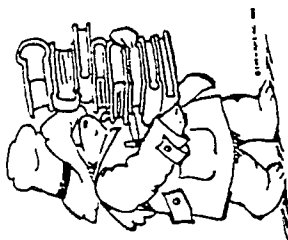
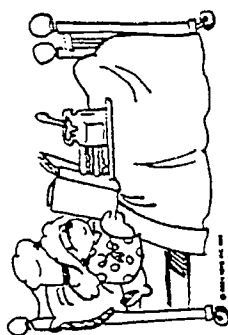

Adventures With  
"Paddington"  
Reading Club

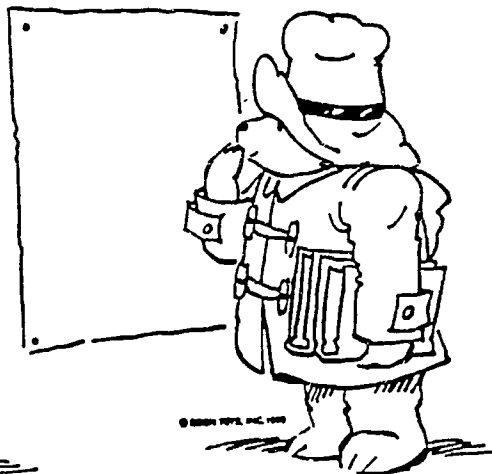

# Adventures With Paddington™ Reading Club





© EDEN TOYS, INC. 1989

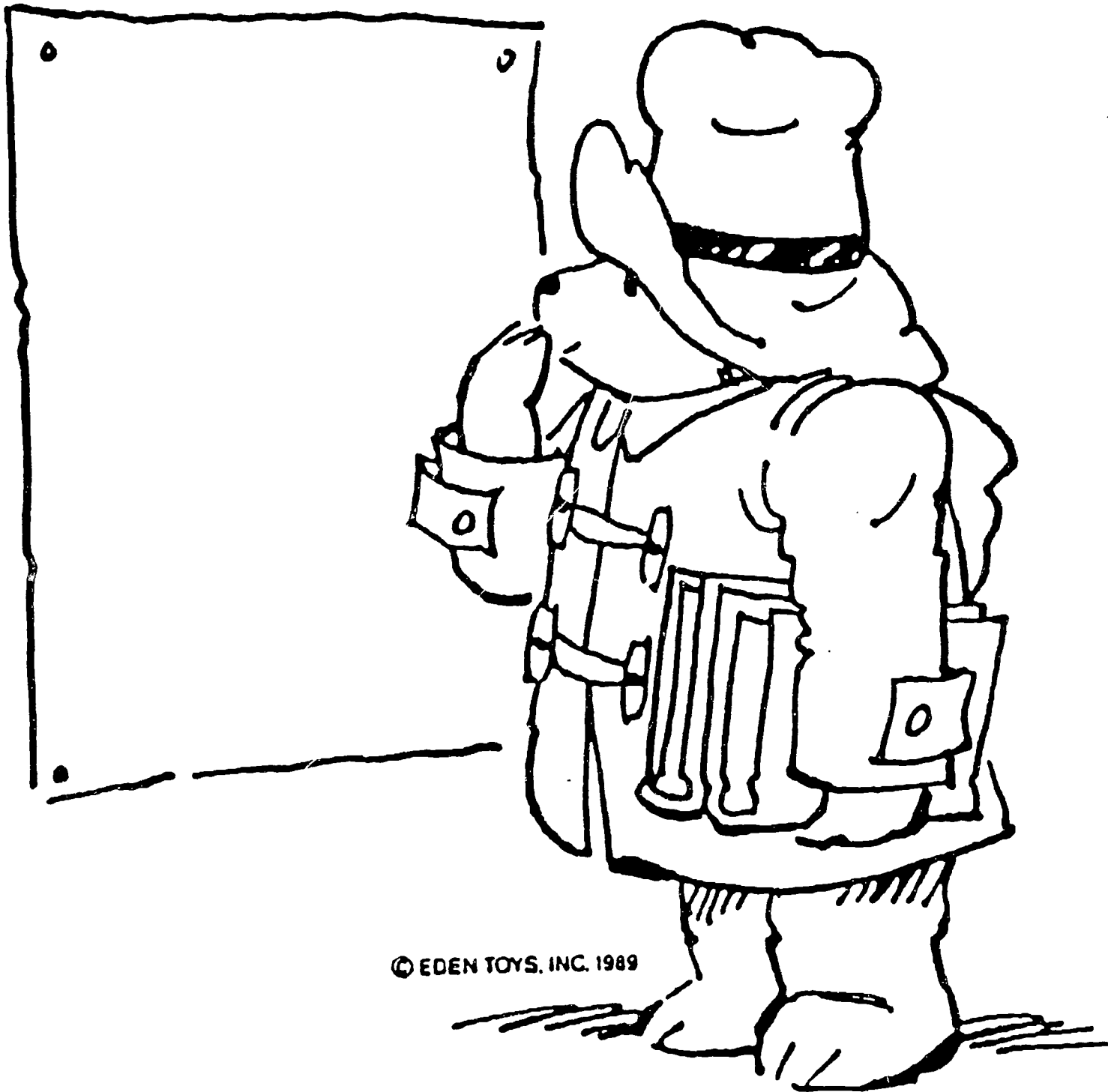

© EDEN TOYS, INC. 1989

## SPINNER PATTERNS

Reproduce or trace desired pattern or patterns onto card stock. Place a small pencil through the center and spin like a top. A spinner may be used in place of a die to determine the number of spaces to be moved on a game board.

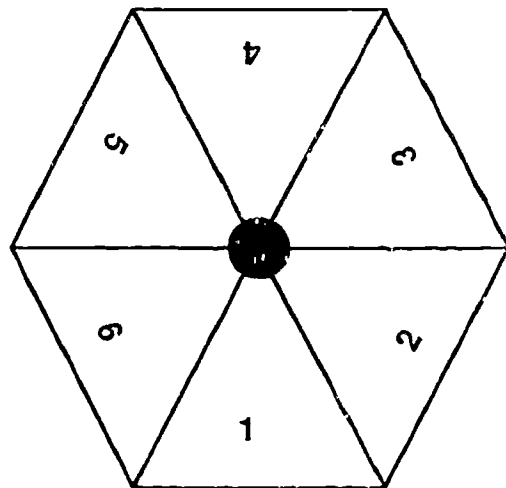
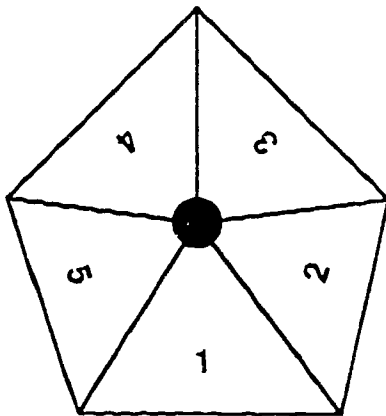
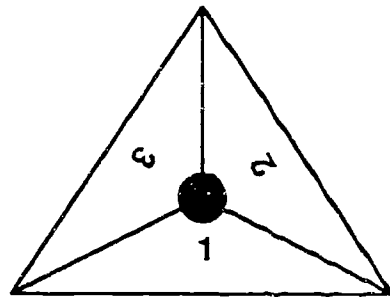
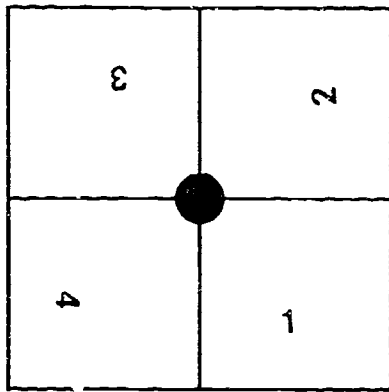

## RESOURCES

## ITEMS OF INTEREST RELATED TO THE SUMMER READING PROGRAM

### **Paddington Bear Doll and Paddington rubber stamp**

American Library Association  
Order Department  
50 East Huron Street  
Chicago, IL 60611

Phone: 312/944-6780

### **A variety of Paddington Bear items including stickers, note cards, wrapping paper, toys, etc...**

Current  
Express Processing Center  
Colorado Springs, CO 80941-0001

Phone: 800/525-7170 or 719/593-5900

### **A Paddington Bear mobile, bookmarks and other bear items**

The Highsmith Company, Inc.  
W5527 Hwy 106  
P. O. Box 800  
Fort Atkinson, WI 53538-0800

Order toll free 800/558-2110

### **Animal sticker paper dolls and several children's book related paper doll sets**

Dover Publications, Inc.  
31 East 2nd. Street  
Mineola, New York 11501

### **Two sizes of Paddington Bear stuffed toys and a variety of books, audio cassettes and videos**

Listening Library BOOKMATES  
Listening Library, Inc.  
1 Park Avenue  
Old Greenwich, CT 06870-9990

Phone: 800/243-4504



**Several Paddington Bear items; Paddington Bear Paint with Water book, Paddington Bear color/activity book, Paddington Bear Sticker book and several Winnie the Pooh related items**

Department M  
Western Publishing Company, Inc.  
P. O. Box 700  
Racine, Wisconsin 53401

20% discount to libraries

**Computer software to design teddy bear artwork**

Home Computing Catalog  
P. O. Box 18890  
Encino, California 91416-8890

Phone: 800/950-8030

**Colorful 1" teddy bears, scratch and sniff stickers, bookmarks and pencils**

New England School Supply  
Division of Chaselle, Inc.  
P. O. Box 1581

Phone: 800/628-8608

**Bear cookies available at most grocery stores**

"Teddy Grahams" Graham Snacks by Nabisco  
available in Chocolate, Cinnamon and Honey flavors

"Grahamy Bears" Honey Graham Crackers by Sunshine

**Catch the Wave mobile, buttons and book bags**

UPSTART  
Box 889  
Hagerstown, MD 21741

Phone: 800/448-4887



From Deepest Darkest Peru to your library...

### Adventures With Paddington Reading Club

For thirty years Paddington Bear has delighted children with his well-meaning ways and exciting adventures. This lovable bear is the star of a new reading club, complete with a program guide and colorful materials to make your promotion a success.

**A. Paddington poster (419) \$2**  
11" x 17"

**B. Paddington certificate (421) 100/\$6**  
"Adventurous Reader Award."  
8½" x 5½", 100 per pack

**C. Paddington stickers (423) 100/\$4**  
"Adventurous Reader," 2" square.  
100 per pack

**D. Paddington bookmarks (420) 200/\$6**  
2¼" x 5½", 200 per pack

**E. Paddington Program Guide (424) \$4**  
30 pages of program tips, camera-ready art for activity sheets, t-shirts and more.

**F. Paddington booklogs (422) 100/\$6**  
Space to write in 20 titles plus "Paddington Bear Facts," 8½" x 4", 100 per pack

**G. Paddington doll (425) \$12**  
Plush 11" Paddington with sweatshirt. "Please read to this bear." Great for prizes and gifts, displays.

**H. Paddington rubber stamp (426) \$6**  
"Adventurous Reader," top-quality stamp of finest gum rubber mounted on hand-finished hardwood block, 1½" square



See below for Paddington kit.

# Inviting characters motivate kids to read



**Garfield stickers (365) 100/\$4**  
Garfield says "I'm a library cat!"  
1¾" diameter, 100 per pack

**Garfield booklogs (364) 100/\$6**  
"Cat-alog" with space to write in 20 titles plus Garfield Trivia Quiz.  
100 per pack

**Garfield certificates (366) 100/\$6**  
"Purr-fect Reader Award."  
5½" x 8½", 100 per pack

**Garfield Reading Club Program Guide (367) \$4**  
30 pages of program and display tips, camera-ready art.

**C. Garfield doll (369) \$24**  
Large 15" plush Garfield sports "I'm a library cat" t-shirt.  
Great for displays and prizes.

### Haré Whodini's Reading Spectacular

Make your planning woes disappear.

**B. Haré poster (151) \$2**  
11" x 17"

**Haré bookmarks (152) 200/\$6**  
8" x 2½", 200 per pack

**Haré booklogs (153) 100/\$6**  
Space to write 30 titles.  
100 per pack

**Haré certificates (155) 100/\$6**  
5½" x 8½", 100 per pack

**Haré stickers (154) 100/\$4**  
1¾" diameter, 100 per roll

**Haré Whodini Program Guide (156) \$4**  
30 pages of program and display tips, camera-ready art

### Best-Value Kits

**Reading Club Kit (for each character) \$30**

4 posters	\$8
200 bookmarks	6
100 booklogs	6
100 certificates	6
100 stickers	4
1 program guide	4

Kit value \$34  
You save \$4 \$30

**Adventures With Paddington kit (K433) \$30**

**The Garfield Reading Club kit (363) \$30**  
**Haré Whodini's Reading Spectacular kit (157) \$30**



### The Garfield Reading Club

Everyone's favorite feline teams up with libraries to promote reading.

**A. Garfield Reading Club poster (362) \$2**  
11" x 17"

**Garfield Reading Club bookmarks (363) 200 \$6**  
2¼" x 8½", 200 per pack

# Paddington™ Bear

The world's best-loved bear has come to Current—all the way from London's Paddington Station! It's his 50th birthday, and we're celebrating with this page of Paddington™ items chosen especially for you!

© Eden Toys, Inc. 1968.

193 Stickers with the adorable Paddington™

Bear are great for gift packages, envelopes, lunchboxes — anywhere Paddington™ fans will see them! Set of 32 (2 each of 16 designs) 2" self-stick seals.

193-89095 ..... \$3.85/3.00/2.10



194



Birthday Cards

1. Hello! Hope you're having a great birthday! Happy Birthday!

2. Hello! A friend is here to wish you a very Happy Birthday!

3. Hello! Wishing you the best of all! Happy Birthday!

4. Hello! Together we can wish you anything! Happy Birthday!

193 Full Paddington™ Bear in a reusable tote bag and tag



196



196 Paddington™ Note Cards are a delightful way to send a note to a friend. Great invitations, too — especially for children's parties and baby showers! Set of 12 4" by 5 1/4" notes (3 each of 4 designs) with envelopes.

32 196-89059 ..... \$3.95/3.05/2.15

194 Birthday Cards featuring the always personable Paddington™ Bear will delight "children" of all ages! Warmhearted greetings are inside each 5" by 7" card. Set of 4 different designs; blue envelopes.

194-89022 ..... \$3.20/2.50/1.75

195 Bear in a Tote Bag: A darling gift for Paddington™ fans! Plush bear is 5" tall and wears a felt hat and rubber boots! He has movable arms and legs and comes in his own gift bag (2 3/4" by 3 1/2").

195-89102 ..... \$10.85/8.70/6.50

197 • 199 Folded Gift Wrap Assortment includes 4 24" by 30" sheets of wrap (2 of each design) and 4 matching gift cards with envelopes. Single-design packs have 2 sheets and 2 gift cards.

197-89068 Assortment ..... \$5.20/4.05/2.85  
 198-89077 Party ..... \$2.75/2.15/1.50  
 199-89086 All-Occasion ..... \$2.75/2.15/1.50



196

199

ORDER CODE No. Items 1-7 8-15 16+	HOW MANY ITEMS	TOTAL AMOUNT	ORDER CODE No. Items 1-7 8-15 16+	HOW MANY ITEMS	TOTAL AMOUNT	ORDER CODE No. Items 1-7 8-15 16+	HOW MANY ITEMS	TOTAL AMOUNT	ORDER CODE No. Items 1-7 8-15 16+	HOW MANY ITEMS	TOTAL AMOUNT
321-41750 \$11.75/10.00/8.20			353-43553 \$2.65/2.05/1.45			384-22692 \$4.00/3.10/2.20			Wedding, pg. 53		
322-41840 \$3.95/3.05/2.15			354-39452 \$4.55/3.55/2.50			385-40574 \$2.45/1.90/1.35			414-48273 \$3.00/2.35/1.65		
323-41895 \$3.95/3.05/2.15			355-60800 \$8.75/7.00/5.25			386-22585 \$2.65/2.05/1.45			415-60775 \$5.95/4.60/3.25		
324-41868 \$3.95/3.05/2.15			356-23003 \$3.55/2.75/1.95			387-23673 \$4.55/3.55/2.50			416-48264 \$4.65/3.60/2.55		
325-41859 \$3.95/3.05/2.15			357-43642 \$1.75/1.35/0.95			388-21014 \$4.00/3.10/2.20			417-48228 \$4.80/3.75/2.65		
326-76456 \$11.15/9.50/7.80			Kids' Products, pgs. 46-50			389-22647 \$4.00/3.10/2.20			418-48237 \$10.35/8.80/7.25		
327-76474 \$3.85/3.00/2.10			358-15021 \$12.80/10.90/8.95			390-23717 \$2.75/2.15/1.50			419-41920 \$9.50/8.50/7.50		
328-76465 \$3.85/3.00/2.10			359-33984 \$8.70/6.95/5.20			391-23548 \$2.30/1.80/1.25			420-65306 \$12.80/10.90/8.95		
329-77357 \$3.85/3.00/2.10			360-33314 \$8.25/6.60/4.95			392-56673 \$8.95/7.15/5.35			421-65315 \$3.00/2.35/1.65		
330-77366 \$3.35/3.00/2.10			361-33289 \$6.40/4.95/3.50			393-49502 \$3.95/3.05/2.15			422-48246 \$9.25/8.25/7.25		
331-77400 \$11.75/10.00/8.20			362-59965 \$7.10/5.70/4.25			394-49851 \$3.10/2.40/1.70			423-65342 \$10.85/8.70/6.50		
332-77446 \$3.95/3.05/2.15			363-59974 \$5.85/4.55/3.20			395-15156 \$5.15/4.15/3.15			Kaleidoscope of Values, pg. 54		
333-77419 \$3.95/3.05/2.15			364-51222 \$5.95/4.60/3.25			396-49888 \$2.30/1.80/1.25			424-12603 \$2.45/1.90/1.35		
334-77428 \$3.95/3.05/2.15			365-33216 \$6.65/5.15/3.65			397-56726 \$4.75/3.70/2.60			425-44357 \$7.15/6.35/5.50		
335-77437 \$3.95/3.05/2.15			366-33519 \$7.20/5.60/3.95			398-23352 \$2.75/2.15/1.50			426-52089 \$14.25/12.10/9.95		
336-43982 \$6.95/5.55/4.15			367-59466 \$2.85/2.20/1.55			399-48200 \$4.00/3.10/2.20			427-37622 \$6.25/5.25/4.25		
337-44099 \$3.95/3.05/2.15			368-33449 \$12.80/10.90/8.95			400-46676 \$5.65/4.40/3.10			428-12649 \$10.10/8.60/7.05		
338-44062 \$3.95/3.05/2.15			369-22175 \$4.95/3.95/2.95			My Little Pony®, pg. 51			429-64520 \$2.65/2.05/1.45		
339-77375 \$6.95/5.55/4.15			370-59938 \$8.25/6.60/4.95			401-91019 \$4.55/3.55/2.50			430-48219 \$10.85/8.70/6.50		
340-77384 \$3.95/3.05/2.15			371-15343 \$9.35/7.50/5.60			402-18322 \$2.95			Flavia®, p. 63		
341-77393 \$3.95/3.05/2.15			372-33831 \$4.30/3.35/2.35			403-91055 \$4.30/3.35/2.35			431-94052 \$3.20/2.50/1.75		
342-43198 \$5.20/4.05/2.85			373-33252 \$3.55/2.75/1.95			404-91037 \$3.95/3.05/2.15			432-94141 \$3.20/2.50/1.75		
343-43161 \$2.65/2.05/1.45			374-15030 \$3.00/2.35/1.65			405-91091 \$4.55/3.55/2.50			433-94061 \$2.40/1.85/1.30		
344-66715 \$10.25/8.20/6.15			375-23334 \$11.80/10.05/8.25			406-91108 \$2.75/2.15/1.50			Paddington™ Bear, back cover		
345-49691 \$2.10/1.65/1.15			376-22610 \$4.00/3.10/2.20			Baby, pg. 52			434-89095 \$3.85/3.00/2.10		
346-44570 \$8.00/6.40/4.80			377-22718 \$2.10 1.65/1.15			407-48291 \$8.20/6.35/4.50			435-89059 \$3.95/3.05/2.15		
347-22442 \$5.65/4.40/3.10			378-21416 \$2.10 1.65/1.15			408-41902 \$6.25/5.25/4.25			436-89068 \$5.20/4.05/2.85		
348-38836 \$5.65/4.40/3.10			379-22601 \$5.40/4.20/2.95			409-48353 \$8.25/6.60/4.95			437-89077 \$2.75/2.15/1.50		
349-43205 \$5.75/4.45/3.15			380-21210 \$4.00/3.10/2.20			410-48282 \$14.25/12.10/9.95			438-89086 \$2.75/2.15/1.50		
350-23753 \$5.75/4.45/3.15			381-22629 \$5.40/4.20/2.95			411-41939 \$7.45/5.95/4.45			439-89022 \$3.20/2.50/1.75		
351-43651 \$10.85/8.70/6.50			382-55442 \$6.85 5.50/4.10			412-20202 \$6.75/5.25/3.70			Mother's Day/Father's Day Flyer		
352-43615 \$2.95/2.30/1.60			383-22665 \$4.00 3.10/2.20			413-44231 \$7.20/5.60/3.95			440-48754 \$3.20/2.50/1.75		
COLUMN TOTALS:			COLUMN TOTALS:			COLUMN TOTALS:			COLUMN TOTALS:		

100

TOTAL ITEMS ON PAGE F

TOTAL AMOUNT ON PAGE F \$

Transfer Page F totals to Order Summary on last page.

# Current® Order Blank Spring 1989

Get up to \$5.00 savings on your order! (See page A for details.)

This order blank lists products in the Spring 1989 catalog and the enclosed Mother's Day/Father's Day flyer only. To order products from other Current catalogs and flyers, please use the blank spaces on page H.

**STEP 1** Make your selections from pages C through I.

**Important: Please read before ordering:**

**How can I receive your lowest Quantity Discount prices?**

You and your friends can receive a discount, depending on the total number of items in your order! Simply count the total number of items you plan to order and enter the total here:

- If your total order is for 1 through 7 items, use the first price listed.
- If your total order is for 8 through 15 items, use the middle price.
- If your total order is for 16 or more items, use the lowest price.

You may order any combination of items to earn Quantity Discounts. For instance, to earn the lowest price, you may order 16 different products or 16 of one product or any other combination of items that totals 16 or more. (Assortments, such as gift wrap and card assortments, each count as one item.)

**PLEASE NOTE:** Select-A-Card® and Bonus Credits products have special instructions concerning Quantity Discounts. To order these items, please see the special sections on page H of this order blank.

**What's the last date I can order from this catalog?**

Prices in this catalog are guaranteed through May 1, 1989, and most products will be available through June.

**Do I have to pay shipping charges?**

No! Current pays all shipping costs when you enclose payment with your order. You pay only a \$1.00 handling fee.

**May I charge my order?**

Yes! If you prefer to charge your order to Current, we'll bill you for shipping costs (20¢ per item). Payment must be received within 30 days after your order shipment date. Charge orders are subject to credit approval, and you may be contacted by our Customer Service staff. Your daytime phone is required for charge orders (see STEP 5).

**What if I have a question or problem with my order?**

Our Customer Service staff will be happy to answer questions about your order. Just call toll-free 1-800-525-7170 weekdays, 6 a.m. to 6 p.m. Mountain Time.

**If not satisfied, can I get my money back?**

You bet! You must be totally delighted with our products and our service, or we'll promptly replace your order or refund your money.

**A Note about Substitutions:** Normally you can expect all items to be in stock. If, however, an item you've ordered is no longer available, we may substitute a similar item of equal or greater value. If we do substitute an item, you'll receive a notice with your order giving you the opportunity to obtain a refund if you don't want the substitute product.

**When will I receive my order?**

You can expect fast service from Current! Normally you can expect to receive your order in 2-3 weeks. (However, please allow up to 6 weeks for delivery of personalized items.) For an extra charge of \$9.85 per order, we'll ship **available products** by air express, so you can expect delivery in a week or less. For mail orders, be sure to check the Express Delivery box in STEP 3 on the back page of this order blank and include a street address for delivery. For complete details or to order by phone, call (719) 593-5900. (NOTE: Personalized items cannot be shipped by Express Delivery.)

We welcome your comments or suggestions at any time.

EXPRESS PROCESSING CENTER  
COLORADO SPRINGS, COLORADO 80941

ORDER CODE No. Items 1-7 8-15 16+	HOW MANY ITEMS	TOTAL AMOUNT	ORDER CODE No. Items 1-7 8-15 16+	HOW MANY ITEMS	TOTAL AMOUNT
Easter & Spring, pgs. 2-11					
1-76189		\$7.70/6.15/4.60	27-74314		\$12.50/10.65/8.75
2	To order, see Bonus Credits, pg. H		28-74341		\$9.95/8.45/6.95
3-36623		\$9.95/7.95/5.95	29-77687		\$2.75/2.15/1.50
4-80263		\$3.10/2.40/1.70	30-77678		\$7.45/5.95/4.45
5-76134		\$3.00/2.35/1.65	31-76269		\$2.85/2.20/1.55
6-47639		\$8.25/6.60/4.95	32-74350		\$8.85/7.10/5.30
7-55460		\$9.95/7.95/5.95	33-77669		\$9.85/7.90/5.90
8-73949		\$2.85/2.20/1.55	34-73930		\$2.45/1.90/1.35
9-56548		\$5.75/4.45/3.15	35-74485		\$8.10/6.90/5.65
10-74546		\$9.30/7.90/6.50	36-83661		\$3.20/2.50/1.75
11-75616		\$2.55/2.00/1.40	37-55647		\$9.65/8.20/6.75
12-76161		\$3.10/2.40/1.70	38-74369		\$9.60/7.70/5.75
13-76278		\$3.00/2.35/1.65	39-49003		\$10.25/9.25/8.25
14-31968		\$7.20/3.60/3.95	40-98352		\$3.20/2.50/1.75
15-72986		\$3.55/2.75/1.95	41	To order, see Bonus Credits, pg. H	
16-74332		\$7.00/5.45/3.85	42	To order, see Bonus Credits, pg. H	
17-74449		\$12.45/11.20/9.95	43-74555		\$8.25/6.60/4.95
18-73985		\$8.00/7.20/6.85	44-55601		\$6.35/5.10/3.80
19-55629		\$8.25/6.60/4.95	45-83723		\$3.10/2.40/1.70
20-53300		\$9.75/7.80/5.85	46-30399		\$2.40/1.85/1.30
21-76152		\$3.40/2.65/1.85	47-83796		\$3.95/3.05/2.15
22-73805		\$5.40/4.20/2.95	48-60524		\$2.10/1.65/1.15
23-73958		\$4.55/3.55/2.50	49-37506		\$6.75/5.25/3.70
24-73967		\$2.40/1.85/1.30	50-67689		\$3.00/2.35/1.65
25-73976		\$2.40/1.85/1.30	51-60999		\$2.30/1.80/1.25
26-55549		\$12.45/11.20/9.95	52-60953		\$2.75/2.15/1.50
			53-76143		\$3.40/2.65/1.85
COLUMN TOTALS:			COLUMN TOTALS:		

TOTAL ITEMS ON PAGE C \_\_\_\_\_  
TOTAL AMOUNT ON PAGE C \$ \_\_\_\_\_  
Transfer Page C totals to Order Summary on last page.

# ORDER SUMMARY

Remember, you can receive a discount based on the number of items you order. See page C.

## STEP 2 TOTAL ITEMS

PAGE C \_\_\_\_\_ Items  
 PAGE D \_\_\_\_\_ Items  
 PAGE E \_\_\_\_\_ Items  
 PAGE F \_\_\_\_\_ Items  
 PAGE G \_\_\_\_\_ Items  
 PAGE H \_\_\_\_\_ Items  
 PAGE I \_\_\_\_\_ items

If you ordered **SELECT-A-CARD**, add 1: \_\_\_\_\_ item  
 Add total items credit for **BONUS CREDITS** here: \_\_\_\_\_ credits

TOTAL \_\_\_\_\_ ITEMS

## STEP 3 TOTAL AMOUNT

PAGE C \$ \_\_\_\_\_  
 PAGE D \$ \_\_\_\_\_  
 PAGE E \$ \_\_\_\_\_  
 PAGE F \$ \_\_\_\_\_  
 PAGE G \$ \_\_\_\_\_  
 PAGE H \$ \_\_\_\_\_  
 PAGE I \$ \_\_\_\_\_

SELECT-A-CARD \$ \_\_\_\_\_  
 BONUS CREDITS \$ \_\_\_\_\_  
 SUBTOTAL \$ \_\_\_\_\_  
 In Colo. add 3% sales tax \$ \_\_\_\_\_  
 Handling fee \$ **1.00**  
 Check box and add \$9.85 if you want Express Delivery \$ \_\_\_\_\_  
 Subtract coupon or discount, if applicable \$ \_\_\_\_\_  
**TOTAL AMOUNT \$ \_\_\_\_\_**

Is this your complete, correct address? If not, make corrections at left.

## STEP 4 How to get a FREE "Bunny Basket" and redeem your Easter Egg coupons!

Check here if your SUBTOTAL in STEP 3 above is \$55.00 or more. We'll send you the adorable "Bunny Basket" pictured on page A—absolutely FREE!

Also, if you ordered any of the items described in the Easter egg coupons on page A, don't forget to write the appropriate product code numbers on them. Add up your total discount and subtract that amount where indicated in STEP 3 above. Finally, cut out the coupons and return them with your entire order blank.

## STEP 5

In case we have questions about your order (or need information regarding credit approval for charge orders), please give us your **daytime** phone number.

Area Code \_\_\_\_\_ Daytime No. \_\_\_\_\_

## STEP 6 CHECK OR CHARGE?

**Current pays the postage on your shipment when your check or money order is enclosed.** If you charge your order, we'll add postage costs (20¢ per item) to your bill. (For details, please see page C of this order blank.)

Please check one:

**CHECK** My signed check or money order (payable to Current, Inc.) is enclosed. No stamps or cash, please.

Total enclosed \$ \_\_\_\_\_

**CHARGE** Please charge my order to Current, Inc. (subject to credit approval). Be sure to include your phone number in STEP 5 above.

Please do not write in this space

CM \_\_\_\_\_  
 C \_\_\_\_\_  
 % \_\_\_\_\_

## STEP 7

Please check here if this is the **first** time you've ordered from Current.

Please check your address label for accuracy and make any changes in the space provided. **And, to help us improve our service, please answer the question in the box next to your address label.** Then, just return this entire 8-page order blank in the enclosed return envelope.

ob code: **EAL-7**

FO  SVC  NC  NTC  Y/N  A/RP  PB  CA  PO#

PLEASE DO NOT WRITE IN THIS SPACE

Too many catalogs? Do you receive more than a copy of the same CURRENT catalog within a short period of time? To eliminate duplicate copies in the future, just clip the address labels from your extra catalogs and enclose them with your order. We'll make the corrections as soon as possible. (Please be sure your name and address are shown correctly on the order blank you use for your order.)

**CIRCLE ONE:**

To help us improve our service to you, please circle the statement below that best applies to this order (circle only one):

1. I'm ordering for myself.
2. I'm ordering for a group of friends to qualify for Quantity Discounts.
3. I'm ordering for fund-raising purposes.

If address label appears at right, please check information for accuracy. If incorrect, please do not remove or deface label; simply fill in information below. If no label appears at right, or if you would like to have your complete name and address printed on future labels, please fill in your name and address below.

PLEASE PRINT

ORGANIZATION NAME \_\_\_\_\_ (if applicable)

YOUR NAME \_\_\_\_\_ (please use one name for all orders in your household)

STREET ADDRESS \_\_\_\_\_ APT. \_\_\_\_\_

CITY \_\_\_\_\_ STATE \_\_\_\_\_ ZIP \_\_\_\_\_

YOUR ORDER BLANK CODE IS: EAL-7



**Teddy Bear Library Skills Materials and Motivational Tools**

A favorite of young and old alike; the furry, friendly, cuddly teddy bear. Delightful depictions of all types of bears adorn the library skills materials and motivational tools presented on this page. Select worksheets, posters, bookmarks, stamps and more.

**Madame Librarian's Field Guide to Hunting for Bear**

Guide provides fun and inventive ways for students in grades K-4 to learn basic library skills. Reproducible pages enable instruction for an entire classroom. Madame Librarian and a colorful cast of cubs are depicted throughout each activity. The guide begins with 11 posters devoted to proper book care and handling. Also featured are bookmarks and certificates based on the same theme. Activities for students to complete include a fiction mobile, plus task cards for hands-on experience with the card catalog and library location skills. Research units on bears feature activities such as worksheets and report writing. 8 1/2" x 11". ©1987.

L1-90295 ..... \$6.75 ea (2 lbs); 3 or more, \$6.55 ea

**Dewey and Friends Skills Book**

Book introduces the Dewey decimal system to youngsters. Illustrations of costumed bears representing Dewey classifications appear throughout. Activities include reproducible forms and projects for book reports, certificates, bookmarks and creative writing projects. Graphics correspond to Dewey set sold separately below. 115 pages. 8 1/2" x 11". ©1988.

L1-90294 ..... \$8.67 ea (2 lbs); 3 or more, \$8.40 ea

**Dewey and Friends Poster Set**

Set of 36 ready-to-color posters are designed to help students find their way around the library and to reinforce library location skills. Bears dressed in costumes associated with each classification provide a light-hearted approach to learning the Dewey decimal system. Posters illustrate 30 general categories of the Dewey system and 6 popular fiction categories. Just a few of the posters include Santa Bear representing the holidays, Little Red Riding Hood Bear for fairy tales, and Astronaut Bear for space. Posters measure 17"H x 11"W. Printed in black on white stock.

L1-90293 ..... \$14.59 set (2 lbs), 3 or more, \$14.15 ea

**Teacher's Sampler of Bear Stamps**

Stamp a teddy bear on a perfect test paper or a well written book report. Something this simple can mean so much to youngsters. Carefully detailed stamps are a fun way to acknowledge student achievement. The set of four stamps depict lovable teddy bears performing the following circus stunts: riding a unicycle, juggling, tightrope walking, and dog tricks. Illustrations are accomplished by these words: "Fantastic", "Super", "Great", and "Please Sign & Return". Stamps are made of 100% pure rubber and are matted onto hand-turned maple blocks. Laminated top shows stamp image.

L1-11519 ..... \$14.85 set (.4 lb)

**Teddy Bear Stickers**

Reward students for a job well done with teddy bear stickers. The cuddly brown bears are available in three different sizes — 3/4", 1 1/2" and 3 1/2". On rolls packaged in their own colorful box.

L1-38136, 2" blue box. Includes, 252, 3/4" stickers ..... \$5.50 (.1 lb)  
 L1-38134, 3" red box. Includes 100, 1 1/2" stickers ..... \$7.95 (.1 lb)  
 L1-38133, 4" yellow box. Includes 50, 3 1/2" stickers ..... \$11.95 (.2 lb)

**"I Love to Read" Teddy Bear Bookmarks**

Teddy lets youngsters know how he feels about reading. "I love to read" is boldly proclaimed across these colorful bookmarks. Two styles are featured. One is illustrated with a bear cub sitting atop a stack of books, the other style features him clutching his favorite selection — "Bear Stories". The cardstock bookmarks feature a cutout that fits over the top of a page. 5 1/2" x 2 1/2". Package of 36.

L1-48177 ..... \$1.95 pkg (.1 lb); 3 or more pkgs, \$1.85 ea

**Library Bear Stamps**

Hand stamps feature delightful illustrations of bears and books. The "Librarian" stamp shows a bear stretching to reach an overhead book shelf and is accompanied with the phrase "From the library of". Another style shows a bear cub complete with baseball hat and favorite book. Stamps are made of the finest gum rubber and mounted to a hand-finished hardwood block. Design is illustrated on top.

L1-11407 Book Bear ..... \$5.49 ea (1 lb), 3 or more, \$5.25 ea  
 L1-11408 Librarian ..... \$5.75 ea (1 lb), 3 or more, \$5.45 ea

**Paddington™ Bear Library Accessories**

Let cuddly Paddington Bear make his presence known in the form of a mobile or page markers. The familiar, raincoat-clad bear does his part to encourage students to read.

**Mobile.** Paddington and some of his favorite books are suspended from this cardstock mobile. The central message. Reading is a "Bear" Essential is surrounded by titles such as "All About Bears" and "Fairy Tales". 11" x 17"

L1-91504 ..... \$4.60 (5 lb)

**Page Markers.** Bookmarks help "flag" the page when readers are interrupted. Four different designs promote reading. 3" in diameter. Pkg of 16.

L1-91505 ..... \$1.40 pkg (3 lb), 6 or more pkgs, \$1.35 ea

BEST COPY AVAILABLE

103

TOLL FREE ORDERING THROUGHOUT THE U.S. 1-800-558-2110



# ORDER FORM 31L

The Highsmith Company, Inc.  
W5527 Hwy 108, P.O. Box 800, Fort Atkinson, WI 53538-0800

**Toll Free Ordering: 1-800-558-2110**

Monday-Friday, 7:30 AM to 5:00 PM Central Time

① **Billing Address:** (Please print or type)  
This bill to address is  my place of work  my home.

Name \_\_\_\_\_ Title \_\_\_\_\_

Library, School, Corporation, Other Institution \_\_\_\_\_

Street, suite, mail stop, etc. (UPS requires a street address, not a P.O. Box number.) \_\_\_\_\_

City \_\_\_\_\_ State \_\_\_\_\_ ZIP \_\_\_\_\_

② **Delivery Address:** (if different than "Bill to")  
This delivery address is  my place of work  my home.

Name \_\_\_\_\_ Title \_\_\_\_\_

Library, School, Corporation, Other Institution \_\_\_\_\_

Street, suite, mail stop, etc. (UPS requires a street address, not a P.O. Box number.) \_\_\_\_\_

City \_\_\_\_\_ State \_\_\_\_\_ ZIP \_\_\_\_\_

③ **Confirming:**  
Does the order confirm an order placed earlier by telephone?  Yes  No

④ **Who may we contact regarding your order?**  
We will call only if we have questions.  
Name/Title \_\_\_\_\_

Daytime Telephone Number \_\_\_\_\_

## ⑤ Mailing Information:

Mailing Label Code

NOTE: If the name and address of the individual originating this order is not shown, please list separately. We want to include them in our next mailing.

Check here to have your name removed from mailing lists made available to others.

Check here if you would like us to send our catalog to your friends and/or colleagues. Attach a list with names, addresses. Include zip code.

## ⑥ Payment and Terms

Our terms are payment in U.S. dollars within 30 days of invoice date. FOB Fort Atkinson, WI, or factory. Shipping charges are extra.

Purchase Order Number \_\_\_\_\_

**Bill us.** Shipping charges will be added to your invoice.  
Check one of the following:  
 Established Highsmith customer.  
 Name of bank and three credit references attached.

**Check enclosed.** Include shipping charges for all except asterisked items which are shipped by truck. We will bill you for truck charges. See page 368.

**Check here if you have ordered from us in the last year.**

Amount Enclosed \$

Charge my  Mastercard or  VISA



Shipping charges will be added.

Card Number

Expiration Date

Cardholder's Name \_\_\_\_\_

Signature \_\_\_\_\_

Quantity Ordered	Unit: Ea., Pkg., or Box	Product Order No.		Description	Unit Price	Total Price
		Item Number	Color, Finish, Style			

SUBTOTAL

When sending check or money order, see page 368 for SHIPPING CHARGES

WI and AZ residents add 5% SALES TAX unless furnishing tax exempt certificate

TOTAL

or continue on back



# FULL-COLOR PAPER DOLLS

Especially for Young Children

**CURIOUS GEORGE PAPER DOLLS IN FULL COLOR.** H.A. Rey, Kathy Allert. The naughty little hero of children's books recreated in two paper dolls with 48 costumes in full color: pirate, Indian chief, fireman, snake charmer and more. 32pp. 9 1/4 x 12 1/2.



24386-9 Pa. \$3.50

**CUPIE PAPER DOLLS IN FULL COLOR.** Tom Tierney. Stage Cupie plays, etc. with two full-color, Cupid-like paper dolls—two-sided for front/rear views. Cowboy, ballerina, butterfly, 11 more costumes. Two paper dolls and 14 costumes in full color. 32pp. 9 1/4 x 12 1/2. 24621-3 Pa. \$3.95



**BEST FRIENDS PAPER DOLLS IN FULL COLOR.** Queen Holden. Two charming little dolls, a girl and a boy, in 31 typical outfits of the 1930's, rendered by the well-known paper doll artist. 32pp. printed one side only. 9 1/4 x 12 1/2.

24973-5 Pa. \$3.50

**PETER RABBIT PAPER DOLLS IN FULL COLOR.** Kathy Allert. Peter Rabbit dresses up for 29 exciting new adventures as a policeman, archaeologist, magician, sailor, backpacker, spacebunny and more. 32pp. 9 1/4 x 12 1/2. (USO)

24281-1 Pa. \$3.50



**KATE GREENAWAY PAPER DOLLS.** Kathy Allert. Four delightful dolls. 23 authentic period costumes based on the illustrations of one of the greatest dress illustrators of the 19th century. 32pp. 9 1/4 x 12 1/2.

24153-X Pa. \$3.50

Changeable peel & apply costumes—no scissors or cutting necessary!



**LITTLE ANIMAL STICKER PAPER DOLLS WITH CHANGEABLE COSTUMES IN FULL COLOR.** Crystal Collins-Sterling. This unique collection features lovable Kitty, Puppy, Bunny and Teddy with 36 peel and apply sticker costumes, including blue denim overalls, a salmon-pink leotard, polka-dotted party dress, camouflage suit, baseball jacket, jogging suit, plus delightful accessories (sunglasses, bandanas, slippers, bow ties, more). 8pp. 8 1/4 x 11.

25757-6 Pa. \$3.95

**THREE LITTLE KITTENS PAPER DOLLS IN FULL COLOR.** Tom Tierney. Three captivating kittens and their doting nanny, with 12 turn-of-the-century outfits designed to be seen from front and back. 32pp. printed in color on one side only. 9 1/4 x 12 1/2.

25065-2 Pa. \$3.50



**TWO LITTLE DUCKS PAPER DOLLS IN FULL COLOR.** Tom Tierney. Twin ducks, Debbe and Danny, each with seven costume changes: Debbe as a cheerleader, ice skater, astronaut and more; Danny as a rodeo star, Santa Claus, skier and more. Two 2-sided paper dolls with 14 costumes. 32pp. printed one side only. 9 1/4 x 12 1/2.

25674-X Pa. \$3.50



**TEDDY BEAR PAPER DOLLS IN FULL COLOR: A Family of Four Bears and Their Costumes.** Crystal Collins. A family of four Teddy Bear paper dolls and nearly 60 cut-out costumes. 32pp. printed one side only. 9 1/4 x 12 1/2.

24550-0 Pa. \$3.50

**FUN WITH TEDDY BEAR PAPER DOLLS IN FULL COLOR.** Tom Tierney. Two lovable bear dolls and 16 costumes for parties, pageants, square dancing, more. Two-sided. 32pp. 9 1/4 x 12 1/2.

25312-0 Pa. \$3.50

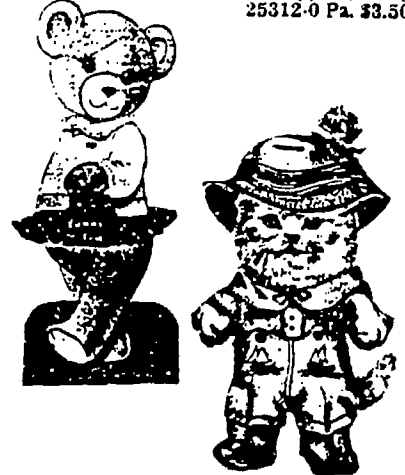

**VICTORIAN CAT FAMILY PAPER DOLLS IN FULL COLOR.** Evelyn Gathings. Dress this feline family in a wardrobe of full-color Victorian fashions and send them to the park, to the beach, to parties and more. 16 plates of color illustrations. 32pp. printed one side only. 9 1/4 x 12 1/2.

24702-3 Pa. \$3.50

**VICTORIAN PETS PAPER DOLLS IN FULL COLOR.** Evelyn Gathings. Eight lovable animal paper dolls with two or three Victorian-style costumes each and charming accessories. 16 full-color plates. 32pp. printed one side only. 9 1/4 x 12 1/2.

25163-2 Pa. \$3.50



**VICTORIAN MOUSE PAPER DOLLS IN FULL COLOR.** Crystal Collins-Sterling. A charming collection of four mouse dolls plus costumes for Midsummer Eve's Ball, visiting a castle, first day of school, holidays, more. Numerous accessories. 32pp. 9 1/4 x 12 1/2.

25045-X Pa. \$3.50

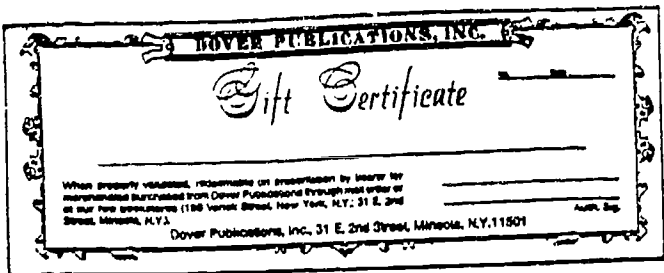

Give a child the pleasure of choosing their own favorite with a Dover Gift Certificate—perfect for birthdays, holidays, anytime!

**DOVER GIFT CERTIFICATES**

Not sure what gift would most please the children? Give them the pleasure of selecting their own favorite books, posters and postcards from Dover's catalog of over 3,000 titles.  
Dover Gift Certificates are available in amounts of \$10.00, \$15.00, \$25.00, \$50.00, \$75.00 and \$100.00. We'll send you each handsomely designed Gift Certificate along with a Complete Dover Catalog in a ready-to-mail envelope. All purchases made with Dover Gift Certificates are covered by our unconditional money-back guarantee.  
Use the convenient order form on p.47 to order your Gift Certificates—the perfect gift for any holiday or special occasion.

**ORDER FORM**

Dover Publications, Inc., 31 East 2nd Street,  
Mineola, New York 11501

Please send me:

QTY	CODE NO.	AUTHOR	TITLE	PRICE

**Please note:**

U.P.S. delivery is not available for Alaska or Hawaii; not available for P.O. boxes.  
Posters are postpaid—do not add any postage or handling charges.  
Free premiums and catalogs—do not count these when adding postage and handling charges.

**DOVER PUBLICATIONS, INC.**  
11 East 2nd St.  
Mineola, N.Y. 11501

Send to:

Name (please print)

Address

Apt. No.

City

State

Zip Code

Special fourth class rate—only if address correction requested. Forwarding and return postage guaranteed.

Number of items ordered	
Total amount	
Sales Tax (New York residents only)	
Postage and Handling Charges (Check ONE BOX ONLY and add appropriate charges):	
<input type="checkbox"/> Bookrate: \$1.25 for one item; \$2.50 (maximum) for two or more items (U.S. only)	
<input type="checkbox"/> U.P.S.: \$3.00 for any order (U.S. only)	
<input type="checkbox"/> Foreign Orders: add 20% of the total	
Please send the following GIFT CERTIFICATES in the quantities indicated:	
___ 99990-4 \$10    ___ 99992-0 \$25    ___ 99994-7 \$75	
___ 99991-2 \$15    ___ 99993-9 \$50    ___ 99995-5 \$100	
<b>TOTAL ENCLOSED</b>	

Payment in full must accompany all orders (except those from libraries or public institutions, who may be billed if order is \$7.50 or more, and if ordered on their official forms or stationery.) Billed orders will be charged postage by weight.  
**GUARANTEE:** All Dover books are unconditionally guaranteed and may be returned (with the original order if possible) within 10 days of receipt for full cash refund. No question asked.

**TO HELP US SERVE YOU BETTER:**

**Important:** Please note any address correction on the label which appears on this order form.  
If you have received a duplication of this mailing, please enclose the address labels from both covers so that we may eliminate the duplicate. Thank you for your cooperation.

For inquiries: NOT relating to this order, please use a separate sheet of paper

JUV. 1288

# Paddington on Parade!

Paddington's creator, Michael Bond, tells of the birth of the winsome little bear from darkest Peru who inspired more than 15 stories, and who is celebrating 30 years of popularity with young and old. "One Christmas Eve — 1956 to be precise — I ... wandered into a large London store, where I chanced upon a small toy bear left alone and unsold. ... Feeling that he couldn't possibly spend Christmas on his own, I bought him as a "stocking-filler" for my wife, and because we were living near Paddington station at the time, that is what we called him."

## PADDINGTON BEAR DOLLS

We offer two. Both are 15" tall, surface-washable, and have just been treated to special new plush fur with a richer feel to help celebrate their thirtieth birthday. They're dressed in blue polar-fleece duffel coats with real wooden toggles so little fingers can button them. Bright-yellow bush hats of authentic design add the finishing touch for exciting adventures. One Paddington is a bare-footed bear who eats his marmalade sitting down, the other stands proudly in red rubber, removable boots with paw prints and his initials.

- Z 319 D bare-footed Paddington doll \$23.95
- Z 322 D Paddington doll with boots \$27.95

## A BEAR CALLED PADDINGTON

Paddington was found on a London railway platform by Mr. and Mrs. Brown. He wore a sign that read: "Please look after this bear." And that is exactly what they did. It hasn't been easy.

- Z 325 P paperback book \$2.95
- Z 328 H hardcover book \$11.95
- Z 331 CX cassette (abridged, read by author) \$9.95

## MINI PICTURE BOOKS

illustrated by David McKee.

Please order by title and number.

1. Paddington's Art Exhibition
  2. Paddington at the Zoo
  3. Paddington at the Fair
  4. Paddington and the Knickerbocker Rainbow
  5. Paddington Cleans Up
  6. Paddington at the Palace
- Z 346 P each picture book \$5.95
  - Order the set and get one book FREE!**
  - Z 347 P set of 6 books \$29.75

## A DISAPPEARING TRICK AND OTHER STORIES

Paddington makes things disappear ... for good! Other stories: *A Family Group*; *A Spot of Decorating*; *Paddington and the Old Master*. Unabridged, read by the author.

- Z 349 CX cassette \$9.95

## PADDINGTON TURNS DETECTIVE

Someone has stolen Mr. Brown's prized marrow squash and Paddington's prized marmalade sandwiches! Pad's on the case. Step aside, Scotland Yard! Also: *Paddington Dines Out*; *Paddington Makes a Bid*; *Do It Yourself*. Unabridged, read by the author.

- Z 352 CX cassette \$9.95

## TROUBLE AT THE AIRPORT

Paddington has a run-in with red tape. Also: *Paddington Prepares* and *Pantomime Time*. Unabridged, read by the author.

- Z 355 CX cassette \$9.95

## PADDINGTON FOR CHRISTMAS

Paddington tales with Christmas themes include *Paddington and the Christmas Pantomime*; *Everything Comes to Those Who Wait*; *Paddington Hits the Jackpot*; *The Last Dance*. Unabridged, read by the author.

- Z 358 CX cassette \$9.95

## A VISIT TO THE DENTIST AND SOMETHING NASTY IN THE KITCHEN

Paddington has to go to the dentist, which is not nearly as much fun as cooking dinner for the ailing Browns in their soon-to-be-nasty kitchen. Unabridged, read by the author.

- Z 361 CX cassette \$9.95

## A BIRTHDAY TREAT AND OTHER STORIES

Paddington's family takes him to the beach to celebrate his summer birthday. Nothing goes smoothly. Also: *A Bear at Sea* and *In and Out of Trouble*. Unabridged, read by the author.

- Z 364 CX cassette \$9.95

Buy the complete set and SAVE!

- Z 366 CX Set of 6 cassettes \$49.95



Children won't want to miss a single Paddington escapade!

## PADDINGTON SOUNDBOOK

Four purely-Paddington stories in a set, with guide. Nearly four hours of enjoyment. Includes: *A Bear Called Paddington*; *A Disappearing Trick*; *Paddington for Christmas*; *Paddington Turns Detective*. Unabridged, read by the author.

- Z 367 CX 4 cassettes \$29.95

Each of the following filmstrip/cassette sets is narrated by Michael Hordern, and features the bear doll and an illustrated background.

## PADDINGTON AT WORK

Includes: *Paddington Buys a Share* and *Paddington in a Hole*.

- Z 370 CFX 2 filmstrips/cassettes \$58.95

## PADDINGTON BEAR PICTURE BOOK

Includes: *Paddington's Patch* and *Paddington at the Tower*.

- Z 373 CFX 2 filmstrips/cassettes \$58.95

## PADDINGTON :HELPS OUT

Includes: *Paddington Dines Out* and *Picnic on the River*.

- Z 376 CFX 2 filmstrips/cassettes \$58.95

## A BEAR CALLED PADDINGTON

Includes: *A Visit to the Theatre*; *Picture Trouble*; *Trouble on the Beach*.

- Z 377 CFX 3 filmstrips/cassettes \$78.95

## PADDINGTON AT LARGE

Includes: *An Outing in the Park*; *Trouble in the Bargain Basement*; *Paddington Takes the Stage*.

- Z 379 CFX 3 filmstrips/cassettes \$78.95

## PADDINGTON TAKES TO TV

Includes: *Paddington Bakes a Cake*; *Paddington Clears the Coach*; *Paddington Weighs In*.

- Z 382 CFX 3 filmstrips/cassettes \$78.95

## PADDINGTON ON TOP

Includes: *In Court*; *Keeping Fit*; *In Touch*; *Comings and Goings*.

- Z 385 CFX 4 filmstrips/cassettes \$98.95

## PADDINGTON GOES TO THE MOVIES

The best show is in the audience when Paddington acts up. You won't want to miss his version of "Singin' in the Rain." Added attraction: *Parsley the Lion*. 22 mins.

- Z 1272 V video \$19.95

## PADDINGTON'S BIRTHDAY BONANZA

Well-meaning Paddington needs to earn money for Mr. Brown's birthday present. Watch the fun as he tries his paw at being a waiter. 25 mins.

- Z 1275 V video \$19.95

## PADDINGTON AT SCHOOL

Paddington's performance at school exceeds his wildest dreams — or was it a dream? 28 mins.

- Z 1278 V video \$19.95

## READ ALONG WITH PADDINGTON BEAR

Four *Talking Bookworm* read-alongs, performed by Broadway star Lee Roy Reams, get to the heart of Michael Bond's celebrated bear. Please order by title and number.

1. Please Look After this Bear
  2. Paddington and the Christmas Shopping
  3. Paddington Goes to School
  4. Paddington Goes to Town
- Z 269 SP each cassette/paperback book \$9.95



1.

FREE WITH PURCHASE, OUR EXCLUSIVE FERDINAND THE BULL AND CHESHIRE CAT. DETAILS ON ORDER FORM. OVER 30 NEW STORYBOOK CHARACTER DOLLS AND RELATED MEDIA ALL WITH A 1 YEAR GUARANTEE. ORDER TOLL-FREE 800-243-4504.

2.

If above name or address is incorrect or missing, please print correct information here

street \_\_\_\_\_  
 city, state, zip \_\_\_\_\_  
 name \_\_\_\_\_ phone (\_\_\_\_) \_\_\_\_\_  
 title \_\_\_\_\_  
 organization \_\_\_\_\_

When using a purchase order, please be sure to include the three-digit code that appears on the first line of the addressed panel above.

3.

catalog #	product title	quantity	price each	total

Need more room?  
 Please attach a separate sheet and enclose in postage-free return envelope.

total cost of items above \_\_\_\_\_  
 plus 5% shipping (\$3 min) \_\_\_\_\_  
**4.** \_\_\_\_\_  
**5.** \_\_\_\_\_  
**6.** TOTAL \_\_\_\_\_

7.

**Yes!** I qualify for one of the following free premiums! (See front of order form for details). Please check the appropriate box:

**FREE** Cheshire Cat Desk Mate (a \$7.95 value!)  
 — OR —  
 **FREE** Ferdinand the Bull doll (a \$12.95 value!)

*Thank you!*

8.

**My method of payment is:**

purchase order # \_\_\_\_\_  
 check or money order enclosed  
 bill me (sorry, we can only offer billing privileges when shipping to a school/library address.)

**CREDIT CARDS (\$20 mln.):**

Visa  
 MasterCard      date: \_\_\_\_\_

signature \_\_\_\_\_

**ORDER TOLL-FREE! (800) 243-4504**  
 9:00 a.m. to 5:00 p.m., Eastern Time  
 In Conn., call collect: (203) 637-3616

card number \_\_\_\_\_  
 expiration date \_\_\_\_\_

Prices in this catalog are NET to schools, libraries, and allied purchasers, and are subject to change without notice.  
 Tear off postage-free envelope here

This flap is gummed and ready to moisten and seal. Have you enclosed your check or purchase order number?

## It's easy to order...

- If the addressed label is incorrect or missing, please print correct information in box number 2. If you are using a purchase order, please be sure to include the three-digit code that appears on the first line of the addressed panel.
  - Make address corrections here, if they do not appear correctly in the panel above. Please give a street address to ship to; we use UPS whenever possible, and they can't deliver to a box number.
  - Fill in the catalog number, product title, quantity, price for the single item, and total price for each item that you'd like.
  - Add up the total costs for all items.
  - Add 5% to cover shipping and handling (the minimum shipping charge is \$3.00).
  - Enter the total of steps 4 and 5.
  - Check off for your FREE Cheshire Cat Desk Mate or Ferdinand the Bull doll.
  - Check off how you will pay for your order. If you're using a purchase order, please write in the number. If you're using a credit card, please be sure to include your complete card number and expiration date. Our payment terms for organizational orders are NET 30 days.
- OR...**  
 ...simply call us toll-free (800) 243-4504. Our customer service representatives are ready to take your order (with a credit card or purchase order number) from 9:00 a.m. to 5:00 p.m., Eastern Time. In Connecticut, call collect: (203) 637-3616.

**Satisfaction Guaranteed!**



20% DISCOUNT

FEBRUARY 1989

DEPARTMENT M
WESTERN PUBLISHING COMPANY, INC.
P.O. Box 700 • Racine, Wisconsin 53401

20% DISCOUNT

Name
Street and Number
City State Zip Code No.

REMITTANCE WITH ORDER IS REQUIRED
PLEASE ALLOW 4-6 WEEKS FOR DELIVERY
Total Amount of Order \$
Handling Charge \$2.00
Total Amount Enclosed \$

20% DISCOUNT

\* Table of Contents on Page 10 \*

20% DISCOUNT

TERMS: All returns must be authorized by a company representative in accordance with the then existing Western Publishing Company, Inc. return policy.

All orders accepted subject to the approval of the home office and prices and terms in effect at the time of shipment. Prices and terms subject to change without notice. Resellers are free to charge any prices they desire for these products.

Table with columns: Item No., Qty., DESCRIPTION. Includes sections for VIDEO (VHS ONLY), \$13.00 GOLDEN BOOK VIDEO (Kids 2-6), \$13.00 MUSIC VIDEO, and \$13.00 STEP AHEAD VIDEO.

Table with columns: Item No., Qty., DESCRIPTION. Includes sections for \$13.00 EASTER VIDEO, \$13.00 GOLDENVISION, and LONG-FORM VIDEO.

Table with columns: Item No., Qty., DESCRIPTION. Includes sections for \$39.99 VIDEO CLASSICS and \$109.

BEST COPY AVAILABLE

Item No	Qty	DESCRIPTION
<b>COLORING AND ACTIVITY PRODUCTS</b>		
<b>\$1.06 BIG COLOR &amp; ACTIVITY BOOKS 56 Pages</b>		

- (1) 1102-1 \_\_\_\_\_ ABC
- (1) 1104-2 \_\_\_\_\_ Fun Mother Goose
- (1) 1108 \_\_\_\_\_ Hot Wheels 3/6
- (8) 1126 \_\_\_\_\_ Dinosaurs
- (2) 1197 \_\_\_\_\_ Paddington Bear ✓
- (9) 1198 \_\_\_\_\_ Purr-Tenders
- (5) 1199 \_\_\_\_\_ Easy Mazes
- (9) 1204 \_\_\_\_\_ Poky Puppy
- (6) 1231 \_\_\_\_\_ Snow White
- (4) 1128-9 \_\_\_\_\_ A Day on Sesame Street
- (8) 1128-10 \_\_\_\_\_ City
- (6) 1128-11 \_\_\_\_\_ Fire Dept
- (4) 1129-10 \_\_\_\_\_ Seasons of the Year
- (2) 1129-11 \_\_\_\_\_ Tiddlebug
- (1) 1129-12 \_\_\_\_\_ Sesame Street Numbers Activity
- (1) 1130-11 \_\_\_\_\_ Finish the Pictures
- (9) 1130-12 \_\_\_\_\_ First Day of School
- (3) 1131-13 \_\_\_\_\_ New Baby
- (8) 1131-16 \_\_\_\_\_ Grover's Book of Colors
- (1) 1132-12 \_\_\_\_\_ Big Bird's Book of Rhymes
- (1) 1132-13 \_\_\_\_\_ Sesame Color
- (6) 1132-15 \_\_\_\_\_ Ernie's Book of Animals
- (6) 1133-13 \_\_\_\_\_ More Who's Who on Sesame Street
- (2) 1133-15 \_\_\_\_\_ A Rainy Day on Sesame Street
- (1) 1133-16 \_\_\_\_\_ A To Z
- (7) 1134-16† \_\_\_\_\_ Disney Busy Book 4/3
- (5) 1134-17† \_\_\_\_\_ Mickey & Minnie
- (3) 1134-18† \_\_\_\_\_ Mickey and Friends Dot
- (1) 1134-19† \_\_\_\_\_ Mickey Mouse
- (1) 1135-9† \_\_\_\_\_ Donald Duck and Friends
- (4) 1135-10† \_\_\_\_\_ Disney Characters
- (2) 1135-11† \_\_\_\_\_ Duck Tales
- (1) 1135-12† \_\_\_\_\_ Duck Tales
- (2) 1136-6† \_\_\_\_\_ Disneyland
- (1) 1136-7† \_\_\_\_\_ Walt Disney World
- (7) 1137-7† \_\_\_\_\_ Disney Babies
- (1) 1138-12† \_\_\_\_\_ Pinocchio
- (2) 1138-16† \_\_\_\_\_ Disney's Oliver
- (1) 1138-17† \_\_\_\_\_ Disney's Oliver
- (3) 1138-24† \_\_\_\_\_ Winnie The Pooh 3/20 ✓
- (5) 1139-18† \_\_\_\_\_ Disney Dot
- (3) 1139-19 \_\_\_\_\_ Favorite Friends
- (7) 1139-20† \_\_\_\_\_ Walt Disney's Fairy Tales 4/3
- (5) 1139-21† \_\_\_\_\_ Disney Color
- (1) 1191-8† \_\_\_\_\_ Alice in Wonderland
- (8) 1191-9† \_\_\_\_\_ Dumbo 4/3
- (1) 1191-11† \_\_\_\_\_ Snow White
- (6) 1191-13† \_\_\_\_\_ Lady & The Tramp
- (3) 1194 \_\_\_\_\_ Roger Rabbit
- (4) 1224-3 \_\_\_\_\_ Rescuers
- (4) 1110 \_\_\_\_\_ Snoopy
- (5) 1124 \_\_\_\_\_ Land, Sea & Air
- (4) 1127 \_\_\_\_\_ Silly Animals
- (1) 1140-19 \_\_\_\_\_ Bugs Bunny
- (5) 1140-20 \_\_\_\_\_ Bugs Bunny and Friends 3/6
- (3) 1140-21 \_\_\_\_\_ Bugs & Friends
- (5) 1147 \_\_\_\_\_ Barbie and the Rockers
- (8) 1161 \_\_\_\_\_ Mad Scientist
- (1) 1191-7 \_\_\_\_\_ Bambi 3/6
- (1) 1195 \_\_\_\_\_ Dino Riders
- (5) 1205 \_\_\_\_\_ Barbie
- (4) 1146-8 \_\_\_\_\_ Barbie
- (7) 1146-15 \_\_\_\_\_ Tropical Barbie Activity
- (1) 1146-18 \_\_\_\_\_ Barbie Jewel Secrets
- (1) 1160 \_\_\_\_\_ Birds
- (8) 1190 \_\_\_\_\_ Mapletown
- (6) 1196 \_\_\_\_\_ Garfield
- (3) 1200 \_\_\_\_\_ Wizard of Oz
- (2) 1203 \_\_\_\_\_ Mr. Army
- (1) 1205 \_\_\_\_\_ Winnie The Pooh 3/6 ✓
- (1) 1207 \_\_\_\_\_ Nintendo Super Mario Brothers NEW

Item No	Qty	DESCRIPTION
<b>\$1.49 GIANT COLOR AND ACTIVITY BOOKS 98 Pages</b>		

Item No	Qty	DESCRIPTION
<b>\$2.10 DELUXE COLOR 126 Pages</b>		

Item No	Qty	DESCRIPTION
<b>\$1.06 STICKER FUN 24 Pages</b>		

Item No	Qty	DESCRIPTION
---------	-----	-------------

Item No	Qty	DESCRIPTION
<b>\$1.50 DOLL BOOKS 16 Pages</b>		

Item No	Qty	DESCRIPTION
<b>\$1.06 PAINT WITH WATER BOOKS 48 Pages</b>		

Item No	Qty	DESCRIPTION
<b>\$1.06 PAINT 'N' MARKER BOOKS 32 Pages</b>		

Item No	Qty	DESCRIPTION
<b>\$1.06 FIRST FUN ACTIVITY BOOKS 48 Pages</b>		

Item No	Qty	DESCRIPTION
<b>\$1.06 TRACE AND COLOR 64 Pages</b>		

**BEST COPY AVAILABLE**  
110

# HOME PRODUCTIVITY: Art

CALL/WRITE TO JOIN THE HOME COMPUTING CLUB, RECEIVE A 10% DISCOUNT.

## ■ PRODUCTIVITY SOFTWARE ■

Personal finance products are a big favorite among Home Computing customers... keep that checking account straight, balance those budgets. Given the time of year, programs that help organize and actually produce a tax return are popular as well. Variety of functions in one package are frequently ideal for the new user who is looking for the right combination of features and ease of use. Appleworks GS is finally available and should prove to be a boon for Apple GS owners.



### CREATE WITH GARFIELD! DELUXE EDITION by DLM, Inc.

A two-disk program that enables users to create elaborate cartoons, labels and posters with over 200 pieces of art and borders. A textwriter is included with various typefaces for writing captions and special messages. The user can also use his/her own backgrounds, props and borders for an unlimited variety of Garfield scenes. The cartoons, labels and posters can be printed using over thirty printers, including color printers.

- ▶ Apple (DLM34AP) . . . . . \$39.95
- ▶ Comm 64 (DLM34COMD) . . . . . \$39.95
- ▶ IBM (DLM34PC) . . . . . \$39.95
- ▶ IBM 3.5 (DLM34PC3) . . . . . \$39.95

### GARFIELD COMPANION DISK

This program allows you to create additional artwork, cartoons, posters and labels to be used with Create with Garfield! and Create with Garfield! Deluxe Edition.

- ▶ Apple (DLM69AP) . . . . . \$19.95

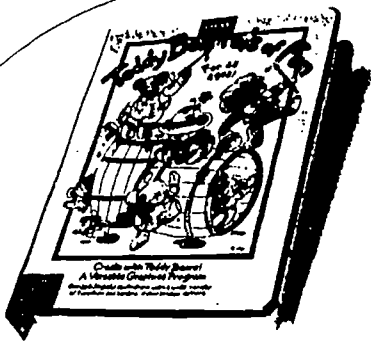

### TEDDY BEAR-RELS OF FUN by DLM, Inc.

Offers everything needed to design and create delightful Teddy Bear artwork. This two-disk program enables young children to create Teddy Bear stories, pictures, posters, labels, stickers, cards and stationery. Includes over 200 pieces of art, backgrounds, borders, textwriter, and an activities booklet.

- ▶ Apple (DLM35AP) . . . . . \$39.95
- ▶ Comm 64 (DLM35COMD) . . . . . \$39.95



### TOP HONORS by Springboard

Start with a pre-designed certificate template (portrait or landscape format). Then, simply click on the design elements you want in your certificate. The program provides a full range of choices in borders, seals, graphics, font formats and sizes.

- ▶ Mac 1mg (CP33MC) . . . . . \$99.95



### COLOR ME: THE COMPUTER COLORING KIT by Mindscape, Inc.

Each of the activities in this program represents an enjoyable and important way for students to express themselves. The program has many functions, each of which gives the student several dimensions to explore. Students can create original art or, by using the picture disk and the "Cut and Paste" option, may mix and match pictures to create new masterpieces.

- ▶ Apple (LS92AP) . . . . . \$39.95



### DESIGN TO PRINT by Britannica Software from Designware™

Design to Print™ gives you a more powerful way to say anything. It combines in one package all the features you need to create banners, signs, greeting cards, posters, report covers, certificates, newsletters, and more. Desktop publishing functions are the same for everything you create, so you spend time creating instead of remembering program commands. People who could never draw a straight line become graphic designers. The program is limited only by one's imagination.

- ▶ IBM 512K (DW12PC) . . . . . \$49.95

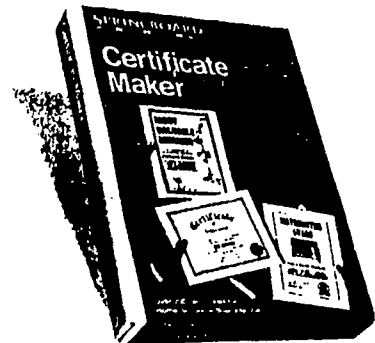

### CERTIFICATE MAKER by Springboard Software, Inc.

Personalize and print out over 200 certificates to recognize, reward and encourage all kinds of achievements. Personalize each with your message, signature and date. A wide variety of categories, including sports, business, recreation, religious and other themes. Offers both serious and funny certificates to cover every occasion. Requires IBM Color Graphics Card.

- ▶ Apple (CP20AP) . . . . . \$39.95
- ▶ Comm 64 (CP20COMD) . . . . . \$19.95
- ▶ IBM (CP20PC) . . . . . \$39.95
- ▶ IBM 3.5 (CP20PC3) . . . . . \$39.95
- ▶ Mac (CP20MC) . . . . . \$39.95

**HOME**  
COMPUTING CATALOG

P.O. BOX 18890  
Encino, California 91416-8890

**CALL TO ENQUIRE ABOUT THE OVER 3,000 ITEMS  
AVAILABLE IN OUR FULL LINE CATALOG  
USE THIS FORM TO SEND IN  
YOUR ORDER OR USE OUR**



**TOLL FREE HOTLINE  
1-800-950-8030**

**24 HOURS A DAY 7 DAYS A WEEK  
FOR CUSTOMER SERVICE AND TECHNICAL SUPPORT CALL (818) 881-6600**

**LARGEST SELECTION OF SOFTWARE AVAILABLE  
CALL FOR DETAILS**

**WE WILL SHIP WITHIN 24 HOURS**  
All Orders Paid by Credit Cards or Money Orders.  
Orders paid by personal check will be shipped within 14 days.

When using the

**TOLL FREE HOTLINE**

please have the following ready:

- 1) Your **VISA or MASTERCARD**
- 2) Your Key Code on your mailing label above your name.
- 3) Item Number
- 4) Product Title

From Canada Please Call 1-818-881-6600

**SAVE ON DELIVERY CHARGES**

There is a minimal charge of \$5.00 for handling and delivery FOR THE FIRST ITEM ON YOUR ORDER ONLY. ALL OTHER ITEMS get a FREE RIDE so ORDER MORE THAN ONE AND SAVE!!

**YOUR SATISFACTION GUARANTEED**

We're not kidding when we say that we want you to be 100% pleased with your order. If, for any reason, you are not completely satisfied, return the item in its original condition and we'll be glad to exchange it or refund your money, as you wish. With your purchase, you also receive the guarantee offered by the publishers.

**NEED TECHNICAL SUPPORT?**  
Our technical support specialists are at your service.  
CALL 1-818-881-6600  
Monday-Friday 9-5 PST

I've enclosed a check or money order in the amount of \$ \_\_\_\_\_ payable to HOME COMPUTING CATALOG. (SORRY, no C.O.D.'s.)

Please charge my credit card.

MasterCard  VISA

Credit Card Number (all digits please)

--	--	--	--	--	--	--	--	--	--

For all credit card orders, we must have your signature and credit card expiration date. Please make sure cardholder's address is provided at full.

Signature of Cardholder \_\_\_\_\_

Expiration Date \_\_\_\_\_

Please print name above \_\_\_\_\_

My daytime telephone number is ( \_\_\_\_\_ ) \_\_\_\_\_-\_\_\_\_\_  
**113**

Ordered By: **XXXXXXXXXXXXX 5-DIGIT 23233**  
**T0502**  
**PEGGY RUDD**  
**OR CURRENT RESIDENT**  
**25 MILHAVEN SQ**  
**RICHMOND VA 23233**

For mailing address corrections only.  
Please print correct name and mailing address.

ITEM NUMBER	HOW MANY	DESCRIPTION	PRICE EACH	TOTAL
		ANNUAL CLUB MEMBERSHIP FEE OPTIONAL SEE NEXT PAGE FOR DETAILS	\$18.00	

PLEASE SEND ME MY FREE GIFT!  
MY ORDER IS OVER \$85.00  
(See next page for details)

**112**

**FOR THE COMPREHENSIVE FULL LINE 3,000 ITEM CATALOG... SEND \$5.00.  
I THANK YOU FOR YOUR ORDER**

<b>SUBTOTAL</b>	<b>TOTAL</b>
LESS 10% Club Members Only	
ADD 6.5% SALES TAX CALIF. RESIDENTS	
SHIPPING HANDLING	\$5.00

SPECIAL SHIPPING & HANDLING FOR:  
RURAL ROUTE }  
P.O. BOX } ADD \$2.50  
FPO/APO }  
Next Day Air Delivery Available



**A. USEFUL SIGNS**

Grade Level: K-3  
 30 extra-large 11" x 14" picture cards portray various common street signs and symbols. Students identify and interpret the signs to develop readiness and communication skills.  
 MB7509 ..... \$12.95

**B. FLANNEL BOARD CAPITAL LETTERS**

Words and sentences can be built with over 100 red letters, 3" tall.  
 MB7801 ..... \$7.95

**C. FLANNEL BOARD LOWER CASE LETTERS**

Over 100 red letters, 3" tall. Great for word and sentence building.  
 MB7804 ..... \$7.95

**D. FOUR HELPERS**

Grade Level: K-3  
 Requires no reading  
 Multi-ethnic play people, 10" tall, and built sturdy to last! Children will have hours of story-telling pleasure with male and female counterparts of these occupations: Postal Worker, Doctor, Police Officer, Construction Worker, and Business Executive. Stands included.  
 MB7831 ..... \$19.95

**E. MY FIRST PUZZLE**

Great "first puzzles" that provide children with entertainment and reinforcement of basic skills. 4 puzzles from 7 to 10 pieces each.  
 MB7806 ..... \$8.95

**F. BLOCKS 'N' BEARS**

**NEW**  
 Grade Level: pre-K-3  
 Requires no reading  
 Popular manipulatives together in one box—Teddy Bear Counters and Cubical Counting Blocks. One suggested activity is to have children follow a path with the blocks, use the spinner to make moves along the path by color, and move bears accordingly. Many other activities help develop counting, matching, and sorting skills, as well as listening skills and following directions. Add more blocks to your set with Cubical Counting Blocks (MB8039), or increase building with Cubical Block Pattern Cards (MB8207), both found on page 5 of this catalog. Blocks and bears come in 6 colors each: red, yellow, green, orange, and purple.  
 MB8210 42 Bears (7 each of 6 colors) and 60 Blocks (10 each of 6 colors) .. \$19.95

**G. BOWLS 'N' BEARS**

**NEW**  
 Grade Level: pre-K-3  
 Requires no reading  
 The set of 6 Bowls (1 each of 6 colors) and 102 Teddy Bears (17 each of 6 colors) is the perfect introduction to sorting and counting skills. The easy-to-handle bears will also enhance color recognition and logical thinking skills. All are made of durable plastic. Yellow, red, blue, green, orange, and purple.  
 MB8215 ..... \$17.95

**H. SORTING BOWLS**

**NEW**  
 Now's the perfect tool for early counting, sorting, and color skills! The red, yellow, blue, green, orange, and purple Bowls match up well with our Teddy Bear Counters (MB7622), and with Blocks 'N' Bears (MB8210), both on this same page. Durable, brightly colored plastic construction, 3" diameter, shallow enough for easy access to both hands.  
 MB8216 ..... \$6.95

**I. TEDDY BEAR COUNTERS**

**NEW**  
 Now's the perfect tool for early counting, sorting, and color skills! Several suggested activities are included to develop number counting skills, and mathematical relationships. Early Childhood teachers tell us youngsters love to tell stories with the bears, too! Four color set adds red, yellow, blue, and green. Six color set adds orange and purple.  
 Bears (25 each of 4 colors) .. \$10.95  
 Bears (17 each of 6 colors) .. \$10.95

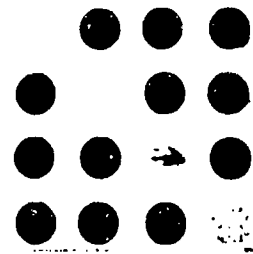
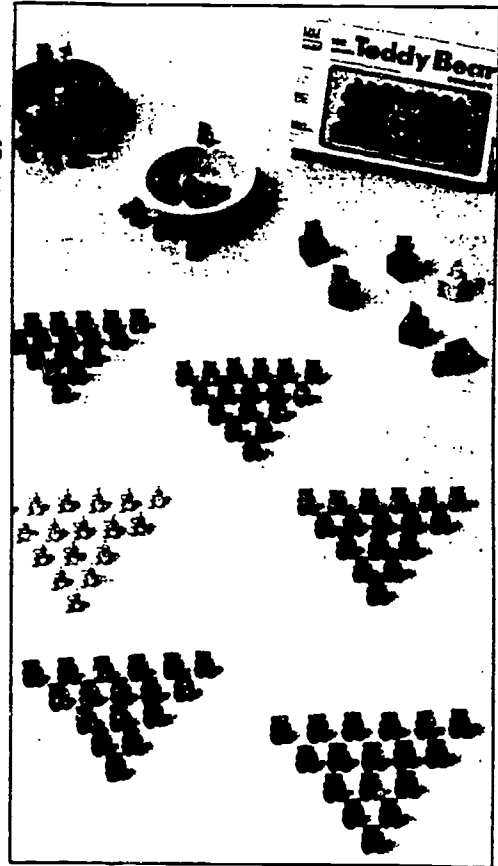
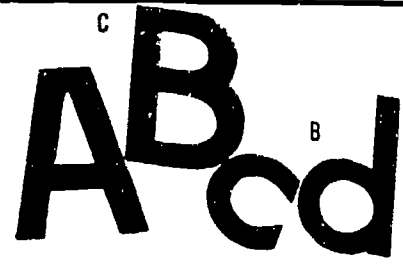
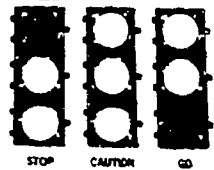

**J. TEDDY BEAR BINGO**

Grade Level: K-3  
 Requires no reading  
 A class color discrimination game! Children will learn the 4 basic colors (red, yellow, blue, and green), and exercise eye-hand coordination by matching the colored Teddy Bears with the colored circles on the bingo-like cards. Comes with 64 non-toxic plastic Teddy Bears, 4 boards, and spinner.  
 MB7214 ..... \$9.95

**K. TEDDY BEARS IN A TUB**

**NEW**  
 Grade Level: K-3  
 Requires no reading  
 Bears galore! Favorite Teddy Bears are perfect for teaching basic math, number, color, and learning concepts. 4 color set includes red, yellow, blue, and green. 6 color set adds orange and purple.  
 MB2000 300 Bears (75 each of 4 colors) .. \$32.95  
 MB2005 300 Bears (50 each of 6 colors) .. \$32.95





CATALOG ITEM NUMBER	QUANTITY	DESCRIPTION	UNIT OF MEASURE	UNIT PRICE	TOTAL AMOUNT

SUB TOTAL					
TAX EXEMPT NO _____		OR INCLUDE SALES TAX WHERE APPLICABLE			
ADD 15% FOR APPROXIMATE SHIPPING & HANDLING CHARGES					
TOTAL					

**MINIMUM ORDER \$25.00**

Orders over \$500.00 will be delivered free within the 48 contiguous states. Exception items are furniture and equipment items designated with a "Y" suffix following a catalog number, which are F.O.B. Shipping Point.

**SORRY NO C.O.D.s**

FOR OFFICE USE ONLY
CHECK OR MONEY ORDER # _____
AMOUNT RECEIVED \$ _____
ACCOUNT # _____
CONTROL # _____

**PAYMENT**

CHECK OR MONEY ORDER  
 VISA     MASTERCARD

CREDIT CARD NO. \_\_\_\_\_  
 4 DIGIT INTERBANK NO. \_\_\_\_\_  
 EXPIRATION DATE \_\_\_\_\_  
 SIGNATURE \_\_\_\_\_

NEW ACCOUNT  
 EXISTING ACCOUNT

<b>PLEASE CHECK FOR ADDITIONAL FREE CATALOGS</b>
<input type="checkbox"/> ART & CRAFT MATERIALS
<input type="checkbox"/> PRE-SCHOOL & ELEMENTARY SCHOOL MATERIALS
<input type="checkbox"/> "BASIC LIFESKILLS"
<input type="checkbox"/> GENERAL SCHOOL AND OFFICE PRODUCTS
<input type="checkbox"/> EDUCATIONAL SOFTWARE

**SHOP OUR CONVENIENT TEACHER CENTERS**

**RETAIL STORE ON PREMISES  
CHASELLE, INC.**  
 9645 GERWIG LANE  
 COLUMBIA, MD 21046  
**Weekday Hours:**  
 9:30 a.m.-5:30 p.m.  
 Thurs. 9:30 a.m.-8:00 p.m.  
**Saturday Hours:**  
 9:30 a.m.-5:30 p.m.  
**Store Phone:**  
 301-381-7828

**RETAIL STORE ON PREMISES  
NEW ENGLAND SCHOOL SUPPLY**  
 609 SILVER ST.  
 AGAWAM, MA 01001  
**Weekday Hours:**  
 10 a.m.-5:30 p.m.  
**Saturday Hours:**  
 10 a.m.-3 p.m.  
**Store Phone:**  
 413-786-9800

**Fast Delivery!**

We know there's no time to waste when you need supplies, so we maintain a complete inventory year-round, making fulfillment of your order quick and easy!



**Toll-free Ordering**

For convenience, call us toll-free! Operators are available 8:30 a.m. to 4:00 p.m. Eastern Standard Time. Please have your catalog and Visa or MasterCard (for personal orders) handy.

**1-800-448-4887**  
In Maryland, call 301.797-9689

**Guarantee of Satisfaction**

Our guarantee is easy to understand. Your satisfaction is *always* guaranteed. Any Upstart product may be returned for a full refund or credit. Order with confidence from Upstart!



**Turn Teens On...**

**Catch the wave!**

Make your library *the* cool place to be seen! Here's a campaign that's especially geared to excite young adults. Vivid "party" graphics in bold, hot colors mirror today's newest fashion trends. Catch-y slogans will "power-up" those oh-so-hard-to-impress YAs. Use these outrageous promotionals this season to create a sensational new look in your library!



**CATCH THE WAVE POSTER**

Make a splash with this high-voltage poster—it's a big, brilliant 22x34".

**J132-313 \$3.95**

**GOOD STUFF BOOK BAGS**

Carry a kaleidoscope of color! Roomy 13½x17½x3" bag is made of tough doublewall Superfilm with drawstring. Order in packages of 25; packages cannot be broken. **J118-033**

**\$7.95** per package (25)  
20 pkgs. or more: **\$7.25/pkg.**

**CATCH THE WAVE BUTTONS**

Flashy, splashy, not at all trashy! Be sure to get enough for staff, faculty, and friends! 2¼" diameter. Order in packages of 5; packages cannot be broken. **J128-026**

**\$2.35** per package (5)  
10 pkgs. or more: **\$2.25/pkg.**  
20 pkgs. or more: **\$2.00/pkg.**

**CATCH THE WAVE BANNER**

8x36" banner is perfectly sized for those hard-to-decorate spots—stack ends, desk fronts, ceiling beams and ducts, over doors—use your imagination!

**J132-327 \$3.50**

**CATCH THE WAVE 3-in-1 DECORATOR**

Create hot spots with these five dazzling designs. Use 'em as handdowns, or stickups, or on a bulletin board. Graphics printed both sides; slogans (same as bookmarks) on one side only. Pieces are 10 1/2 x 23 1/2" long. String for handdown use included. **J124-269 \$6.50**

*Special Value Kit!*

- Catch the Wave Kit**
- 1 Catch the Wave Poster
- 1 pkg. Catch the Wave Bookmarks (200)
- 1 Catch the Wave Banner
- 1 Catch the Wave 3-in-1 Decorator
- 1 pkg. Catch the Wave Buttons (5)

**J142-120**

Value **\$22.05**  
You Pay **\$19.95**

**Save Over 9%**

**CATCH THE WAVE BOOKMARKS**

Five different dynamic slogans in each package of 200—"Hot News," "Good Stuff," "Let's Read," "Great Books," and "Cool Facts." Order in packages of 200; packages cannot be broken.

**J122-068 \$5.75** per package (200)

3 pkgs. or more: **\$5.50/pkg.**

**BEST COPY AVAILABLE**



Box 889,  
Hagerstown, MD 21741

Address NOT correct? Make corrections below.  
 Please ship and/or bill my order to address below:  
 CODE 180253 CUST 0122339  
 IFA R. PATTON  
 VIRGINIA STATE LIBRARY  
 201 EAST MARKET STREET  
 CHARLOTTESVILLE VA 22901

**IT'S EASY TO ORDER FROM UPSTART**  
 To speed your order please include this form, even if you use a purchase order. PLEASE PRINT!

For Office Use

2B

**Payment Method**

Check or money order enclosed  
 C.O.D. \$4.00 additional charge  
 Bill my school or library  
 P.O. No. \_\_\_\_\_ if required

Card number \_\_\_\_\_  
 Signature \_\_\_\_\_  
 Expires \_\_\_\_\_

**Ship To:** (if DIFFERENT from Customer Address at left):  
 We need street address for UPS delivery.

NAME \_\_\_\_\_  
 STREET ADDRESS \_\_\_\_\_  
 CITY \_\_\_\_\_ STATE \_\_\_\_\_ ZIP \_\_\_\_\_  
 APT \_\_\_\_\_  
 ATTENTION \_\_\_\_\_ TITLE \_\_\_\_\_

**Bill To:** (if DIFFERENT from Ship To Address above):

NAME \_\_\_\_\_  
 ADDRESS \_\_\_\_\_  
 CITY \_\_\_\_\_ STATE \_\_\_\_\_ ZIP \_\_\_\_\_  
 APT \_\_\_\_\_  
 ATTENTION \_\_\_\_\_ TITLE \_\_\_\_\_

Phone number to call if there is a problem with your order: ( \_\_\_\_\_ ) \_\_\_\_\_

Item No.	Qty.	Product Description	Per Approval Item		Unit Price	Total Price
			Style	Color		
118						
<b>Subtotal</b>						
Maryland Customers add 5% Tax or tax-exempt no.						
<b>Service &amp; Handling Charges</b>						
<input type="checkbox"/> UPS <input type="checkbox"/> AIR Air Mail shipments require extra postage.						
<b>Total</b> Thank you!						

**SERVICE, HANDLING & INSURANCE CHARGES** includes postage or UPS, handling and our insurance for guaranteed safe delivery. Orders under \$20.00 add \$2.00. Orders \$20.00 and over add 10%. Maximum Service, Handling & Insurance Charge \$20.00.

**AIR MAIL SHIPMENTS** Orders under \$20.00 add \$4.00. Orders \$20.00 and over add 20%. No maximum charge.

**C.O.D.** add \$4.00 to the above charges.

*Important Information*

Prices in this catalog are guaranteed through December 31, 1988.

To order by phone call **TOLL FREE:**  
**1-800-448-4887**

Maryland Customers call:  
**1-301-797-9689**

To speed ordering - **PLEASE** use this order form to organize your order **BEFORE** calling.

# **BUSCH GARDENS**

## **THE OLD COUNTRY**

WILLIAMSBURG, VA.

*presents*

## **Summer Reading Spectacular**

Busch Gardens is proud to be a part of the Virginia 1989 Summer Reading Program. This year, Busch Gardens offers a world of excitement to Summer Reading participants as we help them explore Europe of the 17th century. Librarians can look forward to receiving:

- "Faraway Places" a free loan film/video and accompanying teaching unit available to libraries upon request. Imagination and creativity are untapped resources that are often neglected in today's technological society. The purpose of this one-of-a-kind educational unit developed by educators and child psychologists is to stimulate a child's imagination as well as encourage self-expression.
- "A Look at The Old Country" Busch Gardens suggested reading list for all ages of interesting stories, fact or fancy, of 17th century Europe including fairy tales, folk tales, plays, classical novels, historical novels, and more!
- Colorful posters and brochures announcing this event to all your readers.
- Summer is meant for activity and Busch Gardens provides discounted admission tickets for all your readers to explore the beauty and excitement of Europe on this side of the Atlantic. Summer Readers, their families and friends can visit Busch Gardens at \$4.50 off the regular admission price August 12-27, 1989.
- The Old Country Activities Packet including special activities for your young readers.
- "Busch Gardens Most Outstanding Reader Award" to be given to your best reader. Winners from all libraries will be eligible for the Grand Prize drawing to win 8 (eight) complimentary admissions to Busch Gardens and \$40 worth of Old Country Currency.

Help your readers visit the magic of 17th century Europe with their imagination and Busch Gardens, The Old Country.

For more information, please contact Busch Gardens, The Old Country at P.O. Drawer FC, Williamsburg, VA 23187, (804) 253-3350, Northern Virginia (703) 522-1387.

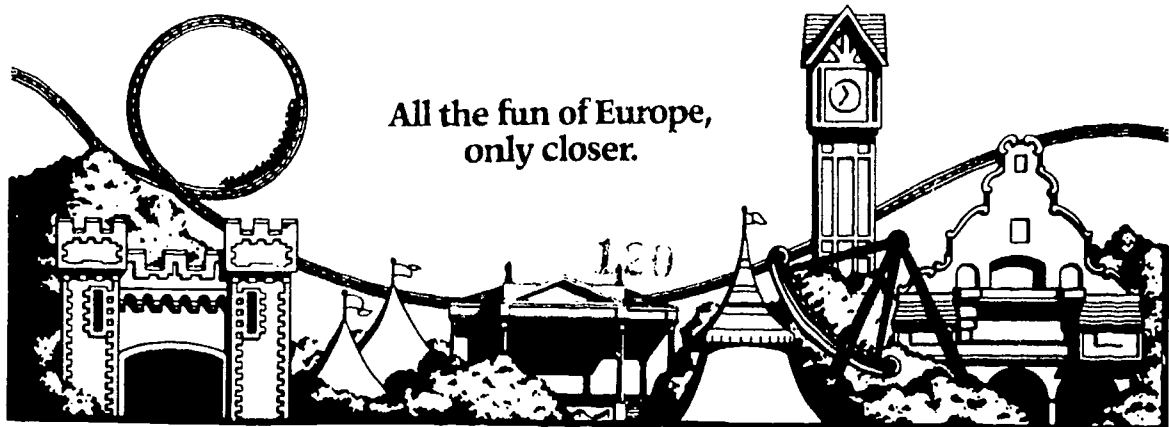

# Kings Dominion

ANNOUNCES

## 1989 Summer Reading Incentive Program!

AUGUST 5 - 13, 1989

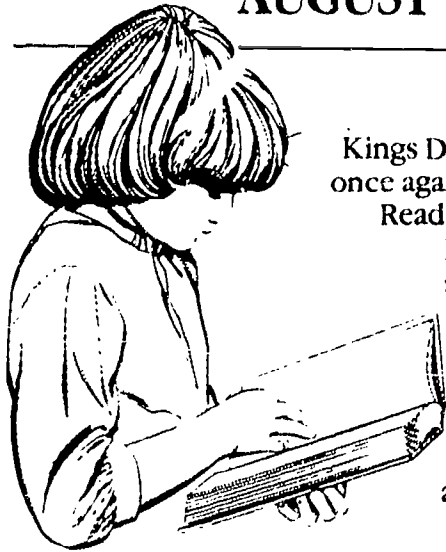

Kings Dominion is proud to once again offer the Summer Reading Program to your library in 1989! The tremendous success of the program has depended on the participation and support of libraries such as yours. We look for 1989 to be the most successful so far!

Through this Incentive Program, Kings Dominion rewards today's youth for their time spent reading. There are so many entertaining alternatives available today that reading can often be lost amidst home video equipment, electronic games, movies, etc. Incentives that reward reading should really make a difference!

### Special Reading Incentive!

Kings Dominion will honor those who complete the Summer Reading Program with discount coupons—each worth \$5.00 off the normal \$18.95 admission. These coupons will be valid August 5 through 13, 1989. A day at Kings Dominion for \$13.95 per person is the best deal around!

### Bring Family Members & Friends!

These coupons may be used by friends and family members of the children receiving these coupons, but, should only be awarded to those meeting their library requirements for the Summer Reading Program.

### How To Get Involved

Simply complete the attached reply card and return it to Kings Dominion by April 1, 1989. We will then send you a supply of coupons, color posters and brochures to help promote your library's participation.

**IF** you have any questions or need additional coupons/posters, please call us at (804) 876-5000 or write Kings Dominion, Summer Reading Program, Doswell, VA 23047.

(please cut and mail)

## Kings Dominion 1989 Summer Reading Incentive Program

**YES!** I want to enhance our Summer Reading Program with the Kings Dominion incentive. Please send me a supply of \$5.00 discount coupons along with the quantity of posters indicated.\*

INDICATE QUANTITY:

- \_\_\_\_\_ 17" × 25" color posters for bulletin board display  
\_\_\_\_\_ 8½" × 14" color posters for bulletin board display  
\_\_\_\_\_ 8½" × 14" color posters mounted on easels for counter display

The number of children participating in our local Summer Reading Program in 1988 was \_\_\_\_\_

The number of children who met the program requirements was \_\_\_\_\_

Name of Librarian \_\_\_\_\_

Library \_\_\_\_\_

Address \_\_\_\_\_

City/State \_\_\_\_\_ Zip \_\_\_\_\_

Phone \_\_\_\_\_

ATTN: LIBRARIAN

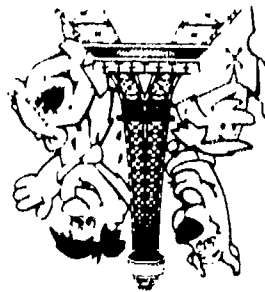

Kings Dominion  
DOSWELL, VA 23047

# NEW IN 1989: SKY PILOT

Take over the flight controls for a sky-high adventure **OR** spin upside down through thrilling aerobatic maneuvers — It's exciting and it's your choice! Challenge the only ride of its kind on the East Coast — **NEW** at Kings Dominion!



Doswell, VA 23047

**Kings Dominion**

POSTAGE WILL BE PAID BY ADDRESSEE

**BUSINESS REPLY MAIL**  
FIRST CLASS PERMIT NO. 4 DOSWELL, VA



122



NO POSTAGE  
NECESSARY  
IF MAILED  
IN THE  
UNITED STATES





**KINGS DOMINION  
1989 SUMMER READING INCENTIVE PROGRAM  
AUGUST 5-13, 1989**

Kings Dominion is proud to announce it's annual **SUMMER READING INCENTIVE PROGRAM**. Over the years, libraries from Virginia, Maryland, West Virginia, Pennsylvania and Washington, DC have participated in the program. Thousands of readers have benefitted from meeting their requirements and have enjoyed a fun-filled day at Kings Dominion!

**WHAT IS IT?**

The Summer Reading Incentive Program rewards reading. The libraries set up the reading requirements for the program, and those readers who meet the requirements receive discount coupons to Kings Dominion. Participants may share these coupons with friends and family members.

**WHEN IS IT?**

Readers participating in the Summer Reading Program have the entire summer to complete their reading requirements and can then reward themselves with a day at Kings Dominion. These discount coupons are redeemable August 5-13, 1989.

**WHO IS RESPONSIBLE FOR .....?**

- ° Reading Requirements - The library sets up the reading requirements which must be met.
- ° Coupons - Kings Dominion will have the coupons printed and sent to your library. The library then handles the distribution of coupons to those meeting the requirements.
- ° Promotional Pieces - Kings Dominion will also print posters and counter cards to help promote your participation in the program.

Kings Dominion will send to each library information pertaining to the program which includes a reply card to indicate the quantity of promotional pieces and coupons you will need.

**A GOOD VALUE**

These discount coupons are good for \$5.00 off the normal front gate admission price of \$18.95. For only \$13.95 per person you can enjoy all the rides, shows and attractions that Kings Dominion has to offer.

More information on the Summer Reading Incentive Program can be obtained by writing Kings Dominion, Summer Reading Incentive Program, Doswell, Virginia 23047 or calling (804) 876-5000.

## EVALUATION

# 1989 SUMMER READING PROGRAM EVALUATION FORM

This information will be used to evaluate and improve the Virginia Summer Reading Program in the future. Your assistance is greatly appreciated.

LIBRARY NAME: \_\_\_\_\_

PROGRAM ADMINISTRATOR: \_\_\_\_\_ Phone: \_\_\_\_\_

\_\_\_\_\_ VA \_\_\_\_\_  
(street address) (city) (zip)

This library used Paddington \_\_\_\_\_ Catch the Wave \_\_\_\_\_ Another \_\_\_\_\_  
(title)

## STATISTICS

Dates of program: Began \_\_\_\_\_ Ended \_\_\_\_\_ # Weeks \_\_\_\_\_

Number of children enrolled in Paddington \_\_\_\_\_ Number completing \_\_\_\_\_

Number enrolled in Catch the Wave \_\_\_\_\_ Number completing \_\_\_\_\_

Number enrolled in other program \_\_\_\_\_ Number completing \_\_\_\_\_

Were pre-readers included? \_\_\_\_\_ yes \_\_\_\_\_ no Ages \_\_\_\_\_

Were young adults included? \_\_\_\_\_ yes \_\_\_\_\_ no Ages \_\_\_\_\_

Estimated number of children in your service area. \_\_\_\_\_

Program budget \$ \_\_\_\_\_ Sources \_\_\_\_\_

Did you use incentives? \_\_\_\_\_ yes \_\_\_\_\_ no If yes, please describe. \_\_\_\_\_

Number of teen volunteers \_\_\_\_\_ Number of adult volunteers \_\_\_\_\_

Volunteer duties/responsibilities \_\_\_\_\_

## ACTIVITIES

Please check the types of activities conducted during the summer:

\_\_\_\_\_ Arts & Crafts      \_\_\_\_\_ Booktalks      \_\_\_\_\_ Booktalks  
\_\_\_\_\_ Drama      \_\_\_\_\_ Films/ videos      \_\_\_\_\_ Films/ videos  
\_\_\_\_\_ Games      \_\_\_\_\_ Music      \_\_\_\_\_ Programs with speakers  
\_\_\_\_\_ Puppet shows      \_\_\_\_\_ Special finale program      \_\_\_\_\_ Storyhours  
\_\_\_\_\_ Other (Please describe) \_\_\_\_\_

**PUBLICITY**

Please indicate the types of publicity used to promote your program.

- \_\_\_\_\_ Cable
- \_\_\_\_\_ Club visits
- \_\_\_\_\_ Displays
- \_\_\_\_\_ in library
- \_\_\_\_\_ outside of library
- \_\_\_\_\_ Electronic bulletin boards
- \_\_\_\_\_ Flyers/ brochures
- \_\_\_\_\_ Press release
- \_\_\_\_\_ Paper
- \_\_\_\_\_ Radio
- \_\_\_\_\_ TV
- \_\_\_\_\_ Photo/ slide show
- \_\_\_\_\_ School visits
- \_\_\_\_\_ Other (Please describe) \_\_\_\_\_

**MATERIALS**

Please indicate which materials you received from the Virginia State Library & Archives and rate the usefulness of each by circling the appropriate number on the scale.

(1 = Not useful; 2 = Somewhat useful; 3 = Useful; 4 = Very Useful)

- |   |   |   |   |   |
|---|---|---|---|---|
| _____ ALA Program guide                   | 1 | 2 | 3 | 4 |
| _____ VSL&A Manual                        | 1 | 2 | 3 | 4 |
| _____ Paddington Bookmarks (ALA)          | 1 | 2 | 3 | 4 |
| _____ Paddington Stickers (ALA)           | 1 | 2 | 3 | 4 |
| _____ Paddington Reading Logs (VSL&A)     | 1 | 2 | 3 | 4 |
| _____ Paddington Certificates (VSL&A)     | 1 | 2 | 3 | 4 |
| _____ Catch the Wave Bookmarks (UPSTART)  | 1 | 2 | 3 | 4 |
| _____ Catch the Wave Reading Logs (VSL&A) | 1 | 2 | 3 | 4 |
| _____ Catch the Wave Stickers (UPSTART)   | 1 | 2 | 3 | 4 |

Library \_\_\_\_\_

Did you receive adequate amounts of requested items? \_\_\_\_\_ yes \_\_\_\_\_ no

Were there any problems associated with the materials you received from ALA, UPSTART or

VSL&A? \_\_\_\_\_ yes \_\_\_\_\_ no

(If yes, please describe.) \_\_\_\_\_

Did you develop additional materials? \_\_\_\_\_ yes \_\_\_\_\_ no (If yes, please enclose samples)

What other materials would you have liked to have had provided? \_\_\_\_\_

What suggestions do you have for improving the Virginia Summer Reading Program in the future.

Did you attend one of the April Reading Program workshops? \_\_\_\_\_ yes \_\_\_\_\_ no

What suggestions do you have for improving the workshops?

#### ADDITIONAL COMMENTS