

DOCUMENT RESUME

ED 358 661

EC 302 225

AUTHOR Hoge, Robert D.; Renzulli, Joseph S.
 TITLE Self-Concept and the Gifted Child. Research-Based Decision Making Series, Number 9104.
 INSTITUTION National Research Center on the Gifted and Talented, Storrs, CT.
 SPONS AGENCY Office of Educational Research and Improvement (ED), Washington, DC.
 PUB DATE Dec 91
 CONTRACT R206R00001
 NOTE 57p.
 AVAILABLE FROM NRC/GT, The University of Connecticut, 362 Fairfield Rd., U-7, Storrs, CT 06269-2007.
 PUB TYPE Information Analyses (070)

EDRS PRICE MF01/PC03 Plus Postage.
 DESCRIPTORS Ability Identification; *Academically Gifted; Counseling; Elementary Secondary Education; *Homogeneous Grouping; *Labeling (of Persons); Research Methodology; Research Needs; *Self Concept; *Self Esteem; Self Evaluation (Individuals); Special Classes; Student Development

ABSTRACT

Three issues are addressed in this research review. First, do gifted and average children differ in their self-concepts? Second, what, if any, are the effects on self-concept of labeling a child as gifted or exceptional? Third, does placing the child in a separate enriched or accelerated classroom have any impact on self-concept? The paper begins with a discussion of issues relating to self-concept and giftedness constructs. This is followed by a review of the research evidence bearing on the three questions. That research is shown to yield variable results and to exhibit some methodological flaws. Nevertheless, some conclusions are drawn, including the following: (1) gifted students as a group show no major deficits in self-esteem; (2) indirect evidence suggests that labeling a child gifted may have a positive impact on self-esteem; and (3) there is some support, based on social comparison processes, that moving a child from a regular classroom to a homogeneous, highly gifted group may have a negative impact on self-concept. Implications of the results for future research and for the counseling of gifted students are offered, including the recommendation that researchers should pay more attention to treatment of self-concept and giftedness variables and that counseling with gifted and talented students should have a developmental focus. (Contains approximately 100 references.) (Author/DB)

 * Reproductions supplied by EDRS are the best that can be made *
 * from the original document. *

ED358661

U.S. DEPARTMENT OF EDUCATION
Office of Educational Research and Improvement
EDUCATIONAL RESOURCES INFORMATION
CENTER (ERIC)

- This document has been reproduced as received from the person or organization originating it
- Minor changes have been made to improve reproduction quality
- Points of view or opinions stated in this document do not necessarily represent official OERI position or policy

FC302225

Self-Concept and the Gifted Child

Robert D. Hoge, Ph.D.
Carleton University
Ottawa, Ontario, Canada

Joseph S. Renzulli, Ed.D.
The University of Connecticut
Storrs, Connecticut

December 1991
Number 9104



RESEARCH-BASED DECISION MAKING SERIES

THE NATIONAL RESEARCH CENTER ON THE GIFTED AND TALENTED

The National Research Center on the Gifted and Talented (NRC/GT) is funded under the Jacob K. Javits Gifted and Talented Students Education Act, Office of Educational Research and Improvement, United States Department of Education.

The Directorate of the NRC/GT serves as the administrative unit and is located at The University of Connecticut.

The participating universities include The University of Georgia, The University of Virginia, and Yale University, as well as a research unit at The University of Connecticut.

The University of Connecticut
Dr. Joseph S. Renzulli, Director
Dr. E. Jean Gubbins, Assistant Director

The University of Connecticut
Dr. Francis X. Archambault, Associate Director

The University of Georgia
Dr. Mary M. Frasier, Associate Director

The University of Virginia
Dr. Carolyn M. Callahan, Associate Director

Yale University
Dr. Robert J. Sternberg, Associate Director

Copies of this report are available from:

NRC/GT
The University of Connecticut
362 Fairfield Road, U-7
Storrs, CT 06269-2007

Research for this report was supported under the Javits Act Program (Grant No. R206R00001) as administered by the Office of Educational Research and Improvement, U.S. Department of Education. Grantees undertaking such projects are encouraged to express freely their professional judgment. This report, therefore, does not necessarily represent positions or policies of the Government, and no official endorsement should be inferred.

Note to Readers...

All papers that are commissioned by The National Research Center on the Gifted and Talented for the Research-Based Decision Making Series may be reproduced in their entirety or in sections. All reproductions, whether in part or whole, should include the following statement:

Research for this report was supported under the Javits Act Program (Grant No. R206R00001) as administered by the Office of Educational Research and Improvement, U.S. Department of Education. Grantees undertaking such projects are encouraged to express freely their professional judgment. This report, therefore, does not necessarily represent positions or policies of the Government, and no official endorsement should be inferred.

If sections of the papers are printed in other publications, please forward a copy to:

The National Research Center on the Gifted and Talented
The University of Connecticut
362 Fairfield Road, U-7
Storrs, CT 06269-2007

About the authors....

Dr. Robert D. Hoge is Professor of Psychology at Carleton University. His research and teaching activities focus on issues relating to assessment and evaluation in educational and social service settings. Recent research projects have dealt with the assessment of gifted potential in young children, the diagnosis of family dysfunction and stress, and the assessment of risk for delinquency. Correspondence may be addressed to: Department of Psychology, Carleton University, Ottawa, Ontario K1S 5B6, Canada.

Dr. Joseph S. Renzulli is a Professor of Educational Psychology at The University of Connecticut where he also serves as Director of The National Research Center on the Gifted and Talented. Throughout his professional career, he has actively engaged in research on creativity, the education of the gifted and talented and various aspects of program evaluation. He has contributed several books and numerous articles to the literature in gifted education and program evaluation.

Dr. Renzulli is a former President of The Association for the Gifted and is a member of the Board of Directors of The National Association for Gifted Children. He is a Fellow in the American Psychological Association and currently serves on the Education Boards of the *Gifted Children Quarterly*, *Learning Magazine*, *Gifted Child Monthly*, *The Journal of Law and Education*, and *Gifted Education International*. He has been a consultant to several school districts and agencies, including the Office of Gifted and Talented (U.S. Office of Education) and The White House Task Force on the Education of the Gifted and Talented.

Self-Concept and the Gifted Child

Robert D. Hoge, Ph.D.
Carleton University
Ottawa, Ontario, Canada

Joseph S. Renzulli, Ed.D.
The University of Connecticut
Storrs, Connecticut

ABSTRACT

Three issues are addressed in this monograph. First, do gifted and average children differ in their self-concepts? Second, what, if any, are the effects on self-concept of labeling a child as gifted or exceptional? Third, does placing the child in a separate enriched or accelerated classroom have any impact on self-concept? The paper begins with a discussion of issues relating to self-concept and giftedness constructs. This is followed by a review of the research evidence bearing on the three questions. That research is shown to yield variable results and to exhibit some methodological flaws. Nevertheless, some conclusions regarding the three issues are stated. The monograph concludes with discussions of the implications of the results for future research and for the counseling of gifted students.

Self-Concept and the Gifted Child

Robert D. Hoge, Ph.D.
Carleton University
Ottawa, Ontario, Canada

Joseph S. Renzulli, Ed.D.
The University of Connecticut
Storrs, Connecticut

EXECUTIVE SUMMARY

Objectives

Three general issues are addressed in this monograph. First, do gifted and average children differ in their self-concepts? Second, what, if any, are the effects on self-concept of labeling a child as gifted or exceptional? Third, does placing the child in a separate enriched or accelerated classroom have any impact on self-concept?

Examinations of Self-Concept and Giftedness Constructs

The monograph begins with discussions of self-concept and giftedness constructs: we show that there is less than perfect agreement on the way in which they should be defined and measured.

For example, while there is something of a consensus that self-concept refers in very general terms to the image we hold of ourselves, there is considerable disagreement over the precise way in which self-concept should be defined. The major issues concern the way various components of self-concept should be conceptualized and with the way the specific components combine to form a composite construct. The absence of an agreement on the treatment of self-concept is shown to complicate analyses of the relation between giftedness and self-concept.

Complications also exist with respect to the measurement of self-concept. In part, the difficulty arises from disagreements over definition. Different conceptualizations of self-concept imply different measurement tools. This situation creates difficulties in assessing the construct validity of self-concept measures. There also exist problems with the reliability and criterion-related validity of some of self-concept measures. Progress is being made in the refinement of the instruments, an encouraging development from the point of view of establishing a better understanding of the giftedness/self-concept relation.

Problems associated with the definition and measurement of the giftedness construct are also discussed. Alternative conceptualizations of giftedness exist. These are shown to vary along five dimensions: (a) breadth of the construct; (b) the content of the definition; (c) the level of exceptionality represented in the definition; (d) whether the definition represents a static or dynamic focus, and (e) the precision of the definition. It should be understood that this variability considerably complicates analyses of the relation between giftedness and self-concept. For example, a definition based narrowly on IQ test performance may have very different implications for a child's self-esteem than one based on a broad range of academic aptitudes and achievement levels.

Issues relating to the measurement of giftedness are also discussed. Several points are developed. Considerable variability exists across applied and research settings in the type of measure employed and in the way in which the same measure is sometimes used. Second, a discrepancy often exists between formal or official definitions of giftedness and the operational definition actually employed in a selection situation. Third, problems exist with respect to the reliability of some of the measures, and, in particular, with their construct and criterion-related validity. These problems are also shown to complicate investigations of the links between giftedness and self-esteem.

The Relation Between Giftedness and Self-Concept

Theoretical considerations. A set of hypotheses regarding the link between giftedness and self-concept are developed from various sources.

There are two bases for hypothesizing more positive self-concepts on the part of gifted children. The first rests on the assumption that, to the extent that performance is higher in the gifted, higher self-concepts will ensue. The second consideration derives from the assumption that the act of labeling a child as gifted will contribute positively to their self-esteem.

On the other hand, some reasons exist for hypothesizing that self-esteem in the gifted might be more negative than in less gifted peers. First, under some circumstances, it is likely that the high expectations communicated to the gifted child will be translated into failure experiences. The child never quite measures up to the expectations and self-esteem suffers. Second, many exceptional children are cognitively advanced and may be more sensitive to social cues and more analytic about them. This may, under some circumstances, incline children toward a more critical attitude of their abilities and performances. A third basis for predicting lowered self-esteem relates to the social comparison process. We would expect this process to be involved in those cases where children are identified as gifted, removed from the regular classroom, and placed into homogeneous groups of gifted or exceptional children. This might lead to decreased feelings of self-esteem since the child is now exposed to heightened competition.

The research evidence. Four sets of published studies relevant to the hypotheses are reviewed. These involve (a) direct comparisons of gifted and nongifted students; (b) studies exploring moderator variables; (c) studies of the labeling process; and (d) studies of program effects.

The first type of study entails direct comparisons of gifted and nongifted students in terms of self-concept. The 18 studies within this category employed one of three designs. In the first design, children identified as gifted and placed in special classes were compared with more average students in regular classes. The second design involved contrasting children identified as gifted on the basis of standardized test scores with students not meeting the criteria of giftedness. In this case, there are no labelling or special education elements involved. In the third design, the self-esteem scores of students identified as gifted and in special programs were compared with normative scores reported in connection with the self-concept measure employed in the study.

Overall, the results of these studies indicated higher general self-concept scores for the gifted children compared with their nongifted counterparts. Further, two of the three studies focusing on academic self-concept showed higher levels of self-esteem in that area for the gifted pupils. Finally, no evidence exists that social self-esteem is lower in gifted

children than more average children; in fact, the single study showing a difference favored the gifted group.

There are, on the other hand, some qualifications developed with respect to these conclusions. These qualifications have to do with the high level of variability in the results of the studies and with certain methodological weaknesses in the research.

The second set of studies focused on moderator variables; that is, variables that might mediate the relation between giftedness and self-concept. Some research is available for the following variables: gender, level of exceptionality, and level of achievement. Unfortunately, only a small number of studies show variable results, but no firm conclusions were reached regarding the operation of moderators.

The third issue concerned the effects of the labeling process on self-concept. Unfortunately, we found no studies dealing directly with the effects of the gifted label on the child. There is, however, research showing that the labeling of a child as gifted does have a definite impact on the expectations and attitudes held by parents and teachers, and one would expect that this would eventually impact on the child's self-esteem.

The fourth set of studies explored the effects of programming on the self-concept of gifted pupils. Two types of studies are relevant here. The first involved a comparison of gifted children in enrichment programs with gifted children not in special programs, or, alternatively, gifted children in different types of programs. The second examined changes in self-concepts of students before and after entrance to such programs. These studies are potentially useful in providing information about the effects of exposure to special programming on self-esteem. In particular, they provide information regarding the impact of the social comparison process.

Ten studies on program effect are reviewed and are shown to reveal highly variable effects. Thus, in some cases exposing the gifted child to special programming seems to have no effect on self-concept, in other cases it leads to enhanced self-esteem, and in still other cases it has a negative impact. Unfortunately, the design of the studies is not such that one can determine the conditions under which positive, negative, or no effects are obtained.

Conclusions and Guidelines

The following conclusions and guidelines have emerged from a review of the research evidence linking self-concept and gifted constructs. Each conclusion or guideline is followed by a brief discussion of the research-supported rationale.

Conclusion One: The direct comparisons of gifted and nongifted students revealed that the gifted students as a group showed no major deficits in self-esteem.

Discussion: The majority of students seemed to indicate somewhat higher levels of general and academic self-esteem for the exceptional group. These conclusions are, however, qualified by a number of considerations, including: (a) the variable results yielded by the studies; (b) methodological flaws in many of the studies; and (c) a lack of attention to moderator and interacting variables.

Conclusion Two: Some indirect evidence exists that labeling a child gifted would have a positive impact on self-esteem, but direct evidence is lacking.

Discussion: The impact of labeling a child gifted is an important issue, but one that has been virtually ignored in the research literature.

Conclusion Three: There is some support for a social comparison type of process; that is, that moving a child from a regular classroom to a homogeneous, highly gifted group will have a negative impact on self-concept.

Discussion: Research regarding the impact of gifted programming on self-esteem has yielded variable results. The evidence was, however, by no means consistent, and this body of research sometimes displays methodological flaws.

Implications for Research

Many problems exist in this area of research on self-concept and the gifted child. Yet, important issues are being addressed, and some exciting challenges exist with respect to research opportunities. The research methodology in the areas of self-concept and gifted is improving. It is important, however, to build further strength in this area, and we will offer some guidelines.

Guideline One: It is imperative that future researchers pay more careful attention to their treatment of self-concept and giftedness variables.

Discussion: Considerable progress has been made in the development of some of the measures, particularly the Perceived Competence Scale for Children (Harter, 1982, 1985), the Piers-Harris Children's Self-Concept Scale (Piers, 1984), and the Self-Description Questionnaire (Marsh, 1988; Marsh & O'Neill, 1984). Researchers are advised to use one of these standardized instruments and to score them for specific domain scores as well as general self-esteem.

Guideline Two: There is a need for more attention to the definition and measurement of the giftedness construct (Hoge, 1988, 1989; Hoge & Cudmore, 1986; Renzulli, 1978, 1986).

Researchers must be explicit about the definition of giftedness they are employing. There is certainly room for variable types of definitions, but it is imperative that the construct being employed in the study be made explicit and related clearly to the purpose of the research. In addition, the actual selection devices employed should be assessed in terms of their psychometric properties and should be explicitly related to the giftedness construct being measured.

Guideline Three: Future research must attend more closely to experimental design.

Discussion: A major problem with much of the research being reported is that it confounds critical variables. For example, as we have seen, much of the research on program effects confounds three processes: (a) the effects of labeling the child gifted; (b) the effects on the social comparison process of placing the child in a homogeneous group; and (c) the impact of the placement on actual achievement levels.

There are, to be sure, practical and ethical limits to the type of research that can be conducted in this area. For example designs employing random assignment of children to enriched and non-enriched classrooms are probably unacceptable. Still, we are going to have to be more ingenious in our choice of designs and analytic tools if we hope to make real progress in sorting out these issues. We note, as well, that there is room in this process for more qualitative research methodologies.

Guideline Four: There is a need for longitudinal studies in which changes in the relation between giftedness and self-concept can be explored at different age levels.

There are clearly developmental processes at work here (cf. Feldman & Benjamin, 1986), and these should be attended to more closely in research efforts in our field.

Some Implications for Counseling

The results of research reviewed above revealed no drastic problem areas for the gifted group as a whole. In general, their levels of self-esteem appeared no more problematic than those of more average students. This does not mean, however, that attention should not be paid to the special needs of this group. Several considerations lead to this point. First, the majority of the results reviewed in this paper were based on group data. These can be somewhat deceptive, often concealing problems revealed in individual cases. Second, and as we emphasized, the research is limited in some respects and, hence, not a perfect guide to practice. Third, there is ample evidence from clinical sources that exceptional children may be especially vulnerable to certain types of social and emotional problems (cf. McMillan & Loveland, 1984; Schneider, 1987).

Guideline Five: Counseling with gifted and talented students should have a developmental focus.

Discussion: Zaffrann and Colangelo (1979) have presented a useful general model for thinking about the counseling of gifted students. They believe that "counseling with gifted and talented students should take place within a developmental program organized and maintained for these youngsters...A developmental guidance program for gifted and talented youth must be based on the unique needs and concerns of these students" (Zaffrann & Colangelo, 1979, p. 168).

This type of advice is especially relevant when considering the issue of self-esteem. Our earlier discussion indicates that the nature of self-esteem and the processes affecting it change over the childhood and adolescent years. In developing intervention programs it is important to take account of these developmental changes.

Guideline Six: Exceptional children often have special needs with respect to emotional health and social competence, and that systematic efforts should be made to accommodate these needs.

Discussion: Zaffrann and Colangelo (1979) acknowledge that exceptional children often have special needs with respect to emotional health and social competence, and that systematic efforts be made to accommodate these needs.

Summary Statement

Three broad objectives were represented in this paper. First, we were concerned with explicating the various questions raised regarding the link between giftedness and self-concept. Many discussions of this issue, as well as many of the research activities in the area, are guided by simplistic conceptualizations, and we have endeavored to introduce some conceptual clarity.

Second, we have made an effort to synthesize the research results available on the issues raised. Unfortunately, that synthesis did not yield a great deal in the way of conclusive answers to our questions. Research methodologies were highly variable and, in some cases, flawed, and results tended to be inconsistent. Yet, the review helped to create a foundation upon which to build a sounder body of research.

Finally, specific recommendations for future research and for the counselling of gifted children are offered. The research recommendations focus on the need for (a) more adequate treatments of self-concept and giftedness variables; (b) improved design and analytic procedures; and (c) attention to moderator and interacting variables. The counseling recommendations focus generally on the need for an increased sensitivity to the effects of the gifted label and gifted programming on the self-concept of children.

References

- Feldman, D. H., & Benjamin, A. C. (1986). Giftedness as a developmentalist sees it. In R. J. Sternberg & J. E. Davidson (Eds.), *Conceptions of giftedness* (pp. 285-305). Cambridge: University of Cambridge Press.
- Harter, S. (1982). The Perceived Competence Scale for Children. *Child Development*, 53, 87-97.
- Harter, S. (1985). *Manual for the Self-Perception Profile for Children*. Unpublished Manuscript, University of Denver.
- Hoge, R. D. (1988). Issues in the definition and measurement of giftedness construct. *Educational Researcher*, 17, 12-16.
- Hoge, R. D. (1989). An examination of the giftedness construct. *Canadian Journal of Education*, 14, 6-17.
- Hoge, R. D., & Cudmore, L. (1986). The use of teacher-judgment measures in the identification of gifted pupils. *Teaching and Teacher Education*, 2, 181-196.
- Marsh, H. W. (1988). Causal effects of academic self-concept on academic achievement: A reanalysis of Newman (1984). *Journal of Experimental Education*, 56, 100-104.
- Marsh, H. W., & O'Neill, R. (1984). Self Description Questionnaire III: The construct validity of multidimensional self-concept ratings by late adolescents. *Journal of Educational Measurement*, 21, 153-174.
- McMillan, E., & Loveland, G. (1984). Counseling for the gifted. *Special Education in Canada*, 58, 125-126.
- Piers, E. (1984). *Piers-Harris Children's Self-Concept Scale: Revised manual*. Los Angeles: Western Psychological Services.
- Renzulli, J. S. (1978). What makes giftedness? Reexamining a definition. *Phi Delta Kappan*, 60, 180-184, 261.
- Renzulli, J. S. (1986). The three-ring conception of giftedness: A developmental model for creative productivity. In R. J. Sternberg & J. E. Davidson (Eds.), *Conceptions of Giftedness*.
- Schneider, B. H. (1987). *The gifted child in peer group perspective*. New York: Springer-Verlag.
- Zaffrann, R. T., & Colangelo, N. (1979). Counseling with gifted and talented students. In J. C. Gowan, J. Khatena, & E. P. Torrance (Eds.), *Educating the ablest* (2nd ed.) (pp. 167-181). Itasca, IL: F. E. Peacock.

Table of Contents

Abstract	vii
Executive Summary	ix
Conceptualizing and Measuring Self-Concept	1
Alternative Conceptualizations of Self-Concept	1
The Formation of Self-Concept	5
Implications of Self-Concept	7
Measurement Issues	8
Conceptualizing and Measuring Giftedness	13
Alternative Conceptualizations	13
The Measurement of Giftedness	14
Giftedness and Self-Concept	17
Theoretical Considerations	17
The Research Evidence	18
Conclusions and Guidelines	29
Implications for Research	29
Some Implications for Counseling	30
Summary Statement	33
References	35

List of Tables

Table		
1.	Commonly Used Self-Concept Measures	8
2.	Sample Items from the Self-Perception Profile for Children	9
3.	Sample Items from the Piers-Harris Children's Self-Concept Scale	10
4.	Major Types of Measures Used in the Identification of Gifted Students	14
5.	Summary of Studies Comparing Gifted and Nongifted Children in Terms of Self-Concept Measures	18
6.	Studies Exploring Program Effects	23

List of Figures

Figure		
1.	Model of the Structure of Self-Concept	3
2.	Model of the Academic Self-Concept	4
3.	A Model of Factors Affecting Self-Concept	6

Self-Concept and the Gifted Child

Robert D. Hoge, Ph.D.
Carleton University
Ottawa, Ontario, Canada

Joseph S. Renzulli, Ed.D.
The University of Connecticut
Storrs, Connecticut

Three general issues are addressed in this paper. The first concerns the question of whether intellectual, academic, or creative exceptionalism is associated in any way with self-concept. Does, for example, the mathematically precocious child display higher self-esteem with respect to math achievement? The second question concerns the effects of labeling a child as gifted. Third, we are concerned with the effects of gifted programming: Does the experience of being in a gifted class have any impact on self-esteem?

The paper is organized as follows. A discussion of some conceptual, theoretical and measurement issues relating to self-concept are presented first. Second, alternative ways of defining and measuring the giftedness construct are suggested. Third, a review of the research bearing on the questions of concern is presented. The final section of the paper contains a summary of the conclusions of the review and a set of guidelines regarding (a) directions for future research and (b) means for serving the self-esteem needs of the gifted child.

Conceptualizing and Measuring Self-Concept

Self-concept refers in very general terms to the image we hold of ourselves. A somewhat more specific definition refers to "...our attitudes, feelings and knowledge about our abilities, skills, appearance, and social acceptability" (Byrne, 1984, p. 429). Still another type of definition refers to self-concept as a theory:

It is a theory that the individual has unwittingly constructed about himself as an experiencing, functioning individual, and it is part of a broader theory which he holds with respect to his entire range of significant experience (Epstein, 1973, p. 407).

There are several facets to self-concept, including cognitive, perceptual, affective, and evaluative dimensions. The evaluative component concerns the way in which children evaluate or assess the various aspects of their personality, achievements, social status, etc. This component is sometimes referred to more specifically as self-esteem, but the usual practice of using the general term self-concept to refer to this evaluation process will be used in this review.

Alternative Conceptualizations of Self-Concept

While there may be agreement on the general definitions of self-concept presented above, there is, in fact, considerable disagreement in the literature over the way in which the construct should be operationally defined. This complex controversy will not be reviewed in detail, but it is necessary to outline the various competing positions by way of background to our subsequent discussion. Our discussion in this case is based largely on the reviews of Byrne (1984), Harter (1986), and Marsh (1990b).

Three positions have been advanced with regard to the self-concept construct. The first of these is the single score or unidimensional model advanced by Coopersmith (1967), among others. This position acknowledges that there are various aspects to self-concept (relating, for example, to academic achievement, physical appearance, athletic ability), but it postulates that the only meaningful way of conceptualizing the construct is in terms of a general construct of self-worth. One implication of this position is that the assessment of self-concept can be based on one's feelings of self-esteem in any specific area. Thus, if the child shows high self-esteem with respect to social competencies, then it is likely he/she will show high self-esteem in all other areas. Most of the empirical evidence supports some sort of multidimensional conception, and this unidimensional type of model has relatively little appeal today.

The multidimensional models constitute the second means of conceptualizing self-concept. These models generally postulate that self-concept is composed of a set of relatively independent dimensions or factors. For example, Harter's (1982, 1983) original model identified four differentiable aspects of self-concept; these corresponded to the domains of scholastic competence, athletic competence, social acceptance, physical appearance, and behavior or conduct. A similar conceptualization was offered by Winne and Marx (1981) who also postulated four dimensions: academic, social, physical, and emotional. While the research evidence indicates that relations among the various facets of self-concept are complex, strong support exists for the relative independence of some facets (e.g., Byrne, 1986; Harter, 1982; Marsh & O'Neill, 1984), and, hence, the results are generally supportive of this type of view.

The hierarchical models constitute a third way of conceiving self-concept. These models use the multidimensional construct as the starting point, but they then postulate a hierarchical organization for the various facets. For example, Shavelson, Hubner, and Stanton (1976) proposed the model outlined in Figure 1. The model portrays self-concept as deriving from evaluations of specific behaviors at the base through increasingly broad areas of evaluation to General Self-Concept at the peak. The model corresponds to the hierarchical model of cognitive abilities, with specific abilities showing some independence from one another, but with enough shared variance to talk of a General Intelligence factor.

More recent efforts have produced even more differentiated constructs. An example may be found in Figure 2 which indicates that feelings of competence in the broad Math and Verbal achievement areas can be further broken down into even more specific areas; that model is based on the work of Marsh, Byrne, and Shavelson (1988).

Some empirical support for these types of hierarchical models is available, but controversies exist. The empirical data are not entirely consistent with the formulation (cf. Byrne, 1984; Marsh, 1990b). Also, as Harter (1986) has pointed out, some conceptual problems exist. For example, there is often an absence of theory specifying the way in which the various components organize themselves into a hierarchy. Related to this is a failure to adequately operationalize the various components of the hierarchy, a point which will be pursued in more detail in discussing measurement issues. Finally, a failure exists in these models to acknowledge that different aspects of self-esteem might be differentially weighted for the individual. In conclusion, while the hierarchical model is a promising one, more research is needed.

Figure 1. Model of the Structure of Self-Concept.

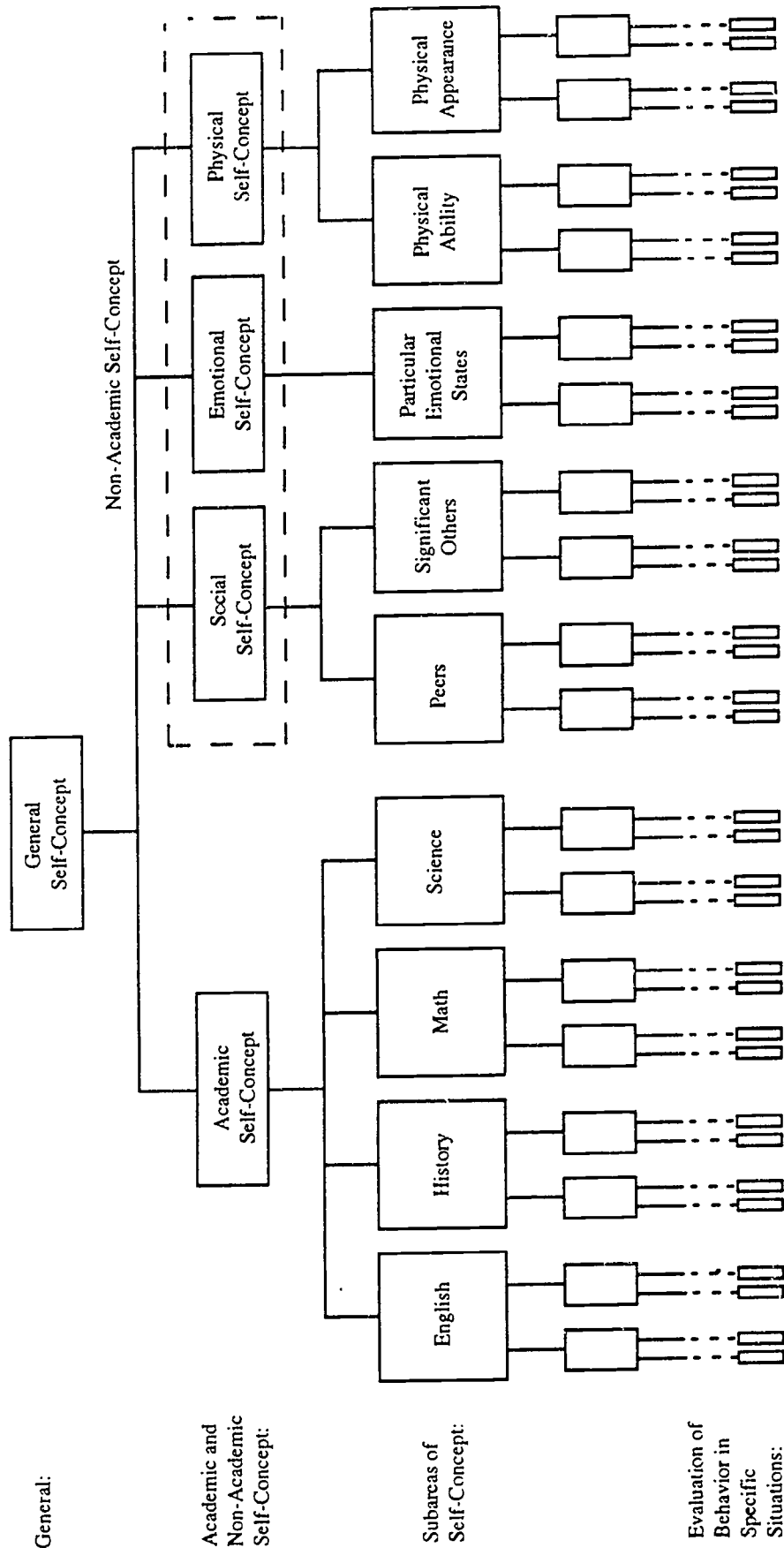

Source: Shavelson, R.J., Hubner, J.J., & Stanton, G.C. (1976). Self-concept: Validation of construct interpretations. *Review of Educational Research*, 46, 407-441. Reprinted by permission.

Figure 2. Model of Academic Self-Concept.

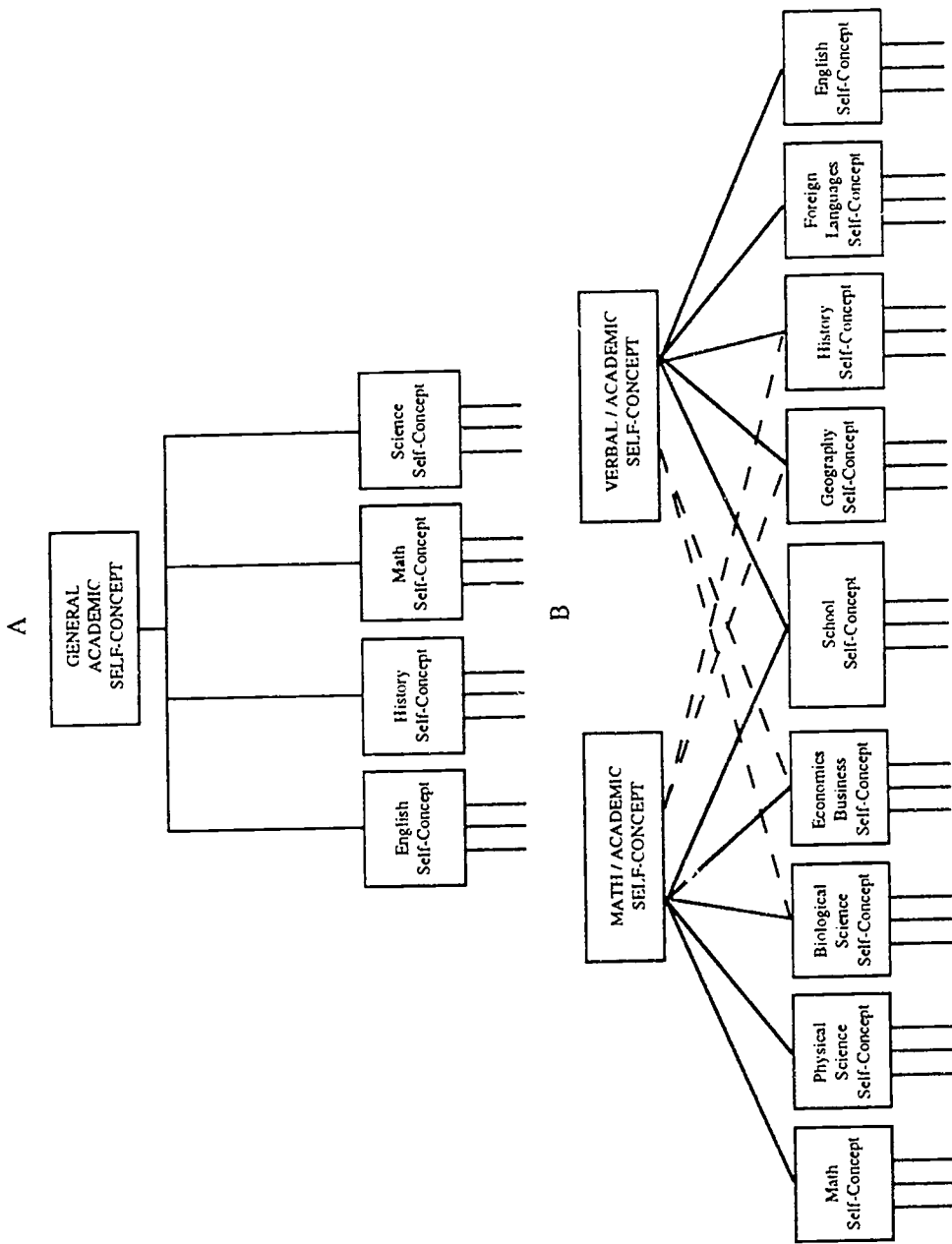

Source: Marsh, H.W., Byrne, B.M., & Shavelson, R.J. (1988). A multifaceted self-concept: Its hierarchical structure and relations to academic achievement. *Journal of Educational Psychology, 80*, 366-380. Reprinted by permission.

One other issue relevant to the hierarchical models concerns the meaningfulness of a concept of global self-worth. Most of the hierarchical models postulate a general self-concept factor at the apex of the hierarchy. The meaning of that general factor is, however, not always clear, nor is it clear whether the general factor is a simple additive product of responses to the specific factors or a more complex product of those responses.

Something of a solution to this dilemma is found in the work of Harter (1986) and Rosenberg (1979). These researchers proposed the existence of a global self-worth factor that is, in part, a product of feelings of competence in specific domains but also has, in part, an independent existence. The construct refers to "...the degree to which one likes oneself as a person, likes the way one is leading one's life, is happy with the way they are, feels good about oneself, and so on" (Harter, 1986, p. 142). This construct will be discussed later as related to measurement issues.

Efforts to conceptualize self-concept entail a unidimensional, multidimensional or hierarchical approach. There are also some theoretical issues relating to the formation of self-concept and its effects on behavior that need to be addressed by way of background to our subsequent discussions.

The Formation of Self-Concept

Two classic positions exist with respect to the development of self-concept. The first derives from William James (1892) and asserts that one's self-image and self-evaluation develop in terms of a cognitive process whereby individuals assess their competencies and accomplishments against the expectations they hold for themselves. Thus, if we fail at an athletic competition where we had expected to do well, and we hold performance in that area to be important, self-esteem would suffer. On the other hand, a poor performance in that case would have little impact where we had low expectations or attached little value to the endeavor.

The second basic position derives from the writings of Cooley (1902) who emphasized the role of significant others in the development of self-concept. Cooley actually talked of three processes: (a) individuals' perceptions of the images held of them by the 'other' person; (b) their perceptions of the 'other's' evaluation of them; and (c) their affective responses to the situation. Self-esteem derives, then, from the opinions communicated by parents, teachers, and peers.

Theoretical developments since these early efforts display two general characteristics. First, there is less concern about choosing between the two alternatives; most theorists now acknowledge that both external and internal forces operate to affect self-concept. Second, recent efforts have attempted to be more explicit about the processes underlying the development of self-concept. Some recent developments are especially relevant to our subsequent discussion.

Harter (1986) has presented a theoretical model of the determinants and consequences of self-concept that incorporates both internal and external factors and that is useful for organizing the discussion (see Figure 3). The model represents global self-worth as a product of two phenomena: the competence/importance discrepancy and social support/positive regard. In turn, self-worth is seen as impacting on both affect and motivation. The focus here is on global self-worth; however, more specific aspects of self-esteem can also be conceptualized within the model.

Figure 3. A Model of Factors Affecting Self-Concept.

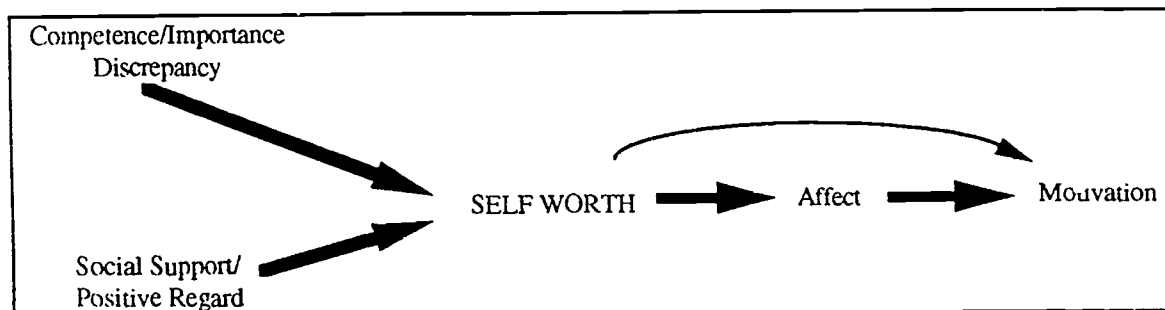

Source: Harter, S. (1986). Processes underlying the construction, maintenance, and enhancement of the self-concept in children. In J. Suls & A. G. Greenwald (Eds.), *Psychological perspectives on the self* (Vol. 3, pp. 137-181). Hillsdale, NJ: Lawrence Erlbaum Associates. Reprinted by permission.

The two 'causal' factors will be discussed in this section and the issue of consequences will be introduced in a later section.

The first of the factors postulated as affecting self-worth is the competence/importance discrepancy. The basic hypothesis is that one's feelings of global self-worth represent a product of one's perceptions of competence in the various specific areas of self-concept and the importance attached to those areas by the individual:

More specifically, building upon James' contention, we have hypothesized that general self-worth among older children will be, in large part, based on the discrepancy between their domain-specific competence/adequacy evaluations and their attitudes concerning the importance of success in each of these domains. (Harter, 1986, p. 142)

Harter believes that these cognitive processes are not as fully developed in the child as in the adult, but they are operative and they are developing.

An alternative view exists of this internal comparison process. Winne and Marx (1981) have advanced what is termed a compensatory model. This model views the various facets of self-concept as inversely related to one another; thus, low perceived competence in one area tends to be compensated by higher perceived competence in another. (See Marsh, 1990a, for a similar formulation.) However, research on this issue (and on these internal cognitive processes) is somewhat sparse and has yielded inconsistent results thus far.

Considerable attention has also been paid to the social support/positive regard factor within the model. The reference is to the processes whereby individuals use the reactions of significant others in their environment to assess their performances and competencies. The two major categories of significant others in the life of the child are parents and peers, though the relative importance of these varies with the developmental level of the child.

An interesting aspect of this social comparison issue, particularly where academic self-concept is concerned, has to do with the impact of the role of the larger school environment in affecting self-concept. Marsh (1990a) has postulated the Big-Fish-Little-Pond Effect in this connection. The basic hypothesis is that children's feelings of self-worth regarding academic performance will depend to some extent on the average level of performance displayed in their school or their class. This is an issue of some consequence when it comes to considering the effects of placing gifted children in special classes.

It is also important to mention some theoretical considerations bearing on developmental issues. Since the earliest analyses it has been assumed that self-concept evolves through a developmental process (Cooley, 1902; Mead, 1934). Of particular interest is the hypothesis that self-esteem in the various domain specific areas becomes increasingly more differentiated with age (Harter, 1982, 1986). In other words, while young children may not make fine distinctions among competencies in athletic or academic areas, older children and adolescents are quite sensitive to the distinctions. Harter also hypothesizes that a true sense of self-worth does not emerge until middle childhood.

Another developmental issue concerns the way in which the social comparison process operates over the age range. The usual assumption is that younger children are primarily influenced by parents and other adults, while, with increasing age, the reactions of peers assume increasing importance. An explicit statement of this is provided in Erik Erikson's (1963) personality theory. The theory envisions peer group approval and acceptance as becoming increasingly important over the childhood and adolescent years. Erikson also represents fluctuations in self-concept through those years as a product of shifts in the importance attached to different areas of competence (e.g., academic accomplishments becoming less important and social acceptance more important).

Implications of Self-Concept

Harter's (1986) model (Figure 3) indicates that self-concept has an impact on two factors, affect and motivation. In this case, affect refers to the individual's emotional state (happy, content vs sad, depressed). The model implies a causal link between self-worth and affect, such that low self-worth produces negative affect and high self-worth would produce positive affect. In fact, there is some ambiguity about the direction of effect in this case, with some arguing that depressed states contribute to a poor self-concept rather than depression being a product of a low self-esteem. However, no matter what the direction is, it is clearly the case that low self-esteem represents a negative state for the individual.

The model also postulates a link between affect and motivation. It is asserting, in other words, that a strong self-concept will be associated with a positive affective state and, in turn, high levels of motivation. A weak self-esteem will, in turn, be eventually associated with low levels of performance and motivation. There is, in fact, empirical support for such a hypothesis (e.g., Harter & Connell, 1984), though the literature also reveals some ambiguity about whether a poor self-concept leads to low motivation and low performance or whether low performance leads to a poor self-image (cf. Byrne, 1984; Marsh, 1990c):

Perhaps the most vexing theoretical question in academic self-concept research involves determining the causal ordering of academic self-concept and academic achievement. This question is of practical importance because many self-concept enhancement programs are based on the assumption that an improvement in self-concept will lead to gains in academic achievement. (Marsh, 1990c, p. 646)

Unfortunately, the data on the issue tend to be highly inconsistent, with some researchers demonstrating that academic performance has an impact on self-esteem (e.g., Hoge, Smit, & Hanson, 1990; Marsh, 1990c) and others failing to demonstrate an effect (e.g., Byrne, 1986).

Measurement Issues

Considerable efforts have been devoted to developing and evaluating instruments for the measurement of self-concept. The most widely used measures are listed in Table 1. The majority of these self-report measures provide both a general self-concept score and domain specific scores, though they vary in terms of the specific areas of competence assessed. We will discuss two measures for illustrative purposes.

Table 1 Commonly Used Self-Concept Measures

Measure	Reference
How I See Myself Scale	Gordon (1969)
ME Scale	Feldhusen & Kolloff (1981)
Piers-Harris Children's Self-Concept Scale	Piers (1984)
Rosenberg Self-Esteem Scale	Rosenberg (1965)
Sears Self-Concept Inventory	Sears (1966)
Self-Concept of Ability Scale	Bilby, Brookover, & Erickson (1972)
Self-Description Questionnaire	Marsh (1988); Marsh & O'Neill (1984)
Self-Esteem Inventory	Coopersmith (1967)
Self-Perception Inventory	Soares & Soares (1969)
Self-Perception Profile for Children	Harter (1982, 1985)
Tennessee Self-Concept Scale	Fitts (1964)

Harter (1985) developed The Self-Perception Profile for Children (SPPC) from her earlier instrument, The Perceived Competence Scale for Children (Harter, 1982). The SPPC is composed of six subscales, each containing six items (see Table 2 for some sample items). Each item entails what Harter terms a "structured alternative format" to reduce socially desirable responding. The format is illustrated in Table 2.

Table 2 Sample Items from the Self-Perception Profile for Children

	Really True for me	Sort of True for me
1. Some kids feel that they are very good at their school work	_____	_____
But		
Other kids worry about whether they can do the school work assigned to them	_____	_____
2. Some kids find it hard to make friends	_____	_____
But		
Other kids find it's pretty easy to make friends	_____	_____
3. Some kids do very well at all kinds of sports	_____	_____
But		
Other kids don't feel that they are very good when it comes to sports	_____	_____
4. Some kids are happy with the way they look	_____	_____
But		
Other kids are not happy with the way they look	_____	_____

Note. The source is Harter (1985).

The six subscales include the general self-concept construct, Global Self-Worth, and five specific areas: Scholastic Competence, Social Acceptance, Athletic Competence, Physical Appearance, and Behavioral Conduct. The subscores were empirically derived through factor analytic studies (Harter, 1982, 1985). Norms and psychometric information are presented in a manual (Harter, 1985).

One of the most widely used scales is the Piers-Harris Children's Self-Concept Scale (Piers, 1984). Samples from this 80-item scale are included in Table 3. The scale yields a total self-concept score as well as subscores in six areas: behavior, intellectual and school status, physical appearance, anxiety, popularity, and happiness and satisfaction. Typically, though, only the total score from the scale is employed. The scale is accompanied by an especially detailed manual containing psychometric information, as well as normative data.

Table 3 Sample Items from the Piers-Harris Children's Self-Concept Scale

-
1. My classmates make fun of me
 2. I am a happy person
 3. It is hard for me to make friends
 4. I am often sad
 5. I am smart
 6. I am shy
 7. I get nervous when the teacher calls on me
 8. My looks bother me
 9. When I grow up, I will be an important person
 10. I get worried when we have tests in school
 11. I am popular
 12. I am well behaved in school
 13. It is usually my fault when something goes wrong
 14. I cause trouble to my family
 15. I am strong
 16. I have good ideas
 17. I am an important member of my family
 18. I usually want my own way
 19. I am good at making things with my hands
 20. I give up easily
 21. I am good in my school work
 22. I do many bad things
 23. I can draw well
 24. I am good in music
 25. I behave badly at home
 26. I am slow in finishing my school work
 27. I am an important member of my class
 28. I am nervous
 29. I have pretty eyes
 30. I can give a good report in front of the class
 31. In school I am a dreamer
 32. I pick on my brother(s) and sister(s)
 33. My friends like my ideas
 34. I often get into trouble
 35. I am obedient at home

Note. Each item calls for a 'yes'-'no' response. Source is Piers (1984).

Byrne (1984), Harter (1983), and Shavelson et al. (1976) have provided reviews of the psychometric properties of the major self-concept measures. In general, the reliability of the measures tends to be satisfactory, though stability coefficients (test-retest reliability) seem to vary with the area being assessed, with general self-concept more stable than assessments in more specific areas.

Some support for the criterion-related validity of the measures is also available. For example, there is considerable evidence that self-concept measures predict academic performance (though see Marsh, 1990c for a fuller discussion of this issue). Links have also been established between these measures and indices of affective state. Harter (1986), for example, has linked self-concept scores with depression in children.

The issue of construct validity is somewhat more problematic. The question here is the extent to which these measures actually measure self-concept. The problem, as explained earlier, is that less than perfect agreement exists on the nature of construct. The major issue seems to revolve around the question of whether there exists a general self-concept, and, if so, how it should be formed. As the Byrne (1984) and Shavelson et al. (1976) reviews make clear, this issue has not yet been resolved. This does not mean we should not use the measures; it is just that they should be interpreted with some caution.

Conceptualizing and Measuring Giftedness

Alternative Conceptualizations

This paper deals with self-concept in the gifted child. Difficulty exists with conceptual issues, because there is less than total agreement on how the giftedness construct should be defined. Considerable variation is also formed in the way in which the construct is defined in different research and educational contexts. Conclusions about the operation of self-concept in the gifted depends to a great extent on the way in which the giftedness construct is treated.

Feldhusen (1986), Gallagher and Courtright (1986), Hoge (1988, 1989), and Renzulli (1978, 1986) have provided useful discussions of the conceptualization of giftedness, and all those discussions indicate considerable variability in the way in which giftedness is defined in different contexts.

As Gallagher and Courtright (1986) have pointed out, two types of definitions are encountered. They refer to the first type as psychological conceptions and the second as educational conceptions. The former operate in most cases where giftedness is the object of theoretical and research attention and the latter where children are being identified for placement in gifted classes. Often very different conceptualizations of giftedness emerge from these, and, as we will see, this sometimes presents difficulty in interpreting research.

Hoge (1989) has also attempted to describe the variability existing with respect to definitions of giftedness. Five dimensions of variability are discussed.

Breadth of the construct. The first source has to do with the breadth of qualities or traits represented in the definition. At one extreme of this continuum are definitions based on a single characteristic such as mathematical aptitude (e.g., George, 1979) or creativity (e.g., Torrance, 1965). At the other extreme are complex, multivariate definitions that include a broad range of traits or qualities. An example of the latter is Hagen's (1980) definition based on 15 separate dimensions of cognitive, academic, and personality functioning. As Gallagher and Courtright (1986) note, the psychological conceptions of giftedness tend to be broader in scope than educational conceptions, though there is at least a trend in school settings to broaden the definition of giftedness employed (see, for example, Feldhusen, 1986, and Renzulli, 1986).

Content of the definition. The actual qualities included in the definitions provide a second dimension of variability. Educational conceptions of giftedness have traditionally emphasized cognitive capacities and have depended heavily on IQ tests as selection devices. Psychological conceptions, on the other hand, have often attempted to incorporate motivational, personality, and attitudinal variables in addition to cognitive variables. Further, their treatment of the cognitive variables is often more analytic and detailed than that reflected in IQ tests (see, for example, Sternberg, 1981, 1986).

Level of exceptionality. A third dimension of variability concerns the level of exceptionality represented in the construct. This dimension is largely defined by the selection models employed in the situation. Thus, a 90th percentile cut-off on the WISC-R implies a different definition of giftedness than a 70th percentile cut-off. Similarly, a different definition derives from the case where teachers are to identify all students in the class who are above average than the case where they are to identify as gifted only the four students with the highest potential.

Static vs dynamic focus. The definitions also differ in the extent to which they incorporate a static vs a dynamic view of giftedness. On the one hand, narrowly cognitive definitions derived from IQ test performance conceptualize giftedness as a relatively static set of cognitive-academic skills. At the other extreme are conceptualizations of giftedness that entail a set of potentialities that may or may not be developed depending on the circumstances. While the static view is the traditional one, there is evidence of a shift away from that position: "It would also be desirable to reconceptualize the identification process and move away from the hereditary based concept of a general, fixed, stable, permanent giftedness...and attend to the identification of those youth who are not using or developing the full potential of their superior talent or ability" (Feldhusen et al., 1984, p. 150). A similar argument has been presented by Gallagher and Courtright (1986), Renzulli (1984, 1986), and Treffinger (1984).

Precision of the definition. A fifth dimension of variability refers to the precision with which the construct is defined. Ideally, the elements of a construct will be explicitly stated, linked to specific measuring instruments, and supported with construct validity data (Anastasi, 1986; Landy, 1986; Messick, 1980, 1981). Unfortunately, we rarely encounter this state of affairs, and what we usually see are global, vaguely defined constructs.

The Measurement of Giftedness

Traditionally, the measurement of giftedness for both psychological and educational purposes has been based on IQ test performance. For example, Terman's (1925) extensive studies of genius were all based on IQ test performance. Similarly, the identification of gifted children in schools is often based solely on performance on the WISC-R or Stanford-Binet; and if not based solely on these tests, they are at least the most heavily weighted components in the battery.

This does not, of course, describe the complete situation since there is, in fact, a wide range of instruments used in this identification process. Surveys of these measures are available from Alvino, McDonnell, and Richert (1981) and Spina and Crealock (1985), and the major categories of the instruments are listed in Table 4. Identification procedures are sometimes based on the use of a single instrument and sometimes on sets of instruments.

Table 4 Major Types of Measures Used in the Identification of Gifted Students

Individual IQ Tests
 Group IQ Tests
 Standardized Achievement Tests
 Standardized Personality Tests/Inventories
 Tests of Creativity
 Teacher Rating and Nomination Procedures
 Parent Rating Procedures

Hoge (1988, 1989) has identified a wide range of problems associated with measurement of the giftedness construct, three of those especially relevant to our subsequent discussion. First, there is, in fact, considerable variability across applied and

research settings in the type of measure employed and in the way in which the same measure is sometimes used. Individual IQ tests constitute the most heavily used type of measure, but these tests are used in different ways, in different situations, and are used with various combinations of other instruments. This means among other things that there is variability in the nature of the giftedness construct being assessed across these settings.

Second, there is often a discrepancy between formal or official definitions of giftedness in a situation and the operational definition actually provided by the selection instruments. For example, formal definitions of giftedness often incorporate some statements about levels of motivation, creativity, and, perhaps, leadership. Yet, the actual identification of gifted students may be based solely on scores from an individual IQ test such as the WISC-R, an instrument whose scores carry no connotations with respect to academic motivation, creativity levels, or leadership qualities.

Third, all of the instruments used in the identification of the gifted rest on a very thin validity foundation. For example, even though instruments such as the WISC-R are being used to screen out children who are expected to perform effectively in enrichment classes, there is virtually no evidence bearing on the actual predictive validity of these scores or of scores from any of the other measures used in identification of the gifted (Hoge, 1988). Similarly, little information supports the construct validity of the measures. The problem here, of course, is that we do not have a distinct, universally accepted, definition of giftedness.

It should be clear that variability, in the way in which the giftedness construct is defined and measured, has important implications for research on the link between giftedness and self-concept. Considerable variability exists in the outcomes of studies of that link, and much of that variability can be traced to inconsistent treatments of the giftedness construct.

Giftedness and Self-Concept

As indicated earlier, three related questions are being raised with respect to self-concept in the gifted child. First, do gifted and average children differ in self-esteem? The other two questions bear on factors that might affect differences between the two groups. The second question is whether or not labeling a child as gifted has an impact on his or her self-concept. The third question concerns the effect of gifted programming: Does placing a child in a separate enriched or accelerated classroom have any impact on self-esteem?

Theoretical Considerations

There are several bases for hypothesizing that intellectually exceptional children will have more positive self-concepts than those of average ability. First, to the extent that high levels of ability are translated into actual accomplishments, one might expect self-esteem to be enhanced. In other words, self-esteem in the very able child should be high simply because he or she is achieving at a high level. This relates to the internal cognitive processes postulated in the Harter (1986) model.

Additional considerations should be noted in connection with this point. First, the hypothesis is based on the premise that exceptional ability is, in fact, expressed in terms of enhanced performance. Such is not always the case. Second, it does not follow from the hypothesis that all domains of self-worth will be more positive in the gifted child. In fact, the more specific hypothesis would be that self-concept in the gifted child will be enhanced in those areas in which exceptionalities are exhibited. Third, whether general self-esteem or global self-worth are enhanced will depend on the relative importance attached by the child to the areas in which exceptionalities are exhibited. The latter is another implication of the Harter (1986) model. Finally, in connection with this hypothesis, previous observation supports that the relation between performance and self-concept is not necessarily a simple one (cf. Marsh, 1990c).

Our second basis for hypothesizing a more positive self-concept in the gifted child derives from the labeling process. To the extent that the child is overtly labeled as intellectually or creatively gifted, positive expectations are being communicated (Cornell, 1983; Sapon-Shevin, 1984, 1987, 1989). The Social Support/Positive Regard component of the Harter (1986) model implies that this will result in enhanced self-esteem. This effect will obtain, of course, only to the extent that the child attaches importance to the opinions being expressed.

There are, on the other hand, some reasons for hypothesizing that self-esteem in the gifted might be more negative than in less gifted peers.

First, under some circumstances it is likely that the high expectations communicated to the gifted child will be translated into failure experiences. The child never quite measures up to the expectations and self-esteem suffers.

A second basis for predicting lowered self-esteem in the gifted follows from Freeman's (1985) speculations that, because the exceptional child is cognitively advanced, he or she may be more sensitive to social cues and more analytic about them. This may, under some circumstances, incline the child toward a more critical attitude of his/her abilities and performances.

A third basis for predicting lowered self-esteem relates to the Social Support/Positive Regard dimension within the Harter (1986) model. As has been noted,

this factor operates, in part, in terms of a social comparison process. This process may be involved in those cases where children are identified as gifted, removed from the regular classroom, and placed into homogeneous groups of gifted or exceptional children. The prediction is that this will lead to decreased feelings of self-esteem since the child is now exposed to heightened competition. This hypothesis is consistent with Marsh's (1990a) speculations regarding the Big-Fish-Little-Pond effect (also see Coleman & Fults, 1982).

The Research Evidence

Our review of the relevant research is confined to published studies; we have generally excluded research reported in conference papers, Dissertation Abstracts, etc.

Direct comparisons of gifted and nongifted students. One set of studies has provided more-or-less direct comparisons of gifted and nongifted students in terms of self-concept. These studies are capable of providing us with information about one of the basic questions raised above: Do exceptional children exhibit different levels of self-esteem than children of normal ability? The available studies are listed in Table 5, in which is listed the study, the age or grade level involved, the area of self-concept assessed, and the nature of the comparison provided.

Table 5 Summary of Studies Comparing Gifted and Nongifted Children in Terms of Self-Concept Measures

Study	Age/Grade Level	Self-Concept Areas	Comparison
Bracken (1980)	M = 9.8 yrs	GSC	Gifted in program with norms
Brody & Benbow (1986)	M = 13.7 yrs	GSC	Gifted in program with regular students
Colangelo, Kelly, & Schrepfer (1987)	grades 7-9	GSC, ASC, BSC, SSC	Gifted in program with regular & LD students
Coleman & Fults (1982)	grades 4-6	GSC	Gifted in program with norms
Davis & Connell (1985)	grades 4-6	GSC	Gifted as per tests with nongifted
Hoge & McSheffrey (1991)	grades 5-8	GSC, ASC, BSC, PSC, SSC	Gifted in program with norms

Note. GSC = general self-concept, ASC = academic self-concept, BSC = behavioral self-concept, PSC = physical self-concept, and SSC = social self-concept.

Table 5 Summary of Studies Comparing Gifted and Nongifted Children in Terms of Self-Concept Measures (continued)

Study	Age/Grade Level	Self-Concept Areas	Comparison
Janos, Fung & Robinson (1985)	5-10 yrs	GSC	Gifted in program with norms
Karnes & Wherry (1981)	grades 4-7	GSC	Gifted in program with norms
Kelly & Colangelo (1984)	grades 7-9	GSC, ASC, PSC, SSC	Gifted in program with regular students
Ketcham & Snyder (1977)	grades 2-4	GSC	Gifted as per tests with nongifted
Lehman & Erdwins (1981)	grade 3	GSC	Gifted in program with regular students
Maddux, Scheiber, & Bass (1982)	grades 5-6	GSC	Gifted in program with norms
Milgram & Milgram (1976)	grades 4-8	GSC, PSC, SSC	Gifted in program with regular students
O'Such, Havertape, & Pierce (1979)	8-12 yrs	GSC	Gifted in program with regular students
Robison-Awana, Kehle, & Jenson (1986)	grade 7	GSC	Gifted in program with regular students
Schneider, Clegg, Byrne, Ledingham, & Crombie (1989)	grades 5, 8, & 10	GSC, ASC, PSC, SSC	Gifted in program with regular students
Tidwell (1980)	grade 10	GSC	Gifted in program with norms
Winne, Woodlands, & Wong (1982)	grades 4-7	GSC, ASC, PSC, SSC	Gifted as per tests with nongifted

Note. GSC = general self-concept, ASC = academic self-concept, BSC = behavioral self-concept, PSC = physical self-concept, and SSC = social self-concept.

Three types of comparisons are involved in the studies. In the first case, children identified as gifted and placed in special classes are compared with more average students in regular classrooms. In the second type of study, children are identified as gifted on the basis of standardized test scores and are compared with students not meeting the criteria. In this case there are no labeling or special education elements involved. In the third case, the self-esteem scores of students identified as gifted and in special programs are compared with normative scores reported in manuals. There are two sets of studies represented in Table 5. The first includes those investigations providing a measure of general or global self-concept, while the second includes those assessing specific aspects of self-concept.

The study reported by Brody and Benbow (1986) represents an example of a focus on general self-concept. This study will be discussed for illustrative purposes and then we will summarize the set of investigations. These researchers contrasted four groups, three of them comprised of gifted students and one of students from regular classrooms. The three gifted groups were as follows: (a) a 'regular' gifted group meeting criteria on IQ and achievement tests; (b) a gifted group with exceptionally high mathematics aptitude scores; and (c) a gifted group with exceptionally high verbal reasoning scores.

A variety of personality and social dimensions were measured in the study, including self-esteem. The latter was assessed by means of an 8-item self-report measure yielding a single score, presumably reflecting general self-worth.

The results of this study indicated that the mathematically precocious group displayed somewhat higher self-esteem scores than the other three groups. However, the differences among the groups were quite small and statistically nonsignificant. In general, these gifted students displayed neither higher nor lower levels of self-esteem than the average ability students.

All eighteen of the studies summarized in Table 5 provided information about general self-esteem. Nine of those studies reported significantly higher self-concept scores for their gifted sample relative to the control sample (Coleman & Fults, 1982; Janos et al., 1985; Karnes & Wherry, 1981; Kelly & Colangelo, 1984; Ketcham & Snyder, 1977; Lehman & Erdwins, 1981; Milgram & Milgram, 1976; O'Such et al., 1979; Robison-Awana et al. 1986). Six researchers reported no significant differences between gifted and comparison samples in general self-concept (Bracken, 1980; Brody & Benbow, 1986; Davis & Connell, 1985; Hoge & McSheffrey, 1991; Schneider et al., 1989; Winne et al., 1982). Three studies reported mixed results. Thus, Maddux et al. (1982) demonstrated significantly higher general self-concept scores for gifted students at the grade 6 level but not the grade 5 level. Tidwell (1980) reported significantly higher scores for the gifted students where self-concept was assessed with the Piers-Harris but not with the Coopersmith. Colangelo et al. (1987) found no significant differences in general self-concept for gifted girls compared with girls in regular classrooms. The same result obtained for boys as compared with boys in regular classrooms, though the gifted boys did score significantly higher than those in special learning classes. Finally, none of the researchers reported significantly lower general self-concept scores for gifted children.

These results have all provided for a focus on general self-concept. However, our earlier discussion indicates construct of this type of conceptualization may not be that meaningful; self-esteem is a complex construct and should be assessed in terms of its component parts. It is unfortunate that relatively few comparisons of gifted and nongifted students have provided assessments in specific domains. There are, however, five exceptions, as can be seen in Table 5. The most thorough of these investigations is that reported by Schneider et al. (1989). This study will be discussed for illustrative purposes and the results summarized from the other four.

Schneider et al. (1989) investigated three areas of adjustment in gifted children relative to more average students: degree of peer acceptance, attitudes toward school, and self-concept. It is the latter variable that primarily concerns us here.

Three groups of children were compared: (a) gifted students in a self-contained enrichment program; (b) gifted students (meeting the same IQ test criterion as the previous group) in regular classrooms; and (c) students with average IQ in regular classrooms. Self-concept was measured for grade 5 and 8 children by means of Harter's Perceived Competence Scale for Children and for grade 10 children by means of the Self-Description Questionnaire III. These measures were chosen because they provide for assessments in specific areas of self-concept (academic, social, physical appearance), as well as general self-esteem.

The results indicated no significant differences among the three groups for general, social, or physical self-concept. In other words, the gifted students, whether in a separate program or not, were neither at an advantage or disadvantage when it comes to self-esteem with respect to social relations or physical appearance. The gifted students did show higher levels of academic self-esteem relative to the control students, and this effect was more pronounced for those gifted children in regular classrooms than those in self-contained enrichment classes. The result held for all three grade levels. This result has some implications for the social comparison process, and we will discuss it more fully in a later section of the paper.

The findings by Schneider et al. (1989) of higher academic self-concept in gifted students compared to nongifted is consistent with the result reported by Kelly and Colangelo (1984) (though they found a significant effect only for boys), Colangelo et al. (1987) and by Hoge and McSheffrey (1991). The latter researchers, however, based their comparisons on normative data and did not provide statistical tests of the comparisons. Winne et al. (1982), on the other hand, failed to demonstrate any significant difference between gifted and regular classroom students for a measure of academic self-esteem.

Although, both Colangelo et al. (1987) and Kelly and Colangelo (1984) did report significantly higher social self-concept scores for the gifted boys in their comparison, failure to obtain differences between gifted and nongifted samples on social self-esteem scores in the study by Schneider et al. (1989) is consistent with the results of Milgram and Milgram (1976) and Winne et al. (1982). Finally, while Kelly and Colangelo (1984), Schneider et al. (1989), and Winne et al. (1982) reported nonsignificant differences for comparisons involving physical self-concept, Milgram and Milgram (1976) have provided indications that gifted children have more negative self-concepts in this area than nongifted controls.

In summary, the majority of the studies (12/18) focusing on general self-concept provided indications that the gifted students exhibit higher self-esteem than the nongifted counterparts. Further, four of the five studies focusing on academic self-concept showed higher levels of self-esteem in that area for the gifted students. Finally, we note no evidence that social self-esteem is lower in gifted children than more average children; in fact, the single study showing a difference favored the gifted group.

There are, on the other hand, some qualifications that have to be stated with respect to these results. We note, first, that the set of results are, in fact, highly variable; some results are favoring the gifted group, some the nongifted group, and many studies indicating no differences. This issue is complicated by the fact that most researchers have not provided for a systematic investigation of variables that might help to account for the variable results. To put this another way, there are few opportunities in this research to

assess any of the hypotheses we discussed earlier in the section entitled Theoretical Considerations. There are a few exceptions to this, cases where researchers explored moderator or interacting variables, and we will discuss those a little later in the paper.

Our second qualification relates to the high degree of variability exhibited in the methodology of this research. This variability relates to the procedures used to identify the gifted sample, the self-concept measures employed, the length of time involved, etc. Because of this variability, and because the effects of these variables are unknown, it is difficult to generalize the results obtained.

Finally, some criticisms have been advanced with respect to the research methods employed. For example, four of the studies demonstrating higher self-concept scores in gifted students relative to nongifted students did not actually involve a comparison of gifted and nongifted students. What these researchers did was to compare scores from the gifted students with normative scores from average students provided in the test manual. This is, however, a questionable practice in light of the suggestion that the normative scores may provide underestimates of self-concept scores (Janos and Robinson, 1985). A second problem is that some of the studies have used self-esteem measures of questionable reliability and validity (Schneider, 1987).

Studies exploring moderator variables. Most of the studies summarized in Table 5 employed a very simple design in which gifted students were contrasted with samples of nongifted or average children. The problem with this design is that it does not reflect reality: the relation between giftedness and self-concept likely depends on a number of factors. Unfortunately, relatively few studies included moderator or interacting variables in their analyses. We can, however, note some exceptions and will use these to illustrate the way in which moderator variables might be involved.

One possible moderator that has received some attention is that of gender. The general hypothesis in this case would be that the relation between giftedness and self-concept might vary between boys and girls. Kelly and Colangelo (1984) did find some support for this hypothesis. The gifted boys in their sample displayed significantly higher general self-concept and academic self-concept scores than the nongifted boys, but no significant differences were found in comparisons of gifted and nongifted girls. On the other hand, Hoge and McSheffrey (1991), Karnes and Wherry (1981), Milgram and Milgram (1976), and Schneider et al. (1989) failed to find any evidence that gender might operate as a moderator of the giftedness-self-concept relation, though in some cases they established overall gender differences.

A second variable that has been explored as a moderator has to do with level of exceptionality. The general hypothesis in this case would be that the very highly gifted might show a different pattern of self-esteem than the less highly gifted. Brody and Benbow (1986) explored this issue and found no differences between very highly gifted children and more moderately gifted children on their global index of self-esteem. Similar results have been reported by Ketcham and Snyder (1977).

A third potential moderator variable has to do with the actual level of achievement exhibited by the child. In our earlier discussion of self-concept, some relation exists between actual performance and self-concept; in general, the higher the level of achievement in an area, the higher the self-esteem in this area. The issue here would be whether or not this relation varies at all with whether or not the child is gifted. Only one study has been reported on this issue, but it has yielded an interesting result. Ziv, Rimon, and Doni (1977) demonstrated that achievement level had more of an impact on self-concept in a group of average students than in a group of gifted students. There are

probably a number of interpretations that could be offered of this result, but the authors' speculation was that the gifted students had more opportunities to express themselves outside the school setting, and, hence, were less dependent on academic performance as a source of self-esteem.

Studies of the labeling process. All of the studies reviewed in the previous section dealt with children identified as gifted. However, in some cases the child had been explicitly labeled as such, while in other cases he/she simply met some criterion of exceptionality without necessarily receiving a label. However, because the variable was not systematically manipulated in any of these studies, it is impossible to use the results to reach any conclusions about the direct effects of labelling on self-esteem.

in fact, there are no published studies directly investigating the effects on self-esteem of labeling a child as gifted, though there have certainly been calls for such investigations (see, for example, Colangelo & Brower, 1987; Cornell, 1983). There are, however, studies showing that the designation of a child as gifted has definite impacts on the expectations and attitudes held by parents and teachers of the child (Cornell, 1983; Fisher, 1981; Sapon-Shevin, 1989). One would expect similar effects on the child's expectations and attitudes and these would likely eventually affect his/her self-esteem. In any case, there is certainly a need for more research on this issue.

Studies of program effects. Two basic types of studies are relevant. The first involves a comparison of gifted children in enrichment programs with gifted children not in special programs, or, alternatively, gifted children in different types of programs. The second examines changes in self-concepts of students before and after entrance to the programs. These studies are summarized in Table 6.

Table 6 Studies Exploring Program Effects

Study	Age/Grade Level	Comparison
Brody & Benbow (1987)	grades 9-12	Gifted students exposed to various types of enrichment experiences
Coleman & Fults (1982)	grades 4-6	Gifted students in one-day-per-week enrichment vs gifted with no special programming
Coleman & Fults (1985)	grade 4	Groups of gifted students assessed before and after exposure to one-day-per-week enrichment

Table 6 Studies Exploring Program Effects (continued)

Study	Age/Grade Level	Comparison
Feldhusen, Sayler, Nielsen, & Kolloff (1990)	grades 3-8	Gifted students in pull-out program vs gifted with no special programming
Karnes & Wherry (1981)	grades 4-7	Gifted students in enrichment program vs gifted with no special programming
Kolloff & Feldhusen (1984)	grades 3-6	Gifted students in pull-out program vs gifted with no special programming
Kolloff & Moore (1989)	grades 5-10	Gifted students assessed before and after exposure to a summer enrichment program
Maddux, Scheiber, & Bass (1982)	grades 5 & 6	Gifted students in various types of programs as well as no special program
Olszewski, Kulieke, & Willis (1987)	M = 13.5 yrs	Gifted students assessed before and after exposure to two summer enrichment programs
Schneider, Clegg, Byrne, Ledingham, & Crombie (1989)	grades 5, 8, & 10	Gifted students in enrichment program vs gifted with no special programming

These studies are potentially useful in providing information about the effects of exposure to the programs on self-esteem. In particular, they can provide information regarding the impact of social comparison processes. As noted earlier, one might predict that moving a child from the regular classroom to a classroom in which all children are of high ability might have a negative impact on self-esteem, particularly academic self-concept.

One of the earliest studies of the first type is that reported by Maddux et al. (1982). Their comparisons of gifted and regular classroom students have been discussed here. Of

particular interest here are their comparisons of three groups of identified gifted students: (a) those placed in a separated enrichment program; (b) those in regular classrooms but participating in a pull-out enrichment program; and (c) those identified as gifted but not placed in a special program. The latter existed apparently because there were not enough places in the special classes.

Interestingly enough, there were no differences in total Piers-Harris self-concept scores among any of these groups. This was contrary to their hypothesis, since they had expected some negative effects of the gifted programming due to a social comparison effect. Similar results have been reported by Karnes and Wherry (1981) and Kolloff and Feldhusen (1984) in their comparisons of gifted children in special programs with gifted children remaining in regular classrooms. The latter study is particularly interesting because they had assigned subjects randomly to enrichment or no special treatment conditions.

One other study reporting negative results should be mentioned. Brody and Benbow (1987) collected questionnaire data from a group of individuals who had been identified as mathematically precocious during grades 7 and 8. They had been exposed to various forms of accelerated and enrichment experiences during high school, or, in some cases, were exposed to no special treatment. Data were collected from these individuals after they had graduated from high school to assess their perceptions of the impact of the experiences on various aspects of development, including self-esteem. They found no differences in self-esteem among individuals exposed to the different enrichment and acceleration levels.

On the other hand, several studies have established program effects, though the direction of effect is variable. Coleman and Fults (1982) contrasted two groups of identified gifted students; one group was assigned to a one-day-per-week separate enrichment program and the second received no special programming. These fifth and sixth grade children were assessed with the Piers-Harris at three points: (a) six weeks after the experimental group had been assigned to the program; (b) the end of the first academic year; and (c) 18 months following the initial assessment. The children who began the program in grade 6 had returned to regular classrooms by the latter assessment.

Coleman and Fults (1982) determined that both groups of children were, on average, obtaining higher general self-concept scores than students of average ability (with reference to normative data). However, gifted children in the regular classes were demonstrating higher general self-concept scores than children in the enrichment program. There was also a significant interaction indicating that no differences existed between the grade 6 students at the third assessment. This includes the group of gifted children who had returned to the regular classroom during grade 7. A similar type of result was reported in the Schneider et al. (1989) study reported earlier. Gifted children in regular classrooms exhibited significantly higher academic self-concept scores than gifted children in self-contained enrichment classes.

These results would appear to be consistent with a social comparison type of process. Moving the child from the regular classroom to a classroom composed largely of exceptional students would have the effect of altering the gifted child's relative position in the class such that he/she may no longer appear exceptional. Moving the child back to the regular classroom from a special class would have the effect of enhancing his/her self-esteem.

Contradictory results have, on the other hand, been reported by Feldhusen et al. (1990). Two groups of gifted children were compared in terms of changes in self-concept

scores over the course of the school year, a group participating in a pull-out enrichment program and a group receiving no special programming. In general, children in the enrichment program showed greater increases in global self-concept scores over the course of the year than children not in the program.

The three remaining studies in this set are somewhat limited in that they did not include control or comparison groups in their investigations. For example, Kolloff and Moore (1989) and Olszewski et al. (1987) employed a design in which scores of a group of gifted children were assessed prior to entering summer enrichment programs and again at the end of the program. Kolloff and Moore (1989) reported significant gains in global self-concept scores over the course of the program, though inspection of their data indicates that the effect was somewhat variable, with fairly high percentages of children showing declining scores.

The Olszewski et al. (1987) investigation is interesting because it is one of the few studies of this type to provide information about specific domains of self-esteem. These researchers administered the Harter Self-Perception Profile for Children at three points to a group of exceptional children enrolled in a summer enrichment program, prior to entering the program, the first day of the program, and the final day of the program.

Some changes in self-concept were recorded, though they were generally small in magnitude. There was, however, a consistent and statistically significant decline in scholastic self-esteem from time 1 to time 2 to time 3. On the other hand, perceived athletic competence and physical appearance increased over the three testings, though the results were not significant for all comparisons. The results for scholastic competence do support a social comparison type of process.

Finally, a study reported by Coleman and Fults (1985) assessed a group of grade 4 children identified as gifted and destined for an enrichment program. One-half of those subjects were given the Piers-Harris prior to entering the program and the other half were administered the measure eight to ten weeks following entry into the program. The comparison of these two sets of scores was used to infer the existence of program effects. There was, in fact, a decline in total self-concept scores over that period. There was also a significant placement by IQ interaction. Comparisons of high IQ students before and after placement indicated no significant difference. It was, however, with the comparison of lower IQ gifted children that the sharp drop in self-esteem scores was observed. This result would be consistent with a social comparison type of hypothesis. It must be kept in mind, though, that this study is quite limited in that it entails two groups assessed at two different times.

Attempting to interpret the results from this set of studies is rather frustrating since the results are so highly variable. In some cases exposing the gifted child to special programming seems to have no effect on self-esteem, in other cases it leads to enhanced esteem, and in still other cases it has a negative impact.

Much of this variability arises, of course, from variability in methodologies; there is very little consistency among these studies with respect to definitions of giftedness, the type of program the child is exposed to, the nature of measure, or the length of time over which the assessment is made.

The lack of a systematic treatment of these variables also means that the studies cannot really be used for assessing hypotheses. For example, it would be impossible to determine whether changes in self-esteem associated with placement in an enriched program are due to the effects of labeling, to changes in the comparison group to which the

child is exposed, or to changes in performance occurring in the program. Further, it is not possible to determine whether different types of gifted programming might have different implications for self-esteem.

Conclusions and Guidelines

The following conclusions and guidelines have emerged from a review of the research evidence linking self-concept and gifted constructs. Each conclusion or guideline is followed by a brief discussion of the research-supported rationale.

Conclusion One: The direct comparisons of gifted and nongifted students revealed that the gifted students as a group showed no major deficits in self-esteem.

Discussion: The majority of students seemed to indicate somewhat higher levels of general and academic self-esteem for the exceptional group. These conclusions are, however, qualified by a number of considerations, including: (a) the variable results yielded by the studies; (b) methodological flaws in many of the studies; and (c) a lack of attention to moderator and interacting variables.

Conclusion Two: Some indirect evidence exists that labeling a child gifted would have a positive impact on self-esteem, but direct evidence is lacking.

Discussion: The impact of labeling a child gifted is an important issue, but one that has been virtually ignored in the research literature.

Conclusion Three: There is some support for a social comparison type of process; that is, that moving a child from a regular classroom to a homogeneous, highly gifted group will have a negative impact on self-concept.

Discussion: Research regarding the impact of gifted programming on self-esteem has yielded variable results. The evidence was, however, by no means consistent, and this body of research sometimes displays methodological flaws.

Implications for Research

Many problems exist in this area of research on self-concept and the gifted child. Yet, important issues are being addressed, and some exciting challenges exist with respect to research opportunities. The research methodology in the areas of self-concept and gifted is improving. It is important, however, to build further strength in this area, and we will offer some guidelines.

Guideline One: It is imperative that future researchers pay more careful attention to their treatment of self-concept and giftedness variables.

Discussion: Considerable progress has been made in the development of some of the measures, particularly the Perceived Competence Scale for Children (Harter, 1982, 1985), the Piers-Harris Children's Self-Concept Scale (Piers, 1984), and the Self-Description Questionnaire (Marsh, 1988; Marsh & O'Neill, 1984). Researchers are advised to use one of these standardized instruments and to score them for specific domain scores, as well as general self-esteem.

Guideline Two: There is a need for more attention to the definition and measurement of the giftedness construct (Hoge, 1988, 1989; Hoge & Cudmore, 1986; Renzulli, 1978, 1986).

Researchers must be explicit about the definition of giftedness they are employing. There is certainly room for variable types of definitions, but it is imperative that the construct being employed in the study be made explicit and related clearly to the purpose of the research. In addition, the actual selection devices employed should be assessed in terms of their psychometric properties and should be explicitly related to the giftedness construct being measured.

Guideline Three: Future research must attend more closely to experimental design.

Discussion: A major problem with much of the research being reported is that it confounds critical variables. For example, as we have seen, much of the research on program effects confounds three processes: (a) the effects of labeling the child gifted; (b) the effects on the social comparison process of placing the child in a homogeneous group; and (c) the impact of the placement on actual achievement levels.

There are, to be sure, practical and ethical limits to the type of research that can be conducted in this area. For example designs employing random assignment of children to enriched and non-enriched classrooms are probably unacceptable. Still, we are going to have to be more ingenious in our choice of designs and analytic tools if we hope to make real progress in sorting out these issues. We note, as well, that there is room in this process for more qualitative research methodologies.

Guideline Four: There is a need for longitudinal studies in which changes in the relation between giftedness and self-concept can be explored at different age levels.

There are clearly developmental processes at work here (cf. Feldman & Benjamin, 1986), and these should be attended to more closely in research efforts in our field.

Some Implications for Counseling

The results of research reviewed above revealed no drastic problem areas for the gifted group as a whole. In general, their levels of self-esteem appeared no more problematic than those of more average students. This does not mean, however, that attention should not be paid to the special needs of this group. Several considerations lead to this point. First, the majority of the results reviewed in this paper were based on group data. These can be somewhat deceptive, often concealing problems revealed in individual cases. Second, and as we emphasized, the research is limited in some respects and, hence, not a perfect guide to practice. Third, there is ample evidence from clinical sources that exceptional children may be especially vulnerable to certain types of social and emotional problems (cf. McMillan & Loveland, 1984; Schneider, 1987).

Guideline Five: Counseling with gifted and talented students should have a developmental focus.

Discussion: Zaffrann and Colangelo (1979) have presented a useful general model for thinking about the counseling of gifted students. They believe that "counseling with gifted and talented students should take place within a developmental program organized and maintained for these youngsters...A developmental guidance program for gifted and

talented youth must be based on the unique needs and concerns of these students" (Zaffrann & Colangelo, 1979, p. 168).

This type of advice is especially relevant when considering the issue of self-esteem. Our earlier discussion indicates that the nature of self-esteem and the processes affecting it change over the childhood and adolescent years. In developing intervention programs it is important to take account of these developmental changes.

Guideline Six: Exceptional children often have especial needs with respect to emotional health and social competence, and that systematic efforts should be made to accommodate these needs.

Discussion: Zaffrann and Colangelo (1979) acknowledge that exceptional children often have special needs with respect to emotional health and social competence, and that systematic efforts be made to accommodate these needs.

What are these areas of special needs? First, it has been suggested that intellectually exceptional children may be especially sensitive to social cues and sometimes inclined toward an over-critical attitude toward themselves and others (Freeman, 1985; Schneider, 1987). This can create problems of self-esteem.

A second area of concern has to do with peer relations and self-esteem regarding these relations. The best evidence now is that gifted children on the whole have no more difficulty with social relations than less gifted peers (cf. Janos & Robinson, 1985; Schneider, 1987). Still, individual gifted children are sometimes especially vulnerable, with sources of vulnerability including high degrees of engagement in nonsocial kinds of activities or simply boredom with the society of age-mates. This problem may be compounded in those cases where the child is exposed to educational acceleration. Research seems to show that acceleration does not, on the whole, have negative effects on affective or social development (Cornell, Callahan, Bassin, & Ramsay, 1990; Kulik & Kulik, 1984), but there are limitations with this research and it is still an area requiring monitoring.

Parent-child relations constitute another potentially problematic area. For one thing, parents often develop and impose high expectations on children they perceive as especially gifted (Cornell, 1983; Fisher, 1981), and these high expectations often create problems for both the parent and the child. Second, parents sometimes have ambivalent attitudes toward the gifted child, and this is sometimes expressed in overprotective behavior and sometimes even with rejection. All of these situations can have an impact on the child's self-esteem and call for some sort of intervention.

Specific intervention programs are available which address the need for intervening with children and their self-concepts. The Rochester Primary Mental Health Project (Cowen, Trost, Lorian, Dorr, Izzo, & Isaacson, 1975) was not developed specifically for use with gifted children, but it represents an excellent example of an intervention program with primary and secondary components, and it could easily be adopted for such a group.

There are several components to the program. The first involves a mass screening of students with a view toward the early identification of learning, emotional, or social problems. Second, there are programming features included which have a primary prevention focus and which are directed toward students generally. These largely involve training in social and life skills, and included here are exercises directed toward enhancing self-esteem. Third, there are programs included for children exhibiting learning, social, and emotional difficulties. Provisions are often made specifically for counseling of problems relating to self-esteem.

In addition to general programs of this sort, interventions have been developed specifically for exceptional children that contain elements directed toward self-esteem. The Schoolwide Enrichment Model, which combines the previously developed Enrichment Triad Model and the Revolving Door Identification Model (Renzulli, 1977; Renzulli, Reis & Smith, 1981; Renzulli, & Reis, 1985) is a flexible approach to identify children with exceptional talents and provide them with appropriate instruction. One element of the program involves the promotion of task commitment and the enhancement of self-esteem. Evidence indicating that the program has a positive impact on self-concept has been presented by Delisle & Renzulli (1982) and Gubbins (1982). The Purdue Three-Stage Model (Nielsen, 1984) is another program specifically directed towards gifted children with an explicit focus on self esteem. Feldhusen et al. (1990) have presented evidence supporting its positive influence on self-esteem.

Summary Statement

Three broad objectives were discussed in this paper. First, the link between giftedness and self-concept was investigated. Many discussions of the issue, as well as many of the research activities in the area, are guided by simplistic conceptualizations, and an attempt has been made to introduce some conceptual clarity.

Second, we have made an effort to synthesize the research results available on the issues raised. Unfortunately, that synthesis did not yield a great deal in the way of conclusive answers to our questions. Research methodologies were highly variable and, in some cases, flawed, and results tended to be very inconsistent. Yet, the review helped to create a foundation upon which to build a sounder body of research.

Finally, some specific recommendations for future research and for the counseling of gifted children are offered. The research recommendations focus on the need for (a) more adequate treatments of self-concept and giftedness variables; (b) improved designs and analytic procedures; and (c) attention to moderator and interacting variables. The counseling recommendations focus generally on the need for an increased sensitivity to the effects of the gifted label and gifted programming on the self-concepts of children.

References

- Alvino, J., McDonnel, R. C., & Richert, S. (1981). National survey of identification practices in gifted and talented education. *Exceptional Children, 48*, 124-132.
- Anastasi, A. (1986). Evolving concepts of test validation. *Annual Review of Psychology, 37*, 1-15.
- Bilby, R. W., Brookover, W. B., & Erickson, E. L. (1972). Characterizations of self and student decision making. *Review of Educational Research, 42*, 505-524.
- Bracken, B. A. (1980). Comparison of self-attitudes of gifted children and children in a nongifted normative group. *Psychological Reports, 47*, 715-718.
- Brody, L. E., & Benbow, C. P. (1986). Social and emotional adjustment of adolescents extremely talented in verbal or mathematical reasoning. *Journal of Youth and Adolescence, 15*, 1-18.
- Brody, L. E., & Benbow, C. P. (1987). Accelerative strategies: How effective are they for the gifted? *Gifted Child Quarterly, 3*, 105-110.
- Byrne, B. M. (1984). The general/academic self-concept nomological network: A review of construct validation research. *Review of Educational Research, 54*, 427-456.
- Byrne, B. M. (1986). Self-concept/academic achievement relations: An investigation of dimensionality, stability, and causality. *Canadian Journal of Behavioral Science, 18*, 173-186.
- Colangelo, N., & Brower, P. (1987). Gifted youngsters and their siblings: Long-term impact of labeling on their academic and personal self-concepts. *Roeper Review, 10*, 101-103.
- Colangelo, N., Kelly, K. R., & Schrepfer, R. M. (1987). A comparison of gifted, general, and special learning needs students on academic and social self-concept. *Journal of Counseling and Development, 66*, 73-77.
- Coleman, J. M., & Fults, B. A. (1982). Self-concept and the gifted classroom: The role of social comparisons. *Gifted Child Quarterly, 26*, 116-120.
- Coleman, J. M., & Fults, B. A. (1985). Special-class placement, level of intelligence, and the self-concepts of gifted children: A social comparison perspective. *Remedial and Special Education, 6*, 7-11.
- Cooley, C. H. (1902). *Human nature and the social order*. New York: Scribners.
- Coopersmith, S. (1967). *The antecedents of self-esteem*. San Francisco: Freeman.
- Cornell, D. (1983). Gifted children: The impact of positive labelling on the family system. *American Journal of Orthopsychiatry, 53*, 322-335.
- Cornell, D. G., Callahan, C. M., Bassin, L. E., & Ramsay, S. G. (1990, April). *Affective development in accelerated students*. Paper presented at the Annual Conference of the American Educational Research Association, Boston.

- Cowen, E. L., Trost, M. A., Lorian, R. P., Dorr, D., Izzo, L. D., & Isaacson, R. V. (1975). *New ways in school mental health: Early detection and prevention of school maladaptation*. New York: Human Sciences Press.
- Davis, H. B., & Connell, J. P. (1985). The effect of aptitude and achievement status on the self-system. *Gifted Child Quarterly*, 29, 131-136.
- Delisle, J. R., & Renzulli, J. S. (1982). The revolving door identification and programming model: Correlates of creative production. *Gifted Child Quarterly*, 26, 89-95.
- Epstein, S. (1973). The self-concept revisited: Or a theory of a theory. *American Psychologist*, 28, 404-416.
- Erikson, E. (1963). *Childhood and society* (2nd ed.). New York: Norton.
- Feldhusen, J. F. (1986). A conception of giftedness. In R. J. Sternberg & J. E. Davidson (Eds.), *Conceptions of giftedness* (pp. 112-127). Cambridge: Cambridge University Press.
- Feldhusen, J. F., Asher, J. W., & Hoover, S. M. (1984). Problems in the identification of giftedness, talent or ability. *Gifted Child Quarterly*, 28, 149-151.
- Feldhusen, J. F., & Kolloff, M. B. (1981). ME: A self-concept scale for gifted students. *Perceptual and Motor Skills*, 53, 319-323.
- Feldhusen, J. F., Sayler, M. F., Nielsen, M. E., & Kolloff, P. B. (1990). Self-concepts of gifted children in enrichment programs. *Journal for the Education of the Gifted*, 13, 380-387.
- Feldman, D. H., & Benjamin, A. C. (1986). Giftedness as a developmentalist sees it. In R. J. Sternberg & J. E. Davidson (Eds.), *Conceptions of giftedness* (pp. 285-305). Cambridge: University of Cambridge Press.
- Fisher, E. (1981). The effect of labeling on gifted children and their families. *Roeper Review*, 3, 49-51.
- Fitts, W. H. (1964). *Manuals for the Tennessee Self-Concept Scale*. Nashville, TN: Counselor Recordings and Tests.
- Freeman, J. (1985). Emotional aspects of giftedness. In J. Freeman (Ed.), *The psychology of gifted children* (pp. 247-264). New York: Wiley.
- Gallagher, J., & Courtright, R. D. (1986). The educational definition of giftedness and its policy implications. In R. J. Sternberg & J. E. Davidson (Eds.), *Conceptions of giftedness* (pp. 93-111). Cambridge: University of Cambridge Press.
- George, W. C. (1979). The talent-search concept: An identification strategy for the intellectually gifted. *Journal of Special Education*, 13, 221-237.
- Gordon, C. (1969). Self-conceptions methodologies. *The Journal of Nervous and Mental Disease*, 148, 328-364.

- Gubbins, E. J. (1982). *Revolving door identification model: Characteristics of gifted students*. Unpublished doctoral dissertation. The University of Connecticut, Storrs, CT.
- Hagen, E. (1980). *Identification of the gifted*. New York: Teachers College Press.
- Harter, S. (1982). The Perceived Competence Scale for Children. *Child Development*, 53, 87-97.
- Harter, S. (1983). Developmental perspectives on the self-system. In E. M. Hetherington (Ed.), *Handbook of child psychology: Vol. 4. Socialization, personality, and social development* (pp. 275-386). New York: Wiley.
- Harter, S. (1985). *Manual for the Self-Perception Profile for Children*. Unpublished Manuscript, University of Denver.
- Harter, S. (1986). Processes underlying the construction, maintenance, and enhancement of the self-concept in children. In J. Suls & A. G. Greenwald (Eds.), *Psychological perspectives on the self, Vol. 3* (pp. 139-181). Hillsdale, NJ: Lawrence Erlbaum.
- Harter, S., & Connell, J. P. (1984). A comparison of alternative models of the relationships between academic achievement and children's perceptions of competence, control, and motivational orientation. In J. Nicholls (Ed.), *The development of achievement-related cognitions and behaviors*. Greenwich, CT: J.A.I. Press.
- Hoge, D. R., Smit, E. K., & Hanson, S. L. (1990). School experiences predicting changes in self-esteem of sixth and seventh-grade students. *Journal of Educational Psychology*, 82, 117-127.
- Hoge, R. D. (1988). Issues in the definition and measurement of giftedness construct. *Educational Researcher*, 17, 12-16.
- Hoge, R. D. (1989). An examination of the giftedness construct. *Canadian Journal of Education*, 14, 6-17.
- Hoge, R. D., & Cudmore, L. (1986). The use of teacher-judgment measures in the identification of gifted pupils. *Teaching and Teacher Education*, 2, 181-196.
- Hoge, R. D., & McSheffrey, R. (1991). An investigation of self-concept in gifted children. *Exceptional Children*, 57, 238-245.
- James, W. (1892). *Psychology: The briefer course*. New York: Holt Rinehart & Winston.
- Janos, P. M., Fung, H., C., & Robinson, N. M. (1985). Self-concept, self-esteem, and peer relations among gifted children who feel "different". *Gifted Child Quarterly*, 29, 78-82.
- Janos, P. M., & Robinson, N. M. (1985). Psychosocial development in intellectually gifted children. In F. D. Horowitz & M. O'Brien (Eds.), *The gifted and the talented: Developmental perspectives* (pp. 149-195). Washington, DC: The American Psychological Association.

- Karnes, F. A., & Wherry, J. N. (1981). Self-concepts of gifted students as measured by the Piers-Harris Children's Self-Concept Scale. *Psychological Reports, 49*, 903-906.
- Kelly, K., & Colangelo, N. (1984). Academic and social self-concepts of gifted, general, and special students. *Exceptional Children, 50*, 551-554.
- Ketcham, B., & Snyder, R. T. (1977). Self-attitudes of the intellectually and socially advantaged student: Normative study of the Piers-Harris Children's Self-Concept Scale. *Psychological Reports, 40*, 111-116.
- Kolloff, P. B., & Feldhusen, J. F. (1984). The effects of enrichment on self-concept and creative thinking. *Gifted Child Quarterly, 28*, 53-57.
- Kolloff, P. B., & Moore, A. D. (1989). Effects of summer programs on the self-concepts of gifted children. *Journal for the Education of the Gifted, 12*, 268-276.
- Kulik, J. A., & Kulik, C.-L. C. (1984). Effects of accelerated instruction on students. *Review of Educational Research, 54*, 409-425.
- Landy, F. J. (1986). Stamp collecting vs science: Validation as hypothesis testing. *American Psychologist, 41*, 1183-1192.
- Lehman, E. B., & Erdwins, C. J. (1981). The social and emotional adjustment of young, intellectually gifted children. *Gifted Child Quarterly, 25*, 134-137.
- Maddux, C. D., Scheiber, L. M., & Bass, J. E. (1982). Self-concept and social distance in gifted children. *Gifted Child Quarterly, 26*, 77-81.
- Marsh, H. W. (1988). Causal effects of academic self-concept on academic achievement: A reanalysis of Newman (1984). *Journal of Experimental Education, 56*, 100-104.
- Marsh, H. W. (1990a). Influences of internal and external frames of reference on the formation of math and English self-concepts. *Journal of Educational Psychology, 82*, 107-116.
- Marsh, H. W. (1990b). The structure of academic self-concept: The Marsh/Shavelson model. *Journal of Educational Psychology, 82*, 623-636.
- Marsh, H. W. (1990c). Causal ordering of academic self-concept and academic achievement: A multiwave, longitudinal panel analysis. *Journal of Educational Psychology, 82*, 646-656.
- Marsh, H. W., Byrne, B. M., & Shavelson, R. (1988). A multifaceted academic self-concept: Its hierarchical structure and its relation to academic achievement. *Journal of Educational Psychology, 80*, 366-380.
- Marsh, H. W., & O'Neill, R. (1984). Self Description Questionnaire III: The construct validity of multidimensional self-concept ratings by late adolescents. *Journal of Educational Measurement, 21*, 153-174.
- McMillan, E., & Loveland, G. (1984). Counseling for the gifted. *Special Education in Canada, 58*, 125-126.

- Mead, G. H. (1934). *Mind, self, and society*. Chicago: University of Chicago Press.
- Messick, S. (1980). Test validity and the ethics of assessment. *American Psychologist*, 35, 1012-1027.
- Messick, S. (1981). Constructs and their vicissitudes in educational and psychological measurement. *Psychological Bulletin*, 89, 575-588.
- Milgram, R. M., & Milgram, N. A. (1976). Personality characteristics of gifted Israeli children. *The Journal of Genetic Psychology*, 129, 185-194.
- Nielsen, M. E. (1984). An evaluation of a rural gifted program. Unpublished manuscript, Purdue University.
- Olszewski, P., Kulieke, M. J., & Willis, G. B. (1987). Changes in the self-perceptions of gifted students who participate in rigorous academic programs. *Journal for the Education of the Gifted*, 10, 287-303.
- O'Such, T., Havertape, J., & Pierce, K. (1979). Group differences in self-concept among handicapped, normal and gifted learners. *Humanist Educator*, 18, 15-22.
- Piers, E. (1984). *Piers-Harris Children's Self-Concept Scale: Revised manual*. Los Angeles: Western Psychological Services.
- Renzulli, J. S. (1977). *The enrichment triad model: A guide for defensible programming for the gifted*. Mansfield Center, CT: Creative Learning Press.
- Renzulli, J. S. (1978). What makes giftedness? Reexamining a definition. *Phi Delta Kappan*, 60, 180-184, 261.
- Renzulli, J. S. (1984). The triad/revolving door system: A research-based approach to identification and programming for the gifted and talented. *Gifted Child Quarterly*, 28, 163-171.
- Renzulli, J. S. (1986). The three-ring conception of giftedness: A developmental model for creative productivity. In R. J. Sternberg & J. E. Davidson (Eds.), *Conceptions of giftedness*.
- Renzulli, J. S., & Reis, S. M. (1985). *The schoolwide enrichment model: A plan for educational excellence*. Mansfield Center, CT: Creative Learning Press.
- Renzulli, J. S., Reis, S. M., & Smith, L. H. (1981). *The revolving door identification model*. Mansfield Center, CT: Creative Learning Press.
- Robison-Awana, P., Kehle, T. J., & Jenson, W. R. (1986). But what about smart girls? Adolescent self-esteem and sex role perceptions as a function of academic achievement. *Journal of Educational Psychology*, 78, 179-183.
- Rosenberg, M. (1965). *Society and the adolescent self-image*. Princeton: Princeton University Press.
- Rosenberg, M. (1979). *Conceiving the self*. New York: Basic Books.

- Sapon-Shevin, M. (1984, April). *What happens when we call a child "gifted"? The effects of labelling on children, teachers, and parents.* Paper presented at the Annual Meeting of the American Educational Research Association, New Orleans, LA.
- Sapon-Shevin, M. (1987). Giftedness as a social construct. *Teacher's College Record*, 89, 39-53.
- Sapon-Shevin, M. (1989, March). *The effects of gifted programs on regular classroom teachers: If it takes a special person to work with those kids, then what are we?* Paper presented at the Annual Meeting of the American Educational Research Association, San Francisco.
- Schneider, B. H. (1987). *The gifted child in peer group perspective.* New York: Springer-Verlag.
- Schneider, B. H., Clegg, M. R., Byrne, B. M., Ledingham, J. E., & Crombie, G. (1989). Social relations of gifted children as a function of age and school program. *Journal of Educational Psychology*, 81, 48-56.
- Sears, P. S. (1966). *Memorandum with respect to the use of the Sears Self-Concept Inventory.* Unpublished manuscript, Stanford University.
- Shavelson, R. J., Hubner, J. J., & Stanton, G. C. (1976). Self-concept: Validation of construct interpretations. *Review of Educational Research*, 46, 407-441.
- Soares, A. T., & Soares, L. (1969). Self-perceptions of culturally disadvantaged children. *American Educational Research Journal*, 6, 31-46.
- Spina, D. J., & Crealock, C. M. (1985). Identification and programming for the gifted student and the gifted underachiever: A survey of the current situation in Ontario's schools. *Canadian Journal for Exceptional Children*, 2, 8-13.
- Sternberg, R. J. (1981). A componential theory of intellectual giftedness. *Gifted Child Quarterly*, 25, 86-93.
- Sternberg, R. J. (1986). A triarchic theory of intellectual giftedness. In R. J. Sternberg & J. E. Davidson (Eds.), *Conceptions of giftedness* (pp. 223-243). Cambridge: Cambridge University Press.
- Terman, L. M. (1925). *Genetic studies of genius.* Stanford: Stanford University Press.
- Tidwell, R. (1980). A psycho-educational profile of 1,593 gifted high school students. *Gifted Child Quarterly*, 24, 63-68.
- Torrance, E. P. (1965). *Rewarding creative behavior.* Englewood Cliffs, NJ: Prentice-Hall.
- Treffinger, D. J. (1984, April). *Gifted education: Time for a reappraisal?* Paper presented at the Annual Conference of the American Educational Research Association, New Orleans, LA.
- Winne, P. H., & Marx, R. W. (1981, April). Convergent and discriminant validity in self-concept measurement. Paper presented at the Annual Conference of the American Educational Research Association, Los Angeles, CA.

- Winne, P. H., Woodlands, M. J., & Wong, B. Y. L. (1982). Comparability of self-concept among learning disabled, normal, and gifted students. *Journal of Learning Disabilities, 15*, 470-475.
- Zaffrann, R. T., & Colangelo, N. (1979). Counseling with gifted and talented students. In J. C. Gowan, J. Khatena, & E. P. Torrance (Eds.), *Educating the ablest* (2nd ed.) (pp. 167-181). Itasca, IL: F. E. Peacock.
- Ziv, A., Rimon, J., & Doni, M. (1977). Parental perception and self-concept of gifted and average underachievers. *Perceptual and Motor Skills, 44*, 563-568.

Research-Based Decision Making Series

The National Research Center on the Gifted and Talented

The University of Connecticut

362 Fairfield Road, U-7

Storrs, CT 06269-2007

Editor

E. Jean Gubbins

Production Assistants

Dawn Guenther

Renay Midler

Jonathan A. Plucker

Del Siegle

Siamak Vahidi

Series Reviewers

Susan Demirsky Allan

Francis X. Archambault

John Borkowski

James Borland

Carolyn M. Callahan

Pamela Clinkenbeard

Nicholas Colangelo

Gary Confessore

Bonnie Cramond

James Cross

Gary Davis

Marcia Delcourt

John Feldhusen

David Fetterman

William Foster

David Irvine

David Kenny

Joe Khatena

Jann Leppien

Wilma Lund

Marian Matthews

Stuart Omdal

A. Harry Passow

Jonathan A. Plucker

Brian D. Reid

Sally M. Reis

Joseph S. Renzulli

Del Siegle

Virginia Simmons

Robert J. Sternberg

Kazuko Tanaka

James Undercofler

Karen L. Westberg

Also of Interest

The Relationship of Grouping Practices to the Education of the
Gifted and Talented Learner

by Karen B. Rogers

Cooperative Learning and the Academically Talented Student

by Ann Robinson

An Analysis of the Research on Ability Grouping:
Historical and Contemporary Perspectives

by James A. Kulik

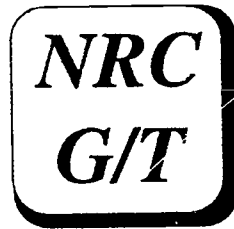

*The
National
Research
Center
on
the
Gifted
and
Talented
Research
Teams*

The University of Connecticut

Dr. Francis X. Archambault, Associate Director
The University of Connecticut
School of Education, U-64
Storrs, CT 06269-2007
203-486-4031

Dr. Alexinia Y. Baldwin
Dr. Scott W. Brown
Dr. Deborah E. Burns
Dr. David A. Kenny
Dr. Jonna Kulikowich
Dr. Sally M. Reis
Dr. Karen L. Westberg
Dr. Michael F. Young

The University of Georgia

Dr. Mary M. Frasier, Associate Director
The University of Georgia
Department of Educational Psychology
323 Aderhold Hall
Athens, GA 30602-7146
404-542-5106

Dr. Scott L. Hunsaker

The University of Virginia

Dr. Carolyn M. Callahan, Associate Director
Curry School of Education
The University of Virginia
405 Emmet Street
Charlottesville, VA 22903
804-982-2849

Dr. Michael S. Caldwell
Dr. Robert W. Covert
Dr. Marcia A. B. Delcourt
Dr. Mary Catherine Ellwein
Dr. Bruce Gansneder
Dr. Brenda H. Loyd
Dr. Donald Ball

Yale University

Dr. Robert J. Sternberg, Associate Director
Yale University
Psychology Department
Box 11-A, Yale Station
New Haven, CT 06520-7447
203-432-4633

Dr. Pamela Clinkenbeard