

DOCUMENT RESUME

ED 357 971

SE 053 263

AUTHOR Lewis, John  
TITLE Electronics Teacher's Guide. Science and Technology Document Series No. 40.  
INSTITUTION United Nations Educational, Scientific, and Cultural Organization, Paris (France). Section of Science and Technology Education.  
REPORT NO ED-91/WS-1  
PUB DATE 91  
NOTE 119p.; Part of the Science and Technology Education Document Series, No. 40.  
AVAILABLE FROM Science and Technology Education Section, Educational Development Division, Education Sector, Unesco, 7 Place de Fontenoy, 75700 Paris, France.  
PUB TYPE Guides - Classroom Use - Instructional Materials (For Learner) (051) -- Guides - Classroom Use - Teaching Guides (For Teacher) (052)  
EDRS PRICE MF01/PC05 Plus Postage.  
DESCRIPTORS Curriculum Guides; \*Electric Circuits; Electricity; \*Electronics; \*Physics; \*Science Activities; \*Science Curriculum; Science Education; \*Science Experiments; Secondary Education; Worksheets  
IDENTIFIERS \*Logic Circuits; UNESCO

ABSTRACT

This is the second document on the teaching of electronics to appear as part of UNESCO's science and technology education program. An introductory section describes the role that electronics plays as part of the physics curriculum. The following section outlines the content of the electronics course. The outline includes guidelines for determining the course content. The remainder of the document is divided into two parts that present the nine sections of the course. The theme of the three sections in the first part is switching. The theme of the six sections in the second part is integrated circuits. The nine section topics are: (1) useful electronic components; (2) switches; (3) logic circuits; (4) logic gates; (5) bistable circuits; (6) drivers; (7) coding; (8) the pulser, the astable, and the clocked bistable; and (9) counting circuits. Each section contains experiments related to the topic that include investigation questions and notes about the experiment. An attached workbook at the back of the document contains student worksheets for the experiments in each of the sections. Two appendices provide a bibliography and technical details for the electronic modules involved in the experiments. (MDH)

\*\*\*\*\*  
\* Reproductions supplied by EDRS are the best that can be made \*  
\* from the original document. \*  
\*\*\*\*\*

ED357971

# Electronics Teacher's Guide

Science and Technology Education



"PERMISSION TO REPRODUCE THIS MATERIAL HAS BEEN GRANTED BY

F. Zanuttini

TO THE EDUCATIONAL RESOURCES INFORMATION CENTER (ERIC)."

U.S. DEPARTMENT OF EDUCATION  
Office of Educational Research and Improvement  
EDUCATIONAL RESOURCES INFORMATION CENTER (ERIC)

This document has been reproduced as received from the person or organization originating it  
 Minor changes have been made to improve reproduction quality

• Points of view or opinions stated in this document do not necessarily represent official OERI position or policy

## Science and Technology Education Document Series (STEDS)

- |                                                                                                                                                                                                                                                                                                                                                                                                                                                                                                                                                                                                                                                                                                                                                                                                                                                                                                                                                                                                                                                                                                                                                                                                                                                                                                                                                                                                                                                                                                                                                                                                                                                                                                                                      |                                                                                                                                                                                                                                                                                                                                                                                                                                                                                                                                                                                                                                                                                                                                                                                                                                                                                                                                                                                                                                                                                                                                                                                                                                                                                                                                                                                                                                                                                                                                                                                                                                                                                                                                                                                                                                                                                                                   |
|--------------------------------------------------------------------------------------------------------------------------------------------------------------------------------------------------------------------------------------------------------------------------------------------------------------------------------------------------------------------------------------------------------------------------------------------------------------------------------------------------------------------------------------------------------------------------------------------------------------------------------------------------------------------------------------------------------------------------------------------------------------------------------------------------------------------------------------------------------------------------------------------------------------------------------------------------------------------------------------------------------------------------------------------------------------------------------------------------------------------------------------------------------------------------------------------------------------------------------------------------------------------------------------------------------------------------------------------------------------------------------------------------------------------------------------------------------------------------------------------------------------------------------------------------------------------------------------------------------------------------------------------------------------------------------------------------------------------------------------|-------------------------------------------------------------------------------------------------------------------------------------------------------------------------------------------------------------------------------------------------------------------------------------------------------------------------------------------------------------------------------------------------------------------------------------------------------------------------------------------------------------------------------------------------------------------------------------------------------------------------------------------------------------------------------------------------------------------------------------------------------------------------------------------------------------------------------------------------------------------------------------------------------------------------------------------------------------------------------------------------------------------------------------------------------------------------------------------------------------------------------------------------------------------------------------------------------------------------------------------------------------------------------------------------------------------------------------------------------------------------------------------------------------------------------------------------------------------------------------------------------------------------------------------------------------------------------------------------------------------------------------------------------------------------------------------------------------------------------------------------------------------------------------------------------------------------------------------------------------------------------------------------------------------|
| <p>No. 1 Glossary of Terms used in Science and Technology Education. 1981 (English)</p> <p>No. 2 Methodologies for Relevant Skill Development in Biology Education. 1982 (English)</p> <p>No. 3 Nutrition Education: Curriculum Planning and Selected Case Studies. 1982 (English) (Reprint in Nutrition Education Series No. 4)</p> <p>No. 4 Technology Education as part of General Education. 1983 (English and French)</p> <p>No. 5 Nutrition Education: Relevance and Future. 1982 (English) (Reprint in Nutrition Education Series, No. 5)</p> <p>No. 6 Chemistry Teaching and the Environment. 1983 (English)</p> <p>No. 7 Encouraging Girls into Science and Technology Education: Some European Initiatives. 1984 (English)</p> <p>No. 8 Genetically-Based Biological Technologies. 1984 (English)</p> <p>No. 9 Biological Systems, Energy Sources and Biology Teaching. 1984 (English)</p> <p>No. 10 Ecology, Ecosystem Management and Biology Teaching. 1984 (Reprint 1986) (English)</p> <p>No. 11 Agriculture and Biology Teaching. 1984 (English)</p> <p>No. 12 Health Education and Biology Teaching. 1984 (English)</p> <p>No. 13 The Training of Primary Science Educators - A Workshop Approach. 1985 (English)</p> <p>No. 14 L'Économie sociale familiale dans le développement rural. 1985 (French)</p> <p>No. 15 Human Development and Evolution and Biology Teaching. 1985 (English)</p> <p>No. 16 Assessment: A Practical Guide to Improving the Quality and Scope of Assessment Instruments. 1986 (English)</p> <p>No. 17 Practical Activities for Out-of-School Science and Technology Education. 1986 (English)</p> <p>No. 18 The Social Relevance of Science and Technology Education. 1986 (English)</p> | <p>No. 19 The Teaching of Science and Technology in an Interdisciplinary Context. 1986 (English)</p> <p>No. 20 Mathematics for All. 1986 (English, French in press)</p> <p>No. 21 Science and Mathematics in the General Secondary School in the Soviet Union. 1986 (English)</p> <p>No. 22 Leisure, Values &amp; Biology Teaching. 1987 (English and French)</p> <p>No. 23 Use of Sea and its Organisms. 1987 (English)</p> <p>No. 24 Innovations in Science and Mathematics Education in the Soviet Union. 1987 (English)</p> <p>No. 25 Biology and Human Welfare. Case Studies in Teaching ... plied Biology. 1988 (English)</p> <p>No. 26 Sourcebook of Science Education Research in the Caribbean. 1988 (English)</p> <p>No. 27 Pour un enseignement intégré de la science et de la technologie : trois modules. 1988 (French)</p> <p>No. 28 Microbiological Techniques in School. 1988 (English)</p> <p>No. 29 Games and Toys in the Teaching of Science and Technology. 1988 (English and French)</p> <p>No. 30 Field Work in Ecology for Secondary Schools in Tropical Countries. 1988 (English, Arabic)</p> <p>No. 31 Educational Materials Linking Technology Teaching with Science Education: Technology in Life. 1988 (English)</p> <p>No. 32 Evaluation and Assessment in Mathematics Education. 1989 (English)</p> <p>No. 33 Systems Thinking in Biology Education. 1989 (English)</p> <p>No. 34 Base physique de l'électronique dans l'enseignement secondaire : module méthodologique. 1989 (French)</p> <p>No. 35 Mathematics, Education, and Society. 1989 (English)</p> <p>No. 36 Bibliography in Integrated Science Teaching. 1990 (English)</p> <p>No. 37 Educación Matemática en las Américas VII. 1990 (Spanish)</p> <p>No. 38 The Teaching of Science and Technology in an Interdisciplinary Context. 1990 (English)</p> <p>No. 39 Teaching Biotechnology in Schools. 1990 (English)</p> |
|--------------------------------------------------------------------------------------------------------------------------------------------------------------------------------------------------------------------------------------------------------------------------------------------------------------------------------------------------------------------------------------------------------------------------------------------------------------------------------------------------------------------------------------------------------------------------------------------------------------------------------------------------------------------------------------------------------------------------------------------------------------------------------------------------------------------------------------------------------------------------------------------------------------------------------------------------------------------------------------------------------------------------------------------------------------------------------------------------------------------------------------------------------------------------------------------------------------------------------------------------------------------------------------------------------------------------------------------------------------------------------------------------------------------------------------------------------------------------------------------------------------------------------------------------------------------------------------------------------------------------------------------------------------------------------------------------------------------------------------|-------------------------------------------------------------------------------------------------------------------------------------------------------------------------------------------------------------------------------------------------------------------------------------------------------------------------------------------------------------------------------------------------------------------------------------------------------------------------------------------------------------------------------------------------------------------------------------------------------------------------------------------------------------------------------------------------------------------------------------------------------------------------------------------------------------------------------------------------------------------------------------------------------------------------------------------------------------------------------------------------------------------------------------------------------------------------------------------------------------------------------------------------------------------------------------------------------------------------------------------------------------------------------------------------------------------------------------------------------------------------------------------------------------------------------------------------------------------------------------------------------------------------------------------------------------------------------------------------------------------------------------------------------------------------------------------------------------------------------------------------------------------------------------------------------------------------------------------------------------------------------------------------------------------|

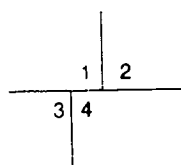

### Cover photos

1. Photo Unesco/Paul Almasy
2. Photo UNATIONS
3. Photo Unesco/D. Bahrman
4. Photo rights reserved

# Science and Technology Education

Document Series No. 40

## Electronics Teacher's Guide

John Lewis

Section of Science  
and Technology Education

UNESCO

ED-91/WS-1

Paris, 1991

## Preface

This document, the second to appear on the teaching of electronics in the 'Science and technology education document series', has been prepared as part of Unesco's science and technology education programme. The previous title, *Base physique d'électronique dans l'enseignement secondaire: module méthodologique* (Science and technology education document series, 34) exists in French only.

*Electronics Teacher's Guide* has been specially written by John Lewis for Unesco. He was one of the leaders of the well known Nuffield O-Level Physics Curriculum project and later the director of the Science & Society Project in the United Kingdom. He has contributed worldwide to many innovations in science education. Mr. Lewis has been Secretary of the International Commission of Physics Education, which awarded him its medal in 1988, and Secretary of the Committee on the Teaching of Science of the International Council of Scientific Unions. His committee organized the Bangalore Conference on 'Science and Technology Education and Future Human Needs' in 1985. He was awarded the OBE for his work in science education.

This work is based on material developed at the Independent Schools Microelectronics Centre (ISMEC) at Westminster College, Oxford. ISMEC itself ceased to exist when its work was completed in 1986. Its place has been taken by the Westminster Centre for Design and Technology.

Unesco wishes to express its appreciation first to John Lewis, Michael Summers and Geoffrey Foxcroft for the original development of the material and then to John Lewis, Geoffrey Foxcroft and David Haynes for the development of this modified version for Unesco. The views expressed in this report are those of the author and not necessarily those of Unesco.

Comments on the contents of this document are welcomed; they should be sent to:

Science and Technology Education Section  
Educational Development Division  
Education Sector  
Unesco  
7 Place de Fontenoy  
75700 Paris  
France

*Base physique d'électronique dans l'enseignement secondaire: module méthodologique* is available free of charge from the same address.

# CONTENTS

Electronics as part of the Physics Curriculum	page 1
An Outline of Content	page 3
The modules for Part 1	page 5
Introduction to Part 1	page 6
Section 1 : Some Useful Electronic Components	page 7
Section 2 : Switches	page 12
Section 3 : Logic Circuits	page 17
The Modules for Part 2	page 24
Introduction to Part 2	Page 25
Section 4 : Electronic Logic Circuits - Logic Gates	page 27
Section 5 : The Bistable Circuit	page 37
Section 6 : Drivers	page 43
Section 7 : Coding	page 48
Section 8 : The Pulser, the Astable and the Clocked Bistable	page 53
Section 9 : Counting Circuits	page 58
Appendix A : Bibliography	page 72
Appendix B : Technical Details	page 73

## Electronics as Part of the Physics Curriculum

Whereas most educators are now agreed on the importance of including electronics within the school curriculum, there are conflicting views on how this should be done. Traditionally, of course, some electronics has always been part of school physics. In the past it has largely been confined to the higher levels, but most people would now agree that a much wider exposure is necessary (in fact many would argue that electronics should be a compulsory part of the curriculum). The problem with the traditional approach to electronics within physics is that it has been centred on particular devices and their characteristics. In earlier days, valves and their uses for rectification and amplification were a focus of attention, and more recently, transistors (both bipolar and FET) and other solid state devices have been prominent in physics curricula at advanced levels.

However, any approach which places too much emphasis on the structure and characteristics of specific devices suffers from two major drawbacks. The first is that these devices are likely to be of only transient importance (witness valves, or indeed, transistors). Secondly, not enough time will be left over to provide experience of designing and building electronic systems to perform useful tasks. The latter is vital if students are to acquire some appreciation and understanding of the power of modern electronics, of its rôle in technology, and of its influence on human societies.

Of course, not all physics courses have adopted this traditional device-centred approach. The most notable exception is the Nuffield Advanced Physics course, which pioneered an approach to electronics teaching using conceptual building bricks. Electronics is still about logic gates, bistables, astables, counters, and so on, even though we now use integrated circuits instead of valves or transistors. The real insight of the Nuffield course (which in fact used transistors) was to realise this basic conceptual durability in the face of rapid technological development at the device level. It is this kind of approach - known as the systems approach - which is now so urgently required at an earlier stage.

Despite the success of the systems approach within the Nuffield course, there are still many physics teachers who argue that this kind of electronics has little to do with physics, and has no place in a physics curriculum. Before considering this fundamental question, let us first identify some of the very practical advantages of keeping electronics (but now a systems approach) within school physics courses.

Of paramount importance is the difficulty of finding time for a new subject - electronics - within an already crowded school curriculum. This problem is resolved if electronics is taught within the existing curriculum structure (physics, of course, is part of that structure).

One has only to look at the requirements of electronics syllabuses to realise the tremendous overlap with the content of physics syllabuses. The physics syllabuses have always dealt with the basic concepts necessary for a sound understanding of electronics and its uses - current, voltage, resistance, power, potential dividers, capacitors, transducers, feedback, measurement and instrumentation, and so on. Electronics can show how these concepts are used and usefully applied, and should be accepted as part of the physics curriculum in the same way that optical instruments have always been accepted. If it is accepted, problems of repetition and of overcrowding the curriculum are removed.

In practice, physics teachers are most likely to have had the widest exposure to electronics, and are the people who most often teach electronics in schools. At the time of writing, there is a shortage of qualified physics teachers, and it is undesirable that they should be taken away from physics and asked to teach electronics. This again argues against the introduction of electronics as a separate subject in the school curriculum.

All of the above are practical reasons for making electronics an integral part of physics courses. So what contrary arguments are there? Why do so many physics teachers themselves resist the introduction of some electronics into the school physics curriculum?



A key argument put forward is that physics and electronics (as manifested in the modern systems approach) are fundamentally different. Whereas physics is concerned with analysis and explanation of the physical world, electronics is concerned with synthesis and application - with the work of the engineer, rather than the physicist. How valid is that argument? How relevant is it in an educational context?

It is suggested that such an argument is based on an inadequate and rather outdated view both of physics itself and of the desirable objectives of a modern school physics curriculum. In the first place, the rather "pure science" conception of physics as a discipline concerned solely with analysis and explanation of the physical world does not adequately reflect the activities of most of the world's physicists. If we accept that a discipline should be defined, at least in part, by what its practitioners actually do, then the need for a wider view soon becomes apparent. In practice, very few physicists are engaged in fundamental research directed at explanation of the natural world. Most are concerned with using accepted ideas and theories with their creative use for solving problems in industry, with development rather than pure research. Such activities often have an applied engineering flavour, but they are the legitimate concern of physics and physicists. It is this broader view of physics that should be reflected in the objectives, and therefore the processes and content, of a school physics curriculum. Indeed many would argue that this is the only way in which the subject can be made relevant and useful to the majority of pupils.

Of course, the skills required of even the research physicist have never been predominantly analytical. Physicists at all levels are concerned with synthesis whenever they are applying physical concepts to solve problems.

Indeed, that key element in scientific method - the generation of hypotheses - is inextricably concerned with both analysis and synthesis. Likewise, it is equally wrong to consider electronics as being concerned predominantly with synthesis. There will inevitably be elements of analysis (for example, thinking out how a particular system functions in terms of simpler conceptual building bricks) in both the work of the electronics engineer and in electronics within the classroom.

There is one last point which should be of great concern to all physics teachers. Considerable evidence now exists to suggest that a systems approach to electronics generates widespread enthusiasm and interest amongst students of all backgrounds and abilities. The inclusion of electronics can do nothing but strengthen physics as a school subject. At the moment there is a considerable danger that physics will lose electronics altogether, and with it a natural source of pupil motivation and involvement. It would be a sad day for physics if this were to happen.



## AN OUTLINE OF CONTENT

### Guidelines determining content

The programme of work for **Electronics** was developed in accordance with a number of guidelines. A brief description of these is necessary if the rationale for the proposed work is to be fully appreciated.

- 1 From the start, the intention was that the proposed work should form part of a lower school physics curriculum. That represents the end of formal contact with physics for many students. Because of this it is important to identify a worthwhile end-point for the study of electronics at this level, and devise content which progresses systematically towards this end-point. Binary counting systems have been chosen for this course.
- 2 The next important guideline was that the work had to be concerned primarily with the conceptual building bricks of electronics. There is no need to elaborate the point here, since the rationale for this approach has already been discussed in the Preface. But having decided on an approach, there remains the problem of identifying an appropriate level of complexity.

Modern digital electronics is not particularly difficult. In principle, it is certainly possible to explain how devices such as decoders, various bistables and counters, memories, and so on, are built up from simpler building bricks (often NAND gates). However, although not difficult, this can be extremely complicated, and many students will lose their way and possibly their interest. The secret is to give a "taste" of how more complex units are built up from simpler building bricks, without making things too complicated. So, for example, we can explain how a simple RS bistable is built up from two NAND gates, but it is probably inappropriate to describe how the more complex master-slave JK bistable is constructed from the same building bricks. The Electronics work tries to avoid too much complexity while providing some insight into the relationship between complex units and simple building bricks such as the NAND gate.

- 3 An obvious factor which had to be taken into account was the question of how much time could be afforded for the study of electronics in a physics course. The assumption underlying the present proposals is that about 9 weeks will be available. This assumes one double and one single period per week for the proposed work, making a total of about 27 periods in all.
- 4 A final guideline was that throughout the proposed work there should be an emphasis on the ways in which electronics is used to perform useful tasks. Although several schemes for a systems approach to learning electronics have been published, they are often concerned predominantly with what electronic units do in a purely electronic environment. So, for example, LEDs and seven segment displays are used to show what bistables and counters do, and so on. Only a few schemes show how electronic systems interact with the real world to control external devices, and that is an important aspect of this Electronics course.

## The course at a glance

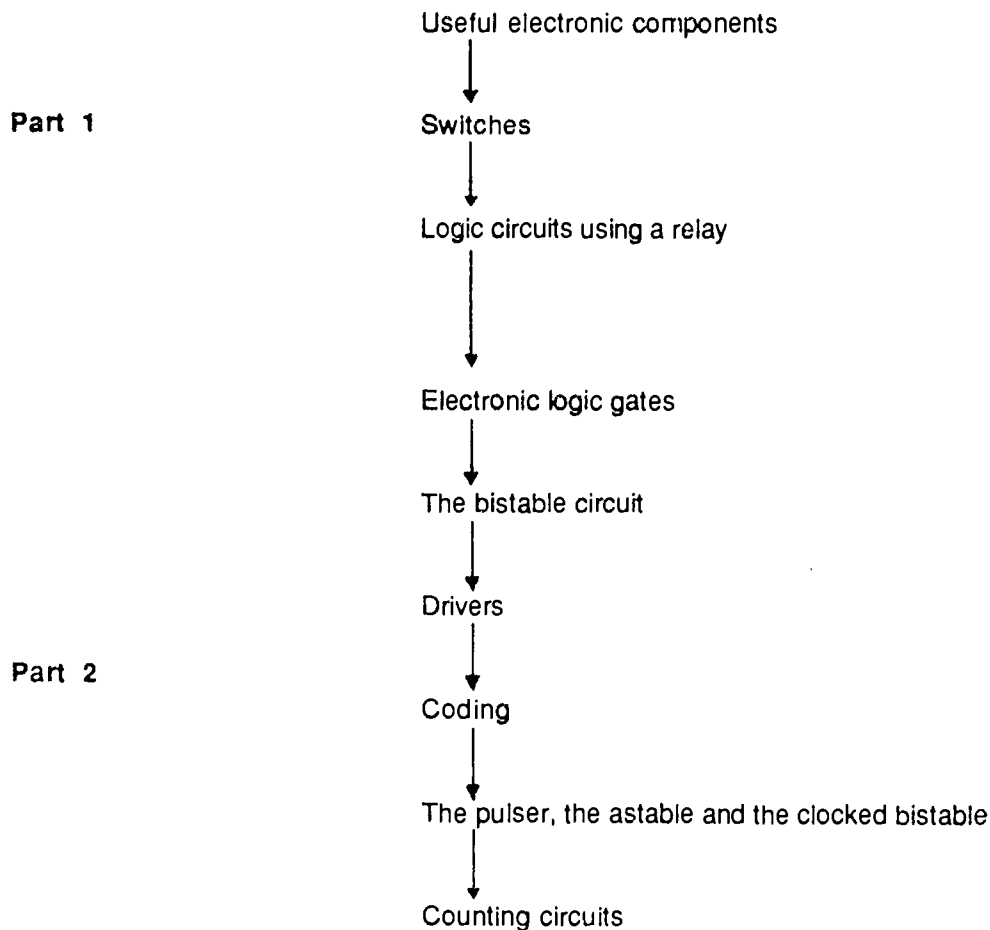

The route mapped out in the diagram above is intended to facilitate a smooth progression to the end-point - some understanding and use of counters. Work which is not essential to this progression (shift registers, multiplexers, comparators, and so on) is not included. Most of the topics fall naturally into the sequence indicated.

The work is conveniently divided into Part 1 and Part 2. The theme of Part 1 is switching. It does not use any active semi-conductor devices and so is eminently suitable for weaving into the early stages of education when circuits are first met. The modules required for this work are comparatively simple.

The work of Part 2 uses modules constructed with various integrated circuits (as well as the modules of Part 1). The CMOS family of integrated circuits has been chosen for these modules - for reasons given in Appendix B.

Note that a section dealing with drivers is included fairly early on to pave the way for experimental work using devices such as electric motors. Applications involving control are an important part of the course, and are prominent in much of the suggested experimental work. Note also that the approach to the astable is operational and no explanation of the ways in which astable circuits function is required. This means that the concept of capacitance need not be covered at this level.

There is one final and very important point to make here. The proposed work assumes that some of the necessary conceptual background will be dealt with in the electricity section of a physics course. For this reason, topics such as, for example, voltage and its measurement, the potential divider, transducers, do not appear above. An advantage of this approach is that the electronics work can go fairly quickly and smoothly with the necessary emphasis on **using** devices.

# THE MODULES FOR PART 1

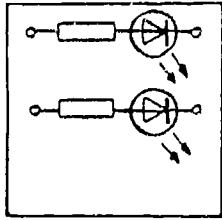

LIGHT EMITTING  
DIODES (RED & GREEN)

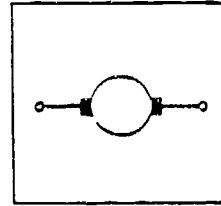

MOTOR

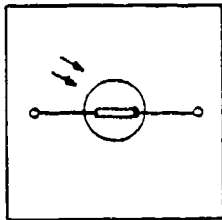

LIGHT DEPENDENT  
RESISTOR

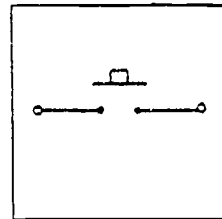

PUSH-BUTTON SWITCH (2)

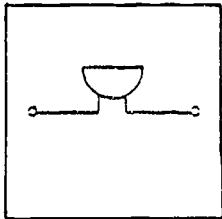

BUZZER

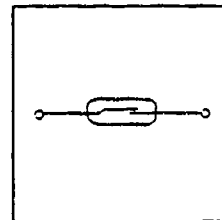

REED SWITCH

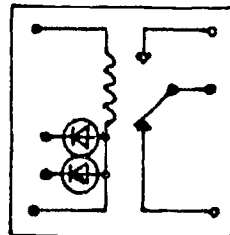

REED RELAY

## Introduction to Part 1

The work of Part 1 is divided into three sections as below. The theme is switching.

Section 1:	Some useful electronic components
Section 2:	Switches
Section 2:	Logic circuits

### Timing

This work could be done during the first two years of a five-year physics course. It should not take up more than about 8 lessons. It is important that this introductory work should link smoothly with the circuit work of the physics syllabus; indeed, Sections 1 and 2 could usefully be woven into that work.

### The Experiments

The course is essentially experimental, and, if possible, pupils should work in pairs. Some work in Section 3 requires modules from two kits so that pupils will then need to work as a group of four. For each experiment, the pupil worksheet is reproduced, followed by 'notes' written for teachers to help them with any teaching which may be required. The worksheets are printed without 'notes', in **Electronics : Worksheets, Part 1**.

### Projects

In Part 1, there are four experiments in which a problem is posed and pupils are invited to find a solution. These problem-type experiments have been called 'Projects'. They illustrate electronics being put to use, and there are many more in Part 2. The pupils' booklet **Electronics : Worksheets, Part 1** does not give the solutions to these projects. Teachers will need to give help and encouragement in solving the problems without immediately revealing a solution. Pupils should be urged to think out a circuit first, and draw a circuit diagram, before connecting it up to see if it works. Then, if the circuit does not behave as expected, they should try to think out why before making any changes.

### Protective components

Teachers should note that some of these modules incorporate protective components to guard against damage which might occur if a circuit were connected incorrectly. So, for example, the reed relay module may have a resistor to limit the current flowing through the relay contacts. Likewise, a push-button switch module may be protected by a series resistor to limit the current through the contacts to a value which will not cause damage even if the battery is connected directly across the switch terminals. In the diagrams on the modules and in the circuit diagrams throughout this booklet, protective components are NOT shown. The only exception is the series resistor on each LED module. This is shown because it is an accepted part of standard circuit design, rather than a device to guard a module against abuse.

There is no need to mention any of this to pupils unless they notice the protective components and raise questions. Even then, it is best to dismiss the matter quickly and avoid detailed explanations.

### The voltage supply

All the experimental work can be carried out using a 6V supply from batteries but the modules will also work from a 4.5V supply. Apart from batteries, each group of pupils will require connecting leads. Teachers may wish to build up their own collection of useful items for demonstration purposes.

## SECTION 1. SOME USEFUL ELECTRONIC COMPONENTS

### Experiment 1.1: Resistor and light emitting diode (LED)

Connect up the circuit shown, using an LED on the LED module and a battery.

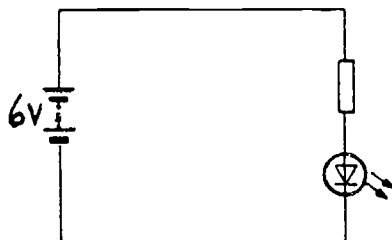

#### Investigations and questions

- 1 What happens to the LED in the above circuit?
- 2 Reverse the connections so that the diode is the other way round. What happens?
- 3 Why do you think this happens?

#### Notes

(1) LEDs are inexpensive and widely used as indicators. The circuit diagram symbol for an LED is shown below. Like ordinary diodes (which pupils have already met), an LED will allow current to pass in only one direction. Unlike an ordinary diode, the passage of current causes the emission of light. The intensity of this light depends on the magnitude of the current.



Note that the direction in which current will flow is the same as that of the arrowhead in the symbol.

(2) If connected directly across the battery in the conducting direction, the LED will be destroyed. In practical circuits a series resistor must be included to limit the current to a value which will not damage the LED (10 milliamperes is a typical value). Note that LEDs are now cheap enough for teachers to demonstrate that the diode is destroyed if connected directly across the battery. This demonstration establishes the need for the resistor.

(3) In their earlier circuit work pupils will have explored the concept of resistance using lamps and resistance wire. They now meet the electrical component known as a resistor. The rôle of resistors in circuits will be explored more fully in the next experiment.

(4) The modern symbol for a resistor should be used in circuit diagrams.



### Experiment 1.2 (Optional): Brightness and current

Connect up the circuit shown, using an LED module, a resistor and a battery. Use a low value resistor first.

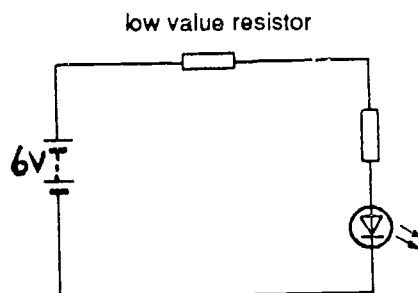

#### Investigations and questions

- 1 Note how brightly the LED glows. Replace the resistor first by the one of medium value, then by one of high value. What happens to the brightness of the LED?
- 2 How does the brightness of the LED depend on the current passing through it?

#### Notes

(1) In this experiment three resistors are required. A suitable value for the high value resistor is  $27\text{k}\Omega$ , while the medium and low values could be  $2.7\text{k}\Omega$  and  $270\Omega$  respectively. The resistors in series with the LEDs on the LED module have a value of  $330\Omega$ . There is no need for pupils to be given any of these numerical values.

(2) In the same way that they know current is measured in amperes, pupils should know that resistance is measured in ohms (symbol  $\Omega$ ). No attempt should be made to give any formal definition of these units.

(3) At this level resistor values can be classified as either high, medium or low. Teachers might like to mention that in electronics a resistance of a few hundred ohms or less is usually regarded as a fairly low value. A medium value would probably be a few kilohms (symbol  $\text{k}\Omega$ ), while a resistance of a few tens of kilohms and above would be regarded as a large value.

(4) There is no need to mention the colour code for identifying resistors of different value unless pupils ask why the colours are there. They do not need to know how to use the code and on no account should they be required to learn it.

### Experiment 1.3: LEDs in parallel

Set up the circuit shown using one red LED, one green LED and a battery.

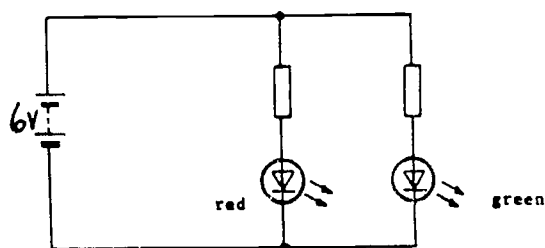

### Investigations and questions

- 1 Explain why both LEDs glow.
- 2 If a second red or green LED were connected in parallel with the above two, how brightly would you expect it to glow? Borrow an LED module from another group and test your answer.

### Notes

(1) This experiment is included to reinforce earlier circuit board work on parallel circuits and to introduce LEDs of different colour.

(2) Two LEDs of the same colour connected in parallel will glow with the same brightness because the currents through each are equal. This, of course, assumes that the series resistors are equal (which they are on the LED module). An LED of different colour with the same value of series resistor may not glow with the same brightness. Measurements with a milliammeter would in fact show that the currents through red and green LEDs with equal series resistors are almost exactly the same. Variations in apparent brightness are due to differences in the materials used to construct LEDs of different colours, and to variations in the sensitivity of the eye to different colours.

(3) It is important that pupils should be able to trace the current paths from the battery through each branch of a parallel circuit. For this experiment the path from the battery through each resistor and LED is shown below.

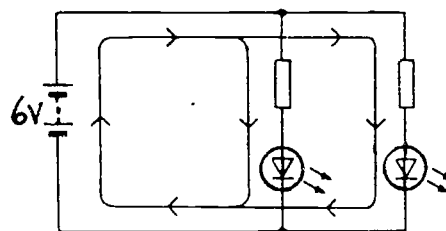

(4) The above experiment can be used to introduce the concept of positive and negative supply rails, as the diagram below shows.

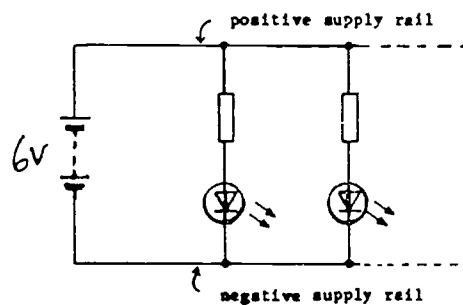

### Experiment 1.4 Project : a current direction indicator

This is the first of a number of projects of varying complexity which pupils should tackle during their electronics work. A problem is presented and pupils attempt to solve it with guidance from the teacher. In the present case the problem is very simple and little guidance should be necessary.

Problem:

Use the LED module to construct a current direction indicator. When a battery is connected one way round to the indicator one of the LEDs should glow. If the battery connections are reversed the other LED should glow.



Solution:

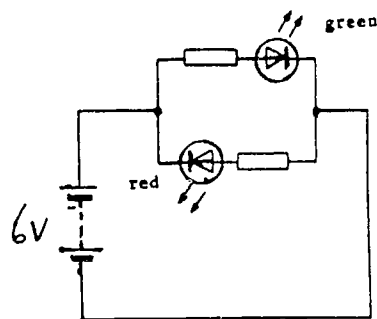

### Experiment 1.5: Light dependent resistor (LDR)

Set up the circuit below which shows a light dependent resistor in series with an LED and a battery.

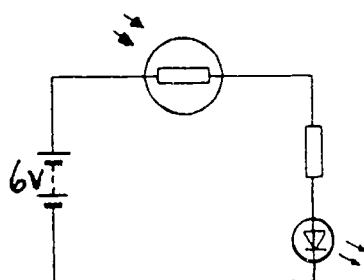

#### Investigations and questions

- 1 What happens to the brightness of the LED when the LDR is covered and uncovered?
- 2 What does this tell you about the resistance of the LDR in the light and in the dark?

#### Notes

(1) The circuit diagram symbol for an LDR is shown in the diagram above.

(2) The current will flow in either direction as with an ordinary resistor. However, the resistance of an LDR is very high in the dark (perhaps a million ohms or more) but falls to a low value (typically one or two hundred ohms) in bright light.

(3) LDRs are known by a variety of different names. Cadmium sulphide cell or resistor is common (most LDRs are made from this substance), as is the term photocell. For simplicity and to avoid confusion with cells in batteries, teachers are advised to use only "light dependent resistor".

Experiment 1.6 Project : a very simple burglar alarm

The problem is to use an LDR module, a buzzer module and a battery to construct a circuit which will sound an alarm when a light comes on. If a burglar were foolish enough to turn on the light in a room, such a circuit could be used to warn the householder. Alternatively, the circuit could be used to detect the light from the burglar's torch.

Solution:

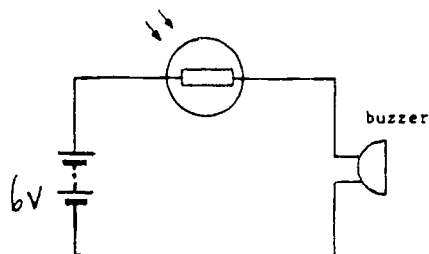

This is the first of a series of burglar alarm circuits appearing in the course. Alarms of increasing sophistication are constructed.

Note that the buzzer is likely to be a device with a definite polarity (in other words, current will pass through it in one direction only). If no sound is emitted when the LDR is illuminated, reverse the connections to the buzzer module.

## SECTION 2. SWITCHES

### Experiment 2.1: Manual control of an LED

Connect a battery, an LED and a push-button switch together in a series circuit. Test whether you have done it correctly by pressing the switch and then releasing it. The LED should light only when the switch is pressed.

- 1 Draw a circuit diagram for this experiment.
- 2 Explain how the push-button switch works.

#### Notes

- (1) This gives practice in drawing circuit diagrams. Pupils will need to know the symbol to use for the switch. They should be encouraged always to draw good, neat circuit diagrams.
- (2) The circuit diagrams below are both correct.

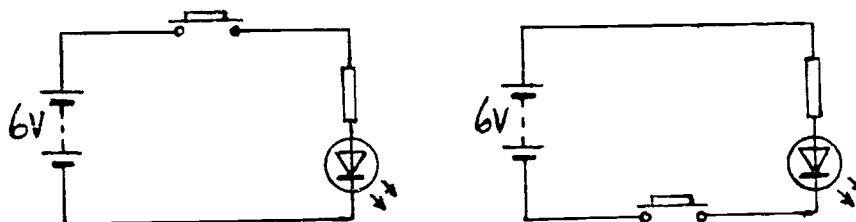

### Experiment 2.2: Reed switch and magnet

Take the reed switch module and examine the two metal contacts inside the glass envelope with a magnifying glass. These contacts are normally open. Now connect the switch in series with a buzzer and a battery.

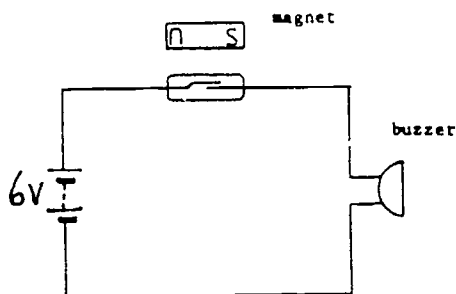

#### Investigations and questions

- 1 Bring a small bar magnet close to the reed switch in the manner shown above. What happens?
- 2 What must have happened inside the glass envelope? Use your magnifying glass to see if you are right.

#### Notes

- (1) The reed switch consists of two metal contacts (called "reeds") inside a glass envelope filled with an inert gas to prevent corrosion. Since the contacts are made of a ferrous metal (a metal containing iron), they can be magnetised by a magnet. If the magnet is brought close to the switch in the manner shown below, the metal strips are magnetised and attract.

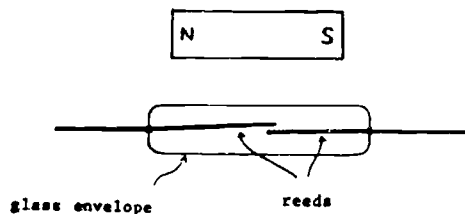

When the contacts close a current flows through the buzzer. There is no need to involve pupils in a detailed explanation of how the reed switch works. Direct experience of its switching action in the presence of a magnet is all that is required.

(2) In this experiment a magnet is used to produce a force which closes the switch contacts. From their earlier circuit board work, pupils will know that a current-carrying coil has a magnetic effect. In the next experiment pupils will meet a device in which switching is controlled by the magnetic effect of such a coil - the electromagnetic relay. The purpose of the present experiment is to bridge the gap between direct manual operation and electromagnetic control of switching. The progression is from direct manual control to magnetic control, and then to electromagnetic control.

(3) Note that the reed switch contacts are either open or closed. Such a switch is called a single pole single throw (SPST) switch. In the present case the contacts are normally open, and are shown as such in the circuit diagram. This is in line with convention.

#### Experiment 2.3: Reed switch and coil - the reed relay

Using a reed relay module, set up the circuit shown below. Note that two separate battery supplies are required. Do NOT use either of the diode connections to the coil of the relay.

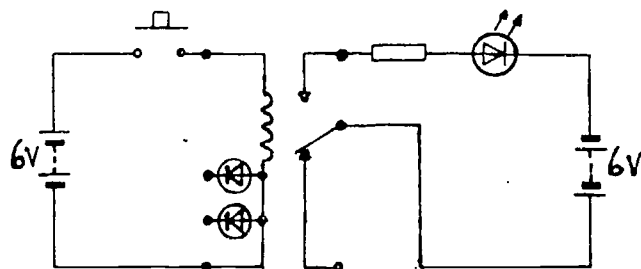

#### Investigations and questions

- 1 What happens to the LED when the switch is closed?
- 2 Try to explain why this happens.
- 3 Now change the switch connections at the relay so that the LED is on until the push-button switch is pressed.

#### Notes

(1) The relay uses a 'change-over' reed switch, also called a single pole double throw (SPDT) switch. Teachers should explain how it works.

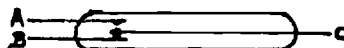

The reed C and contact A are made of magnetic metal; contact B is a non-magnetic metal. C is normally in contact with B, but when a magnetic field magnetises A and C, they are attracted together so that contact with B is broken and C contacts A instead. C springs back to its original position when the field is removed. In this course the reed switch in the relay is shown as below.

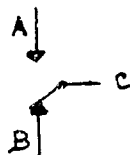

(2) This is an important experiment since it introduces the electromagnetic relay. If a current flows through the coil, the reed switch changes over and the LED lights.

(3) The important points to appreciate are (a) the switching is now determined by the flow of an electric current, (b) although the two circuits are separate, what happens in one is controlled by what happens in the other.

(4) In practice the current through the coil, which is needed to operate the switch, is usually far smaller than the current which is allowed through the switch contacts themselves. So if the LED and resistor were replaced by an electric motor requiring a large current to make it rotate, it could be operated by a much smaller current passing through the coil circuit. This principle is important in electronics, and there are other devices which provide the same capability (the transistor, for example). The particular case of motor control appears in experiment 2.4 and in later experiments.

#### Experiment 2.4: The reed relay used to control a motor

Use the LDR module, the reed relay, the motor module and two batteries to set up the circuit below.

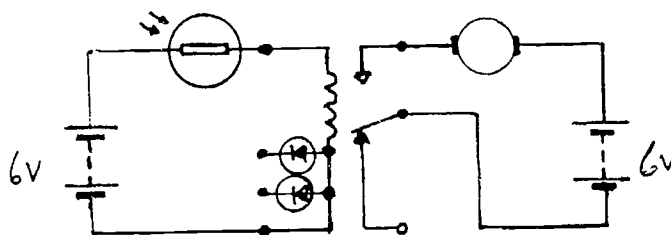

#### Investigations and questions

- 1 What happens when the LDR is covered and uncovered? (You may have to shine a torch on the LDR when you have uncovered it.)
- 2 If possible, use ammeters to measure the current flowing from each of the batteries in the circuit when the motor is running.
- 3 Now connect the LDR module, the motor module and one battery as shown below. What happens this time when the LDR is covered and uncovered?

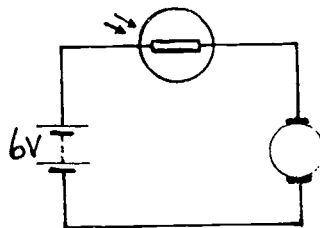

- 4 Try to explain why it was necessary to use the reed relay in the first circuit.

#### Notes

(1) When the LDR is covered, its resistance is high, and not enough current flows through the relay coil to operate the reed switch and switch the motor on. When the LDR is well illuminated, its resistance becomes low and the relay operates.

(2) Ammeters (1A) placed in series with the coil and with the motor will show that the current through the motor (perhaps 0.2A) is a lot more than the current through the coil (a few milliamps). In other words, the flow of a small current is being used to control the flow of a much larger current - an important use of the relay. Of course more sensitive ammeters could be used.

(3) If the reed relay is not used, the change in the resistance of the LDR is not enough to allow the motor to operate. The relay is necessary for the reason given above.

(4) Electric motors require a relatively large current. If pupils leave them running for a long time, the batteries become exhausted.

**Experiment 2.5:** The reed relay with coil and contacts in parallel (using a single power supply)

Connect up the circuit shown below.

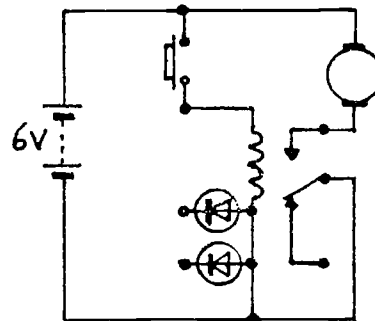

**Investigations and questions**

- 1 What happens to the motor when the switch is closed?
- 2 In this circuit the relay coil and the relay contacts are connected in parallel. Copy the diagram and mark on it the closed current paths from the battery, through each branch of the circuit and back to the battery again.

**Notes**

(1) This circuit uses the concept of positive and negative supply rails first mentioned in Experiment 1.3.

(2) In experiment 2.4 (and 2.6), a small current in one circuit controlled a much larger current in another circuit which was completely separate with its own power supply. In the present experiment, a current through one branch of a parallel circuit (the coil branch) controls a much larger current through another branch (the motor branch). There is only one battery. This latter principle is introduced here because it is fundamental to the operation of the relay module introduced in the next section. If pupils meet transistors in later work, they will again see this same principle in action.

**Experiment 2.6 Project:** automatic washing line

The problem is to use two batteries, the reed relay module, the electric motor module and the rain sensor to make a circuit which switches on an electric motor when rain falls. Such a circuit could be used as the basis for an automatic washing line.

Solution:

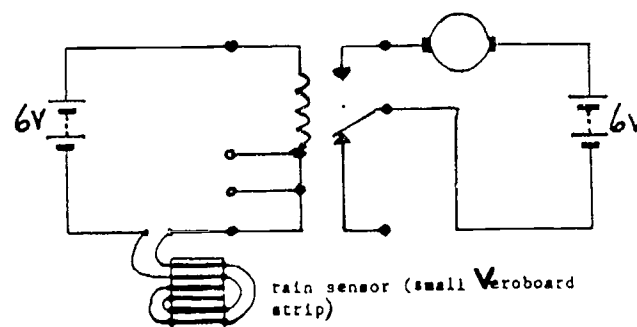

## Notes

(1) The rain sensor can be made from a small piece of stripboard on which are six copper strips connected in the way shown below. If any of the strips are bridged by a conducting solution, the two leads are short-circuited. This allows current to flow through the relay coil.

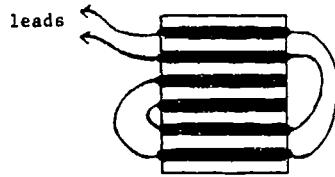

(2) This experiment will not work with ordinary tap water. However, if a pinch of salt is added the water becomes an excellent conductor and the necessary short circuit is provided. Alternatively, see note (3) below.

(3) Rain water conducts electricity, but not sufficiently to operate the reed relay in the above circuit. However the experiment will work with rain if the copper strips are covered by dry blotting paper which has been previously soaked in a solution of salt in water. The salt solution is made simply by adding plenty of table salt to tap water and stirring well. After immersion in the solution, the blotting paper should be dried thoroughly and taped so that it covers the copper strips. If rain falls on the blotting paper, the salt renders it conducting and the necessary short circuit is provided.

### Experiment 2.7 Project: Reversing an electric motor

The problem is to use a push-button switch, the reed relay and three batteries to make a circuit so that the direction of rotation of the motor is reversed when the switch is pressed. Pupils should first draw a circuit diagram and show it for approval.

Solution:

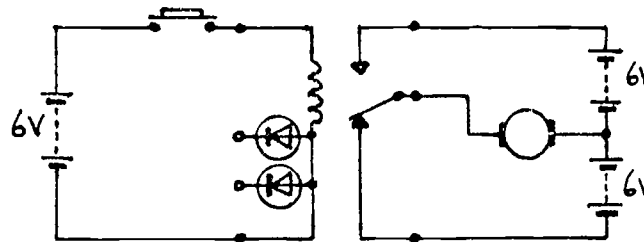

## Notes

(1) Pupils will probably find the need for 3 batteries confusing and care is needed to ensure their correct connection.

(2) The number of batteries required can be reduced to one if a 3V motor is used.



## SECTION 3. LOGIC CIRCUITS

### Experiment 3.1: Simple AND circuit

Connect two push-button switch modules in series with an LED and a battery as shown in the diagram below.

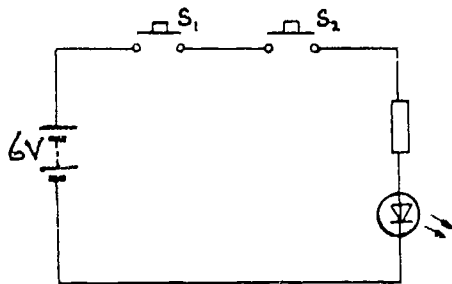

S <sub>1</sub>	S <sub>2</sub>	LED
Not pressed	Not pressed	
Pressed	Not pressed	
Not pressed	Pressed	
Pressed	Pressed	

#### Investigations and questions

- 1 Use the circuit to help you complete the table shown above.
- 2 Why is the circuit called an AND circuit?
- 3 Suggest a use for a circuit such as this.

#### Notes

(1) The above circuit is a simple example of an AND circuit, and the table which pupils complete is known as a "truth table". A truth table is a useful way of summarising the behaviour of the circuit. In this case, the table tells us that the LED is on when S<sub>1</sub> AND S<sub>2</sub> are pressed. This is why the circuit is called an AND circuit.

(2) There are many situations in which such a circuit might be useful. For example, in a motor car we might want the ignition light to come on (indicating the car can be started) only when the driver has engaged his safety belt AND closed his door.

### Experiment 3.2: Simple OR circuit

Using the same modules, connect up the circuit shown below.

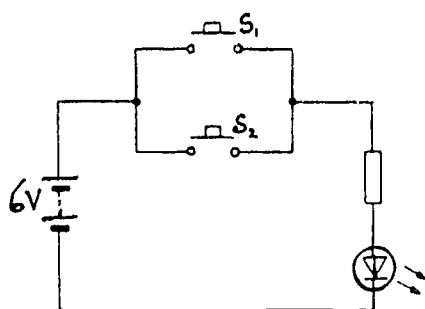

S <sub>1</sub>	S <sub>2</sub>	LED
Not pressed	Not pressed	
Pressed	Not pressed	
Not pressed	Pressed	
Pressed	Pressed	

#### Investigations and questions

- 1 Use the circuit to help you complete the table shown above.
- 2 Why is the circuit called an OR circuit?
- 3 Suggest a use for such a circuit.

## Notes

(1) This time the circuit is an example of an OR circuit, and the completed table is the truth table for an OR circuit. It tells us that the LED is on when either S1 OR S2 (or both) is pressed.

(2) An obvious use for such a circuit is as a simple burglar alarm. It is possible to purchase pressure pads for home security systems which are really no more than a normally open SPST switch. A pad is placed under a carpet near a door so that the switch is closed by the pressure of an intruder's foot. The above circuit could be used with two such switches to protect two doors. An alarm would sound (replace the LED by the buzzer) if entry was through door 1 OR door 2.

### Experiment 3.3: Relay as a NAND circuit

Using the reed relay module, an LED and a battery, set up the circuit shown. Take great care in connecting up the relay. Note that the polarity of the battery must be as in the diagram.

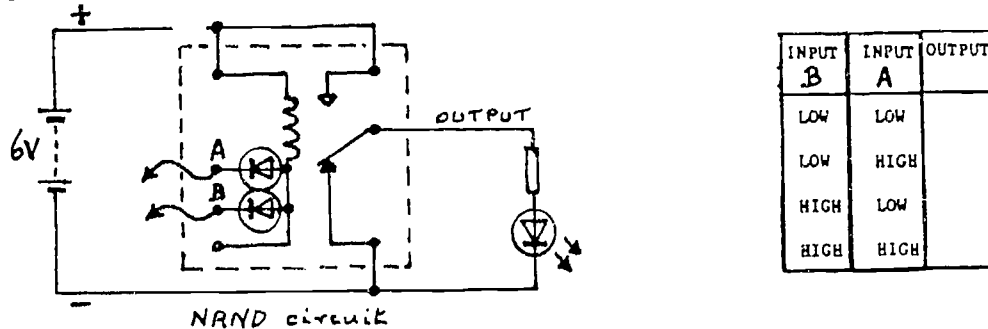

Connect leads to the diode input terminals of the relay module, A and B. When the other end of one of these leads is connected to the positive supply rail we say that the particular input is HIGH. If the lead is connected to the negative supply rail, the input is said to be LOW. The output is HIGH if the LED is on and LOW if the LED is off.

### Investigations and questions

- 1 By connecting the inputs high and low complete the truth table for the NAND circuit.
- 2 Try to explain why the output is high when one or both of the inputs is low. (HINT: consider whether an input has to be high or low for a current to flow through the relay coil.)
- 3 Why do you think a diode is used at each of the two reed relay inputs? (HINT: consider what would happen if input A were high and input B were low in the absence of diodes.)

## Notes

(1) In electronics, a logic circuit is a switching circuit in which the state of the output at any instant depends on the present state of all the inputs. The output is high only for certain input combinations.

(2) If the logic module were an AND circuit one would expect its output to be high when input A AND input B were high, as in the left-hand truth table below. In fact the output is low when input A and input B are high. The module behaves as a NAND circuit (a contraction of negative AND). Its truth table is exactly the inverse of that for an AND circuit (see the second truth table below).

AND circuit

INPUT B	INPUT A	OUTPUT
LOW	LOW	LOW
LOW	HIGH	LOW
HIGH	LOW	LOW
HIGH	HIGH	HIGH

NAND relay module

INPUT B	INPUT A	OUTPUT
LOW	LOW	HIGH
LOW	HIGH	HIGH
HIGH	LOW	HIGH
HIGH	HIGH	LOW

(3) NAND circuits are the most commonly found circuits in modern electronics, and this is one reason why this particular circuit has been chosen for use in the rest of the experiments in this course. Other logic circuits can be constructed using NAND circuits.

(4) The operation of the circuit is easy to understand. The first thing to note is that the contacts at the output form an SPDT switch: the pole of this switch is normally connected to the negative supply rail, that is the output is low. This is the position at the output when there is no current through the relay coil. When either or both inputs are taken low, current flows through the coil and the output contact changes over. The output goes high and the LED module is connected directly to the positive supply rail.

(5) Note that no current can flow through an input if it is high. This is also the case if the input is totally unconnected or "floating". In electronics jargon this would be expressed by saying that the input floats high. All that is meant by this is that an unconnected input behaves as though it were high.

(6) Diodes must be included at the inputs for an obvious reason. If there were no diodes and one input were taken high and the other low, there would be a direct short circuit across the battery. The diodes prevent this condition from arising.

(7) Note that this circuit uses a number of concepts developed in earlier work, including the use of positive and negative supply rails and the actions of relays, SPDT switches and diodes. This systematic development of concepts is in line with the general philosophy of the course.

(8) The NAND relay circuit is constructed with its coil and contacts in parallel with the supply, and its inputs and output are either high or low. In these respects it is similar to electronic logic circuits constructed from transistors or available in integrated circuit form. The use of a relay as a logic circuit is therefore a sound introduction to modern digital electronic circuits.

#### Experiment 3.4: A simple burglar alarm

Connect up the circuit shown. Take care to make the supply rails the correct polarity.

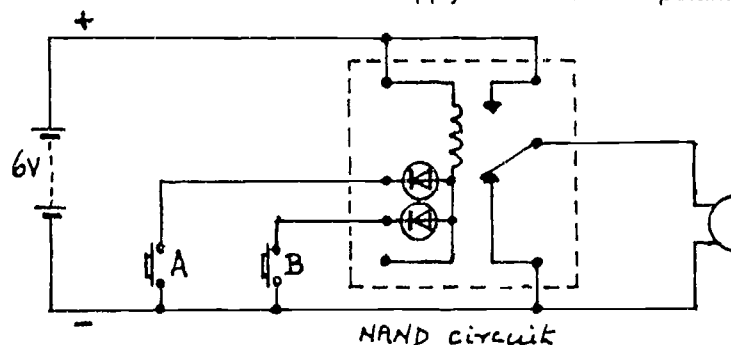

#### Investigations and questions

- 1 What happens when switch A or switch B is pressed (or both are pressed together)?
- 2 Explain why this happens.
- 3 How would you modify this circuit so that the alarm sounded either when a switch was closed or when a light was shone on a LDR?

#### Notes

(1) This circuit is again more realistic if pressure pads are used instead of the switch modules (see Note 2 of Experiment 3.2).

(2) The alarm can be triggered by a light beam (the burglar's torch) simply by replacing one switch module by an LDR module. If the LDR is covered (or the room is dark) it will have a very high resistance and virtually no current can flow through the relay coil. When light falls on the LDR its resistance rapidly falls to a low value and current can flow through the coil, and the LDR thereby operates the relay (the input is now low).

### Experiment 3.5: NAND circuit as an inverter

Connect an LED to the output and a flying lead to one of the inputs of the NAND circuit.

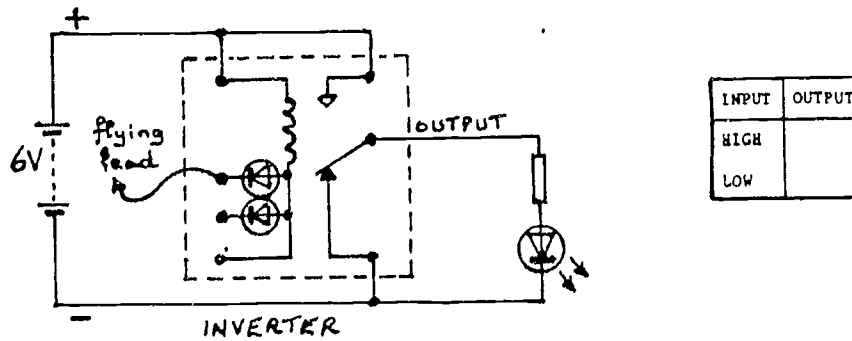

#### Investigations and questions

- 1 Use the flying lead to take the input high and low and then complete the table above.
- 2 In terms of the currents flowing through the coil and the LED, explain the completed truth table.

#### Notes

- (1) When only one input of a NAND circuit is used (or the two inputs of a NAND circuit are joined together and treated as a single input), it behaves as an inverter. Inverters will be used extensively in the rest of the course.
- (2) It follows therefore that when the input is high, the output is low. When the input is low, the output is high.

### Experiment 3.6 Group experiment: Making an AND circuit

Using two NAND circuits (one as an inverter), an LED and a battery, set up the circuit below. Connect a flying lead to each input terminal of the first NAND circuit.

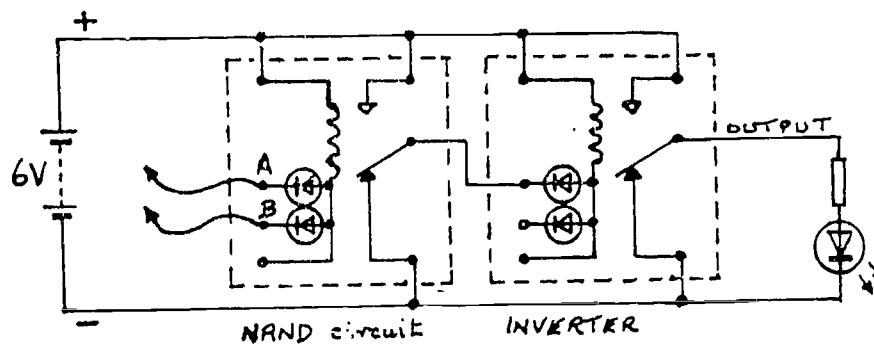

#### Investigations and questions

- 1 By connecting the inputs high and low, complete the table. Does it behave as an AND circuit?
- 2 Compare the table for this circuit with the table for the circuit of Experiment 3.3 (the NAND circuit). What has the inverter done?
- 3 Remove the flying lead from input B and connect a push-button switch between input B and the negative supply rail. Connect the flying lead from input A to the positive supply rail (i.e. high), and then operate the switch several times. Now connect the flying lead from input A to the negative supply rail (i.e. low), and operate the switch. Can you see why the circuit is sometimes called a gate?

INPUT B	INPUT A	OUTPUT
low	low	
low	high	
high	low	
high	high	

## Notes

(1) The explanation of how this circuit operates is given in the notes to Experiment 3.3. The inverter inverts the output of the NAND circuit.

(2) When the lead from input A is connected to the positive supply rail (i.e. high), operating the switch connected to input B causes the LED to go on or off (i.e. the output follows the changes at input B). When input A is low, the LED is off and operating the switch has no effect on it. The action of the circuit can be likened to a gate (hence the name). With input A high, the gate is opened and the signals pass through it; with input A low, the gate is closed and the output is not affected by changes at input B.

### Experiment 3.7 Group experiment (Optional): Detection of an object of a length greater than a specified maximum

Use two NAND circuits (one connected as an inverter), two LDR modules and a buzzer to connect up the circuit below. Each LDR should be illuminated with a light beam. (Such a circuit might be useful to reject overlong objects passing along a conveyor belt in a factory.)

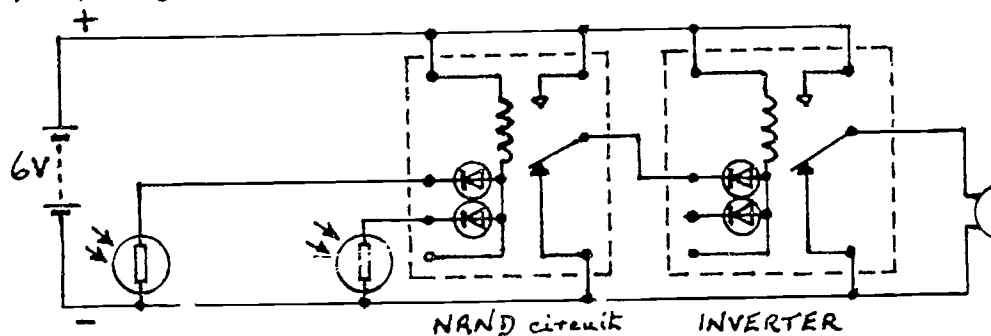

#### Investigations and questions

- 1 What happens when you shade one or both of the LDRs?
- 2 The buzzer sounds only when both the LDRs are shaded. Try to explain why.
- 3 If objects of greater length than the distance between the LDRs pass in front of them, the buzzer sounds. Where might this circuit be useful?
- 4 How would the circuit behave if the inverter were left out and the buzzer connected to the output of the NAND circuit?

## Notes

(1) When light shines on the LDRs their resistance is low. The inputs of the first NAND circuit are therefore low, so its output must be high. The second NAND circuit is an inverter, so its output is low and the buzzer does not sound. If one of the LDRs is covered (but not the other), one of the inputs is still low, a current still flows in the coil, the output of the first NAND circuit is still high, the output of the inverter is low, and nothing happens.

But if both LDRs are covered, the output from the first NAND is low, so that the output from the second is high and the buzzer sounds.

(2) A more realistic set-up can be achieved by fitting tubes over the ends of the LDRs and illuminating them with "pencil" torches.

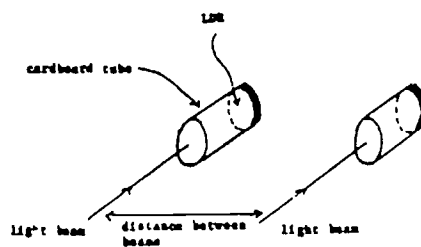

(3) Note that the two relay modules (a NAND circuit followed by an inverter) are together acting as an AND circuit. In other words, the output is high (the buzzer sounds) only when input 1 AND input 2 are high.

The work with the reed relay NAND circuit might conclude with a demonstration of two NAND circuits connected together as a bistable.

Experiment 3.8 Demonstration (Optional): Two NAND circuits as a bistable

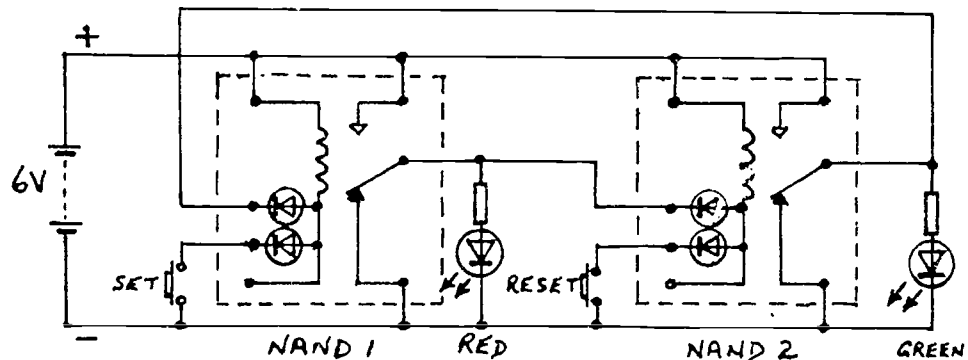

To demonstrate the circuit, first press 'RESET' and show that the green LED is on, the red LED is off. Now press 'SET', when the circuit 'switches over' to red LED on, green LED off. Continued pressing of 'SET' has no further effect. Finally press 'RESET' again (and several times) when the circuit 'switches back' to the original state.

Notes

(1) This experiment introduces a useful electronic circuit known as the "bistable". When the RESET switch is pressed the output of NAND circuit 2 goes high and the output of NAND circuit 1 is low. When the SET switch is pressed the output of circuit 1 goes high and the output of circuit 2 goes low. The bistable circuit has two stable states. One stable state is when the output of 2 is high and the output of 1 is low (the RESET state). The second stable state is when the output of 1 is high and the output of 2 is low (the SET state).

(2) After the SET switch has been pressed, further depressions of this same switch have no effect. The same is true of the RESET switch. This is an important property of the bistable.

(3) Note that the SET and RESET inputs are normally unconnected (they float high). To change from one stable state to the other the appropriate input must be taken low briefly.

(4) The operation of the circuit is quite easy to follow in terms of current flow through the coils and the connections between the two NAND circuits. However, it would be unwise to dwell on these explanations with pupils who find them confusing.

Explanation of the circuit

The two NAND circuits are joined together as shown. The circuits share the same power rails.

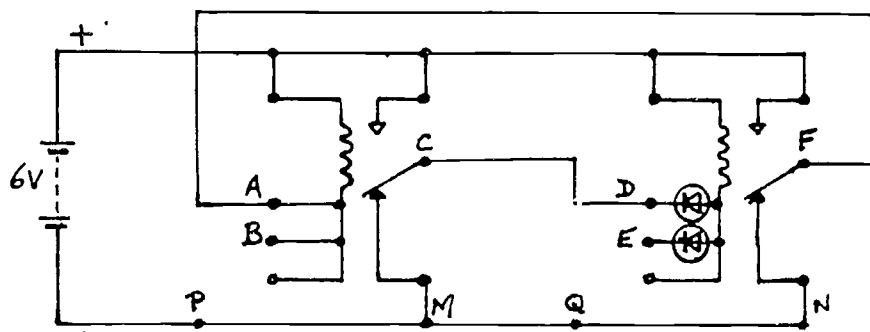

The output C of the first circuit is connected to the input D of the second circuit. Similarly the output F of the second is connected to the input A of the first.

A red LED is connected between C and M. If C is high, the LED will light; if it is low, it will not.

A green LED is connected between F and N. If F is high, the LED will light; if F is low, it will not.

The important thing is that if C is high, the red LED is lit, D will be high and F will be low and the green LED will be out. As F is low, A is low, so C remains high. This is one of the stable states.

Similarly if C is low, the red LED will be out, and D is low. F will then be high, the green LED will be lit. A will be high, so that C remains low. This is the second stable state - and hence the name BISTABLE as it has two stable states.

The significant connections in a bistable are

- the output of the 1st module is connected to the input of the 2nd
- the output of the 2nd module is connected to the input of the 1st.

In order to set the bistable in one stable state or the other, push-button switches are connected between input B and the negative rail (say, at P) and between input E and the negative rail (say, at Q). When the first push-button switch is pressed, a current flows through the relay coil and C becomes high and the red LED is lit - and we have the first stable state. If however the second push button is pressed, F would be high, the green LED is lit - and we have the other stable state.

Pupils may have noticed that the circuit is ideal for the control of simple traffic lights since the red light and the green light cannot be on together. Further simple demonstrations of its use can follow immediately.

#### Experiment 3.9 Demonstration (Optional): A latched burglar alarm

Replace the red LED in the circuit of Experiment 3.8 with a buzzer. Remove the green LED. If the buzzer sounds, press the 'reset' switch to silence it.

The 'set' switch is now the 'trip' switch of the alarm. If it is pressed, the alarm sounds and it cannot be turned off by releasing the 'trip' switch or pressing it again. We say the output is "latched" - the bistable is locked in its second stable state. The alarm can only be turned off by pressing the 'reset' switch. The latched nature of the alarm makes it far more effective than the version constructed in Experiment 3.4.

#### Experiment 3.10 Demonstration (Optional): Using a bistable to control an electric motor

Remove the buzzer from the circuit of Experiment 3.9 (or both LEDs from the circuit of Experiment 3.8) and connect the motor between the outputs of the two NAND circuits (C & F in the diagram: on p 22).

Pressing the 'set' and 'reset' switches alternately changes the direction of rotation of the electric motor. The bistable circuit here is used simply to reverse the polarity of the motor supply.

Much cheaper, more convenient and more versatile ways exist for producing bistable circuits by using micro-electronic logic circuits. Work with these circuits is in Part 2 of the course.



# THE MODULES FOR PART 2

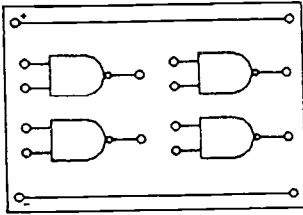

QUAD NAND GATE

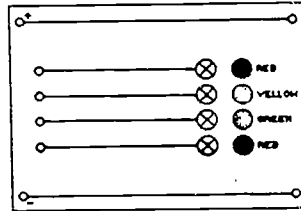

LED INDICATORS

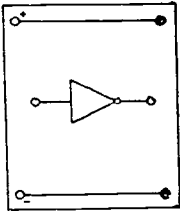

DRIVER AMPLIFIER

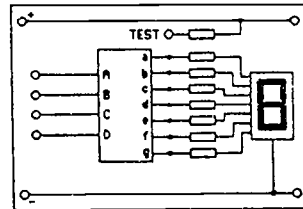

SEVEN SEGMENT DECODER/DISPLAY

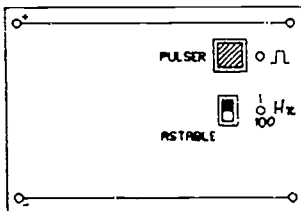

PULSER/ASTABLE

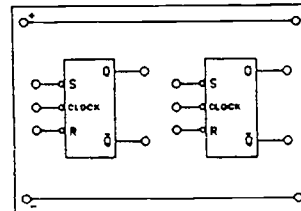

CLOCKED BISTABLES

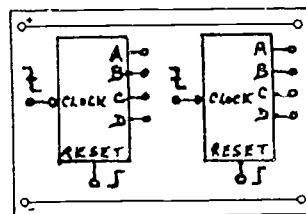

BINARY COUNTERS

## Introduction to Part 2

This part of the course has been divided into six sections as below.

- Section 4 : Electronic logic circuits - logic gates
- Section 5 : The bistable circuit
- Section 6 : Drivers
- Section 7 : Coding
- Section 8 : The pulser, the astable and the clocked bistable
- Section 9 : Counting circuits

### Timing

The work can be conveniently covered in three years if Sections 4, 5 and 6 are taken together in the first year, Sections 7 and 8 in the second year and Section 9 in the third year. If teachers wish to cover the ground in only two years, then Sections 4 to 6 form a suitable group for the first year, leaving Sections 7 to 9 for the second.

### Pupils' backgrounds

The work described follows naturally from **Electronics, Part 1**. If pupils have not followed that course, the introductory work described in the first experiment will have to be approached in a different way and taken more slowly.

### The experiments

The course is essentially experimental. In this booklet, for each experiment there is a 'worksheet' together with 'investigations and questions' for the pupils to consider. These are followed by 'notes' written for teachers to help them weave in any teaching which may be required. These notes also include some background information which may be useful in answering questions. The worksheets are reproduced, without the notes, in **Electronics : Worksheets, Parts 1 & 2**.

### Projects

Most sections finish with 'Applications' in which electronics is put to use. Pupils and/or teachers are able to select from a number of experiments which pose a problem, and pupils are invited to apply their knowledge to find solutions. These problem-type experiments have been called Projects. The pupils' booklet **Electronics : Worksheets, Part 2** lists the projects without solutions.

Clearly the time spent on projects must be limited, and it is suggested that, as a general rule, pupils should attempt two in each case. The wise teacher will make sure that each group starts with an easy one, for it is better to succeed with one than fail to solve two. Teachers will need to give help and encouragement in this work without immediately revealing the 'correct' circuit. Before making up any circuits, pupils should be urged to think out a design on paper. And then, if their circuit does not behave as expected, to think out why before making any changes. There are useful hints in reference 6 of the Bibliography (Appendix A).

### Power requirements for the modules using integrated circuits

A major advantage of CMOS integrated circuits is that they operate over a fairly wide voltage range (3 V to 18 V) and require very little supply current. Indeed, CMOS circuitry only requires significant current when driving external devices such as LEDs and 7-segment displays. Dry cells capable of driving the LEDs and the 7-segment displays are therefore a suitable power source since the current required will rarely exceed 0.2 A.

The performance of CMOS integrated circuits (speed, drive capability, noise immunity) does vary with the supply voltage chosen, but there is no space here to describe the technical details (interested readers are referred to reference 2 in the Bibliography). Voltages near the centre of the allowed range are more satisfactory than those near the limits. However, LEDs (and 7-segment displays) require resistors to limit the current flowing through them, and the resistance value is dependent on the supply voltage used. Because 5 V or 6 V supplies are readily available to schools, the modules using LEDs have been designed for these supply voltages.

#### Using the modules - module protection

Integrated circuits will be damaged if used with the supply polarity reversed. To protect the modules against this possibility, a diode has been connected between the power rails of each module so that the diode conducts if the supply connections are inadvertently crossed (see the circuit diagrams at the end of this book). The reverse voltage is then about 1 V. A 3 A diode (IN5401) has been chosen for this purpose since 3 A is the current, approximately, if any of the power supplies described above is short-circuited. (In the case of the regulated 5 V supply, the 7805 regulator incorporates circuitry which eventually results in the 7805 'closing down' (without damage) when it is short-circuited in this way. Clearly, other components in the supply circuits should also be able to carry a current of 3 A.)

In the experimental work, it will generally be necessary to connect two or more modules together. To minimise the risk of damage, it is wise to cultivate the habit of always linking the corresponding power rails of the modules before connecting them to the supply. Other inter-modular connections can then be made. It is also wise, when adding modules to a circuit, to disconnect the power supply whilst the addition is being made.

## SECTION 4. ELECTRONIC LOGIC CIRCUITS - LOGIC GATES

### Experiment 4.1: The LED indicators

Set up the circuit shown below using the LED Indicators module and a suitable power supply. Take care to connect the power supply correctly.

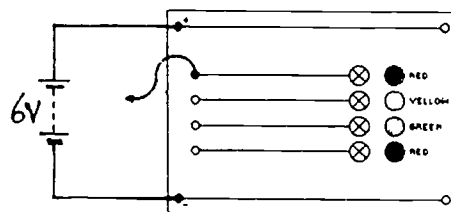

Now plug a lead into the top input socket of the Indicator module. The other end of this lead may be connected to the positive power supply rail or to the negative power supply rail. Such a lead is called a flying lead. If connected to the positive rail, the input is said to be high. If connected to the negative rail, it is said to be low.

#### Investigations and questions

- 1 Find out how the top LED behaves when its input is connected first high and then low.
- 2 Do the other LEDs behave in the same way?

#### Circuit diagrams

In the circuit diagram, an indicator is represented by the symbol below.

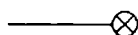

Using this symbol saves having to draw the LED and its associated circuitry every time we need to have an indicator in the circuit. That simplifies the diagram. Indeed, it will be necessary to simplify circuit diagrams even more, for they become difficult to understand and very tedious to draw when several modules are being used. To simplify further, the power supply is not drawn and only those parts of each module in use are included. The diagram above then simplifies to that below. Note that the + and - signs near the power rails show that a power supply is connected between them even though it has not been drawn.

### Experiment 4.2: The NAND gate

#### 4.2 (a) Truth table

Set up the circuit shown below using one of the four NAND gates on the Quad NAND Gate module, and one of the LED indicators.

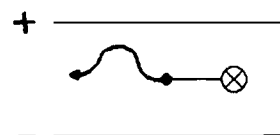
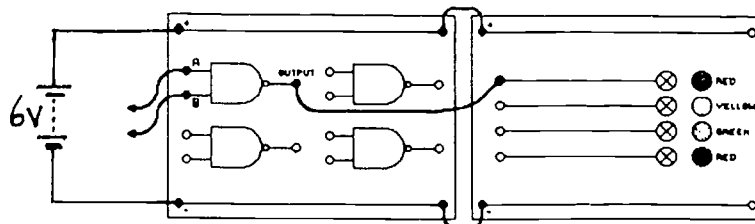

Make sure that the modules have their power supply rails linked correctly.

Each of the inputs A and B can be connected to the positive power supply rail (high) or to the negative power supply rail (low) using a flying lead. The output is high if the LED is lit and low if the LED is unlit.

#### Investigations and questions

- 1 By connecting the inputs high and low, complete the truth table for a NAND gate.
- 2 Does an unconnected input behave as if it is high or low?
- 3 Draw a simplified circuit diagram of the above circuit.

B	A	OUTPUT
LOW	LOW	
LOW	HIGH	
HIGH	LOW	
HIGH	HIGH	

#### 4.2 (b) NAND gate as an inverter (NOT circuit)

Connect the two inputs of a NAND gate together as shown in the diagram below.

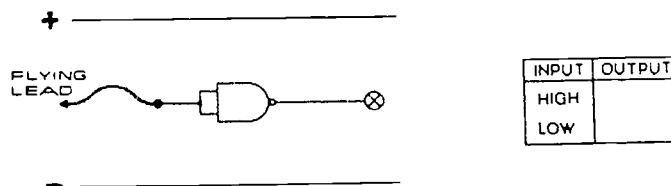

Note that the two joined inputs can now be thought of as a single input. This single input can be taken high or low using the flying lead.

#### Investigations and questions

- 1 By taking the input high and then low, complete the truth table for the inverter (also known as a NOT circuit).
- 2 Instead of joining the two inputs of the NAND gate, connect one of them permanently high (or simply leave it unconnected), and connect the flying lead to the other input. How does the circuit now behave if the input is taken high and low? What happens if one input is tied permanently low?

#### 4.2 (c) AND, OR and NOR gates from NAND gates

Connect the circuit shown below using two gates from the Quad NAND Gate module. Note that the second NAND gate is connected as an inverter (NOT circuit).

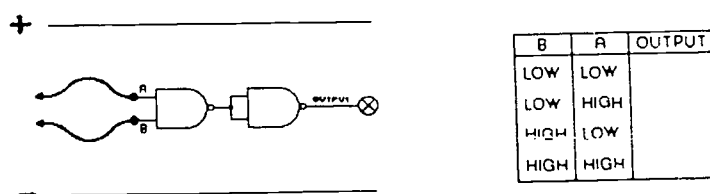

#### Investigations and questions

- 1 The above circuit should behave as an AND gate. Check this by taking the inputs high and low, and completing the truth table.
- 2 Draw and complete the truth table for an OR gate. Compare this with the truth table for a NAND gate. (You should notice that if every high input to the NAND gate became a low, and every low input a high, it would give the OR gate you want. How can you change the inputs to the NAND gate? Clue: you have just learnt about inverters.) Now design an OR gate using three NAND gates. Build the circuit and check that it produces the correct truth table.
- 3 Draw and complete the truth table for a NOR gate. Use the remaining NAND gate on the module to convert your OR gate to a NOR gate. Check that your circuit produces the correct truth table.

## Notes

(1) The approach to logic gates adopted in the present experiment is appropriate for pupils who have previously followed **Electronics, Part 1**. Such pupils will have already met and used resistors, light emitting diodes (LEDs), and light dependent resistors (LDRs). In addition, they will have been introduced to simple AND and OR circuits, and to the use of a relay as a two-input NAND gate. The truth tables summarising the switching behaviour of these circuits will be familiar, and this is why much of the work in the present experiment is orientated towards checking the properties of gates rather than an initial exploration. Integrated circuits were not used in **Electronics, Part 1** so the practical context in which pupils are using familiar concepts is now different.

(2) Pupils who have not previously followed **Electronics, Part 1** will need some background in the areas mentioned above. An adequate preparation for the present course requires at least some experimental work with LEDs, resistors and LDRs, as well as an introduction to truth tables.

(3) When introducing logic gates it is important that pupils should see as early as possible that these circuits have important practical uses. Pupils who have followed **Electronics, Part 1** will already know that gates are useful. For those who have not seen gates performing useful tasks before, it would be a good idea to follow Experiment 4.2 (a) immediately with an application such as that in Experiment 4.3 (a).

(4) In **Electronics, Part 1** pupils did not meet logic symbols. Before starting this experiment, they must be introduced to the symbol for a two-input NAND gate. The symbol used throughout this booklet is as below.



(5) It is vital to point out that in circuit diagrams using logic gate symbols, it is conventional to draw the symbol without power supply connections. Some books, however, do show power supply lines joining on to the symbol. The two methods are shown below for a NAND gate.



If the power supply lines were included in the circuit diagram for the third of the above experiments (AND gate from a NAND gate followed by an INVERTER), it would appear as follows.

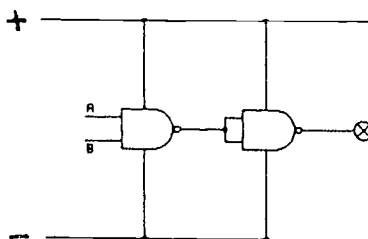

This latter method does have the advantage of emphasising the essential power supply connections to the electronic devices inside the NAND gate, and teachers may wish to use it initially. Omitting power supply connections does, of course, considerably simplify circuit diagrams and, once one is accustomed to the convention, makes them easier to read.

(6) Once the experimental work has been completed, the logic gate symbols for an inverter (the term NOT circuit can now be used) and for AND, OR and NOR gates can be introduced. Pupils should also be able to write down the truth tables for each of these gates. In the case of AND, OR, NAND and NOT this will be revision of Part 1 work. The truth table for NOR should now be added. A summary of the above-mentioned logic gates is given below.

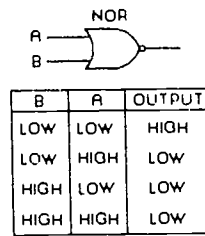
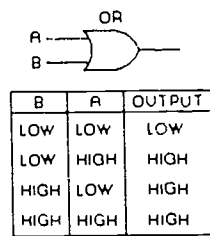
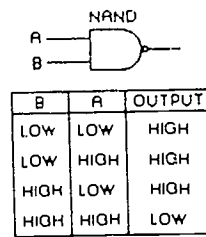
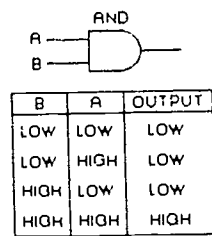

The symbol for an INVERTER (or NOT circuit) is shown on the left below. As an inverter can be made from a NAND gate, the second symbol below will also be used in this booklet.

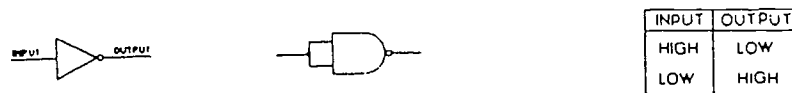

Teachers should point out the presence of an inversion circle at the output of a gate with an inverting function. So, for example, the output of a NAND gate is the inverse of that expected from an AND gate with the same inputs. The same is true of a NOR gate when compared with an OR gate. Pupils should realise that NAND and NOR are contractions of NOT AND and NOT OR, respectively. In terms of symbols,

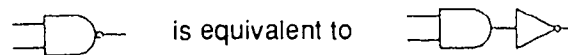

and

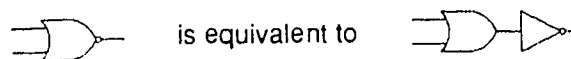

(7) In the present experiment, NAND gates are used to make NOT circuits, AND, OR and NOR gates. One reason for basing logic work in this course on the NAND gate is that the NAND gate can be used for inverting so that other gates can be built from it. This is also true of the NOR gate, but not of the AND gate and OR gate. NAND gates and NOR gates can also be used to build bistable circuits, and this is another reason why they are preferred to AND and OR gates. Both NAND and NOR gates are equally suitable as fundamental building bricks for an introductory course in digital electronics, but in the wider world of electronics NAND gates are encountered more often and are probably the better choice.

(8) Note that a two input NAND gate can be used as an inverter in two ways (see question 2 of Experiment 4.2 b).



The NAND gate module used in the present course has inputs which are high when unconnected. The simplest way to make an inverter is therefore to use just one input of a NAND gate and connect the other to the positive rail or leave it floating. There is some advantage in using the NAND gate in this way. If the two inputs are connected in parallel, the input capacitance is increased and the noise immunity is thereby greater. However, it seems to cause less confusion to pupils if the inverter is shown as in the diagram on the left above, and that will be used in this booklet.



Further information concerning the behaviour of unconnected inputs of the NAND gate module are given in the Appendix B **Technical Details**.

(9) For readers who have not previously used NAND gates to make OR and NOR logic gates, the circuits expected in the answers to questions 2 and 3 following Experiment 4.2 (c) are as below.

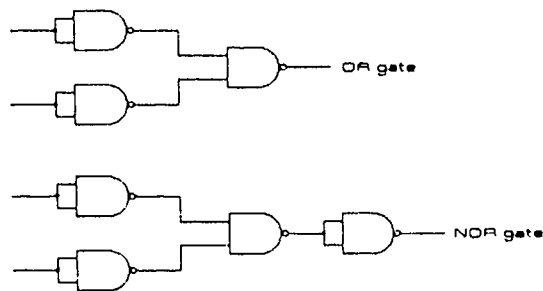

(10) There is one final point which teachers will wish to introduce to pupils. In Part 1, the switching circuit in which the state of the output at any instant depends on the state of the inputs at that instant was called a logic circuit. Now we are using the term gate, rather than circuit. While the use of circuit is not incorrect, no indication has been given why the term gate is appropriate. One way of explaining this is to consider an AND gate and regard one of its inputs as performing a control function.

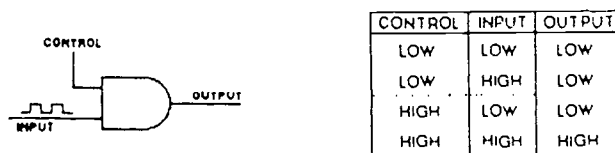

Consider a succession of high and low pulses arriving at the other input. If the control input is held low, the output will be held low irrespective of the state of the other input. The gate is closed. However, if the control input is held high, the output state follows the state of the other input. In other words, the gate is open. The impression of a gate is well conveyed in this way. NAND, OR and NOR gates can be viewed in the same way. A NAND gate is open when its control input is high as with an AND gate, but the pulses arriving at the other input are inverted when they arrive at the output. OR and NOR gates are both open when their control inputs are low, but the output pulses are inverted in the case of the NOR gate.

Question 2 of Experiment 4.2 (b) does, of course, introduce this kind of interpretation. Pupils should see a simple practical demonstration which will clearly illustrate the gating effect. This can be set up using the astable module. Although pupils do not explore the behaviour of this module until much later in the course, it can be introduced earlier by the teacher as a convenient means of taking the input of a gate repeatedly high and low. It is probably best to start with two NAND gates connected as an AND gate.

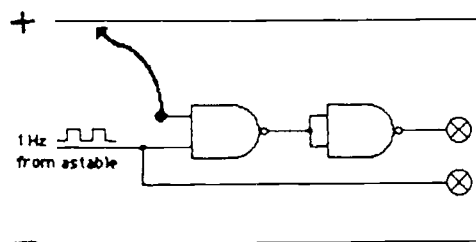

When the control input is high, pulses will pass through the AND gate and the two LEDs will flash on and off together. If the control input is taken low, the LED at the output will be permanently low. If a single NAND gate is used and the control input is high, the output LED will flash on and off but it will be on when the LED at the input is off, and vice versa. When the control input is low, the output LED will be permanently on.

Other gates can, of course, be investigated in the same way.

#### Experiment 4.3: Applications using NAND gates

The projects (and solutions) are detailed below together with notes. The booklet **Electronics : Worksheets, Part 2** lists the problems without solutions.

#### Notes

(1) An essential requirement of this course is to show how electronic circuits can perform useful tasks and control devices such as LEDs, buzzers and motors. Pupils must also be encouraged to apply their knowledge to circuit design and think out how combinations of gates will operate. To achieve these ends, they should be set problems to solve. Experiment 4.3 is a collection of such problems or projects.

(2) Time constraints will inevitably mean that it is impractical for all pupils to attempt all projects, though it is hoped they will attempt two or three of them. Some of these are simple, other are quite difficult and pupils may need a lot of help. Teachers will no doubt ensure that the projects chosen match the ability of their pupils: it is better to succeed with a simple one than to fail with a difficult one. Perhaps a good approach is to allow groups to select problems to work on, and then to have a plenary session in which solutions are discussed and demonstrated.

(3) Some of the applications repeat the work of Part 1, but this time integrated circuit NAND gates are used rather than NAND circuit relays. Note that the circuits are identical whether relay or integrated circuit NAND gates are used. This should facilitate the transition from relays to ICs.

(4) Note that these applications make extensive use of illuminated LDRs to hold inputs low. This is discussed in relation to module circuitry in Appendix B. As far as pupils are concerned, an LDR can simply be regarded as a switch which is open in the dark and closed when illuminated.

It is worth emphasising to pupils that it is necessary to connect input devices such as LDRs between gate inputs and the negative supply rail. Because an unconnected input floats high, an LDR connected to the positive supply rail will not change the logic level at the input when the illumination changes. Connected to the negative supply rail, an LDR will cause a low level input when brightly illuminated (low resistance) and a high level input when dark (high resistance).

A suitable LDR for the work in the present course is the popular ORP 12.

(5) Buzzers are also used extensively in this and later experiments. These are low current (a few mA) d.c. devices which typically operate over a voltage range from, say, 3 V to 15 V. They emit a constant frequency audible tone.

(6) Further suitable projects will be found in reference 6 of the Bibliography (Appendix A).

#### Project 4.3 (a): Burglar alarm (NAND application)

Use a single NAND gate, an LDR, a push-button switch and a buzzer to make a simple burglar alarm. The alarm should sound when the LDR is illuminated (the burglar's torch) or the switch is closed (the burglar's foot).

Solution to 4.3 (a):

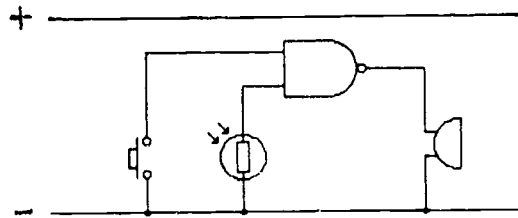

Project 4.3 (b): Length detector (AND application)

Use two NAND gates (one connected as an inverter) together with two LDRs and a buzzer to construct a system which will sound an alarm when an object is longer than a specified maximum length. Such a circuit might be used to reject overlong objects passing along a conveyor belt in a factory.

Solution to 4.3 (b):

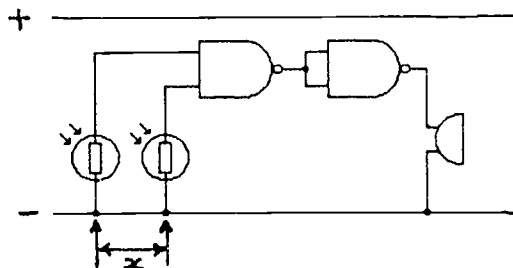

The LDRs are positioned a distance  $x$  apart (where  $x$  is the specified maximum length of the object) and illuminated by "pencil" torches. The alarm sounds when both beams are interrupted.

Project 4.3 (c): Automatic night light

Use two NAND gates (both connected as inverters), an LDR and an LED indicator to make a circuit in which a light (the LED) will come on automatically in the dark. A circuit of this kind would be useful to light up the display in a shop window automatically when darkness falls.

Solution to 4.3 (c):

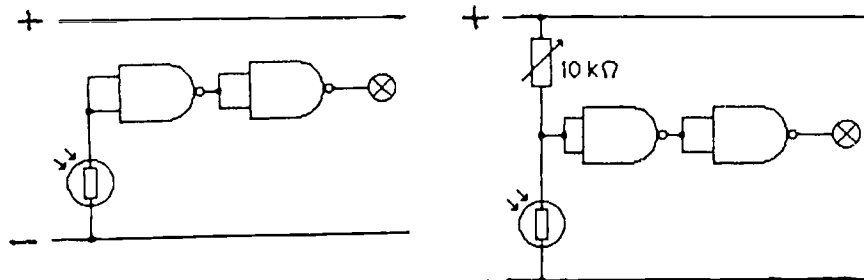

## Notes

(1) This application uses two NAND gate inverters to 'drive' an LED indicator. The circuit on the left above is not very sensitive to changes of light intensity. This is because the LDR and the internal circuitry of the NAND gate module effectively form a potential divider between the supply rails (see right). As R has a high resistance, it needs a large change in the resistance of the LDR to change the voltage level at the NAND gate input appreciably.

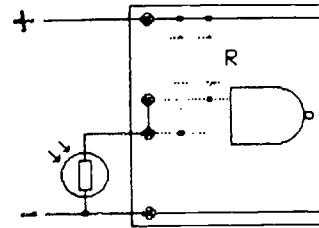

(2) The second circuit at the top of the page allows the sensitivity to be changed. The variable resistor should be set so that the LED is on the verge of switching on. Then any darkening of the LDR will cause the LED to light. The value of the variable resistance to use depends somewhat on ambient light conditions, but 10 k $\Omega$  should suit most circumstances. It is important that pupils should meet the potential divider and teachers could demonstrate the right-hand circuit as an example of its use. If teachers choose to introduce the potential divider as part of the work on Electricity, then this project might well be done there and omitted here.

### Project 4.3 (d): Fire alarm

Use a NAND gate connected as an inverter, a thermistor, a variable resistor and a buzzer to make a simple fire alarm. The alarm should sound when the thermistor is heated.

How would you adjust the circuit so that the alarm sounded when the temperature reached a higher value?

Solution to 4.3 (d):

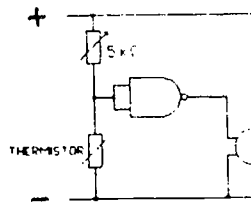

## Notes

(1) It is important that pupils should have previously met the potential divider and the thermistor if they are to solve this problem.

(2) An inexpensive TH3 thermistor can be used for this fourth application. Its resistance at room temperature is about 400 $\Omega$ , and decreases to about 20 $\Omega$  at 100 $^{\circ}\text{C}$ . At room temperature, the 5 k $\Omega$  variable resistor (a 5 k $\Omega$  potentiometer connected as a variable resistor) should be set so that the buzzer is just off. Warming the thermistor with the hand will then cause the buzzer to sound. To increase the temperature at which the alarm responds, the value of the variable resistance should be decreased. Note that a 2.5 k $\Omega$  variable resistor provides greater sensitivity in this application, but with care, a 5 k $\Omega$  or even a 10 k $\Omega$  value can be used satisfactorily.

### Project 4.3 (e): Safety circuit for a safe

A safety circuit for a large safe sounds an alarm only if the door is closed but not locked. Closing the door opens a switch, whilst locking the door closes another switch. What sort of logic gate is required to do this? Set up the circuit and test it. Now adapt your circuit for a safe which has two locks.

Solutions to 4.3 (e):

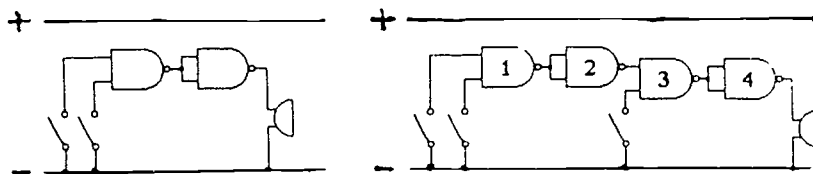

This project introduces the 3-input AND gate which will be used in several projects later in the course. Note that if NAND gate 4 is omitted, the circuit is a 3-input NAND gate.

Project 4.3 (f): The skittle alley winner-indicator!

In a fairground skittle alley, customers try to bowl over three skittles. Each skittle stands on a small switch which it keeps closed until it is bowled over. Design a circuit which lights a lamp only when a customer is successful.

Solution to 4.3 (f):

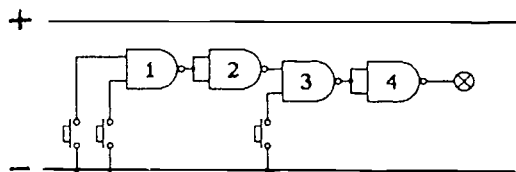

### Notes

(1) This is a similar problem to that of Project 4.3 (e) but somewhat easier to think about. It can, of course, be introduced as a two-skittle problem first.

(2) The project introduces the 3-input AND gate which occurs in later projects. Note that if gate 4 is omitted, the circuit is a 3-input NAND gate.

Project 4.3 (g): Car doors warning light

Design a circuit which will cause a warning lamp on the dashboard of a two-door car to light if either of the doors is not closed. Closing a door closes a switch.

Solution to 4.3 (g):

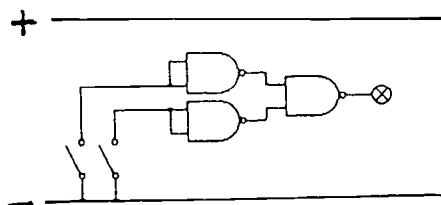

Project 4.3 (h): Circuit Investigation

This is a circuit to investigate rather than a problem to solve. In the truth table, '0' stands for 'low', and '1' stands for 'high'.

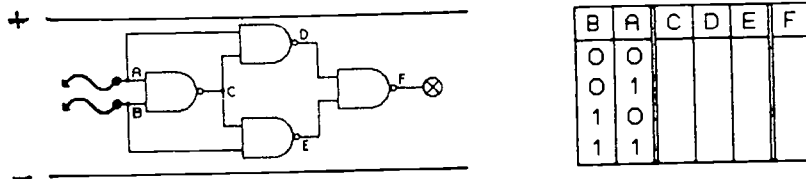

**Investigations and questions**

- 1 Copy the truth table and complete it to show the voltage level at each of the lettered points for each of the level combinations at A and B.
- 2 Set up the circuit and check your predictions for the output F. If you have made an error, use a flying lead from another LED indicator to check your predictions for the level at each of the points C, D and E. Do this by touching the free end of the flying lead on to each of those points in turn.
- 3 Suggest a use for this circuit.

Note

The circuit is an exclusive OR gate. The correct truth table is as shown. Note that F is high when A or B is high, excluding the case when both are high.

B	A	C	D	E	F
0	0	1	1	1	0
0	1	1	0	1	1
1	0	1	1	0	1
1	1	0	1	1	0

It is a "light at the top of the stairs" circuit.

## SECTION 5. THE BISTABLE CIRCUIT

### Experiment 5.1: Making a bistable using two NAND gates

Set up the circuit shown below using two gates from the Quad NAND Gate module.

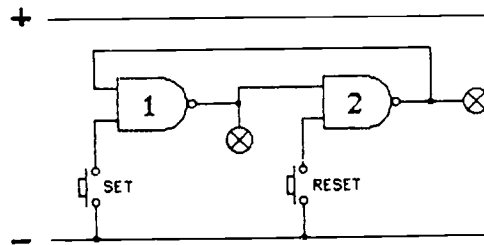

#### Investigations and questions

- 1 First of all press and release the switch marked RESET. Which LED is on and which one off?
- 2 Now press and release the switch marked SET. What happens?
- 3 Press and release the SET switch several more times. What happens?
- 4 Now press and release RESET. What happens?

#### Circuit diagrams

Notice that the LED indicator connected to the output of NAND gate 1 is not drawn beneath the LED indicator of gate 2, even though that is where it is placed on the indicator module. Circuit diagrams are easier to understand if the parts are drawn in convenient places rather than as they are placed on the modules. Notice too that the positive power rail is drawn in the above diagram even though no leads are shown connected to it. Frequently such a power rail is omitted from circuit diagrams. However in this course both power rails will be drawn to remind you that a power supply is needed to make the circuits work.

#### Notes

(1) In **Electronics Part 1**, work with bistable circuits was optional. The bistable is such a vitally important building block in digital electronics that all pupils must now meet it.

(2) Teachers are strongly recommended to start work on bistable circuits by quickly demonstrating, without explanation, the action of a latched burglar alarm (see Experiment 5.2 (a)). This very clearly illustrates the existence of two stable states in a way that pupils are not likely to forget. The usefulness of such a circuit is also readily apparent. When they come to Experiment 5.2 (a) pupils will have to work out how to use a bistable circuit to make this alarm themselves.

(3) The circuit of the present experiment behaves in the following way. When the RESET switch is pressed, the output of NAND gate 2 goes high and the output of NAND gate 1 is low. When the SET switch is pressed, the output of NAND gate 1 goes high and the output of NAND gate 2 goes low. The bistable circuit has two stable states. One stable state is when the output of 2 is high and the output of 1 is low (the RESET state). The second stable state is when the output of 1 is high and the output of 2 is low (the SET state).

(4) After the SET switch has been pressed, further depressions of this same switch have no effect. The same is true of the RESET switch. This is an important property of the bistable.

(5) Note that the SET and RESET inputs are normally high. To change from one stable state to the other, the appropriate input must be taken briefly low.

(6) **Electronics Part 1** explained how a bistable circuit built from two NAND circuit relays worked. In the case of integrated circuit NAND gates, teachers might like to use the following explanation.

Consider two NAND gates connected such that the output of one is joined to the input of the other. If the second input of each gate is not used, both gates act as inverters.

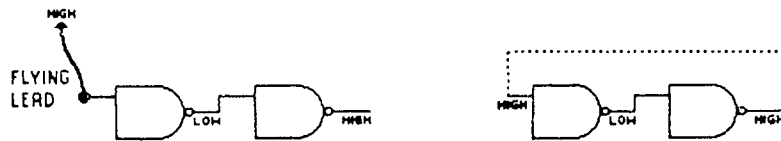

If the input of the first gate is made high, its output will be low (above left). The input of the second gate is therefore low and its output high. If the output of the second gate is now connected to the input of the first gate (dotted line - above right), the original high input to the first gate provided by the flying lead can be removed and the system will be in a completely stable state. The high output of the second gate maintains the high input to the first gate.

A different situation arises if the flying lead to the first gate is originally tied low (below left).



Since the input of the first gate is now low, the output of the second gate is also low. If the output of the second gate is connected back to the input of the first gate, the original flying lead can be removed and we again have a completely stable system. This time, however, the output conditions at the two gates are reversed.

So we see how a system consisting of two inverters can be connected in such a way that there are two stable states. However, for such a system to be useful, a means must be provided of switching between these two states. The second (and so far unused) input of each NAND gate can be used for this purpose.

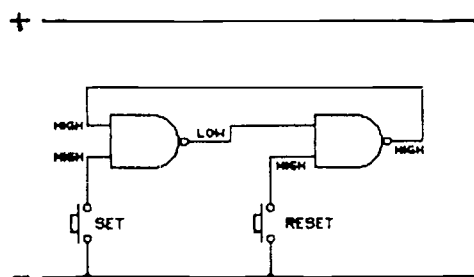

Consider the initial stable state shown in the above diagram. The inputs of the first NAND gate are both high, and its output is, of course, low. But if the SET switch is pressed, one input of the first NAND gate is taken low and so its output goes high. The output of the second gate therefore goes low and this low state is fed back to the other input of the first gate. If the SET switch is now released, the system is in the second completely stable state. Note that pressing the SET switch a second time has no effect. The system can only be switched back to its original state by pressing the RESET switch.

The line shown dotted in the earlier diagrams provides a positive feedback link. In other words, the output of the system is fed back to provide an input of the same polarity.

(7) In electronics literature, the above bistable would usually be drawn as below.



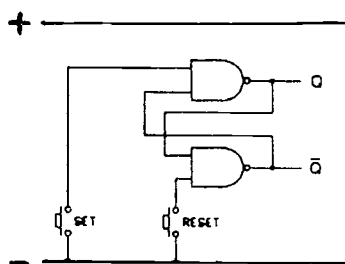

The connections are in fact identical, but the gates are shown one beneath the other. Note that the output of the top gate (with the SET input) is usually labelled  $Q$ , and that of the other (with the RESET input) is labelled  $\bar{Q}$ .

$Q$  and  $\bar{Q}$  are often referred to as complementary outputs, meaning that each is the inverse of the other.

(8) The above diagram is rather cumbersome to use in circuit diagrams. A more convenient symbol in common use is as follows.

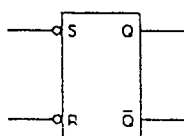

The circles on the S and R input lines indicate that they are active low i.e. the S and R inputs are normally high and must be taken momentarily low to have an effect (this notation to identify active low inputs is conventional in digital electronics).

In summary, this important bistable building block, which is often known as an RS bistable or as an RS flip-flop, has the following properties.

- (a) There are two stable states: SET state ( $Q$  high,  $\bar{Q}$  low) and RESET state ( $Q$  low,  $\bar{Q}$  high).
- (b) Normally the system will be in one of its stable states. In both states the S and R inputs will be high.
- (c) To change from the SET state to the RESET state the R input must be taken momentarily low. If R is taken low again, nothing happens.
- (d) To change from the RESET state to the SET state the S input must be taken momentarily low. If S is taken low again, nothing happens.

This behaviour can be summarised in a truth table, but pupils do not need to know how to do this. For the benefit of teachers, the truth table is given below.

S	R	Q	$\bar{Q}$
HIGH	HIGH	STAYS THE SAME	
LOW	HIGH	HIGH	LOW
HIGH	LOW	LOW	HIGH
LOW	LOW	DISALLOWED	

Note that the state with both S and R low is disallowed, since both  $Q$  and  $\bar{Q}$  are then forced to go high at the same time and the system will be in neither of its stable states. It is perhaps more accurate to say that this state is avoided rather than disallowed, although the latter term is frequently encountered.

(9) Teachers should make sure that pupils understand the difference between a bistable and a logic gate. After all, if we omit the  $\bar{Q}$  output of the former, there are some surface similarities.

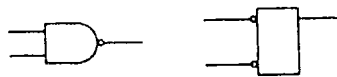

The key point is that a logic gate requires retention of its input signals to remain in a given state. The bistable remains in a stable state when the inputs are removed (the particular state will depend upon which input was last taken low).

### Experiment 5.2: Bistable applications using NAND gates

The projects (and solutions) are detailed below, together with notes. The booklet **Electronics: Worksheets, Part 2** lists the problems without solutions.

#### Project 5.2 (a): Latched burglar alarm

Use two NAND gates, two push-button switches and a buzzer to make a latched burglar alarm. One switch should correspond to the "trip" switch. If this is closed (by the burglar's foot, perhaps) the alarm should sound and stay on even when the switch is released or pressed again. The second switch should correspond to the "reset" switch, and would be hidden away in a place known only to the householder. Only when this switch is pressed should the alarm be silenced.

Once you have built this circuit, convert it to an alarm which will come on and stay on when a light (the burglar's torch) shines on an LDR.

Solution to 5.2 (a):

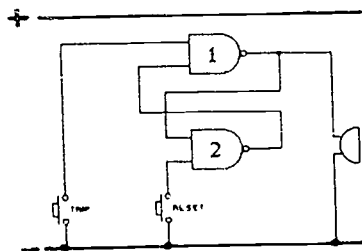

### Notes

- (1) Replace the "trip" switch by an LDR to make a light activated latched alarm. A variable resistor connected between the LDR and the positive supply rail, to form a potential divider, will allow the sensitivity to be adjusted (see 'Notes' to Project 4.3 (c)).
- (2) With CMOS modules, the output of NAND gate 1 may be unable to drive both the buzzer and the input to NAND gate 2. If this is the case, possible courses of action are (a) to use an LED indicator rather than a buzzer, (b) to try "buffering" the buzzer by connecting it to the output of another NAND gate whose inputs go to the output of NAND 2 in the circuit above.
- (3) When the "trip" switch is pressed, the alarm sounds and cannot be turned off by releasing the switch or by depressing it again. We say that the output is latched. The bistable is now locked in its second stable state (the state with the output of the NAND gate connected to the buzzer high, and the output of the other NAND gate low).
- (4) The alarm can only be turned off by pressing the "reset" switch. In a practical system the trip switch might be contained in a pressure pad of the type designed especially for home security systems. Such a pad (effectively a normally open push-button switch) is placed under a carpet near a door so that the switch is closed by the pressure of the intruder's foot. Pressure pads of this kind are available.

Project 5.2 (b): Latched fire alarm using a bistable

Build a fire alarm which, once triggered, will continue to sound until it is reset.

Solution to 5.2 (b):

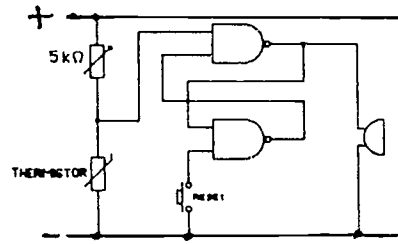

See 'Notes' to Project 4.3 (d) for information regarding a suitable thermistor, and Note (2) of Project 5.2 (a) regarding possible problems with driving the buzzer.

Project 5.2 (c): Simple stop-go traffic lights

Traffic in a one-way street has to cross a bridge which can only have one car on it at a time. The bridge is to be controlled by a set of stop-go lights, activated by switches in the road, so that the lights go red when a car enters the bridge and then green as the car leaves it. Design a circuit to do this job.

Solution to 5.2 (c):

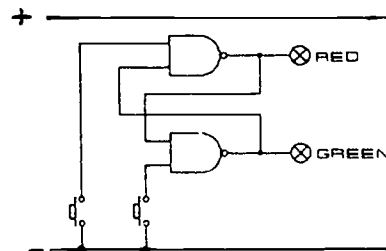

Project 5.2 (d): Traffic lights operated by an SPST switch

A simple set of stop-go traffic lights is to be operated by an SPST switch so that either the red light is on or the green light is on, but not both together. Design a circuit, using a bistable, which will do this.

Solution to 5.2 (d):

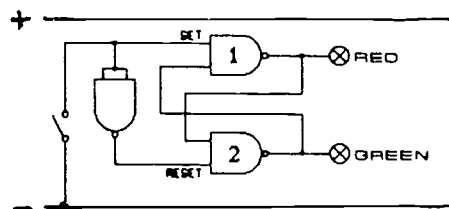

When 'set' is high, 'reset' is low and the green LED is on. Since both inputs to NAND gate 1 are high, the red LED is off. When 'set' is low, the red LED is on, and since both inputs to gate 2 are now high, the green LED goes off.

Project 5.2 (e): Quiz master

A quiz master circuit is used to identify the first contestant to push his or her answer button in a quiz game. Each contestant has a push-button and an indicator light (in this case, an LED). The light of the first person to answer should come on and stay on. At the same time all other lights should be prevented from coming on.

To make such a quiz master is not easy, and you may need help from your teacher. Each contestant in the game will need four NAND gates (two connected as a bistable), a push-button switch and an LED indicator. The best approach is to wire up the four gates for one contestant, and then wire up the four gates for another contestant separately. Finally connect the two sets together and see if your quiz master works!

Solution to 5.2 (e) (for each contestant):

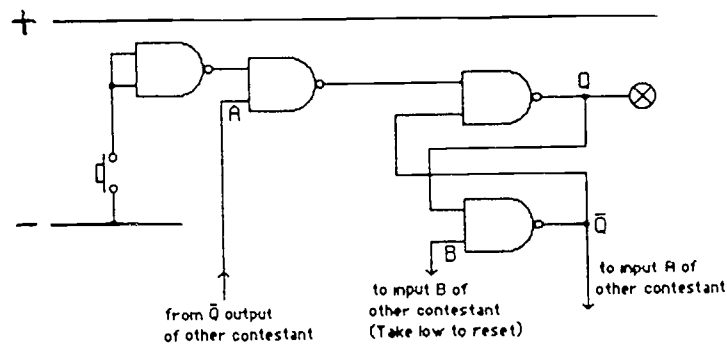

### Note

The above application (the quiz master) is rather complex, and may be too difficult for the majority of students to work out on their own. However, it is worth constructing a quiz master of this kind even if the teacher has to explain its design. Pupils will have great fun playing with it, and the use of logic gates is instructive.

The principle of operation is in fact quite simple. If the B inputs of the two quiz stations are taken low, the bistable circuit formed by the two right hand gates will be reset. In other words, the  $\bar{Q}$  outputs at the stations will be high and the LEDs off.

Consider the station of one particular contestant. The A input will initially be high because it is connected to the  $\bar{Q}$  output of the other station (which has just been reset). The A input effectively "opens" the NAND gate to which it is connected, so if this contestant is the first to press his or her switch, the bistable is set by a low going pulse and the LED indicator comes on. At the same time  $\bar{Q}$  goes low, and since this output is connected to the A input of the other station, the NAND gate controlled by this A input is "closed". This means that a low going pulse from the other contestant's push-button cannot pass to his or her bistable. The bistable therefore remains in the reset state with the indicator light off.

Simpler quiz master stations can be built using fewer NAND gates. However, they are unlikely to have the required properties of simultaneously latching the victor's indicator LED and permanently disabling the switches of all other contestants.

## SECTION 6. DRIVERS

Buffers play an important part in electronics, but in order not to introduce too many new concepts for pupils to understand, they are not referred to in this course. On the other hand drivers are essential to drive heavy current devices such as motors. An operational approach to the driver is therefore advocated below.

Experiment 6.1 (probably a demonstration): Loading an output

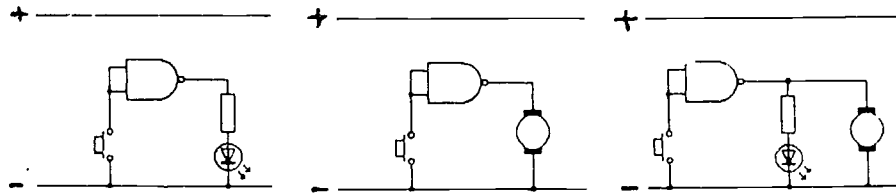

Investigations and questions

- 1 Set up the first circuit shown above. What happens when the push-button is pressed?
- 2 When the switch is closed, is the output of the NAND gate high or low?
- 3 Replace the LED with an electric motor module as shown in the second circuit above. What happens when the push-button is pressed?
- 4 To investigate why the motor did not operate in (3), connect an LED in parallel with the motor as shown in the third circuit above. When the push-button is pressed, is the output of the NAND gate still high as in (1) or is it now low?

Notes

(1) The purpose of this experiment - and teachers may prefer to do it as a demonstration - is to show that a logic gate only operates satisfactorily when small currents (a few milliamps or so) are involved, and that attempts to involve a larger current, as was needed for the motor, may change the logic level of the output. The next experiment shows how this difficulty is overcome using a driver.

(2) Teachers are warned that this experiment may not work if the LED indicator module is used for it. It may be necessary to use an LED in series with a  $330\Omega$  resistor, as in the LED module used in Part 1.

Experiment 6.2: Using a NAND gate to switch an electric motor on or off

Connect the circuit shown below using the Driver Amplifier module and the reed relay.

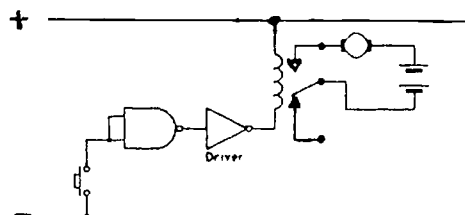

Investigations and questions

- 1 What happens when the switch is pressed?
- 2 When the switch is pressed, will the output of the NAND gate be high or low?
- 3 The driver amplifier is a special kind of inverter. When the switch is pressed, will its output be high or low?

- 4 The relay is connected between the positive supply line and the output of the driver. The motor operates when a current flows through the relay coil. When this happens is the output of the driver high or low?
- 5 Replace the switch by an LDR. What happens to the motor when the LDR is covered and uncovered? Can you think of a use for a circuit such as this?

### Notes

(1) The function of a driver is to provide an interface between a device such as an integrated circuit which is capable of controlling only a small current, and a device, such as a relay or an electric motor, which usually requires a relatively large current for its operation.

(2) The simplest and cheapest inverting driver amplifier consists of a single transistor and one resistor. However, pupils do not need to know anything about the way in which drivers are built. The transistor is not part of the present course, and the following information is for teachers only.

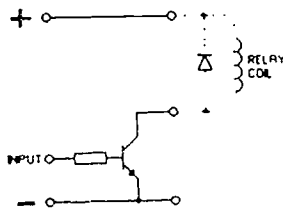

A relay and its protective diode (essential when switching inductive loads) would then be connected between the positive supply line and the transistor collector in the way shown. When the transistor input goes high, the collector current flows through the relay coil into the transistor.

In practice, it is better to use two transistors connected as a Darlington pair. The current gain of such a system is far higher than that of a single transistor, and the base current needed to switch the collector current on is then easily supplied by the high output of any integrated circuit.

(3) Note that the circuit diagram shows the motor being driven by a separate power supply. If separate supplies are not available, the motor may be driven by the supply used for the modules, provided, of course, that this supply is capable of delivering the necessary current. It is a wise precaution to connect a 1000  $\mu\text{F}$  capacitor between the power lines in those circumstances.

(4) In the present experiment the driver amplifier operates a relay which controls the motor. The same job, of course, could be done in other ways.

In the circuit below on the left the relay is omitted entirely. This would be a satisfactory arrangement provided the motor current does not exceed the maximum current allowed by the driver. One possible problem with this arrangement is that the motor and the logic circuitry share the same power supply. This would certainly be a disadvantage with CMOS integrated circuits where only a small battery is needed for the ICs. A motor would soon run this flat, or might not operate at all.

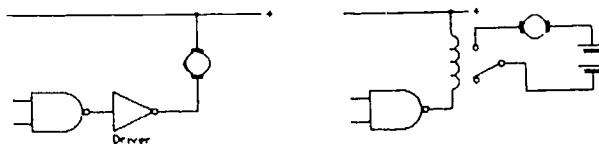

In the circuit on the right, the driver is omitted! Reed relays are available which will operate satisfactorily off a low voltage supply with a coil current of only a few milliamperes, and these can be operated directly using the logic gate output. However, a disadvantage of this type of relay is that the contact ratings are often rather small, and could possibly overheat when used with a motor requiring a large current.

The most versatile arrangement is probably the one actually used in the experiment.

(5) When using the relay module, teachers should ensure that the current requirement of the device to be operated by the relay lies within the current rating of the relay contacts.

**Experiment 6.3:** Applications involving the driver amplifier and reed relay

The projects (and solutions) are detailed below together with notes. The booklet **Electronics: Worksheets, Part 2** lists the problems without solutions.

**Project 6.3 (a):** Reversing an electric motor

Using a push-button switch, a NAND gate and the driver amplifier and reed relay, set up a circuit so that the direction of rotation of a motor is reversed when the switch is pressed. Three batteries will be needed, one for the modules and two for the motor (see Experiment 2.7).

Is the NAND gate really necessary?

Solution to 6.3 (a):

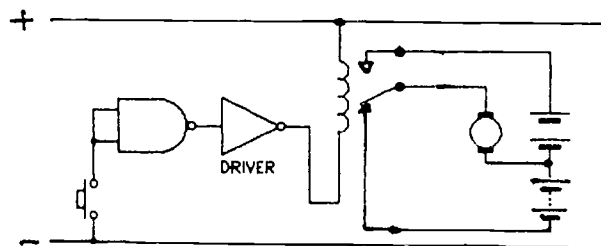

The NAND gate is not necessary if the switch is connected between the driver input and the positive supply rail. See Note (1) to Project 6.3 (b).

**Project 6.3 (b):** Reversing an electric motor with a bistable circuit

Using two push-button switches, two NAND gates, a reed relay and the driver module, set up a circuit which reverses the direction of rotation of a motor when one of the switches is pressed and released. Three batteries will be needed, one for the modules and two for the motor (see Experiment 2.7). Explain how your circuit works.

Solution to 6.3 (b):

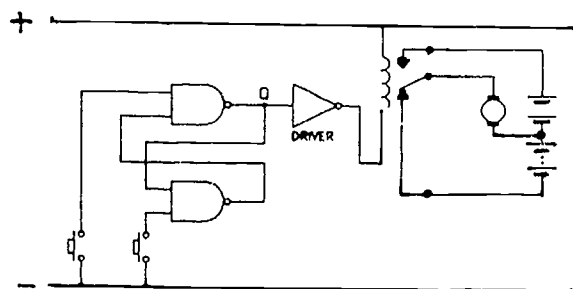

**Notes**

(1) In this and the previous project, care must be taken to ensure that the motor supply is not short-circuited when connecting it to the switches. A low value resistor connected in series with the motor supply will prevent this happening, and teachers may wish to make sure that this protection is

incorporated. However, care must be taken to ensure that the resistor value is low enough not to interfere with the operation of the motor.

(2) The way the circuit operates is very simple. The two NAND gates form an RS bistable. The contact of the relay switch will be in the lower position when Q is low, and the motor will rotate in a certain direction. When the bistable is switched to its other state, Q goes high, the relay operates and the switch goes to the higher position. This reverses the polarity of the supply to the motor which now rotates in the opposite sense. A reversal thus occurs everytime the bistable is switched.

Project 6.3 (c): An automatic light

Use a driver module, a reed relay, an LDR and any necessary gates, to make a circuit in which a filament lamp will come on automatically in the dark.

Solution to 6.3 (c):

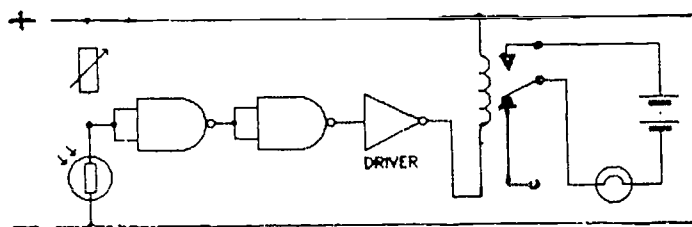

Notes

(1) The lamp should be as bright as possible to make the point that this circuit is controlling a much larger power than the circuit of Project 4.3 (c). Both the lamp voltage and current have limitations, the former because of safety, the latter because of the relay switch contacts. A 12 V 3 W lamp would be ideal, but it is not normally found in schools. A 12 V 0.1 A MES bulb is probably the most easily obtainable.

(2) If a variable resistor is used to adjust the sensitivity so that the lamp is just on, and the lamp is moved to illuminate the LDR, the circuit becomes astable. This is because light from the lamp reduces the LDR's resistance and this switches the lamp off. The fall in light intensity then causes the circuit to switch the lamp on again. Pupils might be shown this effect and asked to explain it.

Project 6.3 (d): Motor vehicle moving backwards and forwards between two light beams

Use the circuit of Project 6.3 (b) together with two inverters and two LDRs to make the motor reverse every time a light beam is interrupted.

Solution to 6.3 (d):

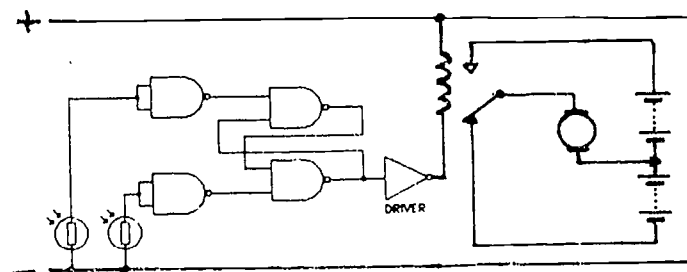



## Notes

(1) The point about this application is that, when illuminated, the resistance of the LDRs will be low. For this reason, they cannot be connected directly to the SET/ RESET inputs of the bistable, since these must both be high. The answer is to use inverters between the LDRs and the SET/RESET inputs.

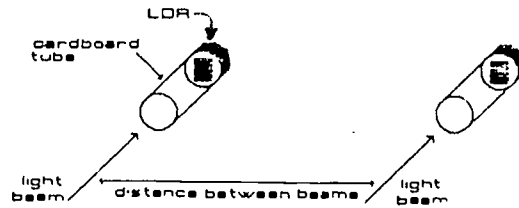

(2) The application has greatest impact if a motor with wheels is available. Two long leads are attached to the motor and connected to the appropriate points in the circuit. If the LDRs are set up in the way indicated above and illuminated by pencil torches, the vehicle should oscillate happily backwards and forwards between the light beams.

A 4.5 V LEGO motor from technical set 107 can be fitted with wheels and works well. A length of LEGO railway track along which the vehicle will run is also useful.

## SECTION 7. CODING

### Experiment 7.1: Sending messages using a 4-bit binary code

Connect a flying lead to each of the four inputs of the LED Indicator module.

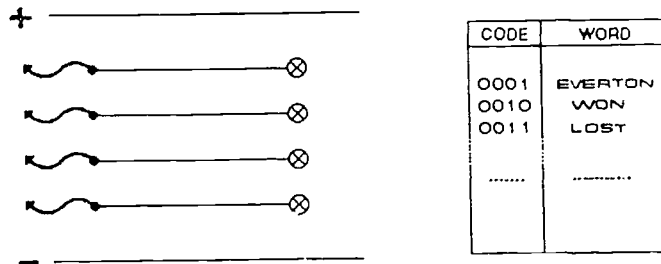

The LEDs are turned on or off by taking the flying leads at the inputs high or low. When an input is high and the corresponding LED is on, we will let it represent the binary digit 1. When an input is low and the corresponding LED is off, we will let it represent the binary digit 0.

Note that the term binary digit is usually shortened to bit. The four LEDs can therefore represent a 4-bit binary pattern.

#### Investigations and questions

- 1 Together with your partner, invent a 4-bit binary code for sending messages. Write your code in a table like that shown above on the right. A few words have been added to start you off, but you can replace them by your own if you prefer.
- 2 How many words can you represent with a 4-bit pattern?
- 3 Give a copy of your code to another group, and then send them a message using the LED indicators. Send the message, word by word, by lighting the agreed 4-bit binary pattern for each word.
- 4 Apart from a copy of your code, what other information did you have to give the other group before they were able to decode your message?

#### Notes

(1) Although very simple, this is an important experiment and should not be omitted. Its purpose is to show that a 4-bit binary pattern can be used to represent non-numerical information, and that an agreed code is necessary if information is to be represented by a binary pattern. The experiment also introduces the important ideas of 'encoding' and 'decoding' which will be explained later.

(2) Pupils will probably have met binary numbers before, but the idea of using a binary pattern to represent non-numerical information may be new to them. Perhaps the most well known example of this latter type of code is the 7-bit ASCII code (American Standard Code for Information Interchange). Pupils may well have come across this code in the instruction manuals for personal computers. Information in computers of this kind is often stored in the ASCII format.

(3) With a 4-bit code it is possible to store 16 ( $2^4$ ) words, since there are 16 distinct binary patterns. In general, an N-bit code provides  $2^N$  distinct patterns. An 8-bit microprocessor is so called because it recognises an 8-bit binary code. In principle, this means that it can recognise up to  $2^8 = 256$  different instructions. In practice, typical microprocessors are designed to recognise less than a half of this total number of possibilities.

(4) Whether using a binary pattern to represent numeric or non-numeric information, it is vital that we know which way round to read the pattern, ie left to right or right to left. Pupils will have come across this problem when they tried to use their own code to send their own messages (see question 4).

Having met the problem, pupils can be introduced to the terms MSB (most significant bit) and LSB (least significant bit). When using any binary code, numerical or non-numerical, it is vital that we know which is the LSB and which is the MSB.

(5) In the present booklet, the LSB will always be shown on the right when binary patterns are written horizontally. This is in line with the normal conventions for numbers, i.e.

MSB				LSB
$2^3$	$2^2$	$2^1$	$2^0$	
1	1	0	1	

represents the number 13 in the scale-of-10 (decimal) notation.

(6) In this experiment, pupils are introduced to using the binary digit 1 to represent a high logic level, and the binary digit 0 to represent a low logic level. This convention is prevalent throughout digital electronics, and will be used hereafter in this book.

(7) The terms 'encoding' and 'decoding' should also be introduced.

Encoding means that information is put into a binary pattern. For numerical information, encoding usually means changing from a scale-of-ten (decimal) to a binary notation.

Decoding is the reverse process. The information is extracted from the binary pattern. In the case of numerical information, this will usually mean changing from a binary to a scale-of-ten (decimal) representation. Decoders are very important in digital electronics.

#### Experiment 7.2: Investigating a seven segment LED display

You should use the seven segment LED display on the Seven Segment Display module for this experiment. The module also includes a decoder, but that is not part of this experiment and can be ignored until experiment 7.3.

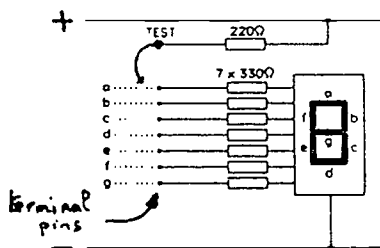

The display has seven segments, labelled a to g in the diagram. A single segment behaves like an ordinary LED, and lights up when current flows from positive (anode) to negative (cathode).

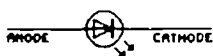

Inside this common cathode display, all the cathodes are connected together and to a single lead (the common cathode lead) which is connected to the negative supply line.

#### Investigations and questions

- 1 Connect a flying lead to the point marked TEST and touch the other end on to the pins marked a to g, one at a time. What happens?
- 2 Copy the tables below and complete them to show how you would display the digits 0 to 9.

number	segments which are lit
0	
1	
2	
3	
4	

number	segments which are lit
5	
6	
7	
8	
9	

### Notes

(1) To save the expense of including a separate seven segment display module in the recommended set of modules, provision has been made on the Display/Decoder module to perform the present experiment.

Terminal pins and a test point have been provided to allow pupils to light individual display segments with a flying lead. A safety resistor is connected between the test point and the supply line to limit the current and prevent any damage to the display in the event of direct contact between the flying lead and wires on the display side of the other resistors.

An additional safety feature is the location of the terminal pins on the decoder side of these resistors. This will prevent damage to the display should a pupil be tempted to make direct contact between a terminal pin and the positive rail (which would damage the module).

(2) If pupils wish to check their answers to question 2, it will be necessary to connect the terminal pins directly to the appropriate power supply rail. This is because the current flowing through each segment also flows through the resistor in series with the test socket. Eventually the voltage drop across this resistor is too large to allow sufficient current to flow to light the segments clearly.

However direct connection of the decoder/driver outputs (ie the terminal pins) to the power rail is not recommended and teachers are advised to remove the integrated circuit before this experiment is done.

### Experiment 7.3: Using a seven segment display with a decoder

In this experiment you will again use the Seven Segment Display module. However, this time the four decoder inputs will be used to light the display.

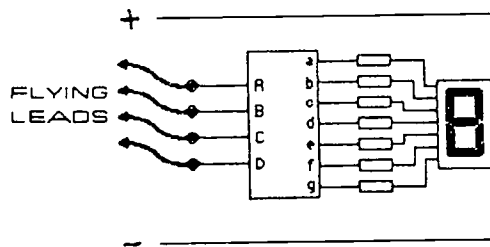

Flying leads are used to take the decoder inputs (A, B, C and D) high or low. In this and future experiments we will let a high input represent the binary digit 1, and a low input the binary digit 0.

### Investigations and questions

1 Use the flying leads to help you complete the tables below

D	C	B	A	digit displayed
0	0	0	0	
0	0	0	1	
0	0	1	0	
0	0	1	1	
0	1	0	0	
0	1	0	1	
0	1	1	0	
0	1	1	1	

D	C	B	A	digit displayed
1	0	0	0	
1	0	0	1	
1	0	1	0	
1	0	1	1	
1	1	0	0	
1	1	0	1	
1	1	1	0	
1	1	1	1	

- 2 When the digit 1 is displayed, segments b and c of the display are lit. Which outputs of the decoder must then be low, and which ones high?

### Notes

(1) As there are four inputs (A, B, C and D) to the decoder,  $2^4$  or 16 separate messages can be conveyed. Thus when the binary number 0000 is received, the decoder gives the message that a, b, c, d, e, f should light - and the number 0 is displayed. Likewise when the input 0001 is received the message goes out that b and c should light - and hence the number 1 displayed. Thus, in the case of a common cathode module, the inputs b and c are high, and all the others low.

(2) The integrated circuit used in this present experiment is called a BCD-to-seven segment decoder/driver. BCD stands for "Binary Coded Decimal". The input is a decimal digit in the binary code (ie 0000 to 1001) and the decoder decodes the input to drive a seven segment display.

In practice, a BCD-to-seven-segment-display decoder may or may not respond to the numbers beyond 1001 (that is, from 1010 to 1111) depending on the particular integrated circuit used. For the recommended CMOS decoder/driver, the display will be blank beyond 1001.

(3) In the remaining experiments in this booklet, a decoder/driver linked to a seven segment display will be represented by the following simplified symbol.

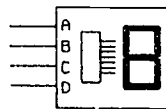

It must be pointed out that this is not an officially recognised symbol (there is no standard symbol for such a system), and it will be used merely as a matter of convenience.

### Notes about decoders

(1) In digital electronics an N-bit binary code is said to be completely decoded if  $2^N$  distinct output signals are produced from N input signals. The diagrams below provide examples.

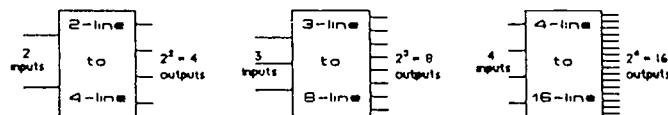

In each case every possible binary pattern present on the input lines activates a distinct output line.

With two inputs there are four possible binary patterns (00, 01, 10 and 11) and therefore four output lines are required. Similarly, with three inputs, eight output lines are required, and with four inputs, 16 output lines are required. In general N inputs require  $2^N$  outputs for complete decoding.

(2) The maximum possible memory size of a microcomputer illustrates the above principle well. In some computers there are typically 16 lines running from the microprocessor to the computer memory. Each memory location is identified by a different binary pattern present on these lines. Moreover, a separate and unique signal must be generated for each location when it is selected for the storage or retrieval of information. If we completely decode the 16 memory input lines, we can generate  $2^{16} = 65536$  distinct signals to select memory locations. This explains why some microcomputers have a memory size of 64 K. In the computing world 1 K = 1024 (not 1000!), so 64 K means that there are  $64 \times 1024 = 65536$  memory locations.

(3) Note that the BCD-to-seven-segment-display decoder used earlier is not a complete decoder since it has 4 inputs, but only 7 (rather than 16) outputs. It is an example of a partial decoder.

#### Experiment 7.4: A 2-line to 4-line decoder from NAND gates

To begin with, consider the pattern of gates shown below.

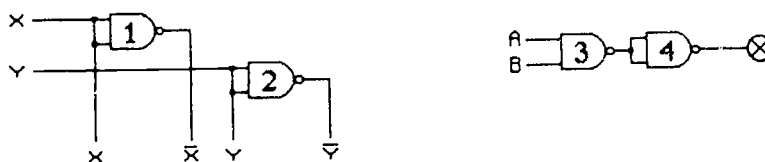

On the left are two inputs labelled X and Y which are inverted by NAND gates 1 and 2 to produce  $\bar{X}$  and  $\bar{Y}$ . On the right is an AND gate, formed from NAND gates 3 and 4, with two inputs A and B.

#### Investigations and questions

- 1 If  $X = 0$  and  $Y = 0$ , how would you connect A and B in order to light the LED? How would you connect A and B to light the LED if  $X = 0$  and  $Y = 1$ ? How would you do it if  $X = 1$  and  $Y = 0$ ? And if  $X = 1$  and  $Y = 1$ ? Build the circuits and check your predictions.
- 2 Use your results from above to draw a circuit diagram of a 2-line to 4-line decoder. If the NAND gates are available, build the decoder.
- 3 NAND gates with 3 inputs are also available in integrated circuit form (the output is low only when all 3 inputs are high). Try to draw a circuit diagram showing how a 3-line to 8-line decoder could be built from 2-input and 3-input NAND gates.
- 4 A 3-line to 8-line decoder can be built using 2-input NAND gates only. How many of these gates would be required? Explain your reasoning.

#### Notes

(1) It should be noted that gate 4 is there merely to provide the high output to light the LED and is not essential to the decoding function. Integrated circuit decoders are often available with high or with low outputs and the choice between these depends on the task the decoder is to perform.

If the 2-line to 4-line decoder in the present application is built as shown in the circuit diagram, ten NAND gates are required. This means that three groups of pupils will have to work together to provide the necessary three Quad NAND Gate modules. An alternative which teachers might prefer is to have pupils build the decoder with low outputs (only six NAND gates required), and provide voltmeters to detect the logic levels. This approach requires only two Quad NAND Gate modules, and means that only two groups of pupils need work together.

(2) Any decoder can be built in the way illustrated by this first application. A 3-line to 8-line decoder would require three NAND gates to invert the three inputs X, Y and Z to produce  $\bar{X}$ ,  $\bar{Y}$  and  $\bar{Z}$ . Eight 3-input NAND gates would then be required to produce a distinct low output for each of the eight possible combinations of X, Y and Z at the decoder inputs. If high outputs are preferred (to light indicators, perhaps) a further eight NAND gates connected as inverters would be needed.

(3) Since three 2-input NAND gates are required to produce one 3-input NAND gate, a total of  $[3 + (8 \times 3) + 8] = 35$  2-input NAND gates would be required to produce a 3-line to 8-line decoder with high outputs! Fortunately such decoders are available as single integrated circuits - an impressive illustration of the benefits of integration.

## SECTION 8. THE PULSER, THE ASTABLE AND THE CLOCKED BISTABLE

### Experiment 8.1: Observing the voltage outputs from the Pulser/Astable module

In this experiment you will use the Pulser/Astable module shown below.

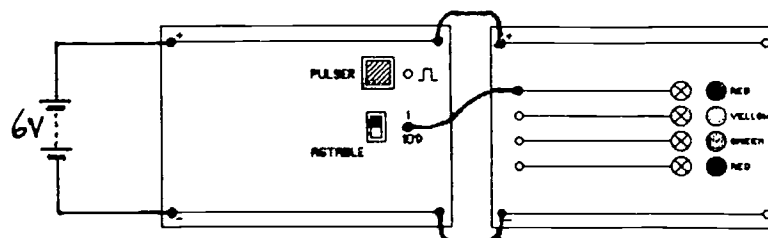

This module has two independent sections. The first is known as a pulser, and has one output socket and a switch. Below this is an astable section also with one output socket and a switch. The two circuits for the pulser and astable sections are completely separate.

Connect the lower astable output to an LED indicator in the way shown in the diagram and move the switch alongside the output socket to the 1 Hz position. Make sure that the module is connected to its power supply.

#### Investigations and questions

- 1 Observe the LED and describe what the astable output is doing. Check by connecting a voltmeter between the output and the negative rail. Sketch the output waveform.
- 2 Move the astable switch to the 100 Hz position. What do you observe? What do you think is happening now? If possible, check your prediction by using an oscilloscope. Can you measure the output frequency?
- 3 Now transfer the LED lead to the pulser output socket from the astable output socket. Operate the switch and see what happens.

#### Notes

(1) Like other digital circuits, the output of an astable can be high or low. However, in the case of an astable the output continually and automatically switches between these two states. The output is stable in neither state - hence the name astable.

Other terms used to describe such a circuit include square wave oscillator, square wave generator, and (free running) multivibrator.

(2) The approach to astables in the present course is operational. Pupils investigate how astables behave, but do not need to know why they behave in this way. Details of internal circuitry are not required.

(3) The astable module used produces square output voltage pulses with a mark-space ratio of approximately 1 (in other words, the period for which the output is high equals the period for which it is low).

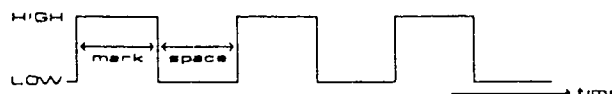

In the present case, two fixed frequencies are available, approximately 1 Hz and 100 Hz. These will be useful in several applications later in the course.



(4) Pupils can be introduced to the term clock signal to describe a constant frequency waveform of the above kind. Clock pulses from the astable unit will be used to provide timing signals for a number of different electronic circuits.

(5) The pulser output goes high when the switch is pressed and returns to low when the switch is released. This provides a convenient way of producing a single pulse and controlling its duration manually.

The pulser is in fact a bounceless switch, although this should not be mentioned to pupils at this stage. In a later section of work the phenomenon of switch contact bounce can be explored experimentally, and it may be possible for pupils to convert an ordinary switch into a bounceless switch using a bistable circuit.

### Experiment 8.2: Investigating a clocked bistable

In this experiment you will use the Pulser/Astable module to help you investigate the behaviour of one of the bistables on the Clocked Bistables module. The set-up is shown below.

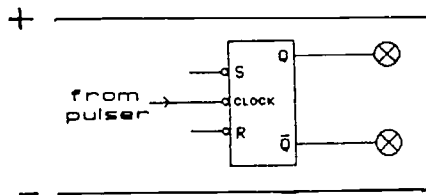

The SET and RESET inputs behave in the same way as with an ordinary bistable.

If the SET input (S) is taken briefly low, the bistable enters the state with  $Q = 1$  and  $\bar{Q} = 0$  (the SET state, in which Q has been set to 1).

When the RESET input (R) is taken briefly low, the state with  $Q = 0$  and  $\bar{Q} = 1$  is entered (the RESET state, in which Q has been reset to 0).

However, the bistable now has a third input - the clock input. In this experiment you will find out what this input does.

#### Investigations and question

- 1 First of all, without the pulser connected, use flying leads to take the SET and RESET inputs low alternately. Check that the bistable behaves in the expected way.
- 2 Now remove the flying leads and leave the SET and RESET inputs unconnected. Apply pulses one at a time to the clock input using the pulser. What happens?
- 3 Does the bistable change state when the pulse is applied ('the rising edge of the clock pulse') or when it is switched off ('the falling edge')?
- 4 Now try clocking the bistable with the 1 Hz output from the astable part of the Pulser/Astable module. What is the frequency of the Q output?

#### Notes

(1) In this experiment, pupils use the pulser to investigate a new type of bistable circuit - a clocked bistable. Like the bistable built from NAND gates earlier in the course, there are SET and RESET inputs, and Q and  $\bar{Q}$  outputs. In fact if the clock input is not used, the new bistable behaves in exactly the same way as the NAND gate version with which pupils are already familiar. However, when the pulser is connected to the clock input and the SET and RESET inputs are not used, it will be found that the bistable changes state every time the pulser is operated. In other words, the bistable changes state every time a clock pulse is applied to its clock input.

(2) Pupils will find that the actual change of state occurs on the falling edge of an applied clock pulse, that is, when the pulser switch is released rather than when it is pressed.



(3) Because the change occurs on the falling edge of the pulse, the consequent changes in Q and  $\bar{Q}$  are summarised in the following diagram.

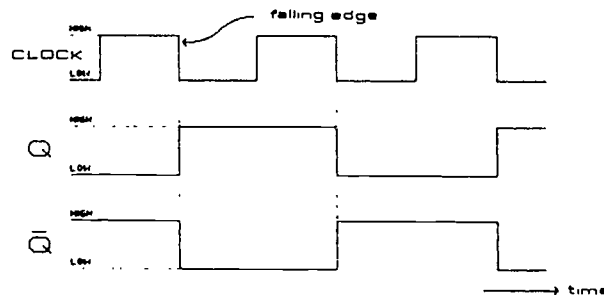

Note that the bistable only changes state on the falling edge of a clock pulse. One complete low-high-low pulse from the Q (or  $\bar{Q}$ ) output is therefore produced for every two complete clock pulses at the input. In other words, the bistable produces one output pulse for every two input pulses.

(4) For the purposes of this course it is unnecessary for pupils to know how clocked bistables work. In the Introduction it was mentioned that while digital electronics is rarely difficult, it can frequently be extremely complicated. The aim of our teaching must therefore be to give some indication of how complex systems are built up from simpler building bricks (NAND gates, for example) while avoiding the kind of complicated detail which would result in many pupils losing their way and possibly their interest. Teachers with a strong electronics background will know that clocked bistables make use of two bistable systems connected in a master-slave configuration. Explanations of such an arrangement are likely to be too complicated for most pupils, and are totally unnecessary for the present course.

(5) A suitable approach at this level is to regard the clock input on the bistable as one through which pulses are routed alternately to the SET and RESET inputs. It is not the basic bistable behaviour which is different, but merely the way in which the switching between stable states is carried out.

Experiment 8.3: Constructing 4-bit binary counters from clocked bistables

8.3 (a) Binary up-counter

Connect four clocked bistables together as shown below, and connect an LED indicator to each of the Q outputs.

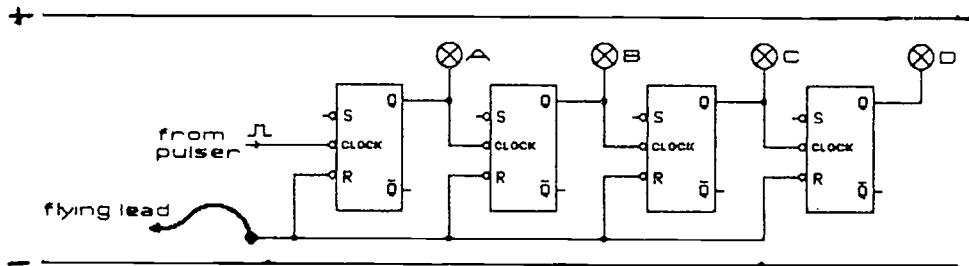

Use the flying lead connected to the RESET inputs to turn all indicators off (all Q outputs low).

Investigations and questions

1 Apply pulses one at a time to the left hand bistable using the pulser. Complete the following tables, noting that the states of indicators ABCD are entered in the order DCBA in the right hand columns.

Pulse Number	D	C	B	A
0	0	0	0	0
1				
2				
3				
4				
5				
6				
7				

Pulse Number	D	C	B	A
8				
9				
10				
11				
12				
13				
14				
15				

Note that the right hand columns represent the number of pulses as a 4-bit binary number. In other words, the four clocked bistables act as a 4-bit binary counter.

- Replace the pulser by a 1 Hz clock signal from the astable. Watch the system continually counting from 0 to 15 in binary.
- Remove the astable and reset all outputs to zero (all indicators off). Use the pulser to apply 16 pulses one at a time to the left hand bistable. Complete the following.

Number of clock pulses at input = 16  
 Number of pulses at output A =  
 Number of pulses at output B =  
 Number of pulses at output C =  
 Number of pulses at output D =

- If a clock signal of frequency 1 Hz were applied to the left hand clock input, what would you expect the frequency of the pulses produced at the D output to be? Use the 1 Hz output from the astable and a stopwatch to check your prediction.

### 8.3 (b) Binary down-counter (Optional)

Change the above circuit so that the clock inputs are driven by the  $\bar{Q}$  outputs, and all the SET inputs are connected together.

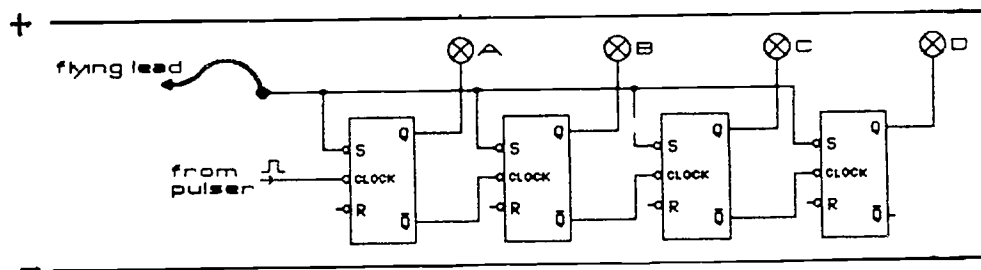

Use the flying lead connected to the SET inputs to turn all indicators on (all Q outputs high).

#### Investigations and questions

Apply pulses one at a time to the left hand bistable. Complete the table below, again noting that the states of the indicators are entered in the order DCBA in the right hand columns.

Pulse Number	D	C	B	A
0	1	1	1	1
1				
2				
3				
4				
5				
6				
7				

Pulse Number	D	C	B	A
8				
9				
10				
11				
12				
13				
14				
15				

Note that at each pulse, 1 is subtracted from the count represented by the LED indicators. This is called a binary down-counter.

#### Notes

- Since two Clocked Bistable modules are required for this experiment, two groups of pupils will have to work together.
- The experiment illustrates how clocked bistables can be linked together to count pulses in binary. With four bistables, counts from 0 to 15 (binary 0000 to 1111) can be displayed. To extend the maximum count, more bistables are added. The maximum count with N bistables is  $2^N - 1$ .
- Note that in experiments where clocked bistables are linked to form binary counters, it is conventional to feed the external clock pulses into the left hand bistable. The Q output of this bistable therefore

represents the least significant bit (LSB) and the Q output of the right hand bistable the most significant bit (MSB). This, of course, results in a display in the reverse order to which binary numbers are usually written. Teachers may need to emphasise this point.

(4) Pupils should be able to draw a diagram showing how each of the Q outputs changes as the clock pulses are fed into the left hand bistable. Consider the timing diagram below for a binary up-counter.

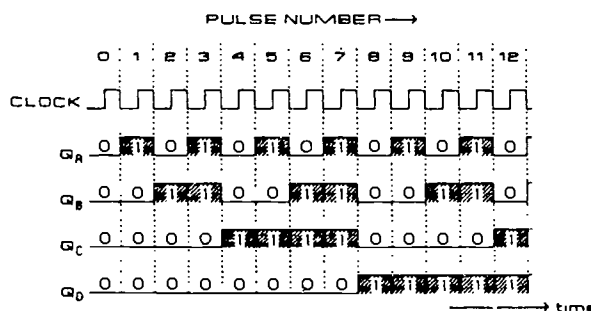

In the diagram, all outputs are initially low. Each bistable changes state on the falling edge of the pulse at its own clock input. In other words, Q<sub>A</sub> changes state on the falling edge of the clock input; Q<sub>B</sub> changes on the falling edge of Q<sub>A</sub>; Q<sub>C</sub> on the falling edge of Q<sub>B</sub>; Q<sub>D</sub> on the falling edge of Q<sub>C</sub>.

We have a binary up-counter, which changes by adding 1 to the count for every clock pulse.

(5) In the final part of their work with the binary up-counter pupils are led to look at the system in a different way (see question 3 of the first part of the experiment). When they feed 16 pulses into the left hand bistable one at a time they will obtain the following results:

Number of clock pulses at input	= 16
Number of pulses at output A	= 8
Number of pulses at output B	= 4
Number of pulses at output C	= 2
Number of pulses at output D	= 1

Each bistable in the chain produced one output pulse for every two pulses at its clock input. If 16 pulses per second arrive at the input of the first bistable, 1 pulse per second will leave the Q output of the fourth bistable. In other words, we have a system which divides the input frequency by 16. Such a system is often called a divide-by-16 counter.

A single bistable divides the frequency of a clock signal at its input by 2, while chains of two, three, four or five bistables provide division by 4, 8, 16 and 32 respectively. In general, a divide-by-N counter will produce output pulses at a frequency 1/N times the input frequency. If it contains x bistables, then  $2^x = N$

Divide-by-N counters are used extensively in electronics systems when it is necessary to generate signals which are known, exact multiples of each other. In one popular contemporary microcomputer, for example, the signal from a master oscillator operating at 16 MHz is divided down in this way to produce the 1MHz clock signal driving the microprocessor.

## SECTION 9. COUNTING CIRCUITS

### Experiment 9.1: 4-bit binary counter integrated circuit

#### 9.1 (a) Counting pulses

Connect the pulser to the input of one of the 4-bit counters of the Binary Counter module. Monitor each of the four output lines with an LED indicator.

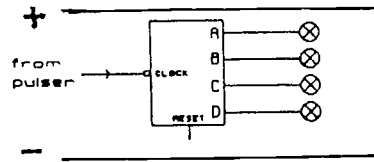

If any of the indicators are lit, use a flying lead to take the RESET input briefly high. Note that the counter can be reset to zero at any time by taking this RESET input high.

#### Investigations and questions

- 1 Apply pulses to the counter one at a time. Does the display change on the rising or falling edge of the clock pulse?
- 2 Send 16 pulses to the counter and check that the indicators correctly display the number of pulses in binary.
- 3 Now replace the pulser by the 1 Hz output signal from an astable unit. Watch the system repeatedly cycle from 0000 through to 1111 and back to 0000 again.
- 4 With the 1 Hz signal still connected, disconnect indicators A, B and C. What is the frequency of the output signal at D? Is this what you expect? Explain.

#### 9.1 (b) Linking the counter to a decoder and seven segment display

Remove the LED indicators and connect the Seven Segment Decoder/Display module as shown below.

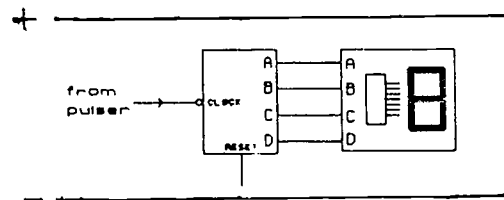

#### Investigations and questions

First reset the counter by taking the RESET input briefly high. Then use the pulser to apply pulses one at a time to the clock input of the counter. Copy down the display after each pulse.

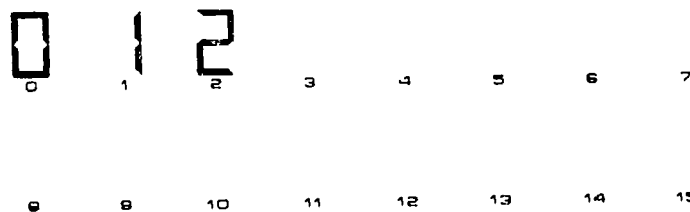

## Notes

- (1) As mentioned earlier, it depends on the particular type of modules whether the display will be blank or show strange patterns for the numbers 10 to 15. This is because the BCD-to-seven-segment decoder and the seven segment display are only designed to show the scale-of-ten (decimal) digits 0 to 9 (binary 0000 to 1001). The binary numbers 1010 to 1111 are of course still generated by the counter, but result in either a blank display or odd patterns.
- (2) Rather than use a chain of bistables every time we wish to count pulses, it is far more convenient to use a single integrated circuit to do the same job. The IC used in the 4-bit binary counter module does the job of four bistables in sequence. It counts from 0000 to 1111, then resets itself automatically to 0000 and starts counting up again. The number of different states a counter goes through before repeating is known as the modulus of the counter (see the next experiment for further details).
- (3) The 4-bit binary counter has the following additional properties: (a) it changes state on the falling (negative) edge of an applied clock pulse; (b) it has a RESET input which is normally held low and taken briefly high to set all outputs to zero.
- (4) The advantage of negative edge clocking in the present course is that several of these counters can be directly cascaded if multi-digit readouts are required.

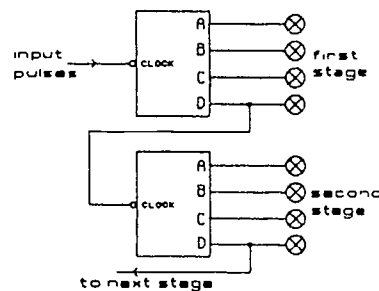

Clock pulses for the second stage are provided by the D output of the first stage. Since this D output has a falling edge after every sixteenth pulse, the system continues to count upwards in the required manner. With counters which change state on the rising edge of a clock pulse, an inverter would be needed between each stage.

- (5) A multi-digit binary-to-scale-of-ten (binary-coded-decimal or BCD) counter can be produced in much the same way except that it is necessary to reset each stage after it has received 10 pulses at its input. This is achieved by using an AND gate (made from two NAND gates) as shown below. The output from the first NAND gate is used to clock the next stage.

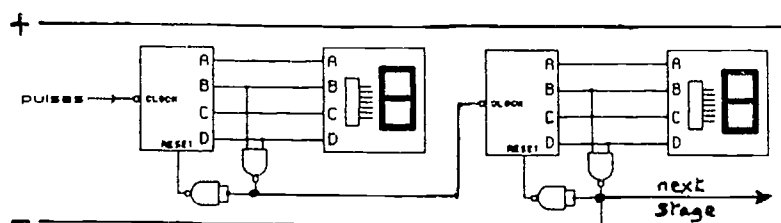

**Experiment 9.2: Counters of different moduli**

Connect an AND gate (use two NAND gates) between the B and D output lines and the RESET input as shown below.

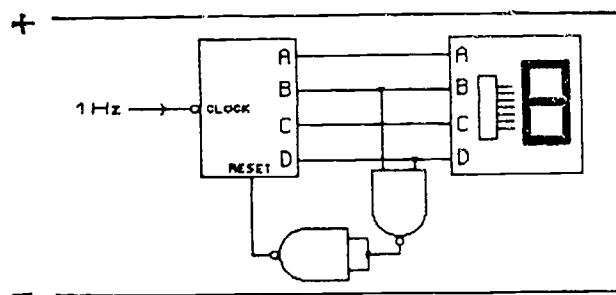

**Investigations and questions**

- 1 Apply a 1 Hz signal from the astable unit to the clock input of the counter. Notice that the system now counts from 0 to 9 and then resets itself and starts counting upwards from zero again. Try to explain why this happens.
- 2 Now connect the same AND gate so that the counter
  - (a) counts to 2 and resets,
  - (b) counts to 4 and resets,
  - (c) counts to 5 and resets,
  - (d) counts to 8 and resets.
 In each case draw a diagram showing the way you connected the AND gate.
- 3 How many AND gates do you need to make a counter which
  - (a) counts to 1 and resets,
  - (b) counts to 3 and resets,
  - (c) counts to 6 and resets,
  - (d) counts to 7 and resets?
 In each case draw a diagram of the connections, and check that the system really does behave in the way you expect.

**Notes**

(1) In this experiment pupils build and test counters of different moduli using the 4-bit Counter module and NAND gates. The key to understanding this work is the 4-bit binary counting sequence. Consider, for example, a counter with modulus 5.

D	C	B	A	Number	
0	0	0	0	0	
0	0	0	1	1	These digits must be displayed on the counter
0	0	1	0	2	
0	0	1	1	3	
0	1	0	0	4	
0	1	0	1	5	
0	1	1	0	6	
0	1	1	1	7	
1	0	0	0	8	
1	0	0	1	9	
1	0	1	0	10	

The numbers 0 to 4 must be displayed. The counter must then reset to zero immediately the next state (0101) appears at the outputs. This is done by using an AND gate (or two NAND gates) to detect when the A and C digits are both 1 and provide the high state necessary to reset the counter.

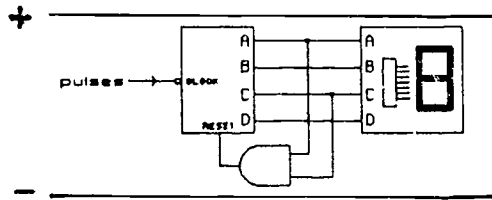

(2) Counters of other moduli are designed in the same way. The connections for all moduli between 2 and 9 are as follows.

Modulus	Connections
2	RESET ← B
3	RESET ← A AND B
4	RESET ← C
5	RESET ← C AND A
6	RESET ← C AND B
7	RESET ← A AND B AND C
8	RESET ← D
9	RESET ← A AND D
10	RESET ← B AND D

The only time more than two NAND gates are required is for the modulo-7 counter. In this case high states must be detected on three lines. Two AND gates (or four NAND gates) will do the job.



### Experiment 9.3: Switch contact bounce (Optional)

#### 9.3 (a) Experimental illustration of contact bounce

In the circuit below a flying lead is connected to a clock input of the 4-bit Binary Counter module.

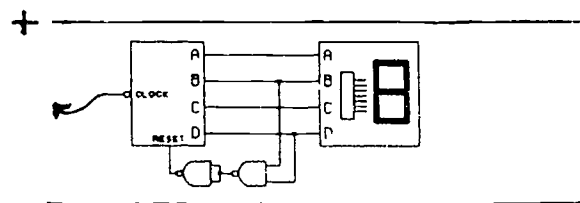

Set up the circuit with the flying lead connected initially to the negative rail.

#### Investigations and questions

Note the number displayed and then pulse the clock input once by touching the lead to the positive rail and then the negative rail. Note the number displayed again. Do this several times. Does the count displayed increase in steps of one?

#### 9.3 (b) Using a bistable circuit to eliminate contact bounce

Connect the bistable circuit, made from two NAND gates, as shown below.

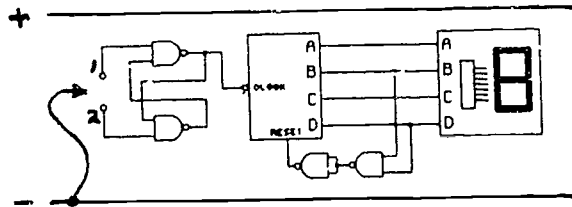

Note that the Q output of the bistable is connected to the clock input of the counter. Connect a flying lead to the negative rail.

#### Investigations and questions

- 1 Use the flying lead to send pulses to the counter by touching it first to input 1 and then to input 2 and so on. Does the count displayed now increase by one each time?
- 2 Try to explain the action of the bistable in the above circuit.

#### Notes

(1) In their work with clocked bistables and counters pupils have frequently used a pulser unit to provide the necessary clock pulses. The purpose of the present experiment is to show why such a special unit is necessary, and the way it is constructed.

(2) In the first part of the experiment pupils will find that the counter behaves erratically - the count displayed may increase by more than one for each cycle of operation. This is because of contact bounce. Any ordinary switch also suffers from contact bounce. Indeed, Experiments 9.3 (a) and 9.3 (b) would be better done with an SPDT switch rather than a flying lead, as in the notes which follow.

(3) Contact bounce arises when the moving contact of the switch bounces on and off a fixed contact before settling in position. This results in the production of a series of pulses rather than a single 'clean' pulse. (Note that the clock input is normally high when unconnected.)

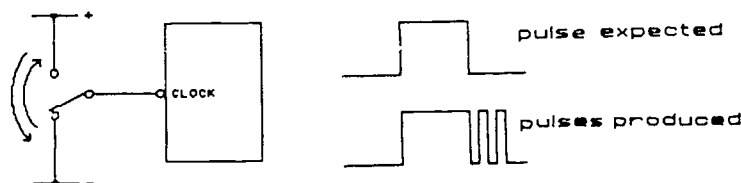

Note that, if the clock input is normally high (which it is on the counter module), the extra pulses are positive going and are generated when the switch goes to its low position. Contact bounce does, of course, also occur when the switch goes to its high position, but in this case extra pulses are unlikely to be produced. This is because the clock input itself will remain in its normally high position during bouncing unless the bounce is so severe that the moving contact touches the low voltage line again.

(4) Contact bounce plays havoc with circuits such as clocked bistables and counters, because the extra pulses are real pulses which clock the system. Hence it is necessary to use some electronic circuitry to remove the effect.

(5) In the present experiment (b) two NAND gates connected as a bistable are used. Pupils should be given the following explanation.



From earlier work pupils will know that the R and S inputs are normally high and that the R input must be taken briefly low to enter the state with  $Q=0$  and  $\bar{Q}=1$ . To enter the other stable state ( $Q=1$  and  $\bar{Q}=0$ ) the S input must be taken briefly low. The key point in the present application is that once the S or R input has been taken low a first time, taking the same input low a second or further time has no effect, provided the switch does not move back to its original position in between.

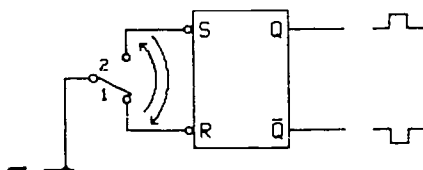

Thus if the bistable is initially in the state with  $Q=0$  and the moving switch contact is pushed from position 2 to position 1, the S input will be taken low and Q will be set high. If the moving contact bounces on and off the fixed contact at position 1, but not so severely as to touch 2 again, the S input will be taken repeatedly low, but this will not affect the state of the bistable (Q remains high).

When the moving contact is pushed back to position 2, the R input will be taken low and Q will be reset to zero. Again, contact bounce will have no effect because the bistable was reset at the moment of first contact and taking the R input low several times in succession produces no further changes. In this way a single low-high, low pulse is produced at the Q output every time the moving contact is moved from position 2 to 1 and back to 2 again.

(6) The single pulser output on the Pulser/Astable module used in this course is, in fact, made in this way in order to avoid contact bounce.

#### Experiment 9.4: Constructing a 1-bit memory from NAND gates and an RS bistable

Set up the circuit below and connect a 1 Hz signal from the Pulser/Astable module to the data input and a flying lead to the hold input.

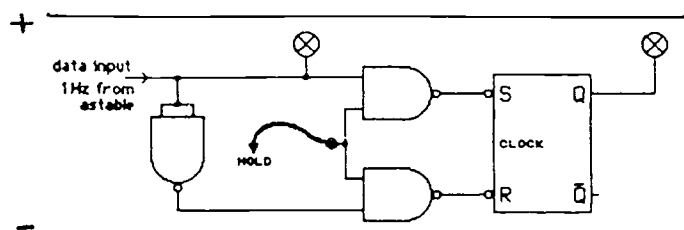

#### Investigations and questions

- 1 Take the hold input high. What happens? Now take the hold input low. What happens?
- 2 Try to explain how the circuit works.

#### Notes

(1) The way the circuit works can be explained as follows. Suppose first the HOLD input is high. Then when the data input is high, the voltage levels are as shown below.

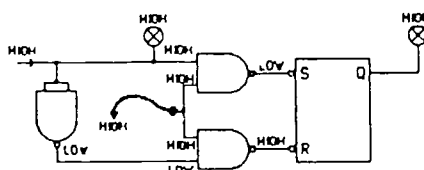

When the data input is low, the voltage levels are as follows.

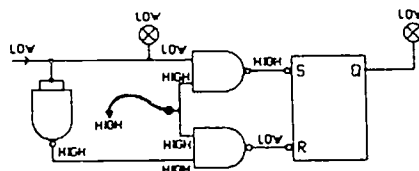

Thus the final output FOLLOWS the input (the two indicators are either both high or both low). When the data input is high, Q is high. When the data input is low, Q is low.

But making the HOLD input low, we have the following.

With high data input

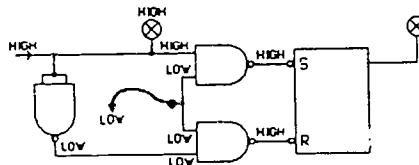

With low data input

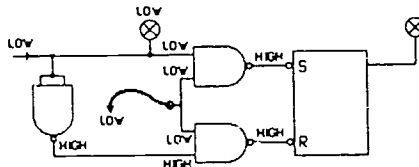

In these two cases, whether the data input is high or low, the outputs of the two NAND gates are both high. But the RS bistable only changes when one of the points S or R goes low, so the output stays as it was when the hold went low. What was then showing is still showing: it is HELD, or MEMORISED.

#### Experiment 9.5: Linking two single digit counters to make a dual decade counter

This experiment might be done as a project.

The aim is to produce a counter which will display counts from 0 to 99 on two seven segment LED displays using an astable (to produce the pulses to be counted), two binary counters, two seven segment displays with decoders and a Quad NAND module.

The solution is:

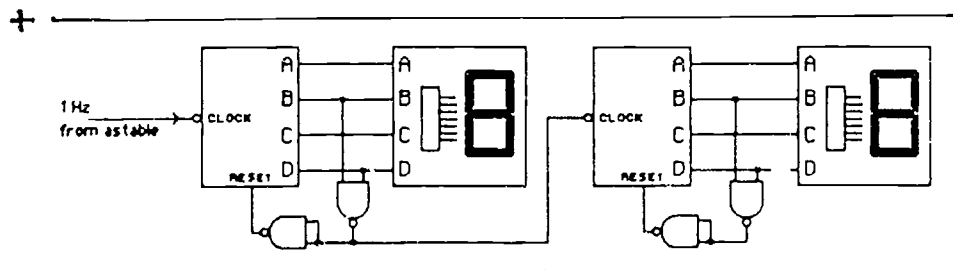



## Notes

(1) Teachers must provide pupils with a suitable source of mains frequency pulses for this experiment. The simple half wave rectifying circuit shown above works well, but the transformer supply for it must be different from any used to provide a stabilised power supply for the modules. An alternative is to use the 100 Hz output of the astable.

(2) There is one important safety precaution. Only positive going pulses should be applied to the input of the NAND gate if it is not to be damaged. Teachers should check pupils' circuits to ensure correct polarity before allowing them to switch on the a.c. supply.

Further, the peak voltage across the 1 k $\Omega$  resistor should not exceed the power supply voltage applied to the modules. For modules operating from 5 V, a 2 V a.c. supply to the half-wave rectifier should be adequate. For modules operating from 6 V, a 4 V a.c. supply should be satisfactory.

(3) Pupils actually measure the frequency at which indicator D on the second counter flashes. They can simply use a stopwatch and measure the time for a number of complete cycles, say 10.

A typical measurement is about 10 cycles in 50 s. The frequency  $f$  of the mains is then calculated as

$$f = \frac{10}{50} \times 256 = 51.2 \text{ Hz.}$$

### Project 9.6 (b): Down-counting (1)

Using a 4-bit binary counter, design a circuit which counts down from 15 (binary 1111) to zero (0000). Use LED indicators to display the count.

Solution to 9.6 (b):

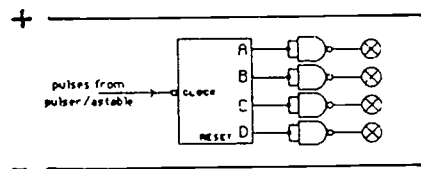

### Project 9.6 (c): Down-counting (2)

Using a 4-bit binary counter, design a circuit which counts down from 7 (binary 111) to zero (000) and then returns to 7. Display the count with a 7-segment indicator.

Solution to 9.6 (c):

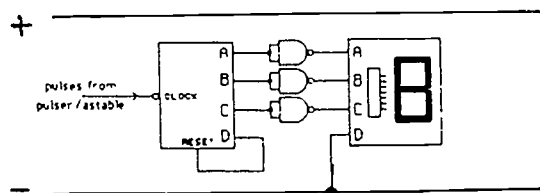

## Note

The D input of the 7-segment display must be connected to the negative supply rail in order to display the digits 0 to 7.

### Project 9.6 (d): Counting the 'swings' of a pendulum

Build a circuit which will count the 'swings' (ie  $\frac{1}{2}$ -cycles) of a pendulum. Use a 4-bit counter and a 7-segment Decoder/Display module for this.

Solution to 9.6 (d):

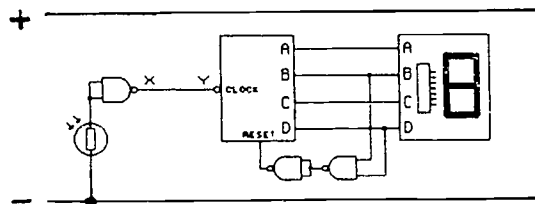

Notes

(1) The circuit above will count the  $\frac{1}{2}$ -cycles of the pendulum if a light beam is arranged to fall on the LDR and if the pendulum bob passes through the light beam.

(2) If the counter is set to zero, it will count '1' the first time the bob passes through the beam, no matter from where the bob is released. Pupils might be challenged to add to the circuit so that counting starts following the first interruption of the beam.

Replacing the direct connection between X and Y above with the circuit opposite should result in the first transit activating the counter if the Q output of the bistable is initially reset to 0 by means of the flying lead.

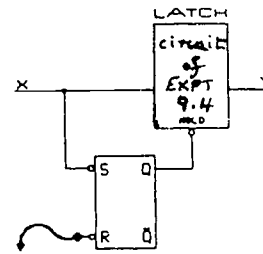

Project 9.6 (e): Controlling a motor (1)

Build a circuit which turns an electric motor on for 10 s in every 20 s.

Solution to 9.6 (e):

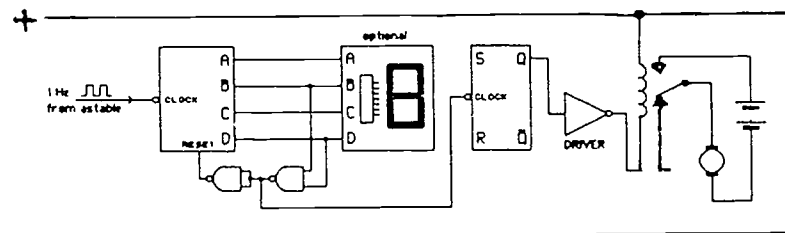

This is a relatively simple control problem.

Note that the negative going pulse, produced by the NAND gate connected to the B and D outputs of the modulo-10 counter every time the count reaches ten, is used to change the state of the clocked RS bistable. Since the Q output is therefore alternately high for 10 s and low for 10 s, the motor is on for 10 s in 20 s.

Project 9.6 (f). Controlling a motor (2)

Build a circuit which turns an electric motor on for 5 s in every 20 s.

Solution to 9.6 (f):

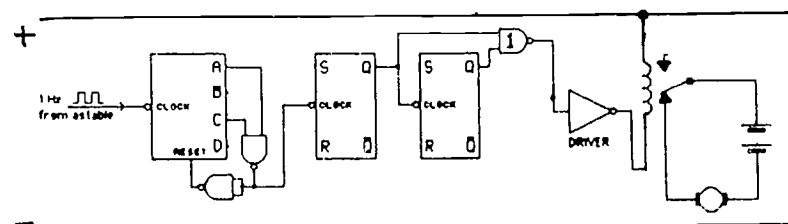

Note that the first bistable is driven by a modulo-5 counter so that its Q output is high for 5 s and then low for 5 s. The Q output of the second bistable is high for 10 s and low for 10 s. The output of NAND gate 1 is therefore low for 5 s in every 20 s.

Project 9.6 (g): Reversing a motor at regular intervals

Design a control circuit for an automatic liquid mixer. The circuit should reverse the direction of rotation of the mixer motor every 5 s.

Solution to 9.6 (g):

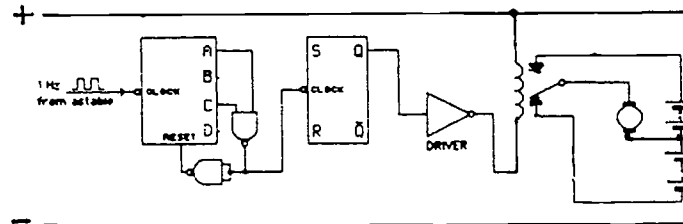

Note that the circuit is similar to that of Project 9.6 (e) except that a modulo-5 counter is required and the relay switch is used with 2 batteries to reverse the motor.

Project 9.6 (h): Flashing a lamp six times - six 'pips'

Design a circuit which will flash a lamp six times when a switch is pressed and released, using the 1 Hz output from an astable. Then modify the circuit so that it will sound a buzzer six times.

Solution to 9.6 (h):

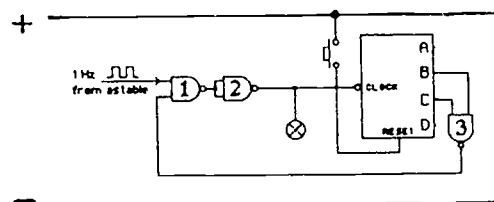

Notes

(1) The counter counts 6 input pulses and NAND gate 3 then causes the AND gate, formed by gates 1 and 2, to close. Pressing the switch resets the counter and the process repeats.

(2) To sound a buzzer 6 times, the LED indicator should be replaced by the buzzer. See note (2) of Project 2.2 (a) for possible difficulties with driving buzzers from CMOS gates. A non-inverting buffer may be needed.

Project 9.6 (i): An automatic light-buoy

A warning buoy in a shipping channel is to have a light which flashes. It is to be on for 1 s and off for 4 s. Design a circuit which will do this. Use the Pulser/Astable module to provide 1 Hz pulses. Then adapt the circuit so that the light only operates when it is dark.

Solution to 9.6 (i):

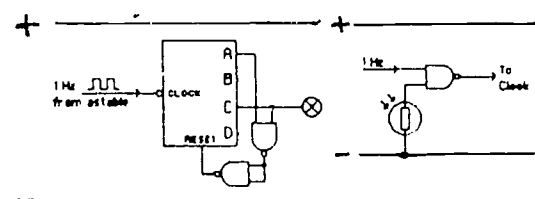

**Project 9.6 (j): An electronic die**

Build an electronic die using clocked RS bistables, an astable, a seven-segment decoder/display and NAND gates. The display should normally cycle from 1 to 6 at high speed. When the hold input on the input gate is taken low, the display should freeze and show the result of the "throw".

Solution to 9.6 (j):

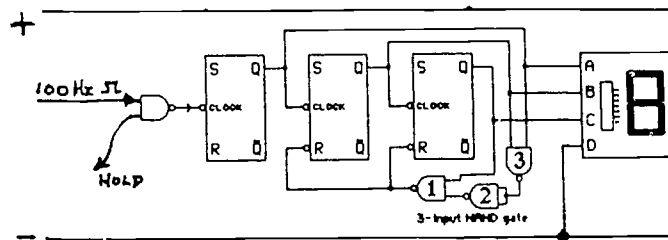

**Notes**

(1) The tricky part of this experiment is to make the display count from 1 to 6, i.e. to reset the count to 1 rather than to 0 after each cycle. This can be done using three clocked RS bistables as a modulo-7 counter and resetting just the two providing the B and C inputs when the count reaches 7. Note that NAND gates 1, 2 and 3 form a 3-input NAND gate which provides the necessary negative going reset pulse when all three Q outputs are high.

(2) The unused D input to the decoder/display must not be allowed to float in this application, since it will assume a high state and upset the display. Tie this input low.

**Project 9.6 (k): Traffic lights**

Build a control circuit for a set of traffic lights. Use the 1 Hz astable output for all timing, and the red, yellow and green LEDs on the Indicator module for lights. The lights must, of course, come on in the normal traffic light sequence (yellow, red, red and yellow, green, and back to yellow again).

Solution to 9.6 (k):

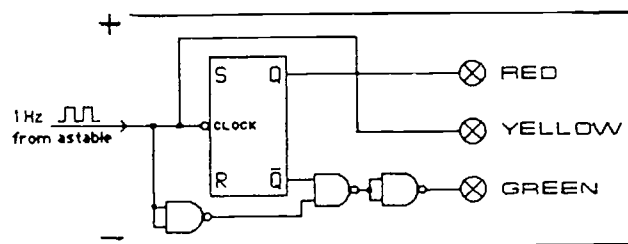

**Note**

A number of different solutions to the traffic lights problem is possible. The above is one of the simplest. To see how the circuit works, consider the following timing diagram.

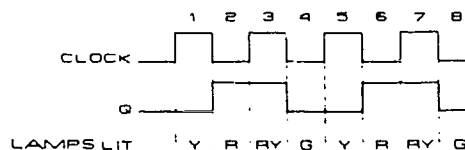

The yellow LED is driven directly from the astable, and lights when the clock is high. With the red LED driven from the Q output, the initial yellow, red, yellow and red output sequence is obtained during the first three half-cycles of the clock. On the fourth half-cycle, both yellow and red are off (as required), and the green LED must be turned on. At this time, both the clock and Q are low, so an AND gate driven by  $\bar{Q}$  and the inverse of the clock will provide a high output to light the green LED.

Project 9.6 (l): Batch counting

Articles in a factory are delivered from an assembly room to a packing room along a conveyor belt. Design a system which will stop the conveyor belt (turn off its motor) every time a batch of five articles has entered the packing room. Provide a switch in this room which can be used to restart the conveyor belt motor once the articles have been removed from the belt for packing.

Solution to 9.6 (l):

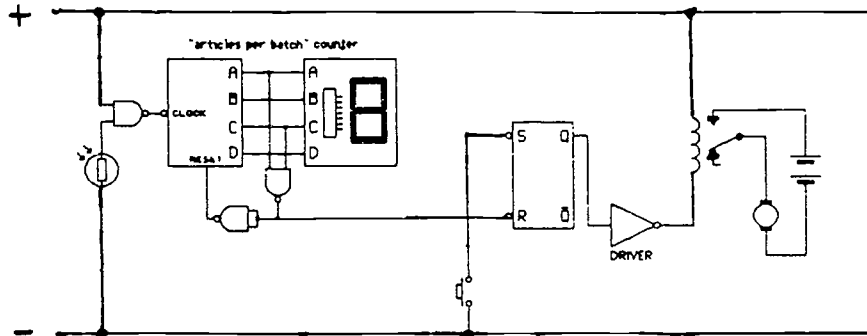

Notes

- (1) In a practical system, the LDR would perhaps be placed at the entrance of the packing room. Each article would be counted as it interrupted a light beam falling on the LDR when entering the packing room.
- (2) The NAND gate connected to outputs A and C of the modulo-5 counter produces a negative going pulse every time five articles have been counted. This pulse resets an RS bistable which turns the conveyor belt motor off. A manual switch is used to set the RS bistable to re-start the motor.

Project 9.6 (m): Reaction time

Build a circuit which can be used to test people's reaction times. A switch should be provided which starts a dual decade counter (see Experiment 9.5) counting 100 Hz pulses from an astable. This switch is operated secretly by the person controlling the test. A second switch should freeze the display. This is operated by the person under test directly the display is seen to change. The dual decade module should then show the time difference between the two switch closures, i.e. the reaction time of the person under test.

Solution to 9.6 (m):

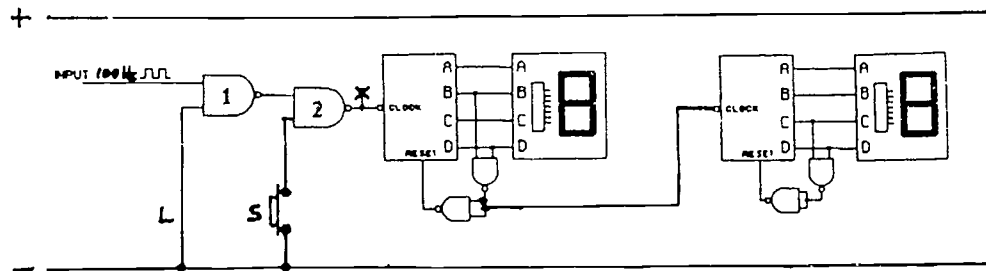

Notes

- (1) The principle of a solution is shown above. First, a flying lead is used to reset the dual decade counter to zero. Then the person controlling the test opens the NAND gate 1 by disconnecting lead L from the negative rail. The person under test responds directly the display is seen to change by using switch S to take the input of NAND 2 low. This freezes the display with the reaction time shown in one hundredths of a second.



(2) In practice, the experiment is likely to be unreliable because of contact bounce problems. Bounce-free switches could be made but that would require four more NAND gates.

An alternative method is to replace the input circuitry to the left of X in the circuit above with that below.

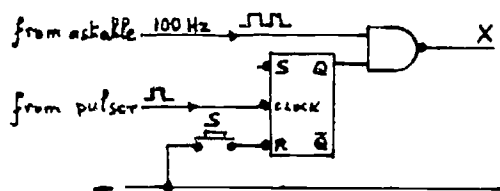

The NAND gate is closed by pressing S so making the Q output low. Counting is started by clocking the bistable once from the pulser output, so opening the NAND gate. The gate is closed again by pressing S when the counter is seen to start.

(3) The experiment can be extended in various ways. One possibility is for a buzzer to sound at the same time as the NAND gate opens. The reaction of the person under test to an audible signal can then be investigated, and compared with the response to a visual stimulus.

## APPENDIX A: BIBLIOGRAPHY

- 1 TTL Cookbook Don Lancaster (Howard W Sams, 1974)

A masterful exposition of basic digital electronics and an authoritative and comprehensive account of TTL devices and their application. Highly recommended.

- 2 CMOS Cookbook Don Lancaster (Howard W Sams, 1977)

As brilliant and authoritative a guide as its TTL predecessor.

- 3 Microelectronics - practical approaches for schools and colleges (BP Educational Service, 1981)

Sections 3.4 to 3.6 of this are particularly good. They describe a modular approach to digital electronics which is much less comprehensive than that of the present course, but which uses electronic systems in a similar way and progresses to memory as an end-point.

- 4 The European CMOS selection  
Low power Schottky TTL

The standard Motorola reference books containing information on their products and complete sets of data sheets. Reprinted and up-dated regularly.

- 5 Adventures with digital electronics Tom Duncan (John Murray, 1982)

Describes plenty of advanced CMOS projects likely to appeal to youngsters. The initial chapters provide a very condensed but clear account of selected aspects of basic digital electronics.

- 6 Electronics G E Foxcroft, J L Lewis and M K Summers (Longman, 1985)

This is a pupil text written to accompany the work of this Electronics course. It contains a larger number of projects than this book does. Teachers may find these useful in the earlier parts of this work. There is also a Teacher's Guide.

## APPENDIX B: TECHNICAL DETAILS

### 1 MODULES FOR PART 1

The following diagrams are module 'plans' for the modules required in Part 1. In these diagrams R is a protective resistor chosen to limit the maximum current through the device to a safe value. In the cases where R protects a switch, its value is given by  $R = 6/\text{max. switch current}$ . In the case of the LDR,  $R = (36/P) - X$ , where P is the maximum power dissipation and X is the minimum resistance of the LDR.

For the motor and buzzer, R is only necessary if the devices are designed to operate from a smaller voltage than 6 V. If these items are designed for V volts, then  $R = (6 - V)/I$  where I is the normal device current.

LEDs Module

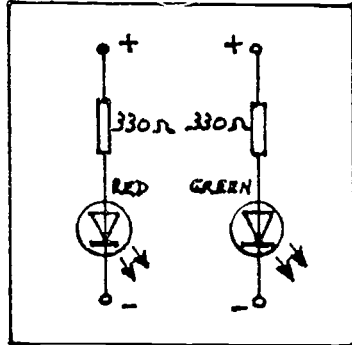

LDR Module

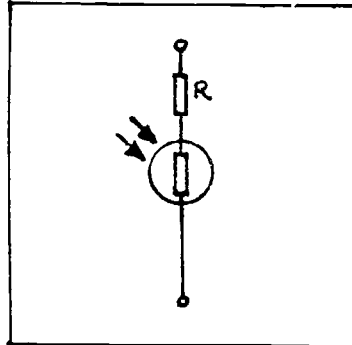

Push-Button Switch Module (2)

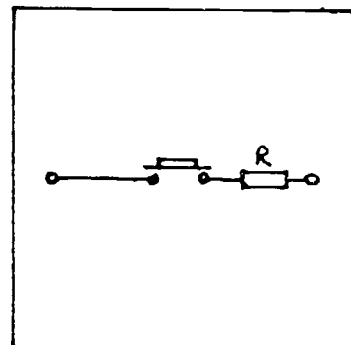

Buzzer Module

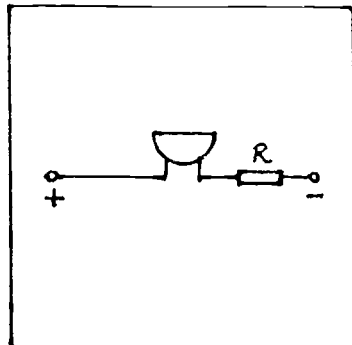

Motor Module

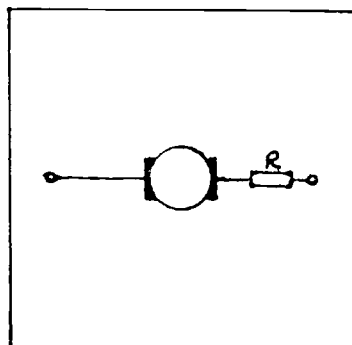

Reed Switch Module

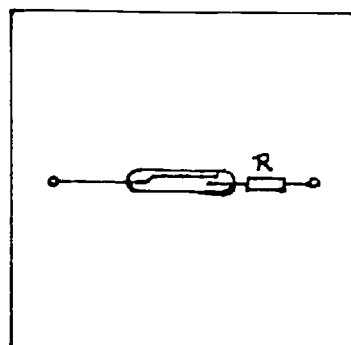

Reed Relay Module

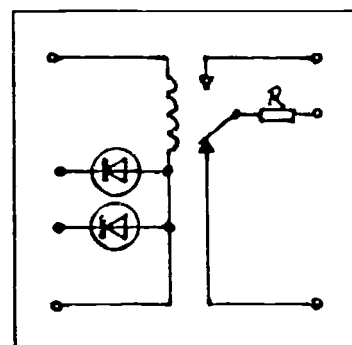

## 2 INTEGRATED CIRCUIT FAMILIES

The electronic functions that the modules of Part 2 perform can be implemented with a variety of different devices - relays, transistors, integrated circuits, for example. Integrated circuits are used in this course for the obvious reasons that they are modern, cheap and provide the necessary circuitry for experimental work in a very compact and convenient form. In addition, they provide the opportunity to show pupils the real meaning of microelectronics - not some new type of electronics but miniaturisation, which has been known to be valuable for a long time. Pupils should have the opportunity, early in the course, of viewing a silicon chip with a microscope.

There are several different families of integrated circuits, which perform the same basic tasks in different ways. For example, a NAND gate from one family will perform the same logical function as one from another family, but the internal processes may be very different. In recent years, two families have gained particular prominence. One is the CMOS family (Complementary Metal Oxide Semiconductor), while the other is the TTL family (Transistor-Transistor Logic). The latter has now been superceded for many applications by a sub-family known as LSTTL (Low power Schottky TTL). LSTTL ICs can directly replace standard TTL chips in most applications.

Since this course is concerned mainly with ways in which building bricks such as NAND gates are used, the particular methods of implementation within an IC are of no great importance. The experimental work can therefore be carried out using any IC family. The relative merits of using CMOS, TTL or LSTTL ICs for this work are discussed below.

## 3 SELECTING AN IC FAMILY FOR WORK AT SCHOOL LEVEL

### CMOS

The features of CMOS integrated circuits are as follows.

- (a) They will operate from any supply voltage from 3 V to 18 V (extremes best avoided).
- (b) The supply current for the ICs is minute (a few microamps in most cases).
- (c) Noise immunity is high (relatively large fluctuations in the voltage level at an input can be tolerated before the output voltage level is affected).
- (d) They can be damaged by static electricity and need handling carefully.
- (e) Inputs cannot be left floating - they must go somewhere (discussed later).

(a) and (b) above are obviously useful for school work, because ordinary batteries can be used and with reasonably long life. However, batteries have also to supply the current to operate LEDs and 7-segment displays, and the current might then be as high as 0.2 A. High noise immunity is a major advantage for complex circuitry, especially if high speed switching is necessary, but it is not important for work in this course.

With modules, the problem of static electricity is not important since pupils will not be handling the ICs directly. However, the need to ensure that all inputs go somewhere is a nuisance, since more wiring and additional resistors are needed.

### TTL

This family of ICs has the following features.

- (a) A 5 V smoothed power supply is essential (the supply voltage range is 4.75 V to 5.25 V). A regulated supply is to be preferred.
- (b) The IC supply current is relatively large (milliamps, or sometimes, tens of milliamps).
- (c) Noise immunity is not so high as for CMOS devices.

- (d) Floating inputs assume a high logic state and can be left floating.
- (e) The ICs are not susceptible to electrostatic damage and are more robust than CMOS ICs.

For work at school level, a regulated supply will almost certainly have to be used, but this can be built quite cheaply (see below). In some of the more complex experiments in the course, the supply current may be as high as  $\frac{1}{2}$  A or more.

The fact that TTL inputs can be allowed to float is very useful when constructing modules, since the necessary wiring is reduced to a minimum (for further information see later). If pupils are to handle chips directly, TTL should be preferred to CMOS and especially as noise immunity problems are unlikely to arise in this experimental work.

### LSTTL

These ICs are functionally identical to TTL. The pin connections are the same and, in most cases, direct replacement is possible. With work at school level, the major advantage of LSTTL compared with TTL is that only about  $\frac{1}{5}$  of the power supply current is needed. Otherwise, the comments above on TTL apply to LSTTL.

The CMOS family have been chosen for this course because of the less stringent demands on power supply requirements, and because pupils will not be handling ICs directly. However, some teachers may wish to use TTL/LSTTL, and so, details are provided in this Appendix for the TTL/LSTTL families as well as the CMOS family. Great care has been taken with circuit design to ensure that modules behave in the same way whichever family is used.

## 4 POWER REQUIREMENTS

CMOS circuits are recommended because they operate over a wide supply voltage range (3 V to 18 V) with higher noise immunity and lower power requirements than TTL/LSTTL. A simple dry-battery supply at 6 V can be used, for rarely will the current required exceed 0.2 A.

For TTL/LSTTL ICs, power requirements are more stringent. For reliability, manufacturers recommend a stabilised supply of between 4.75 V and 5.25 V. (Maximum supply voltage is 7.0 V and maximum input voltage is 5.5 V.) Batteries can be used with the circuit shown. In use, the voltage drop across the IN5401 diode produces an output voltage which is just acceptable for TTL/LSTTL operation. The IN5401 is used for reasons given on page 26.

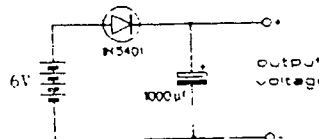

However, it is very convenient to use a fully regulated, mains driven supply. An effective and inexpensive 5 V 1 A supply is shown below. The circuit converts an a.c. or d.c. input in the range 8 V to 12 V to a regulated 5 V supply suitable for CMOS modules as well as TTL/LSTTL modules. Using low voltage transformers, this circuit represents a very cheap way of obtaining a mains operated supply. Note that a bridge rectifier, rated at 3 A, should be used for the reasons given on page 26.

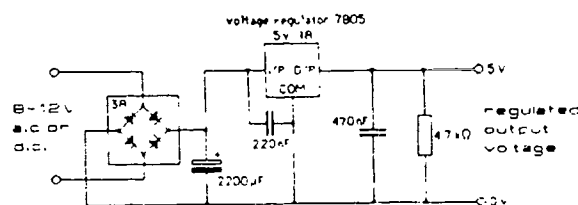

## 5 PULL-UP AND PULL-DOWN RESISTORS

### TTL/LSTTL

The high output voltage level for a TTL/LSTTL logic gate is usually about 3.4 V. If the full supply voltage is required a 2.2k $\Omega$  resistor can be connected between the output and the positive power supply rail. The measured output voltage will be near 5 V in this case. The resistor is called a pull-up resistor. When connecting TTL/LSTTL ICs to each other, pull-up resistors are not required for a voltage input in excess of 2.7 V is recognised as a high voltage. They are useful, however, when interfacing TTL to other families or to non-TTL devices.

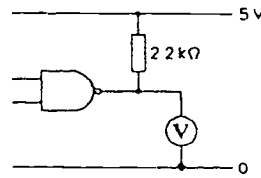

Unconnected inputs float high and for work in this course, this is permissible. In the TTL/LSTTL module designs which follow, nearly all inputs are left floating so simplifying construction. In the case of a more permanent electronic circuit, an unused input should be connected to the positive rail to increase noise immunity.

If the input of a TTL gate is to be normally low, but to go high when a switch is closed, a pull-down resistor must be used to keep the input normally low, for otherwise switch closure would short-circuit the battery. For TTL gates, the pull-down resistor must be less than about 500 $\Omega$  (see reference 1, Appendix A). Thus, when using an LDR to switch a gate, switching only occurs when the LDR is well enough illuminated for its resistance to have fallen below 500  $\Omega$ . In the dark, the resistance is several hundred thousand ohms and the input floats high. A pull-up resistor is unnecessary, except when 'sensitivity' is to be increased.

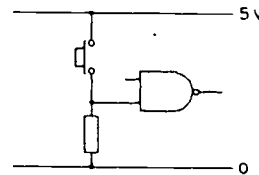

### CMOS

The case of CMOS gates is different because unconnected inputs have an undefined state. Each input acts as a small capacitor. Once the capacitor is charged, the p.d. across it remains constant because the input resistance of the gate is virtually infinite. Thus, the input voltage depends on the past history of the gate and logic states cannot be predicted.

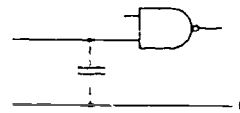

All unused inputs must be connected to one of the supply rails, not only because of the above fact but also to ensure small supply currents (see reference 2, Appendix A).

In the case of inputs which are to be used, it is necessary to ensure that they have a definite logic state when unconnected. This is done by using a pull-up or a pull-down resistor as required (typically 100k $\Omega$ ). Thus CMOS gates can be made to behave like TTL gates by using pull-up resistors to hold unconnected inputs high. In the CMOS module designs which follow this has been done. For example, in the case of

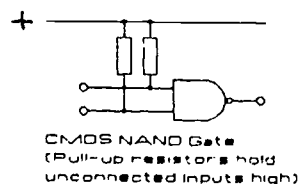

the CMOS NAND gate, the pull-up resistors are part of the CMOS NAND gate module and have not been shown on the circuit diagrams for the pupils' experiments. Diagrams such as that on the right above have been used throughout. The advantage of ensuring that TTL and CMOS modules behave similarly is that the circuit diagrams for the experimental work are then the same for both families.

## 6 THE QUAD NAND GATE MODULE : THE USE OF SCHMITT NANDS

The Quad NAND Gate module is constructed with a quad Schmitt NAND gate IC. The input/output voltage characteristic of an ordinary CMOS NAND gate and a Schmitt NAND gate are shown. The latter exhibits hysteresis, switching from high to low when the input voltage reaches  $V_1$ , but not going back to high until the input voltage falls to  $V_2$ . The output logic level of the Schmitt NAND changes very rapidly even if the input voltage changes comparatively slowly. Clocked circuits need rapid changes at the clock input if they are to function reliably, and the Schmitt gates must be used between bistables etc and components such as LDRs which respond relatively slowly and are somewhat noisy. The effect of using a Schmitt circuit with a slowly changing and noisy input is illustrated in the diagram opposite. The logic level of the output of the Schmitt gate changes rapidly and cleanly, despite the rather erratic and slowly varying input voltage. The hysteresis ( $V_1 - V_2$ ) amounts to about 0.5 V using a 5 V supply.

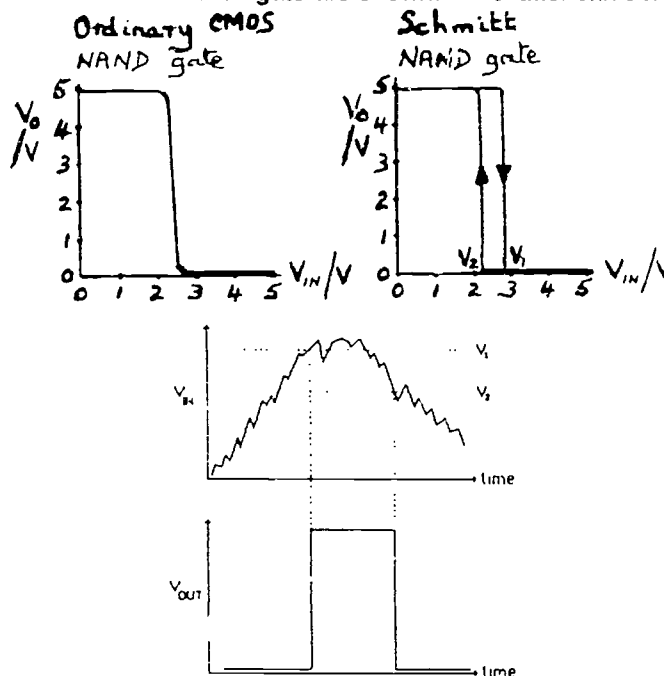

## 7 CIRCUIT DIAGRAMS OF MODULES FOR PART 2

The circuit diagrams on the following pages are drawn for CMOS and for LSTTL ICs. TTL circuits are identical with those for LSTTL, except that the IC type numbers do not include the letter LS. Note that the 7-segment decoder/display for LSTTL ICs uses a common anode display, and has a test socket connected to the negative rail. This is because an active output on the decoder is at a low voltage level.

## QUAD NAND GATE

(a) CMOS version

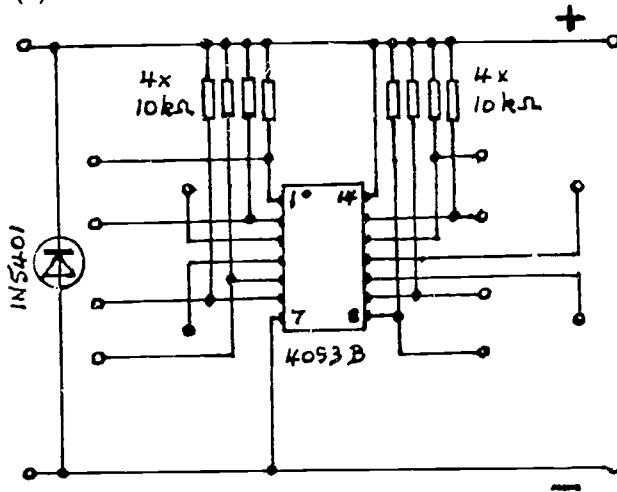

(b) LSTTL version

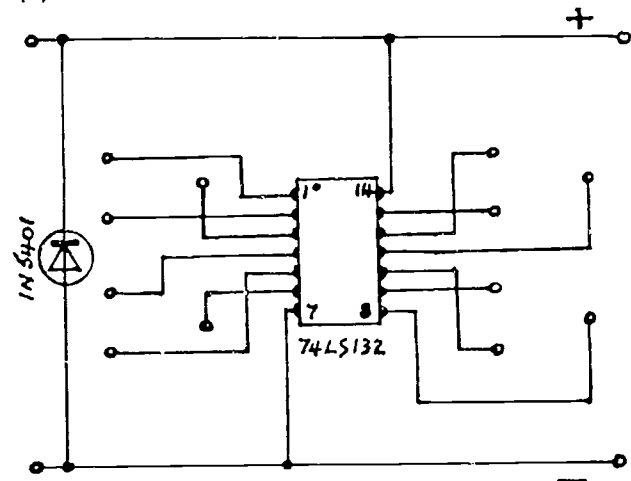

## LED INDICATORS

CMOS and LSTTL versions

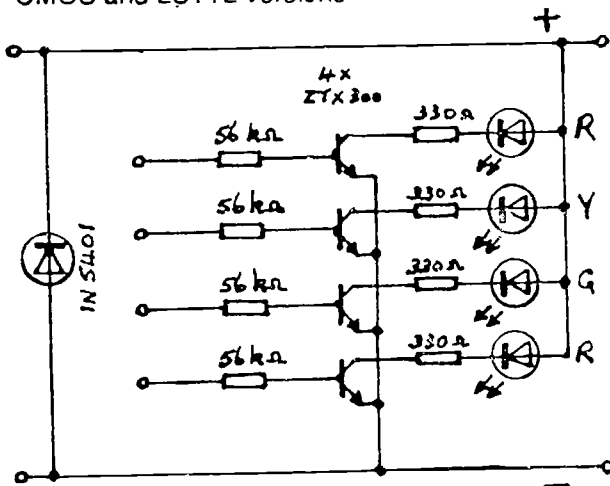

## DRIVER AMPLIFIER

CMOS and LSTTL versions

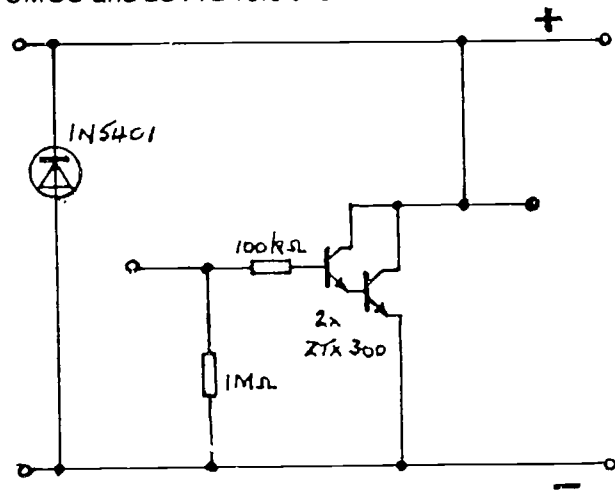

## SEVEN SEGMENT DISPLAY WITH DECODER

(a) CMOS version

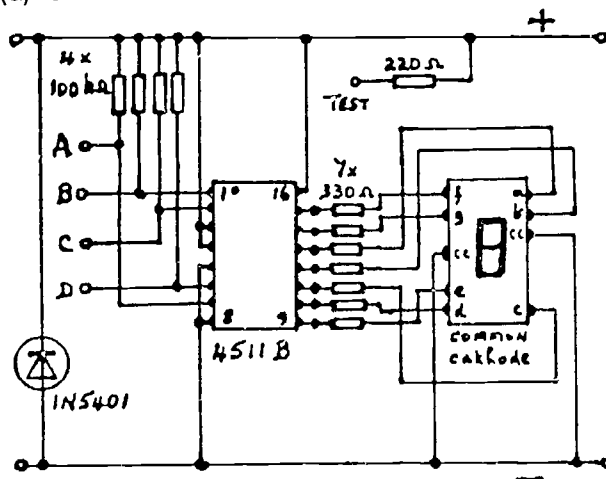

(b) LSTTL version

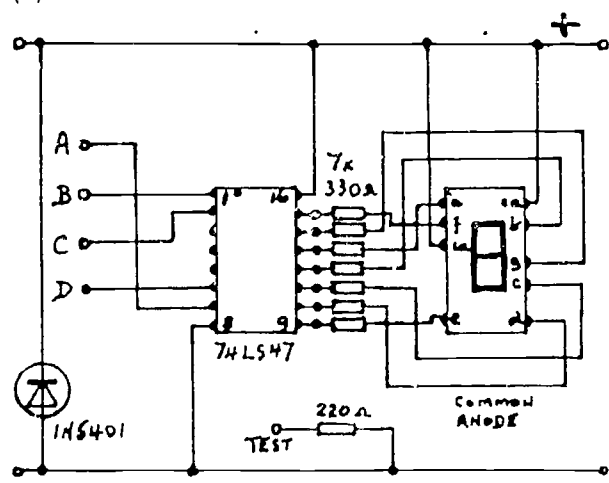

NB Terminal pins are required at each of the decoder outputs.



## CLOCKED BISTABLES

(a) CMOS version

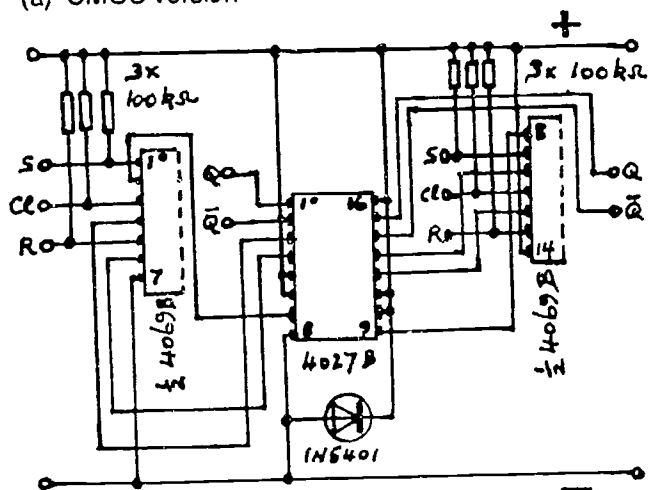

(b) LSTTL version

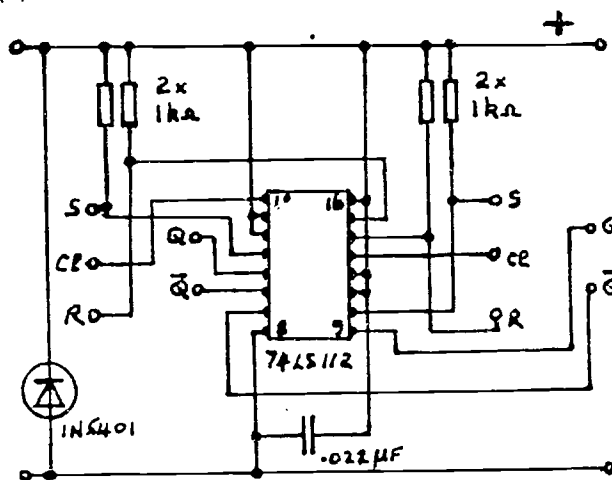

## BINARY COUNTERS

(a) CMOS version

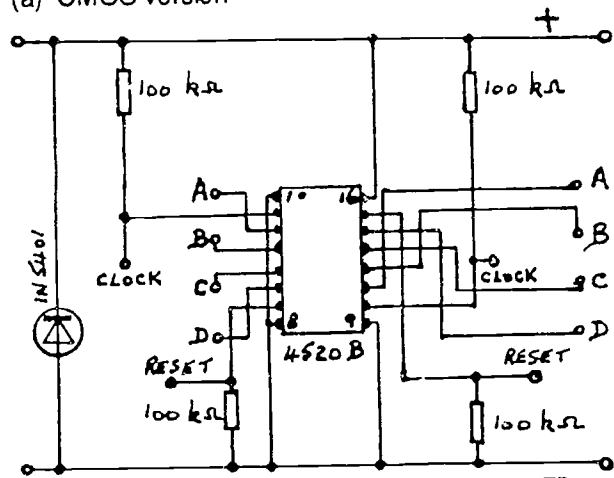

(b) LSTTL version (two on one board)

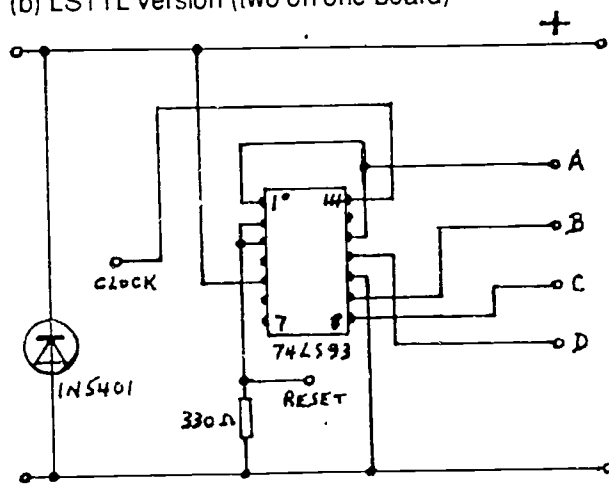

## PULSER and ASTABLE

CMOS and LSTTL versions

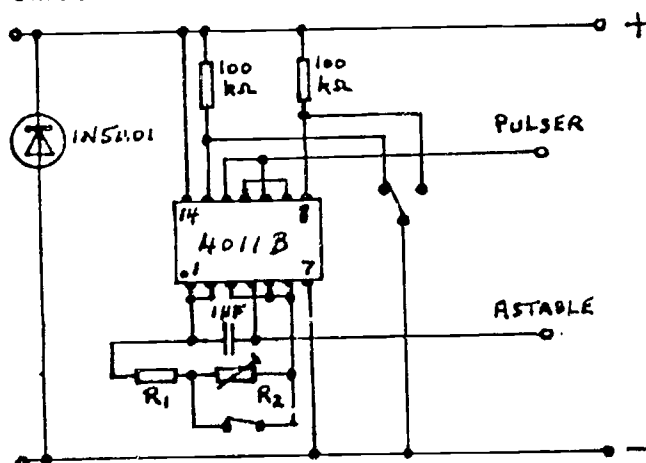

The SPDT press switch is shown in the 'rest' position.

$R_1$  and  $R_2$  should be chosen to give output frequencies of about 1 Hz and 100 Hz. The values are about  $R_1 = 10k\Omega$  and  $R_2 = 1M\Omega$ .  $R_2$  could be a preset.

ELECTRONICS  
WORKSHEETS

This booklet, **Electronics: Worksheets, Parts 1 and 2**, is the experimental work which is being recommended for use by pupils.

The experiments here are presented as circuit diagrams, together with suggestions for investigations and questions to be answered. It is intended that this work should be carried out using the special modules developed for the course.

Further details of all the experimental work and explanations of the electronics involved can be found in the companion booklet **Electronics: Teacher's Guide**.

## PART 1

### THE MODULES

The modules used for the experiments in Part 1 will be similar to those illustrated below. One set is needed for each pair of pupils. The modules work best from a 4-cell battery (6 V) but a 3-cell battery ( $4\frac{1}{2}$  V) may be used also.

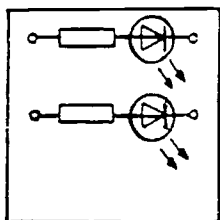

LIGHT EMITTING  
DIODES (RED AND GREEN)

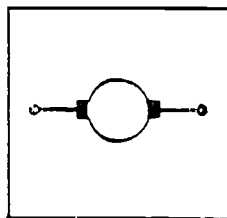

MOTOR

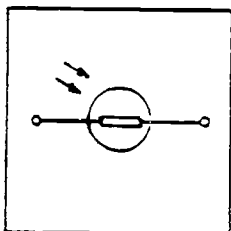

LIGHT DEPENDENT  
RESISTOR

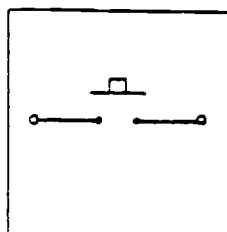

PUSH-BUTTON  
SWITCH (2)

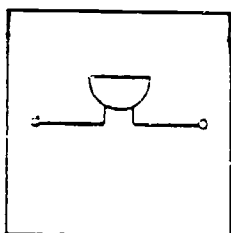

BUZZER

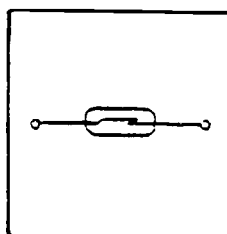

REED SWITCH

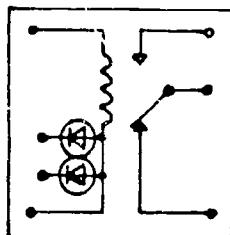

REED RELAY

## SECTION 1. SOME USEFUL ELECTRONIC COMPONENTS

### Experiment 1.1: Resistor and light emitting diode (LED)

Connect up the circuit shown below, using an LED on the LED module and a battery.

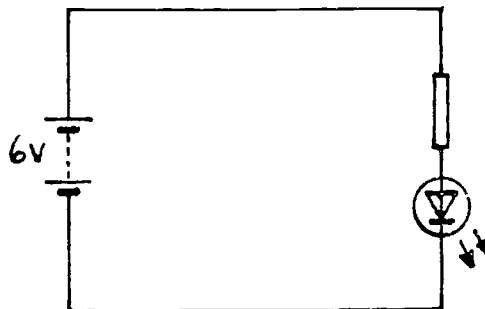

#### Investigations and questions

- 1 What happens to the LED in the above circuit?
- 2 Reverse the connections so that the diode is the other way round. What happens?
- 3 Why do you think this happens?

### Experiment 1.2 (Optional): Brightness and current

Connect up the circuit shown below, using an LED module, a resistor and a battery. Use a low value resistor first.

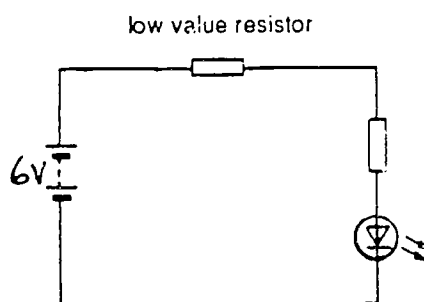

#### Investigations and questions

- 1 Note how brightly the LED glows. Replace the resistor first by one of medium value, then by one of high value. What happens to the brightness of the LED?
- 2 How does the brightness of the LED depend on the current passing through it?

### Experiment 1.3: LEDs in parallel

Set up the circuit shown using one red LED, one green LED and a battery.

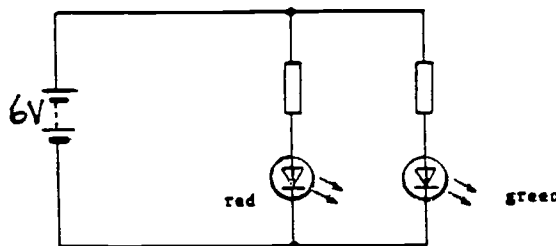

#### Investigations and questions

- 1 Explain why both LEDs glow.
- 2 If a second red or green LED were connected in parallel with the above two, how brightly would you expect it to glow? Borrow an LED module from another group and test your answer.

### Experiment 1.4 Project : A current direction indicator

#### Problem:

Use the LED module to construct a current direction indicator. When a battery is connected one way round to the indicator one of the LEDs should glow. If the battery connections are reversed the other LED should glow.

### Experiment 1.5: Light dependent resistor (LDR)

Set up the circuit below which shows a light dependent resistor in series with an LED and a battery.

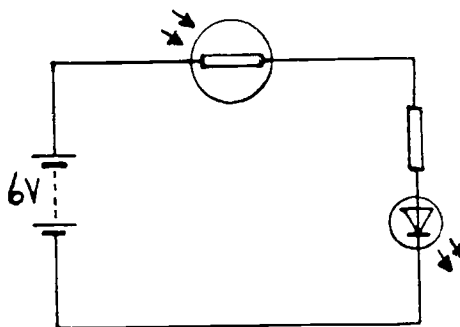

#### Investigations and questions

- 1 What happens to the brightness of the LED when the LDR is covered and uncovered?
- 2 What does this tell you about the resistance of the LDR in the light and in the dark?

### Experiment 1.6 Project : A very simple burglar alarm

#### Problem:

Use an LDR module, a buzzer module and a battery to construct a circuit which will sound an alarm when a light comes on. If a burglar were foolish enough to turn on the light in a room, such a circuit could be used to warn the householder. Alternatively, the circuit could be used to detect the light from the burglar's torch.

## SECTION 2. SWITCHES

### Experiment 2.1: Manual control of an LED

Connect a battery, an LED and a push-button switch together in a series circuit. Test whether you have done it correctly by pressing the switch and then releasing it. The LED should light only when the switch is pressed.

- 1 Draw a circuit diagram for this experiment.
- 2 Explain how the push-button switch works.

### Experiment 2.2: Reed switch and magnet

Take the reed switch module and examine the two metal contacts inside the glass envelope with a magnifying glass. These contacts are normally open. Now connect the switch in series with a buzzer and a battery.

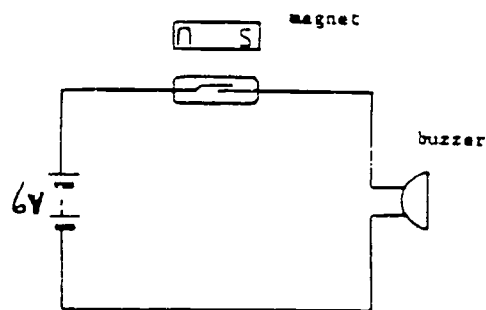

#### Investigations and questions

- 1 Bring a small bar magnet close to the reed switch in the manner shown above. What happens?
- 2 What must have happened inside the glass envelope? Use your magnifying glass to see if you are right.

### Experiment 2.3: Reed switch and coil - the reed relay

Using the reed relay module, set up the circuit shown below. Note that two separate battery supplies are required. Do NOT use either of the diode connections to the coil of the relay.

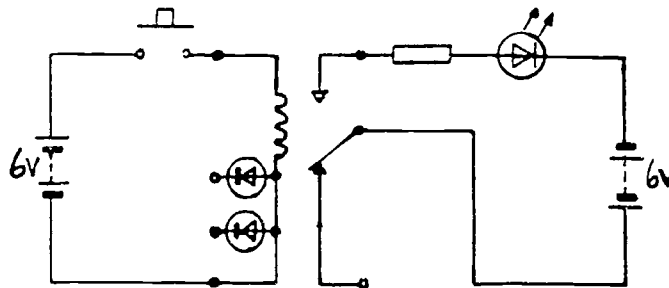

#### Investigations and questions

- 1 What happens to the LED when the switch is closed?
- 2 Try to explain why this happens.
- 3 Now change the switch connections at the relay so that the LED is on until the push-button switch is pressed.

**Experiment 2.4:** The reed relay used to control a motor

Use the LDR module, the reed relay, the motor module and two batteries to set up the circuit below.

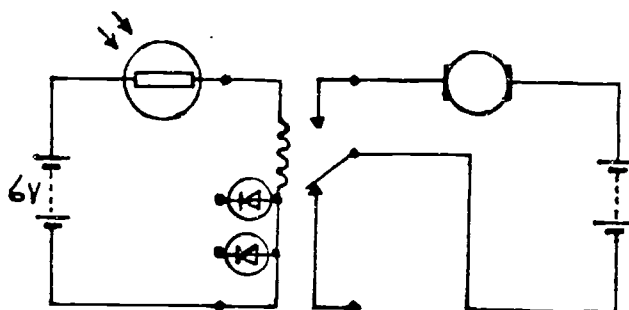

**Investigations and questions**

- 1 What happens when the LDR is covered and uncovered? (You may have to shine a torch on the LDR when you have uncovered it.)
- 2 If possible, use ammeters to measure the current flowing from each of the batteries in the circuit when the motor is running.
- 3 Now connect the LDR module, the motor module and one battery as shown below. What happens this time when the LDR is covered and uncovered?

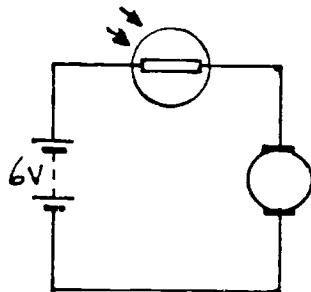

- 4 Try to explain why it was necessary to use the reed relay in the first circuit.

**Experiment 2.5:** The reed relay with coil and contacts in parallel (using a single power supply)

Connect up the circuit shown below.

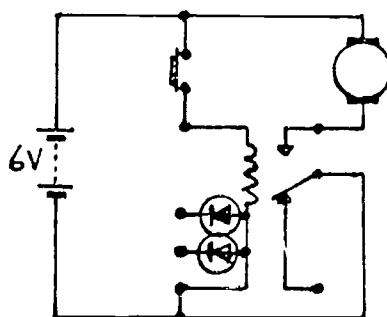

**Investigations and questions**

- 1 What happens to the motor when the switch is closed?
- 2 In this circuit the relay coil and the relay contacts are connected in parallel. Copy the diagram and mark on it the current paths from the battery, through each branch of the circuit and back to the battery again.



Experiment 2.6 Project : Automatic washing line

Problem: Use two batteries, the reed relay module, the electric motor module and the rain sensor to make a circuit which switches on an electric motor when rain falls. Such a circuit could be used as the basis for an automatic washing line.

Experiment 2.7 Project : Reversing an electric motor

Problem: You are to use a push-button switch, the reed relay and three batteries to make a circuit so that the direction of rotation of the motor is reversed when the switch is pressed.

First draw a diagram of your circuit and show it to your teacher. If your teacher agrees, connect up the circuit and try it.

## SECTION 3. LOGIC CIRCUITS

### Experiment 3.1: Simple AND circuit

Connect two push-button switch modules in series with an LED and a battery as shown in the diagram below.

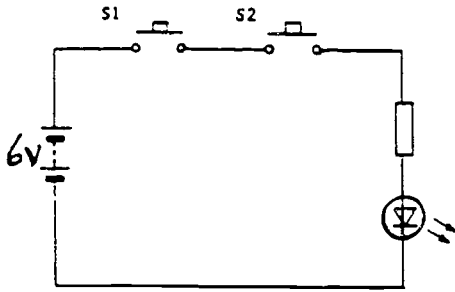

S1	S2	LED
Not pressed	Not pressed	
Pressed	Not pressed	
Not pressed	Pressed	
Pressed	Pressed	

#### Investigations and questions

- 1 Use the circuit to help you complete the table shown above.
- 2 Why is the circuit called an AND circuit?
- 3 Suggest a use for a circuit such as this.

### Experiment 3.2: Simple OR circuit

Using the same modules, connect up the circuit shown below.

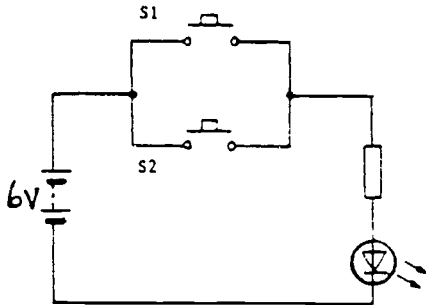

S1	S2	LED
Not pressed	Not pressed	
Pressed	Not pressed	
Not pressed	Pressed	
Pressed	Pressed	

#### Investigations and questions

- 1 Use the circuit to help you complete the table shown above.
- 2 Why is the circuit called an OR circuit?
- 3 Suggest a use for such a circuit.

### Experiment 3.3: Relay as a NAND circuit

Using the reed relay module, an LED and a battery, set up the circuit below. Take great care in connecting up the relay. Note that the polarity of the battery must be as in the diagram.

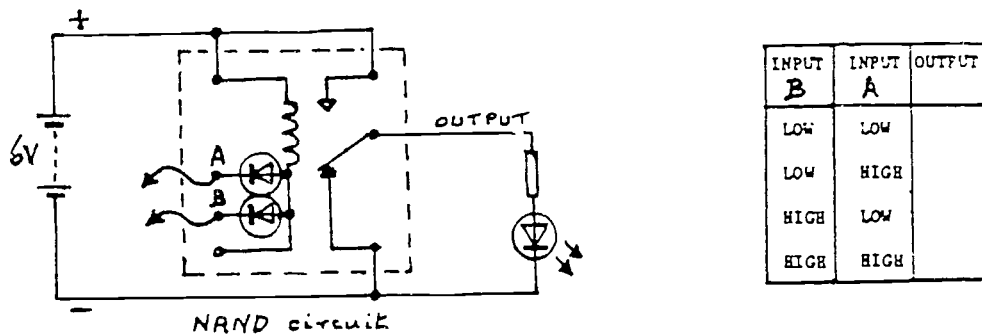

Connect leads to the diode input terminals of the relay module, A and B.

When the other end of one of these leads is connected to the positive supply rail we say that the particular input is HIGH. If the lead is connected to the negative supply rail, the input is said to be LOW. The output is HIGH if the LED is on and LOW if the LED is off.

#### Investigations and questions

- 1 By connecting the inputs high and low, complete the table for the NAND circuit.
- 2 Try to explain why the output is high when one or both of the inputs is low. (HINT: consider whether the input has to be high or low for a current to flow through the relay coil.)
- 3 Why do you think a diode is used at each of the two reed relay inputs? (HINT: consider what would happen if input A were high and input B were low in the absence of diodes.)

### Experiment 3.4: A simple burglar alarm

Connect up the circuit shown. Take care to make the supply rails the correct polarity.

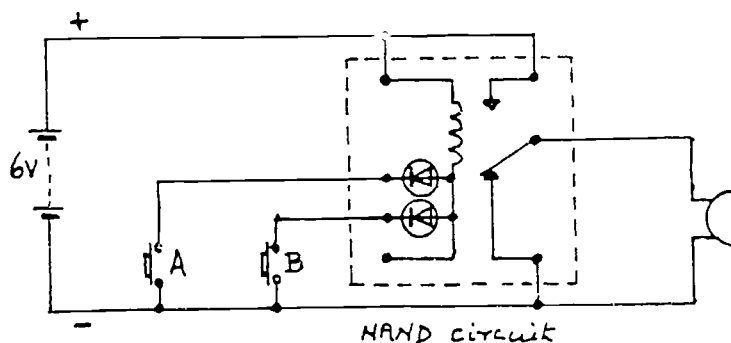

#### Investigations and questions

- 1 What happens when switch A or switch B is pressed (or both are pressed together)?
- 2 Explain why this happens.
- 3 How would you modify this circuit so that the alarm sounded either when a switch was closed or when a light was shone on a LDR?

### Experiment 3.5: NAND circuit as an inverter

Connect an LED to the output of the NAND circuit. Also connect a flying lead to one of the inputs of the NAND circuit.

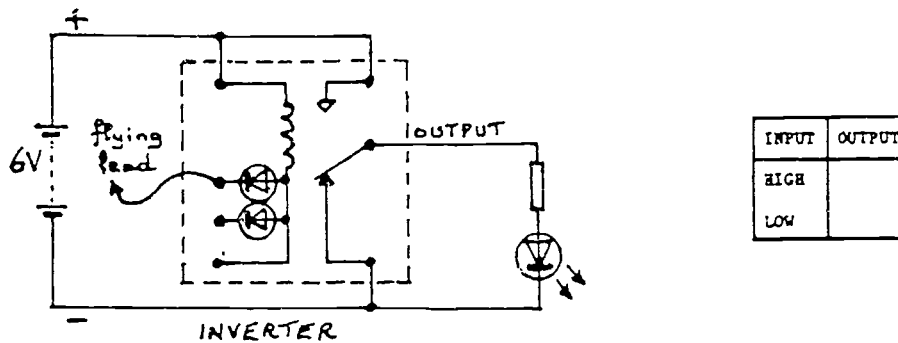

#### Investigations and questions

- 1 Use the flying lead to take the input high or low, and then complete the table above.
- 2 In terms of the currents flowing through the coil and the LED, explain the completed truth table.

### Experiment 3.6 Group experiment: Making an AND circuit

Using two NAND circuits (one as an inverter), an LED and a battery, set up the circuit shown below. Connect a flying lead to each input terminal of the first NAND circuit.

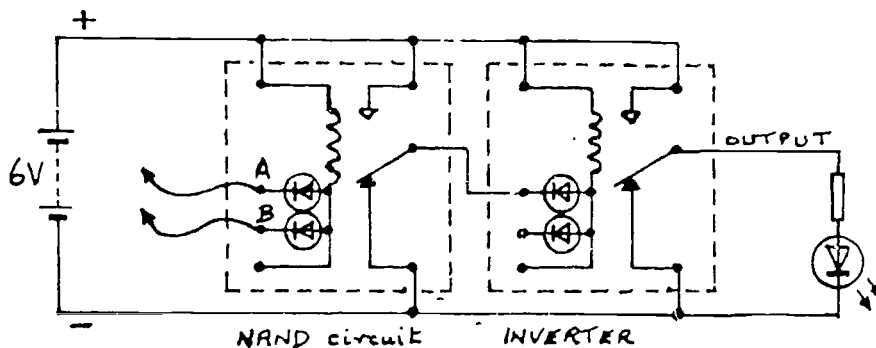

#### Investigations and questions

- 1 By connecting the inputs high and low, complete the table. Does it behave as an AND circuit?
- 2 Compare the table for this circuit with the table for the circuit in Experiment 3.3 (the NAND circuit). What has the inverter done?
- 3 Remove the flying lead from input B and connect a push-button switch between input B and the negative supply rail. Connect the flying lead from input A to the positive supply rail (i.e. high), and then operate the switch several times. Now connect the flying lead from input A to the negative supply rail (i.e. low), and operate the switch. Can you see why the circuit is sometimes called a gate?

INPUT B	INPUT A	OUTPUT
low	low	
low	high	
high	low	
high	high	

**Experiment 3.7** Group Experiment (Optional): Detection of an object of a length greater than a specified maximum

Use two NAND circuits (one connected as an inverter), two LDR modules and a buzzer to connect up the circuit below. Each LDR should be illuminated with a light beam. (Such a circuit might be useful to reject overlong objects passing along a conveyor belt in a factory.)

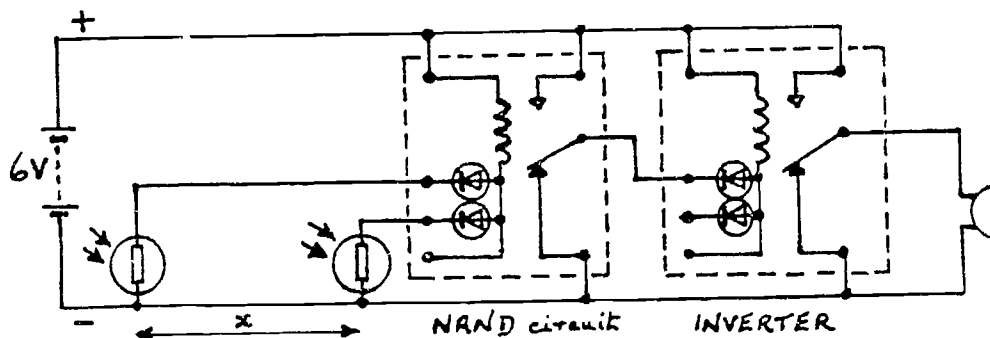

**Investigations and questions**

- 1 What happens when you shade one or both of the LDRs?
- 2 The buzzer sounds only when both the LDRs are shaded. Try to explain why.
- 3 If objects of greater length than  $x$ , the distance between the LDRs, pass in front of them, the buzzer sounds. Where might this circuit be useful?
- 4 How would the circuit behave if the inverter were left out and the buzzer connected to the output of the NAND circuit?

## PART 2

### THE MODULES

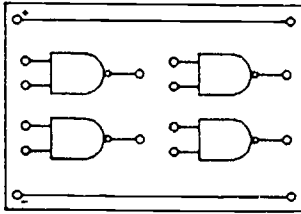

QUAD NAND GATE

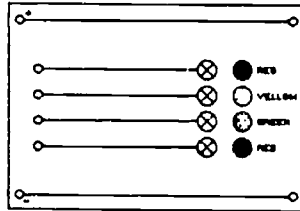

LED INDICATORS

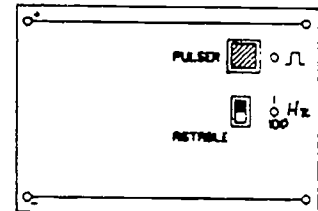

PULSER AND ASTABLE

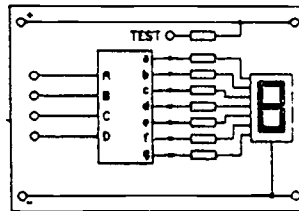

SEVEN SEGMENT DISPLAY  
WITH DECODER

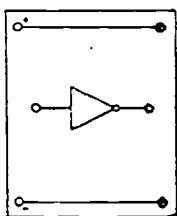

DRIVER AMPLIFIER

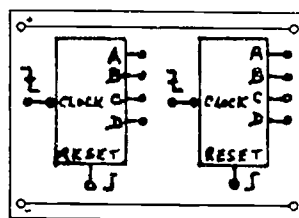

BINARY COUNTERS

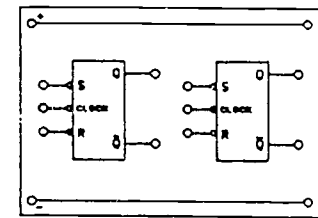

CLOCKED BISTABLES

## SECTION 4. ELECTRONIC LOGIC CIRCUITS - LOGIC GATES

### Experiment 4.1: The LED indicators

Set up the circuit shown below using the LED Indicators module and a suitable power supply. Take care to connect the power supply correctly.

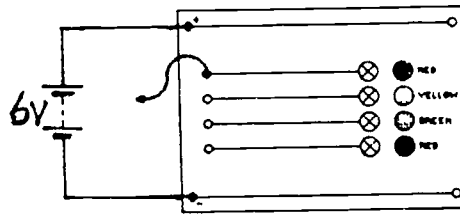

Now plug a lead into the top input socket of the Indicator module. The other end of this lead may be connected to the **positive** power supply rail or to the **negative** power supply rail. Such a lead is called a **flying lead**. If connected to the **positive** rail, the input is said to be **high**. If connected to the **negative** rail, it is said to be **low**.

#### Investigations and questions

- 1 Find out how the top LED behaves when its input is connected first high and then low.
- 2 Do the other LEDs behave in the same way?

#### Circuit diagrams

In the circuit diagram, an indicator is represented by the symbol below.



Using this symbol saves having to draw the LED and its associated circuitry every time we need to have an indicator in the circuit. That simplifies the diagram. Indeed, it will be necessary to simplify circuit diagrams even more, for they become difficult to understand and very tedious to draw when several modules are being used. To simplify further, the power supply will not be drawn and only the parts of a module actually in use will be shown. The diagram at the top of the page then simplifies to that below. Note that the + and - signs near the power rails show that a power supply is connected between them even though it has not been drawn.

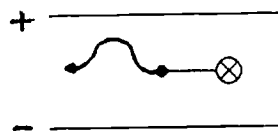

## Experiment 4.2: The NAND gate

### 4.2 (a) Truth table

Set up the circuit shown below using one of the four NAND gates on the Quad NAND Gate module, and one of the LED indicators.

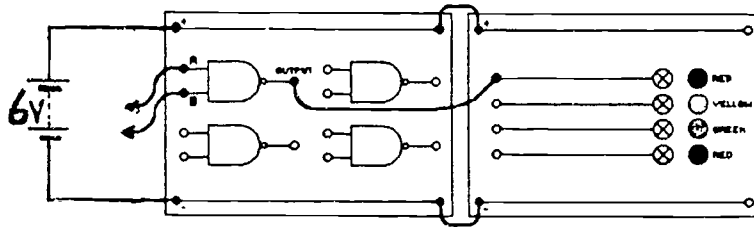

Make sure that the modules have their power supply rails linked correctly.

Each of the inputs A and B can be connected to the positive power supply rail (high) or to the negative power supply rail (low) using a flying lead. The output is high if the LED is lit and low if the LED is not lit.

#### Investigations and questions

- 1 By connecting the inputs high and low, complete the truth table for a NAND gate.
- 2 Does an unconnected input behave as if it is high or low?
- 3 Draw a simplified circuit diagram of the above circuit.

B	A	OUTPUT
LOW	LOW	
LOW	HIGH	
HIGH	LOW	
HIGH	HIGH	

### 4.2 (b) NAND gate as an inverter (NOT circuit)

Connect the two inputs of a NAND gate together as shown in the diagram below.

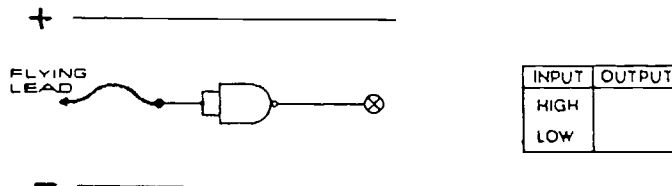

Note that the two joined inputs can now be thought of as a single input. This single input can be taken high or low using the flying lead.

#### Investigations and questions

- 1 By taking the input high and then low, complete the truth table for the inverter (also known as a NOT circuit).
- 2 Instead of joining the two inputs of the NAND gate, connect one of them permanently high (or simply leave it unconnected), and connect the flying lead to the other input. How does the circuit now behave if the input is taken high and low? What happens if one input is tied permanently low?



#### 4.2 (c) AND, OR and NOR gates from NAND gates

Connect the circuit shown below using two gates from the Quad NAND Gate module. Note that the second NAND gate is connected as an inverter (NOT circuit).

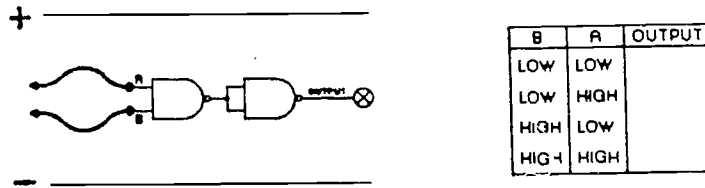

#### Investigations and questions

- 1 The above circuit should behave as an AND gate. Check this by taking the inputs high and low, and completing the truth table.
- 2 Draw and complete the truth table for an OR gate. Compare this with the truth table for a NAND gate. (You should notice that if every high input to the NAND gate became a low, and every low input a high, it would give the OR gate you want. How can you change the inputs to the NAND gate? Clue: you have just learnt about inverters.) Now design an OR gate using three NAND gates. Build the circuit and check that it produces the correct truth table.
- 3 Draw and complete the truth table for a NOR gate. Use the remaining NAND gate on the module to convert your OR gate to a NOR gate. Check that your circuit produces the correct truth table.

### Experiment 4.3: Applications using NAND gates

#### Project 4.3 (a): Burglar alarm (NAND application)

Use a single NAND gate, an LDR, a push-button switch and a buzzer to make a simple burglar alarm. The alarm should sound when the LDR is illuminated (the burglar's torch) or the switch is closed (the burglar's foot).

#### Project 4.3 (b): Length detector (AND application)

Use two NAND gates (one connected as an inverter) together with two LDRs and a buzzer to construct a system which will sound an alarm when an object is longer than a specified maximum length. Such a circuit might be used to reject overlong objects passing along a conveyor belt in a factory.

#### Project 4.3 (c): Automatic night light

Use two NAND gates (both connected as inverters), an LDR and an LED indicator to make a circuit in which a light (the LED) will come on automatically in the dark. A circuit of this kind would be useful to light up the display in a shop window automatically when darkness falls.

#### Project 4.3 (d): Fire alarm

Use a NAND gate connected as an inverter, a thermistor, a variable resistor and a buzzer to make a simple fire alarm. The alarm should sound when the thermistor is heated. How would you adjust the circuit so that the alarm sounded when the temperature reached a higher value?

#### Project 4.3 (e): Safety circuit for a safe

A safety circuit for a large safe sounds an alarm only if the door is closed but not locked. Closing the door opens a switch, whilst locking the door closes another switch. What sort of logic gate is required to do this? Set up the circuit and test it. Now adapt your circuit for a safe which has two locks.

#### Project 4.3 (f): The skittle alley winner-indicator!

In a fairground skittle alley, customers try to bowl over three skittles. Each skittle stands on a small switch which it keeps closed until it is bowled over. Design a circuit which lights a lamp only when a customer is successful.

#### Project 4.3 (g): Car doors warning light

Design a circuit which will cause a warning lamp on the dashboard of a two-door car to light if either of the doors is not closed. Closing a door closes a switch.

### Project 4.3 (h): Circuit Investigation

This is a circuit to investigate rather than a problem to solve. In the truth table '0' stands for 'low', and '1' stands for 'high'.

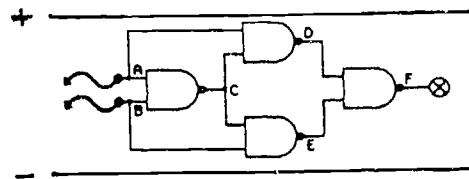

B	A	C	D	E	F
0	0				
0	1				
1	0				
1	1				

#### Investigations and questions

- 1 Copy the truth table and complete it to show the voltage level at each of the lettered points for each of the level combinations at A and B.
- 2 Set up the circuit and check your predictions for the output F. If you have made an error, use a flying lead from another LED indicator to check your predictions for the level at each of the points C, D and E. Do this by touching the free end of the flying lead on to each of those points in turn.
- 3 Suggest a use for this circuit.

## SECTION 5. THE BISTABLE CIRCUIT

### Experiment 5.1: Making a bistable using two NAND gates

Set up the circuit shown below using two gates from the Quad NAND Gate module.

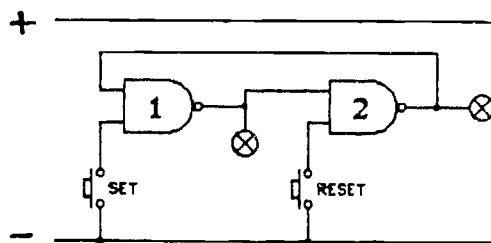

#### Investigations and questions

- 1 First of all press and release the switch marked RESET. Which LED is on and which one off?
- 2 Now press and release the switch marked SET. What happens?
- 3 Press and release the SET switch several more times. What happens?
- 4 Now press and release RESET. What happens?

#### More about circuit diagrams

Notice that the LED indicator connected to the output of NAND gate 1 is not drawn beneath the LED indicator of gate 2, even though that is where it is placed on the indicator module. Circuit diagrams are easier to understand if the parts are drawn in convenient places rather than as they are placed on the modules.

Notice too that the positive power rail is drawn in the above diagram even though no leads are shown connected to it. Often such a power rail is not drawn in the circuit diagrams. However, in this course we will draw both power rails to remind you that a power supply is needed to make the circuits work.

## Experiment 5.2: Bistable applications using NAND gates

### Project 5.2 (a): Latched burglar alarm

Use two NAND gates, two push-button switches and a buzzer to make a latched burglar alarm. One switch should correspond to the "trip" switch. If this is closed (perhaps by the burglar's foot) the alarm should sound and stay on even when the switch is released or pressed again. The second switch should correspond to the "reset" switch, and would be hidden away in a place known only to the householder. Only when this switch is pressed should the alarm be silenced.

Once you have built this circuit, convert it to an alarm which will come on and stay on when a light (the burglar's torch) shines on an LDR.

### Project 5.2 (b): Latched fire alarm using a bistable

Build a fire alarm which, once triggered, will continue to sound until it is reset.

### Project 5.2 (c): Simple stop-go traffic lights

Traffic in a one-way street has to cross a bridge which can only have one car on it at a time. The bridge is to be controlled by a set of stop-go lights, activated by switches in the road, so that the lights go red when a car enters the bridge and then green as the car leaves it. Design a circuit to do this job.

### Project 5.2 (d): Traffic lights operated by an SPST switch

A simple set of stop-go traffic lights is to be operated by an SPST switch so that either the red light is on or the green light is on, but not both together. Design a circuit, using a bistable, which will do this.

### Project 5.2 (e): Quiz master

A quiz master circuit is used to identify the first contestant to push his or her answer button in a quiz game. Each contestant has a push-button and an indicator light (in this case, an LED). The light of the first person to answer should come on and stay on. At the same time all other lights should be prevented from coming on.

To make such a quiz master is not easy, and you may need help from your teacher. Each contestant in the game will need four NAND gates (two connected as a bistable), a push-button switch and an LED indicator. The best approach is to wire up the four gates for one contestant, and then wire up the four gates for another contestant separately. Finally connect the two sets together and see if your quiz master works!

## SECTION 6. DRIVERS

### Experiment 6.1: Loading an output

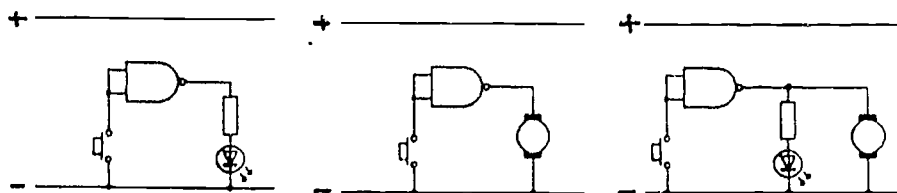

#### Investigations and questions

- 1 Set up the first circuit shown above. What happens when the push-button is pressed?
- 2 When the switch is closed, is the output of the NAND gate high or low?
- 3 Replace the LED with an electric motor module as shown in the second circuit above. What happens when the push-button is pressed?
- 4 To investigate why the motor did not operate in (3), connect an LED in parallel with the motor as shown in the third circuit above. When the push-button is pressed, is the output of the NAND gate still high as in (1), or is it now low?

### Experiment 6.2: Using a NAND gate to switch an electric motor on or off

Connect the circuit shown below using the Driver Amplifier module and the reed relay.

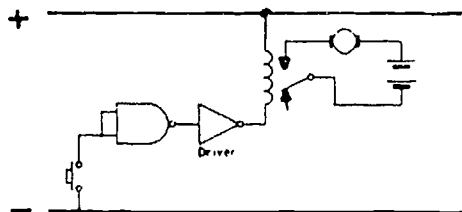

#### Investigations and questions

- 1 What happens when the switch is pressed?
- 2 When the switch is pressed, will the output of the NAND gate be high or low?
- 3 The driver amplifier is a special kind of inverter. When the switch is pressed, will its output be high or low?
- 4 The relay is connected between the positive supply line and the output of the driver. The motor operates when a current flows through the relay coil. When this happens is the output of the driver high or low?
- 5 Replace the switch by an LDR. What happens to the motor when the LDR is covered and uncovered? Can you think of a use for a circuit such as this?

Experiment 6.3: Applications involving the Driver Amplifier module and reed relay

Project 6.3 (a): Reversing an electric motor

Using a push-button switch, a NAND gate, the driver amplifier and reed relay, set up a circuit so that the direction of rotation of a motor is reversed when the switch is pressed. Three batteries will be needed, one for the modules and two for the motor (see Experiment 2.7).

Is the NAND gate really necessary?

Project 6.3 (b): Reversing an electric motor with a bistable circuit

Using two push-button switches, two NAND gates, the driver amplifier and reed relay, set up a circuit which reverses the direction of rotation of a motor when one of the switches is pressed and released. Three batteries will be needed, one for the modules and two for the motor (see Experiment 2.7). Explain how your circuit works.

Project 6.3 (c): An automatic light

Use a driver amplifier, a reed relay, an LDR and any necessary gates, to make a circuit in which a filament lamp will come on automatically in the dark.

Project 6.3 (d): Motor vehicle moving backwards and forwards between two light beams

Use the circuit of Project 6.3 (b) together with two inverters and two LDRs to make the motor reverse every time a light beam is interrupted.

## SECTION 7. CODING

### Experiment 7.1: Sending messages using a 4-bit binary code

Connect a flying lead to each of the four inputs of the LED Indicator module.

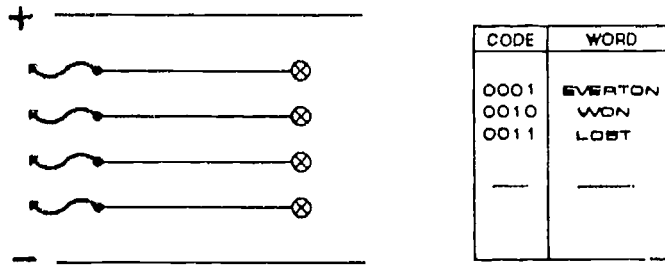

The LEDs are turned on or off by taking the flying leads at the inputs high or low. When an input is high and the corresponding LED is on, we will let it represent the binary digit 1. When an input is low and the corresponding LED is off, we will let it represent the binary digit 0.

Note that the term binary digit is usually shortened to bit. The four LEDs can therefore represent a 4-bit binary pattern.

#### Investigations and questions

- 1 Together with your partner, invent a 4-bit binary code for sending messages. Write your code in a table like that shown above on the right. A few words have been added to start you off, but you can replace them by your own if you prefer.
- 2 How many words can you represent with a 4-bit pattern?
- 3 Give a copy of your code to another group, and then send them a message using the LED indicators. Send the message, word by word, by lighting the agreed 4-bit binary pattern for each word.
- 4 Apart from a copy of your code, what other information did you have to give the other group before they were able to decode your message?



### Experiment 7.2: Investigating a seven segment LED display

You should use the seven segment LED display on the Seven Segment Decoder/Display module for this experiment. The module also includes a decoder integrated circuit, but it is not part of this experiment and can be ignored until Experiment 7.3.

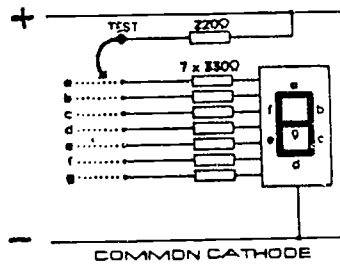

The display has seven segments labelled a to g in the diagram. A single segment behaves like an ordinary LED, and lights up when current flows from positive (anode) to negative (cathode).



Inside this common cathode display, all the cathodes are connected together and to a single lead (the common cathode lead), which is connected to the negative supply line.

#### Investigations and questions

- 1 Connect a flying lead to the point marked TEST and touch the other end on to the pins marked a to g, one at a time. What happens?
- 2 Copy the tables below and complete them to show how you would display the digits 0 to 9.

number	segments which are lit
0	
1	
2	
3	
4	

number	segments which are lit
5	
6	
7	
8	
9	

### Experiment 7.3: Using a seven segment display with a decoder

In this experiment you will again use the Seven Segment Display module. However, this time the four decoder inputs will be used to light the display.

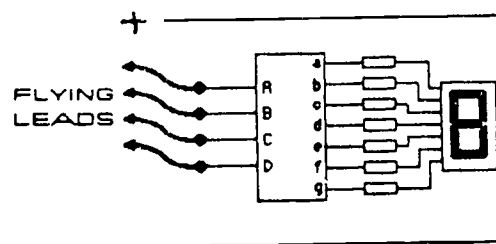

Flying leads are used to take the decoder inputs (A, B, C and D) high or low. In this and future experiments we will let a high input represent the binary digit 1, and a low input the binary digit 0.

#### Investigations and questions

- 1 Use the flying leads to help you complete the table below.

D	C	B	A	digit displayed
0	0	0	0	
0	0	0	1	
0	0	1	0	
0	0	1	1	
0	1	0	0	
0	1	0	1	
0	1	1	0	
0	1	1	1	

D	C	B	A	digit displayed
1	0	0	0	
1	0	0	1	
1	0	1	0	
1	0	1	1	
1	1	0	0	
1	1	0	1	
1	1	1	0	
1	1	1	1	

- 2 When the digit 1 is displayed, segments b and c of the display are lit. Which outputs of the decoder must then be low, and which ones high?

### Experiment 7.4: A 2-line to 4-line decoder from NAND gates

To begin with, consider the pattern of gates shown below.

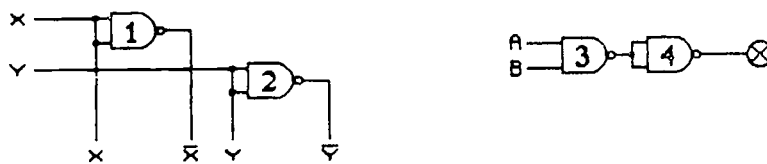

On the left are two inputs labelled X and Y which are inverted by NAND gates 1 and 2 to produce  $\bar{X}$  and  $\bar{Y}$ . On the right is an AND gate, formed from NAND gates 3 and 4, with two inputs A and B.

#### Investigations and questions

- 1 If  $X = 0$  and  $Y = 0$ , how would you connect A and B in order to light the LED? How would you connect A and B to light the LED if  $X = 0$  and  $Y = 1$ ? How would you do it if  $X = 1$  and  $Y = 0$ ? And if  $X = 1$  and  $Y = 1$ ?  
Build the circuits and check your predictions.
- 2 Use your results from above to draw a circuit diagram of a 2-line to 4-line decoder. If the NAND gates are available, build the decoder.
- 3 NAND gates with 3 inputs are also available in integrated circuit form (the output is low only when all 3 inputs are high). Try to draw a circuit diagram showing how a 3-line to 8-line decoder could be built from 2-input and 3-input NAND gates.
- 4 A 3-line to 8-line decoder can be built using 2-input NAND gates only. How many of these gates would be required? Explain your reasoning.

## SECTION 8. THE PULSER, THE ASTABLE AND THE CLOCKED BISTABLE

Experiment 8.1: Observing the voltage outputs from the Pulser/Astable module

In this experiment you will use the Pulser/Astable module shown below.

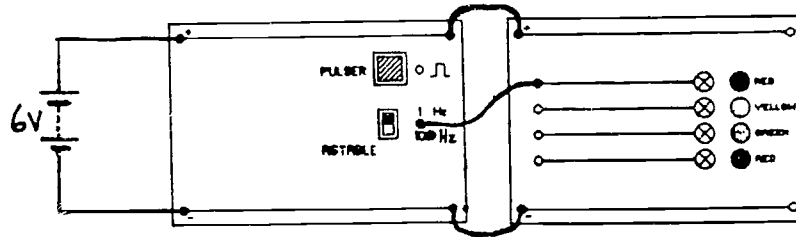

This module has two independent sections. The first is known as a pulser, and has one output socket and a switch. Below this is an astable section also with one output socket and a switch. The two circuits for the pulser and astable sections are completely separate.

Connect the lower astable output to an LED indicator in the way shown in the diagram and move the switch alongside the output socket to the 1 Hz position. Make sure that the module is connected to its power supply.

### Investigations and questions

- 1 Observe the LED and describe what the astable output is doing. Check by connecting a voltmeter between the output and the negative rail. Sketch the output waveform.
- 2 Move the astable switch to the 100 Hz position. What do you observe now? What do you think is happening? If possible, check your prediction by using an oscilloscope. Can you measure the output frequency?
- 3 Now transfer the LED lead to the pulser output socket from the astable output socket. Operate the switch and see what happens.

## Experiment 8.2: Investigating a clocked bistable

In this experiment you will use the Pulser/Astable module to help you investigate the behaviour of one of the bistables on the Clocked Bistables module. The set-up is shown below.

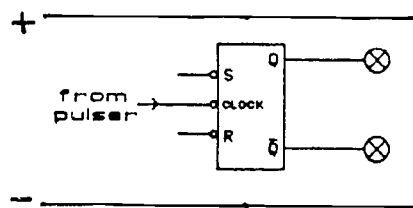

The SET and RESET inputs behave in the same way as with an ordinary bistable.

If the SET input (S) is taken briefly low, the bistable enters the state with  $Q = 1$  and  $\bar{Q} = 0$  (the SET state, in which Q has been set to 1).

When the RESET input (R) is taken briefly low, the state with  $Q = 0$  and  $\bar{Q} = 1$  is entered (the RESET state, in which Q has been reset to 0).

However, the bistable now has a third input - the clock input. In this experiment you will find out what this input does.

### Investigations and questions

- 1 First of all, without the pulser connected, use flying leads to take the SET and RESET inputs low alternately. Check that the bistable behaves in the expected way.
- 2 Now remove the flying leads and leave the SET and RESET inputs unconnected. Apply pulses one at a time to the clock input using the pulser. What happens?
- 3 Does the bistable change state when the pulse is applied ('the rising edge of the clock pulse') or when it is switched off ('the falling edge')?
- 4 Now try clocking the bistable with the 1 Hz output from the astable part of the Pulser/Astable module. What is the frequency of the Q output?

### Experiment 8.3: Constructing 4-bit binary counters from clocked bistables

#### 8.3 (a) Binary up-counter

Connect four clocked bistables together as shown below, and connect an LED indicator to each of the Q outputs.

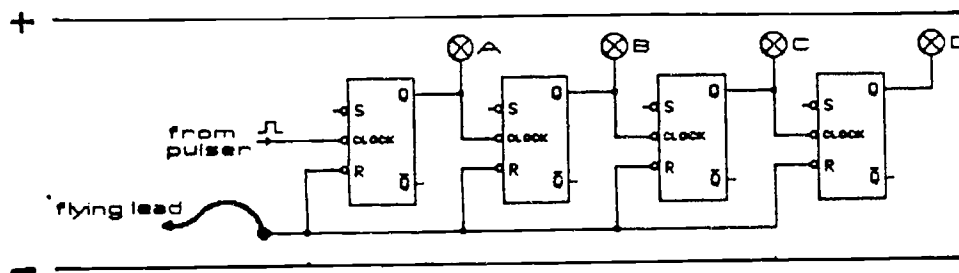

Use the flying lead connected to the RESET inputs to turn all indicators off (all Q outputs low).

#### Investigations and questions

- Apply pulses one at a time to the left hand bistable using the pulser. Complete the following tables, noting that the states of indicators ABCD are entered in the order DCBA in the right hand columns.

Pulse Number	D	C	B	A
0	0	0	0	0
1				
2				
3				
4				
5				
6				
7				

Pulse Number	D	C	B	A
8				
9				
10				
11				
12				
13				
14				
15				

Note that the right hand columns represent the number of pulses as a 4-bit binary number. In other words, the four clocked bistables act as a 4-bit binary counter.

- Replace the pulser by a 1 Hz clock signal from the astable. Watch the system continually counting from 0 to 15 in binary.
- Remove the astable and reset all outputs to zero (all indicators off). Use the pulser to apply 16 pulses one at a time to the left hand bistable. Complete the following.

Number of clock pulses at input	= 16
Number of pulses at output A	=
Number of pulses at output B	=
Number of pulses at output C	=
Number of pulses at output D	=

- If a clock signal of frequency 1 Hz were applied to the left hand clock input, what would you expect the frequency of the pulses produced at the D output to be? Use the 1 Hz output from the astable and a stopwatch to check your prediction.

### 8.3 (b) Binary down-counter (Optional)

Change the above circuit so that the clock inputs are driven by the  $\bar{Q}$  outputs, and all the SET inputs are connected together.

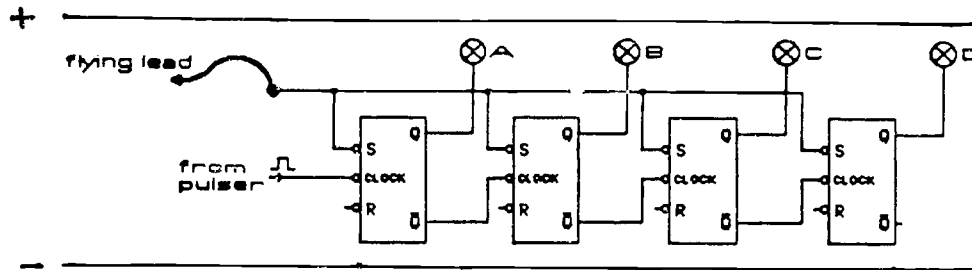

Use the flying lead connected to the SET inputs to turn all indicators on (all Q outputs high).

#### Investigations and questions

Apply pulses one at a time to the left hand bistable. Complete the tables below, again noting that the states of the indicators are entered in the order DCBA in the right hand columns.

Pulse Number	D	C	B	A
0	1	1	1	1
1				
2				
3				
4				
5				
6				
7				

Pulse Number	D	C	B	A
8				
9				
10				
11				
12				
13				
14				
15				

Note that at each pulse, 1 is subtracted from the count represented by the LED indicators. This is called a binary down-counter.

## SECTION 9. COUNTING CIRCUITS

### Experiment 9.1: 4-bit binary counter integrated circuit

#### 9.1 (a) Counting pulses

Connect the pulser to the input of one of the 4-bit counters of the 4-bit Binary Counter module. Monitor each of the four output lines with an LED indicator.

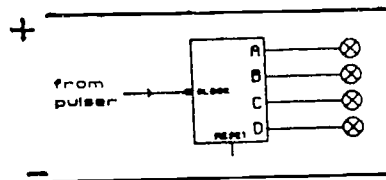

If any of the indicators are lit, use a flying lead to take the RESET input briefly high. Note that the counter can be reset to zero at any time by taking this RESET input high.

#### Investigations and questions

- 1 Apply pulses to the counter one at a time. Does the display change on the rising or falling edge of the clock pulse?
- 2 Sent 16 pulses to the counter and check that the indicators correctly display the number of pulses in binary.
- 3 Now replace the pulser by the 1 Hz output signal from an astable unit. Watch the system repeatedly cycle from 0000 through to 1111 and back to 0000 again.
- 4 With the 1 Hz signal still connected, disconnect indicators A, B and C. What is the frequency of the output signal at D? Is this what you expect? Explain.

#### 9.1 (b) Linking the counter to a decoder and seven segment display

Remove the LED indicators and connect the Seven Segment Decoder/Display module as shown below.

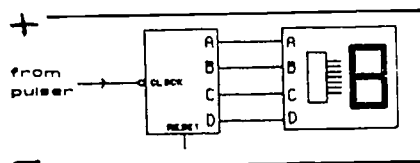

#### Investigations and questions

First reset the counter by taking the RESET input briefly high. Then use the pulser to apply pulses one at a time to the clock input of the counter. Copy down the display after each pulse.

0	1	2	3	4	5	6	7
8	9	10	11	12	13	14	15

## Experiment 9.2: Counters of different moduli

Connect an AND gate (use two NAND gates) between the B and D output lines and the RESET input as shown below.

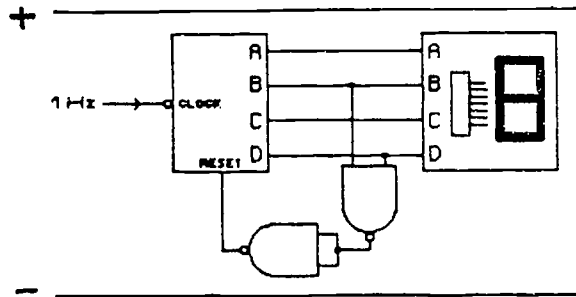

### Investigations and questions

- 1 Apply a 1 Hz signal from the astable unit to the clock input of the counter. Notice that the system now counts from 0 to 9 and then resets itself and starts counting upwards from zero again. Try to explain why this happens
- 2 Now connect the same AND gate so that the counter
  - (a) counts to 2 and resets,
  - (b) counts to 4 and resets,
  - (c) counts to 5 and resets,
  - (d) counts to 8 and resets.In each case draw a diagram showing the way you connected the AND gate.
- 3 How many AND gates do you need to make a counter which
  - (a) counts to 1 and resets,
  - (b) counts to 3 and resets,
  - (c) counts to 6 and resets,
  - (d) counts to 7 and resets?In each case draw a diagram of the connections, and check that the system really does behave in the way you expect.



### Experiment 9.3: Switch contact bounce (Optional)

#### 9.3 (a) Experimental illustration of contact bounce

In the circuit below a flying lead is connected to a clock input of the 4-bit binary counter module.

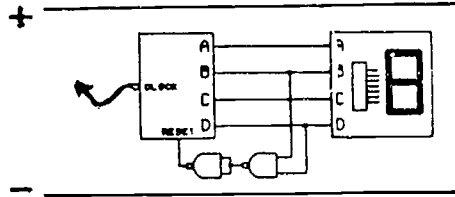

Set up the circuit with the flying lead connected to the negative rail initially.

#### Investigations and questions

Note the number displayed and then pulse the clock input once by touching the flying lead to the positive rail and then the negative rail. Note the new number displayed. Do this several times. Does the count displayed increase in steps of one?

#### 9.3 (b) Using a bistable circuit to eliminate contact bounce

Connect the bistable circuit, made from two NAND gates, as shown below.

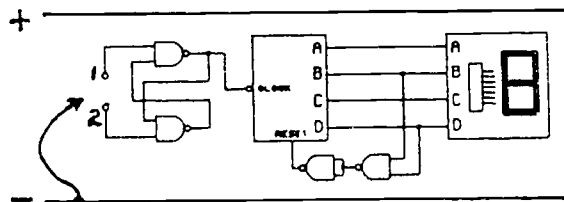

Note that the Q output of the bistable is connected to the clock input of the counter. Connect a flying lead to the negative rail.

#### Investigations and questions

- 1 Use the flying lead to send pulses to the counter by touching it first to input 1 and then to input 2, and so on. Does the count displayed now increase by one each time?
- 2 Try to explain the action of the bistable in the above circuit.

### Experiment 9.4: Constructing a 1-bit memory from NAND gates and an RS bistable

Set up the circuit below and connect a 1 Hz signal from the Pulser/Astable module to the data input and a flying lead to the hold input.

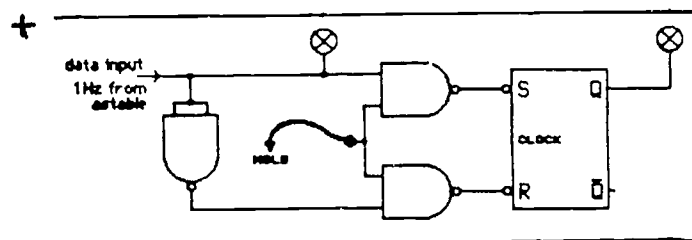

#### Investigations and questions

- 1 Take the hold input high. What happens? Now take the hold input low. What happens?
- 2 Try to explain how the circuit works.

Experiment 9.5: Linking two single-digit counters to make a dual decade counter

Produce a counter which will display counts from 0 to 99 on two seven segment displays using an astable (to produce the pulses to be counted), two binary counters, two seven segment displays with decoders, and a Quad NAND module.

Experiment 9.6: Applications using counting circuits

Project 9.6 (a): Divide-by-N counting

Build a divide-by-256 counter from two 4-bit binary counters. Use the counters to measure the frequency of the a.c. mains.

Project 9.6 (b): Down-counting (1)

Using a 4-bit binary counter, design a circuit which counts down from 15 (binary 1111) to zero (0000) . Use LED indicators to display the count.

Project 9.6 (c): Down-counting (2)

Using a 4-bit binary counter, design a circuit which counts down from 7 (binary 111) to zero (000) and then returns to 7. Display the count with a 7-segment indicator.

Project 9.6 (d): Counting the 'swings' of a pendulum

Build a circuit which will count the 'swings' (i.e.  $\frac{1}{2}$ -cycles) of a pendulum. Use a 4-bit counter and a 7-segment Decoder/Display module for this.

Project 9.6 (e): Controlling a motor (1)

Build a circuit which turns an electric motor on for 10 s in every 20 s.

Project 9.6 (f): Controlling a motor (2)

Build a circuit which turns an electric motor on for 5 s in every 20 s.

Project 9.6 (g): Reversing a motor at regular intervals

Design a control circuit for an automatic liquid mixer. The circuit should reverse the direction of rotation of the mixer motor every 5 s.

Project 9.6 (h): Flashing a lamp six times - six 'pips'

Design a circuit which will flash a lamp six times when a switch is pressed and released, using the 1 Hz output from an astable. Then modify the circuit so that it will sound a buzzer six times.

Project 9.6 (i): An automatic light-buoy

A warning buoy in a shipping channel is to have a light which flashes. It is to be on for 1 s and off for 4 s. Design a circuit which will do this. Use the Pulser/Astable module to provide 1 Hz pulses. Then adapt the circuit so that the light only operates when it is dark.

Project 9.6 (j): An electronic die

Build an electronic die using clocked RS bistables, an astable, a seven-segment decoder/display and NAND gates. The display should normally cycle from 1 to 6 at high speed. When the hold input of the input gate is taken low, the display should freeze and show the result of the "throw".

Project 9.6 (k): Traffic lights

Build a control circuit for a set of traffic lights. Use the 1 Hz astable output for all timing, and the red, yellow and green LEDs on the Indicator module for lights. The lights must come on in the normal traffic light sequence (yellow, red, red and yellow, green, and back to yellow again).

Project 9.6 (l): Batch counting

Articles in a factory are delivered from an assembly room to a packing room along a conveyor belt. Design a system which will stop the conveyor belt (turn off its motor) every time a batch of five articles has entered the packing room. Provide a switch in this room which can be used to restart the conveyor belt motor once the articles have been removed from the belt for packing.

Project 9.6 (m): Reaction time

Build a circuit which can be used to test people's reaction times. A switch should be provided which starts a dual decade counter (see Experiment 9.5) counting 100 Hz pulses from an astable. This switch is operated secretly by the person controlling the test. A second switch should freeze the display. This is operated by the person under test directly the display is seen to change. The dual decade module should then show the time difference between the two switch closures, i.e. the reaction time of the person under test.