

ED 353 477

CE 062 971

TITLE Automotive Technology Curriculum Guide.  
 INSTITUTION Idaho State Dept. of Education, Boise. Div. of Vocational Education.  
 REPORT NO Vo-Ed-120  
 PUB DATE Jul 89  
 NOTE 202p.; For a related technical committee report, see ED 346 269.  
 PUB TYPE Guides - Classroom Use - Teaching Guides (For Teacher) (052)

EDRS PRICE MF01/PC09 Plus Postage.  
 DESCRIPTORS \*Auto Mechanics; Behavioral Objectives; \*Competency Based Education; Diesel Engines; \*Engines; High Schools; \*Motor Vehicles; Occupational Safety and Health; Postsecondary Education; Skilled Occupations; Standards; State Curriculum Guides; Trade and Industrial Education

IDENTIFIERS Idaho

## ABSTRACT

This Idaho state curriculum guide provides lists of tasks, performance objectives, and enabling objectives for instruction in automotive technology. The document begins with a list of all tasks covered by the curriculum, a short course outline, and a curriculum framework that explains major content, laboratory activities, and intended outcomes. Enabling objectives are briefly explained. The bulk of the document consists of 10 modules, each of which is a list of tasks for that module and the performance objectives and enabling objectives that pertain to each task. Each module also contains an illustration master (a labeled drawing of an engine, for instance) pertaining to the material taught. The modules cover these areas: (1) shop safety, work ethics, and employability skills; (2) basic automotive technician skills; (3) diagnosing/troubleshooting electrical/electronic components; (4) engine performance service; (5) engine repair service; (6) automatic transmission/trans-axle service; (7) manual drive train and axle service; (8) steering, suspension, and wheel service; (9) automotive brake service; and (10) engine cooling, air conditioning, and heating service. (CML)

\*\*\*\*\*  
 \* Reproductions supplied by EDRS are the best that can be made \*  
 \* from the original document. \*  
 \*\*\*\*\*

# Curriculum Guide for

# AUTOMOTIVE TECHNOLOGY

ED 359 427

*Invest in Success*

IDAHO

**VTE**

VOCATIONAL TECHNICAL EDUCATION

U.S. DEPARTMENT OF EDUCATION  
Office of Educational Research and Improvement  
EDUCATIONAL RESOURCES INFORMATION  
CENTER (ERIC)

This document has been reproduced as received from the person or organization originating it.  
 Minor changes have been made to improve reproduction quality.

• Points of view or opinions stated in this document do not necessarily represent official OERI position or policy.

**STATE DIVISION OF  
VOCATIONAL EDUCATION**

1989

PERMISSION TO REPRODUCE THIS MATERIAL HAS BEEN GRANTED BY

\_\_\_\_\_

TO THE EDUCATIONAL RESOURCES INFORMATION CENTER (ERIC)

**BEST COPY AVAILABLE**

162971



# Program Standards for Automotive Technicians

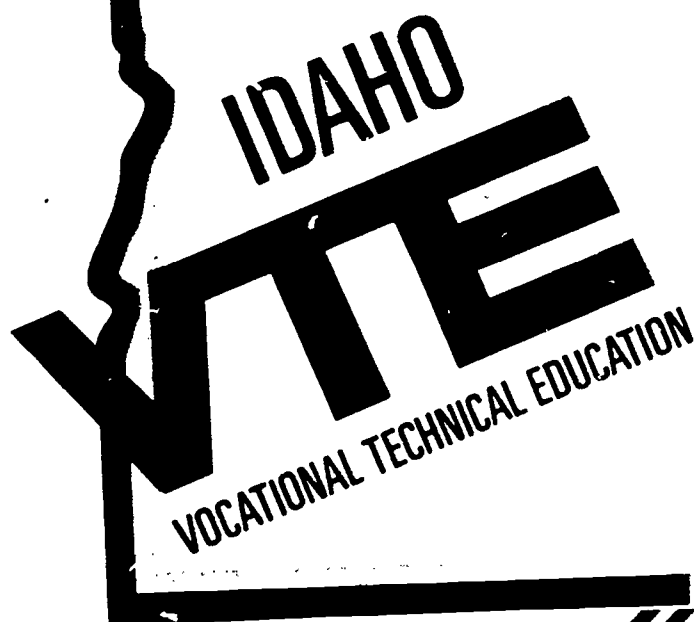
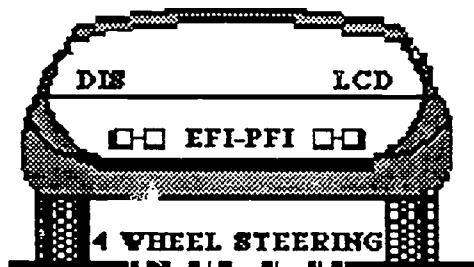

STATE DIVISION  
for  
VOCATIONAL EDUCATION  
1989

PROGRAM STANDARDS FOR  
AUTOMECHANICS

JULY 1989

Idaho Division of Vocational Education

Dr. Don Eshelby  
Project Director

Sho Ueda, Supervisor  
Trade, Industrial and Technical Education

"The Idaho Division of Vocational Education is an equal opportunity employer and does not discriminate or deny services on the basis of age, race, color, national origin, sex, nor handicap."

## TABLE OF CONTENTS

<u>Description</u>	<u>Page</u>
Introduction.....	1
Acknowledgements.....	2
Task List.....	3
Course Outline.....	13
Curriculum Framework.....	14
Performance and Enabling Objectives.....	29
Module 1 Shop Safety, Work Ethics and Employability Skills.....	31
Module 2 Basic Automotive Technician Skills.....	43
Module 3 Diagnosing/Troubleshooting Electrical/ Electronic Components.....	65
Module 4 Engine Performance Service.....	79
Module 5 Engine Repair Service.....	107
Module 6 Automatic Transmission/Trans-Axle Service.....	129
Module 7 Manual Drive Train and Axle Service.....	143
Module 8 Steering, Suspension and Wheel Service....	159
Module 9 Automotive Brake Service.....	179
Module 10 Engine Cooling, Air Conditioning And Heating Service.....	193

## INTRODUCTION

The Idaho Vocational Curriculum Standards Project is a cooperative effort among secondary and postsecondary instructors and administrators to develop competency-based program standards for curriculum content for the Automotive Technician Program.

The Automotive Technician standards were developed utilizing the Catalog of Performance Objectives, Criterion-Referenced Measures, and Performance Guides for Automotive Technician compiled by the States of Alabama and Florida for the Vocational-Technical Education Consortium of States (V-TECS). V-TECS is a multistate organization committed to curriculum research in specific occupational areas. The content of this document is directed toward the occupational area Automotive Technician - not toward a specific institution in the State.

The benefits to students and institutions derived from the development of these curriculum standards should be considerable. Articulation of students from secondary to postsecondary programs will be aided through a single set of curriculum standards. Local evaluation of programs and curricula can be accomplished using the standards as an objective measure. Institutions will be able to utilize the curriculum standards in a flexible manner to assure that vocational programs meet the needs of local business and industry.

## ACKNOWLEDGEMENTS

Planning, developing, and writing this publication required the coordinated efforts of many people involved in Vocational-Technical Education in the State of Idaho. Appreciation is expressed to the instructors and administrators who offered support, encouragement, and technical assistance in the development of this document. Special thanks goes to Alan King, Eastern Idaho Vocational Technical School; Bob Jenkins, Idaho State University; Ira Grass, Lewiston H.S.; Kerry Phelps, Blackfoot H.S.; Ed Traywick, Vallivue H.S.; Howard Garwick, Meridian H.S.; Eldon Winn, Burley H.S.; Richard Tracy, Skyline H.S.; Mike Swaim, North Idaho College; Dave Hemly, Lewis Clark State College; Charles Mikesell, Boise State University; and Ben Madron, College of Southern Idaho.

Technical writing of this publication was provided by Don Siplon of Twin Falls, Idaho.

The State of Idaho greatly appreciates the permission granted by the States of Alabama and Florida to utilize the program standards developed by those state's. Special thanks are extended to Jim Kendrick of Alabama and Dave McQuat of Florida for their assistance in this project.

Don Eshelby  
Director of Program Services

Sho Ueda  
Supervisor, Trade, Industrial  
and Technical Education

## TASK LIST

The task list is a set of occupational skills or "tasks" which are grouped by modules. Each task describes an occupational activity that, when performed, will result in a finished process or product. The nature of the finished process or product can vary, but should always allow an evaluation using the standards which address the operation, appearance, dimensions, or similar characteristics.

The tasks contained in each module represent the fundamental activities that should be required of any student seeking institutional credit for performing at an acceptable level of competency. The tasks are sequenced to reflect a progression from the curriculum standards which are unique to an institution's instructional program and which should be added upon approval of the administration.

The capability for providing instructional experiences and practical application of the tasks contained in each module will determine the scope of the vocational-technical program. Primary considerations will obviously be the availability of equipment and the expertise of the instructional staff.

Individual records of student progress based on the task List should be developed or adapted by the vocational institution for use in recording the student's attainment of competency by task and module.



STUDENT PERFORMANCE STANDARDS

EFFECTIVE DATE: July, 1989

PROGRAM AREA: Trade and Industrial

PROGRAM TITLE: Basic Auto Technician

PROGRAM TASK LISTING

01.0 DEMONSTRATE AND APPLY A BASIC KNOWLEDGE OF SHOP SAFETY, WORK ETHICS AND RESPONSIBILITIES, AND EMPLOYABILITY SKILLS

--The student will be able to:

- 01.01 Apply shop safety rules and procedures.
- 01.02 Apply personal safety rules and procedures.
- 01.03 Apply fire safety rules and procedures.
- 01.04 Apply electrical safety rules and procedures.
- 01.05 Apply rules for hazardous waste disposal.
- 01.06 Identify employment opportunities.
- 01.07 Apply employment-seeking opportunities.
- 01.08 Interpret employment capabilities.
- 01.09 Demonstrate appropriate work behavior.
- 01.10 Maintain a business-like image.
- 01.11 Maintain working relationships with others.
- 01.12 Communicate on the job.
- 01.13 Adapt to change.
- 01.14 Demonstrate a knowledge of business.

02.0 DEMONSTRATE AND APPLY A BASIC KNOWLEDGE OF AUTOMOTIVE TECHNICIANS--The student will be able to:

- 02.01 Use and maintain hand tools such as screwdrivers, special application pliers, hammers, chisels, punches, special application wrenches and sockets, files, hacksaws, bench vises, and C-clamps.
- 02.02 Demonstrate use of precision measuring tools.
- 02.03 Apply basic welding skills related to the automobile industry.
- 02.04 Use and maintain power tools, such as drills, bench grinders, drill presses, hydraulic presses, impact wrenches, air chisels, parts washers, hydraulic jacks, and vehicle hoists.

## Basic Automotive Technician - Continued

- 02.05 Use basic electrical equipment and meters.
- 02.06 Use and install fasteners such as screws and bolts, key screw extractors, helicoil inserts, and thread tap and dies.
- 02.07 Apply basic math skills.
- 02.08 Apply metric math skills
- 02.09 Service vehicle with proper automotive lubricants.
- 02.10 Demonstrate the use of shop manuals and tune-up charts.
- 02.11 Demonstrate a knowledge of automotive tubing types and sizes.
- 02.12 Demonstrate skill in electrical soldering.
- 02.13 Define electrical terms.
- 02.14 Understand and apply the rules of series circuits.
- 02.15 Understand and apply the rules of parallel circuits.
- 02.16 Understand and apply the rules of series-parallel circuits.
- 02.17 Define steering geometry and suspension geometry.
- 02.18 Explain the function of steering and suspension system components.
- 02.19 Explain and describe the components of manual and power steering.
- 02.20 Describe drum brake operation.
- 02.21 Describe disc brake operation.
- 02.22 Describe operation of brake system valves.
- 02.23 Explain proper brake pedal height.
- 02.24 Demonstrate a knowledge of basic automotive engine cooling systems.
- 02.25 Demonstrate a knowledge of automotive heating and air conditioning systems.
- 02.26 Demonstrate knowledge of different wire sizes and different terminal ends.
- 02.27 Demonstrate a knowledge of automotive ignition and fuel system.
- 02.28 Describe rear axle operation.
- 02.29 Describe drive shaft operation.
- 02.30 Describe automatic transmission and trans-axle operation.
- 02.31 Describe clutch operation.
- 02.32 Describe clutch release linkage mechanisms.
- 02.33 Describe manual transmission trans-axle operation.
- 02.34 Describe 4 x 4 transfer case systems.
- 02.35 Demonstrate a knowledge of the internal combustion engine, both diesel and gasoline.

Basic Automotive Technician - Continued

03.0 APPLY ELECTRICAL AND ELECTRONIC SKILLS IN  
DIAGNOSING/TROUBLESHOOTING MALFUNCTIONS OF  
ELECTRICAL/ELECTRONIC COMPONENTS (Computerized or Non-  
Computerized) --The student will be able to:

- 03.01 Demonstrate and apply safety rules and procedures.
- 03.02 Diagnose electrical engine malfunctions.
- 03.03 Perform power checks.
- 03.04 Measure voltage drop, current flow, continuity and resistance in a circuit or component.
- 03.05 Locate an open circuit or a short circuit.
- 03.06 Analyze cranking system malfunctions.
- 03.07 Analyze charging system malfunctions.
- 03.08 Service and test batteries.
- 03.09 Remove and replace light bulbs.
- 03.10 Inspect, remove, and replace alternator belts.
- 03.11 Test, remove, and replace fuses and circuit breakers.
- 03.12 Replace and test starters.
- 03.13 Test and overhaul alternators.
- 03.14 Remove and replace regulators.
- 03.15 Inspect and repair lighting systems.
- 03.16 Diagnose, repair or replace turn signal and stop light switches.
- 03.17 Test and replace electrical system switches.
- 03.18 Diagnose, repair, or replace power window and power seat systems, including motors.
- 03.19 Diagnose, repair, or replace horn systems.
- 03.20 Diagnose, repair, or replace clock systems.
- 03.21 Diagnose, repair, or replace warning buzzer.
- 03.22 Test and replace instrument panel units.
- 03.23 Service or repair windshield wiper/washer systems.
- 03.24 Test and replace electronic control units.
- 03.25 Check, remove, and replace radios.

04.0 DEMONSTRATE PROFICIENCY IN ENGINE PERFORMANCE SERVICE  
--The student will be able to:

- 04.01 Demonstrate and apply safety rules and procedures.
- 04.02 Analyze engine performance.
- 04.03 Perform cylinder compression test.
- 04.04 Check the performance of engines equipped with on-board computers.

Basic Automotive Technician - Continued

- 04.05 Inspect, remove, and replace points and condensers.
- 04.06 Remove and replace distributor.
- 04.07 Check distributor using a distributor tester.
- 04.08 Check the distributor advance in a vehicle.
- 04.09 Overhaul distributor.
- 04.10 Inspect and test primary circuits.
- 04.11 Remove and replace coil.
- 04.12 Remove and replace ignition switch.
- 04.13 Inspect, remove, and replace ignition wire, cap, and rotor.
- 04.14 Remove and replace spark plugs.
- 04.15 Perform cylinder leakage test.
- 04.16 Service electronic ignition system.
- 04.17 Service oxygen feedback system.
- 04.18 Service air cleaner.
- 04.19 Inspect, remove, and replace fuel filters.
- 04.20 Measure fuel flow and pressure.
- 04.21 Remove and replace fuel lines.
- 04.22 Remove and replace fuel pumps, mechanical and electrical.
- 04.23 Adjust idle speed.
- 04.24 Adjust idle mixture (propane).
- 04.25 Clean and adjust choke and check proper operation of electric choke.
- 04.26 Clean and overhaul carburetor.
- 04.27 Inspect, remove, and replace manifold control valve.
- 04.28 Remove and replace turbochargers.
- 04.29 Check and adjust waste gate.
- 04.30 Set idle speed to specification (fuel injection).
- 04.31 Remove and replace fuel injectors.
- 04.32 Service throttle body injection system.
- 04.33 Service ported fuel injection.
- 04.34 Service PCV system.
- 04.35 Service evaporative control system.
- 04.36 Service thermostatic air cleaner.
- 04.37 Service air injection system.
- 04.38 Inspect, remove, and replace air pump and belts.
- 04.39 Service Exhaust Gas Recirculation (EGR) system.
- 04.40 Service ignition timing control.

Basic Automotive Technician - Continued

- 04.41 Test exhaust emission using an HC/CO tester.
- 04.42 Remove and replace catalytic converter beads.
- 04.43 Service diesel injectors.
- 04.44 Remove and replace diesel engine fuel filters and water separator, if one has been added.
- 04.45 Check and adjust injection pump timing.
- 04.46 Remove and replace injection pump.
- 04.47 Check and adjust idle and maximum speeds.
- 04.48 Test and service pre-heat system.
- 04.49 Diagnose diesel fuel emission problems.
- 04.50 Inspect exhaust system.
- 04.51 Remove and replace tail pipe.
- 04.52 Remove and replace muffler.
- 04.53 Remove and replace exhaust pipe.
- 04.54 Inspect, remove and replace catalytic converter.

05.0 DEMONSTRATE PROFICIENCY IN ENGINE REPAIR SERVICE

--The student will be able to:

- 05.01 Demonstrate and apply safety rules and procedures.
- 05.02 Perform running compression tests.
- 05.03 Perform cylinder compression tests.
- 05.04 Perform cylinder leakage tests.
- 05.05 Clean engines.
- 05.06 Determine source(s) of oil loss.
- 05.07 Determine source(s) of coolant loss.
- 05.08 Determine source(s) of excess noise.
- 05.09 Determine cause(s) of over-heating.
- 05.10 Check the engine oil pressure.
- 05.11 Remove and replace motor mounts.
- 05.12 Remove and replace core plugs.
- 05.13 Inspect and measure flywheel runout.
- 05.14 Remove and replace flywheel.
- 05.15 Remove and replace flywheel ring gear.
- 05.16 Remove and replace engine assemblies.
- 05.17 Remove and replace oil pans.
- 05.18 Remove and replace oil pumps.
- 05.19 Clean cylinder blocks, oil passages, and pistons.
- 05.20 Inspect blocks for warpage.
- 05.21 Measure and inspect engine components for proper tolerances.
- 05.22 Remove and replace crankshafts, mains, and rod bearings.
- 05.23 Remove and replace camshafts.
- 05.24 Remove and replace camshaft bearings.
- 05.25 Remove and replace pistons and rings.

Basic Automotive Technician - Continued

- 05.26 Remove ridges and deglaze cylinder walls.
- 05.27 Remove and replace front and rear oil seals.
- 05.28 Remove and replace intake and exhaust manifold.
- 05.29 Remove, clean, inspect and replace cylinder heads; inspect head for cracks and warpage.
- 05.30 Test and replace hydraulic lifters.
- 05.31 Pressure test hydraulic lifter.
- 05.32 Reface valves and seats.
- 05.33 Check valve guides for wear.
- 05.34 Remove and replace timing chains and gears.
- 05.35 Remove and replace timing belt
- 05.36 Test valve springs.
- 05.37 Adjust valve lifters.
- 05.38 Replace rocker-arm assemblies, inspect wear and lubrication.
- 05.39 Change oil and oil filters with proper application.

06.0 DEMONSTRATE PROFICIENCY IN AUTOMATIC TRANSMISSION/TRANS-AXLE SERVICE--The student will be able to:

- 06.01 Demonstrate and apply safety rules and procedures.
- 06.02 Check automatic transmission fluid level.
- 06.03 Performance test automatic transmissions.
- 06.04 Diagnose malfunctions of automatic transmissions.
- 06.05 Diagnose, repair, and replace trans-axles.
- 06.06 Pressure test transmission in vehicles.
- 06.07 Stall test transmissions in vehicles.
- 06.08 Change transmission oil and filter.
- 06.09 Adjust linkage from the engine.
- 06.10 Adjust shift linkage.
- 06.11 Test electrical and computer controls of an automatic transmission and clutch converter.
- 06.12 Adjust neutral safety switches.
- 06.13 Remove and replace external gaskets and seals.
- 06.14 Test vacuum shift modulators.
- 06.15 Adjust bands.
- 06.16 Service governors.
- 06.17 Service valve bodies.
- 06.18 Rebuild transmission assemblies.
- 06.19 Pressure flush converter assemblies.
- 06.20 Pressure flush transmission cooler assemblies and check liquid flow.
- 06.21 Remove and replace extension housings and bushings.

Basic Automotive Technician - Continued

07.0 DEMONSTRATE PROFICIENCY IN SERVICING MANUAL DRIVE TRAINS AND AXLES--The student will be able to:

- 07.01 Demonstrate and apply safety rules and procedures.
- 07.02 Diagnose drive line problems.
- 07.03 Diagnose and performance-test manual transmission problems.
- 07.04 Inspect drive shafts, U-joints, and center bearings.
- 07.05 Lubricate universal joint.
- 07.06 Check the fluid level in a manual transmission.
- 07.07 Check the fluid level in a differential.
- 07.08 Remove and replace transmission mount(s).
- 07.09 Adjust shift linkage.
- 07.10 Adjust clutches.
- 07.11 Remove and replace extension housing seals and bushings.
- 07.12 Rebuild manual transmission.
- 07.13 Remove and replace clutches, release bearings, linkage, and pilot bearing.
- 07.14 Rebuild clutch master and slave cylinders.
- 07.15 Remove and replace universal joints.
- 07.16 Remove and replace speedometer gears and service speedometer cables.
- 07.17 Remove and replace axle bearings and seals.
- 07.18 Overhaul integral differentials.
- 07.19 Overhaul removable differentials.
- 07.20 Overhaul limited slip differentials.
- 07.21 Overhaul transaxle assemblies.
- 07.22 Adjust transaxle shifting controls.
- 07.23 Inspect, remove, replace, and lubricate front-drive-axle flexible joints.
- 07.24 Inspect, remove and replace constant velocity universal joints, and balance.
- 07.25 Service or repair transfer case and vacuum control.

08.0 DEMONSTRATE PROFICIENCY IN STEERING, SUSPENSION, AND WHEEL SERVICE--The student will be able to:

- 08.01 Demonstrate and apply safety rules and procedures.
- 08.02 Diagnose abnormal tire wear problems.
- 08.03 Diagnose suspension problems.
- 08.04 Diagnose wheel/tire vibrations, shimmy, and tramp.
- 08.05 Diagnose steering problems.



Basic Automotive Technician - Continued

- 08.06 Lubricate suspension, steering gear and linkage.
- 08.07 Check manual steering gear fluid level.
- 08.08 Inspect steering systems.
- 08.09 Inspect suspension systems.
- 08.10 Inspect and test shock absorbers and auto leveling system.
- 08.11 Check power steering fluid level.
- 08.12 Replace power steering drive belts.
- 08.13 Identify tires by types and sizes.
- 08.14 Repair tires.
- 08.15 Rotate wheels and tires and torque lug nuts to specifications.
- 08.16 Balance tires by computer, bubble or spin.
- 08.17 Service front wheel bearings and grease seals.
- 08.18 Remove and replace front and rear wheel bearings.
- 08.19 Remove and replace spindles and ball joints.
- 08.20 Remove and replace shock absorbers and mountings.
- 08.21 Measure and adjust torsion bar height.
- 08.22 Remove and replace torsion bars.
- 08.23 Remove and replace coil springs.
- 08.24 Remove and replace control arms and bushings.
- 08.25 Remove and replace steering linkage components.
- 08.26 Remove and replace McPherson strut assembly.
- 08.27 Rebuild a McPherson strut.
- 08.28 Remove and replace rear suspension parts, including independent suspension.
- 08.29 Remove and replace mast jacket of steering assembly.
- 08.30 Repair steering column.
- 08.31 Remove and replace steering wheel.
- 08.32 Remove and replace components in power steering system.
- 08.33 Check two-wheel and four-wheel alignments.
- 08.34 Align rear axle.

09.0 DEMONSTRATE PROFICIENCY IN AUTOMOTIVE BRAKE SERVICE

--The student will be able to:

- 09.01 Demonstrate and apply safety rules and procedures.
- 09.02 Diagnose brake system problems.
- 09.03 Diagnose pressure differential valve malfunctions.
- 09.04 Diagnose proportioning valve malfunctions.
- 09.05 Diagnose brake metering valve malfunctions.
- 09.06 Perform operational inspections.
- 09.07 Inspect brake and wheel assemblies and perform proper cleaning procedures.
- 09.08 Remove and replace calipers and rotors, front and rear.



Basic Automotive Technician - Continued

- 09.09 Refinish rotors, on or off car, and torque lug nuts to specification.
- 09.10 Clean, inspect and rebuild calipers.
- 09.11 Refinish brake drums and torque lug nuts to specifications.
- 09.12 Replace drum brake shoes with proper materials.
- 09.13 Service and/or replace brake pads.
- 09.14 Adjust brake shoes.
- 09.15 Adjust parking brakes.
- 09.16 Rebuild or replace wheel cylinder.
- 09.17 Bleed hydraulic brakes.
- 09.18 Free-up or replace parking brake cables and linkage.
- 09.19 Remove and replace/overhaul master cylinder.
- 09.20 Flush brake systems.
- 09.21 Test and replace vacuum brake power unit.
- 09.22 Test and replace hydro-booster.
- 09.23 Test brake anti-lock system.
- 09.24 Remove and replace anti-lock system components.

10.0 DEMONSTRATE PROFICIENCY IN COOLING, AIR CONDITIONING, AND HEATING SERVICE--The student will be able to:

- 10.01 Demonstrate and apply safety rules and procedures.
- 10.02 Inspect, remove and replace drive belt(s).
- 10.03 Check radiator coolant level.
- 10.04 Test and replace coolant.
- 10.05 Pressure-test cooling systems.
- 10.06 Test radiator caps.
- 10.07 Inspect, remove and replace radiator and heater hoses.
- 10.08 Remove, test and replace thermostats.
- 10.09 Flush cooling system.
- 10.10 Remove and replace radiators.
- 10.11 Remove and replace water pumps.
- 10.12 Inspect and pressure-test air conditioning system.
- 10.13 Discharge, evacuate and charge a basic air conditioning system.
- 10.14 Leak-test basic air conditioning systems.
- 10.15 Service air conditioning electrical circuits.
- 10.16 Service air conditioning vacuum circuits.
- 10.17 Remove and replace components in basic air conditioning systems.
- 10.18 Remove and replace engine fan clutches.
- 10.19 Remove and replace blower motors.
- 10.20 Remove and replace heater cores, control units and cables.
- 10.21 Remove and replace compressor shaft seals.
- 10.22 Service electric engine cooling fan and controls.

## COURSE OUTLINE

The Course Outline provides a means for organizing the content of the occupational area by major subdivisions or "modules." Each module represents a set of skills grouped under a heading and based on one of the following design characteristics:

- 1 the type of equipment used;
- 2 the equipment being serviced;
- 3 the operational functions within the occupation;
- 4 the nature of the operation being performed; or
- 5 a specialized area within the occupation

The Course Outline includes only the skills and knowledge directly applicable to student performance in the occupational area. Related subjects such as Mathematics and Communication Skills are not addressed in the curriculum standards because of the need for individualization of the student's academic or related studies based on counseling and guidance, and diagnostic test results. Academic or related requirements for the vocational student should be addressed through these measures in a method appropriate for each secondary or postsecondary institution. Where appropriate, instructors are encouraged to utilize resources and personnel within the institution to improve or complement the instructional process.

CURRICULUM FRAMEWORK

PROGRAM AREA: Trade & Technical

EFFECTIVE DATE: July, 1989

PROGRAM TITLE: Basic Automotive Technician

CODE NUMBER: 6032

Postsecondary \_\_\_\_\_

CIP 47.060400

SECONDARY

SCHOOL CREDITS \_\_\_\_\_

COLLEGE CREDITS \_\_\_\_\_

POSTSECONDARY ADULT

VOCATIONAL CREDITS \_\_\_\_\_

APPLICABLE LEVELS(S): \_\_\_\_\_ 7-9  9-12  Postsecondary Adult Voc.

Postsecondary Vocational \_\_\_\_\_ Other \_\_\_\_\_

- I. MAJOR CONCEPTS/CONTENT: The purpose of this program is to prepare students for employment as automobile technicians (620.261-010), engine repair specialist (620.261-010), transmission and rear axle specialist (620.281-062) front end specialist (620.281-038), brake specialist (620.281-026) electrical system specialist (825.281-022), engine tune up specialist (620.281.066), heating and air conditioning specialist (620.281-010) automobile service station attendant (620.361.030), new and used car get ready technician (806.361-026), or to provide supplemental training for persons previously or currently employed in these occupations.

The program provides instruction in diagnosis of malfunctions in the repair of engines, fuel, electrical, cooling and brake systems; drive train and suspension systems; and radiators, transmission and carburetors.

The content includes, but is not limited to, communication skills, leadership skills, human relations and employability skills, safe and efficient work practices, basic management concepts, troubleshooting skills, and servicing, maintaining, and repairing all mechanical systems or gasoline and diesel powered automobiles, and related systems.

Listed below are the courses that comprise this program:

<u>Course No.</u>	<u>Module</u>	<u>Description</u>
8709110	01.0	Shop Safety, Work Ethics and Employability Skills
	02.0	Basic Automotive Technician Skills

8709120	03.0	Diagnosing/Trouble Shooting Electrical/ Electronic Components
8709130	04.0	Engine Performance Service
	05.0	Engine Repair Service
8709140	06.0	Automatic Transmission Trans-Axle Service
	07.0	Manual Drive Train and Axle Service
8709150	08.0	Steering, Suspension and Wheel Service
	09.0	Automotive Brake Service
8709160	0.10	Engine Cooling, Air Conditioning and Heating Service

II. LABORATORY ACTIVITIES: Shop or laboratory activities are an integral part of this program and provide instruction in theory, fundamentals, service, and rebuilding of the following areas: engine repair, automatic and manual transmissions, drive trains, steering, suspension, brakes, electrical systems, engine systems performance, and automotive accessories. The tools, equipment, materials, and processes used in the laboratory should be equal to those used in the industry.

III. SPECIAL NOTE: The Vocational Industrial Clubs of America, Inc., is an appropriate vocational student organization for providing leadership training experiences and reinforcing specific vocational skills. When provided, these activities are considered an integral part of this instructional program.

The cooperative method of instruction is utilized for this program. Whenever the cooperative method is offered, the following is required for each student: a training plan, signed by the student, teacher and employer which includes instructional objectives and a list of on the job and in school learning experiences; a work station which reflects equipment, skills and tasks relevant to the occupation the student has chosen as a career goal.

The particular outcomes and student performance standards which the handicapped student must master to earn credit must be specified in the students' individual educational plan (IEP). Additional credits may be earned when outcomes and standards are mastered in accordance with the requirements indicated in subsequent IEP's. The job title for which the student is being trained must be designated in the IEP.

The typical length of this program for the average achieving student AT THE SECONDARY level - 900 hours.  
AT THE POSTSECONDARY level - 2,160 hours.

IV. INTENDED OUTCOMES: After successfully completing this program, the individual will be able to:

- 01.0 Demonstrate and apply safety rules and procedures and employability skills.
- 02.0 Demonstrate basic knowledge of automotive technicians.
- 03.0 Apply electrical and electronic skills in diagnosing/trouble shooting malfunctions of electrical/electronic components.
- 04.0 Demonstrate proficiency in engine performance service.
- 05.0 Demonstrate proficiency in engine repair service.
- 06.0 Demonstrate proficiency in automatic transmission/trans-axle service.
- 07.0 Demonstrate proficiency in servicing manual drive trains and axles.
- 08.0 Demonstrate proficiency in steering, suspension, and wheel system service.
- 09.0 Demonstrate proficiency in automotive brake service.
- 10.0 Demonstrate proficiency in cooling, air conditioning, and heating services.

STUDENT PERFORMANCE STANDARDS

EFFECTIVE DATE: July, 1989

PROGRAM AREA: Trade and Industrial

PROGRAM TITLE: Basic Auto Technician COURSE NUMBER: 870110

COURSE DESCRIPTION:

This course is designed to provide an introduction to the basic automotive technician program. It provides introductory instruction in safety, the requirements of the working environment, and the procedures for obtaining and changing a job. It also provides instruction in basic skills and applications which are common prerequisites to all automotive technician programs.

01.0 DEMONSTRATE AND APPLY A BASIC KNOWLEDGE OF SHOP SAFETY, WORK ETHICS AND RESPONSIBILITIES, AND EMPLOYABILITY SKILLS

--The student will be able to:

- 01.01 Apply shop safety rules and procedures.
- 01.02 Apply personal safety rules and procedures.
- 01.03 Apply fire safety rules and procedures.
- 01.04 Apply electrical safety rules and procedures.
- 01.05 Apply rules for hazardous waste disposal.
- 01.06 Identify employment opportunities.
- 01.07 Apply employment-seeking skills.
- 01.08 Interpret employment capabilities.
- 01.09 Demonstrate appropriate work behavior.
- 01.10 Maintain a business-like image.
- 01.11 Maintain working relationships with others.
- 01.12 Communicate on the job.
- 01.13 Adapt to change.
- 01.14 Demonstrate a knowledge of business.

02.0 DEMONSTRATE AND APPLY A BASIC KNOWLEDGE OF AUTOMOTIVE TECHNICIANS

--The student will be able to:

- 02.01 Use and maintain hand tools such as screwdrivers, special application pliers, hammers, chisels, punches, special application wrenches and sockets, files, hacksaws, bench vises, and C-clamps.
- 02.02 Demonstrate use of precision measuring tools.
- 02.03 Apply basic welding skills related to the automobile industry.

Basic Automotive Technician 1 - Continued

- 02.04 Use and maintain power tools, such as drills, bench grinders, drill presses, hydraulic presses, impact wrenches, air chisels, parts washers, hydraulic jacks, and vehicle hoists.
- 02.05 Use basic welding skills related to the automobile industry.
- 02.06 Use and install fasteners such as screws and bolts, key screw extractors, helicoil inserts, and thread tap and dies.
- 02.07 Apply basic math skills.
- 02.08 Apply metric math skills.
- 02.09 Service vehicle with proper automotive lubricants.
- 02.10 Demonstrate the use of shop manuals and tune-up charts.
- 02.11 Demonstrate a knowledge of automotive tubing types and sizes.
- 02.12 Demonstrate skill in electrical soldering.
- 02.13 Define electrical terms.
- 02.14 Understand and apply the rules of series circuits.
- 02.15 Understand and apply the rules of parallel circuits.
- 02.16 Understand and apply the rules of series-parallel circuits.
- 02.17 Define steering geometry and suspension geometry.
- 02.18 Explain the function of steering and suspension system components.
- 02.19 Explain and describe the components of manual and power steering.
- 02.20 Describe brake drum operation.
- 02.21 Describe disc brake operation.
- 02.22 Describe operation of brake system valves.
- 02.23 Explain proper brake pedal height.
- 02.24 Demonstrate a knowledge of basic automotive engine cooling systems.
- 02.25 Demonstrate a knowledge of automotive heating and air conditioning systems.
- 02.26 Demonstrate knowledge of different wire sizes and different terminal ends.
- 02.27 Demonstrate a knowledge of automotive ignition and fuel system.
- 02.28 Describe rear axle operation.
- 02.29 Describe drive shaft operation.
- 02.30 Describe automatic transmission and trans-axle operation.

Basic Automotive Technician 1 - Continued

- 02.31 Describe clutch operation.
- 02.32 Describe clutch release linkage mechanisms.
- 02.33 Describe manual transmission trans-axle operation.
- 02.34 Describe 4 x 4 transfer case systems.
- 02.35 Demonstrate a knowledge of internal combustion engine, both diesel and gasoline.



-----  
STUDENT PERFORMANCE STANDARDS

EFFECTIVE DATE: July 1989

PROGRAM AREA: Trade and Industrial

PROGRAM TITLE: Auto Electrical/  
Electronic Technician

PROGRAM NUMBER: 870120

COURSE DESCRIPTION:

This course is designed to provide instruction in automotive electrical systems including diagnosing, troubleshooting and repair.

03.0 APPLY ELECTRICAL AND ELECTRONIC SKILLS IN DIAGNOSING/  
TROUBLESHOOTING MALFUNCTIONS OF ELECTRICAL/ELECTRONIC  
COMPONENTS (Computerized or Non-Computerized)

--The student will be able to:

- 03.01 Demonstrate and apply safety rules and procedures.
- 03.02 Diagnose electrical engine malfunctions.
- 03.03 Perform power checks.
- 03.04 Measure voltage drop, current flow, continuity and resistance in a circuit or component.
- 03.05 Locate an open circuit or a short circuit.
- 03.06 Analyze cranking system malfunctions.
- 03.07 Analyze charging system malfunctions.
- 03.08 Service and test batteries.
- 03.09 Remove and replace light bulbs.
- 03.10 Inspect, remove, and replace alternator belts.
- 03.11 Test, remove, and replace fuses and circuit breakers.
- 03.12 Replace and test starters.
- 03.13 Test and overhaul alternators.
- 03.14 Remove and replace regulators.
- 03.15 Inspect and repair lighting systems.
- 03.16 Diagnose, repair or replace turn signal and stoplight switches.
- 03.17 Test and replace electrical system switches.
- 03.18 Diagnose, repair, or replace power window and power seat systems, including motors.
- 03.19 Diagnose, repair, or replace horn systems.
- 03.20 Diagnose, repair, or replace clock systems
- 03.21 Diagnose, repair, or replace warning buzzer.
- 03.22 Test and replace instrument panel units.
- 03.23 Service or repair windshield wiper/washer systems.
- 03.24 Test and replace electronic control units.
- 03.25 Check, remove, and replace radios.

-----  
STUDENT PERFORMANCE STANDARDS

EFFECTIVE DATE: July, 1989

PROGRAM AREA: Trade and Industrial

PROGRAM TITLE: Auto Engine Technician PROGRAM NUMBER: 870130

COURSE DESCRIPTION:

This course will provide instruction in engine performance and repair service.

04.0 DEMONSTRATE PROFICIENCY IN ENGINE PERFORMANCE SERVICE

--The student will be able to:

- 04.01 Demonstrate and apply safety rules and procedures.
- 04.02 Analyze engine performance.
- 04.03 Perform cylinder compression tests.
- 04.04 Check the performance of engines equipped with on-board computers.
- 04.05 Inspect, remove, and replace points and condensers.
- 04.06 Remove and replace distributors.
- 04.07 Check distributors using a distributor tester.
- 04.08 Check the distributor advance in a vehicle.
- 04.09 Overhaul distributor.
- 04.10 Inspect and test primary circuits.
- 04.11 Remove and replace coils.
- 04.12 Remove and replace ignition switch.
- 04.13 Inspect, remove, and replace ignition wire, cap and rotor.
- 04.14 Remove and replace spark plugs.
- 04.15 Perform cylinder leakage test.
- 04.16 Service electronic ignition system.
- 04.17 Service oxygen feedback system.
- 04.18 Service air cleaner.
- 04.19 Inspect, remove, and replace fuel filters.
- 04.20 Measure fuel flow and pressure.
- 04.21 Remove and replace fuel lines.
- 04.22 Remove and replace fuel pumps, mechanical and electrical.
- 04.23 Adjust idle speed.
- 04.24 Adjust idle mixture (propane).
- 04.25 Clean and adjust chokes and check proper operation of electric choke.

Basic Automotive Technician 3 - Continued

- 04.26 Clean and overhaul carburetor.
- 04.27 Inspect, remove, and replace manifold control valve.
- 04.28 Remove and replace turbochargers.
- 04.29 Check and adjust waste gate.
- 04.30 Set idle speed to specification (fuel injection).
- 04.31 Remove and replace fuel injectors.
- 04.32 Service throttle body fuel injection system.
- 04.33 Service ported fuel injection.
- 04.34 Service PCV system.
- 04.35 Service evaporative control system.
- 04.36 Service thermostatic air cleaner.
- 04.37 Service air injection system.
- 04.38 Inspect, remove, and replace air pump and belts.
- 04.39 Service Exhaust Gas Recirculation (FGR) system.
- 04.40 Service ignition timing control.
- 04.41 Test exhaust emission using an HC/CO tester.
- 04.42 Remove and replace catalytic converter beads.
- 04.43 Service diesel injectors.
- 04.44 Remove and replace diesel engine fuel filters and water separator, if one has been added.
- 04.45 Check and adjust injection pump timing.
- 04.46 Remove and replace injection pump.
- 04.47 Check and adjust idle and maximum speeds.
- 04.48 Test and service pre-heat system.
- 04.49 Diagnose diesel fuel emission problems.
- 04.50 Inspect exhaust system.
- 04.51 Remove and replace tail pipe.
- 04.52 Remove and replace muffler.
- 04.53 Remove and replace exhaust pipe.
- 04.54 Inspect, remove and replace catalytic converter.

05.0 DEMONSTRATE PROFICIENCY IN ENGINE REPAIR SERVICE

--The student will be able to:

- 05.01 Demonstrate and apply safety rules and procedures.
- 05.02 Perform running compression tests.
- 05.03 Perform cylinder compression tests.
- 05.04 Perform cylinder leakage tests.
- 05.05 Clean engines.
- 05.06 Determine source(s) of oil loss.
- 05.07 Determine source(s) of coolant loss.
- 05.08 Determine source(s) of excess noise.
- 05.09 Determine cause(s) of over-heating.
- 05.10 Check the engine oil pressure.

Basic Automotive Technician 3 - Continued

- 05.11 Remove and replace motor mounts.
- 05.12 Remove and replace core plugs.
- 05.13 Inspect and measure flywheel runout.
- 05.14 Remove and replace flywheel.
- 05.15 Remove and replace flywheel ring gear.
- 05.16 Remove and replace engine assemblies.
- 05.17 Remove and replace oil pans.
- 05.18 Remove and replace oil pumps.
- 05.19 Clean cylinder blocks, oil passages, and pistons.
- 05.20 Inspect blocks for warpage.
- 05.21 Measure and inspect engine components for proper tolerances.
- 05.22 Remove and replace crankshafts, mains, and rod bearings.
- 05.23 Remove and replace camshafts.
- 05.24 Remove and replace camshaft bearings.
- 05.25 Remove and replace pistons and rings.
- 05.26 Remove ridges and deglaze cylinder walls.
- 05.27 Remove and replace front and rear oil seals.
- 05.28 Remove and replace intake and exhaust manifold.
- 05.29 Remove, clean, inspect and replace cylinder heads; and inspect head for cracks and warpage.
- 05.30 Test and replace hydraulic lifters.
- 05.31 Pressure test hydraulic lifter.
- 05.32 Reface valves and seats.
- 05.33 Check valve guides for wear.
- 05.34 Remove and replace timing chains and gears.
- 05.35 Remove and replace timing belt.
- 05.36 Test valve springs.
- 05.37 Adjust valve lifters.
- 05.38 Replace rocker-arm assemblies, inspect wear and lubrication.
- 05.39 Change oil and oil filters with proper application.

-----  
STUDENT PERFORMANCE STANDARDS

EFFECTIVE DATE: July, 1989

PROGRAM AREA: Trade and Industrial

PROGRAM TITLE: Auto Drive Train and  
Transmission Technician

PROGRAM NUMBER: 870140

This course will provide instruction in manual and automatic transmission service.

06.0 DEMONSTRATE PROFICIENCY IN AUTOMATIC TRANSMISSION/TRANS-AXLE SERVICE--The student will be able to:

- 06.01 Demonstrate and apply safety rules and procedures.
- 06.02 Check automatic transmission fluid level.
- 06.03 Performance test automatic transmissions.
- 06.04 Diagnose malfunctions of automatic transmissions.
- 06.05 Diagnose, repair, and replace trans-axles.
- 06.06 Pressure test transmission in vehicles.
- 06.07 Stall test transmissions in vehicles.
- 06.08 Change transmission oil and filter.
- 06.09 Adjust linkage from the engine.
- 06.10 Adjust shift linkage.
- 06.11 Test electrical and computer controls of an automatic transmission and clutch converter.
- 06.12 Adjust neutral safety switches.
- 06.13 Remove and replace external gaskets and seals.
- 06.14 Test vacuum shift modulators.
- 06.15 Adjust bands.
- 06.16 Service governors.
- 06.17 Service valve bodies.
- 06.18 Rebuild transmission assemblies.
- 06.19 Pressure flush converter assemblies.
- 06.20 Pressure flush transmission cooler assemblies and check liquid flow.
- 06.21 Remove and replace extension housings and bushings.

07.0 DEMONSTRATE PROFICIENCY IN SERVICING MANUAL DRIVE TRAINS AND AXLES--The student will be able to:

- 07.01 Demonstrate and apply safety rules and procedures.
- 07.02 Diagnose drive line problems.
- 07.03 Diagnose and performance-test manual transmission problems.
- 07.04 Inspect drive shafts, U-joints, and center carrier bearings.

## Basic Automotive Technician 4 - Continued

- 07.05 Lubricate universal joint.
- 07.06 Check the fluid level in a manual transmission.
- 07.07 Check the fluid level in a differential.
- 07.08 Remove and replace transmission mount(s).
- 07.09 Adjust shift linkage.
- 07.10 Adjust clutches.
- 07.11 Remove and replace extension housing seals and bushings.
- 07.12 Rebuild manual transmission.
- 07.13 Remove and replace clutches, release bearings, linkage, and pilot bearing.
- 07.14 Rebuild clutch master and slave cylinders.
- 07.15 Remove and replace universal joints.
- 07.16 Remove and replace speedometer gears and service speedometer cables.
- 07.17 Remove and replace axle bearings and seals.
- 07.18 Overhaul integral differentials.
- 07.19 Overhaul removable differentials.
- 07.20 Overhaul limited slip differentials.
- 07.21 Overhaul transaxle assemblies.
- 07.22 Adjust transaxle shifting controls.
- 07.23 Inspect, remove, replace, and lubricate front-drive-axle flexible joints.
- 07.24 Inspect, remove, replace constant velocity universal joints, and balance.
- 07.25 Service or repair transfer-case and vacuum control.

STUDENT PERFORMANCE STANDARDS

EFFECTIVE DATE: July, 1989

PROGRAM AREA: Trade and Industrial

PROGRAM TITLE: Auto Chassis and  
Brake Technician

PROGRAM NUMBER: 870150

This course will provide instruction in automotive suspension, steering alignment, balance, and brake service.

08.0 DEMONSTRATE PROFICIENCY IN STEERING, SUSPENSION, and WHEEL SERVICE--The student will be able to:

- 08.01 Demonstrate and apply safety rules and procedures.
- 08.02 Diagnose abnormal tire wear problems.
- 08.03 Diagnose suspension problems.
- 08.04 Diagnose wheel/tire vibrations, shimmy, and tramp.
- 08.05 Diagnose steering problems.
- 08.06 Lubricate suspension, steering gear, and linkage.
- 08.07 Check manual steering gear fluid level.
- 08.08 Inspect steering systems.
- 08.09 Inspect suspension systems.
- 08.10 Inspect and test shock absorbers and auto leveling system.
- 08.11 Check power steering fluid level.
- 08.12 Replace power steering drive belts.
- 08.13 Identify tires by types and sizes.
- 08.14 Repair tires.
- 08.15 Rotate wheels and tires and torque lug nuts to specification.
- 08.16 Balance tires by computer, bubble or spin.
- 08.17 Service front wheel bearings and grease seals.
- 08.18 Remove and replace front or rear wheel bearings.
- 08.19 Remove and replace spindles and ball joints.
- 08.20 Remove and replace shock absorbers and mountings.
- 08.21 Measure and adjust torsion bar height.
- 08.22 Remove and replace torsion bars.
- 08.23 Remove and replace coil springs.
- 08.24 Remove and replace control arms and bushings.
- 08.25 Remove and replace steering linkage components.

Basic Automotive Technician 5 - Continued

- 08.26 Remove and replace McPherson strut assembly.
- 08.27 Rebuild a McPherson strut.
- 08.28 Remove and replace rear suspension parts, including independent suspension.
- 08.29 Remove and replace mast jacket of steering assembly.
- 08.30 Repair steering column.
- 08.31 Remove and replace steering wheel.
- 08.32 Remove and replace components in power steering system.
- 08.33 Check two-wheel and four-wheel alignments.
- 08.34 Align rear axle.

09.0 DEMONSTRATE PROFICIENCY IN AUTOMOTIVE BRAKE SERVICE

--The student will be able to:

- 09.01 Demonstrate and apply safety rules and procedures.
- 09.02 Diagnose brake and system problems.
- 09.03 Diagnose pressure differential valve malfunctions.
- 09.04 Diagnose proportioning valve malfunctions.
- 09.05 Diagnose metering valve malfunctions.
- 09.06 Perform operational inspections.
- 09.07 Inspect brake and wheel assemblies and perform proper cleaning procedures.
- 09.08 Remove and replace calipers and rotors, front and rear.
- 09.09 Refinish rotors, on or off car, and torque lug nuts to specification.
- 09.10 Clean, inspect and rebuild calipers.
- 09.11 Refinish brake drums and torque lug nuts to specifications.
- 09.12 Replace drum brake shoes with proper materials.
- 09.13 Service and/or replace brake pads.
- 09.14 Adjust brake shoes.
- 09.15 Adjust parking brakes.
- 09.16 Rebuild or replace wheel cylinder.
- 09.17 Bleed hydraulic brakes.
- 09.18 Free-up or replace parking brake cables and linkage.
- 09.19 Remove and replace/overhaul master cylinder.
- 09.20 Flush brake systems.
- 09.21 Test and replace vacuum brake power unit.
- 09.22 Test and replace hydro-booster.
- 09.23 Test brake anti-lock system.
- 09.24 Remove and replace anti-lock system components.



-----  
STUDENT PERFORMANCE STANDARDS

EFFECTIVE DATE: July, 1989

PROGRAM AREA: Trade and Industrial

PROGRAM TITLE: Auto Cooling/Heating and Air Conditioning Technician PROGRAM NUMBER: 870160

This course is designed to provide instruction in automotive cooling, air conditioning and heating systems.

10.0 DEMONSTRATE PROFICIENCY IN COOLING, AIR CONDITIONING, AND HEATING SERVICE--The student will be able to:

- 10.01 Demonstrate and apply safety rules and procedures.
- 10.02 Inspect, remove, and replace drive belt(s).
- 10.03 Check radiator coolant level.
- 10.04 Test and replace coolant.
- 10.05 Pressure-test cooling systems.
- 10.06 Test radiator caps.
- 10.07 Inspect, remove, and replace radiator and heater hoses.
- 10.08 Remove, test, and replace thermostats.
- 10.09 Flush cooling system.
- 10.10 Remove and replace radiators.
- 10.11 Remove and replace water pumps.
- 10.12 Inspect and pressure-test air conditioning system.
- 10.13 Discharge, evacuate, and charge a basic air conditioning system.
- 10.14 Leak-test basic air conditioning systems.
- 10.15 Service air conditioning electrical circuits.
- 10.16 Service air conditioning vacuum circuits.
- 10.17 Remove and replace components in basic air conditioning systems.
- 10.18 Remove and replace engine fan clutches.
- 10.19 Remove and replace blower motors.
- 10.20 Remove and replace heater cores, control units, and cables.
- 10.21 Remove and replace compressor shaft seals.
- 10.22 Service electric engine cooling fan and controls.

## PERFORMANCE AND ENABLING OBJECTIVES

Each task is accompanied by a Performance Objective and a set of Enabling Objectives which describe the conditions, performance, evaluation criteria, and learning outcomes required for completion of the task by the student. In the Performance Objective, the conditions addressed the following:

- (1) tools, equipment, and materials required for the activity; and
- (2) specifications and critical characteristics required for the finished product or process.

Each Performance Objective is followed by a set of Enabling Objectives describing the learning outcomes that should be achieved before the student begins the activity stated in the Performance Objective. Enabling Objectives are expressed in concise statements so their intent is clear to the instructor, who should develop appropriate instructional activities, and to each student, who must master each item. The content addressed in each set of Enabling Objectives generally is directed toward technical terminology, uses of tools and equipment, procedures or techniques associated with the task, use of materials, and safety precautions. Instructional styles or methodologies are not addressed for the instructor, however, because of the various approaches to performance of a task of classroom activity.

Thus, each curriculum standard - Task, Performance Objective, Enabling Objectives - utilizes a competency-based approach to student evaluation based on objective, measurable criteria. Although each standard is listed only one time, tasks can be repeated any number of times until the acceptable level of competency is attained. Repetition of tasks should also occur when several methods or applications can be used to perform the task. For example, the standard for Analyzing Engine Performance appears only once, but should be repeated until an acceptable level of competency is performed for all applications.

MODULE 1

SHOP SAFETY, WORK ETHICS AND EMPLOYABILITY SKILLS

**QUACK  
DOWN  
ON ACCIDENTS**



**OR**

**YOU'LL  
BE A  
DEAD  
DUCK**

30

IDAHO PROGRAM STANDARDS FOR BASIC AUTOMOTIVE TECHNICIAN

MODULE 1

SHOP SAFETY, WORK ETHICS AND EMPLOYABILITY SKILLS

Division of Vocational Education  
State of Idaho  
Boise, Idaho  
1989

## MODULE 1 - SHOP SAFETY, WORK ETHICS AND EMPLOYABILITY SKILLS

This is one of a series of modules which comprise the Idaho Program Standards for Basic Automotive Technician. Each module contains a listing of the tasks, performance objectives, and enabling objectives required to enable a student to achieve competency in a specific system or field of study within the basic automotive technician occupational field. The numbering of these modules is not intended to dictate an order of instruction or scheduling. The order in which these modules may be taught is determined by each institution and its instructors.

Each task describes an occupational activity which will result in a finished process or product. Such a process or product should always allow an evaluation using standards which address the operation, appearance, dimensions, time in which achieved, or similar characteristics. The tasks listed in each module represent the basic activities required of each student to demonstrate entry level competence for that specific system or field of study within the automotive occupation.

The capability for providing instructional experiences and practical application of the tasks contained in each module will determine the scope of the vocational-technical program. In this regard, the student's maturity and preparation to receive instruction as well as the availability of equipment and the expertise of the instructional staff will be of primary importance. Individual records of student performance in completing the tasks listed within each module should be maintained.

Although some provision is made for basic mathematics and communication skills within these standards they may not be adequate to meet the needs of individual students. Counseling, guidance, and diagnostic test results may indicate a need for further preparation in these areas. In such cases, instructors are encouraged to utilize the resources and personnel within the institution to improve or complement the instructional process.

The benefits to students and institutions derived from these curriculum standards should be considerable. Articulation of students from secondary to post-secondary programs will be aided through the use of a single set of curriculum standards. The standards provide a tool for evaluation of local curricula and programs. The standards may be used in a flexible manner to assure that Basic Automotive Technician programs meet the needs of local business and industry.

It is the goal of this program standard to provide a level of instruction which will impart entry level employment skills. Students should be carefully counseled on the importance of attaining competency in the tasks assigned. As in virtually all occupations today, basic automotive technicians will require

IDAHO PROGRAM STANDARDS FOR BASIC AUTOMOTIVE TECHNICIAN

TASK LISTING

MODULE 1 - SHOP SAFETY, WORK ETHICS AND EMPLOYABILITY SKILLS

01.0 DEMONSTRATE AND APPLY A BASIC KNOWLEDGE OF SHOP SAFETY, WORK ETHICS AND RESPONSIBILITIES, AND EMPLOYABILITY SKILLS--The student will be able to:

- 01.01 Apply shop safety rules and procedures
- 01.02 Apply personal safety rules and procedures
- 01.03 Apply fire safety rules and procedures
- 01.04 Apply electrical safety rules and procedures
- 01.05 Apply rules for hazardous waste disposal
- 01.06 Identify employment opportunities
- 01.07 Apply employment-seeking skills
- 01.08 Interpret employment capabilities
- 01.09 Demonstrate appropriate work behavior
- 01.10 Maintain a business-like image
- 01.11 Maintain working relationships with others
- 01.12 Communicate on the job
- 01.13 Adapt to change
- 01.14 Demonstrate a knowledge of business

periodic up-dating and review in the future. It is important that each student understand that meeting the program standards is essential not only to obtain employment today but also to have a base upon which to retain employment in the future.



## BASIC AUTOMOTIVE TECHNICIAN

### PERFORMANCE AND ENABLING OBJECTIVES

#### MODULE 1 - SHOP SAFETY, WORK ETHICS AND EMPLOYABILITY SKILLS .

##### 01.01 TASK: Apply shop safety rules and procedures

PERFORMANCE OBJECTIVE: Given examples of repair jobs and shop situations, apply shop safety rules and procedures by identifying safe and unsafe shop practices.

##### ENABLING OBJECTIVES:

1. Identify common hazards in the repair shop including:
  - a. improper use of tools
  - b. unguarded machinery
  - c. tripping and falling
  - d. excessive exposure to exhaust gases, parts cleaners, paints, and dust
  - e. electrical hazards
  - f. improper lifting
2. Identify and explain warning signs posted in shop area
3. Explain the importance of good housekeeping in the shop
4. Explain the importance of storing materials in a safe and secure manner
5. Explain the potential hazards associated with:
  - a. asbestos
  - b. paints and thinners
  - c. carbon monoxide
  - d. solvents
  - e. dusts
  - f. noise
  - g. hydrogen gas
6. Explain safety rules and procedures for using compressed air equipment
7. Explain the safety rules for welding, cutting, and brazing
8. Conduct an inspection of the shop for conformity with safety rules and procedures

##### 01.02 TASK: Apply personal safety rules and procedures

PERFORMANCE OBJECTIVE: Given examples of repair jobs and shop situations, demonstrate personal safety procedures.

ENABLING OBJECTIVES:

1. Identify types of personal safety equipment and explain their applications
2. Identify types of repair work that require eye protection
3. Identify types of repair work that require hearing protection
4. Identify types of repair work that require respirators
5. Explain the methods of cleaning respirators
6. Explain regulations and procedures pertaining to sanitation in shop and restroom areas
7. Explain personal safety rules and procedures for welding, cutting, and brazing
8. Explain the methods for cleaning and storing personal safety equipment

01.03

TASK: Apply fire safety rules and procedures

PERFORMANCE OBJECTIVE: Given examples of types of fires, types of fire extinguishers, and shop situations, apply fire safety rules and procedures by identifying safe and unsafe practices.

ENABLING OBJECTIVES:

1. Identify and explain the use of the these fire extinguishers:
  - a. foam
  - b. carbon dioxide
  - c. soda acid
  - d. pump tank
  - e. gas cartridge
  - f. dry chemical
  - g. multi-purpose dry chemical
2. Describe the procedures for operating the fire extinguishers listed above
3. Describe common causes of fires in repair shops and explain methods which will prevent them
4. Conduct an inspection of the shop for conformity with fire safety rules and procedures

01.04

TASK: Apply electrical safety rules and procedures

PERFORMANCE OBJECTIVE: Given a check-list identifying electrical hazards and appropriate safety manuals, apply electrical safety rules and procedures. Electrical equipment, exposed wire, frayed cords, and deteriorated insulation must be indicated in the check-list. Junction boxes, outlets, switches, breaker switches, must be identified as to their use.

ENABLING OBJECTIVES:

1. Explain the importance of labeling circuit breakers
2. Explain the importance of grounding electrical equipment
3. Explain the proper methods for using flexible extension cords and drop lights
4. Identify and explain the electrical hazards of, and safety rules and procedures for, welding, cutting, and brazing
5. Identify the approved location for all electrical equipment and power sources in the repair shop

01.05 TASK: Apply rules for hazardous waste disposal

PERFORMANCE OBJECTIVE: Given examples of hazardous waste materials such as asbestos, oils, paints and thinners, and solvents, OSHA, EPA and other manuals and guidelines, explain the proper handling and disposal of such materials.

ENABLING OBJECTIVES:

1. Identify the hazardous waste materials found in a repair shop
2. Explain the proper procedures for disposing of:
  - a. asbestos
  - b. oil and oil based materials
  - c. paint and paint thinner
  - d. solvents
  - e. electrical insulating compounds
3. Conduct an inspection of the repair shop to detect the presence of hazardous wastes in accordance with OSHA and EPA guidelines

01.06 TASK: Identify employment opportunities

PERFORMANCE OBJECTIVE: Given the information resources of a library, obtain and compile the information needed to seek a job.

ENABLING OBJECTIVES:

1. Identify the requirements for a job
2. Investigate educational opportunities
3. Investigate occupational opportunities
4. Locate resources for finding employment
5. Confer with prospective employers
6. Identify job trends

01.07

TASK: Apply employment-seeking skills

PERFORMANCE OBJECTIVE: Given appropriate information, locate a job opportunity, prepare and take an interview for it, complete the required tests, forms and applications, and evaluate your response to the job opportunity.

ENABLING OBJECTIVES:

1. Locate a job opening
2. Complete a resume
3. Prepare for an interview
4. Participate in an interview
5. Complete tests required
6. Complete forms required
7. Complete an application letter
8. Complete a follow-up letter
9. Complete an acceptance letter
10. Evaluate a job offer
11. Evaluate a job rejection

01.08

TASK: Interpret employment capabilities

PERFORMANCE OBJECTIVE: Given the assignment to explain how your capabilities make you employable, demonstrate how to match your skills and experience to a job you seek.

ENABLING OBJECTIVES:

1. Match your interest to the job area
2. Match your aptitudes to the job area
3. Verify your abilities
4. Identify your immediate work goal
5. Develop your career plan

01.09

TASK: Demonstrate appropriate work behavior

PERFORMANCE OBJECTIVE: Given the responsibility of an employ in a new job, demonstrate your knowledge of appropriate behavior in the work place.

ENABLING OBJECTIVES:

1. Exhibit dependability
2. Demonstrate punctuality
3. Follow rules and regulations
4. Explain the consequences of dishonesty
5. Complete assignments accurately and on time

6. Control your emotions
7. Take responsibility for your decisions and actions
8. Take pride in your work and be a loyal worker
9. Learn to handle pressures and tensions
10. Demonstrate ability to set priorities
11. Demonstrate problem-solving skills

01.10 TASK: Maintain a business-like image

PERFORMANCE OBJECTIVE: Given a responsibility to perform the duties of a new job, with a new employer, demonstrate a knowledge of the actions and behaviors which will project a business-like image.

ENABLING OBJECTIVES:

1. Participate in the institution's orientation
2. Demonstrate knowledge of your company's products/services

01.11 TASK: Maintain working relationships with others

PERFORMANCE OBJECTIVE: Given the responsibility to perform the duties of a new job, with a new employer, demonstrate a knowledge of how to successfully work with others.

ENABLING OBJECTIVES:

1. Work productively with others
2. Show empathy, respect, and support for others
3. Demonstrate procedures and assist others when necessary
4. Recognize problems and work toward their solution
5. Minimize the occurrence of problems
6. Channel your emotional reactions in positive ways

01.12 TASK: Communicate on the job

PERFORMANCE OBJECTIVE: Given the responsibility to perform the duties of a new job, with a new employer, demonstrate a knowledge of how to communicate on the job.

ENABLING OBJECTIVES:

1. Read and comprehend written communications
2. Use correct grammar
3. Speak clearly when addressing others
4. Use job-related terminology correctly

5. Be a good listener
6. Write clearly and legibly
7. Use telephone etiquette
8. Follow written and oral directions carefully
9. When in doubt, ask questions
10. Locate the information needed to complete the task
11. Demonstrate keyboarding skills
12. Demonstrate computer literacy

01.13

TASK: Adapt to change

PERFORMANCE OBJECTIVE: Given the responsibility to perform the duties of a new job, with a new employer, demonstrate a knowledge of how to adapt to change

ENABLING OBJECTIVE:

1. Recognize the need to change
2. Demonstrate a willingness to learn
3. Demonstrate flexibility
4. Participate in continuing education
5. Seek challenge in the work place
6. Adjust goals and plans when necessary

01.14

TASK: Demonstrate a knowledge of business

PERFORMANCE OBJECTIVE: Given the responsibility to perform the duties of a new job, with a new employer, demonstrate a knowledge of the role of that business, it's employees, and the free enterprise system.

ENABLING OBJECTIVES:

1. Explain the role of business in the enterprise system
2. Identify the responsibilities of employees
3. Identify the responsibilities of managers and employers
4. Discuss the opportunities for business ownership or management
5. Describe the planning required to start a business
6. Discuss the importance of business meetings

## MODULE 2

### BASIC AUTOMOTIVE TECHNICIAN SKILLS

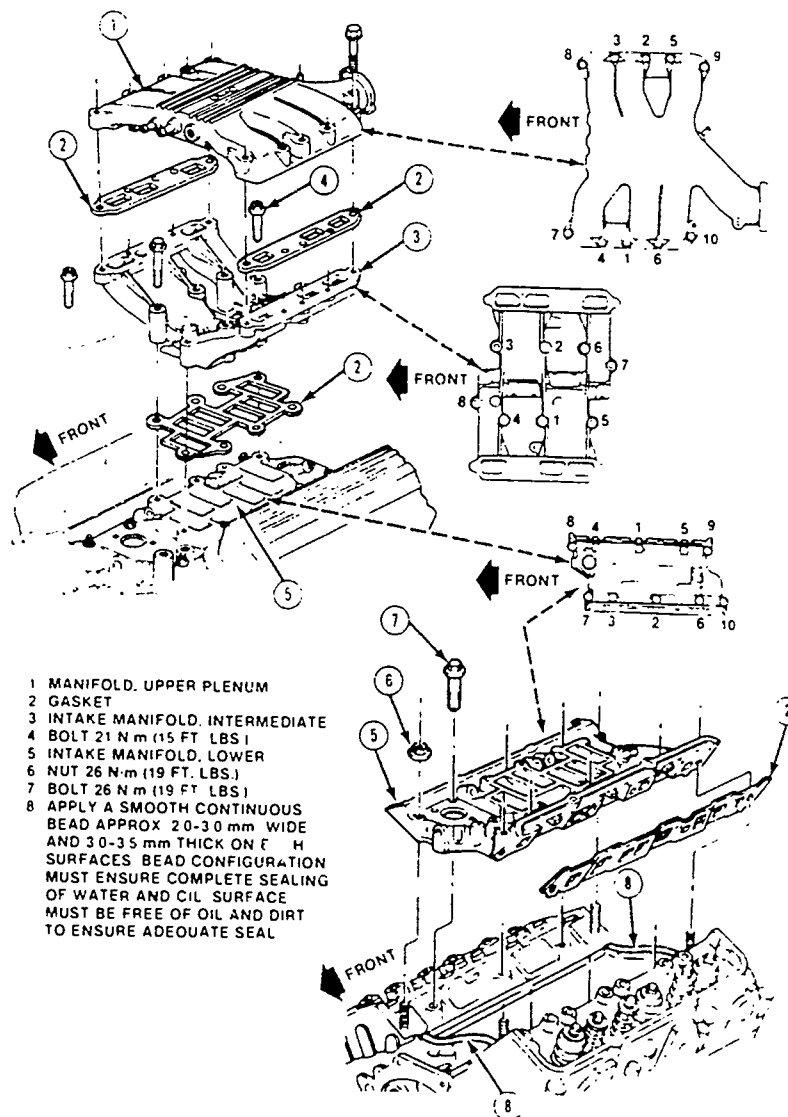

IDAHO PROGRAM STANDARDS FOR BASIC AUTOMOTIVE TECHNICIAN

MODULE 2

BASIC AUTOMOTIVE TECHNICIAN SKILLS

Division of Vocational Education  
State of Idaho  
Boise, Idaho  
1989



## MODULE 2 - BASIC AUTOMOTIVE TECHNICIAN SKILLS

This is one of a series of modules which comprise the Idaho Program Standards for Basic Automotive Technician. Each module contains a listing of the tasks, performance objectives, and enabling objectives required to enable a student to achieve competency in a specific system or field of study within the basic automotive technician occupational field. The numbering of these modules is not intended to dictate an order of instruction or scheduling. The order in which these modules may be taught is determined by each institution and its instructors.

Each task describes an occupational activity which will result in a finished process or product. Such a process or product should always allow an evaluation using standards which address the operation, appearance, dimensions, time in which achieved, or similar characteristics. The tasks listed in each module represent the basic activities required of each student to demonstrate entry level competence for that specific system or field of study within the automotive occupation.

The capability for providing instructional experiences and practical application of the tasks contained in each module will determine the scope of the vocational-technical program. In this regard, the student's maturity and preparation to receive instruction as well as the availability of equipment and the expertise of the instructional staff will be of primary importance. Individual records of student performance in completing the tasks listed within each module should be maintained.

Although some provision is made for basic mathematics and communication skills within these standards they may not be adequate to meet the needs of individual students. Counseling, guidance, and diagnostic test results may indicate a need for further preparation in these areas. In such cases, instructors are encouraged to utilize the resources and personnel within the institution to improve or complement the instructional process.

The benefits to students and institutions derived from these curriculum standards should be considerable. Articulation of students from secondary to post-secondary programs will be aided through the use of a single set of curriculum standards. The standards provide a tool for evaluation of local curricula and programs. The standards may be used in a flexible manner to assure that Basic Automotive Technician programs meet the needs of local business and industry.

It is the goal of this program standard to provide a level of instruction which will impart entry level employment skills. Students should be carefully counseled on the importance of attaining competency in the tasks assigned. As in virtually all occupations today, basic automotive technicians will require

periodic up-dating and review in the future. It is important that each student understand that meeting the program standards is essential not only to obtain employment today but also to have a base upon which to retain employment in the future.

IDAHO PROGRAM STANDARDS FOR BASIC AUTOMOTIVE TECHNICIAN

TASK LISTING

MODULE 2 - BASIC AUTOMOTIVE TECHNICIAN SKILLS

- 02.0 DEMONSTRATE AND APPLY A BASIC KNOWLEDGE OF AUTOMOTIVE TECHNICIANS--The student will be able to:
- 02.01 Use and maintain hand tools, such as screwdrivers, special applications pliers, hammers, chisels, punches, special applications wrenches and sockets, files, hack saws, bench vices and C-clamps
  - 02.02 Demonstrate use of precision measuring tools
  - 02.03 Apply basic welding skills related to the automobile industry
  - 02.04 Use and maintain power tools, such as drills, bench grinders, drill presses, hydraulic presses, impact wrenches, air chisels, parts washers, hydraulic jacks and vehicle hoists
  - 02.05 Use basic electrical equipment and meters
  - 02.06 Use and install fasteners, such as screws and bolts, key screw extractors, helicoil inserts and thread cutting tap and dies
  - 02.07 Apply basic math skills
  - 02.08 Apply metric math skills
  - 02.09 Service vehicle with proper automotive lubricants
  - 02.10 Demonstrate the use of shop manuals and tune-up charts
  - 02.11 Demonstrate a knowledge of automotive tubing types and sizes
  - 02.12 Demonstrate skill in electrical soldering
  - 02.13 Define electrical terms
  - 02.14 Understand and apply the rules of series circuits
  - 02.15 Understand and apply the rules of parallel circuits
  - 02.16 Understand and apply the rules of series-parallel circuits
  - 02.17 Define steering geometry and suspension geometry
  - 02.18 Explain the function of steering and suspension system components
  - 02.19 Explain and describe the components of manual and power steering
  - 02.20 Describe drum brake operation

- 02.21 Describe disc brake operation
- 02.22 Describe operation of brake system valves
- 02.23 Explain proper brake pedal height
- 02.24 Demonstrate a knowledge of basic automotive engine cooling systems
- 02.25 Demonstrate a knowledge of automotive heating and air conditioning systems
- 02.26 Demonstrate knowledge of different wire sizes and different terminal ends
- 02.27 Demonstrate a knowledge of automotive ignition and fuel system
- 02.28 Describe rear axle operation
- 02.29 Describe drive shaft operation
- 02.30 Describe automatic transmission and trans-axle operation
- 02.31 Describe clutch operation
- 02.32 Describe clutch release linkage mechanisms
- 02.33 Describe manual transmission trans-axle operation
- 02.34 Describe 4 X 4 transfer case systems
- 02.35 Demonstrate a knowledge of the internal combustion engine, both diesel and gasoline

MODULE 2 BASIC AUTOMOTIVE TECHNICIAN SKILLS

02.01 TASK: Use and maintain hand tools, such as screwdrivers, special applications pliers, hammers, chisels, punches, special applications wrenches and sockets, files, hack saws, bench vises and C-clamps

PERFORMANCE OBJECTIVE: Given a set of hand tools and access to a tool room, perform an inventory, record any tools that are unsafe, broken or need repairs.

ENABLING OBJECTIVES:

1. Identify basic hand tools
2. Identify special tools used in engine repair
3. Identify tools used to service drive lines
4. Explain in writing the purpose of hand tools
5. Replace a hammer handle
6. Dress a grinding stone
7. Dress a screwdriver
8. Use a flat file
9. Sharpen a twist drill
10. Dress a brass drift
11. Put a new blade on a hack saw
12. Dress a punch or chisel
13. Use a torque wrench, bar and micrometer type
14. Explain four types of files
15. Use an adjustable wrench
16. Use a breaker bar
17. Identify special front-end tools

02.02 TASK: Demonstrate use of precision measuring tools

PERFORMANCE OBJECTIVE: Given the proper measuring tool and a crankshaft, cylinder and flywheel, measure these units. Result should be within .0005 inch of instructor's measurement.

ENABLING OBJECTIVES:

1. Demonstrate how to hold a micrometer while measuring
2. Measure a crankshaft journal
3. Measure a cylinder for taper, out-of-round and diameter
4. Measure flywheel runout
5. Demonstrate the use of a slide caliper

02.03

TASK: Apply basic welding skills related to the automobile industry

PERFORMANCE OBJECTIVE: Given flat metal and the proper welding equipment, apply basic welding skills, following electrical safety rules and acetylene welding rules using the welding manual as a guide for identifying proper welds.

ENABLING OBJECTIVES:

1. Demonstrate safety procedures when welding
2. Demonstrate the ability to start, stop and restart a bead
3. Name the welding positions
4. List reasons for a poor weld
5. Describe the effects of raising and lowering the arc welding current
6. List types of electrodes
7. List rules for safe handling of oxygen and acetylene equipment
8. List causes of a backfire
9. Identify types of oxyacetylene flames
10. Demonstrate the ability to turn on, light, adjust flame and turn off the oxyacetylene equipment
11. Identify the parts of oxyacetylene welding equipment
12. Identify the types of welding goggles and shields

02.04

TASK: Use and maintain power tools, such as drills, bench grinders, drill presses, hydraulic presses, impact wrenches, air chisels, parts washers, hydraulic jacks and vehicle hoists

PERFORMANCE OBJECTIVE: Given repair jobs that use power tools, follow all safety rules and manufacturer's directions.

ENABLING OBJECTIVES:

1. Describe safety rules for power equipment and tools
2. Demonstrate the ability to drill a hole using a drill press
3. Demonstrate the ability to cut metal with a power chisel
4. Raise a vehicle on a vehicle hoist
5. Raise a vehicle using a hydraulic jack, placing jack stands under the vehicle for safety
6. Demonstrate a safe method of washing parts
7. Demonstrate removing a bearing from a shaft using a hydraulic press

02.05      TASK:    Use basic electrical equipment and meters

PERFORMANCE OBJECTIVE:    Given a vehicle, connect the electrical and electronic testers into the electrical system following the instructions in the manufacturer's handbook and charts of the electrical tester.    Test the electrical system using specifications from an auto repair manual.    Record information obtained.

ENABLING OBJECTIVES:

1.    Demonstrate safety precautions when connecting and disconnecting the test equipment
2.    Describe use of the electrical tester
3.    Demonstrate proper connecting and disconnecting of the electrical test equipment
4.    Describe the operation of an electrical analyzer
5.    Demonstrate the use of an ohm meter
6.    Demonstrate the use of a multi-meter
7.    Describe analog and digital test meters
8.    Demonstrate the use of a test light

02.06      TASK:    Use and install fasteners, such as screws and bolts, key screw extractors, helicoil inserts and thread tap and dies

PERFORMANCE OBJECTIVE:    Given a selection of fasteners, screw-extractors, helicoils, tap/die set, basic instruction manual and tools, use fasteners to secure metals or components to vehicle.    Follow manufacturer's specifications on fastener selection and installation.

ENABLING OBJECTIVES:

1.    Demonstrate how to select the proper fasteners for a project
2.    Demonstrate the use of a pitch gauge
3.    Cut external threads using a die
4.    Cut internal threads using a tap
5.    Describe the procedure for removing broken bolts
6.    Describe the procedure for removing broken taps
7.    Explain five types of nuts
8.    Demonstrate the use of pop rivet pliers
9.    Identify a taper tap
10.    Identify a bottoming tap
11.    Explain both the customary and metric thread specifications of bolts

12. Explain how a helicoil is used to repair damaged threads
13. Explain bolt classifications

02.07      TASK: Apply basic math skills

PERFORMANCE OBJECTIVE: Given a basic math problem, find the correct solution.

ENABLING OBJECTIVES:

1. Add using whole numbers
2. Multiply using whole numbers
3. Subtract using whole numbers
4. Divide using whole numbers
5. Change a fraction to a decimal
6. Change a decimal to a fraction
7. Add fractions
8. Divide fractions
9. Multiply fractions
10. Subtract using fractions
11. Add decimal numbers
12. Subtract decimal numbers
13. Multiply decimal numbers
14. Divide using decimal numbers
15. Explain percent
16. Explain angles
17. Demonstrate the ability to use a standard torque wrench

02.08      TASK: Apply metric math skills

PERFORMANCE OBJECTIVE: Given a metric problem and using a math manual, work the problem to its correct solution.

ENABLING OBJECTIVES:

1. Explain the metric system of measurement
2. Define: (a) meter; (b) centimeter; (c) millimeter; and (d) kilometer
3. Explain the Celsius temperature scale
4. Add, subtract, multiply and divide using metric units
5. Demonstrate the ability to use a metric torque wrench



02.09

TASK: Service vehicle with proper automotive lubricants

PERFORMANCE OBJECTIVE: Given a vehicle and access to service manuals, tools and equipment, service the vehicle with the proper lubricants. Follow manufacturer's specifications in selecting the lubricants.

ENABLING OBJECTIVES:

1. Demonstrate safety precautions while servicing vehicle
2. Explain grading of oils
3. Explain properties of grease
4. Change engine oil
5. Change oil filter, being careful to select the proper filter
6. Demonstrate a chassis grease job
7. Explain oil service classifications
8. Explain viscosity numbers
9. Demonstrate how to use special lubrication tools
10. Explain how to service the transmission and trans-axle
11. Explain how to service the differential
12. Explain how to service the transfer assembly

02.10

TASK: Demonstrate the use of shop manuals and tune-up charts

PERFORMANCE OBJECTIVE: Given an automotive repair work order showing repair problems and access to shop manuals, locate the information needed and record it on the work order.

ENABLING OBJECTIVES:

1. Demonstrate the ability to cross-reference from one repair manual to another
2. Explain how to select manuals to locate information needed
3. Demonstrate locating flat rate time
4. Demonstrate locating part's cost
5. Demonstrate locating major repair sections
6. Use a motors manual
7. Use a Chilton's manual
8. Use a Mitchell's manual
9. Demonstrate the ability to use a manufacturer's repair manual
10. Explain how to use a tune-up chart

11. Demonstrate how to locate a tune-up chart
12. Explain the location of tune-up decals
13. Demonstrate the ability to locate and use a wiring diagram
14. Explain how to locate and use an electrical diagram
15. Explain how to locate the vacuum section
16. Explain how to locate the emission section

02.11

TASK: Demonstrate a knowledge of automotive tubing types and sizes

PERFORMANCE OBJECTIVE: Given a variety of sizes and types of automotive tubing, identify them correctly.

ENABLING OBJECTIVES:

1. Define the term "I.D."
2. Define the term "O.D."
3. Demonstrate knowledge of steel tubing
4. Demonstrate knowledge of flex gas tubing
5. Demonstrate knowledge of evaporative hoses
6. Demonstrate correct use of tubing connectors and fasteners
7. Demonstrate knowledge of vacuum hose
8. Explain where each type should be used

02.12

TASK: Demonstrate skill in electrical soldering

PERFORMANCE OBJECTIVE: Given two pieces of wire, the proper tools and a manual, properly join the wires together by soldering.

ENABLING OBJECTIVES:

1. Explain the results of too little heat
2. Explain the results of too much heat
3. Demonstrate knowledge of types of solder: (a) acid core; (b) rosin core; and (c) solid solder
4. Explain the use of soldering paste
5. Explain and demonstrate proper insulation removal
6. Explain and demonstrate proper joining before soldering
7. Explain and demonstrate proper covering after soldering: (a) electrical tape and (b) heat shrink tubing

02.13      TASK:    Define electrical terms

PERFORMANCE OBJECTIVE:    Given proper manuals and test equipment, explain the electrical terms: magnetism, electrical current and Ohm's law, sources and electronic theory.

ENABLING OBJECTIVES:

1. Explain: (a) magnetism; (b) electrical current flow; (c) Ohm's law; and (d) electronic theory
2. Explain what happens when electrical pressure is applied to a magnet
3. Explain what E.I.R. means
4. Explain the difference between voltage current and resistance

02.14      TASK:    Understand and apply the rules of series circuits

PERFORMANCE OBJECTIVE:    Given a bread board, battery wire, resistors and proper test equipment, build a series circuit and explain the series circuit laws.

ENABLING OBJECTIVES:

1. Demonstrate safety precautions when working on live electrical circuits
2. Explain why a closed loop of wire does not necessarily make a circuit
3. State the series circuit laws
4. State total voltage drop in a series circuit
5. State the current flow in the circuit
6. State the total resistance in the circuit

02.15      TASK:    Understand and apply the rules of parallel circuits

PERFORMANCE OBJECTIVE:    Given a bread board, battery wire, resistors and proper test equipment, build a parallel circuit and explain parallel circuit laws.

ENABLING OBJECTIVES:

1. State the parallel circuit laws
2. Explain the difference between series and parallel circuits
3. Explain what happens to current when resistance is added to a parallel circuit

4. Explain what happens to voltage
5. Explain why combined resistance in a parallel circuit is less than the smallest resistor

02.16      TASK:      Understand and apply the rules of series-parallel circuits

PERFORMANCE OBJECTIVE:      Given a bread board, proper manuals and test equipment, build a series-parallel circuit and explain series-parallel circuitry.

ENABLING OBJECTIVES:

1. Demonstrate safety precautions when working on live electrical circuits
2. Explain the differences in series, parallel and series-parallel circuits
3. Explain what happens as you add resistance to the circuit
4. Explain what happens when you add voltage to a series-parallel circuit
5. Explain where a series-parallel circuit would be used in an automobile circuit

02.17      TASK:      Define steering geometry and suspension geometry

PERFORMANCE OBJECTIVE:      Given proper textbooks and repair manuals, explain the following: steering angles, toe in and four-wheel steering.

ENABLING OBJECTIVES:

1. Explain caster angle
2. Explain camber angle
3. Explain toe in
4. Explain toe in and toe out on turns
5. Explain king pin inclination
6. Explain four-wheel steering
7. Explain four-wheel alignment

02.13      TASK:      Explain the function of steering and suspension system components

PERFORMANCE OBJECTIVE:      Given proper textbook and repair manuals, explain the function of the following steering and suspension components.

ENABLING OBJECTIVES:

1. Explain the function of coil springs, leaf spring and torsion bars
2. Explain the terms: twin "I" beams and Quadralinks
3. Explain the function of suspension bushings
4. Explain the function of shock absorbers
5. Explain the function of tie rod ends
6. Explain the function of ball joints and spindle bolts
7. Describe the difference between McPherson struts and control arm suspension
8. Describe the difference between Pitman arms and control arms
9. Explain four-wheel steering

02.19

TASK: Explain and describe the components of manual and power steering

PERFORMANCE OBJECTIVE: Given proper textbooks and repair manuals, explain the function of steering systems.

ENABLING OBJECTIVES:

1. Explain the function of a manual steering gear
2. Explain the operation of power steering gears
3. Explain the difference between integral and linkage type power steering
4. Explain the operation of rack and pinion gears
5. Explain the function of a power steering pump
6. Explain problems that are caused by power steering fluid leakage

02.20

TASK: Describe drum brake operation

PERFORMANCE OBJECTIVE: Given proper textbook and repair manual, explain the following brake components and brake problems.

ENABLING OBJECTIVES:

1. Describe the operation of drum brakes
2. Describe the operation of automatic brake adjusters
3. Describe brake problems that can cause brake pull
4. Describe brake problems that can cause brake chatter
5. Describe brake problems that cause brake pedal pulsations

6. Describe the cause of brake fade
7. Explain the necessity for checking brake linings
8. Explain the function of brake boosters

02.21 TASK: Describe disc brake operation

PERFORMANCE OBJECTIVE: Given proper textbook and repair manuals, explain the operation of disc brakes.

ENABLING OBJECTIVES:

1. Describe the function of a disc brake caliper assembly
2. Explain the causes of brake pull
3. Explain the possible causes of brake pedal pulsations
4. Explain the operation of anti-skid brake systems
5. Explain the causes of low brake pedal

02.22 TASK: Describe operation of brake system valves

PERFORMANCE OBJECTIVE: Given proper textbook and repair manuals and factory handouts, explain brake system valves.

ENABLING OBJECTIVES:

1. Explain the function of pressure differential valve
2. Explain the function of the proportioning valve
3. Explain the function of the brake warning light
4. Explain the function of the brake metering valve

02.23 TASK: Explain proper brake pedal height

PERFORMANCE OBJECTIVE: Given proper textbook and repair manual, explain the term: pedal height.

ENABLING OBJECTIVES:

1. Explain hydraulic principles as they apply to a hydraulic brake system
2. Explain the effect loose brake shoe adjustment has on pedal height
3. Explain how air in hydraulic fluid line affects pedal height
4. Explain the effect master cylinder push rod adjustment will have on brake pedal height
5. Explain the effect worn brake pedal bushings and connecting pins have on brake pedal height
6. Explain the effect that heat has on brake fluid

02.24

TASK: Demonstrate a knowledge of basic automotive engine cooling systems

PERFORMANCE OBJECTIVE: Given proper study materials and information, pass a test covering automotive engine cooling systems.

ENABLING OBJECTIVES:

1. Explain the operation of a radiator
2. Explain the operation of an engine water jacket
3. Explain the operation of a thermostat
4. Explain the operation of a water pump
5. Explain the operation of a radiator cooling fan
6. Explain the operation of hoses and belts

02.25

TASK: Demonstrate a knowledge of automotive heating and air conditioning systems

PERFORMANCE OBJECTIVE: Given proper study materials and information, pass a test covering automotive heating and air conditioning systems.

ENABLING OBJECTIVES:

1. Explain operation of heater hoses
2. Explain operation of water control valves
3. Explain operation of heater cores
4. Explain operation of electrical, vacuum and mechanical heater controls
5. Explain operation of heater ducting
6. Explain operation of air conditioning compressor
7. Explain operation of condenser
8. Explain operation of receiver-dryers and accumulators
9. Explain operation of flow control devices (exp valves, exp tubes)
10. Explain operation of evaporators
11. Explain operation of evaporator control devices, EPR
12. Explain operation of electrical controls, switches, wiring
13. Explain operation of vacuum controls, switches, hoses
14. Explain operation of high pressure and suction hoses
15. Explain temperature-pressure relationship of Freon 12
16. Explain safety precautions when handling Freon 12
17. Explain operation of compressor lubrication systems

02.26 TASK: Demonstrate knowledge of different wire sizes and different terminal ends

PERFORMANCE OBJECTIVE: Demonstrate a knowledge of different wiring sizes and different terminal ends by passing a written examination.

ENABLING OBJECTIVES:

1. Demonstrate knowledge of AWG wire sizes
2. Demonstrate knowledge of metric wire sizes
3. Explain amperage characteristics of different sized wires
4. Explain the differences among various wire terminals
5. Explain different wire material

02.27 TASK: Demonstrate a knowledge of automotive ignition and fuel system

PERFORMANCE OBJECTIVE: Given a vehicle, textbook, repair manual, films, videos and slides, take a test that measures understanding of the ignition and fuel systems.

ENABLING OBJECTIVES:

1. List the components of an ignition system
2. List the components of a fuel system
3. Explain the operation of the ignition system
4. Explain the operation of the fuel system

02.28 TASK: Describe rear axle operation

PERFORMANCE OBJECTIVE: Given proper textbooks and repair manuals, explain the operation of the rear axle.

ENABLING OBJECTIVES:

1. Explain differential operation
2. Explain limited slip mechanism
3. Define floating, 3/4 floating and semi-floating axles

02.29 TASK: Describe drive shaft operation

PERFORMANCE OBJECTIVE: Given proper service manuals and textbooks, explain drive shaft operation and inspection.



ENABLING OBJECTIVES:

1. Explain the working angle
2. Identify worn U-joints
3. Identify slip joint
4. Explain single joint
5. Explain constant velocity joint
6. Explain yoke and phase alignment

02.30 TASK: Describe automatic transmission and trans-axle operation

PERFORMANCE OBJECTIVE: Given proper service manual and textbooks, explain automatic transmission power flow operation.

ENABLING OBJECTIVES:

1. Explain torque converter function
2. Identify gears in the planetary gear system
3. Explain power flow
4. Explain the hydraulic system
5. Explain the operation of the trans-axle transmission
6. Explain how automatic transmission fluid cools and lubricates

02.31 TASK: Describe clutch operation

PERFORMANCE OBJECTIVE: Given the proper textbooks and service manuals, explain the operation of a clutch.

ENABLING OBJECTIVES:

1. Identify the major parts of the clutch
2. Explain the wearing areas of the clutch
3. Explain engagement and disengagement
4. Explain power flow

02.32 TASK: Describe clutch release linkage mechanisms

PERFORMANCE OBJECTIVE: Given the proper textbooks and manuals, identify the different types of clutch linkage.

ENABLING OBJECTIVES:

1. Identify mechanical linkage
2. Identify cable linkage
3. Identify hydraulic linkage

02.33      TASK: Describe manual transmission and trans-axle operation

PERFORMANCE OBJECTIVE: Given transmission textbook and service manuals, explain the operation of a manual transmission.

ENABLING OBJECTIVES:

1. Explain torque multiplication
2. Explain power flow in all gears
3. Explain synchronizer operation
4. Identify the different systems of shift mechanisms
5. Explain the difference in a trans-axle power flow and figuring gear ratio.

02.34      TASK: Describe 4 X 4 transfer case systems

PERFORMANCE OBJECTIVE: Given transfer case manuals and textbooks, identify the difference in transfer cases.

ENABLING OBJECTIVES:

1. Identify part-time transfer cases
2. Identify full-time transfer cases
3. Identify locking hubs
4. Explain adjustments on shifting linkage

02.35      TASK: Demonstrate a knowledge of the internal combustion engine, both diesel and gasoline

PERFORMANCE OBJECTIVE: Given equipment, components and any charts needed, explain the operations of diesel and gasoline internal combustion engines.

ENABLING OBJECTIVES:

1. Explain the operation of the lubrication system
2. Explain the operation of the timing gear system
3. Explain the operation of the valves
4. Explain the operation of the piston assembly
5. Explain the difference in construction and operation of a diesel engine and a gasoline engine

IDAHO PROGRAM STANDARDS FOR BASIC AUTOMOTIVE TECHNICIAN

MODULE 3

DIAGNOSING/TROUBLESHOOTING ELECTRICAL/ELECTRONIC COMPONENTS

Division of Vocational Education  
State of Idaho  
Boise, Idaho  
1989

### MODULE 3 - DIAGNOSING/TROUBLESHOOTING ELECTRICAL/ELECTRONIC COMPONENTS

This is one of a series of modules which comprise the Idaho Program Standards for Basic Automotive Technician. Each module contains a listing of the tasks, performance objectives, and enabling objectives required to enable a student to achieve competency in a specific system or field of study within the basic automotive technician occupational field. The numbering of these modules is not intended to dictate an order of instruction or scheduling. The order in which these modules may be taught is determined by each institution and its instructors.

Each task describes an occupational activity which will result in a finished process or product. Such a process or product should always allow an evaluation using standards which address the operation, appearance, dimensions, time in which achieved, or similar characteristics. The tasks listed in each module represent the basic activities required of each student to demonstrate entry level competence for that specific system or field of study within the automotive occupation.

The capability for providing instructional experiences and practical application of the tasks contained in each module will determine the scope of the vocational-technical program. In this regard, the student's maturity and preparation to receive instruction as well as the availability of equipment and the expertise of the instructional staff will be of primary importance. Individual records of student performance in completing the tasks listed within each module should be maintained.

Although some provision is made for basic mathematics and communication skills within these standards they may not be adequate to meet the needs of individual students. Counseling, guidance, and diagnostic test results may indicate a need for further preparation in these areas. In such cases, instructors are encouraged to utilize the resources and personnel within the institution to improve or complement the instructional process.

The benefits to students and institutions derived from these curriculum standards should be considerable. Articulation of students from secondary to post-secondary programs will be aided through the use of a single set of curriculum standards. The standards provide a tool for evaluation of local curricula and programs. The standards may be used in a flexible manner to assure that Basic Automotive Technician programs meet the needs of local business and industry.

It is the goal of this program standard to provide a level of instruction which will impart entry level employment skills. Students should be carefully counseled on the importance of attaining competency in the tasks assigned. As in virtually all occupations today, basic automotive technicians will require

periodic up-dating and review in the future. It is important that each student understand that meeting the program standards is essential not only to obtain employment today but also to have a base upon which to retain employment in the future.

IDAHO PROGRAM STANDARDS FOR BASIC AUTOMOTIVE TECHNICIAN

TASK LISTING

MODULE 3 - DIAGNOSING/TROUBLESHOOTING ELECTRICAL/ELECTRONIC COMPONENTS

- 03.0 APPLY ELECTRICAL AND ELECTRONIC SKILLS IN DIAGNOSING/TROUBLESHOOTING MALFUNCTIONS OF ELECTRICAL/ELECTRONIC COMPONENTS (Computerized or Non-computerized)  
--The student will be able to:
- 03.01 Demonstrate and apply safety rules and procedures
  - 03.02 Diagnose electrical engine malfunctions
  - 03.03 Perform power checks
  - 03.04 Measure voltage drop, current flow, continuity and resistance in a circuit or component
  - 03.05 Locate an open circuit or a short circuit
  - 03.06 Analyze cranking system malfunctions
  - 03.07 Analyze charging system malfunctions
  - 03.08 Service and test batteries
  - 03.09 Remove and replace light bulbs
  - 03.10 Inspect, remove, and replace alternator belts
  - 03.11 Test, remove, and replace fuses and circuit breakers
  - 03.12 Replace and test starters
  - 03.13 Test and overhaul alternators
  - 03.14 Remove and replace regulators
  - 03.15 Inspect and repair lighting systems
  - 03.16 Diagnose, repair or replace turn signal and stop light switches
  - 03.17 Test and replace electrical system switches
  - 03.18 Diagnose, repair, or replace power window and power seat systems, including motors
  - 03.19 Diagnose, repair, or replace horn systems
  - 03.20 Diagnose, repair, or replace clock systems
  - 03.21 Diagnose, repair, or replace warning buzzer
  - 03.22 Test and replace instrument panel units
  - 03.23 Service or repair windshield wiper/washer systems
  - 03.24 Test and replace electronic control units
  - 03.25 Check, remove, and replace radios

MODULE 3 - APPLY ELECTRICAL AND ELECTRONIC SKILLS IN DIAGNOSING/  
TROUBLESHOOTING MALFUNCTIONS OF ELECTRICAL/ELECTRONIC  
COMPONENTS

03.01 TASK: Demonstrate and apply safety rules and procedures

PERFORMANCE OBJECTIVE: Given examples of repair jobs and shop situations in electrical and electronic repair apply shop safety rules and procedures by identifying safe and unsafe shop practices.

ENABLING OBJECTIVES:

1. Discuss reasons for not wearing rings, watches and jewelry when working on a vehicle
2. State precautions to use when working with gasoline
3. State reasons for not wearing loose clothing, ties and long hair
4. State precautions for priming carburetor with gasoline
5. Apply fire safety rules
6. Apply electrical and electronic safety rules
7. Apply proper jacking and lift precautions
8. Discuss battery handling and charging precautions

03.02 TASK: Diagnose electrical engine malfunctions

PERFORMANCE OBJECTIVE: Given a vehicle, service manual and necessary tools, perform an electrical test for an electrical malfunction.

ENABLING OBJECTIVES:

1. Demonstrate safety precautions when performing electrical tests
2. Explain test equipment hook-ups
3. Describe which test to perform for specific malfunction
4. Explain procedure for removal and replacement of malfunctioning component
5. Demonstrate the ability to put tools and equipment away in proper place after use

03.03 TASK: Perform power checks

PERFORMANCE OBJECTIVE: Given a live fused or circuit breaker circuit, test for serviceability by using an amp meter, test light or volt meter.

ENABLING OBJECTIVES:

1. Demonstrate safety precautions while working on electrical units
2. Explain how an amp meter, test light or volt meter can be used to determine current flow
3. Explain care in handling electrical circuits and test equipment
4. Demonstrate proper knowledge of function switch and lead connections of a VOM

03.04

TASK: Measure voltage drop, current flow, continuity and resistance in a circuit or component

PERFORMANCE OBJECTIVE: Given a vehicle, volt/amp tester and ohm meter, service manual and necessary tools, test electrical unit for amperage and voltage drop and continuity. Record readings and compare with specifications.

ENABLING OBJECTIVES:

1. Demonstrate safety precautions when testing electrical circuits
2. Explain how many amps are being drawn by the unit
3. Explain the various voltage drops
4. Explain hook up and test operation for the unit
5. Describe results of the test
6. Explain parasitic drain

03.05

TASK: Locate an open circuit or a short circuit

PERFORMANCE OBJECTIVE: Given a vehicle with a known ground, short, or open circuit, the proper tools and service manual, locate and repair the condition. The student should achieve accuracy, speed, and safety on the task.

ENABLING OBJECTIVES:

1. Demonstrate safety precautions while working on an electrical circuit
2. Discuss how the whole wiring system of a vehicle can be broken down into individual electrical systems and the problem isolated to a particular system
3. Demonstrate use of test equipment
4. Identify the circuit and type of electrical failure



5. Demonstrate the type of repair necessary to correct problem
6. Demonstrate test for proper operation of repaired circuit

03.06 TASK: Analyze cranking system malfunctions

PERFORMANCE OBJECTIVE: Given a vehicle, service manual, proper tools and test equipment, analyze cranking malfunctions in the starting system.

ENABLING OBJECTIVES:

1. Demonstrate safety precautions
2. Describe how a starting system operates
3. State the purpose of neutral starting switch
4. Test battery cables and connections
5. Test starter current draw
6. Explain the function of the starter solenoid

03.07 TASK: Analyze charging system malfunctions

PERFORMANCE OBJECTIVE: Given a vehicle, service manual, volt amp tester, and necessary tools, test alternator for maximum output. When completed the recorded output should be compared to specifications. Safety precautions must be observed as the vehicle engine is running.

ENABLING OBJECTIVES:

1. Demonstrate safety precautions when using test equipment on an operating engine
2. Explain the different ways that manufacturers check maximum output of their alternators
3. Demonstrate use of and proper "hook-up" of alternator test equipment
4. Explain result of "low" output of alternator
5. Explain result of "high" output of alternator

03.08 TASK: Service and test batteries

PERFORMANCE OBJECTIVE: Given a vehicle with a battery, proper tools, test and cleaning equipment, load test a battery and clean connections.

ENABLING OBJECTIVES:

1. Demonstrate safety precautions when working with battery test equipment
2. Explain amperage draw versus voltage values

3. Demonstrate how to hook up a volt meter, ammeter and carbon pile
4. State sequence of removal of battery cables
5. Describe proper methods and chemicals to clean battery cables
6. Demonstrate use of protective coatings on connections
7. Discuss the advantages and/or disadvantages of a side-mount battery over a top-mount battery
8. Describe proper charging procedures

03.09

TASK: Remove and replace light bulbs

PERFORMANCE OBJECTIVE: Given a vehicle, service manual and necessary tools, remove and replace a light bulb. When completed, all terminals must be secure, wires routed correctly and bulb operate correctly.

ENABLING OBJECTIVES:

1. Demonstrate safety precautions
2. Discuss examples of units and other components that must be removed in order to remove and replace the bulb
3. Demonstrate proper use of tools
4. Demonstrate proper use of service manual

03.10

TASK: Inspect, remove and replace alternator belts

PERFORMANCE OBJECTIVE: Given a vehicle, service manual, and proper tools, inspect, remove, replace and adjust the alternator belt. Check belt condition for serviceability, tension, and bolts for tightness.

ENABLING OBJECTIVES:

1. Demonstrate safety precautions
2. Explain the importance of belt tightness on an alternator-equipped vehicle
3. Inspect drive belt for cracks and excessive wear
4. Demonstrate use of drive belt tension gauge "hand" method test

7.

03.11 TASK: Test, remove and replace fuses and circuit breakers

PERFORMANCE OBJECTIVE: Given a vehicle, service manual, proper tools and replacement parts, test, remove and replace a fuse or circuit breaker. When finished the unit will be securely fastened in place. Circuit should be in operational order when completed.

ENABLING OBJECTIVES:

1. Demonstrate safety precautions while working on electrical unit
2. Explain how an ammeter, volt meter or test light can be used to determine current flow
3. Demonstrate proper use of ohm meter on unit being tested
4. Define circuit breaker and its function

03.12 TASK: Replace and test starters

PERFORMANCE OBJECTIVE: Given a vehicle, service manual, necessary tools and parts, remove, repair or replace starter. When completed all terminals must be secure, all bolts tightened and starter will operate to manufacturer's specifications.

ENABLING OBJECTIVES:

1. Demonstrate safety precautions while working on electrical circuits
2. Explain the need for a starter draw test
3. Explain the need for a voltage drop test on the positive and negative side of the circuit
4. Explain the results of the tests
5. Inspect all parts for burning, wear and general condition
6. Demonstrate bench test for proper operation

03.13 TASK: Test and overhaul alternators

PERFORMANCE OBJECTIVE: Given an alternator, service manual and necessary tools and parts, test and overhaul an alternator. When completed all bolts must be tight, proper points lubricated and terminals secure. Alternator should perform to specifications.

ENABLING OBJECTIVES:

1. Demonstrate safety precautions when servicing an alternator
2. Explain how brushes are loaded and installed in an alternator
3. Demonstrate bearing checks and lubrication
4. Demonstrate tests for positive and negative diodes
5. Demonstrate test for proper output of unit

03.14

TASK: Remove and replace regulators

PERFORMANCE OBJECTIVE: Given a vehicle, service manual and necessary tools, remove and replace the voltage regulator. All bolts, screws and terminal connections must be secure. Check wires for proper positioning.

ENABLING OBJECTIVES:

1. Demonstrate safety precautions when working on electrical circuits
2. Explain which systems have internal and which systems have external regulators and how the procedures for removing or replacing them differ
3. Identify external regulator
4. Demonstrate removal and replacement of external regulator and careful handling of electrical connections
5. Identify internal regulator type of alternator
6. Demonstrate removal and replacement of alternator and replacement of internal regulator

03.15

TASK: Inspect and repair lighting systems

PERFORMANCE OBJECTIVE: Given a lighting system problem, service manual and necessary tools, diagnose the problem and make necessary repairs. Upon completion the system will operate correctly.

ENABLING OBJECTIVES:

1. Demonstrate safety precautions
2. Demonstrate method of testing to be performed on a specific unit
3. Demonstrate removal and installation of components
4. Demonstrate use of wiring schematics
5. Demonstrate proper use of test equipment to include: test light, DVOM, short finder
6. Explain proper wire repair procedures

03.16

TASK: Diagnose, repair or replace turn signal and stop light switches

PERFORMANCE OBJECTIVE: Given a vehicle, service manual and necessary tools, diagnose, remove and replace switch. When completed all terminals must be secure, wires routed correctly and correct wire on correct terminal. The switch must be securely mounted and adjusted as needed.

ENABLING OBJECTIVES:

1. Demonstrate safety precautions while working on an electrical circuit
2. Demonstrate use of DVOM
3. Demonstrate use of wiring schematics
4. Explain complete circuit of unit tested
5. Demonstrate test for proper operation

03.17

TASK: Test and replace electrical system switches

PERFORMANCE OBJECTIVE: Given a vehicle, service manual and necessary tools, test and replace a switch. When completed switch must be mounted securely and adjusted as needed. Switch should control circuit as intended by manufacturer.

ENABLING OBJECTIVES:

1. Demonstrate safety precautions
2. Demonstrate method of testing to be performed on circuit
3. Explain the importance of care to be taken with delicate switches and wiring
4. Explain the procedures for removal and replacement

03.18

TASK: Diagnose, repair or replace power window and power seat systems, including motors

PERFORMANCE OBJECTIVE: Given a vehicle, service manual and proper tools, diagnose and repair power window and power seat circuits. When repair is completed all trim will have been installed correctly and unit will function according to specifications.

ENABLING OBJECTIVES:

1. Demonstrate safety precautions while testing or replacing electrical units
2. Identify the components and circuits
3. Demonstrate use of wiring schematics

4. Demonstrate use of proper test equipment
5. Demonstrate proper procedures of removal of trim panels and upholstery

03.19      TASK: Diagnose, repair or replace horn systems

PERFORMANCE OBJECTIVE:      Given a vehicle, service manual and necessary tools, diagnose and repair a horn system. Upon completion the horn will function properly.

ENABLING OBJECTIVES:

1. Demonstrate safety precautions while testing
2. Explain complete circuit being tested
3. Demonstrate use of wiring schematics
4. Demonstrate knowledge of proper disassembly of horn control circuit
5. Demonstrate test for proper operation of repaired circuit

03.20      TASK: Diagnose, repair or replace clock systems

PERFORMANCE OBJECTIVE:      Given a vehicle, service manual and necessary tools, properly diagnose and repair clock circuit. Upon completion, system will be operational, properly aligned with no rattles.

ENABLING OBJECTIVES:

1. Explain diagnostic procedures
2. Demonstrate proper use of wiring schematics
3. Explain circuit being tested
4. Explain proper disassembly and reassembly of dash board and components

03.21      TASK: Diagnose, repair or replace warning buzzer

PERFORMANCE OBJECTIVE:      Given a vehicle, service manual and necessary tools, diagnose and repair or replace warning buzzer. When completed, buzzer will be properly secured and operational.

ENABLING OBJECTIVES:

1. Demonstrate proper use of shop manual and manufacturer's wiring schematics
2. Explain diagnostic procedures and repair procedures

3. Explain circuit operation
4. Demonstrate test of repaired circuit for proper operation

03.22      TASK:    Test and replace instrument panel units

PERFORMANCE OBJECTIVE:    Given a vehicle, service manual and necessary tools, test and replace instrument panel units. Upon completion unit will be operational, with no rattles or scratches.

ENABLING OBJECTIVES:

1. Observe special procedures and test procedures for electrical safety
2. Demonstrate proper use of shop manual
3. Demonstrate proper use of test equipment
4. Explain operation of circuit being repaired

03.23      TASK:    Service or repair windshield wiper/washer systems

PERFORMANCE OBJECTIVE:    Given a vehicle, service manual and necessary tools and parts, properly service or repair the windshield wiper/washer system. When completed, system will operate as manufacturer intended.

ENABLING OBJECTIVES:

1. Demonstrate proper filling procedures for windshield washer
2. Explain proper procedures for wiper blade replacement
3. Demonstrate knowledge of windshield wiper/washer system
4. Demonstrate proper use of service manual
5. Explain diagnostic procedures
6. Demonstrate proper use of DVOM

03.24      TASK:    Test and replace electronic control units

PERFORMANCE OBJECTIVE:    Given a vehicle with an electronic control unit, service manual and necessary tools, test and replace electronic control unit. Upon completion of repair, system should operate correctly and set no diagnostic codes.

ENABLING OBJECTIVES:

1. Demonstrate proper use of shop manual
2. Explain system operation
3. Explain problem found and proper repair procedures
4. Demonstrate proper use of diagnostic equipment

03.25

TASK: Check, remove and replace radios

PERFORMANCE OBJECTIVE: Given a vehicle with a radio, service manual and necessary tools, check, remove and replace radio. When completed all connections must be tight, radio properly aligned, with no scratches or rattles and fully operational.

ENABLING OBJECTIVES:

1. Demonstrate proper use of manufacturer's service manual for removal procedures
2. Demonstrate use of wiring schematics
3. Demonstrate use of DVOM
4. Explain results of diagnosis
5. Demonstrate test for proper operation of repaired circuit

30



MODULE 4

ENGINE PERFORMANCE SERVICE

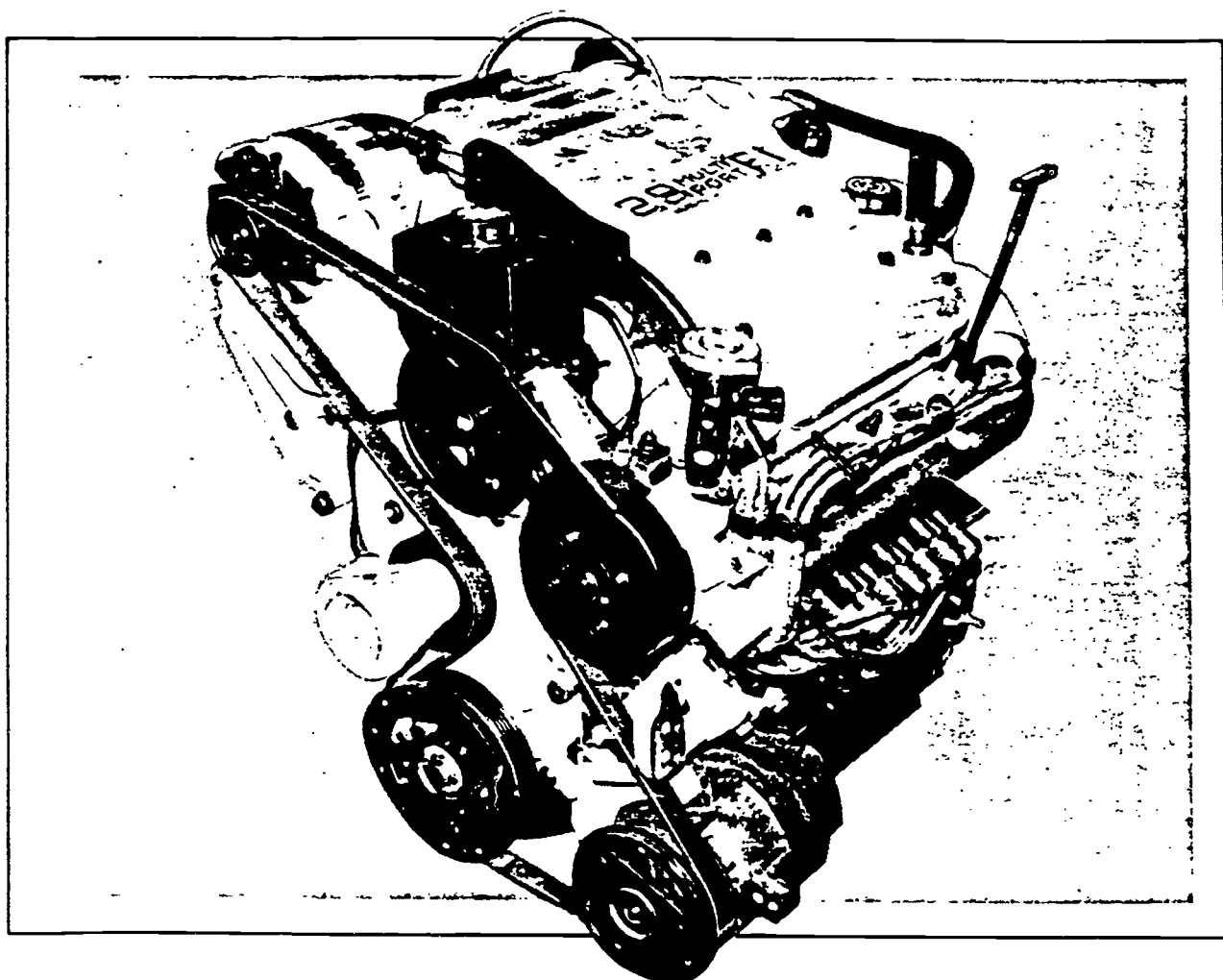

IDAHO PROGRAM STANDARDS FOR BASIC AUTOMOTIVE TECHNICIAN

MODULE 4

ENGINE PERFORMANCE SERVICE

Division of Vocational Education  
State of Idaho  
Boise, Idaho  
1989

#### MODULE 4 - ENGINE PERFORMANCE SERVICE

This is one of a series of modules which comprise the Idaho Program Standards for Basic Automotive Technician. Each module contains a listing of the tasks, performance objectives, and enabling objectives required to enable a student to achieve competency in a specific system or field of study within the basic automotive technician occupational field. The numbering of these modules is not intended to dictate an order of instruction or scheduling. The order in which these modules may be taught is determined by each institution and its instructors.

Each task describes an occupational activity which will result in a finished process or product. Such a process or product should always allow an evaluation using standards which address the operation, appearance, dimensions, time in which achieved, or similar characteristics. The tasks listed in each module represent the basic activities required of each student to demonstrate entry level competence for that specific system or field of study within the automotive occupation.

The capability for providing instructional experiences and practical application of the tasks contained in each module will determine the scope of the vocational-technical program. In this regard, the student's maturity and preparation to receive instruction as well as the availability of equipment and the expertise of the instructional staff will be of primary importance. Individual records of student performance in completing the tasks listed within each module should be maintained.

Although some provision is made for basic mathematics and communication skills within these standards they may not be adequate to meet the needs of individual students. Counseling, guidance, and diagnostic test results may indicate a need for further preparation in these areas. In such cases, instructors are encouraged to utilize the resources and personnel within the institution to improve or complement the instructional process.

The benefits to students and institutions derived from these curriculum standards should be considerable. Articulation of students from secondary to post-secondary programs will be aided through the use of a single set of curriculum standards. The standards provide a tool for evaluation of local curricula and programs. The standards may be used in a flexible manner to assure that Basic Automotive Technician programs meet the needs of local business and industry.

It is the goal of this program standard to provide a level of instruction which will impart entry level employment skills. Students should be carefully counseled on the importance of attaining competency in the tasks assigned. As in virtually all occupations today, basic automotive technicians will require

periodic up-dating and review in the future. It is important that each student understand that meeting the program standards is essential not only to obtain employment today but also to have a base upon which to retain employment in the future.

83

IDAHO PROGRAM STANDARDS FOR BASIC AUTOMOTIVE TECHNICIAN

TASK LISTING

MODULE 4 - ENGINE PERFORMANCE SERVICE

04.0 DEMONSTRATE PROFICIENCY IN ENGINE PERFORMANCE SERVICE

--The student will be able to:

- 04.01 Demonstrate and apply safety rules and procedures
- 04.02 Analyze engine performance
- 04.03 Perform cylinder compression tests
- 04.04 Check the performance of engines equipped with on-board computers
- 04.05 Inspect, remove, and replace points and condensers
- 04.06 Remove and replace distributors
- 04.07 Check distributors using a distributor tester
- 04.08 Check the distributor advance in a vehicle
- 04.09 Overhaul distributors
- 04.10 Inspect and test primary circuits
- 04.11 Remove and replace coils
- 04.12 Remove and replace ignition switch
- 04.13 Inspect, remove, and replace ignition wires, caps, and rotors
- 04.14 Remove and replace spark plugs
- 04.15 Perform cylinder leakage tests
- 04.16 Service electronic ignition systems
- 04.17 Service oxygen feedback systems
- 04.18 Service air cleaners
- 04.19 Inspect, remove, and replace fuel filters
- 04.20 Measure fuel flow and pressure
- 04.21 Remove and replace fuel lines
- 04.22 Remove and replace fuel pumps, mechanical and electrical
- 04.23 Adjust idle speed
- 04.24 Adjust idle mixture (propane)
- 04.25 Clean and adjust choke and check proper operation of electrical choke
- 04.26 Clean and overhaul carburetors
- 04.27 Inspect, remove, and replace manifold control valve
- 04.28 Remove and replace turbochargers
- 04.29 Check and adjust waste gate
- 04.30 Set idle speed to specification (fuel injection)

- 04.31 Remove and replace fuel injectors
- 04.32 Service throttle body injection system
- 04.33 Service ported fuel injection
- 04.34 Service I CV system
- 04.35 Service evaporative control system
- 04.36 Service thermostatic air cleaner
- 04.37 Service air injection system
- 04.38 Inspect, remove, and replace air-pump belts
- 04.39 Service Exhaust Gas Recirculation (EGR) systems
- 04.40 Service ignition timing controls
- 04.41 Test exhaust emission using an HC/CO tester
- 04.42 Remove and replace catalytic converter beads
- 04.43 Service diesel injectors
- 04.44 Remove and replace diesel engine fuel filters and water separator, if one has been added
- 04.45 Check and adjust injection pump timing
- 04.46 Remove and replace injection pump
- 04.47 Check and adjust idle and maximum speeds
- 04.48 Test and service pre-heat system
- 04.49 Diagnose diesel fuel emission problems
- 04.50 Inspect exhaust system
- 04.51 Remove and replace tail pipe
- 04.52 Remove and replace muffler
- 04.53 Remove and replace exhaust pipe
- 04.54 Inspect, remove, and replace catalytic converter

MODULE 4 - ENGINE PERFORMANCE SERVICE

04.01

TASK: Demonstrate and apply safety rules and procedures

PERFORMANCE OBJECTIVE: Given examples of repair jobs and shop situations during engine performance service, apply shop safety rules and procedures by identifying safe and unsafe shop practices.

ENABLING OBJECTIVES:

1. Identify common hazards in the repair shop, including (a) improper use of tools; (b) unguarded machinery; (c) tripping and falling; (d) excessive exposure to exhaust gases, parts cleaners, paints and dust; (e) electrical hazards; and (f) improper lifting
2. Identify and explain warning signs posted in the shop area
3. Explain the importance of good housekeeping in the repair shop
4. Explain the importance of storing materials in a secure manner
5. Identify and explain potential hazards associated with (a) asbestos; (b) carbon monoxide; (c) solvents; (d) paints and thinners; (e) dusts; (f) noise; and (g) hydrogen gas
6. Explain safety rules and procedures for using compressed air equipment
7. Explain safety rules for welding, cutting and brazing
8. Inspect the repair shop for conformity with safety rules and procedures

04.02

TASK: Analyze engine performance

PERFORMANCE OBJECTIVE: Given a vehicle, service manual, access to an engine analyzer and other test equipment, perform an engine performance test. Record any malfunction in the primary circuit, secondary circuit, computer control and sensors, fuel system, emission system and power balance.

ENABLING OBJECTIVES:

1. Demonstrate safety precautions when working with test leads around the engine
2. Describe the function and operation of an engine analyzer

3. Demonstrate operation of an engine analyzer
4. Explain primary circuit
5. Explain secondary circuit
6. Describe and demonstrate emission test
7. Describe and demonstrate power balance test

04.03

TASK: Perform cylinder compression test

PERFORMANCE OBJECTIVE: Provided an engine at normal operating temperatures, tools, gauges and service manual, perform a cylinder compression test. Cylinder pressure variation must test within manufacturer's specifications. Perform wet and dry tests for significant deviations.

ENABLING OBJECTIVES:

1. Demonstrate safety precautions when testing an operating engine
2. Describe steps in preparing an engine for a cylinder compression test
3. Describe how to install gauge and take reading
4. Explain "wet" and "dry" test and the importance of each
5. Explain all deviations found during test

04.04

TASK: Check the performance of engines equipped with on-board computers

PERFORMANCE OBJECTIVE: Given a vehicle with an on-board computer, necessary test equipment, service or repair manual, diagnostic test manual and test codes, diagnose and/or repair computer controls.

ENABLING OBJECTIVES:

1. Demonstrate safety precautions
2. Describe the function of the computer control
3. Determine location of the computer
4. Explain and demonstrate use of test equipment
5. Explain and demonstrate factory test procedure
6. Demonstrate application of plug-in for computer control
7. Explain reason for test codes



04.05

TASK: Inspect, remove and replace points and condensers

PERFORMANCE OBJECTIVE: Given a distributor (or vehicle) requiring point or condenser replacement, access to proper service manual and tools, remove and replace the points and condenser within manufacturer's specifications. All connections must be secure and positioned to avoid shortage in electrical circuit.

ENABLING OBJECTIVES:

1. Demonstrate safety precautions
2. Explain dwell settings
3. Describe the condenser effect

04.06

TASK: Remove and replace distributor

PERFORMANCE OBJECTIVE: Given a vehicle with distributor ignition problem, proper service manual, access to necessary tools, remove and replace distributor unit according to manufacturer's timing specifications within +/- one degree. Tighten down bolt and insert all distributor secondary wires securely in the distributor cap.

ENABLING OBJECTIVES:

1. Explain function of distributor
2. Describe engine timing with distributor
3. Explain timing setting at 180 degrees out
4. Explain extra precautions after doing above operation and before starting the engine

04.07

TASK: Check distributor using a distributor tester

PERFORMANCE OBJECTIVE: Given a vehicle with a timing problem, access to proper service manual, tools and electrical equipment, test initial timing and set distributor to manufacturer's specifications; test centrifugal advance with vacuum disconnected for smooth, even advance; test vacuum advance mechanism by attaching hose. Examine distributor for full curve, smooth, even operation to manufacturer's specifications.

ENABLING OBJECTIVES:

1. Demonstrate safety precautions for working on a live engine
2. Explain spark advance curve
3. Describe equipment hook-up
4. Demonstrate use of specification manual

04.08 TASK: Check the distributor advance in the vehicle

PERFORMANCE OBJECTIVE: Given a vehicle needing timing test, proper service manual and access to necessary tools and equipment, analyze the timing and advance mechanisms. Record any malfunction in the initial ignition timing setting, vacuum spark advance mechanism and centrifugal advance action.

ENABLING OBJECTIVES:

1. Demonstrate safety precautions while testing a "live" engine
2. Describe hook-up of timing strobe light and/or magnetic pick-up.
3. Explain initial ignition timing
4. Explain vacuum spark advance action
5. Explain centrifugal spark advance operation

04.09 TASK: Overhaul distributor

PERFORMANCE OBJECTIVE: Given a vehicle with a defective operating distributor, access to proper service manual, tools and equipment, disassemble and rebuild distributor to manufacturer's specifications.

ENABLING OBJECTIVES:

1. Explain operation of distributor
2. Describe initial timing settings
3. Demonstrate safety precautions

04.10 TASK: Inspect and test primary circuits

PERFORMANCE OBJECTIVE: Given a vehicle with ignition wiring problem, access to necessary tools and equipment, test primary wire circuit to coil from battery for resistance on both circuits. Any deviation from manufacturer's specifications must be corrected.

ENABLING OBJECTIVES:

1. Describe use of test equipment
2. Explain engine cranking current and engine running current variations
3. Demonstrate use of test equipment
4. Define primary and secondary circuits
5. Demonstrate safety precautions

04.11 TASK: Remove and replace coil

PERFORMANCE OBJECTIVE: Given a vehicle with defective coil, access to proper service manual and test equipment, test coil for deviation from manufacturer's specifications. Any variation from specifications is cause for replacement of unit.

ENABLING OBJECTIVES:

1. Explain function of coil
2. Describe wiring procedure of coil
3. Demonstrate use of test equipment
4. Demonstrate safety precautions

04.12 TASK: Remove and replace ignition switch

PERFORMANCE OBJECTIVE: Given a vehicle, necessary service manuals and tools, remove and replace an ignition switch. Care must be taken when installing the ignition switch so the switch locks the steering wheel and operates the ignition system.

ENABLING OBJECTIVES:

1. Demonstrate safety precautions necessary to disconnect battery when working with electrical system
2. Explain operation of the ignition switch
3. Demonstrate removing and replacing the switch
4. Demonstrate operation of the ignition switch after installation

04.13 TASK: Inspect, remove and replace ignition wires, cap and rotor

PERFORMANCE OBJECTIVE: Given a vehicle with defective spark plug wires, necessary service manuals and tools, replace each plug wire, routing wires according to manufacturer's specifications. Replacement wires must meet or exceed manufacturer's specifications.

ENABLING OBJECTIVES:

1. Demonstrate safety precautions
2. Describe engine firing order
3. Explain routing of plug wires
4. Demonstrate replacement of wires
5. Describe operation of the distributor cap and rotor
6. Demonstrate replacement of cap and rotor

04.14 TASK: Remove and replace spark plugs

PERFORMANCE OBJECTIVE: Given a vehicle needing spark plugs, proper service manual, necessary tools and equipment, remove and replace spark plugs, set plug gap and torque plugs to manufacturer's specifications and replace wires securely.

ENABLING OBJECTIVES:

1. Describe spark plug heat range and sizes
2. Explain spark plug gap settings (standard and electronic)
3. Demonstrate removal, gap setting and torque of spark plug
4. Demonstrate safety precautions

04.15 TASK: Perform cylinder leakage test

PERFORMANCE OBJECTIVE: Given an engine at normal operating temperature, tools, equipment and service manual, perform a cylinder leakage test following the manufacturer's recommended procedures. Leakage in excess of manufacturer's specifications must be noted and explained.

ENABLING OBJECTIVES:

1. Demonstrate safety precautions
2. Explain method to prepare engine for cylinder leakage test
3. Identify parts of cylinder leakage
4. Demonstrate use of cylinder leakage tester
5. Record and compute differences in pressure leakage of cylinder
6. Describe deviations from specifications and explain causes

04.16

TASK: Service electronic ignition system

PERFORMANCE OBJECTIVE: Given a vehicle(s), necessary service manuals and tools, test and service electronic ignition system. Student should be able to test and service all makes. Test all systems and follow all test codes. Care must be taken to use proper test equipment.

ENABLING OBJECTIVES:

1. Demonstrate proper safety procedures and use of correct testing equipment
2. Explain how the electronic ignition system works
3. Name the major components of the ignition system
4. Name the systems for Ford, GM, Chrysler and AMC
5. Define CCC, EEC, MCU, C-4, EMC, Hall Effect, C31, SSI, TFI and HEI
6. Explain why computer controls are necessary
7. Describe common precautions and procedures for computer control service

04.17

TASK: Service oxygen feedback system

PERFORMANCE OBJECTIVE: Given a vehicle, necessary service manuals and tools, test and service an oxygen feedback system. Take care to use proper test equipment.

ENABLING OBJECTIVES:

1. Demonstrate safety precautions and use proper test equipment
2. Describe feedback system
3. Locate and test sensors for feedback system
4. Explain closed and open loop
5. Explain limp home mode
6. Explain trouble codes

04.18

TASK: Service air cleaner

PERFORMANCE OBJECTIVE: Given a vehicle, proper tools, shop manual and necessary filter elements, inspect, service or replace carburetor air cleaner. Inspect main filter element and the positive crankcase ventilation system filter (if used). Clean or replace filter(s). When service is completed, the air cleaner will limit induction noise, filter, and serve as a flame arrester.

ENABLING OBJECTIVES:

1. Explain purpose and operation of the air cleaner canister and filters
2. Explain service procedure
3. Demonstrate a simple air filter element test
4. Demonstrate safety precautions

04.19

TASK: Inspect, remove and replace fuel filters

PERFORMANCE OBJECTIVE: Given a vehicle, tubing wrenches, and in-line filter, replace fuel filter. With the engine operating, the installed unit will not leak and will be positioned as recommended by the manufacturer.

ENABLING OBJECTIVE:

1. Demonstrate gasoline handling safety procedure
2. Explain installation procedure; include proper location for safe operation
3. Inspect all connections very carefully for fuel leaks

04.20

TASK: Measure fuel flow and pressure

PERFORMANCE OBJECTIVE: Given a vehicle, tools, equipment and service manual, measure fuel pump volume, pressure and vacuum. Check pressure and volume at specified time and RPM. To test suction side of fuel pump or malfunctioning pump valves, make vacuum test. Disconnect fuel line, connect vacuum gauge at this point on the fuel inlet side of pump and start engine to obtain vacuum reading. Secure the engine side line and the vacuum should remain for the specified time. Pressure, volume and vacuum will meet manufacturer's requirements.

ENABLING OBJECTIVES:

1. Demonstrate safety precautions when working with automobile fuels
2. Explain test procedure of fuel system and safety rules
3. Explain fuel system operation and location
4. Demonstrate use of test equipment

04.21 TASK: Remove and replace fuel lines

PERFORMANCE OBJECTIVE: Given a vehicle and the necessary tools, repair or replace fuel lines and hoses. Hoist car and place safety stands. Inspect fuel lines and hoses from the fuel tank to the inlet side of the carburetor, and repair or replace fuel lines or hoses as required. Lines and hoses will be free of restrictions, leaks or other defects. Remove stands and lower vehicle.

ENABLING OBJECTIVES:

1. Demonstrate safety precautions when working under a raised vehicle and with fuels
2. Explain hose and line selection
3. Demonstrate line repair procedure for metal and flexible lines
4. Inspect all flexible lines for weather and heat cracks

04.22 TASK: Remove and replace fuel pumps (mechanical and electrical)

PERFORMANCE OBJECTIVE: Given a vehicle, service manual, necessary tools and parts, remove and replace the fuel pump. When completed, bolt tightening, gasket installation and proper line hook-up and routing will be checked.

ENABLING OBJECTIVES:

1. Discuss the advantages and disadvantages of mechanical versus electric fuel pumps
2. Explain the differences between a two-line and a three-line fuel pump
3. Describe fuel pump pressures, vacuums and "vapor lock"
4. Inspect connections carefully for fuel leaks
5. Demonstrate safety precautions

04.23 TASK: Adjust idle speed

PERFORMANCE OBJECTIVE: Given a vehicle, necessary service manuals and tools, adjust engine idle speed. When completed the proper curb idle, high idle and air fuel ratio should be within factory specifications.

ENABLING OBJECTIVES:

1. Demonstrate safety precautions
2. Explain function of idle adjustment
3. Explain anti-dieseling solenoid
4. Demonstrate test equipment and operation
5. Explain air fuel adjustment

04.24 TASK: Adjust idle mixture (propane)

PERFORMANCE OBJECTIVE: Given a vehicle, service manual and proper tools, perform a propane enrichment carburetor adjustment. When complete the specifications will be compared to the actual test results. Any deviation will be pointed out by the mechanic. Safety will also be checked.

ENABLING OBJECTIVES:

1. Demonstrate safety precautions
2. Explain the advantage of setting a carburetor by this method rather than the conventional way
3. Demonstrate exhaust emission test (if exhaust emission test equipment is available)

04.25 TASK: Clean and adjust choke and check proper operation of electric choke

PERFORMANCE OBJECTIVE: Given a vehicle, an approved cleaning fluid and access to the proper tools, inspect, clean and adjust choke unit. When completed, the choke should be clean, move or operate freely and at desired temperature ranges. The choke pull-off should have been checked for operation as well as the choke "high" idle.

ENABLING OBJECTIVES:

1. Demonstrate safety precautions
2. Explain choke operation
3. Explain method of adjusting different types of chokes
4. Demonstrate proper cold setting of a standard automatic choke assembly



04.26

TASK: Clean and overhaul carburetor

PERFORMANCE OBJECTIVE: Given a vehicle, service manual and necessary tools and replacement parts, rebuild a carburetor. When completed the carburetor should have all screws, clamps and hoses secured. The carburetor should operate and be adjusted within manufacturer's specifications.

ENABLING OBJECTIVES:

1. Demonstrate safety precautions when using carburetor cleaners
2. Explain disassembly and assembly procedures (include testing and setting assembly parts)
3. Demonstrate cleaning and "blowing" dry procedures and inspection of all parts to be reassembled
4. Define carburetor and exhaust gas recirculation (EGR)

04.27

TASK: Inspect, remove and replace manifold control valve

PERFORMANCE OBJECTIVE: Given a vehicle, tools and an approved high temperature lubricant, service or repair manifold heat controls. The valve will be checked and serviced or replaced as necessary. When operating, the heat riser valve will close when cold, will open when engine is accelerated and will open wide when hot.

ENABLING OBJECTIVES:

1. Demonstrate safety precautions
2. Explain the operation of the manifold heat riser controls
3. Explain reason for carburetor heat
4. Identify a manifold heat riser

04.28

TASK: Remove and replace turbochargers

PERFORMANCE OBJECTIVE: Given a vehicle, necessary repair manuals, access to required tools and equipment, remove and replace turbocharger. Examine each component and record condition. Check carburetor, plenum chamber, turbine assembly, waste gate and actuator, compressor and oiling system.

ENABLING OBJECTIVES:

1. Demonstrate safety precautions
2. Explain turbocharger design and operation
3. Explain troubleshooting the turbocharger
4. Explain each component of the turbocharger
5. Explain and demonstrate the use of the tools and equipment necessary to remove and replace the turbocharger
6. Describe the advantages and disadvantages of turbochargers

04.29

TASK: Check and adjust waste gate

PERFORMANCE OBJECTIVE: Given a vehicle, service manual and necessary tools, test and adjust waste gate. When completed the gate must open properly and smoothly to the desired manufacturer's specifications. If any deviation is noted, a reason must be stated.

ENABLING OBJECTIVES:

1. Explain the purpose of the turbocharger waste gate
2. Identify the waste gate location in the exhaust system
3. Identify the actuator and waste gate activating rod
4. Demonstrate activating rod adjustment
5. Demonstrate safety precautions

04.30

TASK: Set idle speed to specification (fuel injection)

PERFORMANCE OBJECTIVE: Given a vehicle with fuel injection, necessary service manuals and tools, adjust idle speed to specification. Care should be taken to use proper test equipment.

ENABLING OBJECTIVES:

1. Demonstrate safety precautions
2. Explain idle speed adjustments
3. Describe the differences between throttle body and ported injection and their adjustments
4. Explain test equipment required for adjustments

04.31

TASK: Remove and replace fuel injectors

PERFORMANCE OBJECTIVE: Given a vehicle, service manual and tools, replace or service the fuel injection nozzle. When completed all bolts must be properly torqued and any lines or wires must be correctly secured and routed. Any O rings or seals must not leak.

ENABLING OBJECTIVES:

1. Demonstrate safety precautions when handling fuel
2. Discuss the advantages or disadvantages of locally servicing or rebuilding a fuel injection nozzle
3. Demonstrate removal and replacement of injection nozzle
4. Explain job of O rings

04.32

TASK: Service throttle body injection system

PERFORMANCE OBJECTIVE: Given a vehicle, necessary tools and repair manuals, service and/or repair a throttle body injection fuel system. It is necessary to service air control system, computer control system, sensors and fuel delivery system.

ENABLING OBJECTIVES:

1. Demonstrate safety precautions
2. Describe the difference between carburetion and throttle body injection
3. Describe the air control system
4. Describe the different sensors
5. Describe the computer control system
6. Describe the fuel delivery system

04.33

TASK: Service ported fuel injection

PERFORMANCE OBJECTIVE: Given a vehicle, necessary tools and service manuals, service and/or repair ported fuel injection. It is necessary to check or service wiring, sensors, computer system, fuel lines, injectors and pressure pump.

ENABLING OBJECTIVES:

1. Demonstrate safety precautions
2. Describe operation of ported injection
3. Describe necessary service of ported injection
4. Describe timing of injectors
5. Demonstrate service of injection system

04.34      TASK:   Service PCV system

PERFORMANCE OBJECTIVE:   Given a vehicle, service manual and necessary tools, test and/or repair PCV system. Upon completion the mechanic will note any faulty or worn parts. Hoses must be of the appropriate length and correctly routed.

ENABLING OBJECTIVES:

1. Explain the difference between "closed" and "open" crankcase ventilation
2. Describe a "down draft" tube operation
3. Demonstrate manifold vacuum test for PCV hose connection port
4. Demonstrate safety precautions

04.35      TASK:   Service evaporative control system

PERFORMANCE OBJECTIVE:   Given a vehicle, service manual and necessary tools, check and service the fuel evaporation system. When completed the lines will be examined for length, security and proper routing.

ENABLING OBJECTIVES:

1. Explain the purpose of the fuel evaporation system
2. Describe the manner of function of this unit
3. Identify the places where fuel evaporates and explain how evaporation is controlled
4. Demonstrate method for testing the system
5. Demonstrate safety precautions

04.36      TASK:   Service thermostatic air cleaner

PERFORMANCE OBJECTIVE:   Given a vehicle, service manual and necessary tools, service the thermostatic air cleaner. When completed all hoses should be connected correctly, the hot air pipe should be installed, and door operation should have been checked.

ENABLING OBJECTIVES:

1. Describe how this air cleaner functions and how it assists the driveability of a vehicle in cold weather
2. Demonstrate test of air filter element
3. Explain PCV system filter, if equipped
4. Demonstrate safety precautions

04.37      TASK:   Service air injection system

PERFORMANCE OBJECTIVE:    Given a vehicle, service manual, exhaust gas analyzer and necessary tools, test the AIR system. When completed, the student's reading will be compared to actual emission's readings. The student will compare his reading to specifications and determine if the system is functioning properly.

ENABLING OBJECTIVES:

1. Explain the purpose of the AIR system
2. Demonstrate use of an exhaust gas analyzer
3. Demonstrate proper exhaust gas analyzer test connections
4. Solve any exhaust gas problems (leaks and failure to meet specifications)
5. Demonstrate safety precautions

04.38      TASK:   Inspect, remove and replace air pump and belts

PERFORMANCE OBJECTIVE:    Given a vehicle, service manual and necessary tools and parts, remove and replace AIR system components. This will include the air pump, belt, diverter valve, manifold/distribution lines and check valve. When completed the alignment, whether or not bolts have been torqued, leakage and hose and line routing will be examined.

ENABLING OBJECTIVES:

1. Demonstrate safety precautions
2. Explain how a faulty component in the AIR system can cause an explosion in the exhaust system
3. Explain need for AIR system in meeting pollution standards
4. Demonstrate test of system with exhaust gas analyzer

04.39      TASK:   Service Exhaust Gas Recirculation (EGR) system

PERFORMANCE OBJECTIVE:    Given a vehicle, service manual, vacuum pump and necessary tools, test and service the EGR valve and component operation. Upon completion the length and routing of the hose will be examined. Gasket security and positioning will also be checked. When finished the EGR valve must open and close completely when vacuum is applied and released.

ENABLING OBJECTIVES:

1. Explain the purpose of routing burned exhaust gas back into the engine combustion chamber
2. Describe test of EGR valve
3. Explain effect of recirculation of exhaust gases on combustion chamber
4. Demonstrate safety precautions

04.40 TASK: Service ignition timing control

PERFORMANCE OBJECTIVE: Given a vehicle, necessary service manuals, tools and proper test equipment, service controls for ignition timing. Care must be taken to use proper test equipment.

ENABLING OBJECTIVES:

1. Demonstrate safety precautions while working on a live engine
2. Explain operation of electronic timing controls
3. Demonstrate use of test equipment
4. Describe location of sensors for adjusting timing
5. Define EST, ECM, HEI and how they are related
6. Explain trouble codes related to timing controls

04.41 TASK: Test exhaust emission using an HC/CO tester

PERFORMANCE OBJECTIVE: Given a vehicle, necessary service manuals, tools and test equipment, perform two-gas and four-gas emission test. Only HC/CO tester can be used for this test.

ENABLING OBJECTIVES:

1. Demonstrate safety precautions while running the engine
2. Define HC, CO, NOx, soot and smog
3. Describe procedures for testing emission
4. Explain what test equipment is required
5. Define emission requirements
6. Demonstrate test procedures

04.42 TASK: Remove and replace catalytic converter beads

PERFORMANCE OBJECTIVE: Given a vehicle, service manual, required tools and replacement beads, service catalytic converter beads. When completed a check will be made to see if all old beads were removed, the proper amount of new beads were installed, and the filter plug was tightened.

ENABLING OBJECTIVES:

1. Demonstrate precautions when working with exhaust systems
2. Identify what the beads are made of and how they help eliminate emissions
3. Demonstrate test of exhaust emissions using exhaust gas analyzer

04.43

TASK: Service diesel injectors

PERFORMANCE OBJECTIVE: Given a vehicle, service manual and tools, remove and service diesel fuel injectors. When completed test all injectors for proper spray pattern and for "O" ring leaks.

ENABLING OBJECTIVES:

1. Demonstrate safety precautions when handling injector nozzles
2. Demonstrate removal and replacement of injectors
3. Describe and demonstrate servicing injectors
4. Inspect all fuel line fittings for leaks
5. Explain the use of "O" rings

04.44

TASK: Remove and replace diesel engine fuel filters and water separator, if one has been added

PERFORMANCE OBJECTIVE: Given a vehicle, service manual and tools, remove and replace diesel engine fuel filter and service water separator, if so equipped.

ENABLING OBJECTIVES:

1. Demonstrate safety precautions
2. Locate fuel filter on vehicle
3. Locate water separator, if so equipped
4. Describe operation for replacement of fuel filter
5. Describe operation for servicing water separator
6. Check fuel lines for leaks when completed

04.45

TASK: Check and adjust injection pump timing

PERFORMANCE OBJECTIVE: Given a vehicle, service manual and necessary tools, check and adjust injector pump timing. When completed check all lines and mounting bolts, leaks and proper torque.

ENABLING OBJECTIVES:

1. Demonstrate safety precautions when working with injector pumps
2. Describe operation for adjusting pump timing
3. Describe built-in advance in the pump
4. Describe electrical controls for injector pump
5. Describe operation of the injector pump
6. Demonstrate timing of the pump

04.46

TASK: Remove and replace injection pump

PERFORMANCE OBJECTIVE: Given a vehicle, service manual and necessary tools, remove and replace injector pump. When completed check all fuel lines and fittings. Recheck pump timing.

ENABLING OBJECTIVES:

1. Demonstrate safety precautions
2. Describe operation of injector pump
3. Describe the timing of the pump
4. Describe the two types of injector pumps (mechanical and electrical)
5. Demonstrate removal and replacement of pump

04.47

TASK: Check and adjust idle and maximum speeds

PERFORMANCE OBJECTIVE: Given a vehicle, service manual and necessary tools, check and adjust idle and maximum speed of injector pump. When completed recheck idle and maximum speed adjustment. Check all fuel lines and fittings. Also check bolt torques.

ENABLING OBJECTIVES:

1. Demonstrate safety precautions
2. Refer to service manual for adjustments
3. Describe governor operation
4. Describe charging cycle
5. Describe discharge cycle
6. Demonstrate adjustment of idle and maximum speeds

04.48

TASK: Test and service pre-heat system

PERFORMANCE OBJECTIVE: Given a vehicle, service manual, necessary tools and equipment, test and service preheating or glow plug system. Care must be taken not to damage glow plugs when removing or replacing.



ENABLING OBJECTIVES:

1. Demonstrate safety precautions
2. Describe procedures for testing glow plugs
3. Demonstrate test procedures
4. Describe and demonstrate replacement of glow plugs

04.49

TASK: Diagnose diesel fuel emission problems

PERFORMANCE OBJECTIVE: Given a vehicle, necessary service manual, tools and proper test equipment, diagnose a diesel engine emission problem.

ENABLING OBJECTIVES:

1. Demonstrate safety precautions with the engine running
2. Explain the difference between gas and diesel emissions
3. Describe test equipment required for testing emission
4. Name the emission produced by a diesel engine
5. Define particulate matter; define emission requirements
6. Demonstrate testing emission on a diesel engine

04.50

TASK: Inspect exhaust system

PERFORMANCE OBJECTIVE: Given a vehicle, shop manual and necessary equipment, test exhaust system. All leaks, loose connections, misalignment, metal deterioration must be detected. System must function without leaks, noise, rattles or restrictions.

ENABLING OBJECTIVES:

1. Demonstrate safety procedures
2. Explain danger of exhaust fumes in the passenger compartment
3. Describe restriction problems
4. Describe exhaust gas test for pollutants
5. Demonstrate exhaust gas analyzer test
6. Detect metal deterioration

04.51 TASK: Remove and replace tail pipe

PERFORMANCE OBJECTIVE: Given a vehicle, service manual and necessary tools and equipment, remove and replace the tail pipe. The tail pipe must be installed with sufficient clearances and be attached securely. The tail pipe connections must not leak exhaust gases and must not rattle.

ENABLING OBJECTIVES:

1. Practice appropriate safety procedures
2. Describe routing and clearance
3. Explain leak dangers
4. Explain types of hangers

04.52 TASK: Remove and replace muffler

PERFORMANCE OBJECTIVE: Given a vehicle, service manual and necessary tools and equipment, remove and replace the muffler. The muffler must have the specified clearance and all supports must be tightened and clamps on the inlet and outlet torqued to prevent exhaust leakage and rattles.

ENABLING OBJECTIVES:

1. Demonstrate safety procedures
2. Demonstrate clamp bolt "freeing" agent and removal procedures
3. Explain "inlet" and "outlet" of muffler
4. Describe exhaust gas leak dangers
5. Describe clearance of system to include "U" bolt positions
6. Demonstrate methods of removal and replacement of muffler

04.53 TASK: Remove and replace exhaust pipe

PERFORMANCE OBJECTIVE: Given a vehicle, service manual and necessary tools and equipment, install the exhaust pipe. The exhaust pipe must fit the exhaust manifold outlet and be designed to fit supports and clamps. The system must be free of exhaust leaks and rattles.

ENABLING OBJECTIVES:

1. Demonstrate safety precautions
2. Demonstrate use of bolt "freeing" agent and removal procedures
3. Demonstrate bolt torque procedure
4. Explain exhaust gas leak dangers
5. Identify proper exhaust manifold and exhaust pipe gaskets

04.54

TASK: Inspect, remove and replace catalytic converter

PERFORMANCE OBJECTIVE: Given a vehicle with a defective catalytic converter, access to necessary tools and service manual, remove and replace the converter in the system according to manufacturer's procedures. There should be no leaks or excessive back pressure of the exhaust system. The heat shield should be properly placed with proper clearance and no rattles.

ENABLING OBJECTIVES:

1. Practice appropriate safety procedures
2. Explain use of heat shield
3. Explain function of catalytic converter
4. Describe exhaust system back-pressure test
5. Demonstrate exhaust gas analyzer test
6. Explain why leaded fuel must not be used with converters

MODULE 5

ENGINE REPAIR SERVICE

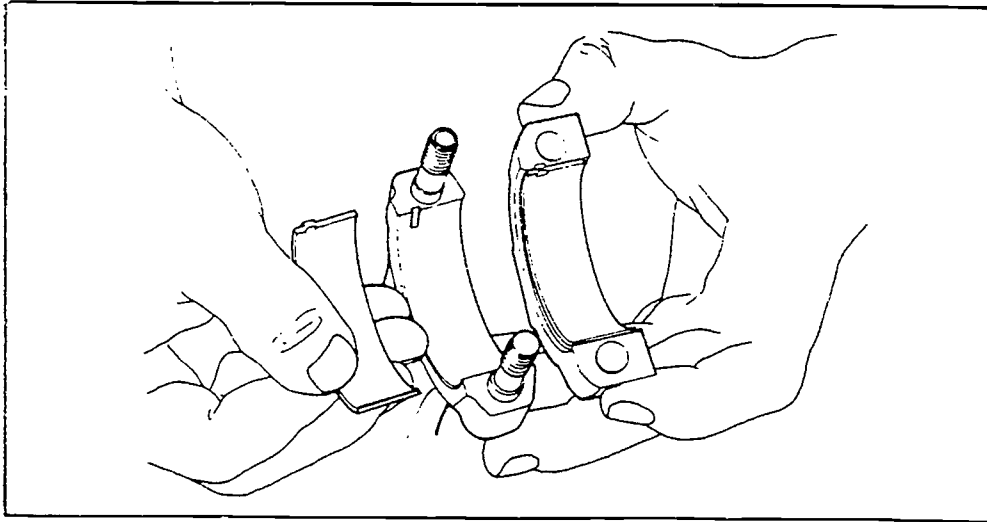

Installing Connecting Rod Bearings

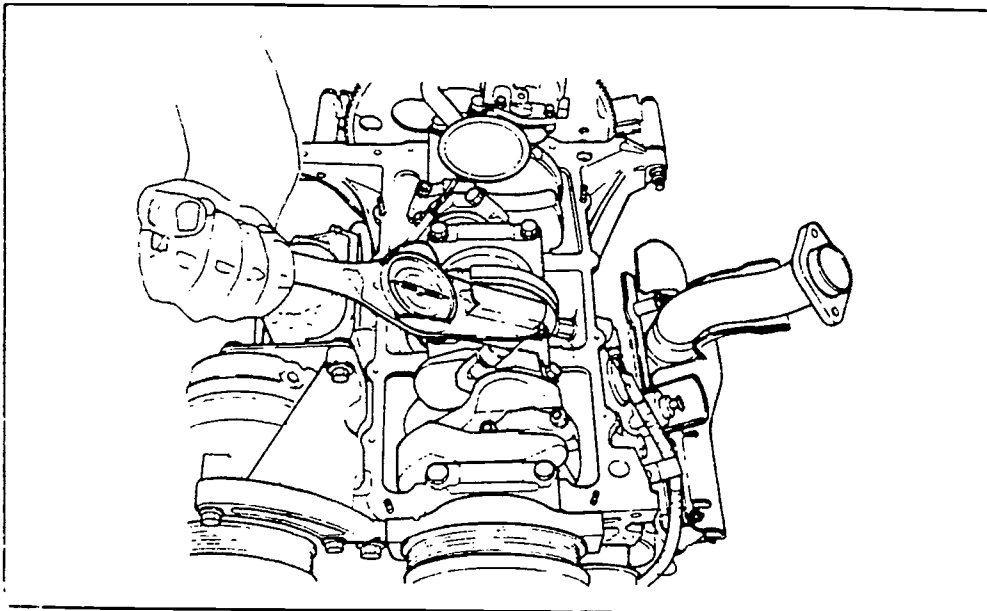

Applying Correct Torque to Rod Bearings

IDAHO PROGRAM STANDARDS FOR BASIC AUTOMOTIVE TECHNICIAN

MODULE 5

ENGINE REPAIR SERVICE

Division of Vocational Education  
State of Idaho  
Boise, Idaho  
1989

109

-109-

## MODULE 5 - ENGINE REPAIR SERVICE

This is one of a series of modules which comprise the Idaho Program Standards for Basic Automotive Technician. Each module contains a listing of the tasks, performance objectives, and enabling objectives required to enable a student to achieve competency in a specific system or field of study within the basic automotive technician occupational field. The numbering of these modules is not intended to dictate an order of instruction or scheduling. Thus the order in which these modules may be taught is determined by each institution and its instructors.

Each task describes an occupational activity which will result in a finished process or product. Such a process or product should always allow an evaluation using standards which address the operation, appearance, dimensions, time in which achieved, or similar characteristics. The tasks listed in each module represent the basic activities required of each student to demonstrate entry level competence for that specific system or field of study within the automotive occupation.

The capability for providing instructional experiences and practical application of the tasks contained in each module will determine the scope of the vocational-technical program. Thus the student's maturity and preparation to receive instruction as well as the availability of equipment and the expertise of the instructional staff will be of primary importance. Individual records of student performance in completing the tasks listed within each module should be maintained.

Although some provision is made for basic mathematics and communication skills within these standards they may not be adequate to meet the needs of individual students. Counseling, guidance, and diagnostic test results may indicate a need for further preparation in these areas. In such cases, instructors are encouraged to utilize the resources and personnel within the institution to improve or complement the instructional process.

The benefits to students and institutions derived from these curriculum standards should be considerable. Articulation of students from secondary to post-secondary programs will be aided through the use of a single set of curriculum standards. The standards provide a tool for evaluation of local curricula and programs. The standards may be used in a flexible manner to assure that Basic Automotive Technician programs meet the needs of local business and industry.

It is the goal of this program standard to provide a level of instruction which will impart entry level employment skills. Students should be carefully counseled on the importance of attaining competency in the tasks assigned. As in virtually all occupations today, basic automotive technicians will require

periodic up-dating and review in the future. Thus, it is important that each student understand that meeting the program standards is essential not only to obtain employment today but to have a base upon which to retain employment in the future.

IDAHO PROGRAM STANDARDS FOR BASIC AUTOMOTIVE TECHNICIAN

TASK LISTING

MODULE 5 - ENGINE REPAIR SERVICE

05.0 DEMONSTRATE PROFICIENCY IN ENGINE REPAIR SERVICE

--The student will be able to:

- 05.01 Demonstrate and apply safety rules and procedures
- 05.02 Perform running compression tests
- 05.03 Perform cylinder compression tests
- 05.04 Perform cylinder leakage tests
- 05.05 Clean engines
- 05.06 Determine source(s) of oil loss
- 05.07 Determine source(s) of coolant loss
- 05.08 Determine source(s) of excess noise
- 05.09 Determine cause(s) of over-heating
- 05.10 Check the engine oil pressure
- 05.11 Remove and replace motor mounts
- 05.12 Remove and replace core plugs
- 05.13 Inspect and measure flywheel runout
- 05.14 Remove and replace flywheel
- 05.15 Remove and replace flywheel ring gear
- 05.16 Remove and replace engine assemblies
- 05.17 Remove and replace oil pans
- 05.18 Remove and replace oil pumps
- 05.19 Clean cylinder blocks, oil passages, and pistons
- 05.20 Inspect blocks for warpage
- 05.21 Measure and inspect engine components for proper tolerances
- 05.22 Remove and replace crankshafts, mains, and rod bearings
- 05.23 Remove and replace camshafts
- 05.24 Remove and replace camshaft bearings
- 05.25 Remove and replace pistons and rings
- 05.26 Remove ridges and deglaze cylinder walls
- 05.27 Remove and replace front and rear oil seals
- 05.28 Remove and replace intake and exhaust manifolds
- 05.29 Remove, clean, inspect and replace cylinder heads; and inspect head for cracks and warpage
- 05.30 Test and replace hydraulic lifters
- 05.31 Pressure test hydraulic lifter
- 05.32 Reface valve and seats
- 05.33 Check valve guides for wear
- 05.34 Remove and replace timing chains and gears
- 05.35 Remove and replace timing belt
- 05.36 Test valve springs
- 05.37 Adjust valve lifters
- 05.38 Replace rocker-arm assemblies, inspect wear and lubrication
- 05.39 Change oil and oil filters with proper application



MODULE 5 - ENGINE REPAIR SERVICE

05.01 TASK: Demor,strate and apply safety rules and procedures

PERFORMANCE OBJECTIVE: Given examples of repair jobs and shop situations, apply shop safety rules and procedures by identifying safe and unsafe shop practices.

ENABLING OBJECTIVES:

1. Identify common hazards in the repair shop including:
  - a. improper use of tools
  - b. unguarded machinery
  - c. tripping and falling
  - d. excessive exposure to exhaust gases, parts cleaners, paints, and dust
  - e. electrical hazards
  - f. improper lifting
2. Identify and explain warning signs posted in shop area
3. Explain the importance of good housekeeping in the shop
4. Explain the importance of storing materials in a safe and secure manner
5. Explain the potential hazards associated with:
  - a. asbestos
  - b. paints and thinners
  - c. carbon monoxide
  - d. solvents
  - e. dusts
  - f. noise
  - g. hydrogen gas
6. Explain safety rules and procedures for using compressed air equipment
7. Explain the safety rules for welding, cutting, and brazing
8. Conduct an inspection of the shop for conformity with safety rules and procedures

05.02 TASK: Perform running compression tests

PERFORMANCE OBJECTIVE: Given an engine at normal operating temperatures, and using the correct test equipment and service manual, perform a cylinder balance test. A cylinder-to-cylinder deviation exceeding manufacturer's specification must be detected.

ENABLING OBJECTIVES:

1. Demonstrate safety precautions when operating test equipment on a running engine
2. Define cylinder power balance
3. Explain the operation of the balance tester
4. Define R.P.M.'s for specific engine balance test
5. Explain the reason for R.P.M. variance or drop

05.03

TASK: Perform cylinder compression tests

PERFORMANCE OBJECTIVE: Provided an engine at normal operating temperatures, tools, gauges, and service manual, perform a cylinder compression test. Cylinder pressure variation must test within manufacturer's specifications. Perform wet and dry tests for significant deviations.

ENABLING OBJECTIVES:

1. Demonstrate safety precautions when testing an operating engine
2. Describe steps in preparing an engine for a cylinder compression test
3. Describe how to install gauge and take reading
4. Explain "wet" and "dry" test and the importance of each
5. Explain all deviations found during test

05.04

TASK: Perform cylinder leakage tests

PERFORMANCE OBJECTIVE: Given an engine at normal operating temperature, tools, equipment, and service manual, perform a cylinder leakage test following the manufacturer's recommended procedures. Leakage in excess of manufacturer's specifications must be noted and explained.

ENABLING OBJECTIVES:

1. Demonstrate safety precautions
2. Explain method to prepare engine for cylinder leakage test
3. Identify parts of cylinder leakage tester
4. Demonstrate use of cylinder leakage tester
5. Record and compute differences in pressure leakage of cylinder
6. Describe deviations from specifications and explain causes

05.05

TASK: Clean engines

PERFORMANCE OBJECTIVE: Given an automobile with a dirty engine and necessary tools and equipment, clean the outer surface of deposits with no damage to related components.

ENABLING OBJECTIVES:

1. Demonstrate safety procedures and precautions
2. Demonstrate equipment operation and material control
3. Describe care of related engine equipment
4. Explain drying of distributor and wiring if a problem develops from moisture
5. Demonstrate care of painted surfaces

05.06

TASK: Determine source(s) of oil loss

PERFORMANCE OBJECTIVE: Given an engine at operating temperature, examine the engine for oil leaks. All gaskets must be securely fitted with no misalignment. No signs of oil should be around the gasket.

ENABLING OBJECTIVES:

1. Demonstrate safety precautions
2. Identify the most likely areas on an engine that develop oil leaks
3. Identify oil leaks that make other areas appear to be leaking oil
4. Distinguish between oil seepage leaks and pressure leakage
5. Describe the function of gaskets, gasket sealers and oil seals
6. Demonstrate proper oil seal installation

05.07

TASK: Determine source(s) of coolant loss

PERFORMANCE OBJECTIVE: Given a liquid cooled engine, test the engine cooling system with a pressure tester. Note any pressure deviation from the specified pressure ranges.

ENABLING OBJECTIVES:

1. Demonstrate safety precautions when external pressure is applied to cooling systems
2. Identify parts of engine cooling system

3. Describe pressure test on cooling system
4. Describe method to pressurize and check radiator caps
5. Demonstrate a pressure test on the cooling system and inspect for leaks

05.08 TASK: Determine source(s) of excess noise

PERFORMANCE OBJECTIVE: Given an engine at normal operating temperature, tools, equipment and service manual, perform an operational test and determine area of noise source.

ENABLING OBJECTIVES:

1. Demonstrate safety procedures while working on and around fan belts and gears
2. Describe types of noises that could be heard
3. Describe what can cause these noises
4. Identify major parts of the engine that can be damaged because of noise malfunctions
5. Demonstrate noise inspection and identify why the noise is present

05.09 TASK: Determine cause(s) of over-heating

PERFORMANCE OBJECTIVE: Given an engine with a liquid cooling system, visually inspect the cooling system for leaks. Radiator fins must be free of foreign matter, the pressure cap relief valve must not discharge pressure lower than permitted on the cap, the hoses must be securely connected, hoses must not restrict flow of liquid, the fan turning freely, and all drive belts must be properly adjusted.

ENABLING OBJECTIVES:

1. Demonstrate safety precautions when working with cooling system components
2. Describe detection technique where coolant track is inspected after area dries
3. Inspect radiator fins for foreign matter and system for leaks
4. Inspect hoses, fan, water pumps, belts, and core plugs for any defects
5. Demonstrate repair of any leak or correction of other defects
6. Demonstrate drive belt adjustment with gauge or by hand method
7. Demonstrate inspection for internal radiator blockage

05.10 TASK: Check the engine oil pressure

PERFORMANCE OBJECTIVE: Given an engine, service manual, and proper tools and test equipment, test the oil pump pressure. Any deviation from manufacturer's specification must be noted.

ENABLING OBJECTIVES:

1. Demonstrate safety precautions
2. Identify connection where oil pressure can be checked closest to the pump
3. Identify oil pump pressure gauge and describe method of operation
4. Inspect oil pressure pump for restrictions or wear, where practical
5. Demonstrate method of obtaining oil pump pressure, record any reading below or above specifications

05.11 TASK: Remove and replace motor mounts

PERFORMANCE OBJECTIVE: Given an automobile in need of engine mounts, tools, equipment, and service manual, remove and replace engine mounts according to manufacturer's procedures.

ENABLING OBJECTIVES:

1. Demonstrate safety procedures
2. Explain the function of engine mounts
3. Demonstrate removal of broken engine mounts (engine will be properly raised)
4. Demonstrate replacement of new mount

05.12 TASK: Remove and replace core plugs

PERFORMANCE OBJECTIVE: Given an engine block and cylinder head, necessary tools and proper equipment, remove and replace core plugs. No leaks should occur.

ENABLING OBJECTIVES:

1. Demonstrate safety precautions
2. Explain the function of freeze plugs
3. Demonstrate method of removal from cylinder head and engine block
4. Explain the need to clean the water jacket and remove rust from plug holes
5. Demonstrate replacement of new plugs of correct size
6. Inspect for leaks

05.13 TASK: Inspect and measure flywheel runout

PERFORMANCE OBJECTIVE: Given a flywheel, service manual, necessary tools, and a dial indicator, measure flywheel runout for serviceability.

ENABLING OBJECTIVES:

1. Demonstrate safety precautions
2. Describe how a dial indicator is used to measure runout
3. Demonstrate the testing procedure of flywheel runout
4. Inspect condition of flywheel surface and starter ring gear

05.14 TASK: Remove and replace flywheel

PERFORMANCE OBJECTIVE: Given a vehicle, service manual and necessary tools, remove and replace the flywheel. Bolt torque will coincide with manufacturer's specifications and locking tabs must be correctly secured.

ENABLING OBJECTIVES:

1. Demonstrate safety procedures when working under a raised vehicle
2. Demonstrate removal of a flywheel and related parts
3. Inspect the flywheel for clutch surface wear and starter ring gear damage
4. Demonstrate replacement of a flywheel, torquing of bolts, and locking procedure of bolts

05.15 TASK: Remove and replace flywheel ring gear

PERFORMANCE OBJECTIVE: Given a flywheel, service manual, and necessary tools, remove and replace the flywheel ring gear.

ENABLING OBJECTIVES:

1. Demonstrate safety precautions
2. Explain methods of removing the old ring
3. Demonstrate how to replace flywheel ring gear
4. Inspect installed ring gear for alignment

05.16

TASK: Remove and replace engine assemblies

PERFORMANCE OBJECTIVE: Given a vehicle in need of engine removal, service manual, tools and hoist equipment, remove and replace engine according to manufacturer's procedures. No damage will be incurred to accessory hardware and equipment.

ENABLING OBJECTIVES:

1. Demonstrate all safety precautions and procedures
2. Demonstrate operation of hoist or other protection
3. Describe protective procedures that can be followed to guard the automobile and accessories in the engine compartment from damage
4. Demonstrate removal of engine
5. Inspect related accessory components and perform repair and maintenance
6. Demonstrate replacement of engine and perform repair and maintenance
7. Demonstrate operational test (check oil, coolant, and wiring)

05.17

TASK: Remove and replace oil pans

PERFORMANCE OBJECTIVE: Given a vehicle with a damaged pan, necessary tools, equipment and service manual, remove pan and replace pan. Oil pan must not leak when finished.

ENABLING OBJECTIVES:

1. Demonstrate safety procedures while working under vehicle
2. Demonstrate proper jacking and supporting of vehicle
3. Discuss handling of fluids
4. Describe procedures of getting proper clearance between pan and frame to remove pan
5. Demonstrate cleaning pan area before reinstalling pan
6. Demonstrate pan removal from engine with engine out of vehicle
7. Explain precautions of installation of new pan gasket when putting pan on engine

05.18

TASK: Remove and replace oil pumps

PERFORMANCE OBJECTIVE: Given automobile engine needing an oil pump, a replacement oil pump, necessary tools, and proper service manual, remove and replace pump according to manufacturer's procedures. The pump must operate after installation at manufacturer's performance level without malfunction.

ENABLING OBJECTIVES:

1. Demonstrate safety precautions
2. Explain working procedure of oil pump and by-pass valve
3. Describe the function of the by-pass valve
4. Demonstrate measurement of gear or rotor of pump for excessive wear
5. Demonstrate operational test for specification pressure
6. Prime oil pump prior to installation

05.19

TASK: Clean cylinder blocks, oil passages, and pistons

PERFORMANCE OBJECTIVE: Given a disassembled engine, with access to proper cleaning equipment and tools, clean engine parts. All parts needing maintenance and repair must be identified. Any cracked or broken parts must be replaced. Each part must meet specifications set by the manufacturer. Parts must be protected from any damage until ready for assembly.

ENABLING OBJECTIVES:

1. Demonstrate safety procedures
2. Explain proper handling order of mixed parts
3. Describe cleaning of mating (machined) surfaces
4. Demonstrate precision measuring of surfaced parts of engine
5. Demonstrate cleaning of piston ring grooves
6. Demonstrate measuring wear in ring grooves

05.20

TASK: Inspect blocks for warpage

PERFORMANCE OBJECTIVE: Given an automobile engine block, with necessary tools and equipment, inspect the machined surfaces for warpage. Any warpage in excess of manufacturer's specifications must be corrected by proper machining. There should not be any cracks or defects in finished block.



ENABLING OBJECTIVES:

1. Demonstrate safety procedures
2. Explain machine surface inspection
3. Explain need for appropriate machining
4. Describe surface defects
5. Inspect engine block, making sure it meets manufacturer's specifications
6. Explain care of straight edge

C5.21 TASK: Measure and inspect engine components for proper tolerances

PERFORMANCE OBJECTIVE: Given engine parts (block, crankshaft, pistons), necessary tools, special measuring instruments, and service manual, measure all engine parts for wear. Any part exceeding manufacturer's wear specifications must be repaired or replaced before engine can be assembled.

ENABLING OBJECTIVES:

1. Demonstrate safety precautions
2. Explain use of micrometers
3. Demonstrate measuring techniques while using inside and outside micrometers (any deviation from manufacturer's specification must be noted)
4. Inspect all parts subject to reuse for wear
5. Describe parts found not to meet specifications

05.22 TASK: Remove and replace crankshafts, mains, and rod bearings

PERFORMANCE OBJECTIVE: Given an engine block prepared for assembly, necessary tools, equipment, and service manual, replace the main bearings, oil seals, and crankshaft according to the manufacturer's procedure. All main bearings' caps will be installed as numbered in indicated position, properly torqued to manufacturer's specification.

ENABLING OBJECTIVES:

1. Demonstrate safety procedures
2. Describe torque procedure for main bearings
3. Explain "line" bored
4. Demonstrate bearing fitting and proper main bearing positioning with oil seals in place
5. Demonstrate proper procedure to examine crankshaft end play

6. Explain use of plasti-gauge for checking clearance
7. Explain care of crank when removing and replacing rods
8. Explain why rods and mains are position marked when disassembled

05.23 TASK: Remove and replace camshafts

PERFORMANCE OBJECTIVE: Given an automobile engine, service manual, necessary tools and equipment, remove and replace the camshaft according to manufacturer's specifications. Inspect camshaft lobes for wear in excess of manufacturer's specification.

ENABLING OBJECTIVES:

1. Demonstrate safety precautions relating to proper timing
2. Explain function of camshaft
3. Demonstrate procedure for determining wear and inspecting lifters
4. Demonstrate removal and replacement of camshaft

05.24 TASK: Remove and replace camshaft bearings

PERFORMANCE OBJECTIVE: Given an automobile engine needing camshaft bearings, service manual, necessary tools and equipment, remove and replace camshaft bearings according to manufacturer's specifications. Camshaft will function without binding.

ENABLING OBJECTIVES:

1. Demonstrate safety precautions
2. Explain camshaft function and need for proper bearing fit and placement
3. Demonstrate replacement of camshaft bearings, using care in placement of oil holes.
4. Replace camshaft gear and timing chain and related parts
5. Demonstrate operational test and inspect for external leakage

05.25 TASK: Remove and replace pistons and rings

PERFORMANCE OBJECTIVE: Given an engine, service manual, tools and special equipment, remove and replace rings, pistons, rods and bearings according to manufacturer's specifications.

ENABLING OBJECTIVES:

1. Demonstrate safety procedures for installation of each component
2. Demonstrate use of ring compressor and explain ring protection
3. Demonstrate torque of rod bearing caps
4. Explain reason for lubricating parts prior to installation
5. Demonstrate procedures for protecting crankshaft when installing pistons

05.26

TASK: Remove ridges and deglaze cylinder walls

PERFORMANCE OBJECTIVE: Given an automotive engine block needing the upper ring-ridge removed and/or cylinder walls deglazed, necessary tools and service manual, remove the cylinder bore upper ring-ridge according to specific ridge reaming tool operation procedures. No excessive ridge will remain in the cylinders. Any cracks or excessive wear will be noted.

ENABLING OBJECTIVES:

1. Demonstrate safety procedures
2. Demonstrate ridge reamer's placement in cylinder
3. Describe removal of cylinder ring ridge
4. Demonstrate removal of ridge from cylinder
5. Explain reason for removal before pistons are removed
6. Explain what may happen to piston and new rings if ridge is not removed properly
7. Explain reason for deglazing cylinder walls
8. Demonstrate deglazing procedure
9. Demonstrate safety practices of deglazing cylinder walls
10. Demonstrate cleaning of cylinder walls after deglazing

05.27

TASK: Remove and replace front and rear oil seals

PERFORMANCE OBJECTIVE: Given a vehicle with bad oil seal(s), necessary tools, equipment and service manual, remove and replace oil seals.

ENABLING OBJECTIVES :

1. Demonstrate safety procedures while working on and under vehicle
2. Describe proper jacking and supporting of vehicle

3. Discuss handling of fluids
4. Describe and demonstrate procedures of getting proper clearance between pan and frame to remove pan
5. Describe and demonstrate procedures to remove and replace rear main seal
6. Describe and demonstrate procedures to remove and replace front main seal

05.28      TASK: Remove and replace intake and exhaust manifold

PERFORMANCE OBJECTIVE: Given a vehicle with an intake manifold problem, service manual, necessary tools and equipment, inspect intake manifold for warpage or cracks. Attachments and intake manifold must be torqued according to manufacturer's specifications. Manifold must not leak vacuum, fluids or exhaust.

ENABLING OBJECTIVES:

1. Demonstrate safety procedures
2. Explain function of intake manifold
3. Describe function of intake manifold heat passage
4. Demonstrate removal of intake manifold and old gasket material
5. Inspect for leaks, warpage, cracks
6. Demonstrate replacement of intake manifold and related parts
7. Demonstrate operational test

05.29      TASK: Remove, clean, inspect and replace cylinder heads; inspect head for cracks and warpage

PERFORMANCE OBJECTIVE: Given a vehicle with cylinder head malfunctions, service manual, necessary tools and equipment, remove and replace cylinder heads in accordance with manufacturer's procedure. All attaching hardware must be torqued and head gasket and manifolds must not leak.

ENABLING OBJECTIVES:

1. Demonstrate safety procedures
2. Explain head bolt torque sequence
3. Demonstrate use of torque wrench
4. Demonstrate removal of cylinder head and related components
5. Inspect cylinder head for warpage, cracks, burned valves, or other damage

6. Describe valve sealing, valve grinding, head milling or other related repairs
7. Identify intake and exhaust ports and explain their functions
8. Locate water jacket
9. Describe front to rear head gasket coolant passage holes
10. Demonstrate replacement of head gasket, cylinder head, intake and exhaust manifold
11. Demonstrate tightening sequence of cylinder head and manifold bolts
12. Demonstrate operational test of engine (recheck cooling system liquid after thermostat opens)

05.30

TASK: Test and replace hydraulic lifters

PERFORMANCE OBJECTIVE: Given an engine with defective hydraulic lifter, necessary tools, equipment and service manual, test and replace hydraulic lifter.

ENABLING OBJECTIVES:

1. Demonstrate safety procedures while working on engine
2. Discuss handling of fluids
3. Diagnose malfunction of lifter
4. Repair and replace defective lifter and associated parts
5. Performance test engine after work is completed

05.31

TASK: Pressure test hydraulic lifter

PERFORMANCE OBJECTIVE: Given a disassembled engine, hydraulic lifter, necessary tools and equipment, pressure test hydraulic lifter.

ENABLING OBJECTIVES:

1. Demonstrate safety procedures
2. Discuss handling of fluids under pressure
3. Diagnose malfunction of lifter
4. Perform pressure bleed down test
5. Describe corrective action if lifter defective

05.32      TASK:   Reface valves and seats

PERFORMANCE OBJECTIVE:   Given an automobile engine needing a valve job, and necessary tools and equipment, perform a valve job in accordance with manufacturer's specifications. All seals must be replaced when the valve is properly installed. Resurfaced valves will perform without leaks, binds or noise.

ENABLING OBJECTIVES:

1. Demonstrate safety precautions.
2. Explain reason for valve seals
3. Demonstrate valve seat and valve face resurfacing
4. Describe valve spring tension and installed height
5. Explain valve seat and valve face lap (mating)
6. Explain valve guide clearance and reaming (replace as necessary)
7. Explain valve stem height adjustment
8. Explain valve seat replacement

05.33      TASK:   Check valve guides for wear

PERFORMANCE OBJECTIVE:   Given a vehicle with valve lifter problem(s), necessary tools, equipment and service manual, test valve lifters for bleed down, and adjust to manufacturer's specification.

ENABLING OBJECTIVES:

1. Demonstrate safety precautions
2. Explain bleed down process
3. Demonstrate adjustment procedures (where possible)
4. Demonstrate bleed down test of valve lifters
5. Explain problems of weak, badly worn or damaged lifters
6. Demonstrate replacement of defective valve lifters

05.34      TASK:   Remove and replace timing chains and gears

PERFORMANCE OBJECTIVES:   Given any automobile engine, service manual, necessary tools and equipment, remove and replace harmonic balancer, timing chain cover, timing gears and chain. Timing must be set according to manufacturer's specifications and cover will not leak. Harmonic balancer must be inspected for wear and slippage.

ENABLING OBJECTIVES:

1. Demonstrate safety precautions
2. Explain timing marks on balancer, cover and gears
3. Explain procedure for proper positioning of timing marks
4. Demonstrate engine timing in accordance with manufacturer's specifications
5. Inspect related parts (harmonic balancer, key, shaft, etc.) for excessive wear and slippage
6. Replace parts and test for operation and leaks

05.35 TASK: Remove and replace timing belt

PERFORMANCE OBJECTIVE: Given an automobile with timing belt, service manual, tools and equipment, remove and replace timing belt. Set timing and tension according to manufacturer's specifications.

ENABLING OBJECTIVES:

1. Demonstrate safety precautions
2. Explain how to avoid damage to valves
3. Explain timing marks
4. Explain procedure for setting timing marks' belt direction before replacing belt
5. Demonstrate method of setting belt tension
6. Demonstrate use of timing light or test operational timing setting

05.36 TASK: Test valve springs

PERFORMANCE OBJECTIVE: Given a set of valve springs, necessary tools, equipment and service manual, inspect and test valve springs.

ENABLING OBJECTIVES:

1. Demonstrate safety procedures while working with tester
2. Discuss handling of springs under pressure
3. Test springs and describe malfunction problems of springs

05.37 TASK: Adjust valve lifters

PERFORMANCE OBJECTIVE: Given an automobile engine with mechanical valve lifters, tools, equipment and service manual, adjust the exhaust and intake valve lash according to manufacturer's specifications.

ENABLING OBJECTIVES:

1. Demonstrate safety precautions
2. Adjust intake exhaust and valve lash using flat feeler gauge of correct thickness according to manufacturer's specifications
3. Explain the necessity for valve lash variation between the intake and exhaust valves
4. Explain "noise" made by mechanical valve lifters
5. Explain various methods of adjusting valve lash

05.38 TASK: Replace rocker-arm assemblies, inspect wear and lubrication

PERFORMANCE OBJECTIVE: Given a vehicle with rocker-arm problem, service manual, and necessary tools, remove valve cover and inspect rocker-arms for proper lubrication and wear, and replace rocker-arm assembly, if necessary.

ENABLING OBJECTIVES:

1. Demonstrate safety precautions when operating an engine with valve cover removed
2. Explain rocker-arm lubricating system
3. Describe valve rocker-arm function
4. Inspect valve rocker-arm assemblies (or independent rockers) for lubrication
5. Describe any rocker-arm problem (lubrication, wear, broken or adjustment)

05.39 TASK: Change oil and oil filters with proper application

PERFORMANCE OBJECTIVE: Given a vehicle in need of oil and filter change, service manual, tools, supplies, hoist or jack, change oil and filter.

ENABLING OBJECTIVES:

1. Demonstrate all safety precautions and procedures
2. Demonstrate operation of hoist or raising device
3. Describe protective procedures for auto finish
4. Demonstrate removal of oil filter
5. Demonstrate proper installation of oil filter
6. Demonstrate proper removal of drain plug
7. Demonstrate proper replacement of drain plug
8. Describe proper oil type for application



MODULE 6

AUTOMATIC TRANSMISSION/TRANS-AXLE SERVICE

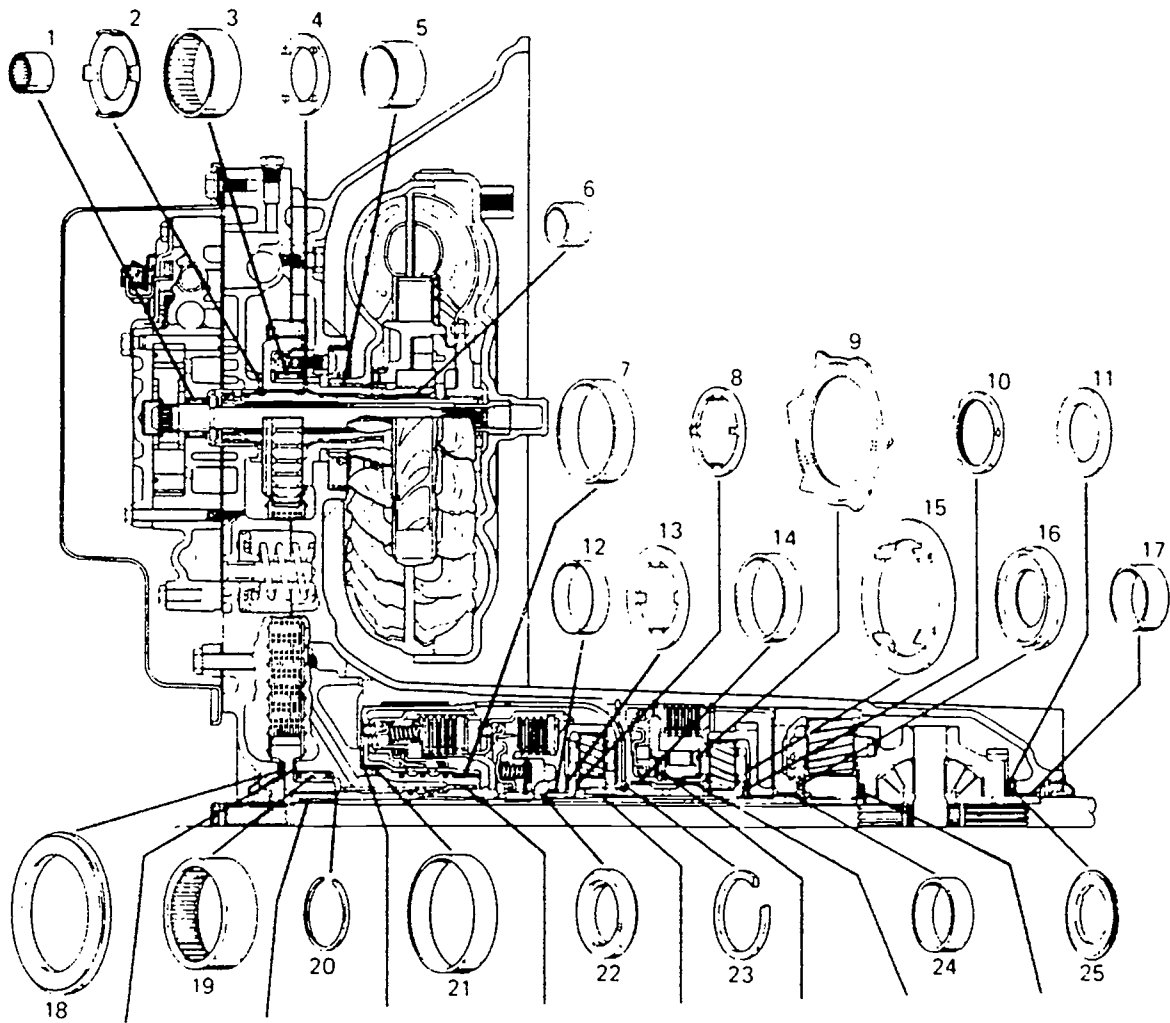

12

IDAHO PROGRAM STANDARDS FOR BASIC AUTOMOTIVE TECHNICIAN

MODULE 6

AUTOMATIC TRANSMISSION/TRANS-AXLE SERVICE

Division of Vocational Education  
State of Idaho  
Boise, Idaho  
1989

139

-131-

## MODULE 6 - AUTOMATIC TRANSMISSION/TRANS-AXLE SERVICE

This is one of a series of modules which comprise the Idaho Program Standards for Basic Automotive Technician. Each module contains a listing of the tasks, performance objectives, and enabling objectives required to enable a student to achieve competency in a specific system or field of study within the basic automotive technician occupational field. The numbering of these modules is not intended to dictate an order of instruction or scheduling. The order in which these modules may be taught is determined by each institution and its instructors.

Each task describes an occupational activity which will result in a finished process or product. Such a process or product should always allow an evaluation using standards which address the operation, appearance, dimensions, time in which achieved, or similar characteristics. The tasks listed in each module represent the basic activities required of each student to demonstrate entry level competence for that specific system or field of study within the automotive occupation.

The capability for providing instructional experiences and practical application of the tasks contained in each module will determine the scope of the vocational-technical program. In this regard, the student's maturity and preparation to receive instruction as well as the availability of equipment and the expertise of the instructional staff will be of primary importance. Individual records of student performance in completing the tasks listed within each module should be maintained.

Although some provision is made for basic mathematics and communication skills within these standards they may not be adequate to meet the needs of individual students. Counseling, guidance, and diagnostic test results may indicate a need for further preparation in these areas. In such cases, instructors are encouraged to utilize the resources and personnel within the institution to improve or complement the instructional process.

The benefits to students and institutions derived from these curriculum standards should be considerable. Articulation of students from secondary to post-secondary programs will be aided through the use of a single set of curriculum standards. The standards provide a tool for evaluation of local curricula and programs. The standards may be used in a flexible manner to assure that Basic Automotive Technician programs meet the needs of local business and industry.

It is the goal of this program standard to provide a level of instruction which will impart entry level employment skills. Students should be carefully counseled on the importance of attaining competency in the tasks assigned. As in virtually all occupations today, basic automotive technicians will require

periodic up-dating and review in the future. It is important that each student understand that meeting the program standards is essential not only to obtain employment today but also to have a base upon which to retain employment in the future.

IDAHO PROGRAM STANDARDS FOR BASIC AUTOMOTIVE TECHNICIAN

TASK LISTING

MODULE 6 - AUTOMATIC TRANSMISSION/TRANS-AXLE SERVICE

- 06.0 DEMONSTRATE PROFICIENCY IN AUTOMATIC TRANSMISSION/ TRANS-AXLE SERVICE--The student will be able to:
- 06.01 Demonstrate and apply safety rules and procedures
  - 06.02 Check automatic transmission fluid levels
  - 06.03 Performance test automatic transmissions
  - 06.04 Diagnose malfunctions of automatic transmissions
  - 06.05 Diagnose, repair, and replace trans-axles
  - 06.06 Pressure test transmissions in vehicles
  - 06.07 Stall test transmissions in vehicles
  - 06.08 Change transmission oil and filter
  - 06.09 Adjust linkage from the engine
  - 06.10 Adjust shift linkage
  - 06.11 Test the electrical and computer controls of an automatic transmission and clutch converter
  - 06.12 Adjust neutral safety switches
  - 06.13 Remove and replace external gaskets and seals
  - 06.14 Test vacuum shift modulators
  - 06.15 Adjust bands
  - 06.16 Service governors
  - 06.17 Service valve bodies
  - 06.18 Rebuild transmission assemblies
  - 06.19 Pressure flush converter assemblies
  - 06.20 Pressure flush transmission cooler assemblies and check liquid flow
  - 06.21 Remove and replace extension housings and bushings

MODULE 6 - DEMONSTRATE PROFICIENCY IN AUTOMATIC TRANSMISSION/  
TRANS-AXLE SERVICE

06.01 TASK: Demonstrate and apply safety rules and procedures

PERFORMANCE OBJECTIVE: Given examples of automatic transmission repair situations, apply shop safety rules and procedures by identifying safe and unsafe shop practices.

ENABLING OBJECTIVES:

1. Explain the importance of disconnecting the battery
2. Demonstrate safety procedures in using a hydraulic press
3. Demonstrate safety precautions when working under a raised vehicle
4. Demonstrate safety precautions when using transmission jacks

06.02 TASK: Check automatic transmission fluid level

PERFORMANCE OBJECTIVE: Given an operating automobile and service manual, check and service the transmission fluid level. The fluid should be at the correct level and should be checked with the vehicle at operating temperature and in the proper gear.

ENABLING OBJECTIVES:

1. Explain procedures for checking fluid level
2. Demonstrate safety in servicing transmissions while the engine is operating
3. Demonstrate proper procedure for checking automatic transmission fluid level
4. Inspect for leaks

06.03 TASK: Performance test automatic transmissions

PERFORMANCE OBJECTIVE: Given an operating vehicle equipped with automatic transmission, service manual and proper tools, perform operational test on automatic transmission.

ENABLING OBJECTIVES:

1. Demonstrate safety precautions when performing operational tests
2. Explain how the manufacturer's manual and charts can be used most effectively
3. Define manifold vacuum
4. Locate the pressure gauge test connections
5. Demonstrate operational test

06.04 TASK: Diagnose malfunctions of automatic transmissions

PERFORMANCE OBJECTIVE: Given an automatic transmission with known malfunctions, service manual and tools, diagnose malfunctions.

ENABLING OBJECTIVES:

1. Demonstrate safety precautions
2. Explain the use of the troubleshooting section of the manual
3. Explain causes of problems such as fluid leaks, fluid condition, slipping, lock-up and shifting problems
4. Explain malfunctions as diagnosed and explain how they may be corrected

06.05 TASK: Diagnose, repair and replace trans-axles

PERFORMANCE OBJECTIVE: Given a vehicle, service manual and necessary tools, repair, replace and rebuild a trans-axle assembly. When complete the unit should not leak fluid, excessive noise should not be present when operating and all bolts must be secured.

ENABLING OBJECTIVES:

1. Distinguish between a split case unit and a one-piece unit
2. Demonstrate safety precautions when working on each type unit
3. Demonstrate removal, disassembly and inspection of all parts for wear and/or damage
4. Demonstrate reassembly and installation on vehicle
5. Demonstrate operational test of vehicle

06.06 TASK: Pressure test transmission in vehicles

PERFORMANCE OBJECTIVE: Given an operating vehicle equipped with automatic transmission, proper manual, necessary tools and gauges, perform pressure tests in the different gear ranges.

ENABLING OBJECTIVES:

1. Demonstrate safety precautions when working on a raised vehicle
2. Explain the different types of pressures (line, modulator, defects, etc.) in a transmission and the purposes of each
3. Demonstrate gauge hook up and gauge read out of the different gear ranges

06.07 TASK: Stall test transmissions in vehicles

PERFORMANCE OBJECTIVE: Given a vehicle with an automatic transmission, service manuals and equipment, stall test a transmission.

ENABLING OBJECTIVES:

1. Demonstrate safety precautions when performing stall test
2. Demonstrate stall test procedure for vehicle on which test is performed
3. Explain the results of the test and how they relate to transmission condition

06.08 TASK: Change transmission oil and filter

PERFORMANCE OBJECTIVE: Given an automatic transmission, service manual and tools, remove and replace or service the transmission filter. All bolts must be torqued and the gaskets and filter must be correctly installed.

ENABLING OBJECTIVES:

1. Demonstrate safety precautions when working under a raised vehicle
2. Explain the difference between a filter that can be serviced or cleaned and one that must be replaced
3. Describe proper procedures for draining transmission fluids



4. Demonstrate removal of oil pan, filter and old gasket material
5. Demonstrate replacement of filter, oil pan and fluid (check fluid level)

06.09 TASK: Adjust linkage from the engine

PERFORMANCE OBJECTIVE: Given a vehicle with an automatic transmission, service manual and proper tools, adjust the manual throttle valve kick-down at the engine or at the transmission.

ENABLING OBJECTIVES:

1. Demonstrate proper adjustment procedures
2. Explain location of adjustments

06.10 TASK: Adjust shift linkage

PERFORMANCE OBJECTIVE: Given a vehicle with an automatic transmission, service manual and proper tools, adjust the shift linkage. When adjustments are completed, appropriate gears should be able to be selected, the quadrant indicator must be positioned correctly and locking devices must be secured.

ENABLING OBJECTIVES:

1. Demonstrate safety precautions while working under a raised vehicle
2. Explain differences between rod linkage and cable linkage and column and floor linkage
3. Define quadrant indicator
4. Demonstrate adjustment of external linkage and quadrant indicator position

06.11 TASK: Test electrical and computer controls of an automatic transmission and clutch converter

PERFORMANCE OBJECTIVE: Given an automatic transmission computer control with code indicating an electrical problem, service manual, multi-meter (volt, amps/ohm), test relays or solenoids relating to the electrical trouble code.

ENABLING OBJECTIVES:

1. Demonstrate the proper use of the multi-meter
2. Compare a bad solenoid to a good one by explanation
3. Demonstrate the proper removal and replacement of relays or solenoid

06.12 TASK: Adjust neutral safety switches

PERFORMANCE OBJECTIVE: Given a vehicle with an automatic transmission, service manual and necessary tools, adjust the neutral safety switch as needed. When adjustments are completed the engine should crank when the gear selector is in park or neutral but fail to crank in any other gear.

ENABLING OBJECTIVES:

1. Demonstrate safety precautions
2. Explain how the neutral safety switch controls engine cranking and why it is necessary
3. Describe adjustment procedure
4. Demonstrate proper neutral safety switch operation when adjustments are made

06.13 TASK: Remove and replace external gaskets and seals

PERFORMANCE OBJECTIVE: Given a vehicle with an automatic transmission, tools and service manual, replace external gaskets and seals.

ENABLING OBJECTIVES:

1. Demonstrate safety precautions
2. Demonstrate removal and replacement of external gaskets and seals

06.14 TASK: Test vacuum shift modulators

PERFORMANCE OBJECTIVE: Given an automatic transmission, service manual, tools and vacuum gauge, test the vacuum modulator.

ENABLING OBJECTIVES:

1. Demonstrate safety precautions
2. Explain the function of the vacuum modulator
3. Demonstrate use of a vacuum gauge
4. Identify vacuum modulator and test instrument
5. Demonstrate modulator test procedure

06.15

TASK: Adjust bands

PERFORMANCE OBJECTIVE: Given an automatic transmission, service manual and proper tools, make band adjustments (external and/or internal). Band must be adjusted within specifications and lock nuts torqued.

ENABLING OBJECTIVES:

1. Demonstrate safety precautions
2. Describe special tools for different band adjustments
3. Distinguish between adjustable and non-adjustable bands
4. Demonstrate proper band adjustments (external or internal)

06.16

TASK: Service governors

PERFORMANCE OBJECTIVE: Given an automatic transmission, service manual and tools, remove, service and replace transmission governor.

ENABLING OBJECTIVES:

1. Demonstrate safety precautions when working on automatic transmission
2. Explain governor operation
3. Demonstrate removal and replacement or service of governor

06.17

TASK: Service valve bodies

PERFORMANCE OBJECTIVE: Given an automatic transmission, service manual and proper tools, service valve body. All gaskets must be installed and valve body torqued to specifications.

ENABLING OBJECTIVES:

1. Explain the importance of precisely handling delicate valves and springs
2. Identify each valve and explain its function
3. Demonstrate safety precautions when working on automatic transmissions
4. Demonstrate removal and replacement of valve body and related parts
5. Demonstrate torquing procedures and explain why torque of valve body is critical

06.18 TASK: Rebuild transmission assemblies

PERFORMANCE OBJECTIVE: Given a rebuildable automatic transmission in an operating vehicle, service manual, tools and replacement parts, rebuild the automatic transmission. The transmission must shift correctly, must not leak and all hoses, lines, clamps and mounts must be properly secured.

ENABLING OBJECTIVES:

1. Demonstrate safety precautions
2. Demonstrate how to safely raise the vehicle and remove the transmission
3. Demonstrate complete disassembly of the transmission and drain or flush converter
4. Inspect all assembly parts for excessive wear and damage and discard any parts not serviceable (very close inspection must be made of pumps)
5. Describe how to rebuild or service a clutch pack, servo, valve body and governor
6. Demonstrate reassembly of all parts and assemblies
7. Explain how to adjust bands and reinstall transmission unit
8. Demonstrate fluid replacement and operational test and the plug fluid leak inspection

06.19 TASK: Pressure flush converter assemblies

PERFORMANCE OBJECTIVE: Given a torque converter, converter flusher machine and service manual, install adapters to clean and flush converter.

ENABLING OBJECTIVES:

1. Explain proper amount of time needed to flush converter
2. Demonstrate installation of adapters

06.20 TASK: Pressure flush transmission cooler assemblies and check liquid flow

PERFORMANCE OBJECTIVE: Given a car with an automatic transmission, service manual and proper tools, pressure flush cooler. No leaks should be visible, lines must be tightly secured and not rub or touch other parts at potential wear points.

ENABLING OBJECTIVES:

1. Demonstrate safety precautions
2. Explain how transmission cooling systems operate
3. Inspect oil lines, oil line connections and cooling unit for leaks, cracks, wear or restrictions
4. Demonstrate repairs to correct malfunctions or to avoid future malfunctions

06.21

TASK: Remove and replace extension housings and bushings

PERFORMANCE OBJECTIVE: Given a vehicle, service manual and necessary tools, remove and replace the extension housing and bushing. The bushing position must be correct.

ENABLING OBJECTIVES:

1. Demonstrate safety precautions while working on a raised vehicle
2. Explain the purpose of the extension housing and bushing
3. Identify special tools necessary to replace bushing properly
4. Demonstrate removal and replacement of extension housing and bushing

MODULE 7

MANUAL DRIVE TRAIN AND AXLE SERVICE

## Types of Gear Teeth used in a Standard Transmission

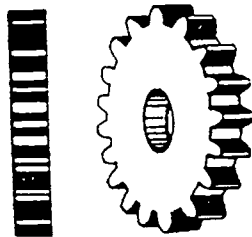

Spur Gear

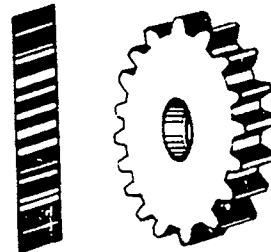

Helical Gear

IDAHO PROGRAM STANDARDS FOR BASIC AUTOMOTIVE TECHNICIAN

MODULE 7

MANUAL DRIVE TRAIN AND AXLE SERVICE

Division of Vocational Education  
State of Idaho  
Boise, Idaho  
1989

143

## MODULE 7 - MANUAL DRIVE TRAIN AND AXLE SERVICE

This is one of a series of modules which comprise the Idaho Program Standards for Basic Automotive Technician. Each module contains a listing of the tasks, performance objectives, and enabling objectives required to enable a student to achieve competency in a specific system or field of study within the basic automotive technician occupational field. The numbering of these modules is not intended to dictate an order of instruction or scheduling. The order in which these modules may be taught is determined by each institution and its instructors.

Each task describes an occupational activity which will result in a finished process or product. Such a process or product should always allow an evaluation using standards which address the operation, appearance, dimensions, time in which achieved, or similar characteristics. The tasks listed in each module represent the basic activities required of each student to demonstrate entry level competence for that specific system or field of study within the automotive occupation.

The capability for providing instructional experiences and practical application of the tasks contained in each module will determine the scope of the vocational-technical program. In this regard, the student's maturity and preparation to receive instruction as well as the availability of equipment and the expertise of the instructional staff will be of primary importance. Individual records of student performance in completing the tasks listed within each module should be maintained.

Although some provision is made for basic mathematics and communication skills within these standards they may not be adequate to meet the needs of individual students. Counseling, guidance, and diagnostic test results may indicate a need for further preparation in these areas. In such cases, instructors are encouraged to utilize the resources and personnel within the institution to improve or complement the instructional process.

The benefits to students and institutions derived from these curriculum standards should be considerable. Articulation of students from secondary to post-secondary programs will be aided through the use of a single set of curriculum standards. The standards provide a tool for evaluation of local curricula and programs. The standards may be used in a flexible manner to assure that Basic Automotive Technician programs meet the needs of local business and industry.

It is the goal of this program standard to provide a level of instruction which will impart entry level employment skills. Students should be carefully counseled on the importance of attaining competency in the tasks assigned. As in virtually all occupations today, basic automotive technicians will require



periodic up-dating and review in the future. It is important that each student understand that meeting the program standards is essential not only to obtain employment today but also to have a base upon which to retain employment in the future.

IDAHO PROGRAM STANDARDS FOR BASIC AUTOMOTIVE TECHNICIAN

TASK LISTING

MODULE 7 - MANUAL DRIVE TRAIN AND AXLE SERVICE

- 07.0 DEMONSTRATE PROFICIENCY IN SERVICING MANUAL DRIVE TRAINS AND AXLES--The student will be able to:
- 07.01 Demonstrate and apply safety rules and procedures
  - 07.02 Diagnose drive line problems
  - 07.03 Diagnose and performance test manual transmission problems
  - 07.04 Inspect drive shafts, U-joints, and center bearings
  - 07.05 Lubricate universal joint
  - 07.06 Check the fluid level in a manual transmission
  - 07.07 Check the fluid level in a differential
  - 07.08 Remove and replace transmission mount(s)
  - 07.09 Adjust shift linkage
  - 07.10 Adjust clutches
  - 07.11 Remove and replace extension housing seal and bushings
  - 07.12 Rebuild manual transmission
  - 07.13 Remove and replace clutches, release bearings, linkage, and pilot bearing
  - 07.14 Rebuild clutch master and slave cylinders
  - 07.15 Remove and replace universal joints
  - 07.16 Remove and replace speedometer gears and service speedometer cables
  - 07.17 Remove and replace axle bearings and seals
  - 07.18 Overhaul integral differentials
  - 07.19 Overhaul removable differentials
  - 07.20 Overhaul limited slip differentials
  - 07.21 Overhaul transaxle assemblies
  - 07.22 Adjust transaxle shifting controls
  - 07.23 Inspect, remove, replace, and lubricate front-drive-axle flexible joints
  - 07.24 Inspect, remove, replace constant velocity universal joints, and balance
  - 07.25 Service or repair transfer case and vacuum control

MODULE 7 - MANUAL DRIVE TRAIN AND AXLE SERVICE

07.01 TASK: Demonstrate and apply safety rules and procedures

PERFORMANCE OBJECTIVE: Given examples of manual transmission repair situations, apply shop safety rules and procedures by identifying safe and unsafe shop practices.

ENABLING OBJECTIVES:

1. Explain the importance of disconnecting the battery
2. Demonstrate safety procedures when using a hydraulic press
3. Demonstrate safety precautions when working under a raised vehicle
4. Demonstrate safety precautions when using transmission jacks
5. Explain the importance of keeping the floor free of transmission fluids

07.02 TASK: Diagnose drive line problems

PERFORMANCE OBJECTIVE: Given a vehicle and necessary manuals and tools, perform an operational test and inspect the drive line(s). The following minimum items should be checked: drive shaft, universal joints, support bearings, rear end supports, hangers and springs, transmission mount, and lug nuts.

ENABLING OBJECTIVES:

1. Demonstrate safety precautions while working under a raised vehicle
2. Explain how a vehicle's "handling reactions" feel when it has drive line slack or loose motion
3. Identify: drive shaft, universal joints, support bearings, rear end supports, transmission mount and lug nuts
4. Demonstrate a complete drive line inspection
5. Describe discrepancies found and repairs needed

07.03 TASK: Diagnose and performance-test manual transmission problems

PERFORMANCE OBJECTIVE: Given a vehicle with a manual transmission and service manuals, perform operational test of a manual transmission.

ENABLING OBJECTIVES:

1. Explain power flow of transmission gears
2. Explain the purpose of all parts within a manual transmission
3. Demonstrate safety precautions
4. Demonstrate operational test to check gear positions for operation, noise or malfunction

07.04 TASK: Inspect drive shafts, U-joints and center bearings

PERFORMANCE OBJECTIVE: Given a drive shaft and proper tools, inspect drive shaft for wear and damage.

ENABLING OBJECTIVES:

1. Inspect bearing support
2. Inspect joints for wear
3. Inspect bearing for noise
4. Inspect yoke for phase

07.05 TASK: Lubricate universal joint

PERFORMANCE OBJECTIVE: Given a vehicle, service manual, necessary tools and grease gun, lubricate universal joint. There should be a sufficient amount of the appropriate grease properly applied without excessive grease remaining on the joint.

ENABLING OBJECTIVES:

1. Demonstrate safety precautions when working under a raised vehicle
2. Identify the special tool required to grease universal joints that have close clearances
3. Demonstrate proper lubrication procedures for serviceable universal joints
4. Inspect all joints for excessive wear and/or loose or missing locks

07.06 TASK: Check the fluid level in a manual transmission

PERFORMANCE OBJECTIVE: Given a vehicle, service manual and tools, lubricate the manual transmission. Fluid level, filler plug tightness and type of lubricant must be correct.

ENABLING OBJECTIVES:

1. Demonstrate safety precautions when working under a raised vehicle
2. Explain what grease (by weight) should be used in the transmission of a specific vehicle
3. Identify the lubricating point and check fluid level

07.07 TASK: Check the fluid level in a differential

PERFORMANCE OBJECTIVE: Given a vehicle, service manual and tools, check the fluid level in a differential. Fluid level must be correct.

ENABLING OBJECTIVES:

1. Demonstrate safety precautions when working under a raised vehicle
2. Explain what grease (by weight) should be used in the differential of a specific vehicle
3. Identify the lubricating point and check fluid level

07.08 TASK: Remove and replace transmission mount(s)

PERFORMANCE OBJECTIVE: Given a vehicle, service manual and proper tools, remove and replace the transmission mount(s). When completed the mount must be secure and properly aligned. Safety will be observed in the process.

ENABLING OBJECTIVES:

1. Demonstrate safety precautions when working under a raised vehicle
2. Explain hazards that exist in the process of raising the transmission during this task
3. Demonstrate removal and replacement of transmission mounts
4. Inspect for security and condition of surrounding components

07.09 TASK: Adjust shift linkage

PERFORMANCE OBJECTIVE: Given a vehicle with a manual transmission, service manual and proper tools, adjust the external shift linkage. When adjustments are completed, the shifter should operate smoothly, appropriate gears should be able to be selected and all nuts and fasteners should be installed correctly.

ENABLING OBJECTIVES:

1. Demonstrate safety precautions
2. Explain how a manual transmission shift is accomplished
3. Identify adjustment points
4. Demonstrate proper shift pattern for specific vehicle when adjustments are made

07.10

TASK: Adjust clutches

PERFORMANCE OBJECTIVE: Given a vehicle with manual clutch, service manual and necessary tools, adjust the clutch as needed. The free travel will be compared to the manufacturer's specifications, all nuts and fasteners must be correctly installed and the return spring must work properly.

ENABLING OBJECTIVES:

1. Demonstrate safety precautions
2. Explain the purpose of clutch free travel
3. Describe adjustment procedure
4. Demonstrate properly adjusted clutch action in relation to transmission shift
5. Identify adjusting mechanism of hydraulic clutch
6. Identify clutch master cylinder and slave cylinder
7. Inspect fluid level of system and correct if low

07.11

TASK: Remove and replace extension housing seals and bushings

PERFORMANCE OBJECTIVE: Given a vehicle, service manual and necessary tools, remove and replace the extension housing seals and bushings. The bushing position and seal installation must be correct.

ENABLING OBJECTIVES:

1. Demonstrate safety precautions while working on a raised vehicle
2. Explain the purpose of the extension housing seals and bushings
3. Identify special tools necessary to replace bushings and seals properly
4. Demonstrate removal and replacement of bushings and seals

07.12

TASK: Rebuild manual transmission

PERFORMANCE OBJECTIVE: Given a transmission, service manual and tools, rebuild a manual transmission. All bolts will be torqued, no leakage will be present and the transmission must operate smoothly. All needle bearings and thrust washers must be correctly installed.

ENABLING OBJECTIVES:

1. Demonstrate safety precautions
2. Explain power flow of the manual transmission in all gears
3. Demonstrate how to use grease to hold needle bearings in position during assembly
4. Demonstrate disassembly of manual transmission
5. Inspect gears and related parts for wear and damage
6. Demonstrate reassembly of gears and examine operation

07.13

TASK: Remove and replace clutches, release bearings, linkage and pilot bearings

PERFORMANCE OBJECTIVE: Given a vehicle, service manual and necessary tools, remove and replace all clutch components, including release bearing, linkage and pilot bearing. All nuts and bolts must be torqued or secured and the clutch should engage and disengage smoothly.

ENABLING OBJECTIVES:

1. Demonstrate safety precautions when working under a raised vehicle
2. Describe how a clutch operates
3. Explain the purpose of free travel in a clutch
4. Demonstrate removal of clutch assembly and related components
5. Identify the throw-out bearing and the pilot bushing; explain the function of each
6. Inspect all clutch assembly parts for wear and damage
7. Demonstrate lubrication, assembly and adjustments of clutch parts and related components
8. Demonstrate operational test

07.14

TASK: Rebuild clutch master and slave cylinders

PERFORMANCE OBJECTIVE: Given required vehicle, manual and necessary tools, remove, replace or rebuild the slave or master cylinder. The cylinder should be bled, have no leaks and all nuts, bolts and bleeder screws secure.

ENABLING OBJECTIVES:

1. Demonstrate safety precautions when handling hydraulic fluid
2. Explain how to bleed a hydraulic clutch
3. Demonstrate removal and disassembly of the specific unit
4. Inspect all parts and replace all worn or damaged parts
5. Demonstrate reassembly and installation of specific unit
6. Demonstrate bleeding of hydraulic system and test for proper operation

07.15

TASK: Remove and replace universal joints

PERFORMANCE OBJECTIVE: Given a vehicle, service manual and necessary tools and parts, remove and replace the universal joints.

ENABLING OBJECTIVES:

1. Inspect U-joint cross for wear
2. Inspect U-joint caps for damage
3. Demonstrate the proper installation of grease zerk
4. Demonstrate the proper seating of the all snap rings
5. Demonstrate proper lube

07.16

TASK: Remove and replace speedometer gears and service speedometer cables

PERFORMANCE OBJECTIVE: Given a vehicle, service manual, necessary tools and lubricant, remove, replace and lubricate speedometer cable and driver gear. The cable must move freely and be free of sharp bends.

ENABLING OBJECTIVES:

1. Explain the differences between the operation of speedometers that work off the front wheel versus the drive shaft or output shaft
2. Demonstrate safety precautions



3. Identify speedometer cable and gear location
4. Demonstrate removal of cable and gear assembly and inspect for damage
5. Demonstrate lubrication (using proper lubricating materials) and replace assembly
6. Demonstrate operational test

07.17

TASK: Remove and replace axle bearings and seals

PERFORMANCE OBJECTIVE: Given a vehicle, service manual and proper tools, remove and replace an axle bearing and seal. When completed the axle bearing and its retainer must be pressed on in the proper position. All nuts and bolts must be properly torqued.

ENABLING OBJECTIVES:

1. Inspect axle bearing and related parts when removed from vehicle
2. Demonstrate safety precautions when working on a raised vehicle
3. Demonstrate how to safely use a hydraulic press to remove and replace an axle bearing
4. Demonstrate seal installation
5. Demonstrate operational test when repairs are completed

07.18

TASK: Overhaul integral differentials

PERFORMANCE OBJECTIVE: Given a differential, service manual and necessary tools, rebuild the assembly. When completed the tolerances must be within manufacturer's specifications and all nuts and bolts secure.

ENABLING OBJECTIVES:

1. Discuss how to adjust a differential using shims for carrier adjustment
2. Demonstrate safety precautions
3. Identify special tools and equipment
4. Demonstrate removal of gears and inspect for wear and/or damage
5. Demonstrate reassembly and adjustments of gear teeth, back lash and bearing preload
6. Demonstrate operational test

07.19

TASK: Overhaul removable differentials

PERFORMANCE OBJECTIVE: Given a differential, service manual and necessary tools, rebuild the assembly. When completed the tolerances must be within manufacturer's specifications and all nuts and bolts secure.

ENABLING OBJECTIVES:

1. Discuss how to adjust carrier bearings using adjusting nuts
2. Demonstrate safety precautions
3. Identify special tools and equipment
4. Demonstrate removal of gears and inspect for wear and/or damage
5. Demonstrate reassembly and adjustments of gear teeth, back lash and bearing preload
6. Demonstrate operational test

07.20

TASK: Overhaul limited slip differentials

PERFORMANCE OBJECTIVE: Given a limited slip differential, service manual and necessary tools, overhaul the assembly. When completed the tolerances must be within manufacturer's specifications, the assembly must transmit driving torque as required and all nuts and bolts must be secure.

ENABLING OBJECTIVES:

1. Demonstrate all overhaul procedures that are common to all differentials, whether they are limited slip or not
2. Discuss different ways manufacturers use to load the clutches in limited slip units
3. Demonstrate disassembly and inspection of all parts for wear and/or damage
4. Demonstrate reassembly
5. Demonstrate safety precautions

07.21

TASK: Overhaul transaxle assemblies

PERFORMANCE OBJECTIVE: Given a vehicle, service manual and necessary tools, rebuild a transaxle assembly. When completed the unit should not leak fluid, excessive noise should not be present when operating and all bolts must be secured.

ENABLING OBJECTIVES:

1. Distinguish between a split-case unit and a one-piece unit
2. Demonstrate safety precautions when working on each type unit
3. Demonstrate disassembly and inspection of all parts for wear and/or damage
4. Demonstrate reassembly and installation on vehicle
5. Demonstrate operational test of vehicle

07.22

TASK: Adjust transaxle shifting controls

PERFORMANCE OBJECTIVE: Given a vehicle with a manual transaxle, service manual and proper tools, adjust the external shift linkage. When adjustments are completed, the shifter should operate smoothly, appropriate gears should be able to be selected and all nuts and bolts must be installed correctly.

ENABLING OBJECTIVES:

1. Demonstrate safety precautions
2. Explain how a manual transaxle shift is accomplished
3. Identify adjustment points
4. Demonstrate proper shift pattern for specific vehicle when adjustments are made

07.23

TASK: Inspect, remove, replace and lubricate front-drive-axle flexible joints

PERFORMANCE OBJECTIVE: Given a front wheel drive vehicle, service manual, necessary tools and lubricant, remove, replace and lubricate the front flex joints. There should be a sufficient amount of grease on the joints and any boots, if used, must be secure and not twisted. All retaining bolts, clips, snap-rings and clamps must be secure.

ENABLING OBJECTIVES:

1. Demonstrate safety precautions when working under a raised vehicle
2. Inspect all joints for excessive wear
3. Identify the various types of joints and boots
4. Demonstrate removal and replacement procedures for flex joints
5. Demonstrate proper lubrication procedures

07.24

TASK: Inspect, remove and replace constant velocity universal joints

PERFORMANCE OBJECTIVE: Given a vehicle, service manual and necessary tools, remove and replace a constant velocity U-joint. All clips, snap-rings and nuts and bolts must be secure.

ENABLING OBJECTIVES:

1. Demonstrate safety precautions when working under a raised vehicle
2. Explain why a constant velocity joint is used and how it functions
3. Demonstrate removal and replacement of the joint
4. U-joints should be properly planed and phased

07.25

TASK: Service or repair transfer case and vacuum control

PERFORMANCE OBJECTIVE: Given a four wheel drive vehicle, service manual and necessary tools, repair a transfer case and/or the vacuum control. When completed the unit should not leak, produce excessive noise when operating, should shift smoothly and transfer torque as required. All nuts and bolts should be secure.

ENABLING OBJECTIVES:

1. Demonstrate safety precautions when working under a raised vehicle
2. Explain various types of transfer cases and methods of transmitting torque
3. Explain various ways that shifting is controlled
4. Demonstrate repair procedures on transfer cases and shift controls
5. Demonstrate an operational test

## MODULE 8

### STEERING, SUSPENSION AND WHEEL SERVICE

#### • Front & Rear Suspension Including Drive Train

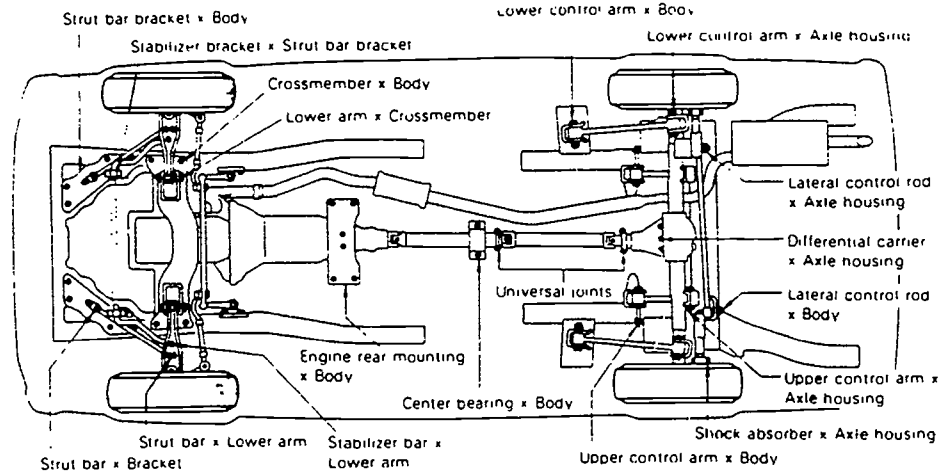

#### • Front Wheel

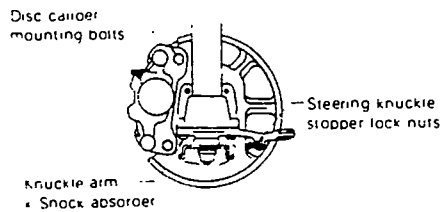

#### • Rear Suspension (with leaf spring)

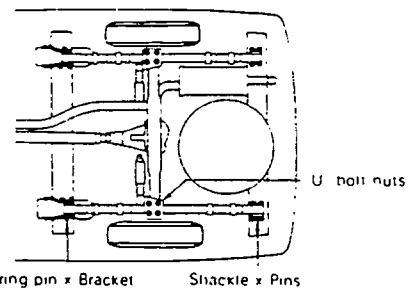

#### • Rear Wheel

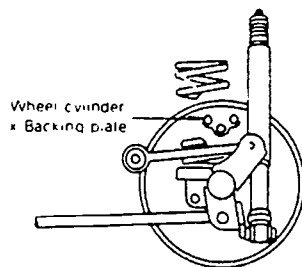

#### • Steering Linkages

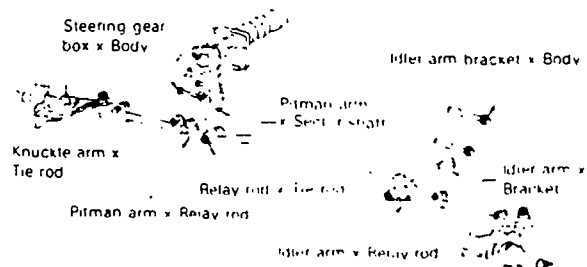

IDAHO PROGRAM STANDARDS FOR BASIC AUTOMOTIVE TECHNICIAN

MODULE 8

STEERING, SUSPENSION AND WHEEL SERVICE

Division of Vocational Education  
State of Idaho  
Boise, Idaho  
1989

153

-161-

## MODULE 8 - STEERING, SUSPENSION, AND WHEEL SERVICE

This is one of a series of modules which comprise the Idaho Program Standards for Basic Automotive Technician. Each module contains a listing of the tasks, performance objectives, and enabling objectives required to enable a student to achieve competency in a specific system or field of study within the basic automotive technician occupational field. The numbering of these modules is not intended to dictate an order of instruction or scheduling. The order in which these modules may be taught is determined by each institution and its instructors.

Each task describes an occupational activity which will result in a finished process or product. Such a process or product should always allow an evaluation using standards which address the operation, appearance, dimensions, time in which achieved, or similar characteristics. The tasks listed in each module represent the basic activities required of each student to demonstrate entry level competence for that specific system or field of study within the automotive occupation.

The capability for providing instructional experiences and practical application of the tasks contained in each module will determine the scope of the vocational-technical program. In this regard, the student's maturity and preparation to receive instruction as well as the availability of equipment and the expertise of the instructional staff will be of primary importance. Individual records of student performance in completing the tasks listed within each module should be maintained.

Although some provision is made for basic mathematics and communication skills within these standards they may not be adequate to meet the needs of individual students. Counseling, guidance, and diagnostic test results may indicate a need for further preparation in these areas. In such cases, instructors are encouraged to utilize the resources and personnel within the institution to improve or complement the instructional process.

The benefits to students and institutions derived from these curriculum standards should be considerable. Articulation of students from secondary to post-secondary programs will be aided through the use of a single set of curriculum standards. The standards provide a tool for evaluation of local curricula and programs. The standards may be used in a flexible manner to assure that Basic Automotive Technician programs meet the needs of local business and industry.

It is the goal of this program standard to provide a level of instruction which will impart entry level employment skills. Students should be carefully counseled on the importance of attaining competency in the tasks assigned. As in virtually all occupations today, basic automotive technicians will require

periodic up-dating and review in the future. It is important that each student understand that meeting the program standards is essential not only to obtain employment today but also to have a base upon which to retain employment in the future.



IDAHO PROGRAM FOR BASIC AUTOMOTIVE TECHNICIAN

TASK LISTING

MODULE 8 - STEERING, SUSPENSION, AND WHEEL SERVICE

08.0 DEMONSTRATE PROFICIENCY IN STEERING, SUSPENSION, AND WHEEL SERVICE--The student will be able to:

- 08.01 Demonstrate and apply safety rules and procedures
- 08.02 Diagnose abnormal tire wear problems
- 08.03 Diagnose suspension problems
- 08.04 Diagnose wheel/tire vibrations, shimmy, and tramp
- 08.05 Diagnose steering problems
- 08.06 Lubricate suspension, steering gear, and linkage
- 08.07 Check manual steering gear fluid level
- 08.08 Inspect steering systems
- 08.09 Inspect suspension systems
- 08.10 Inspect and test shock absorbers and auto leveling system
- 08.11 Check power steering fluid level
- 08.12 Replace power steering drive belts
- 08.13 Identify tires by types and sizes
- 08.14 Repair tires
- 08.15 Rotate wheels and tires and torque lug nuts to specification
- 08.16 Balance tires by computer, bubble, or spin
- 08.17 Service front wheel bearings and grease seals
- 08.18 Remove and replace front and rear wheel bearings
- 08.19 Remove and replace spindles and ball joints
- 08.20 Remove and replace shock absorbers and mountings
- 08.21 Measure and adjust torsion bar height
- 08.22 Remove and replace torsion bars
- 08.23 Remove and replace coil springs
- 08.24 Remove and replace control arms and bushings
- 08.25 Remove and replace steering linkage components
- 08.26 Remove and replace McPherson strut assembly
- 08.27 Rebuild a McPherson strut
- 08.28 Remove and replace rear suspension parts including independent suspension
- 08.29 Remove and replace mast jacket of steering assembly
- 08.30 Repair steering column
- 08.31 Remove and replace steering wheel
- 08.32 Remove and replace components in power steering system
- 08.33 Check two-wheel and four-wheel alignments
- 08.34 Align rear axle

MODULE 8 - DEMONSTRATE PROFICIENCY IN STEERING, SUSPENSION AND WHEEL SERVICES

08.01 TASK: Demonstrate and apply safety rules and procedures

PERFORMANCE OBJECTIVE: Given a vehicle needing service on steering, suspension and/or wheels, demonstrate and apply proper safety rules and procedures.

ENABLING OBJECTIVES:

1. Wear safety glasses
2. Wear cotton clothing
3. Wear leather shoes
4. Do not wear jewelry

08.02 TASK: Diagnose abnormal tire wear problems

PERFORMANCE OBJECTIVE: Given a tire and wheel assembly and proper tools, inspect the assembly for serviceability.

ENABLING OBJECTIVES:

1. Check air pressure
2. Check for irregular wear
3. Check for physical damage (cuts, etc.)
4. Check for radial and lateral run-out

08.03 TASK: Diagnose suspension problems

PERFORMANCE OBJECTIVE: Given a vehicle, service manual and necessary tools, inspect the suspension system components. All parts worn beyond manufacturer's specifications must be detected.

ENABLING OBJECTIVES:

1. Demonstrate safety precautions
2. Identify the different types of suspension systems
3. Demonstrate the proper procedure to inspect the suspension system
4. Describe shock absorber function
5. Identify steering linkage parts
6. Identify defective front and rear suspension assemblies

08.04

TASK: Diagnose wheel/tire vibrations, shimmy and tramp

PERFORMANCE OBJECTIVE: Given a vehicle with a vibration complaint and proper service manuals, troubleshoot the vehicle and make proper recommendation for repair.

ENABLING OBJECTIVES:

1. Diagnose wheel balance
2. Discuss types of tires
3. Discuss types of rims
4. Explain and demonstrate static balance
5. Explain and demonstrate dynamic balance

08.05

TASK: Diagnose steering problems

PERFORMANCE OBJECTIVE: Given a vehicle with steering problems, proper service manual, and using information from customer complaint and a test drive, if possible, recommend the proper repair for the vehicle.

ENABLING OBJECTIVES:

1. Check tie-rod ends
2. Check idler arms
3. Check power steering gears
4. Check manual steering gears
5. Check drag links

08.06

TASK: Lubricate suspension, steering gear and linkage

PERFORMANCE OBJECTIVE: Given a vehicle, service manual and proper tools, lubricate suspension points.

ENABLING OBJECTIVES

1. Demonstrate safety precautions while raising a vehicle on a hoist
2. Describe "greased" joints versus "nongreasable" joints
3. Inspect and clean all fittings to be lubricated
4. Explain use of a lubricating chart for a specific vehicle
5. Demonstrate the lubricating equipment

08.07

TASK: Check manual steering gear fluid level

PERFORMANCE OBJECTIVE: Given a vehicle, service manual and required tools, lubricate manual steering gear box. Proper level will be checked.

ENABLING OBJECTIVES:

1. Demonstrate safety precautions
2. Explain why different gear boxes operate most effectively with varying weights of greases and/or oils
3. Explain how grease or oil level may be determined
4. Demonstrate proper gear box lubricating method
5. Inspect gear box for safe operation

08.08

TASK: Inspect steering systems

PERFORMANCE OBJECTIVE: Given a vehicle, service manual and necessary tools, inspect the steering gear and linkage. Any parts that are worn beyond limits will be listed.

ENABLING OBJECTIVES:

1. Demonstrate safety precautions when working under a raised vehicle
2. Explain the importance safety-wise of inspecting the steering gear and linkage
3. Demonstrate methods of testing parts for excessive wear
4. Identify steering parts to be inspected for wear
5. Describe an excessively worn part

08.09

TASK: Inspect suspension systems

PERFORMANCE OBJECTIVE: Given a vehicle, service manual and necessary tools, inspect the suspension system components. All parts worn beyond manufacturer's specifications must be detected.

ENABLING OBJECTIVES:

1. Demonstrate safety precautions
2. Identify the different types of suspension systems
3. Demonstrate the proper procedure to inspect the suspension system
4. Describe shock absorber function
5. Identify steering linkage parts
6. Identify defective front and rear suspension assemblies

08.10      TASK:    Inspect and test shock absorbers and auto leveling system

PERFORMANCE OBJECTIVE:    Given a vehicle, proper service manuals and proper tools, test the shocks and the leveling system to the manufacturer's specifications.

ENABLING OBJECTIVES:

1. Describe single-action shocks
2. Describe dual-action shocks
3. Describe leveling system operation

08.11      TASK:    Check power steering fluid level

PERFORMANCE OBJECTIVE:    Given a vehicle, service manual and necessary tools, service power steering fluid level. All fluid levels less than operating level must be detected and filled to proper level.

ENABLING OBJECTIVES:

1. Demonstrate safety precautions
2. Describe the differences among several types of fluids on the market that could be used in the steering system
3. Identify power steering major parts
4. Describe method used to determine fluid level and fill to proper level
5. Inspect for power steering fluid leaks and any loose steering parts

08.12      TASK:    Replace power steering drive belts

PERFORMANCE OBJECTIVE:    Given a vehicle, service manual and tools, remove and replace steering belt(s). Upon completion belt tension must be correct, belt must be properly aligned and adjusting bolts secured.

ENABLING OBJECTIVES:

1. Demonstrate safety precautions when working on steering components
2. Describe how belts are sized according to length, design and width
3. Identify belt to be removed and bolts used to release belt tension
4. Demonstrate removal and replacement of selected belt

5. Demonstrate proper gauge tension on replaced belt (or hand method)
6. Demonstrate operational test

08.13 TASK: Identify tires by types and sizes

PERFORMANCE OBJECTIVE: Given several tires, properly identify them by type and size.

ENABLING OBJECTIVES:

1. Identify bias tires
2. Identify radial tires
3. Identify belted tires
4. Define aspect ratio
5. Discuss combination of belted, bias and radial tires

08.14 TASK: Repair tires

PERFORMANCE OBJECTIVE: Given a tire that needs repair, repair the tire by properly dismounting, placing a patch on the inside and remounting the tire.

ENABLING OBJECTIVES:

1. Repair tubeless tires
2. Repair tube-type tires
3. Use hot patches
4. Use cold patches
5. Use boots

08.15 TASK: Rotate wheels and tires and torque lug nuts to specifications

PERFORMANCE OBJECTIVE: Given a vehicle, service manual and proper tools, rotate the tires. When finished, the lug nuts will be torqued to specifications and tires will be positioned considering the types of tires on the vehicle.

ENABLING OBJECTIVES:

1. Demonstrate safety precautions when vehicle is raised and wheels are removed
2. Demonstrate how to properly raise a vehicle to rotate the tires
3. Demonstrate proper handling of tire and hub caps and lug nuts while removed from the vehicle

4. Explain need to check tire and wheel balance at this time
5. Demonstrate proper rotation of tires (bias ply or radial ply)

08.16 TASK: Balance tires by computer, bubble or spin

PERFORMANCE OBJECTIVE: Given a wheel and tire assembly, wheel balancer, proper tools and wheel weights, balance the assembly.

ENABLING OBJECTIVES:

1. Demonstrate safety precautions
2. Define the terms "static" and "dynamic" balancing
3. Demonstrate locating position for wheel weights according to the type of balance
4. Explain why a certain size weight was used
5. Explain varying methods of attaching wheel weights based on wheel construction
6. Demonstrate balancer available

08.17 TASK: Service front wheel bearings and grease seals

PERFORMANCE OBJECTIVE: Given a vehicle, service manual and necessary tools, grease, seal, inspect and service the wheel bearing and seal.

ENABLING OBJECTIVES:

1. Demonstrate safety precautions while removing a wheel from a raised vehicle
2. Explain what will happen if the wheel bearing is over-tightened or under-tightened
3. Demonstrate proper removal, cleaning and grease packing of wheel bearings
4. Demonstrate replacement of bearings and seal
5. Demonstrate bearing adjustment and spindle nut locking procedure of hub
6. Demonstrate proper replacement of dust cap

08.18 TASK: Remove and replace front and rear wheel bearings

PERFORMANCE OBJECTIVE: Given a vehicle with defective front or rear wheel bearings, replace the bearings using the proper tools and service manuals, to manufacturer's specifications.

ENABLING OBJECTIVES:

1. Discuss types of grease
2. Demonstrate proper bearing adjustment
3. Torque lugs to proper specifications

08.19

TASK: Remove and replace spindles and ball joints

PERFORMANCE OBJECTIVE: Given a vehicle, service manual and proper tools, remove and replace the steering spindle and ball joints. When completed all attaching bolts and cotter pins must be checked for security.

ENABLING OBJECTIVES:

1. Demonstrate safety precautions when working on a raised vehicle
2. Discuss the importance of not straightening or heating a bent steering spindle
3. Describe special tools needed to remove a spindle held by ball joints
4. Demonstrate removal of spindle
5. Inspect all related parts (hub, bearings, backing plate, brake parts, etc.)
6. Demonstrate replacement of all related parts
7. Demonstrate removal of ball joints

08.20

TASK: Remove and replace shock absorbers and mountings

PERFORMANCE OBJECTIVE: Given a vehicle, service manual and tools, remove and replace shock absorbers. When finished shock bolts will be correctly tightened and proper shock selection will be appropriate.

ENABLING OBJECTIVES:

1. Demonstrate safety precautions when working under a raised vehicle
2. Explain the difference among standard, heavy duty and special purpose shock absorbers
3. Describe two purposes of shock absorbers
4. Demonstrate torque of shock absorber rubber grommets
5. Demonstrate test for operation and noise of shock absorbers



08.21 TASK: Measure and adjust torsion bar height

PERFORMANCE OBJECTIVE: Given a vehicle with torsion bar suspension and proper service manual, measure and adjust height.

ENABLING OBJECTIVES:

1. Follow proper safety procedures
2. Read ruler
3. Describe where to make adjustment, if not to specifications
4. Make adjustment

08.22 TASK: Remove and replace torsion bars

PERFORMANCE OBJECTIVE: Given a vehicle, service manual and necessary tools, remove and replace the torsion bar(s). When completed proper bolt torque will be checked as well as equal curb height being adjusted.

ENABLING OBJECTIVES:

1. Demonstrate safety precautions when working under a raised vehicle
2. Explain how the curb height can be adjusted on most torsion bar-equipped vehicles
3. Demonstrate removal and replacement of torsion bar and curb height adjustment procedure

08.23 TASK: Remove and replace coil springs

PERFORMANCE OBJECTIVE: Given a vehicle, service manual and required tools, remove and replace the coil spring(s). When completed the springs must be properly seated.

ENABLING OBJECTIVES:

1. Demonstrate safety procedures when working under a raised vehicle
2. Demonstrate the use of a spring compressor
3. Describe special tools needed to release ball joint connection
4. Demonstrate replacing and seating of replacement coil spring

08.24

TASK: Remove and replace control arms and bushings

PERFORMANCE OBJECTIVE: Given a vehicle, service manual and necessary tools, remove and replace control arms and bushings. When finished the control arm bolts must be tightened according to specifications and all retaining devices installed.

ENABLING OBJECTIVES:

1. Demonstrate safety precautions when removing major suspension components
2. Describe several dangerous aspects of removing and replacing a control arm

08.25

TASK: Remove and replace steering linkage components

PERFORMANCE OBJECTIVE: Given a vehicle, service manual and proper tools, remove and replace steering linkage components. When completed all components' attaching nuts are to be checked for torque. All locking devices must be installed correctly.

ENABLING OBJECTIVES:

1. Check tie rod
2. Check center link (drag link)
3. Check Pitman arm
4. Check idler arm
5. Check steering knuckle
6. Check steering sector
7. Check damper

08.26

TASK: Remove and replace McPherson strut assembly

PERFORMANCE OBJECTIVE: Given a vehicle, service manual and proper tools, remove and replace the McPherson strut assembly. All attachment hardware must be torqued to specifications, ride height must be correct and wheels must turn to their extremes without binding.

ENABLING OBJECTIVES:

1. Demonstrate safety precautions when working on a raised vehicle
2. Identify several cars that are McPherson strut-equipped and discuss the differences of such cars
3. Explain special tools used for safe operation
4. Identify a McPherson strut assembly and explain its construction

5. Demonstrate removal of strut assembly and control of the coil spring
6. Demonstrate replacement of strut assembly and all related parts

08.27

TASK: Rebuild a McPherson strut

PERFORMANCE OBJECTIVE: Given a vehicle, service manual and proper tools, rebuild a McPherson strut. Upon completion the strut must not bind, there should be no leaks and all snap-rings and rubber boots should be secured.

ENABLING OBJECTIVES:

1. Demonstrate safety precautions
2. Explain the advantages and/or disadvantages of a McPherson strut as compared to other front-end designs
3. Inspect unit to be disassembled for external damage
4. Demonstrate disassembly of strut and inspection of internal parts
5. Demonstrate assembly, installation and testing for operation of strut assembly

08.28

TASK: Remove and replace rear suspension parts, including independent suspension

PERFORMANCE OBJECTIVE: Given a vehicle with a problem in the rear suspension, determine the type of suspension, make a visual check and check for wear according to manufacturer's specifications.

ENABLING OBJECTIVES:

1. Follow safety procedures
2. Describe leaf-type suspension
3. Describe coil-type suspension
4. Describe independent suspension
5. Describe strut-type independent suspension
6. Adjust curb height
7. Adjust rear alignment

08.29

TASK: Remove and replace mast jacket of steering assembly

PERFORMANCE OBJECTIVE: Given a vehicle, service manual and necessary tools, remove and replace mast jacket. The mast jacket should be tight, in proper alignment and gear selector operational.

ENABLING OBJECTIVES:

1. Demonstrate safety precautions
2. Identify the mast jacket and explain its purpose
3. Demonstrate removal of all related parts
4. Demonstrate removal and replacement of mast jacket
5. Demonstrate operational test of mast jacket and all related parts

08.30 TASK: Repair steering column

PERFORMANCE OBJECTIVE: Given a vehicle, service manual and necessary tools, repair the tilt or telescopic steering column. This will include replacing small parts kit, bearing and locking assembly.

ENABLING OBJECTIVES:

1. Demonstrate safety precautions when working inside a vehicle
2. Identify tilt and/or telescopic steering column of the specific vehicle
3. Explain how each type operates
4. Demonstrate removal of related parts to expose the assembly to be repaired
5. Identify the needed repair and demonstrate removal and replacement of parts
6. Demonstrate operational test of repaired unit and related parts

08.31 TASK: Remove and replace steering wheel

PERFORMANCE OBJECTIVE: Given a vehicle, service manual and tools, remove and replace the steering wheel. The steering wheel should be aligned, bolt tightened, horn connected, and there should not be any damage done to steering wheel cover.

ENABLING OBJECTIVES:

1. Demonstrate safety precautions when working inside a vehicle
2. Demonstrate use of a steering wheel puller
3. Identify thread and bolt size on a specific vehicle so the appropriate puller can be used
4. Demonstrate proper removal and replacement of steering wheel and related parts

08.32      TASK: Remove and replace components in power steering system

PERFORMANCE OBJECTIVE:      Given a vehicle, service manual and proper tools, remove and replace hydraulic components in power steering system. Items to be included are hose(s) and line(s), steering cylinder, control valve and pump. When completed there should be no leaks, all attaching bolts should be secured and all lines and hoses routed properly.

ENABLING OBJECTIVES:

1. Demonstrate safety precautions for working on hydraulic power steering components
2. Explain pressure of these systems
3. Identify all power steering units and explain functions
4. Demonstrate removal and replacement of components selected for removal
5. Inspect for leakage and loose, worn or damaged parts

08.33      TASK: Check two-wheel and four-wheel alignments

PERFORMANCE OBJECTIVE:      Given a vehicle, service manual, necessary tools and equipment, align front end. The toe, caster and camber should meet manufacturer's specifications.

ENABLING OBJECTIVES:

1. Demonstrate safety precautions while working under a vehicle
2. Define toe-in, caster and camber
3. Identify adjustment points of the front end for toe-in, caster and camber setting
4. Describe tools and equipment necessary to align automobile front end
5. Demonstrate front end alignment procedure

08.34      TASK: Align rear axle

PERFORMANCE OBJECTIVE:      Given a vehicle, service manual and necessary tools, align rear axle. Vehicle readings must be within manufacturer's specifications.

ENABLING OBJECTIVES:

1. Demonstrate safety precautions when working under a vehicle
2. Identify several cars that have an adjustable rear axle
3. Locate rear axle adjustment points
4. Demonstrate use of the equipment necessary to align the vehicle's rear axle

IDAHO PROGRAM STANDARDS FOR BASIC AUTOMOTIVE TECHNICIAN

MODULE 9

AUTOMOTIVE BRAKE SERVICE

Division of Vocational Education  
State of Idaho  
Boise, Idaho  
1989

175  
-179-

## MODULE 9 - AUTOMOTIVE BRAKE SERVICE

This is one of a series of modules which comprise the Idaho Program Standards for Basic Automotive Technician. Each module contains a listing of the tasks, performance objectives, and enabling objectives required to enable a student to achieve competency in a specific system or field of study within the basic automotive technician occupational field. The numbering of these modules is not intended to dictate an order of instruction or scheduling. The order in which these modules may be taught is determined by each institution and its instructors.

Each task describes an occupational activity which will result in a finished process or product. Such a process or product should always allow an evaluation using standards which address the operation, appearance, dimensions, time in which achieved, or similar characteristics. The tasks listed in each module represent the basic activities required of each student to demonstrate entry level competence for that specific system or field of study within the automotive occupation.

The capability for providing instructional experiences and practical application of the tasks contained in each module will determine the scope of the vocational-technical program. In this regard, the student's maturity and preparation to receive instruction as well as the availability of equipment and the expertise of the instructional staff will be of primary importance. Individual records of student performance in completing the tasks listed within each module should be maintained.

Although some provision is made for basic mathematics and communication skills within these standards they may not be adequate to meet the needs of individual students. Counseling, guidance, and diagnostic test results may indicate a need for further preparation in these areas. In such cases, instructors are encouraged to utilize the resources and personnel within the institution to improve or complement the instructional process.

The benefits to students and institutions derived from these curriculum standards should be considerable. Articulation of students from secondary to post-secondary programs will be aided through the use of a single set of curriculum standards. The standards provide a tool for evaluation of local curricula and programs. The standards may be used in a flexible manner to assure that Basic Automotive Technician programs meet the needs of local business and industry.

It is the goal of this program standard to provide a level of instruction which will impart entry level employment skills. Students should be carefully counseled on the importance of attaining competency in the tasks assigned. As in virtually all occupations today, basic automotive technicians will require



periodic up-dating and review in the future. It is important that each student understand that meeting the program standards is essential not only to obtain employment today but also to have a base upon which to retain employment in the future.

IDAHO PROGRAM STANDARDS FOR BASIC AUTOMOTIVE TECHNICIAN

TASK LISTING

MODULE 9 - AUTOMOTIVE BRAKE SERVICE

09.0 DEMONSTRATE PROFICIENCY IN AUTOMOTIVE BRAKE SERVICE

--The student will be able to:

- 09.01 Demonstrate and apply safety rules and procedures
- 09.02 Diagnose brake system problems
- 09.03 Diagnose pressure differential valve malfunctions
- 09.04 Diagnose proportioning valve malfunctions
- 09.05 Diagnose brake metering valve malfunctions
- 09.06 Perform operational inspections
- 09.07 Inspect brake and wheel assemblies and perform proper cleaning procedures
- 09.08 Remove and replace calipers and rotors, front and rear
- 09.09 Refinish rotors on or off car, and torque lug nuts to specification
- 09.10 Clean, inspect and rebuild calipers
- 09.11 Refinish brake drums and torque lug nuts to specifications
- 09.12 Replace drum brake shoes with proper materials
- 09.13 Service and/or replace brake pads
- 09.14 Adjust brake shoes
- 09.15 Adjust parking brakes
- 09.16 Rebuild or replace wheel cylinder
- 09.17 Bleed hydraulic brakes
- 09.18 Free-up or replace parking brake cables and linkage
- 09.19 Remove and replace/overhaul master cylinder
- 09.20 Flush brake systems
- 09.21 Test and replace vacuum brake power unit
- 09.22 Test and replace hydro-booster
- 09.23 Test brake anti-lock system
- 09.24 Remove and replace anti-lock system components

MODULE 9 - AUTOMOTIVE BRAKE SERVICE

09.01 TASK: Demonstrate and apply safety rules and procedures

PERFORMANCE OBJECTIVE: Given proper equipment and repair manuals, demonstrate safety while repairing brake systems.

ENABLING OBJECTIVES:

1. Demonstrate safety while hoisting a vehicle using proper lift points and jack stands, if appropriate
2. Demonstrate safety while removing brake dust that may contain asbestos
3. Demonstrate safety while removing and replacing brake parts
4. Demonstrate safety regarding any brake fluid spillage
5. Demonstrate safety after brake work is completed by testing brakes before the vehicle is driven
6. Demonstrate safety during road test

09.02 TASK: Diagnose brake system problems

PERFORMANCE OBJECTIVE: Given a vehicle with brake problems, diagnose the brake system by evaluation of the customer's description of the problem, visual inspection and a road test, if the vehicle can be safely driven.

ENABLING OBJECTIVES:

1. Demonstrate safety procedures
2. Demonstrate visual inspection of external components
3. Demonstrate diagnostic procedure for concealed problems

09.03 TASK: Diagnose pressure differential valve malfunctions

PERFORMANCE OBJECTIVE: Given proper equipment and repair manuals, diagnose a brake problem caused by a malfunctioning pressure differential valve.

ENABLING OBJECTIVES:

1. Demonstrate safety while hoisting vehicle and by using jack stands, if appropriate

2. Demonstrate safety if there is brake fluid spillage
3. Test pressure differential valve according to repair manual
4. Repair or replace pressure differential valve according to repair manual
5. Test brakes for proper pedal height and fluid leakage before vehicle is driven
6. Road test vehicle for proper brake operation

09.04

TASK: Diagnose proportioning valve malfunctions

PERFORMANCE OBJECTIVE: Given proper tools, equipment and repair manuals, diagnose a brake problem caused by a malfunctioning proportioning valve.

ENABLING OBJECTIVES:

1. Demonstrate safety while hoisting vehicle and by using jack stands, if appropriate
2. Demonstrate safety if there is a brake fluid spillage
3. Test a proportioning valve according to instructions in proper repair manual
4. Repair or replace proportioning valve according to directions in repair manual
5. Test brakes for proper operation and fluid leakage before vehicle is driven
6. Road test vehicle for proper brake operation

09.05

TASK: Diagnose brake metering valve malfunctions

PERFORMANCE OBJECTIVE: Given proper equipment and repair manuals, diagnose a brake problem caused by a malfunctioning brake metering valve.

ENABLING OBJECTIVES:

1. Demonstrate safety while hoisting vehicle and by the use of jack stands, if appropriate
2. Demonstrate safety if there is a brake fluid spill
3. Test brake metering valve according to instructions in repair manual
4. Repair or replace metering valve according to instructions in repair manual
5. Test brakes for proper operation and fluid leakage before vehicle is driven
6. Road test vehicle for proper brake operation

09.06

TASK: Perform operational inspections

PERFORMANCE OBJECTIVE: Given a vehicle needing an operational brake test, proper service manual and access to necessary tools and equipment, perform an operational brake test. Record malfunctions for brake warning light operation, brake pedal reserve, brake pedal action, vehicle's braking behavior and braking noises.

ENABLING OBJECTIVES:

1. Demonstrate safety precautions while testing a vehicle with possible brake problems
2. Define pedal reserve
3. Describe vehicle braking behavior
4. Demonstrate vehicle braking action during an emergency stop

09.07

TASK: Inspect brake and wheel assemblies and perform proper cleaning procedures

PERFORMANCE OBJECTIVE: Given a vehicle needing a visual brake inspection, proper service manual and access to necessary tools and equipment, perform a visual inspection of all system components. Record findings for master cylinder reservoir fluid level, leaks, brake hose condition, brake lining condition and thickness, brake drum diameter and condition, brake rotor thickness, run-out and parallelism, and brake pad thickness.

ENABLING OBJECTIVES:

1. Demonstrate safety procedures while removing wheels, etc. for inspection
2. Demonstrate how to read micrometers (brake drum type and outside micrometers on rotors)
3. Identify specifications for vehicle in question in proper shop manual
4. Define rotor run-out and parallelism
5. Inspect all brake lines and flexible hoses
6. Demonstrate removal of wheels, etc. for visual lining inspection
7. Demonstrate proper cleaning procedures
8. Discuss danger of materials

09.08      TASK: Remove and replace calipers and rotors, front and rear

PERFORMANCE OBJECTIVE:      Given a vehicle with disc brakes on front and/or rear, replace the calipers and rotors to manufacturer's specifications, torquing wheel nuts to proper torque.

ENABLING OBJECTIVES:

1. Use proper safety procedures
2. Bleed the system
3. Properly fill master cylinder
4. Demonstrate use of proper tools
5. Demonstrate proper lifting and supporting procedures
6. Inspect pads for wear
7. Inspect rotor for wear or warpage
8. Adjust disc brakes
9. Inspect caliper for corrosion and leakage
10. Demonstrate use of dial indicator

09.09      TASK: Refinish rotors, on or off car, and torque lug nuts to specifications

PERFORMANCE OBJECTIVE:      Given a set of brake rotors needing machining, proper service manual and access to tools, equipment and materials, machine rotors. Machine rotors to the tolerance allowed by the manufacturer, with surfaces parallel, no run-out and a non-directional, smooth surface finish.

ENABLING OBJECTIVES:

1. Demonstrate safety procedures when using a disc brake lathe
2. Demonstrate the proper use of a disc brake lathe
3. Describe the use of a special micrometer for measuring rotors
4. Demonstrate procedures for doing the task on a vehicle, if equipment is available

09.10      TASK: Clean, inspect and rebuild calipers

PERFORMANCE OBJECTIVE:      Given a vehicle with a defective disc brake caliper, proper service manual and access to necessary tools and equipment, repair disc brake caliper. The caliper bore will be properly serviced, the piston seal and piston and dust seal properly installed and the machined surfaces of caliper properly serviced.

ENABLING OBJECTIVES:

1. Demonstrate safety precautions when working on a hydraulic brake system
2. Demonstrate use of special caliper tools
3. Demonstrate use of bore or cylinder hone
4. Explain caution and careful inspection necessary in rebuilding a caliper cylinder
5. Demonstrate proper procedure in rebuilding caliper cylinder
6. Explain need for the cylinder dust boot

09.11      TASK: Refinish brake drums and torque lug nuts to specifications

PERFORMANCE OBJECTIVE: Given a set of brake drums needing machining, service manual and access to necessary tools, equipment and materials, machine drums. The drums will be machined to a tolerance allowed by the manufacturer's specifications and D.O.T. regulations, and the surface will be smooth across the width.

ENABLING OBJECTIVES:

1. Demonstrate safety precautions when using a brake drum lathe
2. Demonstrate the proper use of a brake drum lathe
3. Demonstrate the use of a brake drum micrometer
4. Explain when proper cut on brake drum surface has been made

09.12      TASK: Replace drum brake shoes with proper materials

PERFORMANCE OBJECTIVE: Given a vehicle with worn brake shoes, service manual and access to necessary tools and equipment, replace brake shoes. Worn shoes will be removed, backing plate platforms will be serviced, replacement shoes and shoe return springs will be positioned correctly and self-adjusting mechanisms will be correctly positioned and serviced. Front wheel bearings must be lubricated and adjusted to torque specifications.

ENABLING OBJECTIVES:

1. Demonstrate the use of special brake tools
2. Demonstrate safety precautions on the work being done and while working on a brake system
3. Explain need to rebuild wheel and master cylinder

4. Explain how self-adjuster works
5. Demonstrate operation of brakes immediately after brake shoes are replaced
6. Demonstrate precautions necessary in driving the vehicle immediately after brake shoe replacement
7. Demonstrate handling of wheels and hub caps during the brake repair job

09.13

TASK: Service and/or replace brake pads

PERFORMANCE OBJECTIVE: Given a vehicle with worn disc brake pads, proper service manual and access to necessary tools and equipment, service and/or replace pads. Worn pads will be removed, caliper support will be properly serviced, the pads will be properly located and the anti-rattle springs will be properly positioned.

ENABLING OBJECTIVES:

1. Demonstrate safety precautions while working around a raised and supported vehicle
2. Explain proper service needs for the specific vehicle
3. Demonstrate the proper lubricating of wheel bearings, seal inspection and bearing adjustment while caliper is off for pad replacement
4. Demonstrate brake pad removal and safe placement of caliper
5. Inspect and measure wear of rotor with a micrometer
6. Demonstrate replacement of pads and caliper

09.14

TASK: Adjust brake shoes

PERFORMANCE OBJECTIVE: Given a vehicle with non-self adjusting brakes, proper service manual and access to necessary tools and equipment, adjust the brakes. Each wheel must be free of drag, and the vehicle will not pull to either side when brakes are applied. Check tire type, tire size, tread condition and air pressure to avoid erratic brake action.

ENABLING OBJECTIVES:

1. Demonstrate safety precautions when working with a brake system
2. Explain correct direction to move adjuster
3. Demonstrate properly adjusted drum brake system
4. Explain importance of type, size and air pressure of tires on vehicle



09.15      TASK: Adjust parking brakes

PERFORMANCE OBJECTIVE:      Given a vehicle needing parking brake adjustment, proper service manual, proper tools and proper lifting and supporting equipment, adjust the parking brake to manufacturer's specifications.

ENABLING OBJECTIVES:

1. Demonstrate proper safety precautions
2. Demonstrate proper lifting and supporting procedures
3. Use proper tools
4. Test for drag when completed

09.16      TASK: Rebuild or replace wheel cylinder

PERFORMANCE OBJECTIVE:      Given a vehicle with a defective wheel cylinder, proper service manual and access to necessary tools and equipment, repair or replace wheel cylinder. Standard brake system will operate properly with firm pedal and no fluid leaks.

ENABLING OBJECTIVES:

1. Explain the methods used to determine cylinder condition
2. Describe the safety procedures used to repair a cylinder
3. Explain how new parts were installed into cylinder
4. Demonstrate the use of brake cylinder hone
5. Demonstrate the use of brake bleeding tools

09.17      TASK: Bleed hydraulic brakes

PERFORMANCE OBJECTIVE:      Given a vehicle needing the brakes bled, proper service manual and access to necessary tools and equipment, bleed the brakes within twice the time allowed by the flat rate manual. All air from line will be removed and the pedal will be firm.

ENABLING OBJECTIVES:

1. Demonstrate safety precautions when working with hydraulic brake fluid
2. Demonstrate proper use of bleeder tools and equipment
3. Explain brake pedal action when all air has been removed from the system

4. Describe bleeding procedure for removal of air from brake system
5. Check master cylinder fluid level

09.18 TASK: Free-up or replace parking brake cables and linkage

PERFORMANCE OBJECTIVE: Given a vehicle needing brake attention, proper service manual and access to necessary tools and equipment, replace or free-up parking linkage. The linkage must be properly routed, secured and positioned and the vehicle will not roll with the parking brake applied.

ENABLING OBJECTIVES:

1. Demonstrate safety precautions
2. Explain how parking brakes operate
3. Explain how to free-up binding cables
4. Demonstrate parking brake cable adjustment

09.19 TASK: Remove and replace/overhaul master cylinder

PERFORMANCE OBJECTIVE: Given a vehicle with a defective master cylinder, proper service manual and necessary tools, remove, rebuild, then replace master cylinder. Master cylinder must be rebuilt and installed according to manufacturer's procedures. All attaching hardware must be torqued to specifications, pedal must be firm and line connections must not leak.

ENABLING OBJECTIVES:

1. Demonstrate safety precautions when working with a hydraulic brake system
2. Explain the method used to determine master cylinder condition
3. Demonstrate the use of special tools
4. Describe the need to hone the cylinder
5. Describe cleaning all parts and valves
6. Explain how new parts are installed, function of lock screw (if used) and snap-rings
7. Explain the differences in master cylinders

09.20 TASK: Flush brake systems

PERFORMANCE OBJECTIVE: Given a vehicle with contaminated brake fluid and access to necessary tools and ample brake fluid, flush the brake system at each wheel until no air or contamination exists in the fluid.

ENABLING OBJECTIVES:

1. Demonstrate safety procedures while working with a brake hydraulic system
2. Describe proper jacking and supporting of vehicle
3. Discuss handling of fluid (keeping out of eyes and off any painted surface)
4. Explain brake fluid grades or types
5. Demonstrate brake flushing at each wheel

09.21

TASK: Test and replace vacuum brake power unit

PERFORMANCE OBJECTIVE: Given a vehicle with a defective brake power unit, proper service manual and access to necessary tools and equipment, test and replace vacuum brake power unit. Demonstrate that all vacuum connections are properly routed and connected and that brake pedal behavior reflects proper operation, with no vacuum or fluid leaks.

ENABLING OBJECTIVES:

1. Demonstrate safety precautions
2. Describe vacuum effect on unit
3. Demonstrate operation of power brake unit

09.22

TASK: Test and replace hydro-booster

PERFORMANCE OBJECTIVE: Given a vehicle with a defective hydraulic brake booster unit, proper service manual and access to necessary tools and equipment, test and replace hydro-booster. Demonstrate that hydraulic lines are properly routed and connected and that brake pedal behavior reflects proper operation with no hydraulic or brake fluid leaks.

ENABLING OBJECTIVES:

1. Demonstrate safety precautions
2. Describe power steering pump pressure on the brake system
3. Demonstrate proper operation of the hydro-boost unit

09.23

TASK: Test brake anti-lock system

PERFORMANCE OBJECTIVE: Given a vehicle needing the anti-lock system tested, road check the vehicle to determine the problem. No wheel will lock (skid) when brakes are firmly applied or otherwise deviate from manufacturer's specifications.

ENABLING OBJECTIVES:

1. Demonstrate safety precautions when road checking a vehicle with known brake defect
2. Identify which wheel has problems or other system defects
3. Explain the need for proper road check driving procedures
4. Describe any problems with the braking system

09.24

TASK: Remove and replace anti-lock system components

PERFORMANCE OBJECTIVE: Given a vehicle with a defective anti-lock system, proper service manual and access to necessary tools and equipment, repair or replace the component. Components must be installed according to manufacturer's recommendation. All wheels must function properly under firm pedal pressure without lock-up (skid).

ENABLING OBJECTIVES:

1. Demonstrate safety precautions when working on a brake system
2. Identify the component location and function
3. Explain the function of anti-lock system
4. Demonstrate proper function of anti-lock brake system

MODULE 10

ENGINE COOLING, AIR CONDITIONING AND HEATING SERVICE

## What an Air Conditioner Does

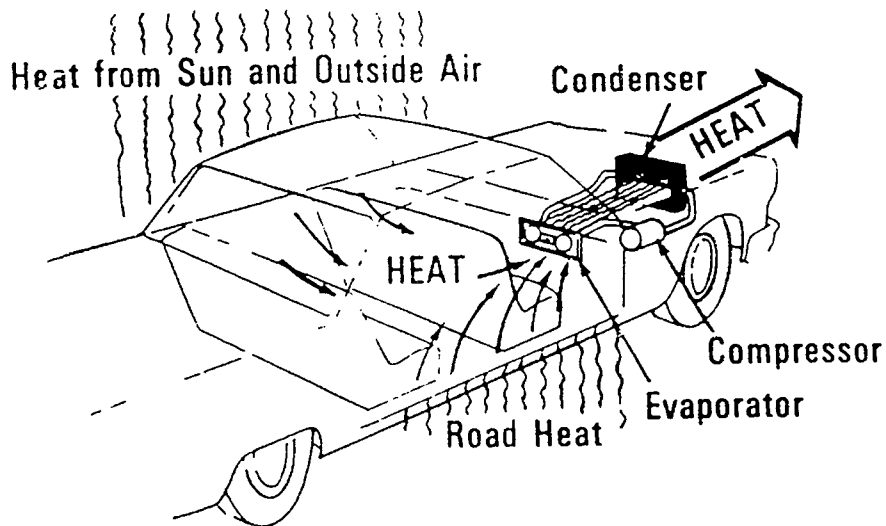

An air conditioner is a simple mechanical device to move heat from the inside of the car to the outside.

IDAHO PROGRAM STANDARDS FOR BASIC AUTOMOTIVE TECHNICIAN

MODULE 10

ENGINE COOLING, AIR CONDITIONING AND HEATING SERVICE

Division of Vocational Education  
State of Idaho  
Boise, Idaho  
1989

## MODULE 10 - ENGINE COOLING, AIR CONDITIONING AND HEATING SERVICE

This is one of a series of modules which comprise the Idaho Program Standards for Basic Automotive Technician. Each module contains a listing of the tasks, performance objectives, and enabling objectives required to enable a student to achieve competency in a specific system or field of study within the basic automotive technician occupational field. The numbering of these modules is not intended to dictate an order of instruction or scheduling. The order in which these modules may be taught is determined by each institution and its instructors.

Each task describes an occupational activity which will result in a finished process or product. Such a process or product should always allow an evaluation using standards which address the operation, appearance, dimensions, time in which achieved, or similar characteristics. The tasks listed in each module represent the basic activities required of each student to demonstrate entry level competence for that specific system or field of study within the automotive occupation.

The capability for providing instructional experiences and practical application of the tasks contained in each module will determine the scope of the vocational-technical program. In this regard, the student's maturity and preparation to receive instruction as well as the availability of equipment and the expertise of the instructional staff will be of primary importance. Individual records of student performance in completing the tasks listed within each module should be maintained.

Although some provision is made for basic mathematics and communication skills within these standards they may not be adequate to meet the needs of individual students. Counseling, guidance, and diagnostic test results may indicate a need for further preparation in these areas. In such cases, instructors are encouraged to utilize the resources and personnel within the institution to improve or complement the instructional process.

The benefits to students and institutions derived from these curriculum standards should be considerable. Articulation of students from secondary to post-secondary programs will be aided through the use of a single set of curriculum standards. The standards provide a tool for evaluation of local curricula and programs. The standards may be used in a flexible manner to assure that Basic Automotive Technician programs meet the needs of local business and industry.

It is the goal of this program standard to provide a level of instruction which will impart entry level employment skills. Students should be carefully counseled on the importance of attaining competency in the tasks assigned. As in virtually all occupations today, basic automotive technicians will require

periodic up-dating and review in the future. It is important that each student understand that meeting the program standards is essential not only to obtain employment today but also to have a base upon which to retain employment in the future.



IDAHO PROGRAM STANDARDS FOR BASIC AUTOMOTIVE TECHNICIAN

TASK LISTING

MODULE 10 - ENGINE COOLING, AIR CONDITIONING, AND HEATING SERVICE

10.0 DEMONSTRATE PROFICIENCY IN COOLING, AIR CONDITIONING, AND HEATING SERVICE--The student will be able to:

- 10.01 Demonstrate and apply safety rules and procedures
- 10.02 Inspect, remove, and replace drive belt(s)
- 10.03 Check radiator coolant level
- 10.04 Test and replace coolant
- 10.05 Pressure-test cooling systems
- 10.06 Test radiator caps
- 10.07 Inspect, remove, and replace radiator and heater hoses
- 10.08 Remove, test, and replace thermostats
- 10.09 Flush cooling system
- 10.10 Remove and replace radiators
- 10.11 Remove and replace water pumps
- 10.12 Inspect and pressure-test air conditioning system
- 10.13 Discharge, evacuate, and charge basic air conditioning system
- 10.14 Leak-test basic air conditioning systems
- 10.15 Service air conditioning electrical circuits
- 10.16 Service air conditioning vacuum circuits
- 10.17 Remove and replace components in basic air conditioning systems
- 10.18 Remove and replace engine fan clutches
- 10.19 Remove and replace blower motors
- 10.20 Remove and replace heater cores, control units, and cables
- 10.21 Remove and replace compressor shaft seals
- 10.22 Service engine electric cooling fan and controls

19.

MODULE 10 - ENGINE COOLING, AIR CONDITIONING AND HEATING SERVICE

10.01 TASK: Demonstrate and apply safety rules and procedures

PERFORMANCE OBJECTIVE: Demonstrate ability to safely diagnose, test and repair engine cooling, air conditioning and heating systems.

ENABLING OBJECTIVES:

1. Demonstrate proper storage and use of Refrigerant 12
2. Describe steps for discharging, repairing, evacuating and charging air conditioning systems
3. Describe steps for diagnosing and repairing engine cooling systems and vehicle heating systems
4. Explain safety precautions necessary when diagnosing, servicing and repairing heating, air conditioning and engine cooling systems
5. Explain proper disposal of old antifreeze

10.02 TASK: Inspect, remove and replace drive belt(s)

PERFORMANCE OBJECTIVE: Given a vehicle and access to the appropriate service manual, tools and equipment, inspect, remove and replace the drive belt(s). All components will be tight, and the tension on drive belt(s) will be correct.

ENABLING OBJECTIVES:

1. Explain use of drive belt gauge
2. Demonstrate caution to be used in moving alternator or other belt-driven accessories
3. Explain mechanical operation of pulleys
4. Explain methods of tightening belts
5. Demonstrate safety precautions
6. Demonstrate "hand" test for drive belt tension (when no gauge is available)
7. Demonstrate inspecting, removing and replacing belt(s)

10.03 TASK: Check radiator coolant level

PERFORMANCE OBJECTIVE: Given a vehicle with a liquid-cooled engine, perform a radiator coolant level check.

ENABLING OBJECTIVES:

1. Demonstrate safety precautions when working on engine cooling systems
2. Describe how to check coolant level
3. Check coolant level

10.04

TASK: Test and replace coolant

PERFORMANCE OBJECTIVE: Given a liquid-cooled engine at operating temperature, tools and equipment, test the coolant freezing point and specific gravity. The reading must be within +/- 5 degrees of established reading. Drain and replace the engine coolant.

ENABLING OBJECTIVES:

1. Demonstrate safety precautions
2. Explain boiling and freezing point of water and antifreeze mix
3. Demonstrate use of hydrometer for antifreeze solution
4. Explain results of freezing coolant in an engine
5. Inspect system for leaks
6. Explain types of testers
7. Explain types of coolants
8. Test the coolant
9. Explain how to safely drain the cooling system
10. Explain correct mixture of water and antifreeze for proper protection
11. Drain old antifreeze
12. Install new antifreeze
13. Tell how to properly dispose of old antifreeze

10.05

TASK: Pressure-test cooling systems

PERFORMANCE OBJECTIVE: Given a liquid-cooled engine and a radiator pressure tester pump, pressure-test the cooling system. Any pressure drop in the system will be noted. System must hold pressure within manufacturer's specifications with no leaks.

ENABLING OBJECTIVES:

1. Demonstrate safety precautions
2. Explain operation of pressure tester
3. Explain pressure drop problems
4. Inspect system for signs of leakage
5. Pressure-test the system

10.06 TASK: Test radiator caps

PERFORMANCE OBJECTIVE: Given a vehicle with a liquid cooled engine which is pressurized, a radiator cap and a radiator cap tester, test cap for proper operation.

ENABLING OBJECTIVES:

1. Demonstrate safety precautions
2. Describe how the radiator cap controls the sealed system and explain the purpose for pressurizing the system
3. Test the radiator cap

10.07 TASK: Inspect, remove and replace radiator and heater hoses

PERFORMANCE OBJECTIVE: Given an automobile that is operational, visually inspect and physically examine heater and radiator hoses, and replace them if necessary. All cracked, soft or worn hoses and leaks must be detected.

ENABLING OBJECTIVES:

1. Demonstrate safety precautions while working with a cooling system
2. Explain heater and radiator hose functions
3. Describe preformed hoses and flexible hoses
4. Inspect hoses for faulty conditions, cracks, and soft hard or worn spots
5. Inspect all hose clamps and tighten
6. Remove and replace all hoses found to be defective

10.08 TASK: Remove, test and replace thermostats

PERFORMANCE OBJECTIVE: Given an automobile that is operational but has thermostat problems and the necessary tools, test and replace thermostat. There must be no leaks, and the coolant level must be at the correct point at normal operating temperature.

ENABLING OBJECTIVES:

1. Demonstrate safety precautions
2. Explain purpose of thermostat
3. Determine location of thermostat
4. Explain how to test thermostat
5. Demonstrate removal of thermostat and clean gasket surfaces

6. Demonstrate proper tightening procedure of housing bolts
7. Test the thermostat

10.09      TASK: Flush cooling system

PERFORMANCE OBJECTIVE: Given a liquid-cooled engine in operating condition and the necessary tools and equipment, clean and flush cooling system. After using proper procedures for cleaning and flushing the system, all connections must be leak-proof and coolant must be at correct level at operating temperature. System must be rechecked after thermostat opens.

ENABLING OBJECTIVES:

1. Demonstrate safety precautions
2. Explain the effect of the cooling system on the life of the engine
3. Identify types of antifreeze
4. Demonstrate safety rules when operating flush equipment
5. Inspect system for leaks
6. Inspect coolant level again after thermostat has opened
7. Explain reason for reverse flush of engine cooling system
8. Flush the cooling system

10.10      TASK: Remove and replace radiators

PERFORMANCE OBJECTIVE: Given a vehicle with defective radiator and access to appropriate tools, equipment and service manual, remove and replace radiator. The radiator and its connecting components must not leak.

ENABLING OBJECTIVES:

1. Explain purpose of radiator
2. Demonstrate safety procedures (hot pressure)
3. Explain radiator construction and liquid flow direction
4. Demonstrate care in handling radiator to avoid damage
5. Inspect for leaks
6. Remove and replace radiator

10.11

TASK: Remove and replace water pumps

PERFORMANCE OBJECTIVE: Given a liquid-cooled engine, necessary tools, equipment and service manual, remove and replace water pump. The pump should function as specified without leaks or noise at normal operating temperature. Coolant level must be rechecked after engine thermostat opens.

ENABLING OBJECTIVES:

1. Demonstrate safety precautions
2. Explain how to use belt tension gauge
3. Explain how the cooling system works
4. Explain how to use pressure tester
5. Explain how to check water pump for end play and roughness in bearings and leakage
6. Demonstrate removal of all old gasket material from mating surfaces
7. Remove and replace water pump
8. Torque water pump bolts according to manufacturer's specifications

10.12

TASK: Inspect and pressure-test air conditioning system

PERFORMANCE OBJECTIVE: Given a vehicle with an air conditioning problem, necessary tools and equipment and service manual, inspect and pressure-test air conditioning system.

ENABLING OBJECTIVES:

1. Demonstrate safety procedures
2. Explain inspection procedures
3. Explain pressure-test procedures
4. Inspect and pressure-test the system and record your findings
5. Use proper service manual and charts to diagnose problems in the system

10.13

TASK: Discharge, evacuate and charge a basic air conditioning system

PERFORMANCE OBJECTIVE: Given an automobile with an air conditioning system, refrigerant, necessary tools and equipment, discharge, evacuate and charge an air conditioning system to the correct pressures with the proper air temperature coming out the in-car ducts.

ENABLING OBJECTIVES:

1. Demonstrate safety precautions
2. Explain purpose of Refrigerant 12
3. Explain purpose of evacuating the system
4. Explain dehydration
5. Explain effects of moisture in the system
6. Explain temperature-pressure relationship charts
7. Demonstrate discharging, evacuating and recharging the system to manufacturer's specifications

10.14 TASK: Leak-test basic air conditioning systems

PERFORMANCE OBJECTIVE: Given an automobile air conditioning system, leak-test the system. The system should not leak.

ENABLING OBJECTIVES:

1. Demonstrate safety precautions
2. Explain purpose and methods of leak detection
3. Explain use of gauge and manifold
4. Demonstrate method of leak detection and repair, as necessary

10.15 TASK: Service air conditioning electrical circuits

PERFORMANCE OBJECTIVE: Given an automobile with problems in the air conditioning electrical circuits, service manuals, necessary tools, meters and test equipment, service air conditioning electrical circuits.

ENABLING OBJECTIVES:

1. Demonstrate safety precautions
2. Demonstrate use of a wiring schematic to trace circuits
3. Explain how the circuits work
4. Diagnose problems in the circuits
5. Service and repair problems in circuits

10.16 TASK: Service air conditioning vacuum circuits

PERFORMANCE OBJECTIVE: Given an automobile with problems in the air conditioning vacuum circuits, service manuals, necessary tools and equipment, service air conditioning vacuum circuits.

ENABLING OBJECTIVES:

1. Demonstrate safety precautions
2. Demonstrate use of vacuum schematic to trace vacuum circuits
3. Explain how the vacuum circuits work
4. Diagnose problems in the vacuum circuits
5. Service and repair problems in the vacuum circuits

10.17 , TASK: Remove and replace components in basic air conditioning systems

PERFORMANCE OBJECTIVE: Given a vehicle with a basic air conditioning system, service manuals, tools and equipment, remove and replace components in a basic air conditioning system.

ENABLING OBJECTIVES:

1. Demonstrate safety precautions
2. Explain purpose and functions of compressors
3. Explain purpose and functions of condensers
4. Explain purpose and functions of receiver-dryers and accumulators
5. Explain purpose and functions of expansion valves and orifice tubes
6. Explain purpose and function of evaporators.
7. Explain purpose and function of evaporator pressure regulators
8. Explain purpose and function of connecting hoses
9. Explain how to remove and replace items listed in items 2 through 8 above
10. Demonstrate how to correctly remove and replace items listed in 2 through 8 above.

10.18 TASK: Remove and replace engine fan clutches

PERFORMANCE OBJECTIVE: Given a vehicle with a fan clutch, service manual, necessary tools and equipment, test, remove and replace the fan clutch.

ENABLING OBJECTIVES:

1. Demonstrate safety precautions
2. Describe operation and function of fan clutches
3. Explain use of fan shroud and the horsepower advantage of fan clutches
4. Demonstrate removal and replacement procedures



10.19

TASK: Remove and replace blower motors

PERFORMANCE OBJECTIVE: Given a vehicle with a blower motor, service manuals, tools, equipment and materials, remove and replace the blower motor.

ENABLING OBJECTIVES:

1. Demonstrate safety precautions
2. Explain operation of blower motor
3. Explain removal and replacement procedures
4. Remove and replace blower motor

10.20

TASK: Remove and replace heater cores, control units and cables

PERFORMANCE OBJECTIVE: Given a vehicle with a heater, service manual, tools, equipment and materials, remove and replace heater core, heater and/or air conditioning control units and control cables.

ENABLING OBJECTIVES:

1. Demonstrate safety precautions
2. Explain the function and operation of heater cores, control units and cables
3. Describe removal and replacement procedures
4. Demonstrate removal and replacement
5. Demonstrate how to properly adjust control cables

10.21

TASK: Remove and replace compressor shaft seals

PERFORMANCE OBJECTIVE: Given an air conditioning compressor, service manual, necessary tools, equipment and materials, remove and replace the compressor shaft seal.

ENABLING OBJECTIVES:

1. Demonstrate safety precautions
2. Explain function and location of compressor shaft seals
3. Explain procedure for removal and replacement of compressor shaft seals
4. Demonstrate removal and replacement of compressor shaft seal

10.22

TASK: Service electric engine cooling fan and controls

PERFORMANCE OBJECTIVE: Given a vehicle with an electrical cooling fan, service manuals, necessary testers, tools, equipment and supplies, service the electric cooling fan system.

ENABLING OBJECTIVES:

1. Demonstrate safety precautions
2. Explain function and operation of electrical cooling fans and circuitry
3. Trace cooling fan system circuitry on a wiring schematic
4. Explain procedures for testing and servicing electric cooling fans
5. Demonstrate testing and servicing electric cooling fans

202