

DOCUMENT RESUME

ED 353 472

CE 062 946

AUTHOR de Leeuw, David; And Others
 TITLE Examples of Integrated Academic and Vocational Curriculum from High School Academies in the Oakland Unified School District.
 INSTITUTION National Center for Research in Vocational Education, Berkeley, CA.
 SPONS AGENCY Office of Vocational and Adult Education (ED), Washington, DC.
 PUB DATE Dec 92
 CONTRACT V051A80004-92A
 NOTE 157p.
 AVAILABLE FROM NCRVE Materials Distribution Service, 46 Horrabin Hall, Western Illinois University, Macomb, IL 61455 (order no. MDS-483: \$7.25).
 PUB TYPE Reports - Research/Technical (143)

EDRS PRICE MF01/PC07 Plus Postage.
 DESCRIPTORS *Academic Education; Allied Health Occupations; *Allied Health Occupations Education; Curriculum; Curriculum Development; *Engineering; Engineering Education; High Risk Students; High Schools; *Integrated Curriculum; Journalism; *Journalism Education; *Magnet Schools; Models; Program Descriptions; Program Design; Secondary School Teachers; State Programs; Vocational Education; Vocational Schools

IDENTIFIERS *Oakland Unified School District CA

ABSTRACT

This report provides examples of curricular integration produced by teachers in three career academies in Oakland, California. It describes ways in which academic and vocational teachers have created explicit connections between their separate subjects. Following a preface, "Oakland Academies Magnet Programs--An Overview" (Allie Whitehurst-Gordon), explains how career academies are implemented in the Oakland Unified School District. These aspects of program design are considered: student selection, program structure, community support, and district and school support. The next three sections describe the health (life science), media (humanities), and preengineering (physical science) academies. Each section begins with a description of the academy program and an outline of the 3-year sequence of courses for students in that academy. Specific illustrations of integrated curriculum are then given in detail for each academy. "Health Academy" (David de Leeuw) provides information for teachers and student worksheets on these topics: clinical applications of knowledge about the heart, vital signs lab, and family medical history. "Media Academy" (Stephen O'Donoghue, Michael Jackson) contains materials for teachers, procedures, and example(s) of student work for book of essays, book of bimodal biographies, student magazine, and advertising project. "Pre-Engineering Academy" (Carl Hertenstein) provides materials for engineering graphics, descriptive geometry, and physics I, II, and III. (YLB)

ED 353 472



National Center for Research in Vocational Education

University of California, Berkeley

EXAMPLES OF INTEGRATED ACADEMIC AND VOCATIONAL CURRICULUM FROM HIGH SCHOOL ACADEMIES IN THE OAKLAND UNIFIED SCHOOL DISTRICT

U.S. DEPARTMENT OF EDUCATION Office of Educational Research and Improvement EDUCATIONAL RESOURCES INFORMATION CENTER (ERIC)

- This document has been reproduced as received from the person or organization originating it. Minor changes have been made to improve reproduction quality. Points of view or opinions stated in this document do not necessarily represent those of ERIC position or policy.

BEST COPY AVAILABLE

Supported by the Office of Vocational and Adult Education, U.S. Department of Education

062 946



This publication is available from the:

National Center for Research in Vocational Education
Materials Distribution Service
Western Illinois University
46 Horrabin Hall
Macomb, IL 61455

800-637-7652 (Toll Free)

3

BEST COPY AVAILABLE

**EXAMPLES OF INTEGRATED
ACADEMIC AND VOCATIONAL
CURRICULUM FROM
HIGH SCHOOL ACADEMIES
IN THE OAKLAND UNIFIED
SCHOOL DISTRICT**

**David de Leeuw
Carl Hertenstein
Michael Jackson
B. Jeannie Lum
Stephen O'Donoghue
Mikala Rahn
Victor Rubin
David Stern
Allie Whitehurst-Gordon**

**Institute of Urban and Regional Development
University of California at Berkeley**

**National Center for Research in Vocational Education
University of California at Berkeley
1995 University Avenue, Suite 375
Berkeley, CA 94704**

**Supported by
The Office of Vocational and Adult Education,
U.S. Department of Education**

December, 1992

MDS-483

7E 062946

FUNDING INFORMATION

Project Title: National Center for Research in Vocational Education

Grant Number: V051A80004-92A

Act under which
Funds Administered: Carl D. Perkins Vocational Education Act
P. L. 98-524

Source of Grant: Office of Vocational and Adult Education
U.S. Department of Education
Washington, DC 20202

Grantee: The Regents of the University of California
National Center for Research in Vocational Education
1995 University Avenue, Suite 375
Berkeley, CA 94704

Director: Charles S. Benson

Percent of Total Grant
Financed by Federal Money: 100%

Dollar Amount of
Federal Funds for Grant: \$5,775,376

Disclaimer: This publication was prepared pursuant to a grant with the Office of Vocational and Adult Education, U.S. Department of Education. Grantees undertaking such projects under government sponsorship are encouraged to express freely their judgement in professional and technical matters. Points of view of opinions do not, therefore, necessarily represent official U.S. Department of Education position or policy.

Discrimination: Title VI of the Civil Rights Act of 1964 states: "No person in the United States shall, on the ground of race, color, or national origin, be excluded from participation in, be denied the benefits of, or be subjected to discrimination under any program or activity receiving federal financial assistance." Title IX of the Education Amendments of 1972 states: "No person in the United States shall, on the basis of sex, be excluded from participation in, be denied the benefits of, or be subjected to discrimination under any education program or activity receiving federal financial assistance." Therefore, the National Center for Research in Vocational Education project, like every program or activity receiving financial assistance from the U.S. Department of Education, must be operated in compliance with these laws.

Special Note: The project from which this book evolved was made possible by a Presidential Grant for School Improvement from the University of California Office of the President to the University-Oakland Metropolitan Forum at the University of California at Berkeley. The printing of this document was made possible by the National Center for Research in Vocational Education.

TABLE OF CONTENTS

Preface	i
Oakland Academies Magnet Programs - An Overview	
by Allie Whitehurst-Gordon	1
The Oakland Academies Model	3
Program Design	4
A Model For Positive Educational Change	6
Health Academy	
by David de Leeuw	7
Clinical Applications of Knowledge about the Heart	9
For Teachers	9
Student Worksheet: The Heart	11
Worksheet Key for Teachers	15
Heart Beat Cycle Worksheet	21
Vital Signs Lab	23
For Teachers	23
Student Worksheet: Lab 1 - Resting	25
Student Worksheet: Lab 2 - Exercise and Recovery	28
Student Worksheet: Lab 3 - Comparing Fitness	34
Family Medical History	36
For Teachers	36
Student Assignment	39
Media Academy	
by Stephen O'Donoghue & Michael Jackson	41
Book of Essays (Seniors)	45
For Teachers	46
Procedures	46
Examples of Student Work	49
Book of Bi-modal Biographies (Sophomores)	53
For Teachers	53
Procedures	54
Example of Student Work	58

Student Magazine (Juniors)	60
For Teachers	60
Procedures	61
Example of Student Work	63
Advertising Project (Sophomores and Seniors)	68
For Teachers	68
Procedures	69
Examples of Student Work	71
Pre-Engineering Academy	
by Carl Hertenstein	75
Engineering Graphics	78
Descriptive Geometry	79
Sample Problem A: Icosahedron Geodesic	81
Physics 1 (HP) Physics Mechanics	88
Area I: Two-Dimensional Statics	89
Sample Problem A: 2-D Statics	89
Sample Problem B: 2-D Statics	92
Area II: Calculus for Physics	95
Sample Problem C: Variable Acceleration	96
Sample Problem D: Freely Falling Bodies	98
Sample Problem E: Motion of Projectiles	100
Area III: Fluid Statics	103
Sample Problem F: Force on Submerged Surface	105
Sample Problem G: Center of Pressure	109
Physics II (AP) Advanced Mechanics	111
Area I: Three-Dimensional Statics	111
Sample Problem A: 3-D Statics	111
Area II: Mass Moment of Inertia	117
Sample Problem B: Acceleration of a System of Bodies ...	125
Sample Problem C: Dynamic Equilibrium of Rotating Bodies	127
Physics III (HP) Strength of Materials	131
Sample Problem A: Beam Design	131
Examples of Student Work	138

PREFACE

Both in the U.S. and abroad there has been growing interest in recombining the academic and vocational sides of the secondary curriculum. In the U.S. the 1990 Perkins Act has given impetus to this movement. Generally, integrating the vocational and academic curriculum is seen as a means to improve the teaching of academic subjects by relating them to a practical context, improve instruction in vocational subjects by upgrading the academic content, and minimize invidious tracking of students.

While there is much agreement about the goals of curricular integration, examples of how to do it are still scarce. The purpose of this booklet is to provide such examples.

These particular examples have been produced by teachers in three career academies in Oakland, California. Career academies are schools-within-schools, usually encompassing grades 10 through 12 (see Stern, Raby, and Dayton, 1992). The curriculum, organized around an occupational theme, also allows students to qualify for two- or four-year college. The academy model has been evolving since its first introduction in Philadelphia in 1969. It represents a relatively far-reaching approach to integrating vocational and academic instruction (Grubb and others, 1990).

Career academies combine vocational and academic learning in many ways. This booklet describes some of the ways in which academic and vocational teachers have created explicit connections between their separate subjects. In the health and media academies teachers have devised projects for students to earn credit in more than one class at the same time. In the health academy the connection illustrated here is between a health occupations class and a class in physiology. In the media academy the joint assignments link English with production journalism. At the pre-engineering academy the coordination illustrated here is sequential: drafting courses teach geometric analysis, which students then use in their physics courses.

These explicit links between academic and vocational classes can be seen as first steps toward breaking down barriers between separate subjects. It is possible to

achieve some degree of integration without breaking down these barriers—for instance, teachers in academic courses can explain how their own subject relates to a vocational field of practice, and vocational teachers can make reference to theoretical concepts from related academic disciplines. But courses are a means to an end, not an end in themselves. The purpose of curricular integration is to help students learn certain things about the world in a more efficient and interesting way. Coursework should be coordinated to facilitate acquisition of the desired knowledge, skill, and understanding. For instance, this coordination might include projects that satisfy requirements for several courses at the same time. It might also include more flexible scheduling, giving groups of students different amounts of time with each teacher from one week to another. Coordination may also involve some actual team-teaching. The boundaries between disciplines should be less important than the issues being analyzed, skills being mastered, concepts being understood. Ultimately, students in a highly integrated program would not even need to know which course they were in at any particular moment!

Teachers reading this booklet will be able to see how the authors have begun working toward a higher level of curricular integration. Included here are examples from life science (the health academy), humanities (media academy), and physical science (pre-engineering). Some teachers may be able to adapt material here for use in their own programs. Others may get ideas about how they might organize analogous projects in different fields. For administrators, school board members, policy makers, or other readers who are not high school teachers, this booklet will serve to illustrate what integrating academic and vocational curriculum may mean.

The organization of this volume is as follows. The next section gives an overview of career academies as implemented in the Oakland Unified School District. Then come sections describing the Health, Media, and Pre-Engineering academies. Each of these sections begins with a description of the academy program and an outline of the three-year sequence of courses for students in that academy. Specific illustrations of integrated curriculum are then given in detail for each academy.

David Stern

REFERENCES

- Grubb, W. N., Davis, D., Lum, J., Plihal, J., & Morgaine, C. (1990). *"The cunning hand, the cultured mind": Models for integrating vocational and academic education*. Berkeley: National Center for Research in Vocational Education, School of Education, University of California at Berkeley.
- Stern, D., Raby, M., & Dayton, C. (1992). *Career academies: Partnerships for reconstructing American high schools*. San Francisco, CA: Jossey-Bass.

ACKNOWLEDGEMENTS

Preparation of this booklet was made possible by a Presidential Grant for School Improvement from the University of California Office of the President to the University-Oakland Metropolitan Forum at the University of California, Berkeley. David Stern served as principal investigator, helped guide the writing process, and edited the manuscript. The grant was administered by the University-Oakland Metropolitan Forum, headquartered at the University of California, Berkeley. Victor Rubin, executive director of the Forum, was chiefly responsible for obtaining the grant and overseeing the project. Jeannie Lum made major contributions to writing the grant proposal and getting the project started while she was finishing her graduate work at Berkeley; she then joined the faculty at the University of Minnesota, where she continued to act as a consultant, providing feedback on drafts and helping to edit the final manuscript. Mikala Rahn, a graduate student at Berkeley, carried much of the week-to-week responsibility for maintaining communications and making sure everything got done. Daniel Rolinek prepared the figures in the pre-engineering unit. Dr. David Shearn reviewed the health academy unit, and Professor Richard Reimer reviewed parts of the material from the pre-engineering program. Jay Tharp, at the Forum, worked the manuscript into final form. Additional support for the Forum's work on curriculum with Oakland's Academies comes from a three-year grant of the Educational Partnerships Program, U.S. Department of Education. Drafts of this publication were produced by the Forum, with the final version published under the auspices of the National Center for Research in Vocational Education.

OAKLAND ACADEMIES MAGNET PROGRAMS – AN OVERVIEW

Allie Whitehurst-Gordon, Program Manager

In 1986 the Oakland Unified School District initiated an effort to establish a district-wide Academies Magnet Program. The program was founded upon the philosophy

that students should develop the skills, knowledge and attitudes necessary for achieving success in institutions of higher learning, entering the work force, and functioning as responsible and productive citizens . . . that if students are able to realize a relationship between what they are required to learn and its relevancy to the real world they are more motivated. As a result of higher motivation and satisfaction, students perform well academically and at the same time acquire marketable skills.

An adaptation of the California Partnership Academy model, the Oakland academies are school-within-school magnet programs designed to provide academic instruction and career preparation in a range of industries such as health, business, communications, engineering, computer technology, law, visual arts, and transportation.

Some of the major factors that contributed to the decision to launch this effort included the following:

- The desire and direction of the Board of Education to develop and implement programs to (1) serve as "holding power" to reduce the flight of students from neighborhood "flatland" schools and (2) serve as magnets to attract students.
- By mid-year 1986, the preliminary results from the Health Academy as a pilot program at Oakland Technical High School were positive. These positive indicators provided impetus to replicate the program at three additional high schools.

- The need to strengthen linkages with businesses and institutions of higher education to provide support in developing programs to meet current and future employment needs of the local community.
- The need to offer relevant, challenging, and innovative programs and educational approaches for all students aimed at preparing students for college and the work force upon graduation from high school, particularly students who may be identified as "at risk."

The goals of the Academies Magnet Program embrace the mission of the district to address the wide range of educational problems that most urban school districts such as Oakland face.

These goals include

- To provide an academic program to students based on student need, skills, interest, and potential.
- To produce graduates who perform well academically.
- To produce graduates who can compete successfully in a changing job market.
- To prepare students to succeed in the endeavors they choose beyond high school in work and/or higher education.
- To teach students to value democratic processes and know how to function as effective members of a democratic society.
- To teach students to respect and prize the universal qualities that cultures and races share and those that make them unique.
- To teach students to have pride in their own social or ethnic identities but at the same time feel part of the larger human community.
- To provide innovative and relevant programs designed to serve as "holding power" and reduce student flight from their attendance area schools.

The Oakland Academies Model

The major components of the California Partnership Academy are included in the Oakland Academies Magnet Program. However, The California Partnership Academies model was adapted to meet the needs of the Oakland Unified School District's student population and of the Oakland community. Unlike the California Partnership Academies, the Oakland Academies were not implemented solely as a program for "at-risk" students or a "drop-out" prevention program. The district's profile of the student population indicates a number of "at-risk" factors for a large portion of the population, including a district-wide drop-out rate over thirty percent. The increase of the graduation rate is one of the intended student outcomes. The implementation of academies provides a broad strategy to reduce the number of "at-risk factors" for students and/or decrease or eliminate the negative effects "at risk" factors may have on student success. Instead of a special program for "at-risk" students, the Oakland Academies Model is designed to attract and support a heterogeneous student population that reflects the district's student profile. As magnet programs, in addition to attracting students based on interest, efforts are made to recruit and select students to improve racial, ethnic, and gender diversity in the program or who are members of underrepresented groups in the industry in which an academy is focused.

The Oakland Academies were not implemented as vocational education programs because of the traditional narrow description of vocational programs in providing job specific training for entry level jobs. The academies concept for Oakland extended beyond preparing students with skills for specific jobs and altered the vocational education paradigm to include preparing students for a range of careers in an industry, both those requiring post-secondary education and those that do not. This concept recognizes the need not only to prepare students for careers but to prepare them to improve the quality of life for themselves and others.

Program Design

Student Selection

The average enrollment in an academy program is 175 students. Each year approximately fifty to sixty sophomores enroll in each program. Special effort and attention are given to select a heterogeneous group of students based on program

criteria which includes a target to select fifty to sixty-five percent of students who meet "at-risk" criteria.

Program Structure

The program structure is based on the concept of curriculum wholeness which calls for a curriculum process that is adaptive, coherent, and enhances interrelatedness. One of the major approaches to developing curriculum wholeness is the integration of academic and vocational/technical education. Organizing courses into blocks and integrating the curriculum around the industry theme to reduce fragmentation, provide instructional relevance, and improve the untracking of students are key elements of the program structure.

Regularly scheduled team meetings during common planning periods each day or one to two hour meetings after school each week are provided to promote teacher collaboration, collegiality and to provide opportunities for planning and developing integrated instructional approaches and other program improvement strategies.

The adaptation of the curriculum extends beyond the formal course of study to include the external curriculum which occurs outside school. The external curriculum is influenced by implementing strategies such as mentoring, internships, community-based projects, and parent involvement.

Study tours (field trips) are planned as instructional strategies to increase instructional relevance; enhance awareness, sensitivity, and appreciation of cultures and races; and develop and enhance aesthetic sensibilities. Several of these study tours bring academy students together from different programs in a non-competitive environment—providing students with a sense of belonging to a larger community that is diverse but share common interests, goals, and values.

Community Support

The support of industry and institutions of higher learning is a key ingredient to the success of the program. Although there are many businesses in Oakland, there are many programs vying for their support. The industry focus of the academy has helped to attract and increase business support. In addition to an advisory

committee at each site, a district-wide Joint Academies Support Committee was established to support and promote the overall program.

In 1990, the City of Oakland became a major partner. As a result of a survey of employers in the central district of downtown Oakland, the City of Oakland entered into a contract with Oakland Unified School District totaling \$1.2 million to support the academies program. This partnership demonstrated the City of Oakland's commitment to support Oakland Public Schools in the preparation of a well-trained work force to meet future employment needs of downtown Oakland. This support made it possible to implement many of the program components, such as paid internships, that would have been difficult to implement. The partnership has led to increased involvement from businesses, community organizations, and institutions of higher learning.

Special efforts have been made to increase parental involvement. Parent liaisons work with academy staff to develop and implement strategies to establish and sustain linkages between the home and the program.

District and School Support

In several districts across the nation, initial support for establishing academies came from local businesses. The Oakland Academies started as a district initiative designed to involve local businesses and institutions of higher learning in education as partners. Because the district has demonstrated a commitment to establish academies to address the employment needs of the community, community support for the programs has grown.

The Board of Education approved a Five-Year Educational Plan in 1990. The expansion of academies to include five to six programs in a high school is one of the major strategies outlined in the Plan to achieve the goal of preparing students to obtain and succeed in the occupation of their choice.

Since the inception of the program in 1986, the district has experienced some instability as a result of fiscal constraints. In spite of this instability the programs have managed not only to survive but to grow. This growth can be attributed to district support and the hard work and dedication of the teachers who are committed to making the programs successful. District support of a coordinator for

all of the academy programs has provided continuity and district credibility. Enough credit cannot be given to the teachers who work tirelessly and endlessly to meet the needs of students.

A Model For Positive Educational Change

Since 1986 the Oakland Academies have made steady progress in effecting positive educational change in the district. Barriers between disciplines have crumbled. Support from the community has increased. Parents are more involved in their children's education. Teachers have developed integrated curriculum. Teacher collaboration and involvement in decisions about the programs have empowered teachers and provided them with a sense of program ownership. Most important, students are experiencing success.

There is a clear vision and purpose for the academies in Oakland. Commitment to achieving this vision has required that the District support the need to do some things differently. This kind of commitment continues to be the driving force behind this model for positive educational change.

HEALTH ACADEMY
Oakland Technical High School

Clinical Applications of Knowledge about the Heart	9
For Teachers	9
Student Worksheet: The Heart	11
Worksheet Key for Teachers	15
Heart Beat Cycle Worksheet	21
Vital Signs Lab	23
For Teachers	23
Student Worksheet: Lab 1 – Resting	25
Student Worksheet: Lab 2 – Exercise and Recovery	28
Student Worksheet: Lab 3 – Comparing Fitness	34
Family Medical History	35
For Teachers	35
Student Assignment	38

HEALTH ACADEMY

David de Leeuw, Physiology Teacher

The Oakland Health Academy is a school-within-a-school at Oakland Technical High School for students interested in health careers. Some want to be doctors; some are interested in nursing; a few want to be veterinarians, radiation technologists, research biologists, or chiropractors; many are unsure about specific career goals. Many students come to us well below grade level; others are well-prepared; we try to maintain this full range of students in the core Academy classes.

Students are scheduled as a group for their science, science lab, English and social studies classes, and are in Health Academy math sections when possible. Tenth grade students take Biology and a Biology Lab (Table 1). Eleventh grade students take a two-period-a-day block of Physiology (really, Human Anatomy and Physiology), with one period designated as "lecture" and one as "lab". Many of the vocational skills are taught in the Biology and Physiology Lab sections, along with dissections and experiments which supplement the textbook material. Twelfth grade students have a variety of choices, which include a two-period Advanced Health Occupations class in which students spend the second semester at health-care placements, accumulating the hours necessary for certification.

Many students get some hospital or health facility experience as volunteers during tenth grade. Students are matched with mentors who work in many different health care jobs. Students who want vocational certification and employability enroll as juniors or seniors in an Advanced Health Occupations class. Most students will work at a paid internship at a local health care facility (hospital, clinic, nursing home, Red Cross) or in a local biological science laboratory during or following 11th or 12th grade.

The curriculum topics presented here have been part of our tenth and eleventh grade curriculum. "Clinical Applications of Knowledge about the Heart" uses students' study of physiology and anatomy to help them understand the occupational skills. "Heart Beat Cycle" helps students to see the relationships

between the different types of heart examinations. It is an effective visual check for comprehension or assessment—in thirty seconds I can see whether the student understands a complex topic. "Vital Signs - Resting and Exercising" uses the students' occupational skills to deepen their understanding of physiology. Their accuracy and speed in taking vital signs become crucial to collecting accurate physiological data that they analyze on individual and group levels. "Family Medical History" is a student-centered project through which students learn about diseases, medical histories and health statistics, and think about their own health risks. An earlier version of the "Family Medical History" unit was developed as part of a California Academic Partnership Project curriculum project.

Table 1
Health Academy Core Courses

10th Grade Courses

English II
Biology
Biology Lab (1 semester)
Computer Lab (1 semester)
World Cultures
Academy English
Academy Math (various levels)

Eleventh Grade Courses

Physiology
Physiology Lab
American History
Academy English
Academy Math (various levels)

Twelfth Grade Classes

Advanced Health Occupations or
Chemistry or
Advanced Biology
American Government (semester)
Economics (semester)
Academy English
Academy Math (various levels)

Clinical Applications of Knowledge about the Heart

For Teachers

This unit helps students to extend their studies in physiology into the understanding of medical practice. The medical applications make the physiology concepts more interesting and more real; the physiology helps students to understand, rather than just memorize, the medical techniques.

Knowledge about human physiology and anatomy is closely connected to medical skills and procedures, but textbooks rarely make these connections. Physiology and anatomy texts often include some information on specific diseases or disorders, but rarely anything on medical procedures. Available vocational materials concentrate on what students must learn to do without explaining why it's done that way; the checklist of steps in a procedure is a primary form of both instruction and assessment.

Using the Heart Worksheet

The worksheet that follows could be used, section by section, as an accompaniment to studying the circulatory system, or it could be a follow-up assignment to working on this material in the textbook. It could be used as an individual assignment, a small-group assignment, as a list of topics for class discussion or as some combination of these.

Students will vary in their ability to complete the questions on the worksheet without help. Many are initially hesitant about trying to answer questions for which they cannot find a clear statement of the answer in their textbook. Teachers will need to encourage students to take these risks, and will need to grade the resulting answers accordingly.

Texts

This unit uses section headings and page numbers from *Structure and Function of the Body*, by Anthony and Thibodeau (8th edition, 1988, Times

Mirror/Mosby). This includes more medical application information than most texts, but any standard text would contain the basic information needed. Study of the major diseases of the circulatory system also helps students to make connections between physiology and medicine; we use copies of the *American Medical Association Family Medical Guide* as a text. The section of the worksheet on blood pressure requires reading sections of the AMA Guide or its equivalent. The *American Red Cross Standard First Aid Workbook* has answers to the First Aid questions.

Collaborating with Other Teachers and Courses

Ideally, other teachers in the Academy or school would work on "The Heart" unit with you to create a more "integrated" and interdisciplinary curriculum for students. For example, in History students could be studying the discovery of circulation or religious and cultural beliefs about dissection. In English, students could read literature such as "The Heart is a Lonely Hunter" by Carson McCullers or "The Telltale Heart" by Edgar Allan Poe. In Math, students could be learning charting and graphing skills, which students apply later in the unit to complete the electrocardiogram ("Heart Beat Cycle") worksheet. Other topics to be addressed in collaboration with other courses include cardiovascular disease with a discussion of lifestyle and prevention. The focus of this kind of curriculum developed by teachers collaborating would be connecting for students how classes relate to each other and how the content of classes relate to the world outside of school.

Student Worksheet: The Heart

The purpose of this worksheet is to help you use what you learn about the heart to understand some common medical and first aid procedures:

- Chest compressions for CPR
- Using a stethoscope to listen to heart sounds
- Taking a pulse
- Locating and stopping arterial bleeding.
- Defibrillation to end cardiac arrest
- Preparing patients for electrocardiograms (EKGs or ECGs)
- Measuring blood pressure

This worksheet is designed to be used with a human anatomy and physiology textbook. The page numbers are for *Structure and Function of the Body*, by Thibodeau and Anthony, but most human anatomy and physiology texts will have similar sections. Information about CPR, taking a pulse, and arterial bleeding can be found in the *American Red Cross Standard First Aid Workbook*.

Please write your answers on a separate sheet of paper.

Understanding CPR

Read "Location, Size, Position" on 253 and look at Figure 11-1, showing the location of the heart.

- A1 Explain why pressing down directly on the sternum is an effective way to compress the heart during CPR.
- A2 Explain why the victim must be lying on his/her back on a hard surface for chest compressions to be effective.
- A3 Explain why a stethoscope is often placed several inches to the left of the sternum to listen to the heart.

Read "Heart Valves" on 256-7 and look at Figure 11-2, which diagrams blood flow through the heart.

- B1 What is the purpose of the heart valves?
- B2 Explain how the heart valves make CPR possible.

Read "Blood Flow through the Heart" on page 257 and look at Figure 11-2, which diagrams blood flow through the heart.

During CPR chest compressions, you are compressing both ventricles.

- C1 When you compress the right ventricle, where does the blood go?
- C2 When you compress the left ventricle, where does the blood go?

Read "The Mechanics of Breathing" on page 347.

The objective of CPR is to keep oxygen flowing to vital organs of the body, particularly the brain and the heart. Chest compressions circulate blood, but air must also be supplied to the lungs, or there will not be enough oxygen in the circulating blood. Supplying air to the lungs is accomplished with rescue breathing. When we breathe, we actually use only a small portion of the oxygen in each incoming breath. The air we breathe out still contains enough oxygen to be useful to someone who is not breathing.

- D1 When you are breathing in, what are the diaphragm and the external intercostal muscles doing?
- D2 When you are breathing out, what are the diaphragm and the external intercostal muscles doing?
- D3 Explain why an unconscious accident victim can breathe out without assistance, but may be unable to breathe in.
- D4 If your textbook includes this information, answer the following questions: What is the oxygen content of the air we breathe in? What is the oxygen content of the air we breathe out?

Understanding Heart Sounds

Read "Heart Sounds" on page 257

- E1 What makes the "lub" sound of the heart?
- E2 What makes the "dub" sound of the heart?

Heart murmurs are any abnormal heart sounds. Most people with a heart murmur have no functional problem with their heart, but in other individuals, it may be the only detectable symptom of a life-threatening condition. Listening to heart sounds is used as a screening test -- a test to find people who might have a heart problem. Defects in heart valves are the problems most likely to be detected by listening to heart sounds.

To understand why a valve problem would make a noise, think about the noise that comes from a kink in a garden hose: Closed valves and open valves make very little noise, but as the valve closes, the flow is more turbulent, and makes a noise. If blood leaks through the valve when it should be closed, a sound will be produced by the turbulent flow through the small hole, after the valve closes. If the valve is not able to open completely when it should be open, a different noise will occur -- during the period when that valve should be open.

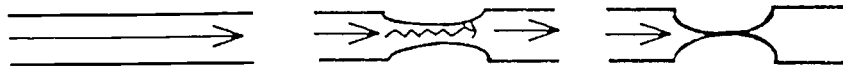

Free Flow
Smoothly flowing
water makes very
little noise.

Kinked Hose
Turbulent flow in
the narrowed sec-
tion makes noise.

Closed Hose
If the kink is tight
enough to close off
flow, noise stops.

See if you can use this information, along with your knowledge of which valves close when, to decide what these abnormal sounds might mean. Which valves might be damaged? Are they unable to open, or unable to close?

- E3 What might a noise after the "dub" noise mean? (This noise usually sounds like blowing or hissing.)
- E4 What might a noise before the "lub" mean? (This usually sounds like a low rumbling.)
- E5 What might a noise between the "lub" and "dub" noises mean? (Can you think of two possibilities?)

You are practicing with the stethoscope, listening to heart sounds on many individuals to practice your skills. You think that you hear a consistent murmur in the heart you are listening to.

- F1 Should you yell "Hey, come listen, here's a murmur!!!"? List as many reasons not to act this way as you can think of. Include both social (how you treat other people) and medical reasons in your list.
- F2 What should you say to the person? Explain your answer.

Understanding the Pulse

Read "Pulse" on page 273 and look at Figure 11-9 "Principal arteries of the body"

- G1 What happens in the heart that creates the pulse in the body's arteries?
- G2 Explain why you can feel the pulse in the arteries but not in the veins.
- G3 List some reasons why it would be useful for first aid to know several different locations where the pulse can be taken.
- G4 List several reasons why the carotid pulse is the one checked for in the CPR procedure.
- G5 Explain why major arterial bleeding is much more dangerous than other types of bleeding.
- G6 List some locations where major arterial bleeding could occur that might not be obvious to someone administering first aid.

Understanding the Heart's Electrical Activity

Read "Conduction System" on page 259 and look at Figure 11-5 "Conduction system of the heart"

When parts of the conduction system are damaged, by a heart attack or other disorders, an artificial pacemaker can help the heart maintain a normal rhythm. The pacemaker is an electronic device which delivers a tiny shock (measured in thousandths of a volt) to the appropriate part of the heart at a regular interval.

- H1 Pacemakers can be used to treat irregular atrial beats. Which part of the conduction system has probably failed in these cases?
- H2 Pacemakers can also be used to treat heart block, in which the atria beat normally, but the signal is not passed on to the ventricles, which then beat irregularly. Which part of the conduction system has probably failed in these cases?

Defibrillation: You've all seen it on TV and in movies, and maybe in real life. The patient's heart has stopped, and the doctor puts two paddles (really, large electrodes) on the patient's skin on either side of the torso and delivers a high-voltage shock in an attempt to restart the heart. The defibrillator causes the heart muscle to contract all at once, and then, hopefully, to start its rhythmic beat again.

- J1 Why is clothing pulled aside before a defibrillator is used?
- J2 Why does the patient's body jerk in response to the shock?

Read "Electrocardiogram" on page 259-262

- K1 Why must the skin be clean before electrodes are attached for taking an electrocardiogram? Why is a watery gel placed on the skin under the electrode?
- K2 Why don't these electrodes give the patient a shock?

Understanding Blood Pressure

Read "Blood Pressure" on pages 269-273.

Blood pressure is measured using two tools, a sphygmomanometer and a stethoscope. The sphygmomanometer consists of an inflatable cuff that goes around the patient's arm, a simple pump that inflates the cuff, and a pressure gauge that measures the air pressure in the cuff. The stethoscope is used to listen for the sounds of blood flowing through the brachial artery, just below the cuff.

The pressure in the cuff is raised above the pressure in the arteries and then gradually released. As the pressure in the cuff drops, the highest and lowest pressures at which the sound of the pulse can be heard through the stethoscope are recorded.

Pressure in the arteries rises and falls with the rhythm of the heart beat. As the ventricle contracts (systole) and push blood into the arteries, the pressure rises. Between beats (diastole), the pressure falls again. For a blood pressure reading, we want to know the highest (systolic) and lowest (diastolic) pressures in the artery during the heartbeat cycle. These are written with the systolic pressure above and the diastolic pressure below—it is not a fraction, even though it is written like one.

When you are taking a blood pressure, the cuff is inflated above the normal blood pressure range and then gradually deflated while listening with the stethoscope directly over the brachial artery. If the cuff pressure is higher than the highest pressure in the artery, the artery is squeezed shut, no blood passes through, and no noise is heard. When the cuff pressure is between the highest pressure in the artery and the lowest, blood squeezes through with each beat of the heart, but closes again between beats. Just as we saw with heart valves, this opening and closing makes a noise that we can hear in the stethoscope. When the pressure in the cuff drops below the lowest pressure in the artery, blood flows freely during the whole heartbeat cycle, and makes little noise. So the pressures at which the sounds of the pulse appear and disappear again are a measure of the highest and lowest pressure in the arteries.

- L1 Why can't you hear the pulse if you listen to the brachial artery without a pressure cuff?

(You may need to look in a medical reference book like the AMA Family Medical Guide to answer the following questions.)

- L2 What is a normal blood pressure reading? How does it vary with age?

- L3 How high does someone's resting blood pressure have to be for them to have "high blood pressure" or hypertension?
- L4 When is the blood pressure in a healthy person this high?
- L5 How does hypertension damage the body?
- L6 List factors which make an individual more likely to develop hypertension.
- L7 What serious medical emergencies would result in extremely low blood pressure? Look up "Shock" in a medical reference book if you need ideas.
- L8 How would extremely low blood pressures damage the body?

Worksheet Key for Teachers

Below are the answers to the "Student Worksheet: The Heart." The answers to the worksheet could be discussed as a large group or passed out to small groups for peer review.

- A1 Explain why pressing down directly on the sternum is an effective way to compress the heart during CPR.

Most of the heart lies underneath the sternum. Pressure on the sternum evenly compresses the whole heart.

The flexible cartilage connections of the sternum to the ribs allows the sternum to be depressed without bending any bones. Ribs (over the apex of the heart) are more fragile and must be bent to be depressed.

- A2 Explain why the victim must be lying on his/her back on a hard surface for chest compressions to be effective.

The heart is being compressed between the sternum above and the spinal column below. If the spinal column moves, most of the energy put into compression will be wasted. If the victim is lying on his or her back on a hard surface, the spinal column cannot move when the sternum is depressed.

- A3 Explain why a stethoscope is often placed several inches to the left of the sternum to listen to the heart.

This is done in order to hear the beating of the apex of the heart. The apex is several inches to the left of the sternum.

B1 What is the purpose of the heart valves?

They prevent blood the blood from flowing backwards, into a chamber from which it has already been pumped out.

B2 Explain how the heart valves make CPR possible.

When the heart is compressed, the blood can only move in the correct direction because of the valves. Without valves, compressions would only move the blood back and forth—there would be no circulation through the body.

C1 When you compress the right ventricle, where does the blood go?

It goes to the lungs to pick up oxygen.

C2 When you compress the left ventricle, where does the blood go?

It goes to the aorta and distributes oxygen to the organs.

D1 When you are breathing in, what are the diaphragm and the external intercostal muscles doing?

They are contracting.

D2 When you are breathing out, what are the diaphragm and the external intercostal muscles doing?

They are relaxing.

D3 Explain why an unconscious accident victim can breathe out without assistance, but may be unable to breathe in.

Breathing out is a passive process which depends on the elasticity of the lungs and other tissues, not on muscles. Breathing in depends on the contraction of muscles, and this in turn depends on nerve impulses from the brain. Anything which interferes with the ability of muscle to contract, or with the ability of nerves to carry impulses, or with the ability of the brain stem to initiate these impulses will prevent breathing in.

D4 If your textbook includes this information, answer the following questions: What is the oxygen content of the air we breathe in? What is the oxygen content of the air we breathe out?

Inspired air is about twenty-one percent oxygen. Expired air is about sixteen percent oxygen. There is plenty of oxygen left in the expired air to oxygenate the oxygen-starved blood of a non-breathing person.

E1 What makes the "lub" sound of the heart?

The atrio-ventricular valves closing. These are also called the tricuspid (right) and bicuspid or mitral (left) valves.

E2 What makes the "dub" sound of the heart?

The semilunar valves closing.

E3 What might a noise after the "dub" noise mean?

That one of the semilunar valves is not closing completely, or closing slowly, allowing blood to flow back into that ventricle when the ventricle is at rest.

E4 What might a noise before the "lub" mean?

That one of the atrioventricular valves is not opening completely, so that when the atrium contracts, the flow of blood is obstructed.

E5 What might a noise between the "lub" and "dub" noises mean? (Can you think of two possibilities?)

That one of the semilunar valves is not opening completely, obstructing blood flow out of that ventricle.

That one of the atrioventricular valves is not closing completely, so that when the ventricle contracts blood flows back into that atrium.

F1 Should you yell "Hey, come listen, here's a murmur!!!"? List as many reasons not to act this way as you can think of. Include both social (how you treat other people) and medical reasons in your list.

Social reasons: It is inconsiderate. It makes the person embarrassed. Noise in the room will prevent other students from taking accurate blood pressures. You might be wrong.

Medical reasons: Medical information is confidential. If patients think their medical information will become public knowledge, they won't want to be screened.

F2 What should you say to the person? Explain your answer.

You should inform the person of what you hear without creating unnecessary fear. You may be wrong about what you hear, and if there is a murmur, it may not be creating any problem in the functioning of the heart. On the other hand, in those cases where a previously undetected murmur does indicate something wrong, it is important that the person see a doctor about it. You might say, "I think I hear an extra heart sound, but I can't be sure. Next time you're seeing a doctor, you should ask them to listen for it."

If your teacher or someone else with more experience in listening to heart sounds is available, you should go over to them and quietly ask them to come listen.

G1 What happens in the heart that creates the pulse in the body's arteries?

The left ventricle contracts. ("The ventricles contract." is an acceptable answer, but the right ventricle's contraction does not contribute to the pulse that is felt in the systemic circulation.)

G2 Explain why you can feel the pulse in the arteries but not in the veins.

The arteries are the vessels that carry blood away from the heart. Blood is pushed into the arteries with each contraction of the ventricles, and the pressure in the arteries rises. Veins are the vessels that return the blood from the capillaries to the heart. As blood passes through the numerous tiny capillaries, the pressure and the pulse are absorbed by surrounding tissues, so that there is no pulse on the far side, in the veins.

G3 List some reasons why it would be useful for first aid to know several different locations where the pulse can be taken.

If you cannot locate the pulse at one location, you can try another one.

The victim may be in a position where some of the pulse points are not accessible.

G4 Give several reasons why the carotid pulse is the one checked for in the CPR procedure.

It is usually the easiest pulse to find because it is one of the strongest pulses. This is especially important in patients in which the pulse is weak.

It is immediately accessible while the victim is in the standard CPR

position.

It is critically important that oxygen flow to the victim's brain, and the carotid artery is the one carrying blood to the brain. If there is a carotid pulse, the blood is circulating to the brain.

- G5 Explain why major arterial bleeding is much more dangerous than other types of bleeding.

Because the pressure created by ventricular contraction actually pushes blood out of the body. A large amount of blood can be lost in a fairly small amount of time.

- G6 List some locations where major arterial bleeding could occur that might not be obvious to someone administering first aid.

In the groin, behind the knee, inside the abdominal or thoracic cavities.

- H1 Pacemakers can be used to treat irregular atrial beats. Which part of the conduction system has probably failed in these cases?

The sino-atrial node is no longer initiating a steady beat.

- H2 Pacemakers can also be used to treat heart block, in which the atria beat normally, but the signal is not passed on to the ventricles, which then beat irregularly. Which part of the conduction system has probably failed in these cases?

The atrioventricular node or the atrioventricular bundle which passes from the node down through the septum has probably been damaged.

- J1 Why is clothing pulled aside before a defibrillator is used?

To improve the electrical contact between the electrode and the patient's skin.

- J2 Why does the patient's body jerk in response to the shock?

Because all muscles contract in response to the electric current, not just the heart muscle.

K1 Why must the skin be clean before electrodes are attached for taking an electrocardiogram? Why is a watery gel placed on the skin under the electrode?

Both of these measures improve the electrical contact between the electrode and the patient's skin. Dirt, and especially oily substances, act as insulators.

K2 Why don't these electrodes give the patient a shock?

Because they are receiving electrodes, not sending electrodes. They and the equipment to which they are attached, are designed to "listen to" the tiny changes in electrical activity that control the contraction of muscle.

L1 Why can't you hear the pulse if you listen to the brachial artery without a pressure cuff?

Because the blood is flowing freely through the artery at all times. Without obstruction of the artery by the cuff, no sound is produced.

L2 What is a normal blood pressure reading? How does it vary with age?

For a normal 16-20 year old, systolic pressures will range from about 105 mmHg to about 125 mmHg. Normal diastolic pressures will range from about 60 mmHg to about 75 mmHg. Both of these numbers will gradually increase with age.

L3 How high does someone's resting blood pressure have to be for them to have "high blood pressure" or hypertension?

Resting systolic pressures over 140 mmHg in a younger person, or 150 mmHg in an older person are considered too high. A resting diastolic pressure over 90 mmHg for a younger person or 100 mmHg is considered too high. Blood pressure changes some from one time of day to another and from one day to another, but blood pressures which are this high in an individual who is resting and is not under other unusual stresses are a cause for concern and should be evaluated by a doctor.

L4 When is the blood pressure in a healthy person this high?

When the person is exercising.

L5 How does hypertension damage the body?

The heart is forced to work harder to maintain this pressure. Blood vessels are more likely to develop atheroma and harden, leading to heart attacks and strokes. Small vessels in other organs, such as the kidney or eyes may burst and cause damage to those organs over time.

L6 List factors which make an individual more likely to develop hypertension.

Family history of hypertension, being overweight, smoking, high salt intake, lack of relaxation.

L7 What serious medical emergencies would result in extremely low blood pressure? Look up "Shock" in a medical reference book if you need ideas.

Hemorrhage, cardiac arrest or other heart failure.

L8 How would extremely low blood pressures damage the body?

Not enough blood would circulate to the brain, heart and other essential organs, and these tissues would die from lack of oxygen. Patients with a weak pulse and presumably low blood pressure should lie down so that their heart will not have to pump against gravity to deliver oxygen to the brain.

Heart Beat Cycle Worksheet

Toward the end of the physiology unit on the heart (after students have completed The Heart Worksheet), I assign the Heart Beat Cycle Worksheet to students. This Worksheet has students apply the knowledge they have attained throughout the heart unit in a medical context. Once again, the medical application will make the physiology concepts more interesting and more real. Students need to be introduced to how academic concepts apply in vocational or "real life" experiences in order to retain the knowledge.

The Worksheet is partially filled in so that students can see how it is supposed to be done. Students need to fill in the appropriate squares on the remaining lines.

Vital Signs Lab

For Teachers

This unit is used in the lab section of Academy Physiology as part of the unit on the heart. Students practice their occupational skills at taking vital signs in a context in which both speed and accuracy are essential to the results. They also learn to work in coordinated teams. Mathematical topics (types of graphs, averages, percentage increase, and slopes) could also be addressed in a math class.

Time frame

The entire lab will require about six standard class periods for most groups of students. The resting vital signs section of the lab will need two class periods with most groups, since they will need to practice their skills before collecting data. At the conclusion of this, or the next day, students can be asked to put their data points onto the various group charts. Some time for discussion of this data (e.g., What are the normal ranges? What are some reasons for the observed variation?) is useful, but could also be postponed until the end of the unit.

The after-exercise vital signs lab requires some initial explanation and coaching; student teams need to be well-prepared if they are to collect useful data. The data-collection for groups of four will require two class periods. Students can be asked to take home the Measurements sheet about them and to complete the calculations and the recovery graph for homework. Depending on math abilities, students may need to see examples before doing the calculations, and may need help if they get stuck. When all the individual calculations are completed, a final day is needed for students to work on the summary sheet, to put their after-exercise data points onto the group charts, and to discuss the results: Which vital signs increased the most with exercise? Do students who are the most fit have the steepest recovery slopes? Did individuals with low resting blood pressures increase more or less than others? Good discussions might carry over into another class period.

Equipment

Stethoscopes and blood pressure cuffs are needed. Each group of four in the after-exercise vital signs section will need their own equipment; the groups of two in the resting vital signs section could share equipment if necessary.

Graphs

There is a list of the group graphs at the end of the resting vital signs section. Large sheets of graph paper with lines about an inch apart are needed for the group graphs. These sheets need to be labelled in advance with the name of the graph, and the increments of the y-axis need to be labelled (e.g. blood pressures from 50 mmHg to 170 mmHg in increments of 10 mmHg). Brightly colored stick-on dots can be purchased at office supply stores.

Student Worksheet

Vital Signs Lab 1 – Resting

This lab will be followed by one in which you compare these vital signs before and after exercise, and track their return to normal. That lab cannot be successful without (1) reliable resting measurements for each individual and (2) considerable practice in taking these measurements quickly and accurately.

Work with one partner for this section. All vital signs recorded on your worksheet should be about you. You and your partner should turn in your papers together.

Pulse

- A Taking pulses at different locations. Look at Thibodeau and Anthony, p. 273, for a list of some of the locations at which a pulse can be detected in the body. Each of you should try finding a pulse at locations 1-5. Different pulse-taking points may work best in different individuals.
- B At which points was it easy to find a pulse on you?
- C Determining your resting pulse. Sit in a chair. Try to be as relaxed as possible—we want to establish a resting pulse rate for you. Using the carotid artery and two others that your partner can feel distinctly, have your partner record the number of pulses in thirty seconds at each location.

Average these three numbers, then multiply by two to calculate your heart rate per minute.

Resting Pulse	
<u>name of artery</u>	<u>pulses in 30 seconds</u>
_____	_____
_____	_____
_____	_____
$\frac{\text{total} \div 3 = \text{average}}$	
$\frac{\text{average} \times 2 = \text{resting heart rate (beats/minute)}}$	

- D What is the difference between the highest and lowest counts? A difference of more than two beats in thirty seconds means that you are not very relaxed, or that your partner is not feeling/counting accurately, or both. If you think either of these is true, try another set of three 30 second counts at the same locations and record them to the right of the first set. Use this second group to average and determine your resting heart rate.
- E Why is the pulse present only in the arteries and not in the veins?

Breath Rate

- A Determining your resting breathing rate. Sit in a chair. Try to be as relaxed as possible. Have your partner count the number of breaths you take in one minute and record it below. Then switch, and count your partner's breaths. Then switch again, and count the first partner's breaths; a final switch and you're done.

First minute count _____

Second minute count _____

Average breath at rest _____

- B Breath rate varies between individuals more than pulse rate. It also varies more in a given individual (at rest) from day to day, or from one postural position to another (standing, sitting, lying down). Can you suggest some reasons for this variability?

Heart Sounds

- A Get a stethoscope from the supply table. Disinfect its working surfaces (earpieces and endpiece) with a paper towel and the disinfecting solution on your table. Let your partner place the stethoscope on his/her chest, then put on the earpieces. Listen directly over the manubrium of the sternum, and again about one inch to the left of its base. (Move gently or the noise will be too loud for the listener.)

Count the number of heartbeats in 30 seconds _____.

If this is more than two beats different from the average resting pulse you determined before, repeat the procedure and record here: _____

- B Can your partner hear any sounds other than "lub-dub"? What do they sound like? Where in the cycle do they occur?
- C Each cycle consists of a period of sound ("lub-dub") followed by a period of silence. Estimate the percentage of each cycle taken up by the "lub-dub" sound when you are at rest.

Is that sound half the time (50%) of a complete cycle? 25%? 66%?

% of cycle estimate: _____

Disinfect the stethoscope and switch places. When you are done, disinfect the stethoscope again.

Blood Pressure

Determining resting blood pressures

This section must be done in a quiet room! Whisper! Use the xeroxed hand-out which outlines the procedure for taking a blood pressure reading. Go through the procedure three times on each partner. (Practice makes perfect!).

Measurement 1 systolic _____ mmHg / diastolic _____ mmHg _____/_____

Measurement 2 systolic _____ mmHg / diastolic _____ mmHg _____/_____

Measurement 3 systolic _____ mmHg / diastolic _____ mmHg _____/_____

If your measurements are very different in three trials, take sets of three measurements until they vary by less than 5 mm Hg.

Average the systolic pressures from your last three readings.

Average resting blood pressure: systolic _____ mmHG / diastolic _____ mmHg

Factors affecting blood pressure

List some factors that might lead to higher-than-resting blood pressure readings in a given individual for a relatively short period of time (minutes, hours, days).

List some factors that might lead to a long-term rise in blood pressure.

Graphing the Resting Vital Signs

There will be pieces of graph paper on the wall around the room. Write your name on six of the stick-on dots of the color designated for resting measurements. Use the dots to place your data on each graph. Before you put up a dot, write the measurement on the dot (e.g., "110" for systolic blood pressure).

- Average Resting Pulse (one for everyone, one for males, one for females)
- Breath Rate
- Diastolic Blood Pressure
- Systolic Blood Pressure

These graphs have a horizontal axis showing pulse rate, breath rate or blood pressure. The vertical axis will represent the number of students in each category. Put your dot in the center of the lowest unoccupied square of the appropriate column

The last graph will work differently: you will be graphing systolic blood pressure (horizontal) vs. height (vertical). If you do not know your height, we will need to measure it. Dots do not need to be in the center of a box; try to place them exactly where the measurements indicate. If necessary, you may overlap other dots.

Student Worksheet

Vital Signs Lab 2 - Exercise and Recovery

You should by now be fairly competent at measuring pulse rate, breath rate and blood pressure, and at listening to heart sounds. If you need to, practice more at home.

You will work in groups of four - one subject, one pulse rate counter, one blood pressure taker, and one person listening to heart sounds; the subject will count breath rate. Each student will take a turn being the subject. Each group will use one lab table.

Smaller groups can be formed only if the teacher agrees. Groups of three, if they are necessary, should drop the Heart Sounds task. Groups of two, if they are necessary, should have the subject count their own pulse while the second person takes blood pressures on the subject's non-writing arm.

This procedure will be synchronized for the entire class!

Procedure to be followed for each subject

The student who is going to be the subject should adjust the height of one of the lab stools so that the fore-arms can be comfortably rested on the table. The three measurement takers will quickly adjust the pressure cuff, find the best location for heart sounds and pulse, and will take resting measurements and record them. (Five minutes maximum!)

The subjects will then go to the stairs and will walk/run up and down the flight of stairs between the first and second floor for seven minutes. Do not go so fast that you are unsafe! If you feel faint, slow down! If you are not breathing hard - speed up! Different students will have different speeds; the objective is to exercise as hard as your body is comfortable with. Keep track of how many times you climb the stairs in the 7-minute exercise period; have someone record it when you re-enter the lab.

Immediately following the last time the subject climbs the stairs, they will sit on their pre-adjusted seat at the lab table. The three measurement-takers will follow the instructions below, continuing for twelve minutes.

Schedule

The entire procedure should take twenty-five minutes. The first day you will form groups, get equipment, measure your first subject, and have a few minutes to discuss needed improvements in skills and procedure. The second day, you should be able to measure two subjects. The third day you will measure the last subject and, if necessary, re-measure the subject for whom you have the least reliable data. Finally, each student will graph the data about them as an individual, and will put data on the whole-class graphs.

Measurement Tasks

Pulse

You will be counting the subject's pulse for fifteen seconds, then recording what you counted for fifteen seconds, then counting again for fifteen seconds, then recording again for fifteen seconds. You will continue to do this for the entire 12-minute recovery period, even after the subject's pulse seems to return to normal.

Start when the second hand is on the minute or half-minute, as soon as possible after the subject sits down. Count the number of pulses in fifteen seconds, then record it on the Measurements Worksheet. Look up soon enough to be ready to start counting again at next half-minute or one-minute mark. (Don't try to calculate 1-minute rates until after the measuring is finished).

Measurements Worksheet

AFTER-EXERCISE VITAL SIGNS

name of subject _____

Time since exercise	Pulses in 30 seconds	Pulses per minute
0 min.	_____	_____
1/2 min.	_____	_____
1 min.	_____	_____
1 1/2 min.	_____	_____
2 min.	_____	_____
2 1/2 min.	_____	_____
3 min.	_____	_____
3 1/2 min.	_____	_____
4 min.	_____	_____
4 1/2 min.	_____	_____
5 min.	_____	_____
5 1/2 min.	_____	_____
6 min.	_____	_____
6 1/2 min.	_____	_____
7 min.	_____	_____
7 1/2 min.	_____	_____
8 min.	_____	_____
8 1/2 min.	_____	_____
9 min.	_____	_____
9 1/2 min.	_____	_____
10 min.	_____	_____
10 1/2 min.	_____	_____
11 min.	_____	_____
11 1/2 min.	_____	_____
12 min.	_____	_____

Calculate the one-minute rates column.

What was your resting pulse rate?

Before exercise on this day _____ beats/min.

Average rate from resting vital signs lab _____ beats/min.

Rise in rate after 7 minutes of exercise _____ beats/min.

∅ Rise in rate after 7 minutes of exercise

$\frac{\text{rise in rate}}{\text{resting rate}} \times 100 = \%$ rise _____ % rise _____

Blood Pressures

Time	Diastolic	Systolic
_____ min	_____	_____
_____ min	_____	_____
_____ min	_____	_____
_____ min	_____	_____
_____ min	_____	_____
_____ min	_____	_____
_____ min	_____	_____
_____ min	_____	_____

What were your resting blood pressures?

Before exercise on this day

Average rate from Part 1 _____

Rise in rate after 7 minutes of exercise _____

∅ Rise in rate after 7 minutes of exercise _____

Breath Rate

Time	in 30 seconds	in 1 min.
_____ min	_____	_____
_____ min	_____	_____
_____ min	_____	_____
_____ min	_____	_____
_____ min	_____	_____
_____ min	_____	_____
_____ min	_____	_____
_____ min	_____	_____
_____ min	_____	_____
_____ min	_____	_____

What was your resting breath rate?

Before exercise on this day _____/min.

Average rate from resting vital signs lab _____/min.

Rise in rate after 7 minutes of exercise _____/min.

∅ Rise in rate after 7 minutes of exercise _____ % rise _____

Graphing Your Recovery Worksheet

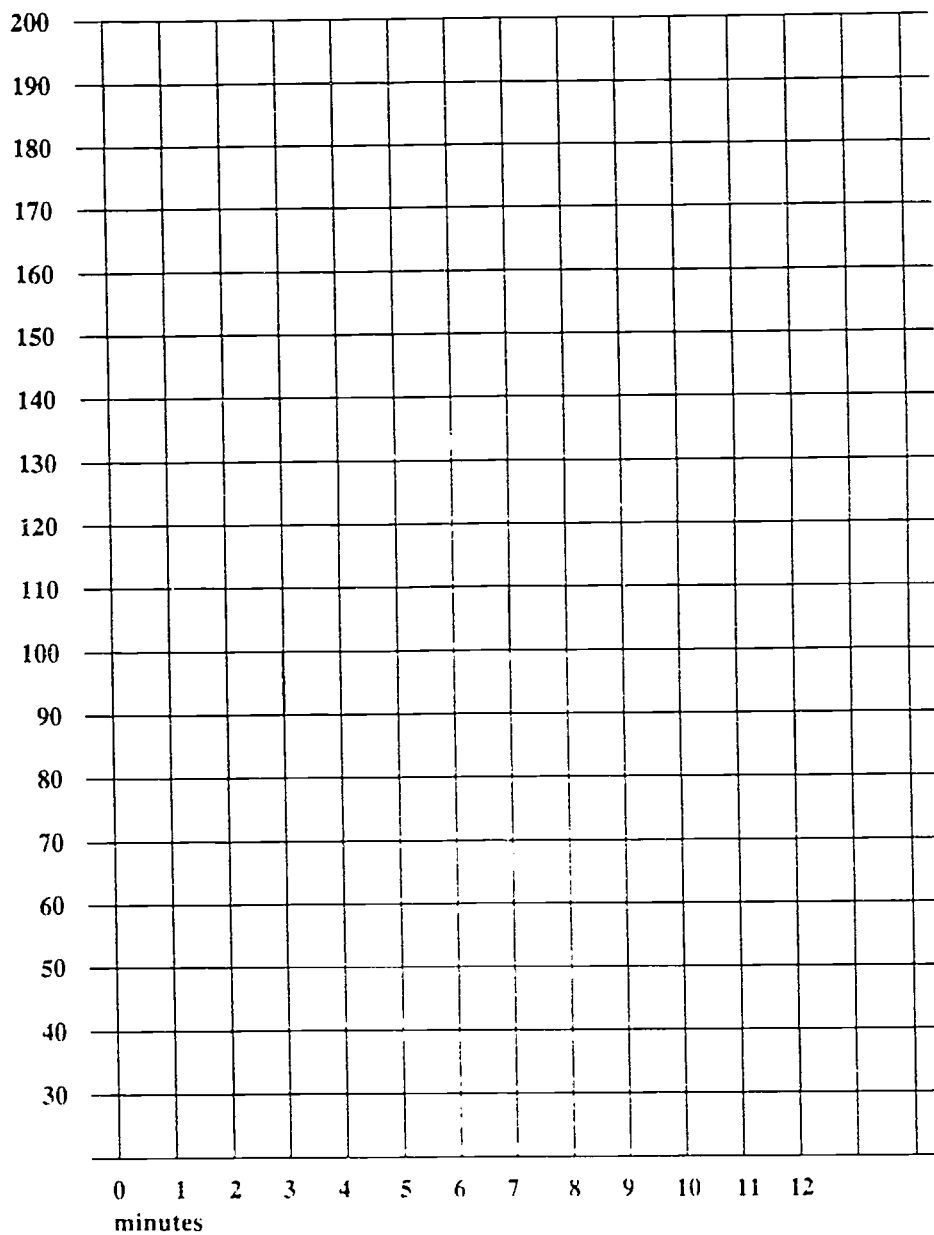

Blood Pressure

On a piece of scratch paper, write down the exact time that the subject sits down. Put the cuff on as soon as possible after the subject sits down. Listen carefully for first the systolic pressure and then the diastolic pressure. Immediately release the pressure in the cuff. Write down the pressures on your piece of scratch paper and next to it write down the number of minutes since the subject sat down. Wait one minute from when the cuff was deflated to allow the arm to recover, then re-inflate and repeat your measurements. You should never have the cuff inflated for longer than one minute. You should be able to record the blood pressure about once every two minutes for the entire 15-minute recovery period. Then transfer your measurements to the Measurements sheet (which the pulse recorder had during the 15-minute measuring period).

Breath rate and heart sounds

On a sheet of scratch paper, write down the exact time that the subject sits down. Ask the subject to tell you the number of times they climbed the stairs in seven minutes. Have the subject silently count the number of breaths in thirty seconds as soon as they sit down. Write this number on the piece of scratch paper. Then have the subject place the stethoscope on their chest. While you listen to their heart sounds, ask the subject to count breaths for another thirty second period. How are these heart sounds different from resting heart sounds? Are there any sounds other than "lub-dub"? Any breathing sounds? How much of the heartbeat cycle does the beat take up? Is the rest between beats equal to the beating noise? Half as long? A quarter as long?

Ask the subject for the second 30-second breath count and write it on your piece of scratch paper. Next to that, write the number of minutes since the subject sat down. Continue to record 30-second breathing rates until the 12-minute measurement period is up. Then transfer your measurements to the Measurements sheet (which the pulse recorder had during the 15-minute measuring period).

Analyzing Your Data

Calculations

After the measurements for the entire 15-minute measuring period are completed and transferred to the Measurements sheet, each student should complete the calculations on the sheet which has measurements about them. You will need to write down resting measurements from Part 1 of this lab. You will convert 15-second pulse rates and 30-second breath rates to 1-minute rates, and compute the $\%$ rise in each vital sign.

Class graphs

Once you have done your calculations, graph your vital signs measurements immediately after exercise onto the class charts where resting vital signs are already graphed, using a new after-exercise dot color. You will need five dots; write your first name on each one. Put each dot in the center of the appropriate square.

Pulse Recovery Graph

Each student needs to graph the recovery of their pulse rate, systolic blood pressure and diastolic blood pressure during the 12-minute measurement period. They should all be graphed on the Graphing Your Recovery Worksheet. Some examples of individual and group graphs are shown in Figure 1.

Graph each vital sign in a different color. Put dots at each actual data point, then use a ruler to make straight lines between the dots. Label each line.

Figure 1
Example Graphs

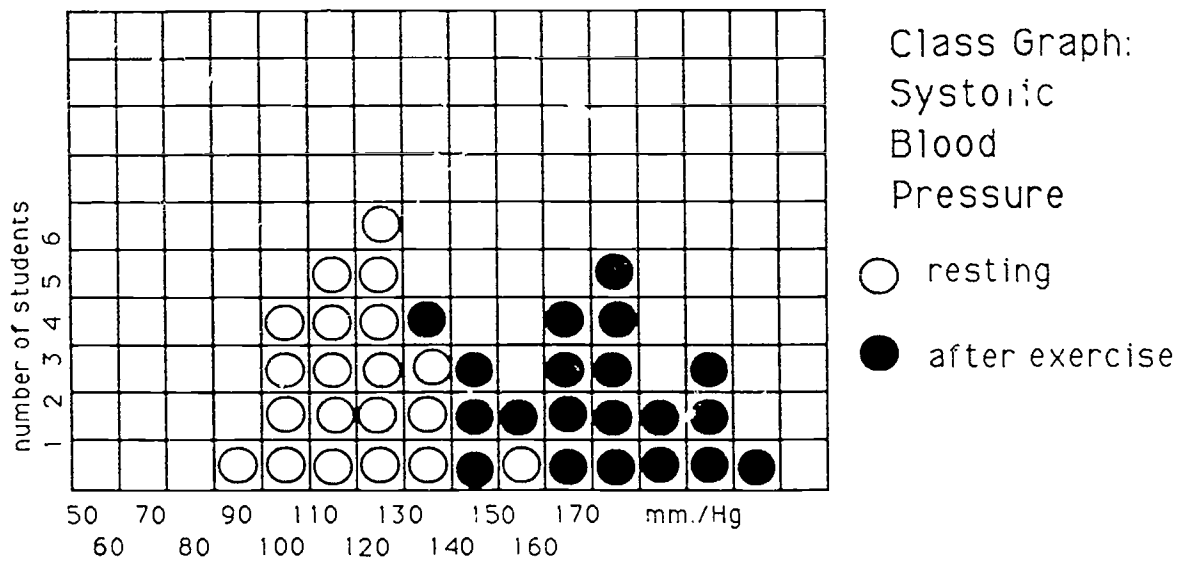
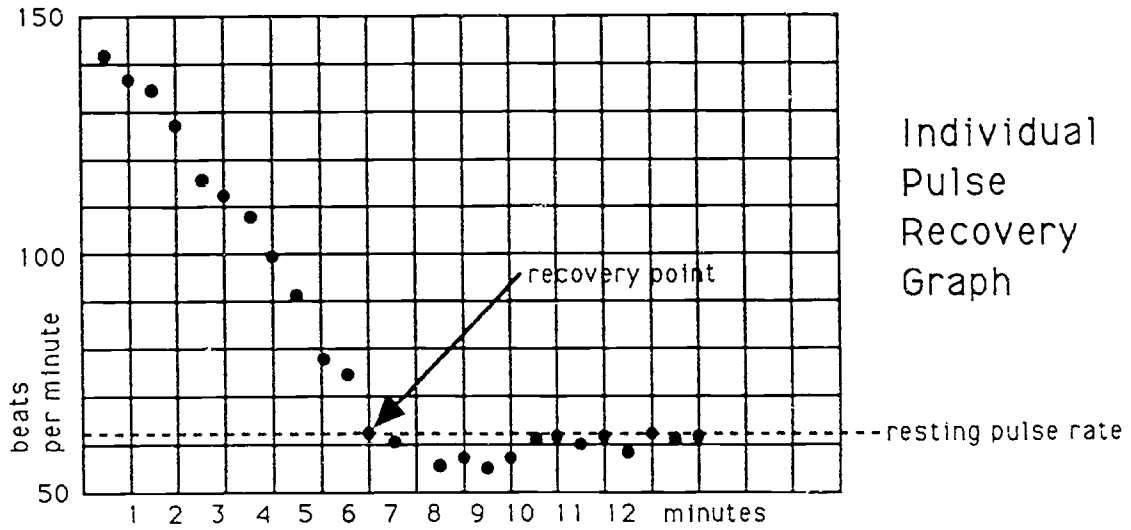

Make a dotted horizontal line of the same color at the resting rate for that vital sign.

You should have data for every half-minute for pulse rate. For blood pressure, be sure that you record each measurement at the correct number of minutes after exercise.

A Fitness Measurement

How much harder your heart and lungs work during exercise, and how quickly they return your body to normal (return to resting vital signs level) is a very good indicator of overall cardiovascular condition. But how can we compare different individuals? People with different weights and different leg lengths are doing different amounts of work climbing the same number of stairs. Some people will climb more or less stairs than others. So the rise in pulse rate after seven minutes of exercise is not a very accurate way to compare individuals.

A better comparison is the overall slope of the recovery curve. Individuals with steep curves are recovering faster, an indicator, an indication that their heart and lungs are more fit. Measure this slope by comparing the pulse rate measurement one minute after exercise and the pulse rate at the recovery point—the point at which it first returned to the resting rate. If it did not return to the resting rate within twelve minutes, you will use the last measurement you took. The procedure for calculating this slope is shown below.

Slope of the Recovery Curve

(pulse rate at one minute after exercise)
- (pulse rate at recovery point): _____

number of minutes from first pulse measurement
to recovery point: _____

Show your calculations here:

Calculated Slope = _____
beats/minute

Student Worksheet

Vital Signs Lab 3 – Comparing Fitness

Use the information you have attained on your vital signs in Vital Signs Lab 2 to complete the following questions. Next you will record data for five other students in order to compare your fitness with theirs.

Comparing Fitness

STEP 1

What was the slope of your pulse recovery (in Vital Signs Lab 2)?

_____ beats/min.

What was your % rise in pulse rate?

_____ %

What was your % rise in breath rate?

_____ %

What was your % rise in systolic blood pressure?

_____ %

STEP 2

Record the same data for five other students.

name	slope of PR recovery	% rise in PR	% rise in SBP	% rise in BR
_____	_____	_____	_____	_____
_____	_____	_____	_____	_____
_____	_____	_____	_____	_____
_____	_____	_____	_____	_____
_____	_____	_____	_____	_____

- Do you think the slope of pulse recovery accurately indicates cardiovascular fitness? Explain your answer. Do the results from Step 2 in Table 4 confirm or contradict this hypothesis? Why should this measure be accurate / inaccurate?
- Does the % rise in any vital sign seem to be a good indicator of fitness? Explain your answer.
- Can you suggest a better way to measure fitness?

Use the class charts and the information in Step 2 of Table 4 to answer the following questions:

- Which vital sign increases the most (= greatest % rise) following vigorous exercise?
- Which rises more after exercise – systolic or diastolic blood pressure?
- Using the blood pressure as a rough indicator of increased output by the heart (it is an underestimate), how much harder is the 'normal heart' working immediately following seven minutes of exercise:

$$(100\% + \% \text{ rise for pulse rate}) \times (100\% + \% \text{ rise for blood pressure}) = \% \text{ increase in cardiac output}$$

Family Medical History

For Teachers

In this unit, students interview relatives about their health history, using a checklist, and then reflect on the relevance of this information to their own health. This is one of the introductory assignments in Health Academy Physiology; students learn about specific diseases and disorders that they will study during the year. Many of the topics covered are important for health occupations: students learn about the reasons for personal and family medical histories, about patient confidentiality, and about the importance of accurate records. They also work on patient interview skills in a realistic context. Discussion of the mathematical issues (databases, samples, reliability, random and non-random clusters, and so forth) might take place in a math class.

Many students have said this was their favorite assignment of the year, because they learned things that felt real and personally relevant. The data gathered can also be used as a springboard for many different investigations, as class activities or as extra or advanced work for a few students.

Time frame

I introduce the assignment and then give students three to four weeks to complete it, so that they have time to do the interviews and to contact relatives who may live far away. The first day I introduce the assignment and have students do the self-interview. On another day, we go over basic information about some of the health problems on the list. (Student reports would take longer.) During that week, we will talk about what it would mean for an individual to know that they had a family history of heart disease or cancer, and what they could do about it. The day the assignment is due, we spend some time talking about what they learned from it. Later, we tabulate the data and then have a presentation of the tabulated data and discussion of what our results are and about health statistics in general.

Introduction

The assignment should be introduced with a discussion of why a family medical history is important to personal health. The concept of a range in the heritability of various health problems—from purely inherited conditions such as sickle-cell anemia or male pattern baldness, to conditions where heritability is

significant but not determining, such as cancer, heart disease or diabetes, to conditions with no heritability, such as hepatitis or measles—should be introduced. We've had some interesting discussions about whether the children of people who break their bones are more likely to break their bones, and why.

Students should be told what will be done with the data they collect. If the records will be tabulated in some way as a whole class, the need for confidentiality of medical records, and therefore for not putting names on the data sheets should be discussed.

Remind them every few days to do their interviews. If relatives live far away, encourage them to get in on a family phone call for a few minutes, or to mail data sheets and a copy of the instructions.

Students who cannot interview blood relatives

There will be students who cannot interview seven blood relatives, or cannot interview any, because of adoption, absence, divorce, death or other reasons. These are sensitive subjects for students. I ask students to see me about what to do if they cannot complete the assignment, rather than announcing the alternate assignment, so that as many as possible will interview relatives. I don't ask for any response in class, asking students to see me before or after class or at lunch. I tell those students who do see me to complete their seven interviews using unrelated individuals with a range of ages, and I explain how their data will be used, so that they will see that they also have a contribution to make to the group data. Sometimes students wait until a week before the assignment is due before coming to talk to me; they thought they would be able to interview relatives, but couldn't, or they just don't want to have to say anything about their situation.

On the Conclusions sheet, those students with few or no blood relatives to interview can be asked to list the problems shared by two or more persons in that group of seven (or five) unrelated individuals. If the class is going to analyze class data, these individuals, designated "unrelated" in the data sheet box, can serve as a control/comparison group for the class data, and the number of shared cases among unrelated individuals can be used to show that chance, as well as heritability, may lead to clusters of common diseases.

"Self" interview

When I introduce the assignment, I have students fill out the first data sheet, about themselves, in the classroom, so that they know how to fill in the sheet.

Deceased relatives

I encourage students to interview relatives about other relatives who have died. These may be the most important for the students own health information, even though the data may be less complete than with actual interviews.

Background information about diseases

Students will need background information on many of the health problems on the data sheet checklist. The teacher can provide this information in class, or students or groups of students can be assigned to report on the health problems needing review. The American Medical Association Family Medical Guide or similar books are the best information resources for this.

Data processing

So far, I've had students sort the data sheets by age and sex and then tally the totals onto blank data sheets. This is useful for demystifying the process of data processing, but very tedious and not very powerful. I keep meaning to teach students how to enter the results on a computer database so that we can then question the database about incidence of heart disease by age, etc.

Discussion of the results of these tallying activities, with or without the computer, can be very interesting in talking about samples, sample bias, reliability and other topics relevant to any type of health statistics. The summary information could be used by interested or advanced students for extra credit reports, science fair projects, etc. (How do the rates of disease in our sample compare with national rates of these disorders? What are the major health differences between men and women?)

Student Assignment

Family Medical History

Your assignment is to interview as many of your blood relatives as possible about their medical histories. The more closely related they are to you, the more useful the information will be to you. Try to interview parents and grandparents on both sides. You must interview at least seven relatives, in addition to yourself. If you can interview more relatives, please do. Relatives by marriage are not blood relatives, and are not useful for this assignment. If you cannot do this assignment because of problems with contacting blood relatives, please talk to me as soon as possible. You will be assigned to interview other people, who will serve as a control group for our class data.

This data will be used in two ways. First, you will learn about health problems that may run in your family. Secondly, we will enter information from all students into a computer data-base so that we can look at rates of different health problems, compare the health problems of different age groups, etc.

If one of your close relatives has died, it would be useful to you to collect data for that person from other relatives. If you do this, enter the age they would have been if they were alive this year with a D for deceased following the age. If the person(s) you are interviewing about this relative isn't sure about the answer to a question, put a slash (----) through that box.

Filling Out Data Sheets

"Interview" yourself first. In the first column of your first Interview Data Sheet write "self" as the relationship, and fill it out for yourself.

Please do not include the names of anyone, including yourself, on the interview data sheets. Medical information should be confidential. Put your name on the conclusions sheet and turn in your data sheets stapled in back of that page, so that I can check that you did them. Once they are checked off, the data sheets will be removed from the conclusions sheet and no one will know whose data sheets they are.

For each interview, you will need to explain to the person why you are doing the interview, then go through the checklist on the data sheet and record all responses.

The first few questions are "non-medical" data needed for comparing different groups. For sex, enter M or F. For age, enter the person's current age in years. For race, enter white, black, hispanic, asian, or other--race is much more complicated than this, but we need to have standard categories for comparison.

Some questions (small boxes) require only yes or no answers. If the answer is "yes" write a Y in that box. If the answer is "no", put an N in that box. Other questions (longer boxes) require longer answers, such as the name of the bone that was broken, the location of a cancer, etc. At the end are some "other" questions, such as "other operations" Try to summarize these in one to five words.

Interview Data Sheet

Relationship to interviewer

age

sex

race

broken bones: name

bb age

arthritis

ruptured or "slipped" disk

other back problem

blood type if known

sickle cell anemia

varicose veins

high blood pressure

chest pain; heart disease

heart attack

stroke

hay fever

other allergies: type

ever smoke cigarettes

asthma

pneumonia

kidney stone

gall stone; gall bladder problem

ulcer

appendicitis

diabetes

thyroid problem

epilepsy: seizures

migraine headaches

other severe headaches

nearsighted

farsighted

cancer: location

measles

mumps

chicken pox

malaria

other serious infectious illnesses

tonsils removed

other operations

transfusions: reason

other major health problems

any hospital admissions not noted

Conclusions

Answer these questions after you have finished your interviews. Staple your interview data sheets behind it before you turn it in.

- 1 What health problems did two or more of your relatives (including yourself) have? You must list any problem, serious or not, reported by two or more of the people you interviewed. (If you got permission from the teacher to interview non-relatives, please write "Unrelated individuals" at the top and then list any problem, serious or not, reported by two or more of the people you interviewed.)
- 2 For each problem listed in #1, state whether you think this problem would run in families, or whether the fact that several people in your family have had this problem is accidental. Briefly state your reason for making this choice. You can write your answer next to the problem in your list.
- 3 What should you be doing about these problems or about the possibility that you might develop these problems? List what you might do about the two or three most important problems on the list.

MEDIA ACADEMY
Fremont High School

Book of Essays (Seniors)	45
For Teachers	46
Procedures	46
Examples of Student Work	49
Book of Bi-modal Biographies (Sophomores)	53
For Teachers	53
Procedures	54
Example of Student Work	58
Student Magazine (Juniors)	60
For Teachers	60
Procedures	61
Example of Student Work	63
Advertising Project (Sophomores and Seniors)	68
For Teachers	68
Procedures	69
Examples of Student Work	71

MEDIA ACADEMY

Stephen O'Donoghue, Journalism Teacher

Michael Jackson, English Teacher

The Media Academy is a three-year, school-within-a-school program located at Fremont High School, an inner city comprehensive high school that enrolls 1600 students, tenth through twelfth. Fremont is located in an increasingly diverse neighborhood; this is reflected in its student body, which includes, African American, Hispanic, Asian, Filipino, Pacific Islander and Native Americans. Over twenty-seven languages are spoken by Fremont students. Incoming sophomores average two or more years below grade level on standardized Language Arts and math tests (California Test for Basic Skills). Over fifty percent of the student body comes from family on some form of social assistance; single parent families predominate, and the immigrant population of the school is growing each year from the large influx of Asian and Latin American immigrants in the surrounding community.

The Media Academy combines academic and vocational subjects to prepare students to meet the challenges and opportunities of the future. The program is a three-year program, built around writing and other Language Arts skills; its primary objective is to graduate At Risk high school students, while enhancing their skills to better prepare for employment, post-secondary education, and job training.

The Academy primarily focuses on print and broadcast journalism careers. The Bay Area media employs substantial numbers of people from all ethnic backgrounds. Within the curriculum, journalism allows us to emphasize writing and other language arts skills considered academically important, and in which many of our students are seriously deficient. Because these skills are not vocationally-specific; they are vital in any career area students choose. However, through our job internship program, the Media Academy has placed students in paying jobs at radio, television, and print facilities in the Bay Area.

The Academy functions through the integration of its curriculum. English, Journalism, Social Studies and Math classes are taught in a block, where possible with two subjects back-to-back, to facilitate cross-curricular activities. (For example,

sophomore English and Journalism work on writing projects together. While performing a dramatic reading of "Julius Caesar" in English, students write a "news" story about the murder of Caesar in journalism.)

Vocational integration allows students to produce a magazine, a newspaper, and radio/television broadcasts, using forms and content learned in English, journalism, social studies and math classes at all grade levels, applying a broad cross-section of skills: planning, writing, researching, editing, designing, public speaking, advertising, distributing. These activities require students to use higher level critical thinking skills as a team. These productions demonstrate student mastery of basic and advanced academic and vocational skills. The integration of academic and vocational subjects forms the core of our curriculum.

The Media Academy does not track students by test scores or perceived abilities. We mix our students across a spectrum of abilities and talents. Students with higher test scores in reading, assist peers with lower scores, bringing them to collectively and individually higher levels over the course of three years of study in the Academy.

We reject the idea that certain students are destined to have difficulty graduating from high school while others are labeled "college material". Our mission is not only to keep our students in high school but to prepare all of them for college or post-secondary vocational education immediately after graduation, if that is what they choose to do.

The Media Academy is both a program for students at risk and a college preparatory program. The tie that binds both together is a career focused curriculum.

Description of Curriculum

The curriculum engages students in productive applications of knowledge and skills learned in academic subjects. Student projects involve following production methods which are exactly the kind of tasks performed in media-related organizations. For example, researching, interviewing, writing, editing, designing, mechanical production using desktop publishing.

Off campus activities, such as field trips to see professional theater, visit job sites, Outward Bound and the Yosemite Trip, are built into the curriculum to expose students to experiential learning, team building, and reinforce Academy esprit de corps. The Center for Living Skills builds student self-esteem and leadership qualities.

Juniors and seniors are paired with a mentor from a career area of their choice; they are also placed in summer jobs (termed "internships") for work experience and career exploration.

The three-year sequence of courses for Academy students is detailed in Table 1.

Table 1
Media Academy Curriculum

10th Grade Courses

English II
Journalism I
World Cultures
Math (appropriate level)
Foreign Language
Biology
(Physical Education is waived by district dispensation)
Center for Living Skills Training
(Youth leadership and development course)
Outward Bound Experiential Education training

11th Grade Courses

English III
U.S. History
Chemistry or Physiology
Math (appropriate level)
Foreign Language or Physical Education
Advanced Journalism/Newspaper Production or
Advanced Journalism/Magazine Production or
Radio/Television Broadcasting
Yosemite National Park Junior Class Trip
Mentor Program Begins
Summer Internships

12th Grade Courses

English IV
American Government
Journalism/Magazine Production or
Radio/Television Broadcasting
Hearst Castle Senior Trip
Mentor Program
Spring Work Experience

Curriculum Projects

Projects are activities, sometimes grouping small teams of students, involving one or more academic subject and a vocational component. Projects measure the degree of mastery of student outcomes through a final product. The projects serve as examinations by portfolio in more than one academic discipline; therefore, they are an integral part of the curriculum. Curriculum projects not only connect for students and teachers the content of seemingly isolated coursework, but apply academic content in a vocational context.

Book of Essays (Seniors) Applies critical thinking skills to a formal essay; students focus on their career direction while reflecting on a formative autobiographical incident. Students use desktop publishing, photography and other journalistic skills to produce a book. (*Involves: English IV & Journalism.*)

Bi-Modal Biographies (Sophomores) An assignment early in the year, it reinforces research, writing and editing skills and introduces students to cross-curricular projects, team assignments, and the concept of knowledge as universal as opposed to just discrete units (e.g., History, English, Math as separate). (*Involves: English II, World Cultures, & Journalism.*)

Magazine Project (Juniors) Practice in the application of journalism techniques, writing and editing skills, and further work in teamwork and cooperative learning. Important for students moving up to staff positions in newspaper or magazine. (*Involves: Journalism & English.*)

Advertising Project (Sophomores and Seniors) Students study and apply techniques of propaganda and persuasion. Students apply knowledge from academic subject to vocational activity; produce a story board, write, direct and star in their own commercial. (*Involves: English II, English IV, & Advanced Broadcasting.*)

Book of Essays (Seniors)

Courses: English IV, Journalism

Senior year places great responsibilities on students. They must complete their course work, often after school and on weekends, while they simultaneously apply for college, training schools, scholarships, and financial aid.

Since teaching essay writing is an important part of senior English, we sought to combine these responsibilities by having students write a reflective essay that would also qualify as a college application essay for admission, or financial aid. Further, the essay would be published in book format by advanced journalism students as an outside project; for example, an activity involving teams of students that takes the content of the essays but formats them as a magazine or news feature. The final product is a Senior Book of Essays, an activity designated to reinforce publishing skills—editing, headline and caption writing, design, computer-aided production—that are an important part of the Journalism Course. Students now have something for their portfolios they will be able to take to an employer; they are much more likely to be hired, they have demonstrated their capacity to work for a publication.

All seniors in the Media Academy write, revise, and type, using computer word processing, a reflective essay assigned in English IV. The reflective essay is considered one of the more difficult type of essays to write. It requires high level critical thinking. Writing this kind of essay also prepares students for higher level assignments in all subject areas. We have chosen, as our subject, an essay that will also be used to apply for acceptance to a college, and for financial aid, since most of our students require such aid to cover the expenses of higher education or vocational training.

The Book of Essays is an example of using a vocational subject, journalism, as a vehicle to advance skills from academic subjects, in this case Language Arts and Social Studies. Producing a book is an example of what professionals in the industry of publication do for a living.

For Teachers

Who Does What

The English teacher provides content, as well as instruction in correct form, style and revision of all writing; he or she also reviews the preliminary drafts as they are typed and saved on the computer.

The Journalism teacher supervises the formatting and production of the senior book itself. Journalism students use desktop publishing software to assemble and produce the Book of Essays (Vocational class application). Both teachers supervise the project, provide individual feedback, and teach writing and publishing skills. Both provide ongoing evaluation of layout and design.

Evaluation

Journalism students are graded on how well they planned, designed and edited the book, measured against standard journalism criteria (National Scholastic Press Association critique guidelines, Associated Press Stylebook). The essays are graded on how well they meet the criteria stated in Lesson 2. The finished book is a compilation of the best of these essays. During the following year, a survey of students and teachers who use the Book of Essays will provide feedback on its effectiveness and allow for revising later editions.

Procedures

Lesson 1

First, students respond to a list of questions. A two-part worksheet produced by ACCESS (Alliance for Collaborative Change in School Systems), a college preparatory service of the University of California, Berkeley, helps the student recall a personal experience to be expanded into a "college essay". Second, students read and critique two samples of successful senior essays which are used as models. The secret is to show how the format is applied regardless of topic. Third, use the personal experience, and show how that experience has affected your life.

Student Worksheet, Part 1

Questionnaire for Senior Essay

From the list below, choose five categories that capture your interest and you feel you have something to write about. Of the five, choose the two that seem the most interesting or important to you.

- Something I accomplished that made me feel great.
- Something I have struggled to overcome or change about myself or my life.
- An event or experience that taught me something about myself or about life.
- A "downer", a real drag of an experience that I had to get past.
- Someone's strength or courage that affected me.
- A family experience that influenced me in some powerful way.
- A lesson, class project, activity, or job that had an impact on my academic or career goals.
- A time I failed or made a bad choice, and how I got past it.
- A memorable event or advice involving an older person.
- An event that helped me understand myself better (my background, culture, heritage, past) better.

Then use the Planning Sheet (Part 2 of the worksheet) for taking notes on these two events; its purpose is to provide content for the essay.

Lesson 2

Students write the essay at home. Divide students into groups of four for in-class conferences. This is highly teacher-student interactive and will mandate a second assignment—silent reading, a research assignment, or group work—to allow the teacher quiet space to think while conferring with students in small groups wherein several students can apply the instruction and critique to their papers at the same time. Teacher uses a thesis-based essay criteria. The essay must contain an introduction, a thesis, and develop the autobiographical incident. Through reflection the student must connect their past experience with its impact on their future.

Lesson 3

Journalism teacher instructs students in inputting and formatting essays with computer word processing software. Allow two to five days, depending on availability of computers, for students to type their revised essays on computer disk. Students print out a copy for English instructors.

Student Worksheet, Part 2

Planning Sheet for Senior Essay

EVENT	KEY MOMENTS, DETAILS	WHAT STAYS WITH ME MOST	SIGNIFICANCE, MAKES ME SPECIAL

61

61

62

Lesson 4

A second class session of student-teacher editing in English, followed by student conferences in peer groups. Depending on amount of help individual students need, this editing session may take more than one class period.

Lesson 5

Allow one or two class periods to revise the essays and produce final drafts on computer disks. Students print out one copy for English teacher, one for Journalism teacher, and one for themselves; both teachers will grade the papers. Student disks are left with the Journalism teacher. Students use Advanced Journalism time to revise, refine and complete their essays.

Lesson 6

Advanced Journalism students copy student essays onto master disk. Design, format, layout, add art and prepare for duplication a book using PC and Macintosh desktop publishing software. This component will take a few students up to two weeks, depending on the complexity of the final design; e.g., whether art or photographs are used. Students can paste pages back-to-back and staple them to bind together a real "book". These students select the best examples as models for future students.

Examples of Student Work

MOTHER DAUGHTER

By Tanisha Lofton

When I was in the seventh grade I went through many changes. I was getting bad grades. My mother and I were always arguing, and at each other's throats. All she did was add to my problems. When things were really getting me down, she would say, "That it is why it is so important for you to do well in school."

I never thought she really understood. She wanted me to be mommy's little girl forever. I wasn't supposed to have a boyfriend or either talk to boys for that matter. She used to say: Tanisha, you better try and do better because I am not always going to be around."

Then I'd say, "I know mama I'm going to do better."

"It's easier said than done," she'd reply in a very smart and sarcastic way.

Seventh grade year went by so fast you wouldn't believe it. At the end of the year I found myself way behind. It was a lot of work that I had to catch up on, just so I could graduate with my classmates. It was so hard for me to try and do all of that and not get along with my parents. I couldn't take it all so I had to move out. I thought that this would makes things easier on me.

In the eight grade I moved out, I moved into my uncle's house. I thought it would be a good idea because we are very close, and he is very understanding. But as time went on I realized that it was only natural for me to be having a lot of problems because of my age, and by me just being a teenager. We go, through a lot of things.

I soon came to the conclusion that you can't run from our problems. You can only make them worse. It won't help you at all. Running from your problems can only make things harder on you.

Now I am living back at home. My mother is trying to be a little more understanding. I guess she realized some of the things I was going through, so she is trying to help me now. She is more like a good friend then anything else. I didn't mean to hurt her in any way and now I realize that she didn't mean to hurt me.

As time went on I knew that their were a lot of decisions that I had to make. I also had to realize that you can't have everything that you want. I know you are probably asking yourself what does this have to with college well, It has a lot to do with it. It's really made me grow up and stop acting like the spoiled person I would like to be. After I think about all of this I know that when I graduate from high-school and I go to college I would like to major in Business. I plan to go to San Diego State. I'm not sure how long that you have to go to college before you get your masters degree. But I'm willing to go no matter how long it takes. I want this really bad.

I don't think that it would be a hard for me to find living arrangements, because my mother is moving out their this year. Not saying that I am going to stay with her forever but hey she is my mother. That's what she's there for . . .

WORDS TO LIVE BY

By Ashanti Branch

In my life I have faced many problems but one stands out the most and it is one that I can never forget, but any person that lives without dilemma never learns to conquer predicaments that comes his way.

I was reared in a single parent home because my father perished before I was born. I had known that he was dead ever since I was very young, I just didn't know how or why. When I found out I was eleven years old and in the 7th grade. My mother told me because I was so persistent, I kept at her. She said he had been injected with some drugs and his heart could not handle it: unfortunately before he reached the hospital he was pronounced dead. For the rest of the night I cried and cried and didn't get much sleep.

During the rest of that school year and most of the 8th grade my grades suffered greatly and I cared about school as much as I cared about what the Supreme Court had on its agenda. My life was full of sorrow. I started feeling sorry for myself because I had no one to look up to, no one to call "Dad".

I began to feel helpless, believing in the phrase "Like Father, Like Son" was destined to be my future. I felt that it was very possible my life could end in the same way. Everything you hear is not always true but in my eleven-year-old mind it was true.

Then one day a caring teacher saw I had potential but just didn't use it. She sat me down and talked with me, and we talked and talked. She told me something I will never forget. She said: "Life doesn't always give you what you feel you should have, but it's up to you to take what it gives you and make the best out of it, regardless. You can't run away from your past, but you can prepare for what is to come in the future."

From that day on I set the pace for my future. From the words of that teacher I learned if you want anything to happen in your life, you have to take the first step. Not many people you run across will stretch their neck out to help you reach your highest goal, so you must succeed on your own, no matter what the odds.

Since the day that teacher talked with me my grades have taken a leap for the better. Besides a 9th grade 3.0 GPA, I have maintained above a 3.50 GPA in my high school courses. I have also enriched my knowledge by taking very challenging courses, including

classes that are not required. Other than participating in extra activities at school and in the community, playing Varsity Football and being in the Drama Club, I am very concerned about problems facing my community and the society around me. Overall I strive to be the best that I can be.

Since the day that teacher talked with me I started thinking about my future and reflected back over my life. Since I was in the 3rd grade I realized I had a love for math, I was at the top of my class in math. Now even as the math gets harder I still love it because I enjoy being challenged. In my sophomore year I doubled up on math classes so that by the time I graduated I could be already in Calculus. My love for math has expanded my curiosity in the field of engineering and its concepts to make life better for the world.

The summer of my junior year, the advisor for the MESA (Math, Engineering, and Science Achievement) Program, Ms. Annette Hilts, and the Marcus Foster Upward Bound Director, Ms. Smith, recommended me for a summer internship at Brown and Caldwell Engineering Consultants. This was a wonderful experience for me and it gave me a chance to experience engineering close up. It also taught me another small lesson about myself: that I am responsible. While most of my friends were at home relaxing, having fun, and enjoying their last summer as a student, I was giving myself a better understanding of the profession that I plan to pursue.

I am a dedicated member of the Partnership Program at UC Berkeley, which is a student incentive program to help get underprivileged students into college, and also MESA (Math, Engineering, and Science Achievement), a program for students that are interested in engineering or the field of sciences. In some of my spare time I work with children at Eastlake YMCA, located in a high drug and crime infested part of the town I grew up in. I am there to give them a helping hand with some of their problems and to provide the young kids with children at Eastlake YMCA, located in a high drug and crime infested part of the town I grew up in. I am there to give them a helping hand with some of their problems and to provide the young kids with someone to look up to.

Even though I never saw my father, before my life is done, no matter how hard I have to work, no matter what I decide to do with my life, I will make sure that if my father were here he would be proud of me!

Book of Bi-Modal Biographies (Sophomores)

Courses: English II, World Cultures and Journalism I.

Students are required to do research on a historical figure; part of the research activity takes place in each subject. Bi-modal biographies look at a historical figure from two perspectives, one emphasizing his or her accomplishments in a positive, uncritical vein; the second from a more critical, debunking side. The objectives are to improve student research and study skills, such as note taking, outlining using note cards, using the electronic Periodical Guide, footnoting, compiling a bibliography. Also, practice writing, learn research paper format, invoke higher level thinking skills, and practice vocational skills by producing a book of student work. This unit combines reading, thinking, writing and communication skills, as well as teamwork. The writing, editing and design aspects of this activity integrate the vocational elements of the curriculum into this project with the core academic subjects.

Multi-Subject Research Papers

This is phase one of a two-part activity. It prepares the way for producing a book of bi-modal biographies. Students will each write an individual research paper, on an historical figure. This part of the project helps students learn journalistic skills, such as obtaining information, writing from a point of view, attribution, copy editing, and word processing.

Producing a Book of Bi-modal Biographies

After the initial planning, research and preliminary writing and editing, students revise their material for formatting into a book of biographies on historical figures, each portrayed from two different points of view. Students will apply higher level thinking—selection, interpretation, evaluation and persuasion—in the lessons that will be taught in the three sophomore subjects.

For Teachers

Who Does What

The World Cultures teacher introduces basic research skills, including bibliography and footnote. This teacher also provides information about the events and issues that shaped some of the prominent historical figures. The World

Cultures teachers assists with research, helps find sources that might be unknown or inaccessible to students, supervises note taking and organizing information gathered.

The Journalism teacher introduces the vocational component of the project and reinforces skills taught in World Cultures as well as instruction in editorial and pro-con opinion writing, word processing, document design, and final production of the book of bi-modal biographies. The Journalism teacher reinforces point-of-view and perspective with writing models from print journalism and begins training in word processing.

The English teacher provides a format for the essay. For instance, one possible format divides the paper into eight content areas: historical Claim to Fame, the Life and Times of the person, Historical Significance of his/her contribution, their Rise to the Top, the Climax of their life, the Kitchen Sink, details that might be of interest for further research a Footnote page, and Sources, which include a formal bibliography.

The English teacher supervises the initial and revised writing, and assists in formulating the two sides of the argument for each historical figure.

Evaluation

Journalism students are graded on how well they planned, designed and edited the magazine, measured against standard journalism criteria (National Scholastic Press Association critique guidelines, Associated Press Stylebook). The biographies are graded on how well they meet the criteria stated in Lesson 2. The World Cultures teacher grades the biographies on how much historical content is included in the final product.

Procedures

Lesson 1

The Journalism teacher takes two sophomore classes to the library for two days. The librarian needs one day for student orientation, especially explaining and practicing the use of the Readers Guide to Periodical Literature, encyclopedias, the Microfiche reader, CD-ROM encyclopedia, electronic Periodical Guide, and reference works of particular use for finding information on people (Who's Who, etc.).

On the second day the journalism teacher begins individual student researching their assigned biographical figure, advising on likely resources, critiquing notes, assisting individuals (with librarian) in using electronic search methods. Emphasis is on gathering sources first, specific information second. On subsequent days students in small groups (teams) will be sent to library to complete gathering of information and visits to city and university libraries will be assigned as homework.

Lesson 2

In Journalism, initial training in how to input and format a report on a computer word processor begins. The English teacher instructs in the format for a biographical essay. One possible format is as follows:

- *Claim to Fame* tells us why this is an important historical person, who the person was, and what he or she accomplished.
- *Life and Times* tells what it was like to be alive during the era when this historical figure lived.
- *Historical Significance* places what he or she accomplished in historical perspective and speculates on how history would have been different had the person not lived.
- *Rise to the Top* places in sequence the events in the person's life as they lead to the historical climax, the critical time or event in his or her life, obstacles in the path of achievement or infamy.
- *Climax* dramatizes the most important historical moment in the subject's life.
- *The Kitchen Sink* includes basic information not called for in other sections, such as place of birth, ancestors, family, etc.
- *Footnotes*, placed on a final page.
- *Sources*, placed on the same page. The World Cultures instructor will teach how to format footnotes and bibliography; the English teacher will re-teach

it, since students often fail to master the format the first time; the Journalism instructor will teach students how to follow the format on the word processor. Each report must include at least one quote.

Lesson 3

The World Cultures classes spend another two days in the library gathering material on their topic. Students then spend considerable time outside of class trying to find multiple sources. The teacher assists students in their search for material, particularly in cross-referencing. A hand-written first draft of the paper is due to World Cultures instructor.

The papers are reviewed by World Cultures, English and Journalism teachers prior to the final deadline. Students make final revisions. Students turn in the paper. This individual research paper will receive a major grade in World Cultures, English and Journalism. Final grades depend on how well students meet the criteria stated in Lesson 2. Papers are returned to students.

In Journalism students type in corrected final version of papers on word processor and store on individual computer disks under the supervision of the Journalism instructor.

The three subject teachers select the best historical subjects for the final bi-modal biographies based on the availability of information and quality of student research and writing.

Lesson 4

Teams of three to four students will be assigned to write a pro and con profile of one historical figure selected from the larger set. Individual teams may divide up the responsibilities according to their design; One possible division of labor would include a team leader responsible for coordination and general research, one member researching and writing from the "pro" side, and one member researching and writing from the "con" side. Alternately, students may write each section together. By taking sides, students learn to express different points of view.

Lesson 5

In English students practice the process of taking a side and writing a piece of historical propaganda. This is reinforced in World Cultures where the instructor brings in other historical perspectives on selected individuals and/or events.

Lesson 6

In Journalism students complete opinion writing unit with pro and con exercises and study editorial and other forms of opinion writing that seeks to persuade.

Student groups type their bi-modal biographies into word processor in Journalism class. This will take at least two or three days. Each team prints out four copies: one each for English, Journalism and World Cultures teachers, one for the team to keep. Each instructor meets with each group and gives feedback and corrections.

You don't need computers for this project; typewriters and dittos are suitable "low-tech" alternatives. For final production students can cut out and paste passages typed out onto pages and add their own art or photos.

Lesson 7

Teams edit final versions and print out new copies. Disk are turned in to the Journalism instructor with the paper copies. Advanced Journalism students under the supervision of the Journalism instructor combine profile files into one document, design, format and produce on desktop publishing software A Book of Bi-Modal Biographies. Final product may possibly include computer scanned pictures or student art of the historical figure.

The teamwork involved in putting together a book like this prepares students for advancement to magazine and newspaper employment; students practice writing, editing, design and computer production techniques.

Example of Student Work

WILLIAM RANDOLPH HEARST

By Tuwanna Peters, Rodney Brown, Fernando Lira and Marcella Pullen

THE GOOD SIDE: William Randolph Hearst believed anything was possible. He worked day and night to make sure his newspaper got out the next day. Nothing was too hard for Hearst.

His first run with a newspaper was in 1887 when he bought the struggling San Francisco Examiner from his father, George Hearst. It soon showed progress and he moved on to New York and began the Morning and Evening Journal. Within a few years he owned newspapers in Chicago, New York, Boston and San Francisco. William R. Hearst later purchased magazines, from the famous Cosmopolitan to The World Today. He also published books on fiction and produced motion pictures.

Hearst, with Pulitzer, helped develop the modern newspaper, with columnists, sports pages, features, comics, entertaining packages that were more than just news. Their papers were copied all over the world.

Even though Hearst was known as mainly for his newspapers, he also played the field in politics. In 1904 he received support for the Democrat presidential nomination and in 1905 he ran for mayor of New York City, but he was never

THE BAD SIDE: William Randolph Hearst built a newspaper and magazine empire out of greed and power hunger that still survives today with many of his sons and grandchildren. His first newspaper, The San Francisco Examiner, is now run by a grandson.

Hearst started in newspapers by accident, in 1887, after being expelled from Harvard University for playing a practical joke on one of his professors.

William Randolph Hearst was well known for creating the largest newspaper chain in the nation but although he ran in a presidential race and fought for social reform, he often misused the power of his newspapers, especially in encouraging the United States to attack Spain.

During the Spanish-American War, he and Joseph Pulitzer, publisher of the New York World, went head-to-head to see who's newspaper was better. Both papers "resorted to sensationalism and yellow journalism." Neither of them spared expenses in covering the Spanish-American War.

In 1895, Hearst bought the New York Morning Journal. His sensational breed of journalism was known as "yellow journalism."

elected to office.

Early in his career Hearst fought for the working man and those out of power in society. He used the power of his newspaper to argue for reforms.

In some ways the biggest achievement in Hearst's life was building his famous San Simeon "castle" in California. It was so big and everything in it and around it was all anyone could ever desire. He was a great art collector and put all the art he loved into this castle which is still visited by million of people every year.

Hearst always thought of his family and today many of his sons and grandchildren still run businesses he started.

William Randolph Hearst was well known for creating the largest newspaper chain in the nation, although he served in congress, ran in a presidential race and fought for social reform.

During Hearst's lifetime he witnessed the Spanish-American War and the Great Depression.

Without William Randolph Hearst, we probably wouldn't have the great newspapers we have today. They couldn't use the "Hearst" style they use today. Today's newspapers wouldn't have his breed of newspaper to look up to or model themselves after.

In 1896, he introduced the New York Evening Journal. Though his papers cost one cent, it provided the reader with illustrations, color magazine sections, comics, and extraordinary headlines. These were popular but helped develop the sensational breed of journalism known as "yellow journalism."

William Randolph Hearst was accustomed to having his own way in everything. In 1903, when he was 40, he married Millicent Wilson, a 21-year old actress, against his mother's wishes. Together they had five sons.

Their marriage survived despite several affairs on his part but in 1918 Hearst met 21-year-old Marion Davies, 30 years younger than he. He fell head over heels in love with her and began an affair that lasted for 33 years, until his death.

In 1922 he asked Millicent for a divorce, but she said no. Hearst moved most of his operations to California where he lived with Davies and produced movies that she starred in. He never really lived with his wife again and almost went bankrupt building his "castle" at San Simeon.

Student Magazine (Juniors)

Courses: Journalism (or English)

The purpose of this project is to produce a magazine. In our case, the topic of the magazine is the Media Academy program itself.

This unit is synergistic. It can bring together loose ends of the curriculum that are difficult to integrate normally. It is also a project that crosses skill levels and provides an outlet for students who may be creatively but not scholastically inclined. Finally, it is an ideal team project, with opportunities for peer evaluation. While it is primarily a journalism activity, it can incorporate the knowledge, skills, and concepts of Social Studies, Language Arts, Math, Science and Foreign Languages.

All juniors in the Media Academy, in teams of four, design, write, edit and produce a magazine. Students will use computers to input their stories, layout their pages on screen, and print their finished product. This project calls for different styles of writing—straight news, opinion, feature, analysis that allow varying interpretations of the same subject matter and broad coverage of the curriculum. Since students are working to finish a real product that will be judged not only by themselves and the teacher but also by their peers, there is extra incentive. Editing, revision, and meeting deadlines are an integral part of this project and all transferable, learned behaviors.

For Teachers

Who Does What

The Journalism teacher instructs students in publication design, basic journalistic principals, and reviews journalist styles of writing covered earlier in the year. He also defines the criteria for the publication, brings in speakers as topics for articles, and assigns other writing to be incorporated into the magazine. The English teacher stresses composition, reviews correct grammar and syntax, and assigns writings that can be incorporated into the magazine, especially analytical, opinion and feature writings. The social studies instructor is consulted and gives assignments based on current material that students can use for story topics. Other program instructors assign stories based on their field; e.g., the spread of Spanish language advertising in print media, television and radio programming, aimed at a

growing market of Hispanics, would be an appropriate Foreign Language assignment

Evaluation

Self-editing, team evaluation, teacher evaluation of product. Teacher evaluation is divided into two parts: a Checklist (see page 67) of required elements against which the finished product can be measured, and a holistic evaluation of the content, style and quality of student writing.

Procedures

Lesson 1

Students meet and are given fifteen to twenty minutes to group themselves into four person "staffs" or teams. Each team submits a list of staff members to the Journalism instructor. The criteria checklist (see page 67) for the magazine is then distributed to teams who meet and select responsibilities.

- *Editor-in-Chief* is responsible for coordinated the entire publication and insuring it meets deadline. This person needs to be a leader.
- *Managing Editor* keeps track of all stories and art, when they are do, and who is responsible for producing them. Needs to be someone organized who will keep after their peers.
- *Design Editor* is responsible for overall design of the publication, selecting type styles, column widths, and meeting the criteria that pertain to design. Designs a news, opinion, feature and sports or second feature page. This is a spot for someone creative.
- *Production Editor* is responsible for seeing that all stories, headlines, captions are typed into the computer and saved on disks for later insertion through page layout software into pre-designed pages. Someone steady who works every day is needed here.

Lesson 2

Mini-units in journalistic style, typography, design, legal issues are built into the production schedule approximately every three days. In English writing activities support magazine assignments and reinforce grammar, syntax and writing style skills.

Lesson 3

Team production time is scheduled for four weeks. This includes the mini-units, time to do research and interviewing, type in stories, mock up pages, copy edit stories, produce artwork, and staff planning and meeting time. This schedule can be adjusted to meet differing circumstances.

Lesson 4

Copy deadline is two weeks into the schedule. All articles are due at this time. Stories are checked off by the managing editors against their "news budget" and by the Journalism teacher for an interim grade. Meeting deadlines is stressed; this is an important behavior to learn, one that carries over into every school activity.

Lesson 5

Copy editing of submitted stories by the teams is next. Stories are edited by each member and passed on to the next teammate until each story has been read and marked by three people and returned to the author. A minimum of two days is set aside for this activity.

Lesson 6

Production is in two phases: One, typing in and spell checking each story in the word processor, then revising stories to conform to corrected hard copies from copy editing sessions. Second, stories, captions, headlines and art are loaded from staff members' disks into page layout software with pre-designed defaults.

Example of Student Work (Sample Pages)

KNOWLEDGE FROM THE UNKNOWN HAS
ALL THE ANSWERS

**STREET
FIGHTER**

VOL. 1, NO. 1

MARCH 12, 1992



"WE DON'T MIX BUSINESS
WITH PLEASURE."

THE HULKSTER BRINGS THE
EXCITEMENTS!

REPORTING IS THE BEST CAREER FOR THOMAS

By: Thao Vu

Ron Thomas sometimes felt pressure as a black reporter for the San Francisco Chronicle, but his heart is still in the business.

Thomas was a political science major at the University of Rochester. He decided to pursue a career as a reporter under the influence of his father who was always taking him to ball games. He obtained his Master Degree in Journalism at Northwestern University in 1973. Currently, he is a sports writer.

"I didn't want to be a lawyer or anything else" was a sign of how obsessed he is toward writing. He wouldn't give up his career for another occupation. Giving up being a reporter would mean giving up a high salary, the special treatment when going to basketball games--being close to where the action is, and the chances to travel around the country with all expenses paid by the company. The most important reason Thomas seems to express was his love for writing.

"We don't mix business with pleasure," said Thomas as he recalled from his business trip to San Diego with his wife. His job is so frustrating and time consuming that he hardly has much time with his wife.

"The most important thing about being a reporter is accuracy," said Thomas. This was not a little tip to those who are amateurs. Thomas strongly expressed the point of being careful as to what we write. His key to good reporting is based on the curiosity he has for the career. Without curiosity, there is just no spark in the writing



WRESTLING: WHY DO WE LIKE IT?

By Tiffany Rogers

The lights go down. Everyone rises for the playing of the National Anthem. Then the excitement begins. The light goes from Old Glory to the middle of the arena. The squared circle. The ring.

Professional wrestling has been around for several years and with every new year it gets more and more popular. However, what makes this sport so popular?

"It's the electricity," said Steven Smith, a thirteen year old fan. "The arena gets so filled with tension that you could cut it with a knife."

Smith tells the truth. Whenever wrestling comes to the Oakland Coliseum, it sells out in a matter of weeks.

As of late, there has been a lot to be excited about. What with everything that's happened in the past few weeks alone fans should feel that they are getting their money's worth.

However, this is not always the case. "Sometimes it's pretty boring," says Vicky Patrickson who attends every many wrestling matches. "Sometimes you think 'I paid 20 dollars for this?' But the majority of the time it's really worth it."

Who, however, is the greatest wrestler to watch? Of all the people interviewed, everyone agreed that the greatest wrestler today is Hulk Hogan. Why? "He brings the excitement with him wherever he goes," Smith said.



WWF Magazine
Hulk Hogan: Everyone's
favorite.

And millions of "Hulkamaniacs," as they are so called, agree. "If Hogan were to jump off of the Empire State building, 20 million people would either follow him or they'd still love him, I among them," Smith said.

So now we know. We know what it is that makes wrestling enjoyable. The next main event at the Coliseum is March 15. It will be a match involving three legends and one youth breaking into the sport. So, I hope to see you at ringside.



Art by Thao Vu

MY FIRST LOVE

By Tiffany Rogers

It was the ninth grade, for them, the last year of junior high school. Stephanie had been going to Jefferson junior high for three years. She was a member of the band, which is where she first saw him. She looked up and she saw a face. It was a new face, one she had never seen before. He was with John, the class clown, which brought her to the conclusion that he was a clown too. So she decided to ignore him and he'd leave her alone.

Her plan worked for awhile. She ignored him and he never spoke to her. Until one day when she became a member of his Algebra class. Unavoidably, she ended up sitting in a group with him. She tried to ignore him but they had to talk. It was inevitable.

"Hi," came an unfamiliar, yet friendly voice. "We haven't actually met yet. I'm Joey." "Hello Joey," said Stephanie. "I'm..." "...Stephanie," interrupted Joey. "I know you from music class." Stephanie was in complete shock. She could not believe he had been paying that much attention to her. They started talking and they found that they had a lot in common. Much more than she had expected. She knew that she had found a new, good friend in this stranger who suddenly was a part of her life.

After a few months they really started to

get to know each other. She started to like him a little, but she put that behind her. She thought she had been in love before, but it hurt. It was a feeling she never wanted to feel again. So she decided that a friendship with him would be best and she left it alone. Then she heard about a dance that was coming up. She wanted to ask him so badly but around boys, she was very shy. So, once again, she left it alone.

After a few more weeks she heard some terrible news. Joey was moving to Indiana. Stephanie realized at that moment that she really did love him. But she couldn't tell him. Three more weeks passed and she still couldn't tell him. He left that night. That was the night Stephanie wrote this letter:

Dear Joey,

I don't quite know what to say or how to say it. I'll try to make this as simple as possible. I love you. But it's time for me to start a new life. You and I were never meant to be, and I want my new life to be one with you as only a friend. Please never stop being my friend. Whatever you do, please remember me. I'll always remember you as my first true love.

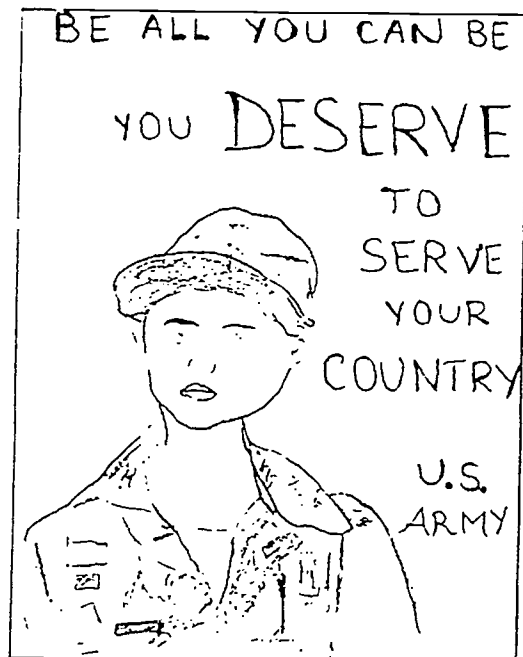

Student Checklist

Magazine Project Specifications

This is a team project for four students. Produce a four-page (8 sides) magazine in one month (set a specific date and time as a deadline). The requirements are:

The team shall consist of:

- Editor-in-Chief: responsible for seeing that everyone understands the instructions, make sure all members participate, that all members get the help they need, and the magazine is completed on time. Checks copy for spelling, grammar and correct style.
- Design Editor: studies professional magazines for models, mocks-up a 2-page model for staff, responsible for design and typography consistency, suggesting layouts to fit stories.
- Managing Editor: responsible for keeping track of all stories, art, photos that go into the magazine, checking with reporters to make sure they make their deadlines, checking final copy against specs to insure everything required is in.
- Production Editor: responsible for seeing that all copy, headlines, captions are typed onto disks, assembling all elements into final product, making sure correct art and copy are on right pages, editing headlines and captions.

Required Elements:

- 1 cover page with nameplate (logo), teasers, folios
- folios on every page
- captions on every photo
- headlines on every story
- staff box, index/contents, optional teasers on Page 2
- Pages 3-8 shall contain, in any order you choose,
 - 1 personality profile
 - 1 consumer column or review
 - 1 advice column
 - 2 student designed ads, minimum two columns by four inches
 - 2 short stories
 - 2 general features

Rules:

- Consistent margins, internal and external
- Copy on every spread
- Bylines on every story
- Facing pages designed as a single element
- No trapped white space
- Consistent use of typography and other design elements
- One body copy typeface throughout.

Advertising Project (Sophomores and Seniors)

Courses: English II, IV, Advanced Broadcasting

Since students choose to enter the Media Academy to learn skills necessary to pursue careers in the mass media, it seemed important for them to study advertising. In fact, we had spent a brief time earlier in the year talking about commercials as part of a unit introducing radio and television.

Because students are constantly bombarded with advertisements, or "filtered truth," it is important to give them tools for understanding. Students must either learn to interpret ad messages for themselves or become part of the mass cultural "message"—the indoctrination into a world of wish fulfillment through commercial buying.

Ads tell us that the American Dream can be purchased, and that the Dream changes from day to day. When students are asked what will make them happy, they tend to produce a list of items to buy: the condo, the car, expensive cosmetics, a computer. Tomorrow's Dream makes today's obsolete. This unit was designed to equip students with some essential concepts necessary for critically viewing advertisements and determining their underlying messages.

For Teachers

Writing skills: Students were given two different methods for analyzing advertisements and completed written analyses of several ads. They also create their own advertisements, designed to communicate messages of their own choosing.

Throughout the unit students are asked to think critically, both in identifying hidden messages in commercial advertisements and in designing their own ads. In discovering the difference between carefully constructed, logical arguments (where opinions are supported by facts and other forms of evidence) and persuasive messages (communicated by propaganda techniques), students describe, analyze, evaluate and compose.

Evaluation

Peers share storyboards, watch the taping sessions, and view the final product. Feedback is personal through the passing of notes with comments for each student from each student. The teacher evaluates the work based on whether or not criteria was met, and to what degree were concepts of persuasion and propaganda

applied. There is an element of creativity involved, which is not easily justified objectively. Grading therefore is somewhat subjective.

Procedures

Lesson 1 (1-2 days)

Students were asked to apply the public speaking model (used earlier in the semester for composing a three-minute public address) to print and TV advertisements. First I asked them to choose a print ad to analyze. (I began with print ads because students could examine them for an extended period of time.) The model included:

- The attention step – how does the ad get your attention?
- The need step – how need does the ad create in the mind of the potential consumer?
- The satisfaction step – how can this need be satisfied? (By buying the product, of course.)
- The visualization step – how do they picture the product? What are the advertisers trying to make you identify with?
- Outcome step – once you own this product, what does the ad imply or suggest that you will attain? Once students got the idea from print ads, we watched television ads, repeatedly, applying this public speech model.

Lesson 2 (2 days)

Students then wrote a commercial, using the five step model. I asked them to answer the questions posed at each step before writing the ad. On the next day they shared their rough draft with a small group. They then had an opportunity rewriting their ad before submitting it for a grade.

Lesson 3

To deepen their understanding of how ads work, I had them repeat the process described in Lesson 1 above. Students identified dominant images, propaganda techniques, types of appeals, and distorting information used in the ads.

Lesson 4

For an examination on what they had learned in the unit, students analyzed 30-second commercials, identifying techniques used from the second model of analysis. I encouraged them to see the same add several times; one popular ad was viewed five times.

Lesson 5

The examinations were graded and returned. I discussed each commercial with the whole class. Students then picked one of the three ads chosen for heir examination and wrote a more extended analysis in paragraph form for homework.

Lesson 6

I gave students several days to write their own commercials outside of class. They were asked to perform their commercials, and they were also allowed to explain them to the class.

Lesson 7

Each student had a week to produce a commercial story board. They had to identify the audio content (what would be said frame by frame), the visual content (what we would see, including camera angles), and provide a drawn or cut-out picture to represent the visual image. On the back of the story board they were to write the criteria they had chosen to help design their ad, based on criteria derived from the second model of analysis, described in Lesson 3 above.

Lesson 8

Students directed some of the commercials. We had only one camera, no external mike, and the sound quality was very poor, because people kept knocking on the doors to get into the room. However, the students were very excited about the assignment.

Teachers who want to tape anything will find some students are at first reluctant to be taped, but quickly become hams, eager to see themselves on television. It doesn't take any special expertise to have the lesson be productive. Students can learn a lot just by hearing and seeing themselves.

Examples of Student Work

Storyboard: Barbie and Her Products

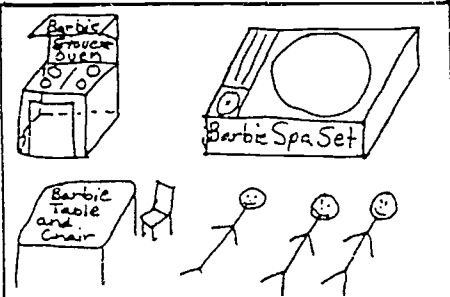
1) 
 This panel shows two product boxes at the top: 'Barbie Tropical Spa Set' and 'Barbie Spa Set'. Below them is a table labeled 'Barbie Table and Chair' with a chair. Three stick figures are standing to the right.

Video: Establishing Shot, slow zoom to next shot.

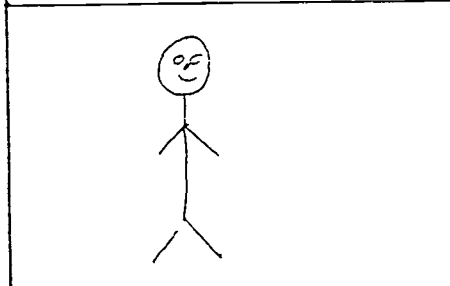
3) 
 This panel shows a single stick figure with a smiling face.

Video: Still Long Shot of Barbie #1.
Audio: Kiesha- I got a Tropical Barbie,

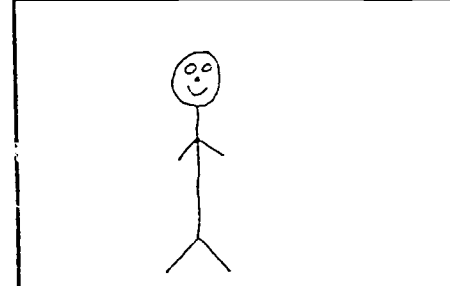
5) 
 This panel shows a single stick figure with a smiling face.

Video: Still Long Shot of Barbie #3.
Audio: Kiesha- And Shamiel Barbie.

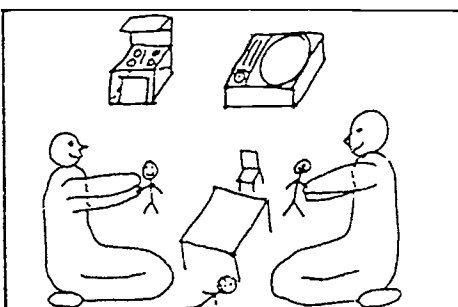
2) 
 This panel shows two figures kneeling on the floor, playing with Barbies. Product boxes are visible in the background.

Video: Long Shot of Kiesha and Janell playing with the Barbies.
Audio: Kiesha- Lookit what my mommie got me for Christmas. (Talking to Janell.)

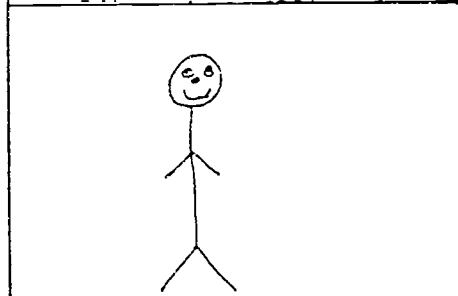
4) 
 This panel shows a single stick figure with a smiling face.

Video: Still Shot of Barbie #2.
Audio: Kiesha- Vanessa Barbie,

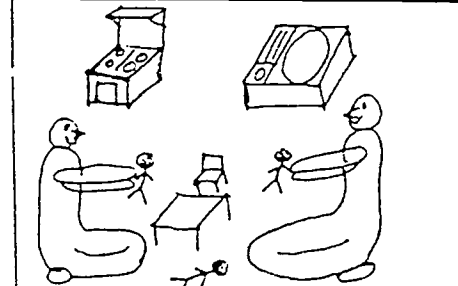
6) 
 This panel shows two figures kneeling on the floor, playing with Barbies. Product boxes are visible in the background.

Video: Long Shot of Janell and Kiesha.
Audio: Janell- Lookit what my mommie got me for Christmas. (Looking at Kiesha.)

7)

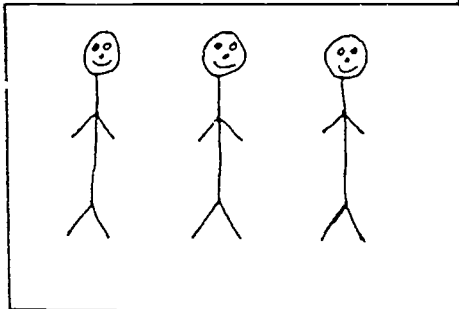

Video: Still Long Shot of all the Barbies.
 Audio: Janell- I got these three dresses made by Oscar DelaRenta from my mommie.

9)

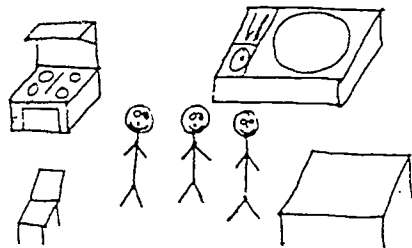

Video: Still Long Shot of all three of the Barbies with Barbie toys around them.
 Audio: Narrator- A barbie for your little girl would be just what she wants for Christmas.

8)

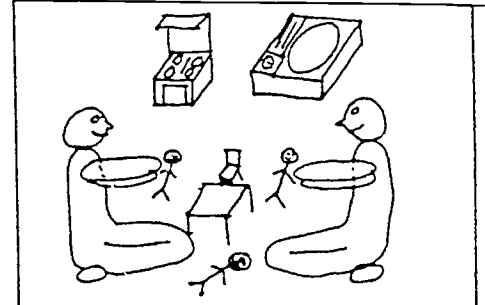

Video: Long Shot of Janell and Kiesha holding the dolls.
 Audio: Kiesha- Come on go get your Barbies and play with us. (Kiesha says to the viewers looking into the camera.)

Slogan: A Barbie for your little girl would be just what she wants for Christmas.

Attentions: Barbie products being played with by Janell and Kiesha.

Need: To be like everyone else. To have more friends and fun. (The bandwagon.)

Satisfaction: Happiness, fun and more friends.

Visualization: Be like the people in the commercial: happy, with what they wanted for Christmas.

Outcome: happiness, fun and more friends. To be like the girls in the commercial, or like everyone else.

Appeals: Bandwagon, youth and plain people.

Claims: To become like everyone else: happy, having more fun, getting more friends, and getting what you want for Christmas. What's better than your friends. Presents.

Storyboard: All-Purpus Cleaner

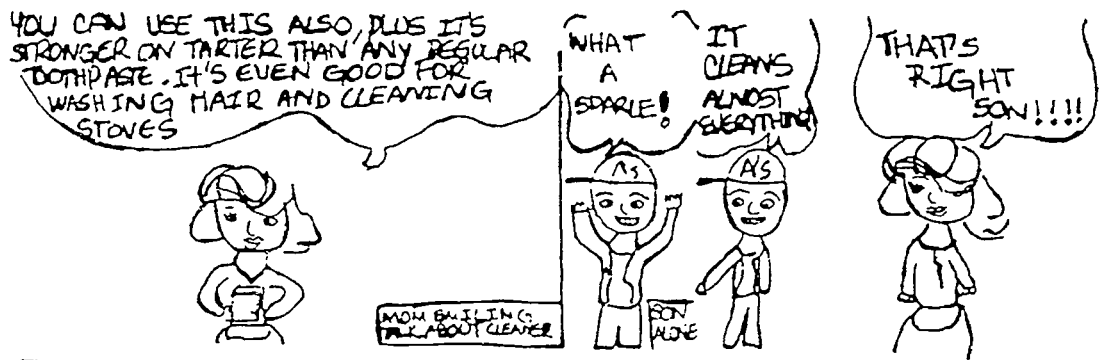
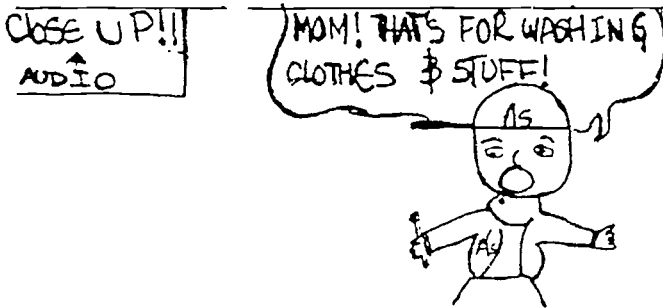

SHOW PICTURE OF PRODUCT **JINGLE**



The Cleaner That Cleans Almost Anything

PRE-ENGINEERING ACADEMY
Oakland Technical High School

Engineering Graphics	78
Descriptive Geometry	79
Sample Problem A: Icosahedron Geodesic	81
Physics I (HP) Physics Mechanics	88
Area I: Two-Dimensional Statics	89
Sample Problem A: 2-D Statics	89
Sample Problem B: 2-D Statics	92
Area II: Calculus for Physics	95
Sample Problem C: Variable Acceleration	96
Sample Problem D: Freely Falling Bodies	98
Sample Problem E: Motion of Projectiles	100
Area III: Fluid Statics	103
Sample Problem F: Force on Submerged Surface	105
Sample Problem G: Center of Pressure	109
Physics II (AP) Advanced Mechanics	111
Area I: Three-Dimensional Statics	111
Sample Problem A: 3-D Statics	111
Area II: Mass Moment of Inertia	117
Sample Problem B: Acceleration of a System of Bodies	125
Sample Problem C: Dynamic Equilibrium of Rotating Bodies	127
Physics III (HP) Strength of Materials	131
Sample Problem A: Beam Design	131

PRE-ENGINEERING ACADEMY

Carl Hertenstein, Physics Teacher

The primary objective of the pre-engineering program is to improve the preparation of our students in physics and mathematics. This is accomplished through an integrated curriculum. Instruction is provided in five core engineering areas: Descriptive Geometry, Statics, Dynamics, Physics Mechanics, and Strength of Materials.

A course in science is often regarded by students as difficult and uninteresting. The difficulty stems from the extent to which reasoning from fundamentals, as distinguished from rote learning, is required. This attitude is traceable to the frequent tendency in the presentation to use problems mainly as a vehicle to illustrate theory rather than to develop theory for the purpose of solving problems. The lack of interest that is frequently experienced is due primarily to science being presented as an academic discipline lacking any evident real-life purpose.

During the past twenty years, there has been a strong trend in math and science education to increase the extent and level of theory. However, a significant disparity has appeared between coverage and comprehension. This may be attributable to diminished emphasis on the physical and geometrical meaning of mathematics along with a significant reduction and elimination of instruction in graphics which in the past served to enhance the visualization and representation of math and physics problems. In the mathematical treatment of physics problems there has been a tendency to allow the manipulation of formulas to mask or replace geometric visualization. Physics is inherently a subject which depends on geometric and physical perception, and we should increase our efforts to develop this ability.

The department structure employed in most high schools has fostered a separatist view of curriculum delivery. Students may observe some curricular interrelationships; however, no recognizable effort has been made to integrate closely related subjects. The inability of the present school structure to adopt an integrated approach has resulted in a student population that views its education as a series of disconnected hourly events. The problem is exacerbated by the practice

of exposing students to a broad survey of disciplines and endless sets of skills and competencies. The academic agenda includes a wide variety of topics; to cover them all, students are allowed time to develop only the most superficial understanding. Students learn most material in order to use it on one or two brief occasions, after which the material is quickly forgotten. Under this system, students are denied opportunities to develop their intellect fully. Instead of superficial exposure, curricula should emphasize sustained study aimed at developing complex understanding.

The Pre-Engineering program (see Table 1) is therefore based on the following principles:

- decide on what is essential and proceed to provide a sequence of courses designed to provide depth of coverage.
- Integrate the curriculum horizontally and vertically.
- Give real life purpose by relating the theme of the program to an occupation.
- Strive to reach the level of performance necessary for college level proficiency.
- Set entrance standards and institute a flexible program of ability grouping.

Progression through the curriculum is not bound to the student's grade level. The core program includes Descriptive Geometry and Advanced Algebra & Trigonometry at the entry level, Physics I (HP) and Pre-Calculus at the next level of study, with most students completing Physics II (AP) and Calculus (AB) in the 12th grade.

The sample problems presented are not intended to convey method although detailed solutions are provided, but rather to give a feel for the curriculum flow within the pre-engineering program. The problems represent windows through which the reader can view the curriculum at various stages of progression. These windows of information demonstrate an integrated curricula approach involving skills developed in at least two areas of study.

Table 1
Program Sequence

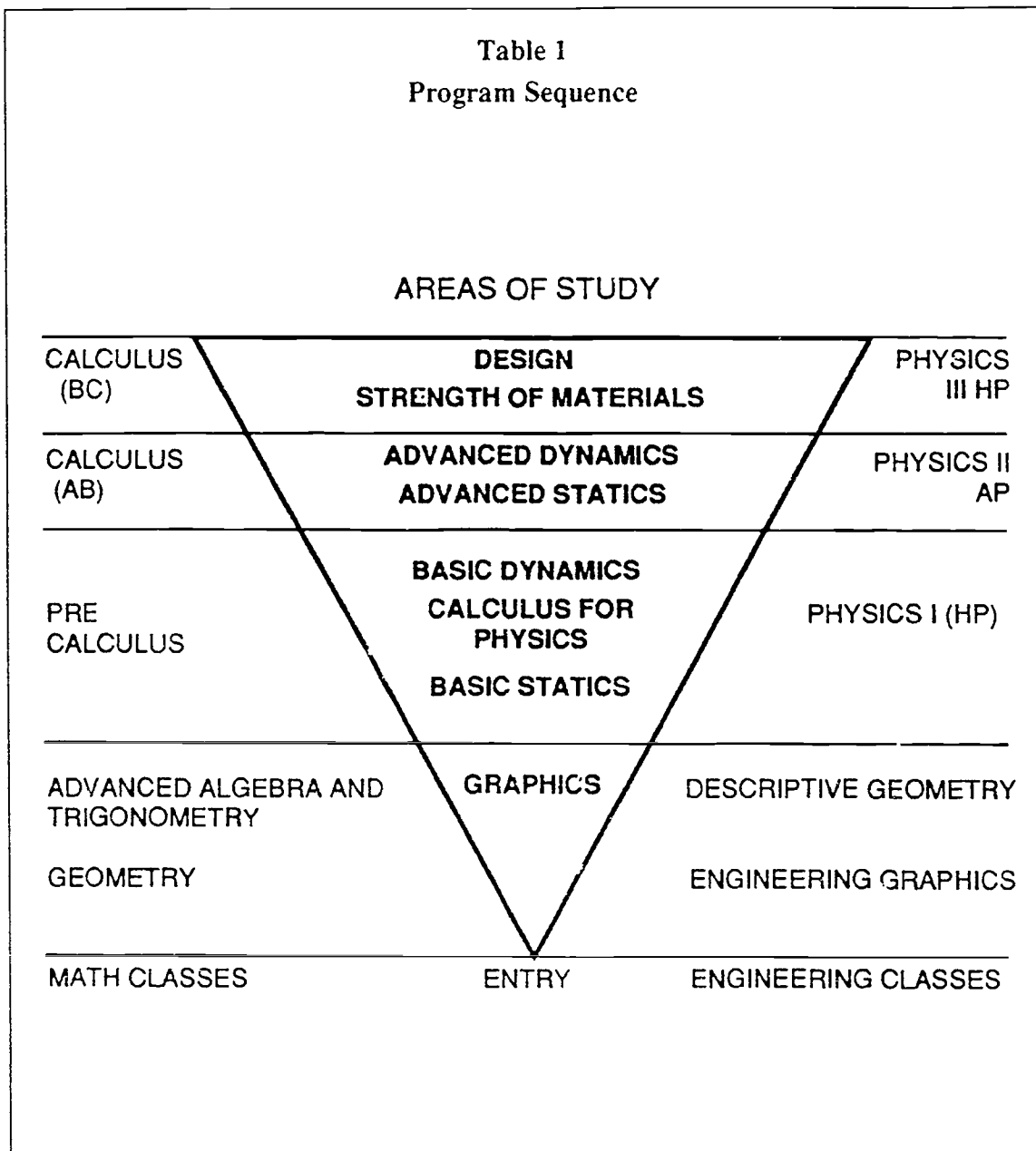

The representative problem treating spherical geodesics offers a view of the Descriptive Geometry (entry) course. Three topics from Physics I (HP) are then presented: 2-dimensional statics, calculus for physics, and fluid statics. The 3-dimensional statics and mass moment of inertia problems are from Physics II (AP). A single view of Physics III (HP) treats problems relating to beam design.

Engineering Graphics

The major purpose of the Pre-Engineering Program's graphic sequence is for students to develop accurate visualization skills. This is recognized as an imperative skill for careers in engineering, mathematics, science, and architecture. Students begin with a course in Engineering Graphics and then progress to Descriptive Geometry. Topics to be mastered in Engineering Graphics include: multiview and isometric projection, dimensioning, oblique projection, primary and successive auxiliary views, sectional views, revolution, surface development, and perspective drawing.

Students learn Engineering Graphics by using three different drafting techniques. First, traditional freehand sketching, for developing ideas quickly. Second, traditional technical drawing, for developing the drafting skills of neatness and accuracy, and to produce a finished drawing which is technically and dimensionally correct. This type of drawing can be extremely time-consuming. Third, technical sketching to produce a mechanical drawing quickly. These drawings are neat and clean, but do not require perfect intersections of lines nor precise measurements. They are to be drawn proportionately correct by eye rather than by ruler. Students will graphically display their knowledge of these three drafting methods by using traditional mechanical drawings and computer-aided design (CAD) throughout the course.

After reviewing the graphics throughout the pre-engineering section of this book, it will be clear that students attain high level visualization and graphic design skills in this program. The basis of these skills begins in the Engineering Graphics and Descriptive Geometry courses and continues to evolve in the advanced physics courses as students use these skills to solve problems. All of the figures in this section were created on a computer by a pre-engineering student. The mechanical drawings were also prepared by students as solutions to sample problems at various points in the pre-engineering curriculum.

Descriptive Geometry

From a historical perspective, descriptive geometry was invented to perform calculations more efficiently. The main purpose of presenting descriptive geometry in the pre-engineering program is to develop within our students the ability to visualize and model mathematical and physical concepts (Table 2). The correct understanding of these concepts can be more effectively presented when given a graphical interpretation. The introduction of certain mathematical concepts should be preceded by a graphic analogy. For example, the fundamental calculus processes of integration and differentiation have clear geometric interpretations. By applying these methods of graphic calculus, the students are able to construct physical representations that model abstract theories.

Table 2
DESCRIPTIVE GEOMETRY Course Outline

Orthographic Projection
Primary Auxiliary Views
Lines
Planes
Successive Auxiliary Views
Piercing Points
Intersections of Planes
Angle Between Planes
Parallelism
Perpendicularity
Angle Between Line and Oblique Plane
Revolution
Concurrent Vectors
Intersections of Planes and Solids
Developments
Intersections of Surfaces
Conics
Spherical Triangles
Solid Analytical Geometry and Vectors
Graphical Calculus

Descriptive geometry is analogous to solid analytic geometry. This natural relationship indicates that the most effective teaching of solid analytic geometry will result when graphical and mathematical methods are employed. When dual graphic and mathematical solutions are performed, students develop a clear understanding of concepts and methods. For example, operations in vector algebra have algebraic, geometrical, and physical interpretations. The application of vector algebra to the

solution of physics problems combined with graphical and mathematical methods of analysis fosters an ability to fully understand interrelationships between different disciplines. Identification of natural interdisciplinary relationships has led to the development of an integrated curriculum within the pre-engineering program.

The graphic solution is accomplished through the application of the principles of descriptive geometry. Descriptive geometry may best be described as a graphic method that allows the observer to view an object from any desired direction. This is achieved by the construction of a series of related views until the desired viewing direction is obtained.

The plane onto which the object is projected is between the object and the viewer. Respective adjacent viewing planes are mutually perpendicular. They are unfolded so that they may be represented on a two-dimensional drawing surface. The difficulty is that the viewer must be able to visualize the two-dimensional representation in three-dimensional form. This requires students to develop the ability to visualize. The development of this skill addresses one of the concerns listed in the introductory statement.

Three-dimensional geometry problems require a visualization and accurate representation of the relationship between various elements prior to an analytical solution. Consider the following written description and the prospect of a successful mathematical solution without a graphic representation.

A geodesic is formed by the projection of icosahedron grid points onto an encompassing spherical surface. The connection of the spherical points will form a geodesic surface. The vertices of the icosahedron must coincide with the encompassing spherical surface. The grid on each icosahedron face is formed by dividing each edge into equal parts and connecting each division point to an adjacent point. Find the length of each geodesic chord when the radius of the sphere is unity.

Without a graphical representation, the problem cannot be solved. When, by the methods of descriptive geometry, the true spatial relations of all points in the problem are correctly visualized, the solution becomes possible as follows

Sample Problem A: Icosahedron Geodesic

An icosahedron is a regular polygon consisting of twenty equilateral triangular faces. The symmetry of this polygon allows circumscription of concentric spheres so that the vertices of the icosahedron will coincide with the surface.

The process of creating a spherical geodesic starts with the division of the icosahedron face edges into equal parts. The edge division points are connected to form a triangular grid on the icosahedron face. The spherical geodesic grid is formed by projecting from the spherical center the facial grid points onto the encompassing spherical surface. The spherical points are then connected to form the geodesic polyhedron. The chord lengths when the sphere radius is unity can be calculated graphically or mathematically. Students are asked to perform both solutions. Points on the triangle are denoted by the subscript Δ , points on the sphere by subscript s (Figure 1).

Figure 1
Icosahedron Geodesic

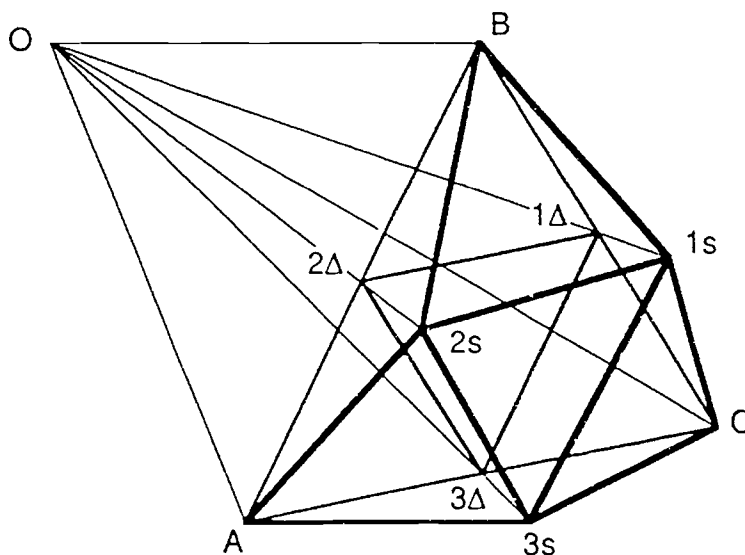

Graphic Solution

The angle formed by the icosahedron edge and endpoint projections to the spherical center is the central angle. This angle for an icosahedron is $63^{\circ} 27'$.

The graphic solution is accomplished through a sequence of steps. The first step is to represent two adjacent perpendicular views of an icosahedron face. The icosahedron face vertices will form the vertices of a spherical triangle. The sides of this spherical triangle are equal to the central angle for an icosahedron.

To lay out the adjacent views of the icosahedron triangle draw the front and top views of any conveniently sized sphere. Lay out the sides of the spherical triangle in the front view (Figure 2). With line OB as an axis, face BOA is assumed revolved into the same frontal plane. About side OC as an axis, face COA is revolved into this same frontal plane. The spherical triangle is unfolded into the frontal plane. By considering the spherical pyramid unfolded into the frontal plane, the three sides may be accurately measured with a protractor. The front view at this

Figure 2
Icosahedron Geodesic

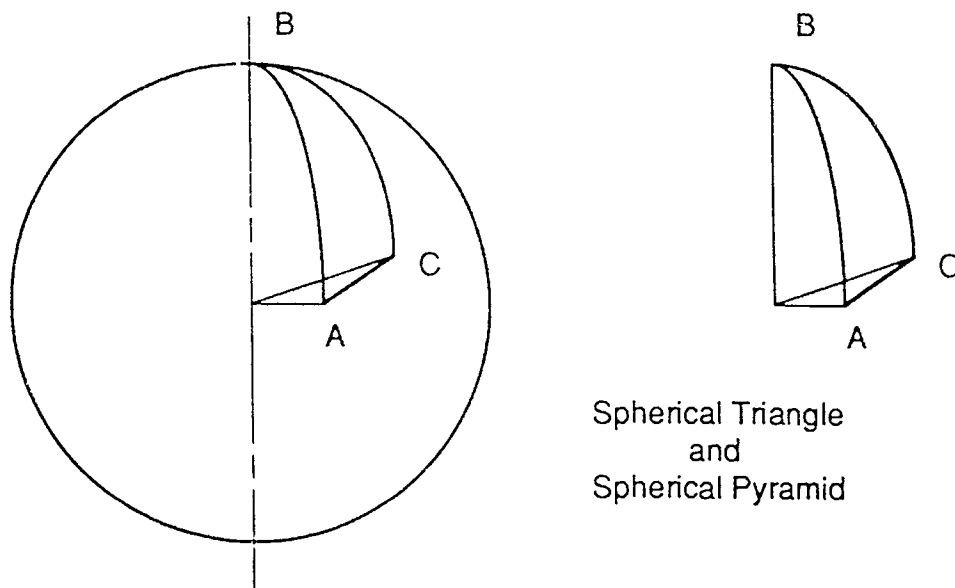

stage is thus a development of the faces of the spherical pyramid. To complete the views of the actual pyramid, only point A needs to be located. The front view of A is secured by counterrevolution about the true-length axes of revolution OB and OC. These paths of revolution, which appear perpendicular to the true axes, intersect to locate A. The path of revolution about the vertical axis OB appears as a true arc in the top view. The intersection of this arc with a projector from A in the front view locates A in the top view.

The edges of the icosahedron face are divided into two equal parts. This is only possible in the true shape views of the spherical pyramid faces AOC, COB, and BOA (Figure 3). Face COB is true shape in the front view. Face BOA is shown as an edge view in the top view. Its true shape may be found by constructing an auxiliary view with a line of sight perpendicular to the edge view. Face AOC

Figure 3

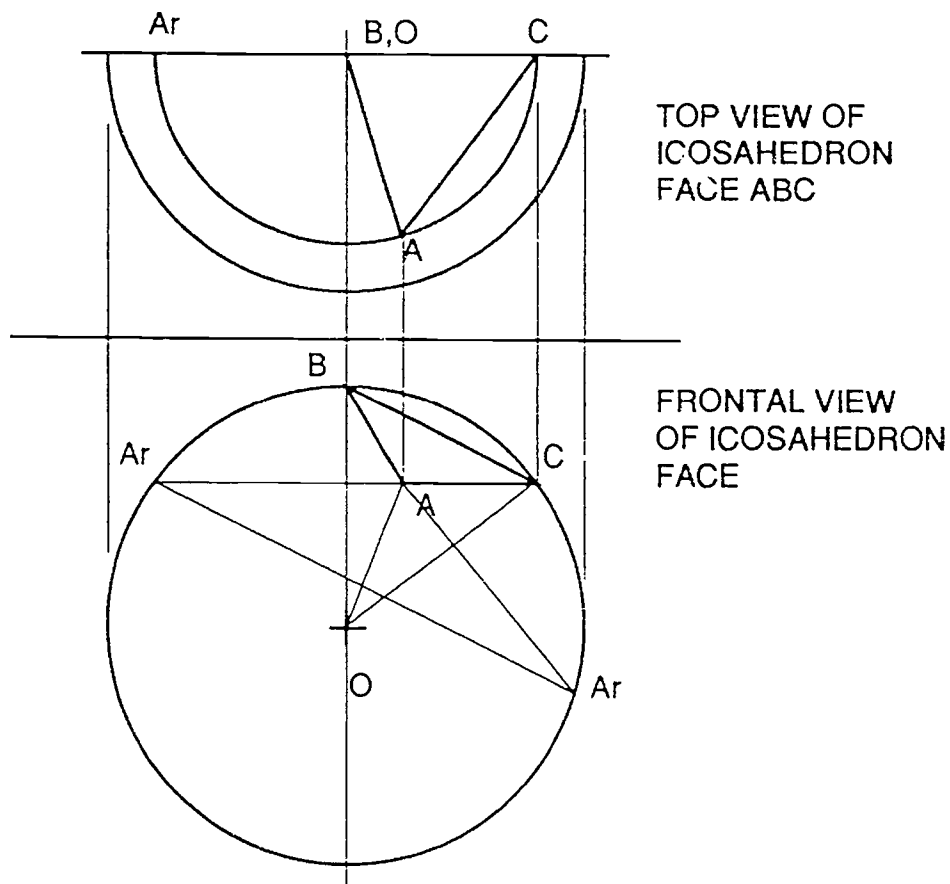

contains true length line AC which may be viewed as a point. This point view will result in an edge view of face AOC. The true shape is then easily found. A spherical great circle arc is drawn in each true shape view. The midpoint of each icosahedron edge is projected onto the spherical arc. The projection of all midpoints and spherical points into the primary views will allow the representation of the geodesic surfaces.

This geodesic grid results in two different chord lengths. The central angle corresponding to chord A is found in each spherical pyramid true shape. The spherical connection of the midpoint projections yields chord B. The true shape of the triangular face containing chord B and endpoint projection lines to the spherical center must be found. The central angle for chords A and B are measured in the true shape views. Using the measured central angles and the half-angle formula $2(\sin CA/s)$ the chord factors are "graphically" calculated. See Figures 4 and 5.

Mathematical Solution

The mathematical solution relies on an interesting relationship between icosahedron symmetry and the divine proportion. The divine proportion, or 1.6180339... is the relationship between the diagonal of a regular pentagon and its edge. When three rectangles whose side length s are in divine proportion and placed in the x-y, x-z, and y-z planes of a three dimensional rectangular coordinate system so the center of each rectangle is at the origin, an icosahedron can be formed by connecting rectangle vertices. See Figure 6.

This system allows the calculation of the coordinates of the vertices of an icosahedron face. The coordinates are adjusted to correspond to a spherical radius of unity by proportion. The midpoint formula may then be used to find the coordinates of the center point of each icosahedron edge. Using the distance formula the distance from the origin to the midpoint can be found. The coordinates of the spherically projected midpoints may be found by proportion. The distance formula is used to find the desired chord length. Since the sphere radius is unity these chord lengths are the chord factors.

From the given ratios, we can calculate the proportional locations of the three vertices A, B and C. *Point = (x, y, z)*

Figure 4
 Icosahedron Geodesic
 Graphical Solution

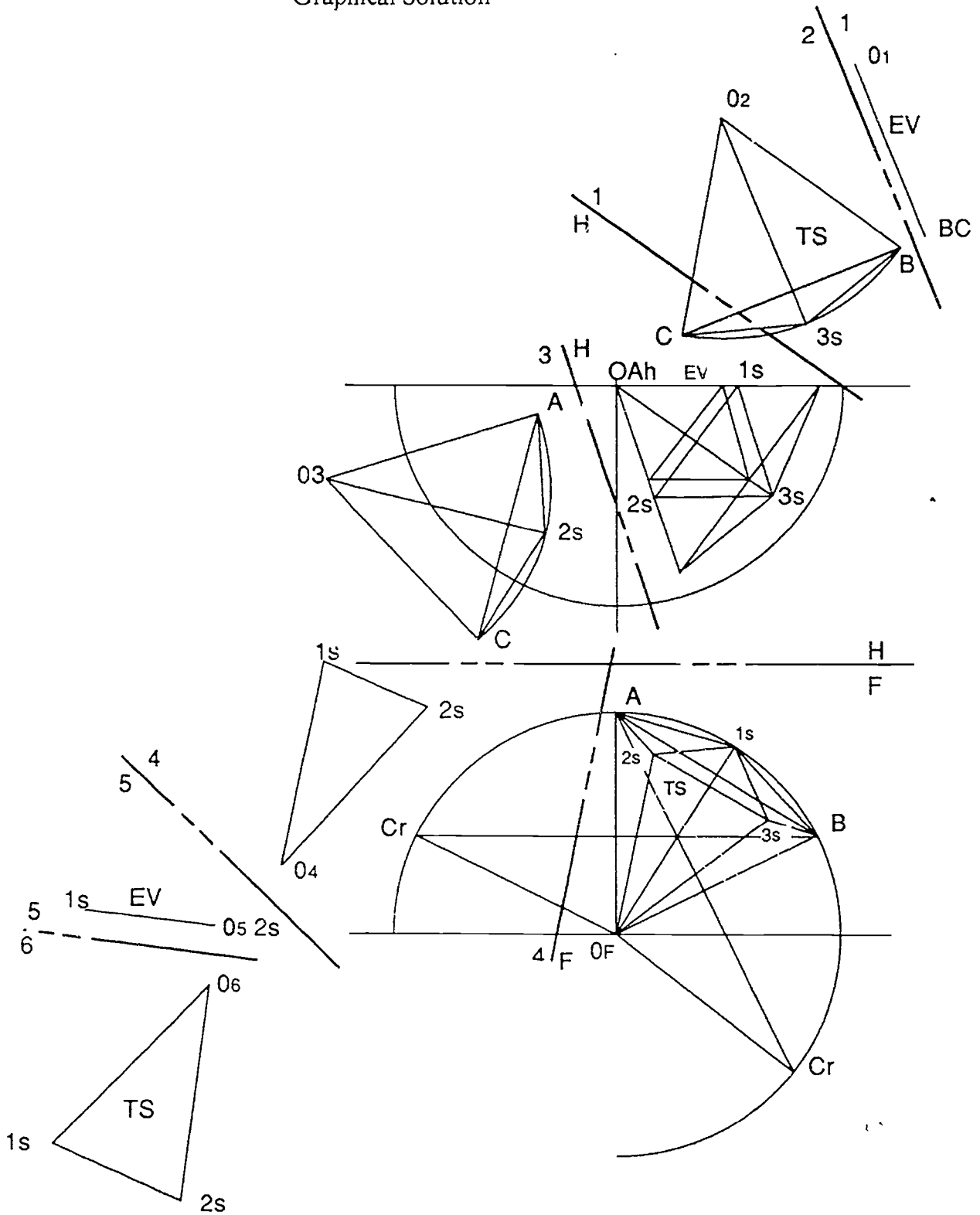

Figure 5
Icosahedron Geodesic

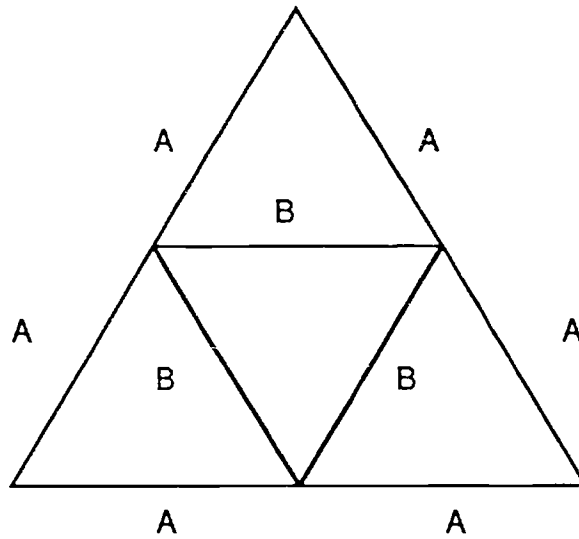
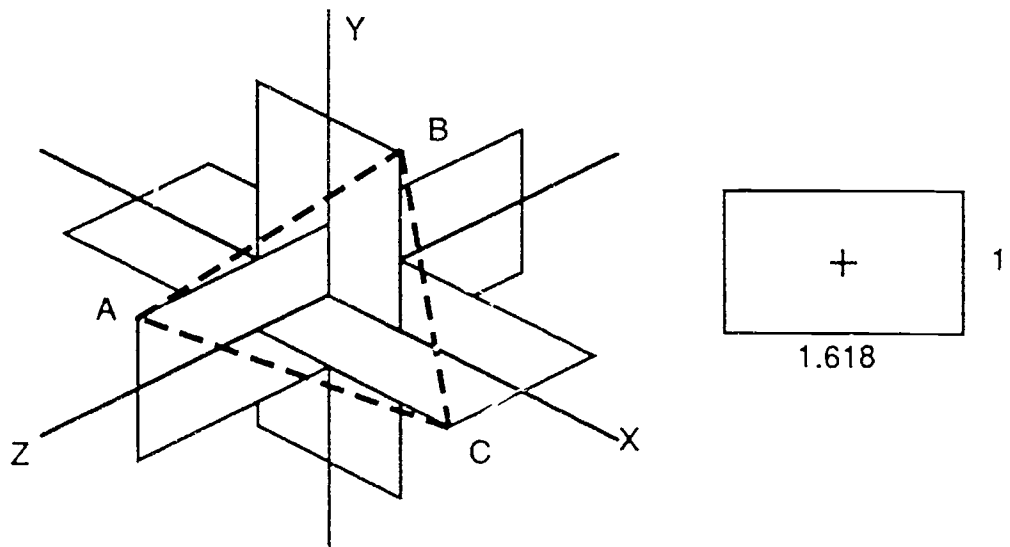

Figure 6
Icosahedron Geodesic



$$A = (0, 0.809, 0.5)$$

$$B = (0.809, 0.5, 0)$$

$$C = (0.5, 0, 0.809)$$

The lengths of OA, OB and OC are then $(0.809^2 + 0.5^2 + 0) = 0.951$

Because we want points A, B, and C to be on the spherical surface, we then multiply the components of vectors OA, OB and OC by the inverse of their length to give them unit length. The new points of the off-origin endpoint are denoted by " ' ".

$$1/0.951 = 1.052$$

$$A' = (0 \times 1.052, 0.809 \times 1.052, 0.5 \times 1.052) = (0, 0.851, 0.526)$$

$$B' = (0.809 \times 1.052, 0.5 \times 1.052, 0 \times 1.052) = (0.851, 0.526, 0)$$

$$C' = (0.5 \times 1.052, 0 \times 1.052, 0.809 \times 1.052) = (0.526, 0, 0.851)$$

We use the midpoint formula to determine the location of the points on the inset triangle, denoted by Δ_1 , Δ_2 , Δ_3

$$\Delta_1 = (0.425, 0.688, 0.263)$$

$$\Delta_2 = (0.263, 0.425, 0.688)$$

$$\Delta_3 = (0.688, 0.263, 0.425)$$

We find the lengths of vectors from the origin to these three points using the distance formula, and repeat the above process to unitize their lengths. This will give us the location of the midpoints projected onto the spheres, denoted by Δ_{1S} , Δ_{2S} , Δ_{3S}

Lengths of Δ_1 , Δ_2 , Δ_3 are $(0.425^2 + 0.688^2 + 0.263^2)^{1/2} = 0.851$

$$1/(0.851) = 1.174$$

$$\Delta_{1S} = (0.425 \times 1.174, 0.688 \times 1.174, 0.263 \times 1.174) = (0.499, 0.809, 0.309)$$

$$\Delta_{2S} = (0.263 \times 1.174, 0.425 \times 1.174, 0.688 \times 1.174) = (0.309, 0.499, 0.809)$$

$$\Delta_{3S} = (0.688 \times 1.174, 0.263 \times 1.174, 0.425 \times 1.174) = (0.809, 0.309, 0.499)$$

To check that they are on the sphere, we check the lengths of $O\Delta_{1S}$, $O\Delta_{2S}$, $O\Delta_{3S}$; they are $(0.809^2 + 0.309^2 + 0.499^2)^{1/2} = 1.000$

We then use the distance formula to determine the lengths of the chords A and B.

Length of chord A is given by the distance from A' to Δ_{3S} ,

$$A = [(0 - 0.499)^2 + (0.851 - 0.809)^2 + (0.526 - 0.309)^2]^{1/2} = .547 \text{ ans.}$$

Length of chord B is given by the distance from Δ_{2S} to Δ_{1S} ,

$$B = [(0.309 - 0.499)^2 + (0.499 - 0.809)^2 + (0.809 - 0.309)^2]^{1/2} = .545 \text{ ans.}$$

Physics 1 (HP) Physics Mechanics

The subject of mechanics is logically divided into two parts: statics which concerns the equilibrium of bodies under the action of forces, and dynamics, which concerns the motion of bodies. Dynamics in turn includes kinematics, which is the study of the motion of bodies without reference to the forces that cause motion, and kinetics, which relates the forces and the resulting motions (Table 3).

Table 3
PHYSICS I (HP) Course Outline

Statics (First Semester)

- Basic Principles of Statics
- Coplanar, Parallel Force Systems
- Coplanar Concurrent Force Systems
- Coplanar Nonconcurrent Force Systems
- Noncoplanar Parallel Force Systems
- Noncoplanar, Concurrent Force Systems
- Noncoplanar, Nonconcurrent Force Systems
- Friction
- Centroids and Centers of Gravity
- Moments of Inertia of Areas
- Basic Calculus for Physics

Dynamics (Second Semester)

- Basics
- Kinematics of Rectilinear Motion
- Kinetics of Rectilinear Motion
- Curvilinear Motion
- Kinematics of Rotation
- Kinetics of Rotation
- Plane Motion
- Work, Energy, and Power
- Impulse, Momentum, and Impact
- Dynamics Methods Review

The purpose of the study of mechanics is to be able to predict through calculation the behavior of bodies and systems of connected bodies involving force and motion. Successful prediction requires the careful formulation of solutions with the aid of a dual thought process of physical understanding and mathematical reasoning. This involves the process of constructing a mathematical model which incorporates approximate physical assumptions and mathematical approximations and approaches the actual situation. This process of matching a symbolic model physical reality is one of the most valuable experiences of mechanics study.

Success in analysis depends to a surprisingly large degree on a well-disciplined method of attack from hypothesis to conclusion where a clear path of rigorous application of principles has been followed. Students are urged to develop an ability to represent their work in a clear, logical, and neat manner. The basic training in mechanics is an excellent place for early development of this disciplined approach which is so necessary in the study of mathematics and science.

The principles of mechanics are few and relatively simple. The applications however are infinite in their number and variety, and frequently appear to be formidably complicated. Students should be encouraged to grasp mechanics not as a series of formulas and manipulative operations, but rather as a well-coordinated mechanism for stripping problems of their extraneous confusing aspects. This outlook will allow students to break problems down into relatively simple, easily analyzed elements.

What follows are examples of three topic areas addressed during the course: two-dimensional statics (2 problems), calculus for physics (3 problems), and fluid statics (2 problems).

Area I: Two-Dimensional Statics

Two-dimensional statics is presented during the first semester of Physics I (HP). The objective is to introduce basic vector operation and relate the application of these fundamental concepts to the fundamentals of statics. The mathematics used at this level is limited to algebra, geometry, and trigonometry. Two dimensional graphics methods are introduced concurrently with mathematical methods to foster the ability to develop geometric and physical perception. The final objective is to develop a disciplined approach to the solution of mechanics problems.

Sample Problem A: 2-D Statics

Given: The two-member frame in Figure 7 consists of weightless members joined by pin connections. It is subject to the forces as located in the figure.

Figure 7
2-Dimensional Statics

Free Body Diagram

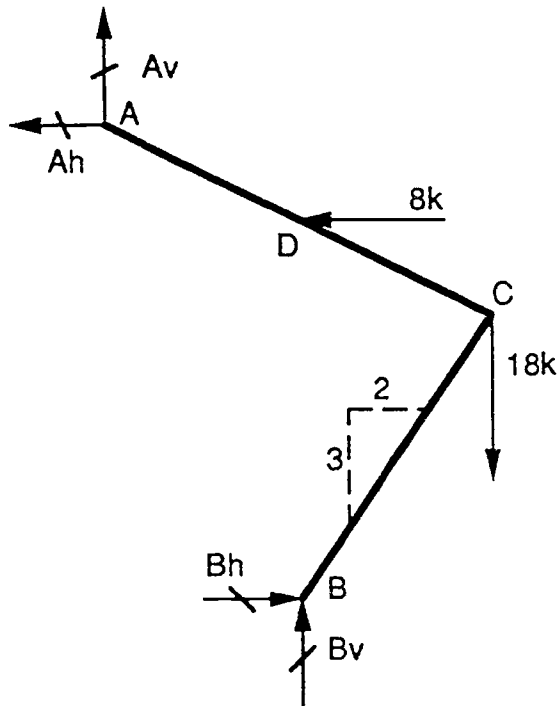

Space Diagram

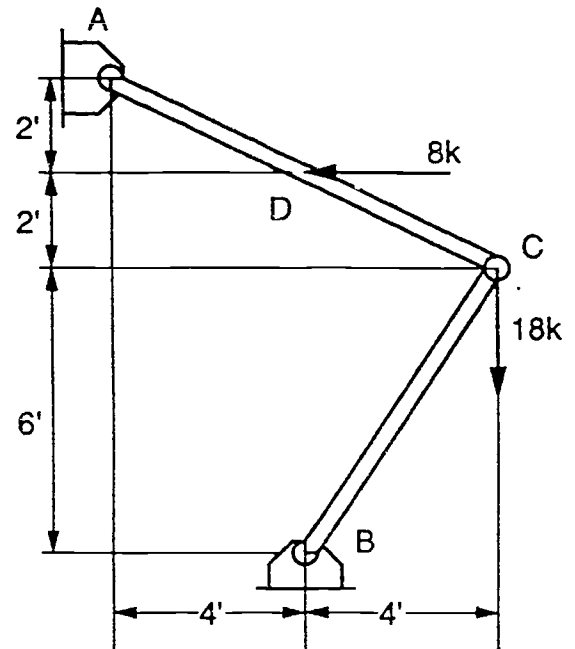

Find: The vertical and horizontal reaction components at supports A and B of the frame.

Solution: the two supports are removed and are replaced by the vertical and horizontal components of the support reactions. We shall assume their directions to be as indicated. Because as a three force member, no known relationship exists between the components A_v and A_h . Member BC, however is a two-force member with a slope of 3 vertical and 2 horizontal. Therefore $B_v/3 = B_h/2$, from which $B_v = 3/2 B_h$. We now solve for B_h by taking moments about "A." If we assume that the reaction at B acts against point B, both of its components B_h and B_v will act against B. Then:

$$\begin{aligned}
 [\Sigma M_A = 0] \quad 10B_H + 4(3/2 B_H) &= (8)(2) + (18)(8) \text{ or} \\
 10B_H + 6B_H &= 16 + 144 \text{ and} \\
 B_H &= 10 \text{ kips} =
 \end{aligned}$$

10

Hence

$$BV = 3/2 BH = 15 \text{ kips } \uparrow$$

The positive sign of BH indicates a correct assumption as to its direction. The reaction components at "A" are now found by the force equilibrium equations. That is:

$$[\Sigma_v=0] A_v + 15 = 18 \text{ and } A_v = 3 \text{ kips } \uparrow$$

$$[\Sigma_H=0] A_H + 8 = 10 \text{ and } A_H = 2 \text{ kips } \leftarrow$$

The values obtained should be checked by a moment equation in which is included all of the computed forces.

Figure 8
2-Dimensional Statics

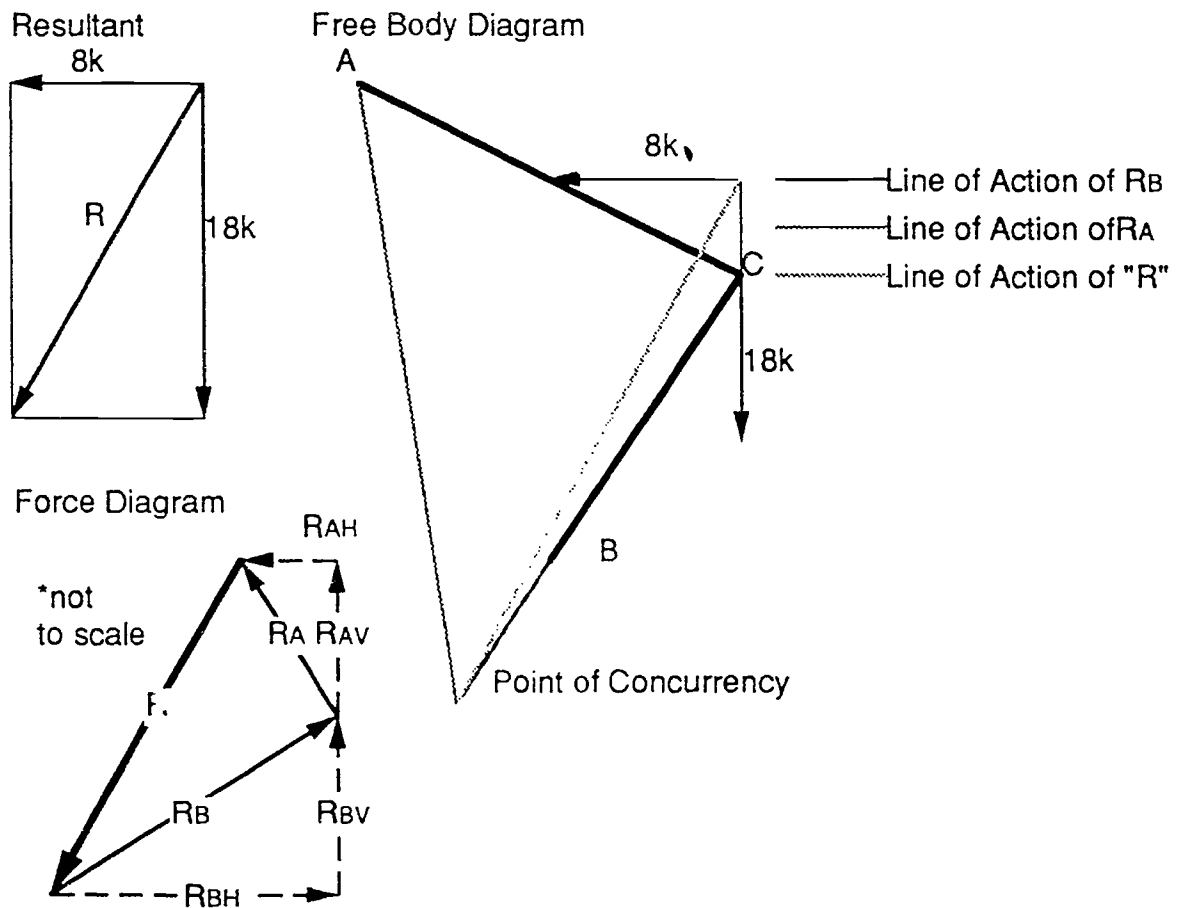

$$[\Sigma M_A = 0] \quad (18)(4) - (10)(8) - (2)(2) + (3)(4) = 0$$

$$0 = 0$$

This problem is easily checked graphically if the two known forces are combined into their resultant. The line of Action of R_A may then be found by the three force principle and R_A , R_B by a simple force diagram (Figure 8).

Sample Problem B: 2-D Statics

Given: The two-member frame in Figure 9 consists of weightless members joined by pin connections. It is subject to the forces as located in the figure.

Find: The vertical and horizontal reaction components at supports A and B of the frame.

Figure 9
2-Dimensional Statics

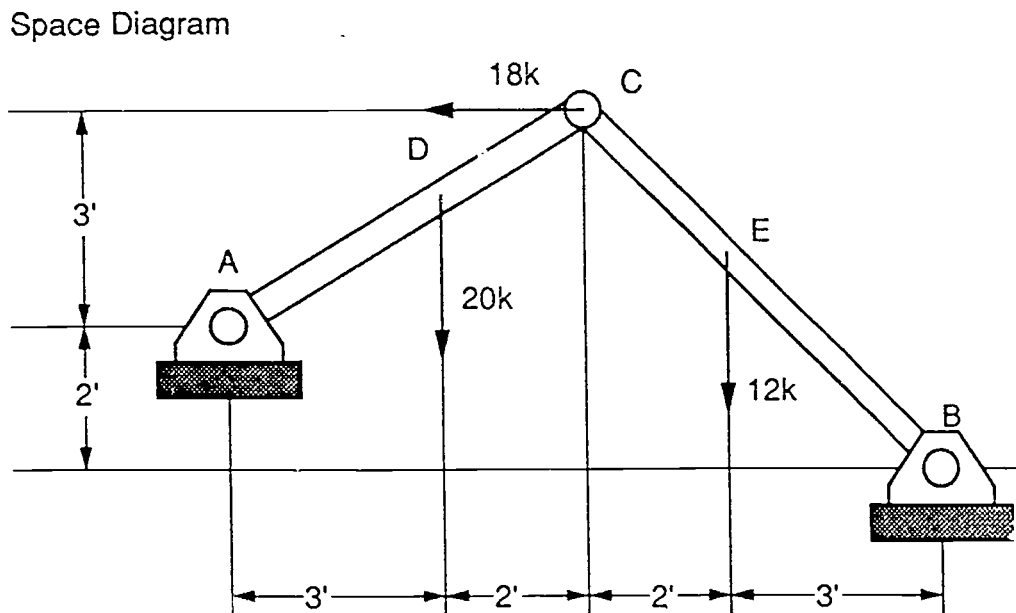

Solution: In this problem AC and BC are both three force members. Therefore, no known relationship exists between the v and h components at either support, such as that which simplified the solution of the previous problem. A summation of moments about either A or B will give an equation involving two unknown forces,

unknowns. A simultaneous solution of these two equations will then give the unknown forces.

Using the entire frame as a free body, we select point A as the center of moments, and assume that B_v and B_H both act against joint B. Then we have:

$$\begin{aligned} [\Sigma M_A = 0] \quad 10B_v + (8)(3) &= 2B_H + (20)(3) + (12)(7) \\ 10B_v - 2B_H &= 120 \end{aligned} \quad \text{Eq.(a)}$$

If member BC is now isolated, we write a second independent equation by a summation of moments about C. The reacting force at C is replaced by its V and H components, as yet unknown. Their moments are zero when c is the center of moments. Then:

$$\begin{aligned} [\Sigma M_C = 0] \quad 5B_v &= 5B_H + (12)(2) \text{ or} \\ 5B_v - 5B_H &= 24 \end{aligned} \quad \text{Eq.(b)}$$

Multiplying Eq.(b) by 2 and subtracting it from Eq.(a) we have:

$$\begin{aligned} 10B_v - 2B_H &= 120 \\ \underline{10B_v - 10B_H} &= 48 \\ 8B_H &= 72 \\ B_H &= 9 \text{ kips } \Leftarrow \end{aligned}$$

Substituting this value of B_H into Eq.(a) we have:

$$\begin{aligned} 10B_v - (2)(9) &= 120 \\ B_v &= 13.8 \text{ kips } \uparrow \end{aligned}$$

By use of the values of B_H and B_v just obtained, the reaction components are solved for by applying the equations $[\Sigma V = 0]$ and $[\Sigma H = 0]$. If we assume A_v to be acting upward and A_H to be acting from left to right, we obtain:

$$\begin{aligned} [\Sigma V = 0] \quad A_v + 13.8 &= 20 + 12 \text{ or } A_v = 18.2 \text{ kips } \uparrow \\ [\Sigma H = 0] \quad A_H &= 9 + 8 \text{ or } A_H = 17 \text{ kips } \Rightarrow \end{aligned}$$

Figure 10
2-Dimensional Statics

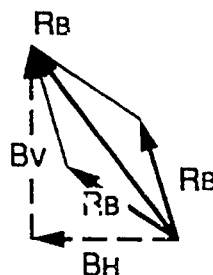
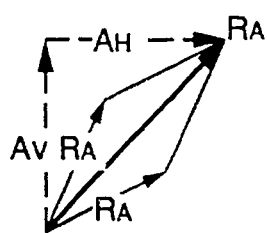
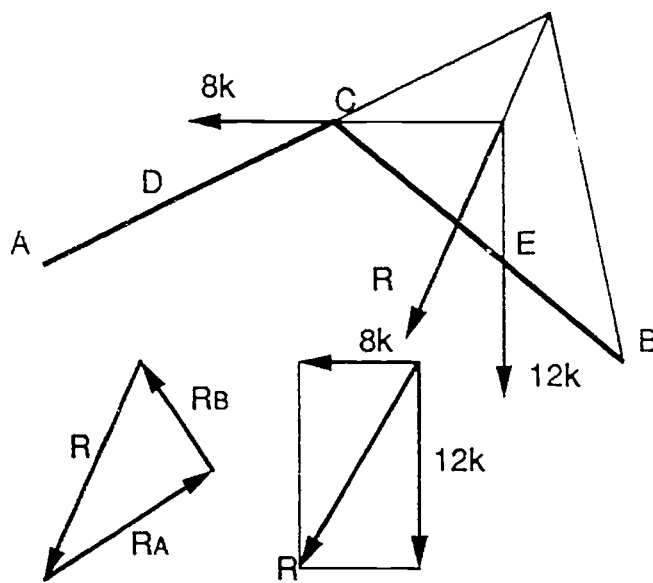
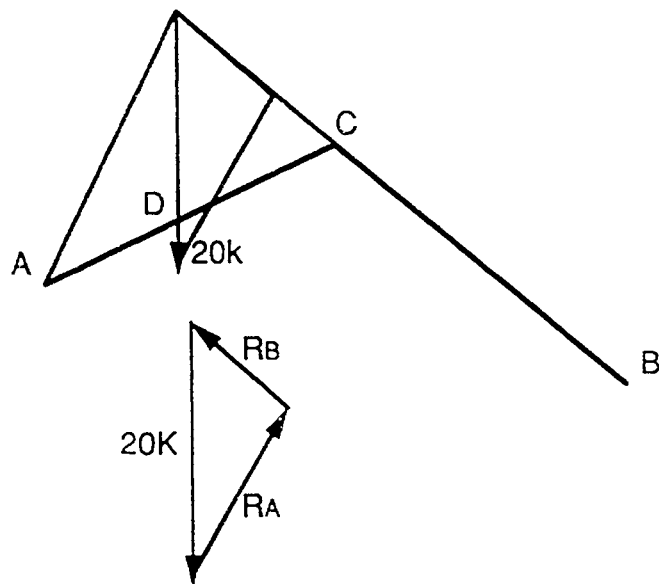

105

The positive signs of all computed components indicate a correct assumption as to their senses. If an unknown force is incorrectly assumed, the correct numerical value may be obtained but will be preceded by a negative sign. The components A_v and A_H depend of B_v and B_H . Therefore, a check by summation of moments of all forces acting on the frame, preferably about a point that does not eliminate a computed force, is absolutely essential. If we select point C as the center of moments, we have:

$$[\Sigma M_c = 0] \quad (18.2)(5) - (17)(3) - (20)(2) + (12)(2) + (9)(5) - (13.8)(5) = 0$$

$$0 = 0$$

The problem is of a type generally referred to as the three hinged arch. A graphic solution (see Figure 10) is most easily obtained by removing loads C and E and solving for the reactions at A and B due to load D only. Next, remove load D and solve for reactions at A and B due to loads C and E only. The two reactions at each support are then readily combined into a resultant reaction by constructing parallelograms. from which the true reactions or their components may be scaled.

Area II: Calculus for Physics

Calculus can be defined as the mathematics of change and clearly relates to dynamics which is the study of the change of motion of physical bodies. The presentation of physics without calculus results in the manipulation of a series of formulae with little understanding of the fundamentals on which the formulas are based. To develop an adequate understanding of the concepts of dynamics the presentation should be made with calculus interpretations. Calculus should first be presented by developing geometric and graphic interpretations. The mathematical manipulations that follow will then have meaning resulting in a more complete understanding. When basic calculus concepts are related to dynamics, problems may be solved by relying on fundamental theories, rather than memorized formulae.

The geometric interpretation of a derived function has a direct application to the solution of motion problems. The plots of acceleration, velocity, and displacement with respect to time are motion diagrams. When the displacement of a particle is a function of time, the velocity of the particle can be defined as the rate of change of displacement with respect to the time. The instantaneous velocity may be geometrically interpreted as the slope of the tangent curve at the desired time.

The acceleration is determined by finding the slope of the velocity curve at the desired time. The determination of the slope of a tangent to a curve has a geometric interpretation that is readily applied to physics.

Sample Problem C: Variable Acceleration

Given: The velocity of a particle starting from rest is expressed by the relation $v = 8T + 6T^2$ in feet per second. Algebraic functions are often used to approximate mathematically complex or indeterminate physical relations.

Find: The acceleration a , velocity v , and total displacement s at the end of three seconds. Accurately graph the motion diagrams for $0 < T < 4s$.

Solution: The equation expressing the acceleration of the body is obtained by differentiation of the equation $v = 8T + 6T^2$. We then obtain

$$a = dv/dt = 8 + 12T$$

To obtain a and v at the end of 3s,

$$[a = 8 + 12T] \qquad a = 8 + 12(3) = 44 \text{ ft/s}^2$$

$$[v = 8T + 6T^2] \qquad v = 8(3) + 12(3)^2 = 78 \text{ ft/s}$$

The equation expressing the displacement s is obtained by integrating the velocity equation $v = 8T + 6T^2$ between the lower and upper bounds of time. Then:

$$s = \int_0^T v \, dt = \int_0^T (8T + 6T^2) \, dt$$

$$s = \int_0^T (8T) \, dt + \int_0^T (6T^2) \, dt$$

$$s = 8 \int_0^T T \, dt + 6 \int_0^T T^2 \, dt$$

$$s = 8[\frac{1}{2} (T^2) - (0^2)] + 6[\frac{1}{3} (T^3) - (0^3)] = 4T^2 + 2T^3$$

$$s = 4(9) + 2(9) = 90\text{ft.}$$

See Figure 11.

Figure 11
Variable Acceleration

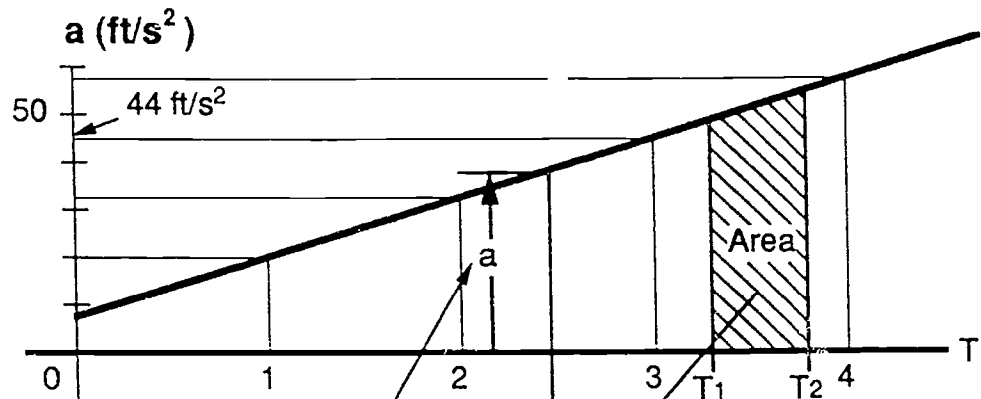

$$a = 8 + 12T$$

T	a
0	8
1	20
2	32
3	44
4	56

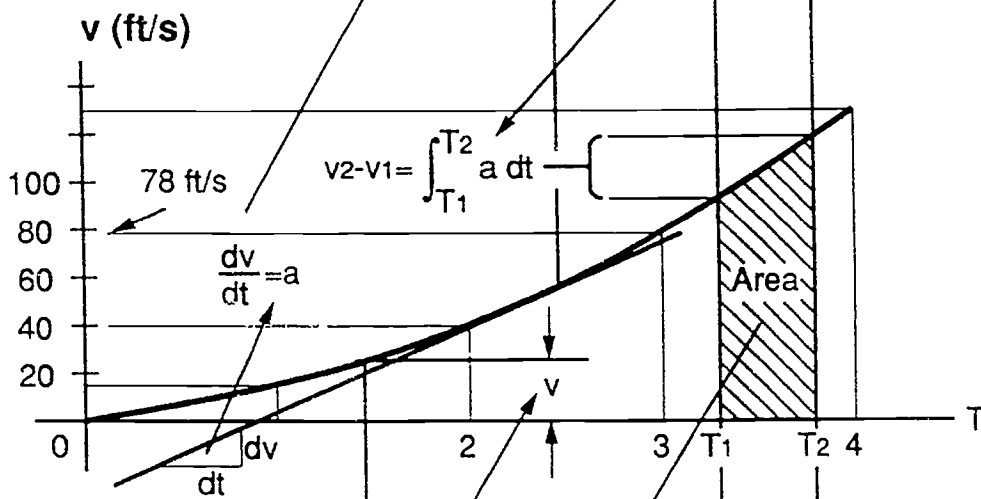

$$v = 8T - 6T^2$$

T	v
0	0
1	14
2	40
3	78
4	128

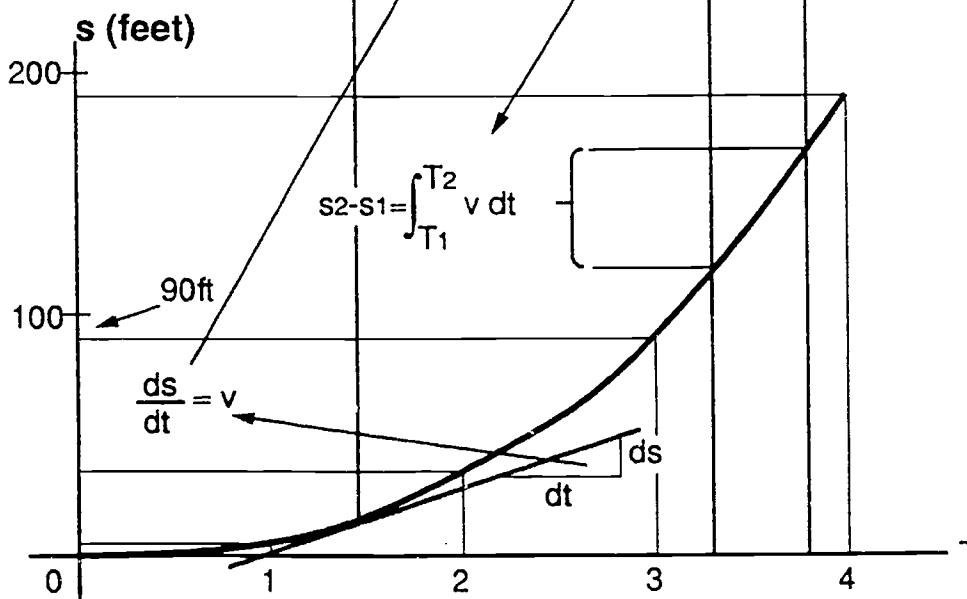

$$s = 4T^2 + 2T^3$$

T	s
0	0
1	6
2	32
3	90
4	192

Sample Problem D: Freely Falling Bodies

Given: A ball is tossed with a velocity of 10 m/s directed vertically upward from a window located 20m above the ground (Figure 12). Knowing that the acceleration of the ball is a constant equal to 9.81 m/s² downward,

Find: (a) the velocity v and elevation y of the ball above the ground at any time T ;
(b) the highest elevation reached by the ball and the corresponding value of T ;
(c) the time when the ball will hit the ground and the corresponding velocity.
Draw the $v(t)$ and the $y(t)$ curves.

Figure 12
Freely Falling Bodies

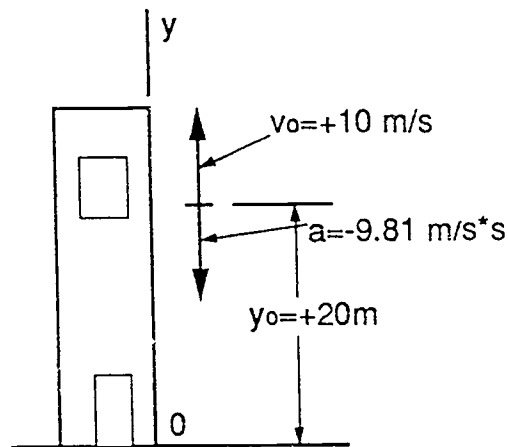

Solution: (a) velocity and elevation

substituting for a in $a = dv/dT$ and noting that at $T=0$, $v_0 = +10 \text{ m/s}$, we have:

$$\frac{dv}{dT} = a = -9.81 \text{ m/s}^2$$

$$\int_{v_0}^v dv = -\int_0^T 9.81 dT$$

$$[v]_{v_0}^v = -[9.81]_0^T$$

$$v - 10 = -9.81T$$

$$v = 10 - 9.81T$$

112

(Eq.1)

substituting for v in dy/dt and noting that at $T=0$, $y_0 = 20\text{m}$ we have:

$$\frac{dy}{dT} = v = 10 - 9.81T$$

$$\int_{y_0}^{y} dy = -\int_0^T 10 - 9.81T dT$$

$$[y]_{20}^y = -[10T - 4.095T^2]_0^T$$

$$y = 20 + 10T - 4.095T^2 \quad (\text{Eq.2})$$

(b) highest elevation (refer to figure 13)

when the ball reaches its highest elevation, we have $v=0$. Substituting into Eq.1 we have:

$$10 - 9.81T = 0 \quad T = 1.091\text{s}$$

substituting into Eq.2, we have

$$y = 20 + 10(1.091) - 4.095(1.091)^2$$

$$y = 25.1\text{ m}$$

Figure 13
Freely Falling Bodies

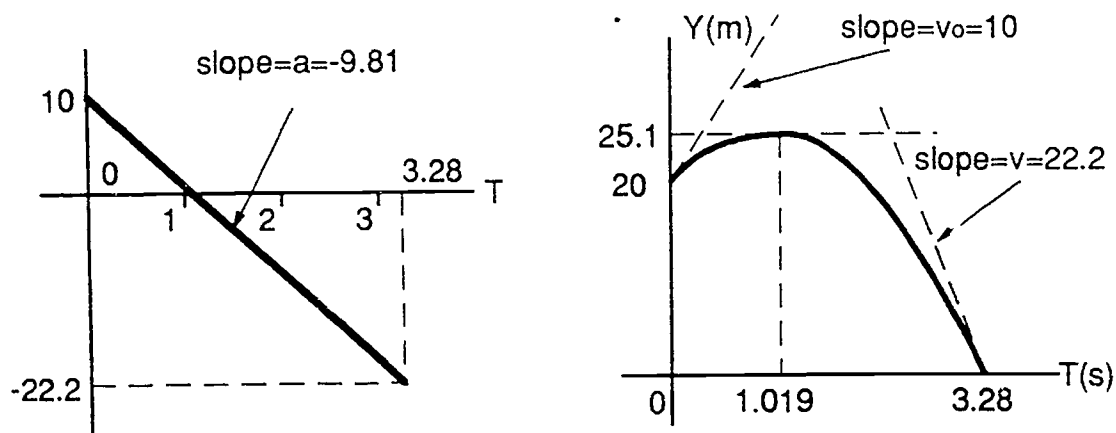

(c) ball hits ground

when the ball hits the ground, we have $y=0$. Substituting into Eq.2, we have

$$0 = 20 + 10T - 4.095T^2$$

$$T = -1.243s \text{ and } T = 3.28s$$

only the root $T=3.28s$ corresponds to a time after the motion has begun. Carrying this value of T into Eq.1 we have

$$v = 10 - 9.81(3.28)$$

$$v = 22.2 \text{ m/s}$$

Sample Problem E: Motion of Projectiles

The motion of a projectile can be represented by two independent rectilinear motions, which are easily visualized if we assume that the projectile is fired vertically with an initial velocity $(v_y)_0$ from a platform moving with a constant horizontal velocity $(v_x)_0$. The coordinate x of the particle is equal at any time to the distance travelled by the platform, while the coordinate y may be computed as if the projectile were moving along a vertical line.

It may be observed that the equations defining the coordinates x and y of a projectile at any instant are the parametric equations of a parabola. Thus the trajectory of a projectile is parabolic (Figure 14).

Figure 14
Motion of Projectiles

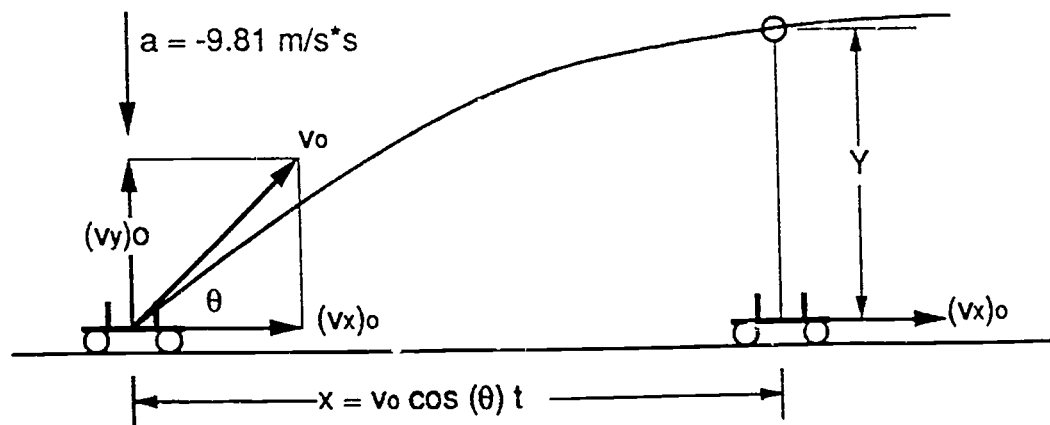

Thus, the horizontal velocity $(v_x)_0$ is a constant and the vertical velocity is changed by the downward gravitational attraction. The vertical motion is treated as a freely falling body.

Given: A projectile is fired from the edge of a 150m cliff with an initial velocity of 150 m/s, at an angle of 30° with the horizontal. Neglecting air resistance,

Find: (a) the horizontal distance from the gun at which the projectile strikes the ground; (b) the greatest elevation above the ground reached by the projectile; (c) graph the projectile motion and the $v(T)$ and $y(T)$ diagrams for vertical motion.

Solution: We shall consider separately the vertical and the horizontal motion.

Vertical motion. Uniformly accelerated motion. See Figures 15.

Figure 15
Motion of Projectiles

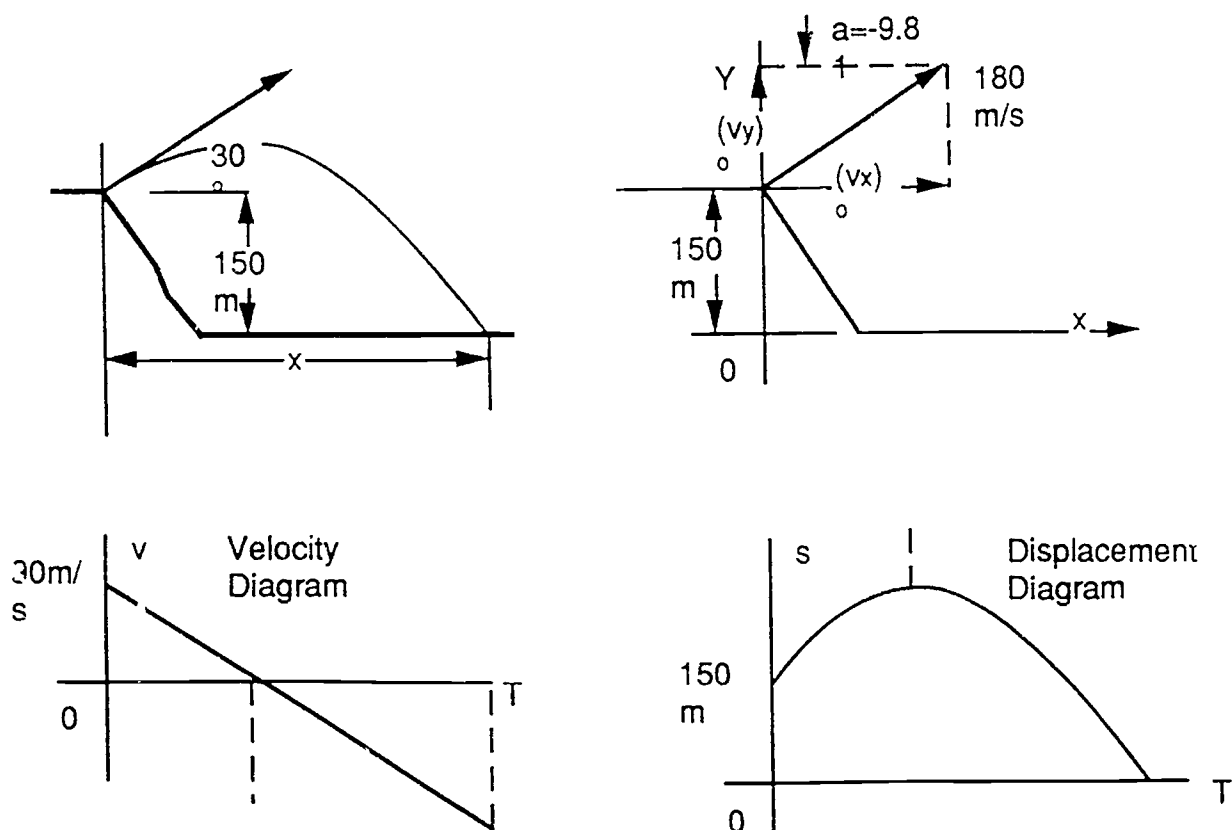

$$(v_y)_0 = \sin(30^\circ) \times 180 = 90 \text{ m/s}$$

$$\frac{dv}{dT} = a = -9.81 \text{ m/s}^2$$

$$\int_{v_0}^{v} dv = -\int_0^T 9.81 dT$$

$$[v]_{90}^v = -[9.81T]_0^T$$

$$v - 90 = -9.81T$$

$$v = 90 - 9.81T \quad \text{Vertical Velocity}$$

$$\frac{dy}{dT} = v = 90 - 9.81T$$

$$\int_{y_0}^{y} dy = -\int_0^T 90 - 9.81T dT$$

$$[y]_{150}^y = -[90T - 4.905T^2]_0^T$$

$$y - 150 = 90T - 4.905T^2$$

$$y = 150 + 90T - 4.905T^2 \quad \text{Vertical Distance}$$

(b) greatest elevation

When the projectile reaches its greatest elevation, we have $v_y = 0$; carrying the value into the displacement equation, we write:

$$v = 0 = 90 - 9.81T$$

$$T = 9.17\text{s}$$

$$Y_{(\text{max})} = 150 + 90(9.17) - 4.905(9.17)^2$$

$$Y_{(\text{max})} = 562.84$$

(a) horizontal distance: Horizontal motion. Uniform motion.

$$(v_x)_0 = \cos(30^\circ) \times 180 = 155.89 \text{ m/s}$$

find the roots of the displacement equation

$$T = \frac{-90 \pm \sqrt{90^2 - 4(150)(-4.905)}}{2(-4.905)}$$

$$T = -1.539\text{s} \text{ or } 19.89\text{s}$$

The positive root corresponds to the time at which the projectile strikes the ground. For bodies of uniform velocity, the displacement is the product of the velocity and time.

$$x = v t$$

$$x = (155.89)(19.89)$$

$$x = 3100.54 \text{ m}$$

The projectile strikes the ground at a point 3100 horizontal meters from the firing point.

Area III: Fluid Statics

Forces on submerged surfaces

This is an example of the use of first moments and centroids of areas by considering the forces exerted on a surface submerged in a liquid. The pressure at any given point in a fluid is the same in all directions. (Pascal's law.) In all fluids at rest, the pressure is a function of the vertical dimension. This is called gage pressure (Figure 16).

Figure 16
Force on Submerged Surface

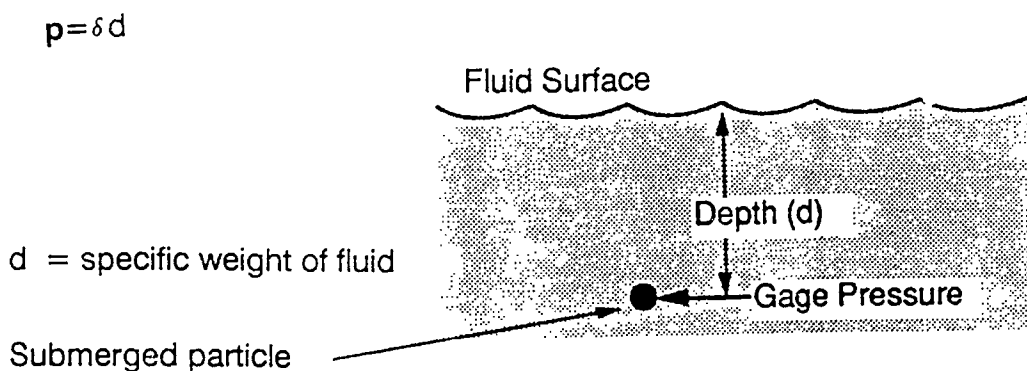

Since the gage pressure in a liquid is $p = \delta d$, where δ is the specific weight of the liquid and d the vertical distance from the fluid surface, the pressure p on a submerged particle varies linearly with the depth.

Consider the rectangular curved plate shown in Figure 17. It has a length defined by a function, and its width, perpendicular to the plane of the figure, is assumed equal to one unit.

Figure 17
Force on Submerged Surface

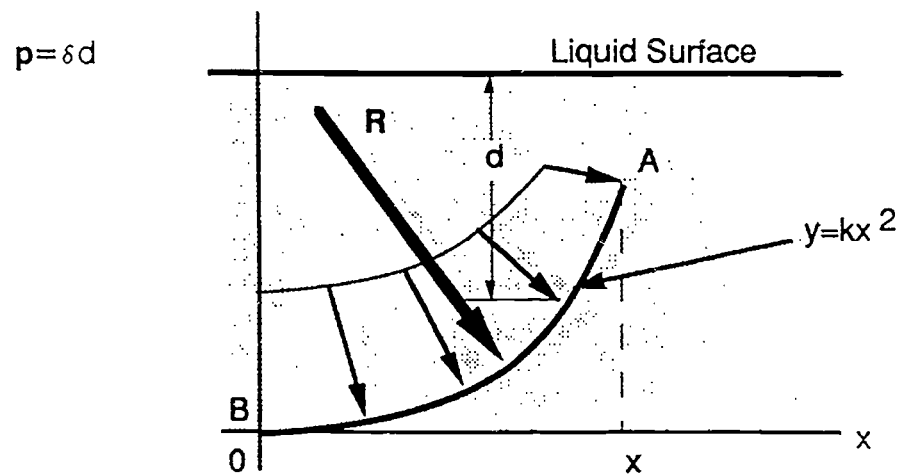

Since the determination of the resultant of the infinite number of gage pressure vectors by direct integration would not be easy, we shall consider the free body obtained by detaching the volume of liquid ABD bounded by the curved surface AB and by the two plane surfaces AD and DB (Figure 18).

The forces acting on the free body ABD consist of the weight W of the volume of liquid above the curved plate, the resultant P_1 of the pressure forces acting on the vertical surface AB to the left of the plate, the force on face BD, and the equilibrant $-R$ of the forces exerted by the plate on the water.

Figure 18
Force on Submerged Surface

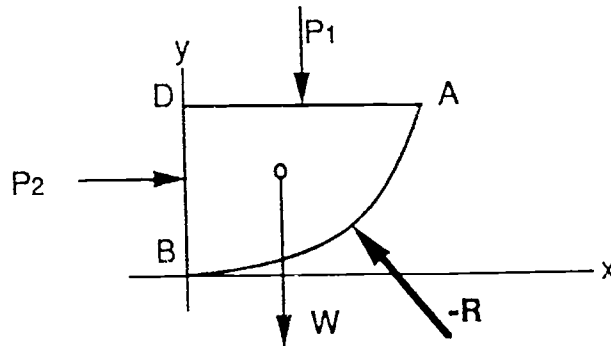

Sample Problem F: Force on Submerged Surface

The curved plate corresponds to the equation $y = x^2 + 2$ between the values $x=0$ and $x=2$. The water surface is at $y=8$, and all dimensions are in feet. The density of water is 62.4 pounds per cubic feet. The plate measures four feet perpendicular to the x-y plane. See Figure 19.

Figure 19
Force on Submerged Surface

$$\rho_{\text{water}} = 62.43 \text{ lb/ft}^3$$

The plate is 4 feet wide measured perpendicular to the plane of the figure

Edge View of Curved Plate

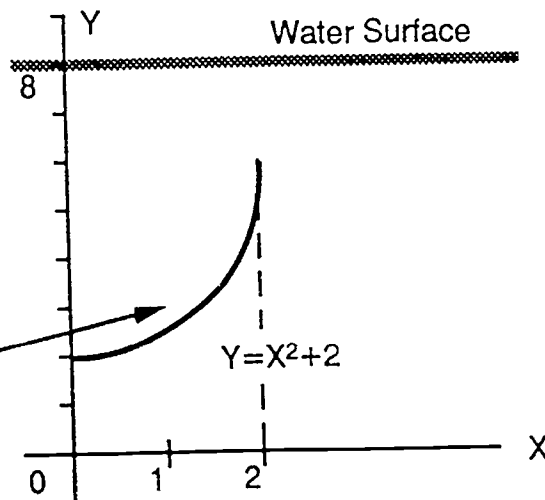

Calculate the required gage pressures p and resultant pressures P .

$$p_1 = 2\text{ft}(62.4) = 124.8$$

$$P_1 = 124.8(4\text{ft})(4\text{ft}) = 1996.8 \text{ lb}$$

$$p_2 = 6\text{ft}(62.4) = 374.4$$

$$P_2 = [374.4 - 124.8] (.5) (4)(4) = 1996.8$$

$$P_3 = 124.8(2)(4) = 998.4$$

Calculate the resultant water pressure on the upper surface of the plate.

$$\Sigma H = 1996.8 + 1996.8 = 3993.6 \quad \Sigma V = 998.4 + 1331.2 = 2329.6 \text{ lb}$$

$$R^2 = (\Sigma H)^2 + (\Sigma V)^2 = 3993.6^2 + 2329.6^2$$

$$R = 4623.4 \text{ lb}$$

Find the x-intercept for the line of action of the resultant by calculating the sum of the moments about the origin.

$$[\Sigma M_o = 0]$$

$$P_1 d_1 + P_2 d_2 + P_3 d_3 + W(<x>) = \Sigma V(x\text{-intercept})$$

$$1996.8(4) + 1996.8() + 998.4() + 998.4() + 1331.2() = 2329.6(x\text{-int})$$

$$17305 = 2329.6(x\text{-int})$$

$$x\text{-int} = 7.4 \text{ ft.}$$

Students must graphically represent a two-dimensional view of all forces acting on the submerged curved plate. They must also draw a three dimensional illustration of all forces acting on the plate. Completing this process a few times will allow students to solve these problems only from the two-dimensional view.

Forces on Vertical Submerged Surfaces

The liquid pressure on a vertical submerged plate varies with depth and is distributed over the area of the plate. When the intensity of the distributed force varies over an area, the pressure diagram becomes a volume. See Figure 21. the distributed pressure is applied to the area in the x-y plane and the ordinate p located along the z-axis represents the intensity of the fluid pressure per unit area in psf.

Figure 2.1
Force on Vertical Submerged Surface

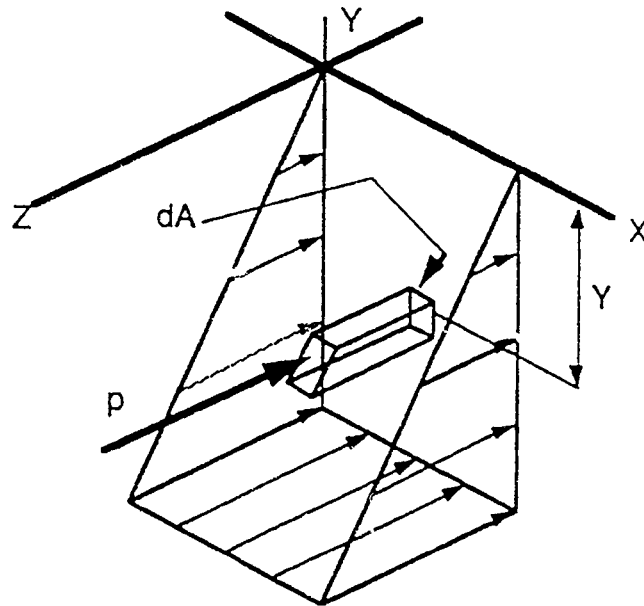

$$p = \delta(y)$$

gage pressure = density (depth)

The force of the pressure on an element of area dA is:

$$P = \delta(y)dA$$

This is the first moment of the area with respect to the liquid surface multiplied by the density of the liquid. The total pressure on the entire area would be equal to the summation of all of the elemental areas times the density of the liquid.

$$P_T = \delta \int x(y) dy$$

The center of pressure is the point on the surface of the plate at which the total pressure may be concentrated and represented by a single resultant force. The line of action of this force will pass through the centroid of the pressure volume. The centroid of the analytical surfaces may be determined by the integrals

$$\langle x \rangle V = \int x dV$$

$$\langle y \rangle V = \int y dV$$

$$\langle z \rangle V = \int z dV$$

Since the total pressure P_T is also equal to the volume of the pressure diagram, the $\langle y \rangle$ coordinate for the center of pressure can be found by writing:

$$\langle y \rangle \delta \int_a^b x(y) dy = \delta \int_a^b x(y)(y) dy$$

$$\langle y \rangle = \frac{\delta \int_a^b x(y)(y) dy}{\delta \int_a^b x(y) dy}$$

The depth of the center of pressure below the surface of the liquid is equal to the moment of inertia of the area divided by the first moment of the area, each with respect to the surface of the liquid.

Sample Problem G: Center of Pressure

Given: A vertical plate is submerged in a fluid of density 48 pounds per cubic foot. The plate is shaped as a bounded region defined by the relations $y^2 = 9x$ and $x = 4$. The fluid surface lies at $y = 3$. See Figure 22.

Find: The resultant of the pressure forces and its location on the plate.

$$P = 48 \int_0^3 (4 - y^2/9)(3 - y) dy$$

$$P = 48 \int_0^3 12 - 4y - 1/3y^2 + 1/9y^3 dy$$

$$P = 48 [12(3 - (-6)) - 4(1/2(3^2 - (-6)^2)) - 1/3(1/3(3^3 - (-6)^3)) + 1/9(1/4(3^4 - (-6)^4))]$$

$$P = 4860$$

$$\langle P \rangle = \int_0^3 (4 - y^2/9)(3 - y)^2 dy / 101.25$$

$$\langle P \rangle = \int_0^3 -1/9y^4 + 2/3y^3 + 3y^2 - 24y + 36 dy / 101.25$$

$$\langle P \rangle = [-1/9(1/5(3^5 - (-6)^5)) + 2/3(1/4(3^4 - (-6)^4)) + 3(1/3(3^3 - (-6)^3)) - 24(1/2(3^2 - (-6)^2)) + 36(3 - (-6))] / 101.25$$

$$\langle P \rangle = 5.04 \text{ feet below the surface.}$$

Figure 22
Center of Pressure

Liquid Surface: $y = 3$

Bounded Region: $y = 9x^2$

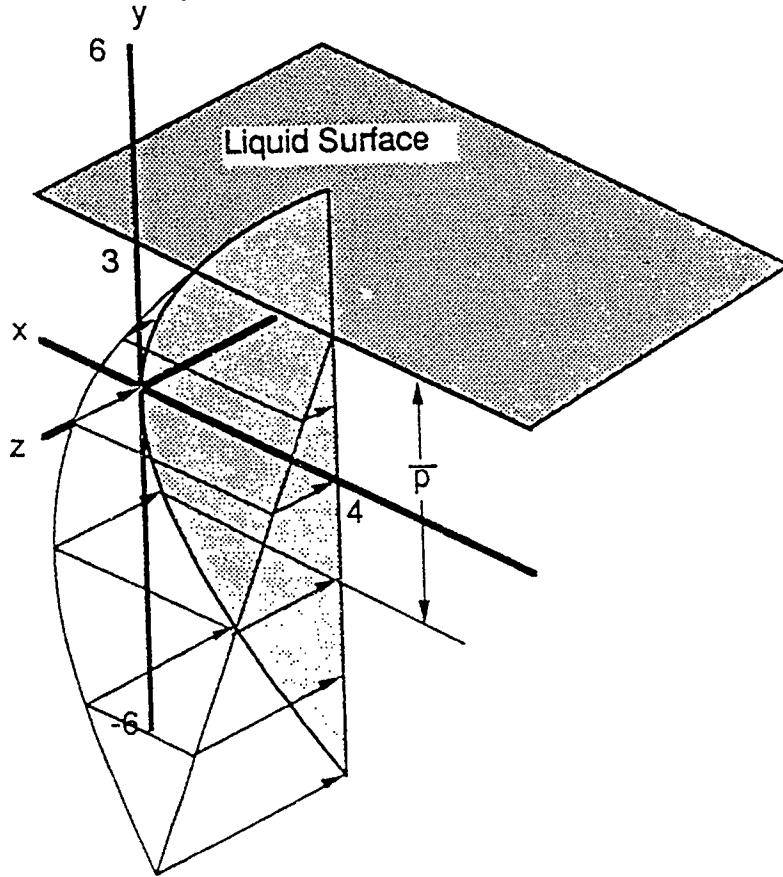

$\delta = 48 \text{ lb/ft}^3$

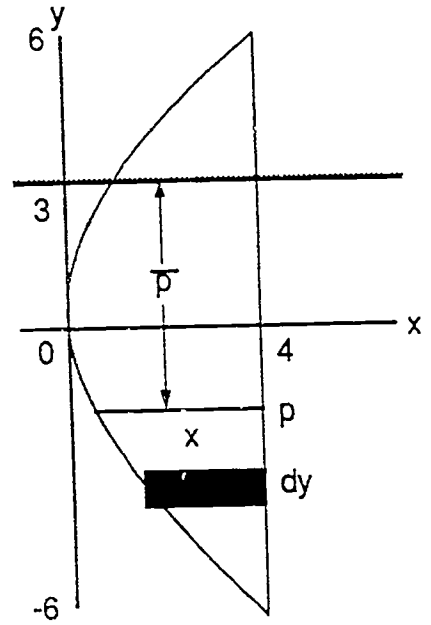

Physics II (AP) Advanced Mechanics

The statics curriculum presented in Physics II (Advanced Placement) involves the study of the equilibrium of rigid bodies (Table 4). The problems are solved by the application of the principles of vector algebra and statics. The interpretation of vector algebra within the context of statics gives a real-life application to the mathematical process. When problems are also solved graphically by the methods of descriptive geometry, we are assured that students have developed the correct physical and geometrical meaning of the concepts.

Table 4
PHYSICS II (AP) Course Outline

Statics (First Semester)

- Introduction
- Statics of Particles
- Rigid Bodies: Equivalent systems of forces
- Equilibrium of Rigid Bodies
- Distributed Forces: Centroids and Centers of Gravity
- Distributed Forces: Moments of Inertia
- Friction

Dynamics (Second Semester)

- Kinematics of Particles
- Kinetics of Particles
- Work and Energy
- Impulse and Momentum
- Kinematics of Rigid Bodies
- Kinetics of Rigid Bodies: Forces and Accelerations
- Kinetics of Rigid Bodies: Work and Energy
- Kinetics of Rigid Bodies: Impulse and Momentum
- Mechanical Vibrations

Area I: Three-Dimensional Statics

Sample Problem A: 3-D Statics

Given: The weightless frame ACD is supported by ball and socket joints at A and D and by a cable GB attached at G and B (Figure 23). Knowing that the frame supports at point C a load of magnitude $P=268\text{N}$, determine the tension in the cable.

Figure 23
3-Dimensional Statics

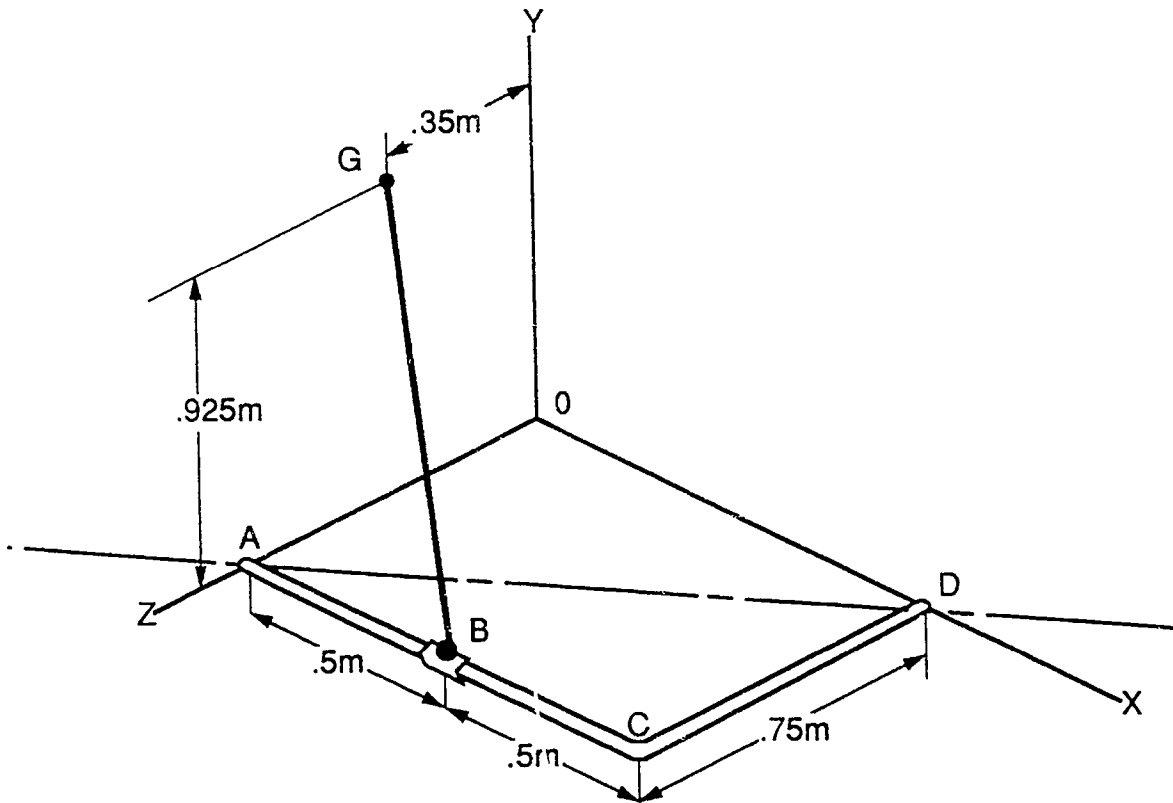

Solution: Since the rigid body ABCD is supported by ball and socket joints at A and D we may assume that the body may rotate about an axis A-D. Load P will tend to cause the frame to rotate about axis A-D and the tension in the cable GB will counteract this rotational tendency and, along with the reaction forces at A and D will keep the frame in equilibrium. The prospective rotation effects induced by load P and counteracted by Tension T_{BG} must be equal and opposite with respect to axis A-D. That is, the moment of P and the moment of T_{BG} must be equal and have opposite directions with respect to axis A-D. No other forces acting on the frame contribute to this tendency to rotate about this axis.

Selecting point A as a moment center, we calculate the respective moment vectors of load P and T_{BG} with respect to point A. Equilibrium requires that the projections of the moment vectors on to the line AD will yield equal and opposite

components. Equating these components, one of which is written in terms of the unknown tension T_{BG} will yield a scalar equation from which T_{BG} can be computed.

The moment of a force with respect to a point may be defined as the cross product of a position vector and a force vector. This yields a moment vector perpendicular to the plane containing the position and force vectors. The direction of the moment vector is found by the right hand rule. For this problem, boldface type will denote a vector. i , j , and k denote vectors of unit length in the x , y , and z directions respectively.

$$\mathbf{M}_o = \mathbf{r}_{oA} \times \mathbf{F}$$

By locating a unit vector on an axis we may find the corresponding projection of any vector on the axis by the dot product of the unit vector, say λ_1 , and the associated vector, say \mathbf{M}_o . See Figure 24.

Figure 24
3-Dimensional Statics

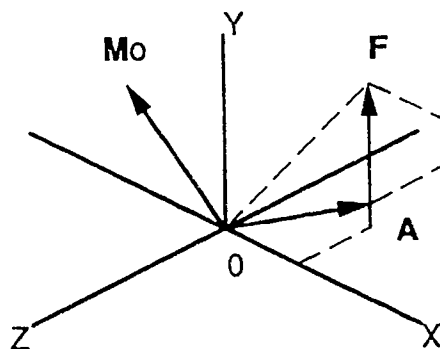

$$M_1 = \lambda_1 \cdot \mathbf{M}_o$$

Where M_1 is the scalar magnitude of the projection of \mathbf{M}_o in direction λ_1 (this projection will be a component of \mathbf{M}_o if λ_1 is a component of an orthogonal reference system).

We may combine dot and cross products into one expression called a mixed triple product; i.e. $M_l = \lambda_l \cdot \mathbf{M}_o = \lambda_l \cdot \mathbf{r}_{oA} \times \mathbf{F}$. For equilibrium, the mixed triple product of load \mathbf{P} must be set equal to the mixed triple product of tension \mathbf{T}_{BG} .

$$\lambda_{AD} \cdot (\mathbf{r}_{AC} \times \mathbf{P}) = \lambda_{AD} \cdot (\mathbf{r}_{AB} \times \mathbf{T}_{BG})$$

Mathematical Solution

The free-body diagram (Figure 25) of the pipe ABCD includes the load $\mathbf{P} = -268\mathbf{j}$, the reactions at A and D, and the force \mathbf{T}_{BG} exerted by the cable. To eliminate the reactions at A and B from the computations, we express that the sum of the moments about AD is zero. Denoting λ by the unit vector along AD we write

$$[\Sigma M_{AD} = 0] \quad \lambda_{AD} \cdot (\mathbf{r}_{AC} \times \mathbf{P}) + \lambda_{AD} \cdot (\mathbf{r}_{AB} \times \mathbf{T}_{BG}) = 0 \quad \text{Eq.1}$$

Figure 25
3-Dimensional Statics

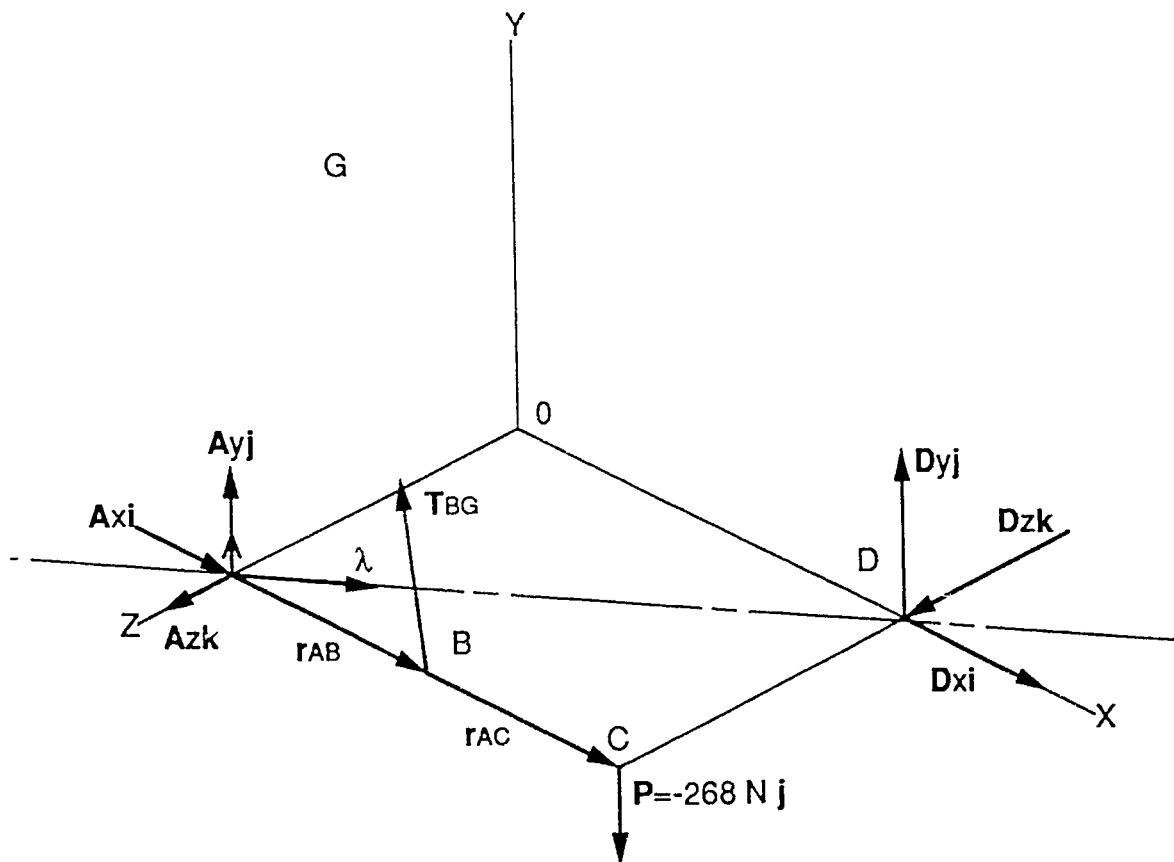

The second term may be computed as follows:

$$\mathbf{r}_{AC} \times \mathbf{P} = 1\mathbf{i} \times -268\mathbf{j} = -268\mathbf{k}$$

$$\lambda_{AD} = \mathbf{AD}/AD = (1\mathbf{i} - .75\mathbf{k})/1.25 = .8\mathbf{i} - .6\mathbf{k}$$

$$\lambda_{AD} \cdot (\mathbf{r}_{AC} \times \mathbf{P}) = 160.8 \text{ N}\cdot\text{m}$$

The components of the force T_{BG} may be expressed in terms of the unknown magnitude T_{BG} by writing:

$$\mathbf{T}_{BG} = T_{BG} (\mathbf{BG}/BG) = T_{BG} (-.44\mathbf{i} + .822\mathbf{j} - .355\mathbf{k})$$

The first term of Eq.1 may be computed as follows:

$$\begin{aligned} \mathbf{r}_{AC} \times \mathbf{T}_{BG} &= (.5\mathbf{i}) \times T_{BG} (-.44\mathbf{i} + .822\mathbf{j} - .355\mathbf{k}) \\ &= T_{BG} (.177\mathbf{j} + .411\mathbf{k}) \end{aligned}$$

$$\begin{aligned} \lambda_{AD} \cdot (\mathbf{r}_{AC} \times \mathbf{T}_{BG}) &= (.8\mathbf{i} - .6\mathbf{k}) \cdot T_{BG} (.177\mathbf{j} + .411\mathbf{k}) \\ &= -.2466 T_{BG} \end{aligned}$$

Substituting the values obtained into Eq. 1, we write

$$-.2466 T_{BG} + 160.8 \text{ N} = 0$$

$$T_{BG} = 648.65 \text{ N}$$

Graphic Solution

Clearly central to the mathematical solution was the computation of the moment of a force about a point by the cross product of a position vector and a force vector. See Figure 26. The cross product of two vectors may be interpreted as the area of the parallelogram spanned by the vectors. The magnitude of the moment is represented by a vector perpendicular to the plane formed by the vectors.

By constructing horizontal and frontal views of the free-body diagram and applying the fundamentals of descriptive geometry a true shape of the plane formed by the position and force vectors may be found. By constructing a parallelogram in

Figure 26
3-Dimensional Statics

Distance Scale 3" = 2m
Vector Scale 3" = 200N
Moment Scale 3" = 200N.m

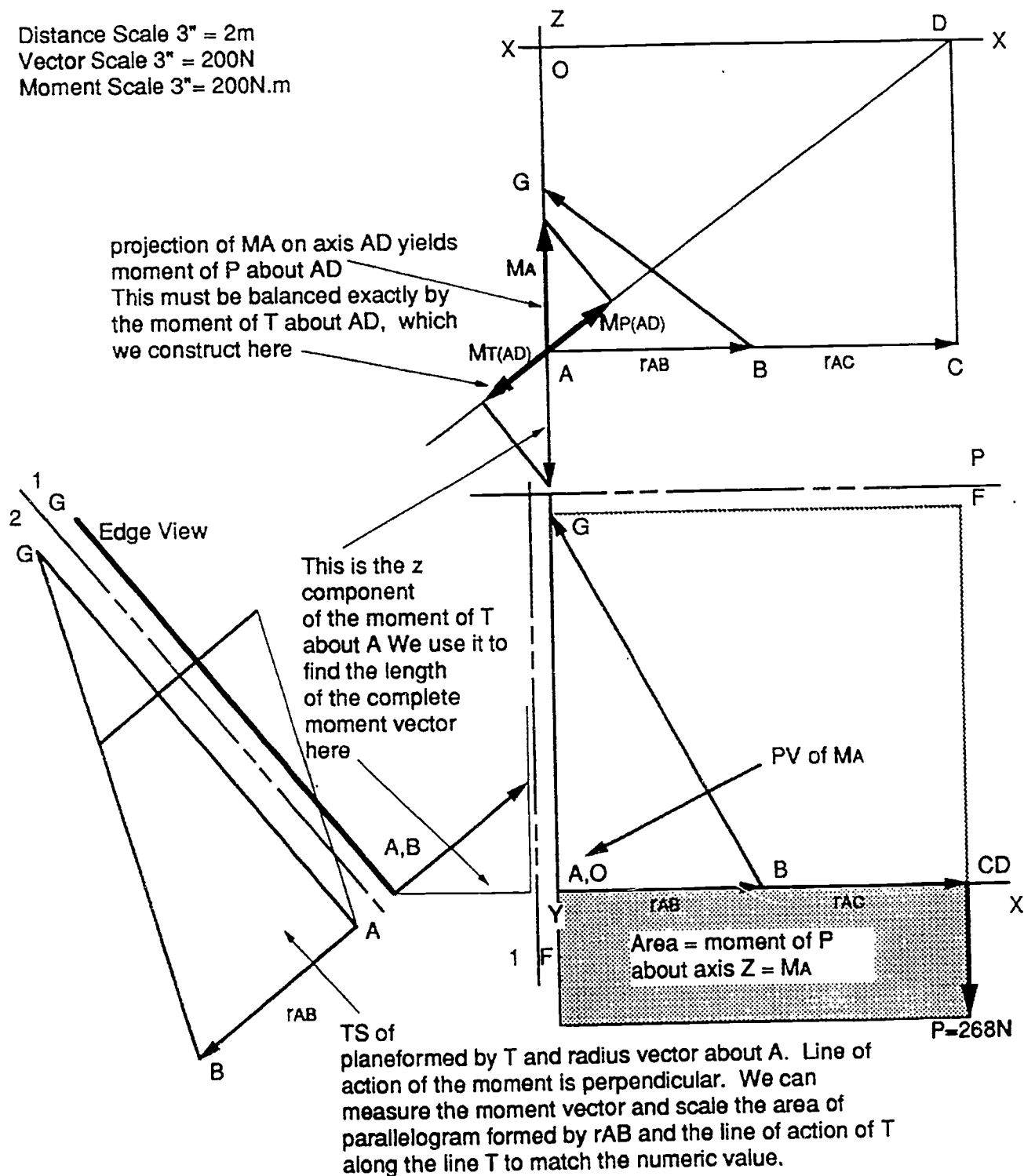

the true shape view, the required moment may be constructed. By applying the right hand rule in the true shape view, the sense of the moment vector may be determined. The moment vector is then projected into the horizontal and frontal views.

By finding the true shape of the plane formed by the moment vector and the axis of rotation the projection of the moment vector onto the axis may be accomplished. This process determines the value of the component of the moment vector which represents the moment of the force vector with respect to the axis of rotation. This component value is equal to the mixed triple product referred to earlier.

The moment of the known force P is projected onto the axis A-D through the described graphic process. The line of action of the moment of the unknown tension T_{BG} is found by selecting an arbitrary value for T_{BG} and applying the described graphic process. This allows the computation and representation of a moment vector. The line of action of this moment vector will be correct. This false moment vector is projected onto axis A-D. The components of the two moment vectors must be equal and opposite. Using this fact, adjust the false moment component to equal the known moment component. This will yield the correct moment for tension T_{BG} . Projection of this corrected moment vector back into the true shape view will allow the adjustment of the area of the parallelogram formed by the position vector r_{AB} and the tension vector T_{BG} to the correct value. This will result in obtaining the graphic value for the tension in cable GB.

Area II: Mass Moment of Inertia

The objective of this section is to explain the development of the concept of mass moment of inertia of a rotating body and relate its application to the the calculation of the acceleration of a body or system of bodies.

Consider the motion of a particle travelling in a circular path with constant speed. The velocity at any point is tangent to the path of the motion of the particle. Since the direction of motion is constantly changing, the particle is undergoing a continuous and constant acceleration towards the center of rotation. We may evaluate this normal acceleration as follows.

continuous and constant acceleration towards the center of rotation. We may evaluate this normal acceleration as follows.

Let the body move from A to B along the horizontal circular path shown in Figure 27. The vector difference of the tangential velocity vectors v_A and v_B represent the change in velocity Δv or acceleration.

Figure 27
Mass Moment of Inertia

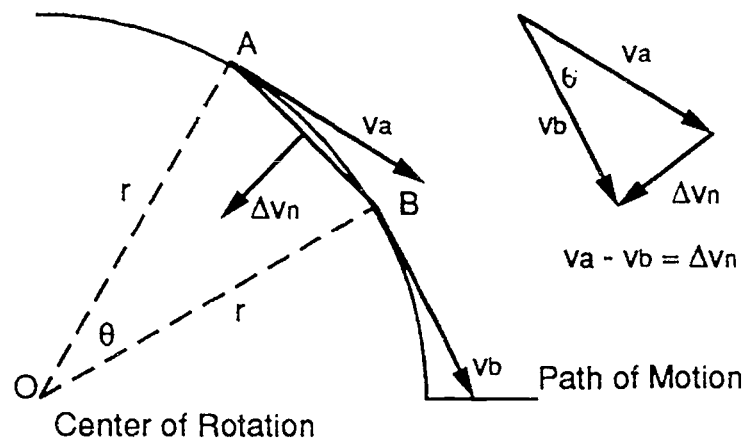

When the angle θ approaches zero, the chord AB will equal arc AB. The triangles ABO and FGH are similar because they are isosceles with mutually perpendicular sides. Hence we have:

$$\frac{AB}{r} = \frac{\Delta v_N}{v} \quad \text{Eq.(a)}$$

When the speed along the path is uniform, distance AB is equal to velocity times time.

$$AB = vt$$

a change in velocity is acceleration which is constant in this case.

$$\frac{dv}{dt} = a$$

$$\int_{v_0}^v dv = \int_0^T a dt$$

$$v - v_0 = at$$

Figure 28
Mass Moment of Inertia

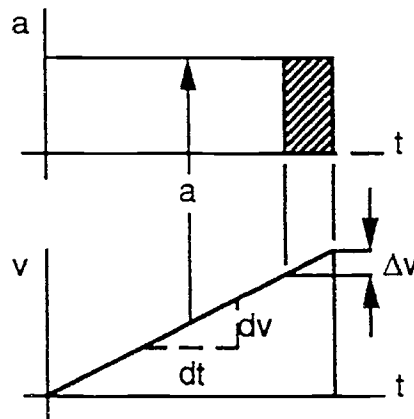

The area of the acceleration diagram (Figure 28) is equal to the change in velocity between the ordinates, therefore

$$v - v_0 = \Delta v = at$$

When these substitutions are made into Eq.(a) we obtain

$$\frac{vT}{r} = \frac{aT}{v}$$

from which

$$a_n = v^2/r \quad \text{Eq.(b)}$$

Since a_n , v , and r are instantaneous quantities, Eq.(b) holds for variable as well as for uniform conditions of plane curvilinear motion. See Figure 29.

Figure 29
Mass Moment of Inertia

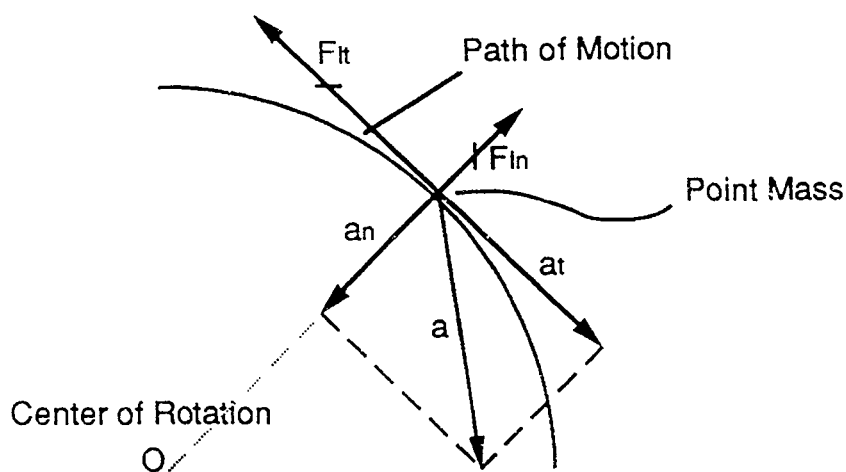

Should the speed of the body be changed along its path of motion, as the result of a tangential acceleration a_t , its true acceleration would be the resultant of a_n and a_t . An inertia force is produced when a change in motion (acceleration) occurs. The accelerating and inertia forces are always collinear, have opposing senses, and act through the center of gravity of the body. This is stated as force equals mass times acceleration, or $F_i = ma$. Therefore, every acceleration is related to a proportional inertia force.

Consider a disk rotating about an axis C that is composed of an infinite number of point masses (Figure 30). The disk is accelerated by force P causing the disk to rotate about C in a counterclockwise direction.

The point mass m is affected by two accelerations and two inertia forces, F_{in} and F_{it} . The normal inertia force F_{in} exists when the disk is rotating. The tangential inertia force exists only when there is a change in speed. The normal inertia forces F_{in} on every point mass m have lines of action that pass through the axis of rotation C. The moment of these forces is zero with respect to axis C and do not affect rotation (Figure 31). However, the tangential inertia forces F_{it} have a moment with respect to axis C which is $F_{it}(r)$. The sum of the moments of all of the inertia forces on the point masses which compose the disk is a torque opposing angular acceleration.

Figure 30
Mass Moment of Inertia

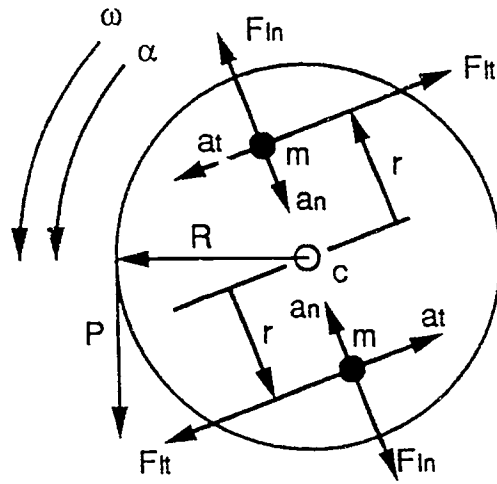
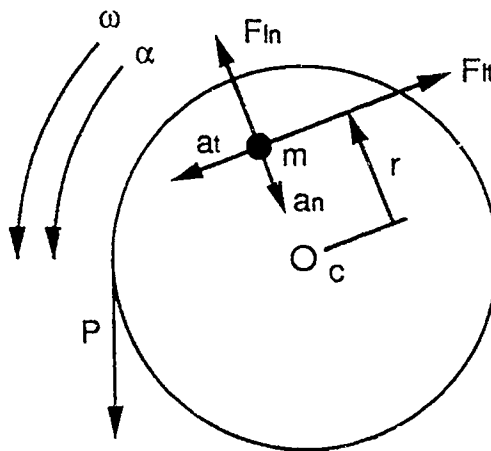

Figure 31
Mass Moment of Inertia



The normal inertia force F_{in} is:

$F_{in} = ma$ and since

$a_n = v^2/r$ we write $F_{in} = mv^2/r$

Since linear velocity is equal to angular velocity times the radius, we write

$$v = r\omega \quad \text{and}$$

$$F_{in} = mr^2\omega^2/r = mr\omega^2$$

The tangential inertia is

$$F_{it} = ma \quad \text{and} \quad a = r\alpha$$

$$F_{it} = mra$$

The moment of the tangential inertia force F_{it} with respect to the axis of rotation C is

$$mr\alpha(r) = mr^2\alpha$$

which is mass times the distance squared times acceleration. In rotation, $mr^2\alpha$ represents the internal inertia-moment reaction on a particle of mass m to an external accelerating moment action. Since for dynamic equilibrium action and reaction must be equal and opposite, the torque, an externally applied action, must be equalled by the sum total of the internal reacting inertia moments of all particles comprising the body. Let all particles of the body be of equal masses, and let their different radii be denoted as $r_1, r_2, r_3, \dots, r_n$. Since these particles have the same angular acceleration α we have :

$$\text{Torque} = mr_1^2\alpha + mr_2^2\alpha + mr_3^2\alpha + \dots = \Sigma mr^2\alpha$$

The term is called the moment of inertia of the body and is denoted by the symbol I . Therefore, $\text{Torque} = I\alpha$ where torque is the accelerating moment, I the moment of inertia of the body, and α the angular acceleration. When the mass of each particle is infinitesimally small, or dm , and when a variable radius p replaces r , the moment of inertia becomes $I = \int p^2 dm$. If the mass distribution is constant throughout the body, the moment of inertia becomes

$$I = m \int p^2 dV$$

Where dV is the element of volume. It is particularly important that we make a good choice of element of volume dV . For example, in finding the moment of inertia of a solid right circular cone about its centroidal axis (Figure 32), we

should choose an element in the form of a cylindrical shell that is parallel with the central axis. In this case, all of the mass of the element is at the same distance p from the inertia axis, the differential moment of inertia for this element is merely $p^2 dm$ where dm is the mass of the elemental shell.

Figure 32
Mass Moment of Inertia

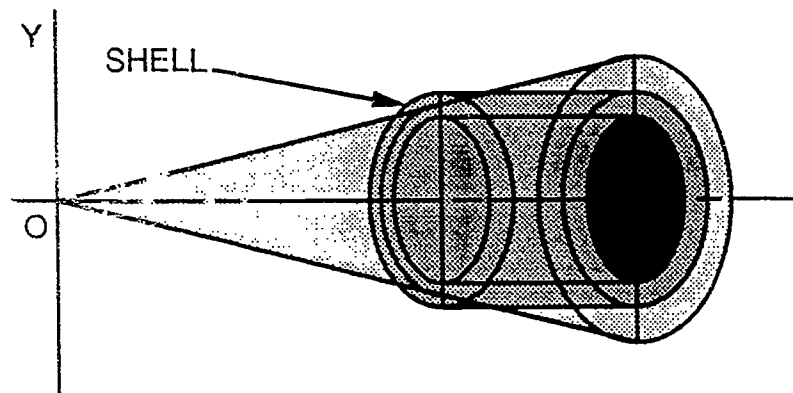

The shell method for finding the volume of a solid of revolution is defined as the first moment of the differential strip with respect to the axis of rotation times 2π .

$$\text{Volume} = 2\pi \int x(y) dy$$

The volume of the shell of an infinitesimal thickness equal to the height x times the area of the base which is 2π times the average radius y . The summation of the volume of an infinite number of concentric shells will equal the volume of the solid of revolution. Consider the solid of revolution formed by revolving a rectangle about the x -axis. This rotation generates a solid cylinder whose volume is to be calculated by the shell method. See Figure 33.

$$V = 2\pi \int_0^3 2(y) dy$$

$$V = 2\pi [1/2 (3^2 - 0^2)]$$

$$V = 2\pi 2[4.5]$$

$$V = 56.55 \text{ cubic units.}$$

Figure 33
Mass Moment of Inertia

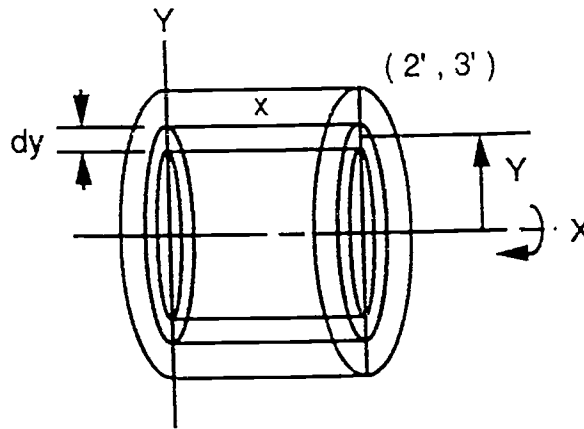

A simple arithmetical check can be provided as follows.

$$V = \text{area of base} \times \text{height}$$

$$V = \pi r^2 h = \pi(3^2)(2)$$

$$V = 56.55 \text{ cubic units.}$$

The moment of inertia of the cylinder can be calculated by including an expression for distance squared into the shell integral:

$$I_x = 2\pi \int x(y) (y^2) dy$$

$$I_x = 2\pi \int_0^3 2y^3 dy$$

$$I_x = 2\pi 2 \left[\frac{1}{4}(3^4 - 0^4) \right]$$

$$I_x = 2\pi 2 [20.25]$$

$$I_x = 254.47$$

This answer represents the sum of the elements of volume times distance squared. Multiplying this expression by the mass of the body, assuming uniform density, will result in the mass moment of inertia.

$$I_{\text{cm}} = m 2\pi \int xy^3 dy$$

Assuming that the dimensions of the cylinder are in feet and the density of the material to be 490 lb/ft³ we write :

$$I_{cm} = (490 \text{ lb/ft}^3)/g \int 2\pi r^3 dy$$

$$I_{cm} = 3872.4 \text{ ft lb s}^2$$

A check can be provided by using a developed formula found in physics and engineering texts.

$$I_{cm} = 1/2 (\delta/g) V r^2$$

$$I_{cm} = 3872.45 \text{ ft lb s}^2$$

Sample Problem B: Acceleration of a System of Bodies

To demonstrate the application of mass moment of inertia to find the acceleration of a system of bodies, consider the physics problem shown in Figure 34.

Given: Block B is attached to a weightless cord which is wrapped around disk D causing it to rotate about its centroidal axis c. I_c is equal to 3872.4 lb ft s², and B weighs 500lb.

Figure 34
Acceleration of a System of Bodies

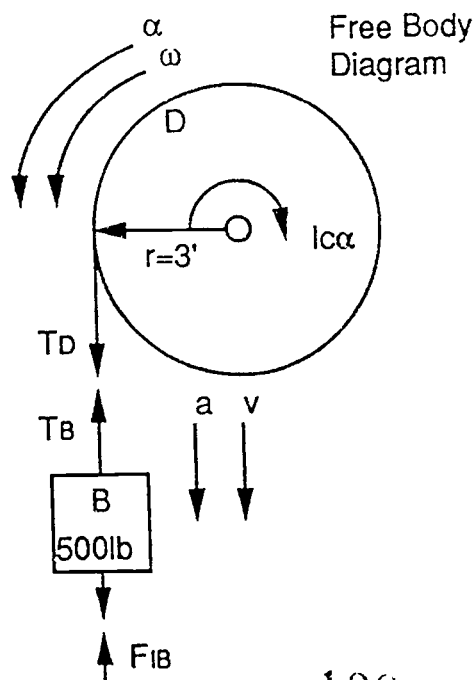

Find: the angular acceleration of disk D, the linear acceleration a of block B, and the tension in the cord.

Solution: the unbalanced moment $T_D(r)$ acting on the disk is counterclockwise, thus causing counterclockwise acceleration and motion, indicated by the motion arrows α and ω shown on the free-body diagram. The inertia moment $I_c\alpha$ is directed opposite to α . Block B moves downward with accelerated motion, and its inertia force F_{IB} is directed opposite to a . Since $a = r\alpha$, we have

$$F_{IB} = \frac{W_B a}{g} = \frac{W_B r \alpha}{g}$$

Two equations, a moment equation about the center c and a force equation involving the free-body B will now determine a . That is

$$[\Sigma M_c = 0] \quad T_D(r) = I_c \alpha$$

$$T_D = \frac{I_c \alpha}{r} \quad \text{Eq.A}$$

$$[\Sigma V = 0] \quad T_B = W_B - F_{IB}$$

$$T_B = W_B - \frac{W_B r \alpha}{g} \quad \text{Eq.B}$$

$$T_D = T_B, \text{ therefore:}$$

$$\frac{I_c \alpha}{r} = W_B - \frac{W_B r \alpha}{g}$$

Substituting:

$$\frac{3872.4\alpha}{3} = 500 - \frac{500(3)\alpha}{32.2}$$

$$\alpha = .37 \text{ rad/s}^2$$

To obtain the acceleration a , we have

$$[a = r\alpha] \quad a = 3(.37) \quad \text{or}$$

$$a = 1.11 \text{ ft/s}^2$$

Substituting the value of a into Eq.A to obtain tension gives

$$T_D = \frac{3872.4(.37)}{3} = 477.6 \text{ lb}$$

Sample Problem C: Dynamic Equilibrium of Rotating Bodies

Given: Block B is attached to a weightless cord wrapped around disk A causing it to rotate around its centroidal axis C (see Figure 35). Disk A is generated by rotating the region bounded by $x = \frac{1}{8}y^2 + \frac{1}{2}$, $y=4$, $y=\frac{1}{4}$ and the y-axis about axis c. $\delta_{\text{cast iron}} = 450 \text{ lb/ft}^3$. The friction coefficient $f = 0.02$.

Figure 35
Dynamic Equilibrium of Rotating Bodies

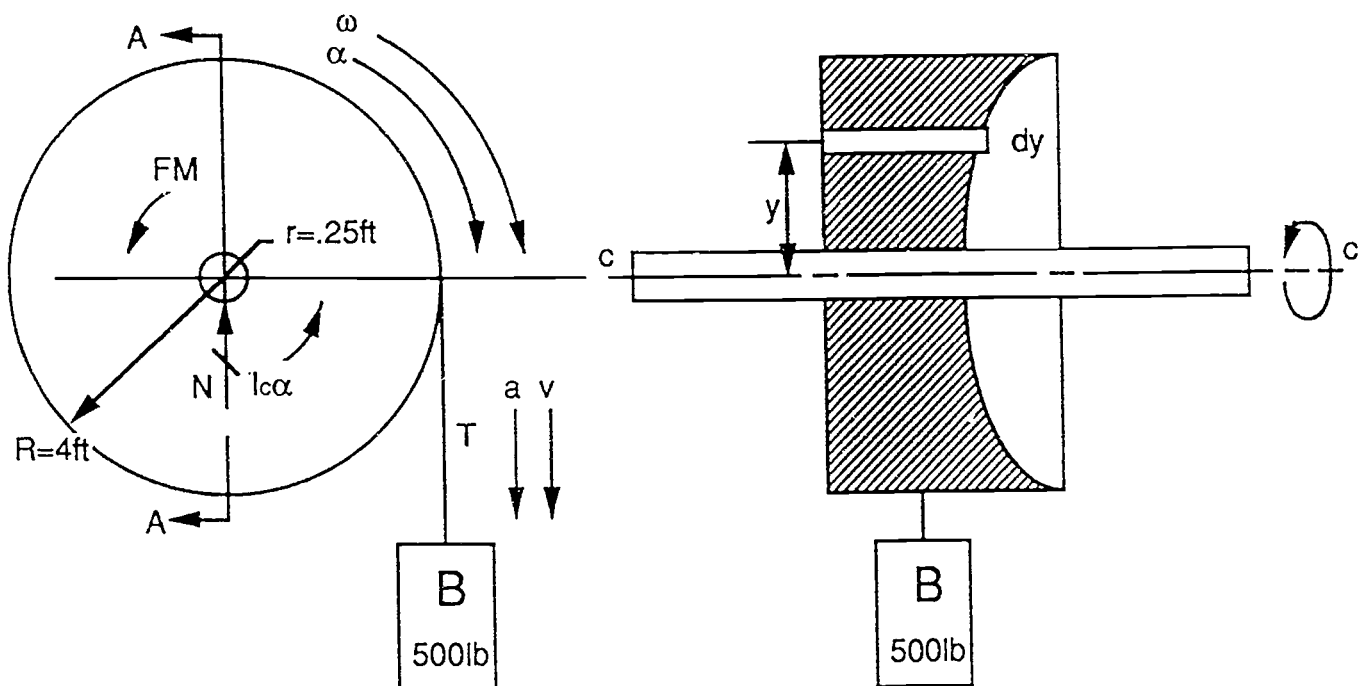

Find: The angular acceleration α of disk A, the linear acceleration a of block B, and the tension T in the cord and the linear velocity of block b after it moves 20 ft from rest.

Mass Moment of Inertia (refer to Figure 36)

$$I_c = (\delta/g) 2\pi \int_{.25}^4 (\frac{1}{8}y^2 + \frac{1}{2}) (y^3) dy$$

$$I_c = (\delta/g) 2\pi \int_{.25}^4 (\frac{1}{8}y^5 + \frac{1}{2}y^3) dy$$

$$I_c = (\delta/g)(2\pi) \{ \frac{1}{8} [\frac{1}{6} (4^6 - .25^6)] + \frac{1}{2} [\frac{1}{4} (4^4 - .25^4)] \}$$

$$I_c = (\delta/g)(2\pi) [85.33 + 32]$$

$$I_c = 10302.86 \text{ ft-lb-s}^2$$

Figure 36
Dynamic Equilibrium of Rotating Bodies

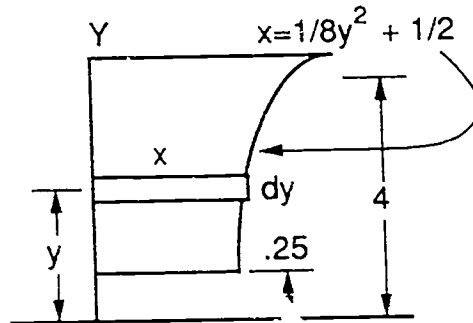
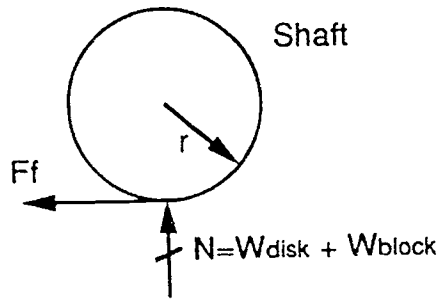

Figure 37
Dynamic Equilibrium of Rotating Bodies



Static Friction Moment (refer to Figure 37)

$$V = 2\pi \int_{.25}^4 (1/8 y^2 + 1/2) (y) dy$$

$$V = 2\pi \int_{.25}^4 (1/8 y^3 + 1/2 y) dy$$

$$V = 2\pi \{ 1/8 [1/4 (4^4 - .25^4)] + 1/2 [1/2 (4^2 - .25^2)] \}$$

$$V = 2\pi [8 + 3.98]$$

$$V = 75.27 \text{ cu ft.}$$

14~

$$W = \rho V = 33872.65 \text{ lb.}$$

$$F_f = (W_D + W_B) f = 687.45 \text{ lb}$$

$$\text{Friction Moment} = F_f (r) = 687.45 (.25) = 171.86 \text{ ft-lb}$$

Figure 38
Dynamic Equilibrium of Rotating Bodies

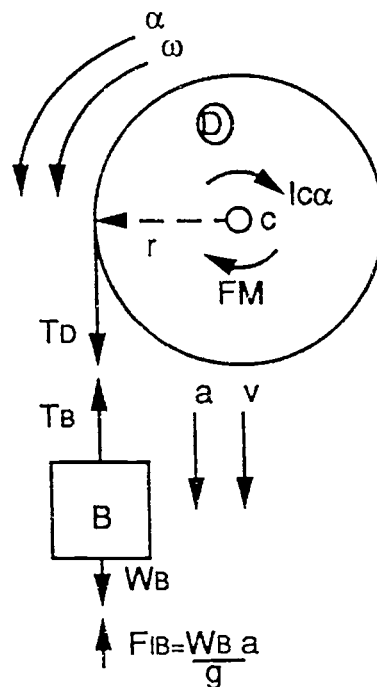

Refer now to Figure 38.

$$r(T_D) = I_c \alpha + FM$$

$$T_D = \frac{I_c \alpha + FM}{r}$$

$$T_B = W_B - \frac{W_B a}{g}$$

$$[T_D = T_B]$$

$$\frac{I_c \alpha + FM}{r} = W_B - \frac{W_B a}{g}$$

$$\frac{10302.8\alpha + 171.86}{4} = 500 - \frac{500(4)\alpha}{32.2}$$

$$a = .1733 \text{ rad/s}^2$$

$$T_D = \frac{I_c \alpha + FM}{r} = \frac{10302.86(.1733) + 171.86}{4}$$

$$T_D = 489.24$$

$$[a = r\alpha]$$

$$a = 4 (.1733)$$

$$a = .6932 \text{ ft/s}^2$$

$$T_B = W_B - \frac{W_B a}{g} = 500 - \frac{500(.6932)}{32.2}$$

$$T_B = 489.24 \text{ lb}$$

Physics III (HP) Strength of Materials

The traditional content of a course in strengths of materials can be described as the "statics of deformable elastic bodies" (Table 5). The subject involves the calculation of stresses and deflections or deformations in beams, shafts, pipes, or other structures as functions of the loads imposed upon them and the dimensions of the structure. These stresses are usually independent of the material; a steel beam and a wooden beam of the same dimensions under the same loads will experience the same stresses. The question of the conditions of failure, surprisingly enough, is of only secondary significance in this subject. In a typical calculation, almost all the work, say ninety-five percent, will be "statics," independent of the material used, and only in the end will we substitute values for an allowable working stress and modulus of elasticity to determine necessary strength and actual deflections.

Table 5
PHYSICS III (HP) Course Outline

Strength of Materials (First Semester)
Stress and Deformation
Engineering Materials and their Properties
Torsion
Centroids and Moments of Inertia
Shear and Moment in Beams
Stresses in Beams
Design of Beams
Deflection of Beams
Statically Indeterminate Beams
Combined Stresses
Columns
Special Topics
Design Projects Involving Three Courses
Electricity and Magnetism (Second Semester)
Electrostatics
Electric Circuits
Magnetostatics
Electromagnetism

Sample Problem A: Beam Design

Given: Beam AB is sixteen feet long with a distributed load defined by the general function $y = kx^2$ (Figure 39).

Figure 39
Beam Design

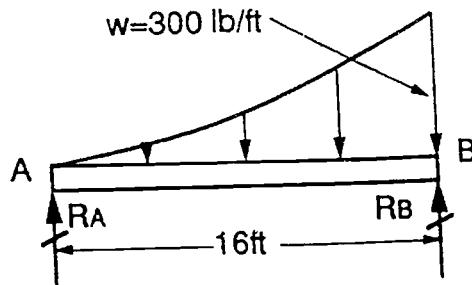

Find: The total load on the beam. Use integral calculus. Represent this load by a single resultant vector at the centroid of the given load. Construct shear and bending moment diagrams. Determine the maximum shear and bending stresses. Select a material that will withstand such stress.

To find the specific function of the load, solve for k given the information on the illustration

$$y = kx^2$$

$$300 = k(16)^2$$

$$k = 300/256 = 1.171$$

$$y = 1.171 x^2$$

Compute the total load on the beam using integral calculus.

$$\begin{aligned} \text{Load} &= \int_0^{16} 1.171 x^2 dx \\ &= 1.171 \left[\frac{1}{3} (16^3 - 0^3) \right] \\ &= 1600 \text{ lb} \end{aligned}$$

$$\langle x \rangle = \text{distance to centroid of load}$$

$$\langle x \rangle = \frac{\int_0^{16} 1.171 x^2 (x) dx}{\int_0^{16} 1.171 x^2 dx} = 12 \text{ ft}$$

Reactions at A and B can be computed with basic statics principles.

$$[\Sigma M_A = 0] \quad 1600(12) = R_B (16)$$

$$R_B = 1200\text{lb}$$

$$[\Sigma H = 0] \quad R_A + R_B = 1600$$

$$R_A = 400\text{lb}$$

We may now construct the shear and bending moment diagrams, keeping in mind the definitions of shear and bending moment and the laws of beam diagrams.

First Law of Beam Diagrams:

Slope of a curve in any diagram = length of ordinate at the same point in the next higher diagram.

Second Law of Beam Diagrams:

The difference in length of any two ordinates in one diagram equals the area between the corresponding ordinates in the next higher diagram.

Shear = V

It is defined as the sum of the forces to the left of any given point x on the beam.

$$V = 400 - \int_0^x 1.171 x^2 dx$$

$$V = 400 - 1.171 \left[\frac{1}{3} (x^3 - 0^3) \right]$$

$$V = 400 - .391x^3$$

Bending Moment = M

It is defined as the algebraic sum of the moments of the forces to the left of any given point x on the beam.

$$M = \int V$$

$$M = \int_0^x (400 - .391x^3) dx$$

$$M = \int_0^x (400) dx - \int_0^x (.391x^3) dx$$

$$M = 400x - .098x^4$$

The shear and moment equations may be used to plot the graphs of the bending moment and shear variations.

The maximum bending moment will occur when the shear is zero. Therefore

$$0 = 400 - .391x^3$$

$$x_{(\text{maximum bending})} = 10.1 \text{ ft}$$

$$M_{\text{max}} = 400 (10.1) - .098 (10.1)^4$$

$$M_{\text{max}} = 3020 \text{ ft-lb}$$

The internal resisting moment must equal the external bending moment if the beam is to remain static. To compute the maximum internal stress due to the external bending moment, the moment of inertia of the cross section must be calculated (Figure 40).

Figure 40
Beam Design

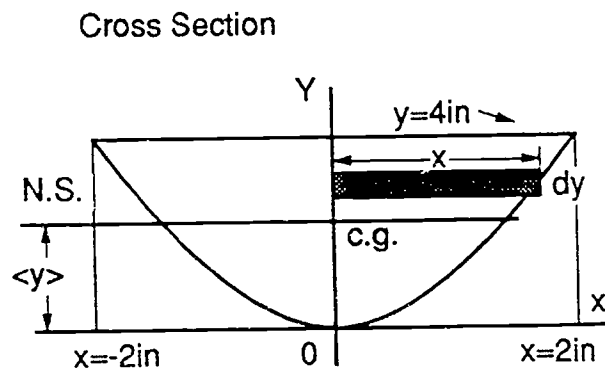

$$x = y^2$$

$$\langle y \rangle = \frac{\int_0^4 y^{1.5} y \, dy}{\int_0^4 y^2 \, dy} = 2.4 \text{ ft}$$

$$I_x = 2 \int_0^4 y^{1.5} y^2 \, dy$$

$$I_x = 73.14 \text{ in}^4$$

The moment of inertia must then be transferred to a centroidal axis parallel with the x-axis.

$$[I_{x'} = I_x - A \langle y \rangle^2] \quad I_{x'} = 73.14 - 5.33 (2.4)^2 = 42.42 \text{ in}^4$$

The flexure tendency of a beam supported at both ends and under a load is illustrated in Figure 41. Fibers in the top of the beam are made shorter, and are thus under compressive stress. Fibers in the bottom of the beam are stretched, and therefore under tensile stress. Between the top and bottom exists a neutral surface; because it remains the same length, it has no compressive or tensile stress. It lies at the centroid of the cross section. The farther from this surface, the greater the deformation, and implicitly, the greater the stress necessary to create it.

Figure 41
Beam Design

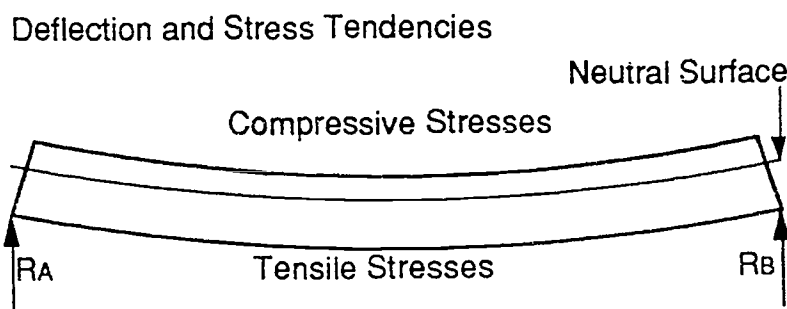

The flexure formula computes the fiber stress at a distance c from a neutral surface of a beam, given the Area moment of inertia of the beam and the the bending moment at that location. Use the flexure formula to determine the maximum stress due to bending.

The Flexure Formula: [Stress = Mc/I]

The lowest fiber undergoes tensile stress. It is 2.4in from the neutral surface.
 $I = 2057 \text{ lb/in}^2$ $M = 3020 \text{ lb ft}$

$$T = 3020\text{lb} (2.4\text{in})(12\text{in})/42.42 \text{ in}^2 = 2057.4 \text{ lb/in}^2$$

The highest fiber undergoes compressive stress. It is 1.6in from the neutral surface. $I = 2057\text{lb/in}^2$ $M = 3020\text{lb ft}$

$$C = 3020\text{lb} (1.6\text{in})(12\text{in})/42.42 \text{ in}^2 = 1371.6 \text{ lb/in}^2$$

The strengths of various materials in bending are tabulated in engineering manuals. For example, if the beam is made of wood, the allowable bending stresses for various species are listed in Table 6. below.

Table 6
Allowable Unit Stresses in Psi

<u>Species and Commercial Grade</u>	<u>Maximum Fiber Stress</u>
Fir, Larch	
Dense select structural	1900
Select Structural	1600
Dense no. 1	1550
No. 1	1300
Hemlock, Eastern	
Select Structural	1350
No. 1	1100
Pine, Ponderosa or Lodgepole	
Select Structural	1100
No. 1	925

Refer to Figure 42. From our analysis, we can see that a beam with this cross section and load should not be made from these materials.

Figure 42
Beam Design

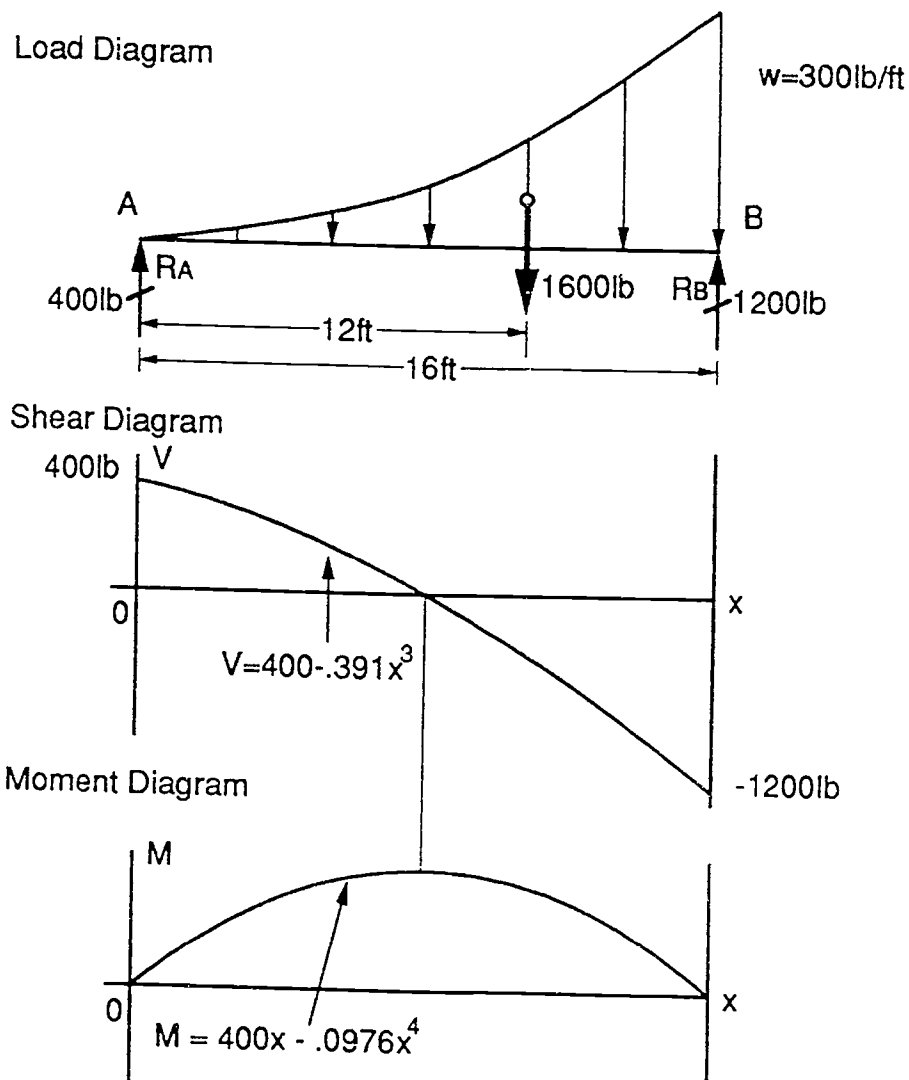

Examples of Student Work (Various Sample Problems)

A	FEB 14, 1992	NGUYEN, THUAN P.2	4
---	--------------	-------------------	---

BOUNDED REGION. $Y^2 = 9X$
 WATER SURFACE. $Y = 3$

$\delta = \frac{48 \text{ lb}}{\text{FT}^3}$

$P = 48 \int_{-6}^3 \left(4 - \frac{Y^2}{9}\right) (3 - Y) \, dY$

$= 48 \int_{-6}^3 12 - 4Y - \frac{1}{3} Y^2 + \frac{1}{9} Y^3 \, dY$

$= 48 \left[12(3 - (-6)) - 4\left(\frac{1}{2}(3^2 - (-6)^2)\right) - \frac{1}{3}\left(\frac{1}{3}(3^3 - (-6)^3)\right) + \frac{1}{9}\left(\frac{1}{4}(3^4 - (-6)^4)\right) \right]$

$= 48(101.25)$

$P = 4860 \text{ lb}$

$\bar{P} = \frac{\int_{-6}^3 \left(4 - \frac{Y^2}{9}\right) (3 - Y)^2 \, dY}{101.25}$

$= \frac{-\frac{1}{9} \int_{-6}^3 Y^4 \, dY + \frac{2}{3} \int_{-6}^3 Y^3 \, dY + 3 \int_{-6}^3 Y^2 \, dY - 24 \int_{-6}^3 Y \, dY + 36 \int_{-6}^3 \, dY}{101.25}$

$= \frac{-178.2 - 202.5 + 243 - (-324) + 324}{101.25} = 5.04$

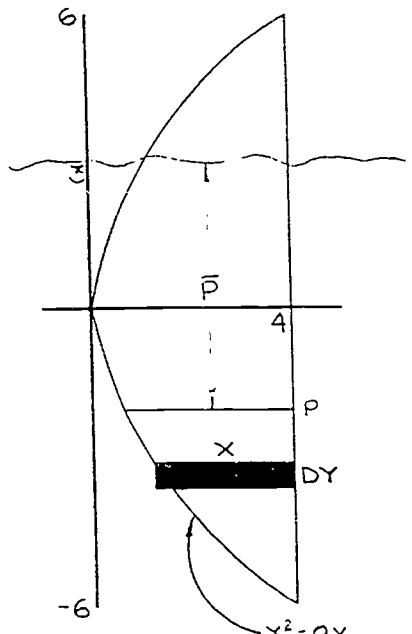

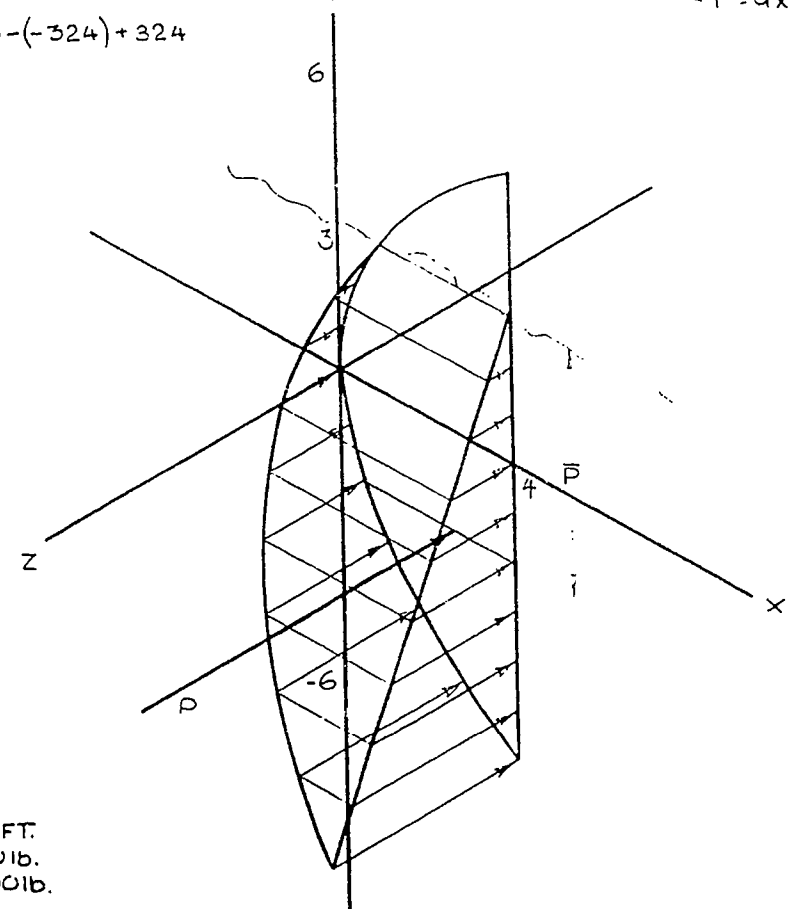

DISTANCE SCALE: 1" = 3 FT.
 VECTOR SCALE: 1" = 300 lb.
 = 2000 lb.

MASS MOMENT OF INERTIA

$$I_{cm} = \frac{\delta}{9} 2\pi \int_a^b x(Y)(Y^2) dY$$

$$\frac{\delta}{9} 2\pi \int_{.25}^4 \left(\frac{1}{8}Y^2 + \frac{1}{2}\right)(Y^2) dY$$

$$\frac{\delta}{9} 2\pi \int_{.25}^4 \left(\frac{1}{8}Y^4 + \frac{1}{2}Y^3\right) dY$$

$$\frac{\delta}{9} (2\pi) \frac{1}{8} \left[\frac{1}{6}(4^6 - .25^6)\right] + \frac{1}{2} \left[\frac{1}{4}(4^4 - .25^4)\right]$$

$$\frac{\delta}{9} (2\pi) \frac{1}{8} \left[\frac{1}{6}(4096 - .00024)\right] + \frac{1}{2} \left[\frac{1}{4}(256 - .0039)\right]$$

$$\frac{\delta}{9} 2\pi (85.33 + 32)$$

$$\frac{450}{32.2} (737.2) = 10302.8 \text{ FT} \cdot \text{LB} \cdot \text{s}^2$$

STATIC - FRICTION MOMENT (VOLUME)

$$2\pi \int_{.25}^4 \left(\frac{1}{8}Y^2 + \frac{1}{2}\right)(Y) dY$$

$$2\pi \int_{.25}^4 \left(\frac{1}{8}Y^3 + \frac{1}{2}Y\right) dY$$

$$2\pi \left[\frac{1}{8}\left(\frac{1}{4}\right)(4^4 - .25^4)\right] + \frac{1}{2} \left[\frac{1}{2}(4^2 - .25^2)\right]$$

$$2\pi \left[\frac{1}{32}(256 - .0039)\right] + \frac{1}{4}(16 - .0625)$$

$$2\pi (8 + 3.98) = 75.27 \frac{\text{CU.}}{\text{FT}}$$

WEIGHT = 75.27 (450) = 33872.65 LB

F_f = (33872.65 + 500) (.02) = 687.45 LB

FRICTION MOMENT = 687.45 (.25) = 171.86 FT · LB

R(T₀) = I_{cm} + FM

$$T_0 = \frac{I_{cm} + FM}{R}$$

$$T_0 = W_0 - \frac{W_B}{g} a$$

[T₀ = T₀]

$$\frac{I_{cm} + FM}{R} = W_0 - \frac{W_B}{g} a$$

$$\frac{I_{cm} + FM}{R} = W_0 - \frac{W_B}{g} R\alpha$$

$$\frac{10302.8\alpha + 171.86}{4} = 500 - \frac{500}{32.2} (4)\alpha$$

$$2575.7\alpha + 42.97 = 500 - 62.11\alpha$$

$$2637.81\alpha = 457.03$$

$$\alpha = .1733 \frac{\text{RAD}}{\text{s}^2}$$

$$T_0 = \frac{I_{cm} + FM}{R} = \frac{10302.8 (.1733) + 171.86}{4}$$

$$T_0 = 489.24 \text{ LB}$$

[a = Rα]

$$a = 4 (.1733)$$

$$a = .6932 \frac{\text{FT}}{\text{s}^2}$$

$$T_0 = W_0 - \frac{W_B}{g} a = 500 - \frac{500}{32.2} (.6932)$$

$$T_0 = 489.24 \text{ LB}$$

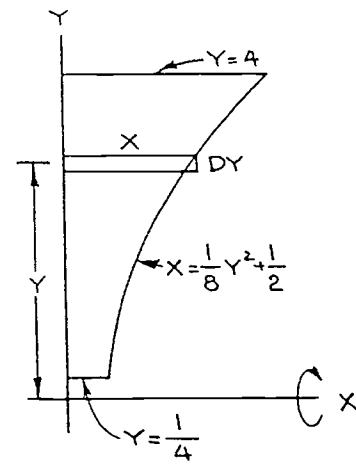

SHAFT

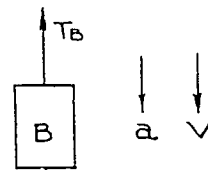
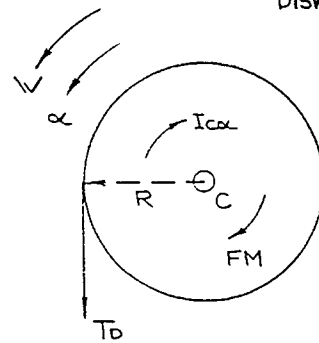
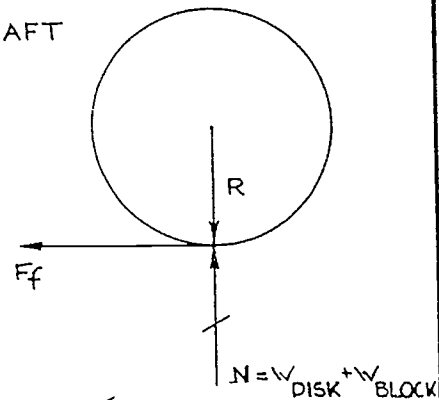

$$F_{T_B} = \frac{W_B}{g} a$$

$$a = R\alpha$$

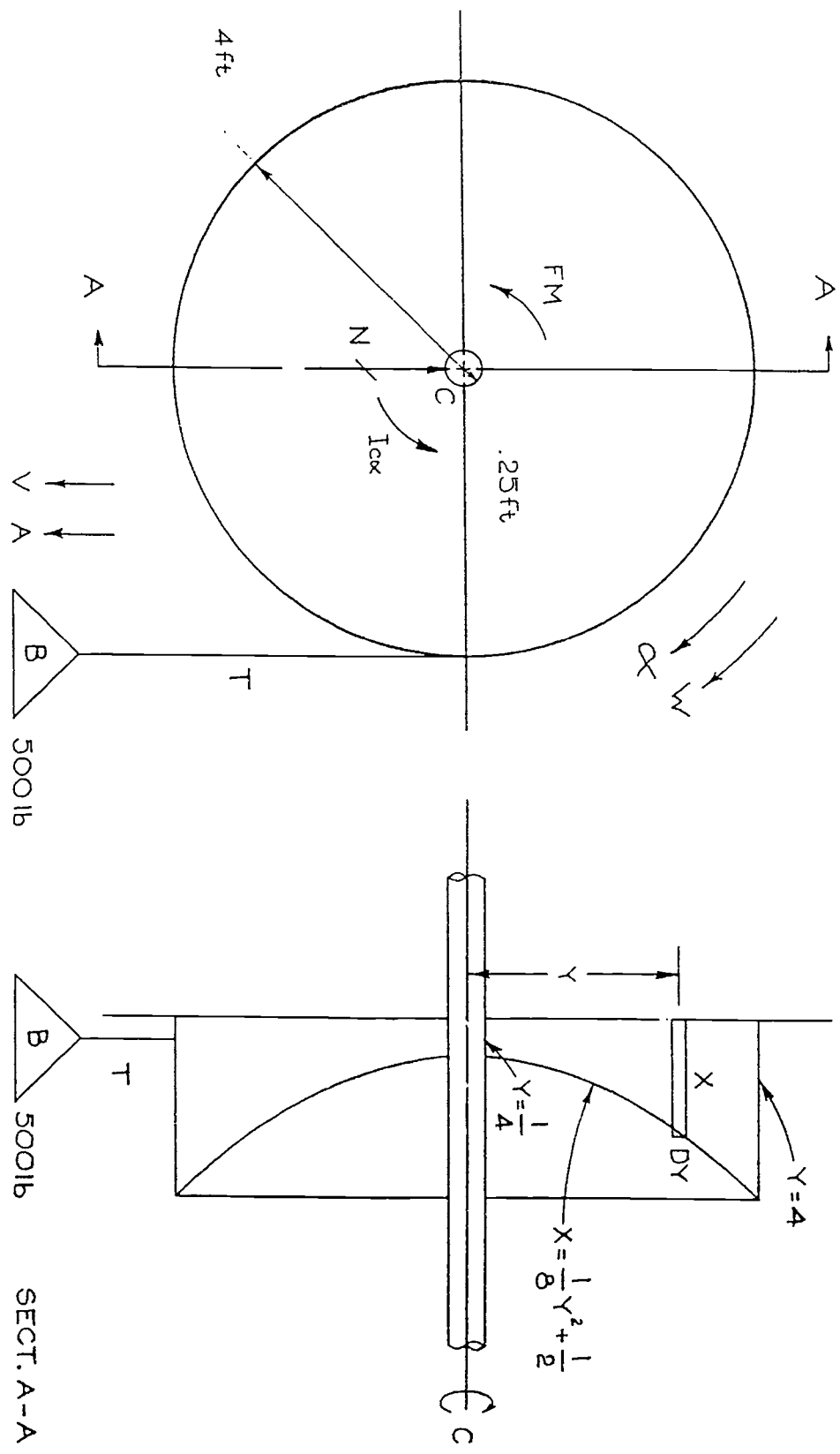

A

MARCH 4, 1992

NGUYEN THUAN D. P.2

3

5

$$H = \cos 30^\circ (180) = 155.885$$

$$V = \sin 30^\circ (180) = 90$$

$$A = -9.81$$

$$DV$$

$$DT = A = -9.81$$

$$\int_{90}^V DV = \int_0^T -9.81 DT$$

$$V - 90 = -9.81T$$

$$V = -9.81T + 90$$

$$0 = -9.81T + 90$$

$$T = \frac{90}{9.81}$$

$$T = 9.174 \text{ s} \quad \textcircled{B}$$

$$S = -\frac{9.81}{2} (9.174)^2 + 90(9.174) + 150$$

$$S = 562.816 \text{ M} \quad \textcircled{B}$$

$$\frac{DS}{DT} = V = -9.81T + 90$$

$$\int_{150}^S DS = \int_0^T -9.81T + 90 DT$$

$$S - 150 = -\frac{9.81}{2} T^2 + 90T$$

$$S = -\frac{9.81}{2} T^2 + 90T + 150$$

$$T = \frac{-90 \pm \sqrt{(90)^2 - 4 \left(-\frac{9.81}{2}\right) (150)}}{2 \left(-\frac{9.81}{2}\right)}$$

$$T = \frac{-195.086}{-9.81}$$

$$T = 19.886 \text{ s} \quad \textcircled{A}$$

$$X = 155.885 (T)$$

$$X = 3099.993 \text{ M} \quad \textcircled{A}$$

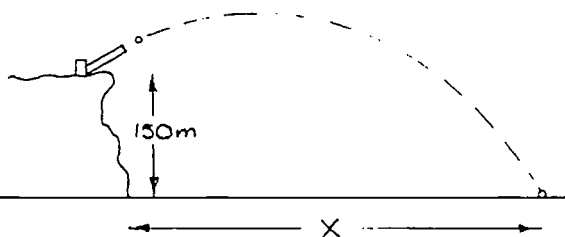
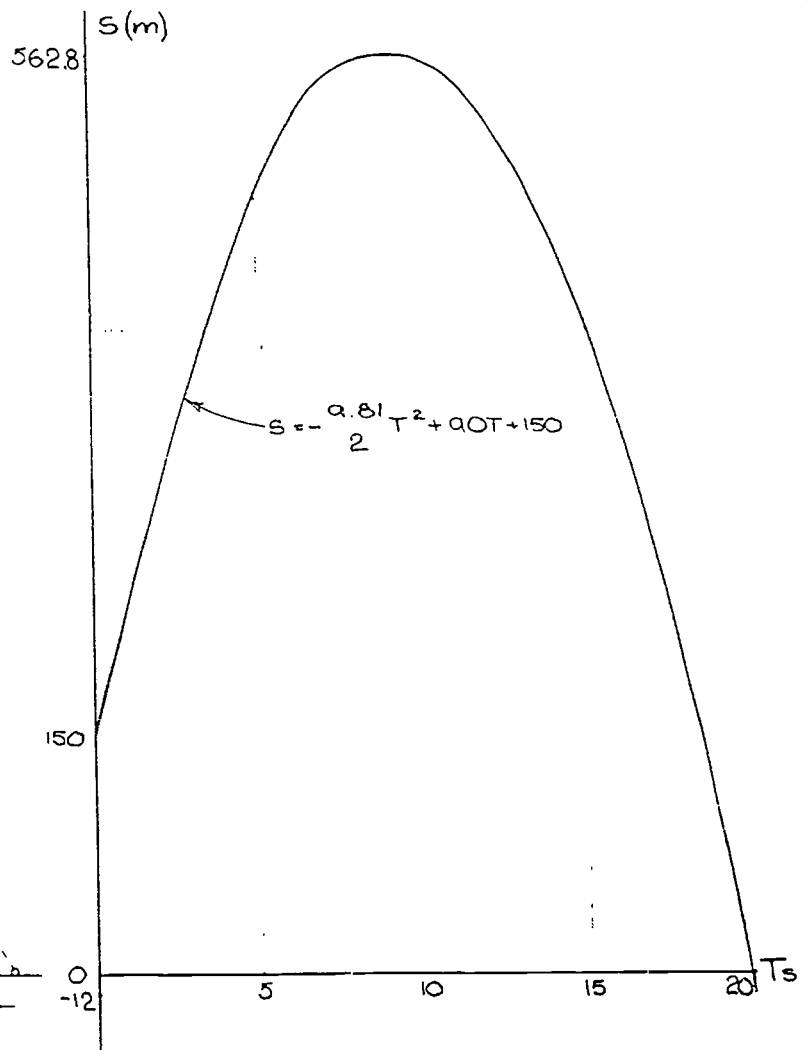
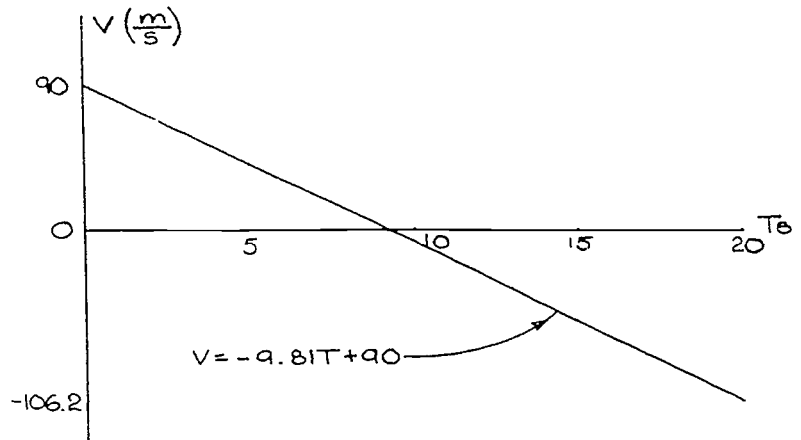
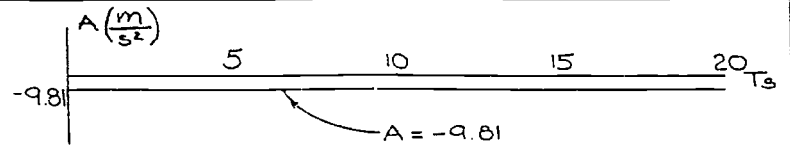

GRAPH

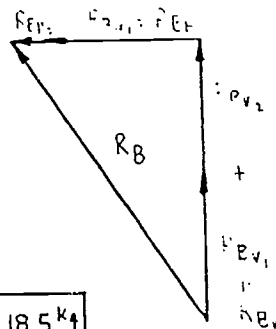
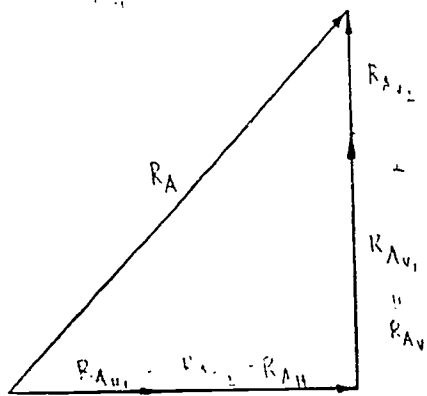
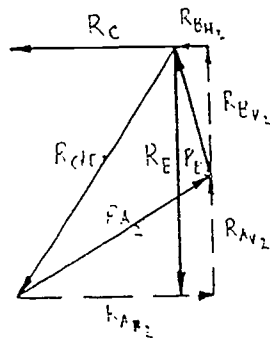
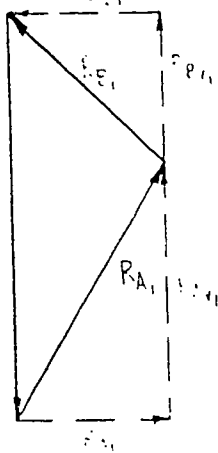
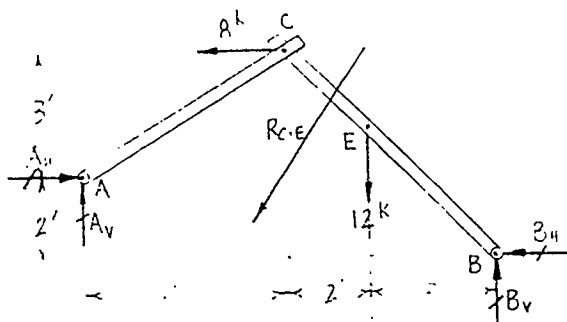
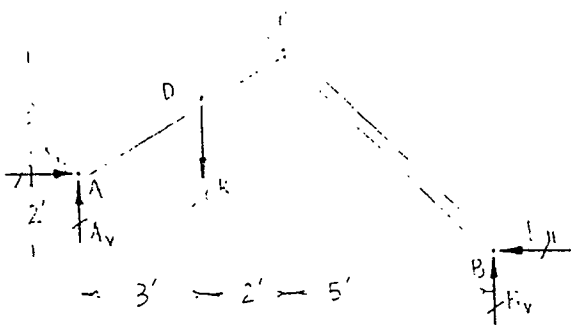
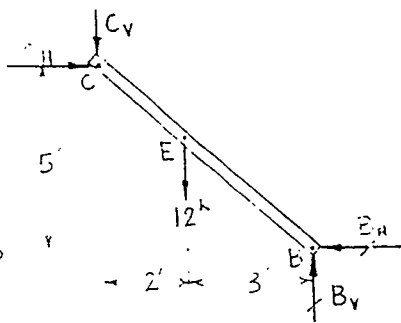
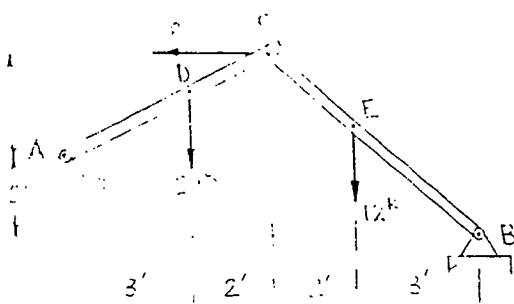

GRAPH	$R_{AH} = 17k \leftarrow$	$R_{AV} = 18.5k \uparrow$
	$R_{BH} = 9k \leftarrow$	$R_{BV} = 14k \uparrow$

PETER LY

OAKLAND TECHNICAL HIGH SCHOOL

MARCH 11, 1992

+ FIND THE VERTICAL AND HORIZONTAL REACTION COMPONENTS AT SUPPORTS A AND B

MATH

$$[\Sigma M_A = 0] \quad 10B_v(18)(4) - 2B_H(120)(3) + (12)(17)$$

$$18B_v - 2B_H = 120$$

$$[\Sigma M_B = 0] \quad 5B_v - 5B_H = (2)(2)$$

$$B_v - B_H = 2$$

$$10B_v - 2B_H = 120 \quad 10B_v - 2(4) = 120$$

$$(10B_v - 10B_H = 48) \quad 10B_v = 138$$

$$B_v = 13.8 \text{ k}\uparrow$$

$$3B_H = 72$$

$$B_H = 9 \text{ kIPS} \leftarrow$$

$$[\Sigma V = 0] \quad A_v + 13.8 = 20 + 12$$

$$A_v = 18.2 \text{ kIPS} \uparrow$$

$$[\Sigma H = 0] \quad A_u = 9 + 9$$

$$A_u = 17 \text{ kIPS} \rightarrow$$

MATH	$A_u = 17 \text{ kIPS} \rightarrow$	$A_v = 18.2 \text{ kIPS} \uparrow$	$B_H = 9 \text{ kIPS} \leftarrow$	$B_v = 13.8 \text{ kIPS} \uparrow$
------	-------------------------------------	------------------------------------	-----------------------------------	------------------------------------