

DOCUMENT RESUME

ED 348 478

CE 061 466

TITLE Horticulture Materials for Agricultural Education Programs. Core Agricultural Education Curriculum, Central Cluster.

INSTITUTION Illinois Univ., Urbana. Office of Agricultural Communications and Education.

SPONS AGENCY Illinois State Board of Education, Springfield. Dept. of Adult, Vocational and Technical Education.

PUB DATE 89

NOTE 886p.; For related documents, see CE 061 464-467.

PUB TYPE Guides - Classroom Use - Teaching Guides (For Teacher) (052)

EDRS PRICE MF06/PC36 Plus Postage.

DESCRIPTORS Agricultural Education; Behavioral Objectives; Botany; *Business Administration; *Core Curriculum; Engines; *Floriculture; High Schools; *Horticulture; Instructional Materials; *Landscaping; Pests; Plant Growth; Plant Identification; *Plant Propagation; Plants (Botany); Soil Science; State Curriculum Guides; Turf Management

IDENTIFIERS Illinois

ABSTRACT

This curriculum guide contains five units with relevant problem areas for horticulture. These problem areas have been selected as suggested areas of study to be included in a core curriculum for secondary students enrolled in an agricultural education program. Each problem area includes some or all of the following components: related problem areas, prerequisite problem areas, occupational tasks addressed, learning assessment plan sheets, instructor's guide, information sheets, student worksheets or assignment sheets and keys, demonstrations, transparency masters, and a discussion guide for transparencies. Suggestions are made for use of the core materials, including specific suggestions for using the different components of a problem area. The five units are as follows: (1) horticultural business operation and management; (2) horticultural science and production; (3) horticultural mechanics; (4) landscaping; and (5) floral design. (NLA)

* Reproductions supplied by EDRS are the best that can be made *
* from the original document. *

7-911-201

ED348478



Agricultural Education Curriculum

Central Cluster

Agricultural Business and Management Cluster

■ Horticulture Cluster

Agricultural Resources Cluster

U.S. DEPARTMENT OF EDUCATION
Office of Educational Research and Improvement
EDUCATIONAL RESOURCES INFORMATION
CENTER (ERIC)

- This document has been reproduced as received from the person or organization originating it
- Minor changes have been made to improve reproduction quality
- Points of view or opinions stated in this document do not necessarily represent official OERI position or policy

CE 061 466

"PERMISSION TO REPRODUCE THIS MATERIAL HAS BEEN GRANTED BY

R. Bemis

TO THE EDUCATIONAL RESOURCES INFORMATION CENTER (ERIC)."

Illinois State Board of Education

Louis Mervis
Chairman

Robert Leininger
State Superintendent
of Education

Department of Adult,
Vocational and Technical
Education

AN INTEGRATED CURRICULUM
FOR TECHNICAL PREPARATION
IN AGRICULTURE

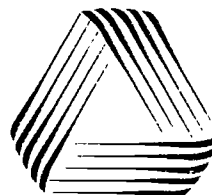

**Horticulture Materials
for Agricultural
Education Programs**

Project Staff:

Director: Dale A. Law,
Ed.D.

Principal Investigator:
Jerry D. Pepple, Ed.D.

Developers:

Paul Hemp
Chris Roegge
Robert Petrea
Janis Anderson
Randy Bernhardt
Jim Shinn
Doug Stockely
Ron Biondo
Edward Osborne
Carrie Batty
David Bennett

Agricultural
Communications and
Education, University of
Illinois at Urbana-
Champaign
(217) 333-3165

**Sponsored by Illinois
State Board of
Education**

Thomas Lay Burroughs
Chairman

Robert Leininger
*State Superintendent of
Education*

Richard J. Miguel
*Asst. Superintendent and
State Director of
Vocational Education*

Kathleen Nicholson-
Tosh
*Manager, Vocational
Education Program
Services*

William B. Schreck
Thomas R. Wiles
Ronald L. Reische
*Agricultural Education
Consultants*

**Department of Adult,
Vocational and
Technical Education**

Program Improvement
Section

1989

This publication was prepared pursuant to a grant with the Illinois State Board of Education, Department of Adult, Vocational, and Technical Education, and funded 100 percent through the Carl D. Perkins Vocational Education Act.

An Equal Opportunity/Affirmative Action Employer

Core Curriculum Design Team:

Leonard Harzman, Agricultural Education, WIU
William Hunter, Vocational Agriculture Service, UIUC
James Legacy, Agricultural Education, SIU-Carbondale
Edward Osborne, Agricultural Education, UIUC
Ronald L. Reische, Agricultural Education Consultant, ISBE
Fred Reneau, Agricultural Education, SIU-Carbondale
Earl Russell, Agricultural Education, UIUC
William B. Schreck, Agricultural Education Consultant, ISBE
John Smith, Vocational Agricultural Service, UIUC
Thomas Stitt, Agricultural Education Consultant, ISBE
Robert Wolff, Agricultural Mechanics, SIU-Carbondale
Jeff Wood, Agricultural Education, ISU

Core Curriculum Advisory Committee:

Tom Weston, Vocational Agriculture Teacher,
Orion High School, Orion, Illinois
Larry Lowe, Vocational Agriculture Teacher,
Normal Community High School, Normal, Illinois
Jay Runner, Vocational Agriculture Teacher,
Northwestern High School, Sciota, Illinois
C. Eugene McGrew, Vocational Agriculture Teacher,
Bushnell-Prairie City High School, Bushnell, Illinois
Robin Harlan, Vocational Agriculture Teacher,
Armstrong High School, Armstrong, Illinois
Glen Mills, Vocational Agriculture Teacher,
St. Elmo High School, St. Elmo, Illinois
Don Jenkins, Vocational Agriculture Teacher,
Dwight High School, Dwight, Illinois
Allen Hornbrook, Vocational Agriculture Teacher,
Paris High School, Paris, Illinois
Sam Robb, Vocational Agriculture Teacher,
Pinckneyville High School, Pinckneyville, Illinois

Acknowledgements

Appreciation is expressed to the many agricultural educators who shared their time, knowledge, and instructional aids for the preparation of this core curriculum. Without their cooperation and input, this printing would not have been possible.

Suggestions for Using Core Materials

It is recommended that teachers planning to use the attached curriculum guides and teaching aids refer to the **Illinois Plan for Agricultural Education: Secondary Core Curriculum Implementation Guide** for specific guidelines. This booklet includes ideas, suggestions and a step-by-step set of instructions for revising local programs and courses. These curriculum guides and teaching aids have been designed to improve instruction in agri-science and business management and to enhance student learning in these areas. Each problem area includes some or all of the following components:

1. Related problem areas
2. Prerequisite problem areas
3. Occupational tasks addressed
4. Learning assessment plan sheets
5. Instructor's guide
6. Information sheets
7. Student worksheets or assignment sheets and keys
8. Demonstrations
9. Transparencies
10. Discussion guide for transparencies

This curriculum guide should be utilized as a source unit. This means that teachers should selectively choose those components which they need to achieve their teaching objectives. The project staff does not recommend that teachers "teach" the core program as it is presented. Instead, the teacher should personalize and localize the materials for the particular group taught and, wherever possible, add other materials and teaching techniques to enrich the core program.

Teachers could teach everything included in the core curriculum but this would not be advisable considering the variations which exist in agriculture programs, students' needs and interests, and program objectives. Instead, teachers should select problem areas for a "local core" and supplement them with other problem areas important in the local area. Another suggestion is that an entire unit need not be taught to a given group during a given year. For example, teachers may want to teach part of the Food Science and Technology Unit to freshmen and teach the remaining part to an advanced class.

Specific suggestions for using the different components of a problem area are presented in the following section.

1. **Related problem areas.** These problem areas are included to assist teachers in planning their programs and course outlines. Teachers should review these problem areas when scheduling their courses to get an overview of the subject matter included in the core which is related to selected agricultural topics.
2. **Prerequisite problem areas.** Many of the core problem areas may require a current knowledge of science, mathematics, communications, or basic agricultural concepts. This section will alert the teacher if this problem area requires any previous or specific instruction.
3. **Occupational tasks addressed.** Instructors in Education for Employment programs have identified the occupational tasks which are to be taught in their courses. This section identifies those tasks from the state developed task lists which can be addressed within the context of this problem area.
4. **Learning assessment plan sheets.** The recently amended School Code of Illinois requires that goals for learning be identified and taught. This section identifies those State Goals for Learning and Learning Objectives which can be addressed within the context of this problem area.
5. **Instructor's guide.** The instructor's guide is not a lesson plan. It is a source of teaching ideas which may be implemented by the agriculture teacher to conduct an effective instructional program. Each guide includes more material than most teachers would use. Teachers should select from the several interest approaches and teaching activities those suggestions which seem most appropriate for the local situation. The instructor's guide emphasizes a problem-solving method and a student-centered, activity approach. Lecture-presentation and rote memorization of facts should be kept to a minimum. The instructor's guides include suggestions for carrying learning to the "doing" level. Application of classroom learning to SAEPs and FFA activities is an important part of the teaching process.
6. **Information sheets.** These sheets have been prepared for those problem areas where technical information on the subject may be difficult to locate. If reference materials are not available, the teacher may want to duplicate copies of the information sheets for class use.

7. **Student worksheets or assignment sheets and keys.** These exercises are designed as classroom activities for student use. They may provide a change of pace for students when introducing, reinforcing or mastering certain agricultural concepts. Most exercises include a teacher's key with suggested answers.
8. **Demonstrations.** The teaching of certain problem areas often calls for demonstrations of manipulative skills or scientific principles. The demonstration outline may be used by the teacher or students to conduct demonstrations of science principles and manipulative skills. Teachers may want to change some of the student activities included in the instructor's guide into student demonstrations.
9. **Transparencies.** Some of the problem areas include transparency masters which can be used to prepare transparencies for the teachers to use when discussing certain concepts and subject matter.
10. **Discussion guide for transparencies.** Most of the transparencies included in the core materials do not include on the overlay any narration or explanation. The discussion guide provides teachers with some suggested points to bring out in the discussion of a transparency including explanations, descriptions, and discussion questions related to the transparency. The information sheets may also provide pertinent information useful in the discussions associated with the transparencies.

The core materials, if used properly, can improve the teaching process and save valuable teacher time. At the same time, misuse or overuse of these materials may lead to a lock-step approach to teaching and learning with the teacher adding little in the way of resourceful innovations and creative techniques. **The Illinois Plan for Agricultural Education: A Planning Guide** stresses the need to broaden local curricula in order to meet the needs of several audiences. It emphasizes the need to address several objectives at each level of a comprehensive program. It is recommended that this booklet be reviewed as you are evaluating your local program needs.

For best results when using the Core Curriculum materials, teachers should:

1. Use the curriculum but don't handle it like a teaching plan.
2. Localize the curriculum for their community.
3. Personalize the curriculum for their students.
4. Supplement the curriculum to achieve local objectives.

Illinois State Board of Education

Department of Adult, Vocational and Technical Education
Program Improvement Section
Product Abstract

1. Title of material: Horticulture Materials for Agricultural Education Programs
2. Date material was completed: June 1989
3. Please check one: New material Revised
4. Originating agency: University of Illinois
Address: Urbana, Illinois Zip Code: 61801
5. Name of developer: Dale A. Law
Address: 1301 West Gregory, Urbana, IL Zip Code: 61801
6. Developed pursuant to Contract Number: OT-10-688

7. Subject Matter (Check only one according to USOE Code):
USOE Code
 01 Agricultural Education 10 Industrial Art Education
 03 Business and Office Education 16 Technical Education
 04 Distributive Education 17 Trade and Industrial Education
 07 Health Occupations Education Career Education
 09 Home Economics Education Other (Specify)

8. Education Level:
 Pre-K Thru 6 7-8 9-10 11-12
 Post-Secondary Adult Teacher (Pre-service)
 Administrator (Pre-Service) Other (Specify)

9. Intended for Use By:
 Student Classroom Teacher Local Administrator
 Teacher Educator Guidance Staff State Personnel
 Other (Specify)

10. Student Type:
 Regular Disadvantaged Handicapped
 Limited English Proficiency Other (Specify)

11. Medium and Format of Materials:
 Hardcopy Videotape Film Microfiche
 No. of pages Minutes Minutes B & W
 Paper bound B & W B & W Color
 Hard bound Color Color
 Loose-leaf inches mm
Photos: Yes No
Diagrams: Yes No

BEST COPY AVAILABLE

Slides Film Strips Audio Other
 No. of frames No. of frames Automatic synch Specify:
 B & W B & W Hz
 Color Color Manual cue
 Audio Audio Reel
 Carousel provided Cassette
 Other packaging used Cartridge
 (Specify) _____

12. Availability:

One copy free For sale @ \$ _____ per copy Not available
 in ERIC system (No. _____) Loan copy available
 Contact: Dale A. Law Phone (217) 333-3165
 Address: 1301 West Gregory, Urbana, IL Zip Code 61801

13. Copyright Restrictions:

Contact: Name _____ Phone () _____
 Address _____ Zip Code _____

14. Is Training Required for Optimum Use of These Materials? Yes No _____

15. Are Consultive/Training Services Available? Yes No _____

Contact: Illinois Board of Education
Department of Adult, Vocational and Technical Education
Program Improvement Section
100 North First Street
Springfield, IL 62777
(217) 782-4620

16. General Description:

This curriculum guide includes teaching units for the Horticulture Cluster problem areas selected as suggested areas of study to be included in a core curriculum for secondary students enrolled in an agricultural education program.

17. Person Completing this Abstract: Dale A. Law

Full Address: University of Illinois
124 Mumford Hall
1301 W. Gregory Drive
Urbana, IL 61801

**ILLINOIS AGRICULTURAL CORE CURRICULUM REVISION
UNITS AND PROBLEM AREAS**

Horticulture Cluster

Unit A: Horticultural Business Operation and Management

1. Marketing Horticultural Products and Services
2. Financing the Horticultural Business
3. Insuring the Horticultural Business
4. Planning and Organizing the Horticultural Business
5. Advertising and Selling Horticultural Products
6. Operating the Horticultural Business

Unit B: Horticultural Science and Production

1. Propagating Plants
2. Understanding Plant Germination, Growth, and Development
3. Classifying Horticultural Plants
4. Understanding Plant Anatomy and Physiology
5. Growing Ornamental Plants
6. Growing Vegetables
7. Growing Fruits
8. Processing Fruits and Vegetables
9. Controlling Plant Pests
10. Enhancing Soil Fertility
11. Developing Growing Media
12. Growing Plants Hydroponically

Unit C: Horticultural Mechanics

1. Designing, Building, and Maintaining Horticultural Structures
2. Utilizing Energy Alternatives
3. Repairing and Maintaining Small Engines
4. Repairing, Maintaining and Operating Horticultural Equipment

Unit D: Landscaping

1. Designing and Drawing Landscape Plants
2. Establishing and Maintaining Turf Plants
3. Transplanting and Maintaining Landscape Plants
4. Surveying, Grading, and Tilling
5. Interior Plantscaping

Unit E: Floral Design

1. Handling and Preparing Cut Flowers
2. Designing Silk and Dried Arrangements
3. Designing Live Arrangements
4. Identifying the Principles in Floral Design

UNIT A: Horticultural Business Operation and Management

Problem Areas:

1. Marketing Horticultural Products and Services
2. Financing the Horticultural Business
3. Insuring the Horticultural Business
4. Planning and Organizing the Horticultural Business
5. Advertising and Selling Horticultural Products
6. Operating the Horticultural Business

CLUSTER: HORTICULTURE

UNIT: Horticultural Business Operation and Management

PROBLEM AREA: Marketing Horticultural Products and Services

RELATED PROBLEM AREAS:

1. Operating the Horticultural Business
2. Processing Fruits and Vegetables
3. Repairing, Maintaining, and Operating Horticultural Equipment
4. Marketing Agricultural Products and Services (Agricultural Business and Management Cluster)
5. Advertising and Selling Horticultural Products

PREREQUISITE PROBLEM AREA(S):

1. Understanding the World Food and Fiber Chain (Central Core Cluster)
2. Applying Basic Economic Principles in Agribusiness (Central Core Cluster)

LEVEL: Preparatory

OCCUPATIONAL TASKS ADDRESSED:

Horticulture Cluster

Duty N: Performing Sales Duties

1. Plan territory management
2. Determine customer needs
3. Identify potential buyers
4. Conduct sales meetings
5. Evaluate sales process
6. Plan marketing strategy

Duty O: Performing Sales-Related Duties

1. Prepare advertisements

Duty Q: Managing the Business

1. Develop marketing plan
2. Select computer software for records and reports
3. Use computerized network on agricultural marketing and management

Note to Instructor: The additional contents of this problem area are identical to the contents found in the Agricultural Business and Management Cluster, Agribusiness Operation and Management Unit, Marketing Agricultural Products and Services Problem Area. Please refer to the referenced problem area.

REFERENCES:

1. *Greenhouse Operation and Management*. (1980). Nelson, Paul V. Prentice Hall, 200 Old Tappan Road, Old Tappan, NJ 07675. (800) 223-2348.
- *2. *Nursery Management*. (1988). Davidson, H., Mecklenburg, R., Peterson, C. Prentice Hall, 200 Old Tappan Road, Old Tappan, NJ 07675. (800) 223-2348.
3. *The Retail Florist's Business*. (1983). Pfahl, Peter. Interstate Publishers, Inc., P.O. Box 50, Danville, IL 61834-0050. (217) 446-0500.
4. *Profitable Garden Center Management*. (1982). Berninger, Louis. Prentice Hall, 200 Old Tappan Road, Old Tappan, NJ 07675. (800) 223-2348.
5. *Management for a Retail Florist*. (1980). Sullivan, G., Robertson, J. W.H. Freeman and Company, 4419 West 1980 South, Salt Lake City, UT 84104. (801) 973-4660.
6. *Greenhouse Management*. (1980). Kennard, N.S. Interstate Publishers, Inc., P.O. Box 50, Danville, IL 61834-0050. (217) 446-0500.

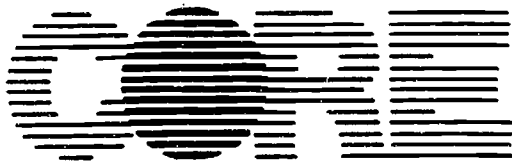

Illinois Agricultural Core Curriculum

Agricultural Education 124 Mumford Hall 1301 W. Gregory Drive University of Illinois Urbana, IL 61801

Director: Dale A. Law, Ed.D.

Principal Investigator: Jerry D. Pepple, Ed.D

Research Assistant: Douglas L. Stockley

CLUSTER: HORTICULTURE

UNIT: Horticultural Business Operation and Management

PROBLEM AREA: Financing the Horticultural Business

RELATED PROBLEM AREAS:

1. Marketing Horticultural Products and Services
2. Planning and Organizing the Horticultural Business
3. Managing Entrepreneurship Opportunities (Agricultural Business and Management Cluster)
4. Financing the Agribusiness (Agricultural Business and Management Cluster)

PREREQUISITE PROBLEM AREA(S):

1. Applying Mathematics Skills in Agriculture (Central Core Cluster)
2. Keeping and Using Records in Agriculture (Central Core Cluster)
3. Applying Basic Economic Principles in Agribusiness (Central Core Cluster)

LEVEL: Preparatory

OCCUPATIONAL TASKS ADDRESSED:

Horticulture Cluster

Duty Q: Managing the Business

1. Maintain business records
2. Prepare financial statements
3. Interpret financial statements
4. Complete business loan application process
5. Develop credit plan
6. Prepare budget
7. Prepare depreciation schedule
8. Select computer software for records and reports
9. Maintain inventory records
10. Prepare periodic reports and financial statements using computer system
11. Analyze financial statements using financial ratios
12. Input accounting entries in computerized bookkeeping system

Note to Instructor: The additional contents of this problem area are identical to the contents found in the Agricultural Business and Management Cluster, Agribusiness Operation and Management Unit, Financing the Agribusiness Problem Area. Please refer to the referenced problem area.

REFERENCES:

1. *Greenhouse Operation and Management.* (1980). Nelson, Paul V. Prentice Hall, 200 Old Tappan Road, Old Tappan, NJ 07675. (800) 223-2348.
- *2. *Nursery Management.* (1988). Davidson, H., Mecklenburg, R., Peterson, C. Prentice Hall, 200 Old Tappan Road, Old Tappan, NJ 07675. (800) 223-2348.

3. *The Retail Florist's Business.* (1983). Pfahl, Peter. Interstate Publishers, Inc., P.O. Box 50, Danville, IL 61834-0050. (217) 446-0500.
4. *Profitable Garden Center Management.* (1982). Berninger, Louis. Prentice Hall, 200 Old Tappan Road, Old Tappan, NJ 07675. (800) 223-2348.
5. *Management for a Retail Florist.* (1980). Sullivan, G., Robertson, J. W.H. Freeman and Company, 4419 West 1980 South, Salt Lake City, UT 84104. (801) 973-4660.
6. *Greenhouse Management.* (1980). Kennard, N.S. Interstate Publishers, Inc., P.O. Box 50, Danville, IL 61834-0050. (217) 446-0500.



Illinois Agricultural Core Curriculum

Agricultural Education 124 Mumford Hall 1301 W. Gregory Drive University of Illinois Urbana, IL 61801

Director: Dale A. Law, Ed.D.

Principal Investigator: Jerry D. Pepple, Ed.D

Research Assistant: James K. Shinn

CLUSTER: HORTICULTURE

UNIT: Horticultural Business Operation and Management

PROBLEM AREA: Insuring the Horticultural Business

RELATED PROBLEM AREAS:

1. Operating the Horticultural Business
2. Designing, Building, and Maintaining Horticultural Structures
3. Repairing, Maintaining, and Operating Horticultural Equipment
4. Insuring the Agribusiness (Agricultural Business and Management Cluster)
5. Planning and Organizing the Horticultural Business

PREREQUISITE PROBLEM AREA(S): None

LEVEL: Preparatory

OCCUPATIONAL TASKS ADDRESSED:

Horticulture Cluster

Duty D: Applying Fertilizer and Chemicals

1. Determine insurance coverage

Duty Q: Managing the Business

1. Maintain business records
2. Complete business loan application process
3. Prepare budget
4. Calculate net worth
5. Maintain inventory record
6. Conduct inventory of merchandise

Note to Instructor: The additional contents of this problem area are identical to the contents found in the Agricultural Business and Management Cluster, Agribusiness Operation and Management Unit, Insuring the Agribusiness Problem Area. Please refer to the referenced problem area.

REFERENCES:

1. *Greenhouse Operation and Management.* (1980). Nelson, Paul V. Prentice Hall, 200 Old Tappan Road, Old Tappan, NJ 07675. (800) 223-2348.
- *2. *Nursery Management.* (1988). Davidson, H., Mecklenburg, R., Peterson, C. Prentice Hall, 200 Old Tappan Road, Old Tappan, NJ 07675. (800) 223-2348.
3. *The Retail Florist's Business.* (1983). Pfahl, Peter. Interstate Publishers, Inc., P.O. Box 50, Danville, IL 61834-0050. (217) 446-0500.
4. *Profitable Garden Center Management.* (1982). Berninger, Louis. Prentice Hall, 200 Old Tappan Road, Old Tappan, NJ 07675. (800) 223-2348.

5. *Management for a Retail Florist.* (1980). Sullivan, G., Robertson, J. W.H. Freeman and Company, 4419 West 1980 South, Salt Lake City, UT 84104. (801) 973-4660.
6. *Greenhouse Management.* (1980). Kennard, N.S. Interstate Publishers, Inc., P.O. Box 50, Danville, IL 61834-0050. (217) 446-0500.

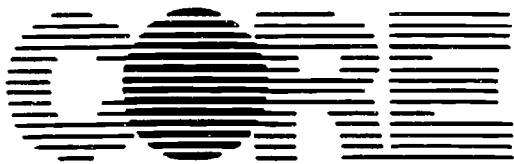

Illinois Agricultural Core Curriculum

Agricultural Education 124 Mumford Hall 1301 W. Gregory Drive University of Illinois Urbana, IL 61801

Director: Dale A. Law, Ed.D.

Principal Investigator: Jerry D. Pepple, Ed.D

Research Assistant: James K. Shinn

CLUSTER: HORTICULTURE

UNIT: Horticultural Business Operation and Management

PROBLEM AREA: Planning and Organizing the Horticultural Business

RELATED PROBLEM AREAS:

1. Marketing Horticultural Products and Services
2. Financing the Horticultural Business
3. Insuring the Horticultural Business
4. Planning and Organizing the Agribusiness (Agricultural Business and Management Cluster)
5. Advertising and Selling Horticultural Products

PREREQUISITE PROBLEM AREA(S):

1. Understanding Basic Business Organization (Central Core Cluster)

LEVEL: Preparatory

OCCUPATIONAL TASKS ADDRESSED:

Horticulture Cluster

Duty Q: Managing the Business

1. Maintain business records
2. Plan work schedules
3. Determine labor needs
4. Prepare reports
5. Develop business agreements
6. Develop credit plan

Note to Instructor: The additional contents of this problem area are identical to the contents found in the Agricultural Business and Management Cluster, Agribusiness Operation and Management Unit, Planning and Organizing the Agribusiness Problem Area. Please refer to the referenced problem area.

REFERENCES:

1. *Greenhouse Operation and Management.* (1980). Nelson, Paul V. Prentice Hall, 200 Old Tappan Road, Old Tappan, NJ 07675. (800) 223-2348.
- *2. *Nursery Management.* (1988). Davidson, H., Mecklenburg, R., Peterson, C. Prentice Hall, 200 Old Tappan Road, Old Tappan, NJ 07675. (800) 223-2348.
3. *The Retail Florist's Business.* (1983). Pfahl, Peter. Interstate Publishers, Inc., P.O. Box 50, Danville, IL 61834-0050. (217) 446-0500.
4. *Profitable Garden Center Management.* (1982). Berninger, Louis. Prentice Hall, 200 Old Tappan Road, Old Tappan, NJ 07675. (800) 223-2348.

5. *Management for a Retail Florist.* (1980). Sullivan, G., Robertson, J. W.H. Freeman and Company, 4419 West 1980 South, Salt Lake City, UT 84104. (801) 973-4660.
6. *Greenhouse Management.* (1980). Kennard, N.S. Interstate Publishers, Inc., P.O. Box 50, Danville, IL 61834-0050. (217) 446-0500.

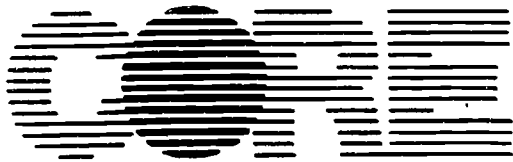

Illinois Agricultural Core Curriculum

Agricultural Education 124 Mumford Hall 1301 W. Gregory Drive University of Illinois Urbana, IL 61801

Director: Dale A. Law, Ed.D.

Principal Investigator: Jerry D. Pepple, Ed.D

Research Assistant: James K. Shinn

CLUSTER: HORTICULTURE

UNIT: Horticultural Business Operation and Management

PROBLEM AREA: Advertising and Selling Horticultural Products

RELATED PROBLEM AREAS:

1. Marketing Horticultural Products and Services
2. Recognizing the Role of Agriculture in Society (Central Core Cluster)
3. Developing Communication Skills in Agriculture (Central Core Cluster)
4. Developing Human Relation Skills in Agriculture (Central Core Cluster)
5. Identifying and Practicing Ethics in Agricultural Occupations (Central Core Cluster)
6. Advertising and Selling Agricultural Products and Services (Agricultural Business and Management Cluster)

PREREQUISITE PROBLEM AREA(S): None

LEVEL: Preparatory

OCCUPATIONAL TASKS ADDRESSED:

Horticulture Cluster

Duty M: Performing General Office Work

1. Process incoming telephone calls
2. Process outgoing telephone calls
3. Clean work area
4. Process incoming mail
5. Process outgoing mail
6. Maintain mailing list
7. Schedule appointments and meetings
8. Write field reports

Duty N: Performing Sales Duties

1. Conduct sale
2. Close sale
3. Plan territory management
4. Complete business forms
5. Determine customer needs
6. Conduct sales meetings
7. Identify potential buyers
8. Provide customers with technical assistance
9. Recommend plant maintenance procedures
10. Prepare sales options
11. Secure consumer approval for sales option
12. Implement approved sales option
13. Evaluate sales process

Note to Instructor: The additional contents of this problem area are identical to the contents found in the Agricultural Business and Management Cluster, Agribusiness Operation and Management Unit, Advertising and Selling Agricultural Products and Services Problem Area. Please refer to the referenced problem area.

14. Plan marketing strategy
15. Develop promotional aids
16. Prepare plants for sale
17. Prepare floral arrangements
18. Process telephone orders
19. Prepare invoices
20. Assist customer in locating merchandise
21. Inform customer of warranty or guarantee specifications
22. Compute sales tax
23. Complete sales slip
24. Inform customer of guarantee specifications
25. Identify plants
26. Identify plant diseases
27. Identify common lawn and garden insects
28. Identify garden crops
29. Suggest procedures for fungus control
30. Suggest procedures for insect control
31. Suggest procedures for weed control
32. Suggest procedures for disease control

Duty O: Performing Sales-Related Duties

1. Open store or department
2. Process cash sales transaction
3. Process debit card sales transaction
4. Process charge card sales transaction
5. Package customer purchase
6. Process customer complaint
7. Close out cash register
8. Close store or department
9. Process customer returned sales
10. Greet and meet people
11. Maintain customer file system
12. Interpret market information
13. Label and price products
14. Prepare advertisements
15. Code and date merchandise
16. Rotate horticulture and nursery products
17. Arrange delivery of merchandise
18. Order supplies and stock
19. Process incoming order
20. Return unusable merchandise
21. Update prices on merchandise
22. Stock merchandise displays
23. Store merchandise in storage area
24. Read lawn and pest management calendar
25. Design and letter show cards
26. Build counter and table-top displays
27. Stock shelves, gondolas, and counter tops with merchandise
28. Prepare merchandise orders for wholesalers
29. Gift wrap purchases
30. Wire flowers by telephone

REFERENCES:

1. *Greenhouse Operation and Management*. (1980). Nelson, Paul V. Prentice Hall, 200 Old Tappan Road, Old Tappan, NJ 07675. (800) 223-2348.
- *2. *Nursery Management*. (1988). Davidson, H., Mecklenburg, R., Peterson, C. Prentice Hall, 200 Old Tappan Road, Old Tappan, NJ 07675. (800) 223-2348.
3. *The Retail Florist's Business*. (1983). Pfahl, Peter. Interstate Publishers, Inc., P.O. Box 50, Danville, IL 61834-0050. (217) 446-0500.
4. *Profitable Garden Center Management*. (1982). Berninger, Louis. Prentice Hall, 200 Old Tappan Road, Old Tappan, NJ 07675. (800) 223-2348.
5. *Management for a Retail Florist*. (1980). Sullivan, G., Robertson, J. W.H. Freeman and Company, 4419 West 1980 South, Salt Lake City, UT 84104. (801) 973-4660.
6. *Greenhouse Management*. (1980). Kennard, N.S. Interstate Publishers, Inc., P.O. Box 50, Danville, IL 61834-0050. (217) 446-0500.



Illinois Agricultural Core Curriculum

Agricultural Education · 124 Mumford Hall 1301 W. Gregory Drive University of Illinois Urbana, IL 61801

Director: Dale A. Law, Ed.D.
Principal Investigator: Jerry D. Peple, Ed.D.
Research Assistant: James K. Shinn

CLUSTER: HORTICULTURE

UNIT: Horticultural Business Operation and Management

PROBLEM AREA: Operating the Horticultural Business

RELATED PROBLEM AREAS:

1. Marketing Horticultural Products and Services
2. Managing Entrepreneurship Opportunities in Agriculture (Agricultural Business and Management Cluster)
3. Identifying and Practicing Ethics in Agricultural Occupations (Central Core Cluster)
4. Using Microcomputers in Agribusiness Management (Agricultural Business and Management Cluster)
5. Operating the Agribusiness (Agricultural Business and Management Cluster)
6. Advertising and Selling Horticultural Products

PREREQUISITE PROBLEM AREA(S):

1. Planning and Organizing the Horticultural Business

LEVEL: Preparatory

OCCUPATIONAL TASKS ADDRESSED:

Horticulture Cluster

Duty I: Storing, Shipping, and Taking Inventory

1. Check received merchandise against invoice listings
2. Keep current inventory of products for sale

Duty M: Performing General Office Work

1. Order supplies and equipment

Duty Q: Managing the Business

1. Maintain business records
2. Plan work schedules
3. Determine labor needs
4. Evaluate employee performance
5. Maintain inventory records
6. Establish computerized inventory control system
7. Conduct periodic inspection of merchandise
8. Conduct inventory of merchandise
9. Orient new employees

Note to Instructor: The additional contents of this problem area are identical to the contents found in the Agricultural Business and Management Cluster, Agribusiness Operation and Management Unit, Operating the Agribusiness Problem Area. Please refer to the referenced problem area.

REFERENCES:

1. *Greenhouse Operation and Management*. (1980). Nelson, Paul V. Prentice Hall, 200 Old Tappan Road, Old Tappan, NJ 07675. (800) 223-2348.
- *2. *Nursery Management*. (1988). Davidson, H., Mecklenburg, R., Peterson, C. Prentice Hall, 200 Old Tappan Road, Old Tappan, NJ 07675. (800) 223-2348.
3. *The Retail Florist's Business*. (1983). Pfahl, Peter. Interstate Publishers, Inc., P.O. Box 50, Danville, IL 61834-0050. (217) 446-0500.
4. *Profitable Garden Center Management*. (1982). Berninger, Louis. Prentice Hall, 200 Old Tappan Road, Old Tappan, NJ 07675. (800) 223-2348.
5. *Management for a Retail Florist*. (1980). Sullivan, G., Robertson, J. W.H. Freeman and Company, 4419 West 1980 South, Salt Lake City, UT 84104. (801) 973-4660.
6. *Greenhouse Management*. (1980). Kennard, N.S. Interstate Publishers, Inc., P.O. Box 50, Danville, IL 61834-0050. (217) 446-0500.

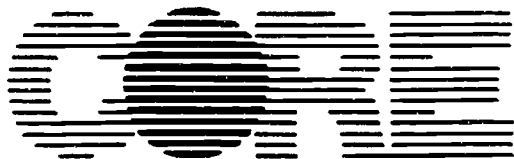

Illinois Agricultural Core Curriculum

Agricultural Education 124 Mumford Hall 1301 W. Gregory Drive University of Illinois Urbana, IL 61801

Director: Dale A. Law, Ed.D.

Principal Investigator: Jerry D. Pepple, Ed.D

Research Assistant: James K. Shinn

UNIT B: Horticultural Science and Production

PROBLEM AREAS:

1. Propagating Plants
2. Understanding Plant Germination, Growth, and Development
3. Classifying Horticultural Plants
4. Understanding Plant Anatomy and Physiology
5. Growing Ornamental Plants
6. Growing Vegetables
7. Growing Fruits
8. Processing Fruits and Vegetables
9. Controlling Plant Pests
10. Enhancing Soil Fertility
11. Developing Growing Media
12. Growing Plants Hydroponically

CLUSTER: HORTICULTURE

UNIT: Horticultural Science and Production

PROBLEM AREA: Propagating Plants

RELATED PROBLEM AREAS:

1. Understanding Plant Germination, Growth, and Development
2. Classifying Horticultural Plants
3. Understanding Plant Anatomy and Physiology
4. Growing Ornamental Plants
5. Growing Fruits
6. Processing Fruits and Vegetables
7. Enhancing Soil Fertility
8. Developing Growing Media
9. Growing Plants Hydroponically
10. Understanding Basic Soil Science Principles (Central Core Cluster)

PREREQUISITE PROBLEM AREAS:

1. Understanding Basic Plant Science Principles (Central Core Cluster)
2. Understanding Basic Genetics and Reproduction (Central Core Cluster)

LEVEL: Orientation

OCCUPATIONAL TASKS ADDRESSED:

Horticulture Cluster

Duty A: Propagating Plants, Seeds, and Cuttings

1. Plant seed in flats or growing benches
2. Prepare plants and cuttings for propagation
3. Take cuttings
4. Stick cuttings
5. Transplant cuttings
6. Apply rooting hormone

STATE GOALS FOR LEARNING:

In planning the instruction for this problem area, teachers can promote the development of several student learning objectives which are related to the State Goals for Learning in Biological and Physical Sciences. These objectives are listed on the Learning Assessment Plan forms included on the following page(s). Those learning objectives marked with an asterisk (*) are taken from the sample lists provided by the Illinois State Board of Education.

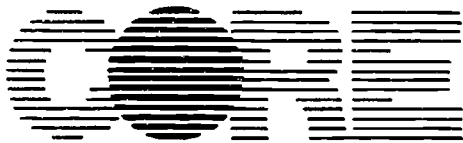

Illinois Agricultural Core Curriculum

Agricultural Education 124 Mumford Hall 1301 W. Gregory Drive University of Illinois Urbana, IL 61801

Directors: Dale A. Law, Ed.D.
Principal Investigator: Jerry D. Pepple, Ed.D.
Research Assistant: Janis L. Anderson

ILLINOIS STATE BOARD OF EDUCATION
 Department of School Improvement Services
 100 North First Street
 Springfield, Illinois 62777-0001

LEARNING ASSESSMENT PLAN

Instructions and codes for this form are provided on a separate sheet.

Submission Date _____ Page _____ of _____

Original submission Revision

I. LEARNING AREA (check one)

Language Arts Fine Arts

Mathematics Social Sciences

Sciences Physical Development/Health

(Affix label or complete district information.)

COUNTY _____ DISTRICT _____ ESC _____

District Name _____

City _____

Contact Person: _____

Title: _____

Phone: (_____) _____

II. STATE GOAL FOR LEARNING
 As a result of their schooling, students will have a working knowledge of the concepts and basic vocabulary of biological, physical, and environmental sciences and their application to life and work in contemporary technological society.

III. LEARNING OBJECTIVES	IV. ASSESSMENT				V. EXPECTATIONS
	A Types	B Validity/ Reliability	C Commercial Test(s)	D Evidence of Nondiscrimination	
By the end of grade (circle one) 3 6 8 (11) students should be able to:					
*1. Relate environmental conditions to the diversity of the structures and functions among plants and animals.					
*2. Know the genetic basis of diversity.					
*3. Support the statement that living things receive their characteristics from the parent organism(s).					
*4. Recognize and compare major cell processes such as respiration, protein synthesis, and photosynthesis.					
5. Understand the function of seeds and know how and when to collect specimens.					
6. Understand how environmental factors affect sexual propagation.					
7. Understand limitations of sexual propagation.					
8. Develop an ability to propagate plants sexually in the proper germination environment.					
9. Develop the ability to control the external factors so that seeds will germinate successfully.					
10. Understand the terminology associated with asexual propagation.					
11. Identify reasons why plants are propagated by seed.					
					25

INSTRUCTOR'S GUIDE**CLUSTER: HORTICULTURE****UNIT: Horticultural Science and Production****PROBLEM AREA: Propagating Plants****STUDENT LEARNING OBJECTIVES:**

Upon completion of their study of this problem area, students will be able to:

Sexual Propagation

1. Understand the function of seeds and know how and when to collect specimens.
2. Identify reasons why plants are propagated from seeds.
3. Demonstrate familiarity with terms that pertain to seeds, seedlings, seeding in flats, and the materials involved.
4. Demonstrate knowledge of the steps in seed germination.
5. Name and identify factors affecting seed germination.
6. Identify factors affecting viability.
7. Develop an understanding of the treatments which are effective for inducing germination and overcoming germination inhibitors.
8. Understand how environmental factors affect sexual propagation.
9. Understand limitations of sexual propagation.
10. Develop an ability to propagate plants sexually in the proper germination environment.
11. Demonstrate skill in the propagation of seedlings in seed flats, and in preparing a seed flat.
12. Develop the ability to control the external factors that affect successful seed germination.
13. Identify advantages of using containers in seeding propagation.
14. State the information necessary on container labels.

15. Develop an understanding of the storage conditions necessary to preserve viability and purity of seeds.

*Asexual Propagation***A. Cuttings**

1. Understand the importance and selection of growing media for cuttings.
2. Properly select and remove cuttings from stock plants.
3. Formulate different concentrations of rooting hormones.
4. Perform steps to properly remove cuttings from herbaceous, softwood, and hardwood stock plants.
5. Properly store cuttings.
6. Properly care for and transplant cuttings.
7. Understand the terminology associated with asexual propagation.

B. Layering

1. Develop the ability to asexually propagate selected plants through air layering.
2. Identify and describe several different layering techniques.
3. Identify the steps necessary for successful air-layering.
4. Define air layering.
5. Demonstrate air-layering procedures including care of the new and mother plant before and after layering.

INSTRUCTOR'S GUIDE**CLUSTER: HORTICULTURE****UNIT: Horticultural Science and Production****PROBLEM AREA:** Propagating Plants**STUDENT LEARNING OBJECTIVES (con't)****INSTRUCTOR'S NOTES AND REFERENCES****C. Division and Separation**

1. Identify two types of bulbs and methods of propagating bulbs, corms, runners, offsets, suckers, and viviparous plants.
2. Demonstrate the ability to propagate given plants by all the above means.
3. Develop an understanding of how to increase plants by divisions.
4. Propagate selected plants by division.
5. Describe the processes of division.

D. Grafting

1. Define grafting.
2. Understand the various methods of grafting.
3. Demonstrate herbaceous grafting procedures.
4. Explain why persons in the field would use grafting, and give some examples of this use.
5. Understand the factors associated with grafting.

E. Budding

1. Define budding.
2. Identify reasons why budding is used.
3. Perform budding techniques.

F. Tissue Culture

1. Define tissue culture and understand related terms.
2. Identify materials and equipment used in tissue culture.
3. Understand steps used in tissue culture.

80

INSTRUCTOR'S GUIDE**CLUSTER: HORTICULTURE****UNIT: Horticultural Science and Production****PROBLEM AREA: Propagating Plants****PROBLEMS AND QUESTIONS FOR STUDY***Sexual Propagation***A. Collection and storage of seeds**

1. What is a seed? How and where are seeds produced?
2. Name the parts of a seed and their functions.
3. What is a seed variety and how do the varieties originate?
4. Define viability and seed quality.
5. How are seeds collected and what factors should be considered when collecting seeds?
6. Describe the process of cleaning a seed and of testing a seed for quality or viability.
7. Name groups of plants most commonly grown from seed.
8. When storing seeds what conditions are best for vegetable seeds? Oily seeds? Citrus seeds? Coniferous seeds? Seeds from fleshy fruit?
9. Why are some plants propagated by seed and others not?

B. Germination

1. Define and explain:
 - a. Germination
 - b. Emergence
 - c. Seedcoat
 - d. Dormancy
 - e. Segregation
 - f. Stratification
 - g. Scarification
 - h. Drilling

2. Is there a need to schedule sexual propagation? If so, why?
3. How are seeding rates determined?
4. Describe the following:
 - a. Steps in seed germination.
 - b. Conditions necessary for seed germination.
 - c. Environmental factors affecting seed germination.
 - d. Factors causing delay in seed germination.
 - e. Reasons for failure of seed germination.
 - f. Ways of testing seeds for viability.
 - g. Seed treatments to enhance germination.
5. What is the optimal temperature range for germination of specified seeds, and how can this information be found?
6. What effect does "too cool" temperature have on seed germination?

C. Seeding in flats

1. What are the various types of flats?
2. List qualities of a good growing medium and sources of obtaining growing media.
3. Why do we use seed flats over other methods?
4. Define and explain broadcast seeding and seed vibrator.
5. In the process of seeding in flats, how are seeds sown, how deep are seeds planted, and how are seedlings cared for?
6. What is a label and how should it be completed?

INSTRUCTOR'S GUIDE**CLUSTER: HORTICULTURE****UNIT: Horticultural Science and Production****PROBLEM AREA: Propagating Plants****PROBLEMS AND QUESTIONS FOR STUDY (con't)***Asexual Propagation***A. Cuttings**

1. What does it mean to propagate plants asexually?
2. Are there advantages to using asexual methods over sexual methods? If so, what are they?
3. Which portions of the plants can be used for cuttings? Which are the best?
4. Is there a best time of day or year to take cuttings? If so, when?
5. Identify and explain the equipment used in taking cuttings and the procedure for doing so on herbaceous and woody cuttings.
6. Explain how one can tell if a cutting is softwood or hardwood.
7. What types of growing media are necessary to help in the rooting process?
8. Are rooting hormones necessary? If so, why? How are they formulated?
9. List the characteristics of a good cutting. Is uniformity better? How are cuttings stored, cleaned, and classified?
10. How does one know when it is time to transplant cuttings? List the steps of transplanting.
11. Explain the environmental conditions necessary to root cuttings.

B. Layering

1. What does it mean to layer a plant?

2. Explain the different types of layering and list some plant species most often associated with the types of layering.
3. Why is wounding important? Are treatments necessary to stimulate root growth?
4. Explain when and how to perform the process of air-layering, and identify some plants associated with this method.
5. Why do we air layer plants?
6. When can the plant be separated and what care do the plants need after separation?

C. Division and separation

1. Define bulb, bulb scale, laminate bulb, tunicate bulb, bulbil, and bulblet.
2. How and when are bulbs propagated?
3. What should be done with the vegetative growth of a bulb after flowering?
4. Define cormel and list flowers that have corms.
5. How and when are corms propagated?
6. Explain the difference between rhizomes and stolons. How is each propagated?
7. What are runners and what plants naturally form runners?
8. Define tubers and explain why polarity is important.
9. Define sucker and explain how it is propagated.
10. Define division and separation and explain the difference between them.

INSTRUCTOR'S GUIDE**CLUSTER: HORTICULTURE****UNIT: Horticultural Science and Production****PROBLEM AREA:** Propagating Plants**PROBLEMS AND QUESTIONS FOR STUDY (con't)**

11. List plants associated with division and separation, and describe how plants are propagated by each method.

D. Grafting

1. Define grafting and list the various types of grafts.
2. Why is it necessary to graft plants?
3. Define rootstock and scion. Give the characteristics of a good rootstock.
4. Why must stock and scion be compatible?
5. List the tools and materials necessary to graft.
6. What does it take to prepare a graft?
7. List the requirements necessary for a successful graft. Why is sanitation so important? How long does it take for callus to form?
8. How will the characteristics of the stock influence the scion?
9. What plants most benefit from grafting and why?

E. Budding

1. Define budding and the various types of budding.
2. What plants benefit most from budding?
3. How and when is budding used?
4. What steps should be taken to ensure a successful bud?
5. How does one know if two plants are compatible?

F. Tissue culture

1. Define tissue culture and list some plants most commonly propagated by this method.
2. What equipment and materials are used in tissue culture?
3. How is tissue culture propagated and is the life stage of the plant important? If so, why?
4. What are the advantages and disadvantages to using tissue culture?

INSTRUCTOR'S NOTES AND REFERENCES

30

INSTRUCTOR'S GUIDE**CLUSTER: HORTICULTURE****UNIT: Horticultural Science and Production****PROBLEM AREA: Propagating Plants****SUGGESTED TEACHING ACTIVITIES AND PROCEDURES***Sexual Propagation*

1. Have students bring in 2 seeds from fruits and vegetables, such as apple, orange, pineapple, kiwi, papaya, to germinate in class. Display the germinated fruit or vegetable plants in a school exhibit or open house.
2. Have students conduct experiments on germination rates and seed viability, using seeds from seed packets. Have them compare their germination results to the descriptions given on the seed packets.
3. Test the difference between treated and untreated seeds through a germination experiment.
4. If possible, visit a facility that specializes in seed production and packaging.
5. An excellent SAE project would be to have students start with a few plants and, through collection and propagation of seeds, to increase the number of plants in their inventory.
6. Have the class go on a seed-collecting field trip. Afterwards, have the students clean and treat the seeds collected, and then either plant them immediately or store them for later planting.
7. Experiment with various inhibitors on seed germination.
8. With an advanced class conduct the more scientific experiment on pollen germination.

*Asexual Propagation***A. Cuttings**

1. Let students take cuttings from their favorite plants in the greenhouse to propagate and take home.
2. Split the class into groups and have a contest, using different plants with various types of cuttings, to see which group can produce the most rooted cuttings. Discuss the reasons for the different results and what might have been done differently to produce faster rooting.

3. Experiment with various hormones and growing media.
4. Take a trip to a nursery that uses propagation in their business practice.

B. Layering

1. Have class observe air-layering techniques.
2. Let students attempt to layer greenhouse plants by covering a portion of a stem with soil in the pot. Observe the plants to find out the success rate.

C. Division and separation

1. Identify plants in the greenhouse that need to be divided and divide them.
2. Have the class propagate a hyacinth bulb.
3. Practice propagating offshoots.

D. Grafting

1. Take a trip to an orchard or nursery to see working grafts or grafts actually being performed.
2. Graft cacti for a school display, open house, or home.
3. Have the students do research to determine what other plants can be grafted.
4. As an attention getter, graft several potato sprouts and tomato seedlings together.
5. Have some ambitious students graft two or three varieties of one plant together to produce a multi-colored plant, flower, or foliage.

E. Budding

1. Have the students observe the results of budding and how it is done.

F. Tissue culture

1. If possible, tour a facility that propagates its material by tissue culture.
2. Show examples of the different stages of tissue culture growth and then do a demonstration of the procedure.

INSTRUCTOR'S GUIDE**CLUSTER: HORTICULTURE****UNIT: Horticultural Science and Production****PROBLEM AREA: Propagating Plants****REFERENCES**

1. *The Science Workbook*. (1985). Darrow, Edward E. (ed.). College of Agriculture, The Ohio State University, 2120 Fyffe Road, Columbus, OH 43210.
2. *Horticulture: A Basic Awareness*. (1982). Baudendistel, Robert F. Reston Publishing Co., Inc., A Division of Prentice-Hall, 200 Old Tappan Road, Old Tappan, NJ 07675. (800) 223-2348.
3. *Plant Propagation: Principles and Practices*. (1983). Hartmann and Kester. Prentice-Hall, Inc., Englewood Cliffs, NJ 07632.
4. *Park's Success With Seeds*. (1978). Reilly, Ann. Geo. W. Park Seed Co., Inc., Greenwood, SC.
5. *Methods in Plant Tissue Culture*. (1981). Bottino, Paul J. Carolina Biological Supply Co., 2700 York Road, Burlington, NC 27215. (800) 334-5551.
- *6. *Experiments in Plant Tissue Culture*. (1985). Doddst, John H., Roberts, Lorin W. 2nd edition. Carolina Biological Supply Co., 2700 York Road, Burlington, NC 27215. (800) 334-5551.
7. *Pruning and Grafting*. University of Illinois, Cooperative Extension Service, College of Agriculture, 69C Mumford Hall, 1301 W. Gregory Drive, Urbana, IL 61801. (217) 333-2007.
8. *Laboratory Procedures for Tissue Culture: A Beginner's Guide (VT-234); Handling Tissue Culture Plants in the Nursery (VT-233)*. Publications, Institute of Food and Agricultural Sciences, Building #664, University of Florida, Gainesville, FL 32611.
- *9. *Plant Propagation*. Prentice-Hall, Inc., Englewood Cliffs, NJ 07632.
- *10. *Plant Tissue Culture; African Violet Cloning Kit*. Carolina Biology Reader, Carolina Biological Supply Co., 2700 York Road, Burlington, NC 27215. (800) 334-5551.

*Indicates highly recommended reference

INSTRUCTOR'S NOTES AND REFERENCES

INSTRUCTIONAL RESOURCES

These resources are intended for use by teachers in planning and teaching the materials for this problem area and may be adapted to fit the teaching method(s) used.

INFORMATION SHEET #1 — Terms to be Defined

INFORMATION SHEET #2 — Grafting Cactus

INFORMATION SHEET #3 — Tissue Culture Supplier List

TRANSPARENCY MASTER #1 — Cleft Grafting of Epiphyllum onto a Pereskia (with discussion guide)

TRANSPARENCY MASTER #2 — Cleft Grafting of Christmas Cactus onto Myrtillocactus (with discussion guide)

TRANSPARENCY MASTER #3 — Flat Method of Grafting Cactus (with discussion guide)

TRANSPARENCY MASTER #4 — Flat Method of Grafting Cactus (with discussion guide)

TRANSPARENCY MASTER #5 — Examples of Cacti Cleft Grafted and Grafted by the Flat Method

TRANSPARENCY MASTER #6 — Grafting Changes a Plant (with discussion guide)

TRANSPARENCY MASTER #7 — A Reason for Grafting (with discussion guide)

TRANSPARENCY MASTER #8 — Natural Grafts (with discussion guide)

TRANSPARENCY MASTER #9 — Cross Section of a Graft Union (with discussion guide)

TRANSPARENCY MASTER #10 — Side Graft - A — Preparing the Stock (with discussion guide)

TRANSPARENCY MASTER #11 — Side Graft - B — Preparing the Scion (with discussion guide)

TRANSPARENCY MASTER #12 — Side Graft - C — Uniting the Stock and Scion

TRANSPARENCY MASTER #13 — T-Budding - A — Preparing the Stock (with discussion guide)

TRANSPARENCY MASTER #14 — T-Budding - B — Preparing the Scion (with discussion guide)

TRANSPARENCY MASTER #15 — T-Budding - C — Successful Growth of the Bud (with discussion guide)

TRANSPARENCY MASTER #16 — Whip and Tongue Graft - A — Preparing the Stock (with discussion guide)

TRANSPARENCY MASTER #17 — Whip and Tongue Graft - B — Preparing the Scion

TRANSPARENCY MASTER #18 — Whip and Tongue Graft - C — Uniting Stock and Scion

INFORMATION SHEET #1

Terms to be Defined

- Absciscic acid** — naturally occurring inhibitor associated with ripening.
- Air layering** — technique used in greenhouses on some tropical and subtropical plants.
- Bud** — a dormant or undeveloped, branch, leaf, or flower, usually enclosed by protective scales.
- Callus** — hard protuberance; the new tissue that covers an injury.
- Cutting** — a severed part of a plant used in propagation.
- Division** — process by which the plant is cut into sections.
- Dormant** — at rest, not growing.
- Germination** — sprouting of seed.
- Graft** — a branch or bud inserted into another plant with the intention that it will grow there.
- Hybrid** — a plant resulting from a cross between parents that are different. It may occur naturally or artificially.
- Layering** — propagating a plant by covering a portion of the stem with soil or other rooting medium to force roots on the covered portion.
- Scarification** — scratching of the seed coat to facilitate germination.
- Scion** — a short piece of detached shoot containing several dormant buds. In a graft it is the upper portion of the graft.
- Seed** — ripened ovule.
- Stock** — the lower portion of the graft which develops into the root system for the graft.
- Stratification** — a process used to overcome dormancy of a seed. Usually a cold treatment in the refrigerator or freezer.
- Viability** — the ability of seeds to germinate.
- Viviparity** — production of seeds that germinate in the fruit while still attached to the plant.

INFORMATION SHEET #2

Grafting Cactus

Plant growers sometimes wish to put a slow-growing species onto a strong, quicker growing stock in order to raise a large plant more speedily. The same process can be used to obtain a number of cuttings, since some plants do not normally branch freely in their own roots but will do so when grafted. In addition to using grafting as a means of getting surplus cuttings or growing a plant very quickly, it can be done in order to save a valuable plant which has lost its roots, or to provide an alternate root system. For example, many cristate plants form into tight mounds, and when grown on their own roots in a damp humid winter atmosphere, rotting can occur because there is insufficient air circulation around the plant. This can be avoided by growing such a plant on a graft.

A plant can be grafted at any age, although it is easier to carry it out on a young specimen which has not yet become woody. It is a very simple matter to graft young plants between one and two years of age, but it can also be done with very young seedlings. All one needs is a very sharp knife or razor blade, plus a steady hand. A page of diagrams follows, with an accompanying key describing the various stages. This is more or less self-explanatory, and it is only necessary to mention two other points: (a) the stock to use, and (b) the after-care of freshly grafted plants.

Any cactus can be grafted onto another, but a strong growing stock has obvious advantages. We can highly recommend the following: *Opuntia* pads (thick varieties with as few spines as possible) and various *Trichocerei*, *Cerei*, *Myrtillocactus geometrizans*, *Pereskia*, *Pereskioopsis*, and *Hylocereci*. When grafting the other succulents it is essential to use plants of the same family. At this stage many of you may be more interested in grafting cacti than other succulents.

Once plants have been grafted, the stock should be kept moist by watering at the base, and the scion — the new top of the plant — should be kept shaded and in a warm place for 10-14 days. At the end of this period the fixings or weights can be removed, and provided the scion does *not* drop off, the whole plant can then be treated normally. However, if the stock used is not an *Opuntia*, *Trichocereus* or *Cereus*, it will be necessary to winter the plant in a minimum temperature which does not drop too far below 50° F (10° C). There are a few *Opuntias* which are tender, but by far the majority likely to be grown will stand fairly cool winter conditions.

INFORMATION SHEET #3**Tissue Culture Supplier List**

Carolina Biological Supply Company
Biology/Science Materials
Burlington, NC 27215
(800) 334-5551

Gibco Laboratories
3175 Staley Road
Grand Island, NY 14072
(800) 828-6686

Magenta Corporation
4149 W. Montrose Ave.
Chicago, IL 60641
(312) 725-8604

Sigma Chemical Company
P.O. Box 14508
St. Louis, MO 63178
(800) 325-3010

Baxter Scientific Products
1430 Waukegan Road
McGraw Park, IL 60085-6787
(800) 325-4520

Allied Fisher Scientific
1241 Ambassador Blvd.
P.O. Box 14989
St. Louis, MO 63178
(800) 325-4075 (Southern Illinois)
(800) 942-4543 (Northern Illinois)

VWR Scientific
P.O. Box 66929
O'Hare AMF
Chicago, IL 60666
(800) 932-5000

42

TRANSPARENCY MASTER #1

Cleft Grafting of Epiphyllum Onto a Pereskia



1. CUT UNDERSTOCK



2. TRIM SCION



3. FIT SCION INTO UNDERSTOCK



4. FASTEN

TRANSPARENCY MASTER #2

Cleft Grafting of Christmas Cactus onto Myrtillocactus

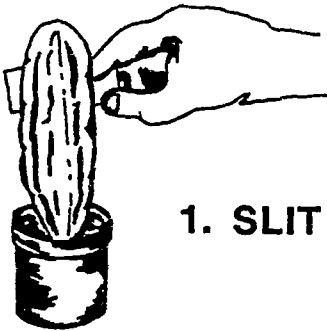

1. SLIT UNDERSTOCK



2. CUT SCION

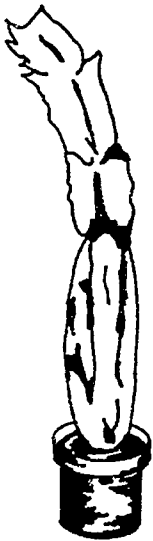

3. INSERT SCION INTO UNDERSTOCK



4. FASTEN

42

TRANSPARENCY MASTER #3

Flat Method of Grafting Cactus

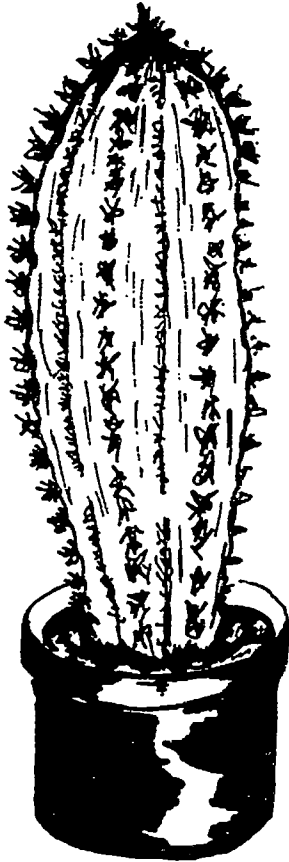

1. CUT
UNDERSTOCK

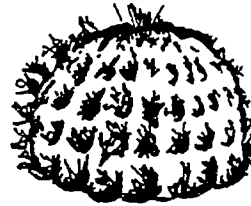

2. CUT SCION



3. FASTEN UNDERSTOCK
AND SCION TOGETHER
WITH STERILE PINS

TRANSPARENCY MASTER #4

Flat Method of Grafting Cactus

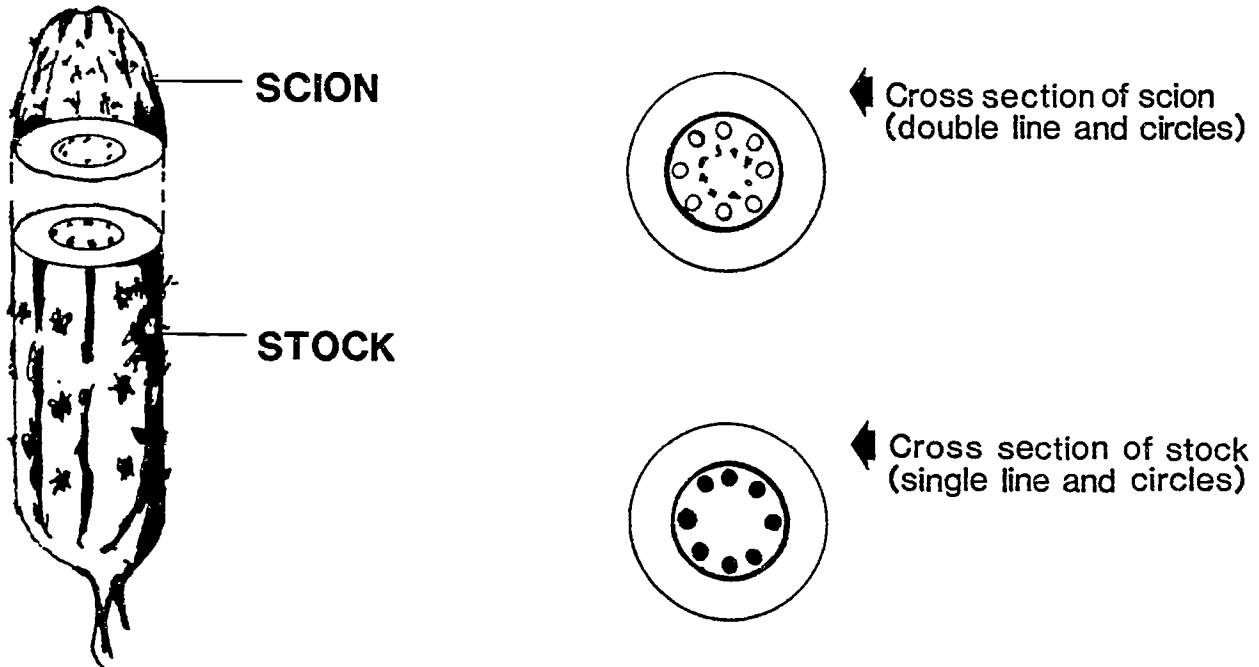

The rings of food-conveying vascular channels in the scion and the stock should coincide for the best graft.

TRANSPARENCY MASTER #5

Examples of Cacti Cleft Grafted and Grafted by the Flat Method

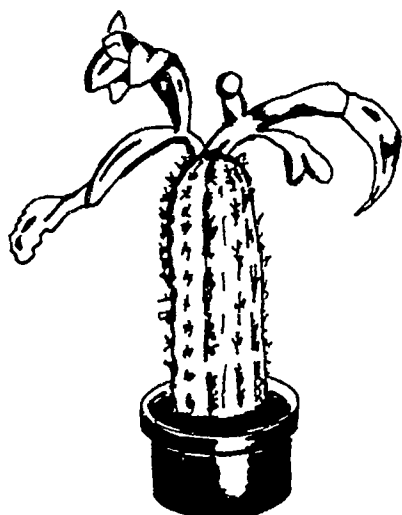

**CHRISTMAS CACTUS
GRAFTED ON
TRICHOCEUREUS**

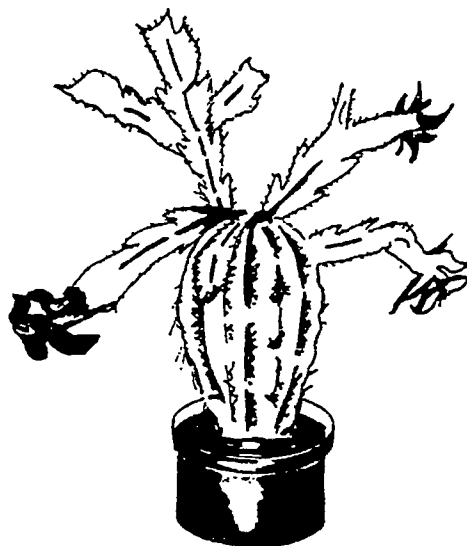

**CHRISTMAS CACTUS
ON OPUNTIA
(PRICKLY PEAR)**

**NOTOCACTUS ON
SPACHIANUS**

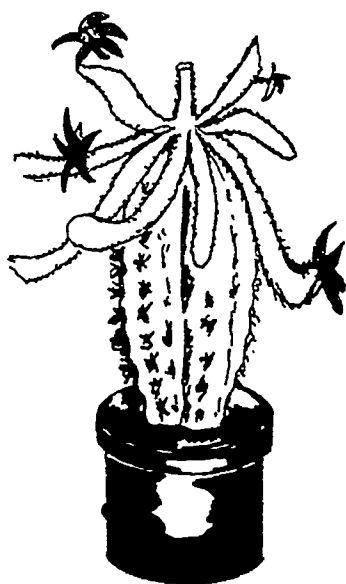

**RAT-TAIL CACTUS
(APOROCACTUS) ON
TRICHOCEUREUS**

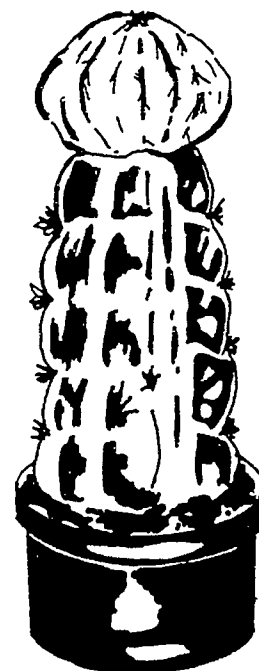

**CEREUS UNDERSTOCK
WITH OLLOCEREUS SCION**

TRANSPARENCY MASTER #6

Grafting Changes a Plant

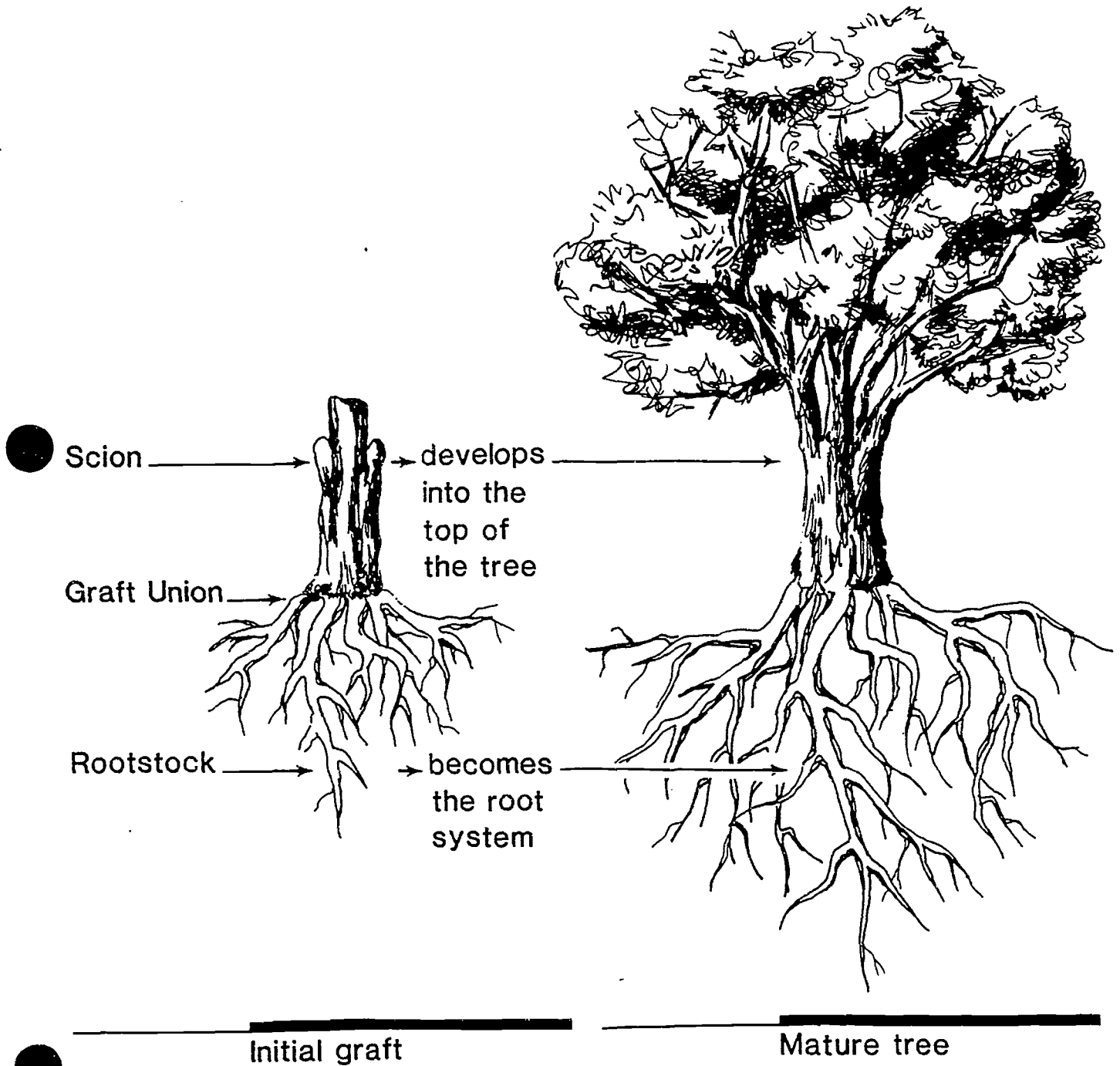

Initial graft

Mature tree

TRANSPARENCY MASTER #7

A Reason for Grafting

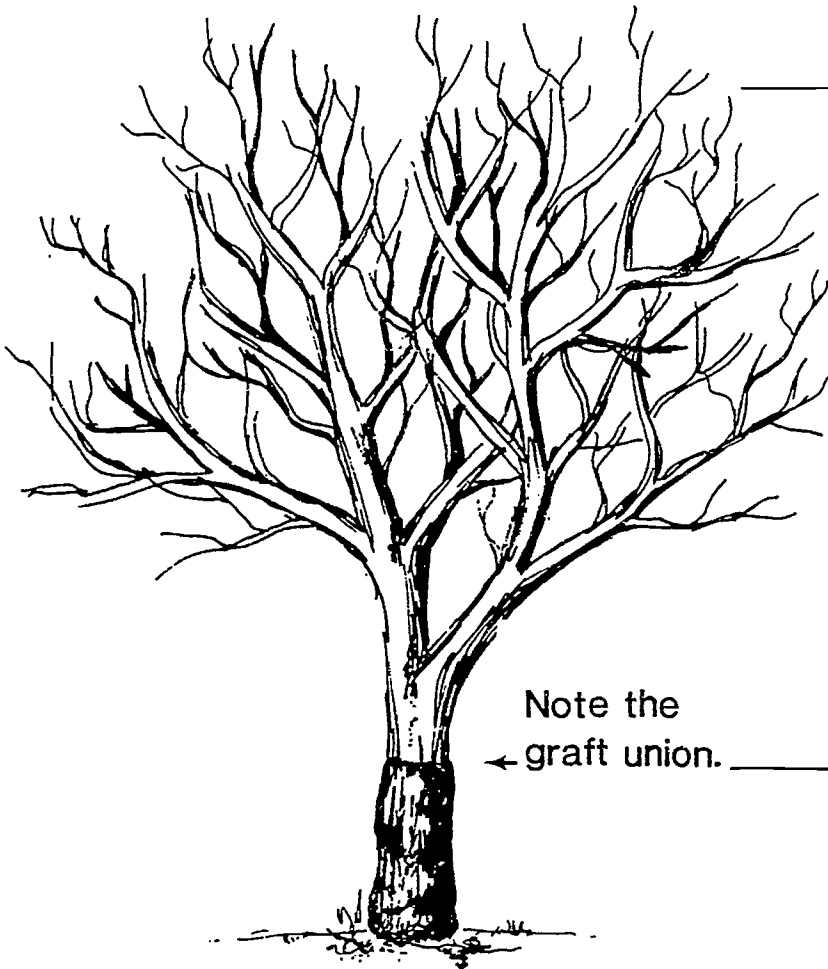

Note the
← graft union. →

The characteristics of the stock and scion are distinctly different

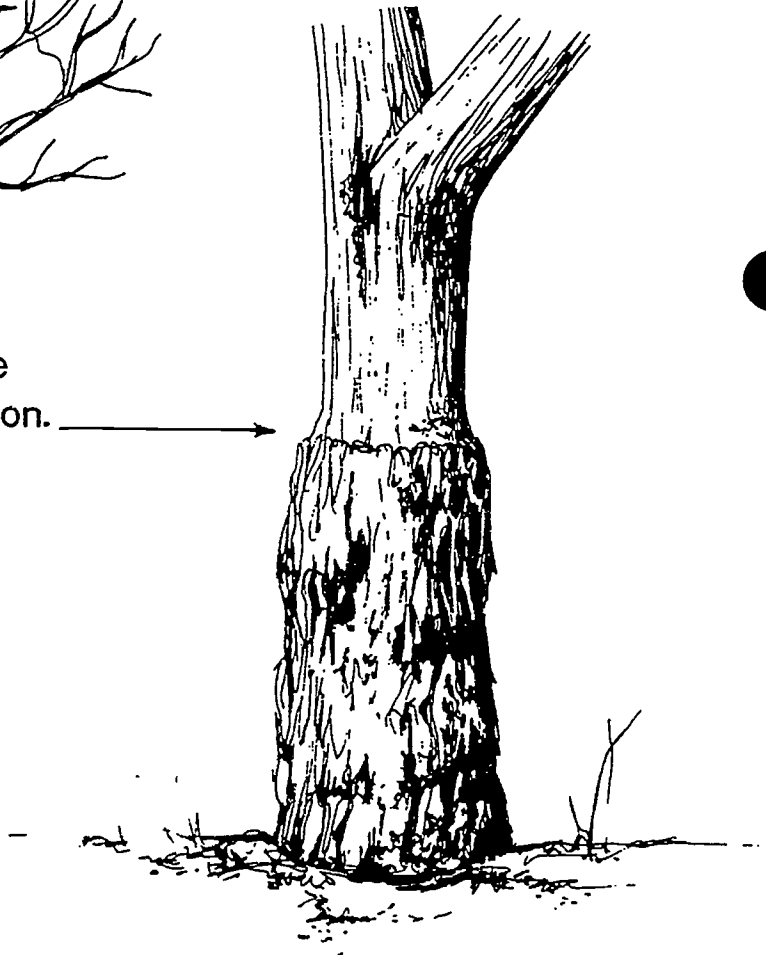

TRANSPARENCY MASTER #8

Natural Grafts

Natural grafts of plant roots.

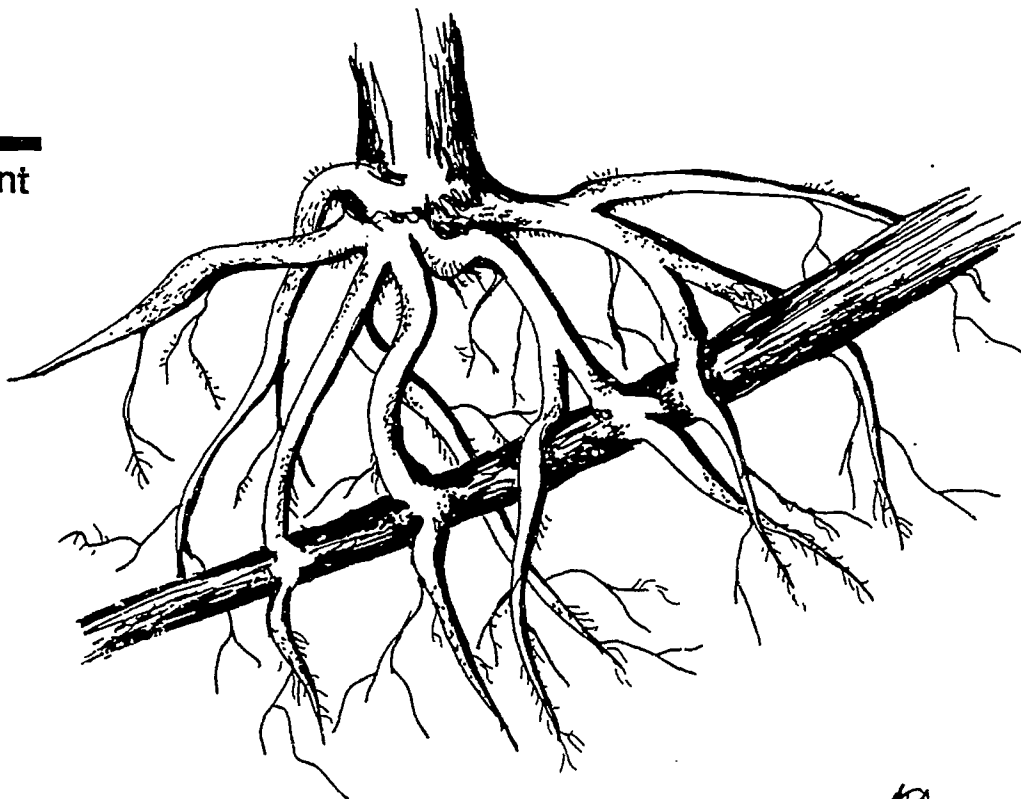

Natural graft of two tree branches.

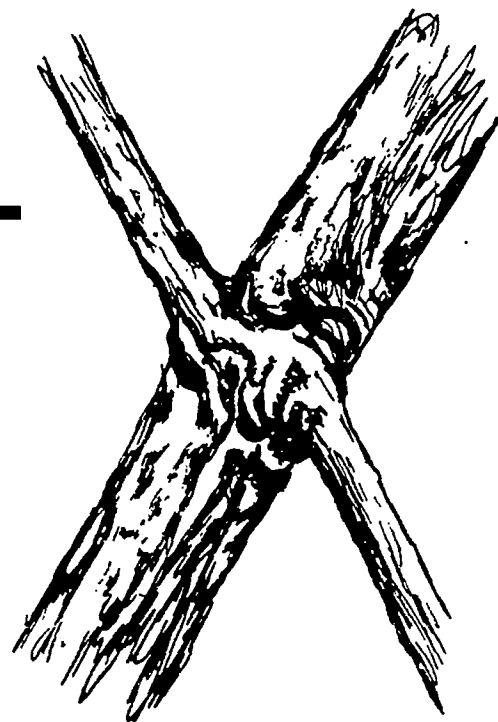

2.3

TRANSPARENCY MASTER #9

Cross Section of a Graft Union

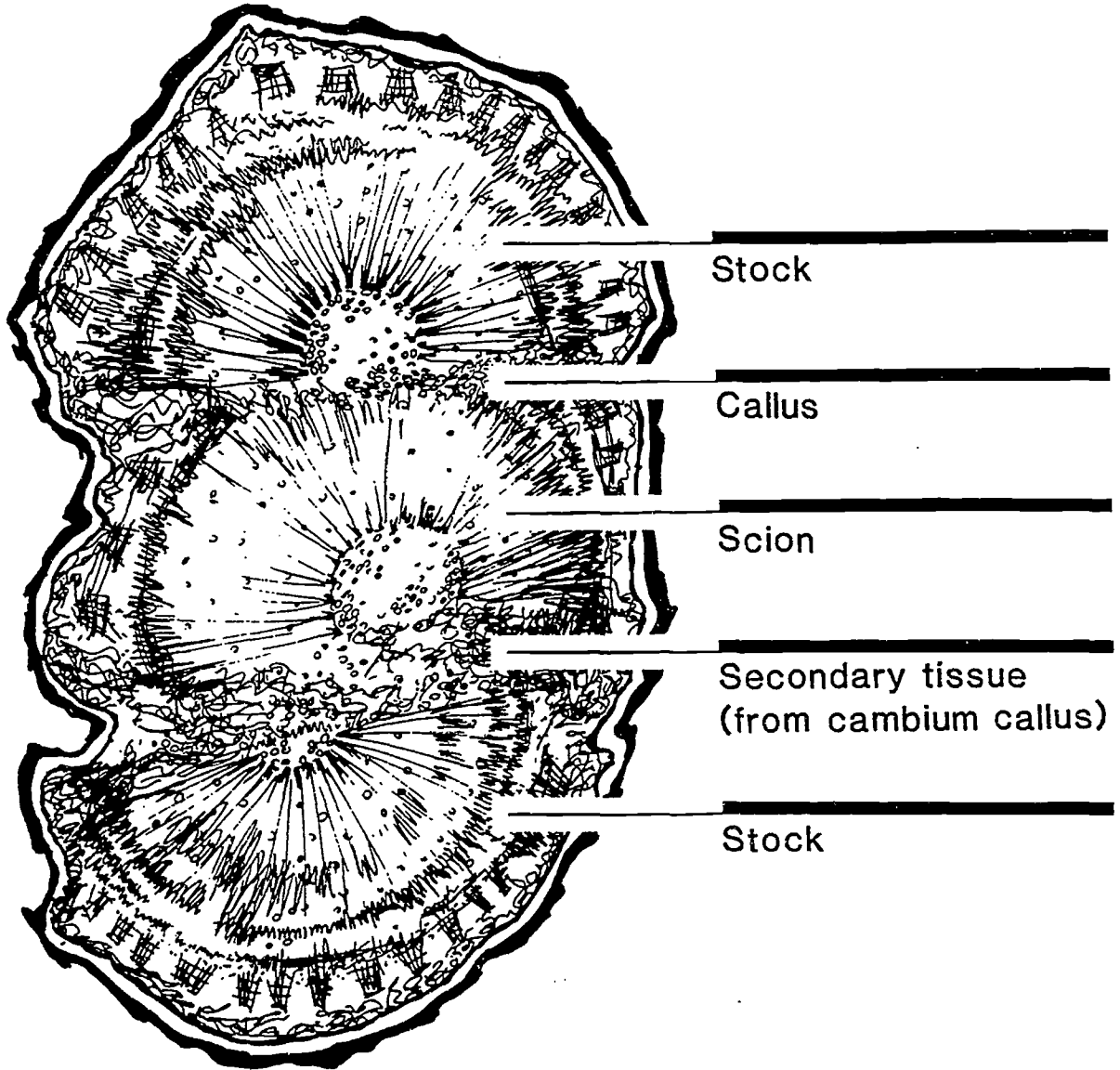

.TRANSPARENCY MASTER #10

Side Graft - A

Preparing the Stock



A long shallow cut is made into one side of the stem.

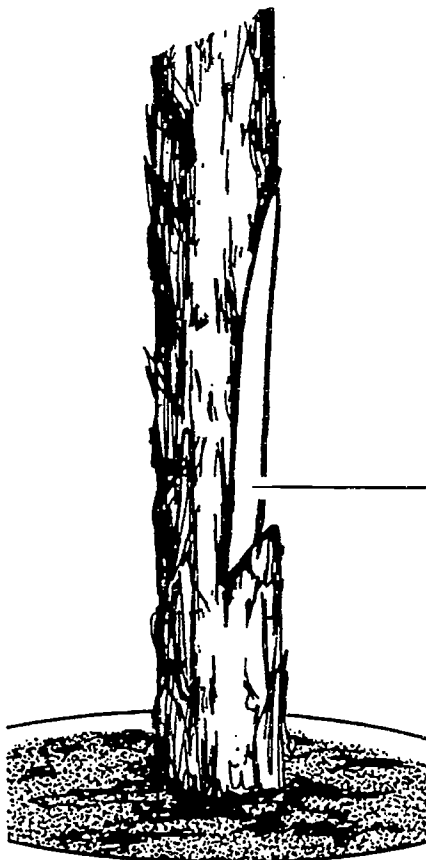

A short, second downward cut is made at the base of the first, removing a piece of the bark and wood.



Discard the removed piece.

TRANSPARENCY MASTER #11

Side Graft - B

Preparing the Scion

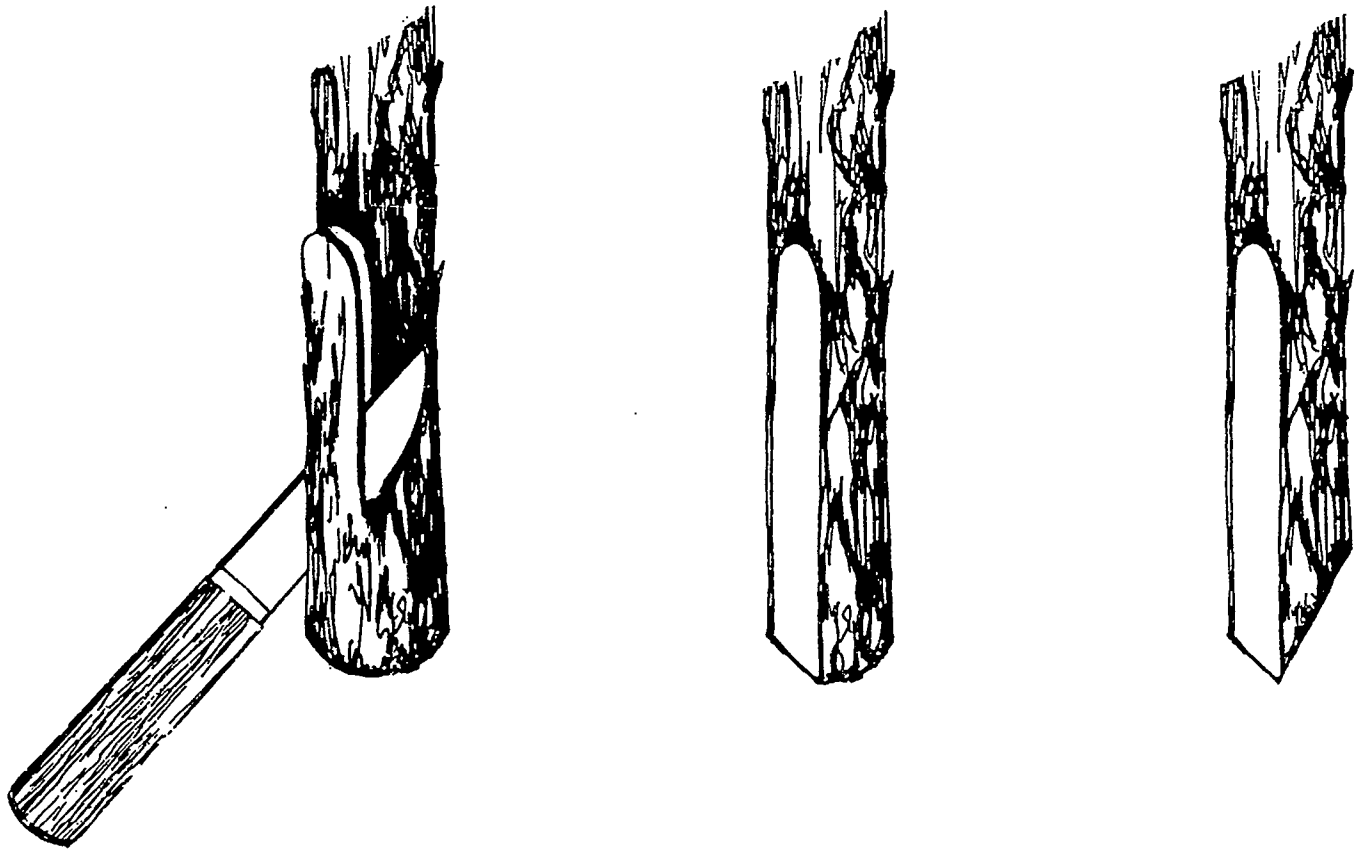

A short, slanting cut is made on the opposite side.

A long, shallow cut is made into one side of the stem.

TRANSPARENCY MASTER #12

Side Graft - C

Uniting the Stock and Scion

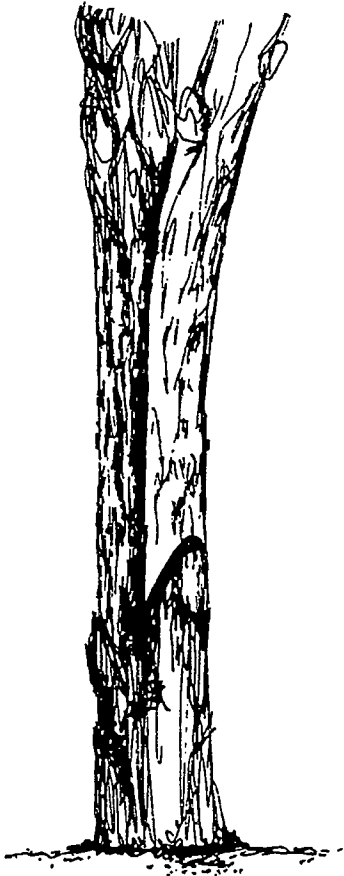

Place the scion into the stock so that the cambium layers match at least along one side.

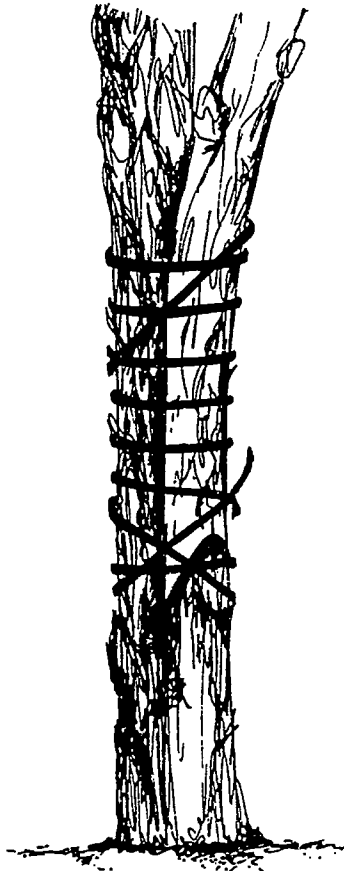

The graft union is tied tightly with a string or rubberband.

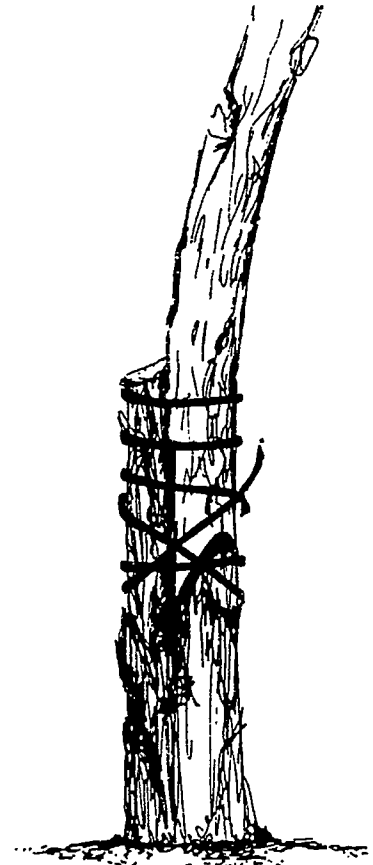

The stock is cut back gradually to the scion.

TRANSPARENCY MASTER #13

T-Budding - A

Preparing the Stock

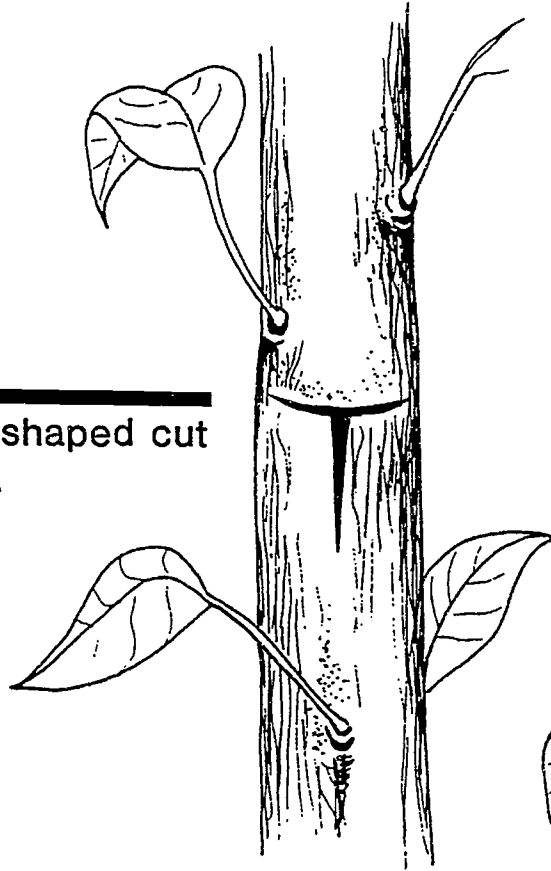

Make a T-shaped cut
in the bark.

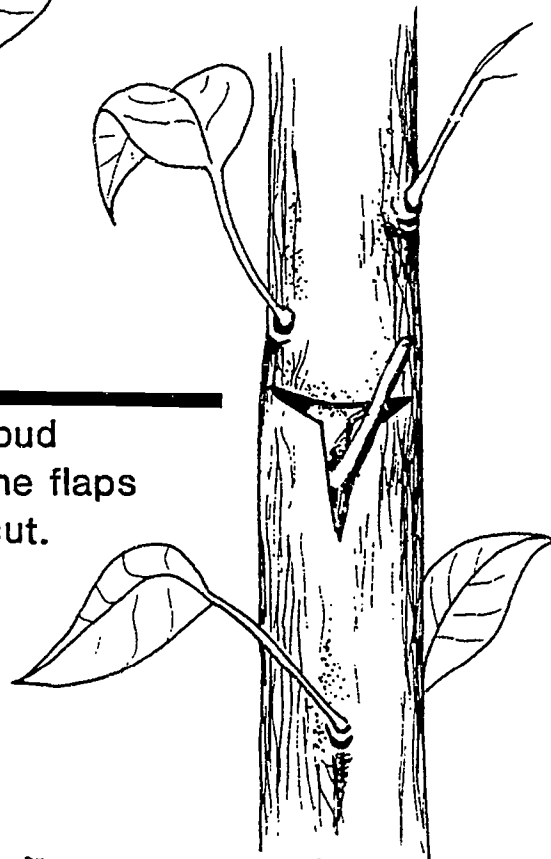

Insert the bud
between the flaps
of the T-cut.

TRANSPARENCY MASTER #14

T-Budding - B

Preparing the Scion



Remove the leaves from the scion wood.

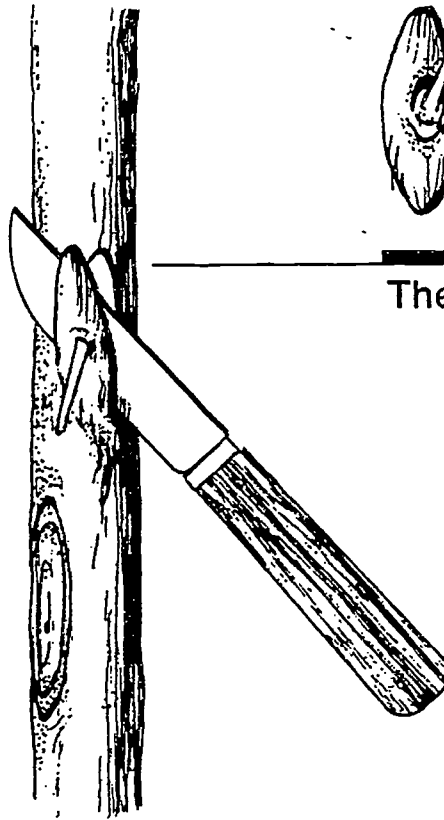

Remove a bud.

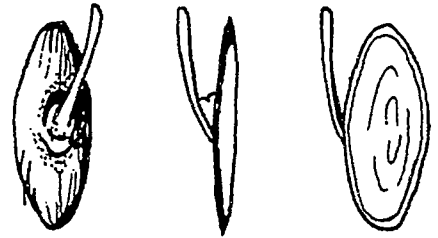

The removed bud.

TRANSPARENCY MASTER #15

T-Budding - C

Successful Growth of the Bud

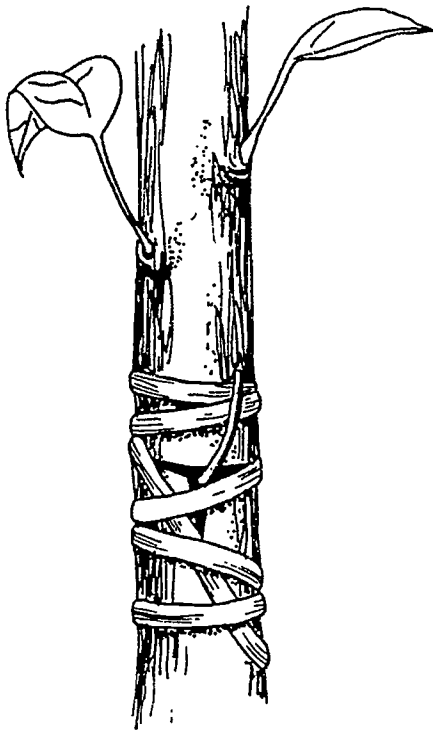

Tie the bud under the flaps.

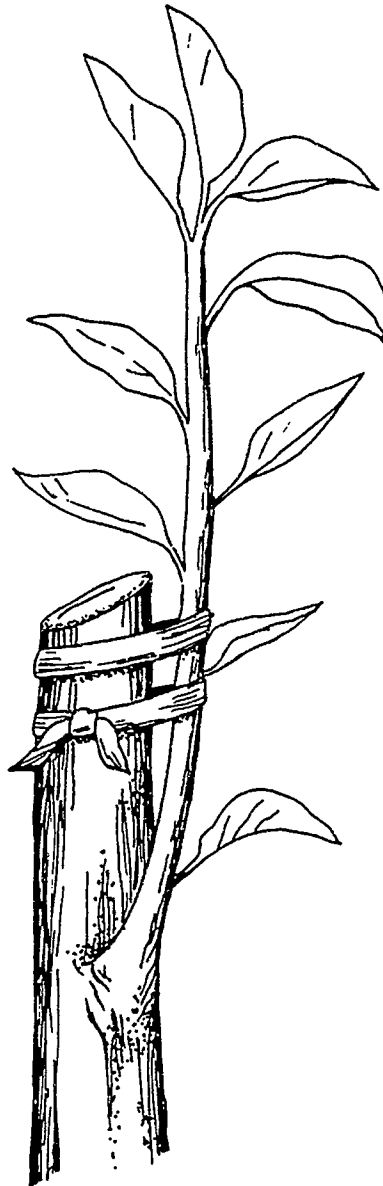

When the bud begins to grow, the stock is cut back.

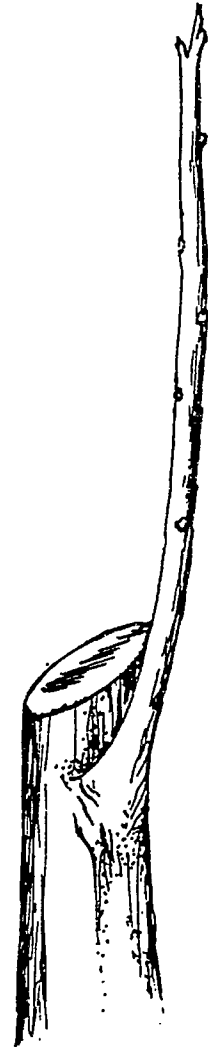

The stock is cut back to the budding point.

TRANSPARENCY MASTER #16

Whip and Tongue Graft - A Preparing the Stock

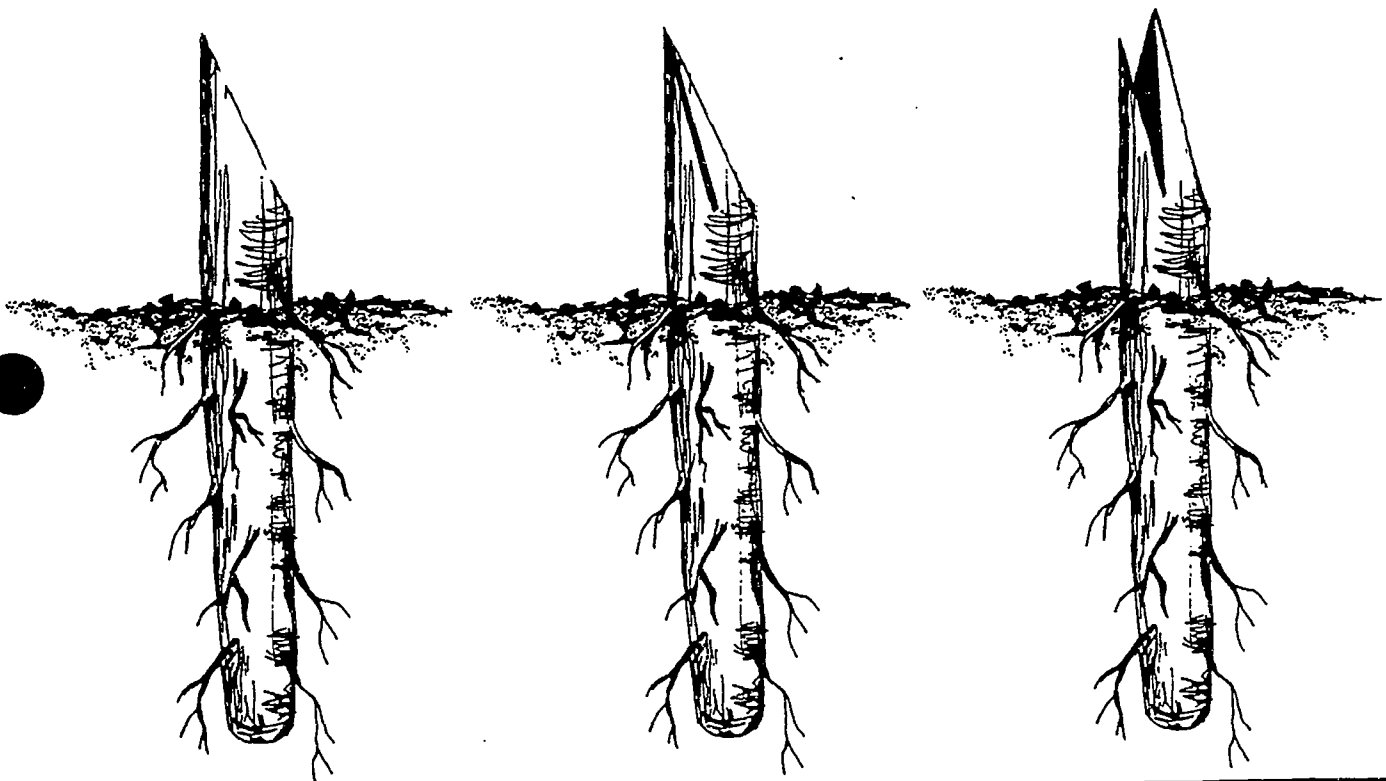

Cut across the stock on an angle.

A second cut is made lengthwise.

The cut when pulled apart.

23

TRANSPARENCY MASTER #17

Whip and Tongue Graft - B

Preparing the Scion



An angle cut is made
across the scion.

Next, a lengthwise cut is
made on the scion.

TRANSPARENCY MASTER #18

Whip and Tongue Graft - C

Uniting Stock and Scion

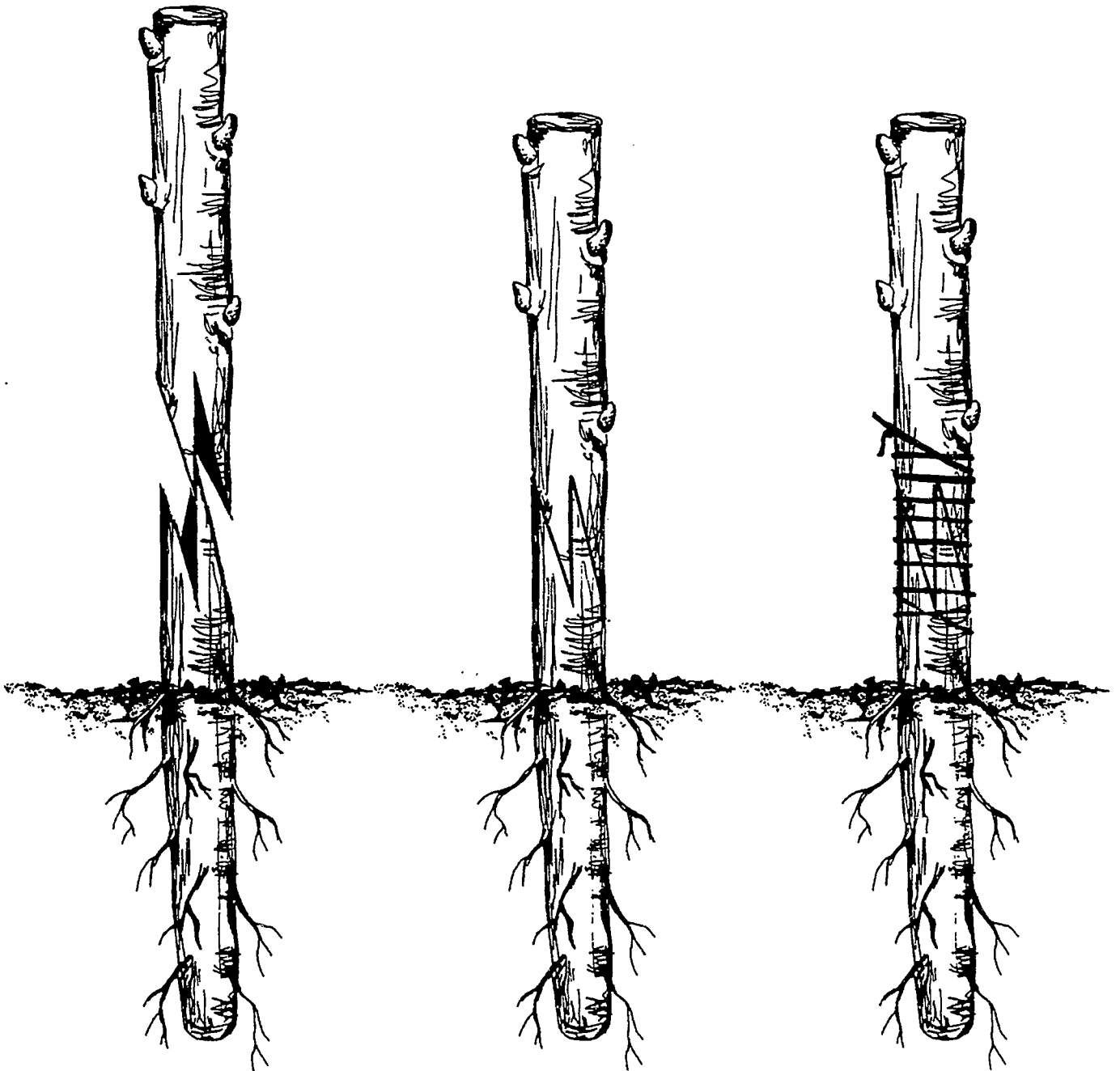

The tongues of the stock and scion are interlocked.

The graft is tied together.

TRANSPARENCY MASTER DISCUSSION GUIDES

Transparency Master #1

1. Cut the understock (frequently a well-rooted *Pereskia*) at the desired height. Then, make a vertical wedge.
2. Trim the scion (an *Epiphyllum*) so the base is wedge shaped.
3. Fit the cleft into the stock.
4. Hold the materials together by pinning.

Transparency Master #2

1. Slit the *Myrtillocactus* with a razor blade.
2. Cut a very thin piece from the base of the Christmas Cactus.
3. Insert the Christmas Cactus into the split.
4. Secure with pins or a rubber band.

Transparency Master #3

1. Use this method with barrel-like types of cactus in the summer when they are actively growing.
2. Be sure the central rings of the scion and stock match.
3. Frequently, cross sections of cacti are somewhat different in their structure.

Transparency Master #4

1. Cut off horizontally a well-rooted cereus at the desired height.
2. Slice the bottom of the scion (*Notocactus*).
3. Place them together at once and rub them together gently to eliminate air pockets. Then fasten the scion and stock with sterile pins so they cannot shift.

Transparency Master #6

1. Use this transparency to discuss how plants can be improved by grafting.
2. Discuss several varieties of fruits that are grafted.

Transparency Master #7

1. Discuss why trees, roses, and other plants are improved by grafting.
2. Point out the obvious graft union. Explain that it will always remain evident throughout the plant's life.

Transparency Master #8

1. Use this transparency to discuss natural grafts found in nature. Ask the students if they can find some in their own gardens.

Transparency Master #9

1. Explain how the stock and scion become one by the development of callus tissue.

Transparency Master #10

1. Discuss how this type of graft is used mostly upon ornamentals.
2. The stock is prepared by removing a chip from its side.

Transparency Master #11

1. It is important to match the cambium layers when inserting the scion into the stock.
2. Gradually upper portions of the stock are pruned away, leaving only the scion.

Transparency Master #13

1. Carefully make a T-shaped cut through the bark.
2. This technique is also called shield budding because the flaps shield the bud.

Transparency Master #14

1. Remove leaves next to the bud.
2. Remove bud from twig carefully

Transparency Master #15

1. When the bud shows growth, the stock is gradually cut back on the budding point.

Transparency Masters #16 and #17

1. An angle cut is made. Note that it should be the same size as the angle cut made to the scion.
2. Make a lengthwise cut to an identical depth as the first angle cut.

STUDENT ACTIVITIES

- STUDENT WORKSHEET #1 — Seed Germination Laboratory Exercise
- STUDENT WORKSHEET #2 — Seed Collection and Extraction Laboratory Exercise
- STUDENT WORKSHEET #3 — Seed Germination and Seedling Development Laboratory Exercise
- STUDENT WORKSHEET #4 — Factors Affecting Seed Germination Laboratory Exercise
- STUDENT WORKSHEET #5 — Seed Testing, Germination Percentage Laboratory Exercise
- STUDENT WORKSHEET #6 — Testing Seed Viability Laboratory Exercise
- STUDENT WORKSHEET #7 — Seed Sowing Laboratory Exercise
- STUDENT WORKSHEET #8 — Transplanting Seedlings Laboratory Exercise
- STUDENT WORKSHEET #9 — Effect of Inhibitors on Germination Laboratory Exercise
- STUDENT WORKSHEET #10 — Effect of Light on the Germination of Seeds Laboratory Exercise
- STUDENT WORKSHEET #11 — Asexual Propagation — Leaf Sections Laboratory Exercise
- STUDENT WORKSHEET #12 — Asexual Propagation — Leaf Bud and Petiole Cuttings Laboratory Exercise
- STUDENT WORKSHEET #13 — Making Herbaceous Cuttings Laboratory Exercise
- STUDENT WORKSHEET #14 — Herbaceous Stem Cuttings Laboratory Exercise
- STUDENT WORKSHEET #15 — Softwood Cuttings Laboratory Exercise
- STUDENT WORKSHEET #16 — Using Root-Promoting Compounds Laboratory Exercise
- STUDENT WORKSHEET #17 — Using Leaves, Stems, and Roots to Reproduce Plants Asexually and the Effects of Polarity on the Propagation of Plants Laboratory Exercise
- STUDENT WORKSHEET #18 — Maintaining a Propagation Log Laboratory Exercise
- STUDENT WORKSHEET #19 — Removing Rooted Cuttings from a Propagation Bench Laboratory Exercise
- STUDENT WORKSHEET #20 — Asexual Propagation by Stem-Tip and Stem Cuttings Laboratory Exercise
- STUDENT WORKSHEET #21 — Propagation by Air Layering I Laboratory Exercise
- STUDENT WORKSHEET #22 — Propagation by Air Layering II Laboratory Exercise
- STUDENT WORKSHEET #23 — Asexual Propagation by Offsets or Offshoots Laboratory Exercise
- STUDENT WORKSHEET #24 — Asexual Propagation of Tubers Laboratory Exercise
- STUDENT WORKSHEET #25 — Propagation of Bulbs Laboratory Exercise
- STUDENT WORKSHEET #26 — Asexual Propagation by Division Laboratory Exercise
- STUDENT WORKSHEET #27 — Grafting Cactus Laboratory Exercise

STUDENT WORKSHEET #28 — Potato/Tomato Plant Graft Laboratory Exercise

STUDENT WORKSHEET #29 — A Side Graft (Spliced Side Graft) Laboratory Exercise

STUDENT WORKSHEET #30 — Whip and Tongue Grafting of Redtwig and Yellowtwig Dogwoods Laboratory Exercise

STUDENT WORKSHEET #31 — T-Budding (Shield Budding) Laboratory Exercise

STUDENT WORKSHEET #32 — Influence of Temperature on Pollen Germination and Pollen Tube Growth
Laboratory Exercise

STUDENT WORKSHEET #33 — Plant Tissue Culture Laboratory Exercise

For additional activities, teachers may refer to the "Suggested Teaching Activities and Procedures" section in the Instructor's Guide.

STUDENT WORKSHEET #1**Seed Germination Laboratory Exercise**

The job of sowing seed and handling seedlings up to the time of transplanting can prove to be a very difficult one. Damping off, a condition caused by a certain fungi, often occur in the early seedling stage and may cause the loss of the entire planting. Fungi, such as Pythium, Rhizoctonia, and Fusarium, frequently attack seedlings by killing the tissue of stems and roots near the ground line. In such cases, the young plants will fall over.

Environmental conditions, such as poor air movement and high temperatures, can lead to the loss of many plants. Therefore, a complete understanding of the methods involved in seed preparation and environmental control before and after seed germination is important. It is not intended that complete understanding will be gained from this demonstration alone, but that an introduction will be provided that will lead to further study of germination.

Purpose:

1. To develop an understanding of the external factors that affect germination.
2. To develop the ability to control the external factors so that seed will germinate successfully.

Materials:

1. seeds that have been sown
2. sprinkling can or breakers for hose
3. source of artificial light and a light meter that measures foot-candles (the most satisfactory sources of artificial light are fluorescent tubes of the cool, white type)
4. shade cloth

Procedure:

1. Place containers of sown seed in a place where the temperature can be controlled. The temperature requirements for any given seed may be thought of as being maximum, minimum, and optimum. Both temperature and light may affect the percentage of germination. Temperature and light requirements of some of the more common plants are as follows:

Species or Variety	Optimum Temperature	Light Requirement
Petunia	70° F	first 24 hours
Saint Paulia	70° F	first 5 days
Impatiens	70-75° F	Until germination
Centaurea	60-70° F	Cover first 48 hours

A good rule of thumb that can be followed is that most seeds will germinate readily at temperatures from 65° to 75° F.

2. Each student should have two groups of seeds of the same species and variety. Place one container in an area where the temperature will be constant, as is required for the variety. Place the second container in an environment where the temperature can be altered as follows:

Hold the temperature at the low end of the range for 18 hours and then raise the temperature to the upper level of the range for a period of 6 hours and continue alternating the temperatures throughout the period of the demonstration. This process can be reversed or changed in other ways if a separate study of this phase is desired.

Alternation of temperatures, rather than keeping the temperature at a constant level, will often speed up germination. Be sure to check the temperatures recommended for each species planted.

- Water the seeds according to the type of planting medium used. If the medium contains loam and sand, the percent of moisture should not be less than 10 percent. The moisture content of the planting medium at the time of planting should not be so high that the medium will ball when compressed in the hand, but will crumble slightly when released in the hand.

The correct amount of moisture for the planting medium used can be determined by experimenting with unused portions of medium that is the same as that in which the seeds are planted.

- Make provision for shading the containers of sown seeds. High surface temperatures and the fact that the seeds are planted shallow will make moisture control difficult. The container should be shaded during the bright part of the day. A mulch may be added to the planting medium to help keep the moisture content at the proper level.
- Provide an adequate supply of oxygen. Properly ventilate the area. Oxygen is necessary for the respiration that takes place in all viable seeds.

Make sure that the planting medium has good structure. That is, be sure that it will remain firm, but not harden and crust.

- For lighting, follow the instructions for the variety of seed used.

Place some containers in natural light and some containers with corresponding varieties under artificial light. This light should be from fluorescent tubes. A light intensity of 300 to 500 foot-candles is recommended. For a two-tube light bank, the distance above the container should be approximately 6 inches. A third group of containers may be set aside, if desired, in complete darkness. Place a piece of glass over the container and then cover the glass with several layers of newspaper which acts as a darkener and as insulation.

- Record the results of your demonstration in a chart similar to the following:

Growth	Name of Seed: Temperature		Light Given
	Constant Temp.	Alternating	
Days Seeding to Germination			
Growth — 1 week			
Growth — 2 weeks			
Growth — 3 weeks			

Note: Growth may be recorded in inches of height and diameter of main stems. An average of several plants should be used to record the growth. An alternative method sometimes used by plant scientists, is to use four plus signs (++++) for maximum growth and one plus sign (+) for lowest growth. Of course, two or three plus signs would indicate growth between the minimum and maximum.

Discussion:

1. There are three basic requirements for germination. First, the seed must be viable, or the embryo must be alive. Second, favorable environmental conditions must exist, the principal one being the right combination of oxygen, temperature, light, and water. Once the seeds have germinated and the first leaves have formed and expanded, the watering becomes slightly less critical.
2. The third requirement, that of overcoming any other conditions of the seed which might prevent germination, should be taken care of through special treatment before the seed is planted. Furthermore, a starter fertilizer, applied at the time of germination, will help give a stronger and more even growth.
3. If production is to be based upon the development of plants from seeds, it is essential that the best environment for maximum germination and growth be provided.

63

STUDENT WORKSHEET #2**Seed Collection and Extraction Laboratory Exercise****Materials:**

1. various seeds as below

Procedure:

1. Students should collect seeds from two of their favorite fruits or vegetables, from a grass, and from two or three trees, shrubs, or flowers. They should strive to find unusual seeds. Suggestions for seeds are those from kiwi, okra, melons, cucumber, zinnia, salvia, walnut, maple, and pine.
2. Student should clean and prepare the seeds in the appropriate manner for storage.

Observations:

STUDENT WORKSHEET #3**Seed Germination and Seedling Development Laboratory Exercise****Materials:**

1. bean, pea, squash, onion, corn seed
2. sharp knife
3. magnifying lens

Procedure:

1. At periods of 4 weeks, 3 weeks, and 2 weeks prior to the culmination of this activity, seeds of the recommended plant should be planted. At 1 week before, seeds of the recommended plant should be placed on moist paper and allowed to germinate.
2. On the seeds which have been germinating on the moist paper; remove the seed coat and carefully split the seed down the middle to expose the seedling parts. Be sure to label your drawing as you locate each part.
3. With the magnifying lens, carefully locate the embryo inside the seed. It consists of the cotyledon, root, and growing shoot.
4. After you have labeled the drawing, have your instructor check it for correctness and then compare the other three stages of development and make your observations.

Observations:

STUDENT WORKSHEET #4**Factors Affecting Seed Germination - Laboratory Exercise****Materials:**

1. large seeds (sweet corn, pumpkins, beans)
2. five large-mouth glass jars
3. peat moss, vermiculite, wood shavings or sawdust
4. paper towels

Procedure:

1. Line five large-mouth jars with paper towels.
2. Fill the jars with peat moss, vermiculite, wood shavings, or sawdust.
3. Place some of the large seeds between the paper and the glass.
4. Moisten the filling in three jars and add about one inch of water to the jars.
5. Label one of these jars and place in a warm place to show the effect of high temperature.
6. Label one jar and place in a refrigerator to show the effect of low temperature.
7. Label and tightly seal one jar and place it in a warm place to show the effect of lack of air. (Perhaps it would be good to use a jar which had been inverted over a burning candle to exhaust the atmospheric air supply first.)
8. Fill one jar completely full of water to show the effect of excess water. Label and place in a warm place.
9. Label and do not add any water to the fifth jar to show the effect of lack of water. Place in a warm place.
10. After about 10 days, observe what has happened to the seeds in each jar and record your findings.

Observations:

STUDENT WORKSHEET #5**Seed Testing, Germination Percentage Laboratory Exercise****Materials:**

1. paper towels
2. plastic bag
3. rye grass seed

Procedure:

1. Count out 100 rye grass seeds onto a moistened paper towel.
2. Roll the towel and place it into a plastic bag.
3. Unroll the towel after seed germination and compute the germination percentage. This activity could be called a Rolled Paper Towel Test.

Observations:

STUDENT WORKSHEET #6**Testing Seed Viability Laboratory Exercise****Materials:**

1. 200 corn kernels
2. container to soak seeds
3. boiling water
4. 0.1 percent tetrazolium chloride
5. shallow dish

Procedure:

1. Soak 100 corn seeds overnight.
2. Divide seeds into two equal lots.
3. Kill the seeds in one lot by boiling them for 15 minutes.
4. Cut several of the unboiled seeds in half and place in a shallow dish.
5. Similarly section several of the boiled seeds and place in a shallow dish.
6. Apply tetrazolium to all sectioned seeds and record results.

Observations:**Questions:**

1. Did the embryos of the living or dead seeds change color in the tetrazolium?
2. Why does the seed change color?
3. What is a viable seed?

STUDENT WORKSHEET #7

Seed Sowing Laboratory Exercise

Purpose:

1. To develop an understanding of the uses of suitable containers, proper media, and approved methods for seed sowing.
2. To develop the ability to sow seeds in a manner that will allow for successful germination.

Materials:

1. flats (approximately 14 x 10 x 3 inches), regular flowering pots, saucer pots, some milk cartons cut apart lengthwise, a portion of a greenhouse bench and/or a cold frame, if possible
2. drainage material for the clay containers or commercial devices designed to permit free drainage
3. planting medium mixed as follows:

one-third peat		two parts sand
one-third sand	or	one part loam
one-third soil		one part peat of leaf mold

(Vermiculite or perlite may be used as the sole planting medium or as a 1/4- to 1-inch top layer in the containers.)

4. facilities for pasteurization (If it is necessary to pasteurize the planting medium, it may be done by baking the moistened planting medium in a covered container placed in a pasteurizer at a temperature from 160° to 180° F for 45 minutes. If there is a source of steam that can be used, this is the best method for pasteurization. If neither of the above methods can be used, Formalin (40 per cent commercial formaldehyde) may be used at the rate of 2 1/2 to 3 tablespoons diluted in 6 parts of water. This is an ample supply for one bushel of planting medium. It should be mixed thoroughly with the planting medium just before the medium is placed in the containers. If Formalin is used, the medium must remain covered for a period of 24 hours and cannot be used for a period of 48 hours. **Mix outdoors - the fumes are poisonous to plants and people.** Equipment can be disinfected with a lysol solution or 10% Clorox solution.)
5. healthy, viable seeds of petunia, snapdragon, marigold or aster

Procedure:

1. Have each student prepare one or more of each kind of container to be used. These may include flats, regular flowerpots, saucer-pots, milk cartons cut lengthwise, and a portion of greenhouse bench or cold frame. Put the planting medium into the containers and pack it slightly by lightly jarring the container two or three times on the worktable. Level the medium with a flat marking label or rulerlike object.
2. If flats are used, mark the rows across the flat to limit the spread of damping off if it should occur. If the seeds are to be covered with vermiculite or perlite, only shallow marks will be necessary. In the containers other than the flats, the seeds should be broadcast and, therefore, no row marks will be necessary.
3. Some seed is treated when it is purchased, but if the seed has been grown and obtained locally or without going through any of the processing normally done by the dealer, it will be necessary to treat it if good results are expected and if diseases are to be avoided. Not all seed, especially fine seed like petunia, has been treated and the grower should treat this seed prior to sowing. If the seed has not been previously treated, treatment should be done in the following manner:

- a. There are many commercial seed treatment materials that may be used. These will usually be preferable to treatments prepared by individual growers. Among these are certain zinc and copper fungicides. These should be used according to the directions of the manufacturer.
- b. A second treatment that may be used is to mix one ounce of bichloride of mercury and 7 1/2 gallons of water. Keep the mixture in a glass container as it is very corrosive. The seeds should be soaked for an hour in water and then for ten minutes in the bichloride of mercury solution.

It should also be noted that there are some seeds, such as the Lupine and Morning Glory, that should be nicked before they are planted. This process simply breaks the hard outer cover on the seed.

4. Have each student study the seed that is to be used and group the seeds into fine, medium, and large size seed groups.
5. If balances are available, students should record the amount of seed sown by each method. They would then be able to determine the number of plants produced in relation to the amount of seed used under each of the methods of seeding. Sow the seed as follows:
 - a. Fine seed — Plant the seed in each of the containers used. When planting in the pots, the best method to use is to broadcast the seed or scatter it randomly over the surface of the soaked medium. Very fine seeds do not need to be covered. Larger fine seeds may be covered with a layer of vermiculite approximately 1/8-inch deep.

When using the flats or milk cartons, it is not necessary to mark rows because of the difficulty in handling the seed. But, in order to make comparisons of the total number of plants produced, sow some of the seed in a marked row approximately 1/8-inch deep. Make another row by merely placing the seed in a line on top of the medium. Cover the marked row lightly.

- b. Medium-sized seed — Plant some medium-sized seed in each of the containers used. When planting the seed in pots, use the broadcast system. Two methods should be demonstrated here in order to compare the number of plants produced. Randomly broadcast one group of seed and directly sow another group in rows 1 to 1 1/2 inches apart. The latter group should be thinned until the seeds are ready to be shifted, potted individually, or transplanted.

In flats and milk cartons, make the rows 1/8-inch deep and 2 inches apart in the previously moistened medium. Plant one group in the row at close intervals and directly plant a second group as described above. Identify the rows and the seed used and sprinkle lightly with a layer of soil or vermiculite.

- c. Large seed — Broadcast the seed in a pot and plant a second pot using the system and the spacing previously described for medium-sized seed. The seeds of this size will require the 1 1/2-inch spacing in the row when planted directly. Cover the seed with a layer of vermiculite 1/4 inch deep and water slightly with a sprinkling can.

Plant the seeds of this size in flats and milk cartons just as the medium-sized seeds were planted, except that the rows must be marked to a depth of 1/4 inch or more depending on the size of the seed. Again, plant one row randomly and a second row directly. The seeds should be covered to a depth that is equal to twice their width. Sprinkle and label.

If there is a shortage of containers or other materials, it might be desirable to have students form groups because it is likely that seeds of all the different sizes will produce different-sized plants. Thus, undesirable growing conditions may exist for smaller plants. Also, observation will be more difficult if the plants planted by the various planting methods are mixed. It is recommended that the instructor plan this phase of the demonstration according to the equipment and the facilities available.

6. Maintain a temperature of 65° to 70° F and keep the containers out of direct sunlight as excess heat will cause drying and eventual damage to the seed. The containers may be placed in greenhouse benches or cold frames.

7. The medium should be moist when the seeds are planted and in the case of fine seeds, no more watering should be necessary until the seeds have germinated. Water all seeds only when necessary.
8. To control damping off after the germination is complete, lower the temperature approximately 10° F, reduce the moisture slightly, and if there are any signs of the damping off, make sure that there is plenty of air circulation after the seeds have germinated. The containers and the seedlings may be dusted with commercial powders that have been developed especially for this condition.

An electric fan, placed so that the main air blast is between 2 and 3 feet above the seedlings, will help in controlling damping off. A glass covered with newspapers placed over the containers in which the seeds are planted will help to reduce temperatures until the seeds have germinated. After germination, the covers should be removed.

9. Such observations as the following may be recorded for the fine, medium-sized, and large seeds:
 - a. Number of plants produced per ounce of seed and per square foot of space used.
 1. When broadcast.
 2. When sowed in rows.
 - b. Quality of plants.
 1. From broadcast seeding.
 2. From sowing in rows.
 - c. Amount of handling required, such as transplanting. Record ++++ for high and + for low.
 1. For broadcast plants.
 2. For plants in rows.
 - d. Compare the amount of loss caused by disease between those plants originated from broadcast seed, those from seed which was planted closely in rows, and those from seed which was planted directly.

Discussion:

The beginning of a successful plant production operation is in being able to successfully start the plants. If seeds are to germinate properly, they must be sown in a manner that will allow for the best environmental controls to be applied. What often is believed to be a bothersome task can be accomplished quite easily if the operation is well planned and the correct procedures are used.

STUDENT WORKSHEET #8**Transplanting Seedlings Laboratory Exercise****Purpose:**

1. To learn the proper techniques for the transplanting of young seedlings.
2. To learn how young seedlings should be cared for once they are transplanted.

Materials:

1. pasteurized potting soil
2. propagation flat
3. sprinkling can
4. wooden plant labels
5. pencil or dibble
6. seedlings

Procedure:

1. Seedlings cannot be transplanted (pricked out) and placed individually in a propagation flat unless each one has formed its second pair of true leaves.
2. Fill the propagation flat with the sterilized potting soil
 3. Remove the young seedlings from the seed flat one at a time. This can be effectively done by using a wooden plant label as one might use a shovel.
4. Exercise great care when removing each seedling so that its root system is not damaged.
5. Use a pencil or dibble to make a hole in the soil to accept the seedling.
6. Position the seedlings in the flat so that the space between each one is about two inches (5 cm).
7. Once transplanted, the seedlings must be thoroughly watered but not drenched. Too much water could prove detrimental.
8. After the seedlings have recovered from the shock of being transplanted (2-3 days), they must be checked on a daily basis to determine whether or not they need water.

Questions:

1. What might happen to the newly planted seedlings if their root system were partially damaged?
2. Why is it necessary to wait until each seedling has at least two pairs of leaves before transplanting it?

STUDENT WORKSHEET #9**Effect of Inhibitors on Seed Germination Laboratory Exercise****Purpose:**

1. To learn the effect of various inhibitors on seed germination.
2. To plot on graph paper the comparative results obtained between the experimental control group and the treated group.

Materials:

1. seed packets of bean, cucumber, tomato, and marigold
2. sterilized sand
3. graph paper
4. twenty 4-in (10-cm) plastic bulb pans (one per treatment)
5. wooden plant labels
6. 100-ml beakers
7. sterile glass containers for each inhibitor
8. inhibitors — tomato juice, apple cider, water extracted from cooked spinach, water extracted from soaked grass seed (Other inhibitors that can be tested are diluted lemon juice, and water extracted from cooked carrots or onions.)

Procedure:

1. Count out exactly 10 seeds from one of the seed packets.
2. Fill one of the 4-in bulb pans with sterilized sand.
3. Write your name, the date, the name of seed sown, and the specific treatment the seed will receive on a wooden plant label and place in your pot.
4. Place small-sized seeds just below the sand's surface and large-sized seeds at least one inch below the surface.
5. Once the 10 seeds are sown, water your pot with 100 ml of the correct inhibitor.
6. Continue to apply the same inhibitor to your pot for a total of 10 consecutive days, and make daily observations of the number of seeds that have germinated. Record this information in your notebook.
7. If you have been selected for one of the control groups, you are to water your seeds with tap water and record your seeds' germination rate in your notebook.
8. On graph paper, plot the daily germination rate for both the control and inhibitor-treated groups for the same seed. For class uniformity, use the Y axis for the number of seeds germinated and the X axis for the number of days.

Questions:

1. Which of the inhibitors tested suppressed germination the most? The least?
2. Which of the seeds tested seemed to be the least affected by the addition of inhibitors? The most affected?

Discussion:

1. It may be necessary to delegate a responsible student to both treat and record the data for each of the treatments on the weekend. If this is not possible, all treatments should be left in a cool, low-light environment for the weekend to suppress dehydration as much as possible.
2. To assure uniformity of all inhibitor applications, have each student apply the same volume of liquid, i.e., 100 ml, per day.
3. The exercise as presented suggests the use of four different seeds and five treatments, including the control, to fill 20 pots. If desired, this exercise can be expanded to include other seeds and other inhibitors.

77

STUDENT WORKSHEET #10**Effect of Light on the Germination of Seeds Laboratory Exercise****Purpose:**

1. To determine which seeds germinate faster in the light than in total darkness.
2. To test the effect that colored filters may have on germination.

Materials:

1. two 40-watt cool white fluorescent bulbs
2. four petri dishes, numbered 1 through 4
3. cellophane, one roll red, one roll blue
4. paper toweling
5. roll of aluminum foil
6. seed packets of your choice

Procedure:

1. Cut the red cellophane so that it fits snugly into the top of a petri dish. Label this dish number 2. Do the same with the blue cellophane and label the dish number 3.
2. Cut three layers of paper toweling to fit the bottom of each petri dish.
3. Thoroughly saturate the toweling with water and pour off any excess water.
4. Place ten seeds on the toweling in each dish.
5. Using two layers of aluminum foil, cover each dish completely for 24 hours.
6. Dish 1 is to be kept covered throughout the exercise.
7. Dishes 2, 3, and 4 are to receive one hour of light daily and then be recovered with the aluminum foil. Dish 4 will be clear with no filter.
8. Once germination occurs in any one of the dishes, terminate the exercise and count the number of germinated seeds in each dish. Record the data as follows:

Name of seed tested _____

Date exercise was started _____

Date exercise was terminated _____

Number of seeds germinated in dish 1 _____, dish 2 _____, dish 3 _____,
dish 4 _____

STUDENT WORKSHEET #11**Asexual Propagation — Leaf Sections Laboratory Exercise****Purpose:**

1. To propagate a plant using sections of a leaf.

Materials:

1. leaf of mother-in-law plant
2. knife
3. cell packs with media or propagation bench
4. pencil and plant label

Procedure:

1. Using pen or pencil, draw lines on the leaf, dividing it into at least four equal sections.
2. Draw an arrow on each section pointing downward. Be careful not to puncture the leaf.
3. Slice the leaf on each line.
4. Place half of the leaf sections in the medium with the arrow going down. Place the other half of leaf sections in the medium with the arrow going up.
5. Place on bench. Water thoroughly.
6. Check daily for root growth.

Observations:**Questions:**

1. It is known that the part of a plant nearest the plant crown produces roots more easily while the part of the plant farther from the plant crown, produces shoots more easily. What would cause this? Watch your leaf actions to see what cuttings root first.
2. Where is the crown of a plant? Illustrate in a drawing.
3. By what other asexual methods can the sanseveria be propagated?
4. With the leaf section method, how is the new plant formed? Illustrate with a drawing.

STUDENT WORKSHEET #12**Asexual Propagation — Leaf Bud and Petiole Cuttings Laboratory Exercise****Purpose:**

1. To propagate a plant using the leaf bud portion of the plant.
2. To propagate a plant using the leaf petiole portion of the plant.

Materials:

1. cell packs with soil media or a propagation bench
2. plant materials suitable for this method of taking cuttings

Procedure:

1. Remove five leaves with their petioles from a plant and place them in the propagation medium about 1 1/2 inches deep.
2. Remove five leaves with the accompanying bud and place these in the propagation medium about 1 1/2 inches deep.
3. Write out labels and place them in the appropriate location to identify your cuttings. Be sure to use pencil only.
4. Place in the propagation bench for further observation.

Observation:**Questions:**

1. Which technique do you think will produce a rooted geranium plant? Explain.
2. What reason can you give for taking a leaf bud cutting rather than a stem cutting?
3. How will the medium affect the rooting process?
4. Did all of your cuttings survive? If not, what do you think happened?
5. Did all cuttings form root systems? Did some cuttings root faster than others?
6. How does the new growth compare on the different cutting types?

STUDENT WORKSHEET #13**Making Herbaceous Cuttings Laboratory Exercise****Background:**

Many ornamental plants can be propagated by cuttings taken from parent plants. A cutting is made by removing a vegetative part of the plant and treating it in such a way that roots will form and thus produce a new plant.

Three types of cuttings are commonly used when propagating plants. There are, however, many variations of these three types and the following demonstrations will provide a basic understanding of some of the various methods. The three common types of cuttings to be used for the demonstration are (1) stem cuttings, (2) leaf cuttings, and (3) leaf petiole cuttings

There are other types of cuttings with which students should be familiar, and which they might practice doing. These include root cuttings which are used commercially to propagate garden phlox and oriental poppies, and offset cuttings, which represent a modification of the true cutting propagative method.

It is recommended that a pressure mist system be installed for use with this demonstration and be kept as a permanent part of the plant growing facilities.

Purpose:

1. To develop the ability to propagate plants by making soft wood cuttings of different types.
2. To develop an understanding of the practices to be used in propagating plants by means of cuttings.
3. To develop an understanding of the advantages of vegetative propagation by cuttings.

Materials:

1. a supply of plants from which the various types of cuttings can be made:
 - a. for stem cuttings — plants such as carnation, coleus, geranium, ivy, chrysanthemum, begonia, philodendron
 - b. for leaf cuttings — plants such as sanseveria, rex begonia
 - c. for leaf petiole cuttings — plants such as African violet, gloxinia, tuberous begonia, peperomia
2. rooting medium such as coarse sand, coarse sand and peat, or vermiculite
3. material for shading cuttings such as cheesecloth
4. pots, growing bench, flats, plots for growing the cuttings
5. time clock and interval timer
6. high-pressure mist system

Procedure:

1. Prepare the area in which the cuttings will be placed. This may involve preparing pots, a greenhouse bench, a small area in the greenhouse, or an outdoor plot near the school laboratory.
2. Select the plants to be propagated and determine the kinds of cuttings to be made. If possible, each student should make at least five cuttings of each of the three types. If materials are limited, students may be divided into groups with each group responsible for making a few cuttings of each type.
3. Make the cuttings as follows:
 - a. For stem cuttings, select healthy, rapidly growing stems. Cut the stems in lengths approximately 3-4 inches long, making the base cut just below a node.
 - b. For leaf cuttings, select healthy leaves. Remove the leaves from the stem of the plant. The leaves should lay flat on the growing medium. They should be weighted or pinned to make sure that they will stay in this flattened position. Cut through the veins of the leaf at several points.

If sanseveria is used, the leaf must be chemically treated with a root-inducing hormone and must be placed upright with the base of the leaf in the medium.

- c. For leaf petiole cuttings, remove a number of healthy leaves with their petioles. Place the petioles in the growing medium the same as you would a stem cutting.
4. Treat the cuttings with a root-inducing hormone and stick them into the rooting medium. Be careful not to allow any of the hormone to get on the buds of the stem cuttings.
5. Keep the cuttings moist, but do not saturate the medium. Maintain an even temperature of about 70° F and shade the plants from direct sunlight.
6. Keep a record of the results of the demonstration as follows, recognizing that details of the record will vary according to the material used and the facilities available:
 - a. Kind of plant used.
 - b. Kind of cuttings made.
 - c. Number of cuttings made.
 - d. Kind of plant hormone(s) used.
 - e. Kind of rooting medium used.
 - f. Temperature at which the cuttings were held.
 - g. Per cent of cuttings rooted.
 - h. Time required for the cuttings to produce 1/2-inch roots.
 - i. Point or location on the cutting at which roots were produced.

Discussion:

Production of plants from cuttings is a popular hobby for some people. For others who are interested in commercial production of plants, this method of propagation represents a highly desirable means of producing large numbers of plants, all of which will have the same characteristics. The fact that cuttings are made from vegetative parts of the plant assures the producer that the propagated plants will have identical characteristics to those of the parent plant. This method of propagation also offers a means of reducing the amount of time normally required to grow certain plants to maturity or to a saleable size.

Observations:

STUDENT WORKSHEET #14**Herbaceous Stem Cuttings Laboratory Exercise****Purpose:**

Information about the rooting of a cutting gained through personal experimentation will do much to insure the success of your propagation program. The objectives of this exercise are to experimentally determine four useful pieces of information: (1) the correct procedure for making a stem cutting, (2) the position on the stem where roots develop most readily, (3) the relationship between the amount of leaf surface and the rootings of the cutting, and (4) the best position for making the basal cut. This experiment will require 14 to 21 days to complete, depending on plant materials used and time of year.

Date begun _____ Date completed _____

Materials:

1. plants such as chrysanthemum, poinsettia, geranium, fuschia, coleus, or Swedish ivy
2. foliage from grape ivy, aluminum plant, or wandering jew

Procedure:

1. Students should work in assigned teams.
2. Each team should fill two flats with assigned propagating medium.
3. Proceed to the school greenhouse and determine the location of the plant material to be used in this exercise. The instructor will assign each team one type of plant to use.
4. Each team member should take twenty-five stem cuttings of the assigned plant material.
5. Each stem cutting should be 3 to 5 inches long. All cuttings should be from young, healthy, vegetative growth. The cuttings should be taken from the ends of lateral or terminal shoots.
6. One partner should make all his or her basal cuts just below the nodes. The other partner will make all his or her basal cuts just above the nodes.
7. Each partner will remove all but two leaves from ten of the cuttings and leave all the leaves on the other fifteen cuttings.
8. Open a trench in the propagating medium approximately 1 inch wide and 2 inches deep and place the cuttings into the trench approximately 1 inch apart.
9. After insertion, the medium should be firmed around the base of each cutting with the fingers.
10. Label each flat with your name and the date of the cut. Use only waterproof markers.
11. Water the cuttings and set on the propagation bench. Most of the cuttings should be rooted in 14 to 21 days.

Observations:

STUDENT WORKSHEET #15**Softwood Cuttings Laboratory Exercise****Purpose:**

1. To propagate woody ornamental plants by softwood cuttings.

Materials:

1. pruner
2. chlorine bleach
3. rooting hormone powder
4. plastic garbage bag
5. maple, magnolia, forsythia, lilac, weigela, or juniper
6. rooting media (peat moss and perlite)
7. labels

Procedure:

1. Sterilize the pruner cutting blade with chlorine bleach.
2. Take cuttings about 3-5 inches long from plants in the field. The basal cut should be made just below a node. Store the cuttings in a plastic garbage bag until they are brought to the greenhouse.
3. Remove the lower leaves from the cutting, leaving the petioles on the stem.
4. Score (vertical cuts about 1 inch long through the cambium) the basal end of each stem.
5. Dust the basal end of the stem with rooting hormone powder. Tap any excess rooting hormone from the stem.
6. Stick the cuttings at least 1 but no more than 2 inches into the rooting medium.
7. A mist system set up over the cuttings is ideal for maintaining high humidity. Otherwise, cover with a clear plastic tent.
8. Label the cuttings, indicating what plant they are from and the date they were taken.

Observations:**Questions:**

1. Why are cuttings taken just below a node?
2. Which shoots are best for hardwood cuttings?
3. Why are the lower leaves removed?
4. How does rooting hormone powder aid rooting?

STUDENT WORKSHEET #16**Using Root-Promoting Compounds Laboratory Exercise****Purpose:**

Under good propagating conditions, most greenhouse-grown crops can be propagated without the use of root-promoting compounds. However, there may be times when it becomes necessary to increase either the quality, the speed, or the uniformity of root initiation by applying root-promoting compounds. Therefore, you should be able to identify those commercial root-promoting compounds used in the laboratory and to follow the instructions given for the application of these compounds to specific types of plant materials.

Procedure:

1. Locate the assigned area you are to work in and the tools and plant material you are to work with.
2. Prepare several (depending on the number of cuttings taken) propagation flats using a standard propagating medium. To avoid brushing off the powder during insertion make a trench in the medium.
3. Locate the plant material; take as many cuttings as instructed by the instructor.
4. Cutting materials more than an hour old should not be used. If more than an hour passes after the cuttings are made until the rooting step, fresh basal cuts should be made.
5. Place a small amount of the root-promoting compound into the plastic container, so there is a thin layer of powder, perhaps 1/4 to 1/2 inch thick.
6. Dip the base of each cutting in the powder and rotate it until it becomes coated with the powder.
7. Lightly tap the cutting against the side of the plastic container to remove excess powder.
8. Insert the cuttings into the rooting medium immediately.
9. After all the cuttings have been treated, discard the remaining powder in the plastic container. Do not put this powder back into the original container.
10. Water the flat and place it on the propagation bench.

Observations:

EJ

STUDENT WORKSHEET #17**Using Leaves, Stems, and Roots to Reproduce Plants Asexually
and the Effects of Polarity on the Propagation of Plants Laboratory Exercise****Purpose:**

This exercise is to show how buds, leaves, and stems influence the rooting of cuttings. The exercise will also acquaint the student with the use of other plant structures besides stems for the propagation of plants. Leaves of some seed plants which contain no meristem can be made to develop meristems which give rise to leaves, stems, and roots. Sometimes a leaf plus a bud is necessary to produce a propagated plant. Root cuttings must initiate adventitious buds instead of adventitious roots as on stem cuttings. Since various transport systems exist in the plant and these systems tend to run in one direction the plant is said to be polarized. The polarity of plants must be maintained for them to root properly.

Procedure:**Part 1: Asexual Propagation through Stems.**

1. Prepare five cuttings of *Hedera helix* in each of the following manners:
 - a. complete cutting with buds, stems, and leaves
 - b. cutting with stems and leaves but no buds
 - c. cutting with buds and leaves but very few stems
 - d. cutting with buds and stems but no leaves
 - e. leaves only
2. Insert cuttings in a peat and perlite medium under mist.

Part 2: Asexual Propagation through Leaves.

1. Take several leaves of plants capable of being reproduced through the leaf cutting method. For small-leaved plants such as *Peperomia* and *Saintpaulia*, use the whole leaf. For large-leaved plants such as *Begonia* and *Sanseveria*, use only a portion of the leaf.
2. Take at least one leaf bud cutting from *Camellia* or other plants capable of being reproduced by the leaf bud cutting method.
3. Insert the cuttings in a peat and perlite medium under mist.

Part 3: Asexual Propagation through Roots.

1. Take several 1- to 2-inch pieces of horseradish root and mark them for polarity.
2. Take two cuttings and insert them vertically into a peat and perlite medium. The polarity should be reversed for the two cuttings.
3. Take a 3- to 4-inch piece of horseradish root and cut it into three pieces. Lay these pieces out horizontally on the medium, reversing the ends of one of them.

Observations:

STUDENT WORKSHEET #18**Maintaining a Propagation Log Laboratory Exercise****Purpose:**

To determine the success of your propagation program, it is important to keep accurate records. A successful propagation program requires excellent records on types of material propagated, propagation methods, number of cuttings rooted, dates of transplant, and special treatment which may have been made during the propagating time. You should record in the master log kept by the teacher all the information that relates to (1) all plants that you propagate, (2) all cuttings that you remove from the propagation bed and transplant. The following exercise will give you practice in correctly filling out a master log sheet with appropriate information.

Procedure:

For every plant you propagate, you should fill out a corresponding log sheet neatly, accurately, and completely. You will be able to fill out only half of the form at a time. The procedure below indicates the information that should be included.

1. List the plant name, giving both the common and botanical names.
2. Under the section titled "Propagated by," list:
 - a. Your name
 - b. Today's date
 - c. Number of cuttings made
 - d. Method of propagation (stem cutting, leaf cutting, axillary bud cutting, or other)
 - e. Special consideration given this group of cuttings (root-promoting compounds, increased bottom heat, or fungicide application)
3. Under the section titled "Transplanted by," list:
 - a. Your name
 - b. Today's date
 - c. Total number of cuttings rooted
 - d. The size and kind of container you transplanted into, along with the number of cuttings per container
 - e. Total number of days since the cuttings were made
 - f. Any disease, fungus, or insect problems that may be obvious at time of transplanting.

Observations:

87

Propagation Log Sheet

Propagation Log Sheet # _____

Plant Name: Common _____

Botanical _____

Propagated By:

Transplanted by:

Name _____ Name _____

Date _____ Date _____

of Cuttings _____ # of Cuttings _____

Special Considerations _____ Type _____

_____ Size _____

_____ # of Container _____

_____ Total Days since Cuttings _____

STUDENT WORKSHEET #19**Removing Rooted Cuttings From a Propagation Bench Laboratory Exercise****Background:**

Certain kinds of plants have very brittle roots that are easily broken in handling. Such broken roots are easily infected, and plants may be killed. Gentle handling of rooted cuttings is important.

Rooted cuttings should be moved from the propagation bench to a flat as soon as they have formed roots from 1/4 to 1/2 inch long. Label them clearly. They should be sprinkled with water right after removal from the propagation bench. Rooted cuttings should be placed in a shaded area to prevent wilting until they are planted. Planting should be done as soon as possible — a delay of several hours could be harmful.

Purpose:

1. Given labels, flats, pencil, water sprinkler, and cuttings rooted in a bench, move rooted cuttings from bench to a flat without damaging root system and label correctly. Performance is evaluated by teacher.

Procedure:

1. Gently pull on the top of cutting. If it seems to "tug back" it is rooted. Use this test on a number of cuttings in the same block; if most are rooted, they are ready to remove from the propagation bench.
2. Clean flat with water hose and put clean paper or plastic film in bottom.
3. Using a "garden" label 1 1/2" wide by 12" long, slide under a row of cuttings, and gently lift to loosen the cuttings in the rooting medium.
4. Gently take hold of the tops of the cuttings with the fingers and lift.
5. Place the cuttings in the flat. Repeat Steps 3, 4, and 5 until the flat is filled.
6. Prepare a label (5/8" x 5") by printing the name of the plant on the label in lead pencil (ink would wash away). Copy the name from the label in the propagation bench for this batch of cuttings.
7. Place the new label in the flat with the rooted cuttings.
8. Sprinkle the rooted cuttings in the flat lightly with water.
9. Cover the cuttings with wet paper, wet and *clean* burlap, or plastic film to keep them from drying.
10. If the flats of cuttings are not to be planted within an hour or two, place them in a refrigerator (40° F).

Observations:

83

STUDENT WORKSHEET #20**Asexual Propagation by Stem-Tip Cuttings and Stem Cuttings Laboratory Exercise****Purpose:**

1. To propagate a plant by division.

Materials:

1. coleus, geranium, wandering jew, or Swedish ivy
2. sharp knife
3. label
4. pencil

Procedure:

1. Make 4 stem-tip cuttings and stick them in a mist bench 1 1/2" deep. These stem-tip cutting should be 4-6 inches long, include a terminal bud, have lower leaves and flowers removed, and be cut close to the side bud to avoid leaving a stub on the original plant.
2. Make 4 stem cuttings and stick them in a mist bench 1 1/2" deep. A stem cutting does not have a terminal bud.
3. Place a label with your name and the date, in front of your cuttings in the mist bench.

Observations:**Discussion:**

1. Draw a plant stem and label the terminal bud and the side buds.
2. List the advantages and disadvantages of the stem-tip cutting.
3. List the advantages and disadvantages of the stem cutting.
4. Describe the environment that is best for rooting plants.
5. How long do you estimate it will take each of the types of cuttings to root?
6. Describe the procedure for sticking cuttings in the mist bench.

STUDENT WORKSHEET #21**Propagation by Air Layering Laboratory Exercise****Purpose:**

1. To root a plant while it is still attached to the mother plant.

Materials:

1. plant materials
2. knife
3. toothpicks
4. rooting hormone powder
5. plastic sheets
6. 2 twist ties
7. moist sphagnum moss

Procedure:

1. Remove leaves from a 6-inch area of the *Dracaena* stem.
2. Make a slanted cut about halfway into the stem. Be careful not to cut entirely through the stem.
3. Prop the cut open, using the toothpicks.
4. Place the rooting hormone powder into the cut.
5. Wrap a handful of wet moss around the stem, making sure some wet moss gets into the cut area.
6. Wrap the moss with the plastic sheet. Be sure all the air is removed.
7. Tie a twist tie at both ends of the plastic sheet to secure the moss around the stem.
8. Place on the bench or area assigned.
9. Observe daily to watch when the first root appears.
10. When three roots are visible through the plastic, it is time to plant the air-layered cutting. Remove plastic. Cut through stem *below* the root moss. Transplant into a new pot. Water thoroughly. Keep out of direct sun until established.

Observations:**Questions:**

1. What purpose does the moss serve?
2. Why do we use the hormone powder?
3. What plants, besides the *Dracaena*, can be air layered?
4. Why would we air layer a plant instead of taking a tip cutting?
5. What are the advantages of using this technique to propagate plants?
6. What are the disadvantages of using this technique to propagate plants?

STUDENT WORKSHEET #22**Propagation by Air Layering Laboratory Exercise****Purpose:**

1. To learn the techniques and supplies involved in air layering.
2. To learn a suitable way of shortening a leggy house plant.

Materials:

1. ficus (rubber plant) or dieffenbachia (dumb cane)
2. jackknife
3. sphagnum moss
4. clear polyethylene plastic
5. black plastic electrical tape
6. rooting hormone

Procedure:

1. Make a ball (size of baseball) out of sphagnum moss that has been previously moistened and place this ball on a piece of absorbent paper toweling.
2. Notch the plant stem around its complete circumference, approximately 1/2 in (1.25 cm) deep, with the jackknife.
3. Dust the notch with rooting hormone.
4. Use the jackknife to cut the moistened ball of moss into two equal halves.
5. Position the two halves of the moss in the notched area on opposite sides of the plant stem.
6. Cover the moss with the clear polyethylene plastic, and seal both top and bottom with the electrical tape.
7. Treat the parent plant as usual, supplying the necessary water and fertilizer when needed.
8. Once roots are evident, cut the newly rooted plant section away from the bottom portion and plant it in a suitable container.

Questions:

1. What are some of the advantages to air layering?
2. What are some of the disadvantages?
3. Describe the condition of the sphagnum moss at the termination of this exercise (once rooting has occurred and the plastic has been removed).

STUDENT WORKSHEET #23**Asexual Propagation by Offsets or Offshoots Laboratory Exercise****Purpose:**

1. To propagate a plant by offshoots.

Materials:

1. aloe or sanseveria
2. sharp knife
3. clean pots
4. sterilized soil mix

Procedure:

1. Tap the plant out of the pot.
2. Locate a plantlet and pull it carefully away from the mother plant until you see the main stem connecting the plantlet to the mother plant.
3. Cut the stem between the plantlet and the mother plant so the plantlet has some of its own roots.
4. Repeat steps 3 and 4 until all plantlets are separated from the mother plant.
5. Pot up all the plantlets in pots of appropriate size, typically 3-4" in diameter.
6. Repot the mother plant back in its original pot.
7. Move all the plants to the greenhouse bench as designated by the instructor.
8. Water all your plants.
9. Observe carefully over a period of time.

Questions:

1. What are two other plants which could be propagated by offshoots?
2. What is the difference between propagation by offshoot and propagation by division?
3. How are the plantlets connected to the mother plant?
4. What care, if any, needs to be given to the new plantlets for the first week or so?

STUDENT WORKSHEET #24**Asexual Propagation of Tubers Laboratory Exercise****Purpose:**

1. To develop the skill of dividing potato tubers.

Materials:

1. white or red potato tubers
2. cell packs with soil media or a propagation bench
3. knife

Procedure:

1. Fill a cell pack 1/2" from the top with soil.
2. Divide a potato into sections. Each section should have two or three "eyes."
3. Plant the sections as deeply as possible in the soil.
4. Record your observations for at least 2 weeks in the space provided below.
5. Take your potato plants home and plant them in a large plastic container. The soil in this container should be loose to provide good drainage.
6. In time, you will enjoy your new potatoes at the dinner table.

Observations:**Questions:**

1. What part of the tuber produces new growth?
2. How much time is required for growth to occur?
3. What is the function of the potato in the life cycle of the plant?
4. What are some plants similar to the potato? Give at least two examples.

STUDENT WORKSHEET #25

Propagation of Bulbs Laboratory Exercise

Note: In cases where bulb propagation must be encouraged by special processing, it will take 3 to 6 years for a bulblet to reach a size which is suitable for flowering. Because of the length of time required for a bulblet to reach flowering size, it is recommended that this demonstration be carried out through Step 5 in the procedure section. Then, if it is desired to continue growing the bulblet to maturity, continue growing under forced-growing rather than normal conditions.

Purpose:

1. To develop an understanding of the structure of a bulb.
2. To develop an understanding of the principles of propagating bulbs.
3. To develop the ability to process and propagate bulbs.

Materials:

1. a supply of large, dormant, disease-free, well-developed hyacinth and onion bulbs (The onion bulbs will be used for identification and practice and the hyacinths for actual processing and propagating.)
2. suitable growing medium or outdoor plots
3. potato or melon baller or a sharpened, stainless steel teaspoon
4. *sharp* penknife
5. dark, warm storage areas

Procedure:

1. Let each student take an onion bulb and remove a thick scale, then identify the buds in the axils of the scales. Cut some of the bulbs vertically so that students may observe the basal plate, the overlapping scales, and the large central bud. Note the other steps in the procedure and let the student practice, with the onion bulbs, the procedure they will use when working with the hyacinth bulbs.
2. Let each student select one hyacinth bulb for each of the following methods of preparation:
 - A. Scooping
 1. Lay the bulb on a work table with the basal plate to the right (for right-handed students).
 2. With the bulb remaining on the table, grasp it gently but firmly with the left hand.
 3. Take either the melon baller or the sharpened teaspoon in the right hand.
 4. With a minimum of cutting action, scoop out the basal plate in a manner that will just expose the bulb scales. The scooped-out portion need not be more than 3/8 inch deep.
 - B. Scoring and notching
 1. Hold a bulb on the work table with the basal plate up.
 2. With the sharp penknife, make two or three cuts completely across the basal plate, crossing each other and extending about a third of the way into the bulb.
 - C. Separating and planting scales
 1. Each student may remove a bulb scale.
 2. Identify the buds in the axils of the scale.
 3. Plant the scale in an upside-down position.
 4. Continue as in Steps 5 and 6 which follow.
3. Place the bulbs that have been scooped or scored in a warm, slightly darkened place for two to three months prior to spring planting. The temperature should be maintained between 70° and 80° F.

4. After storage, plant the bulbs in an upside-down position in plots or cold frames. The bulbs should be placed on top of the planting medium and then covered by 2 to 3 inches more of the medium. A "rule of thumb" to follow when planting bulbs is to cover them to a depth one-and-one-half times their length.
5. Care for the planted bulbs as you would under normal conditions.
6. After a growing season and the withering of the foliage, dig up the original bulbs and separate the newly formed bulblets.
7. Replant the separated bulblets to continue their growth into bulbs of flowering size.
8. Compare the results of the different methods of processing the bulbs by recording the numbers of bulblets produced and measuring.

Discussion:

Many bulbs propagate themselves naturally by breaking up into a number of small bulbs. Tulips do this, particularly when planted shallowly. Other bulbs, such as daffodils, will form offsets which are known as slabs. Still others, like the hyacinth, are slow propagators under normal conditions, but by processing a dormant bulb it is possible to greatly increase the number of bulblets produced.

On processed bulbs, more but smaller bulblets will form on scooped bulbs, while fewer but larger bulblets will form on the scored bulbs.

With any type of bulb propagation, several growing seasons are required for the bulblets to acquire a size that is adequate for flowering.

Bulbs are measured by determining the circumference. Grades are assigned in respect to circumference in inches or centimeters. A grade 8-9 would have a circumference of 8-9 inches or centimeters.

It is believed that varietal grades of bulbs may influence the resulting plants. This is true to a point, but it must be remembered that it is important for bulbs to be secured from a reputable firm. While the grade of the bulb is important, the quality of the plant may be greatly influenced by the way in which the parent plant was cared for before the bulb was harvested. It is possible for bulbs to be a good size but lack stored food substances for growth of a new plant.

Observations:

STUDENT WORKSHEET #26**Asexual Propagation by Division Laboratory Exercise****Purpose:**

1. To propagate a plant by division.

Materials:

1. multi-crowned plant
2. knife
3. extra pot
4. soil

Procedure:

1. Tap plant out of pot.
2. Using thumbs, pull apart the plant where it naturally splits apart.
3. Each new section should include a portion of leaf, stem, and root.
4. Repot new sections into pots.
5. Observe carefully.

Questions:

1. How many new plants resulted from the plant you divided?
2. Where is the crown of the plant located?
3. Give three examples of multi-crowned plants.
4. If, after a plant is divided, a section does not have any roots, what can be done to help save that particular section? Similarly, what can be done to help save a particular section of a fern or a fibrous begonia?

STUDENT WORKSHEET #27**Grafting Cactus Laboratory Exercise****Background:**

Any true cactus can be grafted to any other true cactus. Grafting cactus is best done after the cactus has undergone its dormant period.

Materials:

1. stock
2. scion
3. gloves
4. knife or razor
5. newspaper strap
6. kitchen tongs
7. pin or rubber bands
8. alcohol

Procedure:

1. Slice the top off the understock.
2. Prune the edges slightly downward so that they form a slightly inverted bowl.
3. Cut off the root end of the scion and prune the edges slightly upward.
4. Set the scion onto the understock. Make sure the scion fits well.
5. Maintain the contact between the two by weight (cross of rubber bands) or by pinning.
6. Keep the new plant dry and out of the sun for about two weeks.
7. When a gentle tug fails to dislodge the scion, remove the weight and give the new grafted plant its normal culture.

Observations:

99

STUDENT WORKSHEET #28**Potato/Tomato Plant Graft Laboratory Exercise****Purpose:**

1. To propagate the potato and tomato plants and use the approach grafting method to create a potato/tomato plant.

Materials:

1. potato
2. tomato seeds
3. 4" plastic pots
4. potting soil
5. labels
6. knife
7. grafting rubbers

Procedure:**Part 1: Potato Propagation.**

1. Cut a potato into sections. Each section should contain two or three eyes or nodes.
2. Fill a 4" pot half full with dry media. Place one section "eyes up" into the pot and cover with dry medium, leaving a one-inch space at the top. Do not water.
3. Three to four days later, water the plant.
4. Continue watering as needed.

Part 2: Tomato Propagation.

1. Fill a 4" plastic pot with moist medium, leaving a one-inch space at the top.
2. Place three tomato seeds in the center of the pot and cover them lightly.
3. Mist the pots or water lightly.
4. Keep pots under a mist system or cover the pots with clear plastic or glass.
5. Once plants begin to grow, pull them from mist system or remove covering.
6. Choose the best plant in the pot and remove the rest.
7. Continue to grow the plant.

Part 3: Potato/Tomato Graft.

1. Collect the tomato and potato plants once they are 4" or more in height.
2. Find a point on the stems of the plants where they can be pulled together.
3. At that point, cut halfway into the stem and down about 1/2" in one smooth motion.
4. Put the sliced areas together and fasten with the grafting rubbers.
5. The graft should take in two weeks; at that time, cut off the tomato root stock and the potato shoot.
6. One week later, remove the grafting rubber.
7. Repot as soon as possible to a larger pot or garden to give ample room for the potato growth.

STUDENT WORKSHEET #29**A Side Graft (Spliced Side Graft) Laboratory Exercise****Background:**

This variation of side grafting is widely used, especially for grafting small potted plants such as evergreens.

Materials:

1. stock
2. scion
3. knife
4. alcohol
5. waxed string, budding rubbers or raffia
6. peat moss

Procedure:

1. A shallow downward and inward cut from 1 to 1 1/2 inches long is made in smooth area on the stock.
2. At the base of this cut, a second short inward and downward cut is made, intersecting the first cut. Remove the piece of wood and bark.
3. Prepare the scion with a long cut along one side and a very short one at the base of the scion on the opposite side.
4. The cuts on the stock and scion should be the same length and width so the cambium layers can be matched as close as possible.
5. Insert the scion and wrap with waxed (paraffin) string, budding, rubbers, or raffia.
6. Plunge the graft into a damp medium (peat moss) so it just covers the graft union.
7. The newly grafted plant may be placed in a propagation bench.
8. After the union has healed, the stock can be cut back above the scion.

Observations:

100

STUDENT WORKSHEET #30**Whip and Tongue Grafting of Redtwig and Yellowtwig Dogwoods Laboratory Exercise****Background:**

The whip and tongue grafting method allows for a high percentage of cambial contact which heals quickly and results in a strong graft union. To produce a successful graft, the scion and stock should have equal diameters (1/4 to 1/2 inch).

Materials:

1. stock
2. scion
3. knife
4. alcohol
5. waxed string, budding rubbers, or raffia
6. plastic bag
7. peat moss

Procedure:

1. Wrap your hand around the handle of the knife so that it feels comfortable. Hold your thumb parallel with the blade. If you value your thumb, use it as a guide, do not push with it.
2. Hold the scion near your chest and with a slicing motion make a sloping cut from one to two inches long.
3. Make a second cut about 1/2 inch from the end of the twig, parallel with the stem. This cut should be from 1/4 to 1/2 inch deep.
4. Do the same with the stock.
5. Slip the scion and stock together with the tongues interlocking. Both twigs should have two or three buds all facing the same direction.
6. If the two twigs are of different size be sure to line up the cambium on one side.
7. Wrap the graft union with waxed string, grafting rubbers, or raffia.
8. Place the product in plastic bag with moist peat. Put the bag under a bench in the greenhouse for 2-3 weeks in which time callus formation will occur. Remove and root as hardwood cuttings.

Observations:

101

STUDENT WORKSHEET #31**T-Budding (Shield Budding) Laboratory Exercise****Background:**

T-Budding is the most common method of budding and is widely used in propagating nursery stock of most fruit tree species, roses, ash and ginkgo. Budding is limited to stocks approximately 1/4 to 1 inch in diameter with thin bark.

Note: The amount of tension given the budding rubber is very important. Tie from the top down to prevent the bud from popping out.

Materials:

1. stock
2. budding material
3. knife
4. alcohol
5. waxed string, budding rubbers or raffia

Procedure:

1. A vertical cut about 1 inch long is made in the stock.
2. A horizontal cut is made through the bark about one-third the distance around the stock. The knife is given a slight twist to open the two flaps of bark.
3. To prepare the bud, start the cut 1/2" below the bud; a slicing cut is made under and about 1" beyond the bud.
4. About 3/4" above the bud a horizontal cut is made through the bark and into the wood. The bud is removed.
5. Place the bud on the side of the stock that has the greatest protection from the environment.
6. Buds are inserted into the stock 2 to 10 inches above the soil level.
7. Insert the bud by pushing it downward under the two flaps of bark until the horizontal cuts on the stock and scion are even.
8. Wrap the bud union with budding rubbers, waxed string, or raffia.

Observations:

100

STUDENT WORKSHEET #32

Influence of Temperature on Pollen Germination and Pollen Tube Growth Laboratory Exercise

Background:

The various stages of normal plant growth and development are strongly affected by temperature. Higher plants generally reproduce by sexual union of the microgametes (sperm) and megagametes (egg) to produce a new embryonic plant, the seed. The seed may be enclosed in a fleshy covering and the entire organ is called a fruit. Generally, for fruits to develop normally there must be pollination, fertilization, and subsequent seed development. If any of these processes does not occur, fruit set and development will likewise not occur. The processes of pollination, pollen germination, and pollen tube growth must take place first.

Pollen germination and pollen tube growth are greatly affected by temperature. Studies have been made on structure, chemistry, and physiology of pollen and the culture of pollen *in vitro*. Various culture solutions have been proposed, and the necessity for certain nutrients in the medium has been determined.

Purpose:

1. Determine the influence of temperature on pollen germination and pollen tube growth.

Materials:

1. a source of pollen, such as tomato or cucumber plants
2. controlled temperature chambers of about 10°, 21°, and 38° C
3. Culture medium of 10% sucrose + 100 ppm Boron (in the form of Boric Acid available at local pharmacies)
4. microscope, microscope slides, petri dishes, filter paper, dissecting needles
5. 0.25% w/w thionin stain in distilled water (available from Curtin Matheson Scientific, 12101 Centron Place, Cincinnati, OH 45246 [513-671-1200]; Curtin Matheson Scientific, 4540 Willow Parkway, Cleveland, OH 44125 [216-883-2424]; or possibly local hospital laboratories)

Procedure:

1. Place 2-3 drops of the culture media onto a microscope slide and carefully add pollen. (Pollen may be collected on the tip of a dissecting needle after splitting open the anthers of the flower with the needle.) Place the slides on moistened filter paper in petri dishes and place into the temperature chambers. Observe the pollen germination under the microscope after 1/2, 1, 2, and 3 hours. In order to see the pollen tubes more clearly, stain the preparations using 1 or 2 drops of thionin stain before observation under the microscope. Most pollen tubes can be observed under the lowest power of most microscopes.
2. Record the number of pollen grains that have germinated, the number aborted (burst without tube growth), and the number not germinated, so percentages can be calculated. Also, compare the rate of growth of the pollen tubes under all temperature regimes.

Note: *In vivo* pollination effects can also be studied on the plants by pollinating some flowers and not others and by observing results.

References:

1. *An Introduction to the Embryology of Angiosperms*. Maheshwari, P. New York: McGraw-Hill, 1950.
2. Various botany textbooks.
3. Various chapters. *Plant Physiology* 15 (1964): 255-270.
4. Various chapters. *Plant Physiology* 19 (1968): 435-462.

Submitted by Dr. Dale Kretchman, Department of Horticulture, The Ohio State University/ OARDC, Wooster, OH 44691.

STUDENT WORKSHEET #33**Plant Tissue Culture Laboratory Exercise****Background:**

Plant tissue can be stimulated to reproduce whole plants under appropriate environmental and cultural conditions. The plant produced by rooting a stem or leaf cutting is a *clone* of the parent plant and the process is termed *vegetative* or *asexual propagation*, or simply *cloning*. Clones are genetically identical to each other and to the parent plant. Clonal populations are reliably uniform in growth, yield, flowering, disease resistance and other important features which may be variable in *seed* or *sexually propagated* populations.

Plants can be cloned by rooting cuttings, layering, grafting, or dividing specialized reproductive structures such as bulbs, tubers, rhizomes, or runners. Multiplication in tissue culture is much more rapid. Tissue culture involves taking a small piece of plant tissue and placing it in a sterile environment on a medium which contains all the nutrients required for rapid growth and development. The key ingredients that determine the pattern of growth are the plant growth regulators, auxin and cytokinin. Auxins (2, 4D, naphthaleneacetic acid, indoleacetic acid, indolebutyric acid) promote root development. Roughly equal mixtures of auxin and cytokinin together generally promote unorganized growth (callus growth).

Success in regenerating plants from isolated tissues is dependent upon several factors: (1) the appropriate type and concentration of plant growth regulators for the medium must be identified for the plant in question, (2) a suitable responsive tissue must be found, and (3) the tissue must be established in culture under sterile conditions. After plants are produced in culture, similar experiments must be carried out to root these and establish them into greenhouse conditions.

The specific technique used to demonstrate regeneration of plants in tissue culture varies somewhat depending on which species is used. Experimental variables for the development of the system may include: (1) the tissue culture medium to be used, (2) the tissue to be used as an explant (leaf, flower, shoot tip, root, etc.), and (3) the appropriate means for rooting the plants produced. African violet leaf tissue is recommended as a suitable starting point.

Materials:

1. Prepared tissue culture medium is commercially available in a variety of forms and recipes. Some of these do not have growth regulators already added and thus can serve as a starting point for investigations of the effects of the various growth regulators on plant development. Tissues from different parts of the same plant, the same part of a plant at different stages of growth, or the same plant part at different times in the year may respond very differently to the same medium and physical environment. Light, temperature, and daylength may affect the development of plants in culture. The student must remember that whatever the nature of the project, the first stage involves searching the published literature for all available information concerning the plant, and any attempts which have been made to tissue culture it.

References:

Since a small amount of information is available in the popular literature concerning plant tissue culture, contact the author at the address below for a packet of information and some hints about where to start.

Submitted by Dr. R. Daniel Lineberger, Department of Horticulture, The Ohio State University, 2001 Fyffe Court, Columbus, OH 43210.

106

CLUSTER: HORTICULTURE

UNIT: Horticultural Science and Production

PROBLEM AREA: Understanding Plant Germination, Growth, and Development

RELATED PROBLEM AREAS:

1. Understanding Plant Anatomy and Physiology
2. Growing Plants Hydroponically
3. Propagating Plants
4. Growing Ornamental Plants
5. Growing Vegetables
6. Growing Fruits

PREREQUISITE PROBLEM AREA(S)

1. Identifying Basic Principles of Plant Science (Central Core Cluster)

LEVEL: Orientation

OCCUPATIONAL TASKS ADDRESSED:

Horticulture Cluster

Duty A: Propagating Plants, Seeds, and Cuttings

1. Monitor plant growth
2. Select seed varieties
3. Plan planting schedules
4. Prepare seed for resting period

Duty C: Controlling the Plant Environment

1. Control light requirements by using shade cloth
2. Control temperature by setting thermostat
3. Control growth rate by applying retardant
4. Water plants and nursery stock

Duty D: Applying Fertilizer and Chemicals

1. Treat nutrient deficiencies
2. Assess crop nutrient deficiencies

STATE GOALS FOR LEARNING:

In planning the instruction for this problem area, teachers can promote the development of several student learning objectives which are related to the State Goals for Learning in. These objectives are listed on the Learning Assessment Plan forms included on the following page(s). Those learning objectives marked with an asterisk (*) are taken from the sample lists provided by the Illinois State Board of Education.

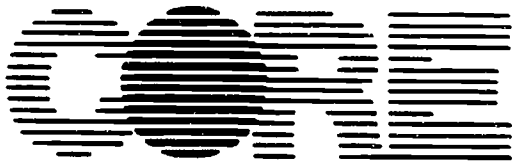

Illinois Agricultural Core Curriculum

Agricultural Education 124 Mumford Hall 1301 W. Gregory Drive University of Illinois Urbana, IL 61801

Director: Dale A. Law, Ed.D.

Principal Investigator: Jerry D. Pepple, Ed.D

Research Assistant: Janis L. Anderson

ICG

ILLINOIS STATE BOARD OF EDUCATION
 Department of School Improvement Services
 100 North First Street
 Springfield, Illinois 62777-0001

LEARNING ASSESSMENT PLAN

Instructions and codes for this form are provided on a separate sheet.

Submission Date _____ Page _____ of _____

Original submission Revision

I. LEARNING AREA (check one)

Language Arts Fine Arts

Mathematics Social Sciences

Sciences Physical Development/Health

(Affix label or complete district information.)

COUNTY _____ DISTRICT _____ ESC _____

District Name _____

City _____

II. STATE GOAL FOR LEARNING

Contact Person: _____

Title: _____

Phone: (_____) _____

III. LEARNING OBJECTIVES	IV. ASSESSMENT				V. EXPECTATIONS	
	A Types	B Validity/ Reliability	C Commercial Test(s)	D Evidence of Nondiscrimination	Percent of Students Expected to Achieve Objective	
By the end of grade (circle one) <u>11</u> students should be able to:						
*1. Recognize that all organisms exhibit responses to stimuli.						
*2. Identify and describe functions of tissues and organs.						
*3. Compare processes by which matter and energy are transported throughout an organism.						
4. Explain the various types of growth and movement of plants as a result of tropisms.						
5. Explain the stages in the plant life cycle from germination to death.						
						100

107

ILLINOIS STATE BOARD OF EDUCATION
Department of School Improvement Services
100 North First Street
Springfield, Illinois 62777-0001

LEARNING ASSESSMENT PLAN

Instructions and codes for this form are provided on a separate sheet.

(Affix label or complete district information.)

COURTY				DISTRICT				ESC			
District Name											
City											

Contact Person: _____
 Title: _____
 Phone: () - -

Submission Date _____ Page _____ of _____
 Original submission Revision

I. LEARNING AREA (check one)
 Language Arts Fine Arts
 Mathematics Social Sciences
 Sciences Physical Development/Health

II. STATE GOAL FOR LEARNING

As a result of their schooling, students will have a working knowledge of the social and environmental implications and limitations of technological development.

III. LEARNING OBJECTIVES

By the end of grade (circle one) 3 6 8 11 students should be able to:

- *1. Analyze the results of an experiment.
- *2. Apply quantitative observation methods to accumulate precise data.
3. Define the plant hormones and their function in plant growth.
4. Explain the various types of growth and movement of plants as a result of tropisms.

IV. ASSESSMENT				V. EXPECTATIONS	
A	B	C	D	Evidence of Nondiscrimination	Percent of Students Expected to Achieve Objective
Types	Validity/Reliability	Commercial Test(s)			

110

INSTRUCTOR'S GUIDE

CLUSTER: HORTICULTURE

UNIT: Horticultural Science and Production

PROBLEM AREA: Understanding Plant Germination, Growth, and Development

STUDENT LEARNING OBJECTIVES

Upon completion of their study of this problem area, students will be able to:

1. Define plant growth and development.
2. Explain the various growth and movement of plants as a result of tropisms.
3. Define the plant hormones and their function in plant growth.
4. Explain the phases of vegetative growth.
5. List the factors affecting plant growth.
6. Explain the stages of seed germination.
7. Understand seed dormancy and the factors affecting it.
8. Explain the stages in the life cycle after germination until death.

INSTRUCTOR'S NOTES AND REFERENCES

INSTRUCTOR'S GUIDE**CLUSTER: HORTICULTURE****UNIT: Horticultural Science and Production****PROBLEM AREA: Understanding Plant Germination, Growth, and Development****PROBLEMS AND QUESTIONS FOR STUDY****INSTRUCTOR'S NOTES AND REFERENCES**

1. What is tropism?
2. List the five types of growth movement and explain each.
3. Define a hormone.
4. Plant auxins can influence a number of plant functions. Can you name some?
5. Why do we use synthetic auxins?
6. What are gibberellins and what do they influence?
7. Cytokinins stimulate what function and where is the greatest concentration?
8. Should ethylene be classified as a plant hormone?
9. What are the three phases of vegetative growth?
10. What is totipotency?
11. Define genetic composition and explain its influence on growth and development.
12. Explain adaptive and constitutive enzymes.
13. Differentiate between primary and secondary plant growth.
14. List the environmental factors that may affect plant growth.
15. Explain the process of meiosis.
16. What part do organelles and starch grains play in geotropism?
17. What is the difference between meiosis and mitosis? When and where do plants use each?
18. What role does genetic composition play in growth and development?

112

INSTRUCTOR'S GUIDE**CLUSTER: HORTICULTURE****UNIT: Horticultural Science and Production****PROBLEM AREA:** Understanding Plant Germination, Growth, and Development**SUGGESTED TEACHING ACTIVITIES AND PROCEDURES****INSTRUCTOR'S NOTES AND REFERENCES**

1. Have the students set up an experiment to determine the answer to the following question. If you had some seeds that would not germinate when you placed them in a moist environment, what *procedures* would you use to cause germination?
2. Use Information Sheets #1 - #4 for background material on various aspects of growth.
3. Use Information Sheet #5 for materials concerning the various stages of growth.
4. Use Transparency Masters #1 - #5 to illustrate aspects of plant growth and development.
5. Use Transparency Master #6 in conjunction with Information Sheet #1.
6. Use Transparency Master #7 in conjunction with Student Worksheet #2 to illustrate geotropism.
7. Use the student activities for experimental practice and student experience in observing, recording, and analyzing data.
8. Plan a field trip to a commercial greenhouse where students can see practical applications of the content material.

110

INSTRUCTOR'S GUIDE**CLUSTER: HORTICULTURE****UNIT: Horticultural Science and Production****PROBLEM AREA:** Understanding Plant Germination, Growth, and Development**REFERENCES****INSTRUCTOR'S NOTES AND REFERENCES**

- *1. *Plant Physiology*. (1982). Tung, Irwin P. Addison-Wesley Publishing Company, 1 Jacob Way, Reading, MA 01867. (800) 447-2226.
2. *The Greenhouse Grower — A Career in Floriculture*. (1977). Nelson, Kennard S. Interstate Publishers, Inc., P.O. Box 50, Danville IL 61834-0050. (217) 446-0500.
3. *Horticulture: A Basic Awareness*. (1982). Baudendistel, R.F. Reston Publishing Company, Inc., Division of Prentice-Hall, 200 Old Tappan Road, Old Tappan, NJ 07675. (800) 223-2348.
- *4. *Plant Science: Growth, Development, and Utilization of Cultivated Plants*. (1981). Hartmann, Flocker, Kofranek. Prentice-Hall, Inc., 200 Old Tappan Road, Old Tappan, NJ 07675. (800) 223-2348.
5. *Introductory Horticulture*. (1988). Reiley, H.E., Shry, C.L., Jr. Delmar Publishing, 2 Computer Drive West, Box 15-015, Albany, NY 12212.
6. *The Sciences Workbook of Student Research Projects in Food - Agriculture - Natural Resources*. (1985). The Ohio State University, Room 100, 2120 Fyffe Road, Columbus, OH 43210-1099.

*Indicates highly recommended reference

114

INSTRUCTIONAL RESOURCES

These resources are intended for use by teachers in planning and teaching the materials for this problem area and may be adapted to fit the teaching method(s) used.

INFORMATION SHEET #1 — Growth and Growth Movement

INFORMATION SHEET #2 — Vegetative Growth

INFORMATION SHEET #3 — Hormones

INFORMATION SHEET #4 — Reproductive Growth

INFORMATION SHEET #5 — Germination, Through Death

TRANSPARENCY MASTER #1 — Plant Growth and Development

TRANSPARENCY MASTER #2 — Cell Division — Mitosis Phases (with discussion guide)

TRANSPARENCY MASTER #3 — Cell Division — Meiosis Phases

TRANSPARENCY MASTER #4 — Genetic Composition

TRANSPARENCY MASTER #5 — Enzymes

TRANSPARENCY MASTER #6 — Tropism

TRANSPARENCY MASTER #7 — Geotropism

TRANSPARENCY MASTER #8 — Thigmotropism

TRANSPARENCY MASTER #9 — Seed Dormancy

TRANSPARENCY MASTER #10 — Dormancy

INFORMATION SHEET #1

Growth and Growth Movement

Many plants are said to have an intermittent growth. This is due to periods of dormancy. Some growth takes place at night when temperature is more favorable and water is more easily obtained.

Growth movements involve:

1. Tropism — unequal growth movements resulting from environmental stimuli. There are two types:
 - a. Phototropic — growth or movement in response to light.
 - b. Geotropic — growth or movement in response to the earth's gravitation. Shoots have a negative geotropism because they grow away from the center of the earth. Roots have a positive geotropism. Rhizomes and stolons grow at a right angle and have diageotropic (i.e., 90°) growth. Lateral branch growth is plagiotropic. Ageotropism is no response to gravity. Gravity is sensed by organelles, called statoliths, using starch grains. Gravity causes these grains to be oriented with its force. Cells with large amounts of starch grains can be found in such areas as the root cap.

2. Nastic growth — growth or movement in which the direction of response is independent of the direction of stimulus. Flower buds opening is a response to light because there is a greater rate of growth on the upper surface so curling results and flowers open. It occurs due to an uneven growth at the sides or surfaces of the growing organs. It can occur due to light, temperature, or other environmental factors.

3. Hydration movement — movement usually associated with nonliving tissue.

4. Thigmotropism — a response to mechanical stimulation. Vine tendrils will wrap around a stake when they come into contact with it.

Plants grow in lengths at active areas called meristems. This is done by cells dividing. Meristematic areas are at the tips of shoots and roots. Plants elongate only in these areas. To observe this growth, measure the distance of a tree branch from the ground. Five years later again measure the distance from the ground of the same branch. It will be found to be the same, despite the fact that the tree is several feet taller. Growth of some plants may be stopped when flowers or fruit appear while others will grow continuously. These cells in the shoot tips eventually form all structures such as leaves, flowers, fruit, bulbs, and corns.

Some plants will also increase in diameter. This is due to the division of cells just inside the surfaces of the stems and roots.

Roots and shoots do not grow at the same rate or time. Roots begin before shoots and leaves

INFORMATION SHEET #2

Vegetative Growth

Vegetative growth occurs in three ways:

1. Cell division — the replication of a cell to form two identical daughter cells. This occurs by:
 - a. Chromosomes duplicating prior to mitosis.
 - b. A division of the nucleus termed karyokinesis.
 - c. A division of the cell termed cytokinesis.

There are five phases to cell division. These are:

- a. Interphase — stage between divisions in which chromosomes replicate.
 - b. Prophase — first stage of karyokinesis; chromosome are seen in the nucleus.
 - c. Metaphase — stage of preparation for migration; chromosomes are seen as double chromatids.
 - d. Anaphase — stage of migration of new chromosomes to opposite poles.
 - e. Telophase — completion of karyokinesis. There are daughter chromosomes on each side of the plate. Cytokinesis begins under this phase. The cell plate eventually becomes the middle lamella between cells. The lamella contains sectinaceous materials which hold the cell together.
2. Cell elongation — expansion of a cell, which is either plastic or elastic, through pressure. Water is necessary for this to occur. Turgor pressure will elongate the cell, but the cell will return to normal when turgor pressure is reduced (elastic). For elongation to occur, plasticity must be increased. This is accomplished by the central vacuole. Plasticity occurs by the alteration of ionic and covalent bonds in the cell wall.
 3. Cell differentiation — the changing of unspecialized cells into specialized cells to perform a specific function.

Totipotency means that all cells of an organism contain the genetic information for its entire cycle.

Not all genes are functional during all periods of growth and development. Genetic composition governs the potential for development and the environment modifies that potential. Genes are composed of particular proteins. Proteins are largely enzymes, and enzymes regulate the metabolism. The metabolism determines the growth and development. All the factors are modified by the environment.

Enzymes are either adaptive (synthesized under specific conditions) or constitutive (present in nearly all cells and most stages of development). Hormones are involved in enzyme activity.

There are two types of plant growth:

1. Primary plant growth — occurs through cell division in the meristematic regions of the plant.
2. Secondary plant growth — occurs through cell division in the cambia.

Environmental factors affect plant growth. The closer a factor approaches an optimal level, the more optimal plant growth occurs. Typically, factors in excessive amounts will inhibit growth. For example, light affects photosynthesis and transpiration. High light levels produce short, stocky plants and low light levels produce tall, spindly plants. The duration of exposure to light affects both reproduction and flowering.

Other factors are temperature, water, and mineral nutrition. Plants can be conditioned to grow within a wide range of temperatures (this is called plasticity). Water is a substrate for many chemical reactions; its availability to plants is dependent on precipitation and evaporation. Mineral nutrition is influenced by soil fertility.

INFORMATION SHEET #3

Hormones

Plant growth substances regulate aspects of growth and development. These substances include auxins, gibberellins, cytokinins, abscisic acid, ethylene, and growth-regulating phenolics.

Plant hormones will be used only on those substances that occur naturally in a plant.

1. Auxins — promote cell elongation. When a plant grows towards the light there is an uneven distribution of the hormone auxin. More auxin will be present on the darker side of the plant. So there is greater elongation of cells on the dark side, thus bending the plant towards the light. This auxin is better known as indoleacetic acid (IAA). Auxin has some influence on:
 - a. dormancy
 - b. flower initiation
 - c. sex determination
 - d. rooting
 - e. growth rates
 - f. fruit growth and ripening
 - g. abscission
 - h. juvenility
 - i. fruit set
 - j. tuberization

Other factors of plant development are also influenced by auxins.

Synthetic auxins are now produced and are relatively inexpensive. These are powerful tools used to regulate plant growth. One example would be indolebutyric acid.

2. Gibberellins — cause stem elongation. Some dwarf varieties such as the dwarf pea will grow the same height as a normal pea with an application of gibberellin. The dwarf plant evidently had a deficiency of indigenous gibberellin.

Stems elongate due to cell enlargement *not* division. Gibberellins have been known to break dormancy in certain seeds, induce flowering in cold dependent photo period dependent plants and stimulate fruit set and development.

3. Cytokinins — stimulate cell division. They are highly concentrated in the embryos of developing fruits. Cytokinins delay senescence of leaves, making them stay greener long after their natural time. They break seed dormancy, stimulate germination, enhance flowering, and induce bud formation.
4. Abscisic acid (ABA) — inhibits growth, linked to the abscission of leaves and fruit. It operates in a manner opposite to gibberellins and cytokinins. Abscisic acid induces dormancy and inhibits seed germination. During drought, water-stressed plants have an increase in leaf ABA, which affects stomates by closing them.
5. Ethylene — has gaseous properties. It causes fruit ripening, senescence, abscission, expansion, and flower induction and dormancy in the leaf. It may inhibit stem elongation and bud development in some plants. It may also interfere with auxin transport.
6. Phenolics — inhibit growth. Phenolics are used in growth retarding chemicals. Some examples are:
 - a. Benzoic acid.
 - b. Gallic acid.
 - c. Caffeic acid.
 - d. Salicylic acid.
 - e. Cinnamic acid.
 - f. Coumarin.

Maleic hydrazide (synthetic growth regulator) is used on potatoes and onions to prevent unwanted growth.

INFORMATION SHEET #4**Reproductive Growth**

Flowers are the sexual organs of angiosperms. The seed is the mature ovule and is made up of three parts. The seed coat, the endosperm, and the embryo.

Asexual reproduction is also known as meiosis. It consists of the following phases:

1. Interphase — Diploid mother cell.
2. Prophase I — Early chromosomes replicate and become visible. Later chromosomes are distinct and double stranded, paired and intertwined.
3. Metaphase I — Chromosomes orient along the equator.
4. Anaphase I — Chromosomes migrate to opposite poles.
5. Telophase I — Chromosomes lengthen and become indistinct.
6. Prophase II — Chromosomes become visible.
7. Metaphase II — Chromosomes align along the equator poles.
8. Anaphase II — Chromosomes divide.
9. Telophase II — Nuclear envelopes reform. Four haploid cells are produced, each containing half of the chromosome number of the mother cell. Each new cell contains one of each chromosome.

110

INFORMATION SHEET #5

Germination Through Death

Seed dormancy is a quiescent period between maturation and germination. It may be the result of a seed coat that is impervious to gases or water, inhibitors contained internally, or lack of the proper thermoperiodic or photoperiodic conditions.

Germination utilizes stored reserves. The three stages of germination are:

1. Imbibition, or the taking up of water by the seed.
2. The metabolic processes occurring within the seed.
3. The emergence.

As the seed takes up water, there is an increase in the rate of respiration. After a few hours imbibition ceases and a plateau of metabolic activity is reached. This occurs just prior to the emergence of the radicle. Very little cell division and DNA synthesis takes place during imbibition and plateau stages. However, there is active RNA synthesis taking place.

The radicle emerges first, followed by the epicotyl and cotyledons (indicots). Timing is important in seed germination so that survival will be guaranteed. This is regulated by the environment according to the seed's special requirements.

Plants used for crop production are selected for their uniform germination. Factors that may affect the timing of germination include:

1. Imperviousness of seed coats (may require scarification).
2. Chemicals released by the seed to measure precipitation.
3. Temperature-sensing factors.
4. Differences among seed coats.

The use of gibberellin will overcome some types of dormancy, probably due to the stimulation of RNA and protein synthesis. Other hormones that may cause germination are cytokinins and ethylene.

Dormancy in plants is defined as a developmental stage brought on by environmental signals to carry the plant through adverse environmental conditions. The effects may include:

1. Dessication of the plants and foliage.
2. Reduced respiration.
3. Low RNA metabolism.
4. Reduced protein synthesis.

Related to dormancy in woody plants is bud formation. During the formation apical meristems stop their growth and scales and bracts are formed to protect the bud. Dormancy and bud formation are related to protein synthesis and thus are active metabolic and physiological processes. Environmental signals that trigger dormancy include:

1. Decrease in water supply.
2. Decrease in photoperiod.
3. Change in temperature (low or high).

In many species, dormancy cannot be broken until there is a period of cold exposure.

After germination, the stages of plant growth are juvenility, maturity, senescence, and death. After dormancy, tissues begin a rapid period of growth which includes high rates of respiration, protein synthesis, and nucleic acid metabolism. This is the juvenile stage. At maturity, metabolism and physiological processes slow down. Auxins and gibberellins are at high levels during these two stages.

Metabolism declines rapidly as senescence begins. Colors change and nutrient reserves are translocated. Phenolics and abscisic acid are at high levels. The next and final stage is death. Dead tissue falls to the ground to nourish the soil and benefit microorganisms.

120

TRANSPARENCY MASTER #1

Plant Growth and Development

Plant Growth

— Irreversible increase in size and volume

Two phases:

1. Cell division
2. Cell enlargement

Development

— Combination of both growth and cellular differentiation

TRANSPARENCY MASTER #2

Cell Division — Mitosis Phases

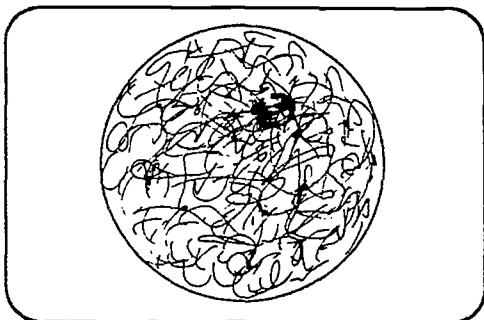

Interphase

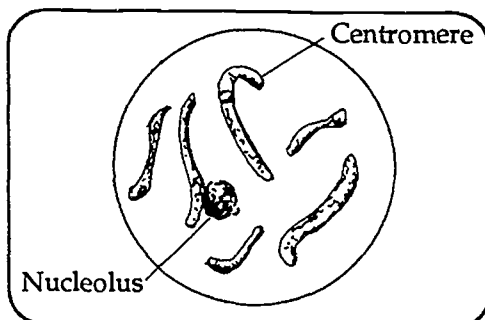

Prophase

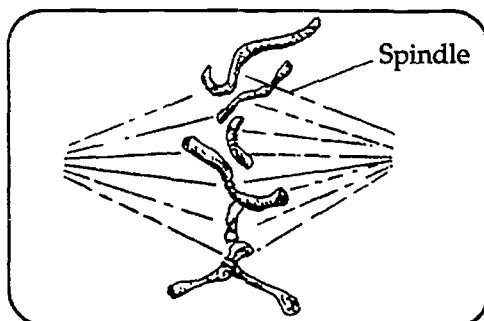

Metaphase

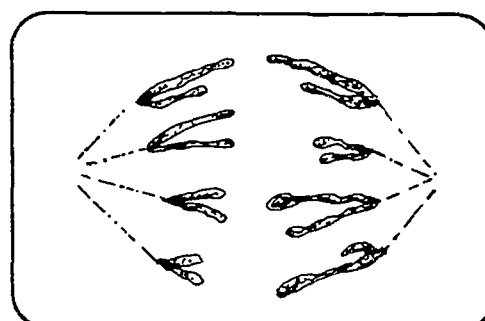

Anaphase

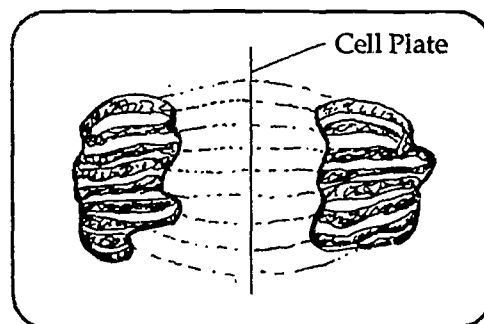

Telophase

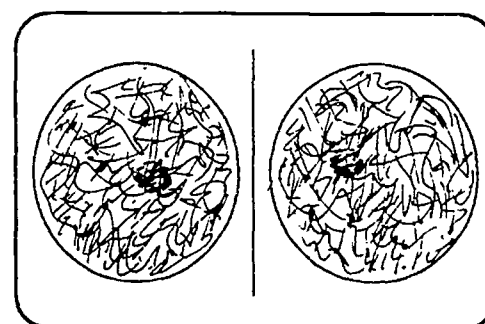

Daughter cells

TRANSPARENCY MASTER #3

Cell Division — Meiosis Phases

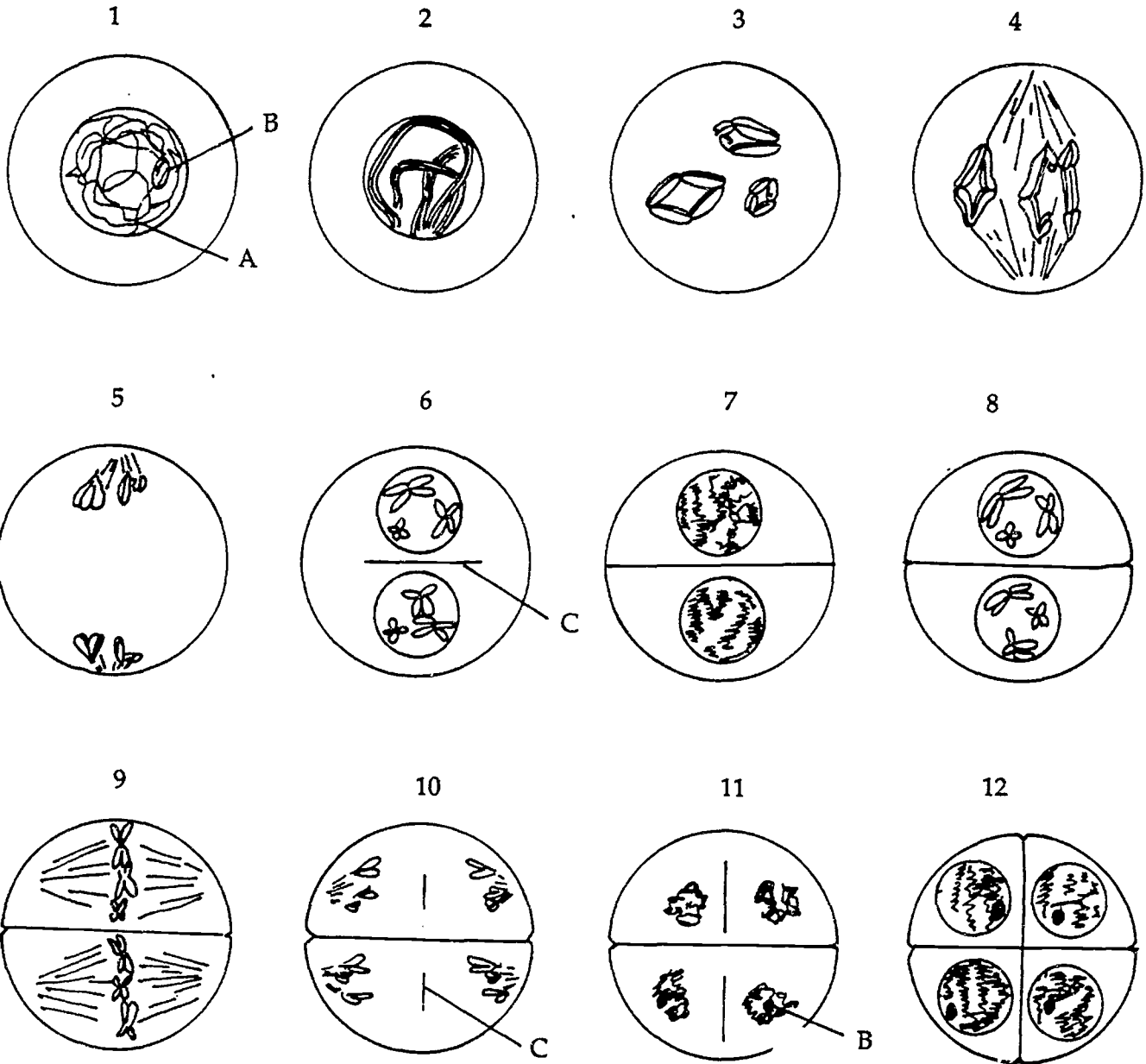

1. Early prophase I
2. Mid-prophase I
3. Late prophase I
4. Metaphase I
5. Anaphase I
6. Telophase I
7. Interphase
8. Prophase II

9. Metaphase II
10. Anaphase II
11. Telophase II
12. Gametophytes

- a. Centromere
- b. Nucleolus
- c. Cell plate

TRANSPARENCY MASTER #4

Genetic Composition

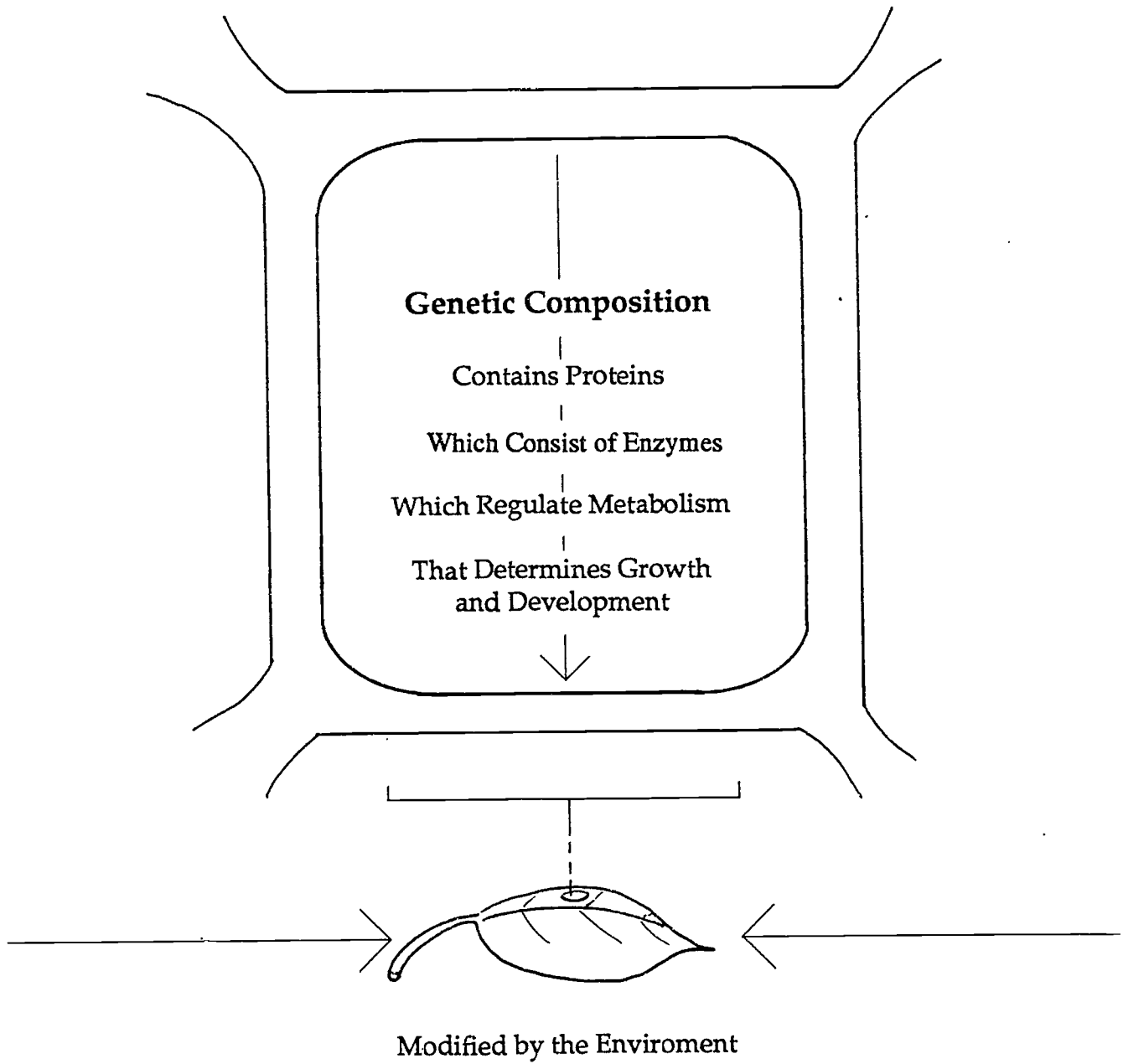

TRANSPARENCY MASTER #5

Enzymes

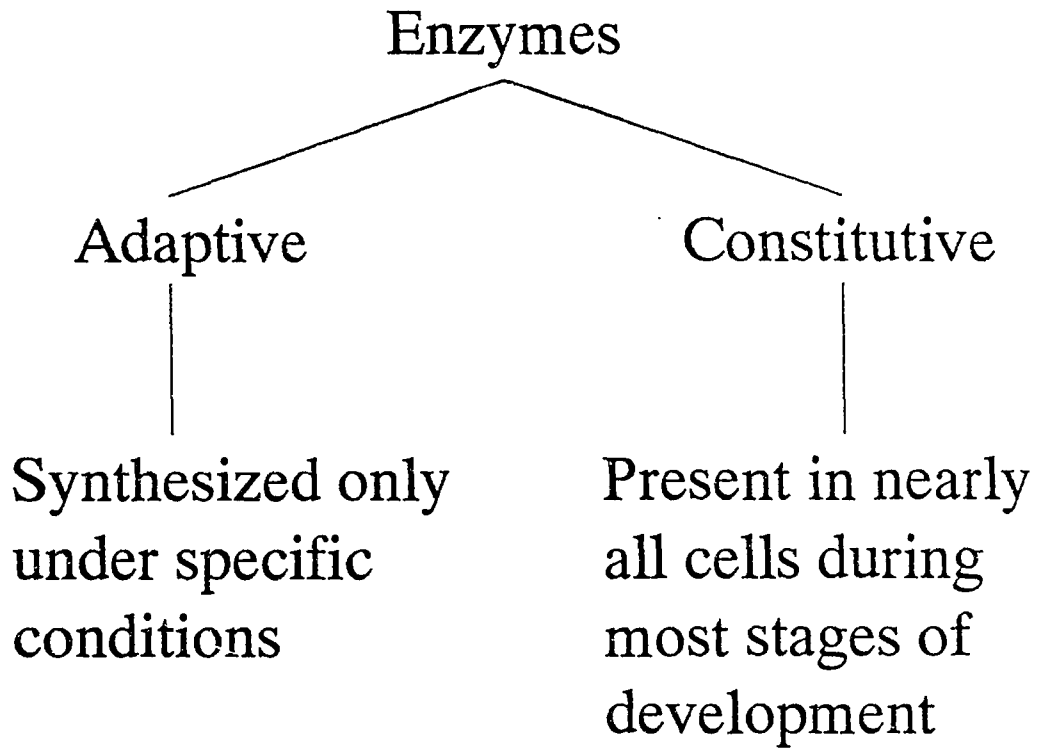

TRANSPARENCY MASTER #6

Tropism

Tropism → Unequal growth movements result from environmental stimuli

Tropic responses

1. Phototropic
2. Geotropic
 - a. Diageotropic
 - b. Plagiotropic

Other movements

1. Nastic Growth
2. Hydration
3. Thigmotropism

TRANSPARENCY MASTER #7

Geotropism

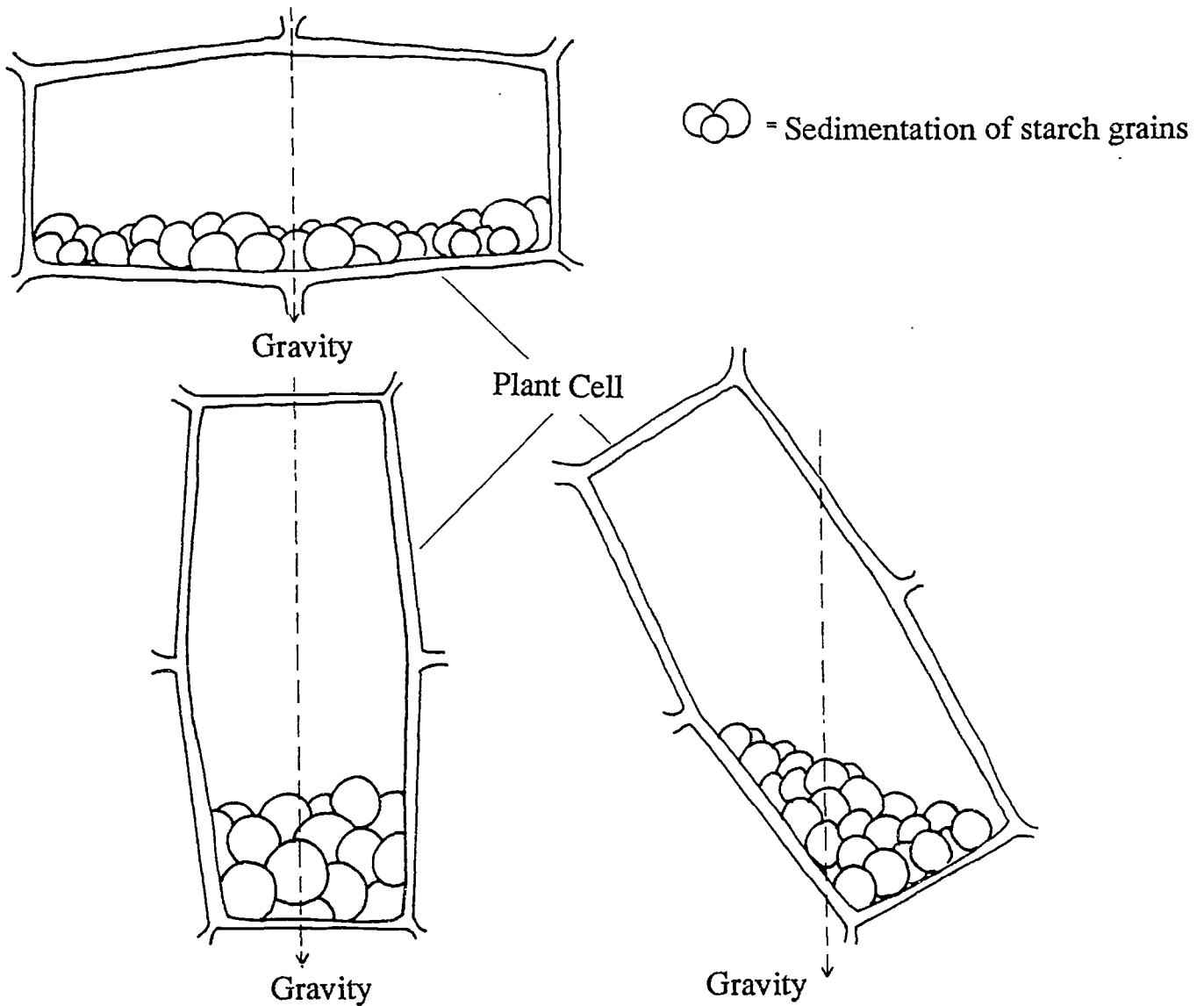

Drawing to illustrate how statocytes are believed to sense gravity. Geotropic stimulation causes sedimentation of starch grains, bringing about the geotropic response. Drawn after L. Hawker, 1932, A quantitative study of the geotropism of seedlings with special reference to the nature and development of their statolith apparatus, *Ann. Bot.* 46:121-157

TRANSPARENCY MASTER #8

Thigmotropism

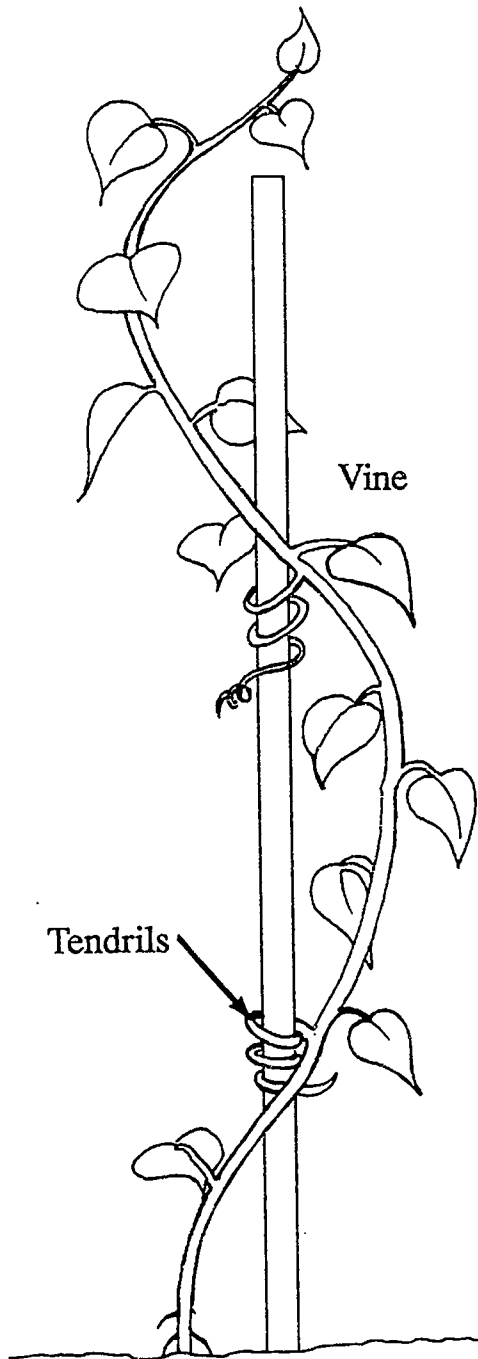

Thigmotropism
↓
Tendrils wrap
around stake when
they come in contact

TRANSPARENCY MASTER #9

Seed Dormancy

Quiescent period — between maturation and germination

Result of:

1. Seed coat impervious to gases or water
2. Inhibitors contained internally
3. Lack of the proper thermoperiodic or photoperiodic conditions

Factors that affect the timing of germination:

1. Imperviousness of seed coat
2. Chemicals released by the seed to measure precipitation
3. Temperature-sensing factors
4. Differences among seed coats

TRANSPARENCY MASTER #10

Dormancy

Environmental signals that trigger dormancy:

1. Decrease in water supply
2. Decrease in photoperiod
3. Change in temperature (low or high)

May affect plants by:

1. Dessication of plants and foliage
2. Reduced respiration
3. Low RNA metabolism
4. Reduced protein synthesis

TRANSPARENCY MASTER DISCUSSION GUIDE**Transparency Master #2**

Cell division — the splitting and replication of a cell to form two identical daughter cells. The chromosomes duplicate prior to mitosis. The division of the nucleus is termed karyokinesis. The division of the cell is termed cytokinesis.

The phases are as follows:

1. Interphase — stage between divisions. Chromosomes duplicate during this phase.
2. Prophase — first stage of karyokinesis. The chromosomes are visible in the nucleus.
3. Metaphase — stage of preparation for migration; chromosomes are seen as double chromatids.
4. Anaphase — stage of migration of new chromosomes to opposite poles.
5. Telophase — completion of karyokinesis. The daughter chromosomes are on each side of the plate. Cytokinesis begins after this phase. The cell plate eventually becomes the middle lamella between cells. The lamella contains sectinaceous materials which hold cells together.

STUDENT ACTIVITIES

STUDENT WORKSHEET #1 — Phototropism Laboratory Exercise

STUDENT WORKSHEET #2 — Geotropism Laboratory Exercise

STUDENT WORKSHEET #3 — Optimum Nutrient Concentration Laboratory Exercise

For additional activities, teachers may refer to the “Suggested Teaching Activities and Procedures” section in the Instructor’s Guide.

STUDENT WORKSHEET #1**Phototropism Laboratory Exercise****Purpose:**

1. To see how light affects the growth movement of plants

Materials:

1. four plants of equal height
2. natural light source
3. ruler
4. log book for observations

Procedure:

Place one plant directly in the light source. Place the other three an equal distance away from the light source.

Observations:

Twice a week for three weeks measure the height of each plant, the direction that each grows, and any other observations.

Conclusions:

Write a conclusion based on your data recorded during the experiment.

STUDENT WORKSHEET #2**Geotropism Laboratory Exercise****Background:**

We take for granted the fact that the photosynthesis portion (shoot) of a plant grows upward while the water and mineral absorbing portion (root) grows downward. However, this is not a matter of chance but instead is a response of the plant to gravity. (Note that seedlings growing in the space shuttle would grow in random directions because of the lack of gravity.) This response of plants to gravity is known as geotropism.

The geotropic response is known to be due to the spatial distribution of hormones within a plant tissue. While the chemistry underlying the response is not completely understood, it is relatively easy to conduct simple studies of the response.

Purpose:

The purpose of this project is to investigate the geotropic response of seedlings and to determine the time required for the induction of response.

Materials:

Seeds of any plant may be used. Corn is recommended because it is readily available, has a large visible embryo, and can be positioned with the point of the root (radicle) emergence down. Sand, vermiculite, or perlite will be convenient for growing seedlings but anything may be used. Clear glass containers (water glasses, jars, etc.), cheesecloth, and rubber bands are required.

Procedure:

Fill containers with growth medium and plant seeds about 1 inch deep at one edge of the container so that the embryo can be seen from the outside. Water until the medium is moist but not soaked; add water as needed to keep the rooting medium moist. Observe germination and early growth and take notes on growth rate.

When coleoptiles (embryonic shoots) have just emerged from the medium, cover containers with a piece of cheesecloth and fasten with a rubber band. Holes for the

coleoptiles can be made by spreading the threads of the cheesecloth with a pencil. Now rotate the containers for several days. Observe and record the direction of growth of roots and shoots.

Conduct an experiment to determine how long seedlings must be placed in a new orientation before roots and shoots respond to gravity by altering their direction of growth. Limit the rotation treatment to horizontal (i.e., 90° from the original position). Suggested times are 1, 2, 4, and 8 hours, i.e., the containers are placed in a horizontal position for these times and then returned to the vertical. The question to be answered is whether any curvature can be detected in the root or shoot. The response may not be visible until the day after the seedlings have been returned to the vertical position. The experiment should be repeated several times, and data on the amount of curvature for each time treatment should be recorded.

Possible variations include:

1. Using different times than those suggested. What is the shortest time in which a change of direction can be detected?
2. Using different seeds. Do all roots and shoots respond to gravity in the same way?
3. Trying to get a root to change directions several times. Can you make a root grow in the shape of a letter "C"? Of a letter "O"?

References:

1. *Botany — A Brief Introduction to Plant Biology*. 2nd ed. Rost, Thomas L. et al. Somerset, NJ: John Wiley & Sons, 1984.
2. *Plant Physiology*. Salisbury, Frank B. and Cleon Ross. Belmont, CA: Wadsworth Publishing Co., 1969.
3. Various botany and biology textbooks, s.v. "geotropism" and "plant hormones."

NOTE: The author may be contacted at the address below if appropriate information is not found in these sources.

Submitted by Dr John Streeter, Department of Agronomy, The Ohio State University/OARSC, Wooster, OH 44691. Taken from *The Sciences Workbook of Student Research Projects in Food - Agriculture - Natural Resources*. (1985). The Ohio State University.

STUDENT WORKSHEET #3

Optimum Nutrient Concentration Laboratory Exercise

Background:

Survival and growth of tree seedlings, as well as other plants, are affected by varying levels of soil fertility. At levels below the "optimum" for a specific species, growth is reduced. At levels above the "optimum," top growth may be excessive in relation to root growth. This results in plants having unfavorable top-root ratios (top weight/root weight) which are less adapted to unfavorable environmental conditions, particularly low soil moisture levels.

Different tree species may vary considerably in the total nutrient concentrations at which optimum growth occurs. However, research by Ingestad (reference below) has shown that many species show best development when grown in nutrient solutions or soils having the same ratio of essential plant nutrients (i.e., ratios of N to P to K to CA, etc.).

Purpose:

The purpose of this project is to determine the rate of survival and growth of tree seedlings when grown using nutrient solutions having different total concentrations but the same ratio of essential plant nutrients.

Materials:

For demonstration purposes, tree species chosen for planting should be relatively fast growing. Suggestions include Virginia pine (*Pinus virginiana*) or shortleaf pine (*Pinus echinata*) which have relatively low nutrient

requirements or one of the broadleaved species such as red maple (*Acer rubrum*) or tuliptree (*Liriodendron tulipifera*) which generally have a somewhat higher requirement. For comparison, one species from each group might be used. A source of seed is listed in the reference below.

Procedure:

Tree seedlings should be grown from seed in a porous, inert, sterile potting medium such as silica sand. Seed can be germinated in pots (2 to 4 per pot) or in separate containers and transplanted to pots shortly after germination. Seedlings should be "watered" with Ingestad's nutrient solutions made up using distilled or demineralized water. To show growth response over a range from suboptimum to at or near the toxic level, at least 5 and preferably 10 different solutions should be used with concentrations ranging from approximately 25 to 1000 ppm. Chemicals and proportions of each needed to prepare nutrient solutions are listed in the table below. Solutions of varying levels should be added to pots periodically to keep the potting medium moist at all times. Trees should be grown in a sunny location or under light (preferably a mixture of incandescent and fluorescent) with a minimum intensity of 1500 foot candles and a minimum 18-hour light period to keep seedlings growing more or less continuously. When trees have reached sufficient size, a representative sample from each group should be "harvested" and measurements made of tops and roots, including lengths, weights (oven-dry) and shoot-root ratios. For exhibit purposes, living seedlings can be presented, along with data in tabular and/or graphic form.

Table 1. Mixtures of chemicals for preparing two nutrient solution concentrates for use in fertility studies

solution 1		solution 2			
chemical	amt./liter (gms or ml)	chemical	amt./liter (gms or ml)	chemical	amt./liter (gms or ml)
NH ₃ (25%)	3.8	KNO ₃	34.4	MnSO ₄ · H ₂ O	0.20
NH ₄ NO ₃	105.0	HNO ₃ (70%)	2.2	CuSO ₄ · 5H ₂ O	0.06
KH ₂ PO ₄	28.6	Mg(NO ₃) ₂ · 6H ₂ O	44.9	H ₃ BO ₃	0.57
K ₂ SO ₄	24.5	Ca(NO ₃) ₂ · 4H ₂ O	20.7	MoO	0.0052
		sequestrene (nAFe, 13%)	3.8	ZnSO ₄	0.066

SOURCE: Ingestad, T. *Methods for Uniform Fertilization of Forest Tree Plants.*

NOTE: Concentrates should be prepared in two separate solutions to prevent precipitation and/or flocculation of chemicals.

Table 2. Amounts of each nutrient solution concentrate needed for each liter of solution to be used in "watering" plants to provide varying solution concentrations (nutrient "levels")

Concentration ppm	ml of EACH "concentrate"	Concentration ppm	ml of EACH "concentrate"
10	0.10	200	1.97
20	0.20	300	2.96
30	0.30	400	3.94
40	0.40	500	4.93
50	0.50	750	7.39
100	0.99	1000	9.86

NOTE: Nutrient solution concentrates are taken from Table 1.

References:

1. *Survival and Growth of Seedlings of Scots Pine Provenances at Varying Nutrient Levels.* Ohio Ag. Res. Dev. Cntr. Res. Bull. 1120. Wooster, OH 1980
2. Ingestad, T. *Methods for Uniform Fertilization of Forest Tree Plants.* XIV International Union of Forest Research Organizations Congress, sec. 22: 266-269. Munich, 1967
3. Various publications from Sheffield's Seed Co., Inc., P.O. Box 624, Ithaca, NY 14851.

Submitted by Dr. James Brown, Division of Forestry, The Ohio State University/OARDC, Wooster, OH 44691. Taken from *The Sciences Workbook of Student Research Projects in Food - Agriculture - Natural Resources.* (1985). The Ohio State University.

CLUSTER: HORTICULTURE

UNIT: Horticultural Science and Production

PROBLEM AREA: Classifying Horticultural Plants

RELATED PROBLEM AREAS:

1. Understanding Plant Anatomy and Physiology
2. Propagating Plants
3. Understanding Plant Germination, Growth, and Development
4. Interior Plantscaping
5. Designing Live Arrangements
6. Basic Principles of Plant Science (Central Core Cluster)

PREREQUISITE PROBLEM AREA(S): None

LEVEL: Orientation

OCCUPATIONAL TASKS ADDRESSED:

Horticulture Cluster

Duty A: Propagating Plants, Seeds, and Cuttings

1. Label planted specimens

Duty E: Harvesting Plants

1. Label harvested plants by common names

Duty N: Performing Sales Duties

1. Identify plants
2. Identify garden crops

STATE GOALS FOR LEARNING:

In planning the instruction for this problem area, teachers can promote the development of several student learning objectives which are related to the State Goals for Learning in Biological and Physical Sciences. These objectives are listed on the Learning Assessment Plan forms included on the following page(s). Those learning objectives marked with an asterisk (*) are taken from the sample lists provided by the Illinois State Board of Education.

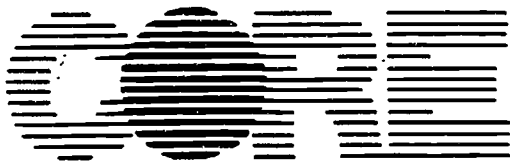

Illinois Agricultural Core Curriculum

Agricultural Education 124 Mumford Hall 1301 W. Gregory Drive University of Illinois Urbana, IL 61801

Director: Dale A. Law, Ed.D.

Principal Investigator: Jerry D. Pepple, Ed.D.

Research Assistant: Janis L. Anderson

88/89

horticulture

horticultural Science and Production



138

Illinois Agricultural Core Curriculum Rev.

INSTRUCTOR'S GUIDE**CLUSTER: HORTICULTURE****UNIT: Horticultural Science and Production****PROBLEM AREA:** Classifying Horticultural Plants**STUDENT LEARNING OBJECTIVES**

Upon completion of their study of this problem area, students will be able to:

1. Understand the use of scientific names in identifying plants.
2. Understand how the differences in plants can be used for the purpose of identification.

INSTRUCTOR'S NOTES AND REFERENCES

INSTRUCTOR'S GUIDE**CLUSTER: HORTICULTURE****UNIT: Horticultural Science and Production****PROBLEM AREA:** Classifying Horticultural Plants**PROBLEMS AND QUESTIONS FOR STUDY****INSTRUCTOR'S NOTES AND REFERENCES**

1. What are the ways of classifying plants which are based on life cycles?
2. Define species and genus.
3. Why should a person training in a horticultural occupation be able to identify plants?
4. What is the purpose of classifying plants?
5. What is the classification of plants based on growth habit?
6. What are the methods used for classifying plants?
7. How are plants classified as to function?
8. How are plants classified as to structure?
9. What is scientific classification of plants?
10. What is the goal of plant taxonomy?
11. List the characteristics of plants that can be used for identification.

INSTRUCTOR'S GUIDE**CLUSTER: HORTICULTURE****UNIT: Horticultural Science and Production****PROBLEM AREA:** Classifying Horticultural Plants**SUGGESTED TEACHING ACTIVITIES AND PROCEDURES****INSTRUCTOR'S NOTES AND REFERENCES**

1. Have students collect leaves from different trees or plants, and have them fill out a form such as on Student Worksheet #2 for each plant. Have them properly dry and preserve specimens. If possible, have them collect flowers, fruit, seed, and bark to complete a plant identification.
2. Have a plant of the day for every day of class. This would include greenhouse plants, bulbs, flowers, and vegetables. Have periodic quizzes or reviews to keep the characteristics of these plants fresh in the students' minds.
3. Have students do the crossword puzzle on Student Worksheet #1 or the word search on Student Worksheet #3. Use as a review or class assignment.
4. Have each student research and prepare a short talk, accompanied by a written paper, on a plant. The talk and paper can include plant history, life cycle, important characteristics, economic importance, problems, etc.
5. Take a walking field trip around school grounds or a neighboring forest preserve to look at plant specimens and growth habits.
6. Plan a field trip to a commercial greenhouse or nursery. Students can use Student Worksheet #2 to note descriptions and common names for growing plants. Later they should find the scientific names. An alternative activity would be handing out pages containing pictures of plants and a list of scientific names. Students should find, for each scientific name, the appropriate plant on the page, describe it, and give its common name.

INSTRUCTOR'S GUIDE**CLUSTER: HORTICULTURE****UNIT: Horticultural Science and Production****PROBLEM AREA:** Classifying Horticultural Plants**REFERENCES****INSTRUCTOR'S NOTES AND REFERENCES**

1. *Manual of Woody Landscape Plants*. Dirr, Michael A. Stipes Publishing Company, 10-12 Chester Street, Champaign, IL 61820.
- *2. *Horticultural Plant Names* (VAS Unit #U5038); *Garden Flower Set* (VAS Filmstrip Set #MF601); *Foliage Plant Identification Set* (VAS Filmstrip Set #MF610); *Ground Covers and Their Uses* (VAS Filmstrip #F646); *Nursery/Landscape Plant Identification* (VAS Filmstrip #F664). Vocational Agriculture Service, College of Agriculture, University of Illinois, 1401 S. Maryland Drive, Urbana, IL 61801. (217) 333-3871.
3. *Plant Systematics*. (1979). Jones, Samuel B., Jr., Luchsinger, Arlene E. McGraw-Hill Book Company.
4. *Introductory Horticulture*. (1988). Reiley, H.E., Shry, C.L., Jr. 3rd edition. Delmar Publishers Inc, Two Computer Drive West, Box 15-015, Albany, NY 12212.

*Indicates highly recommended reference

INSTRUCTIONAL RESOURCES

These resources are intended for use by teachers in planning and teaching the materials for this problem area and may be adapted to fit the teaching method(s) used.

INFORMATION SHEET #1 — Plant Nomenclature

TRANSPARENCY MASTER #1 — Hierarchy of Plants

TRANSPARENCY MASTER #2 — Divisions and Classes of Trees

INFORMATION SHEET #1

Plant Nomenclature

The goal of plant nomenclature is to give one correct name for each taxon. All naming is done in Latin. Linnaeus created the binomial system of naming plants with the genus name and specific epithet.

The scientific name given a plant usually is selected by the discoverer and is normally useful in describing or identifying the plant; however, this is not always true. Some of the names used that indicate the origin of plants are *americana* (American), *koreana* (Korean), *orientalis* (Oriental), and *virginicus* (Virginian). Examples of plant names derived from people's names are *baileyi*, *wilsoni*, and *fortunei*. Descriptive terms used as names of plants are *arborescens* (treelike), *compactus* (compact), and *nanus* (dwarf). Some of the names used for plants may refer to the season of the year in which they bloom: *autumnale* (autumn), *praecox* (very early), and *aestivalis* (spring). If the term "flors" is used as a part of the name, it describes something about the flower. The term may refer to quantity (*floribund*), size (*grandiflora*), or presence of many flowers (*multiflora*).

The botanical names of plants are not always permanent, as is thought by many people. If additional information learned about a plant warrants a change in name, taxonomists will rename the plant.

The botanical name of a plant is composed of two Latin or Latinized word (for example, *Spinacia oleracca*). The first word is always capitalized, is a noun, and is the genus or generic name. The second word, called a specific epithet (a word or phrase accompanying or occurring in place of the name of a person or thing), is never capitalized, is an adjective, and follows gender (trees are feminine). The words are never used alone in referring to a plant, and both words are required to correctly name the plant.

To designate a small difference in plants in a species, taxonomists often use a third word in the plant name. This is called a varietal name. The third word is often the name of the person who first named or described the plant.

The genus is a relatively small group of plants having similar form and structure. The factors considered by taxonomists in determining the genus of a plant are morphology and genetic factors. Plants in one genus cannot cross with plants in another genus.

A species is a group of plants that are similar in form and structure to each other but are dissimilar to other plants in the genus. It is the basic unit of classification. Every species belongs to a series of taxa each of higher rank.

The variety is divided into several subdivisions under the species. In this case, variety refers to botanical variety rather than plant variety. A plant in a species that is particularly different in appearance from other members in the species is called a variety, which is designated by three words. For example, common juniper would be *Juniperus communis* Var. *communis*.

A horticultural variety is called a cultivar: these are cultivated plants that have similar characteristics and retain their distinguishing features when reproduced. The three types of cultivars are clones, lines, and individuals. The propagator of horticultural plants is constantly looking for plants which are mutations and which are particularly attractive and desirable. To reproduce this plant, the propagator develops a clone.

There are several reasons why a person training in a horticultural occupation should be able to identify ornamental plants. Two among these reasons are the need to recognize plants by description, which is important for selling plants, and the need to follow instructions concerning the care of plants.

There are a number of ways of identifying plants. A horticulturist familiar with botanical terms may identify plants by using the botanical key; however, many people must learn to identify plants by their different characteristics. A discussion of several ways of identifying plants follows.

Life Cycle Classification

Based on its life cycle, a plant may be classified as either an annual, biennial, or perennial.

An annual is a plant that completes its life cycle in one year. During this period, the plant blooms, produces seeds, and dies. It is said that an annual is a plant that goes "from seed to seed" in one year in one growing season.

A biennial is a plant that requires two years or a part of two years to complete its life cycle. It goes "from seed to seed" in two years.

A perennial is a plant that usually lives for more than two years. Perennials are of two kinds, herbaceous and woody. A herbaceous perennial is a plant that has soft, nonwoody stems. Most of the herbaceous plants are annuals. Wood perennials are woody stemmed plants that live over winter. Some perennials produce stems and leaves the first year and fruit the second year.

Growth Habit Classification

Based upon their growth habits, plants are classified as trees, shrubs, and vines.

A tree is a woody perennial that has one erect or single stem which exceeds twelve feet in height, a trunk at least three inches in diameter at breast height (DBH), and definite crown, when fully grown.

A shrub, referred to by many as a bush, is a woody plant that arises from the ground with more than one stem and is usually very low (attaining not more than twenty feet in height).

A vine is a plant that requires some type of support and climbs by tendrils or some other means, or creeps along the ground. It may be either a woody or herbaceous plant.

Size Classification

Plants are classified according to size into one of six different classifications:

1. A **climbing vine** is a plant that will climb and grow on some type of support, such as a trellis, fence, or wall.
2. A **ground cover** plant (includes turf) may be either a woody or herbaceous plant. Ground cover attains the height of 1 foot or less, either trails or creeps, and may form a compact mat.
3. **Dwarf shrubs** are woody plants that grow from 1 to 3 feet tall.
4. **Medium shrubs** are plants that grow from 6 to 9 feet tall.
5. **Large shrubs** (small ornamental trees) are woody plants that grow from 10 to 25 feet high.
6. **Standard trees** are woody plants that grow to a height of 30 feet or more.

Evergreen/Deciduous Classification

Another method of classifying plants, which can be helpful in plant identification, is whether they are evergreen or deciduous. An **evergreen** has leaves throughout the year, while a **deciduous** plant loses its leaves in the fall.

Flower Classification

Flowering plants are best identified by their flowers, which are easily seen. There is a basic similarity among the members of a species in the reproductive features of their flowers, fruit, and seeds. The consistency of these features makes using them for identification ideal.

Other Classification

There are a number of other features of plants which can be used for identification, including: (1) stem types, (2) buds, (3) thorns and spines, (4) leaf arrangement and shape, (5) rhizomes, corms, and bulbs, (6) embryos, (7) cell chromosomes, and (8) pollen and spores.

When classifying a newly discovered species, there are a number of steps to be taken. These are:

1. Give it a name.
2. Prepare a Latin description.
3. Designate a type.
4. Publish the name and description.

TRANSPARENCY MASTER #1

Hierarchy of Plants

Hierarchy of botanical taxa
(plant categories)

Word endings

Kingdom

Division

-phyta

Class

-opsida

Order

-ales

Family

-aceae

Genus

Species

Variety

Form

Individual

TRANSPARENCY MASTER #2

Divisions and Classes of Trees

DIVISION: Magnoliophyta
(Angiosperms)

CLASS: Magnoliopsida
(dicots)

CLASS: Liliopsida
(monocots)

DIVISION: Pinophyta
(Gymnosperms)

CLASS: Ginkgoopsida
(Ginkgo biloba)

CLASS: Pinopsida
(conifers)

CLASS: Gnetophytina
(Important in desert areas.)

STUDENT ACTIVITIES

STUDENT WORKSHEET #1 — Crossword Puzzle

STUDENT WORKSHEET #2 — Label for Identification

STUDENT WORKSHEET #3 — Identifying Common Names of Plants Word Search (with solution)

STUDENT WORKSHEET #4 — Collecting Specimens

For additional activities, teachers may refer to the "Suggested Teaching Activities and Procedures" section in the Instructor's Guide.

STUDENT WORKSHEET #1

Crossword Puzzle

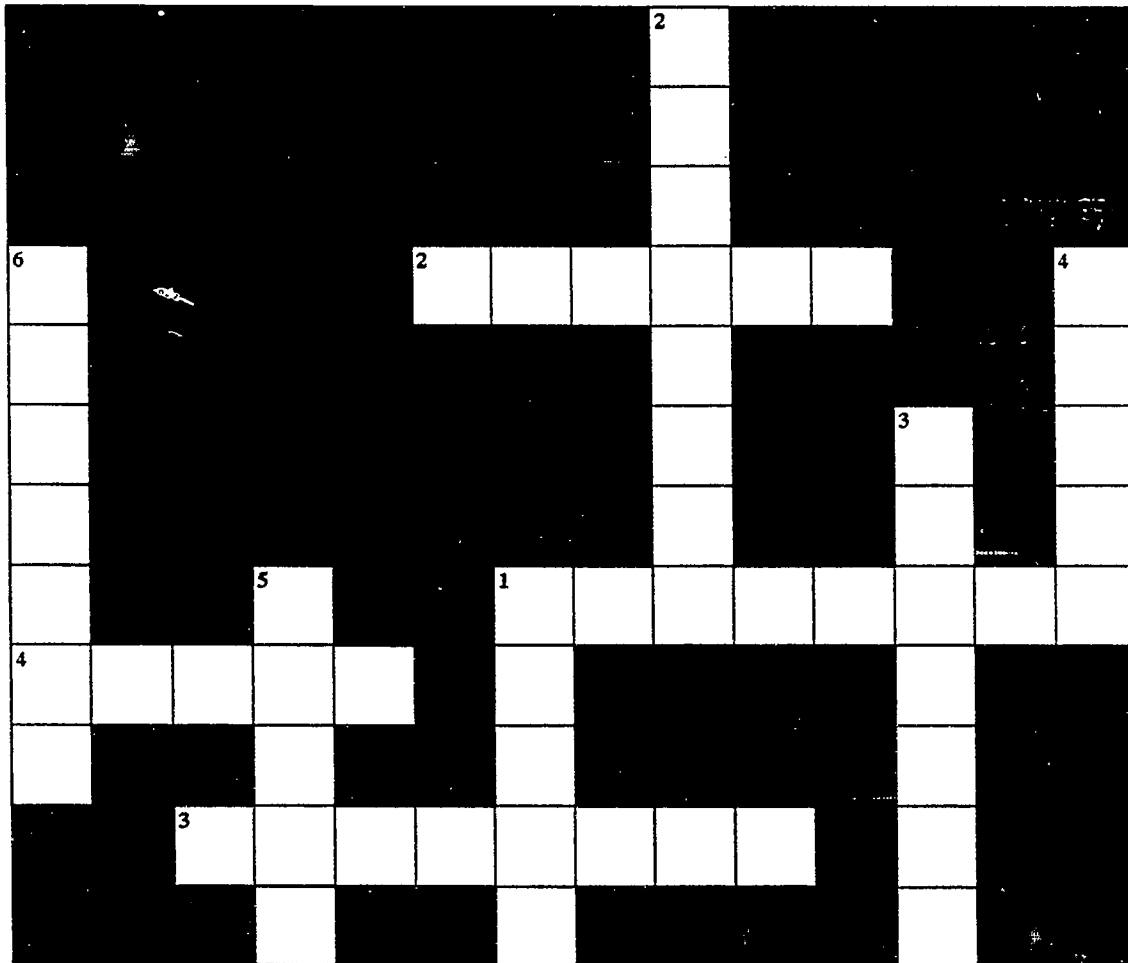
ACROSS

1. Father of Taxonomy
2. Uses reproductive and vegetative features
3. Not propagated by seed
4. Feminine gender

DOWN

1. Language used in Taxonomy
2. Ends in -phyta
3. Basic unit of classification
4. Pinopsida
5. Noun
6. Breeds true to type

STUDENT WORKSHEET #1 — Key

Crossword Puzzle

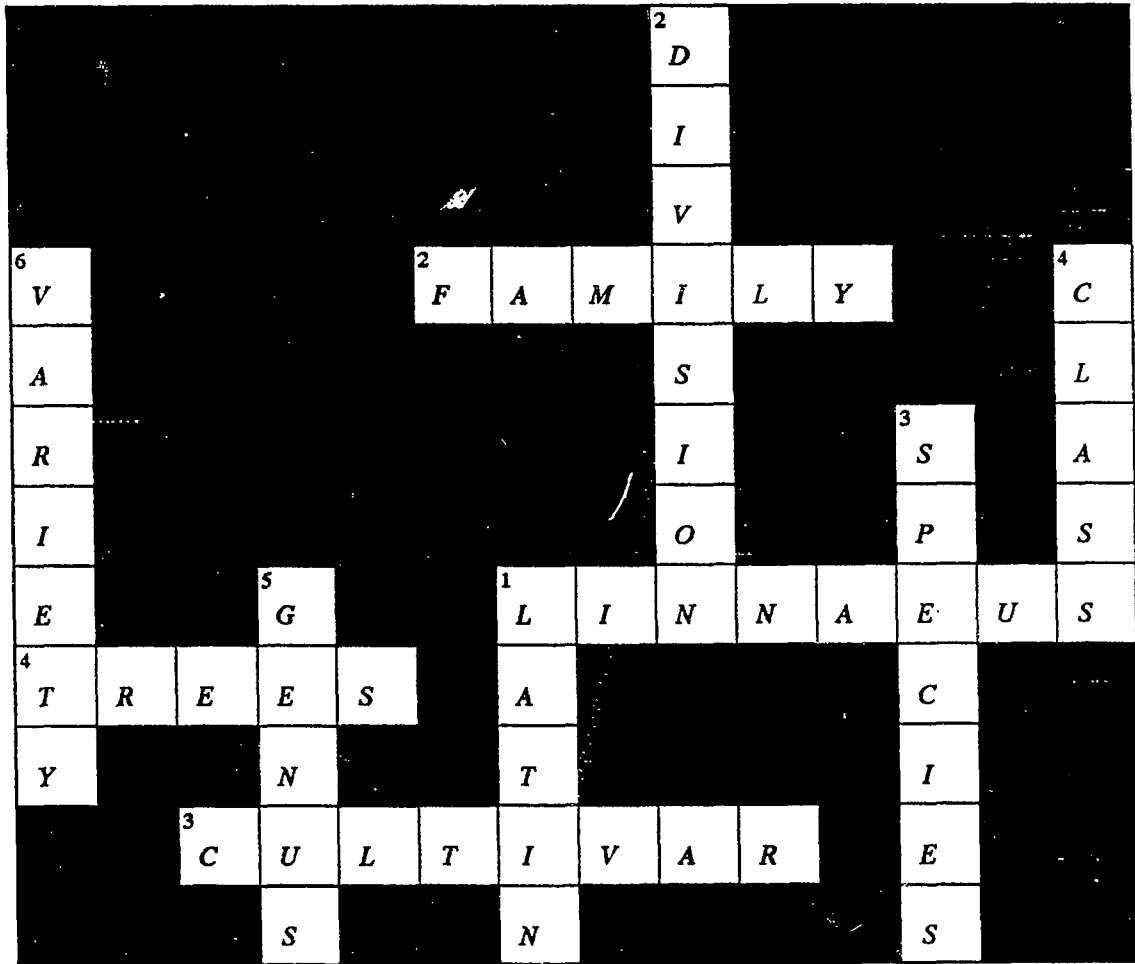

ACROSS

DOWN

1. Father of Taxonomy
2. Uses reproductive and vegetative features
3. Not propagated by seed
4. Feminine gender

1. Language used in Taxonomy
2. Ends in -phyta
3. Basic unit of classification
4. Pinopsida
5. Noun
6. Breeds true to type

STUDENT WORKSHEET #2

Label for Identification

Botanical Name: _____

Common Name: _____

Collection Date: _____ Site: _____

Characteristics: (circle) Mature size _____

Annual, Biennial, or Perennial

Herbaceous or Woody

Tree, Shrub, Vine, Ground Cover, or Vegetable

Deciduous, Evergreen, Narrow-leaf, or Broad-leaf

Foliage plant, Flowering plant, or Bedding plant

Leaves: _____

Bark: _____

Flowers: _____

Instructions:

Using identification keys or information from your teacher fill in the above card for your plant specimens collected or shown in class.

153

STUDENT WORKSHEET #3

Identifying Common Names of Plants Word Search

R U X Q J A P W B A I L A R A E S L A F
 N O R F O L K I S L A N D P I N E D A C
 F E E R T R E B B U R M L E V S U K I E
 G B Y W A N D E R I N G J E W Z G Y N B
 A D T N S F P R I D W S M X T F K G O M
 P S O G J S R I E W N C F X E S L H G O
 M E G W P I D I A I T T E S N I O P E T
 N O I T A N R A C S E G B Q S O K R B H
 N T F U R B C P Y A I E W H N M T D X E
 O R G W L Y H P C A N Y I V E U O L A R
 R O N T O W H U L R S V A X P I K Q W I
 D W I N R S G E A G Y I I S T N W B F N
 N X P R P P T Y M D M H N O Y R S W I L
 E D E E A I N T E E U S C S L R D J O A
 D W E F L D A D N A J I U C O E W G B W
 O S W N M E L Z Y S F D W M I G T P E S
 L W C O D R P T X T P E L H J U C E Q T
 I G C T Y P E D R E H L X V I P W F T O
 H F H S R L D W P R Y S W H D E B H D N
 P Q R O N A A F M L I W A I N I X O L G
 F R Y B E N J A M I N F I C U S P Y O U
 A V S P S T Y R N L O B G T M U C A X E
 E T A O F P G E E Y G S G L K W C E Q O
 L Y N W G B N V J I A O E T X R L G M H
 T W T D B A H U W S R T E R B G Z N J C
 R O H Y C P I F A C D W B C R Y L A D N
 A R E B S C R P H I P A H E T D K R L A
 E G M U S G A I T S A B M K D G Y D Q L
 H U U C M U D S V R N P O R G A F Y C A
 D X M H S U T C A C S A M T S I R H C K

Find the COMMON names for the following words which are located in the word search:

Antirrhinum majus
Araucaria heterophylla
Begonia semperflorens
Cattleya hybrida
Chlorophytum comosum
Chrysalidocarpus lutescens
Chrysanthemum morifolium
Crassula argentea
Cyclamen persicum
Dianthus caryophyllus

Dieffenbachia spp.
Dieffenbachia amoena
Dizygotheca elegantissima
Euphorbia pulcherrima
Exacum affine
Ficus benjamina
Ficus elastica
Hedera helix
Hydrangea macrophylla
Kalanchoe blossfeldiana

Lilium longiflorum
Nephrolepis exaltata
Pelargonium x Domesticum
Philodendron oxycardum
Plectranthus australis
Saintpaulia ionantha
Schlumbergera bridgesii
Sinningia speciosa
Zabrina pendula

STUDENT WORKSHEET #3 — Key

Identifying Common Names of Plants Word Search

. A I L A R A E S L A F
 N O R F O L K I S L A N D P I N E . A .
 . E E R T R E B B U R I E
 . . . W A N D E R I N G J E W . . . N .
 F G O M
 R L . G O
 . . G . P . . I A I T T E S N I O P E T
 N O I T A N R A C S . . . B H
 N . F . R Y A . . . H . M . . X E
 O . G . L C . N Y I . . U . . A R
 R . N . O L . . V . . . I . . W I
 D . I N R S . . . A . Y I I . . N . . . N
 N . P R P P T . M . . H . O . A . . . L
 E . E E A I N . E E . S . . L R . . . A
 D . E F L D A . N A . I . . . E . . . W
 O . W N M E L . . S . D . . . G T . . S
 L . . O . R P . . T . E T
 I . C T . P E . . E . W O
 H . H S . L D . . R . S N
 P . R O . A A . . L . . A I N I X O L G
 F . Y B E N J A M I N F I C U S . . . U
 A . S . . . T L O . . . M U C A X E
 E . A E . Y G E . O
 L . N N A O G . H
 T . T . . . A R N . C
 R . H . C C D A . N
 A . E B H . P R . A
 E . M I . . A D . L
 H U U D N Y . A
 D . M . . S U T C A C S A M T S I R H C K

The following are the common names for the plants to be identified in the word search:

Snapdragon
 Norfolk Island Pine
 Wax Begonia
 Orchid
 Spider Plant
 Parlor Palm
 Chrysanthemum
 Jade Plant

Cyclamen
 Carnation
 Mother-in-laws Tongue
 Dumbcane
 False Aralia
 Poinsettia
 Exacum
 Benjamin Ficus

Weeping Fig
 Rubber Tree
 English Ivy
 Hydrangea
 Kalanchoe
 Easter Lily
 Boston Fern
 Geranium

Heartleaf Philodendron
 Swedish Ivy
 African Violet
 Christmas Cactus
 Gloxinia
 Wandering Jew

STUDENT WORKSHEET #4**Collecting Specimens****Purpose:**

1. Collect specimens for class, and press and dry them according to the following guidelines.

Materials:

1. press (can be made from 2 pieces of 3/8" plywood, each greater than 12" x 18")
2. straps or ropes (webbing with claw buckles or window sash cord)
3. blotters to absorb moisture: 12" x 18" pieces found at paper houses or biological supply houses
4. corrugate ventilators: 12" x 18" corrugated cardboard for air passage
5. torn newspaper slightly smaller than press

Note: Press specimens directly after collection.

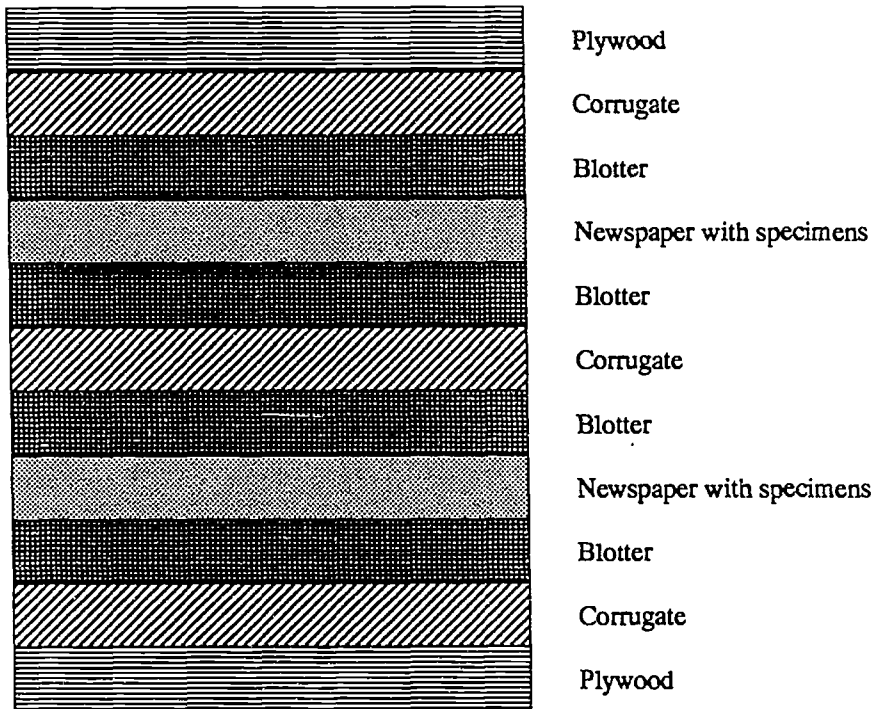
Order of Material in Press:**Notes:**

1. Be sure specimens look natural and show the important details.
2. Waxed or tissue paper may be used for flowers that stick to newspaper.
3. Be aware of native, endangered plants. They are protected by law.
4. For mounting use stiff paper (rag content) and Elmer's Glue All. Put the label in the lower right hand corner.

150

CLUSTER: HORTICULTURE

UNIT: Horticultural Science and Production

PROBLEM AREA: Understanding Plant Anatomy and Physiology

RELATED PROBLEM AREAS:

1. Propagating Plants (Horticulture and Agricultural Business and Management Clusters)
2. Understanding Plant Germination, Growth, and Development (Horticulture and Agricultural Business and Management Clusters)
3. Classifying Plants
4. Transplanting and Maintaining Landscape Plants
5. Establishing and Maintaining Turf Areas

PREREQUISITE PROBLEM AREA(S):

1. Basic Principles of Plant Science (Central Core Cluster)

LEVEL: Orientation

OCCUPATIONAL TASKS ADDRESSED:

Horticulture Cluster

Duty N: Performing Sales Duties

1. Provide customers with technical assistance

STATE GOALS FOR LEARNING:

In planning the instruction for this problem area, teachers can promote the development of several student learning objectives which are related to the State Goals for Learning in Biological and Physical Sciences. These objectives are listed on the Learning Assessment Plan forms included on the following page(s). Those learning objectives marked with an asterisk (*) are taken from the sample lists provided by the Illinois State Board of Education.



Illinois Agricultural Core Curriculum

Agricultural Education 124 Mumford Hall 1301 W. Gregory Drive University of Illinois Urbana, IL 61801

Director: Dale A. Law, Ed.D.

Principal Investigator: Jerry D. Pepple, Ed.D.

Research Assistant: Janis L. Anderson

155

88/89

Horticulture
Horticultural Science and Production



Illinois Agricultural Core Curriculum Rev.

INSTRUCTOR'S GUIDE**CLUSTER: HORTICULTURE****UNIT: Horticultural Science and Production****PROBLEM AREA:** Understanding Plant Anatomy and Physiology**STUDENT LEARNING OBJECTIVES**

Upon completion of their study of this problem area, students will be able to:

1. Identify the external and internal parts of both a monocot and dicot plant.
2. Explain the functions of the external and internal parts of plants.
3. Identify the parts of a flower.
4. Explain the functions of those flower parts.
5. Identify the external and internal parts of a monocot and dicot leaf.
6. Explain the functions of the external and internal parts of a leaf.
7. Understand what the study of plant physiology is and what it aims to do.
8. Explain the laws associated with plant physiology.
9. Identify parts of a cell and their functions.
10. Understand how a plant uses water and minerals, and conducts photosynthesis and respiration.
11. Explain the chemical processes associated with the four functions listed in item 10.

INSTRUCTOR'S NOTES AND REFERENCES

101

INSTRUCTOR'S GUIDE**CLUSTER: HORTICULTURE****UNIT: Horticultural Science and Production****PROBLEM AREA: Understanding Plant Anatomy and Physiology****PROBLEMS AND QUESTIONS FOR STUDY**

1. What are the two main functions of stems?
2. The green color of leaves is caused by what substances or factors?
3. Explain the difference between a monocot and dicot plant.
4. What is the smallest portion of the plant that is capable of regenerating the whole plant?
5. Protoplasm consists of what chemical substance?
6. What is the chemical nature of the protoplasmic surface?
7. The vacuole consists of what chemical substances?
8. What are the basic structural requirements for a living cell?
9. How can living cells be distinguished from dead cells?
10. If an excess of some substance is produced by the cell, in what part of the cell is it most likely to accumulate?
11. Of the cell's wall, protoplasm, and vacuole, which part is alive?
12. If excess fertilizer is absorbed, in what part of the cell is it accumulated?
13. What chemical substance is found in the cell wall?
14. Does the living cell do work when growing or when not growing?
15. When a living cell is placed in water, do the solutes leak out? Explain.
16. Does Brownian movement occur in living or dead cells? What causes it?
17. Diffusion is caused by what kind of movement?
18. What differences must exist in order for diffusion to occur?
19. What effect does temperature have on diffusion?
20. What is meant by osmosis?
21. What is meant by osmotic pressure?
22. What factors must be available in order for photosynthesis to occur?
23. What is the first substance formed as a result of carbon dioxide fixation?
24. Can the photosynthetic conversion of carbon dioxide to carbohydrates occur in the dark?
25. How many photochemical reactions are included in the photosynthetic process?
26. What is the role of chlorophyll in photosynthesis?
27. What factors affect the rate of photosynthesis?
28. What is the first chemical step in respiration?
29. What is anaerobic respiration?
30. What is glycolysis?
31. How is respiration measured?
32. What effect does temperature have on respiration rate?
33. Is water pushed up or pulled up a tree on a sunny day?
34. Where is the greatest resistance to the flow of liquid water in the plant?
35. What is the relation between diffusion and permeability?
36. What is a balanced solution?

INSTRUCTOR'S GUIDE**CLUSTER: HORTICULTURE****UNIT: Horticultural Science and Production****PROBLEM AREA: Understanding Plant Anatomy and Physiology****SUGGESTED TEACHING ACTIVITIES AND PROCEDURES****INSTRUCTOR'S NOTES AND REFERENCES**

1. Have students do the laboratory exercises in Student Worksheets #1 - #3.
2. Set up a demonstration showing osmosis through a semipermeable membrane.
3. Divide the class into groups and have each group research a process of plant physiology. Have the groups visually present or demonstrate the workings of these processes.
4. Some students may be interested in entering a science fair by using an idea related to plant physiology as the basis for their exhibit.
5. Have the class set up demonstrations to be exhibited during parents night.

INSTRUCTOR'S GUIDE**CLUSTER: HORTICULTURE****UNIT: Horticultural Science and Production****PROBLEM AREA: Understanding Plant Anatomy and Physiology****REFERENCES****INSTRUCTOR'S NOTES AND REFERENCES**

- *1. *Introduction to Plant Physiology*. (1969). Levitt, Jacob. C.V. Mosby Company, 11830 Westline Industrial Drive, St. Louis, MO 63141. (314) 872-8370.
- *2. *Organization of Plants*. Baron, W.M.M. John Wiley & Sons, 605 Third Avenue, New York, NY 10158-0012.
3. *Introductory Horticulture*. Reiley, H.E., Shry, C.L., Jr. Delmar Publishers, 2 Computer Drive West, Box 15-015, Albany, NY 12212.
4. *Plant Physiology in Relation to Horticulture*. (1984). Bleasdale, J.K.A. MacMillan Press, 866 Third Avenue, New York, NY 10022. (212) 702-2000.
- *5. *AgriScience Teacher Inservice Program*. Osborne, Edward W., Project Director, October 1988. Agricultural Education, 124 Mumford Hall, 1301 W. Gregory Drive, Urbana, IL 61801. (217) 333-3166.

*Indicates highly recommended reference

164

INSTRUCTIONAL RESOURCES

These resources are intended for use by teachers in planning and teaching the materials for this problem area and may be adapted to fit the teaching method(s) used.

INFORMATION SHEET #1 — What is Plant Physiology

INFORMATION SHEET #2 — The Role of Water in the Plant

INFORMATION SHEET #3 — Photosynthesis, Respiration, and Minerals

INFORMATION SHEET #4 — Laws of Thermodynamics

INFORMATION SHEET #5 — Laws of Plant Physiology

TRANSPARENCY MASTER #1 — Parts of a Monocot (with discussion guide)

TRANSPARENCY MASTER #2 — Parts of a Dicot (with discussion guide)

TRANSPARENCY MASTER #3 — Plant Stems (with discussion guide)

TRANSPARENCY MASTER #4 — External and Internal Parts of a Dicot Leaf (with discussion guide)

TRANSPARENCY MASTER #5 — Parts of a Flower (with discussion guide)

TRANSPARENCY MASTER #6 — Plant Cell (with discussion guide)

TRANSPARENCY MASTER #7 — Respiration

TRANSPARENCY MASTER #8 — Laws of Thermodynamics

INFORMATION SHEET #1**What is Plant Physiology?**

Plant Physiology is a science that attempts to explain all plant processes. This is done by means of physical and chemical principles. The study of these processes begin with making assumptions and formulating hypotheses about them. Through experiment, these hypotheses are proven or disproven.

Two Aims of Physiology

1. Biochemistry — to determine the chemical nature of all materials found in the plant and the way in which the plant obtains or makes them.
2. Biophysics — to understand all kinds of work performed by the plant and the nature of this work.

168

INFORMATION SHEET #2

The Role of Water in the Plant

1. Types of plants
 - a. Mesophytes — plants that require water most of the time.
 - b. Xerophytes — plants that have more or less water requirements than the mesophytes.
2. Uses of water
 - a. Buffers, through high specific heat (i.e., slowness in cooling and heating), the effects of sudden temperature changes.
 - b. Maintains cell orderliness and function in the protoplasm.
 - c. Maintains cells turgidity.
 - d. Replaces water lost in transpiration.
 - e. Assists in photosynthesis.
 - f. Is taken up through root hairs.
3. Ways materials enter and leave plants (All result in energy loss and are dependent upon the external and internal energy supplies of the plant.)
 - a. Diffusion — movement based on concentration differences between substances inside and outside the cell.
 - b. Osmosis — movement of a material through a semipermeable membrane to dilute a stronger solution.
 - c. Hydrostatic pressure differences — mass flow of materials from cell to cell.
 - d. Active (respiration).
4. Leaf transpiration lowers leaf temperature.
5. Plant cells
 - a. Cell walls are usually fully permeable.
 - b. Cytoplasm is semipermeable.
6. Factors determining the uptake of water
 - a. Dissolved substances in the vacuole create an osmotic potential, which is a negative pressure allowing water to enter.
 - b. The elastic cell wall creates a force of the cell wall on the cell contents, creating a positive pressure to force substances out.
 - c. When osmotic potential equals cell wall pressure, then no water is taken up,

INFORMATION SHEET #3

Photosynthesis, Respiration, and Minerals

1. Photosynthesis

- a. The intensity and quality of light affect the rate of food manufactured.
- b. The combination or fixation of carbon dioxide occurs. Hydrogen from water is used to reduce the carbon dioxide to form carbohydrates. Sunlight is needed to split hydrogen and oxygen. This process works because chlorophyll changes light energy to chemical energy according to the chemical equation:

Light Energy



carbon dioxide + water → sugar + oxygen

2. Respiration (see Transparency Master #7)

- a. This process is the reverse of photosynthesis.
- b. Foods (glucose and fructose) are broken down into simpler forms and release energy in the process.

- c. Aerobic respiration (more efficient) proceeds according to the chemical formula:

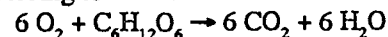

- d. Anaerobic respiration (less efficient) proceeds according to the chemical formula:

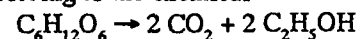

- e. Both aerobic and anaerobic respiration have a common nonoxygen pathway called glycolysis.
- f. An increase in temperature means an increase in respiration.

3. Mineral Uptake

- a. Ions diffuse from the soil to the root hairs. They may be absorbed into cell walls, absorbed into cytoplasm, or stored in the vacuole for later use.
- b. Ions move from cell to cell until they reach the xylem where they are drawn upward in the xylem stream.
- c. Ions are released back into the cells when they reach the leaves.

INFORMATION SHEET #4

Laws of Thermodynamics

First Law of Thermodynamics

1. $\Delta E = q - w$

where: ΔE = change in energy of a body

q = heat or other energy absorbed by the body

w = work done by the body on its environment

2. $\Delta E = q - w$ means that the increase in the plant's energy is equal to the sum of all the forms of energy minus the work done by the plant on its environment.
3. Effects are seen when there is an increase in a plant's energy or growth. This happens if there is more energy absorbed by the plant than expended in doing work.
4. Some ways in which plants do work are:
 - a. Pushing up against gravity.
 - b. Pushing down through soil.
 - c. Evaporation.
 - d. Photosynthesis.

5. Some ways in which plants use energy are:
 - a. Evaporation, which gives off heat energy.
 - b. The uplift of water through the plant, which uses mechanical energy.
 - c. Photosynthesis, which uses chemical energy.

Second Law of Thermodynamics

1. $\Delta E = \Delta A + \Delta TS$

where: ΔA = isothermally available energy

ΔTS = isothermally unavailable energy

T = absolute temperature

S = entropy

2. Not all of the increased amount of energy is free.
3. Heat can pass only from warmer to colder areas.
4. The Laws of Diffusion follow this law.

INFORMATION SHEET #5**Laws of Plant Physiology****Laws of Nutrition and Metabolism**

1. Law of nutrient essentiality — All elements that participate in plant metabolism must be supplied by the plant's environment. The quantity must be sufficient to supply all the metabolic needs for the plant to complete its life cycle.
2. Law of autotrophism — Normal green plants are capable of synthesizing all the organic substances needed to complete their life cycle. An abnormal green plant is deficient in the ability to synthesize one or more of the substances.
3. Law of enzyme control — Enzymes control all the metabolic processes in the plant. These enzymes are organic catalysts consisting of a protein and commonly a nonprotein factor.
4. Law of electron transfer — All living protoplasm contains chemical energy which is constantly being released by electron transfer between substances undergoing oxidation-reduction reactions.
5. Law of cardinal points — Factors that affect various plant processes may be present in varying amounts. There are three critical amounts, or cardinal points, for any factor. The minimum quantity of a factor is the smallest amount capable of supporting a measurable rate of the process. The optimum quantity of a factor is the amount capable of supporting the most rapid rate of the process. The maximum quantity of a factor is the amount above which this process cannot occur at a measurable rate.
6. Law of energy transfer — The conversion of light energy into chemical energy in the form of high phosphates supplies all the energy requirements of the plant.
7. Law of template synthesis — Proteins and nucleic acids in each kind of plant are synthesized on a template nucleic acid molecule. This template can reproduce the same pattern of molecule repeatedly. Templates differ in patterns for each protein or nucleic acid produced.

Laws of Transfer of Materials

1. Law of cell permeability — Cell protoplasm is surrounded by a differentially permeable lipid membrane. This membrane controls the diffusion

of substances into and out of the cell. Some substances are allowed to diffuse rapidly; others are slowed down or prevented from diffusing.

2. Law of water transfer — In the plant, water movement is a passive or purely physical process. By diffusion water moves into and out of the plant. Active processes can only affect water movement by altering the factors that affect diffusion.
3. Law of solute transfer — Solutes move both actively and passively in the plant. Apolar solutes move passively; polar solutes move actively, but are aided by passive processes. Movement in the xylem is passive; in the phloem it is active.

Laws of Growth and Development

1. Law of plant movement — The movement of plant parts is controlled by growth and plant turgor. Permeability can also be a factor.
2. Law of enlargement — Plant growth is a direct result of cell enlargement supported by the force of turgor pressure.
3. Law of regulation of growth and development — Low concentrations of hormones regulate the growth and development of a plant. These are known as growth regulators and they may affect cell division, enlargement, or differentiation, depending on the balance of the substances.
4. Law of plant development — The successive stages or phases of a plant's growth differ both morphologically and physiologically. Development of a plant from one stage to another can be controlled by the environment and the balance of growth and flowering hormones.
5. Law of stress resistance — Plants may survive stress by either avoidance or tolerance or a combination of the two mechanisms. With avoidance, the stress is prevented from penetrating the tissues. With tolerance, the stress is allowed to penetrate, but internal resistance enables the tissues to survive.
6. Law of endogenous rhythm — Changes in plant processes, such as growth rate, are controlled by either an intrinsic or an extrinsic clock that is capable of measuring biological time. The periods measured are usually diurnal but can also be tidal, lunar, or annual.

TRANSPARENCY MASTER #1

Parts of a Monocot

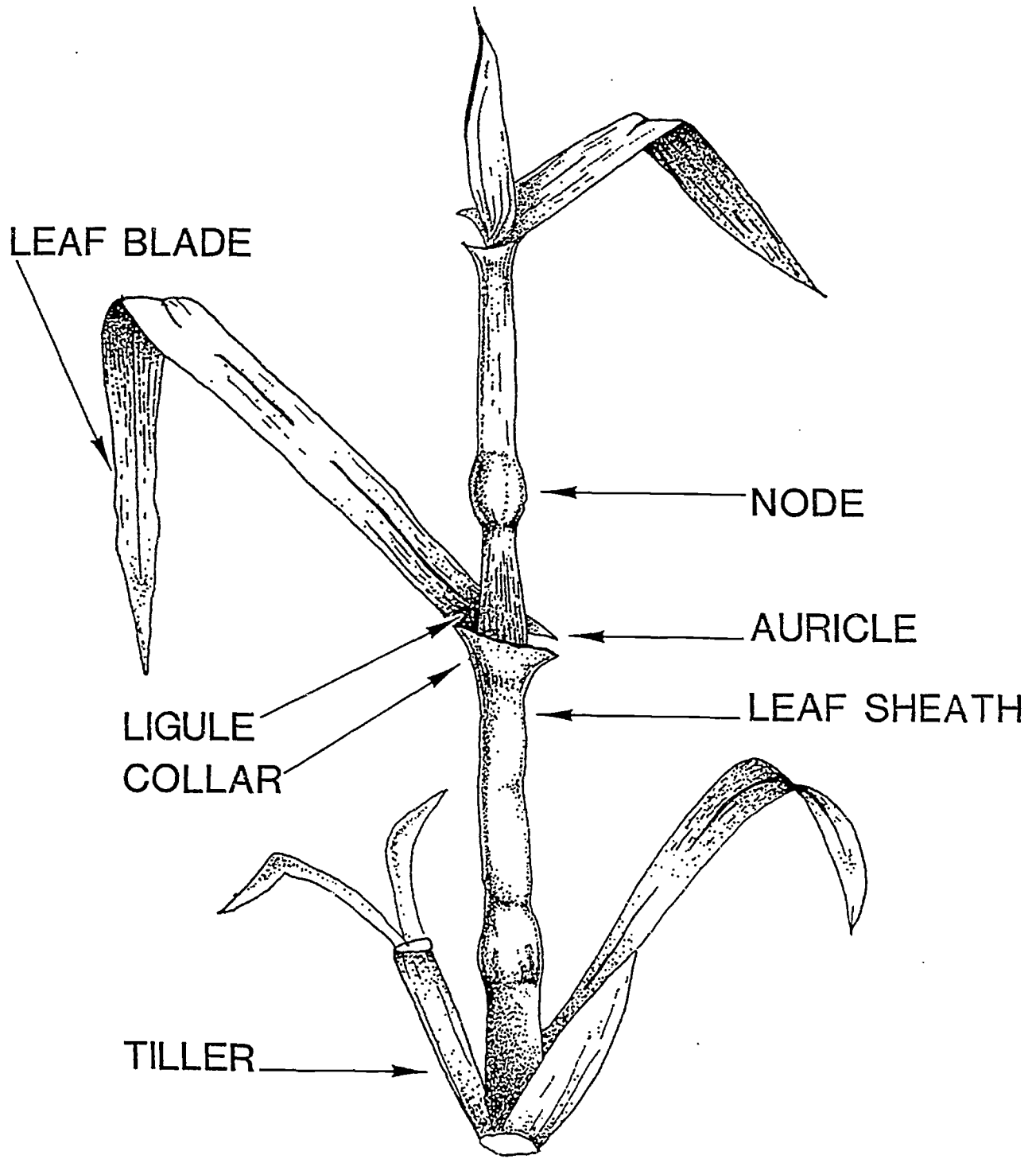

TRANSPARENCY MASTER #2

Parts of a Dicot

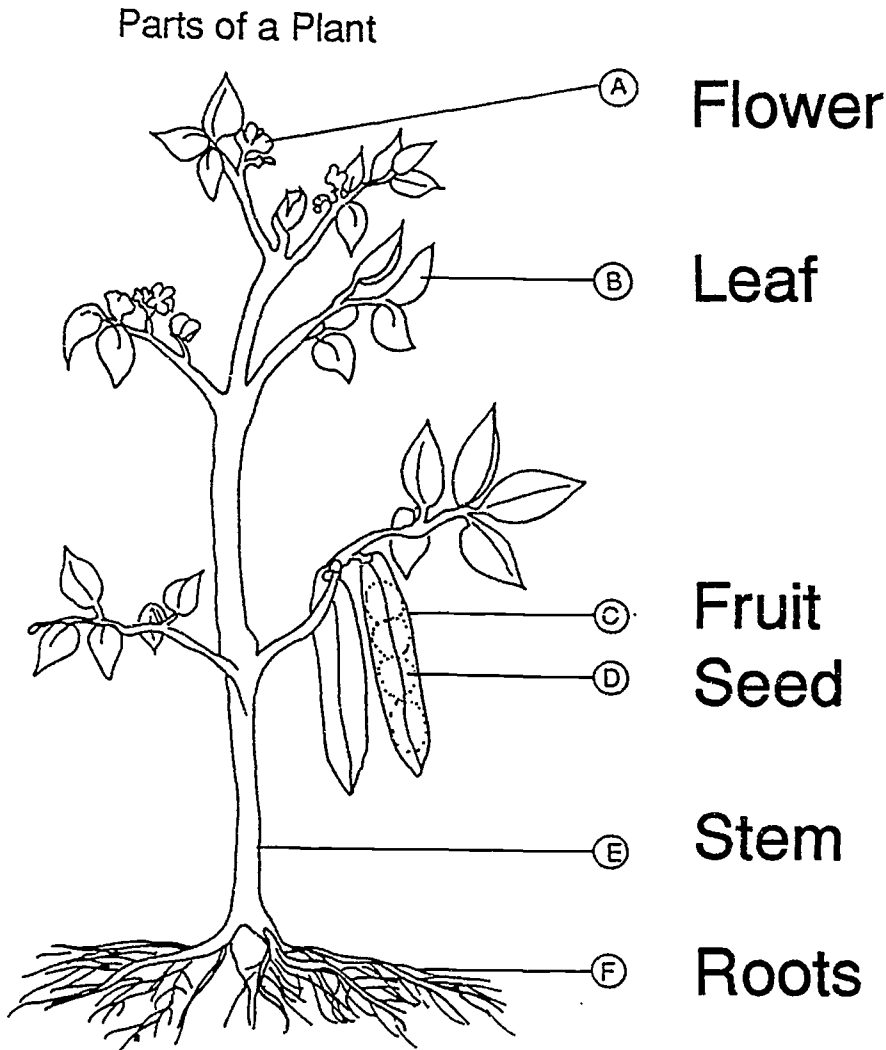

TRANSPARENCY MASTER #3

Plant Stems

DICOT

External

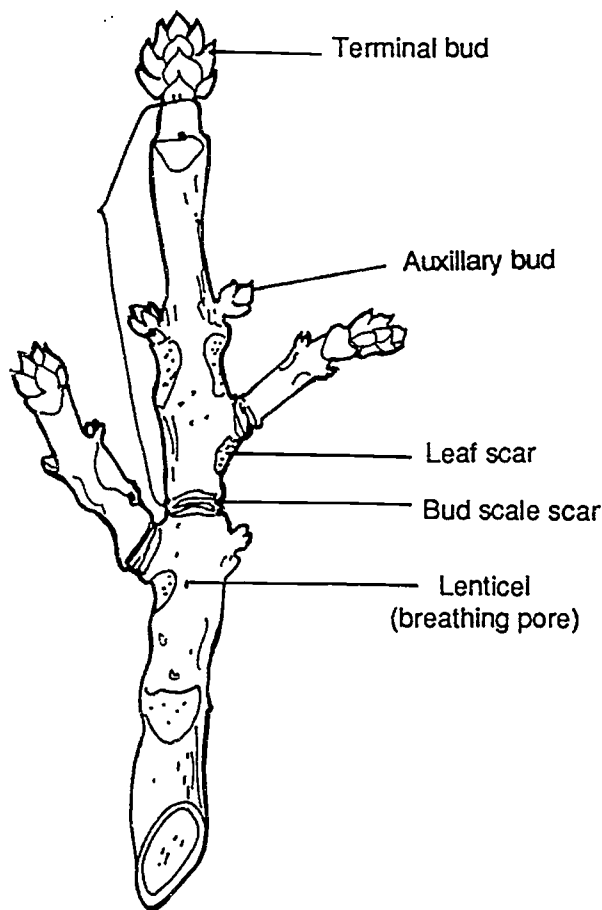

Parts of a stem

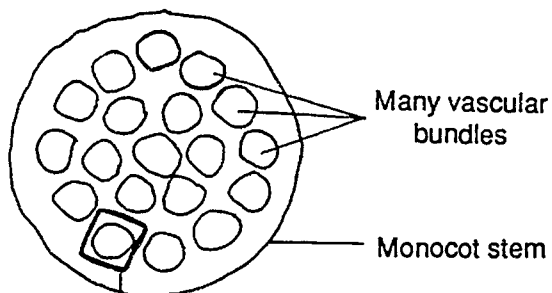

Vascular bundle magnified

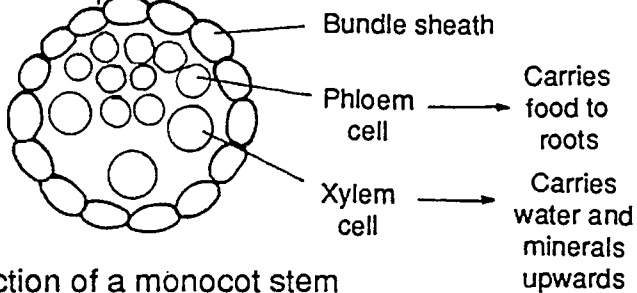

Cross section of a monocot stem

Internal

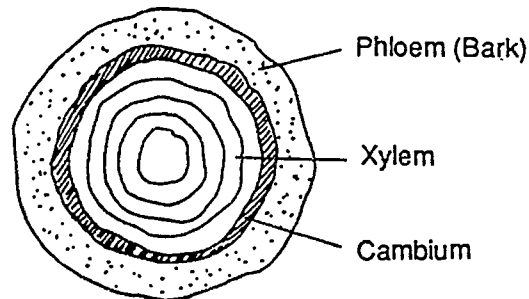

Cross section of a dicot stem

TRANSPARENCY MASTER #4

External and Internal Parts of a Dicot Leaf

DICOT LEAF

External

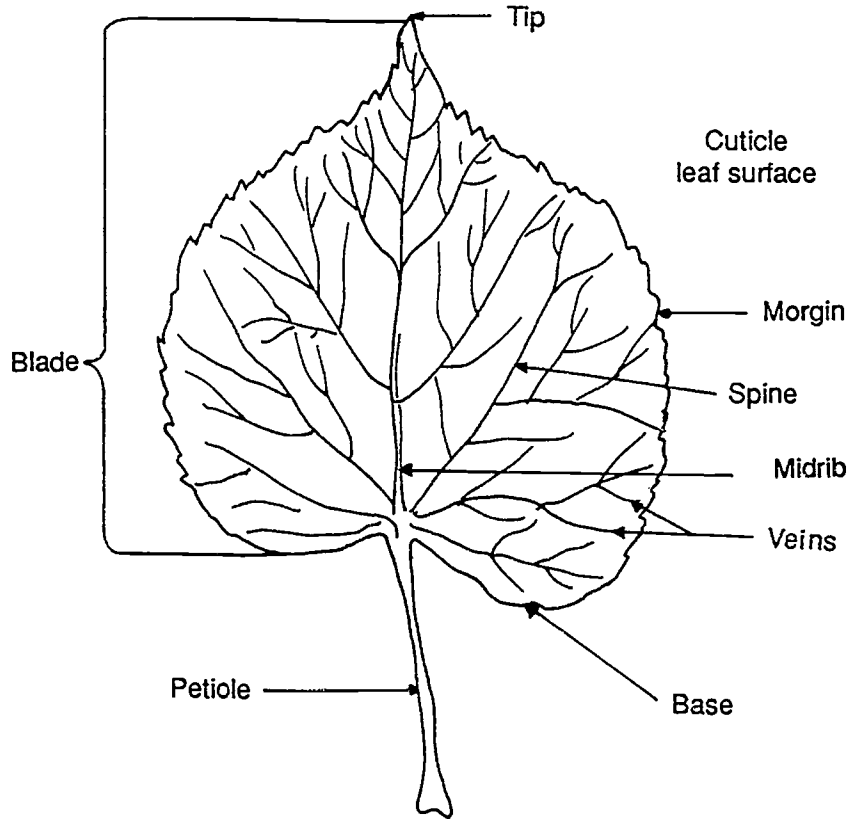

Internal

Cross section of leaf

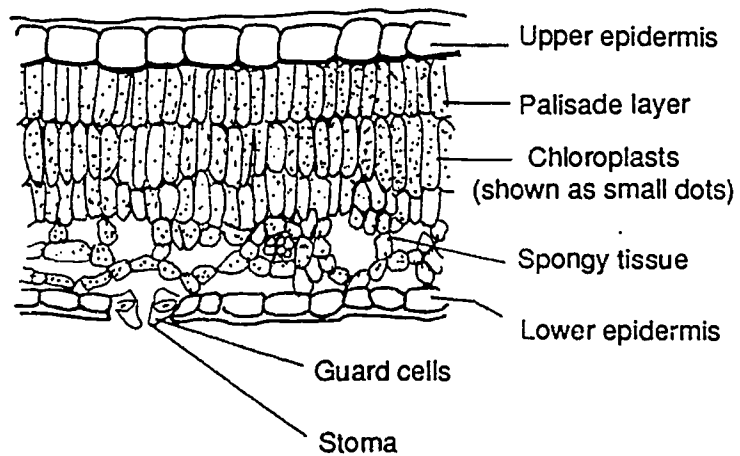

TRANSPARENCY MASTER #5

Parts of a Flower

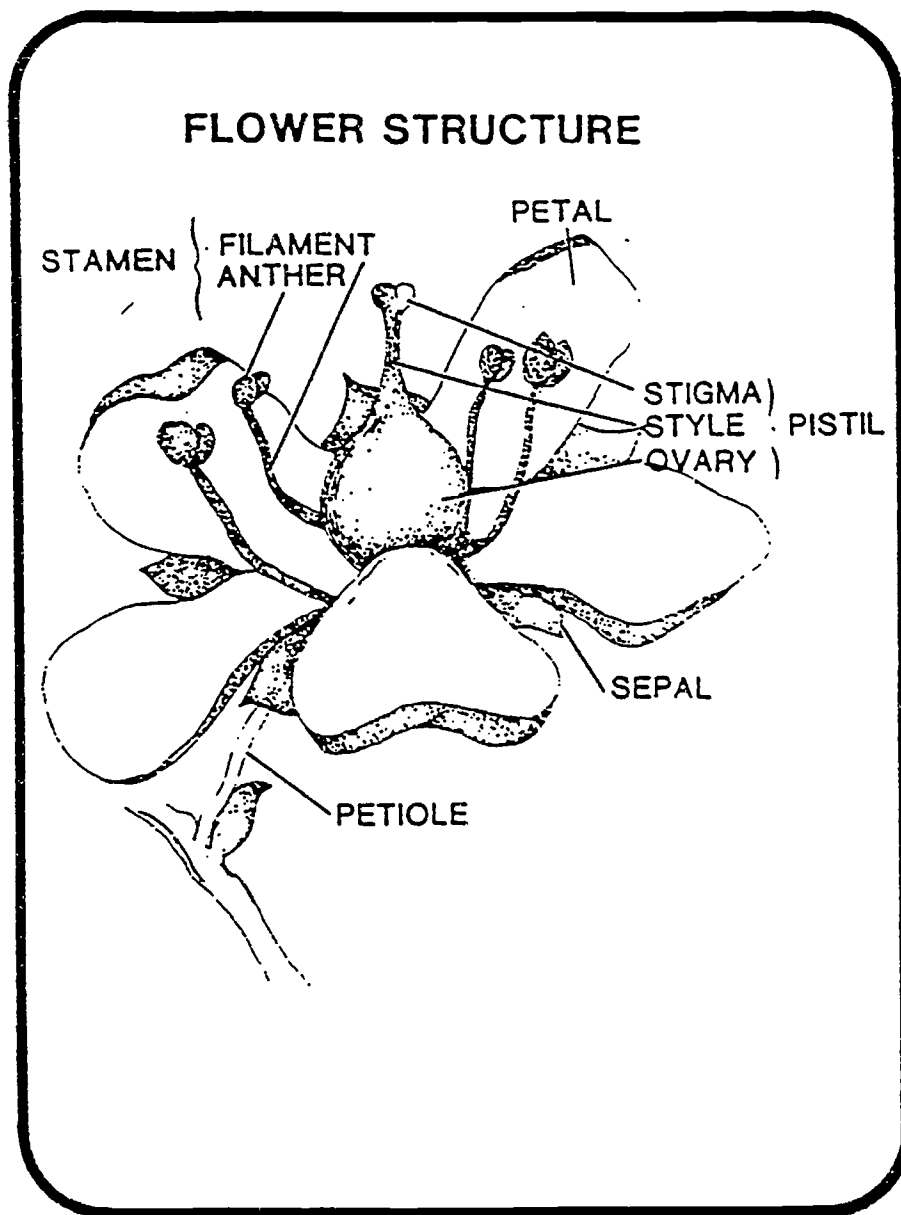

178

TRANSPARENCY MASTER #6

Plant Cell

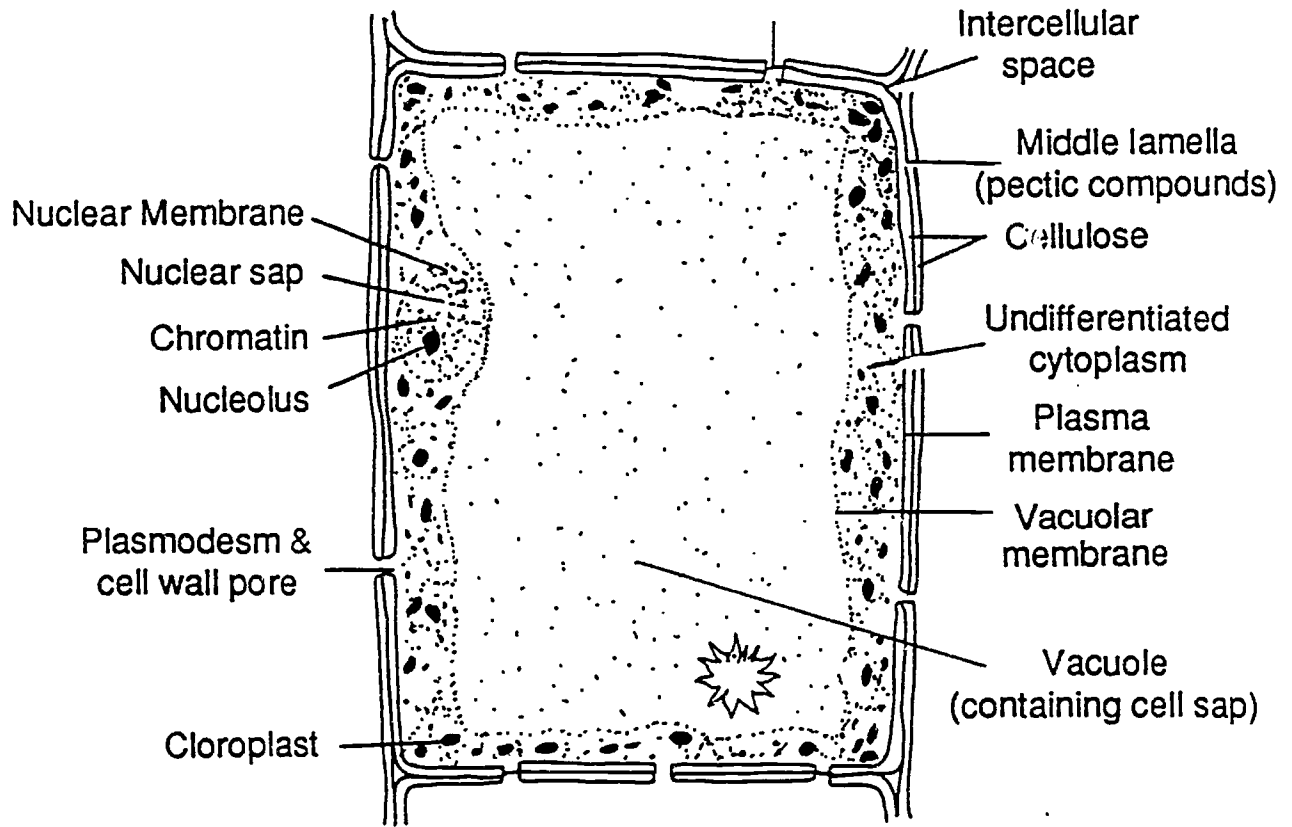

TRANSPARENCY MASTER #7

Respiration

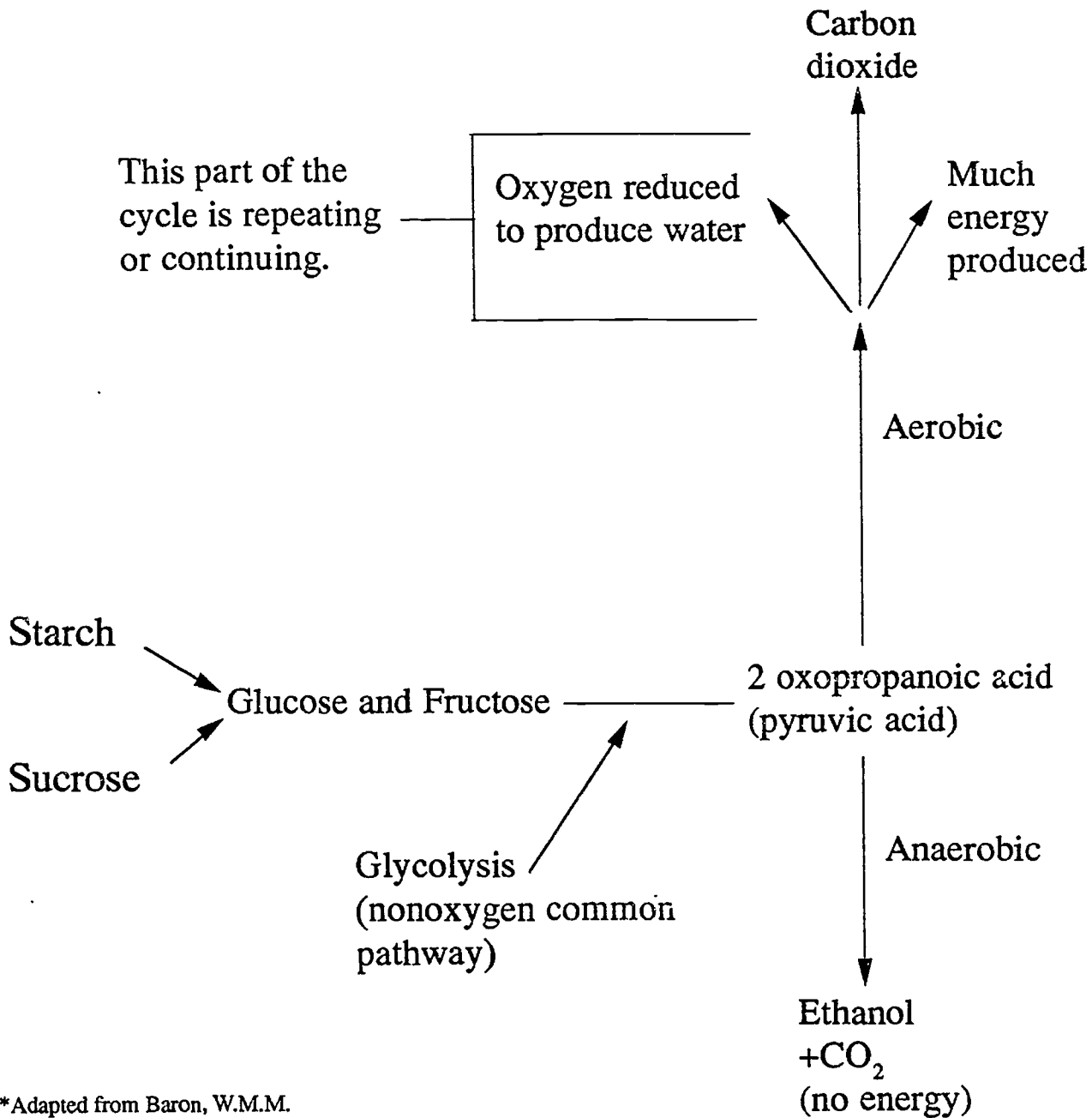

*Adapted from Baron, W.M.M.

TRANSPARENCY MASTER #8

Laws of Thermodynamics

$$\Delta E = q - w$$

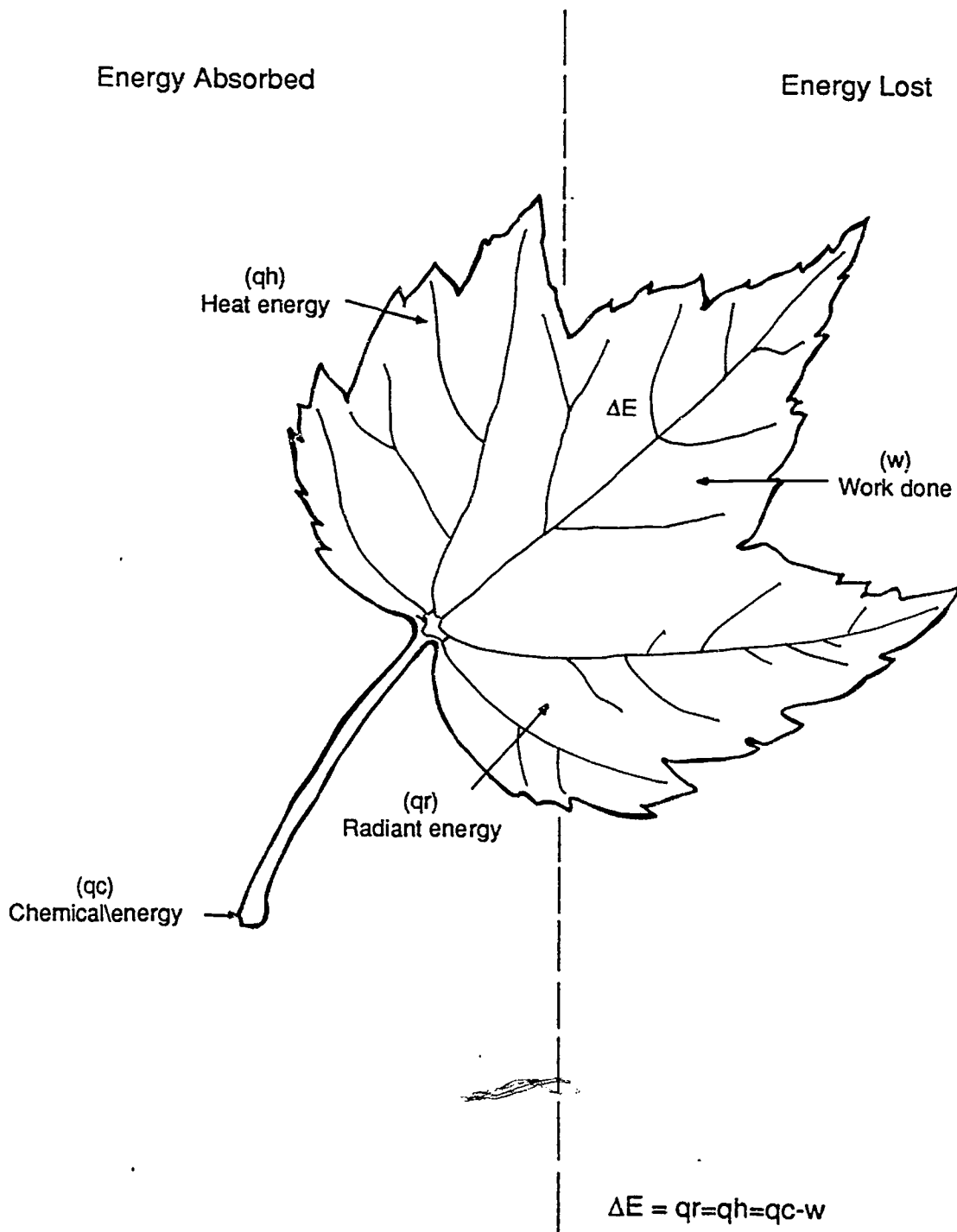

TRANSPARENCY MASTER DISCUSSION GUIDE

Transparency Master #1

1. Internal structure of a monocot
 - a. Vascular bundle — each bundle contains xylem and phloem tissue.
 - b. There is no cambium — all necessary cells are formed initially and just enlarge in size to increase the size of the plant.

Transparency Master #2

1. Parts of a dicot
 - a. Flowers — reproductive organs of a plant that attract bees for pollination.
 - b. Leaves — plant parts that function in food manufacture through photosynthesis.
 - c. Fruit — seed-bearing part of a plant.
 - d. Seeds — fertilized ovule of a plant through which the plant reproduces.
 - e. Stem — main body of the plant that functions as a support for the branches and a passage for food and water.
 - f. Roots — part of a plant growing underground that anchors the plant and absorbs water and minerals from the soil.
2. External structure of a dicot
 - a. Lenticel — a breathing pore along the stem.
 - b. Bud scale scar — scar on the stem where the terminal bud of the previous year was located; distance between successive bud scars is one years growth.
 - c. Leaf scars — points at which leaves were attached.
 - d. Auxiliary buds — side buds along stem.
3. Internal structure of a dicot
 - a. Phloem — the bark of the stem, down which food manufactured in the leaves travels.
 - b. Xylem — sapwood of the stem, up which water and minerals travel to the leaves.
 - c. Cambium — layer that separates the xylem and phloem; the cambium is responsible for producing all the new cells.

Transparency Master #3

1. Stems have two principal and two possible accessory functions:
 - a. Transport of water and minerals up to the leaves; and transport of manufactured food down to the roots.

- b. Support for above ground plant parts.
- c. Food storage (as in potatoes).
- d. Asexual propagation.

Transparency Master #4

External Leaf Parts

1. Petiole — the leaf stalk which attaches leaf to stem.
2. Blade — the large flat part of the leaf.
3. Midrib — the large center vein of a leaf from which other veins extend.
4. Spine and veins — veins that form the skeleton or framework of the leaf.
5. Margin — edge of the leaf; its form aids in the identification of many plants.
6. Tip — point or top of leaf.
7. Base — end opposite the tip.
8. Cuticle — waxy leaf covering that prevents excess water loss.

Internal Leaf Parts

1. Epidermis — leaf skin, consisting of a single layer of cells on the upper and lower surfaces, which protects the leaf from excess moisture loss.
2. Guard cells — cells on the underside of the leaf that regulate the opening and closing of a pore space called the stoma.
3. Stoma — pore spaces through which a plant breathes and transpires, involving the exchange of gases (oxygen and carbon dioxide) and the giving off of moisture.
4. Food-making cells — cells containing chloroplasts which lie between the epidermis layers of a leaf. Chloroplasts contain chlorophyll and manufacture food through photosynthesis. Food is moved from these cells throughout the plant.

Transparency Master #5

- a. Stamen — male reproductive parts.
- b. Anther — saclike structure on top of filament; contain pollen (male sex cell).
- c. Filament — stalk of the stamen.
- d. Petal — flower leaves of bright colors for attracting insects to aid in pollination.
- e. Pistil — female reproductive parts.
- f. Stigma — area on top of pistil; sticky for catching pollen.

- g. Style — tube connecting stigma to ovary.
- h. Ovary — area where egg cells develop and where fertilization occurs.
- i. Sepal — leaflike, green part of a flower that protects the flower bud before it opens.
- j. Petiole

NOTE: After pollen has been deposited on the stigma by wind or insects, the pollen will send a long stalk down the style to the ovary. After the union of pollen (sperm) and egg (ovules), or fertilization, the seeds will start to develop. The ovary will be the seed coat or fruit as it enlarges.

Transparency Master #6

Three Main Cell Components

1. Cell Wall

- a. Contains carbohydrates such as cellulose and, in primary cell walls, possibly proteins such as extensin.
- b. Has the physical properties of elasticity, when water is removed, and plasticity, when the cell enlarges.

2. Protoplasm

- a. Is the most important part of a cell.
- b. Is low in acidity.
- c. Is composed of from 1 to 3 percent nucleic acid.
- d. Is continually moving in streams, a phenomenon called cytoplasmic streaming.
- e. Contains the cytoplasm.
- f. Is mostly composed of protein; is responsible for Brownian movement, which is caused by the moving and colliding of the cytoplasm particles due to thermal activity and protoplasmic streaming.
- g. Contains the nucleus, the controlling unit of the cell, which floats in the cytoplasm and contains the genes, which determine the organization of the cell and direct the synthesis of proteins and enzymes.

3. Vacuole

- a. Is high in acidity and water content.
- b. Contains no proteins or fatty substances.
- c. Serves as a storage unit for excess salts, substances from the protoplasm, nitrates, and phosphates.
- d. Is very important in heavily fertilized plants.

NOTE: A totipotent cell is one that has all the properties necessary for regenerating the whole plant.

STUDENT ACTIVITIES

STUDENT WORKSHEET #1 — Plant Tissues

STUDENT WORKSHEET #2 — Chlorophyll and Food Production

STUDENT WORKSHEET #3 — Photosynthesis in Plants

STUDENT WORKSHEET #4 — Transport in Plants

For additional activities, teachers may refer to the “Suggested Teaching Activities and Procedures” section in the Instructor’s Guide.

181

STUDENT WORKSHEET #1**Plant Tissues****Purpose:**

1. To locate the two vascular and the other four specialized tissues, given a monocot or dicot.
2. To describe the functions of these specialized tissues.

Materials:

1. one large carrot or woody branch
2. one cornstalk or picture of cross section of cornstalk
3. sharp knife

Procedure:

1. Cut the carrot or branch straight across with the knife.
2. Cut the cornstalk straight across. (Have the teacher see that you have made the cuts in the right way.)
3. Locate the vascular tissues in each.
4. Compare them, and draw pictures of what you observe, on your own paper. Label all parts. (Show your labeled drawings to the teacher.)

Discussion:

1. Why don't monocots form annual rings?
2. How many cotyledons does a dicot have?
3. Which plant will have a terminal growing point?
4. What is the usual leaf venation of a monocot?
5. What is the leaf venation of a dicot?

Taken from October 1988 ICAE AgriScience Teacher Inservice Workshop directed by Dr. Edward W. Osborne.

182

STUDENT WORKSHEET #2**Chlorophyll and Food Production****Purpose:**

1. To determine whether chlorophyll in the leaves is essential for the production of plant food.

Materials:

1. potted plant
2. two or more pairs of one-inch-square opaque paper or cloth
3. paper clips
4. wood alcohol in beaker
5. iodine
6. blotting paper
7. pan of water
8. hot plate or bunsen burner

Procedure:

1. Cover portion of two or three leaves with paper (one top, one bottom) and clip together.
2. Leave plant in direct sunlight from early morning to late afternoon.
3. Remove paper and cut off leaves. Immerse leaves in beaker of wood alcohol.
4. Cut off an uncovered leaf and put in beaker also.
5. Place beaker in hot water pan and keep over flame until all green is removed from leaves. (Show the leaves to the teacher to make sure the green has been removed from the leaves.)
6. Wash leaves thoroughly in warm water and dry between pieces of blotting paper.
7. Put leaves in a solution of iodine for a few minutes.
8. Note portions where starch is or is not present.

Discussion:

1. Where do you find the presence of starch?
2. Explain the differences in appearance of the covered portions of the leaves.
4. What appears to be necessary for the manufacture of starch?

Taken from October 1988 ICAE AgriScience Teacher Inservice Workshop directed by Dr. Edward W. Osborne.

183

STUDENT WORKSHEET #3**Photosynthesis in Plants****Purpose:**

1. To determine what raw materials are necessary for photosynthesis to occur.
2. To analyze the plant processes that take place by using a chemical indicator.

Materials:

1. six test tubes
2. six stoppers to fit tubes
3. one soda straw
4. 140 ml of tap water left out overnight
5. four sprigs of elodea, each about 10 centimeters long
6. two pieces of aluminum foil to cover 2 tubes
7. bright lamp source
8. freezer tape
9. test tube rack or jar to hold tubes up
10. dropper bottle of bromthymol blue indicator

Procedure:

1. Thoroughly clean six test tubes and rinse each at least three times.
2. Place a piece of freezer tape on each tube, then number them 1, 2, 3, 4, 5, and 6.
3. Place about 140 ml of tap water in a beaker or jar.
4. Add about 30 drops of bromthymol blue indicator when you are ready. (Your teacher will add the bromthymol blue indicator when you are ready.)
5. Fill test tubes 1, 3, and 5 with the blue water and place them on the rack. Fill to the top (see diagram).

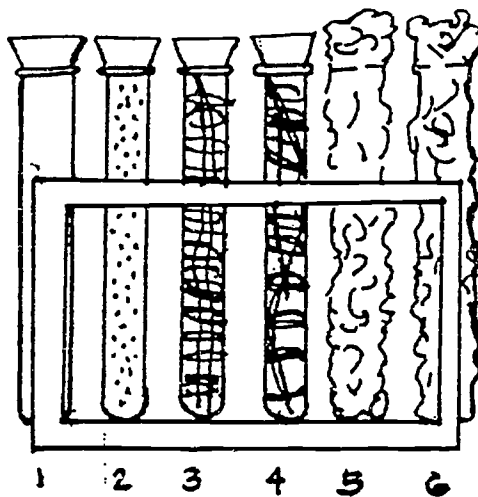

1. Blue water
2. Yellow-green water
3. Blue water and elodea
4. Yellow-green water and elodea
5. Blue water, elodea and aluminum foil
6. Yellow-green water, elodea and aluminum foil

6. Take a soda straw and bubble carbon dioxide from your breath into the remaining blue water you have left in the beaker. Do this for about two or three minutes until the blue water changes to a yellow-green color.
7. Fill test tubes 2, 4, and 6 with the yellow-green water.
8. To test tubes 3, 4, 5, and 6, add a sprig of elodea. (Your teacher will add the elodea when you are ready.)

9. Stopper all six test tubes.
10. Wrap tubes 5 and 6 with aluminum foil.
11. Place tubes in front of light source for 24 hours. Place light source about 50 cm away from tubes.
12. Observe tubes after 24 hours for color changes and gases that collect at the top. Use white paper behind tubes as a background to view true color of liquids.
13. Fill in data chart to show contents and color change of each tube you prepared.

Data Chart:

No.	Color and Contents	24 Hour Observations
1		
2		
3		
4		
5		
6		

Discussion:

1. How can you tell if photosynthesis has taken place in your experiment? Explain.
2. In 24 hours, what change if any took place in test tube 3? Why?
3. Does test tube 5 differ from test tube 3? Explain.
4. What does the color change mean after the 24-hour period?
5. Was there any change in the amount of gas at the top of each tube after 24 hours?
6. Which test tube best shows that photosynthesis took place and why?
7. What is the purpose of test tubes 1 and 2?
8. Compare test tubes 5 and 6 after 24 hours. Explain the reasons for what you observe.

Answer to Questions:

1. Test tube 4 should have a color change in the liquid from yellow-green to blue, and many gas bubbles should be visible around the sprig. Also, more air space should have formed at the top of the tube.
2. No visible changes took place. The carbon dioxide present is insufficient to cause a color change.
3. No. There is no significant color difference.
4. The color change after 24 hours means that the pH of the water changed and that the plants removed the carbon dioxide from the water, turning it back to blue again.
5. Tube 4 showed the greatest increase in gas collected at the top of the tube.
6. Tube 4 best shows that photosynthesis took place because the tube contained all the raw materials (green plant, carbon dioxide, sunlight) necessary.
7. They serve as controls, indicating that the liquid by itself did not cause a color change.
8. Test tube 5 remains blue while test tube 6 should exhibit a color change.

Adapted from "Learning Activity Packages" Office of Vocational Education, Columbia, South Carolina

Taken from October 1988 ICAE AgriScience Teacher Inservice Workshop directed by Dr. Edward W. Osborne.

STUDENT WORKSHEET #4**Transport in Plants**

Water is one of the basic raw materials of photosynthesis. It is the major component of plant tissues, making up 90 percent of the plant body. Water is the substance which carries most of the materials which enter and leave the cells of plants and it is the solvent for the various biochemical reactions that take place in living cells.

The amount of water used by plants is far greater than that used by animals of comparable weight. The reason for this is that a large amount of water used by the animal is recirculated in the form of blood plasma or tissue fluid. In plants, more than 90 percent of the water taken in by the root system is evaporated into the air as water vapor. This process, which largely occurs through the leaves, is called transpiration. Consequently, plants not only have developed extensive and efficient transport systems but have evolved numerous morphological adaptations to conserve water. In this study you will become familiar with some of the regulators of transpiration.

Effect of the Environment on Transpiration Rate

1. Cut a branch from a geranium or *Coleus* plant and insert it into a rubber stopper as shown in Figure 1. Place the branch and stopper as shown into a potometer flask containing distilled water. Insert the stopper slowly to avoid creating bubbles. If this is done properly, water will be forced out of the end of the capillary tubing. However, when the pressure on the stopper is released, the fluid in the capillary tube will tend to recede. If this should occur, fill a 5 ml syringe with water and insert the needle into the rubber coupling between the flask and the capillary tubing. Slowly inject water until it comes out of the end of the tubing. If the apparatus has been properly set up, the water in the tube will begin to recede slowly. The rate that the meniscus moves along the tubing is a measure of the rate of water uptake by the branch and may be used as a measure of the rate of transpiration. Determine the transpiration rate by recording the distance the meniscus moves each minute for a period of ten minutes. If the meniscus goes beyond the graduated scale on the right it may be returned to the "zero" mark by injecting water into the rubber coupling as previously described. Record your results in Table 1. Plot your data in Figure 2.
2. Design and perform experiments to show the effects (if any) of light intensity, air movement, and humidity and the role of the leaves in the process of transpiration. Record the experimental conditions and your results in Table 1. Plot your data in Figure 2. What would be the control for these various experiments?

All aerial parts of plants may lose water by transpiration. In most herbaceous and woody plants, a large proportion of the water is lost through openings called stomates. Discuss the effects that the various environmental conditions have on transpiration in terms of their effects on the activity of the stomates.

Why is it important that ornamental evergreen plants be thoroughly watered before winter sets in?

In what way is transpiration a beneficial process to the plant?

Figure 1.
Procedure for determining the rate of transpiration.

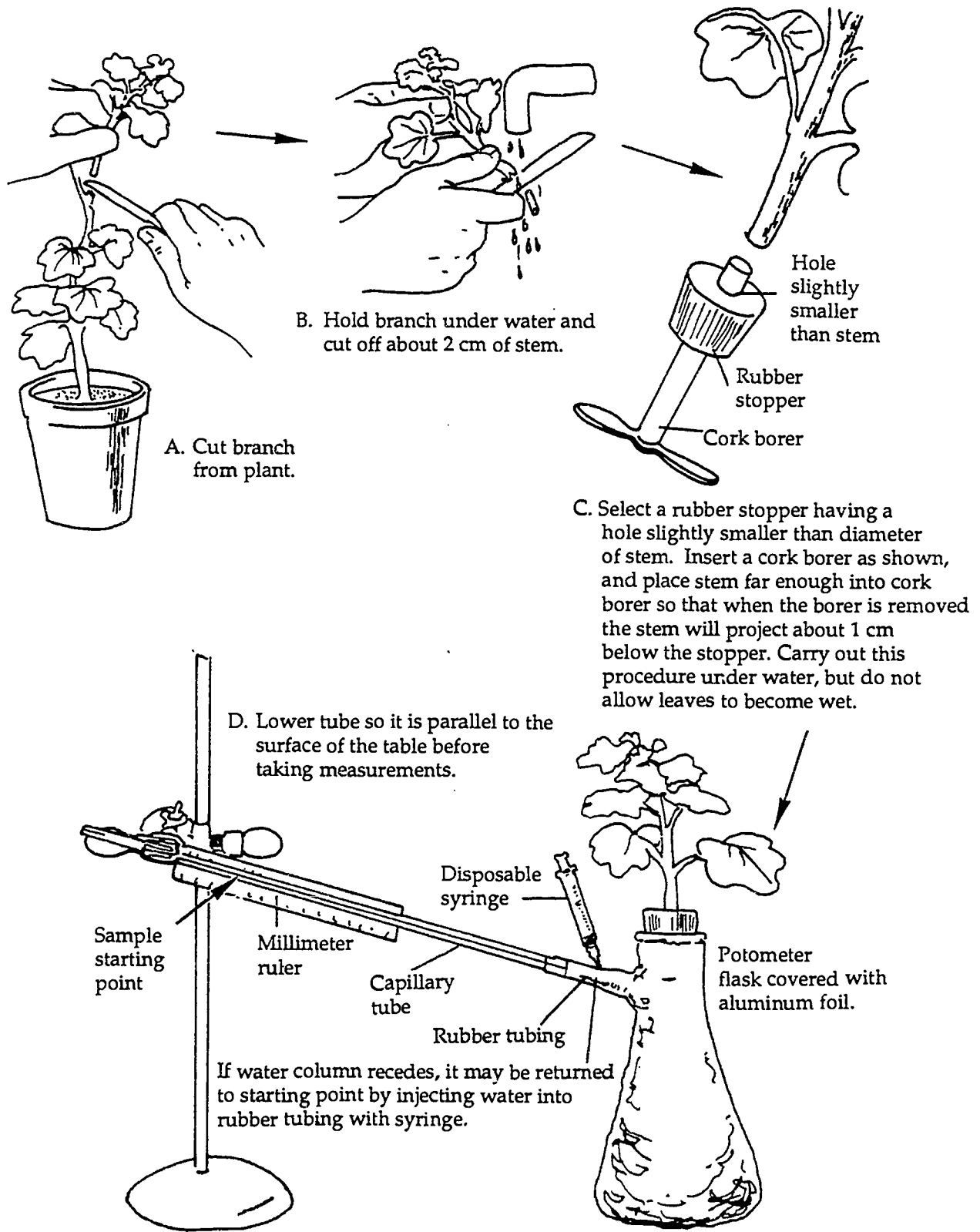
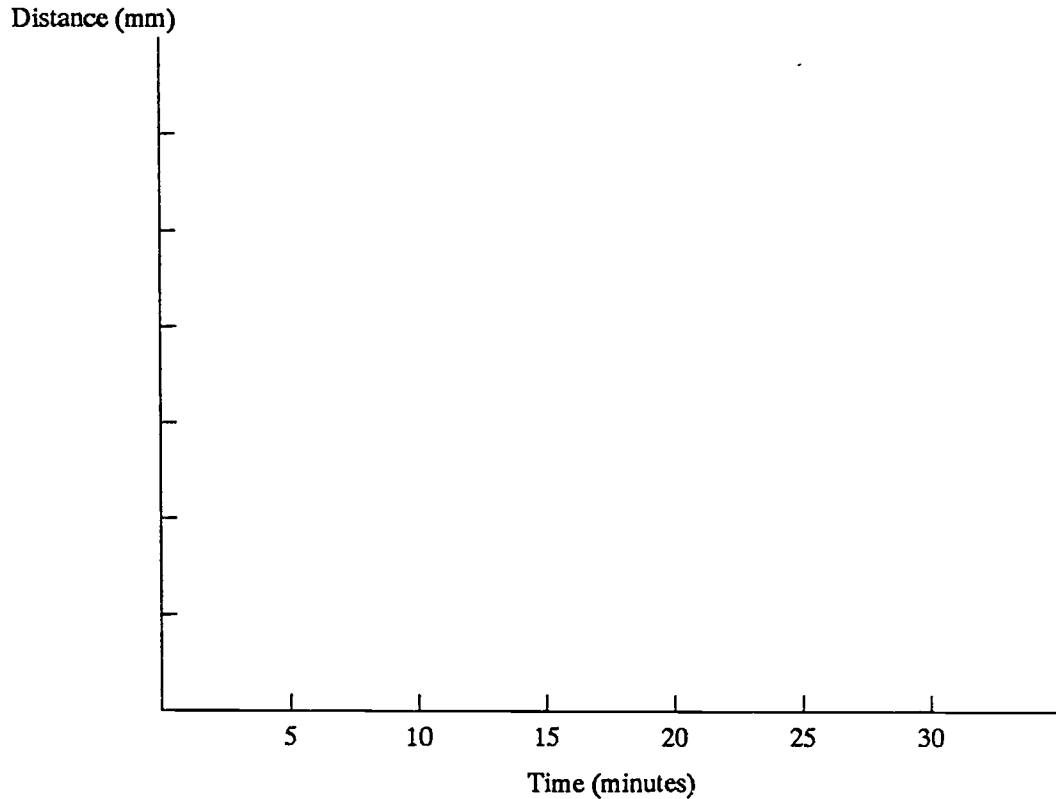

Table 1.
Effect of various environmental conditions on transpiration.

Time (minutes)										
Experimental conditions	1	2	3	4	5	6	7	8	9	10
Distance (mm)										
Control										
Light intensity										
Air movement										
Humidity										
Effect of leaves										

Figure 2.
Comparison of transpiration rates under various environmental conditions.



Taken from *An Experimental Approach to Biology*, 2nd ed., Abramoff, Peter and Thomson, R.G. (W.H. Freeman and Company), included in the October 1988 ICAE AgriScience Teacher Inservice Workshop directed by Dr. Edward W. Osborne.

CLUSTER: HORTICULTURE

UNIT: Horticultural Science and Production

PROBLEM AREA: Growing Ornamental Plants

RELATED PROBLEM AREAS:

1. Marketing Horticultural Products and Services
2. Advertising and Selling Horticultural Products
3. Operating the Horticultural Business
4. Propagating Plants
5. Understanding Plant Germination, Growth, and Development
6. Classifying Horticultural Plants
7. Understanding Plant Anatomy and Physiology
8. Controlling Plant Pests
9. Enhancing Soil Fertility
10. Developing Growing Media
11. Growing Plants Hydroponically
12. Designing, Building, and Maintaining Horticultural Structures

PREREQUISITE PROBLEM AREA(S):

1. Propagating Plants
2. Understanding Plant Germination, Growth, and Development
3. Classifying Horticultural Plants
4. Understanding Plant Anatomy and Physiology
5. Controlling Plant Pests
6. Enhancing Soil Fertility
7. Developing Growing Media

LEVEL: Preparatory

OCCUPATIONAL TASKS ADDRESSED:

Horticulture Cluster

Duty A: Propagating Plants, Seeds, and Cuttings

1. Monitor plant stock
2. Prepare plants and cuttings for propagation
3. Take cuttings
4. Transplant cuttings

Duty B: Preparing Soils and Planting Media

1. Mix media materials
2. Mix fertilizer into media
3. Prepare seedbed
4. Level or smooth planting area
5. Mark off location of beds

Duty C: Controlling the Plant Environment

1. Control light requirements by using shade cloth
2. Control temperature by setting thermostat
3. Cultivate plants
4. Water plants and nursery stock
5. Apply mulches
6. Control pests
7. Treat diseased plants, bulbs, and corms
8. Remove diseased plants
9. Set time clock for automatic mist propagation system
10. Aerate compacted soil
11. Pinch and disbud flowering plants
12. Force potted plants to bloom at seasonal times
13. Condition flowers and plants
14. Thin nursery stock
15. Force bulbs

Duty D: Applying Fertilizer and Chemicals

1. Calculate fertilizer and chemical applications
2. Formulate fertilizer
3. Collect soil sample for fertility test
4. Test soil
5. Make fertilizer and lime recommendations
6. Identify chemical injury of plants
7. Mix chemicals
8. Time chemical applications
9. Apply fertilizer using watering system
10. Apply fertilizer using liquid applicator

Duty E: Harvesting Plants

1. Dig bulbs and corms
2. Remove saleable plants from beds
3. Grade plants

STATE GOALS FOR LEARNING

In planning the instruction for this problem area, teachers can promote the development of several student learning objectives which are related to the State Goals for Learning in Biological and Physical Sciences and Social Sciences. These objectives are listed on the Learning Assessment Plan forms included on the following page(s). Those learning objectives marked with an asterisk (*) are taken from the sample lists provided by the Illinois State Board of Education.

**Illinois Agricultural Core Curriculum**

Agricultural Education 124 Mumford Hall 1301 W. Gregory Drive University of Illinois Urbana, IL 61801

Director: Dale A. Law, Ed.D.

Principal Investigator: Jerry D. Pepple, Ed.D

Research Assistant: Ronald J. Biondo

89/90

101

Illinois Agricultural Core Curriculum Rev.

Horticulture
Horticultural Science and Production

ILLINOIS STATE BOARD OF EDUCATION
 Department of School Improvement Services
 100 North First Street
 Springfield, Illinois 62777-0001

LEARNING ASSESSMENT PLAN

Instructions and codes for this form are provided on a separate sheet.

(Affix label or complete district information.)

COUNTY	DISTRICT	ESC
District Name		
City		

Contact Person: _____
 Title: _____
 Phone: () _____

III. LEARNING OBJECTIVES	IV. ASSESSMENT				V. EXPECTATIONS	
	A Types	B Validity/ Reliability	C Commercial Test(s)	D Evidence of Nondiscrimination	Percent of Students Expected to Achieve Objective	
By the end of grade (circle one) 11 students should be able to:						
*1. Know the principal environmental factors that limit the distribution of plants and animals.						
*2. Recognize that one population of organisms can affect another.						
*3. Compare living organisms by applying a classification scheme.						
4. Identify the major ornamental plants.						
5. Identify the supplies and equipment used in growing ornamental plants.						
6. Describe the growing requirements for the major greenhouse crops.						
						100

102

INSTRUCTOR'S GUIDE**CLUSTER: HORTICULTURE****UNIT: Horticultural Science and Production****PROBLEM AREA:** Growing Ornamental Plants**STUDENT LEARNING OBJECTIVES**

Upon completion of their study of this problem area, students will be able to:

1. Identify the major ornamental plants.
2. Identify the supplies and equipment used in growing ornamental plants.
3. Schedule ornamental plants in the greenhouse.
4. Describe the growing requirements for the major greenhouse crops.

INSTRUCTOR'S NOTES AND REFERENCES

200

INSTRUCTOR'S GUIDE**CLUSTER: HORTICULTURE****UNIT: Horticultural Science and Production****PROBLEM AREA:** Growing Ornamental Plants**PROBLEMS AND QUESTIONS FOR STUDY**

1. What are the major flowering pot crops grown and marketed in Illinois?
2. Why do most greenhouse growers in Illinois produce potted plants rather than cut flowers?
3. Why are many greenhouse growers using soilless mixes instead of preparing media with soil?
4. What are the advantages of clay and plastic pots?
5. How does the use of soilless mix influence the grower's fertilizing and watering practices?
6. What is the advantage of "rolling benches" and limited aisle space?
7. Why do the professionals describe watering as the most important job in the greenhouse?
8. Define the following types of crops:
 - a. warm crop
 - b. cool crop
 - c. short-day crop
 - d. day-neutral crop
9. How can crop growing be scheduled to maintain a full greenhouse and to have crops ready before certain holidays?
10. How can proper spacing improve the quality of a crop?
11. What is photoperiodism?
12. What must be done to get short-day crops to initiate flower buds when days are long?
13. How does temperature affect flower bud development?
14. What different cultural practices must be followed to produce saleable poinsettias, chrysanthemums, Easter lilies, African violets, and bedding plants?
15. What pests become a problem in the greenhouse?
16. How can greenhouse pests be controlled safely?
17. When should bedding plant seeds be planted?

INSTRUCTOR'S NOTES AND REFERENCES

201

INSTRUCTOR'S GUIDE**CLUSTER: HORTICULTURE****UNIT: Horticultural Science and Production****PROBLEM AREA:** Growing Ornamental Plants**SUGGESTED TEACHING ACTIVITIES AND PROCEDURES****INSTRUCTOR'S NOTES AND REFERENCES**

1. Display the various pots, soil, fertilizer, and other supplies to be used in the greenhouse. Discuss the values of each, then administer a practical exam on the items covered.
2. At an appropriate time in the instruction, distribute copies of Information Sheets #1 - #4 along with the related student worksheet.
3. Emphasize "learning by doing" by actually growing crops in the school greenhouse. If the school lacks a greenhouse, try to grow a crop of African violets under lights.
4. Discuss Information Sheet #7 with the students. Work through some problems and apply the knowledge gained in the school greenhouse.
5. Invite an extension service advisor or a greenhouse grower to the school as a guest speaker.
6. Use the transparency masters in this problem area to help explain certain topics.
7. Determine how the greenhouse can be kept full year-round by scheduling major greenhouse crops.

INSTRUCTOR'S GUIDE**CLUSTER: HORTICULTURE****UNIT: Horticultural Science and Production****PROBLEM AREA:** Growing Ornamental Plants**REFERENCES**

- *1. *Ball Redbook*. (1985). Ball, Vic. (ed.). Reston Publishing Company, Inc., Prentice Hall, 200 Old Tappan Road, Old Tappan, NJ 07675. (800) 223-2348.
2. *Greenhouse Operation and Management*. Nelson, Paul V. Reston Publishing Company, Inc., Prentice Hall, 200 Old Tappan Road, Old Tappan, NJ 07675. (800) 223-2348.
- *3. *Bedding Plants III*. Mastalerz, John W. (ed.). Pennsylvania Flower Growers, 103 Tyson Building, University Park, PA 16802.
- *4. *Holland Bulb Forcer's Guide*. Netherlands Flower-Bulb Institute, 5 World Trade Center, Suite 6217, New York, NY 10048.
5. *Greenhouse Management for Flower and Plant Production*. Nelson, K.S. Interstate Publishers, Inc., P.O. Box 50, Danville, IL 61834-0050.
6. *Ecke Poinsettia Manual*. Box 488, Encinitas, CA 92024.
7. *Commercial Flower Forcing*. Laurie, A., Kiplinger, D.C., Nelson, K.S. McGraw-Hill Book Co., 330 W. 42nd Street, New York, NY 10036.
8. *Plant Propagation Principles and Practices*. Hartmann, H.T., Kester, D.E.. Prentice Hall, Inc., 200 Old Tappan Road, Old Tappan, NJ 07675. (800) 223-2348.
9. *Taylor's Guide to Annuals*. Houghton Mifflin Company, 2 Park Street, Boston, MA 02108.
- *10. *Grower Talks Bookshelf & Grower Talks Magazine*. 1 N River Lane, Suite 206, Geneva, IL 60134. (708) 208-9080.
11. *Introduction to Floriculture*. Larson, Roy. Academic Press, Inc., 111 Fifth Avenue, New York, NY 10003.
- *12. *Working in Horticulture*. Richardson, W.B., Moore, G.E. Gregg Division, McGraw-Hill Book Co., 330 W. 42nd Street, New York, NY 10036.
- *13. *Introductory Horticulture*. Reiley, H.E., Shry, C.L., Jr. Delmar Publishers, 9518 Lambert Terrace, St. Louis, MO 63134. (314) 426-2945.

*Indicates highly recommended reference

INSTRUCTOR'S NOTES AND REFERENCES

INSTRUCTIONAL RESOURCES

These resources are intended for use by teachers in planning and teaching the materials for this problem area and may be adapted to fit the teaching method(s) used.

- INFORMATION SHEET #1 — Growing Poinsettias
- INFORMATION SHEET #2 — Growing Pot Chrysanthemums
- INFORMATION SHEET #3 — Growing African Violets
- INFORMATION SHEET #4 — Growing Easter Lilies
- INFORMATION SHEET #5 — The Timing of Easter Lilies by Leaf Counting
- INFORMATION SHEET #6 — Photoperiodism
- INFORMATION SHEET #7 — Computing Parts per Million
- INFORMATION SHEET #8 — Greenhouses, Supplies, and Plants
- TRANSPARENCY MASTER #1 — Pinching Chrysanthemums
- TRANSPARENCY MASTER #2 — Disbudding Chrysanthemums
- TRANSPARENCY MASTER #3 — Center Bud Removal of Chrysanthemums
- TRANSPARENCY MASTER #4 — Potting Lilies
- TRANSPARENCY MASTER #5 — Bulb Growth Cycle
- TRANSPARENCY MASTER #6 — Potting Tulips

INFORMATION SHEET #1

Growing Poinsettias

Poinsettias, with their showy red, white, or pink bracts seen everywhere during the holiday season, have their origin in Mexico. They were introduced to America by the U.S. ambassador to that country, Joel Poinsett. Shortly after 1900, the Ecke family started production of poinsettias as a cut flower in Southern California. At that time air transportation wasn't available so the cut flower could not be shipped quickly across country. To promote the crop, Ecke chose to produce and ship stock plants in small containers called 2 1/4s. The company still does this today.

The first poinsettias dropped their lower leaves creating a leggy appearance, and had small bracts that didn't hold their color. Over the years new production techniques and hybridization have resulted in much superior plants. Mist propagation has greatly improved the rooting of cuttings. The growth regulator Cycocel has been effective in keeping plants compact, and breeding programs have developed cultivars that are compact, long lasting and more colorful. The best poinsettia cultivars belong to the Annette Hegg family, the Gutbier family, the Mikkelson family or the Eckespoint family. The Annette Hegg family is especially good as a multiflowered pinched plant because it has a strong root system and it withstands abuse.

In growing poinsettias the most important practice is preparation of the greenhouse. Eliminate all weeds. Use mechanical methods or Roundup herbicide since it doesn't last in the soil or on wood. Don't use any other herbicide. If geraniums are near, spray the area with Daconil to control botrytis. Then, season the house by wetting down everything in the house 1-2 days prior to sticking cuttings.

Growers can buy stock plants, unrooted cuttings, rooted cuttings or callused cuttings. When starting with unrooted cuttings the grower should allow 3 - 4 weeks for rooting. The recommended procedure follows:

1. Take cuttings 3 - 4" long at the end of July (if working with stock plants, remove the cuttings in the early morning while they are turgid).
2. Dust the end of the cuttings in a rooting hormone and tap off excess powder.
3. Stick the cuttings into the medium or propagation cubes.
4. Place the cuttings under a mist system.

5. Provide continuous mist the first day. Adjust to 15-20 seconds every 3-5 minutes for the first week and ten seconds every hour at night.
6. When root initials form, cut mist back to 10 seconds every 10 minutes.
7. Provide 70-75°F temperature during this stage. Direct sticking of cuttings in finishing pots is okay for pinched plants but a large propagation area is required. Also, note that fertilization during the rooting process does not help. Use of a mist system permits higher light intensity which in turn helps plants produce more food for root production.

Once cuttings are sufficiently rooted (ideally near the end of August) pot them in 6- to 6 1/2-inch azalea pots. It is important that all pots have an equal amount of soil and that all the plants are planted at the same depth, with the soil about 1/2" below the lip of the pot. This helps in watering and in timing the entire crop for the sale date. Place the plant so that the upper surface of the propagation cube is just visible. Poinsettias are basal rooters. This means they will not develop roots along the stem. They also require well-drained or well-aerated soil with a pH from 5.0 to 6.5. Another reason to plant cuttings shallow is that the top few inches of soil have 20-30 percent more air than the lower soil. After potting drench with Lesan and Terrachlor (4 oz 75% wp/100 gallons water) fungicides to control root and stem rots.

Understanding that poinsettias are photoperiodic and thermoperiodic is critical to producing a successful crop. Being short-day plants they initiate flower buds as the days get shorter or when the nights last about 11 hours and 50 minutes. Initiation is also dependent on night temperatures of 62-64°F. Thus, the manipulation of temperatures and day lengths along with careful fertilizing key production. A schedule for growing a 6- to 6 1/2-inch multi-flowered poinsettia in soilless mix follows:

1. Late August (Vegetative stage) — Pot poinsettias in finishing pot. Drench with fungicide and begin fertilizing with 300 parts per million (ppm) nitrogen and potassium. Provide 68-70°F night temperatures and 70-80°F day temperatures. Light the plants from 10 p.m. until 2 a.m. to keep plants vegetative.

2. September 10 — Drench with Cycocel (1 part Cycocel to 40 parts water). Pinch to induce branching, leaving 4 to 6 leaves, and maintain high humidity to encourage breaks. Note that the longer the time between pinch and flower bud initiation, the bigger the plant. Raise fertilizer rate to 350 to 400 ppm nitrogen and potassium. Maintain 68-70°F night temperature.
3. September 20-25 (Flower bud initiation stage) — Turn lights off to give plants short days. Drop temperature to 62-64°F at night and 70-72°F during the day. Fertilize at a rate of 300-350 ppm nitrogen and potassium. Initiation occurs over a period of 8-10 days. After initiation growth stops, cells enlarge. Space plants 15 inches apart in 15-inch rows.
4. October 10 (Flower bud development stage) — Raise temperature to 64-66°F at night and 70-75°F during the day. Fertilize at 300 ppm nitrogen and potassium. Drench with Subdue (1 oz/100 gallons water) and Benlate or Banrot (4 oz/100 gallons water). Do not use Cycocel after October 15 as the bracts are developing.
5. November 15 (Finishing stage) — Drop temperature to 58-62°F at night. Reduce fertilizer to 200-300 ppm up until sale.

White fly is the main insect pest of poinsettias. Maintaining a clean, weed-free greenhouse and using regular applications of pesticides labeled for this pest will keep populations under control. Poinsettias are also very susceptible to a variety of fungal rots including pythium, rhizoctonia, and thielaviopsis. Well-timed fungicidal drenches will reduce losses. Lesan and Subdue control pythium, Terrachlor controls rhizoctonia, and Benlate and Banrot control thielaviopsis. Note that thielaviopsis can become a serious problem during cold, cloudy weather and when soil is poorly drained. Also, Terrachlor should not be used more than once during production of a crop unless transplanting is done.

Proper watering can reduce disease problems. Light waterings can result in a build-up of soluble salts that damage poinsettias. Too frequent watering places a plant under stress, making it susceptible to fungal infection. The rule of thumb is to let the soil become nearly dry before watering, then water heavily.

In preparation for sale, poinsettias can be carefully placed in paper sleeves. Plastic sleeves, if used, must have perforations to prevent a build-up of condensation and subsequent damage from botrytis. Avoid leaving the plants in the sleeves for an extended period of time as this may cause leaf drop. Store the plants in a lit room with temperatures 60-65°F. Keep the plants away from cold and warm drafts. Do not let the plants sit in water or, in the other extreme, dry out. Do not leave plants in a cold car for an extended period of time — they will freeze!

INFORMATION SHEET #2

Growing Pot Chrysanthemums

Chrysanthemums, commonly called mums, are the most popular flowering pot plant in the United States. Mums have a long shelf life, bright-colored flowers and a variety of flower types. Since the 1940s chrysanthemums have been produced on a year-round basis. Before then they were available only during the fall.

The key to the year-round production of chrysanthemums is the understanding that they are photoperiodic and thermoperiodic. Mums are classified as short-day plants because they will flower naturally as days get shorter (mid-August to late September) or around the time daylight lasts 12 hours and night 12 hours. Over the years, extensive breeding programs have produced a large number of varieties that can be categorized based on the number of weeks it takes for them to flower once short days are given. Three main response groups are 7-8 week varieties, also called garden mums, 9-11 week varieties which flower in October, and 12-14 week varieties which flower in November. A ten-week variety will flower ten weeks from the time it receives short days. Initiation of flowering will be delayed by turning on the greenhouse lights, shining automobile headlights into the greenhouse, and allowing parking lot lights to illuminate the greenhouse. By controlling the day lengths and the temperature, greenhouse growers can produce any mum variety at any time of the year.

The production process can be broken down into four main growing periods:

1. The vegetative or starting climate.
2. The period of flower bud initiation.
3. The period of flower bud development.
4. The flowering stage.

Each period has different requirements in terms of day length, temperature, and fertilization.

The *vegetative stage* begins with the propagation of chrysanthemums by stem cuttings. Cuttings 2 1/2" to 3" in length with three leaves are snapped off the stock plant in the morning hours when the plants are turgid. The cuttings are dipped in rooting hormone and stuck in a propagation bench. Bottom heat of 70-75°F is provided. Mums are basal rooters, and they should develop sufficient roots in about 18 days. During the time they are kept in the bench they are lighted at night to prevent flower bud set.

Growers may purchase the cuttings for potting corresponding to their scheduled sale dates. About 70 percent of the mums are sold as rooted cuttings and 30 percent as unrooted cuttings. Upon receipt, the grower grades the cuttings according to the number of roots, stem thickness, and length. The idea is to pot similar-size cuttings in the same pot, resulting in a well-balanced pot plant. Following are the suggested number of cuttings per pot:

- 1 cutting in a 4 1/2-inch azalea pot
- 3-5 cuttings in 5-, 6-, or 6 1/2-inch azalea pots
- 6-7 cuttings in a 7-inch azalea pot
- 9-12 cuttings in an 8-inch azalea pot

When planting, the cuttings should be placed at about a 45 degree angle just over the lip of the pot in a well-drained soil. The medium should be 1/3 soil, 1/3 peat, 1/3 perlite, or a soilless mix with a pH of 6.0-6.5. Also, it is important to plant mums fairly shallow. Remember they are basal rooters. Be careful not to press the soil down over the roots as this will damage them. All the pots should be the same size, with the same variety, and the same amount of soil. This permits them to be grown as a unit.

Once potted, the mums should receive full sun, high humidity, and night temperatures of 65-68°F. When root growth is noted, apply high-nitrogen (250-350 ppm nitrogen) fertilizer. The goal of this stage is to obtain a healthy root system and lower leaf development, which will result in more breaks after pinching. Ensure long days to prevent flowering by lighting the crop from 10 p.m. until 2 a.m. Grow the mums for about 10-14 days or until the roots appear at the bottom of the pot before pinching.

Pinching is a process designed to encourage branching of a plant. More branching results in a fuller plant and a greater number of flowers. Three common methods of pinching are used:

1. Roll out pinch — removal of just the meristematic tip (be sure you've gotten the whole tip!); recommended for winter.
2. Soft pinch — removal of 1/2" to 3/4", leaving 5 or 6 leaves on the cutting.
3. Hard pinch — similar to a small cutting, leaving 3 or 4 leaves on the cutting; used in summer if cuttings are tall.

Watering chrysanthemums properly is critical for producing a successful crop. There are three basic watering practices used: subirrigation or pad watering, spaghetti tube or drip irrigation, and hand watering. Mums need a steady supply of water. If allowed to wilt badly, they will never totally recover. A good soil mix will permit the grower to water frequently without damage to the plants.

Growth regulators such as B-nine may be used to guarantee compact plants. Application of B-nine can be timed 7-18 days after the mums have been pinched or when about 2" of new growth has occurred. Used at a rate of .35 percent to .5 percent, B-nine should be sprayed on the leaves until it drips from the foliage. The mums should be well watered before application. Short varieties and 9-week varieties don't need B-nine.

The second stage is *flower bud initiation*, which is triggered by short-day treatments. Chrysanthemums may be tall, medium, or short varieties, and timing is different for each. Following is a general rule for each variety:

Tall varieties — Grow vegetative 1 week, give short days, grow another week, pinch.

Medium varieties — Grow vegetative 1-2 weeks, pinch, give short days.

Short varieties — Grow vegetative 2 weeks, pinch, grow 1 week, give short days.

Once short day treatment is given, drop the greenhouse night temperatures to 62-65°F and reduce fertilizer rates to 200 ppm nitrogen and potassium.

Shading is required if the goal is to have flower buds initiate between March 15 and September 15. The artificial darkness is necessary because the days are naturally long. Everyday black cloth is drawn over the crop from 7 p.m. until 8 a.m.

Final spacing of the pots can be done after the vegetative stage. Give each pot as much space as economically possible to maintain the lower leaves. Suggested spacing follows:

4" pot - 8" x 8"

5" pot - 11" x 11"

6" pot - 14" x 14"

7" pot - 18" x 18"

Flower bud development occurs after initiation. During this period, greenhouse temperatures should be dropped to 60-62°F at night. High temperatures at night will cause a delay of flowering. Also, maintain a constant feed program of 200-250 ppm nitrogen and potassium.

As the flower buds crack or begin to open, the plants are entering the flowering stage. Drop greenhouse temperatures to 55-58°F at night, continue fertilizing, and allow the soil to become nearly dry between waterings.

Disbudding or center bud removal is advised for some varieties to improve the display of flowers. Disbudding involves the removal of all side buds on a stem, leaving the terminal bud. Disbudding results in larger, well-spaced flowers. Center bud removal is common with daisy varieties, and only the terminal bud is removed. The outcome is more flowers per stem.

There are numerous insect and disease problems with chrysanthemums. Some common problems and their controls include:

Aphids	Metasystox, Pirimor
Leaf miners	Diazinon, Orthene, Metasystox
Cabbage loopers	Bacillus Thurengiensis
Mites	Pentac, Kelthane
White fly	Resmethrin, PT 1200, Thiodan 50 percent wp
Pythium	Lesan and Terrachlor
Rhizoctonia	Lesan and Terrachlor
Botrytis	Reduce humidity, induce air movement

203

INFORMATION SHEET #3

Growing African Violets

African violets were discovered in East Africa in 1896. They have become very popular as house plants in the United States since World War II and the advent of central heat. African violets come in a large number of varieties, they are compact, and they flower year-round. They are produced commercially for Valentine's Day, Easter, and Mother's Day.

African violets can be produced by seed or leaf petiole cuttings. Germination of seed occurs in about 25 days if kept at 70°F. When taking leaf petiole cuttings, choose the second-stage leaves which are still developing. Remove about 1" to 1 1/2" of the petiole with the leaf blade. A new plant will arise from vascular bundles with a total of 8-10 new plants developing from one leaf. Stick the cutting at an angle to a depth of about 1/2" into a sterile medium of peat, sand, perlite, styrofoam, or vermiculite. Rooting takes 2-3 weeks and plantlets are ready in another 3-4 weeks. Provide the cuttings with 70-75°F temperature, artificial light for 16-18 hours a day, and high humidity.

Plantlets are divided and transplanted to small containers called 2 1/4s for 6-8 weeks. Only one plantlet should be placed in a pot as single crown plants are the most desirable. The 2 1/4s can be transplanted to the finishing pot in a peat lite soilless mix or a medium with 2/3 peat moss and a pH of 6.0 to 6.5. When potting, it is very important to be careful not to cover the crown (base) of the plant because this may cause rot. A 4-, 4 1/2-, or 5-inch plastic azalea pot is recommended. Clay pots often have soluble salts accumulate on the rim; leaves resting on the rim are then damaged.

Watering African violets must be done with care. Water 10-15 degrees cooler than the air temperature applied from above will spot leaves. The cold water causes enzymes in the plant cells to coagulate and the cells to die. To avoid the spotting condition, water by capillary action. Simply place the pots on felt pads or sand and keep the felt or sand moist (do not move the pots as this breaks the water bridge). The moist pads also contribute to a high humidity around the plants. Never let the soil dry completely because the roots are very fine and are easily damaged.

Provide African violets with 1000-2000 foot-candles of light. Light of less than 1000 foot-candles results in vegetative growth only. Light of greater than 2000 foot-candles will induce flowering to occur when the plants are small.

Other cultural requirements include fertilizing and temperature. Fertilize about 100-150 parts per million (ppm) nitrogen and potassium every watering. Lower the rate if the light intensity is less than the desired amount.

Growers can purchase 2 1/4s, place them in a finishing pot and have the plants ready in 12-14 weeks for Valentine's Day and 8-10 weeks for Mother's Day. The plants sold should display a full head of flowers held above the foliage. The foliage should be blemish-free and symmetrical.

Major pests of African violets include mealy bugs, spider mites, cyclamen mites, fungus gnats, and flower thrips. Mealy bugs and fungus gnats can be controlled with a systemic insecticide. Mites are best controlled with Kelthane or Pentac, and Orthene is recommended for use on flower thrips.

200

INFORMATION SHEET #4

Growing Easter Lilies

Not surprisingly, Easter lilies are grown for Easter. They are produced in the United States and Canada as pot plants, and in Europe they are grown year-round for use as a cut flower. Bulbs are grown in sandy soil along the California and Oregon coasts under cool, wet conditions. They are dug and shipped throughout the United States in the fall. Today anywhere from 8 to 10 million bulbs are produced a year.

The two most commonly grown Easter lily varieties are "Ace" and "Nellie White." Both have large white flowers, but Nellie White is shorter, has larger leaves, and is easier to force.

Lilies are propagated by bulbets or scalettes. Bulbets are small bulbs which form along the stem underground. They are 1/2" to 3/4" in diameter. Scalettes form on bulb scales. The scales are planted in September, and the following September scalettes 1" to 2" in diameter are dug. The large ones are replanted. A year later they are 4" to 6" in circumference and called a yearling. They too are dug, graded, and replanted. The next year bulbs 7" to 10" in circumference are dug and sold. The third and last year in the ground is the most important in terms of the number of flower buds. Approximately half the lilies are grown from scalettes and half from bulbets.

As with other greenhouse crops, production of lilies hinges on correct timing. Unlike other crops though, the sale date changes every year. Easter is always the first Sunday after the full moon following March 21st. The latest Easter can be is April 20th. The varying dates make Easter lilies a very difficult crop.

Easter lilies must go through a vernalization (cold) period to properly initiate flowers. Typically, they require 6 weeks or 1000 hours at 40-45°F to simulate winter before taken to the greenhouse. Precooling is a term used to describe a cold-moist treatment prior to planting which induces rapid stem elongation and flowering. Natural cooled, controlled temperature forced, case cooled by the broker, and case cooled by the forcer are four methods of cooling. A short description of each follows:

Natural cooled — Nonprecooled bulbs are potted upon arrival at the grower's facility and grown under cool natural conditions, usually in a coldframe before entering the greenhouse.

Controlled temperature forced — The grower pots nonprecooled bulbs in October and roots them for 1-2 weeks at 50°F, then places them in a cooler. This results in longer lower leaves and more flowers than other methods.

Case cooled by the broker — Bulbs are cooled while in the packing case in large stacks before being shipped to the grower.

Case cooled by the forcer — In this method bulbs are kept in the packing case upon arrival from the broker and undergo the vernalization period in a cooler prior to potting.

The potting procedure should be preceded by a miticide dip. Bulb mites are quite common, but they can be controlled by soaking the bulbs in a Kelthane treatment for about 2 hours.

Just about any well-drained soil is conducive for potting lilies. One exception involves the use of perlite which contains fluorides. The fluorides may cause leaf tip burn so a substitute soil amendment such as styrofoam is advised. Dolomitic lime can be added to the soil mix to raise the pH to the desired 7.0. Six-inch standard pots are most commonly used for lilies.

When planting, place the bulb near the bottom of the pot so that approximately 2" of soil covers the bulb. It is important that the bulb is level. If it is on an angle, the shoot may sprout along the side of the pot. Also it should be noted that desirable roots will develop along the stem. Bottom roots often die as the stem roots develop but this doesn't present a problem as long as the stem roots are healthy.

Temperature plays an important role in getting lilies to flower on time. It takes 100-120 days to force lilies in the greenhouse. Flowering should begin 8 days before Easter. Bulbs case cooled by the broker should be potted, then receive 1-2 weeks of 50-60°F night temperatures before forcing. Recommended forcing temperatures vary with Easter:

- If Easter is early — 63-65°F nights
- If Easter is middle — 62°F nights
- If Easter is late — 60°F nights

Temperatures can be adjusted to speed up or slow down development.

Lighting can also influence lily growth. Although lilies will flower under short-day conditions, they develop faster during long days. They should receive full sun as this produces a shorter plant. Other lighting considerations follow:

1. Light the lilies for 10-14 days (10 p.m. to 2 a.m.) if they are slow to emerge. This type of lighting can make up for insufficient cooling (1 night light = 1 day cooling).
2. Plants 4 to 6 weeks into their development can be forced more quickly by lighting for 4 hours at night. This amounts to giving them the same day length they would receive naturally. The growth retardant Arest should be applied at the same time to reduce stretching.
3. Towards the end of forcing, lighting may be used (as a last resort) to speed the growth along.

Humidity within the greenhouse is another important factor. In general, the higher the humidity, the taller the lily and the larger the leaves. Dryness causes the lower leaves to drop.

Maintaining a humid greenhouse reduces the frequency of watering. When lilies are first planted, they should be watered sparingly. In addition, root rots will become a problem if the soil is kept too wet. Fertilize at a rate of 350-400 ppm nitrogen with a 16-18-20 fertilizer if the lilies are being grown in soilless mix. 300 ppm is sufficient if a soil

mix is being used. Fertilizer will improve the color of the plant and help the development. Drop the rate to 200-250 ppm once flower buds begin to develop. Interestingly, more fertilizer results in a shorter lily. The reason is the sugars produced are used in leaf development rather than stem development.

Occasionally a growth regulator, Arest, is needed to reduce the size of the lilies. It should be applied 2-3 weeks prior to the appearance of the flower buds or when the plants are 6-8" tall. Applications any later may result in stunted flowers or a deformed plant. The recommended spray rate is 20-30 ppm with 10-15 ppm one week and another 10-15 ppm a week later.

Easter lilies have several pest and disease problems. Rhizoctonia and pythium rots seem the most damaging. A Lesan drench for rhizoctonia at planting and a Terrachlor drench for pythium at the second watering are suggested. Aside from bulb mites, fungus gnats can be a problem. Allowing the soil to dry as a means of control is not recommended because the plants will suffer. Instead drench with a Diazinon wettable powder.

If the lily flower buds are not visible 2 to 3 weeks prior to sale, several things can be done. Raise the temperature to 70-75°F at night and 85°F during the day, light them for 4 to 6 hours, and maintain high humidity. A plastic tent over the lilies can produce the warm, humid climate needed. However, these measures or temperatures over 100°F can cause the abortion of small flower buds.

INFORMATION SHEET #5

The Timing of Easter Lilies by Leaf Counting*

Flower initiation in the Easter lily, *Lilium longiflorum*, does not occur until the previously cooled bulbs have been placed in the greenhouse and shoots have emerged to a height of 4 to 6 inches. Assuming that you are following one of the programming phases of either the natural-cooling method, controlled temperature forcing (CTF), the home case-cooled method, or the commercial case-cooled system, flower initiation takes place between Jan. 20-29. At this time the apical meristem changes from making leaves to forming floral parts.

The number of leaves present at the time of floral initiation can vary each season. Environmental factors perceived by the Easter lily in this bulb production field, as well as cultivar differences, affect this number. Therefore, the number of leaves to be unfolded to obtain visible bud (30 days before Palm Sunday) in 1991 probably differed from the number present in 1990 and will differ from the number in 1992.

Easter falls on different dates each year. This means the length of the greenhouse phase of forcing Easter lilies varies each season. Consequently, with either an early or a late Easter there can be either a small or large number of leaves that must be unfolded within a defined time period.

There are four dates of importance in the production of Easter lilies: (a) programmed bulbs should be placed into the forcing phase in late December; (b) 30 days before Palm Sunday the first visible buds must be present; (c) on Palm Sunday the first open flower on each plant should appear; and (d) by Easter Sunday there should be few if any remaining Easter lilies in your greenhouse. To meet this final date, it is important for you to know how many leaves are present after floral initiation and the rate at which they must be unfolded.

The leaf counting technique and time schedule method of forcing Easter lilies was developed by Dr. H. F. Wilkins in the Department of Horticulture at the University of Minnesota. This concept accounts for both the different number of days in the greenhouse phase and leaf number experienced each season.

In summary, the total number of leaves to be unfolded by the visible bud date in the greenhouse phase is determined after floral initiation, the number of days to visible bud is calculated, and finally, the weekly unfolding rate of leaves to meet this goal is determined. The procedure is as follows:

1. Record the average date of shoot emergence.
2. When the plants are 4-5 inches tall (Jan. 29), flower buds should be present. At this time, cut off 10 random shoots at soil level for every 2,000 bulbs from each clone and bulb source.
3. Take these shoots to a well-lighted area, count, record, and average the total number of leaves per sample lot. A large needle and magnifying lens (reading glass) will help you remove small, scale-like leaves near the growing point. The embryo-like flower buds should be present.
4. Randomly select and mark 10 average plants in the greenhouse that will correspond to individual sample lots whose total leaf counts were just determined. Count and average the number of leaves that have unfolded to a 45-degree angle on these plants. A bamboo stake with a paper label wired to it will help in marking these plants and in recording weekly individual leaf data.
5. On a routine, weekly basis count and record the number of leaves unfolded to a 45-degree angle from the stem. The last individual leaf counted can be marked weekly with a paper-punch hole to avoid repetitious counting. Then, only unfolded leaves above the most recently marked leaf need to be counted each week.
6. Subtract the average number of leaves that have unfolded from the predicted average leaf total. This will tell you how many leaves are yet to be unfolded.
7. Divide the number of leaves already unfolded by the number of days from emergence until the present date. This will tell you how many leaves have been unfolding each day.
8. Determine the visible bud date. This is 30 to 35 days before Palm Sunday. It takes at least 30 days to develop an open flower from the time first buds are seen.
9. Divide the number of leaves left unfolded by the number of days left from the date of counting to 30 days before Palm Sunday (visible bud date). This figure tells how many leaves you must unfold each day to make the estimated visible bud date.

10. Each week count, record, and determine the average number of leaves unfolded daily the previous week. Compare the data and determine if the leaf number was greater or smaller than the number required to keep the crop on time.
11. If the crop is developing off-schedule, the greenhouse temperatures should be increased or decreased appropriately to attain the desired rate of leaf unfolding.

*The above article by Mr. Stimart is from *The Maryland Florist*, Nov. 1979.

INFORMATION SHEET #6

Photoperiodism
(period of light)

Definition: The effect of the amount of light per day on the growth of plants.

Plants can be classified into 3 groups:

1. short-day plants
2. long-day plants
3. day-neutral plants

Shortening the Day: To obtain the short-day effect, the night period must be uninterrupted; a short-day plant could also be called a long-night plant.

A short-day plant must have 12-14 hours of uninterrupted darkness in order to produce flower buds.

Lights in the immediate area outside the greenhouse may interrupt the night period. Black sateen cloth or heavy black plastic can be used to insure total darkness. The amount of light given off from a flashlight is strong enough to interrupt the night period.

(Examples of short-day plants: chrysanthemums, poinsettias, kalanchoe)

Lengthening the Day: Provides a long day for promoting the flowering of long-day plants or maintaining the vegetative growth of short-day plants.

Some long-day plants can be matured earlier if they are lighted. Calceolarias and many annuals will flower earlier if lighted.

To prevent bud formation in short-day plants and encourage vegetative growth, short-day plants must be lighted. The number of lighted days depends on the crop.

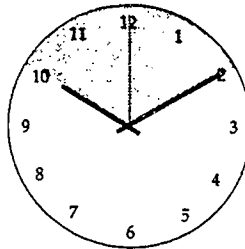

(Examples of long-day plants: lettuce, radishes, petunia)

Day-Neutral Plants: Plants will flower regardless of the day length. No beneficial effects will be seen either from using supplemental light or shortening the day.

(Examples of day-neutral plants: tomato, African violet)

INFORMATION SHEET #7

Computing Parts Per Million (ppm)

Soluble fertilizers are commonly used today in the greenhouse industry because it is easy to adjust the rate of application. There is a simple method to determine ppm. First, 1 ounce of anything in 100 gallons of water is 75 ppm. Multiply the percent of the element in any given fertilizer by 75 to get the ppm of 1 ounce fertilizer in 100 gallons of water.

Example: A 20-20-20 fertilizer contains 20% nitrogen. Multiply 20% by 75 to get 15 ppm from 1 ounce of fertilizer in 100 gallons. To get 300 ppm solution, merely divide 300 by 15. The answer is 20 ounces in 100 gallons.

Sample problem #1: A hozon proportioner delivers fertilizer solution at a rate of 1:15. You have a 5-gallon bucket of concentrate. You need to apply 150 ppm nitrogen. You have a 15-16-17 peat lite-soluble fertilizer. How much fertilizer do you place in the bucket?

$15\% \text{ N} \times 75 = 11.25 \text{ ppm N 1 ounce/100 gallons}$
 $5 \text{ gallons} \times 15 = 75 \text{ gallons/5 gallon fertilizer concentrate}$
 $150 \text{ ppm wanted} + 11.25 \text{ ppm N} = 13.33 \text{ ounces/100 gallons}$
 $13.33 \text{ ounces} \times .75 = 10 \text{ ounces/75 gallons solution}$
 $10 \text{ ounces/5 gallons}$

Sample problem #2: If you put 2 ounces 20-20-20 in 10 gallons of water, how many ppm nitrogen and potassium do you have in the solution?

$20\% \text{ (or } .20) \times 75 = 15.0 \text{ ppm N and K 1 ounce/100 gallons}$
 $15 \times 10 = 150 \text{ ppm 1 ounce in 10 gallons}$
 $2 \text{ ounces} \times 150 \text{ ppm} = 300 \text{ ppm N and K}$

Sample problem #3: You have an injector which delivers 1:100 with a 30-gallon concentrate tank. You need 200 ppm nitrogen and potassium. You choose to use a 15-10-15 fertilizer.

$15 \times 75 = 11.25 \text{ ppm 1 ounce/100 gallons}$
 $200 \text{ ppm} + 11.25 = 17.77 \text{ ounces/100 gallons}$
 $17.77 \times 30 = 533 \text{ ounces 15-10-15 fertilizer needed}$

Note that the Ball Red Book has tables for determining fertilizer rates.

INFORMATION SHEET #8

Greenhouses, Supplies, and Plants

1. National Greenhouse Company, P.O. Box 100, Pana, IL 62557.
2. AM Leonard Horticultural Tools and Supplies, 6665 Spiker Road, Piqua, OH 45356.
3. Stuppy Greenhouse Supply Catalog. 1212 Clay Street, North Kansas City, MO 64116. (800) 821-2132.
4. Florist Products, Inc., 2242 N. Palmer Drive, Schaumburg, IL 60173. (708) 885-2242.
5. Lord and Burnham, Division Burnham Corp., Irvington-on-Hudson, NY 10533.
6. Midwest Trading, Horticultural Supplies, Equipment, and Tools, P.O. Box 384, St. Charles, IL 60174. (708) 742-1840.
7. Ball Seed Catalog. Ball Seed Co., Box 335, West Chicago, IL 60185. (708) 231-3500.
8. Park Seed, Flower and Vegetable Catalog. Geo. W. Park Seed Co., Inc., Cokesbury Road, Greenwood, SC 29647. (800) 845-3366.
9. Wayside Gardens Catalog. Wayside Gardens, Garden Lane, Hodges, SC 29695. (803) 374-3387.
10. Vaughan's Flower and Vegetable Seed Catalog. Vaughan's Seed Company, 5300 Katrine Avenue, Downers Grove, IL 60515. (708) 969-6300.
11. Peters Fertilizers Sales Manual. Peters Fertilizer Manual, W. R. Grace and Co., Iron Run Industrial Park, Fogelsville, PA 18051. (215) 395-7105.
12. Northrup King Co., Horticultural Supplies Department, Bedding Plant Seeds/Grower Supplies, 1500 Jackson Street NE, Minneapolis, MN 55413.
13. Burgess Seed and Plant Co, 904 Four Seasons Road, Bloomington, IL 61701.
14. Germania Seed Company, 5952 N. Milwaukee Avenue, Chicago, IL 60646. (312) 631-6631.
15. Ron Clesen's Ornamental Plants, Inc., 45W464 Ramm Road, Maple Park, IL 60151-8665. (708) 365-6244.
16. Fison's Western Corp., 1100 31st Street, Suite 120, Downers Grove, IL 60515. (Soiless Mixes) (708) 468-7472.
17. ABG International, P.O. Box 1490, Lincolnshire, IL 60069. (Greenhouses) (708) 634-3131.
18. JM Trading Corporation, 241 Frontage Road, Suite 47, Burr Ridge, IL 60521. (800) 323-7638.
19. Arnold J. Kiehm Grower, Inc., 44W637 Route 72, Hampshire, IL 60140. (708) 683-4761.
20. Nexus Greenhouse Corporation, 10983 Leroy Drive, Northglenn, CO 80233. (303) 457-9199.
21. Pan American Seed Company, P.O. Box 438, West Chicago, IL 60185. (708) 231-1400.
22. Plant Marvel Laboratories, Inc., 371 East 16th Street, Chicago Heights, IL 60411 (Fertilizers) (708) 757-7500.
23. Shady Hills Gardens, 821 Walnut Street, Batavia, IL 60510. (708) 879-5665.
24. Strong-Lite Products, P.O. Box 140, Shipyard Road, Seneca, IL 61360. (815) 357-6001.
25. Suburban Plastics Company, 340 Renner Drive, Elgin, IL 60123. (708) 741-4900.
26. Midwest Gromaster, P.O. Box 1006, St. Charles, IL 60174. (Fertilization, Irrigation, and Climate Systems) (708) 888-3558.
27. Midwest Growers Supply, Inc., 2613 Kaneville Road, Geneva, IL 60134. (708) 232-8800.

TRANSPARENCY MASTER #1

Pinching Chrysanthemums

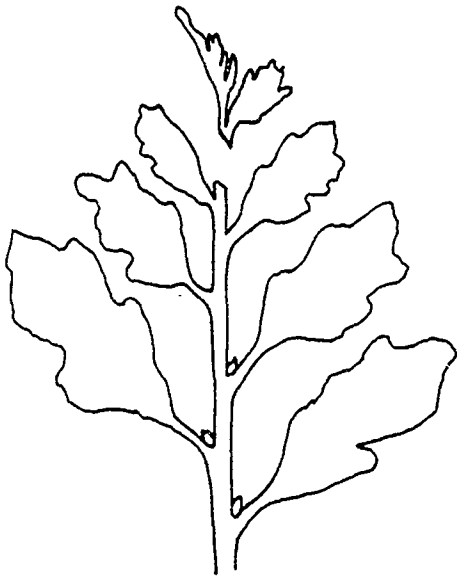

Roll out pinch — remove just the meristematic tip

Soft pinch — remove 1/2 - 3/4" leaving 5 - 6 leaves

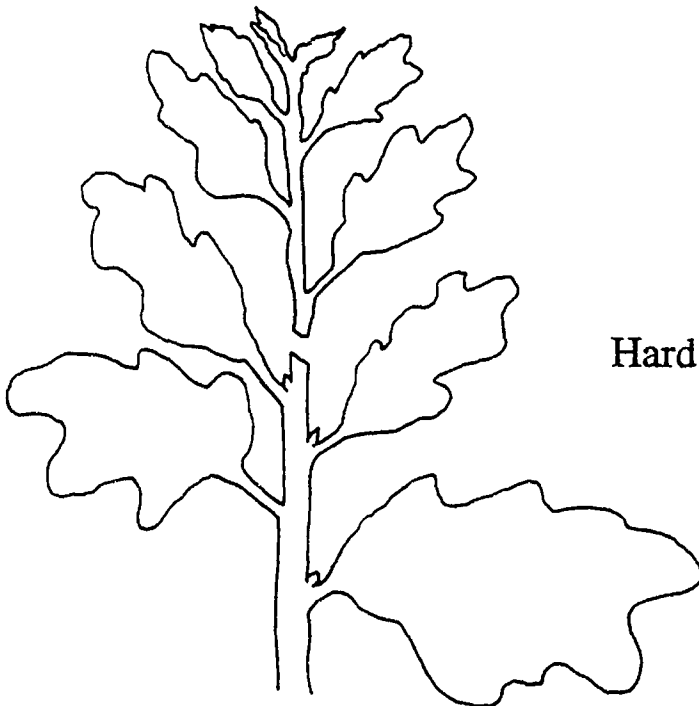
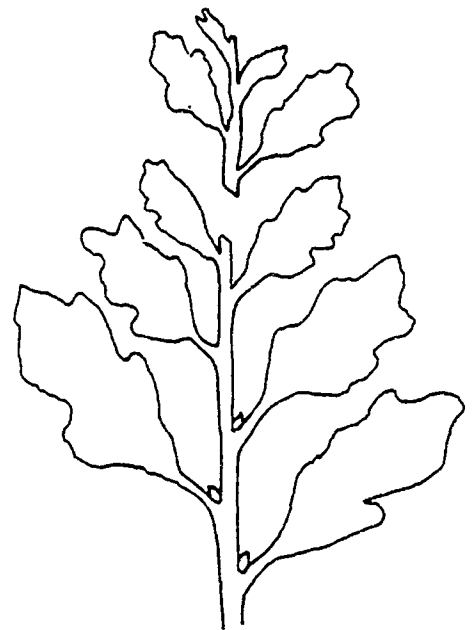

Hard pinch — remove all but 3 - 4 leaves

TRANSPARENCY MASTER #2

Disbudding Chrysanthemums

Leave the
terminal bud.

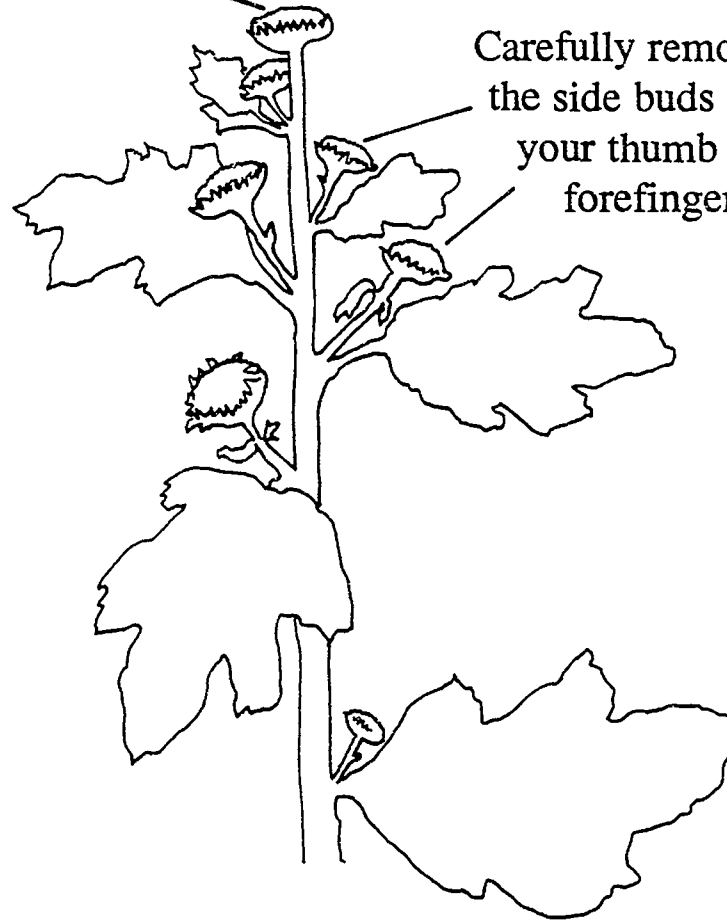

Carefully remove all
the side buds using
your thumb and
forefinger.

All the plant's energy will be concentrated on the development
of the remaining terminal bud.

TRANSPARENCY MASTER #3

Center Bud Removal of Chrysanthemums

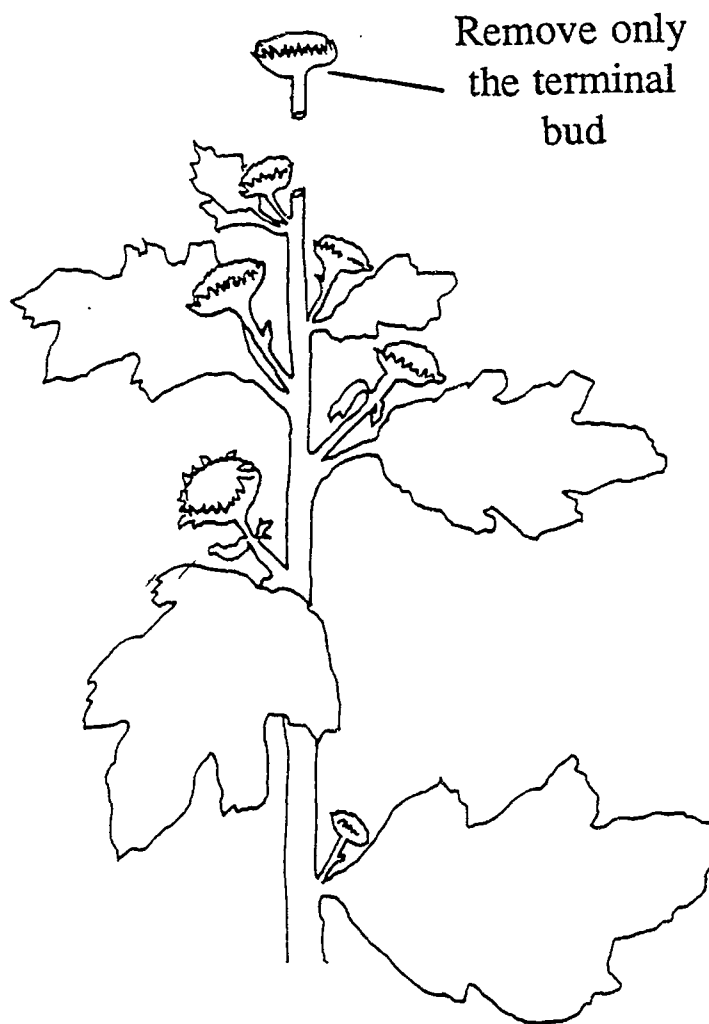

This encourages the development of auxiliary buds.

210

TRANSPARENCY MASTER #4

Potting Lilies

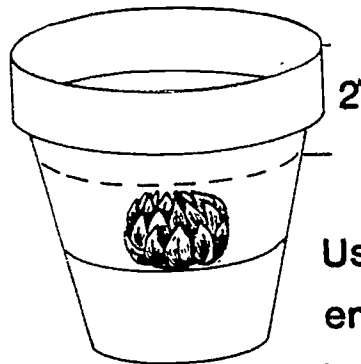
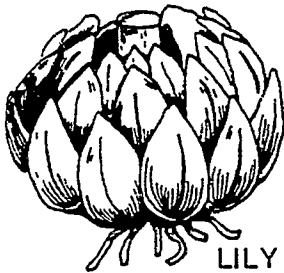

Use a standard pot. Fill with enough soil so the nose of the bulb is about 2" below the rim.

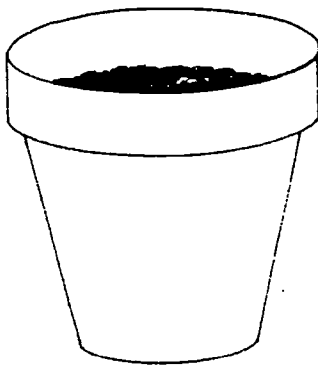

Fill with soil, firm the soil, and water.

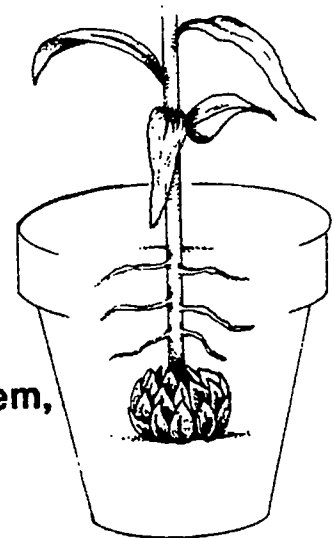

Roots develop along the stem, which anchor the plant and absorb nutrients.

220

TRANSPARENCY MASTER #5

Bulb Growth Cycle

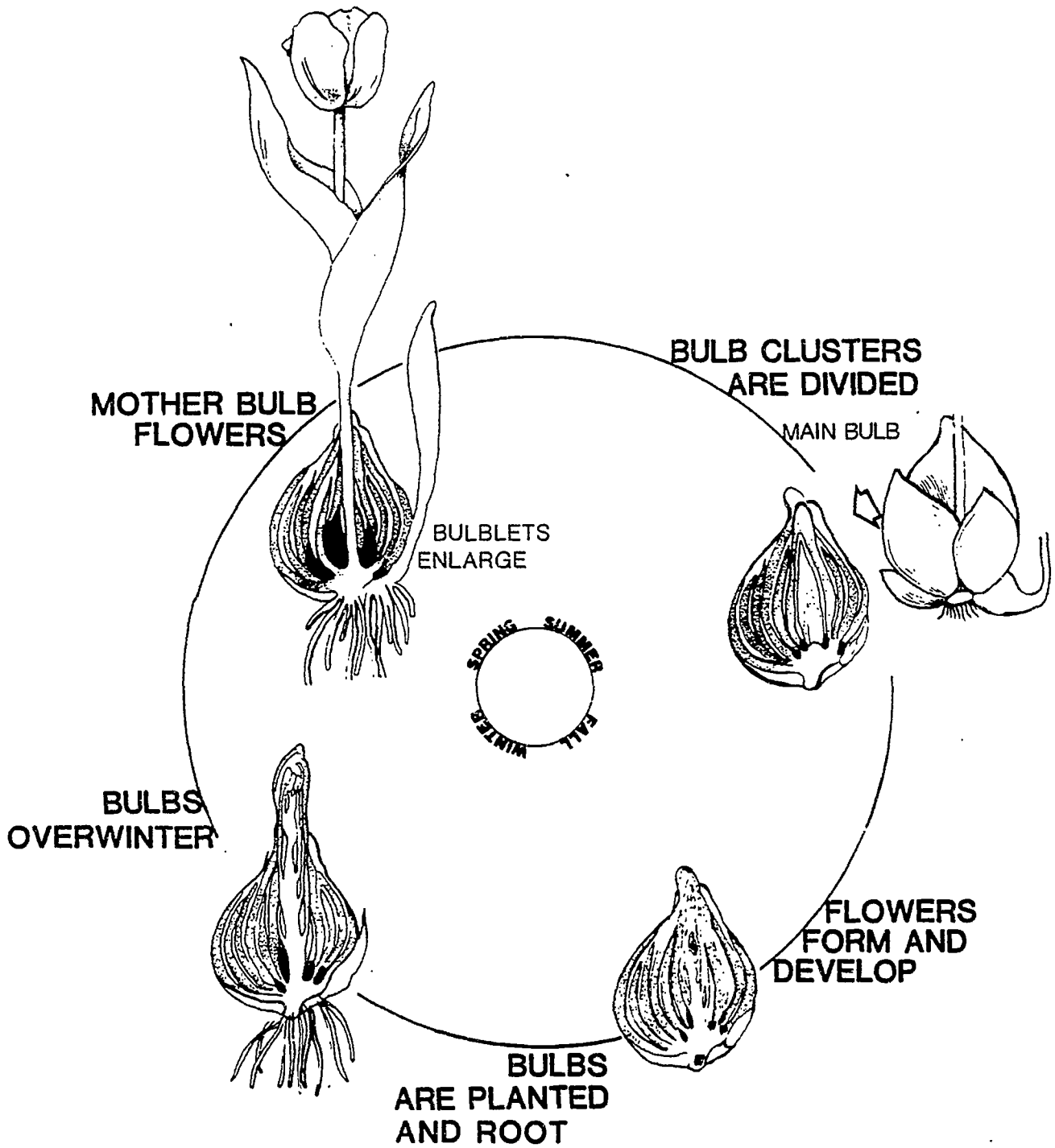

TRANSPARENCY MASTER #6

Potting Tulips

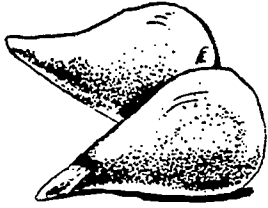

TULIP

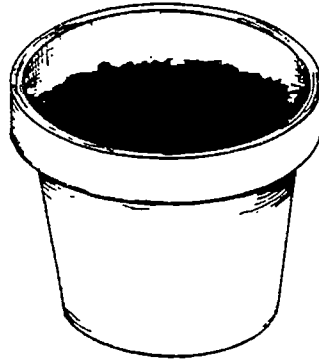

Fill container to within 2" of the top of the pot with planting medium.

Place bulbs so the nose of each is about even with the top of the container.

The flat side of the tulip bulbs should face outward

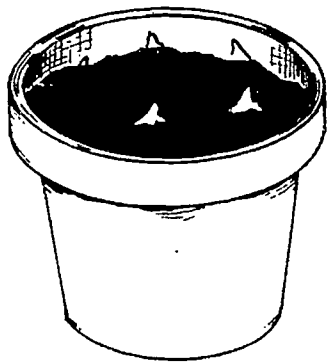
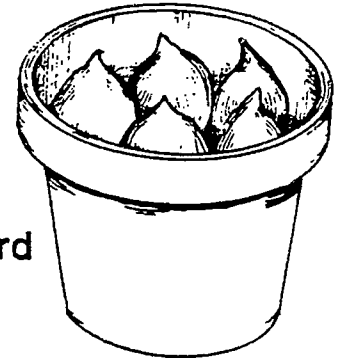

Cover the bulbs with planting medium.

SYSTEM OF LABELING
POTS OR FLATS

FLOWERING PERIOD

CT-1

GROUP NUMBER

3
CULTIVAR NAME

222

STUDENT ACTIVITIES

- STUDENT WORKSHEET #1 — Practices Used in Growing Ornamental Plants Word Search (with solution)
- STUDENT WORKSHEET #2 — Greenhouse Crop Word Search (with solution)
- STUDENT WORKSHEET #3 — Growing Poinsettias
- STUDENT WORKSHEET #4 — Growing Pot Chrysanthemums
- STUDENT WORKSHEET #5 — Growing African Violets
- STUDENT WORKSHEET #6 — Growing Easter Lilies
- STUDENT WORKSHEET #7 — Scheduling Bedding Plants
- STUDENT WORKSHEET #8 — Bedding Plant Word Search (with solution)
- STUDENT WORKSHEET #9 — Individualized Crop Report Laboratory Exercise
- STUDENT WORKSHEET #10 — Horticulture Baseball, Elimination, Horticulture Bee

For additional activities, teachers may refer to the "Suggested Teaching Activities and Procedures" section in the Instructor's Guide.

210

STUDENT WORKSHEET #1

Practices Used in Growing Ornamental Crops Word Search

A Z B A N O I T A T I N A S R R J G G E
 G Z J N L M T E Z S N S D F J V N N I E
 L V T W D A G N I L O O C M E I I I Q D
 B B R P G D V X F F N G J R W D Q H R E
 N C A N X N G O O E N K N O N G X E R W
 Y Y N N V U I R M I R A S E L E N G S W
 G X S E N K C R N E L T M N P C R Z E X
 R J P L F I O U E I R A I H H O P H B W
 B U L G N G R D Z T I D C L W B B U G U
 Q F A G N P N A T J A N U T I B P R K S
 T H N M T I T I U W I W H B E Z E S G C
 Q B T V T I D Z T P F R Y N R Y I N A T
 S R I B O X R D T H E Z O V W E I N C Y
 N M N N Q J S U U T G M E R M T T H G O
 Q N G R F G O H A B R I E Q T V E N E L
 C C V H B L S R A O S Q L O X A F M E Y
 R M K C L O D W H D J I P E T X M T K C
 E Y Q O H A F X W U I N D I V R R Z G M
 K Q R X N U X A K P W N N J B U D J Y X
 N Y F T I R M T I G H G G W R M B L L U

The following words are hidden in the puzzle:

Amending
 Center Bud Removal
 Cooling
 Disbudding
 Drench
 Fertilizing
 Forcing
 Growth Retardant
 Heating
 Hormone

Lighting
 Potting
 Pruning
 Roll Out Pinch
 Sanitation
 Shading
 Sowing
 Transplanting
 Vernalization
 Watering

224

STUDENT WORKSHEET #1 — Key

Practices Used In Growing Ornamental Crops Word Search

. . . . N O I T A T I N A S . . . G G .
 L V N N . .
 . . T . . A G N I L O O C . E I I . . D
 . . R . G . V . F F . G . R W D . . R .
 . . A . . N . O O E N . N O N . . E . .
 . . N . . . I R M I R A S E . . N G . .
 . . S . . . C R N E L T M . . C R . . .
 . . P . . I . U E I R A I H H O
 . . L G N G R . Z T . D C L W
 . . A G N P N A . . A N U T I
 . . N . . I T I . . I W H B E Z . . G .
 . . T . . I D . T P . R . N R . I N . .
 . . I . O . . D T H E . O . . E I N . .
 . . N N . . S U U T G M . . . T T H G .
 . . G . . . O H A B R I . . T . E N . .
 L . R A O S . L O . A . . E .
 L . D . H D . I P . T C
 . . . O . A I . D I
 . . R . N N N
 . . . T G G

The following words are hidden in the puzzle:

Amending
 Center Bud Removal
 Cooling
 Disbudding
 Drench
 Fertilizing
 Forcing
 Growth Retardant
 Heating
 Hormone

Lighting
 Potting
 Pruning
 Roll Out Pinch
 Sanitation
 Shading
 Sowing
 Transplanting
 Vernalization
 Watering

220

STUDENT WORKSHEET #2

Greenhouse Crop Word Search

Y N M Q Y L I L R E T S A E J E R M O Q
 N R A G C I N E R A R I A E Q P V A E L
 C C A I V S H B S Q X F A M E Y Z R M S
 K C F O T W U J G E X I M R T A K E P Y
 Q H R F X T W T U E N N S V L R R I Z G
 M K I Q X U E X C I R I A E K P L P W J
 B U C D J S Y S X A A B A X M U O N Y F
 I R A M A T I O N N C I E U T C I G H F
 W R N M B E L L V I S S M R K L L U U W
 K X V R S G G I A E O E A E A M G C Z N
 A E I C U U O N E X H P T M U D H V E Q
 A J O Y R L S R A T O B O I T S A M M O
 D J L I E O F S N R O G N I I S A I U A
 N U E T D E C A I O D A W A V L I D S D
 I J T W E Q S U K C R Y J E C M M R W Y
 Z R G S F Y P P S E R V H Y I U D V H W
 U L Y I R D L O G P N A C D X V L T G C
 L U Q H D A I U V B F K N L I N M P Z L
 L W C Z N J C Q R Q S Y M E I M W Y I X
 P B H T G B P D S C L F V V J F M Z P T

The following words are hidden in the puzzle:

African Violet
 Azalea
 Christmas Cactus
 Chrysanthemum
 Cineraria
 Crocus
 Cyclamen
 Easter Lily
 Freesia
 Fuchsia

Geranium
 Gerbera Daisy
 Gloxinia
 Hydrangea
 Narcissus
 Oxalis
 Persian Violet
 Pocket Book Plant
 Poinsettia
 Tulips

220

STUDENT WORKSHEET #2 — Key

Greenhouse Crop Word Search

. . . . Y L I L R E T S A E
 . . A . C I N E R A R I A . . P . A . .
 . . A I . S A . E . Z . . S
 . . F . T . U . G . . I . R . A . . P .
 . . R . . T . T . E N . S . L . . I . .
 . . I . . . E . C I R I . E . . L P . .
 . . C . . S . S X A A B A . M U O . . .
 . . A . A . I O N N C I E U T C . . . F
 . . N . . E L L V I S S M R K . . . U .
 . . V . S G G I A E O E A E A M . C . N
 . . I C . U O N E X H P T M U D H . E .
 . . O . R L S R A T O B . I T S A M . .
 . . L . E O F S N R O . N . I S A I . .
 . . E T . . C A I O D A . A . L I . S .
 . . T . . . S U K C R Y . . C . . R . Y
 Y . P S E R . H Y H .
 R . L . G . . A C C
 . . . H . A N
 . . C . N
 . . . T

The following words are hidden in the puzzle:

African Violet
 Azalea
 Christmas Cactus
 Chrysanthemum
 Cineraria
 Crocus
 Cyclamen
 Easter Lily
 Freesia
 Fuchsia

Geranium
 Gerbera Daisy
 Gloxinia
 Hydrangea
 Narcissus
 Oxalis
 Persian Violet
 Pocket Book Plant
 Poinsettia
 Tulips

237

STUDENT WORKSHEET #3

Growing Poinsettias

1. Poinsettias have their origin in _____ .
2. The _____ family receives much credit for developing the poinsettia industry.
3. Improved success in propagation of cuttings is a result of _____ .
4. _____ is used to slow growth of plants.
5. Greenhouse growers can buy poinsettias as _____ , _____ , _____ , or _____ .
6. Cuttings take _____ to root.
7. Cuttings should be about _____ long.
8. Use of a mist system permits _____ .
9. Placing the same amount of soil in all the pots helps _____ .
10. Poinsettias require a _____ with a pH of _____ .
11. The photoperiodic response group of poinsettias is _____ .
12. Up until about September 10, the plants are kept _____ by lighting them from _____ .
13. Poinsettias are _____ to encourage branching.
14. Poinsettias will initiate flower buds when given _____ .
15. 6" poinsettias should be spaced about _____ .
16. _____ is the main insect pest.
17. Poinsettias are susceptible to fungus disease including _____ , _____ , and _____ .

18-31. Complete the following chart:

	Night temperature	Fertilization rate
Propagation bench	18. _____	25. _____
Vegetative stage	19. _____	26. _____
After pinch	20. _____	27. _____
Flower bud initiation	21. _____	28. _____
Flower bud development	22. _____	29. _____
Finishing stage	23. _____	30. _____
Storage in plant sleeves	24. _____	31. _____

STUDENT WORKSHEET #3 — Key

Growing Poinsettias

1. Poinsettias have their origin in *Mexico*.
2. The *Ecke* family receives much credit for developing the poinsettia industry.
3. Improved success in propagation of cuttings is a result of *Mist Systems*.
4. *Cycocel* is used to slow growth of plants.
5. Greenhouse growers can buy poinsettias as *stock plants, unrooted cuttings, rooted cuttings, or callused cuttings*.
6. Cuttings take *3 - 4 weeks* to root.
7. Cuttings should be about *3 - 4"* long.
8. Use of a mist system permits *higher light intensity which in turn helps plants produce more food for root production*.
9. Placing the same amount of soil in all the pots helps *in watering and in timing the entire crop for the sale date*.
10. Poinsettias require a *well-drained soil* with a pH of *5.0 to 6.5*.
11. The photoperiodic response group of poinsettias is *short-day plants*.
12. Up until about September 10, the plants are kept *vegetative* by lighting them from *10 p.m. until 2 a.m.*
13. Poinsettias are *pinched* to encourage branching.
14. Poinsettias will initiate flower buds when given *short days*.
15. *6"* poinsettias should be spaced about *15 inches apart in 15-inch rows*.
16. *White fly* is the main insect pest.
17. Poinsettias are susceptible to fungus disease including *Pythium, Rhizoctonia, and Thieleleopsis*.

18-31. Complete the following chart:

	Night temperature	Fertilization rate
Propagation bench	18. <u>70 - 75°F</u>	25. <u>None</u>
Vegetative stage	19. <u>68 - 70°F</u>	26. <u>300 ppm N and K</u>
After pinch	20. <u>68 - 70°F</u>	27. <u>350 - 400 ppm N and K</u>
Flower bud initiation	21. <u>62 - 64°F</u>	28. <u>300 - 350 ppm N and K</u>
Flower bud development	22. <u>64 - 66°F</u>	29. <u>300 ppm N and K</u>
Finishing stage	23. <u>58 - 62°F</u>	30. <u>200 - 300 ppm N and K</u>
Storage in plant sleeves	24. <u>60 - 65°F</u>	31. <u>None</u>

STUDENT WORKSHEET #4

Growing Pot Chrysanthemums

Please circle the correct answers below:

1. Chrysanthemums are "short-day" plants. This means that as days get shorter they :
 - a. Begin to die
 - b. Begin vegetative growth
 - c. Initiate flower buds
 - d. Don't have to be pinched

2. Chrysanthemums are pinched to:
 - a. Increase branching
 - b. Decrease branching
 - c. Enlarge flower size
 - d. Decrease water requirements

3. When planting chrysanthemums it is best to:
 - a. Place the cuttings deep so they have more support
 - b. Place the cuttings deep so plenty of water is available
 - c. Place the cuttings shallow so stem rot and root rot problems are reduced
 - d. Place the cuttings shallow even though mums root along the stem

4. When watering Chrysanthemums you should:
 - a. Keep them wet at all times
 - b. Let them dry out until they wilt between waterings
 - c. Allow the soil to become nearly dry between waterings
 - d. Water them every day

5. Chrysanthemums:
 - a. Should be fertilized every other watering
 - b. Require constant fertilizer
 - c. Require a heavy dosage of fertilizer with the first watering only
 - d. Don't need much fertilizer

6. B-Nine is used on Chrysanthemums to:
 - a. Increase flowering
 - b. Increase plant size
 - c. Decrease flowering
 - d. Decrease plant size

7. How far apart in a staggered fashion should Chrysanthemums grown in 4- to 4 1/2-inch pots be spaced?
 - a. 4"
 - b. 8"
 - c. 12"
 - d. 18"

8. A 12-week Chrysanthemum variety:
 - a. Takes 12 weeks to flower from time of potting
 - b. Takes 12 weeks from potting to pinch date
 - c. Takes 12 weeks to root
 - d. Takes 12 weeks from start of short days to flower

9. Disbudding is done to:
 - a. Enlarge flowers
 - b. Increase the number of flowers
 - c. Increase branching
 - d. Decrease vegetative growth

10. Chrysanthemums are "started" with warm nights to encourage rooting, and they are "finished" with cool nights to:
 - a. Increase the number of roots
 - b. Increase flower size
 - c. Improve branching
 - d. Improve flower color and quality

11-23. Fill in the chart.

Stage	Day length	Temperature	Fertilizer rate
Vegetative stage			
		62-65°F	
	Short day		
			200-250 ppm N and K

24-30. True/False

24. _____ Chrysanthemums flower naturally as the days lengthen in the spring.
25. _____ Chrysanthemums are the most popular flowering pot plant in America.
26. _____ Care must be taken not to light cuttings while they are developing roots.
27. _____ As a rule, chrysanthemums are grown in azalea pots.
28. _____ A roll-out pinch involves the removal of about 1/2" to 3/4" of the growing tip.
29. _____ Chrysanthemums will recover totally if watered thoroughly after wilting severely.
30. _____ Temperature affects flower bud initiation and development.

201

STUDENT WORKSHEET #4 — Key

Growing Pot Chrysanthemums

Please circle the correct answers below:

1. Chrysanthemums are "short-day" plants. This means that as days get shorter they :
 - a. Begin to die
 - b. Begin vegetative growth
 - c. Initiate flower buds
 - d. Don't have to be pinched

2. Chrysanthemums are pinched to:
 - a. Increase branching
 - b. Decrease branching
 - c. Enlarge flower size
 - d. Decrease water requirements

3. When planting chrysanthemums it is best to:
 - a. Place the cuttings deep so they have more support
 - b. Place the cuttings deep so plenty of water is available
 - c. Place the cuttings shallow so stem rot and root rot problems are reduced
 - d. Place the cuttings shallow even though mums root along the stem

4. When watering Chrysanthemums you should:
 - a. Keep them wet at all times
 - b. Let them dry out until they wilt between waterings
 - c. Allow the soil to become nearly dry between waterings
 - d. Water them every day

5. Chrysanthemums:
 - a. Should be fertilized every other watering
 - b. Require constant fertilizer
 - c. Require a heavy dosage of fertilizer with the first watering only
 - d. Don't need much fertilizer

6. B-Nine is used on Chrysanthemums to:
 - a. Increase flowering
 - b. Increase plant size
 - c. Decrease flowering
 - d. Decrease plant size

7. How far apart in a staggered fashion should Chrysanthemums grown in 4- to 4 1/2-inch pots be spaced?
 - a. 4"
 - b. 8"
 - c. 12"
 - d. 18"

232

8. A 12-week Chrysanthemum variety:

- a. Takes 12 weeks to flower from time of potting
- b. Takes 12 weeks from potting to pinch date
- c. Takes 12 weeks to root
- d. Takes 12 weeks from start of short days to flower

9. Disbudding is done to:

- a. Enlarge flowers
- b. Increase the number of flowers
- c. Increase branching
- d. Decrease vegetative growth

10. Chrysanthemums are "started" with warm nights to encourage rooting, and they are "finished" with cool nights to:

- a. Increase the number of roots
- b. Increase flower size
- c. Improve branching
- d. Improve flower color and quality

11-23. Fill in the chart.

Stage	Day length	Temperature	Fertilizer rate
<i>Vegetative stage</i>	<i>Long day</i>	<i>65 - 68°F</i>	<i>250-350 ppm N and K</i>
<i>Flower bud initiation</i>	<i>Short day</i>	<i>62-65°F</i>	<i>200 ppm N and K</i>
<i>Flower bud development</i>	<i>Short day</i>	<i>60 - 62°F</i>	<i>200-250 ppm N and K</i>
<i>Flowering</i>	<i>Short day</i>	<i>55 - 58°F</i>	<i>200-250 ppm N and K</i>

24-30. True/False

- 24. F Chrysanthemums flower naturally as the days lengthen in the spring.
- 25. T Chrysanthemums are the most popular flowering pot plant in America.
- 26. F Care must be taken not to light cuttings while they are developing roots.
- 27. T As a rule, chrysanthemums are grown in azalea pots.
- 28. F A roll-out pinch involves the removal of about 1/2" to 3/4" of the growing tip.
- 29. F Chrysanthemums will recover totally if watered thoroughly after wilting severely.
- 30. T Temperature affects flower bud initiation and development.

STUDENT WORKSHEET #5

Growing African Violets

1. African violets are native to _____ .
2. Give three reasons African violets are popular.
 - a. _____
 - b. _____
 - c. _____
3. Propagation can be accomplished by _____ or _____ .
4. Each leaf cutting may produce _____ new plants.
5. The time from sticking to transplanting takes _____ .
6. What three cultural conditions are ideal for rooting?
 - a. _____
 - b. _____
 - c. _____
7. Plantlets are transplanted to a small container known as a _____ .
8. After about 13-15 weeks, the plant is ready for a _____ pot.
9. _____ that accumulate on a pot or in the soil can damage or stunt growth.
10. Water _____ cooler than the air causes _____ if applied from above.
11. Watering is commonly done by placing the pots on moist felt or sand. The moist pads also contribute to _____ .
12. Give the response of African violets to the following light intensities.

Less than 1,000 foot-candles _____

1,000 to 2,000 foot-candles _____

More than 2,000 foot-candles _____
13. African violets respond best to _____ nitrogen and potassium.
14. The total time to produce a saleable plant from the finishing pot to Valentine's Day is _____ and to Mother's Day _____ .

STUDENT WORKSHEET #5 — Key

Growing African Violets

1. African violets are native to *East Africa* .
2. Give three reasons African violets are popular.
 - a. *They are compact.*
 - b. *They flower year around.*
 - c. *Many varieties are available.*
3. Propagation can be accomplished by *seed* or *leaf petiole cuttings*.
4. Each leaf cutting may produce *8 - 10* new plants.
5. The time from sticking to transplanting takes *5 - 7 weeks*.
6. What three cultural conditions are ideal for rooting?
 - a. *70 - 75°F temperatures*
 - b. *16 - 18 hours artificial light per day*
 - c. *High humidity*
7. Plantlets are transplanted to a small container known as a *2 1/4*.
8. After about 13-15 weeks, the plant is ready for a *4-, 4 1/2-, or 5-inch azalea* pot.
9. *Soluble salts* that accumulate on a pot or in the soil can damage or stunt growth.
10. Water *10 - 15 degrees* cooler than the air causes *leaf spots* if applied from above.
11. Watering is commonly done by placing the pots on moist felt or sand. The moist pads also contribute to *high humidity around the plants* .
12. Give the response of African violets to the following light intensities.

Less than 1,000 foot-candles	<i>Vegetative growth only</i>
1,000 to 2,000 foot-candles	<i>Flowering will occur on good-sized plants</i>
More than 2,000 foot-candles	<i>Flowers form on small plants</i>
13. African violets respond best to *100 - 150 ppm* nitrogen and potassium.
14. The total time to produce a saleable plant from the finishing pot to Valentine's Day is *12 - 14 weeks* and to Mother's Day *8 - 10 weeks*.

STUDENT WORKSHEET #6

Growing Easter Lilies

1. The two most common Easter lily varieties are _____ and _____ .
2. Easter lilies are propagated by _____ or _____ .
3. It takes about _____ years to get a bulb large enough for sale.
4. A _____ period of _____ is required before forcing the bulbs in the greenhouse.
5. A cold-moist treatment of bulbs before planting to induce rapid stem elongation and flowering is known as _____ .
6. Four methods of cooling are _____ , _____ , _____ , _____ , and _____ .
7. Before potting, the lily bulbs should undergo a _____ to control mites.
8. Easter lilies demand _____ soil and are potted in _____ pots.
9. Lilies are planted so the top of the bulb is covered by about _____ . This permits the desired growth of _____ .
10. It takes about _____ days to force lilies in the greenhouse.
12. If Easter is late the greenhouse temperature should be _____ than when it is early.
13. Lilies will develop more quickly when given _____ days.
14. High humidity will result in a _____ lily with _____ .
15. Lilies should receive _____ ppm fertilizer until flower buds begin to develop if grown in a soilless mix and _____ ppm afterwards.
16. Higher fertilizer rates result in a _____ lily.
17. If cultural practices aren't enough to keep the lilies short, _____ may be used when the plants are _____ tall.
18. Easter lilies suffer from diseases such as _____ and _____ .
19. In case flower buds are not visible 2-3 weeks before sale, lilies can be forced quickly by covering them with _____ , _____ the temperature, and _____ at night.

STUDENT WORKSHEET #6 — Key

Growing Easter Lilies

1. The two most common Easter lily varieties are "Ace" and "Nellie White."
2. Easter lilies are propagated by *bulbets* or *scalettes*.
3. It takes about *three* years to get a bulb large enough for sale.
4. A *vernalization* period of *6 weeks or 1000 hours* is required before forcing the bulbs in the greenhouse.
5. A cold-moist treatment of bulbs before planting to induce rapid stem elongation and flowering is known as *precooling*.
6. Four methods of cooling are *natural cooled*, *controlled temperature forced*, *case cooled by the broker*, and *case cooled by the forcer*.
7. Before potting, the lily bulbs should undergo a *miticide dip* to control mites.
8. Easter lilies demand *well-drained* soil and are potted in *6" standard* pots.
9. Lilies are planted so the top of the bulb is covered by about *2 inches of soil*. This permits the desired growth of *stem roots*.
10. It takes about *100 - 120* days to force lilies in the greenhouse.
12. If Easter is late the greenhouse temperature should be *lower* than when it is early.
13. Lilies will develop more quickly when given *long days*.
14. High humidity will result in a *tall* lily with *larger leaves*.
15. Lilies should receive *350 - 400 ppm* fertilizer until flower buds begin to develop if grown in a soilless mix and *200 - 250 ppm* afterwards.
16. Higher fertilizer rates result in a *shorter* lily.
17. If cultural practices aren't enough to keep the lilies short, *Arest* may be used when the plants are *6" - 8"* tall.
18. Easter lilies suffer from diseases such as *Rhizoctonia* and *Pythium*.
19. In case flower buds are not visible 2-3 weeks before sale, lilies can be forced quickly by covering them with a *plastic tent*, *raising* the temperature, and *lighting* at night.

STUDENT WORKSHEET #7**Scheduling Bedding Plants**

There are several reasons for developing and utilizing crop growing schedules:

1. To provide maximum crop production in the available greenhouse and/or land laboratory space.
2. To predict future sales and anticipate available cash flow.
3. To have a step-by-step record of cultural practices for certain crops.
4. To provide useful information for advertising and marketing schedules.
5. To ensure that crops are mature and saleable by the targeted market dates.
6. To have an accurate record of supplies and plant materials for proper inventory control.
7. To have an overall, long-term view of space utilization in the greenhouse and/or land laboratory.

Crop schedules need to be planned and evaluated before putting them in operation. Some supplies and materials may need to be ordered several weeks or months in advance of actual use. Inventory counts, harvest dates, and other crop records can be stored on microcomputer discs for future reference. Using the microcomputer to keep crop records will acquaint students with equipment currently being used in the horticulture industry. Regardless of the method employed, record keeping is an essential component of any crop schedule plan. The efficient planning, implementing, and evaluating of crop schedules can be achieved through accurate record keeping.

Directions: With the following information, complete the scheduling chart for the school's bedding plants:

1. Sale date
2. Bedding plants to be grown
3. Seed catalogs from the supplier
4. Types of cel-paks to be used
5. Calendar
6. List of weeks from seed to sale for bedding plants (can be found in Ball Red Book)

238

STUDENT WORKSHEET #8

Bedding Plant Word Search

S B E G O N I A D Q H U G P Z M D X E
 Q Q B A H S K T D U N S S C O L E U S
 X U E S D N A I L L A W O R B V G F K
 X V I W L A M W G O R U Z V M P C S L
 G X W M M P N D L J R P Q H A J I A Q
 G N Z D V D H R A M E T L S U M Z C K
 D A I P Q R M Q A P E W D Z P G M N Y
 A I N P L A A I P H H A P A E S I I F
 H D N L L G S E G I I O T R N D V V M
 L S I G V O R S M N R I A U U E C U E
 I A A T L N O A U T E N K S Q C T G K
 A O X E K Q R T U N I B T Y S A Y I M
 U N C N F I E L S U O Y S A R N P Z B
 X W R R G P A A M T M V L E E E J S S
 S B S O S C A Q A I Z V G F W B J Y F
 N J L U A K U M L F I A P A A R I S Z
 B D R N E L O L C A U B W N M E L N T
 E Y B H S T E H H Z V Q T L B V F A L
 G C B A C R B Y F I F F Q R S I U P D

The following words are hidden in the puzzle:

Ageratum
 Begonia
 Browallia
 Celosia
 Coleus
 Dahlia
 Dusty Miller
 Geranium
 Impatiens
 Marigold

Pansy
 Pepper
 Petunia
 Portulaca
 Salvia
 Snapdragon
 Tomato
 Verbena
 Vinca
 Zinnia

STUDENT WORKSHEET #8 — Key

Bedding Plant Word Search

• B E G O N I A • • • • • • • • • •
 • • • • • S • • • • • • • C O L E U S
 • • • • • N A I L L A W O R B • • • •
 • • • • • A • • • • • • • • • • • •
 • • • • • P • • • • • P • • • • I A •
 • • Z • • D • • • • E • • • • M • C •
 D • I • • R • • A P • • • • P G • N •
 A • N • • A • I P • • A P A E • • I •
 H • N • • G S E • • I O T R • D • V M
 L • I • • O R • M N R I A • U • • U •
 I • A • L N • A U T E N • S • • T • •
 A • • E • • R T U N I • T • S A • • •
 • • C • • I E L S U O Y • A R N • • •
 • • • • G P A • M T M • L E • E • • •
 • • • O • C • • A I • V G • • B • Y •
 • • L • A • • M L • I A • • • R • S •
 • D • • • • O L • A • • • • • E • N •
 • • • • • T E • • • • • • • V • A •
 • • • • • R • • • • • • • • • • P •

The following words are hidden in the puzzle:

Ageratum
 Begonia
 Browallia
 Celosia
 Coleus
 Dahlia
 Dusty Miller
 Geranium
 Impatiens
 Marigold

Pansy
 Pepper
 Petunia
 Portulaca
 Salvia
 Snapdragon
 Tomato
 Verbena
 Vinca
 Zinnia

241

STUDENT WORKSHEET #9**Individualized Crop Report Laboratory Exercise**

Assignment: During the course of the year, you are to conduct research on a greenhouse crop assigned to your care. Initially, you should make yourself familiar with the origin, history, and cultural requirements of the particular plant. It will be helpful to find answers to the following 7 questions.

1. What size pot is best?
2. What is the best soil media to use?
3. What is the watering requirement and procedure for your crop? Explain in sufficient detail that someone off the street could understand.
4. How frequently should the crop be fertilized and what analysis (N-P-K) is optimum?
5. What are the light requirements for your crop? Explain.
6. What temperature does the crop prefer at night and day?
7. Are any fungicide or growth regulator applications required? Explain.

When the plants, cuttings, or seeds arrive, you will be required to pot them; water, fertilize, and pinch them; control pests; disbud them; and perform any other tasks necessary to produce a saleable crop.

You are required to keep detailed records on the time you have spent growing the crop as well as observations you have noted concerning the crop. When the crop matures, you will have the opportunity to be actively involved with the sale.

Evaluations:

1. Present your knowledge of the crop in a typewritten paper 2-5 pages in length.
2. You will give an oral report to your classmates. Include live plants, charts, slides, or other visual aids.
3. Submit your records for grading.
4. A portion of your grade will be based on your work habits, diligence, and attitude.

242

STUDENT WORKSHEET #10**Horticulture Baseball, Elimination, Horticulture Bee****Horticulture Baseball**

Divide the class into two teams. Arrange the chairs in the classroom so there are two "dugouts" and a chair at each base. When a student comes to "bat," the "batter" is given a question. If answered correctly, the student will hit a single, double, triple, or home run based on the difficulty level of the question. Students who fail to answer a question correctly are declared "out." Three outs and the side is retired. Keep score on the scoreboard (chalkboard). Students on base only advance the number of bases the batter advances.

Elimination

Distribute a green card and a red card to each student. Have a prepared list of true/false statements at hand. With all the students standing, make a statement. All those who believe the statement to be true should hold up a green card. All those who think it is false should hold up a red card. For fairness and to keep the game rolling, demand an immediate response. Students who answered incorrectly sit. Each statement will reduce the number of participating players until the winner remains.

Horticulture Bee

Divide the class into two teams. Ask the first player in line from team A a question related to ornamental plants. With a correct answer, the student stays with the team. An incorrect answer will have the student dismissed from the team. The game continues until one team outlasts the other. Help from team members or talking will cause ejection of the guilty party.

CLUSTER: HORTICULTURE

UNIT: Horticultural Science and Production

PROBLEM AREA: Growing Vegetables

RELATED PROBLEM AREAS:

1. Processing Fruits and Vegetables
2. Propagating Plants
3. Understanding Plant Germination, Growth, and Development
4. Growing Fruits
5. Enhancing Soil Fertility

PREREQUISITE PROBLEM AREA(S):

1. Identifying Basic Principles of Plant Science (Central Core Cluster)

LEVEL: Orientation

OCCUPATIONAL TASKS ADDRESSED:

Horticulture Cluster

Duty A: Propagating Plants, Seeds, and Cuttings

1. Plan planting schedules
2. Plant seed in flats or growing benches
3. Select seed varieties

Duty B: Preparing Soils and Planting Media

1. Mark off location of beds

Duty C: Controlling The Plant Environment

1. Apply mulches

Duty D: Applying Fertilizers and Chemicals

1. Collect soil sample for fertility test

STATE GOALS FOR LEARNING:

In planning the instruction for this problem area, teachers can promote the development of several student learning objectives which are related to the State Goals for Learning in Biological and Physical Sciences. These objectives are listed on the Learning Assessment Plan forms included on the following page(s). Those learning objectives marked with an asterisk (*) are taken from the sample lists provided by the Illinois State Board of Education.



Illinois Agricultural Core Curriculum

Agricultural Education 124 Mumford Hall 1301 W. Gregory Drive University of Illinois Urbana, IL 61801

Director: Dale A. Law, Ed.D.

Principal Investigator: Jerry D. Pepple, Ed.D.

Research Assistant: Janis L. Anderson

88/89

Horticulture
Horticultural Science and Production



245

Illinois Agricultural Core Curriculum Rev.

INSTRUCTOR'S GUIDE**CLUSTER: HORTICULTURE****UNIT: Horticultural Science and Production****PROBLEM AREA: Growing Vegetables****STUDENT LEARNING OBJECTIVES**

Upon completion of their study of this problem area, students will be able to:

1. Plan and organize a vegetable garden.
2. Select and prepare a garden site.
3. Prepare a crop growing and maintenance schedule.
4. Know the factors to consider when selecting vegetable varieties and seed.
5. Know how and when to start seeds or transplants for the garden.

INSTRUCTOR'S NOTES AND REFERENCES

INSTRUCTOR'S GUIDE**CLUSTER: HORTICULTURE****UNIT: Horticultural Science and Production****PROBLEM AREA:** Growing Vegetables**PROBLEMS AND QUESTIONS FOR STUDY****INSTRUCTOR'S NOTES AND REFERENCES**

1. What are the reasons for constructing a garden on paper first?
2. What factors need to be considered relative to the time planting?
3. Do the types of vegetables to be grown make a difference when selecting the garden site?
4. How much does row spacing affect the garden plan?
5. When deciding how much to plant, should yields be taken into consideration?
6. How do nearby plants affect crop growth?
7. What is the purpose of planting flowers around your garden?
8. Identify the various plant parts for which the vegetables are grown.
9. Should your garden soil be tested before planting? If so, why?
10. How can your garden tilth be improved before planting?
11. What are the benefits of using transplants over seeds?
12. Explain why freeze dates are important to a vegetable grower.
13. What mulches are acceptable or unacceptable for use in a vegetable garden?
14. Are chemicals a problem? Can they be used at all to control insects and weeds?
15. Can one fertilizer concentration be used for the entire garden or are there specific differences for each plant?

INSTRUCTOR'S GUIDE**CLUSTER: HORTICULTURE****UNIT: Horticultural Science and Production****PROBLEM AREA:** Growing Vegetables**SUGGESTED TEACHING ACTIVITIES AND PROCEDURES**

1. If possible have a garden on school grounds for the students to plan, plant, and manage.
2. Have students make a scale drawing of their homes and select a spot for a garden. Let them measure the space and take a family survey of vegetables to plant. Students will then create a plan and growing schedule for the garden. The plan and schedule should include the amount of each vegetable to be planted, expected yield, number and length of rows, freeze dates, planting dates, seeds needed, depth of planting, and which crops will be started from transplants. Use Student Worksheet #1.
3. Have students start vegetables from seed. Discuss the information given on the seed package. These plants then can be used for a sale, school garden, or for students to take home.
4. Hold a discussion on seed varieties and hybrids. Discuss a new technology, such as one involving genetics, relating to vegetable growing.
5. View the VAS Filmstrip or Slide Set *Diseases of the Vegetable Garden*. Discuss the material viewed and any personal experiences with various diseases.
6. Visit an area vegetable grower and have the students make observations on:
 - a. What crops were grown.
 - b. Where in the field they were grown.
 - c. Which crops were planted next to each other.
 - d. Whether any mechanical devices or chemicals were used in the field to assist plant growth.
 - e. Any other conditions relevant to growing vegetables.
7. Do some vegetable judging in class on vegetable quality. Then have a class picnic.
8. Vegetable gardens grown during spring and summer can be used to establish a fresh vegetable stand, or students may want to can the harvest and sell in the fall.
9. Students may want to do a vegetable garden for their SAE.
10. Have students complete Student Worksheet #3.

INSTRUCTOR'S NOTES AND REFERENCES

INSTRUCTOR'S GUIDE**CLUSTER: HORTICULTURE****UNIT: Horticultural Science and Production****PROBLEM AREA: Growing Vegetables****REFERENCES****INSTRUCTOR'S NOTES AND REFERENCES**

1. *Preparing For the Vegetable Garden* (VAS Unit #U5030); *Planting the Vegetable Garden* (VAS Unit #U5031); *Caring For the Vegetable Garden* (VAS Unit #U5032); *Diseases of the Vegetable Garden* (VAS Filmstrip #F1108-2.3 or Slide Set #S1108-2.3). Vocational Agriculture Service, College of Agriculture, University of Illinois, 1401 S. Maryland Drive, Urbana, IL 61801. (217) 333-3871.
2. *Vegetable Gardening for Illinois*. (Circular 1150). Vandemark, J.S., Courter, J.W. University of Illinois, Cooperative Extension Service, College of Agriculture, 69C Mumford Hall, 1301 W. Gregory Drive, Urbana, IL 61801. (217) 333-2007.
3. *Vegetable Gardening Basics*. (1976). Johnstone, D.B., Brindle, E.H. Burgess International Group, Inc., 7110 Ohms Lane, Edina, MN 55435. (612) 831-1344.
4. *Producing Vegetable Crops*. (1980). McCollum, J.P., Ware, G.W. Interstate Publishers, Inc., P.O. Box 50, Danville, IL 61834-0050. (217) 446-0500.
5. *The Science Workbook: Student Research Projects in Food - Agriculture - Natural Resources*. (1985). College of Agriculture, Ohio State University, Room 100, 2120 Fyffe Road, Columbus, OH 43210.

*Indicates highly recommended references

INSTRUCTIONAL RESOURCES

These resources are intended for use by teachers in planning and teaching the materials for this problem area and may be adapted to fit the teaching method(s) used.

INFORMATION SHEET #1 — Terms to be Defined

INFORMATION SHEET #1

Terms to be Defined

- Aeration** — keeping the soil's ventilating spaces open and functioning. This is usually done by nature as rainwater carves tubes in the soil through which air then circulates. Earthworms and other beneficial tunneling organisms also do their part, as do freezing and thawing.
- Aerobic bacteria** — bacteria that can function only when supplied with oxygen.
- Ammonium nitrate** — fertilizer with high nitrogen content (about 1/3 of its weight) which should be used carefully, because it may burn foliage; and stored carefully, because it may be explosive under certain conditions.
- Ammonium sulfate** — fertilizer with low (about 2%) nitrogen and high sulfur content, useful in acidifying soils with high pH level.
- Anaerobic bacteria** — bacteria that can survive and work only without plentiful or free oxygen.
- Anthracnose** — fungus that causes diseases that produce dead areas on plants; is most likely to occur, or be spread, in wet weather.
- Biological control** — an adjunct of organic gardening by which harmful insects and other pests are controlled without the use of chemicals. Natural enemies, sterilized mates, insect parasites, sex attractants, and other devices are employed to keep the pest population down.
- Blight** — disease that causes sudden spotting, wilting, or death of plants.
- Bolting** — sudden, untimely production of flowers or seeds caused by a plant reacting to drought, excess heat, or lack of nutrients. Also, the second-year growth (flowering) of a biennial.
- Chlorosis** — yellowing of foliage caused by a lack of chlorophyll. This is usually induced by a mineral deficiency, excessive soil alkalinity, or lack of moisture.
- Cover crop** — a fast-growing crop (such as ryegrass) that is turned under in the fall as a soil conditioner. Also known as a green manure crop.
- Crown** — growing point above root where tops originate.
- Crucifer** — a member of the mustard family (radish, turnip, cabbage, etc.), all of which have four-petaled cross-shaped flowers.
- Cucurbit** — any member of the gourd family (pumpkin, squash, cucumber, melon, etc.).
- Dibble** — pointed tool for making holes in soft soil to accommodate transplants.
- Early** — describing a plant variety, a term referring to one that is fast-maturing; in describing a crop, one that should be planted early in the season.
- Fertilizer:**
- Commercial** — fertilizer purchased rather than produced by a grower's compost heap or domestic animals.
 - Complete** — fertilizer containing all three essential elements: nitrogen, phosphorus and potassium.
 - Slow-release** — fertilizer that gradually dissolves, releasing its nutrients to the soil in regular amounts over a long period of time.
 - Filler** — inert material added to fertilizer mixtures to permit even distribution, reduce moisture uptake from the air during storage, and decrease likelihood of fertilizer burn.
- Heterosis** — the increased vigor that results from a hybridization or crossing of two lines or races within a species.
- Leggy** — descriptive of weak-stemmed, overly tall plants that have been given improper care, such as excessive heat, too many nutrients, crowding, or insufficient light.
- Loam** — the ideal soil mixture for gardening, with a consistency that is somewhere between clay and sand.
- Long-day plant** — plant that blooms in late spring or summer, responding to the lengthened daylight at that time of the year.
- Mutant** — plant exhibiting a sudden change in heredity, with new characteristics that breed true.

Nitrogen fixation — the transformation of free nitrogen into nitrogen compounds that can be absorbed as food by a plant. This is done naturally through bacterial decomposition, nitrogen nodules on plant roots, or by lightning. The nitrogen in commercial fertilizers is fixed by chemical or electrical processes.

Potherb — any plant raised for its greens.

Rouging — an off-type or diseased plant. "To rouge" means to remove an off-type or diseased plant.

Short-day plant — one that blooms in fall or winter, responding to the shortened daylight at that time of year.

Tilth — term used to describe the condition of a soil. "Good tilth" means it has the right mixture of moisture, sand, clay, and soil conditioners for easy workability.

STUDENT ACTIVITIES

STUDENT WORKSHEET #1 — Family Survey

STUDENT WORKSHEET #2 — Planning a Vegetable Garden

STUDENT WORKSHEET #3 — Maintaining Your Vegetable Garden

STUDENT WORKSHEET #4 — Garden Vegetables

STUDENT WORKSHEET #5 — Vegetable Gardening

STUDENT WORKSHEET #6 — Effect of Plant Growth Regulations on Tomato and Cucumber Plants

For additional activities, teachers may refer to the "Suggested Teaching Activities and Procedures" section in the Instructor's Guide.

STUDENT WORKSHEET #1

Family Survey

Number of persons in family: _____

List favorite vegetables

- | | | |
|----------|----------|----------|
| 1. _____ | 2. _____ | 3. _____ |
| _____ | _____ | _____ |
| _____ | _____ | _____ |

Continue on back side.

List vegetables that are liked by everyone:

List vegetables liked by only a few:

Will any of the harvest be used for canning? _____

If so, which ones: _____

Use the information gathered on this worksheet and the size of your garden plot to determine what and how much to grow. Now complete Student Worksheet #2.

STUDENT WORKSHEET #2

Planning A Vegetable Garden

Name of Vegetable	Number of Plants	Distance between:		Length of Row	Expected Yield	Date of Planting	Type of Planting Seed/Transplant	Depth of Seed
		Rows	Plants					
<i>Tomato "Early Girl"</i>	<i>4</i>	<i>3'</i>	<i>2'</i>	<i>8'</i>	<i>53 lbs</i>	<i>May 15</i>	<i>Transplant</i>	<i>—</i>

STUDENT WORKSHEET #3

Maintaining Your Vegetable Garden

Vegetable Variety	Fertilizer	Fertilizer Schedule	Special Conditions	Irrigation	Pests and Diseases	Control of Pests & Diseases	When to Harvest	Post Harvest Care

STUDENT WORKSHEET #4

Garden Vegetables

List 6 vegetables grown for their leaves or greens.

- 1. _____
- 2. _____
- 3. _____

- 4. _____
- 5. _____
- 6. _____

List 6 types of vegetables usually transplanted to the garden.

- 1. _____
- 2. _____
- 3. _____

- 4. _____
- 5. _____
- 6. _____

List 6 types of vegetables started in the garden as seed.

- 1. _____
- 2. _____
- 3. _____

- 4. _____
- 5. _____
- 6. _____

List 6 vegetables grown for their fruit.

- 1. _____
- 2. _____
- 3. _____

- 4. _____
- 5. _____
- 6. _____

List 6 vegetables grown for their underground structures (roots, tubers, bulbs).

- 1. _____
- 2. _____
- 3. _____

- 4. _____
- 5. _____
- 6. _____

STUDENT WORKSHEET #5

Vegetable Gardening

1. A plant that can withstand light frosts and cool temperatures is considered _____.
2. Young plants which are crowded should be _____ to allow plenty of room for growth.
3. Moving a plant from one location to another is called _____.
4. _____ may be added to soil to improve tilth.
5. Dead leaves, food scraps, and grass clippings can be placed on a _____ pile to decay.
6. Soil tests tell you the _____ of the soil and content of _____, _____, _____, and _____.
7. When watering the vegetable garden it is good practice to soak the soil to the depth of _____ inches.
8. Leaves that remain wet for extended periods of time may be susceptible to _____.
9. During the drought periods watering may be necessary every _____ days.
10. _____ is the best time of the day to water the garden.

Short Answer:

1. List 4 factors to consider when selecting a vegetable garden site.
2. List 3 types of mulches.
3. List 3 types of vegetables usually transplanted to the garden.
4. List 3 types of vegetables started in the garden as seed.
5. List 3 vegetables grown for their fruit.
6. List 3 vegetables grown for their underground structures (roots, tubers, bulbs).

True - False:

- _____ 1. Use of herbicides is the most common method of weed control in the vegetable garden.
- _____ 2. All vegetables must be planted after the average frost free date in your area.
- _____ 3. Transplants will recover from transplant shock more quickly if planted on a cloudy day or in the evening.
- _____ 4. The quality of the soil will affect the quality of your vegetables.
- _____ 5. All vegetables do equally well in full sun or deep shade.
- _____ 6. Vegetable gardening is rising in popularity partly because of high food costs.
- _____ 7. Proper spacing of vegetables reduces competition for light, water, and nutrients.
- _____ 8. Planning a garden on paper helps eliminate the chance of underplanting or overplanting.
- _____ 9. Different vegetable seeds have different germination requirements.
- _____ 10. Soil tilth can be improved only by roto-tilling.
- _____ 11. The three major nutrients used by plants are nitrogen, phosphorus, and potassium.
- _____ 12. It is a good practice to water your garden for about five minutes every day.
- _____ 13. Some vegetable varieties are more desirable than others.
- _____ 14. Soil tests and the gardener's plan are important in determining how much, if any, fertilizer, organic matter, lime, or acidifying material should be added.
- _____ 15. It is best to work soil after a heavy rain.

201

STUDENT WORKSHEET #5 — Key

Vegetable Gardening

1. A plant that can withstand light frosts and cool temperatures is considered *hardy*.
2. Young plants which are crowded should be *thinned* to allow plenty of room for growth.
3. Moving a plant from one location to another is called *transplanting*.
4. *Organic matter* may be added to soil to improve tilth.
5. Dead leaves, food scraps, and grass clippings can be placed on a *compost* pile to decay.
6. Soil tests tell you the *pH* of the soil and content of *nitrogen*, *organic matter*, *phosphorus*, and *potassium*.
7. When watering the vegetable garden it is good practice to soak the soil to the depth of 6 - 8 inches.
8. Leaves that remain wet for extended periods of time may be susceptible to *disease*.
9. During the drought periods watering may be necessary every 7 - 10 days.
10. *Morning* is the best time of the day to water the garden.

Short Answer:

1. List 4 factors to consider when selecting a vegetable garden site.
 - a. *Soil*
 - b. *Sunlight*
 - c. *Distance from obstructions*
 - d. *Proximity to home*
2. List 3 types of mulches.

a. <i>Wood chips</i>	d. <i>Peat moss</i>
b. <i>Grass clippings</i>	e. <i>Black plastic</i>
c. <i>Straw</i>	
3. List 3 types of vegetables usually transplanted to the garden.

a. <i>Broccoli</i>	d. <i>Tomatoes</i>
b. <i>Brussels Sprouts</i>	e. <i>Peppers</i>
c. <i>Cauliflower</i>	f. <i>Rhubarb</i>
4. List 3 types of vegetables started in the garden as seed.

a. <i>Beans</i>	d. <i>Cucumbers</i>
b. <i>Carrots</i>	e. <i>Lettuce</i>
c. <i>Sweet Corn</i>	f. <i>Radish</i>
5. List 3 vegetables grown for their fruit.

a. <i>Beans</i>	d. <i>Cucumbers</i>
b. <i>Peppers</i>	5. <i>Tomatoes</i>
c. <i>Sweet Corn</i>	6. <i>Pumpkins</i>
6. List 3 vegetables grown for their underground structures (roots, tubers, bulbs).

a. <i>Beets</i>	4. <i>Potatoes</i>
b. <i>Carrots</i>	5. <i>Turnips</i>
c. <i>Onions</i>	6. <i>Parsnips</i>

True - False:

- F 1. Use of herbicides is the most common method of weed control in the vegetable garden.
- F 2. All vegetables must be planted after the average frost free date in your area.
- T 3. Transplants will recover from transplant shock more quickly if planted on a cloudy day or in the evening.
- T 4. The quality of the soil will affect the quality of your vegetables.
- F 5. All vegetables do equally well in full sun or deep shade.
- T 6. Vegetable gardening is rising in popularity partly because of high food costs.
- T 7. Proper spacing of vegetables reduces competition for light, water, and nutrients.
- T 8. Planning a garden on paper helps eliminate the chance of underplanting or overplanting.
- T 9. Different vegetable seeds have different germination requirements.
- F 10. Soil tilth can be improved only by roto-tilling.
- T 11. The three major nutrients used by plants are nitrogen, phosphorus, and potassium.
- F 12. It is a good practice to water your garden for about five minutes every day.
- T 13. Some vegetable varieties are more desirable than others.
- T 14. Soil tests and the gardener's plan are important in determining how much, if any, fertilizer, organic matter, lime, or acidifying material should be added.
- F 15. It is best to work soil after a heavy rain.

STUDENT WORKSHEET #6

Effect of Plant Growth Regulators on Tomato and Cucumber Plants

Background:

The story of our understanding of plant growth regulators is one of the interesting chapters in science. As with most discoveries and developments, this understanding developed with a gradual unfolding of theories from a great number of workers over a long period of time. The growth-stimulating effects of the gibberellins and the growth-inhibiting effects of compounds like Alar (daminozide) have been studied extensively. A more recently developed compound is Ethrel (ethephon) that releases ethylene in plant tissues. Ethylene has many effects on plants including promoting root formation, fruit ripening and senescence.

Depending upon the species of plants used, it would take a complete growing cycle of 3 to 4 months to observe all the responses of plants to these growth regulators. Consequently, this experiment is designed for young seedlings. It is also possible to conduct this experiment with one or two of the chemicals on either cucumber or tomato seedlings if time and space are limited.

Problem:

What are the effects of plant growth stimulators and inhibitors and a senescence-promoting compound on young tomato and cucumber plants? What are some possible reasons for these results?

Materials:

1. seedling tomato and cucumber plants
2. GA₄₊₇ (from Abbott Laboratories, Chemical and Agricultural Products Division, North Chicago, IL 60064)
3. Alar (from Uniroyal Chemical, Naugatuck, CT 06770)
4. Ethrel (from Union Carbide Agricultural Products Co., P.O. Box 12014, Research Triangle Park, NC 27709)
5. 10- to 15-cm pots
6. potting soil
7. area for growing plants
8. spray applicator for applying chemicals

Procedure:

1. After calculating the correct amounts of the basic chemicals needed, make the following concentrated solutions:
 - a. check or control
 - b. GA₄₊₇: 150 ppm
 - c. GA₄₊₇: 300 ppm
 - d. Alar: 5,000 ppm
 - e. Alar: 10,000 ppm
 - f. Ethrel: 250 ppm
 - g. Ethrel: 500 ppm
2. Spray the plants with the solutions prepared in step 1 at each of three treatment times as follows:
 - a. When the first true leaf is visible and is about 2.5 cm long or wide.
 - b. At the three-leaf stage when the third true leaf is about 2.5 cm long or wide.
 - c. At the five-leaf stage when the fifth true leaf is about 2.5 cm long or wide.
3. Gather the following data:
 - a. Foliage color
 - b. Plant height
 - c. Internode length
 - d. Number of nodes to the first flower or flower cluster
 - e. Number of flowers per cluster, and the number of flowers that set fruit on the first cluster (tomato only)
 - f. Sex expression of the first flower, i.e., staminate or pistillate (cucumber only)
 - g. Presence of adventitious roots on the stems (tomato only)

References:

1. *Encyclopedia of Science and Technology*. New York: McGraw-Hill, 1981.
2. *Plant Growth Regulating Chemicals*, vol. I and II. Nickell, N.G. Boca Raton, FL: CRC Press, Inc., 1982.
3. *Plant Growth Substances in Agriculture*. Weaver, Robert J. San Francisco: W.H. Freeman and Co., 1972.

Submitted by Dr. Dale Kretchman, Department of Horticulture, The Ohio State University/DARDC, Wooster, OH 44691. Taken from *The Science Workbook: Student Research Projects in Food - Agriculture - Natural Resources*. (1985). College of Agriculture, Ohio State University, Room 100, 2120 Fyffe Road, Columbus, OH 43210.

CLUSTER: HORTICULTURE

UNIT: Horticultural Science and Production

PROBLEM AREA: Growing Fruits

RELATED PROBLEM AREA(S):

1. Propagating Plants
2. Processing Fruits and Vegetables
3. Growing Vegetables
4. Controlling Plant Pests
5. Understanding Plant Germination, Growth, and Development

PREREQUISITE PROBLEM AREA(S): None

LEVEL: Preparatory

OCCUPATIONAL TASKS ADDRESSED

Horticulture Cluster

Duty D: Applying Fertilizers and Chemicals

1. Calculate fertilizer and chemical applications
2. Calibrate fertilizer application equipment
3. Make fertilizer and lime recommendations
4. Compute fertilizer costs

Duty F: Harvesting Fruit and Vegetable Crops

1. Pick small fruits
2. Pick tree fruits
3. Pick bush fruits

Duty J: Designing/Installing Landscapes

1. Design landscape plan/paper and pencil

Duty K: Maintaining and Protecting Fruit Trees

1. Perform annual pruning for shape and fruit set

STATE GOALS FOR LEARNING:

In planning the instruction for this problem area, teachers can promote the development of several student learning objectives which are related to the State Goals for Learning in Biological and Physical Sciences and Mathematics. These objectives are listed on the Learning Assessment Plan forms included on the following page(s). Those learning objectives marked with an asterisk (*) are taken from the sample lists provided by the Illinois State Board of Education.

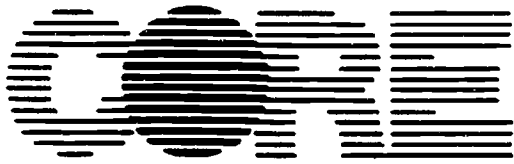

Illinois Agricultural Core Curriculum

Agricultural Education 124 Mumford Hall 1301 W. Gregory Drive University of Illinois Urbana, IL 61801

Director: Dale A. Law, Ed.D.

Principal Investigator: Jerry D. Pepple, Ed.D

Research Assistant: Robert E. Petrea

266

ILLINOIS STATE BOARD OF EDUCATION
 Department of School Improvement Services
 100 North First Street
 Springfield, Illinois 62777-0001

LEARNING ASSESSMENT PLAN
Instructions and codes for this form are provided on a separate sheet.

Submission Date _____ Page _____ of _____

Original submission Revision

I. LEARNING AREA (check one)

Language Arts Fine Arts

Mathematics Social Sciences

Sciences Physical Development/Health

II. STATE GOAL FOR LEARNING
 As a result of their schooling, students will have a working knowledge of the concepts and basic vocabulary of biological, physical, and environmental sciences and their application to life and work in contemporary technological society.

(Affix label or complete district information.)

COUNTY _____ DISTRICT _____ ESC _____

District Name _____

City _____

Contact Person: _____

Title: _____

Phone: (_____) _____

III. LEARNING OBJECTIVES	IV. ASSESSMENT				V. EXPECTATIONS
	A Types	B Validity/ Reliability	C Commercial Test(s)	D Evidence of Nondiscrimination	
By the end of grade (circle one) 3 6 8 11 students should be able to:					
*1. Understand the importance of acids, bases, and salts in industry and the home.					
*2. Know the principal environmental factors that limit the distribution of plants and animals.					
*3. Identify and describe functions of tissues and organs.					
4. Know how to plant and to maintain small fruits and brambles.					
5. Know how to select and prepare a site for growing fruit trees.					
6. Plan and maintain a year-round schedule that deals with insects, weeds, and disease prevention or control.					
267					263

ILLINOIS STATE BOARD OF EDUCATION
Department of School Improvement Services
100 North First Street
Springfield, Illinois 62777-0001

LEARNING ASSESSMENT PLAN

Instructions and codes for this form are provided on a separate sheet.

Submission Date: _____ Page _____ of _____

Original submission Revision

I. LEARNING AREA (check one)

Language Arts Fine Arts

Mathematics Social Sciences

Sciences Physical Development/Health

II. STATE GOAL FOR LEARNING

As a result of their schooling, students will have a working knowledge of the principles of scientific research and their application in simple research projects.

III. LEARNING OBJECTIVES

By the end of grade (circle one) 3 6 8 **11** students should be able to:

*1. Demonstrate the ability to draw conclusions from collected data.

IV. ASSESSMENT

A Types _____

B Validity/Reliability _____

C Commercial Test(s) _____

D Evidence of Nondiscrimination _____

V. EXPECTATIONS

Percent of Students Expected to Achieve Objective _____

Contact Person: _____
Title: _____
Phone: (_____) _____

(Affix label or complete district information.)

COUNTY: _____ DISTRICT: _____

District Name: _____

City: _____

ILLINOIS STATE BOARD OF EDUCATION
 Department of School Improvement Services
 100 North First Street
 Springfield, Illinois 62777-0001

LEARNING ASSESSMENT PLAN

Instructions and codes for this form are provided on a separate sheet.

Submission Date _____ Page _____ of _____

Original submission Revision

I. LEARNING AREA (check one)

Language Arts Fine Arts

Mathematics Social Sciences

Sciences Physical Development/Health

II. STATE GOAL FOR LEARNING

As a result of their schooling, students will be able to understand and use methods of data collection and analysis, including tables, charts, and comparisons.

III. LEARNING OBJECTIVES

By the end of grade (circle one) 3 6 8 **11** students should be able to:

- *1. Analyze data from an experiment.

IV. ASSESSMENT

A Types _____

B Validity/Reliability _____

C Commercial Test(s) _____

D Evidence of Nondiscrimination _____

V. EXPECTATIONS

Percent of Students Expected to Achieve Objective _____

Contact Person: _____

Title: _____

Phone: () _____

(Affix label or complete district information.)

COUNTY _____ DISTRICT _____ ESC _____

District Name _____

City _____

270

274

INSTRUCTOR'S GUIDE**CLUSTER: HORTICULTURE****UNIT: Horticultural Science and Production****PROBLEM AREA: Growing Fruits****STUDENT LEARNING OBJECTIVES:**

Upon completion of their study of this problem area, students will be able to:

INSTRUCTOR'S NOTES AND REFERENCES

1. Identify the small fruit varieties grown in Illinois.
2. Prepare a site for growing small fruits and brambles.
3. Know how to plant and to maintain small fruits and brambles.
4. Identify, prevent, and control insects, diseases, and seeds affecting small fruits and brambles.
5. Identify and utilize approved training methods and pruning practices on fruits and brambles.
6. Harvest small fruits and brambles.
7. Know how to select and prepare a site for growing fruit trees.
8. Plan and space fruit trees for sufficient pollination.
9. Incorporate fruit trees into the home landscape.
10. Plan and maintain a year-round schedule that deals with insects, weeds, and disease prevention or control.
11. Plan a fertilization schedule for fruit trees.
12. Be able to properly prune fruit trees.
13. Harvest fruit.

275

INSTRUCTOR'S GUIDE**CLUSTER: HORTICULTURE****UNIT: Horticultural Science and Production****PROBLEM AREA:** Growing Fruits**PROBLEMS AND QUESTIONS FOR STUDY**

1. How does one distinguish between a small fruit and a bramble?
2. What are the steps in preparing a site for the planting of small fruits and brambles?
3. Are soil amendments necessary?
4. Is it always necessary to use a square or rectangle garden area? What other bed shapes or areas can be used to grow small fruits and brambles?
5. Is spacing important? Why?
6. How can insects, weeds, and diseases be controlled before they become a problem?
7. Can mulching aid crop growth?
8. How does pruning affect drop yield?
9. What varieties of grapes are used to make raisins? How are raisins made?
10. What can be done to control animals around a crop?
11. Why should raspberries and blackberries be grown 1000 feet from each other?
12. Why is it important to avoid planting brambles in an area previously grown with solanaceous crops such as tomatoes, potatoes, or tobacco?
13. Are the site and soil requirements different for fruit trees than small fruits and brambles?
14. What types and varieties of fruit trees are suited to your area?
15. Why is a long range plan for tree spacing so important?
16. How many years must one wait for different fruit trees to bear fruit?
17. Can fruit trees be incorporated into the landscape and still produce efficiently? What other requirement might be necessary?
18. What are the important points in a fruit tree maintenance schedule?
19. What is the best fertilizer to use for each of the various fruit trees? When, how, and in what quantity should the fertilizer be applied by the homeowner or orchard grower?
20. Why and how is a fruit tree pruned? Are fruit trees pruned differently than ornamental trees?
21. How does a grower know when it is the proper time to harvest fruit?

INSTRUCTOR'S NOTES AND REFERENCES

276

INSTRUCTOR'S GUIDE

CLUSTER: HORTICULTURE

UNIT: Horticultural Science and Production

PROBLEM AREA: Growing Fruits

SUGGESTED TEACHING ACTIVITIES AND PROCEDURES

1. Stimulate student interest by growing some uncommon fruits in the greenhouse. Suggestions are: kumquat (*Fortunella japonica*), olive (*Olea europea*), monstera (*Monstera deliciosa*), pineapple (*Ananas comosus*), pomegranate (*Punica granatum*), passionfruit (*Passiflora edulis*), Brazilian cherry (*Eugenia uniflora*), banana (*Musa cavendishii*), and water chestnut (*Trapa natans*). You may want to do the water chestnut with a hydroponics problem area.
2. Ask what fruits the students see growing in the community, being sold at fruit stands, or growing at home. Discuss why some are grown here and why others are not.
3. Have students draw a landscape plan which includes some fruit trees, small fruits, and brambles. The plan could be one of their own design or one supplied by you.
4. Have some advanced students do Student Worksheet #1.
5. Conduct Student Worksheet #2.
6. Some students may want to grow fruits, small fruits, or brambles as an SAE Project.
7. Visit an area orchard so students can see the equipment used and how it is operated, and the arrangement of the orchard.
8. Have each student pick a type of fruit and research the requirements of that plant for planting, nutrients, maintenance, growth, and harvest, and the products that are made from that fruit.
9. Have the students determine the number of plants needed to plant on an acre based on their research done in item 8. Then have them calculate the production costs of establishing a one-acre orchard. Include costs such as those for trees, fertilizer, mulching, and spraying over the time required till first harvest.
10. After reading VAS Unit *Pruning Fruit Trees* (see references), have students complete Student Worksheet #8. Once they have finished, discuss and review the concepts contained in the worksheet, and practice pruning.
11. Bring in samples of different types of soil. Give students the pH level and nutrient content of each soil sample. Ask students if the soil is adequate for the growth of various small fruits and brambles. If not, ask the students how they would prepare the soil.
12. Discuss the importance of watering and irrigating small fruits and brambles.
13. Make a display of the equipment used for applying chemicals for commercial and home use. Demonstrate how to use and calibrate (if necessary) the applicators. Prepare a safety demonstration for use of this equipment.
14. Bring in samples of small fruit at various stages of development. Have students taste the fruit. Ask students why they selected the various pieces of fruit they ate. Discuss when and how small fruits should be harvested. Show students commercial mechanical harvesters by means of audio-visuals or a field trip.
15. Have each student or small group of students study a particular growth-training technique for use with small fruits or brambles. Have them construct a scaled-down version of the training system using twigs, wire, and other materials. Then discuss what items found in a home can be used to train small fruits and brambles. The models can be displayed at an open house with students present to explain the display. Show the transparencies on training techniques.

INSTRUCTOR'S GUIDE**CLUSTER: HORTICULTURE****UNIT: Horticultural Science and Production****PROBLEM AREA: Growing Fruits****REFERENCES****INSTRUCTOR'S NOTES AND REFERENCES**

1. *Growing Unusual Fruit*. (1972). Simmons, A.E. Walker Publishing Company, 720 Fifth Avenue, New York, NY 10019.
- *2. *Pruning Fruit Trees* (VAS Unit #U4043); *Growing Raspberries and Blackberries in the Midwest* (VAS Unit #U5026); *Growing Strawberries, Supp-Strawberry Cultivars* (VAS Unit #U5027); *Growing Blueberries* (VAS Unit #U5028); *Growing Grapes* (VAS Unit #U5029). Vocational Agriculture Service, College of Agriculture, University of Illinois, 1401 S. Maryland Dr., Urbana, IL 61801. (217) 333-3781.
3. *The Science Workbook of Student Research Projects in Food, Agriculture, and Natural Resources*. (1985). College of Agriculture, The Ohio State University, 2120 Fyffe Road, Columbus, OH 43210.
4. *Identifying and Selecting Cultivars of Tree Fruits and Nuts* (Subject Matter Unit #8964-A); *Identifying and Selecting Cultivars of Small Fruits* (Subject Matter Unit #8964-B); *Identifying and Selecting Cultivars of Vegetables and Herbs* (Subject Matter Unit #8964-C); *Soil Nutrient Requirements* (Subject Matter Unit #8966-A); *Harvesting Tree Fruits and Nuts* (Subject Matter Unit #8973-A); *Harvesting Small Fruits and Vegetables* (Subject Matter Unit #8973-B). Instructional Material Service, Texas A & M University, P.O. Box 2588, College Station, TX 77843-2588.

*Indicates highly recommended reference

INSTRUCTIONAL RESOURCES

These resources are intended for use by teachers in planning and teaching the materials for this problem area and may be adapted to fit the teaching method(s) used.

INFORMATION SHEET #1 — Small Fruit Varieties (Suggested)

INFORMATION SHEET #2 — Selected Sources of Small Fruit Plants and Fruit Trees

TRANSPARENCY MASTER #1 — Fruit Climate Zones for Illinois

TRANSPARENCY MASTER #2 — Transplanting Fruit Trees

TRANSPARENCY MASTER #3 — Size of Peach Trees

TRANSPARENCY MASTER #4 — Parts of the Strawberry Plant

TRANSPARENCY MASTER #5 — Planting Strawberries Correctly

TRANSPARENCY MASTER #6 — Removing Strawberry Plant Flowers

TRANSPARENCY MASTER #7 — The Spaced Matted-Row System for Training Strawberries

TRANSPARENCY MASTER #8 — Grapevine Training Systems

TRANSPARENCY MASTER #9 — Training Brambles

TRANSPARENCY MASTER #16 — Pruning Raspberries

INFORMATION SHEET #1

Small Fruit Varieties (Suggested)

<u>Crop</u>	<u>Southern IL</u>	<u>Central IL</u>	<u>Northern IL</u>
Strawberries	Earliglow Sunrise Surecrop Redchief Raritan Cardinal	Earliglow Sunrise Honeoye Surecrop Redchief Raritan	Earliglow Sunrise Honeoye Surecrop Redchief Guardian Raritan Sparkle
Red Raspberry	Heritage September Fallred	Heritage September Fallred	Latham Heritage September
Black Raspberry	Bristol Allen	Bristol Allen Jewel (trial)	Bristol Allen Jewel (trial)
Purple Raspberry	Clyde Brandywine	Clyde Brandywine	Clyde Brandywine
Grapes (American)	Fredonia Buffalo Niagara Steuben Concord Catawba Delaware	Fredonia Niagara Concord Delaware	Fredonia Concord
Grapes (French Hybrid: trial)	Vignoles Foch Baco Noir Seyval DeChaunac	Vignoles Foch Baco Noir Seyval DeChaunac	none
Thornless Blackberries	Dirksen Black Satin Hull	Dirksen Black Satin Hull	none
Blueberries	Collins Bluecrop Blueray Jersey Berkeley Herbert Coville Lateblue	Collins Bluecrop Blueray Jersey Berkeley Herbert Coville Lateblue	Collins Bluecrop Blueray Jersey Berkeley Herbert Coville Lateblue

Varieties are listed from the earliest to latest ripening order.

INFORMATION SHEET #2**Selected Sources of Small Fruit Plants and Fruit Trees¹****General Nurseries**

These nurseries offer strawberries, blackberries, raspberries, grapes, blueberries, currants, and gooseberries, in addition to ornamentals and tree fruits.

Ahrens Nursery, R.R.1, Box H089, Huntingburg, IN 47542
Ames' Orchard and Nursery, 6 E. Elm St. Fayetteville, AR 72703

Burpee Seed Co., 300 Park Avenue, Warminster, Pa 18974
Gurney Seed and Nursery Co., Yankton, SD 57078
Henry Field Seed and Nursery Co., Shenandoah, IA 51602
Hidden Springs Nursery, Rte 14, Box 159, Cookeville, TN 38501

Hillemeyer Nurseries, Lexington, KY 40500
Kelly Bros. Nurseries, Dansville, NY 14437
Mooseball Fruit Trees, Route #1, Box 240, St. Francis, ME 04774

New York State Fruit Testing Cooperative Assn., PO Box 462, Geneva, NY 14456
Stark Bros. Nurseries and Orchards Co., Louisiana, MO 63353

Blueberries

A.G. Ammonn Nursery, Box 488F, Chatworth, NJ 08019
DeGrandchamp Blueberry Farm, 15037 77th St., South Haven, MI 49090

Dyke Bros. Nursery, Rt 1 Box 251A, Vincent, OH 45784
Finch's Blueberry Nursery, Dept. AFG PO Box 699, Bailey, NC 27807

Galleta Bros. Blueberry Farms, Hammonton, NJ 08037
Highlander Nursery, PO Box 177FG, Pettegrew, AR 72752
Michigan Blueberry Grower's Assn., Grand Junction, MI 49056

Tower View Nursery, 70912 CR-388, South Haven, MI 49090

Blackberries and Raspberries²

Champlain Isle Agro., Isle Lamotte, VT 05463
Daisy Farms, 91098 60th St., Decatur, MI 49045
Maklielski Berry Nursery, 7130 Platt Rd., Ypsilanti, MI 48197

Nourse Farms, Inc., RFD, Box 485, Dept. H, South Deerfield, MA 01373

Rayner Bros., Dept. A4729, Salisbury, MD 21801
Sunshine Farm, R1 Box 92, Macon, MS 39341

Currants and Gooseberries

Foster Nursery Co., Inc., Fredonia, NY 14063
Maklielski Berry Nursery, 7130 Platt Rd., Ypsilanti, MI 48197
Southmeadow Fruit Gardens, 15210 Red Arrow Hwy., Lakeside, MI 49116

Elderberries

New York State Fruit Testing Cooperative Assn., Geneva, NY 14456

Grapes

Boordy Nursery, Box 38, Riderwood, MD 21139
Boston Mountain Nursery, Rt 2 Box 405-A, Mountainburg, AR 72906
Foster Nursery Co., Inc., PO Box 150, Fredonia, NY 14063
Southmeadow Fruit Gardens, 15210 Red Arrow Hwy., Lakeside, MI 49116

Strawberries³

Carroll Gardens, PO Box 310, Westminster, MD 21157
Daisy Farms, 91098 60th St., Decatur, MI 49045
Nichols Garden Nursery 1190 N. Pacific Hwy, Albany, OR 97321
Nourse Farms, Inc., RFD, Box 485, Dept. H, South Deerfield, MA 01373
Rayner Brother, Dept. A4729, Salisbury, MD 21801
Southern Fruit Orchards, Box 256, Omega, GA 31795
Surry Gardens, PO Box 145, Surry, ME 04648
TyTy South Fruit, Nut, and Berry Nursery and Farm Market, Box 159, TyTy, GA 31795
Wm Krohne Plant Farms, Rt #6 Box 586-FG, Dowagiac, MI 49047

Fruit Trees

Adams County Nursery, Inc., PO Box 108, Nursery Rd, Aspers, PA 17304
C & O Nursery, PO Box 116, Wenatchee, WA 98807-0116
Cumberland Valley Nursery, PO Box 471, McMinnville, TN 37110
Fowler Nurseries, Inc., 525 Fowler Rd., Dept. AFG, New Castle, CA 95658
Grootendorst Nurseries, Lakeside, MI 49116
Haley Nursery, Smithville, TN 37166
Hilltop Nursery, PO Box 578, Hartford, MI 49057
Kelly Bros. Nursery, Dansville, NY 14437

Knolview Nursery and Farms, Inc., 10906 Monitor-McKee
Rd N.E., Woodburn, OR 97071
Lawyer Nursery, Inc., Plains, MT 59859-9706
Miller Nurseries, Canandaigua, NY 14424
Raintree Nursery, Dept. HF, Morton, Wash. 98356
Stark Bros. Nursery, Louisiana, MO 63353
TyTy South Fruit, Nut, and Berry Nursery and Farm
Market, Box 159, TyTy, GA 31795
Van Well Nursery, Box 1339 Wenatchee, WA 98807
Waynesboro Nursery, Waynesboro, VA 22980

¹This is a partial list of nurseries and seed companies that offer small fruit for sale. Interested persons should obtain catalogs from several nurseries before choosing. The nurseries listed under the individual small fruit categories offer a wide selection of cultivars for that crop. For cultivar recommendations, consult your county extension adviser in Agriculture or write to the Department of Horticulture, 1005 Plant Science Lab, 1201 S. Dorner, Urbana, IL 61801.

²Raspberry plants should be designated as "essentially virus-free." Such plants are definitely superior.

³Strawberry plants should be designated as "essentially virus-free." Such plants are definitely superior.

TRANSPARENCY MASTER #1

Fruit Climate Zones For Illinois

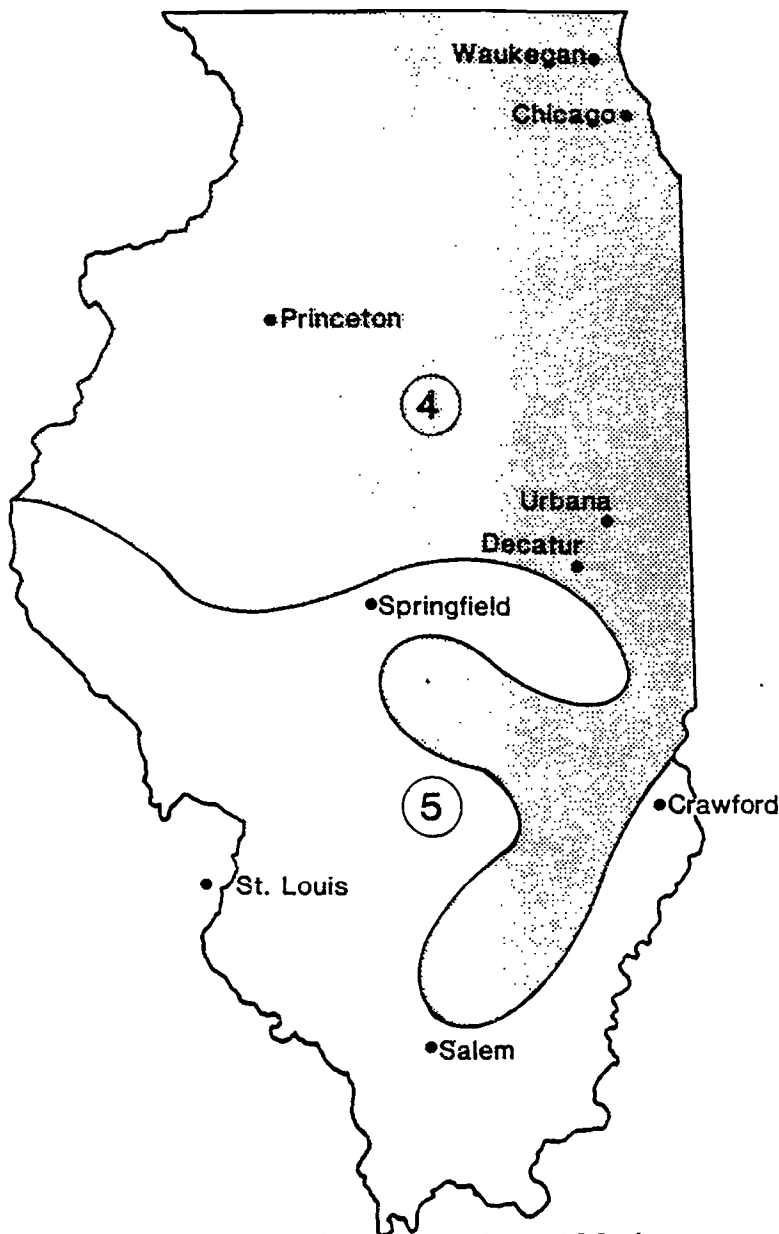

ZONE 4—Growing Season 150 to 180 days

ZONE 5—Growing Season 180 to 210 days

TRANSPARENCY MASTER #2

Transplanting Fruit Trees

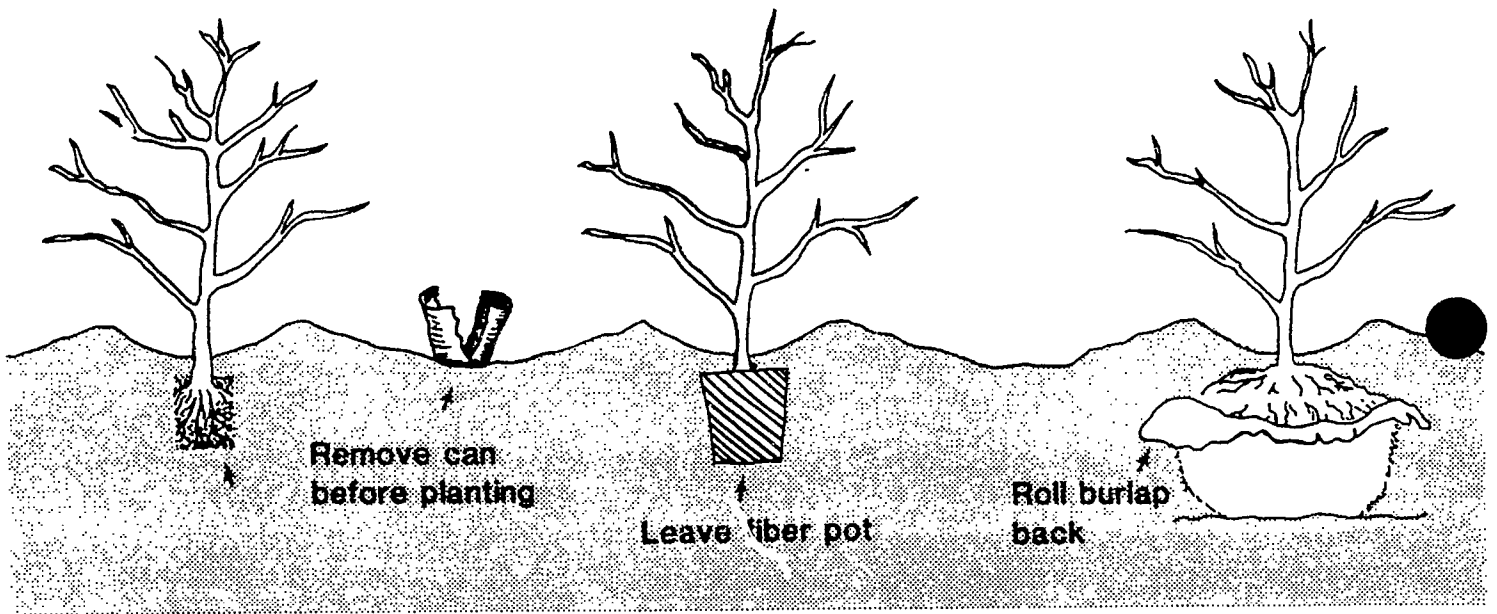

TRANSPARENCY MASTER #3

Sizes of Peach Trees

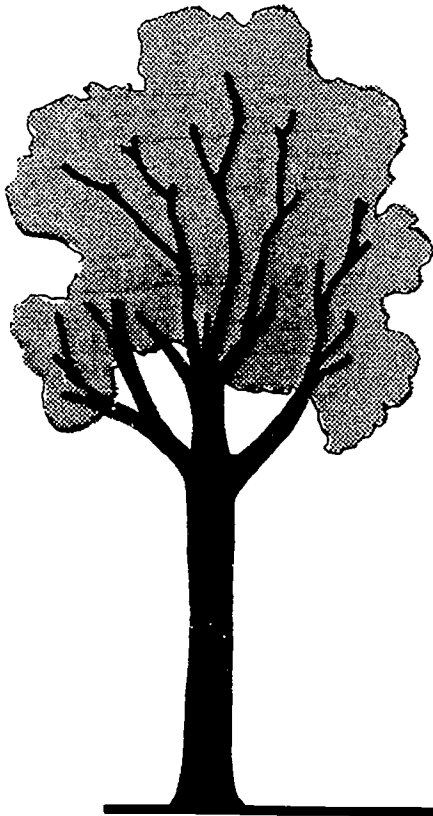

STANDARD
15'-18'

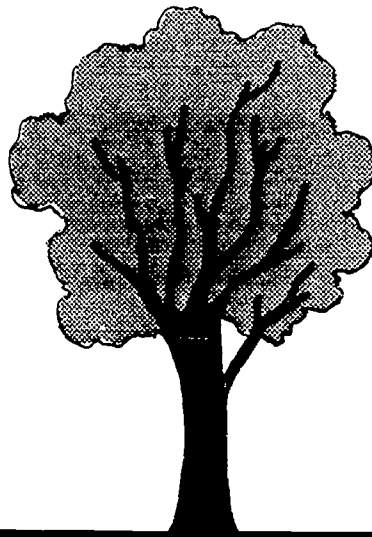

SEMIDWARF
7'-9'



GENETIC DWARF
4'-6'

TRANSPARENCY MASTER #4

Parts of the Strawberry Plant

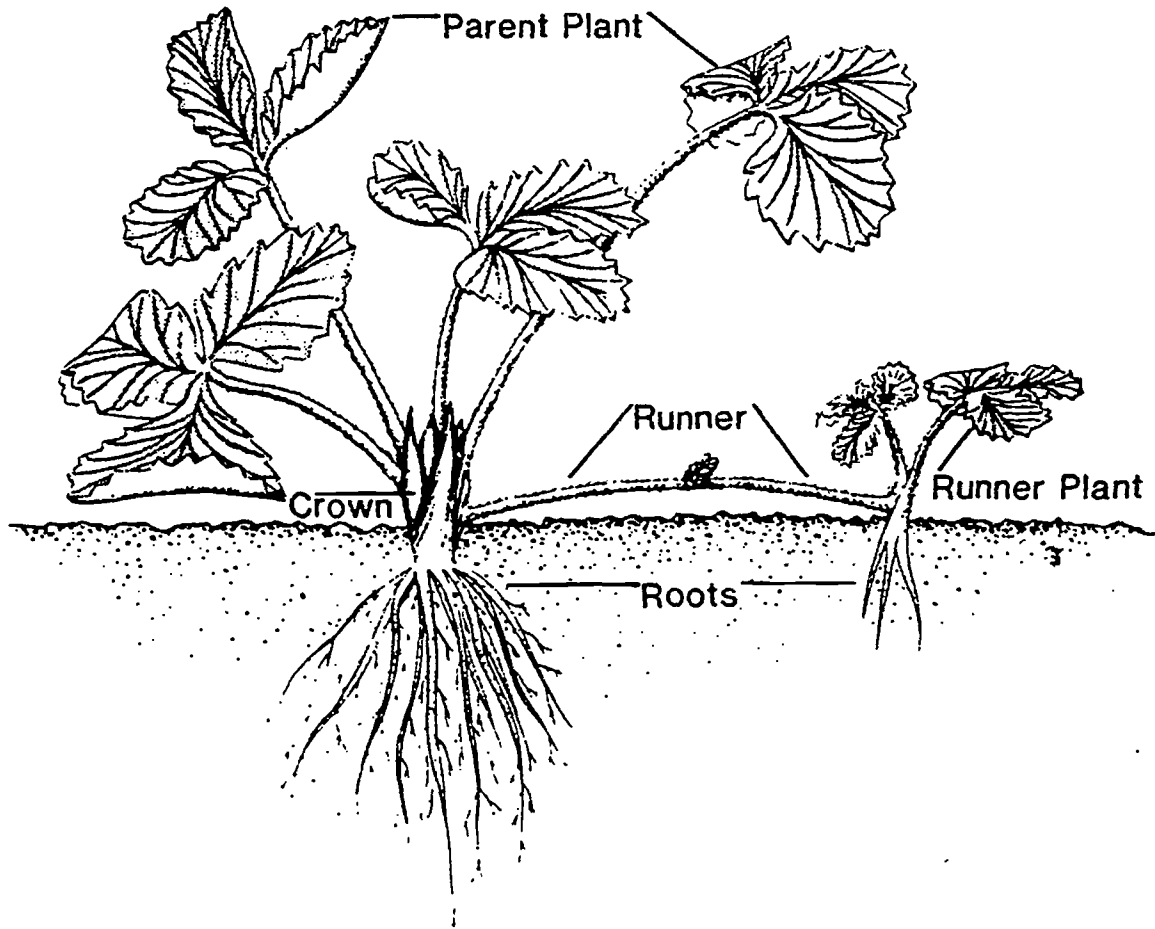

TRANSPARENCY MASTER #5

Planting Strawberries Correctly

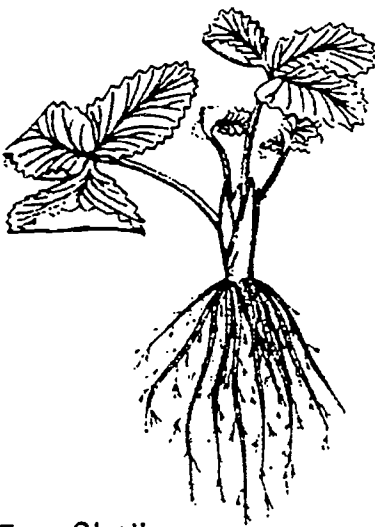

Too Shallow

Crown of plant set too shallow

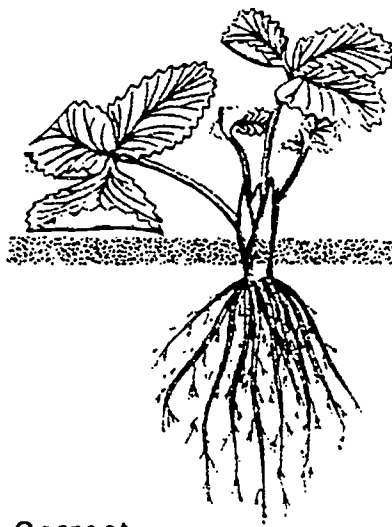

Correct

Plant set so crown is even with ground surface after the soil has been firmed around the roots

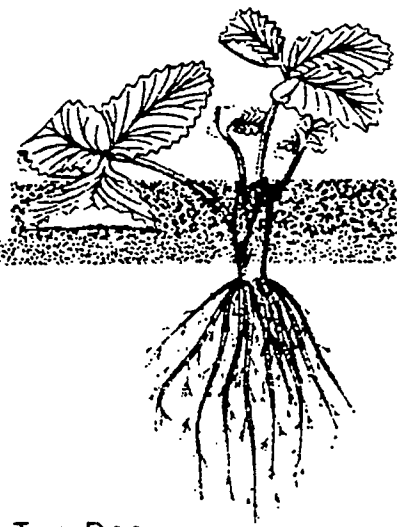

Too Deep

Crown of plant set too deep

TRANSPARENCY MASTER #6

Removing Strawberry Plant Flowers



Flower stems of newly set strawberry plants are removed during the first season as they appear in order to:

1. Strengthen the plant.
2. Encourage vigorous growth.
3. Increase the number of runner plants which produce the most fruit the following year.

TRANSPARENCY MASTER #7

The Spaced Matted-Row System for Training Strawberries

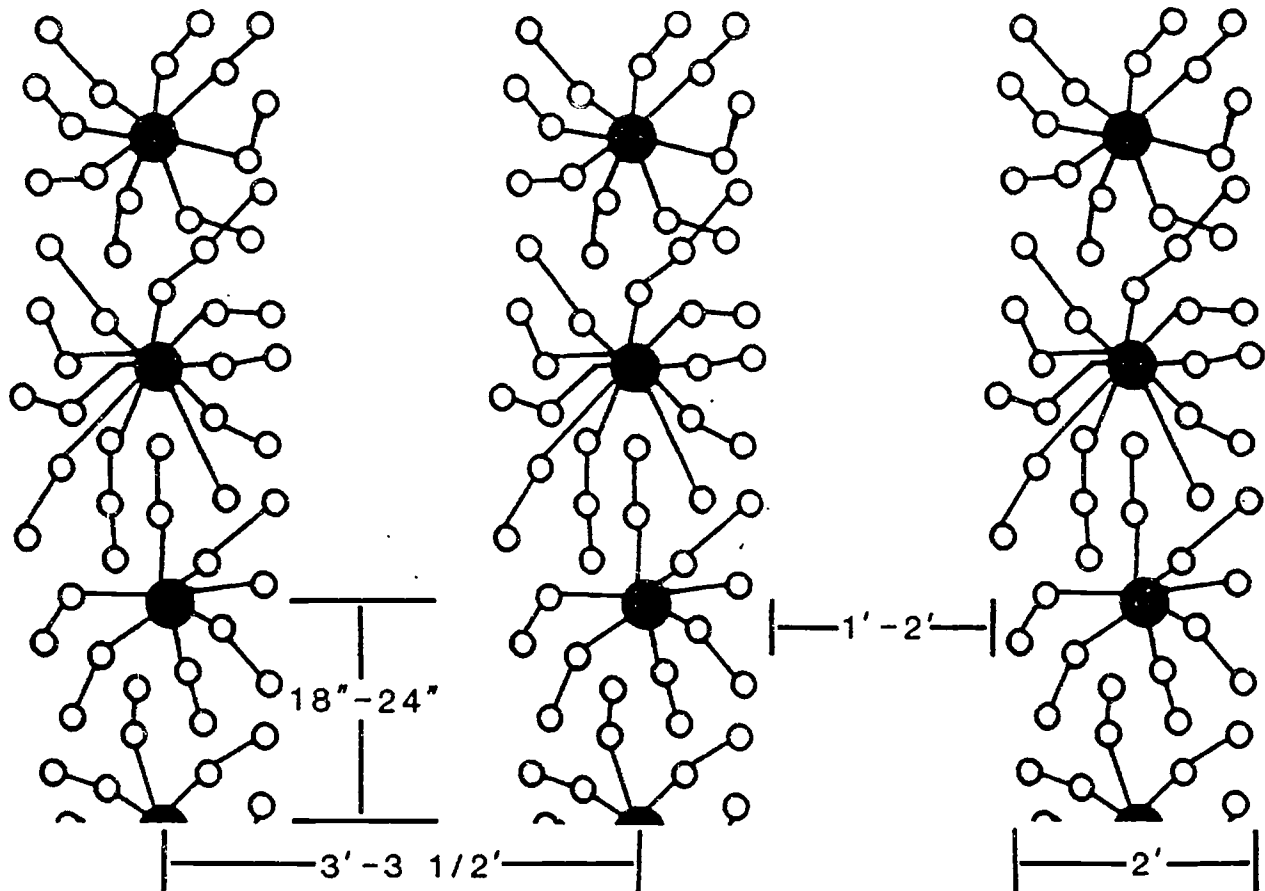

- Parent Plant
- Runner Plant

Plants are spaced 18 - 24 inches apart in single rows. A 3- to 3 1/2-foot aisle is left between each row. Runner plants are arranged by hand at 6 inch intervals until desired spacing is obtained. Final rows are 2 feet wide.

TRANSPARENCY MASTER #8

Grapevine Training Systems

Four-Arm Kniffin Training System

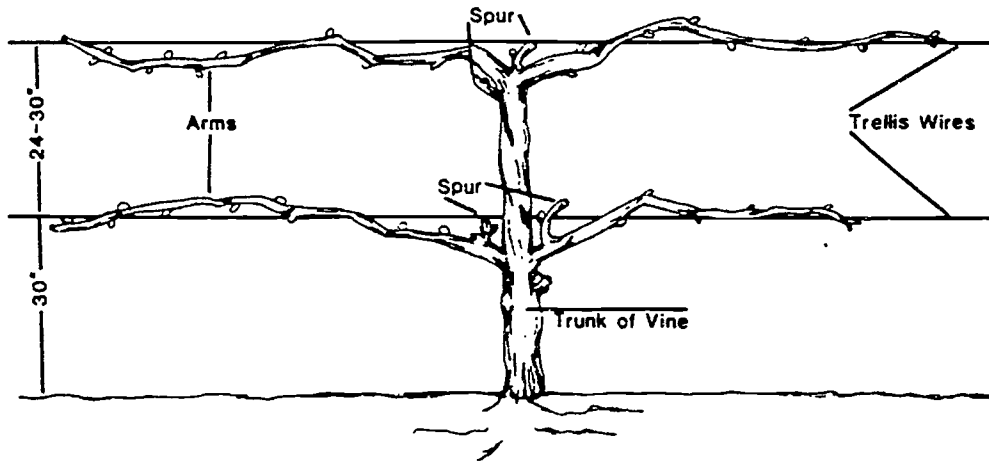

Umbrella Kniffin Training System

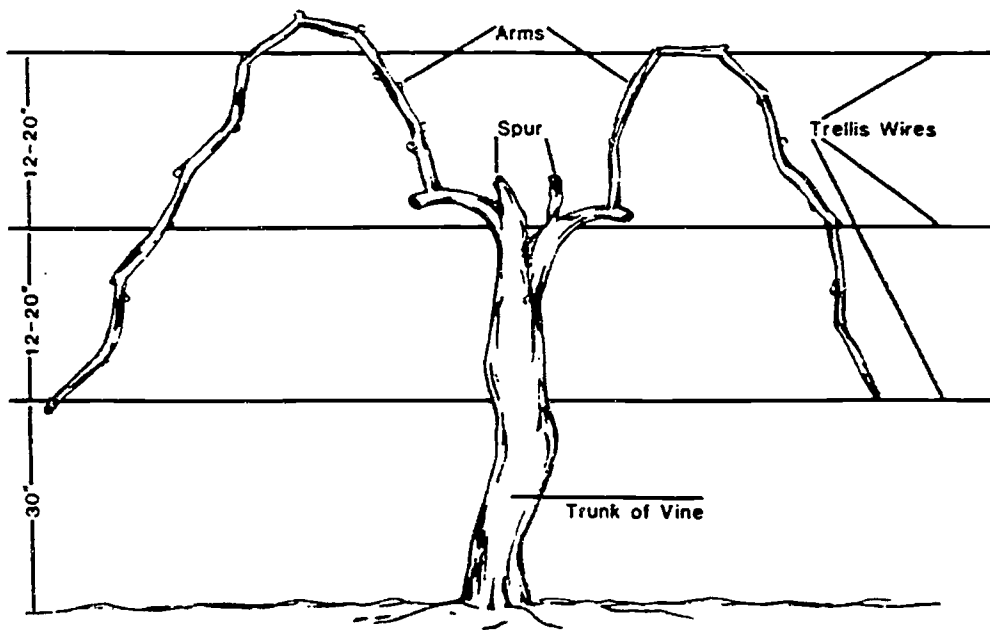

Munson System

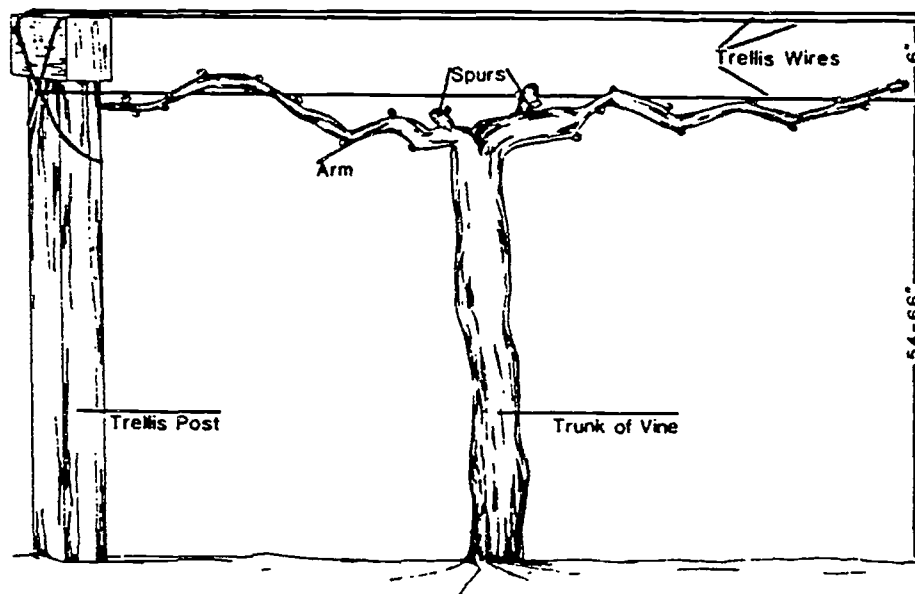

Keuka High Renewal Training System

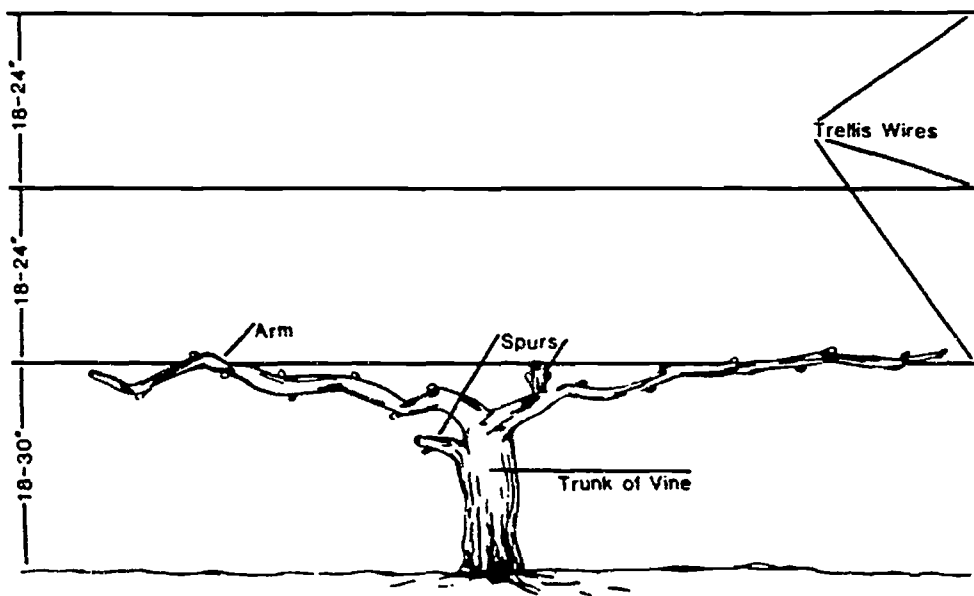

Geneva Double Curtain System

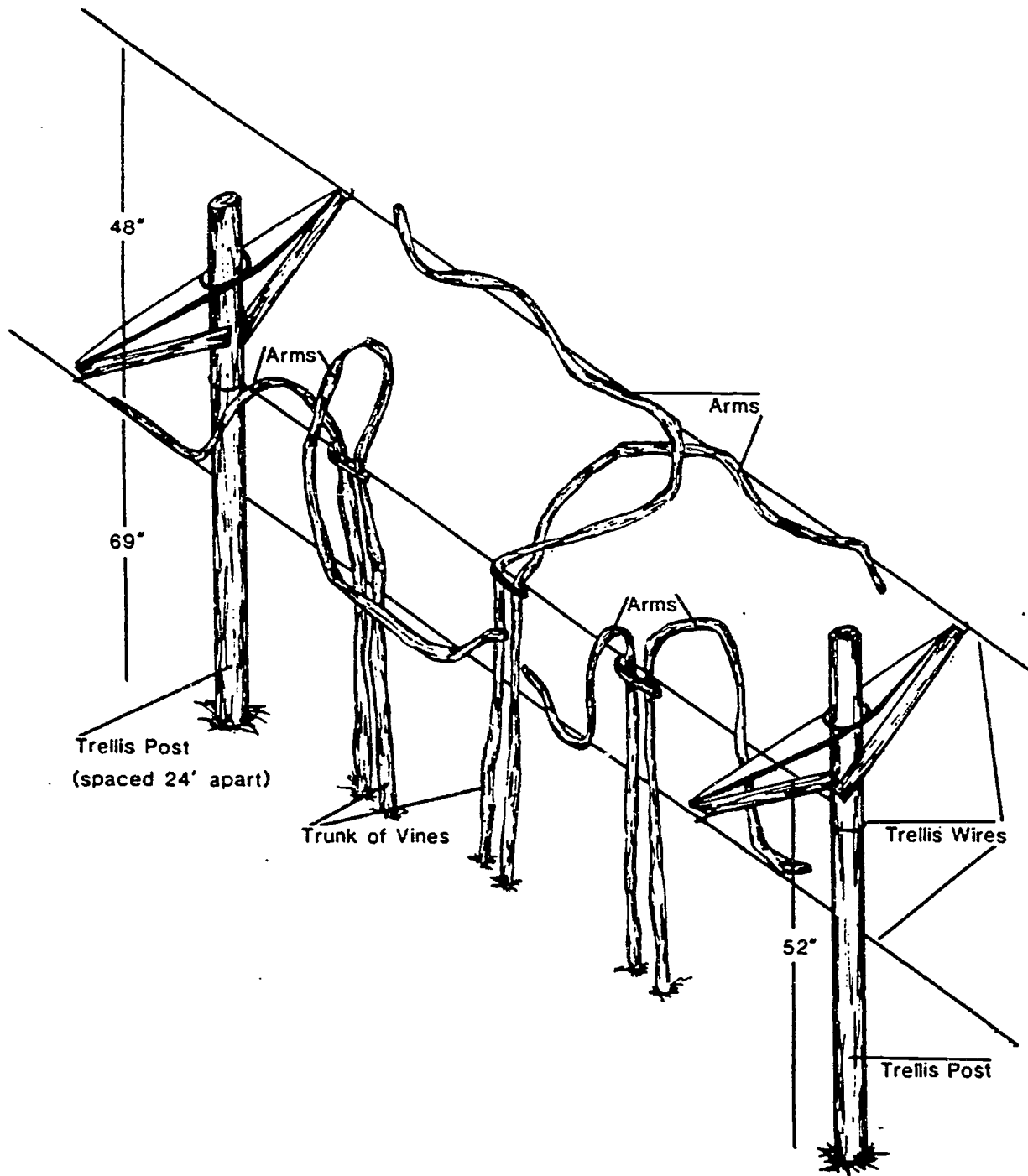

TRANSPARENCY MASTER #9

Training Brambles

The Hill System

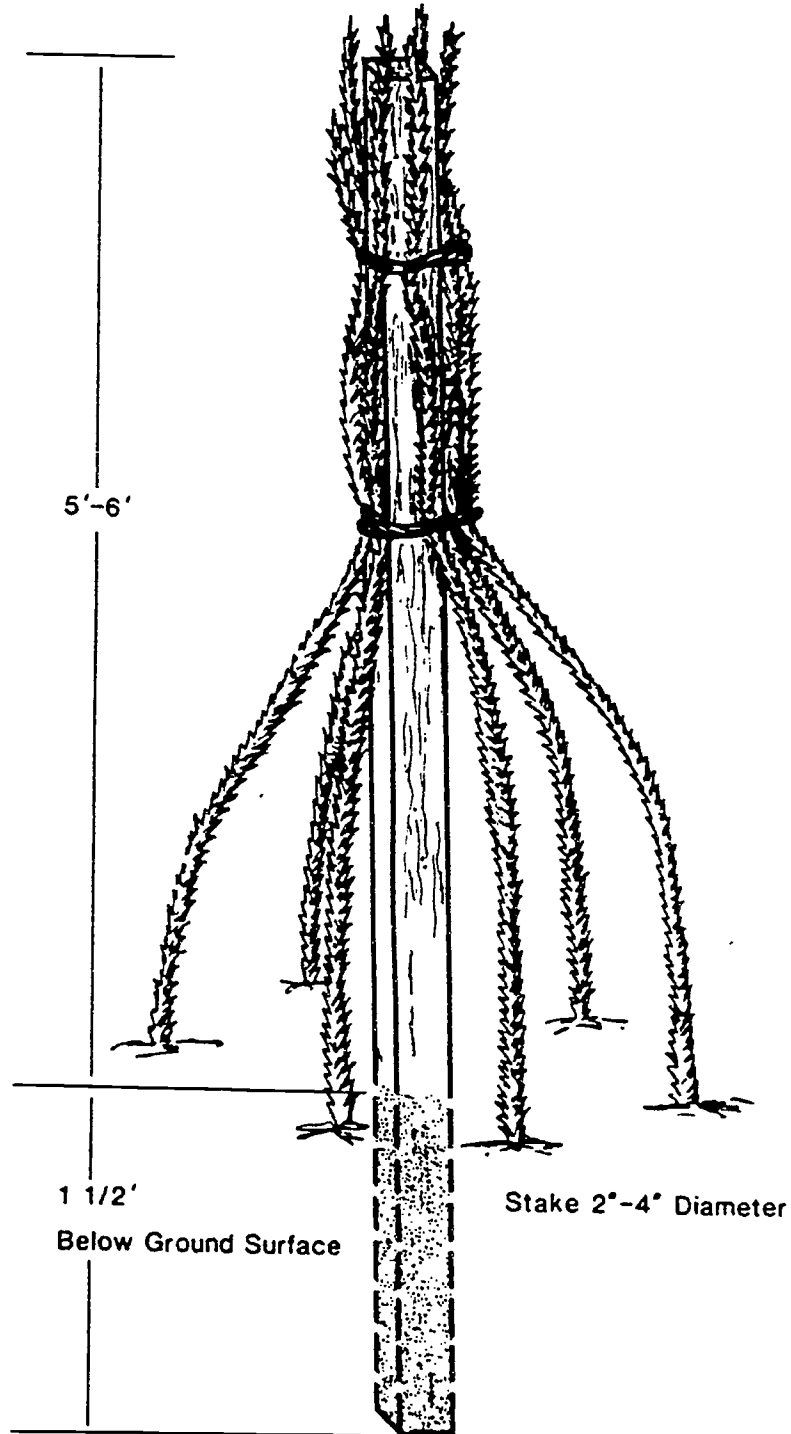

Vertical Wire Trellis System

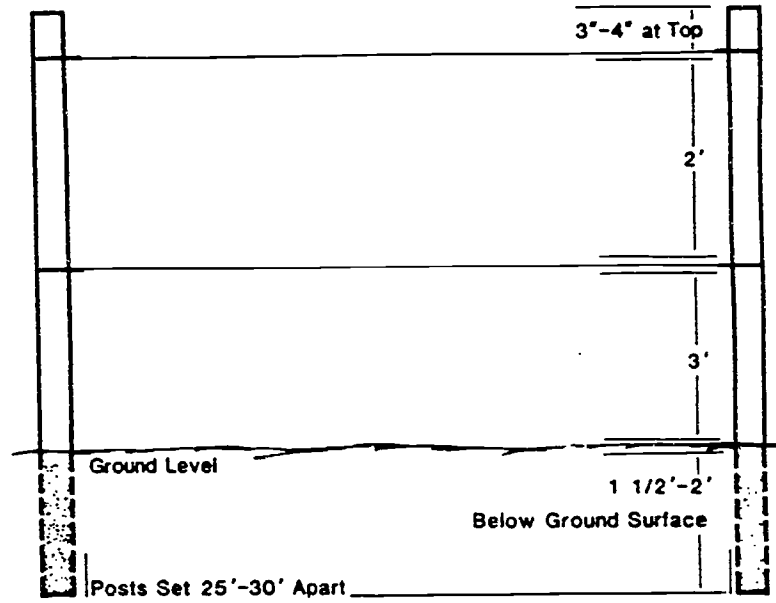

Trailing Blackberries on Vertical Trellis

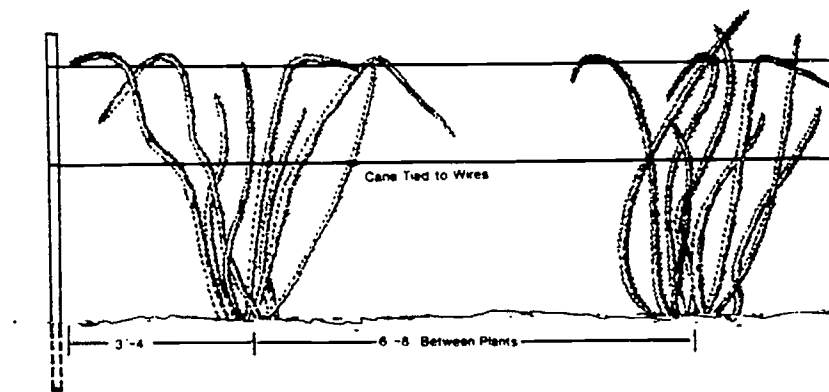

Horizontal Wire Trellis System

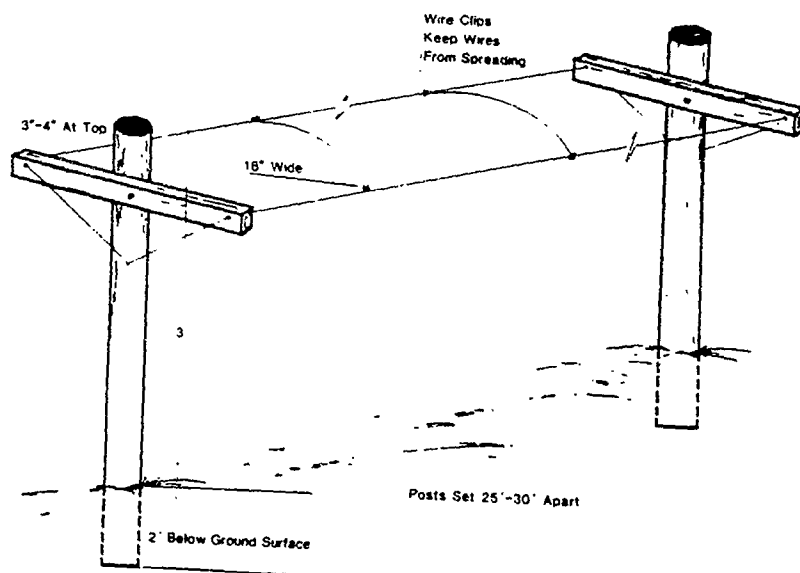

Red Raspberries on Horizontal Trellis

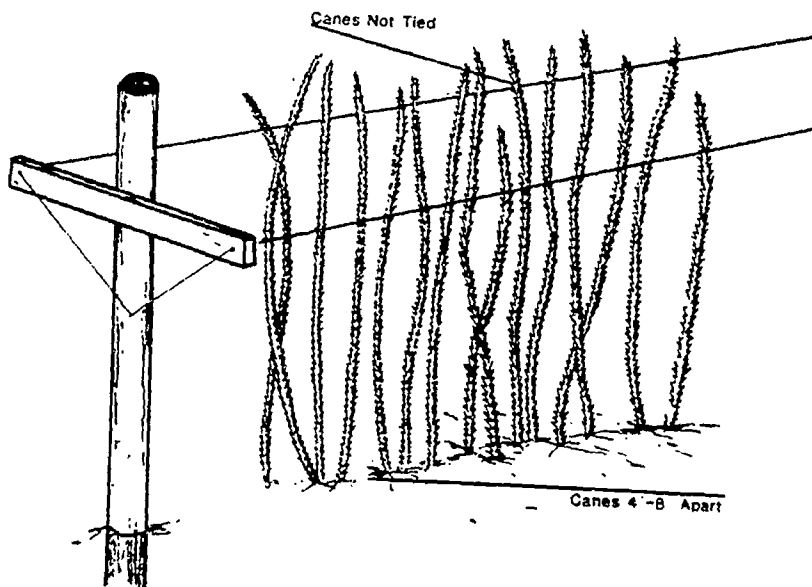

895

TRANSPARENCY MASTER #10

Pruning Raspberries

Black and Purple Raspberry



Before Pruning (shaded areas show part of plant that remains after pruning)



After Pruning

Red Raspberry



Before Thinning and Pruning (shaded areas show part of plant that remains after thinning and pruning)



After Thinning and Pruning

STUDENT ACTIVITIES

- STUDENT WORKSHEET #1 — Major Organic Acids in Fruits
- STUDENT WORKSHEET #2 — Effects of Salinity on Strawberry Plant Growth in Containers
- STUDENT WORKSHEET #3 — Terms to be Defined
- STUDENT WORKSHEET #4 — Comparison of Small Fruit Varieties
- STUDENT WORKSHEET #5 — Selecting and Preparing a Site for Small Fruits and Brambles
- STUDENT WORKSHEET #6 — Planting, Culture, and Harvesting of Small Fruits and Brambles
- STUDENT WORKSHEET #7 — Pruning and Training Brambles
- STUDENT WORKSHEET #8 — Pruning Fruit Trees
- STUDENT WORKSHEET #9 — Growing Tree Fruits
- STUDENT WORKSHEET #10 — Growing Small Fruits and Brambles

For additional activities, teachers may refer to the "Suggested Teaching Activities and Procedures" section in the Instructor's Guide.

207

STUDENT WORKSHEET #1

Major Organic Acids in Fruits

Background:

Organic acids are of great significance in plants. As intermediates in the metabolic processes of the fruit, these acids are directly involved in growth, maturation, and senescence. Fruit juices have a low pH, because they contain high levels of organic acids. The total acid content varies widely, from approximately 0.2% in pear juice to 0.8% in lime. Some of the major acids in fruits include citric, malic, and tartaric acids. Organic acids also influence the growth of microorganisms in fruit juices and therefore affect the keeping quality of the product. At proper levels certain acids are inhibitory to most bacteria. Another aspect of organic acids is their influence on the sensory properties of juice products. Acids are responsible for the fresh, tart taste of fresh fruits and their processed products. Color is also related to the type and level of acids present in the product.

Problem:

Identify the major organic acids in various fruits by paper chromatography. What are the major organic acids in grapes, apples, and strawberries? Do the organic acids differ between varieties of strawberries or grapes? Between varieties grown in the midwest versus California? Between grapes grown in a warm versus a cool climate? If so, why?

Materials:

1. chromatographic jar — a one-gallon mayonnaise jar with lid is suitable for this technique.
2. chromatographic paper — designated "for chromatography" and cut into 20 x 30 cm rectangles; Whatman No. 1 or Schleicher and Schuell No. 2043 chromatographic paper is suitable for this technique.
3. 100-ml and 25-ml graduated cylinders (used in measuring reagents for the chromatographic solvent).
4. indicator solution — prepared by dissolving 1 g of water-soluble bromocresol green in 100 ml water (used in the chromatographic solvent).
5. micropipettes, 1.1- to 1.2-mm inside diameter (used to spot wines on the chromatography paper).
6. 500-ml separatory funnel (used in preparing the chromatographic solvent).

Setup:

To prepare the solvent for this chromatographic technique, transfer the following into the separatory funnel: 100 ml water, 100 ml reagent grade n-butanol, 10.7 ml reagent grade concentrated formic acid and 15 ml indicatory solution. Then, thoroughly shade the solvent mixture and allow two layers to form. The lower layer is discarded (aqueous phase) and the upper phase can be used more than once. It is advisable to transfer the solvent to the separatory funnel periodically to remove any additional aqueous phase.

Procedure:

1. Obtain the chromatography paper (20 x 30 cm) and draw a pencil line parallel to the length of the longest side of rectangle (30 cm) about 2.5 from the edge.
2. Draw into the micropipette by capillary action a sample of juice.
3. Touch the pipette to the paper on the pencil line and make a spot about 1 cm in diameter.
4. Repeat the step for each juice to be tested, about 2.5 cm apart.
5. When the spots are dry, staple the short edges of the rectangle to form a cylinder. The edges should not overlap.
6. After adding 70 ml of the solvent to the chromatography jar, place the paper cylinder into the jar with the spotted edge towards the bottom and secure the line.
7. When the solvent has ascended to near the top edge of the paper cylinder, remove the paper and place it in a well-ventilated area.
8. Leave undisturbed until the paper is thoroughly dry, yellow spots on a blue background.
9. In order to identify these spots as to specific organic acids, the R_f value of each acid should be determined.
10. Measure the distance that the solvent traveled, from the pencil line to the solvent front.
11. Then measure the distance between the center of each acid spot and the pencil line.
12. The R_f value is calculated by dividing the measured distance of the solvent front into that measured for the acid spot.
13. Each organic acid will have a different R_f value, such as 0.78 for succinic acid, 0.75 for lactic acid, 0.5 for malic acid, 0.45 for citric acid, and 0.26 for tartaric acid.

References:

1. "The Ripening of Fruit." Biale, J.B. *Scientific American* (May 1954).
2. *Modern Fruit Science*. Childers, N.F. Gainesville, FL: Horticultural Publications, 1978.
3. *The Manual for Wine Analysis and Laboratory Techniques*. Gallander, J.F. The Ohio State University/Ohio Agricultural Research and Development Center.
4. *Food Science*. Potter, N.N. Westport, CT: AVI Publishing Co., 1978.
5. "Chromatography." Stein, W.H., and S. Moore. *Scientific American* (March 1951).

Submitted By Dr. James Gallander, Department of Horticulture, The Ohio State University/Ohio Agricultural Research and Development Center, Wooster, OH 44691. Taken from *The Science Workbook / Student Research Projects in Food - Agriculture - Natural Resources*. (1985). The Ohio State University.

STUDENT WORKSHEET #2**Effects of Salinity on Strawberry Plant Growth in Containers****Background:**

Soils vary in the concentration of salts present in the soil water. Salts are released into the soil solution as soils weather. Salts can also be added in fertilizers, in saline irrigation water, or in water from almost all sources. Of course, the more pure the water, the less salt is added.

Species of plants vary in their growth response to soil salinity. Some species of plants can grow well in very saline soils. These plants are called halophytes. Halophytes are often found growing near the oceans or in deserts. None of our agricultural plants are halophytes.

In the midwestern part of the U.S., high salt levels are not usually a problem in soils or in crop production. The rainfall and melting snowfall leach away salts from the topsoil. In other areas of the country, salt buildup can be a stress factor limiting agricultural crop productivity. For example, in the southwest and parts of California almost all water is supplied to plants by irrigation. Over the years, salts build up in the soil from soil weathering and evaporation of water from the surface with little leaching.

Our common fruit plants, such as strawberries, are grown throughout the temperate zone. This zone includes the rain-leached soils of the midwest and the irrigated soils of the southwest and California. Are fruit plants sensitive, moderately sensitive, moderately tolerant, or tolerant of soil salinity? The more salt sensitive a plant is, the more yield decreases as salinity rises. At what level of soil salinity does salt become a limiting or stressful factor to fruit plant growth? The strawberry plant provides a good test case as it is fine rooted and responds quickly to changes in the environment.

Problem:

To study the effects of various concentrations of saline water on strawberry plant growth and determine an approximate minimum salt concentration which is harmful to growth.

Materials:

1. twenty-five strawberry plants of any cultivar (may be ordered in late winter as dormant crowns from various nursery catalogs)
2. plastic pots (5-6")
3. soil mix (combination of the soil, vermiculite, perlite, peat)

4. slow release fertilizer, e.g., Osmocote 10-10-10, incorporated at recommended rate into soil mix prior to planting
5. saline solutions made by adding NaCl or KCl to warm/distilled water in the following amounts: 0 mg/liter, 300 mg/liter, 600 mg/liter, 1200 mg/liter, 2400 mg/liter

Procedure:

1. Combine enough soil for one pot with recommended amount of Osmocote fertilizer for one pot and shake well for 30 seconds in a plastic bag. Pour "soil plus fertilizer mix" into a pot while planting the strawberry crown (may require 3 hands). Do this for each of the 25 plants. Place pots on greenhouse bench and randomly assign to each plant one of the 5 salt solutions (up to 5 plants per solution). Label each pot with the appropriate solution concentration. Water each plant with the labeled solution.
2. Grow the plants in a warm greenhouse for 6-8 weeks. Water each pot as necessary with the proper salt solution. Record observations (made visually or photographically) on each plant's growth and development once per week.
3. To terminate the experiment, wash each plant well (tops plus roots) and record the fresh weight. Visually or photographically compare root growth among treatments.

Conclusion:

Prepare a chart summarizing the effects of the salt solutions on plant growth. It should be divided into the following sections: treatment, week number, description of visual effects on plant development, and plant fresh weights.

Questions:

1. Are strawberry plants sensitive to salt? Did higher concentrations alter plant growth more than lower concentrations?
2. Was there a variation in growth response among the individual plants watered with the same solution? If so, what are the factors which could be responsible?

3. Did different treatments use different amounts of saline solution? Which treatment required the most? The least? Why?
4. Were salts added to the pots from any other source than the saline solution?
5. Were there differences in plant root growth among treatments? Do you think it is the strawberry root system or the shoot system that is first affected by salt?
6. Would you expect a different cultivar of strawberries to respond differently to these treatments? What about a different fruit plant?
7. Could strawberries growing near a highway in the midwest be affected by salt?
8. What are possible reasons why some plants can tolerate salts and others cannot?

References:

1. *California Agriculture* 38 (October, 1984 [Special issue: Salinity in California]).
2. *Plant Physiology*. Salisbury, F.B., and C. W. Ross. 2nd edition. Belmont, CA: Wadsworth Publishing Co., 1978.
3. Other botany textbooks dealing with stress physiology.

Submitted by Dr. Diane Miller, Department of Horticulture, The Ohio State University, 2001 Fyffe Ct., Columbus, OH 43210. Taken from *The Science Workbook of Student Research Projects in Food - Agriculture - Natural Resources*. (1985). The Ohio State University.

301

STUDENT WORKSHEET #3**Terms to be Defined**

Instructions: Find the definitions of each term by looking these words up in various references including the dictionary or horticultural textbooks covering tree fruits.

1. Dwarf —
2. Semidwarf —
3. Genetic Dwarf —
4. Spur —
5. Hardiness Zone —
6. Malling/Merton Malling Rootstock —
7. Thinning the Fruit —
8. Herbicide —
9. Insecticide —
10. Fungicide —
11. Crotch Angle —
12. Scaffold —
13. Hand Pruning Shears —
14. Lopping Shears —
15. Pruning Saw —
16. Pole Pruner —

STUDENT WORKSHEET #3 — Key**Terms to be Defined**

Instructions: Find the definitions of each term by looking these words up in various references including the dictionary or horticultural textbooks covering tree fruits.

1. Dwarf — *A tree made up of two distinct tree parts. A dwarfing rootstock is used to limit the tree growth up to 50% of the standard size. This is done by horticulturists.*
2. Semidwarf — *A tree that grows to 60-75% of the standard size. This is done by horticulturists.*
3. Genetic Dwarf — *A tree with a growth-limiting genetic make-up. This is a natural event.*
4. Spur — *Place where the fruit grows on an apple tree.*
5. Hardiness Zone — *Zones of cold hardiness of plant and tree varieties. Some varieties may not grow in certain hardy zones. Illinois has two zones.*
6. Malling/Merton Malling Rootstock — *Dwarfing and semidwarfing rootstocks used in grafts to determine tree size. They are shorter than the standard tree.*
7. Thinning the Fruit — *Operation performed once the fruit crop is starting to grow, involving the removal of some fruits to allow for the best growth possible without crowding.*
8. Herbicide — *Chemical used in weed control.*
9. Insecticide — *Chemical used in insect control.*
10. Fungicide — *Chemical used in some disease control.*
11. Crotch Angle — *The angle where branches fork or where a main limb joins the trunk. A strong crotch angle is an angle of 45 degrees or more.*
12. Scaffold — *The main limbs branching from the trunk.*
13. Hand Pruning Shears — *Tool for pruning branches up to 1/2" in diameter.*
14. Lopping Shears — *Tool for pruning branches 1/2" to 1" in diameter.*
15. Pruning Saw — *Tool for pruning branches over 1" in diameter.*
16. Pole Pruner — *Tool for pruning up to 2" diameter wood, 12-16 feet above the ground.*

STUDENT WORKSHEET #4

Comparison of Small Fruit Varieties

Fruit Type (List two different varieties for each)	Planting Distance		Time Interval from Planting to Fruiting	Approx. Life of Plants	Height of Mature Plant
	Between Rows	Between Plants			
Strawberry 1. 2.					
Raspberry 1. 2.					
Blackberry 1. 2.					
Blueberry 1. 2.					
Grape 1. 2.					

Fruit Type (List two different varieties for each)	Estimated Annual Yield Per Plant	Suggested No. of Plants for Family of Five	Cost of Plants	Quality Characteristics	Size and Durability of Fruit	Plant Hardiness
Strawberry 1. 2.						
Raspberry 1. 2.						
Blackberry 1. 2.						
Blueberry 1. 2.						
Grape 1. 2.						

STUDENT WORKSHEET #5**Selecting and Preparing a Site for Small Fruits and Brambles**

1. What is the difference between blackberries and raspberries and what is the term that refers to both plants?
2. Do brambles prefer full shade, partial shade, or full sunlight?
3. Name 3 major factors to consider when selecting a site to grow brambles.
4. Brambles should be planted in soil that is _____ and high in _____.
5. Why should brambles not be planted in areas where solanaceous crops (potatoes, tomatoes, peppers, tobacco) have previously been grown?
6. Why should raspberries and blackberries never be planted together, and how far apart should they be planted?
7. How far in advance should you begin preparing the site selected for growing brambles?
8. What should the soil pH be for growing brambles?
9. What type of soil is the best for growing strawberries, and why is drainage important?
10. Why should strawberries not be planted in areas where solanaceous crops (potatoes, peppers, tomatoes and corn) have previously been grown?
11. Name 2 reasons why a site with a gentle slope is suitable for strawberries.
12. Name 4 reasons for fumigating the soil prior to planting strawberries.
13. What should the soil pH be for growing strawberries?
14. Should you apply lime directly on established strawberries to raise the pH? Why or why not?
15. Describe a 4-step recommended rotation to precede strawberry establishment.

STUDENT WORKSHEET #5 — Key

Selecting and Preparing a Site for Small Fruits and Brambles

Use VAS Units #U5026 *Growing Raspberries and Blackberries in the Midwest* and #U5027 *Growing Strawberries* as references for this worksheet.

1. What is the difference between blackberries and raspberries and what is the term that refers to both plants? *Raspberries and blackberries are known as brambles. Plants with ripe fruit that slips easily from the receptacle are known as raspberries. Plants with ripe fruit that does not slip easily from the receptacle are known as blackberries.*
2. Do brambles prefer full shade, partial shade, or full sunlight? *Brambles prefer full sunlight.*
3. Name 3 major factors to consider when selecting a site to grow brambles.
 - a. *Soil type*
 - b. *Air circulation*
 - c. *Previous crop history*
4. Brambles should be planted in soil that is *well drained* and high in *organic matter*.
5. Why should brambles not be planted in areas where solanaceous crops (potatoes, tomatoes, peppers, tobacco) have previously been grown? *Brambles should not be planted where solanaceous crops have previously been grown because these crops are hosts to diseases that infect brambles. Some of these disease organisms can live in the soil for many years away from the solanaceous host plant.*
6. Why should raspberries and blackberries never be planted together, and how far apart should they be planted? *Raspberries and blackberries should be planted 600 to 1000 feet apart to lessen the chance of virus spreading between the plants.*
7. How far in advance should you begin preparing the site selected for growing brambles? *You should begin preparing the soil site at least one year prior to planting brambles.*
8. What should the soil pH be for growing brambles? *The soil pH should be in the range of 5.5 to 7.5 for growing brambles.*
9. What type of soil is the best for growing strawberries, and why is drainage important? *Strawberries grow best on a loam or sandy loam soil. A well-drained soil is important because standing water can kill strawberry plants in a short period of time.*
10. Why should strawberries not be planted in areas where solanaceous crops (potatoes, peppers, tomatoes and corn) have previously been grown? *Strawberries should not be planted where solanaceous crops have previously been grown due to the chance of verticillium wilt carry-over to the new strawberry planting. If strawberries are planted after corn, root aphids may be present and injure the strawberry roots.*
11. Name 2 reasons why a site with a gentle slope is suitable for strawberries.
 - a. *It allows surface water to drain quickly.*
 - b. *Cold air will drain away to a lower level.*
12. Name 4 reasons for fumigating the soil prior to planting strawberries.
 - a. *To control root diseases, soil insects and weeds*
 - b. *To prevent plant losses*
 - c. *To produce higher yields*
 - d. *To reduce labor costs for weeding.*
13. What should the soil pH be for growing strawberries? *The soil pH should be in the range of 6.0 to 6.5 for growing strawberries.*

14. Should you apply lime directly on established strawberries to raise the pH? Why or why not? *Lime should not be applied directly to established strawberry plants because the calcium in lime can cause reduced plant growth and berry size.*
15. Describe a 4-step recommended rotation to precede strawberry establishment.
- Step A. Plow the site in fall and sow rye or clover.*
- Step B. Plow the site in spring and raise cultivated vegetables or row crops (other than corn or those that carry verticillium wilt).*
- Step C. Plow again in the fall and sow rye or clover.*
- Step D. Plow the cover crop under in the spring and plant strawberries.*

303

STUDENT WORKSHEET #6**Planting, Culture, and Harvesting of Small Fruits and Brambles**

1. When can brambles be planted?
2. What type of fertilizer should be used when planting brambles?
3. Name the three basic types of training systems for brambles.
4. When should strawberries be planted?
5. How deep should strawberries be planted?
6. What type of fertilizer should be used when planting strawberries?
7. Name the four basic types of training systems for strawberries.
8. How much water do strawberries and brambles require weekly?
9. How can weeds in brambles be controlled?
10. Name 2 reasons for mulching a strawberry planting.
11. Why are flower trusses removed from newly set strawberries the first year they are planted?
12. What is the accepted practice for strawberry frost protection?
13. When are bramble fruits ready for harvesting, and what is the best time of day to pick them?
14. When are strawberries ready for harvesting, and what is the best time of day to pick them?
15. Why should the caps be left on when picking strawberries?

STUDENT WORKSHEET #6 — Key

Planting, Culture, and Harvesting Small Fruits and Brambles

Use VAS Units #U5026 *Growing Raspberries and Blackberries in the Midwest* and #U5027 *Growing Strawberries* as reference for this worksheet.

1. When can brambles be planted? *Brambles can be planted as soon as the soil can be prepared in the spring.*
2. What type of fertilizer should be used when planting brambles? *A starter solution containing a 10-52-17 or 10-50-10 fertilizer should be used when planting brambles.*
3. Name the three basic types of training systems for brambles.
 - a. *Vertical wire trellis system*
 - b. *Horizontal wire trellis system*
 - c. *The staked hill system*
4. When should strawberries be planted? *Strawberries should be planted in early spring so the plants can become established before hot weather.*
5. How deep should strawberries be planted? *Strawberries should be planted so that 1/3 of the crown is buried.*
6. What type of fertilizer should be used when planting strawberries? *A starter solution containing a 10-50-10 fertilizer should be used when planting strawberries.*
7. Name the four basic types of training systems for strawberries.
 - a. *Hill system*
 - b. *Broadcast system*
 - c. *Matted-row system*
 - d. *Spaced matted-row system*
8. How much water do strawberries and brambles require weekly? *Strawberries and brambles require 1 to 1 1/2 inches of water weekly.*
9. How can weeds in brambles be controlled? *Weeds in brambles can be controlled with mulches of black plastic, straw or sawdust.*
10. Name 2 reasons for mulching a strawberry planting. *Mulching a strawberry planting helps avoid damage to roots from alternate freezing and thawing of the soil and may prevent excessive drying of the plants.*
11. Why are flower trusses removed from newly set strawberries the first year they are planted? *Removing flower trusses from newly set strawberry plants during the first year they are planted promotes the formation of runners for a better established planting.*
12. What is the accepted practice for strawberry frost protection? *The accepted practice in strawberry frost protection is to turn on the water when temperatures drop to 34° F at plant level in the field, run it continuously, and turn it off only when all the ice on the plant has melted.*
13. When are bramble fruits ready for harvesting, and what is the best time of day to pick them? *Bramble fruits are ready for harvesting when sweet and firm. They should be picked in the early morning.*
14. When are strawberries ready for harvesting, and what is the best time of day to pick them? *Strawberries are ready for harvesting when they are approximately three-fourths red. They should be picked in early morning when the berries are still cool.*
15. Why should the caps be left on when picking strawberries? *The caps should be left on when picking strawberries to prevent the fruit from shriveling.*

STUDENT WORKSHEET #7**Pruning and Training Brambles**

1. Name 3 tools used for pruning brambles and the major purpose of each.
2. How should pruning tools be cared for after their use?
3. How often and when are red and yellow raspberries pruned each year?
4. How often and when are black and purple raspberries and erect blackberries pruned each year?
5. How often and when are semi-erect and trailing blackberries pruned each year?
6. How often and when are highbush blueberry plants pruned each year?
7. When is the best time to spring prune brambles?
8. When is the best time to remove fruited canes from bramble plants? Why?
9. What should be done with the fruited canes pruned from the plants?
10. How many canes should remain on a red or yellow raspberry plant growing in the hill and other training systems after spring pruning?
11. When pruning everbearing varieties of red and yellow raspberries, should the shoots that bear fruit in the fall be removed after harvest? Why or why not?
12. How many canes should remain on black or purple raspberries or erect blackberries after spring pruning, and what should be done with the lateral branches?
13. How should black or purple raspberries and erect blackberries be pruned during the summer?
14. After spring pruning how many canes should remain on semi-erect and trailing blackberries?
15. Name 3 different training systems for brambles.
16. Name 3 advantages of using some type of training system when growing brambles.
17. Which bramble training systems are the most practical for a large-scale planting of brambles?
18. Which bramble training system does not require the tying of canes?
19. What is the most common system of training brambles and which type of wire trellis is used?
20. Which bramble training system is most useful in home garden plots? Why?

STUDENT WORKSHEET #7 — Key

Pruning and Training Brambles

Use VAS Unit #U4048 *Pruning and Training Bramble Fruits and Highbush Blueberries* as a reference for this worksheet.

1. Name 3 tools used for pruning brambles and the major purpose of each.
 - a. *Hand pruning shears - to cut back laterals and summer topping*
 - b. *Long-handled or lopping shears - to remove canes at ground level*
 - c. *Bramble hook - to remove canes at ground level*
2. How should pruning tools be cared for after their use? *Pruning tools should be cleaned and their cutting surfaces wiped with an oily cloth to prevent rust. Cutting surfaces must be kept sharp.*
3. How often and when are red and yellow raspberries pruned each year? *Red and yellow raspberries are pruned twice yearly, once in early spring and again after fruiting.*
4. How often and when are black and purple raspberries and erect blackberries pruned each year? *Black and purple raspberries and erect blackberries are pruned three times yearly, once in early spring, during the summer, and after fruiting.*
5. How often and when are semi-erect and trailing blackberries pruned each year? *Semi-erect and trailing blackberries are pruned twice yearly, once in early spring and after fruiting.*
6. How often and when are highbush blueberry plants pruned each year? *After the end of the third year in the field, highbush blueberry plants are pruned once a year during the dormant season (early spring is preferred.)*
7. When is the best time to spring prune brambles? *Spring pruning should be done in early spring before the buds begin to swell, but after danger of severe cold is past.*
8. When is the best time to remove fruited canes from bramble plants? Why? *Fruited canes can be removed any time after harvest. Cutting the canes off immediately after harvest is the best time, because it facilitates new growth and reduces possible infestation of diseases and insects.*
9. What should be done with the fruited canes pruned from the plants? *They should be removed from the planting site and burned.*
10. How many canes should remain on a red or yellow raspberry plant growing in the hill and other training systems after spring pruning? *Five to eight canes should be left per stake in the hill system. Canes should be spaced 4 - 8 inches apart in the horizontal or vertical trellis training system.*
11. When pruning everbearing varieties of red and yellow raspberries, should the shoots that bear fruit in the fall be removed after harvest? Why or why not? *The shoots of everbearing varieties should not be removed after harvest, because these shoots will bear fruit again the next spring.*
12. How many canes should remain on black or purple raspberries or erect blackberries after spring pruning, and what should be done with the lateral branches? *Four to five canes should be left per plant and the lateral branches should be thinned out and shortened.*
13. How should black or purple raspberries and erect blackberries be pruned during the summer? *New shoots of black raspberries are pinched back 3 - 4 inches when they reach 24 inches in height. Purple raspberries and erect blackberries are pinched when they reach 30 - 36 inches in height. Shoots of both plants are allowed to grow an additional 6-8 inches more before pinching if grown with supports.*
14. After spring pruning how many canes should remain on semi-erect and trailing blackberries? *The best four to eight canes are left on semi-erect varieties, and eight to sixteen canes are left on trailing varieties of blackberries.*

15. Name 3 different training systems for brambles. *The staked-hill system, vertical wire trellis and horizontal wire trellis are three training systems used for brambles.*
16. Name 3 advantages of using some type of training system when growing brambles.
 - a. *Facilitates harvesting and other cultural practices*
 - b. *Prevents crop losses due to breakage of canes by wind, cultivation, and picking*
 - c. *Keeps the fruit on the canes cleaner*
17. Which bramble training systems are the most practical for a large-scale planting of brambles? *Wire trellising systems are the most practical for large-scale plantings of brambles.*
18. Which bramble training system does not require the tying of canes? *The horizontal wire trellis system does not require the tying of canes.*
19. What is the most common system of training brambles and which type of wire trellis is used? *The hedgerow system is the most common system of training brambles and the horizontal wire trellis is used.*
20. Which bramble training system is most useful in home garden plots? Why? *The staked-hill system for training brambles is the most useful for home garden plots because a small power cultivator can be used, very little hand hoeing is needed, and the fruit is easy to pick.*

STUDENT WORKSHEET #8**Pruning Fruit Trees**

1. What are the primary purposes of pruning fruit trees?
2. How does pruning increase the vigor of growth of a tree?
3. Why would pruning delay fruiting and lessen the yield of the tree?
4. What is a weak crotch angle? Diagram a weak crotch angle.
5. What is the most desirable angle between the branches of fruit trees?
6. Why is it better to prune out some large upper branches?
7. How does pruning affect fruit quality and condition?
8. Name 3 ways that pruning helps control diseases and insects.
9. When is the best time of year to prune fruit trees? Explain your answer.

STUDENT WORKSHEET #8 — Key

Pruning Fruit Trees

Use VAS Unit #U4043 *Pruning Fruit Trees* as a reference for this worksheet.

1. What are the primary purposes of pruning fruit trees?
 - a. *To reduce total growth*
 - b. *To increase vigor of growth*
 - c. *To delay fruiting and lessen yield*
 - d. *To avoid narrow angled branches and weak crotch angles*
 - e. *To improve fruit quality and condition*
 - f. *To aid in controlling diseases and insects*

2. How does pruning increase the vigor of growth of a tree? *Pruning a tree causes the remaining branches to grow larger. The lateral branches will also develop faster and grow longer.*

3. Why would pruning delay fruiting and lessen the yield of the tree? *Any cultural practice which tends to maintain a vigorous shoot growth delays the formation of fruit buds. Pruning young trees either before or after they reach a fruit-bearing stage also lowers fruit yields.*

4. What is a weak crotch angle? Diagram a weak crotch angle. *A limb that branches from the trunk at a narrow angle forms a weak crotch angle.*

5. What is the most desirable angle between the branches of fruit trees? *An angle of 40-60° is the most desirable angle between the branches of fruit trees.*

6. Why is it better to prune out some large upper branches? *It is better to prune out large upper branches which shade out and decrease fruit yields on the lower branches.*

7. How does pruning affect fruit quality and condition? *Pruning can improve fruit quality and condition by letting in more light to give better color to the fruit. Pruning also removes limbs that may rub against fruit and damage it.*

8. Name 3 ways that pruning helps control diseases and insects.
 - a. *By allowing more complete coverage of the branches when spraying preventative pesticides*
 - b. *By eliminating a harboring place for insects and disease in dead or dying wood*
 - c. *By removing dead, weak and useless limbs, resulting in a stronger and more disease resistant tree*

9. When is the best time of year to prune fruit trees? Explain your answer. *Pruning should be done during the dormant season. The open wounds caused by pruning are less susceptible to insects and disease at this time, thus causing less stress to the tree. In addition, when the leaves have dropped, the proper pruning cuts can be easily and readily determined.*

STUDENT WORKSHEET #9

Growing Tree Fruits

True or False:

- ___ 1. Mulching, cultivating, mowing, and using herbicides are common methods of disease control.
- ___ 2. Herbicides can be wettable powders, liquids, or granules.
- ___ 3. Fruit trees should be protected from weed competition for five years after planting.
- ___ 4. A herbicide is used for weed control.
- ___ 5. The same herbicides cannot be used on apple, peach, and cherry trees.
- ___ 6. It is best to follow a year-round schedule when maintaining fruit trees.
- ___ 7. Most pruning of apple and peach trees is done in the spring.
- ___ 8. Any variety of fruit can be planted in any geographical area.
- ___ 9. Fruit trees will do best in full sun.
- ___ 10. Pruning fruit trees has no effect on fruit yield.

Short Answer:

1. A tree consisting of parts from 2 or 3 trees is a _____ tree.
2. Dwarf apple trees can vary in size from _____ feet to _____ feet.
3. On apple trees the fruit grows on a _____.
4. The most troublesome insect for apples is the _____.
5. The three major varieties of apples are _____, _____, and _____.
6. Peach trees may be purchased in three sizes: _____, _____, and _____.
7. Peaches grow on _____ growth.
8. A _____ can be used to prune branches that are 12 - 16 feet above the ground.
9. _____ are used to prune trees with wood diameters of 1/2 - 1 inch, while _____ are used to prune trees with wood diameters up to 1/2 inch.
10. Once the fruit crop is starting to grow, _____ is done to allow for the best growth possible without crowding.

STUDENT WORKSHEET #9

Growing Tree Fruits

True or False:

- False 1. Mulching, cultivating, mowing, and using herbicides are common methods of disease control.
- True 2. Herbicides can be wettable powders, liquids, or granules.
- True 3. Fruit trees should be protected from weed competition for five years after planting.
- True 4. A herbicide is used for weed control.
- False 5. The same herbicides cannot be used on apple, peach, and cherry trees.
- True 6. It is best to follow a year-round schedule when maintaining fruit trees.
- True 7. Most pruning of apple and peach trees is done in the spring.
- False 8. Any variety of fruit can be planted in any geographical area.
- True 9. Fruit trees will do best in full sun.
- False 10. Pruning fruit trees has no effect on fruit yield.

Short Answer:

1. A tree consisting of parts from 2 or 3 trees is a *dwarf tree*.
2. Dwarf apple trees can vary in size from 4 feet to 18 feet.
3. On apple trees the fruit grows on a *spur*.
4. The most troublesome insect for apples is the *codling moth*.
5. The three major varieties of apples are *Delicious*, *Jonathon* and *McIntosh*.
6. Peach trees may be purchased in three sizes: *Standard*, *Semidwarf*, and *Genetic dwarf*.
7. Peaches grow on *last year's* growth.
8. A *pole pruner* can be used to prune branches that are 12 - 16 feet above the ground.
9. *Lopping shears* are used to prune trees with wood diameters of 1/2 - 1 inch, while *handpruning shears* are used to prune trees with wood diameters up to 1/2 inch.
10. Once the fruit crop is starting to grow, *thinning out* is done to allow for the best growth possible without crowding.

STUDENT WORKSHEET #10

Growing Small Fruits and Brambles

Multiple Choice:

1. The most popular training system for bunch grapes is
 - a. trellis
 - b. 4-arm kniffen
 - c. Keuka high
 - d. Geneva double curtain

2. When planting strawberries the crown should be set
 - a. completely above the ground
 - b. completely below the ground
 - c. so that 1/3 of it is buried and it is even with the ground surface after the soil has been firmed around the roots
 - d. none of the above

3. The matted-row system for training strawberries is the major system used by Illinois commercial strawberry producers because
 - a. it is better adapted to machine cultivation
 - b. less weed control is needed
 - c. there is no runner placement so fruit size and yields may be smaller
 - d. all of the above

4. The three major training systems for growing brambles are the
 - a. 4-arm kniffen, munson, and umbrella kniffen
 - b. hill, spaced matted row, and vertical trellis
 - c. staked hill, vertical wire trellis and horizontal wire trellis
 - d. staked hill, horizontal trellis, and umbrella trellis

5. The vertical wire trellis system for growing brambles
 - a. requires no tying of canes
 - b. allows better weed, disease, and insect control
 - c. is the most useful for home garden plots
 - d. utilizes wire clips to prevent bramble canes from spreading the trellis wires apart

True or False:

1. Grapes may be trained on an arbor, a trellis, a fence, or other suitable structure.
2. The soil pH for strawberries should be between 5.5 and 6.5 for optimum production.
3. The first-year blossoms should be removed from newly set strawberry plants.
4. Irrigation can be used for frost control of strawberries in early spring.
5. Strawberry patches do not need to be renovated to improve fruit production.
6. Blueberries need a pH of between 4.8 and 5.2 for optimum growth.
7. Blackberries and raspberries can be interplanted.

- _____ 8. Pruning tools should be cleaned and their cutting surfaces wiped with an oily cloth after each use.
- _____ 9. The staked hill training system is the most practical for large-scale plantings of brambles.
- _____ 10. Brambles should be planted on sites where solanaceous crops (potatoes, tomatoes, tobacco) have been grown because these crops rid the soil of insects and diseases affecting brambles.

Short Answer:

1. What is the difference between blackberries and raspberries and what is the term that refers to both plants?
2. List 3 major factors to consider when selecting a site to grow brambles.
3. Why is irrigation important for a small fruit planting?
4. List 4 factors to consider when selecting which small fruit varieties to plant.
5. When is the best time of day for harvesting small fruits?

STUDENT WORKSHEET 10 — Key

Growing Small Fruits and Brambles

Multiple Choice:

1. The most popular training system for bunch grapes is
 - a. trellis
 - b. 4-arm kniffen
 - c. Keuka high
 - d. Geneva double curtain

2. When planting strawberries the crown should be set
 - a. completely above the ground
 - b. completely below the ground
 - c. so that 1/3 of it is buried and it is even with the ground surface after the soil has been firmed around the roots
 - d. none of the above

3. The matted-row system for training strawberries is the major system used by Illinois commercial strawberry producers because
 - a. it is better adapted to machine cultivation
 - b. less weed control is needed
 - c. there is no runner placement so fruit size and yields may be smaller
 - d. all of the above

4. The three major training systems for growing brambles are the
 - a. 4-arm kniffen, munson, and umbrella kniffen
 - b. hill, spaced matted row, and vertical trellis
 - c. staked hill, vertical wire trellis and horizontal wire trellis
 - d. staked hill, horizontal trellis, and umbrella trellis

5. The vertical wire trellis system for growing brambles
 - a. requires no tying of canes
 - b. allows better weed, disease, and insect control
 - c. is the most useful for home garden plots
 - d. utilizes wire clips to prevent bramble canes from spreading the trellis wires apart

True or False:

- True 1. Grapes may be trained on an arbor, a trellis, a fence, or other suitable structure.
- True 2. The soil pH for strawberries should be between 5.5 and 6.5 for optimum production.
- True 3. The first-year blossoms should be removed from newly set strawberry plants.
- True 4. Irrigation can be used for frost control of strawberries in early spring.
- False 5. Strawberry patches do not need to be renovated to improve fruit production.
- True 6. Blueberries need a pH of between 4.8 and 5.2 for optimum growth.
- False 7. Blackberries and raspberries can be interplanted.

- True 8. Pruning tools should be cleaned and their cutting surfaces wiped with an oily cloth after each use.
- False 9. The staked hill training system is the most practical for large-scale plantings of brambles.
- False 10. Brambles should be planted on sites where solanaceous crops (potatoes, tomatoes, tobacco) have been grown because these crops rid the soil of insects and diseases affecting brambles.

Short Answer:

1. What is the difference between blackberries and raspberries and what is the term that refers to both plants? *Blackberries and raspberries are known as brambles. Plants with ripe fruit that slips easily from the receptacle are known as raspberries. Plants with ripe fruit that does not slip easily from the receptacle are known as blackberries.*
2. List 3 major factors to consider when selecting a site to grow brambles.
 - a. *Soil type*
 - b. *Air circulation*
 - c. *Previous crop history*
3. Why is irrigation important for a small fruit planting? *Small fruits have shallow root systems and require large quantities of water (1 - 1 1/2 inches per week). Irrigation is essential for producing larger, high-quality fruit. In some cases, such as with strawberries, irrigation can be used as a method of frost protection.*
4. List 4 factors to consider when selecting which small fruit varieties to plant.
 - a. *Adaptability to regional conditions*
 - b. *Season of maturation*
 - c. *Disease resistance*
 - d. *Fruit size and yield*
5. When is the best time of day for harvesting small fruits? *The best time of day for harvesting small fruits is the early morning after the dew has evaporated and when the fruit is still cool.*

CLUSTER: HORTICULTURE

UNIT: Horticultural Science and Production

PROBLEM AREA: Processing Fruits and Vegetables

RELATED PROBLEM AREA(S):

1. Understanding Food Science Technology (Central Core Cluster)
2. Processing Agricultural Products (Agricultural Business and Management Cluster)

PREREQUISITE PROBLEM AREA(S):

1. Growing Fruits
2. Growing Vegetables

LEVEL: Preparatory

OCCUPATIONAL TASKS ADDRESSED:

Horticulture Cluster

Duty G: Grading and Packaging Fruit and Vegetable Crops

1. Cool crops using a cooler room

STATE GOALS FOR LEARNING:

In planning the instruction for this problem area, teachers can promote the development of several student learning objectives which are related to the State Goals for Learning in Biological and Physical Sciences. These objectives are listed on the Learning Assessment Plan forms included on the following page(s). Those learning objectives marked with an asterisk (*) are taken from the sample lists provided by the Illinois State Board of Education.



Illinois Agricultural Core Curriculum

Agricultural Education 124 Mumford Hall 1301 W. Gregory Drive University of Illinois Urbana, IL 61801

Directors: Dale A. Law, Ed.D.

Principal Investigator: Jerry D. Pepple, Ed.D

Research Assistant: Janis L. Anderson

88/89

INSTRUCTOR'S GUIDE

CLUSTER: HORTICULTURE

UNIT: Horticultural Science and Production

PROBLEM AREA: Processing Fruits and Vegetables

STUDENT LEARNING OBJECTIVES:

Upon completion of their study of this problem area, students will be able to:

1. Explain the biochemical process of respiration and the difference between aerobic and anaerobic respiration.
2. List the reasons for and ways of blanching.
3. Understand and explain the storage conditions necessary for fruits and vegetables.
4. List reasons why fruits and vegetables are processed.
5. Know who processes fruits and vegetables.

INSTRUCTOR'S NOTES AND REFERENCES:

INSTRUCTOR'S GUIDE**CLUSTER: HORTICULTURE****UNIT: Horticultural Science and Production****PROBLEM AREA:** Processing Fruits and Vegetables**PROBLEMS AND QUESTIONS FOR STUDY****INSTRUCTOR'S NOTES AND REFERENCES:**

1. What is respiration?
2. What is blanching?
3. How should fruits and vegetables be stored?
4. Why is cooling important?
5. What types of storage can be done at home?
What materials can be used to make a storage facility?
6. How do we can fruits and vegetables? What is the environment we are trying to create? Why are some steps in the process absolutely necessary?
7. Why is the same product stored in different ways?

INSTRUCTOR'S GUIDE**CLUSTER: HORTICULTURE****UNIT: Horticultural Science and Production****PROBLEM AREA:** Processing Fruits and Vegetables**SUGGESTED TEACHING ACTIVITIES AND PROCEDURES****INSTRUCTOR'S NOTES AND REFERENCES:**

1. Have the students do Student Worksheet #1.
2. Have the students do Student Worksheet #2.
3. Have the students do some canning as an experiment. Refer to Cooperative Extension Service Circular 1112 (see references), which contains quick and easy instructions for canning. Consult with the home economics instructor for advice, materials, and equipment.
4. Have the students diagram the biochemical processes that occur with various enzymes, or with anaerobic respiration, or other acids in Student Worksheet #2.
5. Conduct a field trip to a local supermarket or grocery store. Methods and techniques of processing and storing fresh fruits and vegetables may be observed.
6. Conduct a field trip to a local orchard and/or market. Many local markets process some fruits into juice for sale. Methods of harvesting, cleaning, and packaging may be observed. Note sanitation requirements and techniques.
7. Use the problem area *Recognizing the Impact of Technology on Agriculture: Electronics* and the prerequisite problem areas as a source of equipment and processes used in processing fruits and vegetables.

330

INSTRUCTOR'S GUIDE**CLUSTER: HORTICULTURE****UNIT: Horticultural Science and Production****PROBLEM AREA:** Processing Fruits and Vegetables**REFERENCES****INSTRUCTOR'S NOTES AND REFERENCES:**

1. *Introduction to Food Processing*. (1985). Jelen, Pavel. Reston Publishing Co. Inc., Prentice Hall, 200 Old Tappan Road, Old Tappan, NJ 07675. (800) 223-2343.
2. *Knott's Handbook For Vegetable Growers*. (1980). Lorenz, O.A., Maynard, D.N. John Wiley & Sons, Inc., 605 Third Ave., New York, NY 10158-0012.
3. *Food Science*. (1986). Potter, N.N. The AVI Publishing Company, Inc., Division of Van Nostrand Reinhold, 115 Fifth Avenue, New York, NY 10003-1004.
4. *Experiments in Food Science*. (Student and Teacher's Guides). The Institute of Food Technologists, 221 N. LaSalle Street, Chicago, IL 60601.
5. *Producing Vegetable Crops*. (1980). Ware, G.W., McCollum, J.P. Interstate Publishers, Inc., P.O. Box 50, Danville, IL 61834-0050.
6. *Canning Fruits and Vegetables* (Circular 1112); *Vegetable Gardening for Illinois* (Circular 1150). University of Illinois, Cooperative Extension Service, College of Agriculture, 69C Mumford Hall, 1301 W. Gregory Drive, Urbana, IL 61801. (217) 333-2007.

*Indicates highly recommended reference

INSTRUCTIONAL RESOURCES

These resources are intended for use by teachers in planning and teaching the materials for this problem area and may be adapted to fit the teaching method(s) used.

INFORMATION SHEET #1 — Background in Fruit and Vegetable Processing

INFORMATION SHEET #2 — Storage Conditions of Vegetables

INFORMATION SHEET #3 — Respiration Rates of Vegetables

INFORMATION SHEET #4 — Respiration-Generated Heat by Fresh Vegetables Stored at Various Temperatures

INFORMATION SHEET #5 — Precooling of Vegetables

TRANSPARENCY MASTER #1 — Equations

TRANSPARENCY MASTER #2 — Home Storage Facilities for Vegetables (with discussion guide)

INFORMATION SHEET #1

Background in Fruit and Vegetable Processing

The processing of fruits and vegetables has grown and expanded with the U.S. population. What was first done in the home is now done on a very large scale with high technology machines. Production occurs during a relatively short season, but produce must last throughout the remainder of the year. Thus, storage and processing are essential to preserve the fruits and vegetables.

We are very interested in the micronutrients that we receive from the harvest. Since there is a high water content in fruits and vegetables, proper storage is vital to diminish water loss. Products will respire, creating humidity which will eventually cause spoilage (through bacteria, yeast, and molds) if not removed. There are a number of biochemical processes which occur in all fruits and vegetables through enzymes. Our goal is to minimize enzyme action which will lessen deterioration of the product.

Fruits and vegetables cannot grow without the process of photosynthesis. In simple words, photosynthesis is the production of organic matter from oxygen and carbon dioxide, aided by light and heat using chlorophyll and plant enzymes. The chemical equation is:

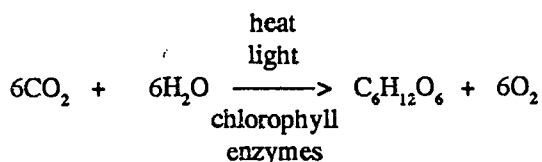

Excess production is thus synthesized and stored by the plant using its own storage mechanism. Examples are:

potato->starch apples->sugars
peas->protein kiwi fruit->Vitamin C

Respiration reverses this process and is a major component after harvest. The chemical equation is:

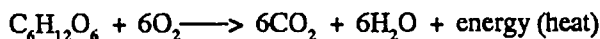

Today almost all harvesting is done mechanically. Because of this, some harvesting is done before ripening occurs. Ethylene gas is what causes ripening to occur and used in appropriate concentration in ripening chambers will ripen harvested material for later sale or processing.

Storage of fruits and vegetables requires proper ventilation to supply oxygen and a regulated temperature to remove and control the heat generated by respiration.

Without this, inadequate oxygen will create an anaerobic respiration. At this point fruits and vegetables will breakdown (sugars->alcohol). The chemical equation is:

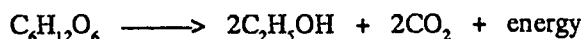

Using a controlled atmosphere (airtight) has been very successful with apples. A controlled atmosphere for storing fruits at home such as lettuce, carrots, and apples can be accomplished by using a polyethylene bag or container that does not allow gas to penetrate. To avoid anaerobic respiration it must be kept in a cool environment and checked periodically. Each fruit or vegetable may have its own special storage requirements. One example is the potato. After being dug, potatoes need to be exposed to large amounts of oxygen for 5-7 days so a new protective skin can be formed over any lesions. This is called suberisation. For winter storage potatoes should be kept in darkness at 4-5° C with humidity at 80-90%. Some other storage conditions can be found on Information Sheet #2.

Blanching is a very important process. There are various ways of blanching, but the result of each is a prevention of deterioration. Blanching techniques vary with the material. Factors affecting the technique used are:

1. Composition and texture of the fresh material.
2. Uniformity and particle sizes of pieces.
3. Nature of the final product.
4. Blanching medium to be used.
5. Available machinery.

The two factors that will determine a successful blanch are time and temperature. One method is that of immersion in hot water for a specified time. Another method uses steam. This minimizes nutrient loss but is more difficult to use and control. The Canadians have developed a blancher that uses steam, but is safer and easier to use. For blanching to be successful, significant enzymes must be deactivated. Testing is done to find the presence or absence of heat-resistant enzymes. The inactivity of Peroxidase is used for this purpose since it is found in most plant material. It is one of the most heat-resistant enzymes.

An alternative to blanching is that of using food additives. The additives block enzymatic reactions in material for which heat blanching would be damaging. An example is using chemical preservatives on mushrooms for freezing due to their delicate nature. If storage requires a longer time span, then further processing is required.

INFORMATION SHEET #2

Storage Conditions of Vegetables

<u>Vegetable</u>	<u>Temperature(°F)</u>	<u>Relative Humidity(%)</u>	<u>Storage Life</u>
Artichoke, globe	32	95	2-4 weeks
Artichoke, Jerusalem	31-32	90-95	2-5 months
Asparagus	32-36	95	2-3 weeks
Bean, Lima	32-40	90	1-2 weeks
Bean, snap	40-45	90-95	7-10 days
Beets, bunched	32	95	10-14 days
Beets, topped	32	95	3-5 months
Broccoli	32	90-95	10-14 days
Brussels sprouts	32	90-95	3-5 weeks
Cabbage, early	32	90-95	3-6 weeks
Cabbage, late	32	90-95	3-4 months
Cabbage, Chinese	32	90-95	1-2 months
Carrots, topped	32	90-95	4-5 months
Cauliflower	32	90-95	2-4 weeks
Celeriac	32	90-95	3-4 months
Celery	32	90-95	2-3 months
Collards	32	90-95	10-14 days
Corn	32	90-95	4-8 days
Cucumbers	45-50	90-95	10-14 days
Eggplant	45-50	90	1 week
Endive, escarole	32	90-95	2-3 weeks
Garlic	32	65-70	6-7 months
Ginger	55	65	6 months
Horseradish	30-32	90-95	10-12 months
Kale	32	90-95	10-14 days
Kohlrabi	32	90-95	2-4 weeks
Leeks	32	90-95	1-3 months
Lettuce	32	95	2-3 weeks
Melons			
Muskmelon (3/4 slip)	36-40	85-90	15 days
Muskmelon (full slip)	32-35	85-90	5-14 days
Casaba	45-50	85-90	4-6 weeks
Crenshaw	45-50	85-90	2 weeks
Honeydew	45-50	85-90	3-4 weeks
Persian	45-50	85-90	2 weeks
Watermelon	40-50	80-85	2-3 weeks
Mushrooms	32	90	3-4 days
Okra	45-50	90-95	7-10 days
Onions, dry	32	65-70	1-8 months
Onions, green	32	90-95	—
Parsley	32	90-95	1-2 months
Parsnip	32	90-95	2-6 months
Peas	32	90-95	1-3 weeks
Peppers, green	45-50	90-95	2-3 weeks
Peppers, ripe	40-45	90-95	1 week
Potatoes, early	-- ¹	90	-- ¹
Potatoes, late	-- ²	90	-- ²
Pumpkins	50-55	70-75	2-3 months
Radish, spring	32	90-95	3-4 weeks

<u>Vegetable</u>	<u>Temperature(°F)</u>	<u>Relative Humidity(%)</u>	<u>Storage Life</u>
Radish, winter	32	90-95	2-4 months
Rhubarb	32	95	2-4 weeks
Rutabaga	32	90-95	2-4 months
Salsify	32	90-95	2-4 months
Spinach	32	90-95	10-14 days
Squash, summer	32-50	90	5-14 days
Squash, winter	50-55	50-75	... ³
Sweet potato	55-60	85-90	4-6 months
Tomato, mature — green	55-70	85-90	1-3 weeks
Tomato, firm — ripe	45-50	85-90	4-7 days
Turnip	32	90-95	4-5 months
Turnip greens	32	90-95	10-14 days
Watercress	32-35	90-95	3-4 days

Adapted from J.M. Lutz and R.E. Hardenburg, *The Commercial Storage of Fruits, Vegetables, and Florist and Nursery Stocks*, USDA Agricultural Handbook 66 (1977).

¹Most summer-harvested potatoes are not stored. However, they can be held 4-5 months at 40° F if cured 4 or more days at 60-70° before storage. They can be stored 2-3 months at 50° without curing. Potatoes for chips should be held at 70° or conditioned for best chip quality.

²Fall-harvested potatoes should be cured at 45-60° F and high relative humidity for 10-14 days. Storage temperatures for seed or table stock should be lowered gradually to 38-40° F. Potatoes intended for processing should be stored at 50-55° F. Those stored at lower temperatures or with a high reducing sugar content should be conditioned at 70° F for 1-4 weeks or until trial cooking tests are satisfactory.

³Winter squash varieties differ in storage life. For example, Table Queen squash can be stored for 35-55 days; Butter-nut, 60-90 days; Hubbard 180 days.

INFORMATION SHEET #3

Respiration Rates of Vegetables

Very LowPotato
Onion**Moderate**Squash (winter & summer)
Tomato
Beet
Pepper**High**Lettuce
Bean
Lima Bean**Low**Sweet Potato
Turnip
CabbageCelery
Cucumber
Muskmelon
Carrot**Very High**Spinach
Pea
Corn
Broccoli
Asparagus

INFORMATION SHEET #4

Respiration-Generated Heat by Fresh Vegetables Stored at Various Temperatures

Heat Generated (100 Btu/ton-day)

Vegetable	32°F	40°F	60°F	68-70°F	77-80°F
Artichoke, globe	5.5- 9.9	7.7-13.2	20.9-31.9	30.1-51.3	33.9- 66.2
Asparagus	6.2-13.2	13.0-23.1	25.5-51.5	38.2-59.2	81.8-104.7
Beans, Lima	2.3- 6.6	4.3- 7.9	22.0-27.4	29.2-39.4	—
Beans, Lima (shelled)	3.9- 7.7	6.4-13.4	—	46.5-58.4	—
Beans, snap	5.5- 9.0	9.2-11.4	32.1-44.1	45.4-53.0	—
Beets (topped)	2.7	4.1	7.2	—	—
Broccoli	4.1- 4.7	7.6-35.2	38.2-74.8	61.2-75.0	123.2-193.6
Brussels sprouts	2.2- 6.6	4.8-10.6	14.1-29.9	18.9-37.8	—
Cabbage	1.0- 1.4	1.7- 2.7	4.1- 5.7	6.1-10.8	10.7- 14.0
Carrots	2.1- 4.5	2.8- 5.8	5.7-11.8	10.1-20.9	—
Cauliflower	3.6- 4.2	4.2- 4.8	9.4-10.8	16.5-18.9	18.5- 30.8
Celery	1.6	2.4	8.2	14.2	—
Corn	6.6-11.3	9.4-18.3	33.3-38.4	59.0-68.4	62.0- 95.8
Cucumber	—	—	3.3- 7.3	3.1-10.6	4.2- 12.1
Garlic	0.9- 3.1	2.0- 7.3	3.1- 6.4	2.9- 5.5	—
Horseradish	1.8	3.1	7.2	9.8	—
Kohlrabi	2.2	3.6	10.8	—	—
Leek	2.1- 7.3	4.3- 6.4	18.2-25.7	—	23.6- 26.1
Lettuce, head	1.3- 3.7	2.9- 4.4	7.0- 9.9	11.2-13.2	16.1- 20.1
Lettuce, leaf	4.2- 6.0	5.3- 7.6	11.3-16.3	18.1-26.1	26.4- 38.0
Lettuce, romaine	—	4.0- 5.1	8.6-10.9	13.3-16.9	21.0- 26.7
Melons					
Muskmelon	1.1- 1.3	1.9- 2.2	7.4- 8.5	9.8-14.2	13.7- 15.7
Honeydew	—	0.7- 1.1	2.6- 3.5	4.4- 5.9	5.8- 7.6
Watermelon	—	0.7- 0.9	—	3.8- 5.5	—
Mushrooms	6.2- 9.6	15.6	—	58.0-69.6	—
Okra	—	11.6-12.9	30.4-33.7	54.5-60.3	72.1- 79.7
Onions, dry	0.6- 0.7	0.7- 0.8	2.3- 2.5	3.1- 4.2	6.0- 6.4
Onions, green	2.3- 4.9	3.8-15.0	14.5-21.4	17.3-34.3	21.5- 46.1
Parsnip	2.6- 3.4	1.9- 3.9	7.1- 9.4	—	—
Peas	6.7-10.3	12.1-16.8	39.3-44.5	54.0-79.5	75.5- 82.9
Peas, shelled	10.4-16.6	17.4-21.4	—	76.7-122.4	—
Pepper, sweet	—	1.1- 4.7	4.4-12.6	5.0-14.3	7.9- 16.3
Potato, immature	—	2.6	2.9- 6.8	4.0- 9.9	—
Potato, mature	—	0.6- 1.9	1.3- 2.6	1.8- 3.5	—
Radish, bunched	3.2- 3.8	4.2- 4.6	15.4-17.1	27.3-30.0	34.8- 42.4
Radish, topped	0.7- 2.1	1.3- 2.9	4.9- 9.3	9.8-12.7	13.3- 19.5
Rhubarb	1.8- 2.9	2.4- 4.0	6.8-10.6	8.8-12.5	—
Spinach	4.2- 4.9	7.6-12.7	29.5-49.2	37.9-63.2	—
Squash, Butternut	—	—	—	—	14.5- 26.8
Squash, yellow summer	2.6- 2.8	3.1- 4.1	16.5-20.0	18.7-21.4	—
Sweet potato, uncured	—	—	6.3	—	11.9- 16.1
Sweet potato, cured	—	—	4.3- 5.3	—	—
Tomato, mature — green	—	1.1- 1.8	3.6- 6.2	6.2- 9.1	7.6- 11.2
Tomato, mature — ripening	—	1.3	5.3- 6.4	5.3- 9.7	6.6- 11.5
Turnip	1.9	2.1- 2.2	4.7- 5.3	5.3- 5.5	—
Watercress	4.3- 5.8	9.6-10.7	36.4-45.0	—	—

Adapted from J.M. Lutz and R.E. Hardenburg, *The Commercial Storage of Fruits, Vegetables and Florist and Nursery Stocks*, USDA Agricultural Handbook 66 (1977).

INFORMATION SHEET #5

Precooling of Vegetables

What is precooling? It is the rapid removal of field heat from vegetables before storage or shipping. The goal of precooling is to maintain vegetables for a period of time in good condition. Precooling will help lengthen storage time by removing field heat to the cooling medium. A cooling medium is usually water, ice, and air. The time it takes to precool an item varies from 30 minutes to 24 hours and depends on the crop and the method. The rate for precooling is effected by:

1. The kind of cooling medium.
2. The difference in temperature between the produce and the cooling medium.
3. The velocity of the cooling medium.
4. The amount of time required to get the produce to the cooling medium.

Hydrocooling is done by immersion in water. The produce is immersed in very cold water for a sufficient time. This is the quickest and most effective means of cooling. Circulating the water will help remove foreign matter and decaying material which later could have harmful effects on storage conditions. Produce placed in crushed ice or produce placed on top of crushed ice will also work. Leafy vegetables will cool well with ice in storage rooms, trucks, and railcars.

First used in 1948, vacuum cooling is effective with cauliflower, peas, and corn, among other vegetables. Produce is placed in a container which is hermetically (airtight) sealed and evacuated rapidly. Pressure is reduced, effecting a moisture loss in the produce. For example, leafy vegetables will lose from 1.5 to 4.7 percent of their moisture, or about 1 percent for every 10°F of temperature reduction.

One way to standardize the cooling of vegetables is to use half-cooling times. Half-cooling time is the interval during which the initial temperature difference between product and coolant is halved.

Half-Cooling Times¹ for Some Vegetables

<u>Vegetable</u>	<u>Coolant</u>	<u>Conditions</u>	<u>Half-Cooling</u>	<u>During Cooling</u>	<u>Time</u>
Artichoke	Water	Single buds, size 36	8 minutes	In crate, uncovered	12 minutes
Asparagus	Water	Single spear	1.1 minutes	In lidded pyramid crate	2.2 minutes
Broccoli	Water	Single head	2.1 minutes	In crate with liner three-quarters filled with water four layers deep	2.2 minutes
				In crate without liners, four layers deep	3.1 minutes
Brussels sprouts	Water	Single sprout	4.4 minutes	In carton 9 in deep filled with water	4.8 minutes
Cabbage	Water	Single head	1.1 hours	In carton, two layers, lid open, filled with water	1.3 hours
Carrot	Water	Single root, 1 1/2-in diameter	3.2 minutes	In 50-lb mesh bag, lying flat	4.4 minutes
Cauliflower	Water	Single head, trimmed	7.2 minutes		
	Air forced	In single-layer cartons; head film wrapped	1.5 hours		
Celery	Water	Single stalk	5.8 minutes	In "Sturdy" crate, lidded on edge, paper liner	9.1 minutes
	Air Forced	In wirebound crates, air movement side to side	35 minutes		
		In two-thirds-size cartons	60 minutes		
Muskmelon	Water	Single fruit, sizes 36 to 27	15 minutes		
	Air	In crate, tunnel cooler, airflow unknown	1.3 hours		

<u>Vegetable</u>	<u>Coolant</u>	<u>Conditions</u>	<u>Half-Cooling</u>	<u>During Cooling</u>	<u>Time</u>
Pea	Water	Single pod	1.9 minutes	In bushel basket, lid off	2.8 minutes
Potato	Water	Single tuber or stacked 9 in. deep	11 minutes		
Radish, bunched	Water	Single bunch	1.1 minutes	In crate, 9 in deep In carton, 9 in deep, filled with water	1.9 minutes 1.4 minutes
Radish topped	Water	Stack, 9 in deep	2.2 minutes		
Sweet corn	Water	Single ear, in husk	20 minutes	In wirebound crates, five ears deep	28 minutes
Tomato	Water	Single fruit	10 minutes	Stack five fruit 10 in deep	11 minutes
	Air	Forced air, pressure difference 0.1 in, water cartons	47 minutes		

Adapted from J.M. Lutz and R.E. Hardenburg, *The Commercial Storage of Fruits, Vegetables and Florist and Nursery Stocks*, USDA Agricultural Handbook 66 (1977).

Half-cooling time is the interval during which the initial temperature difference between product and coolant is halved. For example, if muskmelons are at 92°F and water is at 32°F, a difference of 60°, the time required to cool the melons by 30° is the half-cooling time.

TRANSPARENCY MASTER #1

Equations

Photosynthesis

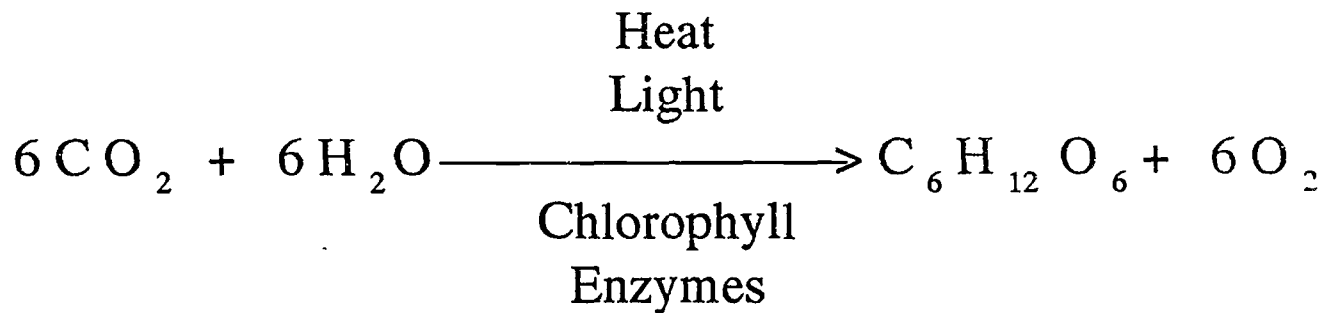

Respiration

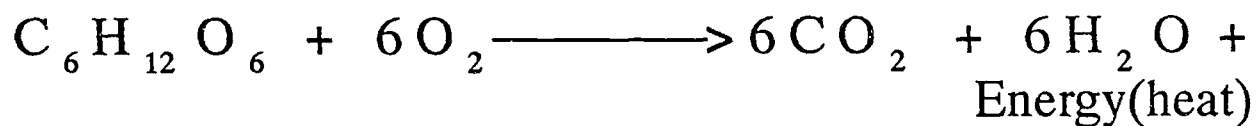

Anaerobic Respiration

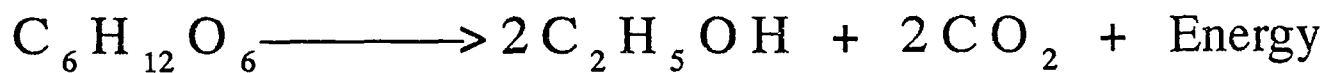

TRANSPARENCY MASTER #2

Home Storage Facilities for Vegetables

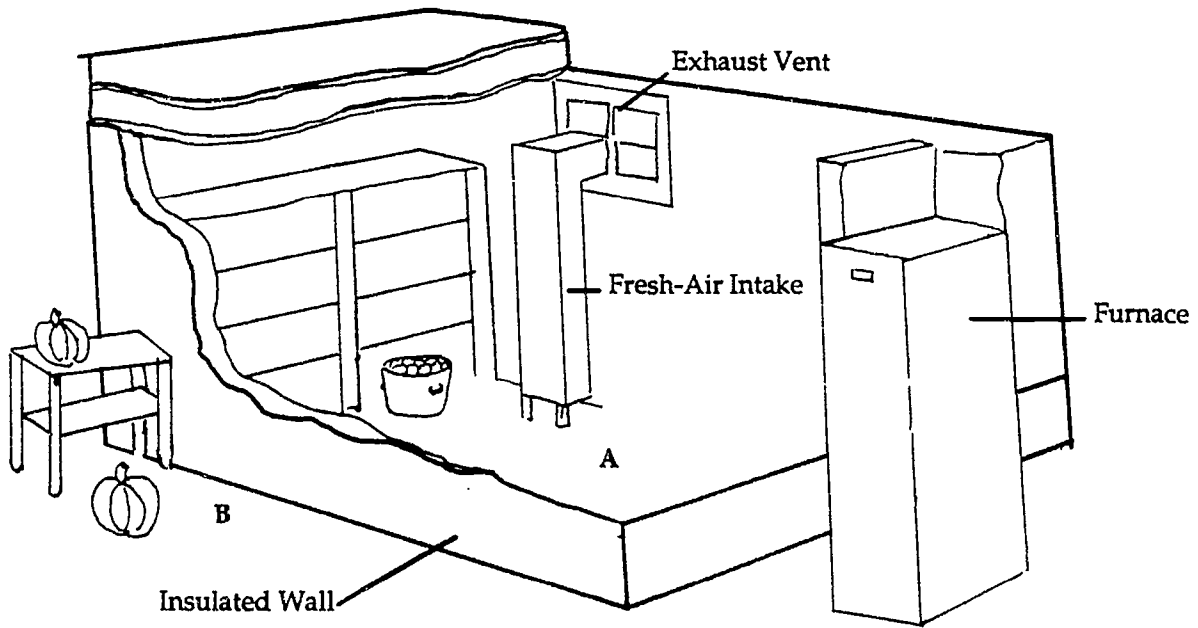
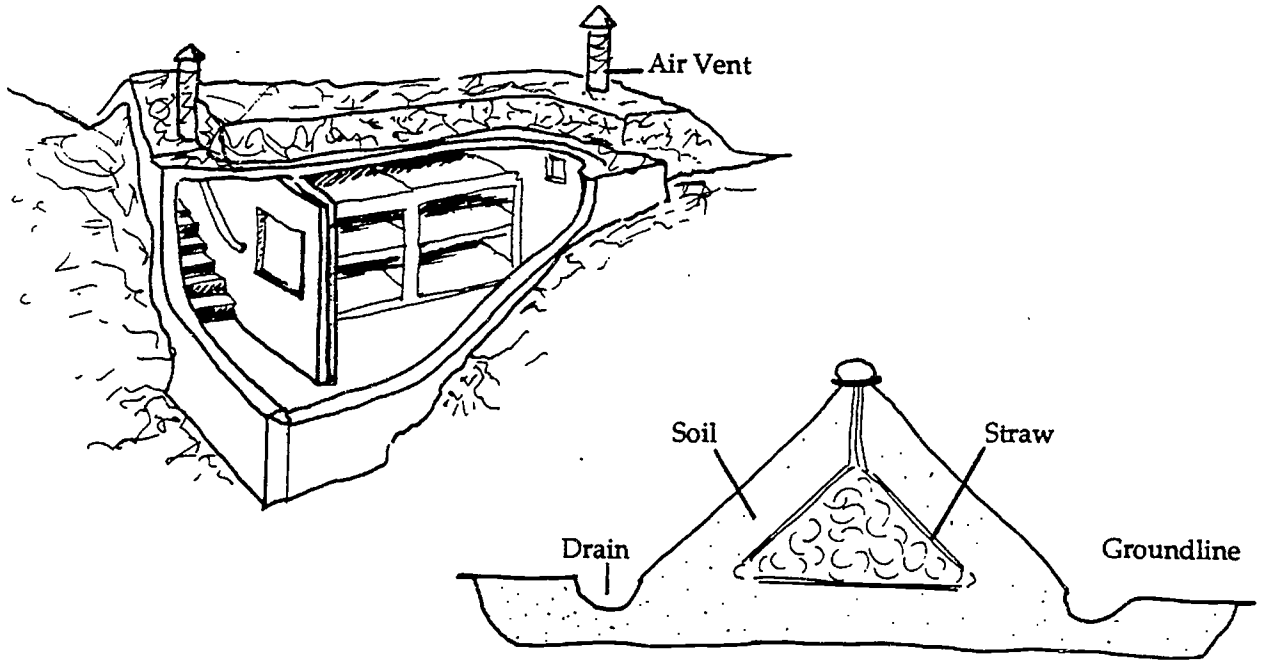

TRANSPARENCY MASTER DISCUSSION GUIDE**Transparency Master #2**

Underground Cellar — Vegetables in the cold-moist and cool-moist groups (cabbage, carrots, potatoes, and other root crops) can be stored in an underground cellar. This cellar can also be used as a storm shelter.

Outdoor Pit — The middle figure shows a cross section of an outdoor storage pit used for vegetables in the cold-moist and cool-moist groups. To construct, place straw on the ground and mound the vegetables on the straw. Cover with 6 inches of straw and at least 6 inches of soil. Leave an air vent to prevent overheating and place a 1-inch board on top of the pit.

Basement Storage — The interior storage area (A) is used for storing vegetables in the cold-moist and cool-moist groups. This area, which is partitioned off from the central heated area, must be insulated and made vaporproof. Vegetables in the cold-dry and cool-dry groups (onions, pumpkins, shallots, and squash) may be stored on shelves outside the interior storage area (B).

From Cooperative Extension Service Circular 1150.

310

STUDENT ACTIVITIES

STUDENT WORKSHEET #1 — Vegetable Storage Questions

STUDENT WORKSHEET #2 — Enzymatic Browning Laboratory Experiment

For additional activities, teachers may refer to the “Suggested Teaching Activities and Procedures” section in the Instructor's Guide.

STUDENT WORKSHEET #1 — Key

Vegetable Storage Questions

1. Name and explain three types of storage methods and structures.
 - a. *In the field. Some vegetables can be stored in trenches, pits, or mounds in the field. Another method is piling the vegetables and covering them with straw or soil to prevent injury from frost. Ventilation can be provided by placing a flue down the center and extended above the pile. This is very labor-intensive and not well liked due to the uncontrollability of factors such as temperature and moisture.*
 - b. *Cellars. Unheated cellars are used somewhat for root crops and potatoes. Unless there is very good ventilation the cellars will be very unsatisfactory because they tend to have high humidities.*
 - c. *Aboveground Houses. Used mainly for crops that need dry conditions for storage. These are usually easy to ventilate and to control for temperature and humidity. The produce can also be easily handled.*
 - d. *Cold Storage. Produce is stored at a low, very controlled temperature. This is the most ideal type of storage except for its high cost and distance from producer. With this type of storage the producer has to sell the produce or have someone or some company store the crop. This is also the best method for long-range storage of some vegetables.*
2. At what point are the processes of respiration and metabolism at their lowest? *Just above their freezing points.*
3. Why is this important to know? *At these low temperatures the produce loses its ability to carry on metabolic processes, so chilling injuries may occur. These may include skin blemishes or internal discoloration, or the produce may fail to ripen or be quicker to decay.*
4. What is important about the condition of the crop when it comes to storage? *Only the best produce should be stored because the physical condition of vegetables will only deteriorate in storage. The lower quality vegetables should be processed.*
5. What is the result of too low or too high moisture and what is the normal needed moisture? *Moisture that is too low will cause leaves to wilt. Moisture that is too high will hasten the process of decay. The normal moisture level is usually at around 90-95%.*
6. Why is aeration necessary during storage? *The circulation of air is needed at first for the removal of field heat and later for the removal of heat generated by respiration.*
7. Why do we need to precool vegetables? *The quicker the field heat is removed from the produce, the longer the vegetables will remain in good condition in storage.*
8. List the five reasons for storing vegetables at low temperatures.
 - a. *Lessens aging.*
 - b. *Slows respiration and metabolic activity.*
 - c. *Lessens moisture loss.*
 - d. *Lessens spoilage due to bacteria, fungi, and yeast.*
 - e. *Stops growths such as potato sprouts.*

STUDENT WORKSHEET #2

Enzymatic Browning Laboratory Experiment

Introduction:

Substances which speed up reactions between other chemicals but which themselves are neither destroyed nor chemically changed during the reaction are called catalysts.

A recent application of catalysts that you have probably heard about is the catalytic converter in automobile exhaust systems. The converter changes potentially harmful exhaust gases into harmless CO₂ and various oxides of nitrogen. The catalyst speeds up the reaction in the converter to greatly minimize the quantity of noxious gases that escape into the atmosphere.

Catalysts can be destroyed or inactivated by a variety of means. This is why all cars equipped with catalytic converters are required to use unleaded gasoline. The tetraethyl lead in the leaded gasolines destroys the catalyst.

One group of catalysts, found in biochemical reactions, is called enzymes. They can be desirable or detrimental to the food processor depending on the particular enzyme activity and the specific food being processed.

Examples of useful enzymes in the food industry include rennin, used to coagulate milk during cheesemaking; protease, used to tenderize meat; and isomerase, used to make liquid sugar. There are many more. Can you think of any?

Examples of undesirable enzymes in the food industry include lipase, which causes rancidity in butter and other cooking oils; and peroxidase, which can lead to the destruction of vitamin C in plant tissue.

Purpose:

The particular enzyme you will be studying in this experiment is polyphenol oxidase. It is the enzyme that is naturally present in many fruits and vegetables, and which causes them to turn brown when they are cut and exposed to air. Specifically, the object of this experiment is to investigate methods used by food processors to inactivate this enzyme.

Materials:

1. food materials
2. organic acids
3. beakers
4. tongs
5. paper towels

Procedure:

1. Your instructor will either provide you with fresh food materials or tell you what to bring to class.
2. Label 5 beakers so you can distinguish among the following solutions:
 - a. Ascorbic Acid 0.1%
 - b. Citric Acid 0.1%
 - c. Acetic Acid 0.1%
 - d. Acetic Acid 1.0%
 - e. Water
3. Fill each beaker with enough solution so that the piece of food can be completely covered.
4. After the solutions are prepared, cut the food into six approximately equal pieces. Using the tongs, dip one of four separate pieces into each of the first four solutions and set them in order on a paper towel. Rinse the tongs in clear water after each dipping. Drop the fifth piece in the water and leave it there. Set the sixth, untreated piece off to one side on a paper towel. Try to prepare all six samples as quickly as possible and note the time when you finished.
5. Check all 6 samples after 5, 10, and 20 minutes. Note the extent of browning on the surface of each piece of food.
6. Prepare a data table in your notebook similar to the one below for recording the color changes observed in step 5.

	Color At		
	5 min	10 min	20 min
Sample 1			
Sample 2			
Sample 3			
Sample 4			
Sample 5			
Sample 6			
	340		

Questions:

1. What can you conclude about the effectiveness of the solutions used to prevent enzymatic browning?
2. Which treatment, if any, appeared to be the most effective? The least effective?
3. What was the specific purpose of the ascorbic acid? Citric acid? Acetic acid?
4. Why didn't the piece of food in the water turn brown as fast as the one in the air?
5. Name some food processes in which enzymatic browning is undesirable.

347

STUDENT WORKSHEET #2 — Discussion Guide**Enzymatic Browning**

Enzymatic browning is a process in which the formation of brown-colored compounds is the end result of enzymatic catalysis of a series of biochemical reactions in certain plant tissues. There are also nonenzymatic browning reactions which are important to the food industry, such as Maillard, caramelization, and ascorbic acid oxidation, but these are not the subject of this experiment.

Chemistry of the Process:

Polyphenol oxidase is an enzyme which is naturally present in many plants. Ordinarily browning of fruits and vegetables after harvesting occurs only very slowly in intact tissue, because the enzyme is not in contact with oxygen. When the fruit or vegetable is bruised or cut, however, the tissue and enzyme are brought into contact with the air, and browning proceeds quite rapidly.

The browning action occurs because the phenolic compounds in the plant tissue are oxidized to orthoquinones which in turn polymerize to form a brown-colored pigment called melanin. Exposure to air (oxygen) thus is a necessary part of the browning reaction.

The enzyme polyphenol oxidase contains copper as a prosthetic group and serves as the catalyst to speed up formation of the melanins. This enzymatic activity is optimum between pH 5 and 6 and at moderately warm temperatures. The catalytic capability of the enzyme can be irreversibly destroyed when it is subject to strong acid (pH of about 3 or less) or high heat.

Processing Considerations:

Enzymatic browning is extremely important to the food processor. Occasionally a processor may want to encourage this reaction as in tea or tobacco; however, more often processors find these color reactions undesirable in their product and seek to prevent the reaction from occurring. There are three ways this can be done.

The first method is, obviously, to exclude or remove oxygen. This can be done by vacuum treatment, by the use of antioxidants, or by submersion under water.

The second method is to add a material which forms a complex with the substrate of a cofactor, such as copper in this case.

The third method is to inactivate the enzyme either by heating or by lowering the pH below 3.

The particular method used by food processors depends on the specific fruit or vegetable and the method of preservation.

The Experiment:

Finding a suitable food material for this experiment may present some problems. While most fruits and vegetables exhibit enzymatic browning, in some the enzymatic activity may be so low that it takes too long; in others it might be too fast. You may wish to pretest this experiment yourself to be sure that the particular food material you select is going to work adequately. In order to see the brown color well, it is recommended that you use a light-colored food, such as apples, peaches, bananas, or avocados.

Ascorbic acid (vitamin C) is an antioxidant which can probably be purchased in crystalline or liquid form at your local drug store if your chemical supplier doesn't have it.

Citric acid is a chelating agent. Others that will work as well are EDTA (Ethylenediaminetetracetic acid) or oxalic acid if they are more available.

Acetic acid is the treatment used to inactivate the enzyme by lowering the pH below 3. Any mineral acid that can produce a solution with a pH of less than 3 will satisfy this treatment.

A sixth treatment not given in the experiment is possible. If you have a vacuum pump or a water aspirator and a vacuum flask available, you might want to have your students try vacuum treatment of the product. For this method, put enough boiled, cooled water in the flasks to immerse the food sample and then attach the flask to the vacuum pump or aspirator. You will notice that the appearance of the food undergoes a substantial change as the air trapped in the food tissue is removed.

Answers to Questions:

Following are answers to some of the questions in the Question section above.

3. Ascorbic acid acts as an antioxidant. Oxygen preferentially oxidizes the ascorbate and not the phenolic compounds. Citric acid acts as a chelating agent. It complexes copper ions that are necessary for the enzyme to be active. Acetic acid, a strong organic acid, reduces the pH below 3 and irreversibly inactivates the enzyme.

4. Oxygen is a necessary part of the browning reaction. Oxygen is readily available to food exposed in air. Immersion in boiled and cooled water restricts the available oxygen.
5. Enzymatic browning is undesirable in various apple products, canned peaches, pears, avocados, etc.

Reference:

T. Richardson, "Enzymes," in O.R. Fennema, ed., *Principles of Food Science*, Part I (New York: Marcel Dekker, Inc., 1976).

CLUSTER: HORTICULTURE

UNIT: Horticultural Science and Production

PROBLEM AREA: Controlling Plant Pests

RELATED PROBLEM AREAS:

1. Recognizing the Impact of Technology on Agriculture: Biotechnology (Central Core Cluster)
2. Conserving Agricultural Resources (Central Core Cluster)
3. Understanding Plant Germination, Growth, and Development (Agricultural Business and Management Cluster)
4. Controlling Plant Pests (Agricultural Business and Management Cluster)
5. Understanding Plant Germination, Growth, and Development
6. Growing Ornamental Plants
7. Growing Vegetable Plants
8. Understanding Plant Anatomy and Physiology
9. Growing Fruits
10. Growing Plants Hydroponically
11. Establishing and Maintaining Turf Areas

PREREQUISITE PROBLEM AREA(S)

1. Identifying Basic Principles of Plant Sciences (Central Core Cluster)

LEVEL: Preparatory

OCCUPATIONAL TASKS ADDRESSED:

Agricultural Business and Management Cluster

Duty I: Assembling, Servicing, and Maintaining Equipment and Facilities

1. Clear and fumigate storage facilities

Duty J: Applying Fertilizers and Chemicals

1. Evaluate chemicals applied to test plots
2. Dispose of chemicals and containers according to manufacturer's specifications
3. Map chemical applications
4. Compute chemical costs
5. Time fertilizer and chemical applications
6. Maintain chemical files
7. Calculate application rates
8. Calculate proportions of chemical and carrying agents

350

Duty L: Growing Corn, Soybeans, Small Grains, or Forage

1. Select pest control program
2. Spray crop for pest control

Duty P: Scouting Fields for Weed, Disease, Insect, or Other Damage

1. Scout fields for weeds
2. Map fields for weed location and severity of weed pressure
3. Scout fields for plant disease damage
4. Collect plant disease specimens
5. Scout fields for insects and pests
6. Map fields for insect and pest damage location and severity of problems
7. Identify crop insects and pests
8. Estimate and monitor insect control
9. Make recommendations for insect control
10. Make recommendations for disease control
11. Make recommendations for weed control
12. Collect insect specimens for identification

Duty R: Applying Safety Practices

1. Comply with shop and equipment safety rules

Horticulture Cluster**Duty D: Applying Fertilizer and Chemicals**

1. Calculate fertilizer and chemical application
2. Mix chemicals
3. Time chemical applications
4. Store chemicals
5. Transport chemicals
6. Map chemical applications
7. Select chemicals for specific problems
8. Maintain chemical inventory files
9. Apply chemicals using boom-type sprayer
10. Apply chemicals using fumigant injector
11. Apply chemicals using air blast sprayer
12. Compute chemical costs
13. Dispose of chemicals and containers according to manufacturer's specifications
14. Suggest lawn chemicals for pest control
15. Interpret chemical labels
16. Suggest chemicals applied to gardens
17. Compute chemicals needed for lawn/garden
18. Suggest chemicals for application to gardens

Duty L: Servicing and Maintaining Equipment and Facilities

1. Clean dusters
2. Clean sprayers
3. Clean and fumigate storage facility
4. Fumigate cold storage facility
5. Suggest cultural practices to control lawn and garden pests

Duty R: Apply Safety Practices

1. Comply with laws regarding notices of chemical application
2. Determine safe weather conditions for chemical application

STATE GOALS FOR LEARNING

In planning the instruction for this problem area, teachers can promote the development of several student learning objectives which are related to the State Goals for Learning in Social Sciences and Biological and Physical Sciences. These objectives are listed on the Learning Assessment Plan forms included on the following page(s). Those learning objectives marked with an asterisk (*) are taken from the sample lists provided by the Illinois State Board of Education.

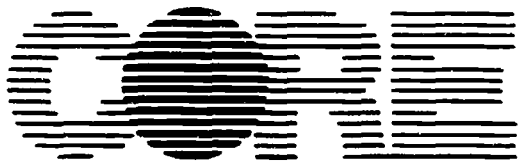
**Illinois Agricultural Core Curriculum**

Agricultural Education 124 Mumford Hall 1301 W. Gregory Drive University of Illinois Urbana, IL 61801

Director: Dale A. Law, Ed.D.

Principal Investigator: Jerry D. Pepple, Ed.D

Research Assistant: Robert E. Petrea

352

89/90

Illinois Agricultural Core Curriculum Rev.

Horticulture
Horticultural Science and Production

ILLINOIS STATE BOARD OF EDUCATION
 Department of School Improvement Services
 100 North First Street
 Springfield, Illinois 62777-0001

LEARNING ASSESSMENT PLAN

Instructions and codes for this form are provided on a separate sheet.

(Affix label or complete district information.)

COUNTY	DISTRICT	ESC
District Name		
City		

Submission Date _____ Page _____ of _____

Original submission Revision

I. LEARNING AREA (check one)

Language Arts Fine Arts

Mathematics Social Sciences

Sciences Physical Development/Health

II. STATE GOAL FOR LEARNING

As a result of their schooling, students will have a working knowledge of the concepts and basic vocabulary of biological, physical, and environmental sciences and their application to life and work in contemporary technological society.

Contact Person: _____
 Title: _____
 Phone: (_____) _____

III. LEARNING OBJECTIVES	IV. ASSESSMENT				V. EXPECTATIONS
	A Types	B Validity/ Reliability	C Commercial Test(s)	D Evidence of Nondiscrimination	
By the end of grade (circle one) <u>3</u> <u>6</u> <u>8</u> <u>11</u> students should be able to:					
*1. Understand the interactions among populations of plants, herbivores, and carnivores.					
*2. Know the principal environmental factors that limit the distribution of plants and animals.					
*3. Compare living organisms by applying a classification scheme.					
4. Define terms integral to controlling plant pests.					
5. Differentiate between harmful and beneficial insects.					
6. Diagnose plant pests and safely apply proper control technique.					
7. Describe conditions which enhance the development of insect and disease problems.					
350					350

INSTRUCTOR'S GUIDE**CLUSTER: HORTICULTURE****UNIT: Horticultural Science and Production****PROBLEM AREA:** Controlling Plant Pests**STUDENT LEARNING OBJECTIVES**

Upon completion of their study of this problem area, students will be able to:

1. Define terms integral to controlling plant pests.
2. Appreciate the importance of prompt identification of pests.
3. Recognize the symptoms of and identify plant pests.
4. Diagnose plant pests and safely apply the proper control technique.
5. Differentiate between harmful and beneficial insects.
6. Understand the problems associated with growing plants and outline applicable preventative measures.
7. Describe the life cycle of common insect pests.
8. Describe conditions which enhance the development of insect and disease problems.

INSTRUCTOR'S NOTES AND REFERENCES

INSTRUCTOR'S GUIDE**CLUSTER: HORTICULTURE****UNIT: Horticultural Science and Production****PROBLEM AREA:** Controlling Plant Pests**PROBLEMS AND QUESTIONS FOR STUDY**

1. What are common pests to plants in Illinois?
2. What are the identifying characteristics of common pests?
3. Why is it important to be able to identify common pests?
4. Why should pests be controlled?
5. What techniques can be used to control or eliminate pests?
6. What management practices can be used to reduce insects and control diseases?
7. How do weather conditions affect common insects and diseases?
8. How are diseases disseminated?
9. What organisms cause diseases?
10. What are the signs and symptoms of various diseases?
11. How do diseases affect plants?
12. What types of insects affect plants?
13. Which insects should one be concerned about?
14. How does one recognize insects of concern?
15. What is the common life cycle of an insect?
16. How long will an insect remain at the particular stage of its life cycle in which it is destructive to plants?
17. What areas of a plant will an insect commonly inhabit during each stage of its life cycle?
18. How does one distinguish between damage due to insects and other types of injury?
19. What are common greenhouse pests?
20. What pests are common in woody plants?
Herbaceous plants?

INSTRUCTOR'S NOTES AND REFERENCES

360

INSTRUCTOR'S GUIDE

CLUSTER: HORTICULTURE

UNIT: Horticultural Science and Production

PROBLEM AREA: Controlling Plant Pests

SUGGESTED TEACHING ACTIVITIES AND PROCEDURES

1. Use problem areas *Controlling Plant Pests* (Agricultural Business and Management Cluster) or *Understanding and Using Pesticides* (Central Core Cluster) as a resource for terms and definitions.
2. Use the problem area *Understanding and Using Pesticides* as a resource for an information sheet on Integrated Pest Management (IPM) and additional resources available on the IPM topic.
3. Lead the class in a discussion on horticultural problems with which they are familiar. Ask students to identify insects, weeds, diseases, and physiological problems separately.
4. Assign groups of students an insect or insects to study. Have them make exhibits of the life cycles of the insects, indicating the locations on the plant where each stage of the life cycle is found, and the stage at which the insect is most easily controlled.
5. Have students make a collection of damaged plant material. Have students identify the pest that caused the damage and appropriate control measures that should be taken.
6. Have students research resistant varieties of plants available in your area and give reports on what these plants are resistant to and the economic significance of the resistant varieties.
7. Use Student Worksheets #1 and #2 for student use in observing diseases and insects.
8. Have students collect five plant problem questions from people in the community and do research to answer those questions. Student Worksheet #3 can be used as a guide to follow in collecting information.
9. Invite a representative from a local lawn care and/or local landscaping contractor to address the class on common pest problems encountered.
10. Have students make a list of pests of the following types and affecting the following plant types:
 - a. insects
 - b. diseases
 - c. pollution
 - d. physiological problems
 - e. indoor flowering and foliage plants
 - f. outdoor flowering and foliage plants
 - g. shrubs and ornamentals
 - h. fruit trees
 - i. shade trees
 - j. lawn or turf areas
11. Conduct a field trip to a park or a community garden area to observe examples of pest problems. Record the observations and determine why a pest was a problem in one location and not in another location.
12. Use the problem area *Understanding and Using Pesticides* in conjunction with this problem area to provide student experiments and practice in selecting and applying pest controls. Use Student Worksheet #1 for additional experience.
13. Use the enclosed Information Sheets as guides for specific insects and diseases to include in subject matter content.
14. Secure copies of VAS Spiral Bound Notebook *Horticulture Plant Diseases* and Insect Sheet *Ornamental Insects I* (see references) for use by students in comparing samples of collected insects and diseased plants. VAS Notebook *Diseases and Pest Notebook* may also be used for this purpose.

INSTRUCTOR'S GUIDE**CLUSTER: HORTICULTURE****UNIT: Horticulture Science and Production****PROBLEM AREA:** Controlling Plant Pests**REFERENCES**

- *1. *Controlling Plant Growth* (VAS Unit #U5005B); *Growing Plants Indoors* (VAS Unit #U5007); *Establishing a Lawn* (VAS Unit #U5008); *Turfgrass Diseases and their Control* (VAS Unit #U5015); *Identifying and Controlling Lawn Insects* (VAS Unit #U5016A); *Careers in Retail Flower Shop Business* (VAS Unit #U5017A); *Identifying Tree and Shrub Insects* (VAS Unit #U5021); *Caring for the Vegetable Garden* (VAS Unit #U5032); *Maintaining a Weed-Free Lawn* (VAS Unit #U5036); *Identifying Common Insect Pests* (VAS Slide Set #S1108-2.2); *Diseases of the Vegetable Garden* (VAS Slide Set #S1108-2.3); *Diseases of the Garden Flowers* (VAS Slide Set #S604); *Horticulture Plant Diseases* (VAS Spiral Bound Notebook #MX699.96); *Ornamental Insects I* (VAS Insect Sheet #X698.16); *Diseases & Pests Notebook* (VAS Notebook #X800). Vocational Agriculture Service, College of Agriculture, University of Illinois, 1401 S. Maryland Drive, Urbana, IL 61801. (217) 333-3871.
- *2. *Insect Pest Management* (Circular 900); *Vegetable Gardening for Illinois* (Circular 1150); *Turfgrass Pest Control* (Circular 1076); *Pest Control and Related Orchard Practices in Commercial Fruit Plantings* (Circular 1151); *Growing Tree Fruits in the Home Orchard* (Circular 1013); *Home Fruit Pest Control* (Circular 1045); *Diseases of Ornamental Plants* (Special Publication #3). University of Illinois, Cooperative Extension Service, College of Agriculture, 69C Mumford Hall, 1301 W. Gregory Drive, Urbana, IL 61801. (217) 333-2007. (The *Illinois Agronomy Handbook* contains many of the circulars listed above.)
3. *How to Collect Insects* (Circular #39) (New manual under development, old copies available through Inter-Library Loan Service); *Tree and Shrub Insect Enemies* (Circular #47). Illinois Natural History Survey, 607 E. Peabody Drive, Champaign, IL 61820. (217) 244-0871.
- *4. *Home, Yard and Garden Newsletter* (Insect, Weed, and Plant Disease Bulletin). University of Illinois, Agricultural Newsletter Service, 116 Mumford Hall, 1301 W. Gregory Drive, Urbana, IL 61801.
5. *Horticultural Science*. (1986). Janick, J. W.H. Freeman and Company, 4419 W. 1980 South, Salt Lake City, UT 84104. (801) 973-4660.

*Indicates highly recommended reference

INSTRUCTOR'S NOTES AND REFERENCES

362

INSTRUCTIONAL RESOURCES

These resources are intended for use by teachers in planning and teaching the materials for this problem area and may be adapted to fit the teaching method(s) used.

- INFORMATION SHEET #1 — Suggested "Insect" Pests for Identification
- INFORMATION SHEET #2 — Insects
- INFORMATION SHEET #3 — Suggested Diseases for Identification
- INFORMATION SHEET #4 — Garden Pest Symptoms and Controls
- INFORMATION SHEET #5 — Diagnosing Greenhouse Crop Problems
- INFORMATION SHEET #6 — Seeding Problems and Treatment
- INFORMATION SHEET #7 — After Transplanting Problems and Vegetables
- TRANSPARENCY MASTER #1 — Insect Parts (with discussion guide)
- TRANSPARENCY MASTER #2 — Insect Types (with discussion guide)
- TRANSPARENCY MASTER #3 — Insect Relatives (with discussion guide)
- TRANSPARENCY MASTER #4 — Insect Differences (with discussion guide)
- TRANSPARENCY MASTER #5 — Mouth Parts (with discussion guide)
- TRANSPARENCY MASTER #6 — Complete Insect Life Cycle (with discussion guide)
- TRANSPARENCY MASTER #7 — Incomplete Insect Life Cycle (with discussion guide)
- TRANSPARENCY MASTER #8 — Causes of Disease (with discussion guide)
- TRANSPARENCY MASTER #9 — Disease Factors (with discussion guide)
- TRANSPARENCY MASTER #10 — Disease Control Measures (with discussion guide)

INFORMATION SHEET #1

Suggested "Insect" Pests for Identification

Flower Pests:

1. Ants
2. Aphids
3. Blister beetles
4. Cutworms
5. Grasshoppers
6. Iris borers
7. Leaf feeding beetles
8. Leaf feeding caterpillars
9. Leafhoppers
10. Mealybugs
11. Scales
12. Slugs
13. Spider mites
14. Thrips
15. White flies

Vegetable Pests:

1. Aphids
2. Bean leaf beetles
3. Cabbage worms
4. Colorado potato beetles
5. Corn borers
6. Cucumber beetles
7. Cutworms
8. Earworms
9. Flea beetles
10. Grasshoppers
11. Hornworms
12. Leafhoppers
13. Mexican bean beetles
14. Mites
15. Squash vine borer

Tree and Shrub Pests:

1. Aphids
2. Bagworms
3. Borers
4. Cankerworms
5. Eastern tent caterpillars
6. Fall webworms
7. Galls
8. Leaf miners
9. Mealybugs
10. Mimosa webworms
11. Mites
12. Sawflies
13. Scales
14. Zimmerman pine moths

Lawn Pests:

1. Aphids
2. Armyworms
3. Chiggers
4. Chinch bugs
5. Cutworms
6. Millipedes
7. Sod webworm
8. White grubs

304

INFORMATION SHEET #2

Insects

Subject Matter Outline:

1. Characteristics of insects
 - a. major parts of insects
 - b. metamorphosis
 - 1) complete
 - 2) incomplete
 - c. life cycle of insects
2. Types of insects
 - a. chewing insects
 - 1) insects on leaves and stems of plants
 - 2) chewing insects infesting seed and grain
 - 3) chewing insects that bore in stems and leaves
 - 4) chewing insects in roots and other underground parts of plants
 - b. sucking insects
 - 1) effect of sucking insects on plants
 - 2) parts of plants attacked by sucking insects
 - c. beneficial insects
 - 1) bees
 - a) fruit pollinators
 - b) alfalfa pollinators
 - d. injurious insects
 - 1) insects that damage plants
 - 2) insects that carry disease
3. Control of insects
 - a. chewing insects
 - 1) stomach poisons
 - 2) break life cycle
 - 3) contact poisons
 - 4) seed and grain treatments
 - a) dry grains
 - b) treat seeds and grain
 - 5) control of borers
 - b. sucking insects
 - 1) contact poisons
 - 2) systemic controls
 - c. soil insects
 - 1) soil treatments (chemical)
 - 2) cultivation
4. Safety with insect controls
 - a. food and drug regulations
 - b. safety to the user

INFORMATION SHEET #3**Suggested Diseases for Identification****Flower Diseases:**

1. Botrytis blight
2. Damping off
3. Powdery mildew
4. Root rot
5. Rust
6. Sclerotinia blight
7. Wire stem

Tree and Shrub Diseases:

1. Anthracnose
2. Cankers
3. Dutch elm disease
4. Fire blight
5. Cedar-apple rust
6. Apple scab
7. Verticillium wilt

Vegetable Diseases:

1. Bacterial wilt
2. Blossom blight
3. Bulb rots
4. Damping off
5. Leaf spot
6. Mosaic
7. Powdery mildew
8. Root rots
9. Rots of ripening fruit

Common Noninfectious Diseases:

1. Chlorosis
2. Frost cracks
3. Mechanical damage
4. Scorch
5. 2,4-D damage

Lawn Diseases:

1. Fairy rings
2. Fusarium blight
3. Helminthosporium
4. Leaf smuts
5. Powdery mildew
6. Rusts
7. Sclerotinia dollar spots
8. Snow molds

INFORMATION SHEET #4

Garden Pest Symptoms and Controls

Pest	Damage or Symptom	Control
Sucking:		
aphids	shriveled leaves	contact spray of systemic stomach poison
scale	brown, black, gray scales	spray winter or summer, hand picking
mealy bugs	yellow leaves, waxy white axils of leaves	contact spray
spittle bugs	spittle	contact spray
red spider mites	small spots of discoloration, silvered leaves	contact spray
leaf roller	nibbled leaves	hand picking
Cuban laurel thrip	folded leaves, red-blotch	systemic stomach poison
thrips	leaf streaks, spread virus	contact dust
Chewing:		
fullers rose	eaten leaf margins	bait
sow and pill bugs	dead and tender leaves	bait
snail, slugs	slime trails, nibbled leaves low on plant	stomach poison
grasshoppers	cut leaves — late summer	contact poison, biological control
caterpillars	cut leaves	bait
earwigs, beetles, weevils	nibbled leaves high on the plant	contact and stomach
Soils pests:		
sod webworm	brown patches in lawn	nematocide
cutworms	stems cut	stomach poison
root knot nematode	galls on roots; dead plants	bait
Miscellaneous:		
borers	sawdust, wilted leaves	
leaf miner fly maggot	mined leaf	
earthworms	small mounds or castings on lawn	
ants	herd aphid, mealy bug	
larger pests		
pets (dogs, cats, etc)	urine, scratch lawn	training pet, design for pets, giving up of gardening
gophers, ground squirrels, moles	tunnels	consult county Agricultural Extension Agent
skunks	scratched turf, nibbled leaves, trampled plants	grub free lawn
people		eradication not feasible, education possible
Fungus:		
powdery mildew	white or grey powder, leaves distorted	sulfur (spray or powder) below 85 degrees; reducing humidity; thinning plants
botrytis, grey mold	blackened, soft; decay on flowers and stems	fungicide, reducing humidity, removing diseased parts
rust	yellow, orange pustules under leaves, mottled	fungicide, clean culture, reducing humidity

Pest	Damage or Symptom	Control
anthracnose	dieback; early leaf drop, brown lesions, cankers	fungicide, pruning diseased portion
leaf spot, leaf blight	shot holes; yellow or red-brown spots on leaves	fungicide, clean culture, pruning diseased parts
wilts, verticillium	root damage; top wilts; partial recovery	fumigating soil before planting, fertilizing, prune diseased portion
root rots	upper root damage (50%), top wilts, alkaline soil	acidifying soil (sulfur, iron), improving drainage, pruning
root rots, water mold damping off, seed collapse	yellowing, droopy leaves seedling failure before sprouting, emerging, or post emergence	fungicide, drench, improving drainage seed fungicide, sterile soil, drenching soil with fungicide
Bacteria:		
fire blight	sooty dark pustules on bark, burned foliage on a branch	Bordeaux, streptomycin (spray on blossoms or prune well below infected portion, burn foliage, and sterilize pruners after each cut)
Virus:		
mosaic	mottled or yellowing stunted leaves, variegated or "breaking" of flower	control of aphids, leaf hoppers, and white flies (no chemical control)

INFORMATION SHEET #5

Diagnosing Greenhouse Crop Problems

Provided by Vaughn Jacklin Corporation

In the eyes of your customers you are a specialist. If your customers are having problems they will almost always ask you for answers — and many times you are not going to be able to answer.

By using the following check list you may be able to “smoke out” the problem when you use the check list in combination with the “Problems and Treatment.”

Keep in mind that your customers live on top of their production and may be overlooking a very obvious cause to their problem — but also remember they probably know a lot more about their own crop than you may think they know.

It sometimes pays handsomely to go over this list with your customers. They have probably gone over some of the questions in their own mind but there may be one or more of the questions they hadn't considered.

Check List:

1. Look for a pattern in symptom development.
 - a. location: portion of bench, house or range; proximity to gutters, shade cloth, CO₂ burners, heaters, etc.
 - b. greenhouse operations: time of planting, water and fertilizer regimens, pinching debudding, transplanting, etc.
 - c. weather: extreme fluctuation in temperature or light, prolonged periods of unusual conditions such as dark weather
2. Obtain history of the problem.
 - a. date symptoms first noted
 - b. rate of development and spread or abatement
 - c. control measures used and effectiveness — any chemical treatment?
 - d. crop rotation in the area
 - e. any problems with the previous crop?
 - f. soil source, treatment
 - g. plant source and original condition (clean starting stock)
 - h. uniformity of greenhouse environment control — temperature, humidity, air circulation
3. Examine plants closely (use hand lens). Are the symptoms pathological, entomological, physiological?

- a. pathological symptoms (usually not uniform throughout greenhouse, specific for certain crops)
 - 1) necrotic (dead) areas on roots, stems, leaves, flowers
 - 2) vascular — discoloration of veins, stem conducting tissue
 - 3) fungus or bacterial growth above or below soil level
 - 4) virus patterns — discoloration or modified growth; symptoms may resemble those by 2,4-D, ethylene, etc.
 - 5) possible laboratory confirmation required
 - 6) faulty (incomplete) soil pasteurization
 - 7) reinnoculation of soil through carelessness
 - 8) ends of hoses hung up
- b. entomological
 - 1) presence of insects on foliage, stems or roots
 - 2) signs of feeding (chewing, sucking or boring)
 - 3) old insecticides — faulty application schedules
 - 4) weeds under benches and outside of air intake areas harboring insects
- c. physiological and cultural symptoms — utilize soil and foliar analysis if necessary (helps eliminate guesswork)
 - 1) nutrient deficiencies
 - a) nitrogen — light green or yellow foliage, more acute on lower leaves
 - b) phosphorus — darkened, dull foliage color, sometimes purpling with yellowing in later stage; reduced growth
 - c) potassium — chlorosis and/or necrosis between veins working in from leaf margins
 - d) magnesium — similar to potassium but leaf margins remain green
 - e) manganese — foliar chlorosis but veins remain green forming a checkered pattern
 - f) boron — new growth gardens, becomes distorted, and lateral growth develops

- 2) nutrient toxicities
 - a) soluble salt accumulation — wilted plants when soil is moist, marginal leaf burn, chlorotic new growth, browning of roots
 - b) ammonium-nitrogen — wilting, chlorosis, root injury
 - c) nitrate-nitrogen — excessive vegetative growth followed by restricted growth at higher levels
 - d) potash, boron, manganese, zinc — necrotic leaf margins
- 3) soil problems
 - a) poor drainage
 - b) poor structure — heavy soil
 - c) unfavorable pH
 - d) too frequent or too infrequent watering
 - e) insufficient water applied to thoroughly wet the soil
 - f) cold soil
- 4) chemical
 - a) excessive rates used
 - b) fumigation of greenhouse when foliage was wet
 - c) application during prolonged dark periods when plants were soft
 - d) particular species or cultivars sensitive to particular chemical product
- e) application at temperatures above 80° to 85° F (especially fumigants)
- f) excessive quantity of wetting agent used — can occur from combining spray materials
- g) weed killer residue in soil or volatile fumes
- h) soil fumigant resident in soil
- 5) climatic
 - a) high or low temperature (including freezing injury — use temperature recorders)
 - b) wrong photoperiod — light interference, burned out light bulbs, faulty controls, holes in black cloth
- 6) miscellaneous
 - a) penta, creosote (wood treatment) injury
 - b) fertilizer injector faulty
 - c) faulty calculations of materials applied
 - d) gas fumes from faulty burners, fresh manure, other pollution sources — mechanical projects (welding, gas engines)
 - e) nematodes — plants grow to limited extent at intervals, may wilt, may develop lumps on roots

Remember: Consult with owner, but don't overlook the grower and other individuals working with the crop. Always check the root condition.

370

INFORMATION SHEET #6

Seeding Problems and Treatment

William H. Carlson
Michigan State University

Provided by Vaughn Jacklin Corporation

Problem	Possible Causes	Suggested Treatment
Poor germination	Improper temperature	Check soil temperature. Be sure it agrees with proper germination temperature for the variety.
	Improper moisture	Correct watering, improve practices.
	Lack of light	Some species require light to germinate; sow this type seed on top of soil.
	Damping off used	Use steamed soil for germination or a synthetic soil that is sterile. Drench with fungicide (Dexon). Improve air circulation. Keep the germination area clean.
	High salts Methyl bromide damage	Don't use soils that have been heavily fertilized. <i>Leach!</i> Make sure treated soil is well aerated. Don't use on carnation or salvia plants.
Poor seedling growth	Improper watering	Check to be sure soil is well drained; water thoroughly so that some leaching occurs. Don't let seedlings stand in water.
	Lack of fertilizer	Seedling will need nutrients. Soil test to determine how much and when to apply.
Poor root growth	Lack of phosphorous	Apply superphosphorus to soil mix or a phosphorous containing fertilizer.
Rooting seedling at soil line	Rhizoctonia	Apply fungicide (Terrchlor).
Wilting of seedling	High salts	Check with solubridge, <i>Leach!</i>
Weak, spindly growth	Low light intensities	Don't keep in dark place for long periods of time.
	High temperature	Use proper growing temperature.
Curvature of leaves	Gas damage	Clean all burners and check gas lines to be sure there are no leaks.

To avoid these problems:

1. Germinate at the proper temperature.
2. Water properly.
3. Use a sterilized soil MIX that contains proper nutrient levels.
4. Germinate area that is clean and well maintained.

The best defense against these problems is a well-planned growing program, plus knowledge of the proper growing practices and procedures to use.

Keep records of seeding practices and procedures. If you then have problems they will be easier to solve.

INFORMATION SHEET #7

After Transplanting Problems and Vegetables

"After Transplanting Problems and Vegetables" is a summary that was prepared by Dr. Jim Boodley of Cornell University and should be helpful in tracking down possible causes of trouble.

Provided by the Vaughn Jacklin Corporation

Problem	Possible Cause	Suggested Treatment
Plants are off color, appear light green	Low nutrition, high soluble salts Too low temperature Waterlogged soil	Apply complete liquid fertilizer. Check total soluble salts level. Leach flats if salts are high. Growing too cold. Use warmer temperature. Raise paks to improve drainage.
Chlorosis Interveinal Yellowing	Root injury due to several causes Improper soil pH Overwatering or underwatering High soluble salts Herbicide residue Trace element deficiency	Apply iron but also try to correctly understand cause. Soil test before using soil to make corrections. Correct watering, improve practices. Leach. No control; investigate soil source before buying. Apply trace elements.
Uneven growth	Poor mixing of soil and fertilizer Nonuniform feeding and watering due to uneven flats Nonuniform moisture levels at transplanting High soluble salts Poor grading of seedlings Phosphorus deficiency	Use liquid feed. Use straw, gravel, or benches to get level platform. Prewet containers at least 24 hours before use. Leach. At transplanting select uniform-sized plants for each pak. Soil test before using soil. Apply high phosphorus liquid feed.
Purple leaves of tomatoes and marigolds	Grown too cold	Check night temperatures: Avoid growing too cold.
Seedlings fall over	Damping off	Use steamed soil. Drench with fungicides. Improve air circulation.
Holes in plants, lower leaves rotting and drying	Slugs, snails, cockroaches, Botrytis Rhizoctonia	Use proper insecticides. Improve air circulation. Use Termil for Botrytis. Use Terrachlor for Rhizoctonia.
Slow growth	Low nutrition Grown too cold Grown too dry Herbicide present	Test soil, apply liquid feed. Increase temperatures. Use 60° night temperatures 2 to 4 weeks after transplanting. Apply proper amounts of water. Know soil history; avoid corn field soils.
Tall and spindly growth	Over-fertilized with nitrogen Grown too warm High natural temperature Excess water Low light intensity	Test soil, check proportion. Cool temperatures, harden plants, improve ventilation via fan. Use B-9 at proper stage. Avoid overwatering. Keep glass clean, wash dust off plastic, paint woodwork white.

TRANSPARENCY MASTER #1

Insect Parts

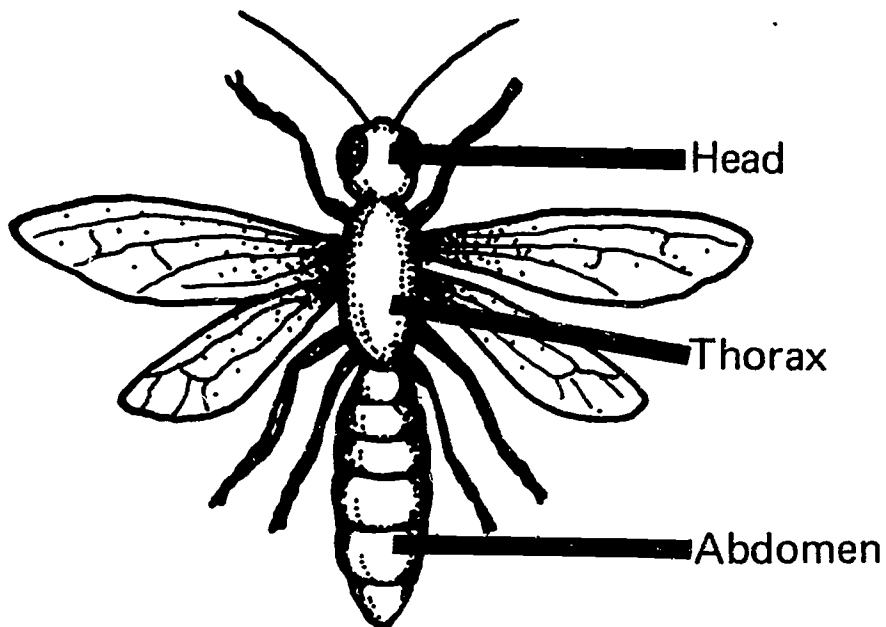

373

TRANSPARENCY MASTER #2

Insect Types

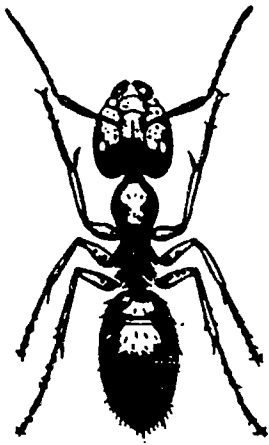

Wingless



Two Wings

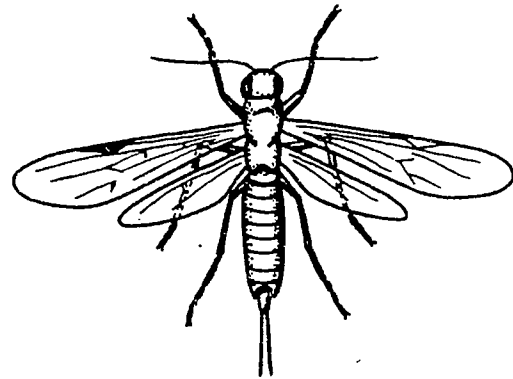

Four Wings

37

TRANSPARENCY MASTER #3

Insect Relatives

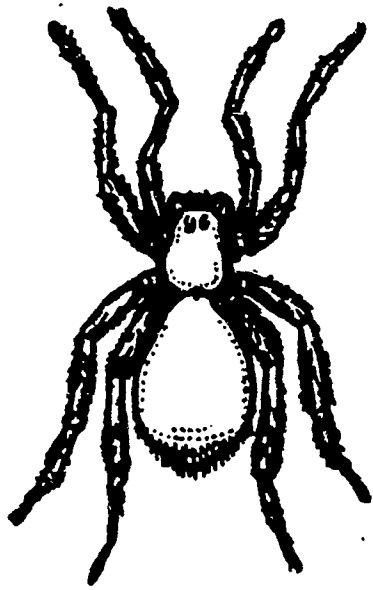

Spider

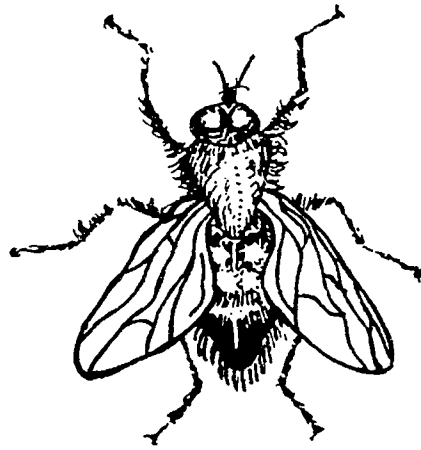

Fly

375

TRANSPARENCY MASTER #4

Insect Differences

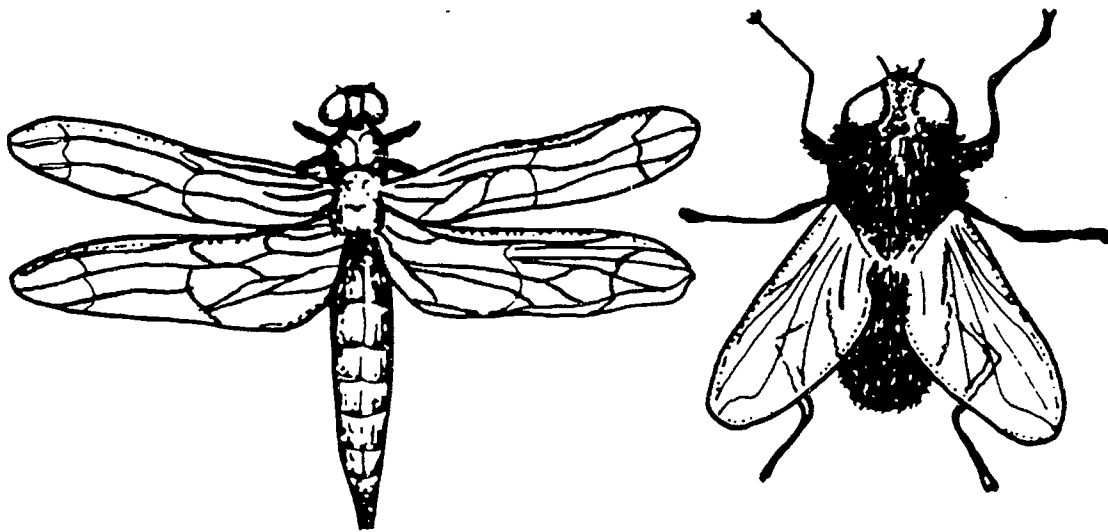

370

TRANSPARENCY MASTER #5

Mouth Parts

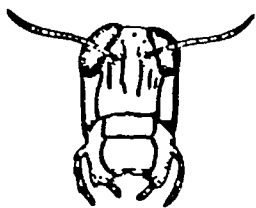

Chewing



Sponging



Piercing-Sucking

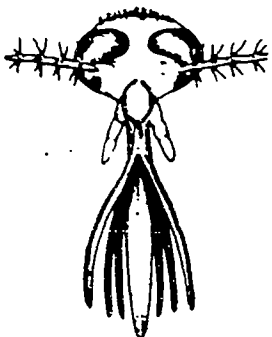

Sucking



Lapping



Siphoning

TRANSPARENCY MASTER #6

Complete Insect Life Cycle

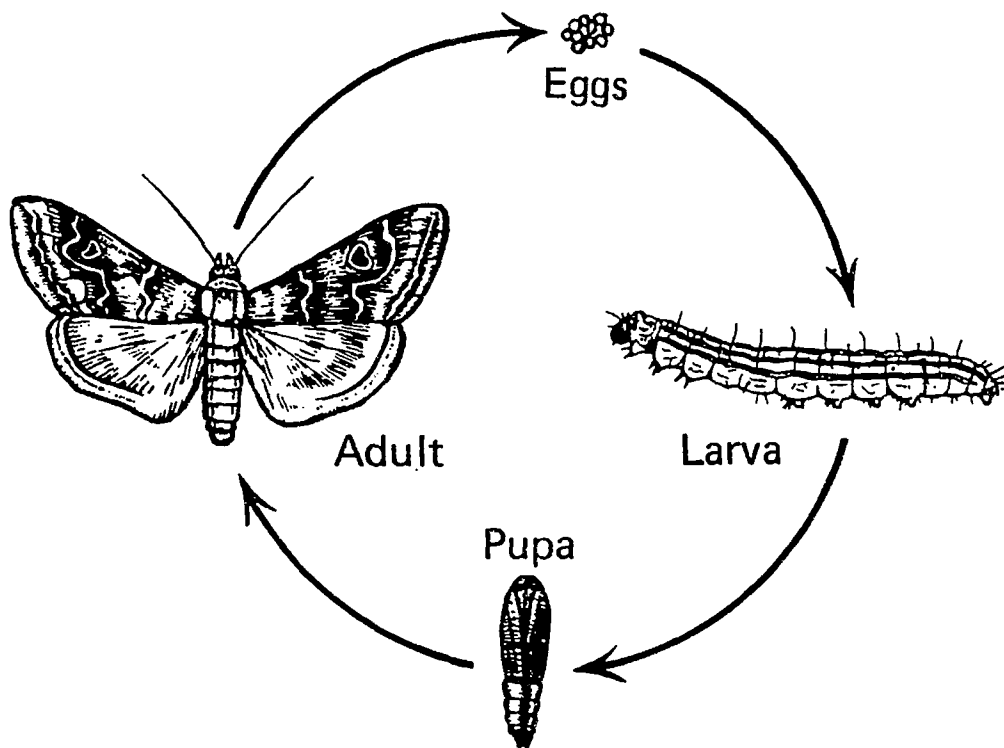

373

TRANSPARENCY MASTER #7

Incomplete Insect Life Cycle

SILVERFISH LIFE CYCLE

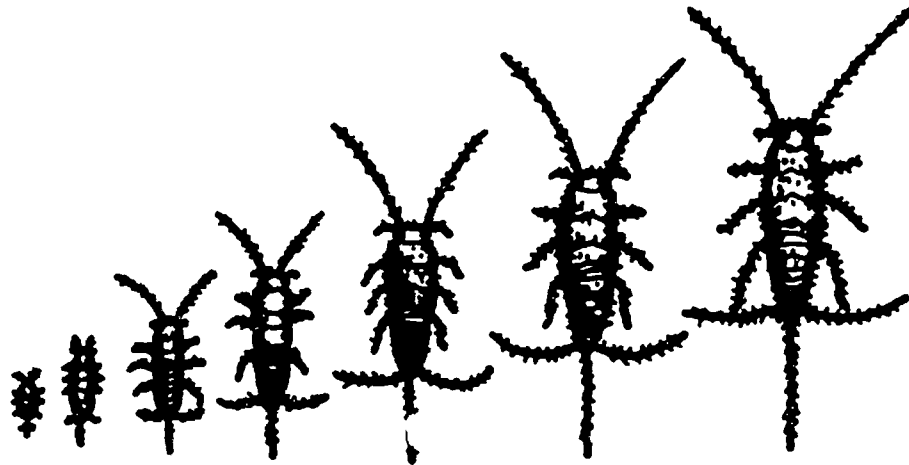

370

TRANSPARENCY MASTER #8

Causes of Disease

Unfavorable environment

- A. Temperature extremes
- B. Chemical injuries
- C. Nutrient imbalances

Pathogens

- A. Fungi
- B. Bacteria
- C. Viruses
- D. Nematodes
- E. Mycoplasma
- F. Parasitic plants

TRANSPARENCY MASTER #9

Disease Factors

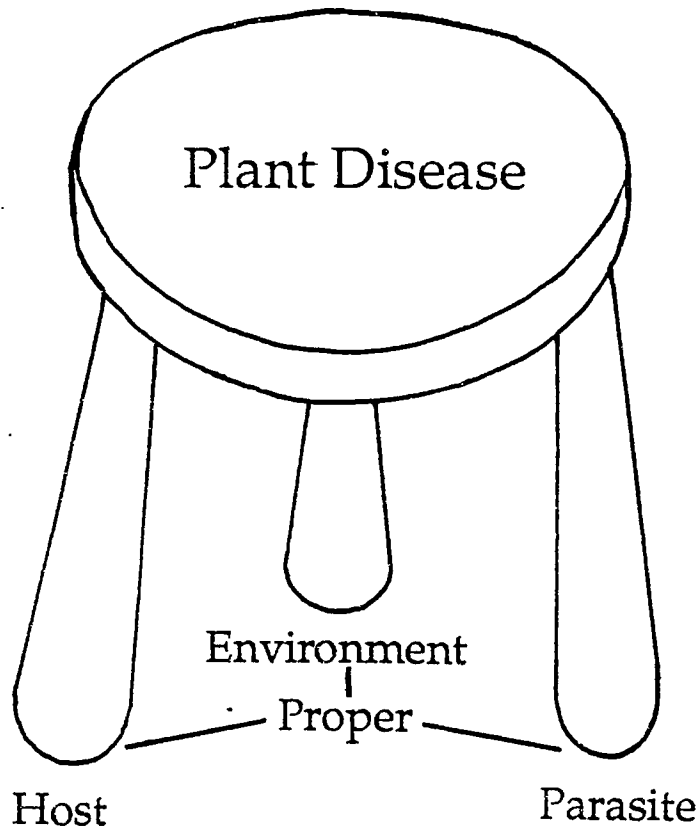

TRANSPARENCY MASTER #10

Disease Control Measures

- 1. Proper soil preparation, planting time, depth, spacing.**
- 2. Well-adapted, top-quality planting stock.**
- 3. Strict sanitation.**
- 4. Insect, mite, and weed control.**
- 5. Fungicide applications RIGHT time, amount, way, and equipment.**

TRANSPARENCY MASTER DISCUSSION GUIDE

Transparency Master #1

An adult insect may be defined as a small invertebrate animal with three body regions and six jointed legs.

Transparency Master #2

An insect may be wingless, or have two or four wings.

Transparency Master #3

Insect relatives are animals closely related to insects by having two body regions, eight or more jointed legs, and no wings.

Transparency Master #4

You can tell one insect from another by looking at the wings and mouthparts. As previously mentioned, some insects have no wings whereas others have two or four. The wings vary in shape, size, thickness, and structure.

Transparency Master #5

Insects also feed in different ways. Those with chewing mouthparts have toothed jaws that bite and tear the food. Insects with piercing-sucking mouthparts have a long beak which they force into a plant or animal to suck out fluids or blood.

Transparency Master #6

Almost all insects change in shape, form, and size during their lives. This change is called metamorphosis. In general, insects develop from eggs in two different ways. One group is said to have a "complete life cycle" and goes through four stages of development.

Transparency Master #7

The other group of insects has only three development stages. This is called an "incomplete life cycle." The adult lays eggs and a nymph, which looks like a tiny adult, hatches from the egg and goes through several growth stages. These nymphs change into wingless adults.

Transparency Master #8

Plant diseases may be divided into two major groups: Those caused by unfavorable growing conditions and those caused by pathogens. It is important that these two groups be distinguished.

A plant disease is any condition which causes abnormal plant development. Plant diseases are most often

infectious, spreading from plant to plant. Diseases may also be noninfectious, such as injury caused by weather conditions, air pollution, or deficiency or excess of water or nutrients.

Transparency Master #9

Three factors are necessary before an infectious disease can occur. These are: (1) a susceptible host plant; (2) a favorable environment; and (3) a casual organism. Effective disease control measures are aimed at breaking this pathogen-host-environment triangle. For example, the plant can be made less susceptible by breeding a resistant variety. The environment often can be changed to be more favorable for the growth of the host plant and be less favorable for the development and spread of the pathogen. Finally, the pathogen can be killed or prevented from reaching the host plant. These basic methods of control can be divided into numerous cultural and chemical practices to keep diseases in check.

Transparency Master #10

Well-adapted, vigorously growing flowers that are planted properly, fertilized, watered, and otherwise cared for are best able to withstand disease and insect attack. Cultural practices that are very helpful include proper preparation of the seedbed and planting at the proper time, depth, and spacing. This information is usually given on the package label and can also be obtained from your local florist or nurseryman. Plant only flower species and varieties that are well adapted to the area. Selecting and planting only top quality seeds and planting stock easily pays for itself. Like anything else, you usually get what you pay for. Be suspicious of advertised "outlandish bargains" in newspapers or magazines; you may be buying diseased planting stock.

Sanitation is also an important control measure. This means promptly collecting and destroying infected plants and plant parts as they appear. Gather all plant refuse at the end of the season and burn or compost this debris. Follow a planting scheme that does not allow closely related annual flowers to grow in the same spot in consecutive years. Follow current insect, mite, and weed control practices suggested by your local teacher or county extension adviser. Your county extension office can also supply you with a wide selection of USDA circulars and leaflets plus the latest information on plant pests and their control from extension specialists at the University of Illinois or other land-grant universities. Other plant experts in a community that would be willing to help include knowledgeable florists, nurserymen, gardeners, garden supply dealers, and personnel of nearby arboretums and botanical gardens.

STUDENT ACTIVITIES

STUDENT WORKSHEET #1 — Observation of Tree, Shrub, Flower, Vegetable, and Turf Diseases

STUDENT WORKSHEET #2 — Observation of Tree, Shrub, Vegetable, and Turf Insects

STUDENT WORKSHEET #3 — Diagnostic Check List and Plant History

STUDENT WORKSHEET #4 — Being a Plant Pest Detective

STUDENT WORKSHEET #5 — Insect Report Outline

STUDENT WORKSHEET #6 — Essay Questions

STUDENT WORKSHEET #7 — The Pyrethrum Test

For additional activities, teachers may refer to the "Suggested Teaching Activities and Procedures" section in the Instructor's Guide.

384

STUDENT WORKSHEET #1

Observation of Tree, Shrub, Flower, Vegetable, and Turf Diseases

Location	Signs and Symptoms of Diseases	Name of Disease	Type of Organism Causing Disease	Preventative Measures	Chemical Control

305

STUDENT WORKSHEET #2

Observation of Tree, Shrub, Vegetable, and Turf Insects

Location	Description of Damage	Description and/or Drawing of Insect Pest	Name of Insect	Control Methods	Time of Control

390

STUDENT WORKSHEET #3**Diagnostic Check List and Plant History**

When definite reasons cannot be given for the poor growth of plants, it is usually because many factors have been overlooked. Although individually each of these factors may be minor, collectively they can significantly impact plant growth. The following questionnaire is designed to collect information on these factors. Because these questions may direct you to areas you have overlooked, when you answer them you may be able to diagnose the problem.

If you can't diagnose your problem alone, bring this completed form to the professional horticulturist of your choice, or to your County Extension Agent. Please attach additional comments as necessary.

Name of Inquirer: _____

Address of Inquirer: _____

Kind of plant _____ Variety of Cultivar _____

Approximate age of plant _____ Height _____ ft; Width _____ ft

What month was the problem first noticed this year? _____

Has the trouble appeared in previous years? _____

What years? (List.) _____

Has the plant recently been transplanted? _____ When? Month _____ Year _____

Is the plant considered winter-hardy for your area? _____

Are other plants of the same kind nearby? _____ How near? _____ Are they having the same trouble? _____

_____ Is the plant in a location exposed to the wind? _____ The sun? _____

Have weed killers been used in the vicinity? _____ How near? _____

What chemical? _____

Is there evidence of injury from lawn mowers, automobiles, machinery, animals, heavy pruning, or faulty planting?

Describe care given to the plant in question for the past two or more years.

1. Fertilizer (kind and amount; foliar or soil application)
2. Insecticides-fungicides (kind; foliar or soil application; systemic; liquid or powder concentrate)
3. Drought and winter protection.
4. Other

387

Comment on unusual weather conditions (extreme temperatures late or early frost, heavy winds, hail and ice storms, drought periods, excessive rainfall or flooding).

Present season _____

Previous season _____

Do cement, asphalt, or other types of pavement occur near the plant? _____ What type? _____

How long has it been there? _____

Are there gas, water, steam, sewer, or other pipes or conduits in the ground near the plant? _____ Have tests been made for leakage? _____

Has the plant been exposed to salt used for ice control along a street or highway or along walkways? _____
 _____ (A salty mist stirred up by auto traffic can cause foliar damage to conifers. A similar problem occurs along sea coasts following storms.)

Soil in which the plant is growing _____

How deep is the surface soil above rock, hardpan, or subsurface layers of soil (soil layers may be detected by different color)? _____ inches. Is the soil clay? _____ Loam? _____ Sand? _____ What is the internal drainage of the site? Good _____ Poor _____ Excessive _____

NOTE: Good, poor, or excessive internal drainage may be determined by the rate at which water disappears from a test hole. A hole may be dug to a depth of three feet, filled with water and a record kept of the time required for the water to disappear. Fill the hole with water three times and record the time of disappearance after each filling. If the water remains in the test hole one or more days, drainage is poor and in need of improvement. If the water drains away repeatedly in less than three minutes, drainage is excessive.

Description of trouble.

Foliage (leaves, needles)

Off color? (spots, yellow, brown, etc.) _____ Describe _____

Symptoms appear on upper leaf surface? _____ Lower leaf surface? _____

Edges of leaves brown? _____ Edges of leaves tattered? _____ Deformed? (galls, twisted, rolled, blisters, callus, etc.) _____ Describe _____

Leaves wilted? _____ Partially devoured by insects? (Holes, leaf mines, leaves chewed on peripheral or interveinal areas) _____ Describe _____

Twigs

Off color? _____ Describe _____

Deformed? (swollen, lesions, cankers, galls, etc.) _____ Describe _____

Bark split? _____ Dark streaks in wood under bark? _____ Channels in wood or under bark? _____

Describe _____

Twig girdled by insects? _____

Flowers

Off color? (spots on petals, etc.) _____ Deformed? _____ Describe _____

Chewed upon or hollowed out by insect?* (describe insect as caterpillar, maggot, grub, beetle, etc.)

Trunk and branches

Oozing sap or flow of resin? _____ Describe _____

Dark streaks in wood under bark? _____ Discolored bark? _____ Swollen? _____

Constricted? _____ Evidence of insects under bark?* (Remove dead bark and determine the extent of injury) _____

Describe _____

Patches of white fluffy material or any other foreign substance on bark? _____ Bark split? _____

Roots

Are some roots exposed? _____ Have roots been covered with soil, sand, or gravel? _____ When?

_____ To what depth? _____

Is there grass growing under the plant? _____ Is it mulched? _____ With what? _____

Is there any unusual growth on the main stem at or just under the soil line? _____

Describe _____

Were there any insects found after a few roots were exposed?* _____ Were the roots malformed? _____

*Collect insect specimens.

NOTE: Sketches or photographs often help to present the facts in a given situation and sometimes furnish valuable clues.

STUDENT WORKSHEET #4**Being a Plant Pest Detective**

Directions:

Use this list to help you remember those things which indicate that the plant is unhealthy.

Kind of Plant _____ Location _____

Question	Yes or No	Description of Symptom
1. Is any part of the plant broken, damaged, or leaking sap?		
2. Is the plant wilted?		
3. Is the plant stunted or not developing a normal shape?		
4. Is any part of the plant rotted?		
5. Is any part of the plant yellowish, brownish, or of a color different from the usual?		
6. Are there any unusual growths on the plant?		
7. Can you spot any pests?		

I have filled in all of the plant symptoms that I can see.

Name _____

390

STUDENT WORKSHEET #5**Insect Report Outline**

The purpose of this insect report is for you to systematically identify in depth an insect; understand its life and its habits. After your study of the insect, you should be able to recommend possible controls for this pest. This step-by-step approach should be common practice whenever considering controls for other insect pests in the future.

Insect

Chemical - Recommendation from the *Annual Pest Control Handbook*

1. Describe the insect and include the scientific information necessary to identify the insect.
2. Describe the areas over which the insect may be found (distribution).
3. Describe the area over which an individual of the species may roam or forage (range).
4. Indicate the insect's host and alternate hosts, their distribution, and numbers.
5. Describe the characteristic damage of the pest on different hosts.
6. Describe the habits of the insect and the characteristics of the infestation, including:
 - a. Individual history (life cycle).
 - b. Generation span.
 - c. Number of individuals per year.
 - d. Vectors.
 - e. Resting sites and times.
 - f. Hibernation (over winter) sites and times.
 - g. Oviposition sites and times.
 - h. Eating habits (when, where, how).
7. Describe the factors that cause the insect to become destructive.
8. Determine possible control measures, including:
 - a. Those indicated by bionomics (there may be several possible methods; outline the one that appears best).
 - b. Use of chemicals (outline one chemical and its activity; include the best places and times of application as a result of the bionomic study).
9. Indicate references used. Cite sources of specific information.

STUDENT WORKSHEET #6 — Key**Essay Questions**

1. List and describe practices other than using insecticides that may help to avoid or reduce destruction by insect pests.

Refer to first paragraph, page 26 of VAS Unit #U5005B.

2. Describe five ways that insects may damage trees and shrubs.

Refer to first paragraph, right column, page 1 of VAS Unit #U5005B.

3. Relate the safety precautions that must be taken with insecticides so they will not be injurious to man and animals.

Refer to page 8 of VAS Unit #U5021.

4. How do you tell a termite from an ant?

Refer to page 3 of VAS Unit #U5021.

STUDENT WORKSHEET #7

The Pyrethrum Test

Materials:

1. water soluble pyrethrum extract
2. water
3. sprinkling can

Procedure:

1. Place one tablespoon of pyrethrum extract in a sprinkling can with one gallon of water. (If the water soluble pyrethrum is not available, liquid household detergents may be used in the same proportion. Those detergents with a wetting solution work best.)
2. Sprinkle one square yard of the turf with the solution. In two to ten minutes the worms that have been hiding in the thatch will come to the surface.

Interpretation:

Accurately measure the surface and count the worms. Try to establish a population that would warrant control measures.

Population Per Square FootComment

1
2
3

Tolerant
Questionable
Use control measures

CLUSTER: HORTICULTURE

UNIT: Horticultural Science and Production

PROBLEM AREA: Enhancing Soil Fertility

RELATED PROBLEM AREAS:

1. Identifying Basic Principles of Plant Science (Central Core Cluster)
2. Enhancing Soil Fertility (Agricultural Business and Management Cluster)
3. Understanding Plant Germination, Growth and Development

PREREQUISITE PROBLEM AREA(S):

1. Understanding Basic Principles of Soil Science (Central Core Cluster)

LEVEL: Preparatory

OCCUPATIONAL TASKS ADDRESSED:

Horticulture Cluster

Duty B: Preparing Soils and Planting Media

1. Mix fertilizer into media

Duty D: Applying Fertilizer and Chemicals

1. Calculate fertilizer and chemical applications
2. Formulate fertilizer
3. Calibrate fertilizer application equipment
4. Collect soil sample for fertility test
5. Test soil
6. Make fertilizer and lime recommendations
7. Assess crop nutrient deficiencies
8. Compute fertilizer costs
9. Apply fertilizer using watering system

STATE GOALS FOR LEARNING

In planning the instruction for this problem area, teachers can promote the development of several student learning objectives which are related to the State Goals for Learning in Biological and Physical Sciences. These objectives are listed on the Learning Assessment Plan forms included on the following page(s). Those learning objectives marked with an asterisk (*) are taken from the sample lists provided by the Illinois State Board of Education.



Illinois Agricultural Core Curriculum

Agricultural Education 124 Mumford Hall 1301 W. Gregory Drive University of Illinois Urbana, IL 61801

Director: Dale A. Law, Ed.D.

Principal Investigator: Jerry D. Pepple, Ed.D.

Research Assistant: Janis L. Anderson

390

88/89

ILLINOIS STATE BOARD OF EDUCATION
Department of School Improvement Services
100 North First Street
Springfield, Illinois 62777-0001

LEARNING ASSESSMENT PLAN

Instructions and codes for this form are provided on a separate sheet.

Submission Date _____ Page _____ of _____

Original submission Revision

I. LEARNING AREA (check one)

Language Arts Fine Arts

Mathematics Social Sciences

Sciences Physical Development/Health

II. STATE GOAL FOR LEARNING

As a result of their schooling, students will have a working knowledge of the social and environmental implications and limitations of technological development.

III. LEARNING OBJECTIVES

By the end of grade (circle one) 3 6 B (11) students should be able to:

- *1. Identify materials now in use that are replacing natural resources.
- 2. Identify the common sources of the major plant nutrients and their methods of application.
- 3. Identify factors that determine the rate of fertilization.

(Affix label or complete district information.)

COUNTY _____ DISTRICT _____ ESC _____

District Name _____

City _____

Contact Person: _____
Title: _____
Phone: () _____

IV. ASSESSMENT

A Types	B Validity/ Reliability			C Commercial Test(s)		D Evidence of Nondiscrimination	V. EXPECTATIONS	
							Percent of Students Expected to Achieve Objective	
								400

390

INSTRUCTOR'S GUIDE**CLUSTER: HORTICULTURE****UNIT: Horticultural Science and Production****PROBLEM AREA: Enhancing Soil Fertility****STUDENT LEARNING OBJECTIVES**

Upon completion of their study of this problem area, students will be able to:

1. Identify the major plant nutrients and their functions in plant growth.
2. Identify the secondary and micronutrients necessary for plant growth.
3. Develop an understanding of how nutrients are absorbed.
4. Determine fertilizer ratios used in commercial horticultural fertilizers.
5. Identify the common sources of the major plant nutrients and their methods of application.
6. Identify factors that determine the rate of fertilization.
7. Calculate the amount of fertilizer to apply in a given situation.
8. Identify the difference between organic and inorganic fertilizers.

INSTRUCTOR'S NOTES AND REFERENCES

401

INSTRUCTOR'S GUIDE**CLUSTER: HORTICULTURE****UNIT: Horticultural Science and Production****PROBLEM AREA:** Enhancing Soil Fertility**PROBLEMS AND QUESTIONS FOR STUDY**

1. What is a fertilizer?
2. What nutrients are in a fertilizer?
3. Where do we get fertilizers?
4. How do plants take up nutrients?
5. What nutrients are required by plants?
6. What are the common signs of nutrient deficiency?
7. What is the meaning of numerals on a fertilizer label?
8. What causes the difference in the price for different fertilizers?
9. How can we determine what is the best buy for a specific situation?
10. What is a tissue test?
11. Are limestone and gypsum considered fertilizers?
12. Where do plants get their vitamins?
13. What happens to the fertilizer that is not used by the plant?
14. What factors determine the rate of fertilization?
15. What are the effects of the primary, secondary, and trace elements?
16. What factors determine inorganic fertilizer selection?
17. How do you apply fertilizers?
18. What is a soluble fertilizer?
19. What are slow-release fertilizers?
20. What are fast-release fertilizers?
21. When should fertilizers be applied?
22. What is pH and how does it affect nutrient availability?
23. What are organic and inorganic fertilizers?
24. How can soil pH be adjusted?
25. What are soluble salts?
26. Where can one get information concerning the amount of fertilizer to apply to a crop?
27. What does lime do?

INSTRUCTOR'S NOTES AND REFERENCES

402

INSTRUCTOR'S GUIDE**CLUSTER: HORTICULTURE****UNIT: Horticultural Science and Production****PROBLEM AREA:** Enhancing Soil Fertility**SUGGESTED TEACHING ACTIVITIES AND PROCEDURES**

1. Use Transparency Master #1 in a discussion of the methods of fertilizer application.
2. Have the students complete Student Worksheets #1, #3, and #4.
3. Discuss pH, what effects it has on plant growth, and how it can be adjusted. Use Transparency Masters #12 - #14.
4. Have the students complete Student Worksheet #2.
5. Have students collect various fertilizer bags. Identify the elements, percent analysis, and ratios contained in the various fertilizers. Obtain the local current fertilizer price and calculate the cost per pound of nitrogen, phosphorus, and potassium. Relate these costs to selected greenhouse systems and house plants.
6. Have the students determine the required amount of fertilizer to cover each of the following areas:
 - a. 10,000 sq ft lawn.
 - b. 1,000 sq ft vegetable garden.
 - c. 1 large tree spread 30 ft in diameter.
 - d. 1 crop of 400 pots of poinsettias.
7. Identify the topics covered in this problem area and organize them into topic areas, such as:
 - a. Major plant nutrients.
 - b. Secondary plant nutrients.
 - c. Micronutrients.
 - d. Soil pH.
8. Identify tentative answers to the questions and problems on the Problems and Questions for Study sheet through class discussions.
9. Have students collect soil samples from turf areas, vegetable gardens, and pot chrysanthemums. Have them analyze the samples and discuss the results of the analyses with the class.
10. Using the appropriate Transparency Masters and the Transparency Master Discussion Guide included in this problem area, discuss nitrogen, phosphorus, and potassium. Also discuss the secondary nutrients and the micronutrients.
11. Set up a demonstration to study effects of different fertilization rates on pot chrysanthemums. Subject three identical plants to different conditions: no fertilizer, the recommended fertilization rate, and double the recommended fertilization rate. Discuss the results with the class.
12. Cut out fertilizer advertisements found in horticulture magazines and pass them around the class. Have students select the brand they would purchase. Identify the specific claims and information contained in the advertisements.
13. Bring into class several plants showing nutrient deficiencies and have a class discussion as to what caused the problems.
14. Separate the class into small groups and have them identify the plant nutrients they feel are essential for proper plant growth. Let each group briefly report their conclusion to the rest of the class.
15. Discuss fertilizer analysis and the calculations required to determine the amounts of nitrogen, phosphorus and potassium.
16. Take a walking field trip. Point out trees with possible iron chlorosis problems, turf needing fertilization, and other plants with fertilizer deficiencies. Also point out lawns, trees, shrubs, and crops showing good, healthy growth.

INSTRUCTOR'S GUIDE**CLUSTER: HORTICULTURE****UNIT: Horticultural Science and Production****PROBLEM AREA: Enhancing Soil Fertility****REFERENCES****INSTRUCTOR'S NOTES AND REFERENCES**

- *1. *Introductory Horticulture*. (1988). Reiley, H.E., Shry, C.L., Jr. Delmar Publishers Inc., 2 Computer Drive West, Box 15-015, Albany, NY 12212.
- 2. *Horticultural Science*. (1986). Janick, Jules. W.H. Freeman and Company, 4419 W. 1980 South, Salt Lake City, UT 84104. (801) 973-4660.
- *3. *Fertilizing and Watering Shade and Ornamental Trees* (VAS Unit #U5003); *Establishing a Lawn* (VAS Unit #U5008); *Preparing for the Vegetable Garden* (VAS Unit #U5030). Vocational Agriculture Service, College of Agriculture, University of Illinois, 1401 S. Maryland Drive, Urbana, IL 61801. (217) 333-3871.
- *4. *Fertilizer Recommendations for Turf* (TG-2-79F); *Organic Gardening and Soil Fertility* (VC-5-80); *Fertilizing Your Vegetable Garden* (VC-9-80); *Iron Chlorosis of Woody Plants: Symptoms and Control* (NC-3-80); *Vegetable Gardening for Illinois* (Circular 1150); *Illinois Lawn Care and Establishment* (Circular 1082). University of Illinois, Cooperative Extension Service, 69C Mumford Hall, 1301 W. Gregory Drive, Urbana, IL 61801.
- *5. *Illinois Agronomy Handbook*. University of Illinois, Cooperative Extension Service, 69C Mumford Hall, 1301 W. Gregory Drive, Urbana, IL 61801.

*Indicates highly recommended reference

404

INSTRUCTIONAL RESOURCES

These resources are intended for use by teachers in planning and teaching the materials for this problem area and may be adapted to fit the teaching method(s) used.

INFORMATION SHEET #1 — Fertilizers

INFORMATION SHEET #2 — Adjusting Soil pH

TRANSPARENCY MASTER #1 — Sample Fertilizer Problem

TRANSPARENCY MASTER #2 — Methods and Timing of Fertilizer Application

TRANSPARENCY MASTER #3 — Acid and Alkaline Soils

TRANSPARENCY MASTER #4 — Essential Elements (with discussion guide)

TRANSPARENCY MASTER #5 — Nutrients in Fertilizers (with discussion guide)

TRANSPARENCY MASTER #6 — Plant Nutrient Blends (with discussion guide)

TRANSPARENCY MASTER #7 — Information Commonly Found on a Fertilizer Bag (with discussion guide)

TRANSPARENCY MASTER #8 — Fertilizer Analysis (with discussion guide)

TRANSPARENCY MASTER #9 — Nitrogen (with discussion guide)

TRANSPARENCY MASTER #10 — Phosphorus (with discussion guide)

TRANSPARENCY MASTER #11 — Potassium (with discussion guide)

TRANSPARENCY MASTER #12 — The Effect of pH on Plant Nutrients (with discussion guide)

TRANSPARENCY MASTER #13 — Neutral Soils (with discussion guide)

TRANSPARENCY MASTER #14 — Soil pH and Plant Nutrients (with discussion guide)

INFORMATION SHEET #1

Fertilizers

	Nitrogen Average % N	Phosphoric Acid Average % P ₂ O ₅	Potash Average % K ₂ O	Speed of avail.	Reaction
1. Dried Blood	13	1.5	.8		
2. Milorganite	5	2	0	Med. Quick	Acid
3. Tankage	8-10	5-12	0	Med. Quick	Neutral
4. Bone Meal Steamed	2-4	22-25	0	Very Slow	Alkaline
5. Bone Meal Steamed	1-2	22-30	0	Slow	Alkaline
6. Sheep Manure	2-3	1	1-2	Slow	
7. Sewage Sludge	3	2.5	.4		
Organic Vegetable Ammoniates					
1. Cottonseed Meal	8	2	2	Slow	Acid
2. Tobacco Stems	2	0	8	Slow	Variable
3. Wood Ashes (Hardwood)	0	2	8	Slow	Alkaline
4. Wood Ashes (Softwood)	0	2	4	Slow	Alkaline
5. Linseed Meal	5	2	2	Slow	Acid
6. Castor Bean Meal	5	2	2	Slow	Acid
7. Soybean Meal	6	3	1	Slow	Acid
8. Peat Soil	2-4	0	0	Slow	Acid to Neutral
Chemical Inorganic and Manufactured Ammoniates					
1. Ammonium Chloride (Muriate of Ammonium)	26	0	0	Quick	Acid
2. Ammonium Sulphate	20	0	0	Quick	Very Acid
3. Ammonium Nitrate	35	0	0	Quick	Acid
4. Nitrate of soda (Sodium Nitrate)	16	0	0	Very Quick	Alkaline
5. Muriate of Pot. (Pot. Chlorate)	0	0	50	Quick	Neutral
6. Potassium Phosphate	0	15	40		
7. Potassium Nitrate	12	0	40		Alkaline
8. Rock Phosphate	0	25	0	Very Slow	Alkaline
9. Sulphate of Potash	0	0	50	Quick	Neutral
10. Super Phosphate	0	20	0	Slow	Neutral
11. Triple Phosphate	0	45	0	Med. Slow	Neutral
12. Ammophos #1 (Ammonium)	10	50	0	Quick	Very Acid
13. Ammophos #2 (Phosphate)	15	20	0	Quick	Very Acid
14. Calcium Nitrate	15	0	0	Quick	Alkaline
15. Diammonium Phosphate	20	53	0	Quick	Alkaline
16. Monoammonium Phosphate	12	60	0	Quick	Very Acid
17. Sodium Nitrate	16	0	0	Very Quick	Alkaline
Synthetic Organic Nitrogens					
1. Urea	45	0	0	Quick	Acid
2. Urea-Formaldehyde	38	0	0	Slow	Acid
3. Cyanamid	20	0	0	Quick	Alkaline
Complete Fertilizers					
1. 5-10-15	5	10	5	Rapid	--
2. 12-12-12	12	12	12	Rapid	--
3. 20-20-20	20	20	20	Rapid	--

INFORMATION SHEET #2

Adjusting Soil pH

Pulverized Limestone Recommendations*

Soil pH	Soil Textural Class					
	Sand		Loam		Clay	
	1000 sq ft	Acre	1000 sq ft	Acre	1000 sq ft	Acre
4.1 - 4.4	115	5,000	255	11,000	280	12,000
4.5 - 4.8	90	4,000	210	9,000	235	10,000
4.9 - 5.2	70	3,000	165	7,000	190	8,000
5.3 - 5.6	50	2,000	115	5,000	140	6,000
5.7 - 6.0	25	1,000	70	3,000	90	4,000
6.1 - 6.4	12	500	50	2,000	50	2,000

*The above recommendations are based on a 6 2/3 inch depth of soil. When the pH is below 5.3 and a new planting is being made, apply 2/3 of the limestone requirement and plow it down. Apply the remaining 1/3 and disk it into the top 2-3 inches of soil.

Acidifying Soils*

Acidifying Material	Soil Textural Class					
	Sand		Loam		Clay	
	1000 sq ft	Acre	1000 sq ft	Acre	1000 sq ft	Acre
Powdered Sulfur	4.5	196	10	440	14	600
Aluminum	30	1300	50	2178	90	3920

*The above recommendations are based upon lowering the pH approximately 1/2 of a pH unit. Mix the acidifying material thoroughly with the top 6 inches of soil.

407

TRANSPARENCY MASTER #1

Sample Fertilizer Problem

How much 12-12-12 Fertilizer is required to provide 2 pounds of Nitrogen per 100 square feet of turf?

Solution:

1. Determine the percent of nitrogen in a 12-12-12 fertilizer.
2. Divide the amount of nitrogen needed by the percentage of nitrogen in the fertilizer.

$$2 \text{ pounds} \div 0.12 = 16.6$$

Answer:

16.6 pounds of 12-12-12 per 1000 square feet

TRANSPARENCY MASTER #2

METHODS AND TIMING OF FERTILIZER APPLICATION

	BROADCAST	DRILL	BANDING	SIDEDRESS	WATER	FOLIAR
HOW	Air or ground rig	← Subsurface Placement →			Dry dissolved or liquid injected in irrigation system	Liquid Spray
WHERE	Surface	Subsurface	Subsurface or surface	Subsurface or surface (in furrow)	Furrow or sprinkler	Foliage surface
	← Near root zone -- avoid injury →					
WHEN	Preplant and post-plant	Preplant, plant and post-plant	Preplant or at planting	Post-plant	Post-plant	Post-plant
	← P and K early in plant growth season →					
FORM			Liquid or dry			Liquid
WHY	Fast Economical	← more efficient → ← Places fertilizer where needed → ← Nitrogen is confined in root zone → ← Longer →			Quick	Quick Efficient with certain elements (i.e. Zn and Fe)

P and K should be drilled, banded and side dressed rather than broadcast whenever possible for maximum efficiency.

TRANSPARENCY MASTER #3

Acid and Alkaline Soils

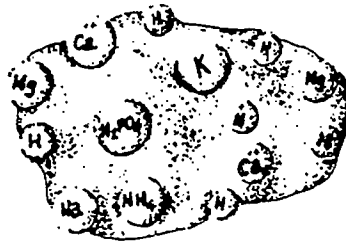

The nutrients held on the surface of a soil particle are absorbed.

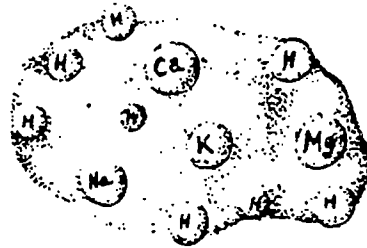

A soil particle with mostly hydrogen ions tests acid.

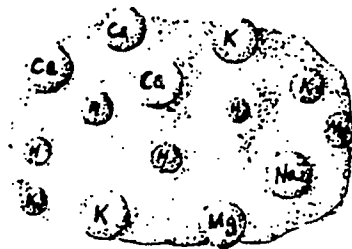

A soil particle with mostly basic ions tests alkaline.

TRANSPARENCY MASTER #4

Essential Elements

ESSENTIAL ELEMENT

SIMPLE SAYING

Carbon (C)
 Hydrogen (H)
 Oxygen (O)
 Phosphorus (P)
 Potash (K)
 Nitrogen (N)
 Sulphur (S)
 Calcium (Ca)
 Iron (Fe)
 Magnesium (Mg)

C.
 H
 O
 P
 K
 N
 S
 CA
 FE
 Mighty Good

C. HOPKINS CAFE Mighty Good

TRANSPARENCY MASTER #5

Nutrients in Fertilizers

Primary

N Nitrogen

P Phosphorus in Fertilizer Phosphate — P_2O_5

K Potassium in Fertilizer Potash — K_2O

Secondary

Ca Calcium

Mg Magnesium

S Sulfur

Micronutrients

B Boron

Cu Copper

Fe Iron

Mn Manganese

Mo Molybdenum

Zn Zinc

Cl Chlorine

TRANSPARENCY MASTER #6

Plant Nutrient Blends

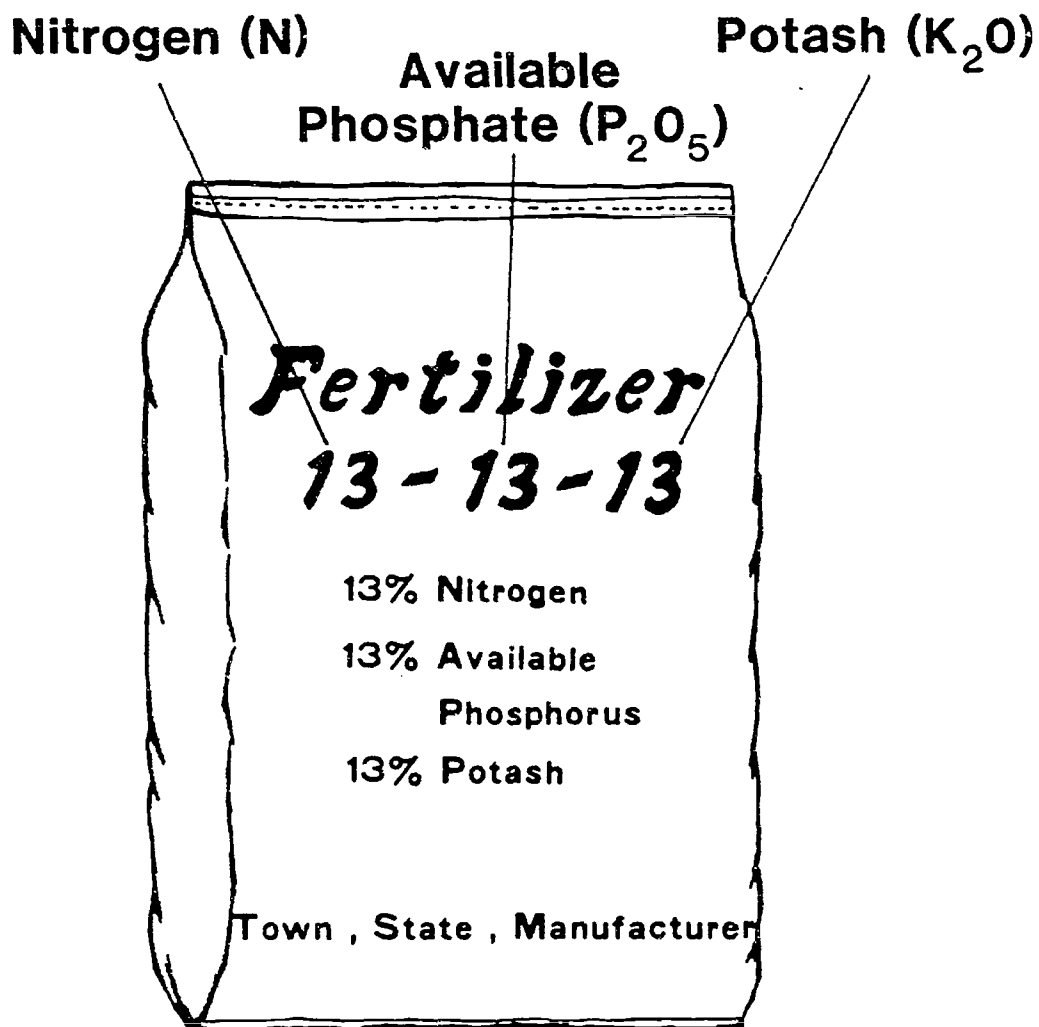

$13\text{ N} - 13\text{ P}_2\text{O}_5 - 13\text{ K}_2\text{O} = 1-1-1$ Ratio

**13 Pounds of Each Primary Nutrient =
39 Pounds per 100 Pounds of Fertilizer**

TRANSPARENCY MASTER #7

Information Commonly Found on a Fertilizer Bag

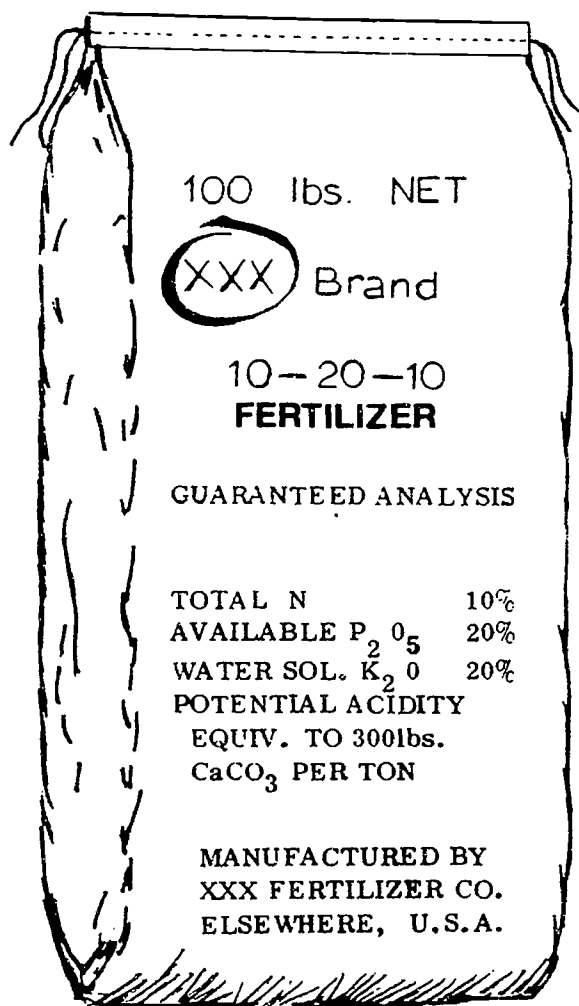

Pounds per Bag

Name or Brand of Fertilizer

**Chemical Composition
Guaranteed
Acid-Forming Tendency**

**Name & Address
of Manufacturer**

414

TRANSPARENCY MASTER #8

Fertilizer Analysis

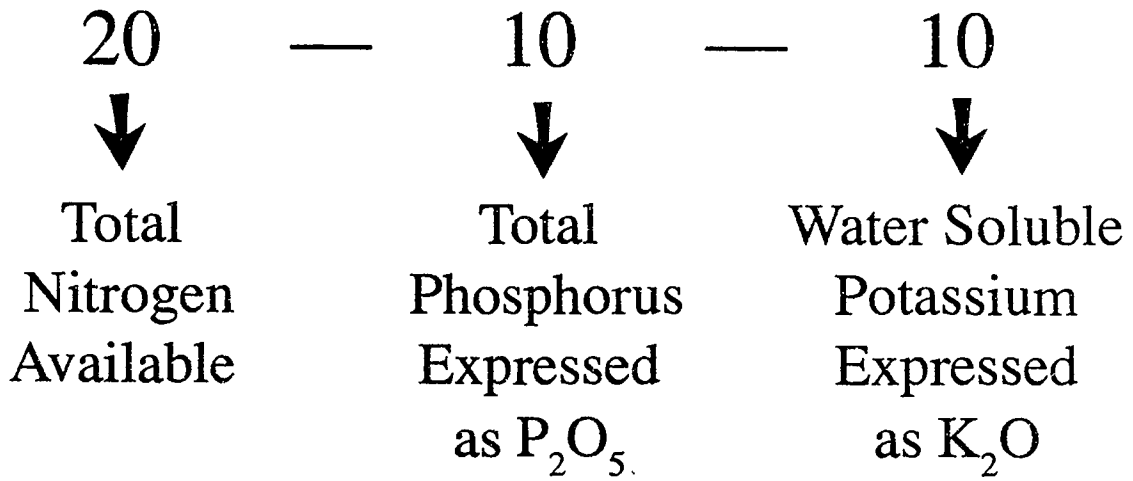

TRANSPARENCY MASTER #9

Nitrogen

Function in Plants

1. Produces vegetative growth.
2. Gives dark green color to plants.
3. Feeds soil microorganisms during their decomposition of low-nitrogen organic materials.
4. Increases efficiency of available moisture.

Hunger Signs

1. Yellowing starting at the tip and extending down the midribs of the lower leaves.
2. Slow and dwarfed growth.
3. Poor root system.

Movement in Soil

1. In the ammonium form, nitrogen moves very little after it is absorbed by the clay particles.
2. In the nitrate form, nitrogen moves with soil moisture; consequently, nitrogen will be more apt to leach on sandy soils than in heavier clays and clay loams since water movement will be greater.

TRANSPARENCY MASTER #10

Phosphorus

Function in Plants

1. Stimulates early root formation.
2. Gives rapid and vigorous start.
3. Hastens maturity.
4. Stimulates blooming.
5. Gives winter hardiness.

Hunger Signs

1. Stunted growth.
2. Slow maturity.
3. Low yield of fruit and seed.
4. Purpling of leaves, stems, and branches in plants.

Movement in Soil

Phosphorus moves very little from its point of application.

TRANSPARENCY MASTER #11

Potassium

Function in Plants

1. Imparts increased vigor and disease resistance.
2. Produces strong, stiff stalks.
3. Essential to the formation and transfer of starches, sugars, and soils.
4. Imparts winter hardiness to crops.

Hunger Signs

1. Scorching or burning of outer edges or tips of lower leaves.
2. Premature loss of leaves.

Movement in Soil

Potassium will move very little in heavy-textured clays and clay loams. It will move with soil moisture in lighter textured sands and sandy loams.

TRANSPARENCY MASTER #12

THE EFFECT OF pH ON PLANT NUTRIENTS

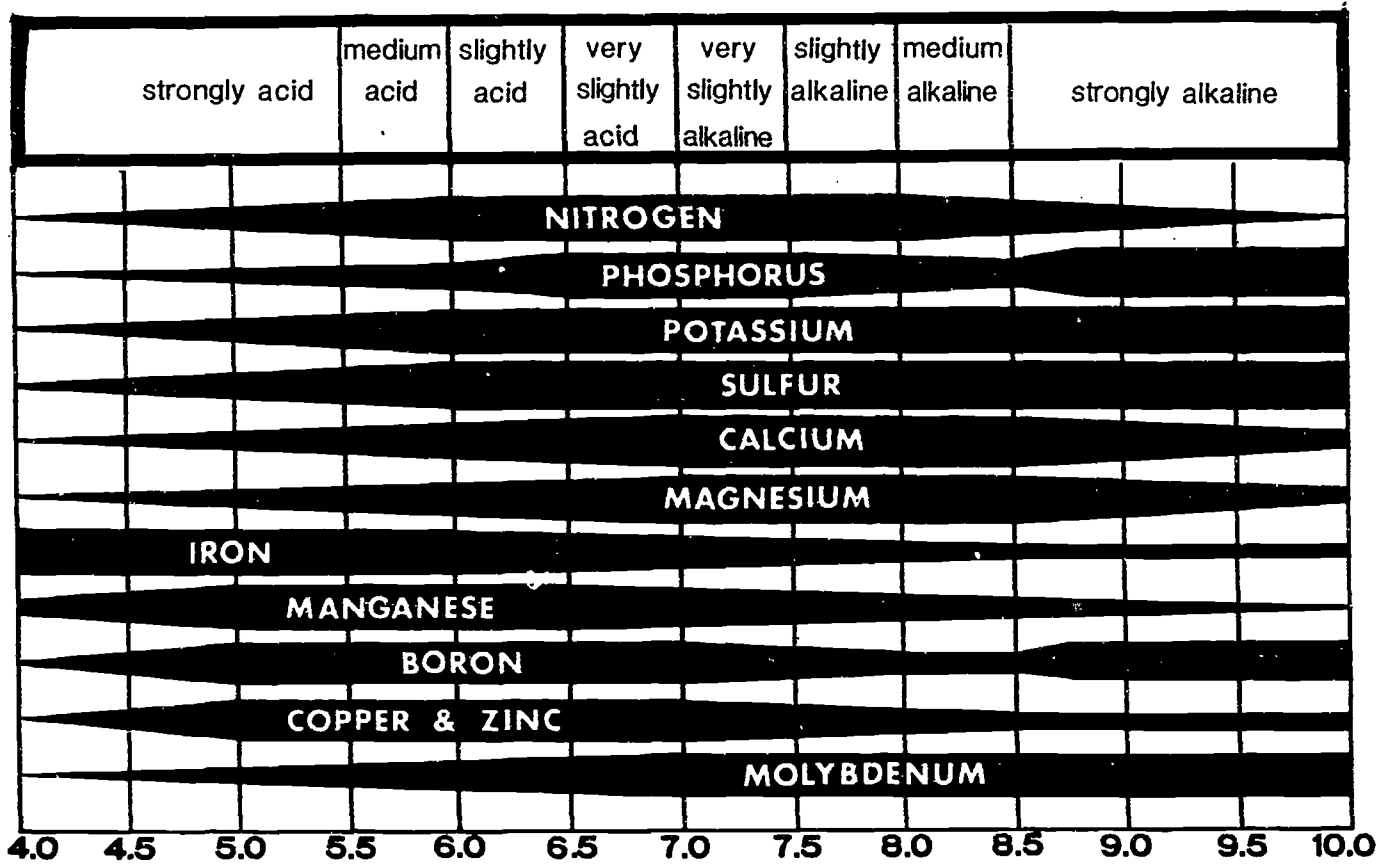

Note: Availability of nutrients to plants decreases as width of line decreases.

410

Neutral Soils

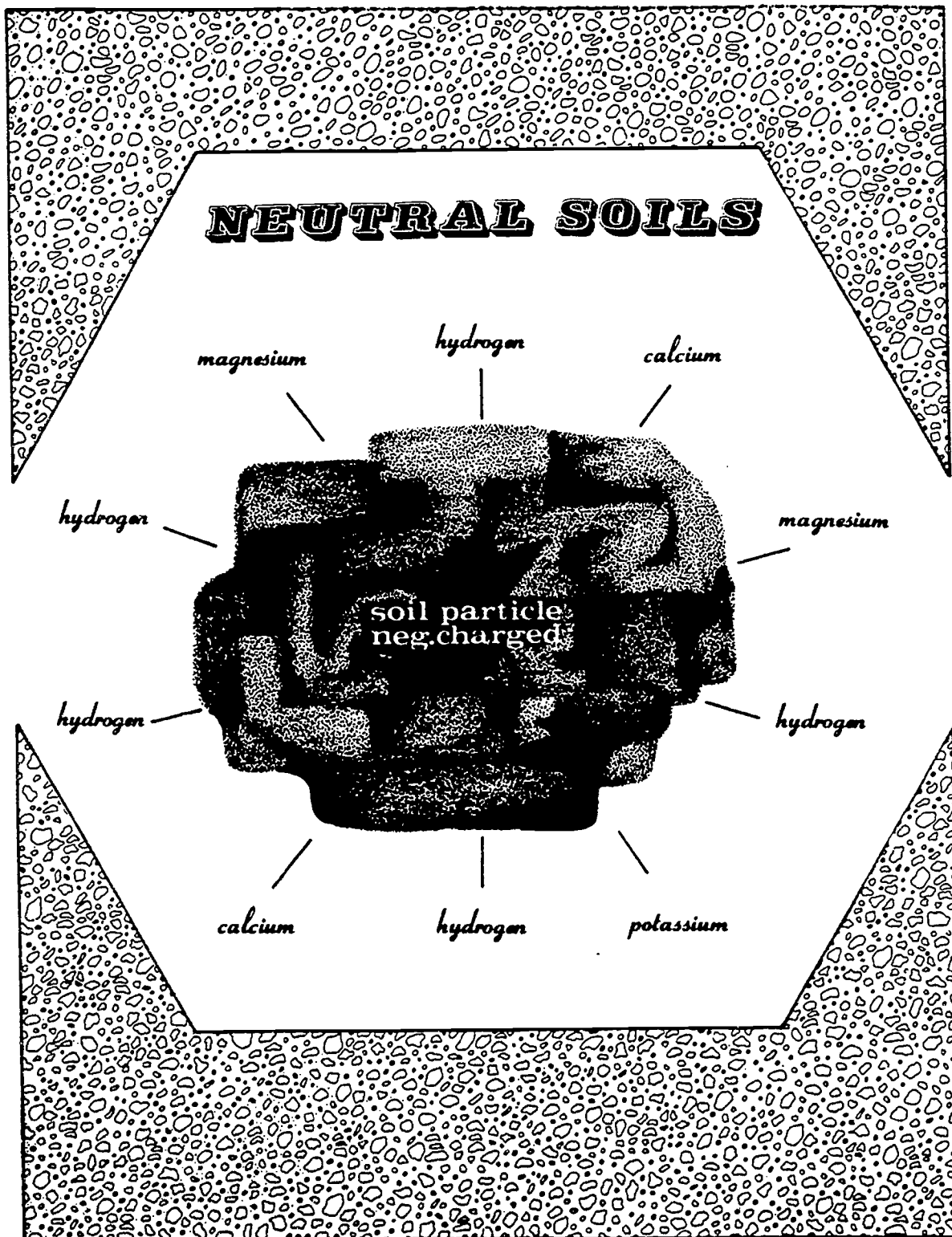

TRANSPARENCY MASTER #14

SOIL pH and PLANT NUTRIENTS

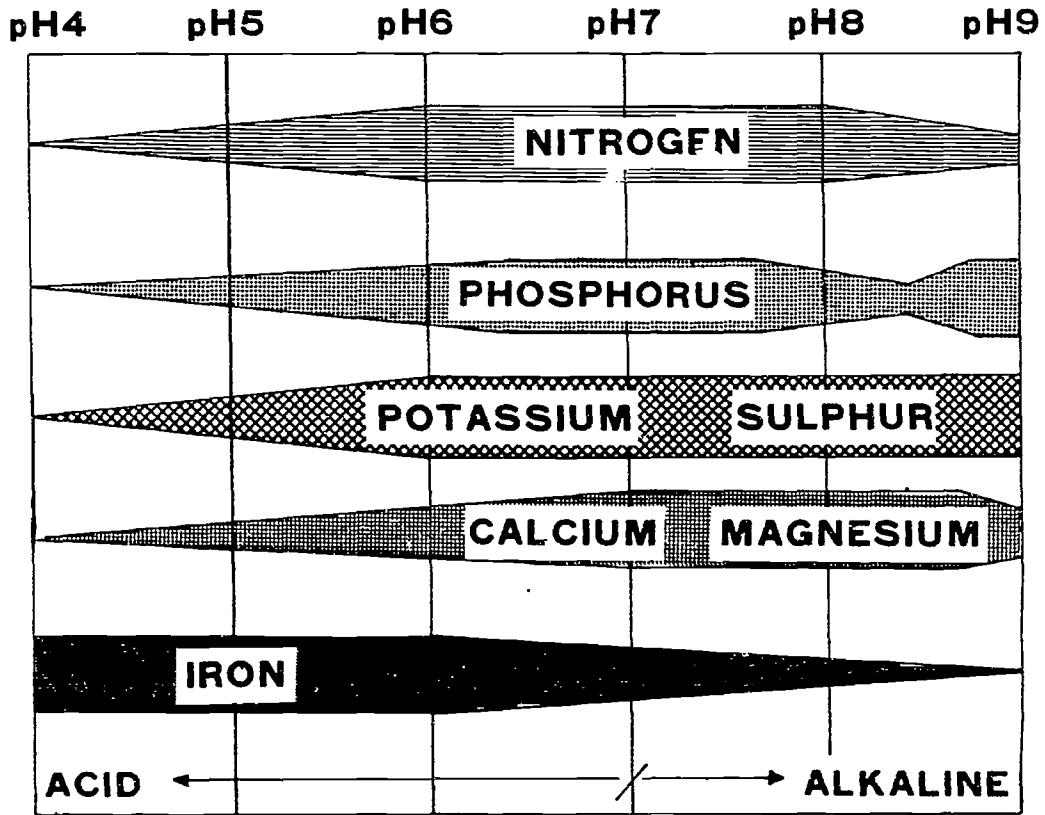

Availability of plant nutrients to plants increases as the width of the bar increases.

421

TRANSPARENCY MASTER DISCUSSION GUIDE

Transparency Master #4

All crops need a number of plant food elements. There are about 92 chemical elements known to exist in the earth's crust and about 2,000 minerals. Some of the most common elements are oxygen 47.3%, silicon 27.7%, aluminum 7.8%, iron 4.5%, calcium 3.5%, sodium 2.5%, potassium 2.5%, magnesium 2.2%, titanium 0.5%, hydrogen 0.2%, carbon 0.2%, phosphorus 0.1%, sulfur 0.1%, and others 0.8%. However, only about 16 of these are currently considered as essential for plant growth. Carbon, hydrogen, and oxygen, which comprise 90 percent or more of the dry matter, are obtained from air and water. The remaining 13 elements are obtained mainly from the soil. Nitrogen, phosphorus, potassium, calcium, magnesium, and sulfur are required in rather large quantities and are referred to as macronutrients or major elements. Nutrients required in considerably smaller quantities are called micronutrients, minor, or trace elements. These include iron, boron, manganese, zinc, copper, molybdenum, and chlorine.

Transparency Masters #5 - #7

- A. Point out the primary information which must be printed on a fertilizer bag.
- B. Display examples of fertilizer bags and have students look for this information.
- C. Point out the major nutrients contained in fertilizer.

Transparency Masters #8 - #11

- A. Point out the nutrients each number represents on a fertilizer analysis.
- B. Discuss the chemical form in which each nutrient is found.
- C. Calculate the total amount of nitrogen, phosphorus, and potassium in a 100-pound bag of fertilizer for several different analyses.

- D. Point out that these three elements are contained in a complete fertilizer.
- E. Briefly discuss the functions, plant hunger signs, and movement in soil for each nutrient.

Transparency Masters #12 and #14

These transparencies illustrate nutrient availability as influenced by pH. As the width of the nutrient line decreases, the availability of the nutrient decreases. Note how potassium is practically nonavailable at pH 4.5, but is little affected from pH 7-10. Notice how pH affects the availability of nitrogen, phosphorus, iron, and zinc in the soil pH range of 5-8.5. Acidic conditions limit or decrease the availability of nitrogen and phosphorus. Iron and zinc are little affected under slightly acidic conditions. However, notice the decreased availability of iron and zinc in the alkaline pH range of 7-8.5.

- A. Define pH.
- B. Discuss the importance of proper soil pH.
- C. Identify the pH levels which are desirable for common crops.
- D. Point out which materials are commonly used to raise soil pH levels, and to lower soil pH levels.

Transparency Master #13

In a neutral pH 7 soil, the negative charges of the soil particles attract both hydrogen and basic ions (examples of basic ions would be calcium, magnesium, potassium, etc.).

There is about a 1 to 1 ratio of hydrogen ions to basic ions; or stated another way, half of the ions attached to the soil particle are hydrogen, and the other half are calcium, magnesium, etc. This is the situation in a neutral soil.

422

STUDENT ACTIVITIES

- STUDENT WORKSHEET #1 — Major Plant Nutrients
- STUDENT WORKSHEET #2 — Micronutrients and pH
- STUDENT WORKSHEET #3 — Calculate Application Rates of Fertilizer
- STUDENT WORKSHEET #4 — Fertilizer Calculations
- STUDENT WORKSHEET #5 — Comparing the Effects of Various Fertilizers
- STUDENT WORKSHEET #6 — Fertilizing Trees
- STUDENT WORKSHEET #7 — Fertilizing Container Grown Stock and Bedding Plants
- STUDENT WORKSHEET #8 — Fertilizer Application

For additional activities, teachers may refer to the “Suggested Teaching Activities and Procedures” section in the Instructor’s Guide.

STUDENT WORKSHEET #1

Major Plant Nutrients

1. Name the three major plant nutrients and the chemical symbol for each.

	Nutrient	Symbol
A.	_____	_____
B.	_____	_____
C.	_____	_____

2. What are the two forms of nitrogen in the soil that plants take up?

A.	_____	_____
B.	_____	_____

3. What are the characteristics of a plant with adequate nitrogen?

4. Commercial fertilizers are available in what three forms?

5. What factors should be considered before purchasing fertilizer materials?

6. Determine the current price per 100-pound bag of the following nitrogen fertilizers:

	<u>Price</u>	<u>Application</u>
A. Ammonium nitrate	\$ _____	\$ _____
B. Diammonium phosphate (DAP)	\$ _____	\$ _____
C. Potassium nitrate	\$ _____	\$ _____

Assume you want to apply 2 pounds of nitrogen to 1000 square feet of turf. Find the total cost of the amount of nitrogen needed for each of the 3 forms of nitrogen.

7. Why can't nitrogen be applied in the fall when soil temperature drops below 50 degrees?

8. In what form is phosphorus expressed on a fertilizer bag? How is this figure converted to percent phosphorus?

9. In what form is potassium expressed on a fertilizer bag? How is this figure converted to percent potassium?

10. What are the major functions of phosphorus in plants?

11. What are the major functions of potassium in plants?

12. Give the percent of P_2O_5 for the following phosphorus materials.

% P_2O_5

- A. Super phosphate _____
- B. Triple super phosphate _____
- C. Monoammonium phosphate _____
- D. Diammonium phosphate _____
- E. Ammonium polyphosphate _____

13. Give the percent K_2O for the following potassium materials.

% K_2O

- A. Muriate of potash _____
- B. Sulfate of potash _____

14. How does soil pH level affect the availability of phosphorus and potassium?

15. Determine the ratios for the following fertilizer mixes:

analysis =	3-9-27	3-12-12	5-20-20
ratio =	---	---	---

analysis =	7-28-14	12-12-12	6-24-24
ratio =	---	---	---

- A. The first number in the ratio is _____
- B. The second number in the ratio is _____
- C. The third number in the ratio is _____

16. Why are fertilizer ratios important?

17. What is the formula for determining the amount of a potash fertilizer to use?

18. Why should potash not be applied close to seeds?

485

STUDENT WORKSHEET #1 — Key

Major Plant Nutrients

1. Name the three major plant nutrients and the chemical symbol for each.

Nutrient	Symbol
A. <u>Nitrogen</u>	<u>N</u>
B. <u>Phosphorus</u>	<u>P</u>
C. <u>Potassium</u>	<u>K</u>

2. What are the two forms of nitrogen in the soil that plants take up?

A. <u>Ammonium</u>	<u>NH₄⁺</u>
B. <u>Nitrate</u>	<u>NO₃</u>

3. What are the characteristics of a plant with adequate nitrogen?

Dark green color
Rapid vegetative growth
Efficient use of available moisture
Good yield
Good quality of crop
Increased protein content of crop
Efficient decomposition by microorganisms of low-nitrogen organic materials

4. Commercial fertilizers are available in what three forms?

Gas, solid, liquid

5. What factors should be considered before purchasing fertilizer materials?

Amount of nutrients needed
Nutrient requirements of crop to be grown
Plant populations
Expected yield
Soil conditions — pH, drainage, organic matter
Cost
Availability of materials

6. Determine the current price per 100-pound bag of the following nitrogen fertilizers:

	<u>Price</u>	<u>Application</u>
A. Ammonium nitrate	\$_____	\$_____
B. Diammonium phosphate (DAP)	\$_____	\$_____
C. Potassium nitrate	\$_____	\$_____

Assume you want to apply 2 pounds of nitrogen to 1000 square feet of turf. Find the total cost of the amount of nitrogen needed for each of the 3 forms of nitrogen.

7. Why can't nitrogen be applied in the fall when soil temperature drops below 50 degrees? *Bacteria have become inactive and will not convert the nitrogen to a nonleachable form.*
8. In what form is phosphorus expressed on a fertilizer bag? How is this figure converted to percent phosphorus?

P₂O₅ - phosphoric acid
Multiply the percent of P₂O₅ by .44

426

9. In what form is potassium expressed on a fertilizer bag? How is this figure converted to percent potassium?

K₂O - potash

Multiply the percent of K₂O by .83

10. What are the major functions of phosphorus in plants?

Stimulates early root growth

Promotes rapid starts

Hastens plant maturity

Stimulates flowering and fruiting

Promotes winter hardiness

11. What are the major functions of potassium in plants?

Stimulates root development

Promotes vigor growth

Promotes disease resistance

Produces strong, stiff stalks

Is essential in formation of starches and sugars

Promotes winter hardiness

12. Give the percent of P₂O₅ for the following phosphorus materials.

	<u>% P₂O₅</u>
A. Super phosphate	<u>16-22</u>
B. Triple super phosphate.	<u>44-47</u>
C. Monoammonium phosphate	<u>46-48</u>
D. Diammonium phosphate	<u>47</u>
E. Ammonium polyphosphate	<u>34-37</u>

13. Give the percent K₂O for the following potassium materials.

	<u>% K₂O</u>
A. Muriate of potash	<u>60</u>
B. Sulfate of potash	<u>48</u>

14. How does soil pH level affect the availability of phosphorus and potassium?

If the pH drops below 6.0, P and K both start to become unavailable to the plants.

If the pH rises above 7.0, P starts to become unavailable to the plants.

15. Determine the ratios for the following fertilizer mixes:

analysis =	3-9-27	3-12-12	5-20-20
ratio =	1-3-9	1-4-4	1-4-4
analysis =	7-28-14	12-12-12	6-24-24
ratio =	1-4-2	1-1-1	1-4-4

- A. The first number in the ratio is nitrogen
- B. The second number in the ratio is phosphorus
- C. The third number in the ratio is potassium

16. Why are fertilizer ratios important?

Different blends allow you to match your cropping needs.

17. What is the formula for determining the amount of a potash fertilizer to use?

Pounds of K₂O needed + percent of K₂O in the fertilizer used.

18. Why should potash not be applied close to seeds?

It can cause salt injury to the seed.

STUDENT WORKSHEET #2**Micronutrients and pH**

1. List the elements that are classified as secondary nutrients and give their chemical symbol.
2. Why has there been an increase in reported sulfur deficiencies in the Midwest in recent years?
3. What is the primary source of sulfur in soils?
4. List the elements that are classified as essential micronutrients and give their chemical symbol.
5. Under what conditions are micronutrient deficiencies likely to appear?
6. What test is used to determine soil acidity levels?
7. How is the pH test read?
8. What is the desired pH range for most greenhouse soils?
9. What materials are commonly used in Illinois horticultural situations to raise pH levels?
10. What factors should be considered when selecting liming materials?
11. How is lime generally applied?
12. What materials are commonly used in Illinois horticultural situations to raise pH levels?
13. What factors should be considered when selecting acidifying materials?

STUDENT WORKSHEET #2 — Key

Micronutrients and pH

1. List the elements that are classified as secondary nutrients and give their chemical symbol.
Calcium Ca
Magnesium Mg
Sulfur S
2. Why has there been an increase in reported sulfur deficiencies in the Midwest in recent years?
Increased use of sulfur-free fertilizer
Decreased use of sulfur as a fungicide and insecticide
Increased crop yields
Decreased atmospheric sulfur supply
3. What is the primary source of sulfur in soils? *Organic matter*
4. List the elements that are classified as essential micronutrients and give their chemical symbol.

<i>Zinc Zn</i>	<i>Boron B</i>
<i>Iron Fe</i>	<i>Molybdenum Mo</i>
<i>Manganese Mn</i>	<i>Chlorine Cl</i>
<i>Copper Cu</i>	
5. Under what conditions are micronutrient deficiencies likely to appear?
Strongly weathered soils
Coarse-textured soils
High pH soils
Organic soils
Soil very low in organic matter
6. What test is used to determine soil acidity levels? *pH test*
7. How is the pH test read?
pH less than 7.0 is acid
pH of 7.0 is neutral
pH greater than 7.0 is alkaline
8. What is the desired pH range for most greenhouse soils? *Between 6.0 and 6.5*
9. What materials are commonly used in Illinois horticultural situations to raise pH levels?
Main source is agricultural ground limestone (lime).

Other materials are:
Hydrated lime
Marl
Chats
Lime sludge
10. What factors should be considered when selecting liming materials?
Neutralizing power
Fineness
Price
Purpose and place of application
11. How is lime generally applied? *By broadcasting*
12. What materials are commonly used in Illinois horticultural situations to raise pH levels?
Powdered sulfur
Aluminum sulfate
13. What factors should be considered when selecting acidifying materials?
Price
Acidifying power
Fineness

STUDENT WORKSHEET #3 — Key

Calculate Application Rates of Fertilizer

Calculate the amount of nutrients needed using different fertilizer analysis. When completed, return to the instructor for evaluation.

1. A homeowner desires to fertilize her lawn with a fertilizer (10-6-4) at a rate of 2 pounds of Nitrogen per 1,000 square feet. How many pounds of fertilizer would be needed to do a lawn of 10,000 square feet?

10% N in 10-6-4

$$2 \text{ lbs} + .10 = 20 \text{ lbs } 10-6-4 / 1,000 \text{ sq ft}$$

$$20 \text{ lbs} \times 10 = \underline{200 \text{ lbs } 10-6-4 / 10,000 \text{ sq ft}}$$

2. How many pounds of 20-12-8 would be needed to apply 6 pounds of Nitrogen per 1,000 square feet of a lawn of 5,000 square feet?

20% N in 20-12-8

$$6 \text{ lbs} + .20 = 30 \text{ lbs } 20-12-8 / 1,000 \text{ sq ft}$$

$$30 \text{ lbs} \times 5 = \underline{150 \text{ lbs } 20-12-8 / 5,000 \text{ sq ft}}$$

3. How many pounds of 20-10-10 would be needed to apply 3 pounds of Nitrogen per 1,000 square feet on a lot 120 feet x 11 feet with the house consuming 1500 square feet of ground space?

20% N in 20-10-10

$$3 \text{ lbs} + .20 = 15 \text{ lbs } 20-10-10 / 1,000 \text{ sq ft}$$

$$100 \times 120 = 12,000 \text{ sq ft}$$

$$12,000 - 1,500 = 10,500$$

$$15 \text{ lbs} + 1,000 \text{ sq ft} \times 10.5 = \underline{157.5 \text{ lbs } 20-10-10}$$

431

STUDENT WORKSHEET #4**Fertilizer Calculations**

Compare the pounds of actual nitrogen, phosphorus, and potassium available for each fertilizer. When you have completed the problems, turn in to your instructor for evaluation. Use 100 pounds as a base for all problems.

1. Fertilizer analysis 10-20-10

$$\text{N} =$$

$$\text{P}_2\text{O}_5 =$$

$$\text{K}_2\text{O} =$$

2. Fertilizer analysis 9-45-15

$$\text{N} =$$

$$\text{P}_2\text{O}_5 =$$

$$\text{K}_2\text{O} =$$

3. Fertilizer analysis 18-46-0

$$\text{N} =$$

$$\text{P}_2\text{O}_5 =$$

$$\text{K}_2\text{O} =$$

4. Fertilizer analysis 13-0-44

$$\text{N} =$$

$$\text{P}_2\text{O}_5 =$$

$$\text{K}_2\text{O} =$$

5. Fertilizer analysis 20-20-20

$$\text{N} =$$

$$\text{P}_2\text{O}_5 =$$

$$\text{K}_2\text{O} =$$

$$\text{P} =$$

$$\text{K} =$$

6. Fertilizer analysis 10-6-4

$$\text{N} =$$

$$\text{P}_2\text{O}_5 =$$

$$\text{K}_2\text{O} =$$

$$\text{P} =$$

$$\text{K} =$$

STUDENT WORKSHEET #4 — Key

Fertilizer Calculations

Compare the pounds of actual nitrogen, phosphorus, and potassium available for each fertilizer. When you have completed the problems, turn in to your instructor for evaluation. Use 100 pounds as a base for all problems.

1. Fertilizer analysis 10-20-10

$$\begin{aligned} \text{N} &= 10 \\ \text{P}_2\text{O}_5 &= 20 \\ \text{K}_2\text{O} &= 10 \end{aligned}$$

2. Fertilizer analysis 9-45-15

$$\begin{aligned} \text{N} &= 9 \\ \text{P}_2\text{O}_5 &= 45 \\ \text{K}_2\text{O} &= 15 \end{aligned}$$

3. Fertilizer analysis 18-46-0

$$\begin{aligned} \text{N} &= 18 \\ \text{P}_2\text{O}_5 &= 46 \\ \text{K}_2\text{O} &= 0 \end{aligned}$$

4. Fertilizer analysis 13-0-44

$$\begin{aligned} \text{N} &= 13 \\ \text{P}_2\text{O}_5 &= 0 \\ \text{K}_2\text{O} &= 44 \end{aligned}$$

5. Fertilizer analysis 20-20-20

$$\begin{aligned} \text{N} &= 20 & \text{P} &= 8.8 \\ \text{P}_2\text{O}_5 &= 20 & \text{K} &= 16.6 \\ \text{K}_2\text{O} &= 20 & & \end{aligned}$$

6. Fertilizer analysis 10-6-4

$$\begin{aligned} \text{N} &= 10 & \text{P} &= 2.6 \\ \text{P}_2\text{O}_5 &= 6 & \text{K} &= 3.3 \\ \text{K}_2\text{O} &= 4 & & \end{aligned}$$

STUDENT WORKSHEET #5**Comparing the Effects of Various Fertilizers****Purpose:**

1. To determine how fertilizers containing different analyses affect plant growth.

Materials:

1. 100-foot measuring tape
2. string or lime marker
3. about 25 pounds of different fertilizer mixes such as:
 - 5-10-10
 - 13-0-44
 - 20-20-20
 - 18-46-0
 - 0-0-60
4. lawn fertilizer spreader

Procedure:

1. Locate a part of the school lawn or home lawn and mark out equal-sized plots.
2. Determine an acceptable rate of fertilizer per plot.
3. Adjust the lawn spreader according to the instruction manual.
4. Spread one analysis of fertilizer on each plot and make observations weekly.
5. Prepare a map of the fertilized plots.

Observations:

1. Record your observations weekly. Note the difference in growth rate, color, hardness, etc., of the grass in each plot.
2. Draw conclusions on the effects of the different fertilizer analyses on the lawn.

Questions:

1. How many square feet are in one acre?
2. How do you convert from pounds/acre to pounds/100 square feet?
3. How do you determine the area of a rectangle?
4. What would be the approximate dimensions of a square which is 1/1000 of an acre? 1/100 of an acre?

STUDENT WORKSHEET #6**Fertilizing Trees****Purpose:**

1. To be able to fertilize a tree in a sodded area given appropriate tools, equipment, and supplies.

Introduction:

Established trees should be fertilized only when there is a shoot growth rate of less than 8 to 12 inches per season. Deciduous trees require more fertilizer than narrow-leaved evergreens. Trees in sodded areas are usually fertilized with granular fertilizers using the punch bar or soil auger methods. Trees may also be fertilized with liquid fertilizers by inserting the fertilizer injector into the soil at the intervals and depth described in the "punch bar" method. Fertilizer "spikes" may also be used, following manufacturer's instructions.

Applications of fertilizer in late summer may stimulate growth of tender shoots that are very susceptible to freeze injury in winter. With this exception, trees in the landscape may be fertilized at any time.

Materials and Tools Needed:

1. weighing scales
2. large funnel
3. tape measure
4. punch bar or soil auger
5. garden hose
6. bucket of sand or mixture of sand and peat moss
7. 10-6-6 fertilizer

Procedure:

1. Mark a line around the tree two feet beyond the drip line (branch tips). A rope, garden hose, or thin line of ground limestone may be used for this purpose.
2. Using the punch bar or soil auger, make holes 12-18 inches deep and two feet apart around the circle.
3. Using the punch bar or soil auger make similar holes two feet apart in the area within the circle, but no closer than 2 feet from the trunk.
4. Measure the diameter of the tree 4 feet above the ground.
5. Calculate the amount of fertilizer needed. If the tree is over three inches in diameter, use 4-5 pounds of fertilizer per inch in diameter. If the tree is under three inches in diameter, use 2-3 pounds per inch in diameter.
6. Measure the fertilizer, using the scales.
7. Using the funnel to put fertilizer into the holes, evenly distribute the fertilizer to all the holes. (This usually amounts to about 1/4 cup per hole.)
8. Using sand, or a mixture of sand and peat moss, fill all the holes.
9. Thoroughly water the entire area fertilized.
10. Clean and return all tools to their proper storage place.

435

Observations:

1. What happened to the surrounding turf?
2. Compare this tree to a tree of the same variety that was not fertilized. What similarities and/or differences were seen?

430

STUDENT WORKSHEET #7**Fertilizing Container Grown Stock and Bedding Plants****Purpose:**

1. To be able to apply the proper formula fertilizer in the correct amounts to maintain the plants in healthy condition given container grown trees, shrubs, and bedding plants (flower and vegetable transplants).

Introduction:

Outdoor plant stock in the garden center should be properly fertilized to maintain them in a healthy condition. Because of the relatively small soil volume, these plants in containers must be fertilized every two weeks until sold. Indoor plants are fertilized once a month, skipping December and January.

Materials Needed:

1. two-gallon bucket
2. garden hose
3. hozon Proportioner
4. fertilizer, soluble 15-15-15 or 20-20-20 containing a dye
5. tablespoon

NOTE: The solution applied to the plants contains 1 ounce of fertilizer to each 2 gallons of water. The Hozon Proportioner picks up 1 gallon of concentrate for every 15 gallons of water running through the device. Since there are 8 ounces of concentrate in every 16 gallons reaching the plants, this gives a dilution of 1 ounce to each 2 gallons of water.

Procedure:

1. Make sure that the soil in all containers is moist before fertilizer is applied, or the roots may be severely damaged by the fertilizer. Water the plants if needed.
2. Assemble the equipment and supplies.
3. Carefully measure one pound, or 16 rounded tablespoons of the fertilizer into the bucket; add exactly 2 gallons of water (warm water, if possible); stir thoroughly to dissolve the fertilizer.
4. Connect the Hozon Proportioner to the water faucet; connect the garden hose to the Hozon Proportioner; place the pick-up tube of the Hozon into the bucket.
5. Open the water valve to about $\frac{2}{3}$ or $\frac{3}{4}$ of the full volume, and apply the diluted solution to the plants as though watering. (Do not use a nozzle or breaker. Any restriction in water flow causes the Hozon to dilute improperly.)
6. If the water runs clear instead of colored by the dye, it means the fertilizer concentrate has been used up and more must be made (step 3).
7. When all of the plants have been fertilized, lightly spray them with clear water over the tops to wash the fertilizer solution off the leaves.
8. Rinse the bucket and Hozon Proportioner, and put all supplies and equipment in their storage places. The fertilizer containers must be stored tightly closed, or the fertilizer will absorb moisture from the air.

Observations:

1. Why is a dye used in soluble fertilizer?
2. Compare the plants fertilized with a part of the same crop that did not get fertilized.

STUDENT WORKSHEET #8**Fertilizer Application****Purpose:**

1. To develop the ability to apply commercial fertilizers to greenhouse crops.
2. To develop an understanding of names and fertilizers, chemical analysis, and proper rates of application of various commercial fertilizers.
3. To develop an understanding of the relationships of type of fertilizer to the method of application.

Materials needed:

1. a balance or scale calibrated in ounces
2. a fertilizer proportioner and other accessory equipment
3. a quantity of complete and single-carrier fertilizers
4. waxed paper or other nonmetallic material to measure and weigh the fertilizer
5. a glass measuring cup
6. potted or bench plants that need fertilizer applications
7. soil test kit

Procedure:

1. Follow the instructions for the soil test kit so that an accurate analysis of the soil may be obtained. If the soil samples were sent for testing, follow the recommendations provided by the testing service.
2. If the fertilizer is to be applied in dry form, measure the bench and calculate the area to which the fertilizer is to be applied. Study the results of the soil test and refer to a table to find the fertilizer that should be used. Calculate the amount of fertilizer to use for the amount of bench area that is to be covered. Cover the platform of the scale with a sheet of waxed paper. Note the reading of the scale. Weigh out the correct amount of fertilizer needed. It may be helpful to divide this amount into smaller portions, i.e., fourths, and apply each of these to an equivalent portion of the bench. When weighing, be sure to allow for the weight of the cover material that is on the platform of the scale. If potted plants are being treated, the area of the pots (or the volume of soil) will need to be calculated and the amount of fertilizer required for each pot determined.

Be sure that all of the lumps are out of the fertilizer before it is applied. Water the bench or the soil in the pots before adding the fertilizer. Pick up as much fertilizer as possible, or as much as is necessary, in a closed fist and distribute it between the rows of the plants by tipping the hand downward slightly and rolling the thumb over the first finger. If smaller amounts are used, the fertilizer can be picked up between the thumb and the first two fingers and slowly sprinkled. Do not allow any of the fertilizer to remain on any part of a plant as burning will result.

After all of the fertilizer has been applied, the soil should be sprinkled with water in order to dissolve the fertilizer into the soil.

3. If the fertilizer is to be applied in liquid form, measure and calculate the area of the bench or of the pots. Find the fertilizer and the corresponding mixing rates in the table and calculate the amounts of fertilizer and water to use. Determine and identify the area of the bench to be covered by the quantity of mixed fertilizer. Add the fertilizer solution to the proportioner. Attach the proportioner to the water source and apply the solution to the soil. Follow instructions for the particular type of proportioner that you are using.
4. Make comparisons of the effect of the different methods of application on rate of growth, symptoms of excess or continuing deficiencies, and the general plant health. The comparison should be made from the time the demonstration is begun until after the plants have flowered. It will be necessary to continue soil testing throughout the entire period and keep the fertilization process suited to the need of the growing plants.

Discussion:

The application of fertilizer is one of the most important jobs in the greenhouse. Because of the limited amount of soil available to each plant, the soil nutrients are used much more rapidly than they would be out-of-doors. Greenhouse crops are fertilized much more frequently than field crops in order to maintain a nutrient level in the soil that is suitable for maximum production.

Either method of application is satisfactory if it is properly carried out. Dry application may have its widest use with small plants that are easier to work around. Hose-on methods may be more suitable with taller plants that may not be easily reached.

Questions:

1. Determine the cost of applying each type and amount of fertilizer. Which would you suggest to use?

CLUSTER: HORTICULTURE

UNIT: Horticultural Science and Production

PROBLEM AREA: Developing Growing Media

RELATED PROBLEM AREAS:

1. Understanding Basic Soil Science Principles (Central Core Cluster)
2. Enhancing Soil Fertility (Agricultural Business and Management Cluster)
3. Understanding Plant Germination, Growth, and Development (Agricultural Business and Management Cluster)
4. Enhancing Soil Fertility
5. Understanding Plant Germination, Growth, and Development

PREREQUISITE PROBLEM AREA(S): None

LEVEL: Orientation

OCCUPATIONAL TASKS ADDRESSED:

Horticulture Cluster

Duty B: Preparing Soils and Planting Media

1. Mix media materials
2. Pasteurize media with steam
3. Pasteurize media with chemicals
4. Mix fertilizer into media

STATE GOALS FOR LEARNING

In planning the instruction for this problem area, teachers can promote the development of several student learning objectives which are related to the State Goals for Learning in Biological and Physical Sciences. These objectives are listed on the Learning Assessment Plan forms included on the following page(s). Those learning objectives marked with an asterisk (*) are taken from the sample lists provided by the Illinois State Board of Education.

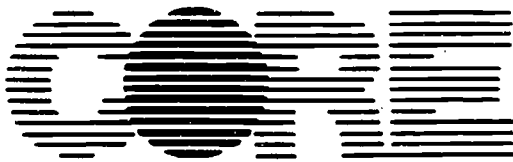

Illinois Agricultural Core Curriculum

Agricultural Education 124 Mumford Hall 1301 W. Gregory Drive University of Illinois Urbana, IL 61801

Director: Dale A. Law, Ed.D.

Principal Investigator: Jerry D. Pepple, Ed.D.

Research Assistant: Janis L. Anderson

88/89

horticulture
horticultural Science and Production



441

Illinois Agricultural Core Curriculum Rev.

INSTRUCTOR'S GUIDE

CLUSTER: HORTICULTURE

UNIT: Horticultural Science and Production

PROBLEM AREA: Developing Growing Media

STUDENT LEARNING OBJECTIVES

Upon completion of their study of this problem area, students will be able to:

1. Know the functions of growing media.
2. Understand the properties of growing media.
3. Identify the components of growing media.
4. Know the differences between soil-based and soilless media.
5. Know the methods of soil sterilization.

INSTRUCTOR'S NOTES AND REFERENCES

INSTRUCTOR'S GUIDE**CLUSTER: HORTICULTURE****UNIT: Horticultural Science and Production****PROBLEM AREA:** Developing Growing Media**PROBLEMS AND QUESTIONS FOR STUDY****INSTRUCTOR'S NOTES AND REFERENCES**

1. Why is the C-N ratio important?
2. What are CEC and water holding capacity?
3. List the functions of growing media.
4. What is pH and why is it necessary to control it?
5. What is peat moss derived from and how is it used?
6. Why is it necessary to compost bark before it is used?
7. What are the differences between perlite and vermiculite and the advantages of each?
8. What are the problems with using field soil?
9. What are the factors to consider when selecting components for a soilless media?
10. What are three methods of soil sterilization?
11. What are the common organic and inorganic amendments?
12. List three amendments used to form large pore sizes and three for small pore sizes.
13. What are the types of media available and their functions?
14. What is the difference between pasteurization and sanitation?
15. Why is it necessary to pasteurize soils?

427

INSTRUCTOR'S GUIDE**CLUSTER: HORTICULTURE****UNIT: Horticultural Science and Production****PROBLEM AREA:** Developing Growing Media**SUGGESTED TEACHING ACTIVITIES AND PROCEDURES****INSTRUCTOR'S NOTES AND REFERENCES**

1. Have students set up an experiment using various media to grow one crop. Have the students make observations, chart growth, and come to a conclusion about the effects of the different media.
2. Have students conduct an experiment using several different crops in the same medium. Students can make observations, chart growth, and determine if the medium is applicable to those particular plants.
3. Use Information Sheet #1 in conjunction with Transparency Master #1 for information on functions and properties of growing media.
4. Use Information Sheet #2 in conjunction with Transparency Master #2 for information on soil components and soil amendments.
5. Use Information Sheet #3 in conjunction with Transparency Masters #3 - #6 for information on characteristics and properties of soil-based or soilless media.
6. Use Information Sheets #4 - #7 in conjunction with Transparency Masters #7 and #8 for information on soil sterilization, pasteurization, and treatments.
7. Use VAS Units *Soils/Plant Growth — Amendments for Container Soils* and *Soils/Plant Growth — Standard Growing Media* at appropriate times during the presentation of the material of this problem area, and as student resources for completing Student Worksheets #1 and #2.
8. Conduct a field trip to a local greenhouse to observe the applications to and variations in soilless medias. Also, ask the greenhouse to demonstrate its pasteurizing and sterilizing techniques. This activity could be conducted prior to students completing Student Worksheet #3.

INSTRUCTOR'S GUIDE**CLUSTER: HORTICULTURE****UNIT: Horticultural Science and Production****PROBLEM AREA:** Developing Growing Media**REFERENCES****INSTRUCTOR'S NOTES AND REFERENCES**

1. *Greenhouse Flowers and Bedding Plants for Agribusiness Studies*. (1983). Williams, G.S., Shumach, R.L. Interstate Publishers, Inc., P.O. Box 50, Danville, IL 61834-0050. (217) 446-0500.
2. *Greenhouse Management for Flower and Plant Production*. (1980). Nelson, K.S. Interstate Publishers, Inc., P.O. Box 50, Danville, IL 61834-0050. (217) 446-0500.
- *3. *Greenhouse Operation and Management*. (1981). Nelson, P.V. Reston Publishing Company, Inc., Prentice Hall, 200 Old Tappan Road, Old Tappan, NJ 07675. (800) 223-2348.
- *4. *Soils/Plant Growth —Amendments for Container Soils* (VAS Unit #U5023); *Soils/Plant Growth — Standard Growing Media* (VAS Unit #U5024). Vocational Agriculture Service, College of Agriculture, University of Illinois, 1401 S. Maryland Drive, Urbana, IL 61801. (217) 333-3871.

*Indicates highly recommended reference

INSTRUCTIONAL RESOURCES

These resources are intended for use by teachers in planning and teaching the materials for this problem area and may be adapted to fit the teaching method(s) used.

INFORMATION SHEET #1 — Functions and Properties of Growing Media

INFORMATION SHEET #2 — Components

INFORMATION SHEET #3 — Soil-Based and Soilless Media

INFORMATION SHEET #4 — Soil Sterilization

INFORMATION SHEET #5 — Treatment, Temperature, and Time

INFORMATION SHEET #6 — Comparative Advantages of Steam and Chemical Treatments of Soil in Common Use in California Nurseries (After Baker)

INFORMATION SHEET #7 — Pasteurizing Soil Media Terms to be Defined

TRANSPARENCY MASTER #1 — Functions of Growing Media

TRANSPARENCY MASTER #2 — Amendments and Pore Size

TRANSPARENCY MASTER #3 — Field Soil in the Greenhouse

TRANSPARENCY MASTER #4 — Desirable Properties for Potted Plants

TRANSPARENCY MASTER #5 — Ideal Soil Mixtures

TRANSPARENCY MASTER #6 — Ideal Soil Characteristics

TRANSPARENCY MASTER #7 — Steam and Chemical Soil Sterilization

TRANSPARENCY MASTER #8 — Pasteurizing Soil Media

INFORMATION SHEET #1

Functions and Properties of Growing Media

1. Growing media have a number of functions related to plant growth. These include:
 - a. Serving as a reservoir for plant nutrients.
 - b. Providing available water to the plant.
 - c. Providing for exchange of gases between roots and atmosphere.
 - d. Providing anchorage or support for the plant.
2. The soil structure is important to plant growth. Some characteristics of soil structure are as follows:
 - a. Humus and microbial secretions bind soil particles together into aggregates.
 - b. Small pores hold water within each aggregate.
 - c. Large pores provide for aeration between aggregates.
3. Organic matter *decomposes* into humus which cements soil particles together.
4. The Carbon/Nitrogen (C:N) ratio is important to plant growth. Microorganisms utilize nitrogen in organic matter during decomposition at a rate of 1:30, or 1 pound of nitrogen to 30 pounds of carbon. An example of organic matter to be decomposed is sawdust, which has a C:N ratio of 1000:1. Therefore 24 pounds of nitrogen are needed to decompose 1 ton of sawdust.
5. Bulk density refers to the weight per unit volume. An acceptable bulk density for potting media is 40 - 75 pounds/cubic foot (after watering).
6. Balance of air and water needs to be maintained. After watering, 10-20% of the volume of the growing medium needs to be air and 35-50% water. Water holding capacity is the percent of water held in soil after gravitational water has drained. For container grown material this capacity to hold water must be higher than that of field soil. Soil should have enough weight and substance so that when dry it can still support the plant material.
7. Cation Exchange Capacity (CEC) is the ability of a growing medium to hold exchangeable cations of fertilizer nutrient elements. CEC is measured in milliequivalents/100 grams of dry medium. The desirable level is 10-30 milliequivalents/100 grams. A component with a high CEC needs to be included in a growing medium.
8. The pH indicates the degree of acidity or alkalinity of a growing medium. Greenhouse crops grow best at a pH of 6.2-6.8 for soil-based media and 5.5-6.0 for soilless media. Acid-loving crops such as azaleas like a pH of 4.5-5.8

451

INFORMATION SHEET #2

Components

1. Field soil is very difficult to find in a reliable source due to cost and the variations from lot to lot .
2. Peat moss is of several types.
 - a. Sphagnum (aquatic moss) has the highest water holding capacity. It holds 60% of its volume in water. It often has an acidic pH of 3-4 and forms large pores.
 - b. Hypnum (aquatic moss) decomposes more rapidly but has the same basic properties as sphagnum moss.
 - c. Reed and sedge peat, derived from swamp plants such as reeds, sedges, cattails, and marsh grasses, is more decomposed than peat moss and has finer particles. It has a lower water holding capacity and pH of 4-7.5 which usually needs to be adjusted for bench or pot crops.
 - d. Humus is dark brown to black and the most highly decomposed medium. It is derived from hypnum or sedge peat and has a pH of 5-7.5. It is high in nitrogen and is rarely used in greenhouses.
2. Bark should be composted. It has a C:N ratio of 300:1. The reason for composting is that some woods contain phenolic compounds that are harmful to some plants. Composting of bark occurs in two ways. If nitrogen is used it takes 4 to 6 weeks and if nitrogen is not used it takes 3 months to a year. The bark should have less than 5% cambium tissue, be less than 3/8" in diameter with a general size of 1/50" to 3/8".
3. Sawdust should also be composted so that it does not use up the available nitrogen. It may also contain certain substances like tannin resins and turpentine. It has a C:N ratio of 1000:1 and should compost with nitrogen for one month.
4. Manure must be pasteurized before use. Cow manure is the best. Manure has a high CEC and water holding capacity and contains micronutrients.
5. Crop by-products can also be used. Examples of crop by-products are straw, peanut hulls, rice hulls, and sugar cane fiber.
6. Vermiculite is mica which has been expanded by heat. Mica is mined in the U.S. and Africa. It is lightweight, helps aeration, and will retain water and nutrients. It breaks down faster than perlite and contains traces of potassium and magnesium.
7. Calcined clay is clay which has been heated to a high temperature to form hardened clay particles.
8. Sand provides aeration and drainage. Be sure that it does not contain salt. It is a good idea to pasteurize the sand before using it.
9. Perlite is a good substitute for sand. Perlite is volcanic rock which is crushed and heated to 1800°F. It will not crush or compress like vermiculite and holds less water, although it does hold three times its own weight in water. It is chemically inert so it has no CEC. It is very costly.

INFORMATION SHEET #3

Soil-Based and Soilless Media

Neither soil-based medium nor soilless medium is superior to the other, when proper adjustments are made for the growing situation. The formulation of soil based is equal parts loam field soil, concrete grade sand, and sphagnum peat moss. To adjust the pH, add phosphorous and dolomitic limestone. Note that sand reduces the CEC and water holding capacity, but the sphagnum peat moss will compensate for this. Perlite can be substituted for the sand but costs ten times as much.

The problems with field soil are:

1. It varies in structure and texture.
2. It is very heavy when shipped.
3. More labor is needed in mixing than required in soilless media, which can be purchased ready to use.

There should be 1-3 components of soilless which will vary with the cost and availability of the components. Components should provide adequate moisture and nutrient retention. The formulation of soilless is peat moss based.

1. UC mixes are:
 - a. 1/2 sphagnum peat moss and 1/2 vermiculite.
 - b. 1/2 hypnum peat moss and 1/2 vermiculite.
2. Peatlite mixes are:
 - a. 1/2 sphagnum peat moss and 1/2 vermiculite.
 - b. 1/2 sphagnum peat moss and 1/2 perlite.
3. Commercial mixes include:
 - a. Redi-Earth.
 - b. Jiffy Mix.
 - c. Pro-Mix A.

The commercial mixes usually contain:

1. Enough limestone to raise the pH to 6.0.
2. Micronutrients.
3. Phosphorous to meet crops needs.
4. Enough nitrogen and potassium to lightly fertilize crop for 2-4 weeks.

Commercial media that contain sand and/or perlite in addition to peat moss and vermiculite are:

1. Pro-Mix BX & C.
2. Metro-Mix Growers Choice.

NOTE: Adding 10-20% field soil to these mixes reduces cost and improves water retention.

The recommended chemical amendments are:

1. Dolomitic limestone which is used to raise the pH to 5.5 to 6.0.
2. Aluminum sulfate or sulphur which is used to lower pH to 5.0 to 5.8.
3. Phosphorous which can be added using super phosphate (0-20-0).
4. A slow release fertilizer which can be mixed into the media.

INFORMATION SHEET #4

Soil Sterilization

Any mixture containing soil should be sterilized.

Methods:

1. Steam for 30 minutes once the temperature reaches 180°F.
2. Chemical methods:
 - a. Methyl cromide is a soil fumigant. It will control weeds, nematodes, and soil-borne insects. Do not use when planning on growing carnations, snapdragons, or salvia. Do not use in the greenhouse.
 - b. Terraclor and Benlate are soil drenches. Use on crops that are susceptible to root and stem rot.
 - c. Dexon and Trubar should be used on water holding plants such as Pythium.
3. Electrically heated sterilizers are only used on small amounts of media.

INFORMATION SHEET #5

Treatment, Temperature, and Time

Temperatures necessary to kill pathogens and other organisms are listed. Most of the temperatures indicated here are for 30 minute exposures under moist condition (after Baker et al.).

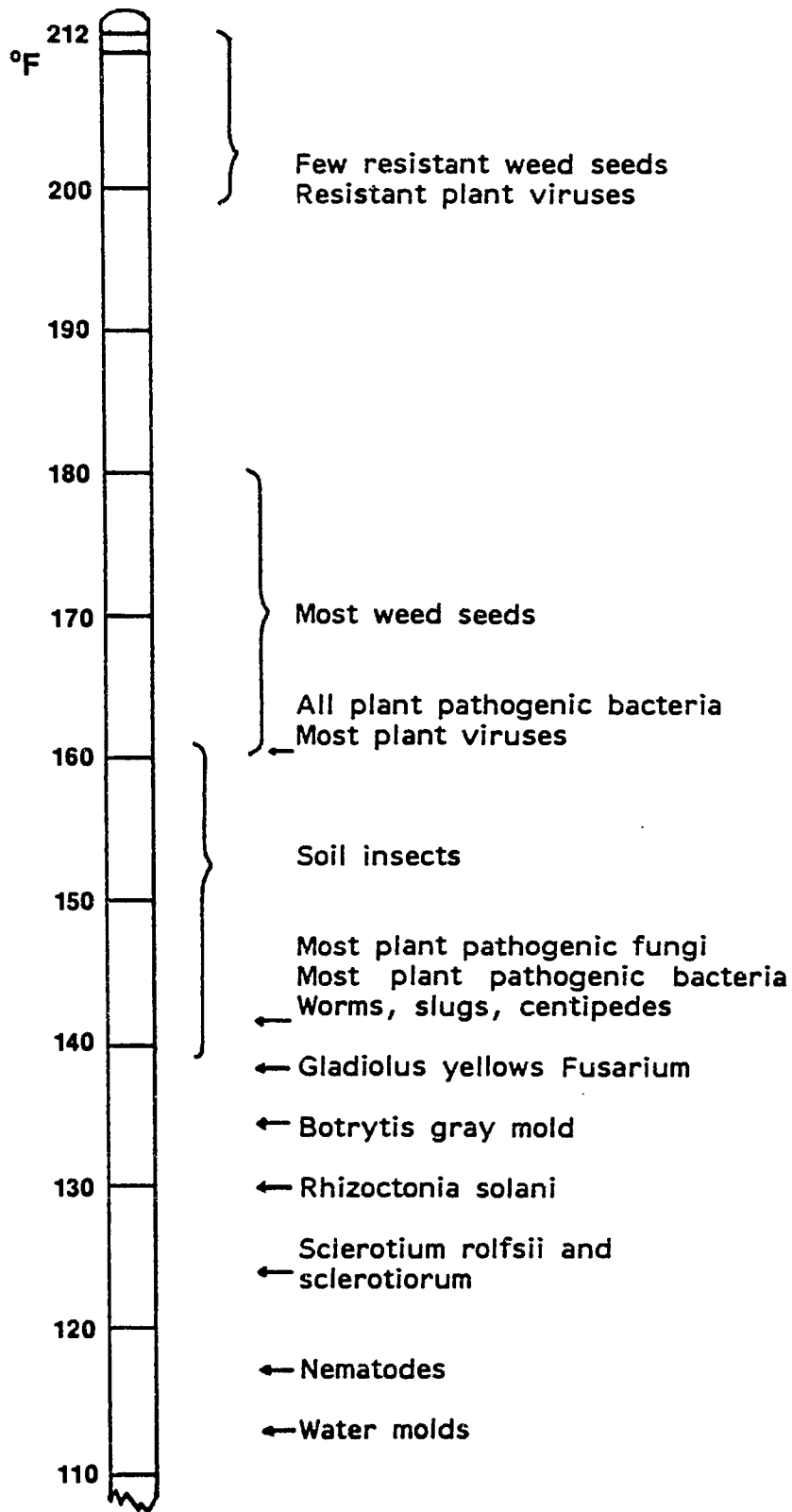

INFORMATION SHEET #6

Comparative Advantages of Steam and Chemical Treatments of Soil in
Common Use in California Nurseries (After Baker)

Provided by Vaughn Jacklin Corporation

Characteristic	Steam, 180°-212°F for 30 min	Methyl bromide 4 lbs per 100 cu ft	Chloropicrin 5 cc per cu ft
How much time is required for treatment?	About 1 hour	24-48 hour	2-3 days
How long between treatment and planting?	About 1-2 hours to cool	24-48 hours	7-10 days
Are all pathogens, weeds, and insects killed?	Yes, best treatment; a few weeds survive	Most, but not vertivillium; a few weeds survive	Yes, a few weeds survive
When can penetration of material be determined, as a measure of effectiveness?	At once, by measured soil temperature	Later, by noting reduction of disease or pathogen	Later, by noting reduction of disease or pathogen
Is there a toxic after-effect to crops?	None with UC-type soil mixes	Yes, for carnations and some others	None when properly aerated
Can it be used near living plants?	Yes	Within 3 feet if adequately ventilated	Only with excellent ventilation
Does it destroy organisms in unrooted crop refuse?	Yes	Yes	Poorly
Can it be used anywhere?	Only if portable boiler is used	Yes	Yes
Is its use limited by environment?	Time and cost increase with cold or wet soil, but can be so used	Not recommended below 60°F.	Dosage increase if soil below 60°F or wet
Is it easy to apply?	Easy	Easy	Obnoxious and time consuming
Is it dangerous to workmen?	No	Yes	Yes
Is large capital outlay required?	Yes, if boiler is available	No	No
What is the cost per cubic foot of soil, exclusive of labor?	Less than 2 cents, including cost of equipment	About 2.9-3.2 cents, excluding cost of equipment	About 1.9-3.0 cents excluding cost of equipment

INFORMATION SHEET #7**Pasteurizing Soil Media Terms to be Defined**

Bacterium — a microscopic unicellular plant that lacks chlorophyll and reproduces by dividing into two parts.

Damping off — decay or rotting of seed or stem near the soil surface.

Fumigant — a volatile pesticide that kills by its vapors.

Fungus — a plant with no chlorophyll, reproducing by sexual or asexual pores, with mycelium and well-worked nuclei.

Gall — outgrowth or swelling of unorganized plant cells, the result of attack by insects, fungi, bacteria, or nematodes.

Grey mold — an aerial plant mold which destroys plant above ground level.

Infection — the process by which a parasite gains entrance and becomes established in the host.

Nematode — minute wormlike animal; some types feed on or in plants.

Pasteurization — heating to kill selected organisms.

Root rot — decay of plant roots because of cultural practices and/or infections.

Stem rot — an aerial decay of the plant, possibly right at the soil.

Sterilization — heating to kill all organisms.

Stunting — reduced size or vigor because of infection.

Water mold — a primitive type of fungus that lives in very moist soil; some are able to parasitize plants.

Wilt — drooping of plants because of inadequate water supply or excessive transportation, a vascular disease interfering with water transfer.

TRANSPARENCY MASTER #1

Functions of Growing Media

- reservoir for plant nutrients
- reservoir for water
- anchorage and support for the plant
- location for exchange of gases between roots and atmosphere

TRANSPARENCY MASTER #2

Amendments and Pore Size

Amendments

Inorganic

Perlite
Vermiculite
Calcined Clay
Sand

Organic

Peat Moss
Sawdust
Pine Bark
Shavings

Pore Size

Large

Perlite
Vermiculite
Calcined Clay
Pine Bark

Small

Peat Moss
Sand
Ash
Loamy Topsoil

TRANSPARENCY MASTER #3

Field Soil in the Greenhouse

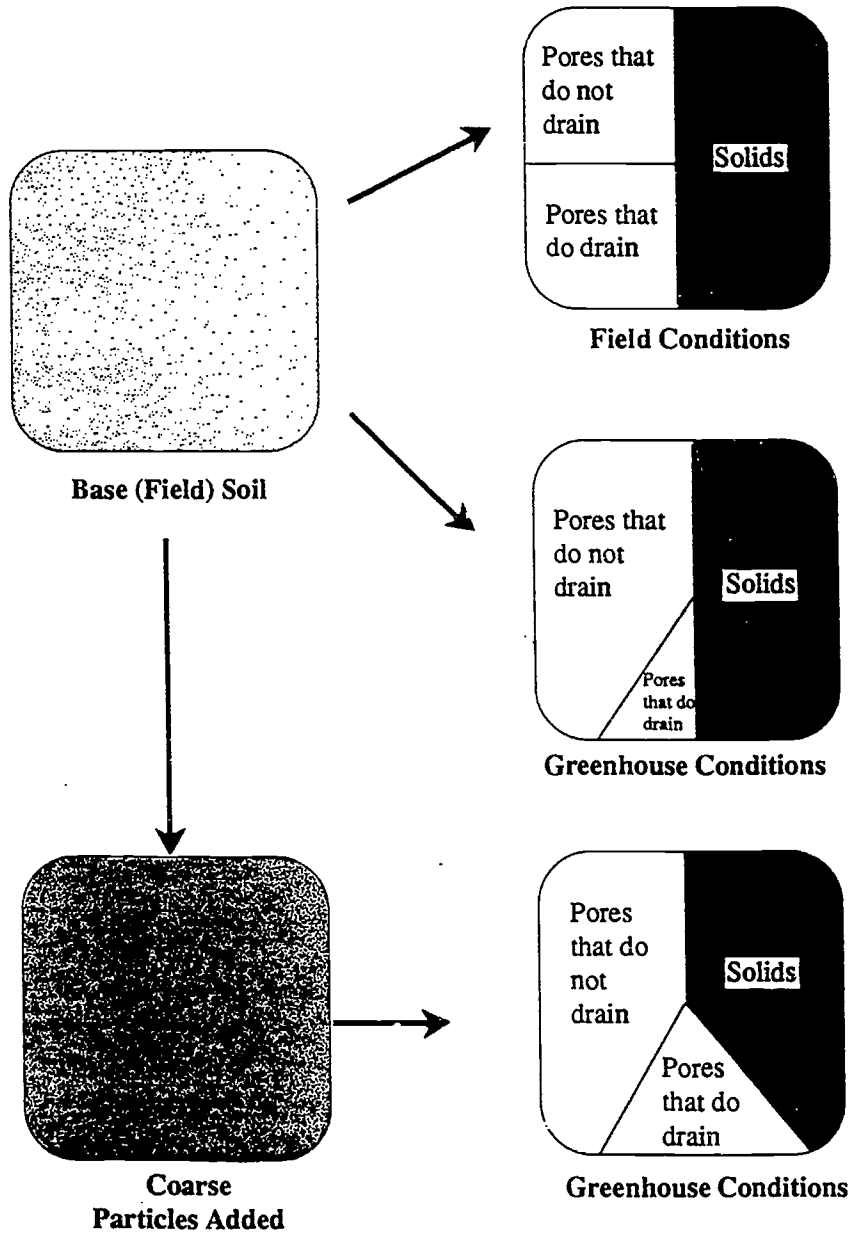

Field soil used in the greenhouse may react differently to the drainage of water. Coarse particles are added to remedy this problem.

TRANSPARENCY MASTER #4

Desirable Properties for Potted Plants

1. Stable organic matter content that does not diminish in volume during growth.
2. Bulk density light enough to lessen handling and shipping costs but heavy enough to prevent plants from tipping.
3. Organic matter with a reasonable rate of decomposition and C:N ratio.
4. High moisture retention along with good aeration.
5. High CEC for nutrient reserve.
6. pH level between 6.2-6.8 for crops in general, lower for acid-loving plants.
7. Sufficient level of all nutrients to prevent deficiency for the length of at least one crop; not including nitrogen and potassium.

TRANSPARENCY MASTER #5

Ideal Soil Mixtures

1. Screen the soil to make it uniform and to eliminate large particles.
2. Moisten slightly extremely dry materials (especially peat).
3. Mix smaller quantities by putting the ingredients in a pile in layers, and turn the pile with a shovel until uniformity is attained.
4. Use a power driven cement mixer or shredder for large-scale mixing operations.
5. Prepare the mixture at least one day in advance of use.

TRANSPARENCY MASTER #6

Ideal Soil Characteristics

1. Uniformity
2. Freedom from Disease
3. Low Soluble Salts
4. Good Drainage
5. Good Moisture Retention
6. No Shrinkage
7. Ease of Preparation and Storage
8. Complete Availability
9. Light in Weight

463

TRANSPARENCY MASTER #7

Steam and Chemical Soil Sterilization

Treatment	Advantages	Disadvantages
Steaming	A very effective job; cost of treatment less per sq ft than for chemicals	High initial cost; edges of benches and growing areas may not receive steam; after steaming, problems frequently occur
Fumigation (Chemical)	Useful when a source of steam is not available; gives good control of insects, weeds, and nematodes	High cost of treatment per sq ft; not very effective against hard-to-kill organisms; a great deal of time required for aeration after treatment

TRANSPARENCY MASTER #8

Pasteurizing Soil Media

Organism	Time To Kill	Temperature
Nematodes	Instantly	140°F
Soil insects	Instantly	140°F
Soil fungi	10 minutes	140°F - 160°F
Soil bacteria	10 minutes	140°F - 160°F
Weed seeds	10 minutes	140°F - 160°F
Soil virus	30 minutes	180°F

465

STUDENT ACTIVITIES

STUDENT WORKSHEET #1 — Soil Media

STUDENT WORKSHEET #2 — Pasteurizing, Preparing, and Using a Growing Medium

STUDENT WORKSHEET #3 — Effect of Pasteurizing Soil on Plant Growth

For additional activities, teachers may refer to the “Suggested Teaching Activities and Procedures” section in the Instructor’s Guide.

STUDENT WORKSHEET #1

Soil Media

1. Why are some loam soils not ideal for growing plants in containers?
2. Name four desirable characteristics of a germination medium.
3. Name two requirements of all growing media.
4. Match the correct letter to the space in the circle graph.

- a.
- b.
- c.
- d.

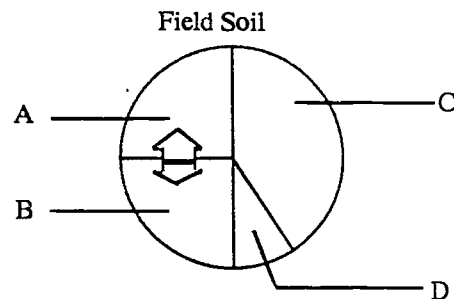

5. The amount of organic material in field soil is
 - a. 1%
 - b. 5%
 - c. 25%
 - d. 45%
 - e. 50%
6. Special materials added to the soil help improve to help improve it are known as:
 - a. Fertilizers
 - b. Amendments
 - c. Compost
 - d. All of these
7. Which amendment in this list is *not* organic
 - a. Peat moss
 - b. Sand
 - c. Sawdust
 - d. Compost
8. A mixture of decomposing organic materials such as leaves, straw, and manure is known as:
 - a. Peat moss
 - b. Perlite
 - c. Compost
 - d. Vermiculite
9. List five types of amendments.

467

10. In the list of characteristics below, place a check next to those which are considered to be desirable properties of mixing media.
- Sufficient firmness and density to hold cuttings or seeds in place.
 - Fairly constant volume whether dry or wet.
 - A pH level suitable for plant being grown.
 - Sufficient cloddiness so that water will not drain off.
 - Freedom from nematodes, seeds, weeds, and noxious disease organisms.
11. Match:
- | | |
|-----------------------|---|
| a. Aeration | 1. A kind of "soil" made up of partly decomposed plant life. |
| b. Dolomite limestone | 2. A heat-treated material, like pumice, made of limestone. |
| c. Perlite | 3. A fertilizer consisting of calcium magnesium carbonate. |
| d. Chelate of iron | 4. Exposure to air. |
| e. Super-phosphate | 5. Several components mixed together that act or serve as an intermediary. |
| f. Peat | 6. A mined micaceous mineral which expands when heated. |
| g. Vermiculite | 7. Calcium, hydrogen phosphate, and calcium sulphate in powder form, to be mixed with fertilizer. |
| h. Medium | 8. A form in which iron can be readily available to plants, when applied to the soil or sprayed on the foliage. |
12. What characteristics are desirable for a soil amendment?
13. Why do container soils need amending?
14. Which of the following is very lightweight?
- Vermiculite
 - Sand
 - Compost
 - Peat moss
15. Which of the following would we add to increase the soil's nutrient holding capacity?
- Sand
 - Perlite
 - Vermiculite
16. Which material in the list is *not* likely to cause temporary nitrogen tie-up?
- Fresh sawdust
 - Peat moss
 - Fresh wood chips
 - Fresh straw
17. Amendments are normally added to soil so they make up about what percentage of the final volume?
- 5%
 - 15%
 - 25%
 - 50%

STUDENT WORKSHEET #1 — Key

Soil Media

- Why are some loam soils not ideal for growing plants in containers?
 - Build-up of high-soluble salts
 - Too quick drying out
 - Shrinkage in the container
 - Compaction
- Name four desirable characteristics of a germination medium.
 - Lightweight, low in nutrients
 - Not costly
 - Able to hold desirable amounts of moisture
 - Sterilized
- Name two requirements of all growing media.
 - To support the plant
 - To provide nutrients to the plant
 - To provide water to the plant

- Match the correct letter to the space in the circle graph.
 - Air
 - Water
 - Inorganic material
 - Organic material

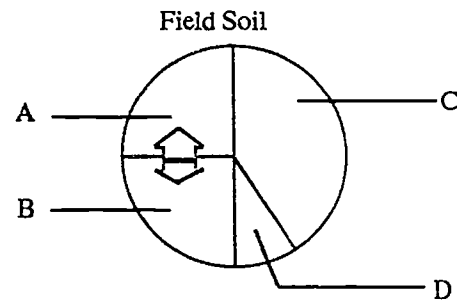

- The amount of organic material in field soil is
 - 1%
 - 5%
 - 25%
 - 45%
 - 50%
- Special materials added to the soil help improve to help improve it are known as:
 - Fertilizers
 - Amendments
 - Compost
 - All of these
- Which amendment in this list is *not* organic?
 - Peat moss
 - Sand
 - Sawdust
 - Compost
- A mixture of decomposing organic materials such as leaves, straw, and manure is known as:
 - Peat moss
 - Perlite
 - Compost
 - Vermiculite
- List five types of amendments.

a. Vermiculite	d. Peat
b. Perlite	e. Sphagnum
c. Sand	f. Others: soil, manure, shredded bark, wood shavings, sawdust

10. In the list of characteristics below, place a check next to those which are considered to be desirable properties of mixing media.

- a. Sufficient firmness and density to hold cuttings or seeds in place.
- b. Fairly constant volume whether dry or wet.
- c. A pH level suitable for plant being grown.
- d. Sufficient cloddiness so that water will not drain off.
- e. Freedom from nematodes, seeds, weeds, and noxious disease organisms.

11. Match:

- | | |
|-----------------------|---|
| a. Aeration | 1. A kind of "soil" made up of partly decomposed plant life. |
| b. Dolomite limestone | 2. A heat-treated material, like pumice, made of limestone. |
| c. Perlite | 3. A fertilizer consisting of calcium magnesium carbonate. |
| d. Chelate of iron | 4. Exposure to air. |
| e. Super-phosphate | 5. Several components mixed together that act or serve as an intermediary. |
| f. Peat | 6. A mined micaceous mineral which expands when heated. |
| g. Vermiculite | 7. Calcium, hydrogen phosphate, and calcium sulphate in powder form, to be mixed with fertilizer. |
| h. Medium | 8. A form in which iron can be readily available to plants, when applied to the soil or sprayed on the foliage. |

12. What characteristics are desirable for a soil amendment? (Refer to VAS Unit #5023, page 2 and 3.)

13. Why do container soils need amending? (Refer to VAS Unit #5023, page 1.)

14. Which of the following is very lightweight?

- a. Vermiculite
- b. Sand
- c. Compost
- d. Peat moss

15. Which of the following would we add to increase the soil's nutrient holding capacity?

- a. Sand
- b. Perlite
- c. Vermiculite

16. Which material in the list is *not* likely to cause temporary nitrogen tie-up?

- a. Fresh sawdust
- b. Peat moss
- c. Fresh wood chips
- d. Fresh straw

17. Amendments are normally added to soil so they make up about what percentage of the final volume?

- a. 5%
- b. 15%
- c. 25%
- d. 50%

STUDENT WORKSHEET #2**Pasteurizing, Preparing, and Using a Growing Medium**

1. Identify 5 advantages of incorporating organic matter and soil "lightening" material with loam soils.
 - a.
 - b.
 - c.
 - d.
 - e.

2. The ideal soil mix has these characteristics:
 - a.
 - b.
 - c.
 - d.
 - e.
 - f.
 - g.
 - h.
 - i.

3. The advantages of an artificial soil mix are:
 - a.
 - b.
 - c.
 - d.

4. An ideal soil mix should be _____. (Select one of the following responses.)
 - a. Uniform
 - b. Low in soluble salt
 - c. Able to provide good drainage
 - d. Light in weight
 - e. All of the above
 - f. Choices a, b, and d only

5. Organic farming can best be characterized by which of the following?
 - a. Using organic materials
 - b. Not using pesticides and herbicides
 - c. Not resorting to the use of chemical additives such as fertilizer
 - d. Using natural farming methods
 - e. Choices a, b, and c

6. Describe the "ideal" soil mixture.

7. Identify as true or false each of the following ingredients that make up the mixture for general container ground nursery stock.
 - a. 1 part sand
 - b. 2 parts loam soil
 - c. 1 part peat moss
 - d. 3 parts nut shells
 - e. 1/2 part sawdust or wood shavings

471

8. When should the materials for the growing medium be mixed?
9. Choose from the following statements those that apply to soilless artificial medium mixtures.
- Grower can obtain fairly reproducible results for his plants.
 - Iron never needs to be applied to this mixture.
 - Trays containing this mixture are 50% lighter than the peat, sand, loam mix.
10. a. State two advantages for using domestic peats in medium mixes.
b. State two disadvantages for using domestic peats in medium mixes.
11. List the three ingredients used in the medium mixture for potting rooted cuttings and young seedlings.
12. State at least four steps in preparing the soil for steaming.
13. Name at least five factors to consider in chemically fumigating soil.
14. Identify as true or false each of the following possible solutions to problems that may occur after steaming:
- Avoid sterilizing in cold water.
 - Use high-quality, long-lasting kinds of peat such as German or Canadian Sphagnum peats, or other forms of organic matter that break down slowly.
 - Don't feed the previous crop after it shows color, and leach it during the last watering.
 - Keep soils cultivated during critical periods to encourage air to enter the lower soil.
 - Keep soils very dry when steaming.
15. State the length of time and the temperature to steam soil.
16. State at least two problems that are likely to occur after steaming soil.
17. List at least four precautions to observe in using chemical soil fumigants.
18. Describe damping off and list possible causes.
19. Identify as true or false each of the following fumigants that are particularly effective against nematodes.
- Dichloropropene-dichloropropane mixtures
 - Ethylene di-bromide
 - Fly sprays
20. Name three sources of disease problems in nurseries and greenhouses.
21. Identify as true or false each of the following phrases concerning the conditions under which soils are sterilized by chemicals.
- When overhead costs are so low that the time required for aeration is not expensive.
 - When weed seeds and soil-borne insects are the main reasons for sterilization.
 - When steam boilers are not available for sterilization.
 - During war when poison gas is more available.
22. Match:
- | | |
|---------------|---|
| a. Sterilize | 1. A chemical treatment that kills all living things in the soil and renders the soil unusable for plants for one to several years. |
| b. Leaching | 2. The dissolving out of toxic materials from soil by running water or percolating water through the soil. |
| c. Fumigant | 3. A small round worm that lives in the soil and does much damage. |
| d. Nematode | 4. A chemical whose vapors are capable of destroying soil-borne insects, bacteria, and weed seeds in an enclosed place. |
| e. Pasteurize | 5. To heat the soil just long enough to kill the harmful microorganisms in the soil. |

23. Name three methods of pasteurizing soil.
24. Identify as true or false each of the following statements concerning the purposes of steam sterilizing.
- a. Kills soil-borne insects
 - b. Kills all of the bacteria, fungi, and virus organisms that are harmful to commercial crops
 - c. Destroys weed seeds
 - d. Promotes fertility in the soil
 - e. Promotes soil granulation
25. Which one of the following statements best sums up the importance of nursery or greenhouse sanitation? Underline the correct response.
- a. The nursery or greenhouse looks nice
 - b. Using clean tools and fumigated soil mix reduces disease and allows increased production

478

STUDENT WORKSHEET #2 — Key

Pasteurizing, Preparing, and Using a Growing Medium

1. Identify 5 advantages of incorporating organic matter and soil "lightening" material with loam soils.
 - a. *Better aeration*
 - b. *Greater ease of working*
 - c. *Better drainage*
 - d. *Better moisture holding capacity*
 - e. *Lighter in weight*

2. The ideal soil mix has these characteristics:
 - a. *Uniformity*
 - b. *Freedom from disease*
 - c. *Low soluble salts*
 - d. *Good drainage*
 - e. *Good moisture retention*
 - f. *No shrinkage*
 - g. *Ease of preparation and storage*
 - h. *Complete availability*
 - i. *Light weight*

3. The advantages of an artificial soil mix are:
 - a. *Light weight*
 - b. *Low cost*
 - c. *Ability to be reproduced, or remixed*
 - d. *Ability to be tailored to the crop*

4. An ideal soil mix should be _____. (Select one of the following responses.)
 - a. Uniform
 - b. Low in soluble salt
 - c. Able to provide good drainage
 - d. Light in weight
 - e. All of the above
 - f. Choices a, b, and d only

5. Organic farming can best be characterized by which of the following?
 - a. Using organic materials
 - b. Not using pesticides and herbicides
 - c. Not resorting to the use of chemical additives such as fertilizer
 - d. Using natural farming methods
 - e. Choices a, b, and c

6. Describe the "ideal" soil mixture. *Large quantities available, not costly, light weight, has water holding capacity and has a known C.E.C.*

7. Identify as true or false each of the following ingredients that make up the mixture for general container ground nursery stock.
 - T a. 1 part sand
 - T b. 2 parts loam soil
 - T c. 1 part peat moss
 - F d. 3 parts nut shells
 - T e. 1/2 part sawdust or wood shavings

8. When should the materials for the growing medium be mixed? *The soil medium can be mixed at any time and should be pasteurized just before use.*

474

9. Choose from the following statements those that apply to soilless artificial medium mixtures.
- ✓a. Grower can obtain fairly reproducible results for his plants.
 - b. Iron never needs to be applied to this mixture.
 - ✓c. Trays containing this mixture are 50% lighter than the peat, sand, loam mix.
10. a. State two advantages for using domestic peats in medium mixes. *Large quantities available in the United States, not as costly as the imported types, and 50% lighter than the other mixes.*
- b. State two disadvantages for using domestic peats in medium mixes. *Variability in nutrient level, decomposition rate, and acidity level, and possible presence of weed seeds and nematodes.*
11. List the three ingredients used in the medium mixture for potting rooted cuttings and young seedlings. *Sand, loam, and peat moss*
12. State at least four steps in preparing the soil for steaming.
- a. *Test soil for moisture*
 - b. *Mix soil to aerate the medium*
 - c. *Add organic material prior to steaming*
 - d. *Check soluble salt level*
13. Name at least five factors to consider in chemically fumigating soil.
- a. *Is there any other less costly method?*
 - b. *Can the crop being planted tolerate the chemical?*
 - c. *Can the employees be protected from the hazards?*
 - d. *Can time be permitted for chemical fumigation?*
 - e. *Will this method control the pest?*
14. Identify as true or false each of the following possible solutions to problems that may occur after steaming:
- F a. Avoid sterilizing in cold water.
 - T b. Use high-quality, long-lasting kinds of peat such as German or Canadian Sphagnum peats, or other forms of organic matter that break down slowly.
 - T c. Don't feed the previous crop after it shows color, and leach it during the last watering.
 - T d. Keep soils cultivated during critical periods to encourage air to enter the lower soil.
 - F e. Keep soils very dry when steaming.
15. State the length of time and the temperature to steam soil. *30 minutes at 180°F*
16. State at least two problems that are likely to occur after steaming soil.
- a. *Soil may nitrify.*
 - b. *Beneficial organisms may be killed.*
 - c. *Ammonia may build up and burn roots.*
17. List at least four precautions to observe in using chemical soil fumigants.
- a. *Do not plant fumigated soil for two weeks.*
 - b. *Avoid inhaling the material.*
 - c. *Avoid skin contact.*
 - d. *Allow for time aeration.*
18. Describe damping off and list possible causes. *Decay or rotting of seeds or stems near the soil surface; may be caused by too cool temperatures, over watering, too much humidity, or pests*
19. Identify as true or false each of the following fumigants that are particularly effective against nematodes.
- T a. Dichloropropene-dichloropropane mixtures
 - T b. Ethylene di-bromide
 - T c. Fly sprays
20. Name three sources of disease pr' . . . in nurseries and greenhouses. *Tools used in infected places, soil not pasteurized, and cuttings or seeds infected prior to planting*

21. Identify as true or false each of the following phrases concerning the conditions under which soils are sterilized by chemicals.

- T a. When overhead costs are so low that the time required for aeration is not expensive.
 T b. When weed seeds and soil-borne insects are the main reasons for sterilization.
 T c. When steam boilers are not available for sterilization.
 F d. During war when poison gas is more available.

22. Match:

- | | | |
|---------------|-------|---|
| a. Sterilize | _____ | 1. A chemical treatment that kills all living things in the soil and renders the soil unusable for plants for one to several years. |
| b. Leaching | _____ | 2. The dissolving out of toxic materials from soil by running water or percolating water through the soil. |
| c. Fumigant | _____ | 3. A small round worm that lives in the soil and does much damage. |
| d. Nematode | _____ | 4. A chemical whose vapors are capable of destroying soil-borne insects, bacteria, and weed seeds in an enclosed place. |
| e. Pasteurize | _____ | 5. To heat the soil just long enough to kill the harmful microorganisms in the soil. |

23. Name three methods of pasteurizing soil.

- a. *Chemicals*
 b. *Electricity (oven heat)*
 c. *Steam*

24. Identify as true or false each of the following statements concerning the purposes of steam sterilizing.

- T a. Kills soil-borne insects
 T b. Kills all of the bacteria, fungi, and virus organisms that are harmful to commercial crops
 T c. Destroy weed seeds
 F d. Promotes fertility in the soil
 T e. Promotes soil granulation

25. Which one of the following statements best sums up the importance of nursery or greenhouse sanitation? Underline the correct response.

- a. The nursery or greenhouse looks nice
 b. Using clean tools and fumigated soil mix reduces disease and allows increased production.

STUDENT WORKSHEET #3**Effect of Pasteurizing on Plant Growth****Purpose:**

1. To show the effects of pasteurization on plant growth and development.

Materials:

1. soil mixture sufficient to fill two small flats
2. two small flats (or pots)
3. thirty rooted herbaceous cuttings
4. oven
5. thermometer

Procedure:

1. Fill the two flats or pots with soil mixture.
2. Place flat number one in the oven and pasteurize the soil by maintaining the soil temperature at 180°F for 30 minutes.
3. The next day plant 15 cuttings in flat number one and 15 cuttings in flat number two.
4. Observe the plants each day for 30 days.

Questions:

1. What effect did the soil that was pasteurized have on plant growth?
2. Why was there a difference in plant growth?
3. Summarize the differences in the two flats every ten days.
 - a. 10 days:
 - b. 20 days:
 - c. 30 days:

477

CLUSTER: HORTICULTURE

UNIT: Horticultural Science and Production

PROBLEM AREA: Growing Plants Hydroponically

RELATED PROBLEM AREA(S):

1. Recognizing the Impact of Technology on Agriculture: Biotechnology (Central Core Cluster)
2. Understanding Plant Anatomy and Physiology
3. Understanding Plant Germination, Growth, and Development

PREREQUISITE PROBLEM AREA(S):

1. Recognizing the Impact of Technology on Agriculture: Biotechnology (Central Core Cluster)
2. Identifying Basic Principles of Plant Science (Central Core Cluster)

LEVEL: Orientation

OCCUPATIONAL TASKS ADDRESSED:

Horticulture Cluster

Duty B: Preparing Soils and Planting Media

1. Mix media materials

STATE GOALS FOR LEARNING:

In planning the instruction for this problem area, teachers can promote the development of several student learning objectives which are related to the State Goals for Learning in Biological and Physical Sciences. These objectives are listed on the Learning Assessment Plan forms included on the following page(s). Those learning objectives marked with an asterisk (*) are taken from the sample lists provided by the Illinois State Board of Education.



Illinois Agricultural Core Curriculum

Agricultural Education 124 Mumford Hall 1301 W. Gregory Drive University of Illinois Urbana, IL 61801

Directors: Dale A. Law, Ed.D. and Jerry D. Pepple, Ed.D.

Principal Investigator: Chris A. Roegge, Ph.D.

Research Assistant: Randy J. Bernhardt

88/89

ERIC
Agricultural Science and Production

Illinois Agricultural Core Curriculum Rev.

ILLINOIS STATE BOARD OF EDUCATION
Department of School Improvement Services
100 North First Street
Springfield, Illinois 62777-0001

LEARNING ASSESSMENT PLAN
Instructions and codes for this form are provided on a separate sheet.

Submission Date _____ Page _____ of _____
 Original submission Revision
I. LEARNING AREA (check one)
 Language Arts Fine Arts
 Mathematics Social Sciences
 Sciences Physical Development/Health

(Affix label or complete district information.)
 COUNTY _____ DISTRICT _____ ESC _____
 District Name _____
 City _____

Contact Person: _____
 Title: _____
 Phone: (_____) _____

II. STATE GOAL FOR LEARNING
 As a result of their schooling, students will have a working knowledge of the social and environmental implications and limitations of technological development.

III. LEARNING OBJECTIVES	IV. ASSESSMENT				V. EXPECTATIONS Percent of Students Expected to Achieve Objective
	A Types	B Validity/ Reliability	C Commercial Test(s)	D Evidence of Nondiscrimination	
By the end of grade (circle one) 3 6 8 11 students should be able to:					
*1. Identify areas of current scientific research that may evolve as technological developments.					
*2. Understand the impact of technological developments on society.					
3. Define the term hydroponics.					
4. Develop an understanding of the nutrient solution involved with hydroponics.					
5. Understand the needs of hydroponically grown plant culture.					
6. Compare soil versus soilless culture.					
7. Recognize the need to pollinate plants grown indoors.					
8. Understand present and future implications of hydroponics.					
9. Understand why there is a need for new crop production techniques.					480

INSTRUCTOR'S GUIDE

CLUSTER: HORTICULTURE

UNIT: Horticultural Science and Production

PROBLEM AREA: Growing Plants Hydroponically

STUDENT LEARNING OBJECTIVES

Upon completion of their study of this problem area, students will be able to:

1. Define the term hydroponics.
2. Develop an understanding of the nutrient solution involved with hydroponics.
3. Understand the needs of hydroponically grown plant culture.
4. Compare soil versus soilless culture.
5. Recognize the need to pollinate plants grown indoors.
6. Understand present and future implications of hydroponics.

INSTRUCTOR'S NOTES AND REFERENCES

INSTRUCTOR'S GUIDE**CLUSTER: HORTICULTURE****UNIT: Horticultural Science and Production****PROBLEM AREA: Growing Plants Hydroponically****PROBLEMS AND QUESTIONS FOR STUDY****INSTRUCTOR'S NOTES AND REFERENCES**

1. What is hydroponics?
2. What is the fertilizer chemical analysis for hydroponics?
3. How do we prepare the nutrient solution?
4. What is the cause of nutrient solution changes?
5. What are the temperature requirements of plants grown hydroponically?
6. What are the water requirements of plants grown hydroponically?
7. What is enrichment of environmental carbon dioxide?
8. What are the feeding requirements of plants grown hydroponically?
9. What are the pollination requirements of plants grown hydroponically?
10. What are the planting schedules of plants grown hydroponically?
11. What are the disease and insect control measures that must be taken care of with hydroponically grown plants?
12. What are the "pros" and "cons" of soilless culture as compared to a soil culture?
13. What are the present and future implications of hydroponics?

455

INSTRUCTOR'S GUIDE**CLUSTER: HORTICULTURE****UNIT: Horticultural Science and Production****PROBLEM AREA:** Growing Plants Hydroponically**SUGGESTED TEACHING ACTIVITIES AND PROCEDURES**

1. Define hydroponics for the class.
2. Discuss fertilizer needs for hydroponics. Refer to Instructional Resources.
3. Describe and show examples of basic hydroponic systems.
4. Have students construct a hydroponics system. Then have them grow agricultural crops in their system.
5. Describe two methods of preparing nutrient solutions for growing hydroponic cultures.
6. Demonstrate how to prepare a ready-made solution and/or an original mix (made yourself). This could be in the form of a demonstration laboratory. Solutions could then be used in the systems constructed in #4 above.
7. Take students on a field trip to a business that grows hydroponic plants or crops. Have an employee conduct a tour explaining the facilities and the methods used.
8. Have students complete Student Worksheet #1.
9. Conduct a class discussion on the importance of periodically changing the nutrient solution and why the solution must be changed.
10. Have students conduct a laboratory experiment on hydroponics. Refer to Student Worksheet #6.
11. Ask students to list the growth requirements of plants in a normal environment. Compare these requirements with the cultural requirements of hydroponically grown plants. Have students complete Student Worksheet #2 as the discussion progresses.
12. Discuss the types of diseases and insects encountered with hydroponics. Include how to prevent and/or control these problems.
13. Have students complete Student Worksheet #3.
14. Ask students the following question: "What are the advantages and disadvantages of soilless culture as compared to a soil culture?" Refer to Instructional Resources.
15. Have students complete Student Worksheet #4.
16. Discuss with students the present and future implications of hydroponics.
17. Have students do Student Worksheet #5 for necessary plants.

INSTRUCTOR'S NOTES AND REFERENCES

INSTRUCTOR'S GUIDE**CLUSTER: HORTICULTURE****UNIT: Horticultural Science and Production****PROBLEM AREA: Growing Plants Hydroponically****REFERENCES****INSTRUCTOR'S NOTES AND REFERENCES**

1. *Hydroponics Worldwide: State of the Art in Soiless Crop Production.* (1985). Savage, Adam J. (ed.). International Center for Special Studies, 400 Hobron Lane, Suite 3502, Honolulu, HI 96815-1209.
2. *Horticulture: A Basic Awareness.* (1982). Baudendistel, Robert F. Reston Publishing Company, Inc., Division of Prentice-Hall, 200 Old Tappan Road, Old Tappan, NJ 07675. (800) 223-2348.
- *3. *Hydroponic Food Production.* (1978). Resh, Howard M. Woodbridge Press Publishing Company, P. O. Box 6189, Santa Barbara, CA 93111.
4. *AgriScience Teacher Inservice Program.* Osborne, Edward W., Project Director, October 1988-January 1989. Agricultural Education, 124 Mumford Hall, 1301 W. Gregory, Urbana, IL 61801. (217) 333-3166.
- *5. *Beginning Hydroponics Soiless Gardening.* Running Press.

*Indicates highly recommended reference

487

INSTRUCTIONAL RESOURCES

These resources are intended for use by teachers in planning and teaching the materials for this problem area and may be adapted to fit the teaching method(s) used.

INFORMATION SHEET #1 — Preparing the Nutrient Solution

INFORMATION SHEET #2 — Causes of Nutrient Solution Changes

INFORMATION SHEET #3 — Plant Cultural Requirements for Success in Hydroponics

INFORMATION SHEET #4 — Diseases and Insects Encountered with Hydroponically Grown Plants

INFORMATION SHEET #5 — Advantages of Soilless Culture versus Soil Culture

INFORMATION SHEET #6 — Present and Future Implications of Hydroponics

TRANSPARENCY MASTER #1 — Hydroponics Defined

TRANSPARENCY MASTER #2 — Elements Supplied by Fertilizer Salts (with discussion guide)

TRANSPARENCY MASTER #3 — Functions of Elements (with discussion guide)

TRANSPARENCY MASTER #4 — Hydroponic Systems (with discussion guide)

TRANSPARENCY MASTER #5 — Hints for Storing and Making Nutrients

TRANSPARENCY MASTER #6 — Causes of Nutrient Solution Changes

TRANSPARENCY MASTER #7 — Plant Cultural Requirements for Success in Hydroponics

TRANSPARENCY MASTER #8 — Recommended Vegetable Varieties for Greenhouse and Hydroponic Culture

TRANSPARENCY MASTER #9 — Planting Schedule for a Spring and Fall Crop of Tomatoes (Two Crops Annually)

TRANSPARENCY MASTER #10 — Combination Crop Schedules

TRANSPARENCY MASTER #11 — Diseases and Insects Encountered with Hydroponically Grown Plants

TRANSPARENCY MASTER #12 — Comparative Yields Per Acre in Soil and Soilless Culture

480

INFORMATION SHEET #1**Preparing the Nutrient Solution**

There are two basic methods of obtaining a nutrient solution: (1) purchasing a pre-mix nutrient solution (which is the most costly), or (2) preparing your own nutrient solution.

Preparing Your Own Nutrient Solution

1. If you are an amateur, contact a professional scientist or company knowledgeable in the hydroponic field to obtain recommendations for preparing a nutrient solution for the particular plants to be grown.
2. Weigh out fertilizer salts individually, arranging them in piles on plastic sheets so there is no loss. This should be done accurately, to within plus or minus 5% using a gram scale.
3. Fill storage tank for nutrient solution 90% full with water.
4. Dissolve each salt individually in a container of water and pour solution into storage tank. Repeat process until all salts have been dissolved. For salts hard to dissolve, use hot water.
5. Dissolve micronutrients first, then macronutrients.
6. In a small backyard greenhouse system, all sulfates can be mixed together in dry form and then dissolved. The nitrates and phosphates can be mixed in dry form and then dissolved.
7. Check the nutrient solution pH and adjust with either sulfuric acid or potassium hydroxide.
8. Circulate nutrient solution through the bed(s). The pH should be adjusted to a level between 6.0 and 6.5.

INFORMATION SHEET #2

Causes of Nutrient Solution Changes

1. Nutrient Solution Life — In a closed system in which the nutrient solution is drained back to the reservoir after use, the life of the solution is approximately two to three weeks, depending upon the plant's stage of growth and the season. During the summer, when growing mature high-yield plants, the solution may have to be changed as often as every week. Plants absorb various elements in differing amounts. Because of this, some elements will be in short supply before others. Atomic absorption analysis of the solution can determine the types of deficiencies, but this is a costly analysis. The simplest safeguard against nutrient deficiencies is to change the solution periodically.
2. Factors Influencing Nutrient Uptake — Relative uptake of various mineral elements by plants is affected by:
 - a. Environment, including factors of temperature, light intensity, and humidity.
 - b. The nature of the crop.
 - c. The stage of plant growth, including germination, juvenile, and adult (reproductive) stages.
3. Nutrient Analysis — Besides testing the solution for depletions of nutrients, a test is also conducted for the accumulation of unused ions such as sodium, chloride, or sulfate, or for the presence of toxic elements in excess amounts such as copper or zinc.
4. Plant Tissue Analysis — By conducting both plant tissue and nutrient solution analysis, problems of plant physiology can be related to mineral element imbalances.
5. Changing of Solutions — No nutrient solution should be used for more than three months without being completely replaced. At the time of replacement, tap water flushing of the system must also be done. For economical purposes, two months is the average life of a solution as long as it has been adjusted by the use of analysis on a regular weekly basis. Without an analysis, as mentioned before, solution life would be only two to three weeks.
6. Maintenance of Solution Volume — Solution volume must be kept quite constant to insure adequate growth. With plants removing more water than essential minerals, the volume of the solution decreases while the solution concentration increases.

Some elements are depleted more quickly than others, and the concentration of nutrients is being increased by the plants natural activity of absorbing more water than salts (nutrients). The pH will also change as a result of this imbalance between water and salt absorption.

Average daily water loss can be anywhere from five to thirty percent depending upon the size of the system, type of plants, stage of growth, and number of plants.

INFORMATION SHEET #3

Plant Cultural Requirements for Success in Hydroponics

1. **Plant-Growing Temperature** — Better quality plants are grown when night temperature is 10°F lower than day temperature. Best temperature range for warm season crops is 60°F night and 75°F day. Cool season crops do better at 50°F night and 60°F day temperature. During cloudy weather a day temperature 10°F lower is best.

If the temperature is too low, plant growth will slow and some purpling of leaves can occur. If temperature is too high, plant growth will be soft and produce "leggy," poor-quality plants.

2. **Watering** — Each watering must soak the medium thoroughly. Water applied uniformly will prevent uneven plant growth. Plants should be watered so the foliage is dry before dark. Plants need less water during periods of dark or cloudy weather. Increasing the day length and the average temperature increases the amount of water needed by the plants.
3. **Light** — During cloudy weather, leaves become low in sugars. Leaves and stems become thin and pale and fruit may be small or not set at all. Too much nitrogen during these periods is harmful. It is economically impractical to supplement with artificial lighting.

During bright, sunny weather sugar production in leaves is high. The stems are dark green and sturdy, leaves are thick and dark, fruit sets well in large clusters, and roots are vigorous.

During cloudy periods of longer than two days, the following practices are recommended:

- a. Use as little water as possible without letting the plants wilt.
- b. Reduce temperatures (day and night) in a greenhouse by 3 to 4°F.
- c. Cut fertilizer recommendations by one-half.

4. **Carbon Dioxide Enrichment** — Carbon dioxide enrichment of greenhouses in northern regions of the U.S. has improved plant productivity. Some greenhouses claim yield increases of from 20 to 30 percent. A better setting of fruit in early clusters is observed.

Carbon dioxide enrichment and supplemental artificial lighting have proved to be economical in greenhouses producing vegetable seedlings and bedding plants. Stronger plants are produced in less time.

5. **Feeding and Watering** — After transplanting plants to a hydroponic system, feeding and watering system cycles must be set. The amount of time between watering cycles depends on: (1) type of growing medium, (2) plant requirements, (3) stage of plant, etc.
6. **Plant Support** — Plants such as cucumbers and tomatoes, which are trained to grow vertically in a greenhouse, must be strong and clamped to give support. The clamps should be located along the plant every foot to give adequate support for the heavy fruit being produced.
7. **Pollination** — In greenhouses, air movement is insufficient for flowers to self-pollinate. Vibration of flower clusters is necessary for good pollination in a greenhouse environment. This is done by tapping the flowers with a stick, fingers, or an electric vibrator such as an electric toothbrush (with its bristles removed). The fine yellow pollen will be seen flowing from the flower when vibrated.

Pollinating is done when flowers are in a receptive state, indicated by petals curling back. Plants should be pollinated every other day. Pollinating is to be done between 11:00 a.m. and 3:00 p.m. under sunny conditions. A 70 percent relative humidity is optimum for pollination, setting of fruit, and fruit formation. High humidity keeps pollen sticky and lessens chances of sufficient pollen transfer. Excessively dry conditions cause drying out and loss of pollen viability.

8. **Planting Schedules** — Several planting schedules are possible depending upon the crop or combination of crops to be grown during the entire year.

INFORMATION SHEET #4

Diseases and Insects Encountered with Hydroponically Grown Plants

Some common diseases include:

1. Leaf Mold (Cladosporium) — Mold begins as a small gray spot on lower side of leaves and spreads until a pale area is evident on the upper surface. Other infection sites develop and the small spots expand. Control through greenhouse sanitation, and regulation of temperature and ventilation to prevent high humidity. Fungicide sprays can be helpful.
2. Wilt (Fusarium and Verticillium) — Initially plants wilt on hot days, then continually. Leaves become yellow. Control through sterilization of growing media. No spray or cultural treatment will control diseases.
3. Early Blight and Leaf Spot (Alternaria and Septoria) — Discolored or dead spots appear on leaves. Leaf spot has small black dots on affected area. Early blight has dark rings on a brown background. Both diseases attack oldest leaves and cause excessive defoliation of lower leaves of plant. Control through proper ventilation, removal of lower dying leaves, and reduction of relative humidity.
4. Gray Mold (Botrytis) — Fungal spores infect wounds such as leaf scars; a water rot and fluffy-looking gray growth forms at infected areas. The rot and growth may form along a stem and girdle it. Control through proper ventilation to reduce humidity, removal of infected plants immediately, scraping and covering infected areas with a fungicide, or spraying entire plant with fungicide (Ferbam).
5. Virus (Tobacco Mosaic Virus, TMV) — A distortion of leaves and a stunting of growth occurs on a variety of susceptible plants, with accompanying yield reductions. Insects sucking the juice from an infected plant can spread the virus to other plants. The hands or tools of people working with the crop can also spread the virus. Control through sanitation, elimination of sucking insects, and avoiding smoking in greenhouses. There is an antibody spray available which is effective. Some plants can be inoculated for TMV.

6. Powdery Mildew — Small snowy white spots initially appear on the top surface of leaves. Then they spread quickly in size and to other leaves. Control through proper sanitation, adequate ventilation, and use of chemicals.
7. Cucumber Mosaic Virus (CMV) — Affected leaves of a variety of susceptible plants are dwarfed in size or narrow and long. Control through proper sanitation.

Some common insects include:

1. Whitefly — This is the most common pest in the greenhouse. Located on undersides of leaves, the insect secretes a sticky substance onto leaves and fruit in which a black fungus later grows. This makes it necessary to clean fruit prior to marketing. Control through the use of pesticides such as parathion, pyrethrin, and vapona. However, these insects build up resistance and it becomes necessary to use different pesticides to maintain control.
2. Two-Spotted Spider Mite (Red Spider) — Webbing appearance on undersides of leaves indicates a heavy presence of this pest. The mites cause leaves to yellow beginning with pin-sized yellow dots which coalesce to eventually form a bronzed appearance. Leaves will become bleached as the mites suck the contents of the leaf cells. Control through thorough eradication and sterilization between crops. Fumigate or spray empty greenhouse with chemicals. Large populations will spread amongst most types of plants.
3. Aphids (including pink, black, and dark green) — Aphids suck juices out of plants, causing leaves to become distorted and sticky from a honey-dew deposit. Control through the use of a weekly spray program of chemicals such as pyrethrin, malathion, and rotenone.

INFORMATION SHEET #5

Advantages of Soilless Culture versus Soil Culture

Cultural Practice	Soil	Soilless
1. Sterilization of growing medium	Steam, chemical fumigants, labor-intensive, time required is lengthy, minimum of 2-3 weeks	Steam, chemical fumigants with some systems; others can use simply bleach or HCl; short time needed to sterilize
2. Plant nutrition	Highly variable with localized deficiencies; often unavailable to plants due to poor soil structure or pH; unstable conditions; difficult to sample, test, and adjust	Completely controlled and relatively stable; homogeneous to all plants; readily available in sufficient quantities; good control of pH; easily tested, sampled, and adjusted
3. Plant spacing	Limited by soil nutrition and available light	Limited only by available light, therefore closer spacing is possible; increased number of plants per unit area, therefore more efficient use of space which results in greater yields per unit area
4. Weed control, cultivation	Presence of weeds requiring regular cultivation	No weeds, no cultivation
5. Diseases and soil inhabitants	Many soil-borne diseases, nematodes, insects, and animals which can attack crop; crop rotation often required to overcome buildup of infestation	No diseases, insects, animals in medium; no root diseases; no need for crop rotation
6. Water	Plants often subjected to water stress due to poor soil-water relations, soil structure and low water-holding capacity; saline waters cannot be used; inefficient use of water; much water is lost by deep percolation past the plant root zone and also by evaporation from the soil surface.	No water stress; complete automation possible by use of moisture-sensing devices and a feedback control mechanism; reduction of labor cost; efficient water use and use of relatively high saline water; no loss of water to percolation beyond root zone or surface evaporation; water loss equal to transpirational loss with proper management
7. Fruit quality	Frequent soft or puffy fruit due to potassium and calcium deficiencies, resulting in poor shelf life	Firm fruit with long shelf life, enabling growers to pick vine-ripened fruit and ship it long distances; little if any spoilage in supermarkets; higher Vitamin A content
8. Fertilizers	Need of broadcasting large quantities over the soil, nonuniform distribution to plants, large amount leached past plant root zone (50-80%), inefficient use	Small quantities required, uniformly distributed to all plants, no leaching beyond plants, no leaching beyond root zone, efficient use
9. Sanitation	Possible human diseases caused by use of organic wastes as fertilizers on edible portions of plants	No biological agents added to nutrients; no human disease organisms present on plants
10. Transplanting	Need to prepare soil, uprooting plants, which leads to transplanting shock; difficult to control soil temperatures and disease organisms which may retard or kill transplants	No preparation of medium required prior to transplanting; transplanting shock minimized, faster "take" and subsequent growth; optimum moderate temperature can be maintained by flooding with the nutrient solution; no diseases present
11. Plant maturity		Faster plant maturation with adequate light conditions
12. Permanence of medium	In a greenhouse, soil change required every several years because of decreased fertility and structure breakdown; in the field, periodic fallow times	No need to change medium in gravel, sand, or water cultures; no need to fallow; several years period between changing sawdust, peat, or vermiculite
13. Yields	Greenhouse tomatoes 8-15 pounds/year/plant	18-20 pounds/year/plant

The information in the list above was adapted from *Hydroponic Food Production: A Definitive Guidebook for the Advanced Home Gardener and the Commercial Hydroponic Grower*, by Howard M. Resh, 4th edition, Santa Barbara, CA: Woodbridge Press, 1989.

The main disadvantages of hydroponics are the high initial capital cost, the possible occurrence of some diseases such as Fusarium and Verticillium which can spread rapidly through the system, and the encountering of complex nutritional problems.

The main advantages of hydroponics over soil culture are more efficient nutrition regulation, availability in regions of the world having nonarable land, more efficient use of water and fertilizers, ease and low cost of sterilization of the medium, and higher density planting, leading to increased yields per acre.

INFORMATION SHEET #6**Present and Future Implications of Hydroponics****Present**

With the development of plastics, hydroponics took another large step forward. Plastics freed growers from costly construction associated with the concrete beds and tanks used previously.

Hydroponics has become a reality for greenhouse growers in virtually all climate areas. Large hydroponic greenhouse complexes are in operation in Tucson, Arizona (11 acres) and Phoenix, Arizona (15 acres). The Canary Islands has hundreds of acres of land covered with plastic supported by posts to form a single continuous structure housing tomatoes grown hydroponically.

Structures help to reduce transpirational loss of water from plants and protect them from sudden rainstorms. Such structures can also be used in such areas as the Caribbean and Hawaii. Almost every state in the U.S. has a substantial hydroponic greenhouse industry.

In arid regions of the world, such as Mexico and the Middle East, where supplies of fresh water are limited, hydroponic complexes are being developed to use sea water as a source of fresh water.

Other countries where hydroponics is used include Canada, Russia, Iran, Malaysia, Singapore, Brazil, Poland, Kuwait, various nations in Central and East Africa, the Bahama Islands, South Africa, Australia, and New Zealand.

Future

Hydroponics is a very young science. It has been used on a commercial basis for only 40 years. It is a space age science, but can be used in developing countries of the Third World to provide intensive food production.

Hydroponics is a valuable means of growing fresh vegetables not only in countries having little arable land and in those which are very small in area yet have a large population. To illustrate the potential use of hydroponics, tomatoes grown this way can yield 150 tons per acre annually. A 10-acre site could produce 3 million pounds annually. In Canada the average per capita consumption of tomatoes is 20 pounds. Thus, with a population of 20 million, the total annual consumption of tomatoes is 400 million pounds. These tomatoes could be produced on 1300 acres of land hydroponically.

TRANSPARENCY MASTER #1

Hydroponics Defined

Hydroponics Involves the Soilless Culture of Plants
Grown in Nutrient Solution.

TRANSPARENCY MASTER #2

Elements Supplied by Fertilizer Salts

<i>Elements Supplied</i>	<i>Fertilizer Salts</i>
Nitrogen and Phosphorus	Ammonium phosphate
Nitrogen and Sulphur	Ammonium sulphate
Boron	Boric acid powder*
Nitrogen and Calcium	Calcium nitrate
Calcium and Sulphur	Calcium sulphate*
Copper	Copper sulphate
Iron	Ferrous sulphate*
Magnesium and Sulphur	Magnesium sulphate* (Epsom salts)
Manganese	Manganese chloride
Nitrogen and Calcium	Potassium nitrate*
Potassium and Sulphur	Potassium sulphate*
Nitrogen	Sodium nitrate
Phosphorus and Calcium	Superphosphate*
Zinc	Zinc sulphate

TRANSPARENCY MASTER #3

Functions of Elements

<i>Element</i>	<i>Function</i>
Primary	
N Nitrogen	Promotes plant growth and leaf, stem, and seed or fruit development
P Phosphorus	Found in all living cells; promotes rapid plant growth and development; aids in hastening plant maturity and development
K Potassium	Promotes plant resistance to disease and other harsh conditions; used during photosynthesis process
Secondary	
Ca Calcium	Used in plant cell walls to hold them together; promotes root growth
Mg Magnesium	Key element in the chlorophyll molecule; promotes movement of phosphates throughout the plant
S Sulphur	Used in cystine, one of the amino acids; aids the plant in using phosphorus

Micronutrients

B Boron	Deficiencies show up as a leaf discoloration; it is not yet understood how plants use this element
Cu Copper	Used in flowering and seed production; needed in chlorophyll production
Fe Iron	Associated with the formation of chlorophyll
Mn Manganese	Associated with the absorption of nitrogen and in the energy transference process
Mo Molybdenum	Associated with the utilization of nitrogen
Zn Zinc	Essential part of plant growth
Cl Chlorine	Necessary for plant growth and development; appears to hasten maturation

TRANSPARENCY MASTER #4

Hydroponic Systems

Figure 1. Waterculture

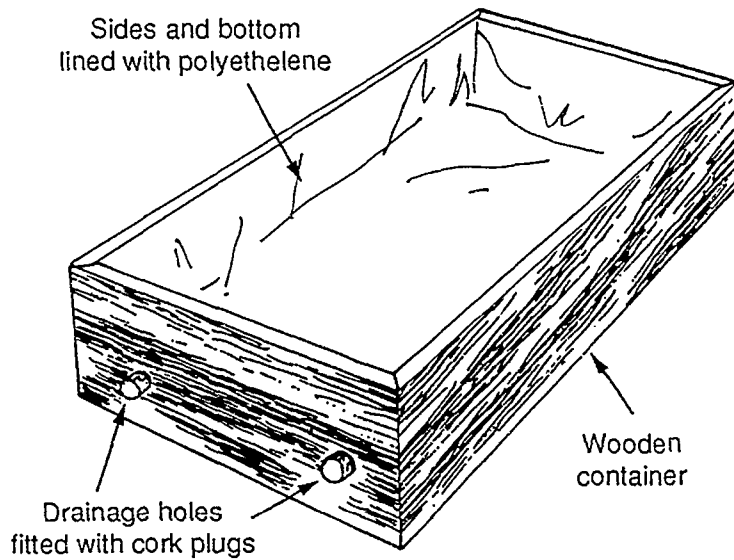
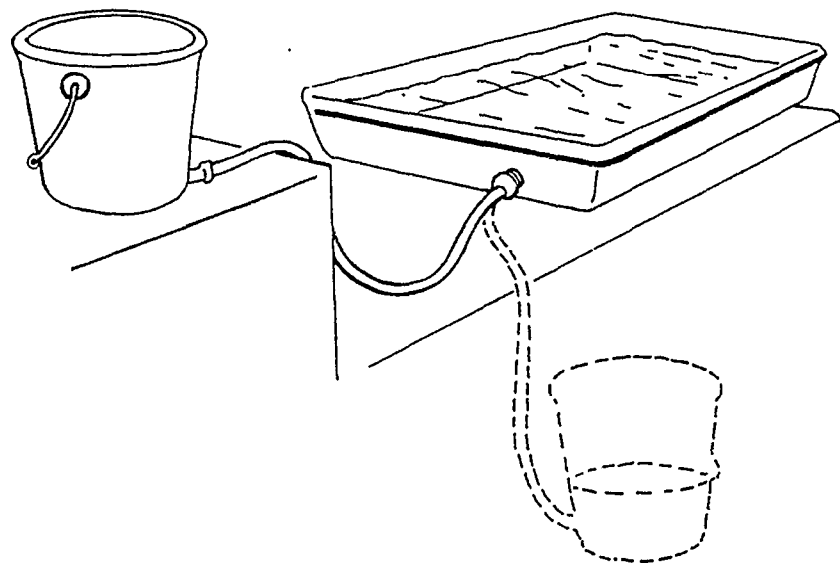

Figure 2. Flood and Drain Hydroponic Garden



500

Figure 3. Automated Hydroponic

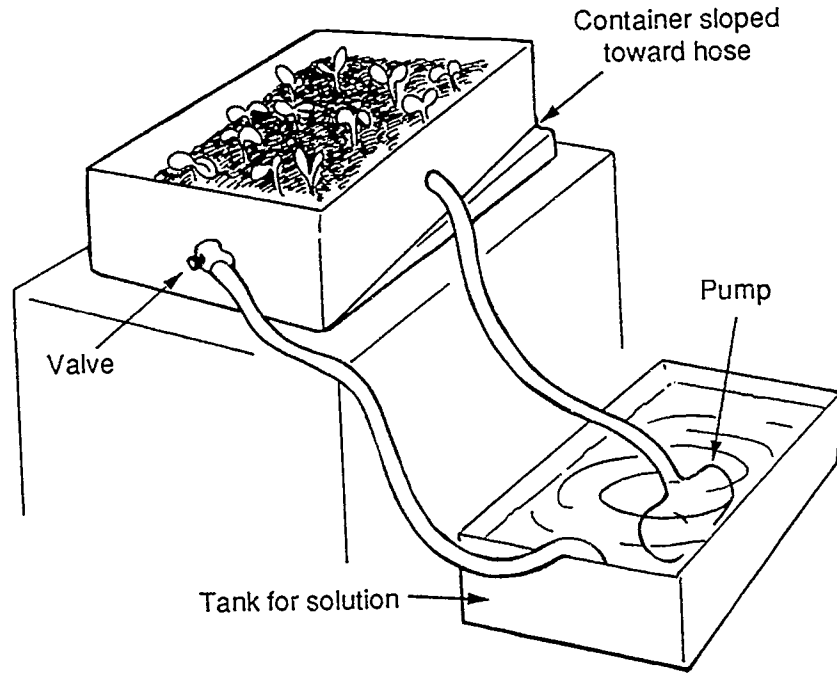

Figure 4. Aquarium Hydroponic Garden

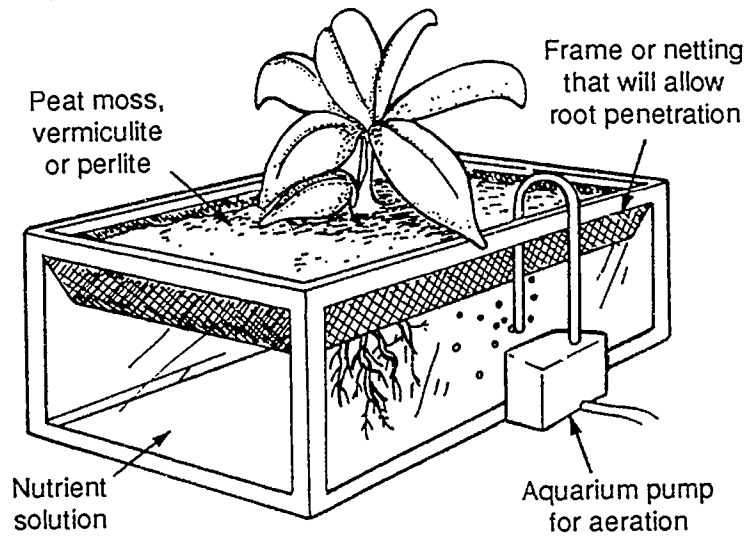
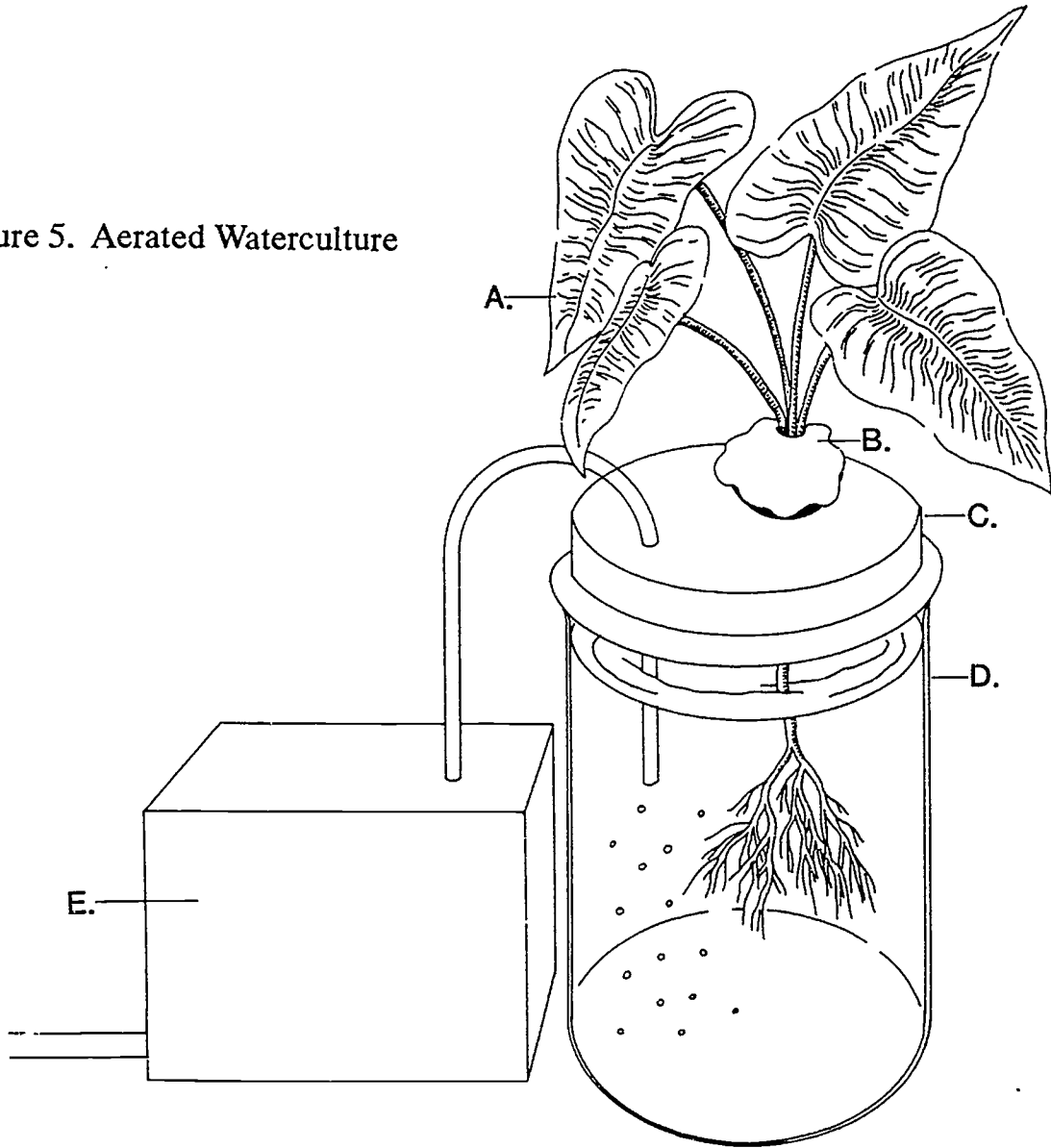

Figure 5. Aerated Waterculture



- A. PLANT
- B. COTTON
- C. CORK
- D. GLASS JAR
- E. AIR PUMP

500

Figure 6. Hydroponic Garden

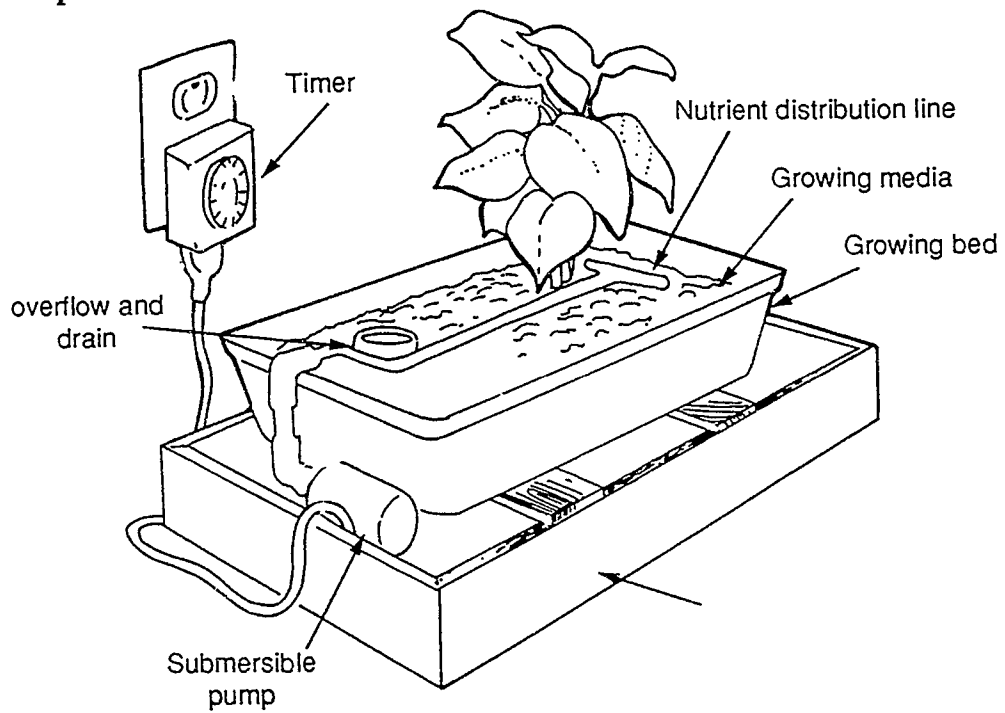
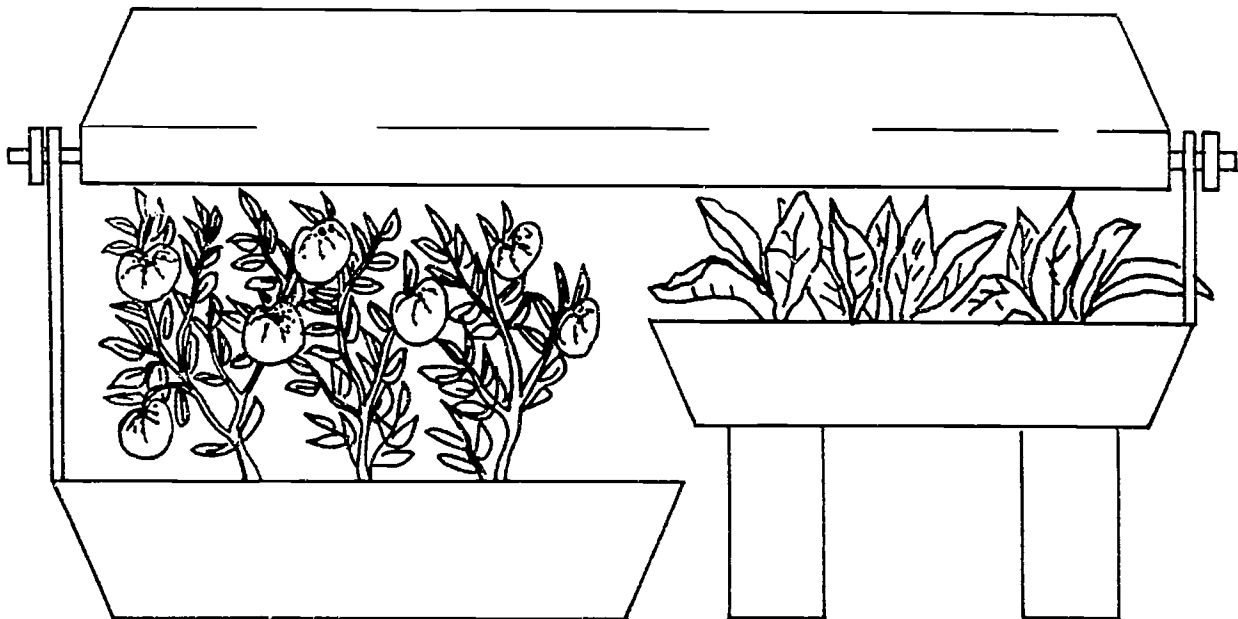

Figure 7. Hydroponic Garden under Artificial Lights



TRANSPARENCY MASTER #5

Hints for Storing and Making Nutrients

1. Keep all fertilizer salts, trace elements, and nutrients away from air and moisture by storing them in airtight containers.
2. Use a mortar and pestle to crush any crystals into a fine powder. They can be found in kitchen supply stores, although the chemist's type is the best. Also, a large clean bowl should be used for mixing your own nutrients.
3. Grind trace elements separately and add these last, stirring everything together very carefully.
4. Dissolve all powders as completely as possible in water before adding them to your hydroponic system.

TRANSPARENCY MASTER #6

Causes of Nutrient Solution Changes

1. General Information
2. Uptake of Minerals Varies
 - a. Environment
 - b. Nature of the Crop
 - c. State of the Plant
3. Nutrient Analysis
4. Plant Tissue Analysis
5. Changing of Solutions
6. Maintenance of Volume

TRANSPARENCY MASTER #7

Plant Cultural Requirements for Success in Hydroponics

1. Plant-Growing Temperature
2. Watering
3. Light
4. Carbon Dioxide Enrichment
5. Feeding and Watering
6. Plant Support
7. Pollination
8. Planting Schedules

TRANSPARENCY MASTER #8

Recommended Vegetable Varieties for Greenhouse and Hydroponic Culture

<i>Vegetable</i>	<i>Varieties</i>
Cucumbers - European	*Toska 70, Rocket, Brilliant, *Pandex, Farbio, La Reine, Sandra, *Uniflora D
Lettuce - European - Novelty - Looseleaf	*Deci-Minor, *Ostinata Buttercrunch *Domineer, *Black Seeded Simpson, Grand Rapids, Waldmann's Dark Green
Tomatoes	*Vendor, Vantage, *Tropic, Manapel, Michigan-Ohio Hybrid, Ohio WR - 25

*Varieties particularly suitable to hydroponic culture

From *Hydroponic Food Production: a Definitive Guidebook for the Advanced Home Gardener and the Commercial Hydroponic Grower*, 4th ed., Howard M. Resh (Santa Barbara, CA: Woodbridge Press, 1989).

TRANSPARENCY MASTER #9

Planting Schedule for a Spring and Fall Crop of Tomatoes (Two Crops Annually)

<i>Date</i>	<i>Activity</i>
Dec. 20-31	Sow lettuce and tomato seeds in peat pellets.
Feb. 1-15	Transplant seedlings into hydroponic beds.
March 15	Harvest lettuce.
April 15	Begin harvesting tomatoes.
May 15	Terminate tomato plants; seed lettuce.
June 1	Sow tomato seeds in peat pellets for fall crop; transplant lettuce intercrop under existing tomatoes.
July 1	Harvest lettuce, pull tomato plants of spring crop, clean greenhouse, sterilize, etc.
July 15	Transplant fall tomato crop and lettuce intercrop into greenhouse beds.
August 15-30	Harvest lettuce.
Sept. 15	Begin harvesting ripe tomatoes.
Nov. 1	Terminate tomato plants.
Dec. 20-31	Pull plants of fall crop, clean up, sterilize, etc.; sow lettuce and tomato seeds of spring crop.

From *Hydroponic Food Production: a Definitive Guidebook for the Advanced Home Gardener and the Commercial Hydroponic Grower*, 4th ed., Howard M. Resh (Santa Barbara, CA: Woodbridge Press, 1989).

TRANSPARENCY MASTER #10

Combination Crop Schedules

Date
Activity

Combination Crop of Late Spring Tomatoes and Two Fall Lettuce Crops

Late Spring Tomatoes:

Dec. 20-31	Sow tomato seeds.
Feb. 1-15	Transplant tomatoes into beds.
May-July	Harvest tomatoes.
July 20-31	Remove plants, clean up, etc.

Fall Lettuce:

First Crop

Aug. 10-15	Sow lettuce seeds.
Sept. 5-10	Transplant lettuce into greenhouse beds.
Oct. 10-20	Harvest crop.

Second Crop:

Sept. 15-20	Sow second crop lettuce seeds.
Oct. 15-25	Transplant lettuce into beds.
Dec. 12-15	Harvest crop.

Combination Crop of Spring Cucumbers and Fall Tomatoes

Spring Cucumbers

Dec. 25-31	Sow cucumber seeds (and lettuce seeds).
Feb. 1-15	Transplant cucumbers (and lettuce) into greenhouse beds.
March 1-15	Harvest lettuce and begin harvesting cucumbers.
June 25-15	Remove cucumbers, clean up, sterilize, etc.

Fall Tomatoes:

June 15-30	Sow tomato (and lettuce) seeds.
July 20-31	Transplant tomatoes (and lettuce).
Sept. 15	Harvest lettuce.
Oct. 1	Begin harvesting tomatoes.
Dec. 15-25	Remove tomato plants, clean up sterilize, etc.

<i>Date</i>	<i>Activity</i>
A Three-Crop Schedule for Annual Cucumber Production	
Jan. 1	Sow cucumber (and lettuce) seeds (first crop).
Feb. 1-15	Transplant into beds (first crop).
March 1	Harvest lettuce.
March 31	Begin harvesting cucumbers.
May 1	Sow cucumber (and lettuce) seeds (second crop).
May 31	Pull cucumbers of first crop, clean up, etc.
June 1-10	Transplant cucumbers (and lettuce) into beds (second crop).
July 1	Harvest lettuce.
July 15	Begin harvesting cucumbers (second crop).
Aug. 1	Sow cucumber seeds (third crop).
Aug. 31	Pull cucumber plants of second crop, clean up, etc.
Sept. 1-10	Transplant cucumbers into beds (third crop).
Oct. 15	Begin harvesting cucumbers.
Dec 20-31	Pull plants (third crop), clean up, sterilize, etc.

From *Hydroponic Food Production: a Definitive Guidebook for the Advanced Home Gardener and the Commercial Hydroponic Grower*, 4th ed., Howard M. Resh (Santa Barbara, CA: Woodbridge Press, 1989).

TRANSPARENCY MASTER #11

Diseases and Insects Encountered with Hydroponically Grown Plants

Some Common Diseases

1. Leaf Mold (Cladosporium)
2. Wilt (Fusarium and Verticillium)
3. Early Blight and Leaf Spot (Alternaria and Septoria)
4. Gray Mold (Botrytis)
5. Virus (Tobacco Mosaic Virus, TMV)
6. Powdery Mildew
7. Cucumber Mosaic Virus (CMV)

Some Common Insects

1. Whitefly
2. Two-Spotted Spider Mite (Red Spider)
3. Aphids (including pink, black, and dark green)

TRANSPARENCY MASTER #12

Comparative Yields Per Acre in Soil and Soilless Culture

<i>Crop</i>	<i>Soil</i>	<i>Soilless</i>
Soya	600 lb	1550 lb
Beans	5 tons	21 tons
Peas	1 ton	9 tons
Wheat	600 lb	4100 lb
Rice	1000 lb	5000 lb
Oats	1000 lb	2500 lb
Beets	4 tons	12 tons
Potatoes	8 tons	70 tons
Cabbage	13,000 lb	18,000 lb
Lettuce	9000 lb	21,000 lb
Tomatoes	5-10 tons	60-300 tons
Cucumbers	7000 lb	28,000 lb

From *Hydroponic Food Production: a Definitive Guidebook for the Advanced Home Gardener and the Commercial Hydroponic Grower*, 4th ed., Howard M. Resh (Santa Barbara, CA: Woodbridge Press, 1989).

TRANSPARENCY MASTER DISCUSSION GUIDE

Transparency Master #2

The most common type of nutrient is one made from fertilizer salts.

The salts marked with an asterisk are the best ones to use because they have superior properties, such as better solubility and stability, lower cost, and longer storage life.

In addition to the three key elements of nitrogen (N), phosphorus (P), and potassium (K) that are essential to all plant growth, there should be at least ten trace elements present in the nutrient solution. These are: sulphur, iron, manganese, zinc, copper, boron, magnesium, calcium, chlorine, and molybdenum.

Transparency Master #3

This list gives the specific function of each element in plant growth.

There are hundreds of different nutrient formulas, but as long as the elements are present in balanced amounts, you will have little worry. Your decision for the best formula will probably be based on cost, availability, and your own preferences. Many experts disagree on the best formula.

Plants do require different nutrients on different days, at different times of the day, and under different conditions. Unless you did exhaustive tests every day, it would be impossible to determine exactly what the plant needs at any one time. This is why it is important to supply plants grown hydroponically with a balanced nutrient solution all the time, allowing plants to use what they need.

The plants will absorb what they need through root hairs. This selectivity makes it impossible to overfeed plants in hydroponics. However, if you mix too high a concentration of nutrient in the water you are using, the plant will be unable to absorb sufficient water. Salts need to be diluted. If the concentration is too high, the plant will start giving off water instead of ingesting it, and the plant will dehydrate itself.

Transparency Master #4

There are two things to accomplish with the system: a structure that allows root system support, and a method of supplying aeration and nutrient solutions to the plants.

Figure 1. Waterculture — The wooden box lined with polyethylene is the simplest hydroponic system. With this system, the box will sit at an angle for adequate drainage. Any material used for a hydroponic tank must be inert, so that no chemical reaction is passed on to the plants.

Figure 2. Flood and Drain Hydroponic Garden — This manually operated system using a pail and a tank is only slightly more automated than the waterculture system pictured in figure 1. The pail is raised above the tank to allow gravity to feed the nutrient solution into the bed. After 30 minutes, the pail is set on the floor so gravity will drain the solution back into the pail. The pail must be adequate in size to flood the system.

Figure 3. Automated Hydroponic — This two-tank system is an automated version of the waterculture system pictured in figure 1. A small submersible pump is placed in the nutrient solution.

Figure 4. Aquarium Hydroponic Garden — The two principal items in this aquarium system are a strong net and an extremely light growing medium. Water should barely touch the seed bed when starting seeds or seedlings. As roots form, gradually lower the water level.

Figure 6. Hydroponic Garden — The nutrient distribution line of this automated system has holes drilled in it. The growing tray should have drainage holes. The timer can be used to automatically turn off and on the submersible pump at predetermined times.

510

STUDENT ACTIVITIES

- STUDENT WORKSHEET #1 — Hydroponic Terms Word Search (with solution)
- STUDENT WORKSHEET #2 — Plant Cultural Requirements for Success in Hydroponics
- STUDENT WORKSHEET #3 — Disease and Insects of Hydroponics Word Search (with solution)
- STUDENT WORKSHEET #4 — Advantages and Disadvantages of Soilless Culture as Compared to a Soil Culture
- STUDENT WORKSHEET #5 — Testing and adjusting the pH Level of a Hydroponic Garden
- STUDENT WORKSHEET #6 — Aerated Waterculture
- STUDENT WORKSHEET #7 — Hydroponic Experiment for Students

For additional activities, teachers may refer to the “Suggested Teaching Activities and Procedures” section in the Instructor’s Guide.

STUDENT WORKSHEET #1

Hydroponic Terms Word Search

S A Z B A R S E S A E S I D R J E G Z J
 N R M T S Y S T E M S E Z S N R S D F J
 I E E L V W D E R U T U F M M M E I Q F
 B B S Z P D S X N J Q H E N C I N T O X
 G K G C I S X O R W Y Y N H V C X O A U
 L E S Y I L T W L G X E P N K R D I N W
 P Z E M G N I C X U R J L F O O P H N B
 W B U D A O O T E I T B B U G N U Q F G
 T J B P R C L P R S K I S T H U M T U W
 E N S T C Q R O O E N B O V T T Z F Y Y
 A O S T E S S O N R F I R N B R X R Z V
 W I C O Y M E N N H D M Q J E I R M O Q
 N T R F I G P / R E U C Y Q V E E L C C V
 H A B S Q L P E U X T E H F M N Y R M K
 C N O W J E L L R T X R T M T T K E Y Q
 H I F X W U N E A A L V I R R S Z G M K
 Q L X U X A K P S N T U W E J B U D J Y
 X L N Y F I R M T S T U C I N G H W R M
 B O N U T R I E N T S S R L L T U W K X
 R P G Z A E U V Q A J Y O E M O S D J I

The following key words, hidden in the puzzle, are important for hydroponics.

Cultures
 Diseases
 Fertilizers
 Food
 Future
 Hydroponics
 Insects
 Macronutrients
 Micronutrients
 Mixing

Nutrients
 pH
 Plants
 Pollination
 Soilless
 Solution
 Systems
 Technology
 Temperature
 Water

515

STUDENT WORKSHEET #1 — Key

Hydroponic Terms Word Search

S S E S A E S I D
 . R . . S Y S T E M S R
 . . E E R U T U F . M M E . . F
 . . S Z . . S I . T O .
 . . . C I S . O H . C X O A .
 . . . Y I L T . L . . . P . . R D I . W
 . . . M G N I C . U O . . N .
 A O O T E . T N . . . G
 C L P R S . I . . . U
 . N . T . . R O O E N . O . . T
 . O S . E S . O N R F I . N . R
 . I . O . M E . N H D I
 . T . . I . P R . U C Y . . . E
 . A . . . L P E U . T E H . . N
 . N L L R T . R T . . T
 . I E A A L . I . . S
 . L S N T U . E
 . L S T U C . N
 . O N U T R I E N T S S R . . T
 . P E . . S

The following key words, hidden in the puzzle, are important for hydroponics.

- Cultures
- Diseases
- Fertilizers
- Food
- Future
- Hydroponics
- Insects
- Macronutrients
- Micronutrients
- Mixing

- Nutrients
- pH
- Plants
- Pollination
- Soiless
- Solution
- Systems
- Technology
- Temperature
- Water

STUDENT WORKSHEET #3

Disease and Insects of Hydroponics Word Search

I Q J A S E S C H J S T R U T F O N F C
 I D O O T V T E Y D L E E O T I N A E W
 Q P G V V L D A Z L D O X H U N S F A T
 F K R V I L F O S I E A D N O D O G D G
 I N A W T D N U P E D A A G I S C A T C
 K V Y J G I J S M C P L F H X T I V G A
 F K M P L T D N W U J T P M H U M V A U
 I E O G O E O O V U I A O G O C S B C M
 W I L P R W M P O E E R I R K L F B B Z
 Z P D D T A D V S T R L O K I S D X I N
 Z I L G C M U E C F B T A P F A K H L A
 V N J Q D N U U R Y A L I C S Q Q Y Q G
 L X X O L I M I L Y T E S C K O M U Q M
 S X J K R X V R R E M R L I I U D X O B
 T F H E R W A M R A J I C A T L R A L J
 S I R P L E Y N T M S G L L F Y L B L Q
 L I W C T L A M R Z H U S D T L R I D C
 Y D G V P R I P G A Z B F A E R R T U J
 E G W H I T E F L Y Z J N M T W E Z O M
 S N S A D F J I E L V W D M I Q B B P B

The following words are hidden in the puzzle.

- | | |
|--------------|----------------|
| Alternaria | Leaf Spot |
| Aphids | Powdery Mildew |
| Botrytis | Red Spider |
| Cladosporium | Septoria |
| CMV | TMV |
| Early Blight | Verticillium |
| Fusarium | Whitefly |
| Gray Mold | Wilt |
| Leaf Mold | |



STUDENT WORKSHEET #4

**Advantages and Disadvantages of Soilless Culture
as Compared to a Soil Culture**

In the boxes below, make a comparison of soilless and soil cultures. List as many advantages and disadvantages of each as you can come up with.

<p>Soilless Culture Advantages</p>	<p>Soil Culture Advantages</p>
<p>Soilless Culture Disadvantages</p>	<p>Soil Culture Disadvantages</p>

533

STUDENT WORKSHEET #5**Testing and Adjusting the pH Level of a Hydroponic Garden****Purpose:**

1. To test the pH level of the nutrient solution, and adjust it to a recommended level if necessary.

Materials:

1. established hydroponic garden and nutrient solution
2. litmus paper or indicator solution
3. white vinegar or phosphoric acid
4. baking soda or dolamitic lime
5. water
6. measuring spoons

Procedure:

1. Test the nutrient solution with the litmus paper or indicator solution.
2. Compare the color of the litmus paper or indicator solution to a chart. If the color indicates the pH is between 5.6 - 6.5 the solution is within the proper range.
3. If the solution is too alkaline (6.5 or above), add 1 tablespoon of white vinegar to 3 gallons of water.
4. Slowly add part of this mixture to the nutrient solution.
5. Stir thoroughly and check the pH again.
6. Continue this process until the nutrient solution reaches the desired range.
7. If the solution is too acid (5.6 or lower), add one tablespoon of baking soda to three gallons of water.
8. Slowly add part of this mixture to the nutrient solution.
9. Stir thoroughly and check the pH again.
10. Continue this process until the nutrient solution reaches the desired range.

STUDENT WORKSHEET #6**Aerated Waterculture****Purpose:**

1. To observe and record plant growth in an aerated water solution supplied with nutrients as compared to a non-aerated water solution.

Materials:

1. complete nutrient solution
2. 2 glass jars
3. aluminum foil
4. cotton
5. 2 corks to fit glass jar
6. air supply, tubes, and hoses (air pump from aquarium can be used)
7. plant material (houseplant, vegetable or soybean plant seedling)

Procedure:

1. Select a well-rooted plant, and remove all soil particles from root systems by washing the plant gently under running water.
2. Cut a slot in the cork for the plant and air hose.
3. Wrap cotton around the stem of the plant where it will be in contact with the cork.
4. Insert cotton-wrapped plant into the slot of the cork.
5. Fill jar with nutrient solution.
6. Fit the cork into the top of the jar carefully so the root system of the plant is not injured.
7. Wrap aluminum foil around the jar to keep out the light. This will help prevent the growth of bacteria in the nutrient solution.
8. On one plant connect the air supply to the jar.
9. Place both the jars in well-lit areas.
10. Record observations; compare the growth of plants in the aerated solution to the growth of plants in the nonaerated solution.

STUDENT WORKSHEET #7**Hydroponic Experiment for Students****Materials:**

1. fish aquarium
2. aerator (the type normally used in fish aquarium)
3. polystyrene (1" thick foam board, available from insulation companies and some lumberyards)
4. fertilizer (Rap-id-gro, Miracle-gro, or any complete, water-soluble fertilizer with minor elements, available at lawn-and-garden centers)
5. Jiffy-7 pellets (available at lawn-and-garden centers)
6. plant seeds (lettuce, spinach, kale, etc.)

Procedure:

1. Cover the sides of the fish aquarium with a dark material to prevent light from entering. This will prevent algae growth in the nutrient solution.
2. Set the aquarium in a south window to allow the plants to receive full light.
3. Fill the aquarium with nutrient solution. Follow the instructions on the label of the packet when mixing the nutrient with water. The proportion should be five grams to one gallon of water.
4. Use the aerator to supply the water with oxygen.
5. Expand the Jiffy-7 pellets by adding water. They will also expand if set in a pan of nutrient solution.
6. Cut the polystyrene so it will float on top of the solution. Cut holes in the polystyrene about 6-7 inches apart to hold the Jiffy-7 pellets. (See figure 1.)
7. Insert the pellets firmly into the holes in the polystyrene board. Plant two seeds in each pellet. If both seeds germinate, pull out one seedling, leaving the healthier one to grow.
8. Keep the tank filled with nutrient solution. The plants will use very little of it when they are small.

NOTE: In winter, it will take 10-14 weeks for the plants to grow to edible size. In summer, it will take only 6 weeks due to the greater number of daylight hours.

Taken from the January 1989 ICAE Agriscience Teacher Inservice Workshop directed by Dr. Edward W. Osborne.

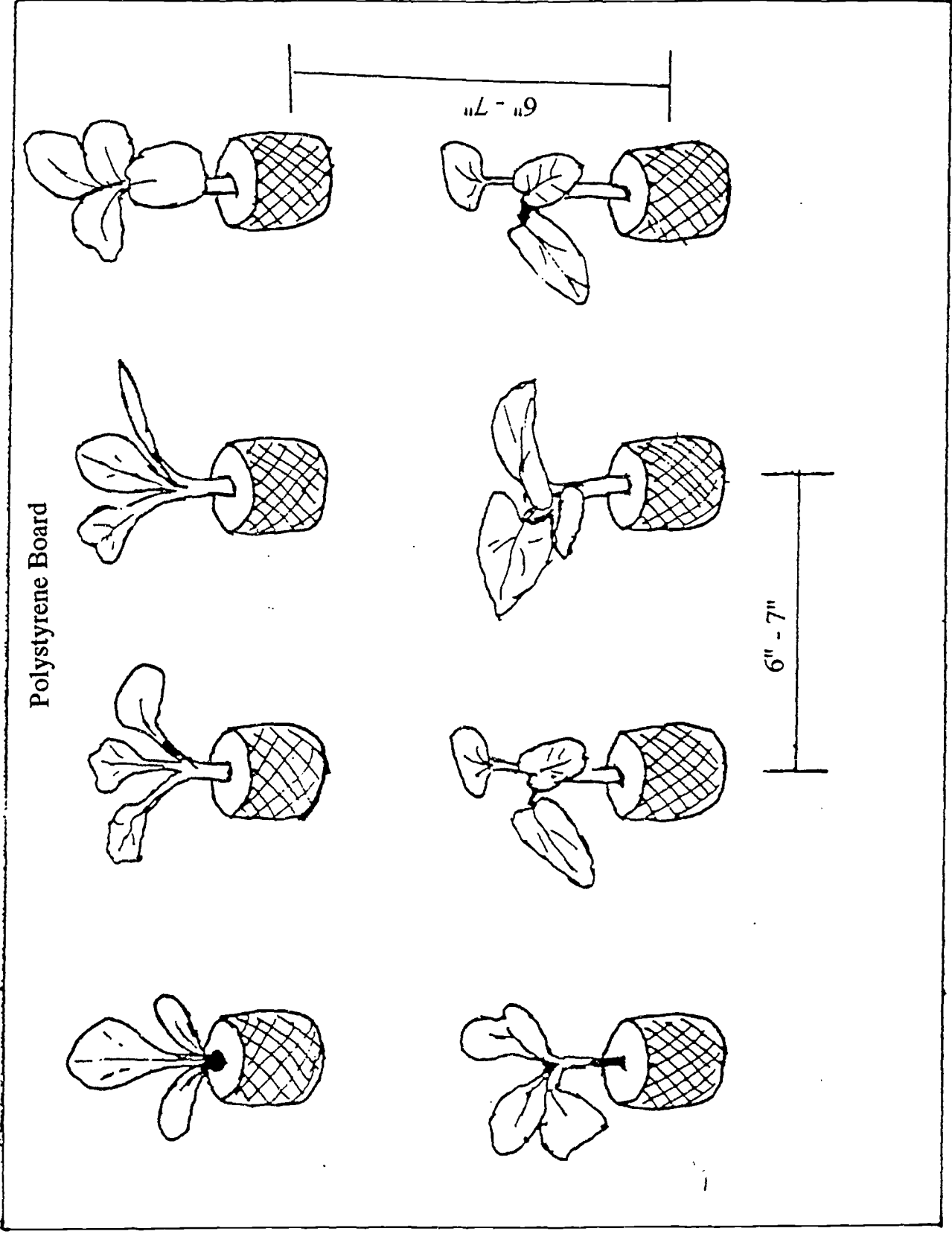

UNIT C: Horticultural Mechanics

PROBLEM AREA:

1. Designing, Building, and Maintaining Horticultural Structures
2. Utilizing Energy Alternatives
3. Repairing and Maintaining Small Engines
4. Repairing, Maintaining, and Operating Horticultural Equipment

CLUSTER: HORTICULTURE

UNIT: Horticultural Mechanics

PROBLEM AREA: Designing, Building and Maintaining Horticultural Structures

RELATED PROBLEM AREAS:

1. Designing, Building, and Maintaining Agricultural Structures (Agricultural Business and Management Cluster)
2. Operating the Horticultural Business
3. Repairing, Maintaining, and Operating Horticultural Equipment

PREREQUISITE PROBLEM AREA(S):

1. Applying Mathematics Skills in Agriculture (Central Core Cluster)
2. Identifying Basic Agricultural Mechanics Principles (Central Core Cluster)
3. Utilizing Energy Alternatives

LEVEL: Preparatory

OCCUPATIONAL TASKS ADDRESSED:

Horticulture Cluster

Duty P: Maintaining and Constructing Structures

1. Construct hot beds
2. Construct cold frames
3. Perform maintenance inspection of facilities
4. Repair roofing and gutters
5. Repair siding
6. Repair doors and entry ways
7. Replace plastic covering on greenhouse structures
8. Repair wooden portions of greenhouse superstructure
9. Replace damaged sections of structures and plastic coverings
10. Repair wooden greenhouse benches
11. Construct packing shed
12. Construct display shelves

Note to Instructor: The additional contents of this problem area are identical to the contents found in the Agricultural Business and Management Cluster, Agricultural Engineering/Mechanization Unit, Designing, Building, and Maintaining Agricultural Structures Problem Area. Please refer to the referenced problem area.

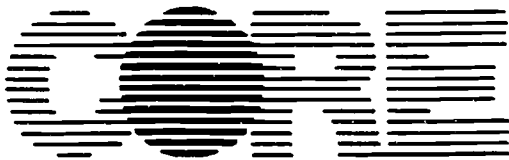

Illinois Agricultural Core Curriculum

Agricultural Education 124 Mumford Hall 1301 W. Gregory Drive University of Illinois Urbana, IL 61801

Director: Dale A. Law, Ed.D.

Principal Investigator: Jerry D. Pepple, Ed.D

Research Assistant: Douglas L. Stockley

523

89/90

Horticulture

Horticultural Business Operation and Management



Illinois Agricultural Core Curriculum Rev.

CLUSTER: HORTICULTURE

UNIT: Horticulture Mechanics

PROBLEM AREA: Utilizing Energy Alternatives

RELATED PROBLEM AREAS:

1. Understanding the Relationship Between Agriculture and the Environment (Central Core Cluster)
2. Recognizing the Impact of Technology on Agriculture and Biotechnology (Central Core Cluster)
3. Using Energy Effectively (Central Core Cluster)
4. Growing Plants Hydroponically
5. Designing, Building, and Maintaining Horticulture Structures

PREREQUISITE PROBLEM AREA(S):

1. Using Energy Effectively (Central Core Cluster)

LEVEL: Preparatory

OCCUPATIONAL TASKS ADDRESSED:

Horticulture Cluster

Duty C: Controlling the Plant Environment

1. Apply mulches
2. Plan conservation practices

Duty K: Maintaining and Improving Grounds

1. Clean grounds of litter and leaves

Duty P: Maintaining and Constructing Structures

1. Construct cold frames
2. Perform maintenance inspection of facilities
3. Maintain ventilation systems of buildings
4. Replace plastic covering on greenhouse structures
5. Repair wooden portions of greenhouse superstructure
6. Replace damaged sections of structures
7. Replace damaged support wires for black cloth and plastic coverings

STATE GOALS FOR LEARNING

In planning the instruction for this problem area, teachers can promote the development of several student learning objectives which are related to the State Goals for Learning in Biological and Physical Sciences. These objectives are listed on the Learning Assessment Plan forms included on the following page(s). Those learning objectives marked with an asterisk (*) are taken from the sample lists provided by the Illinois State Board of Education.

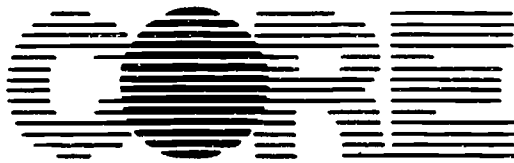

Illinois Agricultural Core Curriculum

Agricultural Education 124 Mumford Hall 1301 W. Gregory Drive University of Illinois Urbana, IL 61801

Director: Dale A. Law, Ed.D.

Principal Investigator: Jerry D. Pepple, Ed.D

Research Assistant: Douglas L. Stockley

535

ILLINOIS STATE BOARD OF EDUCATION
 Department of School Improvement Services
 100 North First Street
 Springfield, Illinois 62777-0001

LEARNING ASSESSMENT PLAN

Instructions and codes for this form are provided on a separate sheet.

Submission Date _____ Page _____ of _____

Original submission Revision

I. LEARNING AREA (check one)

Language Arts Fine Arts

Mathematics Social Sciences

Sciences Physical Development/Health

II. STATE GOAL FOR LEARNING

As a result of their schooling, students will have a working knowledge of the concepts and basic vocabulary of biological, physical, and environmental sciences and their application to life and work in contemporary technological society.

(Affix label or complete district information.)

COUNTY _____ DISTRICT _____ ESC _____

District Name _____

City _____

Contact Person: _____

Title: _____

Phone: (_____) _____

III. LEARNING OBJECTIVES	IV. ASSESSMENT				V. EXPECTATIONS
	A Types	B Validity/ Reliability	C Commercial Test(s)	D Evidence of Nondiscrimination	
By the end of grade (circle one) 3 6 8 (11) students should be able to:					
*1. Demonstrate the distance/current relationship using a solar cell.					
*2. Know the carbon, oxygen, and nitrogen cycles.					
*3. Relate the processes by which organisms capture, utilize, and release energy.					
*4. Identify examples of simple chemical reactions that occur frequently in our daily lives.					
*5. Recognize the results of the effect of heat energy on samples of matter.					
6. Understand the methods of capturing solar energy for heat as well as light.					
7. Demonstrate the practice of composting yard waste materials.					
8. Understand the basic scientific principles involved with heat conduction and retention.					
9. Understand the scientific principles of anaerobic and aerobic fermentation associated with composting.					

INSTRUCTOR'S GUIDE**CLUSTER: HORTICULTURE****UNIT: Horticulture Mechanics****PROBLEM AREA:** Utilizing Energy Alternatives**STUDENT LEARNING OBJECTIVES**

Upon completion of their study of this problem area, students will be able to:

1. Identify various types of energy and their alternative sources.
2. Understand methods of capturing solar energy for heat as well as light.
3. Demonstrate the practice of composting yard waste materials.
4. Describe how recycled materials may be utilized as energy sources.
5. Recognize the many inefficiencies that are involved with energy capture and utilization.
6. Understand the basic scientific principles involved with heat conductance and retention.
7. Understand the basic scientific principles of anaerobic and aerobic fermentation associated with composting.
8. Recognize and explain the need for energy conservation.
9. Describe ways in which renewable sources of energy may be substituted for nonrenewable energy sources.
10. Apply energy-conserving practices to horticultural situations.
11. Recognize the availability of alternative energies for use in horticulture applications.

INSTRUCTOR'S NOTES AND REFERENCES

INSTRUCTOR'S GUIDE**CLUSTER: HORTICULTURE****UNIT: Horticulture Mechanics****PROBLEM AREA:** Utilizing Energy Alternatives**PROBLEMS AND QUESTIONS FOR STUDY****INSTRUCTOR'S NOTES AND REFERENCES**

1. What are the various types of energy?
2. What are the alternative sources of energy?
3. Why are alternative energy sources necessary?
4. How do alternative energy sources compare in efficiency to the common sources?
5. Which alternative energy resources are renewable?
6. Why are some alternative energy sources more applicable to certain uses than others?
7. What is conservation?
8. What conservation practices are applicable to horticultural situations?
9. Which alternative energy sources may be most useful in horticultural situations? Why?
10. Which alternative energy sources are most available for use in horticultural situations?
11. What is solar energy?
12. How does a solar collector function?
13. What are the types of solar collectors?
14. What is composting?
15. Why is composting useful?
16. What materials can be composted?
17. What organisms are responsible for the results of composting?
18. How do the organisms accomplish the results in composting?

INSTRUCTOR'S GUIDE**CLUSTER: HORTICULTURE****UNIT: Horticulture Mechanics****PROBLEM AREA:** Utilizing Energy Alternatives**SUGGESTED TEACHING ACTIVITIES AND PROCEDURES**

1. Use other science personnel as resource persons for ideas, techniques, equipment, and materials.
2. Lead students in a discussion on energy alternatives available to various horticultural applications. Compare and contrast the use of renewable and nonrenewable energy sources.
3. Lead students in a discussion of recycling as a means of both saving energy and supplying energy.
4. Conduct field trips to places where electricity is produced (coal, hydro, nuclear, wind), a recycling center, a composting facility, an ethanol plant, or other places directly involved with alternative energies.
5. Conduct a field trip to a local greenhouse and perform an energy audit. Identify uses of energy, inefficiencies in energy utilization, alternative energy sources, and recommendations.
6. Using Information Sheet #1, lead students in a discussion on saving energy and producing food by using a solar greenhouse attached to the home.
7. Start a composting project at the school. Utilize grass clippings, leaves, wood chips, and other appropriate compost materials. The compost could be used at the school or possibly sold as a fundraising activity.
8. Organize a school energy contest to provide students with an opportunity to use their understanding of energy problems to communicate energy conservation practices to others. See Information Sheet #8.
9. Conduct the demonstrations in Student Worksheets #1 - #8 and the activities in Student Worksheets #9 - #16 at appropriate times during the discussion of relevant subject matter.
10. Show the video *ADM Hydrofarm* (see references). This may be used to lead into discussion of how some businesses utilize energy alternatives.

INSTRUCTOR'S NOTES AND REFERENCES

INSTRUCTIONAL RESOURCES

These resources are intended for use by teachers in planning and teaching the materials for this problem area and may be adapted to fit the teaching method(s) used.

INFORMATION SHEET #1 — Solar Greenhouses

INFORMATION SHEET #2 — Composting Technology and Practice

INFORMATION SHEET #3 — Generation Rates for Landscape Waste

INFORMATION SHEET #4 — Permit Requirements for Setting up a Yard/Landscape Waste Composting Operation

INFORMATION SHEET #5 — A Homeowner's Guide to Recycling Yard Waste

INFORMATION SHEET #6 — Production of Ethanol for Fuel

INFORMATION SHEET #7 — Biomass Energy

INFORMATION SHEET #8 — Organizing a School Energy Contest

TRANSPARENCY MASTER #1 — Carbon/Nitrogen Ratios of Common Organic Waste

TRANSPARENCY MASTER #2 — Generic Compost Site Layout

TRANSPARENCY MASTER #3 — Yard Waste Processing Technology Summary

TRANSPARENCY MASTER #4 — Landscape Waste Densities

TRANSPARENCY MASTER #5 — Landscape Waste Composition

TRANSPARENCY MASTER #6 — Generation Rates per Single-Family Household

TRANSPARENCY MASTER #7 — Troubleshooting Chart to More Efficient Composting

TRANSPARENCY MASTER #8 — Composting Bins to Build (with discussion guide)

TRANSPARENCY MASTER #9 — Simplified Schematic for Composting Yard Wastes

TRANSPARENCY MASTER #10 — Major Compost Uses by User Type

INFORMATION SHEET #1

Solar Greenhouses

Solar greenhouses are useful sun spaces for people who are interested in saving energy and producing some of their own food. Greenhouse construction and operation is simple, and when attached to an existing building or residence, solar greenhouses are one of the most cost-effective solar systems currently available. Solar greenhouses differ from conventional greenhouses in the following ways:

1. Solar greenhouses have large amounts of insulation where there is little or no direct sunlight.
2. Solar greenhouses are oriented to receive maximum solar heat during the winter.
3. Solar greenhouses use heat-storing materials (thermal mass) to retain and control solar heat.
4. Solar greenhouses provide shading and natural ventilation for summer cooling.

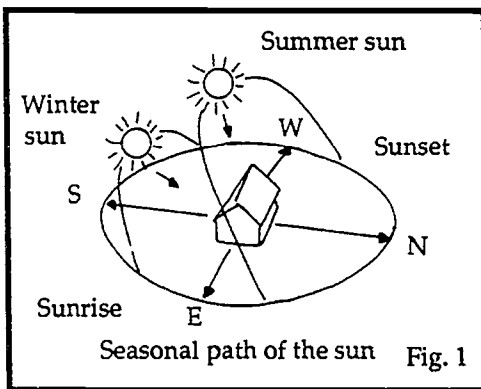

How Solar Greenhouses Operate

Solar greenhouses operate by making use of the seasonal patterns of the sun, local climate, and the landscape of the area.

The path of the sun changes throughout the year (see Figure 1). During the winter, low-angled sunlight passes through the large window area and strikes the inside surfaces of the greenhouse. Upon contact, the sun's radiant energy is transformed to heat energy. Properly placed heat-storing materials then absorb most of the heat while losing some to the surrounding air. At night or on cloudy days, the thermal mass warms the greenhouse by radiating its stored heat into the space.

Proper ventilation and thermal mass provide summertime cooling. And most importantly, shading devices will block out unwanted summer sunshine while allowing winter sunlight to pass through.

The Attached Greenhouse

Most solar greenhouses are attached to the south wall of a building or home (see Figure 2).

Some of the advantages of the solar greenhouse sharing a common wall with the home include:

1. Ease of construction.
2. Low cost of construction.
3. Provision of heat, humidity, and oxygen to the home.

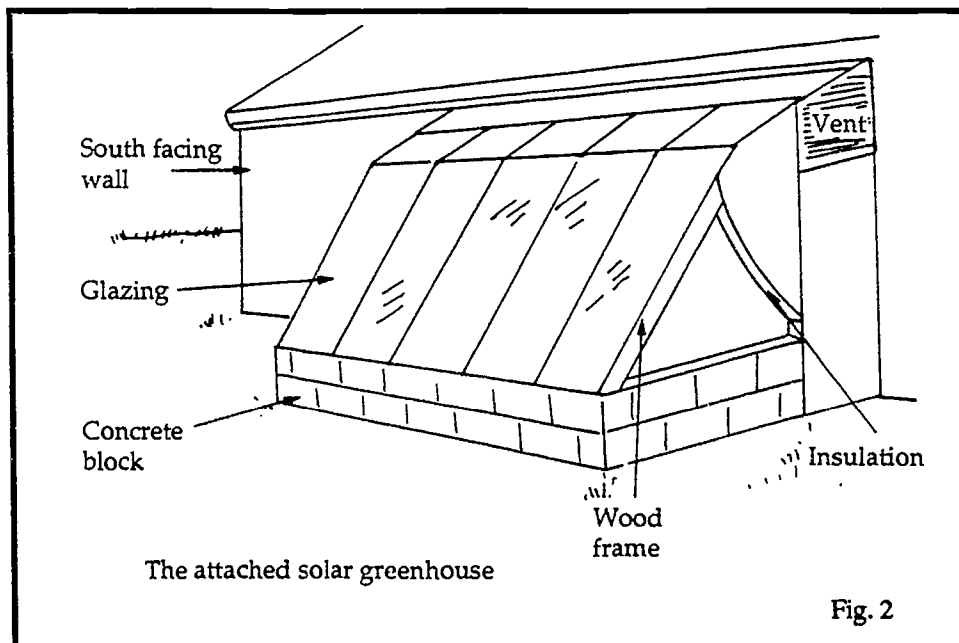

4. Additional living space.
5. Lack of need for back-up winter heater.

Materials for Attached Solar Greenhouse

Building attached solar greenhouses can be done with easy-to-find building materials. The structure usually includes a concrete block foundation with wood-framed walls and ceilings. Because of the high moisture levels usually found in greenhouses, treated wood is required. Concrete, brick, or gravel can be used for the greenhouse floor.

Other basic components of solar greenhouse construction are glazings, vents which open and close, thermal mass and insulation. In order to make your greenhouse work well, each component or part should be sized and located according to basic rules-of-thumb and design recommendations.

Glazing

A glazing is any material which allows sunlight to pass through. Suitable glazing materials for solar greenhouses are glass and plastics such as fiberglass-reinforced polyesters, polyvinyl fluorides, and polycarbonates. Their ability to transmit sunlight and resist scratching and breakage, along with their low cost, light weight, and ease of installation are some factors to consider when making your selection.

Advantages of glass include:

1. Good solar transmittance.
2. Scratch- and weatherproof qualities (except for large hail).
3. Provision for clear view.
4. Thermal stability at high temperatures.
5. Appearance.
6. Availability.

Disadvantages of glass include:

1. Heavy weight.
2. Extra care needed in handling.
3. High cost.

However, thick or tempered glass must be used in greenhouse construction in areas with frequent hailstorms.

Advantages of plastics include:

1. High solar transmittance.
2. Availability in large sheets and rolls.
3. Lower cost than glass.
4. Provision of better plant growth.
5. Strength and resistance to breakage.
6. Light weight and ease of handling.

Disadvantages of plastics include:

1. Possible softening and wrinkling.
2. Distortion of views.
3. Susceptibility to scratching.

Some plastics will last almost 20 years, while others will age in the sunlight and must be replaced after a few years of use.

Greenhouse glazings should be double layered, face the south, and be insulated at night. Windows facing east and west can be used to extend the growing season, but during cold weather it is especially important to insulate these windows at night. Without insulation, the nighttime heat loss will be much greater than the solar heat gained through these areas.

The optimum angle for the south wall lies between 40° and 70° from horizontal. Some attached greenhouse designs use a vertical (90°) south wall. This provides more headroom, cooler temperature in the summer, and easier construction. In addition, with a vertical south wall in the greenhouse, it is easier to use nighttime insulation. An angled south wall has its own advantages such as a greater glazing area for solar gain, extended growing season, and additional sunlight to grow more plants.

Thermal Mass Heat Storage

Heat can be stored either directly or indirectly. Direct storage involves placing thermal mass materials such as rock, concrete, or water directly in the sunlight to absorb the solar heat (see Figure 3).

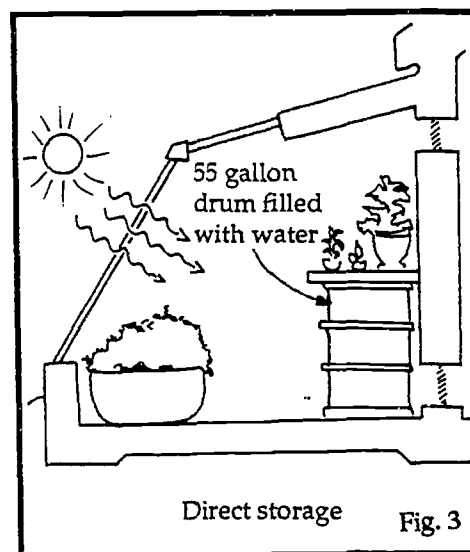

Indirect storage mass is isolated under the floor or in the adjoining north wall of the attached greenhouse. As illustrated in Figure 4, a small fan pulls the hot air from the top of the greenhouse and directs it into the storage compartment. When needed, heat can be drawn from the isolated storage to warm the greenhouse or adjoining space.

Fifty-five gallon drums or plastic containers painted a dark color may be used for holding water. Many people use recycled materials such as plastic milk cartons with dyed water for containers. These materials often work well and help keep costs down.

The best place for direct thermal mass is along the far north wall of the greenhouse. It should receive direct sunlight throughout the winter but avoid exposure during the summer.

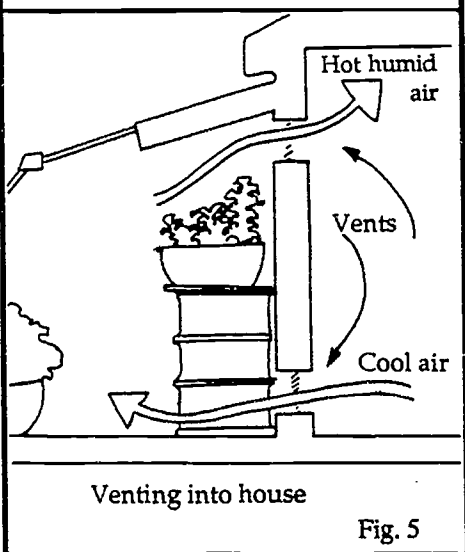
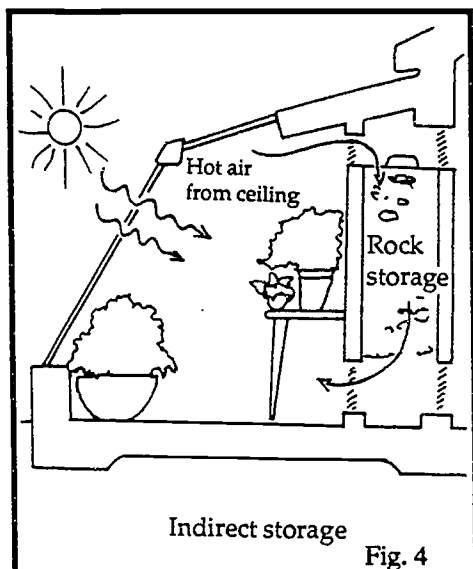

Vents

The attached greenhouse requires two different venting arrangements:

1. Vents which allow warm air into the house during the winter (see Figure 5).
2. Vents which exhaust hot, humid air to the outside for summertime cooling (see Figure 6).

An upper and lower vent is required for both applications. The area of the upper vent should be approximately 1/3 larger than the lower one. In some cases, you can use existing doors or windows for venting warm air into the house.

Summer venting will work well if the lower vent faces the direction of the prevailing summer breezes and the upper vent is high and across the room. In Illinois, the lower vent should be located in the west wall and the upper (exhaust) vent should be located in the east wall or in the roof near the east end of the greenhouse.

Insulation

The more care and attention is given to insulating your solar greenhouse, the better it will perform. Three types of insulation which work well are polyurethane foams, polystyrene foams, and fiberglass batts. Any area which does not admit sunshine such as a wall, ceiling, or foundation should be insulated. It is important to provide a vapor barrier between the greenhouse and the insulation. Heavy-duty polyethylene film is commonly used for vapor barriers.

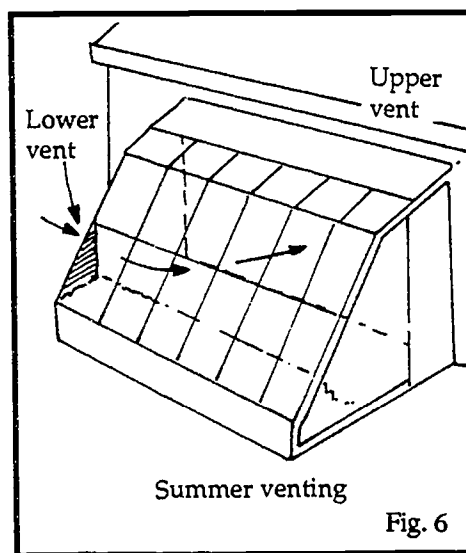

Movable Nighttime Insulation

Providing movable insulation for the greenhouse glazing is important. Without it, a significant amount of heat will be lost and your plants could suffer. Using a sheet of polystyrene foam (styrofoam) is one simple approach to movable insulation. It can be applied with magnetic clips or a velcro material for easy operation. A reduction of almost 90 percent of the heat loss through a glazing can be achieved if two inches of polystyrene foam are used. Figures 7 and 8 illustrate two ways of operating movable insulation. If you decide to make your own, be sure to have a vapor barrier to prevent frost from forming on the windows at night.

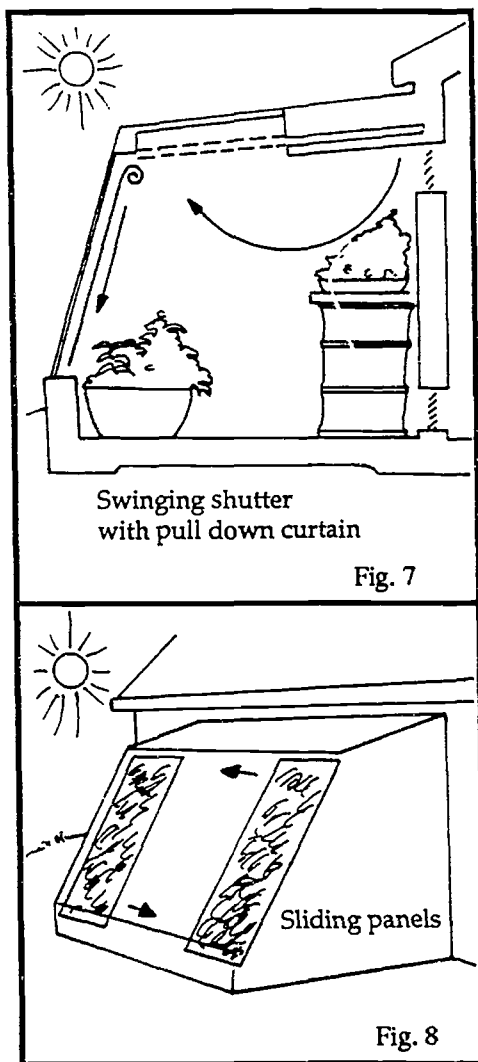

Swinging shutter
with pull down curtain

Fig. 7

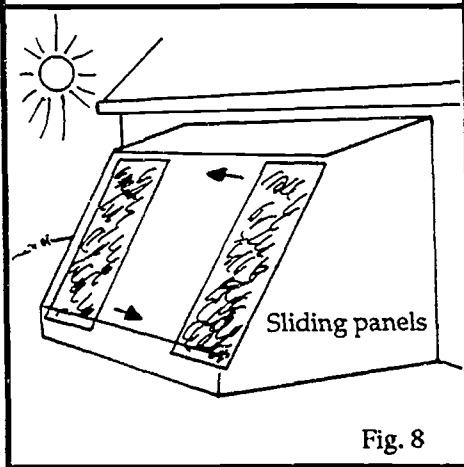

Sliding panels

Fig. 8

Operating A Solar Greenhouse

The attached solar greenhouse is often used as a sun space for sitting and for growing a few plants. In this case, the simple operation of air vents and movable night insulation usually requires little work. However, if you prefer to gain additional benefit by producing fresh food, a few hours a day might be needed for general gardening care.

Illinois Agricultural Core Curriculum Rev.

For the more serious gardener, the solar greenhouse can be used for extending the growing season of the outdoor garden. This usually involves transplanting vegetables in and out of the greenhouse on a seasonal basis.

In the spring, tomatoes, melons, broccoli, and celery are some plants which might be started in the greenhouse for transplanting into the garden after the last frost. Most healthy garden vegetables can be brought into the solar greenhouse to stretch their growing season into winter. Careful selection of winter crops is important. Hardy vegetables such as lettuce, spinach, beets, carrots, onions, radishes, and herbs should grow well through most, if not all, of the winter.

Economic Considerations

Besides providing a pleasant area for winter activities, an attached solar greenhouse has two major economic benefits:

1. Potentially supplying most of your fresh food needs, depending on the size and design of your greenhouse.
2. Supplying up to 50 percent of your household heating requirements.

The cost for an attached solar greenhouse can run between \$5 and \$40 per square foot of floor area. Prices usually depend on the types of materials used, whether you build it yourself or hire a contractor, and whether or not recycled materials are used. Most of the time a well-built solar greenhouse will not exceed the typical residential construction costs per square foot of floor area.

Rules of Thumb for Sizing an Attached Solar Greenhouse

Glazing — For southern to central Illinois, use approximately 1/2 to 1 1/4 square feet of greenhouse glazing for each square foot of heated floor area. For central to northern Illinois, use approximately 3/4 to 1 1/2 square feet of greenhouse glazing for each square foot of heated floor area. Heated floor area includes the greenhouse area and any adjoining space within the house which is to be heated.

Thermal mass — For most of Illinois, thermal storage requires a minimum of 1 2/3 cubic feet of rock or 2 to 3 gallons of water for each square foot of glazing area. For northern Illinois with more severe winters, up to 5 gallons of water per square foot of glazing may be needed.

Venting — For each venting arrangement the total area of the openings should be 1/5 to 1/6 of the greenhouse floor area. For example, a 16-foot-long by 10-foot-wide (160-square-foot floor area) greenhouse would need 26 to 32

544

Horticulture
Horticulture Mechanics

total square feet of venting area to the house. Two-thirds of this area should be upper vent, and one-third lower vent.

Insulation

It is extremely important that greenhouses be well insulated. Recommended R values are given below.

For southern Illinois areas with mild winters:

R-12 for walls
R-19 for ceilings
R-8 for foundations

For all other Illinois areas:

R-19 for walls
R-30 for ceilings
R-16 for foundations

When using movable insulation, a minimum of R-4 is recommended. It is important to have a tight seal between the edge of the insulation and the glazing frame when the insulation is in place.

More Information is Available

The following list contains texts providing additional information on solar greenhouses.

Solar Greenhouse Compendium. Department of Energy and Natural Resources, Solar Section.

The Food and Heat Producing Solar Greenhouse: Design, Construction, Operation. (1976). Rick Fisher and Bill Yanda. John Muir Publications, Box 613, Santa Fe, NM 85701.

Building and Using Our Sun-Heated Greenhouse. (1977). Helen Nearing and Scott Nearing. Garden Way Publishing, Charlotte, VT 05445.

The Complete Greenhouse Book. (1978). Peter Cleg and Derry Watkins. Garden Way Publishing, Charlotte, VT 05445.

The Survival Greenhouse: An Ecosystem Approach to Home Food Production. (1975). J.B. DeKorne. Walden Foundation, Box 5, El Rito, NM 87530.

The Solar Greenhouse Book. (1978). James C. McCullagh, ed. Rodale Press, Emmaus, PA.

Adapted from: Illinois Department of Energy and Natural Resources, Fact Sheet #4.

INFORMATION SHEET #2

Composting Technology and Practice

Overview

The process of composting involves the biological stabilization of organic wastes under controlled conditions. The biological process is similar to the activities which occur on a forest floor. The difference is that composting involves the *active* management and control of these processes. Composting is the process by which aerobic (oxygen-requiring) microorganisms decompose organic matter into a humuslike product. Composting is usually conducted through the use of windrows (which are elongated piles) to actively manage the accelerated decomposition and volume reduction benefits of this technology. The degree of management and control depends on such factors as land availability, materials to be composted, time frame for completion of the composting process, cost considerations, and quality and intended use of the end product.

Elements of Composting

In order to successfully manage a compost site, it is extremely important to have a basic understanding of the underlying biological process that is involved in composting.

A mass of biodegradable waste, containing sufficient moisture and oxygen, will undergo a natural process called "self-heating." Microorganisms, primarily bacteria and fungi, rapidly grow on the organic matter, metabolize it, and release energy in the form of heat as a by-product. The self-heating occurs because the waste material acts like an insulator if the pile is large enough. Intense metabolic activity continues until, eventually, the readily biodegradable food supply is exhausted. Microbial growth and heat generation slow down and the pile eventually cools.

There are seven factors to consider in order to effectively manage a compost pile and maintain optimal efficiency of the microbial activity:

1. **Microorganisms** — Microorganisms found on the surfaces of leaves, grass clippings, and other incoming organic matter are fully capable of starting and sustaining the composting process. This eliminates the need to purchase commercially available inoculants, thus reducing costs.
2. **Moisture** — Adequate moisture in the compost pile is necessary in order to support microbial activity and growth. Moisture levels of 40 - 60 percent are recommended and should be maintained. Too little

water will slow down the composting process. Too much moisture (greater than 60 percent, wet weight basis) will inhibit oxygen penetration into the pile, increasing the risk of inducing odor-causing anaerobic decomposition. Incoming leaves may have a moisture level of only 30 - 40 percent, while grass clippings generally have moisture levels of 60 - 70 percent. To maintain adequate moisture levels, it may be necessary to wet the yard waste upon initial pile formation and as necessary throughout the composting process. A simple test for moisture in compost is to compress a fistful of compost material. If moisture is adequate a few drops of water will be squeezed out. In general, it is better to start with a pile that is too wet than to risk dryness.

3. **Oxygen** — Adequate oxygen penetration into compost piles is necessary to ensure the aerobic (requiring oxygen) decomposition of the yard wastes. Oxygen levels between 5 and 15 percent are recommended. Otherwise anaerobic (without oxygen) conditions can occur. This can slow down decomposition, produce foul odors, and lower pH levels (i.e., increase acidity). In order to maintain adequate oxygen levels, care must be taken to minimize compaction of the yard waste, avoid excess moisture levels, and turn the piles frequently enough to reoxygenate the center of the pile.
4. **Temperature** — Internal compost pile temperatures affect the rate of decomposition as well as the destruction of plant pathogens and weed seeds. Properly decomposing wastes will experience a significant rise in temperature over time, followed by a gradual decrease until decomposition is nearly complete. Temperatures between 68°F and 140°F should be maintained. Precise control over temperature is usually not essential, but gross departure from the desired range should be avoided. Temperature should be monitored on a regular basis and controlled by turning the pile. This turning will also oxygenate the center of the pile. Pile temperature should be allowed to peak for approximately three days to kill pathogens and seeds before the initial turning. This will prevent the sprouting of weeds when finished compost is utilized in its final application.
5. **pH** — The pH scale is a measure of the degree of acidity or alkalinity of material. A pH value of seven is neutral, less than seven is acidic, and greater than seven is alkaline. Yard wastes generally are close to being chemically neutral.

During the initial stages of normal decomposition, the production of organic acids causes the pH to decline to as low as 4.2 if extensive anaerobic conditions develop. The pH will recover to a neutral range (six to eight) as the acids decompose in the presence of oxygen. Persistently acidic pH is indicative of undesirable, prolonged anaerobic decomposition. This can be corrected by increased turning (oxygenation) of the pile. Adding neutralizing agents, such as lime, is not recommended for most facilities.

6. Carbon/nitrogen ratio — Microorganisms use these two elements in a proportion that averages about 30 parts carbon to one part nitrogen. Thus they convert organic material most efficiently when provided with materials having about a 30:1 carbon to nitrogen ratio. Most materials available for composting do not fit the 30:1 ratio. Fresh grass clippings, with a C:N ratio of 20:1, have too much nitrogen. Brown tree leaves, with a 40:1 ratio, have too little. By combining these materials, the proper 30:1 ratio can be obtained, and faster decomposition will occur. The proper ratio of grass to leaves may vary but should not exceed one part grass for one part leaves. If leaves are not available in sufficient quantities, other bulking materials such as straw, sawdust, woodchips, tire chips, etc., may be used.

As a general rule, the carbon and nitrogen content of materials can be judged by their appearance. Fresh green vegetation is high in nitrogen while dried brown vegetation is usually higher in carbon. Transparency Master #1 lists various waste materials and their C:N ratios. Proper quantities of these types of materials must be mixed with grass clippings in order to maintain a 30:1 ratio. It is important to remember that you will have to screen out any bulking materials, such as woodchips, that are not decomposed before marketing the final compost product.

7. Pile size and turning frequency — Compost pile temperature and oxygen content can be regulated to some extent through pile size and turning operations. Larger piles conserve heat but if the piles are too large temperatures may become excessively high and cause anaerobic conditions to occur. As a rule of thumb, the windrows should be turned at least once every two weeks, or whenever temperatures drop to 68°F or rise above 140°F. Piles should be turned less frequently in winter to maintain heat, and more frequently in summer, due to higher microbial activity.

Large piles may also reduce oxygen penetration to the center of the pile with the same result. Proper oxygenation favors small piles but these piles may not sustain proper temperatures, especially in winter. These components can be properly balanced by active management of compost size and turning frequency. Specific recommendations depend on the technology and equipment utilized.

Facility Permits and Siting

Permits for establishing a compost facility are issued by the Illinois Environmental Protection Agency (IEPA).

Site selection for a municipal yard waste composting program is an extremely important decision that should be made only after careful consideration, as each situation is unique. Site selection should take into account factors such as nearness to residences and streams, prevailing winds, traffic patterns, and travel distance and its effect on collection equipment and labor costs. Many of these are discussed below, but familiarity with local circumstances is essential.

1. Area requirements — Estimates of the amount of yard waste generated, amount of materials received at the compost site, spacing between windrows, and volume reduction of the compost, as well as the type of compost technology utilized, are variables considered in determining the size of area required for an adequate site. For initial planning purposes allow a minimum of one acre per 3,500 - 4,000 cubic yards of yard waste delivered to the site.

The amount of yard waste per acre will depend somewhat on the spacing between windrows. If windrows are set up in pairs, aisles between pairs will need to be wide enough to operate a front-end loader (approximately 15 feet) while the spacing between windrows can be only 5 feet. This configuration works well if a straddle-type windrow turner is to be used. However, if a side-mounted turner is used, the spacing between windrows should be 10 - 15 feet.

Additional space is needed to provide adequate room for equipment operation between windrows, a staging pad for incoming material, and storage area for wood waste, finished compost, and equipment. Finished compost volume can range between 10 and 40 percent of incoming volume. A survey of eight facilities across the U.S. shows an average volume reduction of 65 percent. In addition, there must be an adequate buffer zone around the perimeter of the facility. Refer to Transparency Master #2.

2. **Buffer zone** — A buffer zone between the site activities and neighboring areas will minimize possible odor, noise, dust, and visual impacts. There are no hard and fast rules on the size of the buffer zone needed for composting. It is prudent to provide at least 50 feet between the composting operation and the property line. At least 400 - 500 feet should be allowed between the composting activities and any sensitive neighboring land, such as residences. The buffer zone may include a berm consisting, in part, of finished compost. This may serve as a visual and sound barrier and help control access to the site.
3. **Site location** — A centralized area is preferable to reduce transportation time and costs, although such sites are sometimes not available or otherwise practical. Access over uncrowded, nonresidential, hard surface roads is preferable. If residents are to bring materials to the site, the location must be convenient for their participation. In some communities it may be appropriate to establish several sites while others may choose to provide a single centralized site. Sites adjacent to cemeteries, parks, runway buffers at airports, fallow farm fields, golf courses, and areas at local landfills often provide suitable sites for composting.
4. **Slope and grading** — The area should have an adequate drainage pattern for runoff as well as protection for stormwater run-on. A gentle slope of about two percent is desirable to prevent ponding of water. Steep slopes are unsatisfactory because of problems with erosion, vehicular access, and equipment operation. Initial site preparation usually requires grading. Yearly maintenance should include regrading where necessary. Windrows should run parallel with rather than across slopes to allow runoff to move between piles rather than through them. Drainage swales should be marked and properly maintained.
5. **Percolation** — An ideal composting site will have moderate soil percolation, so that ponding will not be a problem. Where percolation is poor, or where an impervious surface is used, particular care must be taken to prevent ponding. An impervious surface such as a paved site offers advantages in terms of vehicle access, equipment operation, and groundwater protection, but these advantages must be weighed against added surfacing costs, as well as the difficulties in managing runoff.
6. **Water supply** — Depending on the materials being composted and the size and shape of the windrows, water will need to be added to the yard waste. Sources of water include city services, wells, and surface water pumping. A water truck is practical for smaller operations. A system with adequate capacity must be included in the site planning.
7. **Security** — The site should be fenced, with a lockable gate at the entrance. Fencing may be unnecessary if natural geographic barriers exist to control access and prevent illegal dumping. A berm consisting of earth and finished compost may serve in place of a fence at some points. Adequate measures should be taken to protect against vandalism. A telephone and/or two-way radio system should be available on the site.
8. **Safety** — Safety precautions usual to any operation involving heavy machinery should be exercised. Road layout should be designed with safety in mind. Public access should be restricted or controlled. Although properly wetted windrows should only burn poorly, vandals may be able to ignite dry surface material. Fire safety considerations should include an adequate water supply and delivery capacity, proper wetting of yard wastes, and sufficient aisle space between windrows. Potential hazards from airborne contaminants should be guarded against by properly wetting facility grounds and windrows to manage dust and other airborne contaminants. Potential workers should be screened for conditions that might predispose them to infection or allergic response.
9. **Roads** — The primary access road should be paved or graveled. Permanent roads to the staging and unloading areas should be built. These areas should be large enough to allow for a circular traffic pattern for easiest drop-off of materials. An all-weather area will ensure smooth operation. If gravel is used at the facility, care should be taken to avoid contaminating the windrows with gravel. Aisles between windrows should not be graveled since windrow location will change frequently. An extensive on-site road network is not necessary.
10. **Public acceptance** — Public acceptance and support for a compost site is critical to program success. Consideration must be given to public concerns in selecting your site. Truck traffic and heavy equipment generate noise and vibrations. Odors, flies, dust, and other nuisances may occur if the facility is mismanaged or if operations are suspended due to equipment breakdowns or inclement weather. Wind-blown debris should not be a problem if incoming materials are windrowed immediately and if windrows are properly wetted. Sites are best located in nonresidential and nonrecreational areas. Active citizen involvement

in the siting process and an effective public information campaign will enhance public acceptance of the facility.

Composting Technologies

Selecting a technology for a municipal yard waste program will depend upon several factors including the anticipated end use of the product; whether it will be sold or given away; the amount of land, equipment, and labor available; and financial resources for capital and operations.

Technologies vary based upon equipment, degree of attention given to the composting process, space requirements, and length of time available to obtain a finished product. The following descriptions provide a general overview of three yard waste composting technologies. Transparency Master #3 qualitatively compares these technologies to one another. It is important to note that these technologies were developed for leaf composting and that their complete applicability to mixed yard waste composting is uncertain and is just beginning to be tested.

All three technologies involve forming moderately sized windrows 6 to 8 feet high and approximately 15 feet wide at the base using a front-end loader. Windrows can be as long as appropriate for the site. (Overwinter windrow size may need to be slightly larger in certain areas to maintain internal temperatures.) Water should be added, if necessary, as the windrows are formed. Woody waste should be kept separate from grass and leaves and chipped for mulch. Large pieces should be cut for use as firewood. Prior to windrow formation all incoming yard waste should be inspected for contaminants. All unwanted materials should be manually or mechanically (by screening) removed. Except for the high-level technology option, initial shredding of the grass and leaves is not necessary and is not recommended. It is costly and grass tends to clog the shredder mechanism.

1. Low-level technology — In the low-level approach the windrows of fall leaves are turned with a front-end loader after about a month and are then left until the following spring. As the spring leaves and grass are delivered to the site, these materials are turned into the fall leaves. Grass is continually mixed into the partially decomposed leaf windrows for the entire season. These mixed piles are turned with a front-end loader approximately once every three months (four times a year). Windrows should be combined as necessary to maintain proper size. The windrows should be allowed to cure (decompose) over a second winter to complete the process. With this

method it is possible to produce a final product in about 18 months.

Infrequent turning may cause the piles to become partially anaerobic. This will most likely produce some unpleasant odors that will be strongest when the piles are turned. Consequently, proper site selection and a sufficiently large buffer zone are important if this method is to be used.

This method is relatively inexpensive because of the relatively low labor and equipment needs. However, the 18-month processing time and the need for a larger buffer zone for odor control mean less cubic yards of material can be processed per acre. This may increase total land requirements. This method may work well for smaller isolated communities with an abundance of open space nearby.

2. Medium-level technology — The medium-level approach builds upon the low-level technology by increasing the frequency of turning and using more specialized equipment.

The use of the specialized equipment and the frequent turning schedule make this method the preferred process technology in most urban and suburban settings and is the recommended technology for most compost facilities in Illinois. The added costs can be readily justified by the many benefits of the method. These include a more rapid decomposition of the yard waste, maintenance of aerobic decomposition which is compatible with sensitive receptors in more urban environments, and improved quality of the final product. The success of this technology scheme depends in part upon a fall program start-up. This will ensure a sufficient supply of leaves, which are a high-carbon material, to offset the high-nitrogen grass clippings delivered to the site later in the program.

After initial windrow formation and wetting in the fall, leaves are turned every one or two weeks until winter sets in. A front-end loader can continue to be used for these and subsequent turnings, but the turning frequency will require that this equipment be dedicated to the facility. To reduce labor costs, and to improve efficiency and the degree of mixing, aerating, and shredding, it is better to utilize a specialized windrow turner for this method. These can be purchased, leased, or rented as appropriate. Use of windrow turners will improve the quality of the finished product as well as minimize the chance the windrows will become anaerobic and cause odor problems.

As the spring leaves and grass are delivered to the site, they are turned into the existing windrows. Grass must be windrowed the same day it arrives at the site. Grass is continually mixed into the windrows for the entire grass season. The windrows are turned at least once a week throughout the spring and summer. (It may be necessary to turn more frequently if the windrows have a high percentage of grass clippings. This will reduce the chance of developing anaerobic conditions.)

Windrows should be combined as necessary to maintain proper size. After 6 to 8 months from initial formation, the windrows should be ready for curing. At this stage the composted material can be screened to remove contaminants and partially decomposed materials. Although this requires specialized screening equipment at additional cost, the improved quality and marketability of the final product may justify the added expense. Whether or not you screen the material, the compost should be placed in curing piles and made available to your markets.

With this medium-level method, finished compost is available by mid- to late summer of the first year and results in a 12-month materials processing cycle.

A properly managed medium-level approach should maintain aerobic conditions within the windrows. This reduces the chance for unpleasant odors to develop. Consequently, this technology is appropriate for urban settings where it may be difficult to locate facilities more than 300 or 400 feet away from adjacent homes or business.

This method is more expensive than the low-level technology because of the use of the specialized windrow turner and screening equipment. However, these costs are somewhat offset by the improved efficiency of the operation, reduced chance for odor problems, and the improved quality of the final compost product.

3. High-level technology — This method is a highly mechanized approach. It involves the shredding of incoming yard waste, the use of a forced aeration system, active moisture control, mechanical turning, and final shredding and screening.

Forced aeration equipment typically uses a network of perforated plastic pipes under the windrows, through which air is drawn or blown by exhaust fans or small blowers. The pipes are positioned in a layer of wood chips to provide a

porous foundation. The windrows are typically covered with a layer of finished compost to reduce evaporation and ensure that all of the compost reaches adequate temperatures. It is important to note that, according to some of the literature, this equipment may not work well with grass clippings.

This process has very high capital costs which make it difficult to justify in Illinois. If landfill tipping fees were to rise to the levels found on the east coast, this method may become cost-effective, but this is currently not the case.

The greatest advantages of this approach are the improved quality of the finished compost, the availability of the finished product in as short a time as three to four months, the minimal site acreage requirements, and the minimization of odor and leachate.

An alternative high-level approach is in-vessel composting. The in-vessel technology is a fully enclosed, often fully automated, operation involving mechanical devices with feedback controls and/or forced aeration. However, due to the high capital costs, such options are not viable unless more than leaves and yard waste are being composted and unless the volumes are such that a quick throughput process is required.

Compost Equipment

Equipment requirements for yard waste composting vary substantially with the type and size of operation. This section briefly discusses the major types of composting equipment available and provides general cost estimates.

1. Front-end loaders — A front-end loader is the most important piece of equipment for yard waste composting. It may be the only piece of equipment needed for smaller facilities using the low-level technology approach. A loader rated for two cubic yards of gravel should be able to handle a four-cubic-yard, light material bucket. A typical loader with self-leveling (automatically returns the bucket to ground level) and a thirty-second cycle time should be able to move 480 cubic yards per hour and operate about 6 hours per day or 130 hours per month. It may be useful to purchase a claw attachment for loading and moving woody wastes. Prices for front-end loaders equipped with the basic accessories range from about \$50,000 to \$150,000. A claw attachment for a small loader costs about \$10,000.
2. Windrow turners — Compost windrow turners are designed especially for windrow turning and

aeration. The large models are self-propelled and straddle the windrow. Smaller units are side-mounted on front-end loaders or tractors that are driven between windrows. Some side-mounted units have their own engine for driving the aerating mechanism and only need to be pulled by the tractor or loader. Other side-mounted units must be attached to a three point tractor hitch and driven off the PTO. These may require a tractor or loader with a larger engine of 100 horsepower or greater. Side-mounted units turn half the windrow at a time which means two passes are needed for each windrow. They also require more space between windrows than the "straddle" units.

Advantages to windrow turners are that they thoroughly aerate and mix the material, turn more yards per hour than front-end loaders, and usually produce a compost with superior texture. They are especially suited for high-volume facilities. Disadvantages to windrow turners are that their design usually limits windrow dimensions to a maximum of 5 to 7 feet high and 14 to 18 feet wide at the base; they usually require level surfaces for efficient operation; and they are difficult, because of their size, to move from site to site.

Depending on the size of the machine, turners generally can process between 700 and 3,000 cubic yards per hour and cost between \$20,000 and \$170,000. It may be more cost-effective to lease a turner, rent it, contract with a compost management firm on a per-hour basis, or even share the cost/use with other compost facilities in the area.

3. Shredders and screeners — Shredders and screening devices are useful for improving the quality of the finished compost by removing contaminants (plastic, rocks, wood chips, debris) and reducing the particle size of the compost material. Shredders can process from 25 to 250 cubic yards per hour and can cost from \$30,000 to \$95,000. Vibrating screens or trommels (rotating screens) can be used for compost. Trommels are preferable since they often have brushes for self-cleaning. Units capable of processing from 20 to 75 cubic yards per hour can cost from \$20,000 to \$50,000.

Compost is more difficult to shred and screen than topsoil or peat because of its moisture content. The drier the final compost, the easier it will be to shred and screen.

4. Tub grinders and chippers — Woody debris, brush, and limbs can occupy a lot of space at a compost facility. Tub grinders and chippers can readily shred this material to greatly reduce its volume. Tub grinders have been successfully used in some operations to handle large quantities of brush and tree limbs. They can also be used to shred leaves. Chippers which can process from 25 to 50 cubic yards per hour should be adequate for most compost facilities.

Grinders can cost from \$60,000 to \$140,000 and require regular maintenance including rotating and replacing the hammers (approximately \$1,000 per set). Chippers can cost from \$10,000 to \$40,000 with replacement blades costing from \$70 to \$200.

5. Monitoring equipment — The most useful instruments for monitoring windrows are good hands, a sensitive nose, and experience. Before these characteristics can be acquired, it may be helpful to have long-stem thermometers capable of penetrating the center of a windrow and an instrument capable of measuring moisture content. Long-stemmed dial-type thermometers with three- to four-foot stems can cost from \$80 to \$100 each. More efficient digital thermometers cost \$250 to \$500 each, but they permit almost instantaneous registration of temperature.

Moisture content can be determined by accurately weighing a representative sample of material before and after evaporating moisture in an oven at 220°F. A sample is dry when two successive weights are the same. Subtracting dry weight from initial weight gives moisture content, and dividing moisture content by initial weight gives percent moisture. Instruments for determining moisture in the field require a capability of measuring in the 20 - 70 percent moisture range. Forage moisture meters fulfill this criterion and cost about \$350.

INFORMATION SHEET #3

Generation Rates for Landscape Waste

The planning and design of programs to collect, compost, and use landscape waste depends on the amount of material generated in the service area. Unfortunately, the amount of yard waste produced in a given area is almost impossible to predict. Such factors as lot size, age of the community, presence or absence of a tree planting program in the community, and even weather will affect the volume and weight of material available for collection.

A search was conducted of both national literature and reports from Illinois communities already involved in yard waste programs. This search revealed a total lack of consistency in both yard waste density factors and generation rates. Much of the information available refers only to leaf collection programs, and most of these programs are not mandatory or designed to capture 100 percent of discarded leaves. For example, many towns have reported the results of their leaf vacuuming efforts. However, in most cases, bagged leaves may also be accepted by the refuse collector, resulting in data relating only to leaves from front yards and street sides.

Density factors are an important tool in calculating collection vehicle size and other program parameters. The density of various landscape wastes is dependent on the degree of compaction and moisture content. The most commonly reported densities for yard waste materials, in terms of pounds per cubic yard, are listed in Transparency Master #4.

An attempt was made to correlate reported amounts of material collected with population of the service area. Again, most reports were for leaves only. Some towns report cubic yards (bagged, vacuumed, or compacted), some report weight only. Very few reports of grass and brush collection programs are available.

The available data was synthesized, normalized, extrapolated, and generally massaged to develop the following estimates. In an average community, the amount of leaves, grass clippings, and brush from all sources will be distributed as represented in Transparency Master #5.

To assist community planning efforts, the amount of expected leaf, grass, and brush material, as analyzed in this literature search, is presented in terms of pounds and cubic yards per single-family household. This presentation assumes that the amount of grass and leaves from multifamily and commercial sources is negligible. Also, at least 50 percent of the brush generated in a particular community may originate from nonresidential sources such as parks and electric utility tree trimming operations. To simplify calculations, brush generation is also presented per single-family household in Transparency Master #6.

The number of bags shown assumes that 30-gallon bags are used and filled to 67 percent of capacity.

These amounts can be multiplied by the number of single-family households in a community to provide an estimate of the total amount of material available for collection and processing. Please consider that these are estimated average figures only; the actual amounts of specific material in a particular community may vary by plus or minus 50 percent. Accordingly, collection and composting operations must be designed with sufficient flexibility to accommodate significant variations in the amount of available material. By the second or third year of operation, sufficient data will be available to modify the size and economics of the program.

10
15
20

INFORMATION SHEET #4**Permit Requirements for Setting up a Yard/Landscape Waste Composting Operation**

Yard waste comprises, on average, 15 to 20 percent of the total annual municipal waste stream. Recognizing that yard waste diversion programs can play an important role in minimizing the amount of waste going into landfills, the General Assembly passed, and the Governor signed into law, three bills affecting the future of yard waste disposal in Illinois. These bills include provisions which (1) prohibit, beginning September 1, 1989, sanitary landfills from accepting for final disposal truckloads composed primarily of leaves; (2) ban, beginning July 1, 1990, the disposal of yard waste at landfills unless the waste is to be composted; (3) prohibit persons from knowingly putting landscape waste into a container intended for collection or disposal at a landfill, unless such container is biodegradable; and (4) prohibit conducting a landscape waste composting operation without an Illinois Environmental Protection Agency permit. Requirements for obtaining these permits and for operating a waste composting facility are given below.

The **Permit Requirements** as specified in Public Act 85-1429 include:

1. A legal description of the site.
2. A topographic map of site of the scale 200 feet/inch or larger.
3. A description of the operation, including the area served.
4. An estimate of the volume of materials to be processed.
5. Documentation that the location of the facility:
 - a. Has a setback of at least 200 feet from any potable water supply well.
 - b. Is outside the boundary of the 10-year floodplain.
 - c. Minimizes the incompatibility of the character of the surrounding area including at least a 200-foot setback from any residence.

Design of the facility should:

1. Be farther than five feet from the water table.
2. Provide for adequate control runoff from the site and management of any leachate that is generated on the site.

Operation of a compost facility shall include:

1. Appropriate dust and odor control measures.
2. Limitations on operating hours.
3. Appropriate noise control measures for the operation of shredding, chipping, and similar noise-producing equipment.
4. Management procedures for containment or disposal of noncompostable wastes.
5. Description of procedures to be used if operation closes.*
6. Recordkeeping sufficient to document the amount of materials received, composted, and otherwise managed.
7. Submittal of a written annual statement to the IEPA on or before April 1 of each year which includes an estimate of the amount of materials, in tons, received for composting.

Permit application reviews may take up to 90 days before a permit is issued. Permits must be renewed every three years.

*Must include an estimate of the potential cost of cleaning up the site should the composting operation be terminated. This would include the cost of removing all composted and uncomposted materials and equipment which might be part of the operation.

Permit applications are available from:

Illinois Environmental Protection Agency
 Permit Section, Land Pollution Control Division
 2200 Churchill Road
 Springfield, IL 62706
 (217) 782-6762

For more information on solid waste management, call 1-800-252-8955 (within Illinois), or write to the following departments.

Office of Solid Waste and Renewable Resources
 325 W. Adams Street, Room 300
 Springfield, IL 62704 (217) 524-5454

Illinois Department of Energy and Natural Resources
 100 W. Randolph, Suite 11-600
 Chicago, IL 60601 (312) 917-3870

553

INFORMATION SHEET #5

A Homeowner's Guide to Recycling Yard Waste

On average, yard waste accounts for 18 percent of all the material buried in Illinois landfills each year. During the summer and fall months, yard waste can amount to 50 percent or more of residential trash (with collection and disposal costs at about \$90 per ton!).

Illinois is fast running out of landfill space. Yard waste not only uses up this valuable space, but contributes to methane gas and leachate problems as well. Yard waste also makes incinerators less efficient because of its high moisture content. So keeping your yard waste out of the garbage truck saves money and protects the environment.

How to Use

1. Grass clippings
 - Leave them on the lawn
 - Mulch
 - Compost
2. Leaves
 - Mulch
 - Compost
3. Wood chips
 - Mulch
 - Pathways

Why Bag Your Grass Clippings?

After all, lawn care is hard work. And bagging your lawn clippings is one of the most time-consuming parts of the job. Sure, your lawn looks great afterwards. But the bigger your lawn, the more clippings, the more trash bags, the more exhausting the process.

Now consider for a moment not bagging your grass. Gone are the hassles of stopping every few minutes to empty the mower bag, of raking, and of wrestling with expensive trash bags. Instead, your clippings are working their way back into the soil.

You may say that not bagging your grass is unhealthy for your lawn because the grass clippings will cause excessive thatch buildup and kill the lawn. But the fact is that thatch is not made up of grass, but of roots, dead leaf sheaths, and rhizomes, which decompose slowly. Grass clippings decompose rapidly and can help make your lawn more vigorous and durable.

Clippings contain the nutrients your lawn needs to grow. Every garbage bag of grass clippings contains up to

1/4 pound of usable organic nitrogen. You can reduce your fertilization costs by recycling lawn clippings back into the lawn.

Grass clippings benefit a lawn by:

1. Reducing water evaporation from the lawn.
2. Reducing lawn wear through creation of a cushioning layer.
3. Facilitating better lawn growth through provision of nutrients and maintenance of cooler soil temperature.

Successfully recycling grass clippings back to your lawn requires only the kind of attention all lawns should have on a regular basis.

1. Mow when your grass is dry and 3" to 4" tall. Never cut it shorter than 2" to 2 1/2" in height. This height will allow your lawn to have a larger and deeper root system, providing a stronger defense against weeds and droughts.
2. Use a sharp mower blade (a mulching mower if you have one). A sharp blade and frequent mowing will mean finer clippings that will decompose quickly.
3. Avoid overfertilizing your lawn. If it becomes too dense with growth, your clippings won't reach the soil to decompose.
4. Remove excessive thatch before leaving your clippings on the lawn. Although a half inch of thatch is no problem, a thick layer will keep clippings from reaching the soil.
5. Limit the use of lawn chemicals. Save money and allow soil organisms to return nutrients to the soil by first correctly diagnosing lawn problems and then applying corrective measures only when needed.

Mulching Tips

1. Grass clippings can be spread in thin layers over vegetable and flower beds, or mixed with leaves and spread in a thicker layer.
2. Leaves of deciduous trees can be spread around shrubbery in the fall.

3. Wood chips can be spread around trees and shrubs or used to create a good-looking, long-lasting footpath.

The Benefits of Reusing Yard Wastes

Yard wastes can be used to provide mulch, which benefits the soil in a number of ways. Mulch reduces evaporation from the soil surface, keeps down weeds, and keeps soil temperatures from becoming too hot or too cold. Mulch also protects sloping ground from soil erosion and stops soil compaction caused by driving rain on any soil surface.

In addition, mulch provides ideal conditions for earthworms and other soil organisms that are necessary for a healthy soil. When mulches break down, they become a compost that feeds the soil.

Compost, which can also be derived from yard wastes, provides many benefits to the soil. Composting is the controlled decomposition of organic materials using aerobic bacteria. The composting process reduces material volume by 70 - 80 percent. By using compost you return organic matter to the soil in a usable form. Organic materials in the soil improve plant growth by loosening heavy clay soils, which allows better root penetration; by improving the capacity of sandy soils to hold water and nutrients; and by adding essential nutrients to any soil. Improving your soil is the first step toward improving the health of your plants. Healthy plants help clean our air, conserve our soil, and beautify our landscapes.

There are other benefits to reusing yard wastes. Water usage is reduced, fewer plastic trash bags need to be purchased, and the need to use peat moss and other soil conditioners on the lawn and garden is eliminated.

How to Make Compost

Remove grass and sod cover from the area where you will construct your compost pile to allow materials direct contact with soil microorganisms. The following "recipe" for constructing your compost heap is recommended for best results:

1. First layer — Place 3 to 4 inches of chopped brush or other coarse material on top of the soil surface. This will allow air circulation around the base of the heap.
2. Second layer — Add 6 to 8 inches of mixed kitchen scraps, leaves, grass clippings, sawdust, etc., to the heap. These materials should be "sponge damp."

3. Third layer — Add 1 inch of soil to the heap. This will serve as an inoculant by adding microorganisms to the heap.

4. Fourth layer — Add 2 to 3 inches of manure or commercial fertilizer to the heap. This will provide the nitrogen needed by microorganisms. Sprinkle lime, wood ash, and/or rock phosphate over the layer of manure to reduce the heap's acidity. Add water if the manure is dry.

5. Additional layers — Repeat steps 1 through 4 until the bin is almost full. Top off the heap with a 4- to 6-inch layer of straw, and scoop out a "basin" at the top for catching rain water.

A properly made heap will reach temperatures of 140°F - 160°F in four to five days. At this time, you'll notice the pile "settling," a good sign that your heap is working properly.

After five to six weeks, fork the materials into a new pile, turning the outside of the old heap into the center of the new pile. Add water if necessary. You shouldn't need to turn your heap a second time. The compost should be ready to use within three to four months. A heap started in late spring can be ready for use in the autumn. Start another heap in autumn for use in the spring.

You can make compost even faster by turning the pile more often. Check the internal temperature regularly; when it decreases substantially (usually after about a week), turn the pile.

Compost is ready to use when it is dark brown, crumbly, and earthy smelling. Let it stabilize for a few extra days and screen it through a 1 1/2" screen if you want the finest product. Turn your soil, apply a 1- to 3-inch layer of compost, and work it in well, up to one pound (a heaping, double handful) per square foot. See Transparency Master #7.

The Essentials of Composting

Biological process — The compost pile is really a teeming microbial farm. Bacteria, the most numerous and effective composters, almost immediately begin to break down the plant tissue in the compost pile. They are soon joined in this work by protozoans, and then by fungi. Somewhat later, earthworms and insects such as centipedes, millipedes, and beetles assist in the breakdown.

Materials — Anything growing in your yard is potential food for these tiny decomposers. Microorganisms use the carbon in leaves or woodier wastes as an energy source. The nitrogen in the waste is the element used by the microbes and small animals in building proteins.

Everything organic has a ratio of carbon to nitrogen (C:N) in its tissues. Refer to Transparency Master #1.

A C:N ratio of 30:1 is ideal for the activity of compost microbes. This balance can be achieved by mixing two parts grass clippings with one part fallen leaves. This combination is the "backbone" of most compost systems.

Surface area — The more surface area the microorganisms have to work on, the faster the materials decompose. Chopping your garden wastes with a garden tool, or running them through a shredding machine or lawnmower, will speed their composting.

Volume — A large compost pile will insulate itself and hold the heat of microbial activity. Its center will be warmer than its edges. Piles smaller than three feet on a side (27 cu ft) will have trouble holding this heat, while piles larger than five feet on a side (125 cu ft) do not allow enough air to reach the microbes at the center. These proportions are of importance only if your goal is a fast, hot compost. Slower composting requires no exact proportions.

Moisture and aeration — All life on earth, including compost microbes, needs a certain amount of water and air to sustain itself. Microbes function best when the compost heap has many air passages and is about as moist as a wrung-out sponge. Extremes of sun or rain can adversely affect this moisture balance.

INFORMATION SHEET #6

Production of Ethanol for Fuel

Ethanol (or ethyl alcohol) can be produced from a wide variety of materials. Prior to World War II, most ethanol was produced from the fermentation of grain and other starchy materials. Synthetic ethanol gained acceptance in the 1950s, and soon most of the industrial ethanol was being produced from petroleum. Beverage ethanol continued to be produced from fermented grain.

With the shortage of petroleum fuels, there is much renewed interest in producing ethanol from nonpetroleum sources. The raw materials fall into three categories:

1. Cellulosic materials such as corn stalks or other residues.
2. Starchy materials such as grain or potatoes.
3. Sugary materials such as sweet sorghum, sugar cane, or sugar beets.

Cellulosic and starchy materials must first be converted to sugar before alcohol can be produced. Conversion of cellulose is not yet a commercially developed process and is the subject of research in the chemical engineering department at Purdue University. The beverage industry has many years of experience in converting starch to dextrins (high molecular weight sugars) which are subsequently converted to fermentable sugars.

The basic steps in ethanol production are:

1. Preparation of the raw material by grinding, slurring in water, and heating.
2. Conversion into sugar, if starchy materials are used, by use of enzymes.
3. Fermentation of the sugars into alcohol and carbon dioxide by brewer's yeast. The fermented mash contains about 10 percent alcohol because the yeast cannot survive in higher concentrations of alcohol.
4. Distillation of the fermented mash by heating, collecting the vapors, and cooling to condense the vapors to a liquid.

The distillation process yields an alcohol containing at least five percent water. The proof is twice the percentage of alcohol, for example, 2 x 95 percent = 190 proof. The last five percent of water can be removed by blending with a hydrocarbon such as benzene and redistilling. When all the water is removed, the alcohol is 200 proof.

The material remaining after the alcohol is distilled off is known as stillage. If the raw material was grain, the stillage consists of a high-protein, low-carbohydrate residue that can be used as a livestock feed. It will spoil unless fed or dried quickly. The dried product is known on the commercial market as dried distiller's grain.

Basic Steps in Alcohol Production

1. Milling — The starch source (usually corn, wheat, rye, or barley) is ground into a fine meal. This exposes the starch granules and permits suspension and dispersion in the following step.
2. Slurring — Water is added to the meal to form a mash (typically 10 - 30 gallons of water per 56-lb bushel of grain). The pH is adjusted and liquefaction enzymes are added.
3. Liquefaction — The mash is heated to gelatinize the starch (140°F - 170°F) and render it susceptible to enzyme breakdown. The starch is converted into soluble high molecular weight sugars called dextrins.
4. Conversion — The mash is cooled to conversion temperature (130°F - 140°F). The pH is adjusted, and conversion enzymes are added. The mash is held long enough to permit some of the dextrins to be converted into fermentable sugars. It is then cooled further to fermentation temperature (85°F - 90°F). Solids at this point should comprise from 8 to 12 percent (about 30 gallons/bushel) of the mash. Water can be added to aid cooling if the solid content was high in the previous steps.
5. Fermentation — Distiller's yeast is added and the mash is held 48 - 120 hours. During this time the conversion enzymes continue to break down dextrins to fermentable sugars while the yeast converts these sugars to alcohol and carbon dioxide. The fermentation process produces heat so that cooling is necessary to maintain yeast survival.
6. Distillation — The fermented mash is heated to vaporize the alcohol, and the vapors are collected and cooled to condense the alcohol back to a liquid. The residue contains the residual grain, spent yeast, and water. The residual grain and spent yeast are generally used in animal feeds. The water is usually recycled.

INFORMATION SHEET #7

Biomass Energy

Biomass is a form of solar energy stored in a wide variety of plant and animal organic matter. The key process in the creation of biomass, photosynthesis, uses sunlight to convert carbon dioxide and water into higher energy products such as carbohydrates and oxygen. Forest materials and residues, grains, crops, animal manures, and aquatic plants are the principal resources of biomass. These raw materials can be transformed into liquid or gaseous fuels and petrochemical substitutes, as well as heat, electricity, and steam. Biomass products have numerous industrial applications and residential uses. The primary objective of the Department of Energy (DOE) Biomass Energy Systems (BES) Division is to supplement fossil fuel resources through the growth, harvest, and use of plant and animal residues.

Biomass has important energy supply potential because of its extensive and well-located resources in the United States, the potential of conversion technologies, and the availability of a strong commercial market. Biomass is already providing approximately two percent of our energy needs, primarily by the direct combustion of wood. The forest products industry and the pulp and paper industry are major biomass consumers. They are working toward 100 percent energy self-sufficiency in the near future by using manufacturing and forest residues for production processes.

Annual biomass production goals for the year 2000 are about seven quads of energy. One quad, or quadrillion BTUs, is equivalent to approximately 494,000 barrels of oil per day for one year, or enough energy to heat 500,000 homes for 20 years.

History

Biomass is the oldest source of energy known. For thousands of years, people have burned wood for both heat and protection. Until the mid-19th century, wood accounted for about 90 percent of the energy supply in the United States. In 1940, 20 percent of U.S. homes still used wood for space heating.

Although fossil fuels replaced wood as the prime energy source in the 20th century, interest in biomass never completely faded. During the 1930s, several American studies investigated the feasibility of converting grain to ethyl alcohol as a gasoline substitute. During World War II, many nations worked to develop the fuel potential of trees. Sweden, for example, cultivated large forest areas specifically for energy consumption and research. Today, private industry and government in the United States have renewed interest in biomass by researching conversion

methods and encouraging the application of available technologies.

Resources

Because biomass is 50 to 90 percent water, the most cost-effective way to utilize the organic matter is at or near its source. If converted into liquids or gases, however, it can be transported easily and economically. Because biomass is available in wooded areas, on farm land, and in water, conversion sites are located throughout the country.

Wood, of course, is a major biomass resource. It serves as a fuel in the form of logs or residues. Residues consist of excess forest growth, insect-infested and diseased trees, and mill remains. To improve wood fuel production, researchers are developing new tree varieties such as hybrid poplars which grow rapidly and are totally consumable. Silvichemicals such as turpentine and resin, and carbon-based compounds made from lignin and cellulose are other energy-related wood derivatives. These materials serve as feed-stocks for the production of a variety of chemicals such as alcohol, aldehydes, ketones, ethylene, acids, and ammonia which can be used as petrochemical substitutes.

Nonwoody plants such as herbs and grasses have potential as cost-effective energy feedstocks. These plants have a high yield capacity and can grow in arid or marginal land with minimal management.

Crops are another popular biomass resource. Sugar beets, sugar cane, sweet sorghum, and grains such as corn and wheat are processed for their carbohydrate content to make ethanol (ethyl alcohol). Cellulosic materials found in herbaceous crops such as corn and rye are converted by liquefaction to fuel oil. Alcohol development is receiving special emphasis under the new DOE Office of Alcohol Fuels.

Animal manure is an excellent source of methane gas which can be manufactured by a process called anaerobic digestion. This fuel supplies farmers with the energy necessary to grow crops and raise livestock. It can be viewed as completing a biomass energy cycle whose goal is energy self-sufficiency on farms.

Kelp and algae are aquatic sources of biomass. Through a process called biophotolysis, blue-green algae produces hydrogen as a waste product. Kelp produces hydrogen gas through photoelectrolysis, a photochemical process which uses a catalyst to separate hydrogen and oxygen.

Thermochemical Conversion Techniques

The direct combustion of wood is the most common biomass conversion method. The number of wood-burning stoves in homes has increased dramatically in the past few years, indicating a resurgence in the popularity of wood as a residential heating fuel. It is estimated, for example, that 40 percent of the homes in Maine use wood stoves. Wood can also supplement oil, natural gas, or solar energy heating systems. Nationwide, approximately five million American homes already have a working wood stove, and the practical potential exists for another 13 to 18 million homes.

Direct combustion of biomass residues has industrial applications for the production of process heat or electricity. Currently, direct burning is economically competitive with fossil fuels for some industries, especially those having easy access to biomass resources. A sugar company in Hawaii meets 75 percent of its mill and irrigation pump electricity needs from the burning of bagasse, or sugar cane residue.

Utility plants in Vermont and Oregon also produce electricity from direct combustion. Two 10-megawatt units in Burlington, Vermont are 100 percent wood burning. They serve 40,000 people and sell an additional 15 percent of their output to surrounding utilities. In Eugene, Oregon, a 33.8-megawatt utility plant has been producing steam and electric power since the 1930s by burning mill wastes supplied by local sawmills. In addition to proving very economical, this plant reduces air pollution and helps solve wood residue waste disposal problems.

Other direct combustion efforts include brick and textile industries in the South which burn sawdust and wood, respectively, to provide process heat. DOE is working with industry to evaluate wood conversion processes and to retrofit large conventionally fueled heat boilers for direct firing of green wood.

Gasification and liquefaction are two technologies which convert biomass into gas or liquid fuels. Gasification is the reaction of biomass with steam and oxygen at high temperature and pressure. The resulting products include synthetic natural gas (methane), low and medium BTU gas, and hydrogen. DOE sponsors five process development units which perform catalytic and noncatalytic gasification processes. The units are located in Texas, Ohio, New York, Washington, and Missouri.

A large scale, experimental liquefaction facility in Albany, Oregon, uses wood chips to produce oil. Biomass reacts with carbon monoxide in the presence of an alkaline catalyst under moderate temperature and high pressure. The resulting oil product has a consistency similar to heavy

heating oil and a heating value (15,000 BTU/lb) similar to bunker fuel oil. The Albany facility has proven that liquefaction is an energy-efficient process which produces nonpolluting water, flue gases, and ash.

Pyrolysis is a thermochemical conversion process which functions without oxygen and at a lower temperature than gasification. Residue materials are gasified, ignited, and completely burned in a thermal reactor to produce gases. The biomass resources used in pyrolysis include manure, agricultural and wood wastes, and municipal solid wastes. Oil, charcoal, and synthetic gas, as well as steam, are the products.

Biochemical Conversion Techniques

Anaerobic digestion is the controlled decomposition of organic matter. In the absence of oxygen, bacteria decays the material, producing methane. The feasibility of using animal manure in this process is being tested at a full-scale facility in Bartow, Florida. Located in the state's largest slaughtering and packing plant, this facility can handle 25 tons of manure daily. By processing the wastes from 10,000 cattle, the operation can produce enough methane to meet nearly all of the packing plant's energy needs, the equivalent of 35 barrels of oil per day. A by-product of this process, protein-rich digester solids, will be concentrated to serve as a dietary supplement for 6,000 cattle. Anaerobic digestion also plays a large role in the production of energy from aquatic plants.

In addition to liquid and gaseous fuels, biochemical and thermochemical conversion systems produce petrochemical substitutes such as aldehydes, ketones, ethylene, acids, and ammonia. These chemical compounds are used in a wide variety of manufacturing processes.

Markets

Certain biomass conversion technologies, most notably direct combustion, anaerobic digestion, and gasification, are sufficiently advanced for near-term energy development. Direct combustion of wood is providing energy to the residential, industrial, and utility sectors. Anaerobic digestion of manure and agricultural wastes on farms is the first step in the attempt to make farmers energy self-sufficient. Low BTU gasifiers using wood as a feedstock are already in use by industry.

The national program for biomass research and development, directed by BES, will further advance the applications of these technologies. The large resource potential of agricultural and forest residues and other organic wastes should encourage the commercialization of biomass technologies.

Future Outlook

The BES Program is rapidly reaching its goal of providing a reliable alternative energy source. Although most near-term accomplishments have come in the areas of liquefaction, gasification, and direct combustion, early advances are expected in anaerobic digestion, biophotolysis, and photoelectrolysis.

Energy farms are being used in herbaceous and silviculture research to grow terrestrial and aquatic plants throughout the country. Research management is performed at the 1,000-acre silviculture test plantation established in Aiken, South Carolina, to investigate the forestry concept of short rotation. Consistent accomplishments in the development of all biomass technologies are expected to meet biomass goals for the year 2000.

Adapted from: Department of Energy *Biomass Energy* (#DOE / CS - 0202)

500

INFORMATION SHEET #8

Organizing a School Energy Contest

Purpose:

To provide students with an opportunity to use their understanding of energy problems to communicate energy conservation practices to others.

Sponsoring an energy contest will afford students an excellent opportunity to apply their knowledge about current energy sources and uses, and the need for conservation. There are numerous possibilities for contests or related activities, including poster, photography, or essay contests; speeches; and debates. You will want to consider the following questions when developing a plan for the contest.

1. What specific kind of contest will it be?
2. What energy topics (problems, concerns, technologies) will be included?
3. Who are eligible to enter? How may they enter?
4. What criteria apply to the specific contest (e.g., if photography, the size, color, and mounting of photographs)?
5. What prizes or awards (e.g., cash, savings bonds, certificates) will be offered?
6. Who will select winners (students, a panel of community members)? What criteria will be used to select judges?
7. When would the contest begin and end?
8. To whom are entries submitted (a program coordinator, a teacher, the chairman of the panel of judges)?
9. How will publicity be handled?
10. What companies or organizations might sponsor the contest?
11. Will there be an awards ceremony (reception, assembly, or luncheon) to announce the winners?

501

TRANSPARENCY MASTER #1

Carbon/Nitrogen Ratios of Common Organic Waste

Waste Type	C:N Ratio
Sewage Sludge: Activated	6:1
: Digested	16:1
Food Wastes	15:1
Fruit Wastes	35:1
Grass Clippings (fresh)	20:1
Manure	20:1
Weeds (fresh)	25:1
Hay (dry)	40:1
Corn Stalks	60:1
Leaves (fresh)	40-80:1
Leaves and Weeds (dry)	90:1
Straw (dry)	100:1
Sawdust	500:1
Wood	700:1

TRANSPARENCY MASTER #2

Generic Compost Site Layout

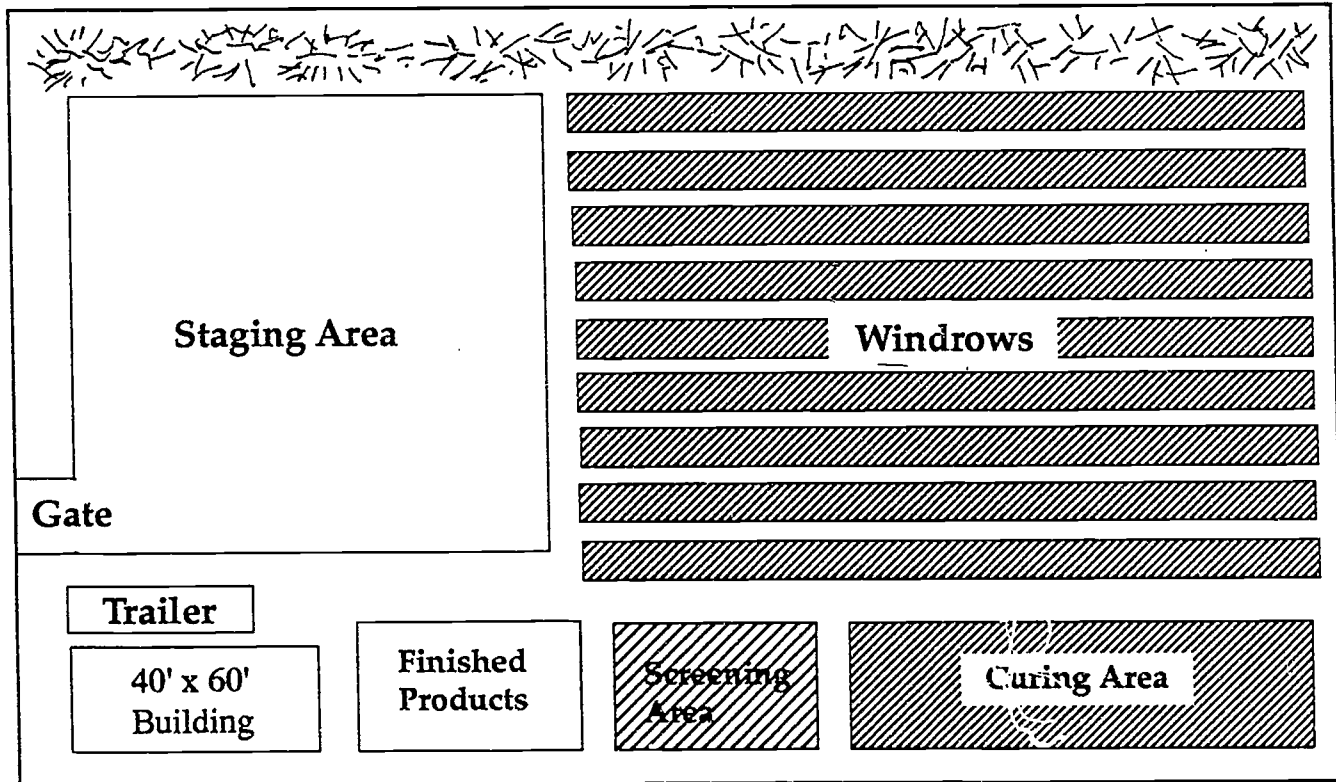

Source: Michigan Department of Natural Resources, 1988

TRANSPARENCY MASTER #3

Yard Waste Processing Technology Summary

	Low Tech.	Medium Tech.	High Tech.
Process Retention Period ¹	Long	Short	Very Short
Buffer Zone ²	Large	Small	Small
Quality of Product ³	Unrefined	Refined	Highly Refined
Capital Cost	Low	Moderate	High
O&M Cost	Low	Moderate	High

¹ Long (Approximately 2 to 5 years)

Short (Less than 1 year)

² Large (In excess of 500 yards)

Small (200 to 500 feet)

³ Unrefined (Product contains rocks, pebbles, sticks, and twigs)

Highly Refined (Product is clean humus, particle size less than 0.05 inches)

Adapted from DPRA, Incorporated, 1989

TRANSPARENCY MASTER #4

Landscape Waste Densities

	Loose (lbs/cu yd)	Compacted (lbs/cu yd)
Leaves	200	400
Grass	400	800
Brush	300	900

565

TRANSPARENCY MASTER #5

Landscape Waste Composition

	By Weight	By Volume	
		Loose	Compacted
Leaves	12%	20%	22%
Grass	65%	54%	59%
Brush	23%	26%	19%

TRANSPARENCY MASTER #6

Generation Rates per Single-Family Household

Material	Pounds	Cubic Yards		Bags	Pounds/Bag
		Loose	Compacted		
Leaves	160	0.80	.040	8	20
Grass	1,040	2.60	1.30	26	40
Brush	300	1.00	0.33	—	—
Total	1,500	4.40	2.03		

567

TRANSPARENCY MASTER #7

Troubleshooting Chart to More Efficient Composting

<i>Symptoms</i>	<i>Problem</i>	<i>Solutions</i>
The compost has a bad odor.	Insufficient air	Turn the pile. Add dry material if the pile is too wet.
The center of the pile is dry.	Insufficient water	Moisten and turn the pile.
The compost is damp and warm only in the middle.	Insufficient quantity of compost	Collect more material and mix the old ingredients into a new pile.
The heap is damp and sweet smelling but still will not heat up.	Lack of nitrogen	Mix into the pile a nitrogen source like fresh grass clippings, fresh manure, or bloodmeal.

TRANSPARENCY MASTER #8

Composting Bins to Build

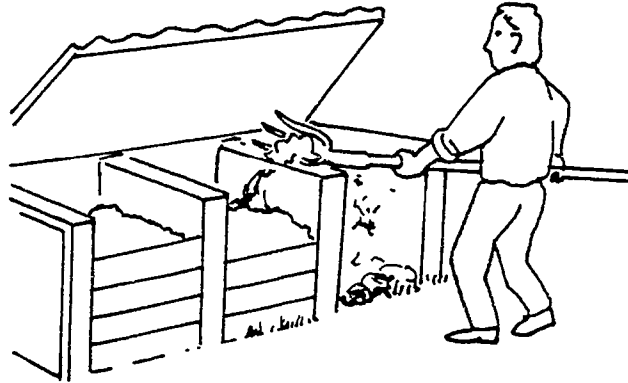

Turning Bins

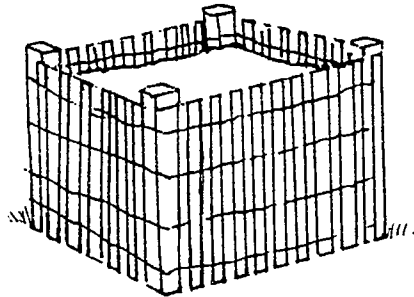

Snow Fence Bin

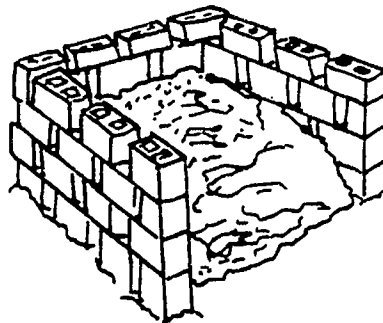

Block or Brick Bin

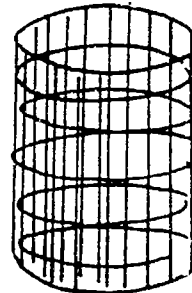

Woven Wire Bin

560

SIMPLIFIED SCHEMATIC FOR COMPOSTING YARD WASTES

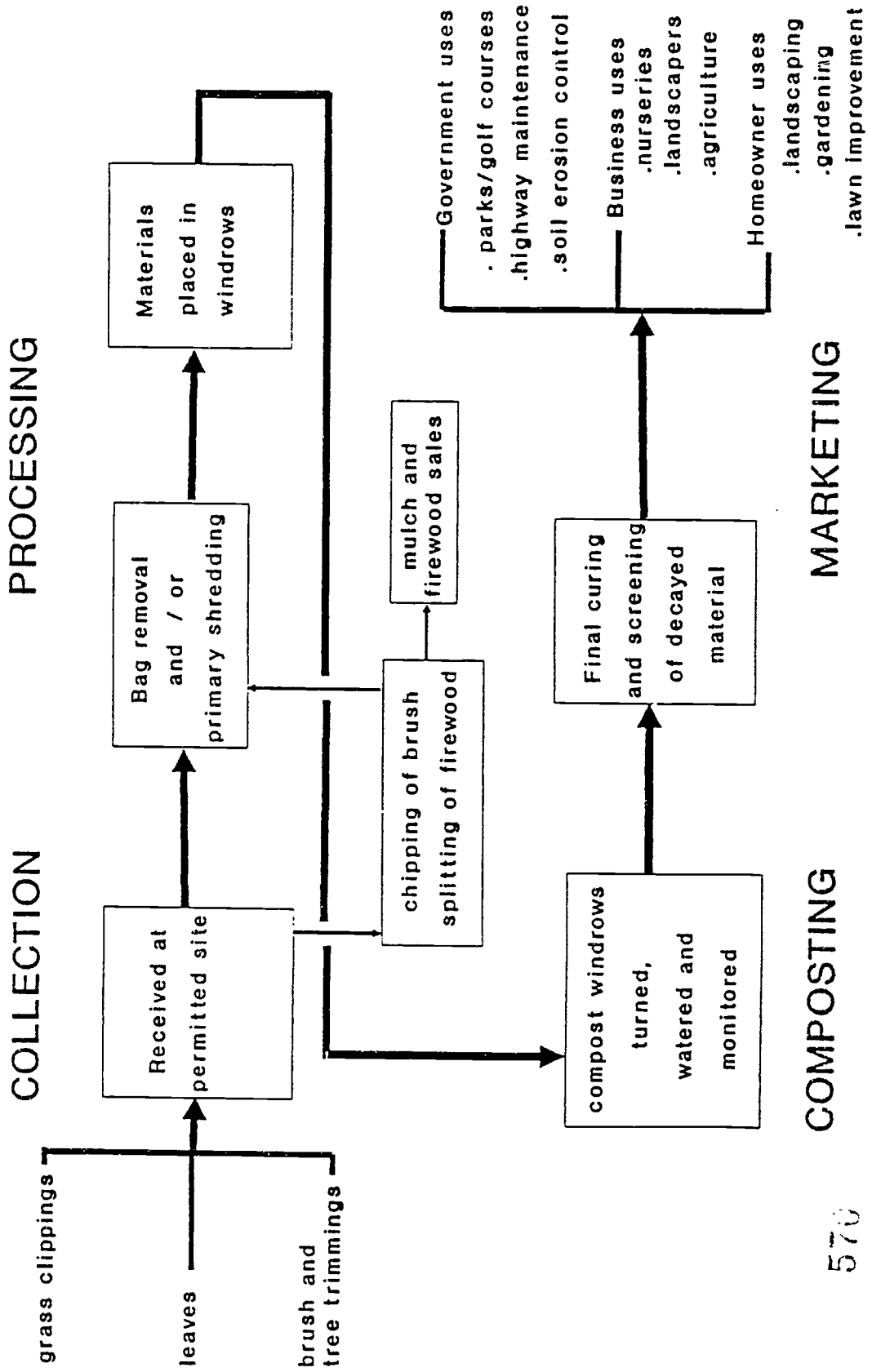

TRANSPARENCY MASTER #10

Major Compost Uses by User Type

1. Private residential
 - a. Garden application for food
 - b. Nonfood applications

2. Private commercial
 - a. Greenhouses
 - b. Nurseries
 - c. Golf courses
 - d. Landscaping
 - e. Turfgrass farming
 - f. Industrial park grounds
 - g. Cemeteries
 - h. Agriculture
 - i. Topsoil

3. Public agencies
 - a. Public parks
 - b. Playgrounds
 - c. Roadside and median strips
 - d. Military installation

4. Land reclamation
 - a. Landfill cover
 - b. Strip-mined lands
 - c. Sand and gravel pits

572

TRANSPARENCY MASTER DISCUSSION GUIDE**Transparency Master #8****Snow Fence Bin**

Bins made with prefabricated snow fencing are popular because they are simple to make and easy to move and store. To build such a bin, buy the appropriate length of prefabricated fencing and fasten two-by-fours (2x4s) to the bottom to form a square.

Woven Wire Bin

One easy-to-make, economical container requires only a length of woven wire fencing. Multiply the diameter you want for the compost heap by 3.2 to get the length of fencing you need to buy. Fasten the ends with wire or with three or four small chain snaps (available at any hardware store) to make a circle.

Block or Brick Bin

Compost bins can be made with bricks, cement blocks, or rocks. Just lay the blocks without mortar. Leave spaces between each block to permit aeration. Pile them up to form three sides of a square container or a three-bin unit. This bin is sturdy, durable, and easily accessible.

Wooden Bin

Covered wooden bins allow convenient protection from pests and heavy rains. Construct bins with removable fronts or sides so that materials can be easily turned. Old wooden pallets can be used for construction. Wire mesh can be substituted for wooden sides to increase air flow.

Prefabricated compost bins can also be purchased through most gardening catalogues.

Turning Bins

This is a series of three or more bins that allows you to make compost in a short time by turning the materials on a regular schedule. Turning bins are most appropriate for gardeners with a large volume of yard waste and the desire to make a high-quality compost. You can also turn your compost with only one bin. Simply remove the bin from around the heap when it's time to turn it, set up the empty bin nearby, and fork the material back into it.

STUDENT ACTIVITIES

- STUDENT WORKSHEET #1 — How Much Solar Heat Comes From the Sun to You?
- STUDENT WORKSHEET #2 — Which Batch-Type Solar Collector Gets the Hottest After 15 Minutes in the Sun?
- STUDENT WORKSHEET #3 — How Many Times Do You Have to Run Water through a Flat-Plate Collector to Get a 10°F Rise in Temperature?
- STUDENT WORKSHEET #4 — Which Color Liquid Absorbs the Most Solar Energy?
- STUDENT WORKSHEET #5 — How Hot Will the Water Get in a Solar Water Heater after 20 Minutes of Exposure to the Sun?
- STUDENT WORKSHEET #6 — How Hot Does a Box Get with a Convection-Type Solar Collector in 5, 10, and 15 Minutes?
- STUDENT WORKSHEET #7 — How Much Better is a Solar Greenhouse Than a Standard Greenhouse at Keeping a Steady Temperature in the Winter?
- STUDENT WORKSHEET #8 — Which Substance Will Retain the Most Heat: Water, Gravel, or Hypo (Sodium Thiosulfate)?
- STUDENT WORKSHEET #9 — Let's Power Spaceship Earth with the Sun
- STUDENT WORKSHEET #10 — What Happened?
- STUDENT WORKSHEET #11 — Future Lifestyles
- STUDENT WORKSHEET #12 — Nuclear Energy and Fossil Fuel Energy: A Comparison
- STUDENT WORKSHEET #13 — Nuclear Energy: Its Benefits and Problems
- STUDENT WORKSHEET #14 — Jumbles
- STUDENT WORKSHEET #15 — Solar Energy Quiz
- STUDENT WORKSHEET #16 — A Solar Perspective

For additional activities, teachers may refer to the "Suggested Teaching Activities and Procedures" section in the Instructor's Guide.

572

STUDENT WORKSHEET #1

How Much Solar Heat Comes From the Sun to You?

Materials:

1. 2 foam cups
2. 2 thermometers
3. food colors; aluminum foil
4. graduated cylinder
5. metric ruler; watch
6. insulation material (packing foam, crumpled newspaper, etc.)
7. cardboard box (should be same height as cups; trim if necessary)

Note: Scientists have measured the amount of solar energy beyond our atmosphere at about 2.0 calories per square centimeter per minute. About 1.5 calories per square centimeter per minute reaches earth after passing through our atmosphere. This is called the Solar Constant.

Procedure:

1. Fill the foam cups with identical measured amounts of cold water.
2. Add food colors to one cup.

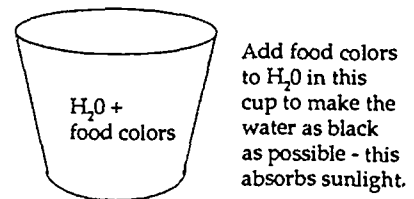
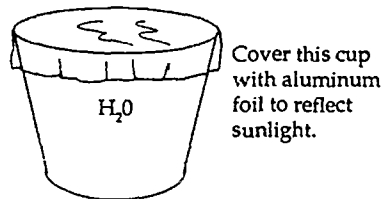

3. Trim a cardboard box to the same height as the cups.
4. Put the cups in the box and add the insulation material.
5. Put the box in the sun for 10 minutes (noon to 1 p.m. is usually the hottest time).
6. Stir the water in the cups with the thermometers and record the temperatures.

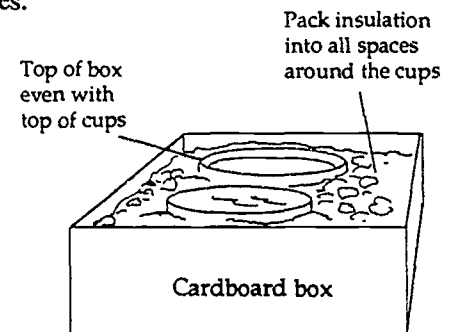
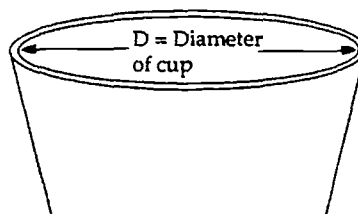

Discussion:

Calculate the surface area on the top of each cup according to the following formula:

$$\text{Area} = \pi d^2 + 4 = \underline{\hspace{2cm}} \text{ square centimeters}$$

Calculate the number of calories absorbed by the heated cup according to the following formula:

$$\text{Calories} = (\text{ml of water in 1 cup}) \times (\text{difference in temperature between the cups after being in the sun for 10 minutes}) + (\text{surface area of water in square centimeters} \times 10)$$

The number of calories calculated is the amount of solar heat received on 1 square centimeter in 1 minute at your location. Multiply this figure by 10,000 to get the resulting number of calories for 1 square meter of water surface area.

STUDENT WORKSHEET #2

Which Batch-Type Solar Collector Gets the Hottest After 15 Minutes in the Sun?

Materials:

1. plastic trash bags; one each white, green, and black (local grocery store)
2. insulating material (styrofoam, cardboard, newspaper, etc.)
3. aluminum foil
4. 3 thermometers
5. tape

Procedure:

1. Make 3 plastic trash bag solar collectors by following the drawing below.
2. On the ground outside, put down insulating material, and then aluminum foil. The bags go on top in a row.

Make a small hole in each bag and insert a thermometer. Tape tightly so the bags don't leak!

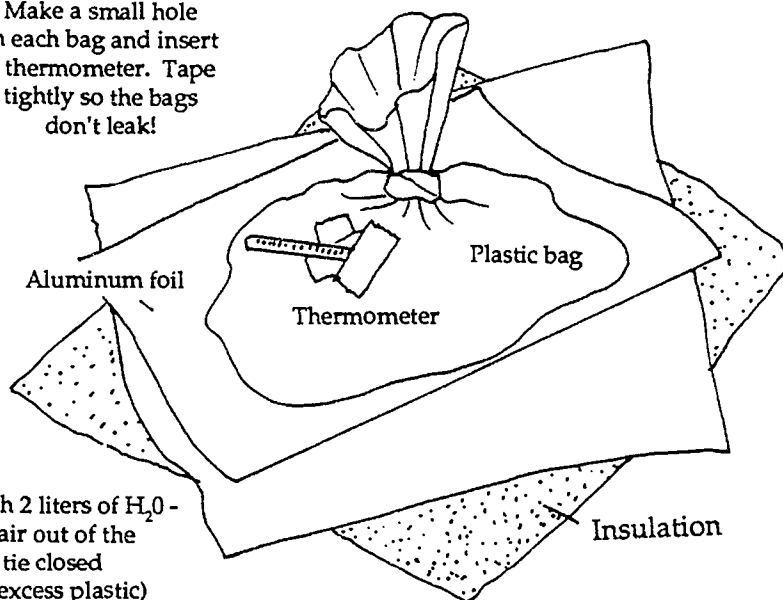

Fill each bag with 2 liters of H_2O - squeeze the air out of the bags and tie closed (trim off any excess plastic)

3. Record, in the graph at right, the temperatures of the 3 collectors. Then place the collectors on the foil in the sun.
4. Record the temperatures again in 15 minutes.

Questions:

1. What causes the differences in temperatures recorded?
2. How could this affect other solar experiments?

	Temp. before	Temp. after
Green		
White		
Black		

STUDENT WORKSHEET #3**How Many Times Do You Have to Run Water through a Flat-Plate Collector to Get a 10°F Rise in Temperature?****Materials:**

1. 1 piece of galvanized sheet metal, 25 cm square, as thin as possible (local hardware store or building supply)
2. 1 piece of cardboard, 52 cm square
3. flat black spray paint
4. insulation material, 7 cm thick x 25 cm square (styrofoam, cardboard, newspaper, etc.)
5. soft copper tubing, 1 meter long, 3/8- to 1/2-inch diameter (local hardware store or building supply)
6. plastic funnel to fit inside plastic tubing
7. 100- to 200-watt soldering iron and acid-flux solder
8. clear plastic tubing, 30 cm long, 3/8- to 1/2-inch diameter (local hardware store or building supply)
9. razor blade or knife
10. tape or stapler
11. 2 styrofoam cups
12. 2 pieces of 3- or 4-mil clear plastic, 40 cm square (local hardware or garden stores)
13. thermometer

Note: Copper tubing must be bent with a tubing bender (about \$1.50) or tubing can be bent at the hardware store when purchased.

Setup:**Part 1: Construct a Flat-plate Metal Collector.**

1. Bend the copper tubing with tubing bender into the shape shown in the figure at right. Bend carefully to avoid kinks.
2. Solder soft copper tubing to galvanized sheet metal.
3. Spray plate and tubing with flat black paint after construction.

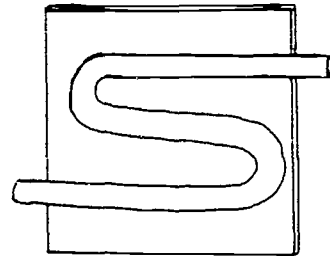
**Part 2: Construct a Box.**

1. Using a piece of cardboard 52 cm square, construct a box, according to the figure at right, to house your flat-plate collectors.
2. Cut on solid lines.
3. Fold on dotted lines.
4. Cut slot and hole to insert flat-plate collector.

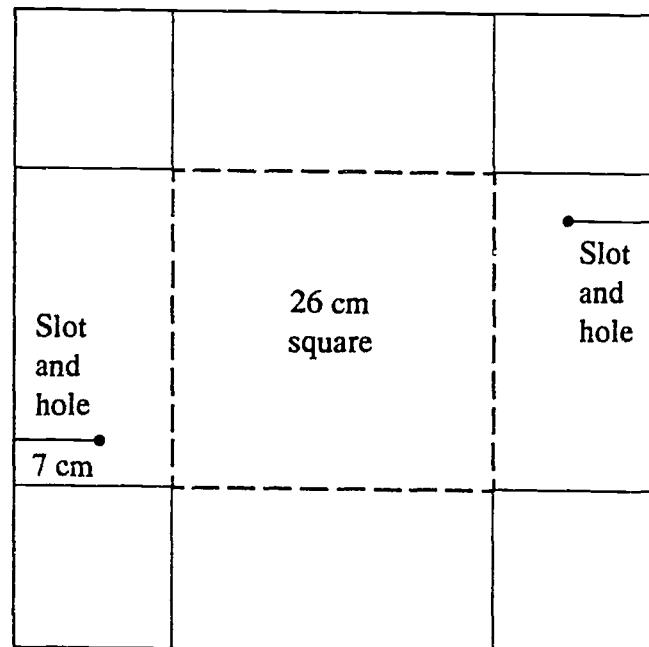

Part 3: Assemble the Collector.

1. Fold and staple or tape cardboard to make a box.
2. Insert the 7 cm of insulation.
3. Fit the collector into the box. Tape the slots tightly closed.
4. Fold and tape the plastic to make a tight but removable cover.
5. Cut the 30-cm length of clear plastic tubing into two 15-cm pieces. Put one piece over each end of the copper tubing.

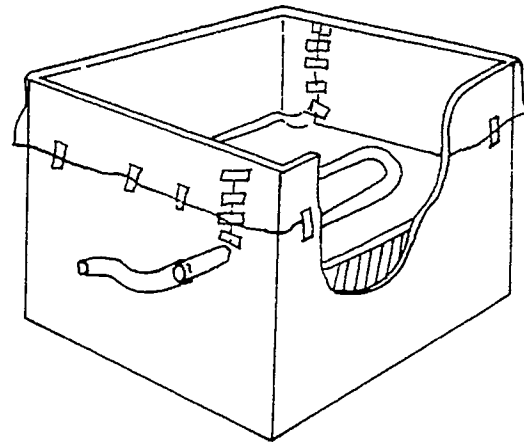
**Procedure:**

1. Check the box to be sure all cracks and holes are tightly sealed.
2. Measure and record the temperature of 100 ml of water.
3. Pour this water, as indicated in the figure, through the flat-plate collector. Note the temperature of the water after passing through the collector.
4. Wait 5 seconds after all the water has passed through. Then again pour the water through the collector. Again note the final temperature. Continue this process until the water temperature has risen 10°F.

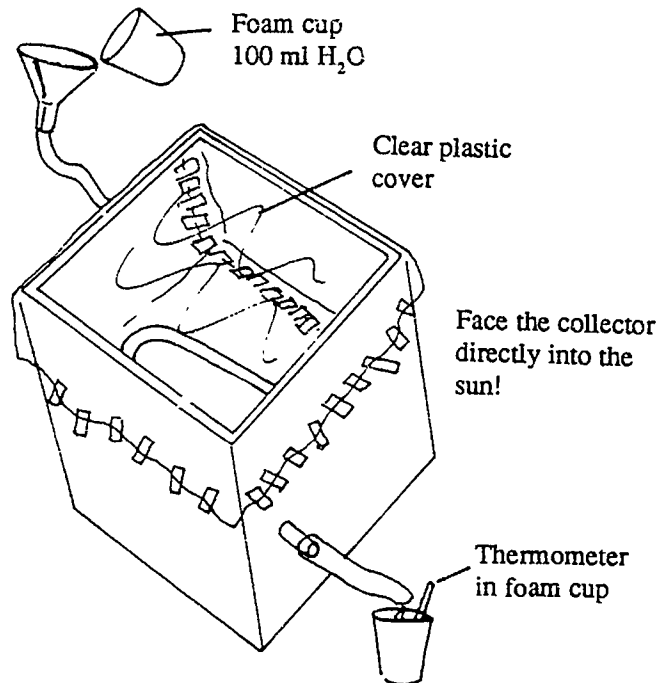
**Question:**

1. How many pourings through the collector were required to raise the temperature of the water 10°F?

07
3
01

STUDENT WORKSHEET #4

Which Color Liquid Absorbs the Most Solar Energy?

Materials:

1. flat-plate metal collector box, plastic cover, and insulation from Student Worksheet #3
2. 1 piece of clear plastic or cardboard, 25 cm square, 1/8 inch or thicker
3. clear plastic tubing, 2 meters long, 3/8- to 1/2-inch diameter (local hardware store or building supply)
4. glue or tape
5. food colors
6. thermometer
7. 2 styrofoam cups
8. funnel

Setup:

Construct a collector plate according to the directions given in the figure.

Place the clear plastic collector plate in the box from Student Worksheet #3, and face the collector directly into the sun.

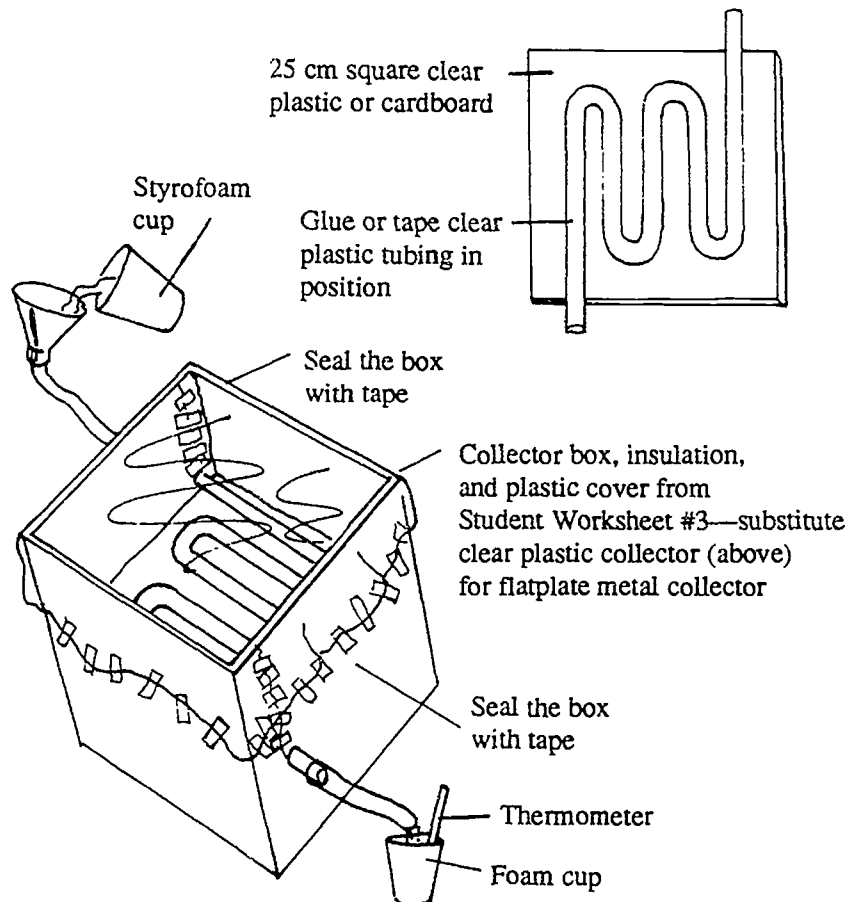

Procedure:

1. Measure and record the temperature of 100 ml of water.
2. Pour the water through the collector 10 times, allowing 5 seconds between pourings. Record the final temperature of the water.
3. Measure and record the temperature of another 100 ml of water. Add 2 to 5 drops of red food color to the water. Pour through the collector 10 times, and record final temperature, as above.
4. Repeat the previous step using various other food colors and compare the temperature results with those of the earlier trials.
5. Repeat step 3 after adding to the water a combination of 2 to 5 drops of each of the different food colors. Compare the results.

STUDENT WORKSHEET #5

How Hot Will the Water Get in a Solar Water Heater after 20 Minutes of Exposure to the Sun?

Materials:

1. flat-plate metal collector, insulation and cover from Student Worksheet #3
2. 1- or 2-pound coffee can with plastic lid
3. 2 pieces of soft copper tubing, 25 cm long, 3/8- to 1/2-inch diameter (local hardware store or building supply)
4. soldering iron and acid-flux solder
5. clear plastic tubing, 1 meter long, 3/8- to 1/2-inch diameter (local hardware store or building supply)
6. celsius thermometer
7. cardboard box, slightly larger than coffee can
8. insulation material (styrofoam, cardboard, newspaper, etc.)

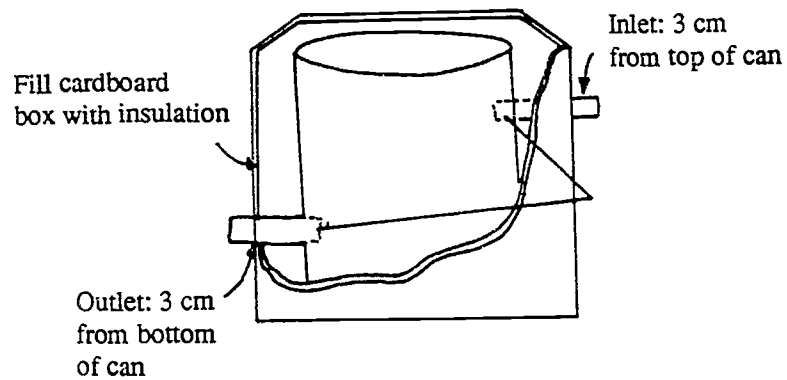

Bottom of can should be above top of solar collector

Setup:

1. Construct a hot water heater, as indicated in the figure, with the coffee can, copper tubing, cardboard box, and insulation material.
2. Punch two holes in opposite sides of the coffee can. Solder a piece of copper tubing into each of the holes in the can. The joints must be watertight. Measure and record the weight of the coffee can with the tubing attached.
3. Place the can in the cardboard box, cutting holes in the box where necessary to accommodate the copper tubing, and fill the remaining space with insulation.
4. After the hot water heater is constructed, hook it up to the solar collector (from Student Worksheet #3) as shown in the figure.

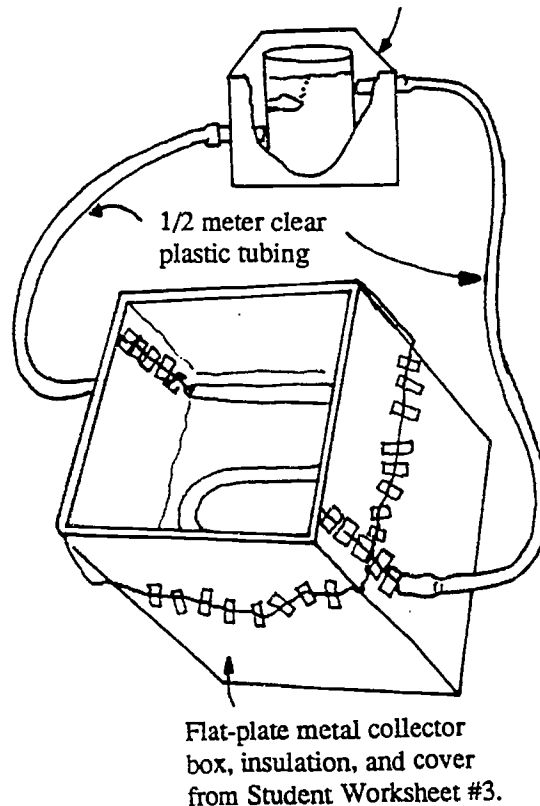

Procedure:

1. Disconnect the plastic tubing from the inlet.
2. Run water through the tubes and the collector until all air is expelled.
3. Reconnect the plastic tubing to the inlet. Measure and record the weight of a volume of water sufficient to fill the coffee can. Pour this water into the can to a level above that of the inlet tube.
4. Record the temperature of the water and replace the lid.
5. Face the collector directly into the sun.
6. Record the temperature of the water again after 20 minutes.
7. Measure the combined weight of the coffee can and the water. To do this, you will either have to stopper the tubing inlet and outlet, or collect the water in a separate container and measure it separately.

Discussion:

1. How hot did the water in the can get after the collector was placed in the sun for 20 minutes?
2. Calculate the number of calories of heat produced in the solar water heater using the following formula:
Calories = (temperature difference x weight of water) + (temperature difference x 1/20 weight of can)

The temperature difference is determined by subtracting the temperature of the water at the beginning of the experiment from the temperature of the water at the end of the experiment.

Questions:

1. Would the solar water heater work if the storage container was placed lower than the collector?
2. Will the solar water heater work in reverse on a cold night?
3. Can you detect the water flow in the system using chalk dust or food coloring?
4. What is the maximum temperature you can record?

STUDENT WORKSHEET #6**How Hot Does a Box Get with a Convection-Type Solar Collector in 5, 10, and 15 Minutes?****Materials:**

1. 2 white or white-painted boxes, at least 35 cm high x 45 cm long x 30 cm wide (dimensions may vary, but boxes should be about the same size)
2. duct tape (local hardware store or building supply)
3. tape or stapler
4. knife or scissors
5. piece of 3- or 4-mil clear plastic approximately 40 cm square (local hardware or garden store)
6. 4 thermometers
7. flat black spray paint
8. galvanized sheet metal (dimensions based on size of cardboard box — see instructions) (local hardware store or building supply)
9. cardboard (see instructions for amount required)
10. insulation material (styrofoam, cardboard, newspaper, etc.)

Setup:**Part 1: Construct a Control Box.**

1. Cut a hinged door in a cardboard box as shown in the top figure. Tape 3- or 4-mil plastic tightly to inside of box. There should be no air leaks.
2. Tape a thermometer inside the window at the top and bottom. Thermometers must be readable through the window.
3. If the box is not white, spray or paint the outside of the box with white paint

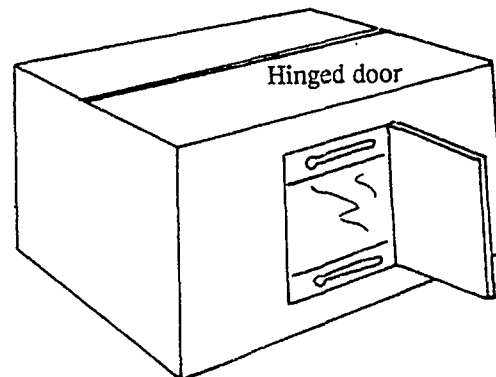
**Part 2: Construct a Solar Collector Box.**

1. Construct another box like that in Part 1, with the addition of a cardboard tray, 6 cm high, as shown in the middle figure. Cut a hole in the large box to hold the tray. Tape the tray to the inside of the box. The tray is labeled "open to box".

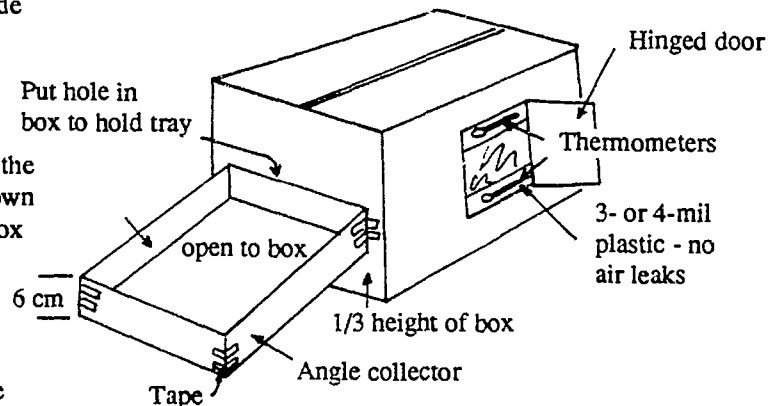
**Part 3: Construct a Flat-plate Collector.**

1. Cut a piece of galvanized sheet metal to a size that will fit snugly into the cardboard tray (from Part 2). Spray paint this sheet with flat black paint.
2. Put a few strips of cardboard on the bottom of the tray to hold insulation 2 cm from the bottom. On top of these strips place a piece of 2-cm-thick insulation the same size as the sheet metal.
3. Place the sheet metal on top of the insulation. There should be approximately 2 cm of air space between the sheet metal and the top of the cardboard tray.

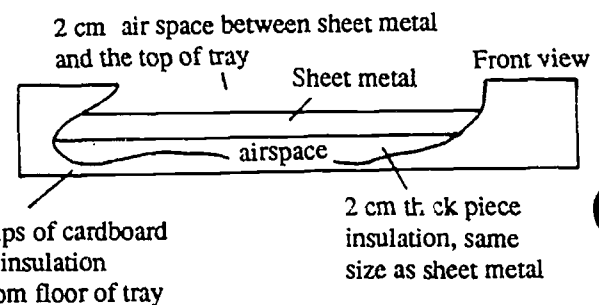

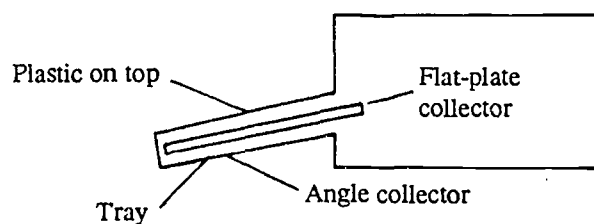
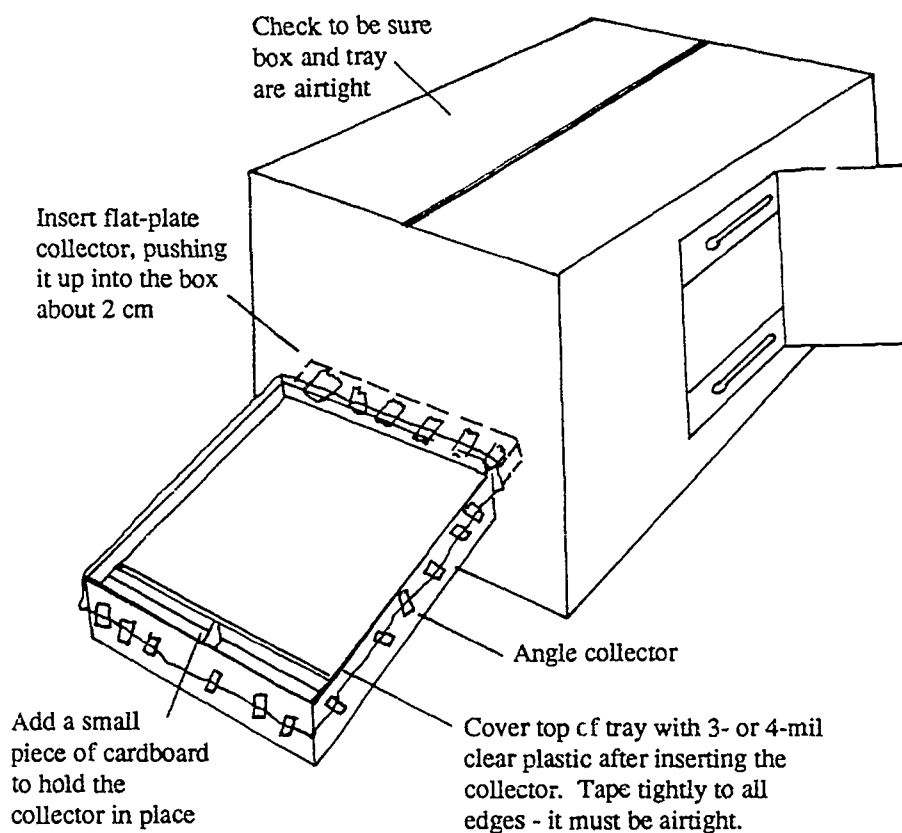
Part 4: Set up the Experimental Box.**Procedure:**

1. Read and record the temperatures of both the thermometers in the control and experimental boxes.
2. Place the boxes in the sun.
3. Record the temperature of each thermometer after 5, 10, and 15 minutes.
4. Compare the results.

Discussion:

1. Describe how the air moves inside the control box. Describe how the air moves inside the experimental box.

STUDENT WORKSHEET #7

How Much Better is a Solar Greenhouse Than a Standard Greenhouse at Keeping a Steady Temperature in the Winter?

Materials:

1. corrugated cardboard (figure amount needed based on drawings)
2. clear plastic, 3- or 4-mil, 50 cm x 450 cm (local hardware or garden store)
3. flat black spray paint
4. white spray paint
5. 2 thermometers
6. plastic wrap (grocery store)
7. tape
8. string or thread
9. tin cans
10. rubber bands
11. insulation material (styrofoam, cardboard, newspaper, etc.)

Setup:

Build a solar greenhouse and a standard greenhouse according to the instructions and dimensions in the figures. Be sure to cut two pieces of each side panel.

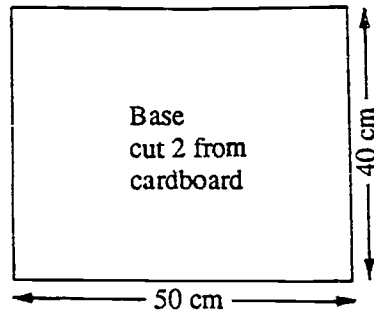
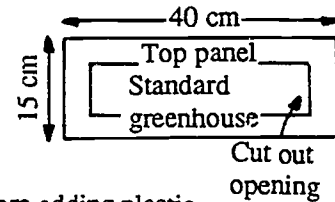
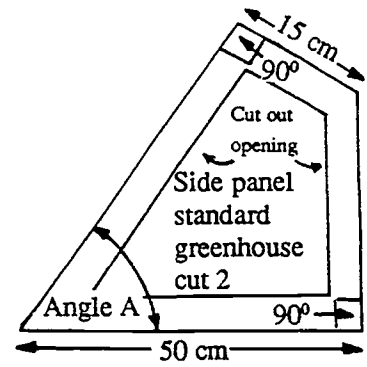
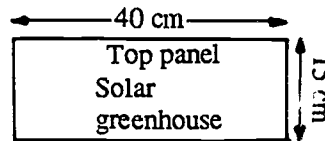
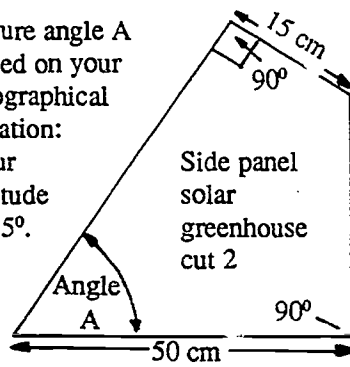
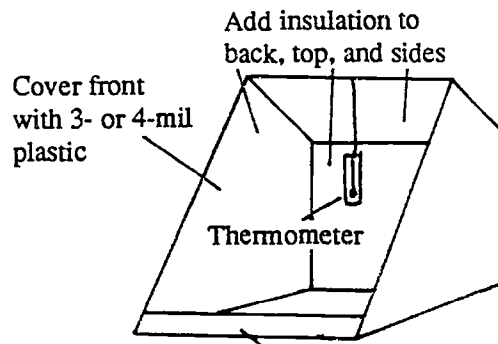

Figure angle A based on your geographical location: your latitude + 15°.



Spray the outside of the greenhouse white before adding plastic.



Add 5 cm cardboard panel for stability.

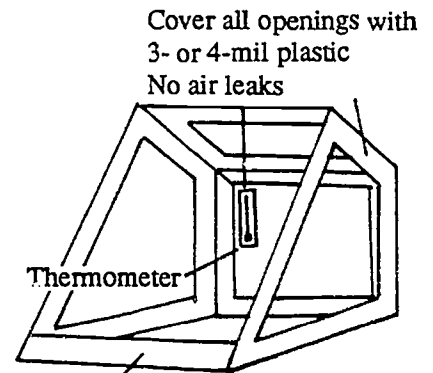

504

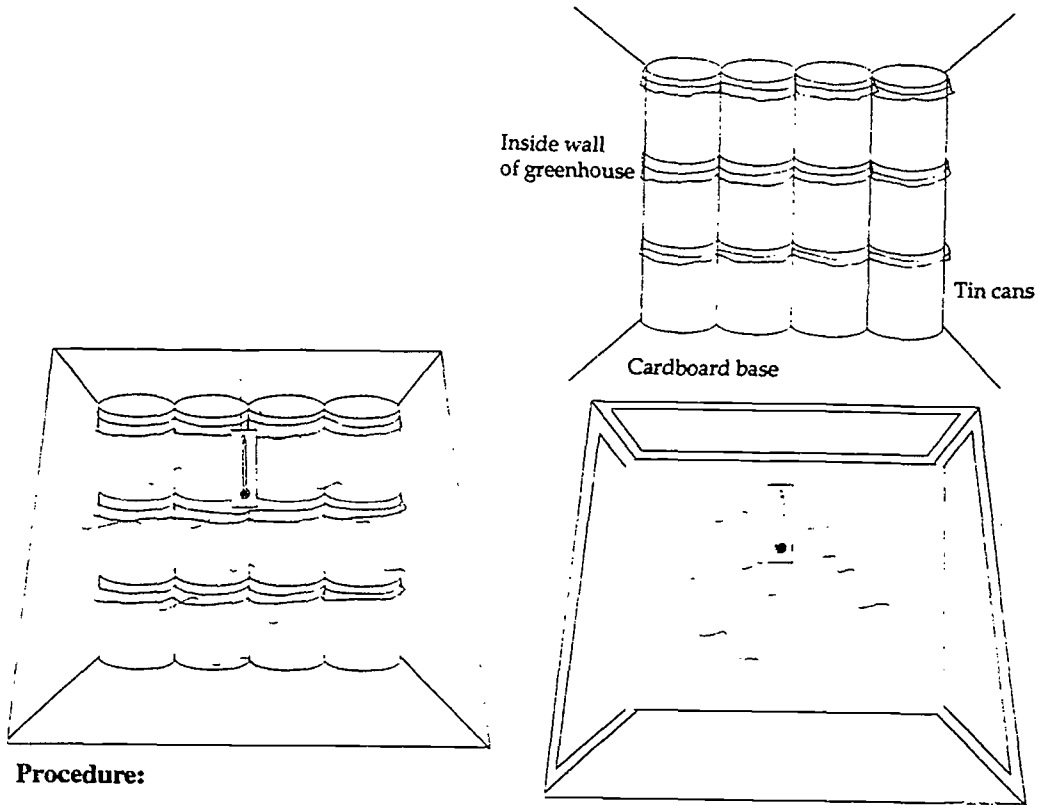

Procedure:

1. Spray the tin cans with flat black paint. Fill them with water and cover tightly with plastic wrap and rubber bands. Stack them in the back of the solar greenhouse.
2. Face both greenhouses directly into the sun.
3. Measure the temperatures in each one as the day progresses. Record these measurements in the graph.
4. After the temperatures have leveled off at a high measurement, place both greenhouses in the shade. Continue to measure and record temperatures as cooling proceeds.

Degrees C

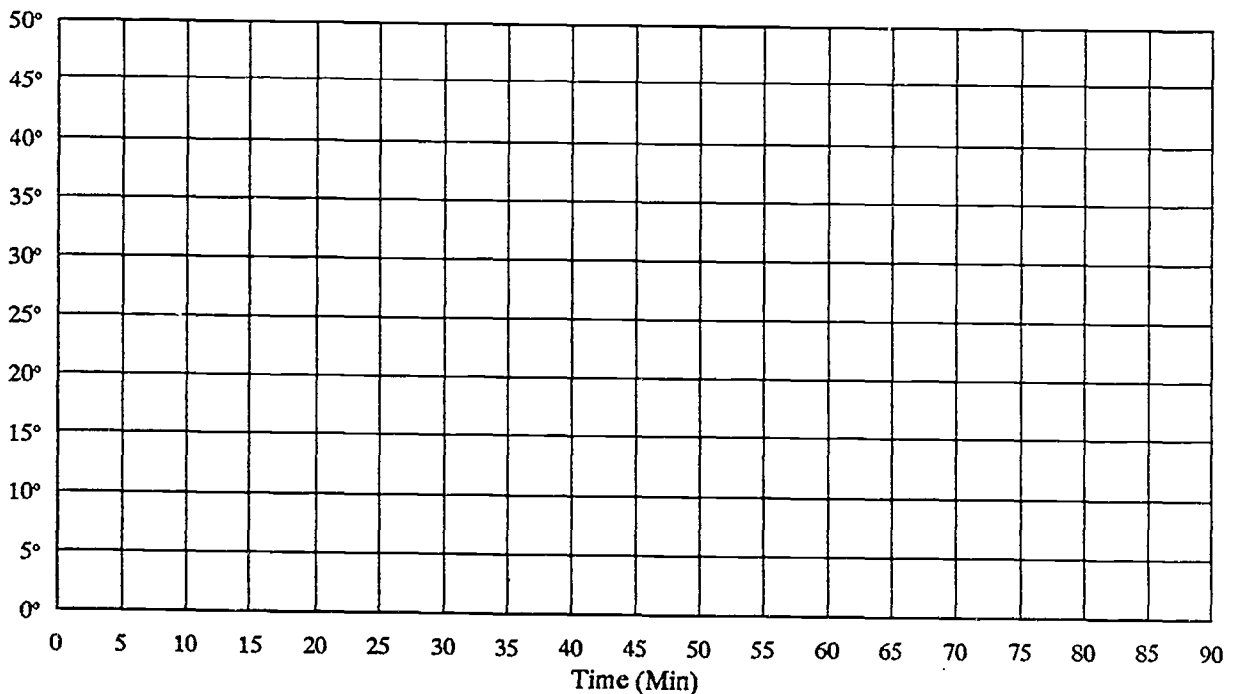

STUDENT WORKSHEET #8

Which Substance Will Retain the Most Heat: Water, Gravel, or Hypo (Sodium Thiosulfate)?

Materials:

1. hot plate
2. pan (same size as hot plate)
3. 3 large test tubes
4. 3 thermometers
5. 3 styrofoam cups
6. equal volumes of gravel, water, and hypo (hydrated sodium thiosulfate, available at local drugstore or photo supply shop; Glauber's salt may be substituted for plain Hypo)

Procedure:

1. Put gravel, water, and hypo into three separate test tubes to a depth of 5 cm.
2. Heat the test tubes in a boiling bath for 5 minutes.
3. Fill three styrofoam cups with equal measured amounts of cold water. Place a thermometer in each cup. Measure and record the water temperatures.
4. Add one of the heated test tubes to each cup. After 15 minutes measure and record the water temperatures again.

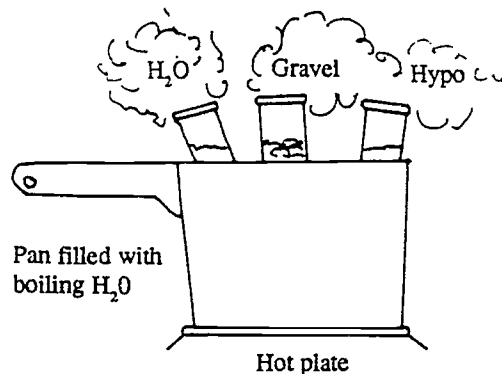

Discussion:

Calculate the number of heat calories gained by the water in each of the three cups using the following formula:

$$C = \text{weight of water} \times \text{temperature difference}$$

The temperature difference is determined by subtracting the temperature of the water at the beginning of the experiment from the temperature of the water at the end of the experiment.

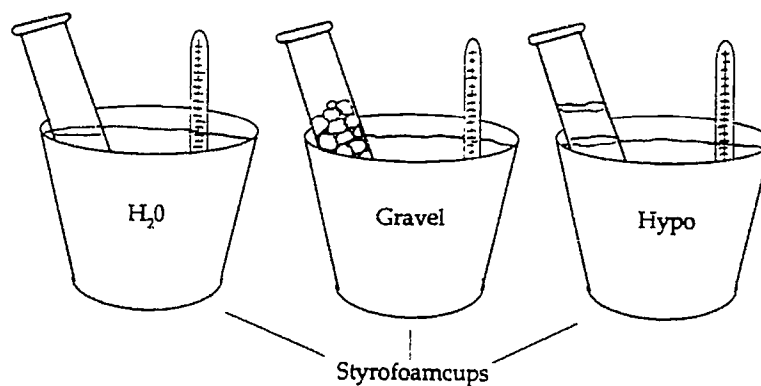

Questions:

1. Which substance gives up the most heat?
2. What are the advantages and disadvantages of using each of the three materials for heat storage?
3. How could the use of each heat storage material be applied to businesses and homes?
4. Are there any materials that can be substituted for hypo in this experiment?

506

STUDENT WORKSHEET #9**Let's Power Spaceship Earth with the Sun**

The sun, 93 million miles away from earth, sends more radiant energy toward us every second than people have used in the course of human history. Thirty percent of this energy is reflected back into space by our atmosphere. Much of the remaining radiant energy of the sun heats the land and the water; it evaporates water and melts the snows. It is the source of energy that creates the winds and great ocean currents, and it warms the atmosphere that surrounds us.

Energy from the sun interacts with oxygen at the top of the earth's atmosphere to create a layer of ozone that protects us from lethal amounts of the sun's radiation. Solar energy reacts with plants in the chemical process of photosynthesis to provide the stored energy that fuels life. Coal, oil, and natural gas, once swamp jungles of the ancient earth, are stored solar energy. All of these are ways in which we benefit from the sun's energy directly.

We also benefit indirectly from the sun's energy when that energy comes to us "secondhand." The electricity generated by a windmill, for example, is the sun's energy once removed. So, too, is the energy our bodies get from the food we eat.

Less than one percent of the incoming solar energy is used to sustain plant and animal life, yet since this amount is many times greater than the total electric generating capacity of the entire world, the sun could be an important answer to our energy dilemma. All we have to do is find the key that unlocks this energy bank.

Humans from the dawn of history have put the energy from the sun to work in keeping warm or growing food or harnessing the wind. In what ways did prehistoric and ancient peoples use the sun to do work for them?

What has the energy from the sun made possible in your life today?

Put a D beside each of the following things that result from energy received directly from the sun. Put an I beside each thing that results indirectly from the sun's energy.

- | | |
|--|--|
| <input type="checkbox"/> coal deposits | <input type="checkbox"/> sugar cane |
| <input type="checkbox"/> sailboats | <input type="checkbox"/> candy bar |
| <input type="checkbox"/> salt flats | <input type="checkbox"/> electric heater |
| <input type="checkbox"/> gasoline | <input type="checkbox"/> leaves turning green |
| <input type="checkbox"/> photosynthesis | <input type="checkbox"/> ocean currents |
| <input type="checkbox"/> mountain stream | <input type="checkbox"/> steam engine |
| <input type="checkbox"/> Hoover Dam | <input type="checkbox"/> ozone layer of the atmosphere |

Think About It:

1. Why is the sun called the source of all energy except nuclear energy?
2. Imagine life on earth in the future if we learn to harness the power of the sun to provide heat, light, and electricity. What problems would be solved? What problems might be created?

STUDENT WORKSHEET #10**What Happened?**

You have just come home from school. You turn on the radio, but nothing happens. You check the cord. No problem there, it's plugged in. Then you notice the clock has stopped. You check around the house and discover there is no electricity. A blackout. It has affected the whole neighborhood, the whole city. There is no indication of when the power will be restored. It may be off for days.

(Write a story describing what happened to cause it and how people reacted. What was life like?)

593

STUDENT WORKSHEET #11**Future Lifestyles**

Choose one of the following situations and write about it. Be creative and use your imagination — but also remember to use what you have learned about energy.

Situation #1

Imagine you are writing in your diary. “It is the first day of the year 2000, and it seems ages ago that I was in school. So much has happened since then.” (Go on to explain.)

Situation #2

Imagine you are age 47 in the year 2000 and are writing to your son. “You have criticized me and my generation for the mess we have made of the world.” (What else would you say?)

STUDENT WORKSHEET #12

Nuclear Energy and Fossil Fuel Energy: A Comparison

One of the energy resources being considered to supplement our limited oil and natural gas supplies is nuclear power, created by the splitting apart of atoms of uranium. This power can be captured and used to create steam which produces electricity much as the power of burning coal is used in an electric generating plant.

The diagrams below show two kinds of electric power plants. They are much alike except that one is powered by nuclear energy produced in a nuclear reactor. Can you label the parts of the two plants? All the words you need appear at the bottom of the page. An encyclopedia or other reference book may help you.

Fossil Fuel Electric Generating Plant

Nuclear Powered Electric Generating Plant

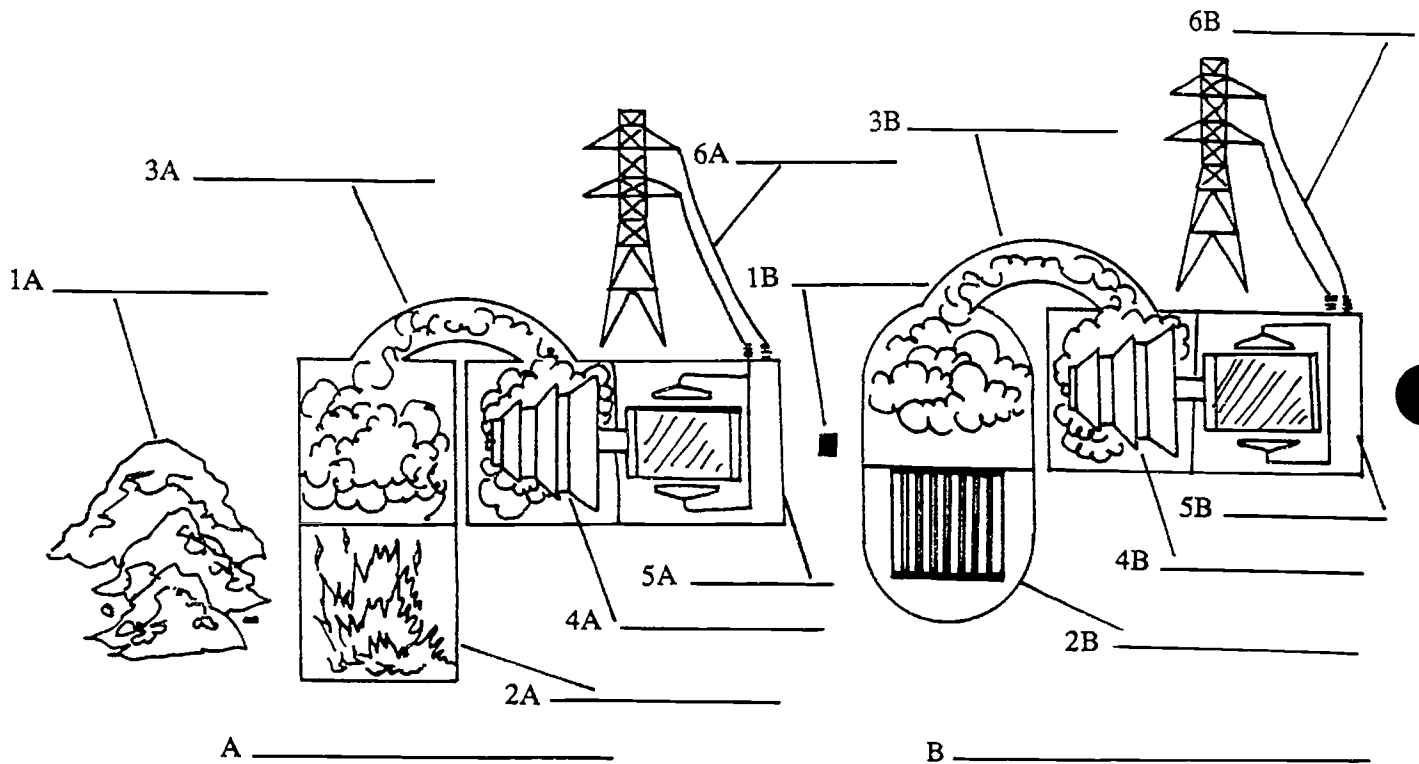

- | | |
|----------------------------|-----------------------|
| Generator | Fuel (1 lb) |
| Boiler | Steam |
| Steam | Reactor |
| Transmission lines turbine | Generator |
| Turbine | Fuel (2.5 million lb) |
| Transmission lines | |

STUDENT WORKSHEET #13

Nuclear Energy: Its Benefits and Problems

The following is a list of benefits and problems associated with nuclear power plants. A key word or phrase in each item is boldfaced. Read the list and put a B in the blank if it is a benefit, a P if it is a problem.

- | | |
|---|--|
| ___ Less need for mining and transport of fuel | ___ Overall cost of electricity will be less than with fossil fuels |
| ___ No pollutants from burning fuel | ___ Higher cost to build |
| ___ Less reliance on imported fuel | ___ Large amounts of plutonium could lead to spread of nuclear weapons |
| ___ Could be targets for terrorists | ___ Possibility of radiation escaping |
| ___ Reactors produce less waste than fossil fuel plants do | ___ Radioactive waste must be handled and disposed of safely for thousands of years |

Now that you have identified the problem areas, look at the arguments below. Each one concerns a problem area and offers arguments for (PRO) and against (CON) expansion of nuclear energy. Complete the arguments by inserting one of the key words or phrases from the section above into the blanks for each problem area.

PRO: The _____ is made into a type of glass or ceramic, put into special containers, and stored in places like salt beds which have been undisturbed for millions of years.

CON: It takes thousands of years for the _____ to lose its radioactive properties. We cannot assure safe disposal for thousands of years and future societies may be hurt.

PRO: In more than 20 years of commercial nuclear power plant operation, no one has suffered any ill effects brought on by _____.

CON: There's always a chance that an accident or mechanical malfunction could present the danger of _____.

PRO: Regulations and safeguards can be strictly enforced to keep the _____ out of the hands of terrorists. This radioactive waste is usually sealed in an unbreakable capsule right after the fuel processing.

CON: Just ten pounds of radioactive _____ is enough to make an atom bomb.

STUDENT WORKSHEET #14

Jumbles

Unscramble the letters below into a word. The letters circled will give the answer to the statement below when unscrambled.

ROALS _ _ _ _ (O) _
 BITGNU _ (I) _ (T) _ _ _ (N) _
 PICSLEE _ _ _ _ _ (S) _ _
 MECTRUPS _ _ _ _ _ _ _ (R) _
 GENREY _ (E) _ _ _ _ _ _

BATHERS' BOTHER _ _ _ _ _ _ _ _

PUSTOSN _ _ (U) _ _ _ (S) _ _
 DUCOL _ _ _ (C) (O) _ _ _
 LMINDIWL (L) _ _ (M) (I) _ _ _ _ _
 GHTIL (G) _ _ _ _ (H) _ _ _
 LOCERCTOL _ _ _ _ (C) _ _ _ _ (L) _

ASTHMATICS' AGGRAVATION _ _ _ _ _ _ _ _

STUDENT WORKSHEET #14 — Key

Jumbles

Unscramble the letters below into a word. The letters circled will give the answer to the statement below when unscrambled.

ROALS

S O L A R

BITGNU

T U B I N G

PICSLEE

E C L I P S E

MECTRUPS

S P E C T R U M

GENREY

E N E R G Y

BATHERS' BOTHER

S U N B U R N

PUSTOSN

S U N S P O T

DUCOL

C L O U D

LMINDIWL

W I N D M I L L

GHTIL

L I G H T

LOCERCTOL

C O L L E C T O R

ASTHMATICS' AGGRAVATION

P O L L U T I O N

STUDENT WORKSHEET #15

Solar Energy Quiz

Match Column A with the scrambled words in Column B

Column A

1. Pyranometer
2. Albedo
3. Langley
4. Collector Box
5. Incident Angle
6. Temperature
7. Pyrheliometer
8. Collector Efficiency
9. Thermometer
10. Absorption

Column B

- mpeeeurtra
 tsrobainop
 dcabol
 lerocto cl oxb
 emrhtoemetr
 gylalne
 idintcne nagel
 ellooctrc fiencifeyc
 retnyrapome
 prhentoilermey

502

STUDENT WORKSHEET #15 — Key

Solar Energy Quiz

Match Column A with the scrambled words in Column B

Column A

Column B

- | | | |
|-------------------------|-------|----------------------|
| 1. Pyranometer | ----- | mpeeeurtra |
| 2. Albedo | ----- | tsrobainop |
| 3. Langley | ----- | deabol |
| 4. Collector Box | ----- | leroctocl oxb |
| 5. Incident Angle | ----- | emrhtoemetr |
| 6. Temperature | ----- | gylaine |
| 7. Pyrneliometer | ----- | idintcne nagel |
| 8. Collector Efficiency | ----- | ellooctrc fiencifeyc |
| 9. Thermometer | ----- | retnyrapome |
| 10. Absorption | ----- | prhentoilermey |

STUDENT WORKSHEET #16

A Solar Perspective

Select the words that best fit the definition and read the vertical message.

When the moon comes between the earth and the sun

— — = — — — — —

Shiny articles _____ the sun's rays

— — = — — — — —

The middle layer of the atmosphere

— — — — = — — — — — — — —

Radiators heat rooms by _____

— — — — = — — — — —

Solar cells are also called _____ cells

— — = — — — — — — — — — — — —

Light can be broken down and observed as a _____

— — = — — — — — — — —

Light we can see is called _____

— — = — — — — — — — —

TV interference is often caused by _____

— — = — — — — — — — — — —

Florists have used this solar collector for years

— — — — = — — — — — — — —

Green plants use the sun for _____

— — — — = — — — — — — — — — — — —

An instrument used to measure temperature

— — = — — — — — — — — — — — —

Found in Holland, they use a form of the sun's energy

— — = — — — — — — — — — —

The ability to do work

— — = — — — — — — — —

Used as piping in solar collectors

— — — — = — — — — —

The sun's rays come to earth as _____

— — — — = — — — — — — — —

Light waves sometimes used in cooking

— — = — — — — — — — — — — — —

STUDENT WORKSHEET #16 — Key

A Solar Perspective

Select the words that best fit the definition and read the vertical message.

When the moon comes
between the earth and the
sun

E C L I P S E

Shiny articles _____
the sun's rays

R E F L E C T

The middle layer of the
atmosphere

S T R A T O S P H E R E

Radiators heat rooms by

C O N V E C T I O N

Solar cells are also called
_____ cells

P H O T O V O L T A I C

Light can be broken down and
observed as a

S P E C T R U M

Light we can see is called

V I S I B L E

TV interference is often
caused by

S U N S P O T S

Florists have used this solar
collector for years

G R E E N H O U S E

Green plants use the sun for

P H O T O S Y N T H E S I S

An instrument used to
measure temperature

T H E R M O M E T E R

Found in Holland, they use a
form of the sun's energy

W I N D M I L L

The ability to do work

E N E R G Y

Used as piping in solar
collectors

C O P P E R

The sun's rays come to earth
as

R A D I A T I O N

Light waves sometimes used
in cooking

I N F R A R E D

CLUSTER: HORTICULTURE

UNIT: Horticultural Mechanics

PROBLEM AREA: Repairing and Maintaining Small Engines

RELATED PROBLEM AREAS:

1. Manufacturing, Distributing, Selling, and Servicing Agricultural Equipment (Agricultural Business and Management Cluster)
2. Repairing, Maintaining, and Operating Horticultural Equipment
3. Understanding and Maintaining Small Engines (Agricultural Business and Management Cluster)

PREREQUISITE PROBLEM AREA(S):

1. Identifying Basic Principles of Agricultural Mechanics (Central Core Cluster)

LEVEL: Preparatory

OCCUPATIONAL TASKS ADDRESSED:

Horticulture Cluster

Duty L: Servicing and Maintaining Equipment

1. Service small four-cycle and two-cycle engines
2. Maintain hand tools
3. Clean work and delivery areas
4. Lubricate and adjust power equipment
5. Troubleshoot equipment failure
6. Calibrate equipment
7. Maintain equipment parts
8. Order equipment parts
9. Perform routine maintenance and repairs
10. Prepare equipment for off-season storage

Note to Instructor: The additional contents of this problem area are identical to the contents found in the Agricultural Business and Management Cluster, Agricultural Engineering/Mechanization Unit, Understanding and Maintaining Small Engines Problem Area. Please refer to the referenced problem area.

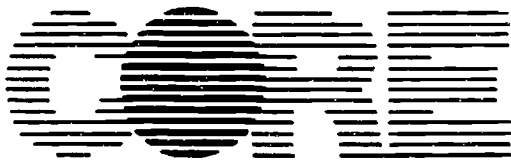

Illinois Agricultural Core Curriculum

Agricultural Education 124 Mumford Hall 1301 W. Gregory Drive University of Illinois Urbana, IL 61801

Director: Dale A. Law, Ed.D.

Principal Investigator: Jerry D. Pepple, Ed.D

Research Assistant: Robert E. Petrea

89/90

Horticulture

Horticultural Business Operation and Management

500

Illinois Agricultural Core Curriculum Rev.

CLUSTER: HORTICULTURE

UNIT: Horticultural Mechanics

PROBLEM AREA: Repairing, Maintaining, and Operating Horticultural Equipment

RELATED PROBLEM AREAS:

1. Manufacturing, Distributing, Selling, and Servicing Agricultural Equipment (Agricultural Business and Management Cluster)
2. Keeping and Using Records in Agriculture (Central Core Cluster)
3. Repairing and Maintaining Agricultural Equipment (Agricultural Business and Management Cluster)
4. Marketing Horticultural Products and Services

PREREQUISITE PROBLEM AREA(S):

1. Applying Mathematics Skills in Agriculture (Central Core Cluster)
2. Developing Communications Skills in Agriculture (Central Core Cluster)
3. Utilizing Energy Alternatives

LEVEL: Preparatory

OCCUPATIONAL TASKS ADDRESSED:

Horticulture Cluster

Duty N: Performing Sales Duties

1. Determine customer needs
2. Provide customers with technical assistance
3. Compute sales tax
4. Complete sales slip
5. Inform customer of warranty or guarantee specifications

Duty O: Performing Sales-Related Duties

1. Process customer complaint
2. Order supplies and stock

Note to Instructor: The additional contents of this problem area are identical to the contents found in the Agricultural Business and Management Cluster, Agricultural Engineering/Mechanization Unit, Repairing and Maintaining Agricultural Equipment Problem Area. Please refer to the referenced problem area.



Illinois Agricultural Core Curriculum

Agricultural Education 124 Mumford Hall 1301 W. Gregory Drive University of Illinois Urbana, IL 61801

Director: Dale A. Law, Ed.D.

Principal Investigator: Jerry D. Pepple, Ed.D

Research Assistant: Douglas L. Stockley

601

89/90

Horticulture

Horticultural Business Operation and Management



Illinois Agricultural Core Curriculum Rev.

UNIT D: Landscaping

PROBLEM AREAS:

1. Designing and Drawing Landscape Plans
2. Establishing and Maintaining Turf Areas
3. Transplanting and Maintaining Landscape Plants
4. Surveying, Grading, and Tiling
5. Interior Landscaping

CLUSTER: HORTICULTURE

UNIT: Landscaping

PROBLEM AREA: Designing and Drawing Landscape Plans

RELATED PROBLEM AREAS:

1. Marketing Horticultural Products and Services
2. Operating the Horticultural Business
3. Understanding Plant Germination, Growth, and Development
4. Classifying Horticulture Plants
5. Understanding Plant Anatomy and Physiology
6. Growing Ornamental Plants
7. Designing, Building, and Maintaining Horticultural Structures
8. Establishing and Maintaining Turf Areas
9. Transplanting and Maintaining Landscape Plants
10. Surveying, Grading, and Tiling

PREREQUISITE PROBLEM AREA(S):

1. Marketing Horticultural Products and Services
2. Operating the Horticultural Business
3. Understanding Plant Germination, Growth, and Development
4. Classifying Horticulture Plants
5. Understanding Plant Anatomy and Physiology
6. Growing Ornamental Plants
7. Designing, Building, and Maintaining Horticultural Structures
8. Establishing and Maintaining Turf Areas
9. Transplanting and Maintaining Landscape Plants
10. Surveying, Grading, and Tiling

LEVEL: Preparatory

600

OCCUPATIONAL TASKS ADDRESSED:

Horticulture Cluster

Duty J: Designing and Installing Landscapes

1. Select plants
2. Design corner planting/paper and pencil
3. Design corner planting/landscape software
4. Design line planting/paper and pencil
5. Design line planting/landscape software
6. Design foundation planting/paper and pencil
7. Design foundation planting/landscape software
8. Design landscape plan/paper and pencil
9. Design landscape plan/landscape software
10. Construct landscape model
11. Price landscape plan
12. Read landscape plan

Duty N: Performing Sales Duties

1. Conduct sale

STATE GOALS FOR LEARNING:

In planning the instruction for this problem area, teachers can promote the development of several student learning objectives which are related to the State Goals for Learning in Fine Arts. These objectives are listed on the Learning Assessment Plan forms included on the following page(s). Those learning objectives marked with an asterisk (*) are taken from the sample lists provided by the Illinois State Board of Education.

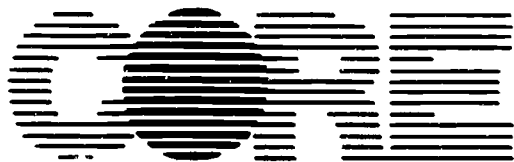

Illinois Agricultural Core Curriculum

Agricultural Education 124 Mumford Hall 1301 W. Gregory Drive University of Illinois Urbana, IL 61801

Director: Dale A. Law, Ed.D.

Principal Investigator: Jerry D. Pepple, Ed.D.

Research Assistant: Ronald J. Biondo

88/89

INSTRUCTOR'S GUIDE

CLUSTER: HORTICULTURE

UNIT: Landscaping

PROBLEM AREA: Designing and Drawing Landscape Plans

STUDENT LEARNING OBJECTIVES

Upon completion of their study of this problem area, students will be able to:

1. Recognize the value of a landscape plan.
2. Define basic landscape design principles.
3. Explain the proper use of drafting equipment.
4. Complete a landscape plan using approved practices.
5. Read a landscape plan.
6. Price the installation of a landscape project based on a landscape plan.

INSTRUCTOR'S NOTES AND REFERENCES

INSTRUCTOR'S GUIDE**CLUSTER: HORTICULTURE****UNIT: Landscaping****PROBLEM AREA: Designing and Drawing Landscape Plans****PROBLEMS AND QUESTIONS FOR STUDY****INSTRUCTOR'S NOTES AND REFERENCES**

1. Why is landscape planning important?
2. How do the following principles of art apply to landscape design?
 - a. Repetition
 - b. Variety
 - c. Balance
 - d. Emphasis
 - e. Sequence
 - f. Scale
3. Why are form, texture, and color important considerations in selecting plants for the landscape?
4. What equipment is commonly used for drafting?
5. How should common drafting equipment be used?
6. What are the steps taken to complete a landscape plan?
7. What are the major areas of a landscape?
8. Define and describe the uses of a plat of survey, a site analysis, and a family inventory checklist.
9. What influence do thorns, messiness, flowers, fruits, roots, hardiness, and strength of wood have on plant selection?
10. What is the center of interest and balance point of all homes?
11. How can trees be used effectively in the home landscape?
12. Why is it helpful to have different symbols for various plant materials?
13. How much does landscape installation cost?
14. How much does a quality landscape contribute to the value of a home?

610

INSTRUCTOR'S GUIDE**CLUSTER: HORTICULTURE****UNIT: Landscaping****PROBLEM AREA:** Designing and Drawing Landscape Plans**SUGGESTED TEACHING ACTIVITIES AND PROCEDURES**

1. Have a local landscape architect or landscape designer appear as a guest speaker.
2. Have the students read Information Sheets #2 - #4. Then have the students complete Student Worksheet #1.
3. Lead a discussion on Student Worksheet #1.
4. Use the Transparency Set to explain the steps students will take in completing their own landscape plan.
5. Provide students with a base plan of a home in the community. Visit the home and have the students conduct a site survey.
6. Conduct a field trip to a landscaping firm.
7. Discuss Information Sheet #1 and demonstrate how to use the various equipment.
8. Show VAS Slidefilm *Introduction to Landscape Design*.
9. Have students complete Student Worksheet #4.
10. Have the students read Information Sheets #5 - #7.
11. Have the students complete Student Worksheet #2.
12. Lead a class discussion on the information contained in each of the Information Sheets. Use the Transparency Masters with discussion guides to help explain principles of design.
13. Show VAS Slidefilm *Creating a Design*.
14. Have the students read Information Sheets #8 and #9.
15. Have the student complete Student Worksheet #3.
16. Discuss Student Worksheet #3 with the class.
17. Show VAS Slidefilm *Putting Plants into the Design*.
18. Explain how a scale is used and have the students complete Student Worksheets #5 and #6.
19. To test their drafting skills, have the students place the base plan of a home on tracing paper using appropriate drafting equipment.
20. Using a family inventory checklist, a site analysis, and the floor plan of the home, students may draw three or four different goose-egg plans.
21. Help the students select one goose-egg plan and have the students create three or more possible bed patterns.
22. Discuss with the class how to design an energy-efficient landscape and how to use the sun calculator (Transparency Master #24).
23. Demonstrate how to draw various landscape symbols and have the students complete Student Worksheet #7 (Transparency Master #21).
24. Have the student locate trees to frame, shade, and serve as backdrops to the home.
25. Show the students how they can group shrubs within the planting beds.
26. Have students select plants which meet the landscape needs.
27. Demonstrate proper labeling techniques and have the students complete Student Worksheet # 8 (Transparency Master #25).
28. Visit a landscape contractor that uses a computerized designing system.
29. Have students complete Student Worksheet #9.
30. Assign Student Worksheet #10 for the students to price their own design.

INSTRUCTOR'S GUIDE

CLUSTER: HORTICULTURE

UNIT: Landscaping

PROBLEM AREA: Designing and Drawing Landscape Plans

REFERENCES

1. *Introduction to Landscape Design* (VAS Filmstrip #F621-1 or Slide Set #S621-1); *Creating a Design* (VAS Filmstrip #F621-2 or Slide Set #S621-2); *Putting Plants into the Design* (VAS Filmstrip #F621-3 or Slide Set #S621-3); *Landscaping Planting Plan* (VAS Filmstrip Set #MF625-1.1 or Slide Set Series #MS625-1.1); *Landscaping — Dos and Don'ts* (VAS Filmstrip #F642 or Slide Set #S642); *Landscape Design* (VAS Filmstrip Set #MF620-1 or Slide Set Series #MS620-1). Vocational Agriculture Service, College of Agriculture, University of Illinois, 1401 S. Maryland Drive, Urbana, IL 61801. (217) 333-3871.
- *2. *Manual of Woody Landscape Plants*. Dirr, M.A. Stipes Publishing Company, 10-12 Chester Street, Champaign, IL 61820.
3. *Photographic Manual of Woody Landscape Plants*. Dirr, M.A. Stipes Publishing Co., 10-12 Chester Street, Champaign, IL 61820.
4. *Dwarf Shrubs for the Midwest*. Keith, Rebecca McIntosh, Giles, Floyd A. University of Illinois Press, 54a E. Gregory, Champaign, IL 61820.
5. *Landscape Construction Procedures, Techniques, and Design*. Giles, Floyd. Stipes Publishing Co., 10-12 Chester Street, Champaign, IL 61820.
6. *Planting Design: A Manual of Theory and Practice*. Nelson, W.R. Stipes Publishing Company, 10-12 Chester Street, Champaign, IL 61820.
7. *Landscape Design*. Hannebaum, Leroy. Reston Publishing Company, Inc., Division of Prentice-Hall, 200 Old Tappan Road, Old Tappan, NJ 07675. (800) 223-2348.
8. "Evergreen Selection for Landscape Use"; "Shrub Selection for Landscape Use"; "Tree Selection for Landscape Use." (IBM PC-compatible software). Illinet Software, University of Illinois, 123 Mumford Hall, 1301 W. Gregory Drive, Urbana, IL 61801.
- *9. *Landscaping Your Home* (Circular C1111); *Designing an Energy Efficient Home Landscape* (Circular C1178). Nelson, W.R. University of Illinois, Cooperative Extension Service, College of Agriculture, 123 Mumford Hall, 1301 W. Gregory Drive, Urbana, IL 61801.
10. Versacad Design System (Computer Graphics), 7372 Prince Drive, Huntington Beach, CA 92647.
11. *Mathematics for Horticulture*. (1982). Peltier, R.A. Ohio Agricultural Education Curriculum Materials Service, The Ohio State University, Room 254, 2120 Fyffe Road, Columbus, OH 43210.

*Indicates highly recommended reference

INSTRUCTOR'S NOTES AND REFERENCES

612

INSTRUCTIONAL RESOURCES

These resources are intended for use by teachers in planning and teaching the materials for this problem area and may be adapted to fit the teaching method(s) used.

- INFORMATION SHEET #1 — Equipment Used in Technical Drawing
- INFORMATION SHEET #2 — Establishing Landscape Needs
- INFORMATION SHEET #3 — Starting a Plan
- INFORMATION SHEET #4 — Analyzing the Site
- INFORMATION SHEET #5 — Selecting Plants to Fit Your Design
- INFORMATION SHEET #6 — Fitting Trees to Your Plan
- INFORMATION SHEET #7 — Fitting Shrubs to Your Plan
- INFORMATION SHEET #8 — Designing the Public Area
- INFORMATION SHEET #9 — Designing the Living Area
- INFORMATION SHEET #10 — Suggested Landscape Planting Plan Values
- TRANSPARENCY MASTER #1 — Plant Forms (with discussion guide)
- TRANSPARENCY MASTER #2 — Texture (with discussion guide)
- TRANSPARENCY MASTER #3 — Texture (with discussion guide)
- TRANSPARENCY MASTER #4 — Color (with discussion guide)
- TRANSPARENCY MASTER #5 — Repetition (with discussion guide)
- TRANSPARENCY MASTER #6 — Variety (with discussion guide)
- TRANSPARENCY MASTER #7 — Balance (with discussion guide)
- TRANSPARENCY MASTER #8 — Emphasis (with discussion guide)
- TRANSPARENCY MASTER #9 — Sequence (with discussion guide)
- TRANSPARENCY MASTER #10 — Scale and Proportion (with discussion guide)
- TRANSPARENCY MASTER #11 — The Base Plan (with discussion guide)
- TRANSPARENCY MASTER #12 — Elevation View and Floor Plan (with discussion guide)
- TRANSPARENCY MASTER #13 — The Site Analysis (with discussion guide)
- TRANSPARENCY MASTER #14 — Family Inventory Checklist (with discussion guide)
- TRANSPARENCY MASTER #15 — Goose-Egg Planning (with discussion guide)
- TRANSPARENCY MASTER #16 — Bed Patterns: 90° Angles (with discussion guide)

- TRANSPARENCY MASTER #17 — Bed Patterns: 45° Angles (with discussion guide)
- TRANSPARENCY MASTER #18 — Bed Patterns: Arc and Tangent (with discussion guide)
- TRANSPARENCY MASTER #19 — Landscape Symbols (with discussion guide)
- TRANSPARENCY MASTER #20 — Designing a Shrub Border (with discussion guide)
- TRANSPARENCY MASTER #21 — Designing a Shrub Border (with discussion guide)
- TRANSPARENCY MASTER #22 — Sun Calculator (with discussion guide)
- TRANSPARENCY MASTER #23 — Lettering (with discussion guide)
- TRANSPARENCY MASTER #24 — Planting Plan (with discussion guide)
- TRANSPARENCY MASTER #25 — Plant List (with discussion guide)

619

INFORMATION SHEET #1

Equipment Used in Technical Drawing

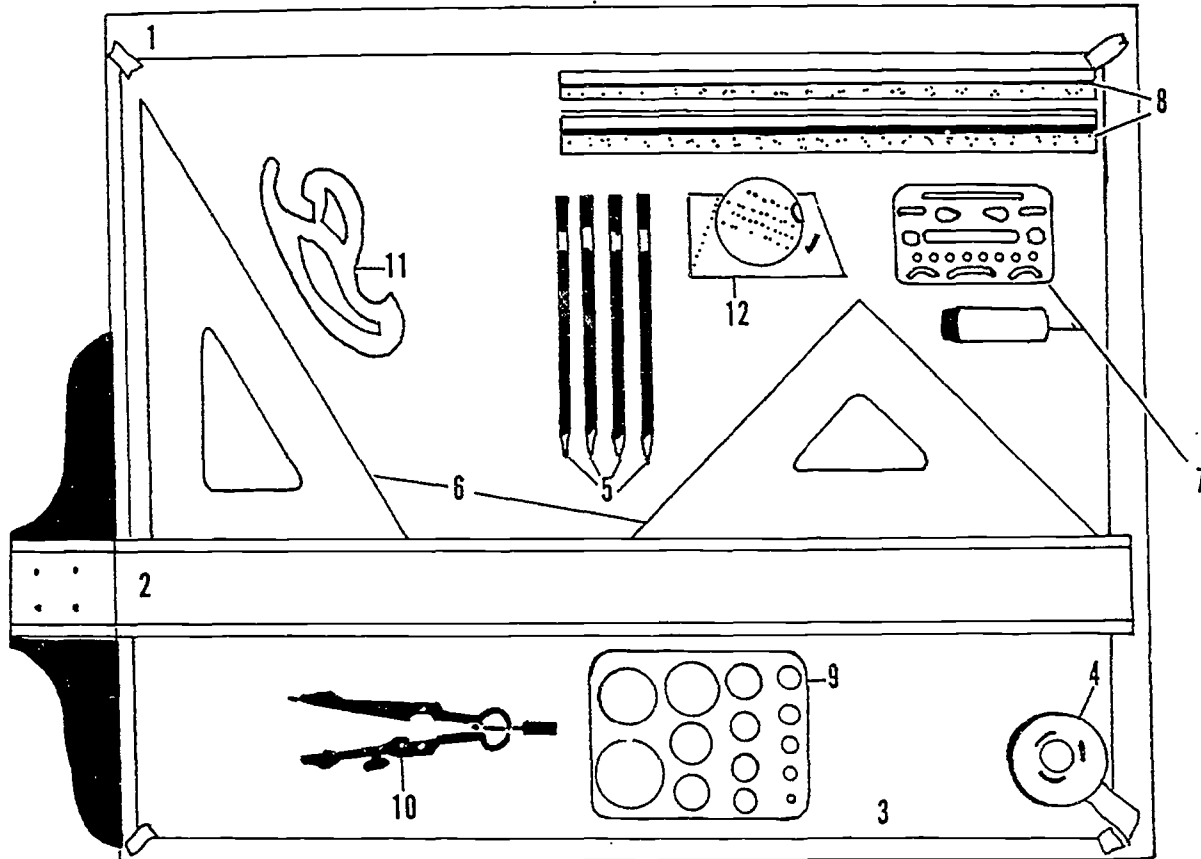

1. Drawing Board: At least one side must be true and the surface must be smooth (minimum size 20" x 24").
2. T-Square: The working edge of the T-square must be straight and at a right angle to the edge of the drawing board. When drawing hold the T-square firmly to the edge of the board. Use the *top* side of the T-square to draw horizontal lines.
3. Drawing Paper: Cream or white vellum or tracing paper are commonly used. Many sizes are available. Use the T-square to line up the top edge of the drawing paper. Fasten the two free corners of the paper while holding it firmly in place. Then, smooth the paper from the center using fingernails and fasten the remaining corners.
4. Drafting Tape: Drafting tape is commonly used to secure drawing paper because it is less sticky than masking tape. Pieces one to two inches in length are sufficient.
5. Drawing Pencil: Select medium grade (3H, 2H, H, F, HB, B) pencils for drawing. 3H grade pencils have harder lead than a B grade pencil, and thus will provide a lighter line. For classroom purposes HB pencils are suggested. Keep your pencil *sharp*! Always *pull* a pencil across the paper while rolling it between the thumb and forefinger. Also, when drawing hold the pencil at a 60° angle to the paper.
6. Triangles: The triangles commonly used are the 45° triangle and the 30° x 60° triangle. Place the triangles on the top side of the T-square to draw vertical and angled lines. Be sure to hold the T-square snug to the board.

7. Eraser and Erasing Shield: Use both items together to remove unwanted lines. Think about every line before it is drawn to avoid erasures. If necessary erase all mistakes completely.
8. Scale: For landscape design purpose the architect's scale is recommended. However, it is useful to have an engineer's scale on hand. An architect's scale is divided into eighths while the engineer's scale is divided into tenths. Never use the edge of a scale for drawing purposes.
9. Circle Templet: This can be used as a guide for the many circles drawn in a landscape plan.
10. Compass: The compass can be used to make the larger curves not possible with the circle templet.
11. French curves: Irregular curves can be drawn with the French curve instrument.
12. Lettering Instrument: This is used to draw light parallel guidelines for lettering. Place a well sharpened pencil in a hole and slide the lettering instrument along the top edge of the T-square. Move the pencil to the next hole and slide the instrument again.

C13

INFORMATION SHEET #2**Establishing Landscape Needs**

Every home deserves the most attractive setting that can be provided. Unfortunately, many homes are over-landscaped or not landscaped at all. It is common to see homes hidden by a forest of plantings or surrounded by an unrelated collection of trees and shrubs. This demonstrates a lack of planning.

Landscaping is more than planting trees and shrubs. It means creating a plan in order to make the best use of the space available in the most attractive way. This involves shaping the land to make the most of the site's natural advantages. It also means building structures such as fences, walls, and patios and selecting and growing the plants which best fit into the design.

A successful landscape plan involves three considerations:

1. Consider the lot to be like a room. The ground is the floor, the property lines are walls, and the sky and tree canopies are the ceiling.
2. Consider the floor plan of the home in order to form a relationship between the indoors and outdoors.
3. Consider the design of the landscape as viewed by those on the outside.

The final landscape plan should depend on the lot and its orientation to wind and sun; the house plan; the amount of money, time, and effort to be spent on maintenance; family interest; and the neighborhood.

Study the views from the house. Those which are good should be framed, while those that are bad, screened. For example, designs for homes adjacent to golf courses or parks should utilize the extra lawn to give a sense of space to the property.

Sunshine, rain, snow, wind, heat, and cold will influence the landscape design. Protection from summer sun and heat, and winter winds and snow must be considered. Proper slope of land is necessary to carry excess water away from the home.

Soil type affects the choice of plants for the design. It is much easier to select plants which do well in a particular type of soil than to try to change the soil for the benefit of plants. The drainage of the soil and the pH should be noted before selecting plants.

The family needs are probably the most important considerations in designing. An inventory of family needs will help to determine which elements will make the landscape most livable, useful, and attractive. Remember, each family's needs are different.

INFORMATION SHEET #3

Starting a Plan

Planning the design on paper is extremely helpful. The more accurate the plan, the more useful it will be. Begin by carefully measuring the location of all the physical objects on site, such as trees, walks, drives, etc. Record the measurements as they are made; then, transfer the measurements to graph paper. The preferred grid is 1/8 inch. Indicate the location of windows and doors to scale. Also indicate the location of any easements. This will serve as the base plan.

Good landscape designs are planned with three major areas in mind: the public area, the living area, and the service area.

The public area lies between the road and the house. Four elements that make up the public area are (1) walks, drives, and public access areas, (2) tree plantings, (3) shrub plantings, and (4) lawn areas. The most important consideration in the public area is the front door. It should be the focal point for the design.

Walks greatly affect the appearance of the public area. the most desirable placement of a walk is parallel to the front of the house connecting the driveway and the porch.

Large expansive driveways detract from the house; hence, keep the width at a minimum — 10 feet for one car and 18 feet for two cars.

Trees make up a second element of design for the public area. Trees should be placed to frame the house, provide shade, and mask undesirable architectural details. Always use a large tree to frame a two-story house. Select trees that will be branched high enough to allow view of the house. The most effective placement of trees to obtain a framing effect is determined by the view of the home from the street at a 30 to 45 degree angle. Passersby do not view homes at sharp right angles.

Shrub plantings make up the third public area design element. These plantings should complement the architecture of the house and tie the house to the surrounding area.

The other element of design is the lawn. The lawn serves to connect all the other elements and gives a broad expansive setting to the house. A lawn unbroken by walks provides best results.

It should be noted here that island flower beds, gazing balls, fountains, pink flamingos, tractor tires, and other novelties have no place in the public area. These novelties break the cardinal rule that the house is the most important feature of the design by diverting attention from it.

The outdoor living area includes all the property to the rear of the house, except for the service area. It usually includes a patio or deck located near a door.

Many design elements can be selected to meet a family's needs and interests. Some of these elements are:

1. Enclosures (fences, walls, and screen plantings).
2. Plantings (shrubs, hedges, flowers, ground covers, and trees).
3. Surfaced areas (patios, paths, sitting areas).
4. Garden embellishments (sculptures, garden furniture, planters, rocks, lighting).

The enclosures form the sides of the outside room, define space, and give organization to the open expanses of land.

The plants provide a pleasing, refreshing, soul-satisfying setting around the home.

Basic surfacing types are (1) paving for heavy traffic, (2) lawn for medium traffic, (3) woodchips, sand, and gravel for little-used areas, (4) ground covers where no one is to walk, and (5) flower beds and shrub beds.

Garden embellishments are similar to home furnishings and accessories.

The service area is set aside for the locating of garbage cans, clotheslines, compost piles, vegetable gardens, and other items. In most cases, the service area is screened from the outdoor living area.

Before any designing is done, it is necessary to determine the needs and interests of the family. This can be accomplished by interviewing the family or by having them complete a family inventory checklist. The checklist should provide information about the family, its gardening interests, and its entertainment interests. Favorite plants of the family and desired landscape structures should be included.

INFORMATION SHEET #4

Analyzing the Site

A record of on-site observations on a sheet of paper is called the site analysis. Analyzing the site is essential for planning the location of plantings and activities.

The most common site conditions to be considered include topography, drainage, soil, existing vegetation, natural features, climate, structures, walks and drives, and the extensional landscape.

Always try to make the best use of the topography that exists on the site and try to preserve the natural features of the land. Also, think of the property as a unit of land and not as an "island" unrelated to the surrounding areas.

Drainage is almost always altered during the course of house construction. Look for the areas in which water collects and stands for long periods. Make certain that water does not flow towards the house or building. A 2% slope away from buildings is recommended.

Soil is important because it is the growing medium for the plants. Determine if fertilizers or amendments are needed.

Existing vegetation should be evaluated to determine its use in the design. The quality, quantity, kind of material (tree or shrub), and genus and species should be considered.

Natural features are the earth, rock, and water on the site. Try to incorporate these natural materials into the plan with the least amount of modification.

Climate is the general expression of temperature, precipitation, humidity, and wind. These factors should be considered for both human comfort and the growing of plants.

In addition to on-site observations, check local zoning and subdivision ordinances for location and height restrictions for fences, walls, plantings, and structures on the property.

Information collected through on-site observations can be used for "Goose-egg" planning. Goose-egg planning is a sketch of approximate locations in which various activity areas (patio, service area, play area, etc.) will take place. Use the family inventory checklist and the site analysis as references, and make quick circular sketches of where activities might best be located.

INFORMATION SHEET #5

Selecting Plants to Fit Your Design

One of the major building materials in a landscape design is plants. Simply planting shrubs here and there is not good design. Good design requires an understanding of each plant's environmental needs and individual qualities. Form, texture, and color are important considerations in selecting plants.

Form is the first design quality of plants to consider. It is the outline of the plant as well as the three-dimensional mass of the plant. Examples of plant forms are columnar, round, vase, weeping, pyramidal, and oval. The more extreme the form, the more attention it attracts; however, to hold attention, color and texture must be considered.

Ascending forms, as of evergreens, give accent to the design. Horizontal and spreading forms emphasize the breadth of space. Rounded forms are the most common and lend themselves well to group and mass compositions.

Using plants of only one form can be monotonous. Use different shapes to provide variety and interest.

Texture is the second design quality of plants to consider. Basically, texture is a plant's qualities of coarseness or fineness, roughness or smoothness, heaviness or lightness, thinness or denseness. Coarse-textured plants appear to move toward the viewer, while fine-textured plants appear to recede. Monotony results when all the plants in a design have similar texture. Use some variation to add interest, but avoid extremes. Never place the finest textured plant next to the coarsest. Also avoid placing coarse plants in small areas as they will make the space appear even smaller.

Color is the third design quality of plants. This element has the greatest appeal and summons the greatest response.

Colors can be divided into two groups — warm colors and cool colors. Warm colors include yellow, orange, and red. Cool colors are green, blue, and violet. Warm colors are striking, cheerful, and stimulating, while cool colors are restful. In design, warm colors tend to advance or appear closer, and cool colors appear more distant.

The main purpose of plants in the landscape is to provide a leafy, green setting that creates an atmosphere of restfulness. To achieve this, green foliage plants should outnumber bright-colored foliage plants by at least 9 to 1.

In addition, foliage color should be in harmony with the color of the house or building. Do not select colors that are going to clash with the house or building color.

Principles of Design

A unified planting composition may be created by manipulating form, texture, and color. Unity can be accomplished by applying the design principles set forth by R.V. Bess, which are simplicity, variety, balance, emphasis, sequence, and scale.

Unity is the quality of oneness. The purpose of unity in a design is to attract and hold attention, to help the viewer "grasp" the design, and to organize the various parts. Other principles of design relating to unity are listed below.

Repetition: (Simplicity) Line, form, texture, and color uniformly repeated or with some variations can produce unity.

Variety: (Contrast) Variations and contrast in line, form, texture, and color will focus attention and add interest to the design.

Balance: (Symmetry, opposition, alteration) Balance implies equilibrium whether it be formal or informal. Formal balance gives a sense of stability and informal balance has a dynamic quality.

Emphasis: (Dominance) Emphasis implies dominance of certain elements and the subordination of others.

Sequence: (Uniformity of change) Change of at least one quality of line, form, texture, or color gives transition from one line to another, from one area to another, or from one mass to another.

Scale: (Proportion) Absolute scale refers to the size of an object with relation to a designated standard such as a building or human body. Relative scale refers to the size of one object in relation to the other objects in a given composition.

While the principles of design are important, a designer must know that plants prefer certain conditions for optimal growth. Therefore, plants should be selected by their ability to thrive in conditions including shade, poor soil, wind, cold, etc. It is the responsibility of the designer to know a plant's attributes or to research a plant's ability to perform in a particular situation.

INFORMATION SHEET #6**Fitting Trees to Your Plan**

The proper selection of trees for a landscape is important because they are the most permanent of all plant materials.

When selecting a tree, decide on the functions it will serve. Trees may provide shade, frame views, mask awkward architectural features, and provide a backdrop for the home. Trees also establish the scale of the landscape. A well-placed tree can shade a play area, frame an off-property view, and serve as a backdrop for the house.

The spacing of trees must allow for their mature spread if they are to be specimens. They may be placed closer if a group effect is desired. Do not use more than two or three different species of trees to compose each planting group.

Other considerations are:

1. Select trees that are hardy.
2. Do not use trees that drop messy fruit or twigs.
3. Avoid selecting trees that have root systems located at the surface.
4. Do not select rapid-growing trees as they are short-lived and subject to storm damage.
5. Group upright evergreens in clumps of three or four.
6. Keep trees away from power lines and telephone wires.

621

INFORMATION SHEET #7

Fitting Shrubs to Your Plan

Shrubs should be selected for their flowers, foliage, branching habits, and suitability for a specific location. There are a great number of shrubs from which to choose, so consider the line, form, color, and texture of each.

Shrubs can be used as specimens, accent plants, group plantings, shrub borders, hedges, screens, and foundation plantings.

Specimen — In most cases, a specimen should be a perfect example of a particular shrub species, displaying outstanding form, texture, color, or a combination of these elements. Though not the same as border plants, specimens should share size, shape, foliage, texture, or color characteristics with the group planting.

Accent Plants — Whereas specimen plants stand alone, accent plants are part of a shrub mass. Accent plants may also differ in form, color, and texture from the shrub mass.

Group Plantings — Shrubs in a group planting have less individuality than specimen plants, since three to five different species are used to make a composition. The value of the group planting is derived from the height, form, and arrangement of the individual plants.

Shrub Borders — A mass planting of shrubs on a border helps to create an outdoor living room, provides a backdrop for flowers, and screens views.

The procedure for designing a shrub border is as follows:

1. Select plant's size, texture, and color — Sketch a series of blocks or rectangles representing the arrangement of the various sizes of plant material desired. The blocks should be drawn as though one were facing the plants from ground level. A scale of 1/8 inch to 1 foot is probably the most practical for this drawing.

Indicate, in each block on the sketch, the texture and color desired in each block area. Indicate textures as C (Coarse), MC (Medium-Coarse), M (Medium), MF (Medium-Fine), or F (Fine). Indicate foliage colors as EG (Emerald Green), BLG (Blue-Green), YG (Yellow-Green), RG (Red-Green), GG (Grey-Green), or BG (Black-Green).
2. Sketch plants at mature growth — Place the block sketch on the drafting table and lay a sheet of tracing paper over it. On the tracing paper, draw a sketch of actual plants, at their mature growth, that fills the various blocks drawn.
3. Place the plants in plan view — From the drawing in step 2, draw an overhead view of the plants. Use the appropriate landscape drawing symbol for each of the desired plants.
4. Select plants — Based on the information above on plant size, texture, and color, make a selection of plants for the landscape design.

Hedges — Hedges can be formal (clipped) or informal (unclipped). Hedges may define space, tie the various planting units together and screen views.

Screens — A solid mass of one plant type will give the effect of a living wall. The ideal growth habit of a screen plant is tall and narrow and with foliage to the ground.

Foundation Plantings — These are shrubs placed around the house to achieve a natural appearance. The best shrubs for foundation planting are those which do not get very large.

622

INFORMATION SHEET #8

Designing the Public Area

The public area, if properly designed, greatly enhances the appearance and market value of the property. The most prominent feature of the public area is the house. Therefore, the design should be dictated by the architecture of the home.

Basic design principles for developing the public area include:

1. Softening the architectural lines of the home.
2. Framing the home with trees.
3. Maintaining open lawn areas.

Blending the structure of the house with the general surroundings should be the main purpose. Plantings at the outside corners of the house will accomplish this. Another important planting site is located on each side of the door.

Plantings on either side of the door may be identical if the house has a formal balance. Homes with asymmetrical balance should have different plantings on either side of the doorway. To determine the height of the plantings draw a line from the threshold of the door to a point two-thirds of a distance from the ground to the eave at the corners. The doorway plants should not be taller than the line.

In most cases, the plants on the corners should not be higher than two-thirds the distance from the ground to the eave. Doorway plants are usually no taller than one-fourth to one-third the distance from the ground to the eave. Taller plants at the corners and shorter ones at the doorway create a concave line which directs attention to the door.

Before selecting special plants and placing them in front of a house, study the architectural lines and masses of the house. Draw a rough sketch to scale of the front of the house. Properly locate the windows, doors, and porches on the drawing. Indicate the dominant lines with colored pencils. Then, determine the balance of the home and how proper placement of planting masses can achieve better balance.

Select trees and shrubs that are going to repeat the dominant lines of the house. For instance, use trees with horizontal branching with houses that have distinct horizontal lines. Houses with dominant pyramidal forms call for trees with pyramidal growth habits. Only houses with pyramidal forms should have pyramidal plants in the public area.

Now it is necessary to consider the masses of the home. On the sketch of the home, note the dominant masses with colored pencils. The planting design should repeat the architectural masses at the end of the house opposite to the end at which the mass is located. This reversal of location provides a pleasing counterplay of masses. In designing masses, use the process of designing a shrub border as mentioned in Information Sheet #7.

Finally, study the architectural details of the home. Different sizes of windows, randomly located shutters, wrought-iron railings, roof supports, changes in building materials, and changes in color lead to a "busy" appearance. When these are present, design simple plantings neutral in color and form to avoid further visual confusion. Houses with windows of equal size and evenly spaced or with little detailing permit more variety in the landscape plantings.

Foundation plants should not get so large as to cover the windows. Consider their mature size when designing, and show their mature size on the plans. If the house has a wide overhang, place the plant material one foot beyond the drip line.

The shrub plantings should not be placed in the lawn. They should be placed in cultivated beds. The outline of the bed may be straight or arc and tangent lines. *Straight line* bed patterns are desirable because they complement the architectural lines of the house. The straight line pattern may consist of lines drawn at *90 degrees* to the house and parallel to the house or lines set at *45 degrees* to the house. *Arc-and-tangent lines* are an effective compromise between the curved and straight line. To be effective, bed patterns must be bold. Wiggly lines are "busy" in appearance and don't "read" well.

Whichever style is used, start and finish the planting beds at architectural features of the house. Some examples are: the edge of a window, a jog in the wall, a change of building material, etc. On wall surfaces devoid of architectural features, begin the bed one-third or two-thirds the distance across the wall.

An open lawn is another principle of public-area design. A broad, expansive, uncluttered lawn provides the best setting for a home.

INFORMATION SHEET #9**Designing the Living Area**

The living area is the area located behind the house. It should be designed for both utility and beauty. Of course, how the area is developed depends upon the family's interest in gardening, outdoor living, and other activities.

Review the family inventory, the site analysis, and goose-egg plans to determine the types of spaces needed for various activities. General living spaces include the patio, outdoor court, and children's play areas; while work spaces might include vegetable gardens and a storage and service areas.

Begin the design of the living area by developing the ground pattern. On a piece of scratch paper, sketch the shape of the lot. It should be no larger than three or four inches and it should be proportional to the dimensions on the base plan. Now sketch several possible bed patterns on tracing paper laid over the initial sketch. Use the goose-egg study as a guide.

Select the best sketch and transfer the lines to tracing paper placed over the base plan. Some adjustments to the pattern may have to be made to permit the desired activities.

Now locate the trees on the plan. Well-placed trees may offer shade and overhead protection and serve as a backdrop for the house.

Decide where vertical elements such as walls, fences, and upright narrow plant material should be placed. The functions of these elements include organizing space, screening views, and providing privacy.

Next, select and arrange plants to strengthen the pattern design and to refine spaces being created. Use the technique described in Information Sheet #7 to locate the shrubs and flowers. Try to make each view as attractive as possible.

The outdoor living area also requires different surfacing materials for the different activities. The most common and functional surface is a lawn. Lawns are attractive and good for play, and walking or lounging on them is pleasant. Other common surfaces are ground covers, paving, and loose aggregate.

Patios are another important element in today's landscapes. They are an extension of the indoors, and they automatically become a good vantage point from which to view the yard. In fact, the yard should be designed to provide an attractive view from the patio. Also, the line of the patio should be reflected in the rest of the design. The minimum size of a patio is 15 feet by 20 feet or 300 square feet, and the recommended size is 400 square feet.

Finally, don't worry about a design not being perfect. The best design for a home is one which is attractive, satisfying, and functional for the family. This can be accomplished in many different ways.

625

INFORMATION SHEET #10

Suggested Landscape Planting Plan Values*

A. Function

1. How well do the use areas function related to the building(s)?
 - a. Public area (front yard)
 - b. Private area (outdoor living space)
 - c. Service area (veg. garden, compost, etc.)
2. Does the plan allow for easy circulation?
 - a. Auto access and usage
 - b. Pedestrian circulation

B. Aesthetics

1. Harmony and unity — Do the component elements of the plan (plants, lawns, fences, walls, patios, building(s) fit together into an attractive, pleasant, overall whole for outdoor living, work, and play?
2. Accent — Are important areas (front door, patio, etc.) emphasized with materials that contrast in form, color, or texture?
3. Screen — Are least desirable items (trash cans, compost heaps, etc.) screened from view?

4. Views — Are interesting and attractive views planned (a) from the house, (b) on the grounds, and (c) off the grounds?
5. Compatibility — Does the plan, the plantings, and materials used complement the architecture of the buildings?
6. Balance — Is there a well-balanced use of sufficient variety of plant and construction materials (color, form, and texture) to provide interest, but not confusion, or is there a monotonous repetition of these elements?

C. Scale (Size Relationships)

1. Are the elements of the plan in scale with the building and with each other?

D. Presentation

1. Is the plan easily understood and well delineated?
2. Is the necessary marginal information shown (scale, north point, client, location)?

*Adapted from Bulletin No. 4, "National FFA Contests."

625

TRANSPARENCY MASTER #1

Plant Forms

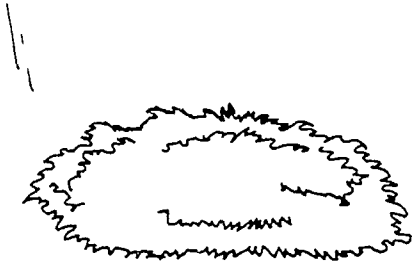

Spreading

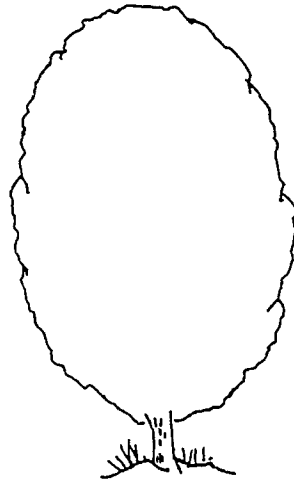

Oval

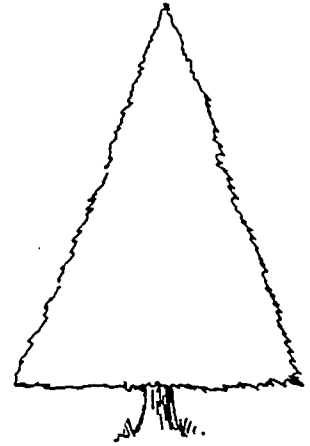

Pyramid



Prostrate

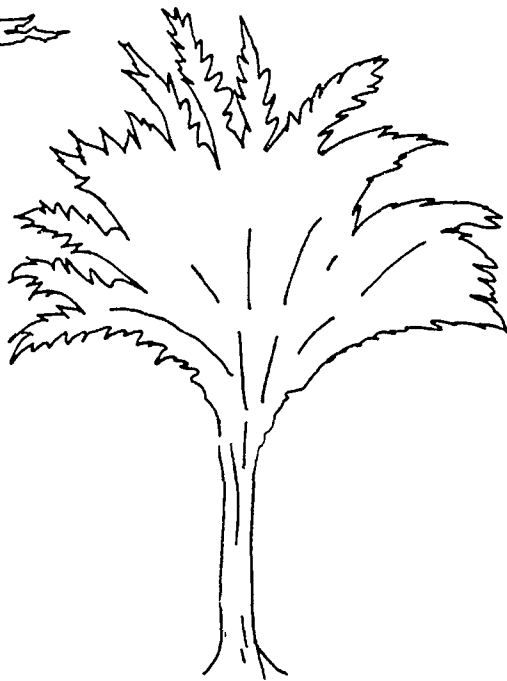

Vase



Round

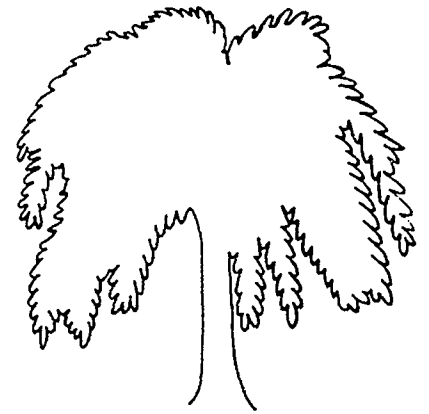

Weeping

625

TRANSPARENCY MASTER #2

Texture

TEXTURE IS :



COARSE



FINE

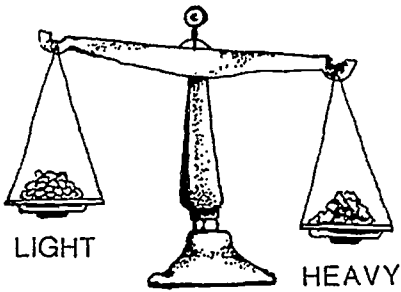

LIGHT

HEAVY



THIN



DENSE



LIGHT AND SHADE

TRANSPARENCY MASTER #3

Texture

TEXTURE RESULTS FROM :

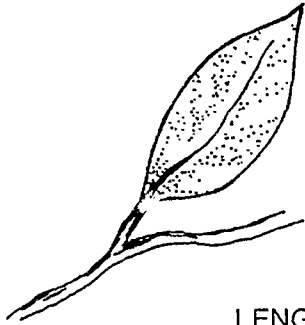

LENGTH OF PETIOLE

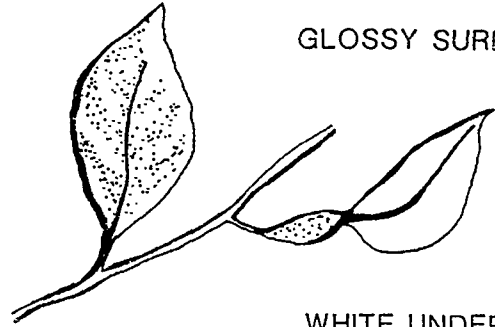

GLOSSY SURFACE

WHITE UNDERSIDE

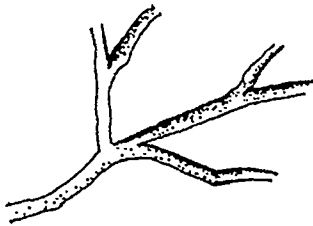

SIZE OF TWIG

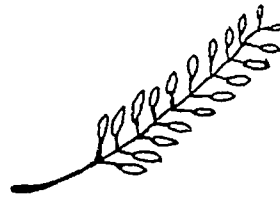

SIZE OF LEAF



ENTIRE OR CUT LEAF



SPACING BETWEEN LEAVES

TRANSPARENCY MASTER #4

Color

Warm

These are cheerful, stimulating, and tend to advance or appear closer.

Yellow

Orange

Red

Cool

These are restful and tend to recede or appear more distant.

Green

Blue

Violet

620

TRANSPARENCY MASTER #5

Repetition

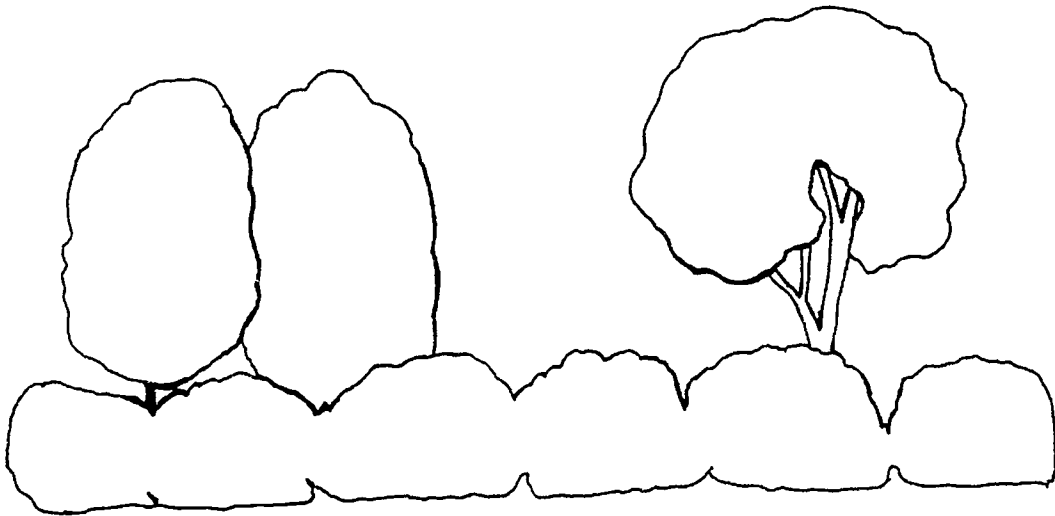

Line, form, texture, and color uniformly repeated can produce unity.

TRANSPARENCY MASTER #6

Variety

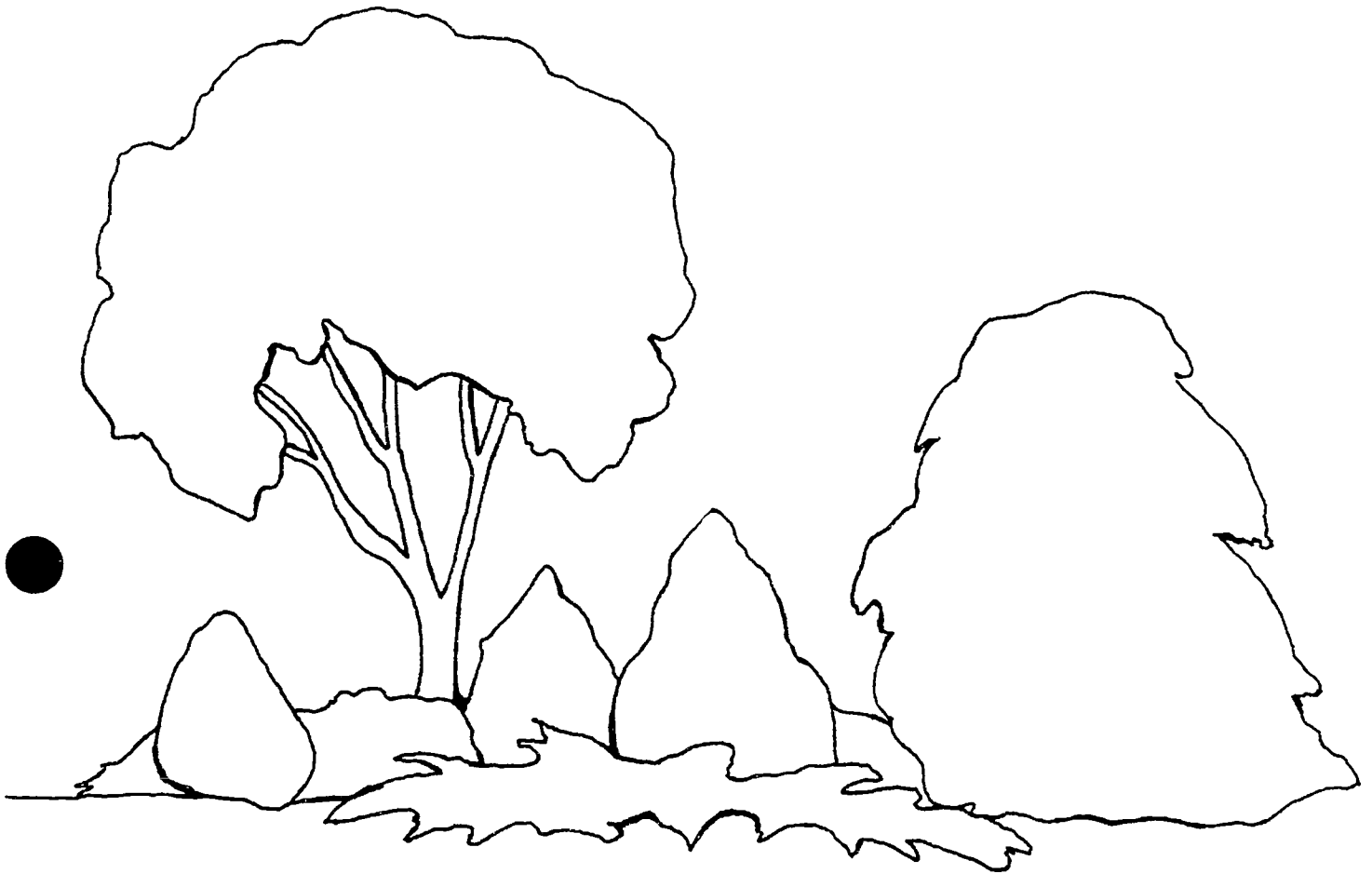

Variations in line, form, texture, and color can focus attention and add interest to the design.

TRANSPARENCY MASTER #7

Balance

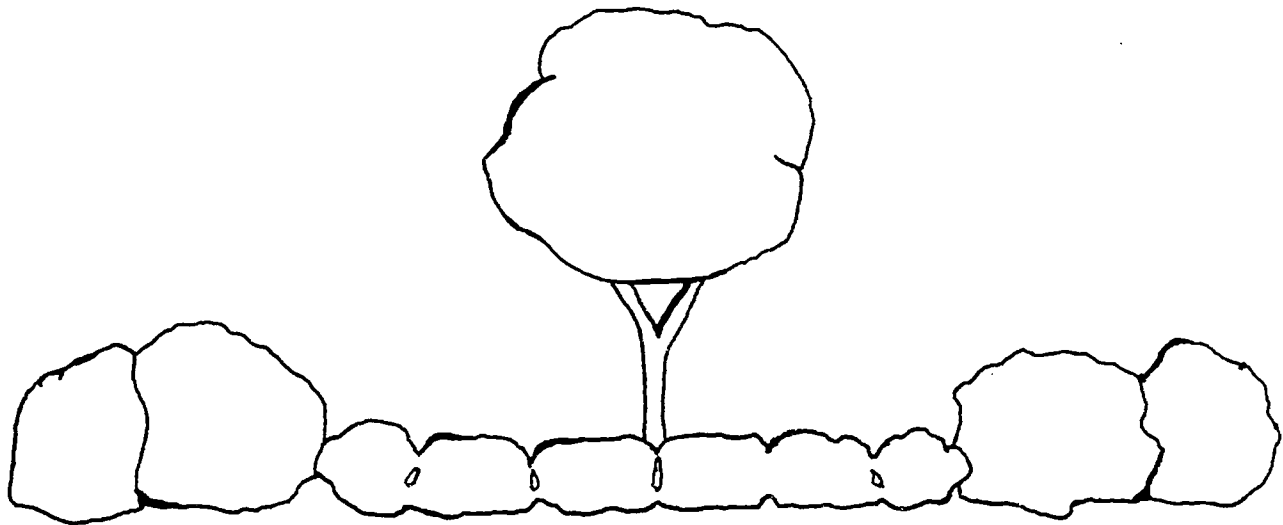

Formal — This gives a sense of stability.

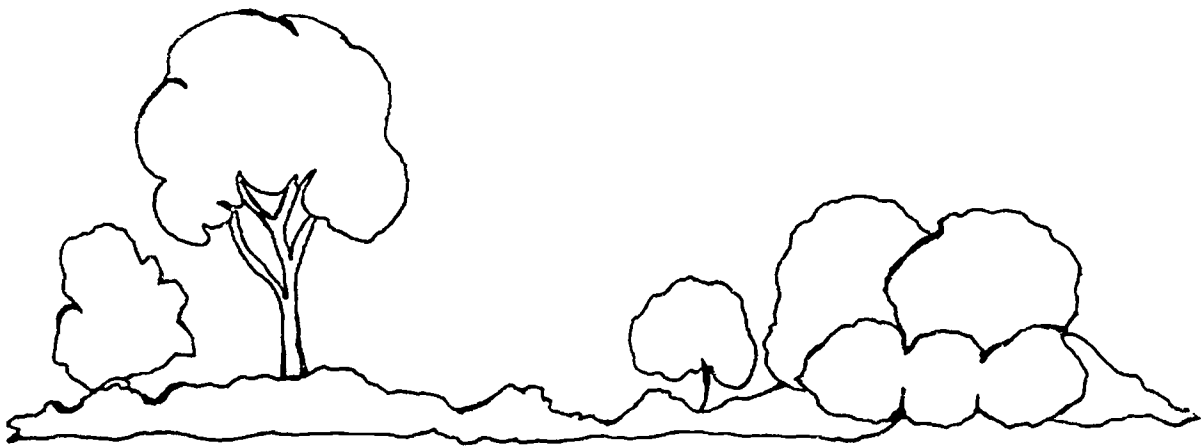

Informal — This has a dynamic quality.

TRANSPARENCY MASTER #8

Emphasis

Emphasis can be achieved through:

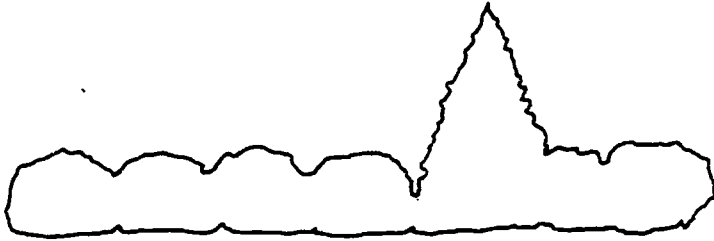

Changes in form



Changes in texture

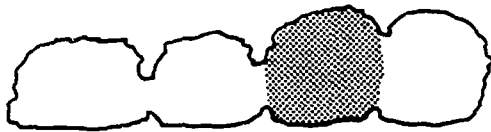

Changes in color

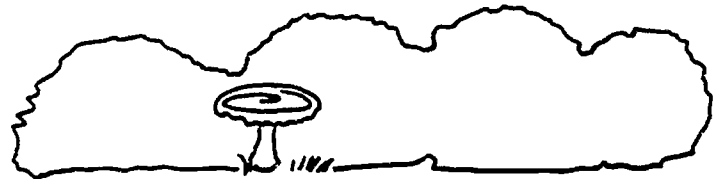

Using garden embellishments

030

TRANSPARENCY MASTER #9

Sequence

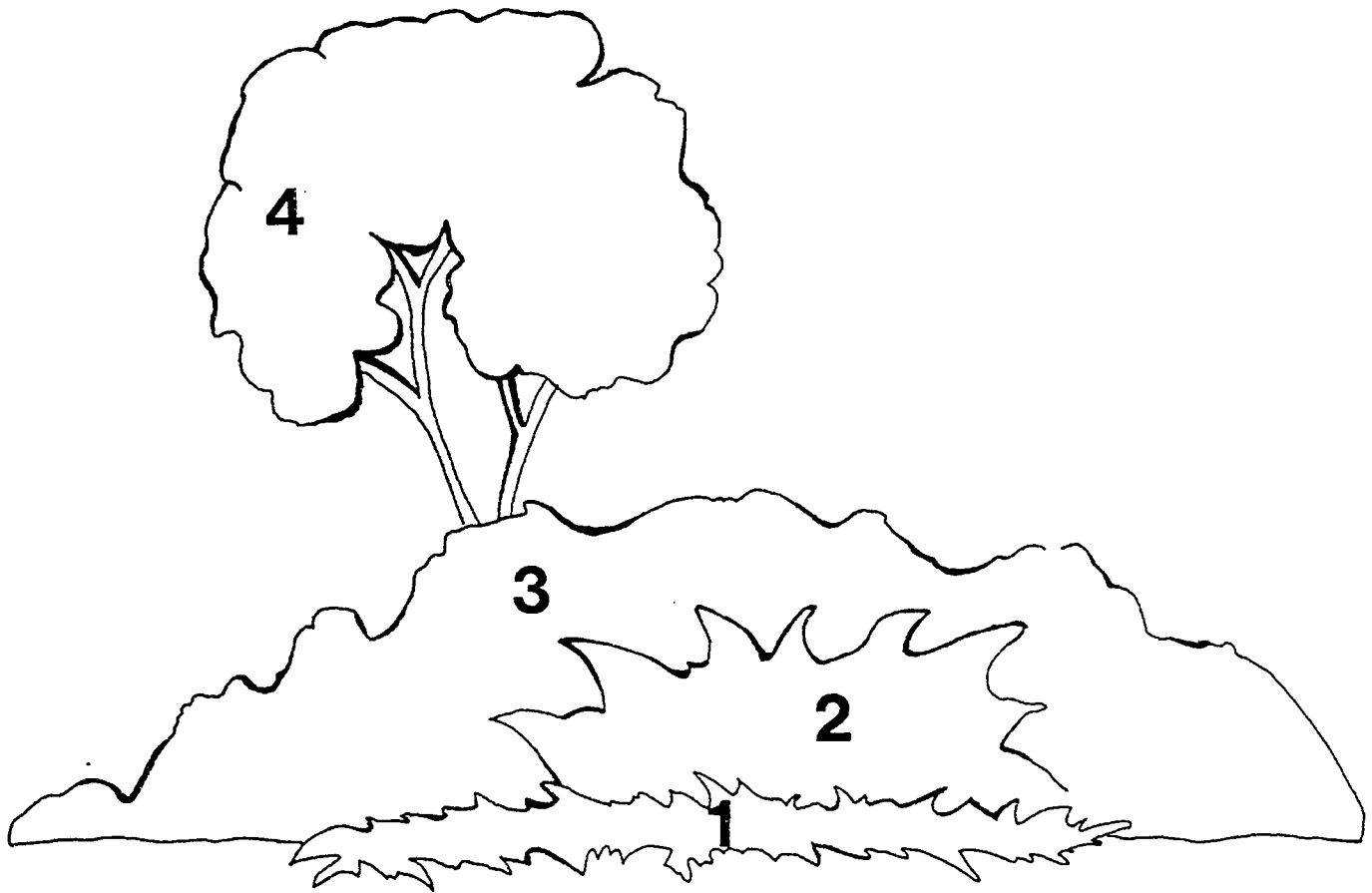

Change of at least one quality of line, form, texture, or color gives transition from one item to another.

TRANSPARENCY MASTER #10

Scale and Proportion

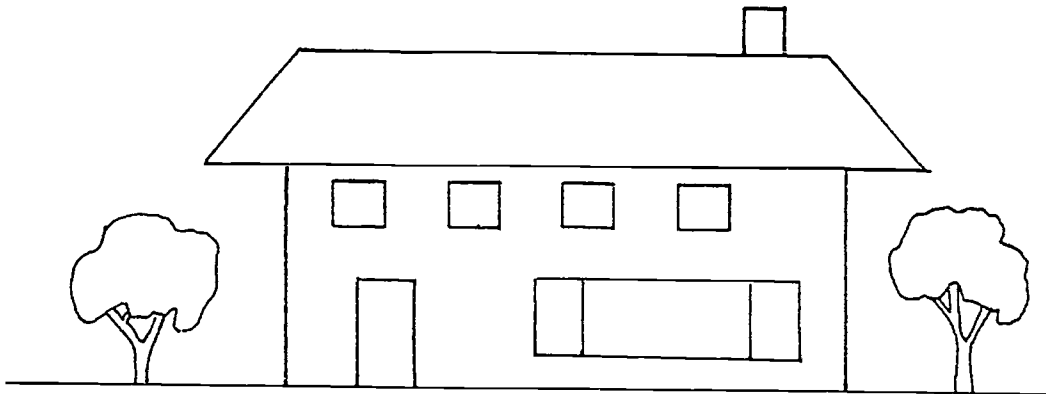

This house appears larger than it is.

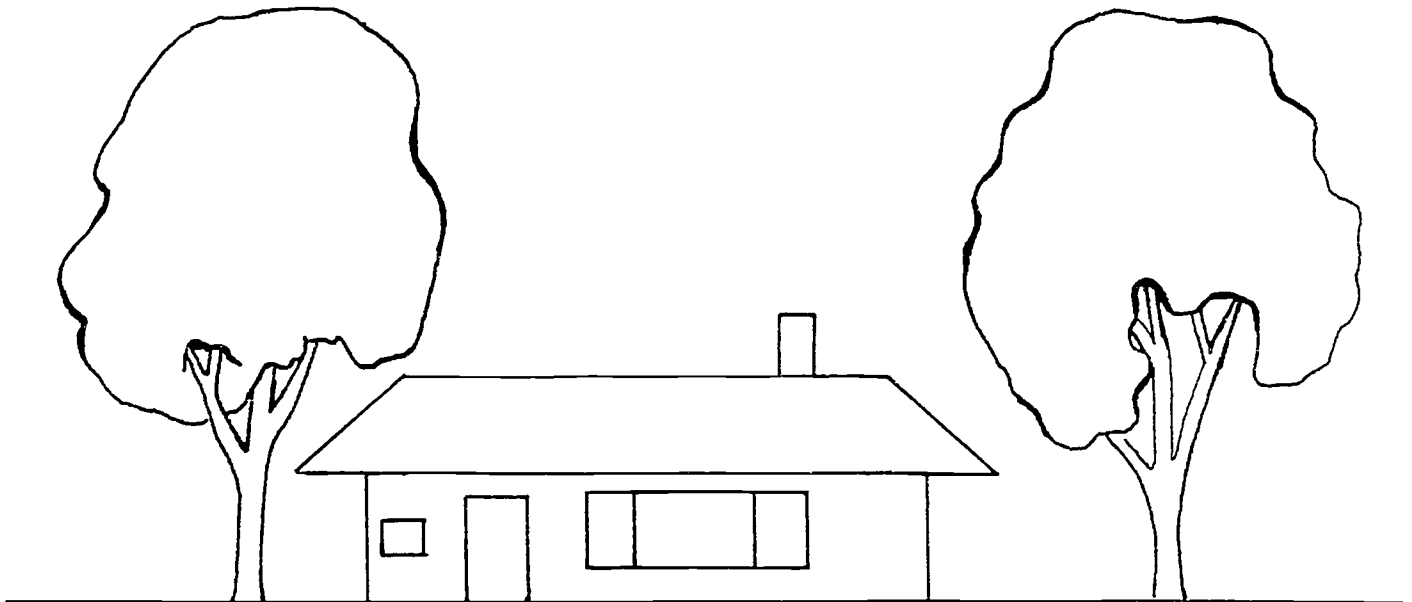

This house appears smaller than it is.

TRANSPARENCY MASTER #11

The Base Plan

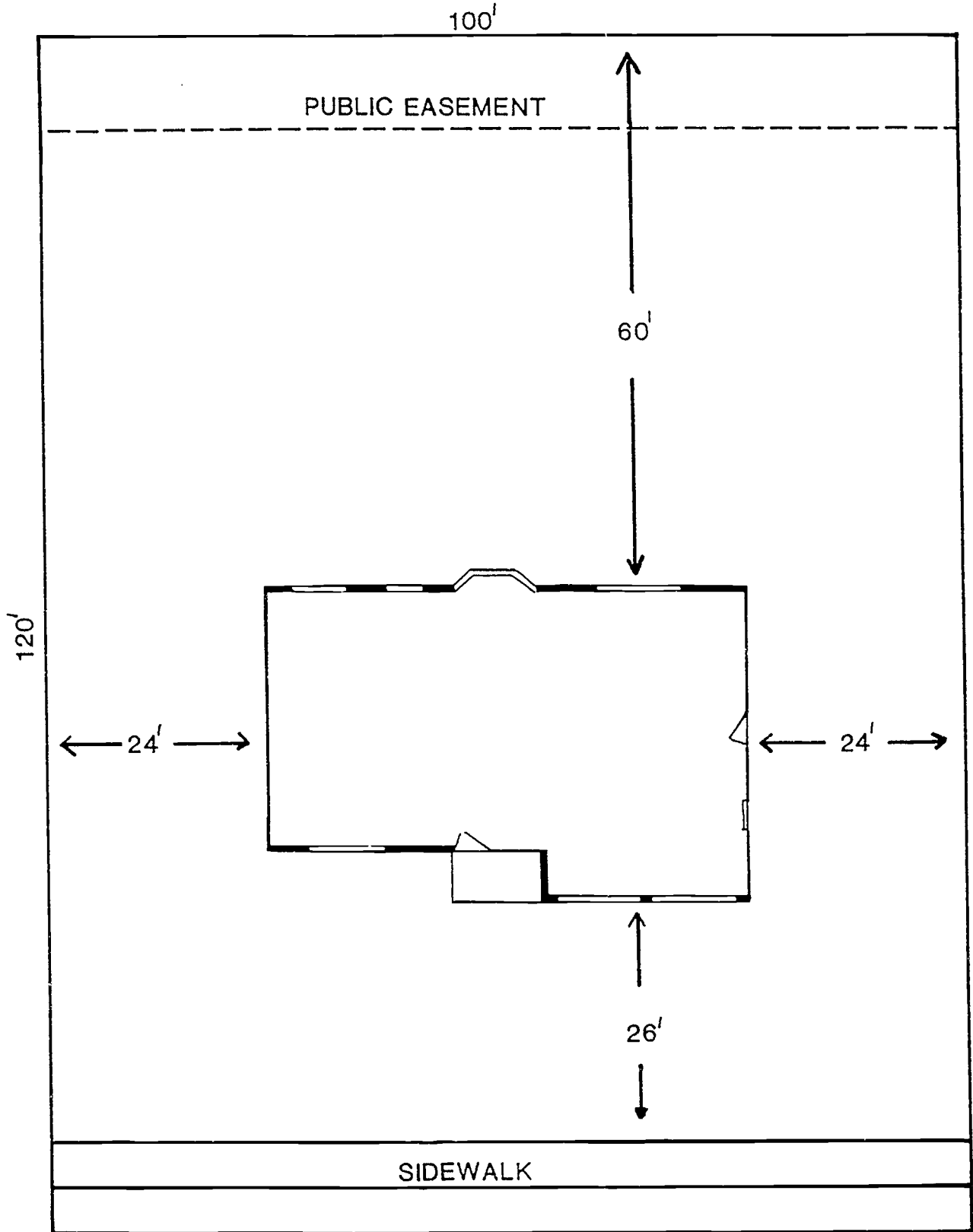

SCALE 1"=16' 0"

Illinois Agricultural Core Curriculum Rev.

TRANSPARENCY MASTER #12

Elevation View and Floor Plan

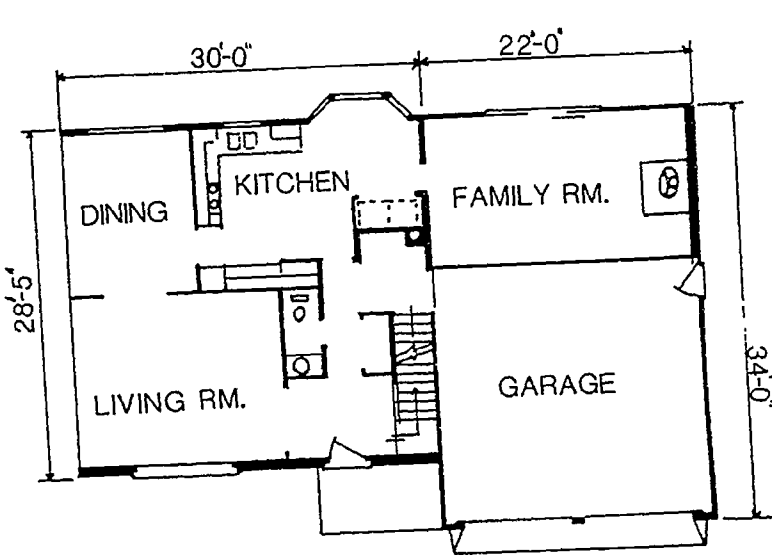
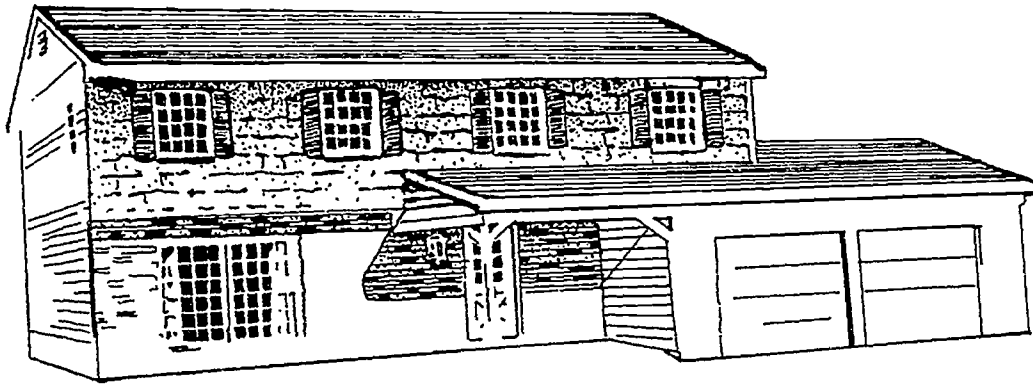

FIRST FLOOR

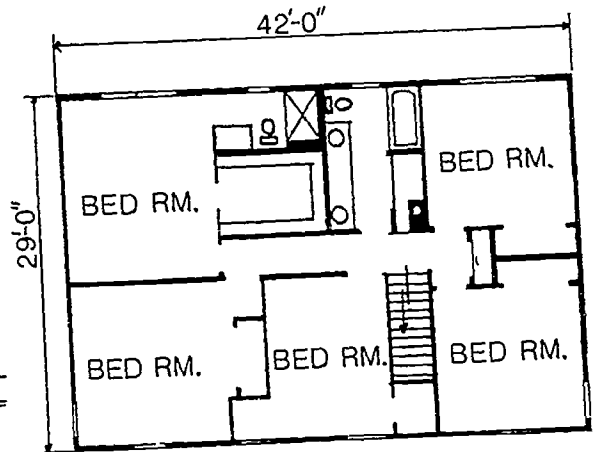

SECOND FLOOR

637

TRANSPARENCY MASTER #13

The Site Analysis

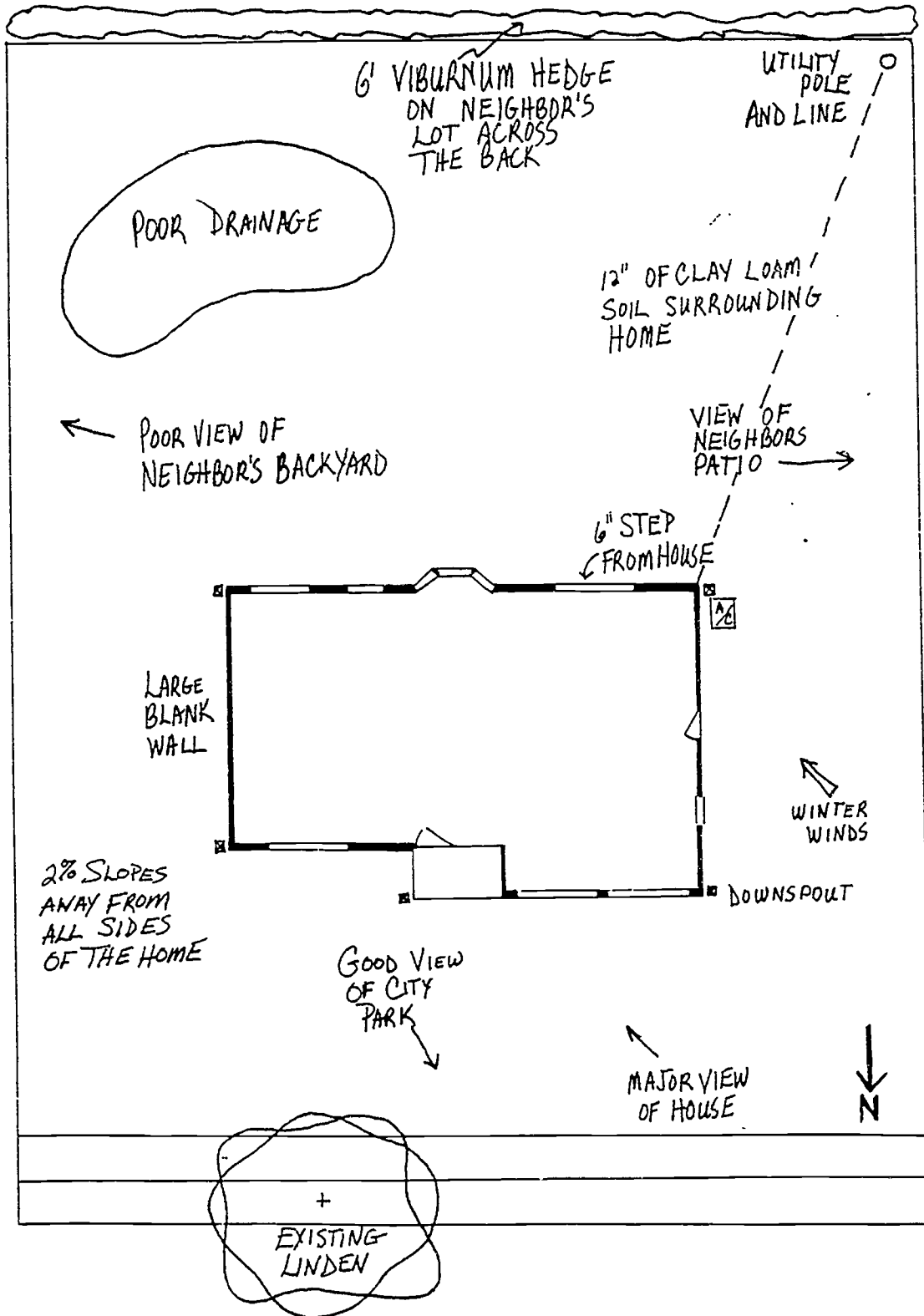

TRANSPARENCY MASTER #14

Family Inventory Checklist

Family Members:

Name	Age	Sex	Hobbies
_____	_____	_____	_____
_____	_____	_____	_____
_____	_____	_____	_____
_____	_____	_____	_____
_____	_____	_____	_____

Public Area:

Driveway _____ Number of cars in family _____
 Off-street parking needed _____
 Privacy from street _____ Entry walk _____ Entry garden or court _____
 Landscape lighting _____ Structures (fences, walls, decks, etc.) _____

Outdoor Living Area:

General Gardening:

Minimum maintenance _____ Moderate maintenance _____ High maintenance _____
 Family allergy considerations _____

Special interests:

Hobby garden (specify) _____

Flower borders: _____ Annuals _____ Roses _____
 _____ Perennials _____ Other _____

Fruit trees _____ Type _____

Small fruits (bush) _____ Type _____

Vine fruits _____ Type _____

Favorite plants _____

Entertaining: Large groups (over 10) _____ Small groups (under 10) _____
 Formal _____ Informal _____
 Patio Material _____

Permanent seating: Benches _____ Seat-height walls or planters _____

Shade required _____ Where _____

Table umbrella _____ Overhead structure _____

Trellis _____ Tree _____ Fabric canopy _____

Lawn games: _____ Area lighted? _____

Specify: _____

Outdoor cooking: _____

Permanent grill _____ Size _____ Gas _____ Charcoal _____

Portable grill _____ Size _____

Barbecue pit _____

Sink _____ Water _____ Electrical outlets _____ Storage _____

Swimming: _____ Portable Pool _____ Size and Shape _____

Permanent Pool _____ Size (16' x 34' minimum) _____

Diving area _____ Shape _____

Paved decks _____ Size _____ Material _____

Enclosure for pool _____ Plants _____ Wire fence _____

Architectural wall or fence _____

Lighting _____ Dressing facility _____ Equipment storage _____

Service Area:

Vegetable garden _____ Size _____

Flower-cutting garden _____ Size _____

Compost bin _____ Cold frames _____

Greenhouse _____ Size _____

Dog run _____ Size _____ Dog house _____

Other pet requirements _____

Clotheslines: Frequent use _____ Occasional use _____

Permanent _____ Portable _____

Recreational vehicle storage: Camper _____ Size _____

Boat _____ Size _____

Trailer _____ Size _____

Lawn and garden storage: _____

Equipment: Mower _____ Hose _____ Sweeper _____

Sprinkler _____ Spreader _____ Sprayer _____

Tools (Itemize) _____

Supplies: Fertilizer _____ Peat Moss _____ Pesticides _____

Patio furniture (itemize) _____

Trash containers: Number _____ Preferred location _____

Children's Play Area:

Climbing ropes _____

Sandbox _____ Slide _____ Swings _____

Playhouse _____ Jungle Gym _____

On paved surface? _____

Shade required? _____

Trees _____ Overhead structure _____

Fence _____ Height _____ Type _____

Surfacing material: Sand _____ Grass _____

Wood chips _____ Small gravel _____

General Garden Accessories and Features:

Sculpture _____ Landscape lighting _____

Water features _____ : Fountain or spray _____

Reflecting pool _____

Fish _____ Plants _____

Bird interests: Bird feeder _____ Bird-attracting plants _____

Birdbath _____ Birdhouses _____

641

TRANSPARENCY MASTER #15

Goose-Egg Planning

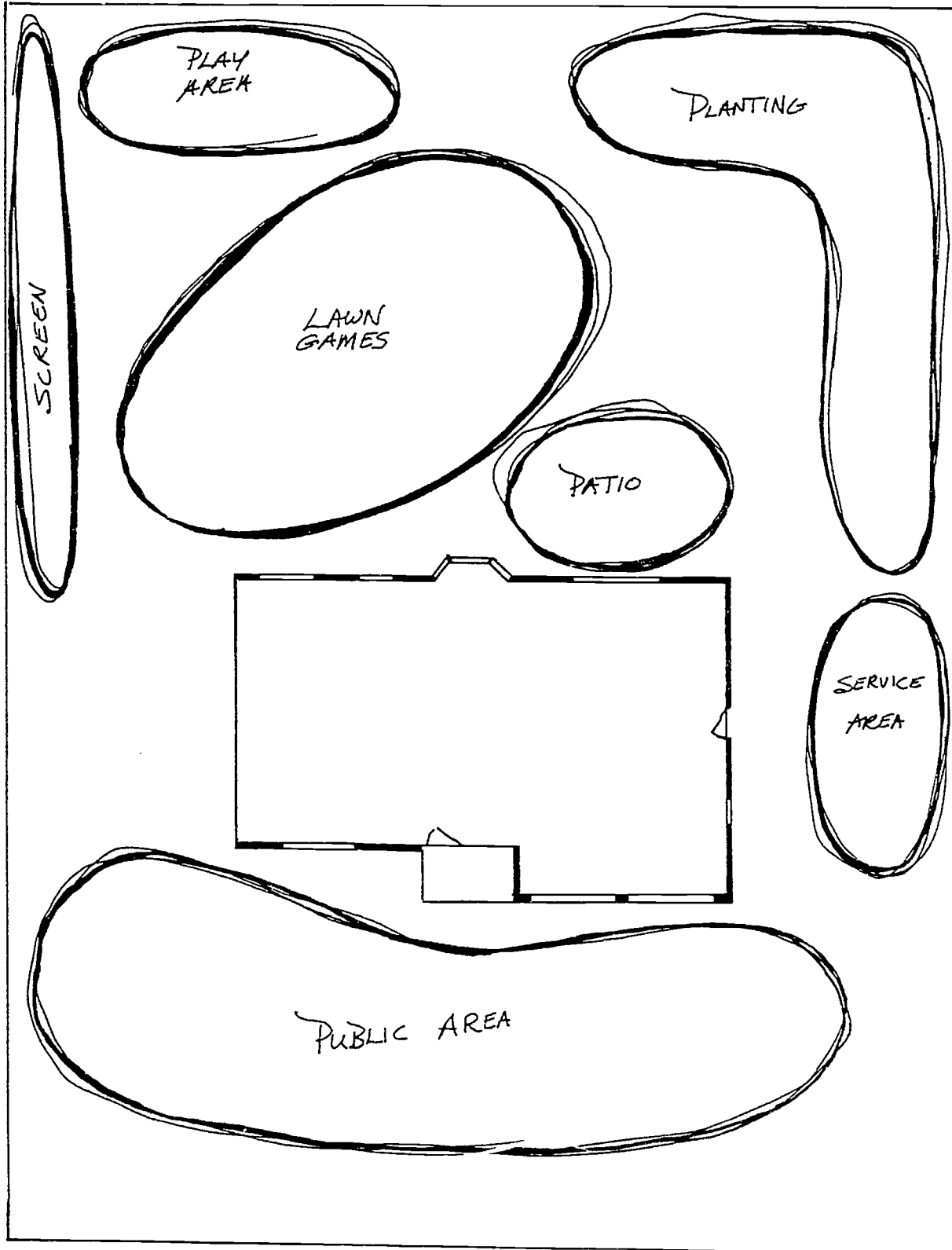

SCALE 1" = 16' 0"

6-12

Illinois Agricultural Core Curriculum Rev.

TRANSPARENCY MASTER #16

Bed Patterns: 90° Angles

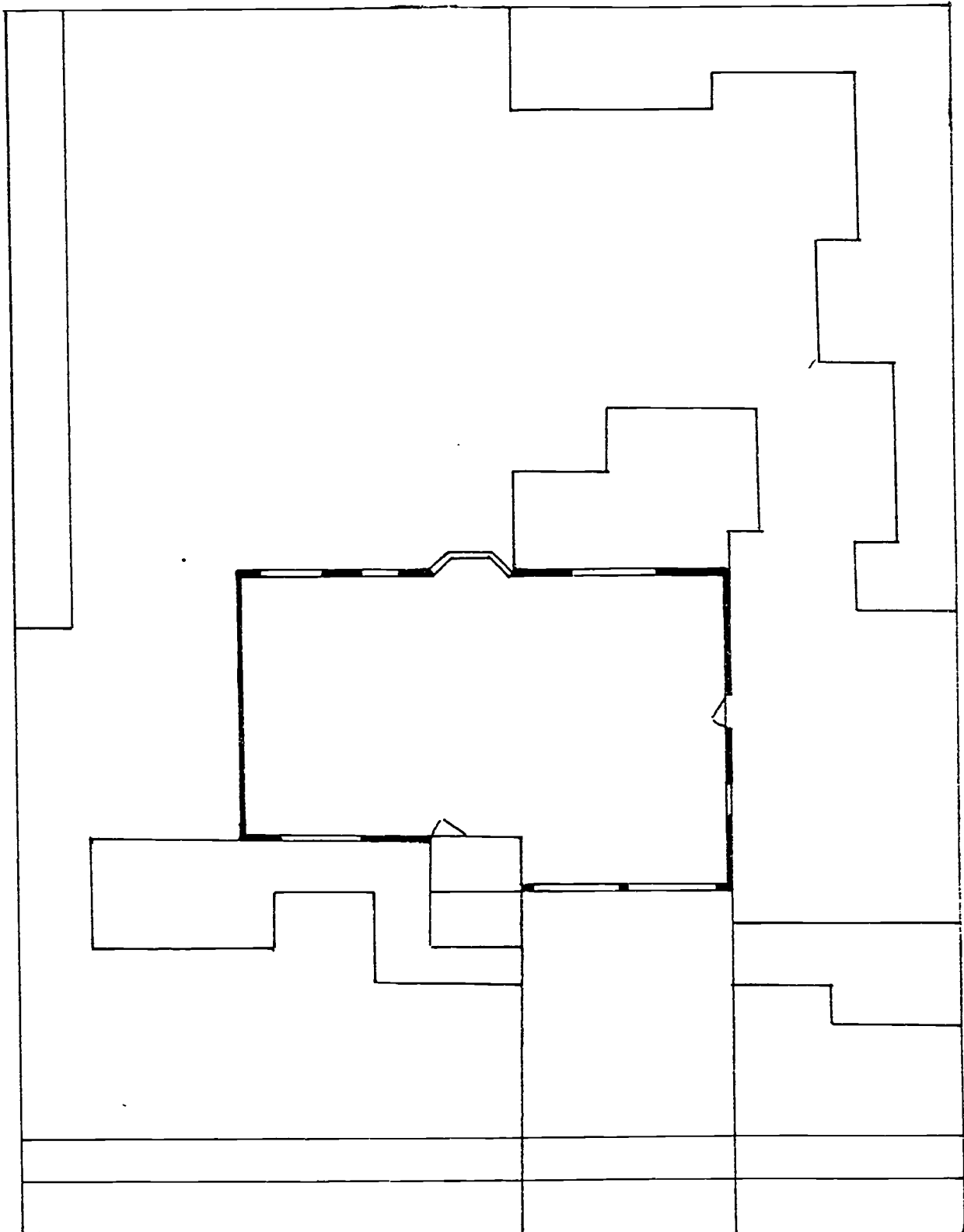

SCALE 1" = 16' 0"

TRANSPARENCY MASTER #17

Bed Patterns: 45° Angles

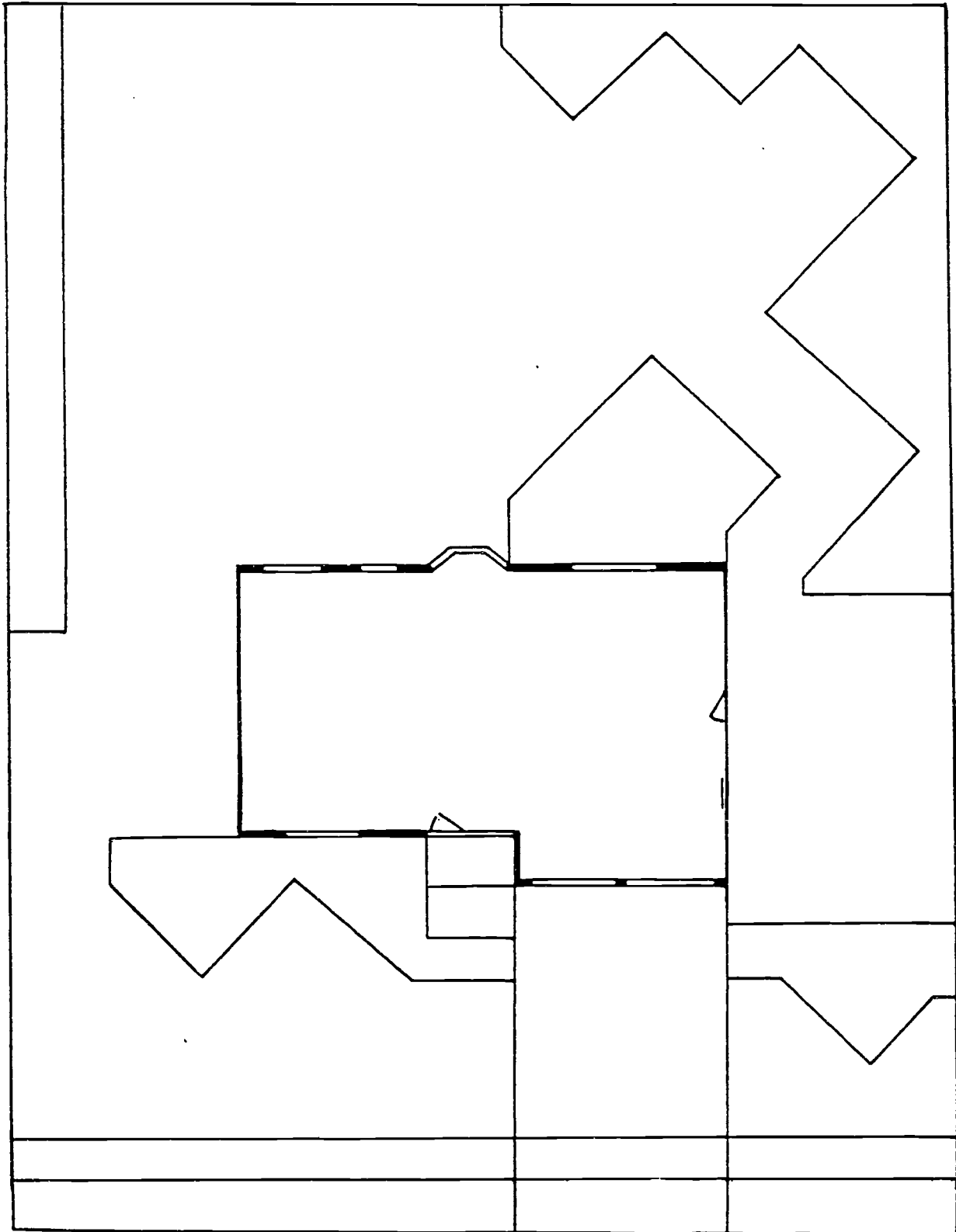

SCALE 1" = 16' 0"

TRANSPARENCY MASTER #18

Bed Patterns: Arc and Tangent

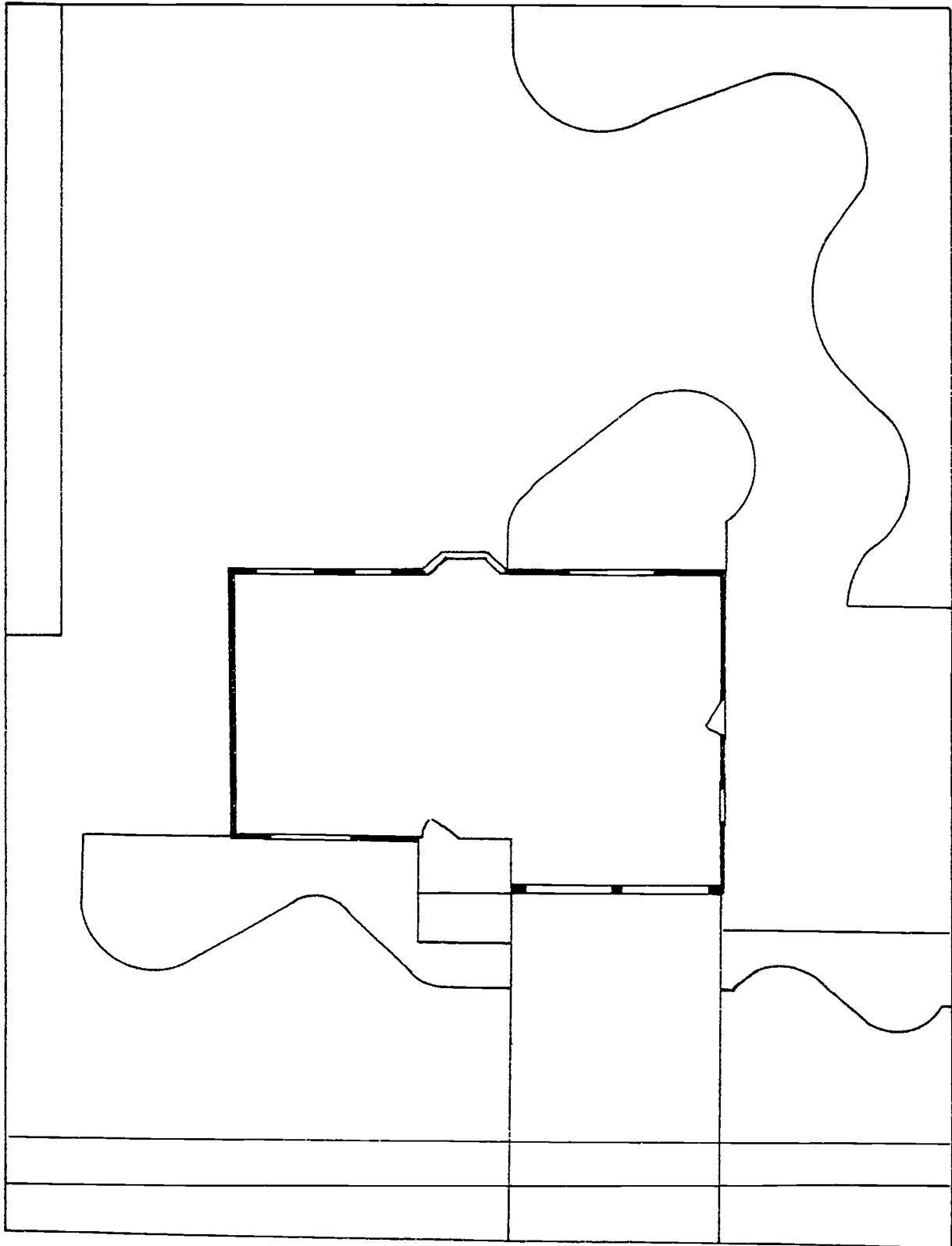

645

SCALE 1"=16'0"

TRANSPARENCY MASTER #19

Landscape Symbols

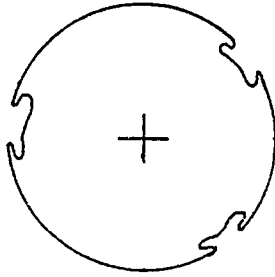

Deciduous Tree

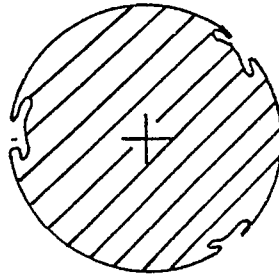

Broadleaf Evergreen Tree

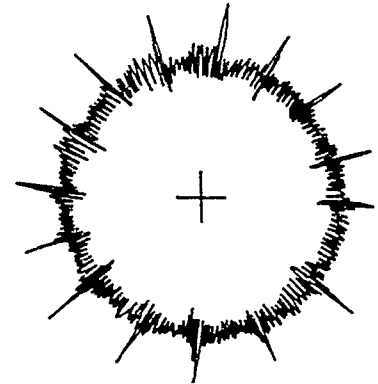

Evergreen Tree

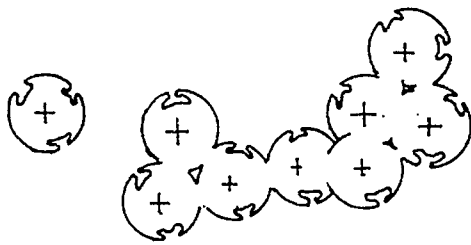

Deciduous Shrubs

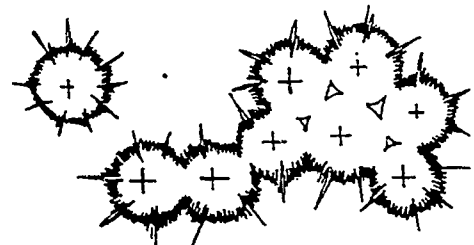

Evergreen Shrubs



Broadleaf Evergreen Hedge

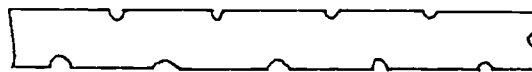

Deciduous Hedge

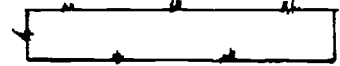

Evergreen Hedge

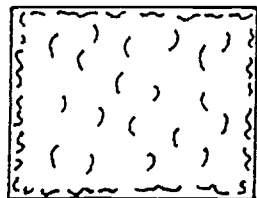

Ground Cover

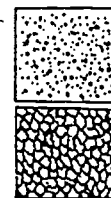

Gravel

Cobbles

TRANSPARENCY MASTER #20

Designing a Shrub Border

Step 1: Select plant's size, texture, and color.

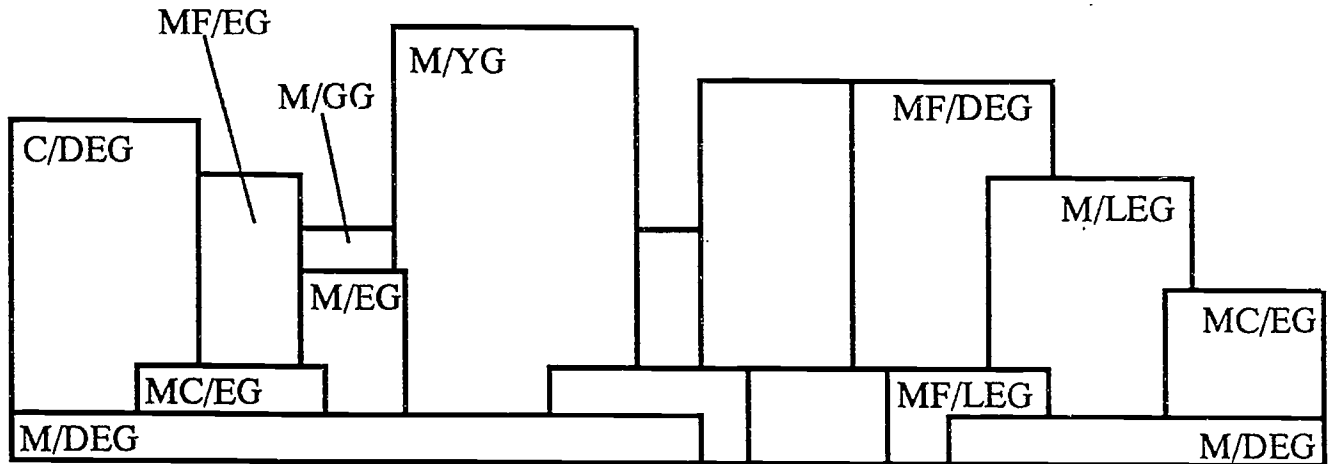

Texture Code

- C Coarse
- MC Medium-Coarse
- M Medium
- MF Medium-Fine
- F Fine

Color Code

- EG Emerald Green
- BLG Blue-Green
- YG Yellow-Green
- RG Red-Green
- GG Grey-Green
- BG Black-Green

TRANSPARENCY MASTER #21

Designing a Shrub Border (cont.)

Step 2: Sketch plants at mature growth.



Step 3: Place the plants in plan view.

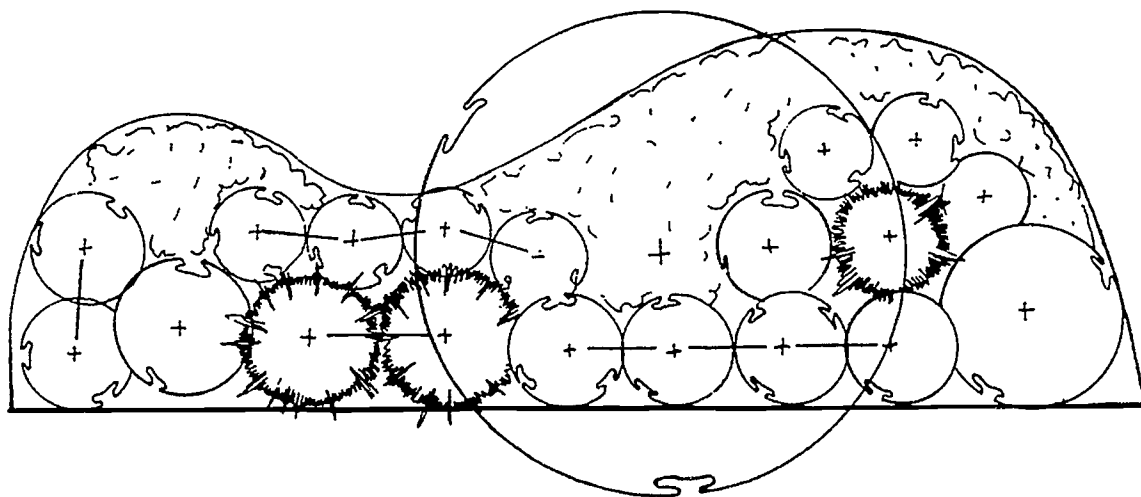

Step 4: Select plants.

Sun Calculator

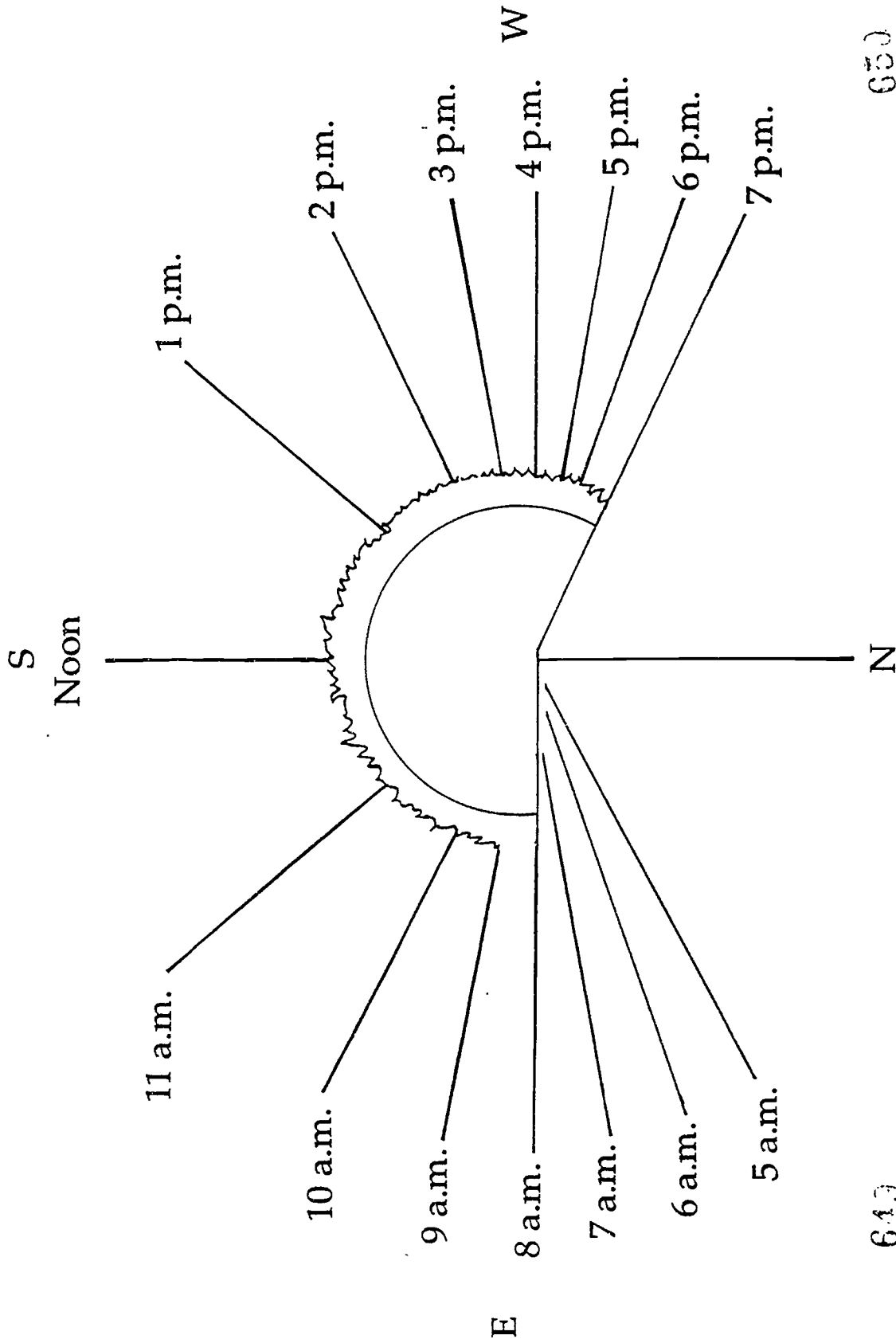

TRANSPARENCY MASTER #22

TRANSPARENCY MASTER #23

Lettering

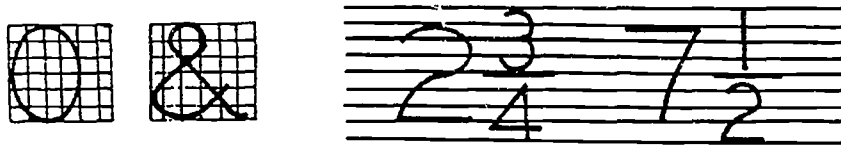
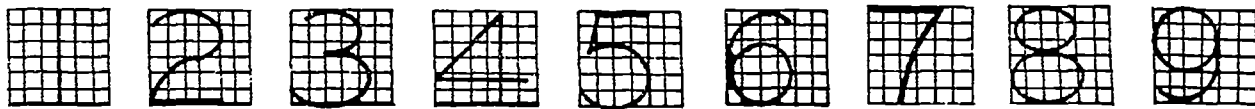
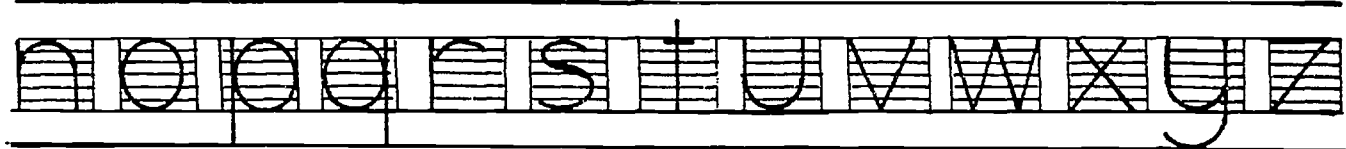
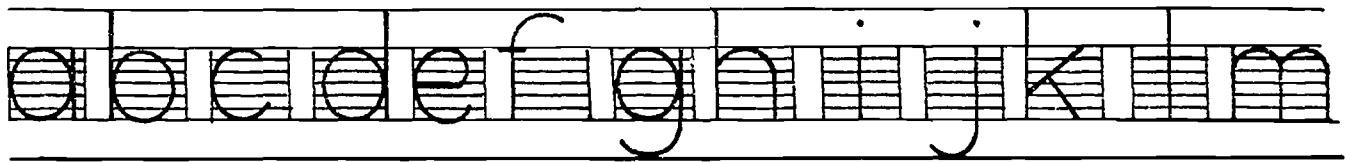
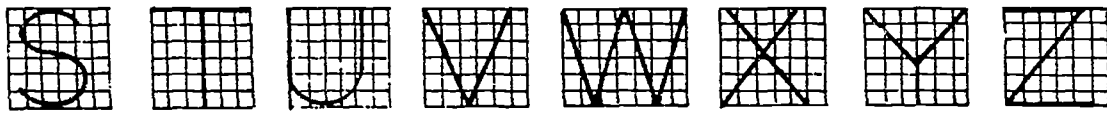
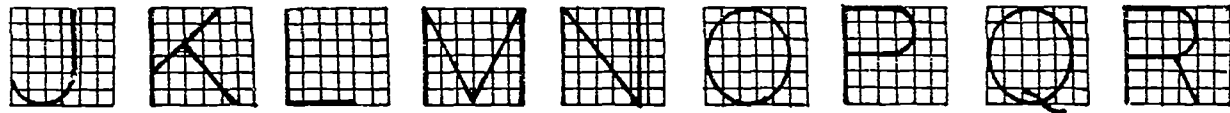
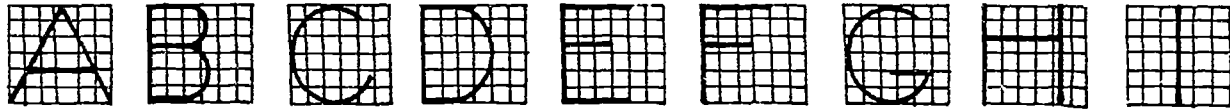

TRANSPARENCY MASTER #24

Planting Plan

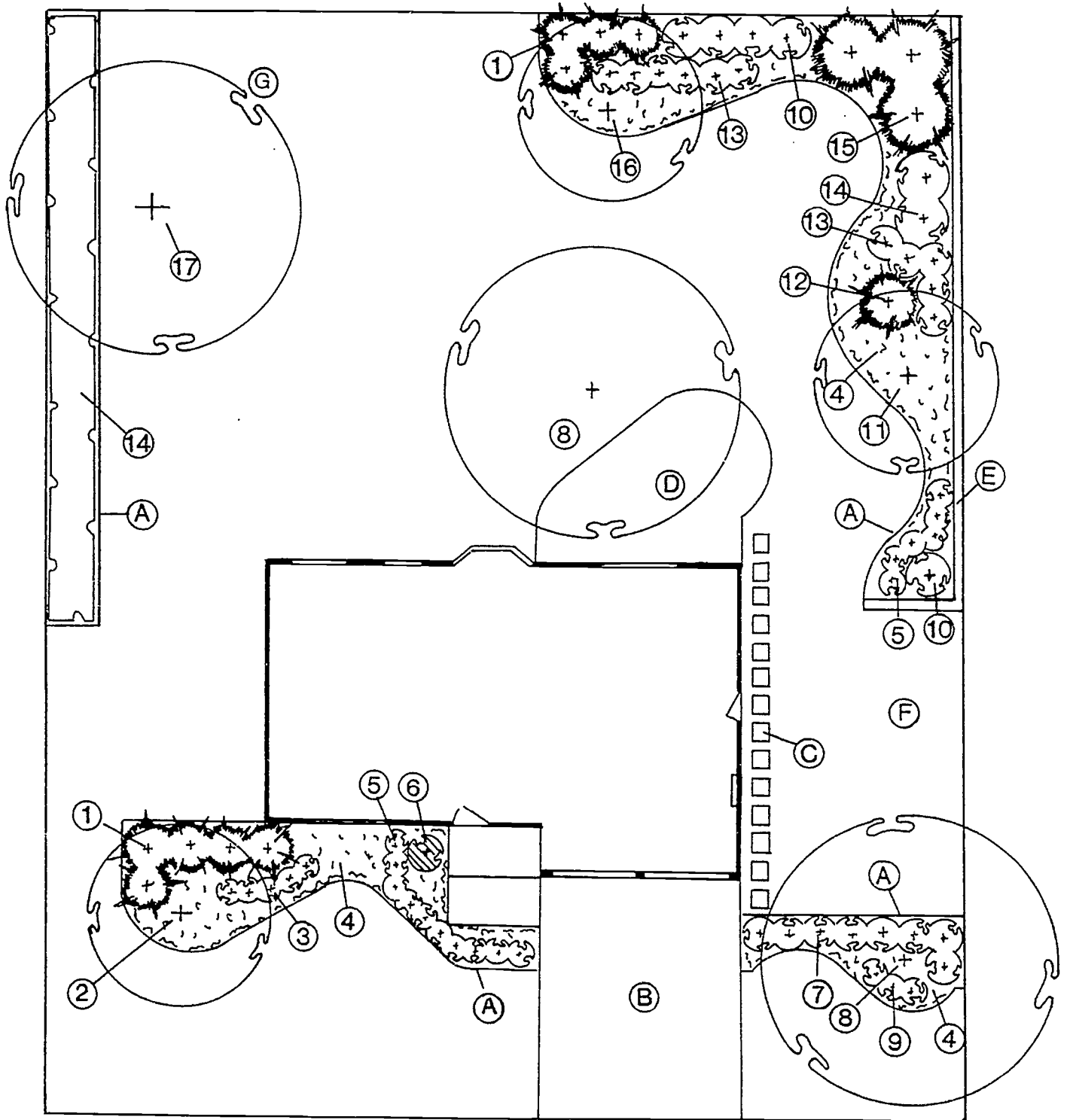

SCALE 1" = 16' 0"

TRANSPARENCY MASTER #25

Plant List

1. Dense Yew
2. Eastern Redbud
3. Dwarf Fothergilla
4. Barren-Strawberry (12" O.C.)
5. Gold Drop Potentilla
6. Rhododendron P.J.M.
7. Clavey Dwarf Honeysuckle
8. Sugar Maple
9. Dwarf European Cranberrybush Viburnum
10. Compact European Cranberrybush Viburnum
11. Snowdrift Crabapple
12. Andorra Juniper
13. Shrubby St. Johnswort
14. Dwarf Winged Euonymus (2' O.C.)
15. Canadian Hemlock
16. Peach Tree
17. Red Oak

Notes

- | | |
|----------------------------|----------------------------|
| A. Ryerson Steel Edging | E. 6' Board-on-Board Fence |
| B. Concrete Drive and Walk | F. Vegetable Garden |
| C. 18" Stepping Stones | G. Play Area |
| D. Brick Patio | |

TRANSPARENCY MASTER DISCUSSION GUIDE

The transparencies and discussion guide are intended to aid teachers in explaining major concepts about designing and drawing landscape plans.

Transparency Master #1

The form of a plant is a result of the outline of the plant and the lines of the trunk and branches. Most plants in nature have rounded, oval, or spreading forms. Most of the plants in landscape design should have the common forms found in nature.

Transparency Master #2

The texture of a plant should also be considered during the design process. Plant textures may be rough, coarse, heavy, dense, smooth, fine, thin, or light. Coarse-textured plants give the impression of being closer to the viewer than they really are, while fine-textured plants appear more distant.

Transparency Master #3

Both leaves and branches determine a plant's texture. Coarse textures result from large leaves and twigs, dull leaf surfaces, short petioles, and entire leaves. Smaller leaves, glossy surfaces, slender twigs, long petioles, and cut leaves contribute to fine textures.

Transparency Master #4

Color has its source from light. The wavelengths not absorbed by a material are reflected to the viewer's eye. Most plants in nature appear green because they absorb all but green wavelengths. Colors can be divided into two major groups: cool, restful colors such as blue, violet and green; and warm stimulating colors including red, orange, and yellow.

Most plants used in the landscape should share green leaf colors. Red-greens and yellow-greens are visually active and seem to approach the viewer. Blue-greens tend to appear more distant. Plants with purple, yellow, bronze, or variegated leaves should be used with caution because they may dominate a landscape. A rule of thumb is to use no more than one colored plant for every nine green ones.

Transparency Master #5

In order to have a landscape appear harmonious the majority of the plant material should share common leaf colors, textures, and forms.

Transparency Master #6

If every plant in the landscape were the same color, texture, or form, the result would be boring. Select a few

plants that differ in color, texture, or form to focus attention or add interest to the design.

Transparency Master #7

Each view in a landscape should appear balanced. That is, each side of the view should have the same visual weight. In formal settings each side would be exactly the same. Informal plantings would have different plant materials on each side but equal visual weight. Homes with an informal architectural design should have informal plantings which would help to balance the entire view of the house.

Transparency Master #8

Key areas in a design such as the front door or focal point in a backyard garden can be stressed with the use of visually active plants. Visual power may result from abrupt changes of shapes, colors, textures, or sizes of plants. Garden embellishments and mixing plants with structural materials may also result in emphasis.

Transparency Master #9

Smooth transition from one element in the landscape to another will contribute to a harmonious view. This can be accomplished by changing form, texture, or color of plant material gradually. For example, step from a coarse texture to a medium texture to a fine texture. Avoid intermittently placing, for example, a fine-textured plant within a series of coarse-textured plants.

Transparency Master #10

Designers need to be aware that the size of the plants around the home may influence a viewer's perception. Exceptionally large trees may cause a house to appear smaller than it is in reality. Also, it is important that plants placed in a location near which people will gather or be present, such as a patio, be of such a size that people can relate to and feel comfortable around them.

Transparency Master #11

Begin the design by placing the plan view of the home and lot on tracing paper. Convert measurements from the Plat of Survey to either 1/8" or 1/16" scale, and include permanent structures such as walks and drives. It is also helpful to carefully locate and draw window and entry locations using home blueprints.

Transparency Master #12

Knowledge of the architectural style of a home greatly influences the selection of plant forms, textures, colors, planting balance, and variety. Sizes of plants will be dictated by the size of the house, the height of the eaves, and the location of windows. The floor plan should be considered by the designer when locating plantings to be viewed from inside or for screening purposes.

Transparency Master #13

The site analysis is a record of on-site observations made by the designer. Notes should be made on a scaled-down version of the base plan on existing vegetation, topography, drainage patterns, soil, structures, climatic conditions, utilities, and views to and from the lot.

Transparency Master #14

Have the family complete a family inventory checklist. The checklist allows the family to organize their thoughts as to what they want in a landscape. Information collected should include family background, gardening interests, entertainment interests, and specific plants or structures desired.

Transparency Master #15

Goose-egg planning is a process in which the approximate locations of the major activities (public area, patio, play area, etc.) are sketched on a sheet of paper placed over the base plan. This should be a relatively quick sketch based on information obtained from the site analysis and family inventory checklist.

Transparency Masters #16 — #18

There are three basic bed patterns in which all shrub plantings are located. They are 90° angles to the home, 45° angles to the home, and arc and tangent. While referring to the goose-egg plan, sketch bed patterns which will reflect the planned activity sites. A chosen bed pattern should be maintained throughout the public area or the outdoor living area. However, a different style may be used in each area. A bold bed pattern provides interest to the design.

Transparency Master #19

Different plant symbols for evergreens, deciduous plants, broadleaf evergreens, hedges, etc., are shown. They make a design interesting and easier to read.

Transparency Masters #20 and #21

The procedure for designing a shrub border is as follows:

1. Select plant's size, texture, and color — Sketch a series of blocks or rectangles representing the arrangement of the various sizes of plant material desired. The blocks should be drawn as though one were facing the plants from ground level. A scale of 1/8 inch to 1 foot is probably the most practical for this drawing.

Indicate, in each block on the sketch, the texture and color desired in each block area. Indicate textures as C (Coarse), MC (Medium-Coarse), M (Medium), MF (Medium-Fine), or F (Fine). Indicate foliage colors as EG (Emerald Green), BLG (Blue-Green), YG (Yellow-Green), RG (Red-Green), GG (Grey-Green), or BG (Black-Green).

2. Sketch plants at mature growth — Place the block sketch on the drafting table and lay a sheet of tracing paper over it. On the tracing paper, draw a sketch of actual plants, at their mature growth, that fills the various blocks drawn.
3. Place the plants in plan view — From the drawing in step 2, draw an overhead view of the plants. Use the appropriate landscape drawing symbol for each of the desired plants.
4. Select plants — Based on the information above on plant size, texture, and color, make a selection of plants for the landscape design.

Transparency Master #22

The sun calculator may be used to locate trees in the landscape for shading purposes. Place the calculator under the tracing paper facing north with the center of the calculator placed where shade is needed. The darkened area indicates the most critical angles for shade with the hours from 4 p.m. to 7 p.m. being especially important.

Transparency Master #23

Neat lettering contributes a great deal to the readability and appearance of a design. Carefully note how each letter is drawn.

Transparency Masters #24 and #25

Every home has many different landscape solutions. Following the basic principles of design will result in a product that will likely increase the aesthetic and monetary value of the home.

STUDENT ACTIVITIES

- STUDENT WORKSHEET #1 — Landscape Needs and Planning
- STUDENT WORKSHEET #2 — Landscape Plants
- STUDENT WORKSHEET #3 — Designing the Living and Public Area
- STUDENT WORKSHEET #4 — Landscape Design Word Search (with solution)
- STUDENT WORKSHEET #5 — Landscape Design — Scale Exercises
- STUDENT WORKSHEET #6 — Scale Drawing
- STUDENT WORKSHEET #7 — Plant Symbol Worksheet
- STUDENT WORKSHEET #8 — Lettering
- STUDENT WORKSHEET #9 — Area and Volume Problems in the Landscape
- STUDENT WORKSHEET #10 — Pricing a Landscape Plan

For additional activities, teachers may refer to the "Suggested Teaching Activities and Procedures" section in the Instructor's Guide.

STUDENT WORKSHEET #1**Landscape Needs and Planning**

Directions: Read Information Sheets #2 - #4 and then answer the following questions.

1. What is landscaping?
2. What are three considerations required in every successful landscape design?
 - a.
 - b.
 - c.
3. On what should the final landscape depend?
4. Name the three major areas that are designed.
 - a.
 - b.
 - c.
5. List four elements which make up the public area?
 - a.
 - b.
 - c.
 - d.
6. What are three functions of trees placed in the public area?
 - a.
 - b.
 - c.
7. List two major benefits from having a large unbroken lawn.
 - a.
 - b.
8. Why are gazing balls, pink flamingos, and other novelties located in the public area considered poor design?
9. Where is the outdoor living area located?

10. List four elements of design which help meet family needs and interests. Give an example of each.
 - a.
 - b.
 - c.
 - d.
11. Give three examples of functions in the service area.
12. What is a site analysis?
13. What observations are noted on a site analysis?
14. What is "goose-egg" planning, and why is it an important step in design?

STUDENT WORKSHEET #1 — Key**Landscape Needs and Planning**

Directions: Read Information Sheets #2 - #4 and then answer the following questions.

1. What is landscaping? *Landscape is creating a plan to best utilize available space in the most attractive way. This involves shaping the land to make the most of the site's natural features, building structures, and selecting and growing plants which best fit into the design.*
2. What are three considerations required in every successful landscape design?
 - a. *Consider the lot to be like a room.*
 - b. *Consider the floor plan of the home.*
 - c. *Consider the landscape as viewed by those on the outside.*
3. On what should the final landscape depend? *The lot and its orientation to wind and sun; the house plan; the amount of money, time, and effort to be spent on maintenance; family interests; and the neighborhood.*
4. Name the three major areas that are designed.
 - a. *The public area*
 - b. *The outdoor living area*
 - c. *The service area*
5. List four elements which make up the public area.
 - a. *Walks and drives*
 - b. *Trees*
 - c. *Shrubs*
 - d. *Lawn areas*
6. What are three functions of trees placed in the public area?
 - a. *Frame the house*
 - b. *Screen architectural details*
 - c. *Provide shade*
7. List two major benefits from having a large unbroken lawn.
 - a. *It connects all other elements.*
 - b. *It gives a broad expansive setting for the house.*
8. Why are gazing balls, pink flamingos, and other novelties located in the public area considered poor design? *They detract from the house.*
9. Where is the outdoor living area located? *In the rear of the house, with the exception of the service area*

10. List four elements of design which help meet family needs and interests. Give an example of each.
 - a. *Enclosures (fences, walls, screens)*
 - b. *Plantings (trees, shrubs, hedges)*
 - c. *Surfaced areas (walks, patios, drive)*
 - d. *Garden embellishments (sculptures, planters, furniture)*
11. Give three examples of functions in the service area. *Garbage cans, clotheslines, compost piles*
12. What is a site analysis? *A record of on-site observations*
13. What observations are noted on a site analysis? *Drainage, soil conditions, existing vegetation, natural features, climatic conditions*
14. What is "goose-egg" planning, and why is it an important step in design? *"Goose-egg" planning is making rough sketches of where various activities will occur in the landscape. These sketches will serve as a guide for designing bed patterns.*

600

STUDENT WORKSHEET #2**Landscape Plants**

Directions: Read Information Sheets #5 - #7 and then answer the following questions.

1. What are three important considerations in selecting plants for the landscape?
2. How do the functions of round plant forms and upright plant forms differ?
3. How can the texture of a plant affect the design?
4. How do warm and cool colors differ in appearance?
5. Unity of composition can be achieved by applying the design principles of R. V. Bess. Briefly explain the importance of each.

Repetition:

Variety:

Balance:

Emphasis:

Sequence:

Scale:

6. List five important factors to consider when selecting trees for the landscape.
 - a.
 - b.
 - c.
 - d.
 - e.

7. Describe the following uses of shrubs.

Specimen —

Accent Plant —

681

Group Planting —

Shrub Border —

Hedge —

Screen —

Foundation Planting —

8. What are the steps in designing a shrub border? Explain each step.

9. What characteristics of a plant are important besides principles of design?

STUDENT WORKSHEET #2 — Key

Landscape Plants

Directions: Read Information Sheets #5 - #7 and then answer the following questions.

1. What are three important considerations in selecting plants for the landscape? *Form, texture, and color*
2. How do the functions of round plant forms and upright plant forms differ? *Upright forms attract attention and are visually active. Round forms are subtle and pleasing to the eye.*
3. How can the texture of a plant affect the design? *Coarse textures attract attention and fine textures appear to recede.*
4. How do warm and cool colors differ in appearance? *Warm colors give the illusion of closeness and may make small areas appear smaller. Warm colors are cheerful and stimulating. Cool colors appear to recede, and they are restive.*
5. Unity of composition can be achieved by applying the design principles of R. V. Bess. Briefly explain the importance of each.

Repetition: *(Simplicity) Line, form, texture, and color uniformly repeated or with some variations can produce unity.*

Variety: *(Contrast) Some variation in form, texture, and color will add interest to the design.*

Balance: *(Symmetry, opposition, alteration) Balance implies equilibrium whether it be formal, which gives a sense of stability, or informal, which is dynamic.*

Emphasis: *(Dominance) Some elements of a design need to have more visual energy than others.*

Sequence: *(Uniformity of change) Uniform change of texture or color provides a pleasant transition from one unit to another.*

Scale: *(Proportion) Absolute scale refers to the size of an object with relation to a designated standard such as a person or a building. Relative scale refers to the size of one object in relation to the other objects in a given composition.*

6. List five important factors to consider when selecting trees for the landscape.

- a. *Hardiness*
- b. *Growth rate*
- c. *Messiness*
- d. *Root growth*
- e. *Mature tree size*

7. Describe the following uses of shrubs.

Specimen — *Outstanding form, texture, and color; shrub can stand alone*

Accent Plant — *Outstanding form, texture, or color but part of shrub mass*

Group Planting — *Less individuality, 3-5 species*

Shrub Border — *Mass planting of shrubs on a border*

Hedge — *Formal or informal row of like plants*

Screen — *Tall, narrow, one type of plant*

Foundation Planting — *Plant materials located to hide a house foundation*

8. What are the steps in designing a shrub border? Explain each step.

The procedure for designing a shrub border is as follows:

- a. *Select plant's size, texture, and color — Sketch a series of blocks or rectangles representing the arrangement of the various sizes of plant material desired. The blocks should be drawn as though one were facing the plants from ground level. A scale of 1/8 inch to 1 foot is probably the most practical for this drawing.*

Indicate, in each block on the sketch, the texture and color desired in each block area. Indicate textures as C (Coarse), MC (Medium-Coarse), M (Medium), MF (Medium-Fine), or F (Fine). Indicate foliage colors as EG (Emerald Green), BLG (Blue-Green), YG (Yellow-Green), RG (Red-Green), GG (Grey-Green), or BG (Black-Green).

- b. *Sketch plants at mature growth — Place the block sketch on the drafting table and lay a sheet of tracing paper over it. On the tracing paper, draw a sketch of actual plants, at their mature growth, that fills the various blocks drawn.*

- c. *Place the plants in plan view — From the drawing in step 2, draw an overhead view of the plants. Use the appropriate landscape drawing symbol for each of the desired plants.*

- d. *Select plants — Based on the information above on plant size, texture, and color, make a selection of plants for the landscape design.*

9. What characteristics of a plant are important besides principles of design? *A plant's ability to thrive in conditions such as poor soil, shade, wind, cold, etc.*

STUDENT WORKSHEET #3**Designing the Living and Public Area**

Directions: Read Information Sheets #8 and #9 and then answer the following questions.

1. Basic design principles for developing the public area include:
 - a.
 - b.
 - c.
2. What are two major plantings in the public area?
3. Plants at the corners should be no taller than _____ and plants at the doorway should be no taller than _____.
4. The growth habits of plants should reflect or repeat _____ of the house.
5. Shrubs should be placed in cultivated beds. The outline of the beds may be _____, _____, or _____.
6. Where should bed lines begin or end?
7. What functions do walls, fences, and upright narrow plants serve?
8. What is the minimum desirable size for a patio?
9. Place the following steps in order.
 - ___ Bed patterns
 - ___ Select plant names based on form, texture, and color
 - ___ Plat of survey, family inventory checklist, site analysis
 - ___ Final plan
 - ___ Place trees in the plan
 - ___ Place shrub symbols within the bed patterns
 - ___ Goose-egg planning
 - ___ Label the plan

665

STUDENT WORKSHEET #3 — Key

Designing the Living and Public Area

Directions: Read Information Sheets #8 and #9 and then answer the following questions.

1. Basic design principles for developing the public area include:
 - a. *Softening the architectural lines of the home.*
 - b. *Framing the home with trees.*
 - c. *Maintaining open lawn areas.*
2. What are two major plantings in the public area? *Corner plantings, doorway plantings*
3. Plants at the corners should be no taller than $\frac{2}{3}$ the distance from the ground to the eave and plants at the doorway should be no taller than $\frac{1}{3}$ to $\frac{1}{4}$ the distance from the ground to the eave.
4. The growth habits of plants should reflect or repeat *architectural lines* of the house.
5. Shrubs should be placed in cultivated beds. The outline of the beds may be *curved, straight, or arc and tangent.*
6. Where should bed lines begin or end? *At architectural features of the house*
7. What functions do walls, fences, and upright narrow plants serve? *Organizing space, screening views, and providing privacy*
8. What is the minimum desirable size for a patio? *300 square feet*
9. Place the following steps in order.
 - 3 Bed patterns
 - 6 Select plant names based on form, texture, and color
 - 1 Plat of survey, family inventory checklist, site analysis
 - 8 Final plan
 - 4 Place trees in the plan
 - 5 Place shrub symbols within the bed patterns
 - 2 Goose-egg planning
 - 7 Label the plan

STUDENT WORKSHEET #4

Landscape Design Word Search

G R O U N D C O V E R T B L L T O E M P H A S I S
 Z P Q R A H M T A E O E A P U X I R L L R W E Q I
 O D T G O B O E R H I D S I N L O R G I T B U R T
 K Y W T V A R I E T Y E E E L F I G D U T H D C E
 J H P I R F Q G P T P M P N G E O D E T L S L Y A
 B G N O W F D E E Y P S L D V I L C O L S A O C N
 O E I L T H C I T S Q U A R E Y N D A T U S Q Z A
 F O F E S V T B I P W M N L D A W I E L A C S O L
 G O X I V P U S T T E I F V L O F K G A P T R C Y
 O N H O A I Y H I G U L Z A B L A E E S R O F I S
 F O I F O E S A O S E A B L S J A P A E E Y I E I
 R A L T M I D N N O A T B D A T A L T B E T F N S
 O B R B F T A M E T L Y X X A C S G C U R R H O T
 L G L X O A T S S H R U B C S U L E S A T D A J G
 O R O I D I R D T T B D T D I A E D O T I H A G V
 C L V M T O A D E O L R N O N L L E R U T X E T A
 L I P D L N S I V O O A L O O D X F G H J W P A T
 R R O L D U I F H S L P F G Z B A G G E E S O O G
 S E Q U E N C E N L T W I N G S C T A C E R C D O
 A C H A R D I N E S S L C S U O U D I C E D F K D

The following words are hidden in the puzzle:

Balance
 Base Plan
 Color
 Deciduous
 Drafting
 Emphasis
 Form
 Focal Point
 Goose Egg
 Ground
 Hardiness

Landscape
 Repetition
 Scale
 Sequence
 Shrub
 Site analysis
 T square
 Texture
 Tree
 Variety
 Vine

607

STUDENT WORKSHEET #4 — Key

Landscape Design Word Search

G R O U N D C O V E R • B • • • E M P H A S I S
 • • • • • • • • • • A • • • • R • • • • • I
 • • • • • • • R • • • S • • • O • • • • • T
 • • • V A R I E T Y • E • F • • • • • E
 • • I • • • • P • • • P • • • O • E • • • • A
 • • N • • • • E • • • L • • • • C • • • • • N
 • E • • • • • T S Q U A R E • N • A • • • • A
 • • • • • • • I • • • N • • A • • E L A C S • L
 G • • • • • • T • • • • • L • • • • • P • • • Y
 • N • • • • • I • • • • A • • • • E • • O • • S
 • • I • • • • • O • • • • B • • • • P • • E • I • I
 R • • • • • • N • • • • • • A • • • • E • • N S
 O • • • F • • • • • • • • • • C • • • • R • • • T
 L • • • • A • • S H R U B • S • • • • • T • • • •
 O • • • • • R • • • • • D • • • • • • • • • •
 C • • • • • D • • • • • N • • • • • E R U T X E T •
 • • • • • • • • • • A • • • • • • • • • • •
 • • • • • • • • • • L • • • • • • G G E E S O O G
 S E Q U E N C E • • • • • • • • • • • • • • •
 • • H A R D I N E S S • • S U O U D I C E D • • •

The following words are hidden in the puzzle:

Balance
 Base Plan
 Color
 Deciduous
 Drafting
 Emphasis
 Form
 Focal Point
 Goose Egg
 Ground Cover
 Hardiness

Landscape
 Repetition
 Scale
 Sequence
 Shrub
 Site analysis
 T square
 Texture
 Tree
 Variety
 Vine

STUDENT WORKSHEET #5

Landscape Design — Scale Exercises

1. Give the length in feet for each of the lines drawn below

_____	1/8" scale	=	_____
_____	1/8" scale	=	_____
_____	1/4" scale	=	_____
_____	1/4" scale	=	_____
_____	1/16" scale	=	_____

2. 72 feet drawn $1/8" = 1'0"$ would be _____ inches long.
3. $7\ 3/4$ inches at $1/4"$ scale equals _____ feet.
4. 17 feet drawn at $1/16" = 1'0"$ would be _____ inches long.
5. 148 feet drawn at $1/8" = 1'0"$ would be _____ inches long.
6. $15\ 1/2$ inches at $1/8"$ scale equals _____ feet.

088

STUDENT WORKSHEET #6

Scale Drawing

Using your scale, measure the lines of this base plan and place the distance in feet of each line in the circle next to the line. (Scale 1/8" = 1'0")

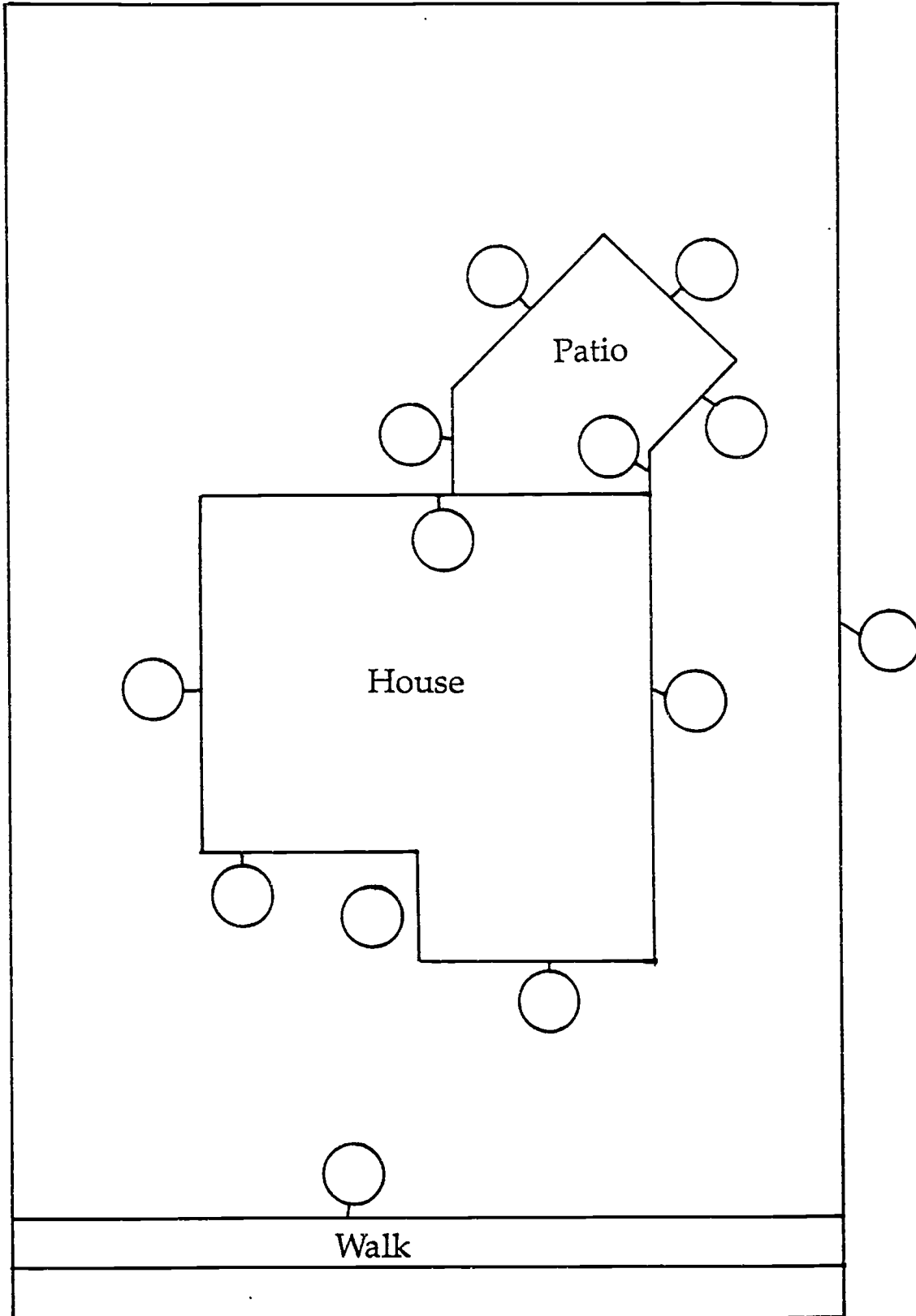

STUDENT WORKSHEET #8

Lettering

Practice lettering by drawing 15 of each letter and number.

A	_____
B	_____
C	_____
D	_____
E	_____
F	_____
G	_____
H	_____
I	_____
J	_____
K	_____
L	_____
M	_____
N	_____
O	_____
P	_____
Q	_____
R	_____
S	_____
T	_____
U	_____
V	_____
W	_____
X	_____
Y	_____
Z	_____

1	_____
2	_____
3	_____
4	_____
5	_____
6	_____
7	_____
8	_____
9	_____
0	_____

STUDENT WORKSHEET #9**Area and Volume Problems in the Landscape**

Given:

Mr. Bill has recently built a new home on a lot measuring 80' wide by 175' long. The home, drive, and entry walks cover 4,300 square feet of the lot. The landscape plan calls for a wood deck in the outdoor living area measuring 30' by 18'.

Corner plantings, doorway plantings, screens, and shrub borders cover 2,750 square feet. However, the soil needs to be amended by adding peat moss 3" deep over the entire planting beds. Sod will be used everywhere except the house, drive, walk, deck, and planting areas.

Questions:

1. How large is the entire lot in square feet?
2. How large in square feet will the deck be?
3. How many square yards of sod will have to be purchased (add 10% for cut and waste)?
4. How many cubic yards of peat moss will be needed?

070

STUDENT WORKSHEET #9 — Key

Area and Volume Problems in the Landscape

Given:

Mr. Bill has recently built a new home on a lot measuring 80' wide by 175' long. The home, drive, and entry walks cover 4,300 square feet of the lot. The landscape plan calls for a wood deck in the outdoor living area measuring 30' by 18'.

Corner plantings, doorway plantings, screens, and shrub borders cover 2,750 square feet. However, the soil needs to be amended by adding peat moss 3" deep over the entire planting beds. Sod will be used everywhere except the house, drive, walk, deck, and planting areas.

Questions:

1. How large is the entire lot in square feet?

$$80 \text{ ft} \times 175 \text{ ft} = 14,000 \text{ sq ft}$$

2. How large in square feet will the deck be?

$$30 \text{ ft} \times 18 \text{ ft} = 540 \text{ sq ft}$$

3. How many square yards of sod will have to be purchased (add 10% for cut and waste)?

$$14,000 - 4,300 - 540 - 2,750 = 6,410 \text{ sq ft of grass}$$

$$9 \text{ sq ft equal one square yard, so } 6,410 \div 9 = 712 \text{ square yards of sod plus } 10\% = 783 \text{ total square yards of sod}$$

4. How many cubic yards of peat moss will be needed?

2,750 square feet. One cubic foot of peat moss will cover 4 square feet 3" deep. There are 27 cubic feet in a cubic yard. One cubic yard will cover 108 square feet (4 x 27) 3" deep. $2,750 \div 108 = 25.46$ cubic yards of peat moss needed.

CLUSTER: HORTICULTURE

UNIT: Landscaping

PROBLEM AREA: Establishing and Maintaining Turf Areas

RELATED PROBLEM AREA(S):

1. Understanding Basic Soil Science Principles (Central Core Cluster)
2. Repairing, Maintaining, and Operating Horticultural Equipment
3. Surveying, Grading, and Tiling
4. Managing Golf Courses (Agricultural Resources Cluster)

PREREQUISITE PROBLEM AREA(S):

1. Understanding Basic Soil Science Principles (Central Core Cluster)
2. Identifying Basic Principles of Plant Science (Central Core Cluster)
3. Enhancing Soil Fertility
4. Classifying Soils (Agricultural Business and Management Cluster)
5. Propagating Plants
6. Understanding Plant Germination, Growth, and Development
7. Controlling Plant Pests
8. Understanding Plant Anatomy and Physiology

LEVEL: Preparatory

OCCUPATIONAL TASKS ADDRESSED:

Horticulture Cluster

Duty A: Propagating Plants, Seeds, and Cuttings

1. Lay sod
2. Maintain sod
3. Select seed varieties

Duty B: Preparing Soils and Planting Media

1. Prepare seedbed
2. Level or smooth planting area

670

Duty C: Controlling the Plant Environment

1. Apply mulches
2. Control pests

Duty K: Maintaining and Improving Grounds

1. Aerify turf
2. Verticut turf
3. Apply topdressing to turf
4. Overseed turf
5. Mow grounds
6. Trim lawn edges
7. Irrigate lawns
8. Sod worn spots in lawn

Duty O: Applying Fertilizer and Chemicals

1. Calculate fertilizer and chemical applications
2. Calibrate fertilizer application equipment
3. Collect soil sample of fertility test
4. Apply fertilizer using cyclone-type spreader

Duty V: Designing/Installing Landscapes

1. Seed Lawns

STATE GOALS FOR LEARNING:

In planning the instruction for this problem area, teachers can promote the development of several student learning objectives which are related to the State Goals for Learning in Biological and Physical Sciences. These objectives are listed on the Learning Assessment Plan forms included on the following page(s). Those learning objectives marked with an asterisk (*) are taken from the sample lists provided by the Illinois State Board of Education.

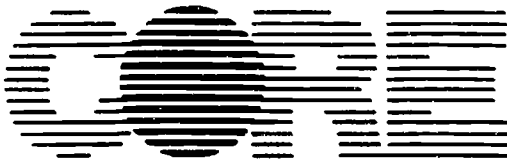

Illinois Agricultural Core Curriculum

Agricultural Education 124 Mumford Hall 1301 W. Gregory Drive University of Illinois Urbana, IL 61801

Director: Dale A. Law, Ed.D.

Principal Investigator: Jerry D. Pepple, Ed.D.

Research Assistant: Ronald J. Biondo

677

INSTRUCTOR'S GUIDE**CLUSTER: HORTICULTURE****UNIT: Landscaping****PROBLEM AREA:** Establishing and Maintaining Turf Areas**STUDENT LEARNING OBJECTIVES**

Upon completion of their study of this problem area, students will be able to:

INSTRUCTOR'S NOTES AND REFERENCES

1. Select turfgrass species and varieties based on their disease resistance and adaptation to local conditions
2. Correctly prepare soil for planting sod or grass seed.
3. Follow recommended procedures in planting sod or seed.
4. Recognize the importance of following proper cultural practices to maintain a healthy turf.
5. Identify and suggest controls for major turfgrass diseases and pests.
6. Identify career opportunities.

630

INSTRUCTOR'S GUIDE**CLUSTER: HORTICULTURE****UNIT: Landscaping****PROBLEM AREA:** Establishing and Maintaining Turf Areas**PROBLEMS AND QUESTIONS FOR STUDY****INSTRUCTOR'S NOTES AND REFERENCES**

1. What types of grass are available?
2. How do the many turfgrass varieties differ?
3. What is a blend?
4. What is a mixture?
5. How should a site be prepared for planting seed or sod?
6. How can perennial weeds be controlled before planting?
7. When is the best time of the year to plant turfgrass?
8. What postplanting care is required?
9. How is sod planted?
10. What are the advantages of sod and seed?
11. What are the recommended procedures for watering, mowing, and fertilizing?
12. What is thatch?
13. What are the major turfgrass weeds, pests, and diseases?
14. How can weeds, pests, and diseases be controlled?
15. What career opportunities are available in the field of turfgrass management?
16. What equipment is used in turfgrass establishment and maintenance?

651

INSTRUCTOR'S GUIDE**CLUSTER:** HORTICULTURE**UNIT:** Landscaping**PROBLEM AREA:** Establishing and Maintaining Turf Areas**SUGGESTED TEACHING ACTIVITIES AND PROCEDURES****INSTRUCTOR'S NOTES AND REFERENCES**

1. Divide the class into small groups, and assign each group a topic for brainstorming, after which the group should report back to the whole class. Topics might include:
 - a. What makes a lawn attractive?
 - b. Why do people place importance on having an attractive lawn?
 - c. What jobs are available to people trained in turfgrass management?
 - d. What can be done to make a lawn more attractive?
2. Conduct a field trip to a sod farm, a golf course, and/or a botanic garden or arboretum.
3. Have the students read Information Sheet #1. Then have them complete Student Worksheet #1.
4. Discuss Information Sheet #1 using Transparency Masters #1 and #2.
5. Show Vocational Agriculture Service Slidefilm *Steps to A Better Lawn*.
6. Bring a yard of sod to class and lead a discussion on how it is grown, harvested, planted, and cared for.
7. Have the students read Information Sheet #2. Then have them complete Student Worksheet #2.
8. Lead a discussion of Information Sheet #2, using Transparency Master #3 as a visual aid.
9. Have the students complete Student Worksheet #3.
10. Have the students complete Student Worksheet #4.
11. Demonstrate how to mow a lawn safely.

652

INSTRUCTOR'S GUIDE**CLUSTER: HORTICULTURE****UNIT: Landscaping****PROBLEM AREA:** Establishing and Maintaining Turf Areas**REFERENCES****INSTRUCTOR'S NOTES AND REFERENCES**

- *1. *Illinois Lawn Care and Establishment*. (Circular 1082). University of Illinois, Cooperative Extension Service, College of Agriculture, 69C Mumford Hall, 1301 W. Gregory Drive, Urbana, IL 61801.
2. *Turfgrass Pest Control*. (Circular 1076). University of Illinois, Cooperative Extension Service, College of Agriculture, 69C Mumford Hall, 1301 W. Gregory Drive, Urbana, IL 61801.
3. *Turfgrass Management*. (1980). Turgeon, A.J. Reston Publishing Company, Inc., Prentice-Hall, 200 Old Tappan Road, Old Tappan, NJ 07676. (800) 223-2348.
- *4. *Establishing a Lawn* (VAS Unit #U5008); *Steps to a Better Lawn* (VAS Filmstrip #F651A). Vocational Agriculture Service, College of Agriculture, University of Illinois, 1401 S. Maryland Drive, Urbana, IL 61801. (217) 333-3871.

*Indicates highly recommended reference

INSTRUCTIONAL RESOURCES

These resources are intended for use by teachers in planning and teaching the materials for this problem area and may be adapted to fit the teaching method(s) used.

INFORMATION SHEET #1 — Establishing Turfgrass

INFORMATION SHEET #2 — Maintaining a Healthy Turfgrass

TRANSPARENCY MASTER #1 — Steps in Preparing the Seedbed

TRANSPARENCY MASTER #2 — Sod or Seed?

TRANSPARENCY MASTER #3 — Cultural Practices to Reduce Disease, Insect, and Weed Problems

624

INFORMATION SHEET #1

Establishing Turfgrass

Turfgrass is one of the most important components found in the landscape. It serves to tie all other landscape elements together, and it provides attractive settings for home, business, and recreational sites. In addition, turfgrass has a cooling effect in summer, it feels good underfoot, it lowers noise levels, and it reduces dust.

Establishing turfgrass properly is the key to having a healthy lawn. Selecting the right turfgrass, preparing the soil before planting, and following recommended planting procedures are essential to success.

Selecting the right turfgrass requires careful consideration. The most common turfgrasses grown in Illinois are Kentucky Bluegrass and Red Fescue, and each species has numerous varieties. Kentucky Bluegrass adapts well to open, sunny locations while Red Fescue performs better in shaded locations. Perennial Ryegrass and Creeping Bentgrass are also used. Perennial Ryegrass is often used as 5 - 15% of a grass seed mix because of its ability to germinate quickly and provide cover. Creeping Bentgrass requires high maintenance and is primarily used for golf greens and fairways.

Seed and sod can be purchased as "mixtures" or "blends." A "mixture" is a combination of two or more species of grass. Red Fescue and Kentucky Bluegrass mixtures are frequently used for lawns that have both sunny and shady areas. A "blend" is a combination of two or more varieties of a species. The advantage of a blend is that the lawn is less likely to be severely damaged by disease or insects because each variety has resistance to different diseases or pests.

Before the seed, sod, or vegetative materials can be planted the soil must be prepared. The first step in soil preparation is to control existing vegetation which could compete with the turfgrass. For effective control, spray the vegetation with a nonselective herbicide about two weeks before planting. Next, rough grade the area to achieve the desired slopes and drainage patterns. Add soil amendments if the soil shows signs of compaction or poor water-holding ability. Peat moss is an amendment that helps loosen the soil and increase water-holding capacity. Sand is often used to improve drainage. However, sand is only beneficial if it makes up at least 50% of the soil. The amendments should be incorporated into the top 6" of the soil.

After amendments have been added, the soil should be tested for pH, phosphorus, and potassium. Nitrogen is not

tested because it leaches through the soil rather quickly. Turfgrass performs best in soils with a pH from 6.0 to 7.0. If necessary add lime to raise the pH or sulfur to lower the pH. Also, fertilize with phosphorus or potassium to correct the deficiencies indicated on the test. Till, plow, or disk the soil to a depth of 6" to mix in the additives, loosen the soil, and break up clumps. Then remove stones, wood, or other debris. Final grade the area by raking it smooth, leaving no materials larger than a marble as they may inhibit the establishment of the grass.

Seeding is probably the easiest and least expensive way to start a lawn. Seeding is best done in late summer when the competition with annual weeds is less of a problem. It is also an accepted practice to sow seed in early spring. Seed should be distributed evenly with the use of a mechanical seeder or fertilizer spreader. After seeding, gently cover the seed with a mulch to shade seedlings, maintain soil moisture, reduce erosion, and maintain a uniform soil temperature. Straw is widely used as a mulch because it has few weed seeds and it decomposes after the grass is established.

Sodding is an alternative to seeding, but it requires more labor and it is more expensive. The major advantages are that it provides an instant, uniform lawn, and it may be planted at any time during the growing season. Sod is sold by the yard with dimensions of 18 inches by 6 feet. Pieces should be rolled out and placed in a brickwork type of pattern. The pieces should be laid snug to each other without excessive stretching. Small stakes or pegs may be needed to hold sod on steep slopes. After the sod is in place, it should be rolled to achieve good contact with the soil and roots.

A third planting method involves the planting of stolons, plugs, or sprigs. Bentgrass lawns are sometimes started by spreading stolons, then partially covering them with soil. Both plugs, which are small pieces of sod, and sprigs, which are individual plants or small clusters of plants, are planted 6 - 12" apart. Vegetative planting of turfgrass is the least common method used.

Upon completion of planting seed, sod, or vegetative materials, watering should take place. Seedbeds should be kept moist for 3 - 4 weeks. Sod should be watered daily for the first week, every other day for the second week and monitored closely thereafter. Vegetative plantings require a moist soil until established. Of course, rainfall, sun, and wind may influence the frequency of watering.

INFORMATION SHEET #2

Maintaining a Healthy Turfgrass

Proper maintenance of turfgrass produces a healthy, attractive lawn. Proper maintenance means following recommended cultural practices including fertilizing, watering, and mowing. Aside from being attractive, a vigorously growing turf is better able to resist disease, insect injury, and weed invasions.

One of the major cultural practices necessary for a healthy turf is fertilization. Fertilizers for turfgrass generally have an analysis higher in nitrogen than potassium or phosphorus. This is because nitrogen is not held in the soil as are phosphorus and potassium, and nitrogen encourages desired leaf growth. To provide a constant supply of nitrogen several applications should be made during the growing season. The months of May, June, and September are the best times to fertilize because the grass is actively growing, as a result of cooler temperatures and moister conditions. Kentucky Bluegrass responds favorably with 2 to 6 pounds of nitrogen per 1,000 square feet each year. Single applications should not exceed 2 pounds of nitrogen per 1,000 square feet, so in order to supply Kentucky Bluegrass with its needs, three applications of 1 1/2 pounds of nitrogen could be made. The equation below helps to determine the amount of fertilizer to use. Apply the fertilizer evenly when the foliage is dry, then water immediately to avoid chemical burn.

Watering is also required when rainfall is inadequate. In general, turfgrass needs about 1" of water, which moistens soils to a depth of 6", every 7 - 10 days. Water can be measured by placing coffee cans under the sprinkler and checking them periodically. Avoid light, frequent waterings as they encourage shallow root growth, which leads to the decline of the lawn. The best time of the day to water is from morning to mid-day so that the leaves will dry quickly, thus reducing disease problems which may occur on leaf blades that are moist all night.

Correct mowing practices are essential in maintaining a healthy lawn. Keeping the mower blades sharp and adjusting the cutting height to a level preferred by the species of grass in the lawn help to maintain a dense turf. A rule of thumb is to remove no more than 1/3 of the leaf blade at any one time. For example: If the desired height of a lawn is 2", (Kentucky Bluegrass is 1 1/2" to 2 1/2") mowing should be done when it reaches 3". Cutting a lawn too short puts a lot of stress on the grass and increases the chance of weed invasion and injury from diseases, insects, and drought. Allowing a lawn to get too tall results in a shaggy appearance and leads to a stressful situation once the grass is mowed. Removal of grass clippings is not necessary unless they form clumps. Clippings return up to 20% of the required nutrients to the soil as they decay. Clippings decay quickly enough so as not to contribute to the thatch layer.

Thatch is a tightly intermingled layer of living and dead stems and roots located between the soil and the green vegetation. It becomes a problem when it accumulates to more than 1/2" thick. When an excessive build-up occurs, grass becomes more susceptible to diseases, and use of a power rake may be needed to remove it in early spring or late summer. In most cases, thatch problems can be prevented by avoiding overfertilization.

Proper cultural practices will reduce weed, disease, and insect problems. However, weeds may occur even in the best kept lawns, in which case they may be removed manually or controlled with a herbicide. Broadleaf weeds can be controlled with selective post-emergence herbicides. Crabgrass, which is an annual, can be controlled with pre-emergence herbicides. Perennial grass weeds are more difficult to control. Small patches can be removed manually, but if the problem is large, re-establishment of the lawn may be necessary. The best way to battle lawn diseases and insect pests after following the proper cultural practices is to correctly identify the disease or insect problem before selecting and carefully using pesticides for their control.

$$\begin{aligned} & (\text{lbs Nitrogen wanted to apply per 1,000 square feet} + \% \text{ Nitrogen in the fertilizer}) \times 100 \\ & = \text{Pounds fertilizer needed per 1,000 square feet} \end{aligned}$$

TRANSPARENCY MASTER #1

Steps in Preparing the Seedbed

1. Control existing weeds and grass.
2. If necessary, rough grade the area.
3. Add soil amendments if needed.
4. Test the soil for pH and nutrients.
5. Apply fertilizer, lime, or sulfur as the soil test dictates.
6. Till the soil to a depth of 6 inches.
7. Remove stones, wood, or other debris.
8. Smooth grade the area, removing particles larger than a marble.
9. Plant seed, sod, or vegetative materials.

TRANSPARENCY MASTER #2

Sod or Seed?**SOD****Advantages**

Provides instant uniform lawn

Can be installed during growing season

Disadvantages

More costly than seed

Requires more labor to install than seed

Availability depends on environmental conditions

Limited grass varieties are available

SEED**Advantages**

Less costly than sod

Easier to install than sod

Adapts to soil conditions better than sod

Better choice of grass varieties

Disadvantages

Best results when planted late summer to early fall

Uniform germination not always achieved

Can be difficult to establish on steep slopes

Weeds can be a problem initially

TRANSPARENCY MASTER #3

Cultural Practices to Reduce Disease, Insect, and Weed Problems

1. Provide good soil drainage and prepare the soil properly for planting.
2. Use blends or mixtures of disease-resistant grasses adapted to the particular location.
3. Plant at recommended times.
4. Avoid over-fertilization and fertilize when the grass is actively growing. Make several small applications a year.
5. Mow frequently. Remove no more than 1/3 of the leaf blade at any one mowing.
6. Provide 1" of water every 7 - 10 days during periods of drought. Water during the morning to mid-day hours.
7. Remove thatch if it has accumulated to more than 1/2 inch in early spring or late summer.

STUDENT ACTIVITIES

STUDENT WORKSHEET #1 — Establishing Turfgrass

STUDENT WORKSHEET #2 — Maintaining a Healthy Turfgrass

STUDENT WORKSHEET #3 — Turf Word Search (with solution)

STUDENT WORKSHEET #4 — Calculating Fertilizer Application Rates

For additional activities, teachers may refer to the “Suggested Teaching Activities and Procedures” section in the Instructor’s Guide.

080

STUDENT WORKSHEET #1

Establishing Turfgrass

(Refer to Information Sheet #1.)

1. List six values associated with turfgrass.

- a. _____
- b. _____
- c. _____
- d. _____
- e. _____
- f. _____

2. What are the two most common turfgrasses used in Illinois?

- a. _____
- b. _____

3. Why is Perennial Ryegrass included in seed mixtures?

4. What grass is used for golf greens?

5. What is a mixture?

6. What is a blend?

7. Place the following soil preparation steps in order from 1 to 8:

- _____ Test the soil for pH, phosphorus, and potassium.
- _____ Smooth grade the area.
- _____ Add soil amendments.
- _____ Till the soil to a depth of 6".
- _____ Control existing vegetation.
- _____ Remove stones, wood, and other debris.
- _____ Apply fertilizer, lime, or sulfur.
- _____ Rough grade the area.

8. What are two advantages of seed?

9. What is the best time to plant seed?

10. Why is mulch placed on a seedbed?

691

11. List two advantages of seed.

- a. _____
b. _____

12. What are two disadvantages of sod?

- a. _____
b. _____

13. What is a third, least common method of planting turf?

14. How should seed be watered after planting?

15. How should sod be watered after installation?

093

STUDENT WORKSHEET #2**Maintaining a Healthy Turfgrass**

(Refer to Information Sheet #2.)

1. Why is it important to follow proper cultural practices?
2. Why is nitrogen the most important nutrient for turf?
3. When is the best time to fertilize?
4. How often should turfgrass be watered?
5. When is the best time to water turfgrass?
6. What is wrong with watering the lawn a little bit every day?
7. How often should grass be mowed?
8. Why is it not a problem to allow grass clippings to remain on the lawn?
9. What is thatch?
10. How can the following be controlled?
 - a. Broadleaf weeds _____
 - b. Crabgrass _____
 - c. Perennial grasses _____
11. What is the best way to control lawn diseases and pests?

STUDENT WORKSHEET #3

Turf Word Search

S I R S M L Y M N G S S S L F B Q L I W
 C T L U S M R O Z M H E G S T L D Y D G
 V G L M P A L I O P G E U A Z B A R R J
 E C N G U O R O F R Z D L J N M T S Z S
 H N S I T I T G E E D F P J I E S L V W
 D M I S W H S D T Q R B B P D A X N N J
 Q H E S G O F S N N C T N X R G I K G X
 R W Y R U L M Y A S E N I G V T U L E S
 W G A E S R X E O T N B E L R K N P Z E
 X D R C D J O D L F O Y G O I O P H B G
 E W U B U A T H D I R P G N E Z B B N U
 G E U Q F H R T P L J E B R I P I I R K
 S T H M A T U G A S N W U E S P R N C Q
 B V T T Z F Y I H Y O T A T S E E D G R
 B X C R Z V N W C G X H Y N T M N E Q J
 E H R M O N Q N R I U F P A G E E Q R V
 E L C C E V H B M S Q O W X L F M Y R C
 M K C R O W J E X M T K R B E Y Q H F X
 W U E N V R R Z G M K Q X U X A K P W J
 B P U K E N T U C K Y B L U E G R A S S

The Following Words are Hidden in the Puzzle:

Blend
 Creeping Bentgrass
 Fertilizing
 Kentucky Bluegrass
 Mixture
 Mowing
 Mulch
 Nitrogen
 Perennial Ryegrass
 Phosphorus

Plugs
 Potassium
 Red Fescue
 Rough Grade
 Seed
 Smooth Grade
 Sod
 Stolon
 Thatch
 Watering

004

STUDENT WORKSHEET #3 — Key

Turf Word Search

. . . S M . . . N . S S S
 . . . U S . . O . M . E G
 . G L M . A L . O . . E U
 . C N . U O R O F R . D L S . .
 H . . I T I T G E E . . P . . . S . . .
 . . . S W H S D T . R A . N . .
 . . . S G O F S . N . T . . R . I . . .
 . . . R U E M . A S E . I G . T
 . . A E S R . . O T . B E L R
 . D . C D . O D . . O Y G O I G
 E . U . . A T H . . R P G N E Z . . N . .
 . E . . . H R . P L . E . R I . I I . . .
 A . . G A S N . U . . P R N . . .
 . . . T . . . I H . O T . . . E E D G . .
 . . C . . . N . . G X H . . T . N E . . .
 . H . . . N . . . I U . P A . E . . R . .
 E . . . M . . O W . L C
 . . . R R B
 . . E
 . P . K E N T U C K Y B L U E G R A S S

The Following Words are Hidden in the Puzzle:

Blend
 Creeping Bentgrass
 Fertilizing
 Kentucky Bluegrass
 Mixture
 Mowing
 Mulch
 Nitrogen
 Perennial Ryegrass
 Phosphorus

Plugs
 Potassium
 Red Fescue
 Rough Grade
 Seed
 Smooth Grade
 Sod
 Stolon
 Thatch
 Watering

695

STUDENT WORKSHEET #4

Calculating Fertilizer Application Rates

Calculate the fertilizer rate for each problem given. Show your work.

Equation:

$$(\text{lbs Nitrogen wanted to apply per 1,000 sq ft} + \% \text{ Nitrogen in the fertilizer}) \times 100 = \text{lbs fertilizer needed} / 1,000 \text{ sq ft}$$

1. A homeowner desires to fertilize her lawn with a 10-6-4 fertilizer at a rate of 2 pounds nitrogen per 1,000 square feet. Her yard measures 10,000 square feet. How many pounds of fertilizer does she need?

2. A park district employee has been given the task of fertilizing a park that has two acres of turf. He has a 27-3-3 fertilizer and he wants to apply 1 pound per 1,000 square feet. How much fertilizer does he need? (1 acre equals 43,560 sq ft.)

3. A high school student has been hired to fertilize his neighbor's lawn. He has measured the lot at 120 feet x 100 feet and has estimated that the house and drive take up 1,500 square feet of the lot. He is to use a 20-10-10 fertilizer at a rate of 2 pounds Nitrogen per 1,000 square feet. How much fertilizer should he apply?

680

CLUSTER: HORTICULTURE

UNIT: Landscaping

PROBLEM AREA: Transplanting and Maintaining Landscape Plants

RELATED PROBLEM AREAS:

1. Designing and Drawing Landscape Plans
2. Surveying, Grading, and Tiling
3. Interior Landscaping

PREREQUISITE PROBLEM AREA(S):

1. Understanding Plant Germination, Growth, and Development
2. Understanding Plant Anatomy and Physiology
3. Understanding Basic Soil Science Principles (Central Core Cluster)
4. Controlling Plant Pests

LEVEL: Orientation

OCCUPATIONAL TASKS ADDRESSED:

Horticulture Cluster

Duty A: Propagating Plants, Seeds, and Cuttings

1. Plant trees and shrubs
2. Transplant cuttings

Duty C: Controlling the Plant Environment

1. Cultivate plants
2. Water plants and nursery stock
3. Apply mulches
4. Remove diseased plants

Duty D: Applying Fertilizer and Chemicals

1. Calculate fertilizer and chemical applications
2. Treat nutrient deficiencies
3. Time chemical applications
3. Apply fertilizer using watering system
4. Apply fertilizer using an auger type distributor
5. Apply fertilizer using cyclone type spreader

Duty E: Harvesting Plants

1. Dig shrubs and trees
2. Ball and burlap shrubs and trees
3. Harvest bare root stock

Duty I: Storing, Shipping, and Taking Inventory

1. Pack shrubs
2. Care for overwintering of container grown plants

Duty J: Designing/Installing Landscapes

1. Plant trees
2. Plant shrubs
3. Plant ground cover

Duty K: Maintaining and Improving Grounds

1. Prune trees
2. Prune plants, hedges, and shrubs

Duty L: Servicing and Maintaining Equipment and Facilities

1. Maintain hand tools

STATE GOALS FOR LEARNING:

In planning the instruction for this problem area, teachers can promote the development of several student learning objectives which are related to the State Goals for Learning in Biological and Physical Sciences. These objectives are listed on the Learning Assessment Plan forms included on the following page(s). Those learning objectives marked with an asterisk (*) are taken from the sample lists provided by the Illinois State Board of Education.



Illinois Agricultural Core Curriculum

Agricultural Education 124 Mumford Hall 1301 W. Gregory Drive University of Illinois Urbana, IL 61801

Director: Dale A. Law, Ed.D.

Principal Investigator: Jerry D. Pepple, Ed.D.

Research Assistant: Ronald J. Biondo

688

88/89

Horticulture
Landscaping



ILLINOIS STATE BOARD OF EDUCATION
 Department of School Improvement Services
 100 North First Street
 Springfield, Illinois 62777-0001

LEARNING ASSESSMENT PLAN
Instructions and codes for this form are provided on a separate sheet.

Submission Date _____ Page _____ of _____

Original submission Revision

I. LEARNING AREA (check one)

Language Arts Fine Arts

Mathematics Social Sciences

Sciences Physical Development/Health

(Affix label or complete district information.)

COUNTY _____ DISTRICT _____ ESC _____

District Name _____

City _____

Contact Person: _____
 Title: _____
 Phone: (_____) _____

II. STATE GOAL FOR LEARNING
 As a result of their schooling, students will have a working knowledge of the concepts and basic vocabulary of Biological, Physical, and Environmental Sciences and their application to life and work in contemporary technological society.

III. LEARNING OBJECTIVES			IV. ASSESSMENT				V. EXPECTATIONS
A Types	B Validity/ Reliability	C Commercial Test(s)	D Evidence of Nondiscrimination	Percent of Students Expected to Achieve Objective			
By the end of grade (circle one) 3 6 8 11	students should be able to:						
*1.	Identify the components necessary for a community to exist and survive.						
*2.	Know the principal environmental factors that limit the distribution of plants and animals.						
3.	Explain the procedure in transplanting trees, shrubs, and ground cover.						
4.	Describe postplanting care for trees, shrubs, and ground cover.						
5.	Describe the methods of fertilizing trees, shrubs, and ground cover.						
6.	Describe proper watering techniques for trees, shrubs, and ground cover.						
						700	

699

700



INSTRUCTOR'S GUIDE**CLUSTER: HORTICULTURE****UNIT: Landscaping****PROBLEM AREA:** Transplanting and Maintaining Landscape Plants**STUDENT LEARNING OBJECTIVES**

Upon completion of their study of this problem area, students will be able to:

1. Explain the procedure in transplanting trees, shrubs, and ground cover.
2. Describe postplanting care for trees, shrubs, and ground cover.
3. Describe the methods of fertilizing trees, shrubs, and ground cover.
4. Describe proper watering techniques for trees, shrubs, and ground cover.
5. Explain approved pruning practices for landscape plants.

INSTRUCTOR'S NOTES AND REFERENCES

701

INSTRUCTOR'S GUIDE**CLUSTER: HORTICULTURE****UNIT: Landscaping****PROBLEM AREA:** Transplanting and Maintaining Landscape Plants**PROBLEMS AND QUESTIONS FOR STUDY****INSTRUCTOR'S NOTES AND REFERENCES**

1. How are plant materials balled and burlapped?
2. What size should the soil ball be for a balled and burlapped tree or shrub?
3. What are the advantages of a mechanical transplanting machine?
4. What is desiccation?
5. When is the best time of the year to transplant trees or shrubs?
6. How do bare-root, balled and burlapped, mechanically transplanted, and containerized trees and shrubs differ?
7. Should twine and burlap be removed from the soil ball when transplanting?
8. What is the purpose of a soil saucer?
9. How should newly planted trees or shrubs be pruned? Protected with tree wrap? Braced? Watered?
10. When and how often should landscape plantings be fertilized?
11. What are the proper procedures for watering established landscape plantings?
12. What are the advantages of using mulch?
13. Why are plants pruned?
14. What are the recommended pruning practices?

702

INSTRUCTOR'S GUIDE**CLUSTER: HORTICULTURE****UNIT: Landscaping****PROBLEM AREA:** Transplanting and Maintaining Landscape Plants**SUGGESTED TEACHING ACTIVITIES AND PROCEDURES**

1. Conduct a field trip to a garden center and a nursery.
2. Arrange a demonstration on how to ball and burlap a tree.
3. Lead a discussion on how trees, shrubs, and ground covers are prepared for sale.
4. Have a local nurseryman demonstrate how trees and shrubs can be dug mechanically.
5. Have the students read Information Sheet #1 then have them complete Student Worksheet #1.
6. Lead a discussion comparing the advantages and disadvantages of bare-root stock, balled and burlapped stock, and containerized stock. Use Information Sheet #2.
7. Plan a tree planting on Arbor Day (last Friday in April) involving the class. Seek help from the City or Park District and make it a community project.
8. Discuss watering, fertilizing, bracing, and wrapping of newly planted trees.
9. Have the students read Information Sheet #3. Then have the students complete Student Worksheet #2.
10. Lead a discussion on how to properly fertilize and water trees.
11. Use Transparency Masters to aid in the discussion of how to plant and fertilize landscape plants.
12. Lead a discussion on the uses and types of mulches in the landscape.
13. Assign Information Sheet #3 for reading. Then have the student complete Student Worksheets #3 and #4.
14. Demonstrate how to prune various plants on the school grounds.
15. Lead a discussion on pruning using the transparencies provided.
16. Allow the students to complete Student Worksheet #5.

INSTRUCTOR'S NOTES AND REFERENCES

700

INSTRUCTOR'S GUIDE

CLUSTER: HORTICULTURE

UNIT: Landscaping

PROBLEM AREA: Transplanting and Maintaining Landscape Plants

REFERENCES**INSTRUCTOR'S NOTES AND REFERENCES**

- *1. *Landscape Construction Procedures, Techniques, and Design*. (1988). Giles, Floyd. Stipes Publishing Co., 10-12 Chester Street, Champaign, IL 61820.
2. *Tree Maintenance*. Pirone, P.P. Oxford University Press, Inc., 16-00 Pollitt Drive, Fair Lawn, NJ 07410. (201) 796-8000.
- *3. *Pruning Evergreens and Deciduous Trees and Shrubs* (Circular 1033). Giles, F.A., Siefert, W.B. University of Illinois, Cooperative Extension Service, College of Agriculture, 69C Mumford Hall, 1301 W. Gregory Drive, Urbana, IL 61801.
4. *Pruning Landscape Plants* (Bulletin 543). Cooperative Extension Service, College of Agriculture, The Ohio State University, Columbus, OH 43210.
5. *Objectives to Pruning Deciduous Trees* (VAS Filmstrip #F615); *Major Pruning of Trees* (VAS Filmstrip #F639); *Mechanical Digging of Trees and Shrubs* (VAS Filmstrip #F641-1); *Hand Digging of Trees and Shrubs* (VAS Filmstrip #F641-2); *Proper Transplanting of Trees* (VAS Filmstrip #F641-3); *Care of Newly Planted Trees* (VAS Filmstrip #F641-4); *Pruning Evergreens* (VAS Filmstrip #F643); *Pruning Deciduous Shrubs* (VAS Filmstrip #F644); *Pruning Flowering Trees* (VAS Filmstrip #F645); *Packaging of Trees and Shrubs* (VAS Filmstrip #F686); *Fertilizing and Watering Shade and Ornamental Trees* (VAS Unit #U5003); *Controlling Plant Growth* (VAS Unit #U5004A). Vocational Agriculture Service, College of Agriculture, University of Illinois, 1401 S. Maryland Drive, Urbana, IL 61801. (217) 333-3871.

*Indicates highly recommended reference

INSTRUCTIONAL RESOURCES

These resources are intended for use by teachers in planning and teaching the materials for this problem area and may be adapted to fit the teaching method(s) used.

- INFORMATION SHEET #1 — Planting a Balled and Burlapped Tree
- INFORMATION SHEET #2 — Advantages and Disadvantages of Bare-Root, Balled and Burlapped, and Containerized Stock
- INFORMATION SHEET #3 — Fertilizing and Watering Landscape Plants
- INFORMATION SHEET #4 — Uses of Mulches
- INFORMATION SHEET #5 — Types of Mulches
- INFORMATION SHEET #6 — Pruning Landscape Plants
- TRANSPARENCY MASTER #1 — Planting a Tree (with discussion guide)
- TRANSPARENCY MASTER #2 — Planting a Tree (with discussion guide)
- TRANSPARENCY MASTER #3 — Planting a Containerized Shrub (with discussion guide)
- TRANSPARENCY MASTER #4 — Fertilizing a Tree with Dry Fertilizer (with discussion guide)
- TRANSPARENCY MASTER #5 — Fertilizing a Tree with Soluble Fertilizer (with discussion guide)
- TRANSPARENCY MASTER #6 — Pruning Tools (with discussion guide)
- TRANSPARENCY MASTER #7 — Pruning Deciduous Trees (with discussion guide)
- TRANSPARENCY MASTER #8 — Removing a Large Limb (with discussion guide)
- TRANSPARENCY MASTER #9 — Renewal Pruning (with discussion guide)
- TRANSPARENCY MASTER #10 — Rejuvenating Techniques (with discussion guide)
- TRANSPARENCY MASTER #11 — Heading Back Techniques (with discussion guide)
- TRANSPARENCY MASTER #12 — Pruning Pines (with discussion guide)
- TRANSPARENCY MASTER #13 — Pruning Spruce (with discussion guide)
- TRANSPARENCY MASTER #14 — Pruning Junipers (with discussion guide)
- TRANSPARENCY MASTER #15 — Pruning Yews (with discussion guide)
- TRANSPARENCY MASTER #16 — Pruning Rhododendrons (with discussion guide)
- TRANSPARENCY MASTER #17 — Pruning Deciduous Hedges (with discussion guide)
- TRANSPARENCY MASTER #18 — Pruning Techniques for Deciduous Hedges (with discussion guide)

INFORMATION SHEET #1

Planting a Balled and Burlapped Tree

Location — Before planting a tree, give careful consideration to its location. Avoid areas that are known to collect water. Most trees will find difficulty growing in compacted soil. If poor soils or poor drainage cannot be corrected, select a tree species that is tolerant of the conditions.

Trees should be planted far enough from buildings and other obstacles to allow for adequate sunshine, rain, air circulation and room for normal growth.

Digging the hole — Dig a hole much larger than the tree ball. Allow for a minimum of 6 inches open space around the entire ball. Dig the hole at least 6 inches deeper than the height of the ball. Recent studies have shown that trees become established more quickly in larger holes.

Improving soil texture — Heavy clay soils common in parts of Illinois often need soil amendments. Thoroughly mix peat moss, compost, or similar materials into the soil to be used for backfilling. The addition of organic materials will insure adequate aeration, water retention, and good root growth. Coarse sand is suggested for loosening soil and improving drainage.

Placing the plant — Place enough soil at the bottom of the hole so the tree can be planted at the same depth at which it was growing before being dug up for transplanting.

Nylon twine and green burlap resist decay and will strangle the tree trunk or roots, possibly killing the tree. To avoid this, remove them before backfilling and throw away.

Brown burlap will rot, so it may be left on. However, peel it back over the ball. Any burlap sticking above the ground will serve as a wick and draw water from the tree ball, possibly damaging roots.

Filling the hole — Once the tree is properly positioned, backfill the hole halfway. Step this soil down to eliminate air pockets. Then fill the hole to the top with water. Allow the water to be absorbed before completing the backfill process. Do not step down wet soil. Leave a soil lip circling the hole to form a basin for holding water. A 2-inch layer of mulch on top of the ball will help to retain moisture.

Pruning — Newly planted trees should be pruned to compensate for the loss of roots when the tree was dug. Select branches to be removed from throughout the crown so as not to lose the natural growth habit of the tree. Make all cuts flush to the adjoining limb. DO NOT remove more than 30% of the existing crown.

Wrapping — Protect the trunks of newly planted trees from sun scald and frost cracks by using tree wrap or burlap. Tightly wrap the material around the trunk and secure it with twine.

Bracing — Newly planted trees should be braced from movement to protect the tiny roots just developing. Use a minimum of two stakes for trees up to 3 inches in diameter. Drive the stakes outside the hole you have dug. This will provide more secure footing. Attach the tree to the stakes with a wire run through a piece of hose to avoid injury to the tree trunk. Trees with diameters larger than 3 inches will need three stakes.

Watering — Recently planted trees need an abundance of water. Supply enough water to soak the soil around the roots at each watering. During prolonged dry periods it may be necessary to soak the soil every 10 days.

700

INFORMATION SHEET #2

**Advantages and Disadvantages of
Bare-Root, Balled and Burlapped, and Containerized Stock**

Bare-Root Stock

Advantages

1. Trees are easily shipped.
2. Trees are lightweight.

Disadvantages

1. Root damage, and therefore transplant shock, is a serious problem, lowering the survival rate.
2. Only smaller material can be sold bare-root.
3. Planting must be done immediately.
4. Plants are slower to establish.

Balled and Burlapped

Advantages

1. Large trees can be balled and burlapped.
2. Most roots are kept intact.
3. Less care in the field is needed than with containerized material.

Disadvantages

1. More labor is required for digging and moving.
2. Digging can be done only at certain times of the year.

Containerized

Advantages

1. Plant material is ready for installation at any time.
2. Root damage, and therefore transplant shock, is slight. Survival rate is high.
3. More plants can be grown per acre.

Disadvantages

1. Frequent watering is required.
2. Fertilizer must be applied on a regular basis.
3. Size of trees is limited.
4. Plants may become pot-bound.

707

INFORMATION SHEET #3

Fertilizing and Watering Landscape Plantings

In order to maintain vigorously growing landscape plantings it is necessary to fertilize and water periodically. Fertility levels in landscape soils drop because the natural process of nutrients being released by decaying plant parts is prevented with the removal of leaves, twigs, and grass clippings. Also, fertilizers and water applied to the lawn seldom reach tree roots in adequate quantities to greatly benefit the tree. Because of this ineffectiveness of lawn-applied fertilizer, and the greater ability of well-nourished plants to defend themselves against disease and insect pests, more effective methods of fertilizer application should be used. The added cost and labor of these methods is justified.

There are four major methods of fertilizing trees: (1) dry fertilizer is placed in the root zone, (2) soluble fertilizer is pumped into the root zone, (3) soluble fertilizers are sprayed onto the foliage, and (4) solid fertilizer capsules are placed in the trunk. The most practical methods involve placing the fertilizer in the root zone. Trees respond best if fertilized in late fall or early spring every 3-4 years.

The method of using dry fertilizer involves the making of a series of holes in the root zone about 18-24" deep. The holes should be under the dripline of the tree starting three feet from the trunk to avoid damage to roots. The holes should be spaced about 2' apart. The holes 2-3" in diameter and 18" deep can be made with an auger. Then a predetermined amount of fertilizer is distributed in the holes, and the holes are filled with water and sealed with soil. Recommended amount of fertilizer to use depends on the tree size. Trees with diameters less than 6" should receive 5 pounds of a 10-6-4 or similar analysis for each inch. Trees larger than 6" in diameter should receive 10 pounds for each inch. It should be noted that simply applying fertilizer on the soil surface is not effective and can damage the turf.

Soluble fertilizers can be pumped under pressure through a needle into the ground. This method has advantages over using dry fertilizers because distribution is more uniform, nutrients are available immediately, the tree receives a good watering, and less labor is required. Two disadvantages are the difficulty of pushing the needle into compacted or heavy clay soils, and the lack of long-lasting effects from soluble fertilizers.

The leaves and trunk are other avenues for supplying trees with nutrients. Foliage sprays using soluble fertilizers have proved very effective on young leaves during extended dry spells. The leaves will actually absorb the nutrients. However, widespread use of this method has not been practical.

The fourth method of fertilizing is primarily used for trees suffering micronutrient deficiencies. If soils are very alkaline the tree cannot absorb certain micronutrients such as iron and manganese. Symptoms of yellowing leaves or chlorosis are commonly seen on Pin Oaks, Red Maples and Sweetgums. Since the soil pH cannot be changed without damaging roots, a solution is to drill holes in the trunk and place "capsules" of iron or manganese just under the bark. The nutrients dissolve and move up to the leaves. The disadvantage is the trunk is damaged, allowing entry for disease and insect pests.

Shrubs can be fertilized by broadcasting the material on top of the soil. Directions concerning the amount to use can be obtained from the fertilizer label. As with trees, fertilizing should take place in late fall to early spring every 3-4 years.

Fertilizer spreaders may be used to fertilize ground covers before July every year. Two to four pounds of 5-10-5 or 5-10-10 fertilizer per 100 square feet should be applied when foliage is dry. The ground should be watered immediately.

Water needs to be provided for landscape plants on a regular basis for the first two growing seasons. Woody plants require about 1" of water every 7-10 days, particularly during warm, dry, windy periods. Water landscape plants thoroughly before the ground freezes in late fall to protect against damage from desiccation (water loss from tissues). Once the plants are well established they may need to be watered only during periods of drought.

A practice that reduces loss of soil moisture is the application of a mulch. Hardwood bark, wood chips, and pine needles spread several inches deep around trees, shrubs, and newly planted ground cover also reduce weeds, keep soil temperatures uniform, and look attractive. Nitrogen should be added with the application of mulch because the process of decomposition tends to draw nitrogen from the soil.

708

INFORMATION SHEET #4

Uses of Mulches

Materials applied to the surface of the soil as a protective covering are called mulches. These materials may be organic or inorganic.

Mulches serve many useful purposes. They can:

1. Suppress weeds.
2. Maintain a uniform soil temperature by acting as an insulator, thus reducing damage by freezing and thawing.
3. Increase the water-holding capacity of light sandy soils.
4. Increase the aeration of heavy clay soils as they become mixed with the top layer of soil.
5. Prevent and reduce surface soil erosion and soil compaction.
6. Add organic matter to the soil and improve soil tilth.
7. Reduce the evaporation of water from the soil.
8. Create a desirable appearance in the landscape setting.
9. Protect fruits and vegetables prior to harvest.
10. Promote extensive root systems in the upper 2 inches of the soil.
11. Increase the breakdown of organic matter, thus releasing nutrients for plant growth.

Mulching materials also have some negative characteristics:

1. Mulches *cannot* suppress large weeds.
2. Some mulches may be flammable.
3. Rodents and insects may live and overwinter in mulch.
4. Mulches cannot prevent disease and may in fact introduce certain plant diseases.
5. Some mulches severely reduce the nitrogen level of the soil.
6. Mulches may encourage slug and snail infestation.
7. Mulches can prevent moisture from penetrating the soil surface.
8. Mulches can be unpleasant and difficult to handle.

700

INFORMATION SHEET #5

Types of Mulches

Name	Positive	Negative	Uses
1. Shredded Bark	<ul style="list-style-type: none"> • long-lasting • allows moisture to penetrate 	<ul style="list-style-type: none"> • can be stringy and difficult to manage 	<ul style="list-style-type: none"> • perennial beds • landscape beds
2. Decorative Wood Chips	<ul style="list-style-type: none"> • long-lasting • available in various sizes 	<ul style="list-style-type: none"> • may be expensive • not a good source of organic matter 	<ul style="list-style-type: none"> • landscape beds in public area
3. Straw	<ul style="list-style-type: none"> • inexpensive • lightweight 	<ul style="list-style-type: none"> • may blow away • may contain weed seeds • flammable • may attract rodents 	<ul style="list-style-type: none"> • turf areas • winter protection of perennials • summer mulch for fruits and vegetables
4. Gravel Chips, Crushed Stones	<ul style="list-style-type: none"> • permanent covering • retain heat and warm the soil 	<ul style="list-style-type: none"> • do not suppress weeds • expensive 	<ul style="list-style-type: none"> • highlight landscape features
5. Black Polyethylene Film	<ul style="list-style-type: none"> • suppresses all weeds • absorbs heat and eliminates moisture evaporation 	<ul style="list-style-type: none"> • may blow away if not weighted down • no aesthetic appeal 	<ul style="list-style-type: none"> • vegetable garden • place beneath wood chips or gravel in landscape beds
6. Crushed Corncobs	<ul style="list-style-type: none"> • good weed inhibitor • retain soil moisture 	<ul style="list-style-type: none"> • tie up nitrogen in soil • difficult for water to penetrate soil surface 	<ul style="list-style-type: none"> • vegetable garden • annual or perennial beds
7. Sawdust	<ul style="list-style-type: none"> • inexpensive • readily available 	<ul style="list-style-type: none"> • ties up nitrogen in the soil • fire hazard • unattractive to worms 	<ul style="list-style-type: none"> • add to compost • vegetable gardens
8. Lawnclippings	<ul style="list-style-type: none"> • readily available • source of nutrients for the soil 	<ul style="list-style-type: none"> • get matted and moldy when wet • when spread thickly will begin to rot 	<ul style="list-style-type: none"> • mix with other organic materials • vegetable gardens
9. Leaves	<ul style="list-style-type: none"> • add essential elements to the soil • readily available 	<ul style="list-style-type: none"> • tend to mat and become soggy 	<ul style="list-style-type: none"> • mix with other organic materials • perennial beds, vegetable gardens
10. Cocoabean Hulls	<ul style="list-style-type: none"> • absorb heat and warm the soil • attractive dark brown color 	<ul style="list-style-type: none"> • develop mold when wet • lightweight; may blow away 	<ul style="list-style-type: none"> • landscape beds in public area
11. Peat Moss	<ul style="list-style-type: none"> • free of weed seed • good soil conditioner 	<ul style="list-style-type: none"> • absorbs surface moisture preventing penetration • dries out rapidly, forming crust on surface 	<ul style="list-style-type: none"> • good mulch for plants requiring an acid soil
12. Shredded Newspaper	<ul style="list-style-type: none"> • readily available • excellent method of recycling 	<ul style="list-style-type: none"> • unattractive • lightweight; may blow away 	<ul style="list-style-type: none"> • mix with other organic materials • vegetable gardens
13. Compost	<ul style="list-style-type: none"> • slowly adds nutrients to the soil • good method of recycling organic materials 	<ul style="list-style-type: none"> • if not properly prepared will tend to mat and rot 	<ul style="list-style-type: none"> • soil conditioner • winter mulch for garden • summer mulch for perennials, annuals, and ornamentals
14. Peanut Hulls	<ul style="list-style-type: none"> • lightweight • decompose quickly and add organic matter to the soil 	<ul style="list-style-type: none"> • may develop mold when wet 	<ul style="list-style-type: none"> • good mulch for tomato plants • annual and perennial beds
15. Pine Needles	<ul style="list-style-type: none"> • lightweight • weed-free • easy to handle • absorb little or no moisture 	<ul style="list-style-type: none"> • unattractive to worms • coarse appearance 	<ul style="list-style-type: none"> • good mulch for broadleaf evergreens and other ornamental shrubs

INFORMATION SHEET #6

Pruning Landscape Plants

The practice of pruning landscape plants is essential for maintaining their desired appearance. A simple definition for pruning is the removal or reduction of certain plant parts. Woody landscape plants are pruned:

1. To restrict the size of the plant.
2. To develop a strong framework of branches.
3. To repair damaged limbs.
4. To improve flowering of trees and shrubs.
5. To remove diseased or insect-infested limbs.
6. To direct growth.
7. To maintain a desired cultivar.
8. To provide safety.

Different types of landscape plants require different methods of pruning. Some rules of thumb that apply to pruning all materials follow:

1. Avoid leaving stubs by making all cuts flush with the parent stem. Stubs do not heal over, and disease may enter as a result.
2. The natural shape of the plant should be maintained with the exception of hedges.
3. Begin pruning while the plants are relatively young.
4. In most cases, prune after the plant flowers.
5. Safely use sharp tools best suited for the job.

Pruning Deciduous Trees

Although trees may be pruned at any time of the year, there are some distinct advantages to pruning in early spring. At that time it is easy to see the framework, wounds heal more quickly, and the chance of infection is less. (Hard maples and birches should be pruned when leaves are on the tree as they bleed heavily in spring.)

Never remove more than 1/3 of the tree's branches at any one time. Excessive pruning weakens the tree.

Some specific considerations follow:

1. Remove dead wood and diseased limbs first.
2. Next, inspect the tree for crossing branches. Movement of the tree can cause open wounds where branches rub upon one another. The less important limb should be removed.
3. Prune watersprouts, which are fast-growing twigs that arise vertically from the stems. Watersprouts seldom flower and they often result in crossing branches.
4. Remove suckers. Suckers differ from watersprouts in that they originate from the base of the tree.
5. Develop a strong framework by eliminating potentially dangerous V-shaped crotches. V-shaped crotches are not as structurally sound as U-shaped crotches and may split apart when limbs grow larger and heavier.

Pruning Deciduous Shrubs

Attention needs to be given to the pruning of shrubs in the landscape. Three major methods used follow:

1. **Renewal Pruning** — In order to renew shrubs a number of older stems are removed, leaving younger stems. This method is commonly used with lilacs to induce flowering.
2. **Rejuvenation** — This method involves the complete removal of all stems, leaving 4" to 6" stubs. It is recommended on certain species when they become overgrown. At the time of pruning it is suggested that the roots are pruned with a spade to balance the root-shoot ratio.
3. **Heading Back** — As with renewal pruning, old or unwanted limbs are removed, but limbs are cut back to main branches rather than ground level. Selective cuts may reduce the size of the plant and open the center of the plant.

Pruning Evergreens

Different evergreens need different pruning care.

1. **Pines** should be pruned in mid-June when they are in the candle stage of growth. Terminal candles should be pruned leaving an 8-12" stub and lateral candles should be pruned 2-4" shorter than the leader. Pines do not tolerate heavy pruning into old wood.
2. **Yews** accept pruning very well, making them a popular choice for hedges. They should be pruned in spring and again in mid-June. The best technique to use is heading back. Yews tolerate severe pruning even when up to 50% of the plant is removed.
3. **Junipers** are best pruned by using the heading back method in mid-April. Caution should be taken not to prune heavily into the dead zone. The dead zone or center of the plant does not produce young shoots. It is important to start a pruning program while the plants are young to avoid situations of overgrowth that cannot be corrected.
4. **Spruce** respond well to light pruning performed in early July. Leaders should be cut leaving at least three buds with lateral shoots 1-2" shorter.
5. **Firs** up to three years old can be pruned in early July because needles do not drop until the fourth or fifth year of the tree's life. At least two branches should remain on the limb following the cut.
6. **Broadleaf evergreens** such as rhododendron, holly, and boxwood should receive very little pruning. Light heading back is the best method used.

Hedges

Hedges are widely used in landscape designs as vegetative walls. To maintain an attractive hedge the plant species should be pruned when it can best tolerate the shock. Also, the key to maintaining good hedge appearance is to prune the base of the hedge wider than the top. This allows enough light to reach the lower limbs, and thus the plant maintains its foliage.

712

TRANSPARENCY MASTER #1

Planting a Tree

1

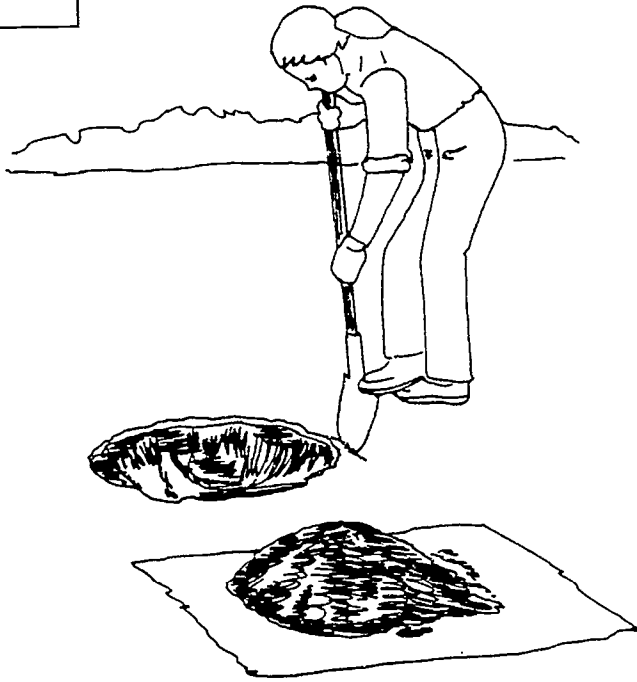

2



3

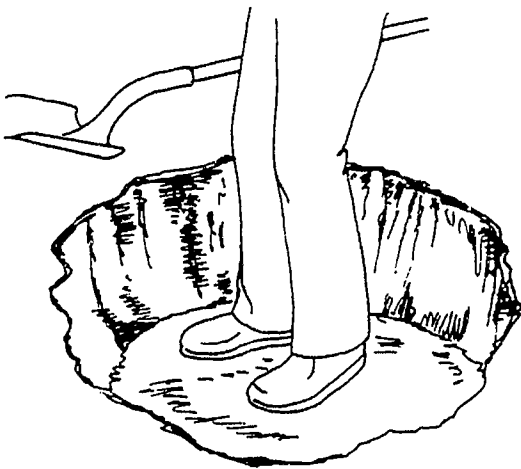

4



TRANSPARENCY MASTER #2

Planting a Tree

5



6

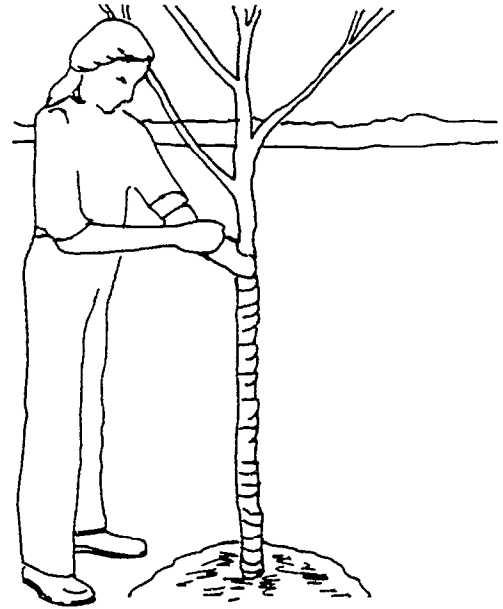

7

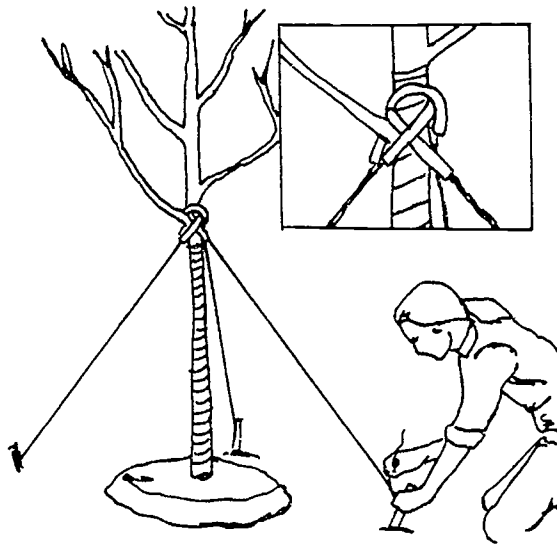

8

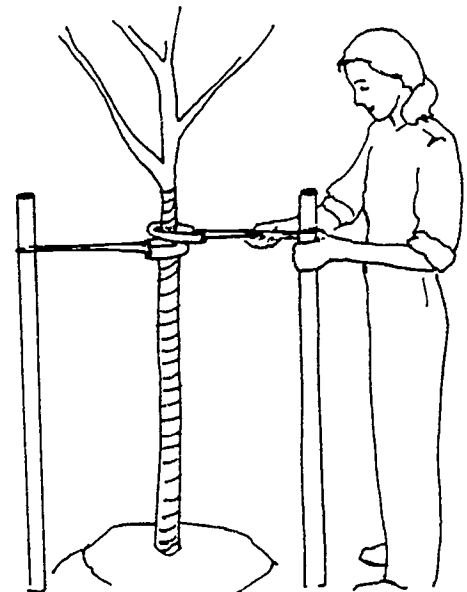

714

TRANSPARENCY MASTER #3

Planting a Containerized Shrub

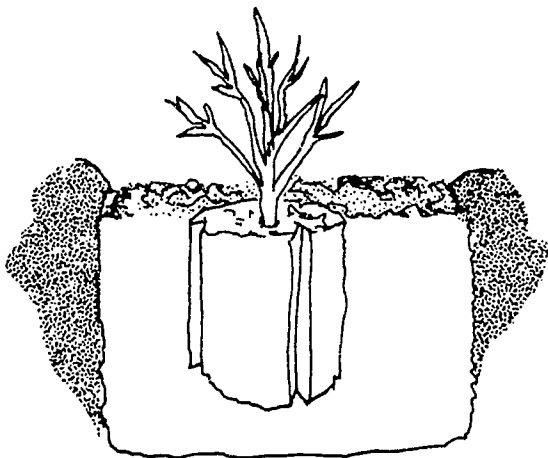
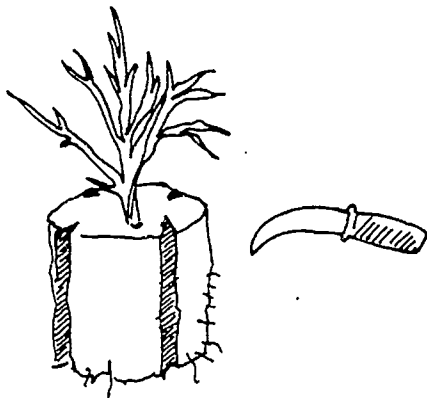
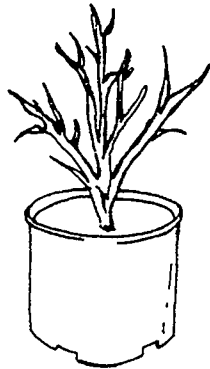

Containerized plants may be purchased in plastic, metal, or paper maché pots. The tendency is for roots to circle within the pot.

Always remove the pot no matter what type of material it is.

Cut the root mass and untangle the mass with your hands. This may seem destructive but it reduces the chance of roots continuing to circle, creating a girdling situation.

Plant the shrub so the top of the potting soil is level with the surrounding soil. Backfill with soil, form a dam or saucer, soak with water, and apply a layer of mulch.

TRANSPARENCY MASTER #4

Fertilizing a Tree with Dry Fertilizer

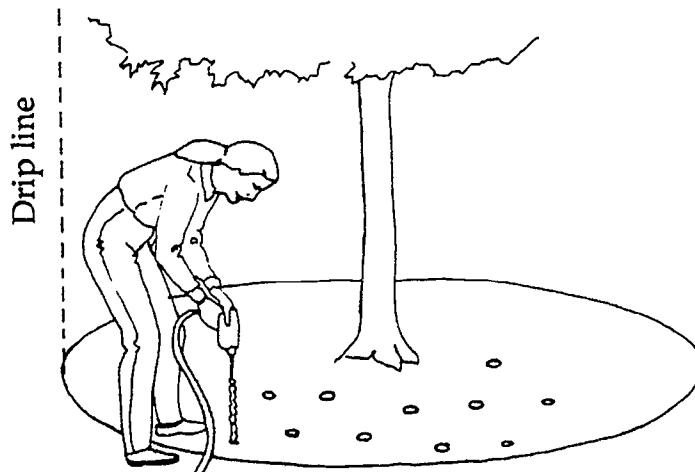
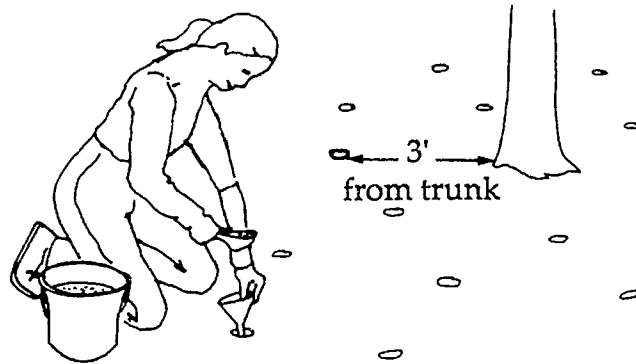
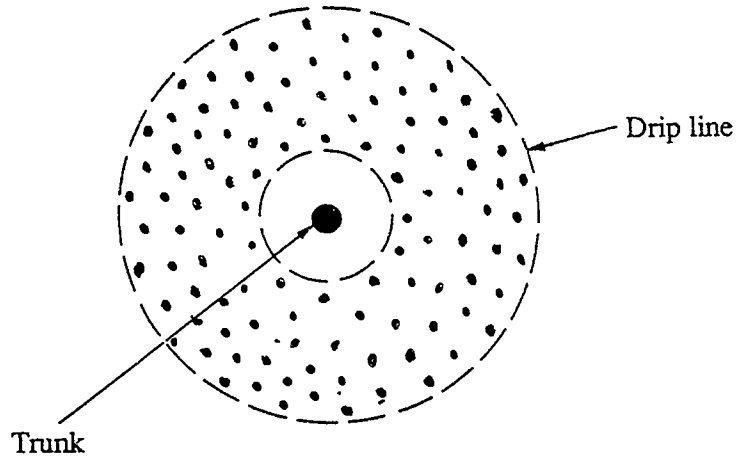

TRANSPARENCY MASTER #5

Fertilizing a Tree with Soluble Fertilizer

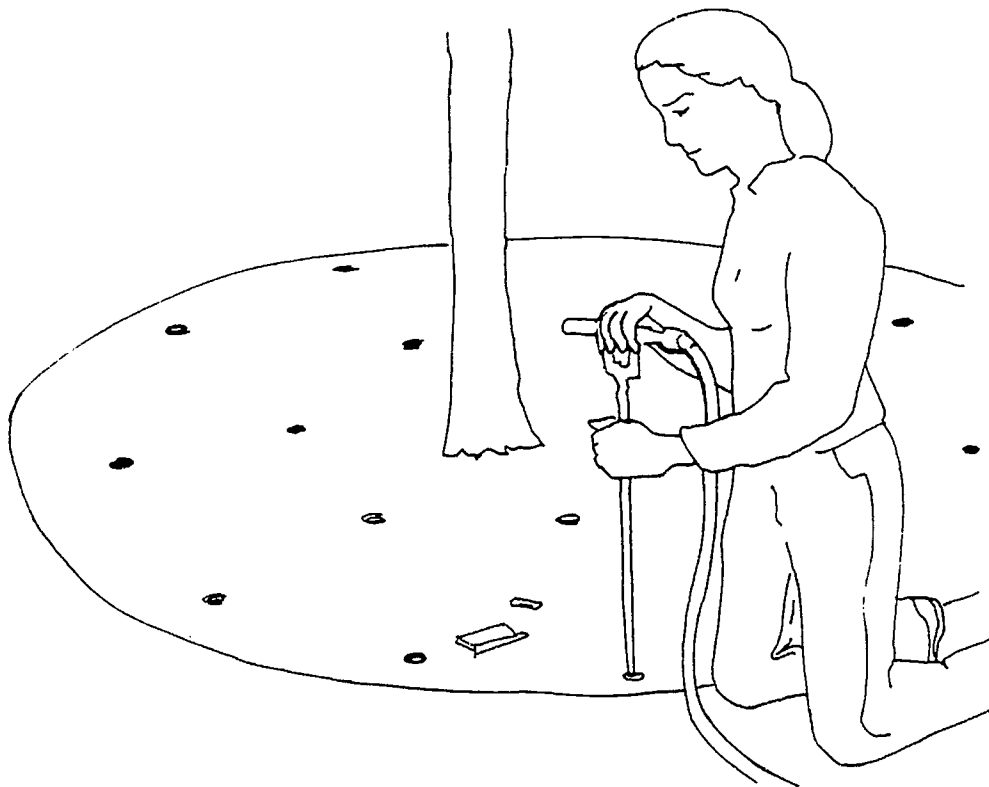
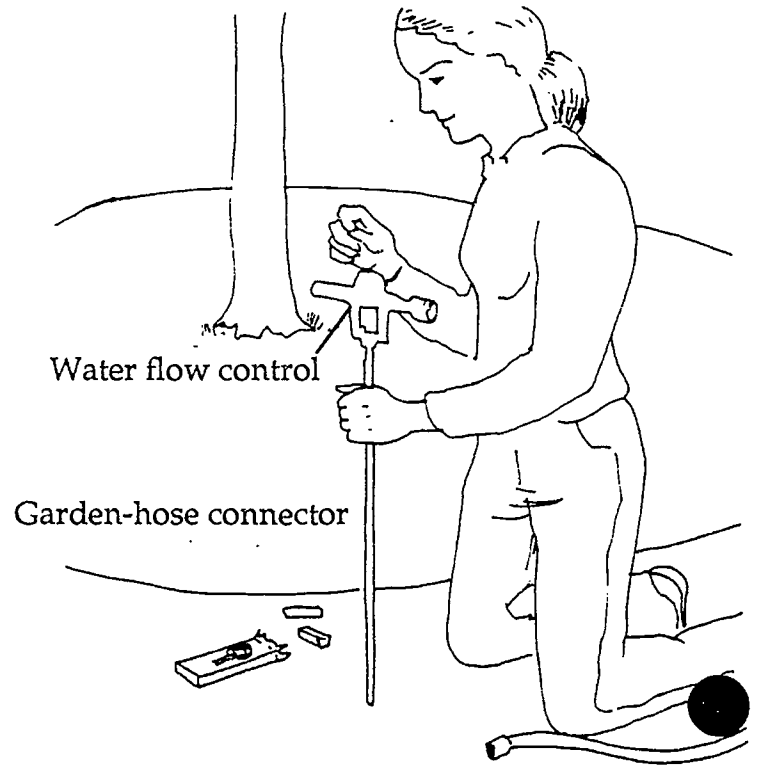
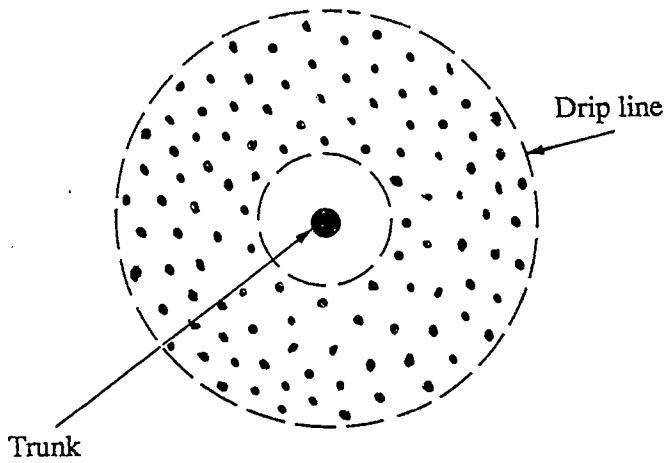

711

TRANSPARENCY MASTER #6

Pruning Tools



Pruning Knife

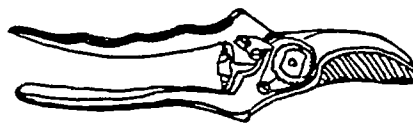

Hand Pruners

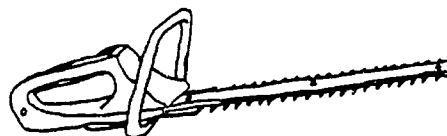

Electric Hedge Shears

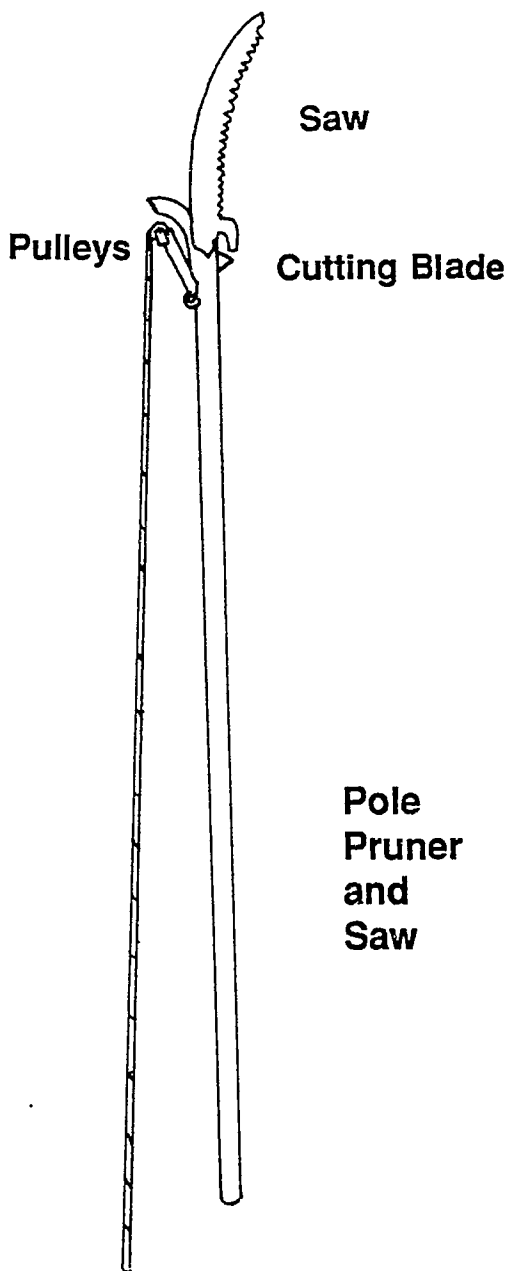

Saw

Cutting Blade

Pole
Pruner
and
Saw



Hand Pruning Saw

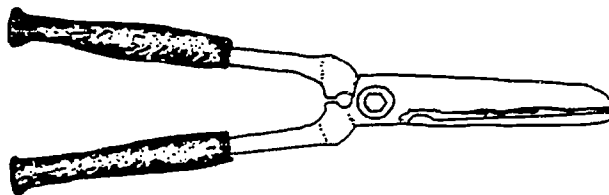

Hedge Shears



Lopping Shears

TRANSPARENCY MASTER #7

Pruning Deciduous Trees

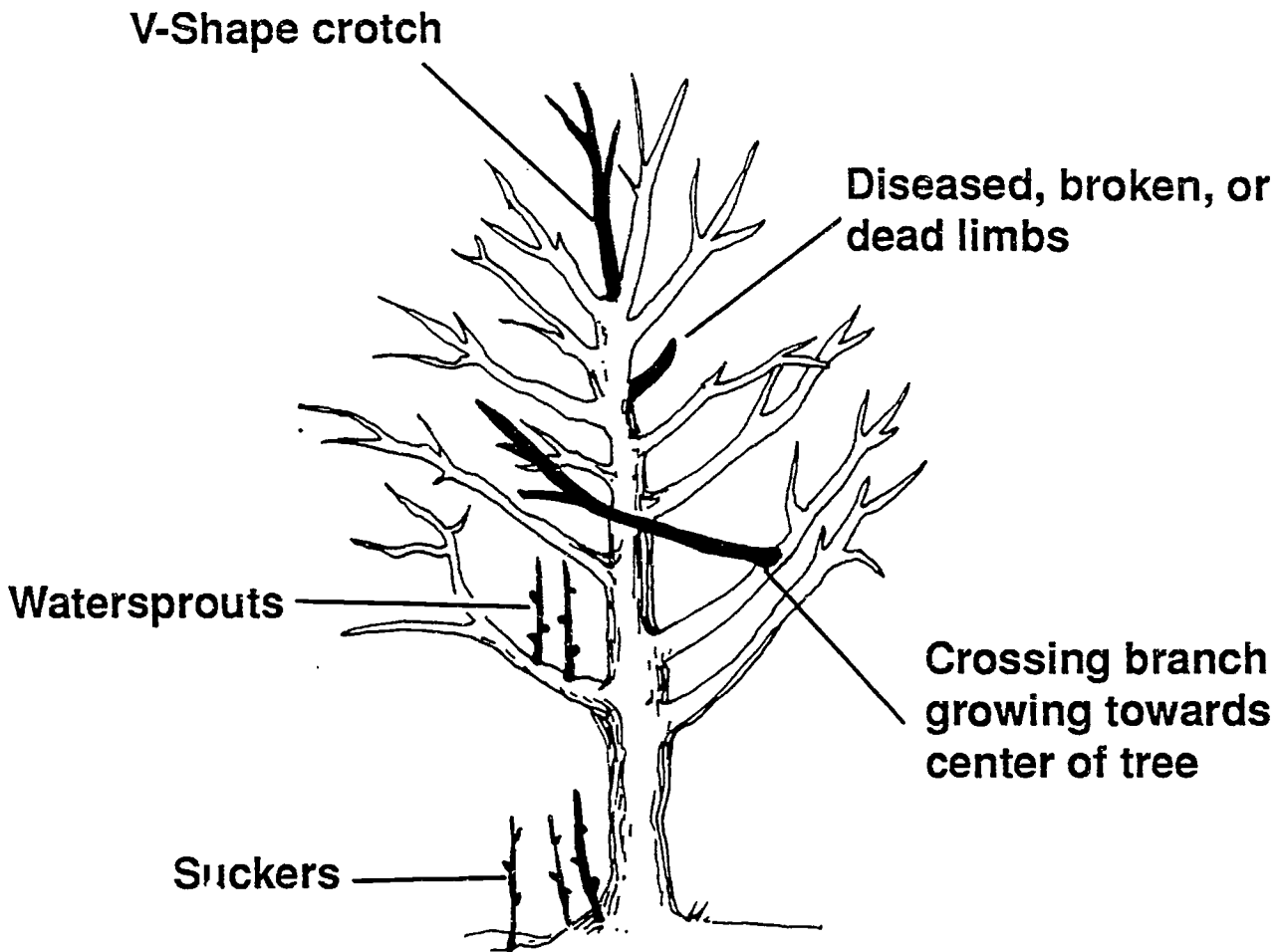

710

TRANSPARENCY MASTER #8

Removing a Large Limb

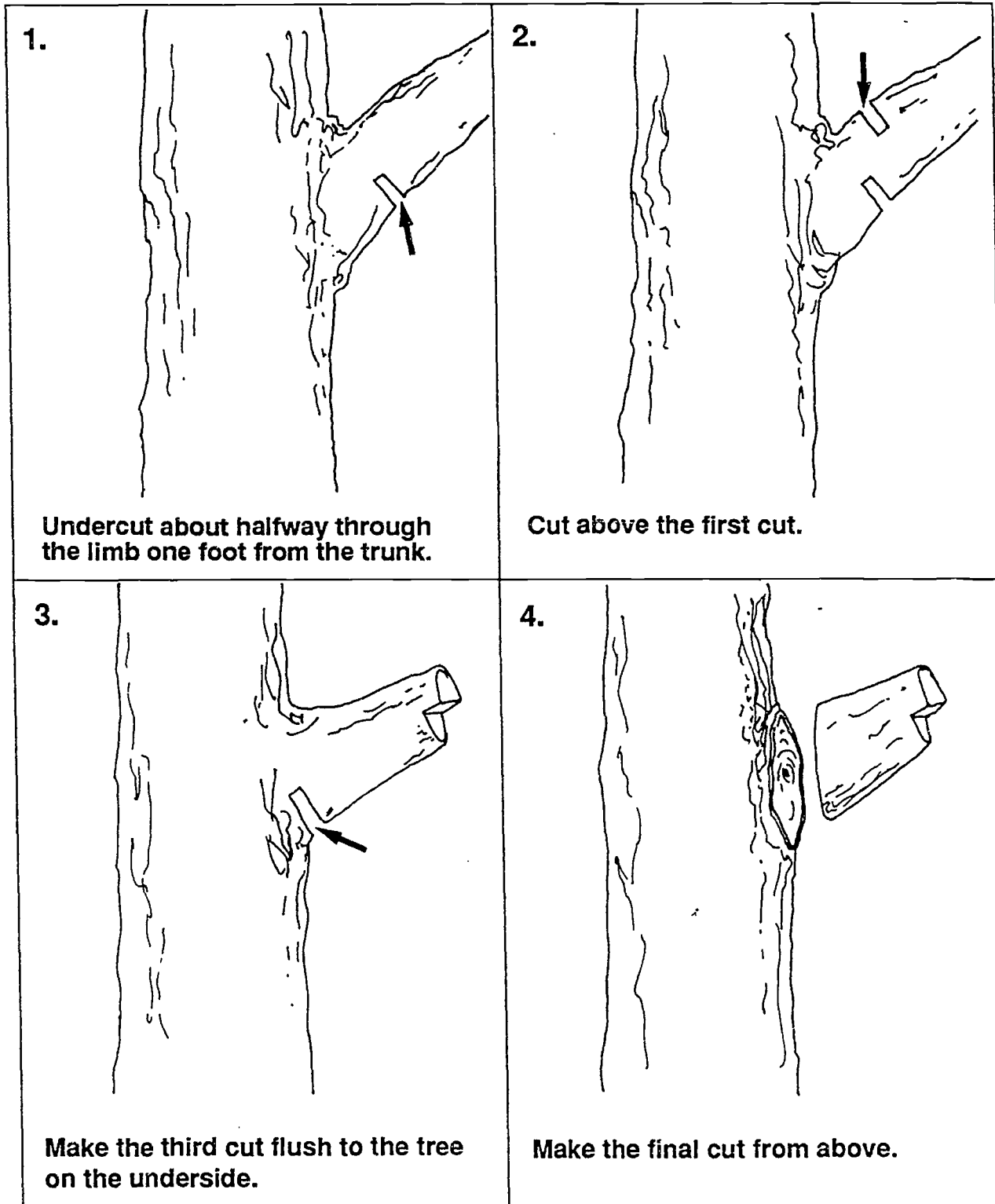

TRANSPARENCY MASTER #9

Renewal Pruning

BEFORE PRUNING

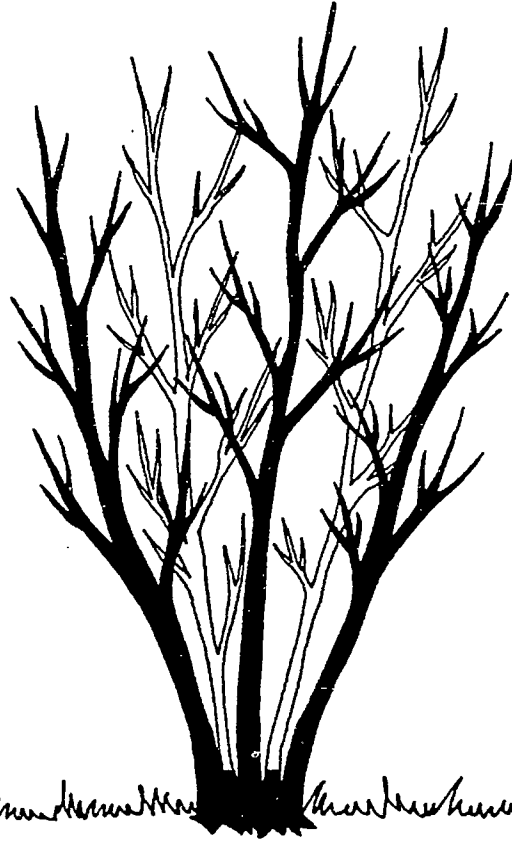

AFTER PRUNING

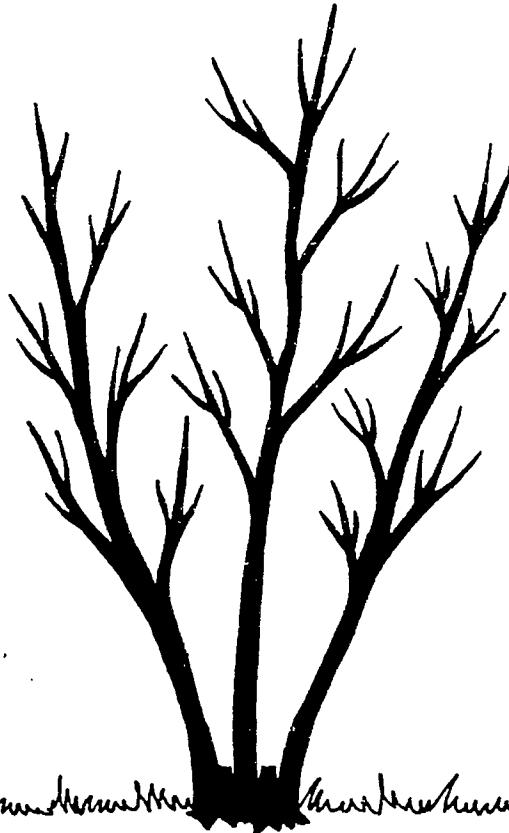

TRANSPARENCY MASTER #10

Rejuvenating Techniques

PROPER REJUVENATION
TECHNIQUES

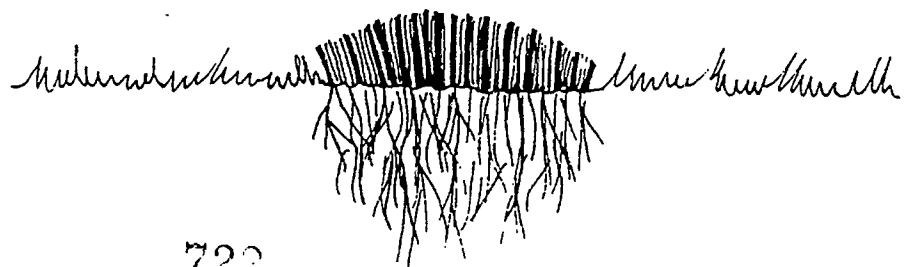
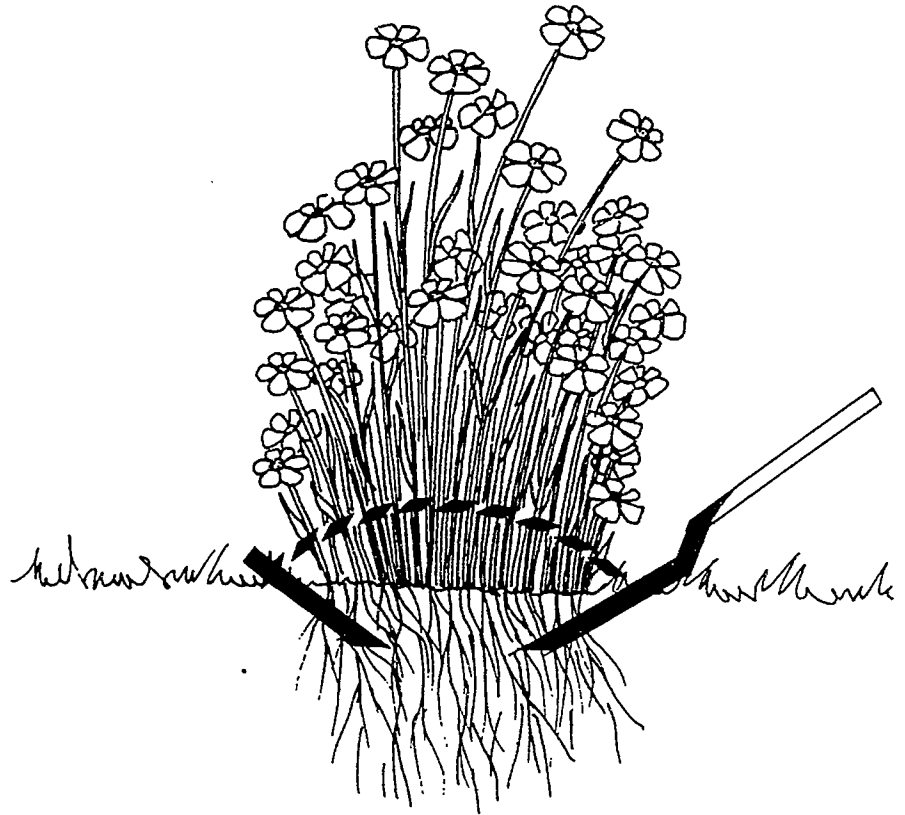

722

TRANSPARENCY MASTER #11

Heading Back Techniques

BEFORE

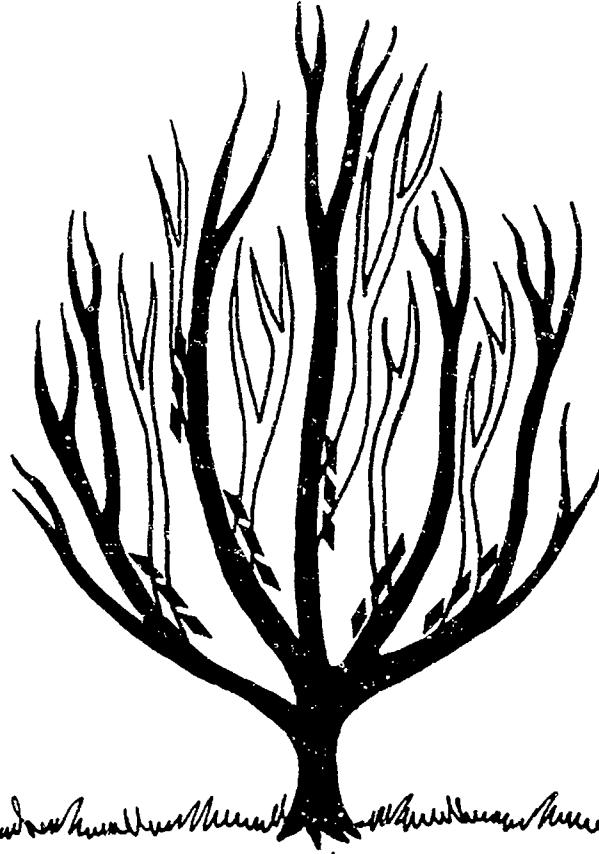

AFTER

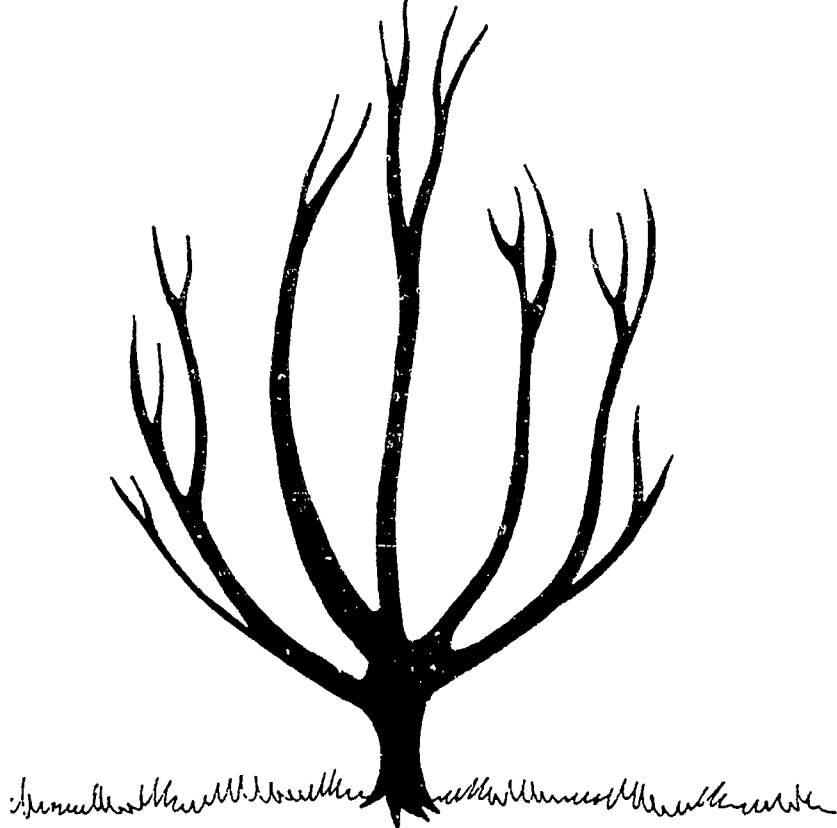

TRANSPARENCY MASTER #12

Pruning Pines

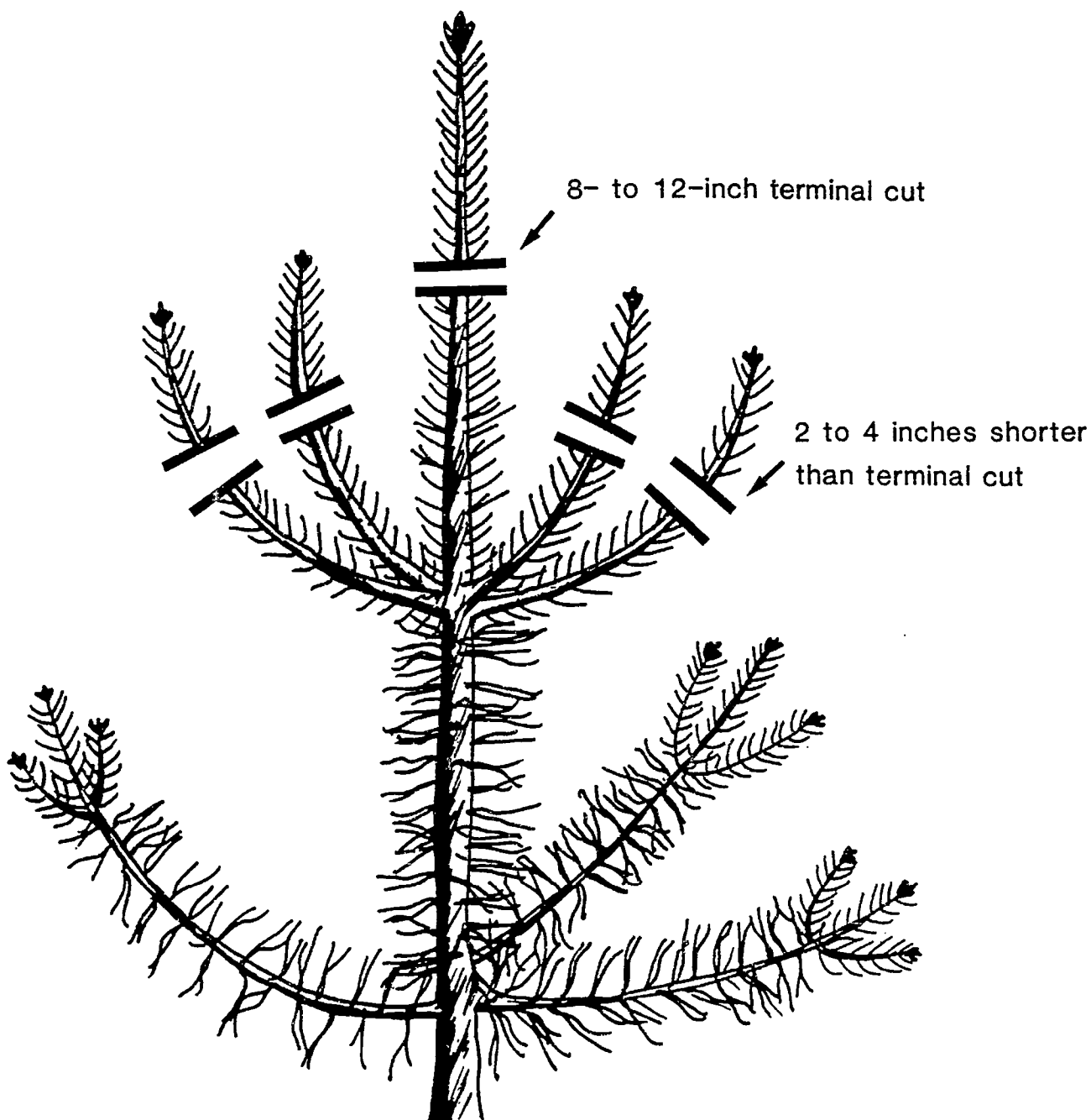

Prune pines to maintain a thick, compact appearance and pleasing shape.

TRANSPARENCY MASTER #13

Pruning Spruce

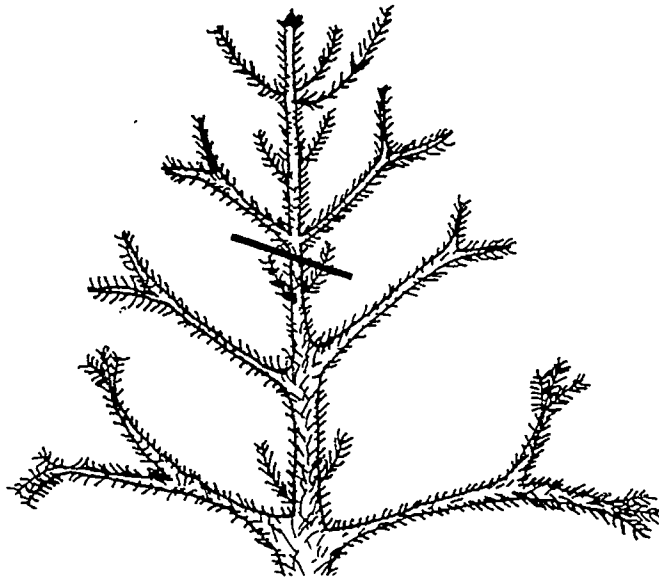

Lines indicate where annual pruning cuts should be made.

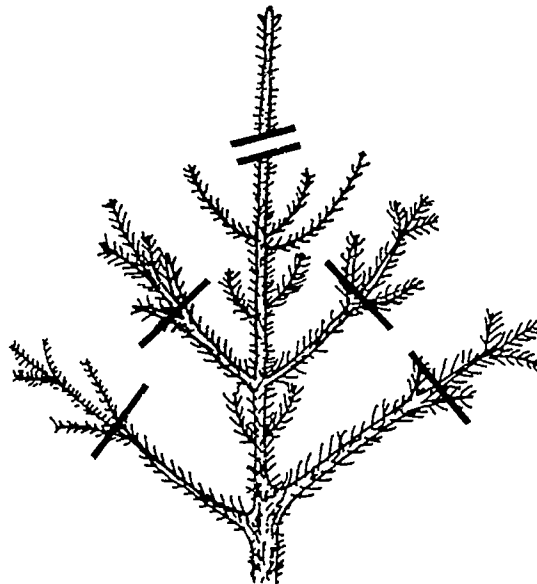

This is the same plant after annual pruning. The line indicates where a cut could be made to reduce the plant's size.

TRANSPARENCY MASTER #14

Pruning Junipers

Dead zone



Cut here

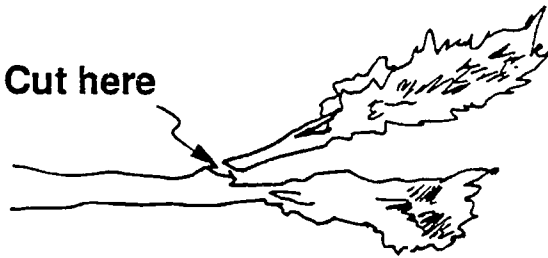

The two shrubs above indicate where cuts should be made to reduce the size or reduce overlapping of spreading junipers. The bottom drawing shows where to make a cut on an individual branch.

Dead zone

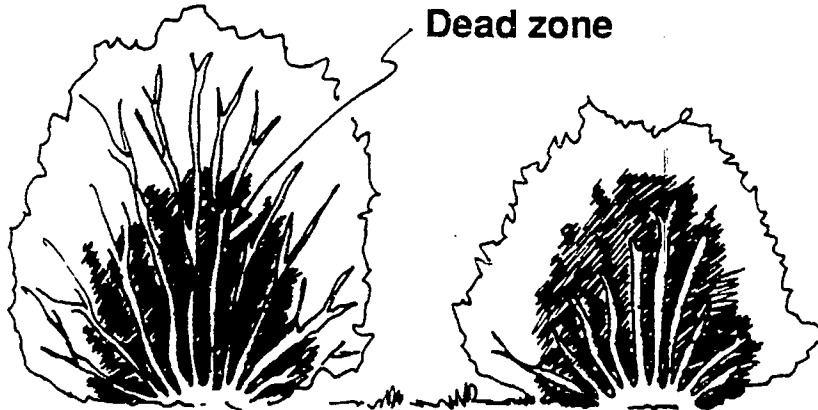

These drawings show where cuts can be made when pruning upright junipers. The drawing on the right shows the plant with natural shape maintained after pruning reduced size.

TRANSPARENCY MASTER #15

Pruning Yews

To maintain size,
cut to second bud

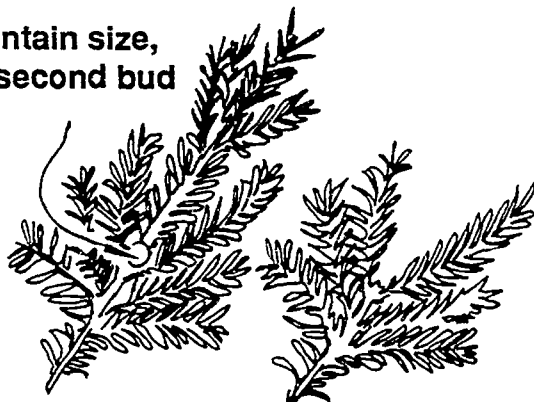

New yew wood
begins here

New yew wood is bright yellow-green and cuts quite easily.

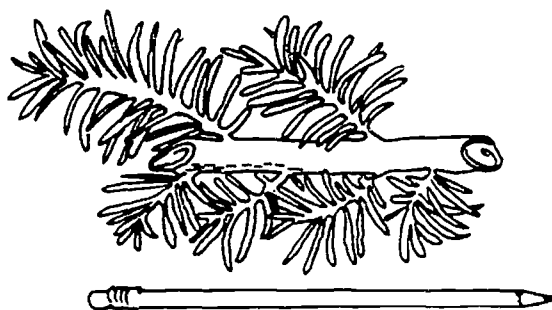

Angle cut at cluster of twigs on a large limb.

TRANSPARENCY MASTER #16

Pruning Rhododendrons

1. Remove faded flower trusses.



2. Pinch back sticky new growth.



3. New shoots will sprout.



TRANSPARENCY MASTER #17

Pruning Deciduous Hedges

PROPER ANGLE FOR PRUNING

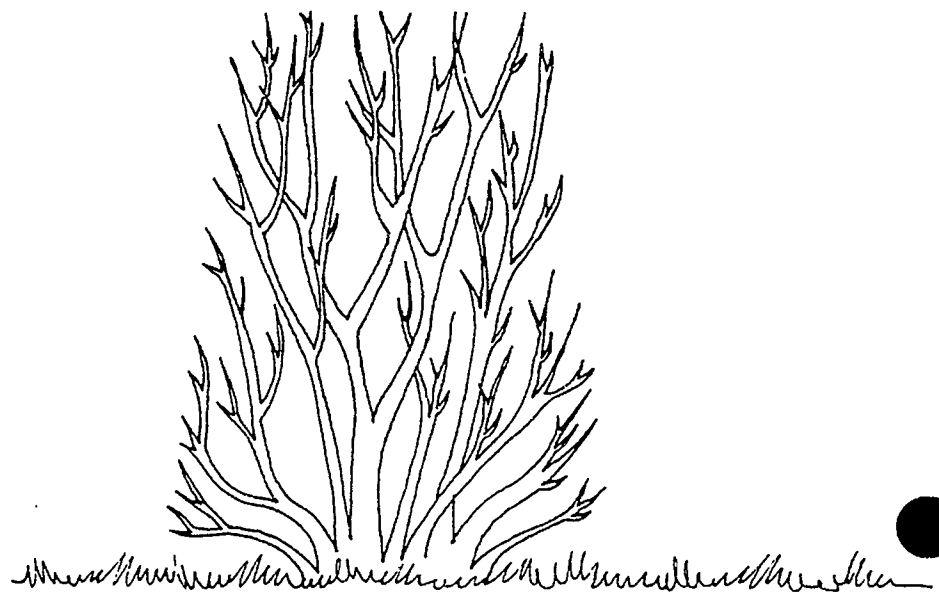
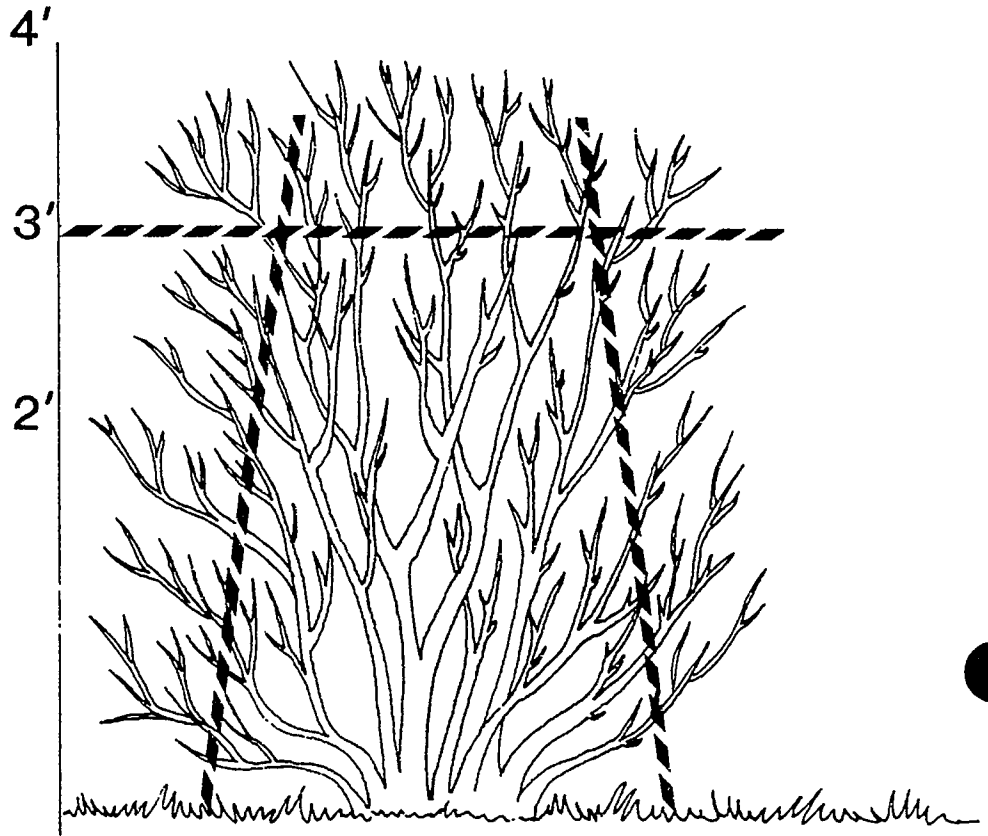

723

TRANSPARENCY MASTER #18

Pruning Techniques for Deciduous Hedges

**CORRECT PRUNING
TECHNIQUE**

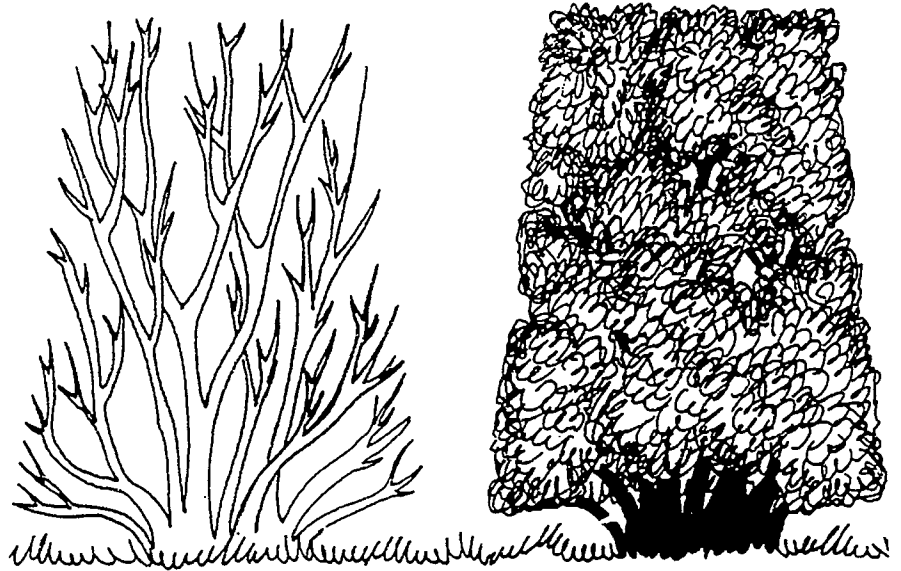

**INCORRECT PRUNING
TECHNIQUE**

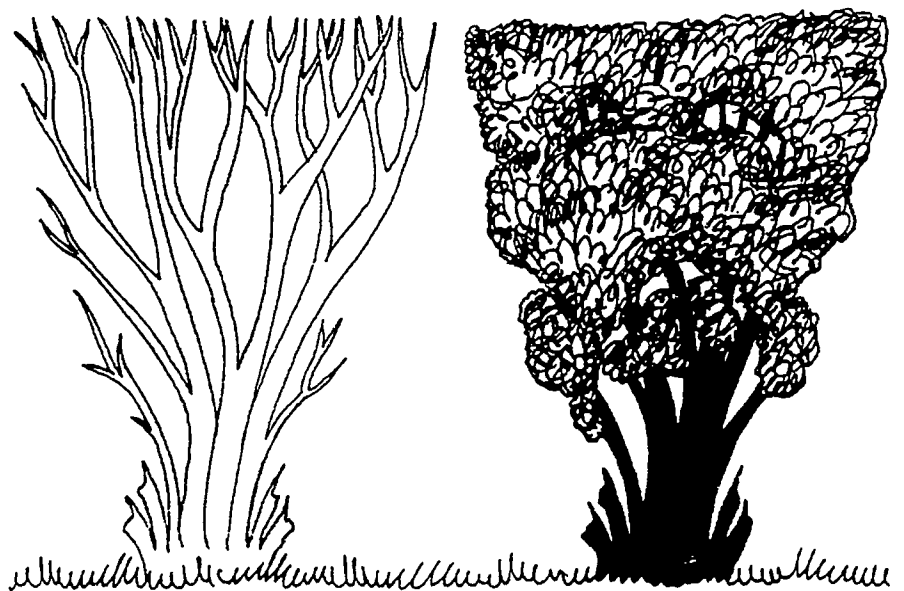

TRANSPARENCY MASTER DISCUSSION GUIDE

Transparency Master #1

1. Dig a hole at least 6" larger than the soil ball to be planted. Place good soil to one side and sod to be discarded in another pile. Recent studies have shown that trees become established more quickly when large holes are dug.
2. Amend the soil with peat moss if necessary.
3. Before placing the tree into the hole, backfill a little bit and step the soil down until the desired depth is achieved.
4. Place the tree in the hole. Use a tool handle laid across the hole to make sure the tree is at the same depth it was growing before. Remove the burlap and twine from the soil ball.

Transparency Master #2

1. Backfill halfway. Step the soil down. Fill the rest of the hole with water. Complete the backfilling process after the water has been absorbed. Do not step the wet soil down. Form a reservoir by piling soil in a ring around the tree.
2. Wrap the trunk with tree wrap to protect it from sun scald and frost cracks. Begin at the bottom to get a shingle affect.
3. Brace the tree to protect the developing roots and to hold it upright. The trunk should be protected from guy wires by running the wires through pieces of hose.
4. The tree may be braced by stakes placed outside of the planting pit.

Transparency Master #3

Containerized products are becoming more common in the nursery industry because they can be planted at any time and more plants can be grown per acre. Special care should be taken in planting them.

Transparency Master #4

Holes should be drilled 18-24" deep and two feet apart below the drip line of the tree. A measured amount of fertilizer is then placed in each hole.

Transparency Master #5

Soluble fertilizers may be pumped into the root zone within the drip line of the tree.

Transparency Master #6

When pruning, choose the tool that will get the job done correctly without strain on the worker.

Transparency Master #7

Look to eliminate diseased, dead, or broken limbs, V-shape crotches, crossing branches, watersprouts, and suckers when pruning deciduous trees.

Transparency Master #8

Large limbs should be removed with care to avoid having bark torn from the trunk. Follow the steps outlined. In step two, a cut outside the first cut will cause the limb to drop straight down and a cut inside the first cut will cause the limb to swing towards the trunk before falling.

Transparency Master #9

Remove the oldest stems at the base. Besides maintaining a plant's size, this type of pruning encourages new growth and flowering.

Transparency Master #10

All stems are cut back to 4-6" stubs in March. To balance the root to shoot ratio, roots are also pruned.

Transparency Master #11

This pruning technique is similar to renewal, but branches are removed at the next largest stem rather than at ground level.

Transparency Master #12

Prune pines in the candle stage in mid-June.

Transparency Master #13

Light pruning can be done in early July.

Transparency Master #14

Prune Junipers in mid-April using heading back techniques. Avoid pruning into the dead zone.

Transparency Master #15

Prune Yews in spring and again in mid-June using heading back techniques.

Transparency Master #16

Lightly head back Rhododendrons in late spring to encourage branching.

Transparency Master #17

The first step in pruning a hedge is to establish lines at the proper angle for cutting. This angle will allow sufficient light to reach the lower branches.

Transparency Master #18

To prevent hedges from becoming tall and leggy with very little foliage at the base, have sides angle in toward the top of the plant. Hedges pruned with sides that angle in toward the base will lose foliage near the base of the plant.

STUDENT ACTIVITIES

- STUDENT WORKSHEET #1 — Planting a Balled and Burlapped Tree
- STUDENT WORKSHEET #2 — Fertilizing and Watering Landscape Plantings
- STUDENT WORKSHEET #3 — Pruning
- STUDENT WORKSHEET #4 — Pruning Review
- STUDENT WORKSHEET #5 — Landscape Word Search (with solution)

For additional activities, teachers may refer to the “Suggested Teaching Activities and Procedures” section in the Instructor’s Guide.

735

STUDENT WORKSHEET #1**Planting a Balled and Burlapped Tree**

(Refer to Information Sheet #1.)

1. How large should a hole be dug for planting a balled and burlapped tree?
2. How can poor soil be improved?
3. How deep should a tree be planted?
4. Explain the procedure for backfilling the hole.
5. Why are newly transplanted trees pruned?
6. What percent of the crown can be removed without damaging the plant?
7. Why is it recommended to remove green burlap or nylon twine?
8. How should brown burlap be dealt with?
9. Why is the trunk of a newly planted tree wrapped?
10. Why is it necessary to brace newly planted trees?
11. What is the proper watering procedure for newly planted trees?

734

STUDENT WORKSHEET #2**Fertilizing and Watering Landscape Plantings**

(Refer to Information Sheet #3.)

1. What are the four major methods of fertilizing trees?
 - a.
 - b.
 - c.
 - d.
2. Why are landscape plants fertilized?
3. When should trees be fertilized?
4. How many pounds of a 10-6-4 dry fertilizer should be used for an 8" diameter tree?
5. What are the advantages of pumping soluble fertilizer into the root zone?
 - a.
 - b.
 - c.
 - d.
6. When would solid fertilizer capsules be used to fertilize a tree?
7. What is the major disadvantage of placing fertilizer capsules in the trunk?
8. How should shrubs be fertilized?
9. How should ground covers be fertilized?
10. How much water do woody landscape plants require?
11. What are four advantages of using mulches?
 - a.
 - b.
 - c.
 - d.

735

6. What is:
 - a. Renewal Pruning?

 - b. Rejuvenation Pruning?

 - c. Heading Back?

7. How should the following be pruned?
 - a. Pines

 - b. Yews

 - c. Junipers

 - d. Spruce

 - e. Fir

 - f. Rhododendrons

 - g. Hedges

737

STUDENT WORKSHEET #5

Landscape Word Search

K P Z L L W Z J N C Q R Q S Y E G D E H
 C I H X P B H G E B P D S C L F V V J F
 A Z R C P T R H E E S N C G D T Q F D K
 B O E G L L B A R F P H Q B D R P G E G
 G N J Y K U G U G W S J R E Z A I L P D
 N Q U L A W M G R E L S L U B N N I P Q
 I O V C R J Q G E L A X O E B S R A A L
 D R E B O M K P V Y A A R M O P C Y L E
 A W N L J N Z T E B T P K U T L A W R X
 E J A M S H T R T J E C F M G A Z T U S
 H T T W I U T A X O R Y J E S N E H B P
 O A I W L R O K I N O E E X D T K P D S
 H I O W E A L U Q N Y R Z G T I O A E N
 D T N E K G W G D T E R E I O N I B L U
 Q F X L J M B E N I G R B R L G Y G L B
 W A T E R I N G N I C M I F A I D Z A O
 U N M V W O P P G E N E Q Z Y B T C B I
 P P Y B V V Y K W P R U D E E G X R X B
 J K G R O U N D C O V E R A C D I O E Y
 O M Z F F J Z S S F M Y U P X X N Z X F

The following words are hidden in the puzzle:

Balled Burlapped
 Bareroot
 Burlap
 Containerized
 Deciduous
 Evergreen
 Fertilizer
 Ground Cover
 Hedge
 Heading Back

Mulch
 Peat Moss
 Pruning
 Rejuvenation
 Renewal
 Shrub
 Transplanting
 Tree
 Watering

STUDENT WORKSHEET #5 — Key

Landscape Word Search

K N E G D E H
 C . H E
 A . R C E . S T . . D .
 B . E . L . B . R . . H . . . R . . E .
 G . J . . U . U G . S . R . . A . . P .
 N . U . . . M . R . . S . U . N . . P .
 I . V C E L . . O . B S . . A .
 D . E . O . . . V . A . . M . P . . L .
 A . N . . N . . E . . P . . T L . . R .
 E . A . S . T . T A . . U .
 H . T . . U T A . O R N E . B .
 . . I . L R O . I . O E . . . T . P D .
 . . O . E A . U . N . R Z . . I . . E .
 . . N E . . W G D . E . E I . N . . L .
 E N I . R . R L G . . L .
 W A T E R I N G N I C . I . A I . . A .
 E N E . Z . B T . B .
 R U D . E . . R . .
 . . G R O U N D C O V E R . . D . . E .
 P F

The following words are hidden in the puzzle:

Balled Burlapped
 Bareroot
 Burlap
 Containerized
 Deciduous
 Evergreen
 Fertilizer
 Ground Cover
 Hedge
 Heading Back

Mulch
 Peat Moss
 Pruning
 Rejuvenation
 Renewal
 Shrub
 Transplanting
 Tree
 Watering

733

CLUSTER: HORTICULTURE

UNIT: Landscaping

PROBLEM AREA: Surveying, Grading, and Tiling

RELATED PROBLEM AREAS:

1. Applying Mathematics Skills to Agriculture (Central Core Cluster)
2. Preventing Soil Erosion and Managing Land (Agricultural Business and Management Cluster)
3. Designing, Building, and Maintaining Horticultural Structures
4. Designing and Drawing Landscape Plans
5. Establishing and Maintaining Turf Areas
6. Transplanting and Maintaining Landscape Plants

PREREQUISITE PROBLEM AREA(S): None

LEVEL: Preparatory

OCCUPATIONAL TASKS ADDRESSED:

Horticulture Cluster

Duty B: Preparing Soils and Planting Media

1. Construct open drainage ditch
2. Prepare seedbed
3. Level and smooth planting area

Agricultural Business Management Cluster

Duty K: Maintaining and Constructing Structures

1. Lay out conservation structures using transit.
2. Lay out building using transits

STATE GOALS FOR LEARNING

In planning the instruction for this problem area, teachers can promote the development of several student learning objectives which are related to the State Goals for Learning in Mathematics and Biological and Physical Sciences. These objectives are listed on the Learning Assessment Plan forms included on the following page(s). Those learning objectives marked with an asterisk (*) are taken from the sample lists provided by the Illinois State Board of Education.



Illinois Agricultural Core Curriculum

Agricultural Education 124 Mumford Hall 1301 W. Gregory Drive University of Illinois Urbana, IL 61801

Director: Dale A. Law, Ed.D.

Principal Investigator: Jerry D. Pepple, Ed.D.

Research Assistant: Ronald J. Biondo

1988

ILLINOIS STATE BOARD OF EDUCATION
Department of School Improvement Services
100 North First Street
Springfield, Illinois 62777-0001

LEARNING ASSESSMENT PLAN

Instructions and codes for this form are provided on a separate sheet.

Submission Date _____ Page _____ of _____

Original submission Revision

I. LEARNING AREA (check one)

Language Arts Fine Arts

Mathematics Social Sciences

Sciences Physical Development/Health

(Affix label or complete district information.)

COUNTY _____ DISTRICT _____ ESC _____

District Name _____

City _____

II. STATE GOAL FOR LEARNING

As a result of their schooling, students will be able to make and use measurements, including those of area and volume.

Contact Person: _____

Title: _____

Phone: (_____) _____

III. LEARNING OBJECTIVES	IV. ASSESSMENT				V. EXPECTATIONS
	A Types	B Validity/ Reliability	C Commercial Test(s)	D Evidence of Nondiscrimination	
By the end of grade (circle one) 3 6 8 (11) students should be able to:					
*1. Find areas and volumes of figures resulting from combining common geometric figures.					
*2. Measure in a variety of contexts using appropriate units.					
*3. Understand measurement systems, instruments, and techniques.					
4. Identify the materials and equipment used in surveying, grading, and tiling.					
5. Perform surveying skills for landscaping purposes.					
6. Calculate areas in the landscape.					
744					744

INSTRUCTOR'S GUIDE

CLUSTER: HORTICULTURE

UNIT: Landscaping

PROBLEM AREA: Surveying, Grading, and Tiling

STUDENT LEARNING OBJECTIVES

INSTRUCTOR'S NOTES AND REFERENCES

Upon completion of their study of this problem area, students will be able to:

1. Identify the materials and equipment used in surveying, grading, and tiling.
2. Define the terminology used in surveying, grading, and tiling.
3. Identify the steps taken to establish the final grade.
4. Demonstrate how to correctly install drainage tile.
5. Perform surveying skills for landscaping purposes.
6. Calculate areas in the landscape.

743

INSTRUCTOR'S GUIDE**CLUSTER: HORTICULTURE****UNIT: Landscaping****PROBLEM AREA:** Surveying, Grading, and Tiling**PROBLEMS AND QUESTIONS FOR STUDY****INSTRUCTOR'S NOTES AND REFERENCES**

1. What is surveying?
2. What equipment is used in surveying?
3. How is slope determined?
4. What is grading?
5. What equipment is used in grading?
6. What slopes are most practical for landscape functions?
7. When are drainage systems necessary?
8. What are the common types of drainage systems?
9. How are the various drainage systems installed?
10. Define and describe the following:
 - a. Slope
 - b. Drainage tile
 - c. Rough grade
 - d. Smooth grade
 - e. Swale
 - f. Berm
 - g. Sub grade
 - h. Cut
 - i. Fill
 - j. Catch basin
11. What are the different implements used with tractors for grading?
12. How can the grade be adjusted around existing trees?

747

INSTRUCTOR'S GUIDE**CLUSTER: HORTICULTURE****UNIT: Landscaping****PROBLEM AREA:** Surveying, Grading, and Tiling**SUGGESTED TEACHING ACTIVITIES AND PROCEDURES****INSTRUCTOR'S NOTES AND REFERENCES**

1. Lead a discussion on surveying and grading, based on the material in Information Sheet #1.
2. Demonstrate how to properly use a landscape level and self-reading rod.
3. Arrange a field trip to a home or homes under construction. Observe rough grades and finished grades.
4. The building trades departments of some high schools build homes as a class project. Gain permission from the school administration to landscape one of these homes. Determine the need for grading and tiling, and the best way to provide adequate drainage.
5. Have the students measure the slope of the land surrounding the school.
6. Have the students read Information Sheet #2.
7. Bring examples of drainage tile to class and discuss the values of each type.
8. Have the students complete Student Worksheet #1.
9. Discuss recommended procedures for grading around established trees. University of Illinois Cooperative Extension Service Circular #1061, *Tree Damage Around Construction Sites*, is helpful.
10. Assign Student Worksheet #2.
11. Arrange a field trip to a golf course, a landscape construction contracting firm, and/or an irrigation system contracting firm.
12. Lead a discussion with students using Information Sheet #3. Then have the students practice their skills on Student Worksheet #3.

INSTRUCTOR'S GUIDE**CLUSTER: HORTICULTURE****UNIT: Landscaping****PROBLEM AREA:** Surveying, Grading, and Tiling**REFERENCES****INSTRUCTOR'S NOTES AND REFERENCES**

- *1. *Landscape Construction Procedures, Techniques, and Design.* (1988). Giles, Floyd. Stipes Publishing Company, 10-12 Chester Street, Champaign, IL 61820.
2. *Landscaping Your Home* (Circular 1111). Nelson, William R. University of Illinois, Cooperative Extension Service, College of Agriculture, 69C Mumford Hall, 1301 W. Gregory Drive, Urbana, IL 61801
3. *Tree Damage Around Construction Sites* (Circular 1061). University of Illinois, Cooperative Extension Service, College of Agriculture, 69C Mumford Hall, 1301 W. Gregory Drive, Urbana, IL 61801.
- *4. *Agricultural Surveying* (VAS Unit #U3010A). Vocational Agriculture Service, College of Agriculture, University of Illinois, 1401 S. Maryland Drive, Urbana, IL 61801. (217) 333-3871.
5. *Mapping and Topographical Drafting.* (1983). Bies, J.D., Long, R.A. South Western Publishing Company, 355 Conde Street, West Chicago, IL 60185. (800) 323-1530.
6. *Mathematics for Horticulture.* (1982). Peltier, Ruth A. Ohio Agricultural Education Curriculum Materials Service, The Ohio State University, Room 254, 2120 Fyffe Road, Columbus, OH 43210.

*Indicates highly recommended reference

740

INSTRUCTIONAL RESOURCES

These resources are intended for use by teachers in planning and teaching the materials for this problem area and may be adapted to fit the teaching method(s) used.

INFORMATION SHEET #1 — Surveying and Grading the Landscape

INFORMATION SHEET #2 — Drainage Systems

INFORMATION SHEET #3 — Measuring Areas

TRANSPARENCY MASTER #1 — Determining Percent Slope

TRANSPARENCY MASTER #2 — Incorrect and Correct Methods of Lowering Grade Around Trees

750

INFORMATION SHEET #1

Surveying and Grading the Landscape

Surveying

Surveying practices are often used in residential and commercial landscape projects. Whereas surveying used to deal with the marking of boundaries and the dividing of land areas, its landscape application now primarily refers to the drainage of water, functional slopes of the land, and construction projects.

Proper drainage is essential to having a successful landscape. Standing water or excessive runoff may result in an unattractive view, poor plant growth, and limited use of the land. Before starting construction, survey the land. The information gathered will help in determining drainage patterns. Remember that water should be directed away from buildings to a disposal area. As the construction progresses, surveys may be taken to check the slope of the land.

Slope is the change in elevation of the land. It is measured by the vertical rise or fall divided by the run or horizontal distance, and a simple equation can be used to calculate the percent of slope, as follows:

$$\text{Percent slope} = \text{Rise} \div \text{Run}$$

For example, if the elevation of land changes 5 feet over a 100 foot span the slope would be 5% ($5 \div 100 = .05$ or 5%). Using a measuring tape, a self-reading rod, and a level, the contractor can periodically determine the slope. Changes in the grade can then be made to obtain the desired slope.

Surveying also helps the contractor establish slopes that will be used for activities. Should the client want a landscape with areas designated for lawn games or recreational activities the contractor and designer can suggest locations on the lot best suited for those activities based on a survey. If the land needs to be resculpted, surveying will help to ensure the area will have sufficient slope for drainage yet still be comfortable under foot.

Proper installation of fences and hedgerows depends on surveying skills. With the use of a tripod and level, fence posts can be located in a straight line. To get a 90-degree corner, the telescope can be swiveled 90 degrees and the next set of fence posts located. This same procedure can be used to locate trees or shrubs to form a screen or hedge. Straight fences and hedgerows appear stable and create a feeling similar to that of a wall in a house.

Another use of surveying involves the installation of *drainage tile*. Since the force of gravity draws water downward drain tile must be placed at a gradual continuous

slope. Profile leveling is used to determine how deep a trench should be dug to maintain the desired slope of the tile. As the elevation of the land changes, the contractor may need to add soil, known as *fill*, or to excavate soil, known as *cut*.

Grading

Grading involves the moving of soil and the reshaping of the land. Grading is done to improve drainage patterns, to create an interesting appearance, to ensure healthy plant growth, and to make areas more useful. Building construction almost always requires some type of grading during the landscape process.

Extensive grading projects should begin with the removal and stockpiling of the topsoil. The subsoil can then be reshaped with the use of heavy equipment. Major changing of the slope and shape of the land is known as *rough grading*. Rough grading of an area will change natural drainage patterns and it can severely damage existing trees. In addition, loosened subsoil creates problems when it settles around construction footings, patios, drives, etc.

Establishing adequate drainage patterns should be the principal concern when rough grading. Thorough planning should take place before grading to keep the on-site topography in harmony with the surrounding properties. Surface water should drain away from buildings but cannot be diverted onto a neighbor's yard. Soil should be graded around homes so that it has a 2% to 4% slope to reduce the chance of flooding or seepage. *Swales*, which are concave depressions or channels formed at 2% slopes, can be established to carry water to a disposal area. Drainage tile and *catch basins* may also be installed to improve drainage.

Proper grading which results in good drainage will improve the health of landscape plants. As a rule, turf and plants perform best on slopes from 1% to 10%. Slopes less than 1% frequently display slowly draining water and poor soil aeration. Slopes greater than 10% often show evidence of erosion caused by water runoff and dry soil conditions.

Function is another important aspect of grading. Most people want a home landscape they can easily maintain and use for recreational purposes. Therefore, avoid grading soil at slopes greater than 15%, and carefully consider the family's needs.

Although function, plant health, and drainage are significant, grading may be done to create interest. Totally flat land has a monotonous appearance which can be made stimulating by varying slopes, adding terraces, or building *berms*. Berms are small hills that can be effective in large landscapes. They should have gentle slopes not to exceed 10% to convince the viewer that they naturally appear in the landscape.

A chart of recommended slopes for the landscape follows:

	<u>Acceptable Percent Slope</u>		<u>Ratio Horizontal : Vertical</u>		<u>Desirable Slope</u>	
	Minimum	Maximum	Minimum	Maximum	Minimum	Maximum
Patios/Decks	.5	2	200:1	50:1	1	2
Entrance Walks	1	4	100:1	25:1	1	4
Driveways	.5	15	200:1	67:1	1	12
Swales	1	10	100:1	10:1	2	10
Ramps		20		5:1	10	15
Grass Banks		33.3		3:1	16.6	33.3
Planted Banks		50		2:1	20	50
Steps		66.5		1.5:1	33.3	50

Once the rough grade has been established, the stockpiled topsoil can be distributed. Ideally, a layer of at least 6 inches should be placed over the subsoil. To obtain the finished or *smooth grade*, soil should be spread using tractors with implements such as box scrapers, rakes, and front-end loaders. Hand raking is suggested to prepare the site for planting. Finally, grading should be done when weather conditions are dry. Soil structure can be badly damaged if it is too wet or too dry when worked.

750

INFORMATION SHEET #2

Drainage Systems

Grading alone will not solve drainage problems in all cases. Therefore, in some cases, the installation of a drainage system is recommended. Drainage systems are commonly used to improve soil drainage in planting beds, to eliminate water collecting in pools, to ensure that water is moved away from buildings, and to prevent water from sitting on patios, walks, and drives.

The best time to install a drainage system is right after the rough grade has been established. Installation at this time is less of a problem than it would be after placement of the top soil. Drain tile should be placed below the frost line or 24" to 36" deep. The tile should be placed on a 4" gravel base with a slope from 2% to 4%. Drain tile may be arranged in herringbone or gridiron patterns.

The landscaper has a choice of various types of systems to install.

Clay Tile: The most common clay tile system consists of pieces of 4" clay pipe laid end to end. For best results, the tile should be laid on gravel and the top portion of the joints should be covered with tar paper to prevent soil from entering the tile. Clay tile is ideal for use under drives and patios. However, the labor required for installing it in a large system may prohibit its use. Clay tile systems operate extremely well if placed at slopes from 2% to 4%.

Rolled Corrugated Plastic: Although rolled corrugated plastic is not as long lasting as clay tile it has the advantage of being easy to install. Rolled corrugated plastic has holes placed at intervals along its sides. It should be placed with its holes facing down below the frost line at a 2% slope on a gravel base and then covered with gravel.

Ridged Plastic: Ridged plastic is more costly than the corrugated plastic, and it is harder to work with due to its lack of flexibility. Ridged plastic tile has a series of holes on one side which should face down to allow only water to enter. As with the other tiles, it should be placed on a gravel bed. One advantage of the ridged plastic is it may be used near the surface in some cases, with little chance of being crushed.

Petro-Mat and Stone: This is a rather simple system in which a petro-mat is placed in a trench dug at a 2% to 4% slope, filled with about one foot of gravel, then folded over the gravel. The mat keeps soil from clogging the air spaces and water flows through the gravel.

French Drain: French drains are useful for improving soil drainage on steeper slopes. A narrow trench is filled with gravel to move water from a planting.

Catch Basin: Surface water and water moved by drain tile can be collected in a catch basin. The catch basin is a concrete or brick tank which holds water until the level rises high enough to flow through an exit pipe to the local system. Catch basins prevent leaves, trash, and soil from entering the larger system.

736

INFORMATION SHEET #3

Measuring Areas

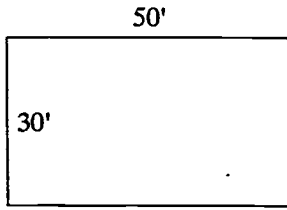

Rectangle or Square

Area = Length x Width

Ex: 50 ft x 30 ft = 1,500 sq ft

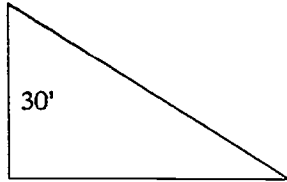

Right Triangle

Area = (Base x Height) + 2

Ex: (50 ft x 30 ft) + 2 = 1,500 ft + 2 = 750 sq ft

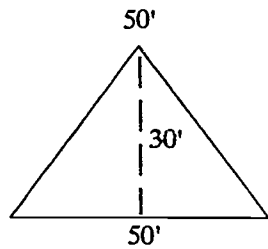

Any Triangle

Area = (Base x Perpendicular Height) + 2

Ex: (50 ft x 30 ft) + 2 = 1,500 ft + 2 = 750 sq ft

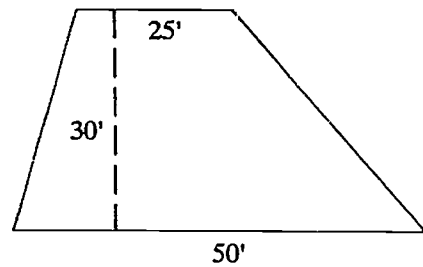

Trapezoid

Area = [(Parallel side + Parallel side) x Height] + 2

Ex: [(25 ft + 50 ft) x 30 ft] + 2 = (75 ft x 30 ft) + 2 = 225 ft + 2 = 112.5 sq ft

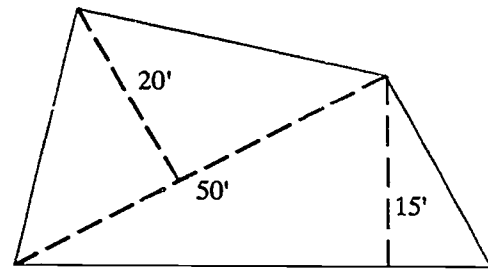

Four sides, none parallel

Divide area into two triangles, then solve for each.

Ex. Area = (50 ft x 15 ft) + 2 + (50 ft x 20 ft) + 2 = 750 ft + 2 + 1,000 ft + 2 = 375 ft + 500 ft = 875 sq ft

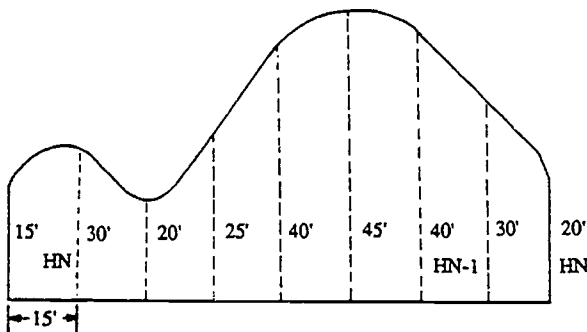

Areas with curves

Area = (HO + 2 + Sum H1 to HN-1 + HN + 2) x D

Ex: Area = [(15 ft + 2) + 30 ft + 20 ft + 25 ft + 40 ft + 45 ft + 40 ft + 30 ft + (20 ft + 2)] x D = 247.5 ft x 15 ft = 3,712.5 sq ft

75

TRANSPARENCY MASTER #1

Determining Percent Slope

Equation: $\text{Slope} = \text{Rise} \div \text{Run}$

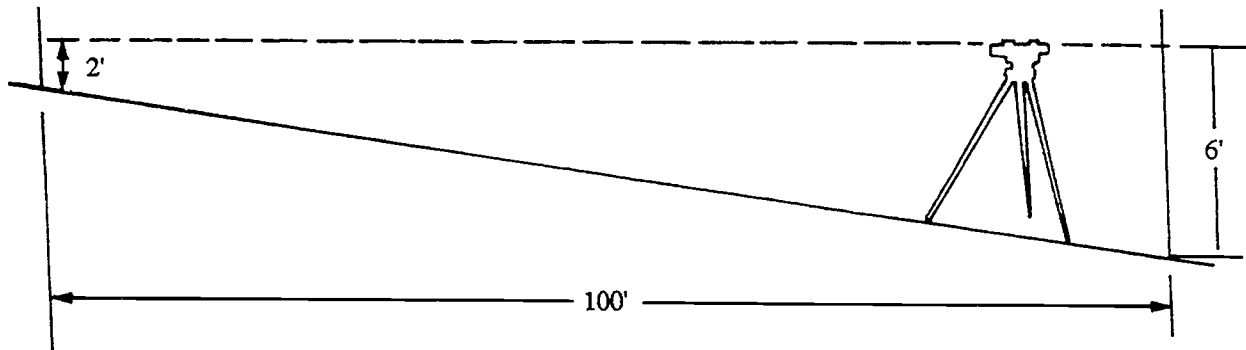

$$\text{Slope} = \text{Rise} \div \text{Run} = (6' - 2') \div 100' = 4' \div 100' = .04 = 4\% \text{ Slope}$$

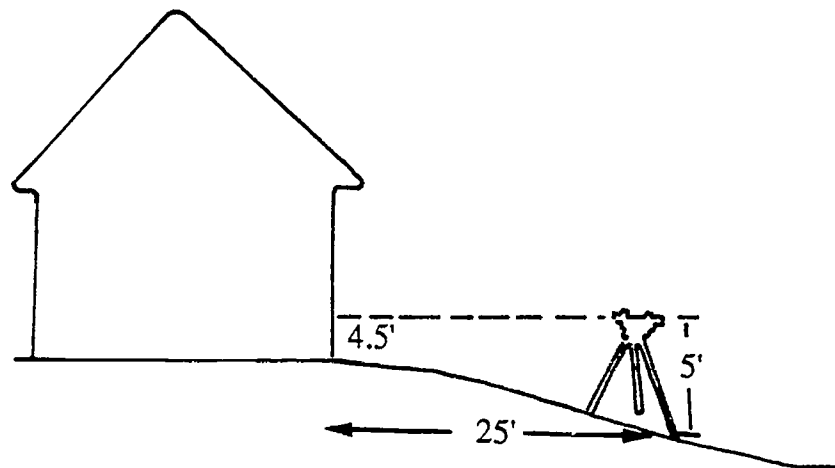

$$\text{Slope} = \text{Rise} \div \text{Run} = (5' - 4.5') \div 25' = .5' \div 25' = .02 = 2\% \text{ Slope}$$

753

TRANSPARENCY MASTER #2

Incorrect and Correct Methods of Lowering Grade Around Trees

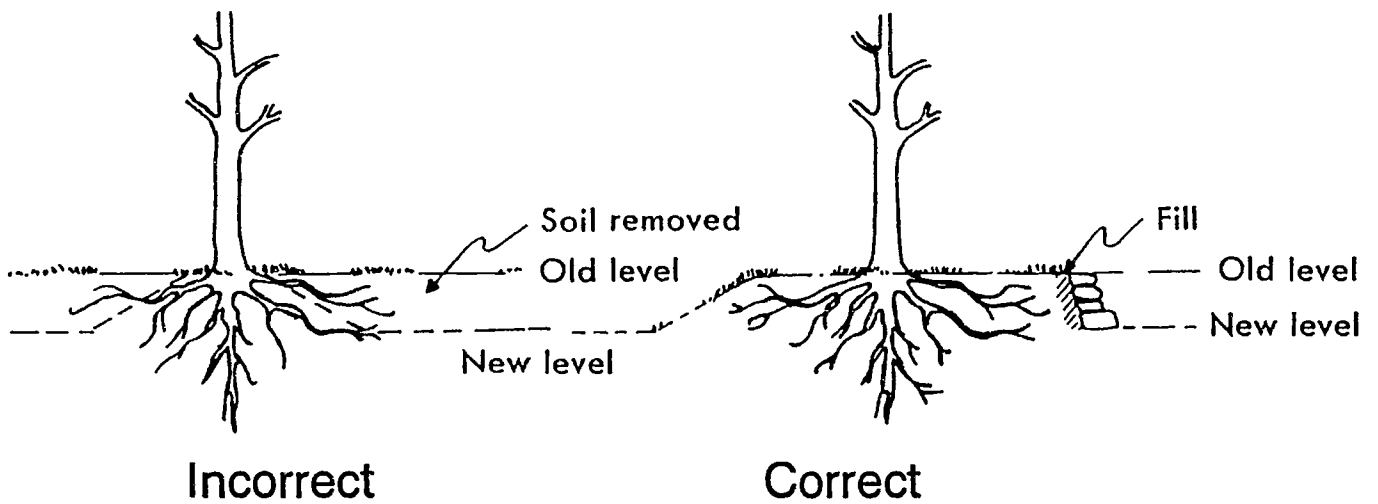

750

STUDENT ACTIVITIES

STUDENT WORKSHEET #1 — Surveying, Grading, and Tiling Word Search (with solution)

STUDENT WORKSHEET #2 — Surveying, Grading and Tiling

STUDENT WORKSHEET #3 — Determining Areas

For additional activities, teachers may refer to the “Suggested Teaching Activities and Procedures” section in the Instructor’s Guide.

757

STUDENT WORKSHEET #1

Surveying, Grading, and Tiling Word Search

P R S G O U U Z I P F P J B B H N B
 Y K L Z R B F P W F O J M Y U P O A
 I E G L M Q L S F J Y Y B A F P U Z
 F G E G S X T C F R C N P A E F I D
 F M T L N R J C L O O Q T O R F H G
 L T O F A I I Q E A J S A R S E E S
 C P H N R J Y C S D Y T T U I T A F
 E O S N F E C E A I A P D L O P O T
 V I H E Y D N L V T E R I O I T O I
 T N T A A E T C W R C Q G P P N V D
 V D A O N Z E A H O U H X H E H E U
 N F A B P D T L R D F S B K G V L F
 O A E D N S L O A G R O G A D U G I
 N R T D N U O E D W E A A G S S O C
 M A T C K V J I V G S T I I J I C R
 L X I G A F K L L E N W R N J U N V
 A D R A I N T I L E L U I O E G O U
 S B C M W I P M O E K F B B D Z Z P

The following words are hidden in the puzzle:

Area
 Berm
 Catch basin
 Clay pipe
 Drain tile
 French drain
 Frost line
 Hand level

Rough grade
 Slope
 Surveying
 Swale
 Target rod
 Topsoil
 Transit
 Tripod

753

STUDENT WORKSHEET #1 — Key

Surveying, Grading, and Tiling Word Search

.

 F
 . . . G S . T C . R . . . A . . .
 . . . L N R . . L . O . T . R . . .
 . . O F A I . . E A . S . R . E . .
 . P . N R . Y C . D Y . T . I . A .
 E . S . . E . E A . A P . L . P . .
 . I H . . . N . V T . R I . I . O .
 T . T A . . T C . R C . G P . N . D
 . . . O N . E A H . U H . H E . E .
 . . . B P D . L R D . S B . G . . .
 . . E . . S L . A G R . . A . U . .
 . R O E . W E A . . S . O .
 M I V . S T I . . I . R
 L E . . R N . . N .
 . D R A I N T I L E L . . O
 D . . .

The following words are hidden in the puzzle:

Area
 Berm
 Catch basin
 Clay pipe
 Drain tile
 French drain
 Frost line
 Hand level

Rough grade
 Slope
 Surveying
 Swale
 Target rod
 Topsoil
 Transit
 Tripod

750

STUDENT WORKSHEET #2

Surveying, Grading, and Tiling

Match the letter to the correct number (questions 1-10).

- | | |
|------------------------|---|
| _____ 1. Swale | A. Evacuated material |
| _____ 2. Berm | B. Vertical distance divided by horizontal distance |
| _____ 3. Slope | C. A small hill |
| _____ 4. Cut | D. Moving of soil to reshape the land |
| _____ 5. Fill | E. Concave depression or channel for water |
| _____ 6. Grading | F. Depth at which the ground freezes |
| _____ 7. Frost line | G. Instrument used in surveying |
| _____ 8. Level | H. Pipe made of clay, concrete, or plastic |
| _____ 9. Drainage tile | I. Underground cavity in which water collects |
| _____ 10. Catch basin | J. Material or soil added to raise the grade |

11. Determine the percent slope for the following readings. Your eye level is 5' 0". NOTE: The distances vary.

- | | |
|------------------------|-------|
| A= 3' 6" Distance 100' | _____ |
| B= 2' 6" Distance 25' | _____ |
| C= 4' 8" Distance 50' | _____ |
| D= 1' 3" Distance 25' | _____ |
| E= 8' 0" Distance 50' | _____ |
| F= 7' 9" Distance 100' | _____ |

12. Calculate the area in square feet of the following:

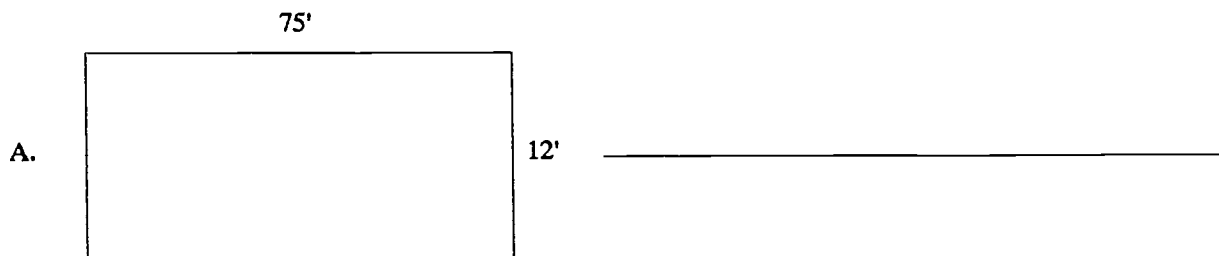

760

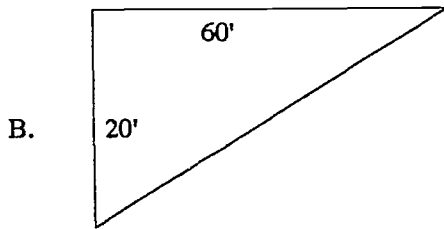

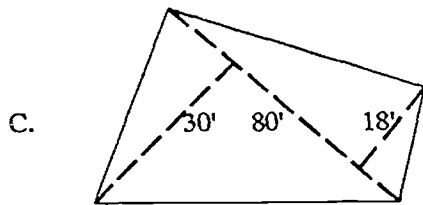

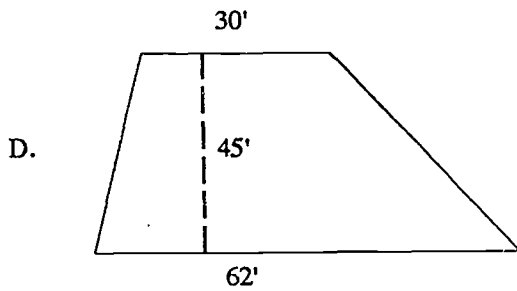

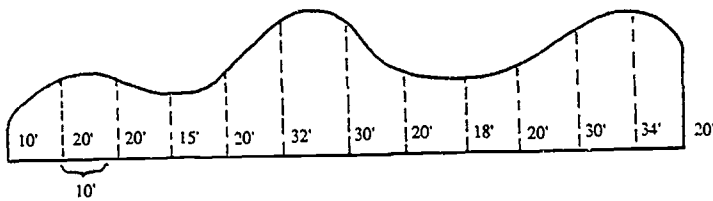

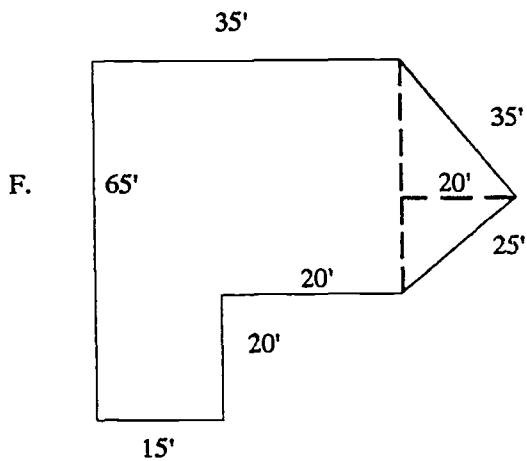

751

STUDENT WORKSHEET #2 — Key

Surveying, Grading, and Tiling

Match the letter to the correct number (questions 1-10).

E 1. Swale

C 2. Berm

B 3. Slope

A 4. Cut

J 5. Fill

D 6. Grading

F 7. Frost line

G 8. Level

H 9. Drainage tile

I 10. Catch basin

A. Evacuated material

B. Vertical distance divided by horizontal distance

C. A small hill

D. Moving of soil to reshape the land

E. Concave depression or channel for water

F. Depth at which the ground freezes

G. Instrument used in surveying

H. Pipe made of clay, concrete, or plastic

I. Underground cavity in which water collects

J. Material or soil added to raise the grade

11. Determine the percent slope for the following readings. Your eye level is 5' 0". NOTE: The distances vary.

A= 3' 6" Distance 100'

1.50%

B= 2' 6" Distance 25'

10.00%

C= 4' 8" Distance 50'

0.67%

D= 1' 3" Distance 25'

15.00%

E= 8' 0" Distance 50'

6.00%

F= 7' 9" Distance 100'

2.75%

12. Calculate the area in square feet of the following:

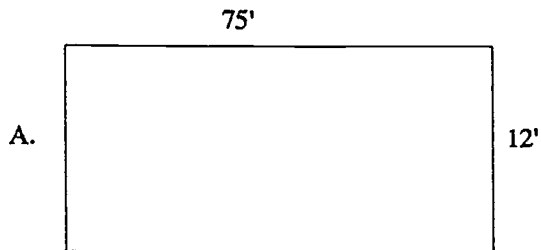

900 sq ft

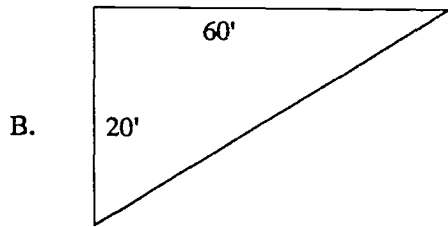

600 sq ft

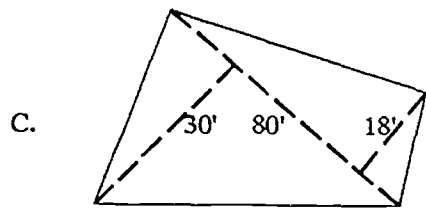

720 ft + 1,200 ft = 1,920 sq ft

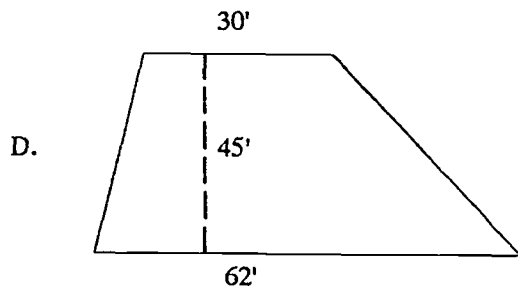

2,070 sq ft

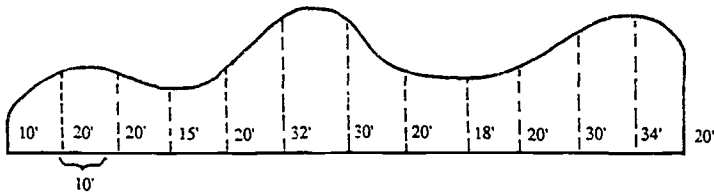

274 ft x 15 ft = 4,110 sq ft

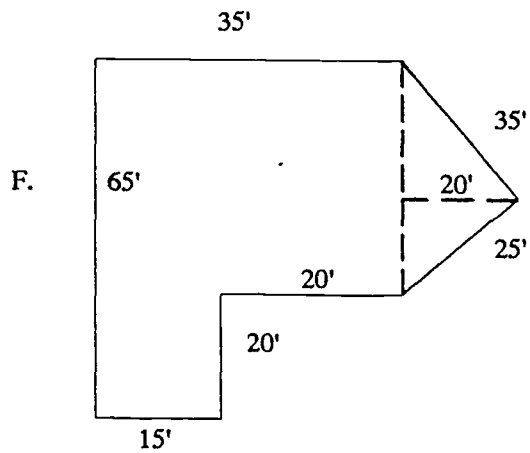

975 ft + 900 ft + 450 ft = 2,325 sq ft

788

STUDENT WORKSHEET #3

Determining Areas

DIRECTIONS: Determine the area in square feet for the lawn, planting, and deck areas. The scale for this exercise is 1' = 16' 0".

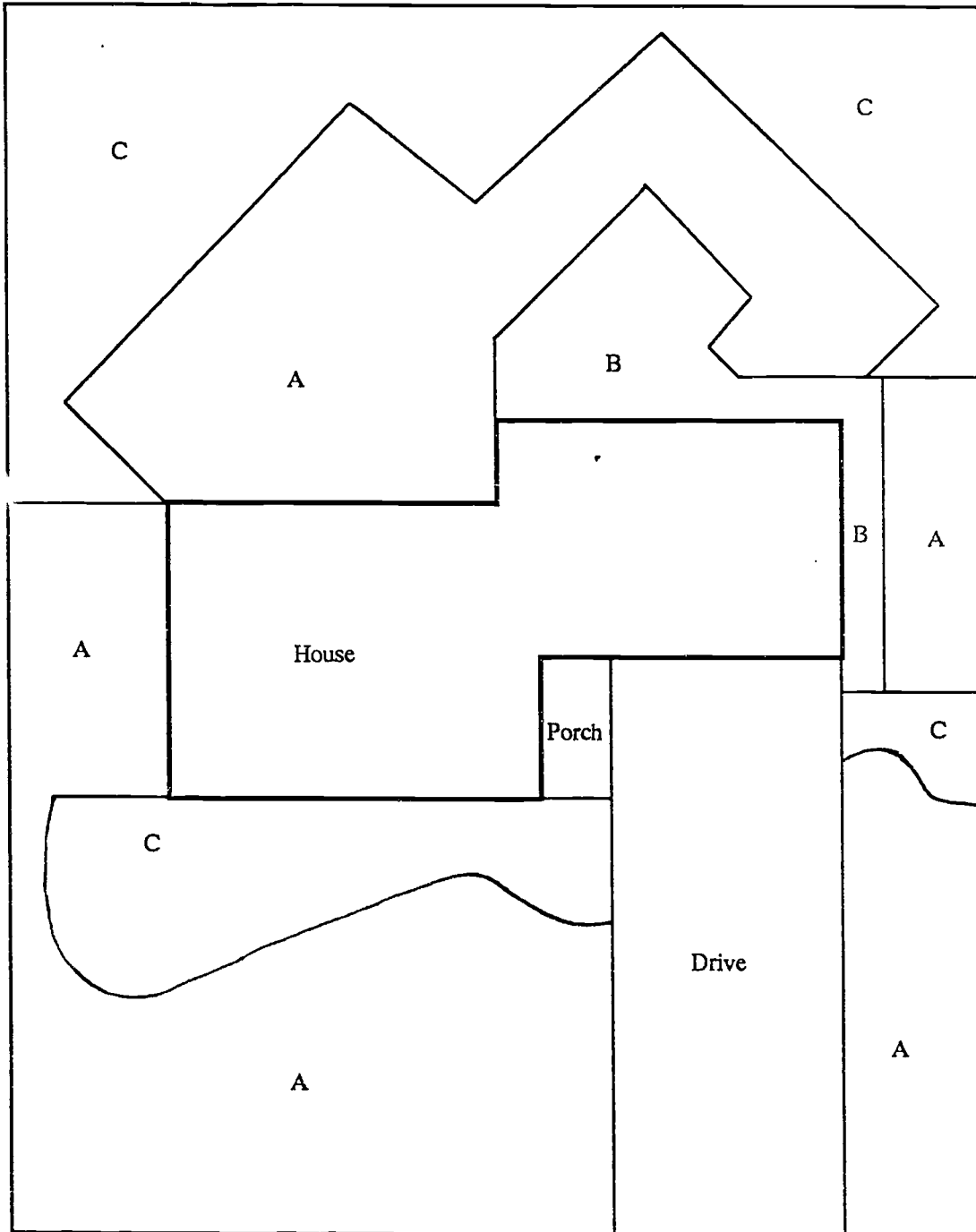

- A — Lawn Area
- B — Brick Patio and Walk
- C — Planting Areas

764

CLUSTER: HORTICULTURE

UNIT: Landscaping

PROBLEM AREA: Interior Plantscaping

RELATED PROBLEM AREAS:

1. Enhancing Soil Fertility
2. Understanding Plant Germination, Growth, and Development
3. Classifying Horticultural Plants
4. Understanding Plant Anatomy and Physiology
5. Growing Ornamental Plants
6. Controlling Plant Pests
7. Developing Growing Media
8. Designing and Drawing Landscape Plans
9. Designing Silk and Dried Arrangements
10. Designing Live Arrangements

PREREQUISITE PROBLEM AREA(S)

1. Enhancing Soil Fertility
2. Understanding Plant Germination, Growth, and Development
3. Classifying Horticultural Plants
4. Understanding Plant Anatomy and Physiology
5. Growing Ornamental Plants
6. Controlling Plant Pests
7. Developing Growing Media

LEVEL: Preparatory

OCCUPATIONAL TASKS ADDRESSED:

Duty A: Propagating Plants, Seeds, and Cuttings

1. Plant trees and shrubs

703

Duty B: Preparing Soils and Planting Media

1. Screen planting media
2. Mix media materials
3. Pasteurize prepared media with steam
4. Mix fertilizer into media
5. Level or smooth planting bed
6. Mark off location of beds

Duty C: Controlling the Plant Environment

1. Control temperature by setting thermostat
2. Cultivate plants
3. Water plants and nursery stock
4. Apply mulches
5. Control pests
6. Treat diseased plants, bulbs, and corms
7. Remove diseased plants
8. Pinch and disbud flowering plants
9. Force bulbs
10. Report disease and spray damage

Duty E: Applying Fertilizer and Chemicals

1. Calculate fertilizer and chemical applications
2. Collect soil for fertility test
3. Assess crop nutrient deficiencies
4. Treat nutrient deficiencies
5. Mix chemicals
6. Time chemical applications
7. Store chemicals
8. Perform safety checks on equipment
9. Transport chemicals
10. Compute fertilizer costs
11. Apply fertilizer using watering system
12. Apply fertilizer using liquid application
13. Select chemicals for specific problems
14. Compute chemical costs
15. Dispose of chemicals and containers according to manufacturer's specifications

Duty K: Designing/Installing Landscapes

1. Obtain plants
2. Follow landscape plan in installing plants
3. Plant trees
4. Plant shrubs
5. Plant ground cover
6. Select plants
7. Price landscape plan
8. Read landscape plan

Duty L: Maintaining and Improving Grounds

1. Prune trees
2. Prune plants, hedges, and shrubs

STATE GOALS FOR LEARNING

In planning the instruction for this problem area, teachers can promote the development of several student learning objectives which are related to the State Goals for Learning in Fine Arts and Biological and Physical Sciences. These objectives are listed on the Learning Assessment Plan forms included on the following page(s). Those learning objectives marked with an asterisk (*) are taken from the sample lists provided by the Illinois State Board of Education.

**Illinois Agricultural Core Curriculum**

Agricultural Education 124 Mumford Hall 1301 W. Gregory Drive University of Illinois Urbana, IL 61801

Director: Dale A. Law, Ed.D.

Principal Investigator: Jerry D. Pepple, Ed.D.

Research Assistant: Ronald J. Biondo

88/89

767

Illinois Agricultural Core Curriculum Rev.

Horticulture
Landscaping

INSTRUCTOR'S GUIDE**CLUSTER: HORTICULTURE****UNIT: Landscaping****PROBLEM AREA:** Interior Plantscaping**STUDENT LEARNING OBJECTIVES**

Upon completion of their study of this problem area, students will be able to:

1. Identify indoor plant needs.
2. Recommend plant materials that will perform well in interior landscaping situations.
3. Identify climatic conditions unique to interior plantscaping.
4. Develop an interior plantscape plan based on the principles of art, function, and plant attributes.
5. Describe uses for silk and plastic plants.

INSTRUCTOR'S NOTES AND REFERENCES

774

INSTRUCTOR'S GUIDE**CLUSTER: HORTICULTURE****UNIT: Landscaping****PROBLEM AREA:** Interior Plantscaping**PROBLEMS AND QUESTIONS FOR STUDY**

1. What environmental factors affect the use of plants indoors?
2. What can be done to improve the growing environment for plants indoors?
3. Which plants perform well indoors?
4. How should one go about selecting plants for an indoor landscape?
5. How are indoor plants installed?
6. What are the symptoms in plants, indicating that something needed is not being received?
7. How can drainage problems be corrected indoors?
8. What does acclimatization mean?
9. How often do plants need to be watered and fertilized?
10. How can artificial lighting be used in interior plantscapes?
11. How are the principles of art used for interior plantscape design?
12. What functional considerations should be made in locating plants?
13. When are artificial plants useful?
14. What are the advantages and disadvantages for using artificial plants?
15. How do traffic patterns affect a design?
16. Why has the interior plantscaping industry grown so rapidly in the last few years?
17. What are the employment opportunities in interior plantscaping?
18. What special problems are there related to pest control for interior plants?

INSTRUCTOR'S NOTES AND REFERENCES

775

INSTRUCTOR'S GUIDE**CLUSTER: HORTICULTURE****UNIT: Landscaping****PROBLEM AREA:** Interior Plantscaping**SUGGESTED TEACHING ACTIVITIES AND PROCEDURES**

1. Lead a discussion on the interest of people in interior plants.
2. Brainstorm with the class to come up with all the advantages and uses of interior plants. Use Transparency Master #1 to help conclude the session.
3. Give students a project requiring them to cut and paste pictures from magazines that illustrate the uses of interior plants.
4. Arrange a field trip to:
 - a. A plant rental company.
 - b. A shopping mall.
 - c. A series of office buildings that have interior plantscapes.
5. Review with the students the environmental requirements for plant growth (refer to problem area *Understanding Plant Anatomy and Physiology*).
6. Have the students compile a list of plants they have seen used as indoor plants.
7. Lead a discussion on the principles of art used in designing interior plantscapes (refer to *Designing and Drawing Landscape Plans*).
8. Lead a discussion on the advantages and disadvantages of using silk or plastic plants for interior landscaping purposes.
9. Lead a discussion on functional uses of plants in interior plantscaping. Main topics might include:
 - a. To soften architectural lines.
 - b. To direct traffic.
 - c. To serve as a screen.
 - d. To define space.
 - e. To serve as a focal point.
 - f. To improve air quality.
 - g. To reduce noise level.
10. Have a group discussion concerning the installation of plant material and the maintenance of established plant material.
11. Arrange for a guest speaker to address the class on job opportunities in the interior plantscaping industry.
12. Address the needs of an integrated pest management (IPM) program for indoor plantscapes.

INSTRUCTOR'S NOTES AND REFERENCES

770

INSTRUCTOR'S GUIDE

CLUSTER: HORTICULTURE

UNIT: Landscaping

PROBLEM AREA: Interior Plantscaping

REFERENCES

INSTRUCTOR'S NOTES AND REFERENCES

- *1. *Interior Landscaping*. (1983). Furvta, Tok. Reston Publishing Company, Prentice-Hall, 200 Old Tappan Road, Old Tappan, NJ 07675. (800) 223-2348.
2. *Interior Landscape Industry*. (monthly publication). American Nurseryman Publishing Company, 111 N. Canal Street, Suite 545, Chicago, IL 60606-7203.
3. *Interior Plantscapes, Installation, Maintenance and Management*. Manaker, George H. Prentice-Hall, 200 Old Tappan Road, Old Tappan, NJ 07675. (800) 223-2348.
4. *Exotica Plant Manual*. (1982). Graf, Alfred Byrd. Roehrs Company Publishers, P.O. Box 125, East Rutherford, NJ 07073.
5. *Hortus III*. (1976). Bailey, L.H. MacMillan Publishing Company, 866 Third Avenue, New York, NY 10022. (212) 702-2000.
6. *How to Sell More Indoor Plants*. Hamilton, David L. Hamilton Publishing Company, P.O. Box 1233, Carlsbad, CA 92008.
7. *Growing Plants Indoors* (VAS Unit #U5007). Vocational Agriculture Service, College of Agriculture, University of Illinois, 1401 S. Maryland Drive, Urbana, IL 61801.
8. *Interior Designer's Handbook on Plants*. Hamilton, David L. Hamilton Publishing Company, P.O. Box 1233, Carlsbad, CA 92008.

*Indicates highly recommended reference

777

INSTRUCTIONAL RESOURCES

These resources are intended for use by teachers in planning and teaching the materials for this problem area and may be adapted to fit the teaching method(s) used.

TRANSPARENCY MASTER #1 — Use of Plants Indoors

778

TRANSPARENCY MASTER #1

Use of Plants Indoors

1. **Plants are used to improve the emotional state of people.**
 - a. Plants brings a touch of nature indoors.
 - b. Plants may be therapeutic by means of reducing stress.
 - c. Plant care may be classified as a recreational activity and is particularly important during the winter months.

2. **Plants are used to improve the decor inside a building.**
 - a. Well-placed plants soften harsh architectural lines or screen awkward architectural features.
 - b. Plants may serve as a wall or be used to define space.
 - c. Plants can serve to frame views.
 - d. Unusual plants or specimens may serve as a focal point of a room.
 - e. Plants may provide privacy.

3. **Interior plants can also perform practical functions.**
 - a. Plant placement may control or direct traffic flow.
 - b. Plants can improve acoustics or reduce sound levels.
 - c. Live plants even clean and refresh the air.

STUDENT ACTIVITIES

STUDENT WORKSHEET #1 — Interior Plantscaping Word Search (with solution)

For additional activities, teachers may refer to the “Suggested Teaching Activities and Procedures” section in the Instructor’s Guide.

780

STUDENT WORKSHEET #1

Interior Plantscaping Word Search

C G I D P O Y T I D I M U H O T V E Y D
 L E N O E T I N A E W Q P V V D A G Z O
 X H F I S N U N F H A T F K V L N F O A
 D N O O T O O G P D O G I N L I T D N U
 D A C G C N S I C L A U A T N I C K V J
 G I A J O C A L T R A X S U I L G G A F
 K L L N N W J L T A U N R E A V A H U I
 E G P O T U S B P C Z P T T P E M W T I
 P S O M R O E H K S F I N E R L B B Z Z
 P T I D O T A V C T N E T U R K A S X I
 N L N Z L I L S G L R A T A C S U N C F
 K A T H R L E A T T U A R V M N J Q T D
 N S U C Q E Q G N F R M E T Y I Q G L X
 X E O L I M T A A E A K M G U Q L M S X
 J L K R X R L A P I U R X O A B T C F H
 E B R W J P C M W A L R D L J N S I C R
 P U L Y M G E L F B Q O L I W C I T L A
 M L R Z H T S T L D Y D F G V P I A P G
 A O N U T R I E N T S Z B A R R J E R G
 Z S J N M T E Z S N S D F J I E L V W D

The following words are hidden in the puzzle:

Acclimatization
 Art
 Drafts
 Drainage
 Focal Point
 Foliage
 House Plant
 Humidity
 Light
 Mulch

Nutrients
 Pest Control
 Planters
 Plant-Rental
 Pruning
 Soluble Salts
 Temperature
 Transplanting
 Water

STUDENT WORKSHEET #1 — Key

Interior Plantscaping Word Search

. G . . P . Y T I D I M U H
 . . N . E G . .
 . . F I S N . . . H N . . .
 . . O . T . O . P . O L I
 . . C . C N . I . L A U . . N I
 . . A . O . A . T R A . S U . L G
 . . L . N . . L T A . N R E A . . H . .
 . . P . T . . . P . Z P T T P E . . T . .
 . S O . R . . H . S . I N E R L
 . T I . O . . . C . N E T U R . A . . .
 . L N . L . . S . L R A T A . S . N . .
 . A T . R . E . T T U A R . M . . . T . .
 . S . . . E . G N F R M E T . I
 . E T A A E A . . G . . L . . .
 . L L A P I . R . . A . . C . .
 . B . . . P . M W . L . D . . N . . C . .
 . U E O I . . A .
 . L . . . T F A . . .
 . O N U T R I E N T S R . . .
 . S D

The following words are hidden in the puzzle:

- Acclimatization
- Art
- Drafts
- Drainage
- Focal Point
- Foliage
- House Plant
- Humidity
- Light
- Mulch

- Nutrients
- Pest Control
- Planters
- Plant Rental
- Pruning
- Soluble Salts
- Temperature
- Transplanting
- Water

782

UNIT E: Floral Design

PROBLEM AREAS:

1. Handling and Preparing Cut Flowers
2. Designing Silk and Dried Arrangements
3. Designing Live Arrangements
4. Identifying the Principles of Floral Design

CLUSTER: HORTICULTURE

UNIT: Floral Design

PROBLEM AREA: Handling and Preparing Cut Flowers

RELATED PROBLEM AREAS:

1. Marketing Horticultural Products and Services
2. Understanding Plant Germination, Growth, and Development
3. Classifying Horticultural Plants
4. Growing Ornamental Plants

PREREQUISITE PROBLEM AREA(S): None

LEVEL: Orientation

OCCUPATIONAL TASKS ADDRESSED:

Horticulture Cluster

Duty E: Harvesting Plants

1. Prepare and place cut flowers in water or preservative

Duty I: Storing, Shipping, and Taking Inventory

1. Check received merchandise against invoice listings
2. Store floral and foliage plants in cold storage units

STATE GOALS FOR LEARNING:

In planning the instruction for this problem area, teachers can promote the development of several student learning objectives which are related to the State Goals for Learning in Biological and Physical Sciences. These objectives are listed on the Learning Assessment Plan forms included on the following page(s). Those learning objectives marked with an asterisk (*) are taken from the sample lists provided by the Illinois State Board of Education.



Illinois Agricultural Core Curriculum

Agricultural Education 124 Mumford Hall 1301 W. Gregory Drive University of Illinois Urbana, IL 61801

Director: Dale A. Law, Ed.D.

Principal Investigator: Jerry D. Pepple, Ed.D.

Research Assistant: Janis L. Anderson

88/89

Horticulture
Landscape Design



INSTRUCTOR'S GUIDE**CLUSTER: HORTICULTURE****UNIT: Floral Design****PROBLEM AREA: Handling and Preparing Cut Flowers****STUDENT LEARNING OBJECTIVES**

Upon completion of their study of this problem area, students will be able to:

1. Explain the steps of processing flowers from the wholesale florist.
2. List the requirements for three or more different flowers in terms of temperature, humidity, ventilation, and lighting.
3. Recognize and explain the damage caused to flowers from ethylene gas.
4. Identify various floral preservatives and their effect on flower life.
5. Identify the availability, vase life, handling and conditioning procedures, and storage of at least five cut flowers used in the floral industry.
6. Know how to eliminate problems such as botrytis, bent neck, and geotropism for longer flower life.

INSTRUCTOR'S NOTES AND REFERENCES

15
6.2.22

INSTRUCTOR'S GUIDE

CLUSTER: HORTICULTURE

UNIT: Floral Design

PROBLEM AREA: Handling and Preparing Cut Flowers

PROBLEMS AND QUESTIONS FOR STUDY

INSTRUCTOR'S NOTES AND REFERENCES

1. What can be done to increase cut flower life?
2. Why can't fruit and flowers be stored together?
3. Why do some flower heads, such as tulips, snapdragons and gladiolus, turn up when set in a horizontal position?
4. What are "bullets"?
5. What temperatures are best for storage?
6. What will cause a quick death in cut flowers?
7. How should flowers be cut on arrival?
8. How are newly purchased flowers prepared?
9. How can bent neck roses be revived?
10. What tools and materials are necessary for handling and preparing cut flowers?

790

INSTRUCTOR'S GUIDE**CLUSTER: HORTICULTURE****UNIT: Floral Design****PROBLEM AREA: Handling and Preparing Cut Flowers****SUGGESTED TEACHING ACTIVITIES AND PROCEDURES****INSTRUCTOR'S NOTES AND REFERENCES**

1. As an interest approach ask the class to complete Student Worksheet #1. Later have them research the answers or use it as a quiz at the completion of the problem area.
2. Have class predict the vase life of various cut flowers.
3. Have class do Student Worksheet #4. Split class into groups.
4. Discuss the effects on flowers produced by ethylene gas and how to remedy them.
5. Discuss or demonstrate how to revive wilted, bent neck, or bullet roses.
6. Discuss how foliage can be stored with flowers.
7. Study the effects of geotropism on various cut flowers. Lead a discussion based on the results of the study, on how geotropism can be a factor to consider when using these flowers in floral designs.
8. Have students research and complete Student Worksheet #2.
9. Assign Student Worksheet #3 .

704

INSTRUCTOR'S GUIDE

CLUSTER: HORTICULTURE

UNIT: Floral Design

PROBLEM AREA: Handling and Preparing Cut Flowers

REFERENCES

INSTRUCTOR'S NOTES AND REFERENCES

1. *A Guide for the Post Harvest Handling of Fresh Flowers to Extend their Useful Life.* (1988)
Meo, N.T., Eisenberg, B.A. The Illinois State Florists Association.
2. *The Commercial Storage of Fruits, Vegetables, and Florists and Nursery Stock.* (USDA Agriculture Handbook 66). (1986 revision).
Lutz, V.M., Hardenburg, R.E. U.S. Department of Agriculture, Washington, DC 20250.
- *3. *Design for Profit Magazine.* c/o Florafax International, Inc., 4175 S. Memorial Drive, Tulsa, OK 74145.
4. *Florist Review Magazine.* P.O. Box 4365, 2231 Wanamaker, Suite 105, Topeka, KS 66614.
- *5. *The Professional Floral Designer Magazine.* American Floral Services, Inc., P.O. Box 12309, Oklahoma City, OK 73157-2309.
- *6. *Floral Design and Management.* McDaniel, Gary L. Reston Publishing Company, Division of Prentice Hall, 200 Old Tappan Road, Old Tappan, NJ 07675. (800) 223-2348.
- *7. *Introductory Horticulture.* (1988). Retley, H.E., Shry, C.L., Jr. Delmar Publishers, Inc., 2 Computer Drive West, Box 15-015, Albany, NY 12212.

*Indicates highly recommended reference

795

INSTRUCTIONAL RESOURCES

These resources are intended for use by teachers in planning and teaching the materials for this problem area and may be adapted to fit the teaching method(s) used.

INFORMATION SHEET #1 — Steps to Follow When Flowers Arrive

INFORMATION SHEET #2 — Effects of Ethylene Gas on Cut Flowers

INFORMATION SHEET #3 — Post Harvest Care of Roses

INFORMATION SHEET #4 — Storage Recommendations for Cut Flowers and Florist Greens

INFORMATION SHEET #5 — Post Harvest Life

780

INFORMATION SHEET #1

Steps to Follow When Flowers Arrive

1. Loosen wrappings
 - a. Blooms will expand as they open.
 - b. Remove wilted, damaged blooms.
 - c. Report damage to wholesaler.
2. Avoid blockages
 - a. Blockage is usually caused by bacteria or minerals from water.
 - b. Remove lower foliage that will be under water.
 - c. While holding the stem underwater, cut 1 - 2" from bottom of stem.
 - d. Then, place the stem in a bucket with prepared water.
3. Angle cut best
 - a. An angle cut prevents stem from "sealing" to bottom of container.
 - b. Remove all foliage which will be under water, as it will rot and release harmful bacteria and ethylene.
 - c. Use a glove or rag to remove foliage so as not to injure bark and prevent water uptake.
4. Clean containers
 - a. Clean with hot, detergent solution, disinfect with bleach, and rinse. Container should be clean enough to drink from.
 - b. Use nonmetallic containers so that no rust or metal ions will interrupt positive actions of preservatives.
 - c. Use 100° -110° F water with preservative.
5. Preservatives
 - a. Use a preservative composed of 1-4 percent sugar plus an anti-microbial agent like hydroquinoline citrate (HQC).
 - b. De-ionized (DI) water can increase longevity if natural water contains over 200 PPM soluble salts.
 - c. An example of a possible preservative would be 200 PPM HQC plus 3 percent sugar.
6. Keep flower blooms dry
 - a. Wet blooms encourage botrytis (a fungus which turns petals brown).
7. Hardening of flowers
 - a. Place flowers in containers filled about 1/3 with water treated with preservative.
 - b. Let stand at room temperature for about 2 hours out of direct sunlight to allow flowers to take up water.
 - c. Place the flowers into a cooler for 12 hours before using to slow their metabolism or growth.

737

INFORMATION SHEET #2

Effects of Ethylene Gas on Cut Flowers

Facts about Ethylene Gas:

1. Ethylene gas speeds up the maturation of plants. Therefore, it causes cut flowers to wilt faster.
2. Ethylene is given off during respiration of mature fruits, flowers, and foliage. Fungus and bacteria also give off ethylene gas.
3. Damaged fruit, flowers, and foliage give off ethylene gas which will cause all plants nearby to age faster.
4. Ethylene gas affects cut flowers and foliage in some of the following ways:
 - a. Carnations go to "sleep."
 - b. Roses turn "blue."
 - c. Snapdragons drop their flirts.
 - d. Leaves turn downward (Epinasty).
 - e. Leaves turn yellow or drop off.

Preventing Ethylene Damage:

1. Do not store fruit with flowers.
2. Do not store old cut flowers with new ones.
3. Use preservatives on fresh cut flowers.
4. Keep the cooler clean.
5. Use commercial ethylene "scrubbers."
6. Use silver thiosulfate (STS) in water for ethylene sensitive flowers. It blocks the *action* of ethylene. CAUTION: Apply only once.
7. Amino-oxyacetic acid (AOA) blocks the *production* of ethylene.

Partial List of Ethylene Sensitive Crops:

Alstroemeria	Lily
Baby's breath	Orchid
Carnation	Poinsettia
Geranium	Snapdragon

788

INFORMATION SHEET #3

Post Harvest Care of Roses

Since cut roses are one of the most expensive, requested, and fragile cut flowers utilized in the floriculture industry, extreme care should be noted during post harvest preparation. The following key points are integral to extending the vase life of roses.

1. Roses should be cut underwater so a small drop of water remains on the newly cut stem at all times. This water bubble insures that the stem won't be blocked by an air bubble to prevent future water uptake.
2. If blockage does occur, recut another inch from the base of the stem.
3. "Bent Neck" occurs when the rose evaporates more water than it takes up through the stem. Since roses are woody and evaporate water through stomates under the leaves, the fewer leaves the less evaporation.
4. "Bullets" are roses cut too tight. Place these roses in a tall container with the rose submerged to the base of the bud in a 110°-120° F preservative/water solution. Cover the top of the can with translucent waxed paper or a plastic bag. Place in good, but not direct sunlight. If roses were not cut too "green," they should open to desired bud stage.
5. To revive wilted roses, remove half the foliage, recut stem, and place in warm preservative water (entire stem submerged) 20 minutes to 1 hour.
6. Store roses at 34° F.
7. Avoid letting water drip on rose petals to prevent botrytis, a fungus disease.
8. Preservatives can increase rose vase life 30 to 50 percent.

799

INFORMATION SHEET #4

Storage Recommendations for Cut Flowers and Florist Greens

Commodity	Storage Temperature °F	Approximate Storage Period
Cut flowers*		
Alstroemeria	40	3 - 4 days
Anemone	40	2 - 3 days
Anthurium	32 - 35	2 weeks
Aster	40 - 45	2 days
Bird-of-Paradise	45 - 46	1 - 3 weeks
Calla	40	1 week
Camellia	45	3 - 6 days
Candytuft	40	3 days
Carnation	31 - 32	3 - 4 weeks
Carnation (miniature)	31 - 32	2 weeks
Chrysanthemum	31 - 32	3 - 4 weeks
Columbine	40	2 days
Cornflower	40	3 days
Crocus	33 - 36	1 - 2 weeks
Dahlia	40	3 - 5 days
Daisy, Shasta	40	7 - 8 days
Delphinium	40	1 - 2 days
Freesia	32 - 33	10 - 14 days
Gardenia	32 - 34	2 weeks
Gerbera	34 - 40	1 - 2 weeks
Gladiolus	35 - 42	5 - 8 days
Gypsophila	40	1 - 3 weeks
Hyacinth	32 - 33	2 weeks
Iris, bulbous	31 - 32	1 - 2 weeks
Lily	32 - 34	2 - 3 weeks
Lily-of-the-Valley	31 - 32	2 - 3 weeks
Lupine	40	3 days
Marigolds	40	1 - 2 weeks
Narcissus	32 - 33	1 - 3 weeks
Orchid, Cattleya	45 - 50	2 weeks
Orchid, Cymbidium	31 - 40	2 weeks
Philox	40	1 - 3 days
Rose (in preservative)	33 - 35	4 - 5 days
Rose (dry pack)	31 - 32	2 weeks
Snapdragon	40	1 - 2 weeks
Statice	35 - 40	3 - 4 weeks
Stephanotis	40	1 week
Sirawflower, fresh	35 - 40	3 - 4 weeks
Sweet-william	45	3 - 4 days
Tulip	31 - 32	2 - 3 weeks
Zinnia	40	5 - 7 days

800

INFORMATION SHEET #4

Storage Recommendations for Cut Flowers and Florist Greens (con't.)

Commodity	Storage Temperature °F	Approximate Storage Period
Florist Greens (cut foliage)*		
Adiantum (maidenhair)	32 - 40	—
Asparagus (sprenger)	32-40	2 - 3 weeks
Buxus (boxwood)	32	—
Camellia	40	—
Cedar	32	—
Croton	35-40	—
Dieffenbachia	55	—
Dracaena	35-40	—
Eucalyptus	35-40	1 - 3 weeks
Hedera	35 - 40	2 - 3 weeks
Ilex (holly)	32 - 40	3 - 5 weeks
Juniper	32	1 - 2 months
Leatherleaf (Baker)	34-40	1 - 2 months
Magnolia	35-40	2 - 4 weeks
Mistletoe	32	3 - 4 weeks
Mountain-laurel	32	2 - 4 weeks
Palm	45	—
Philodendron	35-40	—
Pittosporum	35-40	2 - 3 weeks
Podocarpus	40-45	—
Pothos	35-40	—
Rhododendron	32	2 - 4 weeks
Salal, Lemon Leaf	32	2 - 3 weeks
Smilax, southern	40	—
Vaccinium (huckleberry)	32	1 - 4 weeks
Woodwardia	32-40	—

*USDA Handbook No.66, *The Commercial Storage of Fruits, Vegetables and Florist and Nursery Stocks.*

INFORMATION SHEET #5

Post Harvest Life

Post harvest life is the time that starts when flowers are cut from stock plants and finishes when the consumer throws them away. There are two components that we are concerned with:

1. Genetic makeup—Some flowers just naturally last longer. Retailers and wholesalers most often do not even know the flower varieties they are buying. They purchase by color, size, and stem length. Flowers are not often bred for cut flower life because factors such as disease resistance, flower color, and production number are more important.
2. Environment — There can be variation in environment between handlers of the same flowers. Before they arrive at the wholesaler's or retail shop flowers need to be precooled before storage and shipment. This is to remove field heat. Flowers can be shipped wet or dry. Which method of shipment is chosen depends on the grower or crop. It is necessary to know the proper care for both. Proper refrigeration slows down respiration and the action of microorganisms that may attack flowers. A high relative humidity must be maintained. Relative humidity is the amount of water vapor in the air as compared to the total amount of water vapor the air can hold at that same temperature. Water will move outside the flowers trying to maintain a balance with the surrounding air. This is respiration. Refrigerators should have a relative humidity of 85% or higher. To determine the humidity of a cooler, take the difference between the temperature of the cooling coils and the air inside the cooler. This difference should be no more than 3°. To add humidity, use a commercial humidifier. A "sling psychrometer" is an instrument used to measure the relative humidity of a cooler.

There are also two major components of water quality:

1. pH — Cut flowers tend to take up water more readily if they have an acid pH of 3.0 - 3.5. Tap water is usually around a pH of 7.0. Pharmacies carry products to test the pH levels of water. How can water pH be changed? This is where floral preservatives come in. They contain a pH adjuster. Citric acid can also be used to adjust the pH, but it should not be used as a preservative substitute.

2. Total dissolved solids — The use of floral preservatives to lower pH is only a temporary measure and does not solve the problem. The dissolved solids are the reason for high pH levels. Some common dissolved solids are:

- a. Mg
- b. Ca
- c. Fe
- d. S
- e. Na
- f. Cl
- g. F1

Mg, Ca, Fe, and S make water alkaline. Softened water has high sodium which tends to remove water from the stem. High levels of Cl and F1 can be toxic to cut flowers. Water purification can be done in three ways:

- a. Distillation — This method is impractical in this case
- b. Deionization — This method produces water 99.9 percent free of dissolved solid impurities, but does not remove bacteria from the water.
- c. Reverse osmosis — This method produces water 90-95 percent free of dissolved solid impurities, but it is more expensive than the other methods.

Floral preservatives contain:

1. Carbohydrates — provide food.
2. Fungistats and bacteriostats — prevent fungi and bacteria from breaking down stem tissue.
3. pH adjuster — lowers pH for easier water uptake.

Sanitation is very important in cutting equipment and containers so that the preservatives can do their job.

80%

STUDENT ACTIVITIES

STUDENT WORKSHEET #1 — Flower Care — Myths or Fact

STUDENT WORKSHEET #2 — Fresh Flower Care

STUDENT WORKSHEET #3 — Handling and Preparing cut Flowers

STUDENT WORKSHEET #4 — Effects of Various Preservatives on Cut Flower Life

For additional activities, teachers may refer to the "Suggested Teaching Activities and Procedures" section in the Instructor's Guide.

800

STUDENT WORKSHEET #1

Flower Care — Myths or Fact

Directions: Mark the following statements as either true or false. Explain your reasons in the space provided below each statement.

- _____ 1. Stems cut straight across take up less water than stems cut on an angle.
- _____ 2. One may extend the life of cut flowers by adding a penny and/or aspirin.
- _____ 3. Flowers will store longer when they are kept in water.
- _____ 4. Flowers will drink more water if the container is full than if the container is half full.
- _____ 5. Sprite and 7-Up are effective floral preservatives.
- _____ 6. It is better to smash the ends of woody stems than to cut them.
- _____ 7. Roses with petals slightly open will not last as long as roses with very tight buds.

802

STUDENT WORKSHEET #1 — Key

Flower Care — Myths or Fact

Directions: Mark the following statements as either true or false. Explain your reasons in the space provided below each statement.

- F 1. Stems cut straight across take up less water than stems cut on an angle.

Stems cut both ways take up the same amount of water. Angle cutting is recommended because it makes it easier to insert flowers into floral foam. It also prevents stem ends from sealing to the bottom of the container.

- F 2. One may extend the life of cut flowers by adding a penny and/or aspirin.

Both additives are supposed to act as floral preservatives. However, there is no evidence that either does any harm or good for the flowers.

- F 3. Flowers will store longer when they are kept in water.

Flowers must be conditioned in water before they are used. But, for long-term storage many flowers last longer stored dry. Stored dry at temperatures down to 31° F, the flowers are kept in almost a suspended state. Some species can be dry-stored for up to 4 weeks.

- F 4. Flowers will drink more water if the container is full than if the container is half full.

The flower's vascular system sucks up water as it is needed. Filling containers to the top will not force more water into the stem. Use just enough water to prevent the container from running dry.

- T 5. Sprite and 7-Up are effective floral preservatives.

Both soft drinks provide sugar for the flower as well as citric acid and carbonation to control microorganisms. The recommended mixture is equal parts water and soft drink plus • teaspoon of chlorine bleach to each quart of solution. The bleach helps to cut bacterial growth.

- F 6. It is better to smash the ends of woody stems than to cut them.

Woody stems are poor water carriers and mashing them doesn't make them any better. The best way to get them to take up water is to cut the woody part off the stem.

- F 7. Roses with petals slightly open will not last as long as roses with very tight buds.

According to "Roses, Inc.," vase life is not lost if a rose is allowed a day or two more time on the plant after it reaches the bud stage. If allowed this extra time, the bloom has a greater chance of opening without bent neck and it will last just as long as the one cut very tight. Some very tight buds may have been cut too early and may never open.

805

STUDENT WORKSHEET #2

Fresh Flower Care

Directions: Fill in the squares with the correct information.

Type of Flower	Handling	Conditioning	Vase Life
Rose			
Orchid			
Carnation			
Daisy			
Mum			
Spring Flowers			

800

STUDENT WORKSHEET #3**Handling and Preparing Cut Flowers****True or False:**

- ___ 1. A metal container is the best choice for flower storage since it is unbreakable.
- ___ 2. Flowers that respond to "geotropism" will turn their tips up if shipped laying down.
- ___ 3. The addition of preservatives to the water will increase epinasty occurrence in carnations.
- ___ 4. Botrytis mold is deterred when water is not allowed to drip on flower blooms.
- ___ 5. When new flowers arrive, after proper preparation, place them in containers of older flowers of the same type.

Short Answer:

- 1. Name 3 symptoms of ethylene gas damage.

- 2. What are 2 sources of ethylene gas?

- 3. What are "bullets" in floral shops?

- 4. How can wilted roses be revived?

- 5. What is the general storage time for florist greens?

- 6. List the major components and functions of the ingredients of 7-Up or Sprite soft drinks when they are used as floral preservatives.

- 7. What are 2 reasons florists use an angle cut when preparing flowers for the cooler?

807

STUDENT WORKSHEET #3 — Key

Handling and Preparing Cut Flowers

True or False:

- F* 1. A metal container is the best choice for flower storage since it is unbreakable.
- T* 2. Flowers that respond to "geotropism" will turn their tips up if shipped laying down.
- F* 3. The addition of preservatives to the water will increase epinasty occurrence in carnations.
- T* 4. Botrytis mold is deterred when water is not allowed to drip on flower blooms.
- F* 5. When new flowers arrive, after proper preparation, place them in containers of older flowers of the same type.

Short Answer:

1. Name 3 symptoms of ethylene gas damage.

carnations go to sleep, roses turn blue, snapdragons drop flirts and leaves turn downward (epinasty)

2. What are 2 sources of ethylene gas?

old fruit, old flowers, bacteria and fungus

3. What are "bullets" in floral shops?

roses cut too green

4. How can wilted roses be revived?

remove half the foliage, recut stem, place entire stem in warm preservative water for 20 minutes to 1 hour

5. What is the general storage time for florist greens?

1-4 weeks

6. List the major components and functions of the ingredients of 7-Up or Sprite soft drinks when they are used as floral preservatives.

sugar — food or nutrients for flowers, and citric acid — bactericide or antimicrobial agent

7. What are 2 reasons florists use an angle cut when preparing flowers for the cooler?

stem won't seal on base of container; easier to insert into floral foam; knife cut at angle does not mash stem, therefore water uptake is not prevented

STUDENT WORKSHEET #4**Effects of Various Preservatives on Cut Flower Life Experiment****Conditions:**

1. Select area free from clutter which will be out of the way from daily activities.
2. Be sure there are no drafts, excessive heat or cold, or any other obvious environmental factors which will affect the test.
3. Each preservative's content should be known to you. Be sure you know whether it has sugar, acid, and germicide in it.
4. Use only one type of flower for each test.
5. Use freshest flowers and try to estimate age of flower from cut.

Materials:

1. vases
2. flowers
3. water
4. preservatives
5. chart for recording data

Procedure:

1. Count out 4 flowers for each preservative testing.
2. Place 2 flowers in each vase and add preservative; you will have 6 vases — 2 for each type of preservative.
3. Set up another vase with plain water and 2 flowers for your control group.
4. On a sheet of paper make a chart to record the following: color change of flower, strength of stem, time of day when data was taken, date when data was taken, etc.
5. Have students make predictions as to how each preservative will perform.
6. For at least 10 days take data twice daily (except weekends).
7. At end of test, list conclusions. Determine which of the three preservatives was best and which was worst. Indicate how the control group compared to the experimental groups. Indicate any other relevant factors.

Precautions:

1. Avoid using flowers of different ages.
2. Be sure to give each flower good, clean cuts at beginning of test.
3. Record any operation you do to interrupt test (cutting of stems, movement, drafts, etc.).

CLUSTER: HORTICULTURE

UNIT: Floral Design

PROBLEM AREA: Designing Silk and Dried Arrangements

RELATED PROBLEM AREAS:

1. Principles of Floral Design
2. Designing Live Arrangements

PREREQUISITE PROBLEM AREAS:

LEVEL: Orientation

OCCUPATIONAL TASKS ADDRESSED:

Horticulture Cluster

Duty S: Designing Arrangements

1. Design artificial flower and foliage arrangements
2. Design dried arrangements
3. Spray tint both dried and live floral products
4. Make silk flower and foliage arrangement
5. Design novelty arrangement

STATE GOALS FOR LEARNING:

In planning the instruction for this problem area, teachers can promote the development of several student learning objectives which are related to the State Goals for Learning in Mathematics and Fine Arts. These objectives are listed on the Learning Assessment Plan forms included on the following page(s). Those learning objectives marked with an asterisk (*) are taken from the sample lists provided by the Illinois State Board of Education.

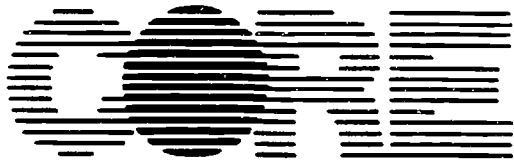

Illinois Agricultural Core Curriculum

Agricultural Education 124 Mumford Hall 1301 W. Gregory Drive University of Illinois Urbana, IL 61801

Director: Dale A. Law, Ed.D.
Principal Investigator: Jerry D. Pepple, Ed.D
Research Assistant: Janis L. Anderson

811

INSTRUCTOR'S GUIDE

CLUSTER: HORTICULTURE

UNIT: Floral Design

PROBLEM AREA: Designing Silk and Dried Arrangements

STUDENT LEARNING OBJECTIVES:

Upon completion of their study of this problem area, students will be able to:

INSTRUCTOR'S NOTES AND REFERENCES

1. Name and identify plant materials suitable for drying.
2. Identify the various methods for collecting and drying different types of plant materials.
3. Demonstrate correct wiring techniques for silk and dried flowers.
4. List the types of containers and foams used for silk and dried arrangements.
5. Identify the methods for dying artificial flowers.
6. Design silk and dried materials into arrangements using the principles of floral design.
7. Demonstrate proper handling and care of artificial flowers.

820

INSTRUCTOR'S GUIDE**CLUSTER: HORTICULTURE****UNIT: Floral Design****PROBLEM AREA:** Designing Silk and Dried Arrangements**PROBLEMS AND QUESTIONS FOR STUDY****INSTRUCTOR'S NOTES AND REFERENCES**

1. What are the advantages and disadvantages of using artificial flowers?
2. Where can one use artificial flowers?
3. Which flowers can be dried?
4. What are the different methods that can be used to dry flowers?
5. Where can one collect materials for drying?
6. What time of year is best to collect materials for drying?
7. Why are different methods used to dry different types of flowers?
8. What special mechanics are needed for artificial arrangements?
9. What types of containers can be used for artificial arrangements?
10. How are flowers supported in the container?
11. How are artificial flowers designed into an arrangement?
12. How can the color of dried materials be changed or improved?
13. How does one care for silk and dried arrangements?
14. How should an artificial arrangement be handled to prevent damage during delivery?
15. What processes happen to plant material during drying?

821

INSTRUCTOR'S GUIDE**CLUSTER: HORTICULTURE****UNIT: Floral Design****PROBLEM AREA:** Designing Silk and Dried Arrangements**SUGGESTED TEACHING ACTIVITIES AND PROCEDURES**

1. Show students a group of plants such as grasses that have been dried, and show how they can be used to make an inexpensive arrangement.
2. Have students collect a variety of plant materials and experiment with different ways of drying them.
3. Have students collect 8-10 samples of flowers and foliages from fields, woods, and roadsides. Dry the plant materials using the hanging and pressing methods described on Information Sheet #2. Complete Student Worksheet #1.
4. Divide students into 4 groups and assign each group a different medium from these listed on Student Worksheet #1. Have each group dry 4-5 types of flowers using this method. Compare the results each group obtained using the different mediums.
5. Wire and tape 4-6 silk flowers following the steps on Information Sheet #4. Use the wired silk flowers to practice making a corsage or boutonniere.
6. Practice wiring, picking, and taping stems on two different types of dried flowers. Form the flowers into clusters and spikes following the steps listed on Information Sheet #3.
7. Display samples of dried flowers and foliage in the classroom. Label each. Have students study the samples and memorize the names of the flowers. Suggested flowers and foliage are listed on Information Sheet #1.
8. Visit a flower shop and note the wiring, picking, and arranging techniques used. Also, check the types of silk and dried flowers available there.
9. Have the class do a display for the school on silk and dried arrangement. Items that could be included are:
 - a. History and background of flower arranging.
 - b. Materials used in flower arranging.
 - c. Methods of flower arranging.
 - d. Examples of table flower arrangements for holidays, for specialty events (e.g., spaghetti dinner, new baby), and from around the world.
10. Show slides of different dried materials and arrangements in order to show the distinction among flowers used for the effects of line, form, focus, and filler; and to offer ideas for creative dried arrangements.
11. Have students bring their own containers to class. Display and discuss the variety of containers. Have the students devise their own holding mechanisms inside the containers.
12. Have the students make dried flower arrangements using the containers they have prepared, and the flowers they have dried. Then, have the students critique one another's arrangements according to the design principles used.
13. Practice dying dried flowers following the methods listed on Information Sheet #6.
14. Have students select a location in their home and complete Student Worksheet #2. Then, have students make a silk arrangement based on the information gathered on the worksheet.
15. Demonstrate the use of a picking machine for dried flower arranging.

822

INSTRUCTOR'S GUIDE**CLUSTER:** HORTICULTURE.**UNIT:** Floral Design**PROBLEM AREA:** Designing Silk and Dried Arrangements**REFERENCES****INSTRUCTOR'S NOTES AND REFERENCES**

1. *Growing and Harvesting Herbs* (VAS Unit #U5033). McPheeters, Ken, Noland, Diane. Vocational Agriculture Service, College of Agriculture, University of Illinois, 1401 S. Maryland Drive, Urbana, IL 61801. (217) 333-3871.
- *2. *Design for Profit Magazine*. c/o Florafax International, Inc., 4175 S. Memorial Drive, Tulsa, OK 74145.
3. *Florist Review Magazine*. P.O. Box 4365, 2231 Wanamaker, Suite 105, Topeka, KS 66614.
- *4. *The Professional Floral Designer Magazine*. American Floral Services, Inc., P.O. Box 12309, Oklahoma City, OK 73157-2309.
- *5. *Floral Design and Arrangement*. McDaniel, G.L. Reston Publishing Company, Division of Prentice Hall, 200 Old Tappan Road, Old Tappan, NJ 07675. (800) 223-2348.

*Indicates highly recommended reference

820

INSTRUCTIONAL RESOURCES

These resources are intended for use by teachers in planning and teaching the materials for this problem area and may be adapted to fit the teaching method(s) used.

INFORMATION SHEET #1 — Common Dried Plant Materials

INFORMATION SHEET #2 — Methods of Drying Flowers and Foliage

INFORMATION SHEET #3 — Wiring and Taping Artificial Flowers into Clusters and Spikes

INFORMATION SHEET #4 — Candle Method of Wiring Silk Flowers

INFORMATION SHEET #5 — Containers and Holders for Artificial Arrangements

INFORMATION SHEET #6 — Methods of Dying Artificial Flowers

INFORMATION SHEET #7 — Picking Methods for Artificial Flowers

INFORMATION SHEET #8 — Care and Handling of Artificial Arrangements

TRANSPARENCY MASTER #1 — Methods of Drying Plant Material

INFORMATION SHEET #1

Common Dried Plant Materials

Focal Materials

Artichoke

Indian Corn

Lotus Pod

Milkweed Pod

Protea

Strawberry Pop Corn

Line Materials

Asparagus

Bamboo

Cattails

Driftwood

Eucalyptus

Ornamental Grass

Sea Oats

Wild Oats

Salvia

Wheat

Form Materials

Artichoke Flower

Cordonne Puffs

Japanese Lantern

Strawflower

Teasel

Yarrow

Filler Materials

Baby's Breath

Bittersweet

Bunny Tails

Leatherleaf Fern

Magnolia

Money Plant

Oak Leaves

Palmetto

Star Flower

Statice

825

INFORMATION SHEET #2

Methods of Drying Flowers and Foliage

For best results during drying, flowers should be picked at their prime, and with the brightest color. Picking should be done on a warm, dry day when there is minimal moisture on the flower surface. After picking, remove all the leaves and all but one inch of stem. Insert a florist's wire into the stem. This wire will become secure during the drying process. Now the flower is ready to be dried. The drying method used for each flower depends on the shape and thickness of the flower. The best way to determine the most effective method for a particular flower is to experiment.

Hanging Method

This method is best for flowers that wilt very little, such as Baby's Breath, Yarrow, and Statice.

1. Tie several stems together tightly in an uncrowded bunch. Large flowers can be hung individually.
2. Hang flowers upside down in a dry, dark, ventilated place.
3. Flowers will take 2-3 weeks to dry thoroughly.

Pressing Method

This method is best for foliage and thin, flat-petaled flowers, such as Pansies, Violets, and Buttercups.

A flower press can be made with several layers of newspaper or paper towels between two flat boards, or a large book.

1. Lay the flowers out flat with newspaper or paper towels between the layers.
2. Weight down the top.
3. Allow the flowers to dry for several weeks in a warm, dry, well-ventilated place.
4. Check the flowers often, and change the paper between the layers to prevent mold.

Alternately, the quick pressing method involves covering the flowers or foliage with waxed paper and a light cloth, and pressing with a warm iron.

Glycerin Method

This method is best for foliage and branches with many leaves, such as Eucalyptus, Oak Branches, and Magnolia Branches.

The procedure for glycerin drying is as follows:

1. Mix 1 part glycerin and 2-3 parts hot water in a container.
2. Split the bottom 2 inches of the flower stem. Crush heavy stems with a hammer.
3. Place stems into about 6 inches of glycerin solution.
4. Keep the stems in solution until they are full of glycerin.

Note: Glycerinized leaves usually become darker during the preserving process. To prevent this darkening, absorption dyes can be added to the glycerin solution, thus retaining the leaf's green color.

Drying with a Medium

This method is best for flowers that wilt readily, have open forms, or have thick deep shapes, such as Lilies, Snapdragons, and Peonies.

Medium 1

sand
(drying time = 2-3 weeks)

Medium 2

Silica Gel
(drying time = 3-7 days)

Medium 3

2 parts Borax
1 part sand, perlite, or cornmeal
3 tablespoons uniodized
salt per quart
(drying time = 1-2 weeks)

Medium 4

2 parts cornmeal
1 part laundry
detergent
(drying time
= 3-7 days)

1. Add wire stems to flowers and tape them with florist's tape.
2. Cover the bottom of a deep container with 1/2 - 1 inch of the drying medium.
3. Lay flat flowers over this layer facing downwards, cup flowers facing upwards.
4. Sift additional media into and around the flowers until they are completely covered with 1/4 inch layer.
5. Store the container in a warm, dry place until the flowers are dry. (Containers with silica gel must be tightly sealed during the drying process).
6. When dry, carefully remove the flowers and dust off the media with a camel-hair brush.

Microwave Method

This method is best for flowers with many petals and deep forms, such as Carnations and Roses.

1. Pour 1/2 - 1 inch of drying medium (one of those listed above) into a glass container.
2. Leave 1 inch of stem on the flower. Do not add wire stems.
3. Place flowers into the medium facing upwards, and cover with 1/2 inch of additional media.
4. Place the container next to a cup of water in the microwave. Heat for 1-3 minutes for thin flowers, 5-8 minutes for thick, fleshy flowers. (A regular oven can be used in the same way at 150-180°F for 8-24 hours.)
5. After heating, flowers should remain in the medium for 1-24 hours.
6. Remove flowers, brush off media, add a wire stem, and tape.

Note: Red, pink, and blue flowers tend to change colors when dried by this method. Experimenting with one or two flowers before drying an entire group is recommended.

Spreading Method

Preparation for drying by spreading is the same as for hanging. Spreading is often used for short-stemmed flowers or those with very small leaves. Spread prepared shoots on trays or drying racks in warm, dark, ventilated area. Turn every day for 7-10 days for uniform drying.

Gluing

This method is used for plant material that has a tendency to shed. The recommended method is to dilute a solution of shellac. Dip the material into the solution and let dry.

Fireproofing

Fireproofing material is a very preventative measure to use on material that may be susceptible to fire or will be displayed in questionable areas. One recommended method calls for dissolving one pound ammonium and one cup of boric acid sulphate in one gallon hot water. Material can be dipped into the solution or sprayed with it. This method is recommended for Christmas greens, wreaths, and paper.

Fire Retardant

Fire retardant is used on evergreens also. Material treated with a fire-retardant substance is not made fireproof; it merely takes a longer time to burn. Recommended method uses 8 ounces of bicarbonate of soda (baking soda) and 8 ounces of alum dissolved in one gallon of water. Alum is available in drugstores. Soak the materials and let them dry before using them in arrangements.

807

INFORMATION SHEET #3

Wiring and Taping Artificial Flowers into Clusters and Spikes

Cluster

1. Wire flowers by insertion into the hollow of the stem.
2. Gather flowers into a cluster and bind all stems tightly with thin copper wire.
3. To complete the cluster, work all around, bending each flower outwards.

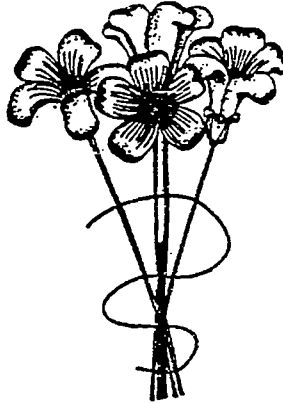
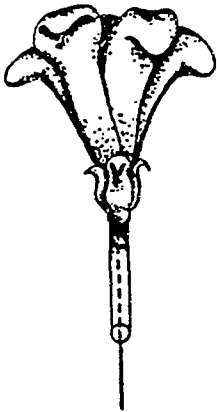

Spikes

1. Using properly wired and taped flowers, create a spike by taping the stems together at different lengths to form a single stalk.
2. Continue adding flowers until the spike reaches the desired length.



INFORMATION SHEET #4

Candle Method of Wiring Silk Flowers

1. Heat the tip of the florist wire over a candle until glowing.
2. Insert the hot tip through the plastic calyx of the flower using the pierce wiring method.
3. Bend the ends of the wire down from the calyx.
4. Tape the calyx and wires together to form a smooth stem.

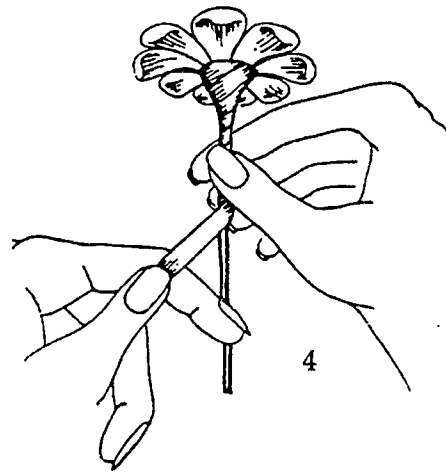
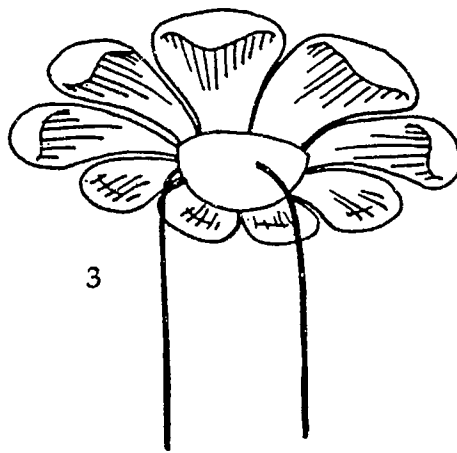
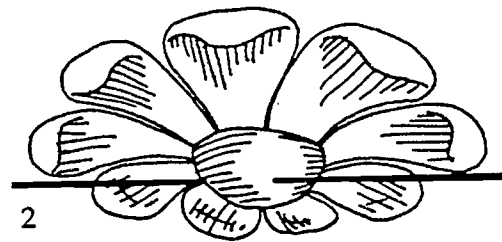
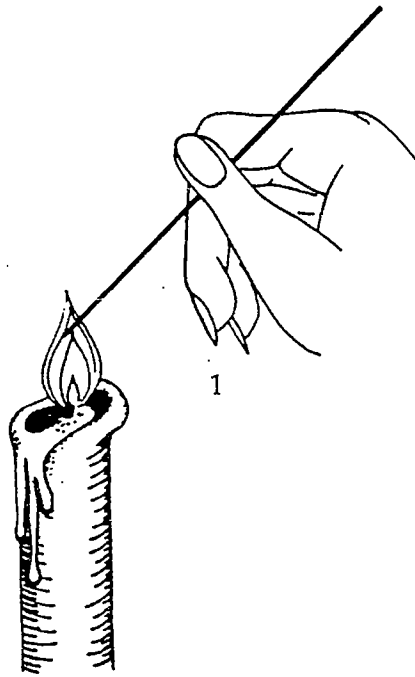

820

INFORMATION SHEET #5

Containers and Holders for Artificial Arrangements

Because artificial arrangements do not need water, virtually any container can be used. When choosing a container keep in mind the size, style, and color the arrangement will be. Generally, dried flower arrangements look best in rustic or natural containers. Silk flowers have a more elegant appearance, and thus look best in glass or ceramic containers. However, these are not strict rules, and under the right circumstances any number of containers may be used.

Suggested containers:

bird's nests
cork bark
driftwood
gourds
tree trunk sections
cornucopia

tin boxes
Japanese rice bowls
leaded glass boxes
brass vases
baskets
enclosed glass bells

There are a number of holding mechanisms available to support artificial flowers in the container. The most commonly used mechanism is dry florist's foam (Sahara) which is available in several grades for heavy or light weight stems. When possible, brown foam should be used with dried arrangements so the foam will be less conspicuous. The foam can be secured in the container with hot glue, sticky adhesives (Cling), or tape across the top. Also, the edges of the foam should be beveled to give more useful surface area for arranging. Other possible holding mechanisms include Styrofoam, liquid glue saturated foams, clay, vermiculite, and pin holders.

INFORMATION SHEET #6

Methods of Dying Artificial Flowers

Dried flowers may be dyed when the flower color has faded or the flower is not the desired tint or shade. However, too much dying gives a very unnatural appearance to the flowers, and thus should be used sparingly.

Florist's Aerosol Spray

1. Hold the plant material 12-18 inches away from the can.
2. Spray the plant material using short bursts rather than one continuous spray to avoid blotchy areas.
3. The darkness of the color can be controlled by the amount of spraying and the distance of the spray from the plant material.
4. Allow the spray to dry before arranging.

Liquid Dye

The liquid dye method is best for flowers that will be dried using the hanging method. Florist's dye, fabric dye, or food coloring may be used for this method.

1. Use fresh flowers that are ready to be dried.
2. Prepare the dye using very hot water.
3. Dip the flowers in the dye bath long enough to achieve the desired color.

4. Let excess dye drip back into the container. Shake the flower if necessary.
5. Place the flower stems in cold water while the dye is drying.
6. Dry the flowers according to the appropriate method.

Chalk

1. Flower petals must be completely dry before chalk can be applied.
2. Drop the flower into a plastic bag of grated chalk and shake the bag until all petals are colored. Or, hold the flower over a sheet of plastic and sift chalk onto it with a tea strainer.
3. Remove the flower and brush the petals with a camel-hair brush to remove the excess chalk.
4. Sift several handfuls of sand over and through the petals and then tap the stem to remove all excess chalk and sand.
5. Dry the flower according to the appropriate method.

Note: To avoid coloring the centers of daisy-type flowers, brush the chalk onto the petals only. Use a clean brush to remove any excess chalk.

INFORMATION SHEET #7

Picking Methods for Artificial Flowers

Artificial arrangements can be made permanent and more stable by dipping any of the picks below into hot melted glue before insertion into the foam material.

1. Natural Picking

This method is the easiest and should be used whenever possible. Simply insert the natural stems of the flowers into the foam material. Natural picking is used almost entirely for flowers dried by the hanging method, since the natural stems remain on these flowers during drying.

2. Wire Picking

Many flowers are dried with an artificial wire stem, and most silk flowers are made with a heavy wire stem attached. These wire stems can be inserted into the foam material as if they were the natural flower stems. Wire stems are usually very stiff and straight and do not have a very natural appearance. These stems should be taped with green or brown tape and curved enough to make them look more realistic.

3. Wood Picking

Thin wire stems that are inserted into the foam material are often unstable or become unstable as the arrangement is moved about. Wooden picks are used in these situations to give the stems a more stable foundation. They may also be used to lengthen short stems as needed. Square picks with a pointed base and a wrapping wire at the top should be used. Simply wire the stem onto the pick with the wrapping wire and tape them together at the joining point.

4. Steel Picking

Steel picks are often used in the flower shop to speed up the wiring and taping of artificial flowers. These picks are attached to the flowers with a picking machine, and the sharp picks are then inserted into the foam material.

832

INFORMATION SHEET #8**Care and Handling of Artificial Arrangements**

Dried flower arrangements should be displayed in a place that is free from drafts and dampness and is not in direct sunlight. Dried arrangements should be dusted regularly with a feather or camel-hair brush. If the arrangement develops a worn-out appearance it can be freshened up by replacing any faded or broken flowers in it.

Silk flowers should be displayed in a place that is free from direct sunlight to avoid fading. Dust can be removed from silk flowers by shaking them inside a paper bag with a few teaspoons of salt.

Artificial arrangements should be transported inside strong cardboard cartons that are at least as tall, and a little wider than the arrangement. Newspaper or tissue paper can be stuffed around the container for support, or clay can be attached to the base of the container and pressed down inside the box. Avoid packing over four arrangements in a single box, and give each arrangement plenty of room inside the box.

830

TRANSPARENCY MASTER #1

Methods of Drying Plant Materials

1. Hanging Method

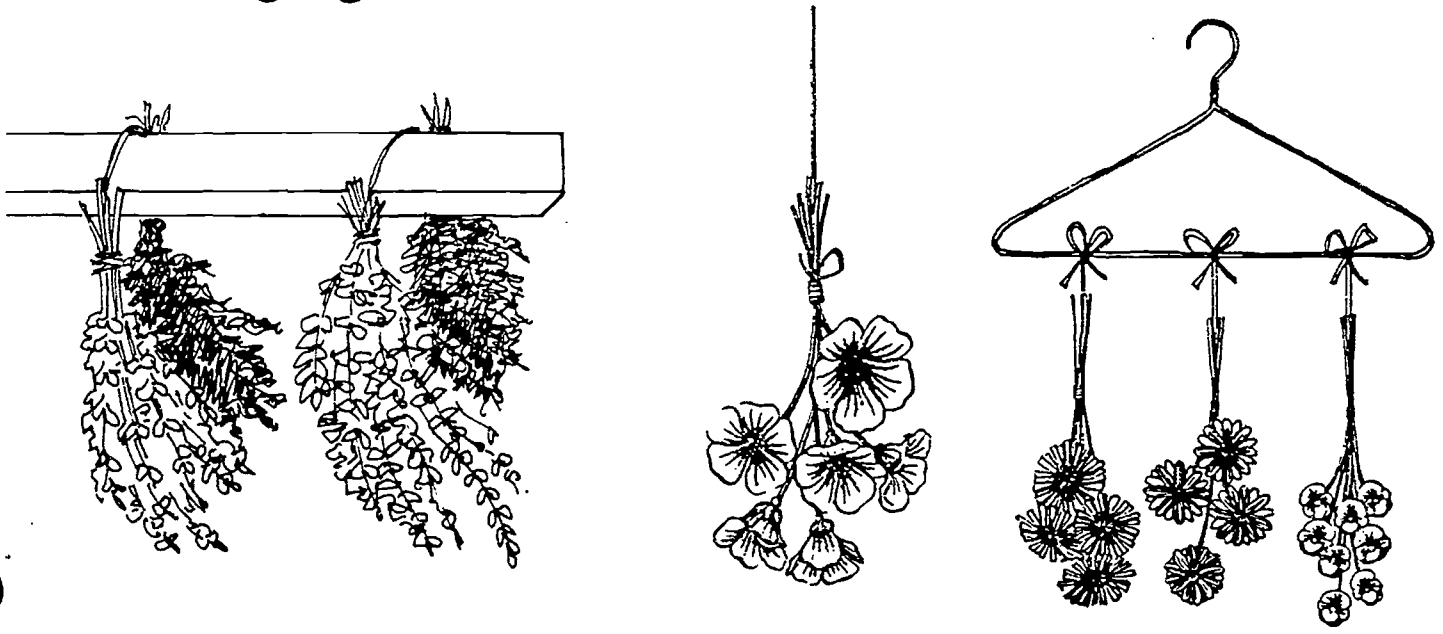

2. Pressing Method

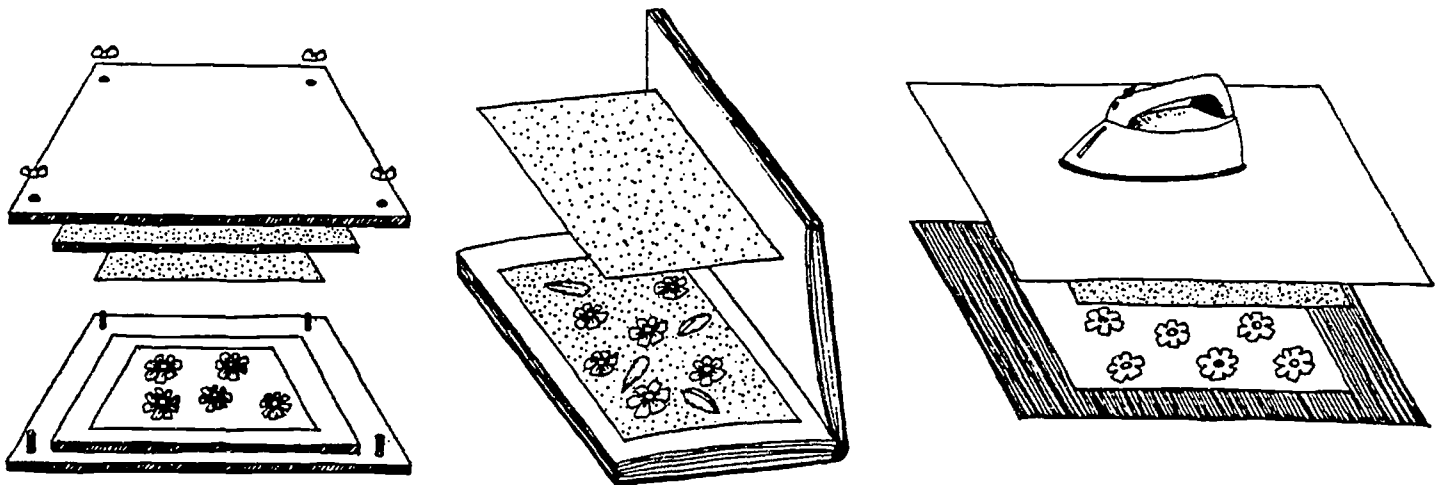

834

3. Glycerin Method

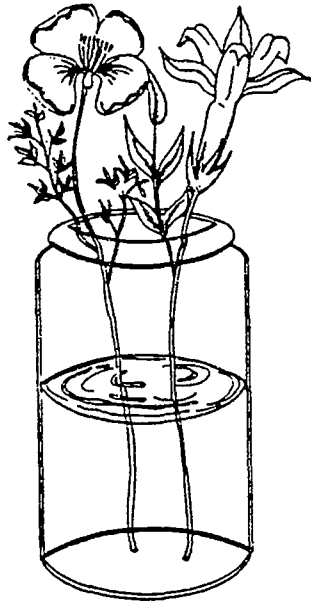

4. Drying With a Medium

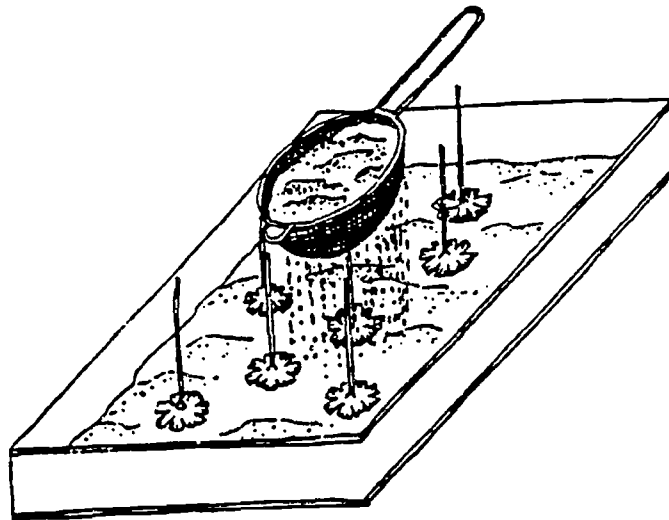

825

5. Microwave Method

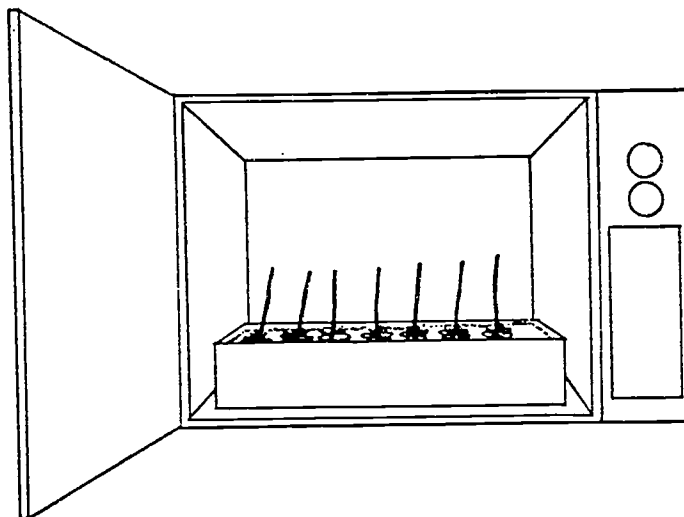

6. Spreading Method

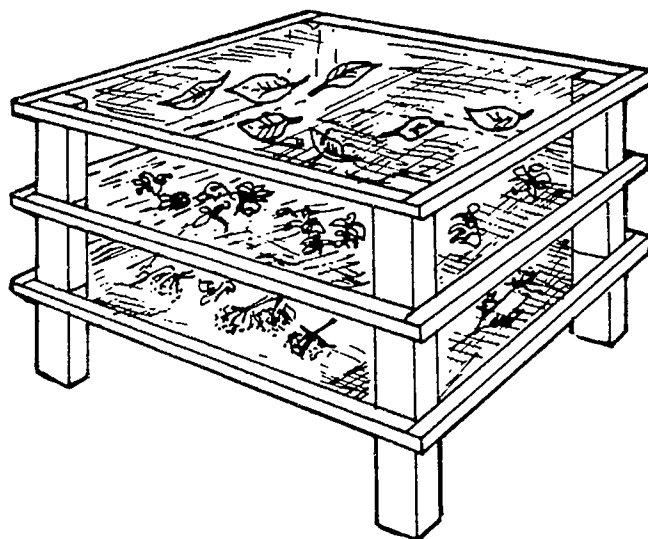

STUDENT ACTIVITIES

STUDENT WORKSHEET #1 — Effectiveness of the Hanging and Pressing Methods of Drying Selected Plant Material

STUDENT WORKSHEET #2 — Custom Designing a Flower Arrangement

STUDENT WORKSHEET #3 — Questions on Designing Silk and Dried Arrangements

STUDENT WORKSHEET #4 — Determining the Effects of Various Drying Mediums on Flowers Experiment

For additional activities, teachers may refer to the “Suggested Teaching Activities and Procedures” section in the Instructor’s Guide.

837

STUDENT WORKSHEET #1

**Effectiveness of the Hanging and Pressing Methods
of Drying Selected Plant Materials**

PROCEDURE: List the various plant materials dried, the amount of time required for each method, and the resulting quality of the dried flowers for each method.

Plant Material	Drying Time (days)		Dried Flower Quality	
	Hanging	Pressing	Hanging	Pressing
Example: Wheat	15	18	good; retained desired color and shape	fair; some broken and disfigured pieces
1. _____				
2. _____				
3. _____				
4. _____				
5. _____				
6. _____				
7. _____				
8. _____				
9. _____				
10. _____				

STUDENT WORKSHEET #2

Custom Designing a Flower Arrangement

Situation: Select a location in your home that would be enhanced by a permanent flower arrangement. Complete the following questions about your chosen location.

1. What room will the arrangement be displayed in? _____
2. Where will the arrangement be located within the room? (coffee table, nightstand, shelf, etc.)

3. What color(s) is the room? _____
4. What style is predominant in the room? (Early American, Victorian, Contemporary, etc.) _____
5. Approximately how much space is available for the arrangement? _____
6. Will the arrangement be seen from one side or all sides? _____

Design Plans: Based on the information collected above formulate a specific design for the arrangement. Completion of the following statements will help guide your design.

1. The dominant color of my arrangement will be: _____
2. The accent color(s) of my arrangement will be: _____
3. The style of my arrangement will be:
 - a. simple/subdued.
 - b. elaborate/bold.
4. My arrangement will be:
 - a. one-sided.
 - b. all-around.
5. The height of my arrangement will be:
 - a. low — less than 10 inches.
 - b. medium — 10 to 20 inches.
 - c. high — over 20 inches.
6. The width of my arrangement will be:
 - a. narrow — less than 8 inches.
 - b. medium — 8 to 14 inches.
 - c. wide — over 14 inches.
7. The shape of my arrangement will be:
 - a. round.
 - b. oval.
 - c. symmetrical triangle.
 - d. asymmetrical triangle.
 - e. other (describe below)

836

STUDENT WORKSHEET #3

Questions on Designing Silk and Dried Arrangements

Short Answer:

1. Name 2 form flowers and 2 line flowers suitable for drying.

a. Form flowers

- 1. _____
- 2. _____

b. Line flowers

- 1. _____
- 2. _____

2. Name 2 methods for preserving foliage.

- a. _____
- b. _____

3. Choose 2 drying methods and briefly describe each one.

- a. _____

- b. _____

4. How can silk flowers without stems be wired? _____

5. Name 3 holding mechanisms used to support artificial arrangements.

- a. _____
- b. _____
- c. _____

6. Briefly explain the 2 most common methods of dying dried flowers.

- a. _____

- b. _____

7. Name the 4 methods of picking artificial flowers.

- a. _____
- b. _____
- c. _____
- d. _____

8. How can dust be removed from silk flowers? _____

True or False:

- _____ 1. When drying flowers with silica gel, the container should be stored air-tight.
- _____ 2. Dried flowers can be dried with food coloring or chalk.
- _____ 3. Protea is a filler flower.
- _____ 4. Laundry detergent can be used to dry flowers.
- _____ 5. The hanging method of drying flowers is best for flowers that wilt very quickly.
- _____ 6. Drying flowers with the sand method takes about 2-3 days.
- _____ 7. Artificial flowers can be glued into the foam to make the arrangement permanent.

841

STUDENT WORKSHEET #3 — Key

Questions on Designing Silk and Dried Arrangements

Short Answer:

1. Name 2 form flowers and 2 line flowers suitable for drying.

<ol style="list-style-type: none"> a. Form flowers <ol style="list-style-type: none"> 1. <i>Strawflower</i> 2. <i>Yarrow</i> 	<ol style="list-style-type: none"> b. Line flowers <ol style="list-style-type: none"> 1. <i>Cattails</i> 2. <i>Wheat</i>
--	--
2. Name 2 methods for preserving foliage.
 - a. *Pressing*
 - b. *Glycerin*
3. Choose 2 drying methods and briefly describe each one.
 - a. *Hanging method. Tie flowers into bunches and hang them upside down in a dry, dark, well-ventilated location.*
 - b. *Drying with a medium. Prepare medium and sift over prepared flowers until covered. Store the container in a warm dry place until the flowers are dry.*
4. How can silk flowers without stems be wired? *Heat the tip of the wire in a candle and pierce it through the plastic calyx. Bend both of the wires down and tape them.*
5. Name 3 holding mechanisms used to support artificial arrangements.
 - a. *Styrofoam*
 - b. *Sahara*
 - c. *Vermiculite*
6. Briefly explain the 2 most common methods of dying dried flowers.
 - a. *Florist's aerosol spray. Spray the flower heads directly with short bursts at a distance of 12-18 inches from the flower.*
 - b. *Liquid dye. Prepare the dye with hot water. Dip the fresh flowers into the dye, allow it to dry on the petals, then dry the flower appropriately.*
7. Name the 4 methods of picking artificial flowers.
 - a. *Natural picking*
 - b. *Wire picking*
 - c. *Wood picking*
 - d. *Steel picking*
8. How can dust be removed from silk flowers? *Put the silk flowers inside a paper bag with some salt and and shake up.*

True or False:

- True _____ 1. When drying flowers with silica gel, the container should be stored air-tight.
- True _____ 2. Dried flowers can be dried with food coloring or chalk.
- False _____ 3. Protea is a filler flower.
- True _____ 4. Laundry detergent can be used to dry flowers.
- False _____ 5. The hanging method of drying flowers is best for flowers that wilt very quickly.
- False _____ 6. Drying flowers with the sand method takes about 2-3 days.
- True _____ 7. Artificial flowers can be glued into the foam to make the arrangement permanent.

STUDENT WORKSHEET #4**Determining the Effects of Various Drying Mediums on Flowers Experiment****Purpose:**

1. To use one of the mediums listed below to dry different types of flowers and to compare the results obtained from each of the four mediums.

Materials:

1. one of the mediums listed below
2. large, deep container
3. florist's wire
4. florist's tape
5. 4-5 types of fresh flowers
6. camel-hair brush

Medium 1
sand

Medium 2
silica gel

Medium 3
2 parts Borax

Medium 4
2 parts cornmeal

1 part sand, perlite, or cornmeal

1 part laundry detergent

3 tablespoons uniodized salt per quart

Procedure:

1. Prepare the assigned medium.
2. Remove all but one inch of stem from the flowers, and insert a wire into the stem. Tape the wire and stem together with florist's tape.
3. Cover the bottom of the container with 1/2 - 1 inch of the medium.
4. Lay flat flowers over this layer facing downwards, cup flowers facing upwards.
5. Sift additional medium into and around the flowers until they are completely covered with a 1/4-inch layer.
6. Store the container in a warm, dry place until the flowers are dry. (If using the silica gel medium, the container must be stored air-tight.)
7. When dry, carefully remove the flowers and dust off the medium with a camel-hair brush.

Observations:

CLUSTER: HORTICULTURE

UNIT: Floral Design

PROBLEM AREA: Designing Live Arrangements

RELATED PROBLEM AREAS:

1. Handling and Preparing Cut Flowers
2. Identifying the Principles of Floral Design
3. Designing Silk and Dried Arrangements

PREREQUISITE PROBLEM AREA(S)

1. Identifying the Principles of Floral Design

LEVEL: Orientation

OCCUPATIONAL TASKS ADDRESSED:

Horticulture Cluster

Duty S: Designing Arrangements

1. Design circle arrangements
2. Design corsages
3. Design novelty arrangements
4. Design oval arrangements
5. Design symmetrically balanced triangle arrangements
6. Make bows
7. Design bud vases

STATE GOALS FOR LEARNING:

In planning the instruction for this problem area, teachers can promote the development of several student learning objectives which are related to the State Goals for Learning in Fine Arts. These objectives are listed on the Learning Assessment Plan forms included on the following page(s). Those learning objectives marked with an asterisk (*) are taken from the sample lists provided by the Illinois State Board of Education.

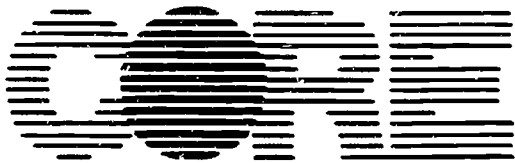

Illinois Agricultural Core Curriculum

Agricultural Education 124 Mumford Hall 1301 W. Gregory Drive University of Illinois Urbana, IL 61801

Director: Dale A. Law, Ed.D.

Principal Investigator: Jerry D. Pepple, Ed.D.

Research Assistant: Janis L. Anderson

848

88/89

ILLINOIS STATE BOARD OF EDUCATION
 Department of School Improvement Services
 100 North First Street
 Springfield, Illinois 62777-0001

LEARNING ASSESSMENT PLAN

Instructions and codes for this form are provided on a separate sheet.

Submission Date _____ Page _____ of _____

Original submission Revision

I. LEARNING AREA (check one)

Language Arts Fine Arts

Mathematics Social Sciences

Sciences Physical Development/Health

II. STATE GOAL FOR LEARNING

As a result of their schooling, students will be able to understand the principal sensory, formal, technical and expressive qualities of each of the arts.

III. LEARNING OBJECTIVES

By the end of grade (circle one) 3 6 8 **11** students should be able to:

- *1. Understand how structural principles (emphasis proportion) contribute to the unity of that image.
- *2. Analyze how balance, rhythm, contrast, unity, and variety are used in that image.
- 3. Display proper principles of floral design.
- 4. Explain proper placement of flowers for corsages and arrangements.

(Affix label or complete district information.)

COUNTY _____ DISTRICT _____ ESC _____

District Name _____

City _____

Contact Person: _____
 Title: _____
 Phone: () _____

IV. ASSESSMENT

A Types _____

B Validity/Reliability _____

C Commercial Test(s) _____

D Evidence of Nondiscrimination _____

V. EXPECTATIONS

Percent of Students Expected to Achieve Objective _____

847

848

INSTRUCTOR'S GUIDE**CLUSTER: HORTICULTURE****UNIT: Floral Design****PROBLEM AREA: Designing Live Arrangements****STUDENT LEARNING OBJECTIVES**

Upon completion of their study of this problem area, students will be able to:

1. Display proper principles of floral design.
2. Construct a:
 - a. Carnation corsage.
 - b. Circle arrangement.
 - c. Oval arrangement.
 - d. Symmetrical arrangement.
 - e. Nosegay arrangement.
3. Wire flowers for arrangements.
4. Explain proper placement of flowers for corsages and arrangements.
5. Construct a bow.

INSTRUCTOR'S NOTES AND REFERENCES

84

INSTRUCTOR'S GUIDE**CLUSTER: HORTICULTURE****UNIT: Floral Design****PROBLEM AREA: Designing Live Arrangements****PROBLEMS AND QUESTIONS FOR STUDY****INSTRUCTOR'S NOTES AND REFERENCES**

1. Why do we wire and tape fresh flowers for corsages?
2. How is foliage wired for corsages?
3. Explain the process of wiring daisys or pompon mums.
4. What material can be used to determine the height, length, or width of an arrangement?
5. How and why are carnations split or feathered?
6. What is the first step in an arrangement after the foam is taped in place?
7. Explain the difference between a symmetrical and an asymmetrical arrangement.
8. Name the geometric shapes used in arrangements.

850

INSTRUCTOR'S GUIDE**CLUSTER: HORTICULTURE****UNIT: Floral Design****PROBLEM AREA: Designing Live Arrangements****SUGGESTED TEACHING ACTIVITIES AND PROCEDURES****INSTRUCTOR'S NOTES AND REFERENCES**

1. Show VAS slide set or slidefilm *Design Materials: Cut Flowers and Foliage*. Have students fill out chart on Student Worksheet #1 while watching. Have them fill out column #5 of the chart for homework and discuss their answer the next day.
2. Show and practice with VAS slide set or slidefilm *Design Techniques: Wiring and Taping Flowers and Foliage*.
3. Have students construct a bow using Student Worksheet #2. Try to use various types of ribbons to show what adjustments may need to be made.
4. Try the various wiring and taping methods on Student Worksheet #1.
5. Have class members construct an oval or circular centerpiece following the principles of floral design. Show T-1 and T-2 for overall flower placement. Give a demonstration and have them follow Student Worksheet #3 as a guide.
6. Show VAS slide set or slidefilm *Design Techniques: Rose Corsage Construction*.
7. Have students construct a corsage after watching a demonstration, using Student Worksheet #4 or #5 as a guide.
8. Making corsages as a fundraiser, such as for homecoming or spring banquets, could be profitable. Done in conjunction with the class it will lessen the cost of supplies.

851

INSTRUCTOR'S GUIDE**CLUSTER: HORTICULTURE****UNIT: Floral Design****PROBLEM AREA: Designing Live Arrangements****REFERENCES****INSTRUCTOR'S NOTES AND REFERENCES**

1. *Design Materials: Cut Flowers and Foliage* (VAS Filmstrip #F605 or Slide Set #S605);
Design Techniques: Rose Corsage Construction (VAS Filmstrip #F606-1 or Slide Set #S606-1);
Design Techniques: Wiring and Taping Flowers and Foliage (VAS Filmstrip #F6060-2 or Slide Set #S606-2). Vocational Agriculture Service, College of Agriculture, University of Illinois, 1401 S. Maryland Drive, Urbana, IL 61801. (217) 333-3871.
- *2. *Design for Profit Magazine*. c/o Florafax International, Inc., 4175 S. Memorial Drive, Tulsa, OK 74145.
3. *Florist Review Magazine*. P.O. Box 4365, 2231 Wanamaker, Suite 105, Topeka, KS 66614.
- *4. *The Professional Floral Designer Magazine*. American Floral Services, Inc., P.O. Box 12309, Oklahoma City, OK 73157-2309.
- *5. *Floral Design and Management*. McDaniel, Gary L. Reston Publishing Company, Division of Prentice Hall, 200 Old Tappan Road, Old Tappan, NJ 07675. (800) 223-2348.
- *6. *Introductory Horticulture*. (1988). Reiley, H.E., Shry, C.L., Jr. Delmar Publishers, Inc., 2 Computer Drive West, Box 15-015, Albany, NY 12212.

*Indicates highly recommended reference

INSTRUCTIONAL RESOURCES

These resources are intended for use by teachers in planning and teaching the materials for this problem area and may be adapted to fit the teaching method(s) used.

TRANSPARENCY MASTER #1 — The Circle or Colonial Arrangement

TRANSPARENCY MASTER #2 — The Oval or Oblong Arrangement

TRANSPARENCY MASTER #3 — The Symmetrical Triangle Arrangement

TRANSPARENCY MASTER #4 — The Asymmetrical Triangle Arrangement

880

TRANSPARENCY MASTER #1

The Circle or Colonial Arrangement

The basic shape of a colonial arrangement is a circle.

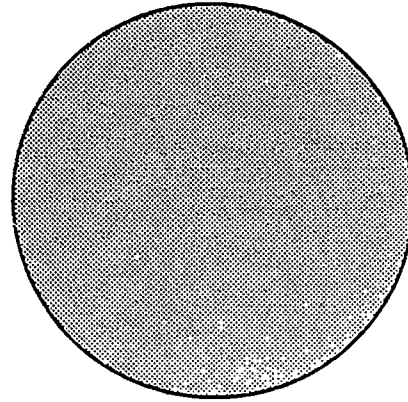

Side view

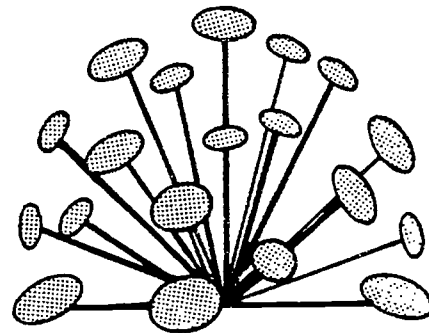

Top view

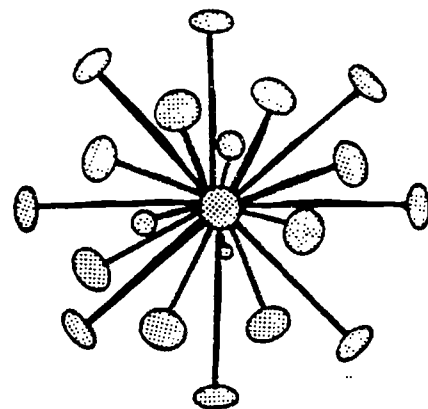

TRANSPARENCY MASTER #2

The Oval or Oblong Arrangement

The basic shape of an oblong arrangement is an oval.

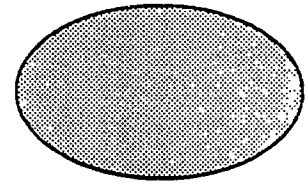
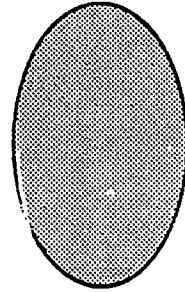

Side view

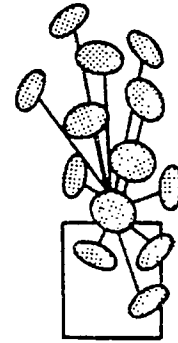
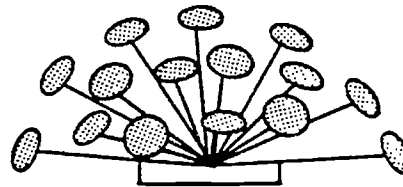

Top view

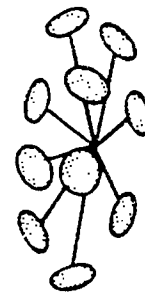
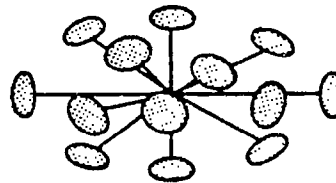

855

TRANSPARENCY MASTER #3

The Symmetrical Triangle Arrangement

One type of floral design is the symmetrical triangle.

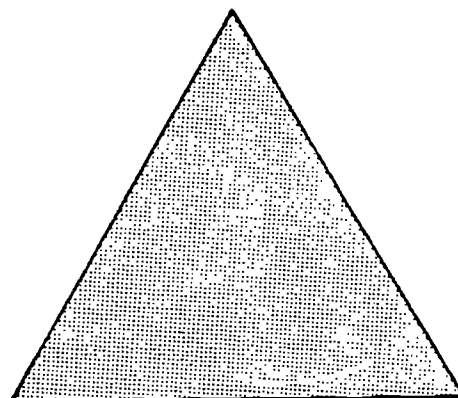

Side view

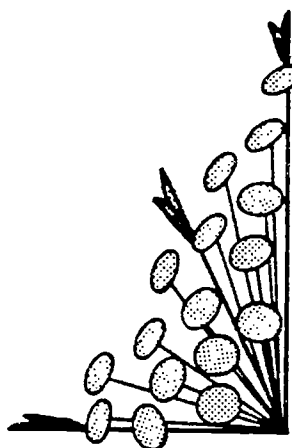

Top view

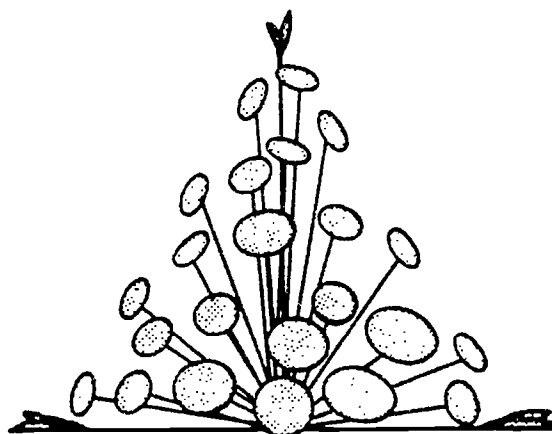

TRANSPARENCY MASTER #4

The Asymmetrical Triangle Arrangement

Variations of the asymmetrical triangle arrangement include:

(A) the inverted "T"

(B) a right

(C) a left

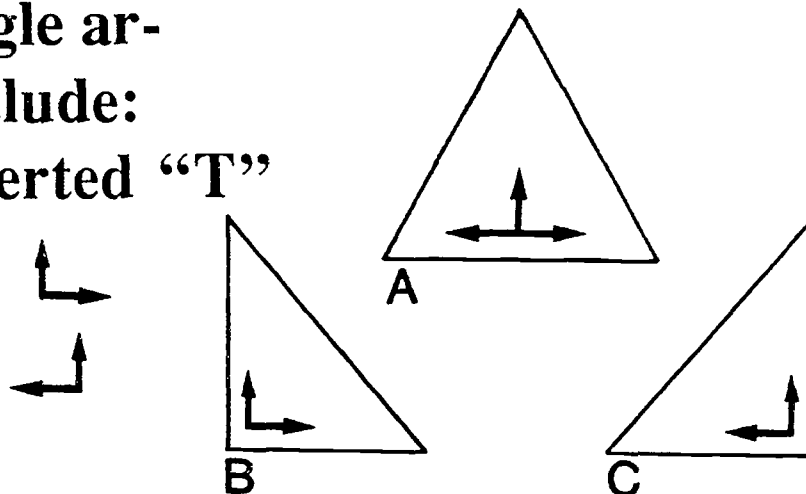

Front views

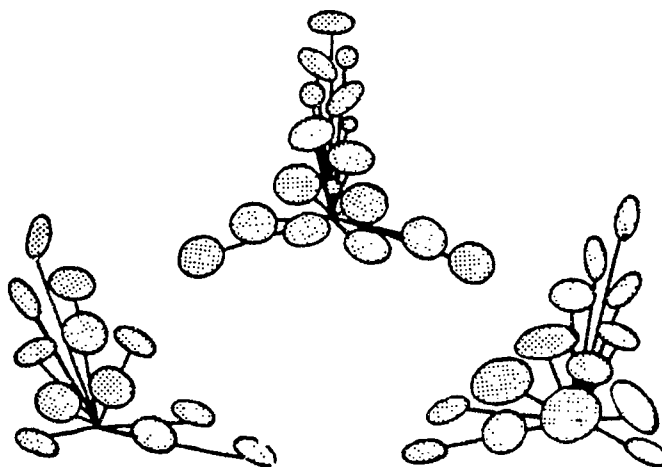

STUDENT ACTIVITIES

- STUDENT WORKSHEET #1 — Wiring and Taping Methods
- STUDENT WORKSHEET #2 — Making a Bow
- STUDENT WORKSHEET #3 — Oval Centerpiece
- STUDENT WORKSHEET #4 — Pompon Mum or Sweetheart Rose Corsage
- STUDENT WORKSHEET #5 — Carnation Corsage
- STUDENT WORKSHEET #6 — A One-Sided (Isosceles or Equilateral) Triangle
- STUDENT WORKSHEET #7 — Asymmetrical Triangle
- STUDENT WORKSHEET #8 — Nosegay in Floral Foam Holder
- STUDENT WORKSHEET #9 — Wired and Taped Nosegay

For additional activities, teachers may refer to the "Suggested Teaching Activities and Procedures" section in the Instructor's Guide.

STUDENT WORKSHEET #1

Wiring and Taping Methods

1. Piercing:

- a. Break and insert carnation or cut stem of rose leaving at least 1/2".
- b. Insert #24 wire crosswise through calyx.
- c. If using a lightweight wire, you may wish to insert two (2) wires forming an "X" in the center of the calyx. This will give more support.
- d. Bend ends down to start stem.

2. Hook:

- a. Break off stem of pompon mum or daisy leaving 1/2".
- b. Insert #24 or #26 wire up through center of stem and flower head.
- c. Bend top of wire into hook.
- d. Pull the hook down into flower head until it is almost invisible. PULL EASY!!

3. Hairpin:

- a. Bend #26 or #28 wire into shape of hairpin.
- b. Hold the ends of the hairpin close together. Insert both ends down through the center of a pompon and along shortened flower stem.
- c. Pull wire ends down. The wire should not be visible in the center of the flower.

4. Stitch Method for Heavy Leaves

- a. Insert #26 wire under main vein from *back side* of leaf.
- b. Bring both wire ends down along the back of the leaf.
- c. Carefully wrap the natural stem of the leaf for a couple of turns with each end of the wire.
- d. Tape with floral tape from the top of the natural stem.

5. Wrapping Method for Leatherleaf and Other Leaves:

- a. Use a hairpin-shaped wire (#26 or #28).
- b. Wind the wire carefully around the natural stem as high as you need to support the leaf.
- c. These leaves are fragile and may break but if you are careful, you add great support with the wiring.
- d. Tape the wire from the top of the natural stem.

6. Taping:

- a. Since floral tape stretches, be sure to stretch it as you tape a wire.
- b. Wrap a little of the tape around the top of a wire to secure.
- c. Twirl the wire in one hand and pull the tape as it is wrapped around the wire.

NOTE: Florist wire is usually green and comes in 12" and 18" lengths. It is gauged according to its weight and commonly ranges from #18 (heavy) to #30 (light). The heavy gauges are used for heavy flower heads and light gauges are used for fragile or lightweight flowers.

Floral tape is available in two widths and many colors. Different florists use different tapes, but for these exercises using the 1/2" width and a green color (as it matches the stem's natural color) is suggested.

Fill out columns one through four of the following table while watching VAS filmstrip #F605 or VAS slide set #S605. *Designing Materials: Cut Flowers and Foliage*. Column five can be completed at home or in class depending on instructions from the teacher.

850

Common and Scientific Names	Colors	Line, Mass, Form or Filler	Expected Life	Possible Uses

800

STUDENT WORKSHEET #2

Making a Bow

Materials:

1. #3 corsage ribbon
2. #30 gauge wire
3. green floral tape

Procedure:

1. Watch a demonstration.
2. (Optional) Hold a #30 wire in one hand and attach the end of the floral tape to one end.
3. (Optional) Twirl the wire while pulling the tape down until the whole wire is taped.
4. Cut the wire in half with wire cutters.
5. Form a small loop (about 2" in diameter) with the corsage ribbon. The shiny side should be facing out. Pinch the base of the loop so the ribbon is crimped where the loop meets the rest of the ribbon.
6. Form a second loop opposite the first one, being sure the shiny side still shows outward. You have to *twist* the ribbon in order to keep the shiny side out.
7. Continue making loops and crimping the center until you have 3 to 5 loops on *each side*.
8. Now you are ready to add a very small loop in the center of the bow to hide the holding wire. Whatever happens next, *do not* let go of the center of the bow or it will unravel.
9. Place your thumb on top of the bow in the center where the ribbon is crimped. Take the ribbon and make a small loop around your thumb, holding the loop with your thumb and forefinger underneath.
10. Take one of the cut pieces of wire from step 4 and place it over your thumb between your thumb and loop.
11. Bring the two sides of the wire down and tightly twist behind the bow. The wire should secure the bow and be available to attach to a corsage.

8.1

STUDENT WORKSHEET #3

Oval Centerpiece

Purpose:

To construct an oval centerpiece. The following illustration shows a two-dimensional placement of the flowers from a side view.

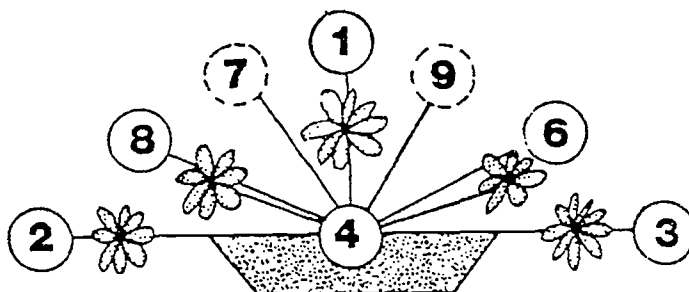

Materials:

1. container
2. floral foam (thoroughly soaked): 1/3 block or one (1) #5 cylinder
3. nine (9) carnations
4. two (2) stems of pompon chrysanthemums
5. 1/3 bunch of leatherleaf

Procedure:

1. Since this arrangement will be seen from all sides, what you do on one side, you will repeat on the other.
2. Place a leatherleaf tip in the top center of the foam. This piece will set the height of the design so make it about 4" to 5" tall.
3. At the rim of the container, insert a piece of leatherleaf on each of the 4 sides. These pieces will determine the length and width of the design. The two (2) pieces should run at least 5" beyond the container and the front and back pieces should run only 2" to 3" beyond the container.
4. Return to the top of the foam; insert pieces of leatherleaf at each corner. Remember all stems go into an imaginary point in the center of the foam! These pieces should be a length to create a curve from the center leatherleaf to the side leatherleaf.

5. Fill in with leatherleaf pieces so the foam is hidden. Follow the rules of design carefully.

6. Placement of carnations should be made as follows: one in the top center just shorter than the leatherleaf, one at each side, one in front and one in back at the container rim. These flowers should be just a bit shorter than the leatherleaf in those areas. One carnation is placed at an angle in each corner on top of the foam.

7. Place the pompon mums at the places where "holes" exist. Use all sizes, even buds, to add depth to the arrangement. Some of the mums should be "hidden" in the arrangement to create a movement for the eye.

Application:

The oval centerpiece is used in situations where the flowers will be viewed from all sides and people must be able to see over the top. It may be placed in the center of an oblong or rectangular table or towards the front as in the case of a head table. Many holiday arrangements are oval centerpieces, so they may be used at the family meal.

Observations and/or Comments:

STUDENT WORKSHEET #4

Pompon Mum or Sweetheart Rose Corsage

Purpose:

To construct a pompon and/or sweetheart rose corsage. The following illustration shows a two-dimensional placement of the flowers.

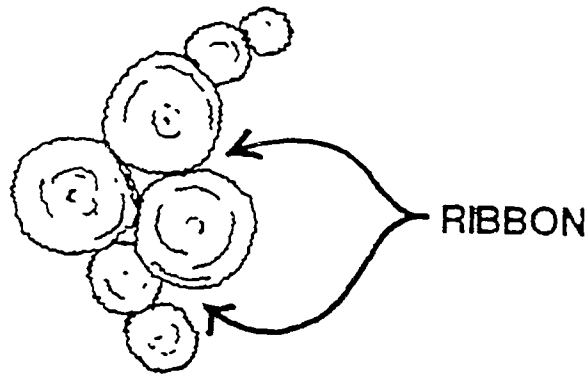

Materials:

1. three (3) larger and four (4) smaller pom pom mums or seven (7) sweetheart roses
2. five (5) small pieces of foliage
3. two (2) corsage bows
4. #24 gauge wire
5. #30 gauge wire
6. #28 gauge wire
7. floral tape

Procedure:

1. Cut three (3) #24 wires in half.
2. Wire each daisy pomp using the hook method.
3. Wrap wire for each flower with floral tape. Stretch tape tightly and tape to the end of the wire.
4. Construct the two (2) corsage bows.
5. Wire and tape the leatherleaf foliage using the hairpin method.
6. Using the bow as a center point, place the three (3) large pomps in a triangle around it. You will have to bend the flowers so that they would face out when placed on the shoulder.
7. Tape the two (2) small pomps together in a line.

8. Wrap the two (2) groups of pomps together with #30 wire. This wire should be close to the lower flowers.
9. Place the foliage in the "spaces" formed by the design of the corsage and attach with your #30 wrapping wire.
10. Cut the wrapping wire and tape over it so as not to scratch the wearer.
11. Place the second bow under the two (2) lowest flowers.
12. Place completed corsage in bag with corsage pins. Refrigerate until time of wearing.

Note: The sweetheart corsage procedure is the same except all the sweethearts are wired with the piece method.

Application:

This corsage is used whenever a pin-on corsage is required (dance, wedding, special event). It can be adapted as a wrist corsage by adding a commercial "wristlet" and cutting the stem short.

Observations and/or Comments:

SLG

STUDENT WORKSHEET #5

Carnation Corsage

Purpose:

To construct a carnation corsage. The following illustration shows a two-dimensional placement of the flowers.

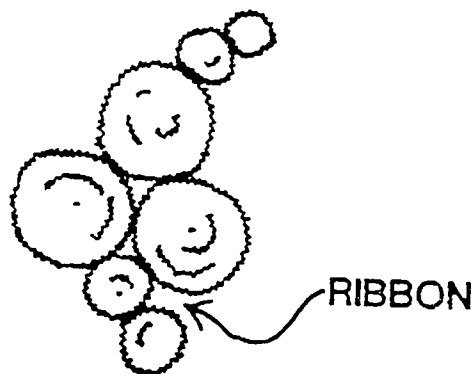

Materials:

1. four (4) carnations
2. seven (7) #24 gauge wires
3. nine (9) #28 gauge wires
4. two (2) #30 gauge wires
5. five (5) small pieces from leatherleaf
6. floral tape
7. corsage ribbon

Procedure:

1. The assembly procedure is the same as for the pompon mum corsage except:
 - a. No bow is placed in the center.
 - b. Small carnations are either miniature carnations or split from whole carnations.

2. Splitting or feathering operations:

- a. Carefully cut carnations into two (2) or three (3) pieces leaving the calyx on each piece. It is easiest to slice the carnations while they are lying flat on the table.
- b. Wrap each piece with a #28 wire.
- c. Pierce each piece with a #24 wire.
- d. Tape securely from the base of the petals down to the end of the wire.

Application:

This corsage is useful in situations where pin-on corsages are requested (dances, weddings, etc.). It can be adapted to a wrist corsage by adding a commercial "wristlet" and cutting the stem short.

Observations and/or Comments:

STUDENT WORKSHEET #6**A One-Sided (Isosceles or Equilateral) Triangle Arrangement****Purpose:**

To construct a one-sided floral design. The following illustration shows a two-dimensional placement of the flowers from a front-view.

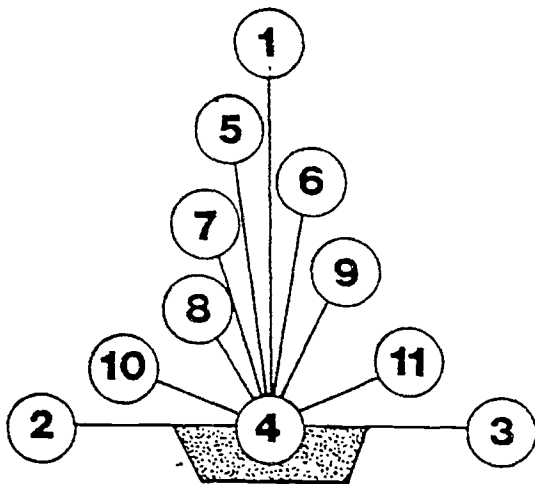
**Materials:**

1. container
2. floral foam (thoroughly soaked): 1/3 block or one (1) #5 cylinder
3. • bunch pom pon chrysanthemums (3 stems)
4. 1/3 bunch leatherleaf (9 pieces)
5. six (6) carnations
6. six (6) pieces of #20 or #22 gauge wire

Procedure:

1. Secure the foam in the container with adhesive tape. Use 1/4" width tape and cross the top of the foam. Bring the tape down over the container about 1/4" - 1". (This tape should be hidden from view at the completion of the design.)
2. Develop your triangle with the leatherleaf. Place one piece vertically in the middle rear of the foam and one piece to each side (horizontal and parallel to the table or bending down slightly).
3. Add one small piece to break the rim of the front of the container.

4. Now you are ready to complete the three-dimensional qualities of your triangle. Place pieces of the leatherleaf inside the line of the triangle with all ends heading to a central point in the middle of the oasis. Remember the rules and try to use just enough foliage to cover the foam and develop the line and mass of the design.
5. Place the flowers using the numerical sequence suggested in the two-dimensional picture.
6. Some of the carnations (or roses) may not be sturdy enough to stand straight. You may use #18 or #20 gauge wire to support the flower. Leaving the natural stem attached, insert the end of the wire vertically into the calyx. Twist the wire around the stem and cut the wire just above where your flower stem will be cut. (Do not tape this wire and be sure to leave the whole natural stem attached!)

Observations and/or Comments:

800

STUDENT WORKSHEET #7

Asymmetrical Triangle

Purpose:

To construct an L-shaped floral design. The following illustration shows a two-dimensional placement of the flowers.

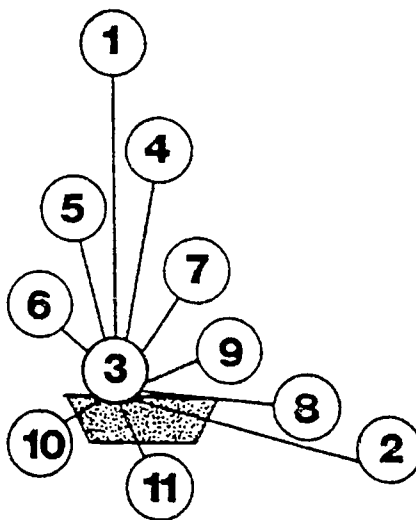

Materials:

1. container
2. floral foam (thoroughly soaked): 1/3 block or one (1) #5 cylinder
3. eleven (11) or nine (9) carnations
4. 1/3 bunch leatherleaf (9 pieces)
5. 1/3 bunch pittosporum (optional)
6. 1/4 bunch baby's breath or statice (optional)

Procedure:

Use the same procedures as with the one-sided except start your vertical piece of leatherleaf to one rear side corner of the oasis. Your design should look like an "L" when completed.

Application:

The L-shaped designs are used where only three sides of the arrangement are viewed and asymmetrical balance is desired. An example of a place where a pair of L-shaped arrangements might be used is a fireplace mantel, with one arrangement on either side. Two L-shapes can "frame" a situation if the Ls face each other (e.g., a wedding altar). This design may be especially good for Christmas when needed greens are used.

Observations and/or Comments:

380

STUDENT WORKSHEET #8**Nosegay in Floral Foam Holder****Purpose:**

To construct a nosegay using a floral foam holder.

Materials:

1. three (3) standard carnations
2. six (6) miniature carnations
3. seven (7) to nine (9) pompons
4. four (4) sweetheart roses
5. 1/3 bunch leatherleaf
6. nosegay foam holder (thoroughly soaked)

Procedure:

1. Use the leatherleaf to green the foam holder. Use the techniques similar to a round centerpiece (See Student Worksheet #3 for review of an oval centerpiece.). Some of the leatherleaf can be used under the foam to hide the holder from the back side.
2. Place one (1) sweetheart rose in the top center of the foam.
3. Place three (3) carnations around the sweetheart rose at about a 45° angle into the foam.

4. Place three (3) or four (4) of the pomps at a 90° angle to the sweetheart rose at the base of the holder. These flowers form the bottom of the nosegay
5. Fill in the three (3) spaces created by the carnations with the three (3) sweetheart roses. Be sure these flowers can be seen as they are usually the most expensive flower of the three.
6. Use the rest of the pomps to fill in the holes in the nosegay.
7. Attach a bow at the point between the top of the handle and base of the foam holder.

Application:

This nosegay is useful when working ahead and flowers need to be stored for a time. It is not recommended for a wedding "throw-away" bouquet as it will shatter on impact. The floral foam nosegay is used whenever a handheld bouquet is required (dances, weddings, etc.).

Observations and/or Comments:

887

STUDENT WORKSHEET #9

Wired and Taped Nosegay

Purpose:

To construct a wired and taped nosegay.

Materials:

1. three (3) standard carnations
2. six (6) miniature carnations, or three (3) carnations split in two
3. seven (7) pompons
4. four (4) sweetheart roses
5. ten (10) pieces pittosporum, about 2" long
6. #26 gauge wire
7. #24 gauge wire
8. #30 gauge wire
9. floral tape
10. corsage ribbon

Procedure:

1. Wire carnations and sweethearts using whole #24 wire.
2. Wire pomps with half of the #24 wire using "hook" method.
3. Wrap carnations and sweetheart roses with floral tape. Stretch tape tightly and tape to end of wire.
4. Set aside completed taped flowers. Place them in a vase so they will not become bruised.
5. Cut your pittosporum so that each stem has one row of foliage.
6. Bend the pomps directly under the flower. Place a piece of pittosporum under the flower head so that the leaves are back of the flower. Tape these pieces together. Use only three (3) or four (4) turns of the tape.

7. Tape a small piece of wired pittosporum around your best sweetheart rose. Place in the center of a bow similar to the size nosegay you desire.
8. Place the three (3) standard carnations around the sweetheart. Bend the carnations outward.
9. Use a #30 wire to hold the bouquet together. Always wrap the wire at the same point — point where the "handle" begins. Be sure to use your wrapping wire with each addition.
10. Add the three (3) sweethearts between the carnations at the outer edges.
11. Place all the pomps with the pittosporum around the carnations and sweetheart roses.
12. Add the miniature carnations at intervals around the pomps.
13. Tape the whole stem. Arrange spaces among the flowers and tuck a bow at the base of the flowers. Cut the stem so it's long enough to hold. Some designers wrap the stem with ribbon and attach another bow at the top of the stem.
14. Be sure all the flowers are in excellent condition. Your nosegay should be a design you would carry.

Note: For a larger bouquet use four (4) whole carnations around the sweetheart rose and increase the number of other flowers.

Application:

This design is utilized for weddings and other occasions where a hand-held bouquet is desired. It is timely to construct and short-lived, but is flexible and may be easily adapted to different styles.

868

CLUSTER: HORTICULTURE

UNIT: Floral Design

PROBLEM AREA: Identifying the Principles of Floral Design

RELATED PROBLEM AREA(S):

1. Designing Silk and Dried Arrangements
2. Designing Live Arrangements

PREREQUISITE PROBLEM AREAS: None

LEVEL: Orientation

OCCUPATIONAL TASKS ADDRESSED:

Horticulture Cluster

Duty S: Designing Arrangements

1. Designing right angle shaped arrangement
2. Design symmetrically balanced triangle arrangements
3. Design asymmetrically balanced triangle arrangements
4. Design vertically shaped arrangements

STATE GOALS FOR LEARNING:

In planning the instruction for this problem area, teachers can promote the development of several student learning objectives which are related to the State Goals for Learning in Fine Arts. These objectives are listed on the Learning Assessment Plan forms included on the following page(s). Those learning objectives marked with an asterisk (*) are taken from the sample lists provided by the Illinois State Board of Education.



Illinois Agricultural Core Curriculum

Agricultural Education 124 Mumford Hall 1301 W. Gregory Drive University of Illinois Urbana, IL 61801

Director: Dale A. Law, Ed.D.

Principal Investigator: Jerry D. Pepple, Ed.D.

Research Assistant: Janis L. Anderson

88/89

ILLINOIS STATE BOARD OF EDUCATION
 Department of School Improvement Services
 100 North First Street
 Springfield, Illinois 62777-0001

LEARNING ASSESSMENT PLAN

Instructions and codes for this form are provided on a separate sheet.

Submission Date _____ Page _____ of _____

Original submission Revision

I. LEARNING AREA (check one)

Language Arts Fine Arts

Mathematics Social Sciences

Sciences Physical Development/Health

(Affix label or complete district information.)

COUNTY _____ DISTRICT _____ ESC _____

District Name _____

City _____

II. STATE GOAL FOR LEARNING

Contact Person: _____

Title: _____

Phone: (_____) _____

III. LEARNING OBJECTIVES	IV. ASSESSMENT				V. EXPECTATIONS
	A Types	B Validity/ Reliability	C Commercial Test(s)	D Evidence of Nondiscrimination	
By the end of grade (circle one) <u>3</u> <u>6</u> <u>8</u> <u>11</u> students should be able to:					
*1. Understand how color is used to create the illusion of space, movement and mood.					
*2. Understand how specific effects are achieved through placement and choice of shapes.					
*3. Recognize visual and physical balance.					
*4. Understand how visual rhythm and visual movement are achieved by repetition and gradation.					
*5. Understand the use of variety in lines, colors, shapes, and textures.					
*6. Understand how regular and irregular patterns form visual rhythm.					
*7. Identify the materials, tools, and processes used to produce that image.					
*8. Identify technical qualities of color.					
*9. Understand how structural principles (emphasis, proportion) contribute to the unity of that image.					
*10. Analyze how color, line, shape, texture, and space interact in that image.					
*11. Analyze how balance, rhythm, contrast, unity, and variety are used in that image.					
*12. Understand how skills, materials, and techniques were used to produce that image.					87%



INSTRUCTOR'S GUIDE**CLUSTER: HORTICULTURE****UNIT: Floral Design****PROBLEM AREA:** Identifying the Principles of Floral Design**STUDENT LEARNING OBJECTIVES**

Upon completion of their study of this problem area, students will be able to:

1. Explain the effects created through placement, size, and shape of material.
2. Create designs with visual balance.
3. Create and explain the harmony, rhythm, and composition of a design.
4. Utilize the geometric form and lines essential for quality designs.
5. Explain the role containers play in floral design.

INSTRUCTOR'S NOTES AND REFERENCES

377

INSTRUCTOR'S GUIDE

CLUSTER: HORTICULTURE

UNIT: Floral Design

PROBLEM AREA: Identifying the Principles of Floral Design

PROBLEMS AND QUESTIONS FOR STUDY

INSTRUCTOR'S NOTES AND REFERENCES

1. What is balance?
2. How is rhythm achieved?
3. What is composition? Harmony? Focal point?
4. What is the difference between symmetrical and asymmetrical? Give some examples.
5. Explain proportion.
6. How does color affect the other variables?
7. What are the different types of lines used in floral design?
8. What role do containers play in floral design?

378

INSTRUCTOR'S GUIDE**CLUSTER: HORTICULTURE****UNIT: Floral Design****PROBLEM AREA:** Identifying the Principles of Floral Design**SUGGESTED LEARNING ACTIVITIES****INSTRUCTOR'S NOTES AND REFERENCES**

1. Break class into groups. Have each group use common materials (combs, rulers) or collect objects from outside to create designs with color, balance, form, and rhythm.
2. Visit a floral designer or have one come in to talk about design principles. Often designers will have pictures to share. Use these pictures to have the class identify all the principles used.
3. Have students complete Student Worksheet #1 on sketching a floral design. They can do this before creating an original arrangement or project.
4. Have students complete Student Worksheet #2 for a summary or test.

876

INSTRUCTOR'S GUIDE**CLUSTER: HORTICULTURE****UNIT: Floral Design****PROBLEM AREA:** Identifying the Principles of Floral Design**REFERENCES****INSTRUCTOR'S NOTES AND REFERENCES**

- *1. *The Principles of Floral Design* (VAS Transparency Set #T620). Vocational Agriculture Service, College of Agriculture, University of Illinois, 1401 S. Maryland Drive, Urbana, IL 61801. (217) 333-3871.
- *2. *Flowers: Geometric Form*. (1986). Benz, M. Buddy, Johnson, James L. San Jacinto Publishing Co., Drawer C, College Station, TX 77843.
- *3. *Design for Profit Magazine*. c/o Florafax International, Inc. 4175 S. Memorial Drive, Tulsa, OK 74145.
- 4. *Florist Review Magazine*. P.O. Box 4368, 2231 Wanamaker, Suite 105, Topeka, KS 66614.
- 5. *The Professional Floral Designer Magazine*. American Floral Services, Inc., P.O. Box 12309, Oklahoma City, OK 73157-2309.
- *6. *Floral Design and Arrangement*. McDaniel, G.L. Reston Publishing Co., Division of Prentice Hall, 200 Old Tappan Road, Old Tappan, NJ 07675. (800) 223-2348.

*Indicates highly recommended reference

880

INSTRUCTIONAL RESOURCES

These resources are intended for use by teachers in planning and teaching the materials for this problem area and may be adapted to fit the teaching method(s) used.

INFORMATION SHEET #1 — Terms to be Defined

601

INFORMATION SHEET #1

Terms to be Defined

Balance — effect derived from the division of materials (color and size); achieved by color and placement related to size.

Compositing — grouping of parts into a pattern (design). Parts need to be coordinated and flow smoothly into one.

Focal point — point that draws the focus of the eye because of the geometric pattern. The focal point is the balance of floral design. Main axis runs through focal point.

Harmony — an ever-changing part of floral design. It is very abstract and depends on personal taste.

Line — visual path created by line produces a sense of motion. Line in the mind's eye becomes form.

Proportion — relationship of the parts of a composition to one another. Things are compared by size, quantity, and placement. Another word for proportion is scale, but scale only deals with size and not shapes or colors. Points about proportion include:

1. Tallest flower or point should be 1 1/2 times the height or width of the container.
2. The proportion of the arrangement to the furniture and room should be considered.
3. The proportion should be maintained between size and quantity of the kinds of materials used.

Rhythm — sense of continuous pattern moving in an orderly fashion. The eye follows the rhythm of a design. The types of rhythm are repeated and variable.

Texture — surface qualities of the plant material and other objects. In a design textures need to blend so that the design is pleasing to the eye.

STUDENT ACTIVITIES

STUDENT WORKSHEET #1 — Sketch Your Design

STUDENT WORKSHEET #2 — Principles of Floral Design Worksheet

For additional activities, teachers may refer to the “Suggested Teaching Activities and Procedures” section in the Instructor’s Guide.

813

STUDENT WORKSHEET #1

Sketch Your Design

Sketch a floral arrangement and be sure to include:

- a. Geometric form
- b. Line
- c. Container
- d. Colors
- e. Materials (list)

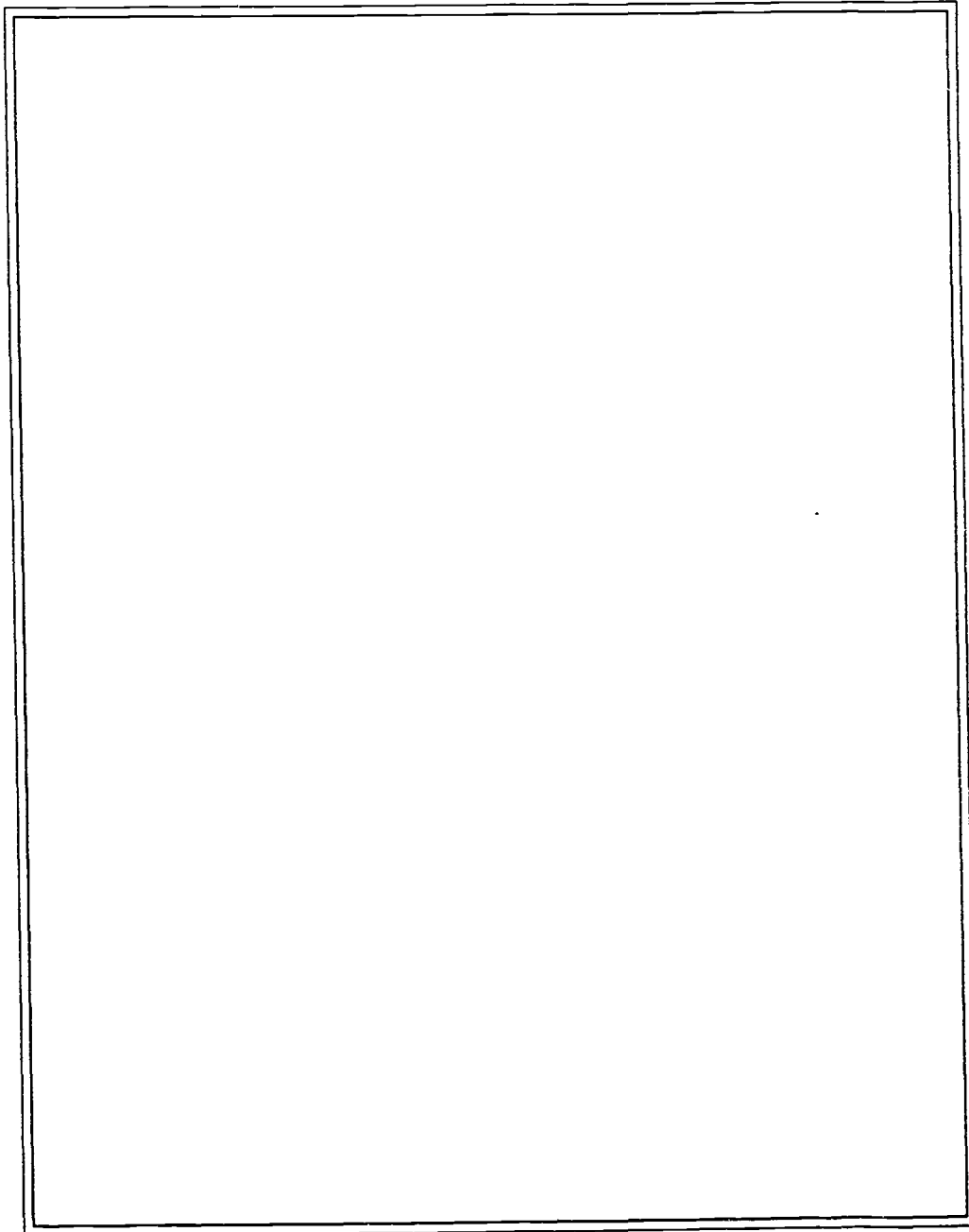

STUDENT WORKSHEET #2

Principles of Floral Design Worksheet

1. What are the three components of proportion that we are concerned with?
 - a.
 - b.
 - c.
2. The plant material should be _____ the height and _____ the width of the container.
3. All parts should _____ from the focal point.
4. The eye will follow the _____ of a design which _____ and maintains the _____.
5. For an upright arrangement the width should be _____ than the height but for a horizontal arrangement the width should be _____ wider than the height.
6. Balance can be both _____ and _____.
7. Form is created by _____.
8. Balance is effected by:
 - a.
 - b.
 - c.
 - d.
 - e.
9. Rhythm is _____ and should not be broken.
10. Container shapes should _____ the line of the arrangement.
11. The dominant point of an arrangement is the _____.
12. Japanese and Oriental designers are known for their _____, _____, and _____ designs.
13. Reds, oranges, and yellows are _____ colors while greens, blues, and purples are _____ colors.
Which group is more dominant? _____
14. Texture refers to the _____ qualities of the materials used in a design.
15. The _____ of a design will run through the focal point.

E.S.S.

STUDENT WORKSHEET #2 — Key

Principles of Floral Design Worksheet

1. What are the three components of proportion that we are concerned with?
 - a. *Between plant material and container.*
 - b. *Between size and quantity of plant material.*
 - c. *Between arrangement and its location.*
2. The plant material should be *1 1/2 times the* height and *1 1/2 times* the width of the container.
3. All parts should *radiate* from the focal point.
4. The eye will follow the *line* of a design which *produces motion* and maintains the *rhythm*.
5. For an upright arrangement the width should be *less* than the height but for a horizontal arrangement the width should be *2-3 times* wider than the height.
6. Balance can be both *visual* and *physical*.
7. Form is created by *line*.
8. Balance is effected by:
 - a. *Color*
 - b. *Size*
 - c. *Shape*
 - d. *Texture*
 - e. *Placement*
9. Rhythm is *continuous* and should not be broken.
10. Container shapes should *complement* the line of the arrangement.
11. The dominant point of an arrangement is the *focal point*.
12. Japanese and Oriental designers are known for their *informal, free form, and airy* designs.
13. Reds, oranges, and yellows are *warm* colors while greens, blues, and purples are *cool* colors. Which group is more dominant? *warm*
14. Texture refers to the *surface/physical* qualities of the materials used in a design.
15. The *main axis* of a design will run through the focal point.