

## DOCUMENT RESUME

ED 342 655

SE 052 576

AUTHOR Pagni, David, Ed.  
 TITLE CAMP-LA: Book 2, Grades 3-4. Calculators and Mathematics Project.  
 SPONS AGENCY California State Univ., Fullerton.; Los Angeles Unified School District, Calif.; National Science Foundation, Washington, D.C.  
 REPORT NO ISBN-1-879853-05-1  
 PUB DATE 91  
 NOTE 326p.; For related documents, see SE 052 574-578.  
 AVAILABLE FROM Cal State Fullerton Press, 2875 Orange Olive Road, Bldg. #2, Orange, CA 92665 (\$14.95).  
 PUB TYPE Guides - Classroom Use - Teaching Guides (For Teacher) (052)

EDRS PRICE MF01 Plus Postage. PC Not Available from EDRS.  
 DESCRIPTORS Addition; Algebra; Arithmetic; \*Calculators; Classroom Techniques; \*Curriculum Development; Curriculum Enrichment; Data Analysis; Decimal Fractions; Discovery Learning; Division; Educational Technology; \*Elementary School Mathematics; Enrichment Activities; Evaluation Methods; Fractions; Functions (Mathematics); Geometry; Grade 3; Grade 4; Intermediate Grades; Lesson Plans; Mathematical Enrichment; Mathematical Logic; \*Mathematics Curriculum; Mathematics Education; \*Mathematics Instruction; Multiplication; Number Concepts; Primary Education; Probability; Problem Solving; Small Group Instruction; Statistics; Subtraction; \*Teaching Methods; Units of Study

IDENTIFIERS Calculators and Mathematics Project CA; \*Mathematics Framework for Calif Public Schools; NCTM Curriculum and Evaluation Standards; Patterns (Mathematics)

## ABSTRACT

The National Science Foundation funded Calculators and Mathematics Project, Los Angeles (CAMP-LA) developed curriculum material; focused solely on the use of calculators. The project was developed in three stages. The first stage studied the mathematics curriculums from different states and identified topics that are not included but should be if every student had a calculator, topics treated in too much detail, and topics no longer appropriate. Based on this information, CAMP-LA compiled a prototype curriculum organized by grade level to be consistent with the "California Mathematics Framework" strands. The second stage developed lessons to cover the topics through the curriculum. The third stage field tested these lessons in various parts of the country. This book is composed of lessons for grades 3-4 in the series. The introduction gives an overview of CAMP-LA, information on how to use the lesson plans, a discussion of assessment approaches, and a scope and sequence for the book. The remainder of the book is composed of 49 lessons in six chapters: Number, Measurement, Geometry, Patterns and Functions, Statistics and Probability, Logic, and Algebra. Each lesson is broken down into three sections. The three sections are labeled: "Grade", including grade level, strand, skill required, and purpose; "Management", including class organization, time frame, materials needed, vocabulary, and prerequisite skills; and "Lesson" including suggestions for directed instruction, guided practice, independent practice, evaluation, and home activity. (MDH)

ED342655

# CAMP - LA

## BOOK 2 GRADES 3 - 4

PERMISSION TO REPRODUCE THIS MATERIAL IN MICROFICHE ONLY HAS BEEN GRANTED BY

Hani Sayegh

TO THE EDUCATIONAL RESOURCES INFORMATION CENTER (ERIC)

U.S. DEPARTMENT OF EDUCATION  
Office of Educational Research and Improvement  
EDUCATIONAL RESOURCES INFORMATION CENTER (ERIC)

- This document has been reproduced as received from the person or organization originating it.
- Minor changes have been made to improve reproduction quality.
- Points of view or opinions stated in this document do not necessarily represent official CEERI position or policy.

Cal State Fullerton Press  
2875 Orange/Olive Rd. Bldg #2  
Orange, CA 92665  
(714) 871-1984

ISBN: 1-879853-05-1

9752576

# CAMP-LA

## BOOK 2

### GRADES 3 - 4

#### CAMP-LA PROJECT STAFF

---

**Co-director** ..... David Pagni

**Co-director** ..... Robert Hamada

**K - 2 Writing Team** ..... Marea Channel  
..... Vicki Newman

**3 - 4 Writing Team** ..... Jan Christinson  
..... William Hammond  
..... Shirley Roberts  
..... Bruce Takashima

**5 - 6 / 7 - 8 Writing Team** ..... Zelda Gold  
..... Elisabeth Javor  
..... Steve Rosentsweig

**K - 2 Spanish Translation** ..... Fred Chavez

**Production Typist and  
Computer Graphics** ..... Donald Luey

# Cal State Fullerton Press

14585074  
ERIC  
Full Text Provided by ERIC

**Limited Reproduction Permission:** Permission to duplicate these materials is limited to the teacher for whom they were purchased. Reproduction for an entire school or school district is unlawful and strictly prohibited. For conditions of use and permission to use materials contained herein for foreign publications or publications in other than the English language, apply either to the Publisher or the copyright owner. Publication pursuant to such permission shall contain the statement: "Some (All) of the materials incorporated in this Work were developed with the financial support of the National Science Foundation. Any opinions, findings, conclusions or recommendations expressed herein do not necessarily reflect the view of the National Science Foundation."

The following mathematics lessons were produced by the Calculators and Mathematics Project, Los Angeles (CAMP-LA). The project was supported by California State University, Fullerton, Los Angeles Unified School District and the National Science Foundation (Grant #MDR - 8651616). However, the opinions, findings, conclusions or recommendations expressed herein are those of the authors and do not necessarily reflect the views of the National Science Foundation. The lessons were developed around mathematics topics that could be taught or enhanced with the use of a calculator. In some cases the calculator is used to explore or learn a mathematical concept; in other cases, it is used as a computing tool. All lessons were field-tested in the Los Angeles Unified School District in a wide variety of school settings. Sample lessons have been used in workshops for teachers and other mathematics educators across the United States. The CAMP-LA lessons have always been well-received. The directors and writers of CAMP-LA believe that you and your students will find these lessons to be fun and challenging!

**Copyright 1991 by Cal State Fullerton Press  
All rights reserved.  
Printed in the United States of America.  
ISBN: 1-879853-05-1**

# ADDITIONAL ACKNOWLEDGMENTS

---

**Advisory Board:** Art Hiatt, California State University, Fresno  
Robert Reys, University of Missouri  
Walter Szetela, University of British Columbia  
Marilyn Suydam, Ohio State University  
J. Fred Weaver, University of Wisconsin (Retired)

**Field Testers:**

Beverly Baba	Joyce Kirsch
Henry Behrens	Elizabeth Lemons
Renee Boswell	Mary Major
Desdra Butler	Geraldean McDaniel
Marjorie Champawat	Polly McDowell
Joan Douglas	Feliciano Mendoza
Donna Edris	Ellen Mitchell
Susan L. Elms	Patti Poon
Cheryl Eppink	Irene Stewart
Juliet Ethirveerasingam	Lynn Tharsing
Michael Gordon	Mary Lou Vanderlip
Shirley Hirschfeld	Merrie Wartik
Jean Huston	Audrey Washington
Yuki Ihara	Diane Weinstein
Jackie Johnson	Kimi N. Yasui

**Consultants:**

Karen Bachofer	Pat Johnson
Adriana Brady	Donna Jorgensen
Becky Breedlove	Judith Koenig
Marjorie Cochran	Beatrice La Pisto
Dennis Dulyea	Kolburn Hughes
Ed Esty	Patti McCullough
Viggo Hansen	Terri Pagni
Claire Heidema	Karen Richey
Chris Holle	Carolina Tercero

## **Books by David Pagni:**

---

**CAMP- LA Book 1**

**CAMP- LA Book 2**

**CAMP- LA Book 3**

**CAMP- LA Book 4**

**Math Lessons for Grades K - 3**

**Math Lessons for Grades 3 - 5**

**Math Investigations for the Months**

# PROJECT BACKGROUND

The Calculators and Mathematics Project, Los Angeles (CAMP-LA) was one of six projects<sup>1</sup> in the country funded by the National Science Foundation, Division of Materials Development and Research Instructional Materials Development Program, under a special program solicitation entitled "Materials for Elementary School Mathematics Instruction" in September, 1986. The special solicitation requested proposals that focused on the use of technology in elementary school mathematics.

Of these six projects, only CAMP-LA focussed its efforts solely on the use of calculators. The CAMP-LA philosophy is that every child should have access to a calculator at all times when investigating, studying, or learning mathematics.

The lesson development process spanned three stages. First, the project teams of writers and the two co-directors studied the mathematics curriculum guides from different states. They looked for:

- Topics not treated but which should be (assuming every child has a calculator)
- Topics treated in too much detail
- Topics no longer appropriate

Based on the results of this research, the CAMP-LA staff compiled a prototype curriculum organized around the strands of the *California Mathematic Framework*: Number, Measurement, Geometry, Patterns and Functions, Statistics and Probability, Logic, and Algebra. The CAMP-LA staff next isolated those topics that lent themselves to being taught with the use of a calculator. These topics were organized by grade level and became the CAMP-LA Calculator Continuum.

The second stage of the lesson development process was the writing of lessons that captured the essence of the Calculator Continuum. At this time, we decided to introduce a new strand, the Calculator Awareness strand for lessons designed to introduce students to the mechanics of operating a calculator. Of course, these lessons for introducing the calculator features are written in a mathematics context.

Drafts of lessons were written during the summer, 1987. During the following fall these skeletal lessons were evaluated to see which ones needed to be fleshed out, which needed to be deleted, and where in the Calculator Continuum additional lessons were needed.

The third stage of the CAMP-LA lesson development process was the field testing of the lessons. Because of a nationwide interest in the project, a few lessons were field tested in schools in various parts of the country. However, all lessons were field tested in the Los Angeles Unified School District in a variety of school settings. The CAMP-LA field test teachers turned in written reports including samples of students' work for each lesson. The field test teachers also met with the project writers to discuss the strengths and weaknesses of the various lessons. The field testing went hand - in - hand with new lesson development throughout 1988, 1989, and 1990. During the summer and fall of 1990 the writing teams completed their work and the final editing was completed by David Pagni, Principal Investigator and Co-director of CAMP-LA.

<b>CAMP-LA Books</b>		
<b>Book</b>	<b>Grade Level</b>	<b>Cost</b>
Book 1	K - 2	\$14.95
Book 2	3 - 4	\$14.95
Book 3	5 - 6	\$14.95
Book 4	7 - 8	\$20.95

<sup>1</sup>The six NSF funded projects were:

- 1) "A Revision of the Geometry and Measurement Strands, K-6" University of Georgia
- 2) "Calculators and Mathematics Project, Los Angeles"  
California State University, Fullerton
- 3) "Development of a Logo-Based Geometry Curriculum"  
Kent State University
- 4) "K-6 Supplementary Mathematics Materials for a Technological Society"  
New York University
- 5) "Reckoning with Mathematics: Tools and Challenges for the Information Age"  
Education Development Center
- 6) "Used Numbers: Collecting and Analyzing Real Data"  
Technical Education Research Centers



# TABLE OF CONTENTS

## Book 2: Grades 3 - 4

CAMP-LA Overview.....	xii
Features of CAMP-LA Lessons.....	xiii
CAMP-LA Lesson Format.....	xiv
CAMP-LA Assessment.....	xvi
Scope and Sequence.....	xvii

### Chapter 1: *Number*

Numbers are used to record and interpret information, solve problems, and to make decisions. Students develop number sense by being asked to make a choice among computational methods: estimation, mental arithmetic, paper and pencil, and the calculator.

Lesson	Title	Objectives	Page
1	Expand Your Knowledge of Numbers	Write numbers in standard and expanded notation.	1
2	Two, Four, Six, Eight, This is How We Estimate	Add and subtract with multi-digit numbers.	5
3	How to Use a Checkbook	Addition and subtraction using money.	10
4	Planning a Reception	Operations involving money.	18
5	Multiple Applications	Find and name the multiples of a given number.	24
6	Finding Factors	List the set of factors of a given number.	28
7	Food Fractions	Identify and rename improper fractions as mixed numbers.	37
8	Making Sense of Cents and Percents Part 1	Find relationship of money and decimals.	41
9	Making Sense of Cents and Percents Part 2	Computation of percentages from fraction - division concept.	47

<b>Lesson</b>	<b>Title</b>	<b>Objectives</b>	<b>Page</b>
10	Pay Me What I'm Worth	Relationship between percent and decimals.	53
11	One The Hard Way	Approximation of decimal fraction and whole number values.	57
12	Toss One	Add, subtract, multiply, and divide decimals.	61
13	How Close Can You Get?	Operations with decimals.	65
	<b>Chapter Assessment</b>		<b>69</b>

**Chapter 2: Measurement**

When we measure, we attach a number to a quantity using a unit which is chosen according to the properties of the quantity to be measured. Estimation plays an important role in the manipulation of non-standard and standard systems as well as conversion within and between systems of measurement.

<b>Lesson</b>	<b>Title</b>	<b>Objectives</b>	<b>Page</b>
14	On Vacation We Will Go	Estimate and measure length in standard units.	73
15	Book Covers Cover a Lot of Area	Estimate and measure area in standard units.	79
16	Newspaper Numbers	Estimate and measure area in standard units.	83
17	Schoolyard Measurement	Estimate and measure area in standard units.	89
18	Time Codes	Estimate and measure units of time.	95
19	Radio Time	Add and multiply quantities of time.	100
20	Carrier Conversions	Convert units within a measurement system.	107
21	Miss Betty and the Beans	Estimate and measure volume/capacity in standard units.	113
	<b>Chapter Assessment</b>		<b>116</b>

### **Chapter 3: Geometry**

The study of geometry enables students to identify, describe, compare, and classify geometric figures. Students develop spatial sense and problem solving skills using geometric models.

<b>Lesson</b>	<b>Title</b>	<b>Objectives</b>	<b>Page</b>
22	Polygon's Perimeters	Estimate and measure perimeter.	120
23	What is the Area?	Estimate and find the area of a plane figure.	125
24	Dinosaur Dimensions	Estimate and find the perimeter and area of a plane figure.	134
25	Push "M" For Area	Estimate and find the area of polygons.	143
26	Estimating Pi	Pi represents a relationship between the circumference and the diameter of a circle.	149
	Chapter Assessment		152

### **Chapter 4: Patterns and Functions**

The study of patterns enables students to see order and predictability in many situations. Students have a powerful tool for solving problems when they understand patterns and functional relationships.

<b>Lesson</b>	<b>Title</b>	<b>Objectives</b>	<b>Page</b>
27	Magic Numbers	Identify, extend, and create number patterns.	155
28	Number Pals	Recognize and extend number patterns.	161
29	Let's Go Bicycle Riding	Discover and state a function rule from a set of data.	168
30	The Pencil Box Problem	Find a function rule from a situation or graph.	174
31	Exploring Nines for Nine Year Olds	Recognition, extension, and creation of patterns when dividing by "nines".	182
32	Squares, Squares and More Squares	Recognize and extend number patterns.	188
33	Squares, Squares and More Squares Revisited	Recognize and extend number patterns.	194

34	Find My Function	Recognize and extend number patterns.	200
	Chapter Assessment		203

### Chapter 5: *Statistics and Probability*

Knowledge of statistics allows students to summarize what they know of the world and to make inferences about what they do not know. The study of probability enables students to indicate how certain they are about a prediction.

Lesson	Title	Objectives	Page
35	Using The Mean	Determine the mean of a set of data.	206
36	Ways to 99,999,999	Determine the mean of a set of data.	211
37	Finding The Average	Determine the mean of a set of data.	214
38	Where Does The Time Go?	Collect and analyze data.	219
39	Temperature Around the World	Use data to describe tendencies and predict the likelihood of future events.	224
	Chapter Assessment		235

### Chapter 6: *Logic*

Logical reasoning develops as students identify attributes, recognize patterns, and use relationships to analyze mathematical situations. Students reason, make conjectures, and draw conclusions as they move from working with concrete materials to abstract thinking.

Lesson	Title	Objectives	Page
40	Big "D's" Parking Garage I	Use charts to organize information to solve simple logic problems.	237
41	Big "D's" Parking Garage II	Use charts to organize information to solve simple logic problems.	246
42	Creature Race	Make a logical conclusion about a situation.	250
43	Animal Babies	Use a logic table and calculator to make logical conclusions about a situation.	254

44	How Old Is Uncle Mark?	Determine reasonable and logical conclusions.	257
45	A Camping We Will Go	Use logical conjectures to reach a conclusion.	261
	Chapter Assessment		265

**Chapter 7: Algebra**

Algebra is studied informally to develop an understanding of abstract relationships. Students learn to express numerical relationships through the use of the variable.

Lesson	Title	Objectives	Page
46	Calculator Sentences	Identify the missing number in a number sentence to make a true sentence.	268
47	Step by Step	Identify a number represented by "n."	273
48	Have You Ever Seen a Square Root?	Identify a number represented by a variable in an equation.	277
49	Dinosaur Derby	Evaluate a simple formula.	282
	Chapter Assessment		288

# CAMP-LA OVERVIEW

The **Calculators and Mathematics Project, Los Angeles (CAMP-LA)** provides materials for grades K-8 that integrate the calculator into the elementary school mathematics curriculum in a meaningful way.



**CAMP-LA lessons focus on problem solving using real life applications.**

**Students explore complex mathematical concepts, discover number patterns, and apply logical reasoning.**

**Students develop confidence in their mathematical thinking as they make appropriate use of the calculator.**



**CAMP-LA lessons were written as supplemental materials for any classroom textbook series, and provide a model for implementing the use of the hand held calculator as a tool in mathematics instruction.**



**CAMP-LA lessons were field tested by teachers and students who used calculators with these features:**

- **constant function for addition, subtraction, multiplication, and division;**
- **clear key which erases everything from the display;**
- **clear entry key which erases only the last entry;**
- **memory recall/clear key which is used to recall information in the memory and to clear the memory.**



**CAMP-LA lessons support the philosophy expressed by the California State Department of Education *Mathematics Framework for California Public Schools* and the National Council of Teachers of Mathematics *Curriculum and Evaluation Standards for School Mathematics*.**

# **FEATURES OF CAMP-LA LESSONS**

---

- **PROBLEM SOLVING**
- **SITUATIONAL LESSONS**
- **COOPERATIVE LEARNING**
- **TRANSPARENCY MASTERS**
- **STUDENT ACTIVITY SHEETS**
- **HOME ACTIVITY SHEETS**
- **ASSESSMENT MATERIALS**

# CAMP-LA LESSON FORMAT

The third and fourth grade lessons are organized by strand with a suggested lesson sequence at the beginning of each sector. The lessons assume that every student has a calculator.

Each lesson includes teacher information and lesson development.

## Teacher Information

<b>CAMP-LA</b>	<b>LESSON TITLE</b>
<b>GRADE LEVEL:</b>	Indicates appropriate level.
<b>STRAND:</b>	Identifies mathematical strand: Number, Measurement, Geometry, Patterns and Functions, Statistics and Probability, Logic, or Algebra.
<b>SKILL:</b>	States the skill developed in the lesson.
<b>MANAGEMENT CLASS ORGANIZATION:</b>	Recommends whole class, small groups, or pairs.
<b>TIME FRAME:</b>	Approximates the time needed to present the lesson.
<b>MATERIALS:</b>	Lists the necessary materials.
<b>VOCABULARY:</b>	Identifies mathematical terms and other vocabulary used in the lesson.
<b>PREREQUISITE SKILLS:</b>	States skills needed for successful completion of the lesson.



## Lesson Development

### **LESSON**

The purpose of this lesson ...

- **DIRECTED INSTRUCTION:** Lessons are developed sequentially within and across strands.

The lessons --

- Stimulate critical thinking
- Focus on concepts
- Encourage student participation

Suggestions for delivery of instruction include the use of --

- Problem solving
- Concrete materials
- Cooperative learning
- Mathematical language
- Situational lessons

- **GUIDED PRACTICE:** Students practice the skill with the teacher's guidance.
- **INDEPENDENT PRACTICE:** Students apply their mathematical knowledge independently. Student Activity Sheets and Teacher Answer Sheets are included.
- **EVALUATION:** Several evaluation methods are suggested to --
  - Assess students' understanding of concepts
  - Evaluate student interaction
  - Bring closure to a lesson
- **HOME ACTIVITY:** Suggestions are provided for extending lesson concepts at home.

# CAMP-LA ASSESSMENT



The purpose of assessment is to enhance learning and improve teaching. For the student, assessment indicates a measure of mathematical knowledge and power. For the teacher, it indicates how the instructional program should be modified. Teacher observation of students' actions and interactions gives information about mathematical knowledge, understanding of concepts, and ability to apply reasoning and analysis to solve problems.



Suggested **CAMP-LA** assessment items appear at the end of each chapter. The assessment items:

- have been written as models of assessment which support the major concepts presented in the **CAMP-LA** lessons;
- provide both open-ended and traditional assessment tasks;
- are meant to be done by pairs and/or small groups;
- indicate anticipated student responses for open-ended questions.

## 3 - 4 SCOPE AND SEQUENCE

NUMBER	MEASUREMENT	NUMBER	PATTERNS AND FUNCTIONS
Lesson 1 Expand Your Knowledge of Numbers	Lesson 14 On Vacation We Will Go	Lesson 22 Polygon's PerimeterS	Lesson 27 Bob's Birthday Party
Lesson 2 Two, Four, Six, Eight, This is How We Estimate	Lesson 15 Book Covers Cover a Lot of Area	Lesson 23 What is the Area?	Lesson 27 Magic Numbers
Lesson 3 How to Use a Checkbook	Lesson 16 Newspaper Numbers	Lesson 24 Dinosaur Dimensions	Lesson 28 Number Pals
Lesson 4 Planning a Reception	Lesson 17 Schoolyard Measurement	Lesson 25 Push "M" For Area	Lesson 29 Let's Go Bicycle Riding
Lesson 5 Multiple Applications	Lesson 18 Time Codes	Lesson 26 Estimating Pi	Lesson 30 The Pencil Box Problem
Lesson 6 Finding Factors	Lesson 19 Radio Time		Lesson 31 Exploring Nines for Nine Year Olds
Lesson 7 Food Fractions	Lesson 20 Carrier Conversions		Lesson 32 Squares, Squares and More Squares
Lesson 8 Making Sense of Cents and Percents Part 1	Lesson 21 Miss Betty and the Beans		Lesson 33 Squares, Squares and More Squares Revisited
Lesson 9 Making Sense of Cents and Percents Part 2			Lesson 34 Find My Function
Lesson 10 Pay Me What I'm Worth	<b>STATISTICS AND PROBABILITY</b>	<b>LOGIC</b>	<b>ALGEBRA</b>
Lesson 11 Tox's One	Lesson 35 Using The Mean	Lesson 40 Big "D's" Parking Garage I	Lesson 46 Calculator Sentences
Lesson 12 One The Hard Way	Lesson 36 Ways to 99,999,999	Lesson 41 Big "D's" Parking Garage II	Lesson 47 Step by Step
Lesson 13 How Close Can You Get?	Lesson 37 Finding The Average	Lesson 42 Creature Race	Lesson 48 Have You Ever Seen a Square Root?
	Lesson 38 Where Does The Time Go?	Lesson 43 Animal Babies	Lesson 49 Dinosaur Derby
	Lesson 39 Temperature Around the World	Lesson 44 How Old Is Uncle Mark?	
		Lesson 45 A Camping We Will Go	

# CAMP-LA

Calculators and Mathematics Project, Los Angeles

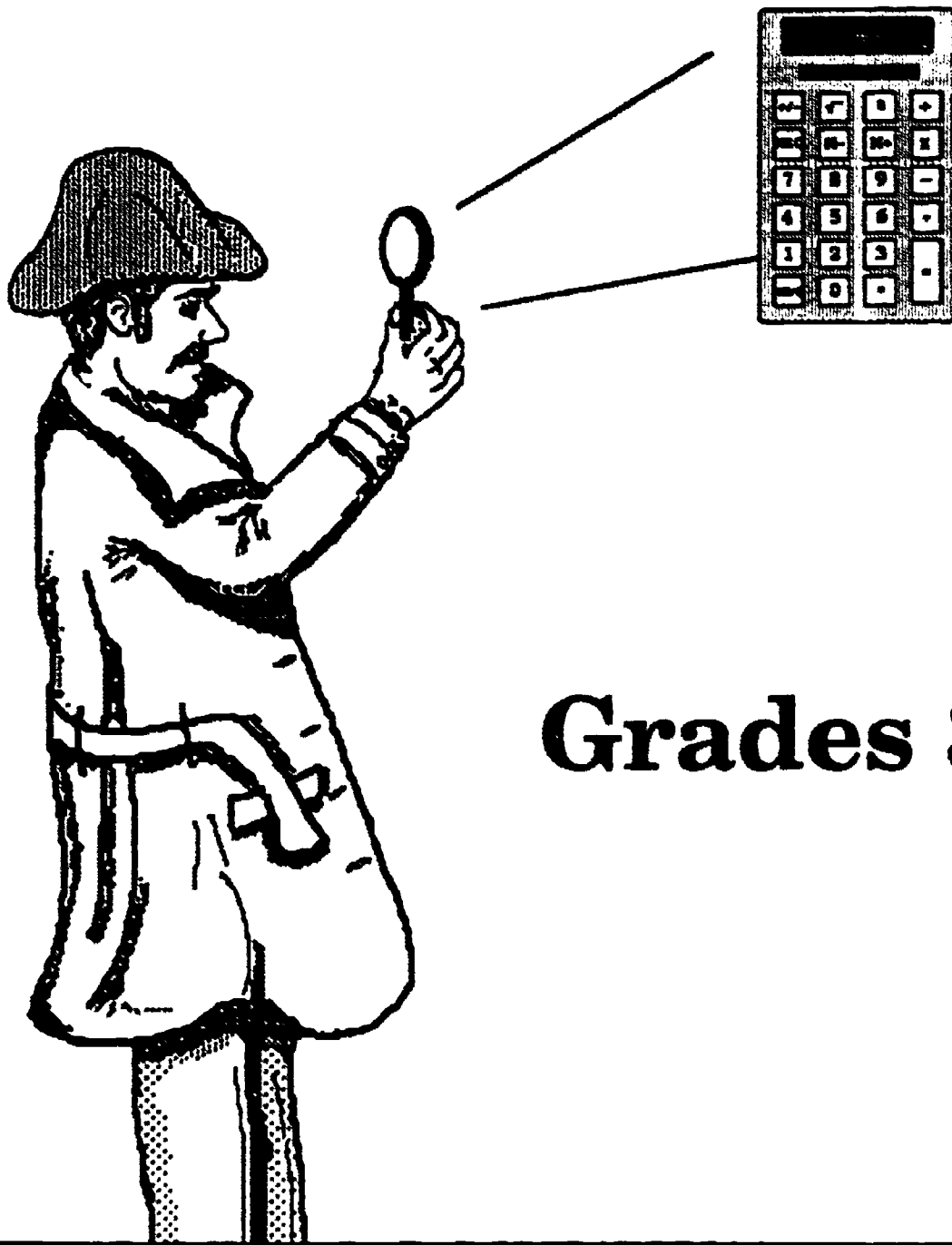

Grades 3 - 4

## CHAPTER 1 NUMBER

## EXPAND YOUR KNOWLEDGE OF NUMBERS

- GRADE:** 3 - 4
- STRAND:** Number
- SKILL:** Write numbers in standard and expanded notation
- MANAGEMENT**
- CLASS ORGANIZATION:** Pairs
- TIME FRAME:** One class period
- MATERIALS:** Calculators
- VOCABULARY:** Expanded notation, standard notation
- PREREQUISITE SKILL:** Mathematics: Basic operations  
Calculators: Basic functions, memory

**LESSON** The purpose of this lesson is to develop understanding of place value.

• **DIRECTED INSTRUCTION:**

Explain expanded notation.

Write the number 13,289 on the board.

1 represents one group of ten thousand ( $1 \times 10,000$ ) which is written as 10,000.

3 represents three groups of a thousand ( $3 \times 1000$ ) which is written as 3,000.

2 represents two groups of a hundred ( $2 \times 100$ ) which is written as 200.

8 represents eight groups of ten ( $8 \times 10$ ) which is written as 80.

9 represents nine ones ( $9 \times 1$ ) which is written as 9.

13,289 in expanded notation is

$(1 \times 10,000) + (3 \times 1000) + (2 \times 100) + (8 \times 10) + (9 \times 1)$ .

• **GUIDED PRACTICE:**

Students use the following calculator sequence to express numbers in standard notation from expanded notations.

Example:  $(2 \times 10,000) + (4 \times 1,000) + (5 \times 100) + (4 \times 10) + (6 \times 1) = ?$

Calculator sequence:

Clear memory (this varies according to calculator).

Clear display.

2	X	10,000	M+
---	---	--------	----

4	X	1,000	M+
---	---	-------	----

5	X	100	M+
---	---	-----	----

4	X	10	M+
---	---	----	----

6	X	1	M+
---	---	---	----

RCM
-----

 (Recall memory)

Display should read 

M
---

 24546.

Give students other numbers expressed in expanded notation and have them express the standard form of the number on their calculator.

• **INDEPENDENT PRACTICE:**

Students work in pairs to complete Student Activity Sheet 1.

• **EVALUATION:**

Teacher observation.

• **HOME ACTIVITY:**

Demonstrate the memory feature of the calculator to a family member.



EXPAND YOUR KNOWLEDGE OF NUMBERS  
Student Activity Sheet

Standard Notation	Expanded Notation
1 5478	
2	$(2 \times 1000) + (9 \times 100) + (5 \times 10) + (1 \times 7)$
3	$(8 \times 10,000) + (6 \times 1,000) + (2 \times 100) + (4 \times 10) + (8 \times 1)$
4 78,204	
5 8,421	
6	$(6 \times 100,000) + (0 \times 10,000) + (1 \times 1,000) + (4 \times 100) + (3 \times 10) + (2 \times 1)$
7	$(7 \times 1,000) + (6 \times 100) + (7 \times 10) + (7 \times 1)$
8 56,488	
9	$(5 \times 10,000) + (6 \times 1,000) + (4 \times 100) + (8 \times 10) + (8 \times 1)$
10 92,269	

11. Write the expanded notation for the largest five-place number you can show on the calculator.
- 
12. Write the expanded notation for a five place number that has the digit 4 in each of the places.
- 
13. Write the expanded notation for 100,001.
- 
14. Write the expanded notation for two million, four hundred fifty-six thousand, nine hundred six.
-

**EXPAND YOUR KNOWLEDGE OF NUMBERS**  
Teacher Answer Sheet

Standard Notation	Expanded Notation
1      5478	$(5 \times 1000) + (4 \times 100) + (7 \times 10) + (8 \times 1)$
2      2957	$(2 \times 1000) + (9 \times 100) + (5 \times 10) + (1 \times 7)$
3      86,248	$(8 \times 10,000) + (6 \times 1,000) + (2 \times 100) + (4 \times 10) + (8 \times 1)$
4      78,204	$(7 \times 10,000) + (8 \times 1,000) + (2 \times 100) + (0 \times 10) + (4 \times 1)$
5      8,421	$(8 \times 1000) + (4 \times 100) + (2 \times 10) + (1 \times 1)$
6      601,432	$(6 \times 100,000) + (0 \times 10,000) + (1 \times 1,000) + (4 \times 100) + (3 \times 10) + (2 \times 1)$
7      7,677	$(7 \times 1,000) + (6 \times 100) + (7 \times 10) + (7 \times 1)$
8      56,488	$(5 \times 10,000) + (6 \times 1,000) + (4 \times 100) + (8 \times 10) + (8 \times 1)$
9      56,488	$(5 \times 10,000) + (6 \times 1,000) + (4 \times 100) + (8 \times 10) + (8 \times 1)$
10     92,269	$(9 \times 10,000) + (2 \times 1,000) + (2 \times 100) + (6 \times 10) + (9 \times 1)$

11. Write the expanded notation for the largest five-place number you can show on the calculator.

$(9 \times 10,000) + (9 \times 1,000) + (9 \times 100) + (9 \times 10) + (9 \times 1)$

12. Write the expanded notation for a five place number that has the digit 4 in each of the places.

$(4 \times 10,000) + (4 \times 1,000) + (4 \times 100) + (4 \times 10) + (4 \times 1)$

13. Write the expanded notation for 100,001.

$(1 \times 100,000) + (0 \times 10,000) + (0 \times 1,000) + (0 \times 100) + (0 \times 10) + (1 \times 1)$

14. Write the expanded notation for two million, four hundred fifty-six thousand, nine hundred six.

$(2 \times 1,000,000) + (4 \times 100,000) + (5 \times 10,000) + (6 \times 1,000) + (9 \times 100) + (0 \times 10) + (6 \times 1)$



## TWO, FOUR, SIX, EIGHT, THIS IS HOW WE ESTIMATE

- GRADE:** 3 - 4
- STRAND:** Number
- SKILL:** Add and subtract multi-digit numbers
- MANAGEMENT**
- CLASS ORGANIZATION:** Whole class, small groups
- TIME FRAME:** One class period
- MATERIALS:** Calculator, student textbooks
- VOCABULARY:** Estimation
- PREREQUISITE SKILLS:** Mathematics: Basic operations, rounding to nearest hundred and thousand  
Calculator: Basic functions

**LESSON** The purpose of this lesson is to use estimation in conjunction with the calculator.

**DIRECTED INSTRUCTION:**

Estimation involves making a close guess or finding a reasonable answer when adding or subtracting two or more quantities. Students estimate the answer to a problem using the hundreds and the thousands places.

For example: Round to the nearest hundred and estimate the sum of 396  
+275

**Estimate**

$$\begin{array}{r} 400 \\ + 300 \\ \hline 700 \end{array}$$

Now find the actual sum using a calculator.

**Actual Sum**

$$\begin{array}{r} 396 \\ +275 \\ \hline 671 \end{array}$$

Compare the actual sum to the estimate.

Ask students when an estimate is useful:  
(Possible answers - to determine if the answer to a computation is reasonable, shopping, planning a party, any situation that involves adding or subtracting two or more numbers).

Estimate using the thousands place.

Example: Round to the nearest thousand and estimate the sum of:

$$\begin{array}{r} 3960 \\ +5123 \\ \hline \end{array}$$

**Estimate**

$$\begin{array}{r} 4,000 \\ +5,000 \\ \hline 9,000 \end{array}$$

Now find the actual sum using a calculator.

**Actual Sum**

$$\begin{array}{r} 3960 \\ + 5123 \\ \hline 9083 \end{array}$$

Compare the actual sum to the estimate.

Ask students how they could make a more accurate estimate: Use the hundreds place.

Do several other estimates using the hundreds and thousands places.

Ask students what happens to the accuracy of the estimate as the place value used for the estimation changes.

• **GUIDED PRACTICE:**

Students work in small groups to estimate the number of pages in their textbooks. Distribute Student Activity Sheet 1. Select 3 textbooks that all students would have: math, social studies, or science.

Complete the following steps:

Estimate, using the hundreds place, how many pages are in the selected books.

Record your estimate on the Student Activity Sheet.

Estimate, using the thousands place, the number of pages in all the books in your group.

Record your estimate.

Estimate, using the thousands place, the number of pages in all the selected books in the classroom.

Record your estimate.

Using the calculator, determine the actual number of pages in your group.

Record each group's total on the chalkboard.

Estimate the classroom total using the group totals on the chalkboard.

Find the actual total of pages in the classroom.

Compare estimates and actual total and record the difference.

• **INDEPENDENT PRACTICE:**

Students work in pairs to complete Student Activity Sheet 2.

Answers to Student Activity Sheet 2:

1. D,B,F

2. A,B,C,F

3. 4949

4. C,F

5. C

6. B,E

• **EVALUATION:**

Teacher observation.

• **HOME ACTIVITY:**

Students select three books, magazines, or newspapers. Estimate, and then find the actual number of pages in the books. Find the difference between the estimate and the actual.

**TWO, FOUR, SIX, EIGHT  
THIS IS HOW WE ESTIMATE**

**Student Activity Sheet 1**

Record the following information:

A. Estimate the number of pages in three of the books on your desk: \_\_\_\_\_

B. Estimate the number of pages in your group: \_\_\_\_\_

C. Estimate the number of pages in the classroom: \_\_\_\_\_

D. Actual desk total: \_\_\_\_\_

E. Actual group total: \_\_\_\_\_

F. Classroom total:

estimate (from totals on board) \_\_\_\_\_

actual total \_\_\_\_\_

difference \_\_\_\_\_

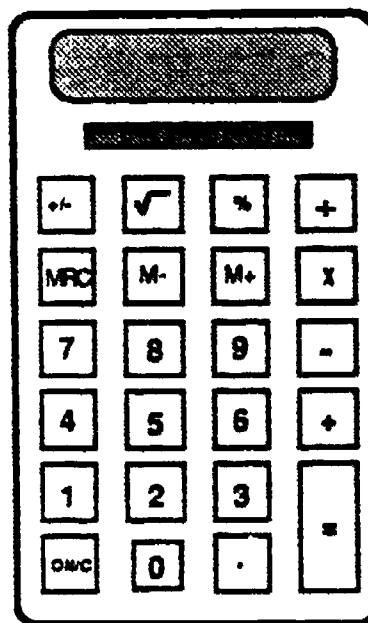
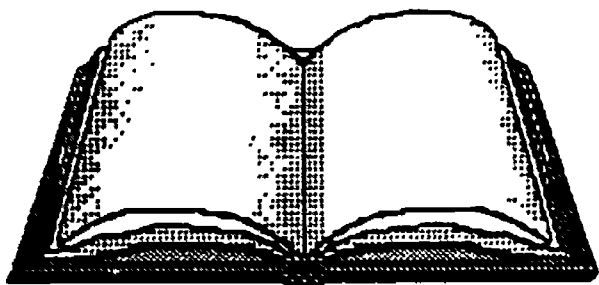

**TWO, FOUR, SIX, EIGHT  
THIS IS HOW WE ESTIMATE  
Student Activity Sheet 2**

**SCHOOLS AND STUDENT POPULATION**

Use estimation to find the answer to each problem. Use a calculator to check your answer.

School A  
758  
students

School B  
829  
students

School C  
376  
students

School D  
1475  
students

School E  
1215  
students

School F  
296  
students

1. Which 3 schools would give a total of 2600 students?

\_\_\_\_\_

2. Which 4 schools would give a total of 2259 students?

\_\_\_\_\_

3. What is the total student population of all 6 schools?

Estimate \_\_\_\_\_

Actual \_\_\_\_\_

Difference \_\_\_\_\_

4. Some schools were closed 5 years later. At that time the student population was 4277. Which schools were closed?

\_\_\_\_\_

5. Ten years later the student population had increased to 4653. Which school was reopened?

Estimate \_\_\_\_\_

Actual \_\_\_\_\_

6. Which 2 schools have a difference in population of 386?

Estimate \_\_\_\_\_

Actual \_\_\_\_\_

## HOW TO USE A CHECKBOOK

- GRADE:** 4
- STRAND:** Number
- SKILL:** Addition and subtraction using money
- MANAGEMENT**
- CLASS ORGANIZATION:** Pairs
- TIME FRAME:** One class period
- MATERIALS:** Calculator, pencil and paper, transparencies
- VOCABULARY:** Checks, register, deposit, withdraw, subtotal, balance
- PREREQUISITE SKILL:** Mathematics: Basic operations  
Calculator: Basic functions

**LESSON** The purpose of this lesson is to apply addition and subtraction to a real life situation.

• **DIRECTED INSTRUCTION/GUIDED PRACTICE:**

How do people deposit money in a bank?  
Once money is in the bank, how do people withdraw it? How do they spend their money?

Use the transparencies to familiarize the students with the deposit slips, check register, and checks.

Demonstrate how to fill out a deposit slip, how to enter the amount in the check register, and keep a running subtotal. Demonstrate how to write a check using words as well as numbers (see sample checks). Each student completes each of the forms.

• **INDEPENDENT PRACTICE:**

Each pair of students will have one check register, a set of checks (10), deposit slips and an activity sheet.

Students read and discuss the activity and begin working. Students will prepare an oral presentation to describe how they earned and managed their money.

• **EVALUATION:**

Student presentations

• **HOME ACTIVITY:**

Use classified advertisements from a newspaper for a shopping expedition. The students write checks for their purchases, record them in their check register, and balance their checkbooks.

The students read about banking to find out what happens to a check after a person writes it and gives it to a clerk in a store.

## HOW TO USE A CHECKBOOK

### Student Activity Sheet

#### DIRECTIONS:

The Toll Street Bank has checking accounts available for children to deposit money they earn. They have special checks and check registers for their young customers.

Suppose you and your partner earn money mowing lawns, baby sitting, or doing chores. You decide to put your money in the bank where it will be safe. Then you can write checks. This situation will last two months.

Work with a partner. You will need a calculator, a check book register, some Toll Street Bank checks, deposit slips, and a pencil.

Talk with your partner and decide how much money you want to deposit to start your account. Fill out your deposit slip. Enter the amount of the deposit. Enter the amount of the deposit in the check register. Number your check as well as your check register.

Make some decisions about your money.

How was the money earned?  
When will you spend your money?  
How much will you spend at each store?  
How much money will you deposit in your account?  
What will happen if you don't have enough money?

Make a deposit to your account every tenth day.

Here is a list of stores and businesses for you to use in your check register.

Bob's Bicycles	Maria's Restaurant
Susan's Sweet Shop	Fred's Toy Store
David's Pet Shop	Lori's Variety Store

The bank charges a fee of \$2.00 for your checking account on the first of each month.

Use your calculator as you write checks and fill out your check register. Remember to add the deposit and subtract the fees and the amount of the check.

**HOW TO USE A CHECKBOOK  
CHECK REGISTER**

Number	Date	Description	Balance





**HOW TO USE A CHECKBOOK**

**SAMPLE CHECKS**

	No <u>01</u>	<u>00-22</u>
		1111
	<u>July 4, 1991</u>	
Pay to the Order of _____	\$ _____	
_____	dollars _____	
Toll Street Bank 1 Toll Street Anytown, USA		
_____		
01 1111 0022 195 2004		

	No <u>02</u>	<u>00-22</u>
		1111
	<u>July 4, 1991</u>	
Pay to the Order of _____	\$ _____	
_____	dollars _____	
Toll Street Bank 1 Toll Street Anytown, USA		
_____		
01 1111 0022 195 2004		

HOW TO USE A CHECKBOOK

SAMPLE CHECKS

	No <u>01</u>	<u>00-22</u>
		1111
	<u>July 4, 1991</u>	
Pay to the Order of _____	\$ _____	
_____	dollars _____	
<b>Toll Street Bank</b> 1 Toll Street Anytown, USA		_____
01 1111 0022 195 2004		

	No <u>02</u>	<u>00-22</u>
		1111
	<u>July 4, 1991</u>	
Pay to the Order of _____	\$ _____	
_____	dollars _____	
<b>Toll Street Bank</b> 1 Toll Street Anytown, USA		_____
01 1111 0022 195 2004		

## HOW TO USE A CHECKBOOK

### DEPOSIT SLIPS

<p>Date _____ 19__</p> <p>_____</p> <p><b>Toll Street Bank</b>  <b>1 Toll Street</b>  <b>Anytown, USA</b></p> <p>01 1111 0022 195 2004</p>	<table border="1" style="width: 100%; border-collapse: collapse;"> <tr> <td rowspan="2" style="width: 15%; text-align: center;">Cash</td> <td style="width: 15%; text-align: center;">Currency</td> <td style="width: 15%;"></td> <td style="width: 15%;"></td> </tr> <tr> <td style="text-align: center;">Coin</td> <td></td> <td></td> </tr> <tr> <td colspan="2" rowspan="5" style="text-align: center; vertical-align: middle;">Checks</td> <td></td> <td></td> </tr> <tr> <td></td> <td></td> </tr> <tr> <td></td> <td></td> </tr> <tr> <td></td> <td></td> </tr> <tr> <td></td> <td></td> </tr> <tr> <td colspan="2" style="text-align: center;">Total</td> <td></td> <td></td> </tr> <tr> <td colspan="2" style="text-align: center;">Net Deposit</td> <td></td> <td></td> </tr> </table>	Cash	Currency			Coin			Checks												Total				Net Deposit			
Cash	Currency																											
	Coin																											
Checks																												
Total																												
Net Deposit																												

<p>Date _____ 19__</p> <p>_____</p> <p><b>Toll Street Bank</b>  <b>1 Toll Street</b>  <b>Anytown, USA</b></p> <p>01 1111 0022 195 2004</p>	<table border="1" style="width: 100%; border-collapse: collapse;"> <tr> <td rowspan="2" style="width: 15%; text-align: center;">Cash</td> <td style="width: 15%; text-align: center;">Currency</td> <td style="width: 15%;"></td> <td style="width: 15%;"></td> </tr> <tr> <td style="text-align: center;">Coin</td> <td></td> <td></td> </tr> <tr> <td colspan="2" rowspan="5" style="text-align: center; vertical-align: middle;">Checks</td> <td></td> <td></td> </tr> <tr> <td></td> <td></td> </tr> <tr> <td></td> <td></td> </tr> <tr> <td></td> <td></td> </tr> <tr> <td></td> <td></td> </tr> <tr> <td colspan="2" style="text-align: center;">Total</td> <td></td> <td></td> </tr> <tr> <td colspan="2" style="text-align: center;">Net Deposit</td> <td></td> <td></td> </tr> </table>	Cash	Currency			Coin			Checks												Total				Net Deposit			
Cash	Currency																											
	Coin																											
Checks																												
Total																												
Net Deposit																												

**HOW TO USE A CHECKBOOK**

**CHECK REGISTER**

Number	Date	Description	Balance

DEPOSIT SLIPS

<p>Date _____ 19__</p> <hr style="width: 50%; margin-left: 0;"/> <p><b>Toll Street Bank</b>  <b>1 Toll Street</b>  <b>Anytown, USA</b></p> <p>01 1111 0022 195 2004</p>	<table border="1" style="width: 100%; border-collapse: collapse;"> <tr> <td style="width: 15%; text-align: center;">Cash</td> <td style="width: 15%; text-align: center;">Currency</td> <td style="width: 15%;"></td> <td style="width: 15%;"></td> </tr> <tr> <td></td> <td style="text-align: center;">Coin</td> <td></td> <td></td> </tr> <tr> <td colspan="2" style="text-align: center;">Checks</td> <td></td> <td></td> </tr> <tr> <td colspan="2"></td> <td></td> <td></td> </tr> <tr> <td colspan="2"></td> <td></td> <td></td> </tr> <tr> <td colspan="2"></td> <td></td> <td></td> </tr> <tr> <td colspan="2" style="text-align: center;">Total</td> <td></td> <td></td> </tr> <tr> <td colspan="2" style="text-align: center;">Net Deposit</td> <td></td> <td></td> </tr> </table>	Cash	Currency				Coin			Checks																Total				Net Deposit			
Cash	Currency																																
	Coin																																
Checks																																	
Total																																	
Net Deposit																																	

<p>Date _____ 19__</p> <hr style="width: 50%; margin-left: 0;"/> <p><b>Toll Street Bank</b>  <b>1 Toll Street</b>  <b>Anytown, USA</b></p> <p>01 1111 0022 195 2004</p>	<table border="1" style="width: 100%; border-collapse: collapse;"> <tr> <td style="width: 15%; text-align: center;">Cash</td> <td style="width: 15%; text-align: center;">Currency</td> <td style="width: 15%;"></td> <td style="width: 15%;"></td> </tr> <tr> <td></td> <td style="text-align: center;">Coin</td> <td></td> <td></td> </tr> <tr> <td colspan="2" style="text-align: center;">Checks</td> <td></td> <td></td> </tr> <tr> <td colspan="2"></td> <td></td> <td></td> </tr> <tr> <td colspan="2"></td> <td></td> <td></td> </tr> <tr> <td colspan="2"></td> <td></td> <td></td> </tr> <tr> <td colspan="2" style="text-align: center;">Total</td> <td></td> <td></td> </tr> <tr> <td colspan="2" style="text-align: center;">Net Deposit</td> <td></td> <td></td> </tr> </table>	Cash	Currency				Coin			Checks																Total				Net Deposit			
Cash	Currency																																
	Coin																																
Checks																																	
Total																																	
Net Deposit																																	



## PLANNING A RECEPTION

- GRADE:** 3 - 4
- STRAND:** Number
- SKILL:** Operations involving money
- MANAGEMENT CLASS ORGANIZATION:** Small groups
- TIME FRAME:** Two class periods
- MATERIALS:** Calculator, paper, pencil, crayons, chart paper, ruler, food ads from a newspaper, transparency
- VOCABULARY:** Advertisements, guidelines
- PREREQUISITE SKILLS:** Mathematics: Basic operations  
Calculator: Basic functions

### **LESSON**

The purpose of this lesson is to use the calculator to compute the cost of refreshments for a reception.

#### **• DIRECTED INSTRUCTION:**

Discuss the following with the students:

What is a reception?

What kind of food would be served?

What things should you consider in order to determine the cost of serving food for the reception?

Students should cover these points:

1. number of people in attendance
2. types of refreshments
3. quantity allotted per person
4. unit cost of refreshment items
5. non-food items required
6. what other things you will need to buy

Project the transparency.

Facts about your reception:

- 55 people
- 3 cookies per person
- 8 oz. cup of punch per person
- 18 cookies per pound
- 32 oz. punch per quart

Chocolate chip cookies sell for \$2.19 per two-pound bag and fruit punch is \$1.29 per gallon.

Demonstrate on the overhead projector:

55 (people) x 3 (cookies per person) = 165 total cookies

165 (cookies) ÷ 18 (per 1 pound bag) = 9.166666 which is rounded to equal 9.17 bags of cookies

How many bags of cookies will be needed?

Students need to understand that they would have to purchase 10 bags in order to have enough.

Demonstrate how to find the amount of fruit punch.

55 people x 8 oz. (punch per person) = 440 oz.

4 quarts x 32 oz. in a qt. = 128 oz.

440 oz. ÷ 128 oz. = 3.4375 rounded to 3.4 gallons

Demonstrate how to use this information to find the cost.

10 bags of cookies x \$2.19 = \$21.90

4 gallons of punch x \$1.29 = \$5.16

Total= \$27.06

Discuss any other expenses people might have for this reception.

• **GUIDED PRACTICE:**

Distribute Student Activity Sheet 1.

The students use the discussion guidelines. Allow the students a short time to complete this practice. Discuss the results and record the different groups' solutions on the chalkboard or overhead projector. Compare the costs and the size of the servings.

• **INDEPENDENT PRACTICE:**

Distribute Student Activity Sheet 2 and read the motivational paragraph. Explain that in this exercise students will apply what they have learned. They make decisions about the number of people present, the amount to spend (up to \$50), the amounts to buy, and the way to present their plan to the class.

Provide students with chart paper and markers to prepare their presentation to the class. Each group presents their reception plan to the class. Adhere to the time limit as stated on Student Activity Sheet 2. Students vote for the plan they prefer (optional).

• **EVALUATION:**

Teacher observation of student participation and interaction.

• **HOME ACTIVITY:**

Students plan a meal with someone in the family. Discuss the plans. How are they different? How are they alike? Arrange the plans in order from least expensive to most expensive.

## PLANNING A RECEPTION

### Student Activity Sheet 1

#### GUIDELINES

1. 18 cookies per pound
2. 32 oz. in each quart of liquid
3. How many cookies will you have for each person? \_\_\_\_\_
4. How many servings will you get from each gallon of fruit punch? \_\_\_\_\_
5. What other things will you need to buy? \_\_\_\_\_

There are thirty people coming to a reception in Room Sixteen. The students will serve two kinds of refreshments. Use the food advertisements to find the two things you will serve and to find the cost.

FOOD/PRODUCT	QUANTITY	COST
TOTAL		

<p><b>COOKIES</b></p> <p>Farms 1 lb. bag \$2.19            Father's 2 lb. bag \$2.69            Nearly Home 2 lb. bag \$3.19            In a Tin 1 lb. bag \$3.09</p> <p><b>FRUIT PUNCH</b></p> <p>Brand A 1 gal. \$1.29            Brand B 2 gal. \$2.59            Brand C 1 gal. \$2.66</p>	<p><b>CUPS</b></p> <p>Prand W 50 6.5oz. cups \$.98            Brand X 100 6.5oz. cups \$1.99            Brand Y 50 8.5oz. cups \$1.08            Brand Z 100 8.5oz. cups \$2.16</p> <p><b>PAPER NAPKINS</b></p> <p>pkg. 100 \$.78            pkg. 200 \$1.60</p>
--	--



**PLANNING A RECEPTION**  
Student Activity Sheet 2

The students in Room Sixteen were planning a reception to honor people in the community who had just become citizens of the United States. They met in groups, planned what they would serve, shopped from the food and product chart on Student Activity Sheet 1, and presented their plans to the class. The class voted to choose a plan for the reception that would give them the most food and drink for their money.

1. Work with a small group. You want your plan to be the one the class chooses. Your plan cannot cost more than \$50.00.

How many people will  
attend the reception? \_\_\_\_\_

How much money will  
your group spend? \_\_\_\_\_

What will you buy?

FOOD/PRODUCTS	QUANTITY	COST
TOTAL		

How can you present your plan to the class?

How much would it cost per person to have your reception?

---



---

Why should the class choose your plan?

---



---

You will have two minutes to "sell" your plan.

## PLANNING A RECEPTION HOME ACTIVITY SHEET

Plan a meal with your family. Use food advertisements to select the foods you will serve and to compute the cost.

What kind of meal will you plan? \_\_\_\_\_

Who will be at the meal? \_\_\_\_\_

FOOD/PRODUCTS	QUANTITY	COST
TOTAL		

What is the cost per person for this meal? \_\_\_\_\_



## **Facts about your reception:**

**55 PEOPLE**

**3 COOKIES PER PERSON**

**8 OZ. CUP OF PUNCH PER PERSON**

**18 COOKIES PER POUND**

**32 OZ. PUNCH PER QUART**

**CHOCOLATE CHIP COOKIES SELL FOR \$ 2.19 PER TWO-  
POUND BAG AND FRUIT PUNCH IS \$ 1.29 PER GALLON.**

## MULTIPLE APPLICATIONS

- GRADE:** 3 - 4
- STRAND:** Number
- SKILL:** Find and name the multiples of a given number
- PURPOSE:** To practice finding multiples of a number using constant key
- MANAGEMENT**
- CLASS ORGANIZATION:** Pairs
- TIME FRAME:** One class period
- MATERIALS:** Calculators
- VOCABULARY:** Multiples, constant
- PREREQUISITE SKILLS:** Mathematics: Basic operations  
Calculator: Basic functions

**LESSON** The purpose of this lesson is to use the constant counting feature of the calculator.

- **DIRECTED INSTRUCTION:**  
Discuss the meaning of multiples. Explain that you can obtain multiples of a number on most calculators by pressing  $\boxed{C}$   $\boxed{+}$  [number]  $\boxed{=}$ , then continue pressing the  $\boxed{=}$  key. Use the calculator to find 6 multiples of 5 by pressing  $\boxed{C}$   $\boxed{+}$   $\boxed{5}$   $\boxed{=}$   $\boxed{=}$   $\boxed{=}$   $\boxed{=}$   $\boxed{=}$   $\boxed{=}$ .
- **GUIDED PRACTICE:**  
Have students find several multiples for 3, 6, and 11. As they are working, have students predict multiples before pressing the = sign.
- **INDEPENDENT PRACTICE:**  
Complete the Student Activity Sheet.
- **EVALUATION:**  
Check the Student Activity Sheet.
- **HOME ACTIVITY:**  
Demonstrate the constant feature of the calculator to your family.



**MULTIPLE APPLICATIONS**  
**Student Activity Sheet**



Find the missing numbers by using the calculator to find multiples of the first number.

1. 2, 4, 6, \_\_\_\_\_, 10, \_\_\_\_\_, 14, \_\_\_\_\_, \_\_\_\_\_

2. 7, 14, \_\_\_\_\_, 28, \_\_\_\_\_, 42, \_\_\_\_\_, \_\_\_\_\_, \_\_\_\_\_, \_\_\_\_\_, 77

3. 12, 24, \_\_\_\_\_, \_\_\_\_\_, 60, \_\_\_\_\_, \_\_\_\_\_, 96, \_\_\_\_\_, \_\_\_\_\_,

132, \_\_\_\_\_, \_\_\_\_\_, 168

4. 15, \_\_\_\_\_, \_\_\_\_\_, \_\_\_\_\_, \_\_\_\_\_, \_\_\_\_\_, \_\_\_\_\_, 120

5. 1, \_\_\_\_\_, \_\_\_\_\_, \_\_\_\_\_, \_\_\_\_\_, \_\_\_\_\_, \_\_\_\_\_, \_\_\_\_\_

6. 78, \_\_\_\_\_, \_\_\_\_\_, \_\_\_\_\_, \_\_\_\_\_

Use multiples to solve these problems.

7. Sam and his brother are both between the ages of 35 and 50. Sam is older than his brother. Both of their ages are multiples of 8. How old is Sam? How old is his brother? \_\_\_\_\_.
  
8. Jeff is between 46 and 60 inches tall. His height is a multiple of 9. How tall is Jeff? \_\_\_\_\_.
  
9. Mary has between 50 and 65 books in her room. The number of books is a multiple of both 4 and 5. How many books does Mary have? \_\_\_\_\_.
  
10. Julie and Stan collected between 30 and 60 pounds of aluminum cans for the school can drive. The number of pounds of cans is a common multiple of 4, 6, and 8. How many pounds of cans did they collect? \_\_\_\_\_.

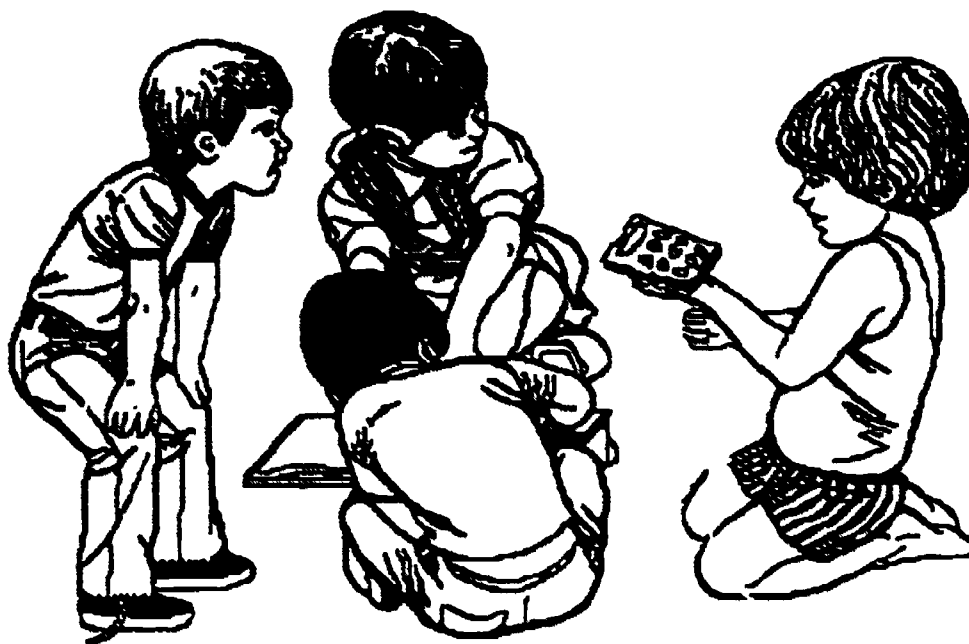

**MULTIPLE APPLICATIONS**  
**Teacher Answer Sheet**

1. 2, 4, 6, 8, 10, 12, 14, 16, 18
2. 7, 14, 21, 28, 35, 42, 49, 56, 63, 70, 77
3. 12, 24, 36, 48, 60, 72, 84, 96, 108, 120, 132, 144, 156, 168
4. 15, 30, 45, 60, 75, 90, 105, 120
5. 1, 2, 3, 4, 5, 6, 7, 8
6. 78, 156, 234, 312, 390, 468
7. Sam 48, Brother 40
8. 54 inches tall
9. 60 books
10. 48 pounds

## FINDING FACTORS

- GRADE:** 3 - 4
- STRAND:** Number
- SKILL:** List the set of factors of a given number
- MANAGEMENT**
- CLASS ORGANIZATION:** Whole class, pairs
- TIME FRAME:** One class period
- MATERIALS:** Calculator, number cards for game, scissors, transparency
- VOCABULARY:** Factor, product, inverse, whole number, quotient, divisor
- PREREQUISITE SKILL:** Mathematics: Basic operations  
Calculator: Basic functions

**LESSON** The purpose of this lesson is to use a calculator to discover the factors of given numbers and make generalizations about patterns of divisibility.

- DIRECTED INSTRUCTION/GUIDED PRACTICE:**  
Students divide to find factors of a number.

Project the transparency and distribute Student Activity Sheet. The number 96, and the number of factors are shown on the "game card." Demonstrate on the transparency and direct the students to enter 96 on the calculator and press  $\boxed{+}$ . Review with students that 96 is an even number and can be divided by 2. Enter 2 and then press  $\boxed{=}$ . If the number displayed on the calculator is a whole number, continue this process until 1 is displayed. If the number on the display is not a whole number, begin the division process again. Use the following example to demonstrate the process on the transparency.

$$\text{ex. } 96 \boxed{+} 2 \boxed{=} 48 \boxed{+} 8 \boxed{=} 6 \boxed{+} 6 \boxed{=} 1$$

Two, eight, and six are factors of 96. This means if we multiply  $2 \times 8 \times 6$  the product will be 96. Use your calculator to check this.

Students find other factors of 96 by beginning with a divisor of 3. Ask the students what they know about the divisibility of a number that will help them get started. [Hint: An even number is divisible by 2.]

Demonstrate the process using a number that does not result in a whole number

$$\text{ex. } 96 \div 7 = 13.714285$$

48



Demonstrate the examples on Parts B and C of the transparency and have the students work along on their Activity Sheet.

$$\begin{array}{l} \text{ex. } 84 \div 4 = 21 \quad 7 \div 3 = 3 \quad 3 = 1 \quad 4 \times 7 \times 3 = 84 \\ 84 \div 2 = 42 \quad 2 \div 3 = 21 \quad 3 \div 7 = 7 \quad 7 = 1 \\ \quad \quad \quad 2 \times 2 \times 3 \times 7 = 84 \end{array}$$

- INDEPENDENT PRACTICE:**  
**Factor Estimation Game.**

Students work in pairs.

Duplicate a set of game cards for each pair of students. Students cut out the cards. The object of the game is to find the single digit factors for a number using the calculator. Point out that the number 1 is a special case, a factor of all numbers, and may not be counted as a factor in this activity. Factors may repeat and there may be more than one set of factors.

Each pair draws a card that contains a product and the number of factors to be found.

One student in the pair tries to find the given number of factors for the number. (Enter the number from the card  $\square \div \square = \square$ ).

The other student in the pair records the factors used and verifies the result. Each time a card is drawn the students switch roles.

**Variations:**

Students play 3 rounds of five minutes each. The goal would be to complete more sets of factors in each round.

Students make a set of game cards and exchange with another pair. Use the game as a five-minute warm-up for a mathematics period.

- EVALUATION:**  
Students share their solutions and explain how they reached their answers.
- HOME ACTIVITY:**  
Students develop a set of game cards.

Transparency

# FINDING FACTORS

LESSON 8

Book 2: Grades 3 - 4

A. \_\_\_\_\_ ÷ \_\_\_\_\_ = \_\_\_\_\_

Number from card



+ \_\_\_\_\_ = \_\_\_\_\_



+ \_\_\_\_\_ = 1

B. Game Card

30

84

3 factors

1

\_\_\_\_\_ ÷ \_\_\_\_\_ = \_\_\_\_\_ ÷ \_\_\_\_\_ = \_\_\_\_\_ ÷ \_\_\_\_\_ = 1

C. Game Card

84

4 factors

\_\_\_\_\_ ÷ \_\_\_\_\_ = \_\_\_\_\_ ÷ \_\_\_\_\_ = \_\_\_\_\_ ÷ \_\_\_\_\_ = \_\_\_\_\_ ÷ \_\_\_\_\_ = 1

50

51

© 1991 Cal State Fullerton Press

CAMP-LA

A.  $\underline{\hspace{2cm}} \div \underline{\hspace{2cm}} =$

Number  
from  
card



**FINDING FACTORS**  
Student Activity Sheet

$\div \underline{\hspace{2cm}} =$



$\div \underline{\hspace{2cm}} = 1$

**Game Card**  
**96**  
**3 factors**

B. **Game Card**  
**84**  
**3 factors**

3 1



**Game Card**  
**84**  
**4 factors**

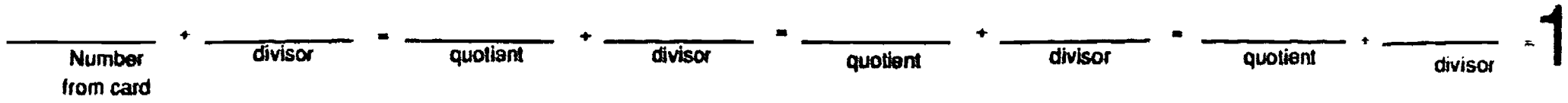

# FINDING FACTORS GAME CARDS

360 4 factors	576 4 factors	162 3 factors
450 4 factors	1008 4 factors	80 3 factors
3645 4 factors	840 4 factors	270 4 factors
625 4 factors	60,480 6 factors	45,360 7 factors
504 6 factors	360 3 factors	945 4 factors

54

# FINDING FACTORS GAME CARDS

504 3 factors	280 4 factors	640 3 factors
210 4 factors	280 3 factors	336 3 factors
512 3 factors	512 9 factors	512 5 factors
512 6 factors	80 4 factors	2520 4 factors
385 3 factors	847 3 factors	2310 5 factors

**FINDING FACTORS  
RECORDING SHEET**

<u>Number</u>	<u>Factors</u>
1.	
2.	
3.	
4.	
5.	
6.	
7.	
8.	
9.	
10.	
11.	
12.	
13.	
14.	
15.	
16.	
17.	
18.	
19.	
20.	
21.	
22.	
23.	
24.	
25.	
26.	
27.	
28.	
29.	
30.	

# FINDING FACTORS

## GAME CARDS

Teacher Answer Sheet

Possible answers are listed.

**360**  
**4 factors**  
**2, 5, 4, 9**

**576**  
**4 factors**  
**3, 4, 6, 8**

**162**  
**3 factors**  
**3, 6, 9**

**450**  
**4 factors**  
**2, 5, 5, 9**

**1008**  
**4 factors**  
**2, 7, 8, 9**

**80**  
**3 factors**  
**2, 5, 8**

**3645**  
**4 factors**  
**9, 9, 9, 5**

**840**  
**4 factors**  
**3, 5, 7, 8**

**270**  
**4 factors**  
**2, 3, 5, 9**

**625**  
**4 factors**  
**5, 5, 5, 5**

**60,480**  
**6 factors**  
**4, 5, 6, 7, 8, 9**

**45,360**  
**7 factors**  
**2, 3, 4, 5, 6, 7, 9**

**504**  
**6 factors**  
**2, 2, 2, 3, 3, 7**

**360**  
**3 factors**  
**5, 8, 9**

**945**  
**4 factors**  
**3, 5, 7, 9**

# FINDING FACTORS GAME CARDS

## Teacher Answer Sheet

Possible answers are listed.

504  
3 factors  
7, 8, 9

280  
4 factors  
2, 4, 5, 7

640  
3 factors  
2, 5, 8, 8

210  
4 factors  
2, 3, 5, 7

280  
3 factors  
5, 7, 8

336  
3 factors  
6, 7, 8

512  
3 factors  
8, 8, 8

512  
9 factors  
2, 2, 2, 2, 2, 2, 2, 2, 2

512  
5 factors  
2, 4, 4, 4, 4

512  
6 factors  
2, 2, 2, 4, 4, 4

80  
4 factors  
2, 2, 4, 5

2520  
4 factors  
5, 7, 8, 9

385  
3 factors  
5, 7, 11

847  
3 factors  
7, 11, 11

2310  
5 factors  
2, 3, 5, 7, 11



## FOOD FRACTIONS

**GRADE:** 3 - 4  
**STRAND:** Number  
**SKILL:** Identify and rename improper fractions as mixed numbers

**MANAGEMENT**

**CLASS ORGANIZATION:** Pairs

**TIME FRAME:** One class period

**MATERIALS:** Calculator

**VOCABULARY:** Improper fraction, mixed number

**PREREQUISITE SKILL:** Mathematics: Fractions, liquid measurement, basic operations

Calculator: Basic functions, constant feature

**LESSON** The purpose of this lesson is to rename improper fractions as mixed numbers using repeated subtraction on the calculator.

**DIRECTED INSTRUCTION:**

Distribute calculators. Demonstrate how to divide the class into teams of 5. Example: Students stand and then sit down in groups of 5, counting the number of groups and the remainder.

Write the improper fraction on the board.

$$\frac{\text{number of students}}{5 \text{ (number on a team)}}$$

Students enter the following calculator sequence.

Total # in class  -  5  =

Students continue to press  = , keeping track of the number of times it takes to reach a number less than the denominator.

Example:  $\frac{31}{5}$   $\frac{\text{number of students in the class}}{\text{number on a team}}$

31 - 5	=	26	
	=	21	
	=	16	
	=	11	This represents 6 teams
	=	6	with 1 person left over, which
	=	1	is written as $6\frac{1}{5}$

Try other examples: 7 members on a team, 8 members on a team, etc.



- **GUIDED PRACTICE:**  
Distribute Student Activity Sheet. Read the situation and discuss what they need to know, and what they are going to do. Guide the students through the first two items on the chart.
- **INDEPENDENT PRACTICE:**  
Complete the Student Activity Sheet.
- **EVALUATION:**  
Teacher observation.
- **HOME ACTIVITY:**  
Make a list of things found in your home that have fractions printed on them.

00

## FOOD FRACTIONS Student Activity Sheet

The planning committee decided on a lunch menu of sandwiches, oranges, and cake for the soccer picnic. Each of the 85 players was to receive one sandwich,  $\frac{1}{2}$  an orange, and  $\frac{1}{6}$  of a piece of a cake.

The committee decided to use  $\frac{1}{8}$  pound of meat,  $\frac{1}{12}$  cup sandwich spread, and two slices of bread ( $\frac{1}{15}$  of a loaf) for each sandwich.

Determine the amount needed for each item in the lunch, to the greatest whole portion, to feed all the kids. Complete the table below.

Food Item	Number of Parts	Mixed Number	Number to Order
orange	$\frac{85}{2}$		
meat			
bread			
spread			
cake			

Plan a picnic menu. How many people will be there?

---



---

Plan what fractional part of the refreshments each person will eat.

---



---



---

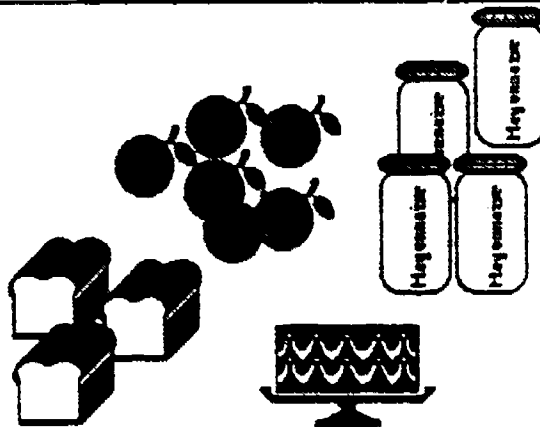

**FOOD FRACTIONS**  
Teacher Answer Sheet

Food Item	Number of Parts	Mixed Number	Number to Order
Orange	$\frac{85}{2}$	$42 \frac{1}{2}$	43 oranges
meat	$\frac{85}{8}$	$10 \frac{5}{8}$	11 lbs. meat
bread	$\frac{85}{15}$	$5 \frac{10}{15}$	6 loaves bread
spread	$\frac{85}{12}$	$7 \frac{1}{12}$	8 cups spread
cake	$\frac{85}{6}$	$14 \frac{1}{6}$	15 cakes

## MAKING SENSE OF CENTS AND PERCENTS - PART 1

- GRADE:** 3 - 4
- STRAND:** Number
- SKILL:** Find relationship of money and decimals
- MANAGEMENT**
- CLASS ORGANIZATION:** Pairs
- TIME FRAME:** One class period
- MATERIALS:** Calculators, transparency
- VOCABULARY:** Fraction, cent, decimal point, unit, denomination, equivalent
- PREREQUISITE SKILLS:** Mathematics: Read money notations; basic operations  
Calculator: Basic functions

### **LESSON**

The purpose of this lesson is to use the calculator to develop an understanding of decimal/common fraction notation as it relates to money.

- **DIRECTED/GUIDED INSTRUCTION:**

Project transparency.  
Discuss with the students that money is expressed in parts of a hundred.  
One dollar is the WHOLE in money. Example:  $\frac{1}{4}$  of a dollar is twenty-five cents ( $1 \div 4 = 0.25$ ) which is written as \$0.25. Twenty-five cents is equal to twenty-five hundredths ( $\$0.25 = \frac{25}{100}$ ).

Distribute Student Activity Sheet 1. Demonstrate how to complete the chart for the half dollar. Use the calculator to convert the "Fraction of a Hundred" column to the "Decimal Calculator Display" column. Students complete the chart with their partner.
- **INDEPENDENT PRACTICE:**

Students complete Student Activity Sheet 2.
- **EVALUATION:**

Check Student Activity Sheet 2.
- **HOME ACTIVITY:**

Make an organized list to show the different combination of coins to equal five dollars, \$5.00, as an extension of the independent practice.



**MAKING SENSE OF CENTS AND PERCENTS - PART 1**  
Student Activity Sheet 1

**%**  
**% %**

	<b>PARTS IN A DOLLAR</b>	<b>FRACTION OF A DOLLAR</b>	<b>VALUE IN CENTS</b>	<b>FRACTION OF A HUNDRED</b>	<b>DECIMAL CALCULATOR DISPLAY</b>	<b>NOTATION MONEY</b>
<b>HALF</b>						<b>\$</b>
<b>QUARTER</b>						<b>\$</b>
<b>DIME</b>						<b>\$</b>
<b>NICKEL</b>						<b>\$</b>
<b>PENNY</b>						<b>\$</b>
<b>DOLLAR</b>						<b>\$</b>

Transparency

**MAKING SENSE OF CENTS AND PERCENTS - PART 1**  
Student Activity Sheet 1



	PARTS IN A DOLLAR	FRACTION OF A DOLLAR	VALUE IN CENTS	FRACTION OF A HUNDRED	DECIMAL CALCULATOR DISPLAY	NOTATION MONEY
HALF						\$
QUARTER						\$
DIME						\$
NICKEL						\$
PENNY						\$
DOLLAR						\$

%  
%  
%

**MAKING SENSE OF CENTS AND PERCENTS - PART 1**

Teacher Answer Sheet 1



	PARTS IN A DOLLAR	FRACTION OF A DOLLAR	VALUE IN CENTS	FRACTION OF A HUNDRED	DECIMAL CALCULATOR DISPLAY	NOTATION MONEY
HALF	2	1/2	50¢	50/100	0.5	\$ .50
QUARTER	4	1/4	25¢	25/100	0.25	\$ .25
DIME	10	1/10	10¢	10/100	0.1	\$ .10
NICKEL	20	1/20	5¢	5/100	0.05	\$ .05
PENNY	100	1/100	1¢	1/100	0.01	\$ .01
DOLLAR	1	1/1	100¢	100/100	1.	\$ \$1.00



**MAKING SENSE OF CENTS AND PERCENTS - PART 1**  
**Student Activity Sheet 2**

Complete the chart. Check off the least number of coins possible for the correct amount. More than one check may be placed on a box.

Fraction of a Dollar	Fraction 100 Cents	Money Notation	penny	nickel	dime	quarter	half
1/4	25/100	\$.25				✓	
2/5				✓	✓	✓	
3/20							
7/10							
3/4							
13/20							
	60/100						
4/5							
	20/100						

1/4   1/4

1/4

70



**MAKING SENSE OF CENTS AND PERCENTS - PART 1**  
**Teacher Answer Sheet 2**

Complete the chart. Check off the least number of coins possible for the correct amount. More than one check may be placed on a box.

Fraction of a Dollar	Fraction 100 Cents	Money Notation	penny	nickel	dime	quarter	half
1/4	25/100	\$.25				✓	
2/5	40/100	\$.40		✓	✓	✓	
3/20	15/100	\$.15		✓	✓		
7/10	70/100	\$.70			✓✓		✓
3/4	75/100	\$.75				✓	✓
13/20	65/100	\$.65		✓	✓		✓
6/10	60/100	\$.60			✓		✓
4/5	80/100	\$.80		✓		✓	✓
2/10	20/100	\$.20			✓✓		

0/0 0/0  
0/0

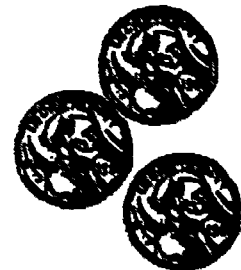

71

## MAKING SENSE OF CENTS AND PERCENTS - PART 2

- GRADE:** 4
- STRAND:** Number
- SKILL:** Computation of percentages from fraction-division concept
- MANAGEMENT**
- CLASS ORGANIZATION:** Groups of four
- TIME FRAME:** One class period
- MATERIALS:** Calculators
- VOCABULARY:** Fraction, percent, cent, decimal point, unit, denomination, equivalent
- PREREQUISITE SKILLS:** Mathematics: Lesson 8, fractions, division  
Calculator: Basic functions

**LESSON** The purpose of this lesson is to give students experience with decimal fractions and percent.

• **DIRECTED/GUIDED INSTRUCTION:**

Children hear the term "one hundred percent," but generally know only that it represents all the parts. After the preceding lesson on place value to hundredths, the students should be ready to convert a decimal fraction to a percent. The "cent" in percent means a hundred parts.

Distribute Student Activity Sheet 1.

Students complete the quiz without putting their names on the paper. Redistribute the papers before scoring. Score the quiz together and have students put the score in common fraction form on the chart on the

Student Activity Sheet (4 correct out of 5 =  $\frac{4}{5}$ ). Students use a calculator to convert the fraction score to a decimal equivalent

( $\frac{4}{5} = 0.80$ ).

Remind students that they are dealing with percent which means they need to express their answer in hundredths, as they did with similar answers when working with money.

Complete the rest of the table before moving to the percent column. Reinforce that the percent symbol (%) means "out of a hundred parts."

• **INDEPENDENT PRACTICE:**

Complete Student Activity Sheets 2 , 3.

• **EVALUATION:**

Correct and discuss results of Student Activity Sheets 2 , 3.

• **HOME ACTIVITY:**

Students complete Home Activity Sheet.

**MAKING SENSE OF CENTS AND PERCENTS - PART 2**  
**Student Activity Sheet 1**  
**Quick Quiz**

Directions: Answer these questions by circling the letter of the correct response following each one.

1. The place on the calculator where you read the information is called  
 a) the keys                      b) the display                      c) an operation                      d) solar cells
2. To enter information into the calculator you use  
 a) the keys                      b) the display                      c) an operation                      d) solar cells
3. The calculator is powered by  
 a) the keys                      b) the display                      c) an operation                      d) solar cells
4. The "C" on the  key stands for  
 a) constant                      b) cash                                      c) calculate                              d) clear
5. The calculator will show a number with no more than \_\_\_\_\_ digits  
 a) twelve                      b) ten                                      c) eight                                      d) six

**QUIZ ANALYSIS**

Directions: Chart all the information for possible scores on this quiz in the table below. Look for patterns as you work.

Number Correct	Raw Score	Decimal Equivalent	Over a Hundred	Percent
5	/5		/100	100%
4				%
3				%
2				%
1				%
0				%

**MAKING SENSE OF CENTS AND PERCENTS - PART 2**  
**Teacher Answer Sheet**  
**Quick Quiz**

Directions: Answer these questions by circling the letter of the correct response following each one.

1. The place on the calculator where you read the information is called  
 a) the keys                    **B) THE DISPLAY**   c) an operation                    d) solar cells
2. To enter information into the calculator you use  
**A) THE KEYS**                    b) the display                    c) an operation                    d) solar cells
3. The calculator is powered by  
 a) the keys                    b) the display                    c) an operation                    **D) SOLAR CELLS**
4. The "C" on the  key stands for  
 a) constant                    b) cash                                    c) calculate                    **D) CLEAR**
5. The calculator will show a number with no more than \_\_\_\_\_ digits.  
 a) twelve                    b) ten                                    **C) EIGHT**                    d) six

**QUIZ ANALYSIS**

Directions: Chart all the information for possible scores on this quiz in the table below. Look for patterns as you work.

Number Correct	Raw Score	Decimal Equivalent	Over a Hundred	Percent
5	5/5	1.00	100/100	100%
4	4/5	.80	80/100	80%
3	3/5	.60	60/100	60%
2	2/5	.40	40/100	40%
1	1/5	.20	20/100	20%
0	0/5	0.0	0/100	0%

74

## MAKING SENSE OF CENTS AND PERCENTS - PART 2

### Student Activity Sheet 2 Quiz Analysis

Directions: Chart all the information for possible scores on a ten-item quiz in the table below. Look for patterns as you work.

Number Correct	Raw Score	Decimal Equivalent	Over a Hundred	Percent
10	/10			100%
9				%
8				%
7				%
6				%
5				%
4				%
3				%
2				%
1				%
0				%

## MAKING SENSE OF CENTS AND PERCENTS - PART 2

### Student Activity Sheet 3 Quiz Analysis

**Directions:** Chart all the information for possible scores on your twenty-item quiz or exercise in the table below. Look back at the other two tables you have created for patterns and similarities as you work.

Number Correct	Raw Score	Decimal Equivalent	Over a Hundred	Percent
20	/20			100%
19				%
18				%
17				%
16				%
15				%
14				%
13				%
12				%
11				%
10				%
9				%
8				%
7				%
6				%
5				%
4				%
3				%
2				%
1				%
0				%

**MAKING SENSE OF CENTS AND PERCENTS - PART 2**  
**Home Activity Sheet**  
**Survey Analysis**

Directions: Survey ten people on any five of the questions below and enter information in the table.

Number Correct	Raw Score	Decimal Equivalent	Over a Hundred	Percent
Has change in pocket or purse > \$1	/10			100%
Owens a dog				%
Family drives a foreign car				%
Knows astrological sign				%
Has ever ridden on a train				%
Likes ice cream				%
				%
				%
				%
				%
				%





## PAY ME WHAT I'M WORTH

- GRADE:** 3 - 4
- STRAND:** Number
- SKILL:** Relationship between percents and decimals
- MANAGEMENT**
- CLASS ORGANIZATION:** Pairs
- TIME FRAME:** One class period
- MATERIALS:** Calculator
- VOCABULARY:** Decimal, percentage, rounding off
- PREREQUISITE SKILL:** Mathematics: Multiplication, Lessons 8 & 9  
Calculator: Basic functions

**LESSON** The purpose of this lesson is to apply knowledge of percent.

• **DIRECTED INSTRUCTION/GUIDED PRACTICE:**

A percent means a part of the whole expressed in hundredths. Percent can be written using the percent sign (%) or as a decimal equivalent.

Example: 25% or .25

Students use decimal notation in this lesson.

Demonstrate how to find a percentage of a number using the following situations.

32 students in a classroom.

What is 50% of the class?

$32 \times .50 = 16$  students.

What is 25% of the class?

$32 \times .25 = 8$  students

What is 10% of the class?

$32 \times .10 = 3.2$  students

Discuss with the students. Can you have 3.2 students? Round off to 3 students.

Demonstrate how to find a percentage using a calculator.

$\boxed{C} \boxed{32} \boxed{\times} \boxed{.50} \boxed{=} \boxed{16}$

• **INDEPENDENT PRACTICE:**

Distribute Student Activity Sheets. Students work in pairs to solve the problems.

• **EVALUATION:**

Student report their solutions to the class.

• **HOME ACTIVITY:**

Use a newspaper to find examples of the use of percentage.

**PAY ME WHAT I'M WORTH**  
**Student Activity Sheet**

1. There are 56 cars in a parking lot and 25% of them are red.

How many are red? \_\_\_\_\_

.25 of 56 = \_\_\_\_\_

2. In a recent survey 1452 people were asked what flavor ice cream they preferred?

Number of people

25% preferred vanilla \_\_\_\_\_

50% preferred chocolate \_\_\_\_\_

What percent of the people preferred other flavors? \_\_\_\_\_

How many people does this represent? \_\_\_\_\_

3. In Mr. Cobb's class there are 35 students. They took a survey of favorite foods. The

results of the survey were: Number of Students

37% like Pizza \_\_\_\_\_

21% like Hamburgers \_\_\_\_\_

16% like Hot dogs \_\_\_\_\_

11% like Tacos \_\_\_\_\_

\_\_\_\_\_ like Fried Chicken \_\_\_\_\_

4. A survey was taken of the 185 third and fourth grade students at Cable Elementary.

Students were asked how many hours of television they watch per day. The results

were: Number of Students

14% one hour \_\_\_\_\_

16% two and a half hours \_\_\_\_\_

18% three hours \_\_\_\_\_

24% five and a half hours \_\_\_\_\_

28% six hours \_\_\_\_\_

# PAY ME WHAT I'M WORTH

## Student Activity Sheet

How many students watch more than  $2\frac{1}{2}$  hours of television per day? \_\_\_\_\_

How many students watch more than thirty hours of television per week? \_\_\_\_\_

5. The star of a hit movie about a rabbit was offered either 12% of the total ticket receipts or \$11,500,000.00. The total ticket receipts were \$96,800,562.00. Which offer should Roger accept and why?

---

---

---

---

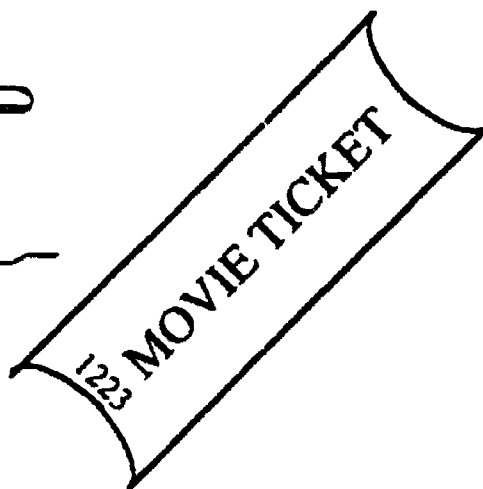

# PAY ME WHAT I'M WORTH

## Teacher Answer Sheet

1.  $.25$  of  $56 = \underline{14}$

2. 25% preferred vanilla 363      25% other flavors  
50% preferred chocolate 726      363 people

3. 37%      12.95 = 13  
21%      7.35 = 7  
16%      5.6 = 6  
11%      3.85 = 4  
15%      liked fried chicken 5

4. 14% = 25.9 = 26  
16% = 29.6 = 30  
18% = 33.3 = 33  
24% = 44.4 = 44  
28% = 51.8 = 52

Rounded off

129 students watch more than  $2\frac{1}{2}$  hours/day.

( $129 \div 5 = 130$  if student adds 18% + 24% + 28% and multiplies by 185)

96 students watch more than 30 hours/week.

5. 12% of \$96,800,562 = \$11,616,067.00 is the best offer.

## ONE THE HARD WAY

- GRADE:** 3 - 4
- STRAND:** Number
- SKILL:** Approximation of decimal fraction and whole number values
- MANAGEMENT**
- CLASS ORGANIZATION:** Pairs within a group of four
- TIME FRAME:** One class period
- MATERIALS:** Calculator, dice
- VOCABULARY:** Parentheses
- PREREQUISITE SKILL:** Mathematics: Basic operations  
Calculator: Basic functions

**LESSON** The purpose of this lesson is to determine the value of decimal numbers.

### • DIRECTED INSTRUCTION:

Project transparency of open frame equation. Roll a pair of dice. In the game, these numbers can only be placed within a pair of parentheses. Demonstrate what happens when the numbers from the dice are placed in the division and subtraction sections of the equation.

Example: Suppose you roll a 2 and 5.

$$(5 + 2) \text{ [answer: 2.5]}$$

$$(2 + 5) \text{ [answer: 0.4]}$$

$$(5 - 2) \text{ [answer: 3]}$$

$$(2 - 5) \text{ [answer: -3]}$$

Students do the calculations mentally or with a calculator. Demonstrate the game. Roll the dice and place the numbers in the equation on the transparency. The pairs of students work the equation with the calculator or mentally. The object of the game is to get an answer close to one. Demonstrate to the students how to use a number line.

### • GUIDED PRACTICE

Distribute Student Activity Sheet 1 and go over the rules. Make sure students know that they are to solve the equations in parentheses first, before they multiply. To multiply by a negative number, use the change sign key  $\boxed{+/-}$ .

Example:

$$5 \times (-7) \rightarrow 5 \boxed{\times} 7 \boxed{+/-} \boxed{-} -35$$

### • INDEPENDENT PRACTICE:

Distribute Student Activity Sheet 2. Students play the game, "One The Hard Way."

### • EVALUATION:

Discuss game results and the strategies used.

### • HOME ACTIVITY:

Teach the game to family members and play it together.

Transparency

One The Hard Way

$$(\_ \div \_) \times (\_ \times \_) \times (\_ - \_) \times (\_ + \_) = \_.$$

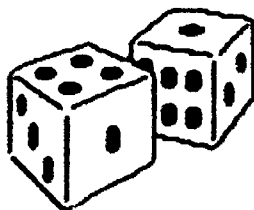
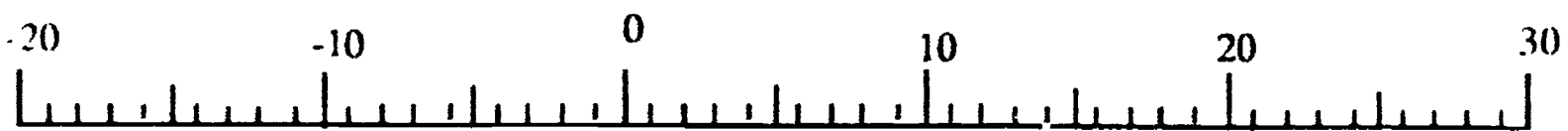

# ONE THE HARD WAY

## Student Activity Sheet 1

**Rules:**

**Equipment:** A pair of dice, game sheet, pencil, and a calculator.

**How to play:**

1. Roll a die to decide who goes first.
2. Players take turns rolling the dice. Play passes to the left around the table.
3. The first player rolls the dice and all players insert the pair of numbers from the dice somewhere into their equation. The numbers from any one roll must be used within the same pair of parentheses. Numbers may not be changed once placed.
4. The next player rolls the dice.
5. After four rolls, all players compute their total. Closest to one wins the round.
6. Play continues to complete five rounds. Compute the total. The total closest to one is the winner.

$$( \quad + \quad ) \times ( \quad \times \quad ) + ( \quad - \quad ) - ( \quad + \quad ) = \underline{\hspace{2cm}}$$

$$( \quad + \quad ) \times ( \quad \times \quad ) + ( \quad - \quad ) - ( \quad + \quad ) = \underline{\hspace{2cm}}$$

$$( \quad + \quad ) \times ( \quad \times \quad ) + ( \quad - \quad ) - ( \quad + \quad ) = \underline{\hspace{2cm}}$$

$$( \quad + \quad ) \times ( \quad \times \quad ) + ( \quad - \quad ) - ( \quad + \quad ) = \underline{\hspace{2cm}}$$

$$( \quad + \quad ) \times ( \quad \times \quad ) + ( \quad - \quad ) - ( \quad + \quad ) = \underline{\hspace{2cm}}$$

Total

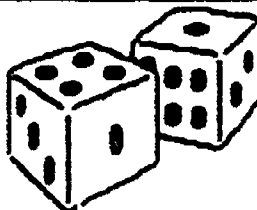
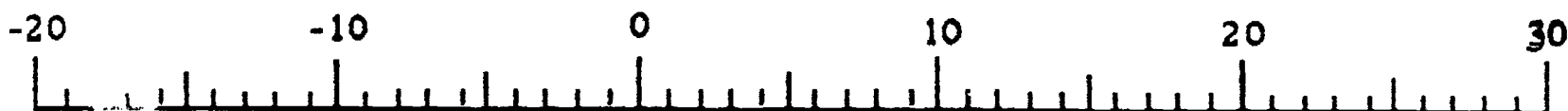

# One The Hard Way

## Student Activity Sheet 2

Book 2: Grades 3-4  
LESSON 11

60

© 1991 Cal State Fullerton Press  
CAMP-LA

$$( \quad + \quad ) \times ( \quad \times \quad ) + ( \quad - \quad ) - ( \quad + \quad ) = \underline{\hspace{2cm}}$$

$$( \quad + \quad ) \times ( \quad \times \quad ) + ( \quad - \quad ) - ( \quad + \quad ) = \underline{\hspace{2cm}}$$

$$( \quad + \quad ) \times ( \quad \times \quad ) + ( \quad - \quad ) - ( \quad + \quad ) = \underline{\hspace{2cm}}$$

$$( \quad + \quad ) \times ( \quad \times \quad ) + ( \quad - \quad ) - ( \quad + \quad ) = \underline{\hspace{2cm}}$$

$$( \quad + \quad ) \times ( \quad \times \quad ) + ( \quad - \quad ) - ( \quad + \quad ) = \underline{\hspace{2cm}}$$

Total

$$( \quad + \quad ) \times ( \quad \times \quad ) + ( \quad - \quad ) - ( \quad + \quad ) = \underline{\hspace{2cm}}$$

$$( \quad + \quad ) \times ( \quad \times \quad ) + ( \quad - \quad ) - ( \quad + \quad ) = \underline{\hspace{2cm}}$$

$$( \quad + \quad ) \times ( \quad \times \quad ) + ( \quad - \quad ) - ( \quad + \quad ) = \underline{\hspace{2cm}}$$

$$( \quad + \quad ) \times ( \quad \times \quad ) + ( \quad - \quad ) - ( \quad + \quad ) = \underline{\hspace{2cm}}$$

$$( \quad + \quad ) \times ( \quad \times \quad ) + ( \quad - \quad ) - ( \quad + \quad ) = \underline{\hspace{2cm}}$$

Total

How close  
to ONE?

---

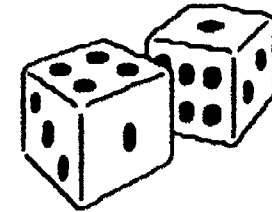

How close  
to ONE?

---

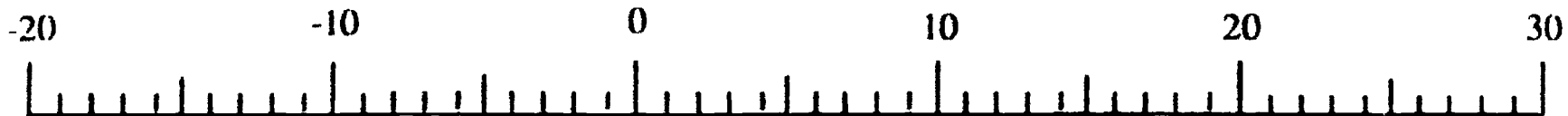



## TOSS ONE

- GRADE:** 3 - 4
- STRAND:** Number
- SKILL:** Add, subtract, multiply, and divide decimals
- MANAGEMENT**
- CLASS ORGANIZATION:** Pairs
- TIME FRAME:** One class period
- MATERIALS:** Calculator, operations cube/pair
- VOCABULARY:** Operation
- PREREQUISITE SKILL:** Mathematics: Basic operations and some concept of fractions  
Calculator: Basic functions

**LESSON** The purpose of this lesson is to apply understanding of decimal numbers.

- **DIRECTED INSTRUCTION/ GUIDED PRACTICE:**  
Prepare operation cubes. Mark operation signs on the faces of the cube: one each multiplication and division; two each addition and subtraction.  
  
Project the transparency. Work through a sample game session with the students. Follow the directions given on the Student Activity Sheet. Discussion should help students understand the effect of decimal numbers on the game.
- **INDEPENDENT PRACTICE:**  
Distribute Student Activity Sheets and operation cubes and instruct students to begin play.
- **EVALUATION:**  
Teacher observation
- **HOME ACTIVITY:**  
Take home an operation cube and copy of the game record sheet with rules and teach some family member how to play Toss One.

**Digits:**

**9 8 7 6 5 4 3 2 1 0**

**First Operation Number Result**

1	+	0	1
---	---	---	---

1	x	.9	.9
---	---	----	----

.9	-	.4	.5
----	---	----	----

.5	x	3	1.5
----	---	---	-----

Result number becomes the First number of the next line.

TOSS ONE

Student Activity Sheet

A Game of Computation for Two Players

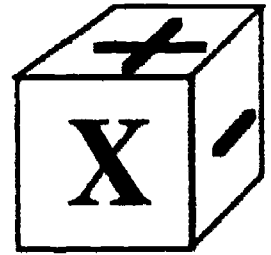
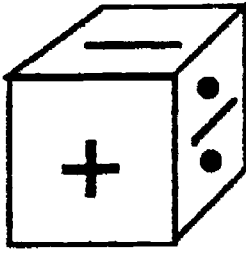

General rules:

**Goal:** Finish with the number closer to one in order to win.

**Equipment:** Calculators (one for each player), operations cube, game recording sheet, and pencil.

**The Play:**

1. Players decide who goes first. Before beginning, agree on the number of rounds to a game.
2. On each player's first move s/he rolls the operations cube then selects two digits from the list to enter as the numbers to be used with that operation. On following moves the previous Result is used as the First number and each player picks only one digit from those remaining in the list.
3. The operation and number/s are entered on the game record sheet and then on the calculator, if necessary.
4. The result of the operation (press  key) is recorded in the box on the record sheet. Digits are scratched off of the common list as they are used and may not be used again during that round.
5. Players may use the decimal point before any digit but may use each of the ten digits only once between them in a given round, including the zero. (e.g. use 7 or .7)

**Note:** If there is a total clearing of the memory, the game can be reentered from the game record sheet.

	9	8	7	6	5	4	3	2	1	0	
	Player A				Player B						
	First	Operation	Number	Result	First	Operation	Number	Result			
	<input type="text"/>	<input type="text"/>	<input type="text"/>	<input type="text"/>	<input type="text"/>	<input type="text"/>	<input type="text"/>	<input type="text"/>	<input type="text"/>	<input type="text"/>	
	<input type="text"/>	<input type="text"/>	<input type="text"/>	<input type="text"/>	<input type="text"/>	<input type="text"/>	<input type="text"/>	<input type="text"/>	<input type="text"/>	<input type="text"/>	
	<input type="text"/>	<input type="text"/>	<input type="text"/>	<input type="text"/>	<input type="text"/>	<input type="text"/>	<input type="text"/>	<input type="text"/>	<input type="text"/>	<input type="text"/>	
	<input type="text"/>	<input type="text"/>	<input type="text"/>	<input type="text"/>	<input type="text"/>	<input type="text"/>	<input type="text"/>	<input type="text"/>	<input type="text"/>	<input type="text"/>	
	[A] Winner of this round				[B]						

**TOSS ONE**  
Student Activity Sheet



Digits:

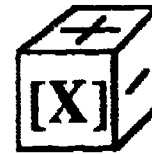

9    8    7    6    5    4    3    2    1    0

Player A				Player B			
First	Operation	Number	Result	First	Operation	Number	Result
<input type="text"/>	<input type="text"/>	<input type="text"/>	<input type="text"/>	<input type="text"/>	<input type="text"/>	<input type="text"/>	<input type="text"/>
<input type="text"/>	<input type="text"/>	<input type="text"/>	<input type="text"/>	<input type="text"/>	<input type="text"/>	<input type="text"/>	<input type="text"/>
<input type="text"/>	<input type="text"/>	<input type="text"/>	<input type="text"/>	<input type="text"/>	<input type="text"/>	<input type="text"/>	<input type="text"/>
<input type="text"/>	<input type="text"/>	<input type="text"/>	<input type="text"/>	<input type="text"/>	<input type="text"/>	<input type="text"/>	<input type="text"/>
[A]				[B]			

Digits:

9    8    7    6    5    4    3    2    1    0

Player A				Player B			
First	Operation	Number	Result	First	Operation	Number	Result
<input type="text"/>	<input type="text"/>	<input type="text"/>	<input type="text"/>	<input type="text"/>	<input type="text"/>	<input type="text"/>	<input type="text"/>
<input type="text"/>	<input type="text"/>	<input type="text"/>	<input type="text"/>	<input type="text"/>	<input type="text"/>	<input type="text"/>	<input type="text"/>
<input type="text"/>	<input type="text"/>	<input type="text"/>	<input type="text"/>	<input type="text"/>	<input type="text"/>	<input type="text"/>	<input type="text"/>
<input type="text"/>	<input type="text"/>	<input type="text"/>	<input type="text"/>	<input type="text"/>	<input type="text"/>	<input type="text"/>	<input type="text"/>
[A]				[B]			

Digits:

9    8    7    6    5    4    3    2    1    0

Player A				Player B			
First	Operation	Number	Result	First	Operation	Number	Result
<input type="text"/>	<input type="text"/>	<input type="text"/>	<input type="text"/>	<input type="text"/>	<input type="text"/>	<input type="text"/>	<input type="text"/>
<input type="text"/>	<input type="text"/>	<input type="text"/>	<input type="text"/>	<input type="text"/>	<input type="text"/>	<input type="text"/>	<input type="text"/>
<input type="text"/>	<input type="text"/>	<input type="text"/>	<input type="text"/>	<input type="text"/>	<input type="text"/>	<input type="text"/>	<input type="text"/>
<input type="text"/>	<input type="text"/>	<input type="text"/>	<input type="text"/>	<input type="text"/>	<input type="text"/>	<input type="text"/>	<input type="text"/>
[A]				[B]			

## HOW CLOSE CAN YOU GET?

- GRADE:** 3 - 4
- STRAND:** Number
- SKILL:** Operations with decimals
- MANAGEMENT**
- CLASS ORGANIZATION:** Pairs
- TIME FRAME:** One class period
- MATERIALS:** Game sheet, calculators, spinner, transparency
- VOCABULARY:** Number squared ( $n^2$ ), decimal numbers (10th)
- PREREQUISITE SKILL:** Mathematics: Basic operations, decimal place value to hundredths  
Calculator: Basic functions

**LESSON** The purpose of this lesson is to approximate the square root of a number.

- DIRECTED INSTRUCTION/GUIDED PRACTICE:**  
Project transparency.

Introduce the game by generating the target number with the spinner. Each spin provides a digit in the "goal." At this point tell the students how accurate their answer should be, eg. 1.0, 0.1, 0.01, (The difference between the RESULT and the TARGET must be less than the ACCURACY LEVEL.) For demonstration purposes a two-digit number is recommended.

Example:

GOAL FOR PLAYERS

		1	9
--	--	---	---

ACCURACY LEVEL: 0.01

POINTS	STUDENT 1		STUDENT 2	
	GUESS	RESULT	GUESS	RESULT
10	4 x 4	16	4.5 x 4.5	20.25
9	4.4 x 4.4	19.36	4.35 x 4.35	18.9225
8	4.36 x 4.36	19.0096		

WINNER: Student 1 since  $19.0096 - 19 = .0096 < 0.01$   
Points awarded: 8

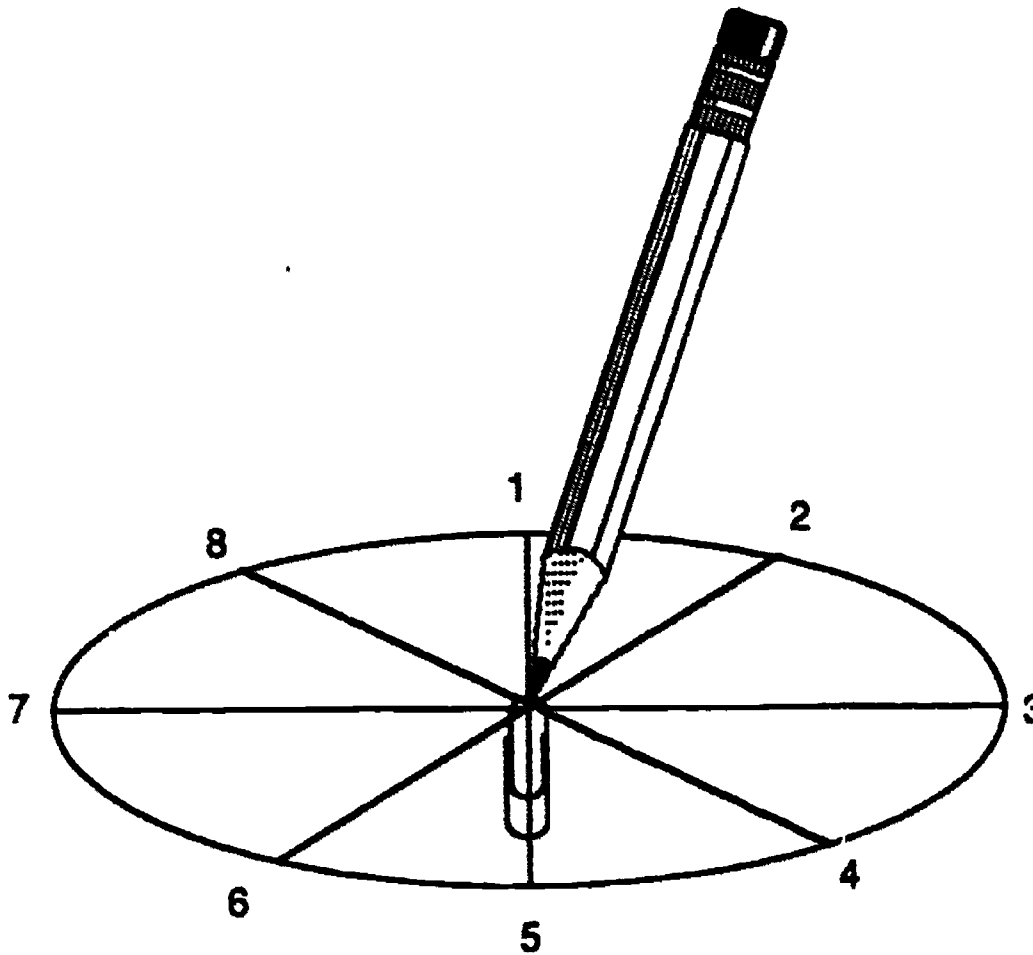

Place the point of a pencil on the center of the circle. Use the paper clip as the spinner.

- **INDEPENDENT PRACTICE:**  
Play the game.
- **EVALUATION:**  
Teacher observation.
- **HOME ACTIVITY:**  
Play the game with a family member.

HOW CLOSE CAN YOU GET?



GOAL

--	--	--	--

ACCURACY LEVEL:

POINTS	STUDENT 1		STUDENT 2	
	GUESS	RESULT	GUESS	RESULT
10	X		X	
9	X		X	
8	X		X	
7	X		X	
6	X		X	
5	X		X	
4	X		X	
3	X		X	
2	X		X	
1	X		X	

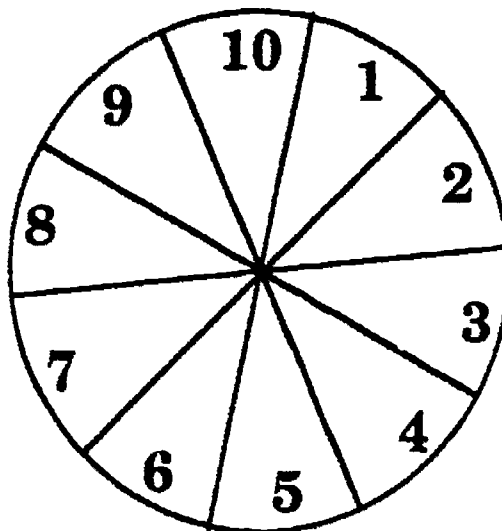

# HOW CLOSE CAN YOU GET?

## Student Activity Sheet

### GAME RULES

1. Spin to see who goes first.
2. Take turns spinning a two-, three-, or four-digit number and place it in the section marked "Goal." Put the first digit in the ones place, the second in the tens place, and so forth.
3. Estimate what number squared would come closest to the "Goal."
4. The team that wins is the one that gets the target number first, or whose final attempt is closest to the "Goal."
5. Award the number of points found to the left of the final move of the game.

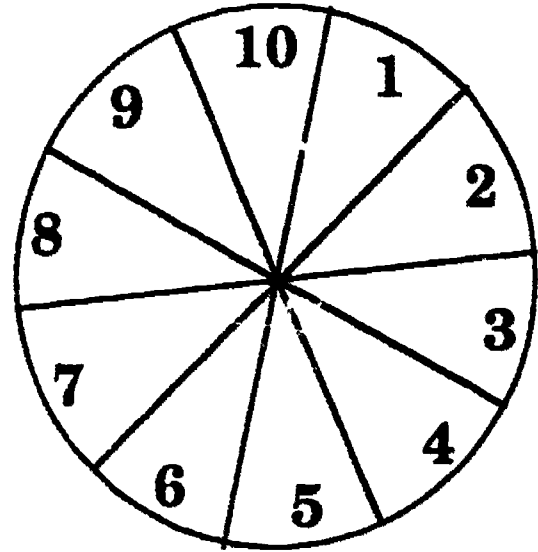

GOAL

--	--	--	--

ACCURACY LEVEL:

POINTS	STUDENT 1		STUDENT 2	
	GUESS	RESULT	GUESS	RESULT
10	X		X	
9	X		X	
8	X		X	
7	X		X	
6	X		X	
5	X		X	
4	X		X	
3	X		X	
2	X		X	
1	X		X	



**CHAPTER 1 ASSESSMENT:  
NUMBER**

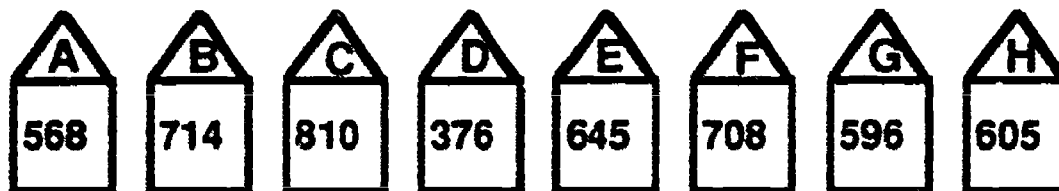

1. The students at 8 schools collect aluminum cans. The total pounds collected by the students in each school is shown. The recycling truck can carry up to 2000 pounds at a time.
  - a. Which schools could be combined into one trip?
  - b. The total number of pounds of aluminum cans for all schools is \_\_\_\_\_.
  - c. The least number of trips it took the truck to collect all the cans from the 8 schools is \_\_\_\_\_.

Student responses should include:

- a. Schools B, C, D, or schools A, C, H, and other combinations possible.
  - b. 5,022
  - c. 3
2. What is the least number of coins that equal \$2.83? If 283 pennies is the greatest number of coins to equal \$2.83, what would be the next greatest number of coins to equal \$2.83?

Penny	Nickel	Dime	Quarter	Half

Student response:

Penny	Nickel	Dime	Quarter	Half
3	1		1	5
278	1			

Other combinations possible.

3. Complete the calculator sentence. Each blank box stands for an operation key.

$$12 \square 4 \square 11 = 176$$

Student responses should include:

$$12 \boxed{+} 4 \boxed{\times} 11 = 176$$

4. Solve this calculator sentence using three numbers from the list.

$$\square \boxed{\times} \square \boxed{+} \square = 30$$

6, 7, 9, 13, 21, 42, 45

Student responses should include:

$$\boxed{45} \boxed{\times} \boxed{6} \boxed{+} \boxed{9} = 30$$

5. Donald brought home some toys from the toy store. Sally wanted to know how much he spent. Donald wouldn't tell Sally, but he would tell her that he paid approximately \$1.00 in tax (6% tax rate). What could Donald have bought from his wish list?

#### Donald's Wish List

Baseball Cards	\$1.23/pack
Pencils	\$.79/pack
Crayons	\$2.64
Markers	\$1.97
Erasers	\$.49
Yo-Yo	\$4.49

Student responses should include:

Any combination of products that total about \$16.50. Students should be able to justify their answers.

6. Yellow Brick Road School plans to take the entire student body to the zoo. Thirty-one teachers, 895 students, 62 parents, 3 office ladies, 2 custodians, and the principal will ride the bus to the zoo. Each bus holds 74 people. How many buses will be needed to make the trip to the zoo?

---

Explain your answer \_\_\_\_\_

---

Student response should include:

It will take 14 buses to take all of the people to the zoo.

$994 \div 74 = 13.43$ . Fourteen buses are needed because it is not possible to have 0.43 of a bus.

7. Strawberries sell for \$1.25 a basket. Mary earned \$450.00 selling strawberries. How many baskets did she sell? \_\_\_\_\_

If there are 12 baskets in a flat how many flats did Mary sell?

Student response should include:

Mary sold 360 baskets of strawberries.

Mary sold 30 flats of strawberries.

8. Vehicles on Highway 3

Vehicle	Length
18 Wheeler	48 feet
Pickup	18 feet
Delivery Van	16 feet
Car	12 feet

Vehicles traveling on Highway 3 have to take a ferryboat to cross the Deep River. The ferry is 20 yards long.

What combinations of vehicles can be on the ferry at any crossing if we want the ferry to be as full as possible?

Student response should include:

Convert 20 yards to 60 feet.

Add to find vehicles whose combined lengths would be 60 feet or less.

1.	1-18 wheeler and 1 car	60
2.	1 pickup and 2 delivery vans	50
3.	1 pickup, 1 delivery van and 2 cars	58
4.	1 pickup and 3 cars	54
5.	2 pickups and 1 delivery van	52
6.	2 pickups and 2 cars	60
7.	3 pickups	54
8.	1 delivery van and 3 cars	52
9.	2 delivery vans and 2 cars	56
10.	3 delivery vans and 1 car	60
11.	5 cars	60

# CAMP-LA

Calculators and Mathematics Project, Los Angeles

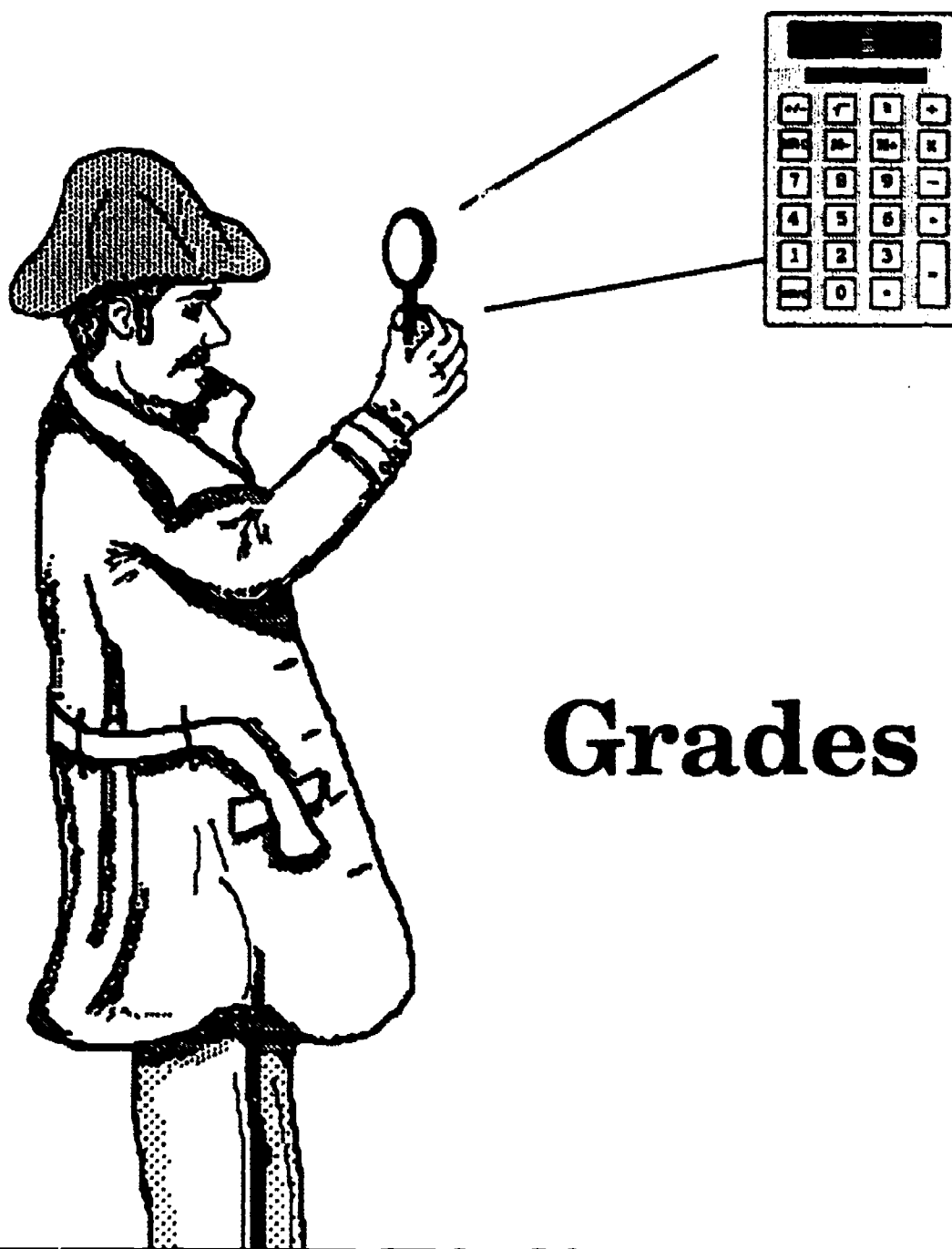

Grades 3 - 4

## CHAPTER 2 MEASUREMENT

## ON VACATION WE WILL GO

<b>GRADE:</b>	3 - 4
<b>STRAND:</b>	Measurement
<b>SKILL:</b>	Estimate and measure length in standard units
<b>MANAGEMENT</b>	
<b>CLASS ORGANIZATION:</b>	Whole class and pairs
<b>TIME FRAME:</b>	Two class periods
<b>MATERIALS:</b>	Ruler, calculator, map, transparency, clear ruler
<b>VOCABULARY:</b>	Scale, conversion, route
<b>PREREQUISITE SKILLS:</b>	Mathematics: Basic operations Calculator: Basic functions

### LESSON

The purpose of this lesson is to have the students use a map, scale, and a calculator to determine distance.

#### • DIRECTED INSTRUCTION:

##### Day One

"How many of you have seen your parents use a road map? Why do we use a map?"

Discuss how to use a map to plan a route of travel.

Project a transparency of the map. Use a transparent ruler to demonstrate how to measure the distance from home to the mountains on the map. Show how to label the inches on the map. Students use their ruler and map to measure and record the distance from home to the mountains.

Next measure from the stadium to the mountains on the transparency. Then have the students record the distance as 2.5 inches on their map. Tell students that  $.5 = 1/2$  and that on this lesson they only need to measure to the nearest  $1/2$  inch mark or full inch mark (we say we are measuring to the nearest half inch).

#### • GUIDED PRACTICE:

Students measure and record several distances on the map. You may want to develop a story to tell why you are going certain places on the map.

#### • INDEPENDENT PRACTICE:

Students complete all measurements on the map.

#### • EVALUATION:

Check students' measurements on map.

## Day Two

- **DIRECTED INSTRUCTION:**

Look at the distance between home and the mountains. Is two inches actually 28 miles on this map? Discuss models and scales (1 in. = 14 miles).

The next two calculations can be done mentally.

Demonstrate how to convert the 2 inches from home to the mountains into 28 mi. by adding 14 miles for each inch.

Demonstrate how to convert the distance between the mountains to the stadium by adding 14 miles for each inch and 7 miles for each 1/2 inch. [answer: 2.5" = 35mi.]

Students use a calculator to do the second conversion:  $2.5 \times 14 = 35$ .



Discuss the most efficient way to do the conversion: addition or multiplication.

- **GUIDED PRACTICE:**

Do 3 or 4 conversions and record the miles on the map.

- **INDEPENDENT PRACTICE:**

Students work with a partner to complete the Student Activity Sheet using the map and a calculator.

- **EVALUATION:**

Check the answers on the students' charts.

- **HOME ACTIVITY:**

Write a letter to a friend describing:

- Where you went
- What you did
- The route you took
- How far you traveled

Students designate their own routes and find the total distance.

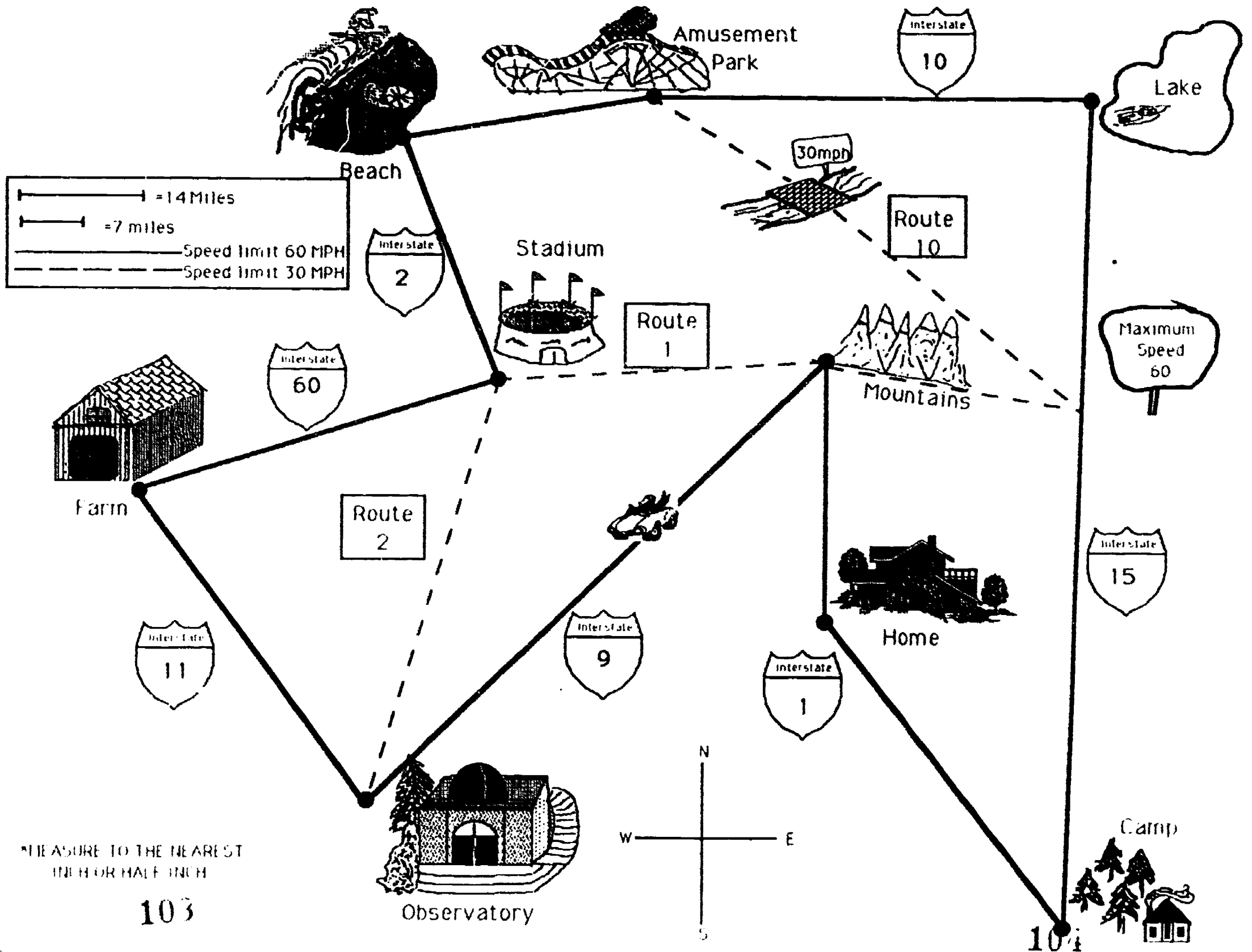

MEASURE TO THE NEAREST  
1/16 INCH OR HALF INCH

103

104



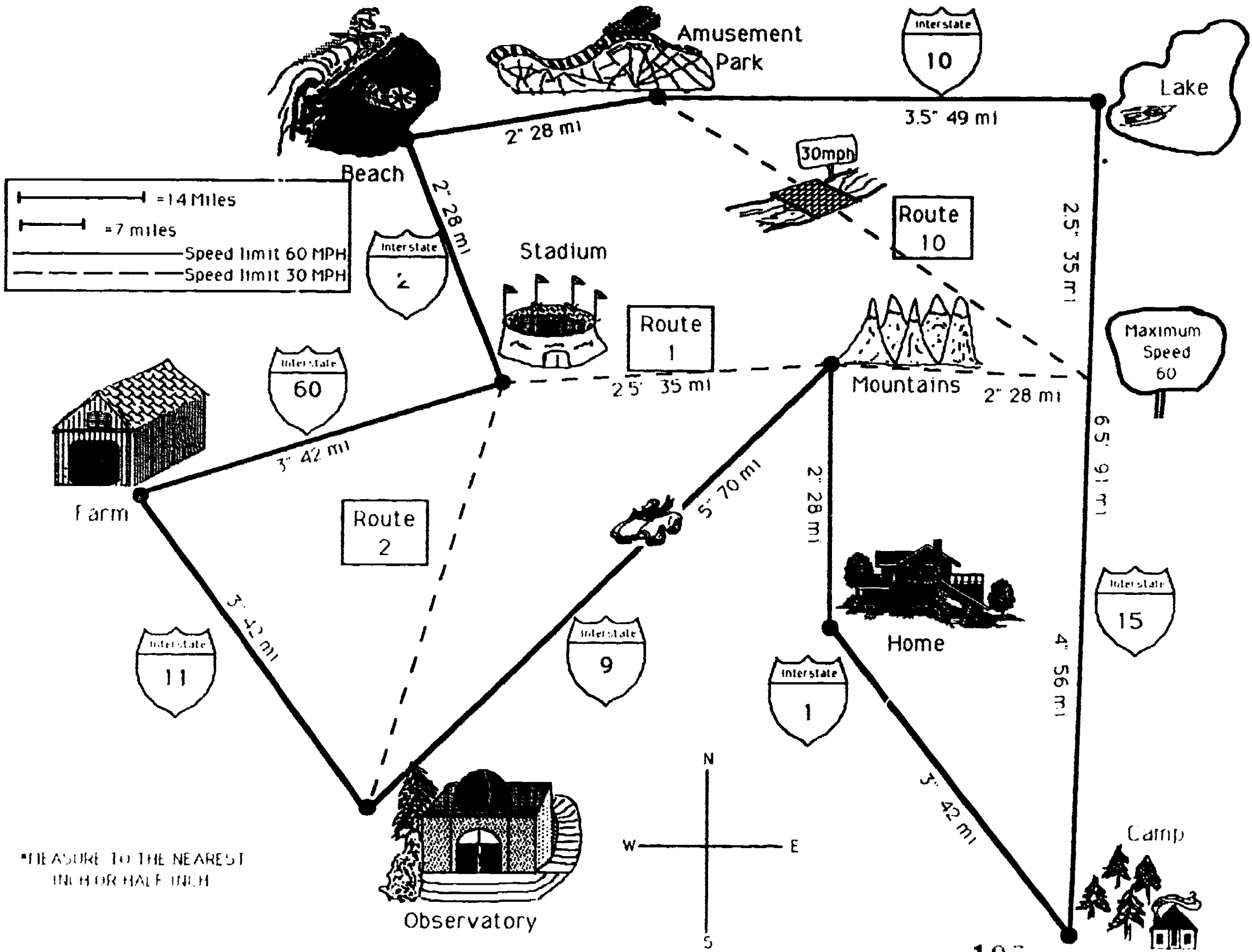

\*MEASURE TO THE NEAREST INCH OR HALF INCH

**ON VACATION WE WILL GO**  
Student Activity Sheet

Use the map and a calculator to find the total miles for each trip.

From	Destination	Route	Miles
CAMP	FARM	11 - 19 - 111	
FARM	LAKE	160 - R1 - 115	
LAKE	BEACH	115 - R1 - 12	
FARM	HOME	160 - R1 - 11	
OBSERVATORY	AMUSEMENT PARK	19 - R1 - R10	

Use the map and a calculator to determine the route that matches the total miles.

From	Destination	Route	Miles
LAKE	OBSERVATORY		231
CAMP	BEACH		266
BEACH	HOME		91
STADIUM	CAMP		343
HOME	AMUSEMENT PARK		350

**ON VACATION WE WILL GO**  
Teacher Answer Sheet

From	Destination	Route	Miles
CAMP	FARM	I1 - I9 - I11	182
FARM	LAKE	160 - R1 - I15	140
LAKE	BEACH	I15 - R1 - I2	126
FARM	HOME	160 - R1 - I1	105
OBSERVATORY	AMUSEMENT PARK	19 - R1 - R10	154

From	Destination	Route	Miles
LAKE	OBSERVATORY	I15 - I1 - I9	231
CAMP	BEACH	I15 - R1 - I9 - I11 - 160 - I2	266
BEACH	HOME	I2 - R1 - I1	91
STADIUM	CAMP	R2 - I9 - R1 - R10 - I10 - I15	343
HOME	AMUSEMENT PARK	I1 - I15 - R1 - R2 - I11 - 160 - I2 - I10	350

## BOOK COVERS COVER A LOT OF AREA

**GRADE:** 3 - 4  
**STRAND:** Measurement  
**SKILL:** Estimate and measure area in standard units

### MANAGEMENT

**CLASS ORGANIZATION:** Whole class, small groups  
**TIME FRAME:** One class period  
**MATERIALS:** Centimeter graph paper, calculator, mathematics textbook, tape  
**VOCABULARY:** Area, cover, centimeter  
**PREREQUISITE SKILLS:** Mathematics: Linear measurement  
Calculator: Basic functions

### LESSON

The purpose of this lesson is to use centimeter graph paper and the calculator to determine area.

#### DIRECTED INSTRUCTION:

Tell the students that a designer wants to change the cover on a mathematics textbook to one of many colored centimeter squares. Each student looks at her/his mathematics book and estimates the number of centimeter squares needed to cover the book.

Students make book covers for their math books with centimeter graph paper.

Students will need to tape sheets together and cut them to the size of the front and back covers and the spine.

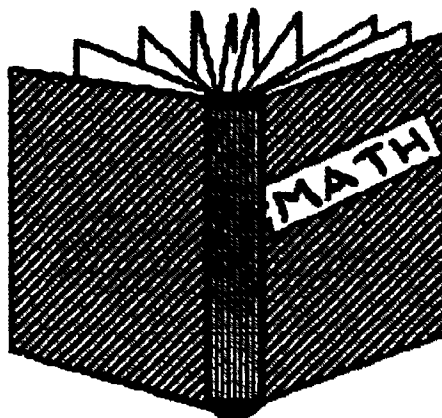

When all students have finished making their book covers, ask how they can determine the total number of squares on the outside of their cover. Their answers will include:

count the squares;

count the squares along the length and width and multiply the two numbers.

Call on students to tell how many centimeter squares cover their textbooks. How close were the estimates? Explain that the number is a measure of the area of the paper. Use the area as they complete the investigations on the student activity sheet. Direct them to work in groups.

• **GUIDED PRACTICE:**

Students determine the area of all the book covers in the room. Use a calculator to enter the area of the paper used to cover the mathematics books. Multiply this number by the number of mathematics books in the room.

• **INDEPENDENT PRACTICE:**

Students use their calculators to find the area of covers of all the third grade mathematics books in the school and the county. They discuss the questions and prepare to report to the class. Students explain how they would answer questions 3 and 4.

• **EVALUATION:**

Teacher observation.

• **HOME ACTIVITY SHEET:**

Complete the Home Activity Sheet.

Answers to Home Activity Sheet:

- 1)  $25.5 \times 21 + 25.5 \times 21 + 25.5 \times 2 = 1122 \text{ cm}^2$
- 2)  $27 \times 22 = 594 \text{ cm}^2$
- 3) 2
- 4)  $(2 \times 594) - 1122 = 1188 - 1122 = 66 \text{ cm}^2$
- 5)  $2 \times 27 = 54$  sheets
- 6)  $27 \times 66 = 1782 \text{ cm}^2$

**BOOK COVERS COVER A LOT OF AREA!**  
Student Activity Sheet

How many centimeter squares  would you need to cover the front and back covers and the spine of your mathematics textbook?

\_\_\_\_\_ sq. cm  
Estimate

\_\_\_\_\_ sq. cm  
Actual number

1. There are 92 third grade mathematics books in the school. How many centimeter squares would cover all of them? \_\_\_\_\_

What is the area of all the book covers? \_\_\_\_\_

2. In Los Angeles County there are 96,500 third grade math books. How many centimeter squares would cover all of them? \_\_\_\_\_

**Discuss these questions in your group. Be prepared to share your answer with the class.**

3. Determine the area of the covers of all the math books in the school.

\_\_\_\_\_

\_\_\_\_\_

\_\_\_\_\_

4. How would you determine how many centimeter squares it would take to cover the following areas of the classroom: The floor: the floor and ceiling; the floor, ceiling, and walls? \_\_\_\_\_

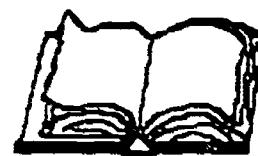
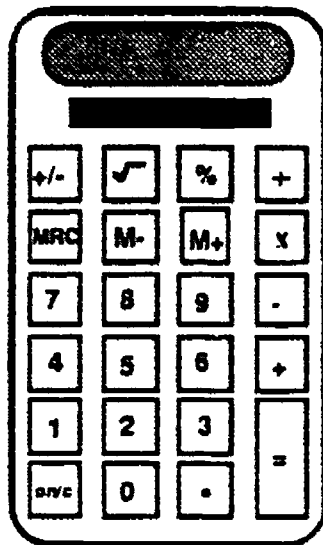
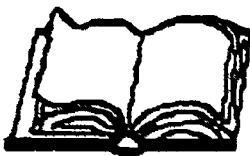

**BOOK COVERS COVER A LOT OF AREA!**  
Home Activity Sheet

The students in Room 53 wanted to find out how much paper they would need to cover the front, back, and spine of all the mathematics textbooks in their classroom.

Use this information.

Textbook measurements

front 25.5 cm x 21 cm

back 25.5 cm x 21 cm

spine 25.5 cm x 2 cm

Twenty-seven textbooks in the room

One sheet of centimeter square paper measures 22 cm x 27 cm

1. How many square centimeters would it take to cover one textbook? \_\_\_\_\_  
\_\_\_\_\_
2. How many square centimeters on one sheet of paper? \_\_\_\_\_  
\_\_\_\_\_
3. How many sheets of centimeter square paper would it take to cover one book? \_\_\_\_\_  
\_\_\_\_\_
4. How much paper would be left over when one book was covered? \_\_\_\_\_  
\_\_\_\_\_
5. How many sheets of centimeter square paper would it take to cover all of the mathematics textbooks in the classroom? \_\_\_\_\_  
\_\_\_\_\_
6. How much paper would be left over when all of the mathematics textbooks were covered? \_\_\_\_\_  
\_\_\_\_\_

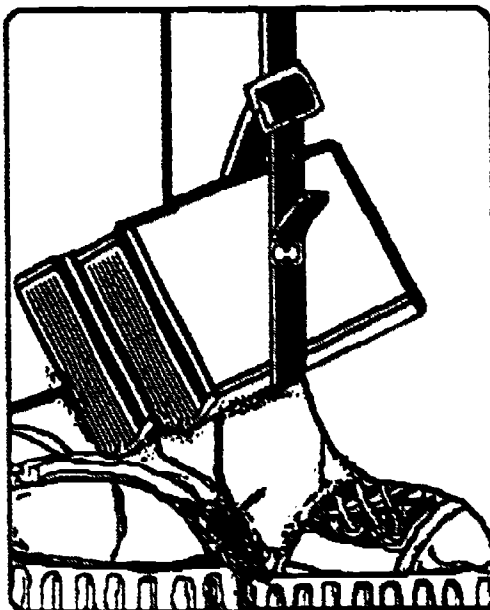

## NEWSPAPER NUMBERS

- GRADE:** 3 - 4
- STRAND:** Measurement
- SKILL:** Estimate and measure area in standard units
- MANAGEMENT**
- CLASS ORGANIZATION:** Whole class, pairs
- TIME FRAME:** One class period
- MATERIALS:** Calculator, cm ruler, a page from a newspaper
- VOCABULARY:** Measurement, length, width, area, article, advertisement, approximate
- PREREQUISITE SKILL:** Mathematics: Measure to the nearest cm, area  
Calculator: Basic functions and memory feature

**LESSON** The purpose of this lesson is to explore estimation of area using a newspaper and a calculator.

• **DIRECTED INSTRUCTION:**

Display a newspaper page.

Is it possible to determine the amount of news on a page of a newspaper?  
Discuss this question with students. How would they find the answer?

A page of a newspaper has pictures, advertisements, and news. Students find out approximately what fraction of the print on a page is actually news. They find the area of the whole page. They find the area of the advertisements. Then they find the difference between these two areas.

The answers will be approximate because there is space between columns of news and around pictures and advertisements. Is an approximate answer appropriate? An approximate answer will work for this problem because students get a general idea about the amount of space used for news compared to the amount of space used for pictures and advertisements. An exact answer (the area actually taken up by the words on the page) would be very difficult to determine.

• **GUIDED PRACTICE:**

Students refer to the Student Activity Sheets 1 and 2. Using calculators, complete this activity together.

1. Start by estimating the amount of news on the page of newspaper on Student Activity Sheet 1. Is it  $\frac{1}{2}$  of the page?  $\frac{1}{3}$ ?  $\frac{1}{4}$ ?



2. Using a cm ruler, measure the length and width of the newspaper page on Student Activity Sheet 1 to the nearest centimeter. Use a calculator to multiply the length and width to find the total area of the page.
3. Use the same procedure to find the area of the picture and advertisements.
4. Find the difference between the total area of the page and the total area of the advertisements and the picture to determine the area of the news.

**Answers to Student Activity Sheet 2:**

1. Answers will vary
2.  $280 \text{ cm}^2$
3.  $16 \text{ cm}^2$  picture  
 $42 \text{ cm}^2$  ad  
 $16 \text{ cm}^2$  ad  
  
Total =  $74 \text{ cm}^2$
4.  $280 - 74 = 206 \text{ cm}^2$   
Area of print

- **INDEPENDENT PRACTICE:**  
Working with a partner, have students do Student Activity Sheet 3.
- **EVALUATION:**  
Groups will share their answer with the entire class.
- **HOME ACTIVITY:**  
Turn to another page of the newspaper. Find the total area of news, pictures and advertisements.

**NEWSPAPER NUMBERS**  
Student Activity Sheet 1  
PAGE OF NEWSPAPER

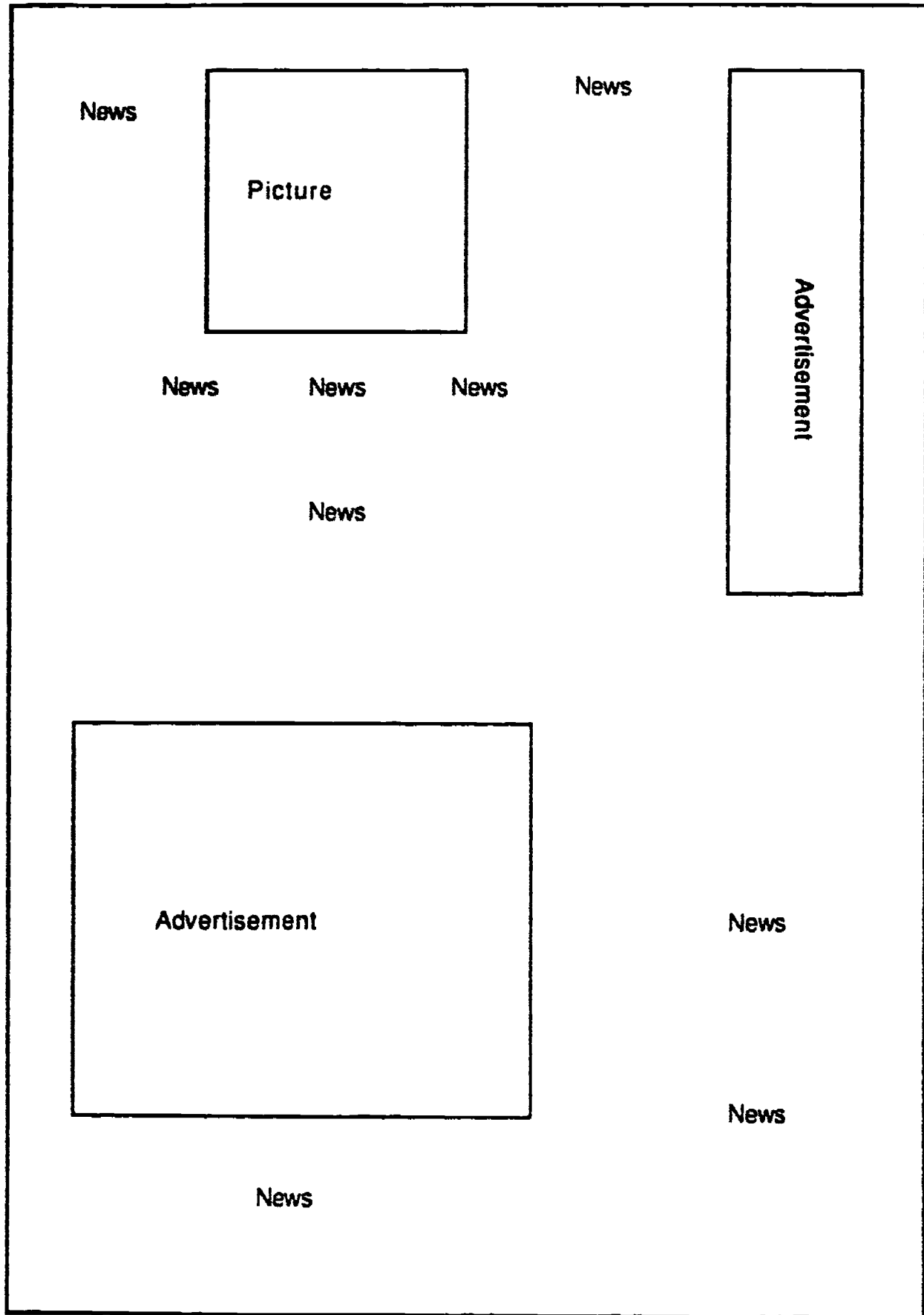

NEWSPAPER NUMBERS  
Student Activity Sheet 1  
Teacher Answer Sheet

14 cm

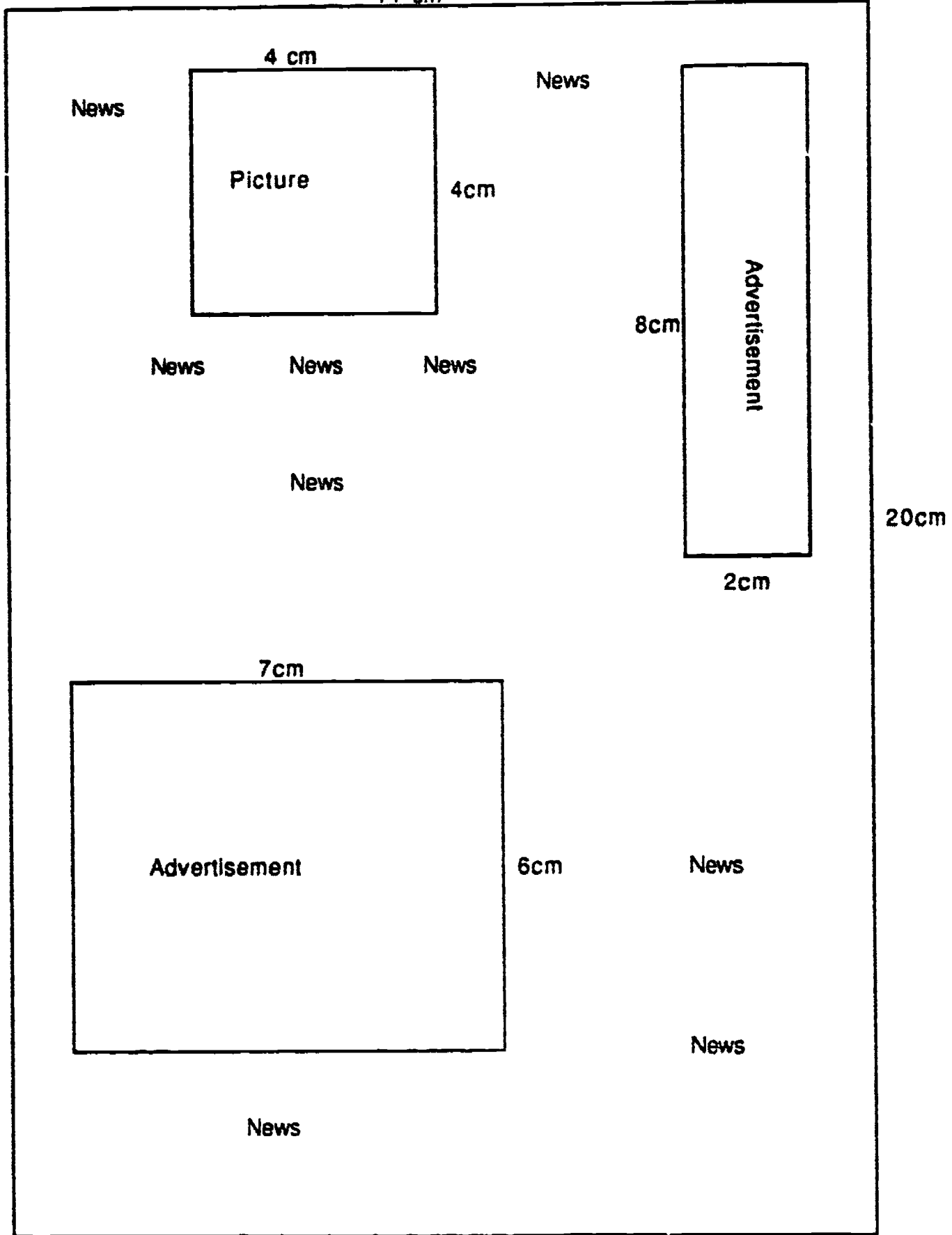

**NEWSPAPER NUMBERS**  
Student Activity Sheet 2

1. Estimate \_\_\_\_\_

2.  $\frac{\text{length}}{\text{length}} \times \frac{\text{width}}{\text{width}} = \frac{\text{Area of newspaper page}}{\text{Area of newspaper page}}$

3.  $\frac{\text{length}}{\text{length}} \times \frac{\text{width}}{\text{width}} = \frac{\text{Area of picture}}{\text{Area of picture}}$

$\frac{\text{length}}{\text{length}} \times \frac{\text{width}}{\text{width}} = \frac{\text{Area of advertisement}}{\text{Area of advertisement}}$

$\frac{\text{length}}{\text{length}} \times \frac{\text{width}}{\text{width}} = \frac{\text{Area of advertisement}}{\text{Area of advertisement}}$

4.  $\frac{\text{Total area of page}}{\text{Total area of page}} - \frac{\text{Total area of pictures and ads}}{\text{Total area of pictures and ads}} = \frac{\text{Area of news}}{\text{Area of news}}$

What fraction of the page is actually printed news? \_\_\_\_\_

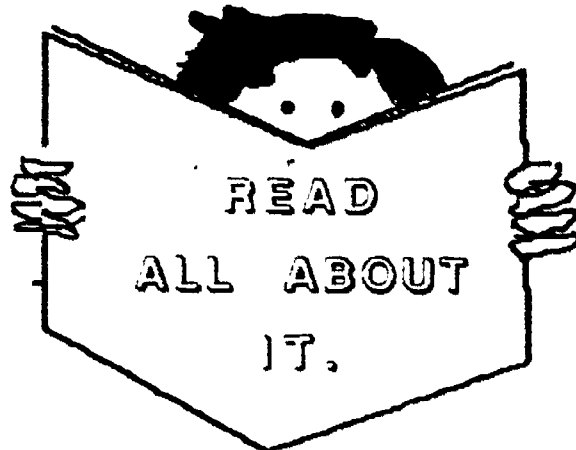

## NEWSPAPER NUMBERS

### Student Activity Sheet 3

Work with a partner. You will need a 30 cm ruler, a page from a newspaper, and a pencil.

- How much news is printed on your newspaper page?  
Find the area of the printed matter on the newspaper page.

$$\frac{\text{length}}{\text{length}} \times \frac{\text{width}}{\text{width}} = \frac{\text{area}}{\text{area}}$$

Find the area of each advertisement and picture.

$$\frac{\text{length}}{\text{length}} \times \frac{\text{width}}{\text{width}} = \frac{\text{area}}{\text{area}}$$

$$\frac{\text{length}}{\text{length}} \times \frac{\text{width}}{\text{width}} = \frac{\text{area}}{\text{area}}$$

$$\frac{\text{length}}{\text{length}} \times \frac{\text{width}}{\text{width}} = \frac{\text{area}}{\text{area}}$$

$$\frac{\text{length}}{\text{length}} \times \frac{\text{width}}{\text{width}} = \frac{\text{area}}{\text{area}}$$

Find the area of print on your newspaper page

$$\frac{\text{Area of page}}{\text{Area of page}} - \frac{\text{area of all pictures and advertisements}}{\text{area of all pictures and advertisements}} = \frac{\text{area of print}}{\text{area of print}}$$

- Is your answer an exact answer or an approximate answer? Why or Why not?

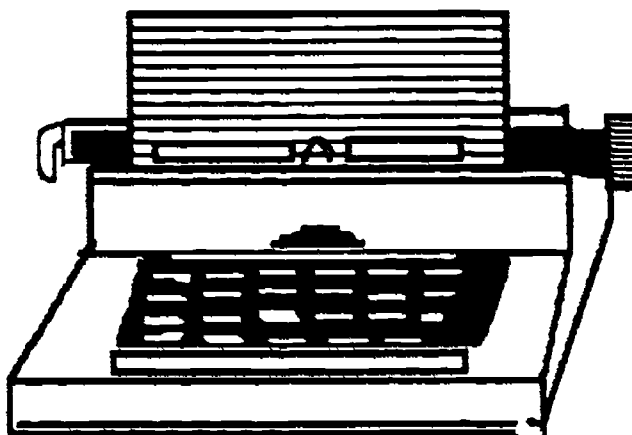

## SCHOOLYARD MEASUREMENT

**GRADE :** 4  
**STRAND:** Measurement  
**SKILL:** Estimate and measure area in standard units

### **MANAGEMENT**

**CLASS ORGANIZATION:** Whole class, pairs

**TIME FRAME:** One class period

**MATERIALS:** Map, centimeter ruler, calculator, meter stick, string, transparency made from Map of Schoolyard

**VOCABULARY:** Perimeter of a polygon  
Area of a rectangle  
Square unit: square inch, square mile, square centimeter, square meter, scale

**PREREQUISITE SKILLS:** Mathematics: Basic operations, area  
Calculator: Basic functions, memory feature

**LESSON** The purpose of this lesson is to measure, use scale, and find area using a map.

#### • **DIRECTED INSTRUCTION:**

Project transparency and distribute the **MAP OF A SCHOOLYARD**. This is a map of a schoolyard. We could use this drawing to find the area of the grass play field. Use this drawing to find the area of the rectangular parts.

This map is a scale drawing. Discuss the scale of a map.

Scale refers to the ratio in which the map represents the real situation. On this map, one centimeter represents 3 meters. Look at the rectangle marked "walkway." When we measure the length of the "walkway" we find it is 3 cm long. Since each cm represents 3 meters, by multiplying 3 cm by 3 we can find out how long the walk really is. The walk is 9 meters long.

Find the actual width of the walk. Measure the width on the drawing: 1cm. The actual width of the walk is 3 meters (1 cm represents 3 meters).

The length of the walk is 9 meters and the width is 3 meters. Area is a measure of covering. Area is expressed in square units. To find the area of a rectangular region you multiply length by width. The area of the walk is found by multiplying (length) 9 meters times (width) 3 meters. The area of the walk is 27 square meters.

The following activity could be used to illustrate the concept of area. Using string, mark an area 3 meters wide by 9 meters long on the playground to represent the walkway on the map. Place students at 1 meter intervals around the perimeter. Students use the 9 meter and 3 meter lengths of string to form a grid covering the outlined area. Count the squares of the grid.

It is obvious that an area this large would not fit on a map. This is why maps are drawn according to scale.

- **GUIDED PRACTICE:**

Identify a rectangular region on the map. Students measure to find the length and width of the chosen rectangle. Use scale to find the actual length and width of the rectangular region represented on the map. Find the area of the selected region.

Follow the same procedure on a region which is not rectangular. Students draw dotted lines to form rectangles to help them find the area of the region.

- **INDEPENDENT PRACTICE:**

Distribute Student Activity Sheet. Students work in pairs to solve the problems on the Student Activity Sheet. Encourage students to utilize  $\boxed{M+}$  and  $\boxed{M-}$  on the calculator when finding the total area.

- **EVALUATION:**

Check students' answers.

- **HOME ACTIVITY:**

Students form other rectangular regions on the school map and find their areas.

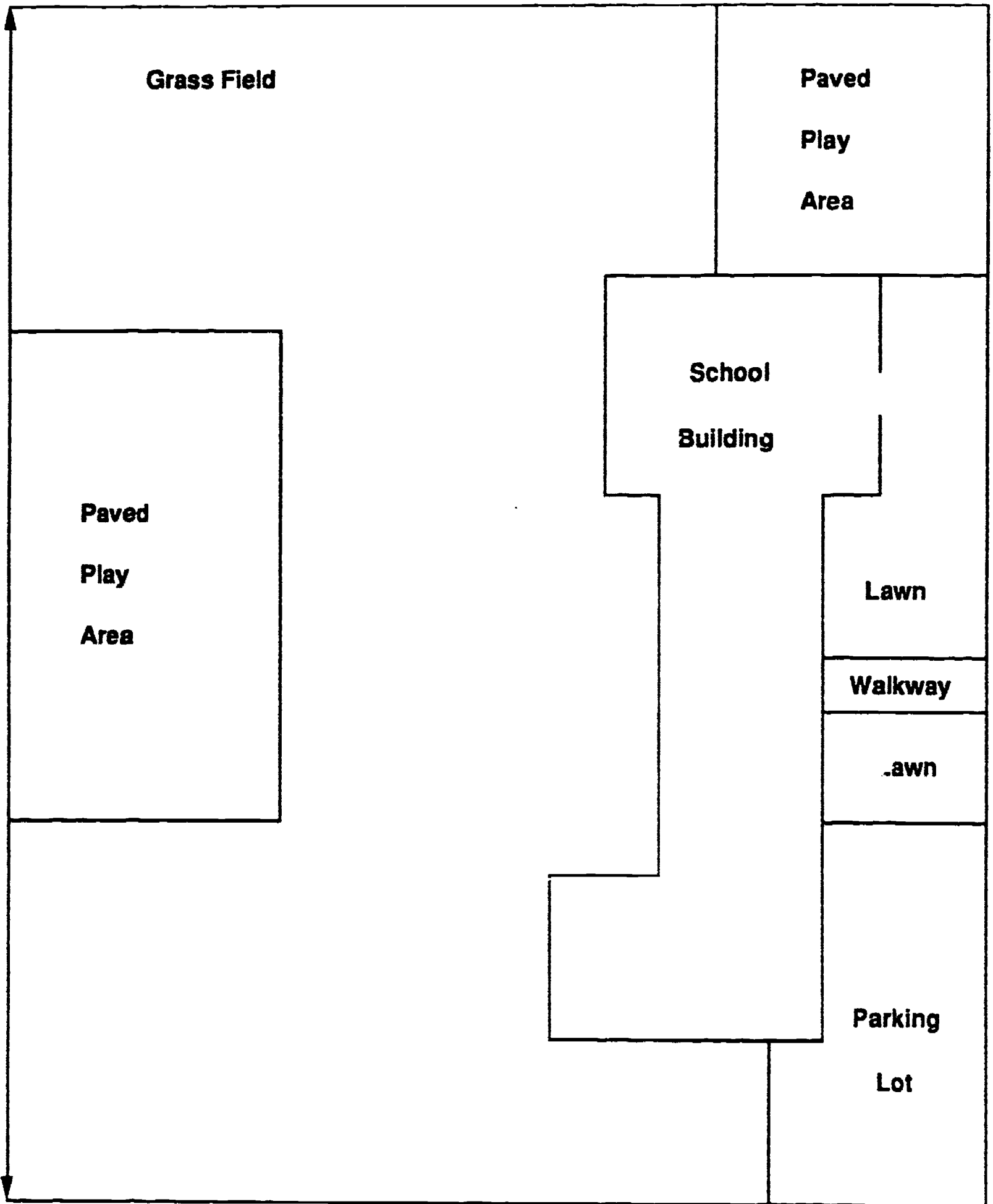



MAP OF A SCHOOLYARD  
 Teacher Answer Key  
 18 cm

Scale 1cm = 3m

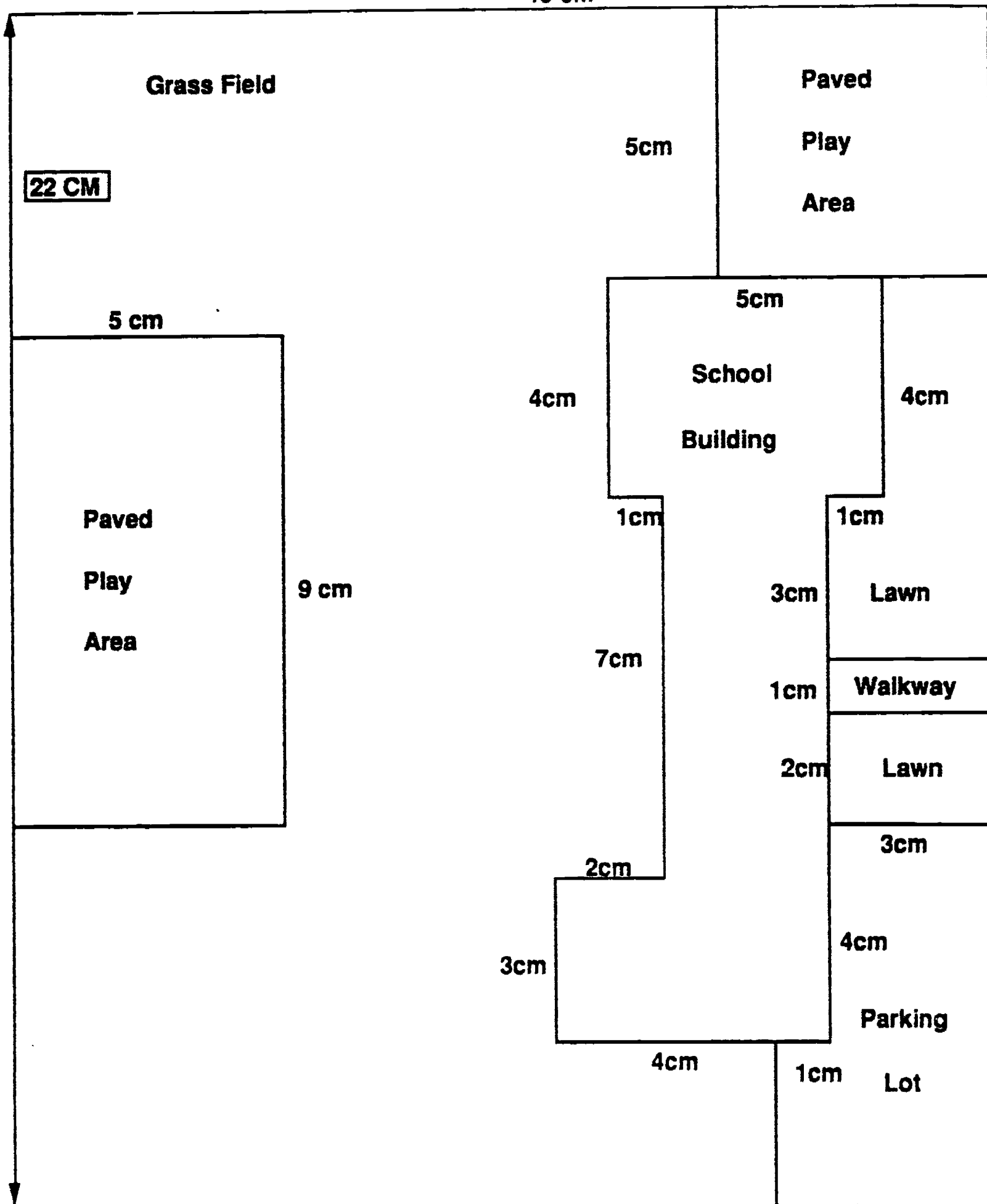

**SCHOOLYARD MEASUREMENT**  
Student Activity Sheet

Use a centimeter ruler and a calculator to find the answers to the following questions:

1. Find the area of:
- A. lawns \_\_\_\_\_
  - B. parking lot \_\_\_\_\_
  - C. building \_\_\_\_\_
  - D. paved play area \_\_\_\_\_
  - E. walkway \_\_\_\_\_
  - F. grass field \_\_\_\_\_

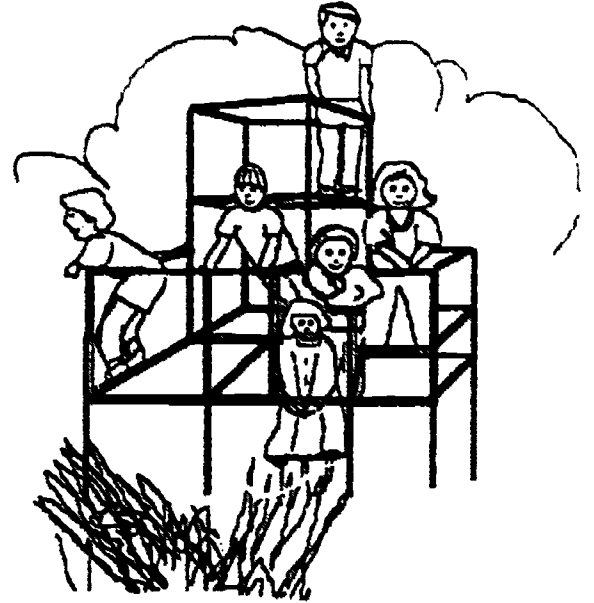

2. The school district decided to build a fence around the paved play areas of the school to keep the balls on the playground. How many meters of fencing would be necessary? \_\_\_\_\_
3. If the grass field was also paved, what would be the total paved area?
4. The school needs more parking space. They plan to increase the parking space by  $\frac{1}{2}$  the area of the existing parking lot by using a portion of the grass field.
- Where would you put the new parking lot? \_\_\_\_\_
- How will this change the area of the grass field? \_\_\_\_\_
5. The city wants to build a sidewalk around the perimeter of the schoolground. The actual size of the sidewalk will be 3 meters wide.
- A. How wide will the sidewalk be on the map of the school yard? \_\_\_\_\_
  - B. Draw the sidewalk on the map.
  - C. What will be the area of the sidewalk? \_\_\_\_\_

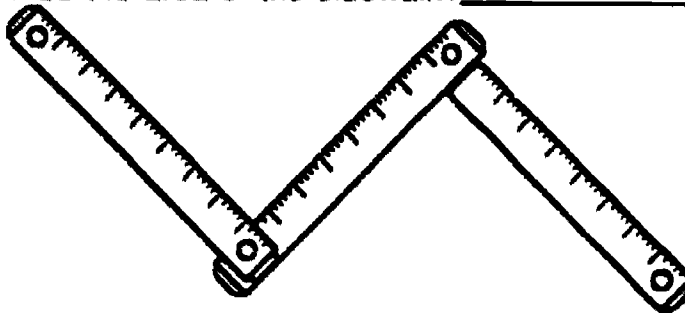

**SCHOOLYARD MEASUREMENT**  
Teacher Answer Sheet

1.
  - A. lawns = 207 square meters
  - B. parking lot = 216 square meters
  - C. building = 504 square meters
  - D. paved play area = 630 square meters
  - E. walkway = 27 square meters
  - F. grass field area:  
 area of school yard = 3564 square meters  
 total other areas (lawns, parking lot, building paved play area, walkway) = 1584 square meters  
 grass field area = 1980 square meters (3564 - 1584 = 1980)

2. 144 meters

3. 2610 sq. meters (1980 + 630)

4. Answers will vary.

5. A. 1 centimeter

B. Sidewalk will be drawn around the school grounds area as illustrated:

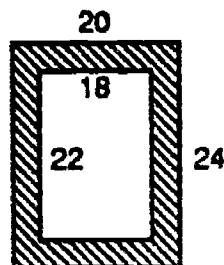

20 x 24 are new outer dimensions

C. Area of sidewalk = 756 sq. meters

Area of school grounds with sidewalk = 4320 sq. meters.

Area of school grounds without sidewalk = 3564

Area of sidewalk = 4320 - 3564 = 756 sq. meters

Another way:

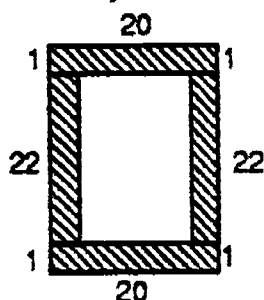

Area of sidewalk =  
 $3 \times 60 \times 2 + 3 \times 66 \times 2 =$   
 $360 + 396 =$   
 756 sq. meters

124

## TIME CODES

- GRADE:** 3 - 4
- STRAND:** Measurement
- SKILL:** Estimate and measure units of time
- MANAGEMENT**
- CLASS ORGANIZATION:** Pairs and small groups
- TIME FRAME:** One class period
- MATERIALS:** Stopwatch (1 per group), calculator, transparency
- VOCABULARY:** per, colon, convert, exceed
- PREREQUISITE SKILLS:** Mathematics: Basic operations  
Calculator: Basic functions, memory feature

### **LESSON**

The purpose of this lesson is to use a calculator code to determine sums of time periods.

#### **DIRECTED INSTRUCTION:**

Students use a calculator to solve the problem stated in the story. Describe the following situation.

Joe has a reel-to-reel tape that his group made. He let Mary listen to the music and she decided she wanted a copy of the tape. Joe's older brother has a tape deck that will make a copy on a cassette. What length blank cassette/s does Mary need so she can get a copy of Joe's music? Cassette tapes come in 30-, 60-, and 90-minute lengths.

Students discuss these questions with their group.

What does Mary need to know before buying a tape?

How would a calculator be useful?

What operations need to be performed?

Ask students what unit of measure they will need to use to solve this problem. Discuss what special problems will arise on the calculator when adding time.

Display the transparency to guide the students through the calculator code to find total minutes.

To make a decision they will need to know total minutes, total seconds and the length of tape in minutes.

Minutes and seconds cannot be entered directly into the calculator because they are based on groups of 60 not groups of 10 or 100.

Example: 4:27 cannot be entered as 4.27.

Use this calculator code and the times noted on the transparency to find the total number of minutes.

One student reads the number to the other who enters it on the calculator.

Calculator code to find total number of minutes

Add minutes and store in memory:

minute  $\boxed{+}$  minute  $\boxed{+}$  minute...  $\boxed{=}$   $\boxed{M+}$

Add seconds, divide by 60 and add to minutes in memory:

seconds  $\boxed{+}$  seconds  $\boxed{+}$  seconds...  $\boxed{=}$   $\boxed{+}$   $\boxed{60}$   $\boxed{=}$

$\boxed{M+}$   $\boxed{MRC}$

Read the whole number on the display (disregard the decimal portion of the number on the display).

Discuss with students why the whole number portion of the answer is sufficient for this problem. The decimal portion represents a fraction of a minute or only a few seconds. The whole number is accurate to within 1 minute which is close enough for this situation and grade level.

[answer: Mary needs a 60-minute tape.]

• **INDEPENDENT PRACTICE:**

1. Students decide on an activity that could be timed (Examples: sharpen pencils, tie and untie shoes, walk a given distance, clean up desk, write alphabet, write numbers from 1 to 50, etc.).
2. Students make individual, group, and class estimates for the chosen activity. Students record their estimates on the Student Activity Sheet.
3. Groups perform the activity and record the individual times on the activity sheet.
4. The groups find and record a group total.
5. Record each group's total on the board.
6. Students determine a classroom total using a calculator. Half the students could use a calculator and the other half use paper and pencil to allow comparison.

The classroom totals may exceed 60 minutes. Explain to students that totals can be left in minutes or can be converted to hours and minutes.

Discuss these questions:

Can the decimal portion of the answer be disregarded?

Will the same calculator code work?

When students reach a total on the calculator remind them that they read only the whole number on the display. The decimal in this problem represents a very small amount of time.

Would you always disregard the decimal portion of an answer? In what situation might you want an exact answer (minutes and seconds)?

- **EVALUATION:**

Students use the calculator sequence to find a total from several times listed on the board or overhead.

- **HOME ACTIVITY:**

Decide upon an activity at home that could be timed. Time your family members (or friends) doing the activity. Find a time total for the activity using the calculator.

**Transparency**

**TIME CODES**

**Song times on Joe's tape:**

- 5:42        Help**
  
- 6:07        Revolution**
  
- 3:59        Hey Jude**
  
- 5:35        Norwegian Wood**
  
- 6:37        Yesterday**
  
- 6:54        She Loves You**
  
- 4:29        Rocky Raccoon**
  
- 7:02        Yellow Submarine**
  
- 5:36        Magical Mystery Tour**
  
- 4:15        Sergeant Pepper**

## TIME CODES Student Activity Sheet

Decide on an activity: \_\_\_\_\_



Use the chart to record each student's name, estimated time, and actual time for your group's activity.

Student	Estimated time	Actual time
	min : sec	min : sec
1.	:	:
2.	:	:
3.	:	:
4.	:	:
5.	:	:

Group total: \_\_\_\_\_ mins. \_\_\_\_\_ mins.

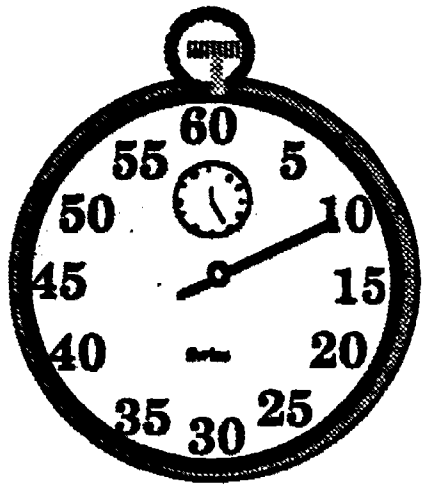

Class total: \_\_\_\_\_ mins \_\_\_\_\_ mins.



## RADIO TIME

- GRADE:** 4
- STRAND:** Measurement
- SKILL:** Add and multiply quantities of time
- MANAGEMENT**
- CLASS ORGANIZATION:** Whole class and small groups
- TIME FRAME:** Two class periods
- MATERIALS:** Calculator
- VOCABULARY:** Memos, announcements, commercials
- PREREQUISITE SKILL:** Mathematics: Basic operations  
Calculator: Basic functions, memory feature

**LESSON** The purpose of this lesson is to add and multiply quantities of time in a problem solving situation.

**DIRECTED INSTRUCTION/ GUIDED PRACTICE:**

Read the story to the students so they can decide what the problem is and how to solve it.

The local radio station, KMTH, is having a week-long celebration to honor the area's top math students. The station will play the top 50 hits, run a special contest, and air interviews with a few of the students.

The program directors, Evelyn Equation and Sara Subtraction, need input from each of the departments so that they can tell "Sales" how much air time to sell in advertising.

**Steps of the lesson:**

Distribute the Job Assignment Memos and Student Activity Sheet 1 to each group of four.

**Fact Finding:**

Read the questions.

Read the information cards. (Job Assignment Memos)

Write in the column the number of the card that has the information you need to answer the question.

**Reporting:**

Students record the information they need to answer the first exercise.

**Sequence:**

Use the following steps to compute the total hours and minutes.

Find the total number of hours for the celebration from Wednesday at 10:00 a.m. to Sunday at 10:00 p.m.

Wednesday	<u>14</u>	hours
Thursday	<u>24</u>	hours
Friday	<u>24</u>	hours
Saturday	<u>24</u>	hours
Sunday	<u>22</u>	hours
Total hours	<u>108</u>	
Total minutes available	<u>6480</u>	

Continue to guide the students through the remaining exercises.

Find the total time for records played.

Suggested sequence to find total playing time for top 50 records:

Top 10 records played 20 times each equals 200 plays  
 $10 \times 20 = 200$

Second 15 records played 12 times each equals 180 plays.  
 $15 \times 12 = 180$

Bottom 25 records played 7 times each equals 175 plays.  
 $25 \times 7 = 175$

Total records played = 555

5 minutes/record  $\times$  555 records = 2775 minutes total playing time

Find the total time needed for news programs.

$108 \times 15 = 1620$ : 108 newscasts  $\times$  15 min/newscast = 1620 minutes

Find the total time needed for the interviews.

13 interviews  $\times$  10 minutes/interview = 130 minutes

Find the total time needed for the contest announcements.

$(108 \times 2)$  contest announcements  $\times$  4 min/announcement = 864 minutes

Add the totals for records, news, interviews and contest announcements.

$2775 + 1620 + 130 + 864 = 5389$  minutes

Subtract that from the total number of minutes in the celebration.

$6480 - 5389 = 1091$

Try the following calculator sequence:

$\underline{\quad 6480 \quad}$ total minutes available	M +	
$\underline{\quad 108 \quad}$ number of hours	x	$\underline{\quad 15 \text{ min.} \quad}$ length of newscast
= M -		
$\underline{\quad 216 \quad}$ numbers of half hours	x	$\underline{\quad 4 \text{ min.} \quad}$ length of announcement
= M -		
$\underline{\quad 13 \quad}$ number of interviews	x	$\underline{\quad 10 \text{ min.} \quad}$ length of interview
= M -		
$\underline{\quad 555 \quad}$ number of records	x	$\underline{\quad 5 \text{ min.} \quad}$ length of record
= M - (Assuming 5 min. per record)		
total playing time $\underline{\quad 1091 \quad}$ answer (minutes available for commercials)		
R-CM		

• **INDEPENDENT PRACTICE:**

(Day 2) Students work in groups using a calculator to complete Student Activity Sheet 2.

Before students begin the activity, review how to find a time total on the calculator. Refer to the lesson **TIME CODES** in which students used the memory features of the calculator to find totals of time. They should round the total on the calculator to the nearest minute. Read the activity sheet with students before they begin.

Top 10 songs: 47 min. 325 sec. = 52.4 min → 52 min x 20 = 1040 min.

Next 15 songs: 63 min. 345 sec. = 68.75 min → 69 min. x 12 = 828 min.

Bottom 25 songs: 4 min. x 25 x 7 = 700 min.

30 sec. x 25 x 7 = 5250 sec = 87.5 min. = 88 min.

Total: (playing time all records): 1040 + 828 + 788 = 2656 min.

Time for commercials: 6480 - 1620 - 864 - 130 - 2656 = 1210 min.

• **EVALUATION:**

Teacher observation.

• **HOME ACTIVITY:**

Students find out how much time is spent watching T.V. in a week, how much free time they have after doing chores, getting ready for school, sleeping or going to school.

**RADIO TIME**  
**JOB ASSIGNMENT MEMOS**

<p><b>KMTH - MEMO- # 1</b></p> <p><b>TO: RANDY RATIO</b></p> <p><b>FROM: EVELYN AND SARA</b></p> <p><b>- PLAY TOP 10 TUNES 20 TIMES</b></p> <p><b>- PLAY SONGS #11 - 25 12 TIMES</b></p>	<p><b>KMTH - MEMO - # 2</b></p> <p><b>TO: FRIEDA FRACTION</b></p> <p><b>FROM: EVELYN AND SARA</b></p> <p><b>- PLAY SONGS #26 - 50 7 TIMES</b></p> <p><b>- EACH RECORD LASTS 4 TO 6 MIN.</b></p> <p><b>- (That is an average of 5 min.)</b></p>
<p><b>KMTH - MEMO- # 3</b></p> <p><b>TO: MONTE MULTIPLICATION</b></p> <p><b>FROM: EVELYN AND SARA</b></p> <p><b>- HAVE A 15-MIN. NEWSCAST EVERY HOUR</b></p>	<p><b>KMTH - MEMO - # 4</b></p> <p><b>TO: DANNY DIVISION</b></p> <p><b>FROM: EVELYN AND SARA</b></p> <p><b>- CONDUCT 6 INTERVIEWS WITH RECORDING ARTISTS</b></p> <p><b>- CONDUCT 7 INTERVIEWS WITH MATH STUDENTS</b></p> <p><b>- EACH INTERVIEW LASTS 10 MIN.</b></p>
<p><b>KMTH - MEMO- # 5</b></p> <p><b>TO: ALICE ADDITION</b></p> <p><b>FROM: EVELYN AND SARA</b></p> <p><b>- MAKE A 4-MIN. CONTEST ANNOUNCEMENT EACH HALF HOUR</b></p>	<p><b>KMTH - MEMO - # 6</b></p> <p><b>TO: EVELYN AND SARA</b></p> <p><b>FROM: THE BOSS</b></p> <p><b>- HOW MUCH TIME WILL THERE BE FOR COMMERCIALS?</b></p>

**RADIO TIME**  
Student Activity Sheet 1

**Card Number**

1. Find the total time available.  
The celebration runs from Wednesday at 10:00 a.m. to Sunday at 10:00 p.m.

\_\_\_\_\_ = \_\_\_\_\_  
hours                          minutes

2. Find the total playing time for the top 50 records.

\_\_\_\_\_  
total minutes

3. Find the total time needed for newscasts.

\_\_\_\_\_  
total minutes

4. Find the total time needed for interviews.

\_\_\_\_\_  
total minutes

5. Find the total time needed for the contest announcements.

\_\_\_\_\_  
total minutes

6. Use the memory feature of the calculator to find how many minutes are available to KMTN for commercials.

\_\_\_\_\_  
minutes available for commercials

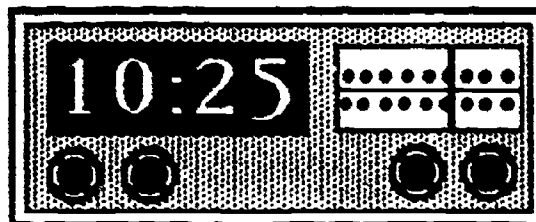

**RADIO TIME**  
**Student Activity Sheet 2**  
**(2nd Day)**

Read the story. Use the record times and the information from Student Activity Sheet 1 to complete this activity.

**Story:**

Evelyn Equation and Sara Subtraction, the station managers at KMTH, decided they needed an exact time total for the records to be played during the celebration. They asked Randy Ratio and Frieda Fraction to list the playing time for each record. Use their list and the information below to find out how much time is available for commercials.

- Newcasts - 15 minutes every hour
- Contest Announcements - 4 minutes every half hour
- Interviews - 13 interviews each lasting 10 minutes
- Contest begins Wednesday at 10:00 a.m. and runs to Sunday at 10:00 p.m.

**Playing Times for Top 50 songs:**

<u>Top 10</u> (20 times each)	<u>2nd 15</u> (12 times each)
1 - 4:15	11 - 4:00
2 - 6:00	12 - 4:05
3 - 5:25	13 - 4:10
4 - 5:37	14 - 4:15
5 - 4:51	15 - 4:20
6 - 5:49	16 - 4:25
7 - 4:30	17 - 4:30
8 - 5:29	18 - 4:35
9 - 4:42	19 - 4:40
10 - 5:47	20 - 4:45
	21 - 4:50
	22 - 4:55
	23 - 5:00
	24 - 5:05
	25 - 5:10

Bottom 25 songs - all songs 4:30 long (7 times each)

**Top 10 songs:**

$$\begin{array}{r}
 \text{total minutes} \quad \xrightarrow{\quad} \quad \text{rounded to nearest} \quad \times 20 = \quad \text{total playing time} \\
 \text{minute}
 \end{array}$$



**RADIO TIME**  
Student Activity Sheet 2

Next 15 songs

$$\frac{\text{total minutes}}{\text{rounded to nearest minute}} \times 12 = \text{total playing time}$$

Calculator sequence to find total playing time for "bottom 25" songs

$$\text{minutes} \times \text{number of songs} \times \text{plays/song} = \text{M+}$$

$$\text{seconds} \times \text{number of songs} \times \text{plays/song} = + 60 =$$

$$\text{M+} \quad \text{RCM} \quad \text{total playing time "Bottom 25" records}$$

Find total time available for commercials (calculator sequence)

Total minutes available \_\_\_\_\_ M+

Newscast minutes \_\_\_\_\_ M-

Announcement minutes \_\_\_\_\_ M-

Interview minutes \_\_\_\_\_ M-

Record playing time \_\_\_\_\_ M-

$$\text{RCM} \quad \text{minutes available for commercials}$$

## CARRIER CONVERSIONS

- GRADE :** 3 - 4
- STRAND:** Measurement
- SKILL:** Convert units within a measurement system
- MANAGEMENT**
- CLASS ORGANIZATION:** Small groups
- TIME FRAME:** One class period
- MATERIALS:** Calculator
- VOCABULARY:** Ultra-large, observations, capacity, tons, pounds, yards, feet, inches

**PREREQUISITE SKILLS:** Mathematics: Basic operations  
Calculator: Basic functions

**LESSON** The purpose of this lesson is to use the calculator to convert units within the same measurement system.

• **DIRECTED INSTRUCTIONS:**

Discuss conversion within the same measurement system. Ask students: How do you convert feet to inches? (answer: multiply number of feet by 12)

How do you convert yards to feet? (answer: multiply number of yards by 3)

How do you convert tons to pounds? (answer: multiply number of tons by 2,000)

• **GUIDED PRACTICE:**

Write these examples on the chalkboard.  
Students work the examples using a calculator:

1) Convert 12 feet to inches  
12 feet = \_\_\_\_\_ inches  
[answer: 12 feet x 12 inches/foot = 144 inches]

2) Convert 54 yards to feet  
54 yards = \_\_\_\_\_ feet  
[answer: 54 yards x 3 feet/yard = 162 feet]

3) Convert 50 tons to pounds  
50 tons = \_\_\_\_\_ pounds  
[answer: 50 tons x 2000 pounds/ton = 100,000 pounds]



- **INDEPENDENT PRACTICE:**  
Students work in small groups to complete Student Activity Sheet.  
  
Read the information given on the chart about the Ultra-Large Crude Carrier.  
  
Discuss what they could do with the information (compare size of tanker to something in their environment, draw a scaled diagram, etc.) Encourage them to be as creative as possible.
- **EVALUATION:**  
Groups develop questions about information on the chart that they could ask other groups.
- **HOME ACTIVITY:**  
Students use the newspaper to find an article about the current price of oil or about an oil spill.

**CARRIER CONVERSIONS**  
Student Activity Sheet



An oil tanker sailed into the Persian Gulf filled with crude oil. This ship is one of 20 ultra-large crude oil carriers. The facts about this ship are on the chart:

**Ultra-Large Crude Carrier (ULCC)**

length	400 yards
width	77 yards
weight	4,582 tons
capacity	33,586 barrels (1 barrel=42 gallons)

Working in small groups have the students do the following activities using a calculator.

1. Using the information on the chart:

Find the length and width of the ship in feet and inches.

<u>length</u>	<u>width</u>
_____ feet	_____ feet
_____ inches	_____ inches

Find the weight of the ship in pounds.

\_\_\_\_\_ pounds

Find the capacity of the ship in gallons.

\_\_\_\_\_ gallons

2. The price of crude oil changes all of the time. It can sell for as little as \$12.00 a barrel or as much as \$37.00 a barrel. What is the value of the ship's cargo at the lowest price per barrel? What is the value at the highest price per barrel? Write a sentence for your answer.

lowest: \_\_\_\_\_  
\_\_\_\_\_  
\_\_\_\_\_

highest: \_\_\_\_\_  
\_\_\_\_\_  
\_\_\_\_\_

**CARRIER CONVERSIONS**  
Student Activity Sheet

3. Pretend each person in your group is the captain of an ULCC. How long a line would your tankers make if they were lined up end to end (stern to bow)? Give your answer in yards, feet, and inches.

\_\_\_\_\_ yds. = \_\_\_\_\_ feet = \_\_\_\_\_ inches.

What other ways could you arrange your tankers? What type of measurements could you find?

4. In 1978, a tanker named the Amoco Cadiz went aground near France and spilled 273,000 tons of oil into the Atlantic Ocean. To find out how many barrels of oil this was, multiply the number of tons by the number of barrels in a ton:

number of tons x 7.33 barrel/ton = number of barrels.

Other oil accidents happened:

1979 - Two tankers collided and spilled 300,000 tons of oil.

1983 - An oil well fire burned 250,000 tons of oil.

1989 - The Exxon Valdez spills 240,000 barrels of oil along the Alaskan coast

Find the number of barrels of oil lost in each accident.

1978 oil spill \_\_\_\_\_ barrels

1979 oil spill \_\_\_\_\_ barrels

1983 oil fire \_\_\_\_\_ barrels

1989 oil spill \_\_\_\_\_ tons

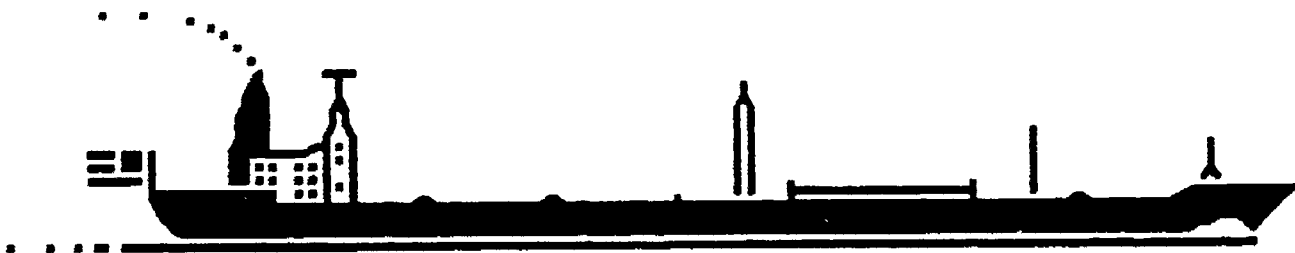

**CARRIER CONVERSIONS**  
Teacher Answer Sheet

An oil tanker sailed into the Persian Gulf filled with crude oil. This ship is one of 20 ultra-large crude oil carriers. The facts about this ship are on the chart:

Ultra-Large Crude Carrier (ULCC)

length	400 yards
width	77 yards
weight	4,582 tons
capacity	33,586 barrels (1 barrel=42 gallons)

Working in small groups have the students do the following activities using a calculator.

1. Using the information on the chart:

Find the length and width of the ship in feet and inches.

<u>length</u>		<u>width</u>
<u>1200</u> feet		<u>231</u> feet
<u>14,400</u> inches		<u>2,772</u> inches

Find the weight of the ship in pounds.

9,164,000 pounds

Find the capacity of the ship in gallons.

1,410,612 gallons

2. The price of crude oil changes all of the time. It can sell for as little as \$12.00 a barrel or as much as \$37.00 a barrel. What is the value of the ship's cargo at the lowest price per barrel? What is the value at the highest price per barrel? Write a sentence for your answer.

lowest: \$403,032

highest: \$1,242,682

**CARRIER CONVERSIONS**  
Teacher Answer Sheet

3. Pretend each person in your group is the captain of an ULCC. How long a line would your tankers make if they were lined up end to end (stern to bow)? Give your answer in yards, feet, and inches. (Answers will vary)

\_\_\_\_\_ yds. = \_\_\_\_\_ feet = \_\_\_\_\_ inches.

What other ways could you arrange your tankers? What type of measurements could you find?

4. In 1978, a tanker named the Amoco Cadiz went aground near France and spilled 273,000 tons of oil into the Atlantic Ocean. To find out how many barrels of oil this was, multiply the number of tons by the number of barrels in a ton:

number of tons x 7.33 = number of barrels.

Other oil accidents happened:

1979 - Two tankers collided and spilled 300,000 tons of oil.

1983 - An oil well fire burned 250,000 tons of oil.

1989 - The Exxon Valdez spills 240,000 barrels of oil along the Alaskan coast

Find the number of barrels of oil lost in each accident.

1978 oil spill 2,001,090 barrels

1979 oil spill 2,199,000 barrels

1983 oil fire 1,832,500 barrels

1989 oil spill 32,742 tons

142

## MISS BETTY AND THE BEANS

- GRADE:** 3 - 4
- STRAND:** Measurement
- SKILL:** Estimate and measure volume/capacity in standard units
- MANAGEMENT**
- CLASS ORGANIZATION:** Small groups
- TIME FRAME:** One class period
- MATERIALS:** Pint containers, beans, tablespoon, calculator
- VOCABULARY:** Sample, approximate
- PREREQUISITE SKILLS:** Mathematics: Basic operations  
Calculator: Basic functions

### **LESSON**

The purpose of this lesson is to approximate the number of objects that will fill a specific container.

#### • **DIRECTED INSTRUCTION/GUIDED PRACTICE:**

Miss Betty, the cafeteria lady, has to report how many beans are in the gallon containers in the storeroom. She does not want to count them one-by-one. Is there a better way to find the number of beans? Discuss taking a sample and using that information to find the total.

#### • **INDEPENDENT PRACTICE:**

Give each group a pint container filled with beans and a tablespoon measure. Students take a sample by filling the tablespoon with beans, and then counting them. Record the results in Part A on the Student Activity Sheet.

Each group estimates and records how many tablespoons of beans are in their container.

Students determine the number of tablespoons of beans in their containers. Record on the Student Activity Sheet.

Compare and discuss group results. Use the calculator:

Enter the number in the sample

Press

Enter the number of tablespoons

Press

The number displayed will be the approximate total of beans per pint container.

Discuss the group totals.

Each group completes Part B on the Student Activity Sheet.

# beans/pint x 2 pints/quart x 4 quarts/gallon = # beans/gallon.

Students' answers will vary depending on their sample.

- **EVALUATION:**

Class discussion and teacher observation.

- **HOME ACTIVITY:**

Students find other containers at home and calculate their capacity.  
Students calculate the number of beans the containers will hold.

# MISS BETTY AND THE BEANS

## Student Activity Sheet

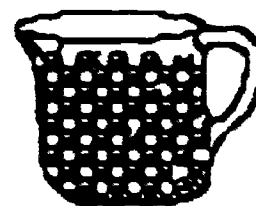
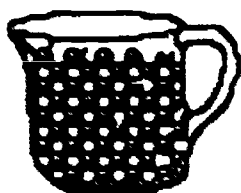

Miss Betty needs to find out how many beans are in a one gallon jar.

A. Number of beans in a tablespoon \_\_\_\_\_

Estimate number of tablespoons  
in the pint container: \_\_\_\_\_

Number of tablespoons in the  
pint container: \_\_\_\_\_

Approximate number of beans in the pint  
container: \_\_\_\_\_

How did you get the approximation of the answer above? \_\_\_\_\_

B. Use this information to answer the questions.



Number of beans in your pint container \_\_\_\_\_

2 pints = 1 quart

4 quarts = 1 gallon

(Miss Betty gets 5 one-gallon jars of beans each week.)

Miss Betty has two one-gallon jars of beans left in the storeroom.

Approximately how many beans has she used this week? \_\_\_\_\_

Approximately how many beans are left in the storeroom? \_\_\_\_\_



## CHAPTER 2 ASSESSMENT: MEASUREMENT

1.

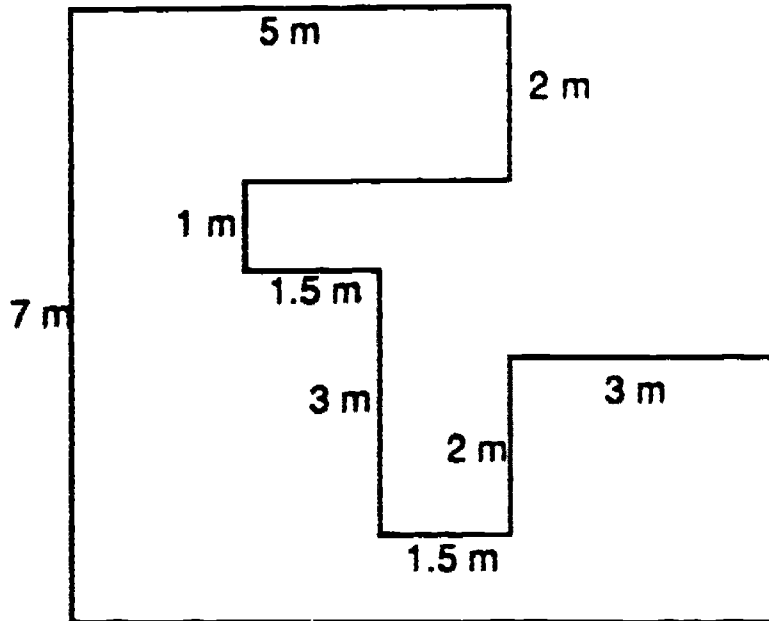

Explain how you would find the area of the floor space in this diagram. Draw a picture, make a table, or whatever you need to show how you got your answer.

1 cm = 1 m

Student responses should include:

- a. division of space into its component rectangles
- b. sides/segments labeled with measurements which complete unspecified edges
- c. computation, including multiplication of various lengths and widths, and subtraction and/or addition of the component rectangles

for example:

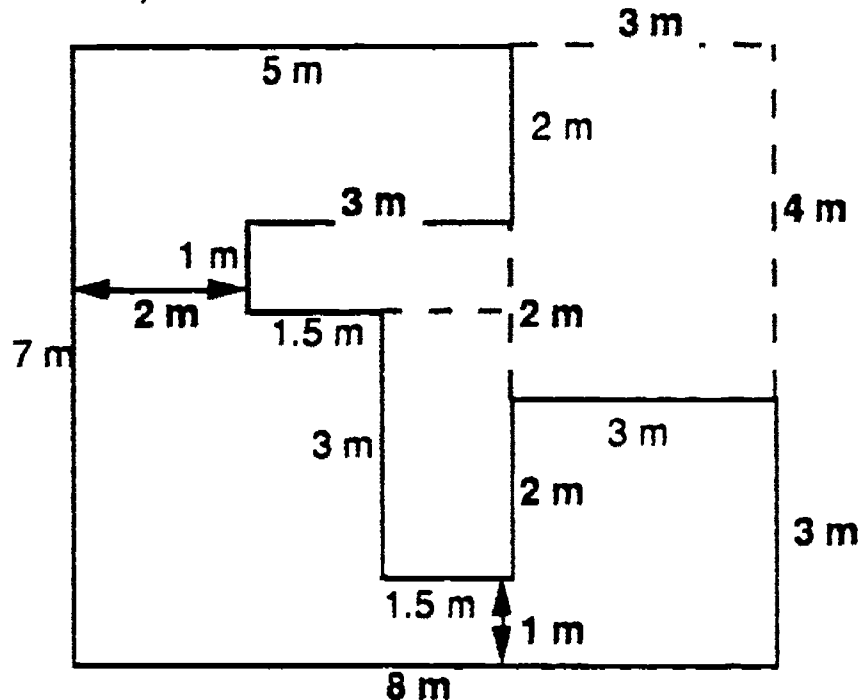

$7 \times 8 =$	<u>56 sq m</u>
$(3 \times 4) =$	<u>12 sq m</u>
$(1 \times 3) =$	<u>3 sq m</u>
$41 \text{ sq m}$	
$(1.5 \times 3) =$	<u>4.5 sq m</u>
	answer: 36.5 sq m

146

116

2. Measure and record the lengths on the map in inches and miles. Find the shortest route to each destination.

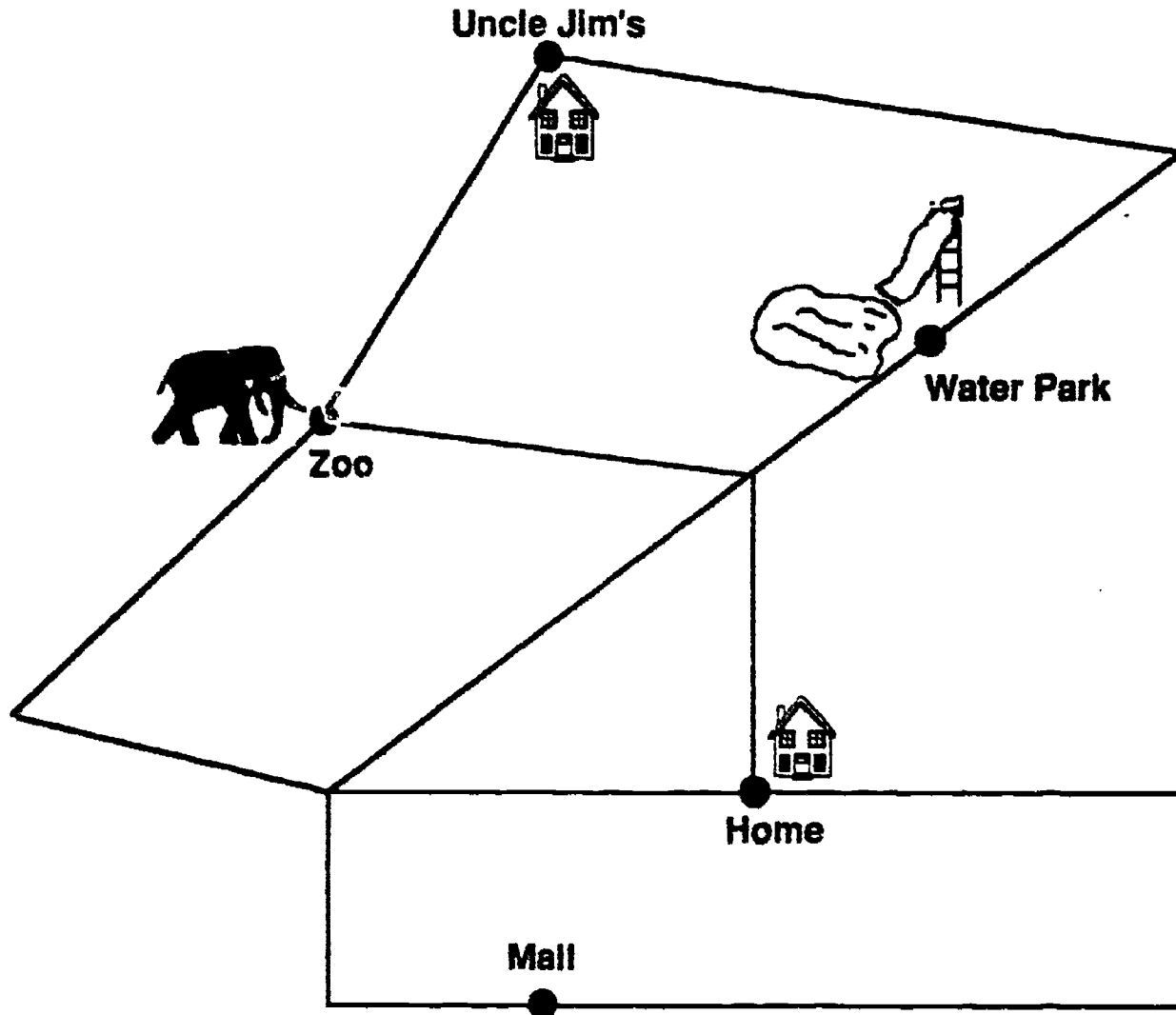
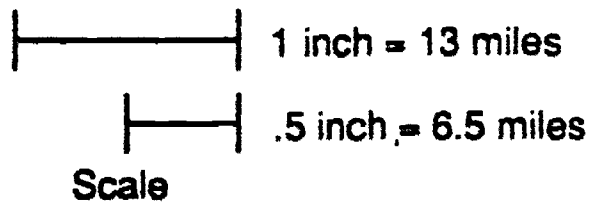

- From Home to Uncle Jim's \_\_\_\_\_
- From Home to the Mall \_\_\_\_\_
- From Home to the Water Park, to the Zoo, and back home  
\_\_\_\_\_
- The shortest route from Uncle Jim's to the Mall? \_\_\_\_\_
- The longest route from the Mall to Uncle Jim's? You may not use the same road twice. \_\_\_\_\_

Student responses should include:

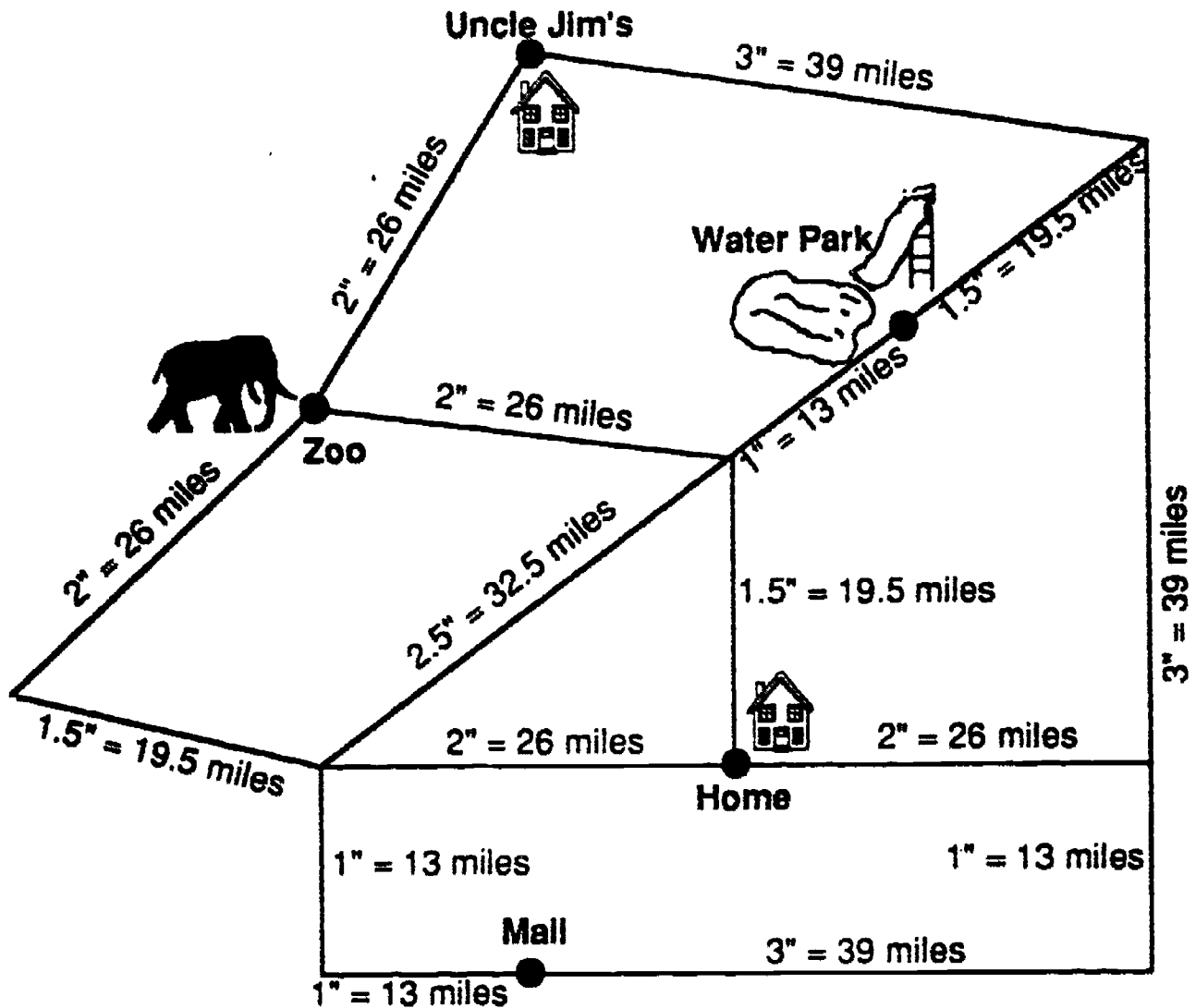

- From Home to Uncle Jim's [ $5.5'' = 71.5$  miles]
- From Home to the Mall [ $4'' = 52$  miles]
- From Home to the Water Park, to the Zoo, and back home [ $9'' = 117$  miles]
- The shortest route from Uncle Jim's to the Mall? [ $7.5'' = 97.5$  miles]
- The longest route from the Mall to Uncle Jim's? You may not use the same road twice. [answers will vary]

3.

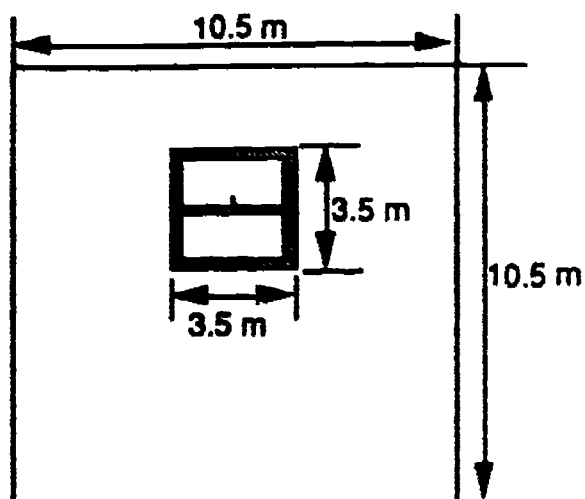

A painter has to paint a wall. He knows that one quart of paint will cover 20 sq meters. How much paint should he buy? Remember you don't paint windows!

- What is the area of the window? \_\_\_\_\_
- What is the area of the wall? \_\_\_\_\_
- What is the area that needs to be painted? \_\_\_\_\_
- How many quarts of paint does the painter need to buy and why? \_\_\_\_\_

Student response should include:

- Find the area of the window [ $3.5 \times 3.5 = 12.25$ ]
- Find the area of the wall [ $10.5 \times 10.5 = 110.25$ ]
- Find the difference [ $110.25 - 12.25 = 98$  sq m]
- The painter must buy 5 quarts of paint.

4. Magic Johnson makes 590 freethrows over a season. The freethrow line is 18 feet from the basket. There are 5280 feet in a mile. How many miles has Magic shot? How many yards? How many feet? How many inches?

\_\_\_\_\_ miles                      \_\_\_\_\_ feet  
 \_\_\_\_\_ yards                      \_\_\_\_\_ inches

Student responses should include:

2.01 miles                      10620 feet  
3540 yards                      127,440 inches

# CAMP-LA

Calculators and Mathematics Project, Los Angeles

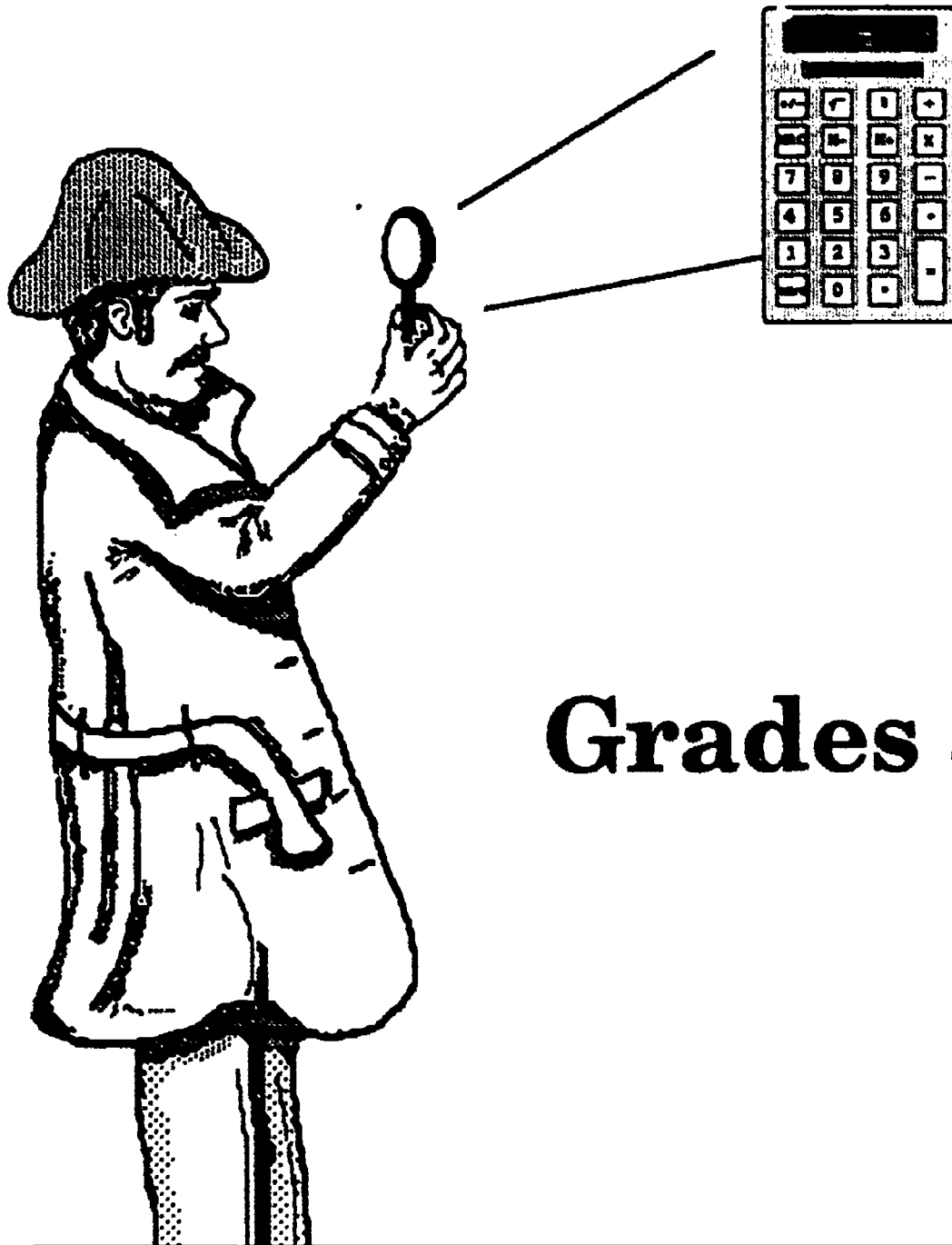

Grades 3 - 4

## CHAPTER 3 GEOMETRY

## POLYGONS' PERIMETERS

**GRADE:** 3 - 4  
**STRAND:** Geometry  
**SKILL:** Estimate and measure perimeter

### **MANAGEMENT**

**CLASS ORGANIZATION:** Small groups

**TIME FRAME:** One class period

**MATERIALS:** Calculators, pencils, 30 cm rulers, scissors, transparency of Student Activity Sheet 1

**VOCABULARY:** Polygons, square, rectangle, triangle, parallelogram, rhombus, trapezoid

**PREREQUISITE SKILL:** Mathematics: Basic operations, knowledge of perimeter  
Calculator: Basic functions

**LESSON** The purpose of this lesson is to measure, compute, and record perimeters of regular and irregular polygons using standard measurement.

#### • DIRECTED INSTRUCTION:

Review perimeter. Direct students to use the cm ruler and the calculator to determine the perimeter of the desk or table at which they are seated.

Distribute Student Activity Sheets 1 and 2. Project the transparency of Student Activity Sheet 1 and identify the polygons while students write the names of the polygons on the appropriate shapes. Tell students that they will measure the perimeter of each polygon to the nearest centimeter and record that measure on Student Activity Sheet 2.

Direct students to carefully cut out the polygons after they have measured them.

#### • GUIDED PRACTICE:

Students combine polygons A and B so that they have sides which are congruent.



(For this lesson, all polygons will be combined on sides that are congruent. Thus the common sides are not a part of the perimeter of polygon AB.)

#### • INDEPENDENT PRACTICE:

Students complete Student Activity Sheet 2

- **EVALUATION:**

Write a description of how the perimeters of polygons are affected when the shapes are joined on one side.

What kind of a formula for this change could you write to help another student understand what happens?

When was it helpful to use the calculator?

- **HOME ACTIVITY:**

Measure the perimeter of various shapes in your home. Work with a parent. Record both parent's and student's estimates and the actual measures on the record sheet.



**POLYGONS' PERIMETERS**  
Student Activity Sheet 1

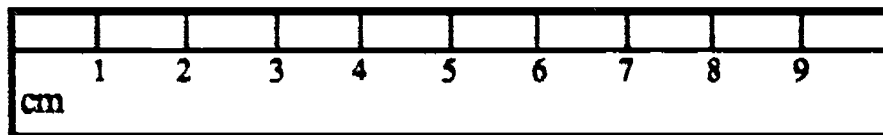
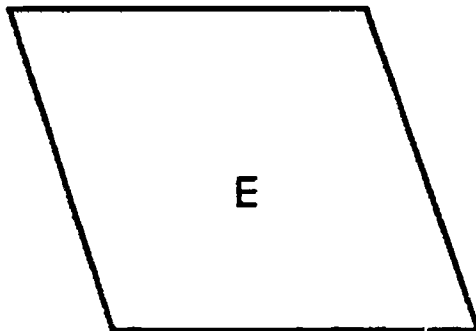
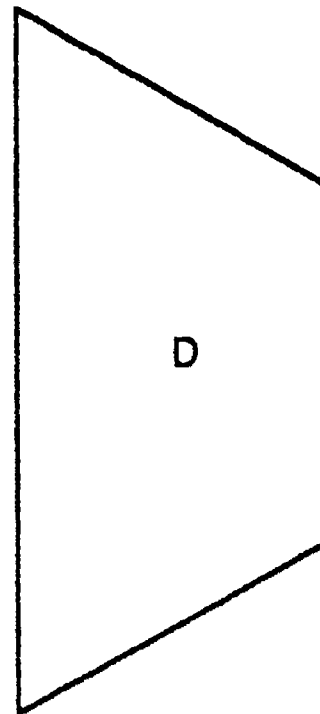
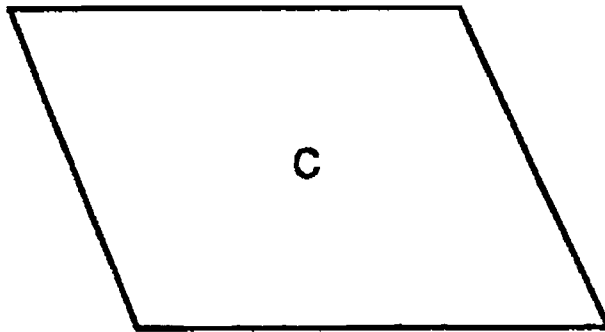
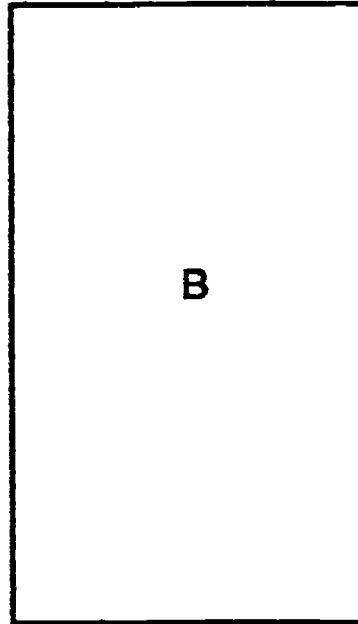
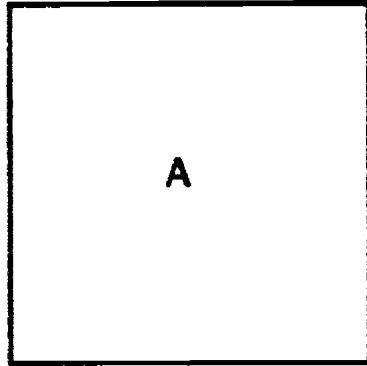





**POLYGONS' PERIMETERS**  
Student Activity Sheet 2

Work with a partner. Measure the sides of the polygons to the nearest cm. Use your calculator to find the total measure of the perimeter. Record your answers.

A. \_\_\_\_\_ B. \_\_\_\_\_ C. \_\_\_\_\_ D. \_\_\_\_\_ E. \_\_\_\_\_

1. Cut out the polygons. Combine the polygons, edge to edge, to form other polygons. Estimate the perimeter, then measure to the nearest cm. Use your calculator to find the total measure of the perimeter.

Polygons	Estimated Perimeter	Actual Perimeter	Difference between estimated and actual
A,B	50 cm	53.4	

2. Write a sentence that tells how you made your estimates.

---



---

3. What combination of polygons will give the greatest perimeter? Draw the resulting figure.

What is the perimeter? \_\_\_\_\_

# POLYGONS' PERIMETERS

## Home Activity Recording Sheet

Find the face (side) of something at home, like the top of a stair step or the front of the TV, and find the perimeter of this polygon.

Work with a parent. Write the name of the items you will measure. Write your parent's estimate and your estimate. Measure and record the perimeters.

What I will measure	Parent's estimate	My estimate	Actual measurement



## WHAT IS THE AREA?

**GRADE:** 3 - 4  
**STRAND:** Geometry  
**SKILL:** Estimate and find the area of a plane figure.

### **MANAGEMENT**

**CLASS ORGANIZATION:** Pairs  
**TIME FRAME:** Two class periods  
**MATERIALS:** Calculator, metric ruler, transparency, transparent metric ruler (for teacher)  
**VOCABULARY:** Rectangle, area, length, width, cm, mm,  $\text{cm}^2$ , approximate  
**PREREQUISITE SKILL:** Mathematics: Basic operations, linear measure to the nearest millimeter  
Calculator: Basic functions

### **LESSON**

The purpose of this lesson is to develop understanding of area. Students progress from counting squares, to computing area from length and width, to drawing rectangles with the approximate areas given.

#### • **DIRECTED INSTRUCTION:**

Display the transparency and read the following story:

The playground planners have planted grass and trees around the equipment spaces. Before they decide what equipment to put in each space, they need to know the area of each one. Look at the diagram of the park. The first play space has a grid on it. How can we use the grid to find the area? [answer: Count the squares.] What is the area? [answer: 30 square units]

Demonstrate how to count centimeter units along the length. Do the same for the width. Write the number on the transparency.

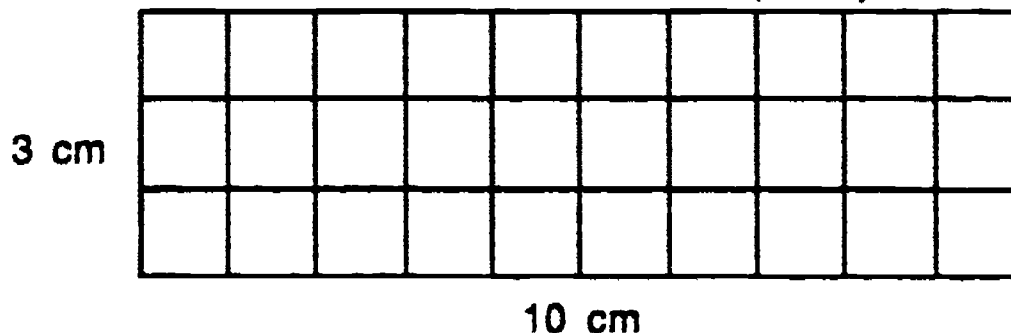

Multiply to find the area:  $10 \times 3 = 30$ . The area is  $30 \text{ cm}^2$ .

Look at the second play space. How does it compare to the first one?  
[answer: It is larger.] Estimate the area of this rectangle. Write the estimates on the board.

Demonstrate how to measure the length and width with a transparent metric ruler on the overhead projector. Write the dimensions on the chalkboard. Length = 10 cm and width = 4 cm.

Use a formula for finding area. The formula is: Area equal length times width ( $A = L \times W$ ). Substitute the numbers in the formula: ( $10 \times 4 = 40$ ). Area is expressed in square units. The area is  $40 \text{ cm}^2$ .

Have the students estimate the area of the other two play spaces. Measure and record the dimensions and find the areas in square centimeters.  
[answers:  $40 \text{ cm}^2$  and  $14 \text{ cm}^2$ ]

Students will draw some rectangles for the Home Activity Sheet. They will know the approximate area and will have to find the length and width.

• **GUIDED PRACTICE:**

Distribute Student Activity Sheet 1.

Students work with a partner to find the area of rectangles 1, 2, and 3.

Ask students why they haven't needed to use the calculator to find the areas of these rectangles. [answer: The numbers have been easy to calculate mentally.]

Note: Rectangle number 4 requires students to measure in millimeters.

Draw a 5.5 cm line on a transparency and measure it with the transparent ruler. Show how to count the millimeters and record the measure as 5.5 cm.

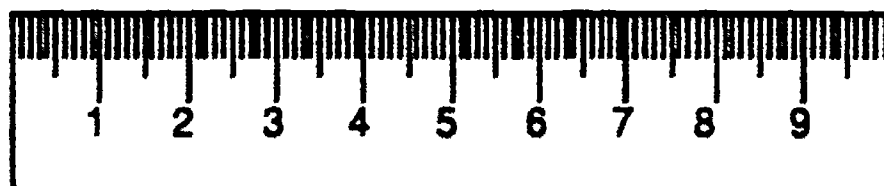

Extend the line three millimeters and record the measure as 5.8 cm.

Students measure the length and width of rectangle 4 to the nearest tenth of a cm, then use the calculator to compute the area of the rectangle.  
[answer:  $5 \times 4.8 = 24 \text{ cm}^2$ ]

Students measure rectangle 5 and use the calculator to compute the area. How is the area of rectangle 5 different from the area of rectangle 4? [answer:  $24.75 \text{ cm}^2$ ] The area is more than 24 and less than 25  $\text{cm}^2$  which is indicated by .75. Discuss the fact that the answer of 24.75 means the area is closer to 25.

• **INDEPENDENT PRACTICE:**

Complete Student Activity Sheet 2. Exercise 5 will require the students to use pairs of factors to find an area of  $65 \text{ cm}^2$ . Encourage the students to use factors which include whole numbers and decimals.

1.  $L = 3 \text{ cm}$   
 $W = 3 \text{ cm}$   
 $A = 9 \text{ cm}^2$

2.  $L = 5 \text{ cm}$   
 $W = 1.7 \text{ cm}$   
 $A = 8.5 \text{ cm}^2$

3.  $L = 7 \text{ cm}$   
 $W = 3 \text{ cm}$   
 $A = 21 \text{ cm}^2$

4.  $L = 5 \text{ cm}$   
 $W = 3.4 \text{ cm}$   
 $A = 17 \text{ cm}^2$

• **EVALUATION:**

Teacher observation.

• **HOME ACTIVITY:**

Complete the Home Activity Sheet.

Transparency

# WHAT IS THE AREA?

How much play area is in the park?

1.

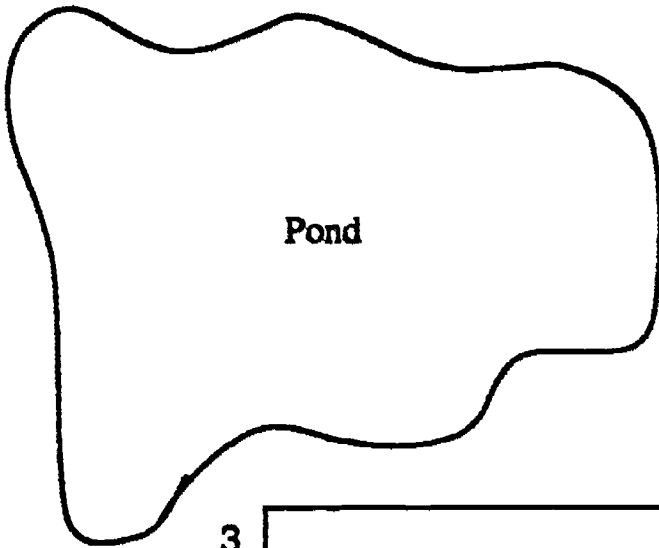
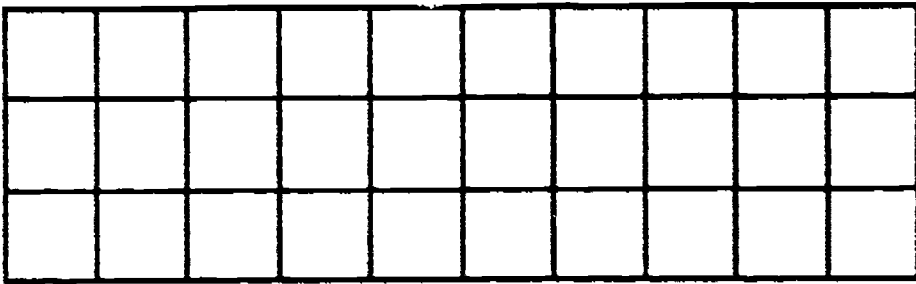

2.

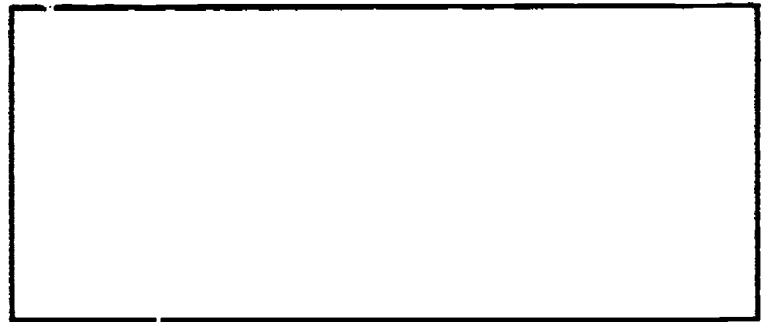

3.

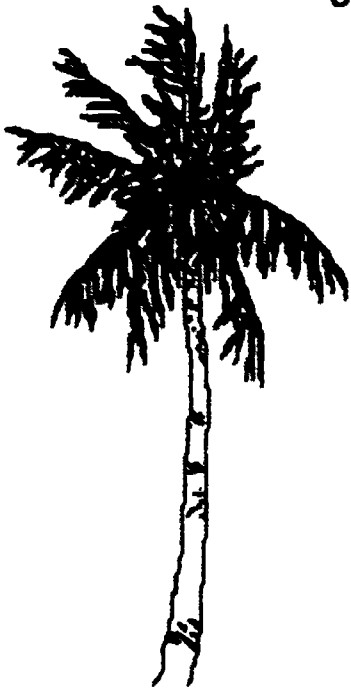
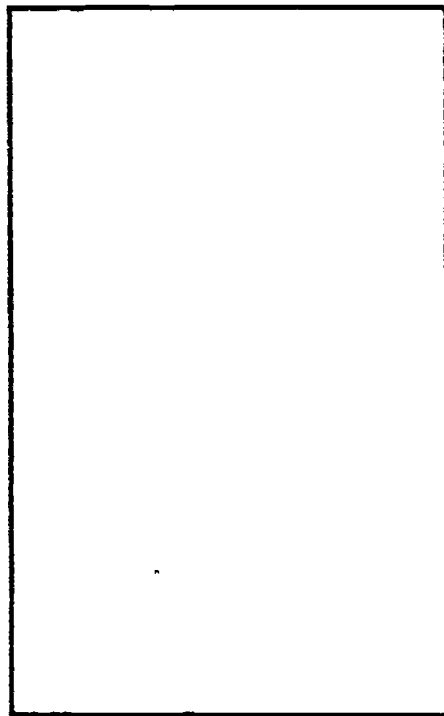

4.



**WHAT IS THE AREA?**  
**Student Activity Sheet 1**

1.

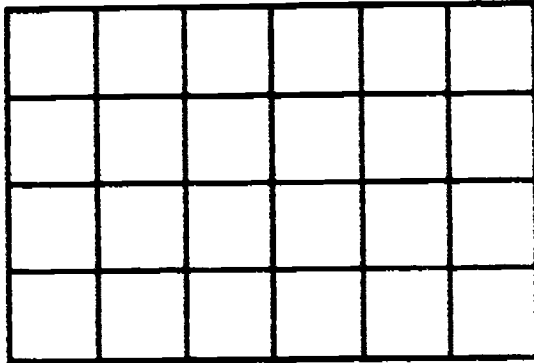

Count the squares.

The length is \_\_\_\_\_ cm

The width is \_\_\_\_\_ cm

The area is \_\_\_\_\_ cm<sup>2</sup>

2.

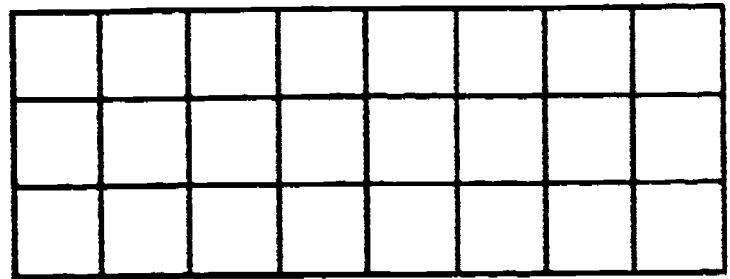

Count the squares.

The length is \_\_\_\_\_ cm

The width is \_\_\_\_\_ cm

The area is \_\_\_\_\_ cm<sup>2</sup>

3.

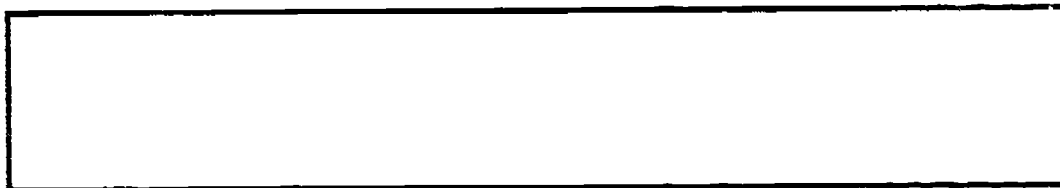

How can we find the area of this rectangle?

Measure to find the length and width.

The length is \_\_\_\_\_ cm

The width is \_\_\_\_\_ cm

Use your calculator. Enter \_\_\_\_\_  \_\_\_\_\_  \_\_\_\_\_ cm<sup>2</sup>

The area is \_\_\_\_\_ cm<sup>2</sup>

**WHAT IS THE AREA?**  
**Student Activity Sheet 1**

4.

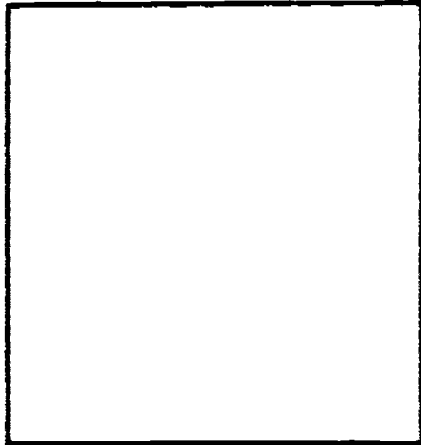

How can we find the area of this rectangle?  
Measure to find the length and width.

The length is \_\_\_\_\_ cm

The width is \_\_\_\_\_ cm

Use your calculator. Enter

The area is \_\_\_\_\_ cm<sup>2</sup>

\_\_\_\_\_ length  x  \_\_\_\_\_ width  = \_\_\_\_\_ cm<sup>2</sup>

Write a sentence or sentences that tell what you learned about the area of rectangles. \_\_\_\_\_

---

---

---

5.

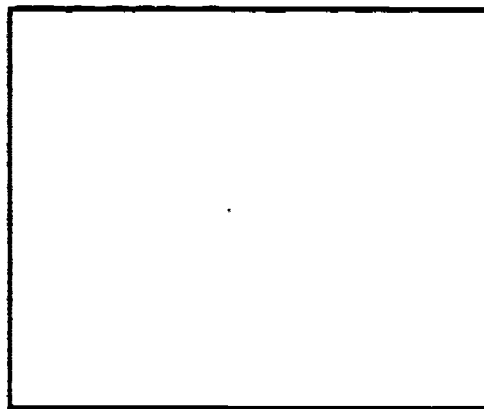

The length is \_\_\_\_\_ cm

The width is \_\_\_\_\_ cm

Use your calculator. Enter

The area is \_\_\_\_\_ cm<sup>2</sup>

\_\_\_\_\_ length  x  \_\_\_\_\_ width  = \_\_\_\_\_ cm<sup>2</sup>



**WHAT IS THE AREA?**  
**Student Activity Sheet 2**

1.

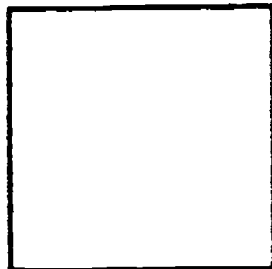

What is the area of this rectangle?

The length is \_\_\_\_\_ cm.

The width is \_\_\_\_\_ cm.

The area is \_\_\_\_\_ cm<sup>2</sup>.

2.

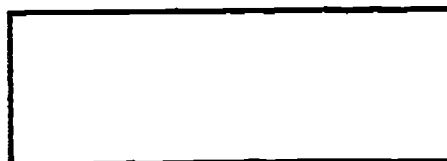

What is the area of this rectangle?

The length is \_\_\_\_\_ cm.

The width is \_\_\_\_\_ cm.

The area is \_\_\_\_\_ cm<sup>2</sup>.

3.

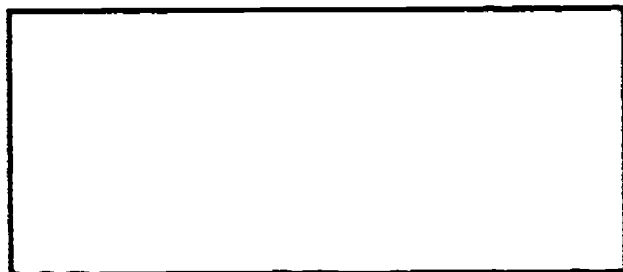

What is the area of this rectangle?

The length is \_\_\_\_\_ cm.

The width is \_\_\_\_\_ cm.

The area is \_\_\_\_\_ cm<sup>2</sup>.

4.

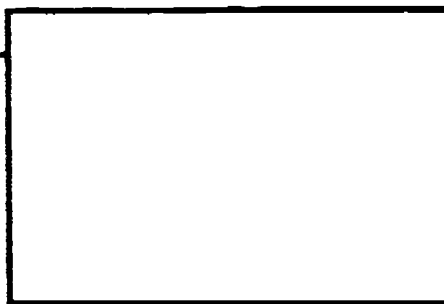

What is the area of this rectangle?

The length is \_\_\_\_\_ cm.

The width is \_\_\_\_\_ cm.

The area is \_\_\_\_\_ cm<sup>2</sup>.

**WHAT IS THE AREA?  
Student Activity Sheet 2**

5. Use this space to draw a rectangle with an area of approximately  $65 \text{ cm}^2$ .

Area = length x width

The length is \_\_\_\_\_cm.

The width is \_\_\_\_\_cm.

The area is \_\_\_\_\_ $\text{cm}^2$ .

Write a sentence that tells what you know about the area of a rectangle. \_\_\_\_\_

---

---

---

**WHAT IS THE AREA?**  
**Home Activity Sheet**

Use this space to draw a rectangle with an area approximately  $37 \text{ cm}^2$ .

Area = length x width

The length is \_\_\_\_\_ cm

The width is \_\_\_\_\_ cm

The area is \_\_\_\_\_  $\text{cm}^2$

Draw a large rectangle and find its area. Pretend it is the floor of your living room. Draw furniture in the room to show how you would decorate it.

## DINOSAUR DIMENSIONS

- GRADE:** 3 - 4
- STRAND:** Geometry
- SKILL:** Estimate and find the perimeter and area of a plane figure.
- MANAGEMENT**
- CLASS ORGANIZATION:** Whole class, pairs
- TIME FRAME:** One class period
- MATERIALS:** Calculator
- VOCABULARY:** Area, perimeter
- PREREQUISITE SKILL:** Mathematics: Basic operations, perimeter, area  
Calculator: Basic functions, memory keys

**LESSON** The purpose of this lesson is to find perimeter and area.

• **DIRECTED INSTRUCTION/GUIDED PRACTICE:**

Read the following story:

Long ago and far away, Dina, the daring director of dinosaurs at the Denver Zoo, wanted to acquire as many dinosaurs for the Zoo as she could. (She knew how kids love dinosaurs.) Dina had a problem. There was only so much space (area) available for dinosaurs at the Denver Zoo. Dina realized she'd better find out the size of each dinosaur and exactly how much space was available for the dinosaurs. She listed the length of each dinosaur on a chart. She wrote the lengths in both meters and feet. The zoo director, Bront Saurus, told Dina the exact size of the space set aside for the dinosaur exhibit (414 square meters). Dina decided each dinosaur should have its own individual fenced space because no one seemed to know which dinosaurs got along with others and which were mean. She thought each space should be big enough to allow the dinosaur to turn around but not run. (Who knows what mischief an escaped dinosaur might get into? It might even head to the local dinosaur disco.) Using the dinosaur data sheet and the graph paper, help Dina decide which dinosaurs will fit in the Denver Zoo Dinosaur Exhibit.

Each centimeter on the graph paper represents 1 meter (scale 1 cm = 1m). Example: A certain dinosaur is 5 meters long. A line 5 centimeters long on the graph paper would represent the dinosaur's length. The 5 centimeters represent 5 meters because the scale is 1 cm = 1 m. Distribute Dinosaur Dimensions Data Sheet, graph paper and Student Activity Sheet 1.

Demonstrate how to find the area the Iguanodon would need at the zoo. The Iguanodon is 9 meters long. If the dinosaur needs a space large enough to turn around, the Iguanodon would need an area 9 meters long and 9 meters wide. Place a ruler vertically then horizontally on the graph to show why the dinosaur would need a square area.

Students use a crayon or marking pen to mark a square 9x9 on the graph paper. Use the calculator to find the area by multiplying length (9) times width (9). Note: the calculator sequence 9 [x] [=] is equivalent to 9 [x] 9 [=]. Find the amount of fence needed (perimeter) by adding together the length of each side.

Students label the area on the graph paper with the dinosaur's name, the area and the perimeter.

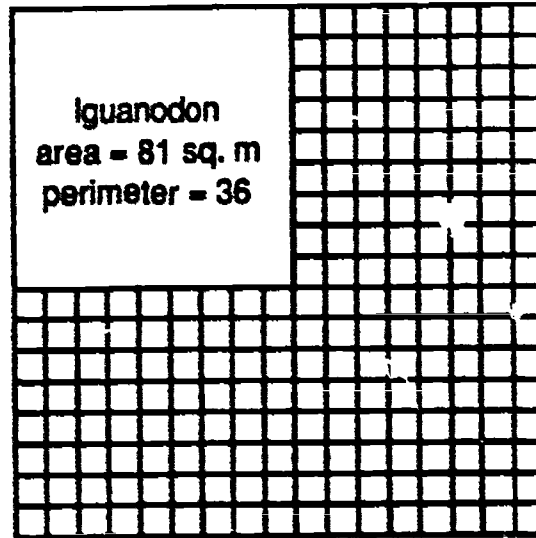

Students complete Student Activity Sheet 1. Students will be graphing their results on a bar graph.

Suggested calculator sequences are included with this lesson which involve using the memory to find a solution to the problem. (See page 138) Teacher may share either method 1 or method 2 with students.

• **INDEPENDENT PRACTICE:**

Distribute Student Activity Sheet 2 and Dinosaur Dimensions New Exhibit Area graph paper. Read the problem together. Students work in pairs to complete the activity. The scale for the New Exhibit Area is 1 mm = 1 ft.

• **EVALUATION:**

Students share their results and explain how they used their calculator.

• **HOME ACTIVITY:**

Students find the area and perimeter necessary to house a pet.



**DINOSAUR DIMENSIONS**  
Data Sheet

**DINOSAUR LENGTHS**

IGUANODON	9 meters	30 feet
TYRANNOSAURUS REX	12 meters	41 feet
STEGOSAURUS	24 meters	80 feet
CORYTHOSAURUS	10 meters	33 feet
CHASMOSAURUS	5 meters	16.5 feet
EUSKELOSAURUS	15 meters	50 feet
SUPERSAURUS	30 meters	100 feet
TARBOSAURUS	14 meters	45 feet
PROSAUROLOPHUS	8 meters	26 feet
DIPLODOCUS	27 meters	90 feet
MASSOSPONDYLLUS	4 meters	13 feet
ISCHISAURUS	2 meters	6.5 feet

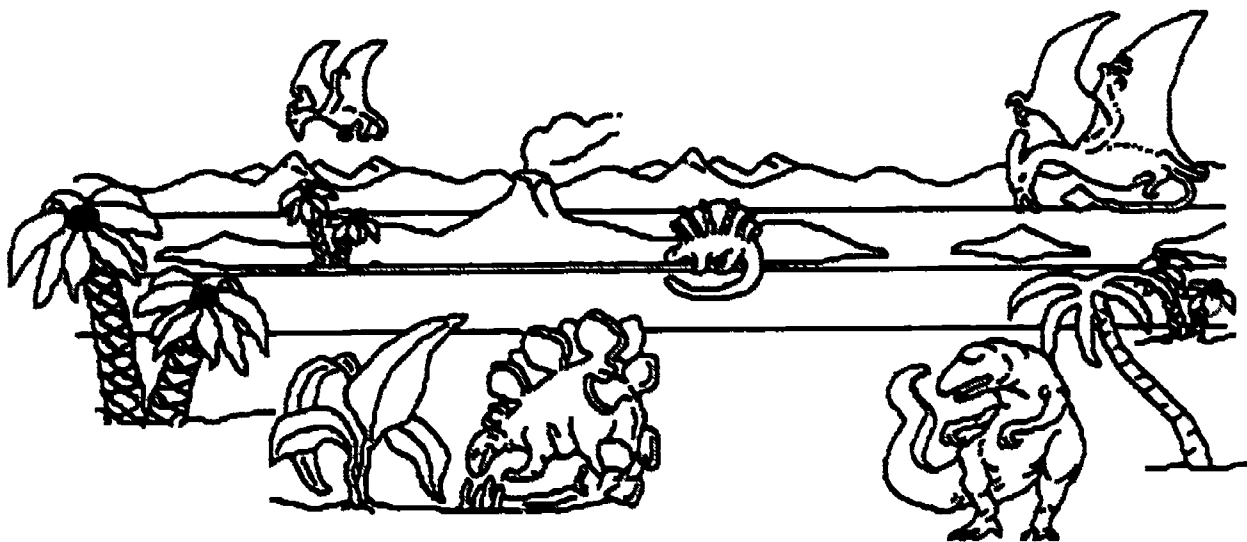

168

**DINOSAUR DIMENSIONS EXHIBIT AREA (414 SQ. METERS)**

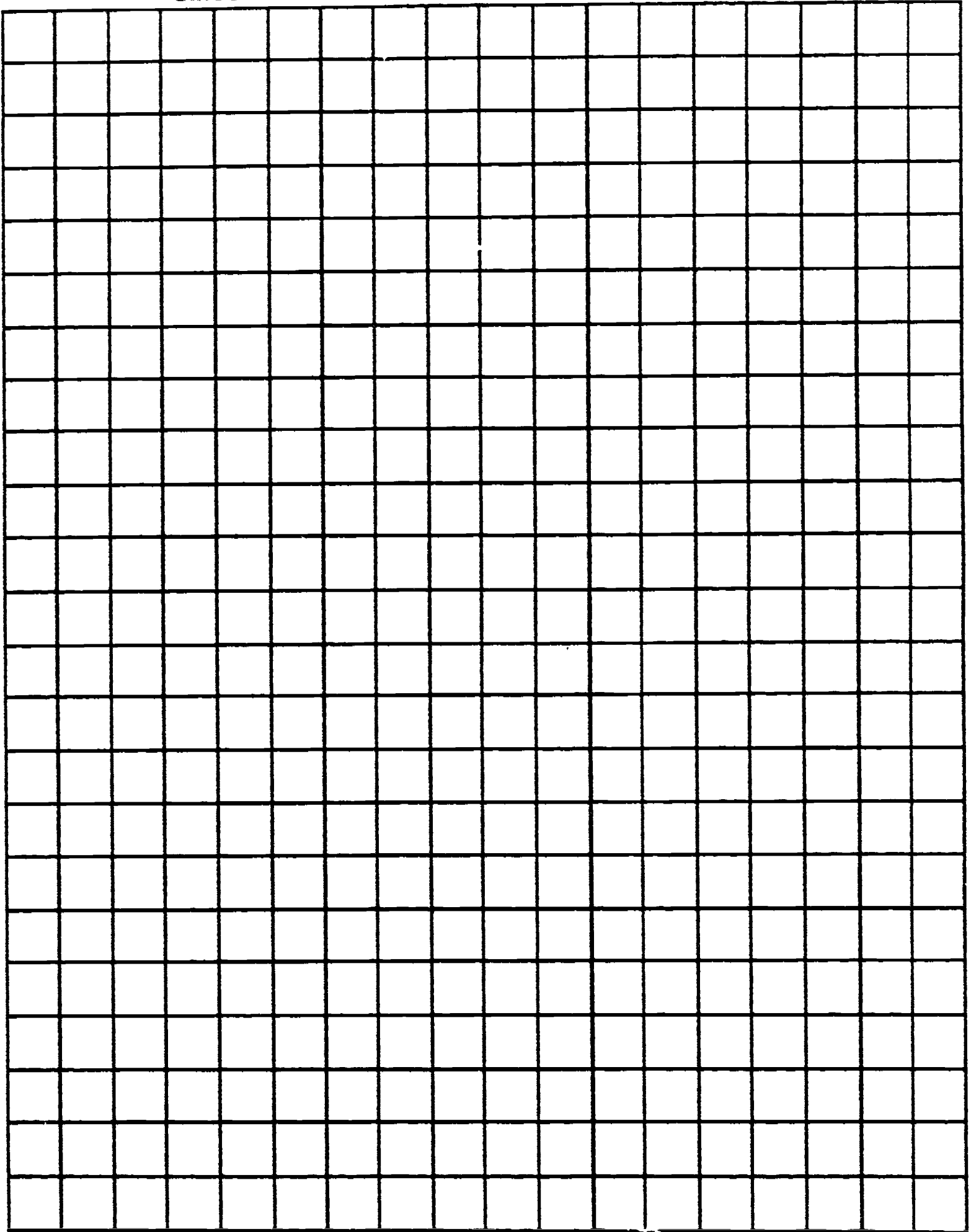



**DINOSAUR DIMENSIONS**  
Student Activity Sheet 1

1. Estimate which dinosaurs will fit in the area given to Dina for the dinosaur exhibit.

---



---



---

2. Use a calculator and the graph paper to find out which dinosaurs will fit in the area and how much fence is needed. (Remember Dina wants to have as many dinosaurs as possible.)

Dinosaur	Area	Perimeter(fence length)

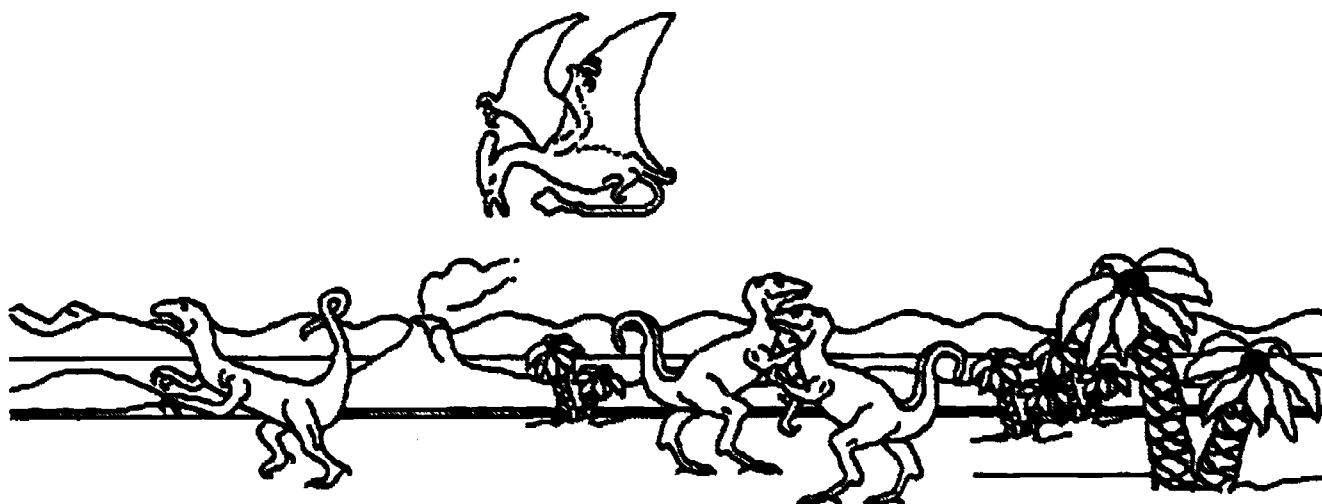

**DINOSAUR DIMENSIONS**  
Student Activity Sheet 1

3. Put the dinosaurs and their areas on the bar graph.

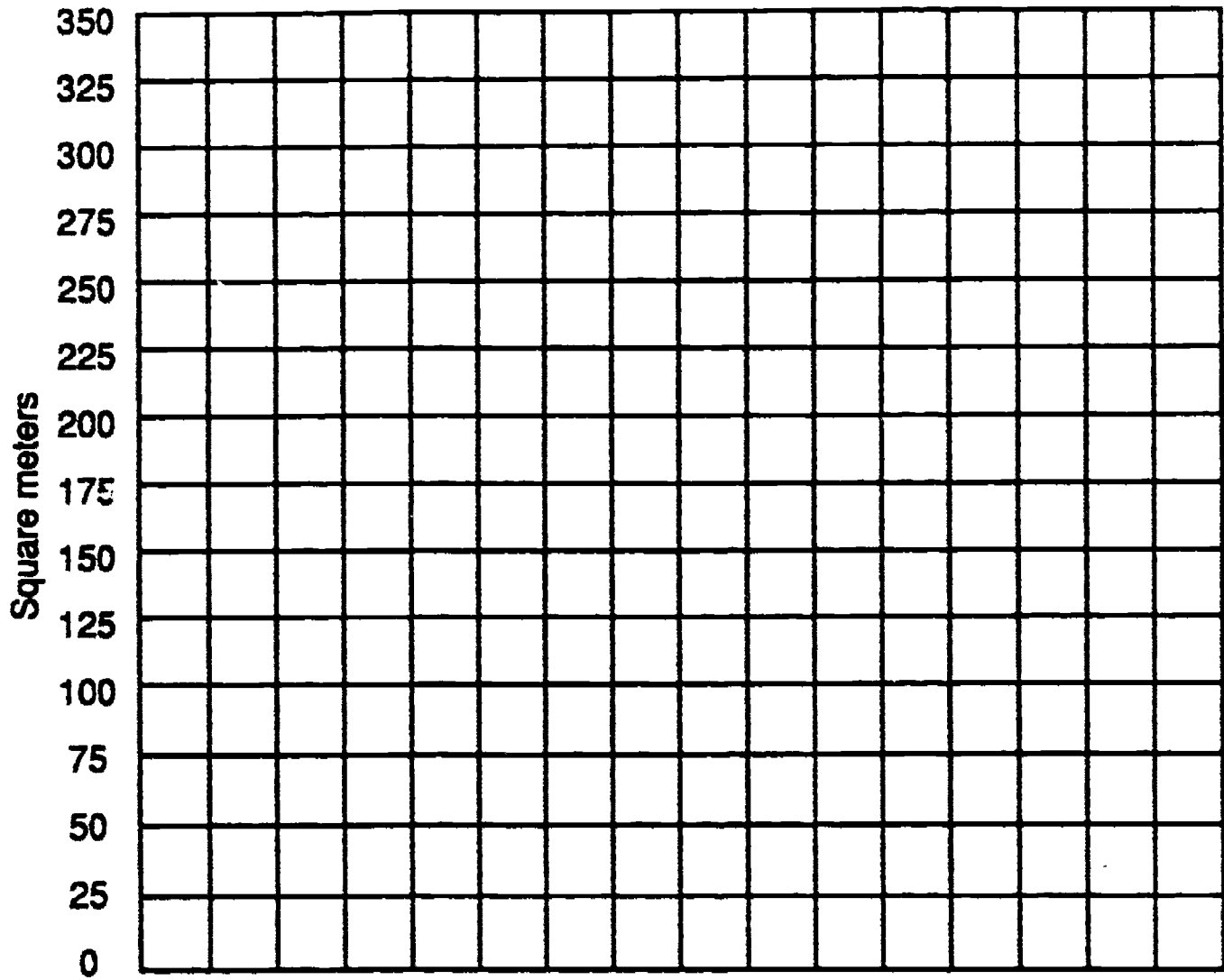

Dinosaur Names

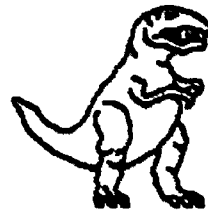

## DINOSAUR DIMENSIONS

### Student Activity Sheet 2

A generous donor gave a large sum of money to the zoo for the dinosaur exhibit. Dina, the dinosaur director at the Denver Zoo, was told she had an acre of land to use for dinosaurs. An acre of land is 43,650 square feet. Dina needs to find out how many of the dinosaurs on the list will fit on an acre of land.

1. Use the dinosaur lengths listed in feet on the student data sheet to help Dina solve her problem. Work with a partner. Use a calculator and the acre (194 ft x 225 ft) graph paper.

Dinosaur	Area	Length

How many dinosaurs will fit on the acre of land? \_\_\_\_\_

Is there any space left? \_\_\_\_\_

How many square feet? \_\_\_\_\_



172

141

DINOSAUR DIMENSIONS NEW EXHIBIT AREA (1 Acre)  
(to accompany Student Activity Sheet 2)

194 ft x 225 ft

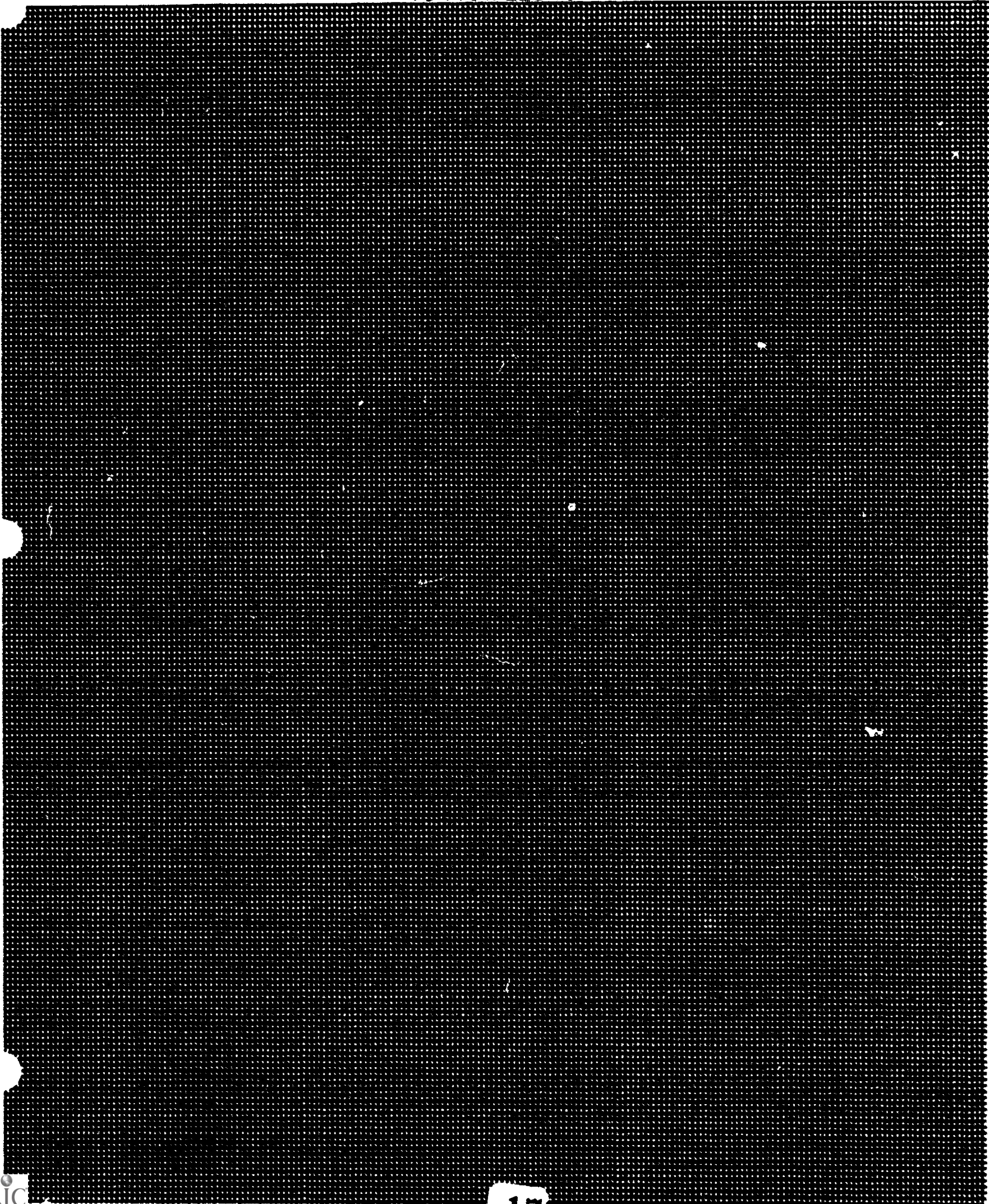

**PUSH "M" FOR AREA**

**GRADE:** 3 - 4  
**STRAND:** Geometry  
**SKILL:** Estimate and find the area of polygons.

**MANAGEMENT**

**CLASS ORGANIZATION:** Pairs

**TIME FRAME:** One class period

**MATERIALS:** Calculator, ruler, transparency

**VOCABULARY:** Area, dimensions, polygon, regular, irregular, memory, recall, decimeter

**PREREQUISITE SKILL:** Mathematics: Basic operations, area of rectangular polygons  
 Calculator: Basic functions, memory feature

**LESSON** The purpose of this lesson is to have the students find the area of irregular polygons.

**• DIRECTED INSTRUCTION:**

Project Transparency 1.

Review how to compute the area of a rectangle.

$$\text{Area} = \text{Length} \times \text{Width}$$

Demonstrate how to find the area of a irregular polygon on the transparency. Partition the irregular polygon into rectangular regions. Find the area of each rectangular region. Use the memory feature of the calculator to find the total area of the irregular polygon.

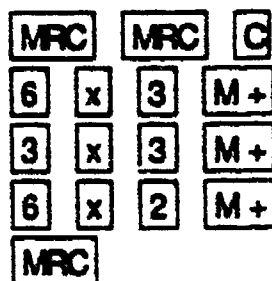
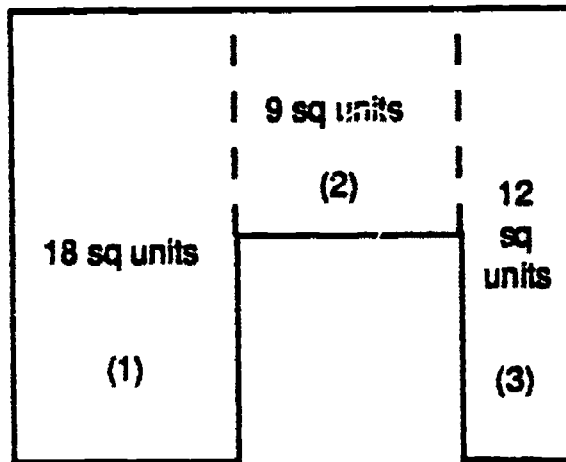

display 39 <sup>174</sup>

- **GUIDED PRACTICE:**  
Project Transparency 2.  
Distribute Student Activity Sheet 1. Determine the area of the irregular polygon with the students. [answer: 42 sq. units]
- **INDEPENDENT PRACTICE:**  
Distribute Student Activity Sheet 2.  
Students work in pairs to complete the activity. [answer: 16848 sq. in.]
- **EVALUATION:**  
Teacher observation
- **HOME ACTIVITY:**  
Students measure (in feet) and make a drawing of a room at home which has a closet. They then find the area of the room with the closet, labeling the area on their drawing. This information can be useful for ordering carpeting or linoleum flooring.

PUSH "M" FOR AREA

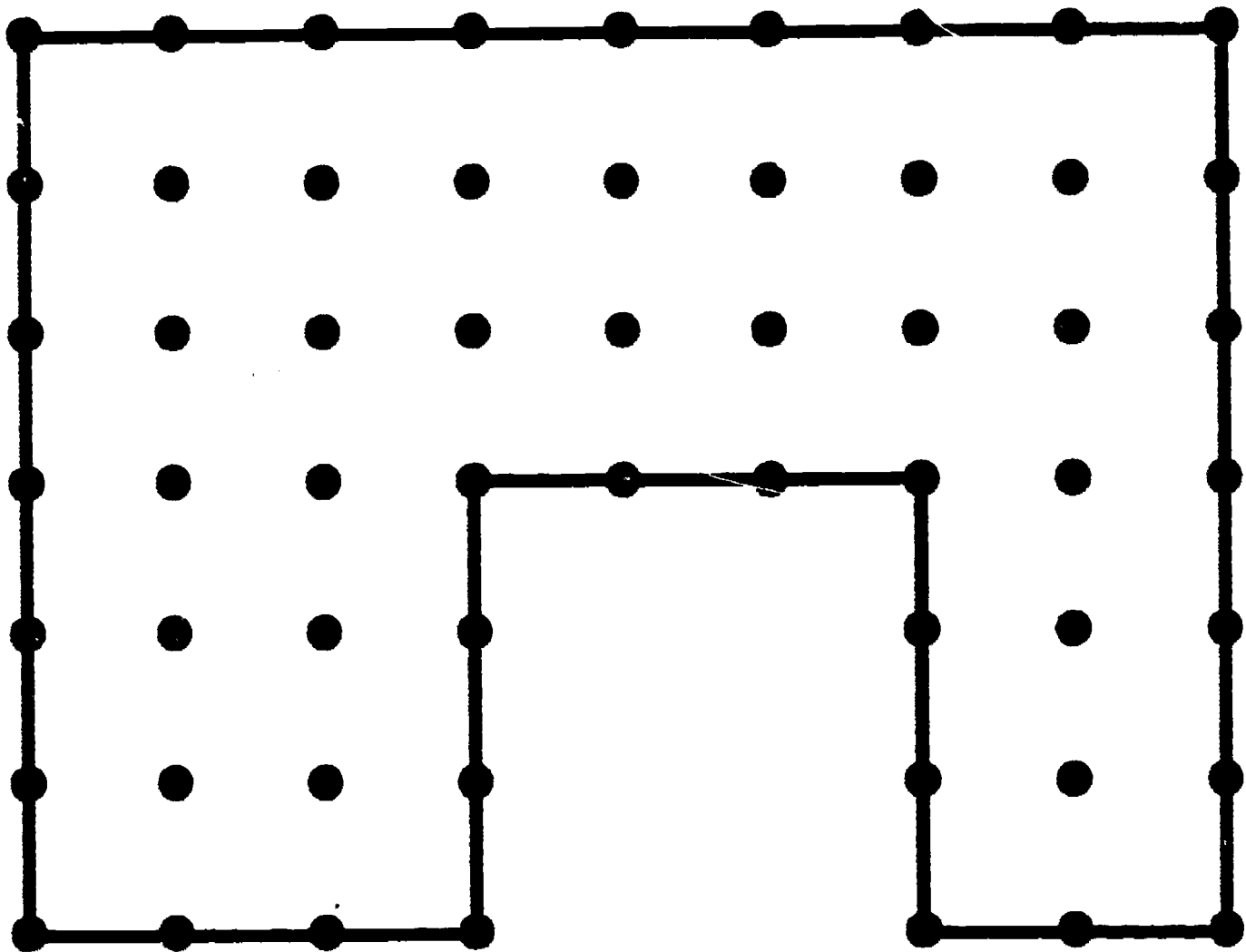

**PUSH "M" FOR AREA**  
**Student Activity Sheet 1**

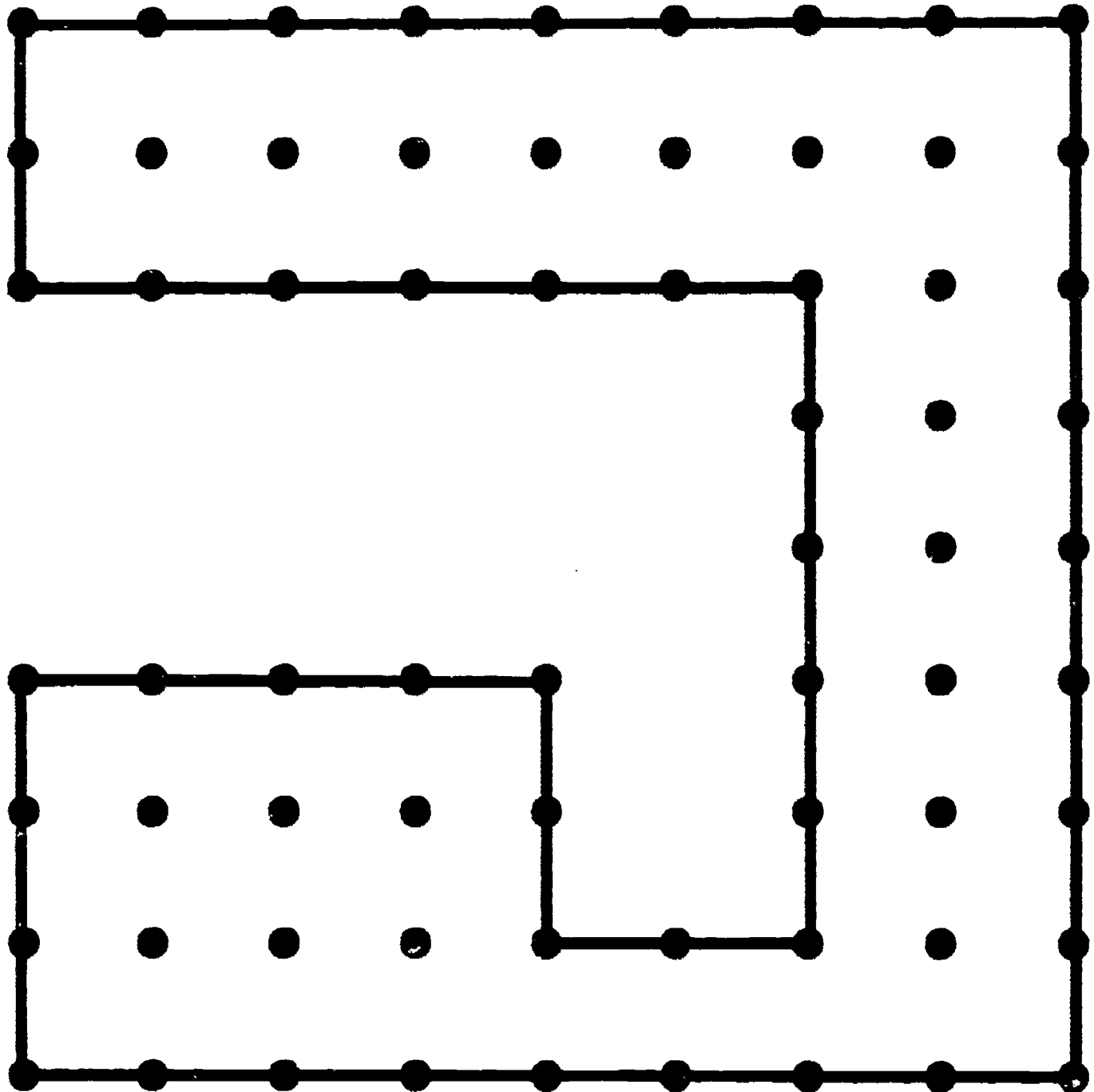



**PUSH "M" FOR AREA**  
**Student Activity Sheet 1**

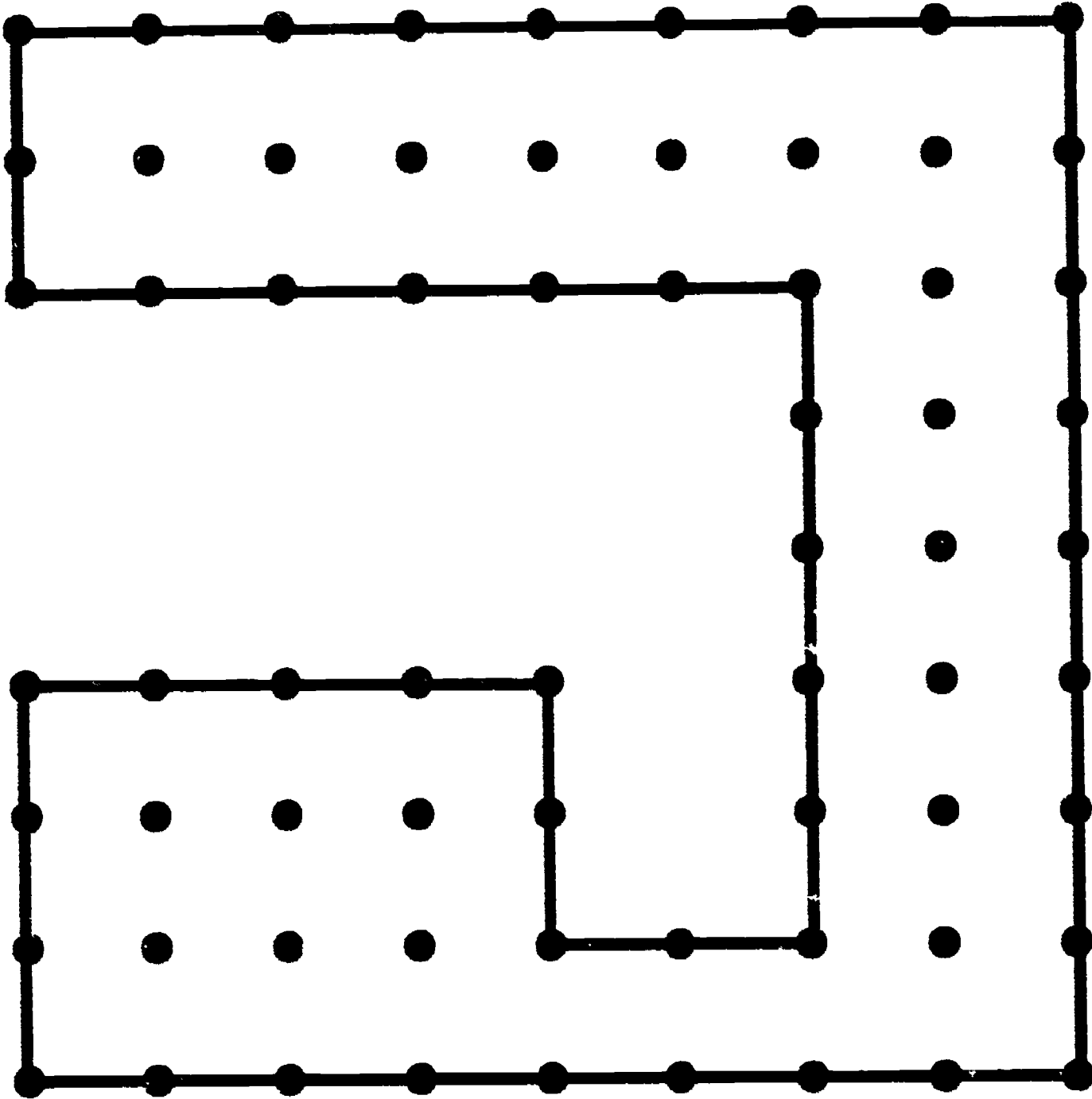

173

**PUSH "M" FOR AREA**  
**Student Activity Sheet 2**

Directions: The diagram below is of a special kitchen counter. It is to be made of marble which is expensive. The builder needs to know the exact area of the counter. Compute the area for the counter.

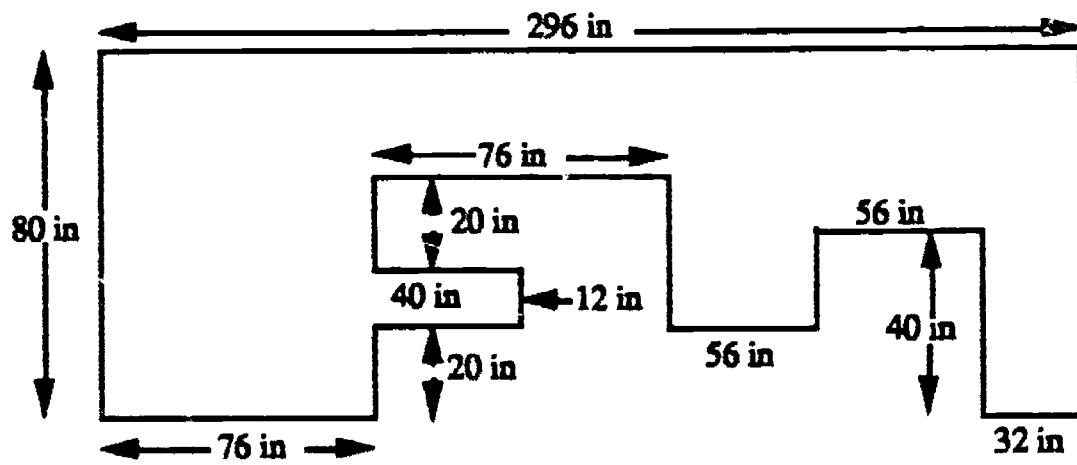

- |            |  |
|------------|--|
| [M +]      | Adds data into the memory                  |
| [M -]      | Subtracts from the memory's total          |
| [MR]/[MRC] | Recalls the current figure from the memory |

## ESTIMATING PI

- GRADE:** 4
- STRAND:** Geometry
- SKILL:** Pi represents a relationship between the circumference and the diameter of a circle.
- MANAGEMENT**
- CLASS ORGANIZATION:** Small groups
- TIME FRAME:** One class period
- MATERIALS:** Several cylinders of various diameters, centimeter tape measures
- VOCABULARY:** Circumference, diameter, ratio, pi, cylinder
- PREREQUISITE SKILLS:** Mathematics: Basic operations, measurement to nearest millimeter, average  
Calculator: Basic functions

**LESSON** The purpose of this lesson is to learn that pi is the name given to the relationship between circumference and diameter of a circle.

• **DIRECTED INSTRUCTION:**

Explain to the students that there is a special relationship that exists between the diameter of a circle and its circumference. The relationship is named pi. In this lesson, students will discover the numerical value of pi.

• **GUIDED PRACTICE:**

Students work in groups of four. Distribute two cylinders, centimeter tapes, and a Student Activity Sheet to each group.

Demonstrate to students how to measure the circumference and diameter of a can.

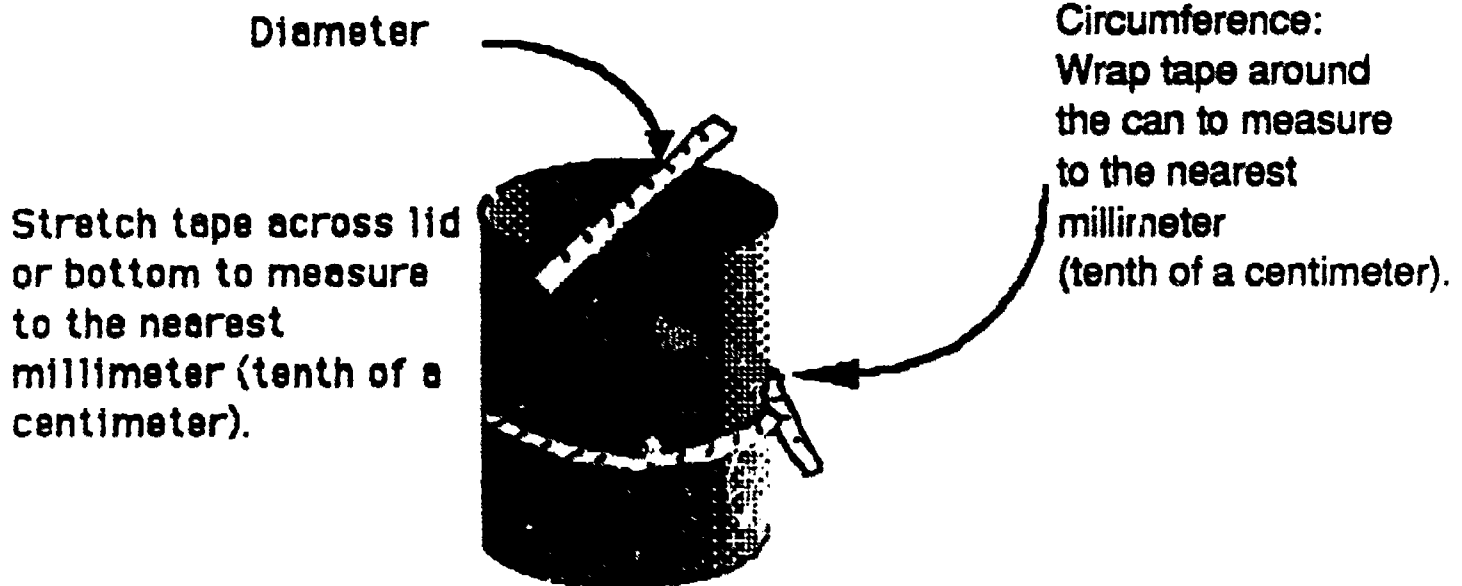

Students measure their cylinders. Accuracy is important, therefore measure the cylinders to the nearest millimeter.

Students record the measurements for the circumference and the diameter of each cylinder in rows 1 and 2 on the Student Activity Sheet.

Demonstrate the calculation necessary to complete the last column of the chart.

$$\frac{C}{d} = \frac{\text{circumference}}{\text{diameter}}$$

Compare results with other groups, then compute the average for the five cylinders.

- **INDEPENDENT PRACTICE:**  
Student groups measure other cylinders to complete Student Activity Sheet.
- **EVALUATION:**  
Students discuss results of the activity.
- **HOME ACTIVITY:**  
Students measure other circular objects around the house, e.g. wheels/tires, plates, pots/pans, baskets.

**ESTIMATING PI**  
**Student Activity Sheet**

Measure five cylinders and record the data on this sheet. Then find  $\frac{C}{d}$ .

Container	Circumference (C) (to the nearest tenth cm)	Diameter (d) (to the nearest tenth cm)	Ratio $\frac{C}{d} = (\pi)$
1			
2			
3			
4			
5			

What was the largest value you calculated for the ratio? What was the smallest?

---

What was the average of your five measurement ratios? What kinds of things would have caused your measurements to be off?

---

The circumference of a circle is about how many times the diameter?

---

Look up "pi" in a dictionary or the glossary of a math book to see what value has been given to this ratio.

---

**CAMP-LA ASSESSMENT  
GEOMETRY**

1.

**Area Needed For Each Animal**

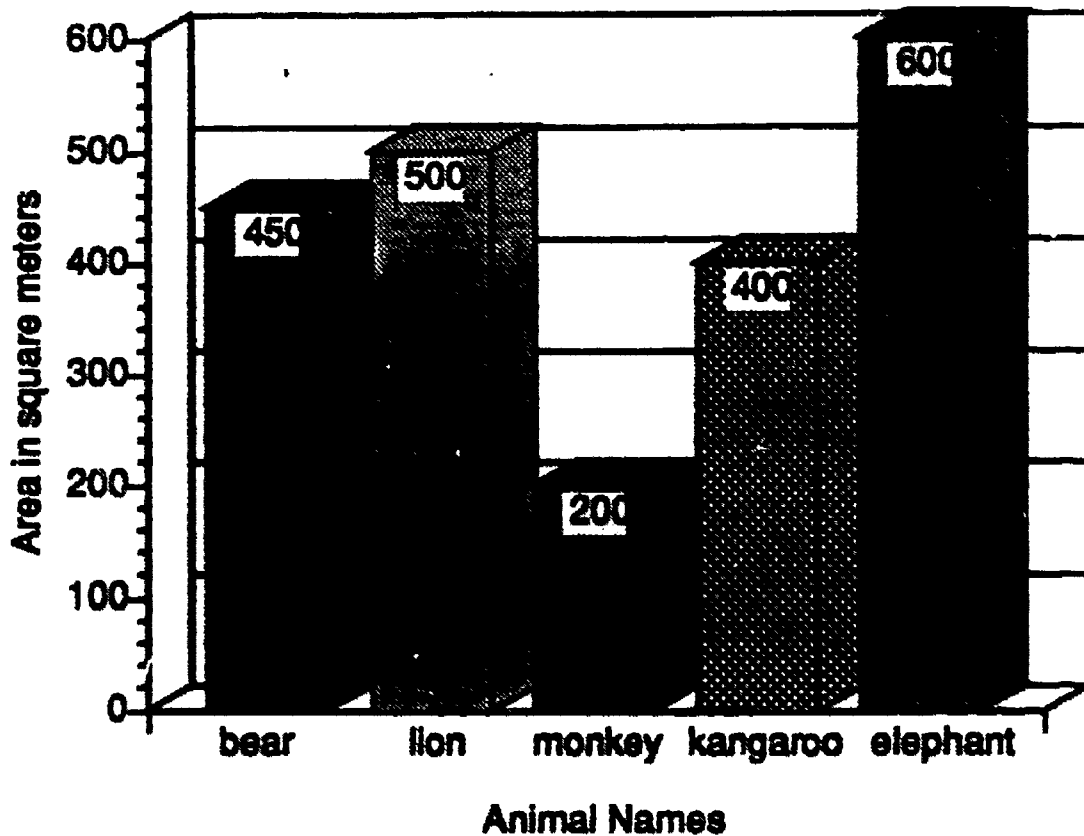

a. The Park City Zoo has 11,950 square meters of land available for animal homes. The Zoo Director needs help to decide what animals to include. Use the graph to find out which animals would fit in the zoo. There must be at least two of each animal and most of the land should be used.

Animal	How Many	Amount of land use
_____	_____	_____
_____	_____	_____
_____	_____	_____
_____	_____	_____
_____	_____	_____
	<b>Total</b>	_____

b. How much land was left over?

c. How would you use the leftover land? Write your suggestions for the zoo director.

Student responses will vary:

a. Example:

Animal	How Many	Amount of land use
bear	3	1350
lion	8	4000
monkey	10	2000
kangaroo	5	2000
elephant	4	2400
Total		11750

b. Student response should indicate how much land would be left.

c. Student responses may include playground, refreshment stand, or picnic tables.

2.

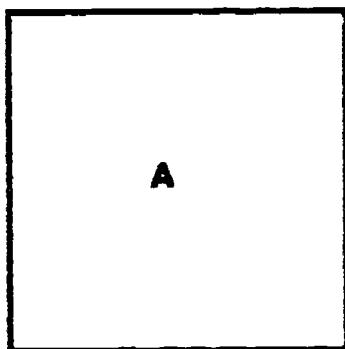

a. Write a sentence to tell how to find the perimeter of a polygon A.

b. Find the perimeter of a polygon A.

c. Find the perimeter of polygon B.

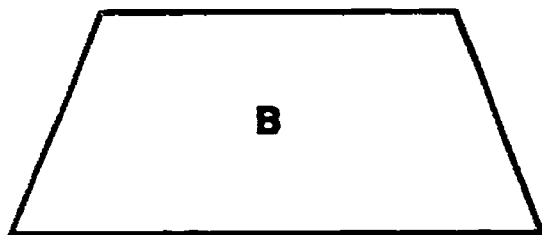

d. If polygon A and B are combined edge to edge, what will be the total perimeter?

e. How could you use the idea of perimeter?

Student responses should include:

a. Perimeter is the measure of the outside edges of a polygon.

Measure each side and find the sum of the measures of the sides.

b. 16 cm

c. 14 cm

d. 22 cm

e. To find the distance around the schoolyard, the classroom, or a play area.

3.

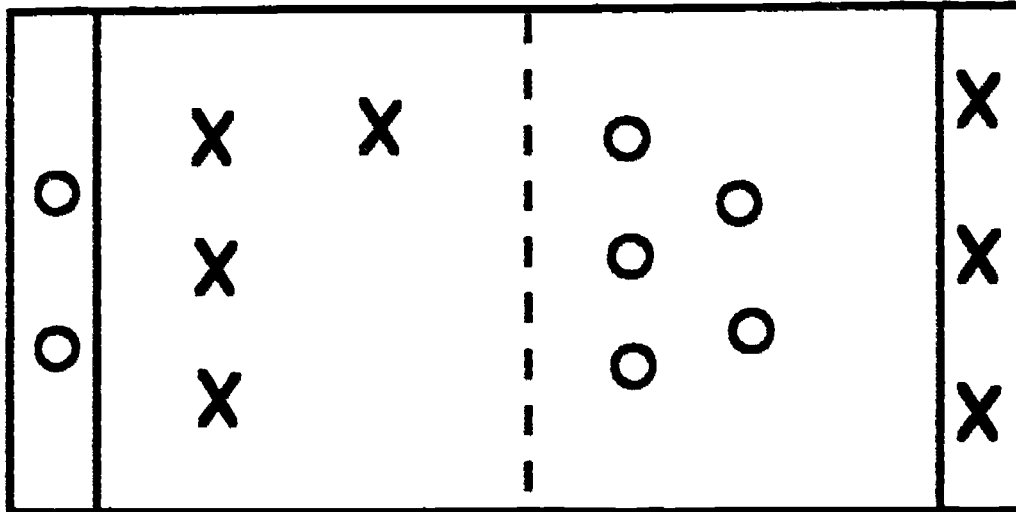

The double dodgeball court is 24 feet long and 16 feet wide. What is the perimeter of the court? \_\_\_\_\_

What is the area of the court? \_\_\_\_\_

How did you use your calculator to find the perimeter and the area? \_\_\_\_\_

Student responses should include:

- The perimeter is 80 feet long.
- The area is 384 square feet.
- Students will add two lengths plus two widths for the perimeter and will not necessarily need the calculator. They multiply length x width for the area using the calculator.



# CAMP-LA

Calculators and Mathematics Project, Los Angeles

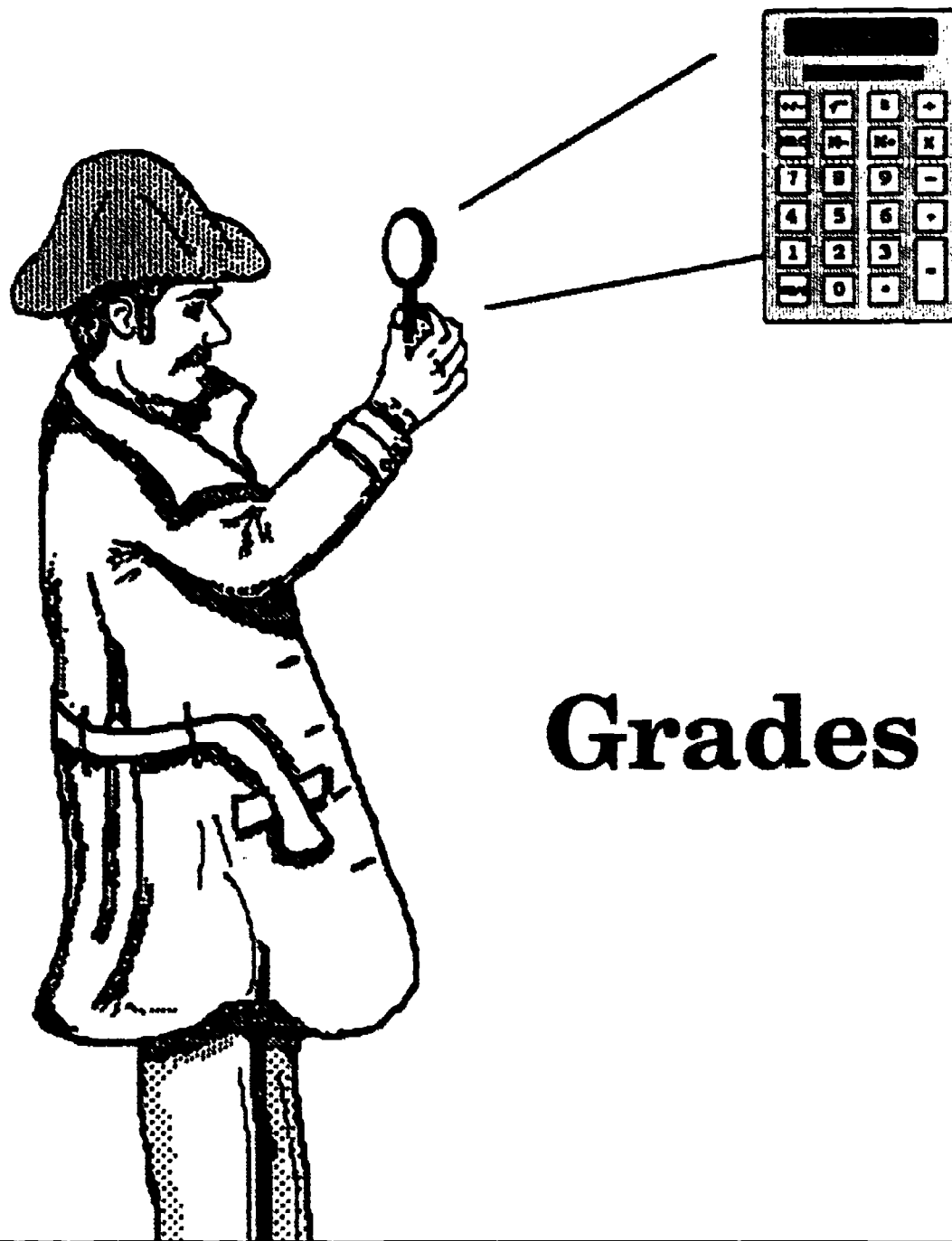

Grades 3 - 4

## CHAPTER 4 PATTERNS AND FUNCTIONS

## MAGIC NUMBERS

**GRADE:** 3 - 4  
**STRAND:** Patterns and Functions  
**SKILL:** Identify, extend, and create number patterns.

### **MANAGEMENT**

**CLASS ORGANIZATION:** Whole class

**TIME FRAME:** One class period

**MATERIALS:** Calculator, transparency

**VOCABULARY:** Rearrange

**PREREQUISITE SKILLS:** Mathematics: Basic operations  
Calculator: Basic functions

**LESSON** The purpose of this lesson is to examine and discover number patterns.

### **DIRECTED INSTRUCTION:**

1. **Magic 495** - In this activity students will arrive at a difference of 495 by continuously rearranging and subtracting the 3 digits in a number. Any 3-digit number may be used that does not contain zero or repeat a digit, for example, 942.

Project transparency and follow these directions:

- arrange the digits to form the largest number (942) and the smallest number (249)
- use a calculator to subtract the two numbers ( $942 - 249 = 693$ )
- rearrange the digits in the difference (693) to form the largest number (963) and smallest number (369)
- subtract the two numbers ( $963 - 369 = 594$ )
- rearrange the difference (594) again into the largest (954) and smallest (459) numbers
- subtract the two numbers ( $954 - 459 = 495$ )
- students should have 495 on their display (if the digits in 495 are rearranged into the largest and smallest numbers, the difference will still be 495.)

Students select a 3-digit number and follow this process. Students record the three digits and the number of times they subtracted to reach 495 on their Student Activity Sheet.

Students share the results of their research in class:

- What was the maximum number of subtractions to reach 495?
- On the average, how many steps (subtractions) were required?
- What was the number of steps (subtractions) most often used?

• **GUIDED PRACTICE:**

**2. Double and Divide -**

Students follow this sequence using a calculator:

- choose a 3-digit number (456)
- make a 6-digit number by repeating the original 3 digits (456456)
- divide by 7
- divide the result by 11
- divide the result by 13
- compare the result with the original 3 place number, (the result and the original 3 place number should be the same)

Students try different 3-digit numbers using this process. Record numbers and results on the Activity Sheet. Discuss why this pattern works.

• **INDEPENDENT PRACTICE:**

**3. Products of 37**

Students read and follow directions.

Discuss the pattern. Will the pattern continue beyond the chart?

**4. A Pattern with 9**

Students complete activity 4. Students look for a pattern, predict the next answer, and check their predictions with a calculator.

**EVALUATION:**

Teacher observation.

**HOME ACTIVITY:**

Students create their own number pattern.

## MAGIC NUMBERS

Transparency

- Example: 

9	4	2
---	---	---

- Arrange the digits:

largest: 942  
smallest: 249



- Subtract

$$\begin{array}{r} \boxed{9} \boxed{4} \boxed{2} \\ - \boxed{2} \boxed{4} \boxed{9} \\ \hline \boxed{6} \boxed{9} \boxed{3} \end{array}$$

- Rearrange the difference and subtract

$$\begin{array}{r} \boxed{9} \boxed{6} \boxed{3} \\ - \boxed{3} \boxed{6} \boxed{9} \\ \hline \boxed{5} \boxed{9} \boxed{4} \end{array}$$

- Rearrange the difference and subtract

$$\begin{array}{r} \boxed{9} \boxed{5} \boxed{4} \\ - \boxed{4} \boxed{5} \boxed{9} \\ \hline \boxed{4} \boxed{9} \boxed{5} \end{array}$$

- How many steps did you use to reach 495?

**MAGIC NUMBERS**  
Student Activity Sheet



**MAGIC 495**

1.

3-digit number					
Number of Times Subtracted					

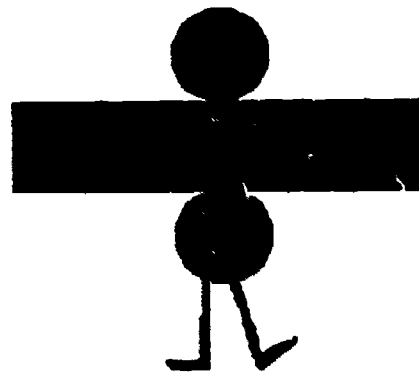
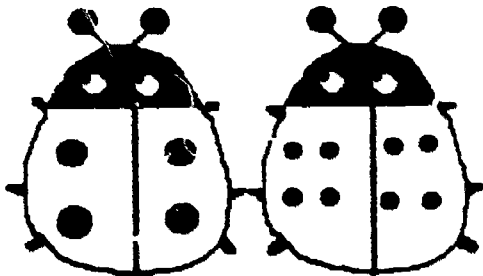

**DOUBLE AND DIVIDE**

2.

3-digit number				
6-digit number				
+ 7 result				
+ 11 result				
+ 13 result				

**MAGIC NUMBERS**  
Student Activity Sheet

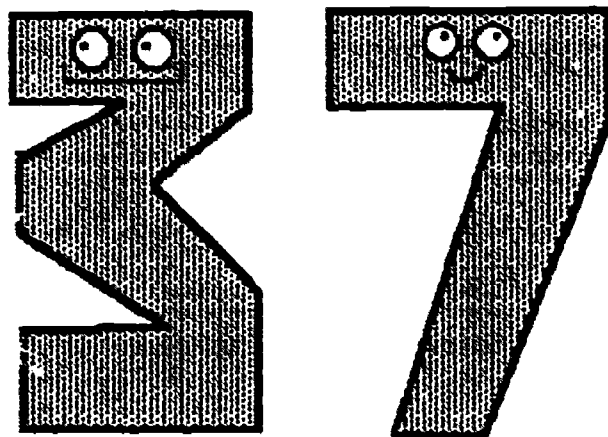

**PRODUCTS OF 37**

Multiply. Record the product.  
Add the digits of each product.  
Compare the sum to the first number listed.

3.

	Product	Sum of Digits
$3 \times 37$	111	3
$6 \times 37$		
$9 \times 37$		
$12 \times 37$		
$15 \times 37$		
$18 \times 37$		
$21 \times 37$		
$24 \times 37$		
$27 \times 37$		

191

MAGIC NUMBERS  
Student Activity Sheet

A PATTERN WITH 9

4.

Complete the pattern

$$1 \times 9 + 2 = \underline{\hspace{2cm}}$$

$$12 \times 9 + 3 = \underline{\hspace{2cm}}$$

$$123 \times 9 + 4 = \underline{\hspace{2cm}}$$

$$\underline{\hspace{2cm}} = \underline{\hspace{2cm}}$$

$$\underline{\hspace{2cm}} = \underline{\hspace{2cm}}$$

$$\underline{\hspace{2cm}} = \underline{\hspace{2cm}}$$

$$\underline{\hspace{2cm}} = \underline{\hspace{2cm}}$$

$$\underline{\hspace{2cm}} = \underline{\hspace{2cm}}$$

$$\underline{\hspace{2cm}} = \underline{\hspace{2cm}}$$

$$\underline{\hspace{2cm}} = \underline{\hspace{2cm}}$$

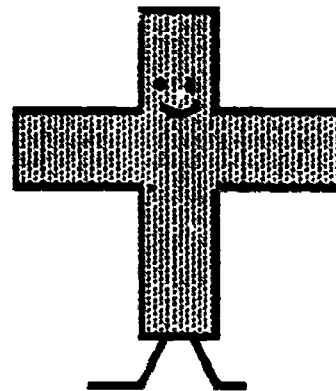
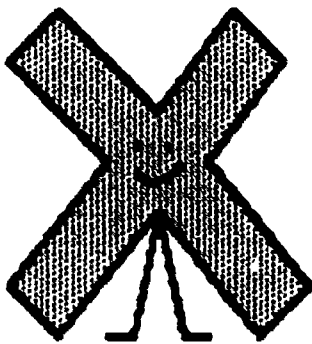

## NUMBER PALS

**GRADE:** 3 - 4  
**STRAND:** Patterns and Functions  
**SKILL:** Recognize and extend number patterns.

### MANAGEMENT

**CLASS ORGANIZATION:** Whole class, pairs

**TIME FRAME:** One class period

**MATERIALS:** Calculator, transparencies

**VOCABULARY:** Palindrome, digit

**PREREQUISITE SKILL:** Mathematics: Basic operations  
Calculator: Basic functions

### LESSON

The purpose of this lesson is to use addition to explore number patterns.

- DIRECTED INSTRUCTION:**  
Display Transparency 1 to discover palindromes.

Number Pals	Transparency
Palindromes	Not Palindromes
12321	17
3333	235
242	36162
50005	4411447
88788	
22	
7723277	

Define a palindrome as a number that reads the same forward or backward. Use Transparency 2 to check for understanding.

Example 1: Demonstrate this sequence:

Select a number:	52
Reverse the digits	<u>25</u>
Add the numbers	77

Note: Graph paper or lined paper turned sideways may help students keep the digits lined up.



Example II:

Try 391		
Begin with the number	391	
Reverse the digits	<u>193</u>	
Add	584	Step 1
Reverse the digits	<u>485</u>	
Add	1069	Step 2
Reverse the digits	<u>9601</u>	
Add	10670	Step 3
Reverse the digits	<u>07601</u>	
Add	18271	Step 4
Reverse the digits	<u>17281</u>	
Add	35552	Step 5
Reverse the digits	<u>25553</u>	
Add	61105	Step 6
Reverse the digits	<u>50116</u>	
Add	111221	Step 7
Reverse the digits	<u>122111</u>	
Add	233332	Step 8

You see that 391 becomes a palindrome in 8 steps.

Sometimes a problem will go on for thousands of steps with no palindrome being formed. 394 is such a number. After a while the calculator cannot handle the whole number and the remaining steps have to be done by hand. You will see an "E" (error message) on the display.

• **GUIDED PRACTICE:**

Distribute Student Activity Sheet 1.

Students begin with 463. Guide them through the process to find the palindrome.

463	
<u>364</u>	Step 1
827	
<u>728</u>	Step 2
1555	
<u>5551</u>	Step 3
7106	
<u>6017</u>	Step 4
13123	
<u>32131</u>	Step 5
45254	

194

Students complete the exercise and fill in the chart at the bottom of the page.

**Answer Key:**

One step - 621                      Four steps - 591  
 Two steps - 804                    Five steps - 463  
 Three steps - 481                   Six steps - 977

• **INDEPENDENT PRACTICE:**

Students complete Student Activity Sheet 2. Students classify the numbers from 10 - 99 according to the number of steps required to turn them into a palindrome. If a number is already a palindrome, it takes 0 steps.

**Answer Key**

0-steps	1-step	2-steps	3-steps	4-steps	5-steps	6-steps	More than 6 steps
11	10    40	19    94	59	69		79	89
22	12    41	28	68	78		97	98
33	13    42	37	86	87			
44	14    43	39	95	96			
55	15    45	46					
66	16    50	47					
77	17    51	48					
88	18    52	49					
99	20    53	57					
	21    54	58					
	23    56	64					
	24    60	65					
	25    61	67					
	26    62	73					
	27    63	74					
	29    70	75					
	30    71	76					
	31    72	82					
	32    80	84					
	34    81	85					
	35    83	91					
	36    90	92					
	38	93					

Students should notice that reversed numbers (12 & 21, 13 & 31, etc.) require the same number of steps. This helps them classify the numbers faster.

Warning, 89 (and thus, 98) requires 27 steps. Students can classify these as "more than 6 steps."

• **EVALUATION:**

Discuss results of the activity.

• **HOME ACTIVITY:**

Students ask family members for three-place numbers and use them to find palindromes, recording the number of steps it takes to reach the palindrome.

# NUMBER PALS

## PALINDROMES

12321

3333

242

50005

88788

22

7723277

## NOT PALINDROMES

17

235

36162

441147

54321

196

# NUMBER PALS

PALINDROMES

NOT PALINDROMES

Where do they belong?

616

56765

2557552

354

21031

96

10002

55

24

555

2001

36963

**NUMBER PALS**  
**Student Activity Sheet 1**

How many steps does it take for each of these numbers to become a palindrome? Work with a partner to place the numbers where they belong on the chart below.

463      481      591      621      804      977

Palindromes in:

One step _____	Three steps _____	Five steps _____
Two steps _____	Four steps _____	Six steps _____

Student Activity Sheet 2

The Numbers From 10 to 99

Number of steps to become a palindrome

0 - Steps	1 - Step	2 - Steps	3 - Steps	4 - Steps	5 - Steps	6 - Steps
199						209

## LET'S GO BICYCLE RIDING

- GRADE:** 3 - 4
- STRAND:** Patterns and Functions
- SKILL:** Discover and state a function rule from a set of data.
- MANAGEMENT**
- CLASS ORGANIZATION:** Whole class pairs
- TIME FRAME:** One class period
- MATERIALS:** Calculator, transparency
- VOCABULARY:** Function rule, graph, ordered pairs, vertical axis, horizontal axis
- PREREQUISITE SKILL:** Mathematics: Basic operations, ordered pairs  
Calculator: Basic functions

**LESSON** The purpose of this lesson is to place ordered pairs on a graph.

- **DIRECTED INSTRUCTION/GUIDED PRACTICE:**
  - Project Transparency 1. Demonstrate how to find ordered pairs. The first number gives the number of bikes and the second number tells the number of wheels. Begin with 1 bike, 2 wheels. This is labeled as the point (1,2) on the graph. Continue plotting other points: (2,4), (3,6), (4,8), etc.
  - Project Transparency 2. Complete the chart.
  - Project Transparency 1. Connect the points to demonstrate that they all lie along a line.
- **INDEPENDENT PRACTICE:**

Students work in pairs to complete the Student Activity Sheet. Students will use Vans Graph to complete the table and answer the questions. (Each van carries 4 bicycles.)
- **EVALUATION:**

Correct answers on the Student Activity Sheet.
- **HOME ACTIVITY:**

Students make a graph and a table of ordered pairs of their own using 10 bicycles per van.

201

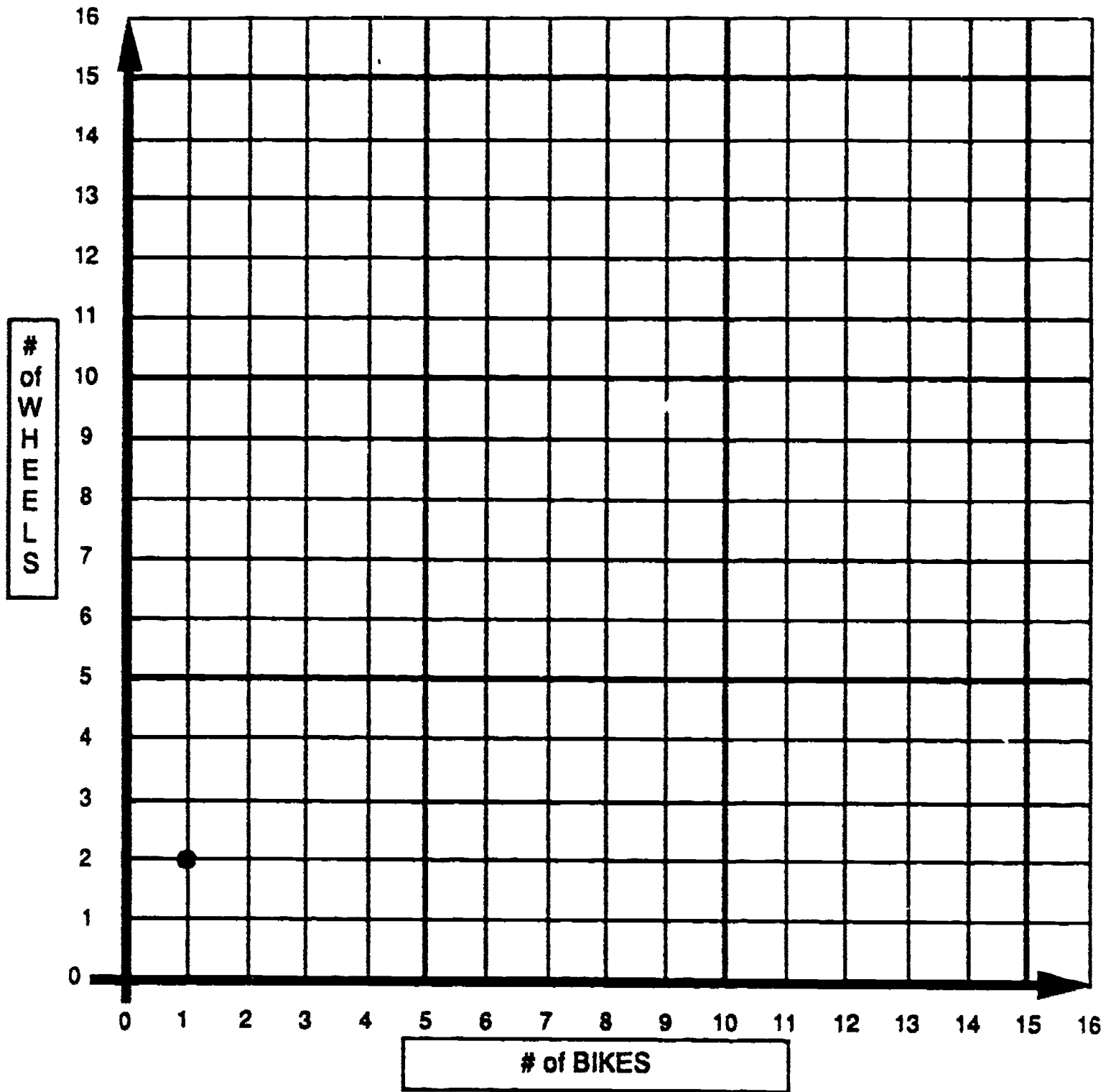



### LET'S GO BICYCLE RIDING

TABLE OF ORDERED PAIRS

# of Bikes	# of Wheels	Ordered Pair
1	2	(1, 2)
2	4	(2, 4)
3	6	(3, 6)

What is the rule? \_\_\_\_\_



203



LET'S GO BICYCLE RIDING: VANS GRAPH  
Student Activity Sheet

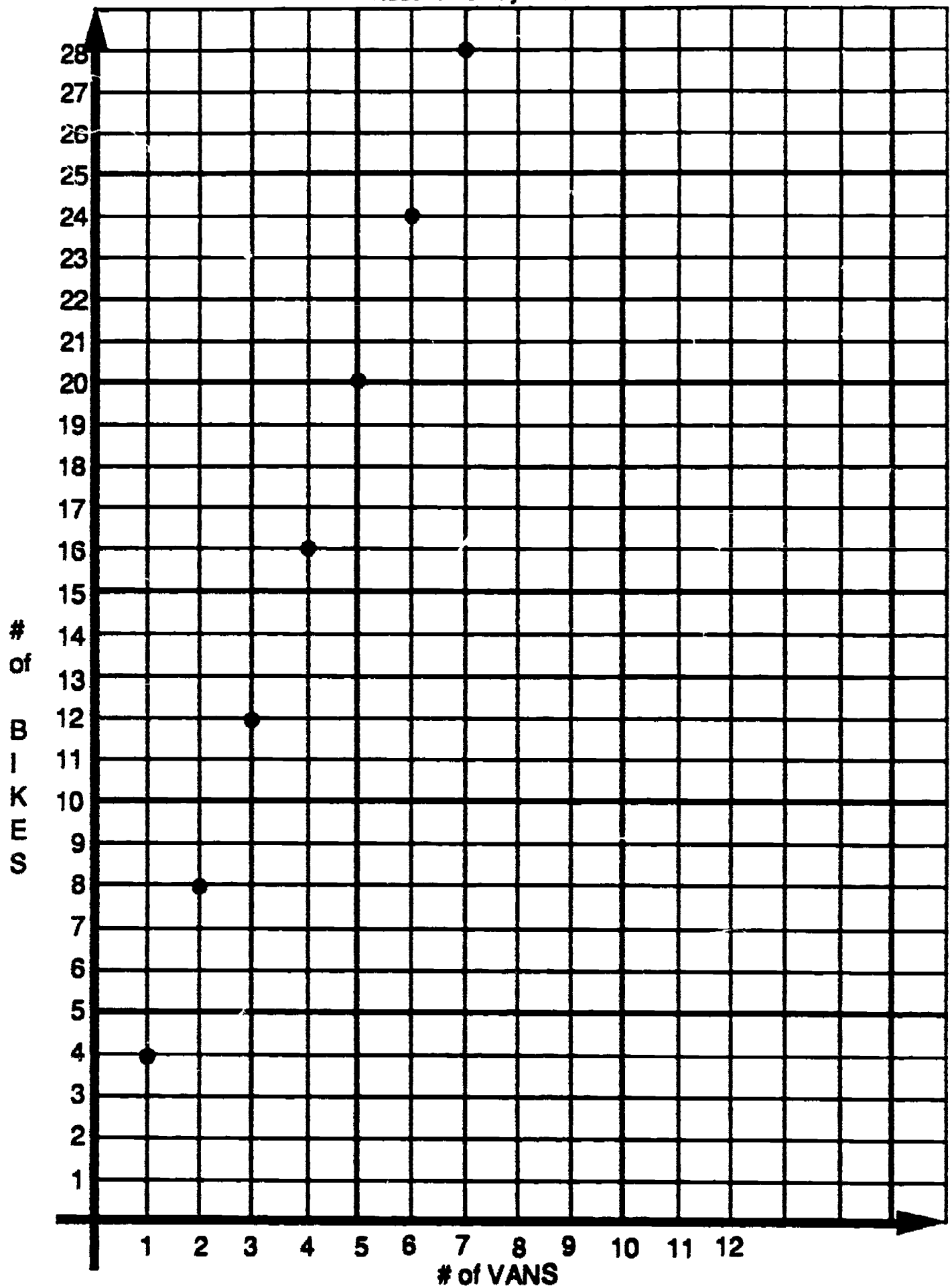

**LET'S GO BICYCLE RIDING**  
Student Activity Sheet

Use the information on the graph to complete the table of ordered pairs.

Number of Vans	Number of Bicycles	Ordered Pairs

Find the answers to these questions:

- How many bicycles can 6 vans carry? \_\_\_\_\_
- How many bicycles can 50 vans carry? \_\_\_\_\_
- How many vans are needed for 44 bicycles? \_\_\_\_\_
- How many bicycles can 256 vans carry? \_\_\_\_\_
- How many vans would be needed to carry 3,940 bicycles? \_\_\_\_\_
- How many vans would be needed to carry 48,989 bicycles? \_\_\_\_\_
- Each bike cost \$79.45. A van cost \$9,599. There are 27 vans, each with a load of bikes, traveling to a race. What is the total cost of the bicycles? \_\_\_\_\_



**LET'S GO BICYCLE RIDING**  
Teacher Answer Sheet

Use the information on the graph to complete the table of ordered pairs.

Number of Vans	Number of Bicycles	Ordered Pairs
1	4	(1, 4)
2	8	(2, 8)
3	12	(3, 12)
4	16	(4, 16)
5	20	(5, 20)
6	24	(6, 24)
7	28	(7, 28)

Find the answers to these questions:

1. How many bicycles can 6 vans carry? 24
2. How many bicycles can 50 vans carry? 200
3. How many vans are needed for 44 bicycles? 11
4. How many bicycles can 256 vans carry? 1024
5. How many vans would be needed to carry 3,940 bicycles? 985
6. How many vans would be needed to carry 48,989 bicycles? 12248
7. Each bike cost \$79.45. A van cost \$9,599. There are 27 vans, each with a load of bikes, traveling to a race. What is the total cost of the bicycles? \$ 8580.60

## THE PENCIL BOX PROBLEM

- GRADE:** 3 - 4
- STRAND:** Patterns and Functions
- SKILL:** Find a function rule from a situation or graph
- MANAGEMENT**
- CLASS ORGANIZATION:** Whole class, pairs
- TIME FRAME:** One class period
- MATERIALS:** Calculator, transparency of Student Activity Sheet 1
- VOCABULARY:** Function rule, ordered pairs
- PREREQUISITE SKILL:** Mathematics: Coordinate graphing  
Calculator: Memory keys

**LESSON** The purpose of this lesson is to use a graph to estimate quantities and to record ordered pairs.

### • DIRECTED INSTRUCTION:

Five hundred prizes are needed for a Mathematics Field Day. The local toy store has a special sale on pencil boxes. Each box has four pencils and three erasers. How many boxes will need to be purchased?

Project the transparency. Explain that a graph is used to record information. Have students read the labels on the graph and identify the ordered pairs for the three points on the line.

(60, 420) (80, 560) (100, 700)

What is the rule? [answer: multiply by 7]

The line on the graph shows the function rule.

Use the line to find the number of items in 70 boxes. Demonstrate how to go over to 70 and up to the intersection with the line. Show that the intersection is between 480 and 500. Apply the rule:

$$7 \times 70 = 490$$

Use the line to find the number of items in 87 boxes. Estimate using the line, and then use the calculator to get the actual number [answer:  $7 \times 87 = 609$ ].

### • GUIDED PRACTICE:

Distribute Student Activity Sheets 1 and 2 to pairs of students. They will use the graph to make an estimate, use the calculator to verify the number of items, and then record the ordered pairs.

Work through the first two examples.

Example 1:

60 boxes. Estimate from the line on the graph: 420

Number of items using the rule: 420

Ordered pair [answer: (60,420)]

Example 2:

65 boxes. Estimate from the line on the graph: 450

Number of items using the rule: 455

Ordered pair [answer: (65,455)]

Students complete Student Activity Sheet 2.

• **INDEPENDENT PRACTICE:**

Distribute Student Activity Sheet 3. Students work together to plot the points for the given ordered pairs and draw the line. Use the line to determine the missing numbers in the remaining ordered pairs. Complete the chart by recording the numbers of boxes and items.

• **EVALUATION:**

Teacher observation.

• **HOME ACTIVITY:**

Students demonstrate understanding of the function rule by completing the home activity sheet.

Answers:

# of People	# of 6 packs
20	4
48	8
5	1
60	10
42	7
54	9

**THE PENCIL BOX PROBLEM**  
Student Activity Sheet 1

Put the ordered pairs on the graph.

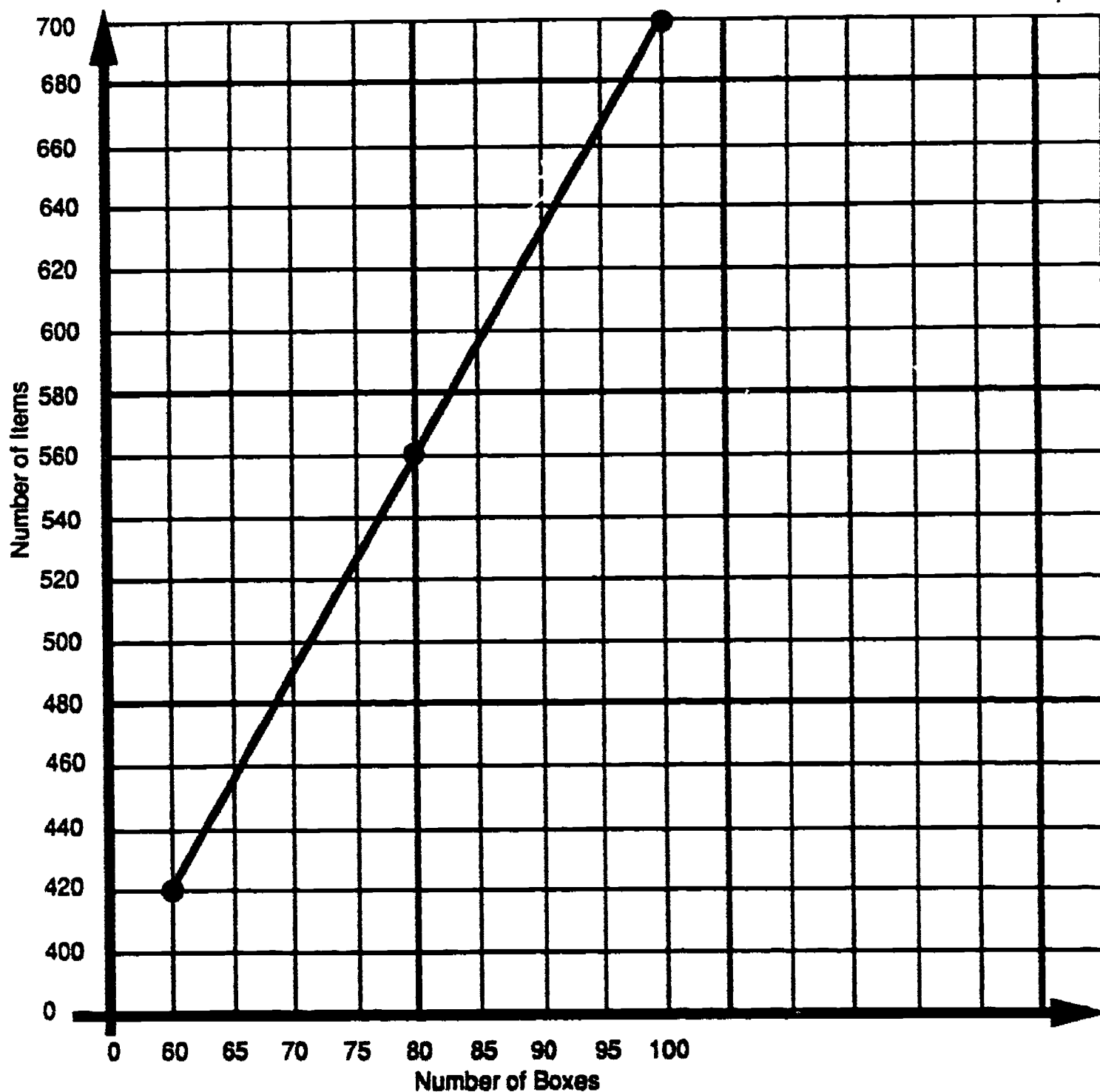

200

**THE PENCIL BOX PROBLEM**  
Student Activity Sheet 2

Number of Boxes	Estimate	Number of Items	Ordered Pairs
60			
65			
70			
73			
75			
80			
95			
87			
90			
93			
95			
97			
99			
100			

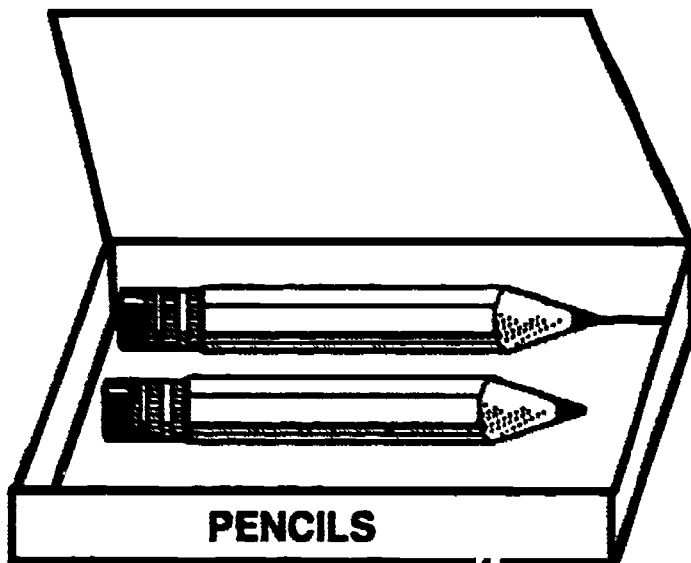

177<sup>210</sup>



### THE PENCIL BOX PROBLEM

#### Student Activity Sheet 3

Directions: Complete the table, plot the points, draw the lines and state the rule.

1

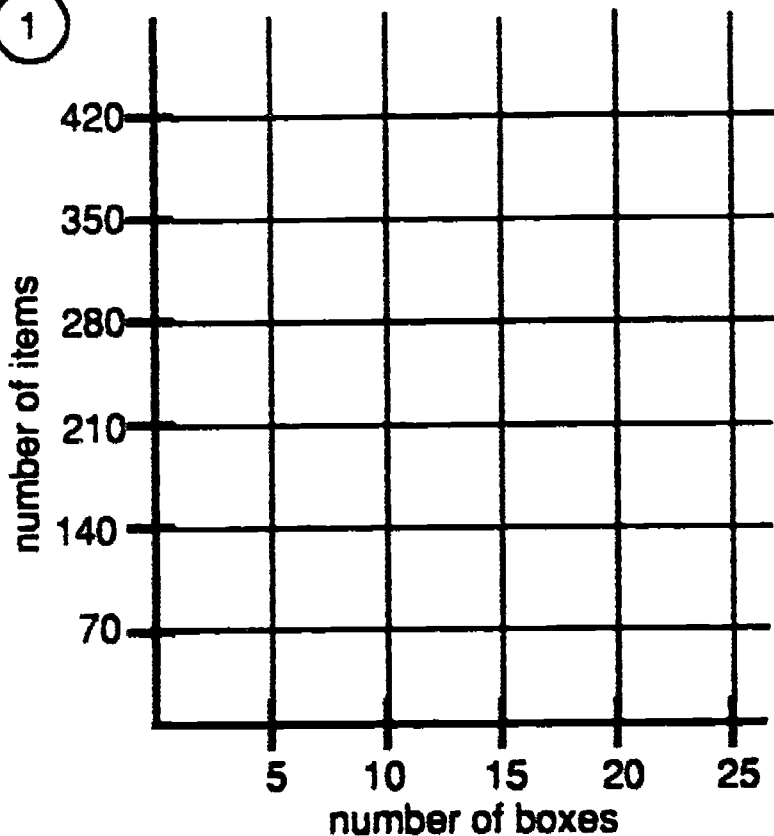

Boxes	Items	Ordered Pairs
5	70	(5, 70)
		(7, )
		(12, )
		(15, 210)
		(17, )
		(20, 280)
		(25, )

Rule \_\_\_\_\_

2

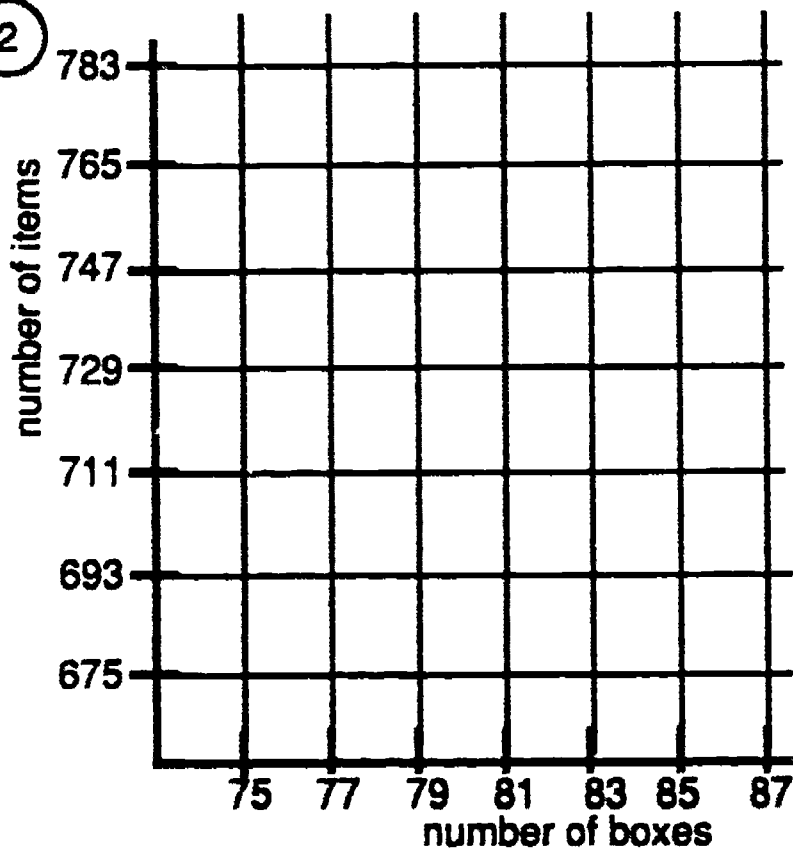

Boxes	Items	Ordered Pairs
		(75, 675)
		(76, )
		(77, )
		(78, )
		(79, 711)
		(80, )
		(81, 729)
		(82, )
		(83, )
		(84, )
		(85, 765)
		(87, )

Rule \_\_\_\_\_

**THE PENCIL BOX PROBLEM**  
Home Activity Sheet

Use the graph to determine how many soft drinks to buy for the given numbers of people. Assume that every person will have one soft drink.

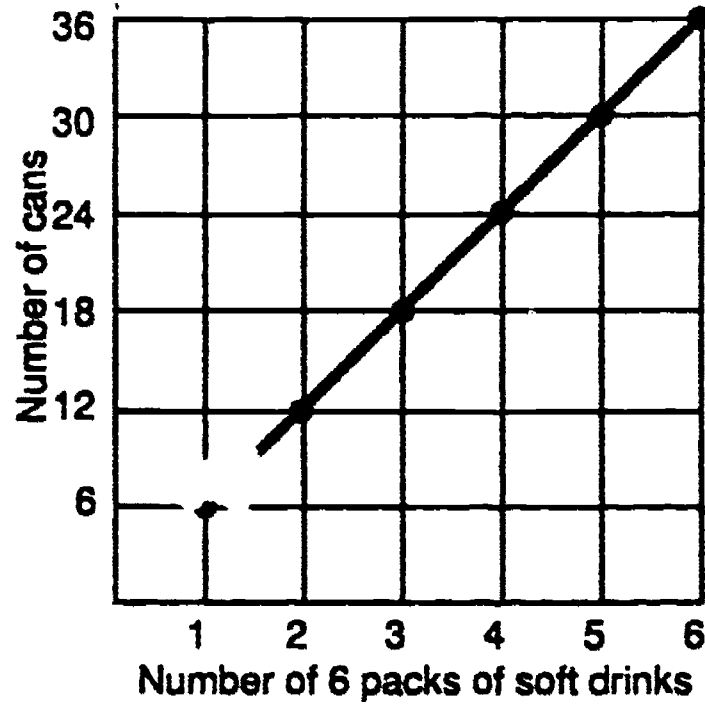

Soft drinks for

How many 6 packs would you need to buy?

20 people

\_\_\_\_\_

48 people

\_\_\_\_\_

5 people

\_\_\_\_\_

60 people

\_\_\_\_\_

42 people

\_\_\_\_\_

54 people

\_\_\_\_\_

**THE PENCIL BOX PROBLEM**  
Teacher Answer Sheet 2

Boxes	Estimate	Number of Items	Ordered Pairs
60		420	(60, 420)
65		455	(65, 455)
70		490	(70, 490)
73		511	(73, 511)
75		525	(75, 525)
80		560	(80, 560)
85		595	(85, 595)
87		609	(87, 609)
90		630	(90, 630)
93		651	(93, 651)
95		665	(95, 665)
97		679	(97, 679)
99		693	(99, 693)
100		700	(100, 700)

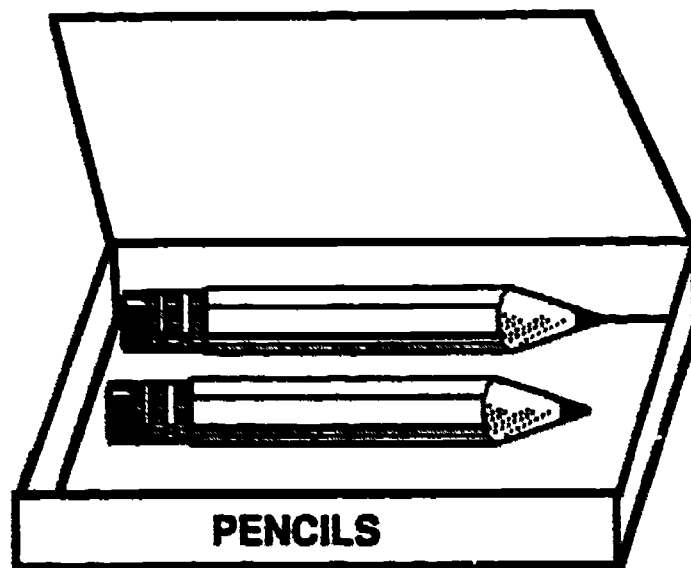

213

**THE PENCIL BOX PROBLEM**  
Teacher Answer Sheet 3

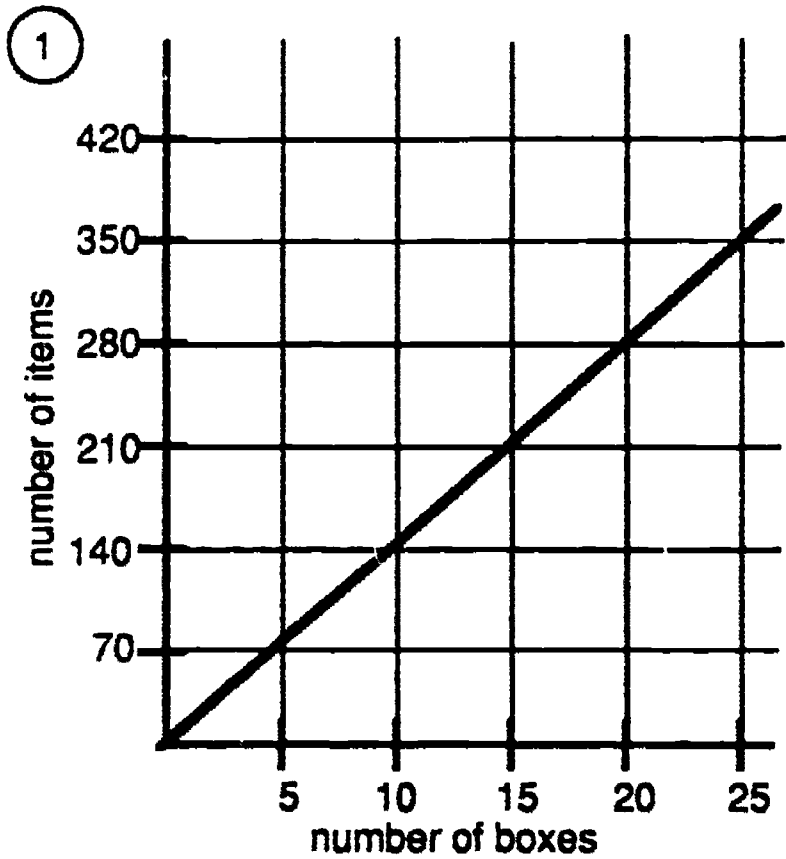

Boxes	Items	Ordered Pairs
5	70	(5, 70)
7	98	(7, 98)
12	168	(12, 168)
15	210	(15, 210)
17	238	(17, 238)
20	280	(20, 280)
25	350	(25, 350)

Rule     Multiply by 14    

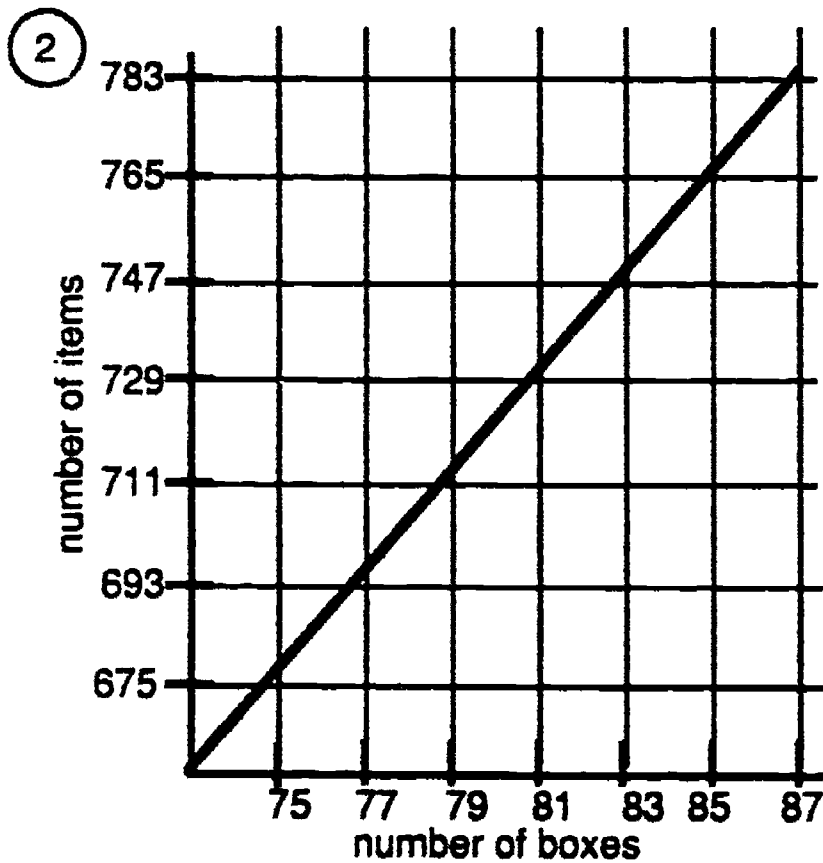

Boxes	Items	Ordered Pairs
75	675	(75, 675)
76	684	(76, 684)
77	693	(77, 693)
78	702	(78, 702)
79	711	(79, 711)
80	720	(80, 720)
81	729	(81, 729)
82	738	(82, 738)
83	747	(83, 747)
84	756	(84, 756)
85	765	(85, 765)
86	774	(86, 774)

Rule     Multiply by 9

## EXPLORING NINES FOR NINE YEAR OLDS

- GRADE:** 4
- STRAND:** Patterns and Functions
- SKILL:** Recognition, extension, and creation of patterns when dividing by "nines"
- MANAGEMENT**
- CLASS ORGANIZATION:** Pairs
- TIME FRAME:** One class period
- MATERIALS:** Calculator
- VOCABULARY:** Divide, divisor, pattern, prediction, observe, digit, consecutive, quotient, dividend
- PREREQUISITE SKILL:** Mathematics: Basic operations  
Calculator: Basic functions

### LESSON

The purpose of this lesson is to discover number patterns and extend them to make predictions.

#### • DIRECTED INSTRUCTION:

1. Students use the number 9 and the calculator to discover number patterns.
2. Work through Exercise 1 on the Student Activity Sheet with the whole class.

Students need to understand that after they have done the first entry, 1  $\div$  9  $=$  they need only to enter a number and the  $\div$ . Their first entry establishes 9 as the constant divisor. This continues in effect as long as no other operation key is pushed, or until the calculator is cleared.

Example: 1  $\div$  9  $=$  0.1111111  
2  $\div$  0.2222222

#### • GUIDED PRACTICE:

Exercise 2.

Students decide which numbers they use to explore dividing a three-digit number by 999. Students discuss their observations.

#### • INDEPENDENT PRACTICE:

Exercise 3.

Students explore number patterns and predict the pattern after only one trial. They can choose any single digit for their exploration.

#### • EVALUATION:

Teacher observation.

#### • HOME ACTIVITY:

Students explore number patterns with new divisors.

**EXPLORING NINES FOR NINE YEAR OLDS**  
Student Activity Sheet

Work with a partner. You will need a calculator, a pencil, and this recording sheet.

1. Use this calculator code to find a pattern when you divide by 9.

\_\_\_\_\_  $\boxed{+}$  9  $\boxed{=}$  \_\_\_\_\_ Example: 1  $\boxed{+}$  9  $\boxed{=}$   
2  $\boxed{=}$

Divide by 9

Dividend	Quotient
1	
2	
3	
4	
5	

What pattern do you observe? \_\_\_\_\_

What predictions can you make for the pattern? \_\_\_\_\_

Clear the calculator.

Use the code with this divisor:            99

Divide by 99

Dividend	Quotient
1	
2	
3	
4	
5	

What pattern do you observe? \_\_\_\_\_

What prediction can you make for the pattern? \_\_\_\_\_

**EXPLORING NINES FOR NINE YEAR OLDS**  
**Student Activity Sheet**

2. Use the same calculator code. Predict the pattern when you enter any three-digit number and divide by 999.

Divide by 999

Dividend	Quotient

What pattern do you observe? \_\_\_\_\_

Predict the pattern when you enter 5 consecutive 3-digit numbers.

(Example: 342, 343, 344, 345, 346 divided by 999)

217

**EXPLORING NINES FOR NINE YEAR OLDS**  
Student Activity Sheet

Predict the pattern when you enter any 3-digit number and these divisors: 9999 and 99999

Divide by 9999

Dividend	Quotient

Divide by 99999

Dividend	Quotient

What conclusions can you reach about these patterns? Record your conclusions.

3. Use the same calculator code and single-digit dividends.

Use these divisors:

.9
.09
.009
.0009

.9
.99
.999
.9999

Example: 1  +  .9  =  
2  =

Divide by .9

Dividend	Quotient

Divide by .09

Dividend	Quotient



**EXPLORING NINES FOR NINE YEAR OLDS**  
**Student Activity Sheet**

Divide by .009

Dividend	Quotient

Divide by .0009

Dividend	Quotient

Divide by .99

Dividend	Quotient

Divide by .999

Dividend	Quotient

Divide by .9999

Dividend	Quotient

Write about your observations!

**EXPLORING NINES FOR NINE YEAR OLDS**  
**Home Activity Sheet**

Explore and record the patterns when you use 0.4 and 0.8 as divisors.

Divide by 0.4	
Dividend	Quotient

Divide by 0.8	
Dividend	Quotient

How can you predict the next numbers in the pattern? \_\_\_\_\_

\_\_\_\_\_

\_\_\_\_\_

## SQUARES, SQUARES, AND MORE SQUARES

- GRADE:** 3 - 4
- STRAND:** Patterns and Functions
- SKILL:** Recognize and extend number patterns
- MANAGEMENT**
- CLASS ORGANIZATION:** Whole class, pairs
- TIME FRAME:** One class period
- MATERIALS:** Calculator, square tiles, pencil
- VOCABULARY:** Multiplied, product, square number, pattern, observe, prediction, sequence
- PREREQUISITE SKILL:** Mathematics: Basic operations  
Calculator: Basic functions

**LESSON** The purpose of this lesson is to explore square numbers, discover number patterns, and make predictions based on number patterns.

• **DIRECTED INSTRUCTION:**

Distribute square tiles, allow time for exploration, and then use the tiles to build squares.

Students use the smallest number of tiles to build a square. How many tiles did you use? (one) The edges of this square are one unit long. Build the next larger square. How long are the edges of this square? (two) How many tiles did you use altogether? (four)

Students build the next larger square. Record the number of units on each side and the number of tiles used altogether. Continue until students have built five squares and have found:

units on a side	number of tiles
1	1
2	4
3	9
4	16
5	25

(Write this table on the chalkboard and fill it in as students report their findings.)

Students predict the next two or three numbers in the pattern.

Students use the calculator to verify what they have learned and explore some larger squares. Any number multiplied by itself gives a product called a "square number" (because it represents the number of tiles in the square). Use the calculator to show this. Enter: 1  $\times$  1  $=$  1. Enter

221

2  $\times$  2 = 4. Compare the answers with the squares built with the tiles. Note, we write  $2 \times 2$  as  $2^2$  (two squared),  $3 \times 3$  as  $3^2$  (three squared), and so forth.

Distribute the Student Activity Sheet. Direct students to work with a partner to fill in the squares of the given numbers. Using the calculator as needed, students will enter the number, the multiplication sign, the number, and then the equals sign to get the squares. Read and follow directions b, c, and d on the Student Activity Sheet.

Students record the square numbers, circle the last digit in each, and record the pattern 1,4,9,6,5,6,9,4,1,0,1,4,9,... The numbers not in the pattern are 2,3,7,8.

• **GUIDED PRACTICE:**

Students work together to predict the pattern and write a description of the patterns.

• **INDEPENDENT PRACTICE:**

Use exercise "e" to explore the patterns found in the squares of the numbers between 40 and 69. They will discover an interesting pattern of numbers in the first two digits.

The last exercise is open-ended. As the students choose the numbers, use the calculator, and record the results. This report can be posted on the bulletin board after the class discussion. Students can compare research findings.

• **EVALUATION:**

Class discussion and teacher observation.

• **HOME ACTIVITY:**

Students use mental arithmetic, the calculator, and their ability to predict patterns to explore squares of numbers between 10 and 19, 100 and 109; and 1000 and 1009.

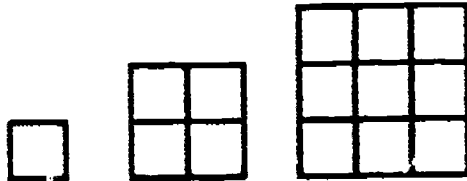

**SQUARES, SQUARES, AND MORE SQUARES**  
Student Activity Sheet

Any number multiplied by itself gives a product called a square number. In this activity you discover patterns using square numbers.

Work with a partner. You will need a calculator, a pencil, and this recording sheet.

- a. Square each of the counting numbers, starting with 1. (Example:  $7^2 = 49$ , since we multiply  $7 \times 7$ ). Record your answers in an orderly way. Use your calculator when you need it.

$1^2 =$ _____	$6^2 =$ _____	$11^2 =$ _____	$16^2 =$ _____
$2^2 =$ _____	$7^2 =$ _____	$12^2 =$ _____	$17^2 =$ _____
$3^2 =$ _____	$8^2 =$ _____	$13^2 =$ _____	$18^2 =$ _____
$4^2 =$ _____	$9^2 =$ _____	$14^2 =$ _____	$19^2 =$ _____
$5^2 =$ _____	$10^2 =$ _____	$15^2 =$ _____	$20^2 =$ _____

- b. Circle the last digit in each number. What do you observe? Write the numbers that form the pattern.

\_\_\_\_\_

\_\_\_\_\_

- c. What counting numbers are not part of your pattern? \_\_\_\_\_

**SQUARES, SQUARES, AND MORE SQUARES**  
Student Activity Sheet

- d. Talk with your partner. What prediction can you make about the answers you will get when you square the numbers 21 to 29? \_\_\_\_\_

Try it.       $21^2 =$  \_\_\_\_\_       $24^2 =$  \_\_\_\_\_       $27^2 =$  \_\_\_\_\_  
                   $22^2 =$  \_\_\_\_\_       $25^2 =$  \_\_\_\_\_       $28^2 =$  \_\_\_\_\_  
                   $23^2 =$  \_\_\_\_\_       $26^2 =$  \_\_\_\_\_       $29^2 =$  \_\_\_\_\_

What pattern can you see in the squares of these numbers? \_\_\_\_\_  
 \_\_\_\_\_  
 \_\_\_\_\_  
 \_\_\_\_\_

- e. Explore the pattern for the squares of the numbers 40 to 69. Complete the chart by writing the number you are squaring in the left corner of each box. Square the numbers. Predict the answers or part of the answers.

$40^2$									
$50^2$									
$60^2$									

Write about the pattern you found in the numbers.  
 \_\_\_\_\_  
 \_\_\_\_\_  
 \_\_\_\_\_



**SQUARES, SQUARES, AND MORE SQUARES**  
Student Activity Sheet

f. Choose a sequence of numbers to square.

--	--	--	--	--	--	--	--	--	--

Patterns:

Units digits : \_\_\_\_\_

Digits of greatest value: \_\_\_\_\_

Any other digit patterns: \_\_\_\_\_

What other numbers did you explore?

---

---

---

Did any numbers you squared exceed the capability of the calculator? \_\_\_\_\_

Did you get an "E" (error message) on the display? \_\_\_\_\_

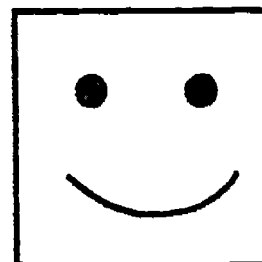
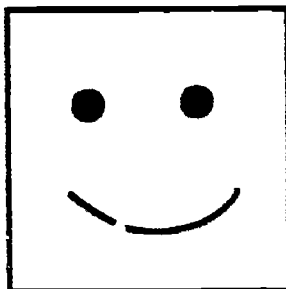

**SQUARES, SQUARES, AND MORE SQUARES**  
Home Activity Sheet

Use mental arithmetic, a calculator, and your ability to predict patterns to complete this exploration.

1.

$10^2$	$11^2$	$12^2$	$13^2$	$14^2$	$15^2$	$16^2$	$17^2$	$18^2$	$19^2$
--------	--------	--------	--------	--------	--------	--------	--------	--------	--------

Patterns: \_\_\_\_\_  
\_\_\_\_\_

2. Look at this series of numbers. What digits will be in the ones place? \_\_\_\_\_

\_\_\_\_\_

Complete the chart.

$100^2$	$101^2$	$102^2$	$103^2$	$104^2$	$105^2$	$106^2$	$107^2$	$108^2$	$109^2$
---------	---------	---------	---------	---------	---------	---------	---------	---------	---------

Patterns: \_\_\_\_\_  
\_\_\_\_\_

3. Look at this series of numbers. What do you predict the pattern will be? \_\_\_\_\_

\_\_\_\_\_

$1000^2$	$1001^2$	$1002^2$	$1003^2$	$1004^2$	$1005^2$	$1006^2$	$1007^2$	$1008^2$	$1009^2$
----------	----------	----------	----------	----------	----------	----------	----------	----------	----------

Patterns: \_\_\_\_\_  
\_\_\_\_\_



## SQUARES, SQUARES, AND MORE SQUARES, REVISITED

**GRADE:** 4  
**STRAND:** Patterns and Functions  
**SKILL:** Recognize and extend number patterns

### MANAGEMENT

**CLASS ORGANIZATION:** Pairs  
**TIME FRAME:** One class period  
**MATERIALS:** Calculator, pencil, color tiles  
**VOCABULARY:** Square, pattern  
**PREREQUISITE SKILL:** Mathematics: Basic operations  
Calculator: Basic functions. Lesson 32

**LESSON** The purpose of this lesson is to use square numbers to discover number patterns.

#### • DIRECTED INSTRUCTION/ GUIDED PRACTICE:

Distribute color tiles, allow time for exploration, and then use the tiles to build squares.

Use the smallest number of tiles to show a square. How many tiles did you use? (one) The edges of this square are one unit long. Subtract the number of tiles equal to the number of units for each edge. Record the number left. How many tiles are left? (zero)

Put this chart on the chalkboard.

number of units for each edge	number of tiles	subtract the number of tiles equal to the units
1	1	$1 - 1 = 0$

Have the students build the next larger square. How many units long are the edges of this square? (two) How many tiles did you use to make this square? (four) Subtract the number of tiles equal to the number of units for each edge (2). How many tiles are left? (two)

Record: 2, 4,  $4 - 2 = 2$

Continue, in this way, to build the next three squares and record on the chart.

227

Number of tiles	Units on edge	Tiles subtract Units
1	1	$1 - 1 = 0$
4	2	$4 - 2 = 2$
9	3	$9 - 3 = 6$
16	4	$16 - 4 = 12$
25	5	$25 - 5 = 20$

Put the tiles away. Look for patterns on the chart. What pattern do you see in the last column on the chart? [The differences between the answers in the last column are 2, 4, 6, 8, ...] Demonstrate:

$$\begin{array}{r}
 1 - 1 = 0 \\
 4 - 2 = 2 \\
 9 - 3 = 6
 \end{array}
 \begin{array}{l}
 \nearrow \\
 \nearrow \\
 \nearrow
 \end{array}
 \begin{array}{l}
 2 - 0 = 2 \\
 6 - 2 = 4
 \end{array}$$

Distribute Student Activity Sheet 1. Most of this chart can be done without using a calculator. Students work with a partner to square the numbers from one to ten, remembering that a number multiplied by itself gives a square number. Students subtract the original number, and then find the pattern in the differences. Students complete the chart and write a sentence to describe the pattern.

Note: Students can use the calculator sequence  $101 \times =$  to square 101.

• **INDEPENDENT PRACTICE:**

Distribute Student Activity Sheets 2 and 3. Use the calculator to discover the pattern of differences with the numbers 101 to 110 and 1001 to 1010. Predict the pattern of differences. Students complete the activities and share the results.

• **EVALUATION:**

Teacher observation and student discussion.

• **HOME ACTIVITY:**

Students use a blank chart. Choose any 10 consecutive numbers to explore and record.

**SQUARES, SQUARES, AND MORE SQUARES, REVISITED**  
Student Activity Sheet1

A: Number	B: Number Squared	B minus A	Difference	Pattern of Differences
1	1	1-1	0	2-0=2
2	4	4-2	2	
3	9	9-3	6	6-2=4
4				
5				
6				
7				
8				
9				
10				

229

**SQUARES, SQUARES, AND MORE SQUARES, REVISITED**  
**Student Activity Sheet 2**

A: Number	B: Number Squared	B minus A	Difference	Pattern of Differences
101				
102				
103				
104				
105				
106				
107				
108				
109				
110				

**SQUARES, SQUARES, AND MORE SQUARES, REVISITED**  
**Student Activity Sheet 3**

A: Number	B: Number Squared	B minus A	Difference	Pattern of Differences
1001				
1002				
1003				
1004				
1005				
1006				
1007				
1008				
1009				
1010				



## FIND MY FUNCTION

- GRADE:** 3 - 4
- STRAND:** Patterns and Functions
- SKILL:** Recognize and extend number patterns
- MANAGEMENT**
- CLASS ORGANIZATION:** Pairs
- TIME FRAME:** One class period
- MATERIALS:** Calculator, transparency, overhead calculator (optional)
- VOCABULARY:** Function, operation, unknown, constant
- PREREQUISITE SKILL:** Mathematics: Basic operations  
Calculator: Basic functions

**LESSON** The purpose of this lesson is to discover number patterns using the constant feature of the calculator.

**• DIRECTED INSTRUCTION/GUIDED PRACTICE:**

Prior to presenting this lesson use the following sequences to hide a function on each of 16 calculators.

The change sign key  $\boxed{+/-}$  is used to hide the addition or subtraction function and return the display to zero.

Constant Operation	Hidden Function	Sequence	Display
addition	+ 8	0 $\boxed{+}$ 8 $\boxed{=}$ $\boxed{+/-}$ $\boxed{=}$	0
subtraction	- 5	0 $\boxed{-}$ 5 $\boxed{=}$ $\boxed{+/-}$ $\boxed{=}$	0
multiplication	x 3	3 $\boxed{\times}$ 0 $\boxed{=}$	0
division	+ 2	0 $\boxed{\div}$ 2 $\boxed{=}$	0

After hiding each function, enter a number and press  $\boxed{=}$  to see what happens.

Distribute the calculators, ONE PER PAIR OF STUDENTS. Direct the pairs to determine the functions hidden in their calculators by entering a whole number and pressing  $\boxed{=}$   $\boxed{=}$   $\boxed{=}$ .

Groups discuss results.

Project the transparency and demonstrate how to hide a function for each operation.

- **INDEPENDENT PRACTICE:**  
Students work in pairs to play **FIND MY FUNCTION**. Distribute additional calculators so each student has one. Each student hides a function in their calculator. Students exchange calculators, enter a number and press  $\square$  ... Using the pattern of numbers that result, students find the function that has been entered in their partner's calculator.
- **EVALUATION:**  
Teacher observation.
- **HOME ACTIVITY:**  
Play "Find My Function" with a family member.

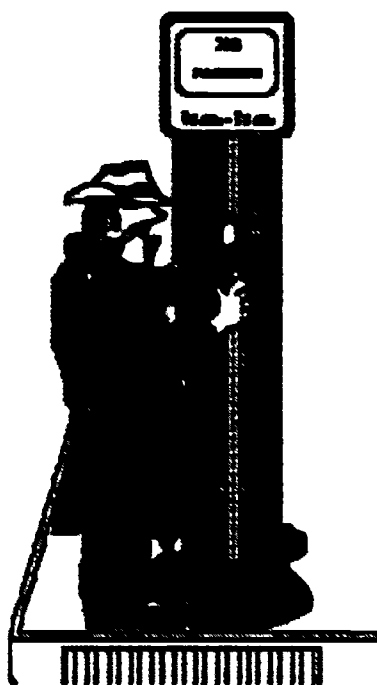



# FIND MY FUNCTION

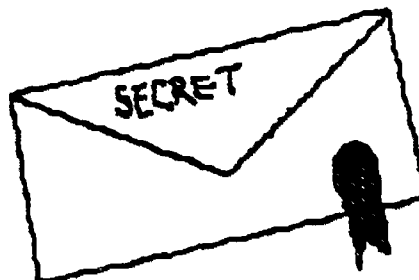
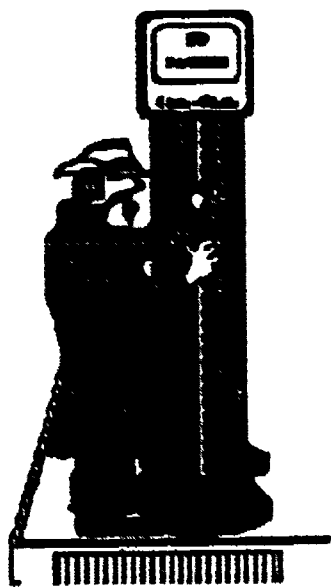

Constant Operation	Hidden Function						Display
addition	+ 8	0	<input type="text" value="0"/>	8	<input type="text" value="8"/>	<input type="text" value="+/-"/>	<input type="text" value="0"/>
subtraction	- 5	0	<input type="text" value="0"/>	5	<input type="text" value="5"/>	<input type="text" value="+/-"/>	<input type="text" value="0"/>
multiplication	3 x	3	<input type="text" value="3"/>	0	<input type="text" value="0"/>		<input type="text" value="0"/>
division	+ 2	0	<input type="text" value="0"/>	2	<input type="text" value="2"/>		<input type="text" value="0"/>

## Test to Guess

### Hidden function

0	<input type="text" value="0"/>	8	<input type="text" value="8"/>	<input type="text" value="+/-"/>	<input type="text" value="0"/>
0	<input type="text" value="0"/>	5	<input type="text" value="5"/>	<input type="text" value="+/-"/>	<input type="text" value="0"/>
3	<input type="text" value="3"/>	0	<input type="text" value="0"/>		
0	<input type="text" value="0"/>	2	<input type="text" value="2"/>		

### Test

100	<input type="text" value="100"/>	<input type="text" value="100"/>	<input type="text" value="100"/>
100	<input type="text" value="100"/>	<input type="text" value="100"/>	<input type="text" value="100"/>
100	<input type="text" value="100"/>	<input type="text" value="100"/>	<input type="text" value="100"/>
100	<input type="text" value="100"/>	<input type="text" value="100"/>	<input type="text" value="100"/>

235

## CHAPTER 4 ASSESSMENT: PATTERNS AND FUNCTIONS

1. Write all you can about this number pattern.  
... 57, 66, 75, 84, 93 ...

Student response should include the following points:

- a. Recognizes difference of nine between consecutive members in the sequence.
- b. All members are multiples of three.
- c. All members are three more than a multiple of 9.
- d. Sum of the digits is twelve.
- e. All are two-digit numbers.
- f. Difference between digits is an even number.

2. A palindrome is a number that reads the same forward, as it does backward. To get a palindrome for a number reverse its digits and add the two numbers. Find the palindrome for 463. How many steps did it take?

Student response should include:

$$\begin{array}{r}
 463 \\
 + 364 \\
 \hline
 827 \qquad 1 \\
 + 728 \\
 \hline
 1555 \qquad 2 \\
 + 5551 \\
 \hline
 7106 \qquad 3 \\
 + 6017 \\
 \hline
 13123 \qquad 4 \\
 + 32131 \\
 \hline
 45254 \qquad 5
 \end{array}$$

3. Study the following number pattern and give the missing numbers.

\_\_\_\_\_, 4015, 4054, 4093, 4132, \_\_\_\_\_, 4210

Describe the process you used to find each of the missing numbers.

Student response should include:

3976, 4015, 4054, 4093, 4132, 4171, 4210

- a. Subtraction of adjacent members to establish difference.
- b. Check to see if all distances are same between given members.
- c. Mention of the rule ( $n + 39$ ).
- d. Application of rule to complete second space.
- e. Inverse application of rule to complete initial space.

4. Use the graph below to chart data on a T-table. When you have found the pattern, use that information to find the number of pencils in 72 boxes.

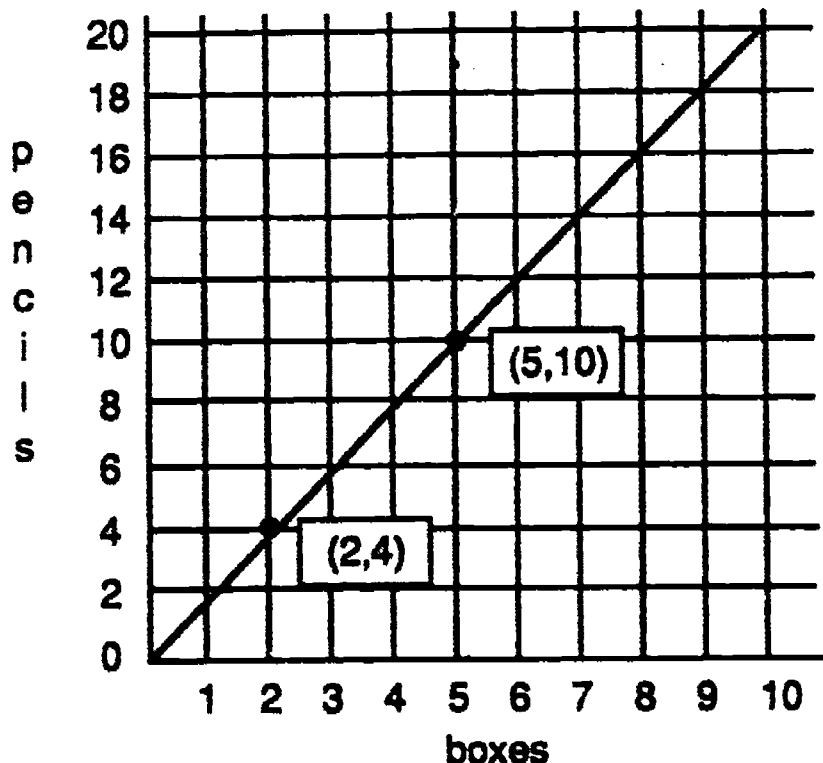

boxes	pencils

There are 72 boxes. How many pencils are there? \_\_\_\_\_

Student response should include:

boxes	pencils
2	4
3	6
4	8
5	10
10	20
50	100
72	144

There would be 144 pencils in 72 boxes.

237

5. Square each of the following numbers and look for a pattern.

21 \_\_\_\_\_ 22 \_\_\_\_\_ 23 \_\_\_\_\_ 24 \_\_\_\_\_ 25 \_\_\_\_\_

26 \_\_\_\_\_ 27 \_\_\_\_\_ 28 \_\_\_\_\_ 29 \_\_\_\_\_ 30 \_\_\_\_\_

Describe the pattern you find.

---



---

Does the pattern remain the same for 31 to 39? \_\_\_\_\_  
 Show your answer.

\_\_\_\_\_

\_\_\_\_\_

Student response should include:

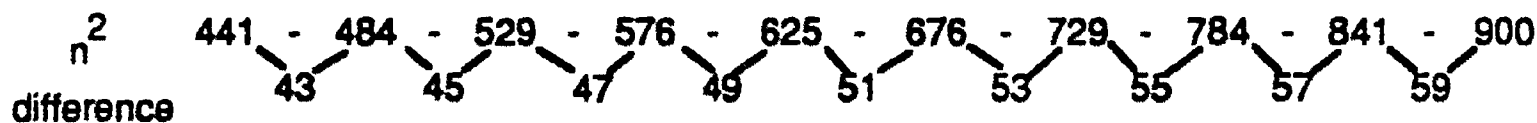

- Multiply each number by itself to find the square number.
- Subtract smaller square number from the next larger square to find the difference between them.
- Recognize pattern of odd numbers in the differences.

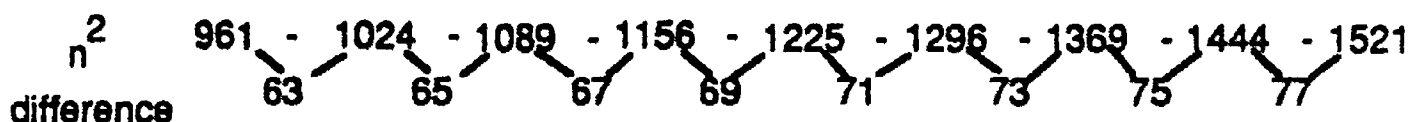

- The differences are the odd numbers from 63 to 77.
- The pattern of odd numbers is the same.

# CAMP-LA

Calculators and Mathematics Project, Los Angeles

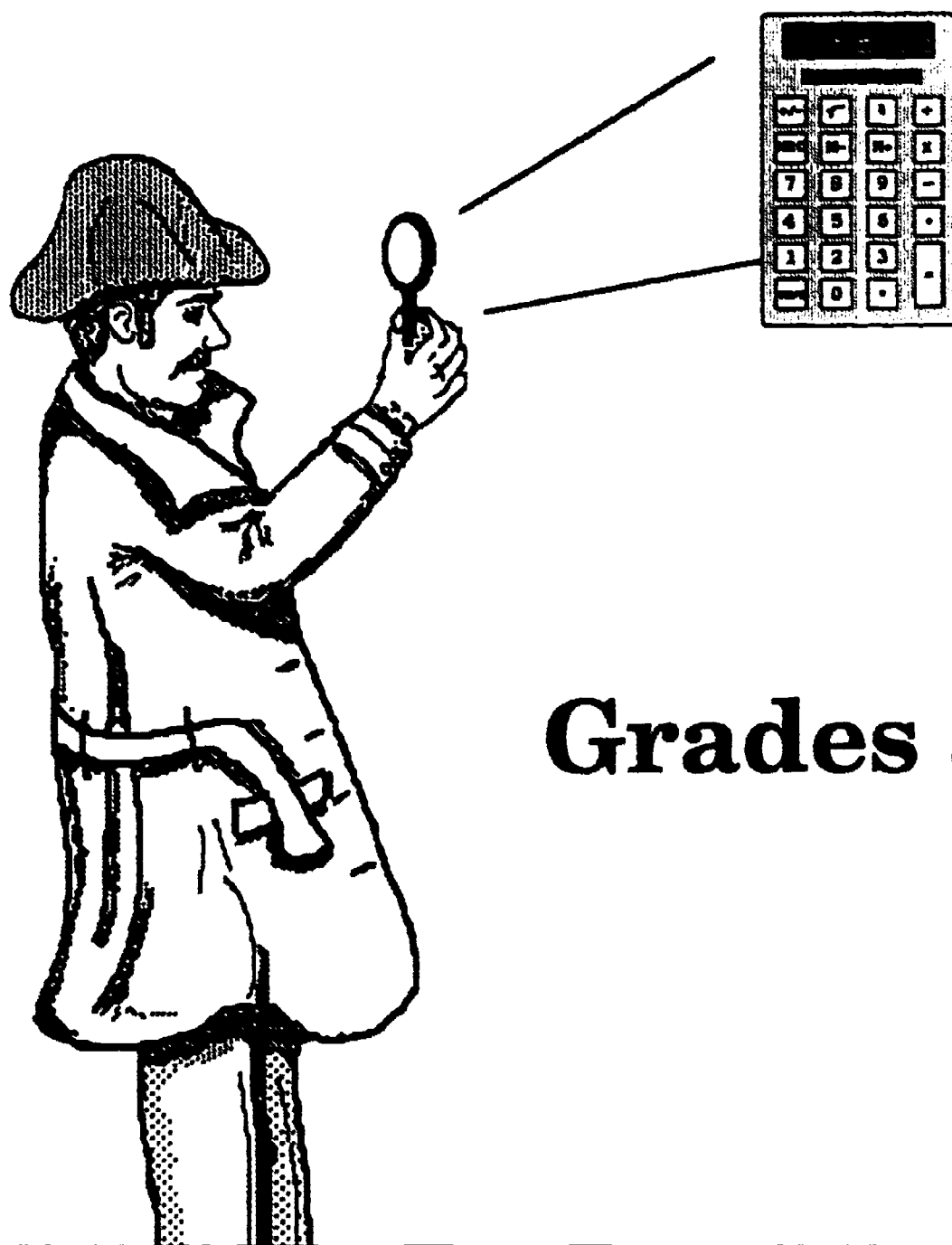

Grades 3 - 4

## CHAPTER 5 STATISTICS AND PROBABILITY

## USING THE MEAN

- GRADE :** 3 - 4
- STRAND:** Statistics and Probability
- SKILL:** Determine the mean of a set of data
- MANAGEMENT:**
- CLASS ORGANIZATION:** Whole class
- TIME FRAME:** One class period
- MATERIALS:** Calculator
- VOCABULARY:** Sum, average, mean, prediction
- PREREQUISITE SKILL:** Mathematics: Basic operations  
Calculator: Basic functions

**LESSON:** The purpose of this lesson is to determine and use the mean.

• **DIRECTED INSTRUCTION/GUIDED PRACTICE:**

Review average or mean with the class.

Example: Last week Jane calculated that she used an average of 10 sheets of paper per day. Does that mean she used exactly 10 sheets every day last week?

Why is it important for the teacher to know the average number of sheets of paper each student uses in a week? [answer: It allows the teacher to know how much paper to order each week or for the month.]

Project the transparency and discuss the following situation.

Anna and Javier order pencils for the school store. Their store has run out of pencils. There are 11 weeks left in the school year.

Anna and Javier do not want to order too many or too few pencils this late in the year.

How can Anna and Javier predict the number of pencils needed for the remainder of the year?

### PENCILS BOUGHT BY STUDENTS FOR THE PAST TWELVE WEEKS

WEEK OF	NUMBER OF PENCILS	WEEK OF	NUMBER OF PENCILS
Jan. 18	54	Mar. 1	37
Jan. 25	30	Mar. 8	29
Feb. 1	23	Mar. 15	32
Feb. 8	19	Mar. 22	25
Feb. 15	34	Mar. 29	33
Feb. 22	12	Apr. 5	32

Demonstrate how to find the mean of the number of pencils bought in the twelve week period.

$$\frac{360}{12} = 30 \text{ pencils is the mean (also called the average)}$$

In the twelve week period 30 pencils were purchased each week on the average. The mean is used to decide how many pencils to order for the last eleven weeks of school.

Javier and Anna multiply  $11 \times 30$  and order 330 pencils for the rest of the year.

• **INDEPENDENT PRACTICE:**

Students complete the Student Activity Sheet.

Answers:

1) Mean:  $\frac{180}{12} = 15$ . Number of erasers:  $15 \times 11 = 165$ .  
Next year:  $36 \times 15 = 540$  (or 270 for half a year).

2) Mean:  $\frac{25640}{5} = 5128$

Some days he won't have enough stamps.

3) a) mean: \$46,000

b) no one

c) Pres., Vice Pres.

d) Secretary, workers 1, 2, 3

e) A salary that is influenced by the large salaries of the president and vice-president

• **EVALUATION:**

Teacher observation.

• **HOME ACTIVITY:**

1) Measure the height of each member of your family in inches. Find the average height of your family.

2) Keep track of how many minutes you study each night for one week. Find the mean number of minutes that you study.

WEEK OF -	QUANTITY PENCILS	WEEK OF -	QUANTITY PENCILS
Jan. 18	54	Mar. 1	37
Jan. 25	30	Mar. 8	29
Feb. 1	23	Mar. 15	32
Feb. 8	19	Mar. 22	25
Feb. 15	34	Mar. 29	33
Feb. 22	12	Apr. 5	32

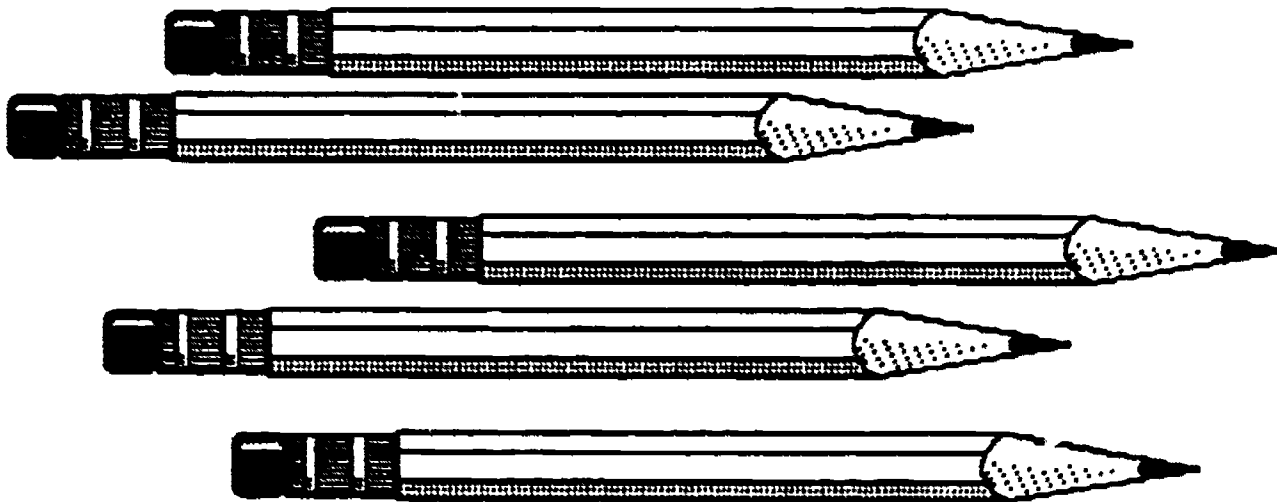



**USING THE MEAN**  
Student Activity Sheet

1. How many erasers must Javier and Anna order for the last 11 weeks of school?

Here are the store records:

WEEK OF	QUANTITY ERASERS	WEEK OF	QUANTITY ERASERS
Jan. 18	24	Mar. 1	32
Jan. 25	12	Mar. 8	4
Feb. 1	6	Mar. 15	6
Feb. 8	24	Mar. 22	12
Feb. 15	12	Mar. 29	24
Feb. 22	18	Apr. 5	6

Mean: \_\_\_\_\_

Number of erasers: \_\_\_\_\_

Next year the school store will be open for 36 weeks. How many erasers should be ordered in advance? \_\_\_\_\_

2. Juan's father works at the Post Office. Last week he sold the following numbers of stamps.

Monday	4614
Tuesday	8350
Wednesday	1268
Thursday	926
Friday	10,482

What was the mean number of stamps sold each day?

\_\_\_\_\_

If Juan's father uses the mean number of stamps to fill his stamp drawer each day, will he have a problem?

## USING THE MEAN

### Student Activity Sheet

3. The people who work in a factory are paid the following salaries:

President	\$152,000
Vice President	\$ 60,000
Secretary	\$ 21,000
Worker 1	\$ 15,000
Worker 2	\$ 14,000
Worker 3	\$ 14,000

a) What is the average (mean) salary for the people working in this factory?

---

b) Which worker earns the average (mean) salary?

---

c) Who earns more than the average (mean) salary?

---

d) Who earns less than the average (mean) salary?

---

e) What does the average salary signify to the workers in this factory?

---

---

---

---

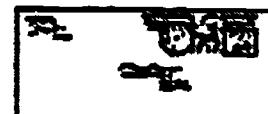
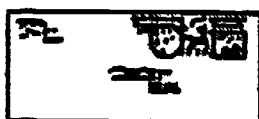

## WAYS TO 99,999,999

**GRADE:** 3 - 4

**STRAND:** Statistics and Probability

**SKILL:** Determine the mean of a set of data

**MANAGEMENT:**

**CLASS ORGANIZATION:** Pairs

**TIME FRAME:** One class period

**MATERIALS:** Textbooks, calculators

**VOCABULARY:** Average, approximate, sample

**PREREQUISITE SKILLS:** Mathematics: Basic operations, rounding  
Calculator: Basic functions

**LESSON** The purpose of this lesson is to approximate an answer using average.

• **DIRECTED INSTRUCTION:**

Discuss with students the largest number that can be displayed on the calculator: [answer: 99,999,999]. What is the minimum number of mathematics books it would take to total at least 99,999,999 pages? Example: Each book has 357 pages.

$$99,999,999 \boxed{+} 357 = 280,112.04$$

There would be 280,113 books because the answers in this lesson should all be rounded up and expressed to the next whole number. There could not be 0.04 of a book.

Note:  $357 \boxed{\times} 280112 = 99,999,984$  (15 pages short)

$357 \boxed{\times} 280113 = 1.0000034$  (Note: The (decimal) point one digit to the right of the 1 means that there is one digit missing at the end of the display. Since this digit is determined by the right most digits of the numbers being multiplied (3 & 7;  $3 \times 7 = 21$ ), the missing digit is a 1.)

$$\begin{array}{r}
 280113 \\
 \times 357 \\
 \hline
 \dots\dots 1 \\
 \dots\dots \phantom{1} \\
 \dots\dots \phantom{1} \\
 \hline
 \phantom{\dots\dots} 1
 \end{array}$$

The answer can therefore be figured out to be  $357 \boxed{\times} 280113 = 100,000,341$  (342 pages over). This feature of the calculator is optional. You may choose not to discuss it with students.

• **GUIDED PRACTICE:**

245

- **GUIDED PRACTICE:**

Work through the following process with the students:

- How many mathematics books would it take to reach at least 99,999,999 words?

Students select a page in their math books and count the words.

Record the samples on the chalkboard.

Students total the samples on the calculator.

Divide the total by the number of samples.

Demonstrate how to use the average to approximate the number of words in the math book.

Example: The average number of words on a page in a math book is 78. The book has 357 pages.

$78 \times 357 = 27,846$  words in a book. This is an approximate answer because an average was used.

The approximate answer is used to find out how many books are needed to reach 99,999,999 words.

$$99,999,999 \div 27,846 = 3591.18 \text{ books}$$

This answer is rounded to 3592 books.

- **INDEPENDENT PRACTICE:**

Students work in small groups to complete the Student Activity Sheet.

- **EVALUATION:**

Teacher observation.

- **HOME ACTIVITY:**

Write an explanation of an approximate answer and tell how you would use an approximation.

**WAYS TO 99,999,999**  
**Student Activity Sheet**

1. How many social studies books would it take to reach 99,999,999 words?

Each student in the group selects a page and counts the words.

Number of Words

---

---

---

---

Average number of words per page \_\_\_\_\_

Total pages in the social studies book \_\_\_\_\_

Approximate number of words in the social studies book \_\_\_\_\_

Minimum number of social studies books to reach at least 99,999,999 words

\_\_\_\_\_

2. Minimum number of \_\_\_\_\_ books it would take to reach 99,999,999 words.  
(name of text)

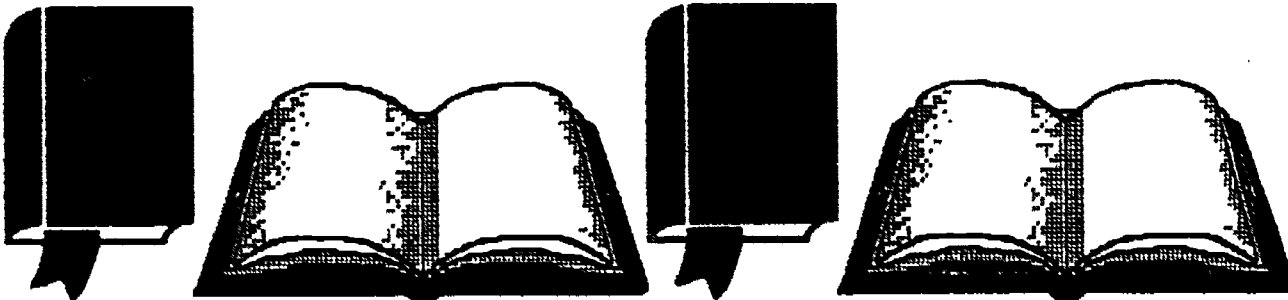

247

## FINDING THE AVERAGE

**GRADE:** 3 - 4  
**STRAND:** Statistics and Probability  
**SKILL:** Determine the mean of a set of data

**MANAGEMENT**  
**CLASS ORGANIZATION:** Whole class and small groups

**TIME FRAME:** One class period

**MATERIALS:** Color tiles, calculators, transparency

**VOCABULARY:** Sum, divide, quotient, average, mean

**PREREQUISITE SKILLS:** Mathematics: Basic operations  
Calculator: Basic functions

**LESSON** The purpose of this lesson is to develop an understanding of mean or average.

• **DIRECTED INSTRUCTION/GUIDED PRACTICE:**

Distribute color tiles, Record Sheet, and calculators to each student. Each student takes one tile for each member of his/her family. (Remind them to include themselves.) Students arrange their tiles in columns in the center of the table. Groups should arrange their columns with the first tile of each aligned along the bottom, as a bar graph, like this:

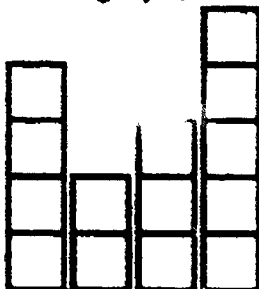

The groups then move tiles from the tallest column/s to the shortest, until they get as close as they can to showing each family (represented by a column) as having the same, or nearly the same, number of members. Record averages on the overhead transparency as groups report them. Students copy the data onto their Record Sheet from the overhead. Complete the class average on the Record Sheet with the students.

- **INDEPENDENT PRACTICE:**  
Distribute Student Activity Sheets.
- **EVALUATION:**  
Teacher observation.
- **HOME ACTIVITY:**  
Find the average age of your family.

FINDING THE AVERAGE  
Record Sheet

CLASS AVERAGE

	GROUP NAME/NUMBER	AVERAGE
1		 (+)
2		 (+)
3		 (+)
4		 (+)
5		 (+)
6		 (-)
7		
8		
		SUM (+)
	NUMBER OF GROUPS	 (=)
	CLASS AVERAGE	

243

215

## FINDING THE AVERAGE Student Activity Sheet

Students from Room 13 at Canco Elementary School collected aluminum cans for a recycling project. The following chart shows the number of cans collected by some of the students.

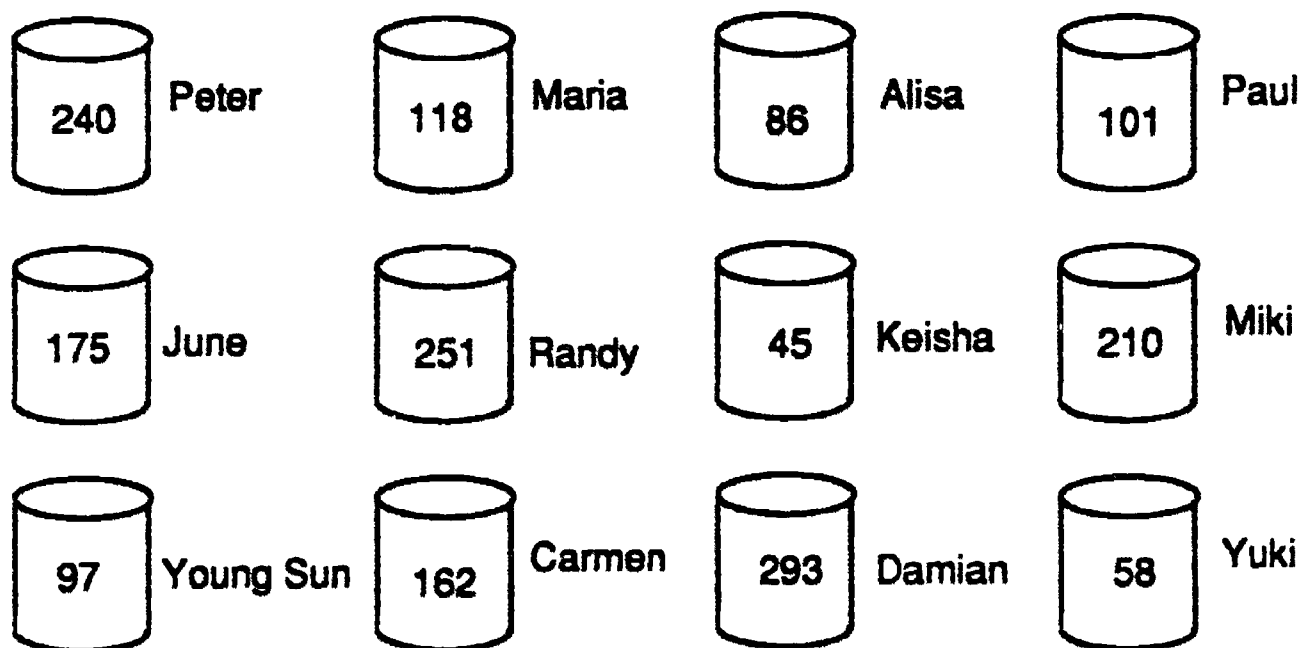

1. What was the total number of cans collected by the students? \_\_\_\_\_
2. What is the average number of cans collected by each student? \_\_\_\_\_
3. Which student collected closest to the average number of cans? \_\_\_\_\_
4. Which student's amount was farthest from the average? \_\_\_\_\_

250





**FINDING THE AVERAGE**  
**Student Activity Sheet**

5. All the 3rd and 4th grade classes participated in the can drive.  
What is the average per student for each room?

Room 17  32 students

Room 14  30 students

Room 15  33 students

Room 16  32 students

Room 13  30 students

Room 13 \_\_\_\_\_

Room 14 \_\_\_\_\_

Room 15 \_\_\_\_\_

Room 16 \_\_\_\_\_

Room 17 \_\_\_\_\_

What is the average per class for all 3rd and 4th grade classes? \_\_\_\_\_

What is the average for each student in the 3rd and 4th grades? \_\_\_\_\_

**FINDING THE AVERAGE**  
Teacher Answer Sheet

Students from Room 13 at Canco Elementary School collect aluminum cans for a recycling project. The following chart shows the number of cans collected by some of the students.

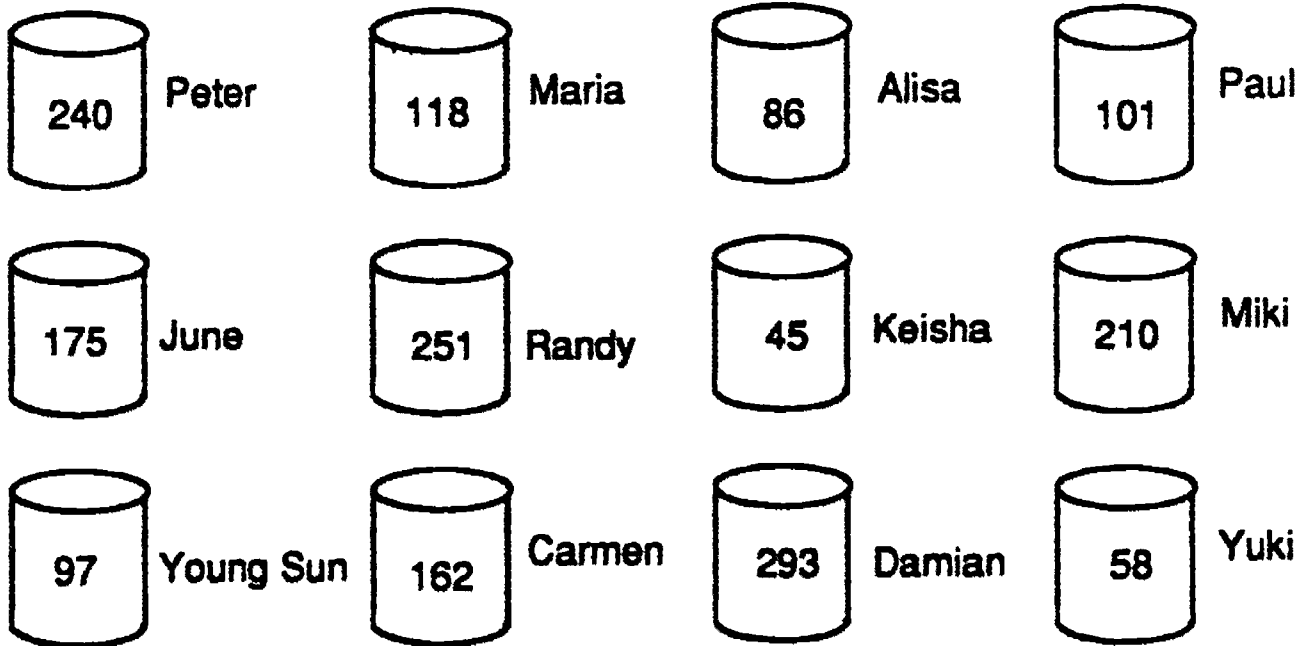

1. What was the total number of cans collected by the students? 1836
2. What is the average number of cans collected by each student? 153
3. Which student collected closest to the average number of cans? Carmen, 162
4. Which student's amount was farthest from the average? Damian, 293
5. All the 3rd and 4th grade classes participated in the can drive.

What is the average per student for each room?

Room 13 172.5

Room 14 173.8

Room 15 121.15 (rounded)

Room 16 152.56 (rounded)

Room 17 153

What is the average per class for all 3rd and 4th grade classes?  $24165 \div 5 = 4833$

What is the average for each student in the 3rd and 4th grades?  $24165 \div 157 = 153.9$

252

## WHERE DOES THE TIME GO?

- GRADE:** 4
- STRAND:** Statistics and Probability
- SKILL:** Collect and analyze data
- MANAGEMENT**
- CLASS ORGANIZATION:** Groups of 4
- TIME FRAME:** One class period
- MATERIALS:** Calculator, one Student Activity Sheet per group
- VOCABULARY:** Survey, average, process, display, approximation
- PREREQUISITE SKILL:** Mathematics: Basic operations  
Calculator: Basic functions

**LESSON** The purpose of this lesson is to collect data, find an average, and use the average to do other calculations that yield an approximation.

• **DIRECTED INSTRUCTION:**

An approximate answer is close to an exact answer.

Demonstrate how to collect and process the information.

How many minutes does the class spend doing mathematics during the year? Write the estimates on the chalkboard. What other information is needed? [answer: number of weeks in the school year, number of days in the school year, and the number of minutes for mathematics each day]. Find the amount of time spent on mathematics in a week. List the days and times on the chalkboard.

Monday	43 minutes
Tuesday	47 minutes
Wednesday	38 minutes
Thursday	52 minutes
Friday	45 minutes

Use calculators to find the total number of minutes. [answer: 225 minutes] Find the average number of minutes spent on mathematics each day. [answer:  $225 \div 5 = 45$ ] Use the number of days we are in school to calculate the number of minutes we spend on mathematics. List students' suggestions and estimates on the chalkboard, and then direct them to enter  $180 \times 45 = 8100$ . Compare this answer to the estimates.

Assign students to groups of 4. Each student needs a calculator and a pencil. Direct the students to complete problems 1 and 2 on the Student Activity Sheet. Students complete the pie chart in problem 1 and total the hours spent in school, sleeping, watching TV, and eating. In problem 2 they find the averages.

253

- **GUIDED PRACTICE:**

In this part of the lesson the students use the average hours to calculate minutes and seconds. The students need to know when they will graduate from high school and how many school years will be after the current one. Students should disregard fractional parts of an hour when performing calculations.

Record the average number of hours your group is in school on the chart in problem 3.

How can you find approximately how many hours your group will spend in school until you graduate from high school? Student responses will include multiplying the years and the hours. How can you find the approximate number of minutes? Responses should include multiplying by 60 for the number of minutes in an hour.

How can you find the approximate number of seconds? Students respond that you multiply by 60 for the number of seconds in a minute. Students complete the chart.

- **INDEPENDENT PRACTICE:**

Students apply what they have learned by completing problem 4 and 5.

In problem 6 students are directed to report to the class. They are also given questions to discuss.

- **EVALUATION:** Teacher observation

- **HOME ACTIVITY:**

Students apply what they have learned in this lesson by taking a survey of their family members.

**WHERE DOES THE TIME GO?**  
Student Activity Sheet

1. Survey your group. Get the following information about each person:

	1	2	3	4	Total hours	Average
How many hours are you in school each day?						hrs.
How many hours do you sleep each night?						hrs.
How many hours do you spend watching television each day?						hrs.
How many hours do you spend eating each day?						hrs.

2. Find the average for each set of data.

Find the average: Enter the sum + number of people in group = \_\_\_\_\_

Record the average on the chart.

Our group is in school an average of \_\_\_\_\_ hours per day.

Find the average for each set of information:

Sleeping	
<u>        </u> sum	<u>        </u> number in group

Watching TV	
<u>        </u> sum	<u>        </u> number in group

Eating	
<u>        </u> sum	<u>        </u> number in group

3. Our group will graduate from high school in \_\_\_\_\_. That is \_\_\_\_\_ school years after this one. Assume that you will continue to go to school 180 days per year. Use the average number of hours you are in school to find approximately how much time you will spend in school until your group graduates.

$$\frac{\text{group average hours in school per day}}{\text{number of school days per year}} \times \text{number of years} = \text{group total number of hours spent in school}$$



**WHERE DOES THE TIME GO?**  
Student Activity Sheet

Record answers on the chart and complete the calculations for minutes and seconds.

Group average number of hours in school per day	Approximate the total hours	Approximate the total minutes	Approximate the total seconds

4. Find how many hours, minutes, and seconds your group will spend sleeping, watching television, and eating by the time all of you are 25.

25 years old. That is \_\_\_\_\_ years from now.

	Group average hours	Approximate the total hours	Approximate the total minutes	Approximate the total seconds
<b>Sleeping</b>				
<b>Watching TV</b>				
<b>Eating</b>				

5. Choose a different age: \_\_\_\_\_.  
That is \_\_\_\_\_ years from now.

	Group average hours	Approximate the total hours	Approximate the total minutes	Approximate the total seconds
<b>Sleeping</b>				
<b>Watching TV</b>				
<b>Eating</b>				

6. Report your approximations to the class.  
Will everyone in your group spend exactly the same amount of time sleeping, watching TV, and eating? Why or why not? How can you explain an approximation to the class?



**WHERE DOES THE TIME GO?**  
Home Activity Sheet

Gather data from your family. Record data rounded to the nearest hour. Find the average for your data. Use the average to approximate the number of minutes your family spends on the activities.

**Family Members**

			<b>Total hrs.</b>
<b>Sleeping</b>			
<b>Watching TV</b>			
<b>Eating</b>			
<b>Playing,Relaxing</b>			

	<b>Group average hours</b>	<b>Approximate the Total hours</b>	<b>Approximate the Total minutes</b>	<b>Approximate the Total seconds</b>
<b>Sleeping</b>				
<b>Watching TV</b>				
<b>Eating</b>				
<b>Playing,Relaxing</b>				

## TEMPERATURES AROUND THE WORLD

- GRADE:** 4
- STRAND:** Statistics and Probability
- SKILL:** Use data to describe tendencies and predict the likelihood of future events.
- MANAGEMENT**
- CLASS ORGANIZATION:** Small groups
- TIME FRAME:** Two math periods. Collect data over the period of one week.
- MATERIALS:** Calculator, names of cities cards, five paper bags, weather data from newspaper
- VOCABULARY:** Continent, temperature, average, comparison, mean, median, mode, encyclopedia, almanac, range, latitude
- PREREQUISITE SKILL:** Mathematics: Basic operations, finding an average  
Calculators: Basic functions

**LESSON** The purpose of this lesson is to study weather charts, record and compare temperature data, and make predictions based on calculations.

### • DIRECTED INSTRUCTION:

Display a weather data chart from the newspaper and a world map. Point out that the various cities all fall along a line, horizontally (line of latitude). Students work together to record the high and low temperatures from various cities around the world. When data has been collected for a week, students use it to do calculations which develop their understanding of temperature variations within climatic areas/latitudes. (Eight sets of latitude/climate zones are provided.)

Use the weather data chart, select a city in the United States, read, and then record its high and low temperature for the day.

Example:

City	Low	High	Precipitation
Los Angeles	64	78	None

This city is along the latitudes between 30° and 35° N, on the continent of North America. Find two or three other cities along the same latitudes. What was the temperature range in each of them? Chart this data together.

Example:

City	Low	High	Precipitation
Little Rock	66	73	Partly cloudy
Dallas			
Phoenix			
Atlanta			

Look at the map. Locate Los Angeles and the others. What prediction can be made about similarity of the temperatures in these cities? What about



their location can be predicted to cause a difference in their temperatures? Find the highest and lowest temperatures along your selected latitude.

What was the range for this zone?

Find the average high and low temperature of all the cities in this latitude.

$$\begin{array}{ll} (78 + 73 = 151 & 151 \div 2 = 75.2) \\ (64 + 66 = 130 & 130 \div 2 = 65) \end{array}$$

Each group will have five members who collect and chart temperature information for each of the cities along their latitudes. Students discuss the cities available along a latitude on the continent(s) of their choice and complete the information on the activity sheet and record the temperatures from the chart.

• **GUIDED PRACTICE:**

Over the course of a week the students use weather data charts to complete Student Activity Sheet 1.

• **INDEPENDENT PRACTICE:**

Students meet in groups and compare data by completing Student Activity Sheet 2. Compare the high temperatures for day one by listing them from highest to lowest. Find the difference between the highest high temperature and the lowest.

Students find the average of their high temperatures and compare the lowest temperatures in the same manner. They then write a paragraph about their observations and plan how to present their discovered information to the class.

• **EVALUATION:**

Class presentations. Establish a time limit and have each group summarize their activity.

• **HOME ACTIVITY:**

Students use the information about the country to write problems for their group to solve.

259

**TEMPERATURES AROUND THE WORLD**  
**Student Activity Sheet 1**

Work in groups of five, each representing a different climate zone, as noted on the bottom of the city card. Each student draws the name of one city from a box/bag to determine the continent and the group with which he/she will work. Use the weather reports to track the data for your climate zone. (Note: Labels apply to latitudes in which cities fall, but do not necessarily indicate the continent on which they are located.)

Individual Data Sheet for \_\_\_\_\_

Climate Zone \_\_\_\_\_ City \_\_\_\_\_ Country \_\_\_\_\_

Date	Temperature	
	Low	High
Average		



**TEMPERATURES AROUND THE WORLD**  
Student Activity Sheet 2

1. Group comparisons of high temperatures and computation of average of the five high temperatures.

Day 1	Temperatures from Highest to Lowest _____	Difference between Highest / Lowest <input type="text"/> - <input type="text"/> = <input type="text"/>	Average of the 5 temps _____
-------	--	---	---------------------------------

Day 2	Temperatures from Highest to Lowest _____	Difference between Highest / Lowest <input type="text"/> - <input type="text"/> = <input type="text"/>	Average of the 5 temps _____
-------	--	---	---------------------------------

Day 3	Temperatures from Highest to Lowest _____	Difference between Highest / Lowest <input type="text"/> - <input type="text"/> = <input type="text"/>	Average of the 5 temps _____
-------	--	---	---------------------------------

Day 4	Temperatures from Highest to Lowest _____	Difference between Highest / Lowest <input type="text"/> - <input type="text"/> = <input type="text"/>	Average of the 5 temps _____
-------	--	---	---------------------------------

Day 5	Temperatures from Highest to Lowest _____	Difference between Highest / Lowest <input type="text"/> - <input type="text"/> = <input type="text"/>	Average of the 5 temps _____
-------	--	---	---------------------------------

261

**TEMPERATURES AROUND THE WORLD**  
Student Activity Sheet 2

2. Group comparison of the low temperatures and computation of the average of the five low temperatures.

Day 1	Temperatures from Highest to Lowest _____	Difference between Highest / Lowest <input type="text"/> - <input type="text"/> = <input type="text"/>	Average of the 5 temps _____
Day 2	Temperatures from Highest to Lowest _____	Difference between Highest / Lowest <input type="text"/> - <input type="text"/> = <input type="text"/>	Average of the 5 temps _____
Day 3	Temperatures from Highest to Lowest _____	Difference between Highest / Lowest <input type="text"/> - <input type="text"/> = <input type="text"/>	Average of the 5 temps _____
Day 4	Temperatures from Highest to Lowest _____	Difference between Highest / Lowest <input type="text"/> - <input type="text"/> = <input type="text"/>	Average of the 5 temps _____
Day 5	Temperatures from Highest to Lowest _____	Difference between Highest / Lowest <input type="text"/> - <input type="text"/> = <input type="text"/>	Average of the 5 temps _____

262

**TEMPERATURES AROUND THE WORLD**  
**Student Activity Sheet 2**

3. Write about your information. Was the highest temperature recorded in the same city each day? Was the lowest temperature recorded in the same city each day? What else does the group see or think about the information on your charts? Did your group find any patterns in your information?

---

---

---

How can your group present the information to the class?

---

---

---

---

Extend the group research.

Use an encyclopedia or an almanac to find information about the city and country from which you have been gathering temperatures. Record on Home Activity Sheet.

203

**TEMPERATURES AROUND THE WORLD**  
**Home Activity Sheet**

Use an encyclopedia or almanac. Get facts about the country you have used in the temperature study. Use the temperature information you gathered and the facts to write problems for your group to solve.

population \_\_\_\_\_

number of cars \_\_\_\_\_

miles of paved roads \_\_\_\_\_

life expectancy \_\_\_\_\_

number of television receivers (sets) \_\_\_\_\_

1.	2.
3.	4.

Belem, Brazil	Equatorial	Baghdad, Iraq	Asia
Boston, MA	NA	Recife, Brazil	Capricorn
Boise, ID	NA	Quito, Ecuador	Equatorial
Des Moines, IA	NA	Santiago, Chile	So. Temperate
Chicago, IL	NA	Singapore, Singapore	Equatorial
Toronto, ON	NA	Bangkok, Thailand	S. E. Asia
New York, NY	NA	Kampala, Uganda	Equatorial

265

Salt Lake City, UT NA	Detroit, MI NA
Buenos Aires, Argentina So. Temperate	Beijing, China Asia
Seoul, So. Korea Asia	Glasgow, Scotland Eurasian North
Tokyo, Japan Asia	Stockholm, Sweden Eurasian North
Tehran, Iran Asia	Okhotsk, USSR Eurasian North
Damascus, Syria Asia	Moscow, USSR Eurasian North



Copenhagen, Denmark Eurasian North	Leningrad, USSR Eurasian North
Trujillo, Peru Capricorn	Jakarta, Java Capricorn
Lisbon, Portugal Mediterranean	Algiers, Algeria Mediterranean
Athens, Greece Mediterranean	Tunis, Tunisia Mediterranean
Palermo, Sicily Mediterranean	Aleppo, Syria Mediterranean
Ankara, Turkey Mediterranean	Phnom Penh, Kampuchea S.E. Asia

<p>Manila, Philippines S.E. Asia</p>	<p>Madras, India S.E. Asia</p>
<p>Khartoum, Sudan S.E. Asia</p>	<p>Cape Town, S. Africa So. Temperate</p>
<p>Nairobi, Kenya Equatorial</p>	<p>Aden, PDR of Yemen S.E. Asia</p>
<p>Sydney, New So. Wales So. Temperate</p>	<p>Montevideo, Uruguay So. Temperate</p>
<p>Perth, W. Australia So. Temperate</p>	<p>Luanda, Angola Capricorn</p>
<p>Kinshasa, Zaire Capricorn</p>	<p>Dar es Salaam, Tanzania Capricorn</p>
<p>Port Moresby, New Guinea Capricorn</p>	

**CHAPTER 5 ASSESSMENT:  
STATISTICS AND PROBABILITY**

1.

COOKIE SALE		
Sales record for Room 16.		
Day	Number of Boxes	Amount Received
Monday	179	\$456.45
Tuesday	196	\$499.80
Wednesday	205	\$522.75
Thursday	182	\$464.10
Friday	189	\$481.95

Use the sales record to answer these questions:

- What is the range of the number of boxes sold? \_\_\_\_\_
- What is the range of the amounts received? \_\_\_\_\_
- What is the average number of boxes sold? \_\_\_\_\_
- What is the average amount of money received for the cookie sale? \_\_\_\_\_
- What is the price of one box of cookies? \_\_\_\_\_
- The cookies cost the school \$1.45 for a box. How much profit does the school make on each box? \_\_\_\_\_  
How much profit does the school make on Room 16's sales? \_\_\_\_\_
- What prediction can you make for the second week of the cookie sale? \_\_\_\_\_  
Explain your prediction. \_\_\_\_\_

Student response should include:

- The range is 26.  $205 - 179 = 26$
- The range is \$66.30  $522.75 - 456.45 = 66.30$
- The average is 190.2 boxes.  $951 \div 5 = 190.2$
- The average amount of money is \$485.01.  $2425.05 \div 5 = 485.01$
- One box of cookies costs \$2.55.  $456.45 \div 179 = 2.55$
- The school makes \$1.10 profit on each box.  $2.55 - 1.45 = 1.10$   
The school makes \$1046.10 profit on Room 16's sales.  $951 \times 1.10 = 1046.10$
- Student responses will vary.

265

2.

Attendance Statistics for Three Amusement Parks			
	Magic Playground	Sandyland	Enchanted Island
January	78,261	76,359	78,103
February	81,026	74,297	75,621
March	78,596	79,485	80,139
Total			

a. Find the average attendance for the three months for each amusement park.

Magic Playground \_\_\_\_\_

Sandyland \_\_\_\_\_

Enchanted Island \_\_\_\_\_

b. Use the average to determine in which month each park might expect its one millionth visitor.

Magic Playground \_\_\_\_\_

Sandyland \_\_\_\_\_

Enchanted Island \_\_\_\_\_

c. How did you find your answers?

\_\_\_\_\_

\_\_\_\_\_

\_\_\_\_\_

Student response should include:

Chart totals:

Magic Playground  
237,883

Sandyland  
230,141

Enchanted Island  
233,863

- a. 79294 (rounded to the nearest person)  
76714 (rounded to the nearest person)  
77954 (rounded to the nearest person)

- b. January of following year  
February of following year  
January of following year

- c. Add the total attendance and the average until the display shows 1,000,000 or more. Use the constant feature for addition. Example:  $237883 + 79294 = \dots$   
Student might also multiply the average by 12 to estimate a full year's attendance, then add the average amount until 1,000,000 is exceeded.

# CAMP-LA

Calculators and Mathematics Project, Los Angeles

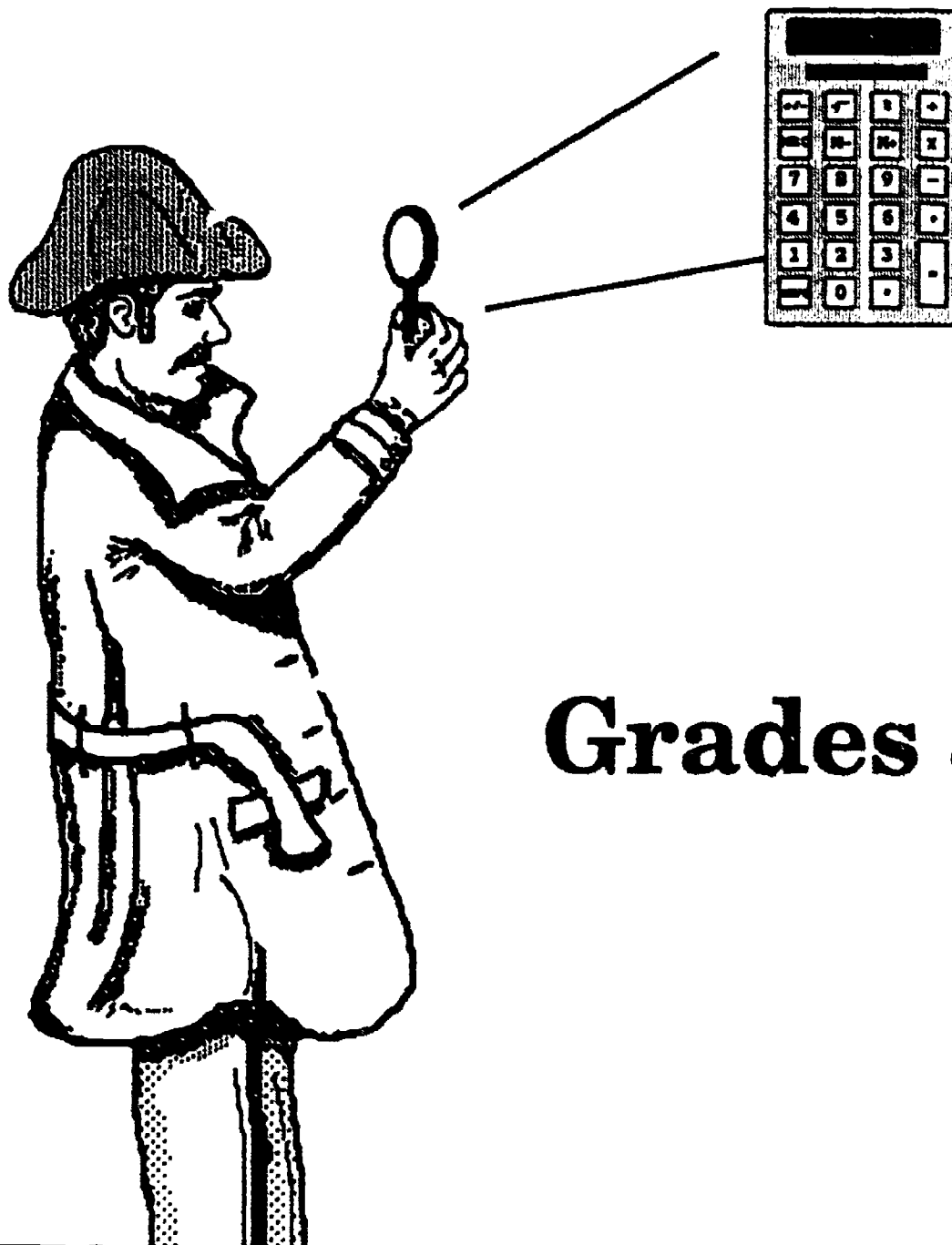

Grades 3 - 4

## CHAPTER 6 LOGIC

## BIG "D'S" PARKING GARAGE I

- GRADE:** 3 - 4
- STRAND:** Logic
- SKILL:** Use charts to organize information to solve simple logic problems
- MANAGEMENT**
- CLASS ORGANIZATION:** Whole class and small groups
- TIME FRAME:** One class period
- MATERIALS:** Calculator, Transparency 1, Transparency of Student Activity Sheet 1
- VOCABULARY:** Logical reasoning
- PREREQUISITE SKILL:** Mathematics: Basic operations, logic grid  
Calculator: Basic functions

**LESSON** The purpose of this lesson is to use logical reasoning to solve a problem.

• **DIRECTED INSTRUCTION:**

Discuss methods to solve a logical reasoning problem. Project Transparency 1 and use the following sequence to demonstrate the use of the logic grid.

1. Read the problem and all of the clues. Clues can be tricky. One clue may give a little information by itself but a lot more information when you fit it together with another clue.  
What is the problem? [answer: Who lives in each different colored house.]  
Who are the people in the problem? [answer: Bob, Terri, Dave]  
What are the colors of the houses?[answer: Green, Yellow, Brown]
2. Demonstrate how to label the grid with the names of the people across the top and the colors down the side.
3. Demonstrate how to mark the grid after reading a clue.

Clue #1 - Dave does not live in the green house.

	Bob	Terri	Dave
Green			no
Yellow			
Brown			

Clue #2 - Terri does not live in the yellow house.

	Bob	Terri	Dave
Green			no
Yellow		no	
Brown			

Clue #3 - Bob's house is not green or brown.

	Bob	Terri	Dave
Green	no		no
Yellow		no	
Brown	no		

Conclusion - Bob lives in the yellow house because he doesn't live in the green or brown house.

	Bob	Terri	Dave
Green	no		no
Yellow	yes	no	
Brown	no		

Conclusion - Dave does not live in the yellow house because Bob lives there.

	Bob	Terri	Dave
Green	no		no
Yellow	yes	no	no
Brown	no		

Conclusion - Terri lives in the green house because neither Bob nor David live there.

	Bob	Terri	Dave
Green	no	yes	no
Yellow	yes	no	no
Brown	no		

Conclusion - Terri does not live in the brown house because she lives in the green house. Dave lives in the brown house because he doesn't live in the yellow or green house.

	Bob	Terri	Dave
Green	no	yes	no
Yellow	yes	no	no
Brown	no	no	yes

• **GUIDED PRACTICE:**

Distribute Student Activity Sheet 1. Project Transparency of Student Activity Sheet 1 and guide students through the process of completing the logic grid.

Discuss the solution to the problem:

Conclusion from Clue #1 - Rosie is not Red or Skipper

Conclusion from Clue #2 - Skipper is female

Conclusion from Clue #3 - Red is not Jose and Jose is not Bud

	Bud	Skipper	Tug	Red
Rosie	yes	no	no	no
Damon	no	no	no	yes
Jose	no	no	yes	no
Wendy	no	yes	no	no

• **INDEPENDENT PRACTICE:**

Read Student Activity Sheet 2A together. Distribute Student Activity Sheets 2B and 2C.

Students work with a partner to solve the problem.

• **EVALUATION:**

Students explain how they arrived at their solution.

• **HOME ACTIVITY:**

Solve this riddle with your family: What can you put in a bucket to make it weigh less?



**Example 1**

**Bob, Terri, and Dave each live in a different house colored green, yellow, or brown.**

**Dave does not live in the green house. Terri does not live in the yellow house. Bob's house is not green or brown.**

**What is the color of each person's house?**

**BIG "D'S" PARKING GARAGE I**  
**Student Activity Sheet 1**

**Example 2**

Rosie, Damon, Jose, and Wendy each have nicknames. The nicknames are Bud, Skipper, Tug and Red not necessarily in that order. Read the clues to find the nickname of each person.

**Clues:**

**Rosie is shorter than Red and is taller than Skipper.**

**Skipper bought her mother a present yesterday.**

**Red is older than Jose and younger than Bud.**

	NICKNAMES			
	Bud	Skipper	Tug	Red
Rosie				
Damon				
Jose				
Wendy				

**BIG "D'S" PARKING GARAGE I**  
**Student Activity Sheet 2A**

Read the story. Read all of the clues. Which clue gives enough information to decide where one of the cars is parked?

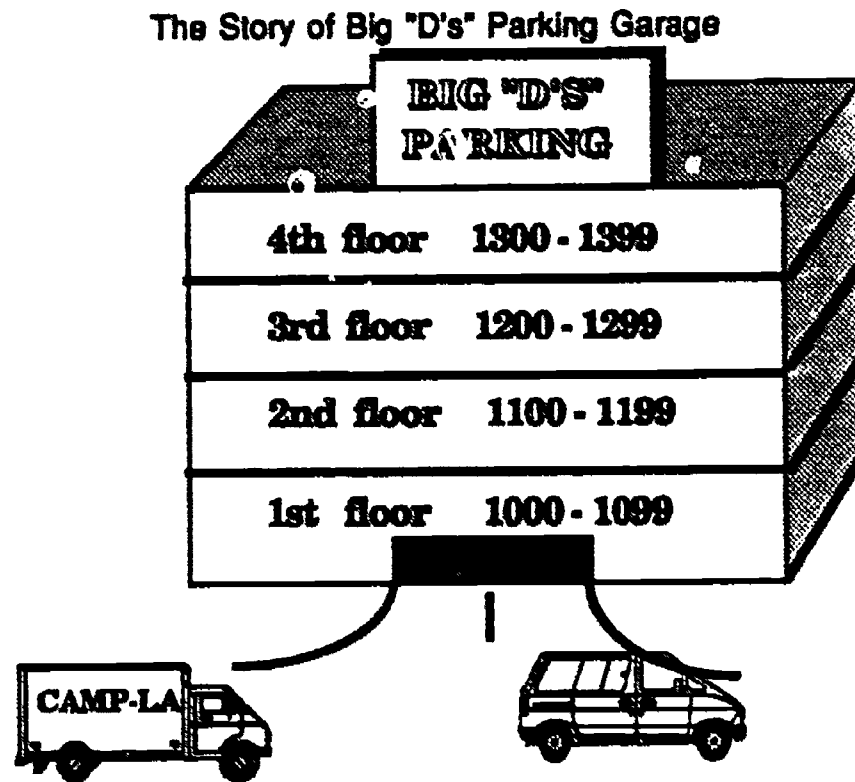

This is Big "D's" Parking Garage. Drivers have assigned parking spaces. Each parking space is numbered. The illustration shows how the spaces are numbered.

One day 4 drivers forgot their parking space numbers. They thought that if they could just find the correct floor then they would remember their parking space numbers. Big "D", the owner of the parking garage, likes logic puzzles and math games. Big "D" said he would help the drivers find their parking spaces by giving them 3 clues. If the drivers could determine the floor they park on, Big "D" would tell them their parking space number. Help the drivers solve their problem.

277

**BIG "D'S" PARKING GARAGE I**  
**Student Activity Sheet 2B**

1. Problem: On which floor is each car parked?

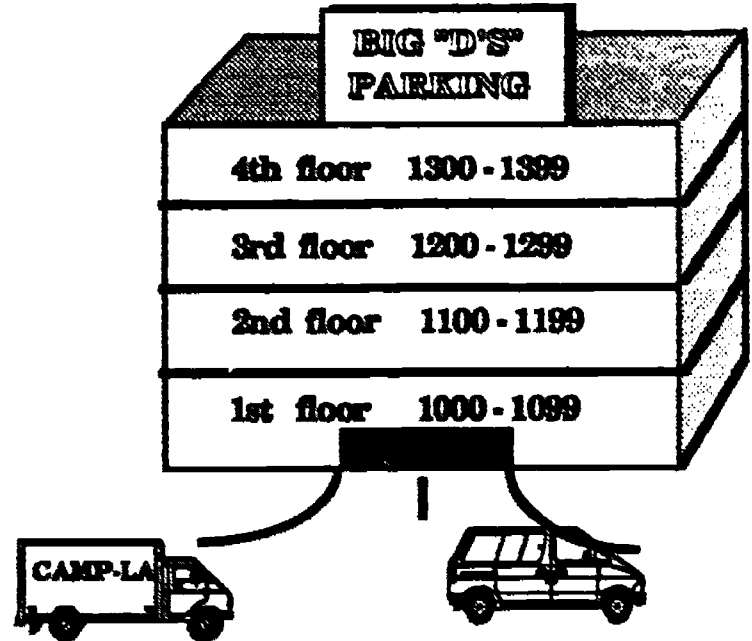

Use the following information, clues, the logic chart, and a calculator to solve the problem:

Clues and Information

Car models and the year each was built:



BMW	BUICK	CHEVY	HONDA
1984	1987	1979	1978

CLUES:

Each car parks on a different floor. The car that parks on the fourth floor was built in a year that is 590 more than its parking space number.

If the Buick parks in the correct space, then the year it was built is close to 800 more than its parking space number.

The car that parks on the third floor was built in a year that is 756 more than its parking space number. It is six years older than the car on the 1st floor.

278

243

**BIG "D'S" PARKING GARAGE I**  
**Student Activity Sheet 2C**

**LOGIC CHART**

	<b>FLOORS</b>			
	1st	2nd	3rd	4th
<b>BMW</b>				
<b>Buick</b>				
<b>Chevy</b>				
<b>Honda</b>				

**2. Problem:** Find the parking space number for each car. Use the clues from the first problem and the 2 clues listed below to solve the problem.

**Clues:**

If you find the average date of manufacture of the four cars, it will be 900 greater than the first-floor parking space.

If you round the year the Buick was manufactured to the nearest decade, then its space number is exactly 200 greater than half its date.

The BMW's parking space is number \_\_\_\_\_ on the \_\_\_\_\_ floor.

The Buick's parking space is number \_\_\_\_\_ on the \_\_\_\_\_ floor.

The Chevy's parking space is number \_\_\_\_\_ on the \_\_\_\_\_ floor.

The Honda's parking space is number \_\_\_\_\_ on the \_\_\_\_\_ floor.



**BIG "D'S" PARKING GARAGE I**  
Teacher Answer Sheet

**LOGIC CHART**

	FLOORS			
	1st	2nd	3rd	4th
BMW	No	No	Yes	No
Buick	No	Yes	No	No
Chevy	No	No	No	Yes
Honda	Yes	No	No	No

2. Problem: Find the parking space number for each car. Use the clues from the first problem and the 2 clues listed below to solve the problem.

**Clues:**

If you find the average date of manufacture of the four cars, it will be 900 greater than the first-floor parking space.

If you round the year the Buick was manufactured to the nearest decade, then its space number is exactly 200 greater than half its date.

The BMW's parking space is number 1228 on the 3rd floor.

The Buick's parking space is number 1195 on the 2nd floor.

The Chevy's parking space is number 1389 on the 4th floor.

The Honda's parking space is number 1082 on the 1st floor.

## BIG "D'S" PARKING GARAGE II

- GRADE:** 3 - 4
- STRAND:** Logic
- SKILL:** Use charts to organize information and solve simple logic problems.
- MANAGEMENT**
- CLASS ORGANIZATION:** Whole class, pairs
- TIME FRAME:** One class period
- MATERIALS:** Calculator, Transparency of Student Activity Sheet 1
- VOCABULARY:** Conditions, factor, product, sum, digit
- PREREQUISITE SKILL:** Mathematics: Basic operations  
Calculator: Basic functions

**LESSON** The purpose of this lesson is to use logical reasoning to solve a problem.

- **DIRECTED INSTRUCTION/GUIDED PRACTICE:**  
Project a transparency of Student Activity Sheet 1. Distribute Student Activity Sheet 1. Read the story, clues, and problems with the students and demonstrate how to find the digits for the BMW [answer: 7, 8, 9].  
  
Students complete the chart and license plates with a partner. Discuss results.
- **INDEPENDENT PRACTICE:**  
Define the word "conditions" as it relates to a logic problem:  
A condition is a rule or set of rules that apply to items involved in the problem. Students work in pairs, using a calculator, to solve the problem on Student Activity Sheet 2.
- **EVALUATION:**  
Students explain how they determined their solutions to the problems.
- **HOME ACTIVITY:**  
Students solve the following riddle with their family. The more you take away, the larger it gets. As you add to it, it gets smaller and smaller. What peculiar thing is this? [answer: a hole in the ground]

281

## BIG "D'S" PARKING GARAGE II

### Student Activity Sheet 1

Big "D", the owner of Big D's Parking Garage, keeps track of who has paid their monthly parking fee by license plate number. One Friday, four drivers forgot their license plate numbers when Big D asked them to pay their parking fee. They had all forgotten their license plate numbers several times before. Big "D" decided to use a math game to help the drivers remember their license plate numbers. He handed the drivers a set of clues, a chart, and a calculator. Big "D" said they could work together to find their license numbers.

Read the clues and help the drivers solve their problem so they can get their cars and go home.

#### CLUES

1. The BMW, Chevy, and the Honda license plates have at least 1 digit in common.
2. The Buick and Honda license plates contain 1 digit in common.
3. Digits on the license plate are listed in order from low to high.
4. Letters on the license plate are related to the numbers on the license plate.
5. Each license plate has 3 letters and 3 digits.

#### Directions for Chart

1. Find three digits for each car that will give you the sum and product listed for each car.
2. The digits represent the number portion of the license plate.

#### CHARTS

Car	Product	Sum	Digits
BMW	504	24	
Buick	40	11	
Chevy	336	21	
Honda	360	22	

#### LICENSE PLATES

**BMW**

**G H I** \_\_\_\_\_

**BUICK**

\_\_\_\_\_

**CHEVY**

\_\_\_\_\_

**HONDA**

\_\_\_\_\_



**BIG "D'S" PARKING GARAGE II**  
**Student Activity Sheet 2**

The four drivers that have had memory problems at Big D's Parking Garage all drive to and from work on freeways. Use the conditions and clues to find out which freeways are used by the four drivers.

**CONDITIONS:**

1. All the highways are used.
2. Each driver takes one highway to work and a different highway home.

**CLUES:**

1. The driver of the BMW and the driver of the Chevy could ride to work together but not home.
2. Two of the drivers live in the same neighborhood.
3. The driver of the Buick travels on even numbered freeways.

**HIGHWAYS**

101
210
134
710
91
605

**CHART**

CAR	PRODUCT OF Highway Numbers (to work and to home)	HIGHWAYS (FACTORS)	
		to work	to home
BMW	61,105		
Buick	149,100		
Chevy	9191		
Honda	81,070		

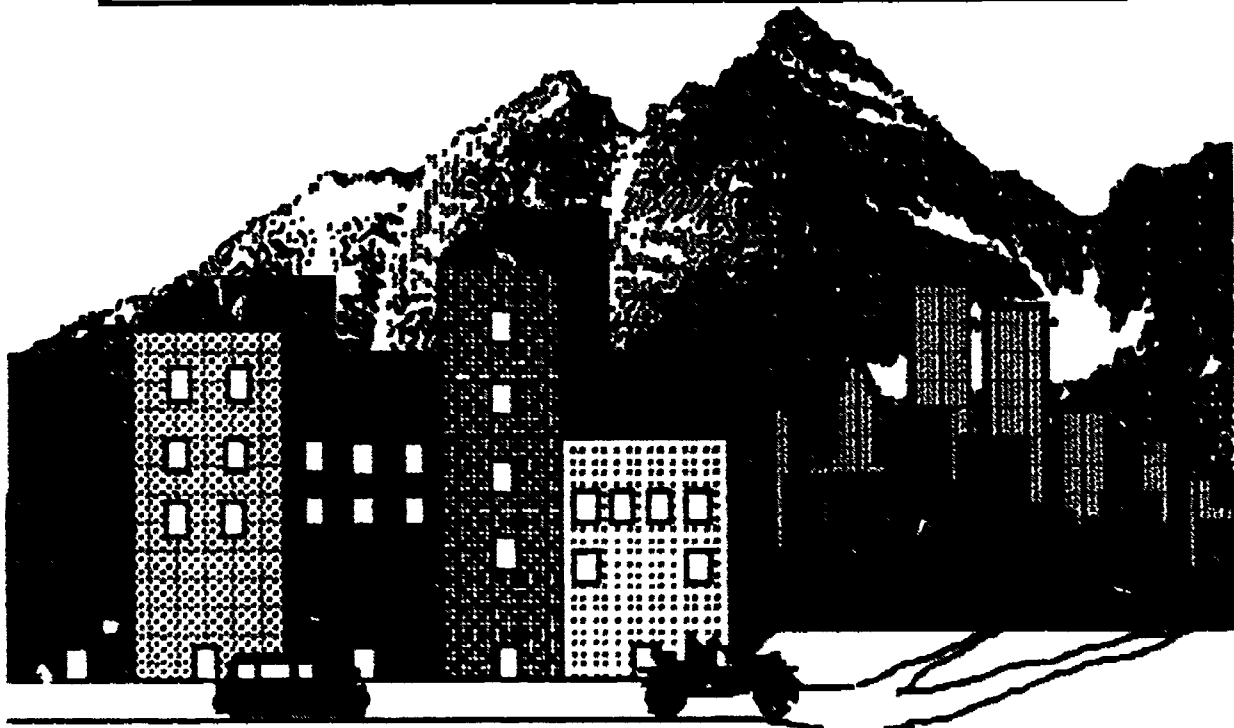

**BIG "D'S" PARKING GARAGE II**  
**Teacher Answer Sheet**

**Student Activity Sheet 1**

**LICENSE PLATES**

BMW 

G	H	I	789
---	---	---	-----

Buick 

B	D	E	245
---	---	---	-----

Chevy 

F	G	H	678
---	---	---	-----

Honda 

E	H	I	589
---	---	---	-----

**Student Activity Sheet 2**

CAR	PRODUCT	HIGHWAY (FACTORS)	
		to work	to home
BMW	61,105	101	605
Buick	149,100	710	210
Chevy	9191	101	91
Honda	81,070	134	605

## THE CREATURE RACE

- GRADE:** 4
- STRAND:** Logic
- SKILL:** Make a logical conclusion about a situation.
- MANAGEMENT**
- CLASS ORGANIZATION:** Partners
- TIME FRAME:** One class period
- MATERIALS:** Calculator
- VOCABULARY:** Logic table, conclusion, rate
- PREREQUISITE SKILLS:** Mathematics: Use of a logic table, multiplication, division, estimation, Lesson 40  
Calculator: Basic functions
- LESSON** The purpose of this lesson is the comparison of data using a logic table.

• **DIRECTED INSTRUCTION:**

1. Review the use of a logic table or chart from the example on the Student Activity Sheet. When a square is eliminated by a clue, mark the square with "no." When a square is identified by a clue, mark the square with a "yes." Refer to Lesson 40

• **GUIDED PRACTICE:**

2. Read the Creature Race story to the students and discuss as needed.

## THE CREATURE RACE

A group of animals decided to have a 5-mile race to raise funds to build a health spa for animals. Five animals were chosen to participate in the race. The participants were Quarterhorse, Greyhound, Spider, Giant Tortoise, and Three-toed Sloth.

The five animals lined up on the starting line and the starter's gun sounded. Quarterhorse quickly pulled ahead and Greyhound followed. Tortoise, Spider, and Three-toed Sloth progressed at a steady pace.

Shortly after reaching the second mile, Greyhound got thirsty and stopped for a drink of water at the local stream. Quarterhorse became confident because of his big lead and slowed his pace. Spider increased his speed, but Tortoise and Sloth kept running at a steady pace.

285

At the three-mile mark, the spectators could see Quarterhorse in the lead and Tortoise bringing up the rear. For some reason, it was difficult to determine the positions of the other three racers.

Mile four brought a change in the race. Quarterhorse and Greyhound had increased their speed dramatically during the third mile. Midway through the fourth mile, Greyhound and Quarterhorse both slowed almost to a walk because of exhaustion. The other three racers, who were within a few yards of each other, were getting closer to the leaders. The finish of the race was close. Use the clues to help determine the winner.

Project a transparency of Student Activity Sheet. Read and discuss the clues. Distribute Student Data Sheet.

**• INDEPENDENT PRACTICE:**

Distribute Student Activity Sheet.  
Students use the information on the Student Data Sheet to complete the Student Activity Sheet.

**CLUES**

- a. The Quarterhorse has a rate that is very close to 316 times faster than the second-place finisher.
- b. The average rate (speed) of the 2nd- and 4th-place finishers is 23.825 miles per hour (MPH).
- c. The 5th-place finisher has a rate that is close to 260 times faster than the 2nd-place finisher.
- d. The 3rd-place finisher is closest in rate to the 2nd-place finisher.

Who won the race? Use the logic table to help you solve the problem.

**EVALUATION:** Check the completed logic table.

	1st	2nd	3rd	4th	5th
Quarterhorse				yes	
Greyhound					yes
Spider	yes				
Giant Tortoise			yes		
Three-Toed Sloth		yes			

**HOME ACTIVITY:**

Have students write an ending to the race to show how the winner won.

**THE CREATURE RACE**  
**Student Data Sheet**

**CREATURE SPEED**

<u>Animal</u>	<u>Rate (Miles Per Hour)</u>
Cheetah	70
Lion	50
Quarterhorse	47.5
Greyhound	39.35
Whippet	35.5
Human	27.89
Spider	1.17
Giant Tortoise	0.17
Three-Toed Sloth	0.15
Garden Snail	0.03

**CLUES**

- a. Quarterhorse has a rate that is very close to 316 times faster than the 2nd-place finisher.
- b. The average rate (speed) of the 2nd-and 4th-place finishers is 23.825 miles per hour (MPH).
- c. The 5th-place finisher has a rate that is close to 260 times faster than the 2nd-place finisher.
- d. The 3rd-place finisher is closest in rate to the 2nd-place finisher.

287

## THE CREATURE RACE Student Activity Sheet

Use the logic table to help solve the problem.

	1st Place	2nd Place	3rd Place	4th Place	5th Place
Quarterhorse					
Greyhound					
Spider					
Giant Tortoise					
Three-Toed Sloth					

The results of the race were \_\_\_\_\_

\_\_\_\_\_

\_\_\_\_\_

\_\_\_\_\_

\_\_\_\_\_

## ANIMAL BABIES

- GRADE:** 3 - 4
- STRAND:** Logic
- SKILL:** Use a logic table and calculator to make logical conclusions about a situation.
- MANAGEMENT**
- CLASS ORGANIZATION:** Whole class, pairs
- TIME FRAME:** One class period
- MATERIALS:** Calculator, transparency of Student Activity Sheet
- VOCABULARY:** Gestation, offspring, logic, average
- PREREQUISITE SKILL:** Mathematics: Basic operations, determine an average, logic grid, Lesson 40  
Calculator: Basic functions

**LESSON** The purpose of this lesson is to use an average of a set of numbers and a logic grid to solve a problem.

- **DIRECTED INSTRUCTION:**

This activity uses information about how long it takes certain animals to produce offspring (gestation period). Define gestation for the students. Refer to the list of gestation periods provided with the lesson. Students identify which animal has the longest gestation period, the shortest period. Point out that the gestation periods are listed in number of days. Discuss the periods in terms of years. (Example: Elephant - 645 days - 1.7 years or almost 2 years).
- **GUIDED PRACTICE:**

Distribute the Student Data Sheet and Student Activity Sheet.  
Project a transparency of the Student Activity Sheet.  
Review the use of a logic grid.  
Direct students to read and discuss all of the clues.  
Guide students to decide with which clue to begin.
- **INDEPENDENT PRACTICE:**

Students complete the Student Activity Sheet.

Answer	
Animal	Gestation Period
Lion	100 days
Polar Bear	240 days
Squirrel	44 days
Mouse	19 days
Buffalo	278 days
- **EVALUATION:**

Students explain how they determined their answers.

**ANIMAL BABIES**  
**Student Data Sheet**

**DATA**

**GESTATION PERIODS**

<b><u>ANIMAL</u></b>	<b><u>DAYS</u></b>
Camel	406
Cat	63
Cow	284
Elephant	645
Giraffe	425
Gorilla	257
Horse	330
Opossum	14
Dog	61
Kangaroo	42

For this problem, assume one offspring for each gestation period.

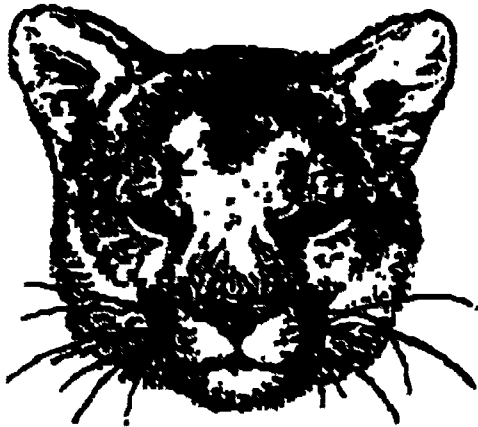



**ANIMAL BABIES**  
Student Activity Sheet

Use a calculator, the logic table, and the clues to find the gestation period for the animals listed on the logic table.



LOGIC TABLE

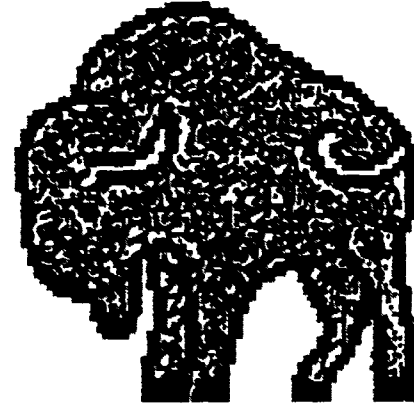

	Days of Gestation				
	19	240	100	44	278
Lion					
Polar Bear					
Mouse					
Squirrel					
Buffalo					

**Clues**

1. The lion produced 5 offspring in 5 years, but it is possible for the lion to produce from 0 to 18 offspring in 5 years.
2. The polar bear's gestation period is closest to the mean (average) gestation period of the animals listed on the Student Data Sheet.
3. The squirrel produces offspring 4 times a year. The squirrel spent 880 days producing offspring in 5 years.
4. The mouse is capable of producing about 15 times as many offspring in a year as the buffalo.

## HOW OLD IS UNCLE MARK?

- GRADE:** 3 - 4
- STRAND:** Logic
- SKILL:** Determine reasonable and logical conclusions
- MANAGEMENT**
- CLASS ORGANIZATION:** Whole class, pairs
- TIME FRAME:** One class period
- MATERIALS:** Calculator
- VOCABULARY:** Digits, even, odd, calculator sentence
- PREREQUISITE SKILL:** Mathematics: Basic operations  
Calculator: Basic functions

**LESSON** The purpose of this lesson is to find an unknown number from several clues.

• **DIRECTED INSTRUCTION/GUIDED PRACTICE:**

Tell this story.

Maria is visiting her Uncle Mark who often does puzzles with her. Maria asked her Uncle how old he is. Uncle Mark responded that he would not tell her his age, but he would give her clues that she could use to find out. Demonstrate how to find Uncle Mark's age using an elimination strategy. Students record results on Student Activity Sheet 1.

Clue #1 - Uncle Mark said, "If you put 101 on your calculator and press     ... and keep pressing  you can get my age on the display."

The following numbers fit clue #1:

1, 6, 11, 16, 21, 26, 31, 36, 41, 46, 51, 56, 61, 66, 71, 76, 81, 86, 91, 96

Clue #2 - Uncle Mark said, "If you put 14 on your calculator and press     ... and keep pressing  you can get my age on the display."

Through the process of elimination this clue produces the following list :

26    41    56    71    86

Clue #3 - "The sum of the digits in my age is odd."

This clue results in 41 and 56.

Clue #4 - "My age is a multiple of seven." Answer - 56

• **INDEPENDENT PRACTICE:**

Students complete Student Activity Sheet 2.

• **EVALUATION:**

Teacher observation.

• **HOME ACTIVITY:**

Students write their own secret number problems.

**HOW OLD IS MARK?**  
**Student Activity Sheet 1**

Clue #1 Uncle Mark said, "If you put 101 on your calculator and press  $\boxed{-}$   $\boxed{5}$   $\boxed{=}$   $\boxed{-}$  ... and keep pressing  $\boxed{-}$  you can get my age on the display."

Results:

\_\_\_\_\_, \_\_\_\_\_, \_\_\_\_\_, \_\_\_\_\_, \_\_\_\_\_, \_\_\_\_\_, \_\_\_\_\_, \_\_\_\_\_, \_\_\_\_\_, \_\_\_\_\_, \_\_\_\_\_

Clue #2 Uncle Mark said, "If you put 14 on your calculator and press  $\boxed{+}$   $\boxed{3}$   $\boxed{-}$   $\boxed{-}$  ... and keep pressing  $\boxed{-}$  you can get my age on the display."

Results:

\_\_\_\_\_, \_\_\_\_\_, \_\_\_\_\_, \_\_\_\_\_, \_\_\_\_\_

Clues #3 "The sum of the digits in my age is odd."

Results:

\_\_\_\_\_, \_\_\_\_\_

Clue #4 "My age is a multiple of seven."

Results:

\_\_\_\_\_  
(answer)



HOW OLD IS MARK?  
Student Activity Sheet 2

Use these clues to find the secret positive number.

Clue #1 : Enter 272 on the calculator

Press  $\square$   $\square$   $\square$   $\square$   $\square$   $\square$   $\square$  ...

One of the number that appears is the secret number.

The number could be 252 or \_\_\_\_\_

Clue #2 : If you use a number from clue #1 and press  $\square$   $\square$   $\square$  ... you can get 300.

The number could be \_\_\_\_\_

Clue #3 : If you use a number from clue #2 and press  $\square$   $\square$   $\square$  the number you get is between 200 and 500.

The number could be \_\_\_\_\_

Clue #4 : If you use a number from clue #3 and press  $\square$   $\square$   $\square$  you can get 360.

The secret number is? \_\_\_\_\_



HOW OLD IS MARK?  
Teacher Answer Sheet 2

Use these clues to find the secret positive number.

Clue #1 : Enter 272 on the calculator

Press  $\square$  20  $\square$   $\square$  ...

One of the numbers that appears is the secret number.

The number could be 252, 232, 212, 192, 172, 152, 132, 112, 92, 72, 52, 32, 12

---

---

Clue #2 : If you use a number from clue #1 and press  $\square$  +  $\square$  6  $\square$  = ... you can get 300.

The number could be 252, 192, 132, 72, 12

---

---

Clue #3 : If you use a number from clue #2 and press  $\square$  x  $\square$  3  $\square$  = the number you get is between 200 and 500.

The number could be 72 or 132

---

---

Clue #4 : If you use a number from clue #3 and press  $\square$  x  $\square$  5  $\square$  = you can get 360.

The secret number is? 72

295

## A CAMPING WE WILL GO

- GRADE:** 3 - 4
- STRAND:** Logic
- SKILL:** Use logical conjectures to reach a conclusion
- MANAGEMENT**
- CLASS ORGANIZATION:** Small groups
- TIME FRAME:** One class period
- MATERIALS:** Calculators
- VOCABULARY:** Logical conclusion
- PREREQUISITE SKILL:** Mathematics: Basic operations  
Calculator: Basic functions

**LESSON** The purpose of this lesson is to have the students reach a reasonable and logical conclusion from given information.

- **DIRECTED INSTRUCTION/ GUIDED PRACTICE:**  
Distribute Student Activity Sheets 1 and 2. Read and discuss the story with the students. The objective is to get everyone and everything across the bridge in the least number of trips without exceeding the weight limit. Three trips is the minimum. There is more than one answer.
- **INDEPENDENT PRACTICE:**  
Students complete Student Activity Sheet 2.
- **EVALUATION:**  
Discuss student results.
- **HOME ACTIVITY:**  
Students take home Student Activity Sheet 1 and have their parents solve the problem. Since students have completed Student Activity Sheet 2 in class, they can check their parents' result.

**A CAMPING WE WILL GO**  
**Student Activity Sheet 1**

Bob and David are on a camping trip with their children Jan, Sally, and Fred. They come to a deep gorge. The only way across is by bridge. In front of the bridge is a sign that says...



The bridge is 100 feet in the air. Bob and David are not going to take any chances. They want to get across as quickly as possible. How many trips would it take?

They have two donkeys, Boomer and Ebert, that must be lead across the bridge. Once across, they can be left unattended. Boomer weighs 350 pounds and Ebert weighs 45 pounds more than Boomer. There are four boxes of food and equipment that weigh 60, 65, 70 and 75 pounds. Bob weighs 200 pounds, and David weighs 15 pounds less than Bob. Fred weighs 120 pounds. Jan weighs 20 pounds less than Fred and Sally weighs 5 pounds less than Jan. Each person can carry only one box at a time but the donkeys can carry two boxes at a time.

Use Student Activity Sheet 2 to organize your data and solve the problem.

297

**A CAMPING WE WILL GO**  
Student Activity Sheet 2

How many trips will it take Bob and David to get across the bridge with their families and provisions?

Donkey	Men	Equipment
<input type="checkbox"/> _____	<input type="checkbox"/> _____	<input type="checkbox"/> Box 1 _____
<input type="checkbox"/> _____	<input type="checkbox"/> _____	<input type="checkbox"/> Box 2 _____
		<input type="checkbox"/> Box 3 _____
		<input type="checkbox"/> Box 4 _____
Children		
<input type="checkbox"/> _____		
<input type="checkbox"/> _____		
<input type="checkbox"/> _____		

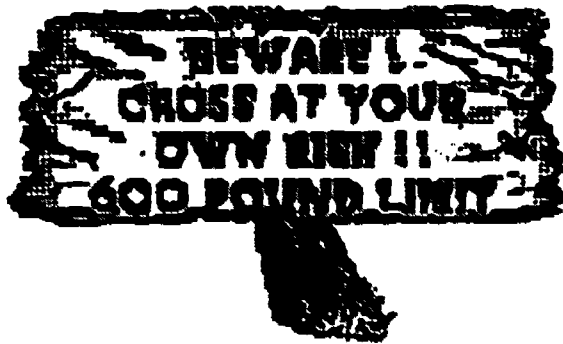

									Total
Trip 1									
Trip 2									
Trip 3									
Trip 4									
Trip 5									
Trip 6									



**A CAMPING WE WILL GO**  
Teacher Answer Sheet

- |   |  |  |  |  |
|---|--|--|--|--|
| <b>Donkey</b>   |  | <b>Men</b>   |  | <b>Equipment</b>                                     |
| <input type="checkbox"/> <u>Boomer</u> <u>350 lbs</u> |  | <input type="checkbox"/> <u>Bob</u> <u>200 lbs</u>   |  | <input type="checkbox"/> <u>Box 1</u> <u>60 lbs.</u> |
| <input type="checkbox"/> <u>Ebert</u> <u>395 lbs</u>  |  | <input type="checkbox"/> <u>David</u> <u>185 lbs</u> |  | <input type="checkbox"/> <u>Box 2</u> <u>65 lbs.</u> |
|   |  |  |  | <input type="checkbox"/> <u>Box 3</u> <u>70 lbs.</u> |
|   |  |  |  | <input type="checkbox"/> <u>Box 4</u> <u>75 lbs.</u> |
| <br><b>Children</b>                                   |  |  |  |  |
| <input type="checkbox"/> <u>Fred</u> <u>120 lbs</u>   |  |  |  |  |
| <input type="checkbox"/> <u>Jan</u> <u>100 lbs</u>    |  |  |  |  |
| <input type="checkbox"/> <u>Sally</u> <u>95 lbs</u>   |  |  |  |  |

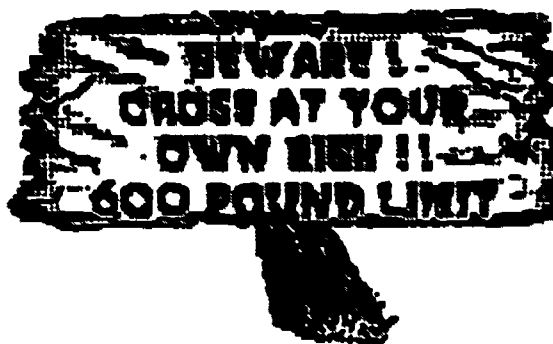

								Total
Trip 1	Ebert 395	Fred 120	Box 4 75					590
Trip 2	Boomer 350	David 185	Box 2 65					600
Trip 3	Bob 200	Jan 100	Sally 95	Box 1 60	Box 3 70			525
Trip 4								
Trip 5								
Trip 6								

Other answers are possible.

299

## CHAPTER 6 ASSESSMENT:

### LOGIC

#### 1. WHAT'S THE NUMBER?

The number is an even number.

It is a multiple of 12.

It is greater than 75 but less than 135.

The sum of the digits is 9.

Student response: 108

#### 2.

	Apartment	Condo	Duplex	House
Bob		no	no	
Juan	no	no	yes	no
Yuki			no	
Hassan		no	no	

a. Look at the logic grid. What do you know about Juan?

b. What can you decide about Yuki?

c. Write a clue that would allow you to complete the logic grid.

Student responses should include:

a. Juan lives in a duplex.

b. Yuki lives in a condo.

c. Answers will vary but the clue must provide information about where Bob or Hassan live.

3.

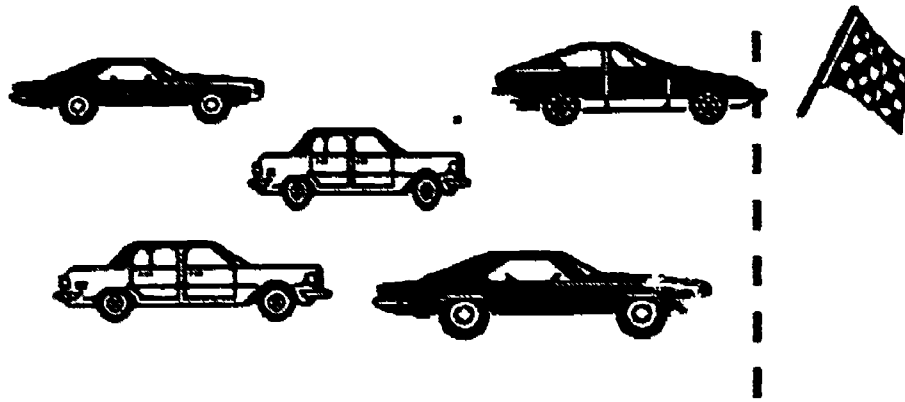

Order of Finish

	1	2	3	4	5
Car Numbers	256				
	512				
	394				
	141				
	253				

The first 5 cars to finish a race lost their car numbers. Use the logic grid and clues to find the numbers of the cars and in what place they finished.

- The car that finished third has a number that is a multiple of 16.
- The number of the car that finished second place is half as large as the number of the third place car.
- The fourth place car's number is a palindrome.
- The sum of the numbers of the cars that finished fourth and fifth place equals the winner's number.

Student responses should include:

	Places				
	1	2	3	4	5
Car Numbers	256	Yes			
	512		Yes		
	394	Yes			
	141			Yes	
	253				Yes

4.

Six students who are in the same class at school live in the 1900's block of their street. Use the clues to position them on the block and put the correct addresses on the houses.

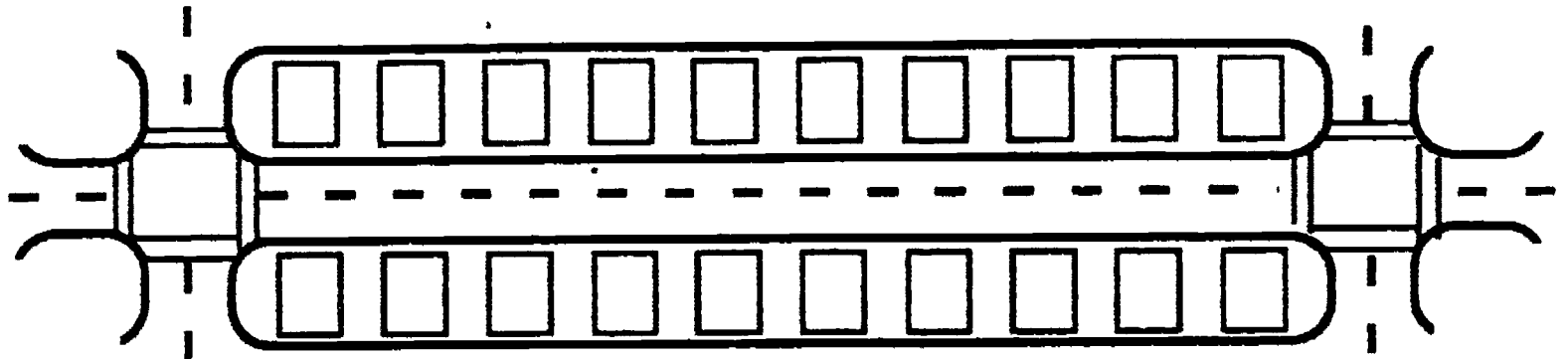

- Bob lives at an address which is a palindrome.
- Theran's house number is a multiple of 100 and is nearly a hundred less than Bob's.
- Each house number is ten different from its next door neighbor.
- Stan's house is next door to Theran's.
- Frieda's house number is 1981.
- Haji's house is across the street from Theran's and 80 less than Frieda's.
- Devon's parents have him help with the yardwork, since their corner lot has so much front yard.

Student response should include:

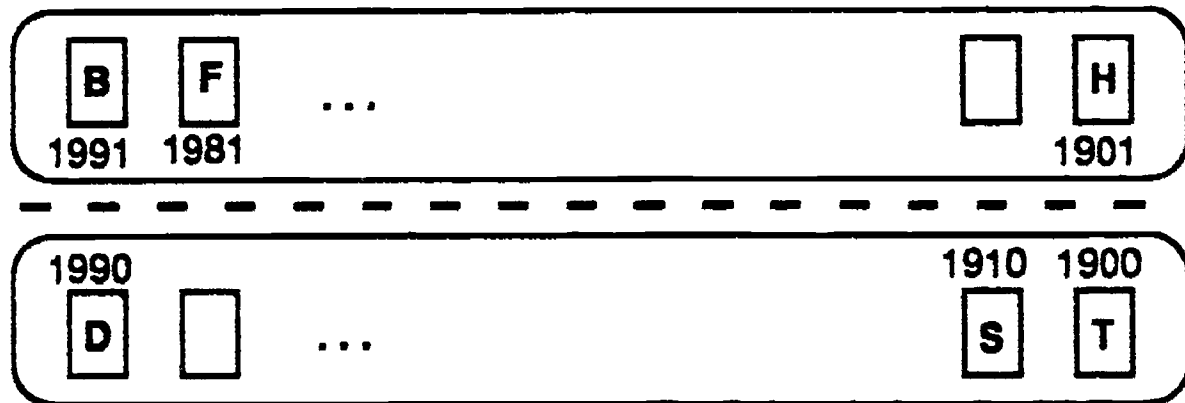

Start on either end of the block.

302

# CAMP-LA

Calculators and Mathematics Project, Los Angeles

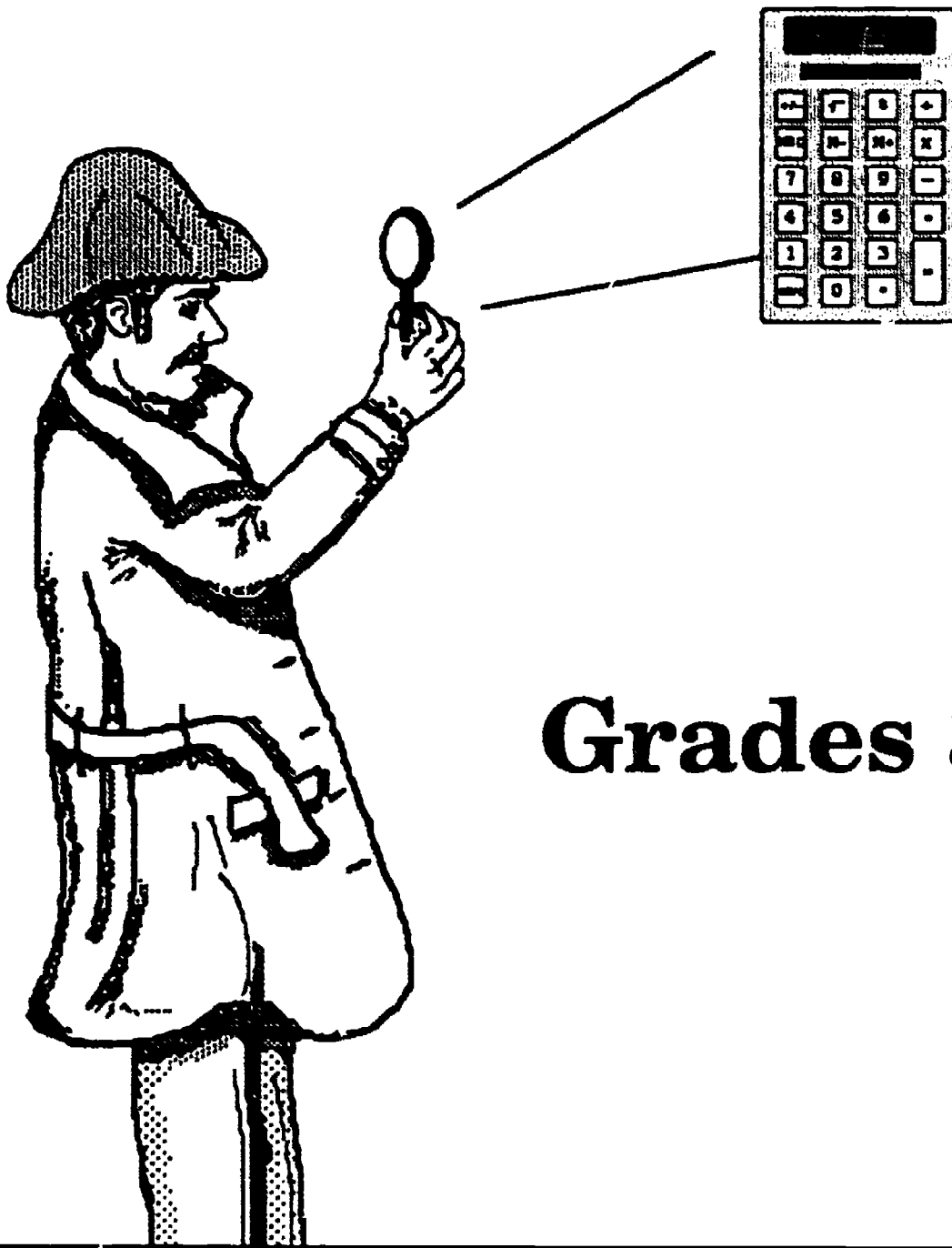

Grades 3 - 4

## CHAPTER 7 ALGEBRA

## CALCULATOR SENTENCES

- GRADE:** 3 - 4
- STRAND:** Algebra
- SKILL:** Identify the missing number in a number sentence to make a true sentence
- MANAGEMENT**
- CLASS ORGANIZATION:** Whole class, individual
- TIME FRAME:** One class period
- MATERIALS:** Calculator
- VOCABULARY:** Number key, operation key, calculator sentence
- PREREQUISITE SKILL:** Mathematics: Basic operations  
Calculator: Basic functions

**LESSON** The purpose of this lesson is to determine the missing number in an equation.

• **DIRECTED INSTRUCTION/GUIDED PRACTICE:**

Write the following calculator sentences on the board. Students complete them. An empty box represents a calculator key, either a digit key or operation key.

$$\begin{array}{cccccc} \boxed{6} & \boxed{\times} & \boxed{4} & \boxed{\phantom{0}} & \boxed{\phantom{0}} & \boxed{-} & 30 \\ \boxed{7} & \boxed{\times} & \boxed{\phantom{0}} & \boxed{+} & \boxed{\phantom{0}} & \boxed{-} & 30 \end{array}$$

Demonstrate what happens when the operation signs are changed. Write  $\boxed{7} \boxed{+} \boxed{4} \boxed{\times} \boxed{2} \boxed{-}$  on the chalkboard. Students work together to enter the numbers and operations. Record the various results.

• **INDEPENDENT PRACTICE:**

Students complete Student Activity Sheets 1 and 2.

• **EVALUATION:**

Teacher observation.

• **HOME ACTIVITY:**

Students write incomplete calculator sentences to try at home with family members.

**CALCULATOR SENTENCES**  
Student Activity Sheet 1

1. Complete the calculator sentences. Each blank box is for a number key.

<input type="text"/>	+	8	x	5	=	Display	75
----------------------	---	---	---	---	---	---------	----

6	x	<input type="text"/>	-	<input type="text"/>	=	14
---	---	----------------------	---	----------------------	---	----

3	6	÷	<input type="text"/>	+	5	=	14
---	---	---	----------------------	---	---	---	----

7	+	<input type="text"/>	÷	2	x	<input type="text"/>	=	32
---	---	----------------------	---	---	---	----------------------	---	----

2. Complete the calculator sentences. Each blank box is for an operation (+, -, x, ÷) key.

6	x	9	<input type="text"/>	3	=	18
---	---	---	----------------------	---	---	----

7	<input type="text"/>	3	<input type="text"/>	5	=	20
---	----------------------	---	----------------------	---	---	----

4	<input type="text"/>	0	<input type="text"/>	7	=	28
---	----------------------	---	----------------------	---	---	----

8	<input type="text"/>	8	<input type="text"/>	8	=	9
---	----------------------	---	----------------------	---	---	---

9	<input type="text"/>	6	<input type="text"/>	2	=	7.5
---	----------------------	---	----------------------	---	---	-----

305

**CALCULATOR SENTENCES**  
Student Activity Sheet 2

1. Complete the calculator sentences. Each blank box is for a number key.

<input type="text"/>	x	<input type="text"/>	÷	1	0	=	3
1	3	-	<input type="text"/>	x	<input type="text"/>	=	35
7	÷	<input type="text"/>	<input type="text"/>	x	3	=	1.5

2. Complete the calculator sentences. Each blank box is for an operation key.

5	<input type="text"/>	4	<input type="text"/>	3	<input type="text"/>	2	=	1
2	<input type="text"/>	3	<input type="text"/>	4	<input type="text"/>	5	=	6

3. Complete the calculator sentences. Each blank box can be for a number or an operation key.

8	<input type="text"/>	3	x	<input type="text"/>	=	25		
4	x	<input type="text"/>	<input type="text"/>	<input type="text"/>	+	9	=	30

4. Find as many combinations as possible for which this could be a calculator sentence. Each blank box is for an operation key.

8	<input type="text"/>	4	<input type="text"/>	2	=
---	----------------------	---	----------------------	---	---

8	<input type="text"/>	4	<input type="text"/>	2	=
---	----------------------	---	----------------------	---	---

8	<input type="text"/>	4	<input type="text"/>	2	=
---	----------------------	---	----------------------	---	---

8	<input type="text"/>	4	<input type="text"/>	2	=
---	----------------------	---	----------------------	---	---

8	<input type="text"/>	4	<input type="text"/>	2	=
---	----------------------	---	----------------------	---	---

8	<input type="text"/>	4	<input type="text"/>	2	=
---	----------------------	---	----------------------	---	---

8	<input type="text"/>	4	<input type="text"/>	2	=
---	----------------------	---	----------------------	---	---

8	<input type="text"/>	4	<input type="text"/>	2	=
---	----------------------	---	----------------------	---	---

8	<input type="text"/>	4	<input type="text"/>	2	=
---	----------------------	---	----------------------	---	---



**CALCULATOR SENTENCES**  
**Teacher Answer Sheet 1**

1. Complete the calculator sentences. Each blank box is for a number key.

	Display
$\boxed{7} \boxed{+} \boxed{8} \boxed{\times} \boxed{5} \boxed{=}$	75
$\boxed{6} \boxed{\times} \boxed{3} \boxed{-} \boxed{4} \boxed{=}$	14
$\boxed{3} \boxed{6} \boxed{+} \boxed{4} \boxed{+} \boxed{5} \boxed{=}$	14
$\boxed{7} \boxed{+} \boxed{1} \boxed{+} \boxed{2} \boxed{\times} \boxed{8} \boxed{=}$	32 (other answers possible)

2. Complete the calculator sentences. Each blank box is for an operation (+, -,  $\times$ ,  $\div$ ) key.

$\boxed{6} \boxed{\times} \boxed{9} \boxed{+} \boxed{3} \boxed{=}$	18
$\boxed{7} \boxed{-} \boxed{3} \boxed{\times} \boxed{5} \boxed{=}$	20
$\boxed{4} \boxed{+} \boxed{0} \boxed{\times} \boxed{7} \boxed{=}$	28
$\boxed{8} \boxed{+} \boxed{8} \boxed{+} \boxed{8} \boxed{=}$	9
$\boxed{9} \boxed{+} \boxed{6} \boxed{+} \boxed{2} \boxed{=}$	7.5

307

**CALCULATOR SENTENCES**  
Teacher Answer Sheet 2

1. Complete the calculator sentences. Each blank box is for a number key.

$5 \times 6 + 10 =$	3
$13 - 6 \times 5 =$	35
$7 + 14 \times 3 =$	1.5

2. Complete the calculator sentences. Each blank box is for an operation key.

$5 + 4 + 3 - 2 =$	1
$2 + 3 - 4 + 5 =$	6

3. Complete the calculator sentences. Each blank box can be for a number or an operation key.

$8 - 3 \times 5 =$	25
$4 \times 5 + 1 + 9 =$	30
$4 \times 4 + 5 + 9 =$	30

4. Find as many combinations as possible for which this could be a calculator sentence. Each blank box is for an operation key.

$8 \square 4 \square 2 =$			
$8 + 4 + 2 =$	14	$8 - 4 + 2 =$	6
$8 + 4 - 2 =$	10	$8 - 4 - 2 =$	2
$8 + 4 \times 2 =$	24	$8 - 4 \times 2 =$	8
$8 + 4 + 2 =$	6	$8 - 4 + 2 =$	2
$8 \times 4 + 2 =$	34	$8 + 4 + 2 =$	4
$8 \times 4 - 2 =$	30	$8 + 4 - 2 =$	0
$8 \times 4 \times 2 =$	64	$8 + 4 \times 2 =$	4
$8 \times 4 + 2 =$	16	$8 + 4 + 2 =$	1

There are 16 possible combinations, resulting in 13 different answers.

## STEP-BY-STEP

- GRADE:** 4
- STRAND:** Algebra
- SKILL:** Identify a number represented by "n."
- MANAGEMENT:**
- CLASS ORGANIZATION:** Whole class, pairs
- TIME FRAME:** One class period
- MATERIALS:** Calculator
- VOCABULARY:** Digit, original, predict, successor, successive, omit
- PREREQUISITE SKILLS:** Mathematics: Basic operations  
Calculator: Basic functions

**LESSON** The purpose of this lesson is to explore number puzzles and their algebraic representations.

**DIRECTED LESSON:**

Project the transparency and do the number puzzle with the students. Explain the algebraic representation for each step. Point out that the algebraic form is cumulative.

Think of a number	$n$
Add 3	$n + 3$
Multiply by 2	$2(n + 3)$
Subtract 4	$2(n + 3) - 4$
Divide by 2	$\frac{2(n + 3) - 4}{2}$
Subtract the original number	$\frac{2(n + 3) - 4}{2} - n$

Students discover that the answer is always 1. Do several examples, emphasizing the algebraic representation.

**GUIDED PRACTICE:**

Complete Student Activity Sheet 1 with the students, emphasizing the algebraic representation.

**INDEPENDENT PRACTICE:**

Students complete Student Activity Sheet 2.

**EVALUATION:**

Teacher observation.

**HOME ACTIVITY:**

Students take home the Student Activity Sheets and calculator and do these activities with a family member.

a. Think of a number  $n$

b. Add 3  $n + 3$

c. Multiply by 2  $2(n + 3)$

d. Subtract 4  $2(n + 3) - 4$

e. Divide by 2  $\frac{2(n + 3) - 4}{2}$

f. Subtract the original number  $\frac{2(n + 3) - 4}{2} - n$

**STEP - BY - STEP**  
Student Activity Sheet 1

		Trial 1	Trial 2
a. Think of a number	$n$		
b. Add 3	$n + 3$		
c. Multiply by 2	$2(n + 3)$		
d. Subtract 4	$2(n + 3) - 4$		
e. Divide by 2	$\frac{2(n + 3) - 4}{2}$		
f. Subtract the original number	$\frac{2(n + 3) - 4}{2} - n$		
Result:			

What do you predict the result will be if you start with a three-digit number?

---



---

Try a four- or five-digit number. Predict your answer:

---



---

What do you think the answer would be if you were to do this puzzle again, but omit step "d"? Prediction: \_\_\_\_\_

---

Try the number puzzle with step "d" omitted. Discuss your results.

---



---





**STEP-BY-STEP**  
Student Activity Sheet 2



2. Try this puzzle. Take turns reading the directions and do two trials.

	Trial 1	Trial 2
a. Think of a number <span style="float: right;"><math>n</math></span>		
b. Add 3 <span style="float: right;"><math>n + 3</math></span>		
c. Multiply by 2 <span style="float: right;"><math>2(n + 3)</math></span>		
d. Subtract 4 <span style="float: right;"><math>2(n + 3) - 4</math></span>		
e. Divide by 2 <span style="float: right;"><math>\frac{2(n + 3) - 4}{2}</math></span>		
f. Subtract the original number <span style="float: right;"><math>\frac{2(n + 3) - 4}{2} - n</math></span>		
<b>Result:</b>		

3. Try the puzzle, again, using a three-digit number as the start.

	Trial 1	Trial 2
a. Think of a number <span style="float: right;"><math>n</math></span>		
b. Add 3 <span style="float: right;"><math>n + 3</math></span>		
c. Multiply by 2 <span style="float: right;"><math>2(n + 3)</math></span>		
d. Subtract 4 <span style="float: right;"><math>2(n + 3) - 4</math></span>		
e. Divide by 2 <span style="float: right;"><math>\frac{2(n + 3) - 4}{2}</math></span>		
f. Subtract the original number <span style="float: right;"><math>\frac{2(n + 3) - 4}{2} - n</math></span>		
<b>Result:</b>		

312

## HAVE YOU EVER SEEN A SQUARE ROOT?

- GRADE:** 4
- STRAND:** Algebra
- SKILL:** Identify a number represented by a variable in an equation
- MANAGEMENT**
- CLASS ORGANIZATION:** Pairs
- TIME FRAME:** One class period
- MATERIALS:** Calculator, transparency
- VOCABULARY:** Square root, substitute
- PREREQUISITE SKILL:** Mathematics: Basic operations, squared numbers  
Calculator: Basic functions

**LESSON** The purpose of this lesson is to explore square numbers and square roots.

• **DIRECTED INSTRUCTION/GUIDED PRACTICE:**

Write this equation on the board:  $n \times n = 36$ .

Ask the students what number times itself would equal 36? The letter  $n$  represents the number.

Substitute the numbers in the equation  $6 \times 6 = 36$ . Thus,  $n = 6$ .

Write these equations on the board.

$n \times n = 81$ ,  $n \times n = 25$ ,  $n \times n = 49$ ,  $n \times n = 144$ ,  $n \times n = 196$

Allow students time to explore.

Discuss what they discovered. Introduce the  $\sqrt{\quad}$  (square root) symbol. For  $n \times n = 81$   $\sqrt{81}$  is the number we are looking for. That is,  $n = \sqrt{81}$  or  $\sqrt{81} \times \sqrt{81} = 81$ .

Students should work Student Activity Sheet 1, making up their own equations when finished. Some students may learn to use the  $\sqrt{\quad}$  key on the calculator to help them find the answer quickly.

**Answers:**

- |             |              |
|-------------|--------------|
| 1. $n = 2$  | 6. $n = 18$  |
| 2. $n = 6$  | 7. $n = 35$  |
| 3. $n = 7$  | 8. $n = 22$  |
| 4. $n = 17$ | 9. $n = 25$  |
| 5. $n = 16$ | 10. $n = 27$ |

If the original equation is  $n \times n = 1061$ , there is not whole number,  $n$ , that will work. In this case students can square numbers to approximate the square root of a given number.

Using transparency, demonstrate how to approximate the square root of 1061.

$$\sqrt{1061}$$

n	x	n	Answer
10	x	10	100
12	x	12	144
25	x	25	625
30	x	30	900
35	x	35	1225
33	x	33	1089
32	x	32	1024

The answer is between 32 and 33.

• **INDEPENDENT PRACTICE:**

Complete Student Activity Sheet 2. Again, some students may discover a quick way to approximate by using the  $\sqrt{\square}$  key on the calculator.

Answer to Student Activity Sheet 2.

$\sqrt{1428}$  is between 37 and 38

$\sqrt{2486}$

$\sqrt{9216}$

$\sqrt{22800}$

• **EVALUATION:**

Correct and discuss Student Activity Sheets.

• **HOME ACTIVITY:**

Students take home Student Activity Sheets and explain the lesson to their parents.



n	x	n	Answer



## DINOSAUR DERBY

**GRADE:** 3 - 4  
**STRAND:** Algebra  
**SKILL:** Evaluate a simple formula

### **MANAGEMENT**

**CLASS ORGANIZATION:** Whole group  
**TIME FRAME:** One class period  
**MATERIALS:** Graph paper, marker or crayon, calculator  
**VOCABULARY:** Scale, rate, time, distance  
**PREREQUISITE SKILL:** Mathematics: Basic operations  
Calculator: Basic functions

**LESSON** The purpose of this lesson is to have students use a simple formula  
 $\text{rate} \times \text{time} = \text{distance}$ .

### • DIRECTED INSTRUCTION/ GUIDED PRACTICE

Tell the students the following background information about dinosaurs' running speeds (rates).

We can learn a lot from fossilized footprints. These often show the shape and size of the animal that made them. We can count the toes, and even see claw marks sometimes. If we measure the distance between two prints made by the same foot (the stride length), and if we know the size of the animal that made the tracks, it is easy to work out how fast it was moving. The faster an animal runs, the further apart its footprints become. Try walking slowly, quickly, and running on a beach or in the snow and see how far apart your footprints are when you run.

These simple observations have shown that dinosaurs walked at speeds ranging from 2.5 to 12.5 miles (4 - 20 km) per hour, depending on size. Small *COELURASAURS* walked at speeds ranging from 2.5 to 8 miles (4-13 km) per hour. The fastest running speed worked out so far is 35 miles (56 km) per hour for *GALLIMIMUS*. We can only measure the speeds we see in the fossilized footprints, which might show slower speeds more often than fast ones. The giant *SAUROPODS* could not have run as fast as *GALLIMIMUS*. Their bodies were too heavy, and the bones of the legs would have been under strain at high speed. *APATOSAURUS* could have reached a speed of 7.5 miles (12 km) per hour. A human being runs at speeds of up to 15 miles (24 km) per hour (but only for short distances)!

If we know how fast a dinosaur runs (rate) and we know for what length of time it runs (time), we can find out how far it ran (distance). A math sentence that describes this is:

$$\text{rate} \times \text{time} = \text{distance}.$$

Students use a calculator and the Student Data Sheet to find out how far (distance) Apatosaurus will run in 4 hours.

$$\begin{array}{rcl} \text{rate} & \times & \text{time} = \text{distance} \\ 7.5 \text{ miles/hour} & \times & 4 \text{ hours} = 30 \text{ miles} \end{array}$$

Do a second example using Sauropods. Students find the shortest distance and the longest distance Sauropods would travel in 5 hours.

$$\begin{array}{rcl} \text{Shortest} & 9 \times 5 = & 45 \text{ miles} \\ \text{Longest} & 12.5 \times 5 = & 62.5 \text{ miles} \end{array}$$

Find out which dinosaurs could complete the race course in 5 hours. Look at the Dinosaur Race Course. Notice that the scale is 2 cm = 2 miles. That means that each 2 cm line represents 2 miles. Students find the length of the race course (52 miles).

Find the distance for Coelurosaurs.

$$\begin{array}{rcl} \text{rate} & \times & \text{time} = \text{distance} \\ 2.5 \text{ min/hour} & \times & 5 \text{ hour} = 12.5 \text{ miles} \end{array}$$

Will the dinosaur finish the race course? (no)

Try the faster rate for Coelurosaurs.

$$8 \times 5 = 40 \text{ miles}$$

Will Coelurosaurs finish at this rate? (no)

Students work with a partner to find out if each dinosaur can finish the Dinosaur Race Course in 5 hours.

Answers:

$$\begin{array}{rcl} \text{Sauropods:} & \text{slow rate: } 9 \times 5 = & 45 \text{ miles (no)} \\ & \text{fast rate: } 12.5 \times 5 = & 62.5 \text{ miles (yes)} \end{array}$$

$$\text{Gallimimus: } 35 \times 5 = 175 \text{ miles (yes)}$$

$$\text{Apatosaurus: } 7.5 \times 5 = 37.5 \text{ miles (no)}$$

• **INDEPENDENT PRACTICE:**

Students use the blank 2-centimeter graph paper and the Student Activity Sheet to design a race course that all the dinosaurs could complete in 7 hours.

• **EVALUATION:**

Students explain how they determined their answer.

• **HOME ACTIVITY:**

Add obstacles to the course that would affect the time needed to complete the course. How would the obstacles affect the length of the course, if you still want all the dinosaurs to complete the course?

# DINOSAUR DERBY

DINOSAUR RACE COURSE

2 cm grid

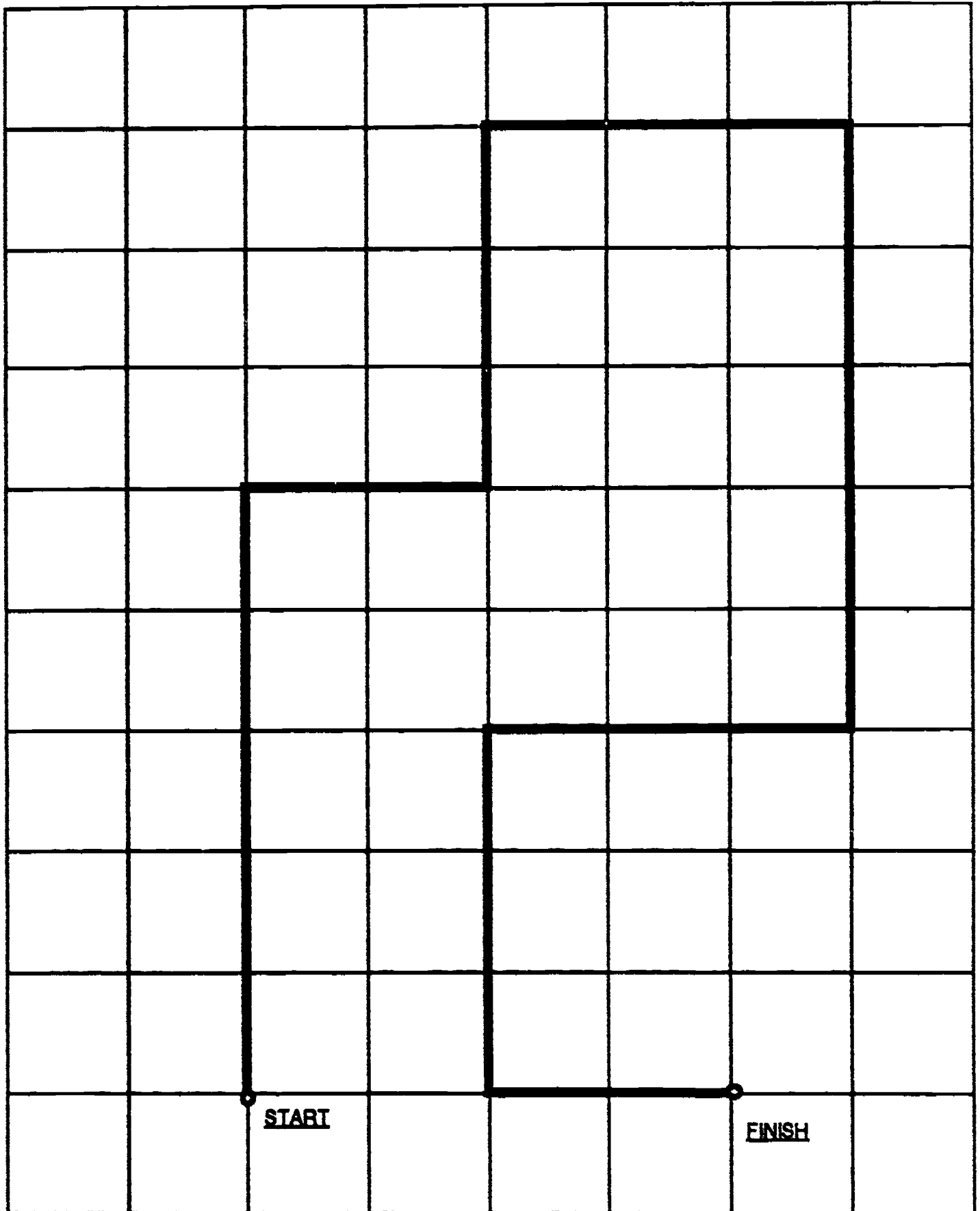

SCALE 2 CM = 2 MILES

# DINOSAUR DERBY

## Student Data Sheet

### *Dinosaur Running Speed (Rate)*

Coelurosaurs .....2.5 to 8 mph

Sauropods .....9 to 12.5 mph

Gallimimus .....35 mph

Apatosaurus .....7.5 mph

### *Human Running Speed*

15 mph for short distances

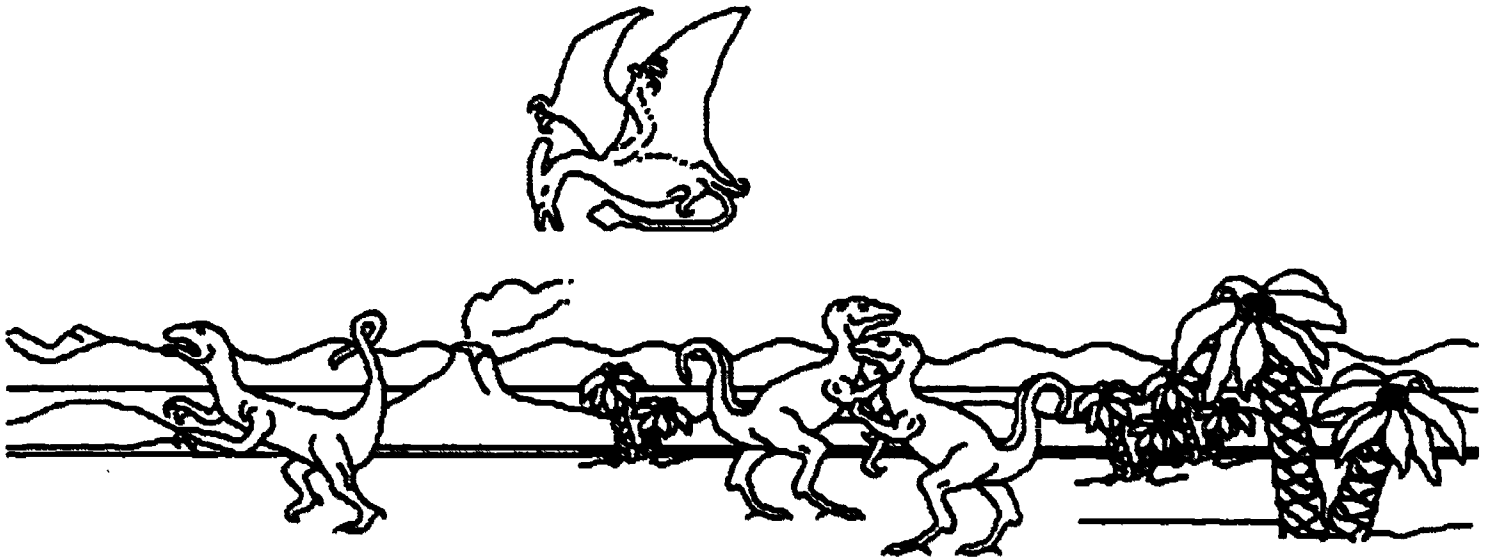

$$\text{Rate} \times \text{Time} = \text{Distance}$$

Which dinosaurs will finish the Dinosaur Race Course in 5 hours?



**HAVE YOU EVER SEEN A SQUARE ROOT?**  
Student Activity Sheet 1

Direction: Solve for n

1.  $n \times n = 4$

$n =$  \_\_\_\_\_

2.  $n \times n = 36$

$n =$  \_\_\_\_\_

3.  $n \times n = 49$

$n =$  \_\_\_\_\_

4.  $n \times n = 289$

$n =$  \_\_\_\_\_

5.  $n \times n = 144$

$n =$  \_\_\_\_\_

6.  $n \times n = 169$

$n =$  \_\_\_\_\_

7.  $n \times n = 1225$

$n =$  \_\_\_\_\_

8.  $n \times n = 484$

$n =$  \_\_\_\_\_

9.  $n \times n = 625$

$n =$  \_\_\_\_\_

10.  $n \times n = 729$

$n =$  \_\_\_\_\_



## HAVE YOU EVER SEEN A SQUARE ROOT?

### Student Activity Sheet 2

$$\sqrt{1428}$$

n	x	n	answer
	x		
	x		
	x		
	x		
	x		
	x		
	x		
	x		
	x		
	x		
	x		

$$\sqrt{2486}$$

n	x	n	answer
	x		
	x		
	x		
	x		
	x		
	x		
	x		
	x		
	x		
	x		
	x		

The  $\sqrt{1428}$  is between \_\_\_\_\_ and \_\_\_\_\_ The  $\sqrt{2486}$  is between \_\_\_\_\_ and \_\_\_\_\_

$$\sqrt{9215}$$

n	x	n	answer
	x		
	x		
	x		
	x		
	x		
	x		
	x		
	x		
	x		
	x		
	x		

$$\sqrt{22800}$$

n	x	n	answer
	x		
	x		
	x		
	x		
	x		
	x		
	x		
	x		
	x		
	x		
	x		

The  $\sqrt{9215}$  is between \_\_\_\_\_ and \_\_\_\_\_ The  $\sqrt{22800}$  is between \_\_\_\_\_ and \_\_\_\_\_

# DINOSAUR DERBY

## Student Activity Sheet

### DINOSAUR RUNNING SPEEDS (RATE)

Coelurosaurs	.....2.5 to 8 mph
Sauropods	.....9 to 12.5 mph
Gallimimus	.....35 mph
Apatosaurus	.....7.5 mph

1. How far (distance) would each dinosaur go in 7 hours?

Coelurosaurs \_\_\_\_\_miles  
\_\_\_\_\_miles

Sauropods \_\_\_\_\_miles  
\_\_\_\_\_miles

Gallimimus \_\_\_\_\_miles

Apatosaurus \_\_\_\_\_miles

2. How many centimeters long does the race course have to be so that all the dinosaurs can finish? (Remember the scale: 2 cm = 2 miles)

3. Draw your Dinosaur Race Course on the 2-cm graph paper.

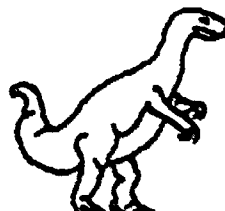



# DINOSAUR DERBY

Dinosaur Race Course

2 cm grid

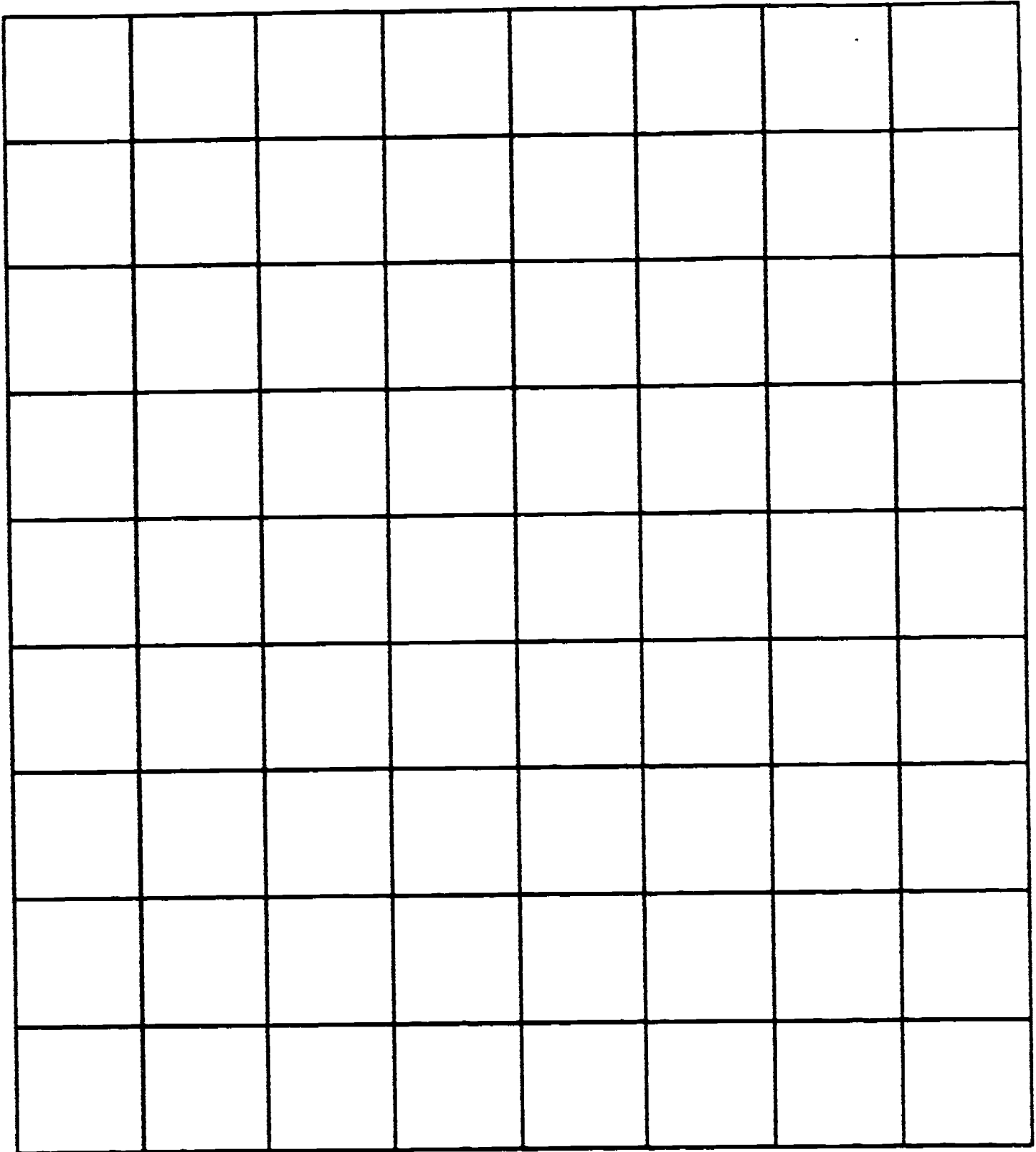

Scale 2 CM = 2 MILES



323

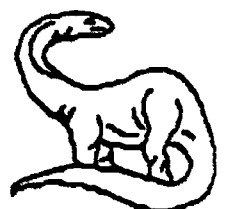

## CHAPTER 7 ASSESSMENT:

### ALGEBRA

1. Complete each of the calculator sentences. An empty box represents a calculator key, either a number or an operation key.

a.  $\square \times 6 + \square = 30$

b.  $30 + \square \times \square = 15$

c.  $\square \times 25 \square . 5 = 100$

Student response:

a.  $4 \times 6 + 6 = 30$

b.  $30 + 10 \times 5 = 15$

c.  $2 \times 25 + .5 = 100$

2. What is the approximate number for each square root?

	n	x	n	=	n <sup>2</sup>
a.		x		=	64
b.		x		=	175
c.		x		=	141
d.		x		=	263

Student response:

	n	x	n	=	n <sup>2</sup>
a.	8	x	8	=	64
b.	13	x	13	=	175
c.	12	x	12	=	144
d.	16	x	16	=	263

3. Use the chart to write equations for each of the stories. Solve the equations.

Speeds of Animals			
Animal	MPH	Animal	MPH
Cheetah	70	Jackal	35
Pronghorn antelope	61	Giraffe	32
Lion	50	Grizzly bear	30
Quarter horse	47.5	Elephant	25
Coyote	43	Squirrel	12

rate x time = distance

a. The three fastest animals ran at full speed across the open fields for 2.75 hours. To find out how far each one ran, write and solve an equation.

Cheetah \_\_\_\_\_

Pronghorn antelope \_\_\_\_\_

Lion \_\_\_\_\_

b. If the grizzly bear can run at full speed for only  $\frac{3}{4}$  (0.75) hour, how far would it travel?

equation \_\_\_\_\_

c. Use the chart. Write a story problem for different animals. Write the equations for each story.

Story \_\_\_\_\_

\_\_\_\_\_

\_\_\_\_\_

Equation \_\_\_\_\_

Story \_\_\_\_\_

\_\_\_\_\_

\_\_\_\_\_

Equation \_\_\_\_\_

Student response should include:

- a. Cheetah:  $70 \times 2.75 = 192.5$  miles  
 Pronghorn antelope  $61 \times 2.75 = 167.75$  miles  
 Lion  $50 \times 2.75 = 137.5$  miles
- b.  $30 \times 0.75 = 22.5$  miles
- c. Stories will vary.  
 Equation: rate  $\times$  time = distance

4. Joe travels 80 miles to Oceanside. He drives 60 miles per hour. How long will it take him to get to Oceanside?

Student response should include:  
 1.3 hours, more than 1 hour.

5. The cafeteria at your school can serve 19 children in one minute. Complete the chart below.

students	19	38			95			950		1710
minutes	1		3	4		10	25		60	

Student response:

students	19	38	57	76	95	190	475	950	1140	1710
minutes	1	2	3	4	5	10	25	50	60	90