

DOCUMENT RESUME

ED 324 745

EA 022 219

AUTHOR Ben-Peretz, Miriam
 TITLE Teachers Document Their Work: A Strategy for School Based Professional Development.
 PUB DATE Apr 90
 NOTE 33p.; Paper presented at the Annual Meeting of the American Educational Research Association (Boston, MA, April 16-20, 1990).
 PUB TYPE Speeches/Conference Papers (150) -- Reports - Research/Technical (143)
 EDRS PRICE MF01/PC02 Plus Postage.
 DESCRIPTORS Case Studies; Classroom Techniques; Elementary Secondary Education; Foreign Countries; Instructional Improvement; *Professional Development; *Self Evaluation (Individuals); *Teacher Improvement; *Teaching Experience; Teaching Methods

ABSTRACT

Teachers' documentations of classroom episodes in their professional lives and group reflections of those episodes are investigated in this report. Documentation is utilized as a history of teaching practice. Forty-four teachers and 19 student teachers documented one classroom episode per week according to structured and unstructured criteria and participated in group discussions of the episodes. Research objectives included: (1) to identify content characteristics of episodes documented by teachers who were asked to document events in their professional lives; (2) to identify linguistic styles of documented episodes, such as rhetorical sequence and level of involvement; (3) to disclose ways in which documented professional episodes may serve the process of school based professional development of teachers; and (4) to create instances of authentic professional "cases" for use in teacher education programs. Findings indicate that analysis of shared experiences contributes to professional growth of teachers by providing resources for self-evaluation and reflection and intercollegial problem solving. One table and figure are included. (7 references) (LMI)

 * Reproductions supplied by EDRS are the best that can be made *
 * from the original document. *

ED324745

Teachers document their work:
A strategy for school-based professional development

Miriam Ben-Peretz
University of Haifa

U.S. DEPARTMENT OF EDUCATION
Office of Educational Research and Improvement
EDUCATIONAL RESOURCES INFORMATION
CENTER (ERIC)

- ✓ This document has been reproduced as received from the person or organization originating it.
- () Minor changes have been made to improve reproduction quality.
- Points of view or opinions stated in this document do not necessarily represent official OERI position or policy.

"PERMISSION TO REPRODUCE THIS MATERIAL HAS BEEN GRANTED BY

Miriam
Ben-Peretz

TO THE EDUCATIONAL RESOURCES INFORMATION CENTER (ERIC)"

Paper presented at the annual meeting of the American Educational Research Association, Boston, April 1990

EA 022 219

The ability and readiness of teachers to reflect on their educational activities is considered of primary importance in their professional lives (Schon, 1983). Sound teaching requires an act of reasoning. According to Shulman (1987) teaching "begins with an act of reason, continues with a process of reasoning, culminates in performances of imparting, eliciting, involving or enticing, and is then thought about some more until the process can begin again" (p. 13). The problem is that the context of teaching is hardly conducive to sustained and interactive reflection on teachers' work (Lortie, 1975).

What are some of the necessary conditions for professional reflection of teachers on their work?

Shulman (1987) mentions the wisdom of practice as an important source of the knowledge base of teaching, which may not be available to practitioners because of the lack of a relevant literature of "cases" of teaching. Shulman claims that "teaching is conducted without an audience of peers. It is devoid of a history of practice" (p. 12).

This study deals with the issue of teachers' own documentation of their professional activities, which would serve as "a history of practice" in the context of a school. The documented cases function as resources for teachers' reflection on their work and as premises for future professional choices and actions.

The main goals of the study were to investigate teachers' documentation of episodes in their professional lives, and to study group reflection on these episodes.

More specifically, the objectives were:

- to identify content characteristics of episodes documented by teachers who were asked to document events in their professional lives;
- to identify linguistic styles of documented episodes, such as rhetorical sequence and level of involvement;
- to disclose ways in which documented professional episodes may serve the process of school based professional development of teachers;
- to create instances of authentic professional "cases" for use in teacher education programs.

Method and data sources

44 teachers and 19 student-teachers participated in the study. Their background characteristics are presented in Table No. 1.

(Insert Table No. 1 about here)

Participants were asked to document one episode per week. Two different task specifications were used:

- 1) open and unstructured. In the open mode participants were asked to document a classroom episode they considered to be important.
- 2) specified focus on teaching episodes and on target audiences. In the structured mode teachers were asked to document a classroom episode, focusing on teaching, and to imagine they were addressing themselves to a colleague.

Analysis was carried out using two sets of categories: 1) content categories, such as: choice of topics; nature of participants in episodes; commonality or variety of episodes; options for solutions of problems; teachers' own evaluation of episodes. 2) linguistic style, following Chafe (1982) and Nir (1984), focusing on rhetoric sequence as reflected, for instance, in causal relationships, and on level of involvement as indicated, for instance, by the use of intensifiers.

Three different documented episodes served as main foci for group reflection. Sometimes one of the teachers participating in the group submitted an episode for discussion. Protocols of group discussions were analyzed for perceived meanings, and for teachers' use of episodes to reflect on their every-day work.

Findings

1) The nature of episodes

Teachers and student-teachers produced detailed documents of professional events. Specification of colleagues as the target audience was found to be most conducive to teachers' involvement in the task, possibly because of teachers' need for peer interaction. Participants in the documented episodes were mostly the teachers themselves and their students, only rarely did colleagues, principals, or parents, figure in the episodes. Most episodes dealt with fairly common classroom situations, though some reflected rare occurrences, such as classroom accidents. Options for solutions of problems were offered in about half of the episodes. Teachers tended to be evaluative and judgmental in

their documentation. This tendency has been shown to be fairly common when teachers discuss each other's teaching. Thus, in a cross-cultural study by Ben-Peretz and Halkes (1987), it was found that teachers who viewed videoed classroom situations in an unfamiliar culture, and in an unknown language, tended to offer evaluative statements about the professional adequacy of the teachers in the video episodes.

Analysis of main topics of episodes showed the following results: Most participants (45) related to instruction (100 episodes). Not all documented episodes focused on one topic only. For instance, of the 100 instructional episodes 61 focused on instruction only and 39 focused on instruction, as well as on other topics, such as classroom discipline. Fig. No. 1 shows the distribution of topics of episodes. The following categories of topics were chosen: instruction, classroom discipline, interpersonal relationships, class organization (such as grouping), focus on self.

(Insert Fig. No. 1 about here)

It is important to note that 38 of the participants submitted one episode each, and 25 participants submitted more than one event. Altogether 59% of episodes focused on one topic only and 41% focused on more than one topic. 54% of all documented episodes dealt with issues of instruction.

More senior teachers submitted more instructional episodes than student-teachers or novices. 32% of the episodes related to classroom discipline, 8% dealt with interpersonal relationships.

In 4% of the episodes teachers focused on themselves as the center of interest. Only 2% of the episodes related mainly to classroom organization.

We turn now to the nature of the description of episodes related to the various topics mentioned above. In the instructional domain teachers tend to evaluate their work according to self-determined criteria.

The following is an episode which reflects this orientation:

"When I handed our test questions the children were very happy, some even said: 'what an easy test'. At the end of the lesson I took their test sheets home, sure that all students had succeeded in passing the test. I was very astonished to find out that sixth grade students don't know to write properly in answering test questions. Their answers were so short that I sometimes thought I was reading a telegram. The grades were rather poor and some students failed the test. I felt disappointed and frustrated.

I discussed this experience with my colleagues in the common room. Some told me that they had had the same experience, whereas others claimed their students knew how to write properly. I concluded to go over the questions with the students, and to compare the answers with them. This is what I did, the students' classroom answers were excellent." (A sixth grade teacher).

This teacher apparently had preconceived notions about the expected level of writing of sixth grade students. These notions may stem from her previous experiences with former students, or from an unexamined reliance on her own standards for writing. The teacher tried to get some feedback, and maybe even advice, from her colleagues. She then devised her own strategy of dealing with the situation, noting again the discrepancy between the oral and written proficiency of her students. This episode may serve as the starting point for a discussion of achievement norms and

other sources. It may also lead to the elaboration of appropriate teaching strategies. Reflecting teachers may be drawn to comment on the necessity of sharing professional experiences, and the role of the common room in providing a setting for such sharing.

We found that respondents, teachers and student-teachers, were inclined to use the documentation of their own teaching as an opportunity to present their teaching strengths.

The following is an episode documented by a student-teacher who provided a case of professional pride.

"My mentor teacher in the practicum was late for the first lesson. I entered the class and began the usual morning routine; singing and conducting the opening classroom discussion. After ten minutes the mother of a student entered the class, quite astonished at the quiet atmosphere. She remarked loudly: "I was sure the class was empty". The children smiled, feeling good about themselves. This strengthened my good feeling about the class, and I complimented them about their behavior. It was very pleasant experience for the children and for me. This was an important event for me, I sensed that I had accomplished something similar to the mentor teacher accomplishments. I felt that the class treated me like a regular teacher".

This episode could be useful in reflecting on several issues related to teaching. One is the issue of professionalism. What, if anything, makes this student-teacher's action different from the possible actions of a mother filling in for a missing teacher? Another issue concerns the notion of professional confidence. What criteria may be used to establish such confidence? The delicate interplay of feelings between teachers and their students could be reflected on especially the manner in which feeling good, or bad, about classroom events is carried over from students to teacher and vice versa.

In another episode an experienced teacher stated that:

"The most important event in to-day's teaching was that a student, who up to now had been very passive, became involved and attentive throughout the lesson. After I had a private conversation with this student he showed great improvement and I was very happy about it". (an elementary school teacher)

Here, too, we have a case of professional pride accompanied by very positive feelings. This episode raises questions about the content of the "private conversation" the teacher had with the student, and about the possible causal relationship between such talks and students' improvement. What is the nature of teacher impact on students, and how do teachers know which strategy to apply in different circumstances?

It is interesting to note that teachers mentioned only seldom issues which relate to the specific teaching requirements of the subject matter, such as the nature of its structure. There was little reference to what Shulman (1987) calls "pedagogical content knowledge", namely, knowledge about appropriate ways of treating and preparing any subject matter for teaching. This lacuna deserves consideration in the writing and using of teaching episodes.

The following is an episode which does focus on pedagogical content knowledge - because it deals not with history but with the educational aspects of teaching history.

"I found out that in teaching history one may provide students with an understanding of the psychological processes which accompany historical events. For instance: In the seventh grade we studied the Roman conquests. We tried to understand the feelings of the conquered people in order to develop empathy. The students suggested two kinds of feelings: a) In spite

of economic advantages the conquered people resented the Romans because the conquest deprived them of their freedom and independence b) The conquered people felt hate, anger and wished for revenge. Some students claimed that these were feelings of defeatism, reflecting weakness and the inability of the conquered to solve their problems. One student argued that such feelings serve as a stimulus for revolt. I was very astonished. This student was able to disclose the positive power of aggressive feelings, especially when these serve social changes". (a history teacher).

This teacher focused on the educational potential embedded in the teaching of history. Her episode presents the manner in which she used historical events for promoting feelings of empathy in her students. The teacher expressed her own feelings of astonishment, and almost of gratitude, that her students were able to see beyond the usually assumed link between "bad" feelings and "bad" results, and to discover the positive power of such feelings.

This episode may serve to reflect on the importance of pedagogical content knowledge, and may provide a starting point for teachers to share their various pedagogical insights.

In the area of classroom discipline most episodes followed a certain pattern: description of the situation; presentation of possible reasons for the problem, steps taken by the teacher and possible solutions. The nature of problems varies according to the students' age. Most documented episodes of classroom discipline occur between students and teachers, the respondents did not tend to report incidents that happened between the student themselves.

The following is an episode dealing with discipline problems at the second grade level.

"In our school we have a competition between classes for the most beautiful garden. All children work very hard at this project. Because of their extreme competitiveness children of class 2a uprooted the plants in the garden of class 2b. A violent fight started. The children turned to the teachers for help and the incident was treated with great seriousness". (related by an elementary teacher).

This episode exemplifies the pattern of teachers' writing about discipline. It starts with a description of the situation (the garden competition and the behavior of the children), presents possible reasoning for this behavior, (extreme competitiveness), and concludes with the solution (teachers' stern interference).

Another episode relates to discipline problems in the junior high school:

"A substitute teacher told me that one student had left her class to go to the bathroom and did not return to class. I went to look for him. Meanwhile another class has started and I was told that a second student was missing. I continued to look for them. One student volunteered to help me search. I let this student walk ahead of me, and followed him to the lower entrance. The two missing students were there, looking anxious. They smelled of cigarettes. I took them to the principal for explanations and reprimands and reported the case". (related by a junior high school teacher)

Again we may note the laconic descriptions of the situation, the behavior of students, and the reaction of the teacher. In this episode the causal chain is implicit in the description of the events. It is taken for granted that at the age of adolescence students will try to smoke, and as this is not allowed will do it clandestinely. It is also taken for granted that the student who volunteered his help in finding his friends intended to warn them and help them escape punishment.

In both cases of discipline problems no alternative explanations of the problem were offered, nor did the teachers suggest any dissatisfaction with the enacted solutions. The episodes seem to be devoid of feeling, no anger, frustration, or even satisfaction with the solution are expressed by the reporting teachers. Such episodes may provide starting points for reflection focusing on some of these missing elements.

In the area of interpersonal relationships teachers seem to be inclined to document mainly positive relationships between themselves and their students.

The following episode exemplifies this tendency. Though the episode starts with a description of problems between teachers and students it concludes with emphasis on the positive relationship:

"Students in my class wrote a letter of complaints about one of the other teachers. We discussed this matter and the students reached the conclusion that their dissatisfaction was due to the behavior of the group (of students). The students suggested that they would try to improve the situation through a series of talks with other students. It was decided that one has to examine oneself prior to blaming others". (a junior or high school teacher)

This episode conveys the message that the teacher has established open, friendly, and productive, relationships with her students. Many questions could be raised in reflecting on this case: what is the role of the reacting teacher? How can we establish trust between ourselves and the students? What are the ethics of the situation? etc.

As noted above in few cases only the teacher him/ or herself was the center of the episode. The following is one case:

"I made an important decision on my way to one of the classes. I decided that the issue of cleanliness was very important to me personally. Therefore, before each lesson I would send 2 students to clean the corridor in which my class is located. It is very difficult for me to pass through a dirty corridor, and therefore I decided to take personal responsibility for this matter instead of getting angry or blaming others". (an elementary teacher)

This is an extremely interesting episode. It illuminates aspects of school ecology and of teachers' personal feelings and needs regarding the environment in which they teach. It also relates to issues of division of labor in school, and the sources of teacher decision-making.

Episodes concerning classroom organization were even rarer. In one episode the teacher reported in great detail on the various organizational questions which had to be solved in the planning of a class party. Such episodes are suited for treating practical problems of organization, and classroom management in teacher education programs. They may also serve reflection on the complexity of teachers' work and on their manifold aspects.

2) Analysis of teachers' linguistic style

The linguistic style of teachers was analyzed according to Chafe (1992) in the following way:

- 1) Counting all word tokens in each episode
- 2) Determining the sum of word tokens in all episodes of each of the seniority groups and each of the school types

- 3) Determining the frequency of each category of linguistic mode in each group of participants

Two main categories of linguistic style (Chafe 1982) were used in the analysis:

- 1) Involvement, namely, the linguistic forms that express the degree of involvement of the speaker (or author) in the message. Expression of involvement are, for instance, intensifiers, topicalization, word modality.
- 2) Integration, namely, the mode adopted by the speaker (or author) in order to integrate the various components of the message into a coherent communication. Examples for integration modes are, for instance, descriptions, causal relations, deductive sequences etc. Analysis of all episodes for each group of participants showed the following results:

The level of involvement was highest for teacher with 1-14 years of seniority. 38% of all word tokens reflected their involvement in the communication. Maybe that this period in teachers' professional lives is, therefore, most suited for adapting self-documentation of teaching episodes as a strategy for improving teaching. The level of involvement of student-teachers was the lowest, 30% of all word tokens were expressions of their involvement in the communication. It may be that this finding is a reflection of their lack of teaching experience.

Many expressions of involvement could be categorized as modality features, reflecting teachers' attitudes and intentions. Examples are: "I have to progress quickly"; "It's

necessary to match teaching strategies to the individual student", "I wanted to speak with him privately", "Teachers should not make mistakes".

Another frequent linguistic feature reflecting involvement is topicalization, namely focusing attention on the content through emphasizing a word, or through changing the expected order of words in a sentence (Nir, 1984). This change dramatizes the message. Examples of topicalization in the documented episodes are: "To me this seems important", "In this class time has come for students to accept responsibility for their learning".

Temporal features at the beginning of a sentence may serve to create a sense of significance, such as, "To-day the students came to me", or "This year I directed my students to..."

Intensifiers are linguistic features which express strength of feeling about the message. Intensifiers were used mainly by student-teachers. Examples are: "Without exception", "Excellent", "In every respect" etc. This finding may be interpreted as reflecting the professional naivete of complete novices.

Analysis showed that description of a situation as a mode of integration prevailed in all episodes, especially those of student-teachers. For instance: "The seventh grade makes me feel inadequate. I don't like the atmosphere in this class. A small group of students cooperate with me and I like working with them. The other students create disciplinary problems that are solved for a short time and repeat themselves lesson after lesson." Teachers with some seniority (1-5 years) used structures of

causal relationship. For instance: "I had to change the topic of the lesson from physics to biology because the students did not understand the materials and were anxious. They had to pass a test in biology after the break." This episode is an example of integration through causal relationship. The most senior teachers tended to use a deductive mode, the transition from generalization to specifics, as their mode of integration. For instance: "Better planning leads to higher achievement. To-day I managed to cover three experiments in my biology class." This finding may be interpreted as reflecting the practical knowledge of more experienced teachers, who have acquired a repertoire of practical rules and principles (Elbaz, 1983).

Linguistic analysis provides important insights into the nature of teachers' documentation of teaching episodes, reflecting their level of involvement in the task. Focusing explicitly on modes of integration of episodes may serve the process of teachers' professional reflection. Teachers may become aware of their own preferred style of integration. They may be directed toward more extensive use of causal relationships, or the deductive mode.

3) Group reflection on episodes.

Three episodes dealing with instructional issues were chosen for cooperative analysis by groups of teachers in two schools, one an elementary school, and one a comprehensive junior high school. Teachers' meetings took place after school hours, in the afternoon or evening, in the presence of the school

principal. In each case the nature of the research project was clarified to the participants. Group reflection was also carried out by student-teachers.

Each group consisted of about 4-10 teachers, or student-teachers, who led their own deliberations. The researchers documented the discussions. Each discussion lasted about 60 minutes focusing on the question: "what can we learn from this episode?"

The participating teachers were very involved in the discussion. In most cases they analyzed the teacher's actions in the episode and asked themselves: "what would I have done in this situation?" Teachers were eager to draw conclusions about ways of improving their teaching strategies. The following are parts of a protocol of such a meeting. The episode was:

"An English lesson in the 9th grade. The students were asked to read a passage and answer some questions. The moment students were confronted with an unknown word in the text they exclaimed: "We don't understand anything". I asked them to underline all words they do understand. Then the students were asked to discover meaning of the text on the basis of the underlined words. The apprehension of the unknown paragraph disappeared once the students realized that it is possible to comprehend a text without understanding every word".

The discussion progressed with the following statements, each statement is followed by the researcher's comments (in parenthesis).

- The symptom of "we don't understand" is very common in lessons of a foreign language. Once students see an unknown word their immediate reaction is: "we don't understand". (The teacher relates the episode to her own classroom experiences in

teaching a foreign language. She suggests a generalization which "puts the blame" on the students).

- This is an example of group pressure. One student claims "I don't understand" and all others follow. (This is an attempt to apply the teacher's psychological knowledge to explain the situation).
- This is an example of lack of motivation to respond to a challenge. (Another explanation is offered, using a professional term "motivation").
- The situation of "not understanding" at the beginning of the lesson, without trying to confront the issue, applies not only to the teaching of a foreign language. When anything new and unusual comes up in the lesson students instinctively claim that they don't understand. They don't have the motivation to try to solve problems. Students seem to think "how can I work with something unfamiliar". (This statement too is a generalization carried beyond the boundaries of the English lesson. The teacher perceives students as unmotivated, not curious, and afraid of the unknown).
- The teacher (in the episode) did the right thing. She lessened the anxiety of her students by asking them to underline all the words they did understand. This action signalled to the students that it was possible to deal with a text even without understanding every word. (The discussion turns from the diagnostic stage to the pedagogical solutions. In this statement the responding teacher identifies herself with the teacher in the episode and accepts both her strategy and her underlying rationale).

- The teacher made the right decision. (This statement is purely evaluative, possibly reflecting this teacher's identification with the teacher in the episode without trying to consider other situations).
- It is possible and necessary to lessen students' anxiety and to encourage them to carry on with the learning task. (The teacher draws some conclusions of the pedagogical principle adopted by the teacher in the episode. The underlying motive of the teacher, to encourage her students to carry on with the learning task, is identified. The scope of applying the teaching strategy is extended beyond English lessons and beyond the comprehension of texts).
- One should use more "unseen" texts in teaching English as a second language. If students will become accustomed to handling unseen texts they won't react with panic to the first unknown word. (This comment brings us back to the context of teaching English and to one specific instructional strategy).
- It is important to discuss this issue in order to neutralize the problem of anxiety in other subject areas and in confronting problems in life. (This statement is a summing up of the whole session. The teacher expresses her view of the importance of the discussion and refers to the possible transfer of some of the issues to other subjects and to life situations).

In another group the following statements were recorded:

- In this case the teacher made the right decision. We see that after becoming aware of the known words the students would

understand the paragraph, while simultaneously overcoming their apprehension. (This comment links the documented outcomes to the instructional strategy of the teacher).

- It is possible to use a Hebrew text with difficult terms as an unseen text. Thus the students will see that it is possible to understand the general meaning of a text without being hindered by unknown words. (This commenting teacher suggests a variant of the strategy in the episode. We can see the stimulating effect of reflecting jointly on documented cases of teaching).
- It is possible to have students work in groups. (Here, again, the comment refers to an additional strategy, possibly based on this teacher's own experiences).
- One can give the text as homework and have students use a dictionary. (Yet, another, more traditional strategy is suggested).

A third group voiced the following comments:

- My first reaction was not to respond at all because the episode deals with an English lesson. (This comment may be interpreted in different ways. The respondent is not an English teacher and, therefore, she does not find it possible to comment. Maybe, too, that this teacher does not feel that she has mastered English herself and, therefore, she is apprehensive about the situation. This is an interesting case in which the reflecting teachers tends to respond like the students in the episode).
- The same thing has happened to me as a student in teacher-training. (The episode causes the respondent to identify with

the students and not with the teacher in the episode. This is an interesting, and probably positive, outcome of reflecting on episodes).

- When we see a film without understanding the text we say that it is boring. (Another case of identification with the students while extending the scope of the documented episode to out-of-school situation), introducing the notion of "boredom" which is highly significant in teaching-learning situations.
- Usually one says "I don't understand" in order to evade some work. (The whole episode is interpreted differently, not as a case of reading comprehension but as a case of student motivation and student diligence. It is important to retain one's openness to different interpretations of the same event).
- When my son was doing his homework, I suggested to him to clarify what, exactly, he did not understand. (This teacher proposes instructional strategies she uses at home as another possibility to solve the instructional problem presented in the episode).
- I agree with the teacher. I can understand the idea of a film in a foreign language, even if I don't understand the words. (Here the analogy to the foreign film comes up again, but this time it is used in order to support the decision of the teacher in the episode).
- Reading well and understanding the meaning is very important, for instance, in test situations. Many people read very superficially and then claim that they don't understand. (This reflection seems to be ambiguous. On the one hand, it is claimed that complete understanding is necessary as opposed to

"superficial reading". On the other hand, it seems that the episode is viewed as an instance for improving comprehension even when words are left unexplained).

- The problem exists even in the first grade. In order to motivate children to continue to read it is necessary to have beautiful illustrations. (Another example of expanding beyond the situation of the episode itself to other age levels, and to reading in one's mother tongue. The proposed solution is substantively different, relating mainly to the issue of student motivation).

Another episode which was discussed by groups of teachers was as follows:

"After a test in Math I returned the marked work sheets to the students. One of the students discovered that I had made a mistake in calculating his grade. He turned to his neighbour and said: "The teacher cheats". I asked him why he said that and he answered that I had purposely given him a lower grade. "Why should I give you a lower grade?" "Because you are a teacher and you made a mistake". I understood that he perceived teachers as being incapable of making such mistakes. The question is how to clarify that teachers are only human and make mistakes, even in simple calculations. I conducted a classroom discussion about this matter."

Some of the comments made by teachers were:

- I have never heard such a reaction by a student. Students say: "you made a mistake, I deserve a higher grade but not "cheat".
- This is a very sharp and unusual word. It is exaggerated to call a teacher "a cheat".
- Students who approach me about their grades may look hurt but they will never use such a word.
- I am not sure what the teacher actually did. She stated her intentions but she did not elaborate on the content of her

classroom discussion and what her message was. She did not relate at all to the issue of teacher trustworthiness "you are a cheat".

- If she had said "teachers don't cheat" it would have been ridiculous and the effect would have been the reverse.
- She should have treated the issue of using inappropriate words.
- But the teacher did conduct a class discussion. I think the teacher's reaction was good. "Why do you think that I gave you a lower grade?" The child concludes that teachers should not make mistakes. Therefore the reaction of the teacher was good. She did not protest that she had not intended to give the student a lower grade, and she did not criticize the student, but asked him questions that would allow him to reach conclusions by himself.
- I cannot evaluate the teacher's reaction because we do not know any details about her conversation with the student. I find the term "cheat" offensive and the teacher did not relate to that aspect at all.
- But the student did not use this term in order to offend the teacher, he said it to his friend.
- The teacher behaved much better than I would have behaved. I would have been offended and would have told him that one does not use this kind of language about teachers.
- I would have asked him "what happened?" and talked with him about the matter.
- I would consider the age of the child and the possible reasons for his reaction.

- That may be right but then one has to discuss principles of interpersonal relationships.

In this group the discussion of the teachers focused mainly on evaluating the teacher's actions in the reported episode. It seems that most participants in the discussion tried to put themselves in this teacher's place, and imagined what they would have done. Some comments introduce additional elements into the discussion. One teacher, for instance, seems to be more interested in the possible connections between the age of the child and the reasons behind his reaction. Another would have liked to dwell more deeply on "principles of interpersonal relationships."

The discussion could have developed in several directions. The notion of "offense" could have been elaborated, possible explanations for the student's behavior could have been sought, principles of interpersonal relationships in the classroom and their problematics could have become the focus of group attention. The question arises how can group discussion and cooperative reflection contribute to the professional development of teachers through focusing on cardinal and pertinent themes. This issue will be treated in the summary discussion of this paper.

What do the participants in group discussions have to say about this experience? Let us listen to some of their voices:

"What we did just now is very useful. These discussions should be held regularly. Teachers could bring their own episodes and discuss them openly with their colleagues. It is important for teachers to put their experiences in writing. The sharing of opinions is

helpful, teacher seniority does not make any difference".

Another teacher said:

"Other people should also participate in these discussions, for instance, students who understand the nature of classroom problems".

One teacher thought that in other countries teachers do have regular meetings for discussing pedagogical cases and voiced his envy:

"I feel that I miss this opportunity to be able to solve problems through sharing ideas with colleagues".

Most teachers stated that they found comfort in the fact that their own problems were shared by others. A common response to problem situations described in the episodes was "this is a typical of students". Some teachers would have liked more detailed episodes as they did not feel that they could follow the teacher's actions. All teachers claimed that they had benefited professionally from group reflection, though with different degrees of enthusiasm. It is interesting to note that in our study Bible and Math teachers were the least interested in this process. Teachers of Literature and English were most interested, with Biology and History teachers in between. In view of the many difficulties that teachers of Math and Bible studies face in their every day work this is a puzzling finding which deserves further investigation.

It seems that the discussion of documented teaching episodes may serve to raise teachers' awareness of classroom problems. The discussion may lead to an extension of teachers' repertoire of

instructional strategies. An important outcome may be the enhancement of teachers' abilities to uncover underlying pedagogical principles, and to weigh their possible applications in different teaching situations.

Discussion and Summing up

The purpose of this study was not to generalize about the nature of teachers' documentation of teaching episodes. Rather, the aim is to suggest a professional mode for teachers to reflect upon their work in order to be more effective in their teaching. The study consisted of two parts;

- 1) Investigating the process of documentation, and
- 2) Documenting teachers' discussion on these episodes.

Regarding the process of documentation the following guidelines for practice may be drawn:

- 1) It may be necessary to structure documentation and to focus the episodes on specific problems in classroom lives. Teachers may decide which kind of issues they would like to deal with at certain times, and direct their documentation to these issues. The level of teachers' involvement in documentation, which was evidenced in this study, is a sign of the potential contribution of this process to the promotion of teachers' professional reflection.
- 2) It is important to encourage teachers to document problems and failures, as well as successes. Linking documentation to problems of students' achievements may lead to greater awareness of the various steps in the instructional process: diagnosing students' needs, trying out modes of instruction,

evaluating students' achievement. This linkage is especially important in the context of effective teaching. An anticipated outcome of the documentation process may be its raising teachers' expectations for their students.

- 3) In this study experienced teachers tended to document their episodes with more emphasis on causal relationships than novice teachers. This tendency seems to be an important feature of teachers' professional thinking and should be encouraged in the analysis of episodes, so that teachers may become more sensitive to the impact of their instructional decisions.

Teachers may benefit from the act of documentation in various ways. It serves to raise one's awareness of modes of thinking about teaching, as well as of modes of acting in the classroom. A steady process of documentation is in itself an act of professional development. On the other hand teachers may be apprehensive regarding the time needed for documenting their work, and may doubt the value of this effort. In different settings teachers may decide on different modes of documentation, voluntary or compulsory, regular or sporadic, elaborate or concise, focusing on problem situations dealing with a variety of pedagogical issues.

It is deemed essential to introduce documentation stepwise into schools. Time has to be set aside and appropriate conditions have to be provided for the process. As documented episodes accumulate these could be catalogued for future use. Documentation centers would become sources for teachers and would allow one to follow

the pedagogical history of schools.

Group discussion of the episodes highlighted several issues.

- 1) Teachers voice a need for opportunities to share experiences. When these experiences are in the form of written episodes this sharing may be highly productive.
- 2) Teachers view the analyzed episodes as problems situations which they try to solve. The closer the episodes are to their own environment the stronger their sense of ownership and their motivation to deal with them.
- 3) It is not necessary for reflecting teachers to teach the same area that is treated in the episode. Teachers use their general professional knowledge in order to deal with the problems posed in the episodes.
- 4) It is important that discussions are guided so that main issues which are raised are treated in appropriate depth. Guided discussions may contribute to the professional growth of teachers through focusing on themes of major importance in specific situations.

Several questions arises:

- how are episodes chosen for group reflection?
- what is the optimal size of the group, and who chairs the discussions?
- should groups be relatively permanent, and should their meetings be open or closed to other colleagues?
- what are the best ways of keeping records of group meetings? maybe records are unnecessary?

These questions can be answered only on the basis of practical experiences in specific school contexts.

Schools may benefit from the process of teacher documentation and group reflection in several ways. The process of documentation may serve to highlight important issues in schools, leading to school improvement. The existence of discussion groups may encourage more interaction among teachers, and more mutual support. On the other hand, this may lead to overexposure of individual problems in teaching, and may create a sense of uneasiness. Much depends on the principal and on the school climate.

On the basis of this study it is suggested that teachers' own documentation of teaching episodes, which then serve as foci for group analysis and deliberation, may serve as one strategy for teachers' professional development. Analysis of teaching episodes is not a new strategy in teacher education programs. The main thrust of this paper is to introduce this strategy for creating a continuous process of reflection and analysis of one's own teaching aided by one's colleagues.

The following are some suggested modes of incorporating documentation and analysis in teacher pre- and in-service education programs:

- 1) Introducing ongoing workshops on documentation and analysis of episodes in pre- and in-service teacher education programs.

- 2) Using documentation and analysis projects as part of the graduation requirements of student-teachers.
- 3) Establishing regular teacher meetings in schools, focusing on the analysis of episodes presented by colleagues.

The last mode of documentation and analysis is viewed as an ongoing process of teacher development, leading to school improvement.

References

- Ben-Peretz, M. and Halkes, R. (1987). "How teachers know their classrooms: A cross-cultural study of teachers understanding of classroom situations". Anthropology and Education Quarterly, 18, 1:17-32.
- Chafe, W.J. (1982). "Integration and involvement" in: D. Tanner (Ed.) Spoken and Written Language: Exploring Orality and Literacy, Norwood, N.J. Ablex.
- Elbaz, F. (1987). Teacher Thinking: A Study of Practical Knowledge, New York, Nichols Publishing.
- Lortie, D.C. (1975). Schoolteacher: A Sociological Study, Chicago, The University of Chicago Press.
- Nir, R. (1984). Language, Medium and Message, Jerusalem, Posner (in Hebrew).
- Schon, D. (1983) The Reflective Practitioner, New York, Basic Books.
- Shulman, L.S. (1987). "Knowledge and teaching: Foundation of the new reform." Harvard Educational Review, 57:1-22.

Table No. 1: Back ground characteristics of participants
 N=63 (44 Teachers and 19 Students teachers)

	No. of Participants
<u>SEX</u>	
FEMAL	59
MALE	4
<u>YEARS OF TEACHING EXPERIENCE</u>	
0 (students-teachers)	19
5-11	11
6-14	12
15+	21
<u>SCHOOL</u>	
PRIMARY SCHOOL	14
HIGH SCHOOL	30
COLLEGE STUDENTS	19

Fig. No. 1 : Distribution of Topics of Events

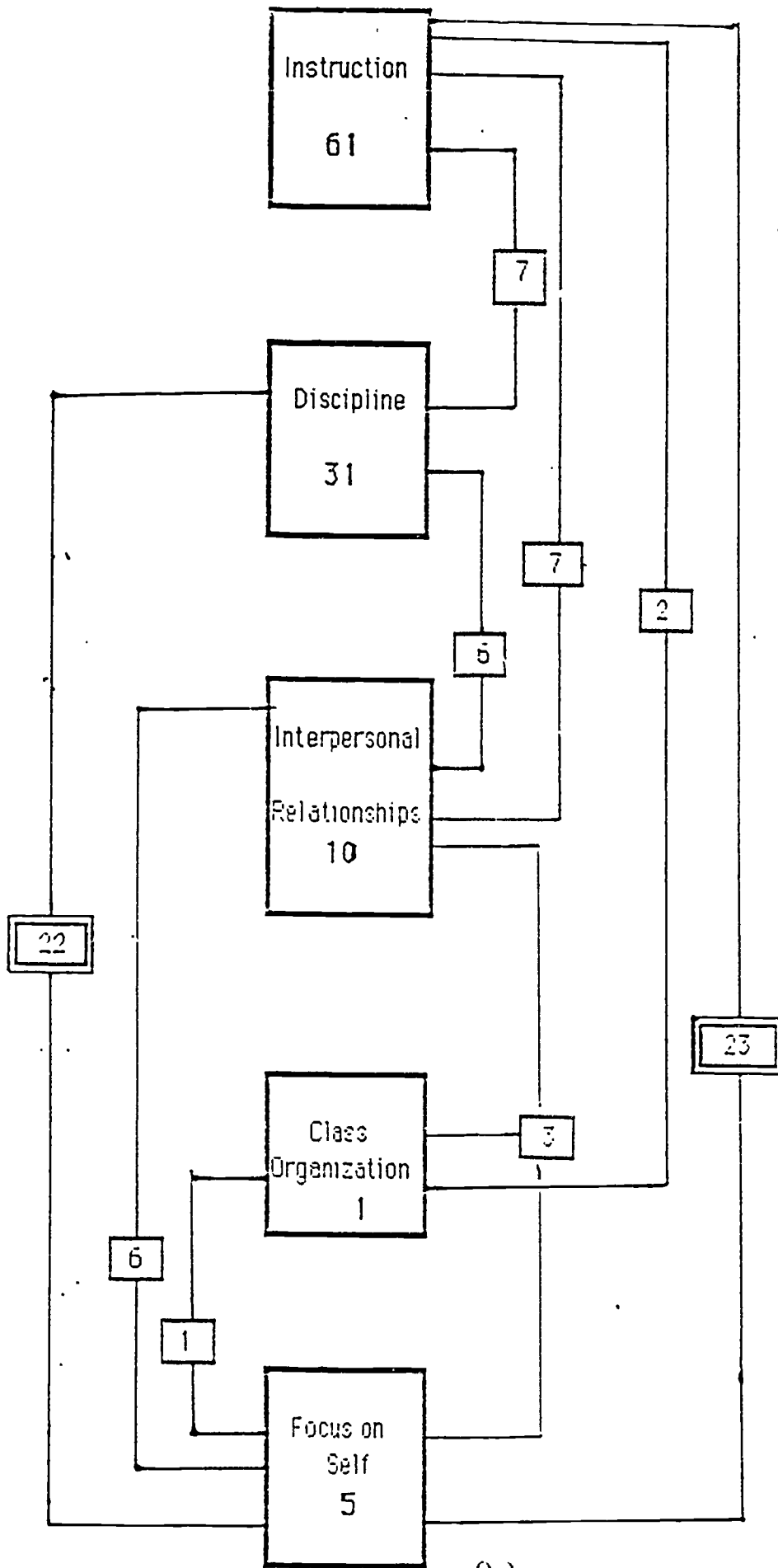

**Post Issuance
Remake
END**

U.S. Dept. of Education
Office of Educational
Research and Improvement (OERI)

ERIC

**Date Filmed
March 25, 1992**