

DOCUMENT RESUME

ED 322 398

CE 055 592

AUTHOR Ritz, John M.; And Others
 TITLE Resources in Technology III.
 INSTITUTION International Technology Education Association, Reston, VA.
 PUB DATE 86
 NOTE 69p.; For related volumes, see CE 055 590-595.
 AVAILABLE FROM International Technology Education Association, 1914 Association Drive, Reston, VA 22091-1502 (\$6.50 members, \$7.50 nonmembers; six-volume set: \$35.00 members, \$37.50 nonmembers).
 PUB TYPE Collected Works - General (020) -- Guides - Classroom Use -- Materials (For Learner) (051)
 EDRS PRICE MF01 Plus Postage. PC Not Available from EDRS.
 DESCRIPTORS Automation; *Communications; Construction Materials; Futures (of Society); *Industrial Arts; Lasers; Learning Motivation; Manufacturing; Microcomputers; Optics; Postsecondary Education; Robotics; Science and Society; Secondary Education; Teacher Influence; *Technological Advancement; Technological Literacy; *Transportation
 IDENTIFIERS Integrated Manufacturing Systems

ABSTRACT

This document--intended to help technology education teachers plan their classroom curriculum for secondary school and college students--contains units on exploring high-impact technology, microcomputers as technological tools, integrated manufacturing systems (the future of design and production), the role of robotics in integrated manufacturing systems, mass transit, communicating with light using lasers and fiber optics, automated warehousing, and new materials. The sociocultural impact of those topics and the relationship of each to the common elements of technological systems are covered in each unit. Units also typically include narrative information, line illustrations, a glossary of technical terms, an audiovisual aid, a construction activity, examples of how math and science can be used to support the students' construction activities and provide the motivation for students to make the connections between technical education and math and science, a student quiz, possible student outcomes, and references. (CML)

 * Reproductions supplied by EDRS are the best that can be made *
 * from the original document. *

ED322398

Resources in Technology

III

U.S. DEPARTMENT OF EDUCATION
Office of Educational Research and Improvement
EDUCATIONAL RESOURCES INFORMATION
CENTER (ERIC)

This document has been reproduced as
presented by the person or organization
originating it.

Minor changes have been made to improve
reproduction quality.

• Points of view or opinions stated in this docu-
ment do not necessarily represent official
IERI position or policy.

PERMISSION TO REPRODUCE THIS
MATERIAL IN MICROFICHE ONLY
HAS BEEN GRANTED BY

[Handwritten Signature]

TO THE EDUCATIONAL RESOURCES
INFORMATION CENTER (ERIC)

International Technology Education Association

ED322398



- 1 Exploring High-Impact Technology**
- 9 Microcomputers As Technological Tools**
- 17 Integrated Manufacturing Systems
The Future of Design and Production
(part 1 of 2 parts)**
- 25 Integrated Manufacturing Systems:
The Role of Robotics
(part 2 of 2 parts)**
- 33 Movin' On With Mass Transit**
- 41 Lasers/Fiber Optics
Communicating With Light**
- 49 Automated Warehousing**
- 57 New Materials**

Contributing Authors

Tidewater Technology Associates

Members:

**John M. Ritz
Paul L. Cummings
John R. Deed III
John M. Fry
John G. Gentry**



Note: These activities may be reproduced without permission for use in the classroom.

What's New This Year

Today's world is much different from that of past generations. Constant changes have occurred since Sputnik I was launched on October 7, 1957. Many new technological devices and systems have emerged. This series of **Resources in Technology** will deal with technological developments that have emerged in the 1970s and will continue to be developed throughout the 1980s.

The next seven issues of *The Technology Teacher* will deal with emerging or **high-impact technologies** that will affect our futures. Last year's Resources were designed to be duplicated and used with students in the classroom. This year's are designed as instructional resources to help teachers plan their classroom curriculum.



Specific topics to be addressed include

- Microcomputers As Technological Tools
- Flexible Manufacturing—Automation
- Flexible Manufacturing—Robotics

- Rapid Mass Transit
- Laser/Fiber Optics
- Automated Warehousing
- New Composite Materials

The issues of **Resources in Technology** will provide an analysis of the above areas, including their social-cultural impacts, their relationship to the common elements of technological systems, an audiovisual aid, a constructional activity, its relationship to math and science, a quiz, and additional references for further study. They will all be classroom oriented so teachers can use them for instructional resources. In the remainder of this issue, we will explain our views on Exploring High-Impact Technology.

Exploring High-Impact Technology

High technology is a common phrase in today's society. However, it is confusing to many people. The meaning of high technology varies according to the society and profession in which it is used. In an undeveloped country or a remote area of South America, Africa, or Asia, an automobile, electric generator, or running water might be considered high technology. However, these are developments commonly used in the United States and other developed countries.

The word *high* signifies a relationship to a scientific or technical knowledge level above the understanding of a common person. Examples of high technology in our society are the space shuttle, the electronic office, genetic engineering, robotics, CAD/CAM, and composite materials. These new developments are based on breakthroughs in several scientific and technical fields that were unknown of 25 years ago.



This series of **Resources in Technology** focuses on an area that can be described as *high-impact technology*. This phrase was drawn from Alvin Toffler's book, *The Third Wave*. Not all high technology has an immediate impact on people—on their jobs, lifestyles, or environment. Examples of high technologies not immediately affecting us are the space shuttle, MX missiles, and genetic engineering. Although they do and will continue to have spin-offs, they do not affect us as much as computers, communication satellites, new composite materials, jet travel, and robotics. These spin-offs are examples of high-impact technology.



Technical Terms

Robotics: The science of designing and building machines that can perform tasks that would normally be done by a human.

Automation: The process of designing and building machines that can perform tasks that would normally be done by a human.

Computer: A machine that can store and retrieve data, and perform calculations and logical operations.

Artificial Intelligence (AI): The science of making machines that can think and learn like humans.

Expert System: A computer program that can solve complex problems by using a set of rules and a knowledge base.

Computer-Aided Design (CAD): The use of computers to assist in the design and manufacturing of parts and products.

Computer-Aided Manufacturing (CAM): The use of computers to control the manufacturing process.

Computer-Integrated Manufacturing (CIM): The integration of CAD, CAM, and other manufacturing processes.

High-Impact Technology: Technology that has a significant impact on society, such as the space shuttle, MX missiles, and genetic engineering.

Spin-off: A new product or technology that is developed as a result of research and development in another area.

Composite Materials: Materials made from two or more different materials, which are combined to create a material with improved properties.

Jet Travel: Travel by airplane, which is a high-impact technology because of its speed and range.

Communication Satellites: Satellites in space that can relay signals between different parts of the world.

Genetic Engineering: The use of genetic engineering techniques to create new organisms or modify existing ones.

Space Shuttle: A reusable spacecraft that can be launched into orbit and return to Earth.

MX Missiles: A type of intercontinental ballistic missile (ICBM) that is designed to be highly accurate and survivable.

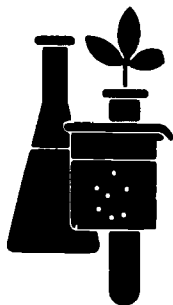

Most of the scientific and industrial research that has led to high-impact technology has resulted since World War II. Since that time, industrial research departments have been combining major advances in the scientific field with technical processes. The first areas to advance were the chemical industries. Now the major advancements are happening in microelectronics, advances that have resulted in new products and technical systems that combine "materials, devices (particularly microprocessors), equipment or systems, or the processes used to produce them (and) offer a significant departure from past technology, and thus offer economical advantages or important new features" (Lauda in Daiber, 1983, p. 16).

The key statements to aid us in understanding high-impact technologies are (a) to com-

bine scientific research with technical processes or products, (b) to offer economic advantages, or (c) to offer new features. Examples of *scientific research* include solid-state science (microelectronics), physics, information theory, ecology, chemistry, genetics, and space science. *Economic advantages* of using high-impact technology may include replacing drafters and machinists with computer programmers (CAD/CAM), using robots on assembly lines, or making automobiles lighter by using synthetic or composite materials. Finally, *new features* added to products or technical systems would include 100-channel television reception made possible through communication satellites, telephone communication using fiber



optics, Europe to Washington, D. C., travel in three hours in supersonic jetlines, or automobile fuel consumption and emissions controlled by microcomputers.

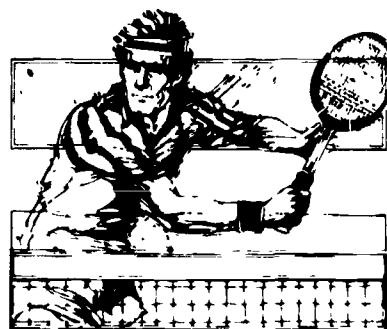

The fields that are presently developing and using most high-impact technology advancements include automated manufacturing, information processing, space exploration, energy alternatives, medical science, and telecommunications (Daiber, 1983). These areas, however, are providing many effects and spin-off to the citizens of the developed countries. Examples include more durable sports equipment, such as skis, tennis rackets, and bob sleds, more humane medical practices, such as artificial limbs and organs and system monitors, electronic video games, cordless telephones, and microcomputers, solar heating and cooling, and water heating.

Social-Cultural Impacts

It is significant that high-impact technologies will have some effects on our futures. They will probably have an impact on the foods we eat (chemical additives, fertilizers, ocean farming, or genetic alterations of animals and crops), the clothes we wear (synthetic fibers, colors, or composite materials), and our environments (materials for home construction, electronic information systems, or recreational product development). If you were to review many old science fiction movies or books, you would see what foresight the authors had. Many of their projections have become realities (e.g., television, space travel, and robots). It has been estimated that more than 75% of George Orwell's projections in his book *1984* have come true.

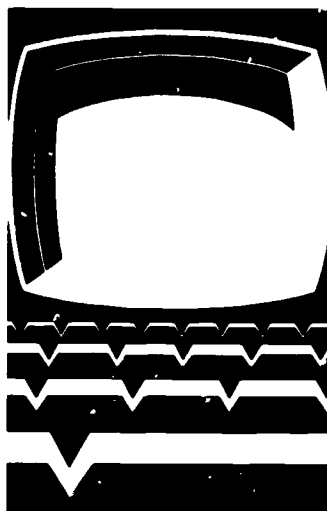

Our occupations will also be altered by high-impact technology. However, most occupations will remain the traditional goods and service providers through the 1990s. According to the Federal Bureau of Labor Statistics (1982),

the decade of the 1990's will not see the demise of America's smokestack industries. Job gains in manufacturing will account for almost 1 of 6 new jobs between 1982 and 1985. Services—including such fields as communications, trade, finance, real estate, transportation and government—will provide three quarters of the 25 million new jobs to be created between now and 1985. The growth rate for high tech jobs, however, will be about 46 percent from about 3.3 million today to 4.8 million in 1995 ("High Technology," p. 1).

The new high-technology jobs are projected to increase in New England, where the traditional machine tool industries are declining. This will happen to take advantage of the educational and research institutions of the region.

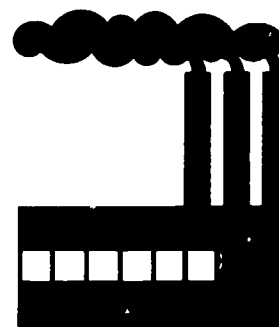

Although only a small segment of the new jobs (3.8% of total jobs), will be in the high-technology field, high technology will have a great impact on many traditional jobs. Computers have altered how teachers submit grades for students, real estate persons advertise homes, and secretaries type letters (word processors). Lasers at cash registers read product codes, calculate the cost, and take inventory of stock. Today, we can call across the U.S., order products on the telephone, and have them charged to our credit cards because of advancements in banking and data processing. All of these high-impact technology advancements have caused worker roles to change, these changes will continue into the future, and their high-impact technological developments will affect you.

Another example of these social/cultural changes happened with the U.S. space shuttle in the spring of 1983. Who would have dreamed 10 years ago that "Ace Satellite Repair Co.," the crew aboard the spaceship Challenger, would pluck an inactive Solar Max satellite from space with a robotic arm, repair it, and place it back in its new sun synchronous orbit ("Challenger Retrieves Errant Satellite," 1984). This feat is accepted by the American people as just another in a long series of daily high-technology breakthroughs.

Engineers who develop and produce high-impact technology are very aware of the impact their products have on our rapidly changing society. Perhaps they are so close to high technology that its impact becomes routine. Yet, there is a growing number of people who view high-impact technology and the changes it brings with conflict and anxiety. This group sees high tech (e.g., robotics and computers) as a threat to their immediate environment, a threat further enhanced by the decline of our industrial era. This decline has brought high unemployment, skyrocketing prices, escalating interest rates, and depressed wages. This is creating even more discomfort among a people who already feel threatened by technology.

As Naisbitt (1982) stated, "High impact technology is the product of modern day society, and as a result, many have found it extremely difficult to cope with the daily stress-driven tram change." And, he goes on "We are a society of events or happenings that seem to happen so fast that rarely do we notice the rationale behind these changes" (p. 2).

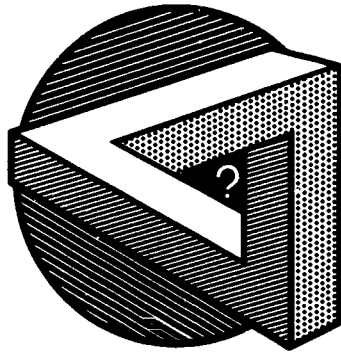

Taffler (1980) seems to share Naisbitt's beliefs "that high impact technology is a positive step forward and that we must analyze change and see if tomorrow's technology will serve society's long-range goals" (p. 151). Taffler also believes that computers, when given a series of assumptions concerning any problem, can systematically provide alternate options. He stated, "While we [humans] may deal with many factors simultaneously on a subconscious or intuitive level, systematic conscious thinking about a great many variables is damnably difficult, as anyone who has tried it knows" (p. 174). However, Naisbitt and Taffler both agree that change is a product of today's technology that, for the most part, is directly related to computers and their associated software.

At present, the English language is considered the universal language in the world, but by the end of the 1980s, this may give way to a new language, a universal machine language, such as Basic, Fortran, and Cobol, which are all used in today's computerized

society. The next few years will see a new machine language using symbolic representation instead of the traditional numerical bases such as Base 2 (binary), Base 8 (octal), Base 10 (decimal), and Base 16 (hexadecimal). This new symbolic representation language will allow computers to attain a higher level of reasoning. This new computerized reasoning is responsible for the rise of a new field in computer science called **artificial intelligence (AI)**. AI is being used extensively in medicine. Medical diagnosis, once limited to a physician's vast experiences, is now being done on a routine basis using AI and computer technology (Harris, 1983, p. 10). This frees doctors from lengthy research into the cause and effect of certain diseases.

Perhaps the biggest change yet to take place in our society is the advent of the personal computer (PC). As high technology continues to develop, the retail price of PCs will continue to drop, making them available to even more people. In a speech, Isaac Asimov (1983) stressed this point "By the year 2020, society will consist of only two social classes of people, those who have access to a computer terminal and those who do not." Asimov's statement is supported by sales figures of personal computers, which reached \$260 million in 1980 and are predicted to exceed \$6 billion by 1989 (Taylor, 1984).



UNEMPLOYMENT

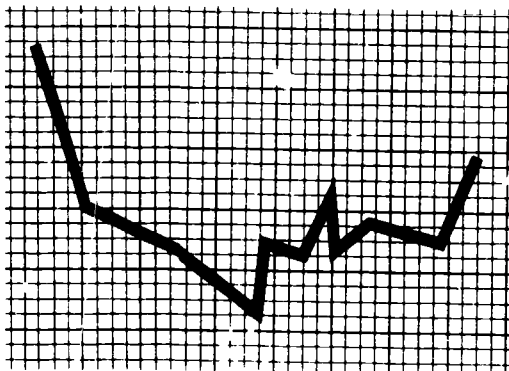

Close on the heels of personal computer sales is the growing business of software. Numerous software programs have been designed to save time and improve the quality of work. As the sales of PCs increase, the software industries will respond with a greater variety of software programs to save time and money. These emerging software industries will be the new giants in the 1990s. In support of this claim, Fred Gibbons, the head of Software Publishing, stated, "Control of the PC industry is shifting from the hardware manufacturers to the software suppliers" (Taylor, 1984). It seems that the future will be governed by software developers who may provide the answers to society's long-range goals.

From this reading, we hope you can better relate to what technology has done to people's attitudes, beliefs, and values. In the next section of Resources in Technology, we will discuss how high-impact technology has influenced the basic elements found in all of our technical systems. These include people, information, capital, energy, tools, materials, and processes.



Common Elements of Technological Systems

We have already reviewed the impact that technology will have on people's work and life-styles. Another element of people adapting to high-impact technology is education. Most high-impact technology jobs will go to those with a four-year college degree. Their work will deal with applying scientific theory to technical systems in such areas as automated manufacturing, space travel, medical sciences, and information processing. Those with the education and technical skill will make better salaries. Fields related to high technology will also need workers who can adapt and change to new technical developments. Thus, education will be a continuous process for those working in or related to high-technology fields.

Workers in high-impact technology areas will be required to process information. Information in the future will be originated, transmitted, and used much faster because of breakthroughs in computer and data processing. These breakthroughs will have many spin-offs in all areas. Finance and government are areas where these high impacts are growing today.



Capital to finance and house these new businesses today are not only coming from U.S. based corporations. A worldwide economy has developed in the second half of the twentieth century. The oil embargos of the 1970s and the recession of the 1980s

emphasized the interrelationship of the world economy. Today, many European and Japanese firms are setting up businesses in the U.S. to be closer to their markets.



Energy is an essential component to power all technical systems. Much high-technology research has been done to find alternatives to finite fossil fuel sources, such as oil, gas, coal, and uranium. Such developments as solar and wind power are being studied to reduce the potential problems created by fossil fuel use. Results of these high-technology research efforts have provided many products that operate with digital outputs that are more accurate because they have fewer or no moving parts. This is another area in which high technology has had an impact on the general public.



The tools and machines of today are being refined by industrial research to perform more accurately and efficiently so better products can be produced at a cheaper price. Many industrial machines are computer and laser controlled. They replace human workers (and thus human error) and can make better products. They are also being made with more durable materials.

The materials of today are replacing many traditional natural materials, such as wood and metals. Because synthetic materials can provide some superior structural and workable benefits, they have replaced applications of natural products. In recent years, science has provided a host of new properties in materials by combining natural and/or synthetic materials in layers. These are known as composite materials. Plywood and fiberglass are the most common examples of these "wonder" materials.

The final area of common elements is processes. The processes performed by today's industrial machines are much more automated than those of the past. Machines are controlled by microprocessors reading input via tapes. The results are more accurate, saving industry materials, time, and money.

With an understanding of high-impact technology and how it has altered our technical systems, let us look at how it can be applied to a laboratory-based technology problem.

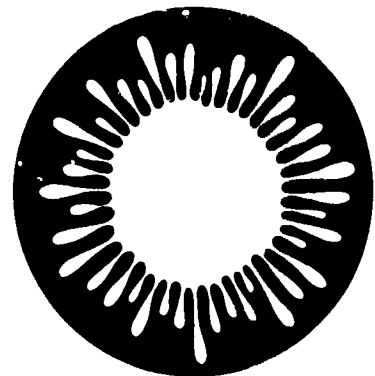

AN AUDIOVISUAL

Photocopy and use with your students.

TECHNOLOGICAL IMPACT

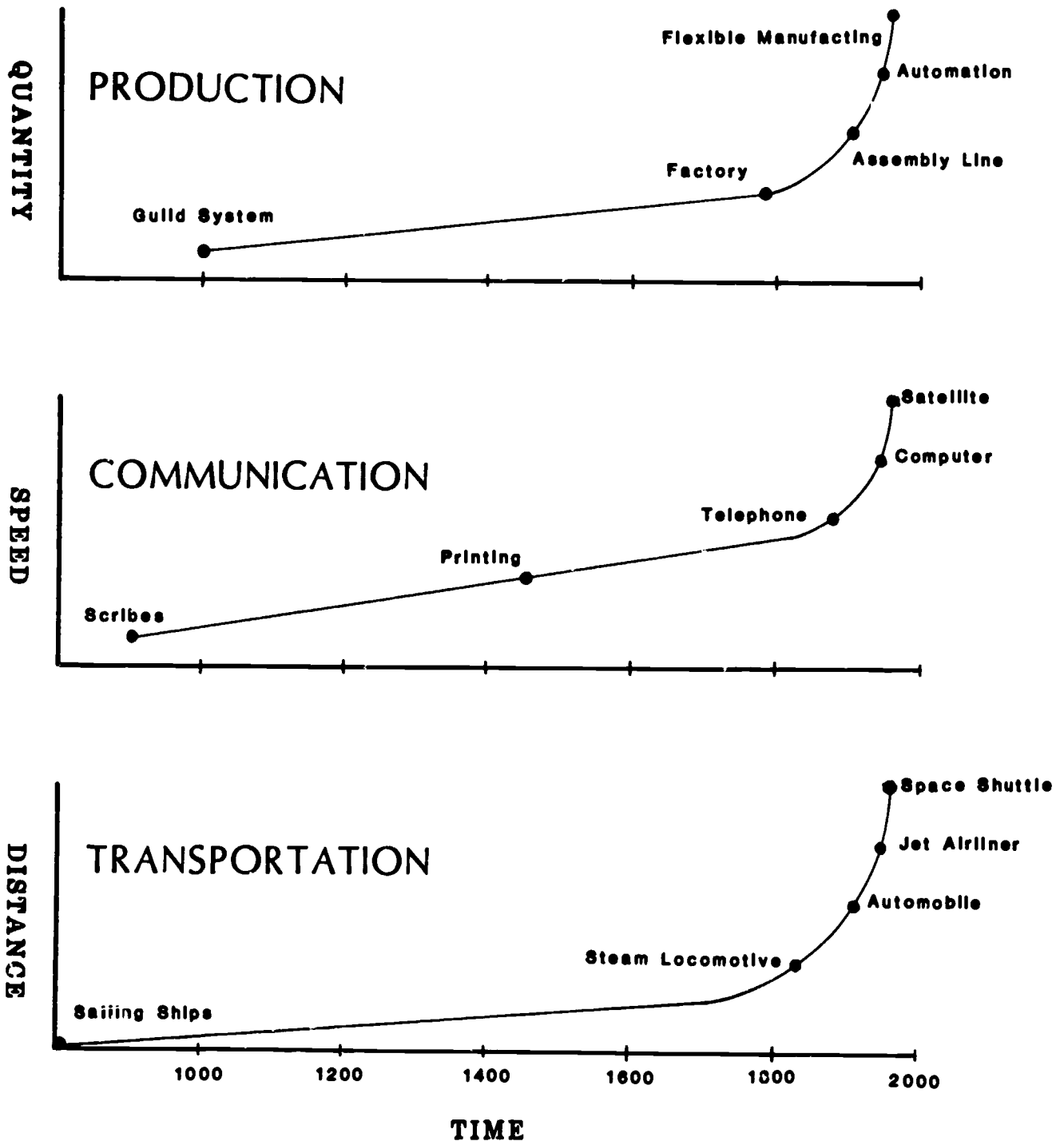

Note: Advances in technology have created more efficient systems resulting in increased quantity, speed, and distance. Dates listed have been approximated.

Constructional Activity

The authors of this series strongly believe in the use of laboratory facilities and equipment to study industrial arts/technology education. In the Constructional Activity section, we will provide a hands-on activity to reinforce the content previously discussed in each issue. In this issue we will use a design type of problem/activity.

The focus of this particular activity is to use tools and materials found in the industrial arts/technology laboratory (metal, wood, plastic, or other synthetics) to build a safe transportation vehicle. The diagram in Figure 1 outlines the thoughts behind this activity. Following are the parameters of the activity.

TECHNOLOGY PROJECT

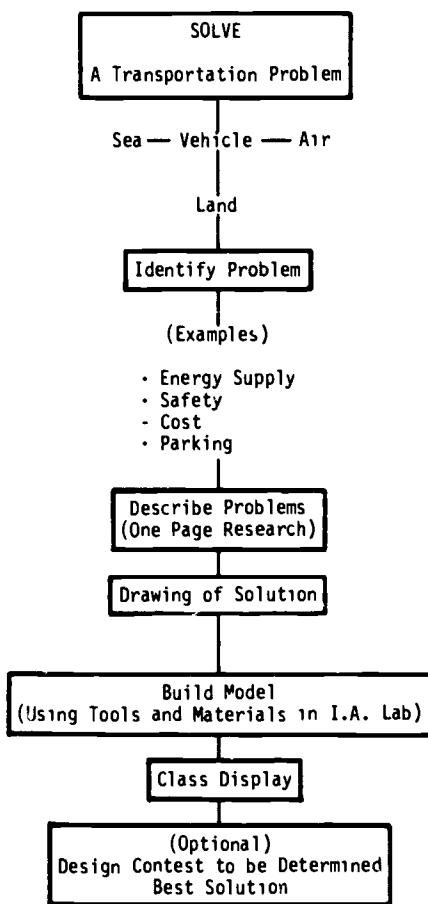

FIGURE 1

This activity shows that activities in industrial arts/technology education programs can address contemporary technological problems. However, to understand better how high-impact technologies operate and change our lives, one must have an understanding of mathematic, scientific, and technological principles. The next section of this article explains this interface. You may want to teach this information while students are working on their transportation activity.

Problem Construct a safe highway transportation vehicle

Description of Problem

Each year, as a result of automobile accidents, 35,000 people are killed. Design and build a model car to protect passengers.

Research Areas

- A Larger shock absorbing bumpers
- B Safety seat/seat belt
- C Find ways to make cars safer
- D Crash cage (race car design)

Selected Solution (Based on Research)

My Model Car will be built with

- A Safety seat/seat belt/passenger restraints
- B Crash cage (race car design)
- C Shock absorbing bumper

Research Limitations

Vehicle with an egg as passenger will be crash tested. Egg should not break. Cracking may be considered. Scale 1/2" to 1'0"

Class Presentation

Give a one- or two-page report to the class about a safety car.

- 1 State the problem
- 2 Support the solution chosen
- 3 Tell about the model built and give conclusions

DRAWING OF POSSIBLE SOLUTION

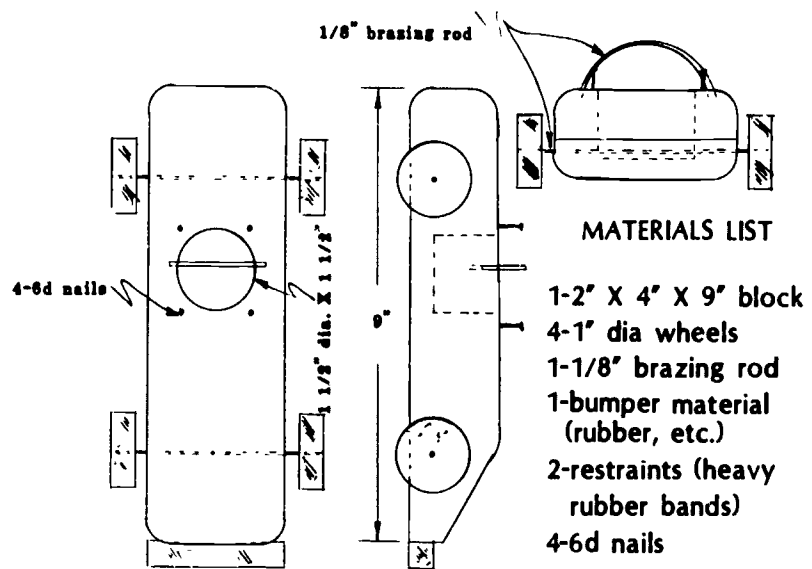

SAMPLE CRASH TEST AREA

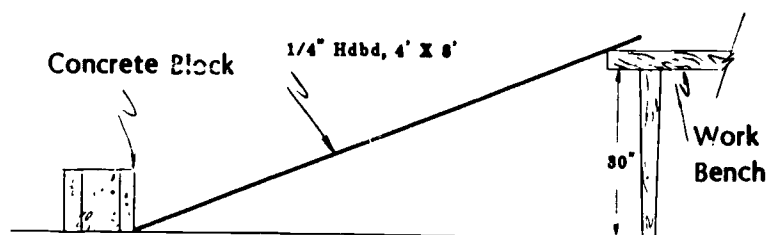

(No Scale)

FIGURE 2

Math-Science-Technology (M/S/T) Interface

Industrial arts/technology education provides an excellent environment to introduce and apply mathematical and scientific concepts and skills to solve technical problems associated with emerging technologies and changing careers. A casual observer of the new careers that are coming "on-line" for the new generation will readily recognize that math, science, and technology are pervasive and will appreciate the need for a reasonable foundation in these disciplines.

The M/S/T Interface section of the units on Exploring High-Impact Technology is designed to provide teachers with several examples of how mathematics and science can be used to support creative technical endeavors by students and provide motivation for students to "make the connection" between these areas.

As shown in the construction activity, the design parameters that can be identified for the development of a transportation vehicle may be specified under one or more of the following heading(s): Safety, Environmental, Economic, Fuel Efficiency, Performance, Passenger Capacity, Conservation of Materials, Aesthetic Design, and Luxury/Styling.

There are several factors to be considered in safety design. These include the structural design of the body or airframe, types of materials, mass or weight, anticipated vehicle speeds, the suspension system, and the medium in which the vehicle travels (land, air, sea, and space). Interior design of the passenger/operator compartments plays a significant role in the level of safety performance. Automobiles are presently equipped with seat belts, padded dashboards, and some are equipped with air bags. Human-engineered interiors, seats, and controls afford additional comfort and protection.

At a very elementary level, the safety and performance of a vehicle are at opposite ends of the design spectrum. The safety of automobile passengers is directly related to the size and weight of an automobile and how those materials are used in the basic structural design. Yet fuel efficiency and economy are improved as the weight, size, and air and rolling resistance are reduced

A common test that is used by automobile manufacturers and the National Transportation and Safety Board is a crash-impact test. In reality this test is nothing more than running a vehicle into a brick wall, measuring its dynamic forces, and assessing the physical damage to the vehicle and its occupants!

A simple test can be simulated by calculating the impact forces of several designs and weights and comparing their values. A cursory evaluation of the data reveals that as the weight increases, the force increases propor-

to technology. See if you and your students can work through this problem.

Try to create a problem of your own by changing the weight of the car, speed it is traveling, and the distance the front of the car is being smashed.

This elemental physics problem can help you to see how interrelated math and science are to a study of technology. Engineers and technicians must make similar calculations each day as they design our products and environments. To really understand the pro-

THE PROBLEM: Eddie Monikin was riding in the HIT (high-impact technology) experimental vehicle at 30 miles per hour. Eddie dozed off and ran into a brick wall that stopped his vehicle on short notice! His vehicle weighed 3,000 pounds and traveled a distance of 2 feet AFTER the impact. Calculate the momentum, acceleration, and impulse (impact) forces of Eddie's crash.

Note: 30 miles per hour = 44 ft/sec

$$(30 \text{ m/h} \times 5,280 \text{ ft} = 158,400 \text{ ft/h} - 60 \text{ min} = 2,640 \text{ ft/min} - 60 \text{ sec} = 44 \text{ ft/sec})$$

$$\text{MASS} = \frac{\text{weight}}{\text{gravity}}$$

$$\text{MASS} = \frac{3,000 \text{ lb}}{32 \text{ ft/sec}^2}$$

$$\text{MASS} = 93.75 \text{ lb/ft/sec}^2$$

$$\text{DISTANCE} = \frac{\text{velocity} \times \text{time}}{2}$$

$$2 \text{ ft} = \frac{44 \text{ ft/sec} \times t}{2}$$

$$\text{Time} = \frac{4 \text{ ft}}{44 \text{ ft/sec}} = \frac{1}{11 \text{ sec}} = 0.090909 \text{ sec}$$

$$(A) \text{ momentum} = \text{mass} \times \text{velocity} = 93.75 \text{ lb/ft/sec}^2 \times 44 \text{ ft/sec} = 4,125 \text{ lb/sec}$$

$$(B) \text{ acceleration} = \frac{\text{velocity}}{\text{time}} = \frac{44 \text{ ft/sec}}{1/11 \text{ sec}} = 484 \text{ ft/sec}^2$$

$$(C) \text{ average force} = \frac{\text{impulse}}{\text{time}} = \frac{\text{mass} \times \text{velocity}}{\text{time}} = 45,375 \text{ lbs}$$

$$(D) \text{ impulse} = ft = mv = 4,125 \text{ lb/sec}$$

tionally. However, the physical damage to the occupants is less severe because of the increased strength resulting from the use of heavier materials. Yet, more power is required to move these vehicles as the weight increases, which emphasizes the weight versus efficiency factor.

Following is a common highway safety problem that applies math and science skills

and products that go on in our laboratories, a little background in math and science is useful.

Now, use the following quiz to see what your students learned in this unit. We hope you found the information in this Resources practical and useful to you and your students. Today's technology will be shaping all of our futures.

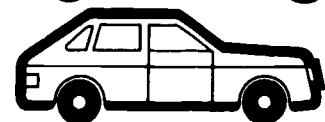
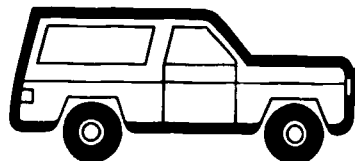
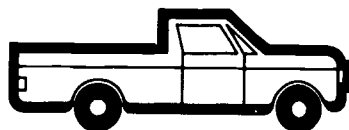
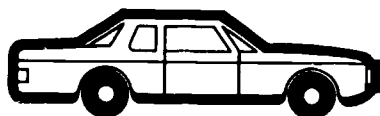
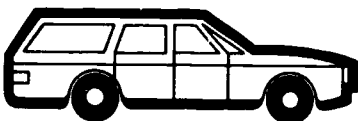

CONSTRUCTION ACTIVITY

PROBLEM: Construct a model IMS to produce a chosen product

DESCRIPTION OF PROBLEM

Integrated manufacturing systems are a reality today and on the increase. Use books, periodicals, and the visual aid (Figure 4) to construct a model IMS.

SELECTED SOLUTION

- A Size limitations
- B Team effort
- C Meets AIASA competition standards

RESEARCH AREAS

- 1 What are the key elements of an IMS?
- 2 What type of product(s) can be produced on an IMS line?
- 3 Will this be a dynamic or a static model?
- 4 What are the sources of supplies for manufacturing model building?
- 5 What are the necessary resources (1) time, (2) materials, (3) funding, and so forth?

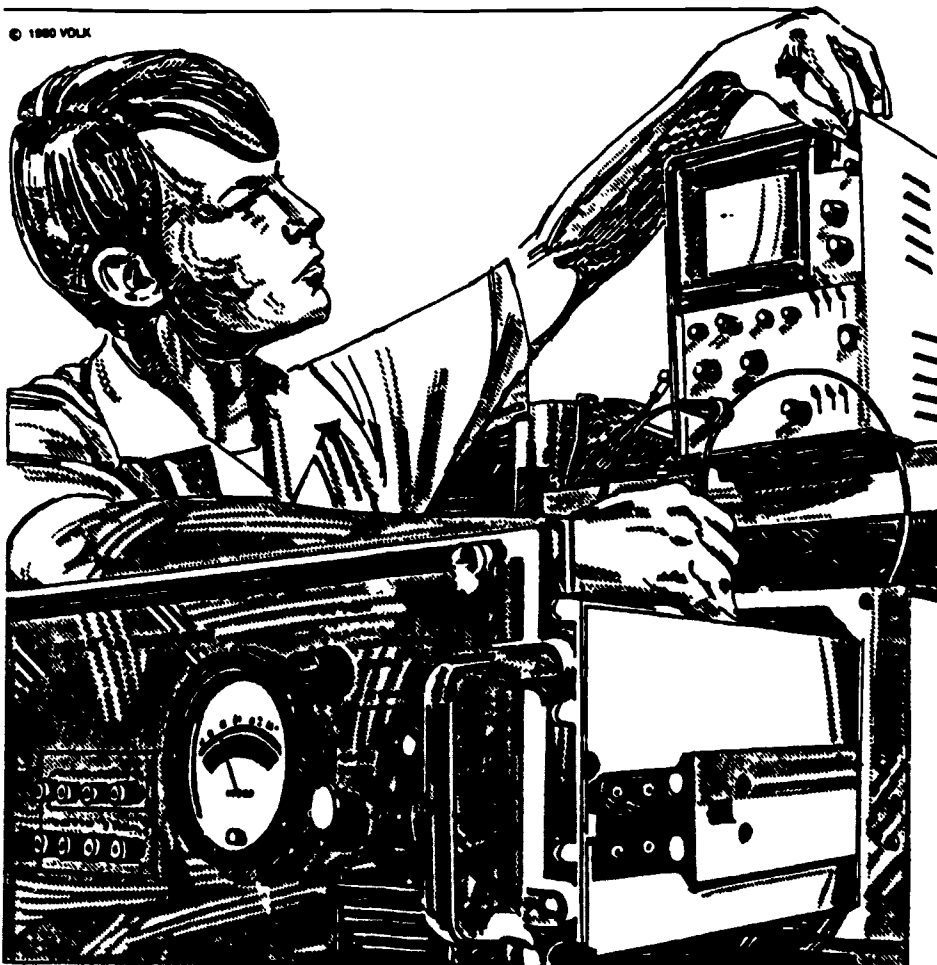

Microcomputers As Technological Tools

A Contemporary Analysis of Microcomputers

Is the United States moving toward a technological "computopia" with our increasing industrial reliance on computer technology? The answer is yes! Productivity is up for the first time in years, and industry has significantly increased spending on the modernization and renovation of old plants with computer technology. Emphasis is being placed on the reduction of human error and a reduction in the time required for routine production and material handling tasks.

Computers have been directly responsible for an increase in productivity during 1984. Many authorities believe that this may be attributed to the use of computer technology—the introduction of robotics and micro-machines, and the concern about our losses in the market place. In addition, many experts have predicted that the increased gains in productivity will continue through 1985.

A significant example of computer technology being directly responsible for increases in productivity is Apple Computer's new factory in Fremont, California. Apple "will be able to produce a Macintosh, with 450 parts, every 27 seconds, or 50,000 a year" ("Manufacturing in Flower," 1984, p. 50). Between computers, robotics, and micromachine technology, there should be substantial improvements in productivity for the rest of this decade and into the next.

Charles Babbage, frequently known as the father of the computer, would certainly be impressed with today's computer technology. It was his desire to build an analytical engine that would perform repetitive calculations, without error, very quickly. Unfortunately, the technology of producing precision gears and linkages that were critical to his invention was not available during his lifetime. Eventually, mechanical calculators became a reality, and by the 1920s electro-mechanical computational devices were being developed.

Many of the developments in the field of computers occurred as the result of changing technology during the 1920s and after. Following are some major discoveries and applications in a "technological development line" for computer technology.

- Thomas J. Watson of IBM developed the devices and circuitry that would

pass data between components and from registers to recording devices. These accomplishments provided the switching functions essential for a fully automated computer.

- The Automatic Sequence Control Calculator (ASCC), better known as the Harvard/IBM Mark I, was developed. The Mark I was a very large automatic electromechanical device consisting of nearly one million parts and more than 500 miles of wire. The machine measured 51 feet long and 8 feet high.

The next major breakthrough in the state of the art was the development of the transistor at the Bell Telephone Laboratory. The persons responsible for this discovery were John Bardeen, Walter H. Brattain, and William B. Shockley. All three ultimately received the Nobel Prize for physics in 1956 (Harmon, 1975).

The major advantages of the transistor to electronics and eventually computers were as follows:

- It was small in size and had low voltage requirements.

Technical Terms

Computer: A term that signifies the extensive and increasing use of computers to perform many varied tasks that people can't do when interfaced with machines.

Micromechanical Electro-mechanical devices: that are usually interfaced with computers to perform operations under the control of a computer.

Relief: The action of an of using machines to perform operations under the control of computers with sufficient precision.

Analyst's Engine: An invention of Charles Babbage, C. G. Babbage, machine that is frequently referred to as the "first computer." Its purpose was to perform repetitive calculations without error.

Integrated Circuit: A significant development in solid-state electronics, represented a complete miniature. Just consisting of transistors and diodes. Some external components are required for its operation.

Small Scale Integrated Circuit: A small integrated circuit that includes transistors, diodes, resistors, and micro-mechanical parts. A complete device is usually called a chip. Therefore, it is often known as an "IC Chip."

Very Large Scale Integrated Circuit: An integrated circuit that contains many more functions than a small scale IC. It includes many more transistors, diodes, resistors, and micro-mechanical parts. It is usually called a chip. Therefore, it is often known as a "VLSI Chip."

CMOS: Complementary Metal Oxide Semiconductor. A type of integrated circuit that uses both n-type and p-type transistors.

Logic: A term that signifies the state of the art was the development of the transistor at the Bell Telephone Laboratory. The persons responsible for this discovery were John Bardeen, Walter H. Brattain, and William B. Shockley. All three ultimately received the Nobel Prize for physics in 1956 (Harmon, 1975).

Relief: The action of an of using machines to perform operations under the control of computers with sufficient precision.

Analyst's Engine: An invention of Charles Babbage, C. G. Babbage, machine that is frequently referred to as the "first computer." Its purpose was to perform repetitive calculations without error.

Integrated Circuit: A significant development in solid-state electronics, represented a complete miniature. Just consisting of transistors and diodes. Some external components are required for its operation.

Small Scale Integrated Circuit: A small integrated circuit that includes transistors, diodes, resistors, and micro-mechanical parts. A complete device is usually called a chip. Therefore, it is often known as an "IC Chip."

Very Large Scale Integrated Circuit: An integrated circuit that contains many more functions than a small scale IC. It includes many more transistors, diodes, resistors, and micro-mechanical parts. It is usually called a chip. Therefore, it is often known as a "VLSI Chip."

CMOS: Complementary Metal Oxide Semiconductor. A type of integrated circuit that uses both n-type and p-type transistors.

- The emitter, base, and collector were similar to the cathode, grid, and plate of a triode vacuum tube that it ultimately replaced
- The transistor, a thin wafer of silicon or germanium to which minute quantities of an impurity have been added to alter its physical and electrical properties, enables the material to be used for amplification and other applications. Further research and experimentation led to the development of gate circuits that could be used in logic applications

In the early 1960s, small-scale integration (SSI) of circuits became a reality. This technology represented major advances in digital electronics and introduced the beginning of the integrated circuit (IC) era. The SSI provided the following advantages.

- All of the electronic components could be combined into one piece of solid state material.
- Up to 12 gates could be placed in a small square of silicon that was the thickness of a business card and no wider than the tip of a felt tip pen
- The silicon chip could use small diameter wires so they could be plugged into a circuit



From a contemporary viewpoint, the integrated circuit (IC) has dramatically changed the world of computer technology. The progression from small-scale integration (SSI) with its 12 gates to the medium-scale integration (MSI) to large-scale integration (LSI) with up to 1,000 gates resulted in an explosion of miniature technology that continues to be realized today.

In the mid 1970s, the very-large-scale integration (VLSI) chip with its 50,000 gates became commonplace. This technology was one of the major keys that opened the door

to the development of the microprocessor that now gives Apple the ability to produce a new Macintosh computer every 27 seconds. This is yet another example of increased productivity that should result in a substantial profit for Apple Computer this year and for many years to come. Subsequently, you can see that several seemingly minor discoveries have led to major advances in technology that have had a substantial impact on the industrial and business sector, which has affected how we communicate and manufacture goods and services.

Social-Cultural Impacts

Not too long ago the general public knew little about the computer. They were massive machines owned by large corporations and the government. We heard about them through the news and press. How fast they could perform mathematical operations and the millions of dollars they cost were commonly reported in the news.

To the ordinary person, the computer's operation was hard to comprehend. If we saw one in operation, it did not help us understand how it operated. We heard of input and output; bit and byte; Cobol, Pascal, and Fortran; and binary, octal, and hexadecimal. But what did all of this mean?

Our early experiences with computers were often filled with dismay. We received bills that were in error and we could not get them corrected. If we would call the biller, we were told it was a computer error—an error that might occur again the next month. Another early encounter with the computer might have been someone shaking a printout in our faces saying, "You see, we need to improve in this or that area. The computer says so!"

During the past five years many of these uncertain attitudes have changed. We do not hear the phrase, "Please do not fold, bend, or mutilate," anymore. This new attitude has

resulted from the introduction of the personal computer and the many electronic games it can operate. The young people of America and the video game industry should receive much credit for the massive acceptance of the personal computer. During the past three Christmas seasons Atari and Commodore have flooded the market with ads for their "home entertainment systems." Other companies, such as Apple, IBM, and Tandy, have focused on the educational and business benefits of personal computers.

With kids accepting computers and the educational and business world seeing the efficiency that they can provide in organizing, manipulating, and retrieving data, computers are now with us until a better form of technology comes along to replace them. With their acceptance as "tools" have come hundreds of applications. We read of the many ways these machines can extend our mental abilities.

Examples of the computer's social applications include doctors diagnosing diseases, police departments checking on stolen vehicles, stockbrokers following the market, legislators tracking the status of proposed bills, lawyers retrieving information on previous court decisions, students tutoring themselves in mathematics, businesses taking

inventory of stock, credit bureaus screening loan applications, realtors identifying homes for clients, schools compiling student records, weather forecasters following storms, and designers and engineers modeling product changes. These are only a few of the hundreds of applications that have been found for computers.

Many believe that the uses of computers are only at a beginning. This is because we are only beginning to learn how to use them. Just think what it will be like in another 10 years when many more are educated in applying computers and when our computer "whiz kids" are in their prime years working in business and industry.

We know we can use personal computers to play games, write letters, compose electronic music, create a work of art, organize our files, balance our budgets, and schedule airline flights. But others believe we can do many more things. According to some authorities, computers will be used to plan balanced diets and meals, shop at home, and provide worldwide banking services and smart credit cards. We will also see sophisticated computer-controlled automobiles to improve traffic safety and flow.

It will take time, capital investment, and education to do many of these things. What-

ever we project, many more applications of computers will be discovered. The reasons to be optimistic are supported by the directions taken by education, business, government, the family, and hobbyists. Secondary schools are investing heavily in computers as remedial education tools and are starting classes in programming. They believe that learners of the future will need to know how to use this technology to survive as progressive citizens and employees.

Business and industry are buying into computer technology because they view it as a means of running their operations more efficiently. This trend runs from the office secretary through the designer/engineer. Computers are being used for inventories, designs, controls, and word processing, to mention a few. Industry hopes these modernizing tactics will enable them to become more competitive and increase their earnings.

Government has also invested in computer technology to enable them to keep up with the enormous amounts of data generated at the local, state, and national level. Larger municipalities each have their own data-processing departments. With these, they process data on their residents and control such items as payrolls, taxes, public utilities, and law enforcement.

Individual families are also investing in computer technology. Besides using computers for home entertainment, families are buy-



ing them for personal efficiency and the education of their children. Some parents believe their children are deprived if they do not have a home computer. This syndrome has been created by advertisements and the press.

Hobbyists are another group that has influenced the computer technology market. Many people treat their home computer as their hobby. CB channels have been created so users can talk to other users across the country. In addition, message boards and

numerous other services have been created so users can entertain themselves and their computer colleagues.

As we have shown, computer technology is affecting the societies of the western world. It seems that their purchasing and usages have snowballed. Many are seeking special education to become computer literate. In the next section, we will investigate how computers interface with our technical systems and how industry is using them to control and monitor industrial operations.

Common Technological Elements Associated With Microcomputers

Microcomputers have had their effect on all the elements that make up our technological systems. These elements include people, information, capital, energy, tools, materials, and processes.

Microcomputers have affected people in many ways. It seems as though our society "has caught" computerphobia. The media makes us think that we must all have computers. Recent visits to 34 industries have shown that microcomputers have invaded our business places. Businesses use microcomputers for word processing, inventory, scheduling, typesetting, and machine operation.

Many of us as teachers also have computerphobia. We use them in our homes and schools to keep records, process data, entertain, and educate.

Through the use of micro- and mainframe computers, individuals and organizations have compiled more data and statistics than the mind can handle. Our magazines, newspapers, books, television shows, and work documents are full of numbers indicating this and that. We hear of economic, population, result, athletic, death, pollu-

tion, and weather statistics. All of this information is computer generated.

Computers are also used to accumulate and control the capital resources of our society. Capital is made up of financial resources and such overhead as inventories, buildings, and equipment. Computers aid us in keeping track of all of these assets. Software has been developed so that with little training, managers and secretaries can keep close reins on our companies' capital.

Computers and microprocessors also aid us in our control of energy. They are used for making home energy audits to controlling the fuel consumption of our automobiles. The energy industry also uses them to account for supplies and monitor equipment and consumer billing, to name a few applications.

The modern machine tools found throughout industry are controlled by microcomputers and computers. Their operations range from controlling a single milling machine or machining center to the entire control of an automated machining and assembly line. New uses of computers in

machine control are found in robotic and design operations.

Computers also help in material acquisition and control. Data can be compiled from testing to aid in finding mineral deposits, and computers assist industry in combining ingredients to mix batches of materials and checking on their quality. Again, the computer is a valuable tool in keeping records of material controlled by industry.

The final common element to all technological systems is processes. As we mentioned earlier, computers do control and monitor many of our industrial operations. The computer-controlled machine is much more accurate than human workers in performing industrial processes. People can make mistakes in the manufacture of products. By employing computers to control the operations, we can reduce error and increase productivity.

With an understanding of computers as technological tools and how they have altered our technical systems, let us look at how they can be applied to a laboratory-based technology problem.

Computer Hardware Interfacing Constructional Activity

The computer offers many opportunities for manipulating and processing data. It is obvious that computers may be used for word processing, data-base management, calculations, graphic displays, and of course games. However, in industry the use of computers to perform control functions for manufacturing is based on programs that allow the computer to actuate servos, valves, relays, and similar devices for process control via an interface. This represents an important application of computers in industry. For example, we can use computers to control machine tool operation, to heat/cool an environment, to control a robot for "pick and place" or spot welding assemblies, or to monitor quality control in manufacturing processes. Given the appropriate interface and hardware, a computer can give graphic displays of progress, make program-based decisions, or alter the function of machines with great accuracy in fractions of a second.

The significant point to remember is that a computer must be INTERFACED with a machine for it to provide the control of the machine that is desired. The activity described here is designed to introduce the concept of interfacing a computer to an external device. The device used in this experiment is a readily available thermistor that may be used to read temperature.

The computer performs an analog-to-digital (A/D) conversion, processes the data, and provides a graphic display of the data according to the instructions that have been programmed into the computer (see Program Listing 1). The activity is designed around the

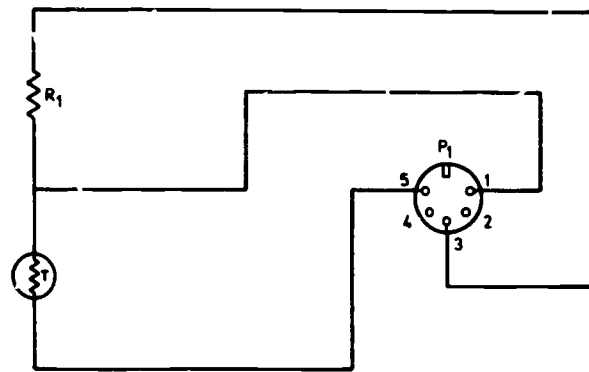

PARTS

- R₁—20,000 Ohm, ½ Watt
- T —Thermistor, 10K Ohm @ 25°C, Workman FR 1007
- P₁—5 Pin DIN Plug for Joystick Port

NOTE: P₁

- Pin 1—Joystick (O)
- Pin 3—Ground
- Pin 5—+5V

FIGURE 1

Schematic Diagram of the Temperature Sensing Circuits

TRS-80 Color Computer but may be adapted to other computers very easily.

There are several ways personal computers may be interfaced for control or sensory input. Methods include interfacing through the joystick port, cartridge port, cassette/tape recorder input, RS-232C, and parallel port, which usually addresses the microprocessor directly. Each access method has advantages and disadvantages. The use of the joystick port(s) provides the simplest inter-

face connection as it performs the analog-to-digital conversion internally and does not connect directly to the microprocessor. This makes it safer because there are no external voltages or active devices required to provide the actual interfacing.

This activity, although very simple, provides an opportunity to explore the concept of interfacing and experiences in writing programs to perform tasks with the computer, thus opening the door to many other applications involving a computer as a control medium. Figure 1 shows the schematic diagram of the interfacing activity.

The operation of the circuit is based on a voltage divider network that consists of a single resistor and thermistor. This conceptually parallels the operation of the joystick. The joysticks are actually 40,000 ohm potentiometers with 5 volts applied across them, with the wiper contact as the input line to the computer's six-bit A/D converter. Thus, the A/D converter reads the voltage level across the potentiometer and displays an "X value" of 0-32 and "Y value" of 0-63. These correspond to the relative voltage input and screen locations. However, the thermistor varies inversely to the ambient temperature, and a mathematical constant must be included to make the temperature displayed correspond to the actual temperature.

The actual component values were determined by experiment. Should your components differ from those used in the authors' set-up, then proceed to experiment with different values of resistors, thermistors, and mathematical constants to arrive at the correct display of temperature.

The interfacing task provides an opportunity to actually use the variable resistance capabilities of a sensor assembly to produce a corresponding voltage change for the computer's analog-to-digital converter to read.

```

10 'PROGRAM LISTING 1
20 'TIDEWATER TECHNOLOGY
30 'ASSOCIATES, NEWPORT NEWS, VA
40 '*****1984*****
50 '***** W.F. DEAL, III *****
60 '*****
70 CLS:PRINT@6,"TIDEWATER TECHNOLOGY"
  :PRINT@43,"ASSOCIATES":PRINT@172,"COMPUTER"
  :PRINT@235,"INTERFACE":PRINT@300,"ACTIVITY"
  :PRINT@452,"OLD DOMINION UNIVERSITY"
80 FOR X=0 TO 12:PRINT@106+X,CHR$(156);
  :PRINT@394+X,CHR$(147);NEXT X
90 FOR Y=0 TO 7:PRINT@128+9+32*Y,CHR$(154);
  :PRINT@128+22+32*Y,CHR$(149);
  :NEXT Y
100 PRINT@105,CHR$(158);:PRINT@118,CHR$(157);
110 PRINT@393,CHR$(155);:PRINT@406,CHR$(151);
  :FORT=1 TO 3000:NEXT
120 '*****
130 '****TEMPERATURE ROUTINE****
140 '*****
150 CLS
160 PRINT@69,"HIGH TECH TEMPERATURE"
  :PRINT@109,"SENSOR"
170 A=JOYSTK(0)/(.25)
180 T=A+INT((5*(80-A)/2.98))
190 PRINT@352+5,"CURRENT TEMPERATURE=";T
200 GOTO 160
  
```

Program Listing 1

The possibilities are only limited to your imagination! You may wish to experiment by adding additional lines to the program to include the control of another circuit by using the cassette relay with the "motoron" and "motoroff" commands or other control functions

Other sensors that may be interfaced

include photosensitive (resistive and generating), pressure transducers, switches, small DC motors as tachometer drives, and so on. Operational amplifiers (Op Amps) may be required, however, to arrive at the necessary voltage levels for the computer's A/D converter in some applications where voltage levels and changes are too small

A few words of caution are in order. Although the joystick parts are "buffered" from the microprocessor, the wiring should be checked carefully. The use of external voltages applied to ANY input port of the computer should be analyzed very carefully for operation and effect on the computer's internal circuitry

Math-Science-Technology Interface (M/S/T)

The microcomputer appears to be a highly complex electronic system that is beyond comprehension unless you spend many years studying computers and their theory of operation. This is not really true. Anyone can become a computer user with some study and practice. Actually, the microcomputer is an electronic system that is designed to perform specific mathematical operations according to an instruction set (program). A block diagram of a computer reveals the operational subsystems that function together to perform the desired task (Figure 2)

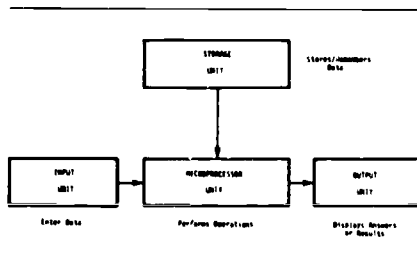

FIGURE 2

A Block Diagram of a Microcomputer

Conceptually, the computer consists of four major subsystems: input, processor, memory, and output. Simply, we input information, the processor acts on that information, the actions and results are stored in memory, and we have some form of output, which may be a CRT display, printer, or other device.

The processor is designed to perform its operations by switching states, either off or on. Mathematically these off-on states use the binary or Base 2 number system. However, other number systems are also used, including decimal (Base 10) and hexadecimal (Base 16).

A significant breakthrough in digital computing was credited to Claude E. Shannon and his master's thesis, *A Symbolic Analysis of Relays and Switching Circuits*. He described how relays and switches could be used to perform mathematical analogies with these two states of "off" or "on." These off-on states were easily represented by the ones

and zeros of the binary system. However, the Base 10 number system is the worldwide standard for mathematical computation. To simplify working with digital computers, spe-

cial encoder circuits are used to convert decimal input to binary values for the processor. Figure 3 shows the conversion of binary-to-decimal values.

| | 128 | 64 | 32 | 16 | 8 | 4 | 2 | 1 | = 2 ⁿ | |
|-----------|----------------|----------------|----------------|----------------|----------------|----------------|----------------|----------------|------------------|---------|
| BINARY | 2 ⁷ | 2 ⁶ | 2 ⁵ | 2 ⁴ | 2 ³ | 2 ² | 2 ¹ | 2 ⁰ | | DECIMAL |
| 0000 0000 | 0 | 0 | 0 | 0 | 0 | 0 | 0 | 0 | | 0 |
| 0000 0001 | 0 | 0 | 0 | 0 | 0 | 0 | 0 | 1 | | 1 |
| 0000 0010 | 0 | 0 | 0 | 0 | 0 | 0 | 1 | 0 | | 2 |
| 0000 0011 | 0 | 0 | 0 | 0 | 0 | 0 | 1 | 1 | | 3 |
| 0000 0100 | 0 | 0 | 0 | 0 | 0 | 1 | 0 | 0 | | 4 |
| 0000 0101 | 0 | 0 | 0 | 0 | 0 | 1 | 0 | 1 | | 5 |
| 0000 0110 | 0 | 0 | 0 | 0 | 0 | 1 | 1 | 0 | | 6 |
| 0000 0111 | 0 | 0 | 0 | 0 | 0 | 1 | 1 | 1 | | 7 |
| 0000 1000 | 0 | 0 | 0 | 0 | 1 | 0 | 0 | 0 | | 8 |
| 0000 1001 | 0 | 0 | 0 | 0 | 1 | 0 | 0 | 1 | | 9 |

FIGURE 3

Conversion Table Illustrating Binary and Decimal Values and Powers of 2

For example, determine the binary equivalent of 25 Base 10

| 128 | 64 | 32 | 16 | 8 | 4 | 2 | 1 | Decimal Value |
|----------------|----------------|----------------|----------------|----------------|----------------|----------------|----------------|---------------|
| 2 ⁷ | 2 ⁶ | 2 ⁵ | 2 ⁴ | 2 ³ | 2 ² | 2 ¹ | 2 ⁰ | |
| 0 | 0 | 0 | 1 | 1 | 0 | 0 | 1 | Binary Value |

0 0 0 1 1 0 0 1 Binary Value

Checking your answer: 16 + 8 + 1 = 25

| | | | | | | | | | | | | | | | |
|----|----|----|----|----|----|----|----|----|----|----|----|----|----|----|----|
| 20 | 21 | 22 | 23 | 24 | 25 | 26 | 27 | 28 | 29 | 2A | 2B | 2C | 2D | 2E | 2F |
| 30 | 31 | 32 | 33 | 34 | 35 | 36 | 37 | 38 | 39 | 3A | 3B | 3C | 3D | 3E | 3F |
| 40 | 41 | 42 | 43 | 44 | 45 | 46 | 47 | 48 | 49 | 4A | 4B | 4C | 4D | 4E | 4F |
| 50 | 51 | 52 | 53 | 54 | 55 | 56 | 57 | 58 | 59 | 5A | 5B | 5C | 5D | 5E | 5F |
| 60 | 61 | 62 | 63 | 64 | 65 | 66 | 67 | 68 | 69 | 6A | 6B | 6C | 6D | 6E | 6F |
| 70 | 71 | 72 | 73 | 74 | 75 | 76 | 77 | 78 | 79 | 7A | 7B | 7C | 7D | 7E | 7F |

FIGURE 4
American Standard Code for Information Interchange (ASCII, 96 Character Set)

To perform a conversion operation from decimal to binary is a simple task. Divide the decimal number by 2 and record the quotient in one column and the remainder most significant bit (MSB) in another. Continue this process until the quotient equals zero and the remainder equals one or zero, the least significant bit (LSB). For example, find the binary equivalent of 25.

| | Quotient | Remainder |
|-------------------|----------|-----------|
| 25 divided by 2 = | 12 | 1 LSB |
| 12 " 2 = | 6 | 0 |
| 6 " 2 = | 3 | 0 |
| 3 " 2 = | 1 | 1 |
| 1 " 2 = | 0 | 1 MSB |

The answer is expressed as 0001 1001 = 25

Why the extra zeros? Mathematicians, computer engineers, and scientists express binary numbers in reference to computers in blocks of 4, 8, 16, or 32 bits of data. Thus, in our example there are two 4-bit blocks of "0001 and 1001." The acronyms LSB and MSB indicate the relative position of the ones and zeros and their respective values.

While the actual mathematical/electrical switching operations are binary analogies and we now have our computer so that the input may be in the form of decimal (Base 10) numbers, the memory locations or addresses are identified by hexadecimal values or Base 16. Again, there is another con-

version process that will allow us to move from one base to another. Remember, though, the computer makes all of these conversions for us, and the real value of number system awareness becomes important when we are writing our own programs. Also, the American Standard Code for Information Interchange (ASCII, pronounced "As-Key") provides a standard hex code that assigns specific bit patterns to the signs, symbols, letters, and numbers that are used for communication between computers, people, and machines. Figure 4 identifies the standard ASCII set and corresponding hex codes.

Figure 5 reveals the relationship between the common number bases that are associated with computers. You will notice that these Base 10 values are represented with the numbers 0 through 9. Base 2 values are represented only with ones and zeros, in the hexadecimal system, the numbers 0 through 9 and the letters A through F are used. By studying Figure 5, you will grasp the relationship between decimal, hex, and binary number systems.

To convert a binary number to hexadecimal, separate the binary number into groups of four bits each, beginning with the Least Significant Bit (LSB), as four bits binary equal one digit in hexadecimal. The figure shown below illustrates the relationships.

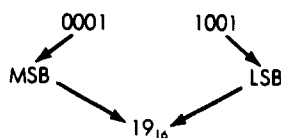

To complete the process, we will convert from hexadecimal back to binary, and then to a decimal number (Base 10).

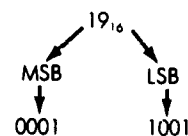

Remember: Four bits of binary data equal two hexadecimal (Base 16) combinations

$$0001 \quad 1001$$

$$16 + 8 + 1 = 25 \text{ Base 10}$$

Check your answer with Figure 5

As you can see, working with different number bases is a matter of understanding relationships between the different systems. When working with computers, it is important that we realize that regardless of how "user friendly" they may be, their internal operation is based on "on-and-off" states that are analogous to the binary number system. The programs that provide the instructions for a computer to function as we direct them to are logical mathematical statements that are written so the computer interprets them as ones and zeros at specific hexadecimal addresses in the random access (RAM) or read only memory (ROM).

Frequently, you will see or hear people say that they "PEEKed" a memory address or "POKEd" a value into RAM. This is where you will actually see those ones and zeros!

| HEX | BINARY | DECIMAL |
|-----|----------|---------|
| 00 | 00000000 | 0 |
| 01 | 00000001 | 1 |
| 02 | 00000010 | 2 |
| 03 | 00000011 | 3 |
| 04 | 00000100 | 4 |
| 05 | 00000101 | 5 |
| 06 | 00000110 | 6 |
| 07 | 00000111 | 7 |
| 08 | 00001000 | 8 |
| 09 | 00001001 | 9 |
| 0A | 00001010 | 10 |
| 0B | 00001011 | 11 |
| 0C | 00001100 | 12 |
| 0D | 00001101 | 13 |
| 0E | 00001110 | 14 |
| 0F | 00001111 | 15 |
| 10 | 00010000 | 16 |
| 11 | 00010001 | 17 |
| 12 | 00010010 | 18 |
| 13 | 00010011 | 19 |
| 14 | 00010100 | 20 |
| 15 | 00010101 | 21 |
| 16 | 00010110 | 22 |
| 17 | 00010111 | 23 |
| 18 | 00011000 | 24 |
| 19 | 00011001 | 25 |

FIGURE 5
The Two's Complement of Numbers

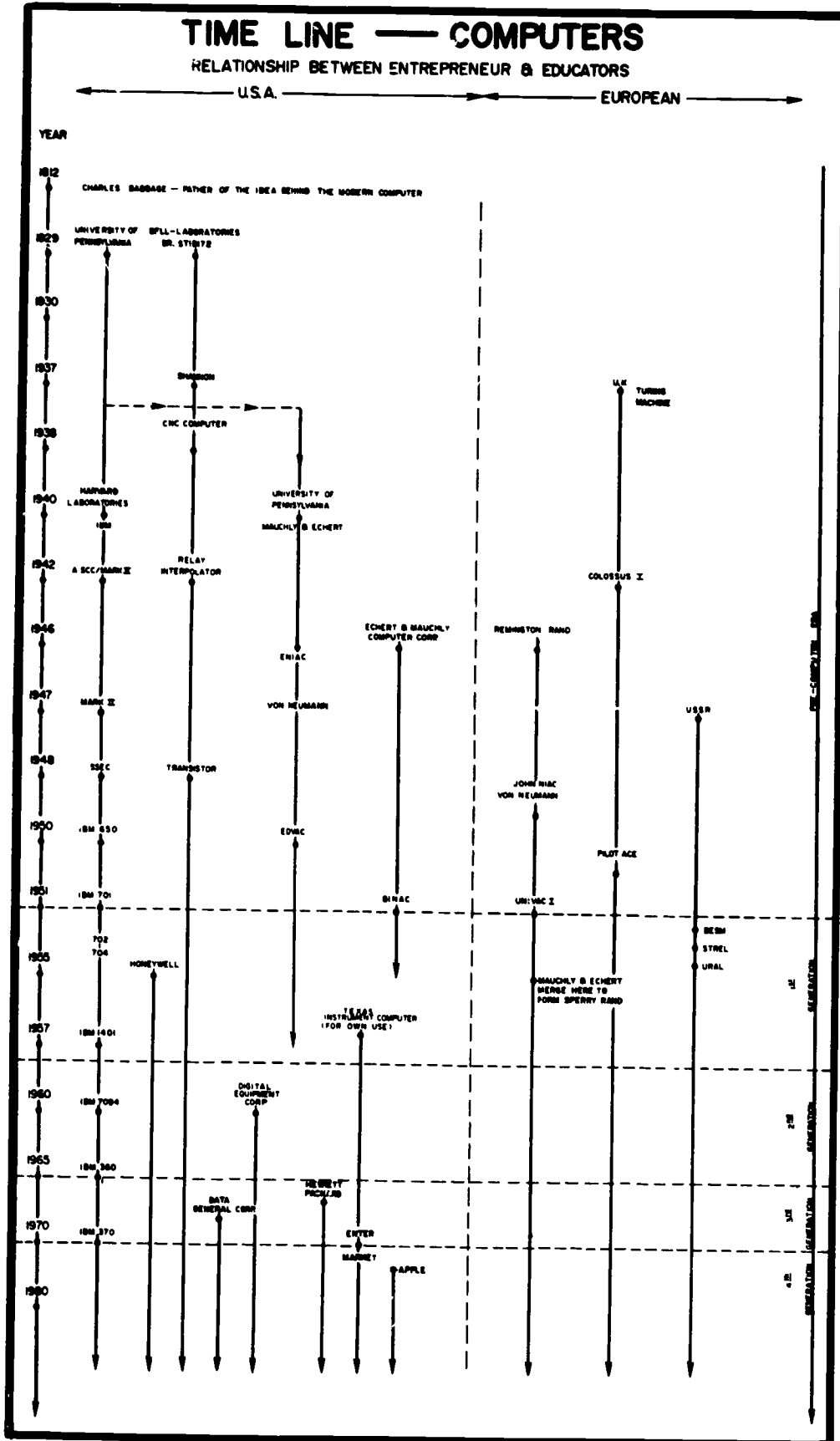

Student Quiz

- 1 What tool is at the base of industrial modernization and renovation?
 - A Robot
 - B Micramachine
 - * C Computer
 - D CAD
- 2 Who is referred to as the father of the computer?
 - A Kendall Starkweather
 - * B Charles Babbage
 - C John Bardeen
 - D Hewlett Packard
- 3 Which of the following replaced the vacuum tube in the manufacture of computers?
 - * A Transistor
 - B Relay
 - C Thermistar
 - D Transducer
- 4 What does the term "IC" stand for in electronics?
 - A Iran City
 - B Inductive capacitance
 - * C Integrated circuit
 - D Internal combustion
- 5 When computers are used to actuate servos, valves, and relays it is referred to as what?
 - A Digitizing
 - B Programming
 - C Manufacturing
 - * D Interfacing
- 6 What are the four major subsystems of a computer?
 - A Keyboard, disk drive, CRT, and printer
 - B Input, processor, output, and display
 - * C Input, processor, memory, and output
 - D Analog, digital, binary, and decimal
- 7 When a computer samples voltage or resistance readings and digitizes it for processing, this is referred to as what type of conversion?
 - A Binary to hexadecimal
 - B Decimal to binary
 - C Electromechanical to electronic
 - * D Analog to digital
- 8 Why can computers lead to greater productivity in industry?
 - A Reduction of human error
 - B Reduction of cost
 - C Increased accuracy
 - * D All of the above
- 9 Who should be credited for the massive acceptance of personal computers?
 - * A Video game industry
 - B U S government
 - C IBM
 - D Public schools
- 10 When people stay home and do their jobs with networks, this is called what?
 - A Office automation
 - B Networking
 - C Home employment
 - * D Electronic cottage



Possible Student Outcomes

- Explain why microcomputers are technological tools
- Describe the historical development of computer technology
- List examples of how business and industry are currently using computer technology
- Analyze how computer technology affects the components of our technological systems
- Apply materials, computer technology, and scientific knowledge to the solution of technical problems
- Associate math and science as an integral part to the study of computer technology

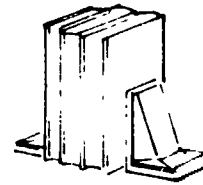

REFERENCES

Harmon, M. (1975) *Stretching man's mind: A history of data processing*. New York: Mason Charter.

Manufacturing in flower. (1984, March, 26) *Time*, p. 50.

BIBLIOGRAPHY

Science 1984, American Association for the Advancement of Science, January/February 1984

Science 1983, American Association for the Advancement of Science, June, 1983

Science 1983, American Association for the Advancement of Science, December 1983

Science 1982, American Association for the Advancement of Science, July/August 1982

Science 1982, American Association for the Advancement of Science, March 1982

Tandy Corporation (1981) *Going ahead with extended color basic*. Fort Worth, TX: Author.

Tandy Corporation (1981) *Color computer disk system*. Fort Worth, TX: Author.

Technology Review, Massachusetts Institute of Technology, May/June, 1983

Technology Review, Massachusetts Institute of Technology, July, 1983

The Futurist, World Future Society: An Association for the Study of Alternative Futures, August, 1984

The Futurist, World Future Society: An Association for the Study of Alternative Futures, June 1983

U S News & World Report, December 5, 1983

Intergrated Manufacturing Systems: The Future of Design and Production

Part 1 of 2 Parts

Driving Forces of Change

Competition is the major force driving international attention toward (a) products that will gain greater customer satisfaction as a result of improved quality (b) that can be manufactured at lower costs

Competition exists between corporations and nations. Japan is the rabbit leading the race to produce high-quality products with a minimum of human involvement, that means automation. If the U.S. and other developed nations wish to maintain a profitable share of world trade, they must be capable of manufacturing products of low cost and good quality, not just HVLC (high volume, low cost), where quality sacrifices are often made.

High volume must remain, but a manufacturing plant also needs flexibility to produce a variety of models to meet customer desires while avoiding the large inventories hard automation normally yields. In addition to yielding high volumes of products, hard automation requires considerable time and great expense to modify.

The ideas that are reported in this Resources in Technology are not science fiction. Large corporations (e.g., IBM, GE, and GM) and small companies are investing billions of dollars to develop and install the systems described.

Labor unions, society, and conservative managements may resist changes that seem likely to foster unemployment and require greater capital investments for equipment with a slow return on the capital. But those corporations who want to compete with products of world trade must employ new and emerging technology to stay competitive. The desire for the perfect mousetrap, more leisure time, and freedom from monotonous and dangerous jobs (jobs done safer with higher quality by robots) makes increased automation inevitable. Large capital investments will often be necessary to upgrade equipment. Managers and stockholders unwilling to invest will meet the same fate as the U.S. auto and steel industries have met.

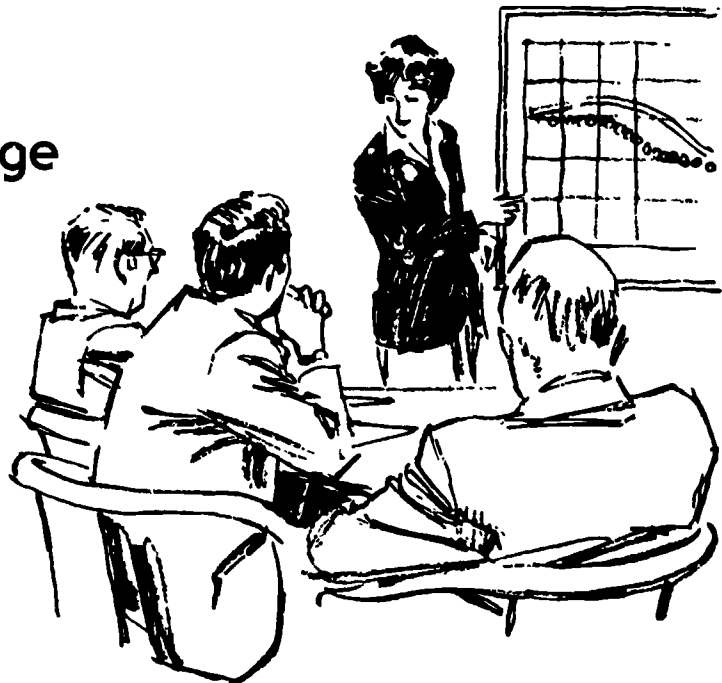

Some companies will be in a position to use the "green field" approach in which they start in an open field to build a new plant for automation. One such example is John Deere and Company's Tractor Works. The Factory of the Future complex in Waterloo, Iowa, is a state-of-the-art integrated manufacturing system (IMS). The complex employs minicomputers tied to large mainframe computers that link together all aspects of materials and parts receiving, inventory, component parts in various stages of completion (known as work in progress or WIPs), materials handling, energy to run the plant, control of all forms of materials processing, and shipping (see Figure 1).

- Less manual labor
- Fewer machine operators
- Fewer assembly jobs
- Fewer inspectors
- More technical knowledge
- Current education
- More creative/technical work

FIGURE 1
People in IMS

- Increased competition for world trade
- Rapid technological development
- More powerful and lower cost computers
- Increased demand for quality
- Increased demand for customized high-tech products
- Improved materials and processes
- Requirements for flexible manufacturing systems

FIGURE 2
Major Forces Driving Changes in Design and Manufacturing

Another approach, Factory With a Future, is General Electric's effort to install new tools and techniques for automation in existing plants. GE began with distributed numerical control (DNC). DNC ties together machine tools with computers and bypasses punched tape, which normally runs numerically controlled (NC) machines. The cost savings accrued through DNC can be used to automate another portion or module of manufacturing, such as parts handling and assembly through robotics. Figure 2 highlights the forces that are improving manufacturing.

New and Emerging Techniques, Tools, and Materials

The rapid development of the computer is the major technology that makes possible predictions of a highly automated, yet flexible, factory in our near future (Figure 3). Computer technology has advanced to a point that personal computers, driven by printed circuit (pc) boards and ceramic memory chips, allow the average person to use these tools with little knowledge of computer programming. The program is already in the chip or pc board.

- Personal Computers
- Microprocessors
- CAD
- CAM
- IMS
- FMS
- CIMS

FIGURE 3

New and Emerging Techniques, Tools, and Materials

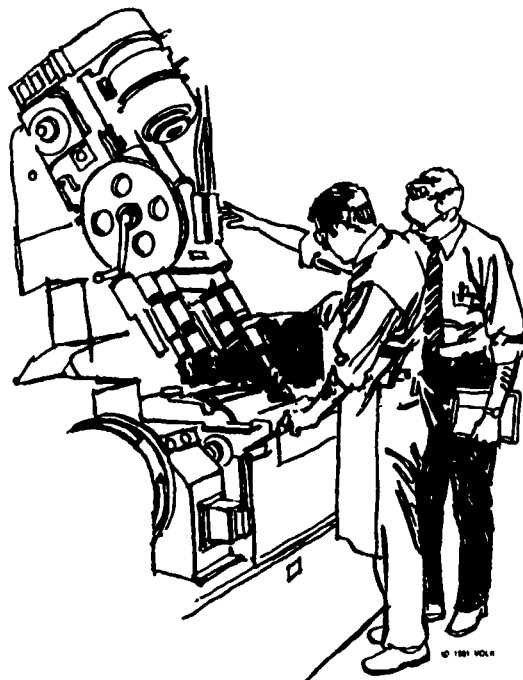

So, the computer becomes both tool and technique. Designers and manufacturing engineers can interact with computers that are programmed to ask questions that aid with problem solving. The computer then has the capability to transfer those solutions (drawings and specifications) to microprocessors, which control graphical equipment that generate drawings, graphs, and other data. This is computer-aided design (CAD).

Computers also have the capability to transmit information to microprocessors that can control machines and processes thus

replacing human operators. This function, known as computer-aided manufacturing (CAM), is in its infancy. But, it will evolve rapidly because numerous manufacturers, technical societies, and governments want it. Rapid development in computers and CAD/CAM (or CAD/M) will bring smaller, more sophisticated chips and pc boards at lower costs, which will then drive down cost and increase capability of automated systems.

Eventually, silicon memory chips will be replaced by gallium arsenide semiconductor chips that allow electron flow four times the

speed found with silicon. "Biochips" may also come into play. These large organic molecules or genetically engineered proteins may be capable of producing electronic circuits thousands of times smaller than silicon semiconductors. Such material developments will allow smaller and more powerful microprocessors and computers.

Small personal computers can be stationed on the manufacturing floor and tied into larger, mainframe computer systems, thus making a vast array of data available to technicians and engineers. Such data can include status reports on out-of-plant supplies and components, production requirements, condition of the production line, and a wealth of other information to aid in managing the line. "Modeling" is another available technique from the personal computer. Modeling allows design, development, and manufacturing to simulate the way a product will perform, how a manufacturing process may operate, and even provide practice to manufacturing managers in dealing with production problems. Modeling can occur before building and then be refined as the product and production line become a reality. As a consequence, the manufacturing manager can continually have predictions of production.

Three techniques, considered as one by some authorities, are beginning to appear in plants: integrated manufacturing systems (IMS), flexible manufacturing systems (FMS), and computer-integrated manufacturing (CIM) (see Figure 4).



Visual Aid

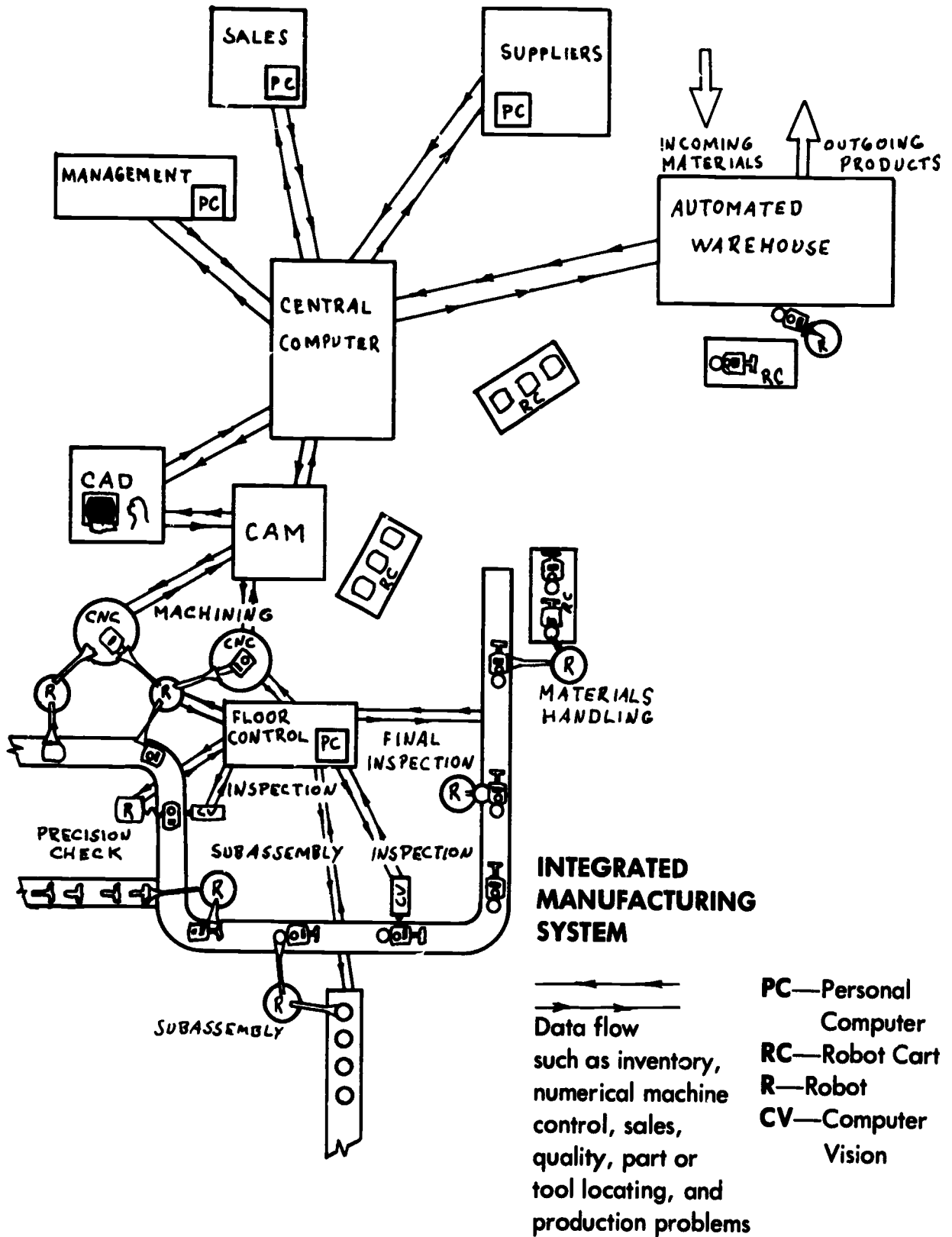

FIGURE 4
Visual Aid

These concepts focus on manufacturing as the dominant force in product design and quality control. They dictate that a product be conceived and designed with manufacturing and testing methods always in the foreground.

In 1982, FMS was reportedly operating in 60 plants. The FMS concept aims to provide a plant with the ability to switch a product line in short order—minutes, hours, or days versus months or years. Today's typical automobile, data processor, or appliance production line, to name a few, is set up for HVLC and requires months or years to design and install.

FMS, employing flexible parts handling (conveyer and robots), versatile assembly systems (robots and humans), and microprocessors, has the capability to change the line quickly to perform new operations for a small batch of products then quickly change it again back to the previous product or a new product. This technique allows economical customization to meet individual needs, or it can stop production of products of low demand without suffering a large loss.

IMS looks at manufacturing as a monolithic (large single unit), indivisible function in which all components are selected and interconnected to provide a higher level capability than the individual components could produce alone. Integration is a result of increased processing complexity that use

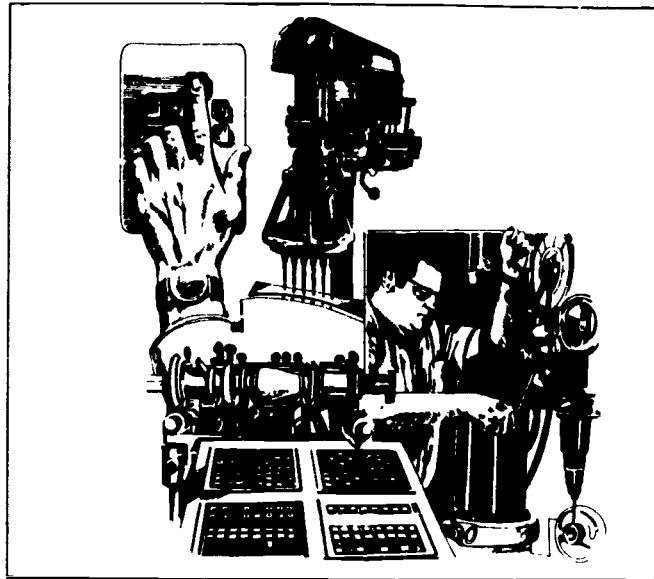

leading-edge technology to manufacture high-quality products at economical rates.

CIM incorporates IMS and FMS principles and components, but it also adds overall control accomplished with computers as shown schematically in Figure 4. Typically, CIMs include most aspects of product design and production (engineering CAD/CAM, parts manufacturing, CNC cells), materials

handling (automated warehouse), and other functions for the data management system.

Industrial robots act as key elements in FMS and CIM. They are built to replicate the motions of the ultimate machine—a human. Today's robots are very crude when compared to the speed and discrimination of humans. However, research and development promises to bring many refinements by the year 2000.

Shifts in Materials, Processes, and Controls

We must start to picture the production line in a very different way than we have in the past. The now familiar techniques of machine tools cutting, presses stamping, then people welding and/or mechanically fastening together parts may change in many product lines (Figure 5). The onslaught of plastics, fiber reinforced plastics (FRP), composites, and ceramics could well mean that products in the year 2000 will proceed through production by CIM plants much more like a chemical processing line than our familiar foundries, machine shops, and mechanical assembly lines. When the need exists for such processes, the underdeveloped nations, using today's technology, may well be performing them.

Developments in advanced composites, reinforced plastics, and metal-based composites have yielded materials of superior strength, reduced weight, and greater design flexibility than traditional monolithic materials, such as steel and plastic. The Pontiac Fiero automobile marked a milestone when

- Plastics
- Composites
- Ceramics
- Thick film
- Thin film
- Semiconductors
- Robots
- Lasers
- Computer vision
- Automated operations
 - Materials handling
 - Machining
 - Stamping
 - Welding
 - Adhesive bonding
 - Assembly
 - Inspection
- Continuous flow manufacturing

FIGURE 5

Shifts in Materials, Processes, Controls

General Motors replaced steel body panels with FRP. All major automakers are moving toward the use of FRP panels to augment the replacement of heavy metal parts.

Plastics have already been substituted in such areas as bumpers, dashboards, handles, housings, and trim. Advanced composites and engineering plastics allow for design of structural components with drastic weight reductions over metals and with improved design flexibility. If you question the use of plastics because of their current dependence on oil and gas, you must realize that coal, soybeans, and wood are a few of the raw materials for plastic synthesis. FRP technology developed for printed circuit boards will continue to advance. These processes lend themselves to closed automated systems with minimal human contact.

Ceramic processing is rapidly advancing to the point that some molding processes once reserved for metals and plastics will surely be reliable by the year 2000. New

formulations of ceramics, such as alumina (aluminum oxide), allow injection molding of parts to replace metals and plastics. Alumina is a low-cost material not threatened by near-term shortages. The work in ceramic engines should also foster improved ceramic processing. Technology for thick film and thin film devices, plus multilayered ceramic composites and silicon semiconductors for micro-

processors, will continue to drive down ceramic processing costs.

Another advance involves robots equipped with laser and computer vision (CV). These robots are already replacing human and contact inspection techniques. Sensing systems, such as television cameras, can monitor an operational sequence and feed the results into computers, which ana-

lyze the data and alert the operator if problems arise. Such inspection systems can feed back data to the production line to make required adjustments. Noncontact laser probes or robots can detect misalignment of panels for automobiles or similar alignment conditions. Such data feed forward to automatically readjust assembly fixtures to realign panels.

Social—Cultural Impacts

Roles for People in Manufacturing in the Year 2000

People will continue to be vital in the successful evolution of manufacturing. However, roles will change. Routine, boring, hazardous, and highly precise tasks not well suited for humans will be done by robots and automated devices. Semiskilled operators, such as machinists, will be replaced by a smaller number of skilled technicians to monitor and adjust automated machines and

robots. Unskilled maintenance people will back up the technicians.

Functions of design, development, and manufacturing will be integrated because of CAD/M and CIM systems. Engineers in traditional design roles will need a greater understanding of design for manufacturing.

Serious concerns must be addressed about aging and perhaps outdated workers,

the unskilled, and minimally educated people. Will the U.S. be able to educate enough technicians and engineers to design and manage these automated plants?

Service-type jobs will increase, but many will be low skill and low pay (e.g., waitresses, fast-food workers, and custodians). Who will be satisfied to fill these jobs?

Emerging Careers

Careers related to design/manufacturing should open for well-educated technicians and engineers in the areas of CAD/CAM, lasers, robotics, and CIM systems (Figure 6). Both industrial jobs in the plants and service positions involving traveling in the field to customer locations will be waiting for the properly prepared people. College preparation for such careers will include traditional studies of math, science, humanities, social sciences, and technology. Added to the technology courses will be computers, CAD, CAM, robotics, lasers, advanced engineering

materials and processes, and other new developments.

- CAD designers
- CAM technologists
- Robot maintenance technicians
- CIMS engineers
- HEW materials engineers
- Laser technologists
- Low-skill service jobs



FIGURE 6

Some Emerging Careers

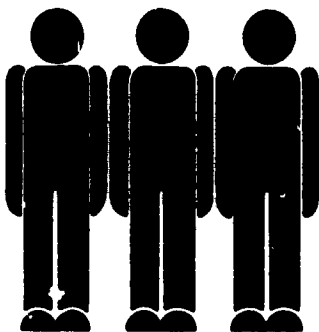

Conclusion

The ideas presented in this Resources in Technology provide a realistic view of the future of design/manufacturing technology for the year 2000. Although some of the forecasts may be slightly askew, you can be certain most will come to pass bringing changes driven by high technology.

The questions you should ask are, How will I fit into the new and exciting environ-

ment emerging from high technology? What contributions can I make? and How will my life be affected?

Use this information as one point of reference to evaluate developments in technology and for assistance in making your decision about your future. The Bibliography at the end can provide sources for further study.

CONSTRUCTION ACTIVITY

PROBLEM: Construct a model IMS to produce a chosen product

DESCRIPTION OF PROBLEM

Integrated manufacturing systems are a reality today and on the increase. Use books, periodicals, and the visual aid (Figure 4) to construct a model IMS.

SELECTED SOLUTION

- A Size limitations
- B Team effort
- C Meets AIASA competition standards

RESEARCH AREAS

- 1 What are the key elements of an IMS?
- 2 What type of product(s) can be produced on an IMS line?
- 3 Will this be a dynamic or a static model?
- 4 What are the sources of supplies for manufacturing model building?
- 5 What are the necessary resources (1) time, (2) materials, (3) funding, and so forth?

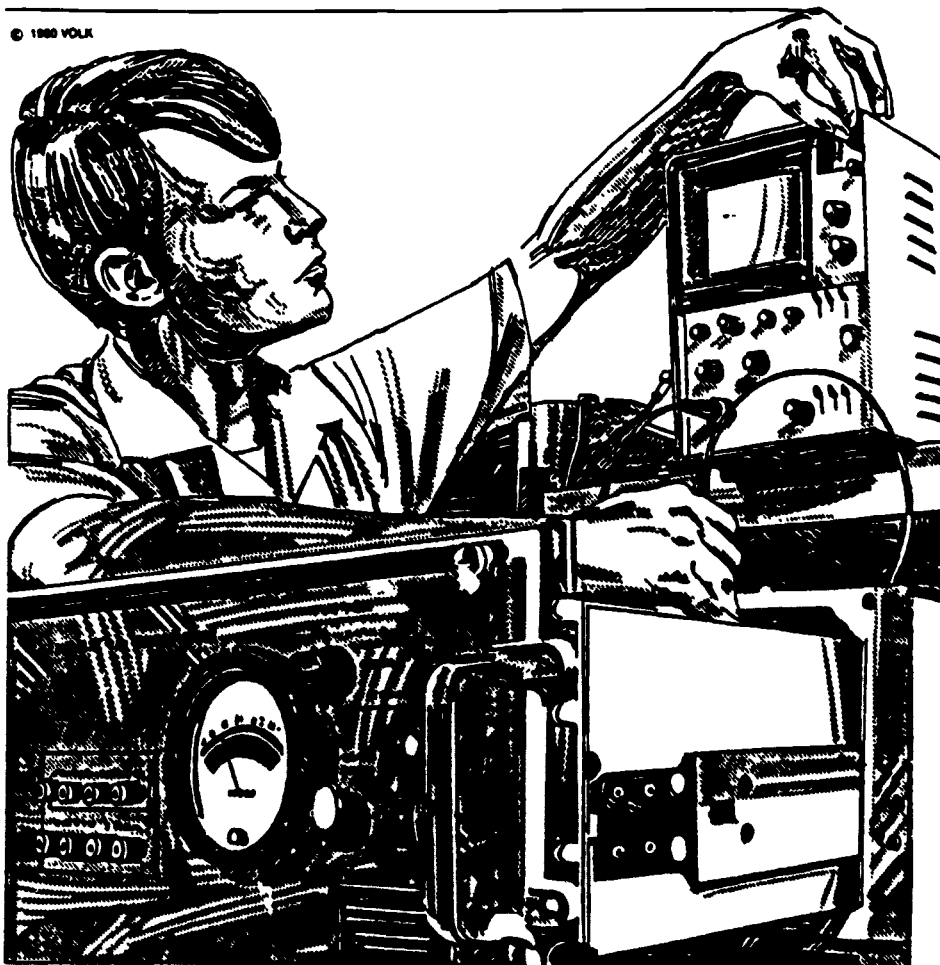

MATH/SCIENCE/TECHNOLOGY INTERFACE

Integrated manufacturing systems depend on people to make them operate. Technicians, technologists, and engineers must develop designs, drawings, and specifications, program computers and other machines, and perform many other tasks. Each person must apply principles of math, science, and technology.

PROBLEM

An industrial process technician must determine the materials required to make the product being manufactured in Figure 4. The T-shaped piece is made by adhesively bonding two pieces of PVC plastic rod together. The technician has to determine the following:

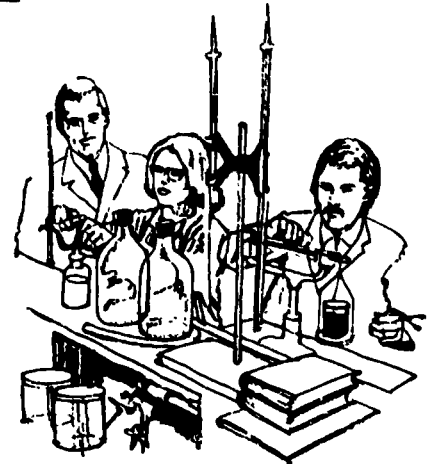

Given: 20 ft 8 in PVC rods
Required: How many 4.25 in pieces can be cut from each rod?

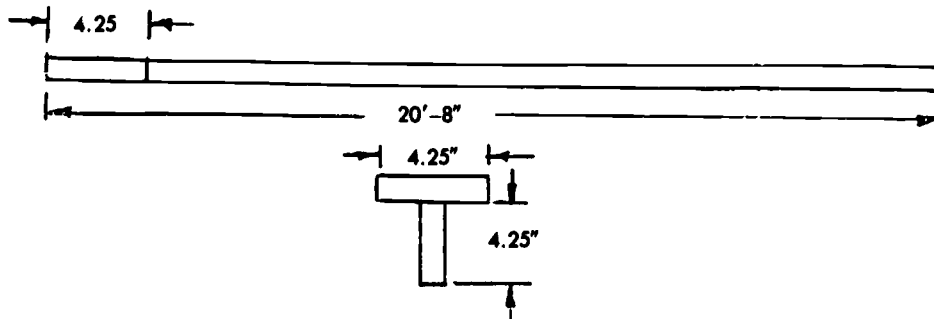

Solution

$$\frac{(20 \text{ ft} \times 12 \text{ in/ft}) + 8 \text{ in}}{4.25 \text{ in/part}} = \frac{(20 \times 12) + 8}{4.25} = \frac{248}{4.25}$$

58.35 pieces (35 × 4.25 in = 1.49 in)
 or
 58 pieces with 1.49 in left

This is only part of the solution. The technician must account for the kerf, which is the amount of materials removed when each piece is cut. A laser cut could be as small as 0.0010 in, or an abrasive cut off saw would make a kerf as much as 0.125 in. Can you calculate how many pieces could be obtained with a 0.125-in kerf?

Also assume that the product is for a world market and that all measurements must be given with the International System (SI) units of millimeters. Convert all dimensions into millimeters.



Possible Student Outcomes

- Cite forces driving manufacturing technology toward greater automation
- List several new and emerging techniques, tools, and materials that will change manufacturing in the year 2000
- Describe the manufacturing plant of tomorrow, using such terms and concepts as CAD, CAM, CIM, IMS, robotics, DNC, modeling, group technology, HVLC, computer vision, and lasers
- Discuss possible career opportunities related to manufacturing in the year 2000 and beyond
- Construct a model of an integrate manufacturing system
- Study about individual components of IMS
- Associate math and science as an integral part of the study of technology



BIBLIOGRAPHY

- Computer and Associated Systems, Association of Society of Manufacturing Engineers (1983) *Autofact 5 conference proceedings* Dearborn, MI Author
- Dorf, R C (1983) *Robotics and automated manufacturing* Reston, VA Reston Publishing
- Feingold, S N (1984, February) Emerging careers Occupations for post-industrial society *The Futurist*, (1983) pp 9-16
- Gardiner, K M (Ed) (1983) *Systems and technology for advanced manufacturing* Dearborn, MI Society of Manufacturing Engineers
- Groover, M P, & Zimmers, E W Jr (1983) *CAD/CAM Computer-aided design and manufacturing* New York Prentice-Hall
- Hegland, D (1982, June) Putting the automated factory together *Production Engineering*, pp 56-64
- Holland, J R (1984) *Flexible manufacturing systems* Dearborn, MI Society of Manufacturing Engineers
- Lardner, J F (1982, June) Start today for the factory of tomorrow *Production Engineering*, pp 50-52
- Main, J (1982, June) Wark won't be the same again *Fortune*, pp 58-65
- Newroth, M J (1982, September) Flex-line Factory of the future from stock components *Assembly Engineering*, pp 132-140
- Susnjara, K (1982) *A manager's guide to industrial robots* New York Prentice-Hall
- Scott, J E (1982) *Introduction to interactive computer graphics* New York John Wiley
- Thompson, H, & Paris, M (1983, June) The changing face of manufacturing technology *Journal of Business Strategy*, pp 45-52
- Till, W C, & James T Luxon (1982) *Integrated circuits Materials, devices, and fabrication* New York Prentice-Hall
- Tucker, J B (1984, February) Biochips Can molecules compute? *High Technology*, pp 36-42
- Ulrich, R A (1983) *The robotics primer* New York Prentice-Hall
- Warring, R H (1984) *Robots and robotology* Blue Ridge Summit, PA Tab Book
- White, J A (1982, March) Long-range view, better systems integration needed in design for material handling *Industrial Engineering*, pp 50-58

Student Quiz

1. What type of production line is most likely to be found in the factory of the future?
 - a. hard automation line
 - b. high-volume, low-cost line
 - c. line requiring much manual labor
 - *d. flexible manufacturing systems
2. What is a major factor driving changes in design and manufacturing?
 - a. requirements for more expensive products
 - *b. rapid technological developments and competition
 - c. more natural resources available at lower costs
 - d. fewer countries involved in world trade
3. Which technique is NOT among the new and emerging technology?
 - a. computer-aided design
 - *b. manual assembly
 - c. computer-aided manufacturing
 - d. computer-integrated manufacturing system
4. While personal computers are becoming more powerful their high cost is keeping them out of use by most people in industry (TRUE or *FALSE)
5. What is a key element of an integrated manufacturing system?
 - a. numerous drafters
 - b. many machinists
 - c. numerous inspectors
 - *d. automated control
6. What key advantage comes from an integrated manufacturing system?
 - a. more semiskilled workers needed
 - b. greater usage of drill jigs
 - *c. all functions interconnected
 - d. more craftsmanship
7. What new materials are expected to find wide acceptance in products of the year 2000?
 - *a. composites and ceramics
 - b. steel and lead
 - c. cast iron and tin
 - d. copper and brass
8. Jobs in the year 2000 will be most plentiful for service positions (e.g., fast food workers and custodians) and for people with a good technical knowledge (*TRUE or FALSE)
9. What is a major concern for people in AD 2000 manufacturing?
 - a. lack of leisure time
 - b. too many engineers and technicians
 - *c. workers with inadequate education
 - d. dangerous production jobs
10. Why are there so few robots in manufacturing today?
 - *a. they are crude compared to humans
 - b. robots do dangerous and routine jobs
 - c. labor unions want them
 - d. robots are not reliable

Integrated Manufacturing Systems: The Role of Robotics

Part 2 of 2 Parts

The first part of this series, *The Future of Design and Production*, provided an introduction to integrated manufacturing systems (IMS) with an explanation of the components that make up an IMS and flexible manufacturing system (FMS). It also described the factors leading toward broad acceptance of IMS concepts and some of the sociological and technological changes likely to result from industry's adaptation of IMS.

Each of the components, such as CAD/CAM, microprocessors, and emerging new materials and processes, easily serve as areas for in-depth study. This part of the series focuses on one of the components of IMS that has gained considerable attention: robotics. Robotics has received wide coverage in the news. Many courses of study, whether technical or not, find robots an item of interest. The intent here is to describe **industrial robots** in relation to IMS.

Industrial robots and their supporting systems provide a means to free humans from jobs that are routine, boring, and hazardous or that require precision beyond human capabilities. Although a type of automated machine, robots differ from *hard automated* equipment in their ability to be routinely reprogrammed for a variety of tasks. This contrasts with the great difficulty, time, and expense of changing over *hard automated* tooling and assembly equipment. FMS requires this quick and easy changeover.

Because they can be reprogrammed and because of the types of movements and sensing abilities that can be built into them, robots may be compared to humans as part of a production system. The comparison, however, stops short. Industrial robots do not begin to approach human capabilities today, nor are they likely to be built with such capabilities in the near future. The ease with which the least intelligent human can be taught to assemble complex objects or perform tasks, such as tying a shoelace or putting together a group of parts (e.g., the wires on an automotive ignition system), points to the enormous superiority humans possess over the most advanced robots.

To program a robot to perform a rather simple assembly task, such as picking up a set of components and placing them on a circuit board, requires some time and knowl-

edge of robotics programming. Once the machine is properly programmed, however, it will conduct the most dangerous, routine, boring, and precise tasks 24 hours a day, 7 days a week, month after month without failure, except as may result from a malfunction of the system. This aspect of industrial robots makes them appealing as components of a production system, especially for FMS and IMS, even though their cost is quite high.

Industrial robots contrast sharply with the type of robots or androids depicted in science fiction. Although some producers of robots do make robots that possess human characteristics, the industrial robot relates to the human only in those features that give the machine a purpose for an industrial task. We will look at some of those features after we describe the requirements of robotics in an IMS.

The basic concept of IMS is to consider all aspects of doing business—from market analysis, research and development, and design to production, distribution, sales, and maintenance. Robotics mainly fits into the production phase, but must be considered during research, development, and design, and can be a component of distribution.

Early robots fitted into the assembly role mainly as pick-and-place devices capable of reprogramming. Now they can be found in nearly all aspects of manufacturing.

In the hot metals area, robots may position a part for forging then move it to heat treating. Or, they may remove parts (metal or plastics) from casting machines. Robots serve as carts to transport parts and assemblies on the production line. Sensors allow robots to inspect parts during assembly and make corrections in the production systems. They weld, insert screws and other fasteners, and apply protective coatings.

For robots to accomplish these tasks, the designers must ensure that parts and assemblies can be handled and processed within the limitations of the robots.

Group technology is a methodology that joins with other techniques, such as design for automation, in an effort to view all parts subject to manufacture in a way as to limit the number of parts, operations, and degree of assembly difficulty. Most of the robots in operation today are limited in their movements. As a consequence, group technology and design for assembly methods try to reduce the complexity of shapes, avoid



Robot loading and unloading three machine tools. (Photo Courtesy of Unimation, Inc., Danbury, CT)

threaded fasteners, and keep the number of processing and fabricating steps to a minimum.

These concepts are not only good design principles for IMS and robotics, but for any design. Good design becomes mandatory when robots are involved because these dumb machines cannot easily adapt to variations of parts or make complex movements to assemble a part. Sensors on newer robotic systems provide a degree of adaptation. Figure 1 depicts the basic movements of robots. Figure 2 shows a robot in a work cell with sensors integrated into its operation.

To approach the manipulation capabilities of a human, sensors become an important part of the robotic system. Figure 3 lists sensors by groups. Sensors allow the robot to approximate the natural senses of humans. For example, when picking up an uncooked egg, a human realizes too much force would crush the egg and that the egg requires balancing because of its nonsymmetrical shape. For a robot to pick up an uncooked egg, it would require either instructions on the exact location of the egg or an optical system, such as a television, special grippers (hands) to grasp the eggs properly, and a tactile sensor consisting of strain gauges that use electrical resistance to feed back information on the gripper in order not to crush the egg.

Other sensors, known as acoustic sensors, can detect sound waves the robot may emit to help it avoid objects in much the same way as a flying bat. Thermal sensors employ thermocouples or thermistors to detect heat. Magnetic sensors respond to changes of electrical/magnetic fields.

Improvements in sensing capabilities coupled with computer improvements are leading toward artificial intelligence (AI). The AI capabilities of computers are a major thrust, especially in Japan where the Ministry of International Trade and Industry (MITI) is pushing toward the "Smart Computer" by 1990. A robot with an AI control system would have the ability for problem solving. At early stages, it could recognize shapes of objects, determine if they are improperly oriented, and then make adjustments to position

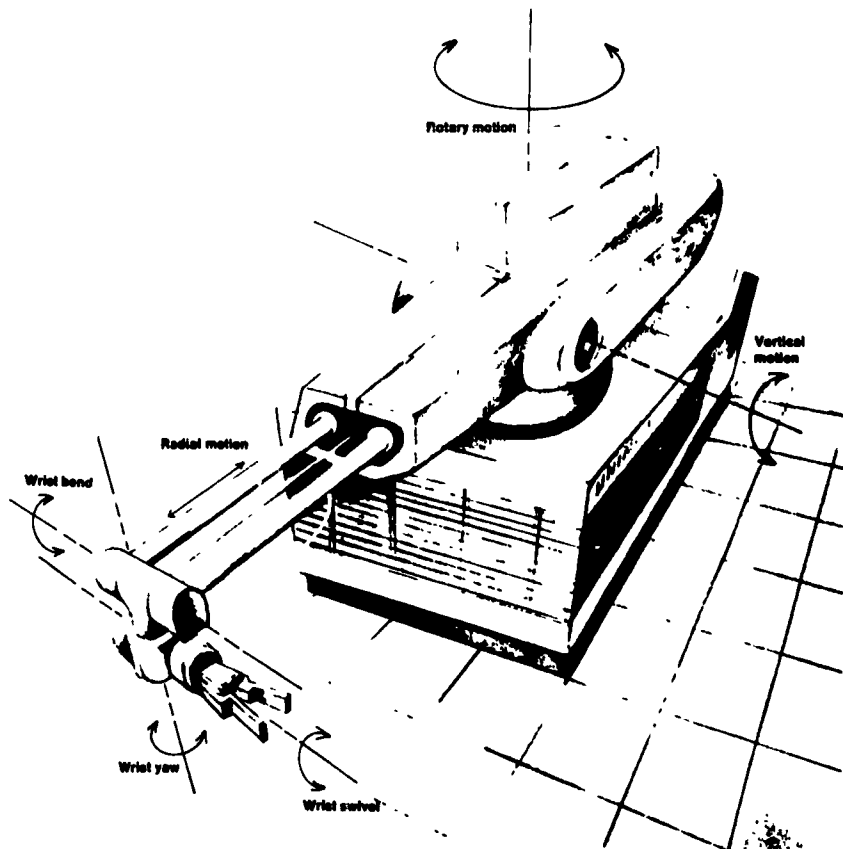

FIGURE 1
Basic Movements of Robots
(Drawing courtesy of Unimation, Inc., Danbury, CT)

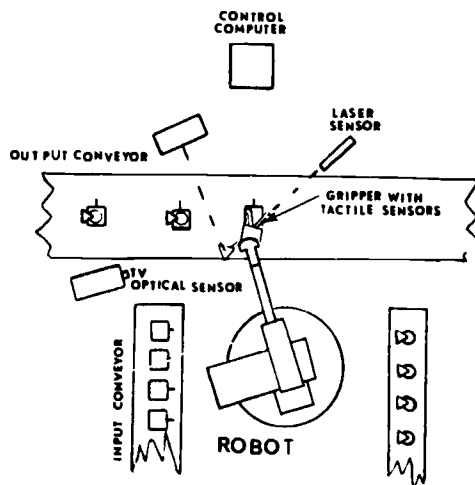

FIGURE 2
Work Cell: Robot in Work Cell With Three Sensing Systems

| TYPE* | EXAMPLE SYSTEMS |
|--------------------------|--|
| Optical | TV Light Emitting Diodes |
| Acoustic | Sound Waves |
| Thermal | Thermocouple Thermistor |
| Tactile (Touch-Force) | Microswitches, Transducers, Strain Gages |
| Magnetic | Magnetic Fields (e.g. Eddy Current) |
| Reflective | Laser |

*Some overlap exists in types of sensors

FIGURE 3
Sensors

a part in the proper orientation for assembly. In other words, the smart robot with AI capabilities would not require that all of its movements be preprogrammed, rather, it could make adjustments to changes in circumstances or solve problems.

These concepts of AI are futuristic but not at all unrealistic. Yet robots today, although quite dumb, still offer industry an opportunity to use machines to free humans from dull, dangerous tasks so they may do more creative, rewarding jobs.

Construction Activity: Robot Conceptor

The following plans for a pneumatic "pick-and-place" robotic system resulted from an industry-university-public school cooperative venture. Through the Norfolk State University Cluster program, arrangements were made for manufacturing engineers R. L. Porter and H. T. Gregg of General Electric's Video Products Department to work together with university professors and secondary school industrial arts personnel to design a low-cost robotic device. The resulting robotic concept was designed to allow most industrial arts departments to reproduce the device. The pneumatic device will operate on portable compressors or a laboratory compressed air system. Newport News Schools (VA) have used the device for manufacturing and silk screen printing. Possibilities also exist to hook up the device to a mini-computer for programmed operation.

Following is a description of how a Newport News industrial arts/technology class, directed by Cecil Holt, worked with the robotic device to integrate it into a manufacturing system.

Using the GE robotic arm, a manufacturing class at Dozier Middle School (VA) designed and manufactured a silk-screened key ring. Using the GE robotic arm in this project, the students set out to design end effectors that could be used for this mass production project. They decided to use the arm in the actual printing process rather than only in the handling mode.

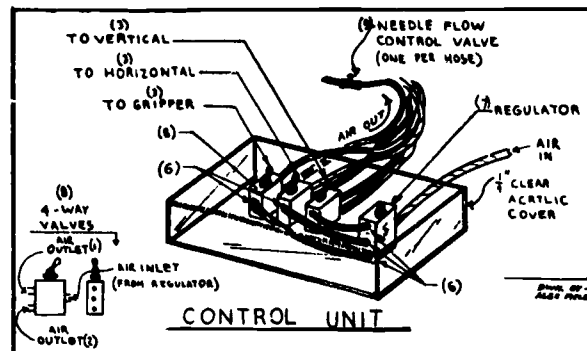

| PARTS LIST | | | | |
|------------|-------------|-----------------|---------------|----------|
| PART NO. | PART NAME | DESCRIPTION | ORDER NO. | QUANTITY |
| (1) | CYLINDER | 12" STROKE | 17-12 UDR | 2 |
| (2) | ROD | CASE 60/22 1/4 | SERIES L | 8 FT. |
| (3) | SWITCH | 4-WAY TOGGLE | MTV-4 | 3 |
| (4) | TUBING | URETHANE 1/2 OD | 3816-6 1/2 LB | 30 FT. |
| (5) | BARBS, HOSE | SWIVEL | 15055 | 6 |
| (6) | BARBS, HOSE | 10-32 | 11752-1 | 10 |
| (7) | REGULATOR | | | 1 |
| (8) | VALVE, FLOW | 4-WAY CONTROL | MFC-1 | 3 |
| (9) | VALVE, FLOW | CONTROL, NEEDLE | MFC-1 | 6 |

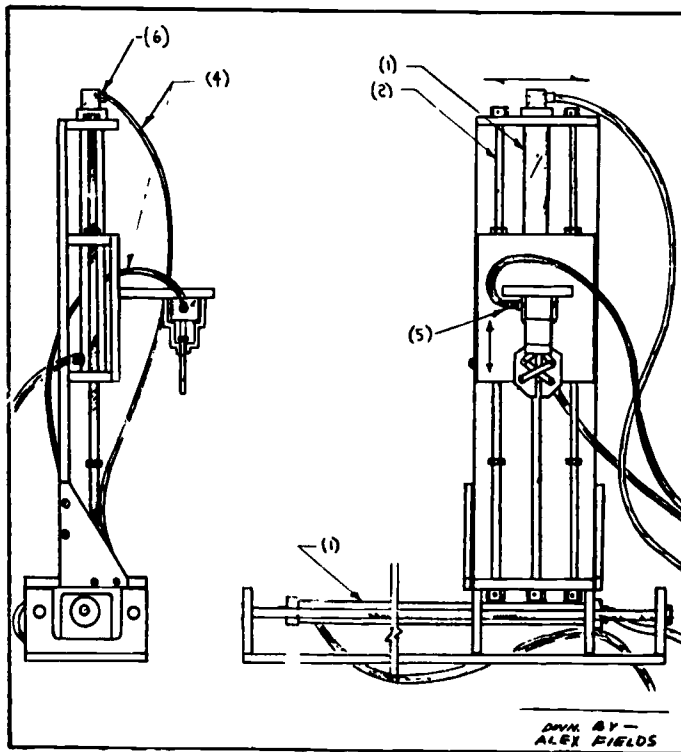

Assembly drawing of robot.

The original end effector design was a gap cut into the squeegee handle with a pin through it for the robotic gripper to clasp upon. This was found to be unstable. The students then attached a bracket to the gripper frame along with the previous mounting point. The students adjusted the rod stops and began to print, only to find they had another problem to overcome.

The raising of the screen frame was difficult for the students to coordinate with the operation of the arm. They had the up-and-down motion of the squeegee and tried to attach a cord to the screening frame. However, this broke after the first print. This led the students to discover the need for flexibility, and they quickly began to hunt for a spring. One was salvaged from a Metric "500" launcher, the spring worked but was found to be too strong. A spring of lesser strength was purchased, and production began on schedule.

This use of robotics gave the students a truer picture of manufacturing. Their research and development of end effectors showed great originality for a class of this level. Research and development is an important part of an industrial arts/technology education program, a fact that should never be forgotten. Many thanks are extended to the people at General Electric in Portsmouth for all their time and help and for providing the students with the opportunity to work with robotics.

YOKE END PLATE - CYLINDER CLEARING END ROBOT TRAINER

MAT'L - ALUMINUM 1/2" PLATE

ONE (1) PER ASSY HTG/RLP 8-83

TAP FOR 1/4-20 X 3/4 TWD (2) PLCS

BORE THRU .377 TWD (2) PLCS

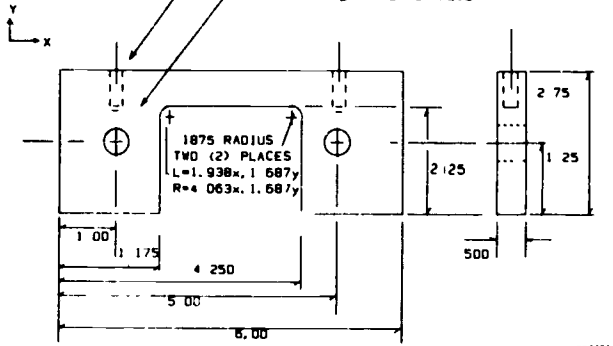

800072

TOP END PLATE - CYLINDER CLEARING END ROBOT TRAINER

MAT'L - ALUMINUM 1/2" PLATE

ONE (1) PER ASSY HTG/RLP 8-83

TAP FOR 1/4-20 X 3/4 TWD (2) PLCS

DRILL THRU .377 TWD (2) PLCS (#V)

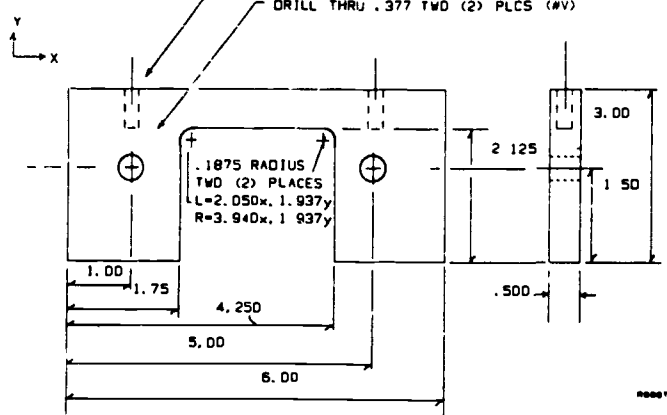

800073

YOKE MOUNTING DECK - VERTICAL TO HORIZONTAL ROBOT TRAINER

MAT'L - ALUMINUM 1/2" PLATE

ONE (1) PER ASSY HTG/RLP 8-83

DRILL THRU 9/32" SIX (6) PLCS.

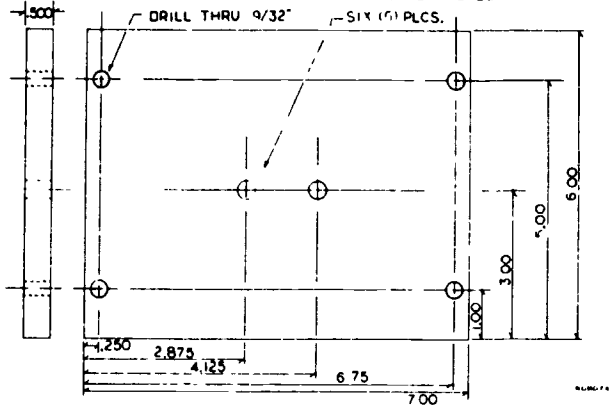

800074

HORIZONTAL DECK YOKE-ROBOT TRAINER, 1/2" ALUMINUM ONE (1) PER

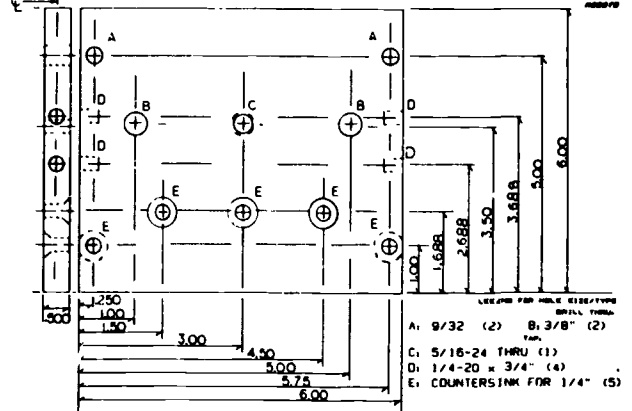

800075

ANGLE SUPPORT BRACKET-VERTICAL TO HORIZONTAL

MAT'L-ALUMINUM 1/2" PLATE

TWO (2) PER ASS'Y HTG/RLP 8-83

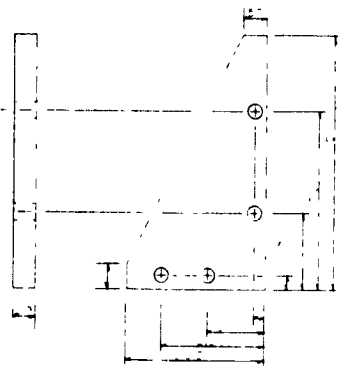

NOTE: USE 9/32 DRILL FOR ALL HOLES (4 PLACES)

MAIN BASE PLATE - VERTICAL AND HORIZONTAL ROBOT TRAINER

MAT'L - ALUMINUM 1/2" PLATE

TWO (2) PER ASS'Y HTG/RLP 8-83

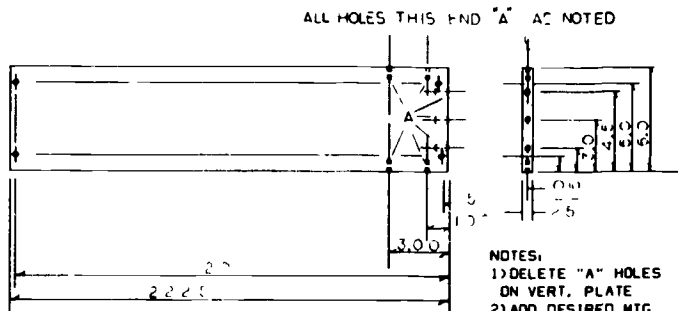

NOTES:
 1) DELETE "A" HOLES ON VERT. PLATE
 2) ADD DESIRED MTG HOLES ON HORIZ. PLATE

800077

YOKE END PLATE - CYLINDER MOUNTING ROBOT TRAINER

MAT'L - ALUMINUM 1/2" PLATE
 TWO (2) PER ASS'Y HTG/R/LP B-B3
 - TAP FOR 1/4-20 X 3/4 TWO (2) PLCS
 - BORE THRU .377 TWO (2) PLCS
 - TAP THRU 5/8 18

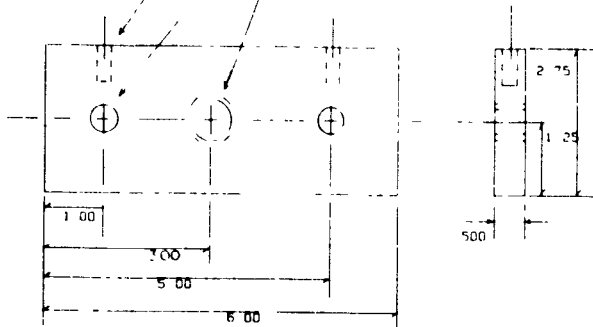

BOTTOM END PLATE - ROBOT TRAINER

MAT'L - ALUMINUM 1/2" PLATE
 ONE (1) PER ASS'Y HTG/R/LP B-B3

DRILL THRU .377 (ØV) TWO (2) PLACES

TAP THRU 5/16-24 ONE (1) PLACE

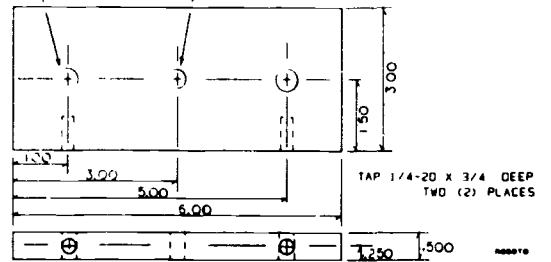

TAP 1/4-20 X 3/4 DEEP
 TWO (2) PLACES

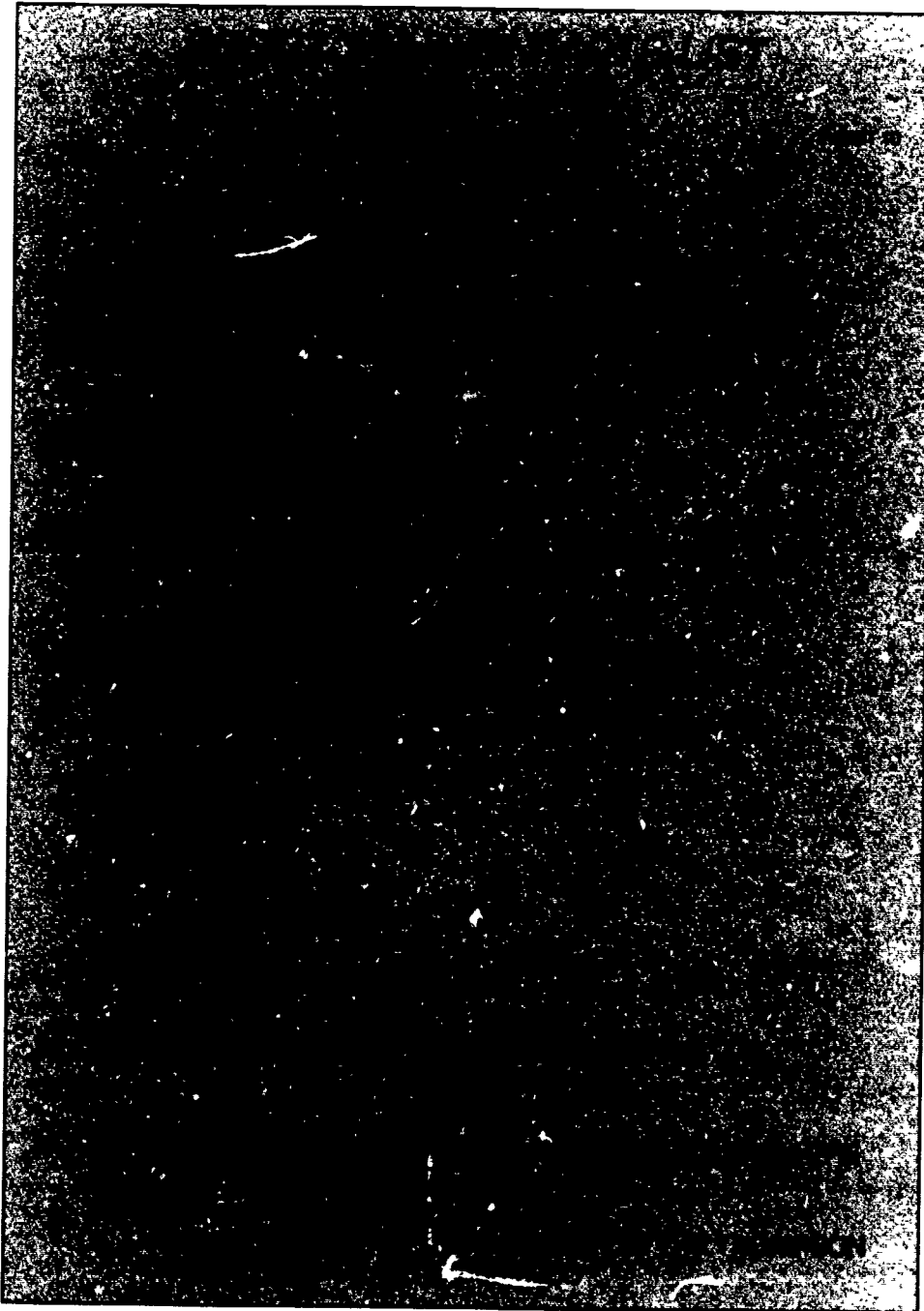

Math—Science—Interface

The "pick-and-place" robotic system that is featured in Resources in Technology uses pneumatic cylinders and actuators to provide the necessary motion for the device to perform its dedicated tasks. There are many options, however, for the robotic designers to select from for actuators and effectors. These components are operated by fluid power—air pressure (pneumatic), liquids (hydraulics), or electricity. And, these actuators may be combined in many ways and interfaced with sensors and computers to provide the required motions. When interfaced with the appropriate sensors and computers, they are able to "see" and measure objects, having a sense of touch nearly as sensitive as the human touch. These characteristics may be achieved efficiently and economically.

A description of the robotic system presented here relies on an understanding of math/science skills related to the compressibility of gases, pressures, forces, areas, and volumetric flow rates. Because the system is pneumatically (air) operated, a suitable air source is required. A small compressor that is rated at 40 PSI (pounds per square inch) at 0.5 CFM (cubic feet per minute) is recommended. In addition, an accumulator (air tank) of 0.5 gal or greater provides sufficient storage for the system's operation.

There are four physical laws that affect the operation of fluid power systems. Most important is Pascal's Law (1653), which states that pressure set up in a fluid exerts a force equally in all directions. And, the pressure exerts a force perpendicular to the confining surfaces.

Boyle (1627–1691) discovered by experimentation that "a given number of gas molecules confined in a given volume will increase in pressure as the volume is reduced; if the temperature remains constant, the pressure will vary "inversely" with the volume

Bernoulli's (1700–1782) Law describes the effects of flow and flow rates. It states that the higher the speed of a flowing fluid or gas, the lower the pressure. As the speed decreases, the pressure increases, and conversely, as the speed increases, the pressure decreases. The importance of Bernoulli's Law is apparent in the time it takes an actuator to complete its "cycle" and the selection of fluid conductors (hoses or air lines).

The last major principle is Charles' Law. Simply stated: The temperature of a gas directly affects both pressure and volume. As the temperature of a gas increases, the volume will increase proportionally by the same fraction of the original volume for each

degree rise in degrees Celsius. Using the Celsius scale, this fraction, a constant, is $1/273$ of the volume at 0° Celsius. This law reveals that the pressure in a system may vary by changing the environmental temperature where the system is located.

The problem that is presented here, which illustrates the math and science concepts that some robotic systems rely on, closely parallels the system described in this text. Specifically, it describes the speeds and forces available at specified system pressures and flow rates.

The application described earlier in this Resources referred to the use of the robot to perform screen process printing operations. In that context, we would be concerned with the force with which the squeegee contacts the screen stencil and the velocity (speed) and distance it travels. These are two variables that affect the quality of the resulting printing cycle. Should the force be "too great," the deposited ink film would be too thin. And if the velocity of the squeegee is too fast, adequate film thickness will not be achieved. Should the velocity be too slow, an economy of time will not be achieved. Experimentation could be used to determine the appropriate flow rates and pressures for the correct performance. By calculation and recording of the appropriate data, the system could be "set-up" and "fine-tuned" to provide exact repeatability before each subsequent "shift" or new product run in the laboratory.

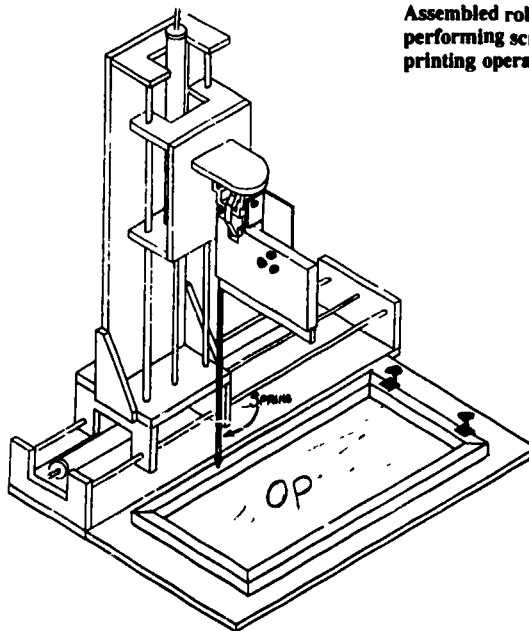

Assembled robot performing screen process printing operation.

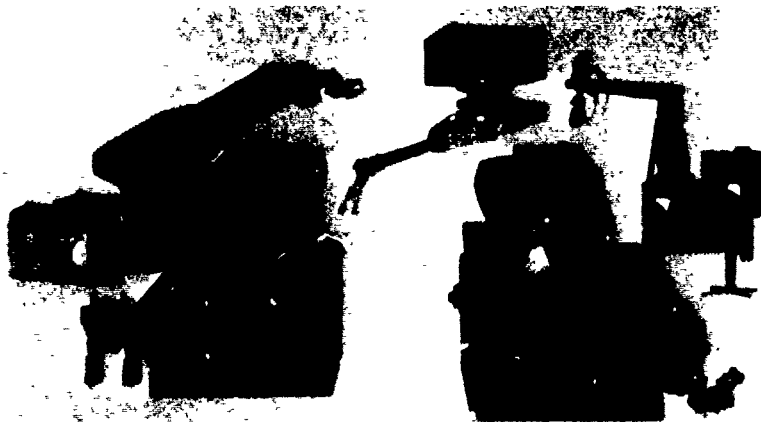

Types of robots. (Photograph courtesy of Unimation, Inc., Danbury, CT)

SAMPLE SITUATION

A sample situation to illustrate the relative velocities and forces for specified pressures and flow rates within the given system is shown below. The robotic system described used two 1¼ in. diameter X 12 in stroke pneumatic cylinders and a rotary actuator. The cylinders are used for "X" and "Y" axis motion, with an effective travel of 10 in. A rotary actuator is used in combination with a second-class lever ("pliers") to provide a prehensile or clamping motion. The system pressure is adjustable from 0-40 PSI at 0.5 CFM.

GIVEN:

$$\text{Force} = \text{Pressure} \times \text{Area}$$

$$\text{Area} = \frac{\pi D^2}{4}$$

$$\text{Volume} = \text{Area} \times \text{Length}$$

$$\text{Work} = \text{Force} \times \text{Distance}$$

$$\text{Horsepower} = \text{Work} / 550 \times \text{time (in seconds)}$$

$$1728 \text{ cubic inches} = 1 \text{ cubic foot}$$

PROBLEM:

Determine the travel time for the X-axis cylinder to move a distance of 10 in. with an air supply of 20 lbs per square inch and a flow rate of 0.1 CFM.

Equation 1

$$\text{Travel Time} = \frac{\text{Volume of Cylinder (cu in)}}{\text{Air Flow Rate (CFM/1728)}}$$

$$\begin{aligned} \text{Volume} &= \text{Piston Area} \times \text{Length} \\ &= (1.2271 \text{ sq in}) (10 \text{ in}) \\ &= 12.27 \text{ cu in} \end{aligned}$$

$$\text{Travel Time} = \frac{12.27 \text{ cu in}}{(0.1 \text{ cu ft}) (1728 \text{ cu in})}$$

$$\begin{aligned} &= \frac{12.27 \text{ cu in}}{172.8 \text{ cu in}} \\ &= 0.071 \text{ mins} \end{aligned}$$

$$\begin{aligned} \text{Converting to seconds} &= (0.071 \text{ mins}) \\ &\quad (60 \text{ seconds}) \\ &= 4.26 \text{ seconds} \end{aligned}$$

PROBLEM:

Determine the maximum force that may be exerted by the X-axis cylinder with an air supply of 20 PSI @ 0.10 CFM.

Equation 2

$$\begin{aligned} \text{Force} &= \text{Pressure} \times \text{Area} \\ \text{Force} &= (20 \text{ PSI}) (1.2271 \text{ sq in}) \\ \text{Force} &= 24.54 \text{ lbs} \end{aligned}$$

PROBLEM:

Determine the work done in a printing operation where a squeegee provides an effective resistance of 5 lbs against the X-axis cylinder and moving the squeegee a distance of 10 in.

Equation 3

$$\text{Work} = \text{Force} \times \text{Distance}$$

$$\text{Work} = (24.54 \text{ lbs}) (10 \text{ in})$$

$$\text{Work} = 245.4 \text{ in lbs}$$

Converting to Foot Pounds

$$= \frac{245.4 \text{ in lbs}}{12 \text{ in}} = 20.45 \text{ ft lbs}$$

PROBLEM:

Determine the horsepower developed in performing the printing operation described above. Using the values from the previous two problems, we can substitute in the equation for horsepower and determine the answer.

Equation 4

Horsepower

$$= \frac{\text{Work}}{550 \text{ ft lb} \times \text{Time (seconds)}}$$

$$\text{Horsepower} = \frac{20.45 \text{ ft lbs}}{550 \text{ ft lbs} (4.26 \text{ sec})}$$

$$= \frac{20.45 \text{ ft lbs}}{2343.58 \text{ ft lbs}}$$

$$\text{Horsepower} = 0.0087$$

Summary

It can be seen in Equation 1 that by changing the flow rate, a corresponding change in travel time results. Thus, it may be stated that the travel time of the rod in the X-axis cylinder is **directly** proportional to the flow rate of air to it.

Equation 2 reveals that the force that may be exerted by the X-axis cylinder is **directly** proportional to the available air pressure. An increase in air pressure will cause an increase in the force available from the cylinder.

Equation 3 indicates that the work done in the system is the product of the force exerted by the cylinder and the distance through which the cylinder moves that force.

Equation 4 provides a measure of the power output of the system. Power adds the

dimension of time to the work done in a system. One horsepower is 550 foot pounds of work per second. Thus, the more work done per unit of time, the greater the horsepower output.

Accordingly, by using the maximum values for the air supply (pressure and flow rate) and specifications for cylinders used in the system (bore and stroke), we can effectively determine the design limits of the system. And, we can predict travel times and forces by using Equations 1 and 2 and substituting the appropriate values.

Following is a quiz that you can use with your students to determine the knowledge they gained from studying this Resources in Technology.



The IBM 7535 Manufacturing System: Its jointed arm can move in four directions and can pick up, assemble, and load parts such as those shown on the table in the foreground. (Courtesy IBM)

Student Quiz

1. (True or false) Many jobs in industry will soon be performed by robots because today they have the same capabilities as humans
2. The major advance of an industrial robotic system over hard automation is _____
 - a greater precision
 - b equipment expense
 - c easier design requirements
 - *d reprogrammable
3. Name one design technique that results from the nature of robotic capabilities (group technology or design for automation)
4. Name a major disadvantage of today's robotic systems (inability to solve problems or limited sensing abilities or limited motions)
5. Explain some major advantages of robots over humans (perform routine, boring, dangerous, and precision tasks continuously without tiring)
6. List four types of sensing used on industrial robotic systems, give an example system for each, then tell how you feel each system could be used in a production system (see Figure 3)



BIBLIOGRAPHY

- Computer and Associated Systems, Association of Society of Manufacturing Engineers (1983) *Autofact 5 conference proceedings* Dearborn, MI Author
- Dorf, R C (1983) *Robotics and automated manufacturing* Reston, VA Reston Publishing
- Feingold, S N (1984, February) Emerging careers Occupations for post-industrial society *The Futurist*, (1983) pp 9-16
- Gardiner, K M (Ed) (1983) *Systems and technology for advanced manufacturing* Dearborn, MI Society of Manufacturing Engineers
- Groover, M P, & Zimmers, E W Jr (1983) *CAD/CAM Computer-aided design and manufacturing* New York Prentice-Hall
- Hegland, D (1982, June) Putting the automated factory together *Production Engineering*, pp 56-64
- Holland, J R (1984) *Flexible manufacturing systems* Dearborn, MI Society of Manufacturing Engineers
- Lordner, J F (1982, June) Start today for the factory of tomorrow *Production Engineering*, pp 50-52
- Main, J (1982, June) Work won't be the same again *Fortune*, pp 58-65
- Newroth, M J (1982, September) Flex-line Factory of the future from stock components *Assembly Engineering*, pp 132-140
- Susnjero, K (1982) *A manager's guide to industrial robots* New York Prentice-Hall
- Scatt, J E (1982) *Introduction to interactive computer graphics* New York John Wiley
- Thompson, H, & Paris, M (1983, June) The changing face of manufacturing technology *Journal of Business Strategy*, pp 45-52
- Till, W C, & James T Luxon (1982) *Integrated circuits Materials, devices, and fabrication* New York Prentice-Hall
- Tucker, J B (1984, February) Biochips Can molecules compute? *High Technology*, pp 36-42
- Ulrich, R A (1983) *The robotics primer* New York Prentice-Hall
- Warring, R H (1984) *Robots and robotology* Blue Ridge Summit PA Tab Book
- White, J A (1982, March) Long-range view, better systems integration needed in design for material handling *Industrial Engineering*, pp 50-58

Possible Student Outcomes

1. Explain what advantages industrial robotics brings to production
2. Describe some of the shortcomings of current industrial robots
3. List four types of robotic system sensors and explain their function.
4. Construct a "pick-and-place" pneumatic robot conceptr.
5. Place the constructed robot conceptr in a production system

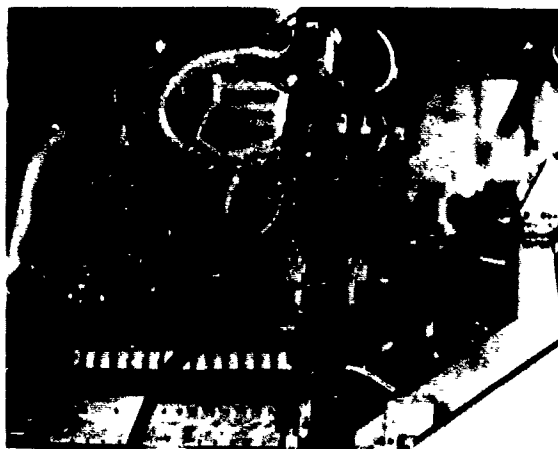

The IBM RS 1, an advanced robotic manufacturing system for precision assembly, electronics parts insertion, and other intricate operations, is moving a power screwdriver toward a workstation (right). The arm, (vertical unit with light-colored metal grippers), can move in six directions. It is controlled by an operator using a hand-held device called a pendant.

NOTE: Special thanks is extended to Bob Porter and Scott Gregg of General Electric's Video Productions Department in Suffolk, Virginia, for their research and development efforts in planning and constructing the robot shown in this article. Special thanks is also extended to Cecil Holt for his willingness to work with us on this project and his innovative practices in the classroom.

Movin' On With Mass Transit

Ever since humans emerged from caves or came down from the trees, transportation has been an almost daily factor in their lives. Without it, they had no hope of securing adequate food, obtaining shelter, or even communicating with their neighbors. People soon discovered that human needs were more easily secured when the searching was done in groups or bands. From that early day until now, people have constantly sought to improve the efficiency and cost effectiveness of transportation modes. Their primary consideration has been the cost in terms of the time involved and the materials or energy expended in relationship to the benefits obtained.

Today, even in our technological-oriented world, the same basic considerations govern the development of newer, more efficient transportation modes. The movement of people, goods, services, and messages from one point to another is an experience common to all persons. Their lives are continually affected by it. Without transportation, life as we now know it would cease to exist.



Social-Cultural Impacts

The development of transportation has taken place over many centuries. Each new innovation has improved the means by which humans transport themselves and their goods, services, or communications from one point on the globe to another. As the means to move individuals or small loads improved, the movement of many of these simultaneously developed. Sea canoes and river rafts, which transported many natives at once, were two early forms of what we today call mass transit.

Perhaps one of the most significant early developments in all of transportation was the invention of the wheel. More than 2,700 years before the birth of Christ, this seemingly simple and obvious development really "got things rolling." It made possible the use of carts, wagons, carriages, and many other wheeled vehicles. Many machines used to power later transporting devices would not have been possible without it. Entire civilizations experienced an accelerated growth rate because of the simple wheel. Everything from a simple pushcart to a wheelbarrow to an underground rapid transit system can be traced directly back to the "lowly" wheel.

Following the invention of the wheel, better paths and roads began to appear. As early as 200 BC, the Chinese designed one of the earliest organized road systems. This and similar efforts in other parts of the world greatly accelerated the growth of commerce and sociocultural interactions between the communities and nations of the world. The development of this system of getting a cargo (people, goods, services, or messages) from one point to another further stimulated the growth and improvement of wheeled vehicles.

In 1662, a significant event occurred in mass transit. Pascal, a French mathematician, developed the horse-drawn omnibus in Paris. This device was capable of transporting from 18 to 20 passengers. This was the first effective effort at mass transit as we know it today. The omnibus permitted several persons to be transported simultaneously to various points of commerce and industry. In the past, as long as any urban area was small enough, those who needed to could move their cargoes by carrying them singly or by transporting them in two's or three's. As the size of cities increased, this method severely

limited markets, the gathering of labor forces, and further urban growth.

Another important development along the not yet finished road to efficient, effective, and generally accepted mass transit was the invention by James Watt in 1769 of the first efficient steam engine. The growth of commerce and travel was greatly stimulated by the dependability and availability of this cheap power. With its discovery, power sources for large shipping companies, cargo-carrying vessels, and railroads became readily available. People and goods were transported faster and much more dependably. Transoceanic travel was no longer subject to the vagaries of the wind as a means of propulsion. The growth of many nations, including our own, occurred as a direct result of the availability of steam power for ships and railroads.

Within America's cities, railroads and large vessels were of little use to the intricate traveler or transporter. Mass transit by Pascal's omnibus was generally accepted by city dwellers. It could carry only a limited number of passengers, was very slow and uncomfortable, and traveled on poor sur-

faces. Yet, the omnibus possessed the virtues of low capital cost and the potential for great flexibility. Despite this, its ultimate demise was determined by the many shortcomings attributed to it.

Urbanites still needed an acceptable means of mass transit. In 1832, the Harlem Railroad developed the first American mass transit system for hauling passengers in regular urban transit service. Using a horse-drawn street car with metal wheels on metal tracks, the Harlem's car proved to be much superior to the omnibus. It required less horsepower and could haul greater loads. Just before the U.S. Civil War, similar systems were in operation in many U.S. cities.

Transit companies were not regulated, so several companies competed within one city. At one time, Philadelphia had 39 of these services operating simultaneously. This usually meant several vehicle changes or transfers on any lengthy intracity trip because of the relatively short runs.

Horse-drawn cars were not without many disadvantages. A horse could be used for only about 5 hours a day, and some operations required the use of more than one animal per run. It could easily have taken as many as 10 horses to keep a car in operation for a 24-hour period. Generally speaking, street railway managers were unhappy with the horse-drawn power, and so they were constantly seeking a new power source.

In 1869, Hallidie invented the cable car mechanism. By 1873, San Francisco had a successful cable car operation. The cars were hauled by a continuous cable powered by remotely placed engines. Development of the city's hilly areas was then possible. Cable cars as mass transit modes were generally accepted in other cities, too. Chicago had the largest cable car system in the United

States at one time. Because of its lack of hills, up to three cars could be used at one time. The movement of thousands of people into a central location allowed the growth of Chicago's inner city.

Cable cars could be operated at a much lower cost than horse-drawn ones, but the cost of building and maintaining a line was prohibitive in cases where great masses of people did not need to be moved on a daily basis. The business community still sought a more cost-effective way to move people.

After many promising but false starts, electric streetcars were developed. In 1888, a successful electric streetcar system was introduced in Richmond, Virginia. Within 2 years, more than 1,200 miles of electric streetcar lines were in operation in this country. One of the primary factors in the rapid implementation of electric streetcars was cost. They were much cheaper to both install and maintain (Smerk, 1976).

Cities grew up along the routes and to the terminal points of many electric streetcar lines. Many of the multiple horse-drawn operations were merged within cities to form large, efficient, electric-powered ones. By World War I, the electric streetcar had become the basic form of transportation for American cities. This was just before the dawning of America's romance with the private automobile. Before the "automobile age," the streetcar was the most decisive factor in the shaping of our cities. People from all walks of life, all forms of employment, and all social structures used them.

In addition to travel by rail or omnibus, another important means of transport—ferryboats—aided in the growth of our cities. Because the engineering technology was not available to build structurally sound bridges or tunnels across our great rivers and har-

bors, America began to use ferryboats. These allowed for the development of areas ordinarily out of the city dweller's reach at a relatively low cost. A worker could live outside the industrialized inner city—just across the river, or a streetcar's ride from the ferry landing.

For those living in the outlying areas, existing railroads between cities began to make intermediate stops. Housing sprang up around these commuter railway stops, and vice versa. The emergence of commuter lines further aided the growth of cities. Persons could live and raise families in one environment outside the city and commute to work. The present geographical layout of New York City is a direct result of the existence of commuter railroads.

Long before the general acceptance of commuter railroads, many people realized that some alternative form of surface travel in the industrialized cities of the world was not only desirable, but necessary. As early as 1850, travel in London, England, was so badly congested that it was said to be "intolerable."

City developers and professionals in transportation fields agreed that more efficient, effective means of mass transit had to be developed, either above or below the grade level of existing facilities. To the delight of all, by 1863, Londoners were riding an underground subway, at least part of the time. New York City was faced with similar problems and introduced the E1 (elevated railroad) in 1868. Both of these innovations were steam powered, but by the late 1800s, they were electrified for safer, faster, and more cost-effective operation.

In about 1900, Boston, Massachusetts, began to operate America's first subway. Up to then, all underground mass transit had been for streetcar-type vehicles. However, in large cities, railroads were also soon routed underground for more efficient operation. In a few short years, the rapid growth of many cities was aided by the introduction of elevated or subway-type systems. Other developments in mass transit systems continued and will be dealt with more extensively later in this Resources in Technology.

For several reasons, many rail-type carriers fell on hard financial times and many simply folded. Streets were often paved right over the old existing tracks. By about 1939, the motor bus had been developed and was in extensive use, as it still is. Powered by diesel engines, these buses offered great flexibility at an inexpensive rate that both operators and commuters could afford. Not restricted by overhead lines or underground cables, buses could operate on the same surface as automobiles. The passenger capacity of buses up to 40-feet long exceeded that of the rail-type carriers by as much as 50%. Because of the general acceptance of buses as a means of mass transit, streetcar lines have all but disappeared from most American cities.

© and public transit system should make good use of an abandoned railroad and use the line in the city.

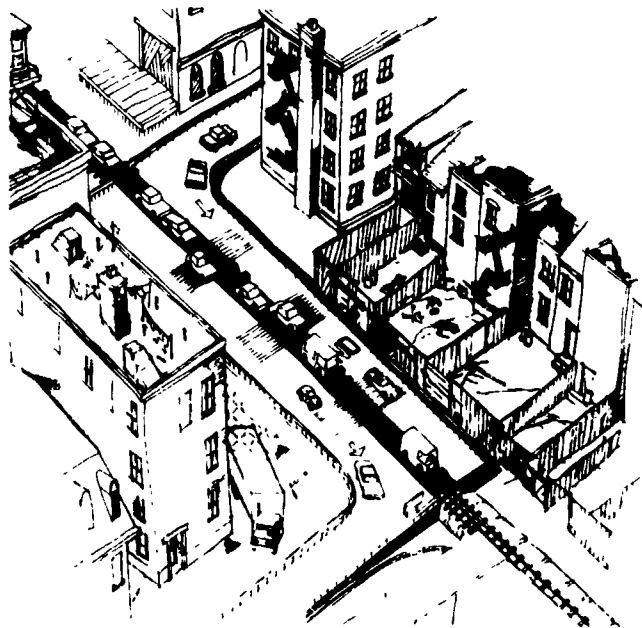

MAJOR DEVELOPMENTS IN MASS TRANSIT

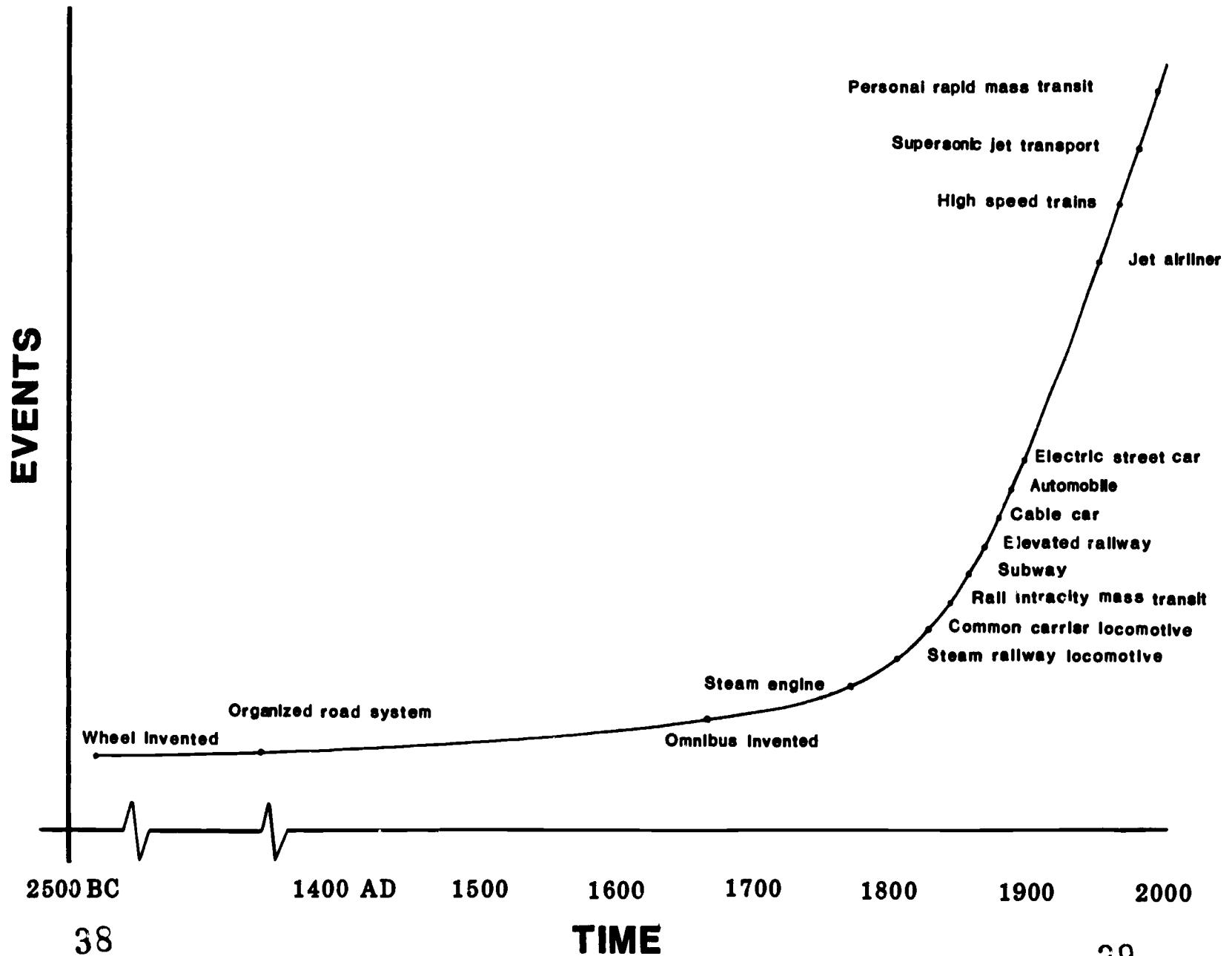

Factors Affecting Development

At present, worldwide efforts are being made to improve the mass transit of people and cargoes. There are many new, exciting ideas in the field. As these concepts emerged for the movement of people, similar growth also occurred in the efficient movement of other cargoes.

Factors similar to those that governed the development of past mass transit methods played a major role in the growth of future cargo-moving methods. These qualities were and still are (Schumer, 1974, pp 21-29)

- speed
- safety
- capacity
- frequency
- regularity
- comprehensiveness
- responsibility
- comfort
- acceptable cost

These facets of each transportation system had to be weighed against the other facets. At times, one might be sacrificed somewhat for another. For example, the carrying capacity might be lessened in an effort to design a vehicle capable of more speed. The effectiveness and efficiency of a transport system could be affected by any one or a combination of the qualities listed above.

Engineers had realized for many years that the individual handling of each piece of cargo was not very efficient. It was not until

World War II, however, that the concept of the unit load was fully developed for the movement of materials.

The need to transport tons of much-needed war materials and supplies during World War II caused a definite improvement in the existing methods. The unit load groups many smaller items or cargoes into a single load for movement to the same destination. These items may be tied together, placed in a single container, or stacked onto some type of portable platform.

In general, loads are sized so that they may be handled throughout transit by the equipment already available at the various stopover points. This saves the cost of expensive, special equipment, reduces the use of "muscle-power", and promotes a more inexpensive mode of transport.

There are five specific advantages to the unit load concept:

- 1 **Economy:** It provides an economical way to handle, store, and transport many small items or loads simultaneously, thus eliminating expensive and repetitive handling.
- 2 **Speed:** Individual consignments can be moved in much less time.
- 3 **Space utilization:** Storage facilities may be used more efficiently because cargoes (units) can be uniformly stacked.
- 4 **Identification:** The identification of unit loads is much easier than that of individual ones.

5 **Safety:** Unit loads can be handled by mechanical means, which is generally a much safer method than manual operations. Theft and damage are also less likely to occur with unit loads. (Schumer, 1974, pp 195-196)

Today, enormous cargo-carrying ships may have their decks stacked with cargo-carrying containers capable of holding truck-sized loads. These containers are simply off-loaded from the vessel, placed on a suitable truck trailer, and hauled away. The cargo inside need never be touched.

The movement of household goods inside large wooden boxes from one home to a new one has been a common sight on America's roads for years. Containers placed on truck trailers may also be put on flatbed railroad cars for transport. The piggyback method, as it is called, permits an enormous amount of cargo to be transported by rail from the port or starting point to a more suitably located truck terminal. The U.S. Department of Transportation is studying the feasibility of the movement of personal automobiles by rail. In effect, rail travelers could take their private transportation means with them to their destination. If the idea were widely accepted, this would lessen the use of roads by private autos. Systems of this type are quite common in Europe and are used to transport passengers and their vehicles from the northeast United States to Florida.

Today's Technology

As transportation technology developed, new ideas in the rapid, mass movement of people emerged. Some were successful, others were not. Some of the features designers consider when trying to develop a new system are listed below:

- The use of automated and continuous type systems. These may be passenger-actuated or operated remotely by computers or some central control system.
- Land conservation and low capital costs. These may be expected in a properly designed small vehicle or in the system's structures or stations.
- Environmental improvements. These may emerge as electric propulsion or small, aesthetically pleasing facilities.
- Shorter or more direct routes. These may reduce travel time. Greater travel speeds also produce this effect.
- Reductions in the inconvenience caused by transfers, waits, and

travel in general. (Gray & Hoel, 1979, pp 666-667)

Using the considerations listed above and previously, many new and innovative concepts have emerged. A representative, although not complete, sampling follows:

Pedestrian aids: Some examples of pedestrian aids that can move a great number of people in a relatively short time are escalators, elevators, and moving walkways. A similar device may locate passengers in some sort of container to allow higher transport speeds. All of these are common sights at many of today's large airports. Shuttle services between airlines use the container method very effectively, as do many "theme" parks.

High-speed railroads: Some designers have suggested rail speeds of up to 500 mph. The Japanese Tokaido Line provides transport between Tokyo and Osaka at speeds up to 120 mph. The efficiency of that route provided keen competition to the

nation's airlines. Designers have developed and operated a "tracked air-cushion" vehicle in France, and even atmospheric pressure driven trains have been suggested. A rocket-propelled train moving through a near-evacuated tube has also been developed. Although these high-speed models may not now be widely used, they indicate a possible direction for future development.

Water transport: Where the traffic is sufficient and economies permit, air-cushion vehicles and hydrofoil boats now provide service. A proposal currently exists for a high-speed catamaran to be used as a ferry at some suitable location. A cable-pulled version is also on the drawing boards. Where the costs of bridges or tunnels are prohibitive, high-speed ferries may provide an acceptable alternative.

Air transport: Short or vertical take-off and landing vehicles do and will provide service to smaller airports or landing areas, providing them with greater cargo and passenger capabilities. Even localities lacking an

airport may be served by these vehicles. In addition, designs for conventional aircraft with greater capacities have emerged. Boeing's 747 can carry nearly 500 passengers, and the military C-5A can transport almost 1,000 persons.

Electric cars: Automobiles employing conventional internal combustion engines produce smog—a major problem in many urban areas. For years, the electric car has seemed to be the obvious solution to this problem, but it has had problems of its own. Although it is not smog producing, its limited range and other performance factors have delayed its general acceptance.

Several other terms are common to transportation's technological research. These may be applied to future developments wherever they are deemed feasible.

● **Automatic headway control:** This generally indicates the interval between trains or vehicles. A train "every 30 minutes" indicates that much headway. Although this system seems to be in use (e.g., by subway stops), it is not. Subways use a "block control

system," and the technology to automate it fully continues to be worked on.

● **Automatic speed control:** This has been in use for many years. A common example is elevators that accelerate or slow down automatically. BART (Bay Area Rapid Transit) and similar people movers use this.

● **Automatic route (steering) control:** The most common example of this is the nearly automatic landing of aircraft on Navy carriers. Fully automated warehouses use automatic vehicles to move and store goods as required.

● **Automatic merging and switching:** Ramp metering on the entrances to many freeways allows automobiles to enter at a safe rate. Automated railways have long used automatic merging and switching because of the relatively long headways between trains. The random headways between cars on a highway present problems that are as yet technologically insurmountable.

● **Automatic distribution of automobiles (any vehicle) over alternate routes:** Traffic control signals represent the only

attempt at this technology over a large system to date. The automatic allocation of traffic over alternate routes is a problem yet to be truly overcome. (*New and Novel Transportation Systems*, 1970, pp. 27–28)

As our population increases and our urban and industrial sectors continue to grow, the need for new and innovative mass transit increases. More effective modes must be developed above and beyond those already in existence. We must continue to address transportation needs of the future also as options that technology can improve and develop. Our transportation needs in the future may be somewhat different than today, and will almost certainly be more technologically involved. Jerry D. Ward, former U.S. Secretary of Transportation, cautioned those of us in technology that we should be wary of eliminating possible alternatives to our future transportation needs simply because they do not conform to present technological thinking. (Gray & Hoel, 1979, p. 698)

Constructional Activity

To help prepare citizens for their future, we must prepare them to solve their environmental and technological problems. In the area of mass transportation, engineers, designers, technicians, and citizens must band together to study the transportation problems that exist and plan for solutions. These solutions must be safe, economical, and relieve the social problems of traffic congestion and the movement of our workforce.

The focus of this constructional activity is to use laboratory tools and materials (cardboard, wood, plastic, metal, or other synthetics) to design and construct an operational model of a mass transit system. The diagram in Figure 1 outlines the thoughts behind this activity. Following are the parameters of the activity.

Problem

Traffic jams are increasing each year. The number of cars is also increasing, creating more traffic problems and polluting the environment. Design a rapid rail system to run between Washington, Philadelphia, New York, and Boston.

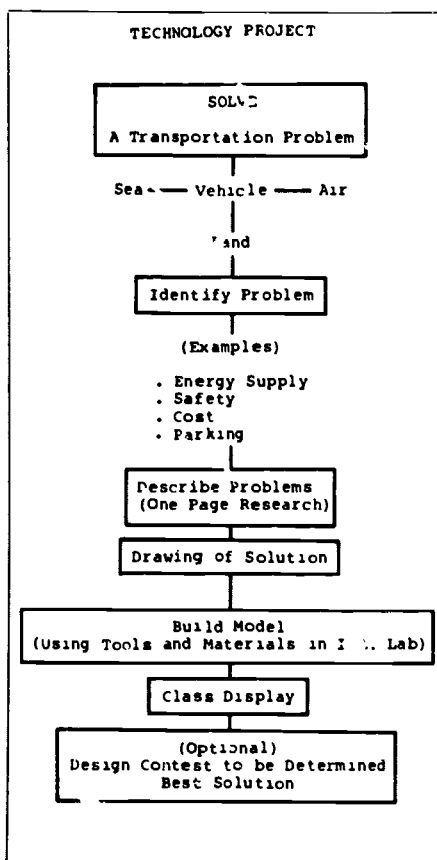

FIGURE 1

Research Criteria

- A High speed vs. low speed
- B Sources of power (electric, magnetic, radiation)
- C Ride comfort
- D Safety, high speed on freight rails
- E Cost per mile to construct

Selected Solutions

My train model will be built

- A Using existing railroad
- B High speed, 150 mph
- C Power source, electric drive wheels

Test Results

Can a train be designed to travel between Washington and Boston (450 miles) in fewer than 3 hrs with comfort and safety? Design and build a model train using new ideas to achieve a smooth, safe ride at speeds over 150 mph.

Drawing of Solution

Train Design

- A Speed 150 mph (+)
- B Tilt ride for comfort
- C Drive motors, power source

Build Model

Using tools and materials in an industrial arts/technology lab (metal, plastic, etc.) build a model of a mass transit train. Materials used will be real to actual conditions. Scale and weight will be followed for feasibility of actual design.

Class Display

Give a one- to two-page report to the class about vehicle design.

- A. State problem
- B. Support solution chosen
- C. Tell about model built and give conclusions

As you can see from this activity, industrial arts/technology education programs can

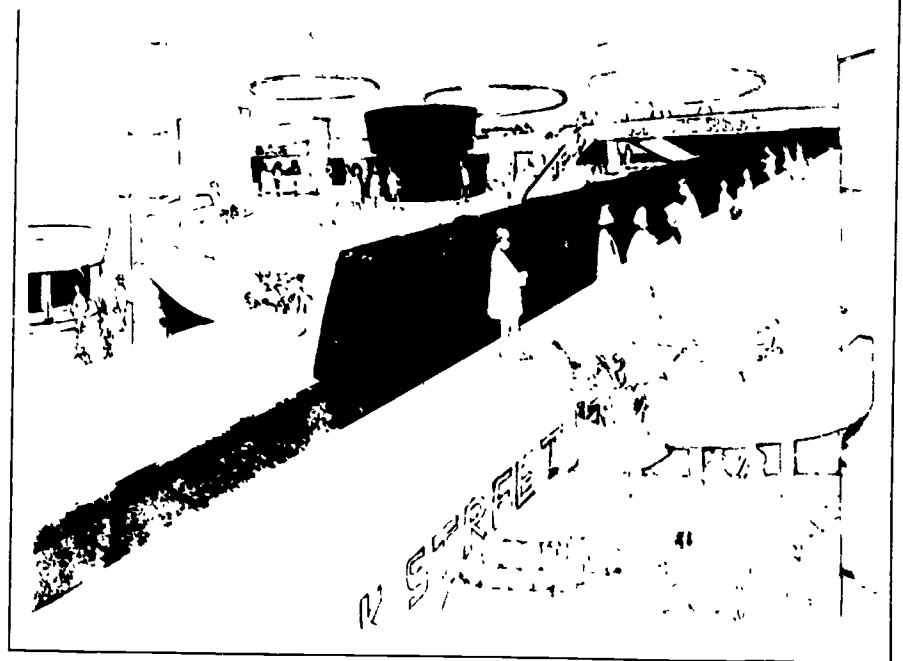

have activities that address contemporary technology problems. However, to understand better how mass transportation technologies operate and alter our lives, one must have an understanding of mathematical, sci-

entific, and technological principles. The next section will focus on aspects of this interface. You may wish to teach this information while students are working on their mass transit designs.

Math/Science/Technology (M/S/T) Interface

Communication and transportation are major technical systems that support a technological society. It is apparent that computers, fiber optics, and lasers have made a substantial impact on communications technology. In the area of transportation, however, new developments and technologies on the horizon are not as well publicized or known. In the realm of transportation technology, the average person is essentially aware of unleaded fuel, catalytic converters, and the rapid escalation of petroleum fuel prices in the past 10 years. For example, in 1970 the average price for gasoline was 30 cents per gallon, today the average price is \$1.10 a gallon. These facts make headlines!

During periods of escalating energy costs, people look for other avenues of energy resources and supplies (e.g., alcohol fuels, synthetic oils, shale oil, solar energy). Fuels are a source of energy, in turn, that energy is usually converted to another form of energy, primarily mechanical, to extend the capabilities of people.

Transportation consumes a major portion of the world's energy resources. For example, transportation occupies 25% of the United States' annual energy consumption.

Considerable research has been done on transportation systems that use alternate energy resources. Some examples are vehicles that use the "stored energy" of flywheels, hybrid systems that combine the advantages of internal combustion engines and electric, the Rankine-cycle, and the Sterling cycle. In the area of mass-transit, considerable attention has been focused on the use of linear induction electric motors (LIM) to move common carriers at very high speeds with moderate to large passenger loads.

High-speed passenger trains that use the technologies of linear induction motors are not severely limited in the maximum speed, as is the conventional rail-type train. Conventional trains are limited to approximately 100 mph. Speeds in excess of this cause narrow safety margins that are significantly affected by the condition of the rail system (rails/tracks, track beds, and grade) and the ability of the driving wheels to maintain sufficient contact with the rails to transfer mechanical energy efficiently.

The linear induction motor, when used for mass transit, offers some attractive

advantages over conventional rail systems. Vehicles with a LIM can move very fast (speeds approaching 300 mph), are quiet, and provide exceptionally smooth rides because of their sophisticated suspension systems. Figure 2 illustrates the concept of a mass transit monorail vehicle that employs a linear induction motor.

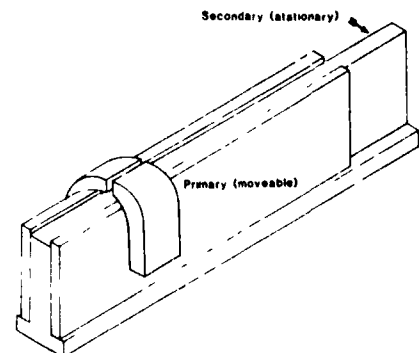

FIGURE 2
A Section of LIM-Powered Mass Transit Vehicle

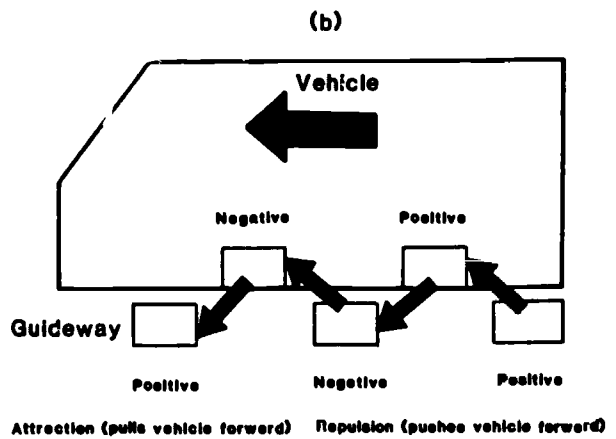
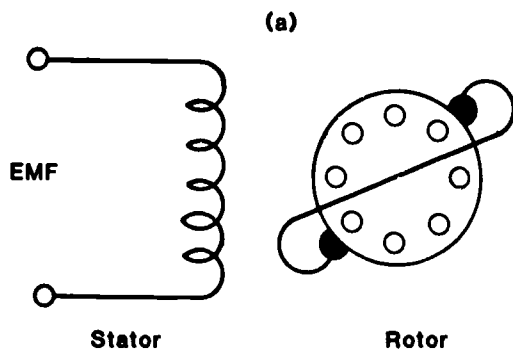

FIGURE 3

Comparison of Conventional Induction Motor and a Linear Induction Motor

A review of the basic electrical laws regarding electromagnetic induction is the key to understanding how a linear induction motor operates. Joseph Henry, in the United States and Michael Faraday in England independently discovered the phenomenon of electromagnetic induction in 1831. Two familiar applications of their discoveries are the transformer and generator. Each of these devices uses the properties of a magnetic field, relative motion, and a conductor. Closely related to these devices is the conversion of electrical energy into mechanical energy in the form of an electric motor, where the repulsive forces of magnetic fields produce the "relative motion" or the actual rotation of a rotor or armature. In the case of a linear induction motor, however, the motion is in a "straight line," hence the term *linear*. Figure 3a illustrates the concept of the typical induction motor, Figure 3b illustrates the linear induction motor.

A major principle in the operation of induction motors is that every current is surrounded by a magnetic field and as a result, the nearby currents exert forces upon one another. The forces are magnetic and do not interact electrically with each other. However, if the current flow or direction is such that the magnetic fields repel each other, then a calculable force of motion will result. A good example is the motion produced by the current through the electrode cables of a large carbon arc welder used in industrial applications. Typically, these machines will use 100 to 400 amps of current during the welding cycle. If the cables are placed parallel or cabled next to each other, then they will literally "jump" each time the current is cycled on or off! The amount of force that they "jump" or move with may be calculated by the equation shown that follows (assuming that they are parallel and in close proximity to each other).

Example

The cables are placed 1 cm apart for a distance of 5 m. When a current of 300 amps is applied, the force between the cables will be as follows:

$$\begin{aligned}
 F &= \frac{\mu_0 I^2 L}{2\pi S} = \frac{(4\pi \times 10^{-7} \text{ T} \cdot \text{M/A}) (300\text{A})^2 (5\text{M})}{2\pi \times 10^{-2} \text{ M}} \\
 &= \frac{4\pi \times 10^{-7} (90000) (5)}{2\pi \times 10^{-2}} \\
 &= \frac{2 \times 10^{-5} \times 9 \times 10^4 \times 5\text{N}}{1} \\
 &= 9 \text{ Newtons} \quad (2.02 \text{ lbs of force})
 \end{aligned}$$

Where: F = Force in Newtons

$\mu_0 = 4\pi \times 10^{-7} \text{ T} \cdot \text{M/A}$ in Free Space

M = Meters

A = Amperes of current

T = N/A · M

N = Newtons

1 Newton = 0.2248 pounds

L = Length

The linear induction motor is essentially a typical "rotating" induction motor that has been "cut apart" and the parts (rotor and stator) laid out flat so that it no longer moves in a rotary motion but rather in a straight line. It is important that the linear induction motor does not involve any moving parts in the traditional sense. There are no gears, pulleys, or belts to transfer the mechanical energy of the motor to move the vehicle; the motion is produced by two magnetic fields—one of the fields originating in the vehicle and the other in the fixed suspension rail. The resulting repulsive forces produce the motion of the vehicle.

This concept may be readily illustrated, as shown in Figure 4, by placing a small permanent magnet on the surface of a piece of glass or Plexiglas and a second magnet of the same pole on the bottom side. As the bottom magnet is moved along in close proximity to the first magnet, the first magnet will be repelled along just ahead of the bottom magnet.

The significance of linear induction motors in rapid transit lies in their advantages of speed, passenger comfort, and travel economy per passenger mile. However, the relative low cost, high convenience, and mobility afforded to individuals by private vehicles may well delay the extensive use of mass transit vehicles and particularly LIM-powered vehicles until the relative energy costs or conveniences become prohibitive for individual vehicles.

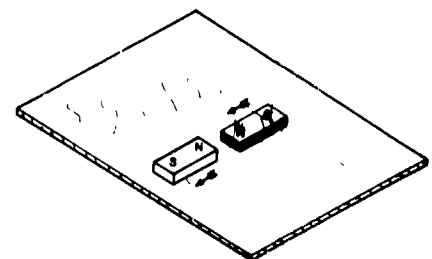

FIGURE 4

Repulsion of Magnetic Poles

Student Quiz

After you present this material or after various group presentations, use a simple multiple-choice quiz to check the student's understanding. You may also wish to use this as a pretest.

Sample Questions

- 1 One of the earliest developments in the field of transportation was
 - *a the wheel
 - b the trolley car
 - c the omnibus
 - d automation
- 2 The first efficient use of mechanical power that helped make mass transit possible was
 - a the horse-drawn cart
 - b the barge
 - c the steam engine
 - d diesel power
- 3 In 1832, the Harlem Railroad provided
 - *a the first mass transit for local passengers
 - b the earliest entrepreneurial effort in transportation
 - c service between Hoboken and Queens
 - d little in the effort to advance mass transit
- 4 After the general public's acceptance of mass transit companies, one of their major problems was
 - a power sources
 - b operating lands
 - c customers
 - *d nonregulation
- 5 The decline in the extensive use of streetcars was caused primarily by
 - a high fares
 - b uncomfortable cars
 - *c automobiles
 - d lack of acceptable routes
- 6 The eventual widely accepted replacement of rail-type carriers was the
 - a electric trolley
 - *b bus
 - c air cushion vehicles
 - d cable car
- 7 The movement of cargoes by the unit load concept was developed during
 - a America's westward expansion
 - *b World War II
 - c trade wars
 - d the Berlin airlift
- 8 Which of the following is an advantage of the unit load concept?
 - a less effective loads
 - b special terminals
 - *c speed
 - d nonduplication
- 9 In developing a new, technologically efficient mass transit system, engineers may consider
 - a automation
 - b land conservation
 - c environmental improvements
 - *d all of the above
- 10 Moving sidewalks are grouped within the concept of
 - *a pedestrian aids
 - b belt-driven transit
 - c shuttle services
 - d personal transport
- 11 One of the most significant limiting factors in the use of electric cars is
 - a cost
 - *b limited range
 - c smog
 - d weight
- 12 Rail speeds for presently proposed transit vehicles are up to
 - a 120 mph
 - b 375 mph
 - *c 500 mph
 - d 270 mph
- 13 In terms of transit control, headway means
 - *a interval between trains
 - b distance from engine to the last car
 - c vehicle's average speed
 - d personal interior head clearance
- 14 A present day example of the automatic distribution of vehicles over alternate routes is
 - a the interstate highway system
 - b traffic light systems
 - c merging and switching
 - *d not truly in use
- 15 Elevators in tall buildings commonly exemplify the use of
 - a automatic route control
 - *b automatic speed control
 - c automatic headway control
 - d automatic deceleration

Possible Student Outcomes

- List modes of mass transit currently being developed
- List mass transit's significant historical developments
- Analyze how and why the growth of our urban areas has been directly affected by the growth of mass transit
- Differentiate between rapid mass transit and personal transit
- Apply materials and scientific knowledge to the solution of technological problems
- Associate math and science as an integral part of the study of the technology of mass transit
- Describe some of the advantages of bus transit over fixed-rail types of transit

References

- Gray, G. E., & Hoel, L. A. (Eds.) (1979). *Public transportation: Planning, operations, and management*. Englewood Cliffs, NJ: Prentice-Hall.
- New and novel transportation systems* (1970). Institute of Transportation and Traffic Engineering, University of California. (Special report)
- Schumer, L. A. (1974). *Elements of transport*. Australia: Butterworth's.
- Smerk, G. M. (1976). 200 years in transit. *Mass Transit*, 3(7), 4-9.

Selected Readings

- Conference proceedings* (1972, May 31-June 2). Washington, DC: Intersociety Conference on Transportation.
- Davis, D. B. (1984, September). "High-speed trains: New life for the iron horse?" *High Technology*, pp. 28-36.
- DeVore, P. W. (1980). *Transportation systems: In Technology: An introduction*, pp. 182-192. Worcester, MA: Davis.
- Hadley, F. (1982). *Movin' on—The major socio-cultural impacts of some significant developments in transportation*. Norfolk, VA: Unpublished document.

ACKNOWLEDGMENT

Art on pages 19, 20, and 24 (top) was taken from a U.S. Government publication, entitled *Tomorrow's Transportation* (U.S. Department of Housing and Urban Development, Washington, DC, 1968, M/M-P-62).

Lasers/Fiber Optics: Communicating With Light

Contemporary Analysis

Laser and fiber optic technology represents a very new area of study in communications. To understand lasers and fiber optics, one must know about light and how it acts and reacts under controlled circumstances.

Obviously, the sun and electric lamps of various kinds produce light. If we were to examine some of the characteristics of light, we would see that it has "color" and intensity, in a very general sense. Scientists, however, define light as "radiant energy" and, accordingly, describe the "colors" of light as being part of a broad range of an electromagnetic spectrum. Thus, scientists say that light has a specific range of frequencies or wavelengths.

Figure 1 shows the relative position of visible light to other forms of electromagnetic radiation, such as radio waves, infrared, and ultraviolet rays. The figure reveals that

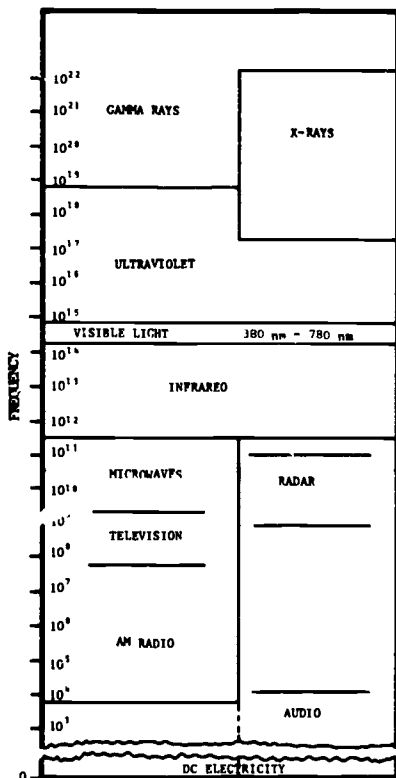

FIGURE 1
Relative Frequencies and Bands of the
Electromagnetic Spectrum

the visible light range is very narrow and the major characteristics of light that we are most familiar with are the colors of the rainbow. Newton first used a triangular prism to illustrate that sunlight could be split up to give a spectrum of colors, which is a familiar physics experiment.

Where does light come from? A logical answer would be that it comes from natural and artificial sources. As mentioned earlier, the sun is a primary or natural source of light. Artificial sources of light include gas and oil lamps, electric lamps, and chemical light sources. An analysis of a light source reveals that when the atoms of a given substance are sufficiently excited, they will produce energy in the form of light, heat, or both. A campfire produces both heat and light. Wood, which may be used as a fuel for the fire, is heated to a temperature level that supports combustion. This causes the atoms of the wood to change energy levels and, in the process, release heat and light energy. A length of resistance wire will produce a red glow. As the current is increased, it may turn "white hot" if a sufficient electric current is passed through it. During this process, the temperature of the wire has increased and light produced has a shorter wavelength. In each of these examples, the light energy radiating from the sources occurs in all directions, in a random pattern, and in a broad range of wavelengths.

A very special kind of light, **coherent light**, may be produced under controlled conditions. This form of light is in phase and monochromatic. The more closely the light is of one color (monochromatic) and in phase or in-step, then the narrower and more intense a light beam will be produced.

Light Amplification by Stimulated Emission of Radiation, or **laser**, produces what is known as coherent light. The monochromatic and high concentration of light produced by lasers make them ideal for communication, data transmission, and industrial applications. Video disks, product bar-code scanners, precision measurement devices, surveying instruments, and machining of materials are typical applications that use lasers.

The rays of light frequently mentioned in the discussion of light are called **photons**. To gain a better understanding of light, it may prove helpful to discuss the absorption and

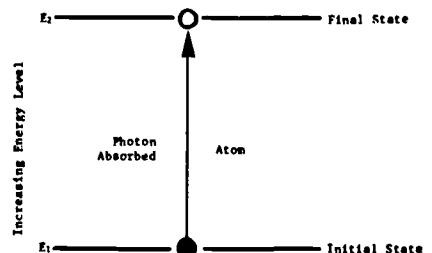

FIGURE 2
Absorption of a Photon by an Atom

emission of photons of light. In the following example, we will discuss a single atom that can exist in two different states at different energy levels, E_1 and E_2 , where E_2 is of a higher energy level. If the atom were "struck" by a photon (Figure 2) in state E_1 , it would be possible for it to absorb a photon under the appropriate conditions and accordingly be raised to energy level E_2 . This process is known as **absorption**.

However, when an atom already exists at energy level E_2 , it is possible for the atom to revert back to energy level E_1 and emit a photon without any external excitation. This process is known as **spontaneous emission** of a photon (Figure 3). This process is the opposite of photon absorption.

There is yet another way for an atom at energy level E_2 to revert back to energy level E_1 . This may be accomplished by striking (incident) the atom at E_2 with a photon at energy level $E_2 - E_1$. The incident photon can excite the atom to revert back to energy level E_1 and emit a second photon with an energy level of $E_2 - E_1$. This process is called **stimulated emission** of a photon and is the means by which a laser generates light (Figures 4a and 4b). Although this discussion has been directed at absorption and emission of photons at two energy levels, actual practice dic-

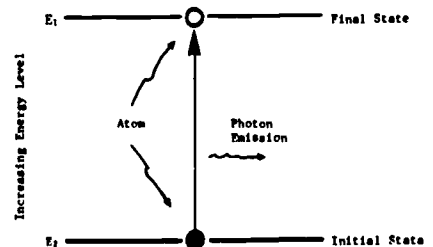

FIGURE 3
Spontaneous Emission of a Photon

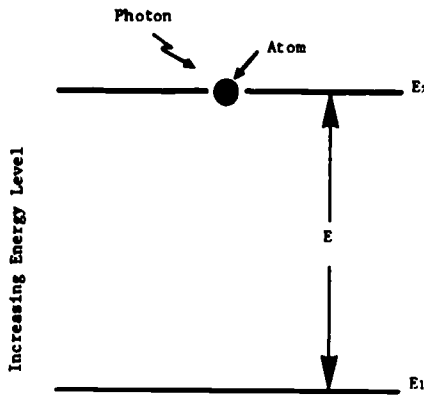

FIGURE 4A
Stimulated Emission of a Photon With an Atom at the Initial State

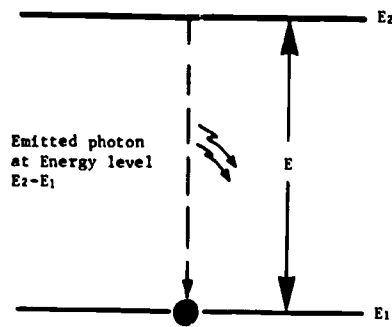

FIGURE 4B
Stimulated Emission of a Photon With the Atom in the Final State

tates that three or four energy levels may be used.

Currently, lasers may be grouped into four different classifications. These classifications, based on the types of materials used to generate the laser light, are (a) solid-state, (b) gas, (c) semiconductor, and (d) liquid lasers.

Conceptually, a ruby laser, which is a gas laser, is easily explained in terms of the system and its respective components. The diagram in Figure 5 illustrates the major components. This "block-representation" shows the ruby rod, the xenon flash tube that is used to "pump" the laser, the xenon tube control unit, the power supply, and the external mirror units.

The laser is operated by reflecting photons back and forth in the ruby rod that were initially generated by the xenon lamp. These emitted photons are continually "bounced" back and forth by the reflecting mirrors (one of which is a partially transmitting mirror and will allow light to escape when it reaches a certain level). The back-and-forth motion of the light causes more and more photons to be emitted. In addition, all of the photons begin to move together (in-step) as they move back and forth. This assists in producing the necessary spatial and temporal coherence. When enough photons have been emitted and have reached a predetermined energy level, they will escape through the partially transmitting mirror in the form of coherent light, such as we call laser light.

The lasing action of this type of laser is not continuous but rather a stream of pulses. These pulses may be thought of as "on-off" periods of time and will allow the ruby rod to cool. Figure 5 also shows a coolant system to dissipate excess heat energy. Other types of lasers are capable of producing continuous wave energy, however, the ruby laser represents the early developments in laser technology.

In the area of communications, lasers present some very significant advantages.

Particularly important is that lasers produce a very narrow beam of light that can be oriented or aimed with great precision. This reduces the possibilities of signal interference. More important is the fact that laser communication systems have extremely wide band widths. This is of particular significance to the telephone and television industries

because of the increased capacity of a system to carry voice and data signals. The net effect is that a laser communication network can carry many signals at the time thus increasing the efficiency of the communication network. Figure 6 shows the relative capacity of typical communication frequencies as compared to laser systems.

There are some problems related to earth-bound laser communication systems, particularly the interference caused by atmospheric conditions, such as smoke, dust particles, and weather conditions. These problems may be overcome by the appropriate medium of transmission. High-quality optical fibers, commonly known as "fiber optics," offer a unique solution to the interference problem of light communications.

The concept of optical communication using lasers and fiber optics is illustrated in Figure 7. The operation of the system involves the digital modulation of a laser and channeling the information through an optical cable. When the laser is in the "on" state, a digital signal is fed to the laser, when the laser is in the "off" state, no information is transmitted. Although this technique does not allow analog information to be transmitted, it does have that capability to operate at very high speeds for data transmission.

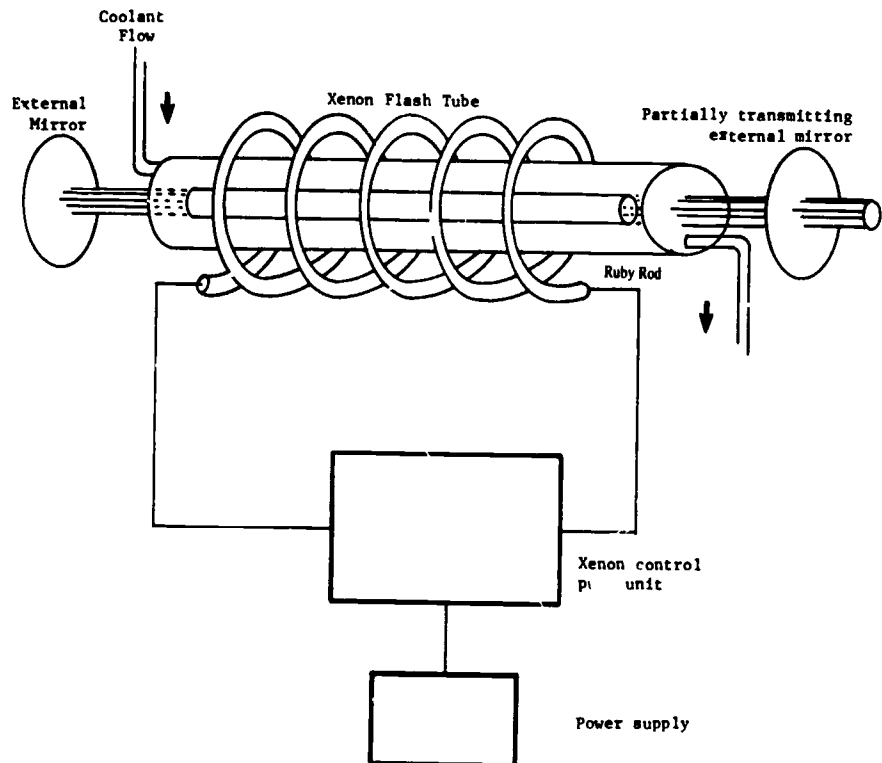

FIGURE 5
Diagram of a Typical Ruby Laser

| Frequency Range | Band | Usable Bandwidth | Approximate Number of Phone Channels | Approximate Number of TV Channels |
|-----------------|-----------|------------------|--------------------------------------|-----------------------------------|
| 300kHz-3MHz | MW | 10% | 25 | - |
| 3MHz-30MHz | SW | 10% | 200 | - |
| 30MHz-300MHz | VHF | 10% | 4000 | 1 to 4 |
| 300MHz-3GHz | UHF | 10% | 10,000 | 10 |
| 3GHz-1THz | Microwave | 10% | 100,000 | 100 |
| 5THz-1000THz | Optical | 0.1% | 10^8 | 10^5 |

FIGURE 6
Relative Capacities of Typical Communication Frequencies

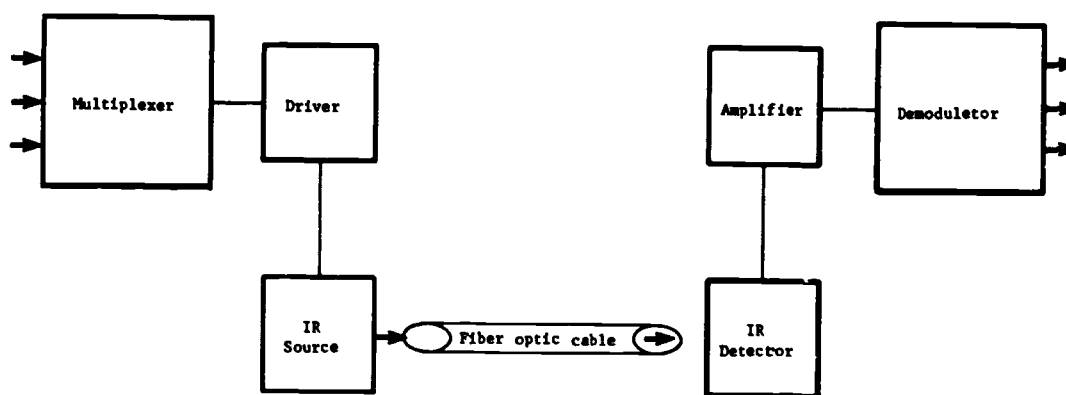
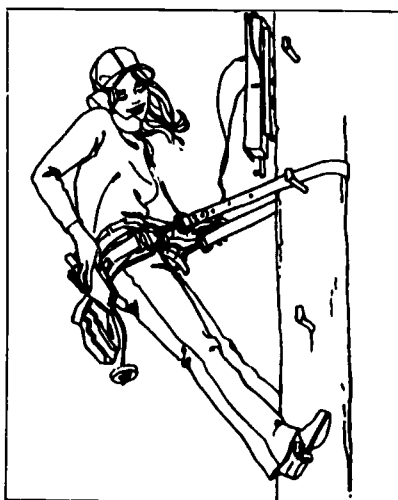

FIGURE 7
Block Diagram of a Fiber Optic Communication System

Social-Cultural Impact

So, lasers and fiber optics have become new forms of technology appropriately being used by the technological areas of communication, construction, manufacturing, and transportation. They have created somewhat of a revolution in measurement, information flow, and material processing because of their relative accuracy, size, and cost. As a result of these characteristics, they are having an impact on business and industry and, indirectly, on the citizens of the developed world.

In the realm of communications, lasers and optics have revolutionized the methods for transmitting information. With information services increasing 15% per year, lasers are much more effective than microwaves and traditional conduits (Gunderson & Keck, 1983, p. 42). Their high capacity and efficiency make optical fibers one of the most cost-effective conduits available. Because of their system characteristics, they are free of electromagnetic interference and are very difficult to eavesdrop on.



Today, optical fiber systems are in use in more than 30 countries. Because networks are cheaper to construct than systems using cable, AT&T is using this technology in constructing a communication system between

Boston and Richmond, Virginia. They expect to save some 49 million dollars in the construction of this system. AT&T also proposes making their next trans-Atlantic cable from optic fiber conduit (Yanowitz, 1983, p. 40). With developments like these, it is projected that lasers and optic fibers will be a \$2.8 billion business in North America in 1990 (Gunderson & Keck, 1983, p. 44).

Besides information transmission, there are many other uses of lasers and fiber optics today. Surgeons have been using lasers to cut out corneas and cancerous growths and to burn away blood clots. In supermarkets, lasers read the codes on products or the cash registers and, at the same time, take inventory. In entertainment, optics and laser can be used to produce light shows or holographs. In the construction field, lasers are used for surveying with their ability to be much more accurate than visual methods. The characteristic of accuracy also makes lasers good for keeping time and for machinery measurement.

Another use for lasers is in material inspection. Material defects may be spotted and quality control in assembly may be monitored with the use of lasers. This has been shown on one automaker's television commercial.

Another industrial use of lasers is to harden metal surfaces. They are able to heat treat sections of metal pieces without altering the characteristics of other sections of the material. Lasers can also be used in the machining of materials. This machining is accurate to 40 millionths of an inch.

Home use of fiber optics is also increasing. With their ability to carry numerous forms of information, experimental systems are being installed in homes in France and West Germany. These systems are able to be used for video programming, stereo, picture phones, data channels, and telephones (Gunderson & Keck, 1983, p. 40).

With research and advancements in laser technology come the fears by the uneducated of the potential destructive use of lasers. Although direct visual contact of laser

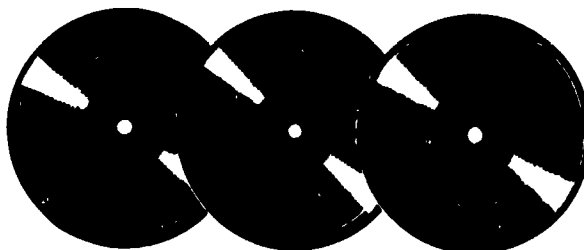

beams will cause damage to the eye, lasers are not much of a threat in terms of death and destruction. These are beliefs left with us from science fiction books and film. It is not likely that in the near future, lasers will replace military weapons because of our present investment and the high developmental costs of using lasers for this purpose.

The use of lasers and fiber optics has advanced in the past 25 years since Theo-

dore H. Maman of Hughes Aircraft invented the first laser in 1960. Business and industry are developing their application. We, as citizens of the developed world, are beginning to benefit from their application. They are just some of the new technologies that will affect our lives for years to come. In the next section, we will see more specifically how laser and optic fibers affect the common elements of our technological systems.

Common Elements: Lasers and Fiber Optics

People

The lives and jobs of all people in their present and future situations may be greatly affected by lasers and fiber optics. The most common application of this technology today is found in the field of surveying. This is because of their ability to produce straight lines, a fundamental requirement in that field. It is also particularly adapted to surveying because of its adaptation to the measure of great or precise distances. For example, the distance to the moon can now be described

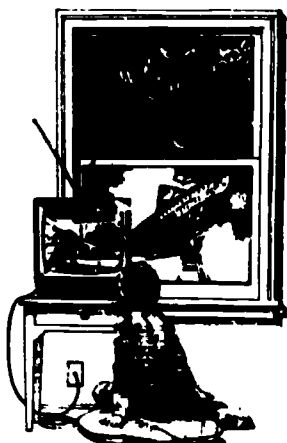

in inches rather than miles, and land distances on earth can be measured even more precisely.

The highly refined practice of medical surgery has been even further refined. Controlled incisions/surgery cuts are another application of this new technology. This is because of the fine focusing and intensity control of the surgical incisions used by doctors today.

The use of lasers and fiber optics will probably have its greatest use and impact on the lives of people in the field of communication or information processing. The potential uses of lasers and fiber optics in producing cheaper and more effective communication are indeed many. All the radio and television signals of today plus all the world's telephone communications could theoretically be transmitted simultaneously over a single light beam.

For industry, there are also many present and future uses. Drilling holes through diamonds, one of the hardest minerals known to science, is relatively easy using a laser beam. The scanner at the checkout counter of your supermarket bounces a laser beam off a pattern imprinted on a product, which gives the customer an immediate updated price and provides the store with a constant read-out on its inventory.

Information

In the various fields of information processing, lasers and fiber optics certainly are capable of generating a real revolution if, in fact, they have not already begun to do so. More than 100 communications links using optical fibers have already been installed in North America alone, and more are being planned worldwide. The number of radio or television stations, which is now restricted by limited available frequencies, can be greatly expanded.

A light beam can be transmitted on a fiber about one-tenth the diameter of a human hair. These tiny fibers can produce an enormous carrying capacity. Because of that, it has been predicted that this technological application of lasers and fiber optics will eventually replace most heavy cables. They may also replace our present satellites.

Capital

The development of lasers and fiber optics is by no means inexpensive. Large amounts of capital are constantly required. Despite this, many U.S. and foreign universities are now engaged in research and devel-

opment because of the significance of the technology

Large corporations are also heavily involved in the research and development efforts. Government grants for laser and fiber optic related projects are now forthcoming. As these studies continue and some of the costs hopefully decrease, the capital requirements for future projects will diminish

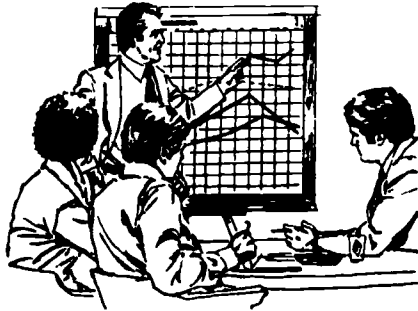

viewed by our astronauts on the moon, while the lights from our "bright" cities were not visible to them. The government also has a laser focused into space that is transmitting information about our planet to distant galaxies. This is an application aimed at extending into the frontier of the future

Also, pulsed lasers can produce trillions of watts of power. Just one such pulsed laser is capable of producing as much power as is produced over the entire earth at one time.

Tools

As stated earlier, the tools that people use in many fields may be vastly affected by lasers and fiber optics, if they have not been already. Industry presently employs multiple applications of this technology. For example, metals may be measured, cut, welded, or bored using it. The jobs formerly done by individuals may now employ this technology and produce a finer, more accurate product using less of a person's or a workforce's efforts.

The tools of today's competent surgical teams may now employ the technology of lasers or fiber optics. In addition, they are especially useful in research because of their precision and predictability. While lasers and fiber optics have already been used in many applications that touch our daily lives, even more are in our technological futures

Materials

As laser/fiber optic technology continues to be developed, new or different materials may be applied to many applications. The example given earlier of a tiny optic fiber replacing enormous communications cables is but one. Also, the precision possible with this technology may result in the use of many present materials being used, cut, measured, applied, and so on in other previously inappropriate ways.

Processes

The final area of common elements is processes. Any existing process that incorporates this emerging technology in the future will undoubtedly be much changed from its present form. We have previously discussed the phenomenal changes possible in information processing, industrial uses, medicine, and research in other fields. Many methods and processes that today we assume will never be altered may, in fact, be greatly changed through the use of lasers and fiber optics

With this overview of how lasers and fiber optics have influenced the basic elements found in all of our technological systems, let us now look at a laboratory-tested technological problem

Energy

The potential of lasers and fiber optics with regard to the energy required to produce them is phenomenal. A laser emitting only one watt of light (one-hundredth of a common light bulb) was so intensified (or concentrated) here on earth that it was

Constructional Activity: Fiber Optic Communication System (FOCS)

The fiber optic construction activity provides an excellent medium for discovering and verifying the concepts and principles that are the foundation of fiber optic communication. The activity also provides for the development of skills in selecting, assembling, and testing electronic components

An analysis of the FOCS activity will reveal that the system converts sound energy into invisible infrared light energy, transmits that energy through a high-purity optical fiber, received by a phototransistor and converted into an electrical signal that corresponds proportionally to the original sound

energy. An amplifier is used to increase the level of the received energy so that it may drive a small loudspeaker. Figure 8 illustrates the process conceptually

The FOCS activity uses three major components to illustrate light communication. The LM386 integrated circuit is a compact 8-

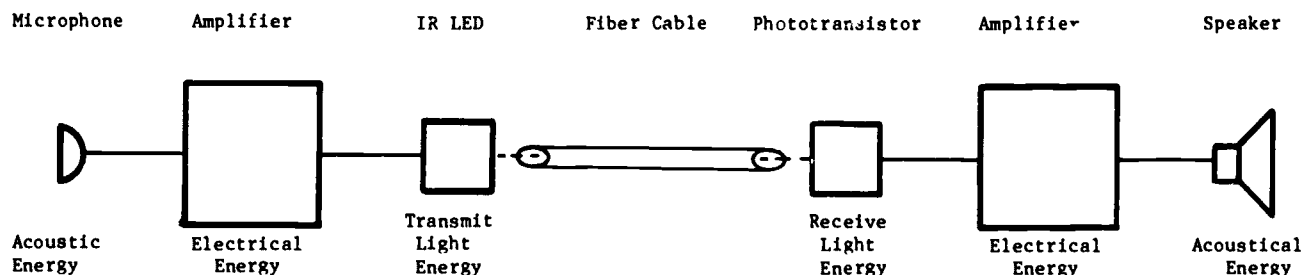

FIGURE 8
Conceptual Diagram of the FOCS Activity

pin dip package that provides the necessary amplification for the transmission and reception of a "modulated" IR signal. The actual IR conversion devices are an IR LED and IR phototransistor. The two units are available in a package for less than \$2.00. The LED and phototransistor are modified by drilling a small depression or dimple in the lens of the devices so that an optical fiber may be epoxied exactly in the center of the lens. Care must be exercised NOT to drill into the actual semiconductor itself. A quick-setting epoxy was used to minimize the problem of holding the optical fiber in place. Figure 9 shows a detail of this technique. After the epoxy has cured, a coat of black paint is applied to the remaining lens area so as to reduce the effects of "stray" light. The fiber optic cable is available from several science supply firms. Also, you may check with your local telephone company. It may be able to supply you with a short length of the cable. The cable used in the author's experiment was supplied by courtesy of ConTel, Chesapeake, Virginia.

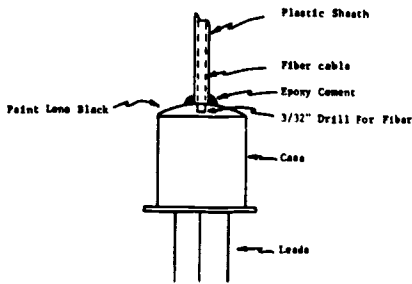

FIGURE 9
Detail Showing Modification of the IR LED to Attach Fiber Optic Cable

The transmitter and receiver units (Figures 10 and 11) were bread-boarded using a 2" by 3 1/2" experimenter sockets. The appropriate connections were made using 28-gauge solid wire. It should be noted that the LM 386 IC's should straddle the "trough" in the middle of the board. The rows of holes are used to make the appropriate connections. The holes that are in-line and perpendicular to the trough are connected to one another. The schematic drawing of the circuits reflect the number and NOT the actual placement of the wires to the various components and pins of the IC's. An electret condenser microphone was used in the prototype circuit; however, a crystal microphone should work equally well. The receiver circuit should be constructed first so that the wiring practices and understanding can be verified. The completed receiver circuit may be tested by aiming the phototransistor toward an artificial light source, which should result in a 60-hertz signal being heard. If not, check the wiring, or maybe the leads of the phototransistor need to be reversed.

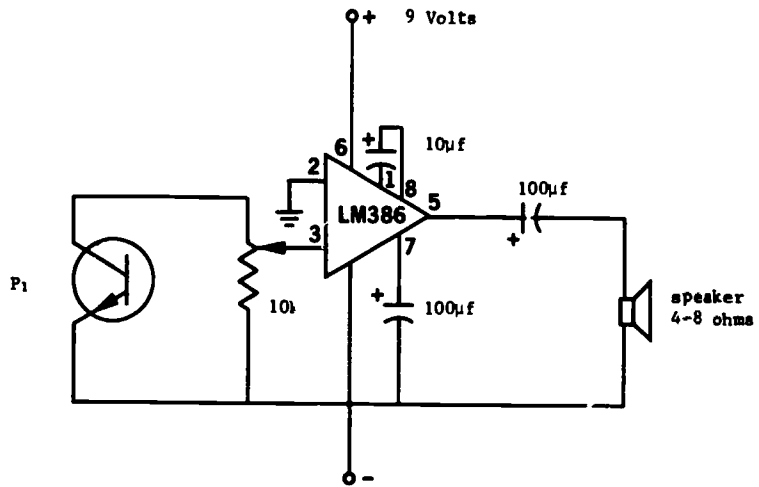

FIGURE 10
Schematic Diagram of the Optical Receiver

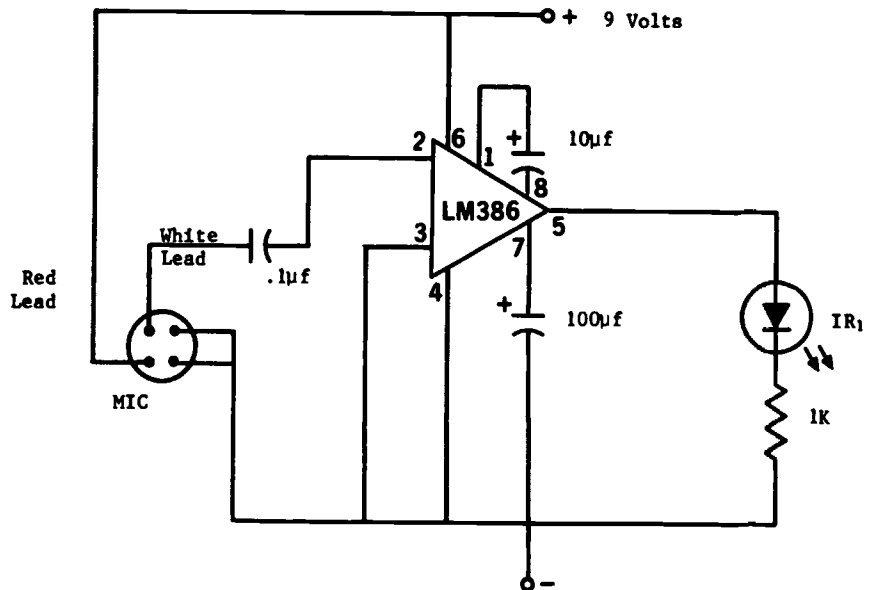

FIGURE 11
Schematic of Optical Transmitter

The power sources for the units are 9-volt alkaline "transistor radio" batteries. The receiver unit uses very little current. The transmitter unit power consumption is determined by the 1,000 ohm resistor in series with the IR LED. The maximum permissible current for the IR LED is 20 ma. The 1,000 ohm resistor value may be changed to increase the output but should not exceed the 20 ma limit of the IR LED. It should be noted that the maximum current drain for the 9-volt transistor batteries is approximately 10 ma.

Conceptually, the FOCS activity converts acoustical energy into electrical energy

that is amplified to drive the IR LED, which in turn converts the electrical signal into infrared light energy. The transmitter unit is coupled to the receiver through an optical cable. The process is then reversed to convert the light energy into an audible signal that we can hear (see Figure 8). This activity is conceptually very simple but closely parallels the process used for telephone communication. With some creative imagination, there are many other experiments that may be developed to use the circuits described in this activity. Your students are sure to be motivated by this high-tech activity.

Math/Science/Technology Interface (M/S/T)

To understand better how lasers and optics work, we have provided a science and math analysis. These discussions should also aid you in understanding the conceptual operation of our constructional activity.

Light: How is light produced?
How does light travel?
How does light act?

Light waves consist of tiny particles or atoms, giving off energy produced by heat or electricity. The unit of light energy given off when one atom gives up an electron is called a "photon" (foton). More light is produced when more heat or electricity is applied.

Light travels at high speed, 186,000 miles per second (300,000 kilometers per second) in a straight line called rays. This high speed makes light an excellent medium for communications. Compare the speed of sound in air with light. Light from the sun takes 8 minutes to reach earth. Light is also measured in light years, or the distance light travels in a year, 9.6 trillion kilometers. The closest star's light takes 4.3 light years to reach earth.

Light acts on two theories. Scientists believe light to be particles or photons that move through air. Question: How does light travel through space when there is no air? Other scientists believe light to be an electromagnetic wave. Today, scientists have accepted that light has both properties of particles and waves.



Math

1. If sound could be heard from the East Coast to the West, 4,000 miles away, how long would it take for a sound message to be sent by air, how long by light through a fiber optical cable? Note: Sound travels at approximately 1,086 feet per second in air.

2. Calculate the "outer space speed limit." Convert 186,000 miles/second to miles per hour.

3. If a 1/2 in. diameter fiber optical equals a 2 in. copper cable in ability to handle 240,000 phone calls, what factor of size difference is there between the two cables?

4. Using the following cost per foot of installed cable, and the factor figure above, calculate the cost savings to install fiber cable between Richmond, VA, and Boston, MA (540 miles)

Fiber optic cable installed—240,000 phone calls, \$18.00 per foot

Copper cable installed—60,000 phone calls, \$20.00 per foot

TECHNICAL TERMS

Coherent: Light waves that are in-phase and monochromatic.

Fiber Optics: A term that is generally used to describe the process where electrical energy is converted to light energy and then transmitted to another location via optical fibers and then converted back to electrical energy.

IC: Integrated circuit

IR: Infrared

Laser: Light Amplification by Stimulated Emission of Radiation

LED: Light emitting diode

Monochromatic: Having the property of or consisting of one color.

Optical Fiber: A single strand high-purity glass suitable for the transmission of light energy.

Optics: The branch of physics concerned with light and vision.

Photon: Very small pulses of light energy. An atom that has been stimulated to an excited state emits a "photon" of light when it reverts to the unexcited state.

Phototransistor: A transistor that is designed for light sensitivity and is used to detect light.

Stimulated Emission: The process of causing an atom at an excited state to revert to a lower level and give off a second photon of energy.

Temporal Coherence: The phase relationship or correlation of waves at a point in space at two intervals of time.

Suggested Parts List for Constructional Activity

| Quantity | Description | Part Number |
|----------|--|-------------|
| 2 | LM386 integrated circuit | 276-1731 |
| 1 | 2" mini-speaker | |
| 1 | Electret mike element | 270-092A |
| 1 | 10,000 ohm trimmer potentiometer | |
| 1 | 1,000 ohm 1/4 watt resistor | |
| 2 | 10 uf 15-volt PC capacitors | |
| 3 | 100 uf 15-volt PC capacitor | |
| 1 | .1 uf mylar capacitor | |
| 1 | Infrared emitter and detector pair | 276-142 |
| 2 | 9-volt transistor batteries | |
| 2 | 9-volt battery snaps | |
| 2 | Experimenter sockets | 276-175 |
| 2 ft. | 20-28 gauge solid hook-up wire (insulated) | |

Student Quiz

- 1 The basics of fiber optics requires
 - a. the understanding of sound and how it interacts with water
 - *b. the understanding of light and how it acts and reacts under controlled circumstances
 - c. the use of light in artificial circumstances
 - d. pure light unaltered by the spectrum of color
- 2 The light produced by lasers that makes them ideal for communication, data transmission, and industrial applications is called
 - *a. coherent light
 - b. incandescent light
 - c. low energy/high output light
 - d. solar enhanced lunar light
- 3 A ruby laser
 - a. is a weak industrial laser
 - b. is a natural liquid laser
 - *c. is a gas laser
 - d. represents the latest development in laser technology.
- 4 The reasons lasers and fiber optics created a revolution in measurement, information flow, and material processing are their.
 - *a. high degree of accuracy, small size, and low cost
 - b. high capacity and large size
 - c. reliance on solar energy and wind velocity
 - d. limited requirements for maintenance and short lifespan.
- 5 Lasers are used to perform which of the following processes?
 - a. surgical cuts
 - b. surveying
 - c. product bar-code scanning
 - *d. all of the above
- 6 Information services are presently increasing at what percentage per year?
 - a. 5
 - *b. 15
 - c. 25
 - d. 50
7. Which of the following is a type of laser?
 - a. gas
 - b. solid-state
 - c. liquid
 - *d. all of the above
- 8 Laser stands for.
 - a. Lunar Assault System for Earth Rotation
 - b. Light Application to Serve Energy Resistance
 - c. Light Aluminum Steel, Epoxy Reinforced
 - *d. Light Amplification by Stimulated Emission of Radiation
- 9 The laser was invented by.
 - a. O F Lassier
 - b. Howard Hughes
 - *c. T. H. Maman
 - d. Dennis Gaber.
- 10 A unit of light energy is called a
 - *a. photon
 - b. kilowatt
 - c. laser
 - d. watt

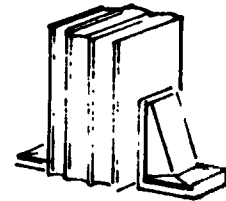
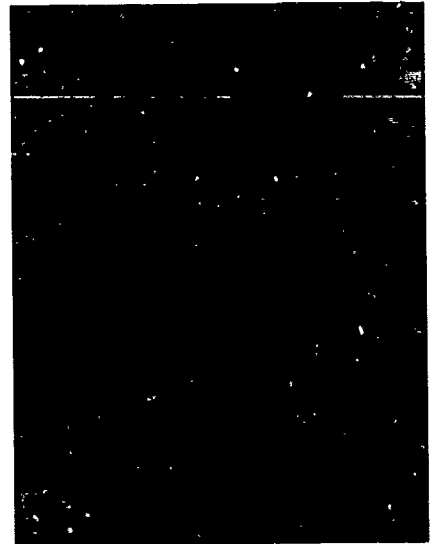

Reference

Gunderson, L. C., & Keck, D. B. (1983) Optical fibers Where light outperforms electrons *Technology Review*, 86(4), 32-44.

Additional Readings

- Beiser, A. (1982) *Physics* Menlo Park, CA Benjamin/Cummings
- Mimms, F. M., III (1981) *Engineer's notebook: A handbook of integrated circuit applications* Ft Worth, TX Radio Shack
- Mimms, F. M., III (1984) *Getting started in electronics* Ft Worth, TX Radio Shack
- Semiconductor reference guide* (1981) Ft Worth, TX, Radio Shack Corporation
- Townes, C. H. (1984) Harnessing light *Science* 84, 5(9), 153-155
- Yanowitz, J. (1983) Fiber optic communications Where will they lead? *Technology Review*, 86(4), 40-41
- Yule, J. (Ed.) (1978) *The concise encyclopedia of the sciences* New York: Van Nostrand Reinhold

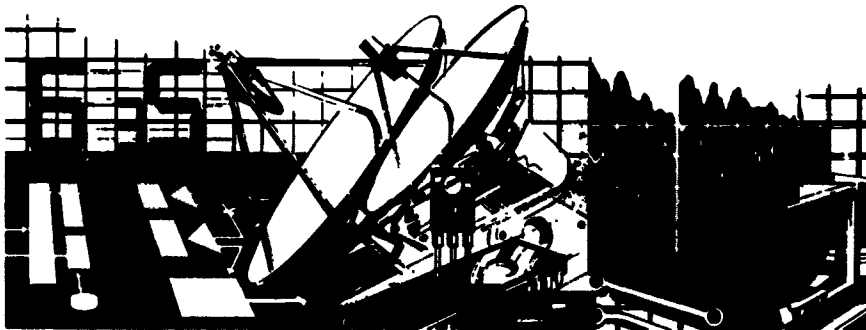

Automated Warehousing

A Contemporary Analysis of an Automated Warehouse

Many companies are in the process of automating their factories and warehouses. In the next 20 years, even more companies, both small and large, will move to automation to improve production and profit.

The move to automate material handling and storage systems has been prompted by a worldwide recession that has caused high interest rates, money shortages, a decline in production, and a loss of profits. Another factor is the "low-wage" foreign competition, which caused the United States to drop in production in the world market. These elements have forced management to rethink the fundamental precepts of manufacturing and warehousing to improve production and reduce overhead costs.

With the growing use of high technology in the United States, two giants in the field of electronics—Motorola and Fairchild Camera and Instrument Corporation—have moved back to the United States. Modern microcomputer manufacturing and automated storage/retrieval systems (AS/RS) are driving costs downward. The United States is once again competitive with third-world countries.



This is a giant step in restoring the United States in the world market ("Asia-Automation," 1982).

To save time and money, many companies have moved to computer-integrated material handling systems to streamline planning, scheduling, production processing, and automated material handling. Automated factories/warehouses are now using man-rails, automatic guided vehicle systems (AGVS), laser bar-code readers, conveyor systems, robotic retrieval systems, and more.

Today's factories must not only concentrate on automating the production line, but they must also consider the entire production process, especially material handling, inventory control, storage requirements, and insurance against pilferage. Improving both the manufacturing and distribution process will depend on how effectively companies can integrate their existing material handling systems with automated material systems.

The newest high technology material handling system to emerge in the past decade is the automated storage/retrieval systems (AS/RS). Sperry, under contract to the United States Navy, has developed an automated warehouse system called NISTARS—the Naval Integrated Storage, Tracking and Retrieval System. This is a highly sophisticated AS/RS system. In an effort to improve response time to "fleet readiness," NISTARS has been installed in Naval supply centers located in Oakland and San Diego, California, and Norfolk, Virginia.

Traditionally, United States warehouses have wasted more than 70% of their available space with the wide-aisle concept and the limited reach capabilities of workers. NISTARS, with its 1.5 miles of 40-ft-high storage shelves and robotic devices (called ministackers), can quickly retrieve trays/parts and deliver them to work stations by a single command from the central controller or from microcomputers at each work station. When the operator is finished with this invoicing process, the ministacker will then return the tray to its original location. While this process is being conducted, the central processor is updating its inventory to show the transaction.

The heart of an automated storage/retrieval system is the modern computer-controlled systems that use mini- and microcom-

AS/RS GOALS

- Improve storage capabilities
- Improve customer service
- Improve inventory accuracy
- Improve security
- Improve workload control
- Improve productivity
- Improve worker accountability
- Improve profit margin

FIGURE 1

puters to direct both robotic and human production. This feat links the worker to the central controller via the work station computer data terminal. If any one of these computer data terminals experiences a problem/failure, the remaining terminals will automatically assume the down terminal's responsibilities. This "fail-safe" capability, or built-in redundancy, is essential in preventing production shutdowns.

Figure 1 highlights the primary reasons U.S. manufacturers are moving toward automated material systems, such as automated storage retrieval. Historically, warehouses have been large, with enormous inventories, a large blue-collar work force, and a large clerical staff. As conventional warehouse systems improved and became somewhat more efficient, the disadvantages still outweighed the advantages of automation. The biggest problem with these noncomputerized systems was the excessive time required to process an order transaction.

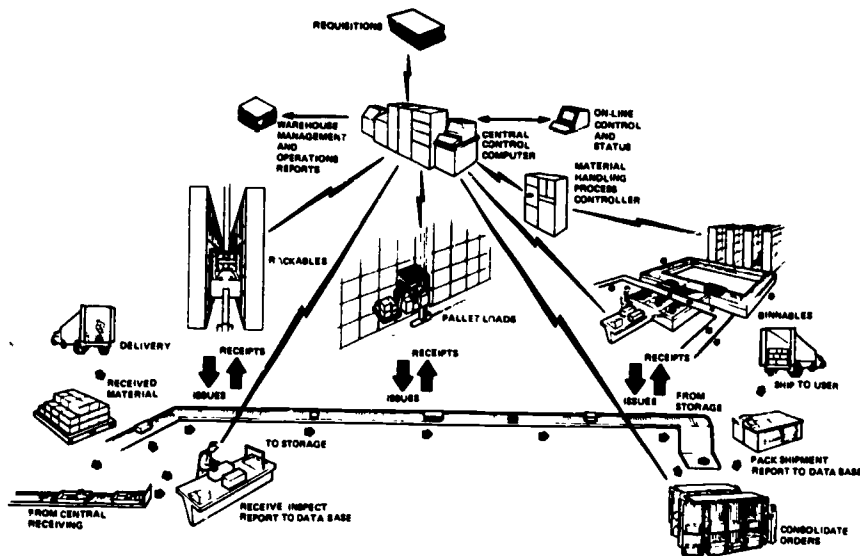

FIGURE 2

With the use of computers and their software programs in the automated warehouse of today, the entire material handling system has changed. In today's automated warehouse (Figure 2), a delivery of material may be made by side-loading trailer trucks whose sides roll up for easy removal of palletized loads. These palletized loads are loaded on an automatic-guided vehicle, then directed by the central control computer to be stored either by a robotic ministacker

(storage in bins) or by a human-operated storage and retrieval machine that moves along high storage racks. If received stock in an automated warehouse is turn-around inventory, it may be delivered by either an automatic-guided vehicle or monorail to the required shipping stations involved in packing and shipping.

The automated factory and warehouse concept grew in the 1970s, when large inventories suddenly became more costly to

maintain. These inventories were an enormous capital drain both in warehouse space and cash outflow/shrinkage. Today, both the automated factories and their supporting warehouses make use of the "just-in-time" concept borrowed from the Japanese KANBAN system. The just-in-time inventory concept is based on the premise that the required material for production arrives at the factory just as it is required for production. This eliminates the need for excessive inventory, huge inventory capital investments, and large storage areas.

The automated warehouse with its AS/RS has made the just-in-time concept a reality by supplying neighboring factories with the required material for production. The automated factories no longer need to maintain large warehouses of their own or maintain large inventories. The automated warehouse can offer competitive prices by servicing many factories. The overall cost to the automated factories is much lower because there is no longer a requirement for large warehouses and cumbersome inventories.

We have developed technology to the point where we can now start implementing the factory of the future. But what impact will automated material systems, such as automated storage/retrieval systems, have on the human work force? In the next section, we will investigate the impact of high technology on the work force and learn what steps are being taken to prevent unemployment and relocation and to institute retraining.

Social-Cultural Impacts

From the start of the industrial revolution to recent times, the primary elements of production have been humans, machines, and profit. To a large extent, they still are today, with one exception—the human element. The new primary elements in today's high-technology society are information (data base), time, and material (automation). The human work force is gradually being replaced by automation (Hess, 1984).

Automation is the substitution of machines, many times robots for human workers. These robots, when used in an automated material system, are designed to perform more and more like human beings. Today, implementation of robotic technology into the automated warehouse requires the remaining human workers to possess robotic technical interfacing skills and the capacity to absorb other automated technologies into one interdisciplinary system. The demands on the warehouse worker will be great; but the demands on the industrial engineers of the future will be even greater. The new industrial engineers who will design the automated warehouses of the 1980s and 90s will have to be formally schooled in

- high-technology management principles
- microcomputer concepts and application
- software integration
- CAD/CAM fundamentals
- automated manufacturing processes
- material handling systems and automated storage and retrieval systems
- micromechanical applications
- knowledge of support systems
- intracommunication skills to work effectively with the remaining people.

The biggest task that faces the industrial engineer and the warehouse worker, however, will be integrating all of these elements into a totally integrated automated factory, automated storage/retrieval system, or both.

The social impact of automation, both favorable and unfavorable, is beginning to emerge. As a result of automation spin-offs, the U.S. economy is on an upswing. Although automation is reducing labor costs, it has and will continue to cause work force reduction and dislocation problems. As automation increases in manufacturing and automated

warehousing, the number of workers involved will steadily decline.

A recent case study of a Japanese company that installed an automated material system in one of its flexible manufacturing plants found that it saved \$1.35 million in annual payroll. This Japanese plant reduced the number of machines required from 50 to 6. The work force was reduced from 70 to 16, and productivity increased. Order lead time, which originally took 18 days, fell to an impressive 4 days. The key to their success was the marriage of robotics, automated material systems, and the use of a central computer controller ("Use Advanced Technologies," 1984).

In the United States, Westinghouse has implemented a state-of-the-art system that involves robots, carousels, conveyors, and special trays that hold parts. This totally automated system has robots retrieving parts from storage and delivering them to robotic stations where other robots prepare kits for printed circuit boards (Klass, 1982).

In both cases, there seems to be a dehumanization of the human work force involvement in an automated factory. How-

ever, there now seems to be a reversal in thinking. Many managers in the warehouse business now consider the most important ingredient in automating a factory or warehouse to be their human employees.

In a recent speech, Dan Ciampa, executive vice president for Rath & Strong, Inc., stated that you cannot initiate an automated factory or warehouse with all the realities of high technology without addressing what management must do to retrain workers for their new roles (Ciampa, 1984). Without people the automated material handling system will not function. To combat this, Ciampa proposed a total integration of all the people, from management to the warehouse workers, in a common vision and a unity of purpose. Rath & Strong, Inc. recognizes that to have a successful computer-integrated manufacturing system, the human element must not feel threatened. Rath & Strong proposed five major steps to accomplish the integration of people into an automated environment (Ciampa, 1984).

The first and perhaps most important step is that present workers must be receptive to retraining to learn new competencies. For example, as automated material systems are installed, workers will have to be trained in the use of microcomputer terminals.

The second step is to improve interpersonal communications at all levels. In the wake of automated material systems, there seems to be a widening of the gap between the warehouse personnel and top management. A hierarchy is growing that is counterproductive to effective interpersonal communications.

The third step is the inevitable change that accompanies any move to automation

and how well workers adapt to these new changes and their new roles. Management must develop job descriptions outlining each worker's area of responsibility and their field of authority/technical expertise.

The fourth step on the "people side" of the scale is decision-making authority. In an automated environment, workers at the lowest level will be making important business decisions daily that could greatly affect overall production.

The final step in the human aspect of implementing an automated material system, such as automated storage/retrieval system, is to talk to the workers who will have to operate the new automated equipment. Documented case studies of factories that installed automated material systems without consulting the workers who ultimately had to operate them showed that in some cases, workers became barriers to the implementation of the automated material handling system. What these case studies revealed was that the workers in the warehouse were not asked what the problems were, if any, and if an automated material system could help solve any of the problems that existed.

Traditionally, workers came to the work force trained in a job skill. They were hired and then performed, using their skills. But with the advent of computer-controlled equipment, data terminals involving complex software programs, integrated manufacturing concepts (e.g., automated material systems), and their spin-offs, a new level of skill has been created. To meet this new skill requirement in automated factories, an entirely new training process must be developed.

In the past 20 years, traditional training was vertical in nature, with specialization a

desired outcome. Today, a worker in an automated warehouse must have a horizontal conceptual knowledge of the receiving stage, warehouse storage capabilities, whether to use automated or nonautomated equipment in transferring the stock, and the stock's destination. The workers' knowledge must be enhanced with basic computer terminal skills, such as the ability to interpret the software commands and instructions required to perform their duties.

In the future, training will move away from producing the specialist to a new direction—the generalist. These new warehouse workers will have to possess an abstract intellectual quality to be able to operate automated material systems. To help workers obtain this training and protect its overall investment, management will have to build a training program into its management function.

This training will require an integration of company training specialists, product specialists (e.g., robot specialists and software experts), academia, and government—a new dimension in integrated training. The companies that succeed in the integrated training of their workers will reduce their operating costs of handling inventory.

The growth of automation, whether good or bad, will have a pronounced influence on how we live over the next few decades. How we deal with automation and people will dictate the direction in which U.S. industry will move. The next section will investigate the various elements of a fully automated material system and how they are integrated into today's modern automated factories and warehouses.

System Elements

The key to automated warehousing is the automated material movement within the warehouse consisting of computer-directed human operation, automated pick/stow capability, automatic cube/weight sensing devices, and a computer back-up system in case of system failure. The only need for human input is when the worker enters the incoming shipment data into the computer data terminal.

In some systems, a robot then inspects the incoming shipment for accuracy and damage. If the shipment is acceptable, the robot places an identification system device (tag) upon it. The tag (required for bar codes and laser readers) enables the incoming shipment to be rapidly stored by robotic minitackers for small items and human-operated storage and retrieval machines for larger items. These items may also be moved by automatic-guided vehicle systems, monorails, or conveyors to specially designed 40 to 60 ft. racks or carousels, containers, and bins

Following are the key elements of an automated material system, with an explanation on how they relate to one another and how they form an integrated material handling system.

Computers

The computer is the cornerstone of the entire automated warehouse system. No other technology has grown as fast as the computer—from the automatic sequence controlled calculator (the Harvard-IBM Mark I computer of the 1940s) to the small compact microcomputer of the 1980s. An automated warehouse of today contains not one large computer but many computers working independently yet interfacing with one another.

In an automated material system, each data terminal must have its own memory and operating program (software) acting inde-

pendently of the total system. This is essential for continuous operations and prevents hard down-time by any one piece of equipment. Also, the use of many microcomputers guarantees continuous operation of the on-line transaction process even if the central controller experiences a catastrophic failure. This no-stop concept ensures that no transactions are lost when failures occur, such as components failure, repairing faulty power supplies, bad input/output devices, or faulty buses between components in the computer system.

This concept of redundancy also allows the automated warehouse to continue to run while new hardware or software changes are added or deleted. If automated warehouses are going to fulfill their obligation to meet the just-in-time concept for surrounding automated factories, they cannot afford on-line system failures that could result in down time, which translates to immediate profit losses.

Robotics

Robots have found a new role in the automated warehouse, from bin-picking to parts inspection. In the Navy's NISTARS program, robots take on a new appearance as "ministackers" (Figure 3). The ministacker, upon computer command, moves through the automated warehouse to the aisle, where the part it is looking for is located. The platform on the ministacker rises to the level where the bin containing the part is located, extracts the bin, and delivers it to the operator's work station (Figure 4). The ministacker, after completing its task, will return the bin to its original position. While this function is being completed by the ministacker, the central controller is adjusting its inventory to reflect the depletion of this particular item.

The newest robotic application in automated warehousing is the robot's ability to see. As parts arrive and before they are placed in storage, a robot with a built-in vision system inspects the incoming shipment for quantity. The robot's visual system is only capable of seeing black and white. This system contains a camera, exterior lighting for the viewing area, and an image processor. Most robots with vision systems have built-in microcomputers, and some have another microprocessor data terminal for external control.

The most commonly used camera for robotic vision systems is the vidicon tube. This tube is similar to the type used in closed-circuit television. The robot vision system uses the principle of a continuous electronic beam that scans a phosphor screen located above the parts. As the part moves beneath the phosphor screen, it will create a charged image on the screen. This image is then compared with a similar image contained in the robot's memory. This system is often used for identification and sorting operations ("Vision Systems," 1984).

For greater detailed vision, automated robots can use either a charge coupled device (CCD) or a charge injection device (CID). In these vision systems, the robot's view is broken down into binary columns/rows of picture elements. These picture elements are often referred to as "pixels." Each pixel in the binary vision system is assigned a value of light up to 64 shades of gray. The outcome of this complicated process compares the object being viewed with the image stored in memory. The robot's vision-memory contains size and shades of gray. If the part being examined by the robot cannot be identified, the robot can be programmed to grasp the part with its grippers and transfer it to a reject bin.

Monorails

The widespread application of automated monorail systems in Europe has resulted in new computerized monorails in

MINISTACKER

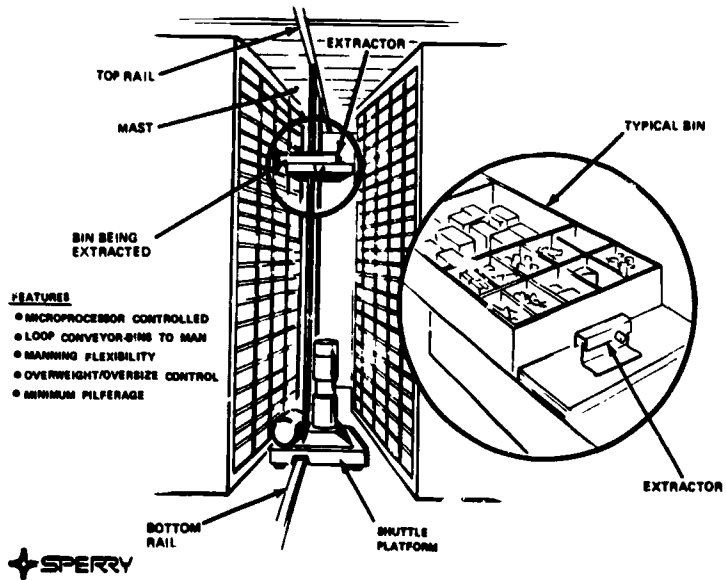

FIGURE 3

U.S. industry today. Monorails have been used successfully in U.S. steel plants and by automakers to move heavy loads.

A new, small, low-capacity, computerized monorail has been developed that is now capable of handling the material needs of industry. These new monorails, with their new lighter weight track, are finding increased usage in automated warehouses. By using overhead dead space, automated warehouses can use the automated monorail system concurrently with conventional conveyors and automatic guided vehicles (AGVs).

The monorail system, with its computerized self-powered carriers, can be programmed to pick up and transport to designated work stations for sorting, packing, and other functions normally associated with

automated warehouses. Monorails can also be integrated with other components in an automated storage/retrieval system. The monorail's capability to self-load and unload makes it especially useful in moving palletized loads. The programmable monorail also has the ability to transfer palletized loads to awaiting AGVs.

It is entirely possible that the automated warehouse of the future will be linked to its automated factory by an automated monorail system. If a factory worker located at a work station data terminal requires a crankcase from stock for the engine he or she is assembling, a command is initiated from the data terminal through the central computer to the automated warehouse. The crankcase is removed from storage by an automated

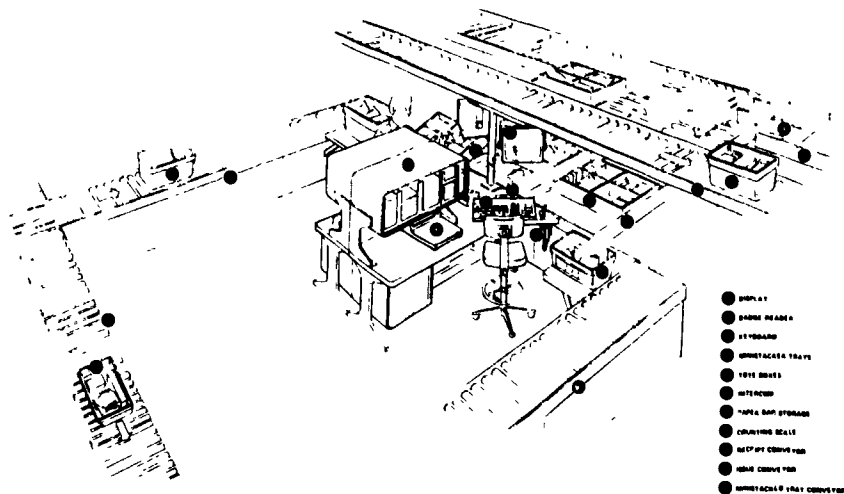

FIGURE 4

Typical Ministacker Stow/Issue Station

retrieval system and delivered to a computerized monorail system that links the two facilities via a canopy monorail. The crane then travels a distance of a mile to its final destination in the automated factory, arriving "just-in-time."

Conveyors

At the Naval Supply Center in San Diego, NISTARS has seven miles of laser controlled conveyors that link more than 300 work stations. The conveyors are interfaced by automation. Figure 4 shows an excellent example of conveyor usage. Since its inception, automated storage and retrieval systems have used conveyor systems in every application, but with varying degrees of automation (Reyes-Guerra, 1983).

In the past, the automobile industry used conventional conveyor systems in the manufacturing of automobiles. These conventional conveyor systems were motor driven and moved a car from one work station to the next. Pontiac's Fiero assembly plant in Michigan recently installed three new separate automated conveyor systems that are uniquely interfaced by a microprocessor.

The plant has four basic operations that require special handling instructions. The most critical of the four in terms of required automation is the body shop, where the underbody is formed on an automated conveyor system. Here, the underbody moves along a 465-ft conveyor loop that has 36 work stations along it. The Pontiac plant has integrated three separate conveyor systems: car-on-track system, free, and inverted power by using a programmable controller. Using inverted power and free conveyors, the car frames are transported via conveyors to an automated washing area before painting. This is accomplished by activating/deactivating switches in the conveyor system that automatically route work from one station to the next.

At the paint station, an optical scanner reads the bar-code label in the body, which is then transmitted to the computer, which matches the bar code identification with the job requirements. After the particular painting requirements have been arranged by the computer, the final process of painting is further controlled by the microcomputer, even down to the level of adjusting the spray painting equipment ("Automated Conveyors," 1984).

Parts Containers: Carousels, Bins, and Racks

The essence of any automated warehouse is the storage area and the arrangement of the contents within it. The container holding the inventory must be designed to accommodate the automated warehouse's inventory.

Most containers today have special inserts or special tabs to support or cradle the container as it is being moved. Because all parts in an automated warehouse are not contained in an AS/R system, each warehouse will have hundreds of different kinds of racks, bins, carousels, and so on. They usually are made of wood, metal, fiberboard, corrugated, and plastic material.

In Sperry's NISTARS warehouse AS/R system, boxes that store the parts are corrugated cardboard. The robotic ministacker is sensitive enough to use this material instead of a more costly material. In this situation, corrugated material is acceptable (Reyes-Guerra, 1983).

Integration

Systems integration is the key to an automated warehouse system with all of its

material handling components. Because any one manufacturer rarely produces more than one element, it is not uncommon to find a host of different manufacturers producing automated material handling system components. The problem then arises as to how to integrate all of the material handling components into a homogenous functioning system. The answer is software. Software is the program that provides commands/instructions to carry out each function in the automated system. Software is the integrator in the automated warehouse.

Integration is also required when there are a dozen or so automated warehouses in a local area. One method that has emerged is the local-area network, referred to as LAN. This allows many local warehouses to pass financial, inventory, and other data between the user's computers and the master central controller.

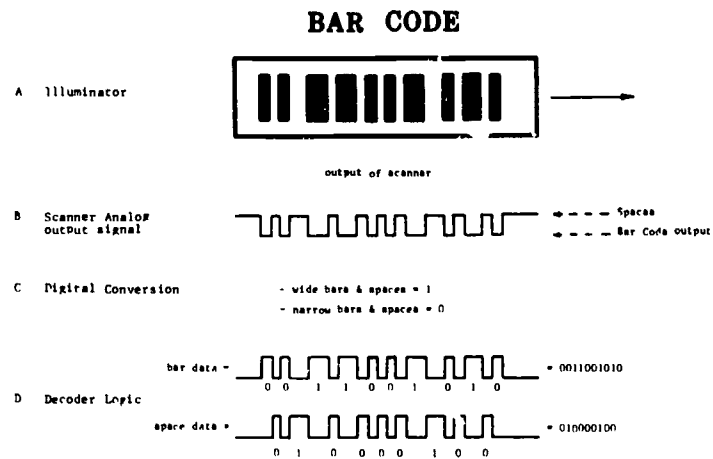

FIGURE 5

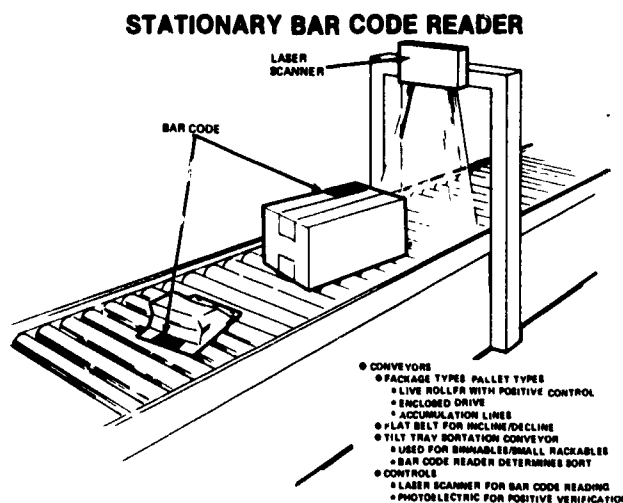

FIGURE 6

SPERRY



Bar-Code Readers

The most popular use of bar-code readers is at the supermarket checkout register. There are currently more than 1,000 supermarkets in the U.S. that use some type of bar coding and associated scanners. In the automated warehouse, the track and divert AS/R systems use bar-code labels for identification. Whether the bar-code label contains Uniform Symbol Description-USD-1 (numeric character set) or USD-2 (alpha-numeric character set), either can be readily integrated into binary. Figure 5 on page 19 shows this process of converting the bar-code symbology to an analog output signal, which is then converted into binary (Willoughby, 1983).

Modern warehouses use a stationary laser bar code reader to direct the material to the proper work station for consolidation of orders, packaging, palletizing, or other internal processing (see Figure 6 on pg. 19). If a part is selected for use it will be transported to the consolidated order station by a second conveyor system and necessary shipping papers will be printed automatically. Then the shipment is loaded into trucks for ultimate delivery to the customer (Reyes-Guerra, 1983).

Automatic-Guided Vehicle Systems

Automatic-guided vehicles (AGVs) are being used in today's warehouses to pick up loads at the receiving area and deliver them

to the AS/RS for further storage. In the automated factory, the parts are picked up at the receiving dock and delivered to the assembly line. The AGV system has been so efficient in the implementation of "just-in-time" inventory that many have paid for themselves in less than a year.

Perhaps the best capabilities of the AGVs are its lifting/lowering, loading/unloading features. These features are especially useful in an automated warehouse where the AGV picks up a load of parts at the receiving dock and delivers them to the ministacker, which files them in their respective storage bins. This entire operation can be directed by a microcomputer at the receiving station. At a General Motors plant in Orion Township, Michigan, 22 guided vehicles deliver almost 75% of all parts to 69 different work stations inside the 77-acre facility.

Constructional Activity

As has been seen, automated materials handling and warehousing are important to the future success of American industry. To allow you to integrate and apply the knowledge you have learned in this issue of Resources in Technology and others on integrated manufacturing, we have created a design problem for you to use. In this activ-

ity, you are to select a mass production product that is usually produced in your industrial arts/technology education laboratory (e.g., a clock, toy, or game). Using drafting instruments, design and draw the floor plans of an automated factory with machines and material handling devices to mass produce this product. Incorporate com-

puters, robots, CAM, lasers, and automated materials handling systems into your designs.

An alternative to this activity is to design material storage for your present lab. Have students redesign your storeroom for more efficient use. Have them analyze the location of materials and design and construct racks and bins for more efficient use.

Math-Science-Technology Interface (M/S/T)

As previously discussed, software programs are the integrators in the automated warehouse. Software programs may be written in different languages, such as Basic, Cobol, and Fortran, as long as the binary code system is used. It is the binary system that makes a computer function as a computer.

The operator at a work-station microcomputer data terminal types a command to the subsystem remote microcomputer, which in turn communicates with the central processor. This simple, yet complex procedure of typing a command/instruction requires one of many conversion steps necessary to change decimal digits into binary code.

The one mathematic system with which most people are familiar is the decimal number system. This is because we are exposed to it all our lives, both in school and later at work. Other digital systems used with computers are more complex and less familiar, such as binary, octal, and hexadecimal.

Early computer designers recognized that people who worked with computer terminals were not likely to become competent with binary, whereas the decimal number system would be more familiar to them. To use this familiarity, the Binary Coded Deci-

mal (BCD) system was developed. The primary reason for the development of the BCD code (combines decimal and binary number systems) was because many computer keyboards required decimal digits for data inputs and outputs.

The BCD code uses the familiar decimal digits 0 through 9 to form a 4 bit binary code. The following list shows the similarities between the three systems (Heath Company, 1977, p. 4-37).

| Decimal | BCD | Binary |
|---------|------|--------|
| 0 | 0000 | 0000 |
| 1 | 0001 | 0001 |
| 2 | 0010 | 0010 |
| 3 | 0011 | 0011 |
| 4 | 0100 | 0100 |
| 5 | 0101 | 0101 |
| 6 | 0110 | 0110 |
| 7 | 0111 | 0111 |
| 8 | 1000 | 1000 |
| 9 | 1001 | 1001 |

Unlike the binary number system, the BCD binary code can be simply converted to its decimal equivalent. To illustrate how simplistically the BCD system can be used,

the decimal number 225 is expressed in BCD code as follows:

$$\begin{array}{ccccccc} 0010 & 0010 & 0101 & = & 225 \\ 2 & 2 & 5 & & \end{array}$$

An added advantage to the BCD system is there are only 10 combinations to remember, whereas the binary system can be extended further than the 0-9 range. Also, the BCD numbers can be learned as quickly as the decimal number system (Heath Company, 1977).

To illustrate the conversion steps required, a hypothetical shipping/ordering transaction in an automated warehouse will be used to show how an executed command to the central processor via a microcomputer terminal keyboard is processed from American Standard Code for Information Interchange (ASCII Code) to Binary Coded Decimal (BCD) and finally into binary. This simple, yet effective system allows the operator to communicate comfortably and effectively with the computer.

The worker at the stow/issue station (see Figure 4) requires a part to complete a shipping invoice. To summon the ministacker to retrieve the part from storage, the employee types the code for this particular item—the

decimal numbers 225—on the terminal. The prearranged code (225) is the programmed location for that particular part. As soon as the operator types 225 on the data terminal, a special form of binary code called ASCII converts the decimal number 225 into its ASCII format. The number 225 in ASCII is shown below:

| Numerical | ASCII Character |
|-----------|-----------------|
| 2 | 0011 0010 |
| 2 | 0011 0010 |
| 5 | 0011 0101 |

The ASCII is a simple 6-bit binary code that has the capability to form 64 different characters, numbers from 0 to 9, the entire alphabet, or other special characters. The ASCII characters can be simply converted to BCD by eliminating the four most significant bits. The remaining binary characters are identical to the BCD presentation. This can be readily seen below:

| ASCII | BCD |
|----------|------------|
| 2 = 0010 | = 0010 = 2 |
| 2 = 0010 | = 0010 = 2 |
| 5 = 0101 | = 0101 = 5 |

The next step in the conversion process is to convert BCD to binary. This is a simple

procedure. The decimal number 225 is expressed in BCD as follows:

| | |
|------|-------------------|
| 0010 | hundred BCD digit |
| 0010 | ten BCD digit |
| 0101 | unit BCD digit |

The 4-bit digit 0010 represents 20, 0010 represents 2, and 0101 represents 5. This is further amplified in the box below, which shows how to convert to binary from BCD.

The value 1110 0001 is the binary equivalent of BCD 225. This binary conver-

sion is accomplished by a software program. This particular software program for changing BCD to binary brings out the basic concept of looping in writing software programs. Often, there is a need to repeat certain steps in order to obtain the desired results (Heath Company, 1977).

We hope this example has shown you the need for an understanding of mathematics for workers in our technological society. No longer can one rely solely on mechanical skills to be employed in contemporary businesses and industries.

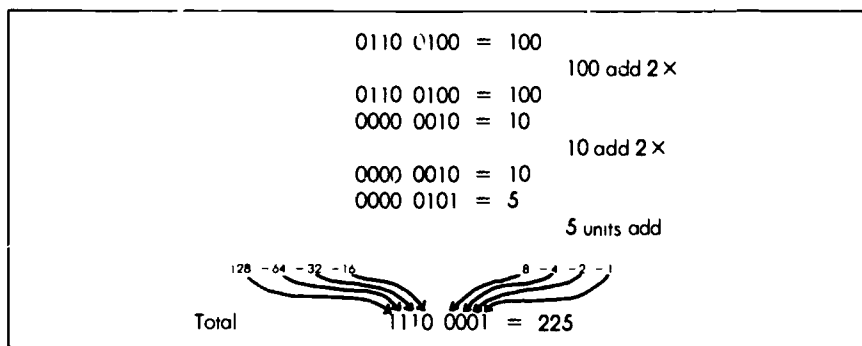

The Future of Automated Warehouses

By the year 2001, many factories and warehouses will implement some type of automated storage and retrieval systems. These systems will require extensive capital investments over a long period. The savings (profit resulting from an AS/RS installation)

must, therefore, be adequate to justify the enormous expenditures. Thus, it is important to investigate the automated material handling requirements, (e.g., storage capacity requirements and stock distribution requirements) before implementing an AS/R system.

To what extent warehouses become automated in the future will depend on local area requirements. However, all warehouses will have to provide high-quality service to the customer in a timely and cost-effective manner.

Student Quiz

- What are the benefits of the "just-in-time" concept?
 - Reduced inventory
 - Smaller warehouse space
 - Less capital expenditures
 - All of the above
- What is programmed into the automated computer system to prevent down-time?
 - Microchips
 - Redundancy
 - Menus
 - Lasers
- What is the term by which the binary columns and rows of picture elements of a robotic camera are sometimes called?
 - Vidicon
 - Pixel
 - Megabit
 - PCB
- What are storage containers for automated systems made of?
 - Metal
 - Cardboard
 - Polypropylene
 - All of the above
- What is an important human consideration when automating a warehouse?
 - Higher wages
 - Shorter hours
 - Well-trained workers
 - Four-day work week
- What is the most important single element necessary to successfully integrate the various components in an automated factory/warehouse?
 - Computers
 - AS/RS ministackers
 - Software
 - Robots
- In an automated warehouse, who must carry out the decision-making process?
 - Management
 - First-line supervisors
 - Each worker, as problems arise
 - All of the above
- In the past, what percentage of available space was wasted in conventional warehouses in the U.S.?
 - 20%
 - 40%
 - 35%
 - 70%

- 9 U S manufacturers are moving to automated storage/retrieval systems to
- Improve inventory accuracy
 - Have greater worker accountability
 - Prevent pilferage
 - All of the above
- 10 The component that is the cornerstone of the automated warehouse is the
- The robots
 - The conveyors
 - The software
 - The computer

Possible Student Outcomes

- Describe the concept of automated warehousing/material handling
- Explain the impact automation is having on the workforce
- List and describe the components of an automated warehouse
- Apply knowledge of automation to the solution of technical problems
- Associate math and science as an integral part of the study of automation

References

- Asia-automation is hitting a low-wage bastion (1982, March 15) *Business Week*, pp 38-39
- "Automated conveyors help us assemble a high quality car" (1984, April 9) *Modern Materials Handling*, pp 47-51
- Ciampa, D (1984) The impact of computer integrated manufacturing *Vital Speeches of the Day*, 50, 534-539
- Heath Company (1977) Individual learning program in microprocessors, unit 4 Introduction to programming Benton Harbor, MI Author
- Hess, G J (1984, July 6) How to get the right start on computer integration *Modern Materials Handling*, pp 58-59
- Klass, P J (1982, August 2) Circuit board assembly plant to test systems *Aviation Week & Space Technology*, pp 66-71

- Reyes-Guerra, D (1983) Automated materials systems improve productivity *Sperry Technology Report*, 2, 1-5
- Use advanced technologies to automate manufacturing (1985, January 23) *Modern Materials Handling*, pp 44-46
- Vision systems—Bring sight to automation (1984, April 9) *Modern Materials Handling*, pp 64-69
- Willoughby, B R (1983, April) Bar coding gaining wider acceptance in manufacturing and distribution functions *Industrial Engineering*, pp 70-76

Selected Readings

- Accumulation conveyors boost efficiency and cut costs (1984, February 6) *Modern Materials Handling*, p 73
- Andel, T (1984, May) Aerospace manufacturer unveils new flexible manufacturing concepts *Material Handling Engineering*, pp 48-54
- Andel, T (1984, May) How to recognize automation's human interface *Material Handling Engineering*, p 88
- Apple, J M, Jr (1983, April) Anticipating the future with step-by-step changes in material handling systems *Industrial Engineering*, pp 52-56
- AGVS—The capabilities continue to grow (1984, January 9) *Modern Materials Handling*, pp 56-61
- "AGVS helps us save millions in inventory" (1984, May 21) *Modern Materials Handling*, pp 40-44
- AS/RS and just-in-time Partners in manufacturing (1984, August 6) *Modern Materials Handling*, pp 56-62
- Bafno, P E, & Kailash, M (1983, June) Part 1 of 2 Procedures for Investigating AS/RS feasibility, suitability are outlined for IES *Industrial Engineering*, pp 60-64
- Bafno, P E, & Kailash, M (1983, August) Part 2 of 2 Procedures given for determining AS/RS system size and preparing specs *Industrial Engineering*, pp 76-81
- Barus, C (1982, March) On costs benefits and malefits in technology assessment *IEEE Technology & Society Magazine*, pp 3-9, 27
- Communication barriers in the factory are falling (1984, May 14) *Business Week*, pp 148-149
- Edson, D (1984, June) Bin-picking robots punch in *High Technology*, pp 57-61
- Filley, R D (1983, June) L L Bean's IEs help mail-order institution handle success while holding onto tradition *Industrial Engineering*, pp 47-58
- From the Houston Forum—"We Have the Technology, We Need the Commitment" (1984, June 8) *Modern Materials Handling*, pp 58-63
- GE is about to take a big step in robotics (1982, March 8) *Business Week*, pp 31-32
- Hand-held code readers—Automatic data gathering anywhere on the shop floor (1984, January 23) *Modern Materials Handling*, pp 38-43
- Klass, P (1982, August 2) Circuit board assembly plant to test systems *Aviation Week & Space Technology*, pp 66-71
- Linking office computers The market comes of age (1984, May 14) *Business Week*, pp 140-152
- Local area networks—The crucial element in factory automation (1984, May 7) *Modern Materials Handling*, pp 50-55
- Monorails A bigger role (1984, July 6) *Modern Materials Handling*, pp 52-57
- New guided carrier automates multi-station delivering (1984, September 21) *Modern Materials Handling*, pp 56-58
- Packer, A F (1984, March) Factories can meet current and future needs by phasing in flexible controls *Industrial Engineering*, pp 72-78
- Parts containers Where your system design begins (1984, May 7) *Modern Materials Handling*, pp 60-63
- Pierson, R A (1984, March) Adapting horizontal material handling systems to flexible manufacturing setups *Industrial Engineering*, pp 62-71
- Plan under way for government investment (1982, August 2) *Aviation Week & Space Technology*, p 66
- Public warehouses Broadening services to meet new needs (1984, March 19) *Modern Materials Handling*, pp 48-51
- Rhea, N W (1983, August) Ten questions and answers about programmable controllers in material handling *Material Handling Engineering*, pp 22-27
- Rhea, N, Schwind, G, & Knill, B (1984, February) Material handling's role in the software solution *Material Handling Engineering*, pp 38-44
- Sadowski, R P (1984, January) Two year series begins Computer-integrated manufacturing series will apply systems approach to factory of future *Industrial Engineering*, pp 35-40
- Schwind, G (1984) Sorting conveyors break free of manual direction *Material Handling Engineering*, 50-60
- Schwind, G (1983, February) Self-powered monorail carriers When and where to use them *Material Handling Engineering*, pp 48-53
- Selecting the right on-site bar code printing techniques (1984, September 21) *Modern Materials Handling*, pp 59-61
- Side-loading trailers speed shipping and receiving (1984, April 9) *Modern Materials Handling*, pp 58-59
- Simple layout and double-duty labels speed picking (1984, February 6) *Modern Materials Handling*, pp 62-63
- The next GM robots may be part Japanese (1982, April 5) *Business Week*, p 35
- Tampkins, J A, & Smith, J D (1983, September) Keys to developing material handling systems for automated factory are listed *Industrial Engineering*, pp 48-54
- Trunick, P A (1983, July) Changes and innovations in warehousing *Handling & Shipping Management*, pp 59-62
- Why hand-held readers are popular today (1984, January 23) *Modern Materials Handling*, p 47

New Materials

Every day, we come into contact with an engineering materials development

- We read about artificial (aluminum and polyurethane) hearts being implanted into humans.
- The space shuttle is grounded because of problems with the thermal protection system's ceramic tiles.
- The Japanese demonstrate a gallium arsenid computer chip that will provide faster computing because electrons move through it four times as fast as through silicon chips
- Pontiac announces Fiero, a new production automobile using fiber reinforced plastic composite body panels to eliminate rust and denting.
- Extended wear contact lenses allow users to wear the lenses without a break for weeks
- Prefinished plank-paneling kits offer a convenient way to panel rooms with genuine hardwood
- Engines with ceramic components can run without the inefficient cooling systems used in automobile, truck, and heavy equipment engines
- An airline crash killed scores of people, probably because of metal fatigue in a bolt
- Many people were killed and injured when a concrete and metal bridge collapsed

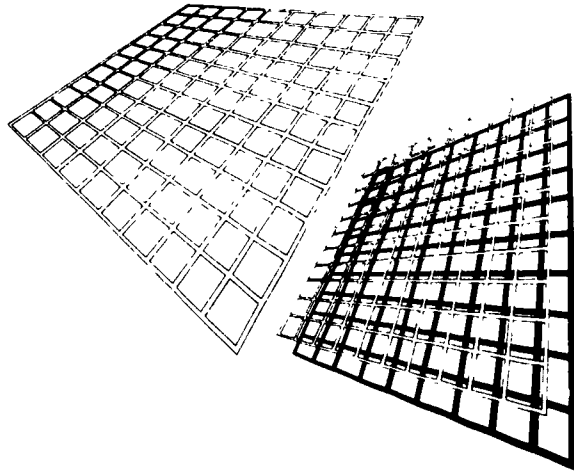

- A new technique of ultrasonically preparing acrylic adhesives will give greater chances of long-term success for patients fitted with an exotic metal alloy and plastic knee-joint replacement
- Advertisements abound for cookware with nonstick surfaces

These examples reflect the constant developments in high, medium, and low technology that bring changes to the materials on which we depend. High technology uses basic scientific research to seek answers on the nature of the atom that will allow improvements in engineering materials. At

the other end of the technology spectrum, we are still learning better ways to work with our earliest materials: wood and stone.

The dramatic and continuous changes in engineering materials technology are a product of evolution in materials science and engineering. This relatively new field grew out of such traditional fields as metallurgy, physics, and chemistry and has spawned new specialties, such as interfacial and adhesive science and technology, polymer science, micro manufacturing, and bioengineering. Materials science has gained international attention because of its potential to contribute to the advancement of civilization.

Social-Cultural Impacts

The history of civilization reflects a constant dependence on materials engineering. Ancient tribes used composites of mud reinforced with straw to construct shelters. Today, there are about 70,000 metallic alloys. We face the end of the availability of fossil fuels and look to materials developments in the form of solar cells and nuclear power to provide us with energy. There is currently disagreement about whether we should engage in trade with South Africa. Many believe that we should not because of South Africa's inhumane apartheid practices against its black majority. Some point out that if we do not buy chrome from South Africa, then we must buy it from Russia or China. And, we may not be able to depend on these countries if a conflict develops. Without chrome, how do we build steam turbine generators or jet turbine engines, which depend on chromium steel alloys?

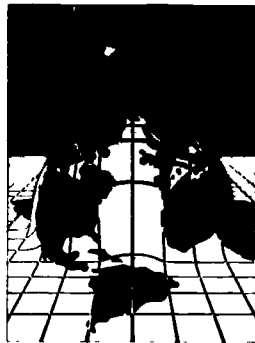

Although a false sense of security seems to exist about the supply of natural resources, the price of energy has brought about efforts to conserve energy wherever possible. Coupled with this concern is the desire to have improved products and systems

An example is the development of glass and plastic optical fibers. These fibers require less energy to produce than copper and aluminum wires, use less space, and provide better communications. The microprocessor is also a result of innovations in materials and processes that touch all facets of society. In transportation, the microprocessor controls the engines and transmissions for improved fuel efficiency. Aluminum alloys joined by plastics and composites have replaced steel on trucks, trains, and other vehicles to reduce overall weight. In production, there is a shift toward synthetics (plastics, rubbers) and ceramics that can be manufactured with automated processes that cut down on nuts, bolts, and welding operations requiring manual labor. These are trends toward continuous flow manufacturing. The medical field employs many materials innovations, from plastic teeth and tooth fillings to devices that

can be implanted in the body to aid hearing, sight, and body rhythms. Robotic arms, covered with synthetic skin, replace lost limbs.

The above examples contribute to the feeling of society that no problems exist that technology cannot solve. This may be true. Yet, technology also creates problems. Many materials, such as nuclear fuel, lead additives for gasoline, and polyurethane foam for insulation, present hazards. How do you dis-

pose of nuclear waste? What happens to the lead introduced into the atmosphere from gasoline emissions? How do you protect people from the cyanide gas produced when a building with polyurethane catches on fire?

Engineering materials technology offers great promise to humanity; but in solving one problem, a larger problem may develop. As individuals, we should learn about materials so that we can make wise purchases and

properly use and maintain our products. In the workplace, there are many job opportunities for people with a knowledge of engineering materials technology, and as citizens we should be able to make informed decisions about public policy on the care and use of natural resources, environmental safety, and consumer protection. To understand the newly developing materials, we need a grasp of the basic concepts of materials.

Nature and Family of Materials

Figure 1 depicts a planetary model of an atom, which can help you grasp the components of the atom even though the model does not provide a true picture. Within the nucleus are neutrons, protons, and some unusual sounding elements, such as quarks, strange particles, leptons, and hundreds of others, with some still to be discovered.

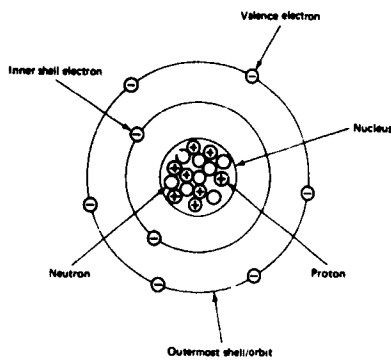
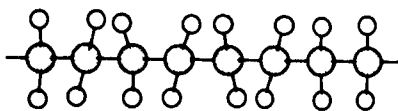
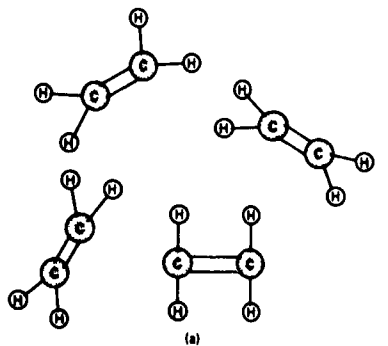

FIGURE 1
Model Atom



○ Carbon
○ Hydrogen
(b)

FIGURE 2
Atomic Chains

TABLE 1
Family of Materials

| Group | Subgroup | Examples |
|----------------------------------|-----------------------|---|
| Metallics (metals and alloys) | Ferrous | Iron Steel Cast Iron Steel alloys |
| | Nonferrous | Aluminum Tin Zinc Magnesium Copper Gold Nonferrous alloys |
| | Powdered metal | Sintered steel Sintered brass |
| Polymeric | Manmade | Plastics Elastomers Adhesives Paper Wood Rubber |
| | Natural | Bone Skin |
| | Animal | |
| Ceramics | Crystalline compounds | Porcelain Structural clay Abrasives Glassware Annealed glass |
| | Glass | |
| Composites | Wood based | Plywood Laminated timber Impregnated wood Fiber glass |
| | Plastic based | Graphite epoxy Plastic laminates Boron aluminum Alumina whiskers |
| | Metallic based | Concrete Reinforced concrete Asphalt concrete |
| | Concrete | Tungsten carbide Chromium alumina |
| | Cermets | |
| | Other | Reinforced glass |
| Others | Electronic materials | Semiconductors |
| | Lubricants | Oil |
| | Fuels | Coal |
| | Protective coatings | Anodized |
| | Biomaterials | Carbon implants |

Atoms come together to form molecules, such as ethylene (Figure 2a). Molecules composed of elements join together in gaseous, liquid, and solid states. For example, ethylene gas is made up of the elements carbon and hydrogen. These are subjected to heat and pres-



AMORPHOUS

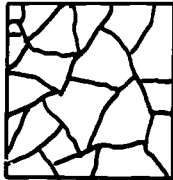

CRYSTALLINE

FIGURE 3

Molecular Structures

sure to form into a long-chain polymer known by the familiar name of polyethylene plastic (Figure 2b).

Solids such as polyethylene or steel develop into basic structures: crystalline and amorphous. Normally, in the solid state, glass and polymers are amorphous and metals and most ceramics are crystalline (Figure 3). These rules are not firm, as we shall see later. It is also possible to have an in-between structure of semicrystalline solids as a result of the forming process such as in extrusion of polyethylene (Figure 4).

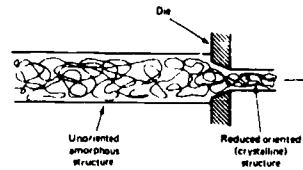

FIGURE 4

Semicrystalline Structure resulting From Extrusion

For convenience of studying the family of materials, we can group them into five categories (Table 1). In general, the materials within a group have the same structure and similar properties. Glass is a notable exception. Most glass is hard and brittle, like other ceramics; but it has an amorphous structure, like a frozen liquid. Composites consist of two or more integrated materials, such as glass and plastic or metal and rubber, with each material maintaining its own identity. From proper integration of materials a superior material emerges.

New Materials Development

In each group of materials shown in Table 1, there are ongoing and dramatic developments taking place. The rewards are high for those who discover a new material or process that allows a breakthrough. For instance, many people are trying to develop smaller and more powerful computer circuits. Others seek an adhesive that would rapidly bond most metals and plastics in an unclean environment, as is found on many production lines. The long duration effects facility (LDEF) launched with NASA's space shuttle is designed to determine how materials react to long-term exposure in space. NASA has conducted materials processing in space and has found important advantages to processing certain materials in a gravity-free environment.

We shall look at a few examples of new materials developments in the four materials groups of the family of materials to demonstrate the dynamic nature of engineering materials technology. These represent only a small sampling.

Composites

Composites offer engineering materials designers almost limitless possibilities since they are free to put together materials from all the major groups to achieve the properties desired. The objective of composite development is to combine two or more materials to obtain the best properties offered by each

and in doing so, gain a material superior to any of the monolithic materials. There are limitations in making composites that center around interface technology and processing technology. Interface technology is concerned with the effects of a substance coming in contact with the same or different substances. For example, dissimilar metals (e.g., copper and aluminum), when in contact, cause galvanic corrosion.

Another problem could develop with the adhesives used to bond material if they are not compatible with the environment in which they will be subjected. Interior plywood will deteriorate if exposed to moisture, whereas a plywood with waterproof glue can resist moisture.

Figure 5 shows three common composite structures. The layered composite (5a) is commonly found in furniture that uses a hard plastic (e.g., Formica™) as the desk top and particle board (wood particles in a plastic resin matrix) in the middle, with Masonite™ glued to the bottom. Other layered composites are common: plywood; clad metals; plastic, aluminum, and paper toothpaste tubes and aseptic milk cartons; rubber, cardboard, and leather shoe soles; laminated silver and copper dimes and quarters; laminated glass and plastic for automobile safety glass windows, and polypropylene used to sandwich styrofoam insulation in ice coolers and thermos jugs. If you look at many objects (e.g., loose-leaf binder notebooks, tennis shoes, television and stereo cabinets, coats and jackets, surfboards, and briefcases), you can

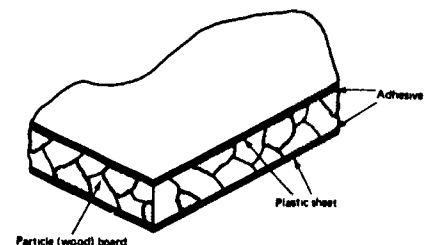

(a)

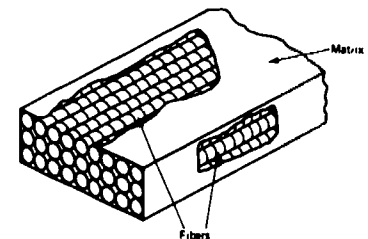

(b)

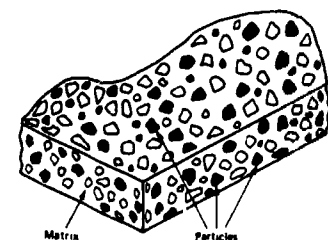

(c)

FIGURE 5

Composite Structures

see they are made of layer or laminated composites

Figure 5b shows a fiber reinforced composite, such as fiberglass or FRP (fiber reinforced plastic), that uses fine glass fibers held together in a matrix of polyester plastic. The glass provides stiffness and tensile strength, and the polyester resin gives flexibility and toughness to the material. FRP is becoming very popular because it is lightweight and has high tensile and impact strength, and it does not corrode. Other fiber composite structures include reinforced concrete, electronic printed circuit boards, reinforced packing tape, automobile and bicycle tires, wire-reinforced glass windows, carpet, plastic/rubber raincoats, pulley and fan belts, and nylon reinforced with glass fibers for Tuff Wheels on bikes.

Just as plywood gains strength by alternating the grain at 90° to each veneer layer, fibers can be oriented in a variety of directions to improve stiffness, compressive, and tensile strength. Particle composites such as the one in Figure 5c might be a matrix of cement with rock aggregate as a reinforcer. Other particle composites are powdered metals such as carbide cutting tools and numerous plastic resins (e.g., kitchen countertops or electrical receptacles of phenolic resins filled with wood particles).

Demands for high-performance aerospace transportation vehicles caused the emergence of advanced composites. These new composites provide tensile strength, stiffness, and lighter weight than found in steel, aluminum, and other metal alloys. Advanced composites using matrices, such as epoxy polyimide or aluminum, are often reinforced with fibers of graphite, aramid (Kevlar)

boron, and some newly developed high-strength glasses. There are also some layered or sandwiched advanced composites, including laminates of aluminum, titanium, and beryllium.

Figure 6 shows how NASA used advanced composites on the high-performance YF-12 aircraft, which holds the record as the world's fastest plane. The LARC polyimide adhesive had to be developed to withstand very hot and very cold temperatures as the aircraft flies on the edge of space. The lower left figure is a cut-away view of the thermal compaction process used to make the panels. An expandable rubber mandrel within metal platens forms the basic panel shape to which a honeycomb structure and flat bottom panel are adhesively bonded. The space shuttle program also makes great use of advanced composites.

Although the aerospace industry is the major developer and user of advanced composites, the recreation industry has been quick to accept them. Tennis racquets, fishing rods, canoes, racing boats, and bicycles are among the products using epoxy matrices reinforced with graphite, boron, and aramid fibers. Race cars have found many uses for advanced composites, even to the point of having entire engines made of plastic-based composites.

Ceramics

Along with wood, ceramics are the oldest of our engineering materials, but only recently have we seen a major effort to develop new ceramics. Currently, ceramic

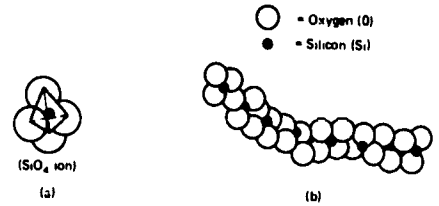

FIGURE 7
Silica Structure

developments are coming at a rapid pace and include such areas as computer circuitry, internal combustion engines, metal cutting tools, telephone cables, machinable glass, catalytic converters, and light-sensing eyeglasses. Why all the new attention to such an old and neglected group of materials?

There are several reasons for the new interest in ceramics. One major raw material used to make many ceramics is silica. This compound of silicon and oxygen (Figure 7) is as plentiful as the sands of the oceans and deserts. New methods of processing ceramics are evolving, including doping and injection molding. Doping metal alloys (electrical conductor) into a ceramic (insulator) can produce semiconductors for computer memories. Injection molding now used with metals and plastics will allow economical precision casting of ceramics. The properties of ceramics also make them valuable. They can withstand the very high temperatures required in high-performance engines and materials processing. Today, experimental engines are operating with no cooling systems because zirconia ceramics insulate the hot combustion chambers from the metal components.

Glass is another ceramic that uses silica as a raw material. The amorphous nature of glass makes it a good transmitter of light, but sometimes it is desirable to change the optical properties. Addition of minute particles of silver to glass will cause them to interact with light. As light-sensing eyeglass lenses, they change from nearly clear glass when exposed to low light to dark glass when subjected to bright light. The amorphous structure of glass can also be altered by implanting seed crystals in the glass formulation, which permits a slow irregular heat treatment (Figure 8) that transforms amorphous structures to polycrystalline glass ceramic.

Glass ceramics are used for cookware and machinable glass. Macor™, a machinable glass, can be turned on a lathe, drilled, or threaded with standard metal working tools. These parts can serve in high temperatures (1000°C) with certain properties found in plastics (good electrical and thermal insulators), but their hardness and high-temperature resistance also compete with metals.

The tiles that act as part of the thermal protection system (TPS) on the space shuttle represent another advancement in ceramics. The felting technique used to produce the 99.5% pure silica tiles lays down silica fibers

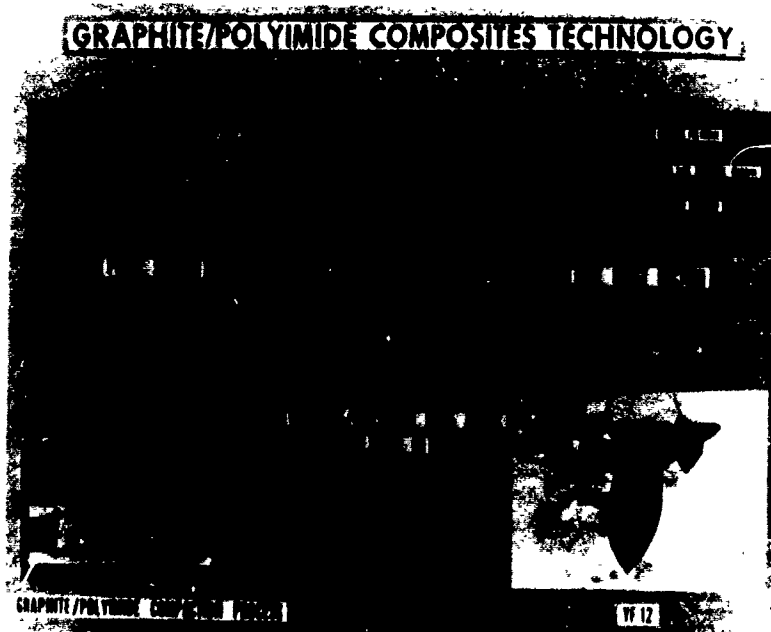

FIGURE 6
Composite Application

in a manner similar to the method used making a felt hat. The tiles are 93% air, which accounts for their light weight and excellent ability to shed the 1260°C heat as the shuttle enters our earth's atmosphere. Figure 9 shows how the tiles are adhesively bonded to the aluminum (Al) structure of the orbiter.

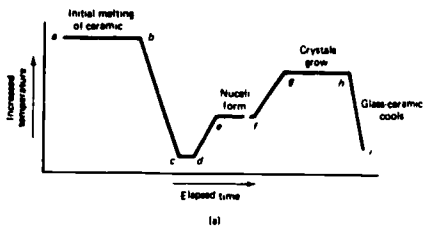

FIGURE 8

Seed Implanting Into Glass

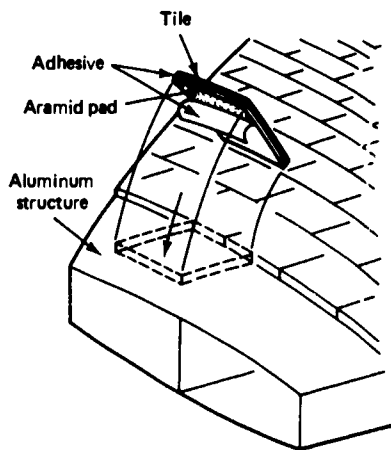

FIGURE 9

Ceramic Tile Attached to Space Shuttle's Orbiter

Metals

Metals, especially steel, have long dominated the structural and engineering uses of materials. But as can be seen in the previous examples, they are facing stiff competition. As you can expect, those involved in metal are not standing still, they too have made advancements. One such case is high-strength, low-alloy steels (HSLA) designed as a low-cost competitor with aluminum and FRP. The high strength of HSLA at 414,000 pascals (60,000 psi) versus 276,000 pascals (40,000 psi) of plain carbon steel allows thinner steel, thus saving weight in automobiles and other vehicles.

Corten™ steel is another low-alloy steel with a small amount of copper alloy. The copper allows a thin, tight layer of rust to form on the steel for protection, eliminating the need for paint. Corten structural parts are seen as towers for high tension electrical power lines, light poles, bridges, and buildings.

Metals are normally crystalline because they cool slowly, which allows for nucleation of crystals, which develop into metal grains. We saw that glass can be changed from an amorphous structure into a polycrystalline structure through thermal processing. Metals can be processed so they do not form crystal but through rapid cooling assume an amorphous or glassy microstructure. Amorphous metals or metglass are made of mixtures of iron, nickel, titanium, molybdenum, or chromium alloyed with carbon, phosphorus, boron, silicon, or other elements that reduce nucleation and crystal formation. The metals are cast on a large, fast-spinning, super-cooled mold with a surface speed of 60 mph. The metal stream is cooled at 1 million degrees (C) per second, which prevents crystallization.

Amorphous metals have unique properties, including low melting points of some alloys, that make them good brazing filler metals that do not require powders or present problems of contamination. Metglass™ is exceptionally easy to magnetize, making it more efficient for electrical power transformers. If all U.S. transformers were made of amorphous metal cores, the electrical energy saved would be about 20 million barrels of oil per year. Other potential applications of glassy metal alloys are for magnetic security strips placed in clothing, books, or other products to prevent shoplifting, composite reinforcers, and flywheels with a high strength-to-weight ratio that could be magnetically driven.

Many other new developments are occurring in metallurgy. Superplastic forming and diffusion bonding (Figure 10) allows high-strength, low-weight alloys, such as titanium, to be economically fabricated into structural aircraft components much in the way a balloon is blown up. Titanium nor-

mally deforms about 20%, but at high temperatures can be superplastically deformed as much as 2,000%. Fiber-reinforced metals composites use reinforcers of tungsten, silicon carbide, sapphire, carbon, boron, nitride, glass, and steel piano wire in matrices of aluminum and titanium alloys. These fiber-reinforced superalloy composites possess such properties as high strength-to-weight ratios, higher thermal conductivity, and lower thermal expansion.

Recycling is another area the metal industry is working to improve. Recycled aluminum uses only 5% of the energy required to produce aluminum from ore.

Alternatives to chromium for corrosion-resistant, high-temperature structural alloys are being developed. Stainless steels with aluminum, manganese, molybdenum, and nickel alloys show promise in eliminating our dependence on chromium, of which about 90% is imparted by risky trading and from undesirable nations.

New thermal processing of metals involves exotic techniques, such as using ion and laser beams to force hardening elements into metal surfaces. These surface-hardening techniques can enhance corrosion resistance and increase surface hardness without reliance on chromium. Replacement elements are yttrium, arsenic, phosphorus, and antimony. These techniques are useful for such components as diesel engine fuel injection pumps, artificial hip and knee-joint replacements, cylinder walls for engines, turbine blades, and other parts subjected to abrasion, high temperatures, and corrosive environments.

Polymers

Although natural polymers, such as wood, bone, and vegetable fibers, are as old as humanity, synthetic polymers, includ-

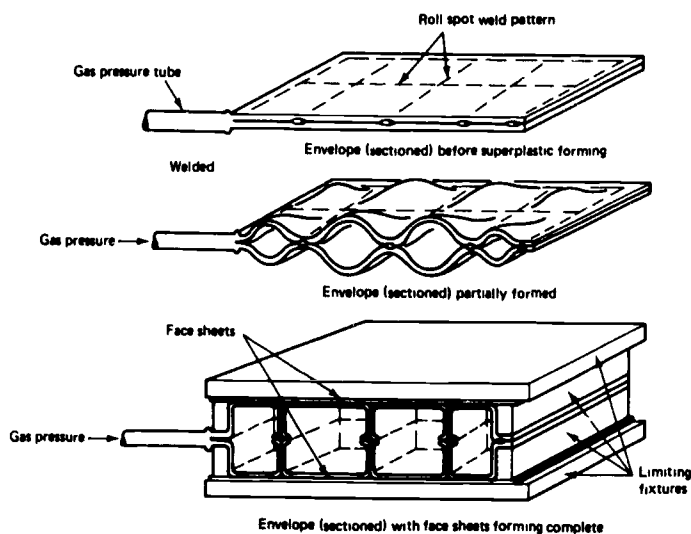

FIGURE 10

Superplastic Forming and Diffusion Bonding

ing plastics, elastomers (rubber), adhesives, and protective coatings, did not gain prominence as engineering materials until about 45 years ago. However, polymer science has been most aggressive over the past 30 years to the point that we depend greatly on synthetic polymers in our daily lives

Wood is still an important engineering material because it is a renewable resource as compared to nonrenewable resources (e.g., oil and minerals). Synthetic polymers have been used to make wood even better as wood based composites. Impreg wood becomes a very weather resistant material when phenolic resin is used to saturate thin veneers, which are stacked together into thick laminated pieces. Impreg wood can be laminated under high pressure into a final shape, such as knife handles, bowls, rigs for manufacturing, and textile looms. Sculptured impreg wood serves as models in developing

huge metal dies to stamp out automobile sheet metal. Flakeboard is much like particle board except it uses thin flakes of wood of various sizes and approximately square that are layered flat and bonded with water-repellent adhesives. Flakeboard can be used as exterior structural panels

There are many valuable synthetic elastomers, yet natural rubber continues to be a valuable engineering material. Because it is made from the liquid resin (latex) from a tree, natural rubber also is a renewable resource, much of which still goes into auto tire manufacturing. Deproteinized natural rubber (DPNR) has some ingredients, like protein and inorganic salts, removed to make it more resistant to fatigue with improved mechanical properties.

A growing trend in plastic and rubber is toward cellular or foamed materials. By entrapping air or emplanting glass spheres,

these synthetic polymers can be made lighter and more impact resistant and are better thermal insulators. Sheet molding compound (SMC) is an example of foamed plastics that can be reinforced with glass fibers to act as structural parts. SMC replaces sheet metal panels in cars, trucks, and tractors. In addition to weight savings, SMC has high toughness, color throughout the material, and will not rust. The Pontiac Fiero is an example of using SMC to replace sheet metal panels.

In a search of improvements over heavy optical glass, the development of CR39, an allyl diglycol carbonate plastic, gave eye-glass wearers a big advantage. CR39 is much lighter, more impact resistant than even chemically toughened glass, and nearly as scratch resistant. By coating these plastic lenses with a thin film of silica, they become quite scratch resistant and make plastic eye-glasses superior to glass lenses.

Construction Activity

Properties of materials indicate how a material will interact with a stress or environment. Strength and hardness are two key material properties. This activity provides plans to construct a hardness testing device. The next section deals with strength of materials.

Figure 11 shows a set of detailed drawings you can use to construct the rebound

hardness tester. With the hardness tester constructed, do the following steps.

1. Select a variety of metal pieces (different steels, aluminum, copper, etc.) about 1/8-in thick.
2. Identify the specimen.
3. Position the specimen under the acrylic tube, keep pressure of the tube on the specimen, and tighten the screw.

4. Drop the steel ball through the tube, and record the height that it rebounds.

5. Perform the test on each specimen three times and determine the average height of rebound.

$$AV = \frac{RH + RH + RH}{3}$$

RH = Rebound height

6. Plot the rebound height on graph paper to compare hardness. The higher the rebound, the harder the metal.

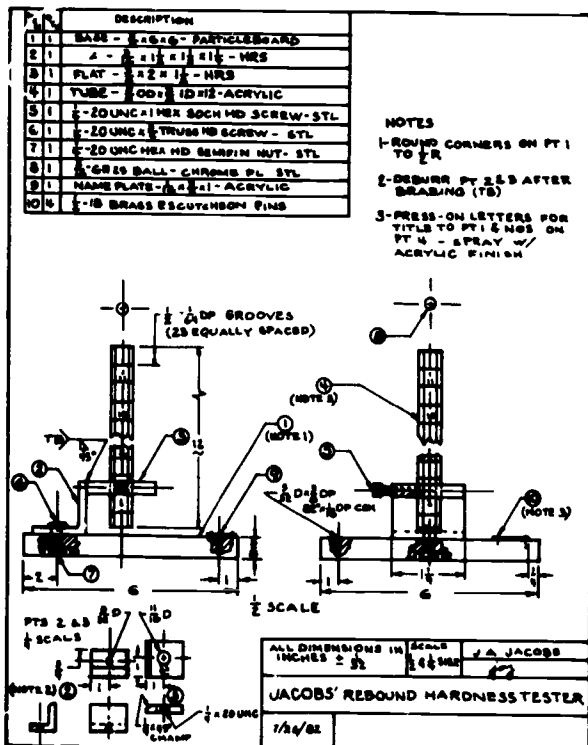

FIGURE 11

Rebound Hardness Tester



Supplementary Activity

Obtain an inexpensive Moh's hardness kit from a science supply company and conduct scratch tests. Use the scales on Figure 12 for a comparison of hardness numbers. The scales on Figure 12 are standard hardness values used in engineering. Note the tensile strength scale. With hardness known, it is possible to determine approximate tensile strength of ferrons (iron-based) metals.

Watch for hardness values such as R30 or BHN 150 on engineering drawings and material specifications. Hardness is very important in a material and affects the difficulty of machining, how the material will resist scratching and wear, and how it will react to impact.

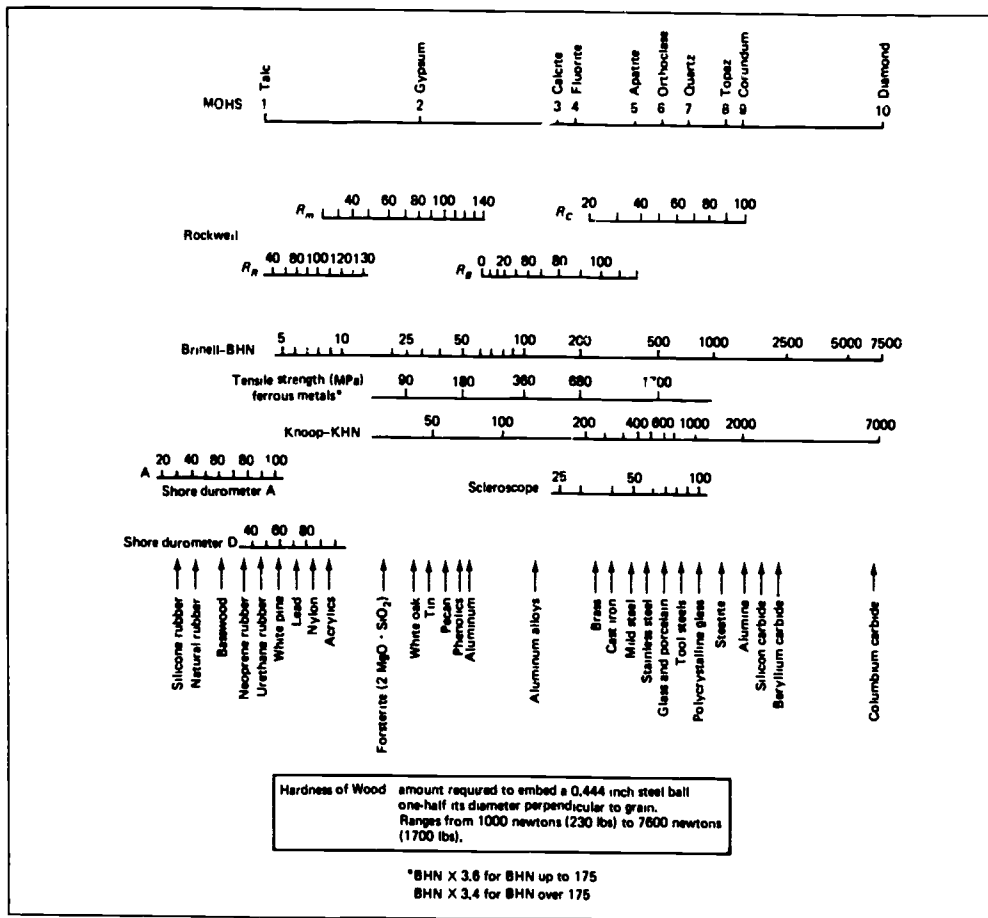

FIGURE 12
Hardness Scales

Math-Science-Technology Interface

One of the first questions asked about a material is, What is the strength? There are a variety of individual strengths, including tensile strength, compressive strength, shear strength, impact strength (toughness), and specific strength. Among these, tensile strength is most often used as a criterion when one wishes to know the strength of a material.

Tensile strength is determined by applying a stress or load in an opposite and por-

allel manner, as shown in Figure 13. On the left, a material has opposite forces trying to pull it apart. On the right, we see a 1/2-inch diameter rod that is holding up a 75-lb road exit sign. The sign is exerting a tensile stress on the rod. To calculate the tensile stress in a standard manner, the following formula is applied:

$$\text{Stress} = \frac{\text{Force}}{\text{Area}} = S = \frac{F}{A}$$

To determine the area, apply this formula. Area = πr^2

$$r \text{ (radius) of } \frac{1}{2} \text{ in dia} = 25 \text{ in}$$

$$r^2 = 25 \text{ in} \times 25 \text{ in} = 0063 \text{ in}^2$$

$$\pi r^2 = 3.14 \times 0063 \text{ in}^2 = 196 \text{ in}^2$$

Then to determine the tensile stress on the 1/2-inch dia rod

$$S = \frac{F}{A} = \frac{75 \text{ lbs}}{196 \text{ in}^2} = 382.65 \frac{\text{lbs}}{\text{in}^2} \text{ or } 382.65 \text{ psi}$$

The tensile stress of 382.65 psi indicates the amount of stress on the 1/2-inch rod. A designer could look up the tensile strength for a specific mild steel (e.g., 1020 SAE) and find a tensile strength of 65,000 psi. This is well above the stress placed on the rod by the exit sign, so the 1020 SAE steel would have suitable strength in this use.

To redo this problem using the SI (International System of Units), apply the following conversions:

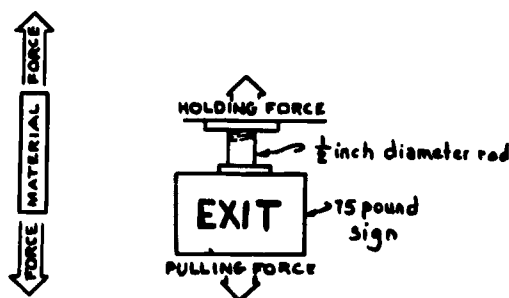

TENSILE STRESS

FIGURE 13

1 psi = 6.895×10^{-3} MPa
 1 in. = 2.540×10^1 mm

Figure 14 (adapted from NDEA Title II Institute for Advanced Study in Industrial Arts, San Jose State College) shows a simple method to measure the tensile strength of wire using a bar clamp and fish scale. Use a micrometer to measure the wire's diameter and a fish scale to determine the amount of load applied to the wire by the clamp as it is unscrewed.

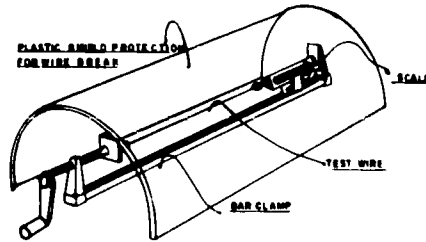

FIGURE 14

The Future of Engineering Materials Technology

The above examples of recent engineering materials technology developments do not even begin to scratch the surface of this deep-rooted technological movement. The United States government, as with many nations, has placed a high priority on funded materials science research. Just as we need to reduce our dependence of scarce strategic materials like chromium, we also need to

develop materials that will create more effective computers, better aerospace and other transportation vehicles, more energy-efficient production methods, and improved medical and life improving products. Private industry also sees the need to keep up with engineering materials technology and invests a lot of research and development money in this area.

Careers

Engineering materials technology offers a wide variety of career opportunities. The opportunities include jobs for technicians, technologists, engineers, and scientists who wish to specialize in such fields as polymer science, ceramics engineering, materials science, metallurgy, and materials engineering.

Also, those entering such technical fields as mechanical design technology, electronics engineering, civil engineering technology, physics, manufacturing engineering or technology, and robotics maintenance will need to study one or many courses in engineering materials technology or materials science.

Possible Student Outcomes

- Describe the importance of a knowledge of engineering materials technology to both technical workers and the average citizen.
- List at least three new materials developments and explain their importance to society.
- Define the following terms and cite examples or make sketches, as appropriate.

| | |
|--------------------|------------------|
| <i>crystalline</i> | <i>polymers</i> |
| <i>amorphous</i> | <i>composite</i> |

| | |
|-------------------------|----------------------------|
| <i>microstructure</i> | <i>advanced composites</i> |
| <i>strength</i> | <i>ceramics</i> |
| <i>hardness</i> | <i>metallics</i> |
| <i>tensile strength</i> | <i>toughness</i> |
| <i>atom</i> | |

- Determine which careers require a degree of competence in dealing with engineering materials.
- Construct devices and conduct experiments to determine the nature and properties of materials.

Student Quiz

1 Name five main family groups of materials and give a specific example of each. (See Table 1.)

2 Match the following terms to their definitions or examples.

- | | |
|------------------------|---|
| (c) 1 crystalline | a resistance to scratching or wear |
| (b) 2 amorphous | b solids that lack regular and orderly patterns or microstructure, such as glass and plastics |
| (d) 3 tensile strength | c solids with regular and repetitive microstructures, such as metals and ceramics |
| (a) 4 hardness | d ability to resist or pulling force |
| (f) 5 toughness | e ability to resist corrosion |
| | f impact strength |

3 Describe one example of a new engineering material development. (Answers may come from this article or student's own experience.)

4 Name two fields that require a knowledge of engineering materials. (Many examples can be given, including mechanical engineering technology, materials science, civil engineering, mechanical design technology, manufacturing technology, industrial arts teaching.)

5 Sketch a planetary model of an atom and label its components.

Bibliography

Jacobs, J. A., & Kilduff, T. F. (1985). *Engineering materials technology*. Englewood Cliffs, NJ: Prentice-Hall.

Periodicals:

High Technology, Machine Design, Materials Engineering, Popular Science, School Shop

For more experiments and activities related to materials and processes technology, request the following: *Materials and Processes Technology*, Industrial Arts Education, Commonwealth of Virginia, Richmond, VA 23216.

Acknowledgment

Figures 1-5, 7-10, and 12 are reprinted with permission from Jacobs, J. A., and Kilduff, T. F. (1985). *Engineering materials technology*. Englewood Cliffs, NJ: Prentice-Hall.

1978

1979

1980

1981

1982

1983

1984

1985

1986

1987

1988

1989

1990

1991

1992

Education Association

(Industrial Arts)

1978-1992

1978-1992

1978-1992

1978-1992