

DOCUMENT RESUME

ED 320 025

CE 055 213

AUTHOR Schertz, Karen
 TITLE Basic Drafting. Revised.
 INSTITUTION Mid-America Vocational Curriculum Consortium,
 Stillwater, Okla.
 PUB DATE 90
 NOTE 1,017p.; Revision of ED 219 653-654.
 AVAILABLE FROM Mid-America Vocational Curriculum Consortium, 1500
 West Seventh Avenue, Stillwater, OK 74074 (order no.
 302001: \$45.50).
 PUB TYPE Guides - Classroom Use - Guides (For Teachers) (052)
 EDRS PRICE MF07 Plus Postage. PC Not Available from EDRS.
 DESCRIPTORS Classroom Techniques; *Computer Assisted Design;
 Construction (Process); Course Content; Curriculum
 Guides; *Drafting; *Entry Workers; Equipment;
 Industrial Arts; *Job Skills; Learning Activities;
 Learning Modules; Lesson Plans; *Orthographic
 Projection; Postsecondary Education; Secondary
 Education; Skill Development; Teaching Methods; Test
 Items; Units of Study

ABSTRACT

This introductory module on drafting includes the technical content and tasks necessary for a student to be employed in an entry-level drafting occupation. The module contains 18 instructional units that cover the following topics: introduction to drafting; tools and equipment; supplies and materials; sketching; scales; drawing format; lettering; lines; reproduction; geometric constructions; orthographic views; auxiliary views; sectional views; axonometrics; obliques; perspectives; dimensioning; and tolerancing. Each instructional unit follows a standard format that includes some or all of these eight basic components: performance objectives, suggested activities for teachers and students, information sheets, assignment sheets, job sheets, visual aids, tests and answers to tests, and assignment sheets. All of the unit components focus on measurable and observable learning outcomes and are designed to be used for more than one lesson or class period. A list of tools, materials, and equipment; 37 references; and instructional/task analyses are also included. (KC)

 * Reproductions supplied by EDRS are the best that can be made *
 * from the original document. *

ED320025

BASIC DRAFTING

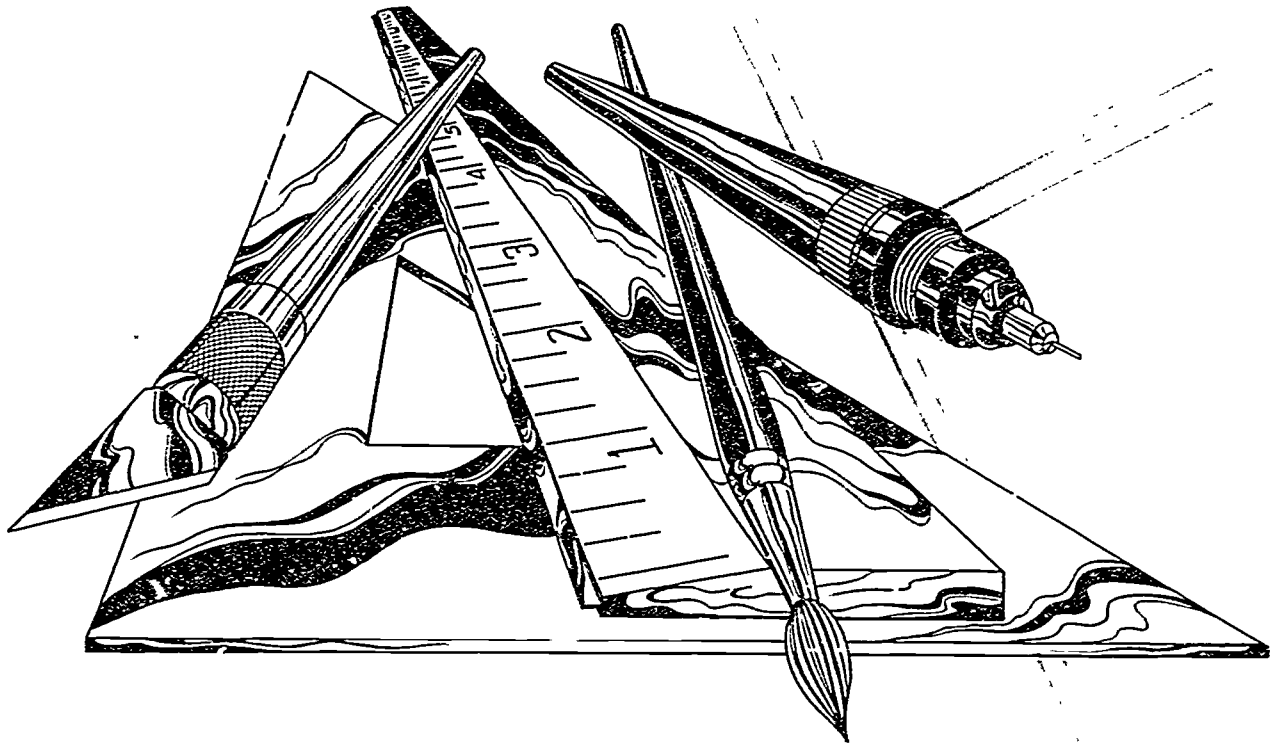

U.S. DEPARTMENT OF EDUCATION
 Office of Educational Research and Improvement
 EDUCATIONAL RESOURCES INFORMATION
 CENTER (ERIC)

- This document has been reproduced as received from the person or organization originating it.
- Minor changes have been made to improve reproduction quality.

• Points of view or opinions stated in this document do not necessarily represent official OE... position or policy

"PERMISSION TO REPRODUCE THIS MATERIAL IN MICROFICHE ONLY HAS BEEN GRANTED BY

R. L. Brannon

TO THE EDUCATIONAL RESOURCES INFORMATION CENTER (ERIC)."

MAVCC

BEST COPY AVAILABLE

Catalog # 302001

CE 055213



BASIC DRAFTING

Revised by

Karen Schertz
Drafting/CADD Technology Department Coordinator
Boulder Technical Education Center
Boulder, Colorado

Edited by

Mary Kellum
Curriculum Specialist

Developed by

The Mid-America Vocational Curriculum Consortium, Inc.

Board of Directors

Ann Masters, Nebraska, Chairman
Sylvia Clark, Texas, Vice-Chairman
Donna Brookhart, Colorado, Parliamentarian
Bruce Simpson, Arkansas
Janet Huss, Iowa
Carol Fagan, Kansas
David Poston, Louisiana
Harley Schlichting, Missouri
Ron Mehrer, North Dakota
Ann Benson, Oklahoma
Larry Nelson, South Dakota

Jim Steward, Executive Director

©1990 by the Mid-America Vocational Curriculum Consortium, Inc.

All rights reserved. No part of this book
may be reproduced in any form or by any
means without written permission from the publisher.

Printed in the United States of America by the
Oklahoma Department of Vocational-Technical Education
Stillwater, OK 74074

Mid-America Vocational Curriculum Consortium, Inc.
1500 West Seventh
Stillwater, Oklahoma 74074-4364

BASIC DRAFTING

TABLE OF CONTENTS

Unit I:	Introduction to Drafting	1
Unit II:	Tools and Equipment	59
Unit III:	Supplies and Materials	129
Unit IV:	Sketching	177
Unit V:	Scales	229
Unit VI:	Drawing Format	289
Unit VII:	Lettering	331
Unit VIII:	Lines	375
Unit IX:	Reproduction	419
Unit X:	Geometric Constructions	455
Unit XI:	Orthographic Views	547
Unit XII:	Auxiliary Views	669
Unit XIII:	Sectional Views	771
Unit XIV:	Axonometrics	859
Unit XV:	Obliques	925
Unit XVI:	Perspectives	967
Unit XVII:	Dimensioning	1005
Unit XVIII:	Tolerancing	1115

FOREWORD

Basic Drafting is the first volume in a series of instructional materials on drafting developed by the Mid-America Vocational Curriculum Consortium (MAVCC). This publication is designed to include the technical content and tasks necessary for a student to be employed in an entry-level drafting occupation. Additional instructional materials have been developed for *Mechanical Drafting*, *Pipe Drafting*, *Light Commercial Drafting*, *Electronic Drafting*, *Civil Drafting*, and *Architectural Drafting*. These areas of specialization are supplements to *Basic Drafting*.

This publication is a revision of *Basic Drafting: Book One* and *Basic Drafting: Book Two*. The revision is in response to the need to update the material and to incorporate computer-aided drafting as a basic tool for drafters.

The success of this publication is due to: (1) teacher response that has helped place the MAVCC format in the forefront in competency-based vocational instructional materials and (2) the capabilities of the people who worked on its development. The technical writer, committee representatives, and curriculum specialist brought with them technical expertise and experience related to the classroom and to the trade.

As this publication is used, it is hoped that student performance and teacher effectiveness will improve. Every effort has been made to make this publication basic, readable, and by all means usable. *Basic Drafting* is written in terms of student performance using measurable objectives. The instructional materials have been developed so that performance objectives are identified, technical information and tasks are written to accomplish those objectives, and criterion-referenced evaluation instruments are provided for uniform measurement of student performance.

As with any MAVCC publication, the teacher must take the instructional materials and (1) localize to fit the community and industry needs, (2) personalize to meet each student's learning style and needs, (3) supplement to match your teaching methods, and (4) motivate. These areas have been left to the individual teacher who should expand and implement each area. Only then will *Basic Drafting* become a vital part of the teaching-learning process.

It is the sincere belief of MAVCC and all those who worked on this publication that *Basic Drafting* will allow students to be better prepared to be effective members of the work force. If there is anything we can do to help this publication become more useful to you, please let us know.

Ann Masters, Chairman
Board of Directors
Mid-America Vocational
Curriculum Consortium

Jim Steward
Executive Director
Mid-America Vocational
Curriculum Consortium

ACKNOWLEDGEMENTS

Appreciation is extended to those individuals who contributed their time and talent to the revision of *Basic Drafting*.

The contents of this publication were planned and reviewed by the following members of the Mid-America Vocational Curriculum Consortium drafting revision committee.

Lanny Auringer	Rysavy Hartman, Associates Sioux Falls, South Dakota
Charles B. Conine	University of Arkansas at Little Rock Little Rock, Arkansas
Doug Elting	Davis, Senton, Stange, and Darling Lincoln, Nebraska
Don Litton	Boulder Technical Education Center Boulder, Colorado
Devin Mogck	Tvenge Associates Bismarck, North Dakota
Willie Norris and Danny Cowart	Tri-County Area Vo-Tech School Bartlesville, Oklahoma
Steve Pierce	Veenstra-Kimm West Des Moines, Iowa
James Platt	Architecture Six, Inc. Lake Charles, Louisiana
Gary Thomas	Martin-Marietta Denver, Colorado

Special recognition is given to the authors of MAVCC's *Basic Drafting, Books One and Two* upon which this revision is based. Their names are **Ronald Davis, Bill Hill, and Bruce Yancey**.

Thanks are extended by the author to **William Christy**, a post-secondary drafting student at Boulder Technical Education Center, for his assistance with artwork, and to **Leland Schertz** for his continued support and understanding.

Special appreciation is extended to **Nancy Hilley** for artwork revision and pasteup of this book and to the employees of the Graphics Division of the Oklahoma Department of Vocational-Technical Education for the phototypesetting and printing of this text.

Thanks are also extended to **Mary Kellum**, MAVCC Curriculum Specialist, for her assistance with the editing of this book, as well as the coordination of the project.

USE OF THIS PUBLICATION

Instructional Units

Basic Drafting contains eighteen units of instruction. Each instructional unit includes some or all of the basic components of a unit of instruction, performance objectives, suggested activities for teachers and students, information sheets, assignment sheets, job sheets, visual aids, tests, and answers to the tests. Units are planned for more than one lesson or class period of instruction.

Careful study of each instructional unit by the teacher will help to determine:

- A. The amount of material that can be covered in each class period.
- B. The skills which must be demonstrated
 - 1. Supplies needed
 - 2. Equipment needed
 - 3. Amount of practice needed
 - 4. Amount of class time needed for demonstrations
- C. Supplementary materials such as pamphlets or filmstrips that must be ordered
- D. Resource people who must be contacted

Objectives

Each unit of instruction is based on performance objectives. These objectives state the goals of the course, thus providing a sense of direction and accomplishment for the student.

Performance objectives are stated in two forms: unit objectives, stating the subject matter to be covered in a unit of instruction, and specific objectives, stating the student performance necessary to reach the unit objective.

Since the objectives of the unit provide direction for the teaching-learning process, it is important for the teacher and students to have a common understanding of the intent of the objectives. A limited number of performance terms have been used in the objectives for this curriculum to assist in promoting the effectiveness of the communication among all individuals using the materials.

Reading of the objectives by the student should be followed by a class discussion to answer any questions concerning performance requirements for each instructional unit.

Teachers should feel free to add objectives which will fit the material to the needs of the students and community. When teachers add objectives, they should remember to supply the needed information, assignment and/or job sheets, and criterion tests.

Suggested Activities for the Instructor

Each unit of instruction has a suggested activities sheet outlining steps to follow in accomplishing specific objectives. Duties of instructors will vary according to the particular unit; however, for best use of the material they should include the following: provide students with objective sheet, information sheet, assignment sheets, and job sheets; preview filmstrips, make transparencies, and arrange for resource materials and people; discuss unit and specific objectives and information sheet; give test. Teachers are encouraged to use any additional instructional activities and teaching methods to aid students in accomplishing the objectives.

Information Sheets

Information sheets provide content essential for meeting the cognitive (knowledge) objectives in the unit. The teacher will find that the information sheets serve as an excellent guide for presenting the background knowledge necessary to develop the skill specified in the unit objective.

Students should read the information sheets before the information is discussed in class. Students may take additional notes on the information sheets.

Transparency Masters

Transparency masters provide information in a special way. The students may see as well as hear the material being presented, thus reinforcing the learning process. Transparencies may present new information or they may reinforce information presented in the information sheets. They are particularly effective when identification is necessary.

Transparencies should be made and placed in the notebook where they will be immediately available for use. Transparencies direct the class's attention to the topic of discussion. They should be left on the screen only when topics shown are under discussion.

Assignment Sheets

Assignment sheets give direction to study and furnish practice for paper and pencil activities to develop the knowledge which is a necessary prerequisite to skill development. These may be given to the student for completion in class or used for homework assignments. Answer sheets are provided which may be used by the student and/or teacher for checking student progress.

Job Sheets

Job sheets are an important segment of each unit. The instructor should be able to demonstrate the skills outlined in the job sheets. Procedures outlined in the job sheets give direction to the skill being taught and allow both student and teacher to check student progress toward the accomplishment of the skill. Job sheets provide a ready outline for students to follow if they have missed a demonstration. Job sheets also furnish potential employers with a picture of the skills being taught and the performances which might reasonably be expected from a person who has had this training.

Test and Evaluation

Paper-pencil and performance tests have been constructed to measure student achievement of each objective listed in the unit of instruction. Individual test items may be pulled out and used as a short test to determine student achievement of a particular objective. This kind of testing may be used as a daily quiz and will help the teacher spot difficulties being encountered by students in their efforts to accomplish the unit objective. Test items for objectives added by the teacher should be constructed and added to the test.

Test Answers

Test answers are provided for each unit. These may be used by the teacher and/or student for checking student achievement of the objectives.

BASIC DRAFTING

TOOLS, MATERIALS, AND EQUIPMENT LIST

Standard triangles, 30°60°, 45°
Adjustable triangle
Compass
Divider
Protractor
Irregular curves
Common templates
Drafting tape
Drafting machine or parallel bar
Blueline machine
Electrostatic (xerographic) machine
Lead holder or mechanical (mm) pencil
Lead (various weights)
Lead pointer
Technical pen set
Ink
Pen cleaning solution
Lint-free cloth or tissue
Erasers for ink and pencil
Erasing brush
Erasing shield
Cleaning pad
Ames-type lettering guide
Braddock Rowe triangle
Leroy-type lettering instrument (optional)
Drawing media (vellum and polyester film)
Film cleaner and cloth
Scales—Architect, metric, civil, mechanical
Metal rule
Standard fit tables
ANSI standards for drafting
CADD system hardware
CADD software
CADD operator's manual
Plotter paper

BASIC DRAFTING

REFERENCES

- A. Anderson, Lawrence C. Jr. *Computer Graphics Mechanical Design Concepts*. Milwaukee, WI: MATC, 1986.
- B. American National Standards Institute (ANSI) standards. Published by The American Society of Mechanical Engineers (ASME). New York.
1. *B4.1-.967 (R1987) — Preferred Limits and Fits for Cylindrical Parts.*
 2. *Y1.1-1972 (R1984) — Abbreviations — For Use On Drawings And In Text.*
 3. *Y14.1-1980 (R1987) — Drawing Sheet Size and Format.*
 4. *Y14.2M-1979 (R1987) — Line Conventions and Lettering.*
 5. *Y14.3-1975 (R1987) — Multi and Sectional View Drawings.*
 6. *Y14.4-1957 (R1987) — Pictorial Drawing.*
 7. *Y14.5M-1982 (R1988) — Dimensioning and Tolerancing.*
 8. *Y14.34M-1982 (R1988) — Parts Lists, Data Lists, and Index Lists.*
- C. Autodesk, Inc. 2320 Marinship Way, Sausalito, CA 94965, (415) 332-2344.
- D. *Basic Drafting*. Natchitoches, LA. Vocational Curriculum Development and Research Center, 1979.
- E. Brown, Walter C. *Drafting for Industry*. South Holland, IL: Goodheart-Willcox Co., Inc., 1984.
- F. Erbes, John, and Victor Langer. *MATC-CAD: Computer-Aided Drafting, Manual and Software*. Milwaukee Area Technical College, 1015 North Sixth Street, Milwaukee, Wisconsin 53203.
- G. French, Thomas E., et. al. *Mechanical Drawing*, 10th ed. New York: McGraw-Hill Book Co., 1985.
- H. French, Thomas E. and Charles J. Vierck. *Engineering Drawing and Graphic Technology*, 13th ed. New York: McGraw-Hill Book Co., 1986.
- I. Fuller, James E. *Using Autocad*, 2nd edition. 2 Computer Dr. West, Box 15-015, Albany, NY 12212: Delmar Publishers, Inc., 1988.
- J. Gerevas, Lawrence E. *Basic Drafting Problems*, 2nd ed. New York. Bobbs-Merrill Co., 1981.
- K. Giachino, J. W. and H. J. Beukema *Engineering Technical Drafting*, 4th ed. Homewood, IL: American Technical Publishers, Inc., 1978.

- L. Giesecke, Frederick E., et. al. *Technical Drawing*, 8th ed. New York: Macmillan Publishing Co., Inc., 1986.
- M. Jenz, Cecil and Jay Helsel. *Engineering Drawing and Design*, 3rd ed. New York. Greg Division/McGraw-Hill Book Co., 1985.
- N. *Koh-I-Noor Rapiddraw Learning Program Workbook*. Bloomsbury, NJ. Koh-I-Noor Rapidograph, Inc.
- O. *The Koh-I-Noor Rapiddraw System*. Bloomsbury, NJ. Koh-I-Noor Rapidograph, Inc.
- P. Lamit, Gary Louis and Vernon Paige. *Computer-Aided Drafting and Design — CADD*. Columbus, OH: Merrill Publishing Co., 1987.
- Q. Lieblich, Jerome H. *Drawing Requirements Manual*, 6th ed. Irvine, CA: Global Engineering Documents, 1986.
- R. Lubow, Martha. *Working Out with AutoCAD*. P.O. Box 4846, Thousand Oaks, CA 91360: New Riders Publishing, 1987.
- S. Merickel, Mark. *Stepping Into CAD*. Thousand Oaks, CA. New Riders Publishing, 1986.
- T. Oberg, Erik, et. al. *Machinery's Handbook*, 23rd ed. New York: Industrial Press, 1988.
- U. Olivo, C. Thomas and Albert V. Payne. *Basic Blueprint Reading and Sketching*, 5th ed. Albany, NY: Delmar Publishers, Inc., 1988.
- V. Slaby, Steve M. *Engineering Descriptive Geometry*. New York. Baynes & Noble Bocks, 1956.
- W. Spence, William P. *Drafting Technology and Practice*. Peoria, IL 61615: Chas. A. Bennett Co., Inc. 1973.
- X. Spence, William P. *Engineering Graphics*, 2nd ed. Englewood Cliffs, NJ. Prentice-Hall, 1988.
- Y. Spencer, Henry C., et. al. *Technical Drawing Problems*. New York: Macmillan Publishing Co., 1980.
- Z. *VersaCAD Design, 2D Training Guide, Version 5.3*. 2124 Main St., Huntington Beach, CA 92648 (714)960-7720: Versacad Corporation, March, 1988.
- AA. *VersaCAD Design — The Total Design Solution*. Versacad Corporation, 2124 Main St., Huntington Beach, CA 92648, 1988.
- BB. Voisinet, Donald D. *AutoCAD Mechanical Lab Manual*. New York. McGraw-Hill, Inc., 1987.
- CC. Wellman, B. Leighton. *Technical Descriptive Geometry*. New York. McGraw-Hill Book, 1957.
- DD. *Xerox-Aided Drafting*. Xerox Square, Rochester, NY 14644: Xerox Corporation.

BASIC DRAFTING

INSTRUCTIONAL / TASK ANALYSIS

RELATED INFORMATION: What
the Worker Should Know
(Cognitive)

JOB TRAINING: What the
Worker Should Be Able to Do
(Psychomotor)

UNIT I: INTRODUCTION TO DRAFTING

1. Terms and definitions
2. Areas of specialization in the drafting profession
3. Industries that employ drafters and CADD operators
4. Related occupational fields that employ drafters and CADD operators
5. Job classifications within a manufacturing structure
6. Job titles for drafters and CADD operators
7. Common types of engineering drawings
8. Types of computer graphics
9. Sequence for the completion of drafting work
10. Advantages and disadvantages of a drafting occupation
11. Advantages of using computers for drafting applications
12. Personal traits or skills that are important for a successful drafter
13. Areas in which a drawing will always be evaluated
14. Abbreviations of professional drafting organizations

RELATED INFORMATION: What the Worker Should Know (Cognitive)

JOB TRAINING: What the Worker Should Be Able to Do (Psychomotor)

15. Drafter's responsibilities in maintaining a safe drafting or CADD lab
16. Reasons for maintaining a clean, orderly lab
17. Specific rules for personal safety in the drafting lab
18. Specific safety rules for using CADD equipment
19. Classes of fires and types of fire extinguishers
20. Take a math pretest
21. Interview a CADD operator
22. Subscribe to a student safety pledge

UNIT II: TOOLS AND EQUIPMENT

1. Terms and definitions
2. Basic drafting tools
3. Types of drafting machines
4. Advantages of each type of drafting machine
5. Parts of a standard protractor head
6. Rules for maintenance and care of drafting machines
7. Types of compasses
8. Types of dividers
9. Types of irregular curves
10. Types of common templates
11. Rules for maintenance and care of drafting machines
12. Types of drafting pencils

RELATED INFORMATION: What
the Worker Should Know
(Cognitive)

13. Types of leads and devices used to sharpen them
14. Tools used for inking
15. Types of pen points
16. Ways to properly use and care for technical pens
17. CADD terminology and definitions
18. Hardware used in a CADD system
19. Types of computer subsystems for CADD
20. Typical routines used for maintaining CADD files

JOB TRAINING: What the
Worker Should Be Able to Do
(Psychomotor)

21. Research computer applications in the drafting field
22. Measure angles with the protractor and vernier scale on a drafting machine
23. Operate an adjustable triangle
24. Draw horizontal and vertical lines with triangles and a drafting machine
25. Divide a circle into 24 parts of 15° by using $30^\circ/60^\circ$ and 45° triangles
26. Use a compass to draw circles and arcs
27. Use a divider to divide a line into equal parts
28. Measure angles with a protractor
29. Use an irregular curve to construct a curved line
30. Format a floppy diskette

RELATED INFORMATION: What
the Worker Should Know
(Cognitive)

JOB TRAINING: What the
Worker Should Be Able to Do
(Psychomotor)

UNIT III: SUPPLIES AND MATERIALS

1. Terms and definitions
2. Types of drafting media and their characteristics
3. Standard media sheet sizes
4. Basic widths and lengths of media roll sizes
5. Characteristics of paper surfaces
6. Precautions when using ink on vellum
7. Characteristics of polyester drafting film
8. Procedures for inking on polyester film
9. Drawing leads and their characteristics
10. Erasers and their characteristics
11. Common sizes of thin-lead mechanical pencils
12. Disadvantages of hard and soft leads
13. Reproduction qualities of lead, plastic lead, and ink
14. Advantages and disadvantages of ink, lead, and plastic lead
15. Types of drawing inks
16. Types of plotter pens
17. Fill a technical pen
18. Clean a technical pen
19. Trace a drawing onto vellum using thin-lead mechanical pencils

RELATED INFORMATION: What the Worker Should Know (Cognitive)

JOB TRAINING: What the Worker Should Be Able to Do (Psychomotor)

20. Trace a drawing onto polyester film using plastic lead
21. Trace a drawing onto polyester film using ink
22. Log on, log out, and file on a CADD system

UNIT IV: SKETCHING

1. Terms and definitions
2. Purposes of sketching
3. Rules in sketching
4. Steps in completing a drawing
5. Types of sketches
6. Factors in center line usage
7. Ways to interpret the meaning of lines
8. Methods for proportioning a sketch
9. Methods for inputting geometry into a CADD system
10. Input devices for menu selection
11. Freehand digitizing on CADD
12. Types of coordinate entries
13. Types of grids used for freehand sketching
14. Types of geometry used to create CADD drawings
15. Reference points used to build existing CADD entities
16. Origins and ends of basic CADD geometry

RELATED INFORMATION: What the Worker Should Know (Cognitive)

JOB TRAINING: What the Worker Should Be Able to Do (Psychomotor)

17. Sketch straight lines
18. Sketch arcs
19. Sketch circles
20. Sketch ellipses
21. Sketch an isometric cube
22. Sketch an oblique cube
23. Sketch a cone
24. Block in a view of a part
25. Specify a 0.25 grid for a CADD system and create a freehand digitized drawing

UNIT V: SCALES

1. Terms and definitions
2. Scales used in drafting
3. Purpose of a scale
4. Rules for measuring with a scale
5. Rules when applying a scale to a drawing
6. Preferred drawing scales
7. Graduations on a full-size scale
8. Locating 1/32 graduations on a full-size scale
9. Fully-divided decimal scale
10. Scale ratios found on various scales and rules
11. Metric scale ratios commonly used
12. Reduction and enlargement scale ratios

RELATED INFORMATION: What
the Worker Should Know
(Cognitive)

JOB TRAINING: What the
Worker Should Be Able to Do
(Psychomotor)

13. Drawing scale when using CADD
14. CADD terminology used for view manipulation
15. Read a full scale
16. Interpret 1/16 and 1/32 graduations on a full-size metal rule
17. Measure lines with a civil engineer's scale
18. Measure lines with an architect's scale
19. Measure lines with a mechanical engineer's scale
20. Measure lines with a metric scale

UNIT VI: DRAWING FORMAT

1. Terms and definitions
2. Types of working drawings
3. Other types of drawings
4. Basic information needed on a drawing
5. Location of various components on a drawing
6. Information found in a title block
7. Information found in a revision block
8. Information found in a parts list
9. Information found in supplementary blocks
10. Use of general notes on a drawing
11. Types of CADD drawing systems
12. Typical considerations in initiating a CADD drawing

RELATED INFORMATION: What
the Worker Should Know
(Cognitive)

JOB TRAINING: What the
Worker Should Be Able to Do
(Psychomotor)

13. Complete a title block
14. Enter drawing parameters onto a CADD system
15. Format a parts storage diskette
16. Draw a title block on a CADD system

UNIT VII: LETTERING

1. Terms and definitions
2. Types of letters
3. Most common font used in drafting
4. Reasons for using single-stroke Gothic lettering
5. Rules for forming Gothic lettering
6. Reasons and rules for neat lettering
7. Rules for spacing
8. Recommended minimum letter heights
9. Common problems in letter uniformity
10. Purposes of guidelines
11. Rules for making guidelines
12. Types of line guides
13. Special rules for left-handed drafters
14. Types of lettering instruments
15. Characteristics of text input on CADD
16. Hand letter an employment application
17. Operate an Ames-type lettering guide to construct guidelines

RELATED INFORMATION: What
the Worker Should Know
(Cognitive)

JOB TRAINING: What the
Worker Should Be Able to Do
(Psychomotor)

18. Operate a Braddock Rowe triangle to construct guidelines
19. Construct vertical Gothic lettering and numerals
20. Construct inclined Gothic lettering and numerals
21. Add text to a title block on a CADD system

UNIT VIII: LINES

1. Uses of basic types of lines
2. Identification of basic types of lines
3. Line widths and recommended pen sizes
4. Rules for using lines
5. Qualities which define good lines
6. Size recommendations for choosing millimeter pencils
7. Techniques for drawing lines with ink
8. Factors that make lines heavier or thinner with a technical pen
9. Using ink on polyester film
10. Using ink on vellum
11. Steps for completing lines on a drawing
12. Common elements of a CADD command for inputting drawing geometry
13. Components of a line used on CADD
14. Modifiers used with a line command

RELATED INFORMATION: What the Worker Should Know (Cognitive)

15. Methods for locating lines on a CADD system
16. Methods for inputting different line types on a CADD system

JOB TRAINING: What the Worker Should Be Able to Do (Psychomotor)

17. Draw lines on vellum using graphite lead
18. Draw lines on polyester film using plastic lead
19. Trace an illustration on vellum using millimeter pencils
20. Draw and erase ink lines on vellum
21. Draw and erase ink lines on polyester film
22. Input lines into a CADD system

UNIT IX: REPRODUCTION

1. Terms and definitions
2. Common reproduction processes used in drafting
3. Steps in the diazo process
4. Factors involved in the diazo process
5. Types of diazo prints
6. Factors that affect the diazo process
7. Advantages of the diazo process
8. How to safely use erasing chemicals in diazo processing
9. Common problems in the diazo process
10. Procedure for making reproducible from existing drawings

RELATED INFORMATION: What the Worker Should Know (Cognitive)

JOB TRAINING: What the Worker Should Be Able to Do (Psychomotor)

11. Ways the electrostatic (xerographic) copier may be used for drafting reproduction
12. CADD output devices
13. Proper use of technical pens with plotters
14. Elements of a proper drawing control system
15. Ways a proper drawing control system benefits a drafting organization
16. Correct storage and distribution of drawings and prints
17. Advantages of microfilm
18. Steps in the procedure for using reprographics in drafting
19. Operate a diazo print machine
20. Plot a drawing from a CADD system

UNIT X: GEOMETRIC CONSTRUCTIONS

1. Basic geometric terms and their definitions
2. Types of angles
3. Types of triangles
4. Types of quadrilaterals
5. Types of polygons
6. Circular shapes
7. Abbreviations for geometric terms
8. Solid geometric figures
9. Special geometric figures
10. Elements needed for measuring parts of a circle

RELATED INFORMATION: What
the Worker Should Know
(Cognitive)

11. Interpreting degrees in a circle
12. Elements of a circle used in CADD
13. Methods used to create circles on CADD
14. Methods used to create arcs on CADD
15. Creating fillets on CADD
16. Creating chamfers on CADD

JOB TRAINING: What the
Worker Should Be Able to Do
(Psychomotor)

17. Bisect a line and an arc
18. Bisect an angle
19. Draw parallel lines
20. Construct a line perpendicular to a line from a point not on the line
21. Construct a line perpendicular to a line through a point on the line
22. Divide a line into equal parts
23. Construct a triangle with sides given
24. Construct a right triangle
25. Construct an equilateral triangle with one side given
26. Inscribe a hexagon inside a circle
27. Construct a hexagon with the distance across the flat sides given
28. Inscribe a pentagon inside a circle
29. Construct a circle through three given points
30. Draw an arc tangent to a straight line and an arc
31. Draw an arc tangent to two arcs

RELATED INFORMATION: What the Worker Should Know (Cognitive)

JOB TRAINING: What the Worker Should Be Able to Do (Psychomotor)

32. Draw an arc tangent to an acute angle and an obtuse angle
33. Draw an arc tangent to a right angle
34. Draw an ellipse using the approximate ellipse with compass method
35. Draw a parabola
36. Join two points with a parabolic curve
37. Draw an involute of a circle
38. Create a part on CADD using circles, arcs, fillets, and lines

UNIT XI: ORTHOGRAPHIC VIEWS

1. Terms and definitions
2. Types of projection systems
3. Planes of projection
4. Steps in visualizing an orthographic projection
5. Six views possible in orthographic projection
6. Three principal views in orthographic projection
7. Steps in selecting correct views of an object
8. Basic dimensions of an object
9. Common methods of transferring depth dimensions
10. Projection of lines in orthographic views
11. Types of planes

RELATED INFORMATION: What
the Worker Should Know
(Cognitive)

JOB TRAINING: What the
Worker Should Be Able to Do
(Psychomotor)

12. Usage of hidden lines
 13. Line precedence in an orthographic drawing
 14. Rounds, fillets, and runouts
 15. Creating a rectangle on CADD
 16. Creating a spline on CADD
 17. Methods used on CADD for view manipulation
18. Identify projection of lines in orthographic views
 19. Identify types of planes in orthographic views
 20. Construct a top view
 21. Construct a front view
 22. Construct a right side view
 23. Construct missing hidden lines
 24. Construct missing visible and hidden lines
 25. Make a two-view sketch
 26. Make a three-view sketch
 27. Construct circles and arcs using a template
 28. Construct elliptical curves
 29. Construct a one-view drawing
 30. Construct a two-view drawing
 31. Construct a three-view drawing
 32. Construct a runout
 33. Construct a point in an orthographic view

RELATED INFORMATION: What the Worker Should Know (Cognitive)

JOB TRAINING: What the Worker Should Be Able to Do (Psychomotor)

34. Construct a line in an orthographic view
35. Construct a plane in an orthographic view
36. Develop orthographic drawings by coordinate input on CADD

UNIT XII: AUXILIARY VIEWS

1. Terms and definitions
2. Descriptive geometry
3. Terms used in descriptive geometry
4. Purpose of auxiliary views
5. Types of auxiliary views
6. Uses of auxiliary views
7. Drafting practices for auxiliary views
8. Projection of measurements in a primary auxiliary view
9. Locations of reference lines
10. Projection of measurements in a secondary auxiliary view
11. Methods for modifying geometry on a CADD drawing
12. Methods for removing or editing geometry on CADD
13. Label points and planes of a three-view object
14. Construct a primary auxiliary of an inclined plane
15. Construct a primary auxiliary of a curved surface
16. Determine true length of an oblique line

RELATED INFORMATION: What
the Worker Should Know
(Cognitive)

JOB TRAINING: What the
Worker Should Be Able to Do
(Psychomotor)

17. Determine true angle and slope of a line
18. Determine visibility of crossing skew lines in space
19. Determine visibility of a line and a plane that cross in space
20. Locate piercing point of a line and a plane
21. Determine point view of a line
22. Construct secondary auxiliary views of an object
23. Construct a secondary auxiliary of an oblique plane
24. Determine the true angle between two planes
25. Determine true angle between two planes in a secondary auxiliary
26. Determine shortest distance between a point and a line
27. Determine shortest distance between two skew lines
28. Modify geometry by using the mirror, mirror and copy, move and copy, and rotate CADD commands
29. Edit geometry by using the delete, blank, divide, and stretch CADD commands
30. Lengthen or shorten lines, arcs, and circles on a CADD system

RELATED INFORMATION: What
the Worker Should Know
(Cognitive)

JOB TRAINING: What the
Worker Should Be Able to Do
(Psychomotor)

UNIT XIII: SECTIONAL VIEWS

1. Terms and definitions
2. Types of sectional views
3. Uses of sections
4. General rules in sectioning
5. Specific rules for specific section types
6. Types of conventional breaks
7. Labeling sectional views
8. Line thicknesses used in sectional drawings
9. Cutting plane lines
10. Material symbols in section
11. Common errors in making section lines
12. Use of unlined sections
13. Methods used to aid equal spacing of section lining
14. Crosshatching and pattern filling on CADD
15. Construct various material symbols in section
16. Construct a full section
17. Construct a half section
18. Construct an offset section
19. Construct a broken-out section
20. Construct a removed section
21. Construct a revolved section
22. Construct a rib section

RELATED INFORMATION: What
the Worker Should Know
(Cognitive)

JOB TRAINING: What the
Worker Should Be Able to Do
(Psychomotor)

23. Construct an aligned section
24. Construct adjacent parts in assembly section
25. Construct conventional breaks
26. Construct an assembly section
27. Crosshatch a part on CADD

UNIT XIV: AXONOMETRICS

1. Terms and definitions
2. Types of axonometric drawings
3. Positions used as axis lines for isometric drawings
4. Plane surfaces on isometrics
5. Rules in constructing an isometric drawing
6. Common errors made in isometric drawing
7. Advantages and disadvantages of isometric drawing
8. Types of three-dimensional drawings created on CADD
9. Model mode and draw mode on CADD
10. Applications for three-dimensional part model building on CADD
11. "Automatic drawings"
12. Sketch an isometric drawing
13. Sketch isometric circles
14. Construct axonometric drawings by box method
15. Construct angles on an isometric
16. Construct isometric circles and arcs

RELATED INFORMATION: What
the Worker Should Know
(Cognitive)

JOB TRAINING: What the
Worker Should Be Able to Do
(Psychomotor)

17. Construct isometric curves by coordinates
18. Measure in isometric by offsets
19. Construct an isometric in the center of a drawing media
20. Create an isometric view of a mechanical part on CADD

UNIT XV: OBLIQUES

1. Terms and definitions
2. Types of oblique drawings
3. Positions used as axis lines on oblique drawings
4. Most common positions used as axis lines
5. Rules in constructing an oblique drawing
6. Common errors made in oblique drawing
7. Types of analysis information capabilities available to the CADD operator
8. Basic options that are retrievable by the LIST command
9. Other CADD commands
10. Sketch an oblique
11. Construct each type of oblique drawing by box method
12. Measure in oblique
13. Construct angles on an oblique object
14. Construct oblique circles

RELATED INFORMATION: What
the Worker Should Know
(Cognitive)

JOB TRAINING: What the
Worker Should Be Able to Do
(Psychomotor)

15. Construct oblique drawings in the centers of drawing spaces
16. Measure and verify a line on a CADD drawing

UNIT XVI: PERSPECTIVES

1. Terms and definitions
2. Types of perspectives
3. Difference between perspectives and isometrics
4. Types of perspective views
5. Types of perspective equipment
6. Uses of perspectives
7. Lines and points in perspectives
8. Perspective terms and their letter designations
9. Perspective projection on CADD
10. Types of CADD drawings created from library parts
11. CADD library parts and symbols
12. Sketch a one-point perspective
13. Sketch a two-point perspective
14. Construct a one-point perspective
15. Construct a two-point perspective
16. Construct curves in a perspective

RELATED INFORMATION: What
the Worker Should Know
(Cognitive)

JOB TRAINING: What the
Worker Should Be Able to Do
(Psychomotor)

UNIT XVII: DIMENSIONING

1. Terms and definitions
2. Size and shape descriptions
3. Types of dimensions
4. Systems of placing dimensions
5. Common abbreviations
6. Common symbols used in dimensioning
7. Basic types of lines used in dimensioning
8. Placement of leader lines
9. Drawing arrowheads
10. Systems for writing dimensional values
11. Rules for dimensional figures
12. Rules for placement of dimensions
13. Steps in applying dimensions to an object
14. Types of finish marks
15. Rules for finish marks
16. Types of notes used on a drawing
17. Rules for notations
18. Ways to avoid superfluous dimensions
19. Common machine manufactured features
20. Rules for dimensioning common machine manufactured features
21. Typical CADD commands used to change linetypes
22. Dimensioning on a CADD system
23. Steps for inserting dimensions on CADD

**RELATED INFORMATION: What
the Worker Should Know
(Cognitive)**

**JOB TRAINING: What the
Worker Should Be Able to Do
(Psychomotor)**

24. Construct arrowheads
25. Dimension arcs
26. Dimension angles
27. Dimension curves
28. Dimension rounded end shapes and slotted holes
29. Dimension spherical objects
30. Dimension cylindrical objects
31. Dimension cones, pyramids, and prisms
32. Dimension features on a circular center line
33. Dimension theoretical points of intersection
34. Dimension an object using a rectangular coordinate system
35. Dimension an object using a polar coordinate system
36. Dimension an object using a tabular coordinate system
37. Dimension an object using an ordinate dimensioning system
38. Dimension common machine manufactured features
39. Apply dimensions to CADD drawings

UNIT XVIII: TOLERANCING

1. Terms and definitions
2. Mating dimensions
3. Types of tolerances
4. General types of fits

RELATED INFORMATION: What
the Worker Should Know
(Cognitive)

JOB TRAINING: What the
Worker Should Be Able to Do
(Psychomotor)

5. Standard classes of fits
6. Basic shaft system and basic hole system
7. Types of dimensioning systems for tolerances
8. Ways to show toleranced dimensions on drawings
9. Layers on CADD
10. Layer commands on CADD
11. Interpret decimal tolerance dimensions
12. Calculate and dimension clearance fit tolerances of mating parts
13. Calculate and dimension interference fit tolerances of mating parts
14. Calculate and assign tolerances to mating parts using standard fit tables
15. Construct a drawing using datum dimensioning

INTRODUCTION TO DRAFTING UNIT I

UNIT OBJECTIVE

After completion of this unit, the student should be able to select areas of specialization within the drafting profession, name areas in which a drawing will be evaluated, discuss drafting and CADD safety, and distinguish between types of computer graphics. Competencies will be demonstrated by completing the assignment sheets and the unit test with a minimum score of 85 percent.

SPECIFIC OBJECTIVES

After completion of this unit, the student should be able to:

1. Match terms related to drafting with their correct definitions.
2. Select areas of specialization in the drafting profession.
3. List industries that employ drafters and CADD operators.
4. Name related occupational fields that employ drafters and CADD operators.
5. Match job classifications within a manufacturing structure with their correct definitions.
6. Match job titles for drafters and CADD operators with the correct job descriptions.
7. List common types of engineering drawings.
8. List types of computer graphics.
9. Arrange in order the sequence for the completion of drafting work.
10. Distinguish between the advantages and disadvantages of a drafting occupation.
11. List advantages of using computers for drafting applications.
12. Select personal traits or skills that are important for a successful drafter.
13. Name areas in which a drawing will always be evaluated.
14. Define the abbreviations of professional drafting organizations.
15. Select true statements concerning the drafter's responsibilities in maintaining a safe drafting or CADD lab.
16. List reasons for maintaining a clean, orderly lab.

SPECIFIC OBJECTIVES

17. List specific rules for personal safety in the drafting lab.
18. List specific safety rules for using CADD equipment.
19. Complete a chart on classes of fires and types of fire extinguishers.
20. Take a math pretest. (Assignment Sheet #1)
21. Interview a CADD operator. (Assignment Sheet #2)
22. Subscribe to a student safety pledge. (Assignment Sheet #3)

INTRODUCTION TO DRAFTING UNIT I

SUGGESTED ACTIVITIES

- A. Provide student with objective sheet.
- B. Provide student with information and assignment sheets.
- C. Make transparencies.
- D. Discuss unit and specific objectives.
- E. Discuss information and assignment sheets.
- F. Take students on a field trip to visit an industry related to drafting.
- G. Arrange for students to interview a person who works as a CADD operator. (Assignment Sheet #2)
- H. Discuss in detail the advantages and disadvantages of being a drafter.
- I. Invite speakers who have experience in various drafting fields to speak to the class about their jobs.
- J. Provide a list of drafting vocabulary words.
- K. Discuss the advantages of belonging to a student vocational or professional organization such as VICA or AIDD.
- L. Discuss steps to be followed in case of an accident in the classroom.
- M. Conduct or arrange for fire and disaster drills.
- N. Discuss your school's evacuation plan.
- O. Indicate where smoking and eating areas are located in your facility.
- P. Show films on drafting or CADD safety.
- Q. Give test.

REFERENCES USED IN DEVELOPING THIS UNIT

- A. Brown, Walter C. *Drafting for Industry*. South Holland, IL: Goodheart-Willcox Company, Inc., 1984.
- B. Giesecke, Frederick E., et al. *Technical Drawing*, 8th ed. New York: Macmillan Publishing Company, Inc., 1986.
- C. Jensen, Cecil and Jay Helsel. *Engineering Drawing and Design*, 3rd ed. New York: Gregg Division/McGraw-Hill Book Company, 1985.

REFERENCES USED IN DEVELOPING THIS UNIT

- D. Lamit, Louis Gary and Paige Vernon. *Computer-Aided Design and Drafting-CADD*. Columbus, Ohio 43216: Merrill Publishing Company, 1987.
- E. *The ABC's of Fire Protection*. Belleville, New Jersey: Kidde Portable Extinguishers/Walter Kiddle and Co., Inc.
- F. *An Accident Prevention Program for School Shops and Laboratories*. Washington, D.C.: Office of Education/U.S. Department of Health, Education, and Welfare.
- G. Robert F. Noll, "Safety in the Drafting Room: Safety Education Data Sheet #95," Chicago, IL 60611: National Safety Council.

SUGGESTED SUPPLEMENTAL RESOURCES**A. Films**

1. Housekeeping Means Safekeeping
2. Stop a Fire Before It Starts

Available from:

Journal Films
909 Diversey Parkway
Chicago, IL 60614

- B. Computer software — Prevocational Math Review (for Apple II+, IIc IIe 48K or IBM-PC 128K)

(NOTE: This consists of 200 arithmetic problems and tutorials for each area where students may be deficient.)

Available from:

AAVIM
120 Driftmier Engineering Center
Athens, GA 30602
404/542-2586

INTRODUCTION TO DRAFTING UNIT I

INFORMATION SHEET

I. Terms and definitions

- A. Accident — Any suddenly occurring, unintentional event which causes injury or property damage
- B. Cartography — The art of map making
- C. Computer — An electronic, information-handling machine capable of performing arithmetic calculations and making logical decisions under the control of programs
- D. Computer-Aided Drafting (CAD) — The use of computers, software, and associated hardware for the production of graphic drawings
- E. Computer-Aided Design and Drafting (CADD) — A process whereby a computer assists in creating or modifying a design as well as the production of graphic drawings

(NOTE: CADD is a tool that produces drawings that are only as good as the operator and the input and output devices. A CADD system is often called an Interactive Graphics System—IGS. In this unit the computer-aided system will be referred to as CADD.)

- F. Computer-Aided Manufacturing (CAM) — A process employing computer technology to manage and control the operations of a manufacturing facility
- G. Craftworker — A skilled worker who practices a trade; a specialist in an area of construction or manufacturing
- H. Drafting — The process of taking ideas, sketches, and specifications from designers and engineers and preparing drawings to scale, using standard symbols and approved drafting techniques to communicate how a product or structure is to be made
- I. Engineering — The application of science and mathematics in making structures, machines, products, systems, and processes useful to humanity
- J. Estimating — Cataloging and pricing all materials needed to build a product
- K. First aid — Immediate, temporary care given the victim of an accident or sudden illness until the services of a physician can be obtained
- L. Graphics — Computer output that is composed of lines rather than letters, numbers, or symbols
- M. Hardware — Any physical equipment that is part of the CADD system
- N. Hazard — A potential source of danger

INFORMATION SHEET

- O. Safety — State or condition of being safe; freedom from danger, risk, or injury
- P. Software — Prepared programs that simplify CPU operations that cause hardware to function
- Q. Technical — Having to do with the practical, industrial, or mechanical arts or the applied sciences
- R. Technician — A specialist in the technical details of a particular subject

II. Areas of specialization in the drafting profession

- A. Mechanical
- B. Structural
- C. Piping
- D. Electrical
- E. Aircraft
- F. Architectural
- G. Pressure vessel
- H. Electronic
- I. Civil
- J. Computer graphics
- K. Sheet metal

III. Industries that employ drafters and CADD operators

- A. Transportation
- B. Energy-related
- C. Architectural
- D. Civil and structural
- E. Communications
- F. Pipeline
- G. Material fabrication
- H. Electrical

INFORMATION SHEET

- I. Military-related
 - J. Public utilities
 - K. Aerospace
- IV. Related occupational fields that employ drafters and CADD operators**
- A. Estimating — Cost analysis
 - B. Inspection — Quality control
 - C. Model fabrication
 - D. Surveying
 - E. Manufacturing engineering aid — CAM
 - F. Sales-Drafting and reproduction equipment
 - G. Technical illustration
 - H. Cartography
- V. Job classifications within a manufacturing structure**
- A. Engineers-Design, management
 - B. Technicians-Development, drafting, and CADD
 - C. Craftworkers-Production, skilled trades
- VI. Job titles and job descriptions for drafters and CADD operators**
- A. Drafting trainee (Draftsperson I)
 - 1. Primary purpose of position — To learn and perform semi-skilled drafting tasks and related functions and duties of the drafting position under close supervision of the drafting manager, supervisor, or designated employee.
 - 2. Required education
 - a. High school diploma (including math--trigonometry and geometry)
 - b. Two years of technical education

INFORMATION SHEET

3. Basic duties
 - a. Utilizes standard drafting techniques, tools, equipment, and drafting machines.
 - b. Reads and interprets design layouts to create engineering drawings.
 - c. Becomes familiar with orthographic projections, dimensioning, and the creation of auxiliary and section views.
 - d. Maintains required drafting logs and records.
 - e. Acquires and develops the knowledge and skills necessary for professional growth.
- B. Drafter II (draftsperson II)
 1. Primary purpose of position — To perform skilled drafting tasks.
 2. Required education
 - a. High school diploma (including math--trigonometry and geometry)
 - b. Two years of technical education
 - c. Two years of drafting experience
 3. Basic skills
 - a. Prepares engineering drawings for details, assemblies, outlines installations, and minor layouts and parts lists.
 - b. Utilizes thorough knowledge of government, industry, and BASD standards.
 - c. Performs minor calculations using known mathematical analysis.
 - d. Resolves technical problems with designers and engineers.
 - e. Maintains required drafting logs and records.
 - f. Aids in the training of the Trainee.

INFORMATION SHEET

- C. Drafter III (draftsperson III)
1. Primary purpose of position — To perform diverse and complex drafting tasks.
 2. Required education
 - a. High school diploma (including math--trigonometry and geometry)
 - b. Two years of technical education
 - c. Three to four years of drafting experience
 - d. Understanding of minor layouts and parts lists
 3. Basic skills
 - a. Works from sketches, verbal/written instructions, or engineering specifications to prepare detailed drawings.
 - b. Uses drafting machines and tools, and should have a basic understanding of the computer-aided design system.
 - c. May develop specialties relating to electrical, mechanical, structural, mechanism, production, or assembly requirements.
 - d. Performs complicated drafting calculations, including the dimensioning of electrical components or mechanical parts.
 - e. Understands standard part numbering systems and creates part numbers as required.
 - f. Assists lower level draftspeople.
 - g. Maintains required drafting logs and records.
- D. Senior drafter (draftsperson senior)
1. Primary purpose of position — To perform the most complicated drafting tasks.
 2. Required education
 - a. High school diploma (including math--trigonometry and geometry)
 - b. Two years of technical education
 - c. Four to five years of drafting experience at all lower levels

INFORMATION SHEET

3. Basic skills
 - a. Works from sketches, verbal/written instructions, or engineering specifications to prepare detailed drawings.
 - b. Uses or operates drafting tools or equipment; should have basic understanding of the computer-aided design system.
 - c. May be assigned to support engineering design or proposal efforts on extremely complicated electrical, mechanical, structural, mechanism, and production or assembly requirements.
 - d. Develops complicated parts or wire lists for detail and assembly drawings.
 - e. Prepares engineering orders and corrects engineering drawings according to written or verbal instructions.
 - f. Assists lower level draftspeople.
 - g. Maintains required drafting logs and records.

E. CADD technician I

1. Primary purpose of position — Responsible for performing moderately complex computerized graphic duties including the process of making mathematical calculations and operating various computer equipment (digitizer, plotter, CRT, tape, disk, or cassette drives).
2. Basic duties
 - a. Sets up and operates graphic and plotter systems software and hardware including digitizing/editing stations, interactive keyboard terminals, minicomputer, teletype, disk, tape drive, and CRT equipment.
 - b. Prepares, edits, and inputs to a graphic system from drawings, plots, and other technical data.
 - c. Performs preventive maintenance of graphic and pen plotter hardware; schedules service as required.
 - d. Maintains documentation and files including data forms, data reference information, engineering document control, films, and database tapes.
 - e. Verifies drawing plots for correct design specifications, mask colors, and scale sizes.

INFORMATION SHEET**F. CADD technician II**

1. Primary purpose of position — Responsible for performing complex computerized graphic duties including the process of making mathematical calculations and operating various computer equipment (digitizer, plotter, CRT, tape, disk, or cassette drives).
2. Basic duties
 - a. Sets up and operates graphic and plotter systems software and hardware including digitizing/editing stations, interactive keyboard terminals, minicomputer, teletype, disk, tape drive, and CRT equipment.
 - b. Prepares, edits, and inputs to a graphic system from drawings, plots, and other technical data.
 - c. Performs preventive maintenance of graphic and pen plotter hardware; schedules service as required.
 - d. Maintains documentation and files including data forms, data reference information, engineering document control, films, and database tapes.
 - e. Verifies drawing plots for correct design specifications, mask colors, and scale sizes.
 - f. May train less experienced personnel.

G. CADD technician senior

1. Primary purpose of position — Responsible for performing complex computerized graphic duties including the process of making mathematical calculations and operating various computer equipment (digitizer, plotter, CRT, tape, disk, or cassette drives).
2. Basic duties
 - a. Sets up and operates graphic and plotter systems software and hardware including digitizing/editing stations, interactive keyboard terminals, minicomputer, teletype, disk, tape drive, and CRT equipment.
 - b. Prepares, edits, and inputs to a graphic system from drawings, plots, and other technical data.
 - c. Performs preventive maintenance of graphic and pen plotter hardware; schedules service as required.
 - d. Maintains documentation and files including data forms, data reference information, engineering document control, films, and database tapes.

INFORMATION SHEET

- e. Verifies drawing plots for correct design specifications, mask colors, and scale sizes.
- f. Trains less experienced personnel.

VII. Common types of engineering drawings

- A. Sketches and preliminary layouts
- B. Detail drawings
- C. Assembly and subassembly drawings
- D. Pattern drawings
- E. Pictorial drawings
- F. Vendor drawings
- G. Engineering change notices (ECN)
- H. CADD drawings
 - 1. Line
 - 2. Pictorial

VIII. Types of computer graphics

- A. Microcomputer-based
- B. Minicomputer-based
- C. Host system-based

IX. Sequence for the completion of drafting work

- A. Preliminary design layout and rough sketches
- B. Set of working drawings with materials list and specifications
- C. Check
- D. Corrections
- E. Engineer's approval
- F. Drawing release
- G. Prints made and sent to fabricators
- H. Revisions (when necessary)

INFORMATION SHEET**X. Advantages and disadvantages of a drafting occupation****A. Advantages**

1. Clean, indoor working conditions
2. Open job market
3. Lots of overtime available
4. Sense of self-satisfaction and pride
5. Stepping stone for higher paying occupations
6. Variety of challenging assignments

B. Disadvantages

1. Confinement to one area
2. Long hours at times of peak production
3. Responsible to both management and production
4. Rigid accountability for accuracy of work
5. Knowledge of many technical fields required
6. Very little physical exercise
7. Rigid time limits for doing work

XI. Advantages of using computers for drafting applications

- A. Keeps data accurate and more consistent.
- B. Makes tedious, error-prone calculations easier and faster.
- C. Provides a broad base of data to build on.
- D. Produces final drawings faster.
- E. Allows simultaneous multi-user access to a common database.
- F. Simplifies data editing.
- G. Creates a library of symbols to be used, moved, and oriented as often as needed.
- H. Allows use of layers. Elements of a project can be assigned to different layers.

INFORMATION SHEET

- I. Allows storage of large projects.
- J. Simplifies data management and billing. The time spent on a project can be recorded and used for billing purposes.
- K. Improves security. Projects in a computer can be accessed only by a password or I.D. number.
- L. Has remote office capability.

XII. Skills and personal traits of a successful drafter**A. Skills**

- 1. Math skills
- 2. Manual dexterity
- 3. Communication skills
- 4. Mechanical aptitude
- 5. Ability to visualize three-dimensional objects recorded on a two-dimensional plane

B. Personal traits

- 1. Listens and follows instructions well
- 2. Is punctual (on time)
- 3. Works well with others
- 4. Works unsupervised
- 5. Is accurate and fast in executing work
- 6. Accepts constructive criticism
- 7. Is attentive to detail

XIII. Areas in which a drawing will always be evaluated

- | | |
|--------------|--------------------|
| A. Accuracy | D. Neatness |
| B. Linework | E. Dimensioning |
| C. Lettering | F. Reproducibility |

INFORMATION SHEET**XIV. Abbreviations of professional drafting organizations and their meanings**

- A. AIDD — American Institute of Design Draftsmen
- B. SME — Society of Manufacturing Engineers
- C. ASME — American Society of Mechanical Engineers
- D. SPE — Society of Professional Engineers
- E. AIA — American Institute of Architects
- F. NHBA — National Home Builder's Association (local association)
- G. ASHRAE — American Society of Heating, Refrigerating and Air-Conditioning Engineers

XV. Drafter's responsibilities in maintaining a safe drafting or CADD lab

- A. Keep your work area (including tables and floor) clean and free of debris.
 - B. Keep your equipment clean and in good working condition.
 - C. Report defective equipment and any safety hazard to instructor immediately.
 - D. Do not abuse or misuse any piece of equipment.
 - E. Store materials and supplies in safe, secure places.
 - F. Conduct yourself in a manner conducive to safe practice.
 - G. Follow proper operating procedures for CADD equipment.
- (NOTE: Many CADD systems require specific environmental conditions.)
- H. Follow correct procedures (as outlined by school or instructor) in case of emergencies such as fires or accidents.

XVI. Reasons for maintaining a clean, orderly lab

- A. To provide the safest working conditions possible
- B. To provide the dust-free, smoke-free environment required by CADD equipment
- C. To make it easier to find necessary tools, supplies, and drawings
- D. To prevent (or lessen) tool damage
- E. To make a more pleasant environment in which to learn and work

(NOTE: Because CADD is often a showcase for the drafting design field, a clean and orderly work area is an important public relations tool.)

INFORMATION SHEET**XVII. Specific rules for personal safety in the drafting lab (Transparencies 1-4)**

- A. Do not misuse electrical tools.
- B. Tag any defective electrical equipment with a "Do Not Use" tag and turn it in to instructor.
- C. Do not throw objects.
- D. Use trimming shears, paper cutters, metal straight edges, and utility knives only for intended purposes.
- E. Handle sharp, pointed instruments with care.

(NOTE: Protect sharp instruments with proper covers and pick up sharp tools from the handle end.)

- F. Avoid horseplay.

(NOTE: More accidents result from horseplay than any other single cause.)

- G. Keep all four feet of drafting stools on the floor.

(NOTE: Leaning back and tilting a drafting stool is a dangerous practice.)

- H. Use the proper procedure to raise and lower drafting table tops.

(NOTE: Be prepared to hold table top as control rod knobs are loosened. Many tables have spring-loaded mechanisms which can be very dangerous.)

- I. Use reproduction equipment with proper care and only after instruction in its use has been given by the instructor or supervisor.

(NOTE: Take care to put long scarves, neck ties, or long hair in an out of the way position!)

- J. Follow all rules and regulations of the drafting lab.

XVIII. Specific rules on safety for using CADD equipment

- A. Do not smoke in the CADD area.
- B. Do not wear polyester or nylon near a CADD system.

(NOTE: Static electricity can destroy data.)

- C. Protect floppy storage diskettes with a dust cover.

- D. Do not bend floppy storage diskettes.

(NOTE: Bending or mishandling destroys stored data.)

INFORMATION SHEET

- E. Do not touch floppy storage diskettes except on the outside corners.
- F. Do not bring food or drink into a CADD area.
- G. Do not restart (reboot) a CADD system if the system crashes (shuts down) without guidance from the systems manager.

XIX. Classes of fires and types of fire extinguishers

Type of Fire	Approved Type of Extinguisher				
	Pressurized Water	Carbon Dioxide	Multipurpose Dry Chemical	Halon Gas	Dry Powder
A. Class A Fires ORDINARY COMBUSTIBLES .Wood .Paper .Cloth, etc.	X		X		
B. Class B Fire FLAMMABLE LIQUIDS, GREASE .Gasoline .Oils .Paints, etc.		X	X	X	
C. Class C Fires ELECTRICAL EQUIPMENT .Motors .Switches, etc.		X	X	X	
D. Class D Fires COMBUSTIBLE METALS .Iron .Magnesium					X

(NOTE. The ingredients of many fire extinguishers will ruin computer components and circuitry. Halon gas is the preferred type of extinguisher around this equipment.)

Use Equipment Properly



Do Not Misuse Electrical Tools

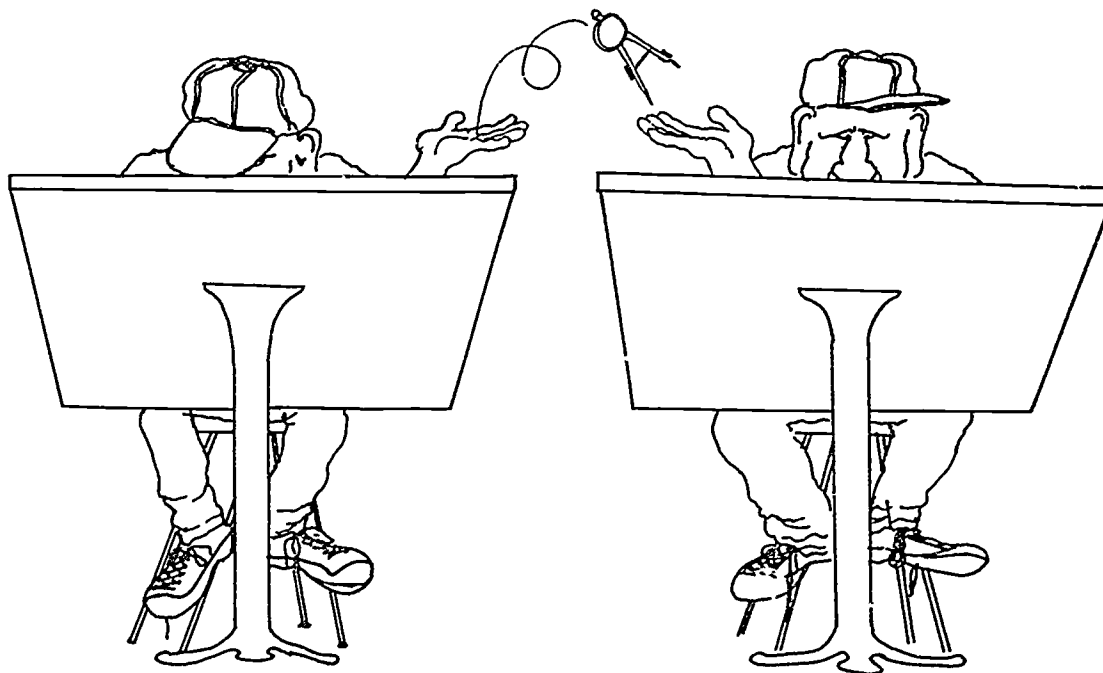

Do Not Throw Objects

Use Equipment Properly (Continued)

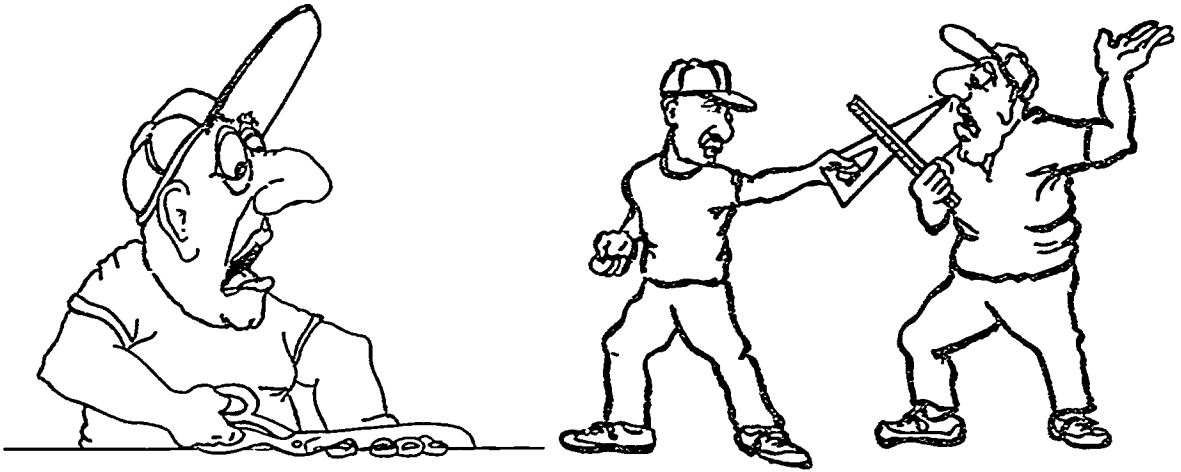

**Use Cutters Only
For Intended Purposes**

Avoid Horseplay

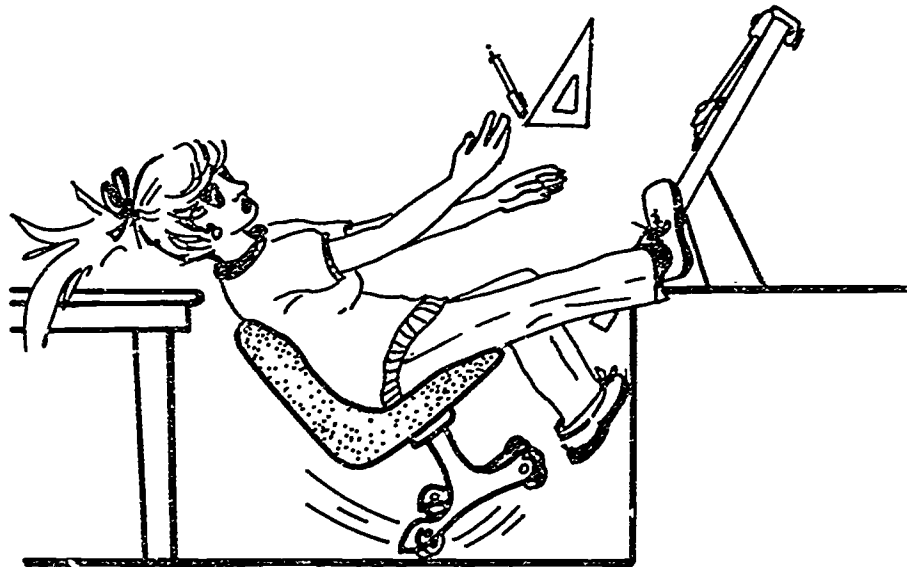

**Keep All Four Feet of
Drafting Stools on Floor**

Use Proper Procedure To Raise And Lower Drafting Table Tops

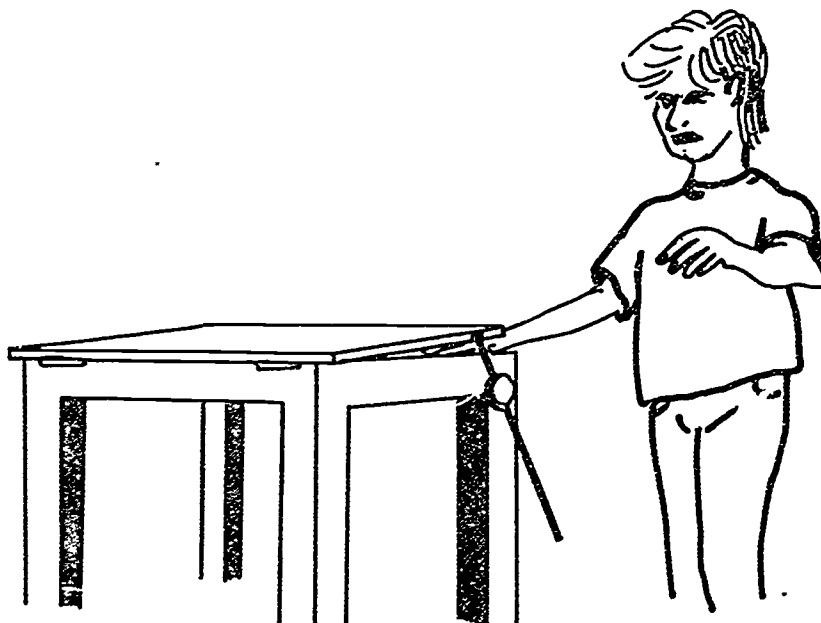
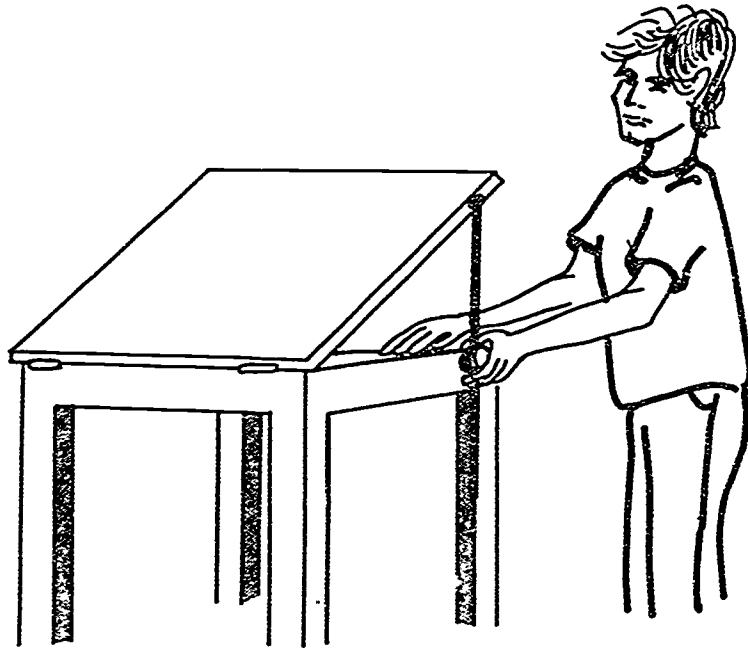

Use Reproduction Equipment With Proper Care



Correct



Incorrect

**INTRODUCTION TO DRAFTING
UNIT I**

ASSIGNMENT SHEET #1 — TAKE BASIC MATH PRETEST

NAME _____ SCORE _____

Directions: The following problems are designed to assess your basic math skills in various areas. Solve each problem and place your answer in the blank or space allowed.

PART A: Addition

1. $\begin{array}{r} 9 \\ + 8 \\ \hline \end{array}$	2. $\begin{array}{r} 8 \\ + 8 \\ \hline \end{array}$	3. $\begin{array}{r} 92 \\ 38 \\ + 77 \\ \hline \end{array}$	4. $\begin{array}{r} 87 \\ 26 \\ + 44 \\ \hline \end{array}$
--	--	--	--

5. $\begin{array}{r} 44 \\ 57 \\ + 63 \\ \hline \end{array}$	6. $\begin{array}{r} 923 \\ 934 \\ 966 \\ + 123 \\ \hline \end{array}$	7. $\begin{array}{r} 327 \\ 240 \\ 136 \\ + 238 \\ \hline \end{array}$	8. $\begin{array}{r} 270 \\ 368 \\ 609 \\ + 224 \\ \hline \end{array}$
--	--	--	--

9. If a crew works 320 hours one week, 416 hours the next week, 345 hours the third week, and 218 hours the fourth week, how many hours did the crew work in that month?

_____ hours

10. While repairing surface failures, a crew laid 528 sq. ft. of aggregate on the first job, 640 sq. ft. on the second job, and 580 sq. ft. on the third job. How many square feet did the crew cover?

_____ sq. ft.

PART B: Subtraction

1. $\begin{array}{r} 84 \\ - 57 \\ \hline \end{array}$	2. $\begin{array}{r} 4635 \\ - 3187 \\ \hline \end{array}$	3. $\begin{array}{r} 4178 \\ - 1539 \\ \hline \end{array}$	4. $\begin{array}{r} 983 \\ - 656 \\ \hline \end{array}$
--	--	--	--

5. $\begin{array}{r} 771 \\ - 289 \\ \hline \end{array}$	6. $\begin{array}{r} 53 \\ - 39 \\ \hline \end{array}$	7. $\begin{array}{r} 356 \\ - 178 \\ \hline \end{array}$	8. $\begin{array}{r} 378 \\ - 179 \\ \hline \end{array}$
--	--	--	--

ASSIGNMENT SHEET #1

9. If the boom on a side boom is 18 ft. and you need 25 ft. to do a particular job, how much boom would have to be added?

_____ ft.

10. If guardrails were placed along 2,488 linear ft. of roadway the first day, and the operator needed to place them along 8,562 linear ft. that week, how much more distance would have to be covered in the remaining four days?

_____ linear ft.

PART C: Multiplication

1.
$$\begin{array}{r} 63 \\ \times 38 \\ \hline \end{array}$$

2.
$$\begin{array}{r} 85 \\ \times 76 \\ \hline \end{array}$$

3.
$$\begin{array}{r} 32 \\ \times 59 \\ \hline \end{array}$$

4.
$$\begin{array}{r} 42 \\ \times 96 \\ \hline \end{array}$$

5.
$$\begin{array}{r} 73 \\ \times 64 \\ \hline \end{array}$$

2.
$$\begin{array}{r} 54 \\ \times 83 \\ \hline \end{array}$$

3.
$$\begin{array}{r} 567 \\ \times 485 \\ \hline \end{array}$$

4.
$$\begin{array}{r} 879 \\ \times 729 \\ \hline \end{array}$$

9. If a load of fill weighs 18,796 lb., how much would 78 loads weigh?

_____ pounds

10. If a dragline could stockpile 676 cubic yd. of dirt in two days, how much could be stockpiled in 14 days?

_____ cubic yards

PART D: Division

1.
$$c \overline{)96}$$

2.
$$12 \overline{)24}$$

3.
$$30 \overline{)90}$$

4.
$$66 \overline{)198}$$

5.
$$15 \overline{)60}$$

6.
$$23 \overline{)276}$$

7.
$$19 \overline{)152}$$

8.
$$62 \overline{)7739}$$

9. If a forklift travels 4,572 miles a year, how far would it travel in one month?

_____ miles

ASSIGNMENT SHEET #1

10. If the distance across a ravine is 13,608 ft., and the equipment can move only 90 ft. per day, how long would it take for the equipment to cross?

_____ days

PART E: Converting fractions

1. Convert each of the following mixed numbers to improper fractions (where the numerator is the same or larger than the denominator such as $4/4$, $5/3$, and $10/9$.) **Do not** reduce answers to lowest terms at this time.

a. $3 \frac{1}{4} =$ _____

f. $2 \frac{1}{2} =$ _____

b. $4 \frac{1}{2} =$ _____

g. $3 \frac{2}{4} =$ _____

c. $7 \frac{1}{3} =$ _____

h. $7 \frac{3}{4} =$ _____

d. $8 \frac{1}{2} =$ _____

i. $9 \frac{2}{3} =$ _____

e. $6 \frac{2}{3} =$ _____

j. $5 \frac{2}{3} =$ _____

2. Convert each of the following improper fractions to mixed numbers. **Do not** reduce answers to lowest terms at this time.

a. $16/5 =$ _____

f. $19/13 =$ _____

b. $12/5 =$ _____

g. $8/7 =$ _____

c. $17/3 =$ _____

h. $75/32 =$ _____

d. $8/3 =$ _____

i. $24/17 =$ _____

e. $9/2 =$ _____

j. $13/9 =$ _____

PART F: Reducing fractions to lowest terms

Reduce the following fractions to the lowest terms.

1. $3/9 =$ _____

6. $5/5 =$ _____

2. $8/24 =$ _____

7. $8/12 =$ _____

3. $10/15 =$ _____

8. $7/21 =$ _____

4. $15/25 =$ _____

9. $4/8 =$ _____

5. $12/48 =$ _____

10. $10/12 =$ _____

ASSIGNMENT SHEET #1

PART G: Finding lowest common denominators (LCD)

Find the lowest common denominator and convert each fraction to its LCD equivalent.

1. a. $2/3, 7/9$ LCD = _____
b. $2/3 =$ _____
c. $7/9 =$ _____
2. a. $7/8, 5/6$ LCD = _____
b. $7/8 =$ _____
c. $5/6 =$ _____
3. a. $1/3, 11/12, 3/8$ LCD = _____
b. $1/3 =$ _____
c. $11/12 =$ _____
d. $3/8 =$ _____
4. a. $1/7, 5/8$ LCD = _____
b. $1/7 =$ _____
c. $5/8 =$ _____
5. a. $1/16, 3/8, 3/4$ LCD = _____
b. $1/16 =$ _____
c. $3/8 =$ _____
d. $3/4 =$ _____

ASSIGNMENT SHEET #1

PART H: Adding, subtracting, multiplying, and dividing fractions

- | | |
|--------------------------------------|---|
| 1. $7/12 + 5/8 =$ _____ | 9. $1\ 1/2 \times 2\ 1/4 =$ _____ |
| 2. $3/5 + 2/3 =$ _____ | 10. $1/2 \times 6\ 1/2 =$ _____ |
| 3. $1/16 + 3/8 + 3/4 =$ _____ | 11. $7/8 \times 2/3 =$ _____ |
| 4. $3/20 + 3/4 + 7/10 + 4/5 =$ _____ | 12. $1/4 \times 1/3 \times 1/2 =$ _____ |
| 5. $7/8 - 2/3 =$ _____ | 13. $3/8 + 1/2 =$ _____ |
| 6. $4/5 - 3/8 =$ _____ | 14. $8 + 3/5 =$ _____ |
| 7. $5/9 - 3/8 =$ _____ | 15. $12\ 3/8 + 1\ 1/2 =$ _____ |
| 8. $1/3 - 5/16 =$ _____ | |

PART I: Converting fractions to decimals

- | | |
|-------------------------|-----------------------|
| 1. $5\ 6/10 =$ _____ | 6. $3\ 3/4 =$ _____ |
| 2. $1\ 2/100 =$ _____ | 7. $55\ 1/2 =$ _____ |
| 3. $87/1000 =$ _____ | 8. $110\ 5/8 =$ _____ |
| 4. $7\ 83/1000 =$ _____ | 9. $77\ 1/50 =$ _____ |
| 5. $5\ 6/100 =$ _____ | 10. $12\ 2/3 =$ _____ |

PART J: Adding, subtracting, multiplying, and dividing decimals

- | | |
|--|---|
| 1. $\begin{array}{r} 5.29 \\ 4.38 \\ + 9.62 \\ \hline \end{array}$ | 2. $\begin{array}{r} 72.24 \\ 16.38 \\ + 92.37 \\ \hline \end{array}$ |
| 3. $868.87 - 516.89 =$ _____ | 4. $\$15 - \$12.53 =$ _____ |
| 5. $2.54 \times 3.1 =$ _____ | 6. $35 \times 8.5 =$ _____ |
| 7. $120 \times 0.33 =$ _____ | 8. $26.4 \times 3.8 =$ _____ |
| 9. $10.71 \div 0.07 =$ _____ | 10. $0.225 \div 0.15 =$ _____ |

ASSIGNMENT SHEET #1

PART K: Converting fractions to percentages

- | | |
|-------------------|------------------|
| 1. $1/4 =$ _____ | 4. $3/4 =$ _____ |
| 2. $2/9 =$ _____ | 5. $2/2 =$ _____ |
| 3. $7/10 =$ _____ | |

PART L: Percentage problems

1. There are 100 bolts in a box. Twenty-five bolts are what percent of the bolts in the box?

2. If 11% of the students in a school are absent, what percent are present?

3. There are 20 students in a class. Sixty percent of the students are boys. How many are boys?

4. One day 5% of the 20 operators in Mr. Moore's group made perfect time completing a job. How many operators made perfect time?

5. Contractor McGill bought a new compressor, regularly selling for \$120, at a sale and saved 20%. What was the sale price?

PART M: Mix ratio problems

1. Given 90 cu. yd. of aggregate, how much sand will you need to mix a 3:2 ratio of sand and aggregate?
_____ cu. yd. of sand
2. You are to mix 1/4" aggregate and 1/2" aggregate to a ratio of 3:2. How much 1/4" aggregate will you need if you have 150 cu. yd. of 1/2" aggregate?
_____ cu. yd. of 1/4" aggregate
3. Given 300 gallons of asphalt concrete, mix asphalt concrete and solvent to a ratio of 75:25. How much solvent will you need?
_____ gal. of solvent

ASSIGNMENT SHEET #1

4. The fuel mixture ratio of gasoline to two-cycle engine oil is 20:1 for your chain saw. How much oil will you add to 5 gal. of gas?

_____ qt. of oil

5. The ratio of an industrial strength cleaner in water is 6 parts cleaner to 100 parts water. You estimate the job will take 15 gallons of water. How much cleaner will you add?

_____ gal. cleaner

PART N: Slope ratio problems

1. Find the slope ratio in feet and in inches. Convert distances to like terms where needed. Round off to the nearest hundredth.

V = vertical distance

H = horizontal distance

	DISTANCES	RATIO (FEET)	RATIO (INCHES)	SLOPE RATIO
a.	V = 12 ft. H = 24 ft.	_____	_____	_____
b.	H = 15 in. V = 5 in.	_____	_____	_____
c.	H = 5 ft. V = 0.05 ft.	_____	_____	_____
d.	V = 1 in. H = 3 ft.	_____	_____	_____
e.	H = 12 ft. V = 4 in.	_____	_____	_____

2. Find the vertical distance.

	SLOPE RATIO	HORIZONTAL DISTANCE	VERTICAL DISTANCE
a.	3:1	24 ft.	_____ ft.
b.	14:1	224 in.	_____ in.

ASSIGNMENT SHEET #1

3. Find the horizontal distance.

	SLOPE RATIO	VERTICAL DISTANCE	HORIZONTAL DISTANCE
a.	25:1	0.5 ft.	_____ ft.
b.	16:3	9 in.	_____ ft.
c.	40:1	4 ft.	_____ ft.

PART O: Measure and volume

1. Conversions. Round answers to nearest tenth.

- a. 48 in. = _____ ft.
 b. 312 ft. = _____ yd.
 c. 8 cu. yd. = _____ cu. ft.
 d. 7 sq. yd. = _____ sq. ft.
 e. 11 gal. = _____ qt.

2. Basic formulas for areas and volumes

- a. 24' long, 18' wide - Surface area = _____
 b. 13" wide, 2 1/2" long - Surface area = _____
 c. 7' long, 2' wide, 1' high - Volume = _____
 d. 1/2' wide, 3" high, 2' long - Volume = _____
 e. 4" long, 2" wide, 1/2" high - Volume = _____

3. Word problems. Round off answers to the nearest tenth. Show your work.

- a. One cubic yard of aggregate weighs 2,550 lb. How many tons would 10 cubic yards weigh?

(NOTE: 1 ton = 2,000 lb.)

_____ tons

- b. What is the surface area of a failure 2 ft. 8 in. by 1 ft. 6 in.?

_____ sq. ft.

ASSIGNMENT SHEET #1

- c. How many cubic feet of concrete will be required to make a pavement patch 8 feet long, 7 feet wide, and 6 inches deep?

_____ cu. ft.

- d. How many square feet have to be painted on a building 20 feet long on each side and 14 feet high if you paint all four sides? If a gallon of paint covers 350 square feet, how many gallons are required?

_____ sq. ft.

_____ gal. of paint

**INTRODUCTION TO DRAFTING
UNIT I****ASSIGNMENT SHEET #2 — INTERVIEW A CADD OPERATOR**

NAME _____ SCORE _____

(NOTE: Complete this assignment after consulting with your instructor.)

Directions: Make an appointment with a local firm who presently employs CADD operators. Request to interview an employee who operates a CADD system. Ask the following questions and record the answers in the blanks provided.

1. What is your career title? _____

2. What tasks do you perform on the job? _____

3. What educational training and occupational experience is required for this job?

4. What personality traits are most important in your field? _____

5. What skills and knowledge are required in this occupation? _____

6. On what CADD system did you learn CADD? _____

7. What is the approximate starting salary of workers in your occupation?

ASSIGNMENT SHEET #2

8. What is the employment outlook for the future in this career? _____

9. What are the possibilities for advancement in this field? _____

10. What is your favorite part of this job? _____

11. What is your least favorite part of the job? _____

12. On which CADD system do you work? _____

13. What types of drawings are you inputting into your CADD system? _____

14. How many CADD operators does your company employ? _____
15. How many board drafters does your company employ? _____

**INTRODUCTION TO DRAFTING
UNIT I**

ASSIGNMENT SHEET #3 — SUBSCRIBE TO THE STUDENT SAFETY PLEDGE

NAME _____ SCORE _____

STUDENT SAFETY PLEDGE FORM FOR VOCATIONAL DRAFTING

(NOTE: Use the form on the back for students not under the supervision of their parents.)

_____, who is enrolled in vocational drafting, will as a part of his/her lab experience operate machines and instruments. It is understood that each student will be given proper instruction, both in the use of the equipment and in the correct safety procedures concerning it, before being allowed to operate it himself/herself.

The student must assume responsibility for safe practices, and we therefore ask that he/she subscribe to the following safety pledge:

1. I AGREE TO ABIDE BY ALL THE SAFETY RULES IN THE DRAFTING LAB, AND WILL MAINTAIN A PROFESSIONAL CONDUCT THAT IS IN KEEPING WITH THE DRAFTING PROFESSION.
2. I PLEDGE THAT I WILL TAKE PROPER CARE OF ANY DRAFTING EQUIPMENT THAT IS ISSUED TO ME OR THAT I USE IN CLASS, AND I AGREE TO RETURN IT TO ITS PROPER STORAGE LOCATION AT THE END OF EACH CLASS.
3. I WILL REPORT ANY ACCIDENT TO THE TEACHER IMMEDIATELY.

DATE _____ STUDENT'S SIGNATURE _____

I hereby give consent to allow my son/daughter to operate all machines and equipment necessary in carrying out the requirements of the course in which he/she is enrolled.

DATE _____ PARENT'S SIGNATURE _____

(NOTE: Parents are cordially invited to visit the school to inspect the drafting lab at any time.)

ASSIGNMENT SHEET #3 — SUBSCRIBE TO THE STUDENT SAFETY PLEDGE**STUDENT SAFETY PLEDGE FORM FOR VOCATIONAL DRAFTING**

_____, who is enrolled in vocational drafting, will as a part of his/her lab experience operate machines and instruments. It is understood that each student will be given proper instruction, both in the use of the equipment and in the correct safety procedures concerning it, before being allowed to operate it himself/herself.

The student must assume responsibility for safe practices, and we therefore ask that he/she subscribe to the following safety pledge:

1. I AGREE TO ABIDE BY ALL THE SAFETY RULES IN THE DRAFTING LAB, AND WILL MAINTAIN A PROFESSIONAL CONDUCT THAT IS IN KEEPING WITH THE DRAFTING PROFESSION.
2. I PLEDGE THAT I WILL TAKE PROPER CARE OF ANY DRAFTING EQUIPMENT THAT IS ISSUED TO ME OR THAT I USE IN CLASS, AND I AGREE TO RETURN IT TO ITS PROPER STORAGE LOCATION AT THE END OF EACH CLASS.
3. I WILL REPORT ANY ACCIDENT TO THE TEACHER IMMEDIATELY.

DATE _____ STUDENT'S SIGNATURE _____

INTRODUCTION TO DRAFTING
UNIT I

ANSWERS TO ASSIGNMENT SHEETS

Assignment Sheet #1

PART A

1. 17
2. 16
3. 207
4. 157
5. 164
6. 2946
7. 941
8. 1471
9. 1,299 hours
10. 1,748 sq. ft.

PART B

1. 27
2. 1448
3. 2639
4. 327
5. 482
6. 4
7. 178
8. 199
9. 7 feet
10. 6,074 linear feet

PART C

1. 2394
2. 6460
3. 1888
4. 4032
5. 4672
6. 4482
7. 274,995
8. 640,791
9. 1,466,088 pounds
10. 4,732 cubic yards

ANSWERS TO ASSIGNMENT SHEETS

PART D

1. 12
2. 2
3. 3
4. 3
5. 4
6. 12
7. 8
8. 124, R51
9. 381 miles
10. 151.2 days

PART E

- | | | | | |
|----|----|-----------------|----|-------------------|
| 1. | a. | $13/4$ | f. | $5/2$ |
| | b. | $9/2$ | g. | $14/4$ |
| | c. | $22/3$ | h. | $31/4$ |
| | d. | $17/2$ | i. | $29/3$ |
| | e. | $20/3$ | j. | $17/3$ |
| 2. | a. | $3 \frac{1}{5}$ | f. | $1 \frac{6}{13}$ |
| | b. | $2 \frac{2}{5}$ | g. | $1 \frac{1}{7}$ |
| | c. | $5 \frac{2}{3}$ | h. | $2 \frac{11}{32}$ |
| | d. | $2 \frac{2}{3}$ | i. | $1 \frac{7}{17}$ |
| | e. | $4 \frac{1}{2}$ | j. | $1 \frac{4}{9}$ |

PART F

- | | | | |
|----|-------|-----|-------|
| 1. | $1/3$ | 6. | 1 |
| 2. | $1/3$ | 7. | $2/3$ |
| 3. | $2/3$ | 8. | $1/3$ |
| 4. | $3/5$ | 9. | $1/2$ |
| 5. | $1/4$ | 10. | $5/6$ |

PART G

- | | | | | | |
|----|----|---------|----|----|---------|
| 1. | a. | 9 | 2. | a. | 24 |
| | b. | $6/9$ | | b. | $21/24$ |
| | c. | $7/9$ | | c. | $20/24$ |
| 3. | a. | 24 | 4. | a. | 56 |
| | b. | $8/24$ | | b. | $8/56$ |
| | c. | $22/24$ | | c. | $35/56$ |
| | d. | $9/24$ | | | |

ANSWERS TO ASSIGNMENT SHEETS

5. a. 16
b. $1/16$
c. $6/16$
d. $12/16$

PART H

1. $1 \frac{5}{24}$
2. $1 \frac{4}{15}$
3. $1 \frac{3}{16}$
4. $2 \frac{2}{5}$
5. $5/24$
6. $17/40$
7. $13/72$
8. $1/48$
9. $3 \frac{3}{8}$
10. $3 \frac{1}{4}$
11. $7/12$
12. $1/24$
13. $3/4$
14. $13 \frac{1}{3}$
15. $8 \frac{1}{4}$

PART I

1. 5.6
2. 1.02
3. .087
4. 7.083
5. 5.06
6. 3.75
7. 55.5
8. 110.625
9. 77.02
10. 12.667

PART J

1. 19.29
2. 180.99
3. 351.98
4. \$2.47
5. 7.874
6. 297.5
7. 39.6
8. 100.32
9. 153
10. 1.5

ANSWERS TO ASSIGNMENT SHEETS

PART K

1. 25%
2. 22.2%
3. 70%
4. 75%
5. 100%

PART L

1. 25%
2. 89%
3. 12
4. 1
5. \$96.00

PART M

1. 135 cu. yd. of sand
2. 225 cu. yd. of 1/4" aggregate
3. 100 gal. of solvent
4. 1 qt. of oil
5. 0.9 gal. cleaner

PART N

- | 1. | RATIO (FEET) | RATIO (INCHES) | SLOPE RATIO |
|----|--------------|----------------|-------------|
| a. | 24:12 | -- | 2:1 |
| b. | -- | 15:5 | 3:1 |
| c. | 5:0.05 | 60:0.6 | 100:1 |
| d. | 3:0.08 | 36:1 | 36:1 |
| e. | 12:0.33 | 144:4 | 36:1 |
-
2.
 - a. 8 ft.
 - b. 16 in.
 3.
 - a. 12.5 ft.
 - b. 4 ft.
 - c. 160 ft.

PART O

1.
 - a. 4 ft.
 - b. 104 yd.
 - c. 216 cu. ft.
 - d. 63 sq. ft.
 - e. 44 qt.

ANSWERS TO ASSIGNMENT SHEETS

2. a. 432 sq. ft.
b. 390 sq. in.
c. 14 cu. ft.
d. 432 cu. in.
e. 4 cu. in.
3. a. 12.8 tons
b. 4 sq. ft.
c. 28 cu. ft.
d. 1120 sq. ft., 3.2 gal. of paint

Assignment Sheets #2 and #3 — Evaluated to the satisfaction of the instructor

INTRODUCTION TO DRAFTING UNIT I

TEST

NAME _____ SCORE _____

1. Match the terms on the right with their correct definitions.

- | | | | |
|-------|---|-----|------------------------------------|
| _____ | a. Cataloging and pricing all materials needed to build a product | 1. | Accident |
| _____ | b. The application of science and mathematics in making structures, machines, products, systems, and processes useful to humanity | 2. | Cartography |
| _____ | c. A skilled worker who practices a trade; a specialist in an area of construction or manufacturing | 3. | Computer |
| _____ | d. Having to do with the practical, industrial, or mechanical arts or the applied sciences | 4. | Computer-aided design and drafting |
| _____ | e. The art of map making | 5. | Computer-aided drafting |
| _____ | f. A specialist in the technical details of a particular subject | 6. | Computer-aided manufacturing |
| _____ | g. Immediate, temporary care given the victim of an accident or sudden illness until the services of a physician can be obtained | 7. | Craftsworker |
| _____ | h. State or condition of being safe; freedom from danger, risk, or injury | 8. | Drafting |
| _____ | i. The process of taking ideas, sketches, and specifications from designers and engineers and preparing drawings to scale, using standard symbols and approved techniques to communicate how a product or structure is to be made | 9. | Engineering |
| _____ | j. An electronic information-handling machine capable of performing arithmetic calculations and making logical decisions under the control of programs | 10. | Estimating |

TEST

- | | | | |
|----------|--|-----|------------|
| _____ k. | Computer output that is composed of lines rather than letters, numbers, or symbols | 11. | First aid |
| _____ l. | Any physical equipment that is part of the CADD system | 12. | Graphics |
| _____ m. | A process whereby a computer assists in creating or modifying a design as well as the production of graphic drawings | 13. | Hardware |
| _____ n. | A process employing computer technology to manage and control the operations of a manufacturing facility | 14. | Hazard |
| _____ o. | Any suddenly occurring, unintentional event which causes injury or property damage | 15. | Safety |
| _____ p. | A potential source of danger | 16. | Software |
| _____ q. | Prepared programs that simplify CPU operations that cause hardware to function | 17. | Technical |
| _____ r. | The use of computers, software, and associated hardware for the production of graphic drawings | 18. | Technician |

2. Select areas of specialization in the drafting profession by placing an "X" in the appropriate blanks.

- _____ a. Piping
- _____ b. Aircraft
- _____ c. Political science
- _____ d. Electronic
- _____ e. Architectural
- _____ f. Sheet metal

TEST

3. List six industries that employ drafters and CADD operators.

- a. _____
- b. _____
- c. _____
- d. _____
- e. _____
- f. _____

4. Name five related occupational fields that employ drafters and CADD operators.

- a. _____
- b. _____
- c. _____
- d. _____
- e. _____

5 Match job classifications within a manufacturing structure with their correct definitions.

- | | |
|--|-----------------|
| _____ a. Design, management | 1. Technicians |
| _____ b. Production, skilled trades | 2. Engineers |
| _____ c. Development, drafting, and CADD | 3. Craftworkers |

6. Match the job titles on the right with the correct job descriptions.

- | | |
|---|---------------------------|
| _____ a. Performs diverse and complex drafting tasks; 3 to 5 years of drafting experience is required | 1. Drafting trainee (I) |
| _____ b. Performs complex computerized graphic duties; assists and trains less experienced personnel | 2. Drafter II |
| _____ c. Learns and performs semi-skilled drafting tasks and duties under close supervision; requires 2 years of technical education but no drafting experience is required | 3. Drafter III |
| | 4. Senior drafter |
| | 5. CADD technician I |
| | 6. CADD technician II |
| | 7. CADD technician senior |

TEST

- _____ d. Performs moderately complex computerized graphic duties; does not train other employees
 - _____ e. Performs skilled drafting tasks; requires 2 years of technical education and 2 years of drafting experience
 - _____ f. Performs most complicated drafting tasks; requires 4 to 5 years of drafting experience
7. List four of the common types of engineering drawings.
- a. _____
 - b. _____
 - c. _____
 - d. _____
8. List two types of computer graphics.
- a. _____
 - b. _____
9. Arrange in order the sequence for the completion of drafting work by placing the correct sequence numbers (1-8) in the appropriate blanks.
- _____ a. Revisions
 - _____ b. Check
 - _____ c. Preliminary design layout and rough sketches
 - _____ d. Prints made and sent to fabricators
 - _____ e. Corrections
 - _____ f. Engineer's approval
 - _____ g. Drawing release
 - _____ h. Set of working drawings with materials list and specifications

TEST

10. Distinguish between advantages and disadvantages of a drafting occupation by placing an "X" by each statement that is an advantage and an "O" by the disadvantages.

- _____ a. Clean indoor working conditions
- _____ b. Open job market
- _____ c. Confinement to one area
- _____ d. Long hours at times of peak production
- _____ e. Responsible to both management and production
- _____ f. Variety of challenging assignments
- _____ g. Stepping stone for higher paying occupations
- _____ h. Rigid accountability for accuracy of work
- _____ i. Knowledge of many technical fields required
- _____ j. Sense of self-satisfaction and pride

11. List seven advantages of using computers for drafting applications.

- a. _____
- b. _____
- c. _____
- d. _____
- e. _____
- f. _____
- g. _____

12. Select personal traits or skills that are important for a successful drafter by placing an "X" in the appropriate blanks.

- _____ a. Listens and follows instructions well
- _____ b. Avoids constructive criticism
- _____ c. Disregards details
- _____ d. Punctual
- _____ e. Works well with others

TEST

- _____ f. Fast in executing work
- _____ g. Slow in executing work
- _____ h. Manual dexterity
- _____ i. Communication skills
- _____ j. Surveying skills
- _____ k. Math skills
13. Name four areas in which a drawing will always be evaluated.
- a. _____
- b. _____
- c. _____
- d. _____
14. Define the abbreviations of the professional drafting organizations listed below.
- a. NHBA _____
- b. SME _____
- c. AIDD _____
- d. AIA _____
- e. ASME _____
15. Select true statements concerning the drafter's responsibilities in maintaining a safe drafting or CADD lab by placing an "X" next to the true statements.
- _____ a. Throw supplies and materials on the floor when you are finished with them.
- _____ b. Keep your equipment clean and in good working condition.
- _____ c. Report defective equipment and safety hazards to your instructor immediately.
- _____ d. Store materials and supplies in safe, secure places.
16. List two reasons for maintaining a clean, orderly lab.
- a. _____
- b. _____

TEST

17. List five specific rules for personal safety in the drafting lab.

- a. _____
- b. _____
- c. _____
- d. _____
- e. _____

18. List four specific safety rules for using CADD equipment.

- a. _____
- b. _____
- c. _____
- d. _____

19. Complete the following chart on classes of fires and types of fire extinguishers by placing "Xs" in the appropriate boxes.

Type of Fire	Approved Type of Extinguisher				
	Pressurized Water	Carbon Dioxide	Multipurpose Dry Chemical	Halon Gas	Dry Powder
a. Class A Fires ORDINARY COMBUSTIBLES .Wood .Paper .Cloth, etc.					
b. Class B Fires FLAMMABLE LIQUIDS, GREASE .Gasoline .Oils .Paints					
c. Class C Fires ELECTRICAL EQUIPMENT .Motors .Switches, etc.					
d. Class D Fires COMBUSTIBLE METALS .Iron .Magnesium					

TEST

(NOTE: If the following activities have not been accomplished prior to the test, ask your instructor when they should be completed.)

20. Take a math pretest. (Assignment Sheet #1)
21. Interview a CADD operator. (Assignment Sheet #2)
22. Subscribe to a student safety pledge. (Assignment Sheet #3)

**INTRODUCTION TO DRAFTING
UNIT I**

ANSWERS TO TEST

1. a. 10 g. 11 m. 4
 b. 9 h. 15 n. 6
 c. 7 i. 8 o. 1
 d. 17 j. 3 p. 14
 e. 2 k. 12 q. 16
 f. 18 l. 13 r. 5
2. a, b, d, e, f
3. Any six of the following:
- a. Transportation
 - b. Energy-related
 - c. Architectural engineering
 - d. Civil and structural engineering
 - e. Communications
 - f. Pipeline
 - g. Material fabrication
 - h. Electrical
 - i. Military-related
 - j. Public utilities
 - k. Aerospace
4. Any five of the following:
- a. Estimating—Cost analysis
 - b. Inspection—Quality control
 - c. Model fabrication
 - d. Surveying
 - e. Manufacturing engineering aid—CAM
 - f. Sales—Drafting equipment and reproduction
 - g. Technical illustration
 - h. Cartography
5. a. 2
 b. 3
 c. 1

ANSWERS TO TEST

6. a. 3
 b. 6 or 7
 c. 1
 d. 5
 e. 2
 f. 4
7. Any four of the following:
- a. Sketches and preliminary layouts
 - b. Detail drawings
 - c. Assembly and subassembly drawings
 - d. Pattern drawing
 - e. Pictorial drawings
 - f. Vendor drawings
 - g. Engineering change notices (ECN)
 - h. CADD drawings
 - 1) Line
 - 2) Pictorial
8. Any two of the following:
- a. Microcomputer-based
 - b. Minicomputer-based
 - c. Host system-based
9. a. 8 e. 4
 b. 3 f. 5
 c. 1 g. 6
 d. 7 h. 2
10. a. X f. X
 b. X g. X
 c. O h. O
 d. O i. O
 e. O j. X
11. Any seven of the following:
- a. Keeps data accurate and more consistent.
 - b. Makes tedious, error-prone calculations easier and faster.
 - c. Provides a broad base of data to build on.
 - d. Produces final drawings faster.
 - e. Allows simultaneous multi-user access to a common database.
 - f. Simplifies data editing.
 - g. Creates a library of symbols to be used, moved, and oriented as often as needed.

ANSWERS TO TEST

- h. Allows use of layers. Elements of a project can be assigned to different layers.
 - i. Allows storage of large projects.
 - j. Simplifies data management and billing. The time spent on a project can be recorded and used for billing purposes.
 - k. Improves security. Projects in a computer can be accessed only by a password or I.D. number.
 - l. Has remote office capability.
12. a, d, e, f, h, i, k
13. Any four of the following:
- a. Accuracy
 - b. Linework
 - c. Lettering
 - d. Neatness
 - e. Dimensioning
 - f. Reproducibility
14. a. National Home Builder's Association
 b. Society of Manufacturing Engineers
 c. American Institute of Design Draftsmen
 d. American Institute of Architects
 e. American Society of Mechanical Engineers
15. b, c, d
16. Any two of the following:
- a. To provide the safest working conditions possible
 - b. To provide the dust-free, smoke-free environment required by CADD equipment
 - c. To make it easier to find necessary tools, supplies, and drawings
 - d. To prevent (or lessen) tool damage
 - e. To make a more pleasant environment in which to learn and work
17. Any five of the following:
- a. Do not misuse electrical tools.
 - b. Tag any defective electrical equipment with a "Do Not Use" tag and turn it in to instructor.
 - c. Do not throw objects.
 - d. Use trimming shears, paper cutters, metal straight edges, and utility knives only for intended purposes.
 - e. Handle sharp, pointed instruments with care.
 - f. Avoid horseplay.

ANSWERS TO TEST

- g. Keep all four feet of drafting stools on the floor.
- h. Use the proper procedure to raise and lower drafting table tops.
- i. Use reproduction equipment with proper care and only after instruction in its use and with the instructor's permission to use it.
- j. Follow all rules and regulations of the drafting lab.

18. Any four of the following:

- a. Do not smoke in the CADD area.
- b. Do not wear polyester or nylon near the CADD area.
- c. Protect floppy storage diskettes with a dust cover.
- d. Do not bend floppy storage diskettes.
- e. Do not touch floppy storage diskettes except on the outside corners.
- f. Do not bring food or drink into a CADD area.
- g. Do not restart a CADD system if the system crashes without guidance from the system's manager.

19.

Type of Fire	Approved Type of Extinguisher				
	Pressurized Water	Carbon Dioxide	Multipurpose Dry Chemical	Halon Gas	Dry Powder
a. Class A Fires ORDINARY COMBUSTIBLES .Wood .Paper .Cloth, etc.	X		X		
b. Class B Fires FLAMMABLE LIQUIDS, GREASE .Gasoline .Oils .Paints, etc.		X	X	X	
c. Class C Fires ELECTRICAL EQUIPMENT .Motors .Switches, etc.		X	X	X	
d. Class D Fires COMBUSTIBLE METALS .Iron .Magnesium					X

20.-22. Evaluated to the satisfaction of the instructor.

TOOLS AND EQUIPMENT UNIT II

UNIT OBJECTIVE

After completion of this unit, the student should be able to identify basic drafting tools, use and care for various drafting tools, and name hardware in a CADD system. Competencies will be demonstrated by completing the assignment sheets job sheets, and the unit tests with a minimum score of 85 percent.

SPECIFIC OBJECTIVES

After completion of this unit, the student should be able to:

1. Match terms related to drafting tools and equipment with their correct definitions.
2. Identify basic drafting tools.
3. Distinguish among the types of drafting machines.
4. List advantages of each type of drafting machine.
5. Identify the parts of a standard protractor head.
6. Select true statements concerning rules for maintenance and care of drafting machines.
7. Identify types of compasses.
8. Identify types of dividers.
9. Identify types of irregular curves.
10. List types of common templates.
11. Select true statements concerning rules for maintenance and care of drafting machines.
12. Distinguish between types of drafting pencils.
13. Match types of leads with the devices used to sharpen them.
14. Identify tools used for inking.
15. List types of pen points.

SPECIFIC OBJECTIVES

16. Select true statements concerning ways to properly use and care for technical pens.
17. Match CADD terminology with the correct definitions.
18. List hardware used in a CADD system and classify as input, output, or neither.
19. Select types of computer subsystems for CADD.
20. List typical routines used for maintaining CADD files.
21. Research computer applications in the drafting field. (Assignment Sheet #1)
22. Demonstrate the ability to:
 - a. Measure angles with the protractor and vernier scale on a drafting machine. (Job Sheet #1)
 - b. Operate an adjustable triangle. (Job Sheet #2)
 - c. Draw horizontal and vertical lines with triangles and a drafting machine. (Job Sheet #3)
 - d. Divide a circle into 24 parts of 15° by using $30^\circ/60^\circ$ and 45° triangles. (Job Sheet #4)
 - e. Use a compass to draw circles and arcs. (Job Sheet #5)
 - f. Use a divider to divide a line into equal parts. (Job Sheet #6)
 - g. Measure angles with a protractor. (Job Sheet #7)
 - h. Use an irregular curve to construct a curved line. (Job Sheet #8)
 - i. Format a floppy diskette. (Job Sheet #9)

TOOLS AND EQUIPMENT UNIT II

SUGGESTED ACTIVITIES

- A. Provide students with objective sheet.
- B. Provide students with information, assignment, and job sheets.
- C. Make transparencies.
- D. Discuss unit and specific objectives.
- E. Discuss information, assignment, and job sheets.
- F. Demonstrate the use and care of all drafting tools and equipment.
- G. Demonstrate the use of an eraser shield and eraser to erase a line.
- H. Demonstrate the proper procedure for adjusting an elbow drafting machine and a V-track drafting machine.
- I. Show examples of common templates, and demonstrate the correct procedure for using them.
- J. Create a bulletin board with brochures of different CADD systems.
- K. Demonstrate the proper use and advantages of the electric eraser.
- L. Stress the need for safety in the drafting and CADD lab. Give examples of accidents that have or could happen.
- M. Give test.

REFERENCES USED IN DEVELOPING THIS UNIT

- A. American National Standards Institute. *Line Conventions and Lettering*. New York: The American Society of Mechanical Engineers.
- B. French, Thomas E., et al. *Mechanical Drawing*, 10th ed. New York: McGraw-Hill Company, 1985.
- C. Gerevas, Lawrence E. *Basic Drafting Problems*, 2nd ed. New York: Bobbs-Merrill Co., 1981.

REFERENCES USED IN DEVELOPING THIS UNIT

- D. Giesecke, Frederick E., et. al. *Technical Drawing*, 8th ed. New York: Macmillan Company, 1980.
- E. Olivo, C. Thomas and Albert V. Payne. *Basic Blueprint Reading and Sketching*, 5th ed. Albany, New York: Delmar Publishers, Inc., 1988.
- F. Koh-I-Noor. *Rapidraw Learning Program Workbook*. Bloomsbury, NJ: Koh-I-Noor Rapidograph, Inc.
- G. *The Koh-I-Noor Rapidraw System*. Bloomsbury, NJ: Koh-I-Noor Rapidograph, Inc.
- H. Lamit, Louis G. and Vernon Paige. *Computer-Aided Drafting and Design: CADD*. Columbus, Ohio 43216: Merrill Publishing Co., 1987.
- I. John Erbes and Victor Langer: *MATC-CAD: Computer-Aided Drafting, Manual and Software*. Milwaukee Area Technical College, 1015 North Sixth Street, Milwaukee, Wisconsin 53203.

SUGGESTED SUPPLEMENTAL RESOURCES

- A. VHS videotapes
 - 1. *Introduction to Drafting*, CAI-BF7501V
 - 2. *Computer-Aided Drafting*, P-05-31150
 - 3. *Autocad Explained*, B-D10

Available from

Teaching Aids, Inc.
 P.O. Box 1798
 Costa Mesa, CA 92628-7098
 714/548-9321
- B. Filmstrips with cassettes and teacher's manual
 - 1. *Modern CAD Systems*
 - 2. *Contemporary CAD Technology*

Available from

Library Filmstrip Center
 236 East Front
 Bloomington, IL 61701

SUGGESTED SUPPLEMENTAL RESOURCES

C. Computer software

1. *CAD Fundamentals* (Apple II+, IIc, IIe)
2. *Computer Aided Drafting* (Apple II+, IIc, IIe 48K or IBM-PC 128K)

Available from:

AAVIM
120 Driftmier Engineering Center
Athens, GA 30602
404/542-2586

**TOOLS AND EQUIPMENT
UNIT II**

INFORMATION SHEET

I. Terms and definitions

A. Drawing media — Any type of drawing material upon which an object is graphically represented

B. Horizontal — Parallel to the plane of the horizon

EXAMPLE: _____

C. Ink — Composed mainly of carbon in colloidal suspension (latex or solutions of special shellac) and gum

(NOTE: The fine particles of carbon give the deep, dark, black appearance to the ink, and the gum makes it quick to dry and waterproof.)

D. Lead — Made of graphite with kaolin (clay) added in varying amounts in order to make the eighteen grades from the hardest (9H) to the softest (7B)

(NOTE: Grade labeling varies according to the manufacturer.)

E. Parallel — Two lines or surfaces side by side, equal distances apart at all points

EXAMPLE: 

F. Perpendicular — At a 90° angle to a given plane or line

EXAMPLE: 

G. Vernier — A measuring device consisting of a main fixed scale and a smaller graduated scale that slides to obtain fine measurements

H. Vertical — A line straight up and down, perpendicular to the horizontal plane

EXAMPLE: 

I. Working surface — Any surface such as a drafting board or desk used to secure drawing media

INFORMATION SHEET

II. Basic drafting tools (Transparencies 1-3)

- A. Adjustable triangle — Used for drawing vertical or inclined lines that are not at the standard 15° increments
- B. Cleaning pad — A loosely woven bag of ground art gum eraser used to remove loose graphite from a drawing
- C. Compass — Used to draw circles and arcs
- D. Compass adapter — A device which holds a technical pen in the proper position on a compass
- E. Divider — Used to transfer dimensions
- F. Drafting tape — A specially-prepared tape used to adhere drawing media to the working surface
- G. Dusting brush — Used to brush loose graphite and eraser dust from a drawing
- H. Eraser — Used to remove pencil lines and graphite smudges from a drawing
- I. Erasing shield — A metal plate with various slots and openings used to protect linework when a portion of the drawing is to be erased
- J. Irregular curve — Used to lay out any noncircular curve
- K. Lead pointer — Used for sharpening mechanical pencil leads
- L. Lettering guide — Used to lay out guidelines for lettering
- M. Mechanical pencil (lead holder) — Used to hold leads of various hardnesses
- N. Protractor — Used to measure angles
- O. Scale — Used to measure the length of a line
- P. Template — A thin, flat, plastic tool with various size openings of different shapes used to expedite the drawing of standard features
- Q. Triangle — A thin, flat, right-angled piece of plastic or metal with acute angles of 45° , or 30° and 60° used for drawing vertical or inclined lines that are multiples of 15°

INFORMATION SHEET

III. Types of drafting machines and how they operate

- A. **Parallel bar** — A parallel bar is a long flat bar similar to a T-square that has a hollow area in its middle through which cables pass. These cables work through a series of pulleys, and the ends are attached to a tension bracket. The cables allow the bar to move in a parallel motion up and down the working surface.

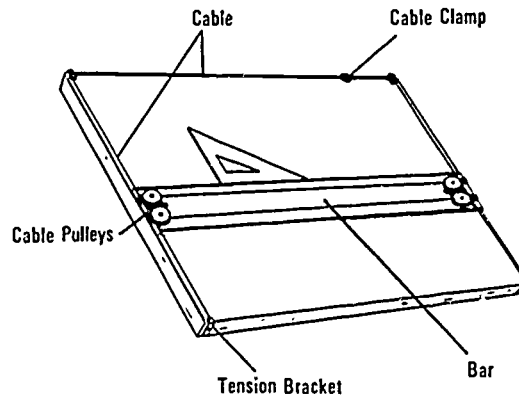

- B. **Elbow drafting machine** — An elbow drafting machine has a protractor head which can be adjusted to any angle measurement accurate to the nearest 5 minutes of a degree. The protractor head moves in any direction on the working surface. The head is mounted at the end of two arms hinged in the middle with an elbow swivel joint. This allows the drafter to make parallel lines at any angle.

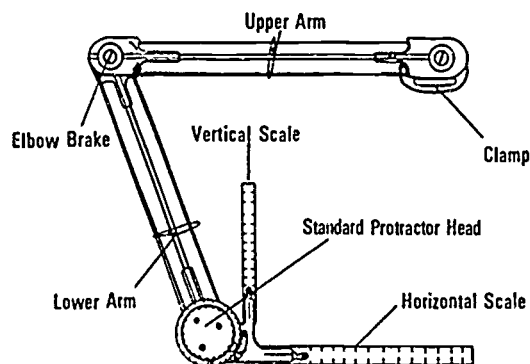

INFORMATION SHEET

- C. V-track drafter — The V-track machine has a protractor head which can be adjusted to any angle measurement accurate to the nearest 5 minutes of a degree; this protractor head moves on a vertical track which in turn moves on a horizontal track. This allows the drafter to make parallel lines in any direction.

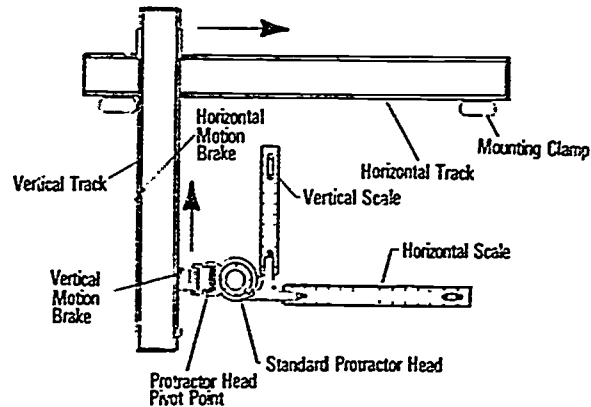

IV. Advantages of each type of drafting machine

- A. Advantages of a parallel bar
1. Easy to make horizontal lines
 2. More accurate than a T-square
 3. Very little maintenance
 4. Simple to operate
- B. Advantages of an elbow drafting machine
1. Increases drafting output
 2. Requires fewer tools to operate
 3. Less expensive than V-track machine
 4. Can be aligned to any base line
- C. Advantages of a V-track drafting machine
1. Simple to operate
 2. Versatile
 3. Accuracy is better maintained.

INFORMATION SHEET

4. All areas of drawing board are accessible.
5. Few working parts

V. Parts of a standard protractor head

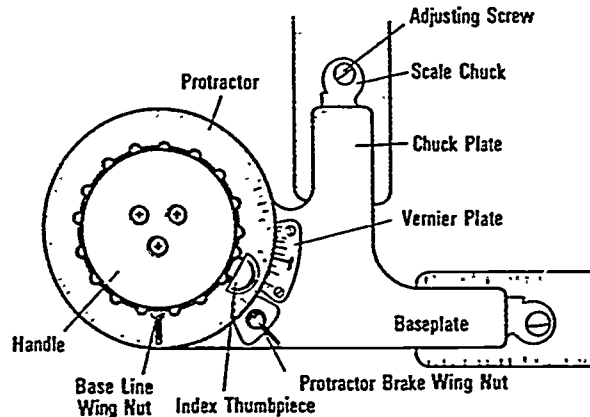

VI. Rules for maintenance and care of drafting machines

- A. Keep support clamps secured snugly to desk.
- B. Keep scales aligned and tight.
(CAUTION: Do not overtighten.)
- C. Keep scales clean.
- D. Keep scales flat on working surface. Do not lift machine by scales.
- E. Keep band tension adjusted properly.
- F. Protractor head line should adjust easily.
(CAUTION: Do not force. Check protractor brake wing nut.)
- G. Tighten baseline and protractor wing nuts snugly but not too tightly.
(CAUTION: Do not force.)
- H. Lift machine by handle to move from position to position.
- I. Make sure scales are never used to cut or tear paper.
- J. Never use scales as straight edges for cutting with a knife.
- K. Never store drafting machine with scales protruding over the edge of the drafting table.

INFORMATION SHEET

VII. Types of compasses

A. Friction

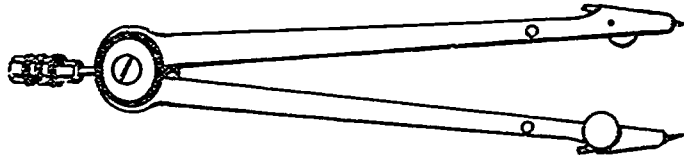

B. Bow

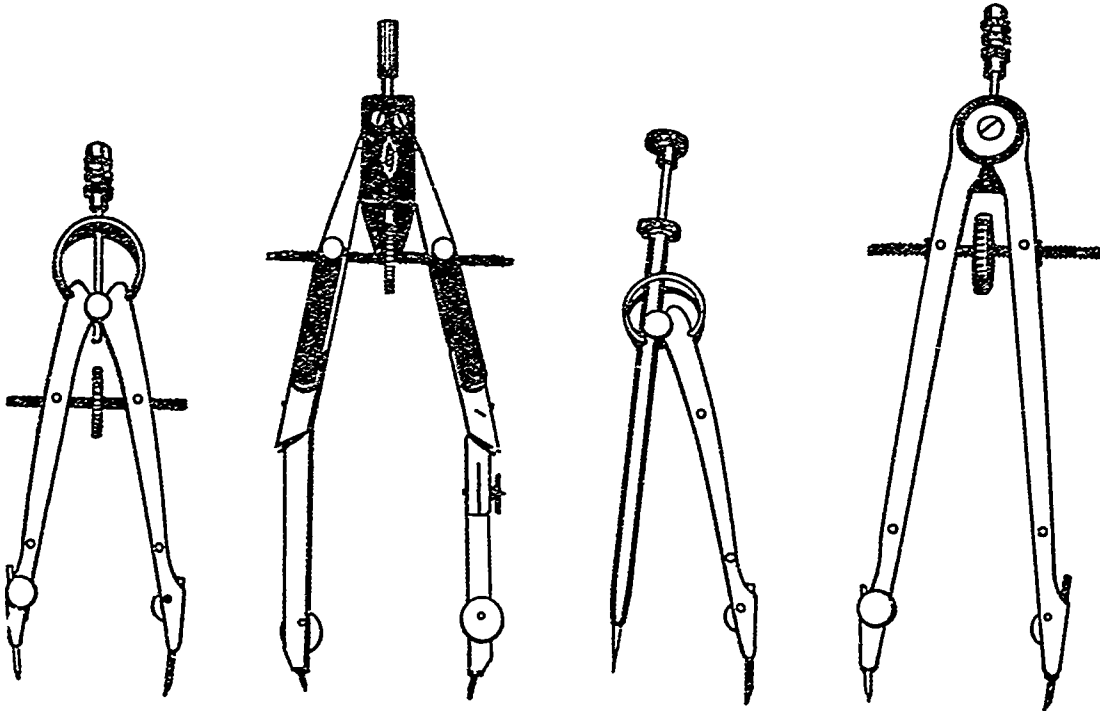

Bow Compass

Jet Bow
Compass

Drop Spring
Bow Compass

Speed Bow
Compass

C. Beam

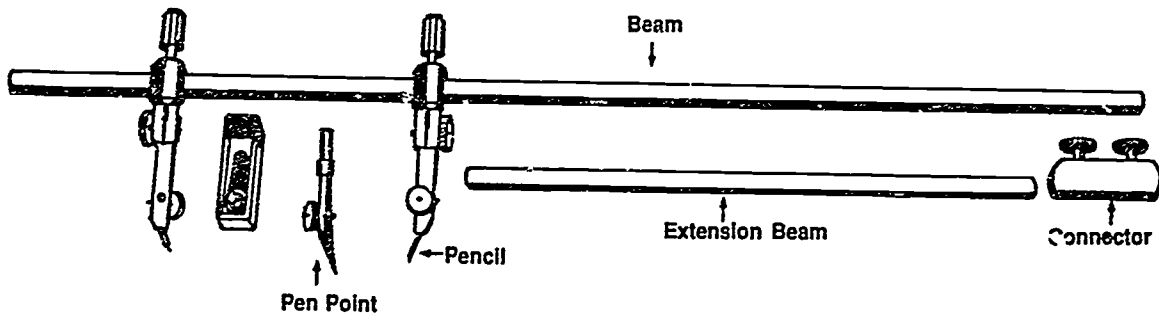

INFORMATION SHEET

VIII. Types of dividers

A. Friction

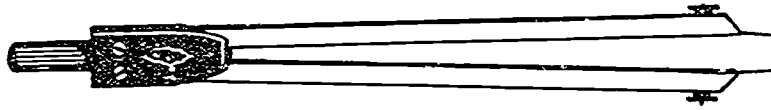

B. Bow

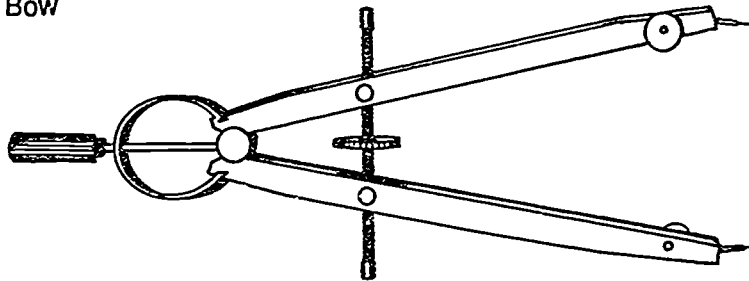

C. Proportional

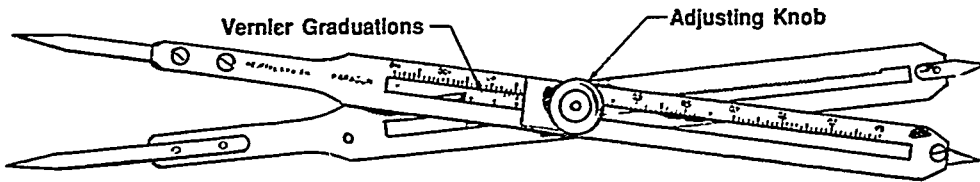

IX. Types of irregular curves

A. Ships curve

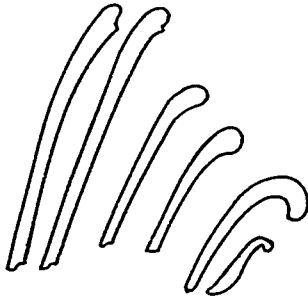

B. Flexible curve

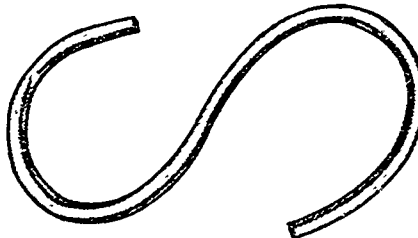

C. Rule curve

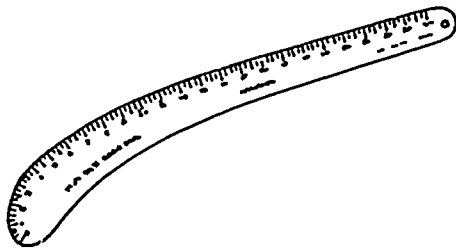

D. French curve

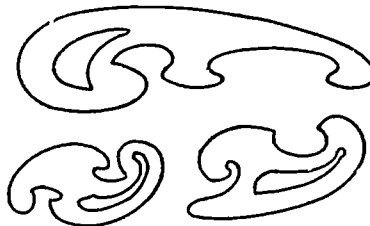

INFORMATION SHEET**X. Types of common templates**

- A. Circle
- B. Ellipse
- C. Isometric ellipse
- D. Architectural
- E. Piping
- F. Structural steel shape
- G. Hex bolt head
- H. Thread
- I. Plumbing
- J. Civil
- K. Electronic

(NOTE: Many others may be added to this list.)

XI. Rules for maintenance and care of drafting tools and equipment

- A. Keep hands and equipment clean.
- B. Keep all instruments clean and dry.
- C. Do not bend templates sharply.
- D. Do not use templates or scales as straight edges for cutting tools.
- E. Do not use templates as eraser shields.
- F. Do not hit scales and triangles on edges.
- G. Do not overextend compasses and dividers.
- H. Clean plastic tools with soap and water only.
- I. Do not stick compass and divider points into scales and triangles.
- J. Never sharpen leads over drawing or table surface.

INFORMATION SHEET

XII. Types of drafting pencils

- A. Mechanical lead holder — Lead requires sharpening

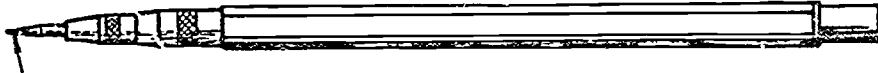

Leads available in all grades

- B. Thin-lead mechanical pencil — Lead does not require sharpening



Leads available in different sizes and grades

(NOTE: Many styles of thin-lead mechanical pencils are available.)

XIII. Types of leads and devices used to sharpen them

- A. Compass leads
1. File
 2. Sandpaper pad
- B. Mechanical lead-holder leads
1. Sandpaper-cone lead pointer
 2. Metal-cutter lead pointer

XIV. Tools used for inking (Transparency 4)

- A. Technical pen
- B. Ink riser
- C. Triangles with inking edges
- D. Inking erasers
1. Plastic vinyl
 2. Chemically-imbibed
 3. Liquid

INFORMATION SHEET

XV. Types of pen points

A. Stainless steel (for hand use and programmed automated digital plotters)

B. Jewel (for hand use and programmed automated digital plotters)

(NOTE: The jewel point can fracture if it is dropped, or if the point should meet with impact on a hard surface; therefore, do not tap a pen with a jewel point on the desk top.)

C. Tungsten-carbide (for use with programmed automated digital plotters)

D. Plotter pens (available in liquid ink plotting points, ball point cartridges, or felt tip pens)

XVI. Ways to properly use and care for technical pens

A. The proper way to hold the technical pen is vertically, with a very light touch.

B. While drawing, always pull the technical pen; never push it.

C. The air channel allows air to enter the ink cartridge in order to replace the ink that has been used.

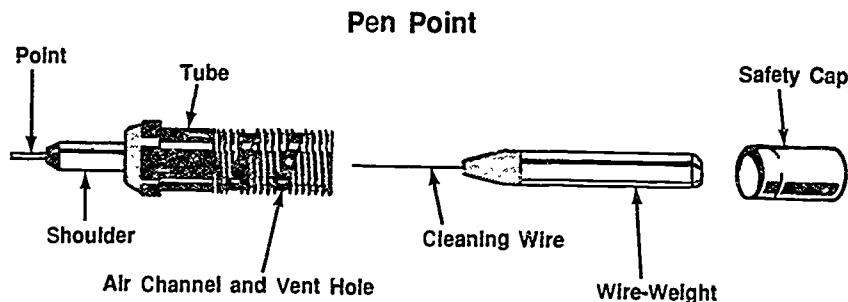

D. The technical pen should always be capped when not in use, even if not used for a short period of time.

E. The wire-weight should never be removed during cleaning, especially sizes .30mm #00 or smaller.

F. When a technical pen is to be stored for an extended period of time, it should be cleaned well and filled with pen cleaning solution.

(NOTE: Check the manufacturer's recommendation.)

G. Before using a pen that has been stored a long time, flush it with warm water, thoroughly dry it, and refill it with ink.

INFORMATION SHEET

XVII. CADD terminology and definitions

- A. Alphanumeric — The set of letters A-Z, the numerals 0-9, and various punctuation marks and special characters
- B. American Standard Code for Information Interchange (ASCII) — Used as a standard code of alphanumeric characters, symbols, and special control characters
- C. *Beginner's All-purpose Symbolic Instruction Code (BASIC)* — A simplified English-like programming language
- D. Binary code — Two-digit numbering system composed of only 0 and 1
- E. Bit — *Binary digit* (0 or 1); the smallest unit of information that can be recognized by a computer
- F. Byte — A collection of eight bits
- G. Chips — Miniaturized integrated circuits which compose ROM memory
- H. *COmmon Business Oriented Language (COBOL)* — A higher-level source programming language designed to process large files used by business
- I. Compiler — A computer program used to translate high-level source language programs into machine language programs
- J. Computer language — A set of mathematical commands such as add, divide, or multiply, or functional commands to "store in memory," "delete," or "draw"
- K. Cursor — Flashing rectangular dot or cross hair that indicates the current position on the screen
- L. Data — Information; facts of all kinds
- M. Digit — Any number from 0 through 9
- N. File — Collection of related data treated as a unit
- O. *FORmula TRANslation (FORTRAN)* — A high-level algebraic and logical language used in engineering and graphic systems
- P. Input — Signals or data transmitted to a microcomputer system
- Q. Interface — The interconnecting methods or devices used in the CADD hardware system
 EXAMPLE: RS-232-C interface
- R. K — Symbol denoting 1024 units (bytes) of storage

INFORMATION SHEET

- S. Machine language — A programming language that can be interfaced directly by the internal circuitry of the computer
- T. Menu — A display of selections that may be chosen, typically on a video display device
- U. Microcomputer — Small, inexpensive computer that has a CPU and one or more input-output devices
- V. Minicomputer — A computer ranked between the mainframe computers and the microcomputers in size, power, complexity, and cost; generally, a 32-bit computer
- W. Output — Signals or data transmitted **from** a microcomputer system
- X. Program — Step-by-step instructions which tell the computer what to do
- Y. Random access memory (RAM) — Memory that can be both written into and read
- Z. Raster scan — A CRT scanning system where the electron beam moves horizontally across all X values first at each Y level, moving down each Y level until the screen is scanned
- AA. Read only memory (ROM) — That portion of the system memory that cannot be changed and may be read but not written into
- BB. Resolution — A measure of the number of separately addressable positions on the coordinate grid

 EXAMPLE: If a 10-inch display has 1023 addressable points along each X-Y axis, the resolution is $1023/10$ or 102.3 points per inch
- CC. Routine — A sequence of instructions to carry out a certain function
- DD. Statement — A complete instruction in machine language such as BASIC or FORTRAN
- EE. Variable — A quantity that can take on any of a given set of values

XVIII. Hardware used in a CADD system (Transparencies 5 and 6)

- A. Central processing unit (CPU) — The main controlling unit in a computer system containing the system's arithmetic, logic, primary storage, and controls of input and output peripheral devices

INFORMATION SHEET

B. Input devices

(NOTE: Some devices are both input and output.)

1. Keyboard console — An input device, consisting of ASCII character keys, numeric keys, and math function keyboard used by the computer operator before, during, and after running programs
2. Monitor/Screen/CRT (cathode ray tube) — A TV-like display device that can be a storage tube, plasma display, or refresh tube display
3. Manual digitizer — An input device where a digit or X-Y points are located by positioning the free-moving cursor or stylus on an electromagnetic grid embedded in the digitized board
4. Digitizer tablet — An input device using stored graphic symbols in the CPU where a designer uses a light pen, stylus, or free-moving cursor by positioning on tablet for each symbol to create a drawing on CRT
5. Free-moving cursor — Contains a sensing coil connected to the digitizer control used for sighting a drawing coordinate X-Y points on the digitizer
6. Light pen — An input device used with a refreshed-picture display to create various edges, contours, or other features in a photographic image
7. Stylus — Used to locate coded programs of X-Y points by pressing at the point of drawing line intersect on digitizer board and input to CRT
8. Joy stick — Used as a graphic input and cursor positioning device to the CRT and CPU

C. Output devices

1. Monitor/Screen/CRT (cathode ray tube) — A TV-like display device that can be a storage tube, plasma display, or refresh tube display
2. Plotter — An X-Y type output device that produces line drawings on paper with a pen controlled by instructions from CPU or tape controller
3. Hard copier — An output device that forms graphic and character images by electronic signals on paper from CPU
4. Line printer — An output device that prints one line of character information at a time from CPU
5. Laser printer — A computer printer that uses an optical or laser scan of image to produce a raster image on media

INFORMATION SHEET**6. Storage devices**

- a. Floppy disk/diskette — A magnetic, flexible, plastic flat plate used for storage of data
- b. Hard disk — A hard, metal plate sealed in a disk drive and used for storage
- c. Magnetic tape — Medium on which data is recorded in the form of magnetized spots on the surface of magnetically sensitive coated tape

XIX. Types of computer subsystems for CADD

- A. CPU
- B. Storage
- C. Graphic input
- D. Graphic output
- E. Monitor

XX. Typical routines used for maintaining CADD files

- A. Formatting blank diskettes for part storage
- B. Repacking data (crunching) on parts diskettes
- C. Transferring files
- D. Naming files
- E. Renaming parts files
- F. Erasing files
- G. Listing part files
- H. Assigning dates to part files

Basic Drafting Tools

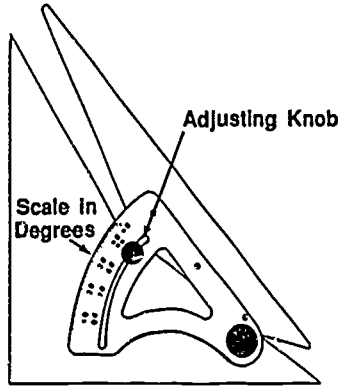

NOTE: In closed position
triangle forms standard 45° triangle

Adjustable Triangle

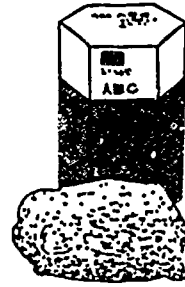

Cleaning Pad

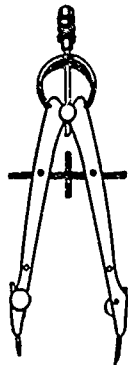

Compass

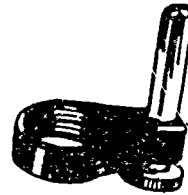

Compass Adapter

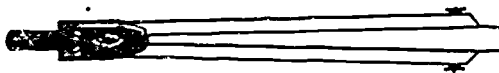

Divider



Drafting Tape

Basic Drafting Tools (Continued)

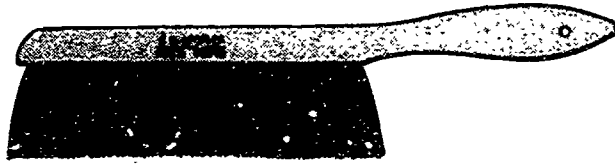
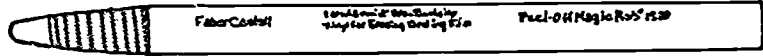

Dusting Brush

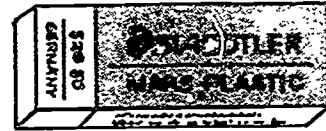

Erasers

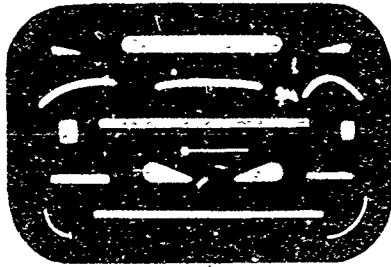

Erasing Shield

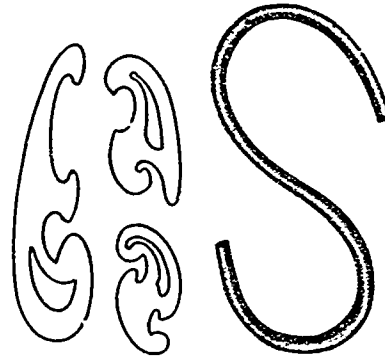

Irregular Curves

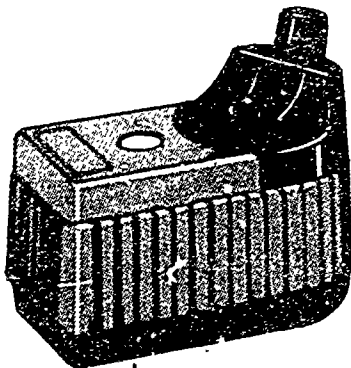

Lead Pointer

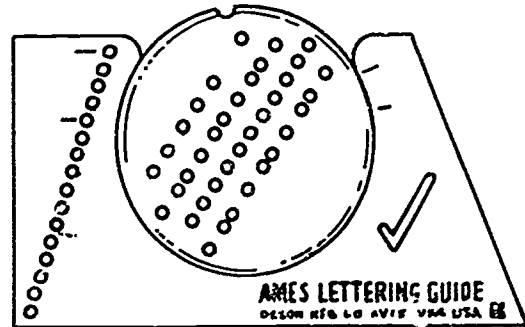

Lettering Guide

Basic Drafting Tools (Continued)



**Mechanical Pencil
(Lead Holder)**

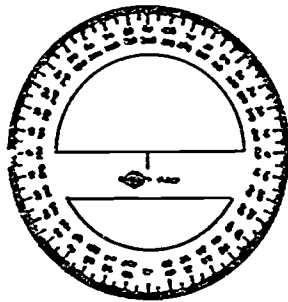

Protractor

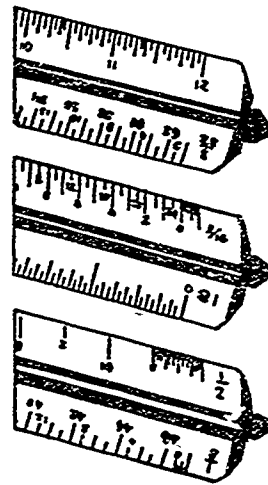

Scales

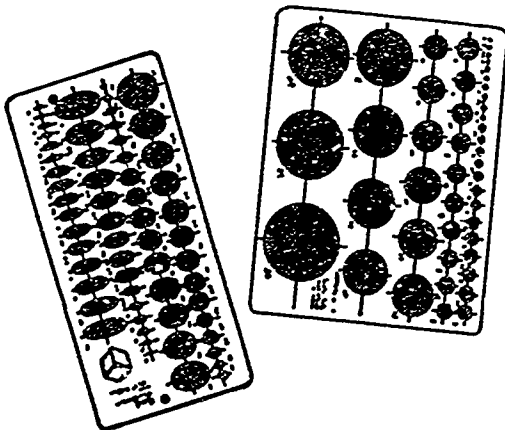

Templates

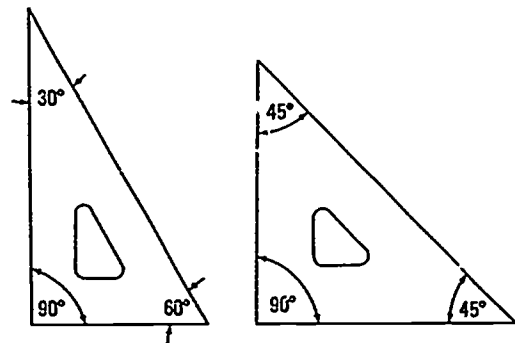

Triangles

Inking Tools



Technical Pen

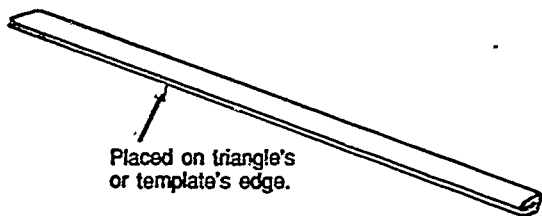

Placed on triangle's or template's edge.

Ink Riser

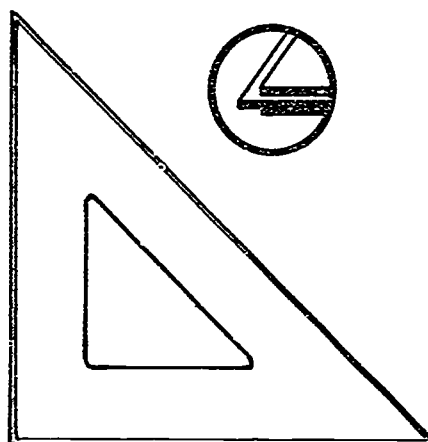

Triangle with Inking Edge

Eraser for use on ink

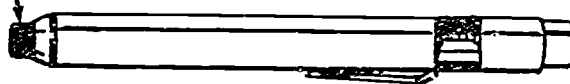

Plastic Vinyl

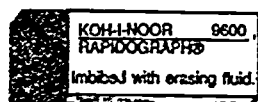

Chemically-Imbibed



Liquid

Inking Erasers

Computer-Aided Drafting System

—Microcomputer—

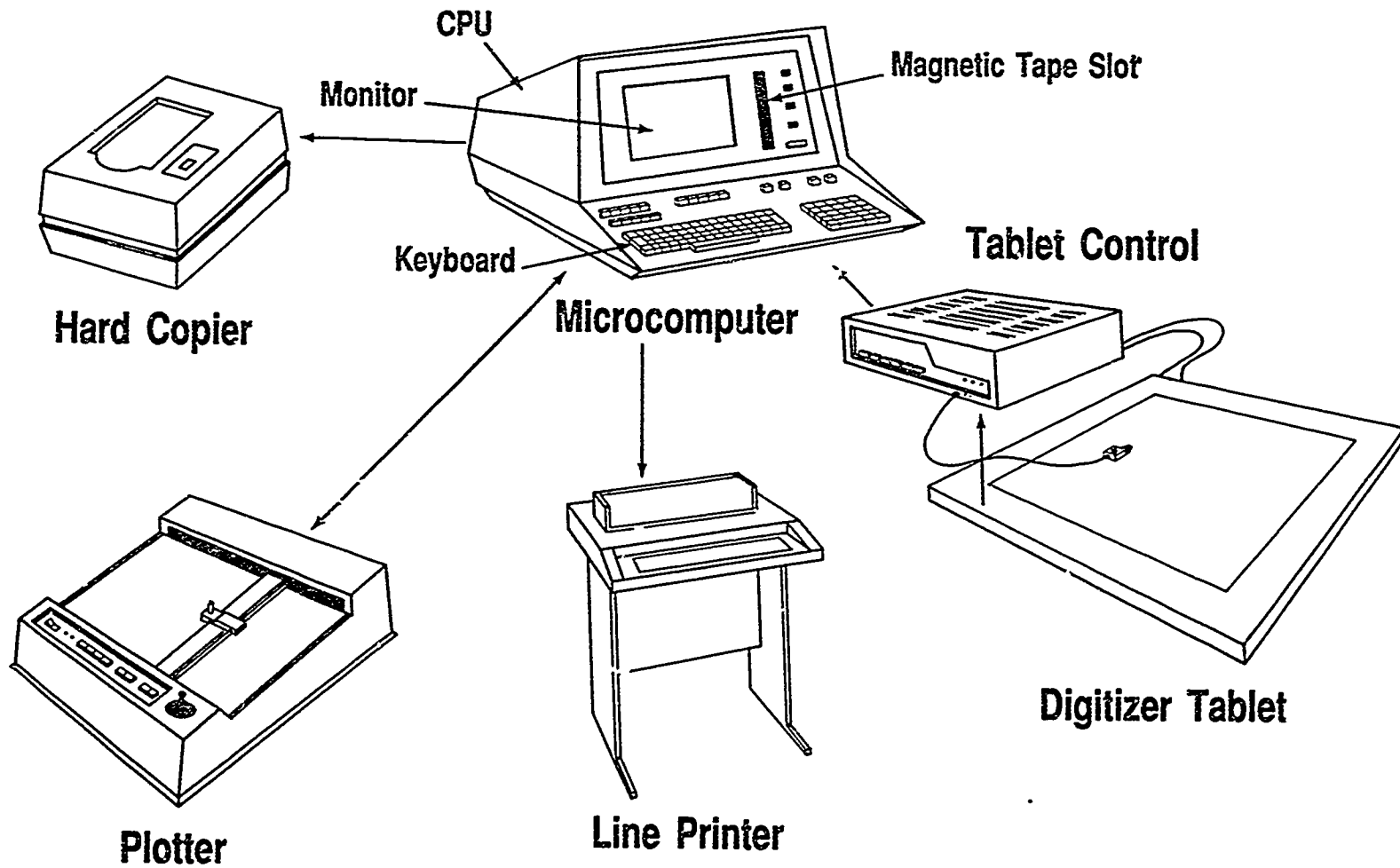

Computer-Aided Drafting System —Large Computer—

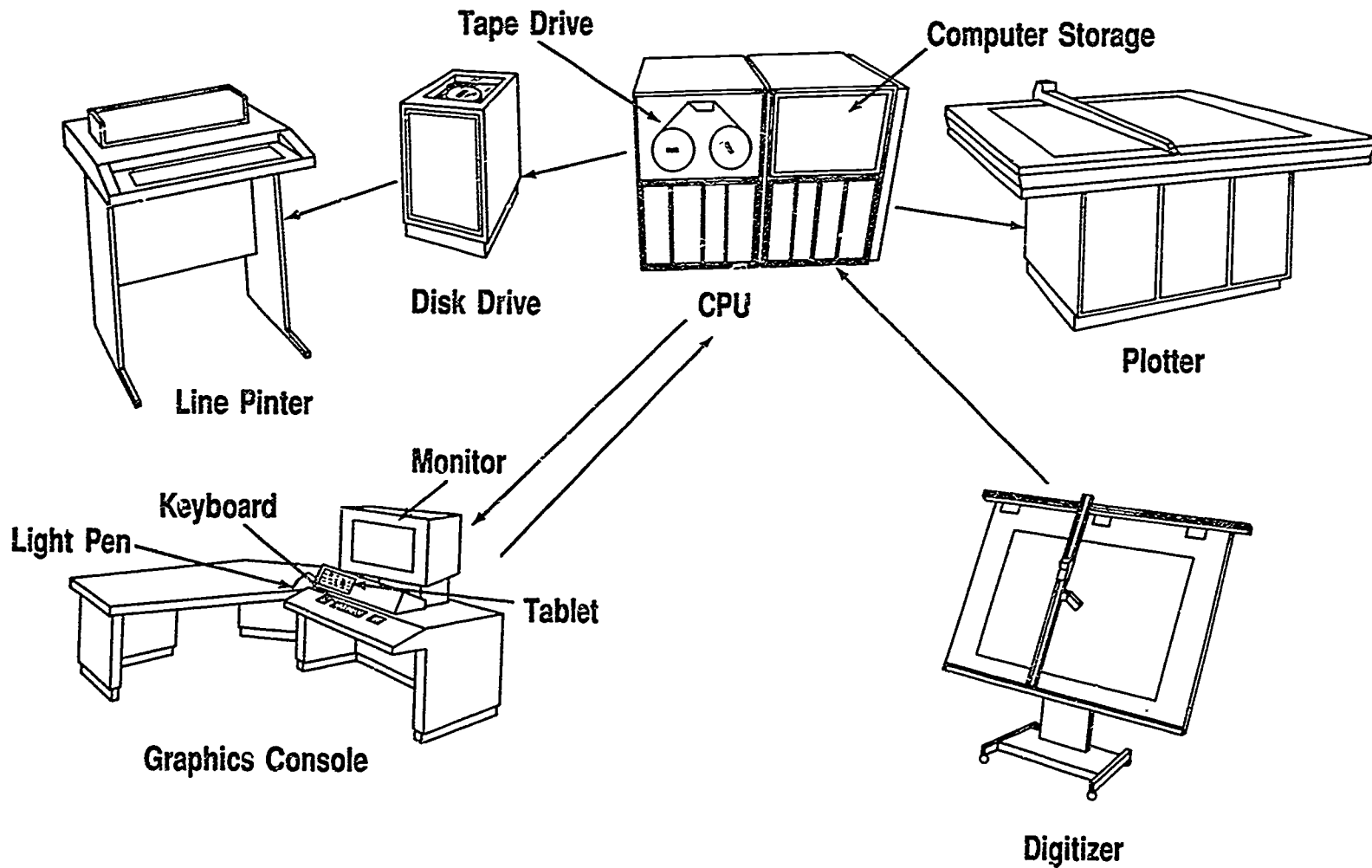

TOOLS AND EQUIPMENT
UNIT II

ASSIGNMENT SHEET #1 — RESEARCH COMPUTER APPLICATIONS
IN THE DRAFTING FIELD

NAME _____ SCORE _____

Directions:

A. Choose three different places in your area that may use computer applications.

- 1. Large corporation
- 2. Private engineering firm
- 3. Government agency

B. Visit or write each place and ask the following questions:

(NOTE: Your instructor may wish for you to accomplish this assignment as a group to lessen the inconvenience to businesses.)

1. What type of computer graphics systems are they using?

2. How many work stations do they have? _____

How many remote work stations? _____

3. What method are they using for data storage?

4. For what drafting applications are they using the system?

5. What kind of equipment are they using for data output? _____

ASSIGNMENT SHEET #1

6. Who uses the computer graphics system? How many people use it?

- _____ Management
- _____ Engineers
- _____ Drafters
- _____ Secretarial/support staff

7. What method do they use for data input?

8. Do they use the layering capabilities? _____

If so, describe how: _____

9. Write a brief description of how they have their database set up.

10. Give an overall impression of the organization structure for the CADD application.

11. Do they hire entry level drafters with CADD training? _____

TOOLS AND EQUIPMENT UNIT II

JOB SHEET #1 — MEASURE ANGLES WITH THE PROTRACTOR AND VERNIER SCALE ON A DRAFTING MACHINE

EVALUATION CRITERIA	
Criteria	Rating
Angles read accurately	_____
Angles set accurately	_____
Equipment operated smoothly	_____

A. Tool needed — Standard protractor head of a drafting machine

B. Procedure

1. Practice operating the standard protractor head. (Figure 1)

(NOTE: The standard protractor head is divided into one degree units with a side-mounted vernier scale divided into five minute readings. The protractor has 4 quarters of 90° each.)

FIGURE 1

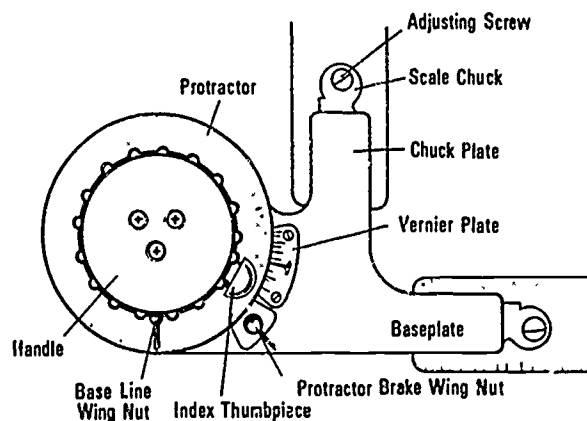

- a. Push index thumbpiece in and rotate head. Protractor will automatically lock every 15 degrees.
- b. Push index thumbpiece in and down. This will lock the indexer in the open position and free the protractor head to completely rotate.

(CAUTION: NEVER FORCE the head if it does not rotate freely; check protractor brake wing nut.)

JOB SHEET #1

2. Read various angles assigned by instructor.

(NOTE: The standard protractor head is designed to read an angle to the nearest 5 minutes of a degree. Remember, there are 360° in a circle and 60 minutes in one degree.)

- Locate the "0" on the protractor and the "0" on the vernier scale.
- Push thumb index in.
- Slide the "0" on the vernier up or down the protractor until it lines up with the degree mark needed on the protractor.

Example: (Refer to Figure 2)

- Assume the vernier is set at a positive (upward) angle.
- Note the reading in Figure 2a is between 7 and 8 degrees.
- Find the 5 minute mark on the upper half of the vernier which is most closely in alignment with a degree mark.

(NOTE: The correct reading is $7^\circ 40'$. The procedure is the same when reading negative (downward); in this case [Figure 2b] the reading is $4^\circ 25'$.)

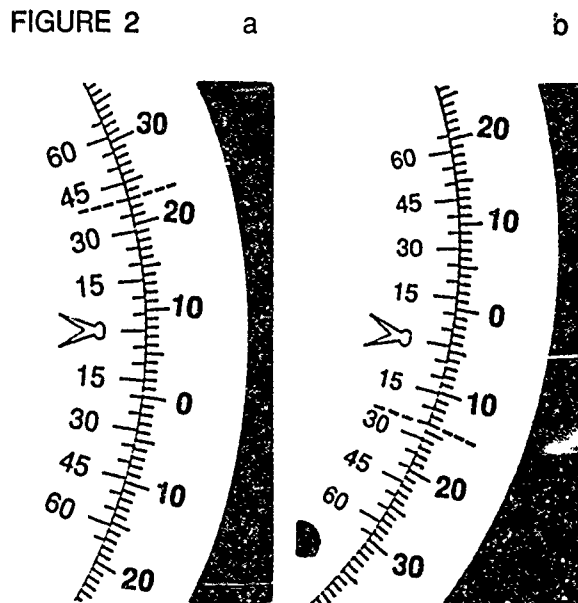

JOB SHEET #1

3. Set various angles assigned by instructor.
 - a. Release the protractor brake wing nut.
 - b. Push the index thumbpiece in and down to release the index.
 - c. Rotate the protractor arm until the zero of the vernier is at the desired degree.
 - d. Rotate (slowly) the protractor arm counterclockwise until the desired minute mark on the upper half of the vernier is precisely aligned with the nearest degree mark on the protractor.
 - e. Lock the protractor brake wing nut.

(NOTE: The procedure for setting negative angles is essentially the same except the protractor head is rotated clockwise.)

**TOOLS AND EQUIPMENT
UNIT II**

JOB SHEET #2 — OPERATE AN ADJUSTABLE TRIANGLE

A. Tools and equipment

1. Adjustable triangle
2. Parallel bar
3. Paper
4. Pencil

EVALUATION CRITERIA	
Criteria	Rating
Angles set accurately	_____
Lines drawn by triangle are parallel	_____

B. Procedure

1. Set required angle on triangle by loosening adjusting knob and setting the scale. (Figure 1)
2. Read numbers on lower half of scale if required angle is greater than 45° . The angle will be the actual angle made by the triangle.
3. Read numbers on upper half of scale if required angle is less than 45° . The angle will be complementary to the triangle.

FIGURE 1

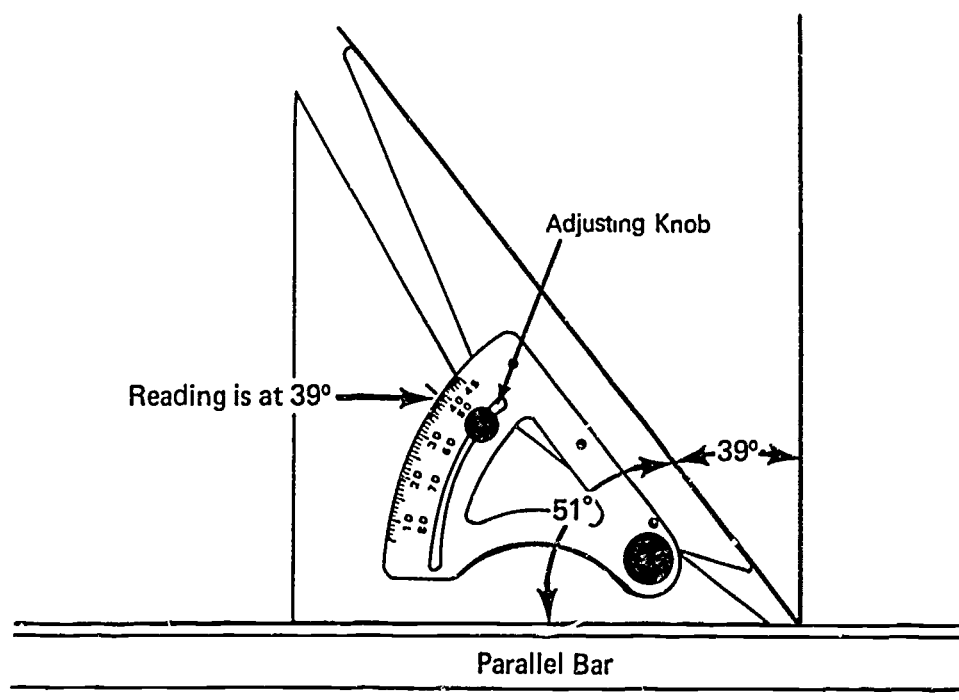

JOB SHEET #2

(NOTE: Adjustable triangle can also be adjusted so that the long side can serve as the base line. This changes the direction the individual lines will run. See Figure 2.)

FIGURE 2

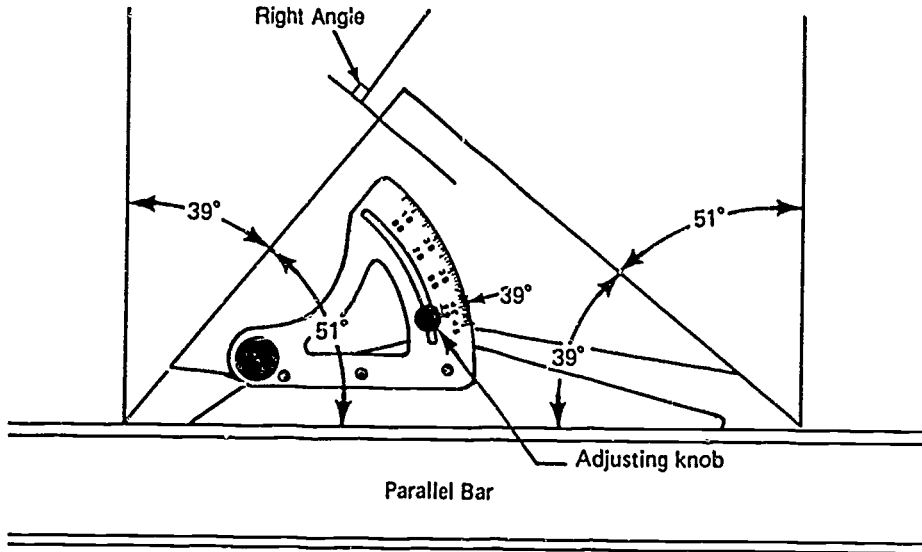

4. Practice setting various angles and rotating triangle to get various line angles.
5. Construct parallel lines by drawing along one edge of the triangle. Slide the triangle along working edge to new position and construct the new line. (Figure 3)

FIGURE 3

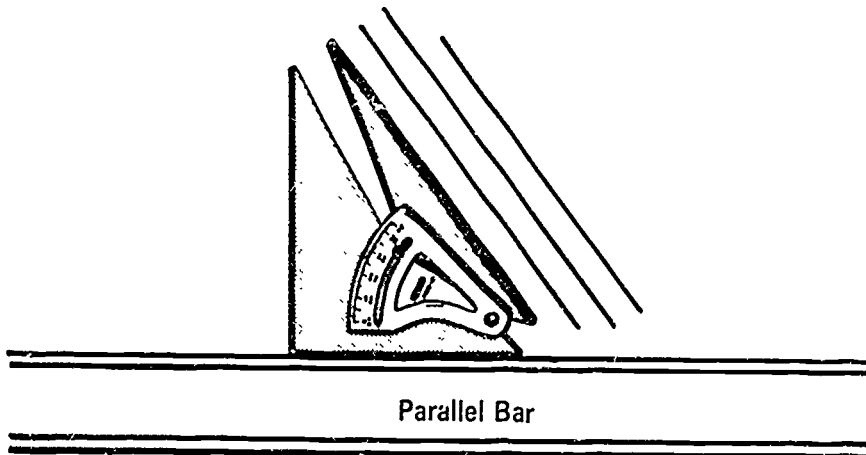

**TOOLS AND EQUIPMENT
UNIT II**

**JOB SHEET #3 — DRAW HORIZONTAL AND VERTICAL LINES
WITH TRIANGLES AND A DRAFTING MACHINE**

A. Tools and equipment

1. V-track or elbow drafting machine
2. Standard triangles
3. Two sheets of drafting media ("B" size vellum — 11" x 17")
4. Drafting pencil
5. Eraser

EVALUATION CRITERIA	
Criteria	Rating
Machine adjusted properly	_____
Problems drawn correctly	_____
Linework	_____
Overall neatness	_____

B. Procedure

1. Place the drawing media on the drawing surface.
2. Set the drafting machine at the "0" mark with parallel scale approximately horizontal to the drawing surface.
3. Align the bottom edge of the drawing media with the parallel scale.
4. Tape the drawing in place.
5. Draw horizontal lines using the parallel scale as a guide.

FIGURE 1

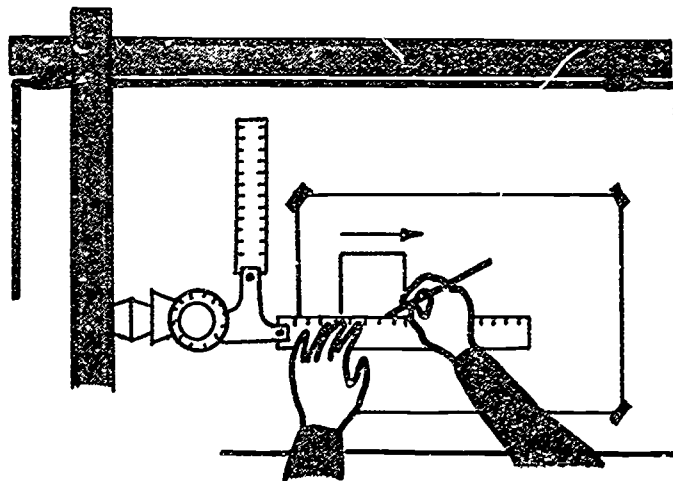

JOB SHEET #3

6. Draw vertical lines by placing a triangle against the parallel scale and using the vertical 90° angle of the triangle to trace along.

FIGURE 2

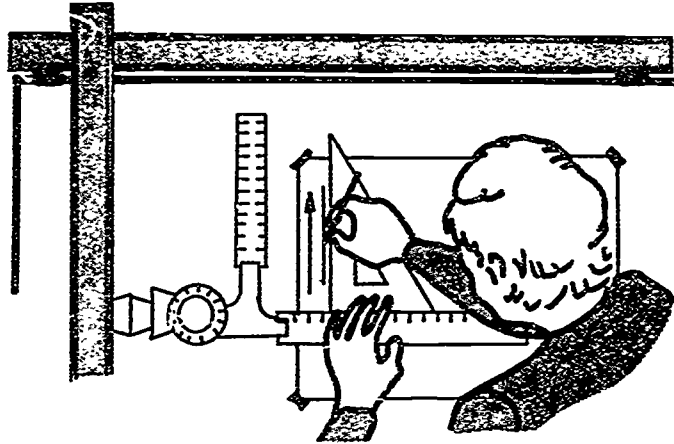

- C. Problems: Using a new sheet of vellum, draw the following figures using the specifications noted. Construct Problem 1 in the left half of the sheet and Problem 2 in the right half of the sheet.

1. Line A-B is divided into 6 equal parts.
Line A-D is divided into 9 equal parts.

FIGURE 3

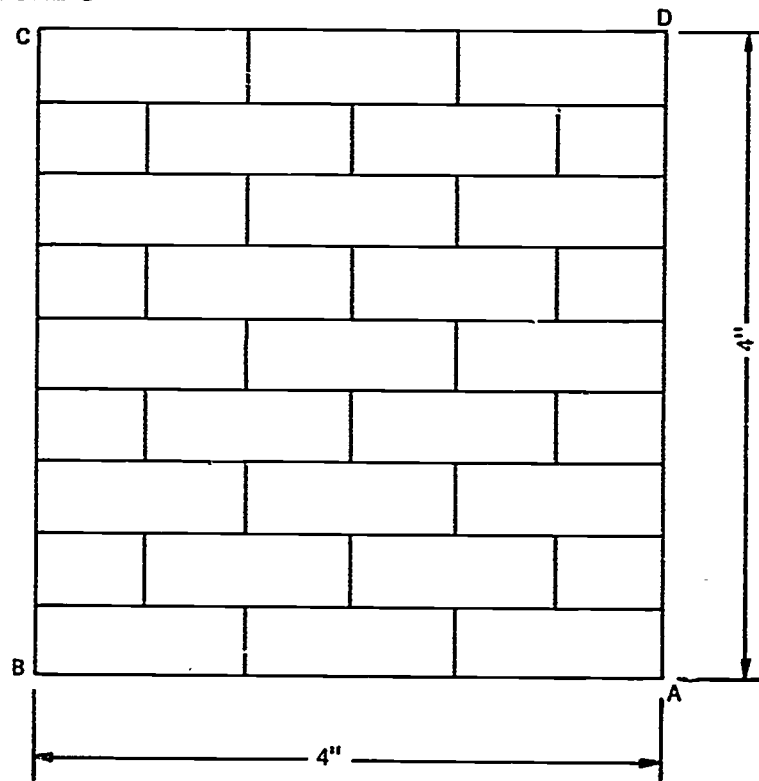

JOB SHEET #3

2.

(NOTE: Accuracy is a "must" for a drafter. Work on accuracy of spacing and keep all corners clean and sharp.)

FIGURE 4

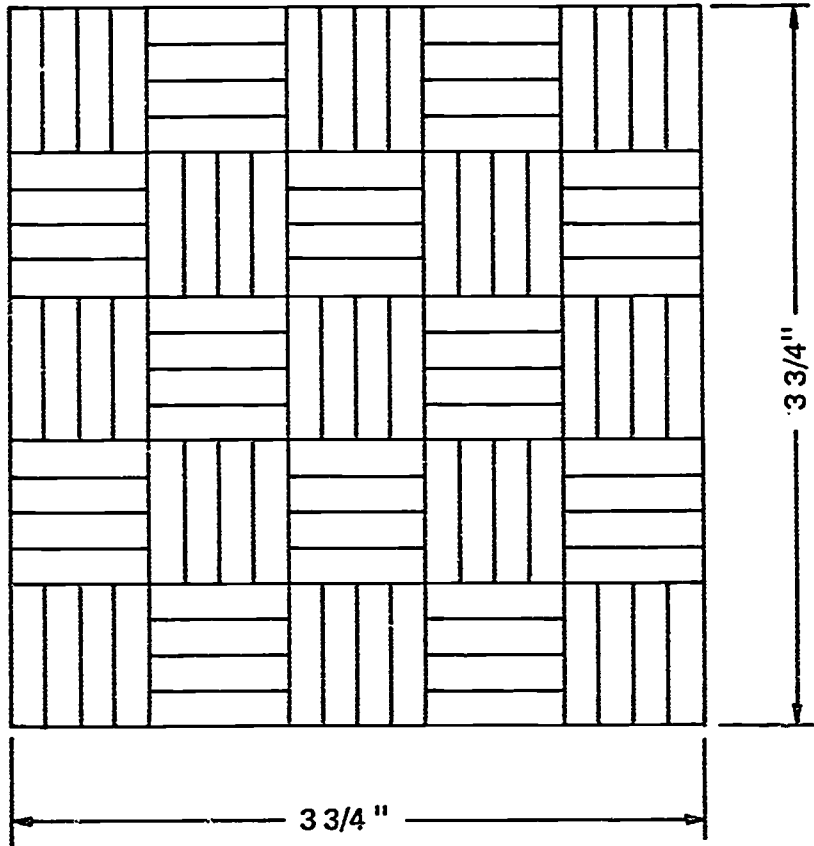

**TOOLS AND EQUIPMENT
UNIT II**

**JOB SHEET #4 — DIVIDE A CIRCLE INTO 24 PARTS OF 15°
BY USING 30°/60° and 45° TRIANGLES**

A. Tools and equipment

1. Triangles — 30°/60° and 45°
2. Drafting machine or parallel bar
3. Drafting media
4. Drafting pencil
5. Eraser

EVALUATION CRITERIA

Criteria	Rating
Problem drawn correctly	_____
Overall neatness	_____

B. Procedure

1. Use the established center point and center lines as a reference point from which two standard triangles can be used to find the first 15° angle. (Figure 1)
2. Use one triangle to find the 30° angle next to the 15° angle.
3. Use one triangle to find the 45° angle next to the 30° angle.
4. Use one triangle to find the 60° angle next to the 45° angle.
5. Use two triangles to find the 75° angle next to the 60° angle.
6. Use one triangle to find the 90° angle next to the 75° angle.
7. Continue with triangles and drafting machine or parallel bar until the circle has been divided into 24 parts and each angle has been correctly labeled.

JOB SHEET #4

FIGURE 1

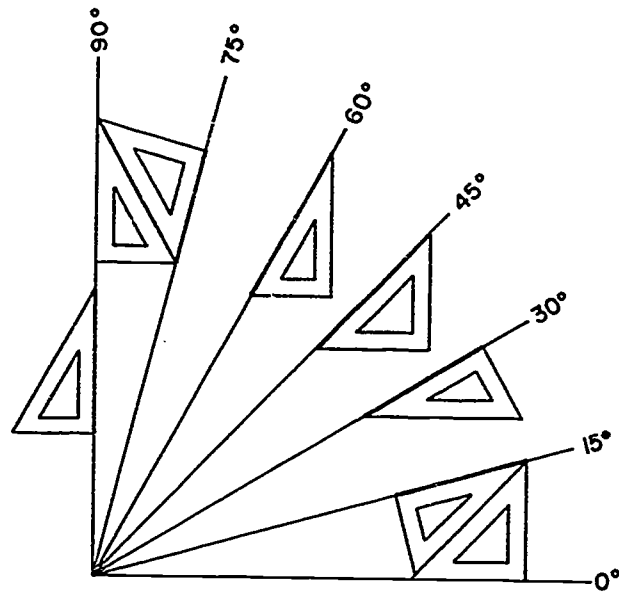

- C. Problem — Divide the circle below into 24 parts of 15°.

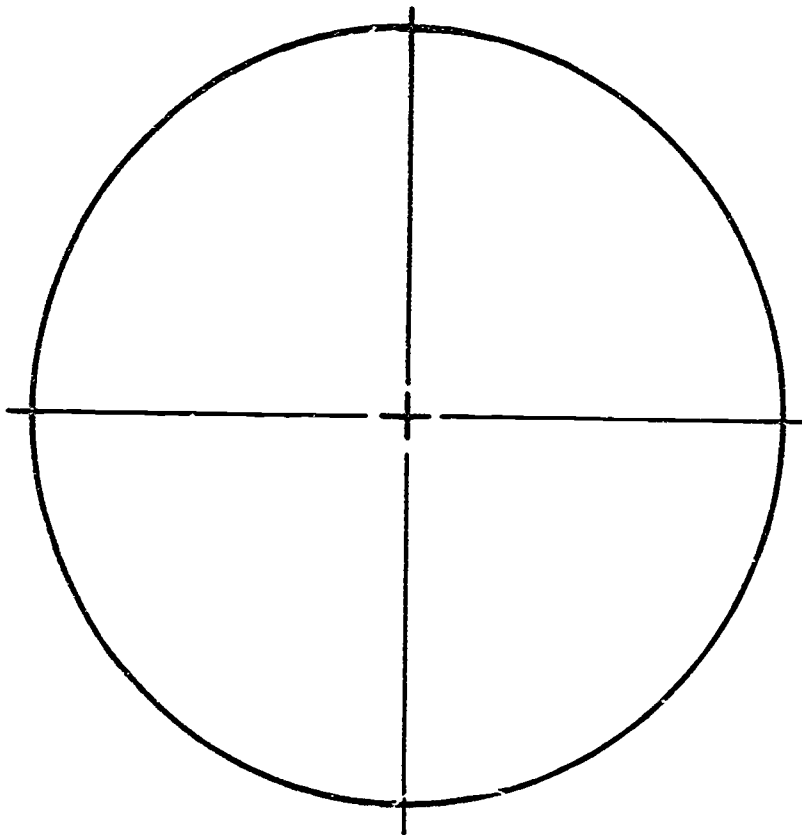

**TOOLS AND EQUIPMENT
UNIT II**

JOB SHEET #5 — USE A COMPASS TO DRAW CIRCLES AND ARCS

A. Tools and equipment

1. Compass
2. Eraser
3. Drafting media ("A" size vellum — 8 1/2" x 11")
4. Drafting pencil

EVALUATION CRITERIA	
Criteria	Rating
Problem drawn correctly	_____
Linework	_____
Overall neatness	_____

B. Procedure

(NOTE: A compass is used to draw circles or arcs that are too large or different in size from a circle template.)

1. Set the radius to be used.

(CAUTION: Do not place the compass directly on the scale because this practice could eventually damage the scale.)

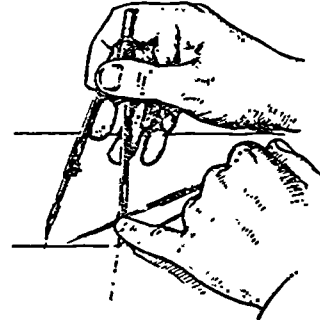

2. After radius is determined, start the circle by holding the compass handle between the thumb and forefinger.

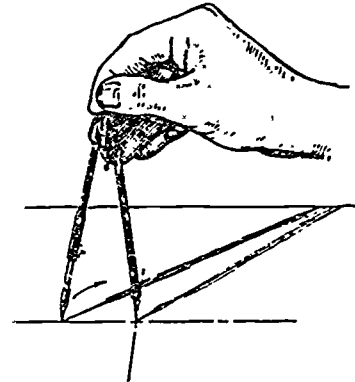

JOB SHEET #5

3. Complete the circle by rotating the compass in a clockwise direction.

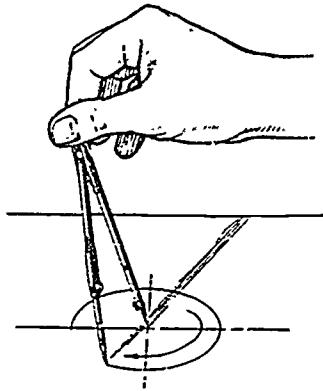

4. Use the scale to check accuracy of the diameter before darkening lines.
- C. Problem — Construct a $3\frac{1}{2}$ " square centered on the vellum and construct a figure like the one shown below in that space. Draw $1\frac{3}{4}$ " radius arcs at A, B, C, and D, and construct small arcs so that they intersect as shown in below. Complete the problem by adding center lines.

(NOTE: Omit radius lines A, B, C, and D from finished drawing.)

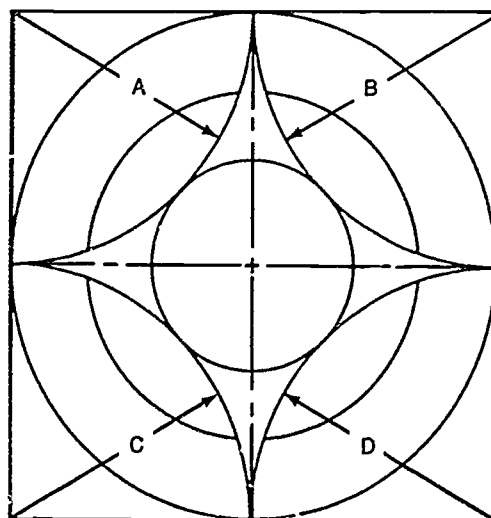

TOOLS AND EQUIPMENT UNIT II

JOB SHEET #6 — USE A DIVIDER TO DIVIDE A LINE INTO EQUAL PARTS

A. Tools and equipment

1. Divider
2. Eraser
3. Drafting media ("A" size vellum)
4. Drafting pencil

EVALUATION CRITERIA

Criteria	Rating
Problem drawn correctly	_____
Line work	_____
Overall neatness	_____

B. Procedure

(NOTE: A divider is used to transfer a dimension from one point to another or to subdivide a line into a given number of equal parts.)

1. To divide a line into a given number of equal parts, set one point of the divider at one end of the line.
2. Use one hand to adjust the divider to approximately $\frac{1}{3}$ the distance of the line.

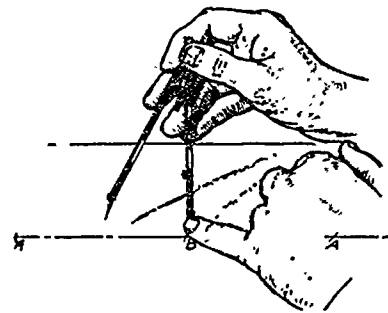

(NOTE: Distance will change depending upon number of divisions.)

3. Swing the divider clockwise to the second point on the line.

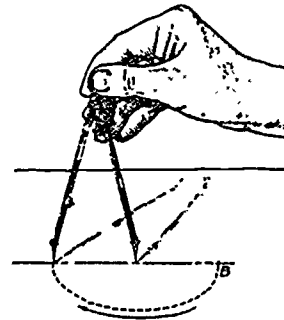

JOB SHEET #6

4. Swing the divider counterclockwise to the third point on the line.

(NOTE: If spacing is too short or too long, lengthen or shorten the divider spacing slightly and try again. This is a trial and error method, but a useful method to practice.)

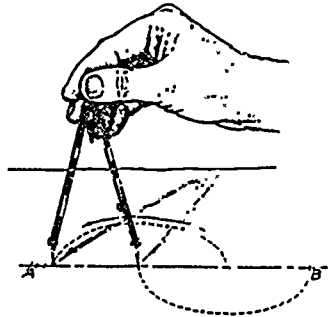

- C. Problem — Construct a 4" square in the center of the working space. Using the figure below as an example, divide lines A-D and B-C into seven equal parts locating the corners of the squares. Construct the squares and complete the figure by adding center lines.

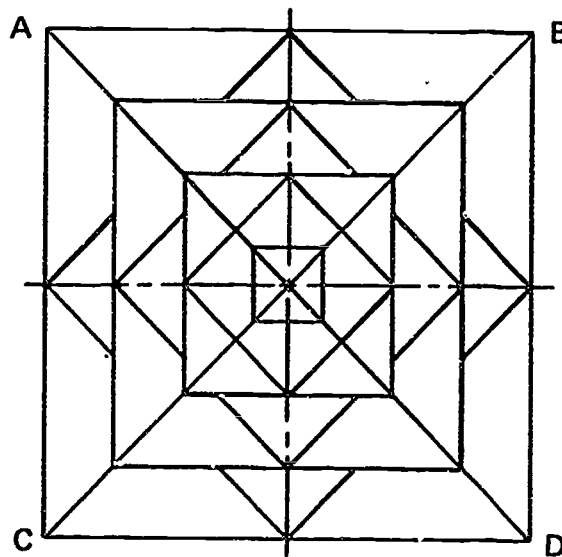

TOOLS AND EQUIPMENT UNIT II

JOB SHEET #7 — MEASURE ANGLES WITH A PROTRACTOR

A. Tools and supplies

1. Protractor
2. Pencil

EVALUATION CRITERIA	
Criteria	Rating
Problems solved correctly	_____

B. Procedure

1. Place the base line or 180° line of the protractor along one leg of angle to be measured with vertex of angle at marked center point of protractor. (Figure 1)
2. Starting at zero, read up the side of the protractor right or left depending on the angle being measured.

FIGURE 1

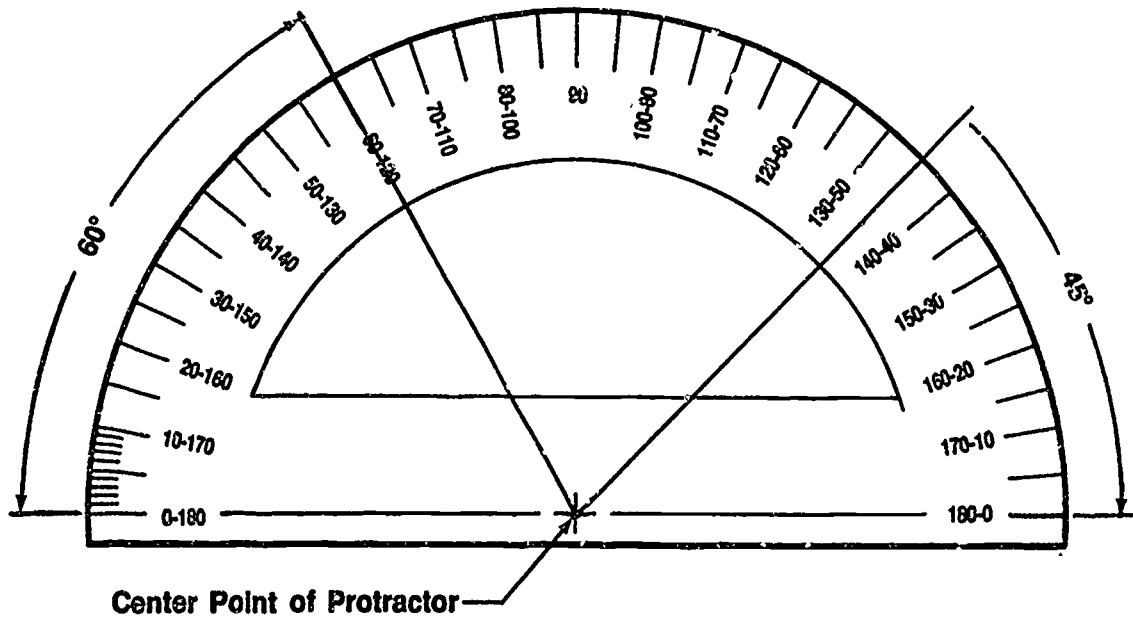

JOB SHEET #7

C. Problems — Measure and record the angles shown in the blanks provided.

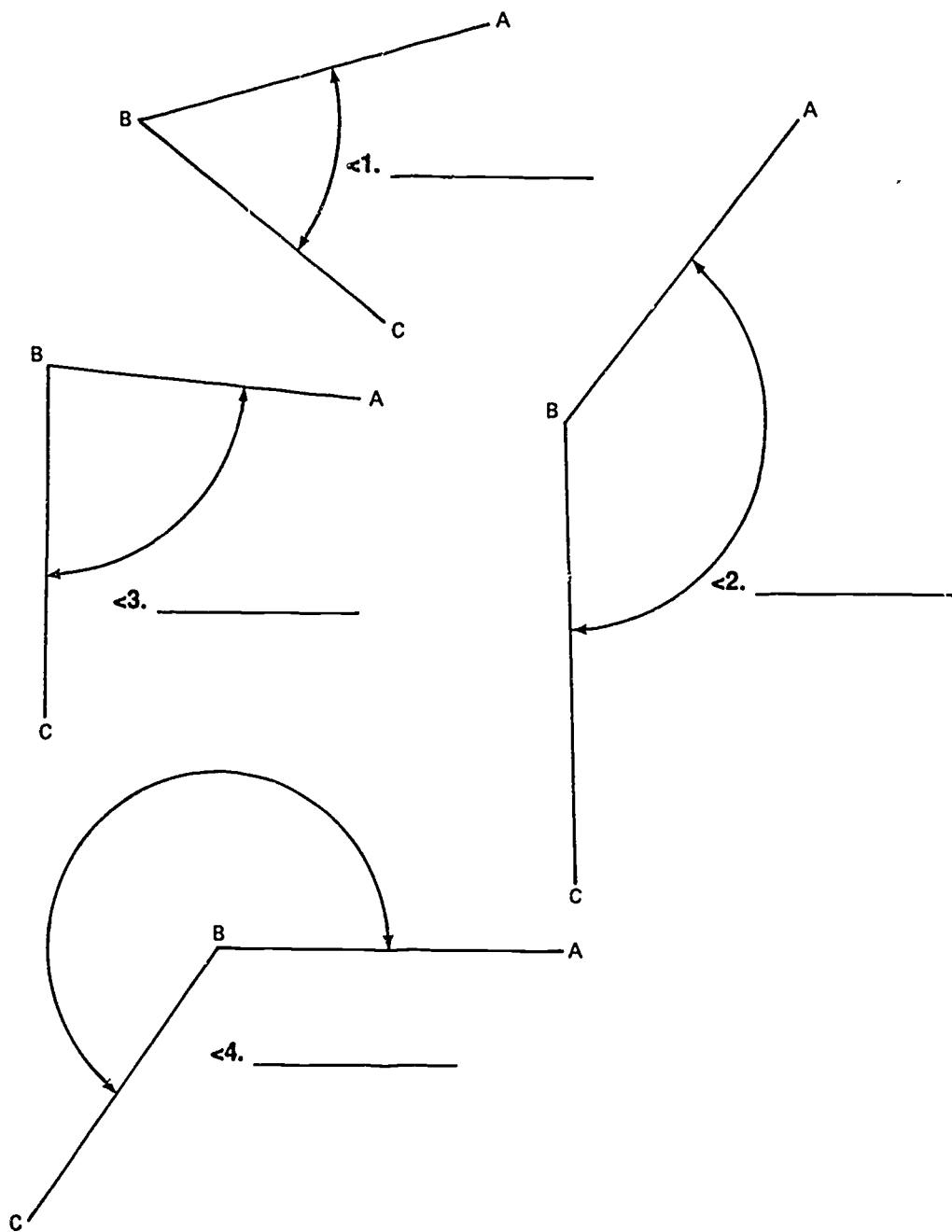

**TOOLS AND EQUIPMENT
UNIT II**

**JOB SHEET #8 — USE AN IRREGULAR CURVE TO CONSTRUCT
A CURVED LINE**

A. Tools and equipment

1. Irregular curve
2. Drafting pencil

EVALUATION CRITERIA	
Criteria	Rating
Problem drawn correctly	_____
Linework	_____
Overall neatness	_____

B. Procedure

(NOTE: The irregular curve is used to construct noncircular arcs.)

1. Move the curve around to connect three or more given points.
2. Connect these points.
3. Move curve to new position using at least two points previously given.

(NOTE: Sometimes a smoother transition is made if the irregular curve template is flipped over and used along the same section on the curve.)

4. Extend line to join new points.(Figure 1)

FIGURE 1

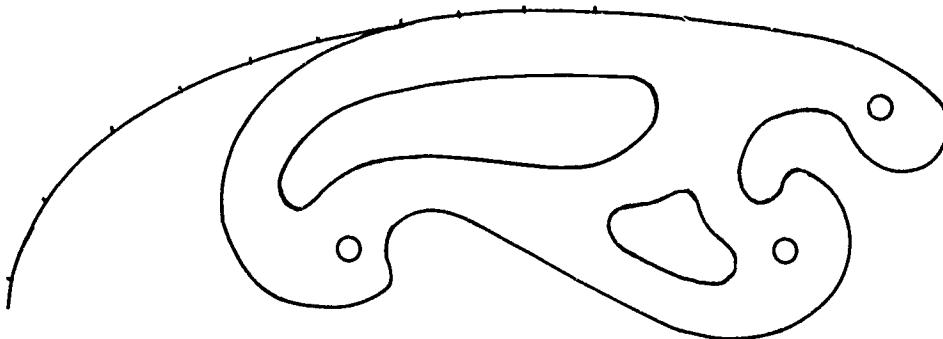

JOB SHEET #8

C. Problem — Complete the following figure using an irregular curve.

FIGURE 2

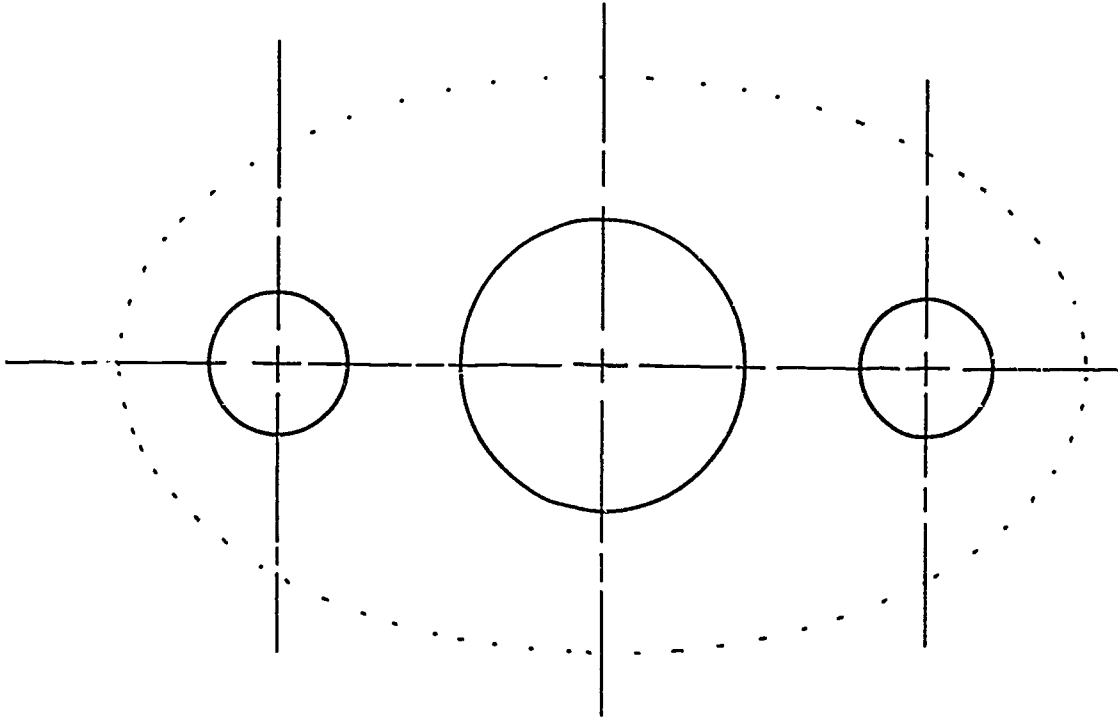

TOOLS AND EQUIPMENT UNIT II

JOB SHEET #9 — FORMAT A FLOPPY DISKETTE

A. Materials and equipment

1. Computer hardware
2. Appropriate CADD software
3. Floppy (flexible) diskette
(single sided, double density, soft
sectored)
4. Instruction manual for CADD system

EVALUATION CRITERIA	
Criteria	Rating
Diskette is properly formatted	_____

B. Procedure: The following procedure is only an example. Discuss with your instructor the exact procedure for your CADD system.

(NOTE: Prior to first use of a floppy diskette, it must be formatted by the proper diskette formatting routine.)

Example:

For the two disk MATC CAD system, formatting is accomplished by:

1. Insert the MATC CAD disk in drive 1 and a blank parts disk in drive 2.
(CAUTION: Take care not to touch the surface of the disk in the oval cut out area.)
2. Turn on the Apple computer with the switch in the back left corner.
3. Turn on the display screen and make sure the CAPS LOCK key is DOWN.
4. When the MATC CAD banner appears, type in the date and press RETURN.
5. When the License banner appears, hold down the Control key and press R. Then release both keys and press number 0.
6. When the systems level prompt "0>" appears, type in UTIL and press RETURN. In a few seconds the UTILITY MENU will appear on the screen.
7. Select the FORMAT DISKETTE option by pressing an F followed by RETURN. Make sure the disk to be formatted is in drive 2.

(NOTE: Formatting a blank diskette will take about 40 seconds.)

(CAUTION: Formatting a diskette will erase any information previously contained on the disk.)

From *MATC CAD Operations and Training Manual*. © Milwaukee Area Technical College.
Reprinted with permission.

C. Format a floppy diskette for parts storage. Follow procedures for formatting a diskette provided for you in your CADD system instruction manual.

**TOOLS AND EQUIPMENT
UNIT II**

TEST

NAME _____ SCORE _____

1. Match the terms on the right with their correct definitions.

- | | | | |
|----------|--|----|-----------------|
| _____ a. | At a 90° angle to a given plane or line | 1. | Drawing media |
| _____ b. | A line straight up and down, perpendicular to the horizontal plane | 2. | Horizontal |
| _____ c. | Made of graphite with kaolin added in varying amounts in order to make the eighteen grades from the hardest to the softest | 3. | Ink |
| _____ d. | A measuring device consisting of a main fixed scale and a smaller graduated scale that slides to obtain fine measurements | 4. | Lead |
| _____ e. | Any type of material upon which an object is graphically represented | 5. | Parallel |
| _____ f. | Two lines or surfaces side by side, equal distances apart at all points | 6. | Perpendicular |
| _____ g. | Composed mainly of carbon in colloidal suspension and gum | 7. | Vernier |
| _____ h. | Parallel to the plane of the horizon | 8. | Vertical |
| | | 9. | Working surface |

2. Identify the following basic drafting tools.

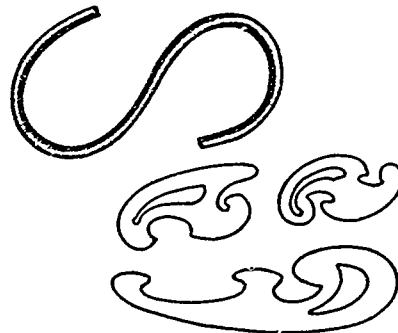
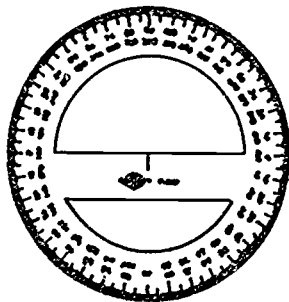

a. _____

b. _____

TEST

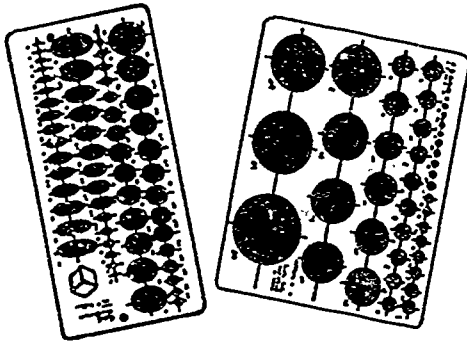

c. _____

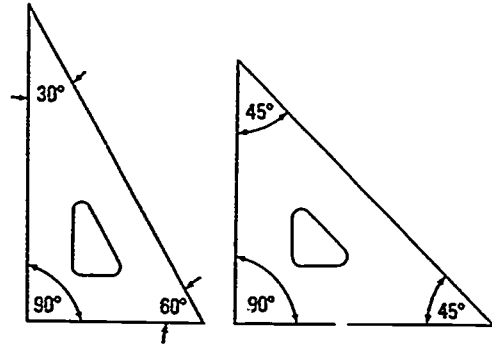

d. _____

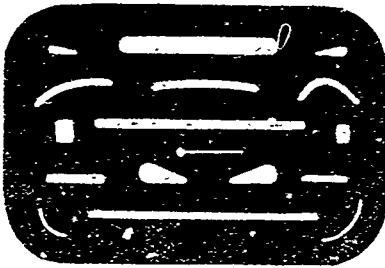

e. _____

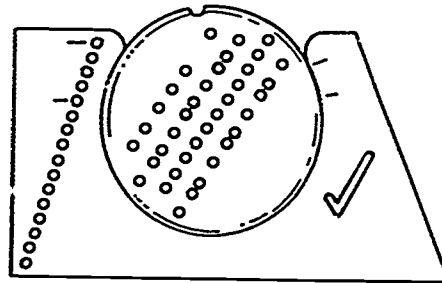

f. _____

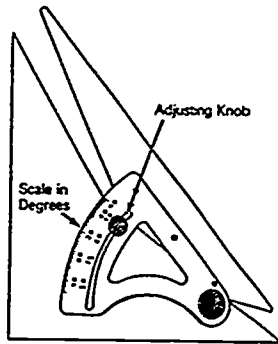

g. _____

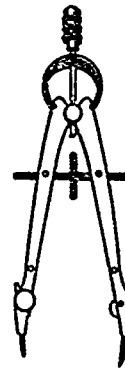

h. _____

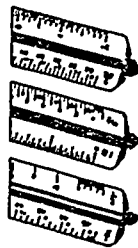

i. _____

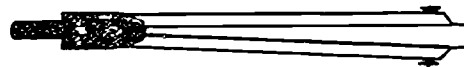

j. _____

TEST

3. Distinguish among the types of drafting machines by placing the following letters next to the correct descriptions:

- E—Elbow drafting machine
- P—Parallel bar
- V—V-track drafting machine

- _____ a. Has a protractor head which can be adjusted to any angle measurement accurate to the nearest 5 minutes of a degree; this protractor head moves on a vertical track which in turn moves on a horizontal track.
- _____ b. Has a protractor head which can be adjusted to any angle measurement accurate to the nearest 5 minutes of a degree. The protractor head moves in any direction of the working surface. The head is mounted at the end of two arms hinged in the middle with a swivel joint.
- _____ c. Is a long flat bar similar to a T-square that has a hollow area in its middle through which cables pass. These cables work through a series of pulleys, and the ends are attached to a tension bracket. The cables allow it to move in a parallel motion up and down the working surface.

4. List two advantages for each type of drafting machine.

- a. Parallel bar

- 1) _____
- 2) _____

- b. Elbow drafting machine

- 1) _____
- 2) _____

- c. V-track drafting machine

- 1) _____
- 2) _____

TEST

5. Identify parts of a standard protractor head.

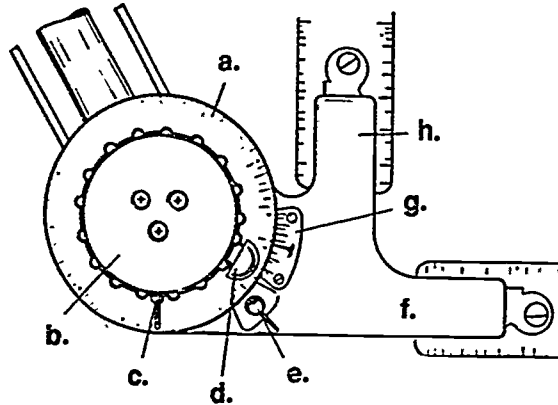

- | | |
|----------|----------|
| a. _____ | e. _____ |
| b. _____ | f. _____ |
| c. _____ | g. _____ |
| d. _____ | h. _____ |

6. Select true statements concerning rules for maintenance and care of drafting machines by placing an "X" next to the true statements.

- ___ a. Keep scales aligned and tight.
- ___ b. Scales can be used as straight edges for cutting knives.
- ___ c. Scales do not need to be kept clean.
- ___ d. Tighten baseline and protractor wing nuts snugly but not too tight.
- ___ e. Store drafting machine with scales protruding over the edge of the drafting table.
- ___ f. Lift and move drafting machine by the scales.
- ___ g. Protractor heads are hard to adjust; force if necessary.
- ___ h. Keep band tension adjusted properly.
- ___ i. Keep support clamps loose when not in use.

TEST

7. Identify the following types of compasses.



a. _____



b. _____

8. Identify the following types of dividers.

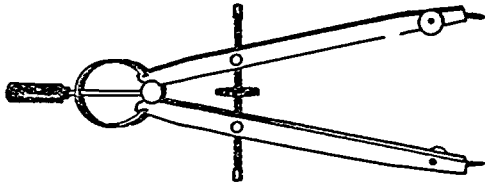

a. _____

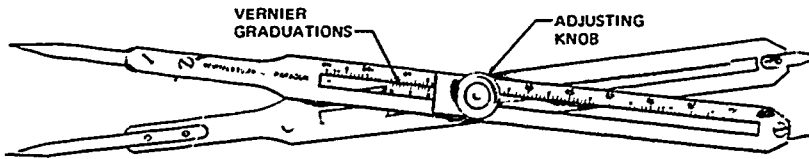

b. _____

TEST

9. Identify the following types of irregular curves.

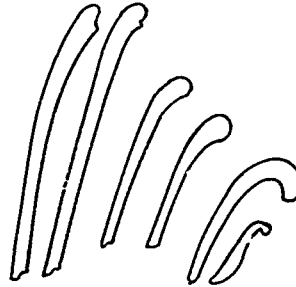
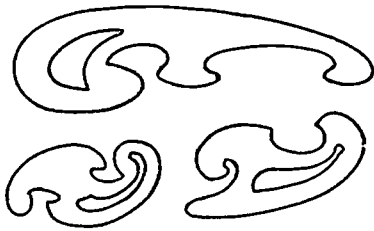

a. _____

b. _____

10. List five types of common templates.

- a. _____
- b. _____
- c. _____
- d. _____
- e. _____

11. Select true statements concerning rules for maintenance and care of drafting tools and equipment by placing an "X" in the appropriate blanks.

- ___ a. Do not bend templates sharply.
- ___ b. Templates and scales can be used as straight edges for cutting.
- ___ c. Keep all instruments clean and dry.
- ___ d. A circle template can be used as an eraser shield.
- ___ e. Do not hit scales and triangles on edges.
- ___ f. Compasses and dividers cannot be overextended.
- ___ g. Clean plastic tools with soap and water only.

TEST

12. Distinguish between the types of drafting pencils by placing an "X" next to the description of the thin-lead mechanical pencil and an "O" next to the mechanical lead holder.

- ___ a. Lead requires sharpening.
- ___ b. Lead does not require sharpening.

13. Match the types of lead on the right with the devices used to sharpen them.

- | | |
|------------------------------------|---------------------------------|
| ___ a. File | 1. Compass leads |
| ___ b. Sandpaper pad | 2. Mechanical lead-holder leads |
| ___ c. Metal-cutter lead pointer | |
| ___ d. Sandpaper-cone lead pointer | |

14. Identify the following tools used for inking.



a. _____

b. _____

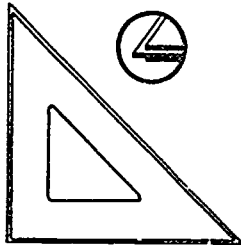

c. _____

15. List three types of pen points.

- a. _____
- b. _____
- c. _____

TEST

16. Select true statements concerning the ways to properly use and care for technical pens by placing an "X" next to the true statements.

- a. The proper way to hold the technical pen is horizontally, with a very heavy touch.
- b. While drawing, always push the technical pen; never pull it.
- c. The air channel allows air to enter the ink cartridge in order to replace the ink that has been used.
- d. The technical pen should be left uncapped when not in use for short periods of time.
- e. The wire-weight should always be removed during cleaning.
- f. When a technical pen is to be stored for an extended period of time, it should be cleaned well and filled with pen cleaning solution.
- g. Before using a pen that has been stored a long time, flush it with warm water, thoroughly dry it, and refill it with ink.

17. Match CADD terminology on the right with the correct definitions.

- | | |
|--|----------------------|
| <input type="checkbox"/> a. Symbol denoting 1024 units (bytes) of storage | 1. Alphanumeric |
| <input type="checkbox"/> b. Flashing rectangular dot or cross hair that indicates the current position on the screen | 2. BASIC |
| <input type="checkbox"/> c. Binary digit (0 or 1); the smallest unit of information that can be recognized by a computer | 3. Binary code |
| <input type="checkbox"/> d. Signals or data transmitted to a microcomputer system | 4. Bit |
| <input type="checkbox"/> e. The set of letters A-Z, the numerals 0-9, and various punctuation marks and special characters | 5. Byte |
| <input type="checkbox"/> f. Memory that can be both written into and read | 6. Chips |
| <input type="checkbox"/> g. A collection of eight bits | 7. COBOL |
| | 8. Computer language |
| | 9. Cursor |
| | 10. Data |
| | 11. Digit |

TEST

- _____ h. A display of selections that may be chosen, typically on a video display device
- _____ i. Miniaturized integrated circuits which compose ROM memory
- _____ j. Information; facts of all kinds
- _____ k. Step-by-step instructions which tell the computer what to do
- _____ l. Two-digit numbering system composed of only 0 and 1
- _____ m. Any number from 0 through 9
- _____ n. A computer ranked between main-frame computers and micro-computers in size, power, complexity, and cost; generally, a 32-bit computer
- 12. File
- 13. Input
- 14. Interface
- 15. K
- 16. Machine language
- 17. Menu
- 18. Microcomputer
- 19. Minicomputer
- 20. Output
- 21. Program
- 22. Random access memory (RAM)
- 23. Read only memory (ROM)
- 24. Routine

18. List six pieces of hardware used in a CADD system and classify as input, output, or neither.

Example: Hard copier—Output device

- a. _____
- b. _____
- c. _____
- d. _____
- e. _____
- f. _____

TEST

19. Select types of computer subsystems for CADD by placing an "X" next to the correct subsystems.

- _____ a. Monitor
- _____ b. Plotter
- _____ c. Keyboard
- _____ d. CPU
- _____ e. Storage

20. List three typical routines used for maintaining CADD files.

- a. _____
- b. _____
- c. _____

(NOTE: If the following activities have not been accomplished prior to the test, ask your instructor when they should be completed.)

21. Research computer applications in the drafting field. (Assignment sheet #1)

22. Demonstrate the ability to:

- a. Measure angles with the protractor and vernier scale on a drafting machine. (Job Sheet #1)
- b. Operate an adjustable triangle. (Job Sheet #2)
- c. Draw horizontal and vertical lines with triangles and a drafting machine. (Job Sheet #3)
- d. Divide a circle into 24 parts of 15° by using $30^\circ/60^\circ$ and 45° triangles. (Job Sheet #4)
- e. Use a compass to draw circles and arcs. (Job Sheet #5)
- f. Use a divider to divide a line into equal parts. (Job Sheet #6)
- g. Measure angles with a protractor. (Job Sheet #7)
- h. Use an irregular curve to construct a curved line. (Job Sheet #8)
- i. Format a floppy diskette. (Job Sheet #9)

TOOLS AND EQUIPMENT
UNIT II

ANSWERS TO TEST

1. a. 6 e. 1
b. 8 f. 5
c. 4 g. 3
d. 7 h. 2
2. a. Protractor
b. Irregular curve
c. Template
d. Triangle
e. Erasing shield
f. Lettering guide
g. Adjustable triangle
h. Compass
i. Scale
j. Divider
3. a. V
b. E
c. P
4. a. Any two of the following:
1) Easy to make long horizontal lines
2) More accurate than a T-square
3) Very little maintenance
4) Simple to operate
- b. Any two of the following:
1) Increases drafting output
2) Requires fewer tools to operate
3) Less expensive than V-track machine
4) Can be aligned to any base line
- c. Any two of the following:
1) Simple to operate
2) Versatile
3) Accuracy is better maintained
4) All area of drawing board accessible
5) Few working parts
5. a. Protractor
b. Handle

ANSWERS TO TEST

- c. Base line wing nut
 - d. Index thumbpiece
 - e. Protractor brake wing nut
 - f. Base plate
 - g. Vernier plate
 - h. Chuck plate
6. a, d, h
7. a. Friction
b. Bow
8. a. Bow
b. Proportional
9. a. French curve
b. Ships curve
10. Any five of the following:
- | | |
|----------------------|------------------|
| a. Circle | g. Hex bolt head |
| b. Ellipse | h. Thread |
| c. Isometric ellipse | i. Plumbing |
| d. Architectural | j. Civil |
| e. Piping | k. Electronic |
11. a, c, e, g
12. a. 0
b. X
13. a. 1
b. 1
c. 2
d. 2
14. a. Ink riser
b. Liquid inking eraser
c. Triangle with inking edges

ANSWERS TO TEST

15. Any three of the following:

- | | | | |
|----|-----------------|----|------------------|
| a. | Stainless steel | c. | Tungsten-carbide |
| b. | Jewel | d. | Plotter pens |

16. c, f, g

- | | | | | | |
|--------|----|----|----|----|----|
| 17. a. | 15 | f. | 22 | k. | 21 |
| b. | 9 | g. | 5 | l. | 3 |
| c. | 4 | h. | 17 | m. | 11 |
| d. | 13 | i. | 6 | n. | 19 |
| e. | 1 | j. | 10 | | |

18. Any six of the following:

- | | |
|----|---|
| a. | Central processing unit—neither |
| b. | Input devices |
| | 1) Keyboard console |
| | 2) Monitor/Screen/CRT |
| | 3) Manual digitizer |
| | 4) Digitizer tablet |
| | 5) Free moving cursor |
| | 6) Light pen |
| | 7) Stylus |
| | 8) Joy stick |
| c. | Output devices |
| | 1) Monitor/Screen/CRT |
| | 2) Plotter |
| | 3) Line printer |
| | 4) Laser printer |
| | 5) Storage devices such as floppy disks/diskettes, hard disks, or magnetic tape |

19. a, d, e

20. Any three of the following:

- | | |
|----|---|
| a. | Formatting blank diskettes for part storage |
| b. | Repacking data (crunching) on parts diskettes |
| c. | Transferring files |
| d. | Naming files |
| e. | Renaming parts files |
| f. | Erasing files |

ANSWERS TO TEST

- g. Listing part files
 - h. Assigning dates to part files
-
- 21. Evaluated to the satisfaction of the instructor

 - 22. Performance skills evaluated to the satisfaction of the instructor

SUPPLIES AND MATERIALS UNIT III

UNIT OBJECTIVE

After completion of this unit, the student should be able to distinguish among the types of drafting media, leads, and inks, list standard sheet and roll sizes, and fill and clean a technical pen. Competencies will be demonstrated by completing the job sheets and the unit tests with a minimum score of 85 percent.

SPECIFIC OBJECTIVES

After completion of this unit, the student should be able to:

1. Match terms related to drafting supplies and materials with their correct definitions.
2. Complete a chart on types of drafting media and their characteristics.
3. Classify standard media sheet sizes into the engineering, architectural, or metric system by letter and dimension.
4. List basic widths and lengths of media roll sizes.
5. Match characteristics of paper surfaces with their correct definitions.
6. Select true statements concerning precautions when using ink on vellum.
7. Select characteristics of polyester drafting film.
8. Complete statements concerning the procedures for inking on polyester film.
9. Complete a chart on drawing leads and their characteristics.
10. Complete a chart on erasers and their characteristics.
11. Select common sizes of thin-lead mechanical pencils.
12. Distinguish between the disadvantages of hard and soft leads.
13. Classify the reproduction qualities of lead, plastic lead, and ink.
14. Distinguish between the advantages and disadvantages of ink, lead, and plastic lead.
15. Select types of drawing inks.
16. List types of plotter pens.

SPECIFIC OBJECTIVES

17. Demonstrate the ability to:
 - a. Fill a technical pen. (Job Sheet #1)
 - b. Clean a technical pen. (Job Sheet #2)
 - c. Trace a drawing onto vellum using thin-lead mechanical pencils. (Job Sheet #3)
 - d. Trace a drawing onto polyester film using plastic lead. (Job Sheet #4)
 - e. Trace a drawing onto polyester film using ink. (Job Sheet #5)
 - f. Log on, log out, and file on a CADD system. (Job Sheet #6)

SUPPLIES AND MATERIALS UNIT III

SUGGESTED ACTIVITIES

- A. Provide students with objective sheet.
- B. Provide students with information and job sheets.
- C. Make transparencies.
- D. Discuss unit and specific objectives.
- E. Discuss information sheet.
- F. Discuss job sheets.
- G. Show students different types of supplies and materials that might be used.
- H. Display examples of different media.
- I. Demonstrate the difference between engineering, architectural, and metric paper sizing.
- J. Invite a vendor to bring samples of various media to class.
- K. Demonstrate the felt side of vellum without a watermark.
- L. Give test.

REFERENCES USED IN DEVELOPING THIS UNIT

- A. Brown, Walter C. *Drafting for Industry*. South Holland, IL 60473: The Goodheart-Willcox Company, Inc., 1984.
- B. Spencer, Henry C., et al. *Technical Drawing Problems*. New York: Macmillan Publishing Co., Inc., 1980.
- C. Giesecke, Frederick E., et al. *Technical Drawing*, 8th ed. New York: Macmillan Publishing Co., Inc., 1986.
- D. Jensen, Cecil and Jay Helsel. *Engineering Drawing and Design*, 3rd ed. New York: McGraw-Hill Book Company, 1985.
- E. *Modern School Supplies Inc. Catalog*, 1988-89, P.O. Box 958, Hartford, Conn. 06143.

**SUPPLIES AND MATERIALS
UNIT III**

INFORMATION SHEET

I. Terms and definitions

- A. Bundles — Drafting media which come in 100-sheet and 250-sheet packages
- B. Dogboning — When ink lines spread out at the beginning and end of a line
- C. Erasing quality — The ability of media to withstand a normal amount of erasing without losing its lead-, plastic lead-, or ink-taking characteristics to a noticeable degree
- D. Feathering — Occurs when an ink line spreads in an uneven fashion; usually due to drawing on the wire side of the vellum
- E. Ghosting — A smudged area or image on a reproduction copy of a drawing caused by a damaged surface due to erasing or mishandling of the original
- F. Ink — A liquid composed mainly of carbon in colloidal suspension (latex or solutions of special shellac) and gum

(NOTE: Fine particles of carbon give ink its deep dark, black appearance, and the gum makes it quick to dry and waterproof.)

- G. Matte side — The drawing side (dull side) of polyester film produced by a process that coats the polyester surface in such a way that drawing materials will more readily adhere to it

(NOTE: It is sometimes applied to both sides of polyester film.)

- H. Medium (media-plural) — Material upon which a drawing is made

Examples: Drawing paper, tracing paper, vellum, tracing cloth, polyester film

- I. Opaque — Not allowing light to pass through
- J. Pen point — Device which consists of a shoulder of metal or plastic in a cylinder placed in a plastic color-coded point tube with an air channel and vent hole, a wire-weight, and a wire-weight safety cap

(NOTE: Pen point width sizes may vary with the manufacturer.)

- K. Polyester drafting film — A tough, translucent drafting medium, usually made by bonding a matte surface to one or both sides of a clear plastic sheet

(NOTE: Polyester drafting film is dimensionally stable and its size changes very little as humidity and temperature change; it withstands much erasing, is almost impossible to tear, and is moisture resistant.)

INFORMATION SHEET

- L. Rag — Cloth (cotton) converted to pulp for paper-making
(NOTE: Various amounts of wood fiber may be added to the cloth to make paper. Paper with 100% rag content is the best paper made.)
- M. Technical pen — A tool consisting of a pen holder, ink cartridge, a point, and a cap; used for drawing with ink
- N. Tooth — Degree of pencil and ink receptivity on the surface of tracing media
(NOTE: Tooth is applied to cloth or film [matte] through a coating operation; in paper, tooth is usually the natural formation of the fibers on the surface of the finished product in a predetermined formation.)
- O. Tracing cloth — Fabric that has undergone a transparentizing process and is sized with a type of starch compound or plastic to provide a good working surface for pencil or ink
(NOTE: Although tracing cloth is commonly referred to as linen, it is usually made of cotton muslin, not linen.)
- P. Translucent — Transmitting and diffusing light so that objects beyond cannot be seen clearly
- Q. Transparent — Transmitting or allowing light to pass through so that objects beyond can be seen clearly
- R. Ultrasonic pen cleaner — Device which uses millions of microscopic bubbles to clean the point of a technical pen
- S. Vellum — Tracing paper which has been treated with a transparentizing agent which normally consists of waxes, oils, and similar substances
- T. Watermark — A marking in paper which is visible when the paper is held up to the light

INFORMATION SHEET

II. Types of drafting media and their characteristics

Evaluation Areas	Types of Media			
	Prepared Tracing Paper	Natural Tracing Paper	Copier & Office System Paper	Drafting Film
Transparency (Visual or Tracing)	Very Good	Very Good	Very Good	Excellent
Transparency (Actinic or Reproductive)	Very Good	Fair	Very Good	Excellent
Strength	Excellent	Good	Excellent	Excellent
Erasability	Excellent	Good	Excellent	Excellent
Permanence	Excellent	Fair	Excellent	Excellent
Cost	Low	Low	Medium	Medium

III. Letters and dimensions of standard media sheet sizes (Transparency 1)

A. "A" Series — Engineering

1. Size A—8 1/2" x 11"
2. Size B—11" x 17"
3. Size C—17" x 22"
4. Size D—22" x 34"
5. Size E—34" x 44"

(NOTE: Use of the standard sheet size of 8 1/2" x 11" and its multiples permits filing in standard files.)

INFORMATION SHEET

B. "B" Series — Architectural

(NOTE: Use of the alternate sheet size of 9" x 12" and its multiples is common in the architectural industry because of the advantage of larger drawing areas.)

1. Size A—9" x 12"
2. Size B—12" x 18"
3. Size C—18" x 24"
4. Size D—24" x 36"
5. Size E—36" x 48"

(NOTE: Roll sizes are also classified. From small to large, these receive a designation of G, H, J, or K.)

C. Metric drawing sheet sizes

1. A6—105 x 148 mm (4.13" x 5.43")
2. A5—148 x 210 mm (5.43" x 8.27")
3. A4—210 x 297 mm (8.27" x 11.69" - approx. "A" size)
4. A3—297 x 420 mm (11.69" x 16.54" - approx. "B" size)
5. A2—420 x 594 mm (16.54" x 23.39" - approx. "C" size)
6. A1—594 x 841 mm (23.39" x 33.11" - approx. "D" size)
7. A0—841 x 1,189 mm (33.11" x 46.81" - approx. "E" size)
8. 2A0—1,189 x 1,682 mm (46.81" x 56.22")
9. 4A0—1,682 x 2,378 mm (56.22" x 93.62")

IV. Basic widths and lengths of media bulk roll sizes

A. Width

1. 24"
2. 30"
3. 36"
4. 42"

INFORMATION SHEET

- B. Length
 1. 20 yards
 2. 50 yards
 3. 100 yards

V. Characteristics of paper surfaces and their definitions

- A. Two-sided — Reference to the fact that all paper has a felt side and a wire side which produces surfaces with different qualities
- B. Felt side — The side of the paper which is up when the paper is processed through a paper-making machine

(NOTE: This side usually presents the watermark straight forward.)
- C. Wire side — The side of the paper which is down when the paper is processed through a paper-making machine

(NOTE: This side usually presents the watermark backward.)
- D. With the grain — The grain produced in the direction of flow as a sheet passes through a paper-making machine
- E. Cross grain — Across the width of a sheet
- F. Closed formation — Formation of fibers in a sheet so that they give a uniform appearance
- G. Open formation — Formation of fibers in a sheet so that they give a mottled appearance
- H. Mottled — Giving the appearance of uneven arrangement of fiber spacing

VI. Precautions when using ink on vellum

- A. Be sure felt side of vellum is up; feathering will result if linework is placed on the wire side.
- B. Before putting any linework on vellum, it should be cleaned and the cleaning material removed.
- C. Ink is difficult to remove from vellum because vellum is a porous material, so work with care.
- D. When linework is erased, it may leave a "ghosting" effect when reproduced, so erase with care.

INFORMATION SHEET

VII. Characteristics of polyester drafting film

- A. Usually made by bonding a matte (dull) surface to one or both sides of a clear polyester sheet to form a tough, translucent drafting medium
- B. Reacts very little to temperature or humidity changes because of its dimensional stability
- C. Will retain stability even after much erasing
- D. Is almost impossible to tear
- E. Is moisture resistant

(NOTE: Polyester film is sometimes called "Mylar," which is a registered trademark of DuPont.)

VIII. Procedures for using ink on polyester film

- A. The matte coating (sometimes called tooth) is applied to polyester film so a line will adhere securely to the surface.
- B. If the polyester film is matte (dull) on both sides, draw on either side. If it is matte on only one side, place the matte side up for drawing.
- C. Before putting any linework on polyester film, the film should be wiped clean with a moist paper towel.

(NOTE: For serious soils, use a liquid film cleaner.)

- D. Ink can be easily removed from polyester film because the ink does not penetrate into the film. Even old ink lines can be removed easily if desired.
- E. Ink lines will flake or chip off the drafting film when some foreign materials are present between the ink line and the polyester film.
- F. For hand drafting, the most common thickness used is 3 mil.

IX. Types of drawing leads and their characteristics

Types of Lead	Media Uses	Lead Hardnesses (Soft to Hard)	Characteristics
Graphite lead	Vellum, paper	6B,5B,4B,3B,2B,HB,F H,2H,3H,4H,5H,6H,7H	Will smudge
Combination graphite/film lead	Vellum	B,HB,F,H,2H,3H,4H,5H	Opaque, dustless

INFORMATION SHEET

Types of Lead	Media Uses	Lead Hardnesses (Soft to Hard)	Characteristics
Film lead	Polyester film, vellum, paper	P1,P2,P3,P4,P5 E0,E1,E2,E3,E4,E5	Smudge-free, long wearing
Hi polymer film lead	Polyester film, vellum, paper	2B,B,HB,F,1,2H,3H 4H,5H,6H	Extra strong, smooth writing
Matte plastic lead	Polyester film	R1,R2,R3,R4,R5,R6	Non-smudging, easily erased low gloss; ideal for microfilming
Sketch lead	Paper	HB,3B,6B	Thick lead
Non-repro blue	Vellum, polyester film, paper	— — —	Non-reproducible, smear proof
Non-print lead	Vellum, polyester film	— — —	Does not appear on diazo prints, not for photographic use

(NOTE: Leads are available in millimeter size, leader holder size, and pencils.)

X. Types of erasers and their applications

Erasers	Characteristics	Media Uses
Pink Pearl	Soft	Vellum with pencil
Red Ruby	Firm	Vellum with pencil
Artgum	Firm	Vellum or paper with pencil
Kneaded	Soft	Vellum or paper with pencil; cleans up smudges
Green rubber	Soft	Cleans tracings and drawing boards
Race Kleen (gray)	Soft	Vellum, paper, or polyester film
White vinyl	Soft	Vellum with pencil
White vinyl/chemical	Firm	Any media with ink or pencil
Chemical imbued	Firm	Vellum or polyester film with ink

INFORMATION SHEET**XI. Sizes of thin-lead mechanical pencils**

- A. .3 mm
- B. .5 mm
- C. .7 mm
- D. .9 mm

XII. Disadvantages of hard and soft leads

- A. Disadvantages of hard leads—Use is restricted; apt to be too light

(NOTE: Humidity is sometimes a problem. On humid days the paper absorbs moisture from the atmosphere and becomes soft; it will expand and become wrinkled. When this occurs, a softer lead will be needed to offset the softening of the paper. For example, if you have been using a 4H lead, use a 2H until the humidity is reduced.)

- B. Disadvantages of soft leads
 - 1. Will result in smudged, rough lines
 - 2. Difficult to erase
 - 3. Must be continually sharpened

XIII. Comparable reproduction qualities of lead, plastic lead, and ink

- A. Lead — Acceptable
- B. Plastic lead — Good
- C. Ink — Excellent

XIV. Advantages and disadvantages of ink, lead, and plastic lead

- A. Ink
 - 1. Advantages
 - a. Produces a clean, dense line
 - b. Does not smudge
 - c. Revisions of original drawings can be made easily with no "ghost" or damage to drawing surface.
 - d. Ink lines are completely readable through microfilm reduction and blowback.

INFORMATION SHEET

2. Disadvantages
 - a. Messy
 - b. Hard to clean up
 - c. Time-consuming maintenance of pens
- B. Lead
1. Advantages
 - a. Quick
 - b. Easy
 2. Disadvantages
 - a. Smudges easily
 - b. Leaves fuzzy lines after reproduction
 - c. Points become dull and break
- C. Plastic lead
1. Advantages
 - a. Does not smudge as easily as lead
 - b. Quick
 2. Disadvantages
 - a. Can only be used on polyester film
 - b. Point dulling and breaking
 - c. Lack of adequate opacity
 - d. Extremely brittle

XV. Types of drawing inks (Handout #1)

(NOTE: Acetate-based ink should not be used in a technical pen unless the pen is specifically made for acetate-based inks or damage to the pen will result. Acetate-based inks have a tendency to dry out faster and, therefore, will clog up the nib faster requiring more frequent cleaning.)

- A. Washable, opaque
- B. Permanent or waterproof black

INFORMATION SHEET

- C. Transparent colors
- D. Opaque colors
- E. Plotter ink

XVI. Types of plotter pens

- A. Liquid ink plotting points
- B. Ball point plotter cartridges
- C. Liquid ink plotter cartridges (fiber tip)
- D. Ball point sealed ink cartridges

(NOTE: All of these are available in many colors.)

Sheet Sizes

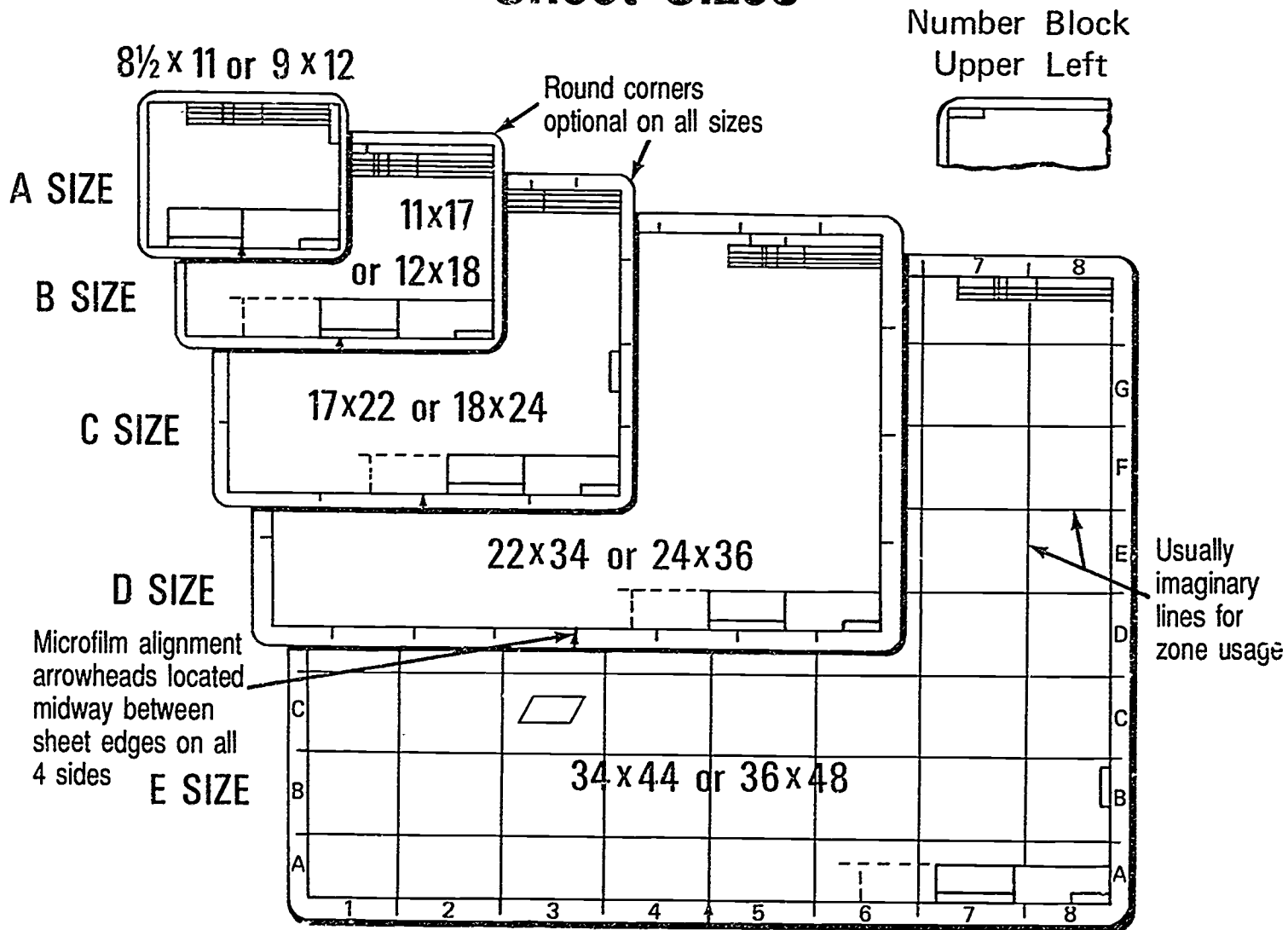

SUPPLIES AND MATERIALS UNIT III

HANDOUT #1 — TYPES OF DRAWING INKS

Media	Application	Requirement									
		Opaque	Trans- parent	Black- ness	Water- proof	Erasa- bility	Drying Time	Choose Ink No.	Filler Bottle F	Dropper Bottle D	
F I L M	Flatbed Plotters. Black	•		90%	Yes	Excel- lent	Slow	3074	•		
	Manual Drawing & Plotters. Black	•		98%	Yes	Good	Medium	3084	•	•	
		•		92%	Yes	Good	Fast	3080	•	•	
	Manual Drawing & Plotters. Colors		•			Yes	Good	Fast	3080	•	•
		•				Yes	Good	Medium	3083	•	
	Overhead Projection Films. Black	•		90%	Yes	Excel- lent	Fast	3071	•		
	Overhead Projection Films. Colors		•			Yes	Good	Fast	3073	•	
Photo Mechanical Opaquing	•		90%	Yes	Good	Medium	3082		•		
P A P E R	Plotters. Black		•	88%	No	None	Medium	3081	•		
	Plotters. Colors		•		No	None	Medium	3081	•		
	Manual Drawing. Black	•		92%	Yes	Good	Fast	3080	•	•	
		•		98%	Yes	Good	Medium	3084	•	•	
	Manual Drawing. Colors		•		Yes	Fair	Fast	3080	•	•	

*In general, smaller point sizes and dryer climates require slower-drying inks.

Courtesy of Koh-I-Noor Rapidograph, Inc.

**SUPPLIES AND MATERIALS
UNIT III**

JOB SHEET #1 — FILL A TECHNICAL PEN

A. Tools and materials

1. Clean technical pen
2. Ink filler bottle
3. Lint-free cloth or tissue

B. Procedure

1. Remove cap.

FIGURE 1



2. Grip clamp ring and unscrew holder (barrel).

FIGURE 2



3. Using light finger pressure, unscrew and remove clamp rings.

FIGURE 3



EVALUATION CRITERIA

Criteria	Rating
Pen is full of ink	_____
Pen is neat and ready for use	_____
Ink will flow	_____

JOB SHEET #1

4. Hold pen point upright and pull off ink cartridge.

FIGURE 4



5. Fill cartridge from ink filler bottle to a line 1/4" from the top, but not past the 1/4" line.

(NOTE: Hold cartridge at a slight tilt while filling cartridge; then turn cartridge upright. If permanent ink should spill on clothing, wash area immediately with soap and cold water.)

FIGURE 5

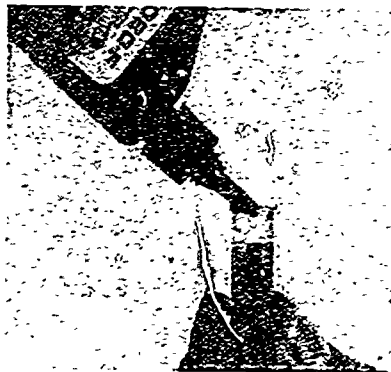

JOB SHEET #1

6. Press filled cartridge slowly onto pen body to prevent residual ink from entering air channel.

FIGURE 6

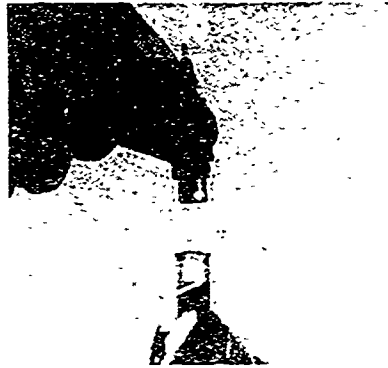

7. Reassemble pen.
8. Wipe off excess ink with a lint-free cloth or tissue.
9. With cap off, gently shake pen horizontally several times to start ink flow.
(NOTE: Always keep cartridge more than half full of ink for proper flow.)

FIGURE 7



**SUPPLIES AND MATERIALS
UNIT III**

JOB SHEET #2 — CLEAN A TECHNICAL PEN

A. Tools and materials

1. Technical pen
2. Lint-free cloth or tissue
3. Cleaning solution
4. Ink

EVALUATION CRITERIA	
Criteria	Rating
All parts are clean	_____
All parts are dry	_____
Pen is correctly assembled	_____

B. Procedure

1. Remove ink cartridge.
2. Pour out ink and flush out excess ink with water.

(NOTE: If working over a sink, be sure to have the drain stopper in place.)

3. Remove the nib from its holder with a key.

(NOTE: Some technical pens have the key built into the pen holder.)

(CAUTION: Nib disassembly is not recommended unless absolutely necessary, and a .30 mm #00 nib or smaller should never be disassembled.)

4. Remove nib safety cap and hold nib point up to allow the wire-weight to fall out into hand.

(CAUTION: NEVER PULL a wire-weight to remove it.)

5. Carefully clean the wire-weight and the nib.
6. Hold nib point down and carefully drop the wire-weight into the writing tube of the nib.
7. Jiggle the pen carefully to allow the wire-weight to fall back into place, but **DO NOT FORCE** the wire-weight back into place.
8. Replace nib safety cap.

JOB SHEET #2

9. Soak cartridge and entire nib in pen cleaner until the dried ink dissolves. (Soak overnight if necessary.)

FIGURE 1

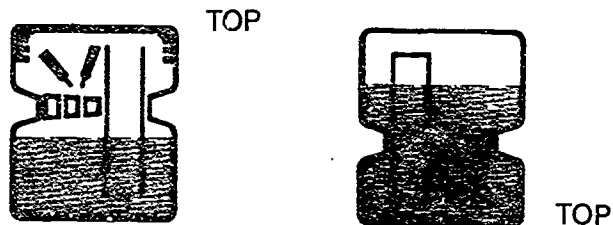

10. Rinse all pen parts to remove cleaning solution.
11. Clean pen body and cap by flushing with warm water.
12. Check air channel and vent hole to make sure they are thoroughly clean.
13. Dry all parts thoroughly with a paper towel.

FIGURE 2

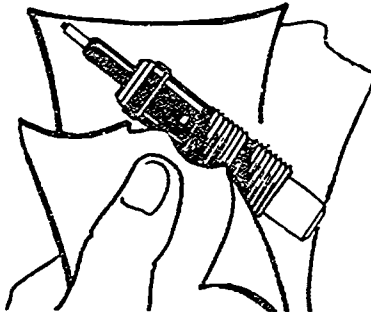

(NOTE: A bellows or ear syringe is handy to use for air drying the nib.)

FIGURE 3

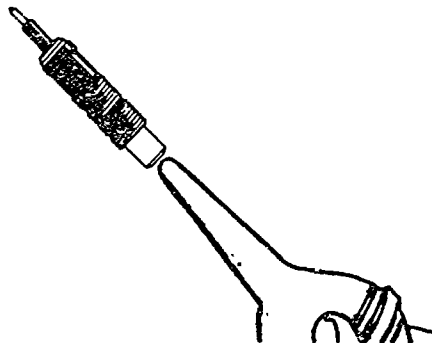

JOB SHEET #2

14. Fill the ink cartridge.
 - a. If pen is to be used in the near future, use standard procedure to refill the ink cartridge with ink.
 - b. If pen will not be used for an extended period of time, fill the ink cartridge with cleaning solution.
15. Press filled cartridge slowly into the body of the pen to prevent residual ink from entering the air channel.
16. Reassemble pen.
17. Wipe off excess ink with a lint-free cloth or tissue.
18. With cap off, gently shake pen horizontally several times to start ink flow.

(NOTE: Pens in normal use should be cleaned on a regular basis, and pens in use should always have cartridges more than half full of ink to ensure proper ink flow.)

*All illustrations for this job sheet are courtesy
of Koh-I-Noor Rapidograph, Inc.*

**SUPPLIES AND MATERIALS
UNIT III**

**JOB SHEET #3 — TRACE A DRAWING ONTO VELLUM USING
THIN-LEAD MECHANICAL PENCILS**

A. Tools and materials

1. 1 sheet of vellum - 8" x 11" (A size)
2. .3 mm thin-lead pencil (3H lead)
3. .5 mm thin-lead pencil (2H lead)
4. .7 mm thin-lead pencil (H lead)

EVALUATION CRITERIA	
Criteria	Rating
Overall neatness	_____
Linework	_____
Correct sizes of pencils used	_____

B. Procedure

1. Lay the A-size sheet of vellum over the problem given below.
2. Center problem under sheet. Tape in place.
3. Trace over lines using the assigned pencils as shown on problem.

C. Problem

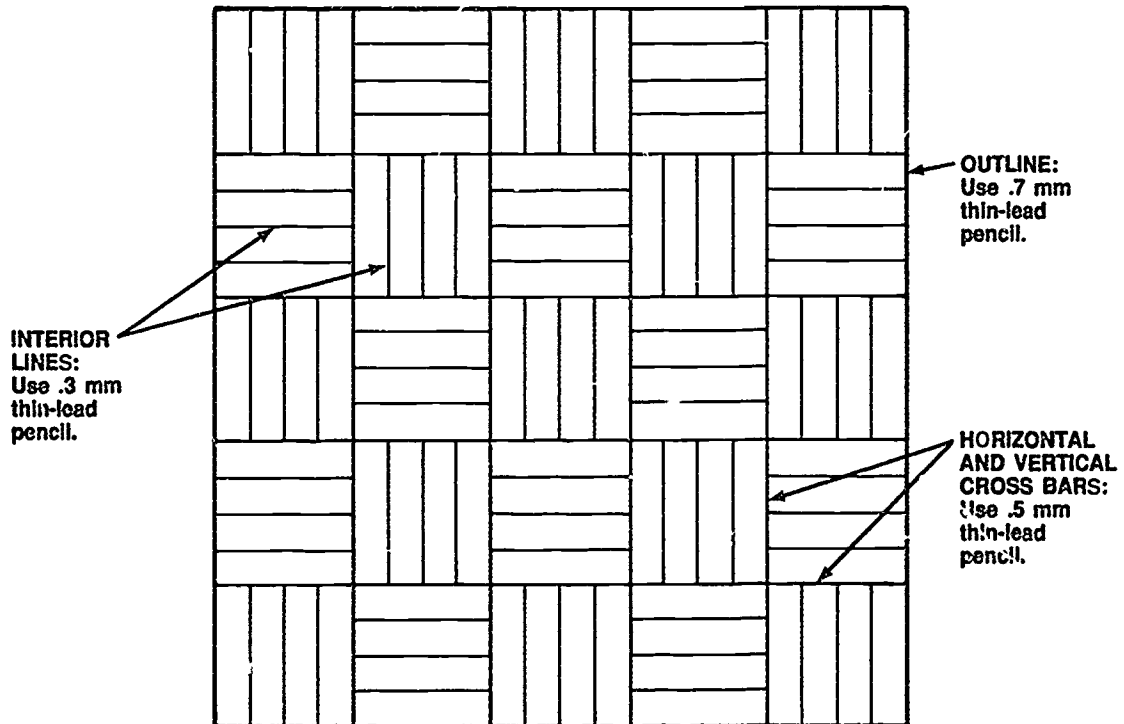

SUPPLIES AND MATERIALS UNIT III

JOB SHEET #4 — TRACE A DRAWING ONTO POLYESTER FILM USING PLASTIC LEAD

A. Tools and materials

1. 1 sheet of polyester film (A size)
2. Lead holder
3. Plastic lead (lead hardness to be chosen by instructor)

EVALUATION CRITERIA	
Criteria	Rating
Overall neatness	_____
Linework	_____

B. Procedure

1. Place the sheet of polyester film over the problem given below.
2. Center problem under the polyester film. Tape in place.
3. Using plastic lead in your lead holder, trace the drawing onto the polyester film.

(NOTE: You may need to retrace the lines several times to create lines which are consistent in density and uniformity. Plastic lead has a waxy feel to it.)

C. Problem

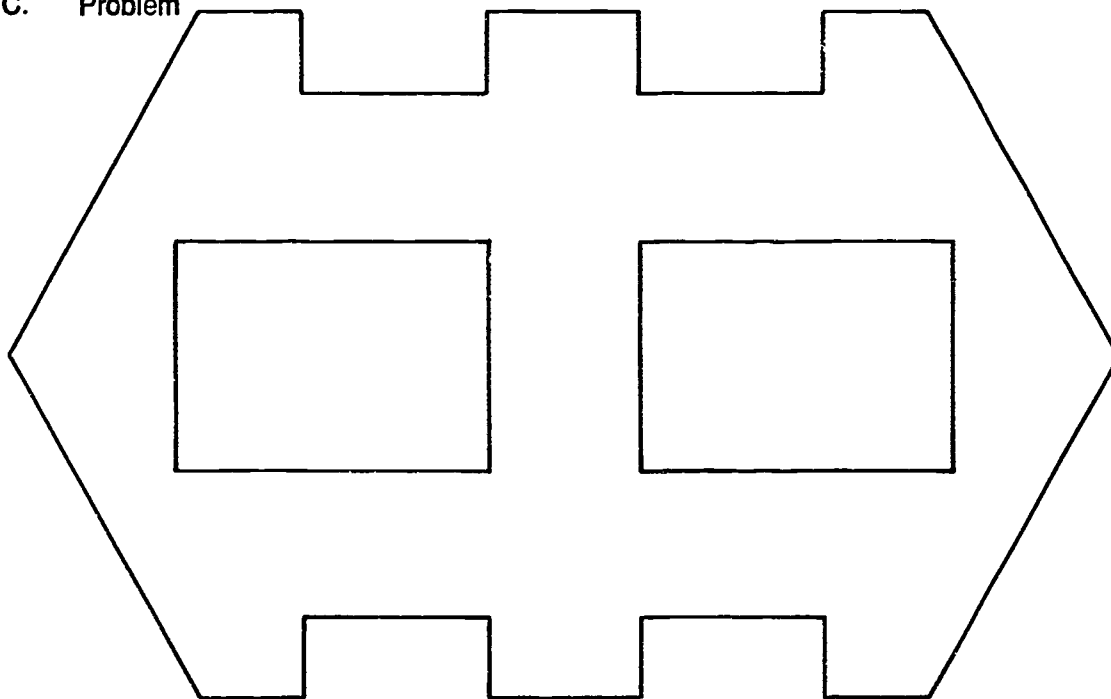

**SUPPLIES AND MATERIALS
UNIT III**

**JOB SHEET #5 — TRACE A DRAWING ONTO POLYESTER
FILM USING INK**

A. Tools and materials

1. 1 sheet of polyester film (A size)
2. Two technical ink pens, #00 and #2
3. Lint-free tissue

EVALUATION CRITERIA

Criteria	Rating
Overall neatness	_____
Linework	_____
Line widths	_____

B. Procedure

1. Place the sheet of polyester film over the problem given below.
2. Center problem under the polyester film. Tape in place.
3. Wipe film with a lint-free tissue to remove any finger prints.
4. Using the technical pens, trace the drawing onto the polyester film.

C. Problem

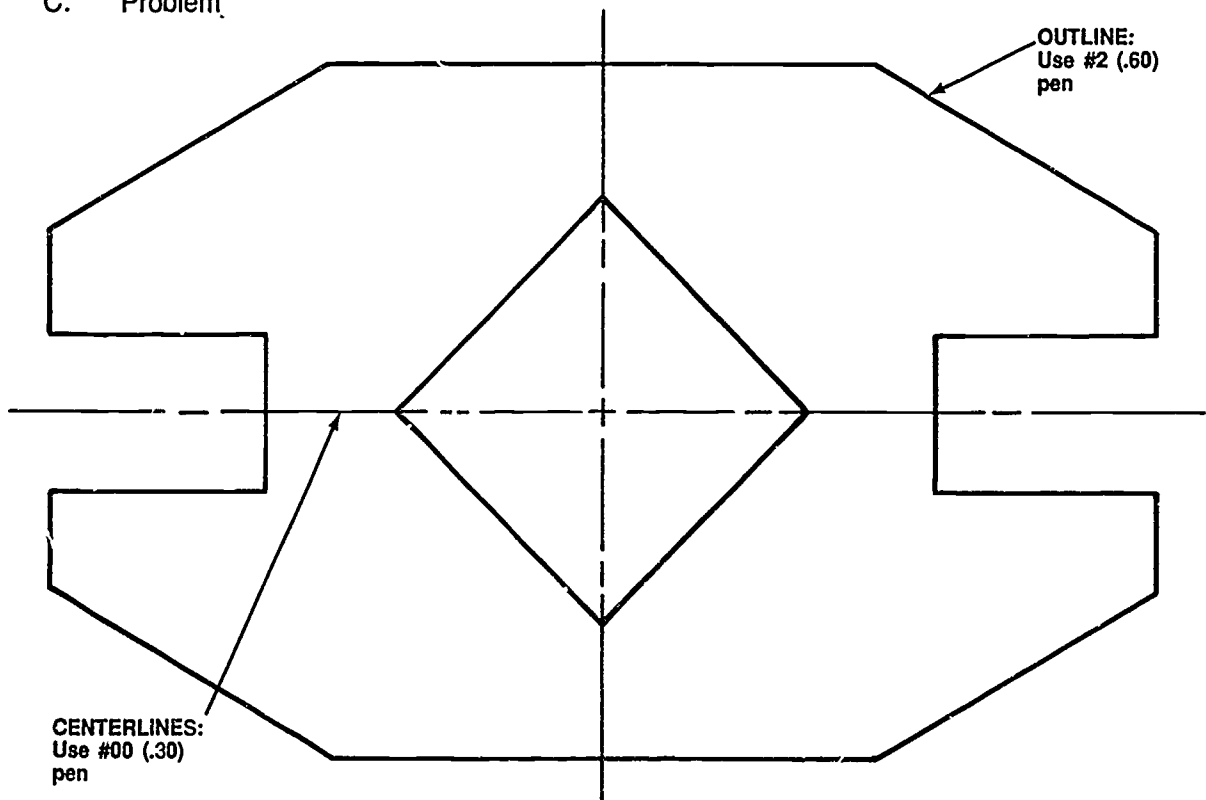

**SUPPLIES AND MATERIALS
UNIT III**

**JOB SHEET #6 — LOG ON, LOG OUT, AND FILE
ON A CADD SYSTEM**

A. Materials and equipment

1. Computer hardware
2. Appropriate CADD software
3. Instruction manual for CADD system

EVALUATION CRITERIA

Criteria	Rating
LINES are on file	_____

- B. Procedure:** The following procedure is only an example. Discuss with your instructor the exact procedure for your CADD system or refer to your system manual.

Example: For the MATC CAD graphics system package: Reprinted with permission.

1. LOG ON PROCEDURE:

- a. Insert formatted parts disk into drive 1 of the computer.
- b. Turn computer on.
- c. Turn display on.

Screen Message

PLEASE ENTER YOUR NAME 3.2:

MATC CAD
COMPUTER-AIDED DRAFTING
COPYRIGHT 1985

ENTER TODAY'S DATE (DD/MM/YY):

LICENSED REPRESENTATIVE

n>

OLDPART=0; NEWPART=N; REPLY=

User Response

Sn) (type in the code name assigned to your workstation by your instructor)

(wa. 20 seconds)

Enter the date (day/month/year)
example 14/05/85)

When the license appears, hold down the CTRL key and press R. Then, release both keys, and then press some number 1 to 9 (or J if using a joystick)

CADDS } * or use CADDSCLR }

N (no RETURN)

JOB SHEET #6

<u>Screen Message</u>	<u>User Response</u>
PART NAME:	(Enter Part Name, RETURN) Note: Part names should consist of 1 to 7 alphanumeric characters (letters and numbers), and always begin with an alphabetical character. Do not include dashes, spaces, dollar signs or any other special characters in the part name. (Enter the graphic commands needed to create your part)
2. FILING AND LOG OUT PROCEDURE:	
<u>Screen Message</u>	<u>User Response</u>
#	EXIT }
FILE=F, DON'T=D; REPLY=	F (no RETURN)
PART NAME:	(enter part name, press RETURN key)
NEWPART=N; OLDPART=O; GOODBYE=G; REPLY=	G (no RETURN)
n>	LOGOUT }
TASK n TERMINATED	(remove diskettes, turn off computer, turn off display)
3. FILING AN UPDATED VERSION OF YOUR PART DRAWING:	
<u>Screen Message</u>	<u>User Response</u>
#	EXIT }
FILE=F; DON'T=D; REPLY=	F (no RETURN after F)
FILING NAME:	Enter the part name, or entering a RETURN at this point will use the old part name
WED.EX1	
PART ALREADY EXISTS TYPE OK TO FILE ANYWAY	OK } Since your part currently exists on the disk and you would like to save the updated version, enter OK
NEWPART=N; OLDPART=O; GOODBYE=G; REPLY=	G (no RETURN after G)
3>	LOGOUT }
TASK 3 TERMINATED	

From *MATC CAD Operations and Training Manual*. © Milwaukee Area Technical College.

JOB SHEET #6

C. Problem

1. Log on to the system using the procedure specific to your CADD system.
2. Input some lines.
3. File this as a part called LINES.

(NOTE: It is important to file often to avoid unnecessary loss of parts drawings.)

4. Log off the system.
5. Check with your instructor, and then turn your CADD station off.

**SUPPLIES AND MATERIALS
UNIT III**

TEST

NAME _____ SCORE _____

1. Match the terms on the right with the correct definitions.

- | | | | |
|----------|---|-----|-------------------------|
| _____ a. | When ink lines spread out at the beginning and end of a line | 1. | Bundles |
| _____ b. | Cloth (cotton) converted to pulp for paper-making | 2. | Dogboning |
| _____ c. | Material upon which a drawing is made | 3. | Feathering |
| _____ d. | Drafting media which come in 100-sheet and 250-sheet packages | 4. | Ghosting |
| _____ e. | A smudged area or image on a reproduction copy of a drawing caused by a damaged surface due to erasing or mishandling of the original | 5. | Matte side |
| _____ f. | Transmitting and diffusing light so that objects beyond cannot be seen clearly | 6. | Medium |
| _____ g. | The drawing side of polyester film produced by a process that coats the polyester surface in such a way that drawing materials will more readily adhere to it | 7. | Opaque |
| _____ h. | Tracing paper which has been treated with a transparentizing agent which normally consists of waxes, oils, and similar substances | 8. | Polyester drafting film |
| _____ i. | A tough, translucent drafting medium, usually made by bonding a matte surface to one or both sides of a clear plastic sheet | 9. | Rag |
| _____ j. | Not allowing light to pass through | 10. | Technical pen |
| _____ k. | A tool consisting of a pen holder, ink cartridge, a point, and a cap; used for drawing with ink | 11. | Translucent |
| | | 12. | Transparent |
| | | 13. | Vellum |

TEST

2. Complete the following chart on types of drafting media and their characteristics by stating Excellent, Very Good, Good, or Fair for the different evaluation areas.

Evaluation Areas	Types of Media			
	Prepared Tracing Paper	Natural Tracing Paper	Copier & Office System Paper	Drafting Film
Transparency (Visual or Tracing)				
Transparency (Actinic or Reproductive)				
Strength				
Erasability				
Permanence				

3. Classify the following standard media sheet sizes as either in the engineering, architectural, or metric system by placing an "E" (engineering), "A" (architectural), or "M" (metric) to the left of the sheet size.

- ___ a. Size A—349" x 12"
 ___ b. Size C—17" x 22"
 ___ c. Size A2—420 x 594 mm (16.54" x 23.39")
 ___ d. Size A1—594 x 841 mm (23.39" x 33.11")
 ___ e. Size D—24" x 36"
 ___ f. Size D—22" x 34"
 ___ g. Size A0—841 x 1,189 mm (33.11" x 46.81")
 ___ h. Size E—36" x 48"
 ___ i. Size B—11" x 17"

TEST

- ___j. Size C—18" x 24"
- ___k. Size A4—210 x 297 mm (8.27" x 11.69")
- ___l. Size A3—297 x 420 mm (11.69" x 16.54")
- ___m. Size E—34" x 44"
- ___n. Size B—12" x 18"
- ___o. Size A—8 1/2" x 11"
4. List two basic widths and two basic lengths of media roll sizes.
- a. Widths
- 1) _____
- 2) _____
- b. Lengths
- 1) _____
- 2) _____
5. Match the characteristics of paper surfaces on the right with their definitions.
- | | |
|---|---------------------|
| ___a. Across the width of a sheet | 1. Two sided |
| ___b. The side of the paper which is up when the paper is processed through a paper-making machine | 2. Felt side |
| ___c. Reference to the fact that all paper has a felt side and a wire side which produces surfaces with different qualities | 3. Wire side |
| ___d. Formation of fibers in a sheet so that they give a mottled appearance | 4. With the grain |
| ___e. Formation of fibers in a sheet so that they give a uniform appearance | 5. Cross grain |
| ___f. The grain produced in the direction of flow as a sheet passes through a paper-making machine | 6. Closed formation |
| ___g. The side of the paper which is down when the paper is processed through a paper-making machine | 7. Open formation |
| | 8. Mottled |

TEST

6. Select true statements concerning precautions when using ink on vellum by placing a "T" or "F" next to the true or false statements.
- a. Be sure wire side of vellum is up.
 - b. Before putting any linework on vellum, it should be cleaned and the cleaning material removed.
 - c. Ink is easy to remove from vellum because vellum is a nonporous material.
 - d. When linework is erased, it may leave a "ghosting" effect when reproduced, so erase with care.
7. Select characteristics of polyester drafting film by placing an "X" in the appropriate blanks.
- a. Will retain stability even after much erasing
 - b. Is very easy to tear
 - c. Is moisture resistant
 - d. Usually made by bonding a matte surface to one or both sides of a clear cotton (or linen) sheet
 - e. Reacts to temperature or humidity changes because it lacks dimensional stability
 - f. Is very delicate
8. Complete the following statements concerning procedures for using ink on polyester film by circling the correct word(s).
- a. If the polyester film is matte on only one side, place the (dull, shiny) side up for drawing.
 - b. Before putting any linework on polyester film, the film should be wiped clean with a (moist, dry) paper towel.
 - c. Ink is (easy, difficult) to remove from polyester film.
 - d. Ink lines (will, will not) flake or chip off the drafting film when some foreign materials are present between the ink line and the polyester film.
 - e. For hand drafting, the most common thickness used is (3, 15) mil.

TEST

9. Complete the following chart on drawing leads and their characteristics.

Types of Lead	Media Uses	Lead Hardnesses (Soft to Hard)	Characteristics
Graphite lead	a. _____	b. _____	Will smudge
Combination graphite/film lead	Vellum	B,HB,F,H,2H,3H,4H,5H	c. _____
d. _____	Polyester film, vellum, paper	P1,P2,P3,P4,P5 E0,E1,E2,E3,E4,E5	Smudge-free, long wearing
Matte plastic lead	Polyester film	R1,R2,R3,R4,R5,R6	e. _____ _____
Non-repo blue	Vellum, polyester film, paper	— — —	f. _____ _____

10. Complete the following chart on erasers and their characteristics.

Erasers	Characteristics (soft or firm)	Media Uses
Pink Pearl	_____	Vellum with pencil
Red Ruby	Firm	_____
Artgum	_____	Vellum or paper with pencil
Kneaded	Soft	_____; cleans up smudges
Green rubber	_____	Cleans tracings and drawing boards
Race Klean (gray)	_____	Vellum, paper, or polyester film
White vinyl	Soft	Vellum with pencil
White vinyl/chemical	Firm	_____
Chemical Imbided	_____	Vellum or polyester film with ink

TEST

11. Select the four common sizes of thin-lead mechanical pencils by placing an "X" next to the appropriate sizes.

<input type="checkbox"/> a. 3 mm	<input type="checkbox"/> g. .007 mm
<input type="checkbox"/> b. .3 mm	<input type="checkbox"/> h. 7 mm
<input type="checkbox"/> c. .003 mm	<input type="checkbox"/> i. .7 mm
<input type="checkbox"/> d. .5 mm	<input type="checkbox"/> j. .9 mm
<input type="checkbox"/> e. 5 mm	<input type="checkbox"/> k. .009 mm
<input type="checkbox"/> f. .005 mm	<input type="checkbox"/> l. 9 mm

12. Distinguish between the disadvantages of hard and soft leads by placing an "H" next to the disadvantages of hard leads and an "S" next to the disadvantages of soft leads.

<input type="checkbox"/> a.	Will result in smudged, rough lines
<input type="checkbox"/> b.	Use is restricted; apt to be too light
<input type="checkbox"/> c.	Difficult to erase
<input type="checkbox"/> d.	Must be continually sharpened

13. Classify the reproduction qualities of lead, plastic lead, and ink as **Acceptable**, **Good**, or **Excellent**.

a. Ink	_____
b. Lead	_____
c. Plastic lead	_____

14. Distinguish between the advantages and disadvantages of ink, lead, and plastic lead by placing an "I" next to the characteristics of ink, an "L" next to the characteristics of lead, and a "P" next to characteristics of plastic lead.

<input type="checkbox"/> a.	Quick and easy, but smudges easily
<input type="checkbox"/> b.	Does not smudge as easily, but can only be used on polyester film
<input type="checkbox"/> c.	Extremely brittle
<input type="checkbox"/> d.	Produces a clean, dense line and does not smudge
<input type="checkbox"/> e.	Messy and hard to clean up
<input type="checkbox"/> f.	Lines are completely readable through microfilm reduction and blowback

TEST

15. Select types of drawing inks by placing an "X" in the appropriate blanks.

- ___ a. Transparent colors
- ___ b. Stamp pad ink
- ___ c. Tempera ink
- ___ d. Washable, opaque
- ___ e. Permanent or waterproof black
- ___ f. Opaque colors

16. List three types of plotter pens.

- a. _____
- b. _____
- c. _____

(NOTE: If the following activities have not been accomplished prior to the test, ask your instructor when they should be completed.)

17. Demonstrate the ability to:

- a. Fill a technical pen. (Job Sheet #1)
- b. Clean a technical pen. (Job Sheet #2)
- c. Trace a drawing onto vellum using thin-lead mechanical pencils. (Job Sheet #3)
- d. Trace a drawing onto polyester film using plastic lead. (Job Sheet #4)
- e. Trace a drawing onto polyester film using ink. (Job Sheet #5)
- f. Log on, log out, and file on a CADD system. (Job Sheet #6)

**SUPPLIES AND MATERIALS
UNIT III**

ANSWERS TO TEST

1. a. 2 e. 4 i. 8
 b. 9 f. 11 j. 7
 c. 6 g. 5 k. 10
 d. 1 h. 13

2.

Evaluation Areas	Types of Media			
	Prepared Tracing Paper	Natural Tracing Paper	Copier & Office System Paper	Drafting Film
Transparency (Visual or Tracing)	Very Good	Very Good	Very Good	Excellent
Transparency (Actinic or Reproductive)	Very Good	Fair	Very Good	Excellent
Strength	Excellent	Good	Excellent	Excellent
Erasability	Excellent	Good	Excellent	Excellent
Permanence	Excellent	Fair	Excellent	Excellent

3. a. A f. E k. M
 b. E g. M l. M
 c. M h. A m. E
 d. M i. E n. A
 e. A j. A o. E

ANSWERS TO TEST

4. a. Widths (any two of the following):
- 1) 24"
 - 2) 30"
 - 3) 36"
 - 4) 42"
- b. Lengths (any two of the following):
- 1) 20 yards
 - 2) 50 yards
 - 3) 100 yards
5. a. 5 e. 6
 b. 2 f. 4
 c. 1 g. 3
 d. 7
6. a. F
 b. T
 c. F
 d. T
7. a, c
8. a. Dull
 b. Moist
 c. Easy
 d. Will
 e. 3
9. a. Vellum or paper
 b. 6B—>7H
 c. Opaque, dustless
 d. Film lead
 e. Non-smudging, easily erased, low gloss, ideal for microfilming
 f. Non-reproducible, smear proof

ANSWERS TO TEST

10.

Erasers	Characteristics (soft or firm)	Media Uses
Pink Pearl	Soft	Vellum with pencil
Red Ruby	Firm	Vellum with pencil
Artgum	Firm	Vellum or paper with pencil
Kneaded	Soft	Vellum or paper with pencil; cleans up smudges
Green rubber	Soft	Cleans tracings and drawing boards
Race Kleen (gray)	Soft	Vellum, paper, or polyester film
White vinyl	Soft	Vellum with pencil
White vinyl/chemical	Firm	Any media with ink or pencil
Chemical imbibed	Firm	Vellum or polyester film with ink

11. b, d, i, j

12. a. S
b. H
c. S
d. S

13. a. Ink — Excellent
b. Lead — Acceptable
c. Plastic lead — Good

14. a. L
b. P
c. P
d. I
e. I
f. I

ANSWERS TO TEST

15. a, d, e, f
16. Any three of the following:
 - a. Liquid ink plotting points
 - b. Ball point plotter cartridges
 - c. Liquid ink plotter cartridges (fiber tip)
 - d. Ball point sealed ink cartridges
17. Performance skills evaluated to the satisfaction of the instructor

SKETCHING UNIT IV

UNIT OBJECTIVE

After completion of this unit, the student should be able to state the purpose and procedures for various types of sketching. The student should also be able to sketch straight lines, arcs, circles, ellipses, and cubes and create a freehand digitized drawing. Competencies will be demonstrated by completing the assignment sheets, job sheet, and the unit tests with a minimum score of 85 percent.

SPECIFIC OBJECTIVES

After completion of this unit, the student should be able to:

1. Match terms related to sketching with their correct definitions.
2. State purposes of sketching.
3. Select true statements concerning rules in sketching.
4. Arrange in order the steps in completing a drawing.
5. Distinguish between types of sketches.
6. Select true statements concerning factors in center line usage.
7. State ways to interpret the meaning of lines.
8. List methods for proportioning a sketch.
9. List methods for inputting geometry into a CADD system.
10. Select input devices for menu selection.
11. Select true statements concerning freehand digitizing on CADD.
12. Identify types of coordinate entries.
13. List types of grids used for freehand sketching.
14. Select basic types of geometry used to create CADD drawings.
15. List three reference points used to build existing CADD entities.
16. Label the origins and ends of basic CADD geometry.
17. Sketch straight lines. (Assignment Sheet #1)
18. Sketch arcs. (Assignment Sheet #2)

SPECIFIC OBJECTIVES

19. Sketch circles. (Assignment Sheet #3)
20. Sketch ellipses. (Assignment Sheet #4)
21. Sketch an isometric cube. (Assignment Sheet #5)
22. Sketch an oblique cube. (Assignment Sheet #6)
23. Sketch a cone. (Assignment Sheet #7)
24. Block in a view of a part. (Assignment Sheet #8)
25. Demonstrate the ability to specify a 0.25 grid for a CADD system and create a freehand digitized drawing. (Job Sheet #1)

SKETCHING UNIT IV

SUGGESTED ACTIVITIES

- A. Provide student with objective sheet.
- B. Provide student with information and assignment sheets.
- C. Make transparencies.
- D. Discuss unit and specific objectives.
- E. Discuss information and assignment sheets.
- F. Discuss advantages and disadvantages of sketching.
- G. Demonstrate to the class the techniques used in making a field sketch.
- H. Demonstrate on your CADD system the methods used to create a digitized drawing.
- I. Discuss applications for freehand digitizing.
- J. Practice sketching techniques.
- K. Show examples of grids used in sketching.
- L. Collect small mechanical parts from local firms to provide sketching projects for Assignment Sheet #8. Provide both simple and complex parts for beginning and advanced projects.
- M. Give test.

REFERENCES USED IN DEVELOPING THIS UNIT

- A. Brown, Walter C. *Drafting for Industry*. South Holland, IL 60473. Goodheart-Willcox Co., Inc., 1984.
- B. Giesecke, Frederick E., et. al. *Technical Drawing*, 8th edition. New York: Macmillan Publishing Co., Inc., 1986.
- C. Jensen, Cecil and Jay Helsel. *Engineering Drawing and Design*, 3rd edition. New York: Gregg Division/McGraw Hill Book Co., 1985.
- D. Lamit, Louis Gary and Vernon Paige. *Computer-Aided Design and Drafting: CADD*. Columbus, OH 43216: Merrill Publishing Company, 1987.
- E. Mark Merickel. *Stepping into CADD*. P.O. Box 4846, Thousand Oaks, CA 91360: New Riders Publishing, 1986.
- F. James E. Fuller. *Using Autocad*, 2nd edition. 2 Computer Dr. West, Box 15-015, Albany, NY 12212: Delmar Publishers, Inc., 1988.

SKETCHING UNIT IV

INFORMATION SHEET

I. Terms and definitions

- A. Arc — Any portion of the circumference of a circle



- B. Diameter — The distance across a circle passing through its center point

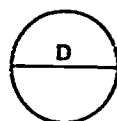

- C. Digitize — To convert lines and shapes into digital form and to specify a coordinate location or entity by using an electronic pen

- D. Ellipse — A foreshortened circle having a major axis and a minor axis

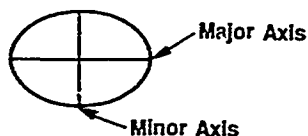

- E. Focus (Foci) — Point(s) at which lines come toward each other or move away from each other
- F. Freehand technical sketching — Making a drawing without the use of instruments, yet with care taken to obtain the correct line widths
- G. Geometry — The elements that make up a graphic drawing on a CADD system such as points, lines, circles, arcs, fillets, and ellipses
- H. Grid — A matrix of uniformly spaced points displayed on a screen for approximately locating and digitizing a position or placing symbols in the creation of a drawing
- I. Input — To enter data or a program into a system
- J. Isometric sketch — A sketch based on the object being drawn on three axes spaced 120 apart
- K. Keyfile — A file that associates specific commands with specific areas of a tablet menu

(NOTE: A keyfile can be edited by the use.)

- L. Major axis — The axis passing through the foci of an ellipse

INFORMATION SHEET

- M. Menu — A listing, either on the screen or on the tablet, of command options that can be selected without entering instructions
- N. Minor axis — The chord of an ellipse passing through the center perpendicular to the major axis
- O. Oblique sketch — A sketch that shows the face of the object parallel with the plane of projection
- P. Origin — An X, Y or X, Y, Z coordinate from which all geometry is referenced
- Q. Proportioning — Drawing parts of an object in the same size relationship as the object itself
- R. Radius — The distance from the center point of a circle to the outside circumference

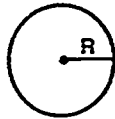

- S. Repaint — To redraw a display image on a CRT to reflect its updated status
 - T. Scale (as referred to in CADD) — To enlarge or shrink an image without changing its shape
 - U. Screen coordinates — The X, Y, and Z axes to which the screen refers; X coordinate is horizontal, Y coordinate is vertical, and Z coordinate extends infinitely out from the computer screen
 - V. Sketch lines — Freehand connections between two or more points
- II. Purposes of sketching**
- A. Preliminary approach to a problem before going to the expense of making an instrument drawing
 - B. To give the drafter a better picture of the object to be drawn
 - C. For recording notes and technical information in the shop or field for future use in the drafting department
 - D. As an aid to "think through" the solution to an engineering-type problem

INFORMATION SHEET**III. Rules in sketching**

- A. A scale is not required.
- B. Sketches are drawn in proportion.
(NOTE: Gridded paper can be helpful to keep objects proportional.)
- C. Small objects are sketched larger than their normal size.
- D. Freehand lines are rough, not rigid.
- E. Line contrast should be used.
- F. A soft pencil should be used.
- G. Finished linework should be dark and conform to line alphabet standards.
- H. Sketches are dimensioned the same as machine drawings.

IV. Steps in completing a drawing

- A. Select necessary views.
- B. Block in lightly the shape of the object.
- C. Block in details in each view.
- D. Erase unwanted construction lines.
- E. Darken lines.

V. Types of sketches (Transparencies 1 and 2)

- A. Pictorial — A picturelike, three-dimensional drawing of an object as it appears to the eye
- B. Multiview — A drawing showing the separate views of an object, arranged so each view is related to the other views

VI. Factors in center line usage

- A. Used to show axis of symmetry
(NOTE: Center lines are sometimes called symmetry lines.)
- B. Used to show the center line of both circles and paths of motion.
- C. Symbol for center line is ϕ .
- D. The center line should extend 1/4" past the visible line.

INFORMATION SHEET

- E. Long dashes should begin and terminate center lines.

(NOTE: Center lines for small holes can be a thin solid lines.)

- F. A gap must be present when a center line is a continuation of a visible or hidden line.

(NOTE: Center lines need not be shown on filleted corners because they are self-locating.)

VII. Ways to interpret the meaning of lines (Transparency 3)

- A. A visible or hidden line can mean (indicate) the intersection of two surfaces.

- B. A visible or hidden line can mean (indicate) an edge view of a surface.

- C. A visible or hidden line can mean (indicate) a contour view of a curved surface.

(NOTE: It is necessary to examine all views carefully to determine their meaning since no shading is used on working drawings.)

VIII. Methods for proportioning a sketch

- A. Approximation by eye method

1. Object is studied for its various shapes.
2. Size of each shape is compared to each other.
3. Size of shape is compared with overall width, height, and depth of object.

(NOTE: Use part of the object as a reference point to compare against.)

- B. Pencil and eye method — The pencil is used as measuring stick to proportion height, width, depth, and angles.

(NOTE: This is commonly known as an artist technique.)

- C. Actual measurement methods

1. Scale
2. Proportional divider
3. Calipers

INFORMATION SHEET

IX. Methods for inputting geometry into a CADD system

- A. Free digitizing method
- B. Coordinate entry method
- C. Menu selection

X. Types of input devices for menu selection

- A. Tablet menu
- B. CRT menu
- C. Keyboard
- D. Button menu

XI. Facts about freehand drawing on CADD (Freehand digitizing) (Transparency 4)

- A. Freehand digitizing uses one of five input devices.

1. Digitizer and stylus (electronic pen)
2. Mouse and pad
3. Light pen on screen
4. Keyboard — Arrow key
5. Optical scanning

(NOTE: Mode of input must be specified for each system. Many systems may have more than one input device.)

- B. Grids are used to help improve the accuracy of freehand digitizing. Inputs snap to grid points that are at a pre-set scale.

- C. Freehand digitizing inputs X, Y coordinates for each geometry location.

(NOTE: For a 3-dimensional system a Z is also used.)

XII. Types of coordinate entries

- A. Absolute — The operator types in absolute X and Y coordinates relative to the origin. The computer software program uses these coordinates to calculate the location of a point.

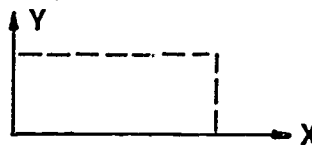

INFORMATION SHEET

- B. Relative (incremental) — The operator types in the relative X and Y coordinates (the difference between the desired location and the existing reference point.)

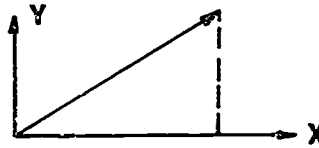

- C. Polar — The operator specifies the X and Y points (Z for 3-dimensional) by entering the angle (in degrees) from the horizontal and the distance of the point from the origin.

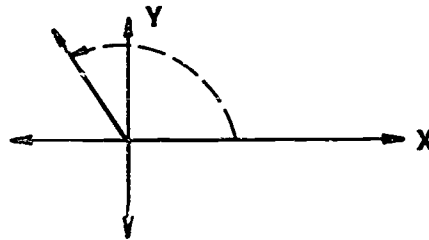

XIII. Types of grids available for freehand sketching

- A. Graph paper — 4, 5, 8, or 10 squares per inch.
- B. Isometric grid — Graph paper with guide lines at 30 angles from the horizontal.
- C. Perspective grid — Graph paper that provides vanishing points and projection lines for one-or two-point perspectives.
- D. CADD grid — A construction aid that provides points on a screen. It works like a graph paper with any desired spacing in any direction.

XIV. Basic types of geometry used to create CADD drawings

- A. Point — A location
- B. Line — The connection between two points
- C. Circle — A complete 360° arc
- D. Arc — A segment of a circle
- E. String — A series of connected lines and arcs

INFORMATION SHEET

XV. Reference points used to build existing CADD entities

- A. Origins
- B. Ends
- C. Intersections

XVI. Origins and ends of basic CADD geometry

- A. Line — Origin is at midpoint of the line.

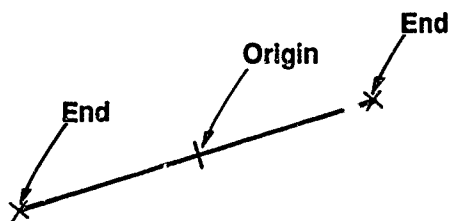

- B. Circle — Origin is at its centerpoint of the circle.

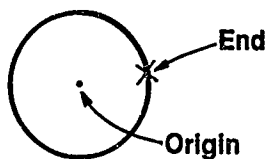

- C. Arc — Origin of an arc is the center point of the circle of which it is a segment.

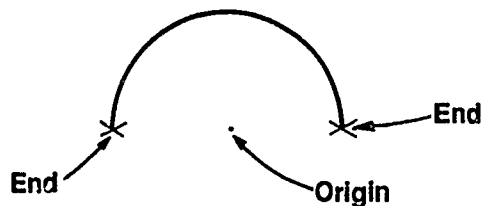

Typical Pictorial Sketch

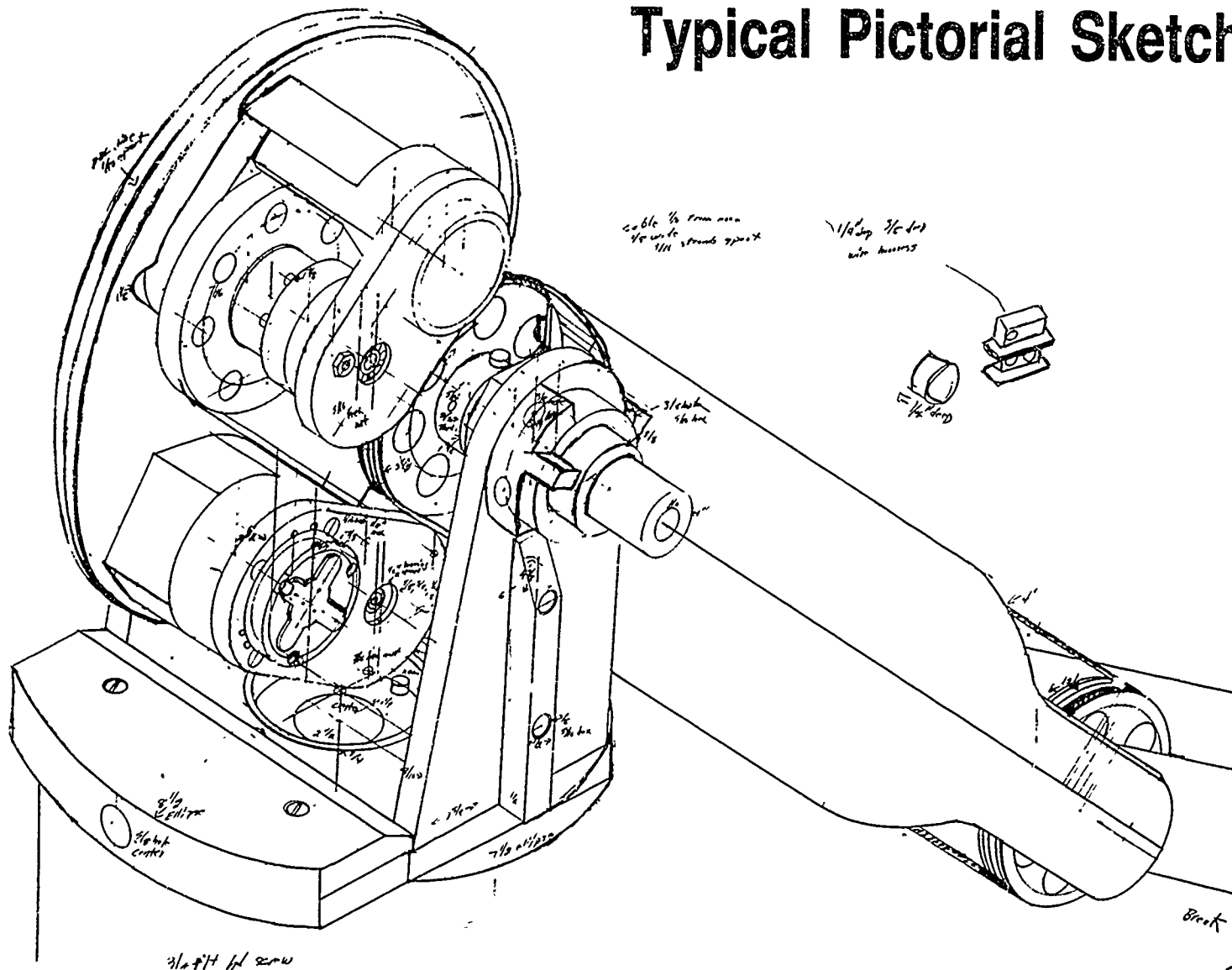

200

201

Meaning of Lines

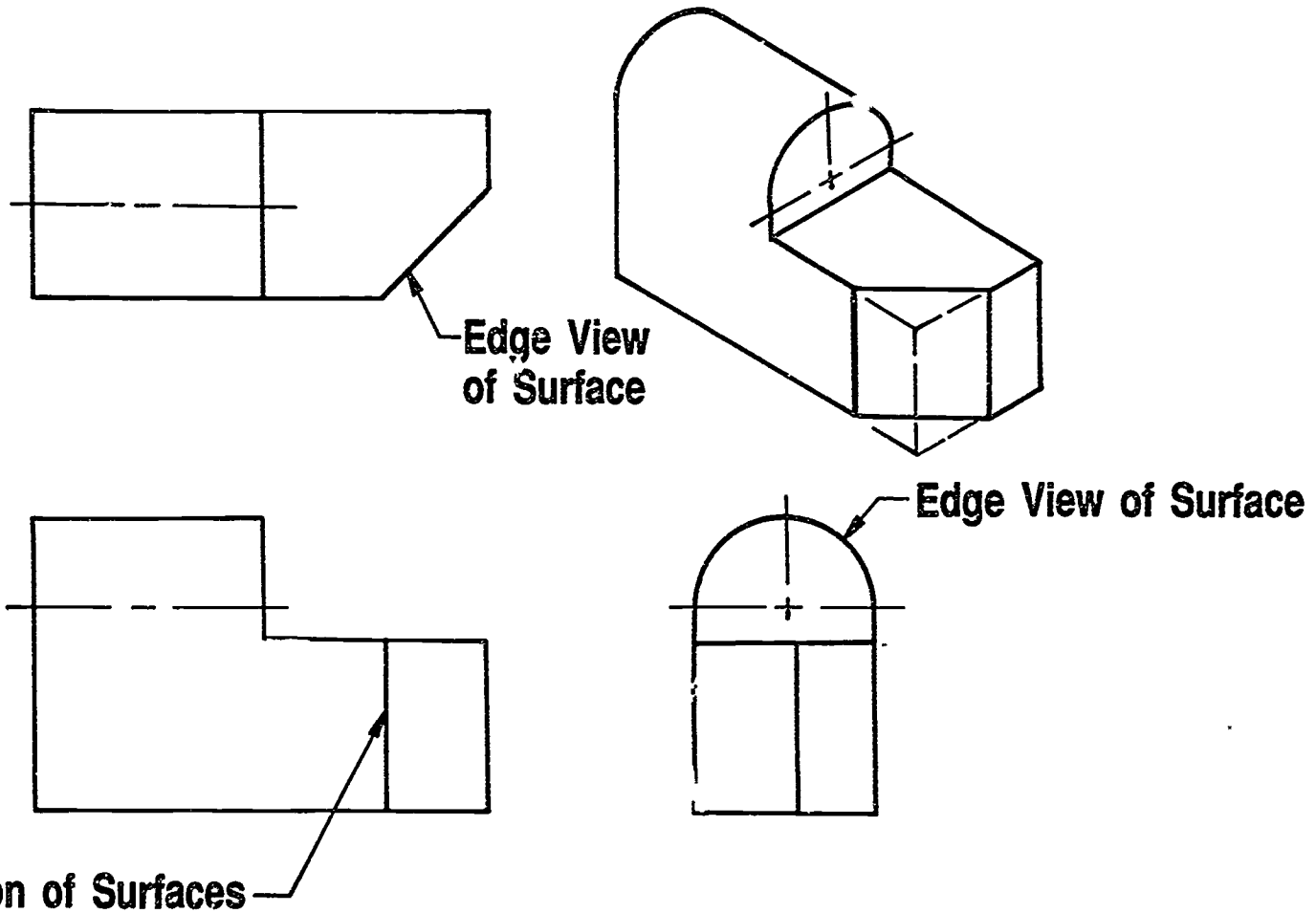

Creating a Point by Free Digitizing

Before

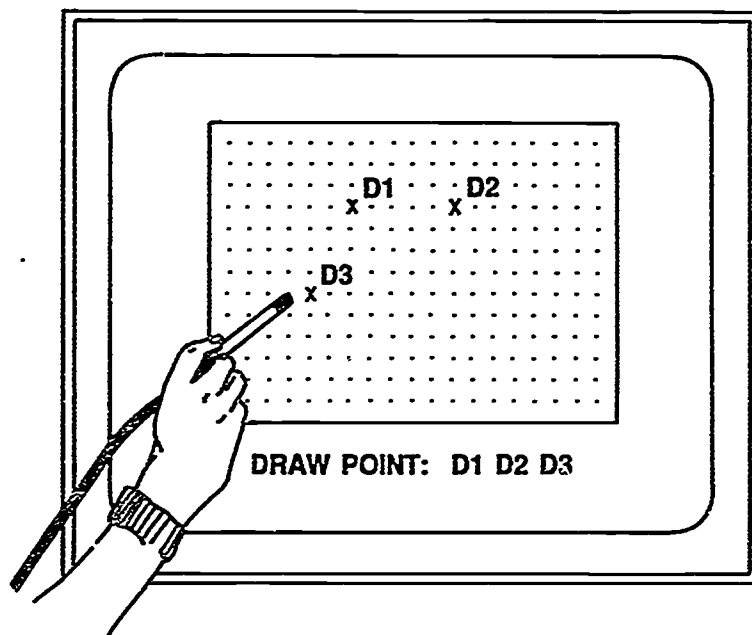

After

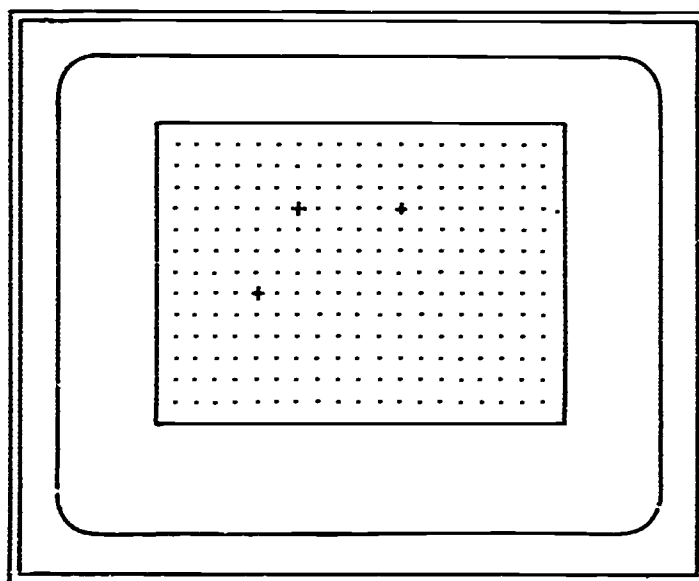

**SKETCHING
UNIT IV**

ASSIGNMENT SHEET #1 — SKETCH STRAIGHT LINES

Name _____ Score _____

A. Guidelines for sketching horizontal and vertical lines

1. Properly locate end points of line.
2. By trial movement from left point to right point, position arm without marking on the paper.
3. Keep your eye on the point where the line will end and sketch short, light lines between points.

(NOTE: Do not permit your eye to follow the pencil.)

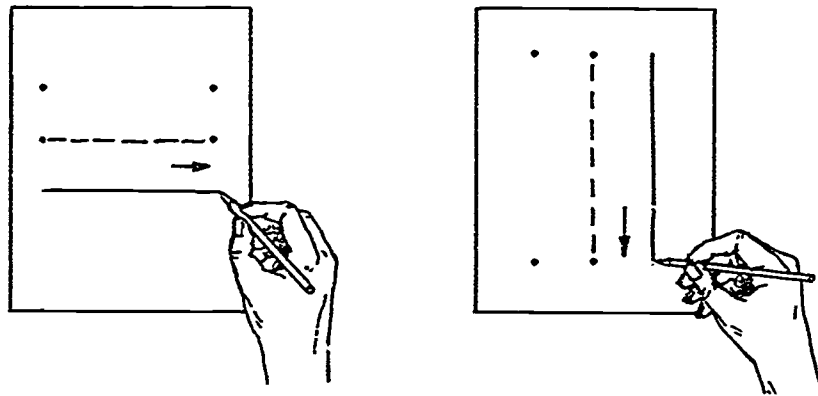

4. Erase unneeded lines with a soft eraser and darken the remaining line to form one uniformly wide, continuous line.

(NOTE: At this stage, your eye needs to lead the pencil along the light sketch line.)

5. Draw straight lines that are parallel to the drafting table edge (border lines) by aligning the paper on the drafting board edge and letting the third and fourth fingers of the drawing hand act as a guide by sliding them along the edge of the board while drawing the line.

(CAUTION: This should be done only on tables with proper edging material.)

ASSIGNMENT SHEET #1

B. Guidelines for sketching inclined lines

1. Rotate the paper for inclined straight lines to a position that would make the horizontal or vertical lines.

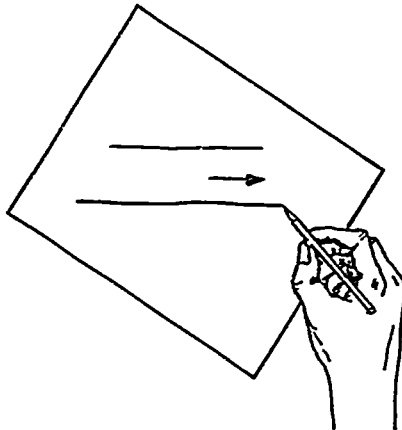

2. Estimate angles by sketching a right angle and a 45° angle, subdivide into 15° angles, and then obtain the required angle.
3. Erase all unneeded construction lines.

Directions: Sketch the following lines by connecting points A to points B.

Problem A: Vertical lines

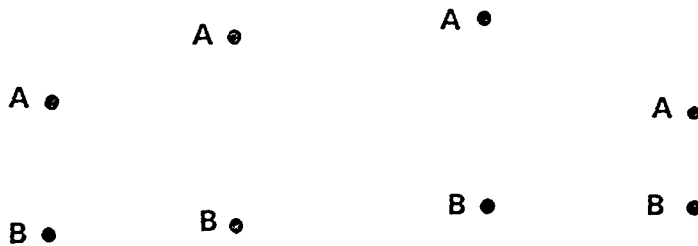

ASSIGNMENT SHEET #1

Problem B: Horizontal Lines

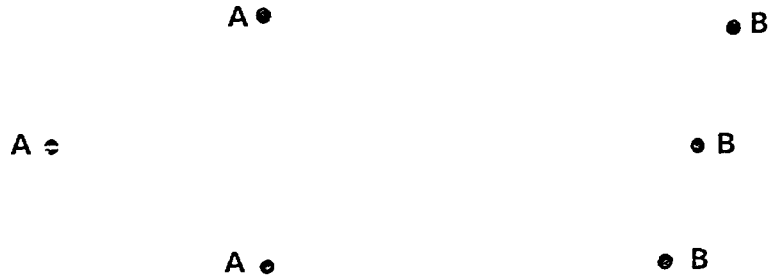

Problem C: Inclined lines



**SKETCHING
UNIT IV****ASSIGNMENT SHEET #2 — SKETCH ARCS**

Name _____ Score _____

A. Guidelines for sketching arcs

1. Sketch a box corner.



2. Mark off radius distance from corner point.

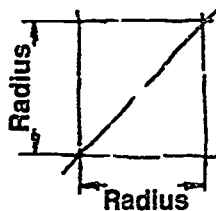

3. Swing a rough arc from center point

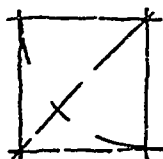

4. Darken arc.

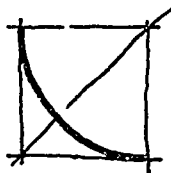

ASSIGNMENT SHEET #2

B. Problem: Sketch arcs in the following corners.

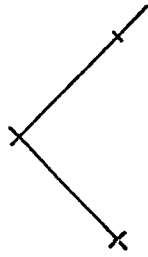
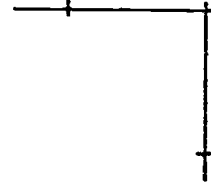
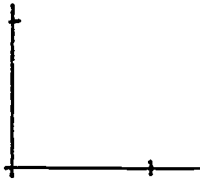

SKETCHING UNIT IV

ASSIGNMENT SHEET #3 — SKETCH CIRCLES

Name _____ Score _____

A. Guidelines for sketching circles.

1. Sketch in center lines.



2. Box in circle at diameter required.

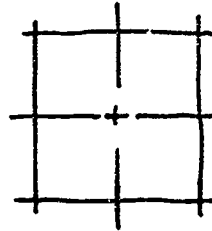

3. Put in diagonal lines and mark radius points from center.

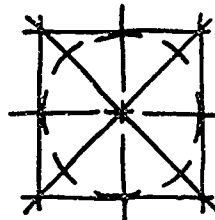

4. Rotate wrist in a circular motion and connect arcs.

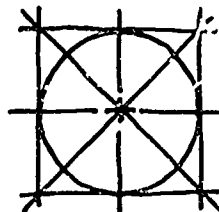

ASSIGNMENT SHEET #3

5. Erase construction lines and darken outline.

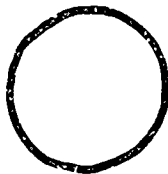

- B. Problems: Sketch three circles below using the given approximate measurements.

1. $\frac{1}{2}$ " radius

2. $\frac{3}{4}$ " diameter

3. 1" radius

213

SKETCHING UNIT IV

ASSIGNMENT #4 — SKETCH ELLIPSES

Name _____ Score _____

A. Guidelines for sketching ellipses

1. Mark off major and minor axes on center lines.

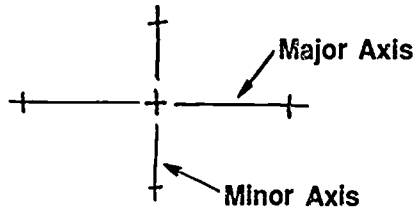

2. Box in outlines of the ellipse.

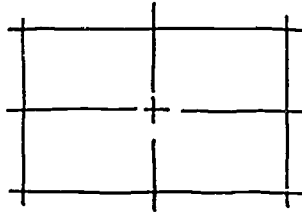

3. Sketch in major and minor arcs of ellipse.

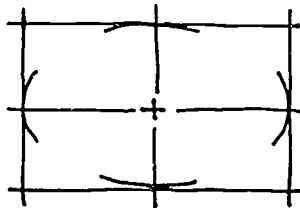

4. Rotate wrist in a curving motion and connect arcs.

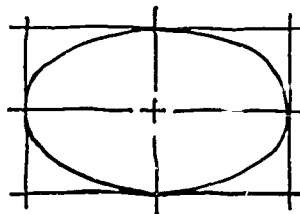

ASSIGNMENT SHEET #4

5. Erase construction lines and darken ellipse outline.

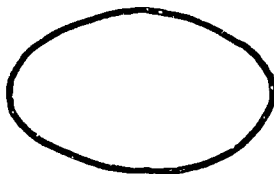

- B. Problems: Sketch three ellipses using the given approximate measurements.

1. $3/4$ " major axis, $1/2$ " minor axis
2. 2" major axis, 1" minor axis
3. 2" major axis, $1/2$ " minor axis

SKETCHING UNIT IV

ASSIGNMENT SHEET #5 — SKETCH AN ISOMETRIC CUBE

Name _____ Score _____

A. Guidelines for sketching an isometric cube

1. Lay out the isometric axes.

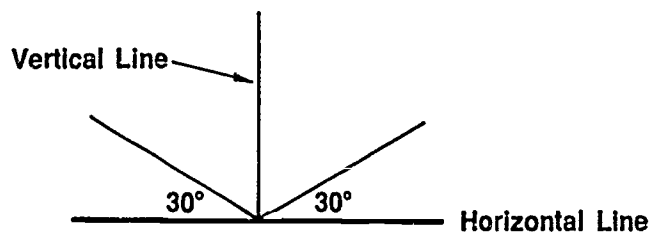

2. Sketch an isometric box so the height, width, and depth of the box are the same as the object (cube).

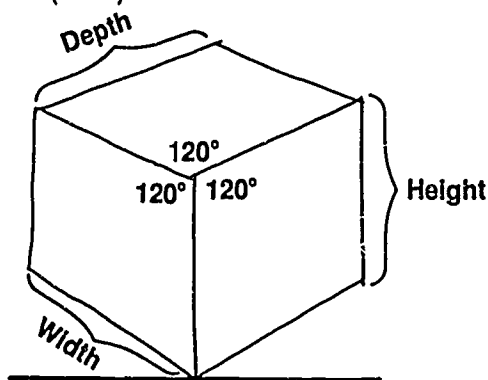

3. Darken all final lines.
 4. Erase construction lines.
- B. Problem: Sketch an isometric cube using the dimensions $1\frac{1}{2}'' \times 1\frac{1}{2}'' \times 1\frac{1}{2}''$.

SKETCHING UNIT IV

ASSIGNMENT SHEET #6 — SKETCH AN OBLIQUE CUBE

Name _____ Score _____

A. Guidelines for sketching an oblique cube

1. Sketch the front view of the object (cube). The height and width are the same as the object.

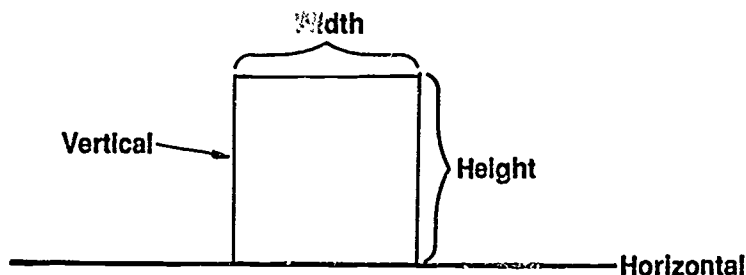

2. Sketch receding axis lines.
(NOTE: 45° angle is a common angle to use.)
3. Estimate the depth. Then draw the back edges.

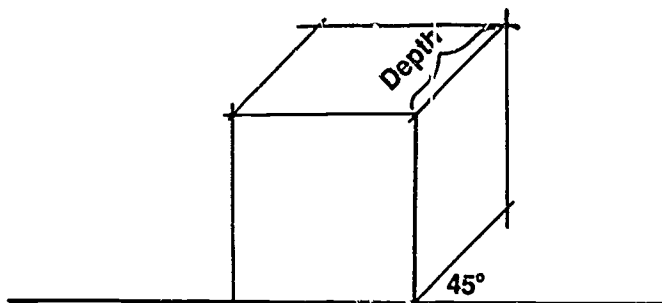

4. Sketch all details.
5. Darken final lines.
6. Erase construction lines.

ASSIGNMENT SHEET #6

- B. Problem: Sketch an oblique cube using the dimensions 2" x 2" x 2".

SKETCHING UNIT IV

ASSIGNMENT SHEET #7 — SKETCH A CONE

Name _____ Score _____

A. Guidelines for sketching cones

1. Sketch an isometric of a rectangular box equal to height and diameter of cone base.
2. Establish the center of the top of the rectangular box. This becomes the top point of the cone.
3. Build an ellipse in the bottom of the rectangular box.
4. Connect point with lines to the outer edges of the ellipse.

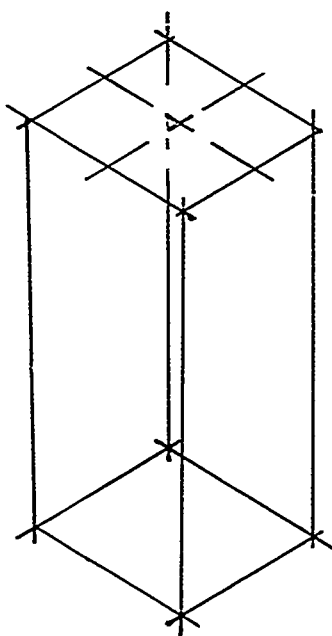

Steps 1 & 2

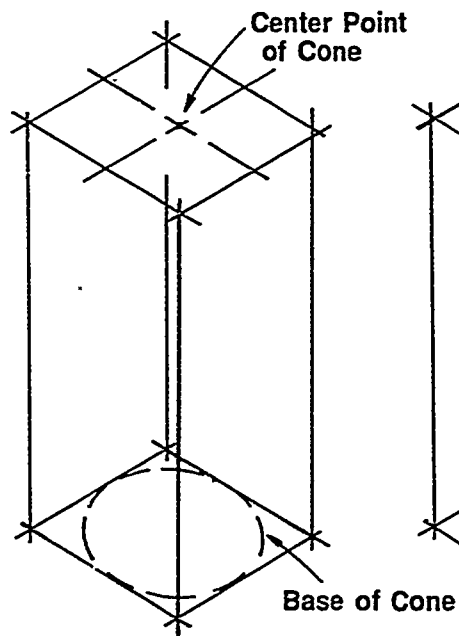

Step 3

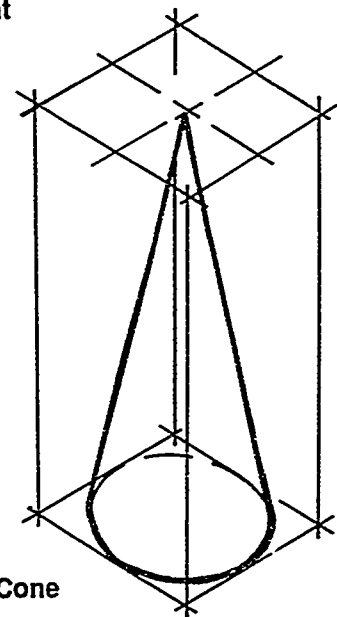

Step 4

ASSIGNMENT SHEET #7

- B. Problem: Sketch a cone with a 2" diameter base and a 3" height.

**SKETCHING
UNIT IV****ASSIGNMENT SHEET #8 — BLOCK IN A VIEW OF A PART****A. Guidelines for blocking in a view of a part**

1. Decide which view of object is to be drawn.

(NOTE: View chosen should give best overall shape of part.)

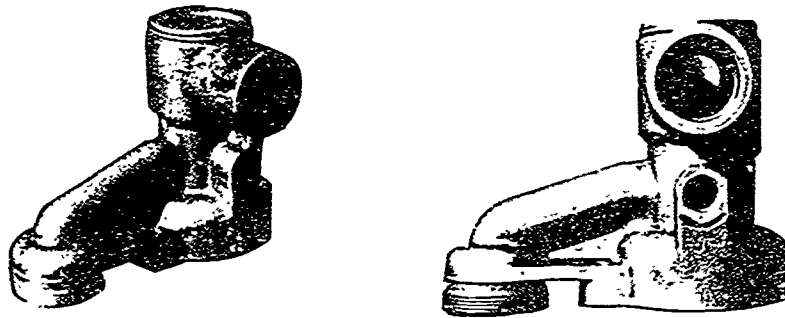

2. Box in overall shape of object.

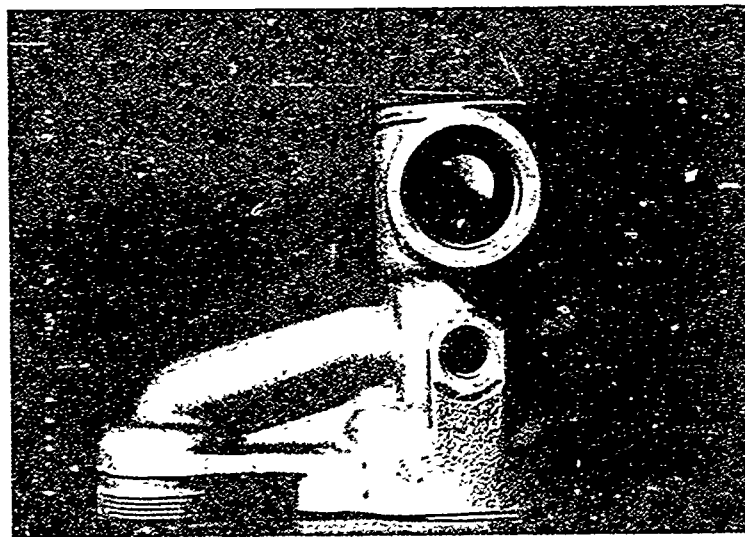

ASSIGNMENT SHEET #8

3. Sketch in arcs and circles.

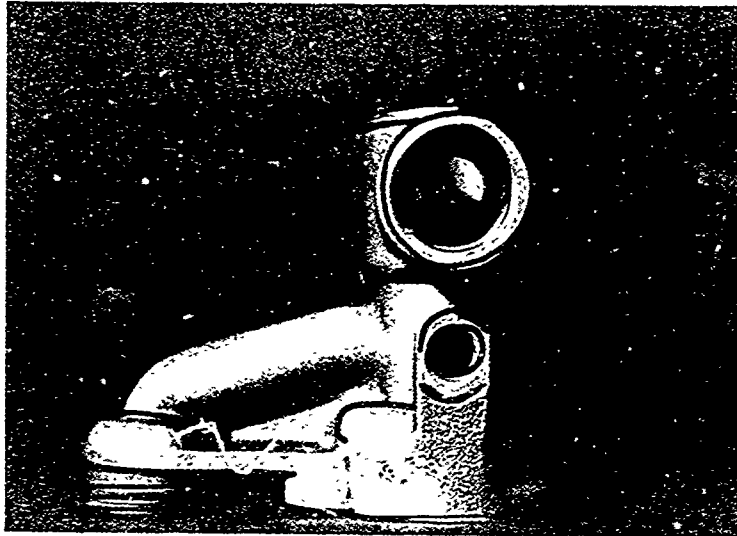

4. Erase construction lines and darken object.

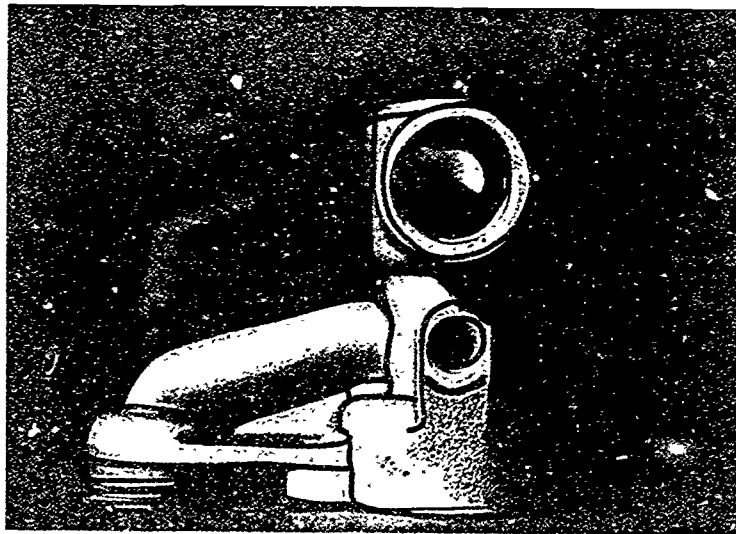

- B. Problem: Block in a view of an actual part provided by your instructor.

222

**SKETCHING
UNIT IV****ANSWERS TO ASSIGNMENT SHEETS**

Assignment Sheet #1 — Lines should be straight, smooth, and neat.

Assignment Sheet #2 — Arcs should be smooth and correctly shaped.

Assignment Sheet #3 — Circles should be correctly shaped and correctly sized (at diameters and radii specified.)

Assignment Sheet #4 — Ellipses should be correctly shaped and correctly sized (at major and minor axes specified.)

Assignment Sheet #5 — Cube should be drawn at correct isometric angles (30°) with interior angles of 120° . Height, width, and depth should all measure $1\frac{1}{2}$ " as specified in problem.

Assignment Sheet #6 — Cube should be drawn at correct oblique angles. (45° is suggested.) Height, width, and depth should all measure 2" as specified in problem.

Assignment Sheet #7 — Cone should be correctly shaped and correctly sized (2" diameter base and 3" height.)

Assignment Sheet #8 — View chosen should give good representation of the object. Geometric shapes should be smooth and drawn correctly. Overall sketch should be neat and proportional.

SKETCHING UNIT IV

JOB SHEET #1 — SPECIFY A 0.25 GRID FOR A CADD SYSTEM AND CREATE A FREEHAND DIGITIZED DRAWING

A. Tools and materials

1. CADD hardware and software
2. Operator's manual

B. Procedure

EVALUATION CRITERIA	
Criteria	Rating
Correct grid was selected	_____
Problems are drawn as shown	_____

(NOTE: The given procedure is for an AutoCAD system. If you have a different system, refer to the manual and ask for assistance from your instructor.)

1. Turn on the grid.

Example:

Enter: COMMAND: GRID ON/OFF/VALUE (X)/ASPECT: ON

2. Set the grid spacing to 0.25 units.

Example:

Enter: COMMAND: GRID ON/OFF/VALUE (X)/ASPECT: 0.25

3. Turn off the grid.

Example:

Enter: COMMAND: GRID ON/OFF/VALUE (X)/ASPECT: OFF
--

(NOTE: All CADD programs provide a grid at a default value.)

Reprinted from the AutoCAD Reference Manual for AutoCAD Release 10 with permission from Autodesk, Inc., Copyright 1989.

JOB SHEET #1

4. Have instructor evaluate present work.

Instructor's signature

5. After you establish a 0.25 grid on your system, freehand digitize the following drawings using the input device appropriate to your CADD system.

(NOTE: Remember to enter proper data to create a file for each drawing when logging on.)

Problem A:

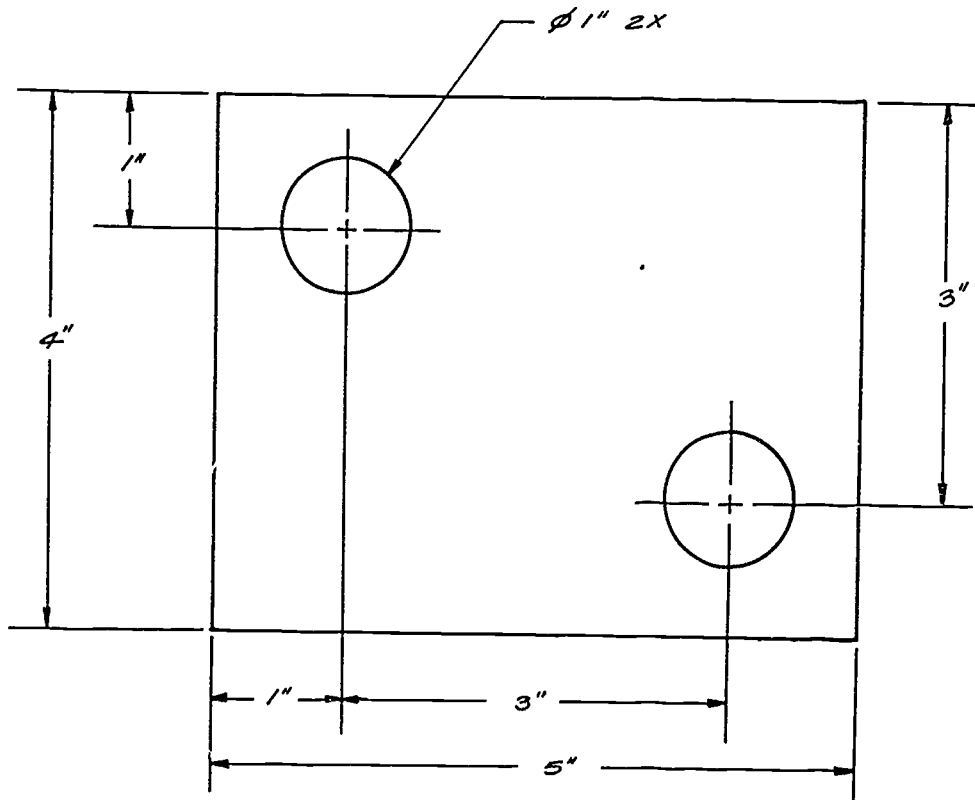

(NOTE: Always remember to file part when work for the session is completed. It is recommended to file often.)

JOB SHEET #1

Problem B:

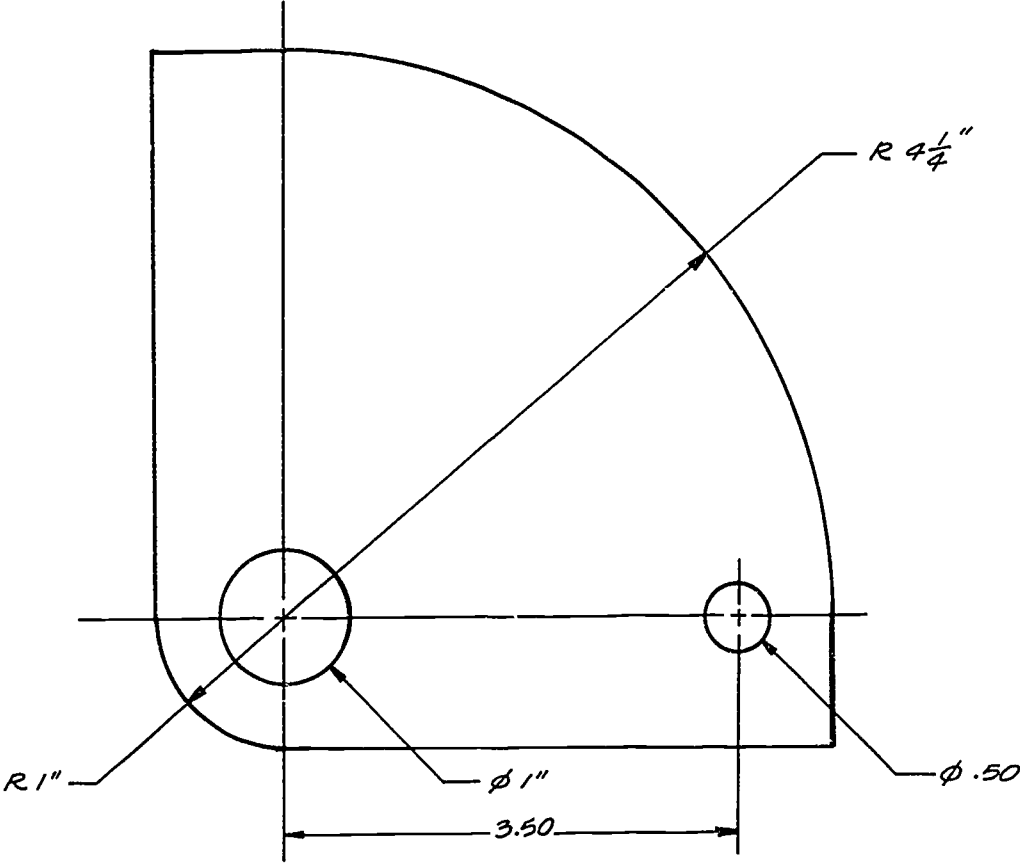

**SKETCHING
UNIT IV**

TEST

Name _____ Score _____

1. Match the terms on the right with their correct definitions.

- | | | | |
|---------|--|-----|------------------------------|
| _____a. | A point at which lines come toward each other or move away from each other | 1. | Arc |
| _____b. | A foreshortened circle having a major axis and a minor axis | 2. | Diameter |
| _____c. | Making a drawing without the use of instruments, yet with care taken to obtain the correct line widths | 3. | Digitize |
| _____d. | The chord of an ellipse passing through the center and perpendicular to the major axis | 4. | Ellipse |
| _____e. | The distance from the center point of a circle to the outside circumference | 5. | Focus |
| _____f. | The axis passing through the foci of an ellipse | 6. | Freehand technical sketching |
| _____g. | Any portion of the circumference of a circle | 7. | Geometry |
| _____h. | The distance across a circle passing through its center point | 8. | Grid |
| _____i. | A sketch based on the object being drawn on three axes spaced 120° apart | 9. | Input |
| _____j. | Drawing parts of an object in the same size relationship as the object itself | 10. | Isometric sketch |
| _____k. | An X, Y or X, Y, Z coordinate from which all geometry is referenced | 11. | Keyfile |

TEST

- | | | | |
|---------|--|-----|----------------|
| _____l. | To convert lines and shapes into digital form and to specify a coordinate location or entity by using an electronic pen | 12. | Major axis |
| _____m. | A matrix of uniformly spaced points displayed on a screen for approximately locating and digitizing a position or placing symbols in the creation of a drawing | 13. | Menu |
| _____n. | Redraw a display image on a CRT to reflect its updated status | 14. | Minor axis |
| _____o. | To enlarge or shrink a CADD image without changing its shape | 15. | Oblique sketch |
| _____p. | To enter data or a program into a system | 16. | Origin |
| _____q. | A listing either on the screen or on the tablet of command options that can be selected without entering instructions | 17. | Proportion |
| _____r. | A file that associates specific commands with specific areas of a tablet menu | 18. | Radius |
| _____s. | The elements that make up a graphic drawing on a CADD system such as points, lines, circles, arcs, fillets, and ellipses | 19. | Repaint |
| | | 20. | Scale |
2. State two purposes of sketching.
- a. _____
- b. _____
3. Select true statements concerning rules in sketching by placing an "X" next to the true statements.
- _____a. An architect scale must be used in sketching.
- _____b. Small objects are sketched larger than their normal size.
- _____c. Freehand lines are finished and rigid.
- _____d. Sketches do not need to be drawn in proportion.
- _____e. Line contrast should be used.

TEST

- ____f. A hard pencil should be used.
- ____g. Finished linework should be dark and conform to line alphabet standards.
- ____h. Sketches are never dimensioned.
4. Arrange in order the steps in completing a drawing by placing the correct sequence numbers in the appropriate blanks.
- ____a. Erase unwanted construction lines.
- ____b. Select necessary views.
- ____c. Block in lightly the shape of the object.
- ____d. Darken lines.
- ____e. Block in details in each view.
5. Distinguish between the types of sketches by placing an "X" next to the description of a pictorial sketch.
- ____a. A drawing showing the separate views of an object, arranged so each view is related to the other views
- ____b. A picturelike, three-dimensional drawing of an object as it appears to the eye.
6. Select true statements concerning factors in center line usage by placing an "X" next to the true statements.
- ____a. Center lines are used to show axis of symmetry.
- ____b. The symbol for center line is ϕ .
- ____c. The center line should extend 1" past the visible line.
- ____d. Long dashes should be begin and terminate center lines.
7. Fill in the blanks in the following sentence on ways to interpret the meaning of lines.

A visible or hidden line can mean _____

or _____

TEST

8. List three methods for proportioning a sketch.

a. _____

b. _____

c. _____

9. List two methods for inputting geometry into a CADD system.

a. _____

b. _____

10. Select from the following list the input devices for menu selection by placing an "X" next to the correct devices.

___ a. Plotter

___ b. Keyboard

___ c. Tablet menu

___ d. Button menu

___ e. Storage disk

11. Select true statements concerning freehand digitizing on CADD by placing an "X" next to the true statements.

___ a. Freehand digitizing is a very accurate form of input.

___ b. One digitizing device is the plotter.

___ c. Grids are used to improve accuracy for freehand digitizing.

___ d. Freehand digitizing inputs points on the computer screen by using an A, B, C coordinate system.

12. Identify types of coordinate entries.

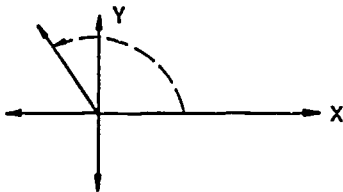

a. _____

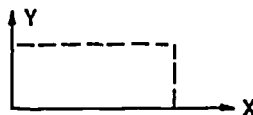

b. _____



c. _____

TEST

13. List three types of grids used for freehand sketching.

- a. _____
- b. _____
- c. _____

14. Select basic types of geometry used to create CADD drawings by placing an "X" next to the correct types.

- ___ a. Point
- ___ b. Circle
- ___ c. Chord
- ___ d. Arc
- ___ e. Line
- ___ f. Square
- ___ g. Rectangle

15. List three reference points used to build existing CADD entities.

- a. _____
- b. _____
- c. _____

16. Label with "X's" and the words "origins" and "ends" for the basic CADD geometry shown.

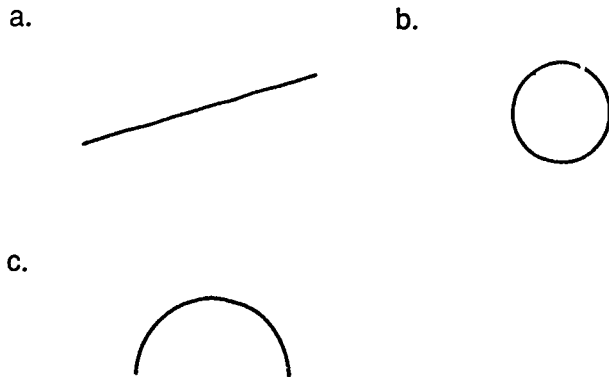

TEST

(NOTE: If these activities have not been accomplished prior to the test, ask your instructor when they should be completed.)

17. Sketch straight lines. (Assignment Sheet #1)
18. Sketch arcs. (Assignment Sheet #2)
19. Sketch circles. (Assignment Sheet #3)
20. Sketch ellipses. (Assignment Sheet #4)
21. Sketch an isometric cube. (Assignment Sheet #5)
22. Sketch an oblique cube. (Assignment Sheet #6)
23. Sketch a cone. (Assignment Sheet #7)
24. Block in a view of a part. (Assignment Sheet #8)
25. Demonstrate the ability to specify a 0.25 grid for a CADD system and create a freehand digitized drawing. (Job Sheet #1)

**SKETCHING
UNIT IV**

ANSWERS TO TEST

- | | | | | |
|----|-------|-------|-------|-------|
| 1. | a. 5 | g. 12 | k. 16 | p. 9 |
| | b. 4 | g. 1 | l. 3 | q. 13 |
| | c. 6 | h. 2 | m. 8 | r. 11 |
| | d. 14 | i. 10 | n. 19 | s. 7 |
| | e. 18 | j. 17 | o. 20 | |
2. Any two of the following:
- a. Preliminary approach to a problem before going to the expense of making an instrument drawing.
 - b. To give the drafter a better picture of the object to be drawn.
 - c. For recording notes and technical information in the shop or field for future use in the drafting department.
 - d. As an aid to "think through" the solution to an engineering-type problem.
3. b, e, g
- 4.
- | | |
|----|---|
| a. | 4 |
| b. | 1 |
| c. | 2 |
| d. | 5 |
| e. | 3 |
5. b
6. a, d
7. Any two of the following:
- a. The intersection of two surfaces
 - b. An edge view of a surface
 - c. A contour view of a curved surface
- 8.
- a. Approximation by eye
 - b. Pencil and eye
 - c. Actual measurements

ANSWERS TO TEST

9. Any two of the following:

- a. Free digitizing
- b. Coordinate entry
- c. Menu selection

10. b, c, d

11. b, c

12. a. Polar
b. Absolute
c. Relative

13. Any three of the following:

- a. Graph paper
- b. Isometric grid
- c. perspective grid
- d. CADD grid

14. a, b, d, e

15. a. Origins
b. Ends
c. Intersections

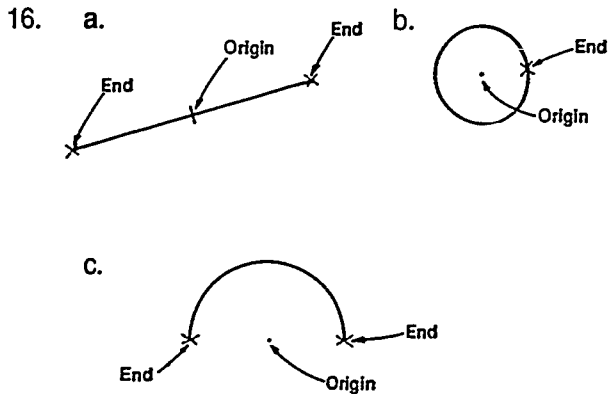

17-25. Evaluated to the satisfaction of the instructor

SCALES UNIT V

UNIT OBJECTIVE

After completion of this unit, the student should be able to describe the most common scales, list scale ratios for each scale, and read each scale. The student should also be able to measure lines accurately using various scale ratios, and define CADD terminology that applies to scale manipulation on a CADD system. Competencies will be demonstrated by completing the assignment sheets and the unit test with a minimum score of 85 percent.

SPECIFIC OBJECTIVES

After completion of this unit, the student should be able to:

1. Match terms related to scales with their correct definitions.
2. Distinguish among the different scales used in drafting.
3. State the purpose of a scale.
4. Select true statements concerning rules for measuring with a scale.
5. Select true statements concerning rules when applying a scale to a drawing.
6. List preferred drawing scales.
7. Interpret $1/16$, $1/8$, $1/4$, and $1/2$ graduations on a full-size scale.
8. Calculate and locate $1/32$ graduations on a full-size scale.
9. Read a fully-divided decimal scale.
10. List scale ratios found on various scales and rules.
11. Select metric scale ratios commonly used for various drafting applications.
12. Distinguish between a reduction scale ratio and an enlargement scale ratio.
13. Select true statements concerning drawing scale when using CADD.
14. Match CADD terminology used for view manipulation with the correct definitions.
15. Read a full scale. (Assignment Sheet #1)
16. Interpret $1/16$ and $1/32$ graduations on a full-size metal rule. (Assignment Sheet #2)

SPECIFIC OBJECTIVES

17. Measure lines with a civil engineer's scale. (Assignment Sheet #3)
18. Measure lines with an architect's scale. (Assignment Sheet #4)
19. Measure lines with a mechanical engineer's scale. (Assignment Sheet #5)
20. Measure lines with a metric scale. (Assignment #6)

**SCALES
UNIT V****SUGGESTED ACTIVITIES**

- A. Provide students with objective sheet.
- B. Provide students with information and assignment sheets.
- C. Make transparencies.
- D. Discuss unit and specific objectives.
- E. Discuss information and assignment sheets.
- F. Develop a display of all types of measuring rules, tapes, scales, and related items used in various machine and building trades. Include all five types of scales used in a drafting room. Discuss this display in depth with students.
- G. Explain why scaling should not be completed on blueprint copies.
- H. Use unit test as a pre-test to determine prior knowledge of scale usage.
- I. Have students practice measuring objects in the classroom.
- J. Use metric comparison charts in discussing the use of metric scales.
- K. Invite resource person to attend class and discuss use and types of scales.
- L. Lead discussion on the advantages and disadvantages of different types of scales.
- M. Provide problems for the students to practice using engineering scales.
- N. Demonstrate on the CADD system the many ways to manipulate views such as zoom, scroll, and pan.
- O. Give test.

REFERENCES USED IN DEVELOPING THIS UNIT

- A. Brown, Walter C. *Drafting for Industry*. South Holland, IL: The Goodheart-Willcox Company, Inc., 1984.
- B. Spencer, Henry C., et al. *Technical Drawing Problems*. New York: Macmillan Publishing Co., Inc., 1980.
- C. Giesecke, Frederick E., et al. *Technical Drawing*, 8th ed. New York: Macmillan Publishing Co., Inc., 1986.
- D. Jensen, Cecil and Helsel, Jay. *Engineering Drawing and Designs*, 3rd ed. New York: McGraw-Hill Book Company, 1985.

SUGGESTED ACTIVITIES

- E. Spence, William P. *Engineering Graphics*, 2nd ed. Englewood Cliffs, NJ. Prentice-Hall, 1988.
- F. Lieblich, Jerome H. *Drawing Requirements Manual*, 6th ed. Irvine, CA: Global Engineering Documents, 1986.
- G. Giachino J. W. and Beukema, H. J. *Engineering Technical Drafting*, 4th ed. Homewood, IL: American Technical Publishers, Inc., 1978.
- H. Lamit, Gary Louis and Vernon Paige. *Computer-Aided Drafting and Design — CADD*. Columbus, OH: Merrill Publishing Co., 1987.

SCALES UNIT V

INFORMATION SHEET

I. Terms and definitions

- A. Actual size — An object's actual dimensions; the size of an object in completed form
- B. Architecture — The design and drawing of public and private buildings
- C. Centimeter (cm) — 1/100 of a meter
- D. Decimeter (dm) — 1/10 of a meter
- E. Draw to scale — Drawing an object at a set proportion such as half its actual size, one-fourth its actual size, or double its actual size
- F. Dynamics — The capability of a CADD system to zoom, scroll, and rotate
- G. Fraction — A part of a whole, such as 1/2 or 1/4
- H. Fully-divided scale — A scale with the basic units subdivided throughout the length of the scale

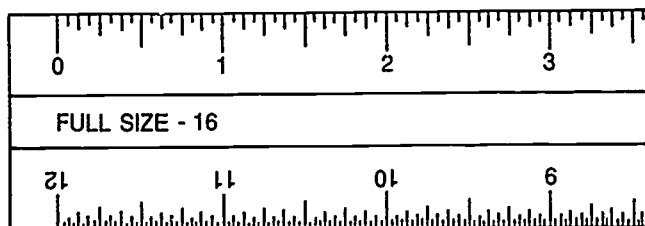

- I. Graduations — The subdivisions in a scale unit, all of which are equal in size or length
- J. Millimeter (mm) — 1/1000 of a meter
(NOTE: This is the primary unit of measurement for engineering.)
- K. Meter (m) — The metric system standard for linear measurement
- L. Metric system — A decimal system of weights and measures based on the meter and the kilogram
- M. NTS — Abbreviation meaning "not-to-scale"

INFORMATION SHEET

- N. Open-divided scale — A scale with only the end unit subdivided into fractional parts

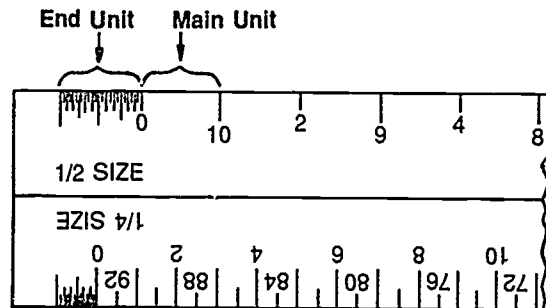

- O. Scale — An instrument used as a standard of reference when drawing an object to a proportional size
- P. Scale — (as applies to CADD)
1. (Verb) To enlarge or diminish the size of a displayed entity without changing its shape, i.e., to bring it into a user-specified ratio to its original dimensions

(NOTE: Scaling can be done automatically by a CADD system.)
 2. (Noun) Denotes the coordinate system for representing an object
- Q. Scale ratio — A relationship between dimension values used to reduce or enlarge the size of an object so that it can be drawn to proportion
- R. SI — The modern form of the metric system; "The International System of Units"

II. Descriptions of the different scales used in drafting

- A. Architect's scale — Used primarily in drawings of buildings, piping systems, and other large structures which must be drawn to a reduced scale to fit on a standard sheet size. It has one full-size scale and ten reduced-size scales.

(NOTE: In all of the reduced scales, the major divisions represent feet, and their subdivisions represent inches and fractions thereof. Thus 3/4" scale means 3/4 inch = 1 foot, NOT 3/4 inch = 1 inch.)

- B. Civil engineer's scale — Used primarily in drawings of public works such as roads, bridges, dams, city subdivisions, etc. It is graduated in units of one inch divided into 10, 20, 30, 40, 50, and 60 parts.

(NOTE: It is used in drawing maps to scales of 1" = 50', 1" = 500', 1" = 5 miles, etc.)

INFORMATION SHEET

- C. Mechanical engineer's scale — Used by mechanical drafters because of its scale ratios. It is divided into units representing full size ($1'' = 1''$), half size ($1/2'' = 1''$), quarter size ($1/4'' = 1''$), and one-eighth size ($1/8'' = 1''$). Used when dimensions are in inches or in fractions.

(NOTE: The mechanical engineer's scale is sometimes called a mechanical drafter's scale.)

- D. Mechanical engineer's decimal scale — Used for mechanical drawings where accuracy of measurement is critical. It is fully divided into 0.1" and 0.02".
- E. Metric scale — Used when dimensions are in millimeters.

III. **Purpose of a scale** — To provide a standard of reference for drawing objects either at their actual size or larger or smaller than actual (full) size

IV. Rules for measuring with a scale

- A. Select proper scale ratio.
- B. Scale should lie flat on the surface being measured.
- C. Scale should be parallel with or on line being measured.
- D. Do not stick compass or divider points into scale.
- E. Edge of the scale should be protected to prevent damage of its graduation marks.
- F. A short dash should be made rather than a point to mark a distance.
- G. If a series of measurements are to be made on full-size scale, do not move scale for each measurement.

(NOTE: Set off measurements with scale in one position.)

- H. Make sure that the line of sight does not create an optical illusion.

(NOTE: This could result in an incorrect measurement.)

- I. New drawings are drawn to scale within .03 inches.

(NOTE: Never scale off a measurement from a drawing. Use the written dimension only.)

V. General rules in applying a scale to a drawing

- A. All drawings are originally prepared to conform with the scale in the scale block, except schematics and wiring diagrams.
- B. Full scale is preferred.

INFORMATION SHEET

- C. Views or sections drawn to any other scale than in the scale block should be labeled below the title of that view or section.
- D. When a dimension is changed but the measurement remains the same, it should be identified by placing a line under the dimension.

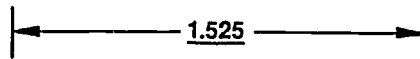

- E. "No Scale" drawings such as schematics or diagrams that have no specific scale are labeled in the scale block as "None".

VI. Preferred drawing scales (*ANSI Y14.5M-1982*)

SCALE	DESIGNATION
Full size	1/1
Half size	1/2
Quarter size	1/4
Tenth size	1/10 (nonpreferred)
Double size	2/1
Four times size	4/1
Ten times size	10/1 (nonpreferred)

VII. How to interpret 1/16, 1/8, 1/4, and 1/2 graduations on a full-size scale (Transparency 1)

(NOTE: On a full scale 12" represents 1'-0".)

- A. Sixteen one-sixteenths (16/16) = One inch (1")

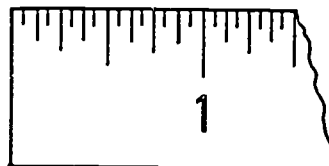

INFORMATION SHEET

- B. Eight one-eighths ($8/8$) = One inch (1"); Two one-sixteenths ($2/16$) = One-eighth inch ($1/8$ ")

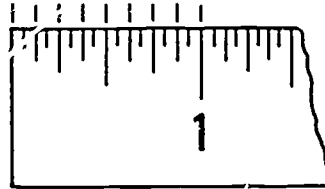

- C. Four one-fourths ($4/4$) = One inch (1"); Four one-sixteenths ($4/16$) = One-fourth inch ($1/4$ ")



- D. Two one-halves ($2/2$) = One inch (1"); Eight one-sixteenths ($8/16$) = One-half inch ($1/2$ ")

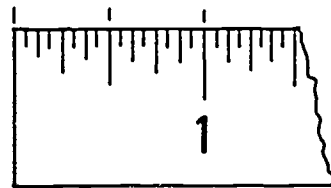

VIII. How to calculate and locate $1/32$ " graduations on a full-size scale

- For $1/32$ increments there are two $1/32$ " in one $1/16$ ".
- Subtract $1/32$ " from the reading being worked with to find the nearest $1/16$ unit under the reading.
- Add $1/32$ " to the reading being worked with to find the nearest $1/16$ unit over the reading.
- Find the lower and higher $1/16$ units on the scale and approximate the center between the two.

INFORMATION SHEET

- E. Mark this approximate center by making a short dash with a sharp light lead and observe reading.

Example: The reading wanted is $11/32$ "

1. Subtract $1/32$ " which gives $10/32$ or $5/16$ ".
2. Add $1/32$ " which gives $12/32$ or $3/8$ ".
3. Locate $5/16$ and $3/8$ and approximate the center.

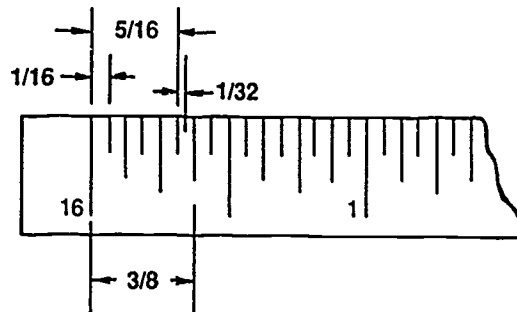

4. Mark approximate $11/32$ " point.

IX. How to read a fully-divided decimal scale

- A. The basic inch on the decimal scale is divided into 10 equal parts (each equal to .10) and 50 subdivisions (each equal to .02).

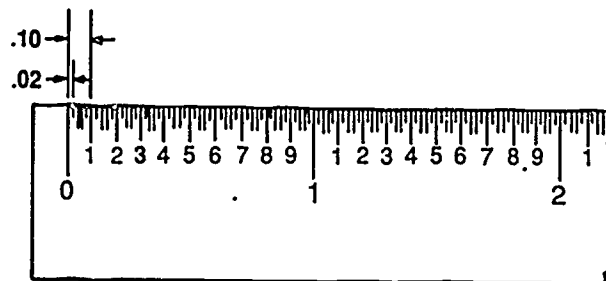

- B. Decimal numbers are written with the larger whole units to the left of the decimal point and the smaller units (parts of a whole unit) to the right of the decimal point. The units are in powers of 10.

Whole Units Parts of a Whole

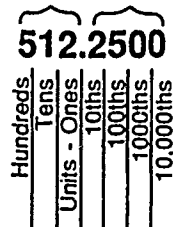

INFORMATION SHEET

- C. When measuring with a decimal scale, determine the whole numbers and write those down followed by the decimal point. Then determine the smaller decimal units; first the tenths, then the hundredths.

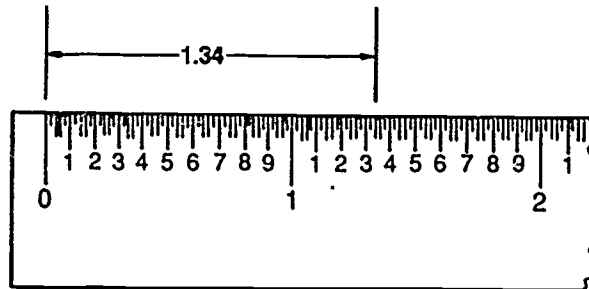

X. Scale ratios

A. Architect's scale (Transparency 2)

1. 12" = 1'-0" — Full size
2. 6" = 1'-0" — Half size
3. 3" = 1'-0" — 1/4 size
4. 1 1/2" = 1'-0" — 1/8 size
5. 1" = 1'-0" — 1/12 size
6. 3/4" = 1'-0" — 1/16 size
7. 1/2" = 1'-0" — 1/24 size
8. 3/8" = 1'-0" — 1/32 size
9. 1/4" = 1'-0" — 1/48 size
10. 3/16" = 1'-0" — 1/64 size
11. 1/8" = 1'-0" — 1/96 size
12. 3/32" = 1'-0" — 1/128 size

B. Civil engineer's scale (Transparency 3)

1. 10 scale — 1" subdivided into 10 parts
2. 20 scale — 1" subdivided into 20 parts
3. 30 scale — 1" subdivided into 30 parts
4. 40 scale — 1" subdivided into 40 parts

INFORMATION SHEET

5. 50 scale — 1" subdivided into 50 parts
 6. 60 scale — 1" subdivided into 60 parts
- C. Mechanical engineer's scale (Transparencies 4 and 5)
1. Fractional scale ratio
 - a. 1" = 1" — Full size
 - b. 1/2" = 1" — Half size
 - c. 1/4" = 1" — Quarter size
 - d. 1/8" = 1" — One-eighth size
 2. Fully-divided decimal scale ratio
 - a. 10 parts per inch — Each division equals .1"
 - b. 50 parts per inch — Each division equals .02"
- D. Machinist steel rule (common) (Transparency 6)
1. Fractions — English
 - a. 32 parts per inch — Each division equals 1/32"
 - b. 64 parts per inch — Each division equals 1/64"
 2. Decimal — English
 - a. 10 parts per inch — Each division equals .1"
 - b. 50 parts per inch — Each division equals .02"
 3. Metric — IS
 - a. Millimeters (mm) — Each division equals 1 mm
 - b. 1/2 millimeters — Each division equals .5 mm

(NOTE: Machinist steel rules may be found in various combinations of fractions, decimals, and metrics in the common scales above or other scales.)

INFORMATION SHEET

E. Metric scale (Transparency 7)

1. 1:1
2. 1:2
3. 1:5
4. 1:10
5. 1:25
6. 1:33 1/3
7. 1:75

(NOTE: The ratio 1:1 would indicate 1 millimeter = 1 millimeter while 1:25 would indicate 1 millimeter = 25 millimeters.)

XI. Metric scale ratios commonly used for various drafting applications

Metric mm:mm	Application
1:1 1:2 1:3 1:5 1:10	Machine drawings
1:20 1:25 1:33 1/3	Architectural construction details
1:75 1:100 1:200	Architectural plans and elevations Architectural plot plans
1:500 1:1250 1:2500 1:10,000 1:50,000	Maps (civil drawings)

INFORMATION SHEET

XII. Reduction and enlargement metric scale ratios (Transparency 8)

- A. Frequently used reduction scales are 1:2, 1:3, 1:5, and 1:10.

(NOTE: 1:2 means 1 mm = 2 mm.)

- B. Frequently used enlargement scale ratios are 2:1 and 5:1.

(NOTE: It is always recommended to use full-size [1:1] whenever possible.)

XIII. General information concerning drawing scale when using CADD

- A. Any size drawing may be determined on a CADD system.

- B. The scale of the geometry in a view of a part can be different for each view.

(NOTE: A part may have several views - top, front, right side, isometric.)

- C. Each view will appear at the scale selected.

- D. The scale of a drawing may be determined at the time of plotting.

XIV. CADD terminology used for view manipulation (Transparency 9)

(NOTE: View manipulation through any of these methods does not change the actual measurement of the part being drawn. View manipulation is performed to modify the display on a CRT screen.)

- A. Restore — To bring back to its original state a design currently being worked on in a CADD system altering modification that the user now wants to cancel or rescind
- B. Scissor — To trim a drawing in the database so that it can be viewed on a CRT screen
- C. Scroll (Pan) — To automatically roll up, as on a spool, a design or text message on a CRT to permit the sequential viewing of a message or drawing too large to be displayed all at once on a screen
- D. Stretch — A CADD design/editing aid that enables the user to automatically expand a displayed entity beyond its original dimensions
- E. Window — A temporary, usually rectangular, bounded area on the CRT that is user-specified to include particular entities for modification, editing, or deletion
- F. Windowing — Proportionally enlarging a figure or portion of a figure so it fills the screen or view port
- G. Zoom — A CADD capability that proportionately enlarges or reduces a figure displayed on a CRT screen

Graduations on a Scale

Halves

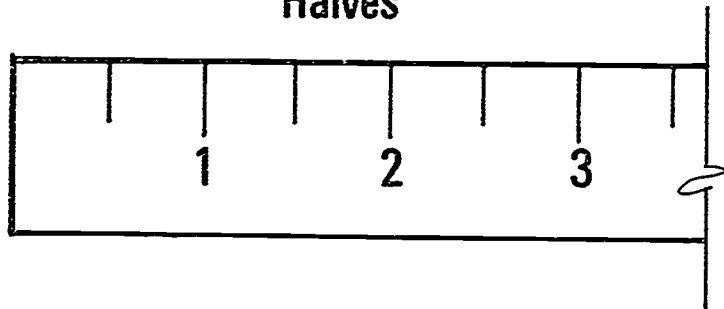

Quarters

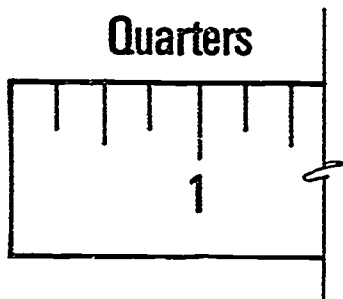

Eighths

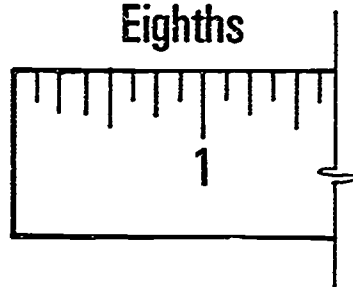

Sixteenths

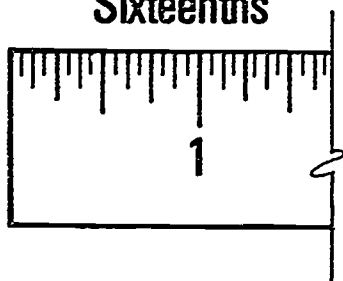

Thirty-Seconds

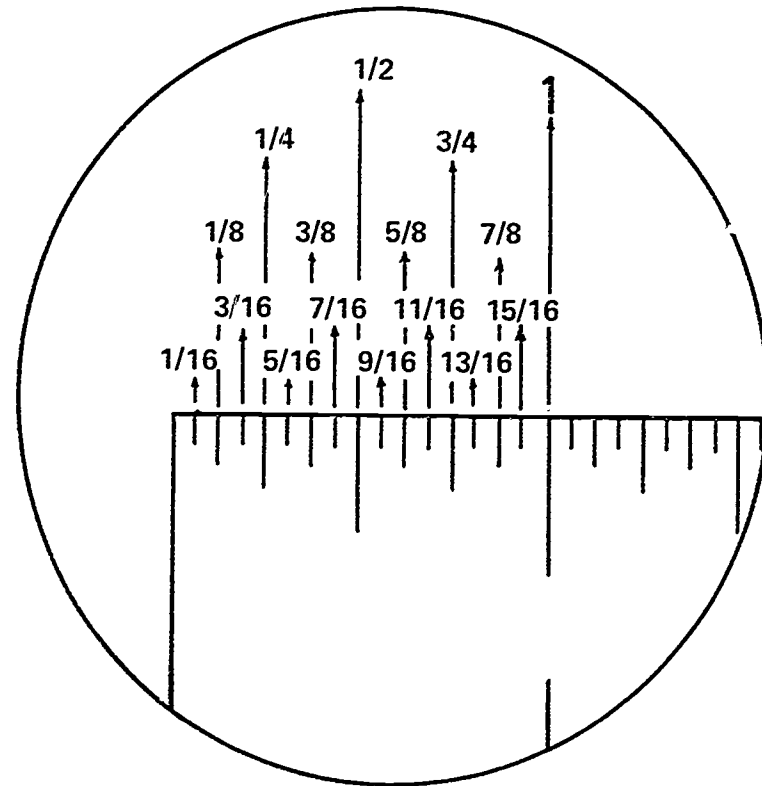
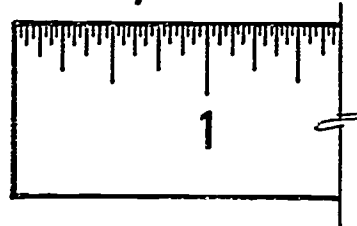

Graduations Applied to a Rule

Architect's Scale

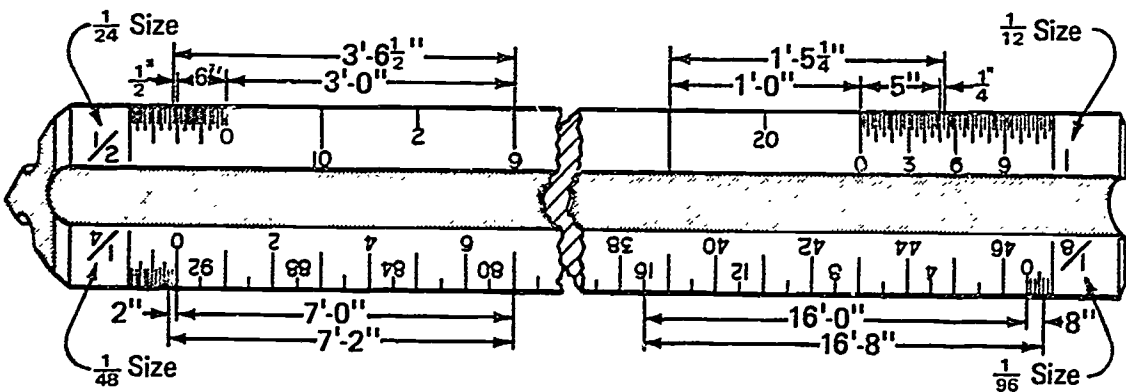
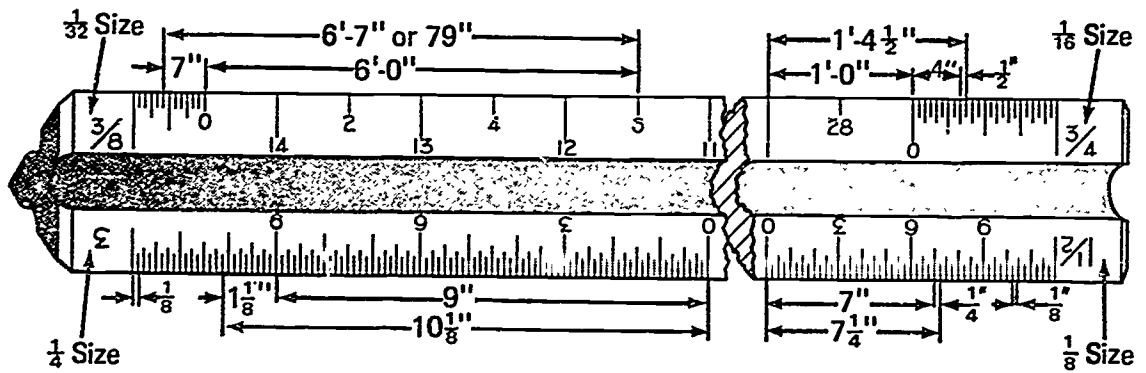
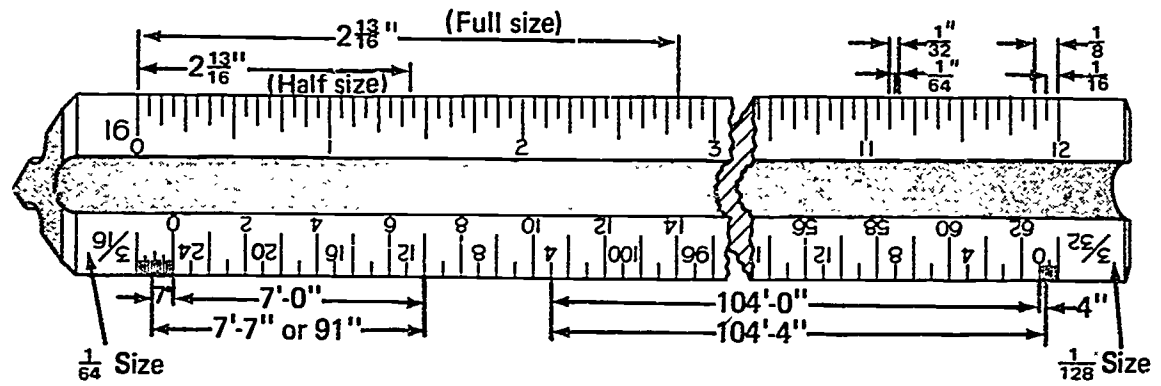

Civil Engineer's Scale

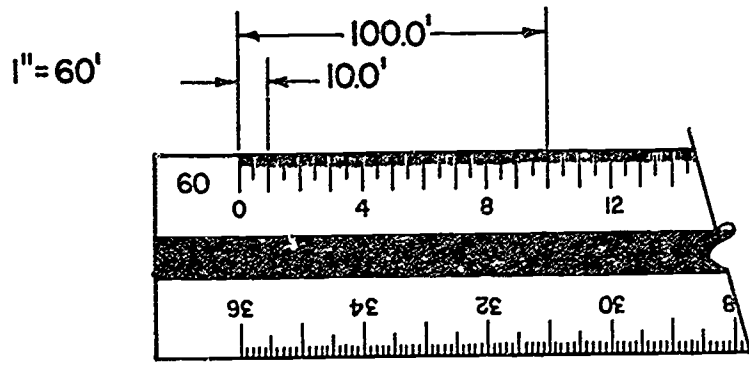
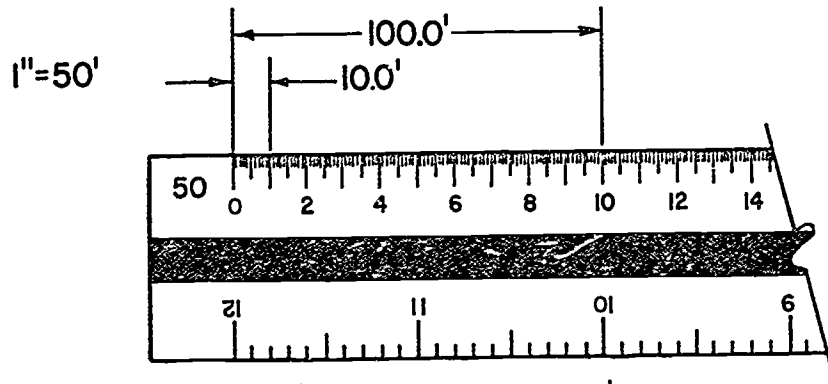
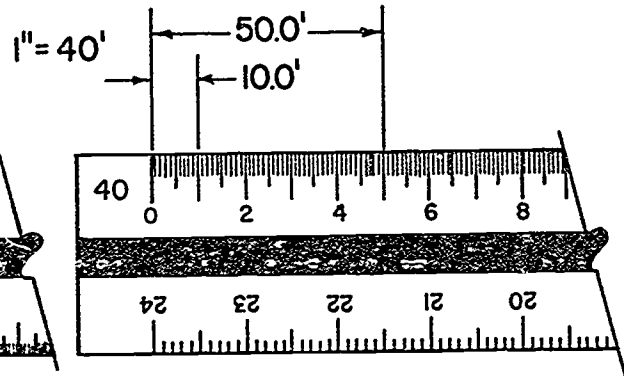
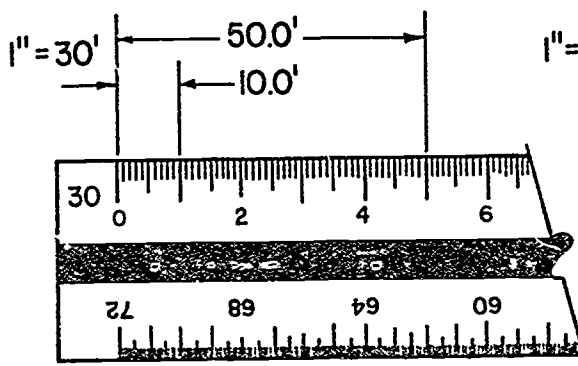
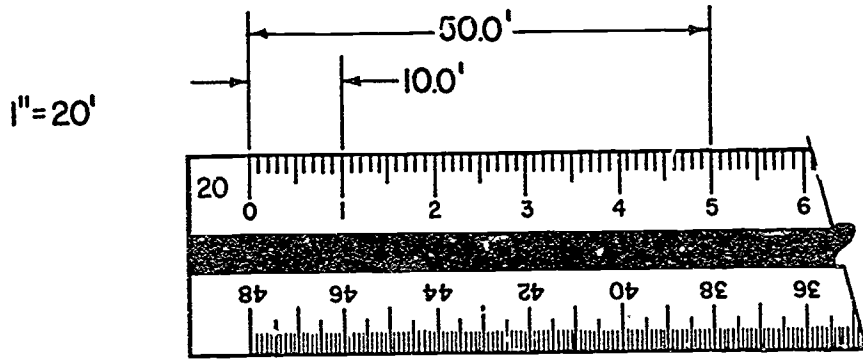

Mechanical Engineer's Scale

Full Size (1" = 1")

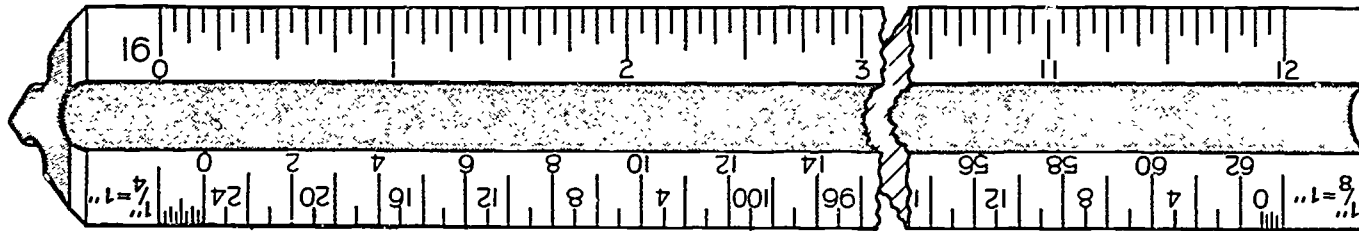

One-Quarter Size (1/4" = 1")

One-Eighth Size (1/8" = 1")

16 Subdivisions
in End Unit

One-Half Size (1/2" = 1")

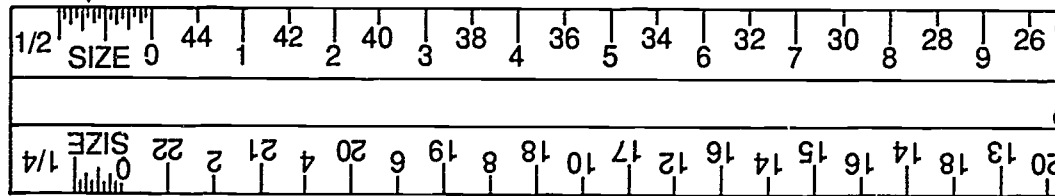

8 Subdivisions
in End Unit

One-Quarter Size (1/4" = 1")

Alternate Form

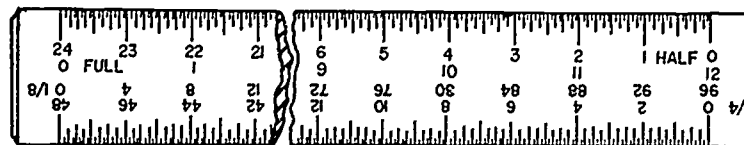

Mechanical Engineer's Scale (Continued)

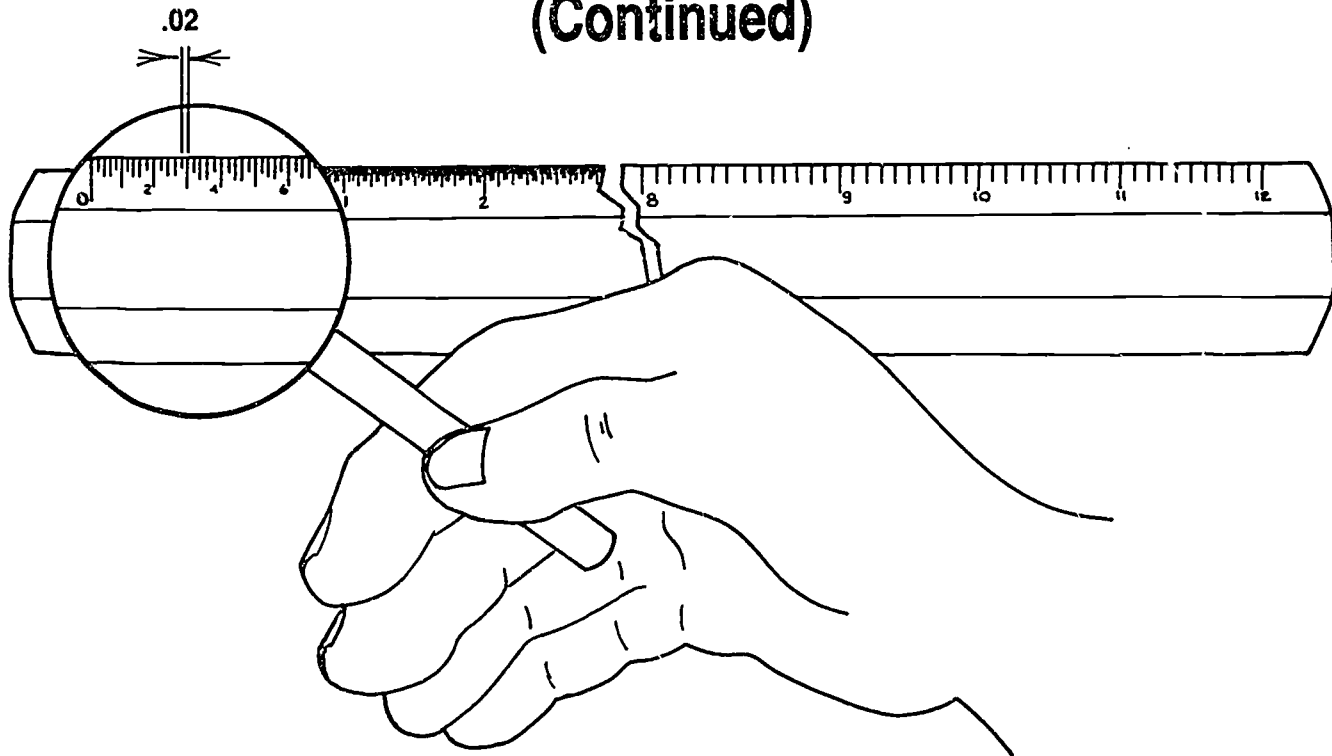

Decimal

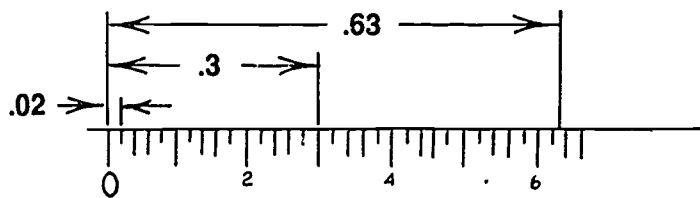

Machinist Steel Rules

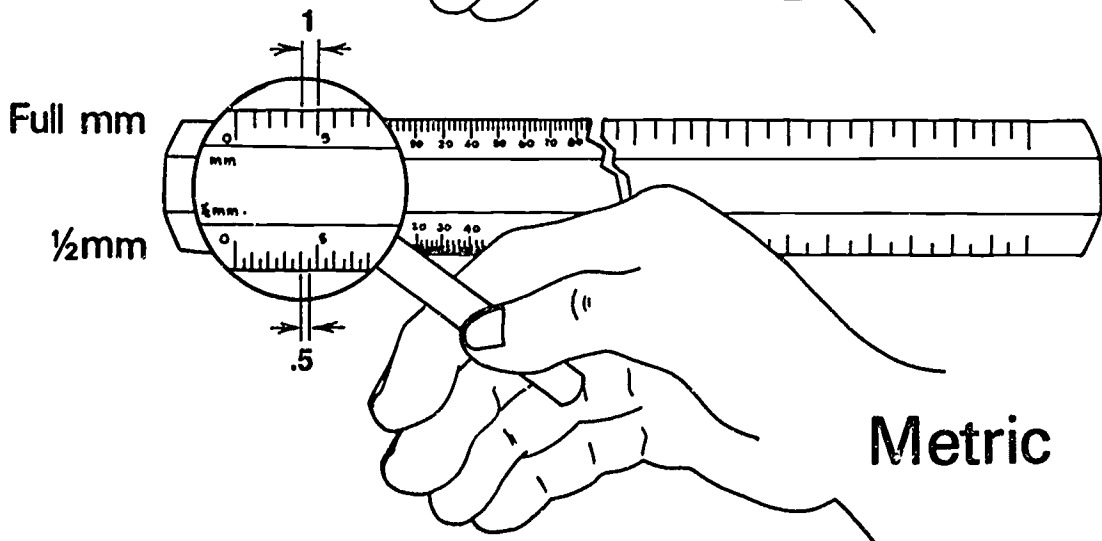
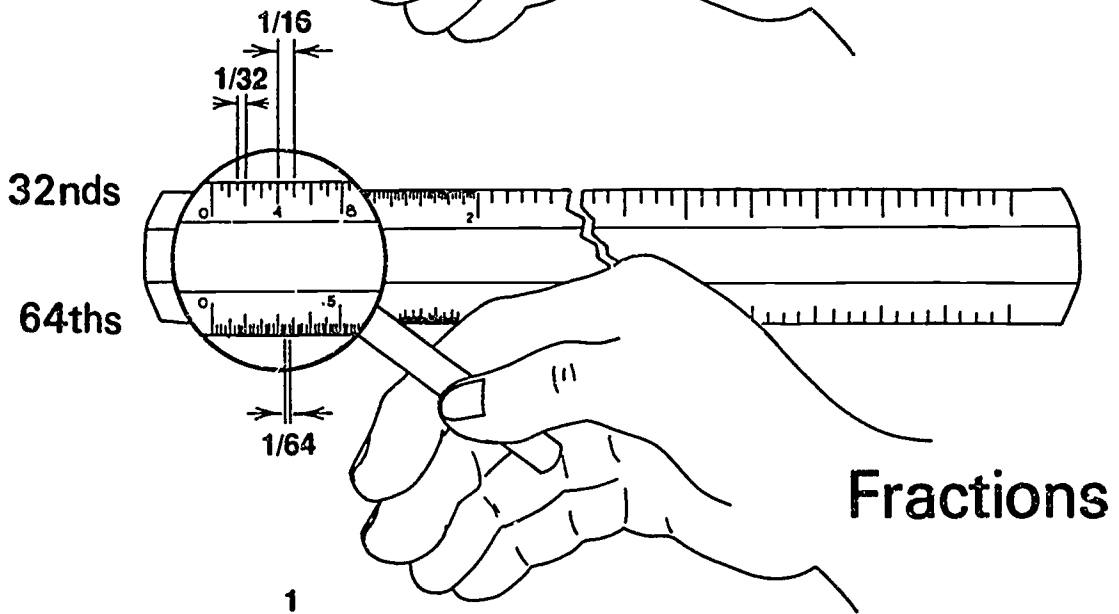
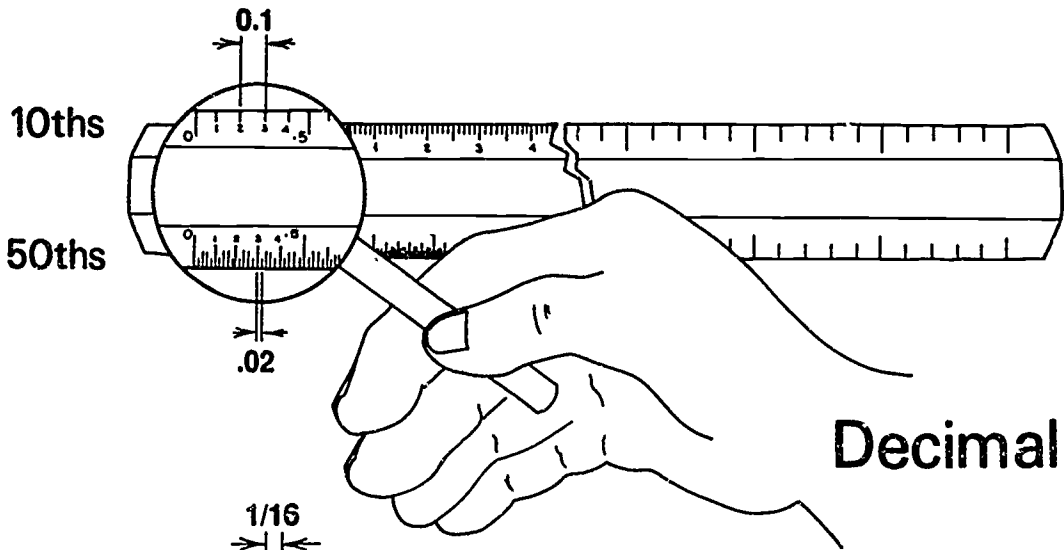

Metric Scales (Triangular)

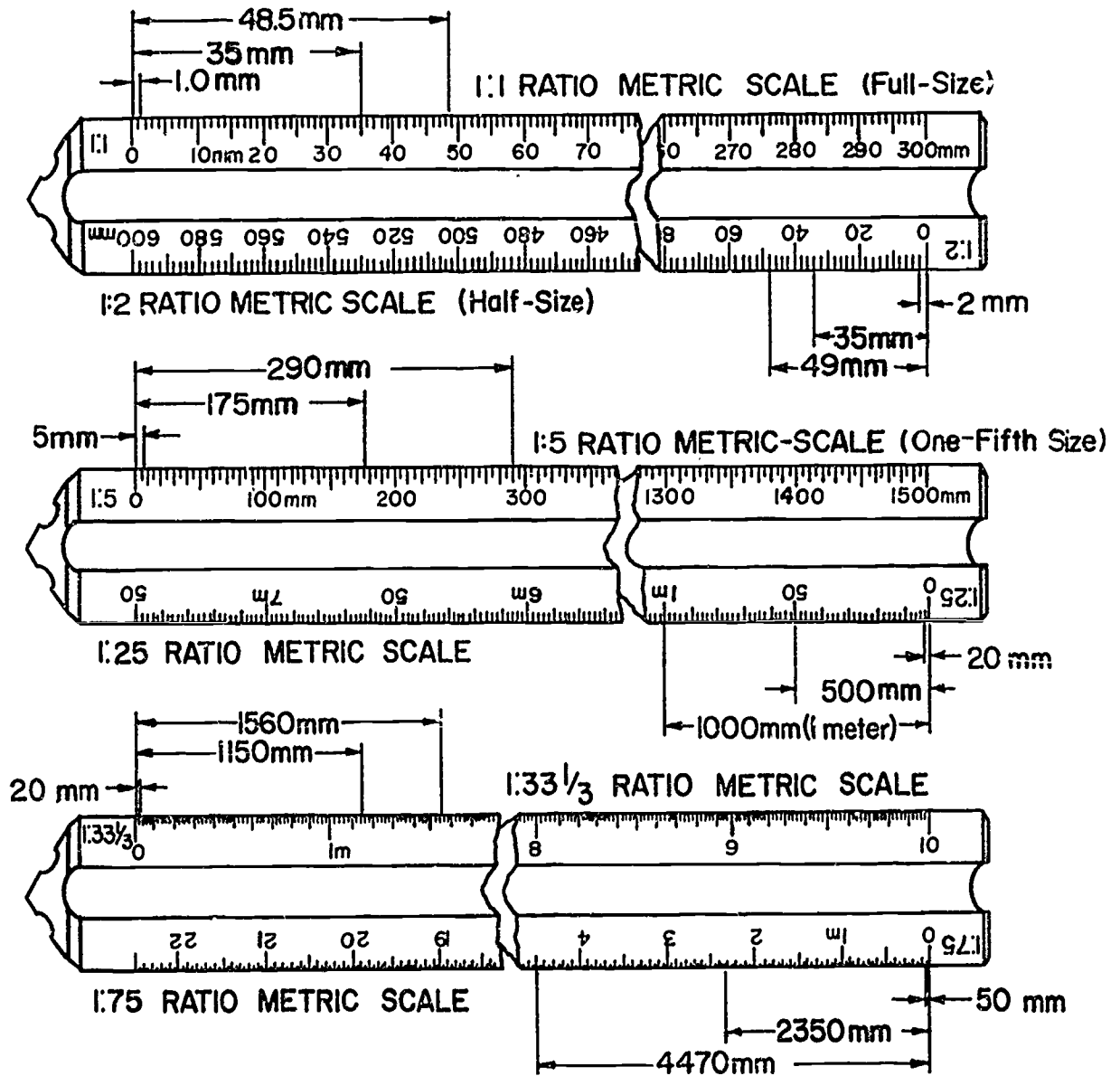

Metric Reduction and Enlargement Scales

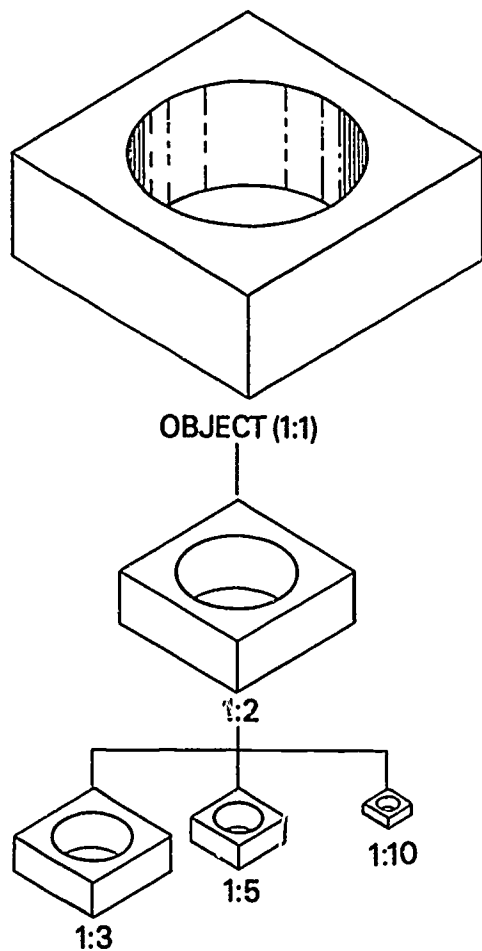

Metric Reduction Scales

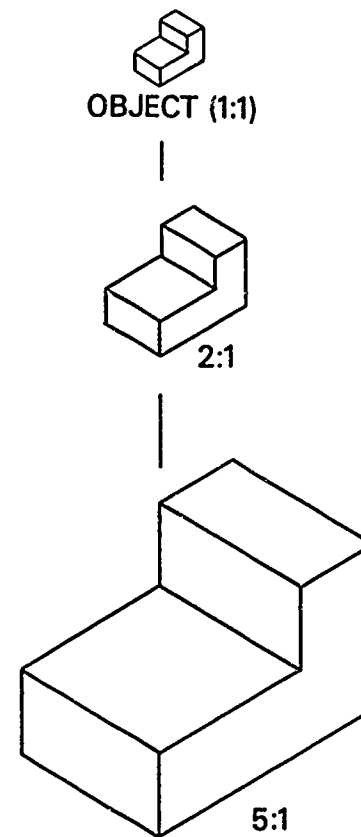

Metric Enlargement Scales

View Manipulation on CADD

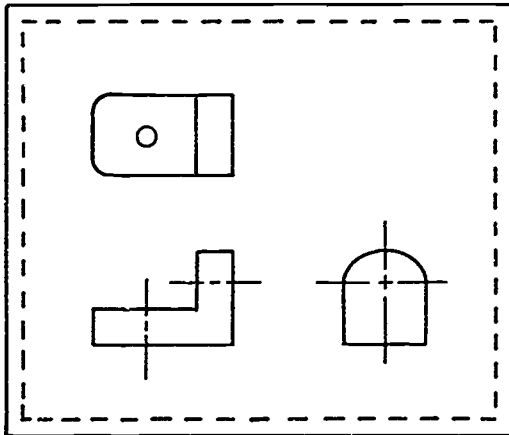

Before

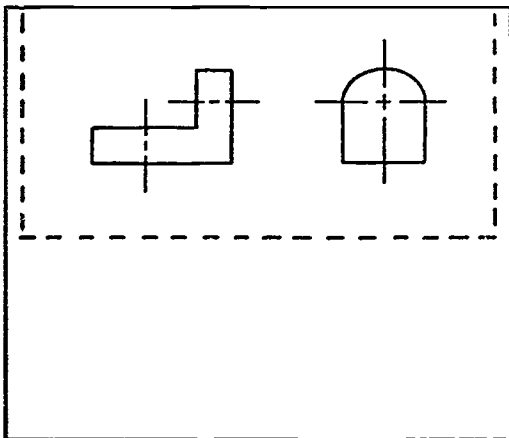

After

Scroll

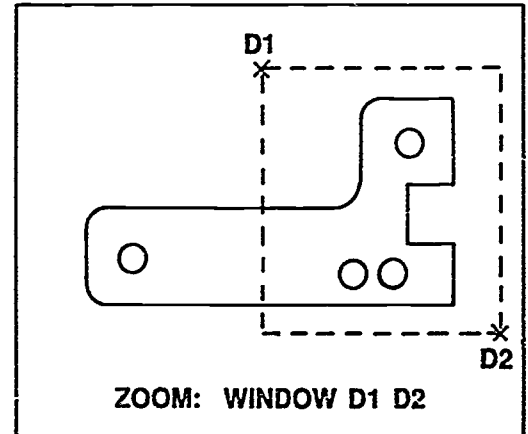

Before

ZOOM: WINDOW D1 D2

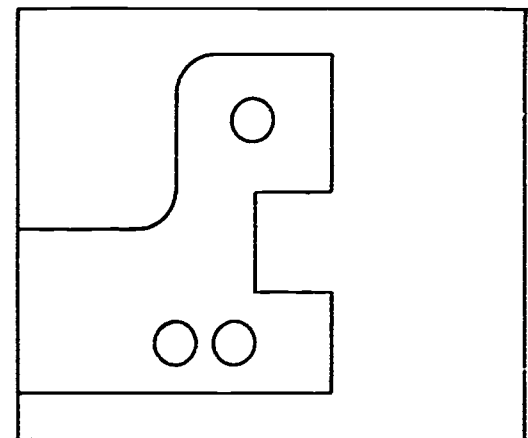

After

Zoom

SCALES
UNIT V

ASSIGNMENT SHEET #1 — READ A FULL SCALE

Name _____ Score _____

Directions: Read the measurements shown below at full scale by reading the distance from "0" at left to points indicated on the scale with letters.

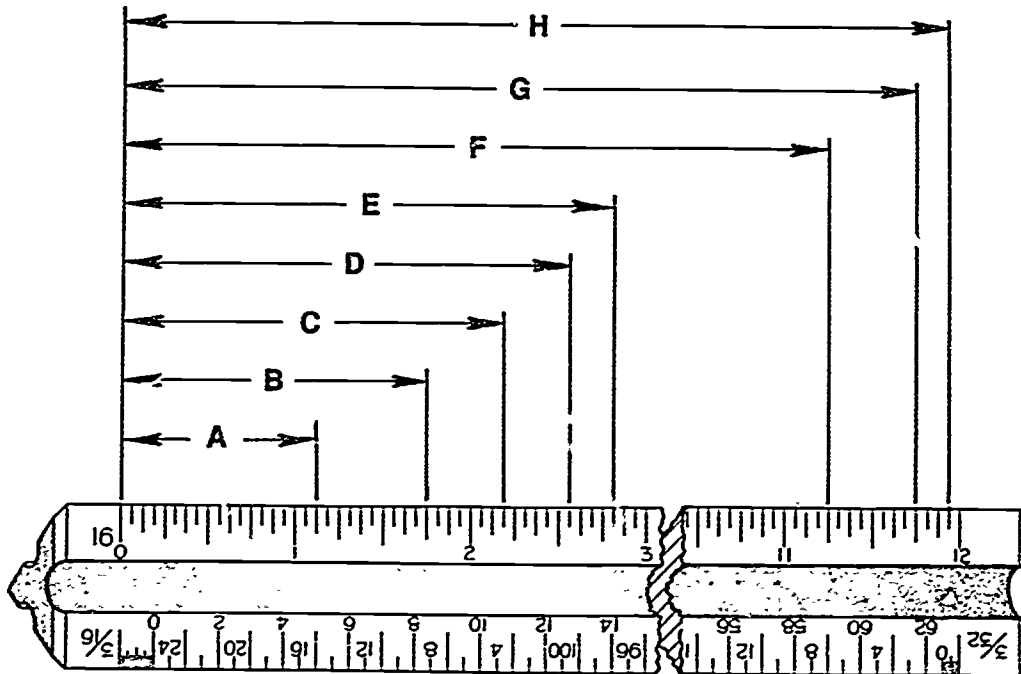

- A. _____
- B. _____
- C. _____
- D. _____
- E. _____
- F. _____
- G. _____
- H. _____

**SCALES
UNIT V**

**ASSIGNMENT SHEET #2 — INTERPRET 1/16 AND 1/32 GRADUATIONS
ON A FULL-SIZE METAL RULE**

NAME _____ SCORE _____

Directions: Read the measurements shown below and on the next page at full size by reading from end of rule at left to points indicated by extension lines.

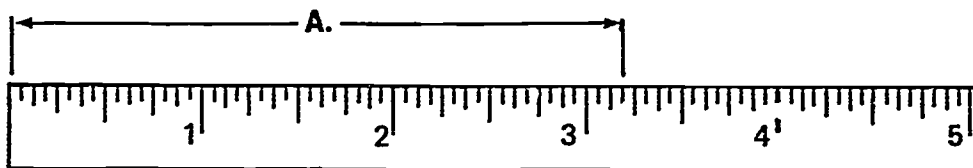

A. _____

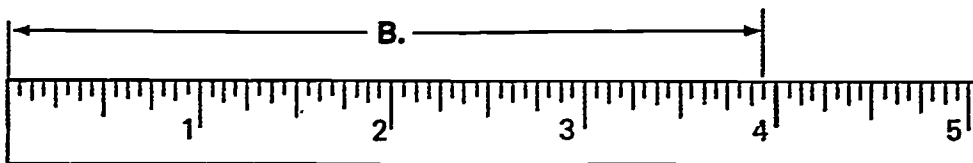

B. _____

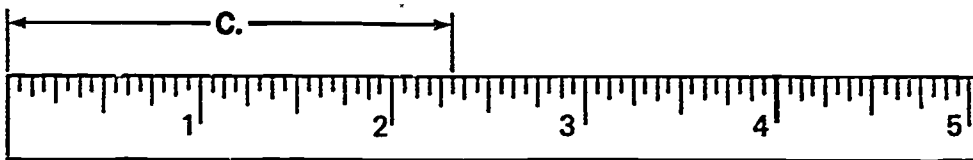

C. _____

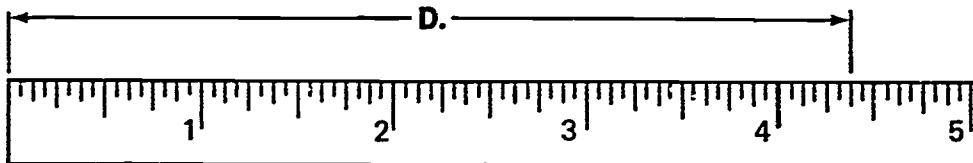

D. _____

ASSIGNMENT SHEET #2

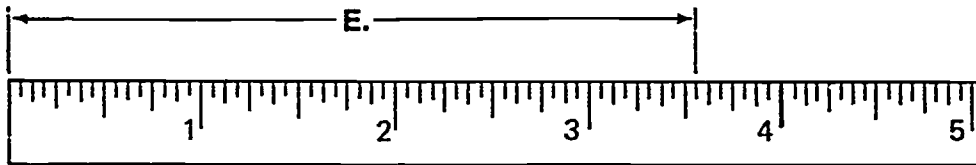

E. _____

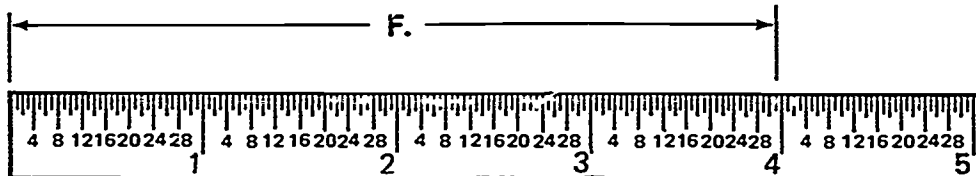

F. _____

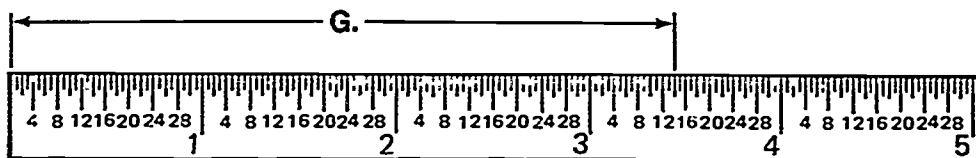

G. _____

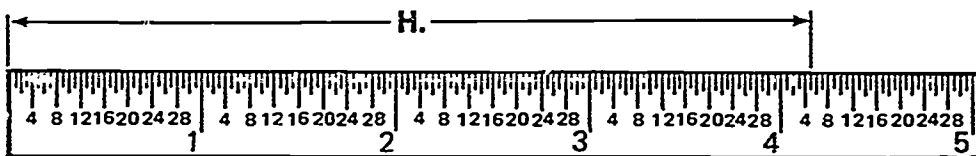

H. _____

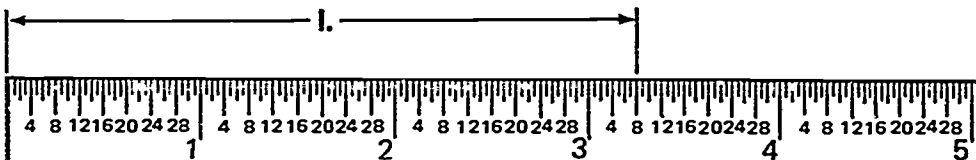

I. _____

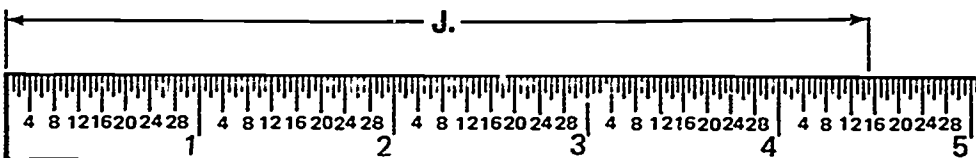

J. _____

**SCALES
UNIT V**

**ASSIGNMENT SHEET #3 — MEASURE LINES
WITH A CIVIL ENGINEER'S SCALE**

NAME _____ SCORE _____

Directions: Measure the lines A through F to the scale ratio heading each column in the table. Letter the scale readings in the appropriate space in table using guidelines for 1/8" lettering.

Example: On a 1" = 10' scale ratio, line A would be 44' long; this figure should be lettered under the 1" = 10' column opposite letter A.

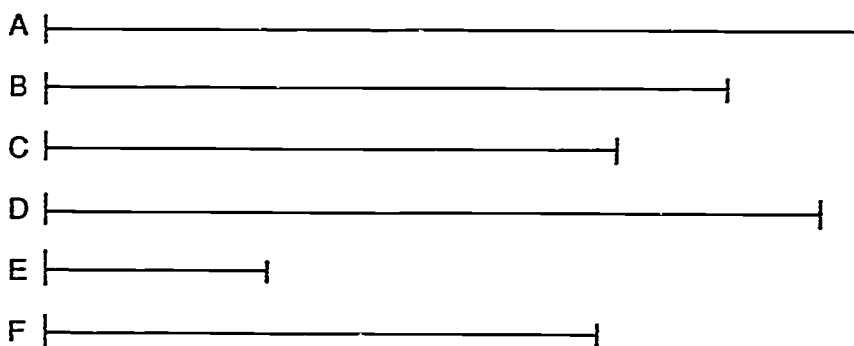

	1"=10'	1"=20'	1"=300'	1"=40'	1"=500'	1"=60'	1"=10 MILES
A							
B							
C							
D							
E							
F							

**SCALES
UNIT V**

**ASSIGNMENT SHEET #4 — MEASURE LINES
WITH AN ARCHITECT'S SCALE**

NAME _____ SCORE _____

Directions. Measure the lines A through J to the scale heading each column in the tables on this page and the next page. Print the scale readings in the appropriate space in the table.

(NOTE: Readings must be accurate or they will be considered wrong, and lettering must be neat and correct.)

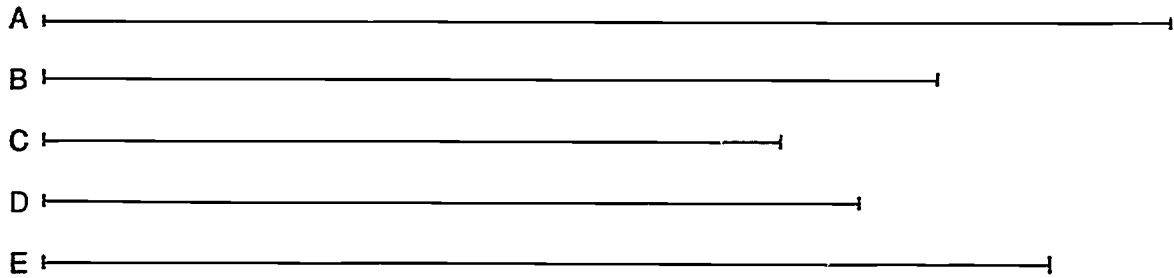

LINE	$\frac{3}{32}'' = 1'-0''$	$\frac{1}{8}'' = 1'-0''$	$\frac{1}{4}'' = 1'-0''$	$\frac{3}{8}'' = 1'-0''$	$\frac{1}{2}'' = 1'-0''$	$1 \frac{1}{2}'' = 1'-0''$	$3'' = 1'-0''$
A							
B							
C							
D							
E							

ASSIGNMENT SHEET #4

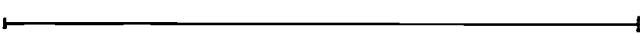
F 

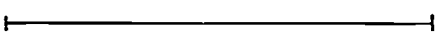
G 

H 

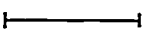
I 

J 

LINE	$\frac{3}{32} = 1'-0"$	$\frac{1}{8} = 1'-0"$	$\frac{1}{4} = 1'-0"$	$\frac{3}{8} = 1'-0"$	$\frac{1}{2} = 1'-0"$	$1 \frac{1}{2} = 1'-0"$	$3 = 1'-0"$
F							
G							
H							
I							
J							

**SCALES
UNIT V**

**ASSIGNMENT SHEET #5 — MEASURE LINES
WITH A MECHANICAL ENGINEER'S SCALE**

NAME _____ SCORE _____

Directions: Measure the lines A through F to the scale heading each column in the table. Letter the scale readings in the appropriate space in the table.

(NOTE: Readings must be accurate or they will be considered wrong.)

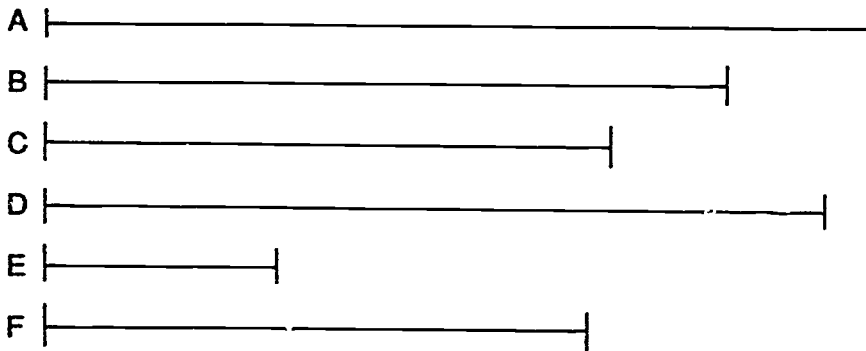

1" = 1"

1/2" = 1"

1/4" = 1"

1/8" = 1"

	1" = 1"	1/2" = 1"	1/4" = 1"	1/8" = 1"
A				
B				
C				
D				
E				
F				

**SCALES
UNIT V**

**ASSIGNMENT SHEET #6 — MEASURE LINES
WITH A METRIC SCALE**

NAME _____ SCORE _____

Directions: Measure the lines A through F to the scale heading each column in the table. Letter the scale readings in the appropriate space in the table. Use guidelines for 1/8" lettering.

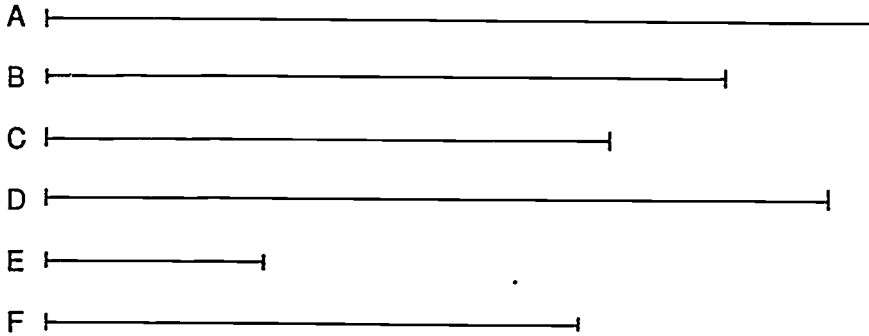

	1:1	1:2	1:5	1:25	1:33 1/3	1:100
A						
B						
C						
D						
E						
F						

SCALES
UNIT V

ANSWERS TO ASSIGNMENT SHEETS

Assignment Sheet #1

- | | | | |
|----|---------|----|-----------|
| A. | 1 1/8" | E. | 2 13/16" |
| B. | 1 3/4" | F. | 11 1/4" |
| C. | 2 3/16" | G. | 11 3/4" |
| D. | 2 9/16" | H. | 11 15/16" |

Assignment Sheet #2

- | | | | |
|----|----------|----|-------------------|
| A. | 3 3/16" | F. | 3 31/32" |
| B. | 3 15/16" | G. | 3 14/32" or 7/16" |
| C. | 2 5/16" | H. | 4 5/32" |
| D. | 4 3/8" | I. | 3 8/32" or 1/4" |
| E. | 3 9/16" | J. | 4 15/32" |

Assignment Sheet #3

	1"=10'	1"=20'	1"=300'	1"=40'	1"=500'	1"=60'	1"=10 MILES
A	44'	88'	1320'	176'	2200'	264'	44 miles
B	37'	74'	1110'	148'	1850'	222'	37 miles
C	31'	62'	930'	124'	1550'	186'	31 miles
D	42'	84'	1260'	168'	2100'	252'	42 miles
E	12'	24'	360'	48'	600'	72'	12 miles
F	30'	60'	900'	120'	1500'	180'	30 miles

ANSWERS TO ASSIGNMENTS SHEETS

Assignment Sheet #4

LINE	$\frac{3}{32}'' = 1'-0''$	$\frac{1}{8}'' = 1'-0''$	$\frac{1}{4}'' = 1'-0''$	$\frac{3}{8}'' = 1'-0''$	$\frac{1}{2}'' = 1'-0''$	$1 \frac{1}{2}'' = 1'-0''$	$3'' = 1'-0''$
A	64'-10"	48'-8"	24'-4"	16'-2 $\frac{3}{4}$ "	12'-2"	4'-0 $\frac{3}{4}$ "	2'-0 $\frac{3}{8}$ "
B	51'-6"	38'-7"	19'-4"	12'-10 $\frac{1}{2}$ "	9'-7 $\frac{3}{4}$ "	3'-2 $\frac{1}{2}$ "	1'-7 $\frac{1}{4}$ "
C	42'-5"	31'-10"	15'-11"	10'-7 $\frac{1}{4}$ "	7'-11 $\frac{1}{2}$ "	2'-7 $\frac{3}{4}$ "	1'-3 $\frac{3}{4}$ "
D	47'-0"	35'-2 $\frac{1}{4}$ "	17'-7 $\frac{1}{2}$ "	11'-8 $\frac{3}{4}$ "	8'-9 $\frac{1}{2}$ "	2'-11 $\frac{1}{4}$ "	1'-5 $\frac{5}{8}$ "
E	57'-11"	43'-5"	21'-9"	14'-5 $\frac{3}{4}$ "	10'-10 $\frac{1}{2}$ "	3'-7 $\frac{1}{2}$ "	1'-9 $\frac{3}{4}$ "
F	36'-7"	27'-5"	13'-8 $\frac{1}{2}$ "	9'-1 $\frac{3}{4}$ "	6'-10 $\frac{1}{4}$ "	2'-3 $\frac{3}{8}$ "	1'-1 $\frac{3}{4}$ "
G	24'-7"	18'-5"	9'-3"	6'-1 $\frac{3}{4}$ "	4'-7 $\frac{1}{2}$ "	1'-7"	0'-9 $\frac{1}{4}$ "
H	14'-4"	10'-9"	5'-4 $1 \frac{2}{3}$ "	3'-7"	2'-8 $\frac{1}{4}$ "	0'-10 $\frac{3}{4}$ "	0'-5 $\frac{3}{8}$ "
I	7'-9"	5'-10"	2'-11"	1'-11"	1'-5 $\frac{1}{2}$ "	0'-5 $\frac{3}{4}$ "	0'-2 $\frac{7}{8}$ "
J	2'-8"	2'-0"	1'-0"	0'-8"	0'-6"	0'-2"	0'-1"

Assignment Sheet #5

	$1'' = 1''$	$\frac{1}{2}'' = 1''$	$\frac{1}{4}'' = 1''$	$\frac{1}{8}'' = 1''$
A	4 $\frac{15}{32}''$	8 $\frac{15}{16}''$	17 $\frac{7}{8}''$	35 $\frac{3}{4}''$
B	3 $\frac{11}{16}''$	7 $\frac{3}{8}''$	14 $\frac{3}{4}''$	29 $\frac{1}{2}''$
C	3 $\frac{1}{16}''$	6 $\frac{1}{8}''$	12 $\frac{1}{4}''$	24 $\frac{1}{2}''$
D	4 $\frac{7}{32}''$	8 $\frac{7}{16}''$	16 $\frac{7}{8}''$	33 $\frac{3}{4}''$
E	1 $\frac{1}{4}''$	2 $\frac{1}{2}''$	5''	10''
F	2 $\frac{15}{16}''$	5 $\frac{7}{8}''$	11 $\frac{3}{4}''$	23 $\frac{1}{2}''$

ANSWERS TO ASSIGNMENT SHEETS

Assignment Sheet #6

	1:1	1:2	1:5	1:25	1:33 1/3	1:100
A	113mm	227mm	566mm	282.5mm	378mm	11,300mm
B	93mm	186mm	466mm	233mm	310mm	9,300mm
C	77mm	154mm	386mm	193mm	257mm	7,700mm
D	107mm	214mm	536mm	268mm	358mm	10,700mm
E	30mm	60mm	150mm	75mm	100mm	3,000mm
F	73mm	146mm	364mm	192mm	244mm	7,300mm

**SCALES
UNIT V**

TEST

NAME _____ SCORE _____

1. Match the terms on the right with their correct definitions.

- | | | | |
|----------|---|-----|---------------------|
| _____ a. | Drawing an object at a set proportion such as half its actual size, one-fourth its actual size, or double its actual size | 1. | Actual size |
| _____ b. | The subdivisions in a scale unit, all of which are equal in size or length | 2. | Architecture |
| _____ c. | A decimal system of weights and measures based on the meter and the kilogram | 3. | Centimeter |
| _____ d. | 1/1000 of a meter | 4. | Decimeter |
| _____ e. | 1/100 of a meter | 5. | Draw to scale |
| _____ f. | 1/10 of a meter | 6. | Dynamics |
| _____ g. | The capability of a CADD system to zoom, scroll, and rotate | 7. | Fraction |
| _____ h. | An instrument used as a standard of reference when drawing an object to a proportional size | 8. | Fully-divided scale |
| _____ i. | A scale with only the end unit subdivided into fractional parts | 9. | Graduations |
| _____ j. | An object's dimensions; the size of an object in completed form | 10. | Millimeter |
| _____ k. | A scale with the basic units subdivided throughout the length of the scale | 11. | Meter |
| _____ l. | The metric system standard for linear measurement | 12. | Metric system |
| _____ m. | The design and drawing of public and private buildings | 13. | Open-divided scale |
| _____ n. | A part of a whole, such as 1/2 or 1/4 | 14. | Scale |
| | | 15. | SI |

TEST

2. Distinguish among the different scales used in drafting by placing the following letters next to the correct descriptions:

A — Architect's scale
 C — Civil engineer's scale
 M — Mechanical engineer's scale
 MD — Mechanical engineer's decimal scale
 MT — Metric scale

- ___ a. Used primarily in drawings of public works such as roads, bridges, dams, city subdivisions, etc; graduated in units of one inch divided into 10, 20, 30, 40, 50, and 60 parts
- ___ b. Used primarily in drawings of buildings, piping systems, and other large structures which must be drawn to a reduced scale to fit on a standard sheet size; it has one full-size scale and ten reduced-size scales
- ___ c. Divided into units representing full size ($1'' = 1''$), half size ($1/2'' = 1''$), quarter size ($1/4'' = 1''$), and one-eighth size ($1/8'' = 1''$)
- ___ d. Used when dimensions are in millimeters
- ___ e. Fully divided into .1" and .02"

3. State the purpose of a scale.

4. Select true statements concerning rules for measuring with a scale by placing an "X" in the appropriate blanks.

- ___ a. Select proper scale ratio.
- ___ b. Scale should be at a 30 degree angle to the line being measured.
- ___ c. Scales can be used as a cutting edge.
- ___ d. Scale should lie flat on the surface being measured.
- ___ e. A short dash should be made rather than a point to mark a distance.
- ___ f. Stick compass or divided points into scale to set instruments.
- ___ g. Edge of the scale should be protected to prevent damage to its graduation marks.

TEST

- _____h. If a series of measurements are to be made on the full size scale, do not move scale for each measurement.
 - _____i. Make sure that the line of sight does not create an optical illusion.
5. Select true statements concerning rules when applying a scale to a drawing by placing an "X" next to the true statements.
- _____a. Views or sections must be drawn at the same scale as the main drawing.
 - _____b. Full scale is preferred.
 - _____c. Never draw a "No Scale" drawing.
 - _____d. When dimensions are changed, the dimension is underlined.
 - _____e. Half scale is preferred.
6. List five of the preferred drawing scales.
- a. _____
 - b. _____
 - c. _____
 - d. _____
 - e. _____

7. Interpret 1/16, 1/8, and 1/4 graduations on the full size scale shown below:

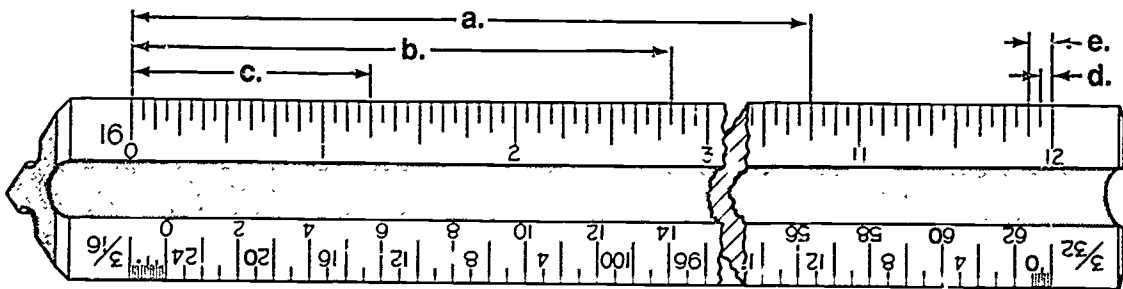

- a. _____
- b. _____
- c. _____
- d. _____
- e. _____

TEST

3. Calculate and locate $1/32$ " graduations on the full size scale shown below by marking each dimension with a $1/8$ " dash and labeling the point with the correct dimension.
- a. $1\ 5/32$ "
 - b. $2\ 21/32$ "
 - c. $11\ 13/32$ "

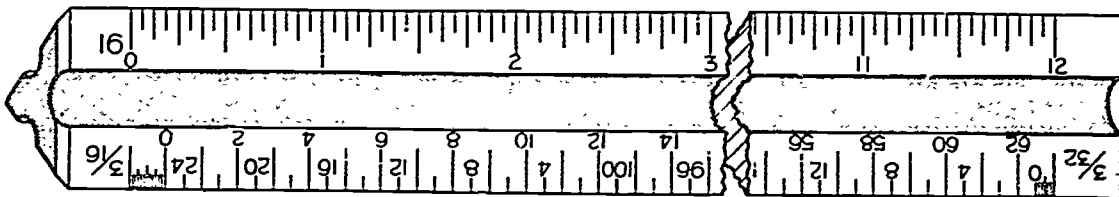

9. Read a fully-divided decimal scale.

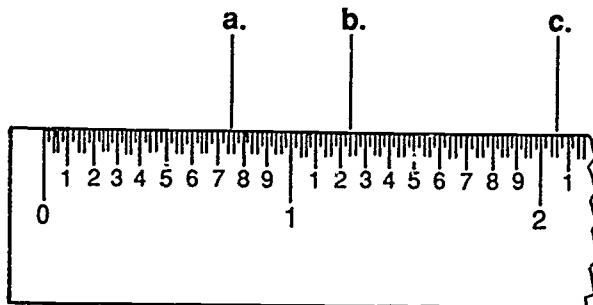

- a. _____
- b. _____
- c. _____

TEST

10. List four scale ratios found on each of the following scales and rules.

a. Architect's scale

- 1) _____
- 2) _____
- 3) _____
- 4) _____

b. Civil engineer's scale

- 1) _____
- 2) _____
- 3) _____
- 4) _____

c. Mechanical engineer's scale

- 1) _____
- 2) _____
- 3) _____
- 4) _____

d. Machinist steel rule (common)

- 1) _____
- 2) _____
- 3) _____
- 4) _____

e. Metric scale

- 1) _____
- 2) _____
- 3) _____
- 4) _____

TEST

11. Select metric scale ratios commonly used for various drafting applications by placing an "MD" by those ratios commonly used for machine drawings; an "AD" by those ratios commonly used for architectural plans, details, and plot plans; and an "M" by those ratios commonly used for maps.
- | | | | |
|--------|--------------------|--------|----------|
| ___ a. | 1:1 | ___ i. | 1:25 |
| ___ b. | 1:50,000 | ___ j. | 1:100 |
| ___ c. | 1:3 | ___ k. | 1:200 |
| ___ d. | 1:500 | ___ l. | 1:5 |
| ___ e. | 1:10 | ___ m. | 1:20 |
| ___ f. | 1:2,500 | ___ n. | 1:10,000 |
| ___ g. | 1:75 | ___ o. | 1:2 |
| ___ h. | 1:33 $\frac{1}{3}$ | | |
12. Distinguish between a reduction scale ratio and an enlargement scale ratio by placing an "X" by each example of a reduction scale ratio.
- | | |
|--------|--------------------|
| ___ a. | 1:2 |
| ___ b. | 5:1 |
| ___ c. | 1:5 |
| ___ d. | 2:1 |
| ___ e. | 1:33 $\frac{1}{3}$ |
| ___ f. | 1:25 |
| ___ g. | 1:1 |
| ___ h. | 10:1 |
13. Select true statements concerning drawing scale when using CADD by placing an "X" next to the true statements.
- | | |
|--------|---|
| ___ a. | Each view will appear at the scale selected. |
| ___ b. | The scale of a drawing cannot be changed at the time of plotting. |
| ___ c. | Any size drawing may be determined on a CADD system. |

TEST

14. Match terms related to view manipulation on CADD listed on the right with the correct definitions.

- | | | |
|----------|---|-----------------|
| _____ a. | A temporary, usually rectangular, bounded area on the CRT that is user-specified to include particular entities for modification, editing, or deletion | 1. Restore |
| _____ b. | Proportionally enlarging a figure or portion of a figure so it fills the screen or view port | 2. Scissor |
| _____ c. | To bring back to its original state a design currently being worked on in a CADD system altering modification that the user now wants to cancel or rescind | 3. Scroll (Pan) |
| _____ d. | To automatically roll up, as on a spool, a design or text message on a CRT to permit the sequential viewing of a message or drawing too large to be displayed all at once on a screen | 4. Stretch |
| _____ e. | A CADD design/editing aid that enables the user to automatically expand a displayed entity beyond its original dimensions | 5. Window |
| _____ f. | A CADD capability that proportionately enlarges or reduces a figure displayed on a CRT screen | 6. Windowing |
| _____ g. | To trim a drawing in the database so that it can be viewed on a CRT screen | 7. Zoom |

(NOTE: If the following activities have not been accomplished prior to the test, ask your instructor when they should be completed.)

15. Read a full scale. (Assignment Sheet #1)
16. Interpret 1/16 and 1/32 graduations on a full-size metal rule. (Assignment Sheet #2)
17. Measure lines with a civil engineer's scale. (Assignment Sheet #3)
18. Measure lines with an architect's scale. (Assignment Sheet #4)
19. Measure lines with a mechanical engineer's scale. (Assignment Sheet #5)
20. Measure lines with a metric scale. (Assignment Sheet #6)

**SCALES
UNIT V**

ANSWERS TO TEST

1. a. 5 h. 14
 b. 9 i. 13
 c. 12 j. 1
 d. 10 k. 8
 e. 3 l. 11
 f. 4 m. 2
 g. 6 n. 7
2. a. C
 b. A
 c. M
 d. MT
 e. MD
3. To provide a standard of reference for drawing objects either at their actual size or larger or smaller than actual size
4. a, d, e, g, h, i
5. b, d
6. Any five of the following:

SCALE	DESIGNATION
Full size	1/1
Half size	1/2
Quarter size	1/4
Tenth size	1/10 (nonpreferred)
Double size	2/1
Four times size	4/1
Ten times size	10/1 (nonpreferred)

ANSWERS TO TEST

7. a. $10 \frac{3}{4}$ "
 b. $2 \frac{13}{16}$ "
 c. $1 \frac{1}{4}$ "
 d. $\frac{1}{16}$ "
 e. $\frac{1}{8}$ "

8.

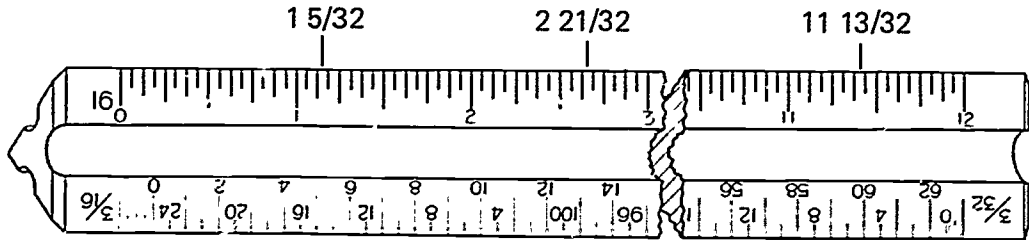

9. a. .75
 b. 1.24
 c. 2.06

10. Any four of the following for each:

a. Architect's scale

- 1) 12" = 1'-0" — Full size
- 2) 6" = 1'-0" — Half size
- 3) 3" = 1'-0" — 1/4 size
- 4) 1 1/2" = 1'-0" — 1/8 size
- 5) 1" = 1'-0" — 1/12 size
- 6) 3/4" = 1'-0" — 1/16 size
- 7) 1/2" = 1'-0" — 1/24 size
- 8) 3/8" = 1'-0" — 1/32 size
- 9) 1/4" = 1'-0" — 1/48 size
- 10) 3/16" = 1'-0" — 1/64 size
- 11) 1/8" = 1'-0" — 1/96 size
- 12) 3/32" = 1'-0" — 1/128 size

b. Civil engineer's scale

- 1) 10 scale — 1" subdivided into 10 parts
- 2) 20 scale — 1" subdivided into 20 parts
- 3) 30 scale — 1" subdivided into 30 parts
- 4) 40 scale — 1" subdivided into 40 parts
- 5) 50 scale — 1" subdivided into 50 parts
- 6) 60 scale — 1" subdivided into 60 parts

ANSWERS TO TEST

c. Mechanical engineer's scale (fractional and decimal)

- 1) 1" = 1" — Full size
- 2) 1/2" = 1" — Half size
- 3) 1/4" = 1" — Quarter size
- 4) 1/8" = 1" — One-eighth size
- 5) 10 parts per inch — Each division equals .1"
- 6) 50 parts per inch — Each division equals .02"

d. Machinist steel rule (fractions, decimals, and metric)

- 1) 32 parts per inch — Each division equals 1/32"
- 2) 64 parts per inch — Each division equals 1/64"
- 3) 10 parts per inch — Each division equals .1"
- 4) 50 parts per inch — Each division equals .02"
- 5) Millimeters — Each division equals 1 mm
- 6) 1/2 millimeters — Each division equals .5 mm

e. Metric scale

- 1) 1:1
- 2) 1:2
- 3) 1:5
- 4) 1:10
- 5) 1:25
- 6) 1:33 1/3
- 7) 1:75

- | | | | | |
|-----|----|----|----|----|
| 11. | a. | MD | i. | AD |
| | b. | M | j. | AD |
| | c. | MD | k. | AD |
| | d. | M | l. | MD |
| | e. | MD | m. | AD |
| | f. | M | n. | M |
| | g. | AD | o. | MD |
| | h. | AD | | |

12. a, c, e, f

13. a, c

- | | | | | |
|-----|----|---|----|---|
| 14. | a. | 5 | e. | 4 |
| | b. | 6 | f. | 7 |
| | c. | 1 | g. | 2 |
| | d. | 3 | | |

15.-20. Evaluated to the satisfaction of the instructor.

DRAWING FORMAT UNIT VI

UNIT OBJECTIVE

After completion of this unit, the student should be able to select items of information required on a drawing sheet layout, list types of CADD drawings, and draw a title block. Competencies will be demonstrated by completing the job sheets and the unit tests with a minimum score of 85 percent.

SPECIFIC OBJECTIVES

After completion of this unit, the student should be able to:

1. Match terms related to drawing format with their correct definitions.
2. Match types of working drawings with their correct definitions.
3. Match other types of drawings with their correct definitions.
4. List basic information needed on a drawing.
5. State the location of various components on a drawing.
6. Select information found in a title block.
7. Select information found in a revision block.
8. Select information found in a parts list.
9. Select information found in supplementary blocks.
10. Select true statements concerning the use of general notes on a drawing.
11. List types of CADD drawing systems.
12. List typical considerations in initiating a CADD drawing.
13. Demonstrate the ability to:
 - a. Complete a title block. (Job Sheet #1)
 - b. Enter drawing parameters onto a CADD system. (Job Sheet #2)
 - c. Format a parts storage diskette. (Job Sheet #3)
 - d. Draw a title block on a CADD system. (Job Sheet #4)

DRAWING FORMAT UNIT VI

SUGGESTED ACTIVITIES

- A. Provide student with objective sheet.
- B. Provide student with information and job sheets.
- C. Make transparencies.
- D. Discuss unit and specific objectives.
- E. Discuss information sheet.
- F. Discuss the procedures outlined in the job sheets.
- G. Use file drawings to demonstrate to the class the location of various information blocks and areas on a set of working drawings.
- H. Invite a checker from a local drafting or architectural firm to speak to the class concerning techniques used in checking drawings.
- I. Using information from various companies, have students complete several title blocks.
- J. Add to your library a current copy of *ANSI Y14.1*.
- K. Give test.

REFERENCES USED IN DEVELOPING THIS UNIT

- A. Brown, Walter C. *Drafting for Industry*. South Holland, IL: The Goodheart-Willcox Company, Inc., 1984.
- B. Spencer, Henry C., et. al. *Technical Drawing Problems*. New York: Macmillan Publishing Co., Inc., 1980.
- C. Giesecke, Frederick E., et. al. *Technical Drawing*, 8th ed. New York: Macmillan Publishing Co., Inc., 1986.
- D. Jensen, Cecil and Jay Helsel. *Engineering, Drawing, and Design*, 3rd ed. New York: McGraw-Hill Book Company, 1985.
- E. *Basic Drafting*. Natchitoches, LA. Vocational Curriculum Development and Research Center, 1979.
- F. *ANSI Y14.1-1980 — Drawing Sheet Size and Format*. New York: The American Society of Mechanical Engineers, 1980, reaffirmed 1987.

SUGGESTED ACTIVITIES

- G. *Drawing Requirements Manual; DOD-D-1000/DOD-STD-100 and Metric*, 5th Ed. Santa Ana, CA: Global Engineering Documents. 1-800-854-7179.
- H. Merickel, Mark. *Stepping Into CAD*. Thousand Oaks, CA. New Riders Publishing, 1986.
- I. Lawrence C. Anderson, Jr. *Computer Graphics Mechanical Design Concepts*. Milwaukee, WI: MATC, 1986.

**DRAWING FORMAT
UNIT VI****INFORMATION SHEET****I. Terms and definitions**

- A. ANSI (American National Standards Institute) — An association formed by industry and the U.S. Government to produce and disseminate drafting and manufacturing standards

Example: *ANSI Y14.1 — Drawing Sheet Size and Format*

- B. Change order — An approved engineering change on an existing drawing
- C. Database — An organized collection of standard parts libraries, completed designs, documentations, and computer programs
- D. Drawing — Graphic and letter information on an original media surface
- E. Federal Supply Code for Manufacturers (FSCM) — A five-digit code identification number assigned to organizations that manufacture or design items used by the U.S. Government
- F. Format — The specific arrangement of data for a list or report
- Example: A pre-printed drawing border, title block
- G. Library — A collection of symbols, components, shapes, or parts stored in the CADD database; templates for future design work on the system
- H. Microfilm alignment — Arrowheads placed in the margins of a drawing to aid in the alignment of drawings to be microfilmed (Transparency 1)
- I. Model — An accurate three-dimensional representation of a part, assembly, or plant designed on a CADD system and stored in the database
- J. Revision — A correction made on a drawing to reflect a needed change
- K. Symbols — Sets of primitive graphic entities, lines, points, arcs, circles, and text that are grouped together as a unit; may be combined or nested to form larger units or drawings
- L. Zones — The areas on the border of a drawing sheet used for locating specific points by the coordinate point system (Transparency 1)

(NOTE: On a complicated drawing, if there is a revision to be made which would be difficult to locate, use zones to determine the revision quickly and accurately.)

INFORMATION SHEET

II. Types of working drawings and their definitions

- A. Working drawing — A drawing needed to manufacture, build, assemble, or install any unit, component, or structure

(NOTE: The drawing must have size and shape descriptions, specifications for the materials to be used, the finish, and completeness of the project.)

- B. Detail drawing — The complete size, material, and specification description of an individual part

(NOTE: Sometimes specifications may be found on a separate sheet.)

- C. Subassembly drawing — A description of how several parts fit together in one unit

- D. Assembly drawing — A description of how several subassemblies and details make up a larger unit

- E. Installation drawing — A description of how an object fits into its working position

- F. Set of working drawings — A number of working drawings bound together to do a complete project or job

III. Other types of drawings and their definitions

- A. Process drawings — Drawings of only one step in a production or manufacturing assembly which enable a machine operator to set up equipment for a single operation

Examples: Drilling, punching holes, milling a surface

- B. Layout drawings — Drawings used in the development of experimental or prototype design

(NOTE: They appear to be assembly drawings; however, layout drawings are used in the early developmental stages of a product, and assembly drawings are for the final fabrication process.)

- C. Checking drawings or check set — Drawings which are carefully checked for accuracy before they are sent into the field or into the shop for fabrication

(NOTE: Checking should be done by a drafter who is not working on the drawing, or by the project engineer or architect, chief drafter, or the checker, depending on the company structure.)

INFORMATION SHEET

IV. Basic information needed on a drawing

- A. Drawing (plate) name
- B. Drawing (plate) number
- C. Scale
- D. Date
- E. Company name and address
- F. Drafter's name
- G. Revision block
- H. Parts list (PL)

(NOTE: A parts list may also be referred to as a list of materials, bill of materials [BOM], stock list, or item list.)

- I. Tolerance
- J. Approval signature

V. Locations of components on a drawing

- A. Title block location — Should be located in the lower right corner of the drawing layout

(NOTE: Some companies may move the locations.)

- B. Drawing number locations — Should be located in the lower right corner of the title block and in at least one other location

- C. Parts list location — Should be located in the lower right corner above the title block or may appear as a separate document

(NOTE: If additional parts lists are needed, they should be located left of or adjacent to the original parts list.)

- D. Supplementary block location — Should be located in the same respective location on all drawings, usually to the left of the title block

- E. Revision block location — Should be located in the upper right corner of the drawing layout

(NOTE: Some companies may move the location.)

INFORMATION SHEET**VI. Information found in a title block (Transparency 2)**

- A. Name and address of company or design firm
- B. Drawing title (name)
- C. Drawing number
- D. Drafter's name
- E. Date drafter completed drawing
- F. Checker's name
- G. Date checker completed checking functions
- H. Approval signatures
- I. Issue (release) date
- J. Contract numbers
- K. Approval by someone in another company

(NOTE: This is used only when a contractor-subcontractor situation exists.)

- L. Scale of drawing
- M. FSCM number of company or design firm
- N. Letter designation of drawing size (A-K)
- O. Actual or estimated weight of item where required
- P. Drawing sheet number for multiple sheet drawings

VII. Information found in a revision block (Transparency 3)

- A. Revision number or letter
- B. Description or identification of the change
- C. Date
- D. Approval
- E. Zone

(NOTE: The zone may not be needed. An additional column may be added if needed for listing the authority for the revision or the reason for the revision.)

288

INFORMATION SHEET

VIII. Information found in a parts list (Transparency 4)

A. Integral parts list (prepared and revised as part of the engineering drawing)

1. Quantity required
2. FSCM number

(NOTE: This is optional for non-government contracts or where the contractor uses only his own part numbers.)

3. Part or identifying number
4. Nomenclature or description

B. Separate parts list (prepared as a document separate from the engineering drawing)

(NOTE: When using separate parts lists, a cross reference note should be located directly above the title block which says, "SEE SEPARATE PARTS LIST.")

1. Design activity identification — Name of originating design activity (government or contractor) whose FSCM number appears
2. Contract number — Government contract number under which the parts list was initially prepared
3. FSCM number — Number of design activity having responsibility for the design
4. Identifying number — The letters PL and then the number of the associated drawing
5. Revision date — For the initial release, enter a dash (-); for subsequent releases, enter the appropriate revision status
6. List title — Title (noun or noun phrase) of the engineering drawing with which the list is associated
7. Authentication — Signature or symbol of the preparing design firm
8. Revision authorization number — Number of the revision authorization document is entered when a revision description or revision record is not provided
9. Sheet of sheets — Enter the appropriate sheet number

INFORMATION SHEET

IX. Information found in supplementary blocks

- A. Notes on dimensioning and tolerances
- B. Usage and general notes
- C. Material
- D. Treatment
- E. Finish

X. Use of general notes on a drawing

- A. General notes are located in the upper left hand corner for drawing sizes "B" through "F".
- B. General notes column shall not exceed 8 inches in length.
- C. General notes are punctuated according to the rules of English grammar.
- D. Abbreviations may be used but must conform to standard abbreviations (*ANSI Y1.1-1972(R1984)*).
- E. General notes should be neatly lettered.

XI. Types of CADD drawing systems (Transparencies 5 and 6)

- A. Three-dimensional
 - 1. Draw mode
 - 2. Model mode
- B. Two-dimensional
- C. Two-and-one-half-dimensional
 - 1. 2D mode
 - 2. Isometric drawing

XII. Typical considerations in initiating a CADD drawing

- A. Operational mode
 - 1. Draw
 - 2. Model
- B. Name of active part

INFORMATION SHEET

C. Name of active drawing

Example: KAS.1. Bracket (Part name)

KAS.1. Bracket 1

KAS.1. Bracket 2

Drawings of the
original part

D. Drawing scale (measurement unit - inches, feet, centimeters)

E. Size of sheet (title block format)

F. Active layer (number - 0 through 255 layers)

G. Active construction plane (corresponds to the view being worked on)

H. Date

Sheet Sizes

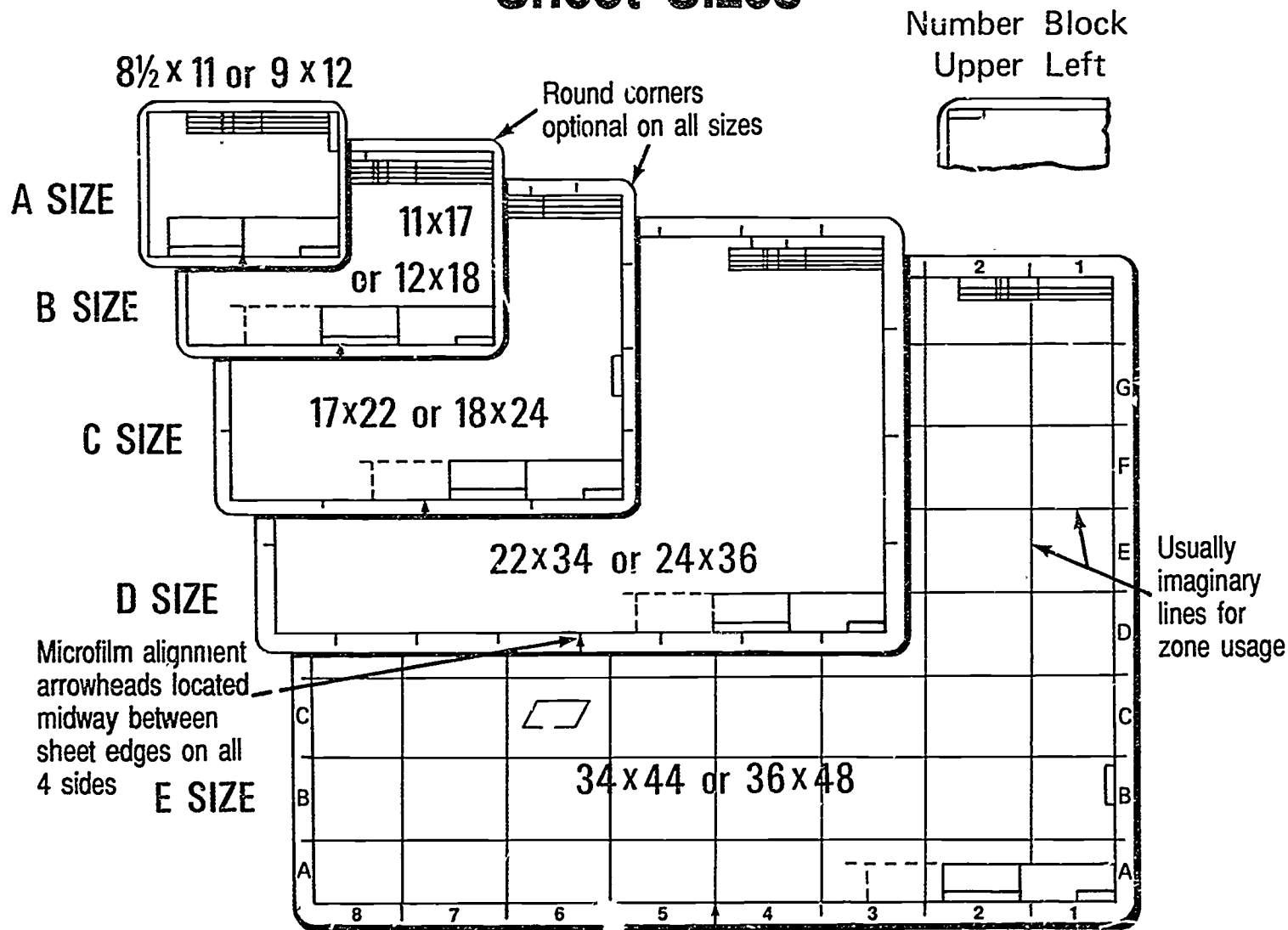

Title Blocks

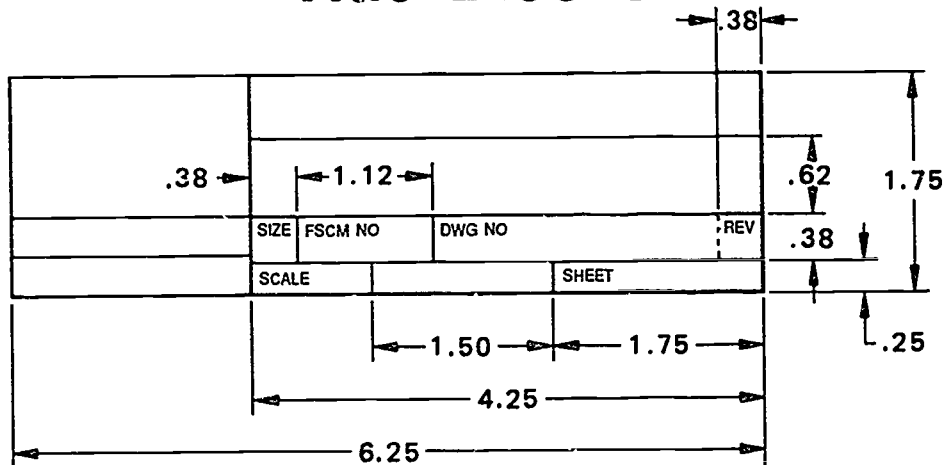

NOTE: All dimensions are in inches. 1 inch = 25.4 mm.

Title Block for A, B, C, and G Sizes

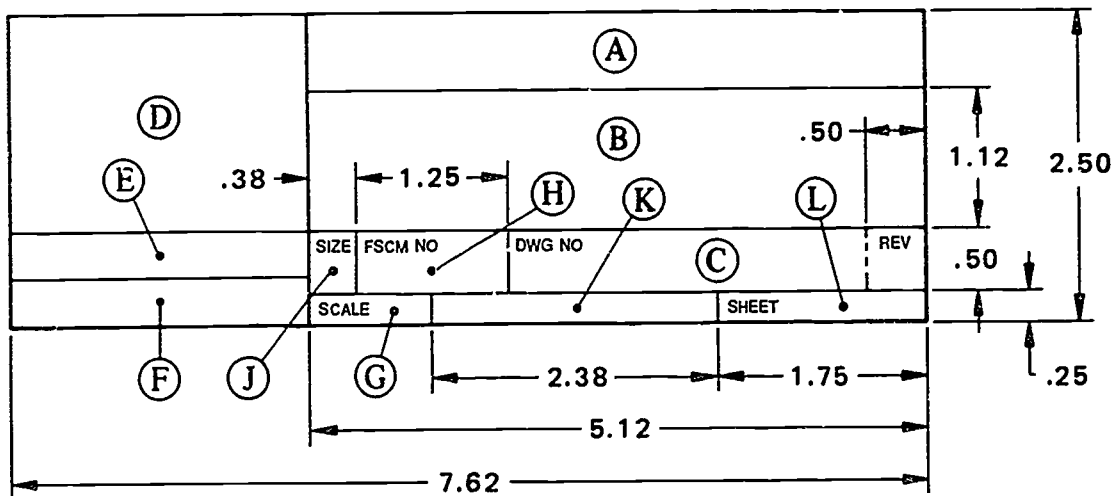

NOTE: All dimensions are in inches. 1 inch = 25.4 mm.

Title Block for D, E, F, H, J, and K Sizes

Letter References

- A. Name and address of company or design firm whose FSCM number appears in H
- B. Drawing title
- C. Drawing number
- D. Drafting Information — Names and dates of drafter, checker, approval, issue date, and contract number
- E. Approval by design firm when different from source preparing drawing (D)
- F. Additional approval if required
- G. Predominant scale of drawing
- H. FSCM number of company or design firm
- J. Drawing size letter designation
- K. Actual or estimated weight of item where required
- L. Sheet number for multiple sheet drawings

ANSI Y14.1-1980. Reprinted with permission of The American Society of Mechanical Engineers.

Revision Blocks

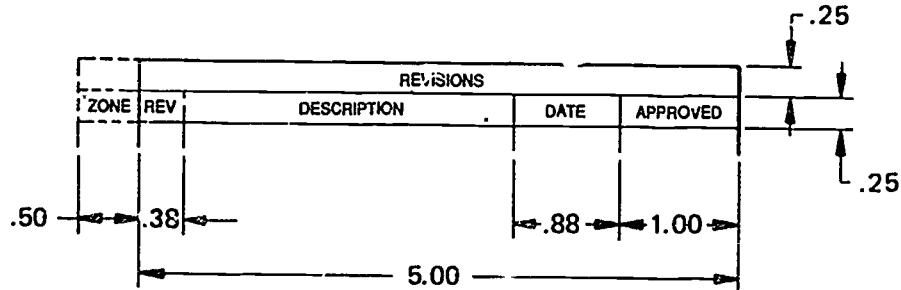

NOTE: All dimensions are in inches. 1 inch = 25.4 mm.

Revision Block for A, B, C, and G Sizes

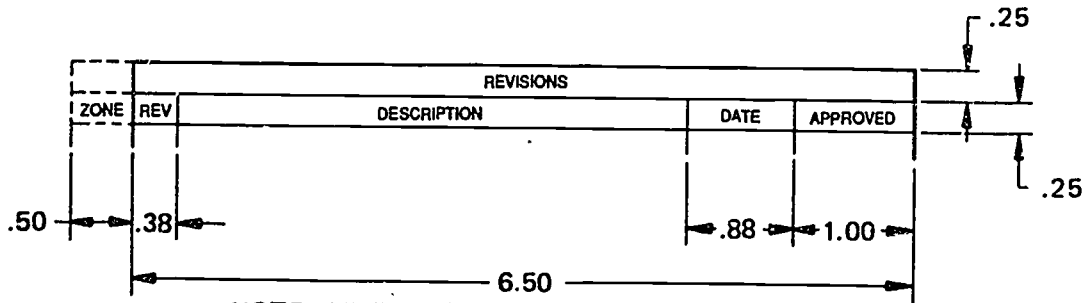

NOTE: All dimensions are in inches. 1 inch = 25.4 mm.

Revision Block for D, E, F, H, J, and K Sizes

ANSI Y14.1-1980. Reprinted with permission of The American Society of Mechanical Engineers.

Parts Lists

QTY REQD	FSCM	PART OR IDENTIFYING NO.	NOMENCLATURE OR DESCRIPTION
PARTS LIST			

Columnar Arrangement for Integral Parts List

PARTS LIST	DESIGN ACTIVITY IDENTIFICATION	CONTRACT NO.	FSCM	PL	REV. DATE
LIST TITLE		AUTHENTICATION	REV. AUTH. NO.	SHEET OF SHEETS	
QTY REQD	FSCM	PART OR IDENTIFYING NO.	NOMENCLATURE OR DESCRIPTION		

Columnar Arrangement for Separate Parts List

ANSI Y14.34M-1982. Reprinted with permission of The American Society of Mechanical Engineers.

Typical CADD Drawings

(3D)

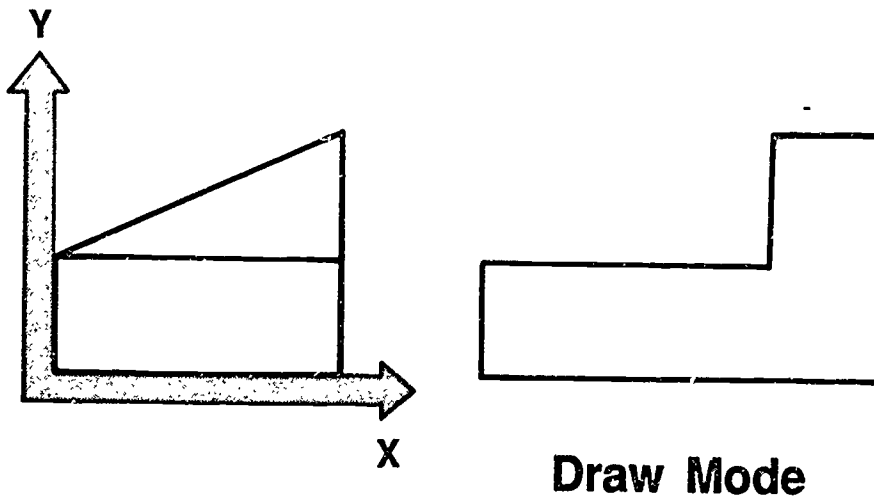
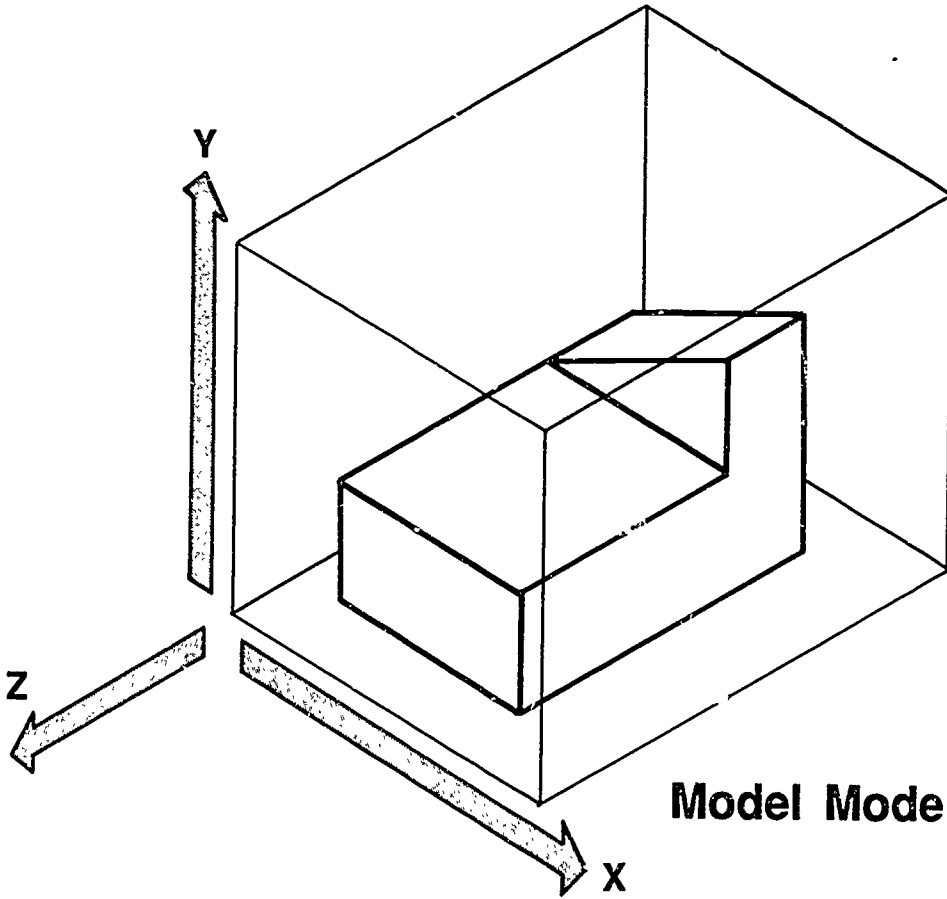

Typical CADD Drawings

(2D & 2½D)

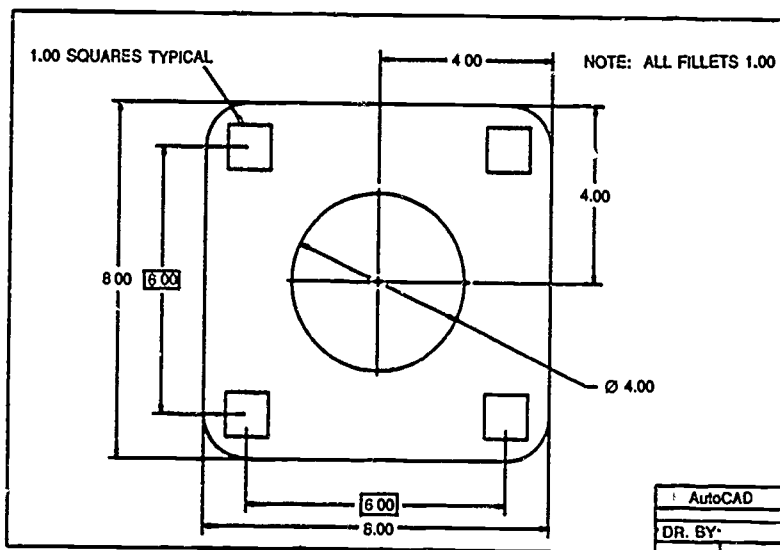

2-Dimensional

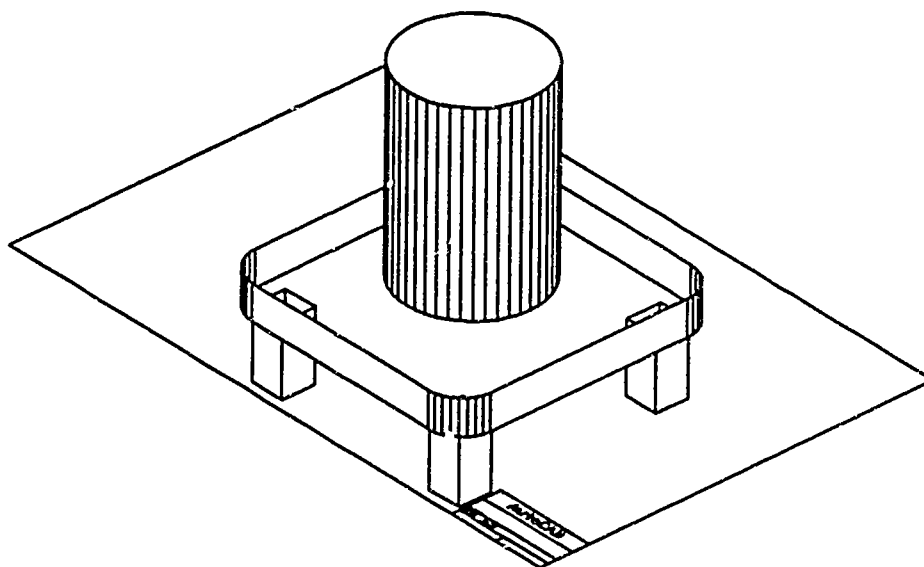

2½-Dimensional

Reprinted with permission from New Riders Publishing, Westlake Village, CA

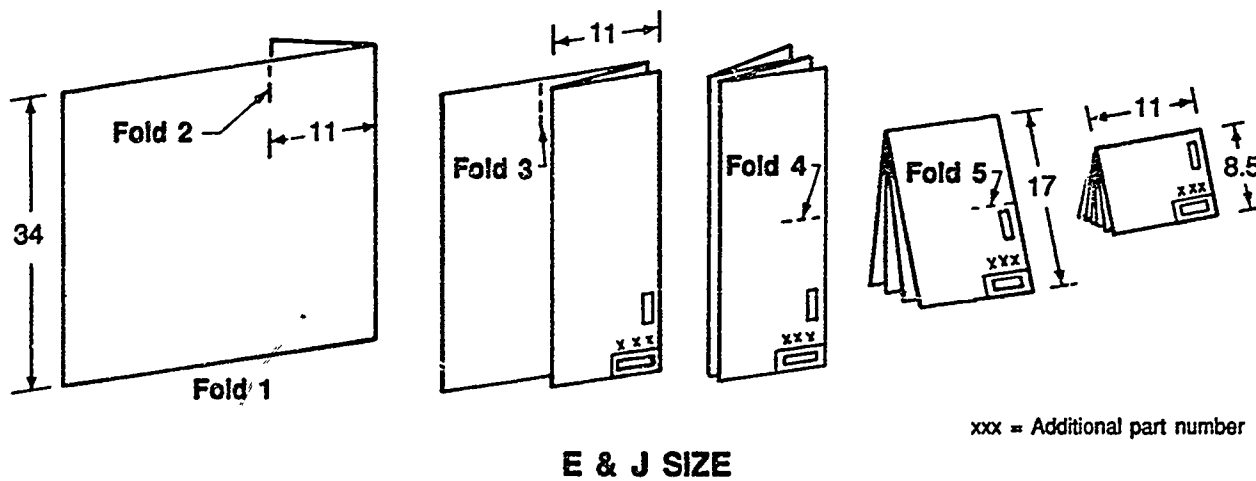
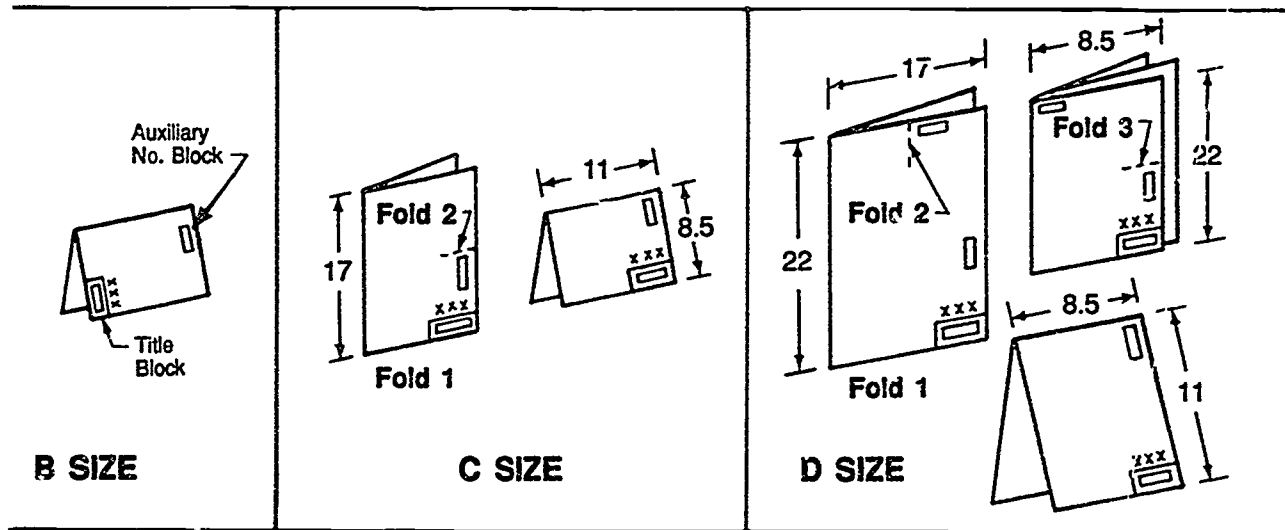

Folding drawings and prints in this manner allows for easier filing and retrieval.

Reprinted with permission of Global Engineering from *Drawing Requirements Manual, DOD and Commercial, 6th edition.*

HANDOUT #1 — STANDARD PROCEDURES FOR FOLDING DRAWINGS

DRAWING FORMAT
UNIT VI

**DRAWING FORMAT
UNIT VI**

JOB SHEET #1 — COMPLETE A TITLE BLOCK

- A. Tools and materials
1. Drafting machine
 2. Drafting pencil

EVALUATION CRITERIA	
Criteria	Rating
Overall neatness	_____
Legible lettering	_____
Information properly placed	_____

- B. Procedure
1. Tape this sheet to drawing surface.
 2. Review the following data:

Given: Drawing Information

- | | |
|----------------------------|--------------------------------|
| 1. MAVCC Manufacturing Co. | 7. Checker: L. Schertz |
| 2. Drawing name: Valve | 8. Check date: 08/01/89 |
| 3. Drawing no.: MV. 101 | 9. Customer: Water Works, Inc. |
| 4. Sheet size - "D" | 10. Contract No: 1001-101 |
| 5. Sheet no.: 1 of 2 | 11. FSCM No. 1391 |
| 6. Scale - Half | 12. Release date: 10/15/89 |

3. Complete the title block below by lettering in the given data in the appropriate places. Use uppercase letters that are neat and legible.

CONTRACT NO.					
CUSTOMER					
DRAFTER	DATE				
CHECKER					
DESIGN APPROVAL		SIZE	FSCM NO.	DWG NO.	REV
RELEASE		SCALE			SHEET

301

**DRAWING FORMAT
UNIT VI**

JOB SHEET #2 — ENTER DRAWING PARAMETERS ON A CADD SYSTEM

A. Tools and equipment

1. CADD system hardware
2. Appropriate CADD software
3. Instruction (user) manual for your CADD system

EVALUATION CRITERIA	
Criteria	Rating
Drawing parameters correctly set	_____

B. Procedure:

1. Log on to your CADD system.
2. Enter into the CADD/Graphic level.
3. Obtain from your instructor a specific part to enter into the CADD.
4. Refer to your CADD manual for commands to establish drawing parameters.

(NOTE: The following is an example for one CADD system. Exact procedures will vary for your system.)

Example: Computervision — CADDs Sample Part I Draw Parameters

Courtesy of Computervision, a Prime Computer Company. Reprinted with permission.

The following pages contain a listing of part, drawing, dimension and text parameters which a user can enable/disable or modify during a work session in CADDs.

CADDs Session

ACTIVATE PART PARTNAME
 ACTIVATE DRAWING DRAWNAME
 SELECT MODE MODEL
 DEFINE VIEW 1 CPLANE
 TOP:X5Y9,X.5Y7,X9Y10.5<CR><CR>
 DEFINE VIEW 2 CPLANE FRONT
 SCALE 4:X5Y5,X.5Y.5,X9Y7<CR><CR>

Y = 11.500000
 View: 6
 View: 5
 View: 4
 View: 1
 View: 2
 View: 3

PART NAME

=users.cadd.s.parts.test1.&pd

Precision: 1
 Dimension: 3
 Model data base units: IN
 Extents:Min X,Y,Z = -512.0 -512.0
 -512.0
 Max X,Y,Z = 512.0 512.0 512.0
 ** Drawing: 1
 Created: 9-25-85, 8:05
 Modified: 7-24-86, 12:00
 Width: 35.000000 Height: 23.000000
 Unit: IN
 Zoom: 0.342379 Scroll: X = 17.500000

LAYERS USED: 0, 5, 10, 51-52

GEOM ONLY: 10, 51

TEXT ONLY: 52

BOTH: 0, 5

The following views are in drawing: 1

View name: 3

Visible entities: 0-255

Visible layers : 0,5,50-56

View Is unblanked

View origin: X = 7.673668 drawing units, Y = 19.75057 drawing units

Clipping extents: X min = 7.088804, X max = 9.520125 drawing units, Y min = 18.95197,

Y max = 20.67166 drawing units, Z min = -2.500000e+24, Z max = 2.500000e+24

model units

JOB SHEET #2

Perspective view point: X = 7.673668
drawing units. Y = 19.75057 drawing units,
Z = -0.0 drawing units
Drawing to view space scale (ZOOM): 0.25
Temporary drawing to view space scale
(ZOOM): 0.25
View scroll: X = -52.00262 drawing units.
Y = -103.5222 drawing units
View rotation (TILT): 0.0 degrees.

DIMENSION PARAMETERS

DIMENSIONING FLAGS

REGENERATION = IMMEDIATE
ASSOCIATIVITY = ENABLED
REALM = DRAW
TEXT FIXED = DISABLED
TEXT CHECKED = ENABLED
USE PROPERTY = DISABLED
SOLID DIMENSION LINE = DISABLED
LEADING ZERO = DISABLED
TRAILING ZERO = ENABLED
AUTOCENTER = DISABLED
DIMENSION STANDARD = ANSI
NOT TO SCALE SYMBOL = DISABLED

TEXT SYMBOLS

PREFIXED DIAMETER = ENABLED
PREFIXED RADIUS = ENABLED
APPENDED RADIUS = DISABLED

DIMENSION FORMAT PARAMETERS

FRACTIONS = DECIMAL
DECIMAL POINT = PERIOD
METRIC FORMAT = ENGLISH
BINARY FRACTION TYPE = LARGE

QUAL DIMENSIONING PARAMETERS

QUAL DIMENSIONS = DISABLED
METHOD = POSITION
DIMENSION FORMAT = PRIMARY

ABOVE SECONDARY

TOLERANCING PARAMETERS

TOLERANCE = DISABLED
TYPE = INCREMENTAL

TAL

LINEAR TOLERANCES

PRIMARY POSITIVE = 0.0
SECONDARY POSITIVE = 0.0
PRIMARY NEGATIVE = 0.0
SECONDARY NEGATIVE = 0.0

ANGULAR TOLERANCES

POSITIVE = 0.0
NEGATIVE = 0.0

HEIGHT RATIO

PRIMARY = 1.0
SECONDARY = 1.0

TEXT POSITION

PRIMARY = CENTER
SECONDARY = CENTER

LAYER PARAMETERS

PRIMARY = CURRENT

LAYER

SECONDARY = DISABLED
QUAL = DISABLED

PRECISION PARAMETERS

LINEAR PRECISIONS

MEASURED VALUE
PRIMARY = 3
SECONDARY = 3

TOLERANCE

PRIMARY = 3
SECONDARY = 3

ANGULAR PRECISIONS

MEASURED VALUE = 2
TOLERANCE = 2

DIMENSION FACTOR

MULTIPLIER VALUE = 1.0

MINIMUM LEADER/ARROWHEAD LENGTH
RATIO = 0.33333

UNIT REPRESENTATIONS

PRIMARY
UNIT SYSTEM = DATABASE UNITS
SECONDARY
UNIT SYSTEM = DATABASE UNITS

ANGULAR

UNIT SYSTEM = DEGREES-MINUT

ES-SECONDS

UNITS = DEGREE

ARROWHEAD PARAMETERS

TYPE = STANDARD
DIAMETER = 0.05
LENGTH = 0.15
LENGTH / WIDTH = 3.0
DIMENSION GAP = 0.0936

CENTERLINE PARAMETERS

LONG SEGMENT LENGTH = 0.75
SHORT SEGMENT LENGTH = 0.125
GAP LENGTH = 0.0625

TEXT PARAMETERS

*** Default parameters ***

TEXT/TEXT/TNOO PARAMETERS

TEXT HGT = 5.0
TEXT WTH = PROPORTIONAL

ONAL

TEXT THK = 0.0
TEXT ANG = 0.0
TEXT SLNT = 10.0
TEXT LNSP = 1.5
TEXT FONT = 2
SPACING = PROPORTIONAL

ONAL

TEXT JUST HOR = LEFT
TEXT JUST VERT = BOTTOM
TEXT MIRR = NOMIRROR
TEXT CASE = UPPER
RGT DELIMITER = >
LFT DELIMITER = <
CAPITALIZATION SYM = ^

DRAWING FORMAT UNIT VI

JOB SHEET #3 — FORMAT A PARTS STORAGE DISKETTE

A. Tools and equipment

1. Computer
2. Computer software diskette programmed for CADD
3. Blank double-density floppy diskette
4. Instruction (user) manual for your CADD system

EVALUATION CRITERIA	
Criteria	Rating
Parts storage diskette properly formatted	_____

- B. Procedure: The following is only an example. Discuss with your instructor the exact procedure for formatting a parts storage diskette on your CADD system or refer to your CADD manual.

Example: (MATC CAD software - Apple II — 5 1/4 inch diskette)

1. Insert MATC CAD disc in Drive I and a blank parts disk in Drive 2.
2. Turn on the Apple computer.
3. Turn on display screen and push the caps lock key down.
4. When MATC CAD software banner appears, type in the date and press return.
5. Wait for license banner to appear on the screen, then hold down the control key and press R. Then release both keys and press number "0".
6. When the systems level prompt "0>" appears, type UTIL and press RETURN. The UTILITY MENU will then appear on the screen.
7. Select the FORMAT DISKETTE option by pressing an F followed by RETURN. Make sure the disk to be formatted is in Drive 2.

(NOTE: This procedure should take about 40 seconds.)

- C. Problem: Format your own parts storage diskette. Refer to your CADD manual for procedures particular to your CADD software.

From *MATC CAD Operations and Training Manual*. © Milwaukee Area Technical College.
Reprinted with permission.

**DRAWING FORMAT
UNIT VI**

JOB SHEET #4 — DRAW A TITLE BLOCK ON A CADD SYSTEM

A. Tools and equipment

1. CADD system hardware
2. Appropriate CADD software
3. Instruction (user) manual for your CADD system

EVALUATION CRITERIA	
Criteria	Rating
Title block properly drawn	_____
Title block properly filed	_____

B. Procedure

1. Log on to your CADD system.
2. Enter into the CADD/Graphic level.
3. Activate a new part file.

(NOTE: The title block will be stored as a part in a part file.)

4. Determine drawing size to be "B" size (11" x 17").
5. Set drawing scale.
6. Refer to Transparency 2 in this unit for the measurements to build a "B" size title block.
7. Proceed to construct a "B" size title block on the CADD system. Place in the lower right hand corner of the drawing sheet (CADD). Extend border lines from the title block around the 11 x 17 sheet. Leave a 1/2" space into the border and title block from sheet edge.
8. File part when completed with the class session or sooner if required.

(NOTE: You will complete the text for this title block format in Unit VII, "Lettering.")

DRAWING FORMAT UNIT VI

TEST

Name _____ Score _____

1. Match the terms on the right with their correct definitions.

- | | |
|--|---|
| <p>_____ a. A correction made on a drawing to reflect a needed change</p> <p>_____ b. Graphic and lettered information on an original media surface</p> <p>_____ c. The areas on the border of a drawing sheet used for locating specific points by the coordinate point system</p> <p>_____ d. An approved engineering change on an existing drawing</p> <p>_____ e. The specific arrangement of data for a list or report</p> <p>_____ f. An association formed by industry and the U.S. Government to produce and disseminate drafting and manufacturing standards</p> <p>_____ g. An organized collection of standard parts libraries, completed designs, documentations, and computer programs</p> <p>_____ h. An accurate three-dimensional representation of a part, assembly, or plant designed on a CADD system and stored in the database</p> <p>_____ i. A collection of symbols, components, shapes, or parts stored in the CADD database; templates for future design work on the system</p> <p>_____ j. Sets of primitive graphic entities, lines, points, arcs, circles, and text that are grouped together as a unit; may be combined or nested to form larger units or drawings</p> | <p>1. ANSI</p> <p>2. Change order</p> <p>3. Database</p> <p>4. Drawing</p> <p>5. Format</p> <p>6. FSCM Number</p> <p>7. Library</p> <p>8. Microfilm alignment</p> <p>9. Model</p> <p>10. Revision</p> <p>11. Symbols</p> <p>12. Zones</p> |
|--|---|

TEST

2. Match the types of working drawings on the right with the correct definitions.

- | | | |
|---------|--|-------------------------|
| _____a. | The complete size, material, and specification description of an individual part | 1. Subassembly drawing |
| _____b. | A drawing needed to manufacture, build, assemble, or install any unit, component, or structure | 2. Assembly drawing |
| _____c. | A description of how an object fits into its working position | 3. Working drawing |
| _____d. | A description of how several subassemblies and details make up a larger unit | 4. Detail drawing |
| | | 5. Installation drawing |

3. Match the other types of drawings on the right with their correct definitions.

- | | | |
|---------|--|-----------------------------------|
| _____a. | Drawings which are carefully checked for accuracy before they are sent into the field or into the shop for fabrication | 1. Process drawings |
| _____b. | Drawings used in the development of experimental or prototype designs | 2. Checking drawings or check set |
| _____c. | Drawings of only one step in a production or manufacturing assembly which enable a machine operator to set up equipment for a single operation | 3. Layout drawings |
| | | 4. Instrumentation drawings |

4. List five basic information items needed on a drawing.

- a. _____
- b. _____
- c. _____
- d. _____
- e. _____

5. State the (most common) location for the following components on a drawing.

- a. Title block location — _____
- b. Drawing number location — _____
- c. Parts list location — _____
- d. Revision block location — _____

TEST

6. Select the information found in the title block by placing an "X" in the appropriate blanks.

- ___ a. Material
- ___ b. Drawing title (name)
- ___ c. Drafter's name
- ___ d. Part number
- ___ e. Checker's name
- ___ f. Approval signatures
- ___ g. Contract numbers
- ___ h. FSCM number of company
- ___ i. Quantity needed
- ___ j. Issue (release) date
- ___ k. Date checker completed checking functions
- ___ l. Date drafter completed drawing
- ___ m. Description of subassembly
- ___ n. Drawing number
- ___ o. Name and address of company or design firm

7. Select the information found in the revision block by placing an "X" in the appropriate blanks.

- | | |
|-----------------------|--|
| ___ a. Date | ___ f. Description or identification of the change |
| ___ b. Tolerance | ___ g. Checker's name |
| ___ c. Approval | ___ h. Revision number or letter |
| ___ d. Zone | ___ i. List of materials |
| ___ e. Drafter's name | |

TEST

8. Select information found in an integral parts list (prepared and revised as part of the engineering drawing) by placing an "X" in the appropriate blanks.
- a. Part or identifying number
 - b. Quantity required
 - c. Writer's name
 - d. Zone
 - e. Nomenclature or description
 - f. FSCM number
 - g. Tolerance
 - h. Checker's name
9. Select information found in supplementary blocks by placing an "X" in the appropriate blanks.
- a. Finish
 - b. Treatment
 - c. Quantity needed
 - d. Material
 - e. Notes on dimensioning and tolerances
 - f. Usage and general notes
 - g. Checker's name
10. Select true statements concerning the use of general notes on a drawing by placing an "X" next to the true statements.
- a. General notes column shall not exceed 8 inches in length.
 - b. General notes should be placed above the title block.
 - c. General notes may include abbreviations.
 - d. General notes should be written in script.
 - e. General notes should not be punctuated.

TEST

11. List two types of CADD drawing systems.

a. _____

b. _____

12. List five typical considerations in initiating a CADD drawing.

a. _____

b. _____

c. _____

d. _____

e. _____

(NOTE: If the following activities have not been accomplished prior to the test, ask your instructor when they should be completed.)

13. Demonstrate the ability to:

a. Complete a title block. (Job Sheet #1)

b. Enter drawing parameters onto a CADD system. (Job Sheet #2)

c. Format a parts storage diskette. (Job Sheet #3)

d. Draw a title block on a CADD system. (Job Sheet #4)

**DRAWING FORMAT
UNIT VI**

ANSWERS TO TEST

1. a. 10 f. 1
 b. 4 g. 3
 c. 12 h. 9
 d. 2 i. 7
 e. 5 j. 11
2. a. 4
 b. 3
 c. 5
 d. 2
3. a. 2
 b. 3
 c. 1
4. Any five of the following:
- a. Drawing name
 b. Drawing number
 c. Scale
 d. Date
 e. Company name and address
 f. Drafter's name
 g. Revision block
 h. Parts list
 i. Tolerance
 j. Approval signature
5. a. Lower right corner
 b. Lower right corner of title block and in at least one other place
 c. Lower right corner above title block (or on separate sheet)
 d. Upper right corner
6. b, c, e, f, g, h, j, k, l, n, o
7. a, c, d, f, h
8. a, b, e, f
9. a, b, d, e, f

ANSWERS TO TEST

10. a, c
11. Any two of the following:
- a. Three-dimensional
 - b. Two-dimensional
 - c. Two-and-one-half-dimensional
12. Any five of the following:
- a. Operational mode
 - b. Name of active part
 - c. Name of active drawing
 - d. Drawing scale
 - e. Size of sheet
 - f. Active layer
 - g. Active construction plane
 - h. Date
13. Performance skills evaluated to the satisfaction of the instructor.

**LETTERING
UNIT VII****UNIT OBJECTIVE**

After completion of this unit, the student should be able to draw both lowercase and uppercase vertical and inclined Gothic letters using guidelines and appropriate instruments. Competencies will be demonstrated by completing the assignment sheet, job sheets, and the unit tests with a minimum score of 85 percent.

SPECIFIC OBJECTIVES

After completion of this unit, the student should be able to:

1. Match terms relating to lettering with the correct definitions.
2. Differentiate between types of letters.
3. State the most common font used in drafting.
4. List reasons for using single-stroke Gothic lettering.
5. Select true statements concerning rules for forming Gothic lettering.
6. Select true statements concerning reasons and rules for neat lettering.
7. Select true statements concerning rules for spacing.
8. Match recommended minimum letter heights with the correct components of a drawing.
9. Identify common problems in letter uniformity.
10. Select the purposes of guidelines.
11. Select true statements concerning rules for making guidelines.
12. Identify types of line guides used for laying out guidelines for lettering.
13. Select true statements concerning special rules for left-handed drafters.
14. Match the types of lettering instruments with the correct descriptions.
15. Select true statements concerning characteristics of text input on CADD.
16. Hand letter an employment application. (Assignment Sheet #1)

SPECIFIC OBJECTIVES

17. Demonstrate the ability to:
 - a. Operate an Ames-type lettering guide to construct guidelines. (Job Sheet #1)
 - b. Operate a Braddock Rowe triangle to construct guidelines. (Job Sheet #2)
 - c. Construct vertical Gothic lettering and numerals. (Job Sheet #3)
 - d. Construct inclined Gothic lettering and numerals. (Job Sheet #4)
 - e. Add text to a title block on a CADD system. (Job Sheet #5)

314

**LETTERING
UNIT VII****SUGGESTED ACTIVITIES**

- A. Provide student with objective sheet
- B. Provide student with information, assignment, and job sheets.
- C. Make transparencies.
- D. Discuss unit and specific objectives.
- E. Discuss information and assignment sheets.
- F. Discuss the procedures outlined in the job sheets.
- G. Use file drawings to demonstrate to the class examples of correct and incorrect lettering.
- H. Show lettering templates that may be used in drafting.
- I. Demonstrate the use of different types of lettering instruments.
- J. Demonstrate the use of the Braddock Rowe triangle, Ames-type lettering guide, and parallelograph.
- K. Display the different text fonts available on the drafting program's CADD system.
- L. Give test.

REFERENCES USED IN DEVELOPING THIS UNIT

- A. Brown, Walter C. *Drafting for Industry*. South Holland, IL. The Goodheart-Willcox Company, Inc., 1984.
- B. Giesecke, Frederick E., et al. *Technical Drawing*, 8th ed. New York: Macmillan Publishing Co., Inc., 1986.
- C. Jensen, Cecil and Jay Helsel. *Engineering Drawing and Design*, 3rd ed. New York. McGraw-Hill Book Company. 1985.
- D. *ANSI Y14.2M-1979, Line Conventions and Lettering*. New York. The American Society of Mechanical Engineers.
- E. *Versacad Design, Version 5.4 Specifications*, Huntington Beach, CA. Versacad Corporation, 1988.
- F. *Drawing Requirements Manual: DOD-D-1000/DOD-STD-100 & Metric*, 5th Ed. Santa Ana, CA: Global Engineering Documents, (800)854-7179.

**LETTERING
UNIT VII****INFORMATION SHEET****i. Terms and definitions**

- A. Character — A letter, number, or other symbol used to represent data, is represented by a byte in the computer
- B. Digit — Either "0" or "1" in binary notation; "0" through "9" in decimal notation
- C. Edit — To change, add, or delete data
- D. Font — An assortment of characters of a given size or style of type
- E. Point — A very small unit for measuring the size of printer's type with 1/72 inch equaling 1 point or 72 points equaling 1 inch
- F. Text — Letters, numbers, and special characters

ii. Types of letters**A. Varying widths of letters**

- 1. Condensed — Letters that are narrower and spaced closer together than normal

Example:

CONDENSED LETTERS

(NOTE: Condensed letters may be referred to as compressed letters.)

- 2. Extended — Letters that are wider than normal

Example:

EXTENDED LETTERS

B. Varying widths of strokes of letters

- 1. Boldface — Letters made up of heavy components

Example:

BOLDFACE
316

INFORMATION SHEET

2. Lightface — Letters made up of thin components

Example:

LIGHTFACE

III. The most common font used in drafting — Single-stroke Gothic, vertical and inclined

Examples:

GOTHIC

(Vertical)

GOTHIC

(Inclined)

IV. Reasons for using single-stroke Gothic lettering

- A. Saves time in production
- B. Easy to read and provides drawing consistency
- C. Easier to learn to use
- D. Cost of drawings is reduced

V. Rules for forming Gothic lettering (Transparency 1)

- A. Vertical Gothic (uppercase)
 - 1. The number 1 and letter I have no width.
 - 2. The width of the letter W is $1 \frac{1}{3}$ times its height.
 - 3. Letters that are equal in height and width are A, M, O, Q, T, V, X, Y.
 - 4. All other letters not noted above have a width $\frac{5}{6}$ their height.
 - 5. All numerals except the numeral one have a width $\frac{5}{6}$ their height.
 - 6. On some letters, if the top portion is the same width as the bottom, the letters appear to be top heavy.

Example:

TOP-HEAVY
LETTERS

d G B E K S X Z 2 3 5 8

- 7. If the center area of the following letters is placed at midheight of the line, it appears to be below center. Therefore, these strokes are placed slightly above the center point of these letters: B, E, F, and H.

INFORMATION SHEET

8. When the heights vary on uppercase letters, the small uppercase letters are to be $\frac{2}{3}$ to $\frac{4}{5}$ the height of the large uppercase lettering.

Example:

LETTERING

9. Lettering is not writing but freehand drawing, and the six fundamental strokes of freehand drawing are used in lettering.

Examples:

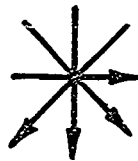

Vertical

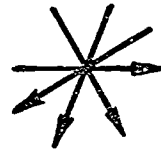

Inclined



B. Vertical Gothic (lowercase)

1. The shapes of vertical lowercase lettering are based on the circle, circular arc, and straight line.
(NOTE: There are some variations.)
2. The third stroke of the e is slightly above mid-height of the letter.
3. The horizontal strokes of the f and t are placed on the waist line, and are an equal distance from stroke number 1.
4. On the letters h, m, n, and r, the curved strokes intersect the first stroke at roughly $\frac{2}{3}$ the distance from the base line to the waist line.
5. On the letters g, j, and y, the descenders form a curve tangent to the drop line.
6. The letters p and q terminate without curves on the drop line.
7. When uppercase and lowercase letters are used, the lowercase letter should be $\frac{2}{3}$ the height of the uppercase letter.
(NOTE: An exception to this rule is lettering for microfilm where all uppercase letters must be used.)
8. On lowercase letters, the ascending or descending stems are equal in length to the height of the uppercase letters.

INFORMATION SHEET

C. Inclined Gothic (uppercase)

1. The same rules for letter sizes and spacing that apply in vertical lettering apply in inclined lettering.
2. The preferred slope for inclined letters is 2 in 5 or approximately 68 degrees with the horizontal.
3. Circular parts of letters should be made elliptical so they will appear to slant properly to the right.
4. The letters A, V, W, X, and Y have sloping sides and are difficult to make unless an imaginary inclined center line is used and the letter is drawn symmetrically around it.

(NOTE: This method is a good one for beginning drafters to practice.)

D. Inclined Gothic (lowercase)

1. The same rules for letter sizes and spacing that apply in vertical lettering apply in inclined lettering.
2. Circular parts of letters should be made elliptical so they will appear to slant properly to the right.
3. The letters c, o, s, v, w, x, and z have the same form as their corresponding uppercase letters.

VI. Reasons and rules for neat lettering

- A. Lettering can greatly affect the overall appearance of a drawing.
- B. Most drawings are reproduced. Therefore, the lettering must be a dense black and be done with neatness, accuracy, speed, and legibility.
- C. The letters must be formed very carefully and not crowded together, or they will run together when reproduced.
- D. When additions or revisions are made to a drawing, the original style of lettering should be matched.
- E. Either inclined or vertical lettering may be used, but only one type shall appear on a single drawing. Don't mix them.

VII. Rules for spacing

- A. Spacing between letters is determined by the *area* between two letters (0.06" or 1.5 mm), not just the *distance* between two letters.
- B. The spacing between words is attained by using an imaginary letter "O" as a spacer.

INFORMATION SHEET

- C. The spacing between two sentences is attained by using an imaginary double letter "OO" as a spacer.
- D. The space between two numerals separated by a decimal point (4.1) should be a minimum of $\frac{2}{3}$ the height of the numerals.
- E. The vertical space between the lines of lettering should be a minimum of $\frac{1}{2}$ the height of the lettering and a maximum of the same height as the lettering.
- F. Notes must be placed horizontally on the drawing and separated vertically by spaces at least double the height of the character size used.
- G. Lettering should not be underlined except when special emphasis is needed. The underline should be a minimum of 0.06" (1.5mm) below the lettering.
- H. The division line in a common fraction should be parallel to the direction the dimension reads, and the numerator and denominator of a fraction should be separated by \approx 0.06" (1.5mm) space.

Correct

$$\frac{1}{2}$$

$$\frac{5}{8}$$

Incorrect

$$\frac{1}{2}$$

$$\frac{5}{8}$$

- I. A diagonal line is permissible only when fractions are placed in lists, tables, or notes.

INFORMATION SHEET

VIII. Recommended minimum letter heights (according to *ANSI Y14.2M-1979*)

	INCH	MM
A. Drawing number in title block		
1. A, B, and C size sheets	0.250	7
2. Larger than C size sheets	0.312	7
B. Drawing title	0.250	7
C. Section and tabulation letters	0.250	7
D. Zone letters and numerals in borders	0.188	5
E. Dimensions, tolerances, limits, notes, subtitles for special views, tables, revisions, and zone letters for the body of the drawing		
1. A, B, and C size sheets	0.125	3.5
2. Larger than C size sheets	0.156	5

IX. Common problems in lettering uniformity

- A. Letters are not uniform in height.

UNIFORM

- B. Letters are not inclined or vertically uniform (mixed inclined and vertical styles).

UNIFORM UNIFORM

- C. Letters are not uniform in stroke thickness.

UNIFORM

- D. Areas are not uniform between letters.

UN I F O R M

- E. Style of letters is not uniform (mixed upper and lower cases).

UniFoRM

INFORMATION SHEET

- F. Areas are not uniform between words.

GOOD LETTERINGSHOULD
BE UNIFORM

X. Purposes of guidelines

- A. To keep letters exactly the same height
- B. To keep letters spaced properly
- C. To keep letters positioned in the same direction
- D. To improve the overall composition of lettered information

XI. Rules for making guidelines

- A. Paper should be aligned and corners secured with tape to working surface.
- B. Horizontal guidelines should be made with the aid of a lettering guide.
- C. Guidelines should not reproduce.
- D. Horizontal guidelines should be accurately spaced.

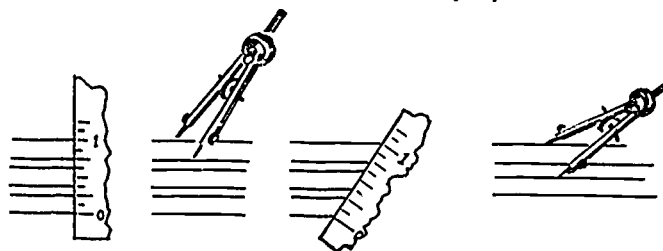

- E. Lead used to make guidelines should be very sharp and of a good quality.
- F. Guidelines should be used for all lettering.

XII. Types of line guides used in laying out guidelines for lettering

- A. Braddock Rowe triangle

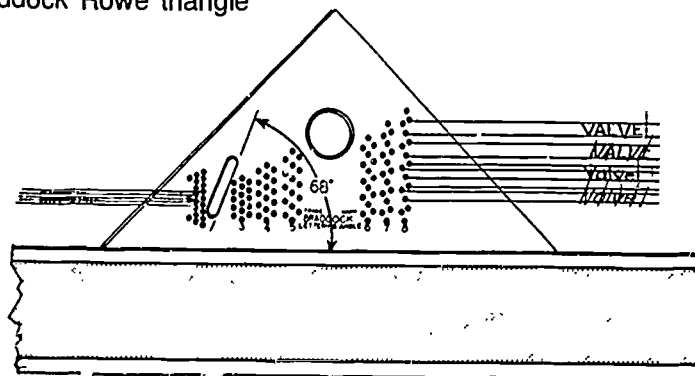

INFORMATION SHEET

B. Ames-type lettering guide

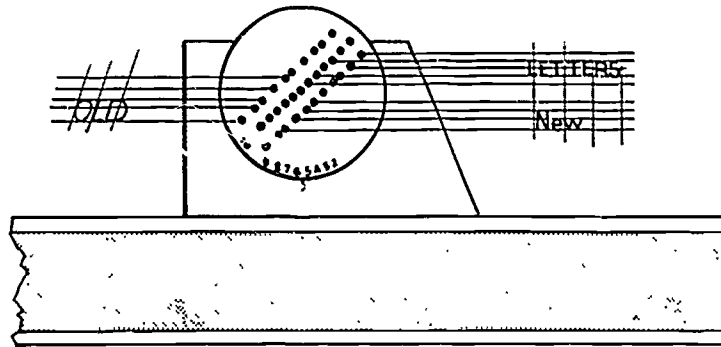

XIii. Special rules for left-handed drafters

- A. The left-handed drafter should follow a system of strokes that will involve pulling the pen or pencil instead of pushing it.

(NOTE: Pushing the pen or pencil tends to dig into the paper.)

- B. Vertical and inclined strokes should be done from top to bottom.
 C. Movement on horizontal strokes should be done from right to left.

(NOTE: When lettering, a lefthander should normally take a position exactly opposite that of a right-hander. The left-handers that letter with a hooked wrist have more difficulty and must adopt a system that seems best for their own particular habits.)

XIV. Description of lettering instruments (Transparencies 2 and 3)

- A. Leroy-type mechanical lettering instrument — An instrument consisting of a template, a scriber, and an inking pen.

(NOTE: A guide pin follows grooved letters in a template, and the ink point moves on the paper. Various sizes and styles of guides are available. Refer to Handout #1 for the procedure for setting up and using this lettering instrument.)

- B. Template — A thin, flat sheet of plastic with letters cut through the sheet.

(NOTE: A pencil is inserted into the groove and moved back and forth to form the shape of the letter. Spacing of individual letters must be done visually.)

- C. Slotted template — A template with slots in standard letter sizes used to control letter heights.

- D. Press-on letters — Letters that are printed on sheets that rub off onto the drawing plates; available in many letter fonts and point sizes.

Example: Chartpak, Lettraset, Format

INFORMATION SHEET

- E. Typewriter — Often information may be typed using a standard typewriter onto sticky backed material and adhered to the drawing plates.
- F. Lettering machine — A machine that produces type on transparent tape that can be attached directly to the surface of the drawing; available in several type styles and sizes.
- G. CADD — Computer software for CADD comes with a variety of different lettering fonts that may be printed out; no manual lettering is required.

XV. Characteristics of text input on CADD

- A. Text may be typed in and placed visually.
- B. A variety of built-in and user-defined text fonts are available.
- C. Text height and width may be input at any time, in any size from .0001 drawing units to 9,999,999.9999 units.
- D. Text can be automatically kept right reading at any angle, and it can be justified by left, right, center, top, or bottom, as well as "Fitted" into any position.
- E. Background objects may be blanked out behind any text input.
- F. Text may be edited after placement.

Gothic Lettering

ABCDEFGHIJKLMN O P

QRSTUVWXYZ &

1234567890

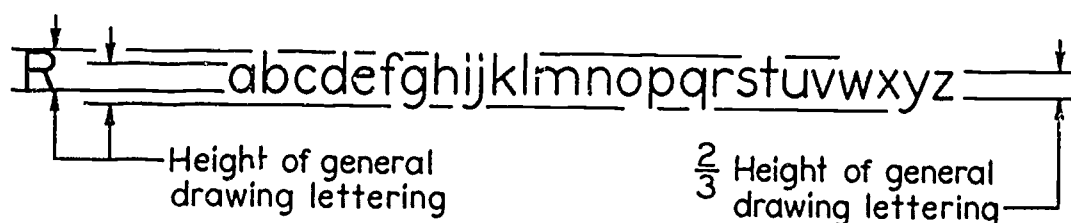

Vertical Letters

ABCDEFGHIJKLMN O P

QRSTUVWXYZ &

1234567890

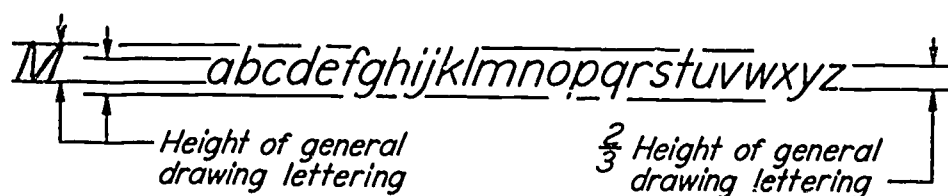

Inclined Letters

ANSI Y14.2-1979, Reaffirmed 1987. Reprinted with permission of ASME.

Types of Lettering Instruments

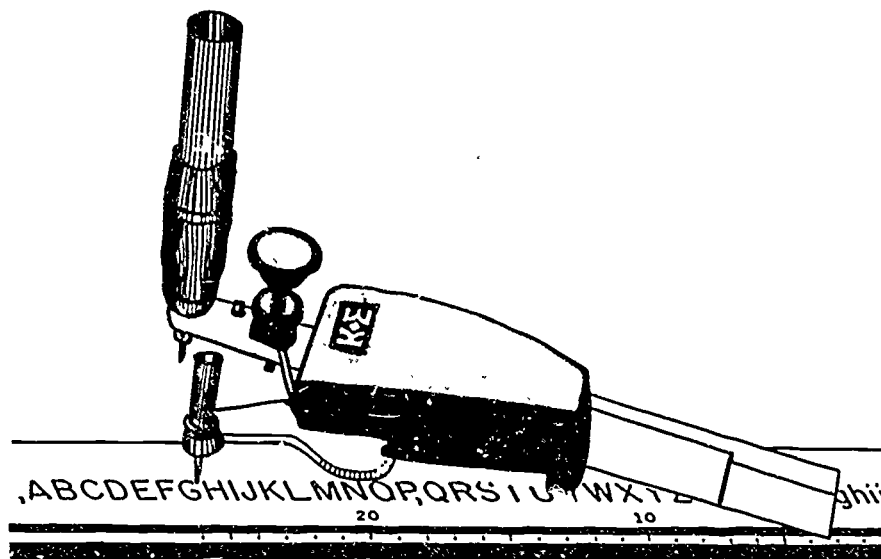

Leroy-Type Lettering Instrument

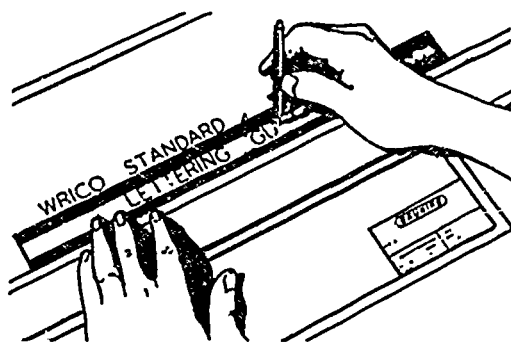

Template

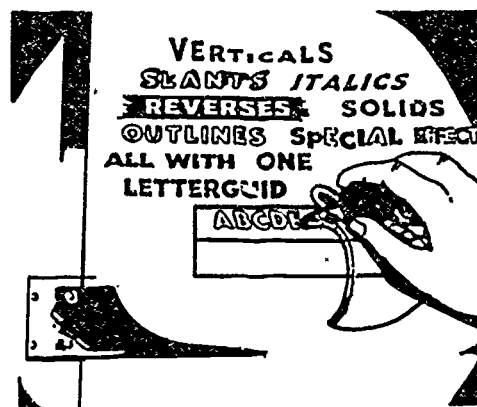

Slotted Template

Types of Lettering Instruments

(Continued)

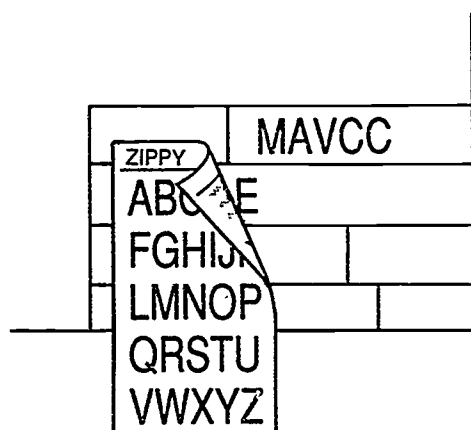

Press-On Letters

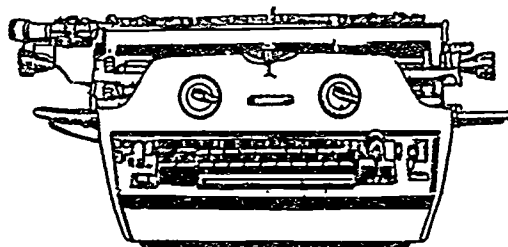

Typewriter

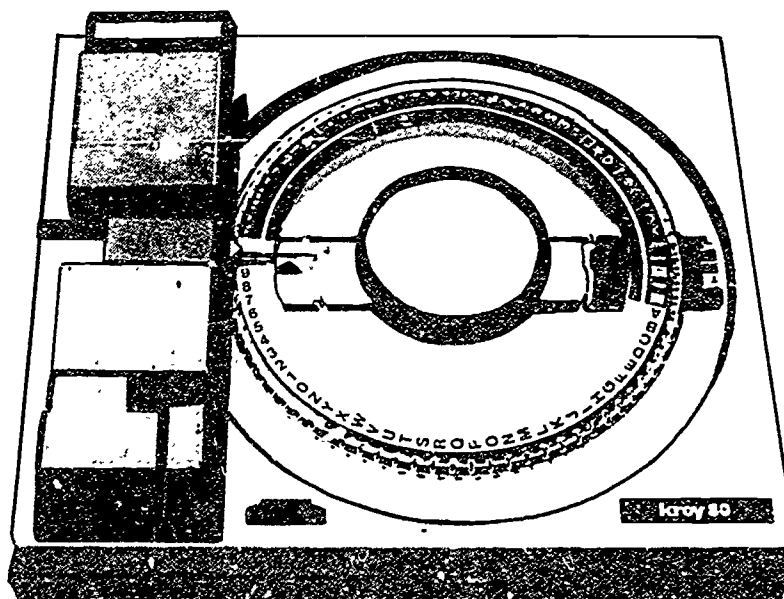

Lettering Machine

LETTERING UNIT VII

HANDOUT #1 — MECHANICAL LETTERING TECHNIQUES FOR RIGHT- AND LEFT- HANDED DRAFTERS

A. Procedure for right-handed drafters

FIGURE 1

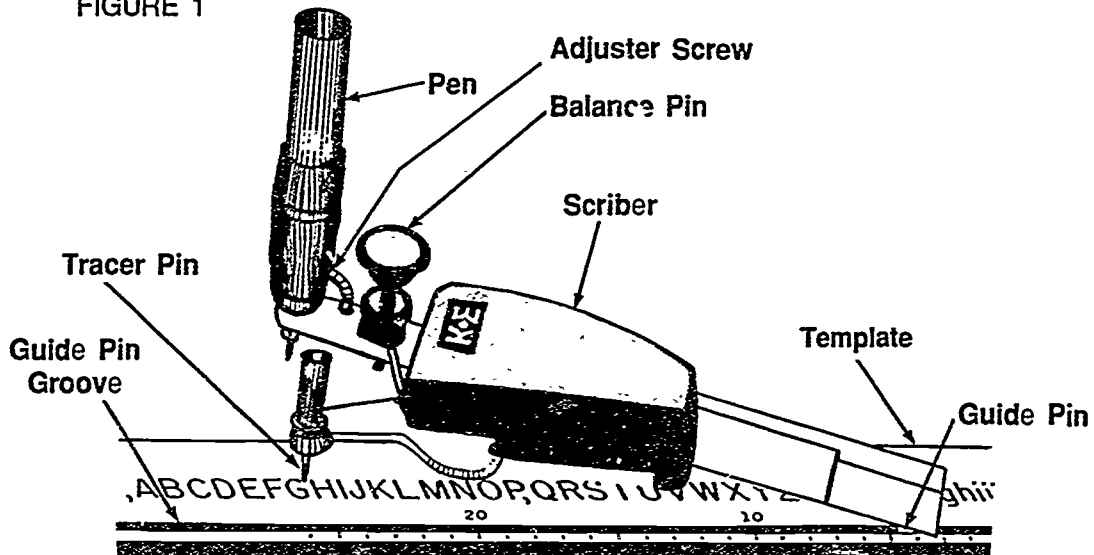

Refer to the above illustration for identification of parts.

1. Choose the necessary template and pen to be used.
(NOTE: Templates require specific pen sizes.)
2. Assemble pen into the scribe as shown above in Figure 1. Tighten into place with adjuster screw.
3. Place the letter template along a straight edge. (A parallel scale or triangle may be used.) Be sure the template slides freely along this edge.
4. Holding the scribe with the pen in place, locate the guide pin in the guide pin groove. Be sure the guide pin moves freely along this groove.
5. Place the tracer pin into the letter that is to be traced. Trace along the groove of the letter with the point of the pen making contact with the drawing media. Do not press too hard!

(NOTE: The pressure placed on the pen point should be enough for a bead of ink to flow between the point and the drawing surface. The balance pin may be used to adjust the level of the pen point.)

HANDOUT #1

FIGURE 2

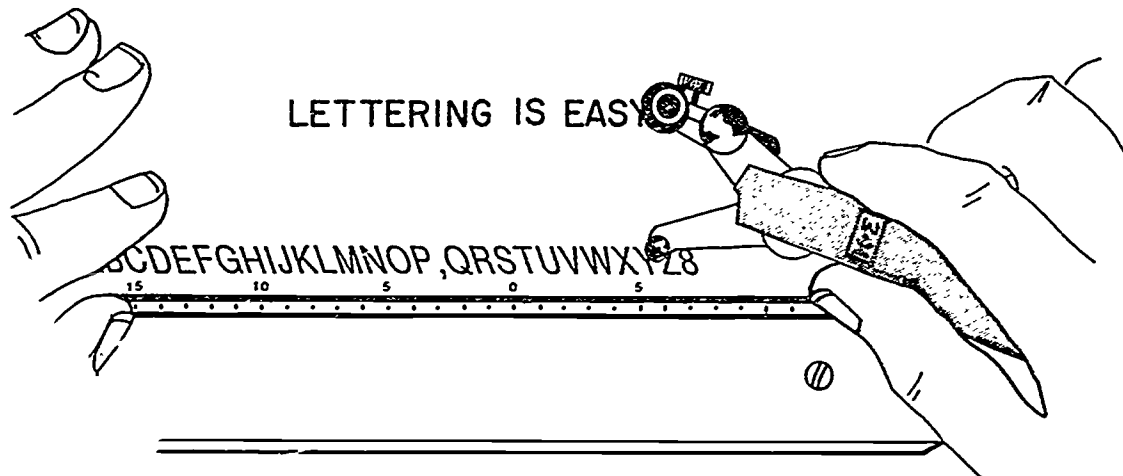

6. To change letters, lift the pen point and tracer pin and slide the guide pin along the guide pin groove to the next letter to be traced. Then repeat the same procedure.
7. When not using the scriber but the pen is still in place, use the kickstand that is under the scriber to keep the pen off of the drawing surface, or lay scriber and pen on its side.

B. Procedure for left-handed drafters

FIGURE 3

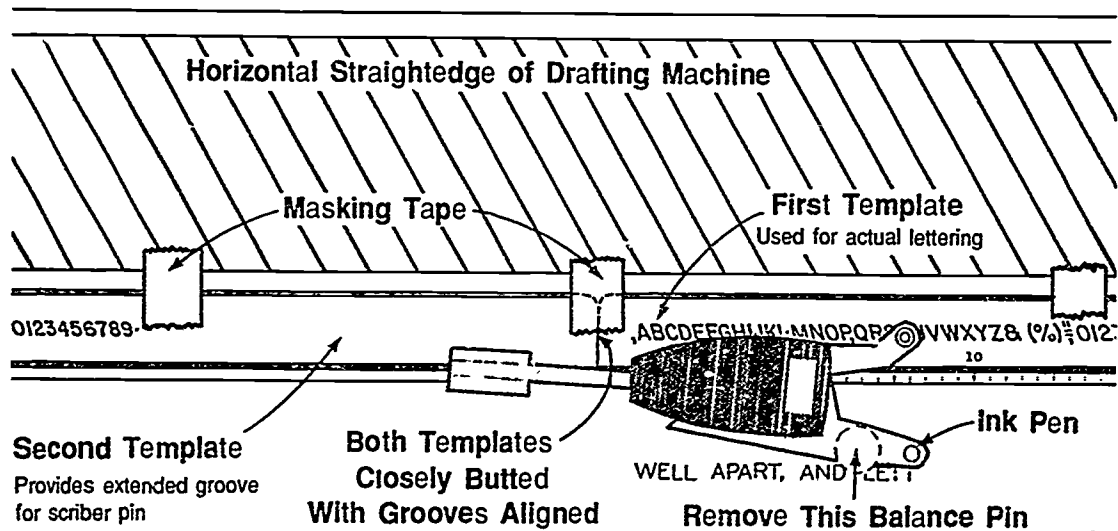

The following procedure shows how to modify a right-handed mechanical (Leroy) lettering set for a left-handed user. (NOTE: Mechanical lettering sets are available for left-handed people, but they are special order items and are expensive.)

HANDOUT #1

1. Choose the necessary template and pen to be used.
(NOTE: Templates require specific pen sizes.)
2. Assemble pen into the scribe. Tighten into place with the adjuster screw.
3. In the right-hand technique the template is placed on top of the straightedge; in the left-hand technique the template is placed below the drafting machine straightedge. (See Figure 3.) This reversal will require a couple of other changes.
4. The balance leg on the scribe must be removed because as a left-handed person is lettering from left to right, the leg will tend to drag through the just-printed letters. Removal of the leg makes balance of the scribe a little trickier.
5. Notice that the etched letters on a template are located on the left of the template face. Since the scribe is reversed in the left-handed technique, it is necessary to provide an extended groove to the left for the scribe's groove pin. This can be done by butting a second template of similar size up against the left end of the first template. (See Figure 3.) These two templates must be butted together so that their grooves match up and so that they are both flush against the drafting machine straightedge. They should be secured to the straightedge with a few pieces of masking tape.
6. Once these changes have been completed, hold the scriber in your left hand. The scriber will be upside down (reversed 180°) from the normal right-handed orientation, and the lettering will be printed below the template.
(NOTE: You will find it is best to work up from the bottom in order to avoid passing down through the work that has just been printed. But, if you are careful, you can work down from the top as a right-handed drafter would normally do.)
7. Next, place the tracer pin into the letter that is to be traced. Trace along the groove of the letter with the point of the pen making contact with the drawing media. Do not press too hard!
(NOTE: The pressure placed on the pen point should be enough for a bead of ink to flow between the point and the drawing surface. The balance pin may be used to adjust the level of the pen point.)
8. To change letters, lift the pen point and tracer pin and slide the guide pin along the guide pin groove to the next letter to be traced. Then repeat the same procedure.
9. When not using the scribe but the pen is still in place, lay scribe and pen on its side.

**LETTERING
UNIT VII**

ASSIGNMENT SHEET #1 — HAND LETTER AN EMPLOYMENT APPLICATION

NAME _____ SCORE _____

- DIRECTIONS:**
1. Collect all personal data and job history necessary to complete this application.
 2. Put 5/32" guidelines in all spaces.
 3. Hand letter in all information. Hand letter N/A on lines that do not apply to you.
 4. Use vertical Gothic lettering.

(NOTE: Keep in file for future reference.)

Type of Work Desired (Please be specific)				Today's Date											
Desired work category				<input type="checkbox"/> Regular		<input type="checkbox"/> Part-time		<input type="checkbox"/> Temporary		<input type="checkbox"/> Summer					
Full Name (Last, First, Middle)				Social Security Number				Date of Birth							
Present Address (Street, City, County, State, Zip Code)						Telephone (Home)			U.S. Citizen						
									<input type="checkbox"/> Yes <input type="checkbox"/> No						
Alternate Address						Telephone (Bus.)			Height Weight						
									Date available for work						
Back trouble? (Year, describe)															
Heart trouble? (Year, describe)															
Describe any uncorrected vision defect						Describe any hearing defect									
Are you presently under treatment or taking medication for any health or disability condition (If so, describe)															
No. working days lost during the last year due to illness						No. days lost in past year due to accidents (Describe)									
Please describe any health condition or physical disability which would limit the types of work you could perform															
Branch of Service		From Mo/Yr		To Mo/Yr		Type of discharge		Rank at discharge		Duties		Reserve Status			
LIST MOST RECENT EMPLOYMENT FIRST — PLEASE COMPLETE EVEN THOUGH YOU ATTACH RESUME															
Name of Employer		Address Street, City & State				From		To		Rate of pay		Duties		Reason for leaving	
						Mo Yr		Mo Yr							
May we contact above employers excluding present															
				YES		NO		Minimum acceptable starting pay \$				Per			

ASSIGNMENT SHEET #1

Explain here any period of unemployment for longer than 30 days						
Have you ever been discharged or forced to resign from a job (Please explain)						
School	Name, City, State	Major	From Mo Yr	To Mo Yr	Circle last Completed Year	Did you graduate?
Grade					4 5 6 7	
High					8 9 10 11 12	
College					1 2 3 4 5 6	
Other Specify						
Will you work any shift any day of the week <input type="checkbox"/> Yes <input type="checkbox"/> No if not, specify availability						
List any special awards, certificates, or licenses issued to you					Typing speed	Shorthand speed
List any trade or profession you have						How many years
List any machines or equipment that you can operate with considerable skill						
List hobbies, activities, or interests						
Which of your listed jobs did you like best (Why)						
Which of your listed jobs did you like least (Why)						
Are you presently employed <input type="checkbox"/> Yes <input type="checkbox"/> No			Why do you want to leave			
Are you a member of the Communist Party or any other organization listed as subversive by the U.S. Dept. of Justice						
Have you ever been convicted of a crime (other than minor traffic violations). List dates, charges, and results						

I certify that the answers given by me to all questions on the application and attachments are true, correct, and complete and without any significant omissions to the best of my knowledge and belief. I understand that any omissions or misrepresentation of fact in the application may result in refusal or separation from employment. I understand that I may be required to sign the company's employment agreement on inventions and confidential information.

Signature (NOT ACCEPTABLE IF NOT SIGNED)

EMPLOYEES ARE OUR MOST IMPORTANT RESOURCE

332

LETTERING UNIT VII

JOB SHEET #1 — OPERATE AN AMES-TYPE LETTERING GUIDE TO CONSTRUCT GUIDELINES

A. Tools and equipment

1. Ames-type lettering guide
2. Drafting machine or parallel bar
3. Lead holder and lead
4. Drawing media
5. Drawing surface

EVALUATION CRITERIA

Criteria	Rating
Guidelines are neat	_____
Guidelines are light	_____
Guidelines are parallel	_____
Guidelines are correct height	_____

B. Procedure

1. Align and secure paper drawing surface with drafting tape on each corner.
2. Place Ames-type lettering guide against top edge of machine or bar.
3. Select appropriate letter height which is expressed in 32nd-of an inch. Line up your selection with the index mark.

(NOTE: It can be selected by rotation of the circular selector.)

FIGURE 1

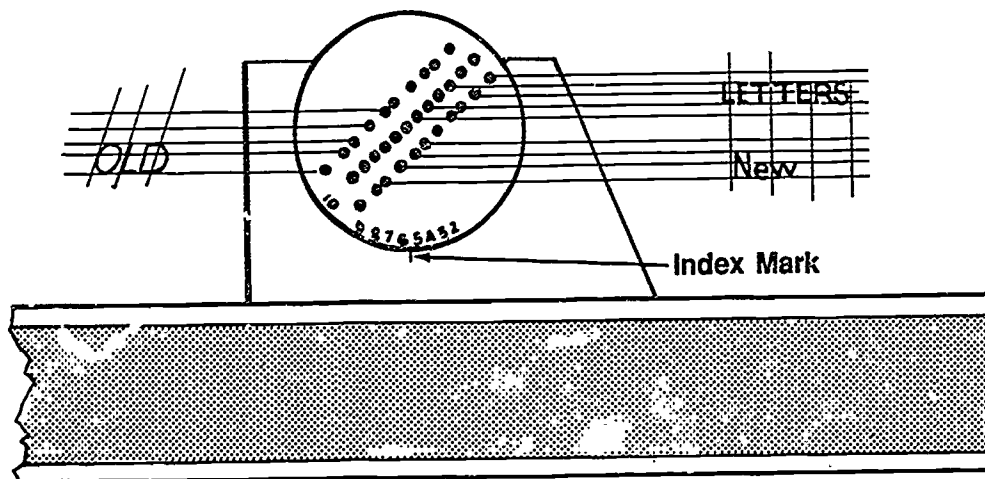

JOB SHEET #1

4. Sharpen lead.
5. Place lead in appropriate holes for height of letter required and move Ames type lettering guide across top edge of blade in a smooth light motion.

(NOTE: Keep guideline light by using a hard lead or a nonreproducible blue lead.)
6. Omit the middle guideline which is used for lowercase letters when lettering uppercase letters.
7. Construct guidelines vertically by using vertical blade or triangle.

FIGURE 2

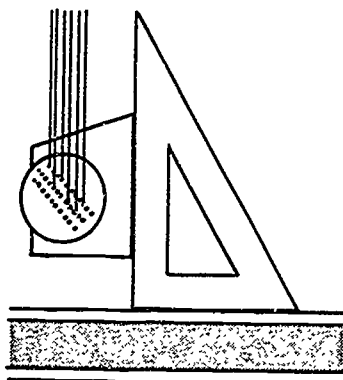

8. Incline guidelines by using the 68° slope on the Ames-type lettering guide.

LETTERING
UNIT VII

JOB SHEET #2 — OPERATE A BRADDOCK ROWE TRIANGLE
TO CONSTRUCT GUIDELINES

A. Tools and equipment

1. Braddock Rowe triangle
2. Drafting machine or parallel bar
3. Lead holder and lead
4. Drawing media
5. Drawing surface

EVALUATION CRITERIA

Criteria	Rating
Guidelines are neat	_____
Guidelines are light	_____
Guidelines are parallel	_____
Guidelines are correct height	_____

B. Procedure

1. Align and secure paper to drawing surface with drafting tape on each corner.
2. Place Braddock Rowe triangle against top edge of machine or bar.
3. Select letter height which is expressed in 32nd of an inch. (3/32 through 8/32 are indicated on the triangle.)

FIGURE 1

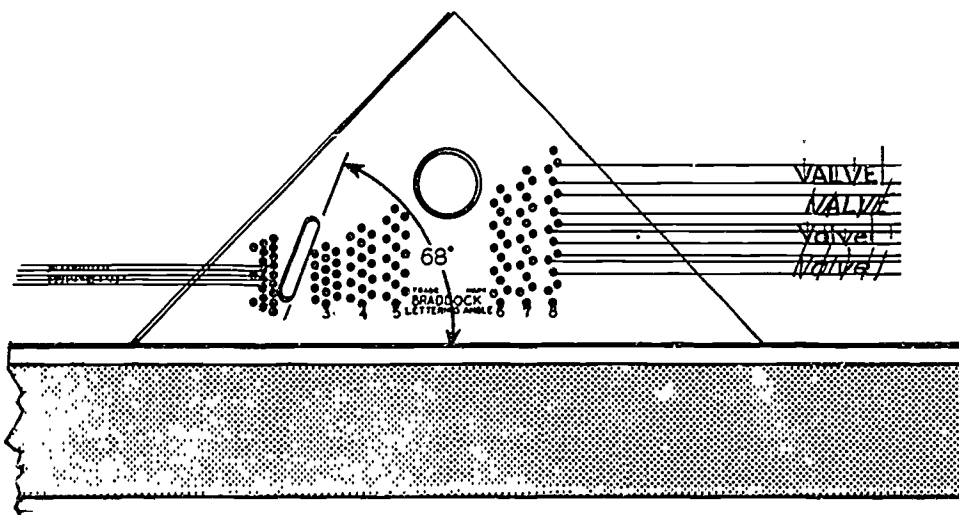

4. Sharpen lead.

JOB SHEET #2

5. Place pencil in appropriate holes for height of letter required and move triangle across horizontal blade.

(NOTE: Keep guidelines light by using a hard lead or nonreproducible blue lead.)

6. Omit the middle guideline which is used for lowercase letters when lettering uppercase letters.
7. Construct guidelines vertically by using vertical blade or a triangle.
8. Incline guidelines by using a 68° notch on the Braddock Rowe triangle.

**LETTERING
UNIT VII**

**JOB SHEET #3 — CONSTRUCT VERTICAL GOTHIC
LETTERING AND NUMERALS**

- A. Tools and equipment
1. Lead holder or pencil
 2. Drafting tape
 3. Drawing surface
 4. Lettering guide
 5. Drafting machine or parallel bar
 6. Pencil pointer
 7. "A" size bordered vellum

EVALUATION CRITERIA	
Criteria	Rating
Letters are correctly formed	_____
Strokes are smooth	_____
Guidelines are evenly spaced and parallel	_____

B. Procedure

1. Obtain "A" size bordered vellum and tape to drawing surface.

FIGURE 1

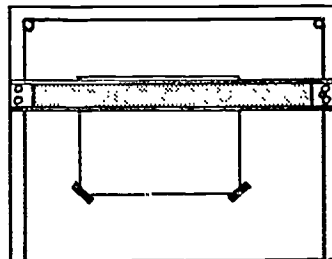

2. Prepare point of lead.

(NOTE: Point should be dulled slightly to give desired width of letter elements.)

3. Hold lead in correct position.

(NOTE: Use an even pressure and rotate the lead in the fingers after every few strokes to get uniform lines.)

JOB SHEET #3

FIGURE 2

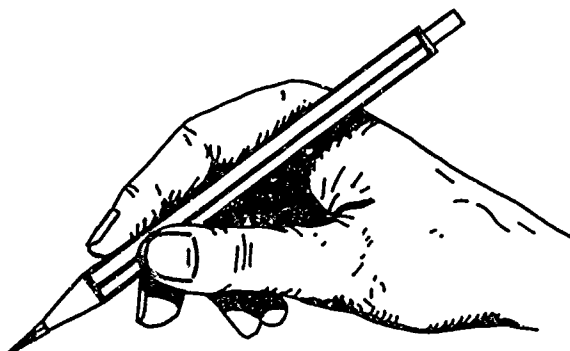

4. Study forms and strokes of vertical Gothic letters and numbers below.
 (NOTE: Trace over letters to learn strokes of each letter and numeral.)

FIGURE 3

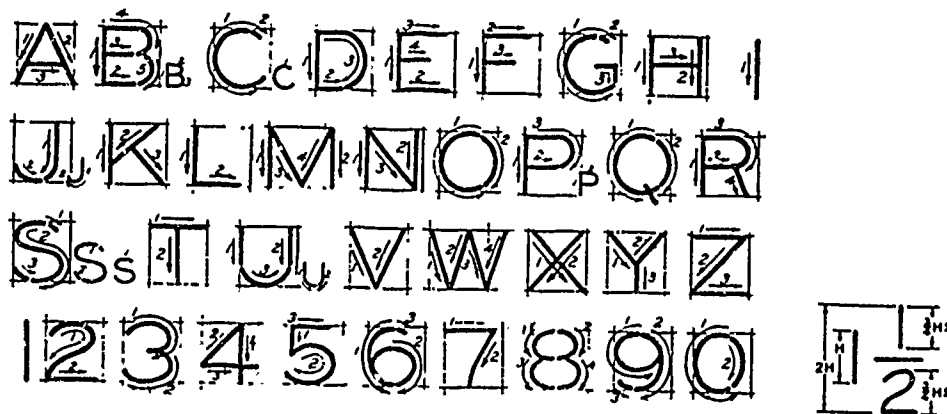

5. Construct guidelines $\frac{5}{32}$ " apart on the vellum using your lettering guide.
6. Copy the vertical Gothic alphabet and numerals. Fill in the drawing plate with vertical Gothic lettering.

LETTERING
UNIT VII

JOB SHEET #4 — CONSTRUCT INCLINED GOTHIC
LETTERING AND NUMERALS

A. Tools and equipment

1. Lead holder or pencil
2. Drafting tape
3. Drawing surface
4. Lettering guide
5. Drafting machine or parallel bar
6. Pencil pointer
7. "A" size bordered vellum

EVALUATION CRITERIA	
Criteria	Rating
Letters are correctly formed	_____
Strokes are smooth	_____
Guidelines are evenly spaced and parallel	_____

B. Procedure

1. Obtain "A" size bordered vellum and tape to drawing surface.

FIGURE 1

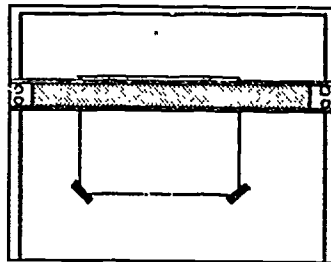

2. Prepare point of lead.

(NOTE: Point should be dulled slightly to give desired width of letter elements.)

3. Hold lead in correct position.

(NOTE: Use an even pressure and rotate the lead in the fingers after every few strokes to get uniform lines.)

JOB SHEET #4

FIGURE 2

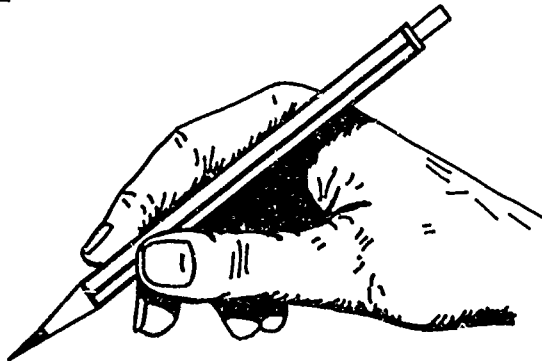

4. Study forms and strokes of inclined Gothic letters and number below.
 (NOTE: Trace over letters to learn strokes of each letter and numeral.)

FIGURE 3

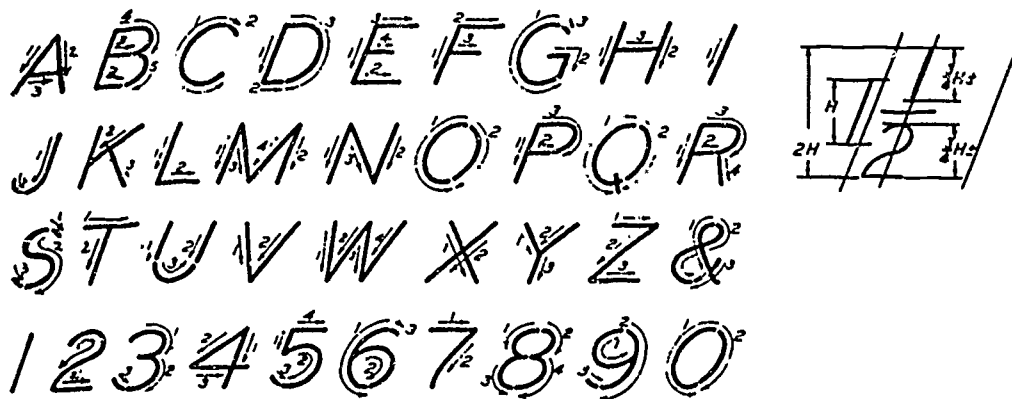

5. Construct guidelines $5/32$ " apart on the vellum using your lettering guide.
 6. Copy the inclined Gothic and numerals. Fill in the drawing plate with inclined Gothic lettering.

**LETTERING
UNIT VII**

**JOB SHEET #5 — ADD TEXT TO A TITLE BLOCK
ON A CADD SYSTEM**

A. Tools and equipment

1. CADD system hardware
2. Appropriate CADD software
3. Instruction (user) manual for your CADD system

EVALUATION CRITERIA	
Criteria	Rating
Text files are properly accessed	_____
Text is properly placed	_____
Text is correct height	_____

B. Procedure

1. Refer to your CADD manual for instructions on how to access the text font stored in your CADD system.
2. Print them on the CRT. Review what is available if there are several fonts.
3. Practice the method of input, placement, and editing of text on your CADD system.
4. Activate the part file for the "B" size title block you completed in Unit VI, "Drawing Format."
5. Add the necessary text to the title block.
 - a. Refer to TM 2, Title Blocks, of Unit VI or *ANSI Y14.1-1980* for wording and arrangement of text.
 - b. Choose a text font.
 - c. Choose a letter height that will be appropriate for the spaces available in the title block.
6. File part again with the added text information.

**LETTERING
UNIT VII**

TEST

NAME _____ SCORE _____

1. Match the terms on the right with the correct definitions.

- | | | |
|----------|--|--------------|
| _____ a. | An assortment of characters of a given size or style of type | 1. Character |
| _____ b. | Letter, number, or other symbol used to represent data; is represented by a byte in the computer | 2. Digit |
| _____ c. | To change, add, or delete data | 3. Edit |
| _____ d. | Either "0" or "1" in binary notation; "0" through "9" in decimal notation | 4. Font |
| _____ e. | A very small unit for measuring the size of printer's type with 72 of them equaling 1 inch | 5. Pica |
| | | 6. Point |

2. Differentiate between types of letters by placing the following letters next to the correct description:

- B — Boldface
- C — Condensed
- E — Extended
- L — Lightface

- _____ a. Letters that are narrower and spaced closer together than normal
- _____ b. Letters that are wider than normal
- _____ c. Letters made up of thin components
- _____ d. Letters made up of heavy components

3. State the most common font used in drafting. _____

4. List three reasons for using the most common font (stated in question 3).

- a. _____
- b. _____
- c. _____

TEST

5. Select true statements concerning rules for forming Gothic lettering by placing an "X" next to the true statements.
- a. In vertical Gothic lettering the number 1 and letter I have no width.
 - b. In vertical Gothic lettering all numerals except the number one have a width equal to their height.
 - c. The same rules for letter sizes and spacing that apply in vertical lettering apply in inclined lettering.
 - d. In inclined Gothic lettering, the letters A, V, W, X, and Y have sloping sides and are difficult to make unless an imaginary inclined center line is used and the letter is drawn symmetrically around it.
 - e. In vertical Gothic lowercase lettering, the letters p and g terminate without curves on the waist line.
 - f. The shapes of vertical lowercase lettering are based on the circle, circular arc, and the straight line.
 - g. In inclined Gothic lowercase lettering, the letters c, o, s, v, w, x, and z have the same form as their corresponding uppercase letters.
6. Select true statements concerning the reasons and rules for neat lettering by placing an "X" next to the true statements.
- a. Lettering can greatly affect the overall appearance of a drawing.
 - b. Although letters must be formed very carefully, skill should be used to crowd letters as much as possible in a limited space.
 - c. When additions or revisions are made to a drawing, the original style of lettering should be matched.
 - d. Most drawings are reproduced. Therefore, the lettering must be a dense black and be done with neatness, accuracy, speed, and legibility.
 - e. Inclined and vertical lettering may be mixed on one drawing as desired.
7. Select true statements concerning rules for spacing by placing an "X" next to the true statements.
- a. The spacing of words is attained by using an imaginary letter "O" as a spacer.
 - b. Notes must be placed vertically on the drawing.
 - c. Use underline lettering only when special emphasis is needed.

TEST

- _____ d. The division line in a common fraction should be parallel to the direction the dimension reads, and the numerator and denominator of a fraction should be separated by a 0.06" space.
 - _____ e. The spacing between two sentences should always be 1/4".
 - _____ f. Spacing between letters is determined by the area between two letters, not just the distance between two letters.
 - _____ g. Each numeral in a fraction should be the same width as a whole number.
8. Match recommended minimum letter heights on the right with the correct components of a drawing.
- | | |
|---|--------------------|
| _____ a. Drawing number in title block (all sheet sizes) | 1. 0.125 and 0.156 |
| _____ b. Drawing title | 2. 0.188 |
| _____ c. Dimensions, tolerances, notes, revisions, tables (all sheet sizes) | 3. 0.250 |
| _____ d. Zone letters and numerals in border | 4. 0.250 and 0.312 |
| _____ e. Section and tabulation letters | |
9. Identify common problems in lettering uniformity by stating the problems under each of the following examples.

GOOD LETTERINGSHOULD
BE UNIFORM

UN IFO R M

a. _____

b. _____

UNiFORM

UNIFORM

c. _____

d. _____

UniFoRM

UNIFORM

e. _____

f. _____

TEST

10. Select from the following list the purposes of guidelines by placing an "X" in the appropriate blanks.
- _____ a. To keep letters spaced properly
- _____ b. To improve the overall composition of lettered information
- _____ c. To keep letters exactly the same width
- _____ d. To maintain correctness in drawing illustrations
- _____ e. To keep letters exactly the same height
- _____ f. To keep letters positioned in the same direction
11. Select true statements concerning rules for making guidelines by placing an "X" next to the true statements.
- _____ a. Make horizontal guidelines with the aid of a lettering guide.
- _____ b. Align paper and secure corners with tape to working surface.
- _____ c. Horizontal guidelines should be accurately spaced.
- _____ d. Although guidelines are often useful, they are not necessary when a Braddock Rowe triangle is used.
- _____ e. Guidelines should be dark and opaque.
12. Identify the types of line guides below used for laying out guidelines for lettering.

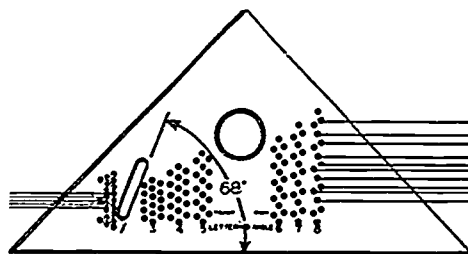
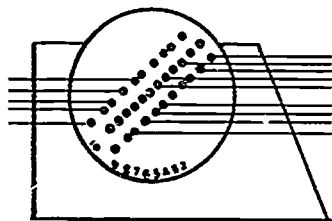

- a. _____ b. _____

TEST

13. Select true statements concerning special rules for left-handed drafters by placing an "X" next to the true statements.
- _____ a. Vertical and inclined strokes should be done from top to bottom.
- _____ b. Movement on horizontal strokes should be done from left to right.
- _____ c. The left-handed drafter should follow a system of strokes that will involve pulling the pen or pencil instead of pushing it.
14. Match the types of lettering instruments on the right with the correct descriptions.
- | | |
|--|------------------------------------|
| _____ a. A machine that produces type on transparent tape that can be attached to the surface of the drawing | 1. Press-on letters |
| _____ b. An instrument consisting of a template, a scribe, and an inking pen | 2. CADD |
| _____ c. A thin, flat sheet of plastic with letters cut through the sheet | 3. Lettering machine |
| _____ d. A computer software that provides a variety of different lettering fonts | 4. Template |
| _____ e. Letters that are printed on sheets that rub off onto the drawing plate and are available in many letter fonts and point sizes | 5. Leroy-type lettering instrument |
| | 6. Typewriter |
15. Select true statements concerning text input on CADD by placing an "X" next to the true statements.
- _____ a. Text may not be edited after placement.
- _____ b. Background objects may be blanked out behind any text input.
- _____ c. A variety of built-in and user-defined text fonts are available.
- _____ d. Text may be typed in and placed visually.
- _____ e. Text inputs on CADD cannot be centered or justified.

(NOTE: If the following activities have not been accomplished prior to the test, ask your instructor when they should be completed.)

16. Hand letter an employment application. (Assignment Sheet #1)

TEST

17. Demonstrate the ability to:
 - a. Operate an Ames-type lettering guide to construct guidelines. (Job Sheet #1)
 - b. Operate a Braddock Rowe triangle to construct guidelines. (Job Sheet #2)
 - c. Construct vertical Gothic lettering and numerals. (Job Sheet #3)
 - d. Construct inclined Gothic lettering and numerals. (Job Sheet #4)
 - e. Add text to a title block on a CADD system. (Job Sheet #5)

347

**LETTERING
UNIT VII****ANSWERS TO TEST**

1.
 - a. 4
 - b. 1
 - c. 3
 - d. 2
 - e. 6

2.
 - a. C
 - b. E
 - c. L
 - d. B

3. Single-stroke Gothic

4. Any three of the following:
 - a. Saves time in production
 - b. Easy to read and provides drawing consistency
 - c. Easier to learn to use
 - d. Cost of drawings is reduced

5. a, c, d, f, g

6. a, c, d

7. a, c, d, f

8.
 - a. 4
 - b. 3
 - c. 1
 - d. 2
 - e. 3

9.
 - a. Areas are not uniform between words.
 - b. Areas are not uniform between letters.
 - c. Letters are not uniform in height.
 - d. Letters are not inclined or vertically uniform (mixed inclined and vertical styles).
 - e. Style of letters is not uniform (mixed upper and lower cases).
 - f. Letters are not uniform in stroke thickness.

10. a, b, e, f

ANSWERS TO TEST

11. a, b, c
12. a. Ames-type lettering guide
b. Braddock Rowe triangle
13. a, c
14. a. 3
b. 5
c. 4
d. 2
e. 1
15. b, c, d
16. Evaluated to the satisfaction of the instructor
17. Performance skills evaluated to the satisfaction of the instructor

349

**LINES
UNIT VIII****UNIT OBJECTIVE**

After completion of this unit, the student should be able to select basic line types used for drafting, define good line quality, and complete a chart on the alphabet of ink lines. The student should also be able to draw graphite, plastic lead, and ink lines on various media and input lines on a CADD system. Competencies will be demonstrated by completing the job sheets and the unit tests with a minimum score of 85 percent.

SPECIFIC OBJECTIVES

After completion of this unit, the student should be able to:

1. Match basic types of lines with their uses.
2. Identify basic types of lines used for drafting.
3. Complete a chart of line widths and recommended pen sizes.
4. Match types of lines with the correct rules for using them.
5. Select qualities which define good lines.
6. Match size recommendations for choosing millimeter pencils with the basic line applications.
7. Select true statements concerning techniques for drawing lines with ink.
8. Distinguish between factors that make lines heavier or thinner with a technical pen.
9. Select true statements about using ink on polyester film.
10. Select true statements about using ink on vellum.
11. Arrange in order the steps for completing lines on a drawing.
12. Label the common elements of a CADD command for inputting drawing geometry.
13. Identify the components of a line used on CADD.
14. Identify modifiers used with a line command.
15. List methods for locating lines on a CADD system.
16. List methods for inputting different line types on a CADD system.

SPECIFIC OBJECTIVES

17. Demonstrate the ability to:
 - a. Draw lines on vellum using graphite lead. (Job Sheet #1)
 - b. Draw lines on polyester film using plastic lead. (Job Sheet #2)
 - c. Trace an illustration on vellum using millimeter pencils. (Job Sheet #3)
 - d. Draw and erase ink lines on vellum. (Job Sheet #4)
 - e. Draw and erase ink lines on polyester film. (Job Sheet #5)
 - f. Input lines into a CADD System. (Job Sheet #6)

**LINES
UNIT VIII**

SUGGESTED ACTIVITIES

- A. Provide student with objective sheet.
- B. Provide student with information and job sheets.
- C. Make transparencies.
- D. Discuss unit and specific objectives.
- E. Discuss information and job sheets.
- F. Demonstrate the use of an eraser shield and eraser to erase a line.
- G. Show students various supplies such as lead, plastic lead, ink, vellum, polyester film, mechanical pencils, thin-lead mechanical pencils, and millimeter pencils.
- H. Demonstrate how to create lines on your CADD system.
- I. Demonstrate how to use technical pens for inking on polyester film and vellum.
- J. Give test.

REFERENCES USED IN DEVELOPING THIS UNIT

- A. *Drawing Requirements Manual: DOD-D-1000/DOD-STD-100 Metric*, 5th ed. 2625 Hickory Street, P.O. Box 2504, Santa Ana, California 92707, (800)854-7179, Global Engineering Documents.
- B. Gerevas, Lawrence E. *Basic Drafting Problems*, 2nd ed. New York. Bobbs-Merrill Co., 1981.
- C. Giesecke, Frederick E., et. al. *Technical Drawing*, 8th ed. New York: Macmillan Publishing Co., 1986.
- D. Olivo, C. Thomas and Albert V. Payne. *Basic Blueprint Reading and Sketching*, 5th ed. Albany, New York: Delmar Publishers, Inc., 1988.
- E. *The Koh-I-Noor Rapiddraw System*. Bloomsbury, NJ. Koh-I-Noor Rapidograph, Inc.
- F. *ANSI Y14.2M-1979, Line Conventions and Lettering*. New York: American Society of Mechanical Engineers, 1979 — Reaffirmed 1987.

**LINES
UNIT VIII****INFORMATION SHEET****I. Basic types of lines and their uses**

- A. Visible lines — Used to show all visible edges or contours of an object
(NOTE: Visible lines are sometimes called object lines.)
- B. Hidden lines — Used to show surfaces or features on an object that are not visible
- C. Center lines — Used to show the centers of holes, round shapes, or the travel of a center (path of motion)
- D. Section lines — Used to show a surface that has been cut in a section view
- E. Extension lines — Used for placing dimensions on drawings; these extend (but do not touch) from the lengths and widths of objects
- F. Dimension lines — Used to show the size (dimensions) of an object; spans from one extension line to the next, has arrowheads at both ends, and is broken in the middle for the measurement number (dimension)
- G. Leader lines — Used to direct descriptive information, notes, or special dimensions to features on the drawing
- H. Cutting-plane lines — Used to show where a section has been taken; arrows on the end show the direction in which the section was taken
- I. Break lines -- Used to show that part of the object has been removed or broken away
 - 1. Short breaks are freehand, jagged lines.
 - 2. Long breaks are solid with a Z symbol inserted in several places.
- J. Phantom lines — Used to show the position of part of an object that moves (rotated position)
- K. Stitch lines — Used to indicate a stitching or sewing process
- L. Chain lines — Used to indicate that a surface or surface area is to receive some additional treatment specified on drawing
- M. Border lines — Used to define the outer edges or margins on the drafting media; the drawing and all other information is inside this border

INFORMATION SHEET

II. Basic types of lines used for drafting (Transparency 1)

A. Visible lines

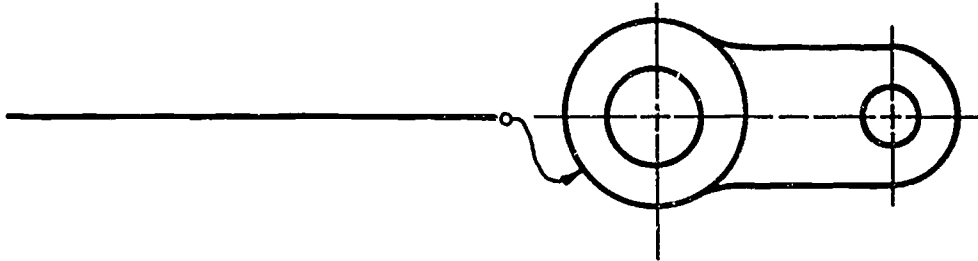

B. Hidden lines

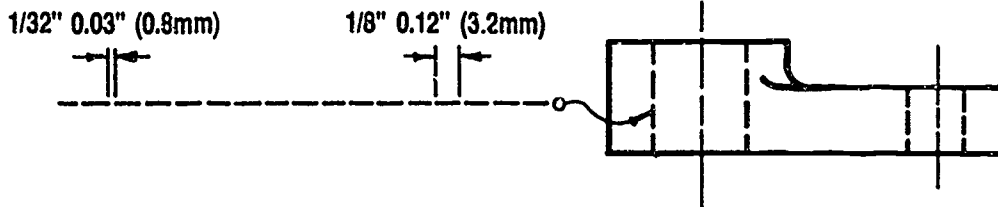

C. Center lines

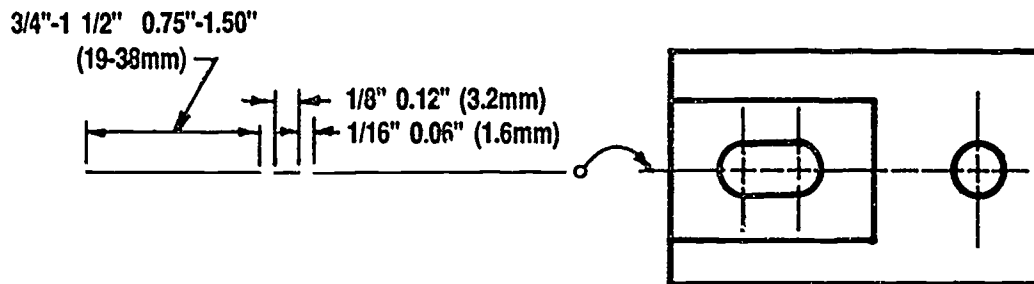

D. Section lines

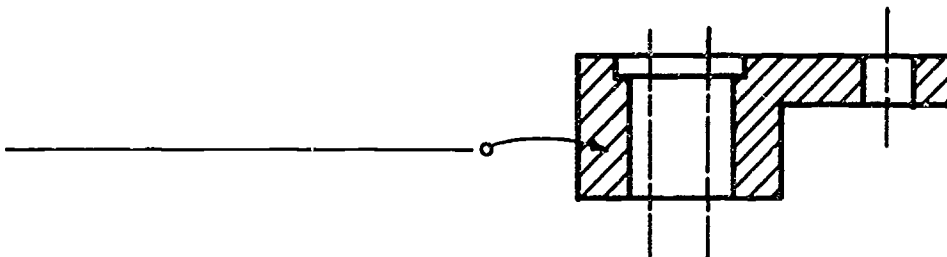

INFORMATION SHEET

E. Extension lines, dimension lines and leader lines

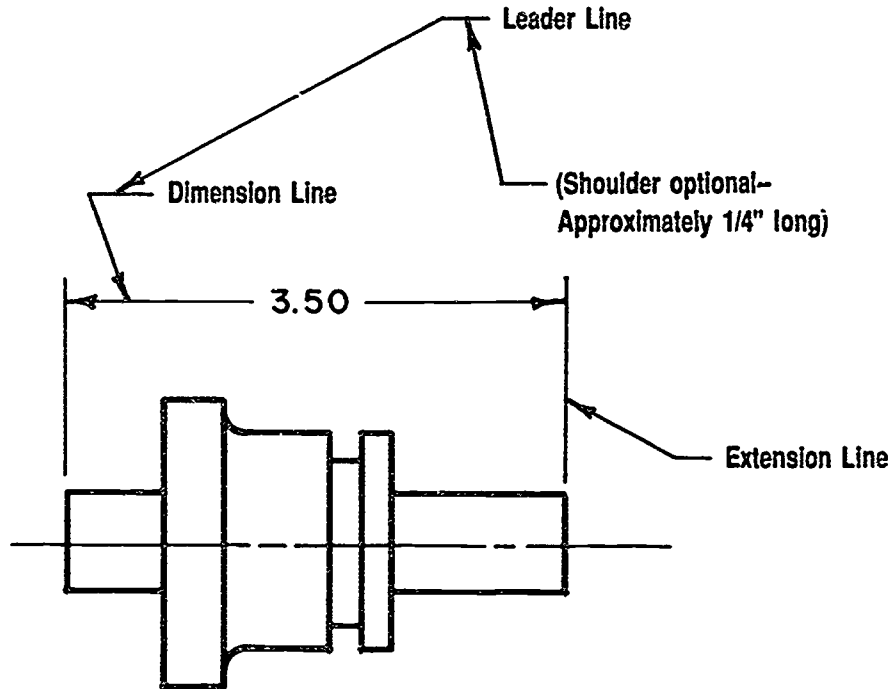

F. Cutting-plane lines

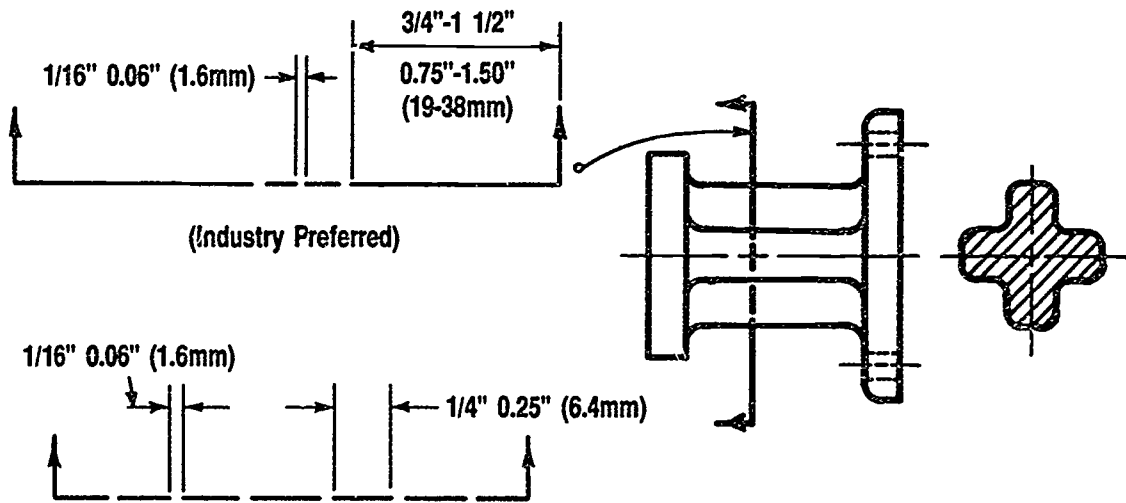

INFORMATION SHEET

G. Break lines

1. Short-break line

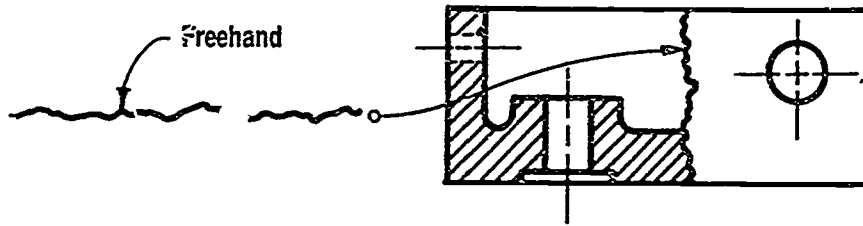

2. Long-break line

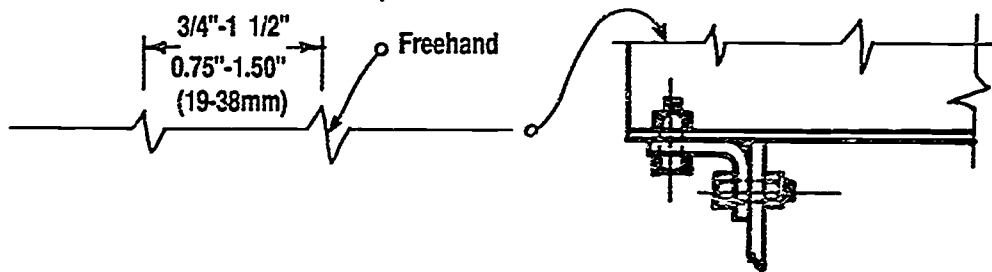

H. Phantom line

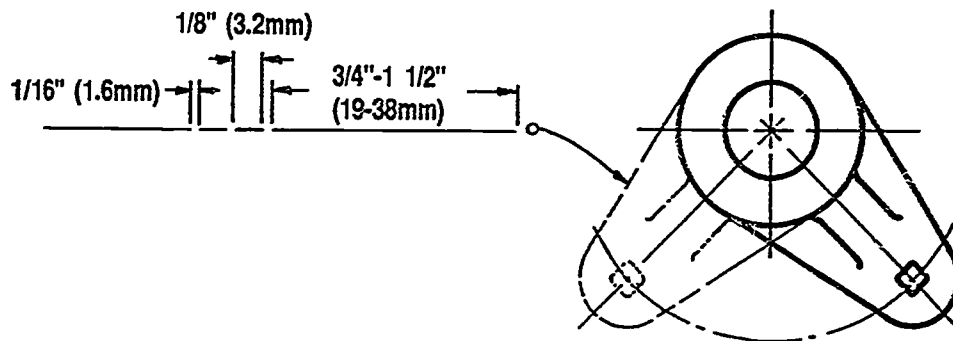

INFORMATION SHEET

I. Stitch lines

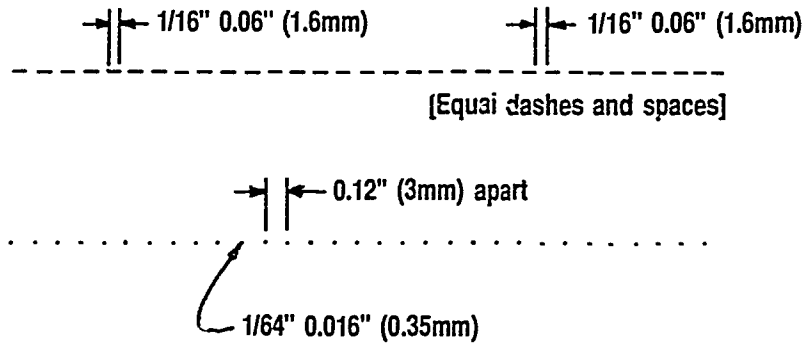

J. Chain lines

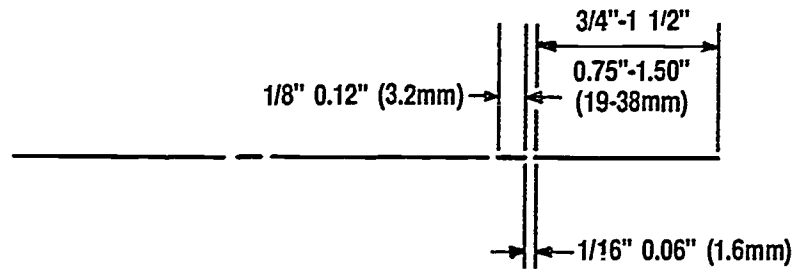

K. Border lines



III. Line widths and recommended pen sizes

Name of Line	Dimension	Approximate Width	Recommended Pen Size & Number
Visible line	Thick	0.032" (0.7mm)	.50 mm 2
Hidden line	Thin	0.016" (0.35mm)	.35 mm 0
Center line	Thin	0.016" (0.35mm)	.35 mm 0
Section line	Thin	0.016" (0.35mm)	.35 mm 0
Dimension line	Thin	0.016" (0.35mm)	.35 mm 0
Extension line	Thin	0.016" (0.35mm)	.35 mm 0

INFORMATION SHEET

Name of Line	Dimension	Approximate Width	Recommended Pen Size & Number
Leader line	Thin	0.016" (0.35mm)	.35 mm 0
Cutting-plane or viewing plane line	Thick	0.032" (0.7mm)	.50 mm 2
Long break line	Thin	0.016" (0.35mm)	.35 mm 0
Phantom line or adjacent part line	Thin	0.016" (0.35mm)	.35 mm 0
Stitch line	Thin	0.016" (0.35mm)	.35 mm 0
Chain line	Thick	0.032" (0.7mm)	.50 mm 2

IV. Rules for using basic line types in drafting (according to ANSI Y14.2M-1979)

A. Hidden lines

1. They should be used only when required for clarity.
2. They should begin and end with a dash in contact with the line from which they start or end, except when such a dash would form a continuation of a visible line.
3. Dashes should touch at corners.
4. Arcs should start with dashes at tangent points.
5. Lengths of dashes may vary slightly in relation to size of drawing.

B. Center lines

1. Long dashes of center lines may vary in length, depending upon size of drawing.
2. Center lines should cross without voids.
3. Very short center lines may be unbroken if there is no confusion with other lines.

051

INFORMATION SHEET

C. Dimension lines

1. They should terminate in arrowheads and should be unbroken except for the insertion of the figures expressing the dimension.

(NOTE: This may vary in architectural applications.)

2. When dimensioning radii, it is permissible to break the dimension line if true center of the radii falls off the drawing in another view, or interferes with the logical dimensioning procedure.

D. Leader lines

1. Leaders may terminate at the lettering end with a line (shoulder) approximately .125 inch long.
2. Leader lines are straight and inclined, not horizontal, vertical, or curved.
3. Leader lines should not cross dimension, extension, or other leader lines. When it is unavoidable to cross a dimension line, the leader line or dimension line is not broken at the point of intersection.
4. The leader line from a dimension and/or local note to a circular area, or hole, shall be directed toward the center of the area, circle, or hole with the arrowhead terminating at the edge of the circle area or hole.
5. Leaders should terminate as follows:
 - a. Without symbol if they end on a dimension.
 - b. With a dot 1.5mm (0.06") minimum diameter if they end within outlines of an object.
 - c. With an arrowhead if they end on the outline of an object.
 - d. With or without a dot or arrowhead on drawings prepared by computer automated techniques.

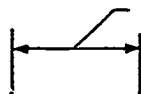

(a) To Dimension



(b) Within Outline

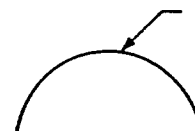

(c) To Outline

V. Definition of good line quality (according to ANSI Y14.2M-1979)

All lines shall be:

- A. Opaque
- B. Of microfilm quality
- C. Of uniform width for each type of line, using the recommended line symbols

INFORMATION SHEET

- VI. Size recommendations for choosing millimeter pencils to draw the basic line applications in drafting

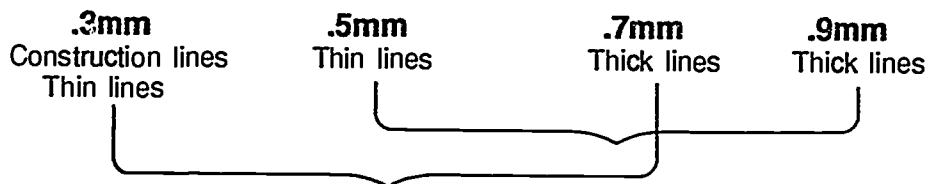

(NOTE: Use .3mm and .7mm together or .5mm and .9mm together for good distinction between thick and thin lines on a drawing.)

- VII. Techniques for drawing lines with ink

- A. The proper way to hold the technical pen is vertically, with a very light touch.
- B. While drawing, always pull the technical pen; never push it.
- C. Periodically check the technical pen for leaking around the tip to prevent your hands from smearing the drawings. Also check the tip for a drop of ink on the tip.



Look for leaks in this area

- D. If an ink riser is not available, place the template over a triangle to raise the template off the paper. The triangle gives good support and adequate clearance to prevent ink from running under template.

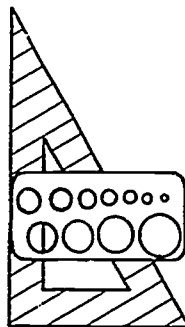

INFORMATION SHEET**VIII. Factors that make lines heavier or thinner when using a technical pen****A. Factors that make a line heavier**

1. Moving the pen too slowly
2. Overfilling the pen
3. Dull nibs
4. Leaning the pen toward the paper
5. Soft working surface
6. Dried ink particles caked on the nibs
7. Drafting surface not sufficiently prepared or cleaned

B. Factors that make a line thinner

1. Moving the pen too quickly
2. Not enough ink in the pen
3. Hard working surface
4. Clean pen and fresh ink

IX. Using ink on polyester film

- A. If the polyester film is matte (dull) on both sides, draw on either side; if it is matte on only one side, place the matte side up for drawing.

(NOTE: The matte coating [sometimes called tooth] is applied to polyester film so a line will adhere securely to the surface.)

- B. Excessive erasing in one area can remove the matte surface. To replace the matte surface, rub the film with Pounce or cleanser to bring a nap back on the film.

- C. Before putting any linework on polyester film, the film should be wiped clean with a moist paper towel.

(NOTE: For serious soils, use a liquid film cleaner.)

- D. Ink can be easily removed from polyester film because the ink does not penetrate into the film.

INFORMATION SHEET

- E. Standard methods for erasing lines on film are with chemically-imbibed erasers or moisture with a white vinyl eraser.

(NOTE: For fine removable of in' lines, an X-acto knife blade may be used. However, this removes the matte surface from the film.)

- F. Ink lines will flake or chip off the drafting film when some foreign materials are present between the ink line and the polyester film.

X. Using ink on vellum

- A. Be sure the felt side of the vellum is up. Feathering will result if linework is placed on the wire side.
- B. Be sure to remove ink quickly after an error has been made. The longer ink is on the vellum, the more difficult it is to remove.
- C. Remove ink from vellum with a pink pearl or red ruby eraser.

XI. Suggested steps for completing lines on a drawing

- A. Lightly layout the drawing with a nonreproducible lead or a .3mm or .5mm pencil.
- B. Using a .7mm or .9mm pencil finalize all object lines. Draw fillets and rounded forms first, then draw in horizontal and vertical lines.

(NOTE: Drawing speed can be increased by drawing all the same type of lines at the same time. For example, draw all circles, then draw all horizontal lines, then vertical lines.)

- C. Using a .5mm or .3mm pencil, finalize the remaining lines — hidden lines, dimension lines, section lines, etc.

XII. Common elements of a CADD command for inputting drawing geometry

VERB / NOUN / MODIFIER (ADJECTIVE) / LOCATION

Example:

INS	LIN	HOR	:DIG D ₁ , D ₂
(INSERT)	(LINE)	(HORIZONTAL)	(WHERE)

INFORMATION SHEET

XIII. Components of a line used on CADD

- A. Lines are geometric items that connect two points.
- B. Each point has a coordinate position.
- C. The end points of connected lines are also the starting points of the lines to which they are connected.
- D. A line's origin is the midpoint.

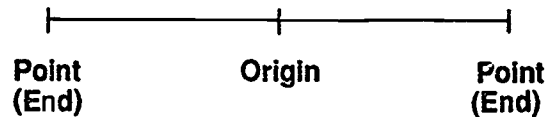

XIV. Modifiers used with a line command (Transparency 2)

- A. Horizontal — Parallel to the X axis
- B. Vertical — Parallel to the Y axis
- C. Angle — Line angled at a specified degree to a given line
- D. Parallel — Parallel to a specified line within a specified distance
- E. Perpendicular — Perpendicular to a specified line
- F. Tangent — Tangent to a circle
- G. Length — Unit long

XV. Methods for locating lines on a CADD system

- A. Coordinate locations
 - 1. Cartesian coordinates
 - 2. Polar coordinates
- B. Free digitized points with explicit grid coordinate points
- C. Menu selection

INFORMATION SHEET

XVI. Methods for inputting different line types on a CADD system

- A. The command "SELECT LINE FONT" used with a type of line desired will input all geometry in that line type until a new font is selected.

(NOTE: Solid lines are the default linetype on most CADD systems.)

- B. The command "CHANGE LINE FONT" will allow the operator to change a line type to a different line type by digitizing the lines to be changed.

(NOTE: Most symbol libraries include different line types.)

Line Applications

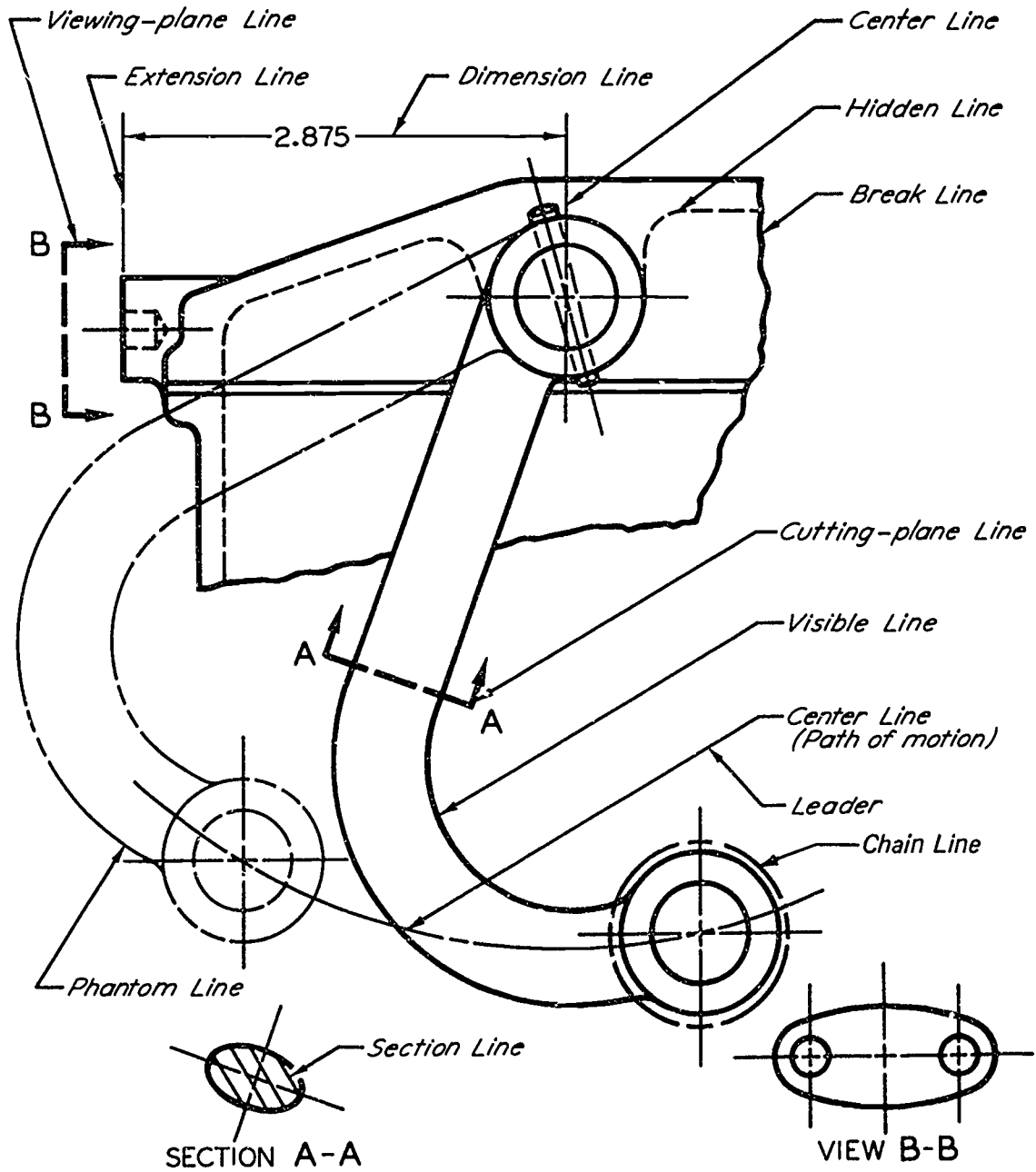

ANSI Y14.2-1979, Reaffirmed 1987. Reprinted with permission of ASME.

Modifiers Used with Lines on CADD



Horizontal

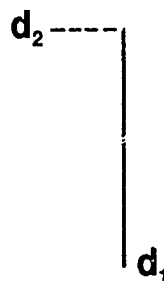

Vertical

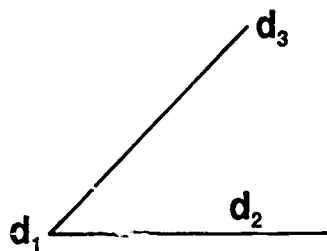

Angle

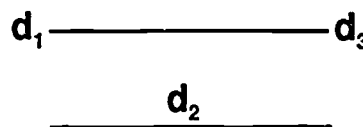

Parallel

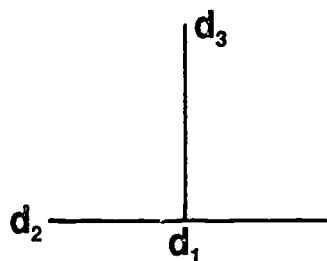

Perpendicular

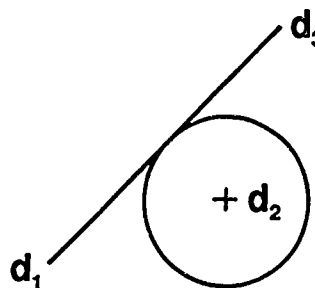

Tangent

**LINES
UNIT VIII**

JOB SHEET #1 — DRAW LINES ON VELLUM USING GRAPHITE LEAD

A. Tools and equipment

1. Drafting machine
2. Graphite lead (size to be determined by instructor)
3. Lead holder
4. Pencil pointer or other lead sharpener
5. Vellum, "A" size
6. Ames lettering guide
7. Drafting tape

EVALUATION CRITERIA

Criteria	Rating
Correct line widths	_____
Good line quality	_____
Good lettering	_____
Line symbols drawn correctly	_____

B. Procedure

1. Tape vellum to drawing surface, felt side up.
2. Align drafting machine parallel edge with edge of vellum so they are parallel.
3. Draw the complete alphabet of lines, showing the appropriate variations in line width.
4. Label the lines with the names above each line in vertical uppercase lettering. Use 5/32 height for lettering.

FIGURE 1

HIDDEN LINE

5. Reproduce on the print machine.

**LINES
UNIT VIII**

JOB SHEET #2 — DRAW LINES ON POLYESTER FILM USING PLASTIC LEAD

A. Tools and equipment

1. Drafting machine
2. Plastic lead (size to be determined by instructor)
3. Lead holder
4. Pencil pointer or other lead sharpener
5. Polyester film, "A" size
6. Ames lettering guide
7. Film cleaner and cloth
8. Drafting tape

EVALUATION CRITERIA

Criteria	Rating
Correct line widths	_____
Good line quality	_____
Good lettering	_____
Lines drawn correctly	_____

B. Procedure

1. Tape polyester film to drawing surface, matte side up.
2. Line up parallel edge of drafting machine with the edge of the polyester film.
3. Clean film if necessary.
4. Draw the complete alphabet of lines, showing the appropriate variations in line width.
5. Label the lines with the names above each line in vertical uppercase lettering. Use 5/32 height for lettering.

FIGURE 1

_____ **CENTER LINE** _____

6. Reproduce on the print machine.

**LINES
UNIT VIII**

**JOB SHEET #3 — TRACE AN ILLUSTRATION ON VELLUM
USING MILLIMETER PENCILS**

A. Tools and equipment

1. Drafting machine
2. .7mm or .9mm pencil with 2H or H lead
3. .3mm or .5mm pencil with 2H or 3H lead
4. Vellum, "A" size
5. Drafting tape

EVALUATION CRITERIA

Criteria	Rating
Correct line widths	_____
Good line quality	_____
Lines drawn correctly	_____

B. Procedure

1. Tape this sheet (back side with illustration) to drawing surface.
2. Line up the horizontal lines with the edge of the parallel edge of the drafting machine.
3. Center vellum over illustration and tape down (Figure 1).
4. Trace the illustration using .7mm or .9mm pencils for thick lines and .3mm or .5mm pencils for thin lines.

(NOTE: Hold pencils vertically for best results.)

JOB SHEET #3

FIGURE 1

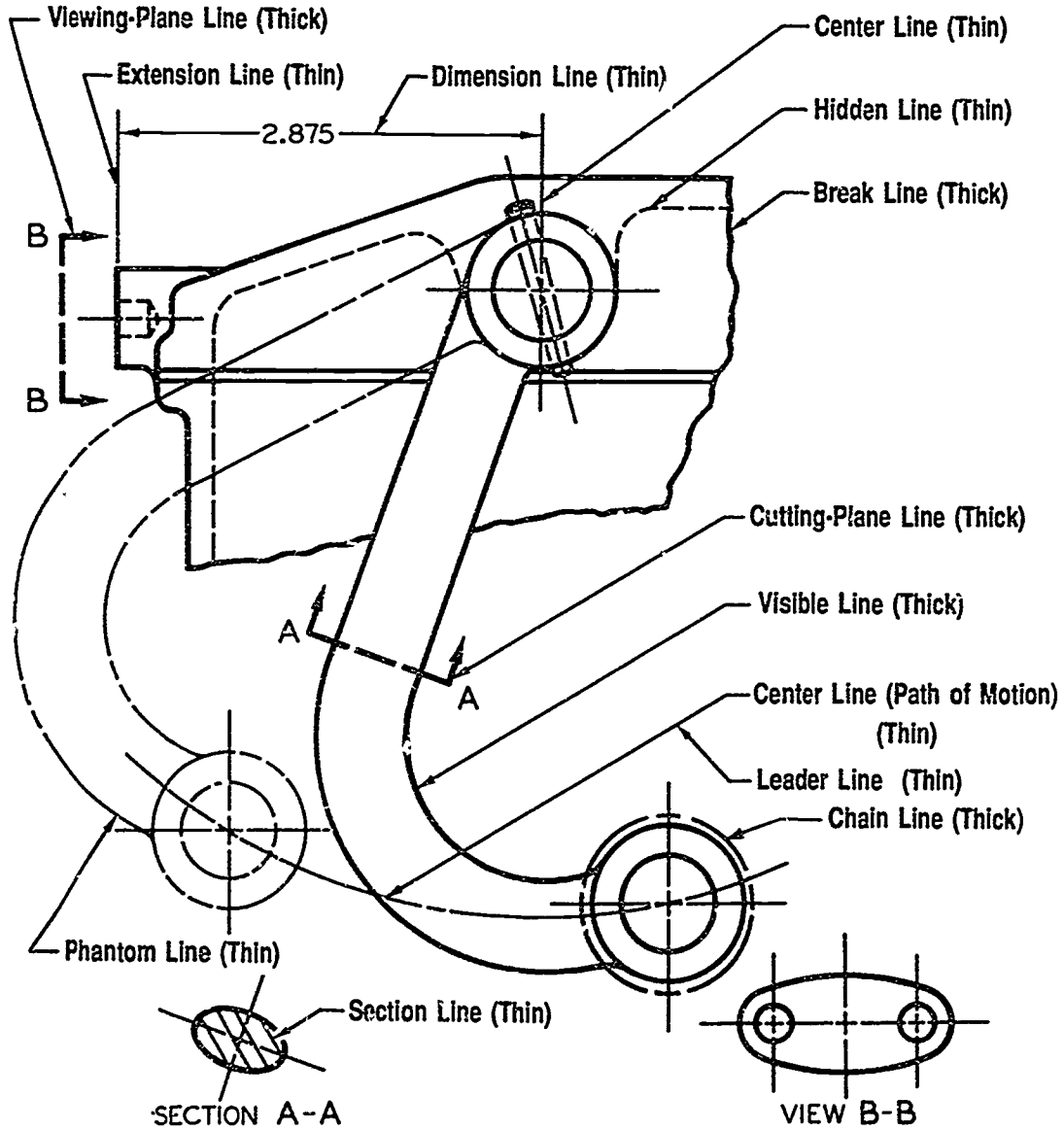

ANSI Y14.2-1979, Reaffirmed 1987. Reprinted with permission of ASME.

**LINES
UNIT VIII**

JOB SHEET #4 — DRAW AND ERASE INK LINES ON VELLUM

A. Tools and equipment

1. Drafting machine
2. Technical pens (appropriate sizes to complete alphabet of lines)
3. Ink risers
4. Lettering device or template
5. Ink (type to be determined by instructor)
6. Eraser appropriate for ink on vellum
7. Erasing shield
8. Vellum (size to be determined by instructor)
9. Drafting tape

EVALUATION CRITERIA	
Criteria	Rating
Good line quality and widths	_____
Good lettering	_____
Lines drawn correctly	_____
Erased lines are not visible	_____

B. Procedure

1. Tape vellum to surface, felt side up.
2. Draw the complete alphabet of lines, showing the appropriate variations in line width.
3. Letter the name of the line above the line in vertical uppercase lettering using a lettering device.
4. Letter in below the line the words "APPROXIMATE WIDTH" and the approximate width figures in English and metric.
5. Letter in the recommended pen size in inclined uppercase lettering.

FIGURE 1

VISIBLE LINE

APPROXIMATE WIDTH 0.032" (0.7mm)
PEN SIZE .50mm 2

371

JOB SHEET #4

6. Erase one half of the drawn lines with an electric or manual eraser. Do not erase the lettering. Use the erasing shield to cover over the lines or lettering that is not to be erased.

(NOTE: In this example only half of the original line is erased.)

FIGURE 2

VISIBLE LINE
APPROXIMATE WIDTH 0.032" (0.7mm)
PEN SIZE .50mm 2

7. Reproduce on print machine to check "ghosting".

372

**LINES
UNIT VIII**

JOB SHEET #5 — DRAW AND ERASE INK LINES ON POLYESTER FILM

A. Tools and equipment

1. Drafting machine
2. Technical pens (appropriate sizes to complete alphabet of lines)
3. Ink risers
4. Lettering device or template
5. Ink (type to be determined by instructor)
6. Eraser or erasing fluid appropriate for ink on polyester film
7. Erasing shield
8. Polyester film (size to be determined by instructor)
9. Film cleaner
10. Drafting tape

EVALUATION CRITERIA	
Criteria	Rating
Good line quality and widths	_____
Good lettering	_____
Lines drawn correctly	_____
Erased lines are not visible	_____

B. Procedure

1. Tape film to surface, matte side up.
2. Clean film if necessary.
3. Draw the complete alphabet of lines, showing the appropriate variations in line width.
4. Letter the name of the line above the line in vertical uppercase lettering using a lettering device.
5. Letter in below the line the words "APPROXIMATE WIDTH" and the approximate width figures in English and metric.
6. Letter in the recommended pen size in inclined uppercase lettering.

FIGURE 1

SECTION LINE

APPROXIMATE WIDTH 0.016" (0.35mm)
PEN SIZE .35mm 0

JOB SHEET #5

- 7. Erase one half of the drawn lines with an ink eraser or erasing fluid. Do not erase the lettering.

(NOTE: In this example only half of the original line drawn is erased.)

FIGURE 2

SECTION LINE

APPROXIMATE WIDTH 0.016" (0.35mm)
PEN SIZE .35mm 0

- 8. Reproduce on print machine to check "ghosting".

374

**LINES
PART VIII**

JOB SHEET #6 — INPUT LINES INTO A CADD SYSTEM

A. Tools and equipment

1. CADD system
2. Appropriate CADD software
3. Instruction (user) manual

EVALUATION CRITERIA	
Criteria	Rating
Problems drawn correctly	_____
Problems filed correctly	_____

B. Procedure — Refer to your CADD system's instruction manual for line entity commands. Then, input the following illustrations. File parts for future use.

(NOTE: A hard copy of this assignment can be done after completion of Unit IX, "Reproduction," Job Sheet #2.)

C. Problems

- 1.

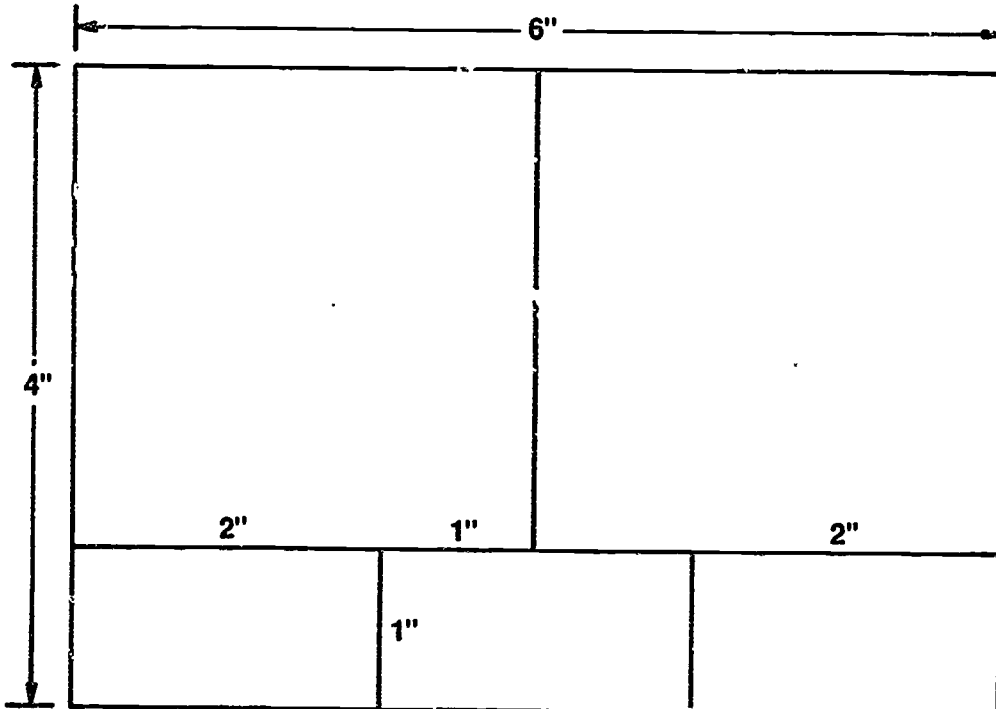

JOB SHEET #6

2.

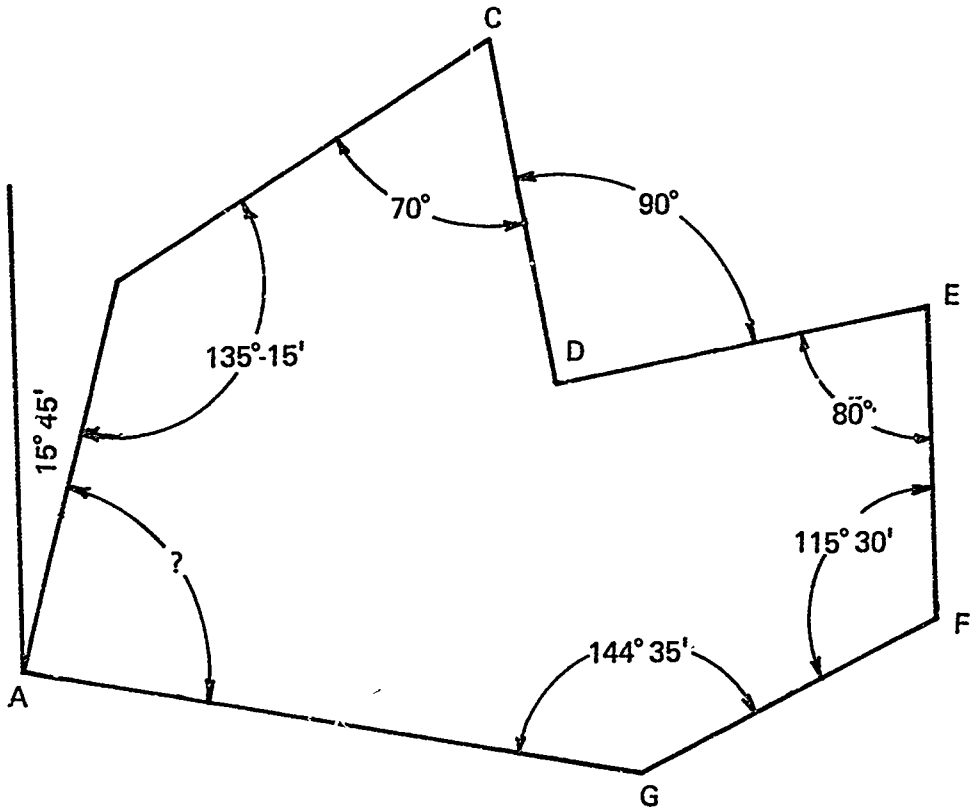

$AB = 2''$

$BC = 2 \frac{11}{32}''$

$CD = 1 \frac{3}{4}''$

$DE = 2''$

$EF = 1 \frac{17}{32}''$

$FG = 1 \frac{3}{4}''$

$GA = \underline{\hspace{2cm}}$

LINES UNIT VIII

TEST

NAME _____ SCORE _____

1. Match the basic types of lines on the right with their correct uses.

- | | |
|---|------------------------|
| _____ a. Used to show surfaces or features on an object that are not visible | 1. Border lines |
| _____ b. Used to show the centers of holes, round shapes, or the travel of a center | 2. Break lines |
| _____ c. Used to show all visible edges or contours of an object | 3. Center lines |
| _____ d. Used to show a surface that has been cut in a section view | 4. Chain lines |
| _____ e. Used for placing dimensions on drawings; these extend from the lengths and widths of objects | 5. Cutting-plane lines |
| _____ f. Used to show that part of the object has been removed or broken away | 6. Dimension lines |
| _____ g. Used to show the size of an object; spans from one extension line to the next | 7. Extension lines |
| _____ h. Used to show where a section has been taken; arrows on the end show the direction in which the section was taken | 8. Hidden lines |
| _____ i. Used to define the outer edges or margins on the drafting media | 9. Leader lines |
| _____ j. Used to show the position of part of an object that moves (rotated position) | 10. Phantom lines |
| | 11. Section lines |
| | 12. Stitch lines |
| | 13. Visible lines |

TEST

2. Identify the basic types of lines below.



a. _____

b. _____

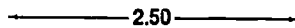

c. _____

d. _____

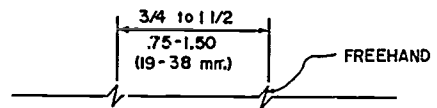

e. _____

f. _____



g. _____

h. _____

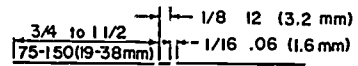
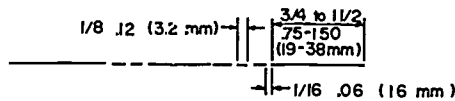

i. _____

j. _____

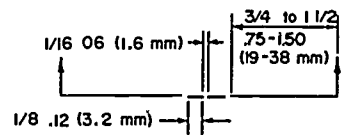
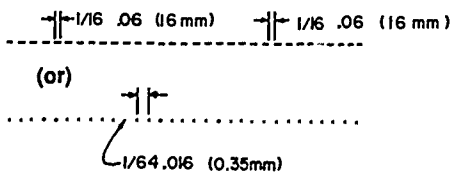

k. _____

l. _____

TEST

3. Complete the following chart of line widths and recommended pen sizes.

Name of line	Thick or Thin	Width in inches or mm	Recommended pen size and number
Visible			
Hidden			
Center			
Section			
Dimension			
Extension			
Leader			
Cutting-plane			
Short break			
Long break			
Phantom			
Stitch			
Chain			

TEST

4. Match types of lines on the right with the correct rules for using them.

- | | | |
|----------|--|--------------------|
| _____ a. | Are straight and inclined, not curved | 1. Hidden lines |
| _____ b. | May terminate at the lettering end with a line .125 inch long | 2. Center lines |
| _____ c. | Lengths of dashes may vary, depending on size of drawing | 3. Dimension lines |
| _____ d. | Should begin and end with a dash in contact with the line from which they start or end | 4. Leader lines |
| _____ e. | Should terminate in arrowheads and should be unbroken except for insertion of the figures expressing the dimension | 5. Extension lines |
| _____ f. | Should terminate with a 1.5 mm dot if they end within outlines of an object or terminate with an arrowhead if they end on the outline of an object | |

5. Select from the following list the qualities which define a good line (according to *ANSI Y14.2M-1979*) by placing an "X" next to the correct qualities.

- _____ a. Translucent
- _____ b. Of uniform width for each type of line
- _____ c. Opaque
- _____ d. Of blueprinting quality
- _____ e. Of electrostatic copying quality
- _____ f. Of microfilm quality

6. Match size recommendations for choosing millimeter pencils with the basic line applications.

- | | | | |
|----------|--------------------|----|-------|
| _____ a. | Construction lines | 1. | .3mm |
| _____ b. | Thick lines | 2. | .5mm |
| _____ c. | Thin lines | 3. | .9mm |
| | | 4. | .15mm |

TEST

7. Select true statements concerning techniques for drawing lines with ink by placing a "T" next to the true statements and "F" next to the false statements.
- a. The proper way to hold a technical pen is vertically, with a light touch.
 - b. Place tape on back of template to act as an ink riser if one is not available.
 - c. Periodically check the technical pen tip for accumulated ink and leaking.
8. Distinguish between the following factors by placing an "H" next to those factors that make technical pen lines heavier and a "T" next to those factors that make technical pen lines thinner.
- a. Moving the pen too quickly
 - b. Moving the pen too slowly
 - c. Dull nibs
 - d. Overfilling the pen
 - e. Not enough ink in the pen
 - f. Soft working surface
 - g. Hard working surface
 - h. Clean pen and fresh ink
9. Select true statements about using ink on polyester film by placing a "T" or "F" next to the appropriate statements.
- a. Ink lines will flake or chip off the drafting film when some foreign materials are present between the ink line and the polyester film.
 - b. Standard method for erasing ink on polyester film is with a pink pearl eraser.
 - c. Ink is very difficult to remove from polyester film.
 - d. Ink is placed on the matte side of the film.
10. Select true statements about using ink on vellum by placing a "T" or "F" in the blanks.
- a. Remove ink from vellum with a chemically-imbibed eraser.
 - b. Be sure to remove ink quickly after an error has been made.
 - c. Place ink on the felt side of the vellum.

TEST

11. Arrange in order the following steps for completing lines on a drawing by placing a 1, 2, or 3 in the blanks.

- _____ a. Using a .5mm or .3mm pencil, finalize the remaining lines -- hidden, dimension, section, etc.
- _____ b. Lightly layout the drawing with a nonreproducible lead or a .3mm or .5mm pencil.
- _____ c. Using a .7mm or .9mm pencil, finalize all object lines. Draw fillets and rounded forms first, then draw in horizontal and vertical lines.

12. Label the common elements of a CADD command for inputting Drawing Geometry.

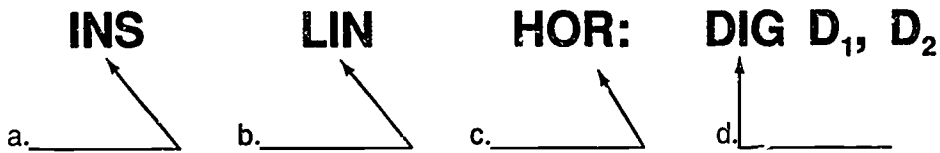

13. Identify the components of a line used on CADD.

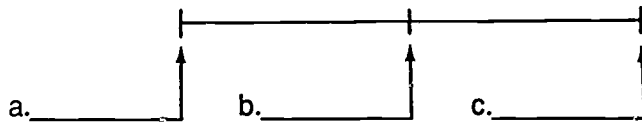

14. Identify the following modifiers used with a line command.

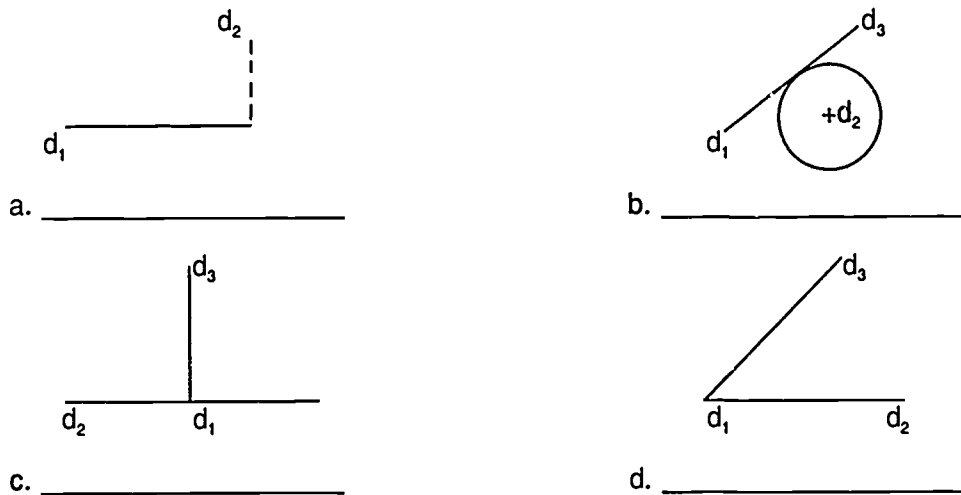

TEST

15. List two methods for locating lines on a CADD system.
- a. _____
- b. _____
16. List two methods (commands) for inputting different line types on a CADD system.
- a. _____
- b. _____

(NOTE: If the following activities have not been accomplished prior to the test, ask your instructor when they should be completed.)

17. Demonstrate the ability to:
- a. Draw lines on vellum using graphite lead. (Job Sheet #1)
- b. Draw lines on polyester film using plastic lead. (Job Sheet #2)
- c. Trace an illustration on vellum using millimeter pencils. (Job Sheet #3)
- d. Draw and erase ink lines on vellum. (Job Sheet #4)
- e. Draw and erase ink lines on polyester film. (Job Sheet #5)
- f. Input lines into a CADD system. (Job Sheet #6)

LINES
UNIT VIII

ANSWERS TO TEST

1.
 - a. 8
 - b. 3
 - c. 13
 - d. 11
 - e. 7
 - f. 2
 - g. 6
 - h. 5
 - i. 1
 - j. 10

2.
 - a. Leader line
 - b. Hidden line
 - c. Dimension line
 - d. Border line
 - e. Short-break line
 - f. Long-break line
 - g. Visible line
 - h. Extension line
 - i. Phantom line
 - j. Center line
 - k. Stitch line
 - l. Cutting-plane line

3. (NOTE: Students may give answers in inches or mm.)

Name of Line	Dimension	Approximate Width	Recommended Pen Size & Number
Visible line	Thick	0.032" (0.7mm)	.50 mm 2
Hidden line	Thin	0.016" (0.35mm)	.35 mm 0
Center line	Thin	0.016" (0.35mm)	.35 mm 0
Section line	Thin	0.016" (0.35mm)	.35 mm 0
Dimension line	Thin	0.016" (0.35mm)	.35 mm 0
Extension line	Thin	0.016" (0.35mm)	.35 mm 0

ANSWERS TO TEST

Name of Line	Dimension	Approximate Width	Recommended Pen Size & Number
Leader line	Thin	0.016" (0.35mm)	.35 mm 0
Cutting-plane or viewing plane line	Thick	0.032" (0.7mm)	.50 mm 2
Short break line	Thick	0.032" (0.7mm)	.50 mm 2
Long break line	Thin	0.016" (0.35mm)	.35 mm 0
Phantom line or adjacent part line	Thin	0.016" (0.35mm)	.35 mm 0
Stitch line	Thin	0.016" (0.35mm)	.35 mm 0
Chain line	Thick	0.032" (0.7mm)	.50 mm 2

4. a. 4
 b. 4
 c. 1 or 2
 d. 1
 e. 3
 f. 4

5. b, c, f

6. a. 1
 b. 3
 c. 2 or 1

7. a. T
 b. F
 c. T

8. a. T e. T
 b. H f. H
 c. H g. T
 d. H h. T

ANSWERS TO TEST

9. a. T
b. F
c. F
d. T
10. a. F
b. T
c. T
11. a. 3
b. 1
c. 2
12. a. Verb
b. Noun
c. Modifier
d. Location
13. a. Point (end)
b. Origin
c. Point (end)
14. Any five of the following:
a. Horizontal
b. Tangent
c. Perpendicular
d. Angle
15. Any two of the following:
a. Coordinate locations
b. Free digitized points with explicit grid coordinate points
c. Menu selection
16. a. Select line font
b. Change line font
17. Performance skills evaluated to the satisfaction of the instructor

REPRODUCTION UNIT IX

UNIT OBJECTIVE

After completion of this unit, the student should be able to describe the procedures for reproduction processes used in drafting, processes in microfilming, and reprographic techniques. The student should also be able to operate a diazo print machine and plot a CADD drawing. Competencies will be demonstrated by completing the job sheets and the unit tests with a minimum score of 85 percent.

SPECIFIC OBJECTIVES

After completion of this unit, the student should be able to:

1. Match terms related to reproduction with their correct definitions.
2. Distinguish among the common reproduction processes used in drafting.
3. Arrange in order the steps in the diazo process.
4. Select true statements concerning factors involved in the diazo process.
5. List types of diazo prints.
6. Match factors that affect the diazo process with the correct definitions.
7. Select advantages of the diazo process.
8. Select true statements on how to safely use erasing chemicals in diazo processing.
9. List common problems in the diazo process and how to correct them.
10. Describe the procedure for making reproducibles from existing drawings.
11. List ways the electrostatic (xerographic) copier may be used for drafting reproduction.
12. Match CADD output devices with the correct definitions.
13. Select true statements on the proper use of technical pens with plotters.
14. List elements of a proper drawing control system.
15. List ways a proper drawing control system benefits a drafting organization.
16. Discuss the correct storage and distribution of drawings and prints.
17. Select true statements concerning the advantages of microfilm.

SPECIFIC OBJECTIVES

18. Arrange in order the steps in the procedure for using reprographics in drafting.
19. Demonstrate the ability to:
 - a. Operate a diazo print machine. (Job Sheet #1)
 - b. Plot a drawing from a CADD system. (Job Sheet #2)

REPRODUCTION UNIT IX

SUGGESTED ACTIVITIES

- A. Provide student with objective sheet.
- B. Provide student with information and job sheets
- C. Make transparencies.
- D. Discuss unit and specific objectives.
- E. Discuss information sheet.
- F. Discuss the procedures outlined in the job sheets.
- G. Discuss with the class the safety precautions required when using chemicals in various reproduction processes.
- H. Show examples of materials reproduced by methods other than blueprinting or the diazo processes.
- I. Demonstrate how to operate a print machine.
- J. Demonstrate how to clean a print machine.
- K. Demonstrate how to set up a drawing to plot on a CADD system.
- L. Discuss other types of reproduction methods.
- M. Give test.

REFERENCES USED IN DEVELOPING THIS UNIT

- A. Brown, Walter C. *Drafting for Industry*. South Holland, IL: The Goodheart-Willcox Company, Inc., 1984.
- B. Giesecke, Frederick E., et al. *Technical Drawing*, 8th ed. New York: Macmillan Publishing Co., Inc., 1986.
- C. Jensen, Cecil and Jay Helsel. *Engineering Drawing and Design*, 3rd ed. New York: McGraw-Hill Book Company, 1985.
- D. Voisinet, Donald D. *AutoCAD, Mechanical Lab Manual*. New York: Gregg Division / McGraw-Hill Book Company, 1987.
- E. Lubow, Martha. *Working Out with AutoCAD*. P.O. Box 4846, Thousand Oaks, CA 91360: New Riders Publishing, 1987.
- F. MIL-M-9868. *Microfilming of Engineering Documents, 35mm*, Requirements of Department of Defense (DOD). Section 5.

SUGGESTED ACTIVITIES

- G. *VersaCad Design, 2D Training Guide, Version 5.3.* 2124 Main St., Huntington Beach, CA 92648 (714)960-7720: VersaCad Corporation, March, 1988.
- H. Erbes, John, and Victor Langer. *Computer-Aided Drafting.* Milwaukee Area Technical College, 1015 North Sixth St., Milwaukee, WI: MATC-CAD, 1986.
- I. Autodesk, Inc. 2320 Marinship Way, Sausalito, CA 94965, (415) 332-2344.
- J. *Xerox-Aided Drafting.* Xerox Square, Rochester, NY 14644: Xerox Corporation.

**REPRODUCTION
UNIT IX****INFORMATION SHEET****I. Terms and definitions**

- A. Autopositive — A print or intermediate made on paper or foil by means of a positive to positive silver-type emulsion
- B. Composite print — Print made by combining the parts of two or more masters
- C. Contact print — Print made by placing a master or an original in contact with light-sensitive material while exposure is being made
- D. Contrast — The difference between the image and background areas of a print
- E. Density — The darkness of an image (linework or lettering) area
- F. Developer — Chemical agent used for treating an exposed light-sensitive material to make the image visible to the eye
- G. Development — Any process used for rendering an image visible
- H. Discoloration — Yellowing or other color changes of white areas on prints
- I. Double-coated stock — Duplicating material which has a sensitized layer on each side
- J. Double feed — Improper feeding of two sheets of duplicating paper instead of one
- K. Drawing reproduction — Making copies from completed drawings
- L. Eradicator — Chemical solution containing acid designed to bleach out unwanted portions of a print
- M. Exposure — Time period that light of a given intensity has been allowed to act on light-sensitive materials
- N. Fading — Loss in density of an image
- O. Gloss — A surface that has a bright, polished finish
- P. Hard copy — A copy on paper of what is shown on the computer screen
- Q. Inches per second (IPS) — The number of inches of magnetic tape that can be recorded or read per second, or the speed of a pen plotter
- R. Intermediate — The translucent reproduction made on vellum, cloth, or foil made from an original drawing and used in place of the original for making other prints

INFORMATION SHEET

- S. Master — Any original to be duplicated
- T. Matte — A slightly rough finish free from shine or highlights
- U. Negative — An image on materials such as paper or film where the background is dense black and the line image appears clear (on film) or white (on paper)
- V. Opaque — Not permitting the passage of light
- W. Overlay — A group of transparent or translucent prints normally used to form a composite
- X. Positive — An image on materials such as paper or film on which light tones appear light and dark tones appear dark when copied from a pencil or ink original
- Y. Translucent — Admitting and diffusing light so that objects beyond cannot be clearly distinguished; partly transparent
- Z. Transparent — Transmitting light without appreciable scattering so that bodies lying beyond are clearly visible

II. Common reproduction processes used in drafting

- A. Diazo (dry) process — Uses light, ammonia vapors, and specially coated diazo paper to make same-size reproductions of translucent drawings (on vellum or film)
- B. Photographic reproduction — Uses light, film processing chemicals, light-sensitized film, and print paper to make variable-sized positive prints from film negatives taken with a camera; can be used to change the size or appearance of a drawing
- C. Electrostatic (Xerox-type) copying — Uses light on an electrically-charged photoconductive surface, resinous powder (toner), and ordinary copying paper to make same-size or different-size reproductions of drawings or prints made on any media (opaque, translucent, or transparent)
- D. Computer data reproduction — Uses computer signals sent to an output device such as a plotter or printer to reproduce data (charts, drawings, etc.)

INFORMATION SHEET

III. Steps in the diazo (dry) process

- A. Original drawing is placed on specially-coated diazo paper.

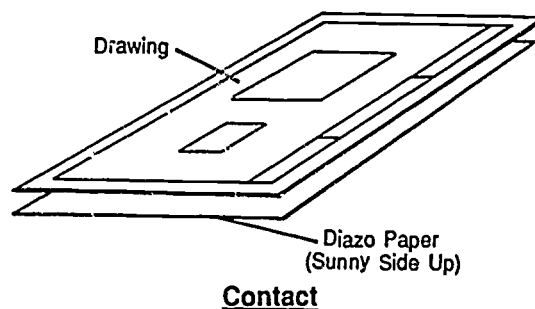

- B. Both drawing and diazo paper are fed into print machine where they are exposed to the light source. Light destroys diazo coating except for what is hidden under lines of original drawing.

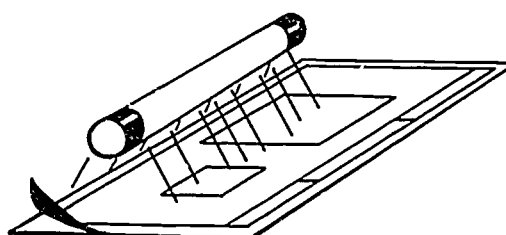

- C. Diazo sheet is then exposed to ammonia vapors which turn lines imprinted from original drawing into blue, black, or brown lines depending on type of diazo paper used.

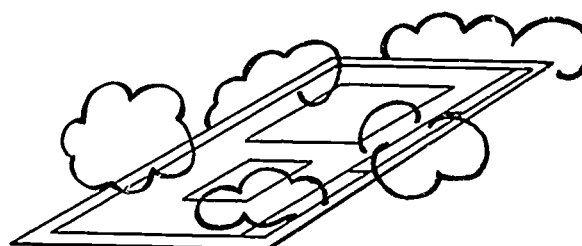

IV. Important factors in the diazo process

- The process depends upon the transmission of light through the original for the reproduction of positive prints.
- Subject matter may be pen, pencil, typewritten, or printed matter, or any opaque image.
- In order for a drawing to reproduce properly, the linework and lettering must be opaque and dense black.
- To determine if linework and lettering are opaque and dense black, simply hold the drawing near a source of light. No light should pass through opaque images.

INFORMATION SHEET

V. Types of diazo prints

- A. Blueline — Blue image on opaque paper (least expensive)
- B. Blackline — Black image on opaque paper
- C. Sepia paper — Brown image, intermediate, can print from this
- D. Sepia mylar — Brown image, mylar base, can print from this
- E. Black mylar — Same as sepia mylar but used more for presentation; will not reproduce as well as sepia mylar
- F. Brownline presentation — Brown image, plastic coating, heavier stock, can color with marker well; used mainly for presentation work
- G. Blackline presentation — Black image, same type of paper as brownline presentation

(NOTE: As you reproduce work in any diazo printing process, you will lose approximately 10% of your line quality each time you reproduce a new generation.)

VI. Factors that affect the diazo process

- A. Printing speed — A media's passage of actinic light which in turn affects the speed of the media's print-making ability through conventional exposure equipment

(NOTE: Printing speed is also the rate of speed at which light-sensitive material is exposed, normally expressed in feet per minute of printer operation.)
- B. Diazo paper — A reproduction paper which depends on the light-sensitivity of the diazo compound (photosensitive emulsion) used during manufacturing
- C. File aging — The change in appearance of a diazo print in storage not exposed to light
- D. Film positive — Film base which carries a positive image, often a photographic material which can serve as master for diazo-type prints
- E. Printer section — Area of print machine used to expose light-sensitive materials
- F. Developer section — Area of print machine used to develop light-sensitive materials
- G. Shelf-life — Time period before deterioration renders a sensitized material unusable
- H. Reproducible — Item capable of being used as a master for making prints
- I. Sensitized — A reproduction material coated with a light-sensitive compound

INFORMATION SHEET

VII. Advantages of the diazo process

- A. Sensitized materials can be handled under normal indoor illumination.
- B. Prints may have various colors of lines on a white background depending upon which paper is used.
- C. Prints can be worked on easily with pen, crayon, or pencil.
- D. Intermediates can be made from the original and then used instead of the original to save wear on the original. These intermediates can be made on a special paper (sepia), cloth, or foil.
- E. Changes can be made to intermediates with correction fluid.

VIII. How to safely use erasing chemicals in diazo processing

- A. Eradicator for sepia intermediates is a one-step process, but the eradicator contains acid and application should be made with care.
- B. Erasing foils is a two-step process.

1. The first fluid containing hydrochloric acid is applied. This reacts with the metallic silver in the sheet to produce a white salt of silver.
2. The second fluid containing thiourea is applied which dissolves the silver salt.

(NOTE: The silver salt must be completely dissolved or it will reappear as a yellow stain when exposed to light.)

3. The second fluid is washed to remove any residual chemicals.

(CAUTION: Prolonged skin contact or ingestion of erasing chemicals is dangerous. In case of skin contact, the chemicals should be flushed thoroughly with water. In case of ingestion, a doctor should be consulted immediately.)

IX. Common problems in diazo processing and how to correct them

- A. Print with a green tint — Ammonia may be too cold or too old or tubes controlling ammonia flow may be clogged, need cleaning, or flow adjusted.
- B. Print with streaking on it — Ammonia flow is excessive and needs to be adjusted.

(NOTE: To remove the ammonia odor from the print, feed the print into the printer section with the back of the print next to the warm glass cylinder surrounding the lamp.)

INFORMATION SHEET

X. Procedure for making reproducibles from existing drawings

(NOTE: Reproducibles are used when a new drawing can be made from an existing drawing with only minor changes.)

- A. Make transparent or translucent print (film or paper sepia) of the original drawing.
- B. Remove unwanted information from old print and then add new information.

(NOTE: A problem may be encountered when old drawings do not conform with the newest drafting standards.)

XI. Ways the electrostatic (xerographic) copier is used for drafting reproduction

- A. **Scissors-and-paste drafting** — Create a new drawing by merging information and views from existing drawings.

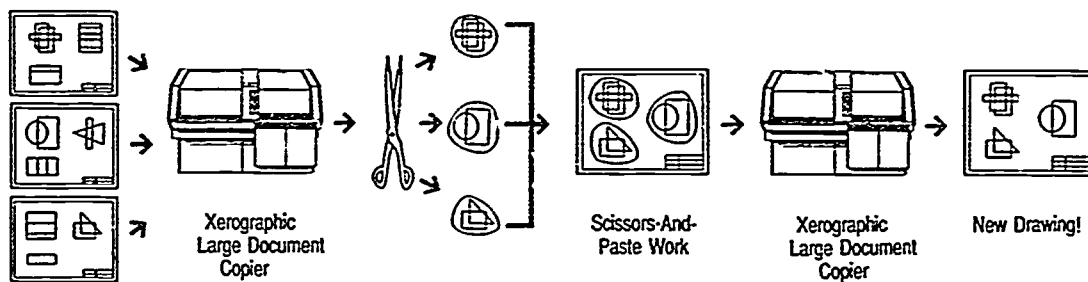

Existing Drawings

- B. **Changes/revisions on engineering documents** — Make changes by using adhesive labels, correction fluid, or masking techniques.

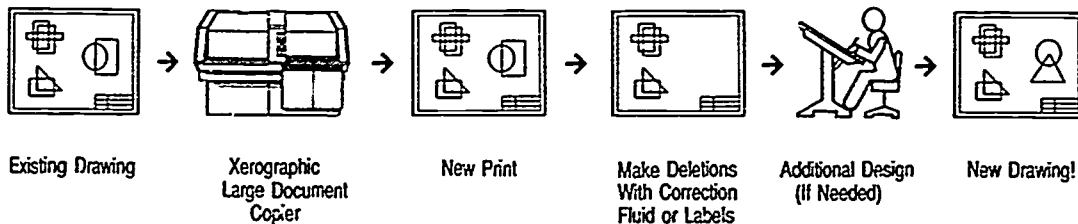

Existing Drawing

Xerographic
Large Document
Copier

New Print

Make Deletions
With Correction
Fluid or Labels

Additional Design
(If Needed)

New Drawing!

INFORMATION SHEET

- C. **Overlay techniques** — Overlay a drawing with a new title block, dot screen, or registered subsystems on a base plan to create new drawings.

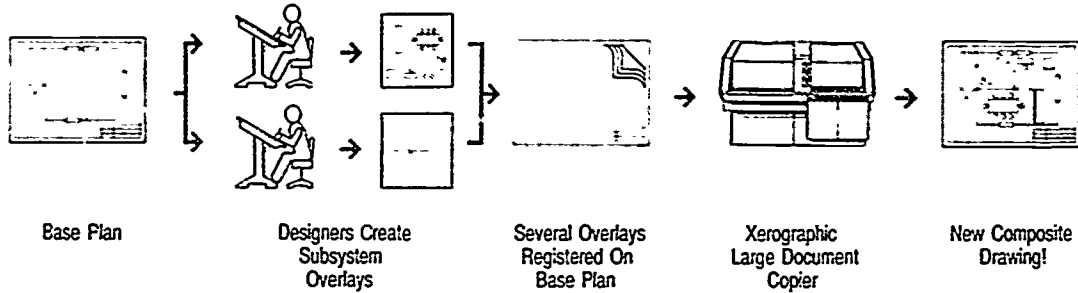

- D. **Non-reproducible-blue techniques** — Copier can be adjusted to drop out light blue grid on original.

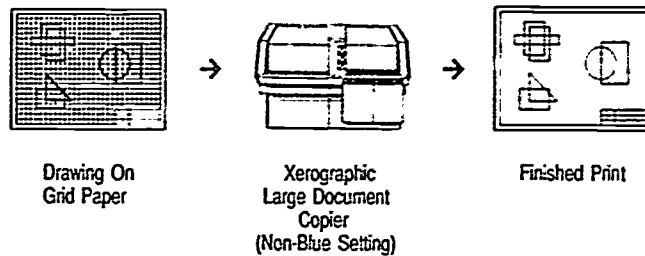

- E. **Reduction techniques** — Use reduction ratio to create smaller copies which are more convenient for handling or distribution.

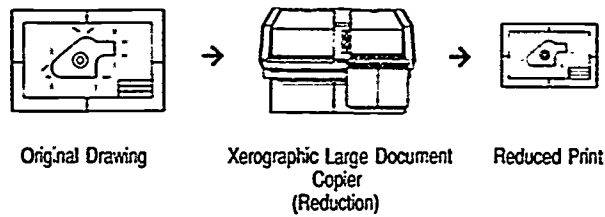

- F. **Enlargement techniques** — Use enlargement ratio to create larger drawings from microfilm or microfiche prints or small CADD plot prints.

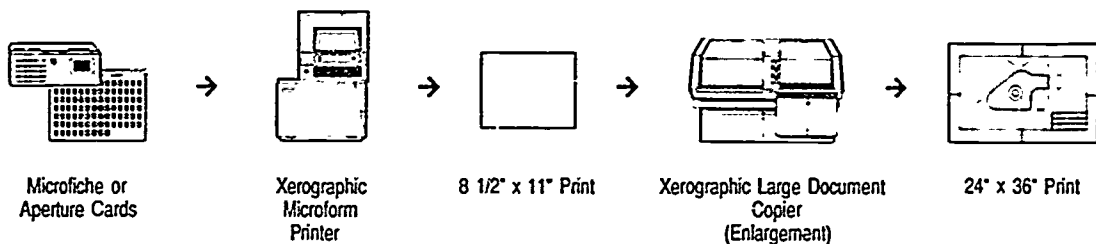

INFORMATION SHEET

- G. Restoring old or damaged drawings — Use scissors-and-paste drafting to restore drawings.**

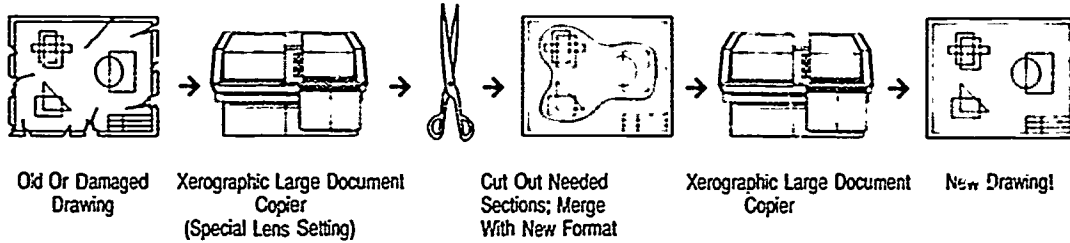

- H. Printing on special materials — Copies can be made onto vellum, polyester drafting film, bond paper, linen, adhesive drafting film, offset masters, and colored papers.**

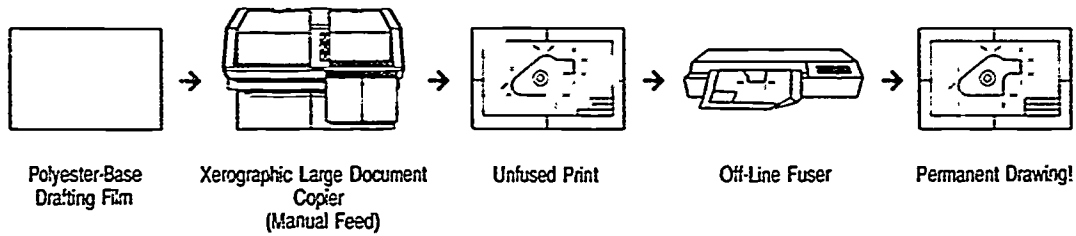

Courtesy of the Xerox Corporation
Xerox-Aided Drafting

INFORMATION SHEET**XII. CADD output devices****A. Plotters**

1. Pen plotter — An electromechanical output device that draws a picture on paper or film using a ballpoint pen or liquid ink
2. Photoplotter — A device used to generate artwork photographically such as for printed circuit boards
3. Drum plotter — An electromechanical pen plotter that draws a picture on paper or film mounted on a drum using a combination of plotting head movement and drum rotation
4. Electrostatic plotter — Wire nibs, spaced 100 to 400 nibs per inch, that place dots where needed on a piece of paper to generate a drawing
5. Flatbed plotter — An electromechanical pen plotter that draws a picture on paper, glass, or film mounted on a flat table; the plotting head provides all the motion

B. Printers

1. Printer — A hard copy unit used to produce "quick look" copies of screen graphics, alphanumeric data, or on-line documentation of commands as they were entered

(NOTE: Some printers have keyboards.)

2. Telewriter — A typewriter-style keyboard device used to enter commands or to point out system messages; can also be used as a printer
3. Line printer — A peripheral device that prints alphanumeric data one line at a time
4. Laser printer — A non-impact printer that uses a narrow beam of pure red light (laser beam) to burn characters or images on a drum which is then transferred to the paper

XIII. Ways to properly use technical pens with plotters

- A. Plotter pen points require instantaneous start-up and shut-off of ink flow.
- B. Tungsten points (used for polyester film) and stainless steel points (used for vellum) are usually recommended for plotters.
- C. The wire-weight should never be removed during cleaning, especially in sizes .30mm (#00) or smaller.

INFORMATION SHEET

XIV. Elements of a proper drawing control system

- A. Drawing numbers
- B. Proper methods of filing
- C. Microfilming
- D. Security files
- E. Print making and print distribution control

XV. Ways a proper drawing control system benefits a drafting organization

- A. Allows the person in charge to know the status of a drawing at all times
- B. Minimizes the possibility that an original drawing will be damaged from being handled for printing, changes, or checking
- C. Controls the distribution of prints to the appropriate people

XVI. Correct storage and distribution of drawings and prints

- A. Drawings may be stored in large, flat file drawers or hung vertically in a cabinet or a free-standing file.
- B. Prints may be folded and filed in standard office file cabinets, or extra large prints can be rolled and stored in cabinets, tubes, or tubes in cabinets.
- C. Whether prints or intermediates, copies should be made for distribution.
- D. The original drawing should NEVER be sent out.

XVII. Advantages of microfilm (Transparency 1)

- A. Used where large numbers of drawings are involved
- B. Used to store drawing duplications in a small amount of filing space
- C. Used to duplicate copies for security purposes
Examples: Burglary, vandalism, fire
- D. Aperture cards may be viewed in a reader. A full-size print may be made from a reader-printer unit when produced through a C size.
- E. Aperture cards are basically the same as cards used in electronic computers. Equipment is capable of sorting, filing, and retrieving these cards.
- F. Duplicate aperture cards and drawing reproductions to any desired size may be produced on specialized equipment.

INFORMATION SHEET

- G. Microfilm drawings may be sent to another office at less expense than standard prints.

XVIII. Procedures for reprographics in drafting

(NOTE: On new designs with features that are repetitive, reprographics [paste-up drafting] reduces drawing and rechecking time.)

- A. Make transparent or translucent print (paper or film sepia) of the original drawing.
- B. Cut out needed existing drawings, charts, notes, or drawing forms.
- C. Arrange information on a clear acetate sheet using the correct size and proper arrangement.
- D. Tape pieces to the acetate sheet with transparent tape.
- E. Make a transparent or translucent print to form a new original.
- F. Remove pieces from the acetate sheet, discard used transparent tape, and remove transparent tape residue from the drawing pieces and acetate sheet.
- G. Store drawing pieces and acetate sheet for future use.
- H. Add additional drawings, dimensions, or notes on new original.

Microfilm System

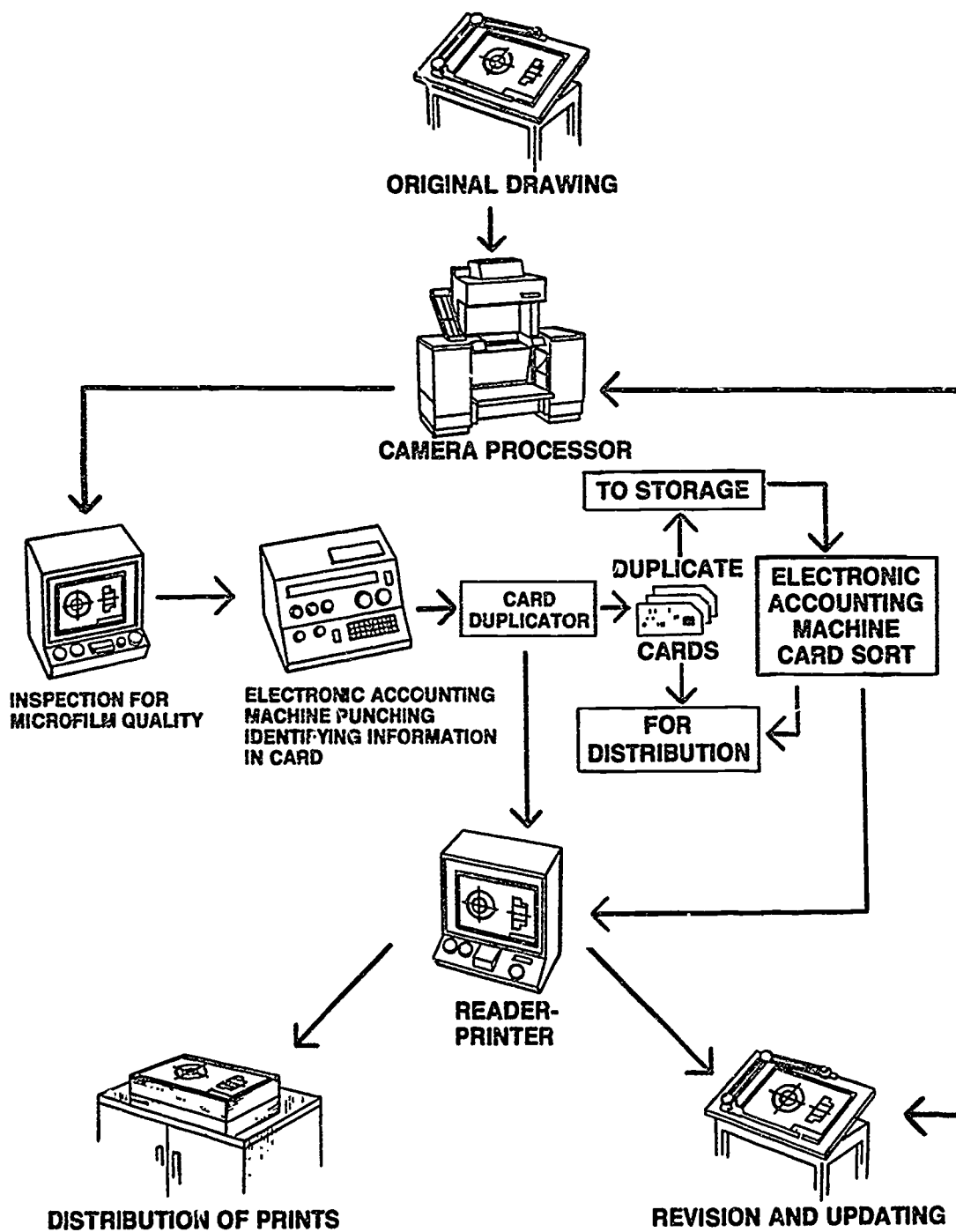

**REPRODUCTION
UNIT IX**

JOB SHEET #1 — OPERATE A DIAZO PRINT MACHINE

A. Tools and equipment

1. Diazo print machine
2. Diazo paper
3. Original drawing
4. Safety gear as specified by instructor

EVALUATION CRITERIA	
Criteria	Rating
Good print quality—no streaks, proper colors, proper line density	_____
Overall neatness	_____

(NOTE: Before doing any of the following, remove all rings, loose jewelry, and if necessary tie back hair.)

B. Procedure

1. Start up machine.
 - a. Remove cover.
 - b. Turn on exhaust fan.
 - c. Turn on ammonia pump BEFORE turning machine on.
 - d. Turn switch from off to blower-dryer motors and wait approximately 5 seconds.
 - e. Turn from blower-dryer motors to heaters and wait approximately 5 seconds.
 - f. Turn from heaters to lamp.
 - g. Be sure switch is set to forward.
 - h. Set ammonia control at approximately 15 drops per minute.

(NOTE: This may vary per machine.)

- i. Set speed control and wait approximately 15 minutes for machine to warm up.
2. Make diazo print of an original drawing that you have successfully completed or one selected by your instructor.
 - a. Select the appropriate size of diazo sheet stock or cut diazo paper from a roll.

JOB SHEET #1

- b. Lay the original drawing to be copied on top of the coated diazo paper.
- 1) Be sure to have the coated side up towards the original. ("Sunny side up")
 - 2) Be sure to lay the original on the diazo paper with the writing in the right read position.

FIGURE 1

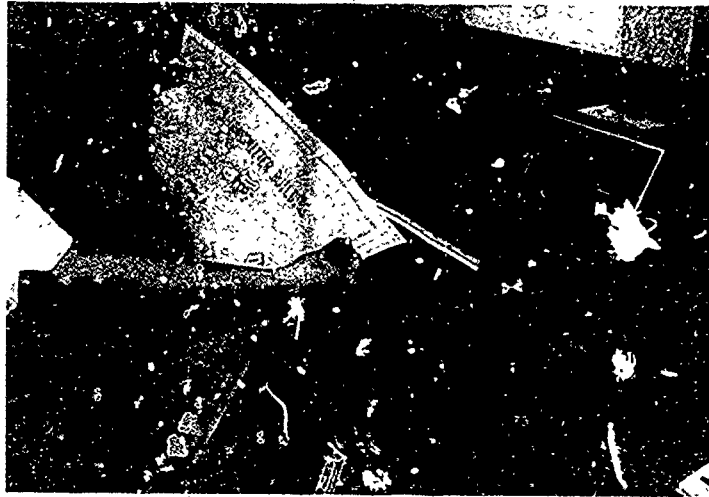

- c. Feed both sheets together into the machine to be exposed to the ultraviolet light.

FIGURE 2



404

JOB SHEET #1

- d. Separate the original from the diazo sheet of paper.
- e. Lay the original aside.
- f. Feed the exposed diazo sheet into the machine to go through the ammonia vapor bath.

FIGURE 3

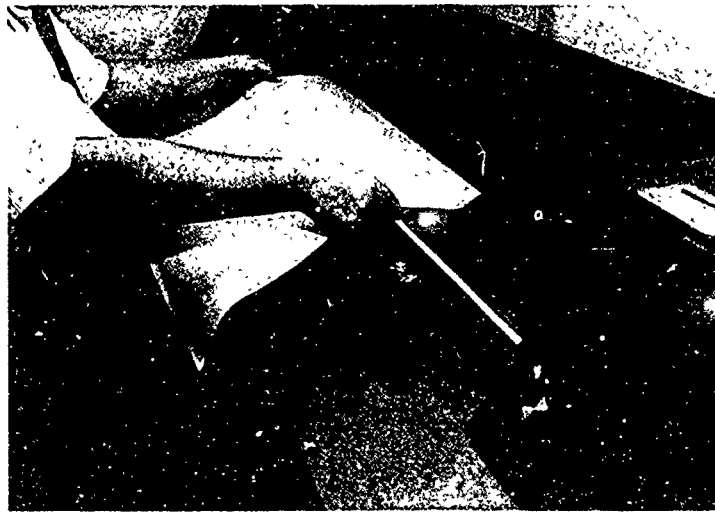

(NOTE: Print quality is dependent on the quality of the linework and the time the print remains under ultraviolet light.)

3. Shut down machine.
 - a. Turn ammonia flow switch off gently.
 - b. Turn switch from lamp to heaters and wait approximately 5 seconds.
 - c. Turn from heaters to blower-dryer motors and wait approximately 5 seconds.
 - d. Turn from blower-dryer motors to off.
 - e. After machine has turned off, turn off the ammonia pump.
 - f. Turn off exhaust fan.
 - g. Cover machine.

**REPRODUCTION
UNIT IX**

JOB SHEET #2 — PLOT A DRAWING FROM A CADD SYSTEM

A. Tools and materials

1. CADD system with plotter
2. Appropriate CADD software
3. Instruction (user) manual for your CADD system
4. Plotter paper

EVALUATION CRITERIA	
Criteria	Rating
Drawing correctly plotted	_____
Correct paper used	_____
Correct pens and ink used	_____

B. Procedure — Refer to your CADD instruction manual for the exact procedure to use on your CADD system. Then plot a drawing that you've completed on the CADD system.

Example: The following procedure for plotting a CADD drawing is from AutoCAD, Autodesk Inc.

Sizes are in inches
 Plot origin is at (0.00,0.00)
 Plotting area is 15.64 wide by 9.96 high (MAX size)
 Plot is NOT rotated 90 degrees
 Pen width is 0.010
 Area fill will NOT be adjusted for pen width
 Hidden lines will NOT be removed
 Plot will be scaled to fit available area

Do you want to change anything? <N> Y

Area fill will NOT be adjusted for pen width
 Hidden lines will NOT be removed
 Plot will be scaled to fit available area

Do you want to change anything? <N> Y

Layer Color	Pen No.	Line Type	Pen Speed	Layer Color	Pen No.	Line Type	Pen Speed
1 (red)	1	0	36	9	3	0	36
2 (yellow)	2	0	36	10	4	0	36
3 (green)	3	0	36	11	5	0	36
4 (cyan)	4	0	36	12	6	0	36
5 (blue)	5	0	36	13	1	0	36
6 (magenta)	6	0	36	14	2	0	36
7 (white)	1	0	36	15	3	0	36
8	2	0	36				

Line types
 0 = continuous line
 1 =
 2 = - - - - -
 3 = - . - . - .
 4 = - . - . - . - . - .
 5 = - . - . - . - . - . - .
 6 = - . - . - . - . - . - . - .

Do you want to change any of the above parameters? <N> Y

JOB SHEET #2

Enter values, blank=Next value, Cn=Color n, S=Show current values, X=Exit

Layer Color	Pen No.	Line Type	Pen Speed	Pen number <1>: X
1 (red)	1	0	36	

Size units (Inches or Millimeters) <I>:

Plot origin in Inches <0.00,0.00>:

Standard values for plotting size

Size	Width	Height
A	10.50	8.00
MAX	15.64	9.96

Enter the Size or Width, Height (in Inches) <MAX>:

Rotate 2D plots 90 degrees clockwise? <N>

Pen width <0.010>:

Adjust area fill boundaries for pen width? <N>

Remove hidden lines? <N>

Specify scale by entering:

Plotted Inches = Drawing Units or Fit or ? <F>:

Effective plotting area: 15.64 wide by 9.54 high

Position paper in plotter.

Press RETURN to continue or S to Stop for hardware setup

Reprinted from the AutoCAD Reference Manual for AutoCAD Release 10 with permission from Autodesk, Inc.

407

**REPRODUCTION
UNIT IX**

TEST

NAME _____ SCORE _____

1. Match the terms on the right with the correct definitions.

- | | | |
|----------|---|--------------------------|
| _____ a. | Chemical agent used for treating an exposed light-sensitive material to make the image visible to the eye | 1. Autopositive |
| _____ b. | Print made by combining the parts of two or more masters | 2. Composite print |
| _____ c. | An image on materials such as paper or film on which light tones appear light and dark tones appear dark when copied from a pencil or ink original | 3. Contact print |
| _____ d. | Not permitting the passage of light | 4. Contrast |
| _____ e. | Time period that light of a given intensity has been allowed to act on light-sensitive materials | 5. Density |
| _____ f. | The darkness of an image (linework or lettering) area | 6. Developer |
| _____ g. | A surface that has a bright, polished finish | 7. Development |
| _____ h. | Chemical solution containing acid designed to bleach certain portions of a print | 8. Discoloration |
| _____ i. | Duplicating material which has a sensitized layer on each side | 9. Double-coated stock |
| _____ j. | The difference between the image and background areas of a print | 10. Double feed |
| _____ k. | A group of transparent or translucent prints normally used to form a composite | 11. Drawing reproduction |
| _____ l. | The translucent reproduction made on vellum, cloth, or foil made from an original drawing and used in place of the original for making other prints | 12. Eradicator |

TEST

- | | | |
|---------|--|-----------------------|
| _____m. | An image on materials such as paper or film where the background is dense black and the line image appears clear (film) or white (paper) | 13. Exposure |
| _____n. | Making copies from completed drawings | 14. Fading |
| _____o. | Transmitting light without appreciable scattering so that bodies lying beyond are clearly visible | 15. Gloss |
| _____p. | Admitting and diffusing light so that objects beyond cannot be clearly distinguished | 16. Hard copy |
| _____q. | Any original to be duplicated | 17. Inches per second |
| _____r. | Print made by placing a master or an original in contact with light-sensitive material while exposure is being made | 18. Intermediate |
| _____s. | A copy on paper of what is shown on the computer screen | 19. Master |
| _____t. | A slightly rough finish free from shine or highlights | 20. Matte |
| | | 21. Negative |
| | | 22. Opaque |
| | | 23. Overlay |
| | | 24. Positive |
| | | 25. Translucent |
| | | 26. Transparent |
2. Distinguish among the following common reproduction processes used in drafting by placing the following letters next to the correct descriptions:
- C — Computer data reproduction
D — Diazo process
E — Electrostatic (Xerox-type) copying
P — Photographic reproduction
- _____a. Uses light, ammonia vapors, and specially-coated paper to make same-size reproductions of translucent drawings
- _____b. Uses light, film processing chemicals, light-sensitized film, and print paper to make variable-sized positive prints from film negatives taken with a camera
- _____c. Uses computer signals sent to an output device such as a plotter or printer to reproduce data
- _____d. Uses light on an electrically-charged photoconductive surface, resinous powder (toner), and ordinary paper to make same size or different size reproductions of drawings or prints made on any media

TEST

3. Arrange in order the steps in the diazo process by placing the correct sequence numbers (1-3) in the appropriate blanks.

- _____ a. Both drawing and diazo paper are fed into print machine and are exposed to light source.
- _____ b. Diazo sheet is exposed to ammonia vapors.
- _____ c. Original drawings is placed on specially-coated diazo paper.

4. Select true statements concerning factors involved in the diazo process by placing an "X" next to the true statements.

- _____ a. The process depends upon the transmission of light through the original for the reproduction of positive prints.
- _____ b. Subject matter may be pen, pencil, typewritten, or printed matter, or any opaque image.
- _____ c. In order for a drawing to reproduce properly, the linework and lettering must be translucent.

5. List four types of diazo prints.

- a. _____
- b. _____
- c. _____
- d. _____

6. Match factors that affect the diazo process with the correct definitions.

- | | | |
|----------|--|----------------------|
| _____ a. | The change in appearance of a diazo print in storage not exposed to light | 1. Developer section |
| _____ b. | Item capable of being used as a master for making prints | 2. Diazo paper |
| _____ c. | A reproduction material coated with a light-sensitive compound | 3. Film aging |
| _____ d. | Time period before deterioration renders a sensitized material unusable | 4. Film positive |
| _____ e. | Film base which carries a positive image, often a photographic material which if necessary can serve as master for diazo-type prints | 5. Printer section |
| | | 6. Printing speed |
| | | 7. Reproducible |
| | | 8. Sensitized |
| | | 9. Shelf-life |

TEST

- _____ f. Area of print machine used to expose light-sensitive materials
- _____ g. Area of print machine used to develop light-sensitive materials
- _____ h. A reproduction paper which depends on the light-sensitivity of the diazo compound (photosensitive emulsion) used during manufacturing
7. Select from the following list the advantages of the diazo process by placing an "X" next to the advantages.
- _____ a. Changes can be made on paper prints and then new prints can be made.
- _____ b. Sensitized materials (diazo paper) will be ruined immediately if they are exposed to any light. They can only be used under red or darkroom lights.
- _____ c. Prints can be worked on easily with pen, crayon, or pencil.
- _____ d. Intermediates can be made of the original to save wear on the original. These intermediates can be made on special paper, cloth, or foil.
- _____ e. Prints may have various colors of lines on a white background depending upon paper used.
8. Select true statements on how to safely use erasing chemicals in diazo processing by placing an "X" in the appropriate blanks.
- _____ a. Eradicator for sepia intermediates is a one-step process, but the eradicator contains acid and application should be made with care.
- _____ b. Erasing foils is a two-step process involving ammonia and water.
- _____ c. After the second fluid is applied on foil, it should be washed to remove any residual chemicals.
9. List two common problems in the diazo process and how to correct them.
- a. _____
- b. _____

TEST

10. Describe the procedure for making reproducible from existing drawings.

11. List four ways the electrostatic (xerographic) copier may be used for drafting reproduction.

a. _____

b. _____

c. _____

d. _____

12. Match CADD output devices with the correct definitions.

- | | | |
|----------|--|--------------------------|
| _____ a. | An electromechanical pen plotter that draws a picture on paper, glass, or film mounted on a flat table; the plotting head provides all the motion | 1. Drum plotter |
| _____ b. | A peripheral device that prints alphanumeric data one line at a time | 2. Electrostatic plotter |
| _____ c. | An electromechanical pen plotter that draws a picture on paper or film mounted on a drum using a combination of plotting head movement and drum rotation | 3. Flatbed plotter |
| _____ d. | Wire nibs, spaced 100 to 400 nibs per inch, that place dots where needed on a piece of paper to generate a drawing | 4. Laser printer |
| _____ e. | A non-impact printer that uses a narrow beam of pure red light to burn characters or images on a drum which is then transferred to the paper | 5. Line printer |
| | | 6. Photoplotter |
| | | 7. Telewriter |

TEST

13. Select true statements on the proper use of technical pens with plotters by placing an "X" next to the true statements.
- a. When cleaning, always remove the wire-weight from the pen point for point sizes .30 mm (#00) or smaller.
 - b. Plotter pen points require instantaneous start-up and shut-off of ink flow.
 - c. Stainless steel points are the correct points to use with both polyester film and vellum.
14. List three elements of a proper drawing control system.
- a. _____
 - b. _____
 - c. _____
15. List two ways a proper drawing control system benefits a drafting organization.
- a. _____
 - b. _____
16. Discuss the correct storage and distribution of drawing and prints.
- _____
- _____
- _____
- _____
17. Select true statements concerning the advantages of microfilm by placing an "X" in the appropriate blanks.
- a. Used to store drawing duplications in a small amount of filing space
 - b. Duplicate aperture cards and drawing reproductions to any desired size may be produced on specialized equipment.
 - c. Used where small numbers of drawings are involved.
 - d. Postage requirements are higher for microfilm when sending to another office becomes necessary.
 - e. Used where large numbers of drawings are involved.

TEST

18. Arrange in order the steps in the procedure for using reprographics in drafting by placing the correct sequence numbers (1-7) in the appropriate blanks.
- _____ a. Cut out needed existing drawings, charts, notes, or drawing forms from new print.
 - _____ b. Arrange information on a clear acetate sheet using the correct size and proper arrangement.
 - _____ c. Add additional drawings, dimensions, or notes on new original.
 - 5 d. Make a transparent or translucent print to form a new original.
 - _____ e. Make transparent or translucent print (paper or film sepia) of the original drawing.
 - _____ f. Tape pieces to the acetate sheet with transparent tape.
 - _____ g. Remove pieces from acetate sheet and store for future use.

(NOTE: If the following activities have not been accomplished prior to the test, ask your instructor when they should be completed.)

19. Demonstrate the ability to:
- a. Operate a diazo print machine. (Job Sheet #1)
 - b. Plot a drawing from a CADD system. (Job Sheet #2)

REPRODUCTION
UNIT IX

ANSWERS TO TEST

1. a. 6 f. 5 k. 23 p. 25
 b. 2 g. 15 l. 18 q. 19
 c. 24 h. 12 m. 21 r. 3
 d. 22 i. 9 n. 11 s. 16
 e. 13 j. 4 o. 26 t. 20
2. a. D
 b. P
 c. C
 d. E
3. a. 2
 b. 3
 c. 1
4. a, b
5. Any four of the following:
 a. Blueline
 b. Blackline
 c. Sepia paper
 d. Sepia mylar
 e. Black mylar
 f. Brownline presentation
 g. Blackline presentation
6. a. 3 e. 4
 b. 7 f. 5
 c. 8 g. 1
 d. 9 h. 2
7. c, d, e
8. a, c

ANSWERS TO TEST

9. a. Print with a green tint — Ammonia may be too cold or too old or tubes controlling ammonia flow may be clogged, need cleaning, or ammonia flow adjusted.
- b. Print with streaking on it — Ammonia flow is excessive and needs to be adjusted.
10. Description should include:
- a. Make transparent or translucent print (film or paper sepia) of the original drawing.
- b. Remove unwanted information from old print and then add new information.
11. Any four of the following:
- a. Scissors-and-paste drafting
- b. Changes/revisions of engineering documents
- c. Overlay techniques
- d. Non-reproducible blue techniques
- e. Reduction techniques
- f. Enlargement techniques
- g. Restoring old or damaged drawings
- h. Printing on special materials
12. a. 3
- b. 5
- c. 1
- d. 2
- e. 4
13. b
14. Any three of the following:
- a. Drawing numbers
- b. Proper methods of filing
- c. Microfilming
- d. Security files
- e. Print making and print distribution control
15. Any two of the following:
- a. Allows the person in charge to know the status of a drawing at all times
- b. Minimizes the possibility that an original drawing will be damaged from being handled for printing, changes, or checking
- c. Controls the distribution of prints to the appropriate people

ANSWERS TO TEST

16. Discussion should include:
- a. Drawings may be stored in large, flat file drawers or hung vertically in a cabinet or a free-standing file.
 - b. Prints may be folded and filed in standard office file cabinets, or extra large prints can be rolled and stored in cabinets, tubes, or tubes in cabinets.
 - c. Whether prints or intermediates, copies should be made for distribution.
 - d. The original drawing should NEVER be sent out.
17. a, b, e
18. a. 2 e. 1
b. 3 f. 4
c. 7 g. 6
d. 5
19. Performance skills evaluated to the satisfaction of the instructor

GEOMETRIC CONSTRUCTIONS UNIT X

UNIT OBJECTIVE

After completion of this unit, the student should be able to match basic geometric terms with their definitions, identify basic geometric shapes, and construct basic geometric forms. Competencies will be demonstrated by completing the assignment sheets and the unit test with a minimum score of 85 percent.

SPECIFIC OBJECTIVES

After completion of this unit, the student should be able to:

1. Match basic geometric terms with their correct definitions.
2. Match types of angles with their correct descriptions.
3. Match types of triangles with their correct descriptions.
4. Match types of quadrilaterals with their correct descriptions.
5. Identify types of polygons.
6. Match circular shapes with their correct descriptions.
7. State the geometric terms for various abbreviations.
8. Identify solid geometric figures.
9. Identify special geometric figures.
10. List three elements needed for measuring parts of a circle.
11. Complete statements on interpreting degrees in a circle.
12. Label elements of a circle used in CADD.
13. Select methods used to create circles on CADD.
14. Select methods used to create arcs on CADD.
15. Select true statements about creating fillets on CADD.
16. Select true statements about creating chamfers on CADD.

/ SPECIFIC OBJECTIVES

17. Bisect a line and an arc. (Assignment Sheet #1)
18. Bisect an angle. (Assignment Sheet #2)
19. Draw parallel lines. (Assignment Sheet #3)
20. Construct a line perpendicular to a line from a point not on the line. (Assignment Sheet #4)
21. Construct a line perpendicular to a line through a point on the line. (Assignment Sheet #5)
22. Divide a line into equal parts. (Assignment Sheet #6)
23. Construct a triangle with sides given. (Assignment Sheet #7)
24. Construct a right triangle. (Assignment Sheet #8)
25. Construct an equilateral triangle with one side given. (Assignment Sheet #9)
26. Inscribe a hexagon inside a circle. (Assignment Sheet #10)
27. Construct a hexagon with the distance across the flat sides given. (Assignment Sheet #11)
28. Inscribe a pentagon inside a circle. (Assignment Sheet #12)
29. Construct a circle through three given points. (Assignment Sheet #13)
30. Draw an arc tangent to a straight line and an arc. (Assignment Sheet #14)
31. Draw an arc tangent to two arcs. (Assignment Sheet #15)
32. Draw an arc tangent to an acute angle and an obtuse angle. (Assignment Sheet #16)
33. Draw an arc tangent to a right angle. (Assignment Sheet #17)
34. Draw an ellipse using the approximate ellipse with compass method. (Assignment Sheet #18)
35. Draw a parabola. (Assignment Sheet #19)
36. Join two points with a parabolic curve. (Assignment Sheet #20)
37. Draw an involute of a circle. (Assignment Sheet #21)
38. Demonstrate the ability to create a part on CADD using circles, arcs, fillets, and lines. (Job Sheet #1)

GEOMETRIC CONSTRUCTIONS UNIT X

SUGGESTED ACTIVITIES

- A. Provide students with objective sheet.
- B. Provide students with information and assignment sheets.
- C. Make transparencies.
- D. Discuss unit and specific objectives.
- E. Discuss information and assignment sheets.
- F. Have students make models of various geometric shapes.
- G. Demonstrate the various methods to create circles, arcs, fillets, and chamfers on your CADD system.
- H. Give test.

REFERENCES USED IN DEVELOPING THIS UNIT

- A. French, Thomas E., et. al. *Mechanical Drawing*, 10th ed. New York: McGraw-Hill Book Co., 1985.
- B. French, Thomas E. and Charles J. Vierck. *Engineering Drawing and Graphic Technology*, 13th ed. New York: McGraw-Hill Book Co., 1986.
- C. Giesecke, Frederick E., et. al. *Technical Drawing*, 8th ed. New York: Macmillan Publishing Co., 1986.
- D. Spencer, Henry, et. al. *Technical Drawing Problems*. New York: Macmillan Publishing Co., 1980.
- E. Lamit, Louis G. and Vernon Paige. *Computer-Aided Design and Drafting — CADD*. Columbus, Ohio: Merrill Publishing Co., 1987.

GEOMETRIC CONSTRUCTIONS UNIT X

INFORMATION SHEET

I. Basic geometric terms and definitions

- A. Point — A small dot or small cross on a drawing or in space that does not have length, height, depth, or width

• +

Point

- B. Line — A connection between two or more points

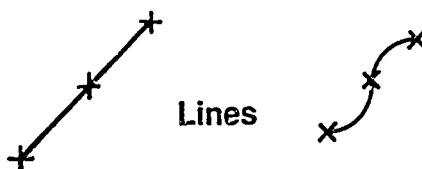

1. Straight line — The shortest distance between two points
2. Curved line — A line in which no segment is straight
3. Line segment — Any part of a line

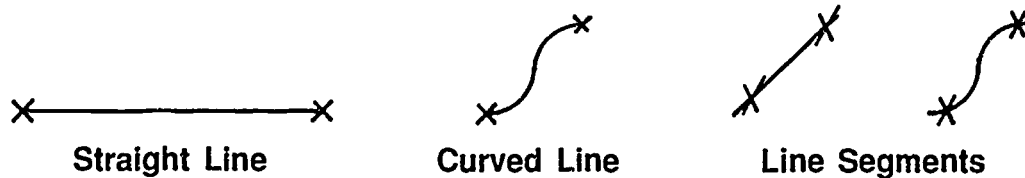

- C. Intersect — To cut across each other

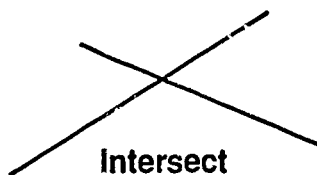

- D. Vertex — The common point where lines or surfaces intersect

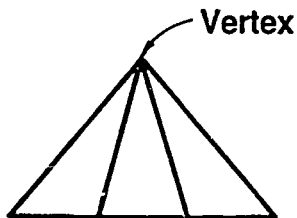

INFORMATION SHEET

- E. Perpendicular — At 90° angles to a given plane or line

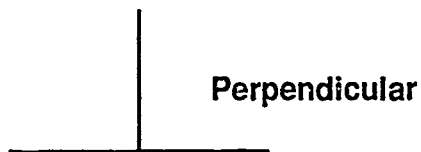

- F. Parallel — Straight lines that do not meet or intersect and are an equal distance apart at all points

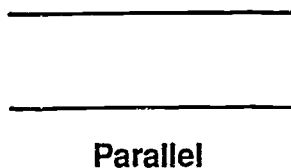

- G. Vertical — A line straight up and down perpendicular to the horizontal plane

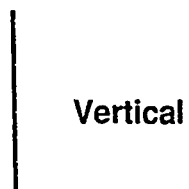

- H. Horizontal — Parallel to the plane of the horizon



- I. Skew (oblique) lines — Straight lines that do not intersect and are not parallel or in the same plane

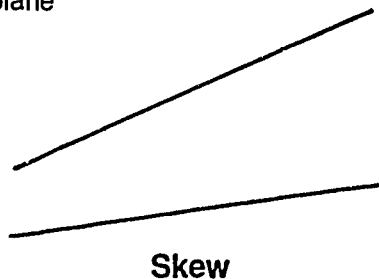

INFORMATION SHEET

- J. Angle — Figure formed by two intersecting lines

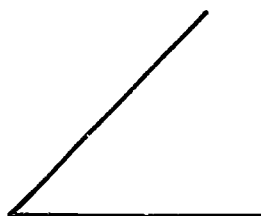

Angle

- K. Bisect — To divide into two equal parts

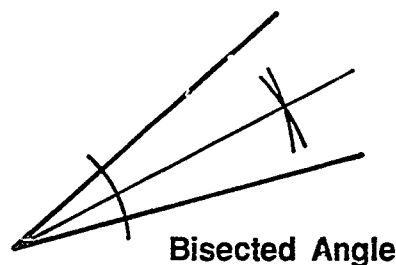

Bisected Angle

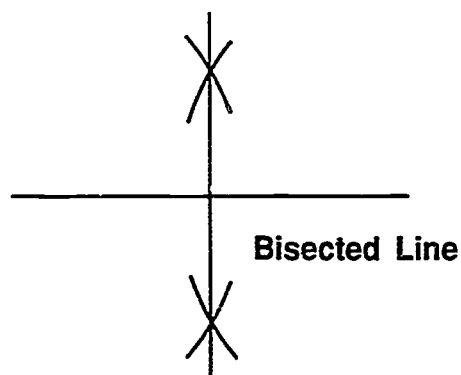

Bisected Line

- L. Plane figure — A flat, level, even surface such as a piece of paper lying flat on a table

(NOTE: This is sometimes referred to simply as a plane.)



Plane Figure

- M. Polygon — Any plane figure with sides of straight lines

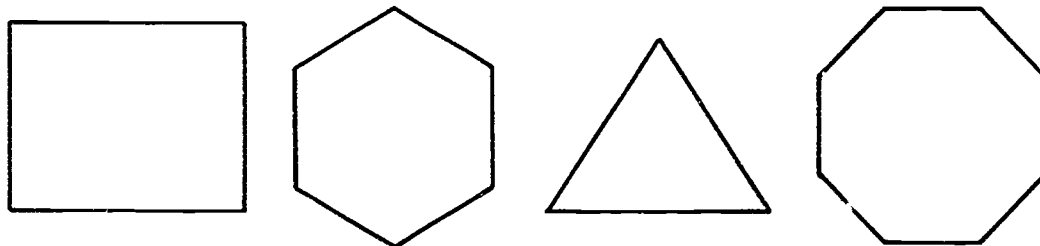

Polygons

(NOTE: All of these figures have their own names, which will be covered later, but they are all included in the general category of polygons.)

INFORMATION SHEET

- N. Triangle — A plane figure bound by three straight sides

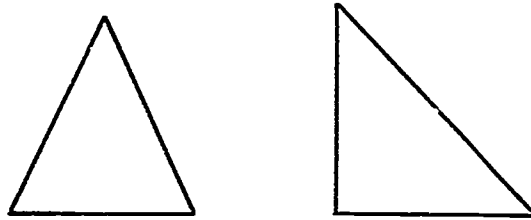

Triangles

- O. Quadrilateral — A plane figure bound by four straight sides

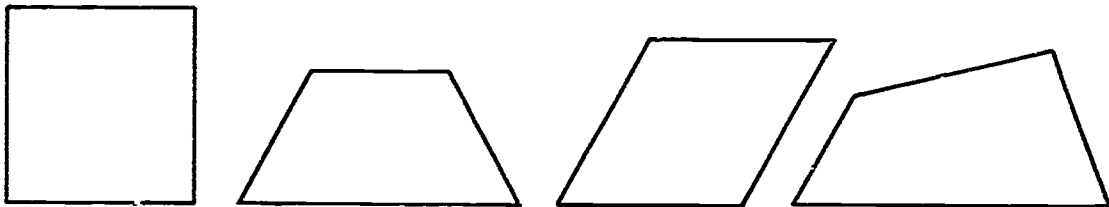

Quadrilaterals

- P. Symmetrical — The same on both sides of a center line

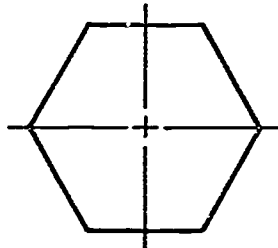

Symmetrical

- Q. Diagonals — Lines connecting opposite nonsymmetrical corners of a polygon

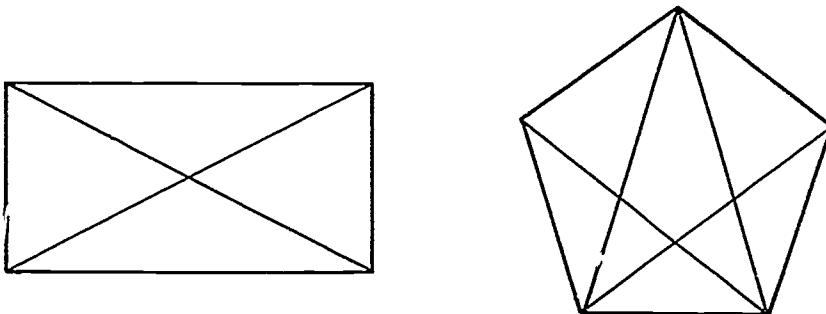

Diagonals

INFORMATION SHEET

- R. Equilateral — All sides are equal

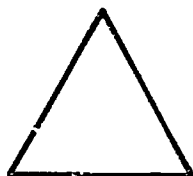

Equilateral Triangle

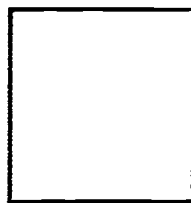

Equilateral Quadrilaterals

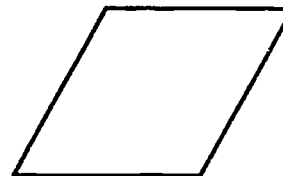

- S. Circle — A closed curve all points of which are an equal distance from the center

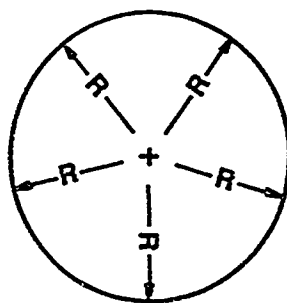

Circle

- T. Inscribed — A figure drawn within another figure so as to touch in as many places as possible

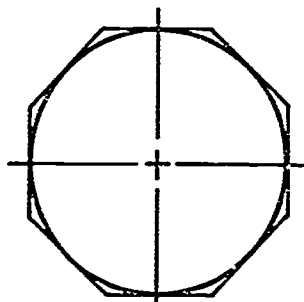

Inscribed
(Circle Inside Octagon)

- U. Circumscribed — A figure encircled so as to touch in as many places as possible

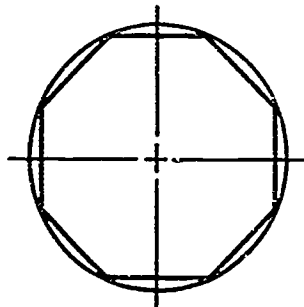

Circumscribed
(Circle Around Octagon)

INFORMATION SHEET

- V. Geometric solid figure — A figure that has height, width, and depth

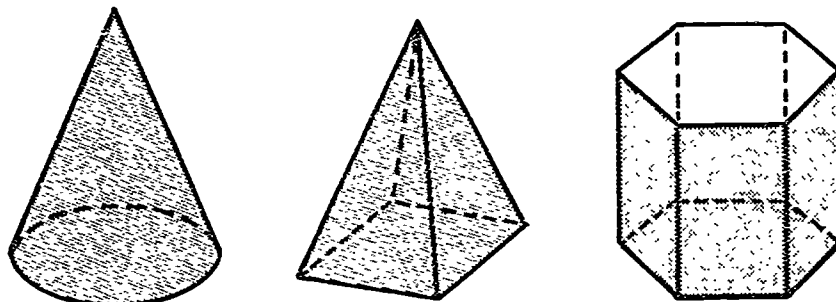

Geometric Solid Figures

- W. Axis — A straight line passing through the center of a geometric body upon which the geometric body rotates

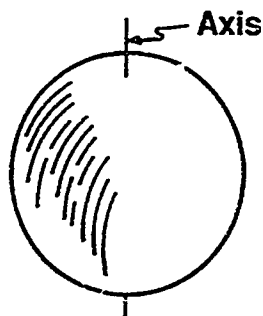

II. Types of angles and their descriptions

- A. Right angle — An angle equal to 90°

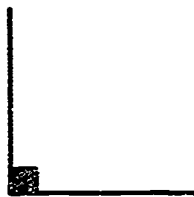

Right Angle

- B. Acute angle — An angle less than 90°

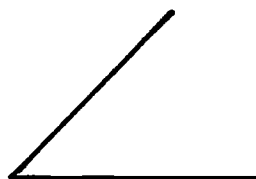

Acute Angle

INFORMATION SHEET

- C. Obtuse angle — An angle greater than 90°

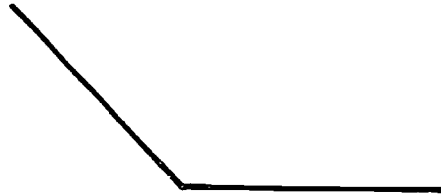

Obtuse Angle

- D. Complementary angles — Two angles whose sum is 90°

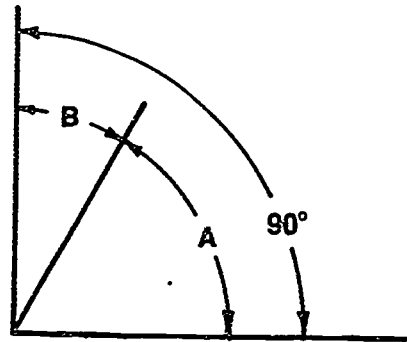

Complementary Angles

- E. Supplementary angles — Two angles whose sum is 180°

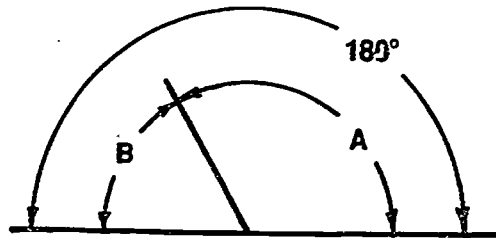

Supplementary Angles

iii. Types of triangles and their descriptions

- A. Equilateral triangles — A triangle with three equal sides and three equal angles

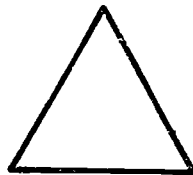

Equilateral Triangle

INFORMATION SHEET

- B. Isosceles triangle — A triangle with two equal sides and two equal angles

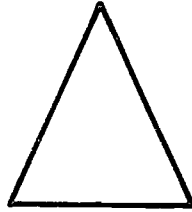
**Isosceles Triangle**

- C. Scalene triangle — A triangle with no angles or sides equal

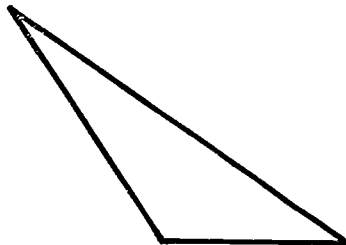
**Scalene Triangle**

- D. Right triangle — A triangle with one 90° angle

(NOTE: The side opposite the 90° angle of a right triangle is the hypotenuse.)

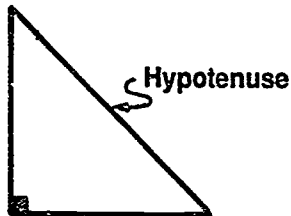
**Right Triangle****IV. Types of quadrilaterals and their descriptions**

- A. Trapezium — Quadrilateral with no sides parallel

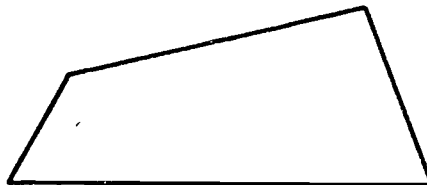
**Trapezium**

INFORMATION SHEET

- B. Trapezoid — Quadrilateral with only two sides parallel

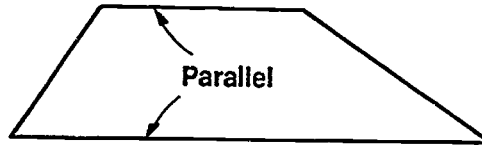

Trapezoid

- C. Parallelogram — Quadrilateral with two sets of parallel lines

1. Square — Parallelogram with four equal sides and four 90° angles (Equilateral parallelogram)

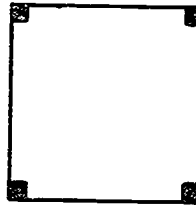

Square

2. Rectangle — Parallelogram with two lengths of sides and four 90° angles

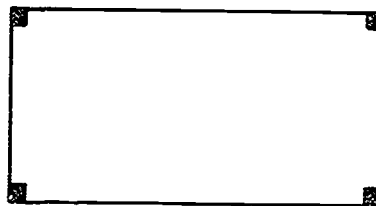

Rectangle

3. Rhombus — Parallelogram with four equal sides and no 90° angles (equilateral parallelogram)

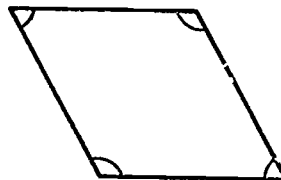

Rhombus

INFORMATION SHEET

4. Rhomboid — Parallelogram with two lengths of sides and no 90° angles

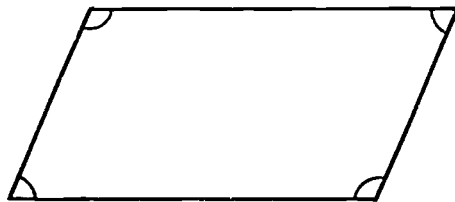

Rhomboid

V. Types of polygons and their descriptions

- A. Regular polygon — A plane figure with equal straight sides and equal angles; it can be circumscribed or inscribed

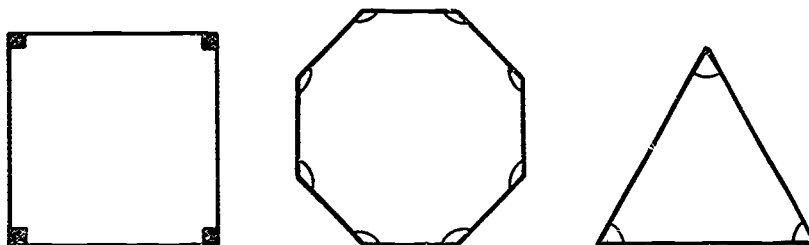

Regular Polygons

- B. Pentagon — A polygon that has five equal sides and five equal angles

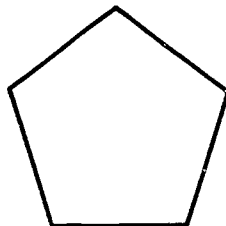

Pentagon

- C. Hexagon — A polygon that has six equal sides and six equal angles

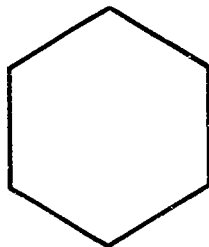

Hexagon

INFORMATION SHEET

- D. Heptagon — A polygon that has seven equal sides and seven equal angles

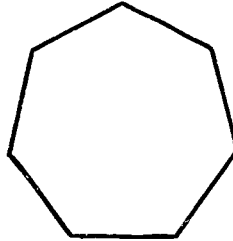
**Heptagon**

- E. Octagon — A polygon that has eight equal sides and eight equal angles

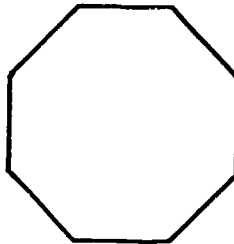
**Octagon****VI. Circular shapes and their descriptions**

- A. Circumference — The distance around a circle

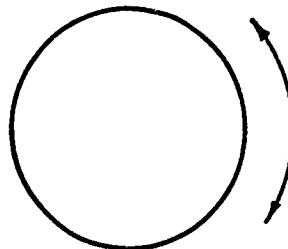
**Circumference**

- B. Arc — Any portion of the circumference of a circle

**Arc**

INFORMATION SHEET

- C. Radius — The distance from the center point of a circle to the outside circumference

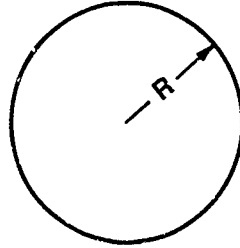
**Radius**

- D. Diameter — The distance across a circle passing through its center point

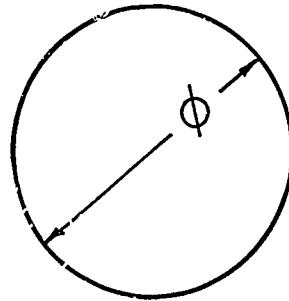
**Diameter**

- E. Chord — Any straight line across a circle that does not pass through the center

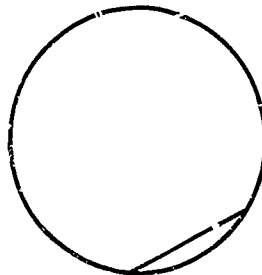
**Chord**

- F. Semicircle — One-half of a circle

**Semicircle**

INFORMATION SHEET

- G. Circular segment — Less than a semicircle

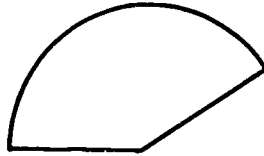

Circular Segment

- H. Quadrant — One-fourth of a circle

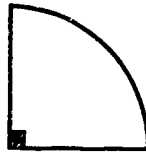

Quadrant

- I. Sector — Less than a quadrant



Sector

- J. Ellipse — A foreshortened circle having a major axis and a minor axis

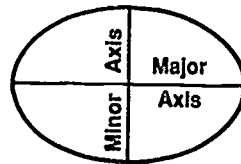

Ellipse

- K. Concentric circles — Having the same point as center

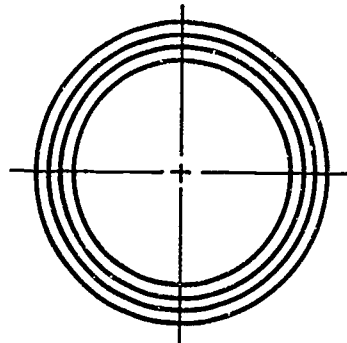

Concentric Circles

INFORMATION SHEET

- L. Eccentric circles — Having different points as center, one within the other

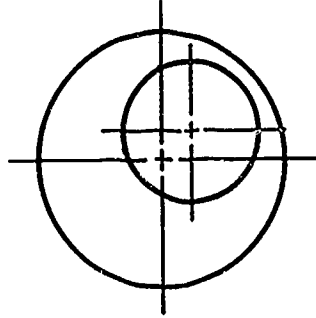

Eccentric Circles

- M. Tangent — Meeting a curved line or surface, touching at one and only one point, but **not** intersecting

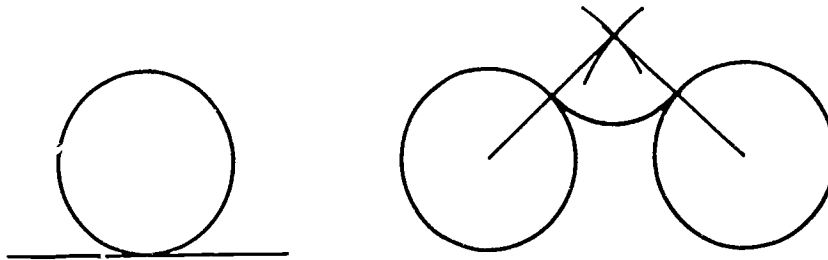

Tangent

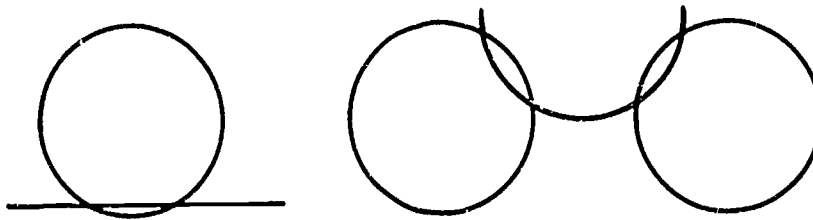

Not Tangent

VII. Geometric terms and abbreviations

- A. Perpendicular — \perp
 B. Parallel — $//$
 C. Angle (singular) — \sphericalangle
 D. Angles (plural) — \sphericalangle 's

- E. Less than — $<$
 F. Greater than — $>$
 G. Diameter — \oslash
 H. Radius — R

INFORMATION SHEET

VIII. Solid geometric figures and their descriptions

- A. Cone — A solid figure with a circle as its base, and a curved surface tapering evenly to the vertex, so that any point on the surface is in a straight line between the circumference of the base and the vertex

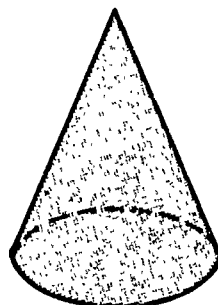

Cone

- B. Pyramid — A solid figure with a polygon for a base and with triangular lateral faces that intersect at the vertex

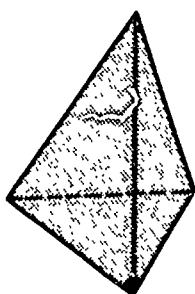

**Right Triangular
Pyramid**

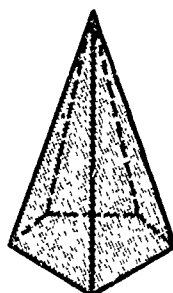

**Pentagonal
Pyramid**

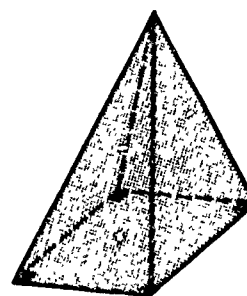

**Square
Pyramid**

- C. Sphere — A round, solid figure which has all points of its circumference an equal distance from its center

Example: Baseball

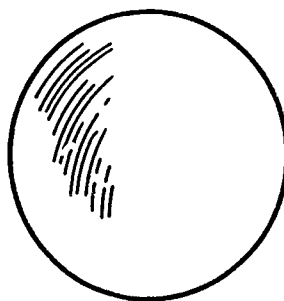

Sphere

INFORMATION SHEET

- D. Prism — A solid figure whose two bases are parallel equal polygons and whose faces are parallelograms

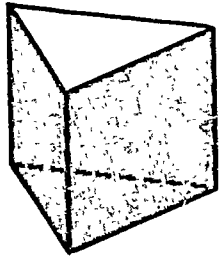

**Right Triangular
Prism**

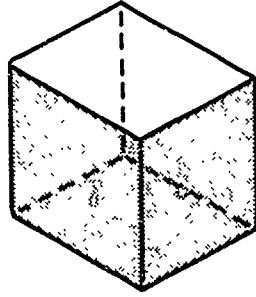

**Rectangular
Prism**

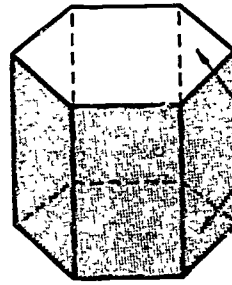

**Hexagonal
Prism**

- E. Torus — A solid figure generated by a circle which is revolving on an axis which is eccentric to the circle

Example: Doughnut

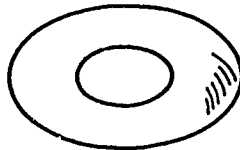

Torus

- F. Cylinder — A solid figure formed by moving a line in a circle around a central axis

Example: Can

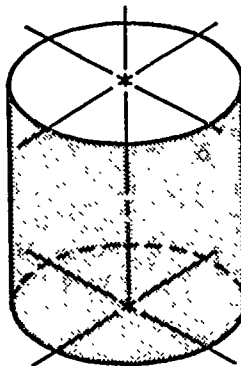

Cylinder

IX. Other special geometric figures (Transparencies 1 and 2)

- A. Conic sections — Curves produced by a plane when it intersects a right circular cone

(NOTE: Types of curves produced are the circle, ellipse, hyperbola, and parabola.)

INFORMATION SHEET

- B. **Parabola** — A curve generated by a point moving so that its distance from a fixed point is equal to its distance from a fixed line
- C. **Helix** — Generated by a point moving along and around the surface of a cone or cylinder with a uniform angular velocity about the axis, and with a uniform linear velocity in the direction of the axis
- D. **Cycloid** — A curve generated by a point located on the circumference of a circle as the circle rolls along a straight line
- E. **Involute** — A curve traced by a point on a thread or string, as the thread or string unwinds from a line (Transparency 2)

X. Three elements needed for measuring parts of a circle

- A. **Diameter** is measured on a straight line passing through the center point of the circle and extending to the circumference.
- B. **Radius** is measured on a straight line from the center of the circle to any point on the circumference; equals one-half the diameter.
- C. **Circumference** is measured by multiplying the diameter of the circle by π (3.1415926 or 3.14).

Formula: $C = \pi D$

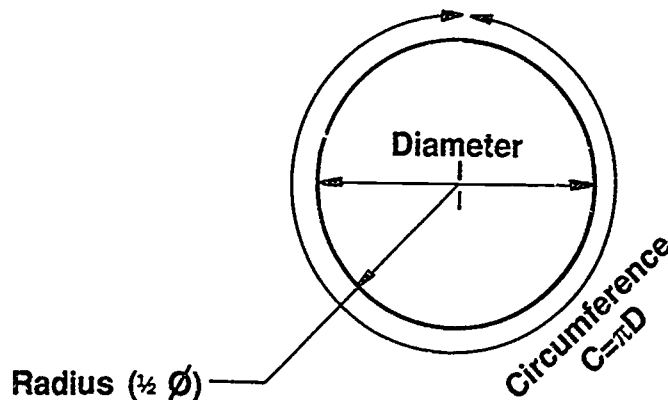

XI. Interpreting degrees in a circle

- A. A full circle has 360 degrees, written as 360° .
- B. Each degree is divided into 60 minutes, written as $60'$.

INFORMATION SHEET

- C. Each minute is divided into 60 seconds, written as 60".

Example: $52^{\circ}14'5''$ would be read as fifty-two degrees, 14 minutes, 5 seconds

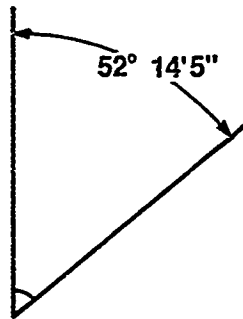

XII. Elements of a circle used in CADD

- A. Origin — Center of circle
- B. Start and end point of circle — At the right 3 o'clock position
- C. Circumference usually begins and ends at the 3 o'clock position.

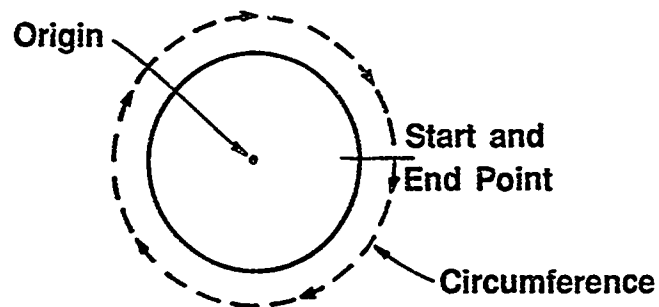

XIII. Methods to create a circle on CADD

- A. Circle is created through three digitized points that establish the circle's circumference.

Draw circle:

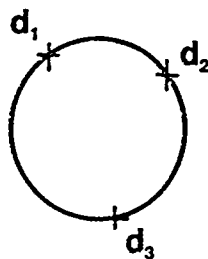

INFORMATION SHEET

- B. Circle is created when given a diameter by digitizing two points.

Draw circle diameter:

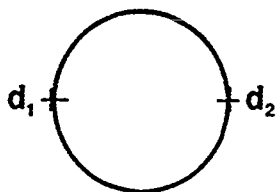

- C. Circle is created when given a radius and the center point is digitized.

Draw circle radius:

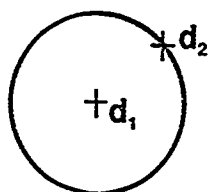

- D. Circle is created with a specified diameter or radius. The D or R value is entered into the computer. Then digitize the center of the circle.

Draw circle .50 D:

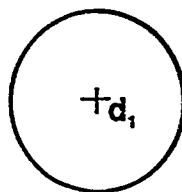

XIV. Methods used to create an arc on CADD

- A. Arc is created with three digitized points — One point to indicate the start point of the arc, one point on the arc path, and the end point.

Draw arc:

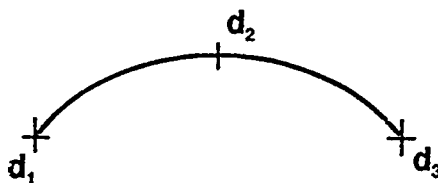

INFORMATION SHEET

- B. Arc is created by a specified diameter or radius and three digitized points — starting, center and ending points.

Draw arc diameter/radius:

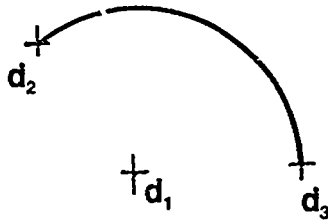

- C. Arc is created by a specified diameter or radius, specified arc center, and beginning and ending angle.

(NOTE: The direction of digitizing [counterclockwise] determines the direction of the arc.)

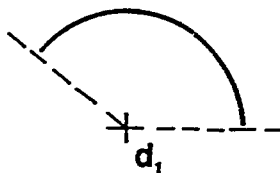

XV. Creating a fillet on CADD

- A. A fillet is an arc tangent to two geometrical items — lines, points, circles or arcs.
- B. Fillets are created by digitizing two pieces of geometry. Fillets will be created to a default value for its radius.

Draw fillet:

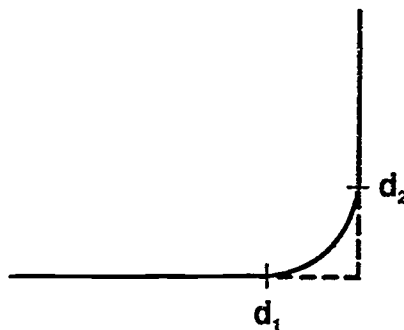

(NOTE: Always digitize fillets in the counterclockwise direction.)

INFORMATION SHEET

- C. Fillets are created by giving a specified value for its radius or diameter and digitizing the two pieces of geometry that it will be tangent to.

Draw fillet radius:

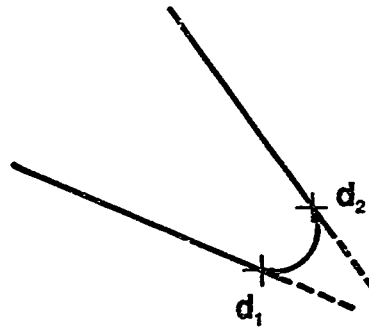

(NOTE: Lines must be unparallel to each other.)

XVI. Creating a chamfer on CADD

- A. A chamfer bevels the corner of a part.
- B. A chamfer is created by specifying the length of the lines and the angle.
- C. A chamfer is created by digitizing the two unparallel lines and using the default value for the angle.

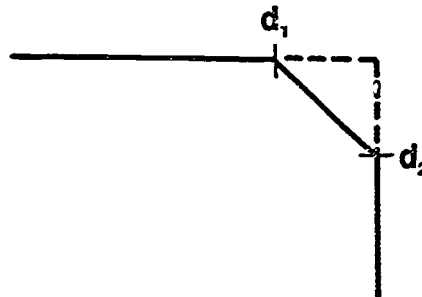

- D. Default value for chamfer is usually 45° .

Special Geometric Figures

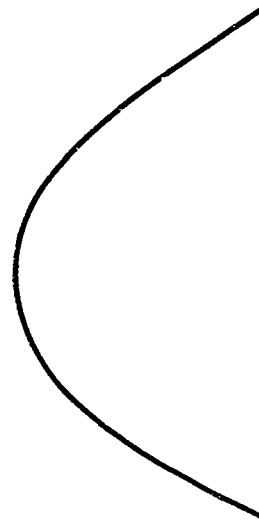
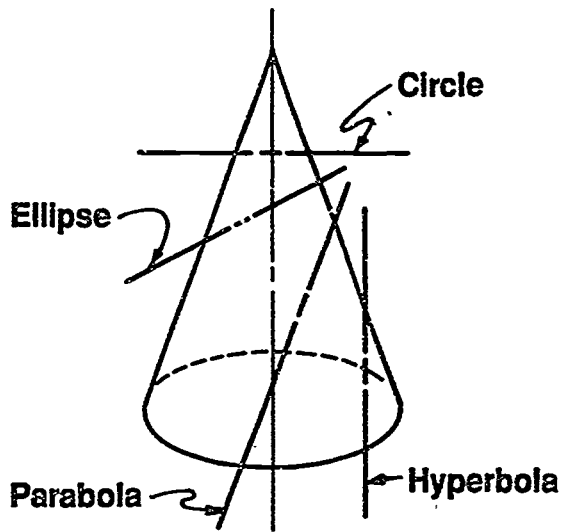

Conic Sections



Circular Section

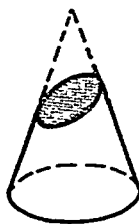

Elliptical Section

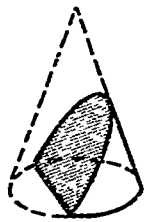

Parabolic Section



Hyperbolic Section

Parabola

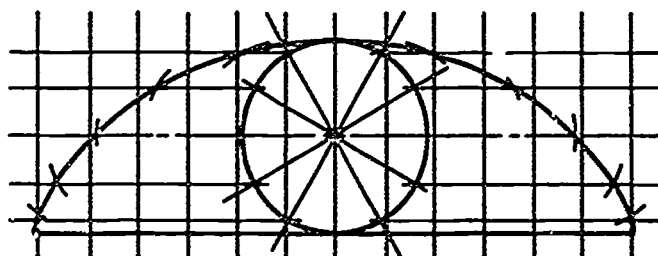
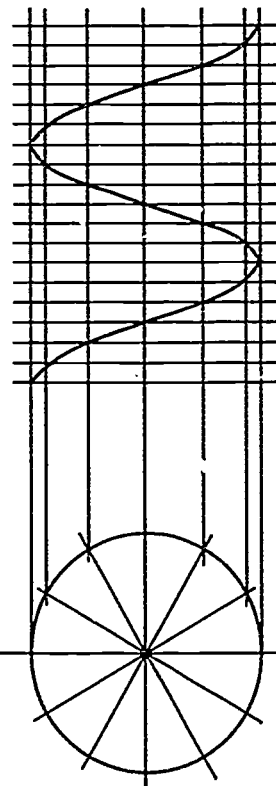

Cycloid

Helix

Involutes

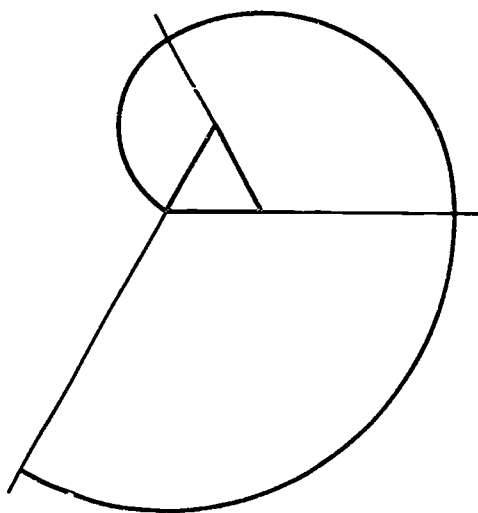

Involute of a Triangle

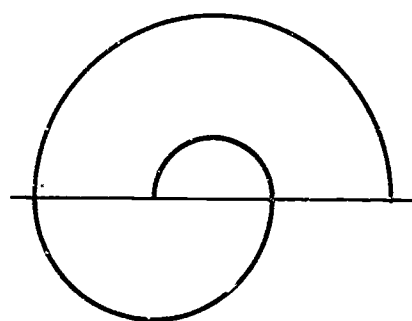

Involute of a Line

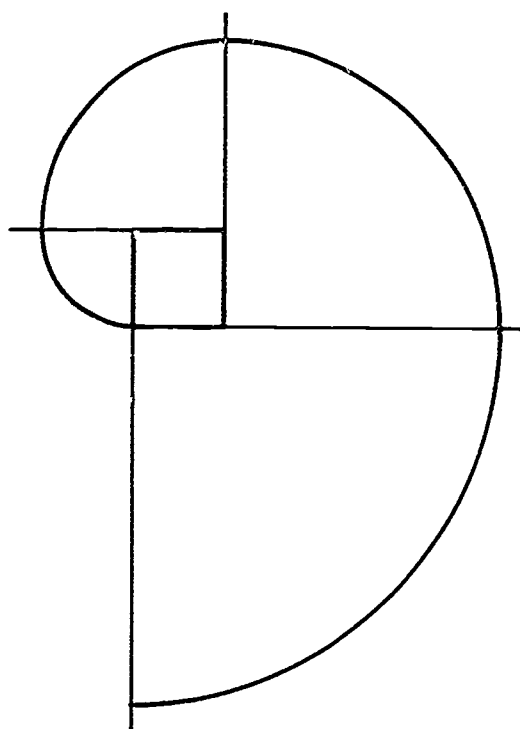

Involute of a Square

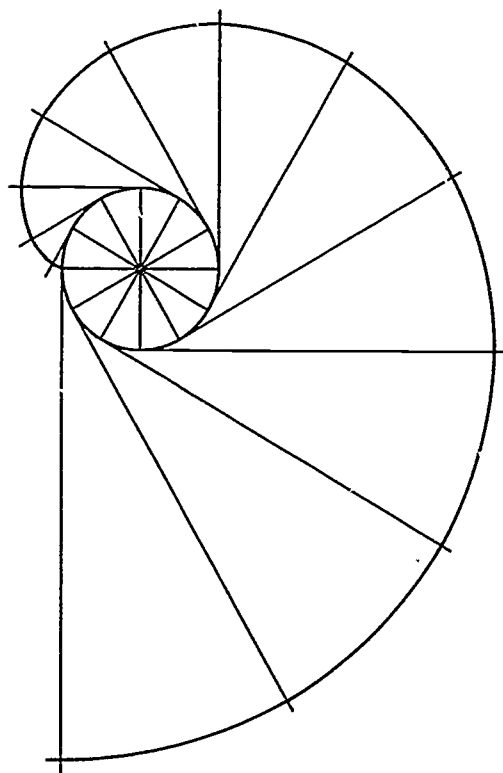

Involute of a Circle

**GEOMETRIC CONSTRUCTIONS
UNIT X**

ASSIGNMENT SHEET #1 — BISECT A LINE AND AN ARC

NAME _____ SCORE _____

Directions: Study the example below and then complete the assigned problems.

Example:

1. Use given line AB.



2. From A and B use compass to draw equal arcs with radius greater than half.

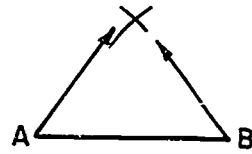

3. Join points D and E with triangle.

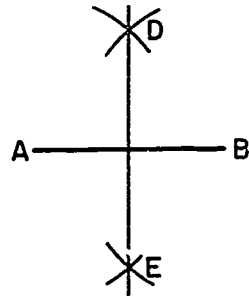

4. Mark point at C.

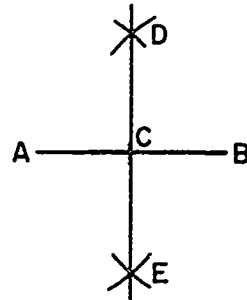

ASSIGNMENT SHEET #1

Problems:

1. Bisect the lines AB and arc AB below. Leave all construction lines.

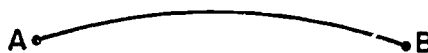

ASSIGNMENT SHEET #1

2. Draw $1/2$ " diameter hole at intersection of perpendicular bisectors of lines AB and CD. Do not erase construction lines.

NOTE: DRAW HORIZONTAL AND VERTICAL CENTER LINES ONLY THROUGH THE HOLE

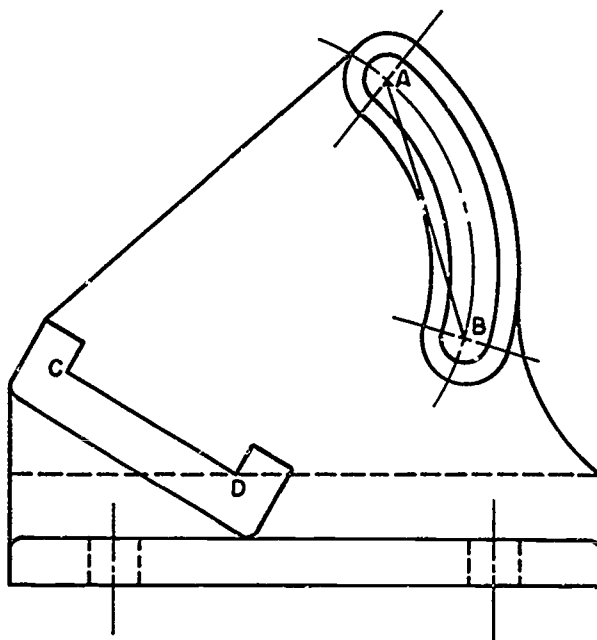

GRINDER ADJUSTING ARM

**GEOMETRIC CONSTRUCTIONS
UNIT X**

ASSIGNMENT SHEET #2 — BISECT AN ANGLE

NAME _____ SCORE _____

Directions: Study the example below and then complete the assigned problems.

Example:

1. Use given angle BAC.

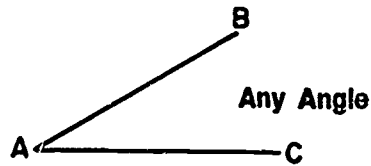

2. Strike a radius using a compass at any radius with point A as vertex.

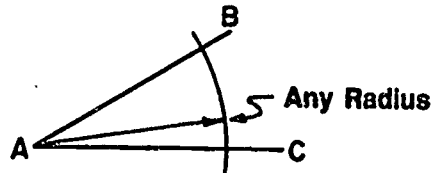

3. Strike equal arcs r with radius larger than half the distance from E to F.

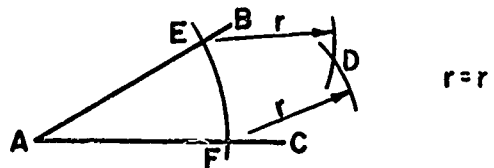

4. Draw a line from arc intersection D to vertex A.

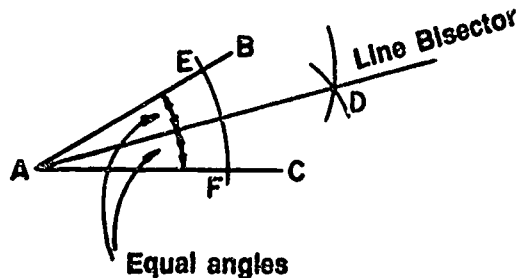

ASSIGNMENT SHEET #2

Problems: Bisect the angles below. Leave all construction lines.

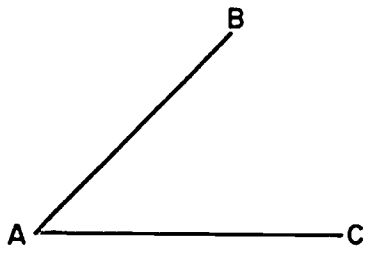
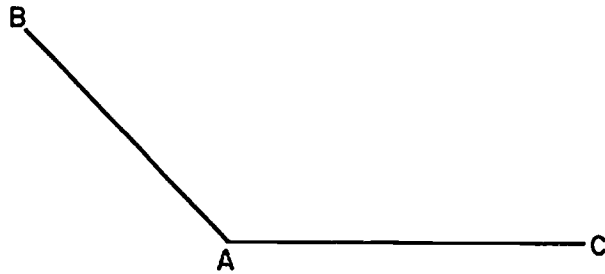

**GEOMETRIC CONSTRUCTIONS
UNIT X**

ASSIGNMENT SHEET #3 — DRAW PARALLEL LINES

NAME _____ SCORE _____

Directions: Study the example below and complete the assigned problem.

Example:

1. Use given line AB.



2. Set compass any desired radius CD and swing two arcs anywhere along AB.

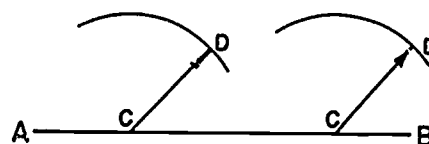

3. Construct line GH tangent to arcs CD (radius CD required distance between parallel lines).

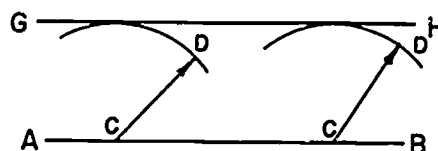

ASSIGNMENT SHEET #3

Problem: Construct a line parallel to line AB 1" below line AB. Leave all construction lines.



**GEOMETRIC CONSTRUCTIONS
UNIT X**

**ASSIGNMENT SHEET #4 — CONSTRUCT A LINE PERPENDICULAR
TO A LINE FROM A POINT NOT ON THE LINE**

NAME _____ SCORE _____

Directions: Study the example below and then complete the assigned problem.

Example:

1. Use given line AB and point C.

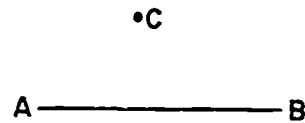

2. Swing any radius from point C as long as it touches two points on line AB.

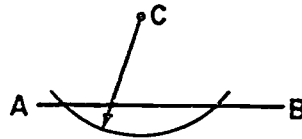

3. Swing radius DF and radius EF equal to radius DC.

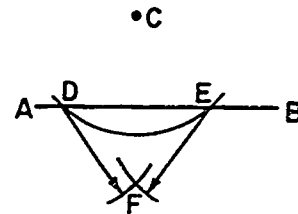

4. Connect point C with point F.
(NOTE: Line CF is 90° to AB.)

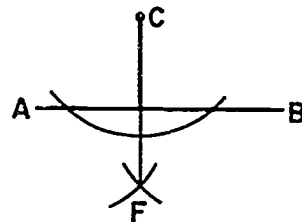

ASSIGNMENT SHEET #4

Problem. Construct a line perpendicular from point C to line AB. Leave all construction lines.

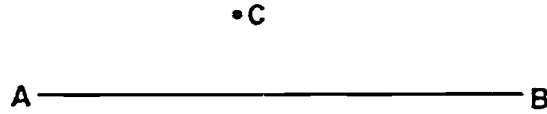

GEOMETRIC CONSTRUCTIONS UNIT X

ASSIGNMENT SHEET #5 — CONSTRUCT A LINE PERPENDICULAR TO A LINE THROUGH A POINT ON THE LINE

NAME _____ SCORE _____

Directions: Study the example below and then complete the assigned problems.

1. Use given line AB with point C located on line AB.

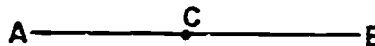

2. Set compass at any radius r and swing arc through line AB from point C.

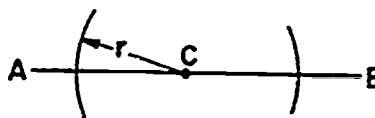

3. Set compass at distance greater than DC and swing arcs from D and E to form points F and G.

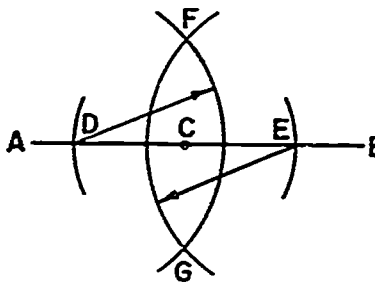

4. Connect points F and G through C.

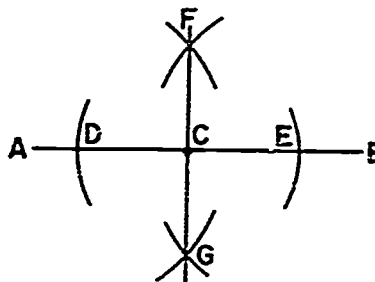

ASSIGNMENT SHEET #5

Problem: Draw a line perpendicular through point C on line AB. Leave all constructions lines.

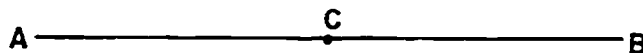

GEOMETRIC CONSTRUCTIONS
UNIT X

ASSIGNMENT SHEET #6 — DIVIDE A LINE INTO EQUAL PARTS

NAME _____ SCORE _____

Directions: Study the example below and then complete the assigned problems.

Example:

1. Use given line AB to divide into five equal parts.



2. Draw a line at any angle and any length and label point C.

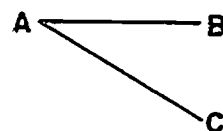

3. Use scale to lay off five equal divisions on line AC. Label the last division D.

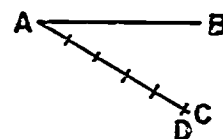

4. Set triangle to project division back to line AB from point D.

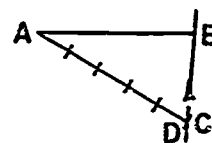

5. Set triangles to be parallel to line BD; mark divisions on line AB parallel to line BD.

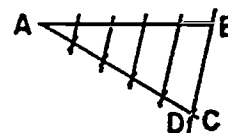

ASSIGNMENT SHEET #6

Problems:

1. Divide line AB into seven equal divisions. Leave all construction lines.

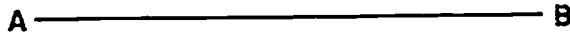

2. Divide horizontal line into six equal parts starting at point A. Draw 60° V notches on the six created points. Draw construction lines lightly and do not erase them.

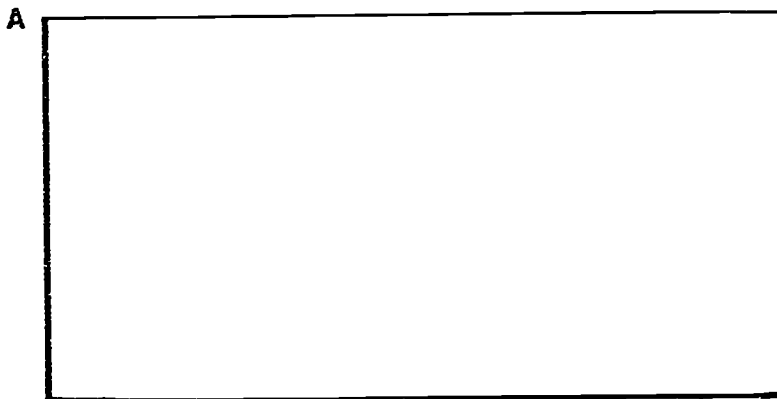
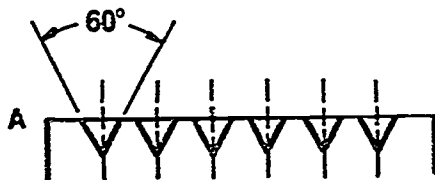

**GEOMETRIC CONSTRUCTIONS
UNIT X**

ASSIGNMENT SHEET #7 — CONSTRUCT A TRIANGLE WITH SIDES GIVEN

NAME _____ SCORE _____

Directions: Study the example below and then complete the assigned problem.

Example:

1. Use given sides A, B, and C.

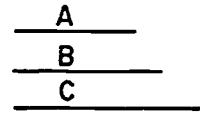

2. Draw one side, the length of C, in desired position, and strike arc with radius equal to given side A.

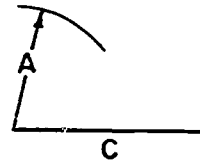

3. Strike arc with radius equal to given side B.

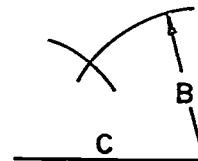

4. Draw sides A and B from intersection of arcs, as shown.

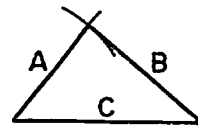

ASSIGNMENT SHEET #7

Problem: Construct a triangle using the three lines given below. Leave all construction lines.

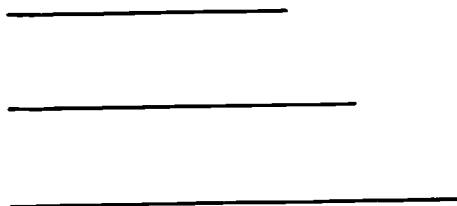

**GEOMETRIC CONSTRUCTIONS
UNIT X**

ASSIGNMENT SHEET #8 — CONSTRUCT A RIGHT TRIANGLE

NAME _____ SCORE _____

Directions: Study the example below and then complete the assigned problem.

Example:

1. Use given sides R and S.

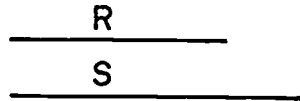

2. Draw in line S with triangle.

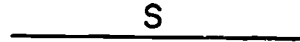

3. Swing arc with radius length as R.

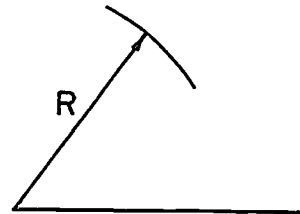

4. Find the middle of line S and use that point with radius 1/2 length of S to swing arc.

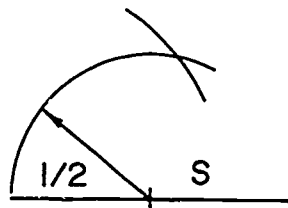

5. At point of arc intersection connect to end points of line S as shown.

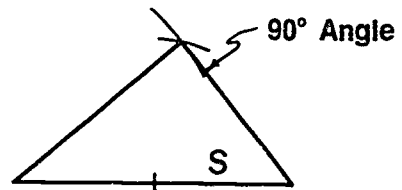

ASSIGNMENT SHEET #8

Problem: Construct a right triangle using the two lines given below. Leave all construction lines.

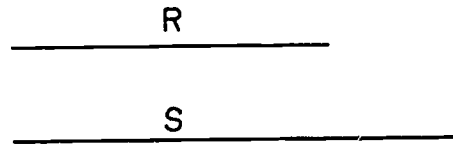

460

**GEOMETRIC CONSTRUCTIONS
UNIT X**

**ASSIGNMENT SHEET #9 — CONSTRUCT AN EQUILATERAL
TRIANGLE WITH ONE SIDE GIVEN**

NAME _____ SCORE _____

Directions: Study the example below and then complete the assigned problem.

Example:

1. Compass method

- a. With A and B as centers and AB as radius, strike arcs to intersect at C.

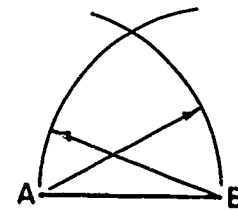

- b. Draw lines AC and BC to complete the triangle.

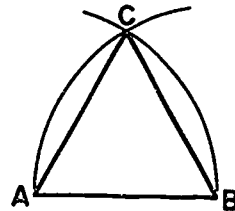

2. Triangle method -- Use 60° triangle to right of A and left of B to intersect at C.

(NOTE: Triangle is parallel to line AB.)

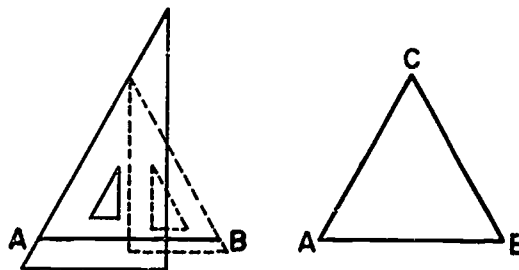

ASSIGNMENT SHEET #9

Problem: Construct an equilateral triangle with side AB given. Use both methods and leave all construction lines.



**GEOMETRIC CONSTRUCTIONS
UNIT X**

ASSIGNMENT SHEET #10 — INSCRIBE A HEXAGON INSIDE A CIRCLE

NAME _____ SCORE _____

Directions: Study the example below and then complete the assigned problem.

Example:

1. Use given circle diameter equal to required distance across corners of hexagon.

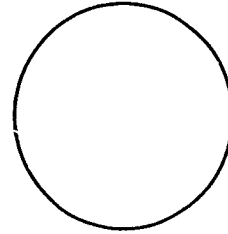

2. Draw vertical and horizontal center lines through circle.

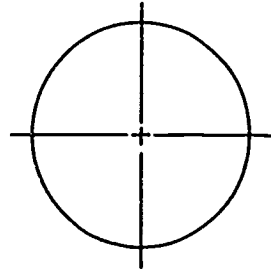

3. Use 30° triangle to construct diagonals AB and CD at 30° with horizontal through center point.

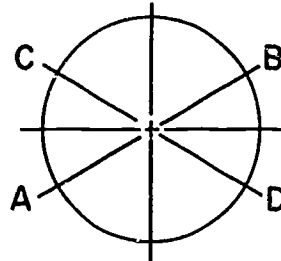

4. Use 30° triangle to construct sides.

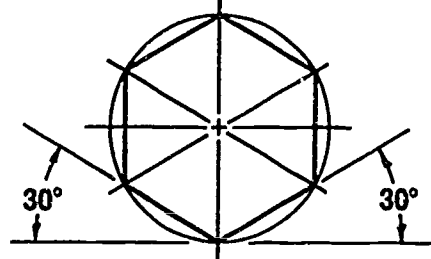

ASSIGNMENT SHEET #10

Problem: Draw a hexagon in the circle below. Leave all construction lines.

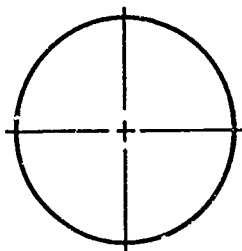

**GEOMETRIC CONSTRUCTIONS
UNIT X**

**ASSIGNMENT SHEET #11 — CONSTRUCT A HEXAGON WITH THE DISTANCE
ACROSS THE FLAT SIDES GIVEN**

NAME _____ SCORE _____

Directions: Study the example below and then complete the assigned problems.

Example:

1. Use given circle diameter or distance across hexagon flats.

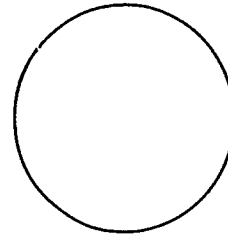

2. Put in vertical and horizontal center lines.

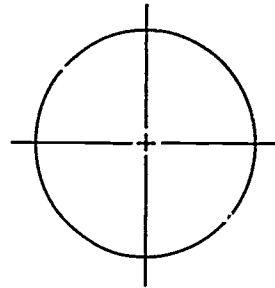

3. With the 30°60° triangle and parallel bar or drafting machine, draw the six sides tangent to the circle. Flats can be on sides or on top and bottom.

Flats on sides

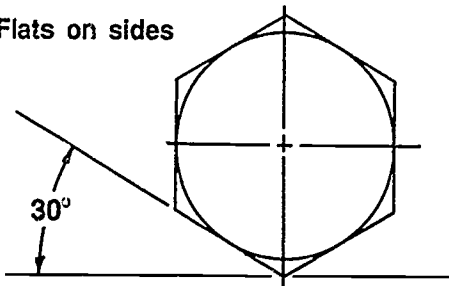

Flats on top and bottom

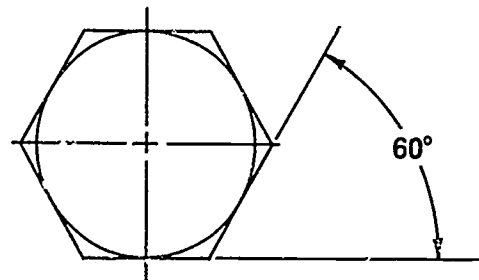

ASSIGNMENT SHEET #11

Problems. Construct a hexagon using this circle as the distance across flats. Leave all construction lines.

1. Put flats on top and bottom.

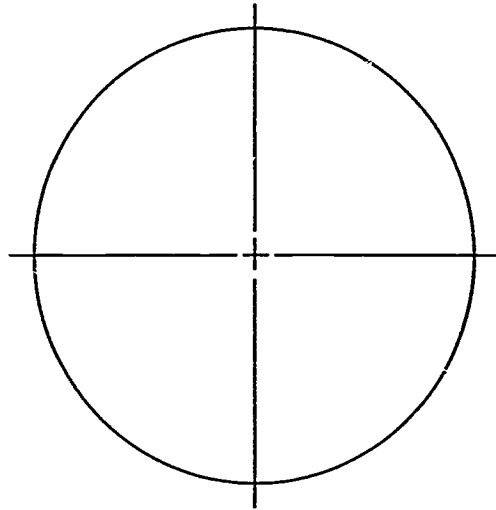

2. Put flats on sides.

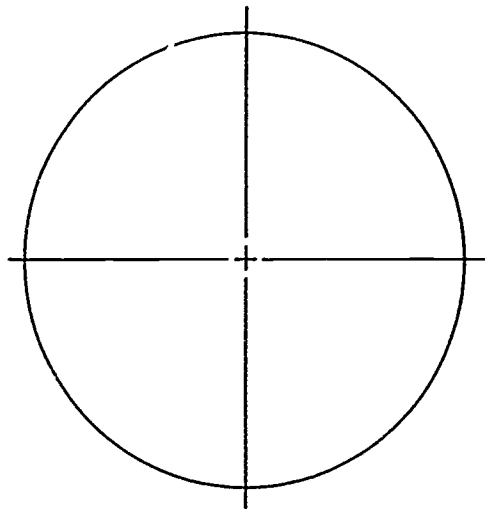

**GEOMETRIC CONSTRUCTIONS
UNIT X**

ASSIGNMENT SHEET #12 — INSCRIBE A PENTAGON INSIDE A CIRCLE

NAME _____ SCORE _____

Directions: Study the example below and then complete the assigned problems.

Example:

1. Use given circle.

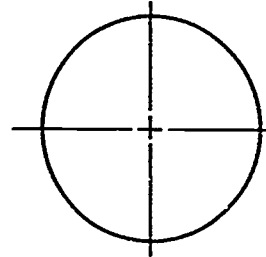

2. Bisect radius OD at C.

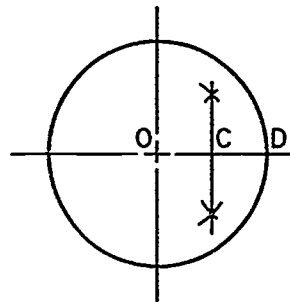

3. With C as center and CA as radius, strike arc AE.

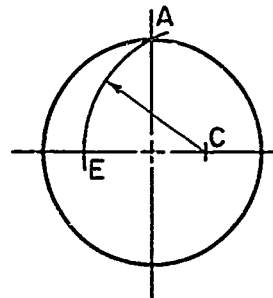

4. With A as center and AE as radius, strike arc EB.
5. Draw line AB.
6. Set off distances AB around the circumference of the circle using compass, and draw the sides through these points.

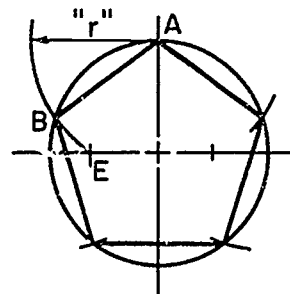

ASSIGNMENT SHEET #12

Problems: Inscribe a pentagon in the circles below. Leave all construction lines.

1.

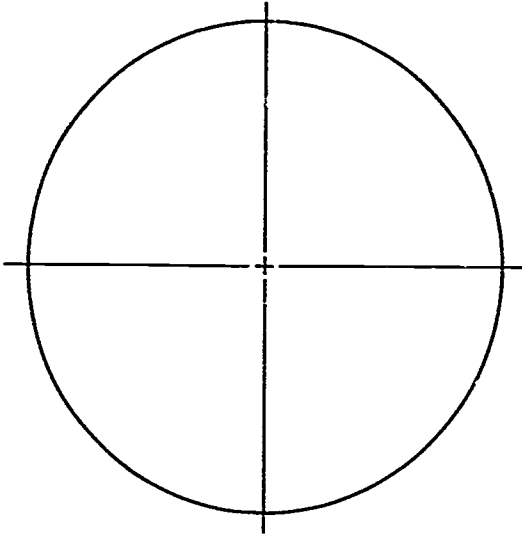

2.

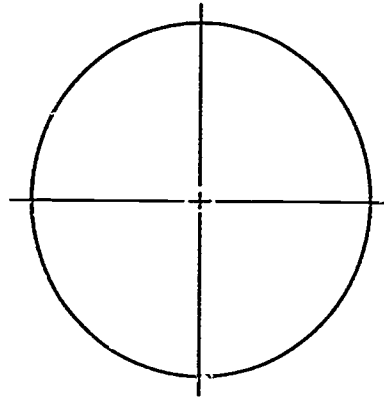

**GEOMETRIC CONSTRUCTIONS
UNIT X**

**ASSIGNMENT SHEET #13 — CONSTRUCT A CIRCLE THROUGH
THREE GIVEN POINTS**

NAME _____ SCORE _____

Directions: Study the example below and then complete the assigned problems.

Example:

- Use given points A, B, and C which are not in a straight line.

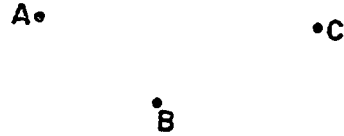

- Connect lines AB and BC.

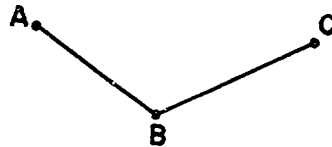

- Find perpendicular bisectors of lines AB and BC. Swing arcs as shown.

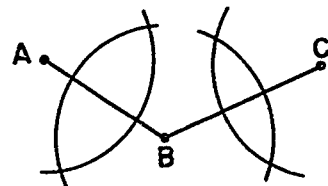

- Extend bisector lines until they intersect. This will be center point of circle.

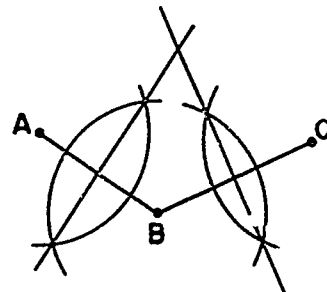

ASSIGNMENT SHEET #13

5. Use this point as center of circle radius.

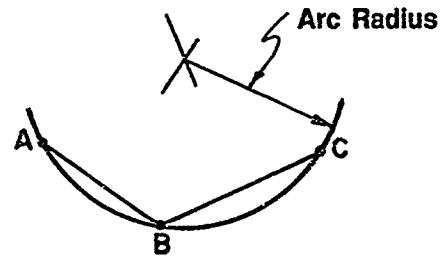

Problems:

1. Construct a circle below that will pass through the three points given. Leave all construction lines.

A +

+c

+
B

ASSIGNMENT SHEET #13

2. Complete the view of the bracket by finding the center of the circle through the three points given. Draw all center lines in pictorial. Scale is 1/2 size. Draw construction lines lightly and do not erase them.

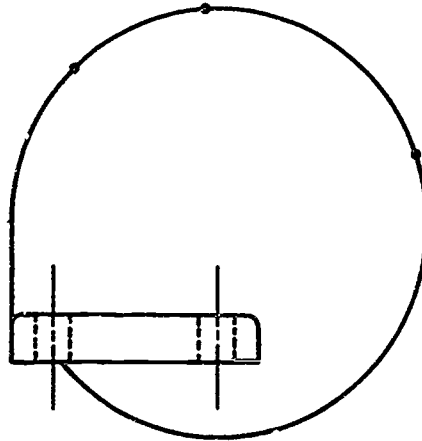
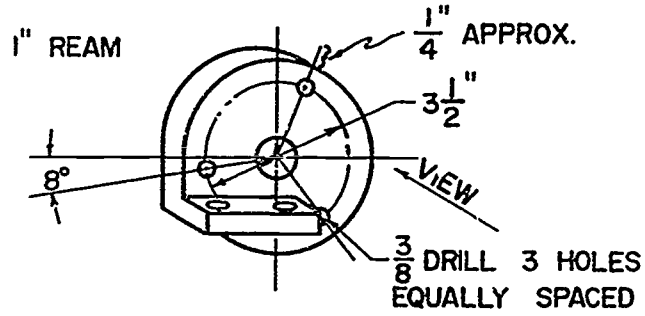

GEOMETRIC CONSTRUCTIONS
UNIT X

ASSIGNMENT SHEET #14 — DRAW AN ARC TANGENT TO
A STRAIGHT LINE AND AN ARC

NAME _____ SCORE _____

Directions: Study the example below and then complete the assigned problems.

Example:

1. Use given arc with radius G and straight line AB .

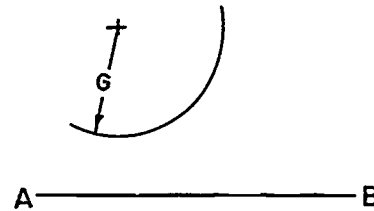

2. Swing given arc r from point B and draw a parallel line tangent to arc r .

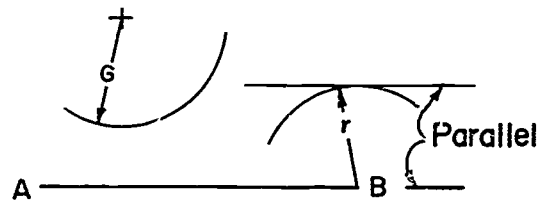

3. Add radius G to radius r and swing arc $G+r$ to point C from point G .
4. Draw line from the center point of radius G and $G+r$ to point C to obtain tangency point.

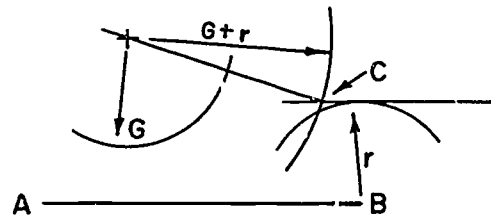

5. With center C and given radius r , draw required tangent arc between the line AB and arc.

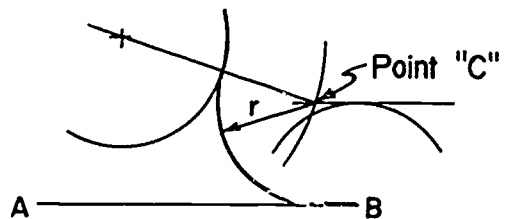

ASSIGNMENT SHEET #14

Problems:

1. Connect line AB to arc OG with 1" R arc. Leave all construction lines.

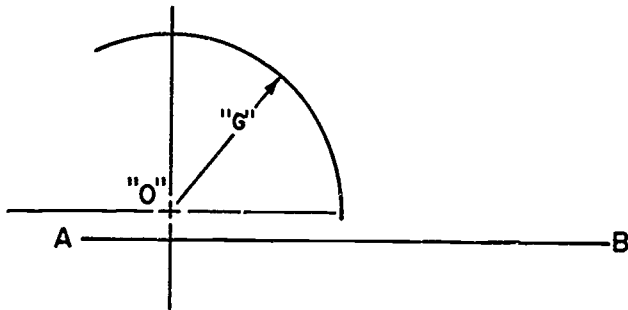
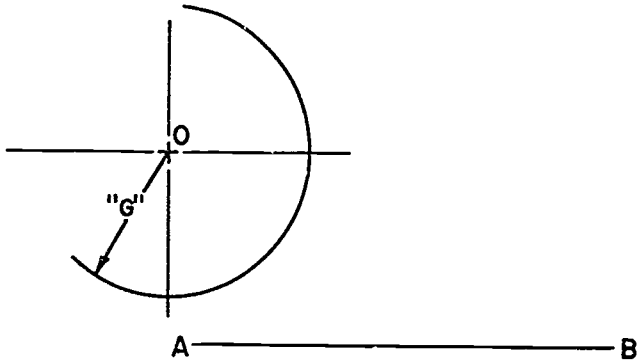

ASSIGNMENT SHEET #14

2. Complete the drawing of a wing nut and mark all points of tangency. Draw construction lines lightly and do not erase them.

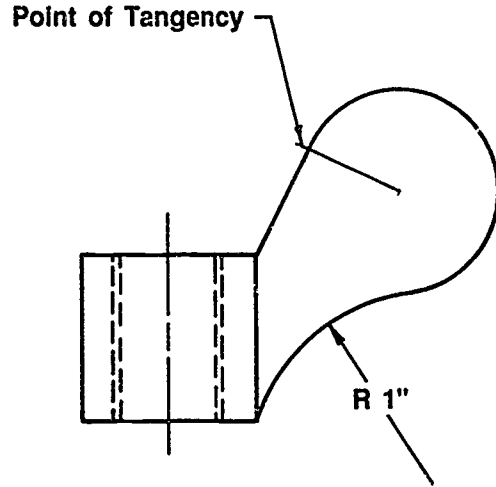
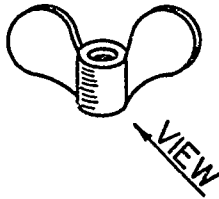

There are _____ points of tangency on this wing nut.

GEOMETRIC CONSTRUCTIONS
UNIT X

ASSIGNMENT SHEET #15 — DRAW AN ARC TANGENT TO TWO ARCS

NAME _____ SCORE _____

Directions: Study the example below and then complete the assigned problems.

Example:

1. Use given arcs with centers A and B and required radius r .

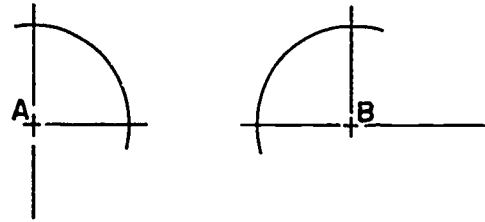

2. Swing arcs r using any point on circles as center point.
3. Swing arc AC and arc BC tangent to given r arcs.

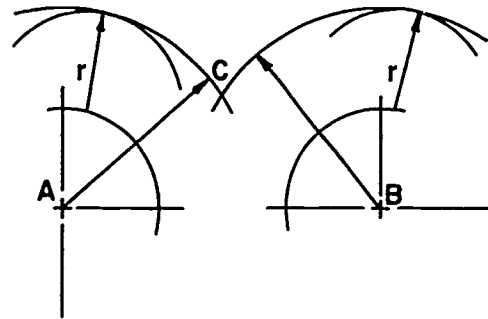

4. Draw lines of centers AC and BC to locate points of tangency T, and draw required tangent arc between the points of tangency, as shown from center C.

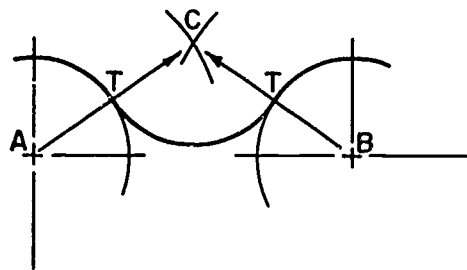

ASSIGNMENT SHEET #15

Problems

1. Connect the two circles with $1/2"$ diameter circle. Leave all construction lines.

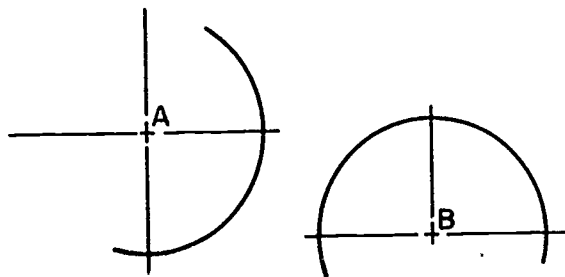

2. Complete the drawing of an operating arm as shown in the following drawing. Draw on size "A" vellum using title block determined by the instructor. Mark points of tangency. Draw construction lines lightly and do not erase them.

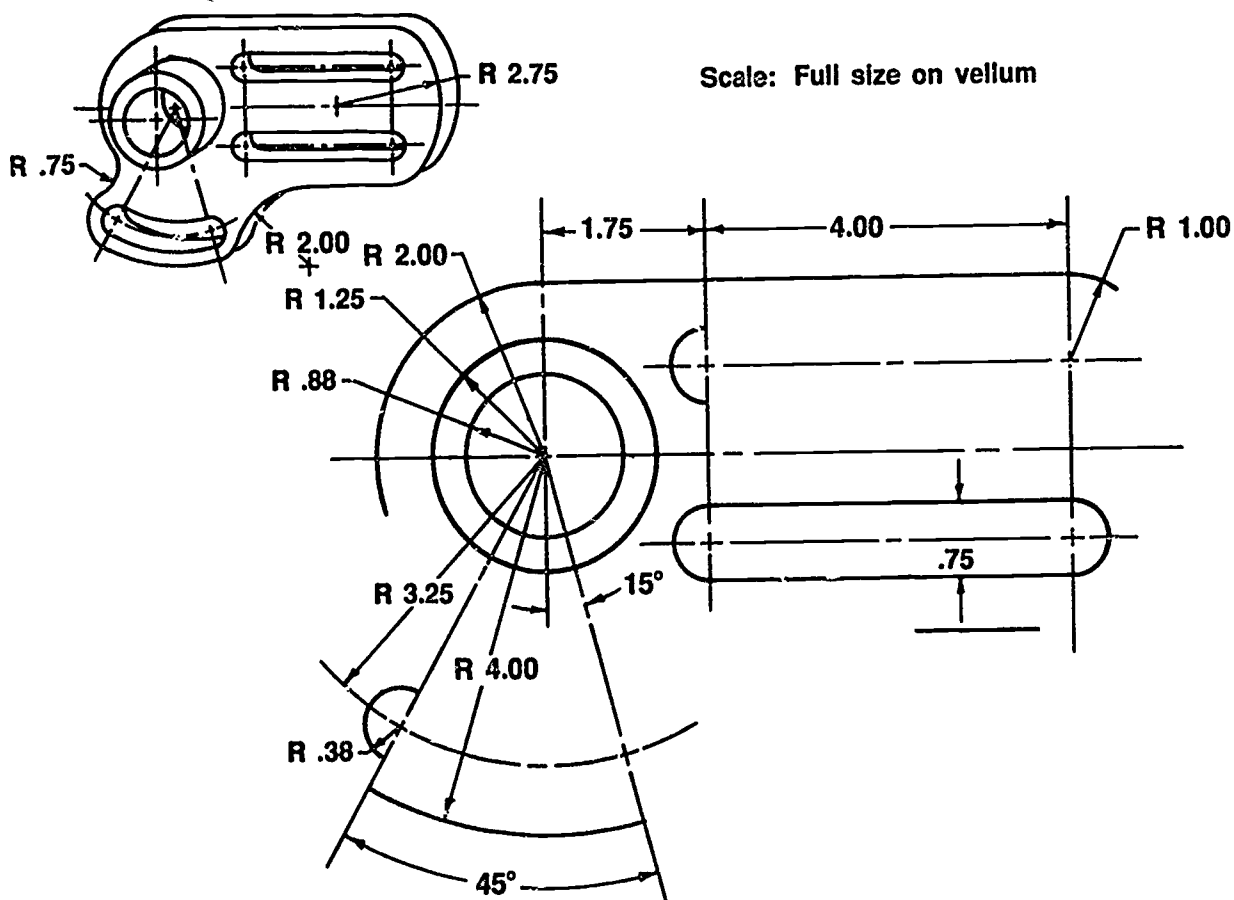

There are _____ tangency points on this view.

**GEOMETRIC CONSTRUCTIONS
UNIT X**

**ASSIGNMENT SHEET #16 — DRAW AN ARC TANGENT TO AN ACUTE
ANGLE AND AN OBTUSE ANGLE**

NAME _____ SCORE _____

Directions: Study the example below and then complete the assigned problems.

Example:

1. Use given acute angle and obtuse angle.

(NOTE: In this example every step will be performed on the acute angle on the left and on the obtuse angle on the right.)

Acute Angle

Obtuse Angle

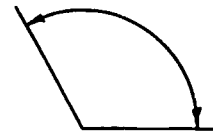
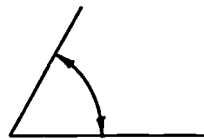

2. Draw lines parallel to given lines at distance R from them, to intersect at C, the required center.

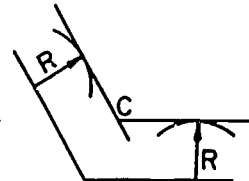
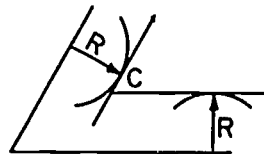

3. From C drop perpendiculars to the given lines respectively to locate points of tangency T.

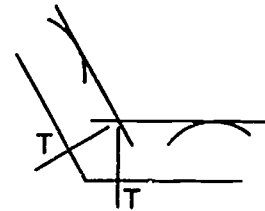
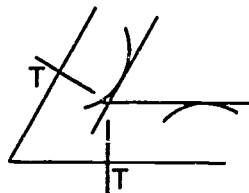

ASSIGNMENT SHEET #16

4. With C as center and with given radius R, draw required tangent arc between the points of tangency.

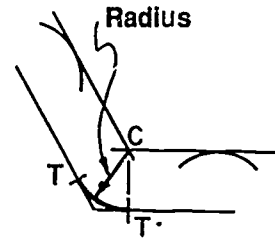
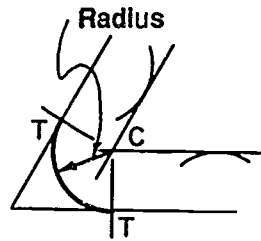

Problems: Connect the sides of the angles below with a $\frac{1}{2}$ " radius arc tangent to the sides. Leave all construction lines.

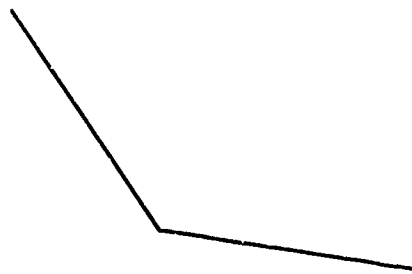
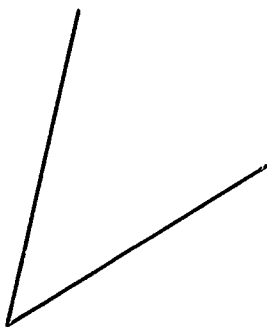
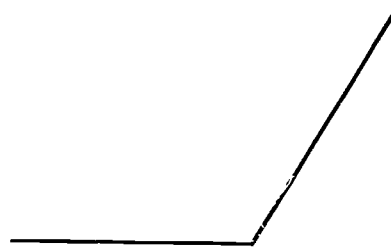

GEOMETRIC CONSTRUCTIONS
UNIT X

ASSIGNMENT SHEET #17 — DRAW AN ARC TANGENT TO A RIGHT ANGLE

NAME _____ SCORE _____

Directions: Study the example below and then complete the assigned problems.

Example:

1. Use given lines at right angles to each other, any radius required.

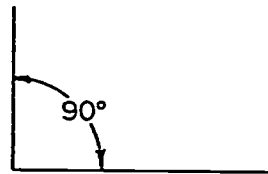

2. With given radius R , strike arc intersecting given lines at tangent points T .

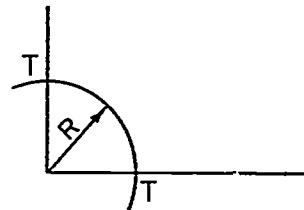

3. With given radius R again, and with points T as centers, strike arcs intersecting at C .

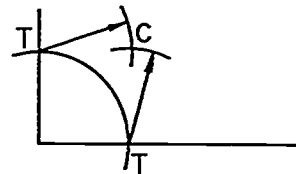

4. With C as center and given radius R , draw required tangent arc.

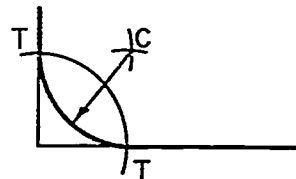

ASSIGNMENT SHEET #17

Problems:

1. Draw a $\frac{3}{4}$ " R arc in the right angles below. Leave all construction lines.



2. Draw arc tangents to complete the drawing as shown in the following bracket. Mark points of tangency. Draw construction lines lightly and do not erase them.

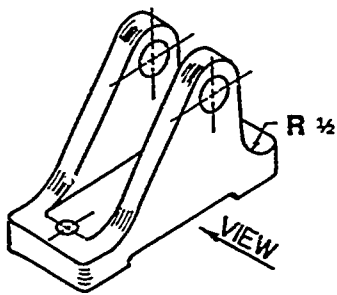

Center point of arc ↗

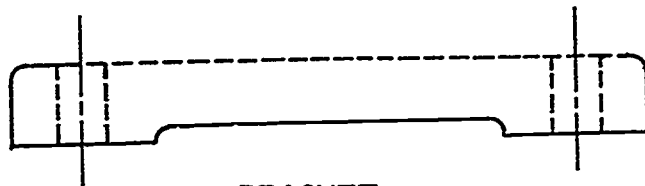
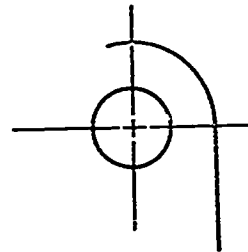

BRACKET

Scale: Full Size

There are _____ points of tangency on this view.

GEOMETRIC CONSTRUCTIONS UNIT X

ASSIGNMENT SHEET #18 — DRAW AN ELLIPSE USING THE APPROXIMATE ELLIPSE WITH COMPASS METHOD

NAME _____ SCORE _____

Directions: Study the example below and then complete the assigned problems.

Example:

1. Use given axis AB and axis CD.

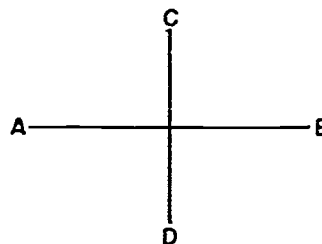

2. Draw line AC.
3. With O as center and OA as radius, strike arc AE.
4. With C as center and CE as radius, strike the arc EF.

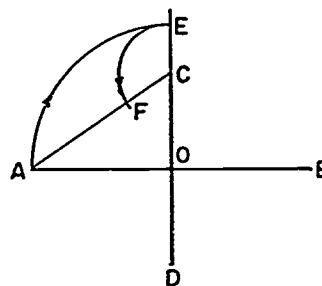

5. Draw perpendicular bisector of the line AF. The points T, K, and J (which intersect the axes) are centers of the required arcs.

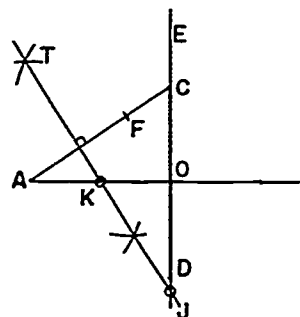

6. Find center M by measuring OJ with compass.

ASSIGNMENT SHEET #18

7. Set compass point at O and strike point M.
8. Find center L by measuring OK with compass.
9. Set compass point at O and strike point L.
10. Draw line M through point K to form point U.
11. Draw line M through point L to form point V.
12. Draw line J through point L to form point W.
13. Keep arcs tangent as shown.
14. Using K as the center point, swing arc KA from point U to point T.
15. Using L as the center point, swing arc LB from point W to point V.
16. Using J as the center point, swing arc JC from point T to point W.
17. Using M as the center point, swing arc MD from point V to point U.

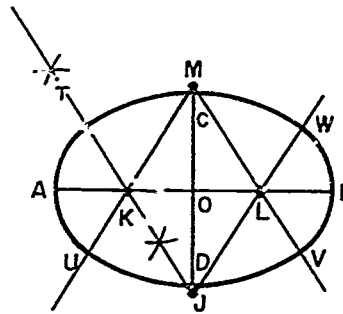

Problems:

1. Construct an approximate ellipse of the axis lines AB and CD. Leave all construction lines.

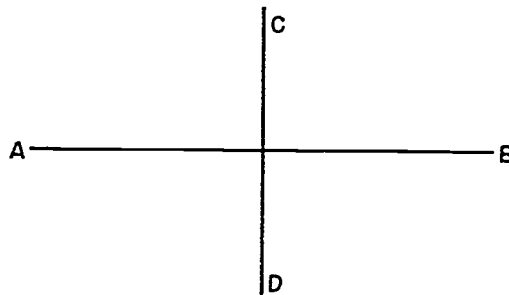

ASSIGNMENT SHEET #18

2. Draw an approximate ellipse $1 \frac{1}{4}" \times 2 \frac{1}{8}"$ as shown in the following bracket. Draw construction lines lightly and do not erase them.

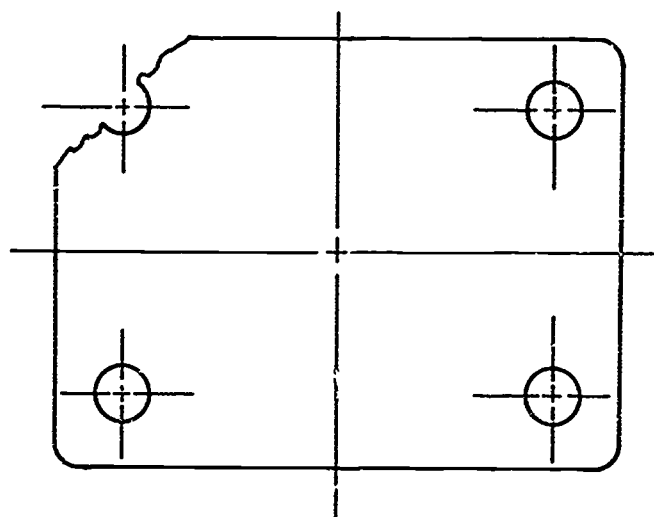
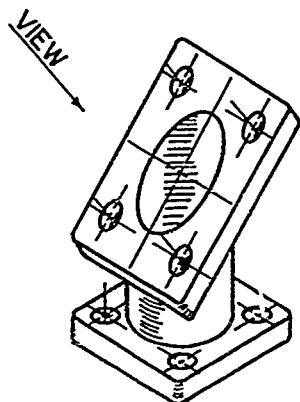

3. Draw an approximate ellipse as shown in the following cam. Draw construction lines lightly and do not erase them.

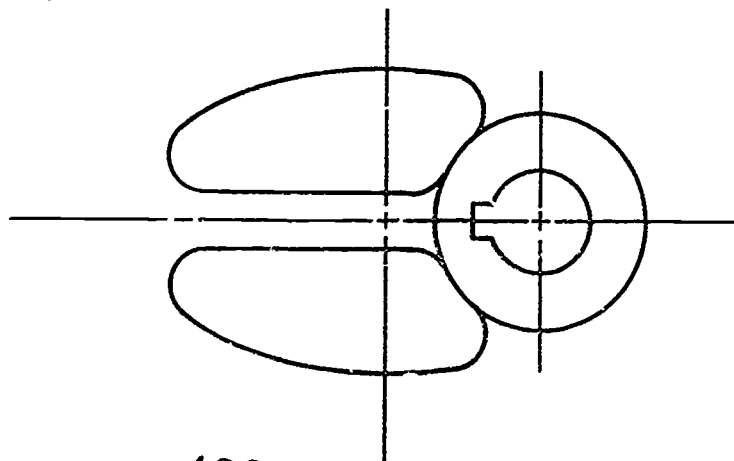
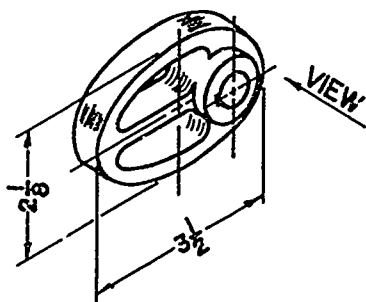

GEOMETRIC CONSTRUCTIONS
UNIT X

ASSIGNMENT SHEET #19 — DRAW A PARABOLA

NAME _____ SCORE _____

Directions: Study the example below and then complete the assigned problem.

Example:

1. Use given lines ABCD.
2. Divide line AD into some number of equal parts.
3. Divide line AB into an equal number of parts amounting to the square of that number.

Example: If A-D is divided into 4 equal spaces, then AB will be divided into 16 equal spaces.

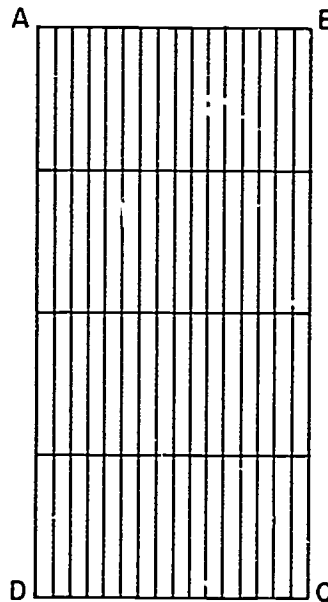

ASSIGNMENT SHEET #19

4. From line AD, mark every point on the parabola that is determined by the number of spacing units equal to the square of the number on AD starting from point D which is also O.

Example: $1=1$, $2=4$, $3=9$, $4=16$

5. Sketch a light line through the points and darken the curve, using an irregular curve.

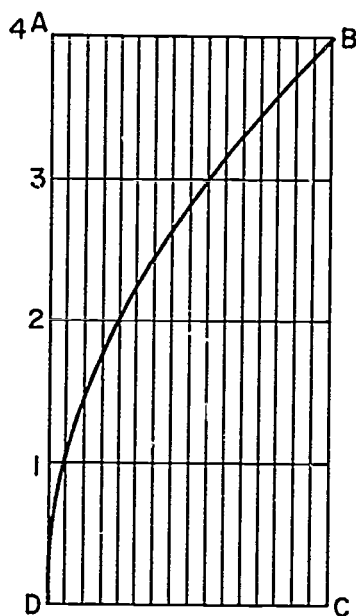

Problem: Construct a parabola in the given area. Leave all construction lines.

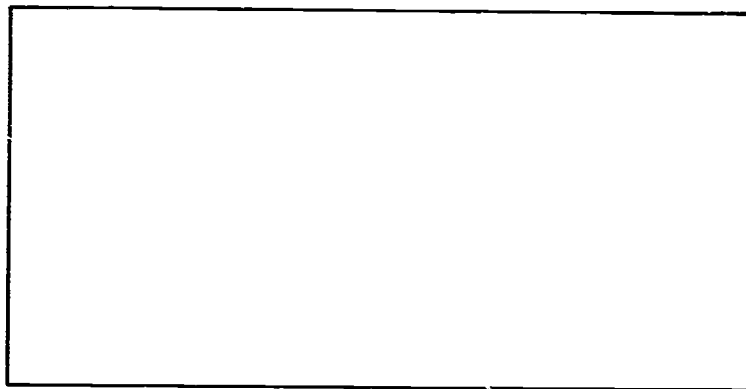

GEOMETRIC CONSTRUCTIONS
UNIT X

ASSIGNMENT SHEET #20 — JOINT TWO POINTS WITH A PARABOLIC CURVE

NAME _____ SCORE _____

Directions: Study the example below and then complete the assigned problem.

Example:

1. Use given lines ABCD.
2. Divide line AD into an equal number of spaces.
3. Divide line DC into the same number of equal spaces.
4. Number the points on AD starting at A as 0 and number the points on DC starting at D as 0.
5. Draw a straight line from point 1 on line AD to point 1 on line DC.
6. Draw a straight line from point 2 to point 2.
7. Continue for all points.
8. Darken the curve, using an irregular curve.

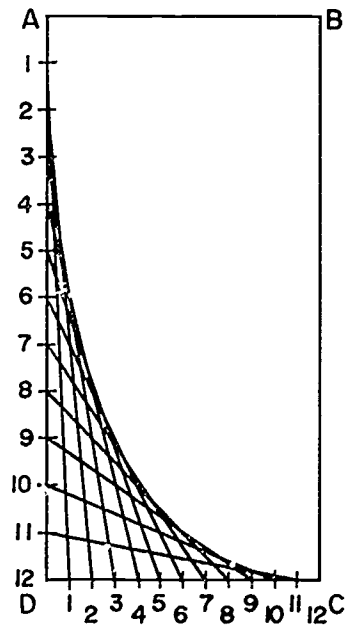
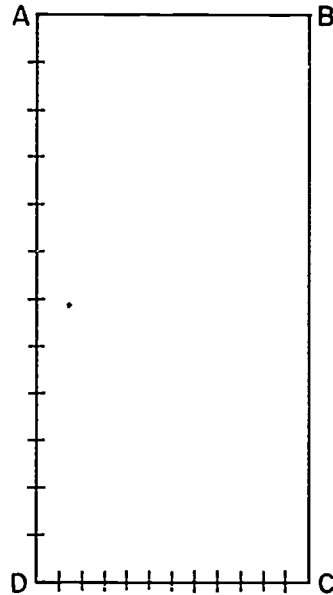

ASSIGNMENT SHEET #20

Problem: Construct a parabolic curve from point B to point D. Leave all construction lines.

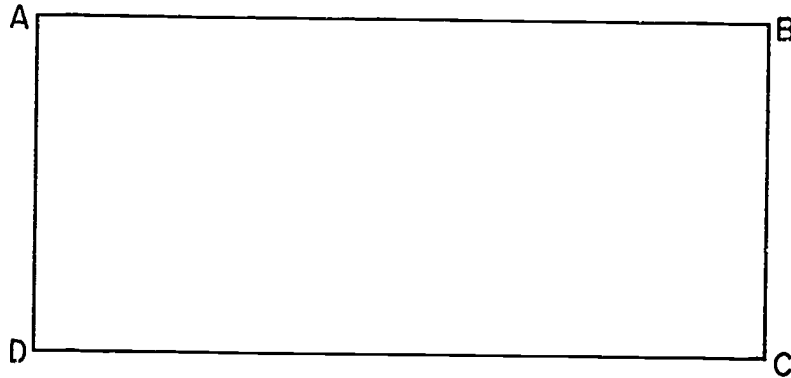

487

**GEOMETRIC CONSTRUCTIONS
UNIT X**

ASSIGNMENT SHEET #21 — DRAW AN INVOLUTE OF A CIRCLE

NAME _____ SCORE _____

Directions: Study the example below and then complete the assigned problem.

Example:

1. Use given circle diameter.

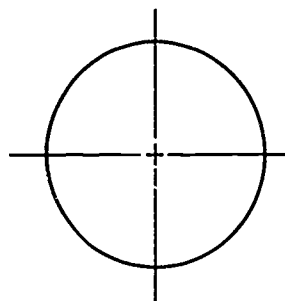

2. Divide circle into a given number of equal parts. (In this case six equal parts.)

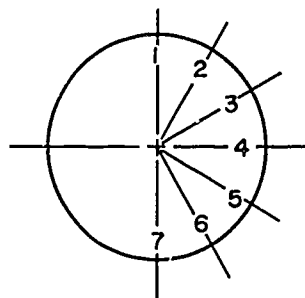

3. At each of these divisions, put in lines tangent to circle and perpendicular to radius lines.

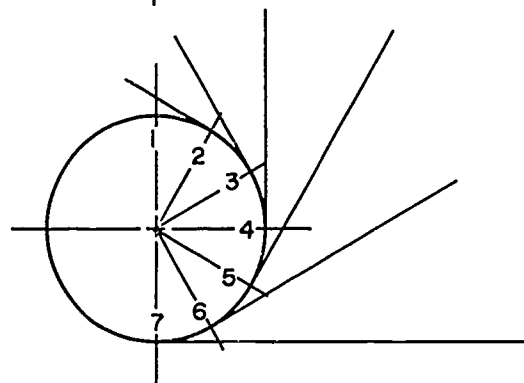

ASSIGNMENT SHEET #21

4. Lay off the length of the arc from point 1 to point 2; using 2 as center point, swing arc from 2 to 2', lay off the length of the arc from 2' to 3 and swing arc 3-3'.

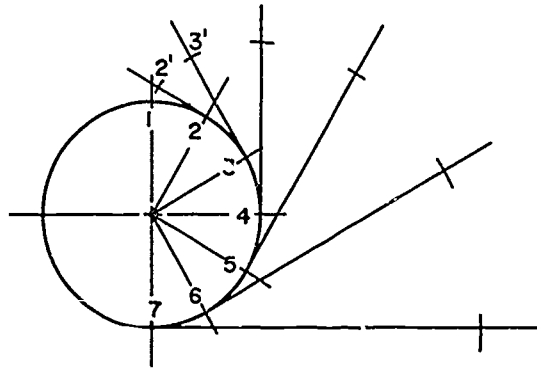

5. Continue in like manner for each point. Sketch a light line through the points and darken the curve, using an irregular curve.

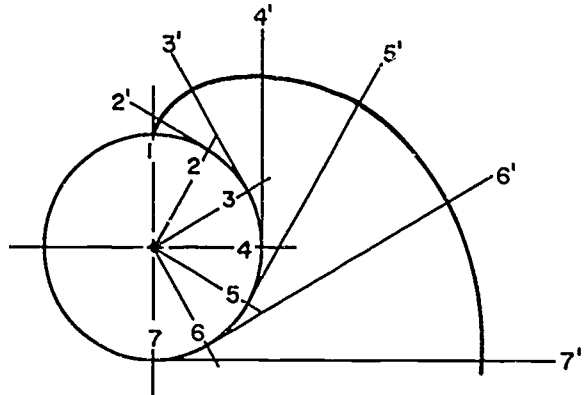

Problem: Construct an involute of the following circle. Leave all construction lines.

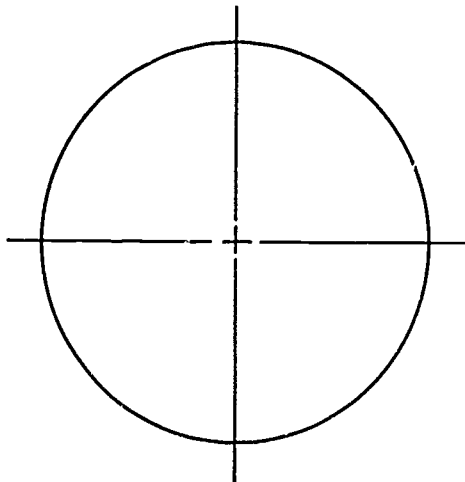

**GEOMETRIC CONSTRUCTIONS
UNIT X**

JOB SHEET #1 — CREATE A PART ON CADD USING CIRCLES, ARCS, FILLETS, AND LINES

A. Tools and equipment

1. CADD system hardware
2. Appropriate CADD software
3. Instruction (user) manual for your CADD system

Evaluation Criteria	
Criteria	Rating
Problems correctly drawn	_____

B. Procedure

1. Log into the CADD system.
2. Create a file for a new part.
3. Name the file with the part's name.
4. Establish a .5 visible grid.
5. Build the part using the appropriate CADD commands to build circles, arcs, fillets, and lines.
6. File and provide hard copy for instructor to evaluate.

C. Problems

1. File name — Plate - 1

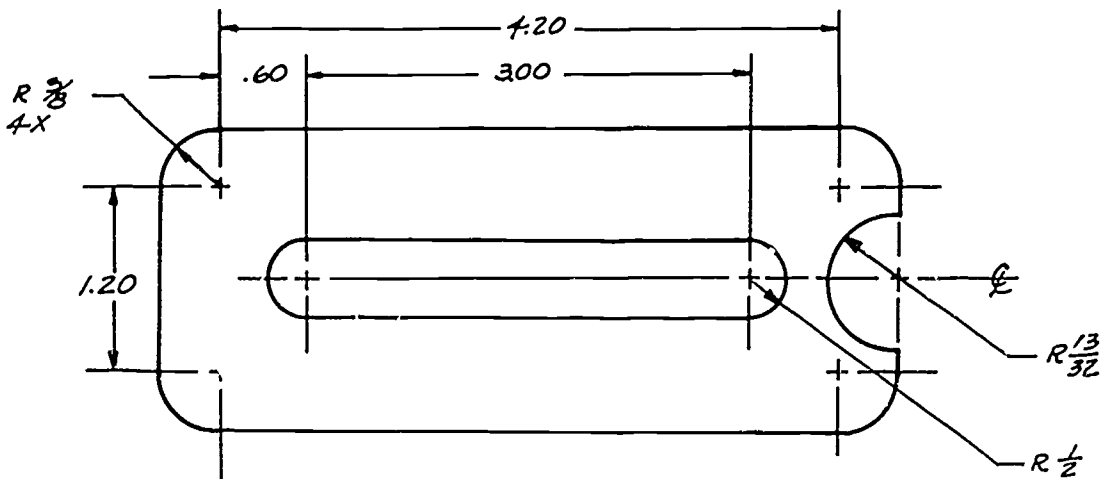

SCALE: FULL

JOB SHEET #1

2. File name — Bracket

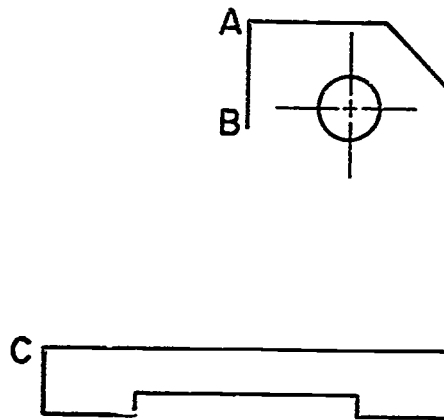
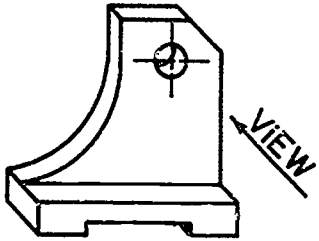

**GEOMETRIC CONSTRUCTIONS
UNIT X**

TEST

NAME _____ SCORE _____

1. Match the terms on the right with their correct definitions.

- | | | | |
|----------|--|-----|------------------------|
| _____ a. | All sides are equal | 1. | Angle |
| _____ b. | Parallel to the plane of the horizon | 2. | Axis |
| _____ c. | Lines connecting opposite nonsymmetrical corners of a polygon | 3. | Bisect |
| _____ d. | To divide into two equal parts | 4. | Circle |
| _____ e. | Straight lines that do not meet or intersect and are an equal distance apart at all points | 5. | Circumscribed |
| _____ f. | Straight lines that do not intersect and are not parallel or in the same plane | 6. | Diagonals |
| _____ g. | To cut across each other | 7. | Equilateral |
| _____ h. | A flat, level, even surface such as a piece of paper lying flat on a table | 8. | Geometric solid figure |
| _____ i. | Figure formed by two intersecting lines | 9. | Horizontal |
| _____ j. | A connection between two or more points | 10. | Inscribed |
| _____ k. | At 90° angles to a given plane or line | 11. | Intersect |
| _____ l. | A small dot or small cross on a drawing or in space that does not have length, height, depth, or width | 12. | Line |
| _____ m. | A closed curve all points of which are an equal distance from the center | 13. | Parallel |
| _____ n. | A plane figure bound by three straight sides | 14. | Perpendicular |
| _____ o. | A line straight up and down perpendicular to the horizontal plane | 15. | Plane figure |

TEST

- | | | | |
|---------|---|-----|---------------|
| _____p. | The common point where lines or surfaces intersect | 16. | Point |
| _____q. | Any plane figure with sides of straight lines | 17. | Polygon |
| _____r. | A plane figure bound by four straight sides | 18. | Quadrilateral |
| _____s. | A figure encircled so as to touch in as many places as possible | 19. | Skew lines |
| _____t. | A figure that has height, width, and depth | 20. | Symmetrical |
| | | 21. | Triangle |
| | | 22. | Vertex |
| | | 23. | Vertical |
2. Match types of angles on the right with their correct descriptions.
- | | | | |
|---------|------------------------------------|----|---------------|
| _____a. | A 90° angle | 1. | Acute |
| _____b. | An angle less than 90° | 2. | Complementary |
| _____c. | An angle greater than 90° | 3. | Obtuse |
| _____d. | Two angles whose sum is 90° | 4. | Right |
| | | 5. | Supplementary |
3. Match types of triangles on the right with their correct descriptions.
- | | | | |
|---------|--|----|-------------|
| _____a. | A triangle with no angles or sides equal | 1. | Acute |
| _____b. | A triangle with one 90° angle | 2. | Equilateral |
| _____c. | A triangle with three equal sides and three equal angles | 3. | Isosceles |
| _____d. | A triangle with two equal sides and two equal angles | 4. | Right |
| | | 5. | Scalene |

TEST

4. Match types of quadrilaterals on the right with their correct descriptions.

- | | | |
|----------|--|--------------|
| _____ a. | Quadrilateral with only two sides parallel | 1. Rectangle |
| _____ b. | Parallelogram with two lengths of sides and four 90° angles | 2. Rhomboid |
| _____ c. | Parallelogram with four equal sides and no 90° angles | 3. Rhombus |
| _____ d. | Parallelogram with four equal sides and four 90° angles | 4. Square |
| _____ e. | Quadrilateral with no sides parallel | 5. Trapezium |
| | | 6. Trapezoid |

5. Identify the following types of polygons.

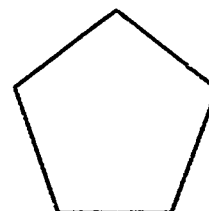
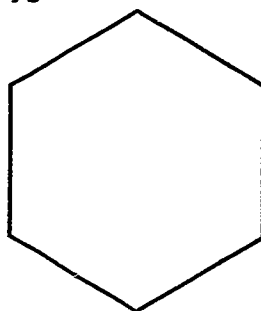
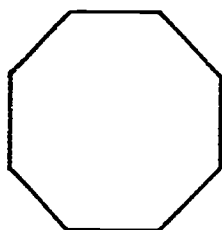

a. _____

b. _____

c. _____

6. Match circular shapes on the right with their correct descriptions.

- | | | |
|----------|---|-----------------------|
| _____ a. | The distance from the center point of a circle to the outside circumference | 1. Arc |
| _____ b. | A foreshortened circle having a major axis and a minor axis | 2. Axis |
| _____ c. | One-half of a circle | 3. Chord |
| _____ d. | One-fourth of a circle | 4. Circumference |
| _____ e. | The distance around a circle | 5. Concentric circles |
| _____ f. | Circles having the same point as center | 6. Diameter |
| _____ g. | Circles having different points as center, one within the other | 7. Eccentric circles |
| _____ h. | Less than a quadrant | 8. Ellipse |
| | | 9. Quadrant |
| | | 10. Radius |

TEST

- ___i. The distance across a circle passing through its center point
- ___j. Any portion of the circumference of a circle
- ___k. Meeting a curved line or surface, touching at one and only one point, but not intersecting
- ___l. Any straight line across a circle that does not pass through the center
11. Sector
12. Semicircle
13. Symmetrical
14. Tangent

7. State the geometric terms for the following abbreviations.

- a. // _____
- b. > _____
- c. \perp _____
- d. \mathbb{R} _____
- e. \emptyset _____

8. Identify the following solid geometric figures.

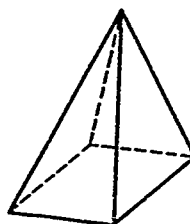
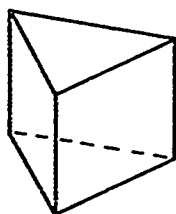

a. _____ b. _____ c. _____

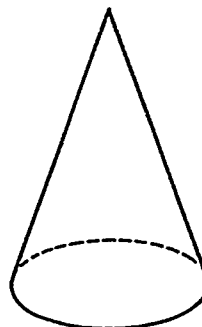
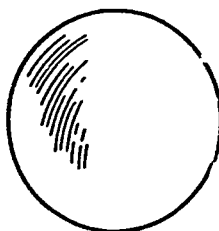
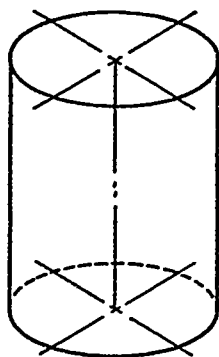

d. _____ e. _____ f. _____

TEST

9. Identify the special geometric figures below.

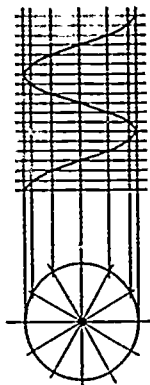

a. _____

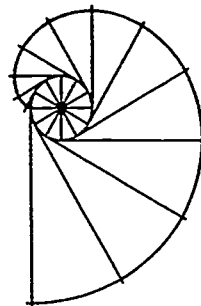

b. _____

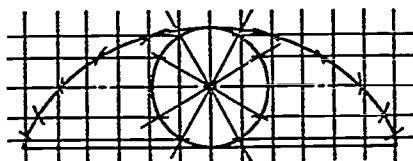

c. _____

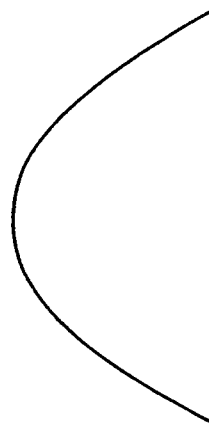

d. _____

10. List three elements needed for measuring parts of a circle.

a. _____

b. _____

c. _____

11. Complete the following statements on interpreting degrees in a circle.

a. A full circle has _____ degrees.

b. Each degree is divided into _____ minutes.

c. Each minute is divided into _____ seconds.

TEST

12. Label the elements of a circle used in CADD.

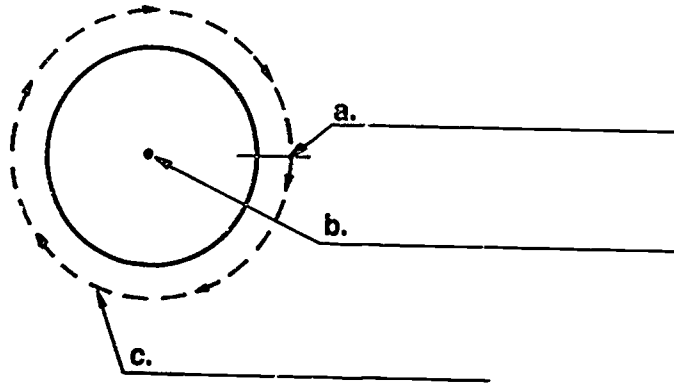

13. Select from the following list the methods used to create circles on CADD by placing an "X" next to the appropriate methods.
- ___ a. A circle can be created through three digitized points that establish the circumference.
- ___ b. A circle can be created when given a radius and the center point is digitized.
- ___ c. A circle can be created by two digitized points that establish the circumference.
14. Select from the following list the methods used to create arcs on CADD by placing an "X" next to the appropriate methods.
- ___ a. Arc is created by a specified diameter or radius and specified arc center and beginning and ending angle.
- ___ b. Arc is created with four digitized points.
- ___ c. Arc is created by the circumference of the circle.
15. Select true statements about creating fillets on CADD by placing a "T" next to the true statements and an "F" by the false ones.
- ___ a. Fillets are created by giving a specified value for its radius or diameter and digitizing the two pieces of geometry that it will be tangent to.
- ___ b. Default value for fillets is 1.00".
- ___ c. A fillet is an arc tangent to two geometrical items--lines, points, circles, or arcs.

TEST

16. Select true statements about creating chamfers on CADD by placing a "T" or "F" in the blanks as appropriate.
- ___ a. A chamfer bevels the corner of a part.
 - ___ b. A chamfer is created by specifying the length of the lines and the angle.
 - ___ c. Default value for chamfer is usually 45° .
 - ___ d. Default value for chamfer is usually 60° .

(NOTE: If the following activities have not been accomplished prior to the test, ask your instructor when they should be completed.)

- 17. Bisect a line and an arc. (Assignment Sheet #1)
- 18. Bisect an angle. (Assignment Sheet #2)
- 19. Draw parallel lines. (Assignment Sheet #3)
- 20. Construct a line perpendicular to a line from a point not on the line. (Assignment Sheet #4)
- 21. Construct a line perpendicular to a line through a point on the line. (Assignment Sheet #5)
- 22. Divide a line into equal parts. (Assignment Sheet #6)
- 23. Construct a triangle with sides given. (Assignment Sheet #7)
- 24. Construct a right triangle. (Assignment Sheet #8)
- 25. Construct an equilateral triangle with one side given. (Assignment Sheet #9)
- 26. Inscribe a hexagon inside a circle. (Assignment Sheet #10)
- 27. Construct a hexagon with the distance across the flat sides given. (Assignment Sheet #11)
- 28. Inscribe a pentagon inside a circle. (Assignment Sheet #12)
- 29. Construct a circle through three given points. (Assignment Sheet #13)
- 30. Draw an arc tangent to a straight line and an arc. (Assignment Sheet #14)
- 31. Draw an arc tangent to two arcs. (Assignment Sheet #15)
- 32. Draw an arc tangent to an acute angle and an obtuse angle. (Assignment Sheet #16)
- 33. Draw an arc tangent to a right angle. (Assignment Sheet #17)

TEST

34. Draw an ellipse using the approximate ellipse with compass method. (Assignment Sheet #18)
35. Draw a parabola. (Assignment Sheet #19)
36. Join two points with a parabolic curve. (Assignment Sheet #20)
37. Draw an involute of a circle. (Assignment Sheet #21)
38. Demonstrate the ability to create a part on CADD using circles, arc, fillets, and lines. (Job Sheet #1)

**GEOMETRIC CONSTRUCTIONS
UNIT X**

ANSWERS TO TEST

- | | | | | |
|----|--|--|--|---|
| 1. | a. 7
b. 9
c. 6
d. 3
e. 13 | f. 19
g. 11
h. 15
i. 1
j. 12 | k. 14
l. 16
m. 4
n. 21
o. 23 | p. 22
q. 17
r. 18
s. 5
t. 8 |
| 2. | a. 4
b. 1
c. 3
d. 2 | | | |
| 3. | a. 5
b. 4
c. 2
d. 3 | | | |
| 4. | a. 6
b. 1
c. 3
d. 4
e. 5 | | | |
| 5. | a. Octagon
b. Hexagon
c. Pentagon | | | |
| 6. | a. 10
b. 8
c. 12
d. 9
e. 4
f. 5 | g. 7
h. 11
i. 6
j. i
k. 14
l. 3 | | |
| 7. | a. Parallel
b. Greater than
c. Perpendicular
d. Radius
e. Diameter | | | |

ANSWERS TO TEST

8. a. Prism
b. Torus
c. Pyramid
d. Cylinder
e. Sphere
f. Cone
9. a. Helix
b. Involute
c. Cycloid
d. Parabola
10. a. Diameter
b. Radius
c. Circumference
11. a. 360
b. 60
c. 60
12. a. Start and end point
b. Origin
c. Circumference
13. a, b
14. a
15. a. T
b. F
c. T
16. a. T
b. T
c. T
d. F
- 17.-38. Performance skills evaluated to the satisfaction of the instructor

ORTHOGRAPHIC VIEWS UNIT XI

UNIT OBJECTIVE

After completion of this unit, the student should be able to identify planes and lines, and construct missing hidden and visible lines, various views, and points, planes, and lines in orthographic views. Competencies will be demonstrated by completing the assignment sheets, job sheets, and the unit tests with a minimum score of 85 percent.

SPECIFIC OBJECTIVES

After completion of this unit, the student should be able to:

1. Match terms related to orthographic views with their correct definitions.
2. Distinguish between the types of projection systems.
3. Match planes of projection with their correct uses.
4. Arrange in order the steps in visualizing an orthographic projection.
5. List the six views possible in orthographic projection.
6. List the three principal views in orthographic projection.
7. Select true statements concerning the steps in selecting correct views of an object.
8. Identify the basic dimensions of an object.
9. List common methods of transferring depth dimensions.
10. Identify projection of lines in orthographic views.
11. Identify types of planes.
12. Distinguish between the correct and incorrect usage of hidden lines.
13. Select correct line precedence in an orthographic drawing.
14. Distinguish among rounds, fillets, and runouts.
15. Select true statements on creating a rectangle on CADD.
16. Select true statements on creating a spline on CADD.
17. Match methods used on CADD for view manipulation with their correct descriptions.

SPECIFIC OBJECTIVES

18. Identify projection of lines in orthographic views. (Assignment Sheet #1)
19. Identify types of planes in orthographic views. (Assignment Sheet #2)
20. Construct a top view. (Assignment Sheet #3)
21. Construct a front view. (Assignment Sheet #4)
22. Construct a right side view. (Assignment Sheet #5)
23. Construct missing hidden lines. (Assignment Sheet #6)
24. Construct missing visible and hidden lines. (Assignment Sheet #7)
25. Make a two-view sketch. (Assignment Sheet #8)
26. Make a three-view sketch. (Assignment Sheet #9)
27. Construct circles and arcs using a template. (Assignment Sheet #10)
28. Construct elliptical curves. (Assignment Sheet #11)
29. Construct a one-view drawing. (Assignment Sheet #12)
30. Construct a two-view drawing. (Assignment Sheet #13)
31. Construct a three-view drawing. (Assignment Sheet #14)
32. Construct a runout. (Assignment Sheet #15)
33. Construct a point in an orthographic view. (Assignment Sheet #16)
34. Construct a line in an orthographic view. (Assignment Sheet #17)
35. Construct a plane in an orthographic view. (Assignment Sheet #18)
36. Demonstate the ability to develop orthographic drawings by coordinate input on CADD. (Job Sheet #1)

**ORTHOGRAPHIC VIEWS
UNIT XI**

SUGGESTED ACTIVITIES

- A. Provide student with objective sheet.
- B. Provide student with information, assignment, and job sheets.
- C. Make transparencies.
- D. Discuss unit and specific objectives
- E. Discuss information, assignment, and job sheets.
- F. Construct a model in a "Glass box" and discuss orthographic projection.
- G. Use blocks to show various angles and use blocks for sketching.
- H. Use Handout #4 to practice plotting CADD coordinate points.
- I. Assignment sheets suggest the use of vellum. Other media may be substituted.
- J. Provide each student the grid sheet Handout #4 and a list of absolute coordinate address and have them plot the location relative to XO, XO location.
- K. Give test.

REFERENCES USED IN DEVELOPING THIS UNIT

- A. Brown, Walter C. *Drafting for Industry*. South Holland, IL: Goodheart-Willcox Co., Inc., 1984.
- B. Giesecke, Frederick E., et. al. *Technical Drawing*, 8th ed. New York: Macmillan Publishing Co., Inc., 1986.
- C. Jensen, Cecil and Jay Helsel. *Engineering Drawing and Design*, 3rd ed. New York: Gregg Division/McGraw-Hill Book Co., 1985.
- D. Voisinet, Donald D. *AutoCAD Mechanical Lab Manual*. New York: McGraw-Hill, Inc., 1987.

ORTHOGRAPHIC VIEWS UNIT XI

INFORMATION SHEET

I. Terms and definitions

- A. Coincide — To match up identically
- B. Fold line — A theoretical line between two views where viewing planes fold
(NOTE: This is used as a reference line on drawings.)
- C. Foreshortened — To appear shorter to the eye than it actually is
- D. Line — Straight element that is generated by a moving point and has extension only along the path of the point
- E. Line of sight — Direction from which an object is being viewed
- F. Line precedence — Lines that are more important to show than others
- G. Multiview drawing — A drawing of a mechanical part that shows exact size by looking straight at the object from one to six positions
- H. Orthographic projection — Right angle projection; projector lines are parallel to each other and perpendicular to the plane of projection
(NOTE: This is one method used to create a multiview drawing)
- I. Projection lines — Lines used to extend from one view to the next view
- J. Repaint — Electronic "redraw or relettering" of latest status of a design, used right after a revision or edit has been executed
- K. String — A CADD command that consists of two or more continuous line segments, which the system considers a single item
(NOTE: This method takes up less space in the database than multiple line segments.)
- L. Transfer — To take from one point of view and put in another view
- M. True size — A surface or line that is shown in its actual size
- N. Visualize — To form a mental picture or image

INFORMATION SHEET

II. Types of projection systems (Transparency 1)

A. First-angle

1. All views are projected onto planes located **behind** the object
2. Used in European and Asian countries

B. Third-angle

1. All views are projected onto planes lying **between** the object and viewer
2. Used in the United States, Canada, and other countries

III. Planes of projection

A. Frontal plane — Used for front and rear views

B. Profile plane — Used for right and left side views

(NOTE: The frontal and profile planes are both vertical planes.)

C. Horizontal plane — Used for top and bottom views

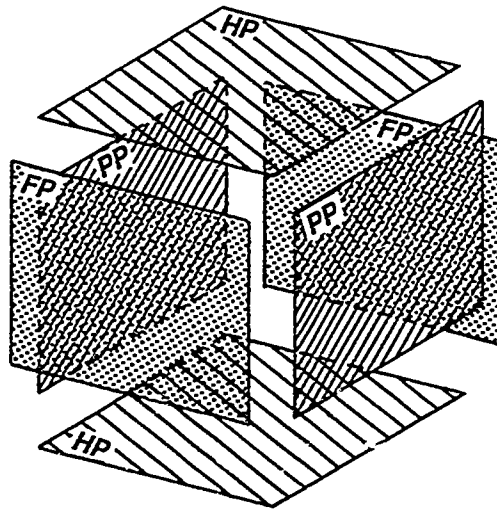

INFORMATION SHEET**IV. Steps in visualizing an orthographic projection (Transparency 2)**

- A. Visualize by looking at the actual object or picture of the object.
- B. To obtain views, project the lines of sight to each plane of projection from all points on the object.
- C. Rotate all planes until they align with frontal plane of projection.
- D. Visualize the six possible views of the object that are revolved into the same plane as on a drawing surface.
- E. Inspect views and determine those needed to adequately represent the object.

V. Views possible in orthographic projection (Transparency 3)

- A. Top
- B. Bottom
- C. Front
- D. Rear
- E. Right side
- F. Left side

VI. Principal views in orthographic projection (Transparency 4)

- A. Top
- B. Front
- C. Right side

(NOTE: Other views may be used if needed to show features that are hidden in the principal views.)

INFORMATION SHEET

VII. Steps in selecting correct views of an object (Transparencies 5-9)

- A. Select the number of views necessary to represent the object. This may required only one view or as many as all six views. Only draw as many views as are necessary. (Transparencies 5-7)
- B. Select the front view which:
 1. Best describes contour shape.
 2. Contains the least number of hidden lines.
 3. Is usually the longest view.
 4. Shows object in normal position.
- C. Select alternate position for right side view if drawing area is crowded. (Transparency 8)
- D. Select view positions to avoid crowding of dimensions and notes. (Transparency 9)

VIII. Basic dimensions of an object

- A. Height — Distance between two horizontal planes (bottom to top)
- B. Width (length) — Distance between two profile planes (left side to right side)
- C. Depth — Distance between two frontal planes (front to back)

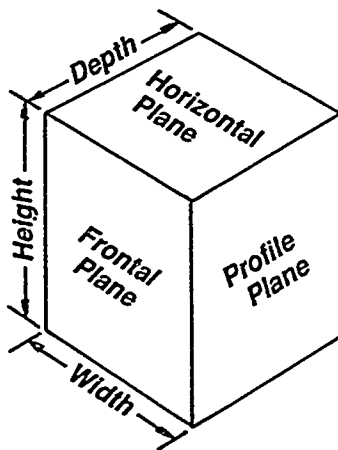

INFORMATION SHEET

IX. Common methods of transferring depth dimensions

(NOTE: Projection lines are used to transfer height and width dimensions to other views, but depth dimensions require other methods.)

A. 45° mitre line

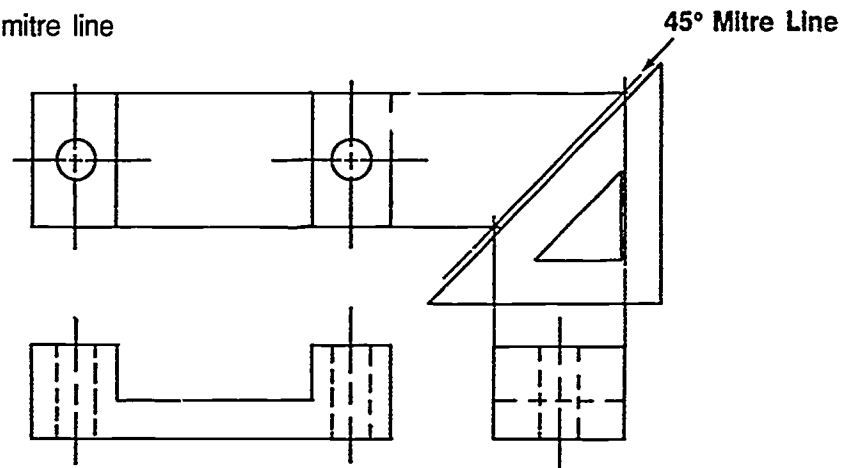

B. Dividers

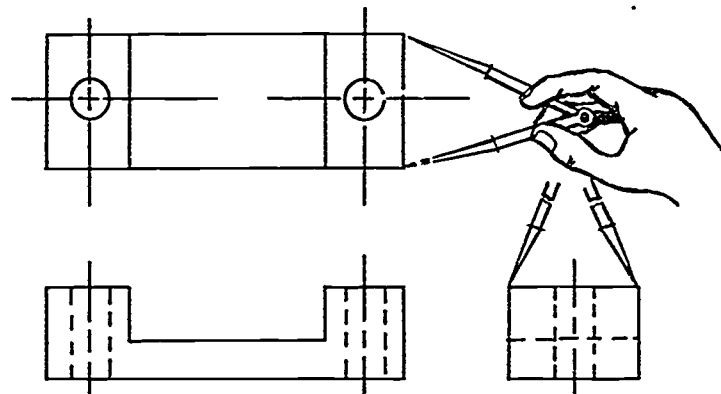

C. Scale

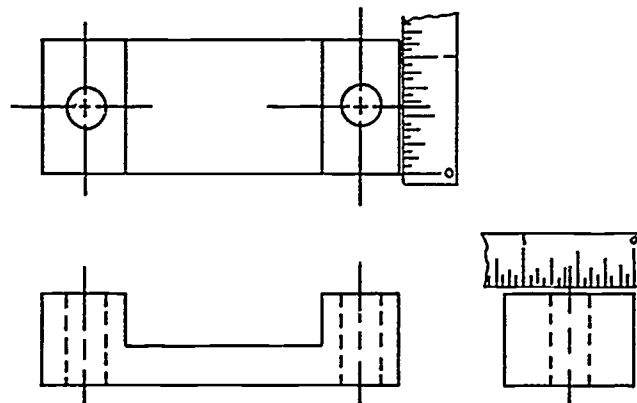

INFORMATION SHEET

X. Projection of lines in orthographic views

A. Point

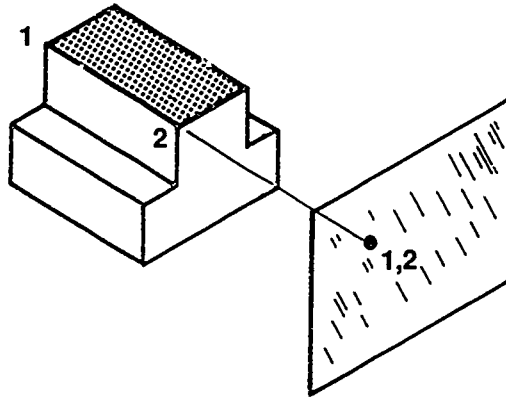

B. True length line

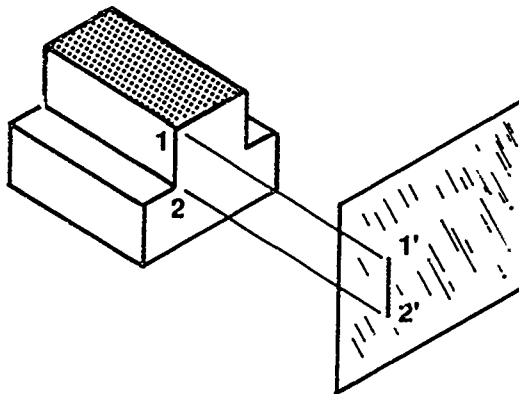

C. Foreshortened line

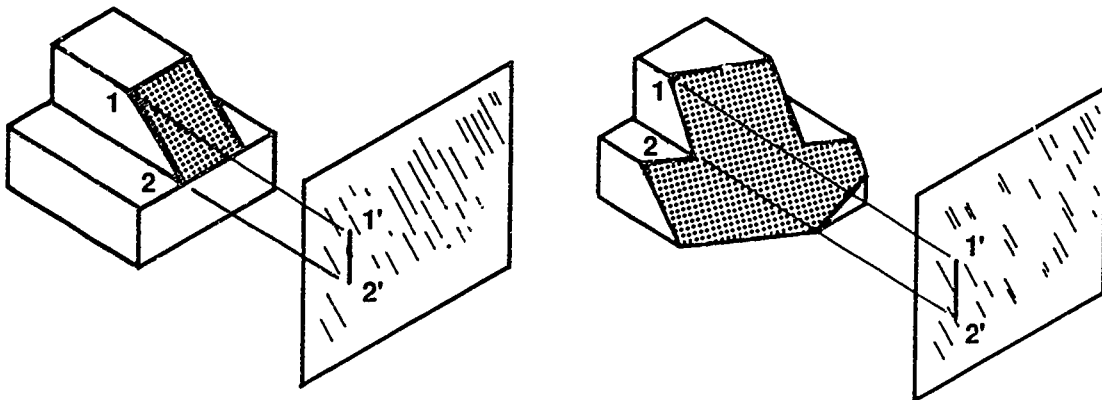

INFORMATION SHEET

XI. Types of planes

(NOTE: TS=True size, EV=Edge view, and FS=Foreshortened.)

- A. Normal plane — True size plane that is parallel to one principal viewing plane and edge view in other two principal planes

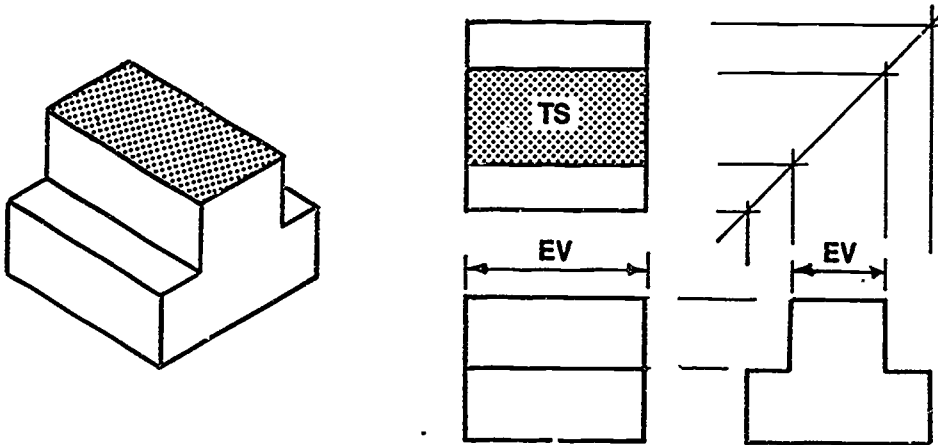

- B. Inclined plane — A plane that is foreshortened in two principal viewing planes and edge view in other principal viewing plane

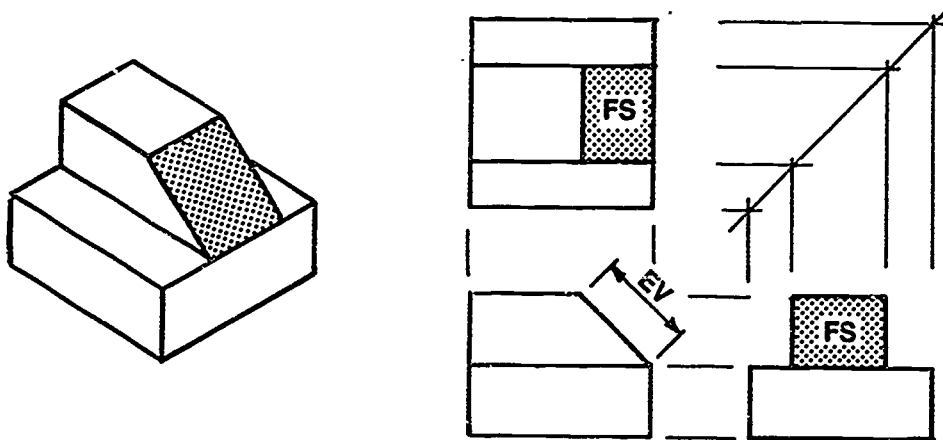

INFORMATION SHEET

C. Oblique plane — A plane that is foreshortened in all three principal viewing planes

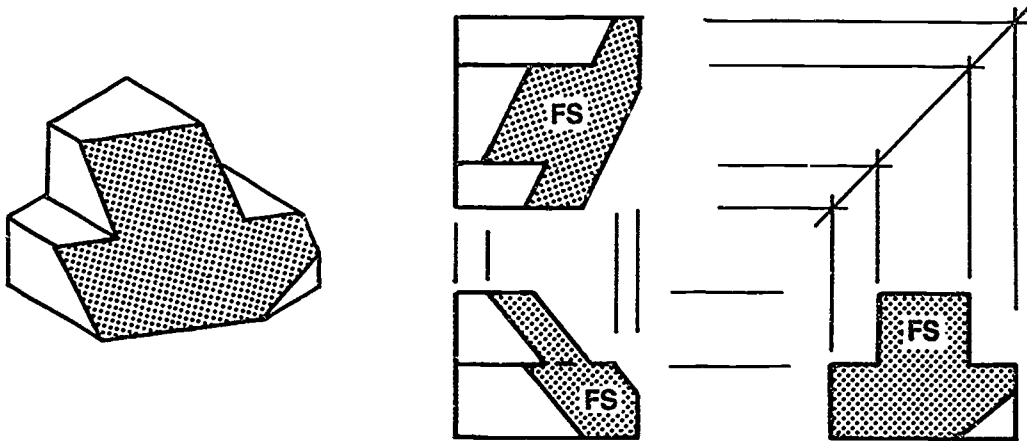

XII. Usage of hidden lines

	Correct	Incorrect
A.		
B.		
C.		
D.		
E.		
F.		

INFORMATION SHEET

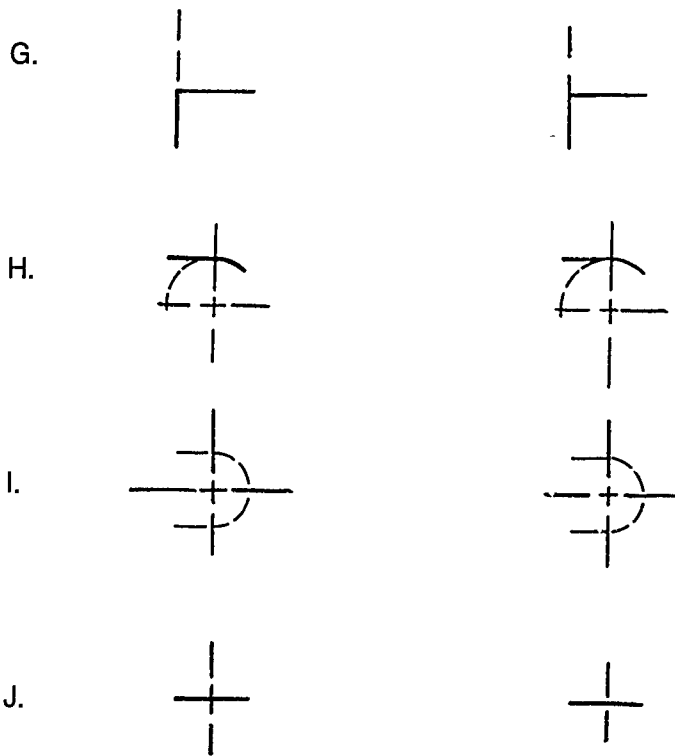
**XIII. Line precedence in an orthographic drawing (Transparency 10)**

- A. Visible line
- B. Hidden line
- C. Cutting plane line
- D. Center line

XIV. Rounds, fillets, and runouts (Transparencies 11 and 12)

- A. Round — Small rounded outside (external) corner of an object
- B. Fillet — Small rounded inside (interior) corner of an object

(NOTE: Fillets and rounds are used to eliminate sharp interior or external corners on objects. Fillet and rounds are normally 1/4" radius or less.)

- C. Runout — Intersection of a fillet or round with another surface which produces an extension of the curved surface

INFORMATION SHEET

XV. Creating a rectangle on CADD

- A. Typical command: *Draw rectangle.*
- B. Rectangle shape is created by digitizing opposite corners.

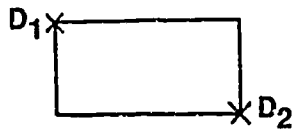

- C. Rectangle shape is created by digitizing opposite corners with a specific width given.

(NOTE: Second digitized point indicates on which side of the first digitized point the width should go.)

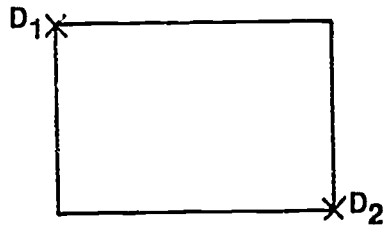

DRAW RECTANGLE 1.500"

XVI. Creating a spline on CADD

- A. A spline is CADD's equivalent to a drafter's french curve.
- B. Typical command: *Draw spline.*
- C. Several points are digitized. The spline will be inserted through or between specific points.

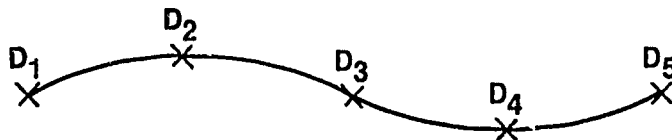

INFORMATION SHEET

XVII. Methods used on CADD for view manipulation

- A. Zoom — A command that increases or decreases the size of the view of the part without changing the size in the database
- B. Pan — A command that allows the operator to look at a different portion of the drawing without changing the magnification
- C. Save view — A command that allows the operator to keep the view that is currently on the screen so that it may be returned to later

(NOTE: Views are helpful when working on complex drawings.)

- D. Window — Portion of a larger design area, filling the screen vertically and horizontally

(NOTE: This allows the operator specific areas to work on or delete.)

Comparison Between First and Third Angle Projection

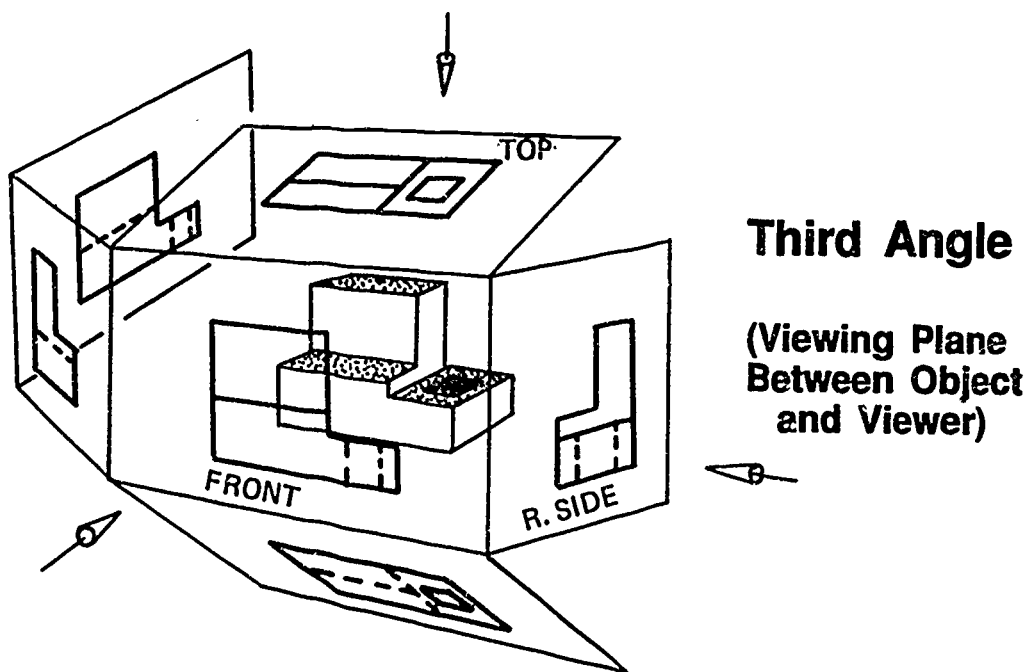
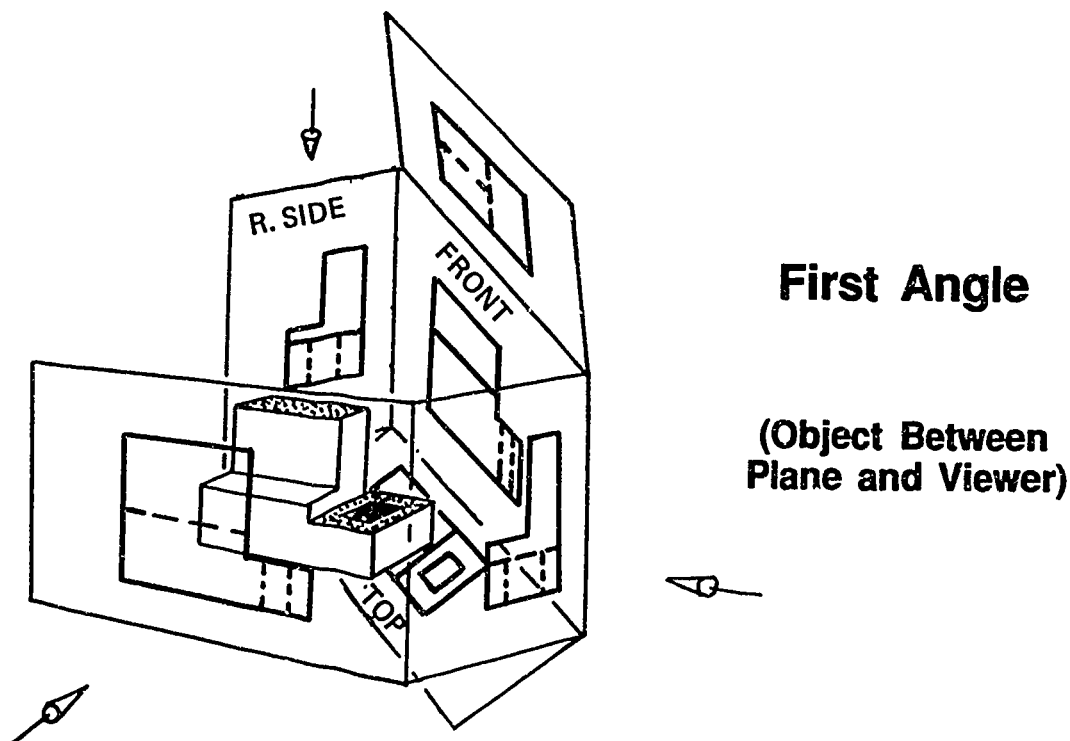

Orthographic Projection

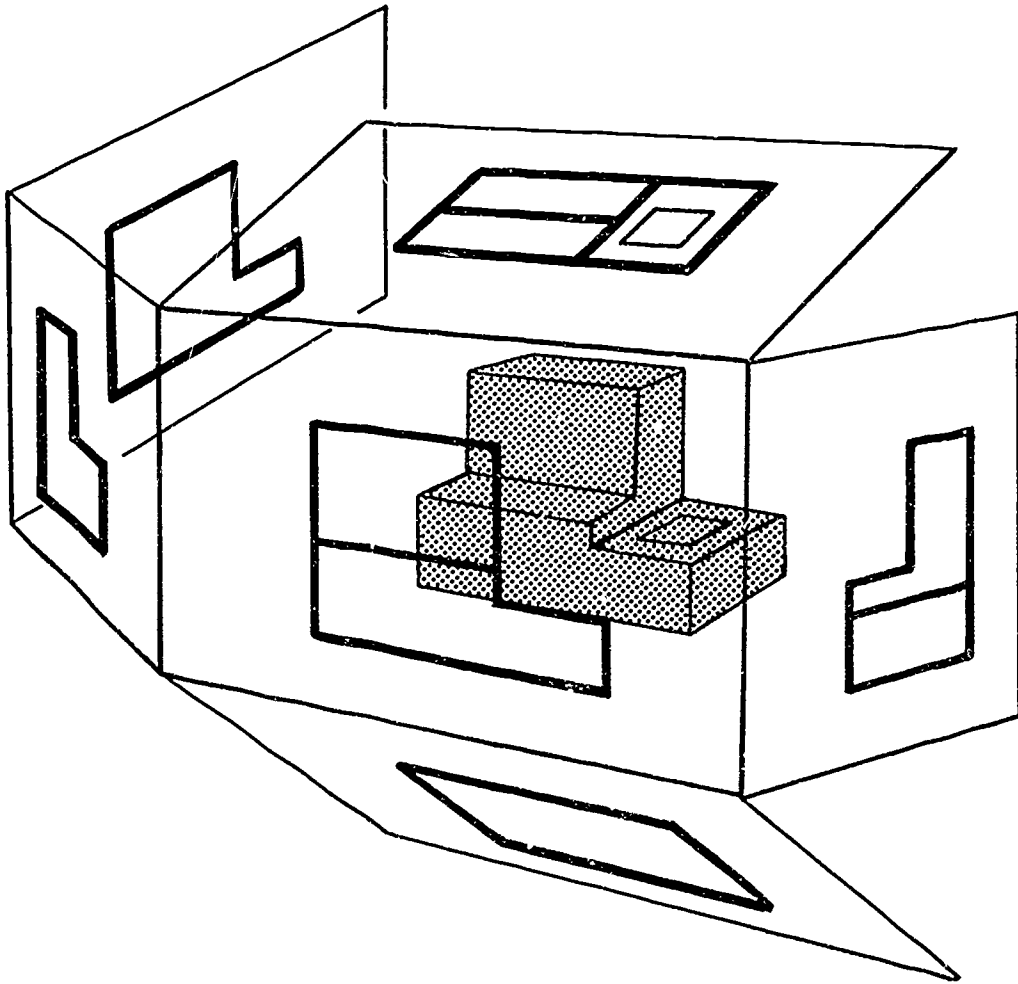

All planes revolve until they align with frontal plane.

Orthographic Projection Views

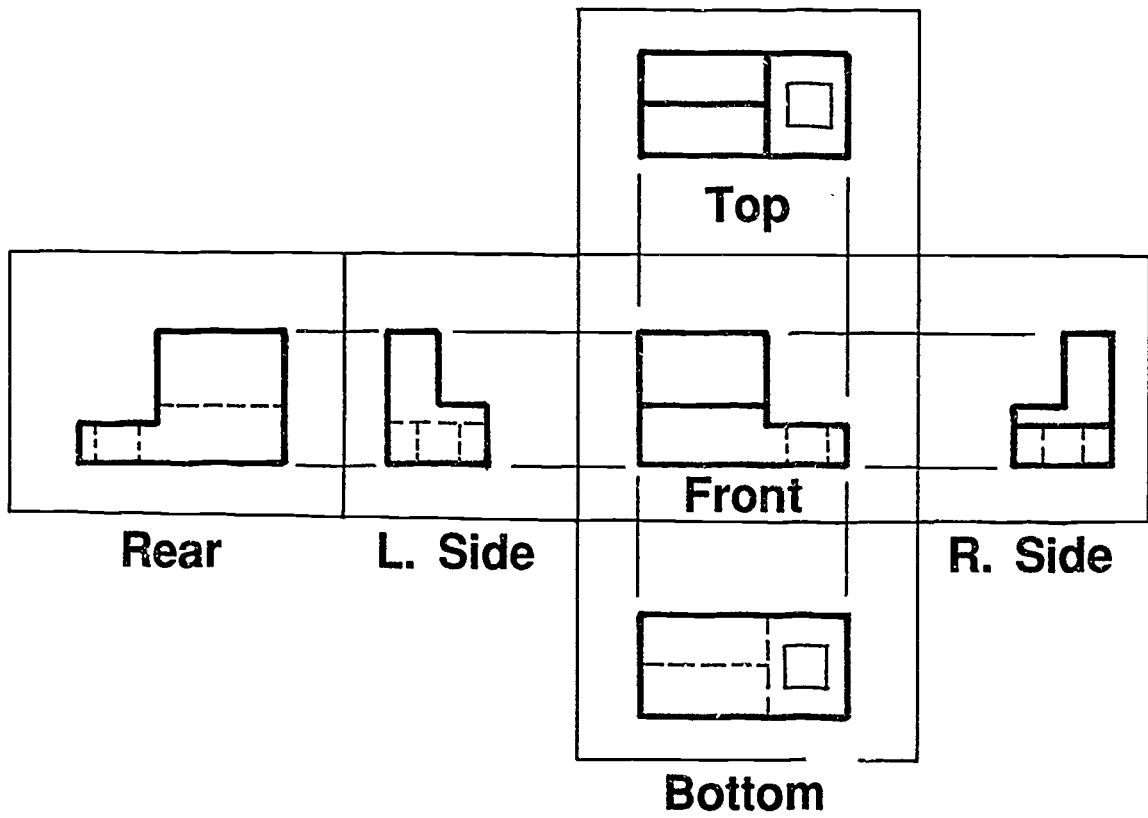

Principal Views in Orthographic Projection

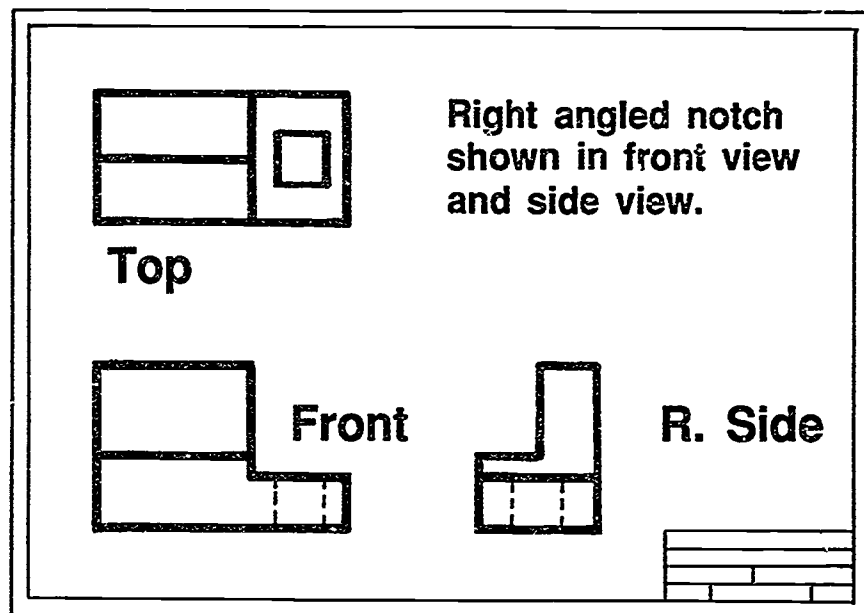

One-View Drawings

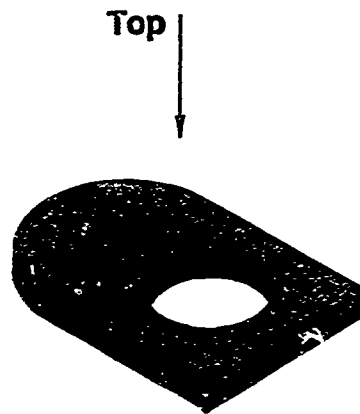

**Objects with very little thickness
require only one view.**

NOTE: .125 THICK

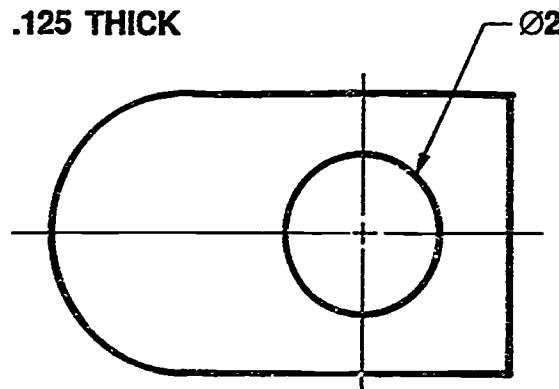

Top View

**Thickness of piece indicated by
a callout in a note.**

Two-View Drawings

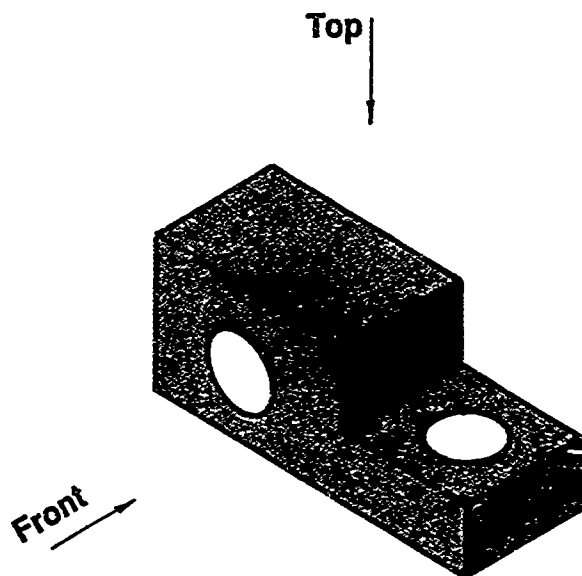

Some objects require only two views.

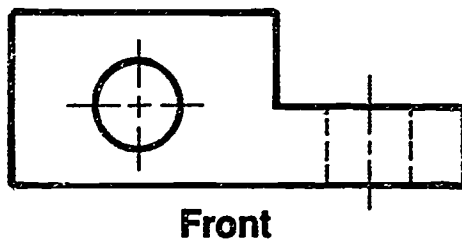
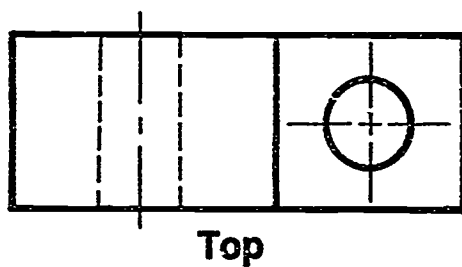

Three-View Drawings

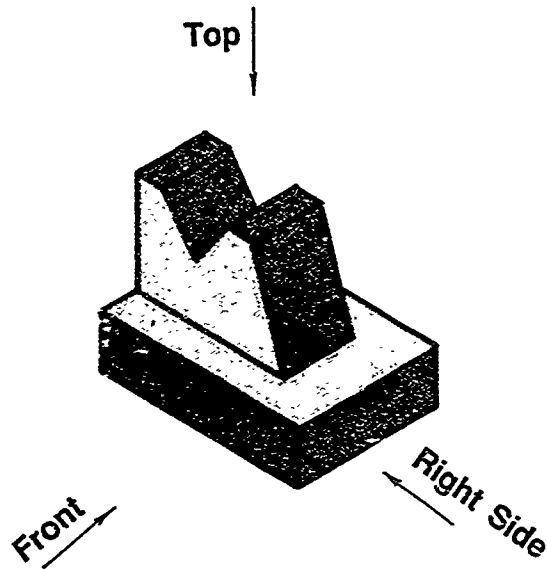

Most objects require three views to describe their shape.

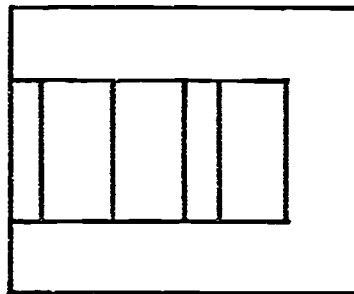

Top

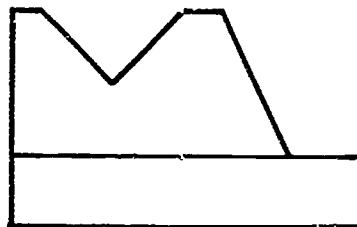

Front

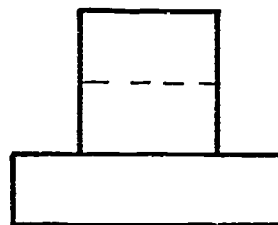

Right Side

Position of Side View

- Shape of object determines best location for side view.
- Side view can be projected off the front view (normal location) or top view (alternate location).

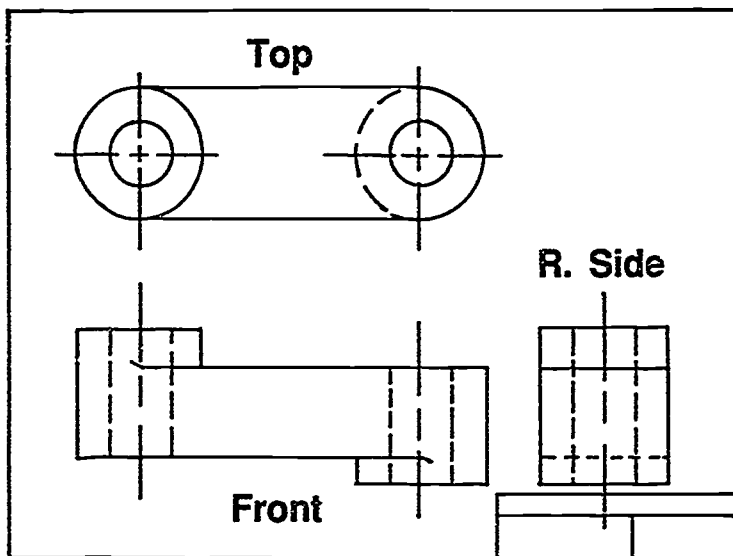

**Normal
Location**

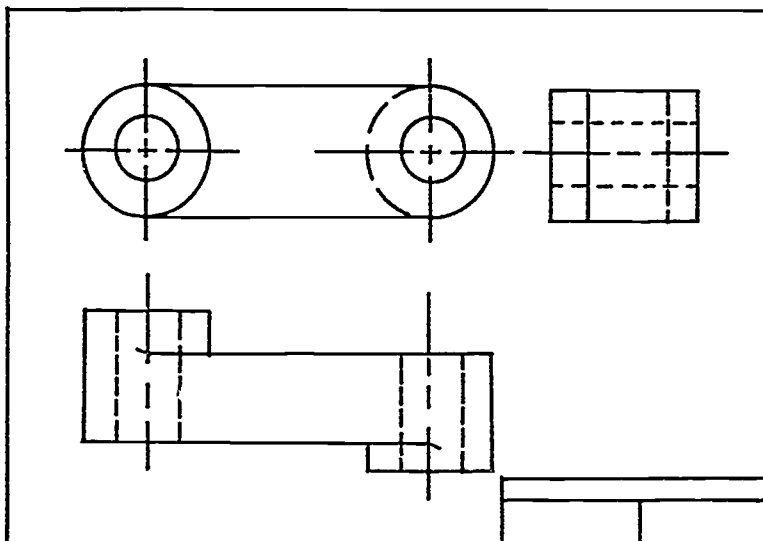

**Alternate
Location**

Positioning of Views

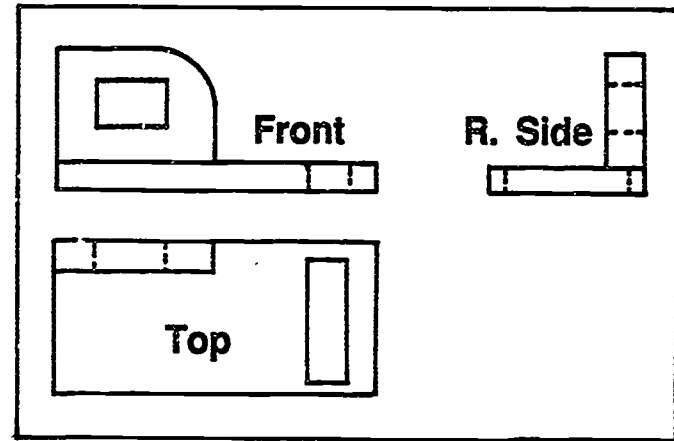
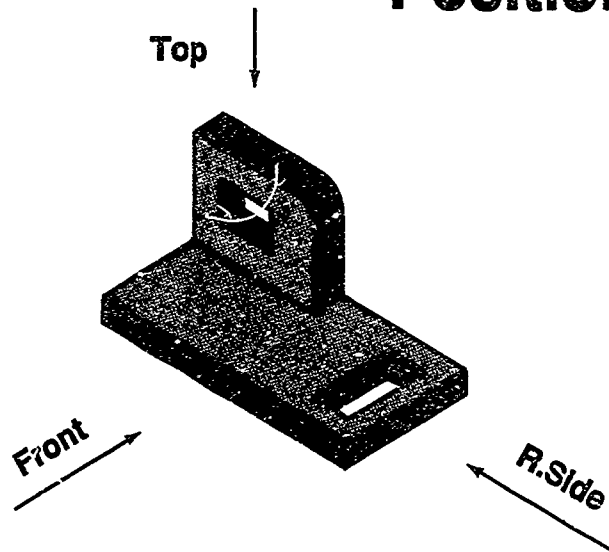

INCORRECT—Top Should Be Above Front

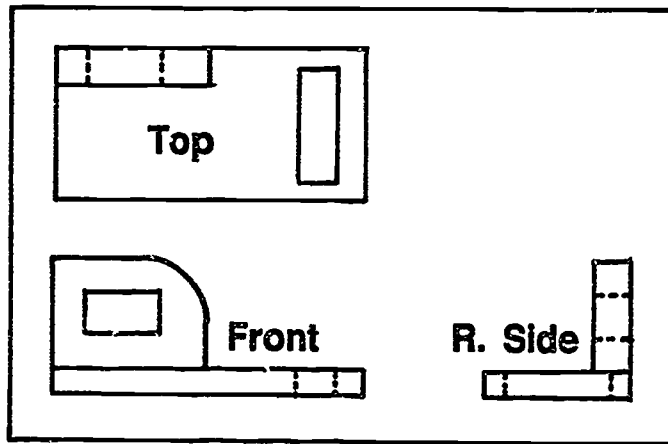

CORRECT

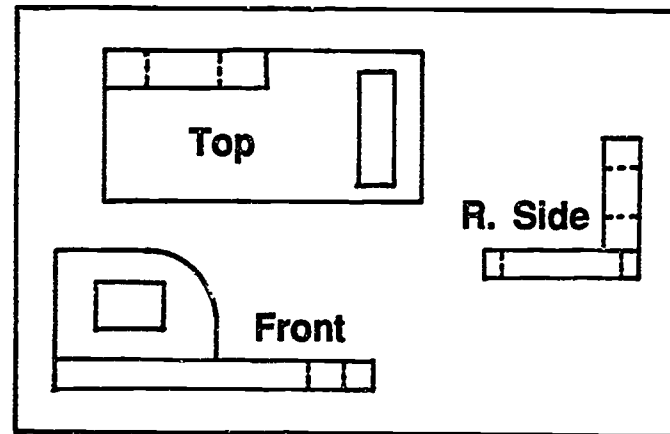

INCORRECT--Views Not Lined Up

Line Precedence

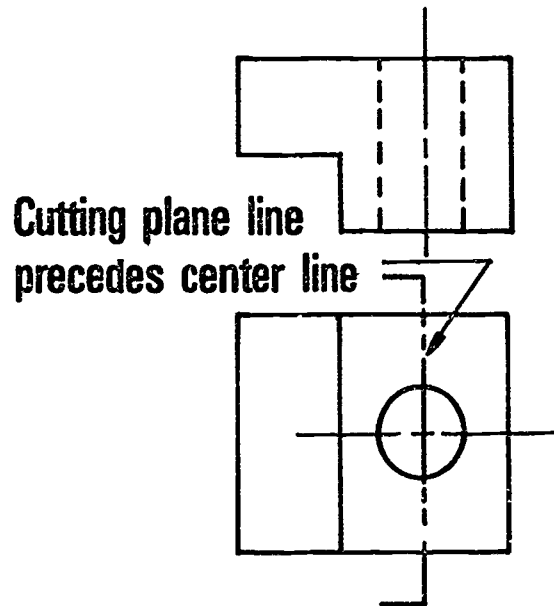
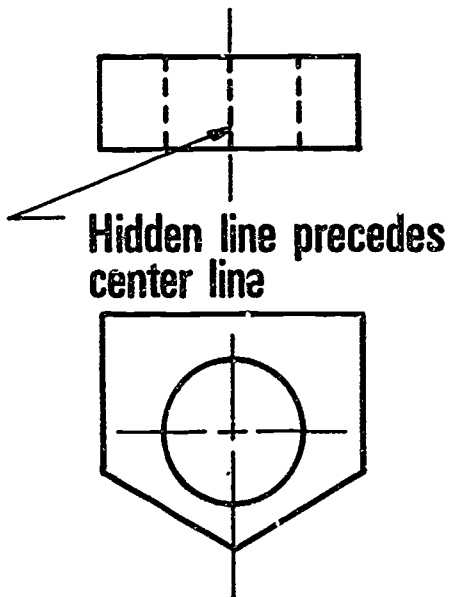
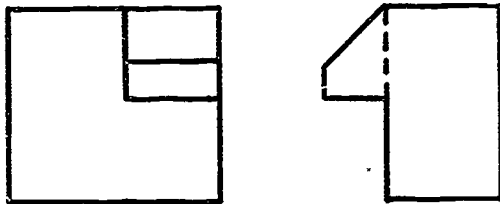
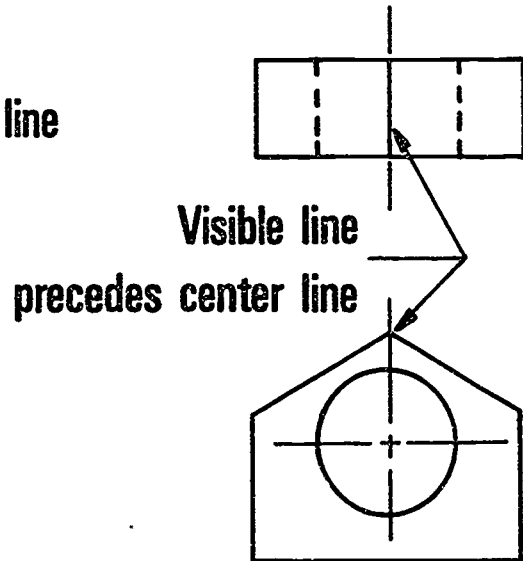
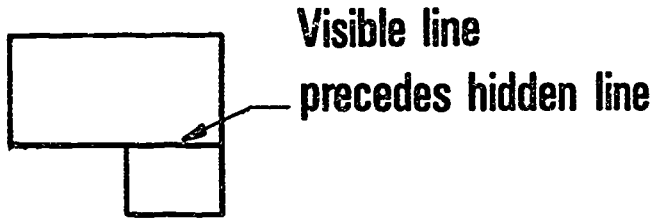

Fillets, Rounds, and Runouts

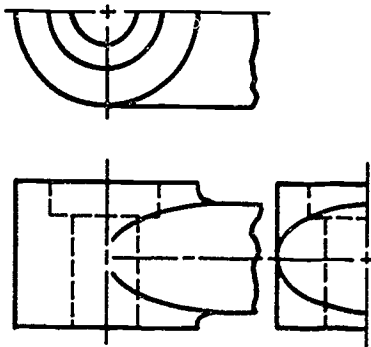
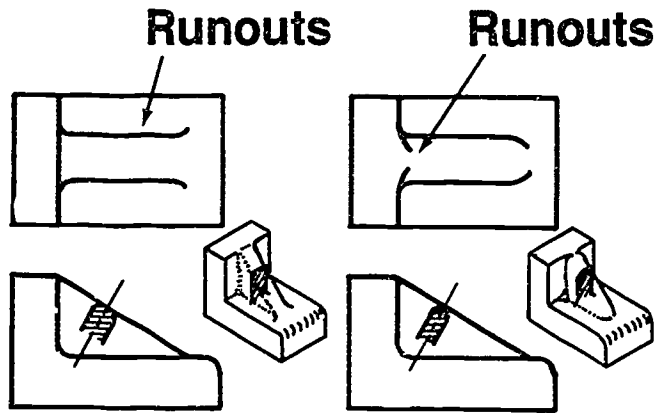
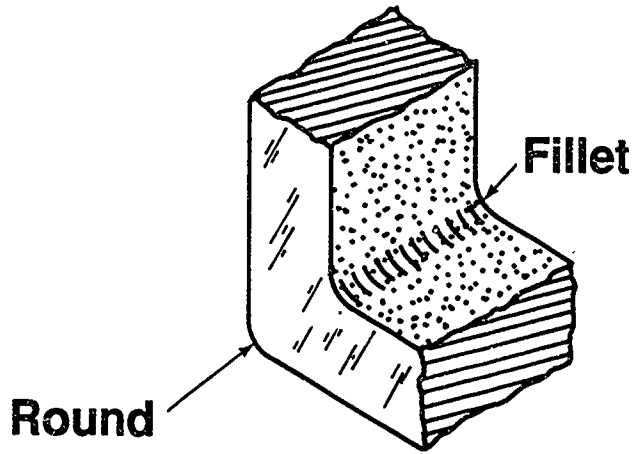

Runout Intersection
Between a Cylinder
and an Elliptical Part

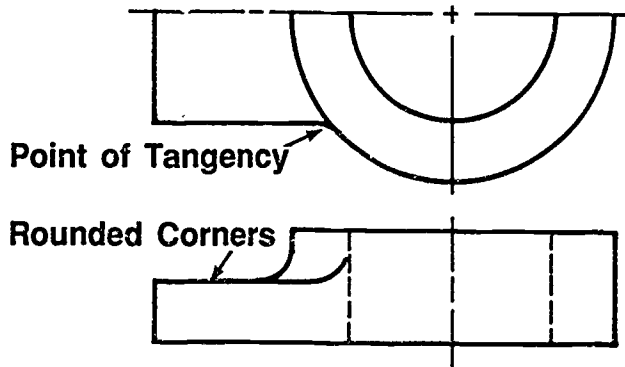

Runout Intersection
Between a Cylinder
and Rounded Part

Projection of Fillet and Round Edges

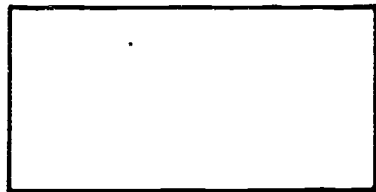

Incorrect

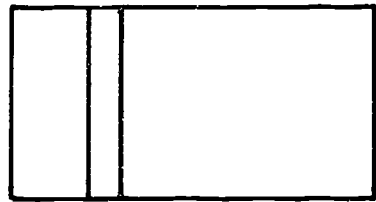

Correct

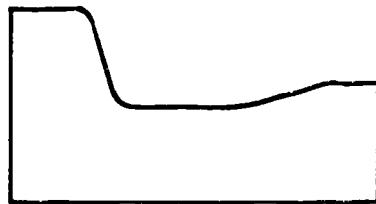

528

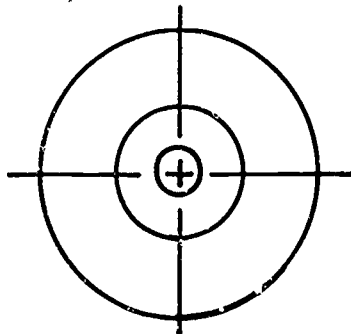

Incorrect

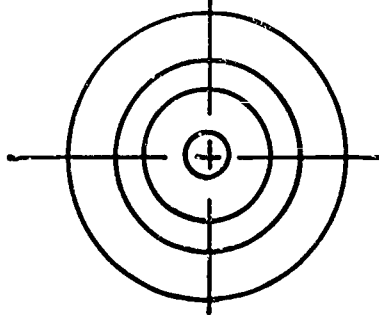

Correct

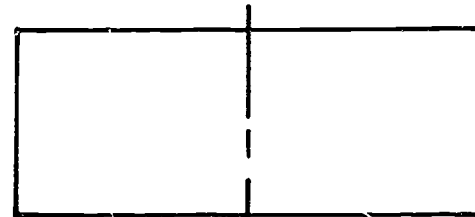
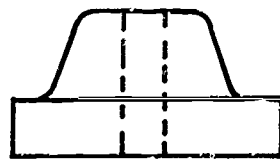

Incorrect

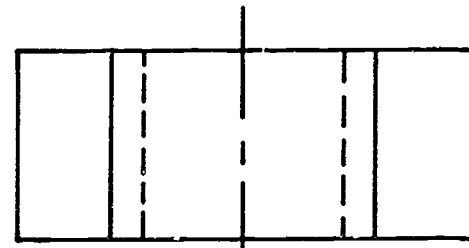

Correct

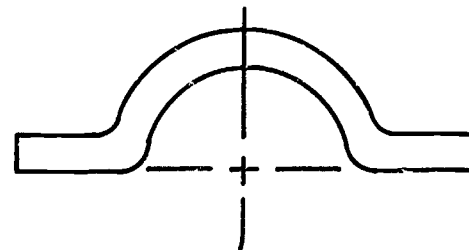

529

ORTHOGRAPHIC VIEWS
UNIT XI

HANDOUT #1 — VISUALIZATION OF A POINT

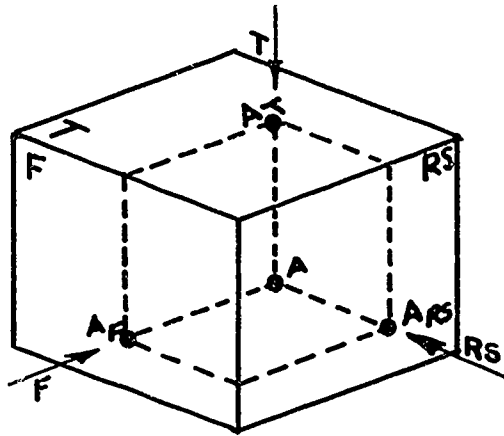

A Point in Space

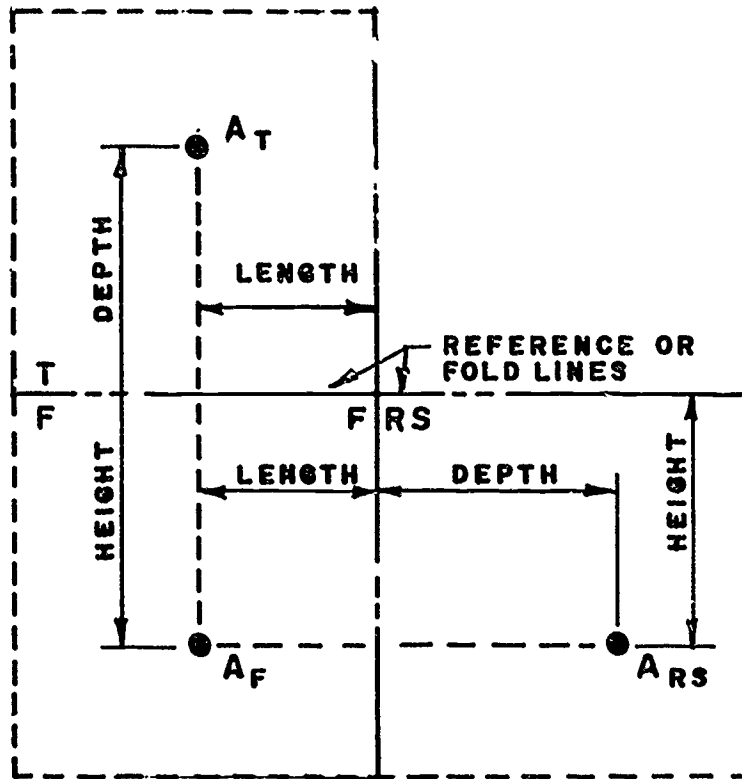

Orthographic View

ORTHOGRAPHIC VIEWS
UNIT XI

HANDOUT #2 — VISUALIZATION OF LINES

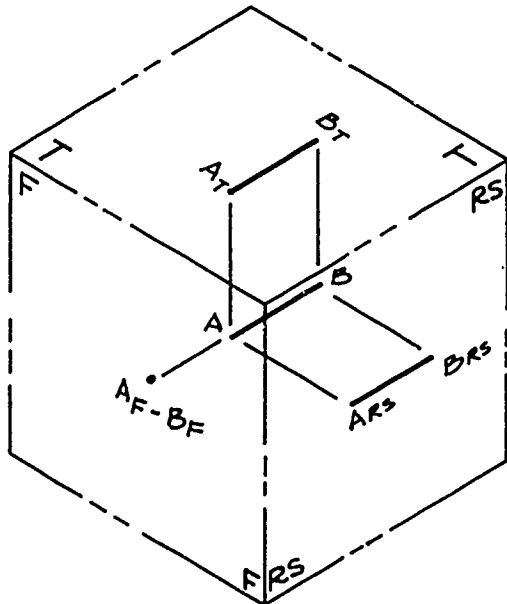

Normal Line

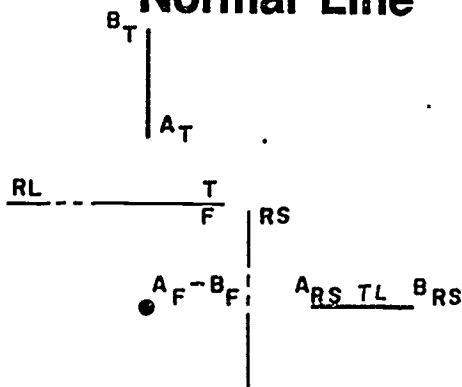

531

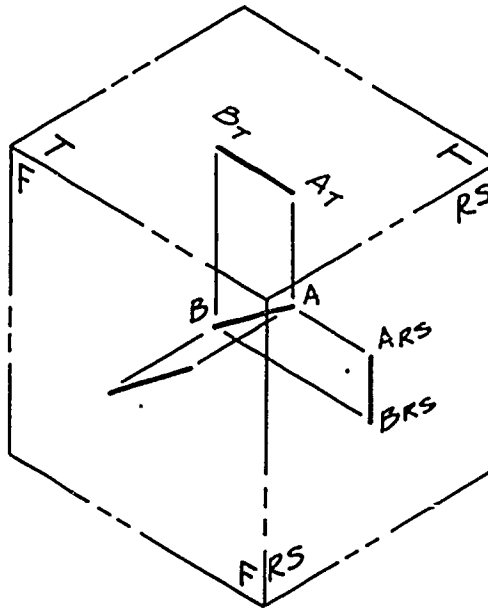

Inclined Line

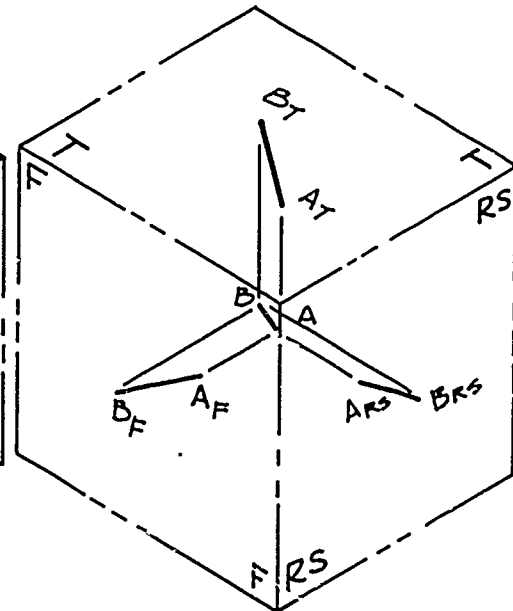
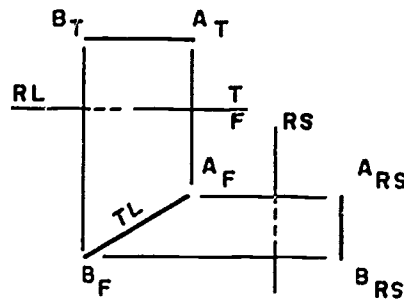

Oblique Line

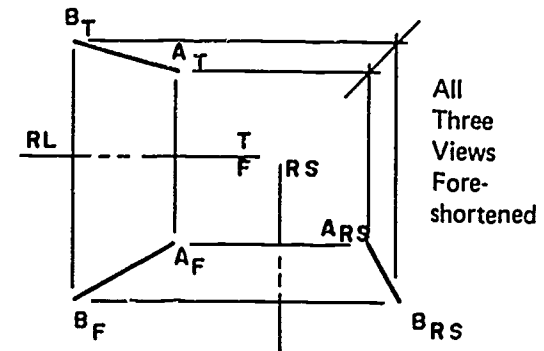

532

ORTHOGRAPHIC VIEWS
UNIT XI

HANDOUT #3 — VISUALIZATION OF PLANES

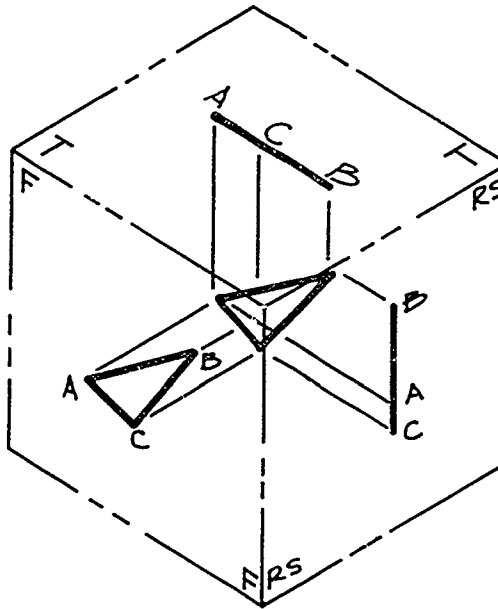

Normal Plane

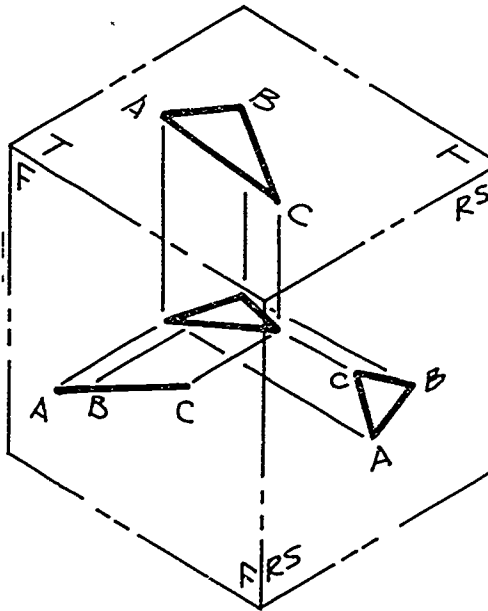
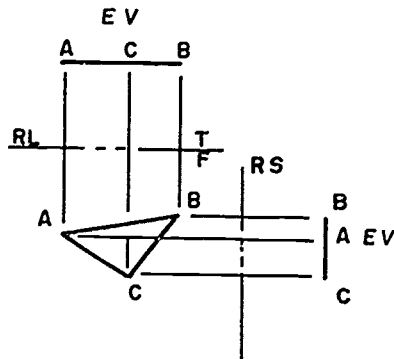

Inclined Plane

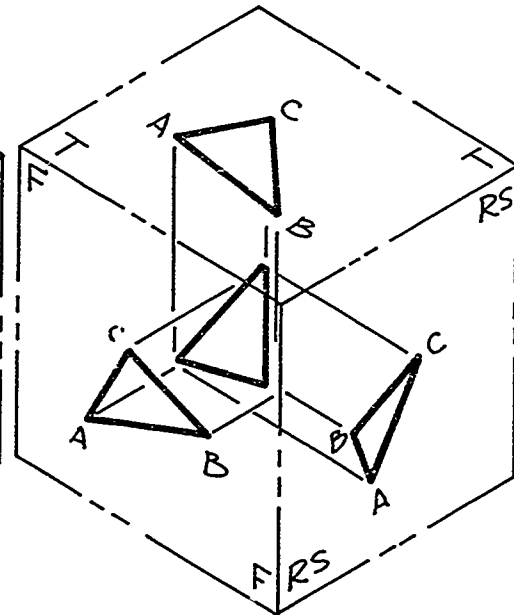
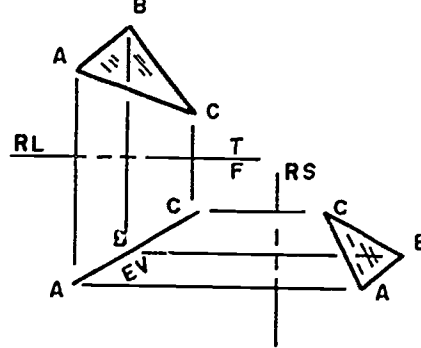

Oblique Plane

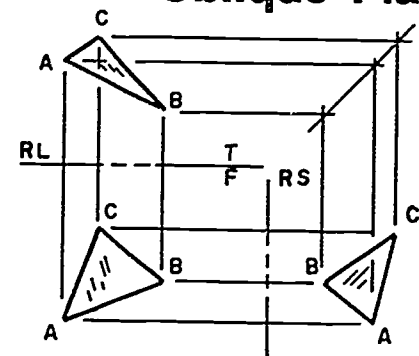

All
Three
Views
Fore-
shortened

ORTHOGRAPHIC VIEWS
UNIT XI

HANDOUT #4 — COORDINATE GRID

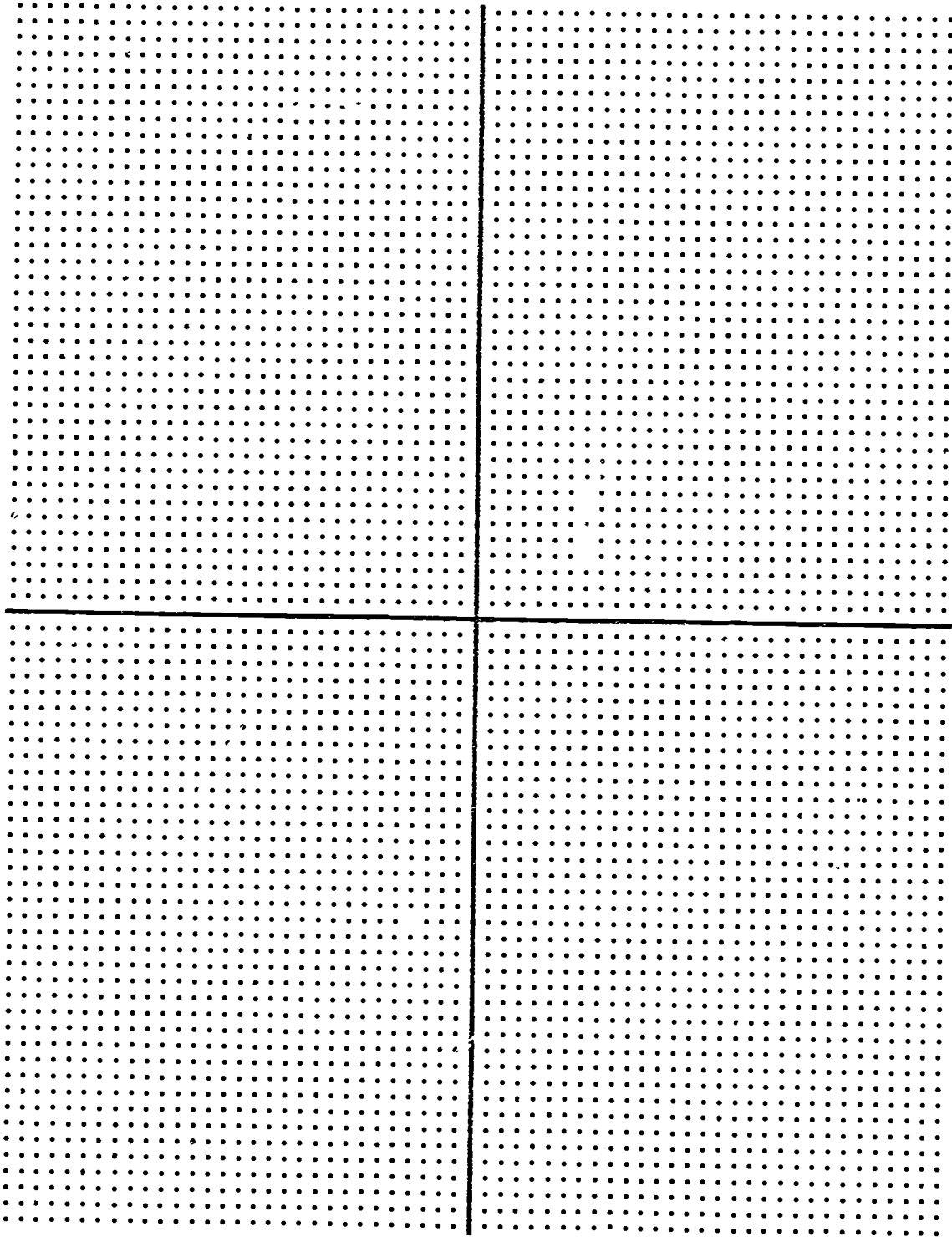

**ORTHOGRAPHIC VIEWS
UNIT XI**

**ASSIGNMENT SHEET #1 — IDENTIFY PROJECTION
OF LINES IN ORTHOGRAPHIC VIEWS**

NAME _____ SCORE _____

Directions: Identify correct projection of lines in the drawings by writing point, true length (TL), or foreshortened (FS) in the chart provided.

Problem 1:

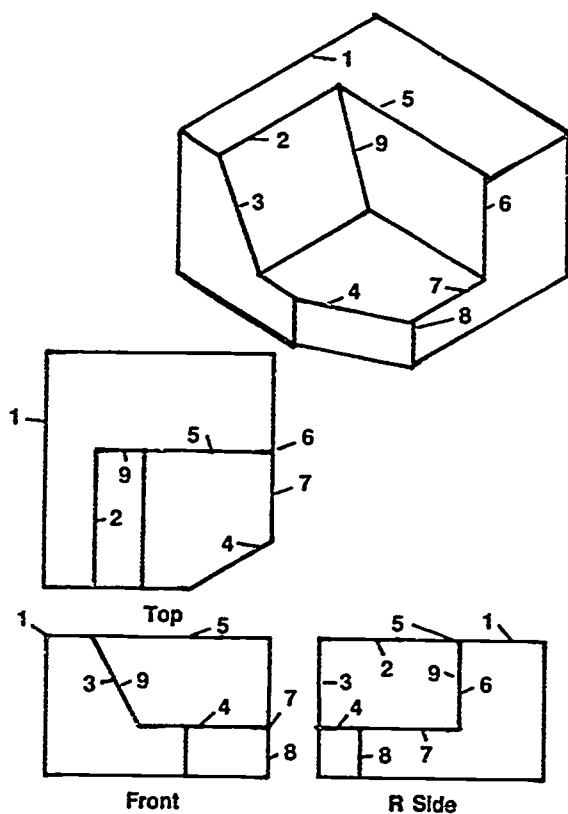

LINE	TOP	FRONT	R SIDE
1			
2			
3			
4			
5			
6			
7			
8			
9			

ASSIGNMENT SHEET #1

Problem 2:

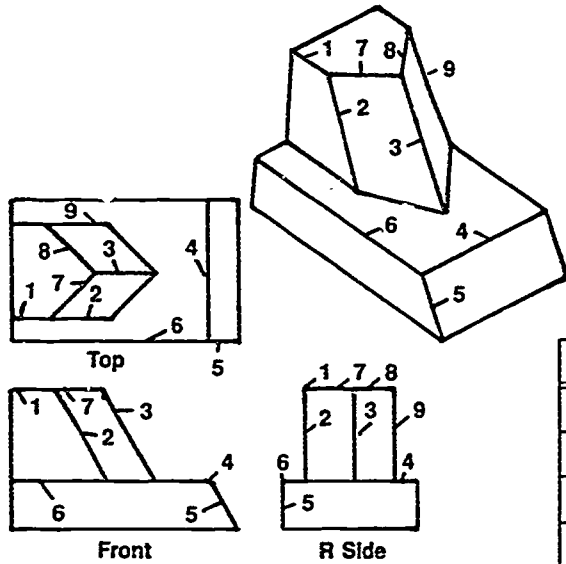

LINE	TOP	FRONT	R SIDE
1			
2			
3			
4			
5			
6			
7			
8			
9			

ORTHOGRAPHIC VIEWS UNIT XI

ASSIGNMENT SHEET #2 — IDENTIFY TYPES OF PLANES IN ORTHOGRAPHIC VIEWS

NAME _____ SCORE _____

Directions: Identify the types of planes in the drawings by writing normal, inclined, or oblique in the chart provided.

Problem 1:

The isometric drawing shows a hexagonal prism with a cutout. The top face is labeled A. The front-left vertical face is labeled B. The front-right vertical face is labeled C. The bottom face is labeled G. The cutout has three faces: F (left), E (bottom), and D (right).

PLANE	TYPE
A	
B	
C	
D	
E	
F	
G	

ASSIGNMENT SHEET #2

Problem 2:

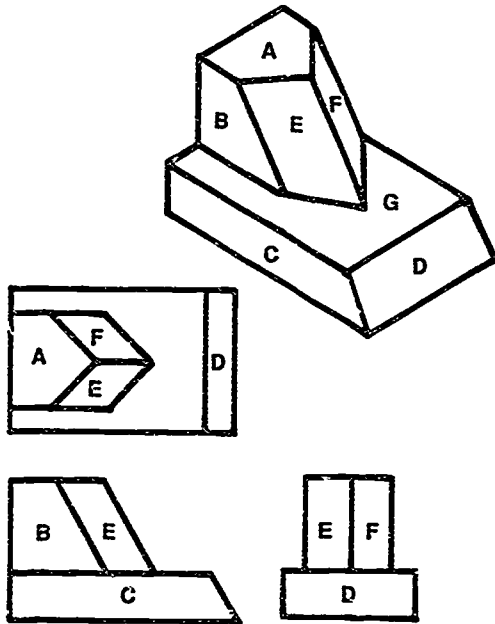

PLANE	TYPE
A	
B	
C	
D	
E	
F	
G	

ORTHOGRAPHIC VIEWS
UNIT XI

ASSIGNMENT SHEET #3 — CONSTRUCT A TOP VIEW

NAME _____ SCORE _____

(NOTE: The top view is first viewed on an imaginary plane, and then drawn in its correct position using mitre method of transferring dimensions.)

Example:

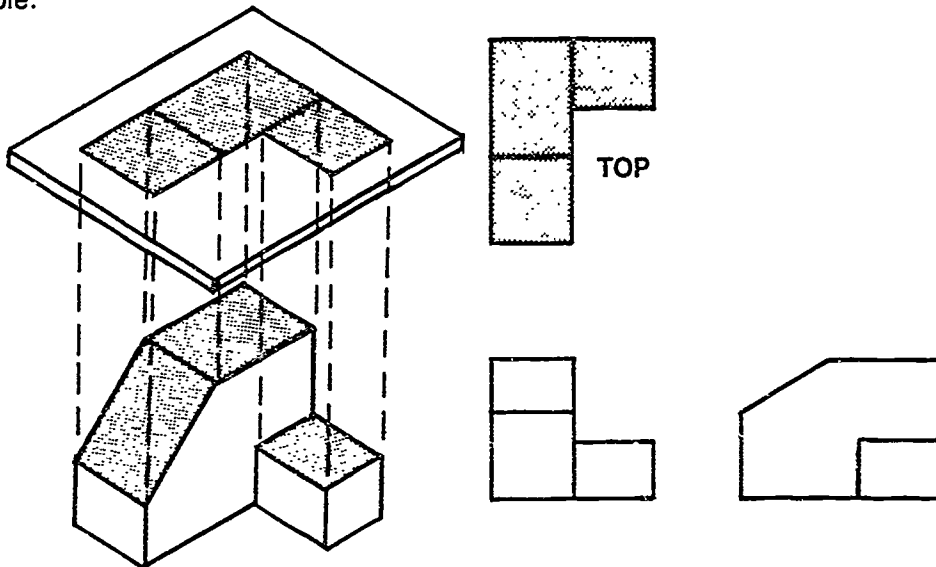

Directions: Align views with drafting machine and tape down. Construct top views of the following objects. Do not show hidden lines.

Problem 1:

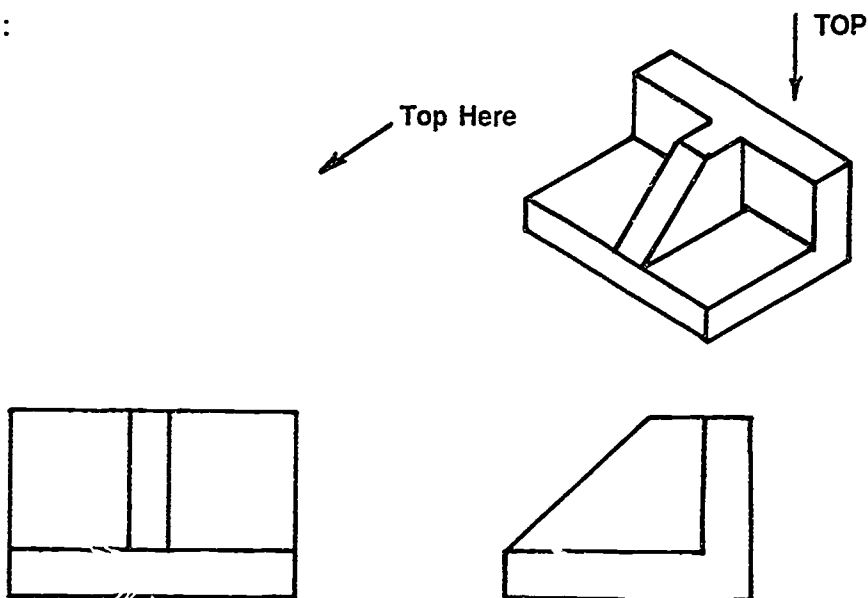

ASSIGNMENT SHEET #3

Problem 2:

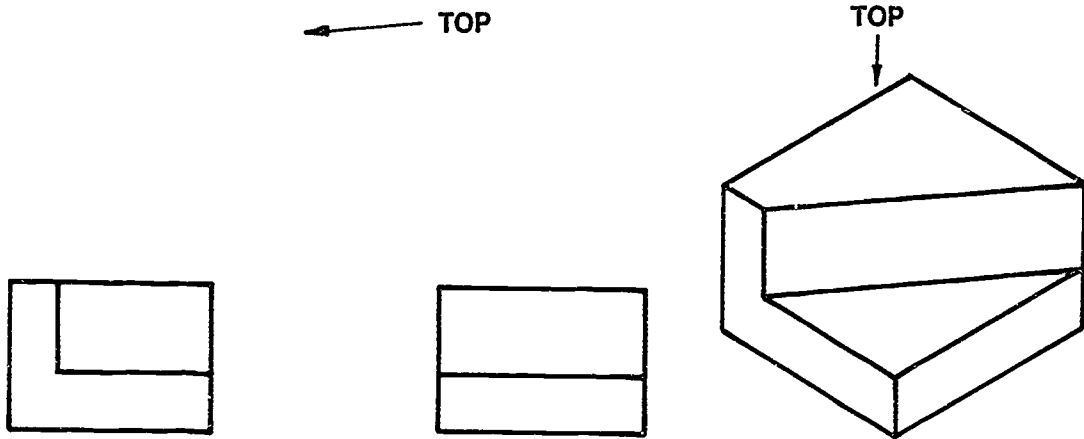

Problem 3:

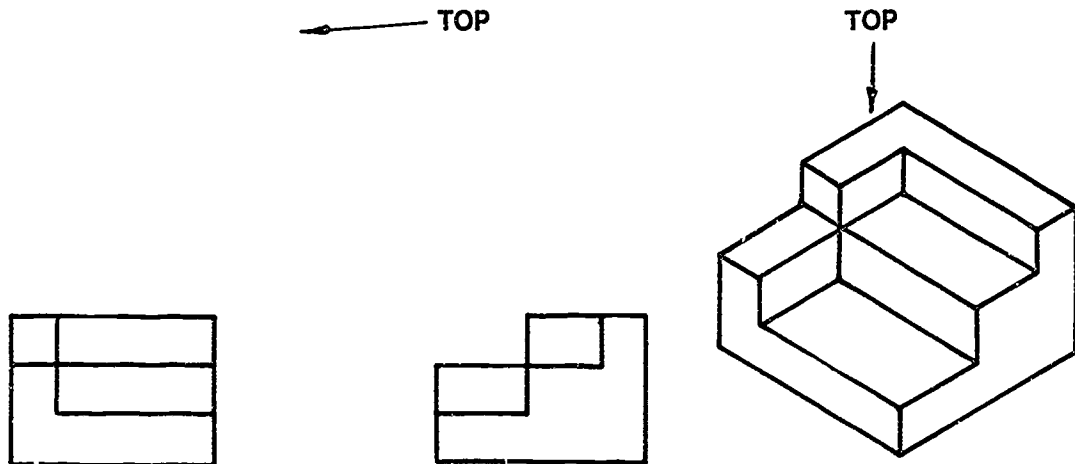

ASSIGNMENT SHEET #3

Problem 4:

← TOP

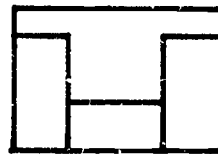
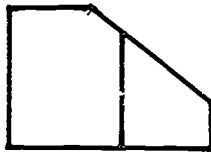

**ORTHOGRAPHIC VIEWS
UNIT XI**

ASSIGNMENT SHEET #4 — CONSTRUCT A FRONT VIEW

NAME _____ SCORE _____

(NOTE: The front view is first viewed on an imaginary plane, and then drawn in its correct position.)

Example:

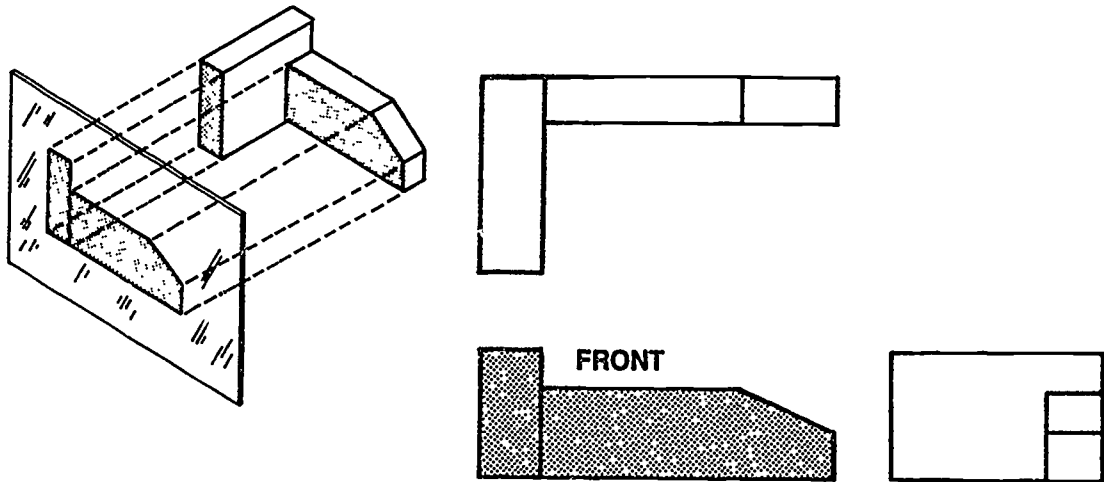

Directions: Construct the front views of the following objects. Align, tape down, and do not show hidden lines.

Problem 1:

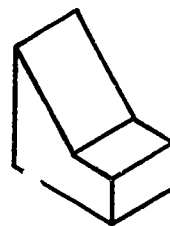

FRONT



Front Here ↗

ASSIGNMENT SHEET #4

Problem 2:

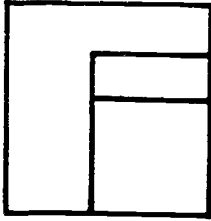

FRONT

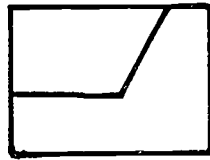

FRONT

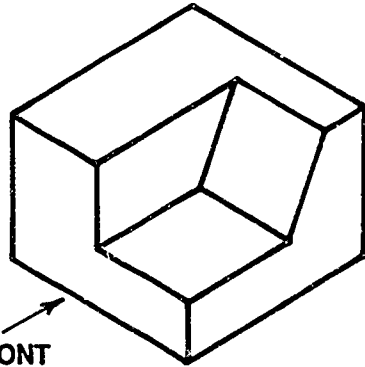

Problem 3:

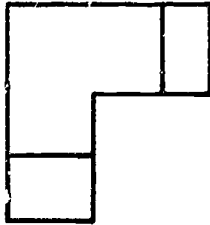

FRONT

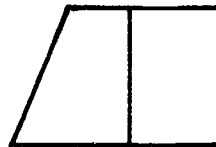

ORTHOGRAPHIC VIEWS
UNIT XI

ASSIGNMENT SHEET #5 — CONSTRUCT A RIGHT SIDE VIEW

NAME _____ SCORE _____

(NOTE: The end view is first viewed on an imaginary plane, and then drawn in its correct position [right or left].)

Example:

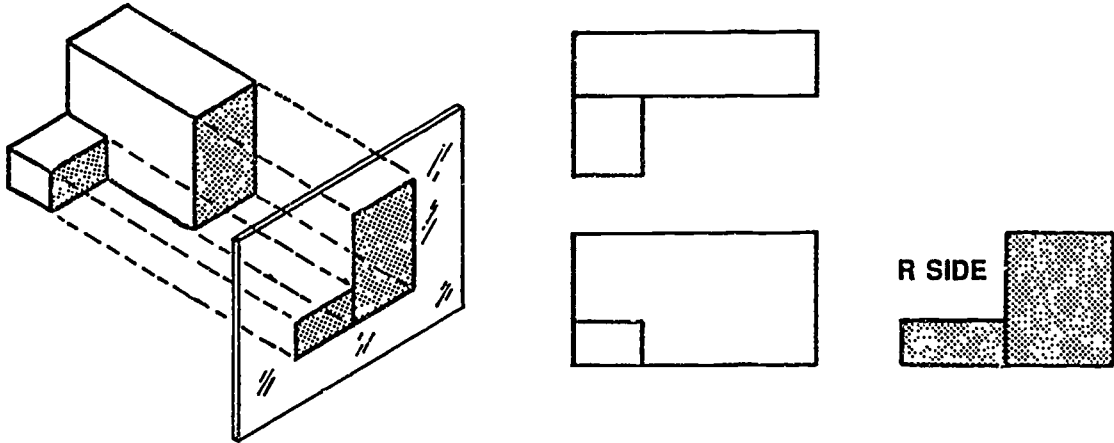

Directions: Align views with drafting machine and tape down. Construct the right side view in the space provided.

Problem 1:

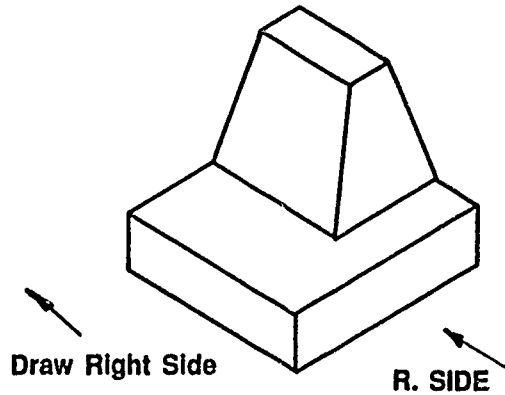
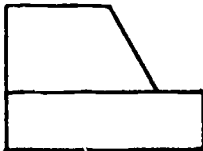
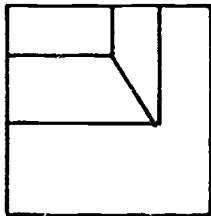

ASSIGNMENT SHEET #5

Problem 2:

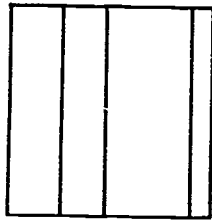

R SIDE

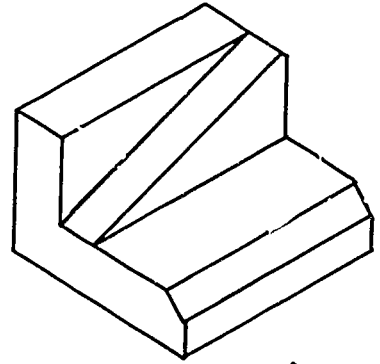
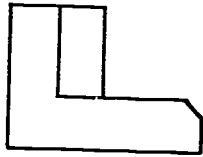

R SIDE

Problem 3:

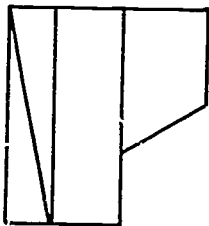

R SIDE

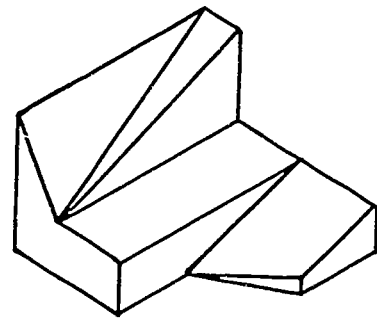
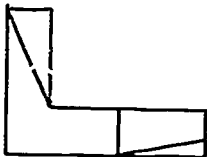

R SIDE

Problem 4:

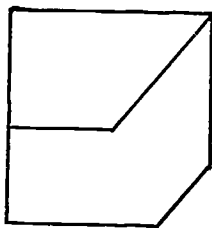

R SIDE

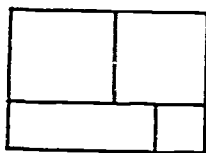

ORTHOGRAPHIC VIEWS UNIT XI

ASSIGNMENT SHEET #6 — CONSTRUCT MISSING HIDDEN LINES

NAME _____ SCORE _____

Example:

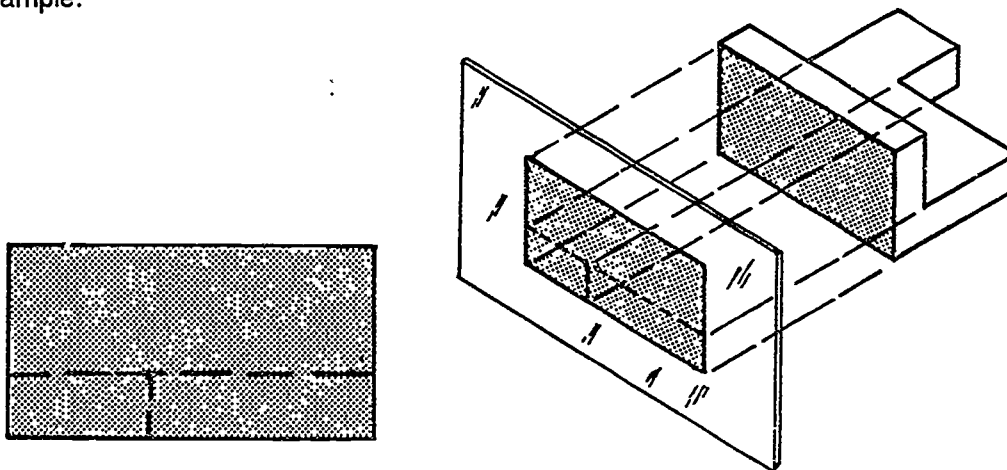

Directions: Construct the missing hidden lines in the views below. Align and tape down.

Problem 1:

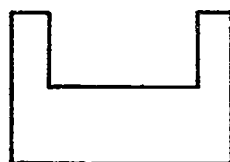
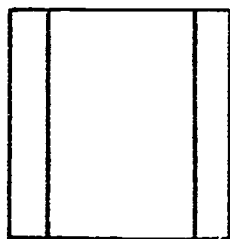

ASSIGNMENT SHEET #6

Problem 2:

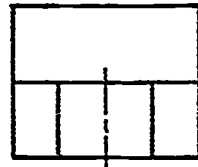
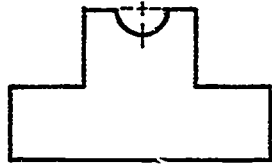
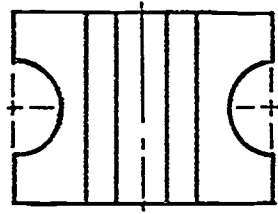

Problem 3:

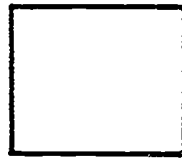
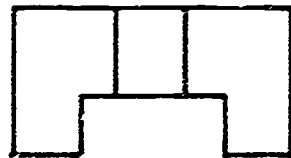
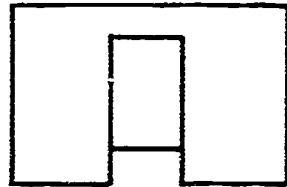

Problem 4:

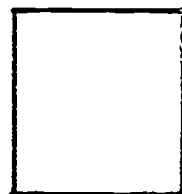
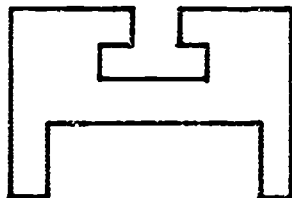
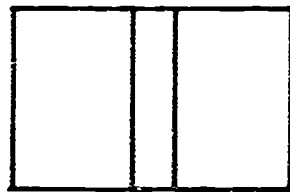

ORTHOGRAPHIC VIEWS
UNIT XI

ASSIGNMENT SHEET #7 — CONSTRUCT MISSING VISIBLE AND HIDDEN LINES

NAME _____ SCORE _____

Directions: Study the views below and construct the missing visible and hidden lines. Align and tape down.

Problem 1:

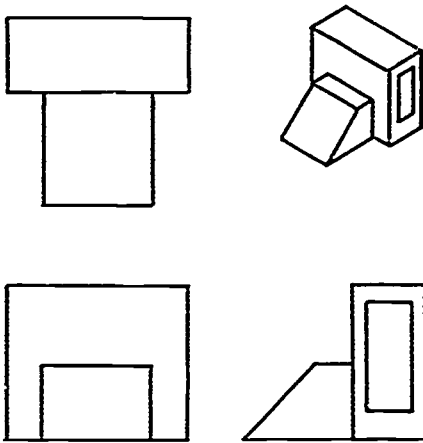

Problem 2:

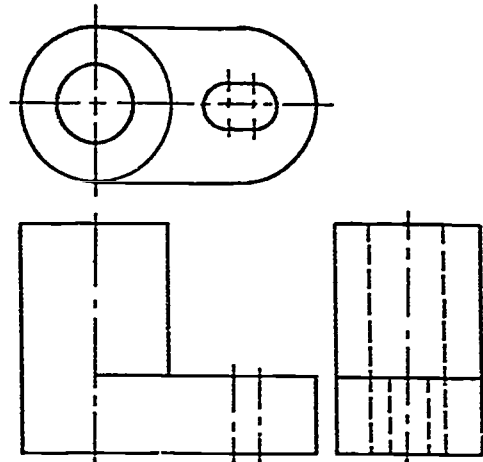

Problem 3:

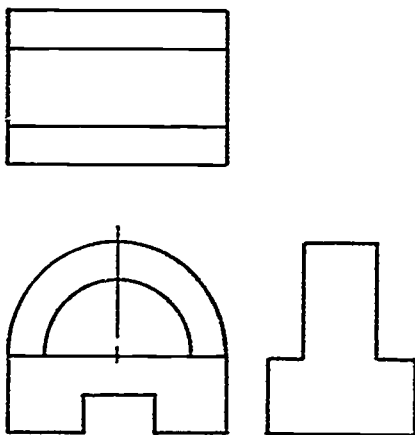

Problem 4:

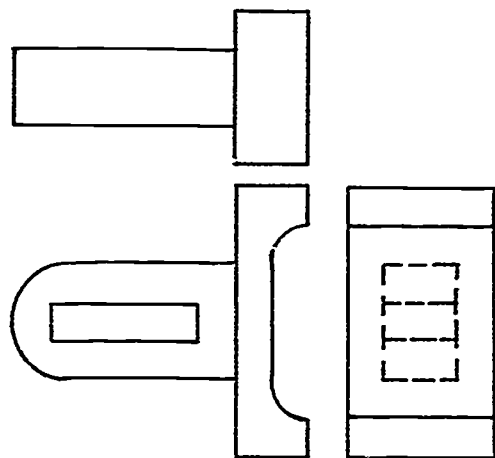

ASSIGNMENT SHEET #7

Problem 5:

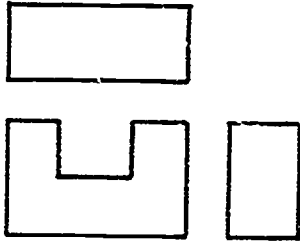

Problem 6:

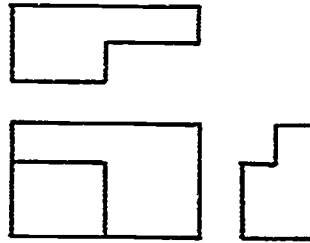

Problem 7:

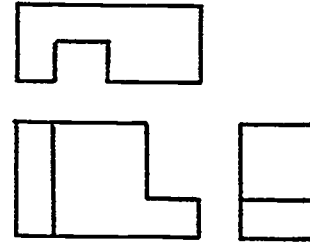

Problem 8:

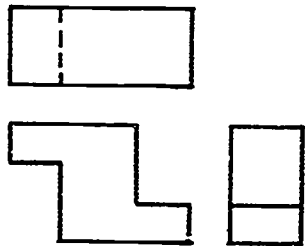

Problem 9:

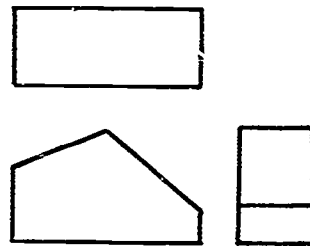

Problem 10:

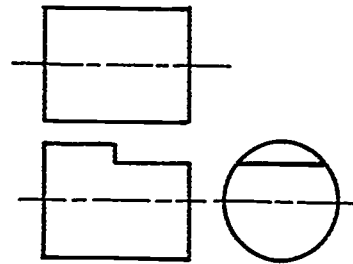

Problem 11:

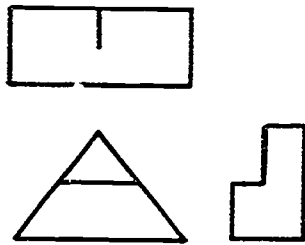

Problem 12:

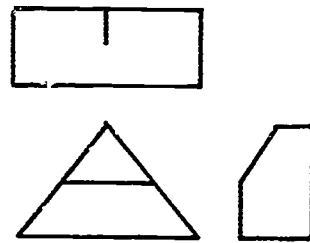

Problem 13:

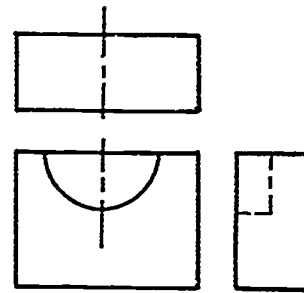

Problem 14:

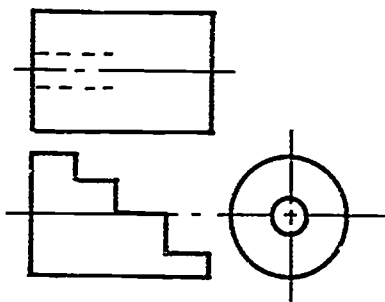

Problem 15:

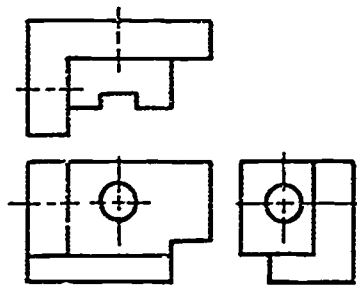

Problem 16:

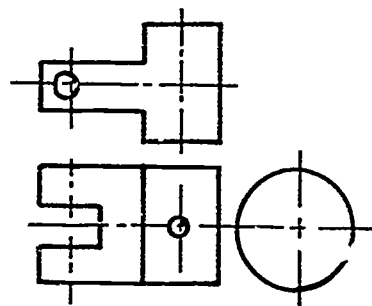

ORTHOGRAPHIC VIEWS UNIT XI

ASSIGNMENT SHEET #8 — MAKE A TWO-VIEW SKETCH

NAME _____ SCORE _____

Directions: Study the example below and then complete the assigned problem.

Example:

1. Sketch the horizontal lines to locate the height of the object.

(NOTE: The distance at the top and bottom of the paper should be the same.)

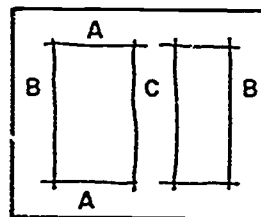

2. Sketch the vertical lines to locate the width and depth of the object.

(NOTE: The distance at the left side and right side of the paper should be the same. The distance between the views can be the same as that on the left side and right side or slightly less than that space.)

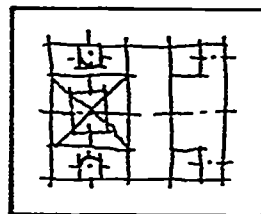

3. Block in details using diagonals to locate centers, and lightly sketch the circles and arcs.

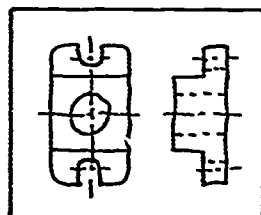

4. Use an artgum eraser to dim construction lines and darken in visible lines.

Problem: Make a two-view sketch of the following object in the space below or on drawing media if requested by instructor.

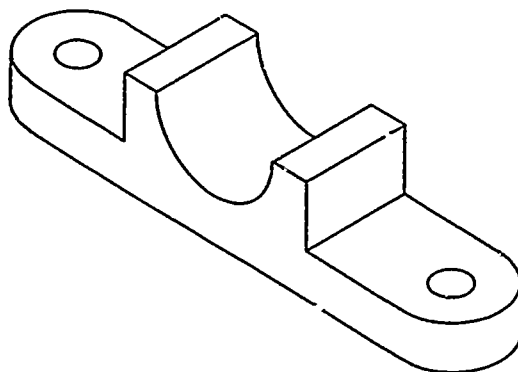

**ORTHOGRAPHIC VIEWS
UNIT XI**

ASSIGNMENT SHEET #9 — MAKE A THREE-VIEW SKETCH

NAME _____ SCORE _____

Directions: Study the example below and then complete the assigned problem.

Example:

1. Sketch the horizontal lines to locate the height of the object.

(NOTE: The distance at the top and bottom of the paper should be the same. The distance between the top and front views can be the same as that on the top and bottom or slightly less than that space.)

2. Sketch the vertical lines to locate the width and depth of the object.

(NOTE: The distance at the left side and right side of the paper should be the same. The distance between the views can be the same as that on the left side and right side or slightly less than that space. In the top and side views, the depth must be equal; this can be done by marking a piece of paper with depth.)

3. Block in details using diagonals to locate centers, if necessary, and lightly sketch the circles and arcs.
4. Add line features to the views of the object.
5. Use an artgum eraser to dim construction lines and darken in visible lines.

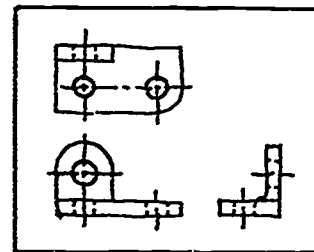
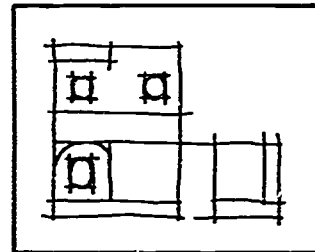
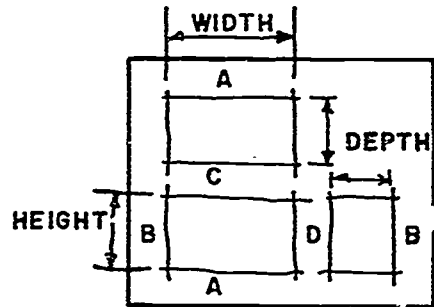

ASSIGNMENT SHEET #9

Problem: Sketch three views of the object below using the grid provided for measurements or gridded drawing media if requested by instructor.

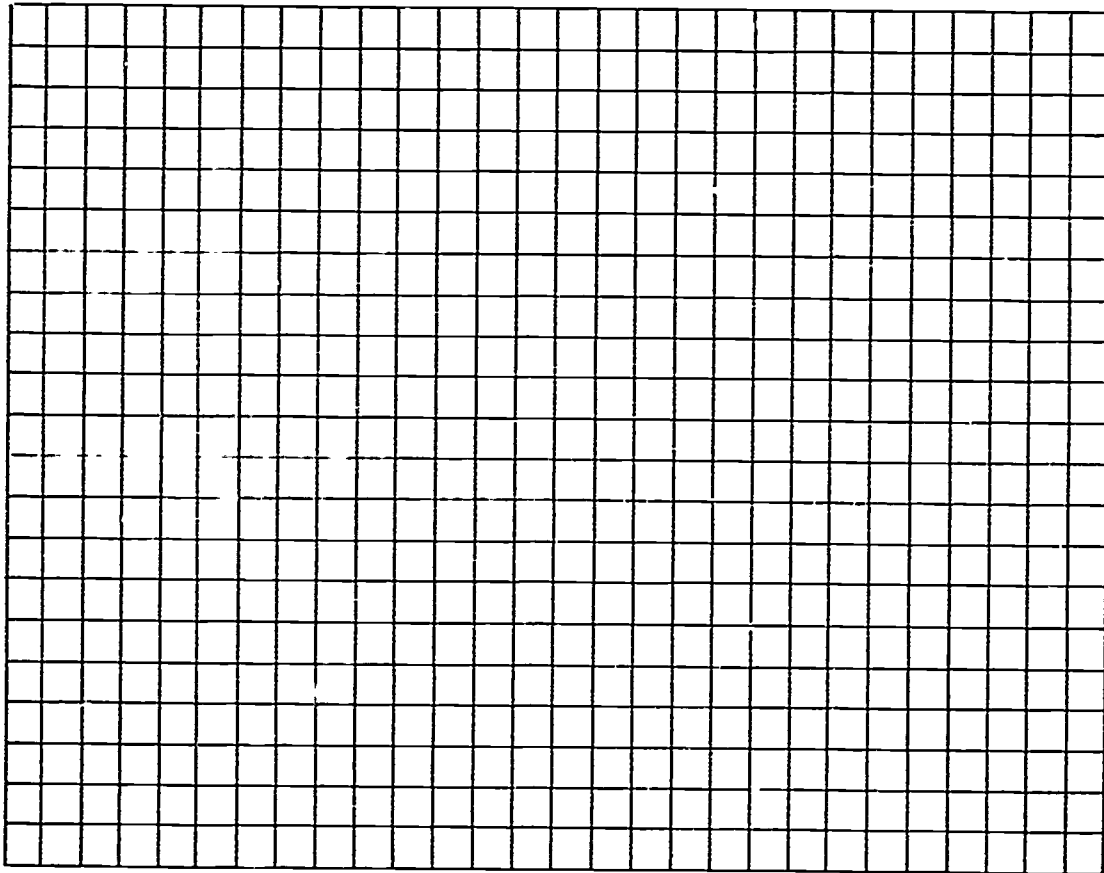
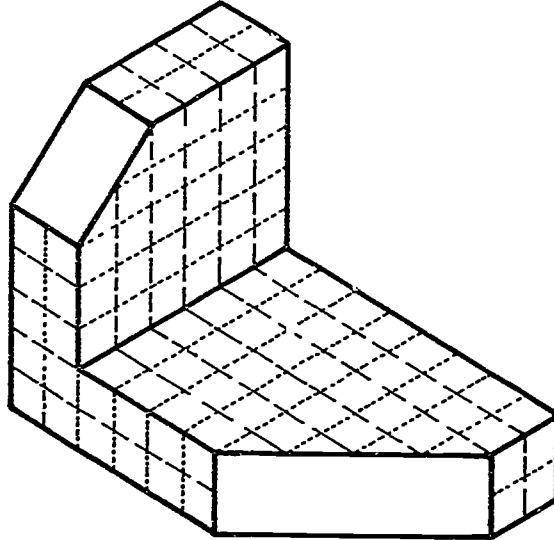

ORTHOGRAPHIC VIEWS
UNIT XI

ASSIGNMENT SHEET #10 — CONSTRUCT CIRCLES AND
ARCS USING A TEMPLATE

NAME _____ SCORE _____

Directions: Study the example below and then complete the assigned problem.

Example:

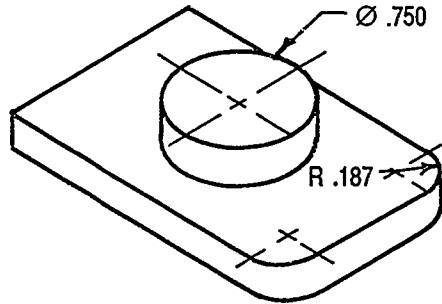

1. Block in object with light construction lines.

2. Locate and construct light center lines for circles and arcs.
3. Select correct hole diameter on circle template.

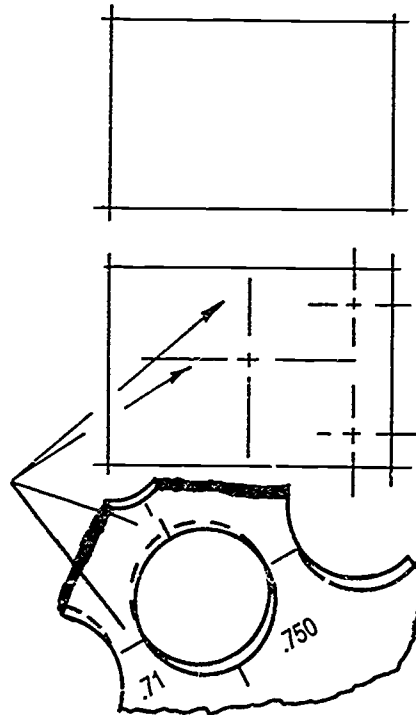

ASSIGNMENT SHEET #10

4. Align marks on template with center lines, and construct the required circle lightly.

(NOTE: Alignment marks on some templates are not printed accurately.)

5. Select correct hole on circle template for arc radius.

(NOTE: Radius is equal to 1/2 diameter.)

6. Align marks on template with center lines, and construct the required arc lightly.

7. Erase all construction lines not needed.

8. Darken in circles and arcs first, then straight lines.

(NOTE: Arcs tangent to straight lines should meet and align smoothly.)

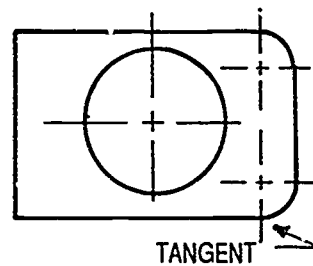
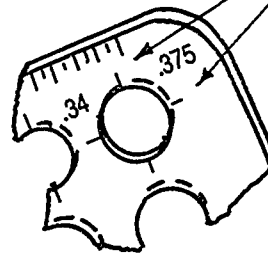
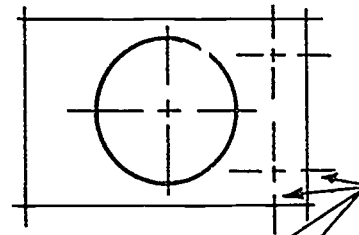

Problem: Construct a one-view drawing of the gasket below using a circle template on "A" size vellum. Erase construction lines and darken in visible and center lines. Do not dimension.

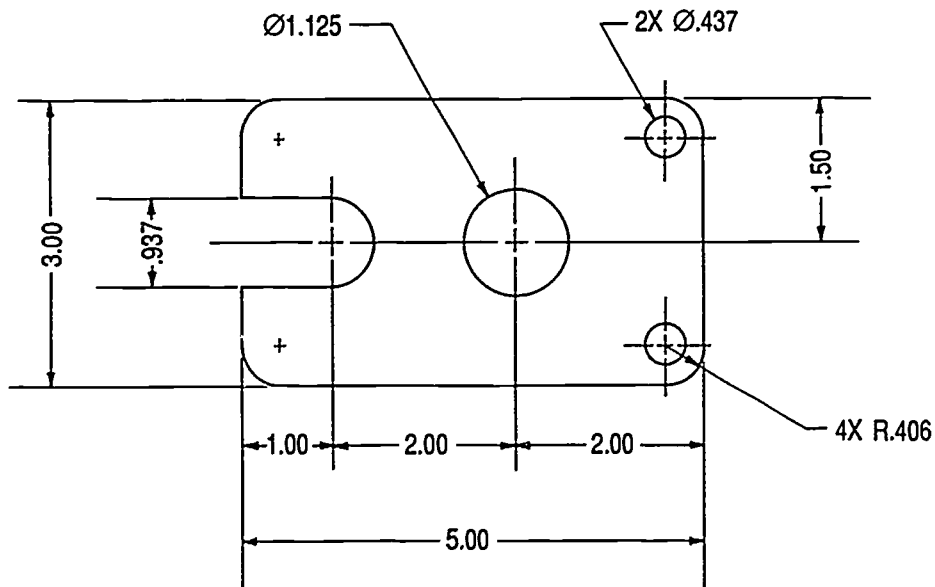

ORTHOGRAPHIC VIEWS UNIT XI

ASSIGNMENT SHEET #11 — CONSTRUCT ELLIPTICAL CURVES

NAME _____ SCORE _____

Directions: Study the example below and then complete the assigned problems.

(NOTE: The intersection of a hole or cylinder with an inclined plane will be shown as an ellipse or elliptical curve. Ellipses can be constructed with templates or by hand. Ellipse templates are available in ellipse angles in 5° intervals, such as 15°, 20°, 25°. If an ellipse template is not available, use the procedure below.)

Example:

1. Construct the three views showing circle or curve and angle of inclined plane.



2. Divide the curve into an equal or random number of points.

(NOTE: Several points are needed for a smooth curve.)

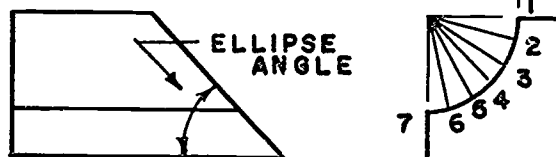

3. Project point marked No. 4 on curve to other views to intersect in top view.

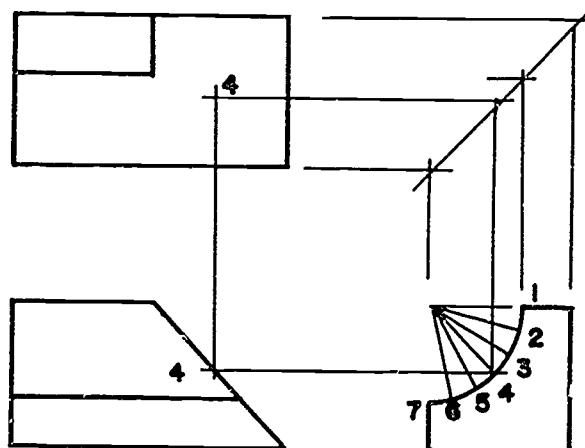

ASSIGNMENT SHEET #11

4. Project the other marked points to intersect, representing inclined edge.

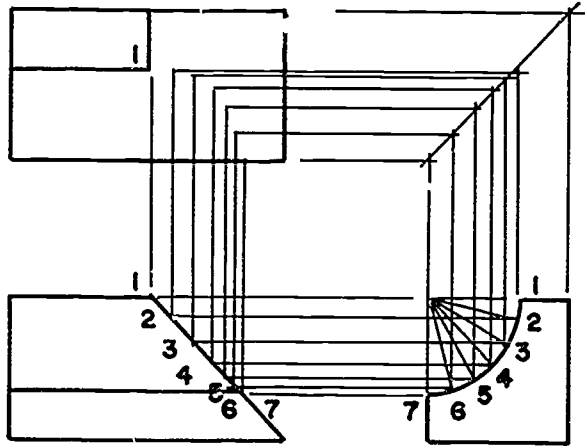

5. Sketch a light curved line through the intersection of points.
6. Erase construction lines and darken in curve line with the aid of an irregular curve.

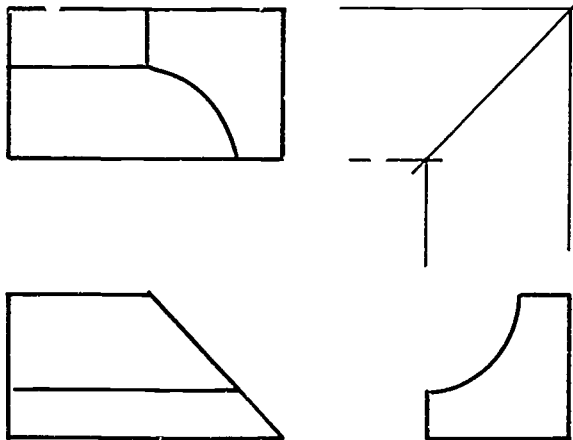

ASSIGNMENT SHEET #11

Problems: Construct three views of the following objects full size on available media. Leave construction lines. Do not dimension. Leave 1" of space between views.

Problem 1:

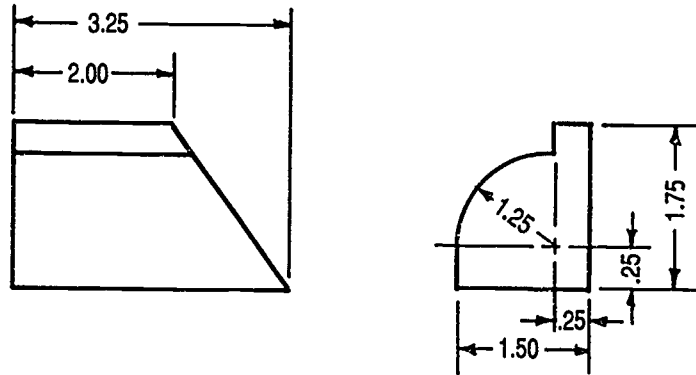

Problem 2:

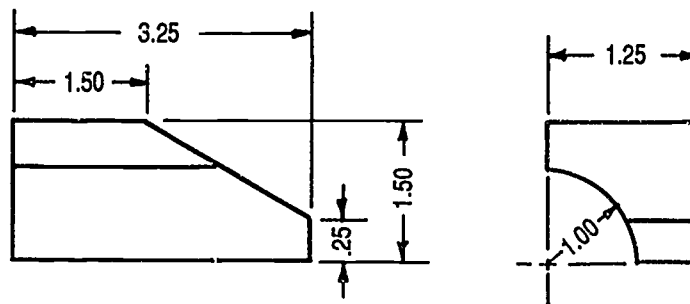

Problem 3:

(NOTE: If ellipse template is not available, use 45° inclined plane angle.)

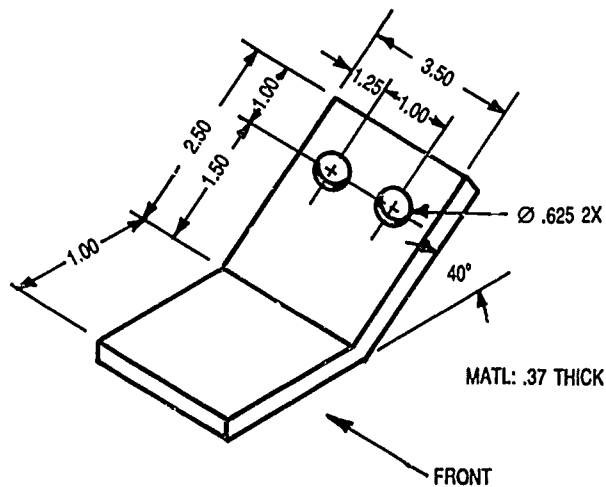

ORTHOGRAPHIC VIEWS UNIT XI

ASSIGNMENT SHEET #12 — CONSTRUCT A ONE-VIEW DRAWING

NAME _____ SCORE _____

Directions: Study the example below and then complete the assigned problem.

(NOTE: It is important for good appearance that views be well balanced on drawing media.)

Example:

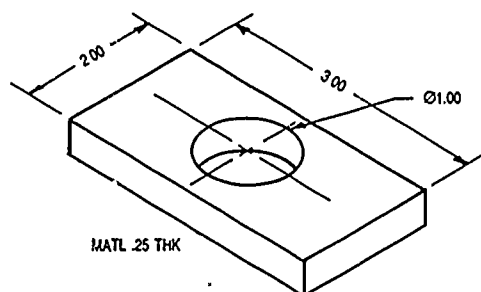

1. Locate the center of the working space by constructing diagonals.

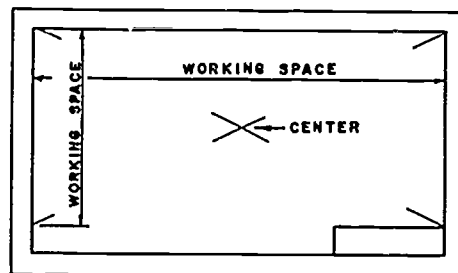

2. Block in lightly horizontal construction lines by measuring the distances.

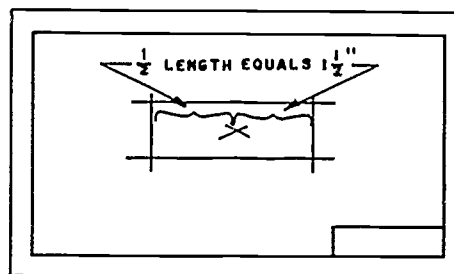

ASSIGNMENT SHEET #12

3. Block in lightly vertical construction lines by measuring the distances.

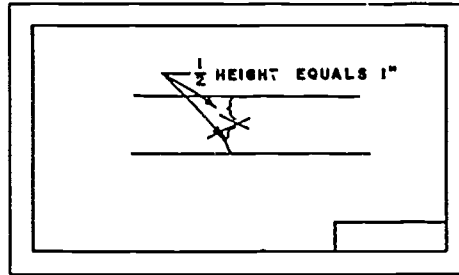

4. Construct the necessary light center lines, circles, arcs and then straight lines.

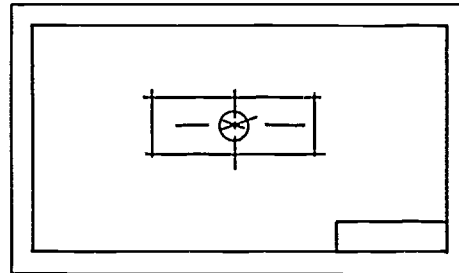

5. Erase construction lines not needed.
6. Darken circles and arcs first, then straight lines.
7. Fill in title block.

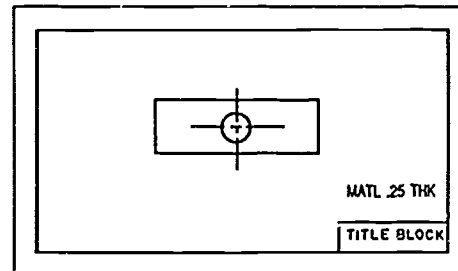

560

ASSIGNMENT SHEET #12

Problem: Center and construct the gasket full size on A size vellum. Use standard title block. Do not dimension.

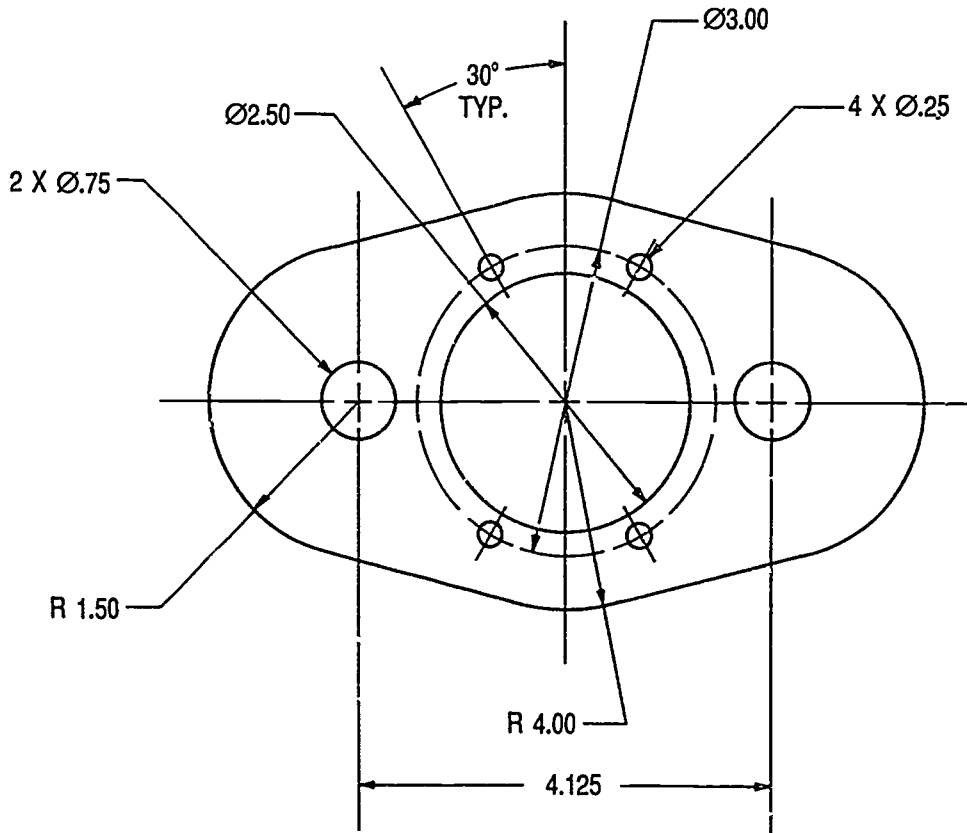

ORTHOGRAPHIC VIEWS
UNIT XI

ASSIGNMENT SHEET #13 — CONSTRUCT A TWO-VIEW DRAWING

NAME _____ SCORE _____

Directions: Study the example below and then complete the assigned problem.

Example:

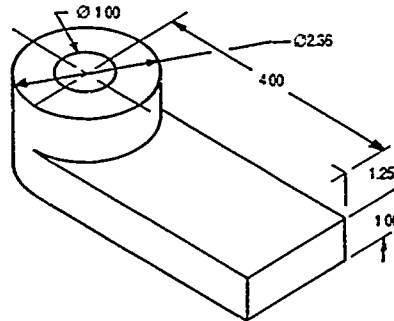

1. Calculate the spacing of views for object shown above.

(NOTE: Spacing is assumed between views when drawing is dimensioned.)

Vertical Spacings

$$\begin{array}{r} 2.36 \quad 8.00 \\ +2.25 \quad -4.61 \\ \hline 4.61 \quad 3.39 \end{array}$$

$$3.39 \div 3 = 1.13 = A$$

Horizontal Spacings

$$\begin{array}{r} 5.18 \quad 10.50 \\ +1.13 \quad -6.31 \\ \hline 6.31 \quad 4.19 = C \end{array}$$

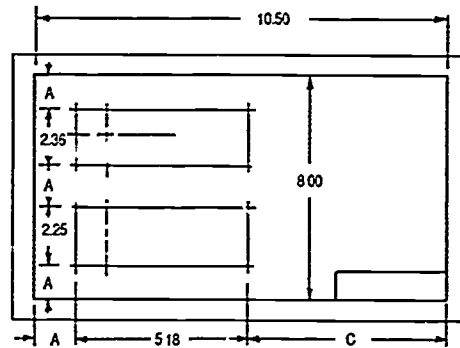

2. Block in views with light horizontal and vertical construction lines through spacing marks.

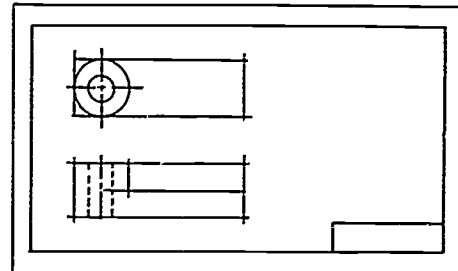

ASSIGNMENT SHEET #13

3. Locate center lines, and then construct light arcs and circles.
4. Add light visible and hidden lines.

(NOTE: Do not complete one view before starting on another.)

5. Erase unnecessary construction lines, and then darken in circles, hidden lines, and visible lines.

(NOTE: Hidden and center lines should be thin in contrast to the visible lines, but should be dark enough to reproduce well.)

6. Letter in title block.

Problem: Construct two views full size on A size vellum. Use standard border and title block. Do not dimension.

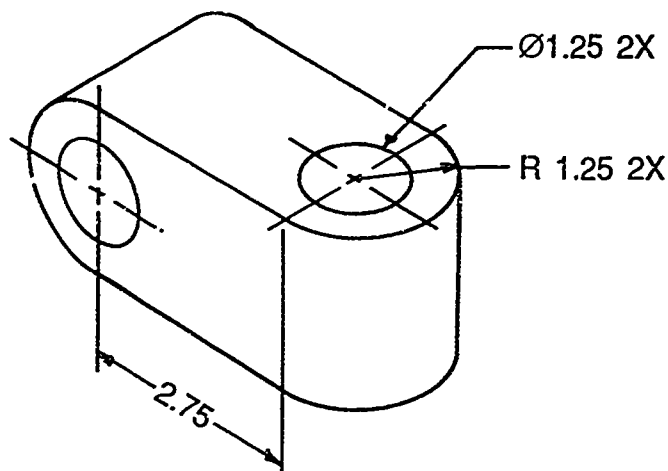

ORTHOGRAPHIC VIEWS
UNIT XI

ASSIGNMENT SHEET #14 — CONSTRUCT A THREE-VIEW DRAWING

NAME _____ SCORE _____

Directions: Study the example below and then complete the assigned problems.

Example:

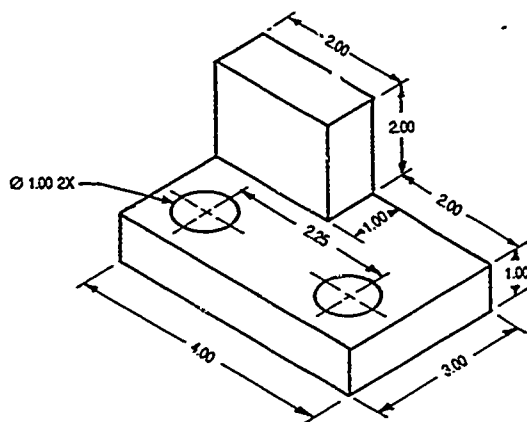

1. Select the proper surface to represent the front view for object above.
2. Construct a three-view sketch to determine dimension for blocking in and to clear up any uncertain details.
3. Select a sheet size and scale that will avoid crowding of views, dimensions, and notes. "B" size is shown.

(NOTE: For this procedure the scale, dimensions, notes, and title block are omitted.)

4. Calculate the spacing of the views for a standard drawing sheet.

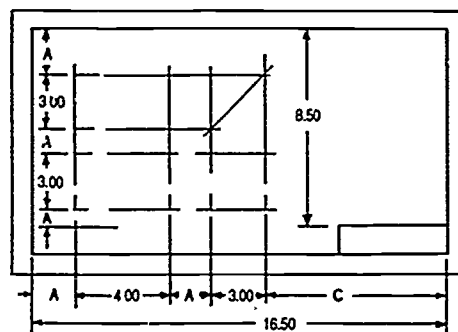

Vertical Spacings

$$\begin{array}{r} 3.00 \\ +3.00 \\ \hline 6.00 \end{array} \quad \begin{array}{r} 8.50 \\ -6.00 \\ \hline 2.50 \div 3 = .83 = A \end{array}$$

Horizontal Spacings

$$\begin{array}{r} 4.00 \\ 3.00 \\ .83 \\ +.83 \\ \hline 8.66 \end{array} \quad \begin{array}{r} 16.50 \\ -8.66 \\ \hline 7.84 = C \end{array}$$

ASSIGNMENT SHEET #14

5. Block in views with light horizontal and vertical construction lines through spacing marks.

(NOTE: Check measurements carefully when blocking in views.)

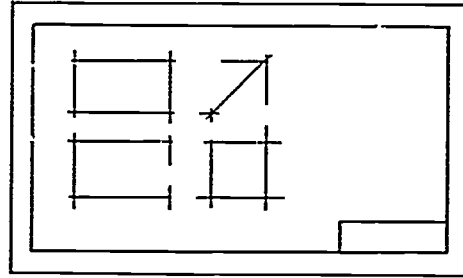

6. Construct mitre line for transferring of measurements in top and right side views.
7. Locate center lines and construct light arcs and circles, straight visible lines, and hidden lines.

(NOTE: Check layout carefully for missing lines, notes, or special shapes required.)

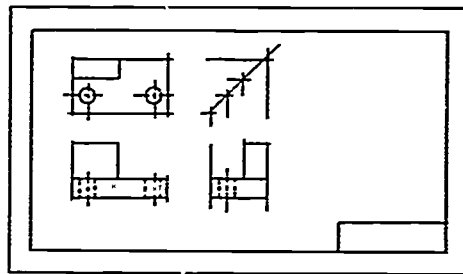

8. Erase unnecessary construction lines and give drawing a good cleaning.
9. Darken in arcs and circles, and then center lines, hidden lines, and visible lines.
10. Letter notes and title block.
11. Check finished drawing carefully for spelling, lineweight, and general appearance.

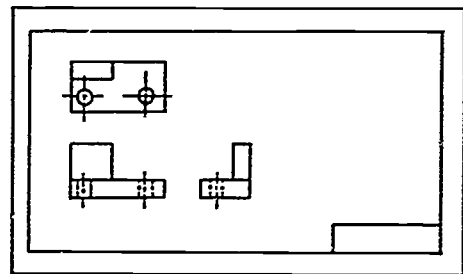

ASSIGNMENT SHEET #14

Problems: Construct three views of objects shown full size on B size vellum. Do not dimension.

1. Normal surfaces

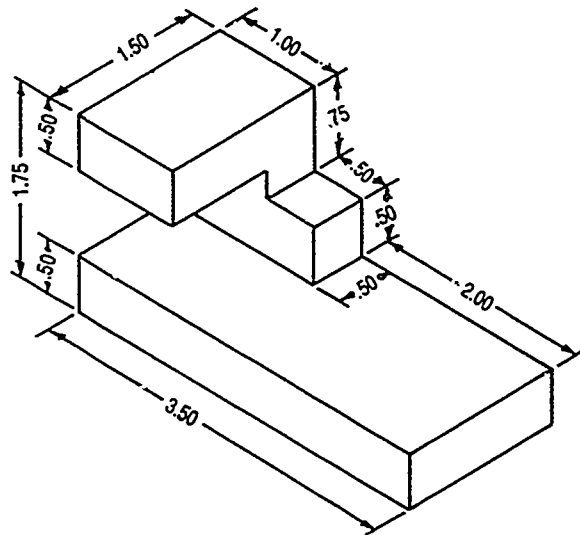

2. Oblique surfaces

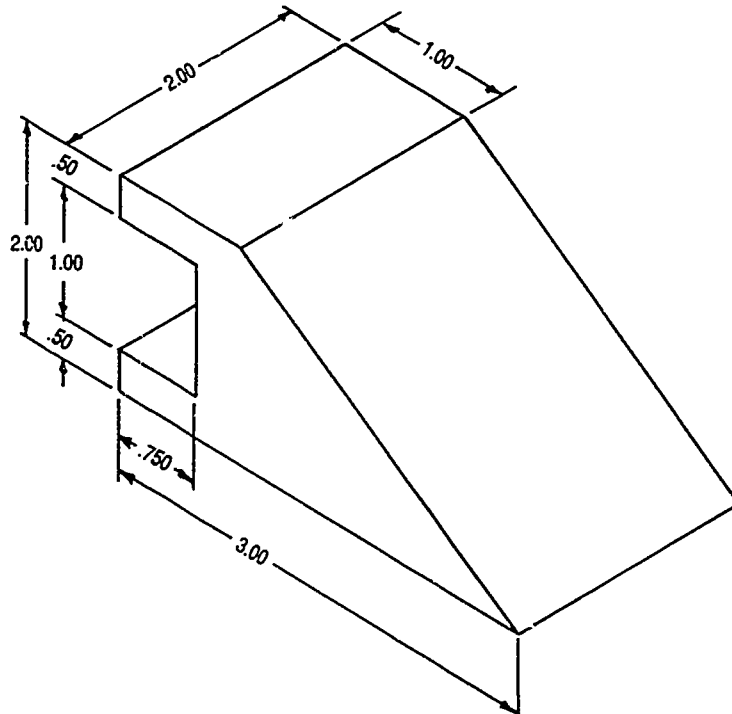

**ORTHOGRAPHIC VIEWS
UNIT XI**

ASSIGNMENT SHEET #15 — CONSTRUCT A RUNOUT

NAME _____ SCORE _____

Directions: Study the example below and then complete the assigned problem.

(NOTE: The arc of the runout is the same radius as the fillet or round. It may be drawn freehand, with an irregular curve, or with a circle template. The circle template procedure is shown.)

Example:

1. Project point of tangency from top to front view.

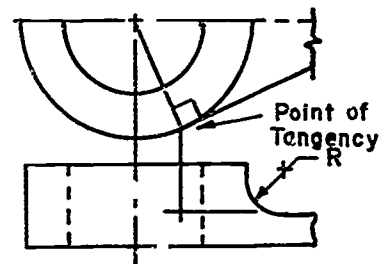

2. Construct 45° line through fillet's center to locate point A, and then project to point A'.

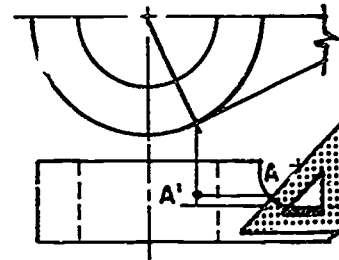

3. Find Center B by projecting from A' to 45° to the horizontal projection through B'.

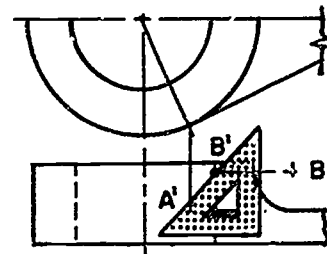

ASSIGNMENT SHEET #15

4. Use circle template to construct runout arc from A' using center B.

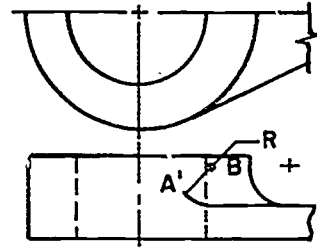

Problem. Align the horizontal center line of the object below with drafting machine. Tape down. Construct the runouts. Do not erase construction lines.

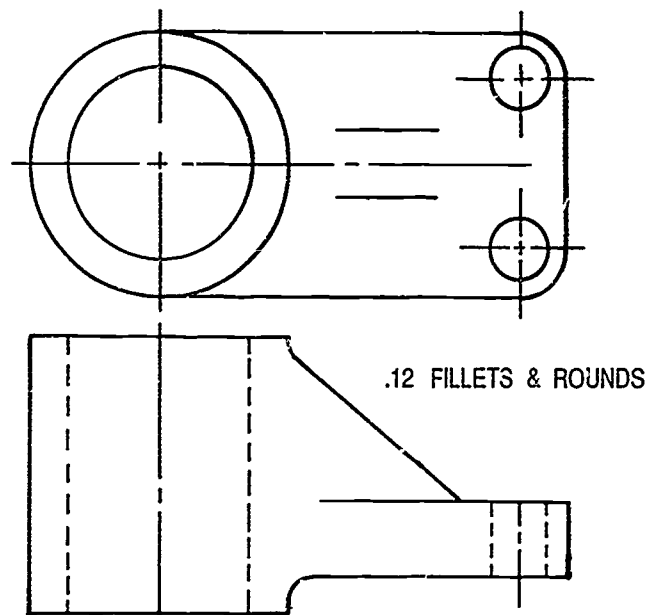

ORTHOGRAPHIC VIEWS UNIT XI

ASSIGNMENT SHEET #16 — CONSTRUCT A POINT IN AN ORTHOGRAPHIC VIEW

NAME _____ SCORE _____

Directions: Study the example below and then complete the assigned problems.

(NOTE: A point in space has position but no extension such as the intersections of two lines. Three dimensions are necessary to fix its position in space. The procedure for the orthographic projection of one point will be used below.)

Example:

1. Use given point A in two views. (Figure 1)
2. Project perpendicular lines from point A to reference lines RL1 and RL2. (Figure 1)

(NOTE: Light project lines perpendicular to reference lines should be used to align the projections.)

3. Construct miter line to project depth dimension from top to right side or right side to top. (Figure 1)

(NOTE: This is needed only to establish position in top view or right side view.)

4. Project points A_T and A_F to intersect in right side view to establish point in third view. (Figure 2)

FIGURE 1

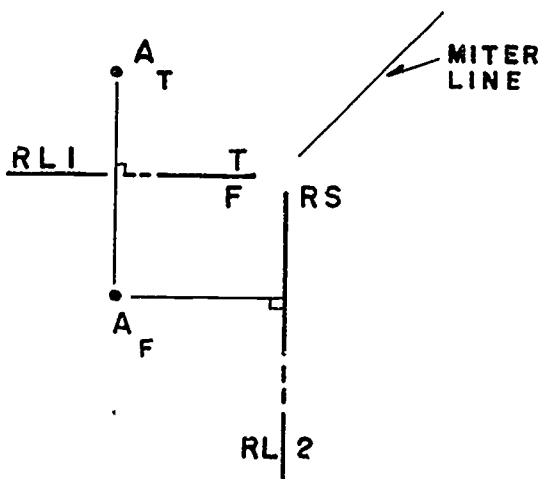
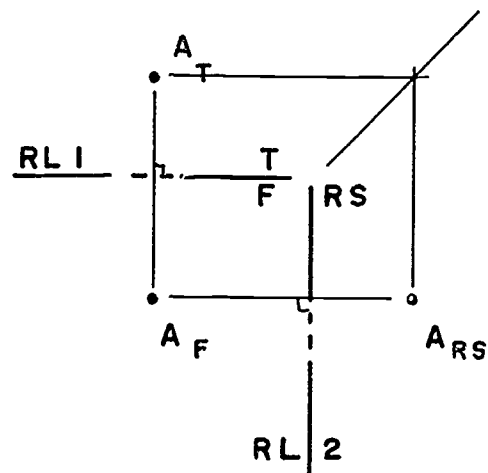

FIGURE 2



ASSIGNMENT SHEET #16

Problems: Align drafting machine with reference line and tape down for the following problems. Leave construction lines. Construct the points in the third view. Label points in third view. Refer to Handout #1 if you need help in visualization.

1.

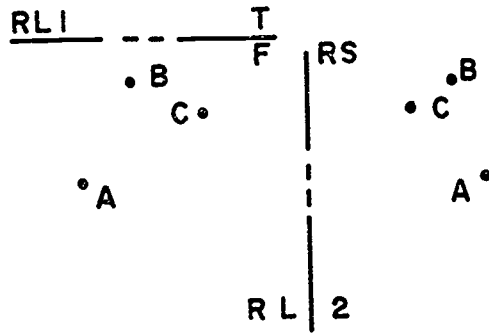

2.

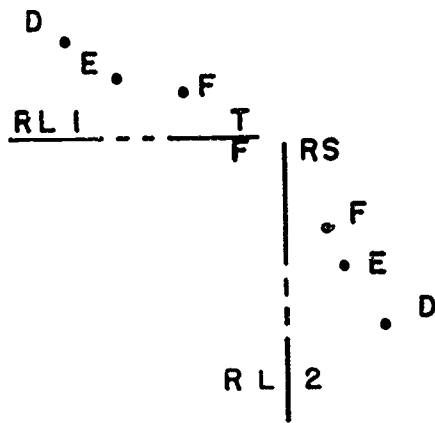

570

ORTHOGRAPHIC VIEWS
UNIT XI

ASSIGNMENT SHEET #17 — CONSTRUCT A LINE IN AN ORTHOGRAPHIC VIEW

NAME _____ SCORE _____

Directions: Study the example below and then complete the assigned problems.

(NOTE: Lines are grouped into types as normal, inclined, or oblique, depending on how they are positioned with relationship to the reference lines. The following procedure for oblique lines can be used for inclined or normal lines.)

Example:

1. Use given line AB in two views.

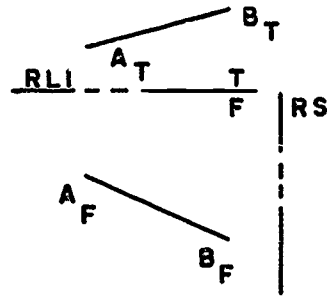

2. Project perpendicular lines from points A and B to reference lines RL1 and RL2.
3. Construct mitre line to project depth dimensions from top to right side or right side to top view.

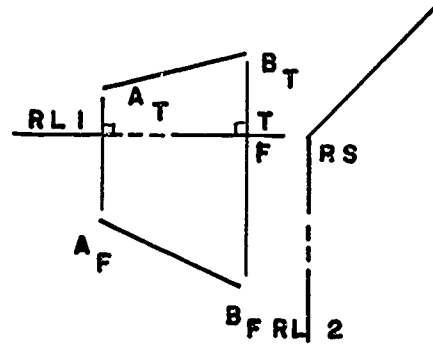

4. Project points A_T, B_T and A_F, B_F to right side view, locating points A_RS, B_RS.

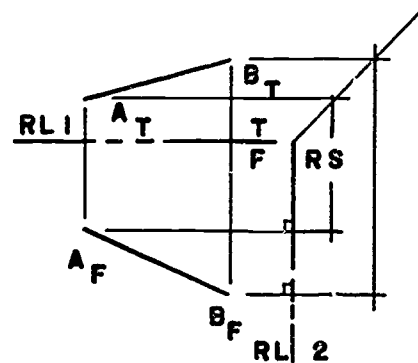

ASSIGNMENT SHEET #17

5. Connect points A_{RS} , B_{RS} with a line.

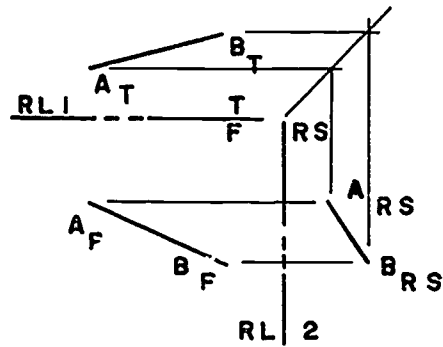

Problems: Align drafting machine with reference line and tape sheet down. Construct the third view of the line or lines given in the space provided. Refer to Handout #2 if you need help in visualization.

1.

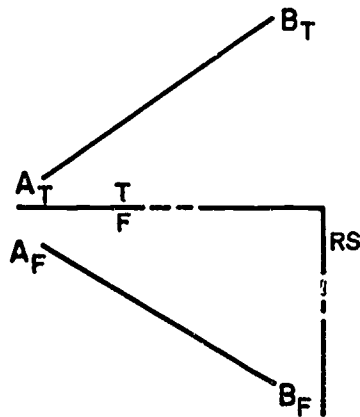

2.

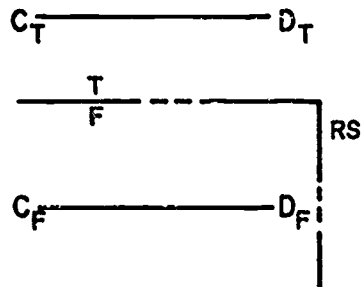

ASSIGNMENT SHEET #17

3.

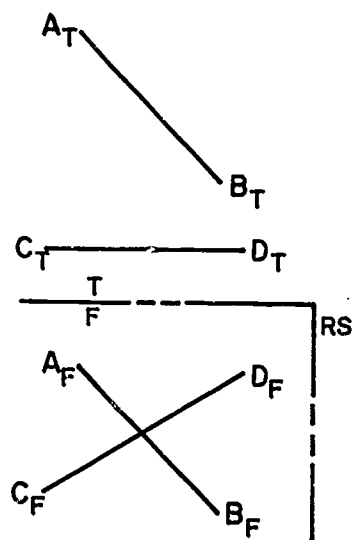

4.

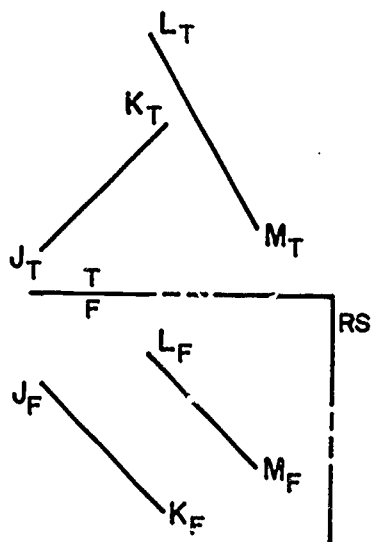

**ORTHOGRAPHIC VIEWS
UNIT XI**

**ASSIGNMENT SHEET #18 — CONSTRUCT A PLANE
IN AN ORTHOGRAPHIC VIEW**

NAME _____ SCORE _____

Directions: Study the example below and then complete the assigned problems.

(NOTE: Planes are without thickness. A plane may be constructed by intersecting lines, two parallel lines, a line and a point, three points, or a triangle. The following procedure is for constructing the third view when two views are given.)

Example:

1. Use given plane ABC in two views.

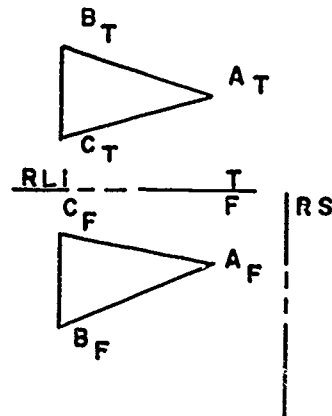

2. Project perpendicular lines from points A, B, and C to reference lines RL1 and RL2.
3. Construct mitre line to project depth dimension from top to right side or right side to top view.

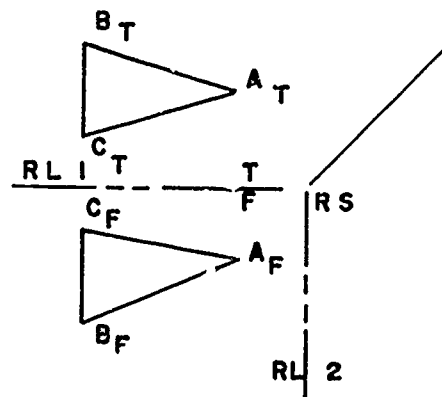

ASSIGNMENT SHEET #18

4. Project points A_T, B_T, C_T , and A_F, B_F, C_F , to right side view, locating points A_{RS}, B_{RS}, C_{RS} .

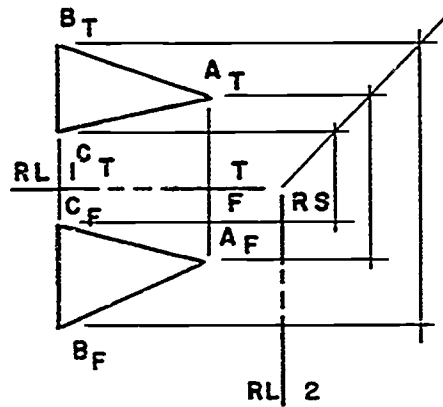

5. Connect points A_{RS}, B_{RS}, C_{RS} with lines to form plane.

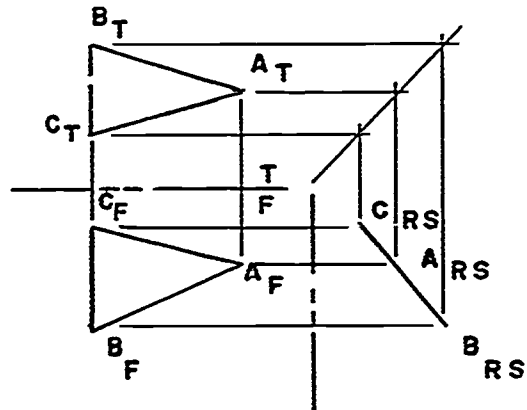

Problems. Align drafting machine with reference line and tape sheet down. Construct the third view of the plane given in the space provided.

- 1.

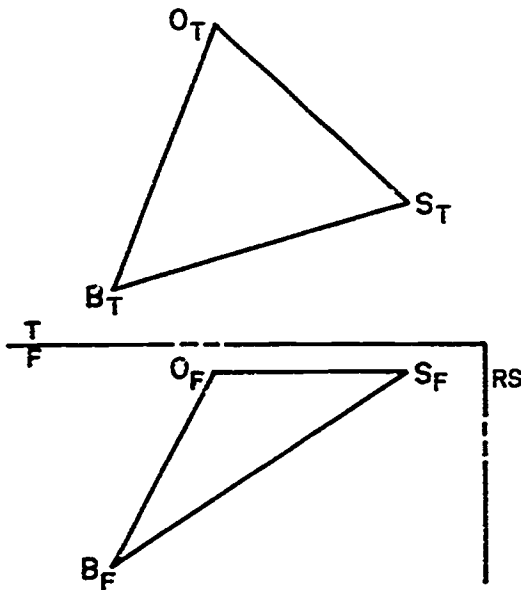

ASSIGNMENT SHEET #18

2.

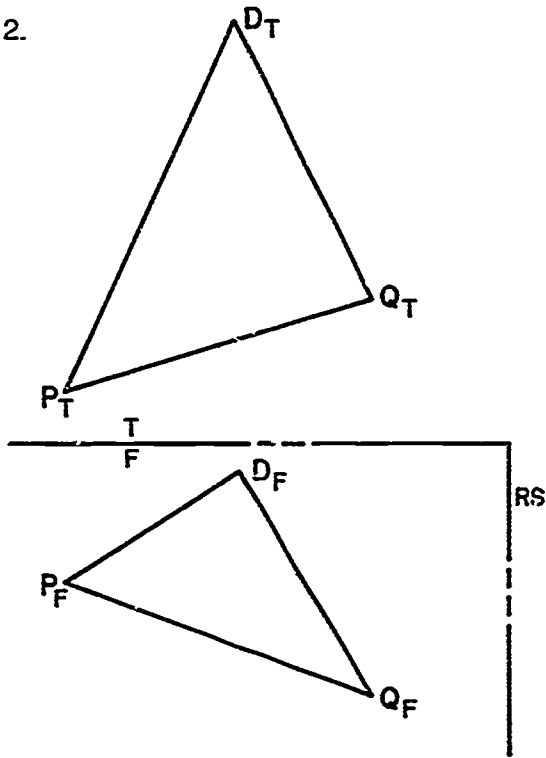

3.

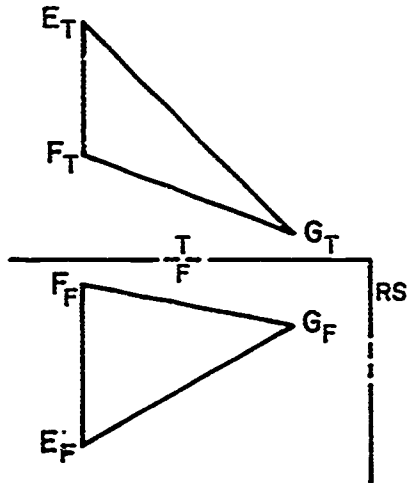

ASSIGNMENT SHEET #18

4.

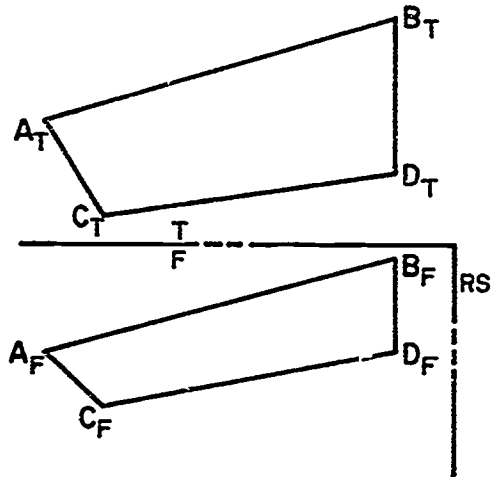

577

**ORTHOGRAPHIC VIEWS
UNIT XI**

ANSWERS TO ASSIGNMENT SHEETS

Assignment Sheet #1

1.

Line	Top	Front	R. Side
1	TL	Point	TL
2	TL	Point	TL
3	FS	TL	FS
4	TL	FS	FS
5	TL	TL	Point
6	Point	TL	TL
7	TL	Point	TL
8	Point	TL	TL
9	FS	TL	FS

2.

Line	Top	Front	R. Side
1	TL	TL	Point
2	FS	FS	FS
3	FS	FS	FS
4	TL	Point	TL
5	TL	FS	FS
6	TL	TL	Point
7	TL	FS	FS
8	TL	FS	FS
9	FS	FS	FS

Assignment Sheet #2

1.

PLANE	TYPE
A	Normal
B	Normal
C	Normal
D	Normal
E	Normal
F	Inclined
G	Inclined

2.

PLANE	TYPE
A	Normal
B	Normal
C	Normal
D	Inclined
E	Oblique
F	Oblique
G	Normal

ANSWERS TO ASSIGNMENT SHEETS

Assignment Sheet #3

1.



2.

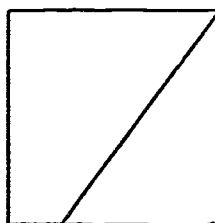

3.

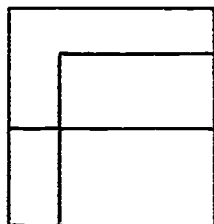

4.

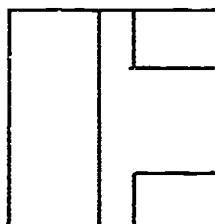

Assignment Sheet #4

1.

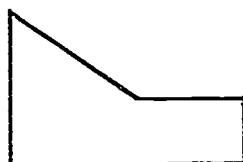

2.

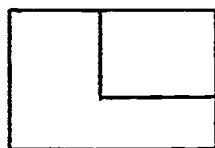

3.



ANSWERS TO ASSIGNMENT SHEETS

Assignment Sheet #5

1.



2.

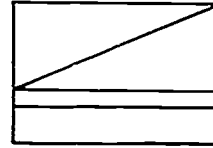

3.

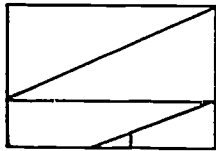

4.

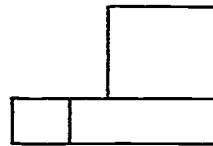

Assignment Sheet #6

1.

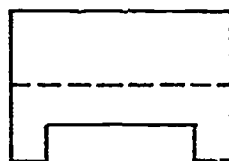
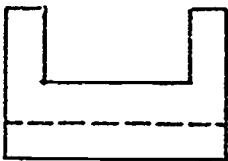
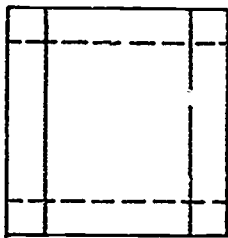

2.

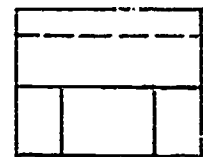
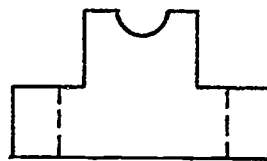
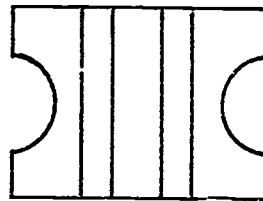

ANSWERS TO ASSIGNMENT SHEETS

3.

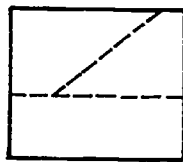
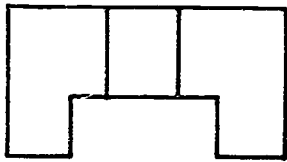
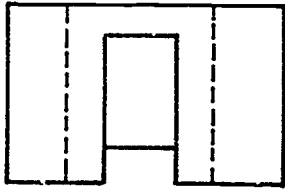

4.

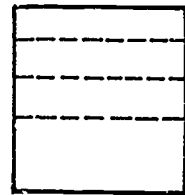
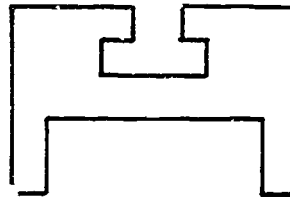
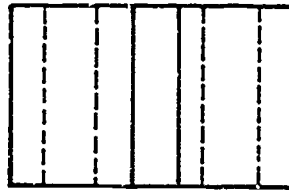

Assignment Sheet #7

1.

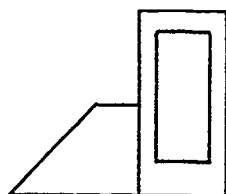
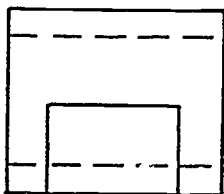
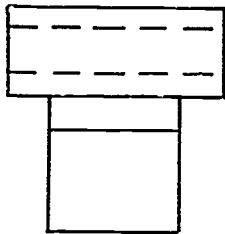

2.

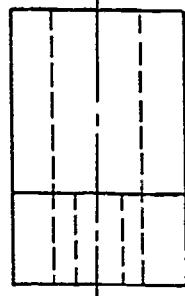
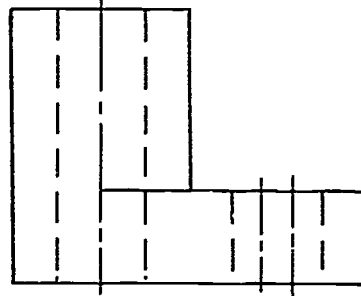
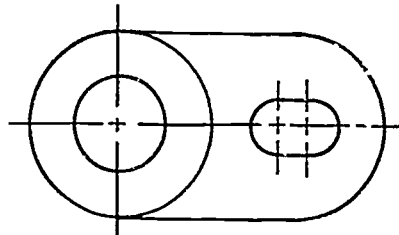

ANSWERS TO ASSIGNMENT SHEETS

3.

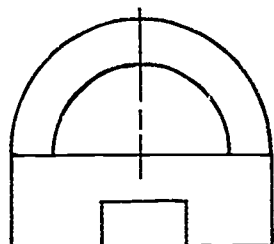
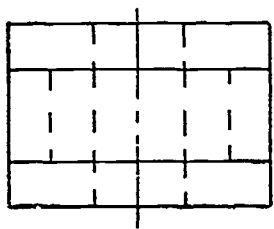

4.

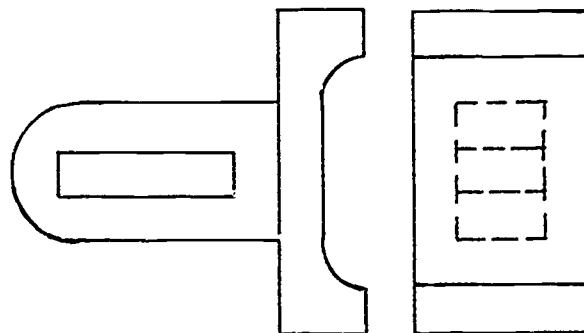
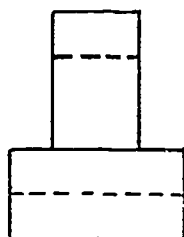
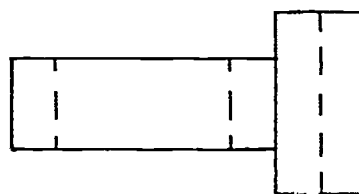

5.

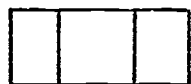

6.

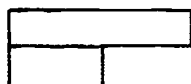

7.

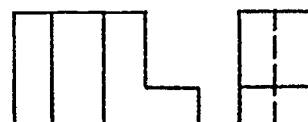
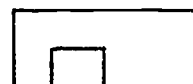

8.



9.

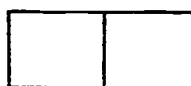

10.

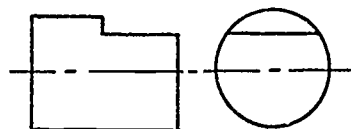
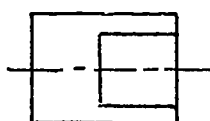

ANSWERS TO ASSIGNMENT SHEETS

11.

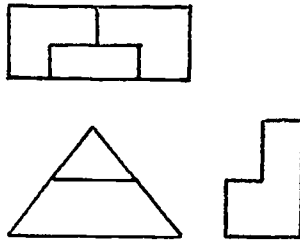

12.

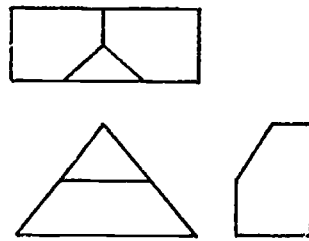

13.

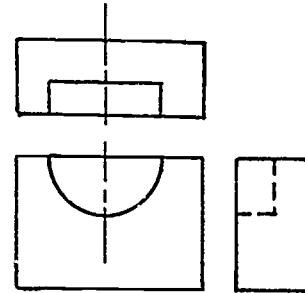

14.

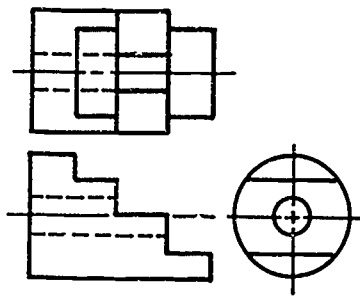

15.

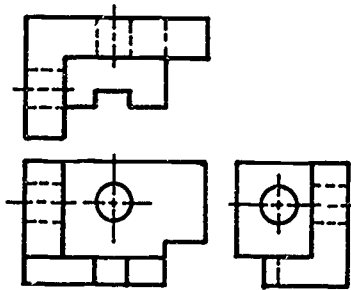

16.

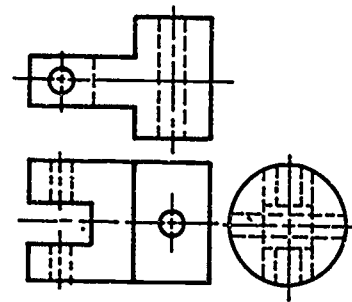

Assignment Sheet #8

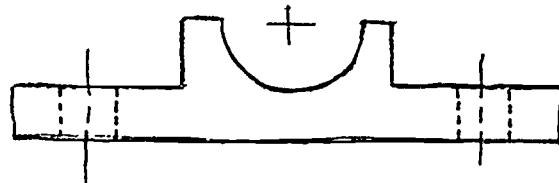
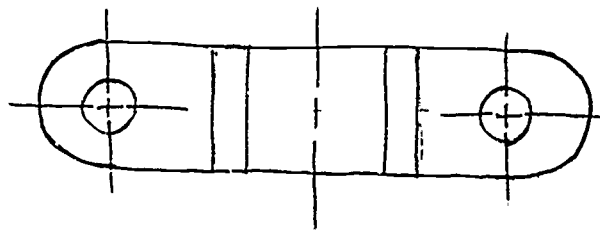

ANSWERS TO ASSIGNMENT SHEETS

Assignment Sheet #9

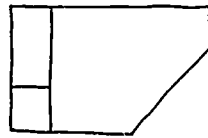

TOP

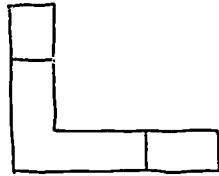

FRONT

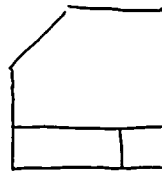

R SIDE

Assignment Sheet #10

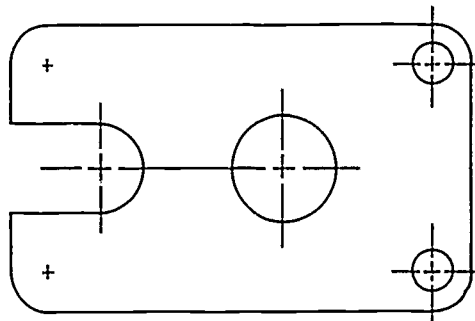

Assignment Sheet #11

1.

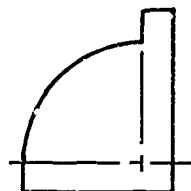
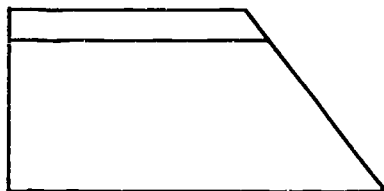
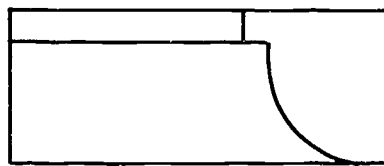

ANSWERS TO ASSIGNMENT SHEETS

2.

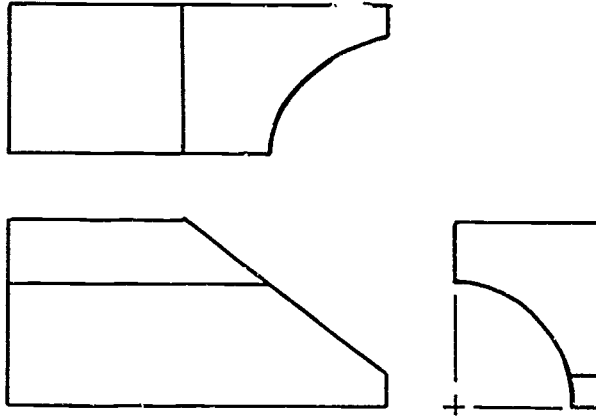

3.

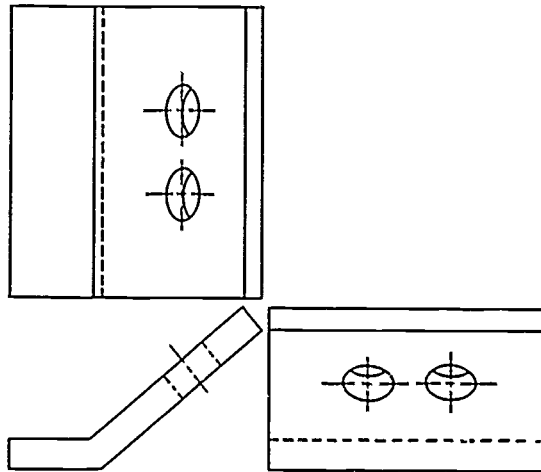

Assignment Sheet #12

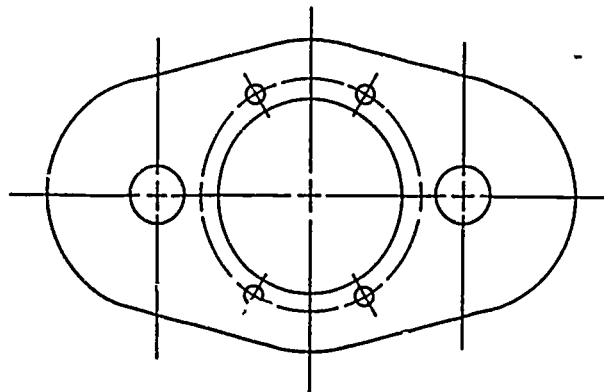

585

ANSWERS TO ASSIGNMENT SHEETS

Assignment Sheet #13

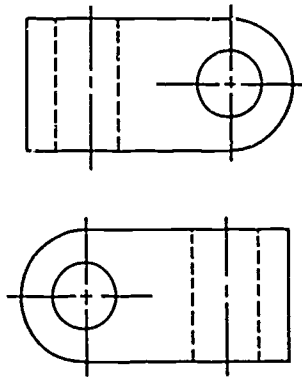

Assignment Sheet #14

1.

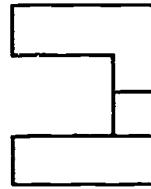
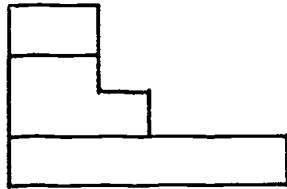
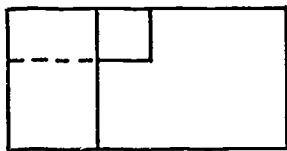

2.

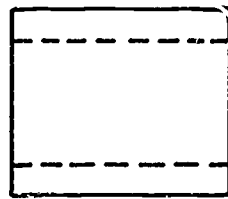
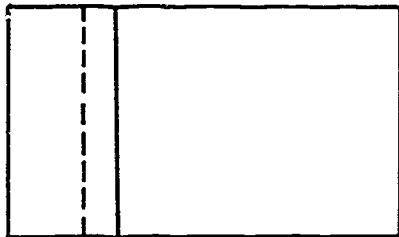

ANSWERS TO ASSIGNMENT SHEETS

Assignment Sheet #15

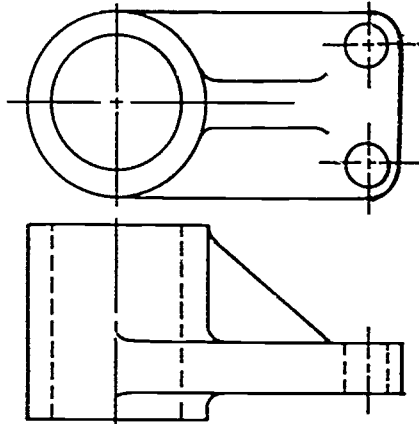

Assignment Sheet #16

1.

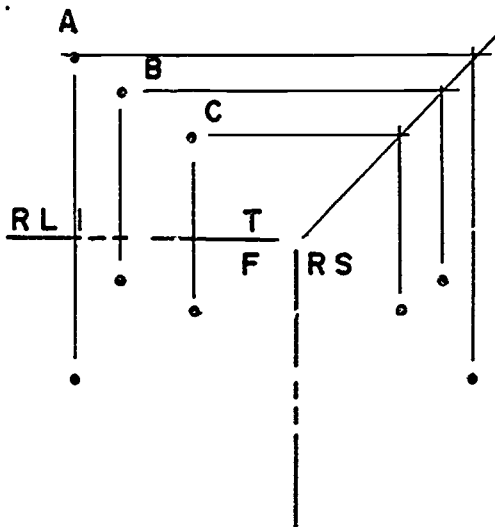

2.

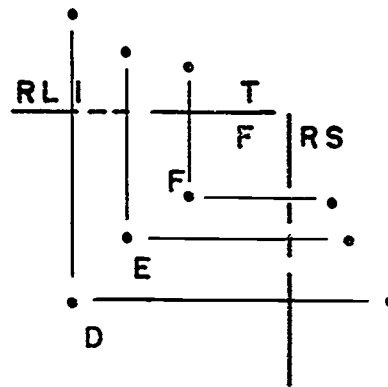

ANSWERS TO ASSIGNMENT SHEETS

Assignment Sheet #17

1.

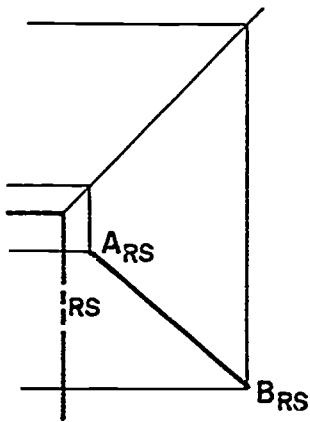

2.

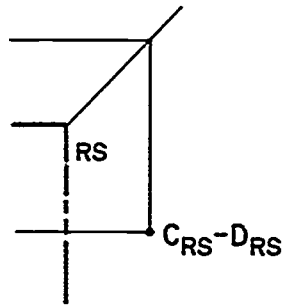

3.

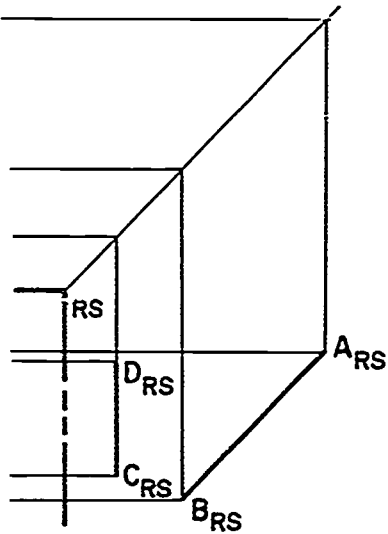

4.

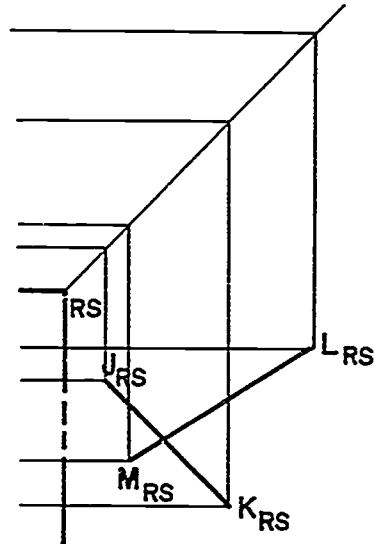

ANSWERS TO ASSIGNMENT SHEETS

Assignment Sheet #18

1.

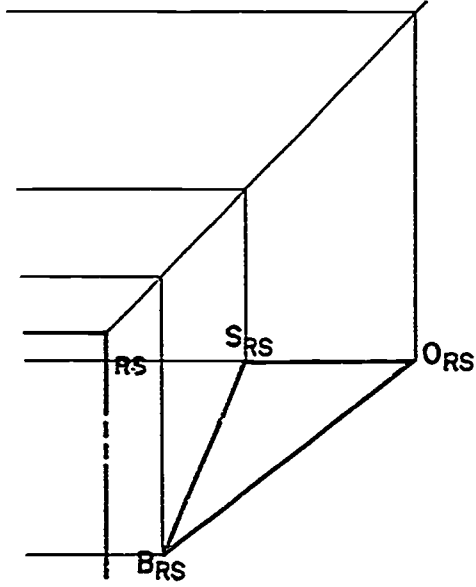

2.

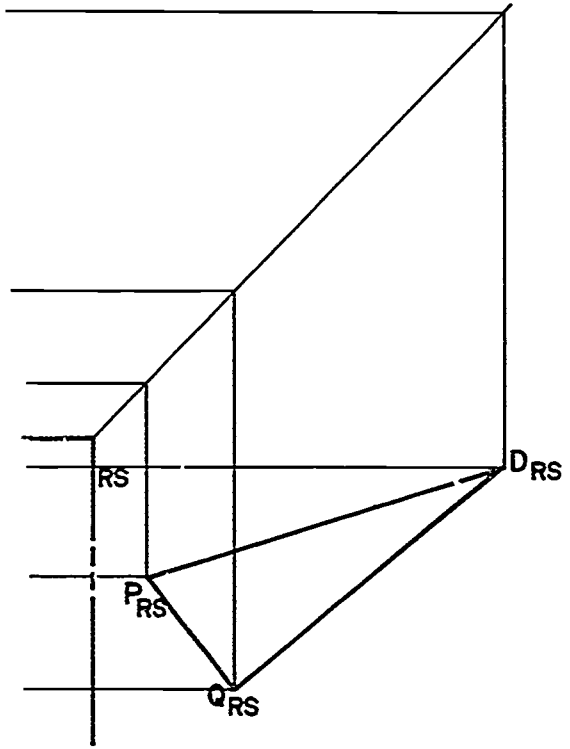

3.

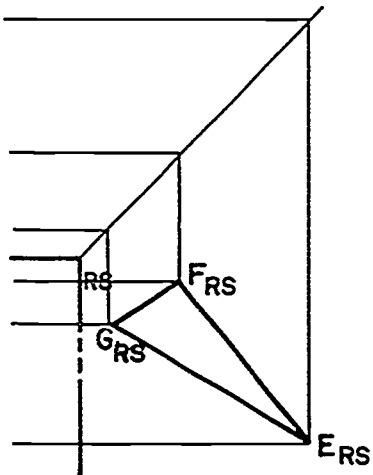

4.

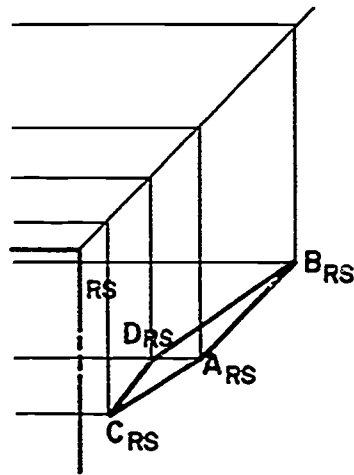

ORTHOGRAPHIC VIEWS UNIT XI

JOB SHEET #1 — DEVELOP ORTHOGRAPHIC DRAWINGS BY COORDINATE INPUT ON CADD

- A. Materials and equipment
1. Computer hardware
 2. Appropriate CAD software
 3. instruction manual for your CADD system

EVALUATION CRITERIA	
Criteria	Rating
Problems drawn correctly	_____
Coordinate points are accurate	_____

- B. Procedure: The following procedure is only an example. Discuss with your instructor the exact procedure for using coordinate inputs on your CADD system or refer to your CADD manual.

Example: AutoCAD

(NOTE: You can develop orthographic drawings on AutoCAD using either absolute coordinates or relative coordinates. Absolute coordinates are located with respect to the origin. Relative coordinates are located with respect to the previous point. The illustration below can be drawn by either method as shown in the following procedures.)

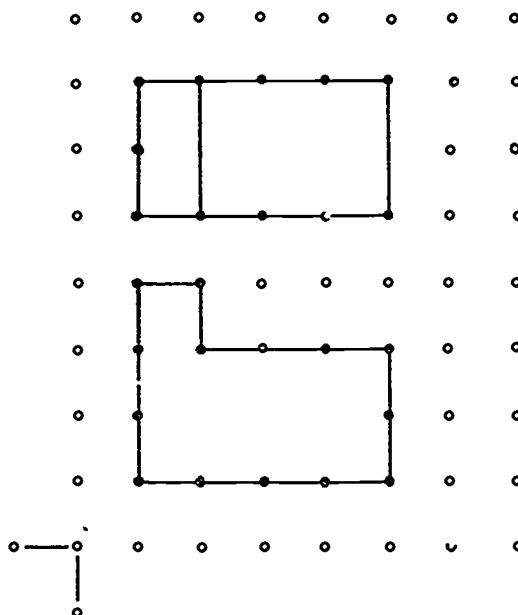

Illustrations for Procedures B1 and B2

JOB SHEET #1

Procedure B1: Absolute Coordinate Input

1. Select LINE command.
2. Type 1, 1 (A)
5, 1
5, 3
2, 3
2, 4
1, 4
1, 1 (or CLOSE from menu)
3. Select LINE command.
4. Type 1, 5 (B)
5, 5
5, 7
1, 7
1, 5 (or CLOSE from menu)
5. Select LINE command.
Type 2, 5 (C)
2, 7

Procedure B2: Relative Coordinate Input

1. Select LINE command.
2. Locate and set cursor at A.
3. Type @ 4,0
@ 0,2
@ -3,0
@ 0,1
@ -1,0
@ 0,-3 (or CLOSE from menu)
4. Select LINE command.
5. Type @ 0,4 (B)
@ 4,0
@ 0,2
@ -4,0
@ 0,-2 (or CLOSE from menu)
6. Select LINE command
7. Type @ 1,0 (C)
@ 0,2

Reprinted from the AutoCAD Reference Manual for AutoCAD Release 10 with permission from Autodesk, Inc.

JOB SHEET #1

- C. Problems: Develop orthographic drawings for the following objects using the absolute coordinate method for Problem 1 and the relative coordinate method for Problem 2. Before filing ask your instructor to check the accuracy of the coordinates.

1.

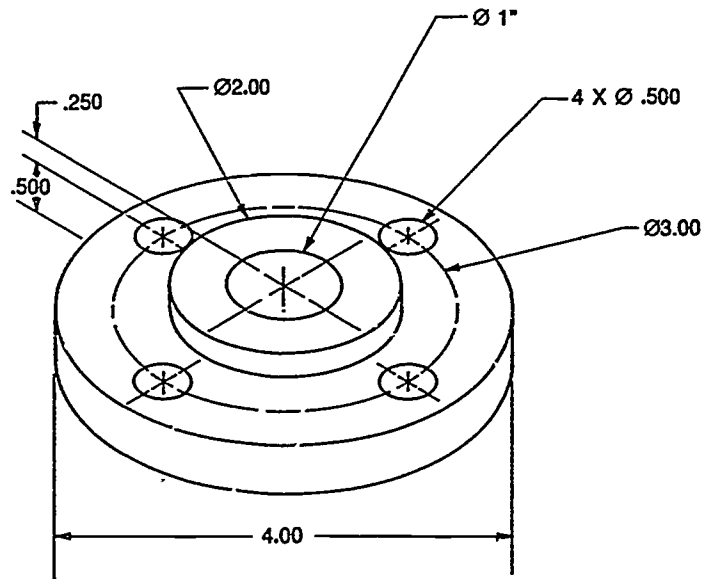

2.

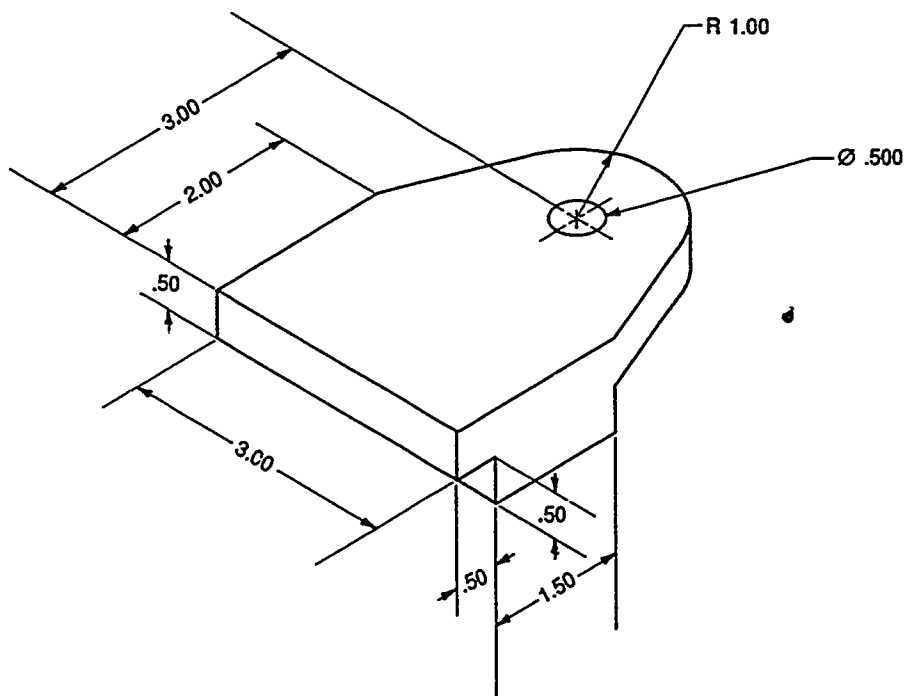

**ORTHOGRAPHIC VIEWS
UNIT XI**

TEST

NAME _____ SCORE _____

1. Match the terms on the right with the correct definitions.

- | | | | |
|----------|---|-----|-------------------------|
| _____ a. | Lines used to extend from one view to the next view | 1. | Coincide |
| _____ b. | A surface or line that is shown in its actual size | 2. | Fold line |
| _____ c. | A theoretical line between two views where viewing planes fold | 3. | Foreshortened |
| _____ d. | To take from one point of view and put in another view | 4. | Line |
| _____ e. | Lines that are more important to show than others | 5. | Line of sight |
| _____ f. | Direction from which an object is being viewed | 6. | Line precedence |
| _____ g. | To appear shorter to the eye than it actually is | 7. | Orthographic projection |
| _____ h. | Right angle projection; projector lines are parallel to each other and perpendicular to the plane of projection | 8. | Projection lines |
| _____ i. | A CADD command that consists of two or more continuous line segments, which the system considers a single item | 9. | Repaint |
| _____ j. | To form a mental picture or image | 10. | String |
| | | 11. | Transfer |
| | | 12. | True size |
| | | 13. | Visualize |

2. Distinguish between the types of projection systems by placing a "1" by the descriptions of first-angle projection and a "3" by those for third-angle projection.

- _____ a. Used in the United States
- _____ b. All views are projected onto planes located **behind** the object
- _____ c. Used in Europe
- _____ d. All views are projected onto planes lying **between** the object and viewer

TEST

3. Match planes of projection on the right with the correct uses.

- | | | |
|-------|------------------------------------|---------------------|
| ___a. | Used for front and rear views | 1. Horizontal plane |
| ___b. | Used for right and left side views | 2. Frontal plane |
| ___c. | Used for top and bottom views | 3. Profile plane |

4. Arrange in order the steps in visualizing an orthographic projection by placing the correct sequence numbers (1-5) in the appropriate blanks.

- ___a. To obtain views, project the lines of sight to each plane of projection from all points on the object.
- ___b. Inspect views and determine those needed to adequately represent the object.
- ___c. Visualize by looking at the actual object or picture of the object.
- ___d. Rotate all planes until they align with frontal plane of projection.
- ___e. Visualize the six possible views of the object that are revolved into the same plane as on a drawing surface.

5. List the six views possible in orthographic projection.

- a. _____
- b. _____
- c. _____
- d. _____
- e. _____
- f. _____

6. List the three principal views in orthographic projection.

- a. _____
- b. _____
- c. _____

TEST

7. Select true statements concerning the steps in selecting correct views of an object by placing a "T" in the appropriate blanks.
- ___ a. Select the number of views necessary to represent the object.
- ___ b. Select the right side view so it best describes the contour shape of the object.
- ___ c. Select the front view so it contains the greatest number of hidden lines.
- ___ d. Select view positions to avoid crowding of dimensions and notes.
8. Identify the basic dimensions of an object.

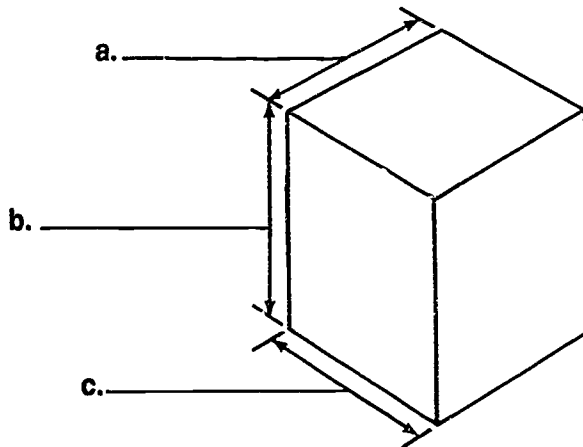

9. List two common methods of transferring depth dimensions.

- a. _____
- b. _____

TEST

10. Identify the projection of the following lines as foreshortened, true length, or point.

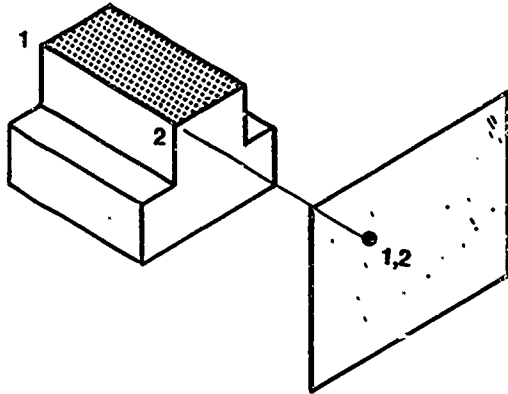

a. _____

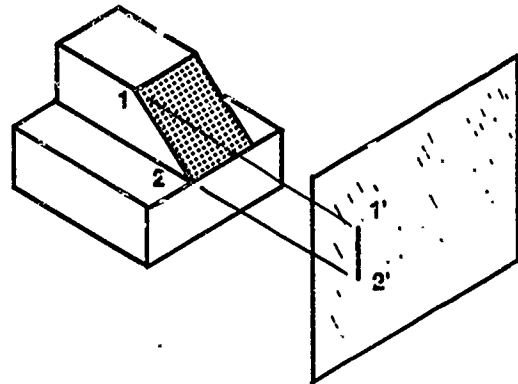

b. _____

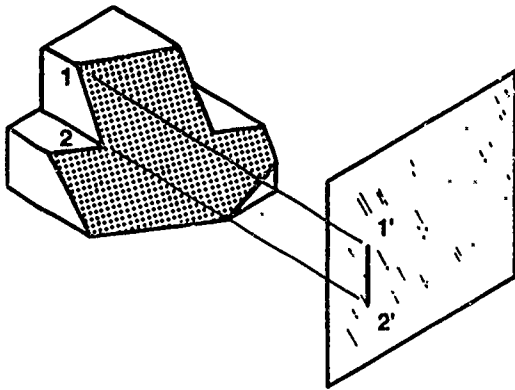

c. _____

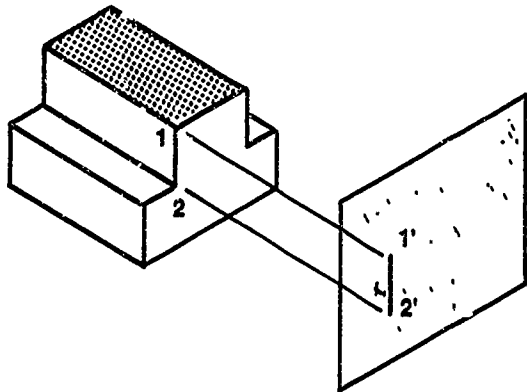

d. _____

TEST

11. Identify the types of planes shown below.

- a. A planes _____
- b. B planes _____
- c. C planes _____

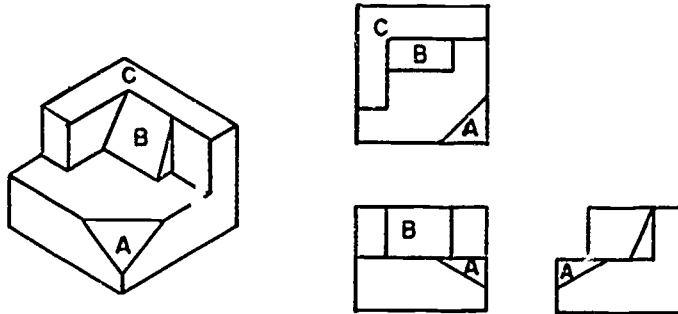

12. Distinguish between correct and incorrect usage of hidden lines by placing a "X" next to the correct uses.



a. _____

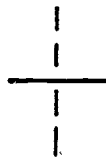

b. _____



c. _____

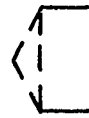

d. _____



e. _____

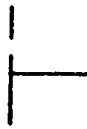

f. _____



g. _____

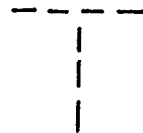

h. _____



i. _____



j. _____

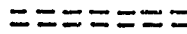

k. _____

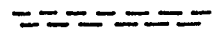

l. _____

TEST



m. _____



n. _____

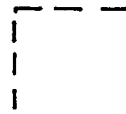

o. _____

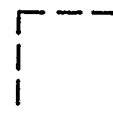

p. _____

13. Select correct line precedence in an orthographic drawing by placing an "X" in the appropriate blanks.

____ a. Cutting plane line

____ b. Center line

____ c. Visible line

____ d. Hidden line

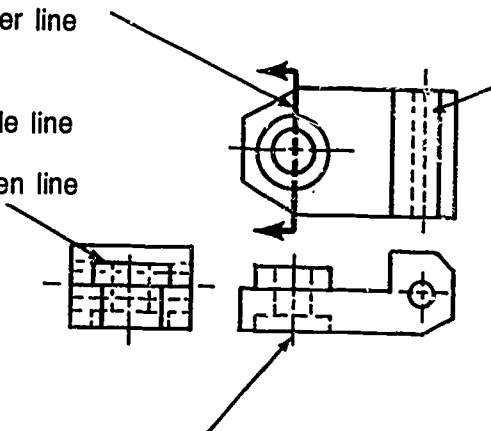

____ g. Center line

____ h. Hidden line

____ e. Center line

____ f. Visible line

14. Distinguish among rounds, fillets, and runouts by placing the following numbers next to the correct descriptions:

• 1 — Round

• 2 — Fillet

• 3 — Runout

____ a. Small rounded inside corner of an object

____ b. Intersection of a fillet or round with another surface which produces an extension of the curved surface

____ c. Small rounded outside corner of an object

TEST

15. Select true statements on creating a rectangle on CADD by placing a "T" or "F" in the appropriate blanks.
- ____a. Typical command is "DRAW BOX".
- ____b. The rectangle shape is created by digitizing opposite corners.
16. Select true statements on creating a spline on CADD by placing a "T" or "F" in the appropriate blanks.
- ____a. A spline is CADD's equivalent to a circle template.
- ____b. Typical command is "DRAW SPLINE".
- ____c. Several points are digitized; the spline will be inserted through or between specific points.
17. Match methods used on CADD for view manipulation with the correct descriptions.
- | | | |
|--------|---|--------------|
| ____a. | A command that allows the operator to keep the view that is currently on the screen so it may be returned to later | 1. Pan |
| ____b. | Portion of a larger design area, filling the screen vertically and horizontally | 2. Save view |
| ____c. | A command that increases or decreases the size of the view of the part without changing the size in the database | 3. Scroll |
| ____d. | A command that allows the operator to look at a different portion of the drawing without changing the magnification | 4. Window |
| | | 5. Zoom |

(NOTE: If the following activities have not been accomplished prior to the test, ask your instructor when they should be completed.)

18. Identify projection of lines in orthographic views. (Assignment Sheet #1)
19. Identify types of planes in orthographic views. (Assignment Sheet #2)
20. Construct a top view. (Assignment Sheet #3)
21. Construct a front view. (Assignment Sheet #4)
22. Construct a right side view. (Assignment Sheet #5)
23. Construct missing hidden lines. (Assignment Sheet #6)

TEST

24. Construct missing visible and hidden lines. (Assignment Sheet #7)
25. Make a two-view sketch. (Assignment Sheet #8)
26. Make a three-view sketch. (Assignment Sheet #9)
27. Construct circles and arcs using a template. (Assignment Sheet #10)
28. Construct elliptical curves. (Assignment Sheet #11)
29. Construct a one-view drawing. (Assignment Sheet #12)
30. Construct a two-view drawing. (Assignment Sheet #13)
31. Construct a three-view drawing. (Assignment Sheet #14)
32. Construct a runout. (Assignment Sheet #15)
33. Construct a point in an orthographic view. (Assignment Sheet #16)
34. Construct a line in an orthographic view. (Assignment Sheet #17)
35. Construct a plane in an orthographic view. (Assignment Sheet #18)
36. Demonstrate the ability to develop orthographic drawings by coordinate input on CADD. (Job Sheet #1)

**ORTHOGRAPHIC VIEWS
UNIT XI****ANSWERS TO TEST**

- | | | | | |
|----|----|----|----|----|
| 1. | a. | 8 | f. | 5 |
| | b. | 12 | g. | 3 |
| | c. | 2 | h. | 7 |
| | d. | 11 | i. | 10 |
| | e. | 6 | j. | 13 |
-
- | | | |
|----|----|---|
| 2. | a. | 3 |
| | b. | 1 |
| | c. | 1 |
| | d. | 3 |
-
- | | | |
|----|----|---|
| 3. | a. | 2 |
| | b. | 3 |
| | c. | 1 |
-
- | | | |
|----|----|---|
| 4. | a. | 2 |
| | b. | 5 |
| | c. | 1 |
| | d. | 3 |
| | e. | 4 |
-
- | | | |
|----|----|------------|
| 5. | a. | Top |
| | b. | Bottom |
| | c. | Front |
| | d. | Rear |
| | e. | Right side |
| | f. | Left side |
-
- | | | |
|----|----|------------|
| 6. | a. | Top |
| | b. | Front |
| | c. | Right side |
-
- | | |
|----|------|
| 7. | a, d |
|----|------|
-
- | | | |
|----|----|----------------|
| 8. | a. | Depth |
| | b. | Height |
| | c. | Width (length) |

ANSWERS TO TEST

9. Any two of the following:
- a. 45° mitre line
 - b. Dividers
 - c. Scale
10. a. Point c. Foreshortened
b. Foreshortened d. True length
11. a. Oblique
b. Inclined
c. Normal
12. a, d, e, g, j, l, m, p
13. a, c, f, h
14. a. 2
b. 3
c. 1
15. a. F
b. T
16. a. F
b. T
c. T
17. a. 2
b. 4
c. 5
d. 1
- 18.-35. Evaluated to the satisfaction of the instructor.
36. Performance skills evaluated to the satisfaction of the instructor.

**AUXILIARY VIEWS
UNIT XII****UNIT OBJECTIVE**

After completion of this unit, the student should be able to label points and surfaces, construct auxiliaries of lines, points, planes, and curved surfaces, determine true angle between planes, determine shortest distance between lines, and modify and edit CADD geometry. Competencies will be demonstrated by completing the assignment sheets, job sheets, and the unit test with a minimum of 85 percent.

SPECIFIC OBJECTIVES

After completion of this unit, the student should be able to:

1. Match terms related to auxiliary views with their correct definitions.
2. Define descriptive geometry.
3. Match terms used in descriptive geometry with the correct definitions.
4. State the purpose of auxiliary views.
5. Distinguish between the types of auxiliary views.
6. Select from a list the uses of auxiliary views.
7. Complete statements concerning drafting practices for auxiliary views.
8. Select true statements concerning projection of measurements in a primary auxiliary view.
9. List locations of reference lines.
10. Select true statements concerning projection of measurements in a secondary auxiliary view.
11. Identify the methods for modifying geometry on a CADD drawing.
12. Match methods for removing or editing geometry on CADD with the correct descriptions.
13. Label points and planes of a three-view object. (Assignment Sheet #1)
14. Construct a primary auxiliary of an inclined plane. (Assignment Sheet #2)
15. Construct a primary auxiliary of a curved surface. (Assignment Sheet #3)
16. Determine true length of an oblique line. (Assignment Sheet #4)
17. Determine true angle and slope of a line. (Assignment Sheet #5)

SPECIFIC OBJECTIVES

18. Determine visibility of crossing skew lines in space. (Assignment Sheet #6)
19. Determine visibility of a line and a plane that cross in space. (Assignment Sheet #7)
20. Locate piercing point of a line and a plane. (Assignment Sheet #8)
21. Determine point view of a line. (Assignment Sheet #9)
22. Construct secondary auxiliary views of an object. (Assignment Sheet #10)
23. Construct a secondary auxiliary of an oblique plane. (Assignment Sheet #11)
24. Determine the true angle between two planes. (Assignment Sheet #12)
25. Determine true angle between two planes in a secondary auxiliary. (Assignment Sheet #13)
26. Determine shortest distance between a point and a line. (Assignment Sheet #14)
27. Determine shortest distance between two skew lines. (Assignment Sheet #15)
28. Demonstrate the ability to:
 - a. Modify geometry by using the mirror, mirror and copy, move and copy, and rotate CADD commands. (Job Sheet #1)
 - b. Edit geometry by using the delete, blank, divide, and stretch CADD commands. (Job Sheet #2)
 - c. Lengthen or shorten lines, arcs, and circles on a CADD system. (Job Sheet #3)

**AUXILIARY VIEWS
UNIT XII****SUGGESTED ACTIVITIES**

- A. Provide student with objective sheet.
- B. Provide student with information, assignment, and job sheets.
- C. Make transparencies.
- D. Discuss unit and specific objectives.
- E. Discuss information and assignment sheets.
- F. Discuss and demonstrate the procedures outlined in the job sheets.
- G. Construct a "Glass Box Model" to demonstrate auxiliary projection.
- H. Bring in blocks or objects with surfaces that require auxiliary views.
- I. Explain the use and need for auxiliary views.
- J. Demonstrate the commands peculiar to your CADD system for editing and modifying geometry.
- K. Give test.

REFERENCES USED IN DEVELOPING THIS UNIT

- A. Giesecke, Frederick E., et al. *Technical Drawing*, 8th ed. New York: Macmillan Publishing Co., Inc., 1986.
- B. Brown, Walter C. *Drafting for Industry*. South Holland, IL 60473: Goodheart-Willcox Co., Inc., 1984.
- C. Jensen, Cecil and Jay Helsel. *Engineering Drawing and Design*, 3rd ed. New York: Gregg Division/McGraw-Hill Book Co., 1985.
- D. Spencer, Henry C., et. al. *Technical Drawing Problems*. New York: Macmillan Publishing Co., Inc., 1980.
- E. Spence, William P. *Drafting Technology and Practice*. Peoria, IL 61615: Chas. A. Bennett Co., Inc., 1973.
- F. Slaby, Steve M. *Engineering Descriptive Geometry*. New York: Baynes & Noble Books, 1956.
- G. Wellman, B. Leighton. *Technical Descriptive Geometry*. New York: McGraw-Hill Book, 1957.

**AUXILIARY VIEWS
UNIT XII
INFORMATION SHEET**

I. Terms and definitions

- A. **Auxiliary view** — A view or surface that is not perpendicular (90°) to the plane of projection

(NOTE: Auxiliary views are infinite in number and may be perpendicular to other inclined projections.)

- B. **Edge view** — A line representing the inclined plane
- C. **Foreshortened** — To appear shorter to the eye than it actually is
- D. **Inclined plane** — A plane that is foreshortened in two principal viewing planes and edge view in one other principal viewing plane
- E. **Oblique plane** — A plane that is foreshortened in all three principal viewing planes
- F. **Partial view** — Shows only pertinent features not described by true projection in the principal or other views
- G. **Skew lines** — Nonintersecting lines; not parallel to each other or to the principal views
- H. **True angle** — An angle formed by two intersecting planes
- I. **True length line** — A line that appears in its actual length
- J. **True size** — A surface that is shown in its actual size

(NOTE: This is based upon the scale used.)

- II. Definition of descriptive geometry** — Mathematical techniques used to describe geometric relationships among three-dimensional structures on a plane surface

(NOTE: Descriptive geometry helps to solve solid [space] geometry problems such as the relationship of points, lines, and planes in space. It is based on the principles of orthographic projection.)

INFORMATION SHEET

III. Terms used in descriptive geometry (Transparency I)

- A. Projection planes — Flat surfaces that are imagined to exist between the observer and an object on which all points of the object are projected (extended forward), resulting in a view of the object

(NOTE: In orthographic projection, the regular planes are at right angles to the line of sight.)

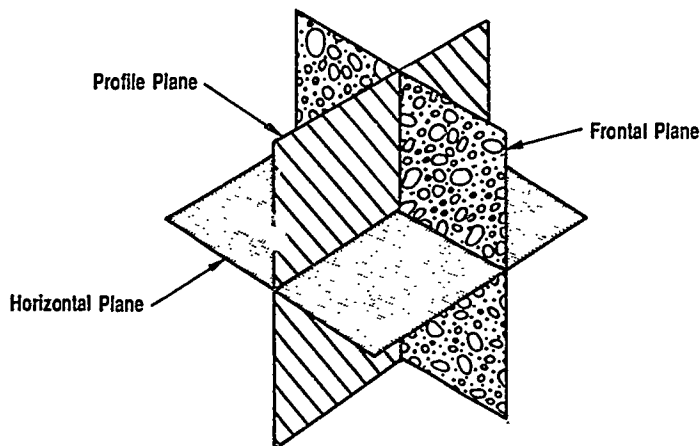

- B. Line of sight — Direction from which an observer views an object in space; is perpendicular to the plane of projection

(NOTE: The line of sight in an auxiliary view is perpendicular to the inclined or oblique surface.)

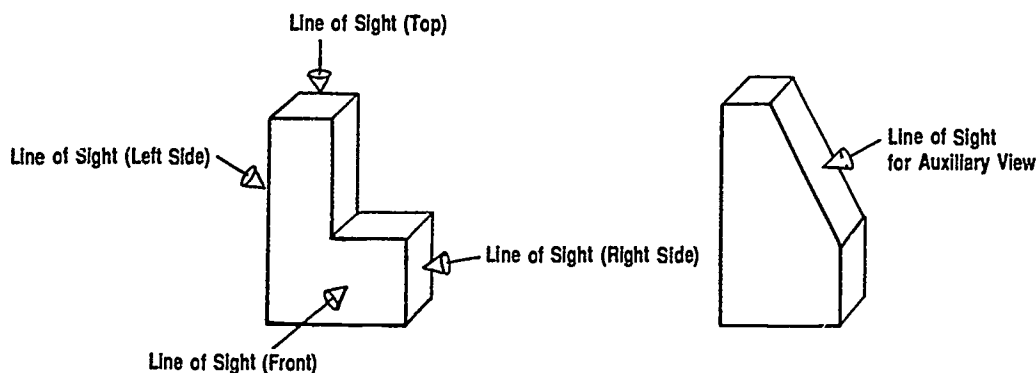

- C. Projection lines (projectors) — Lines drawn from a point or object in space perpendicular to a projection plane
- D. Reference or folding lines — Lines of intersection between two mutually-perpendicular projection planes.

(NOTE. These are used as base lines for all measurements between views.)

INFORMATION SHEET

- IV. Purpose of auxiliary views** — To show true size and shape of an object and relationship of its features when they are not parallel to any of the principal planes of projection (*ANSI Y14.3-1975 R 1987*) (Transparencies 1-3)

(NOTE: The true size and shape of an inclined or oblique surface can not be shown in the principal views; therefore, an auxiliary view is needed.)

V. Types of auxiliary views

- A. Primary auxiliary view — Adjacent to and aligned with a principal view

(NOTE: These are commonly used for objects with inclined surfaces.)

- B. Secondary auxiliary view — Adjacent to and aligned with a primary auxiliary view or with another secondary auxiliary view

(NOTE: These are commonly used for objects with oblique surfaces.)

VI. Uses of auxiliary views

- A. To show the true length of a line
 B. To show the true size and shape of a surface
 C. To show the true size of an angle
 D. To show irregularly shaped parts or features that are not adequately shown in the principal views

VII. Drafting practices for auxiliary views (*ANSI Y14.3-1975 R 1987*) (Transparencies 1-3)

- A. The auxiliary view is projected from the principal view on which the inclined surface appears as a line.

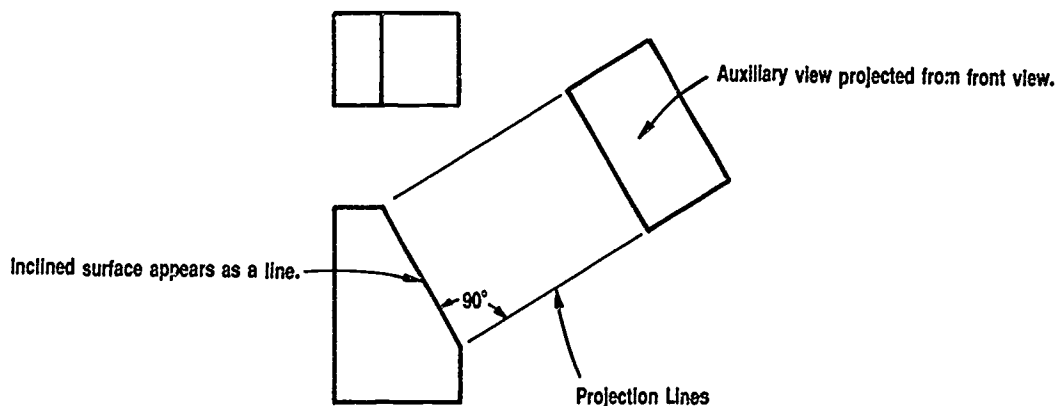

INFORMATION SHEET

- B. Projection lines are drawn at 90° (right) angles to the inclined surface.
- C. Partial auxiliary views may be used to show pertinent features that are not clearly shown on the principal views.
 - 1. They are used instead of complete (full) auxiliary views to simplify the drawing.
 - 2. Usually only the inclined portion of the view is shown.
- D. Primary auxiliary views may be projected from all six principal views; they are most commonly projected from the front, top, and side views.

(NOTE: When an auxiliary view is projected from a front view, it is called a front-auxiliary view; from a top view, a top-auxiliary view, etc.)

VIII. Projection of measurements in a primary auxiliary view (Transparencies 1-3)

- A. Depth and height measurements are transferred with a scale or dividers in their true length from one of five views.
- B. Measurements cannot be made from view with edge view.
- C. Length measurements are projected in their true length perpendicular from edge view to primary auxiliary.

IX. Locations of reference lines (Transparency 4)

- A. Back edge of view
- B. Middle (center line)
- C. Front edge of view
- D. Between views

(NOTE: These are referred to as fold lines.)

X. Projection of measurements in a secondary auxiliary view

- A. Depth measurements are transferred from the edge view of one of the principal views.
- B. Length measurements are projected from the primary auxiliary view.

INFORMATION SHEET

XI. Methods for modifying geometry on a drawing

A. Mirror (imaging) — Creates a reversed (mirror) image of an existing design

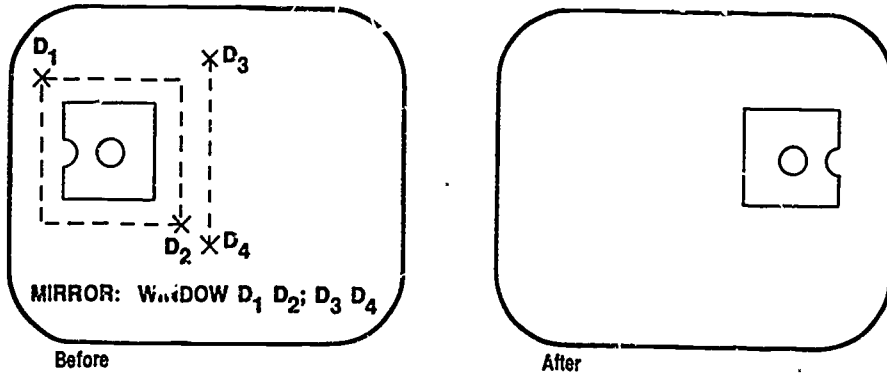

B. Mirror and copy — Duplicates a reversed (mirror) image of the geometry on the other side of an axis

(NOTE: This is a quick method to create symmetrical parts.)

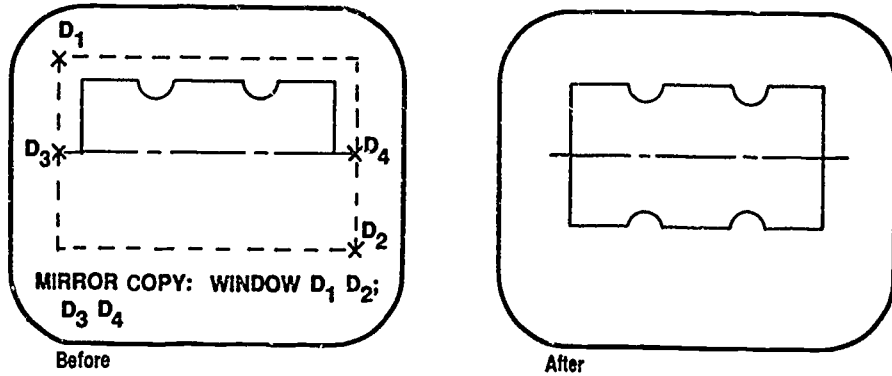

C. Move and copy — Existing geometry is duplicated and re-inserted somewhere else in the drawing

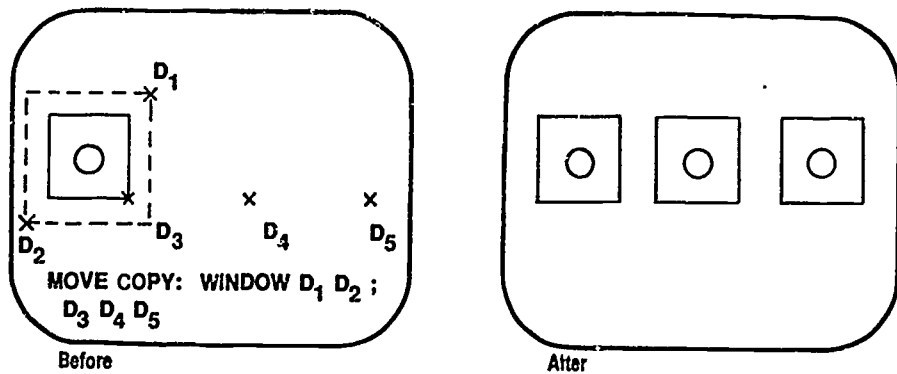

INFORMATION SHEET

- D. Rotate — Moves geometry about a specified axis of rotation

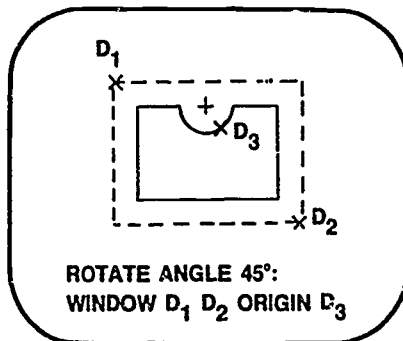

Before

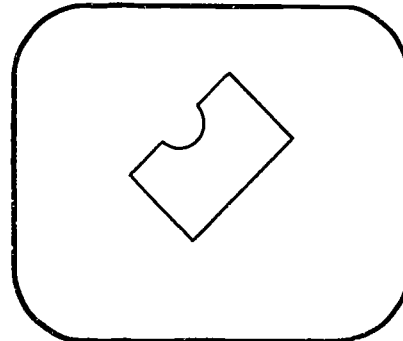

After

- E. Rotate and copy — Duplicates a feature as the object rotates

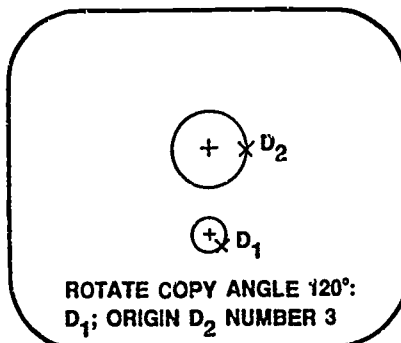

Before

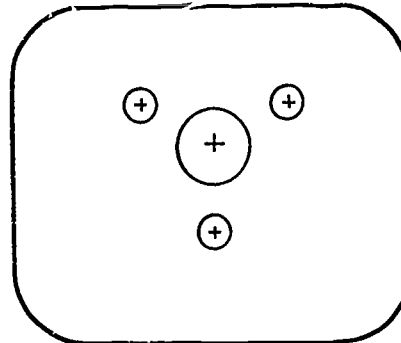

After

XII. Methods for removing or editing geometry on CADD

- A. Blank — Removes selected geometry from all views but the geometry still remains in the database
- B. Delete (Erase) — Removes one or more selected pieces of geometry from the screen drawing **and** the database

(NOTE: You may delete a portion of a drawing by capturing these items in a window. The command "Delete All" will remove the entire drawing from the screen and the database.)

- C. Divide — Breaks a piece of geometry into several pieces that can be revised, manipulated, or deleted individually
- D. Stretch — Allows the operator to lengthen (stretch) an entity from one side of a windowed area to connect with the same entity type on the other side

INFORMATION SHEET

E. Trim — Lengthens or shortens lines, arcs, circles, and splines

Examples:

1. Trimming a line

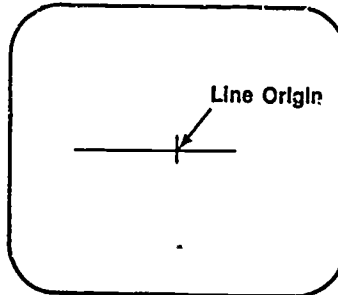
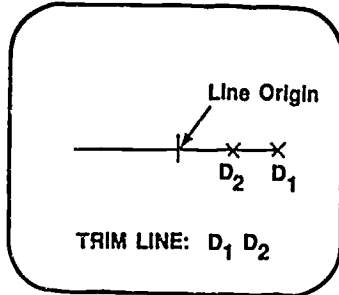

- D₁ — Identifies the line
- D₂ — Identifies where to trim line from
- D₃ — Identifies where to trim line to

2. Trimming an arc

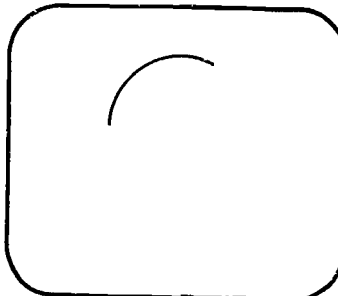
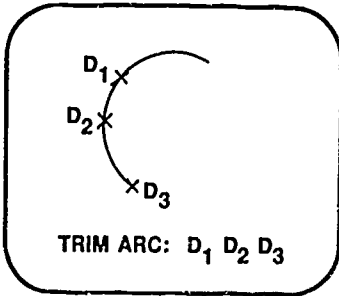

3. Trimming a circle

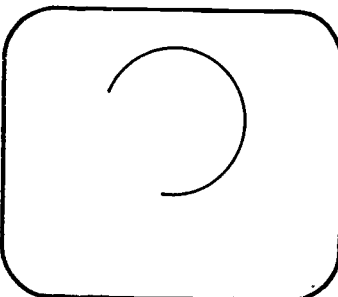
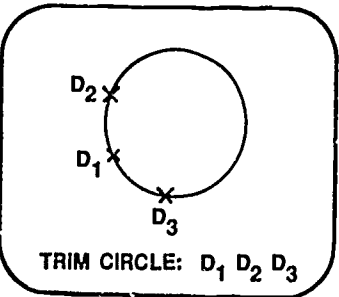

- D₁ — Identifies the circle
- D₂ — Identifies where to trim circle line from
- D₃ — Identifies where to trim circle line to

4. Trimming at the intersection of a line

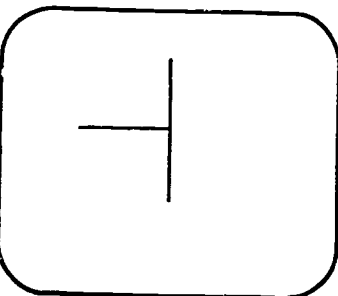
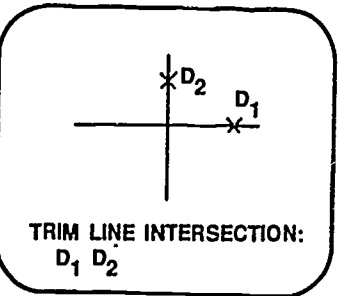

Primary Auxiliary

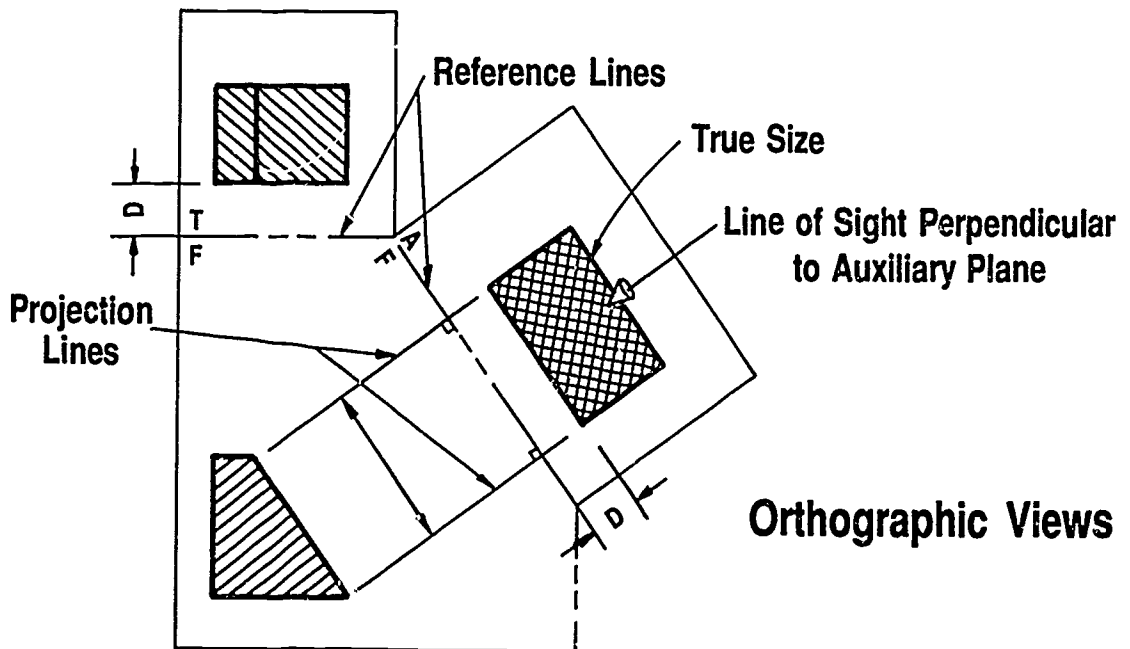
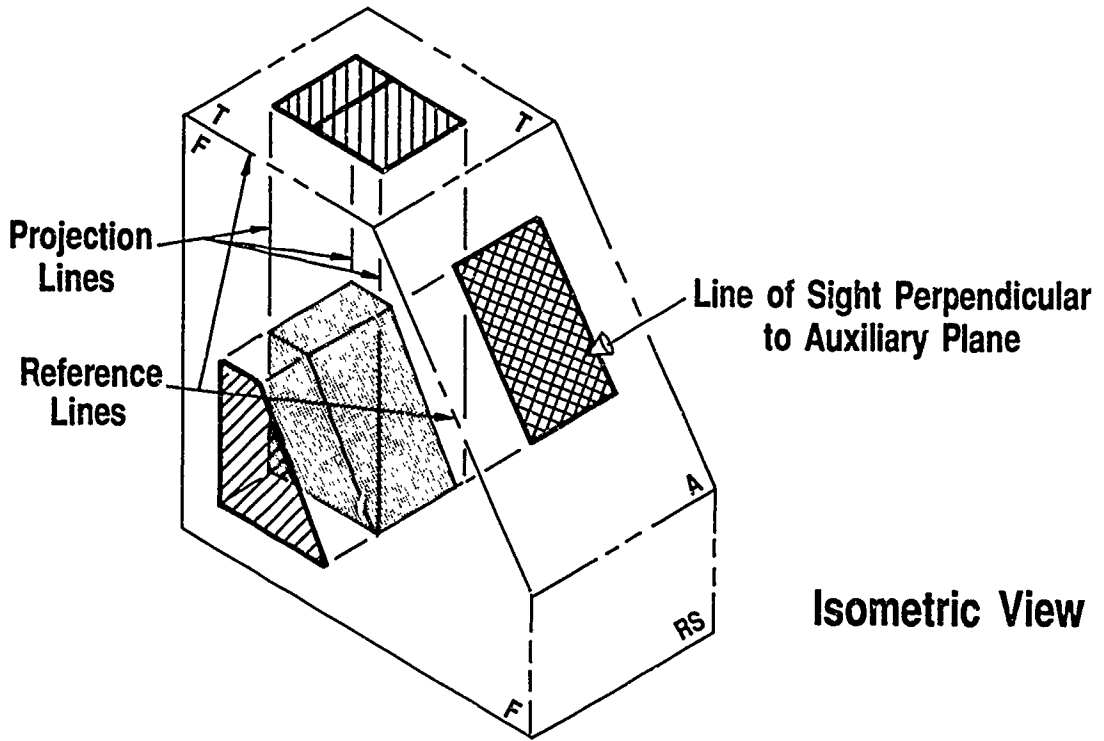

613

Primary Auxiliary (Continued)

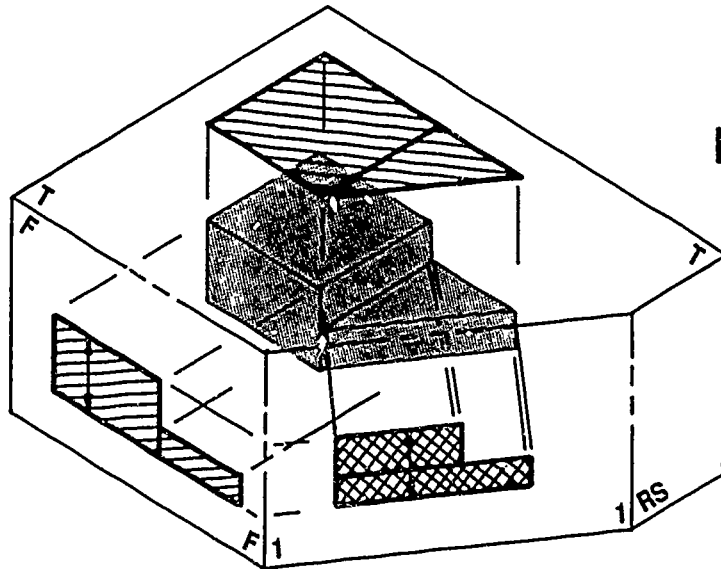

Isometric View

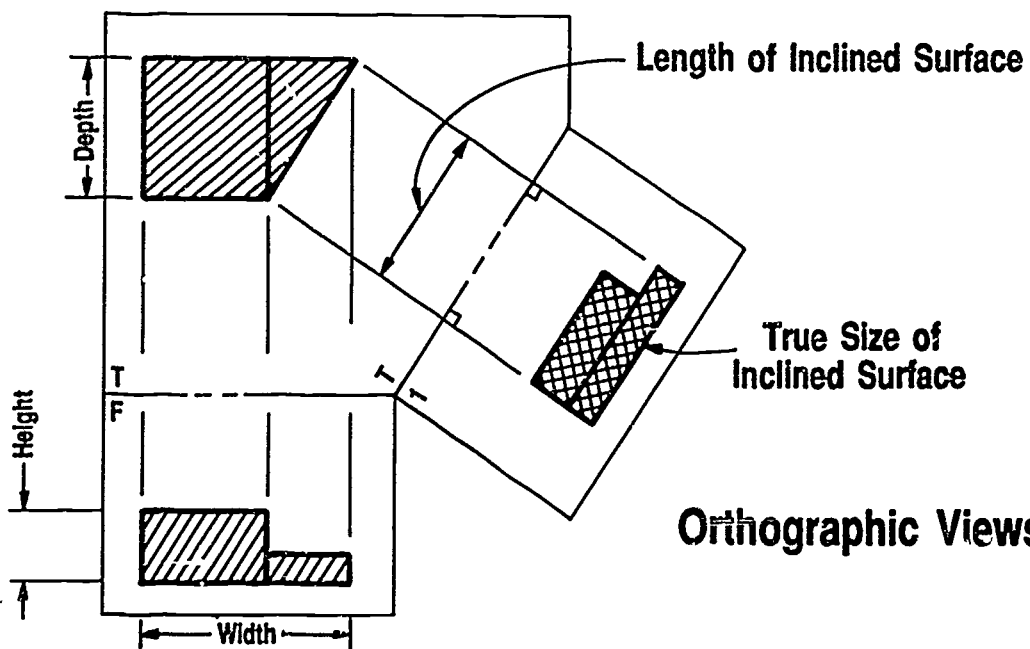

Orthographic Views

Need for Primary Auxiliary View

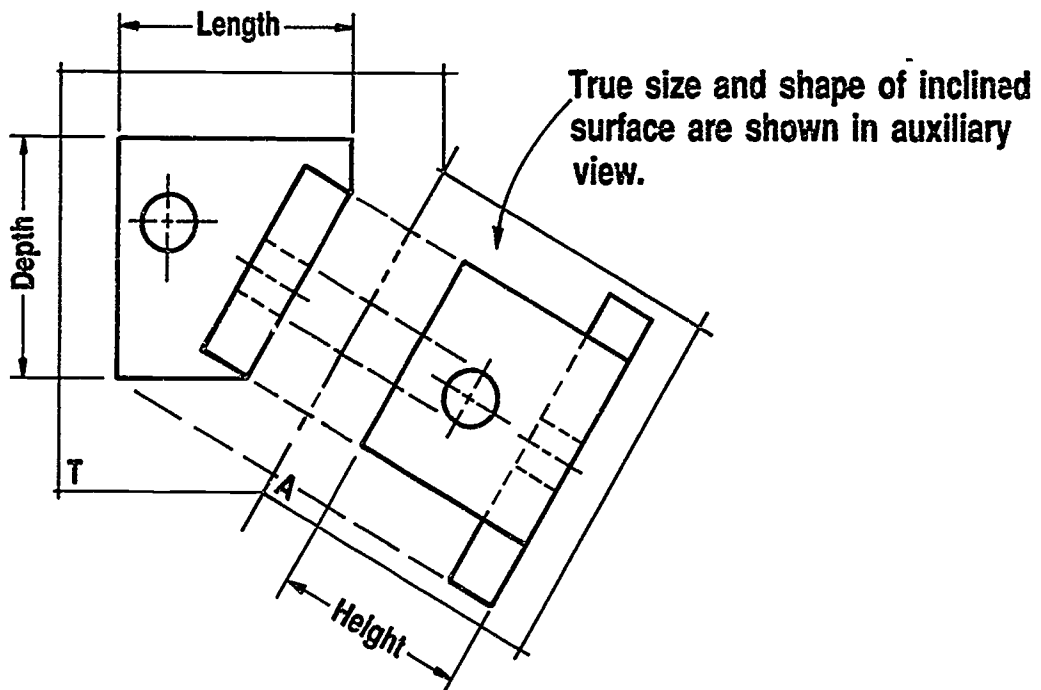
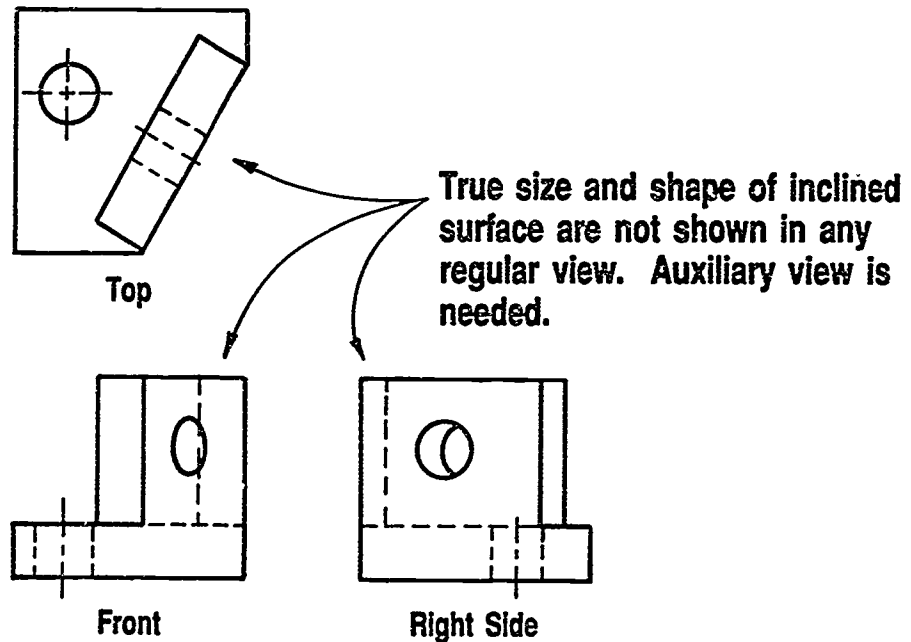

Possible Reference Line Locations

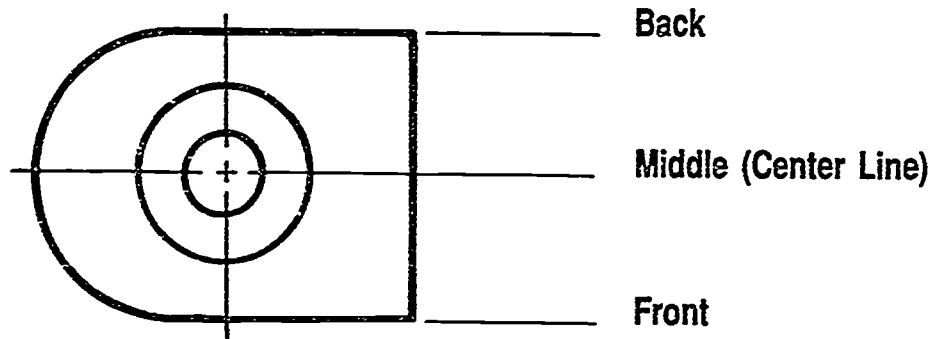

Reference Line _____ Between Views

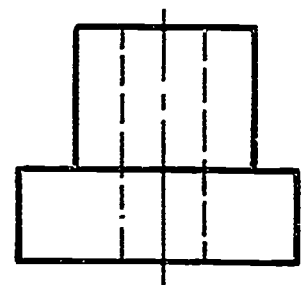
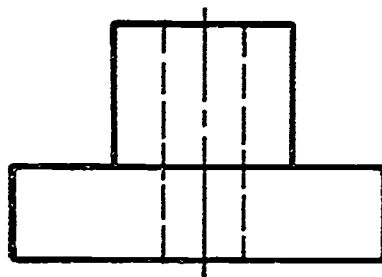

**AUXILIARY VIEWS
UNIT XII**

**ASSIGNMENT SHEET #1 — LABEL POINTS AND PLANES
OF A THREE-VIEW OBJECT**

NAME _____ SCORE _____

Introduction: When two planes meet, they form a line; when two lines meet, they form a point. An object is made of lines, points, and planes. In drawing auxiliary views of an object, it becomes necessary to label these lines, points, and planes with letters or numbers to be absolutely sure that the auxiliary views are formed correctly. Labeling points is not used in all of auxiliary view drawing, but it is beneficial on hard-to-visualize objects. Points and planes of a three-view object can be labelled by using the procedure in the following example.

Example:

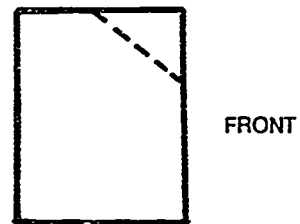
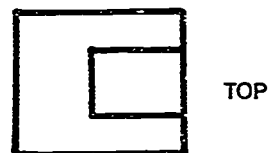
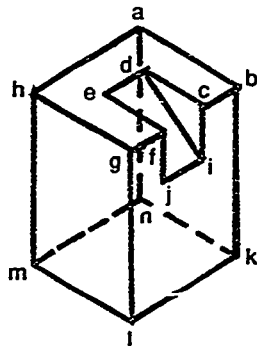

1. Use given two views of an object with a pictorial showing location of all points.

2. Start with top view and label all points that make up the corners of the top plane.

(NOTE: Use lower case letters. If two corners are on the same point, put the letter outside the object to indicate point closest to observer.)

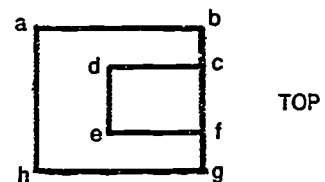

3. Label points that are away from observer by putting their point callout letters inside the object.

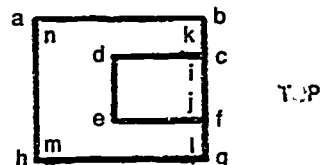

ASSIGNMENT SHEET #1

4. Use same procedure to locate point letter callouts in front view.

(NOTE: Points closest go outside the object; those behind go inside the object.)

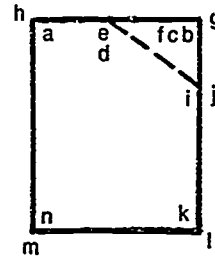

FRONT

Directions: Label points of the object below using lower case letters.

Problem:

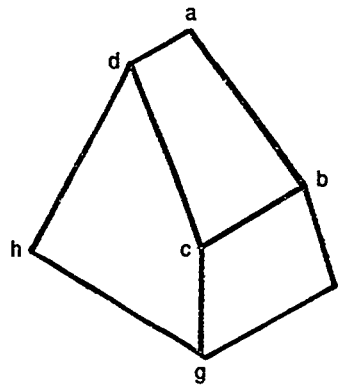
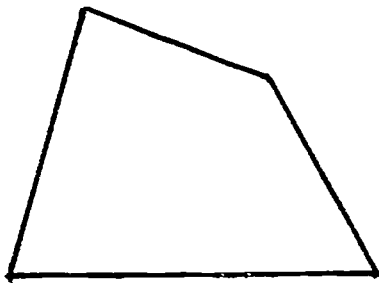
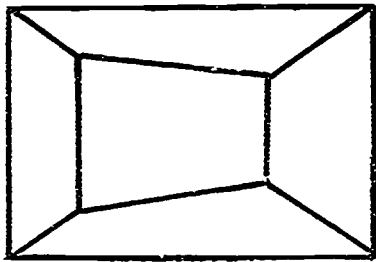

**AUXILIARY VIEWS
UNIT XII**

**ASSIGNMENT SHEET #2 — CONSTRUCT A PRIMARY AUXILIARY
OF AN INCLINED PLANE**

NAME _____ SCORE _____

Introduction: Many objects have a plane that is inclined. If this plane needs to be dimensioned, it will be necessary to draw it true size. A primary auxiliary of an inclined plane can be constructed by using the procedure in the following example.

Example:

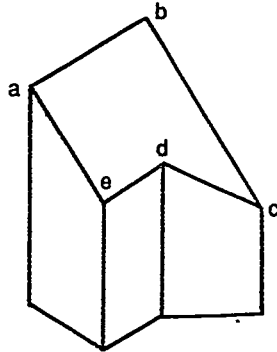

1. Use given top and front view of an object with an inclined plane.

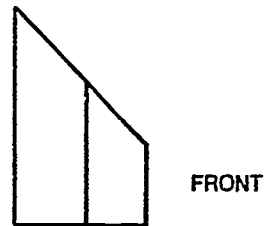

2. Determine line of sight perpendicular to edge view of plane abcde to be drawn to true size.

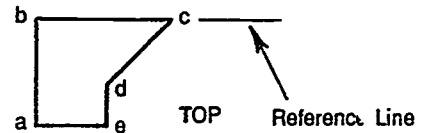

3. Locate reference line in the top view in any of the following places: back, middle, front, or between views.

(NOTE: The back of the top view was used for this example.)

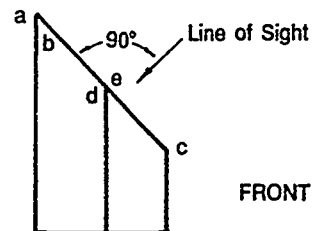

ASSIGNMENT SHEET #2

4. Locate reference line in auxiliary view perpendicular to line of sight at an adequate distance from edge of front view.
5. Draw light projection lines from points of plane to be drawn to true size.

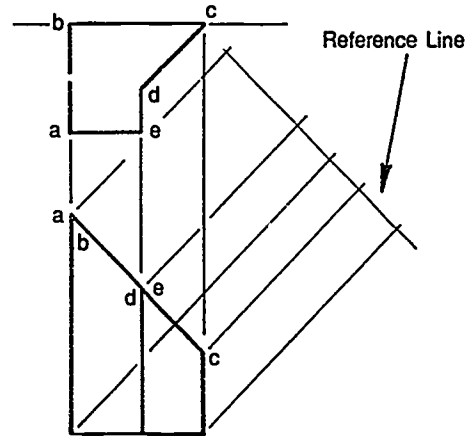

6. Locate points on or in relation to reference plane by transferring measurements from top view with dividers.
7. Connect points in auxiliary view that appear to be connected in top view; darken lines.

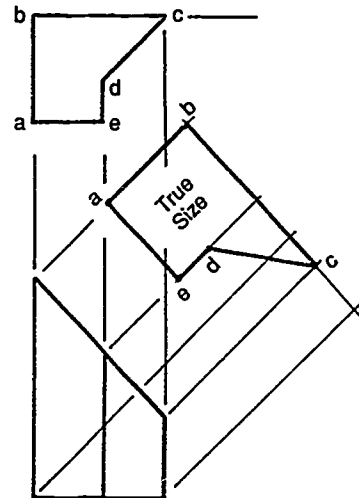

ASSIGNMENT SHEET #2

Directions: Label points and draw an auxiliary view of the inclined planes. Leave all construction lines.

Problem A:

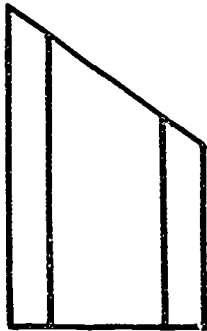
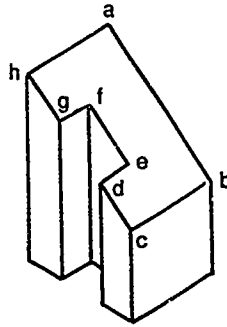

ASSIGNMENT SHEET #2

Problem B:

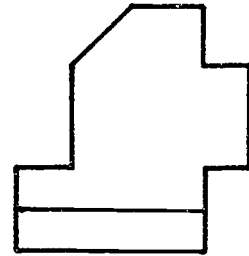
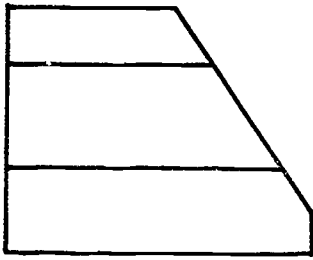

Problem C:

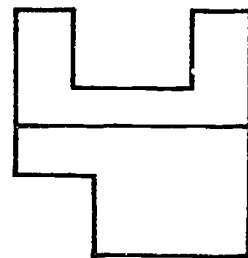
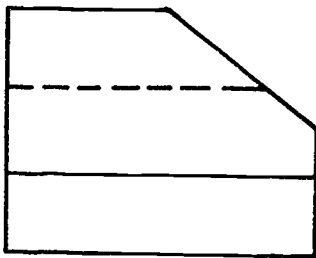

AUXILIARY VIEWS UNIT XII

ASSIGNMENT SHEET #3 — CONSTRUCT A PRIMARY AUXILIARY OF A CURVED SURFACE

NAME _____ SCORE _____

Introduction: A curved surface such as a circle is divided up into a series of points, and points are used to plot the true size of the curved surface. A true size auxiliary of a curved surface can be constructed by using the procedure in the following example.

Example:

1. Given an object that has a surface in the front view that is cut at an angle, divide the top view up into a series of points and number or letter each point.

2. Assume a line of sight perpendicular to the edge of the sloped surface.

3. Project points of circle in top view to edge of surface in front view.

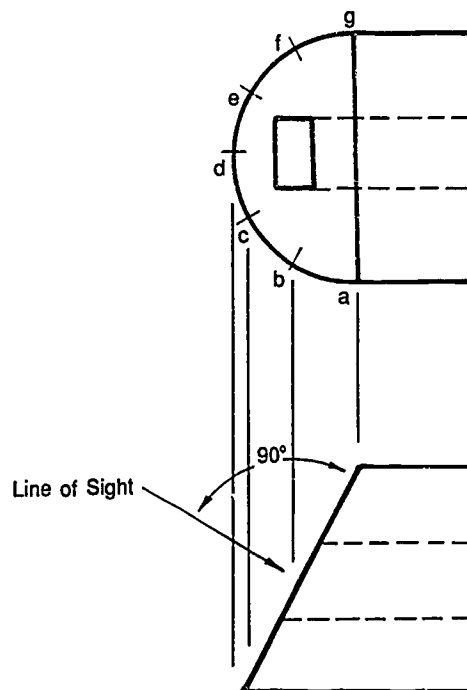

ASSIGNMENT SHEET #3

4. Project these points of intersection perpendicular to the surface edge and introduce reference plane center line.
5. Transfer points from top view center line to auxiliary view center line.

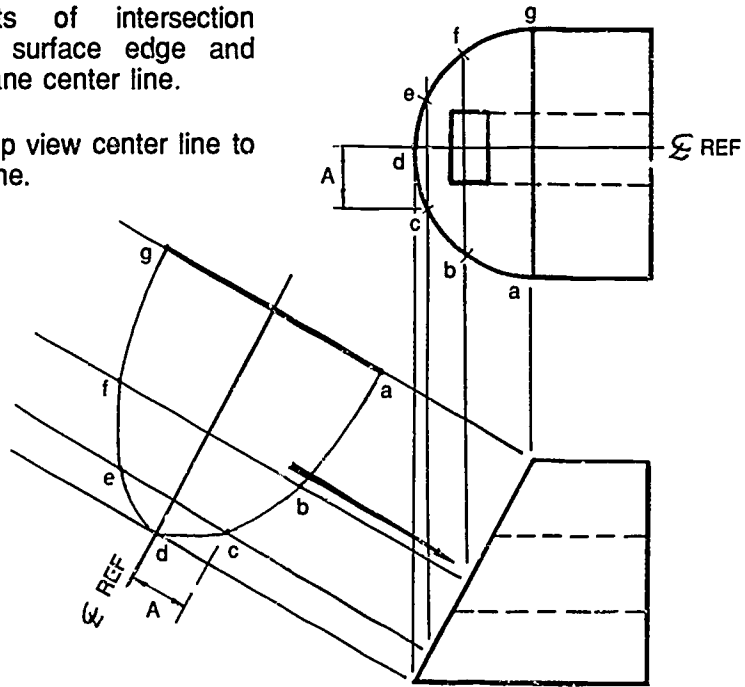

Directions: Construct a true size auxiliary view of the following inclined surfaces.

Problem A:

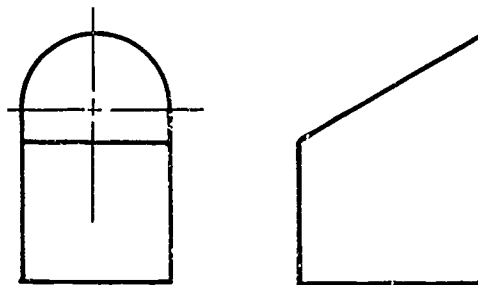

ASSIGNMENT SHEET #3

Problem B:

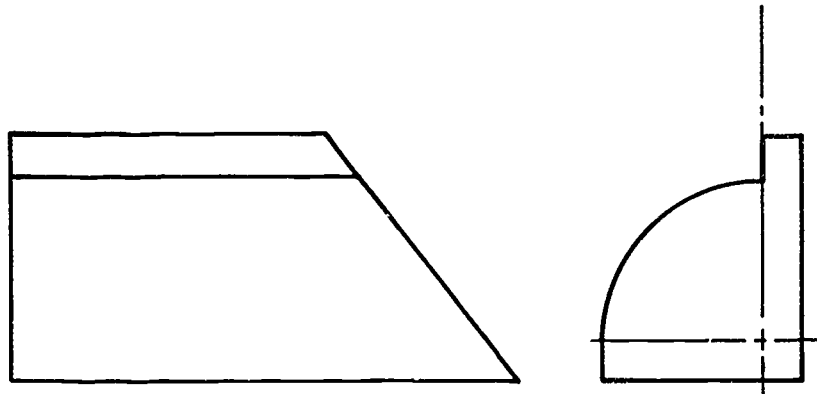

Problem C:

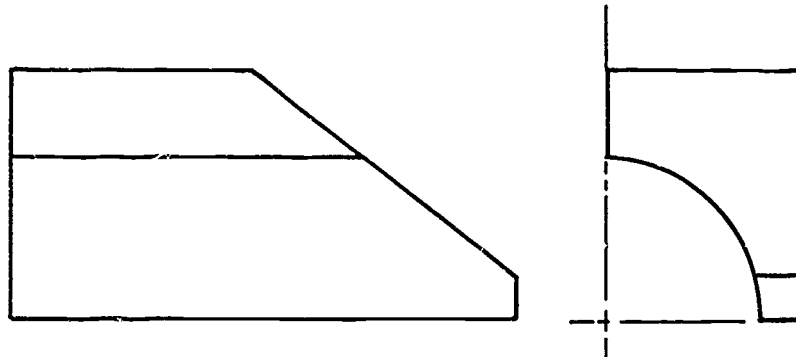

**AUXILIARY VIEWS
UNIT XII**

**ASSIGNMENT SHEET #4 — DETERMINE TRUE LENGTH
OF AN OBLIQUE LINE**

NAME _____ SCORE _____

Introduction: When a line is oblique to any principal view, an auxiliary view is required to find the true length. True length of an oblique line can be determined by using the procedure in the following example.

Example:

1. Use given two views of a skewed line a-b.

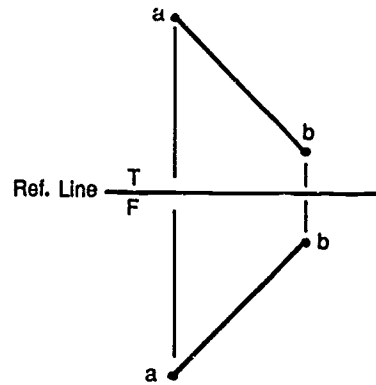

2. Assume 90° line of sight from any one of the four directions shown.

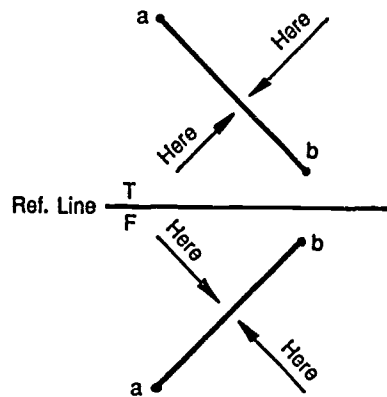

3. Select a line of sight with the least amount of congestion and most drawing space.

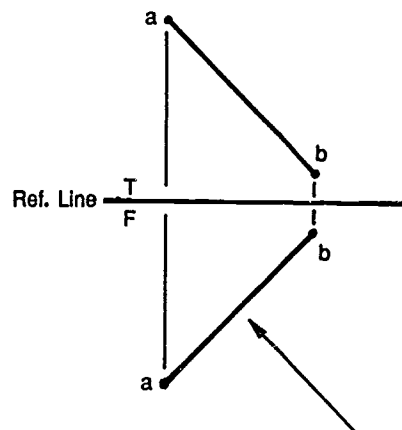

ASSIGNMENT SHEET #4

4. Assume reference line at a convenient distance perpendicular to line of sight; project points a-b through reference plane.

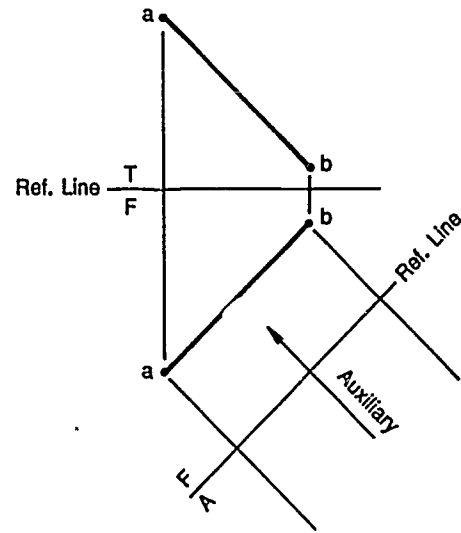

5. Transfer points a and b from top view and connect points to form true length line.

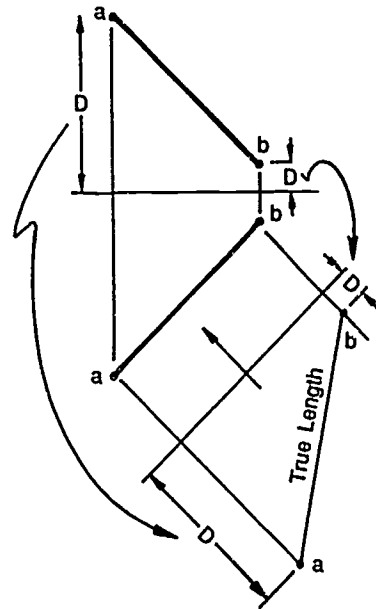

ASSIGNMENT SHEET #4

Directions: Determine true length of the lines given below. Label line TL.

Problem A:

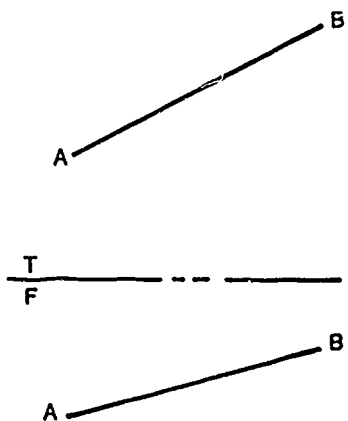

Problem B:

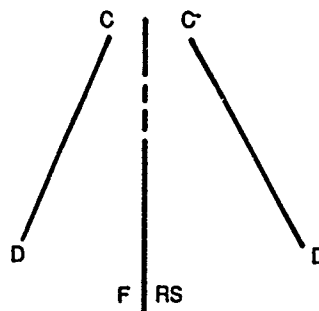

Problem C:

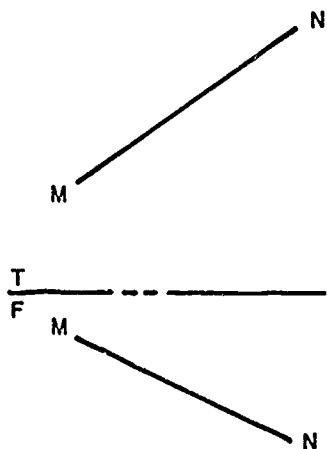

Problem D:

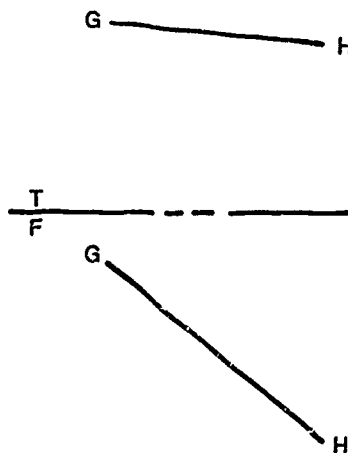

AUXILIARY VIEWS UNIT XII

ASSIGNMENT SHEET #5 — DETERMINE TRUE ANGLE AND SLOPE OF A LINE

NAME _____ SCORE _____

Introduction: The slope of a line is the angle the line makes with the top view. The slope may be expressed in percent or degrees of grade. When the line of slope is oblique to principal views, a primary auxiliary is needed to find true length of line. The true angle and slope of a line can be determined by using the procedure in the following example.

Example:

1. Use given top and front view of slope of line AB.

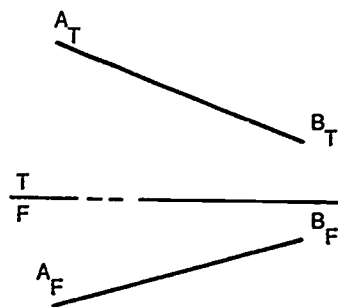

2. Construct reference line RL1 parallel to line A_F B_F.

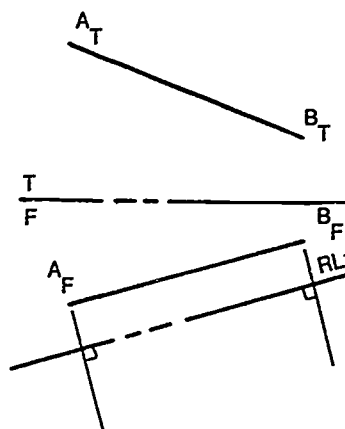

ASSIGNMENT SHEET #5

- Project end points perpendicular to line $A_F B_F$ and transfer distances from top view to establish true length line.

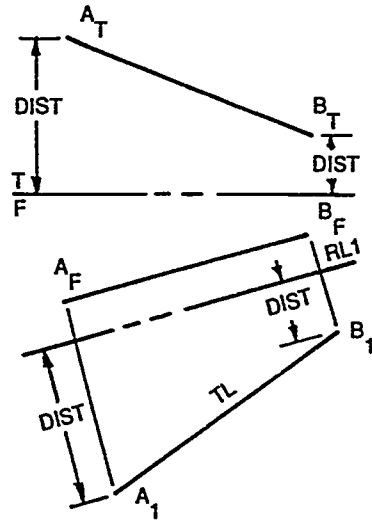

- Construct a line parallel and perpendicular to reference line to establish run and rise to slope.



- Use scale to mark divisions on run and rise lines; calculate percent slope

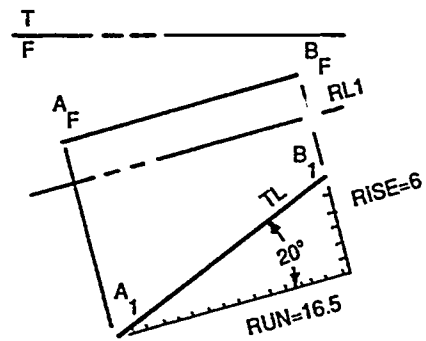

- Measure angle with protractor.

$$\text{SLOPE} = \frac{\text{RISE}}{\text{RUN}}$$

$$\text{SLOPE} = \frac{6}{16.5} = 36\%$$

630

ASSIGNMENT SHEET #5

Directions: Construct the true length of lines in the following problems. Calculate percent slope and measure the angle.

Problem A:

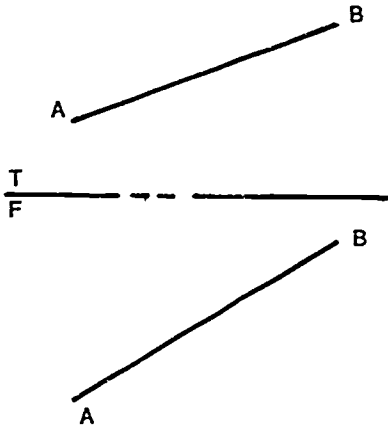

Problem B:

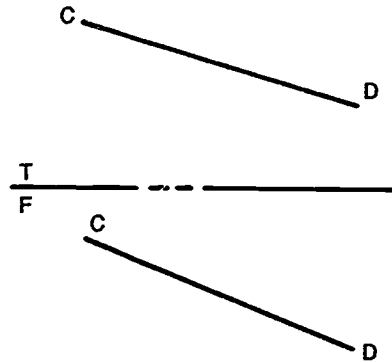

Problem C:

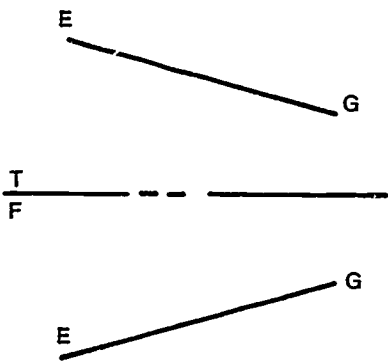

Problem D:

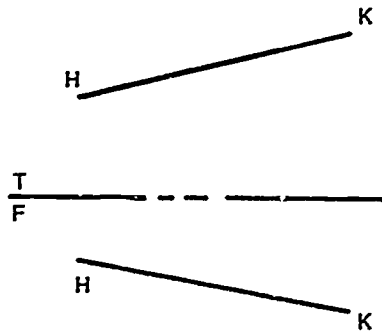

AUXILIARY VIEWS UNIT XII

ASSIGNMENT SHEET #6 — DETERMINE VISIBILITY OF CROSSING SKEW LINES IN SPACE

NAME _____ SCORE _____

Introduction: In the example of two nonintersecting pipes shown below, the visibility of the pipe nearest to the viewer cannot be determined. The procedure in the following example can be used to determine which pipe lies in front of the other.

Example:

1. Use given two views of crossing pipes with center lines labeled.

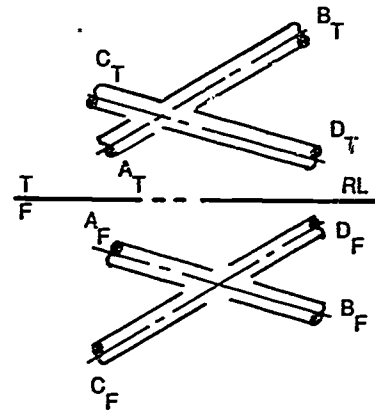

2. Determine visibility of line in top view.
 - a. Label the crossing of lines $A_T B_T$ and $C_T D_T$ as 1,2.
 - b. Project the crossing point to the front view, establishing points 1,2.
 - c. Point 1 is closer to reference line; therefore, line $A_T B_T$ is nearer in top view and is visible.

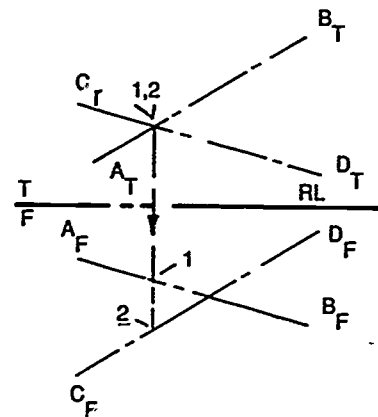

ASSIGNMENT SHEET #6

3. Determine the visible line in front view.
- Label the crossing of lines $A_F B_F$ and $C_F D_F$ as 3,4.
 - Project the crossing point to the top view, establishing points 3,4.

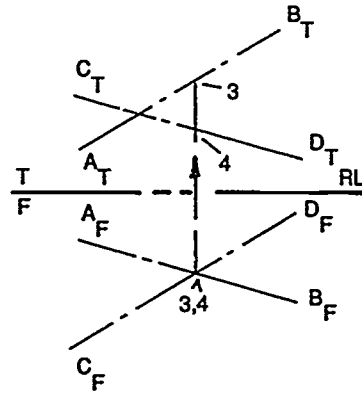

- Point 4 is closer to reference line; therefore, line $A_F B_F$ is nearer in front view and is visible.

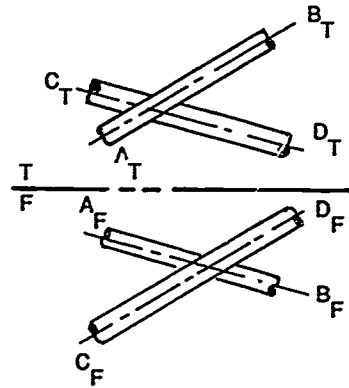

ASSIGNMENT SHEET #6

Directions: Determine which pipe is closer to the viewer in the following views. Leave projection lines.

Problem A:

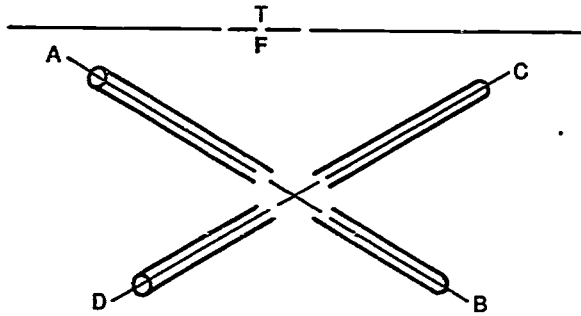
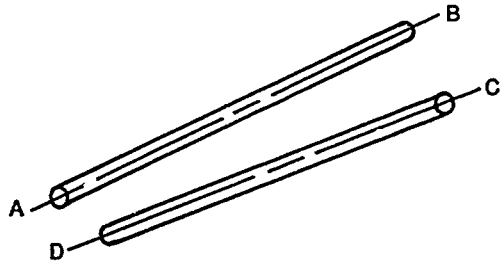

Problem B:

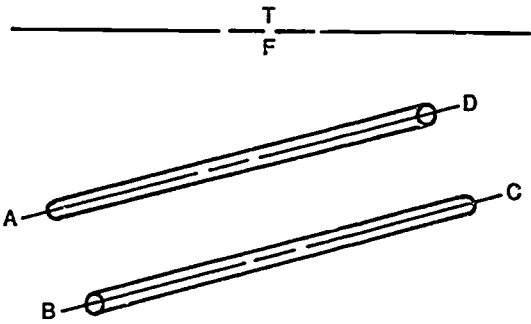
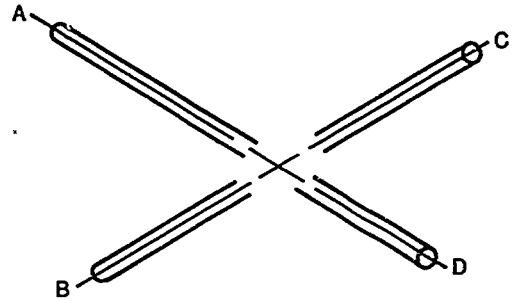

Problem C:

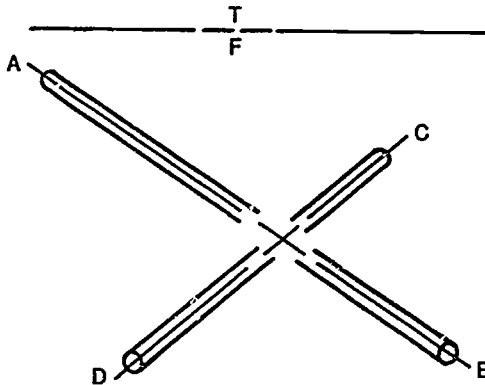
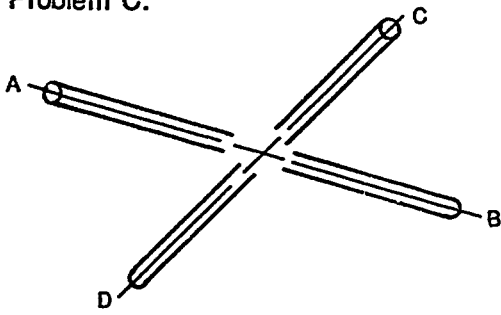

Problem D:

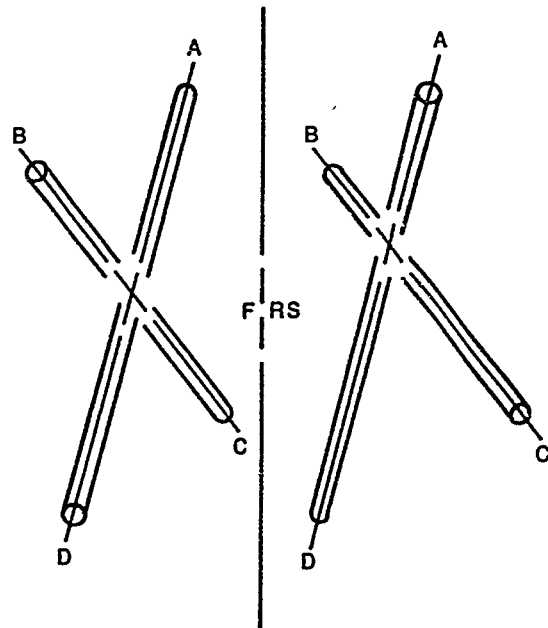

**AUXILIARY VIEWS
UNIT XII**

**ASSIGNMENT SHEET #7 — DETERMINE VISIBILITY OF A LINE
AND A PLANE THAT CROSS IN SPACE**

NAME _____ SCORE _____

Introduction: Determining the visibility of a line and a plane that cross in space is similar to that of crossing lines. The visibility of a line and a plane that cross in space can be determined by using the procedure in the following example.

Example:

1. Use given two views of plane ABC and line XY crossing in space.

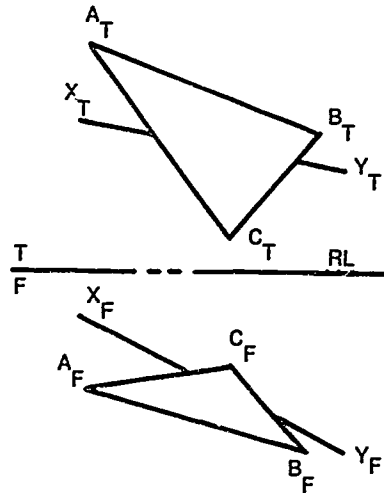

2. Determine visibility of line in top view.
 - a. Label the crossing of line $X_T Y_T$ with plane $A_T B_T C_T$ as 1,2.
 - b. Project the crossing points to the front view, establishing points 1,2.
 - c. The projected lines intersect line $X_F Y_F$ before they intersect the plane; therefore, line $X_F Y_F$ is nearer to top view and is visible.

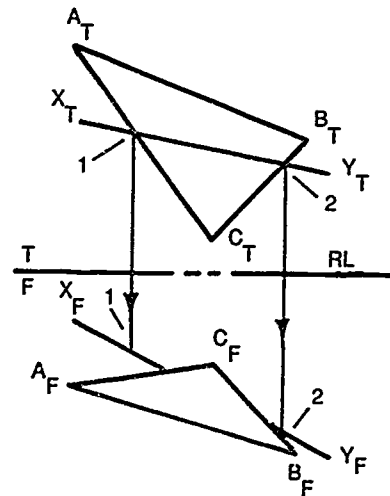

ASSIGNMENT SHEET #7

3. Determine visibility of line in front view.
 - a. Label the crossing of line $X_F Y_F$ with plane $A_F B_F C_F$ as 3,4.
 - b. Project the crossing points to the top view, establishing points 3,4.
 - c. The projected lines intersect the plane before they intersect the line; therefore, line $X_T Y_T$ is hidden in the front view.

(NOTE: The plane is nearer to the front view and line XY crosses behind plane ABC .)

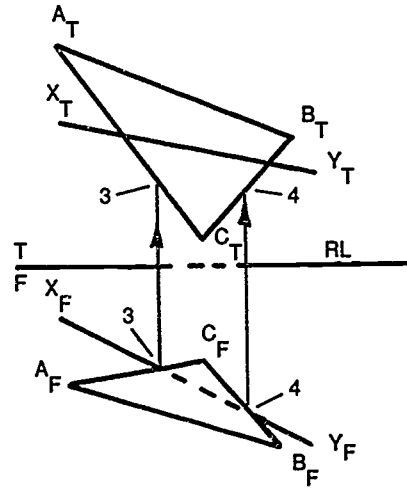

Directions: Complete the following two view drawings showing the visible and hidden lines. Leave projection lines.

Problem A:

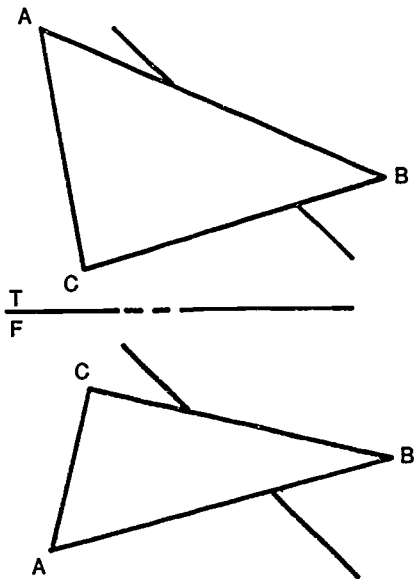

Problem B:

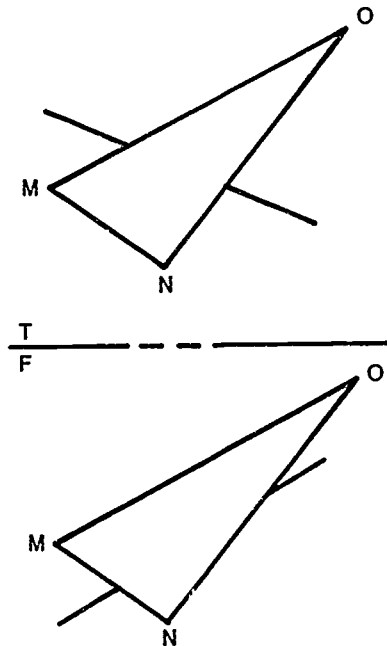

ASSIGNMENT SHEET #7

Problem C:

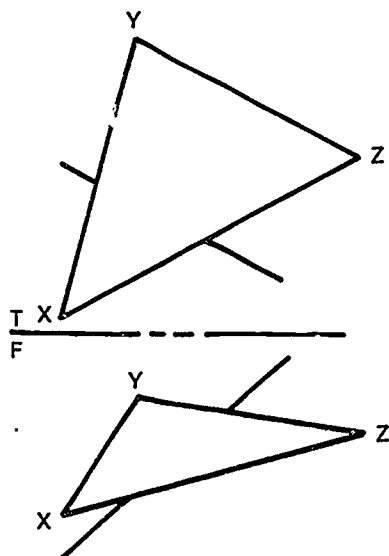

Problem D:

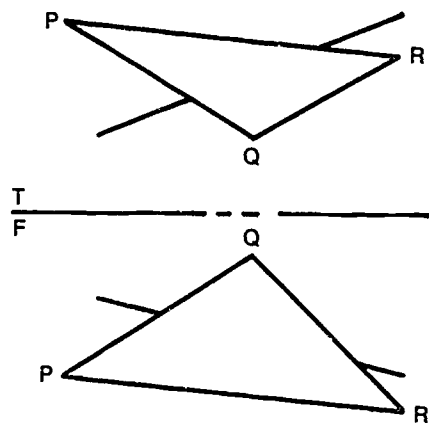

**AUXILIARY VIEWS
UNIT XII**

**ASSIGNMENT SHEET #8 — LOCATE PIERCING POINT
OF A LINE AND A PLANE**

NAME _____ SCORE _____

Introduction: The piercing point of a line and a plane may be located by constructing a primary auxiliary view. An edge view of a plane and a line is projected from one of the planes, and a line is projected from one of the principal views to show intersection. The point where the line intersects the plane is projected to the principal views. The procedure for determining visibility of lines was demonstrated in Assignment Sheets 6 and 7. The piercing point of a line and a plane can be located by using the procedure in the following example.

Example:

1. Use given views of line XY and plane ABC.

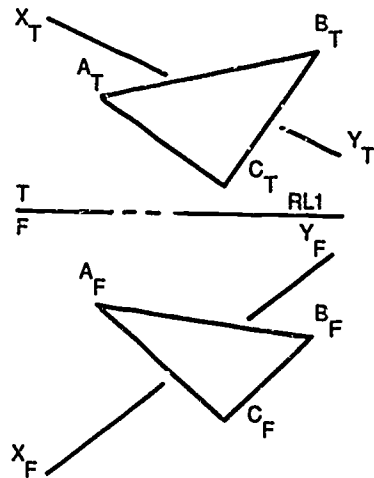

2. Construct line $A_T D_T$ in top view parallel to reference line RL1; then project point D_T to front view, locating point D_F .

(NOTE: Line AD may be constructed parallel to RL1 in front view.)

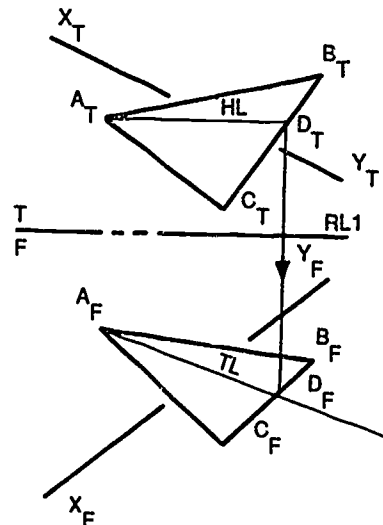

ASSIGNMENT SHEET #8

- Project true length line $A_F D_F$ as line of sight; construct reference line $RL2$ perpendicular to it.

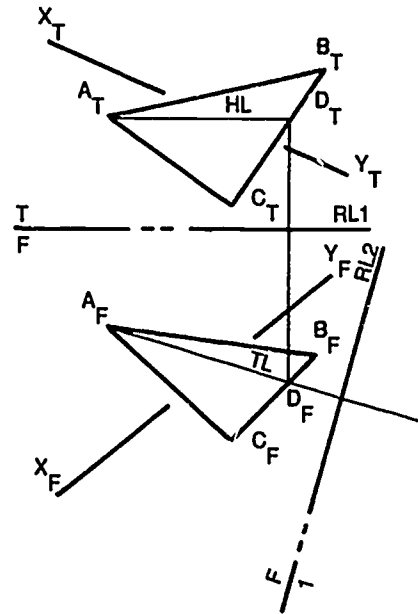

- Project points A_F , B_F , C_F , X_F , and Y_F to auxiliary view and transfer distances from top view to establish piercing point O_1 .

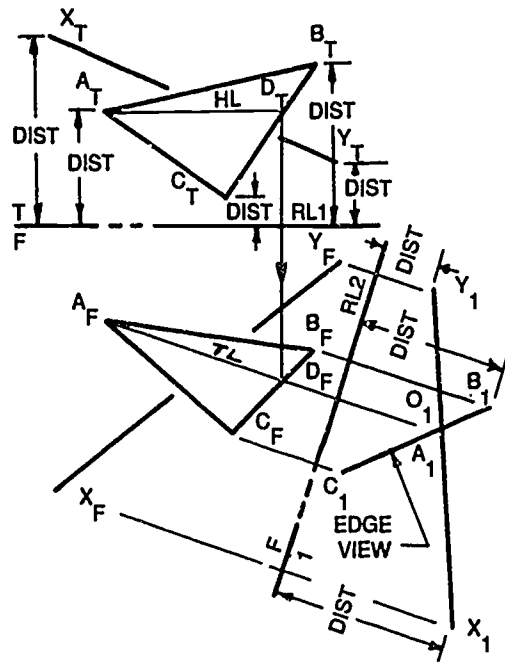

ASSIGNMENT SHEET #8

5. Project the piercing point to front and top views.

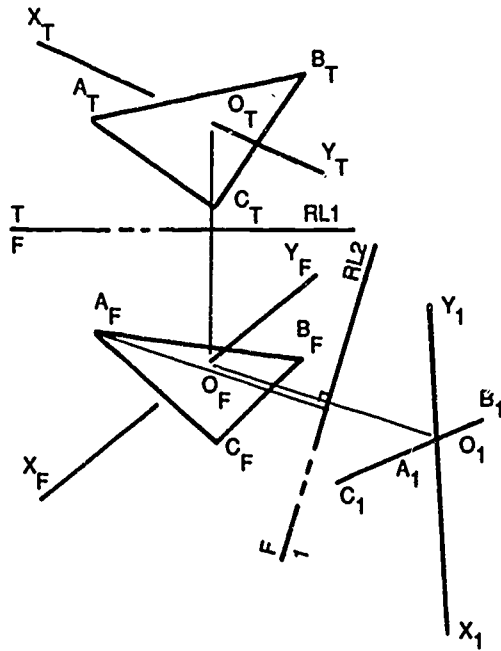

6. Determine visibility of line XY.

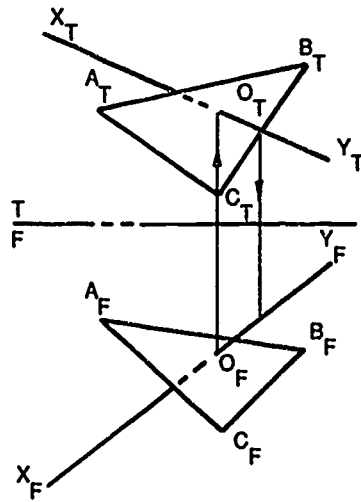

ASSIGNMENT SHEET #8

Directions: Determine piercing point of a line and a plane in the following problems. Leave construction lines and determine visibility of lines.

Problem A:

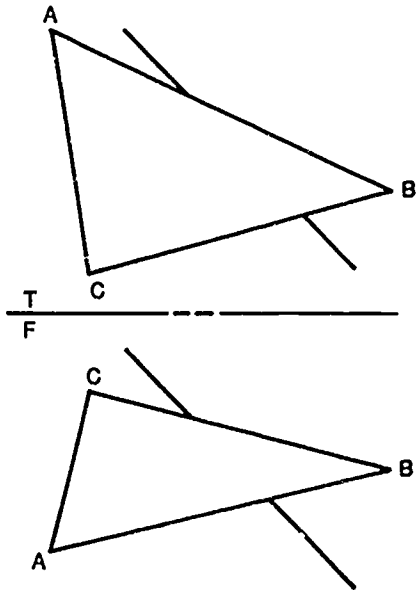

Problem B:

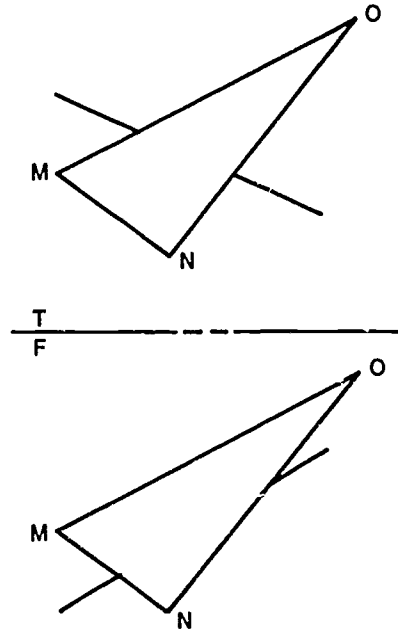

Problem C:

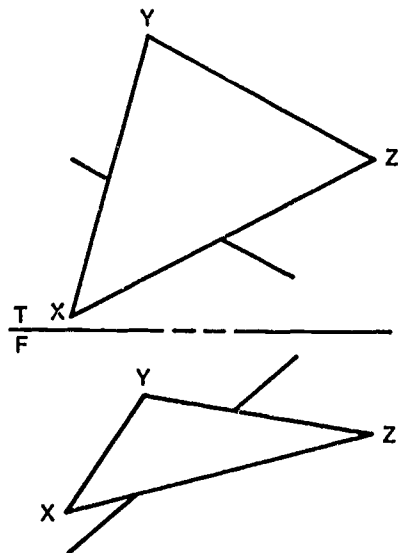

Problem D:

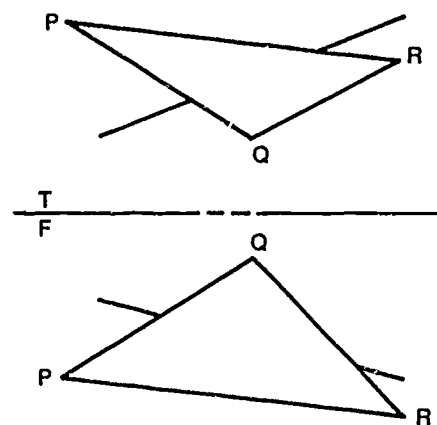

641

**AUXILIARY VIEWS
UNIT XII**

ASSIGNMENT SHEET #9 — DETERMINE POINT VIEW OF A LINE

NAME _____ SCORE _____

Introduction: Determining the point view of a line is basic for projection of a secondary auxiliary view. The procedure given in the example is for determining point view of only one line. The procedure for finding point view of oblique lines is the same. Point view of a line can be constructed by using the procedure in the following example.

Example:

1. Use given top and front view of line AB.

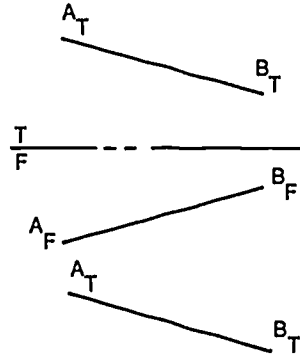

2. Construct reference line RL1 parallel to line A_FB_F.

(NOTE: Top view could have been used.)

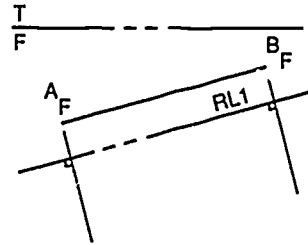

3. Find true length of line A_FB_F by projecting end points from front view; then transfer from top view.

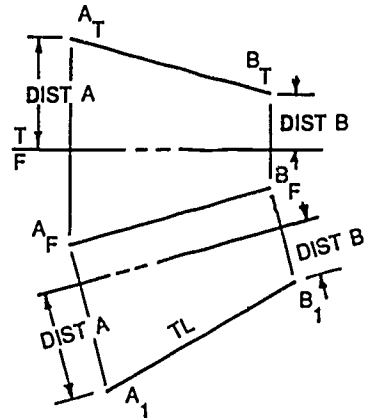

ASSIGNMENT SHEET #9

4. Construct reference line RL2 perpendicular to true length line A_1B_1 .
5. To find point view of line, transfer distance from front view and project line A_1B_1 to secondary auxiliary view.

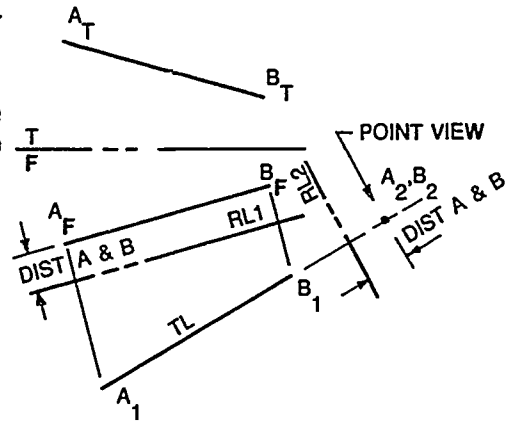

Directions: Construct a point view of a line in the following problems. Label end points of lines in construction. Leave construction lines.

Problem A:

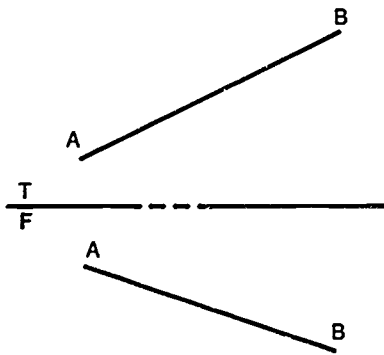

643

ASSIGNMENT SHEET #9

Problem B:

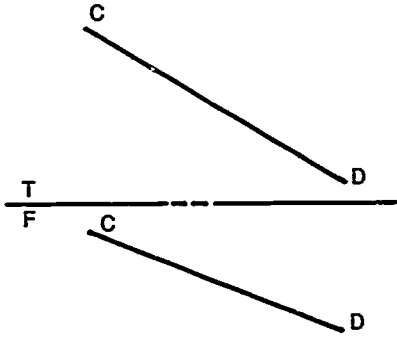

**AUXILIARY VIEWS
UNIT XII**

**ASSIGNMENT SHEET #10 — CONSTRUCT SECONDARY AUXILIARY
VIEWS OF AN OBJECT**

NAME _____ SCORE _____

Introduction: An infinite number of views can be taken from any view of an object. The first auxiliary off the orthographic view is called a primary auxiliary view. An auxiliary off a primary auxiliary view is called a secondary auxiliary. A secondary auxiliary view can be constructed by using the procedure in the following example. An auxiliary can be drawn of any angle desired or needed for this procedure.

Example:

1. Use given top and front view of a simple object. Assume a line of sight at angle indicated.

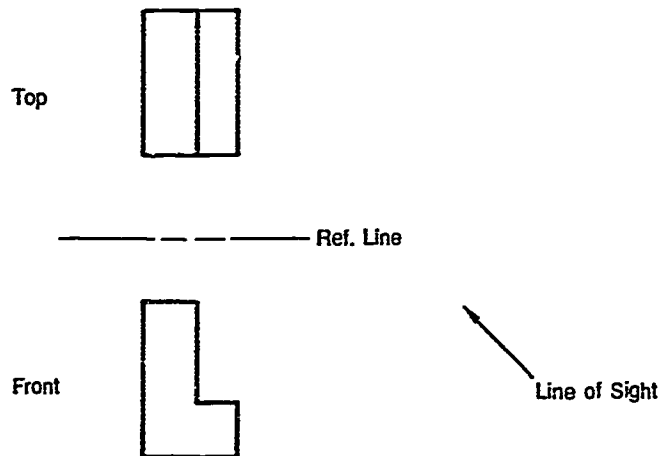

2. Label all points with letters or numbers.

ASSIGNMENT SHEET #10

3. Project each point to auxiliary view and transfer point distances from front view (the offset view).

(NOTE: Always skip a view for transfer of measurements.)

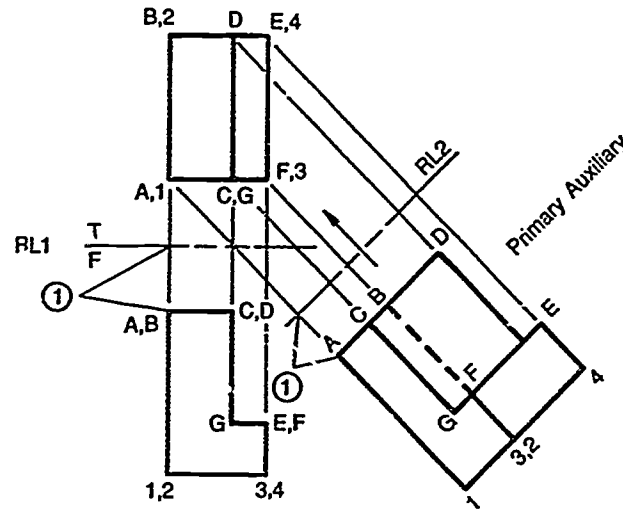

4. Determine visibility of lines in a solid form in an auxiliary view by the following rules:
- a. The outside lines of every view will be visible.
 - b. The corner or edge of the object nearest to the observer will be visible (of the view being folded off of.)
 - c. The corner or edge farthest from the observer will usually be hidden if it lies within the outline of the new view.
 - d. Crossing edges (lines) that are approximately equidistant from the observer must be tested for visibility at the crossing point.

(NOTE: See Assignment Sheets 6 and 7 for this procedure.)

- e. Visibility of the inside lines in any view is primarily determined by reference to an adjacent view.

ASSIGNMENT SHEET #10

5. Assume another line of sight for view number two (the secondary auxiliary). Transfer dimensions from top view.

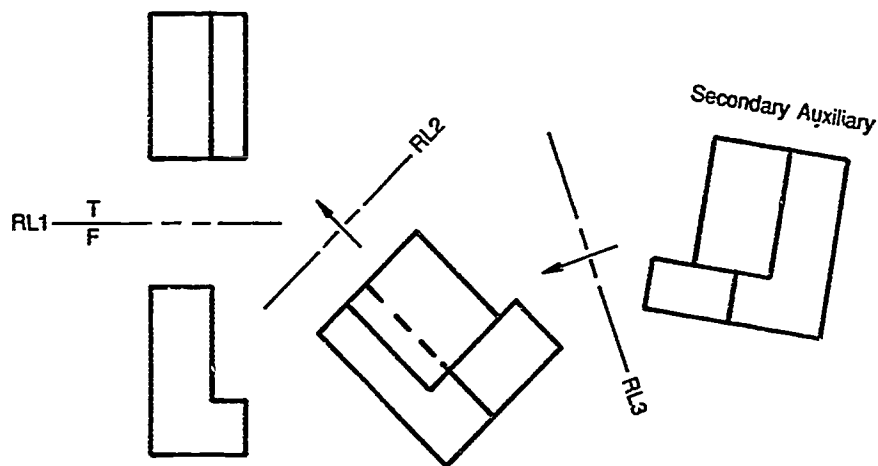

6. Continue to label all points.
7. Draw projector lines at a right angle to the new reference lines to locate new points for the secondary auxiliary view.

(NOTE: Remember the points are taken from the offset view. This process can go on indefinitely from any view in any direction. The principle is the same and the basic steps are the same.)

ASSIGNMENT SHEET #10

Directions: Construct auxiliary views at lines of sight indicated.

Problem:

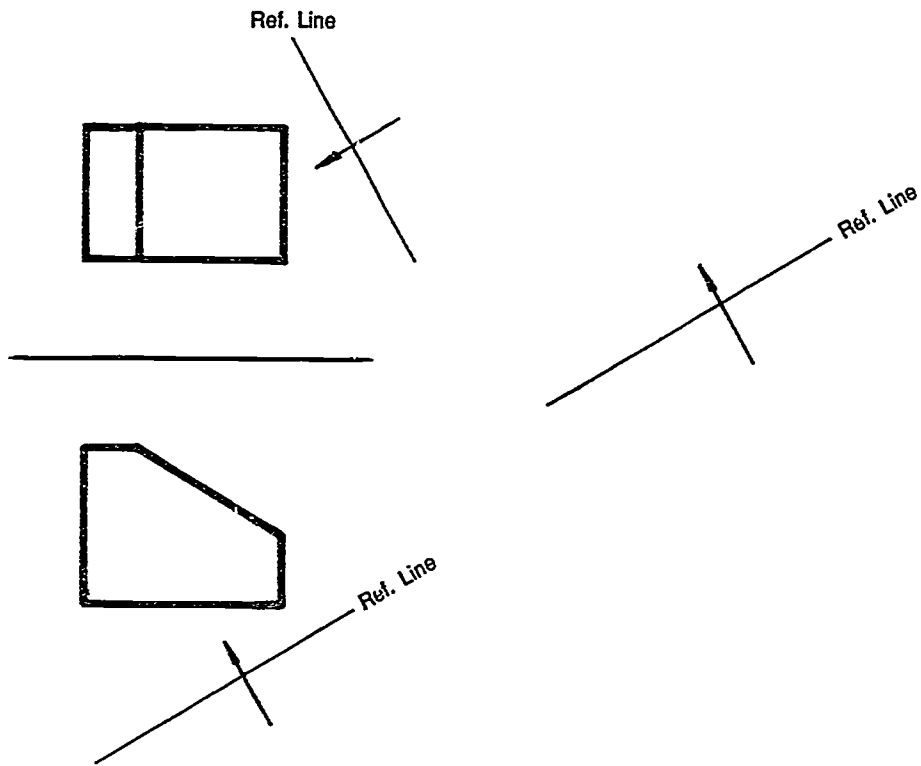

AUXILIARY VIEWS UNIT XII

ASSIGNMENT SHEET #11 — CONSTRUCT A SECONDARY AUXILIARY OF AN OBLIQUE PLANE

NAME _____ SCORE _____

Introduction: An oblique plane is at an angle to three principal views. It will not appear true size in any of the views; therefore, it is necessary to draw an auxiliary view of it. Oblique planes are not uncommon on many types of drawings. A simple example is given, but the basic principles will apply for all situations. An auxiliary of an oblique plane can be constructed by using the procedure in the following example.

Example:

1. Use given surface abcd, top and front view.

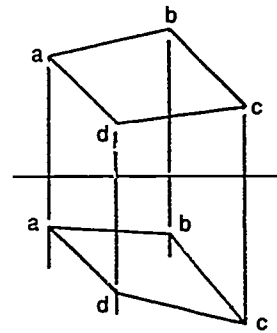

2. Construct a horizontal line either in the top or front view at point a or c in top or point b or d in front.

(NOTE: In this example, use point d in front and extend it horizontally to line bc making a new point e.)

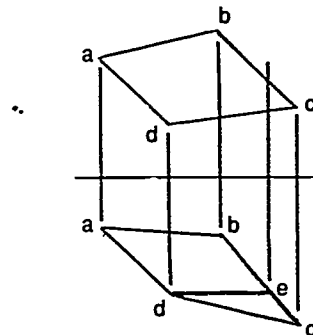

3. Project point e to top view until it crosses line bc and drawn line de in top. Line de is true length.

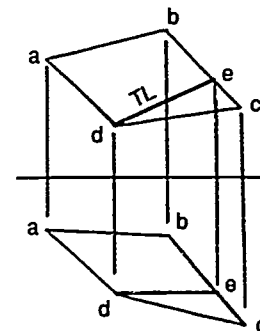

ASSIGNMENT SHEET #11

4. Assume a line of sight looking into the end of line de . Draw reference line perpendicular to line of sight.

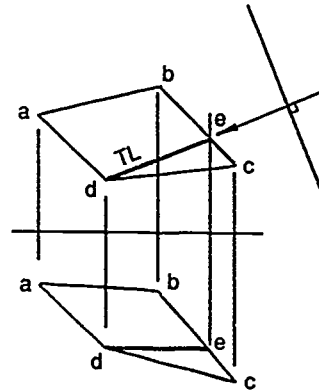

5. Project points $abcd$ through reference line and transfer measurements from front view.

(NOTE: Points $abcd$ will form a straight line which is an edge view of plane.)

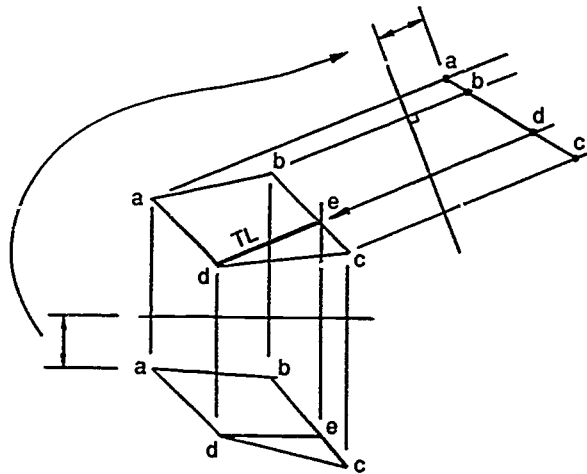

6. Assume a line of sight perpendicular to edge view and draw a true size view of plane $abcd$ by transferring point distances from top view to true size auxiliary view.
7. Connect points to form true size of plane.

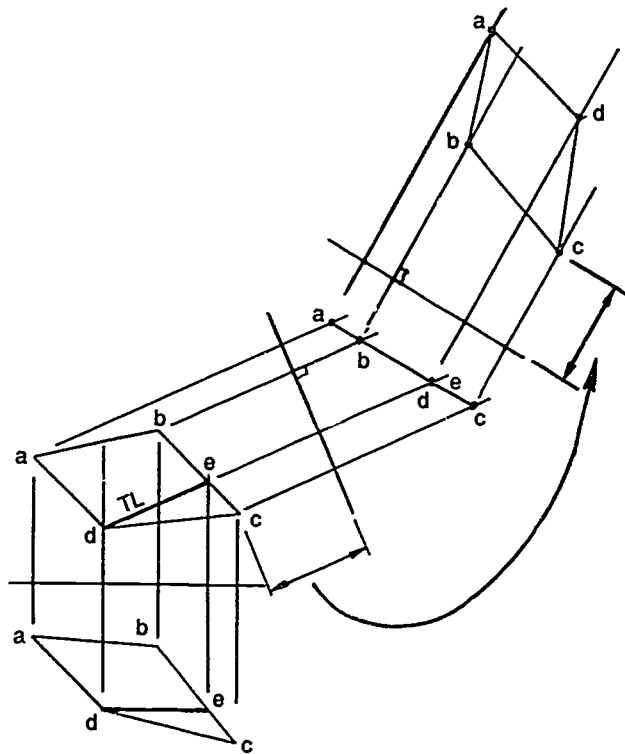

650

ASSIGNMENT SHEET #11

Directions: Construct true size view of the oblique planes in the problems given.

Problem A:

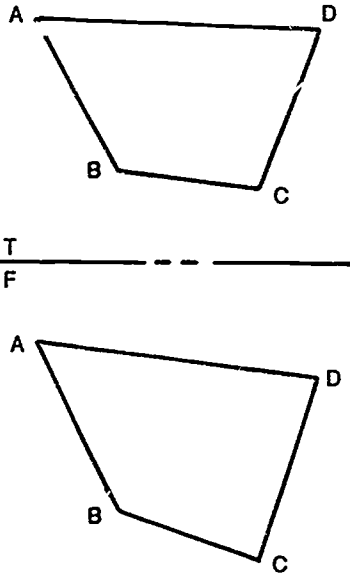

ASSIGNMENT SHEET #11

Problem B:

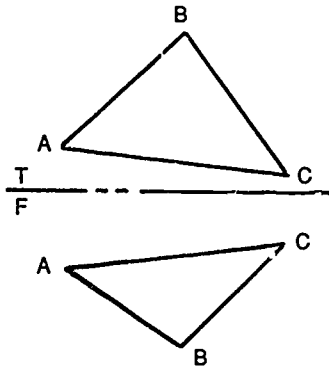

Problem C:

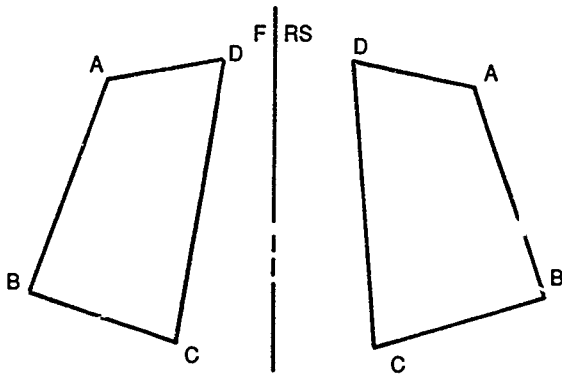

652

AUXILIARY VIEWS UNIT XII

ASSIGNMENT SHEET #12 — DETERMINE THE TRUE ANGLE BETWEEN TWO PLANES

NAME _____ SCORE _____

Introduction: In the design and manufacture of parts, it is sometimes necessary to determine the angle between two planes. This angle can be determined when the line of intersection is parallel to one of the principal views. The true angle between two planes can be determined by using the procedure in the following example.

Example:

1. Use given top and front views of the two planes.

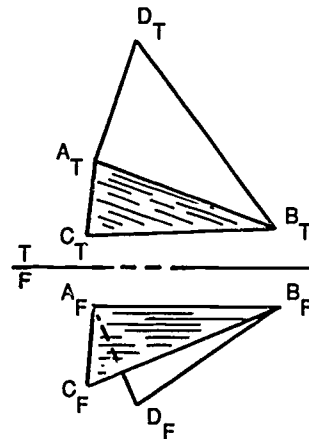

2. Line of intersection at $A_T B_T$ is viewed in its true length in top view.

(NOTE: For this procedure that line of intersection must be parallel to one of the principal planes.)

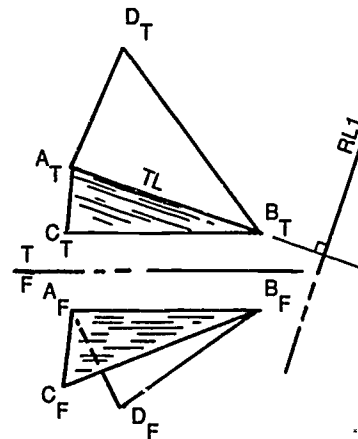

3. Construct reference line RL1 perpendicular to true length line.

ASSIGNMENT SHEET #12

- Project points from top view to primary auxiliary perpendicular to reference line; transfer distances from front view to primary auxiliary to establish edge view of planes.

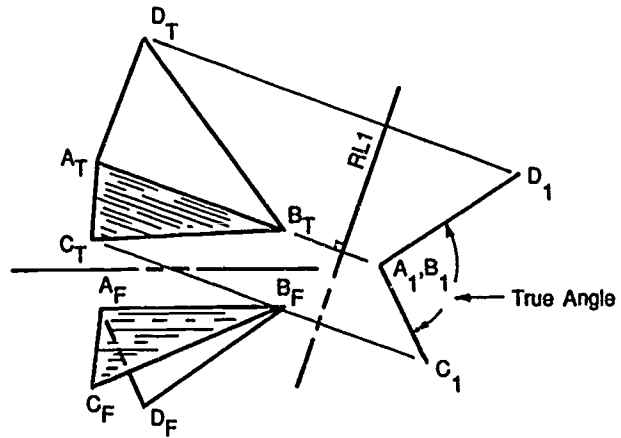

- Measure true angle between the two planes.

Directions: Determine the true angle between two planes in the following problems. Measure angle with protractor. Label corners of planes. Leave construction lines.

Problem A:

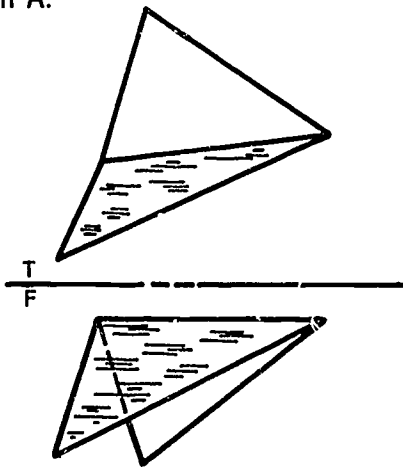

Problem B:

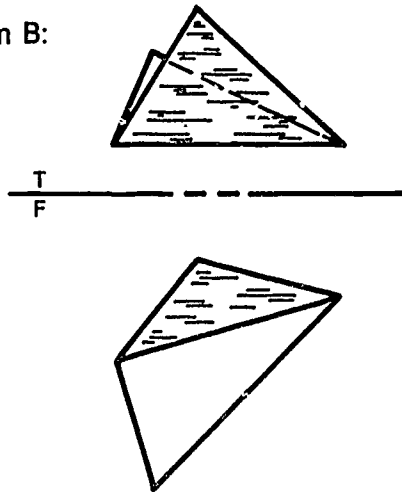

AUXILIARY VIEWS UNIT XII

ASSIGNMENT SHEET #13 — DETERMINE TRUE ANGLE BETWEEN TWO PLANES IN A SECONDARY AUXILIARY

NAME _____ SCORE _____

Introduction: When the line of intersection between two planes is an oblique line, a secondary auxiliary view is required. True angle between two planes in a secondary auxiliary can be determined by using the procedure in the following example.

Example:

1. Use given top and front views of the two planes.

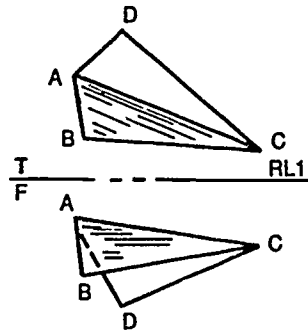

2. Construct primary auxiliary view of planes to determine true length of line of intersection.

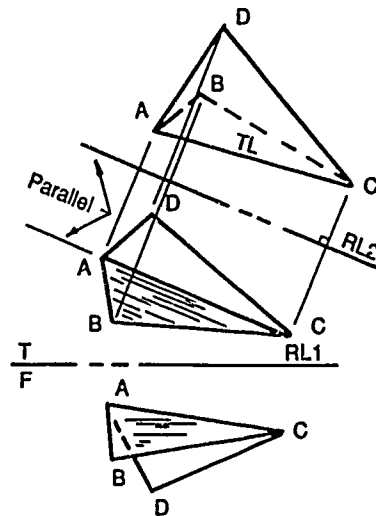

ASSIGNMENT SHEET #13

3. Construct a secondary auxiliary view to determine point of intersection.
4. Locate points B_2D_2 by projecting from primary auxiliary view; transfer distances from top view.
5. Measure true angle between line of intersection of two planes with protractor.

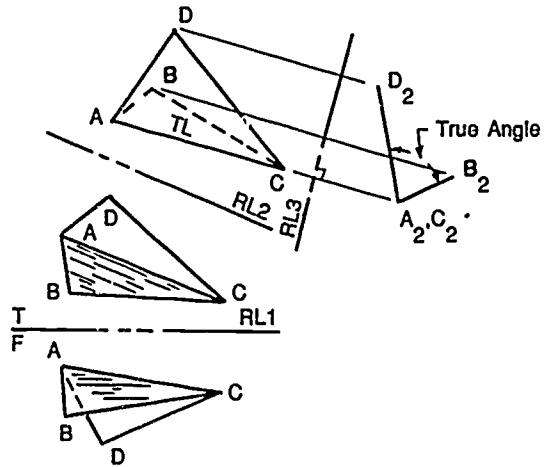

Directions: Determine the true angle between two planes in the following problems. Measure angle with protractor or drafting machine. Leave construction lines.

Problem A:

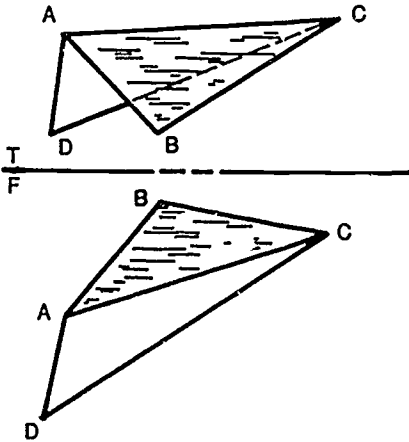

ASSIGNMENT SHEET #13

Problem B:

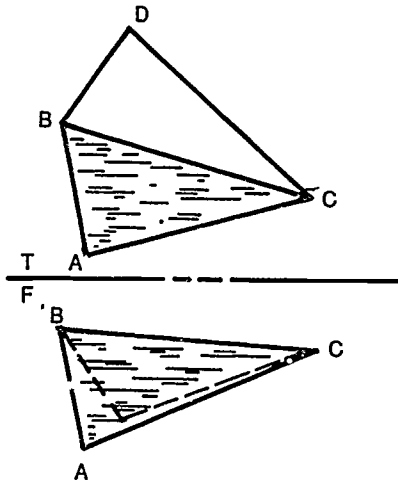

**AUXILIARY VIEWS
UNIT XII**

**ASSIGNMENT SHEET #14 — DETERMINE SHORTEST
DISTANCE BETWEEN A POINT AND A LINE**

NAME _____ SCORE _____

Introduction: In the manufacture of equipment, it is necessary to determine the clearance distance between parts. The shortest distance is determined by secondary auxiliary view. A distance between a point and a line can be determined by using the procedure in the following example.

Example:

1. Use given front and right side views of the line and point.

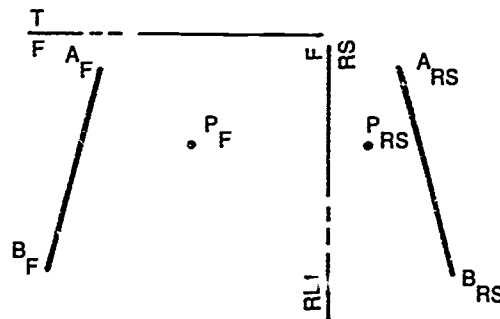

2. Construct reference line RL2 parallel to line A_{RS}B_{RS}.
3. Construct true length of line AB by projecting end points from right side view; then transfer distance from front view.
4. Construct point P in primary auxiliary.

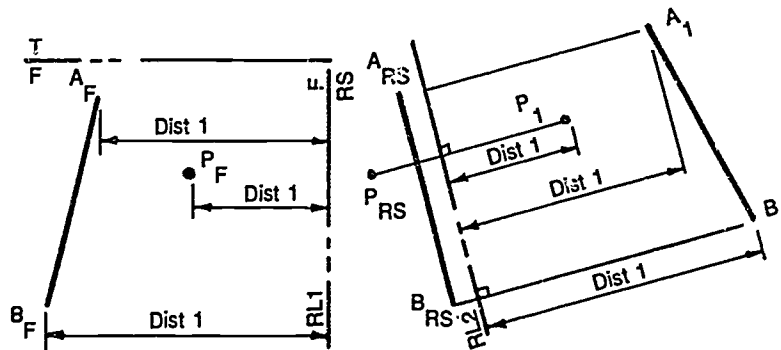

ASSIGNMENT SHEET #14

5. Construct reference line RL3 perpendicular to line A_1B_1 .
6. Transfer distances from primary auxiliary to establish point P_2 and point view of line A_2B_2 .
7. Distance between point P_2 and point view of line A_2B_2 is the shortest distance.

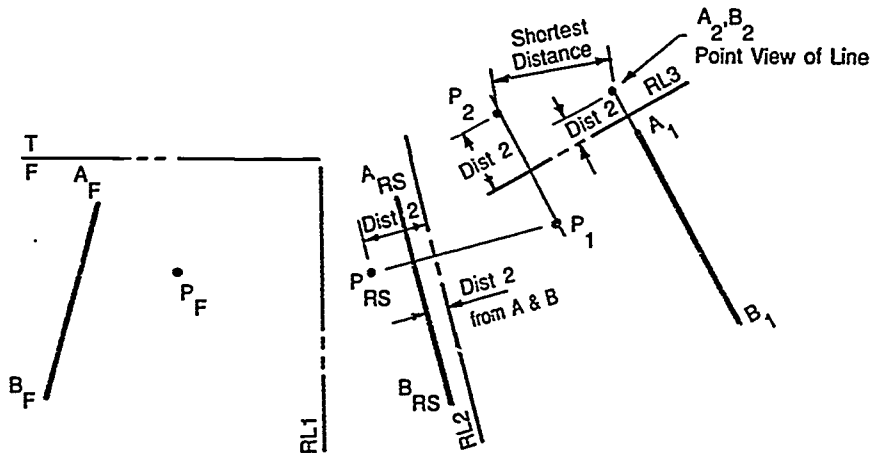

Directions: Using secondary auxiliary procedure, determine shortest distance between a point and a line in the problems given. Measure distance with full size scale.

Problem A:

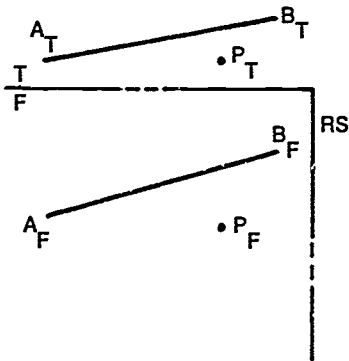

659

ASSIGNMENT SHEET #14

Problem B:

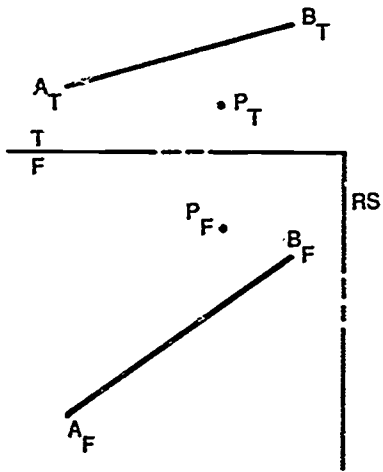

**AUXILIARY VIEWS
UNIT XII**

**ASSIGNMENT SHEET #15 — DETERMINE SHORTEST
DISTANCE BETWEEN TWO SKEW LINES**

NAME _____ SCORE _____

Introduction: Crossing lines in space are not necessarily intersecting lines. Sometimes it becomes necessary to determine clearance distance between two lines. Shortest distance between two skew lines in a secondary auxiliary can be determined by using the procedure in the following example.

Example:

1. Use given top and front views of two skew lines.

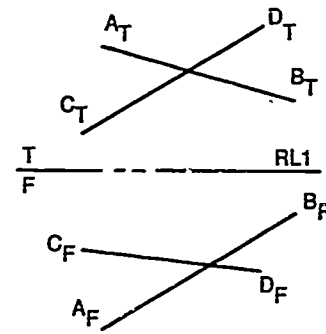

2. Construct reference line RL2 parallel to line $A_F B_F$ in front view.

(NOTE: Top view may be used if reference line is constructed parallel to one of the lines.)

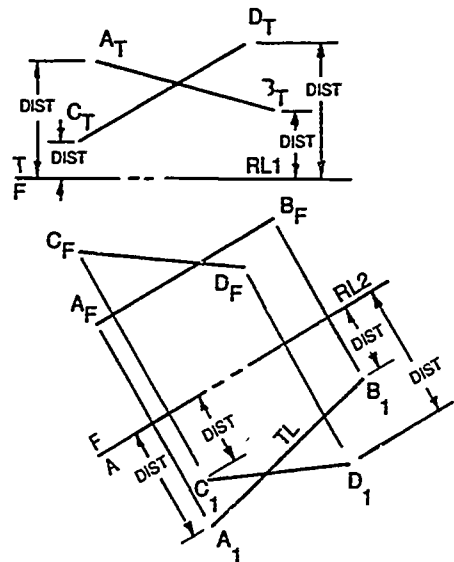

3. Construct primary auxiliary of line $A_F B_F$ to determine true length line.

ASSIGNMENT SHEET #15

4. Construct reference line RL3 perpendicular to true length line.
5. Transfer distances from front view to secondary auxiliary view, then project points from primary auxiliary to secondary auxiliary to establish line and point view of a line.
6. Distance between line C_2D_2 and point view of line A_2B_2 is shortest distance.

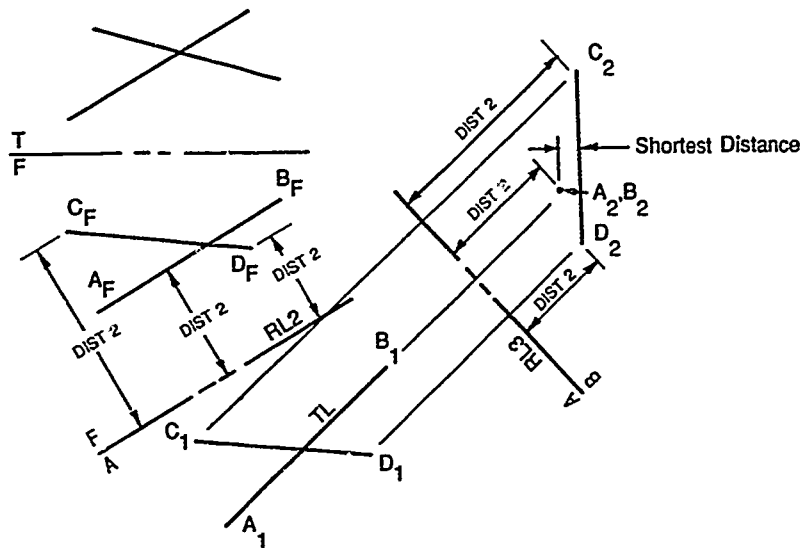

Directions: Determine shortest distance between two skew lines in the problems given. Measure the distance with full size scale.

Problem A:

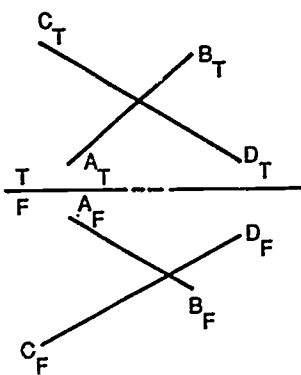

ASSIGNMENT SHEET #15

Problem B:

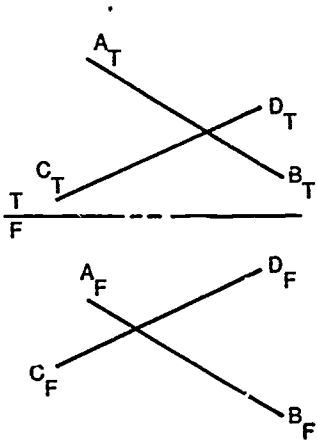

AUXILIARY VIEWS
UNIT XII

ANSWERS TO ASSIGNMENT SHEETS

Assignment Sheet #1

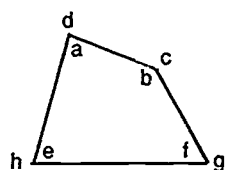
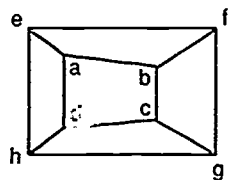

Assignment Sheet #2

A.

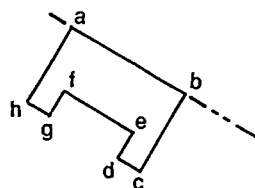

B.

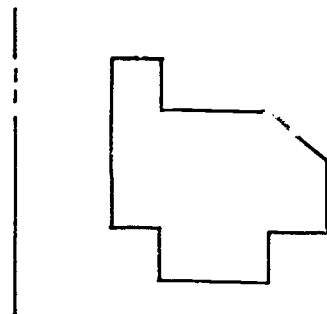

ANSWERS TO ASSIGNMENT SHEETS

C.

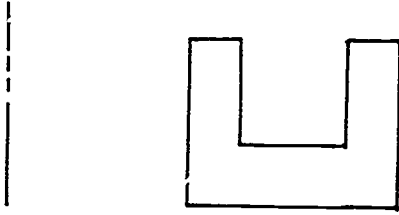

Assignment Sheet #3

A.

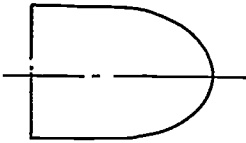

B.

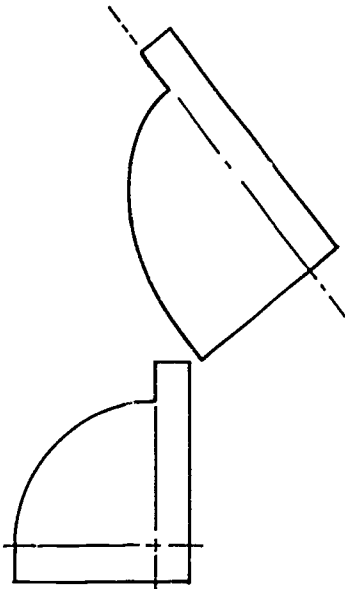

ANSWERS TO ASSIGNMENT SHEETS

C.

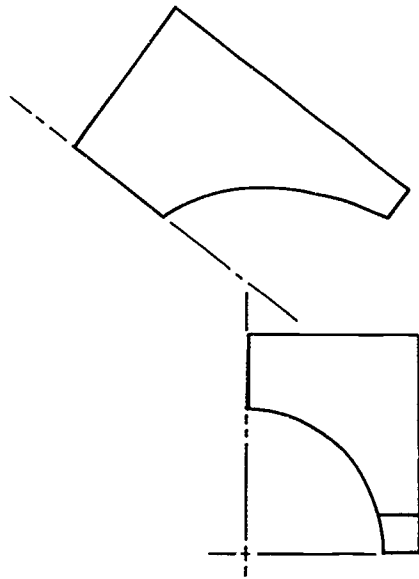

Assignment Sheet #4

A.

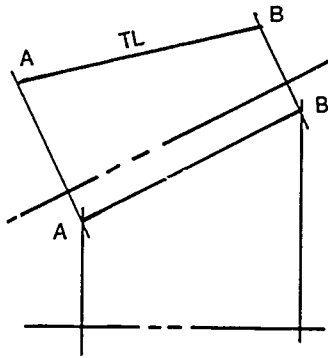

B.

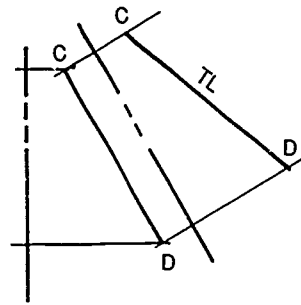

C.

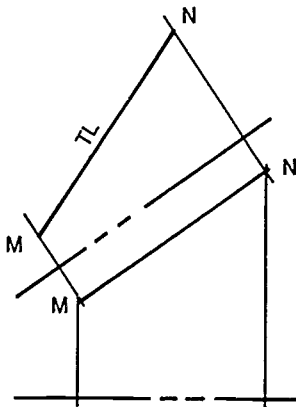

D.

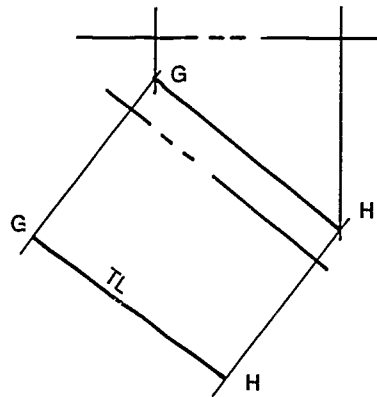

ANSWERS TO ASSIGNMENT SHEETS

Assignment Sheet #5

A.

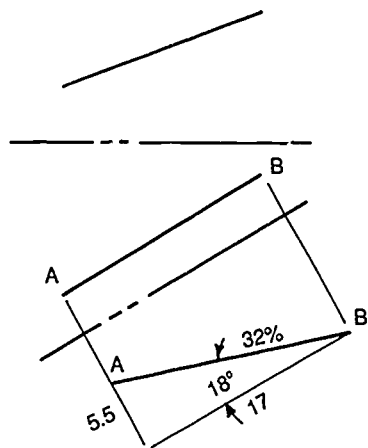

B.

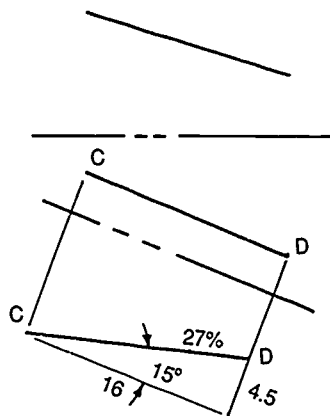

C.

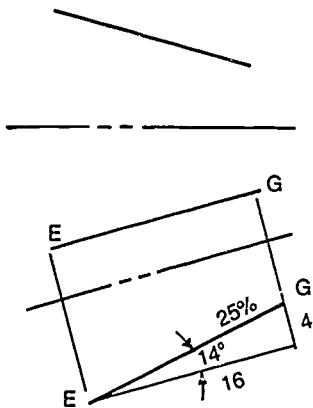

D.

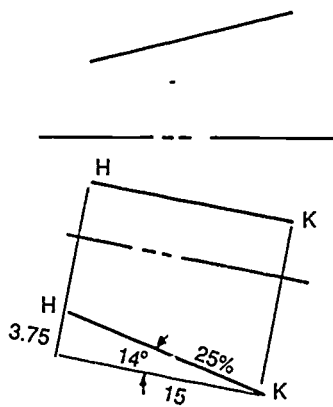

ANSWERS TO ASSIGNMENT SHEETS

Assignment Sheet #6

A.

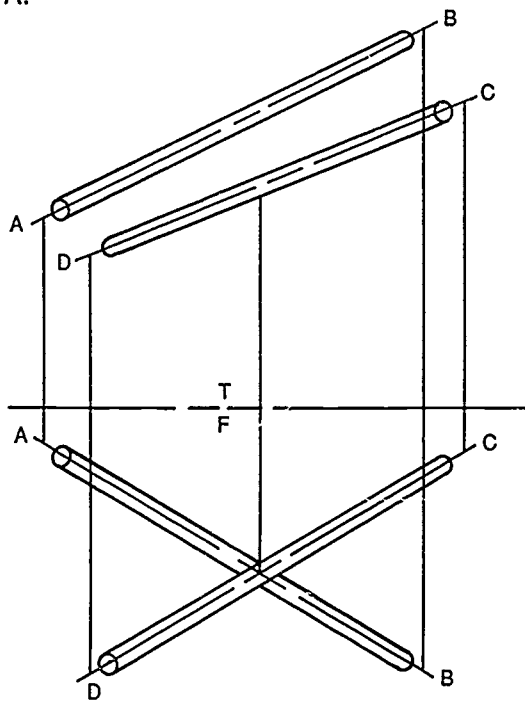

B.

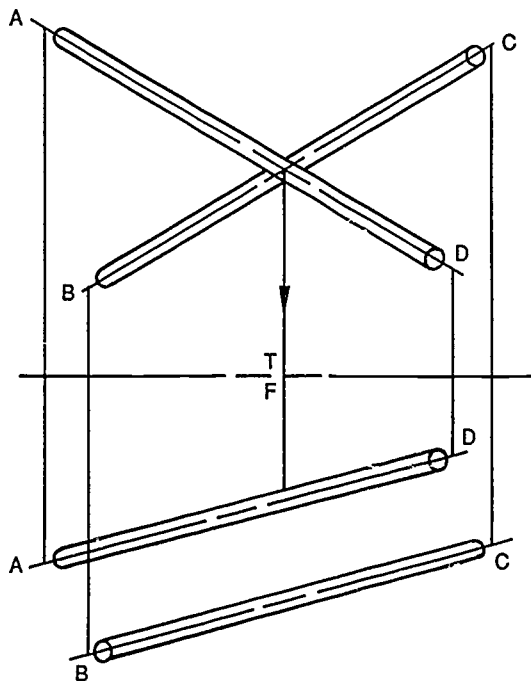

C.

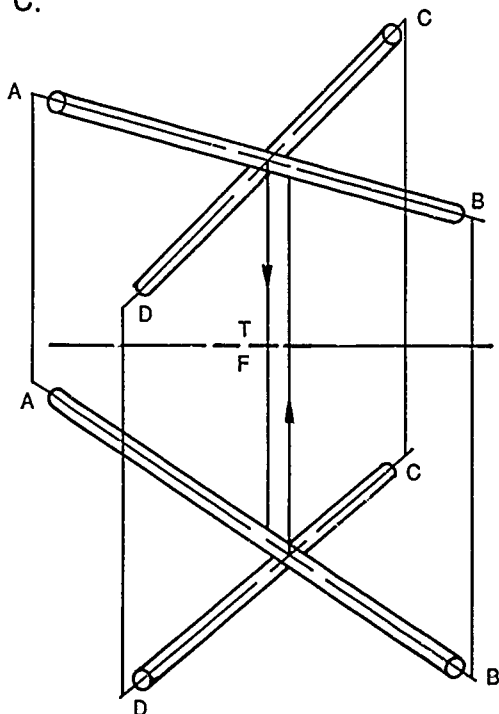

D.

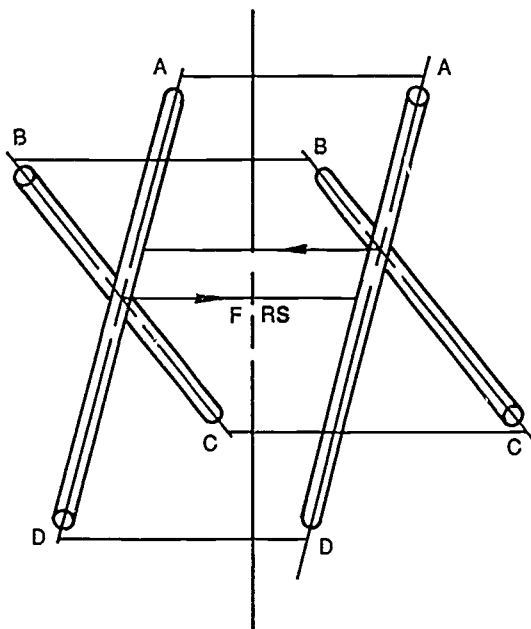

ANSWERS TO ASSIGNMENT SHEETS

Assignment Sheet #7

A.

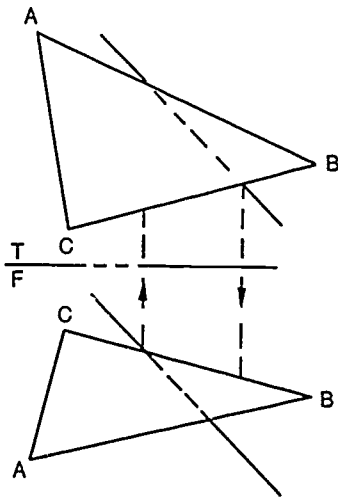

B.

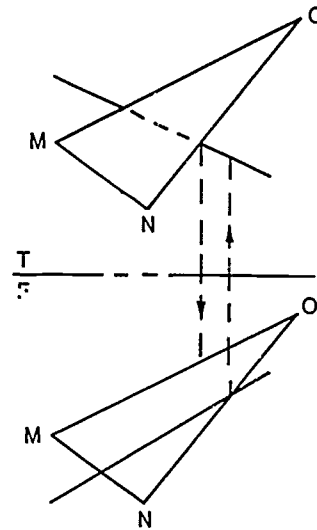

C.

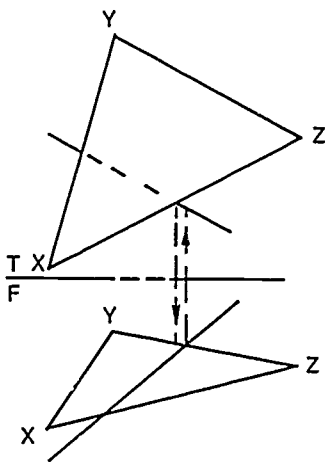

D.

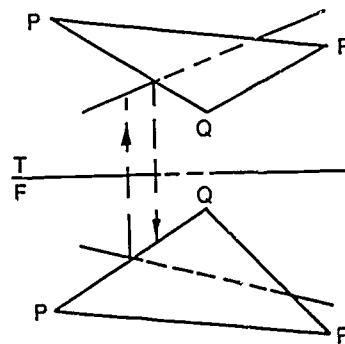

ANSWERS TO ASSIGNMENT SHEETS

Assignment Sheet #8

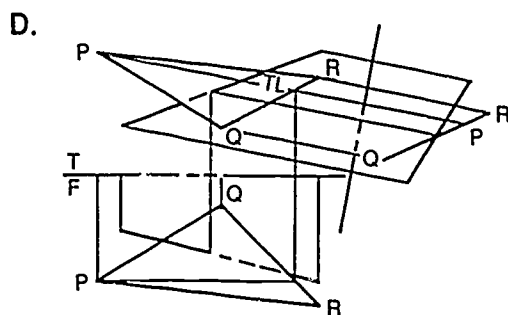
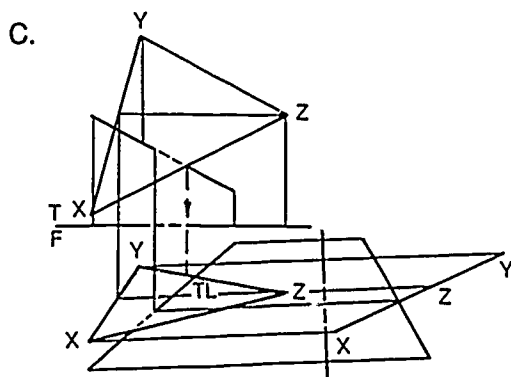
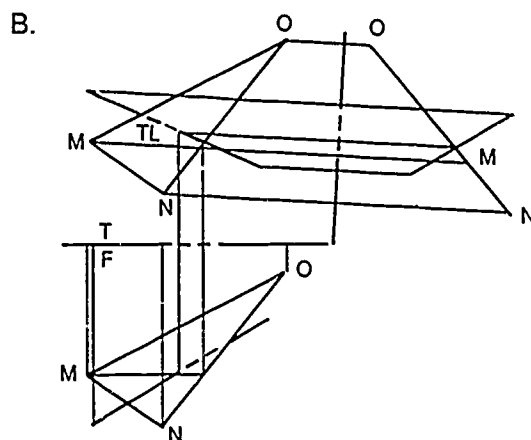
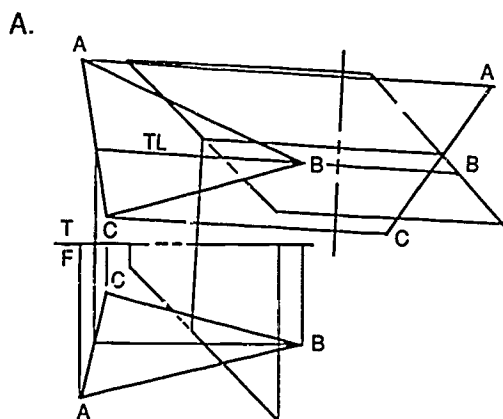

Assignment Sheet #9

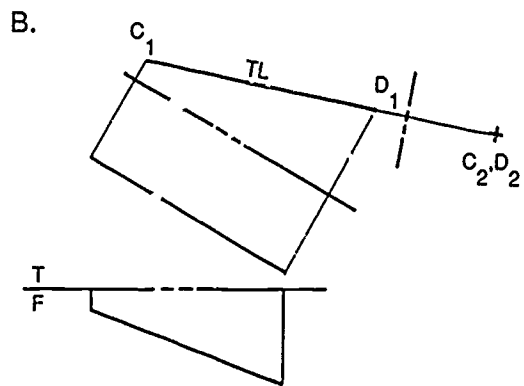
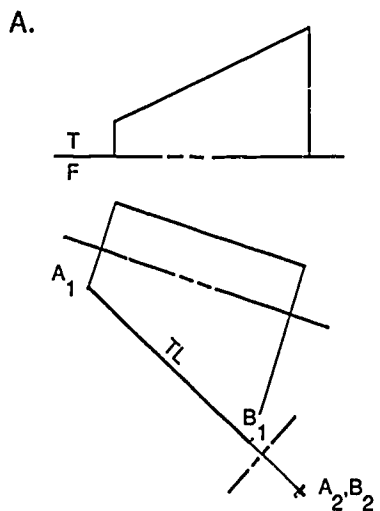

ANSWERS TO ASSIGNMENT SHEETS

Assignment Sheet #10

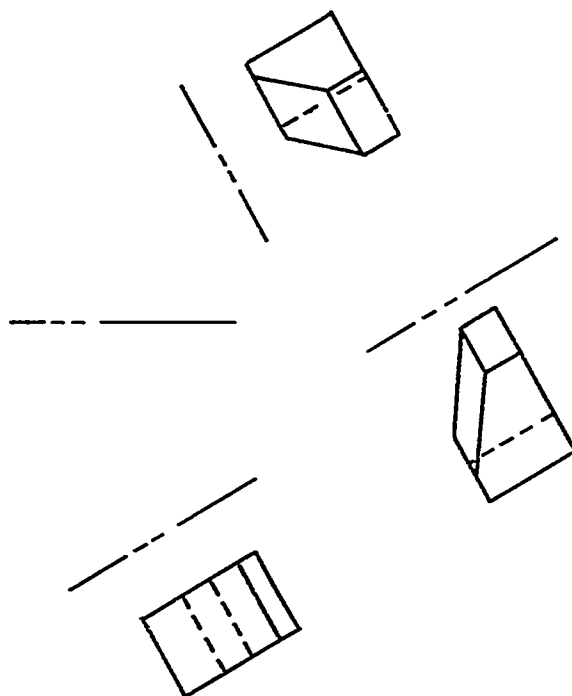

Assignment Sheet #11

A.

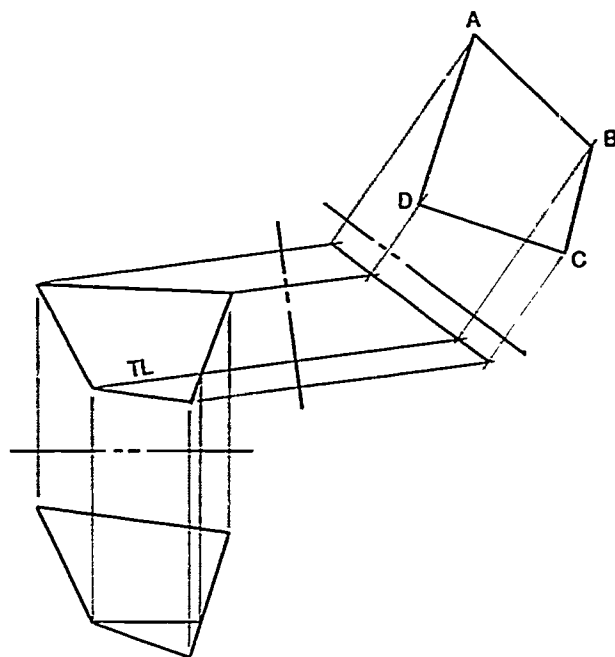

ANSWERS TO ASSIGNMENT SHEETS

B.

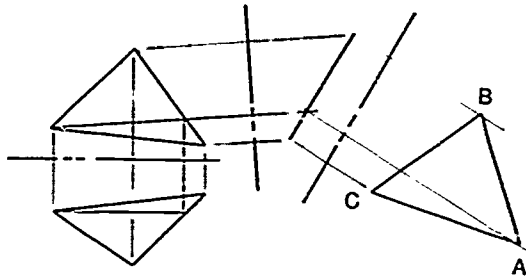

C.

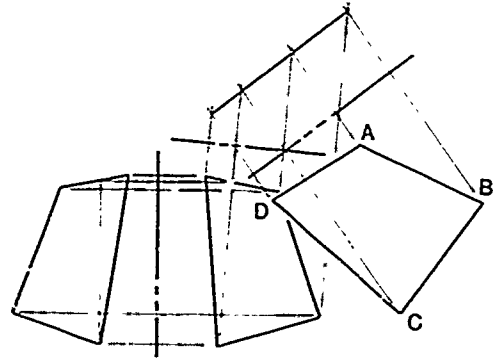

Assignment Sheet #12

A.

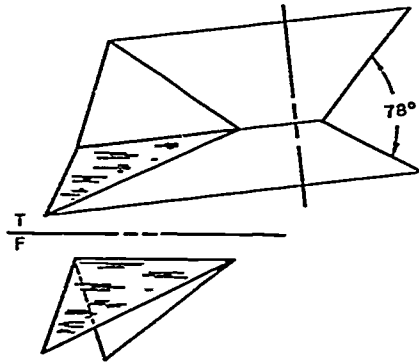

B.

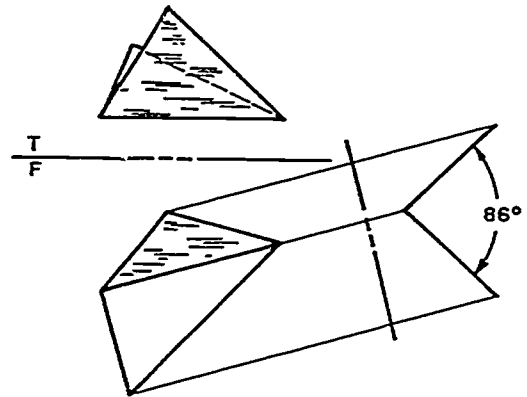

ANSWERS TO ASSIGNMENT SHEETS

Assignment Sheet #13

A.

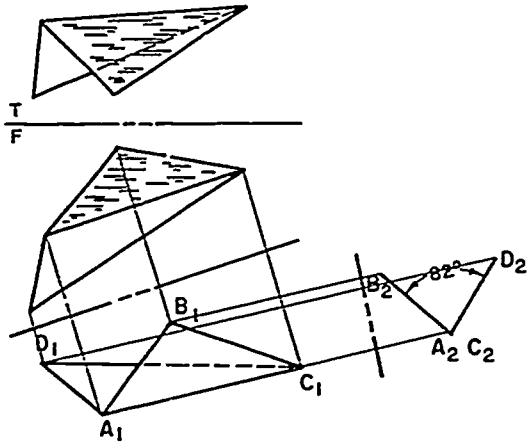

B.

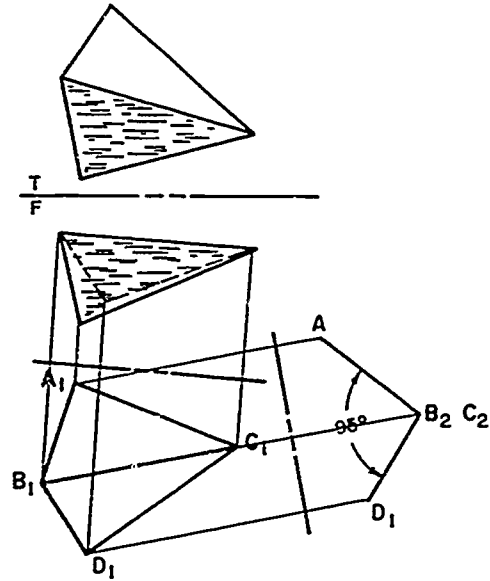

Assignment Sheet #14

A.

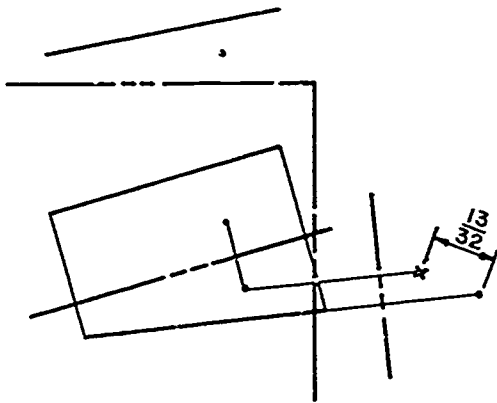

B.

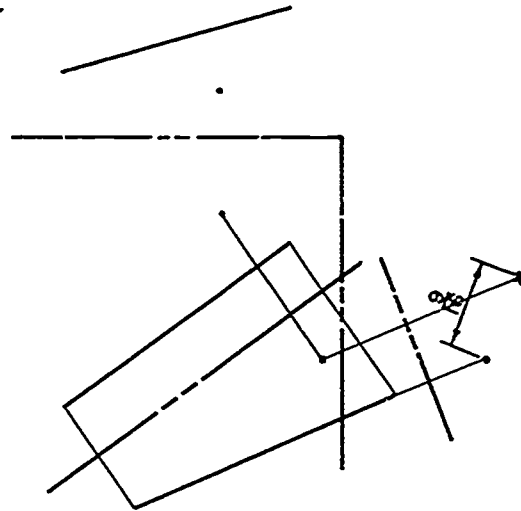

ANSWERS TO ASSIGNMENT SHEETS

Assignment Sheet #15

A.

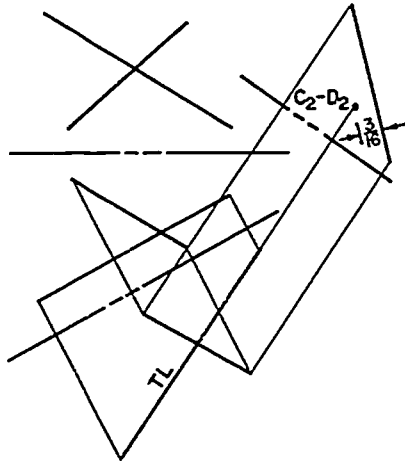

B.

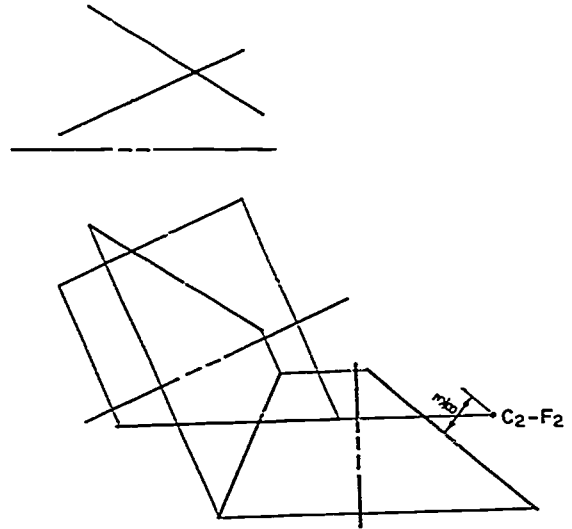

**AUXILIARY VIEWS
UNIT XII**

**JOB SHEET #1 — MODIFY GEOMETRY BY USING THE MIRROR, MIRROR AND COPY,
MOVE AND COPY, AND ROTATE CADD COMMANDS**

A. Tools and materials

1. CADD system
2. CADD manual
3. Drawing problems provided by instructor

Evaluation Criteria	
Criteria	Rating
Geometry successfully modified	_____
Commands used correctly	_____

B. Procedure

1. Log on the CADD system.
2. Activate a new part file.
3. Activate a drawing file.
4. Build the drawing part provided by instructor.
5. Look up in your CADD manual the proper entry commands for the following:
 - a. Mirror
 - b. Mirror and copy
 - c. Move and copy
 - d. Rotate
6. Implement the commands on the part drawing provided by your instructor.

**AUXILIARY VIEWS
UNIT XII**

**JOB SHEET #2 — EDIT GEOMETRY BY USING THE DELETE, BLANK, DIVIDE,
AND STRETCH CADD COMMANDS**

A. Tools and materials

1. CADD system
2. CADD manual
3. A drawing stored on the CADD system

Evaluation Criteria	
Criteria	Rating
Geometry successfully edited	_____
Commands used correctly	_____

B. Procedure

1. Log on to the CADD system.
2. Activate a part file.
3. Activate a drawing file.
4. Determine geometry to be edited.
5. Look up in the CADD manual the proper entry commands for the following:
 - a. Delete
 - b. Blank
 - c. Divide
 - d. Stretch
6. Implement the edit commands according to the procedure shown in the CADD manual.

C. Problems:

1. Delete a piece of geometry.
2. Blank out one piece of geometry.
3. Divide a line into three (3) entities.
4. Stretch the original part 2" to the right.

**AUXILIARY VIEWS
UNIT XII**

**JOB SHEET #3 — LENGTHEN OR SHORTEN LINES, ARCS, AND CIRCLES
ON A CADD SYSTEM**

A. Tools and materials

1. CADD system
2. CADD manual

Evaluation Criteria

Criteria	Rating
Geometry lengthened or shortened correctly	_____
Commands used correctly	_____

B. Procedure

1. Log on to the CADD system.
2. Activate a new part file.
3. Activate a drawing file.
4. Create the following pieces of geometry:
 - a. 2" line
 - b. 2" diameter circle
 - c. 2" diameter circle with a 3" line through the center
 - d. 1" arc
5. Look up in the CADD manual the proper commands to lengthen or shorten lines, arcs, and circles.
 Example: The trim command
6. Implement the command according to the procedure shown in the CADD manual.

C. Problems:

1. Shorten the 2" line to 1" in length.
2. Trim the 2" circle to an arc.
3. Trim 3" line to the intersection of the circle.
4. Shorten the length of the arc.

AUXILIARY VIEWS UNIT XII

TEST

NAME _____ SCORE _____

1. Match the terms on the right with their correct definitions.

- | | | | |
|---------|--|-----|---------------------|
| _____a. | A plane that is foreshortened in two principal viewing planes and edge view in one other principal viewing plane | 1. | Auxiliary view |
| _____b. | An angle formed by two intersecting planes | 2. | Edge view |
| _____c. | A surface that is shown in its actual size | 3. | Foreshortened |
| _____d. | A plane that is foreshortened in all three principal viewing planes | 4. | Inclined plane |
| _____e. | A view or surface that is not perpendicular to the plane of projection | 5. | Line of sight |
| _____f. | A line that appears in its actual length | 6. | Oblique plane |
| _____g. | Nonintersecting lines; not parallel to each other or to the principal views | 7. | Partial view |
| _____h. | To appear shorter to the eye than it actually is | 8. | Perpendicular lines |
| _____i. | A line representing the inclined plane | 9. | Skew lines |
| | | 10. | True angle |
| | | 11. | True length line |
| | | 12. | True size |

2. Define descriptive geometry.

TEST

3. Match the terms on the right with the correct definitions.

- | | |
|---|--|
| <p>_____ a. Flat surfaces that are imagined to exist between the observer and an object on which all points of the object are projected, resulting in a view of the object</p> <p>_____ b. Lines of intersection between two mutually-perpendicular projection planes</p> <p>_____ c. Lines drawn from a point or object in space perpendicular to a projection plane</p> <p>_____ d. Direction from which an observer views an object in space; perpendicular to the plane of projection</p> | <p>1. Line of sight</p> <p>2. Projection lines</p> <p>3. Projection planes</p> <p>4. Reference or folding lines</p> <p>5. Skew lines</p> |
|---|--|

4. State the purpose of auxiliary views.

5. Distinguish between the types of auxiliary views by placing the following letters next to the correct descriptions:

- P — Primary auxiliary view
- S — Secondary auxiliary view

- _____ a. Adjacent to and aligned with a primary auxiliary view or a secondary auxiliary view
- _____ b. Adjacent to and aligned with a principal view

6. Select from the following list the appropriate uses of auxiliary views by placing an "X" next to the correct uses.

- _____ a. To show the true length of a line
- _____ b. To show irregularly shaped parts or features that are not adequately shown in the principal views
- _____ c. To show interior construction of parts that cannot be clearly described by hidden lines
- _____ d. To show true size and shape of a surface

TEST

7. Complete the following statements concerning drafting practices for auxiliary views by circling the correct words.
- a. The auxiliary view is projected from the principal view on which the inclined surface appears as a (point, line).
 - b. Projection lines are drawn at (30°, 60°, 90°) angles to the inclined surface.
 - c. Partial auxiliary views may be used to show pertinent features that are not clearly shown on the (auxiliary, principal) view.
 - d. Primary auxiliary may be projected from (2, 3, 6) principal views.
8. Select true statements concerning projection of measurements in a primary auxiliary view by placing an "X" in the appropriate blanks.
- ___ a. Depth and height measurements are transferred with a scale or dividers in their true length from one of five views.
 - ___ b. Make all measurement views from the edge view.
 - ___ c. Length measurements are projected in their true length perpendicular from edge view to primary auxiliary.
9. List three locations of reference lines.
- a. _____
 - b. _____
 - c. _____
10. Select true statements concerning projection of measurements in a secondary auxiliary view by placing an "X" in the appropriate blanks.
- ___ a. Depth measurements are transferred from the edge view of one of the principal views.
 - ___ b. Length measurements are projected from the edge view.
11. Identify the following methods for modifying geometry on a CADD drawing.

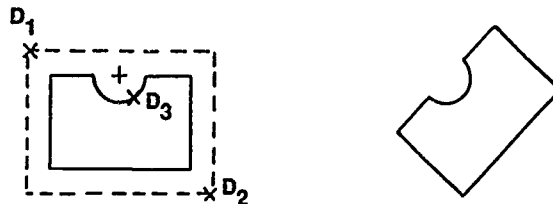

- a. _____

TEST

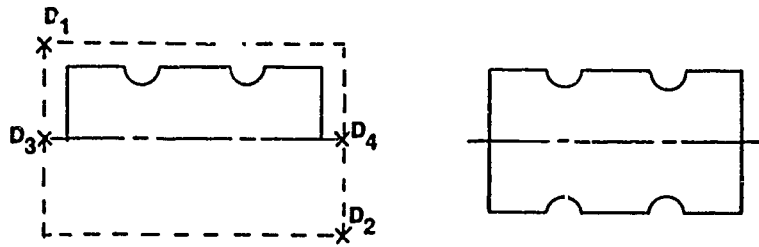

b. _____

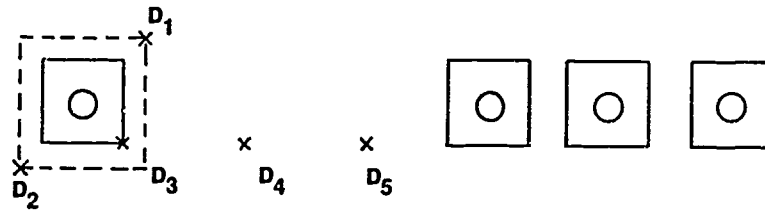

c. _____

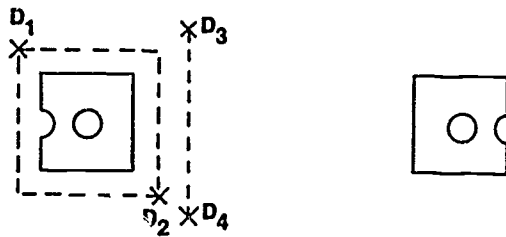

d. _____

TEST

12. Match the methods for removing or editing geometry on CADD listed on the right with their correct descriptions.

_____ a.	Lengthens or shortens lines, arcs, circles, and splines	1. Blank
_____ b.	Breaks a piece of geometry into several pieces that can be revised, manipulated, or deleted individually	2. Delete (erase)
_____ c.	Allows the operator to lengthen an entity from one side of a windowed area to connect with the same entity type on the other side	3. Divide
_____ d.	Removes selected geometry from all views but the geometry still remains in the database	4. Stretch
_____ e.	Removes one or more selected pieces of geometry from the screen drawing <i>and</i> the database	5. Trim
		6. Zoom

(NOTE: If the following activities have not been accomplished prior to the test, ask your instructor when they should be completed.)

13. Label points and planes of a three-view object. (Assignment Sheet #1)
14. Construct a primary auxiliary of an inclined plane. (Assignment Sheet #2)
15. Construct a primary auxiliary of a curved surface. (Assignment Sheet #3)
16. Determine true length of an oblique line. (Assignment Sheet #4)
17. Determine true angle and slope of a line. (Assignment Sheet #5)
18. Determine visibility of crossing skew lines in space. (Assignment Sheet #6)
19. Determine visibility of a line and a plane that cross in space. (Assignment Sheet #7)
20. Locate piercing point of a line and a plane. (Assignment Sheet #8)
21. Determine point view of a line. (Assignment Sheet #9)
22. Construct secondary auxiliary views of an object. (Assignment Sheet #10)
23. Construct a secondary auxiliary of an oblique plane. (Assignment Sheet #11)
24. Determine the true angle between two planes. (Assignment Sheet #12)

TEST

25. Determine true angle between two planes in a secondary auxiliary. (Assignment Sheet #13)
26. Determine shortest distance between a point and a line. (Assignment Sheet #14)
27. Determine shortest distance between two skew lines. (Assignment Sheet #15)
28. Demonstrate the ability to:
 - a. Modify geometry by using the mirror, mirror and copy, move and copy, and rotate CADD commands. (Job Sheet #1)
 - b. Edit geometry by using the delete, blank, divide, and stretch CADD commands. (Job Sheet #2)
 - c. Lengthen or shorten lines, arcs, and circles on a CADD system. (Job Sheet #3)

**AUXILIARY VIEWS
UNIT XII****ANSWERS TO TEST**

1. a. 4 d. 6 g. 9
 b. 10 e. 1 h. 3
 c. 12 f. 11 i. 2

2. Mathematical techniques used to describe geometric relationships among three-dimensional structures on a plane surface

3. a. 3
 b. 4
 c. 2
 d. 1

4. To show true size and shape of an object and relationship of its features when they are not parallel to any of the principal planes of projection

5. a. S
 b. P

6. a, b, d

7. a. Line
 b. 90°
 c. Principal
 d. 6

8. a, c

9. Any three of the following:
 - a. Back edge of view
 - b. Middle (center line)
 - c. Front edge of view
 - d. Between views

10. a

ANSWERS TO TEST

11. a. Rotate
b. Mirror and copy
c. Move and copy
d. Mirror

12. a. 5
b. 3
c. 4
d. 1
e. 2

13-27. Evaluated to the satisfaction of the instructor

28. Performance skills evaluated to the satisfaction of the instructor

SECTIONAL VIEWS UNIT XIII

UNIT OBJECTIVE

After completion of this unit, the student should be able to construct full, half, offset, broken-out, removed, revolved, rib, aligned, and assembly sections. The student should also be able to crosshatch a part on a CADD system. Competencies will be demonstrated by completing the assignment sheets, job sheet, and the unit test with a minimum score of 85 percent.

SPECIFIC OBJECTIVES

After completion of this unit, the student should be able to:

1. Match terms related to sectional views with their correct definitions.
2. Identify types of sectional views.
3. Match types of sections with their correct uses.
4. Select true statements concerning general rules in sectioning.
5. Match specific rules with the correct section types.
6. Identify types of conventional breaks.
7. Select true statements concerning labeling sectional views.
8. Identify line thicknesses used in sectional drawings.
9. Select the most commonly used form of cutting plane lines.
10. Identify material symbols in section.
11. List common errors in making section lines.
12. Select true statements concerning use of unlined sections.
13. List methods used to aid equal spacing of section lining.
14. Select true statements concerning crosshatching and pattern filling on CADD.
15. Construct various material symbols in section. (Assignment Sheet #1)
16. Construct a full section. (Assignment Sheet #2)
17. Construct a half section. (Assignment Sheet #3)

SPECIFIC OBJECTIVES

18. Construct an offset section. (Assignment Sheet #4)
19. Construct a broken-out section. (Assignment Sheet #5)
20. Construct a removed section. (Assignment Sheet #6)
21. Construct a revolved section. (Assignment Sheet #7)
22. Construct a rib section. (Assignment Sheet #8)
23. Construct an aligned section. (Assignment Sheet #9)
24. Construct adjacent parts in assembly section. (Assignment Sheet #10)
25. Construct conventional breaks. (Assignment Sheet #11)
26. Construct an assembly section. (Assignment Sheet #12)
27. Demonstrate the ability to crosshatch a part on CADD. (Job Sheet #1)

SECTIONAL VIEWS UNIT XIII

SUGGESTED ACTIVITIES

- A. Provide student with objective sheet.
- B. Provide student with information, assignment and job sheets.
- C. Make transparencies.
- D. Discuss unit and specific objectives.
- E. Discuss information, assignment and job sheets.
- F. Construct "cutaway models" of various objects to illustrate sectional views.
- G. Display cutaway parts of sectional views in classroom for students to inspect.
- H. Have the machine shop cut actual parts into sectional parts and have the students sketch the section views.
- I. Discuss the use of sectional views.
- J. Give test.

REFERENCES USED IN DEVELOPING THIS UNIT

- A. Giesecke, Frederick E., et al. *Technical Drawing*, 8th ed. New York: Macmillan Publishing Co., Inc., 1986.
- B. Brown, Walter C. *Drafting for Industry*. South Holland, IL 60473: Goodheart-Willcox Co., Inc., 1984.
- C. Jensen, Cecil and Jay Helsel. *Engineering Drawing and Design*, 3rd ed. New York: Gregg Division/McGraw-Hill Book Co., 1985.
- D. Lieblich, Jerome. *Drawing Requirements Manual for Department of Defense and Commerce*. 2625 Hickory St., P.O. Box 2504, Santa Ana, California 92707. 1-800-854-7179, Global Engineering Documents; 5th edition, 1982.
- E. *Multi and Sectional View Drawings*, ANSI Y14.3-1975, Reaffirmed 1987. New York: The American Society of Mechanical Engineers.

**SECTIONAL VIEWS
UNIT XIII****INFORMATION SHEET****I. Terms and definitions**

- A. Conventional break — Used in making a shortened view of a long simple object

(NOTE: Do not remove holes from object in shortened view.)

- B. Cutting plane — An imaginary plane used to cut through an object
- C. Outline sectioning — Section lines are shown only along the borders of a large part for clarity and to save time
- D. Sectional view — A view that shows an internal portion of an object, with part of the object cut away
- E. Section lining — A line symbol that is drawn on an exposed, cut surface; sometimes called crosshatching
- F. Section symbols — Symbolic section lining used for indication of various materials
- (NOTE: Do not use on microfilm drawings; use standard cast iron symbol.)
- G. Subtitles — Labeling with capital letters the sectional view which has a removed section
- H. Symmetry — Being the same on opposite sides of a center line
- I. Unlined section — Used for clarity in sections of assembly drawings of standard parts where the axis of the part lies in the cutting plane

(NOTE: When the axis lies at a right angle to cutting plane, the part is sectioned.)

II. Types of sectional views (Transparencies 1-9)

- A. Full section — The cutting plane passes completely through an object and the cross section behind the cutting plane line is exposed to view.
- B. Half section — The cutting planes are passed at right angles to each other along the center lines and one-fourth of object is removed.
- C. Offset section — Has a cutting plane line to pick up features that are not along a common cutting plane.
- D. Broken-out section — An area broken out of a view that shows only a portion of that view in section.

INFORMATION SHEET

- E. Revolved section — A cutting plane line is passed through an area and then the image is revolved 90° in position.
- F. Removed section — A revolved section drawn off the principal view and placed in another convenient location.
- G. Aligned section — Used to align features such as spokes, holes, and ribs along a common plane so that they can be detailed more easily.
- H. Rib section — Method of not showing the ribs section lined to eliminate the impression of solidity.
- I. Assembly section — Shows all parts of an object as one unit and drawn using section lining to make the individual parts stand out.

III. Types of sections and their uses (Transparencies 1-7)

- A. Full section — Replaces an exterior view in order to show some interior details
- B. Half section — Used to show both interior and exterior features of a symmetrical object
- C. Offset section — Used to show features that are not in a straight line
- D. Broken-out section — Used to show interior detail of objects where less than half section is required
- E. Revolved section — Used to show the true shape of the cross section of a long object such as a bar, spoke, rib, or arm
- F. Removed section — Used for clearness and for easier dimensioning; similar to revolved section except it is placed off the part
- G. Aligned section — Used when true projection would be confusing for spokes, ribs, and holes

IV. General rules in sectioning

- A. Sectional views should be projected in the normal orthographic view, except for revolved sections.
- B. Sections should be placed in line of projection behind cutting plane or else labeled.

INFORMATION SHEET

- C. If two or more sections appear on the same drawing, the cutting plane lines are labeled and the view is subtitled.

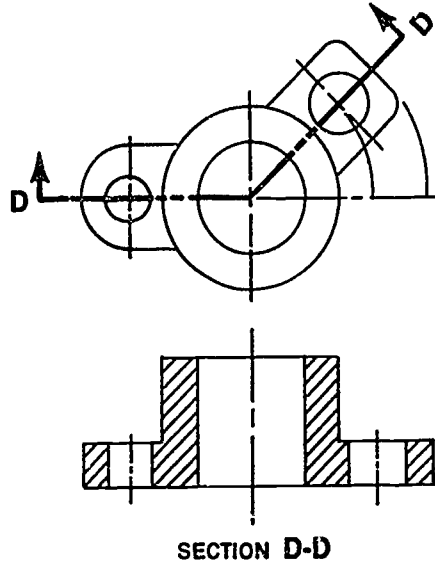

- D. Arrowheads at the end of the cutting plane line indicate the direction in which the section is viewed.
- E. Sectional views are not made from another sectional view, except for clarity.
- F. Sections should be drawn at the same scale as the views from which they were taken.
- G. Sections should appear on the same sheet as the drawing from which they were taken. If placed on a separate sheet, the section view should be oriented as it was projected from the cutting plane and cross referenced by zone designations.
- H. Section lines are thin parallel lines drawn at an angle (usually 45°) to main outline of the view.

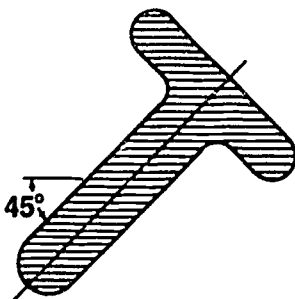

CORRECT

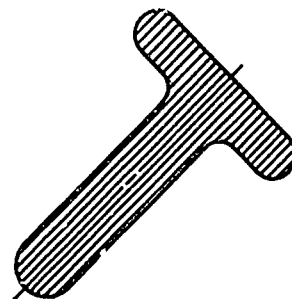

INCORRECT

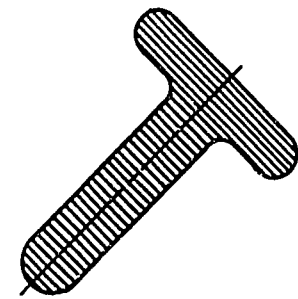

INCORRECT

INFORMATION SHEET

- I. Section lines are uniformly spaced. The spacing should increase as the size of the drawing increases.

(NOTE: Minimum space of .18 is used for microfilm.)

- J. Large surfaces are often sectioned only along the edge of the part.

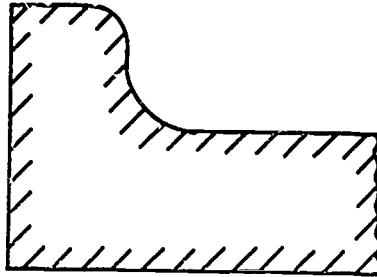

- K. In assembly sectional views, the section lines of adjacent parts should be drawn at a 30°, 45°, or 60° angle to the edge of object.

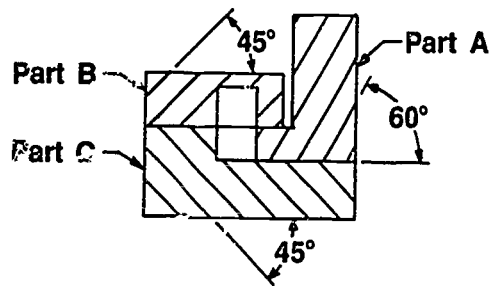

- L. Visible lines behind the cutting plane should be shown.

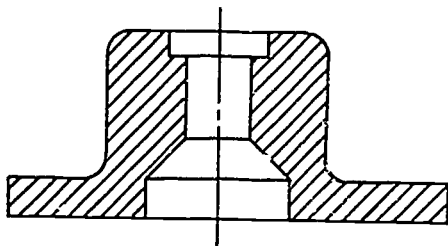

CORRECT
(Visible Lines Shown)

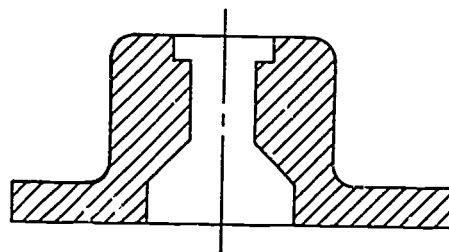

INCORRECT
(Visible Lines Omitted)

INFORMATION SHEET

- M. Hidden lines behind the cutting plane should be omitted.

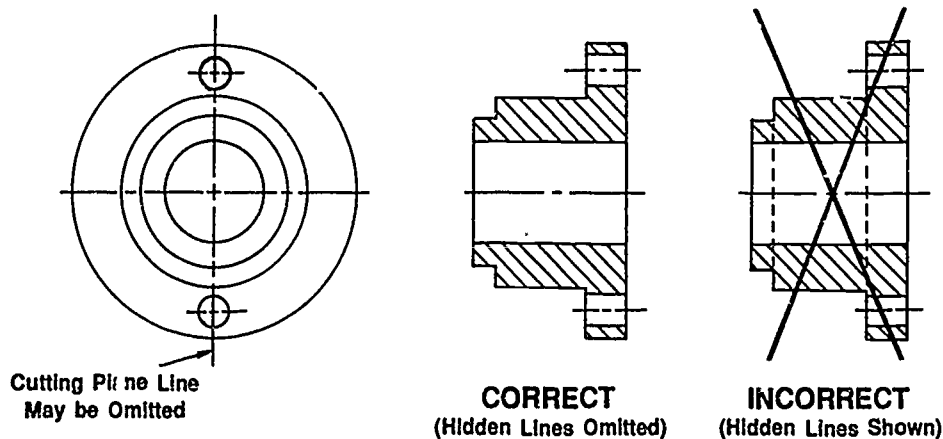

- N. When objects have one major center line, the cutting plane line may be omitted.
- O. When only a single section of a symmetrical part is needed, the cutting plane line may be omitted.
- P. When the cutting plane offsets, a line is not shown in the sectioned view to represent the offset.
- Q. When dimensions on sectioned areas are unavoidable, the section lining should be omitted for the numerals or lettering.
- R. On half sections, hidden lines may be added to the unsectioned half if needed for dimensioning.
- S. On half sections, a center line or a visible line may be used to divide the sectioned half from the unsectioned half.
- T. Where two or more thin sections are shown, a space should be left between them equal to the space necessary for microfilming.

V. Specific rules that apply to different types of sections

- A. Full section — Cutting plane lines and section titles generally are used but may be omitted if they are obvious.
- B. Half section — Cutting plane lines and section titles are omitted.
- C. Offset section — Cutting plane lines and section titles are required.
- D. Broken-out section — Break line convention is used to separate the sectional view portion from the exterior view.

INFORMATION SHEET

- E. Revolved section — Cutting plane lines are omitted in symmetrical sections.
- F. Removed section — Often drawn to larger scale and cutting plane lines are omitted if section is placed right off the part.

VI. Types of conventional breaks

A. Round solid (rod)

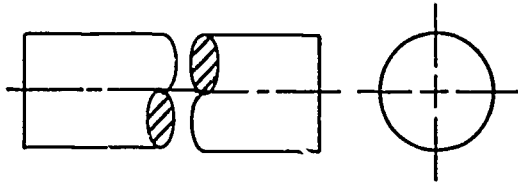

B. Round tubular (pipe)

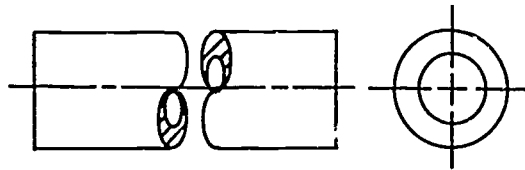

(NOTE: Some companies do not use the crosshatching on these breaks.)

C. Round tubular — Section view

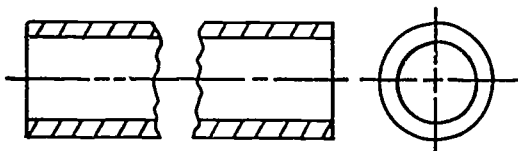

D. Rectangular bar (metal) — Short break symbol



E. Rectangular bar (metal) — Long break symbol

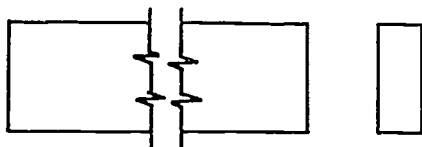

F. Rectangular bar (wood)



VII. Labeling sectional views

- A. More than one removed section view should be labeled with letters corresponding to the ends of the cutting plane line.
- B. Sectional views should be arranged in alphabetical order from left to right on the drawing.
- C. Section letters should be used in alphabetical order.
- D. Letters "I", "O", and "Q" should not be used.
- E. The word "section" should not be abbreviated.





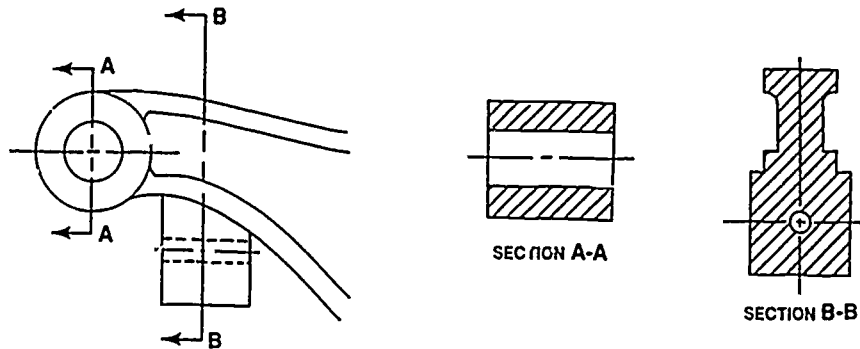

INFORMATION SHEET

- F. Section letters are always used in pairs.
Examples: A-A, B-B, C-C, etc.
- G. If a drawing uses all the available letters of the alphabet, additional sections should be indicated by double letters in alphabetical order.
Examples: AA-AA, BB-BB, CC-CC, etc.
- H. Section letters are placed near the arrowheads of the cutting plane line.

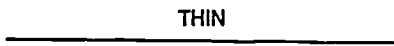

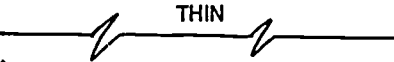
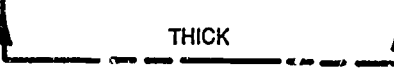
- I. Correct heights for section labeling
 1. The word "SECTION" — .20 (All caps)
 2. Section letters — .40 (All caps)

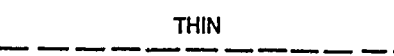
VIII. Line thicknesses used in sectional drawings

- A. Section line, thin—  THIN
- B. Short break line, thick—  THICK
- C. Long break line, thin—  THIN
- D. Cutting plane line, thick—  THICK
- E. Visible line, thick—  THICK
- F. Hidden line, thin—  THIN
- G. Center line, thin—  THIN

INFORMATION SHEET

XI. Forms of cutting plane lines

A.

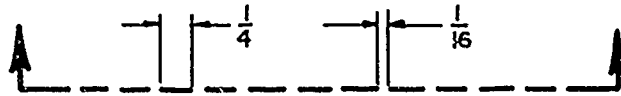

B. Most commonly used form---

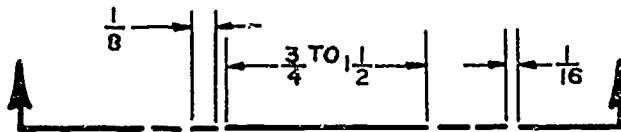

C.



X. Material symbols in section

(NOTE: Where only one material is used on a drawing, the cast iron symbol is used and the material is specified in notes.)

A. Cast iron

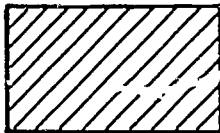

B. Steel

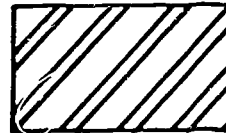

C. Brass, bronze, or copper

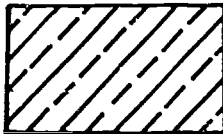

D. Zinc, lead, and alloys

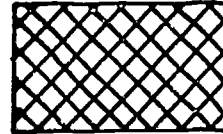

E. Magnesium, aluminum, and alloys

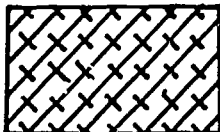

F. Refractory material



INFORMATION SHEET

- G. Rubber, plastic, and electrical insulation



XI. Common errors in making section lines

- A. Irregular spacing

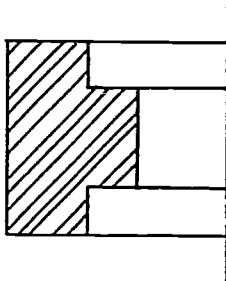

- B. Irregular line weights

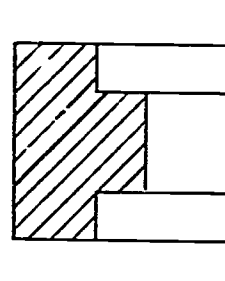

- C. Lines too thick

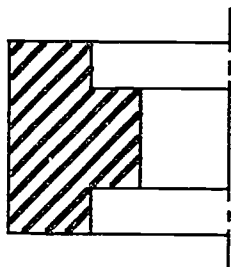

- D. Lines are short or overrun visible lines

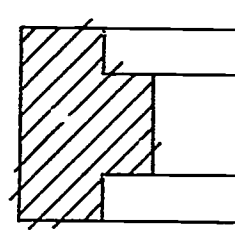

XII. Use of unlined sections

- A. Thin parts are made solid.

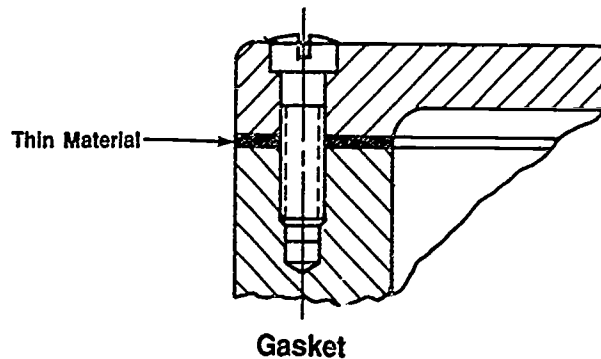

- B. Shafts, bolts, nuts, pins, keys, rivets, gear teeth, and similar parts should not be sectioned if axis lies in cutting plane.

INFORMATION SHEET

- C. Broken-out section of shaft may be made to indicate clearness of key, keyseat, and pin.

XIII. Methods used to aid equal spacing of section lining

- A. Visual spacing
B. Line guide

(NOTE: Scribed line on triangle may be used.)

- C. Trace lines from a grid sheet
D. Measure with scale

XIV. Crosshatching and pattern filling on CADD

- A. The typical command for crosshatching is *HATCH (DRAW CROSSHATCH)*; then the boundaries of the area to be hatched are digitized.

Example:

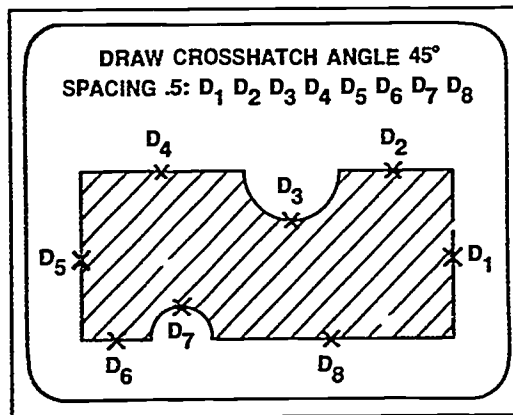

- B. To speed up the digitizing procedure for crosshatching, a "CHAIN" command may be used; CHAIN ties all the geometry together into one unit.

Example:

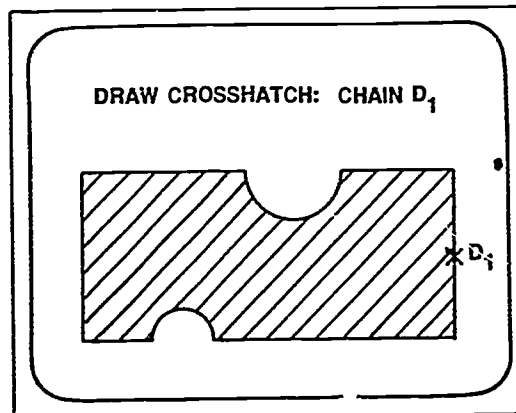

INFORMATION SHEET

- C. Hatching fills an area of the drawing enclosed by boundaries made up of lines, arcs, circles, splines, or other items.
- D. Various hatch patterns are provided on most CADD systems.

Examples:

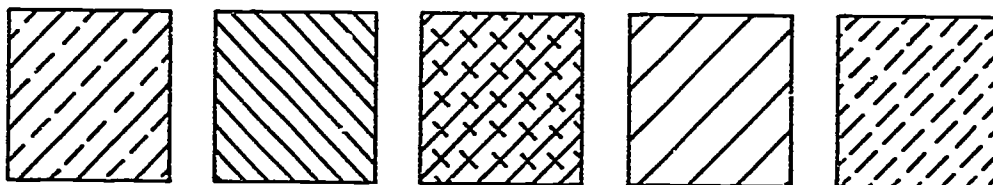

- E. Hatch patterns may be changed by changing the angles of the pattern and the line spacing.

Example: *DRAW CROSSHATCH ANGLE 60°*

Full Section

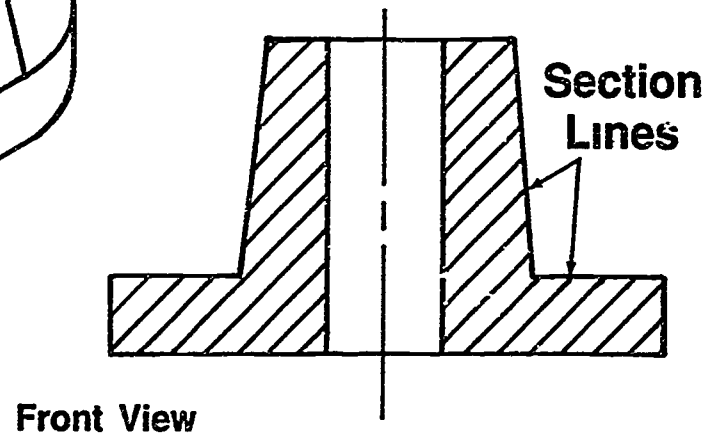
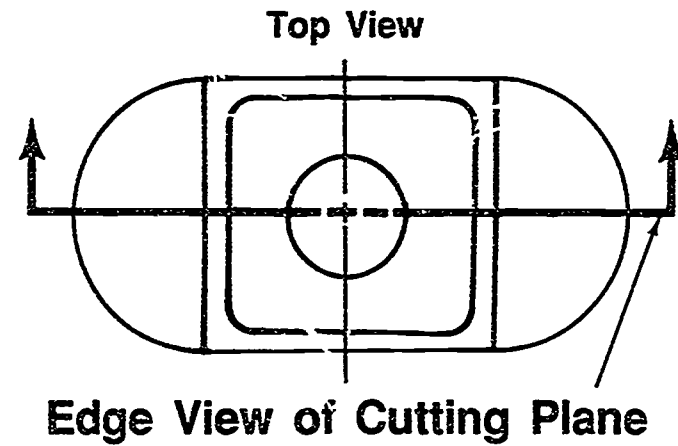
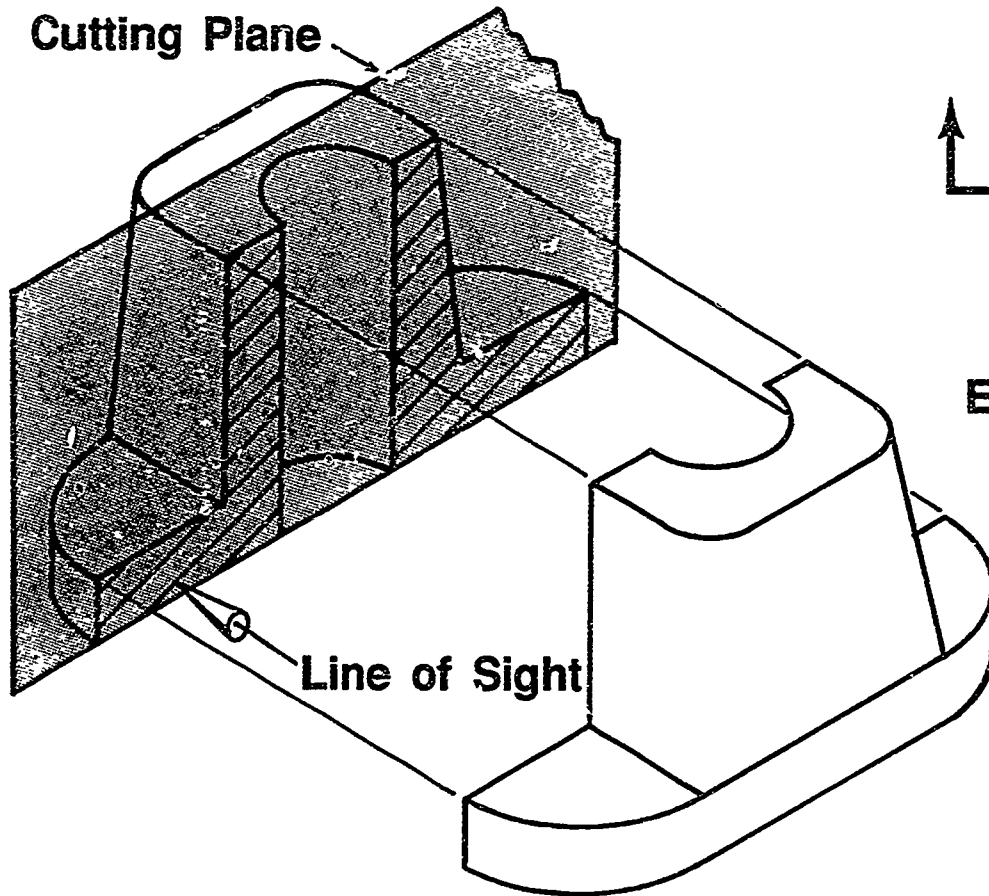

700

701

Half Section

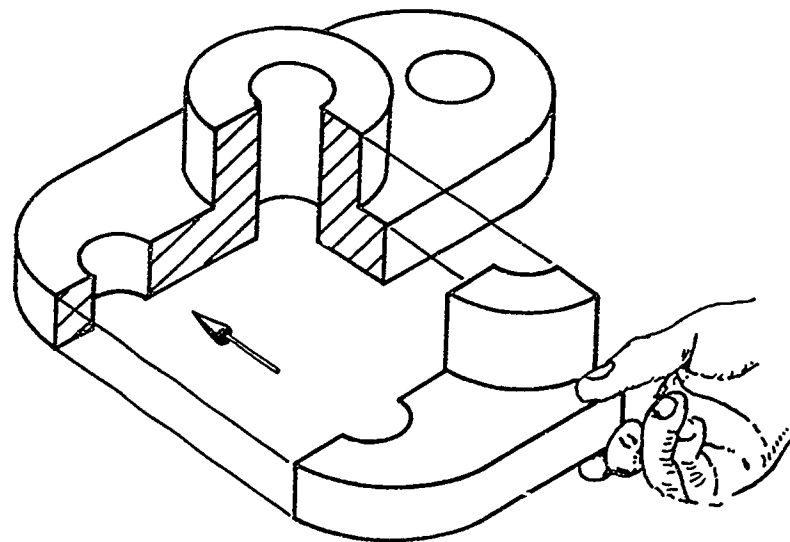
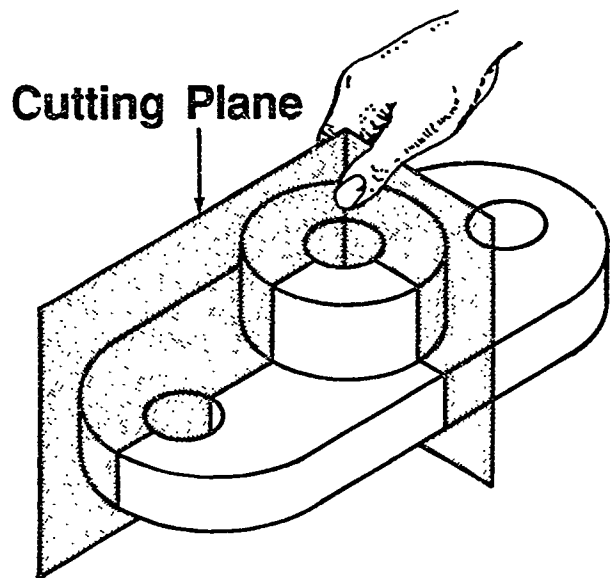

Edge View of Cutting Plane

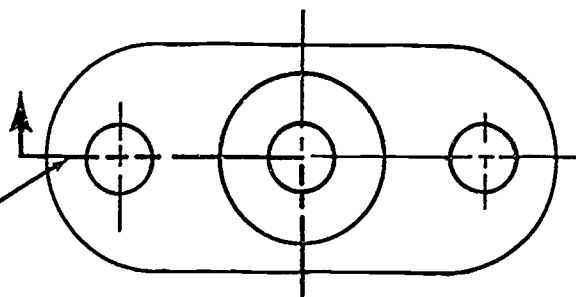

Remove One Quarter

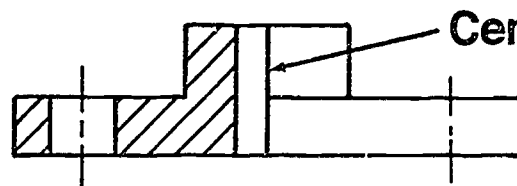

Center Line or Visible Line
(Hidden lines omitted unless used for dimensioning)

Offset Section

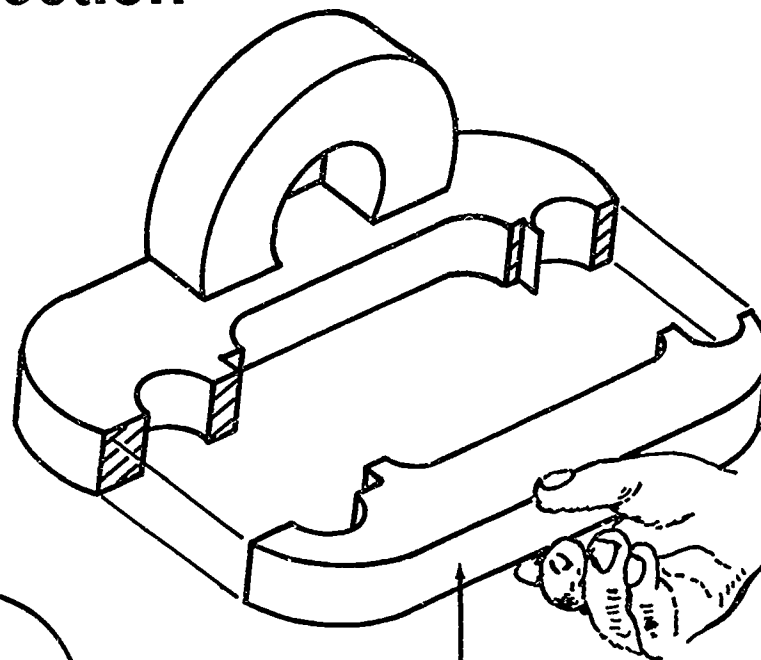
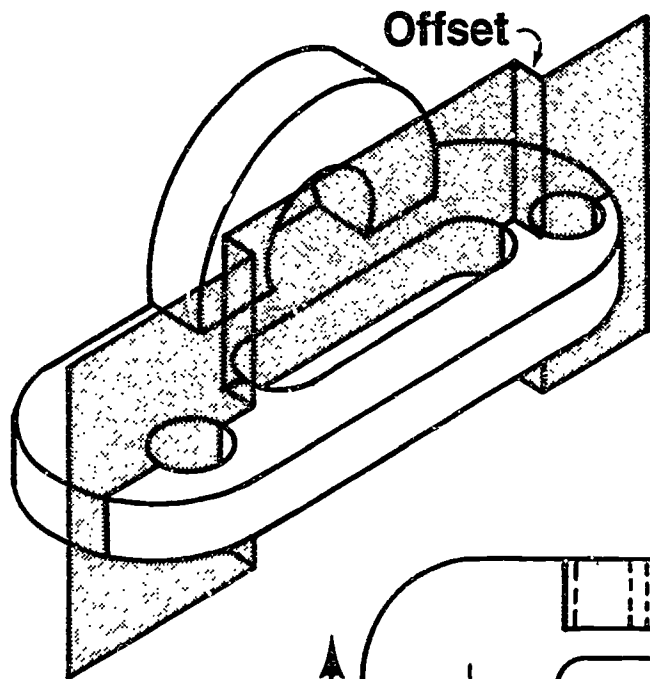

Top View

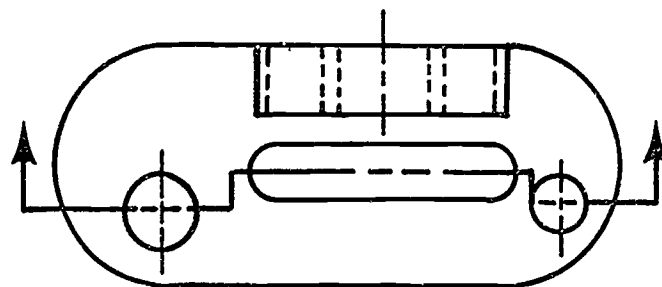

Offset Line Not Shown

Front View

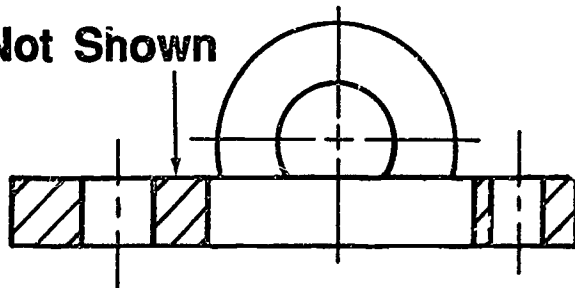

Broken-Out Section

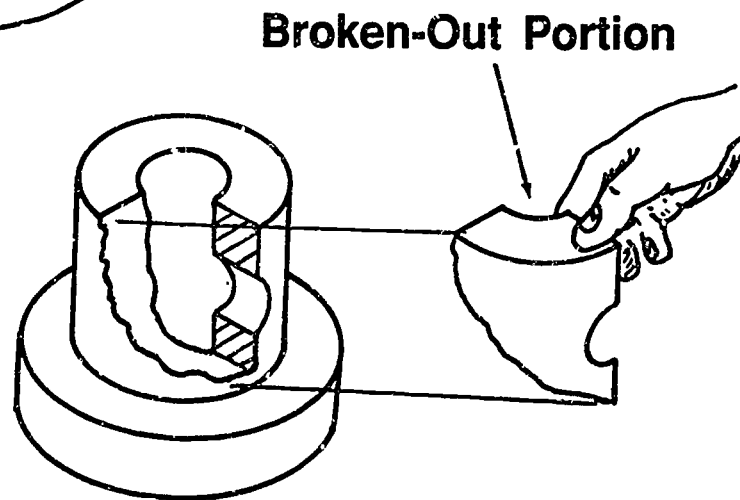
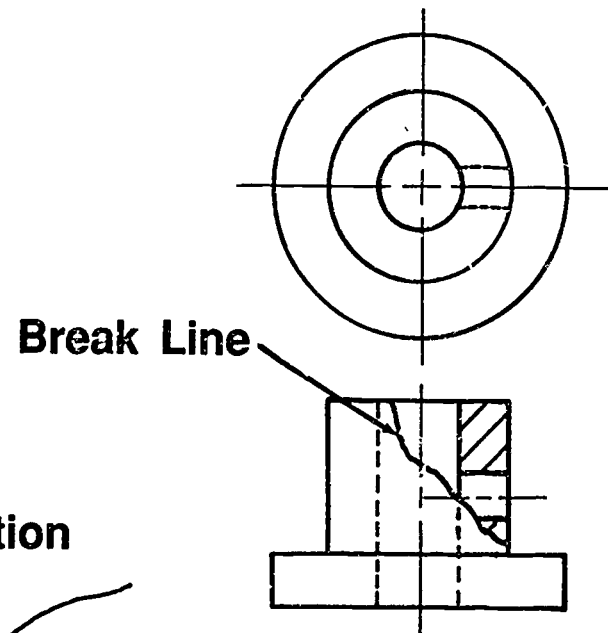
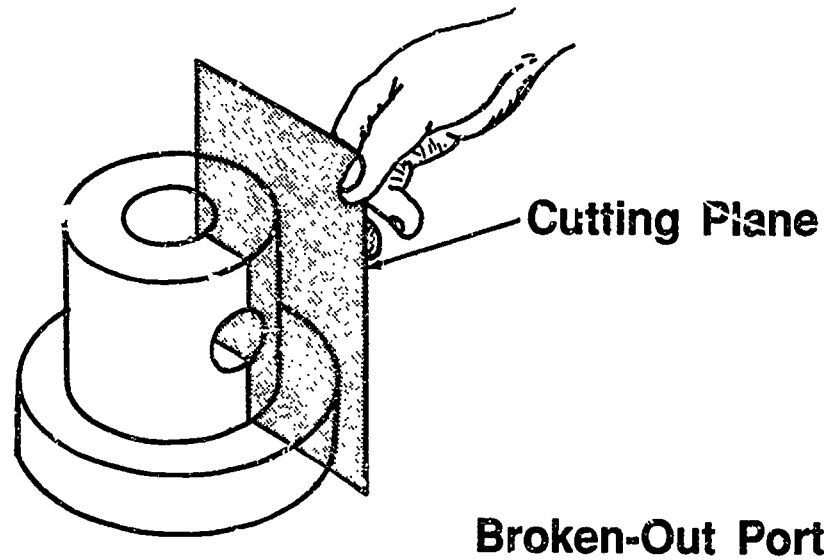

Revolved Section

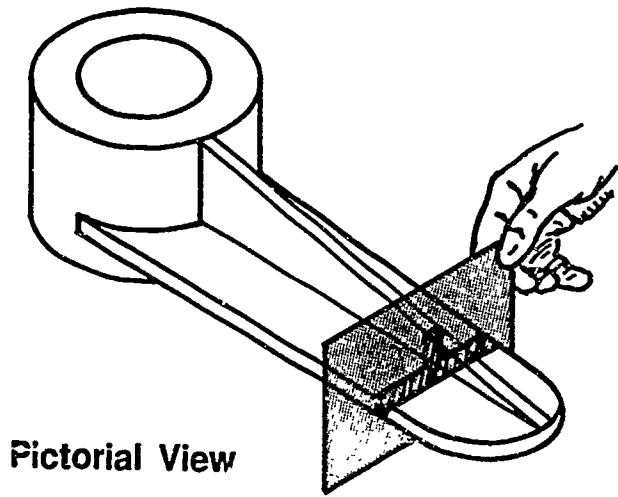

Top View

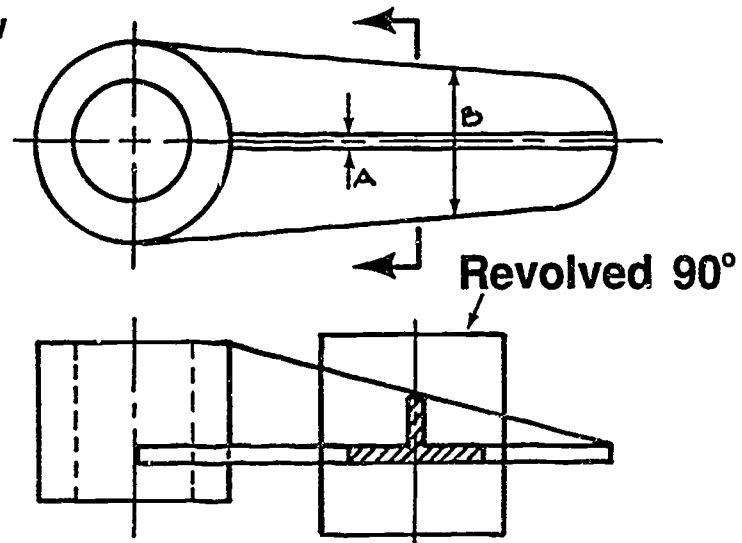

Front View

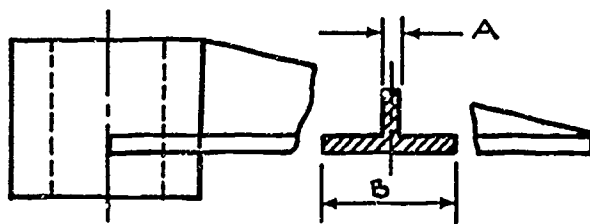

Broken Around Section

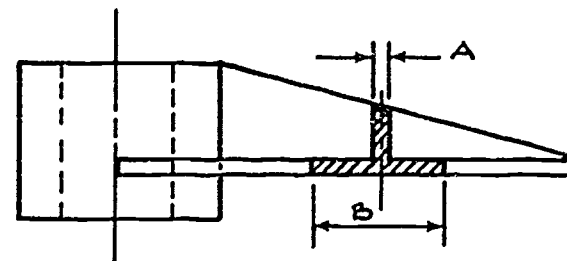

Section in View

Removed Section

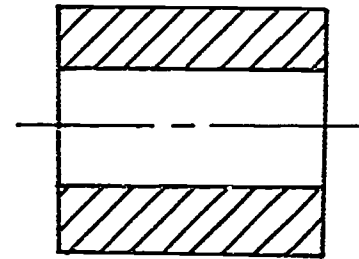
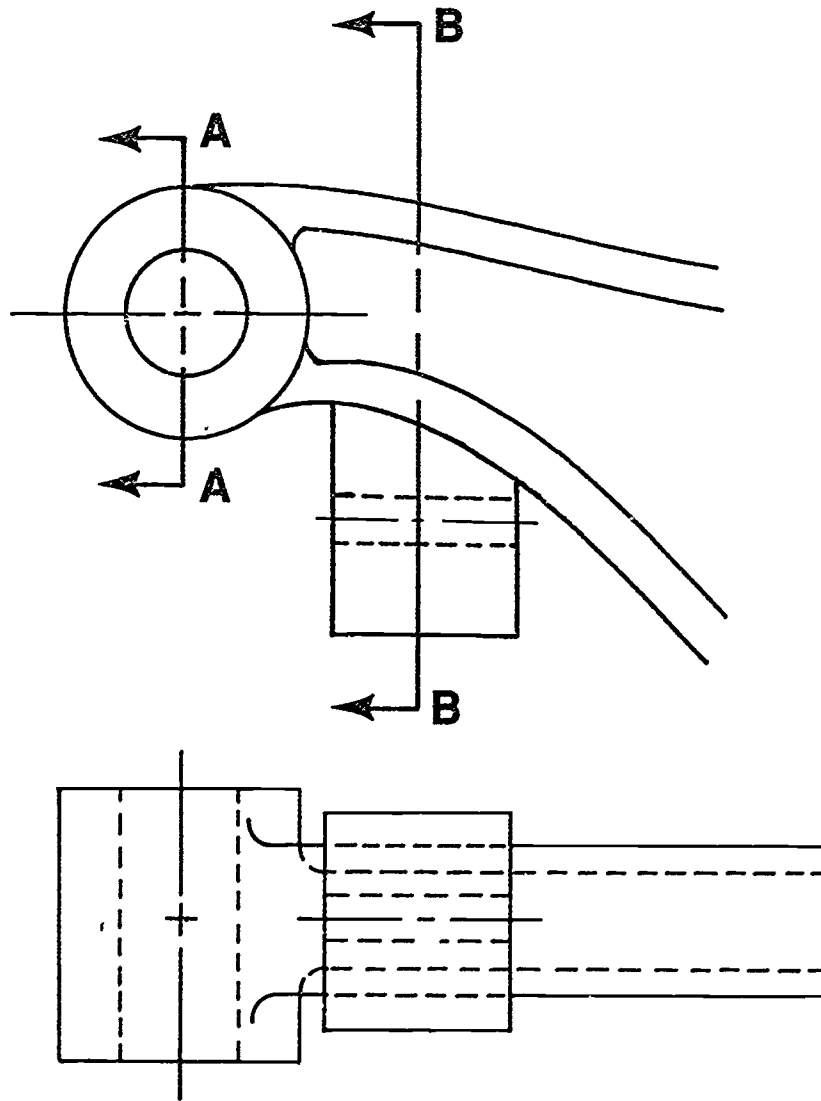

SECTION A-A

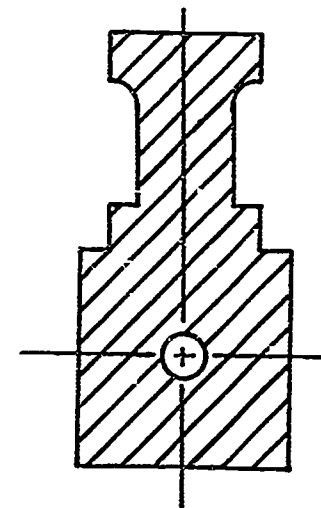

SECTION B-B

Aligned Section

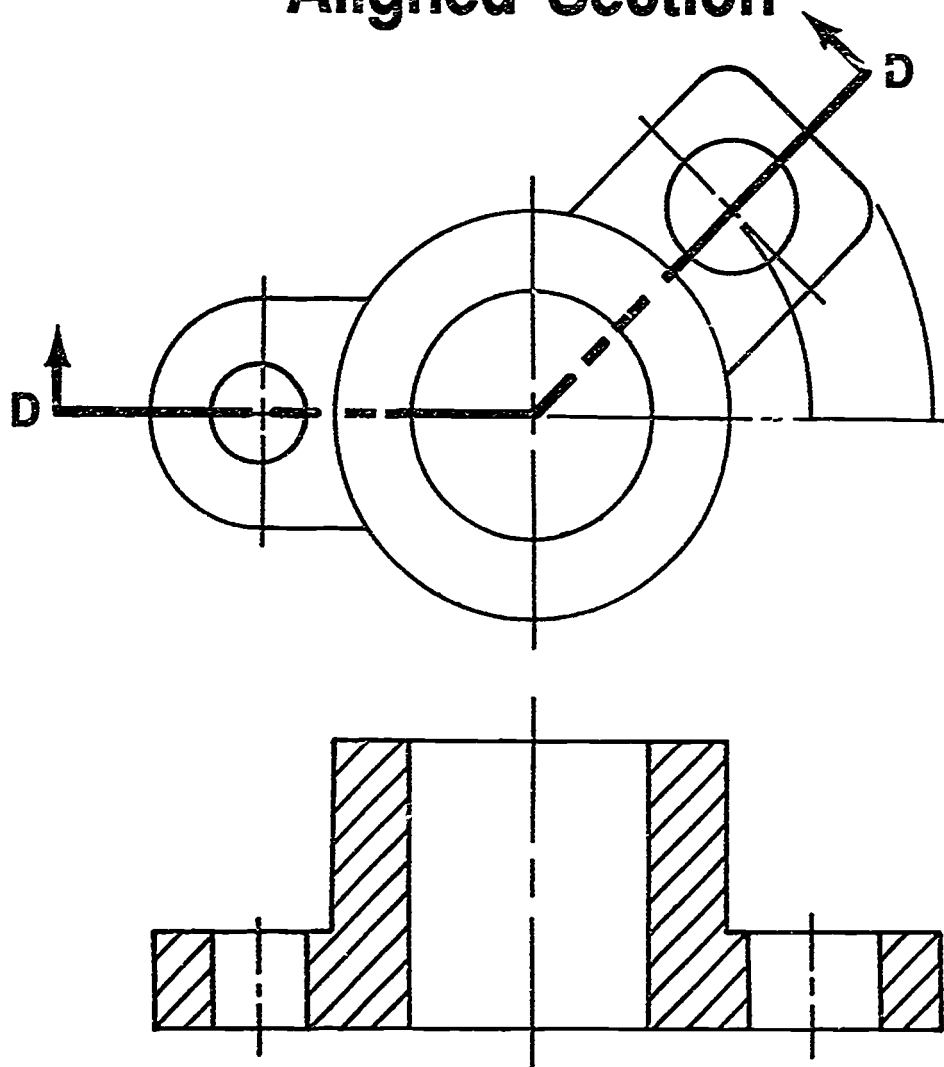

SECTION D-D

Rib Section

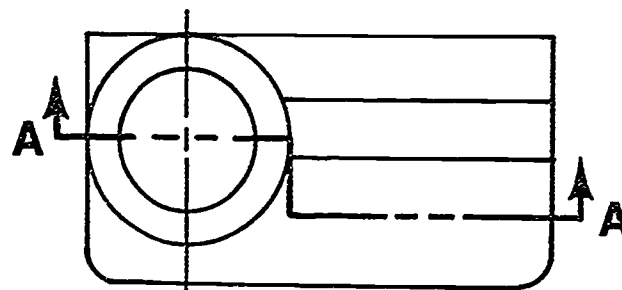
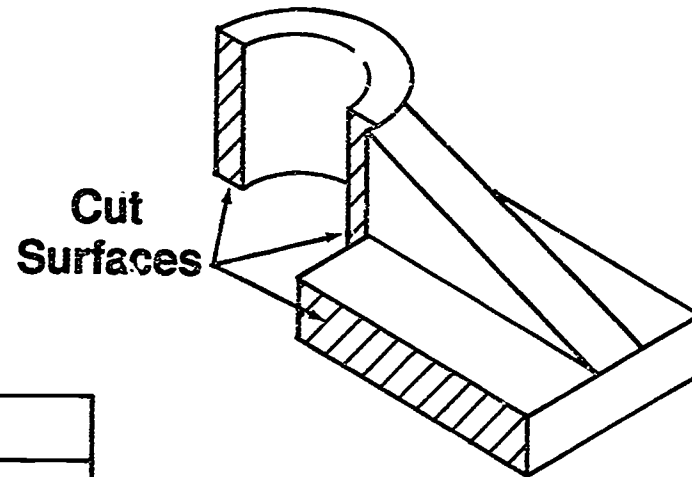
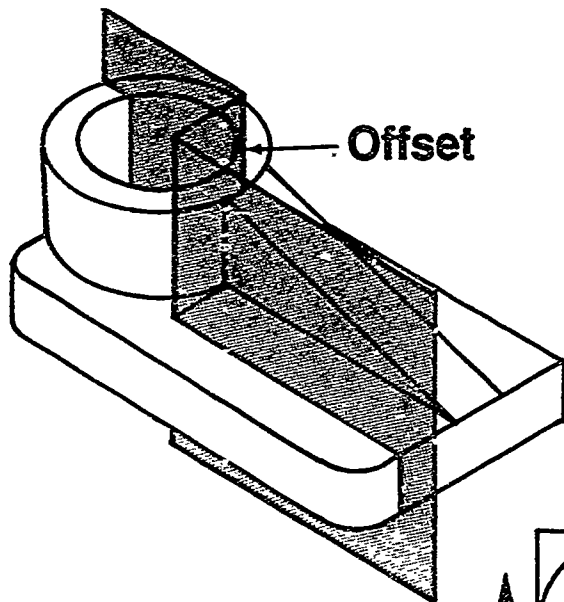

Former hidden lines are now visible lines in section view.

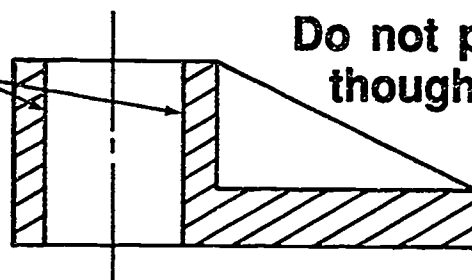

Do not project offset, but show as though a continuous full section.

Assembly Section

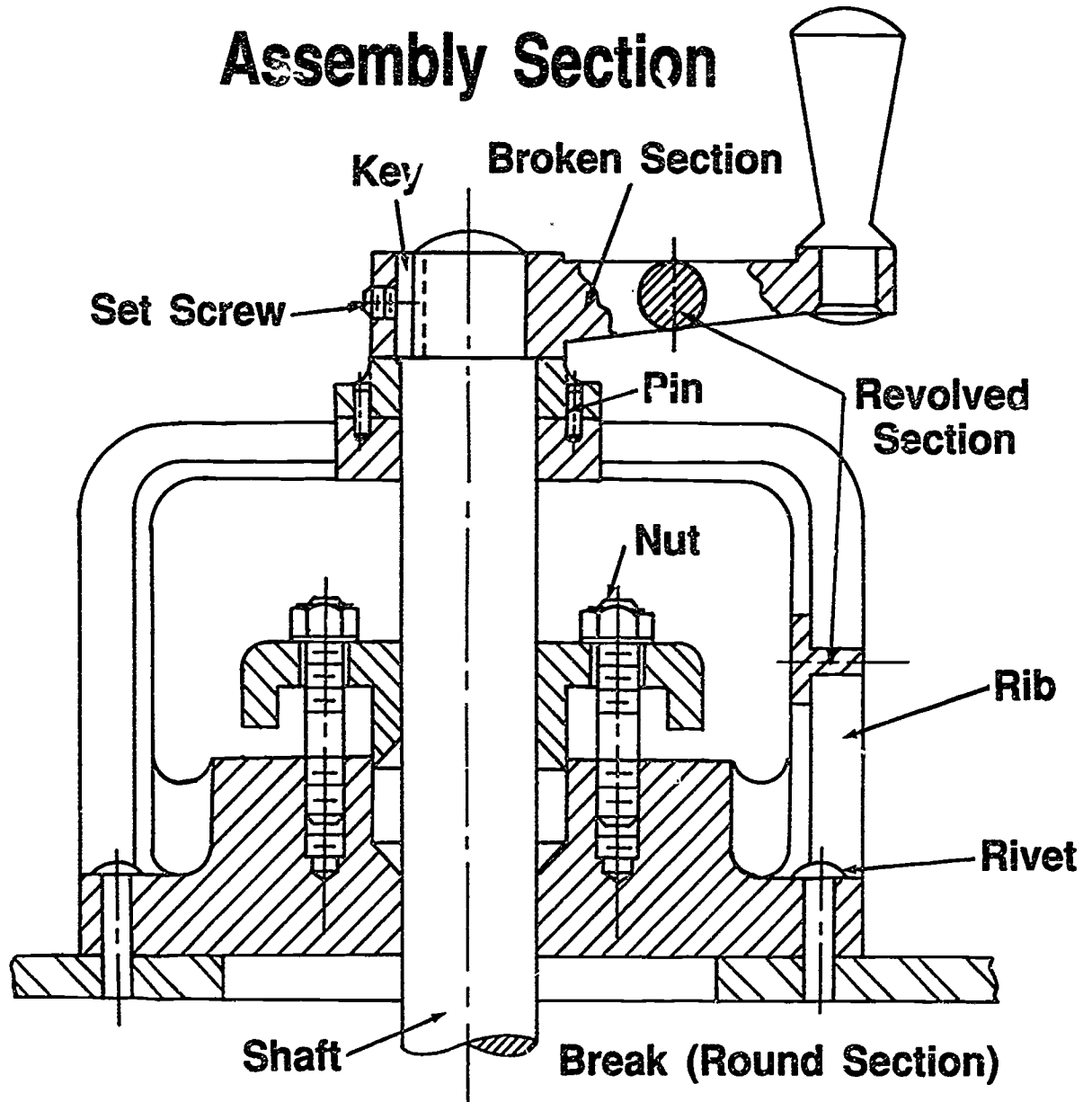

SECTIONAL VIEWS UNIT XIII

ASSIGNMENT SHEET #1 — CONSTRUCT VARIOUS MATERIAL SYMBOLS IN SECTION

Name _____ Score _____

Introduction: The quality of any drawing reproduction depends on the quality of line work. Open space between two adjacent parallel lines should be consistent. Section lines should be thin and dark. Light section lines tend to "fade out." Do not overdo. A minimum of section lining is sufficient to clarify a sectional view.

Directions: Duplicate the given symbols for materials in section in the spaces provided below. Label under each space in 1/8" letters the name of the material.

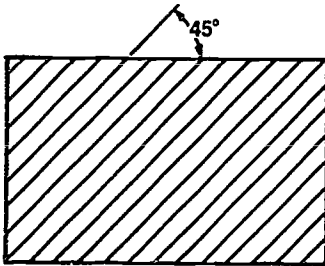

Cast Iron

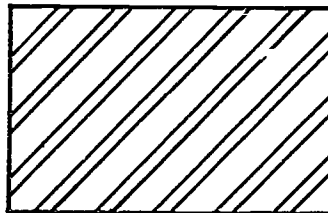

Steel

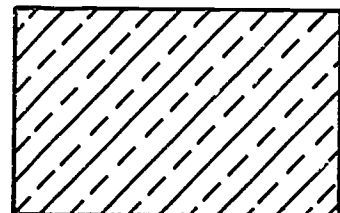

Brass, Bronze, or Copper

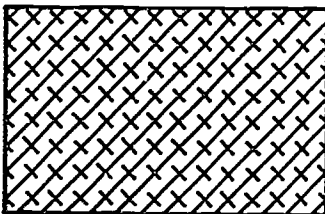

Magnesium, Aluminum,
and Alloys

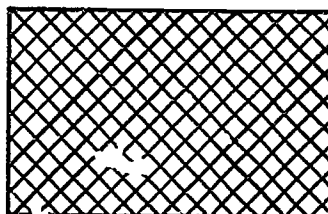

Zinc, Lead, and Alloys

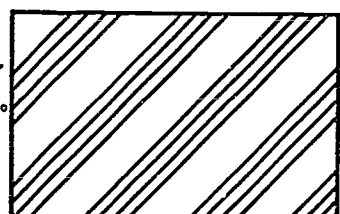

Rubber, Plastic, and
Electrical Insulation

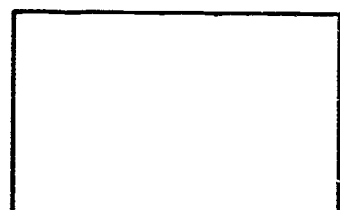
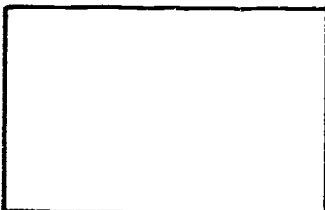
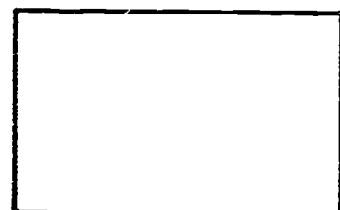
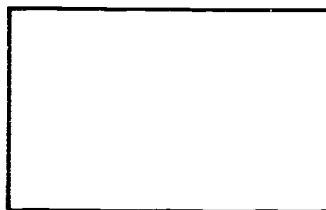
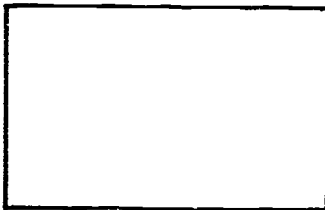

**SECTIONAL VIEWS
UNIT XIII**

ASSIGNMENT SHEET #2 — CONSTRUCT A FULL SECTION

Name _____ Score _____

Directions: Study the following example and then complete the assigned problems.

Example:

1. Imagine cutting an object all the way across with a hacksaw.

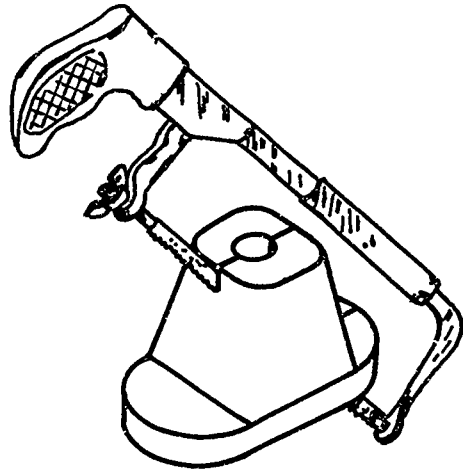

2. Think of the saw cut as an imaginary cutting plane.

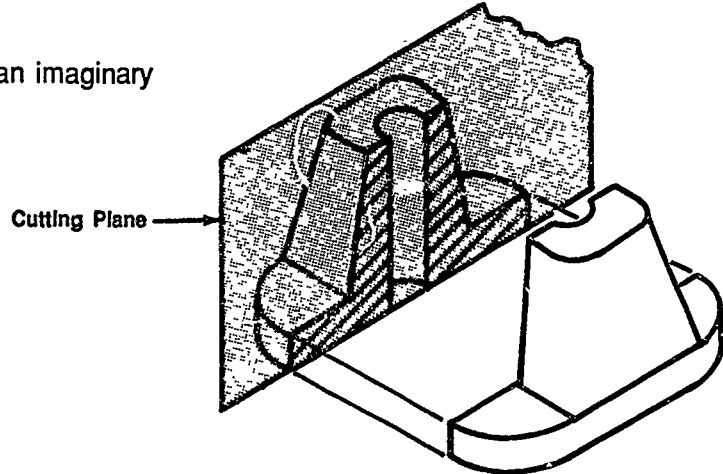

3. With the front half removed, visualize what the front view would look like.

(NOTE: This is a full section.)

TOP

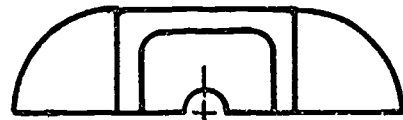

FRONT

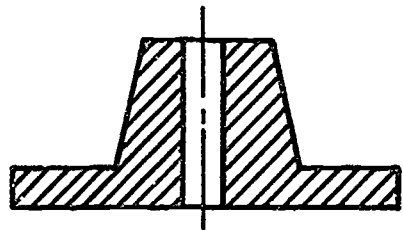

ASSIGNMENT SHEET #2

4. On a drawing you would show the complete top view and its cutting plane line. The area actually cut by the hacksaw would be represented with section lines.

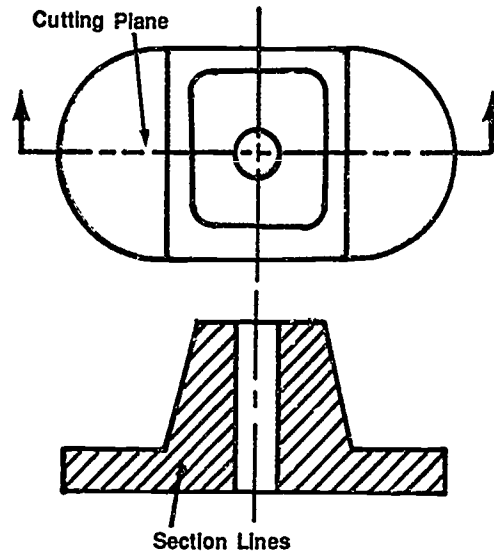

5. On an actual drawing, the two views would be drawn lightly as in orthographic projection with hidden lines, etc. Then the drafter would visualize the internal features of the object and draw that view in section omitting hidden lines.

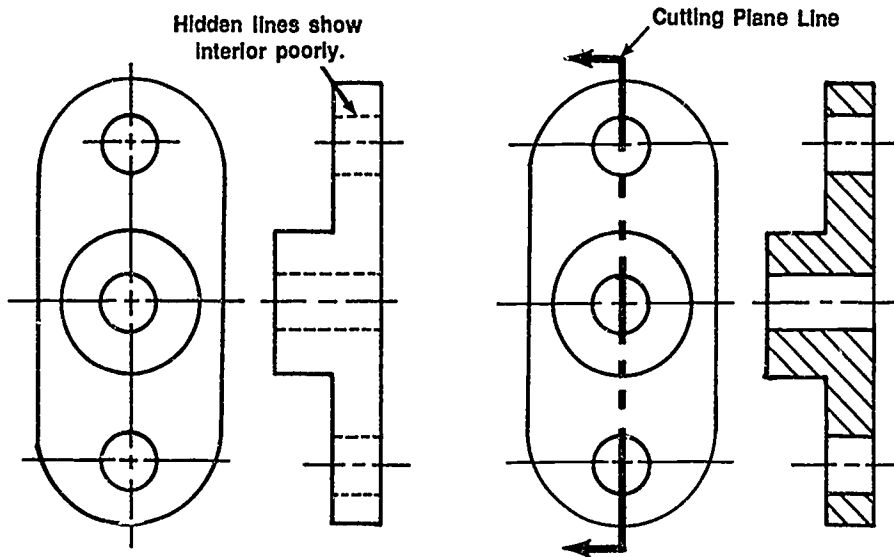

ASSIGNMENT SHEET #2

Directions: Change the front views of objects below to full section views.

Problem A: V Pulley

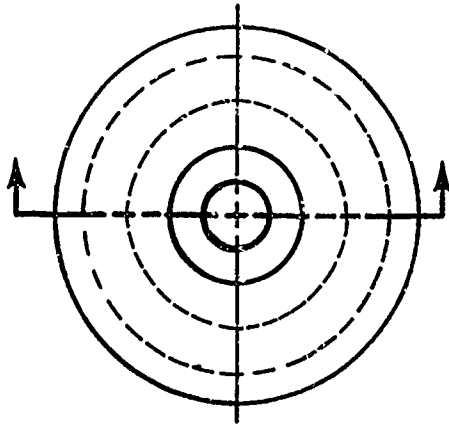

Problem B: Belt Drive

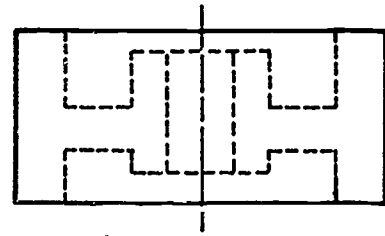
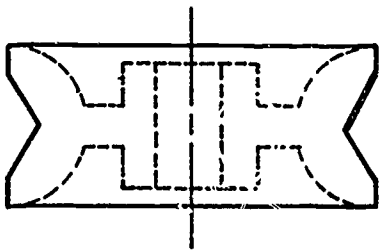
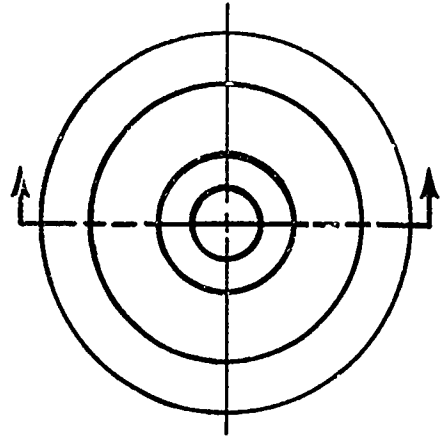

Problem C: Holding Bracket

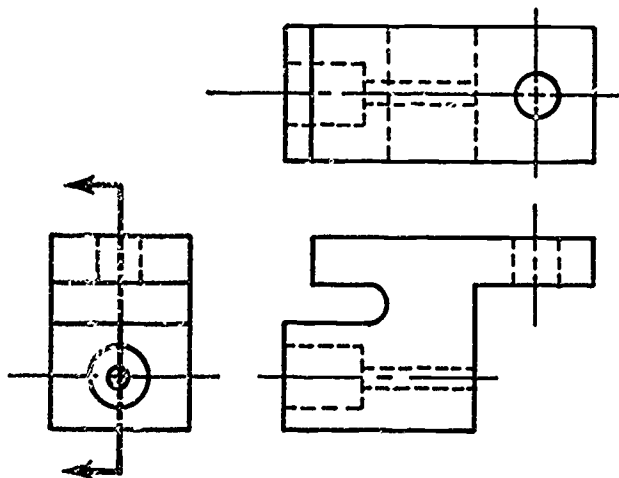

ASSIGNMENT SHEET #2

Directions: Complete the right side views of the following problems to full section views.

Problem D:

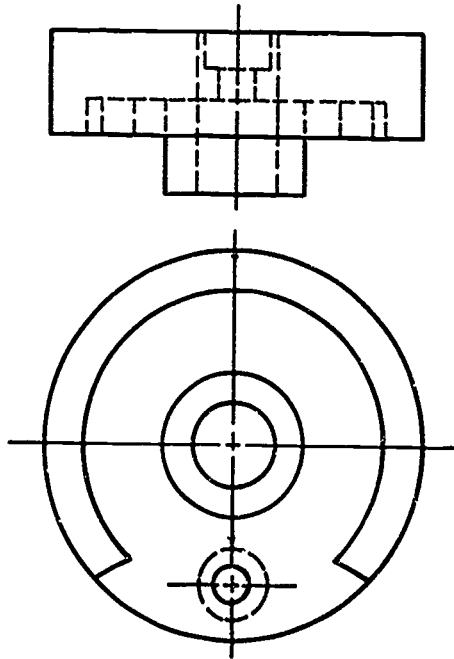

Problem E:

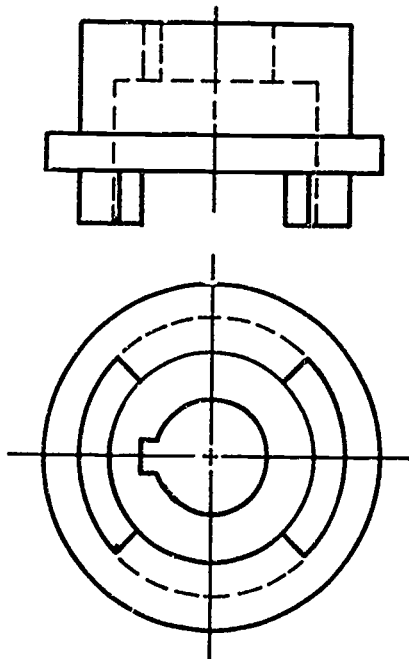

SECTIONAL VIEWS UNIT XIII

ASSIGNMENT SHEET #3 — CONSTRUCT A HALF SECTION

Name _____ Score _____

Directions: Study the following example and then complete the assigned problems.

Example:

1. Think of two imaginary planes at right angles to each other cutting through an object.

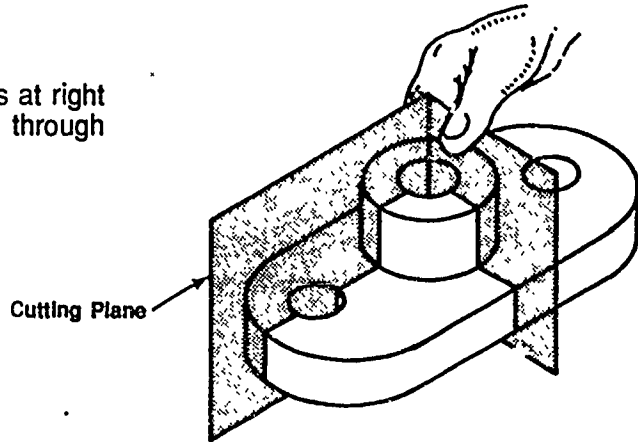

2. Remove the cut quarter section and assume a line of sight looking into the area cut by the planes.

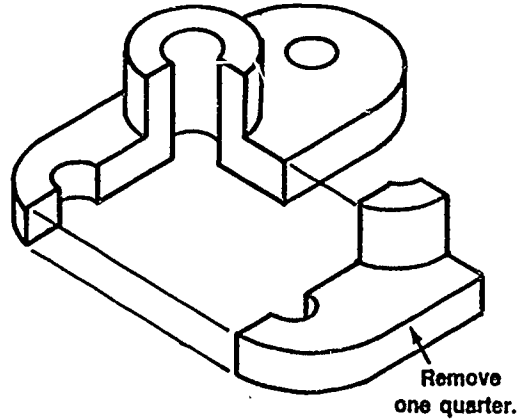

3. Construct top view with a cutting plane line that passes halfway through the object. Project lines to front view and determine areas to be sectioned.

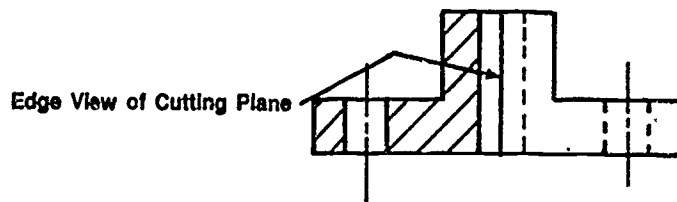
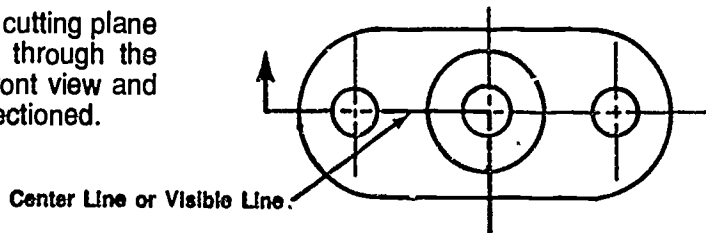

ASSIGNMENT SHEET #3

Directions: Construct section lines in the part of the view behind the cutting plane line.

Problem A: Bushing

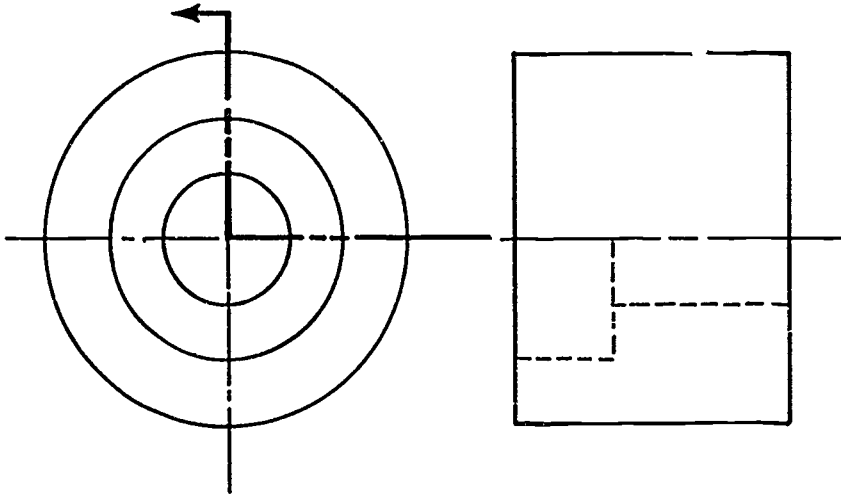

Problem B: Bracket Base

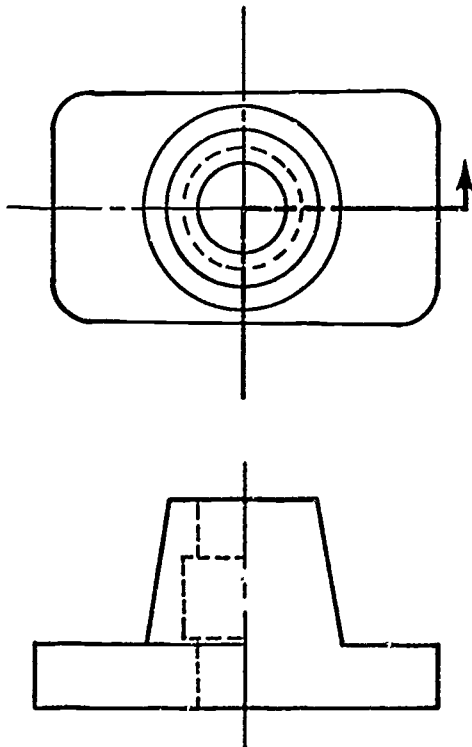

Problem C: Shaft Support

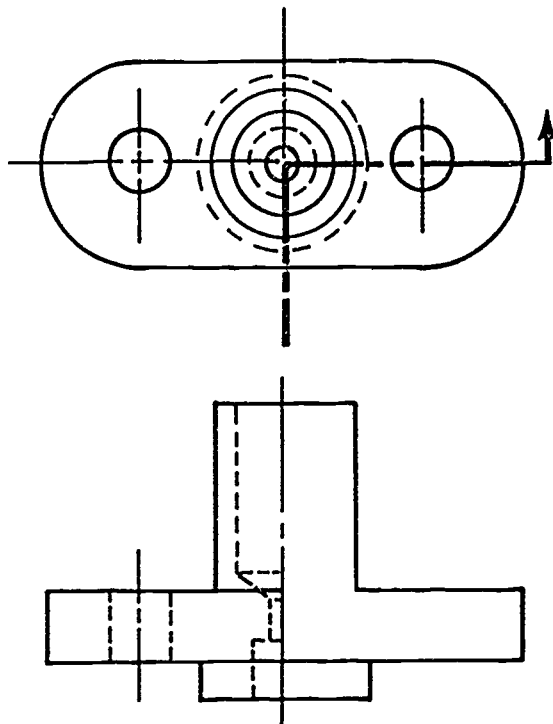

ASSIGNMENT SHEET #3

Directions: Complete top views for the following problems to half sections.

Problem D:

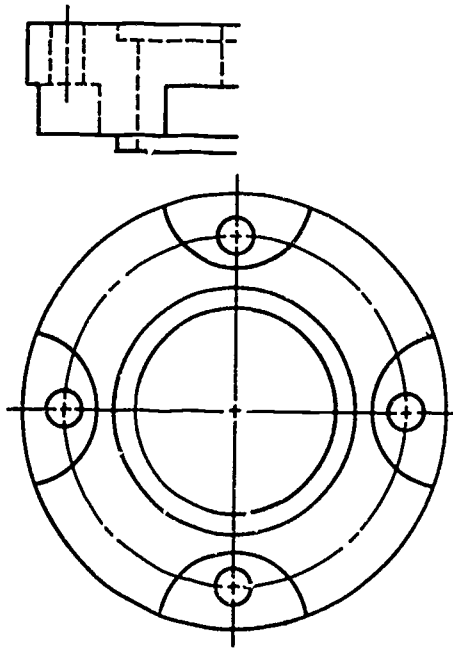

Problem E:

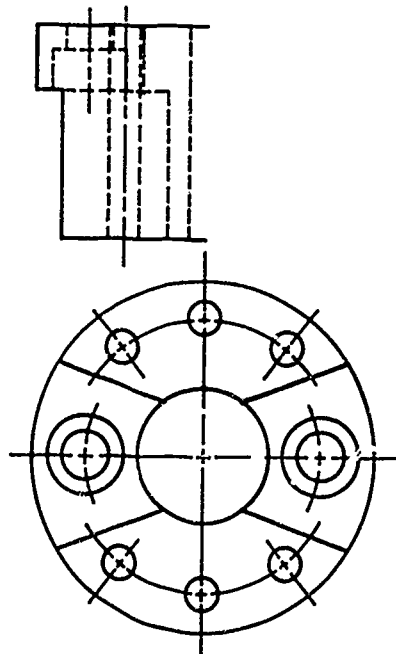

**SECTIONAL VIEWS
UNIT XIII**

ASSIGNMENT SHEET #4 — CONSTRUCT AN OFFSET SECTION

Name _____ Score _____

Directions: Study the following example and then complete the assigned problems.

Example:

1. Decide which features about this object are not in a common line but should be shown in section.

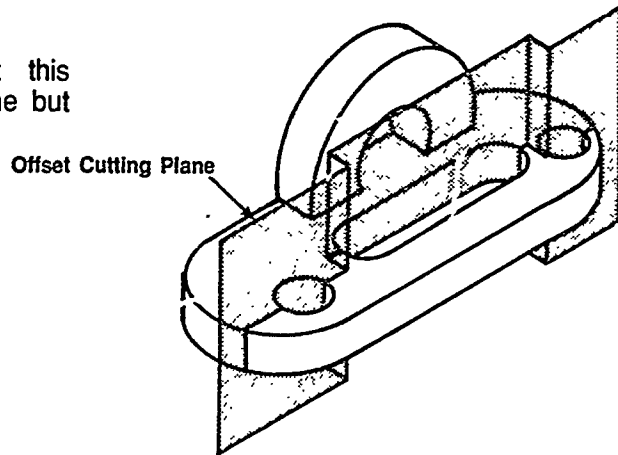

2. Remove the portion in front and look into the object.

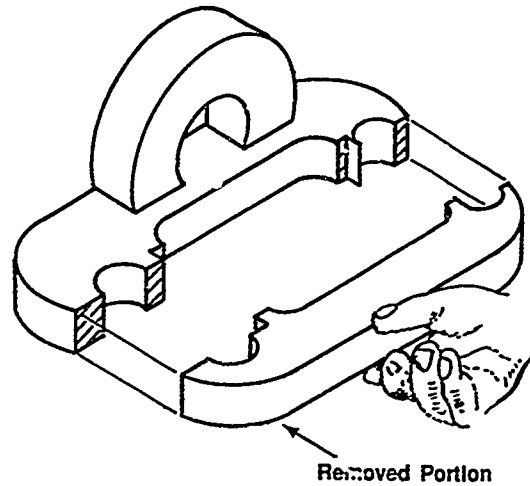

ASSIGNMENT SHEET #4

3. A drawing of the top view would show the offset of the cutting plane. The front section view would show the object as if the slot and holes were all on the same center line.

(NOTE: The offsets in the cutting plane are not shown with a line in the front section.)

Directions: Construct the front view in section.

Problem A:

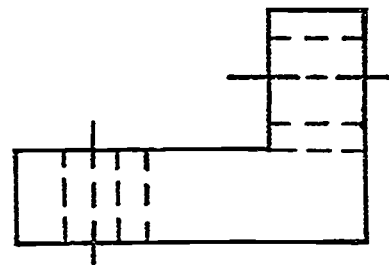
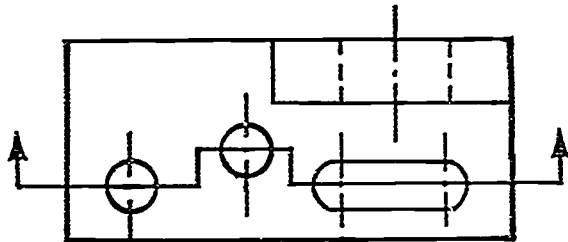
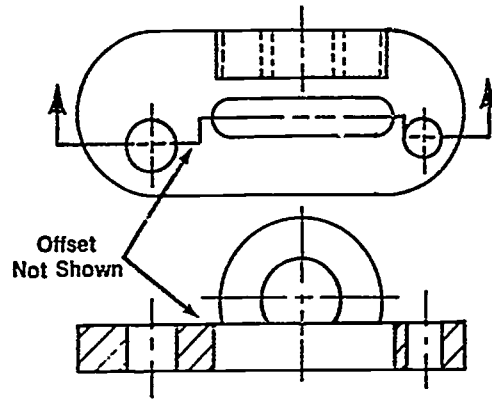

ASSIGNMENT SHEET #4

Directions: Complete the front views to offset sections for the following problems.

Problem B:

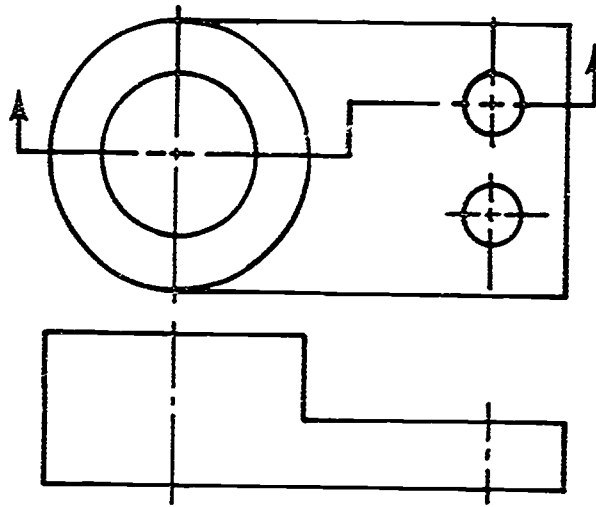

Problem C:

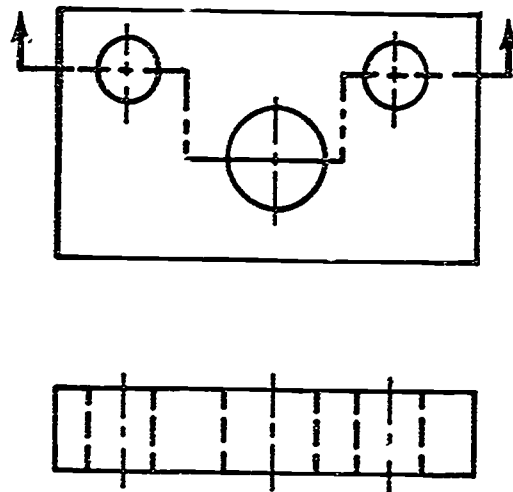

ASSIGNMENT SHEET #4

Directions: Construct the cutting plane in top view and complete the front view to an offset section.

Problem D:

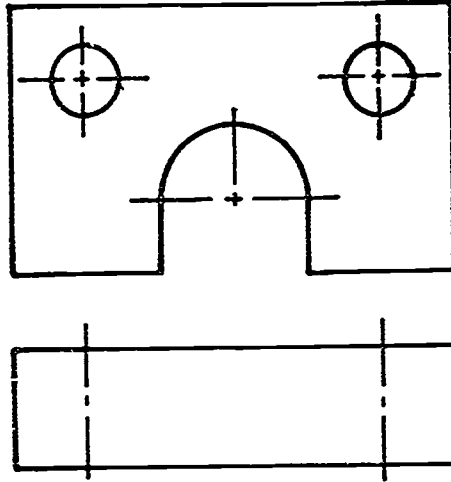

727

SECTIONAL VIEWS UNIT XIII

ASSIGNMENT SHEET #5 — CONSTRUCT A BROKEN-OUT SECTION

Name _____ Score _____

Directions: Study the following example and then complete the assigned problems. A broken-out section needs to be used only when a portion of the whole object needs to be sectioned.

Example:

1. Pass an imaginary cutting plane through the area to be sectioned.

(NOTE: Cutting plane line is not shown on drawing.)

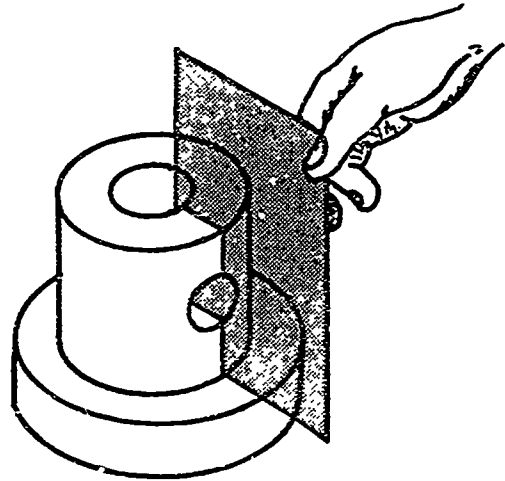

2. Remove the portion by breaking it off and visually lifting it out of position.

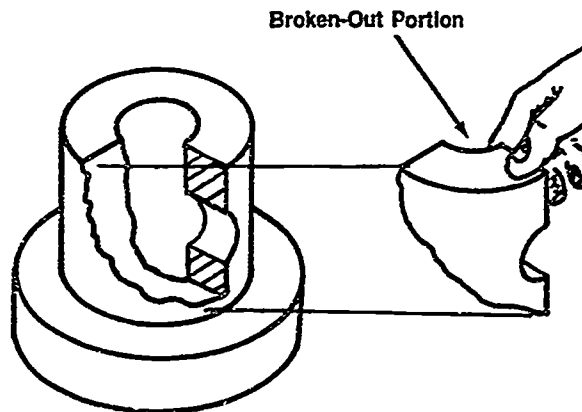

ASSIGNMENT SHEET #5

3. On a drawing, the area cut by the plane would appear in section and the broken area would be represented with a short break line. Draw the top and front view lightly. Then remove the portion that needs to be sectioned.

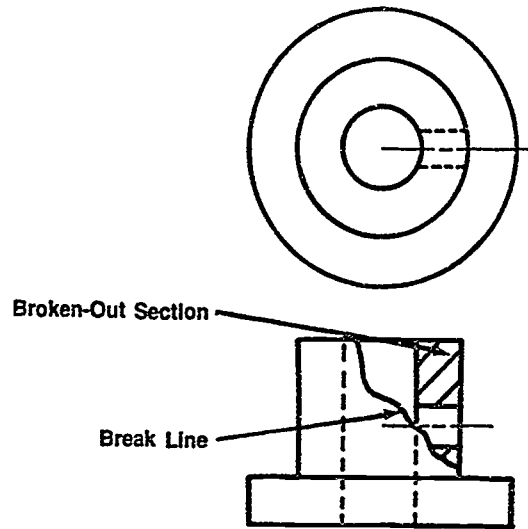

Directions: Construct broken-out sections in front view for the following problems.

Problem A: Bronze material

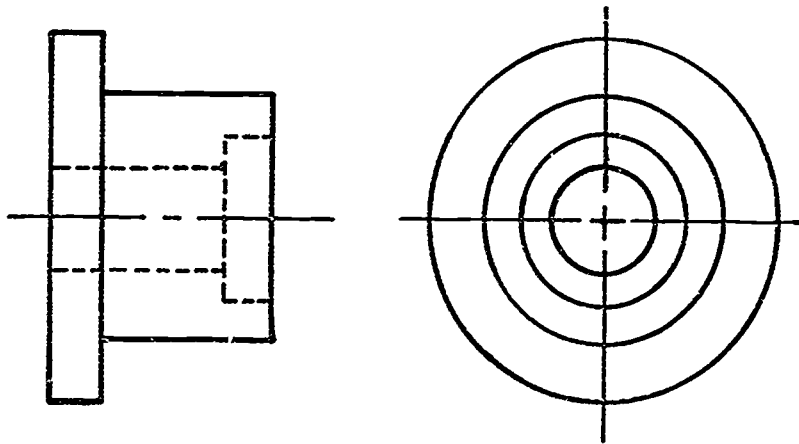

ASSIGNMENT SHEET #5

Problem B: Cast iron material

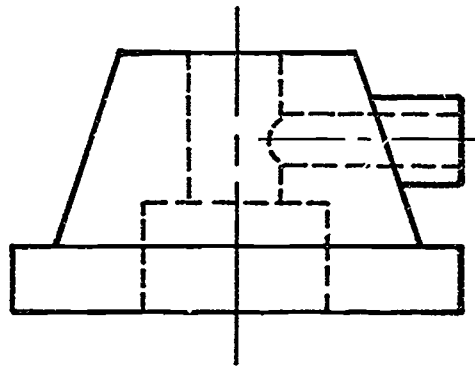
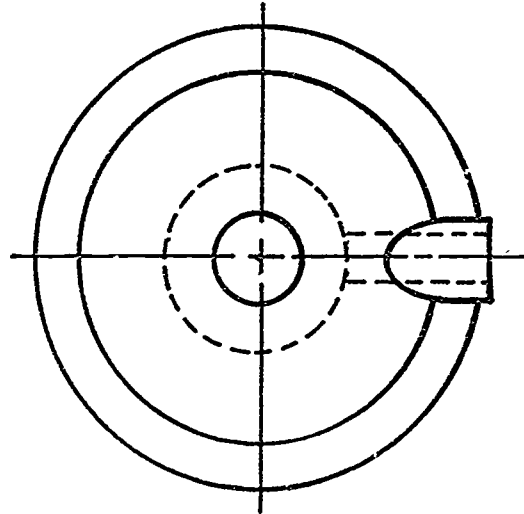

ASSIGNMENT SHEET #5

Directions: Construct a broken-out section of the view below.

Problem C: Material as described by instructor

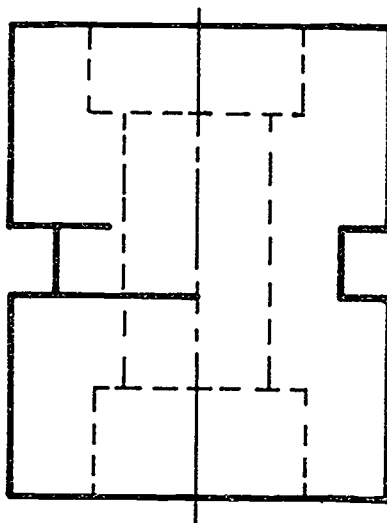

Directions: Construct a broken-out section in right side view.

Problem D: Material as described by instructor

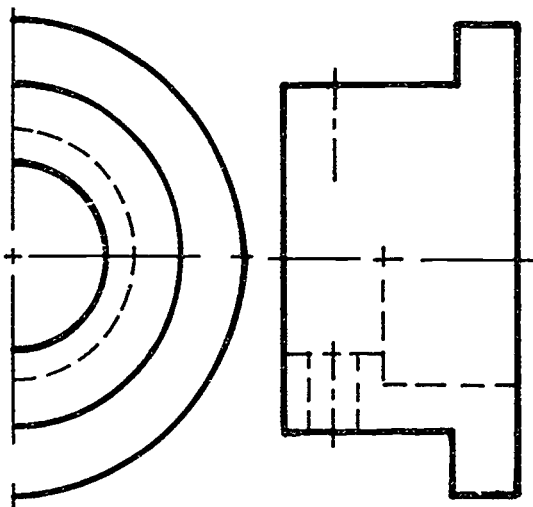

**SECTIONAL VIEWS
UNIT XIII**

ASSIGNMENT SHEET #6 — CONSTRUCT A REMOVED SECTION

Name _____ Score _____

Introduction: A removed section is used to illustrate an area separate from its view by passing an imaginary plane through an area and then drawing it in section and labeling it to correspond to its cutting plane. Removed sections are often used when several sections are taken through one view of an object.

Directions: Study the following example and then complete the assigned problems.

Example:

1. Determine the area to be sectioned and pass a cutting plane through it.

(NOTE: Label the cutting plane lines A-A, B-B, etc.)

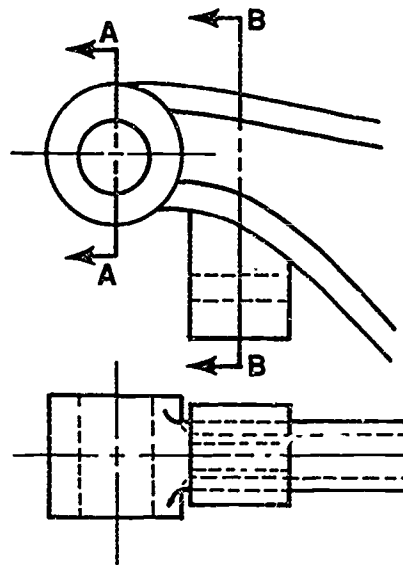

2. Construct the sections indicated by the cutting plane lines on any area of the drawing where space is available. However, keep axis of section the same as the view it was taken from, if possible.

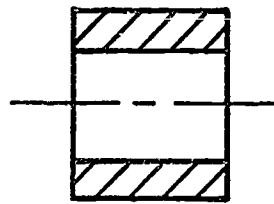

SECTION A-A

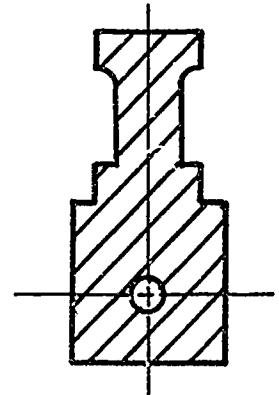

SECTION B-B

ASSIGNMENT SHEET #6

Directions: Pictured below are two views of an object with a series of sections cut through it. Pictured below are three of its sections. Complete the other two sections (D-D and E-E).

Problem A:

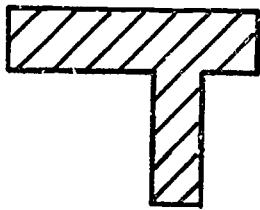
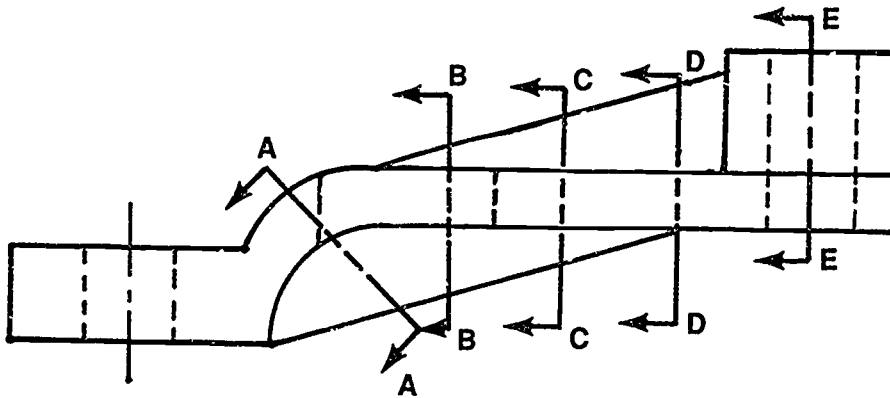
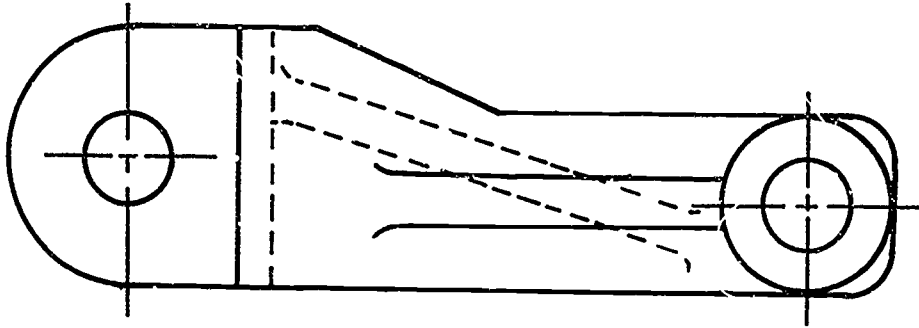

SECTION A-A

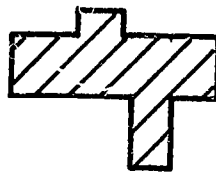

SECTION B-B

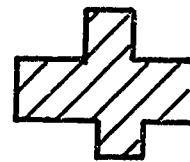

SECTION C-C

SECTION D-D

SECTION E-E

733

ASSIGNMENT SHEET #6

Directions: Construct the removed sections indicated by cutting plane lines for the following problems. Type of material will be assigned by instructor.

Problem B:

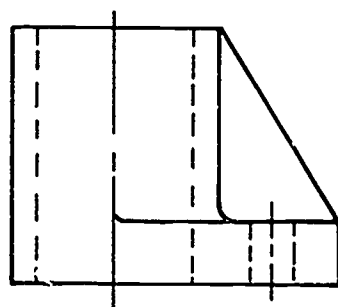
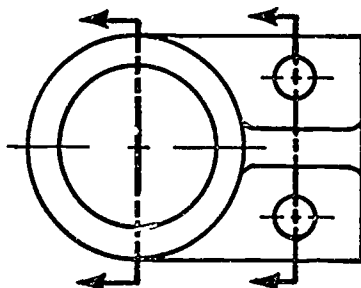

Problem C:

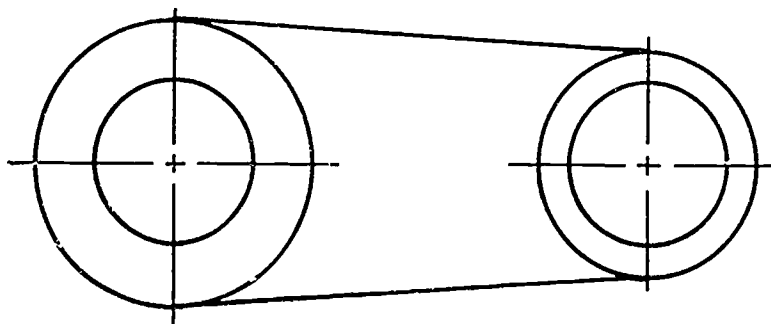
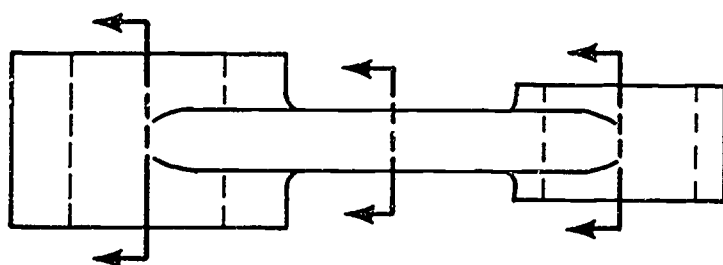

**SECTIONAL VIEWS
UNIT XIII**

ASSIGNMENT SHEET #7 — CONSTRUCT A REVOLVED SECTION

Name _____ Score _____

Directions: Study the following example and then complete the assigned problems. A revolved section is used to illustrate an area of an object without drawing a separate view.

Example:

1. Pass an imaginary plane through the area.

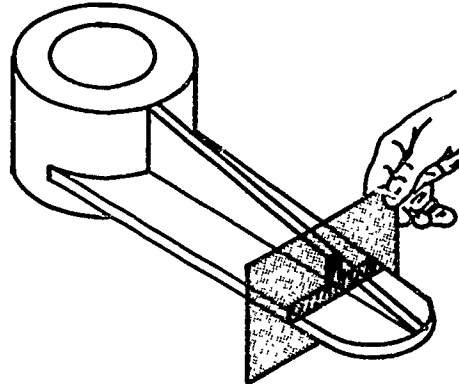

2. Indicate cutting plane line and rotate plane in front view.

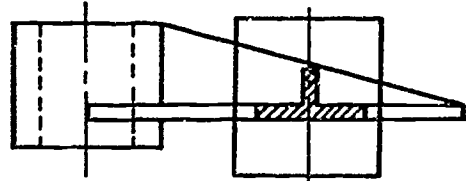
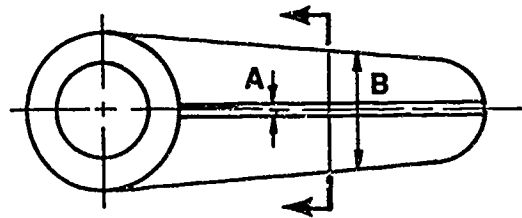

3. The section can be shown in one of two ways: (a) drawn in context or (b) object broken away from section.

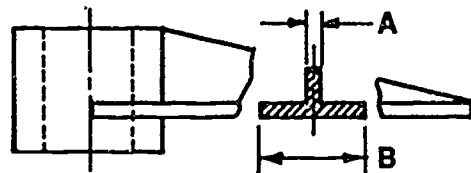
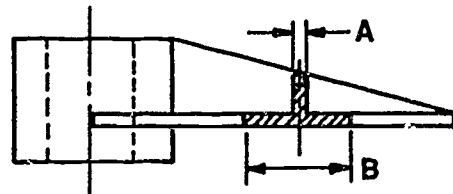

ASSIGNMENT SHEET #7

Directions: Construct a revolved section view in the area indicated for the following problems.

Problem A: Offset Bracket

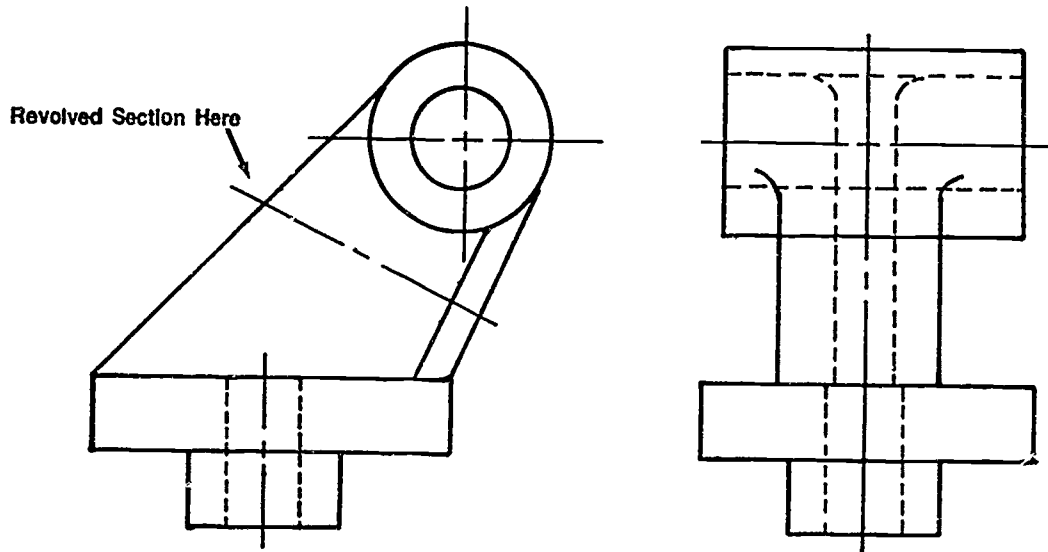

Problem B: Extension Mount

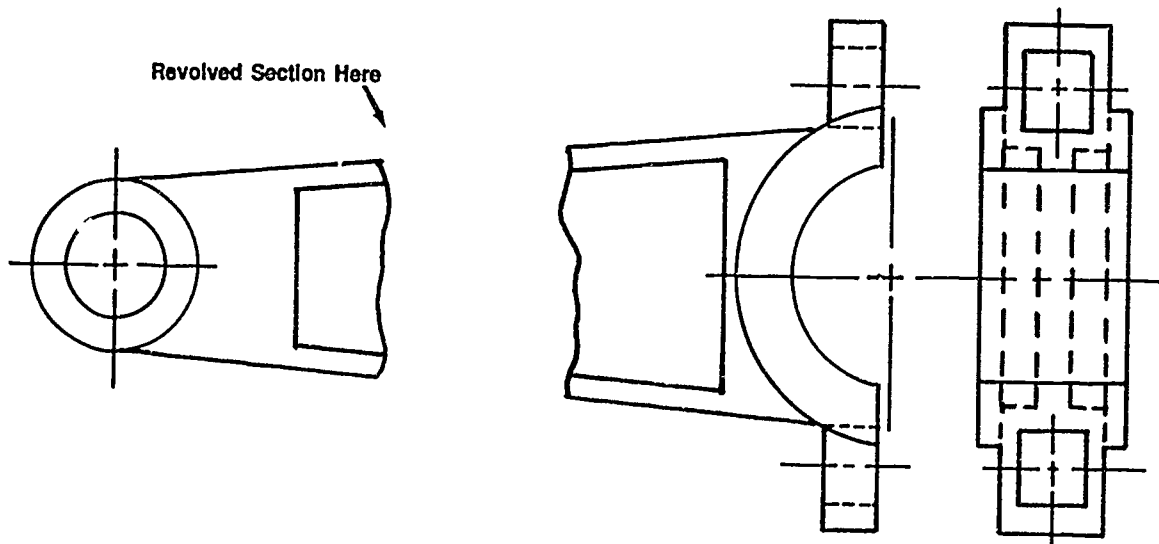

SECTIONAL VIEWS
UNIT XIII

ASSIGNMENT SHEET #8 — CONSTRUCT A RIB SECTION

Name _____ Score _____

Directions: Study the following example and then complete the assigned problems.

Example:

1. When sectioning an area that has a rib or spoke, the cutting plane line offsets in front of the rib.

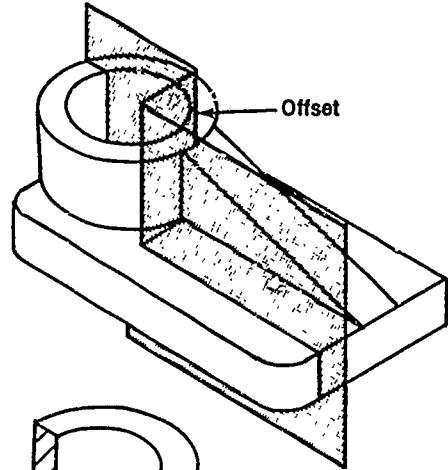

2. Remove front portion and look into the object.

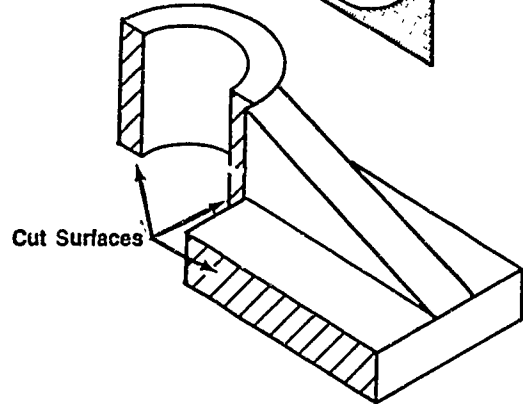

3. Show cutting plane as illustrated in top view. Section front view as shown omitting section lines on rib.

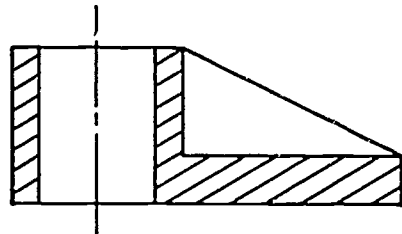
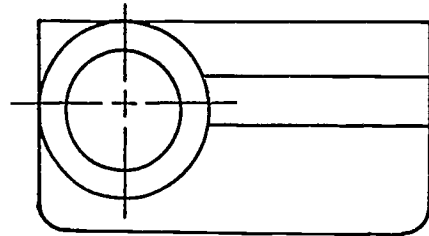

Omit Hidden Line

ASSIGNMENT SHEET #8

Directions: Construct the right side view with rib sectioned properly for the following problems.

Problem A:

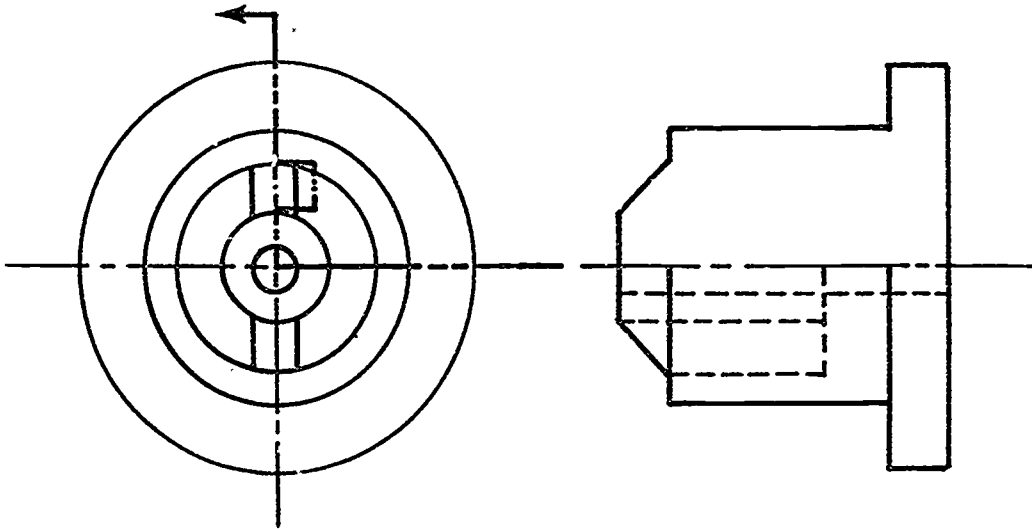

Problem B:

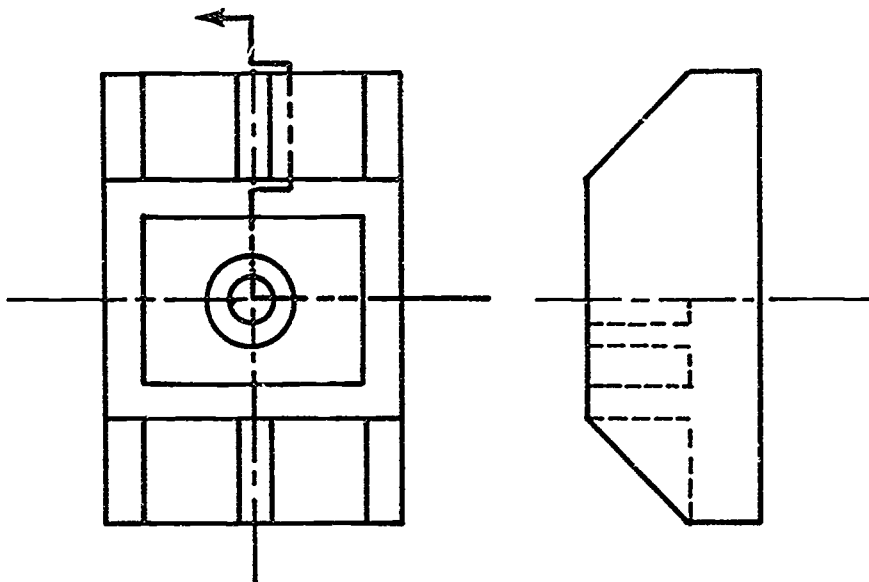

**SECTIONAL VIEWS
UNIT XIII**

ASSIGNMENT SHEET #9 — CONSTRUCT AN ALIGNED SECTION

Name _____ Score _____

Directions: Study the following example and then complete the assigned problems.

Example:

1. Introduce cutting line.

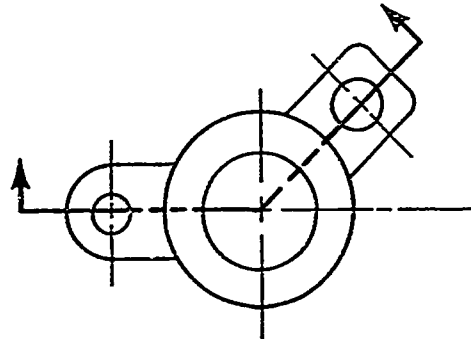

2. Rotate cutting plane to horizontal axis.

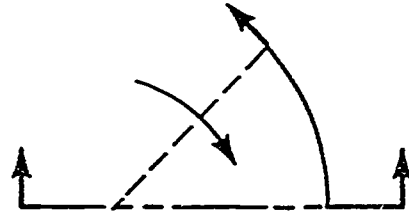

3. Draw in sections as if they were all on horizontal cutting plane.

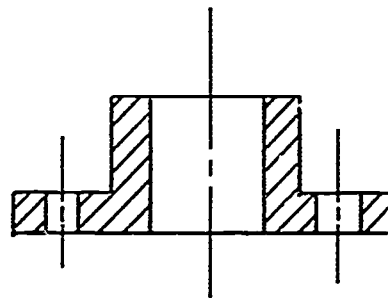

ASSIGNMENT SHEET #9

Directions: Construct front views as aligned sections for the following problems.

Problem A:

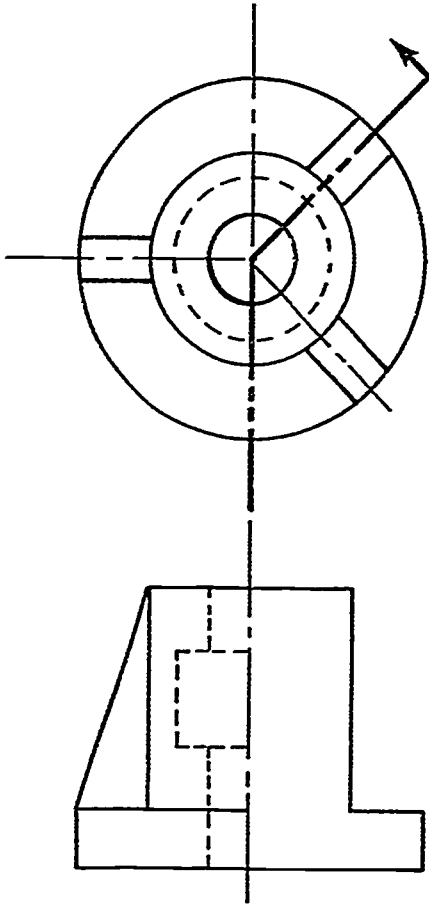

Problem B:

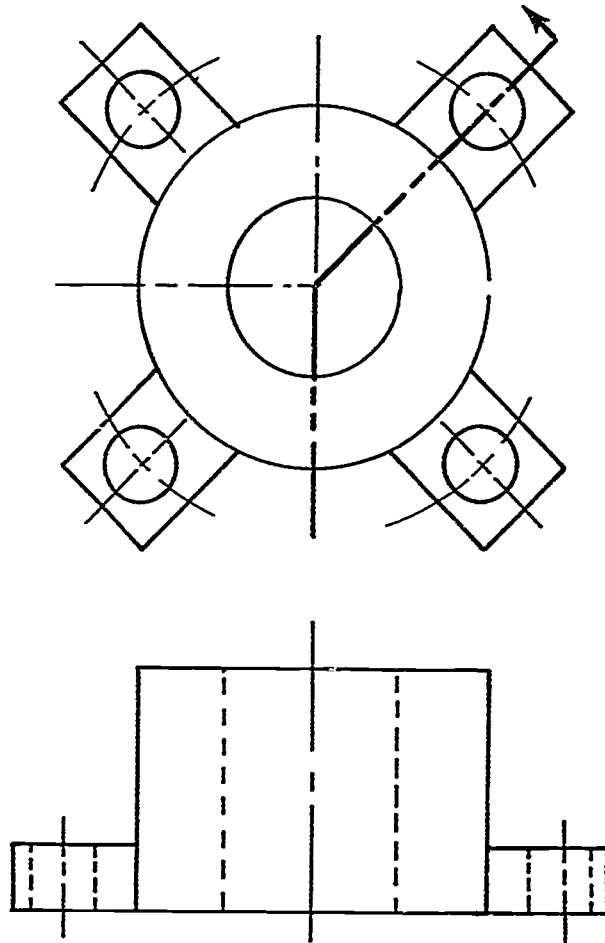

ASSIGNMENT SHEET #9

Directions: Construct the right side into aligned section for the following problems.

Problem C:

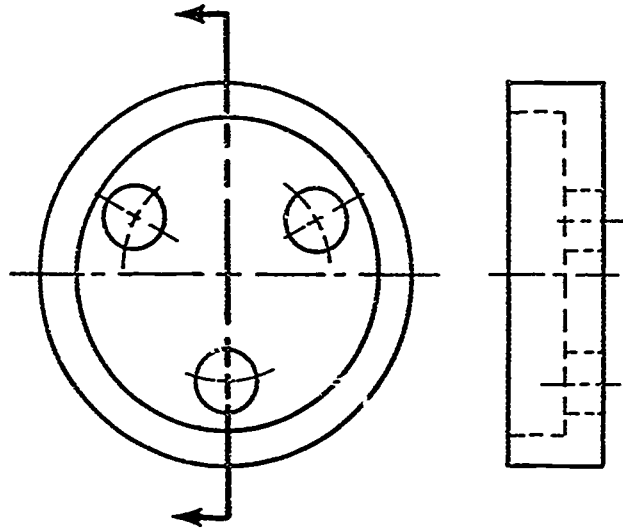

Problem D:

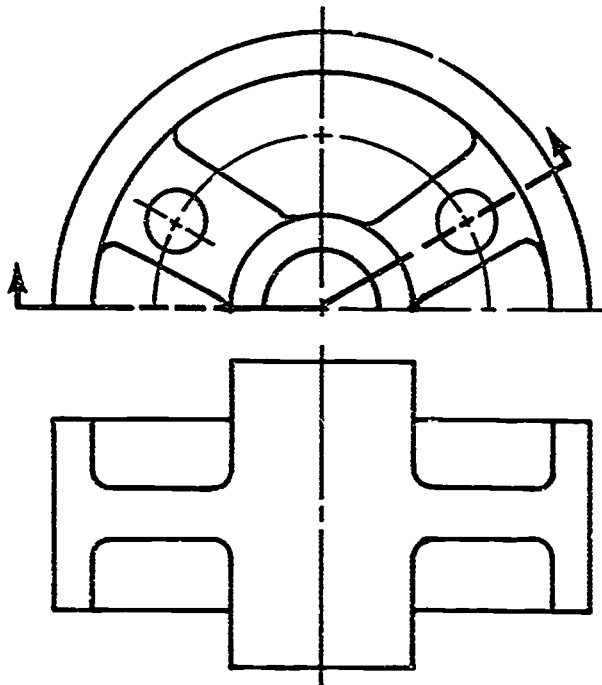

SECTIONAL VIEWS UNIT XIII

ASSIGNMENT SHEET #10 — CONSTRUCT ADJACENT PARTS IN ASSEMBLY SECTION

Name _____ Score _____

Directions: Study the following example and then complete the assigned problems.

Example:

1. The first section lines are constructed at an angle of 45° to the main outline of the object.

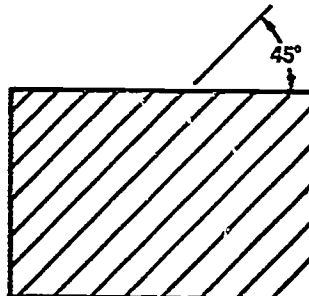

2. On adjacent parts, section lines should be 45° in the opposite direction.

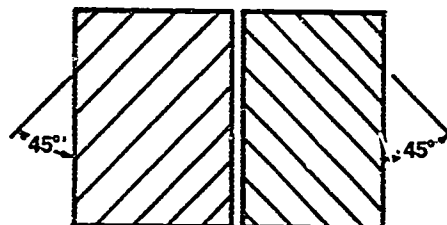

3. For more than two parts adjacent to each other, section lines should be drawn at an angle of 30° or 60° .

(NOTE: Section lines should not be drawn to meet at common lines.)

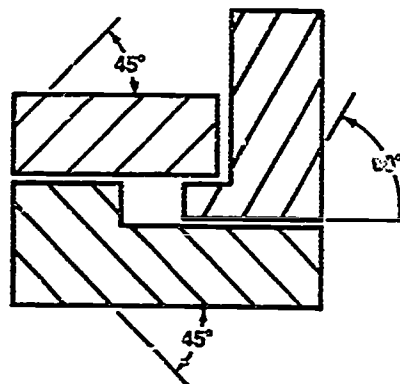

4. Different materials can be used to represent different parts in section.

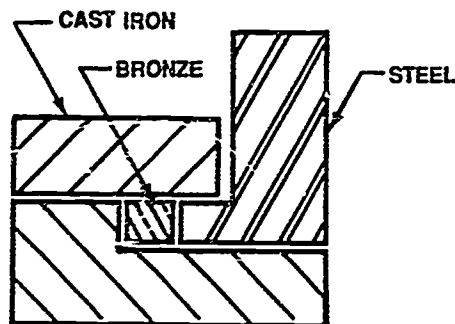

742

ASSIGNMENT SHEET #10

Directions: Complete this assembly as a section using the proper symbols.

Problem A:

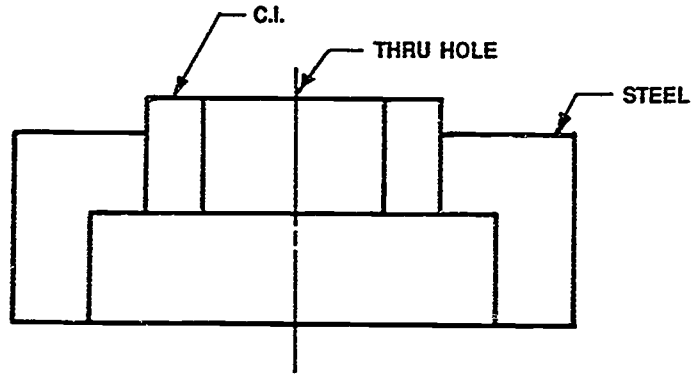

Directions: Complete front view as a section using the symbols called for.

Problem B:

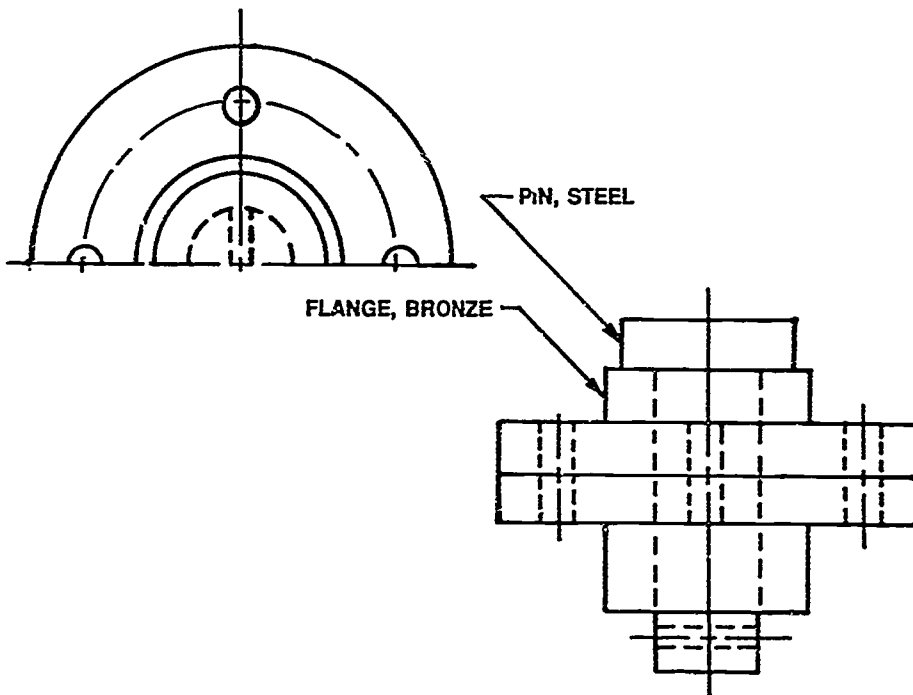

743

SECTIONAL VIEWS UNIT XIII

ASSIGNMENT SHEET #11 — CONSTRUCT CONVENTIONAL BREAKS

Name _____ Score _____

Directions: Study the following example and then complete the assigned problems.

Example:

1. Use given rectangular view for bar or tube.

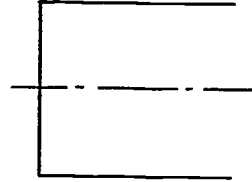

2. Lay off fractional radius widths on end to be sectioned.

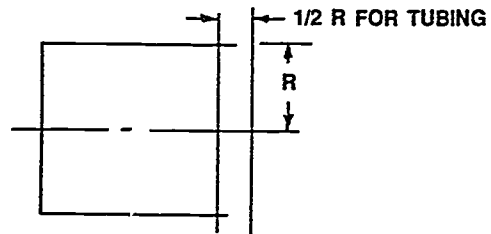

3. Using ellipse template or irregular curve, construct "S" breaks.

(NOTE: Construct "S" break freehand on small diameter bar or tubing.)

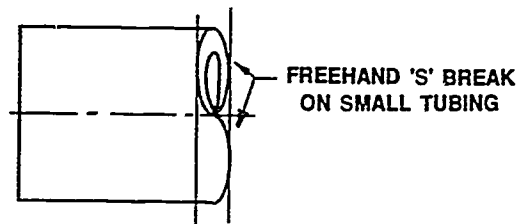
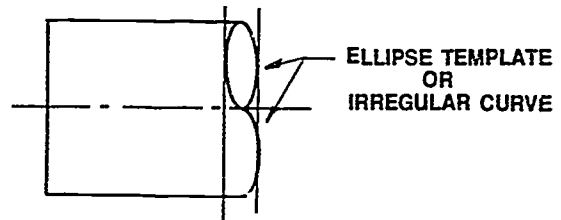

ASSIGNMENT SHEET #11

4. Add section lining to visible sectioned part.

(NOTE: When "S" break is shown with stock continuing on both sides of break, the sectioned faces are diagonally opposite.)

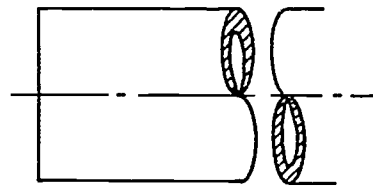
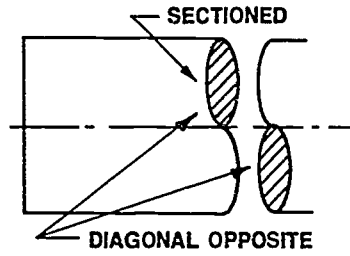

5. Use short or long break symbols on rectangular solids.

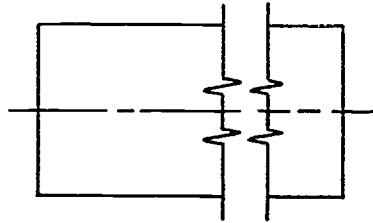

Directions: Construct conventional breaks in the parts below.

Problem A: Round solid — Cast iron

Problem B: Rectangular solid — Steel

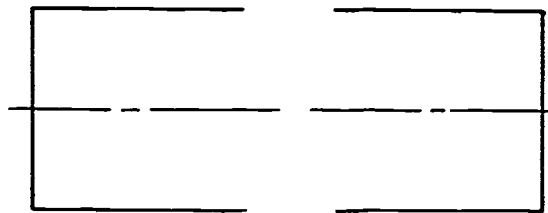
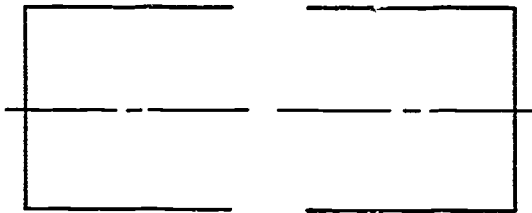

Problem C: Round tubular — Brass

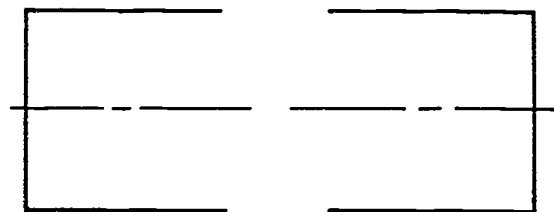

SECTIONAL VIEWS UNIT XIII

ASSIGNMENT SHEET #12 — CONSTRUCT AN ASSEMBLY SECTION

Name _____ Score _____

Introduction: Shafts, bolts, nuts, rods, rivets, keys, pins, and similar parts are not sectioned if the axis lies in the cutting plane. A broken-out section may be used to clarify the key and keyseat.

Directions: Complete a full section of the following coupling assembly using proper material symbols.

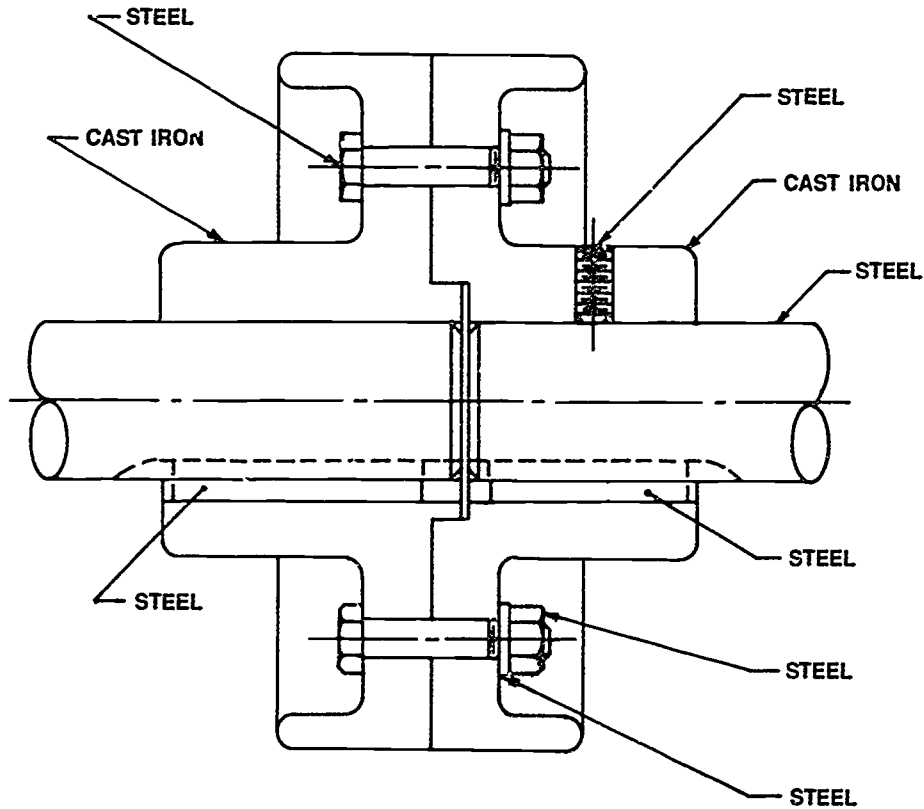

SECTIONAL VIEWS
UNIT XIII

ANSWERS TO ASSIGNMENT SHEETS

Assignment Sheet #1 — Evaluated to the satisfaction of the instructor

Assignment Sheet #2

A.

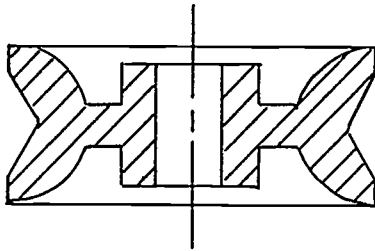

B.

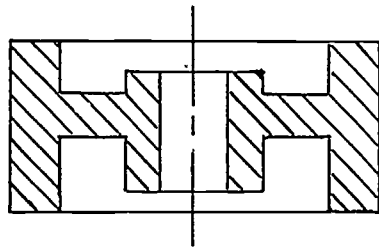

C.

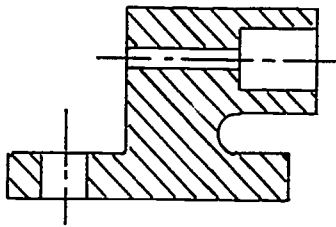

D.

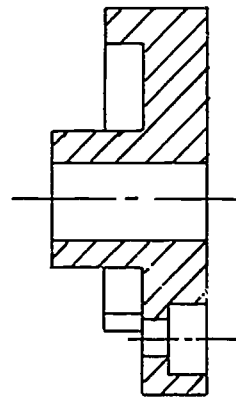

E.

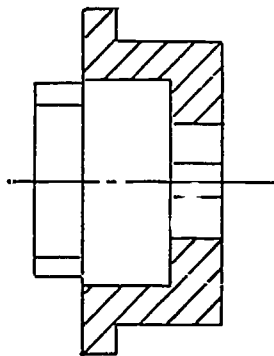

747

ANSWERS TO ASSIGNMENT SHEETS

Assignment Sheet #3

A.

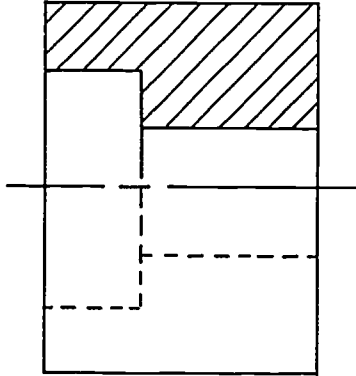

B.

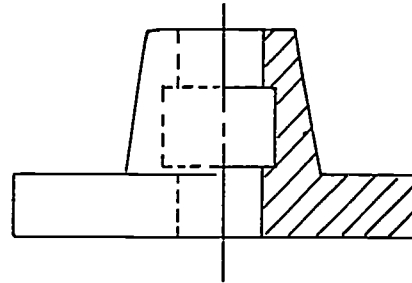

C.

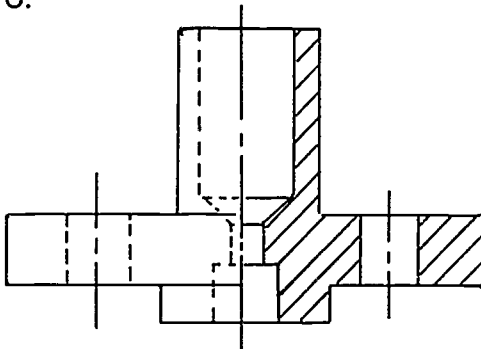

D.

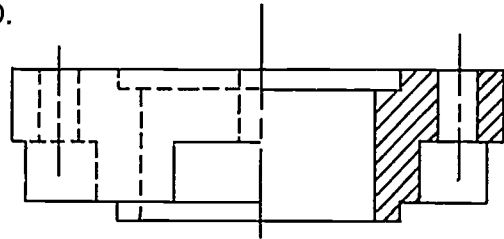

E.

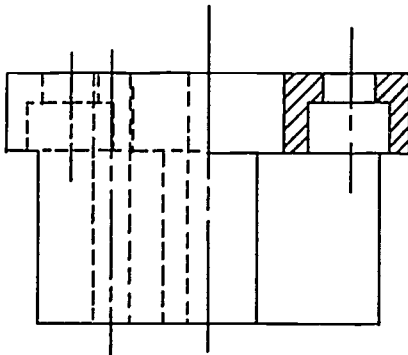

ANSWERS TO ASSIGNMENT SHEETS

Assignment Sheet #4

A.

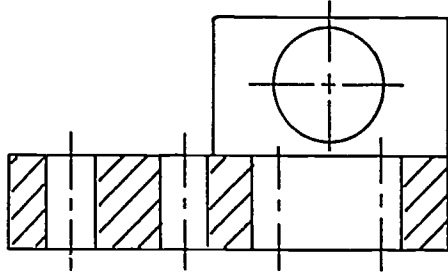

B.

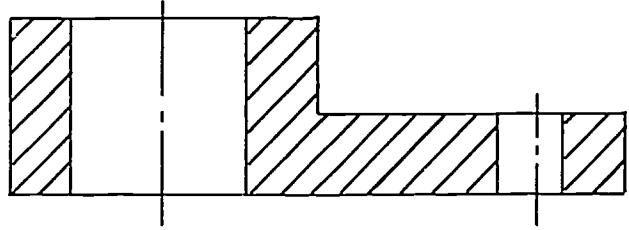

C.

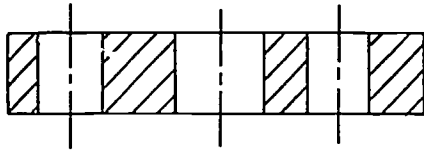

D.

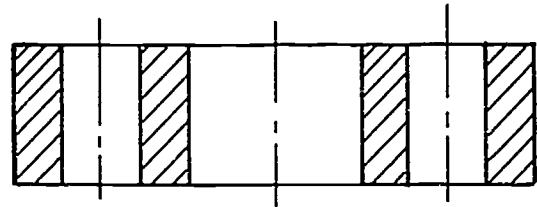

Assignment Sheet #5

A.

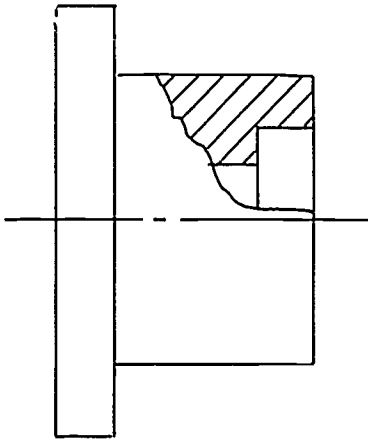

B.

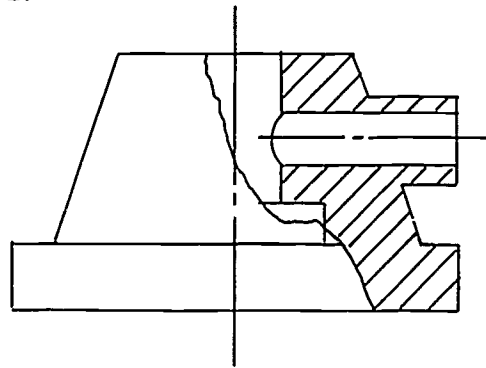

ANSWERS TO ASSIGNMENT SHEETS

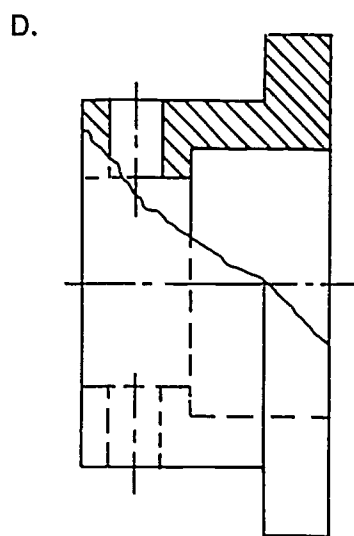
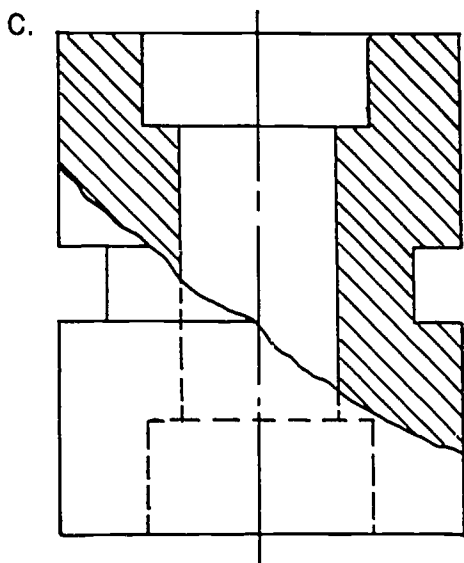

Assignment Sheet #6

A.

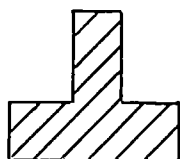

SECTION D-D

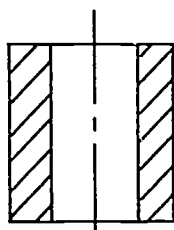

SECTION E-E

B.

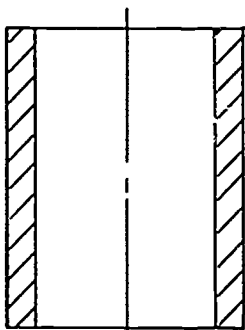

SECTION A-A

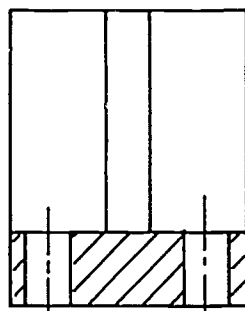

SECTION B-B

ANSWERS TO ASSIGNMENT SHEETS

C.

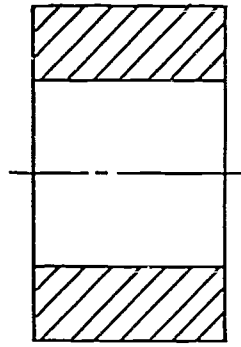

SECTION A-A



SECTION B-B

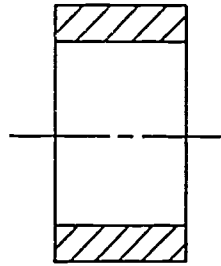

SECTION C-C

Assignment Sheet #7

A.

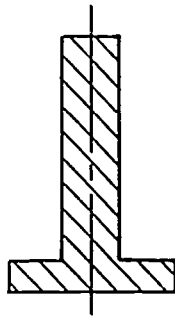

B.

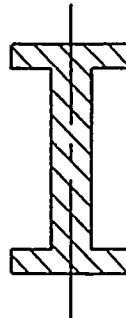

ANSWERS TO ASSIGNMENT SHEETS

Assignment Sheet #8

A.

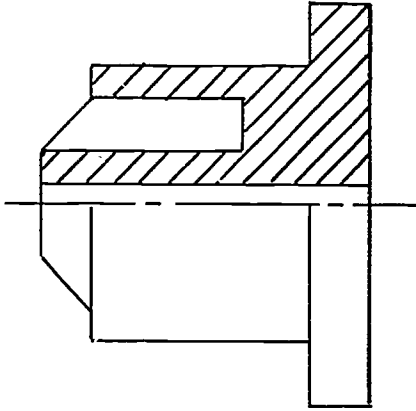

B.

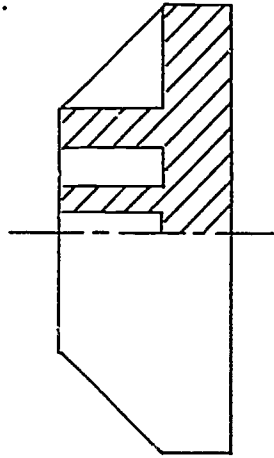

Assignment Sheet #9

A.

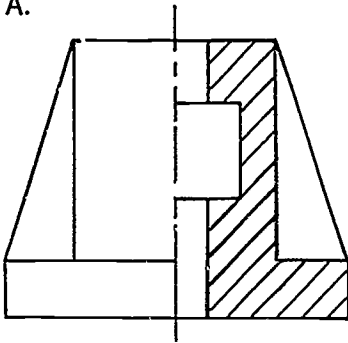

B.

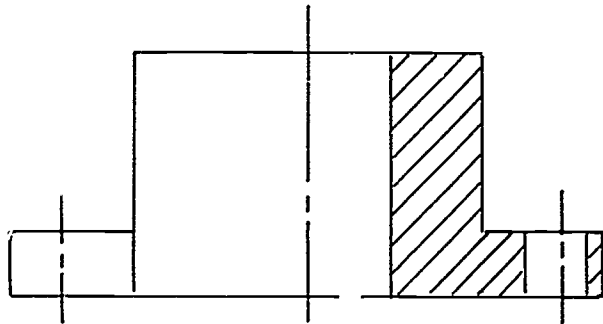

C.

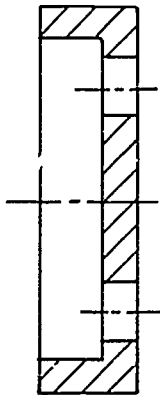

D.

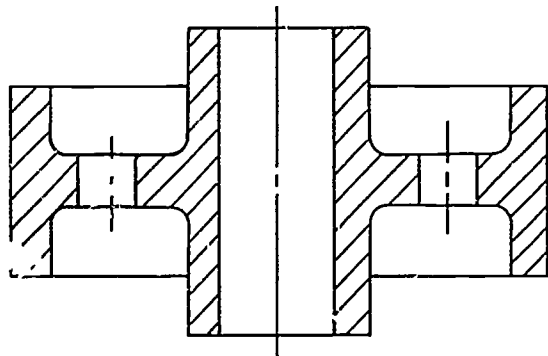

ANSWERS TO ASSIGNMENT SHEETS

Assignment Sheet #10

A.

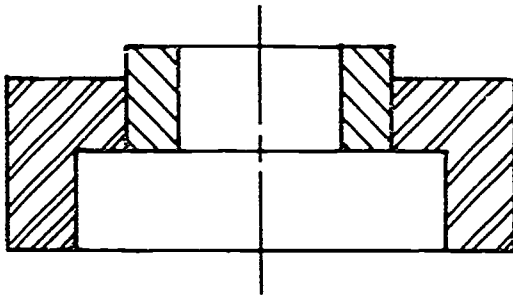

B.

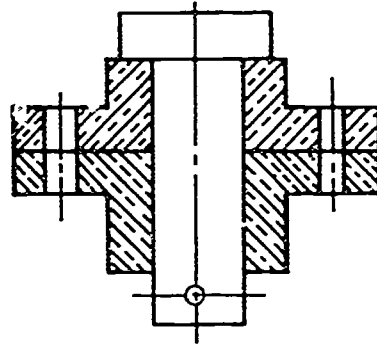

Assignment Sheet #11

A.

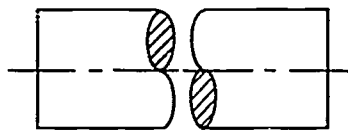

B.

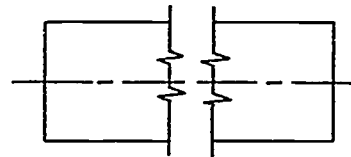

C.

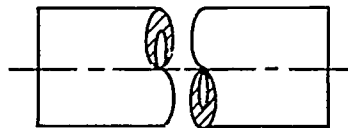

ANSWERS TO ASSIGNMENT SHEETS

Assignment Sheet #12

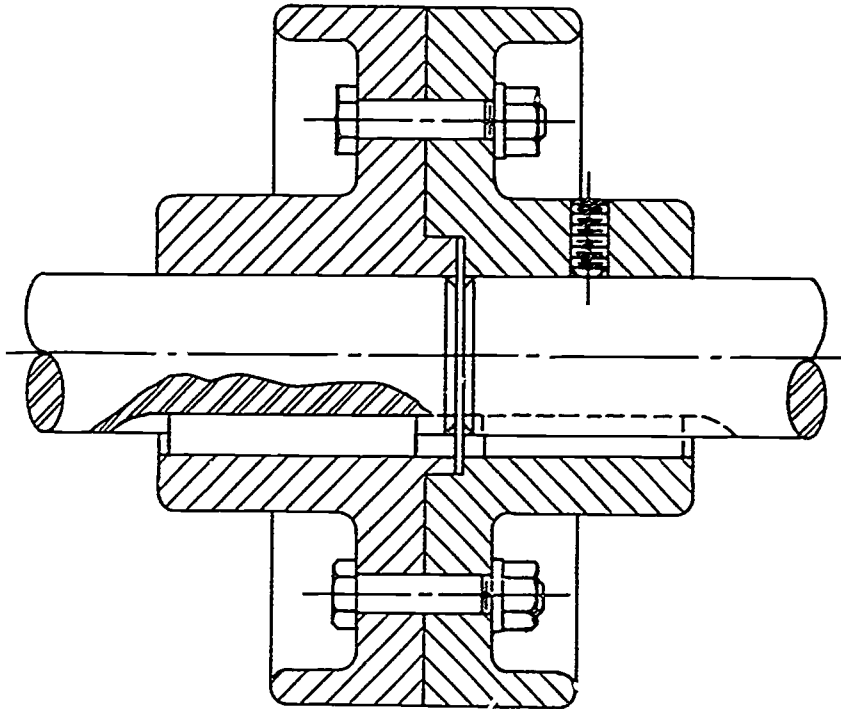

754

SECTIONAL VIEWS UNIT XIII

JOB SHEET #1 — CROSSHATCH A PART ON CADD

A. Tools and materials

1. CADD system
2. CADD manual

B. Procedure

1. Log on to the CADD system.
2. Activate a part file.
3. Activate a drawing file.
4. Determine area to be crosshatched.
5. Look up in your CADD manual the different crosshatch styles available. Choose one that is appropriate for your drawing.
6. Look up the proper entry command for crosshatching a part.

Example: *DRAW CROSSHATCH*

7. Enter the command into the CADD system.
8. Select angle for crosshatching.
9. Digitize the boundaries of the area to be crosshatched.

Example:

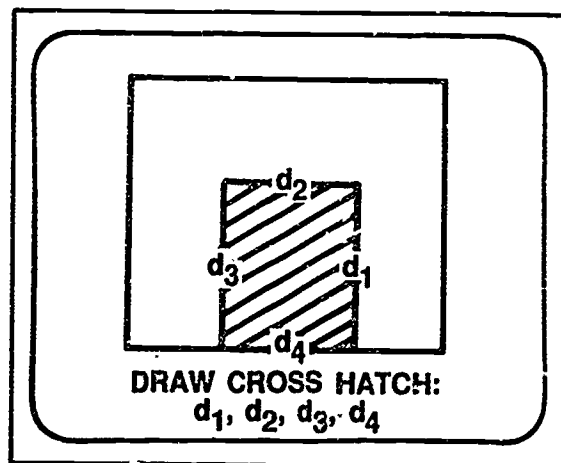

**SECTIONAL VIEWS
UNIT XIII**

TEST

Name _____ Score _____

1. Match the terms on the right with their correct definitions.

- | | | |
|----------|--|-----------------------|
| _____ a. | A line symbol that is drawn on an exposed cut surface; sometimes called crosshatching | 1. Conventional break |
| _____ b. | Symbolic section lining used for indication of various materials | 2. Cutting plane |
| _____ c. | An imaginary plane used to cut through an object | 3. Outline sectioning |
| _____ d. | A view that shows an internal portion of an object, with part of the object cut away | 4. Sectional view |
| _____ e. | Used for clarity in sections of assembly drawings of standard parts where the axis of the part lies in the cutting plane | 5. Section lining |
| _____ f. | Used in making a shortened view of a long simple object | 6. Section symbols |
| _____ g. | Section lines are shown only along the borders of a large part for clarity and to save time | 7. Subtitles |
| _____ h. | Being the same on opposite sides of a center line | 8. Symmetry |
| | | 9. Unlined section |

2. Identify types of sectional views.

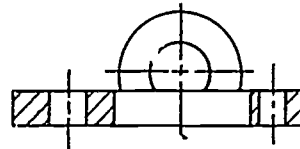
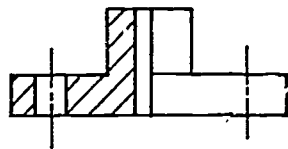
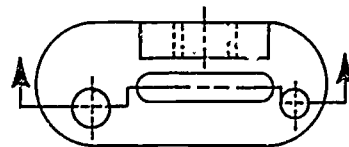
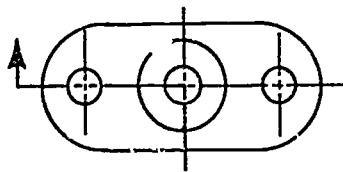

a. _____

b. _____

TEST

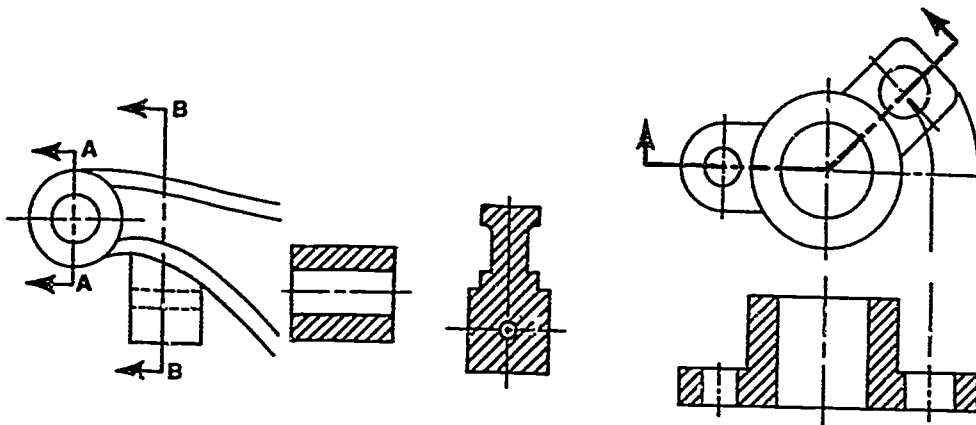

c. _____

d. _____

3. Match types of sections on the right with their correct uses.

- | | | |
|----------|---|-----------------------|
| _____ a. | Used to show both interior and exterior features of a symmetrical object | 1. Revolved section |
| _____ b. | Used to show the true shape of the cross section of a long object such as a bar, spoke, rib, or arm | 2. Broken-out section |
| _____ c. | Used to show features that are not in a straight line | 3. Half section |
| _____ d. | Used to show interior detail of objects where less than half section is required | 4. Aligned section |
| _____ e. | Replaces an exterior view in order to show some interior details | 5. Offset section |
| _____ f. | Used when true projection would be confusing for spokes, ribs, and holes | 6. Removed section |
| | | 7. Full section |

4. Select true statements concerning general rules in sectioning by placing an "X" next to the true statements.

- _____ a. Hidden lines behind the cutting plane should be omitted.
- _____ b. Sections should be drawn only half the size of the views from which they were taken.
- _____ c. Large surfaces are often sectioned only along the edge of the part.
- _____ d. If two or more sections appear on the same drawing, labeling is not necessary.
- _____ e. Section lines are thick wavy lines drawn vertical to main outline of the view.

TEST

- ___ f. Section lines are uniformly spaced 1" apart.
- ___ g. Where two or more thin sections are shown, a space should be left between them equal to space necessary for microfilming.
- ___ h. When the cutting plane offsets, a line is always shown in the sectioned view to represent the offset.
- ___ i. When objects have one major center line, the cutting plane line may be omitted.
- ___ j. Visible lines behind the cutting plane line should be omitted.

5. Match specific rules with the correct section types.

- | | |
|--|-----------------------|
| ___ 1. Cutting plane lines and section titles are required. | a. Full section |
| ___ 2. Often drawn to larger scale. | b. Broken-out section |
| ___ 3. Cutting plane lines and section titles are omitted. | c. Half section |
| ___ 4. Cutting plane lines and section titles generally are used but may be omitted if they are obvious. | d. Offset section |
| | e. Removed section |

6. Identify types of conventional breaks.

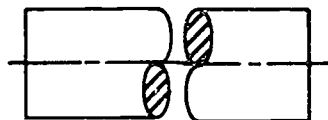

a. _____

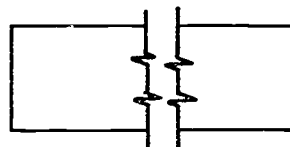

b. _____

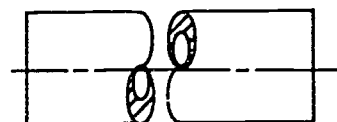

c. _____

7. Select true statements concerning labeling sectional views by placing an "X" next to the true statements.

- ___ a. More than one removed section view should be labeled with letters corresponding to the ends of the cutting plane line.
- ___ b. Sectional views should be arranged in alphabetical order from right to left on the drawing.

TEST

- ____c. Section letters should be used in alphabetical order.
- ____d. Letters "B", "C", and "X" should be omitted.
- ____e. The word "SECTION" may be abbreviated.
- ____f. Section letters are placed near the cutting plane arrows.
- ____g. When labeling a section view, the section letters (A-A, B-B, etc.) should be larger than the word "SECTION".

8. Identify line thicknesses used in sectional drawings.

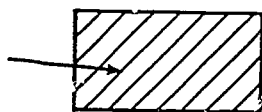

a. _____

b. _____

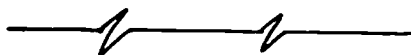

c. _____

d. _____

9. Select the most commonly used form of cutting plane lines by placing an "X" in the appropriate blank.



TEST

10. Identify material symbols in section.

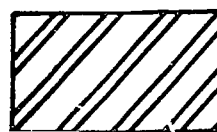
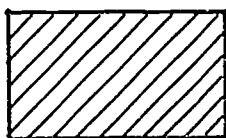

a. _____

b. _____

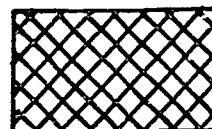
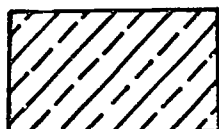

c. _____

d. _____

11. List three common errors in making section lines.

a. _____

b. _____

c. _____

12. Select true statements concerning use of unlined sections by placing an "X" next to the true statements.

____ a. Thin parts are made solid.

____ b. Shafts, bolts, nuts, pins, keys, rivets, gear teeth, and similar parts should always be sectioned if axis lies in cutting plane.

____ c. Broken-out section of shaft may be made to indicate clearness of key, keyseat, and pin.

13. List two methods used to aid equal spacing of section lining.

a. _____

b. _____

TEST

14. Select true statements concerning crosshatching and pattern filling on CADD by placing an "X" next to the true statements.
- _____ a. A chain command may be used to tie all the geometry to be filled with crosshatching into one unit.
 - _____ b. Most CADD systems provide hatch patterns.
 - _____ c. Hatch may be changed by changing the angle of the pattern and the line spacing.

(NOTE: If the following activities have not been accomplished prior to the test, ask your instructor when they should be completed.)

- 15. Construct various material symbols in section. (Assignment Sheet #1)
- 16. Construct a full section. (Assignment Sheet #2)
- 17. Construct a half section. (Assignment Sheet #3)
- 18. Construct an offset section. (Assignment Sheet #4)
- 19. Construct a broken-out section. (Assignment Sheet #5)
- 20. Construct a removed section. (Assignment Sheet #6)
- 21. Construct a revolved section. (Assignment Sheet #7)
- 22. Construct a rib section. (Assignment Sheet #8)
- 23. Construct an aligned section. (Assignment Sheet #9)
- 24. Construct adjacent parts in assembly section. (Assignment Sheet #10)
- 25. Construct conventional breaks. (Assignment Sheet #11)
- 26. Construct an assembly section. (Assignment Sheet #12)
- 27. Demonstrate the ability to crosshatch a part on CADD. (Job Sheet #1)

761

**SECTIONAL VIEWS
UNIT XIII****ANSWERS TO TEST**

1. a. 5 e. 9
b. 6 f. 1
c. 2 g. 3
d. 4 h. 8

2. a. Half section
b. Offset section
c. Removed section
d. Aligned section

3. a. 3
b. 1
c. 5
d. 2
e. 7
f. 4

4. a, c, g, i

5. 1. d
2. e
3. c
4. a

6. a. Round solid (rod)
b. Rectangular bar — Long break
c. Round tubular (pipe)

7. a, c, f, g

8. a. Section line, thin
b. Short break line, thick
c. Long break line, thin
d. Hidden line, thin

9. a

ANSWERS TO TEST

10. a. Cast iron
b. Steel
c. Brass, bronze, or copper
d. Zinc, lead, and alloys
11. Any three of the following:
a. Irregular spacing
b. Irregular line weights
c. Lines too thick
d. Lines are short or overrun visible lines
12. a, c
13. Any two of the following:
a. Visual spacing
b. Line guide
c. Trace lines from a grid sheet
d. Measure with scale
14. a, b, c
- 15.-26. Evaluated to the satisfaction of the instructor
27. Performance skills evaluated to the satisfaction of the instructor

763

AXONOMETRICS UNIT XIV

UNIT OBJECTIVE

After completion of this unit, the student should be able to identify isometric axis line positions and plane surfaces on isometric drawings. The student should also be able to sketch and construct isometric objects. Competencies will be demonstrated by completing the assignment sheets, job sheet, and the unit test with a minimum score of 85 percent.

SPECIFIC OBJECTIVES

After completion of this unit, the student should be able to:

1. Match terms related to axonometrics with their correct definitions.
2. Distinguish between the types of axonometric drawings.
3. Identify positions used as axis lines for isometric drawings.
4. Identify plane surfaces on isometrics.
5. Select true statements concerning rules in constructing an isometric drawing.
6. Match common errors made in isometric drawing with their correct drawings.
7. Distinguish between the advantages and disadvantages of isometric drawing.
8. Distinguish between the types of three-dimensional drawings created on CADD.
9. Distinguish between model mode and draw mode.
10. List applications for three-dimensional part model building.
11. Define the term "automatic drawings."
12. Sketch an isometric drawing. (Assignment Sheet #1)
13. Sketch isometric circles. (Assignment Sheet #2)
14. Construct axonometric drawings by box method. (Assignment Sheet #3)
15. Construct angles on an isometric. (Assignment Sheet #4)
16. Construct isometric circles and arcs. (Assignment Sheet #5)
17. Construct isometric curves by coordinates. (Assignment Sheet #6)
18. Measure in isometric by offsets. (Assignment Sheet #7)

SPECIFIC OBJECTIVES

19. Construct an isometric in the center of a drawing media. (Assignment Sheet #8)
20. Demonstrate the ability to create an isometric view of a mechanical part on CADD. (Job Sheet #1)

765

**AXONOMETRICS
UNIT XIV****SUGGESTED ACTIVITIES**

- A. Provide student with objective sheet.
- B. Provide student with information, assignment and job sheets.
- C. Make transparencies.
- D. Discuss unit and specific objectives.
- E. Discuss information, assignment and job sheets.
- F. Show filmstrips or films which cover the fundamentals of isometric drawings.
- G. Visit an engineering firm that utilizes 3-dimensional CADD in their design process.
- H. Set up the problems on Assignment Sheet #8 on the CADD system.
- I. Give test.

REFERENCES USED IN DEVELOPING THIS UNIT

- A. Giesecke, Frederick E., et al. *Technical Drawing*, 8th ed. New York: Macmillan Publishing Co., Inc., 1986.
- B. Brown, Walter C. *Drafting for Industry*. South Holland, Illinois 60473: Goodheart-Wilcox Co., Inc., 1984.
- C. Jensen, Cecil and Jay Helsel. *Engineering Drawing and Design*, 3rd ed. New York: Gregg Division/McGraw-Hill Book Co., 1985.
- D. *Pictorial Drawing, ANSI Y14.4-1957, Reaffirmed 1987*. New York: American Society of Mechanical Engineers.
- E. *Versacad 2-D Training Guide*. Versacad Corporation, 2124 Main Street, Huntington Beach, CA 92648, (714)960-7720.
- F. *Versacad Design — The Total Design Solution*. Versacad Corporation, 2124 Main St., Huntington Beach, CA 92648, 1988.
- G. Lamit, Louis and Paige Vernon. *Computer-Aided Design and Drafting-CADD*, Columbus, OH 43216: Merrill Publishing Company — A Bell & Howell Information Company, 1987.

**AXONOMETRICS
UNIT XIV****INFORMATION SHEET****I. Terms and definitions**

- A. Axis lines — The lines used to represent surfaces or planes coming together
- B. Axonometric — A type of pictorial with each of the three planes and axes at any angle and not equal to 90°
- C. Construction plane — A plane surface which can be predefined or operator-defined on which digitized points are projected
- D. Ellipse — A foreshortened circle with a major and minor axis
- E. Foreshortened — To appear shorter to the eye than it actually is
- F. Isometric lines — The lines that run parallel to the isometric axis lines
- G. Model — An accurate three-dimensional representation of a part, assembly, or plane designed on a CADD system and stored in the database
- H. Non-isometric lines — The lines that do not run parallel to the isometric axis lines
- I. Offset coordinates — A method of locating a point from a horizontal and a vertical line
- J. Pictorial — Suggesting a picture or mental image
- K. Project (CADD) — Sweeping one or more entities through space in the direction of the axis you specify; the system generates connecting lines between the geometry and the resulting projection
- L. Projection — To extend from one point to another
- M. Surface — Depicts the face of an object and defines the contours of the geometry between edges of a part, providing a "skin" for wire frame models with lines, arcs, and other curves
- N. Wire frame — A picture of a three-dimensional object displayed on the screen as a series of lines that represent the edges of its surfaces; this picture looks as if it were made from coat hangers

INFORMATION SHEET

II. Types of axonometric drawings

- A. Isometric — A type of axonometric drawing with each of the three planes and axes equal to each other

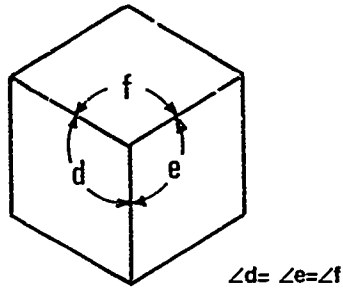

Isometric

- B. Dimetric — A type of axonometric drawing with two planes on equal axes to each other and a third plane of a different angle

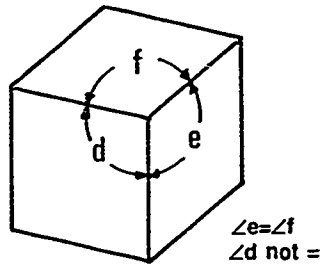

Dimetric

- C. Trimetric — A type of axonometric drawing with all three planes and axes not equal to each other

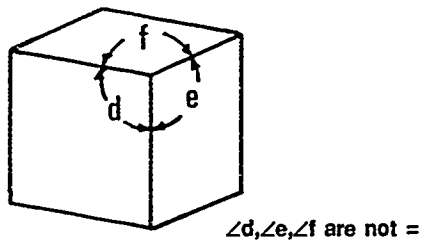

Trimetric

INFORMATION SHEET

III. Positions used as axis lines for isometric drawings

A. Top

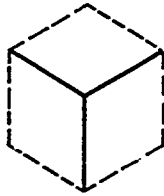

B. Bottom

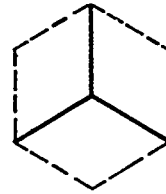

C. Right side

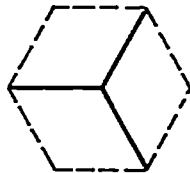

D. Left side

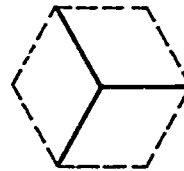

(NOTE: The top position is most commonly used.)

IV. Plane surfaces on isometrics

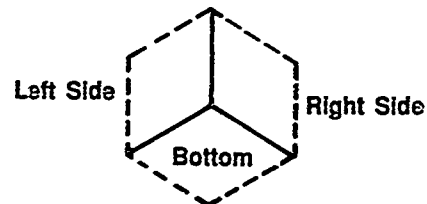
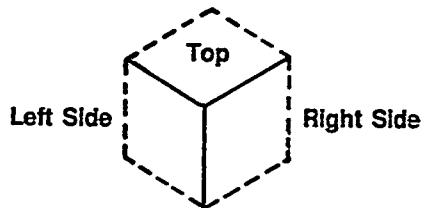

V. Rules in constructing an isometric drawing

- A. All measurements are made parallel to the main edges of the isometric axis lines.
- B. Angles are measured by coordinate offsets and cannot be transferred in degrees.
- C. Hidden lines are omitted on isometric drawings if possible.
- D. A drawing should be centered in the work space and boxed in before adding details.
- E. If isometric templates are not available, then approximate ellipses must be constructed to represent circles.
- F. Always block in a circle before constructing its arcs.

INFORMATION SHEET

- G. The sight direction that best represents the object should be used for the isometric position.
- H. If lines are parallel in two successive orthographic views, they are parallel in isometric views.

VI. Common errors made in isometric drawing

- A. Object viewed from wrong direction

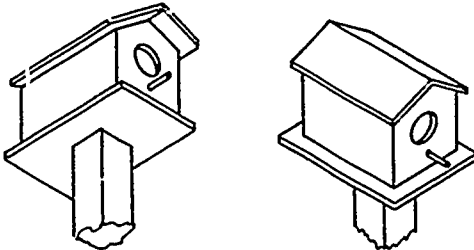

Correct

Incorrect

- B. Circle arcs not tangent to each other

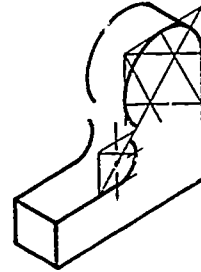

- C. Ellipses not in proper plane

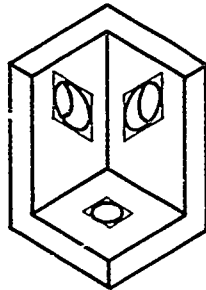

- D. Tangent lines missing from circles and arcs, and rear ellipse of a hole missing

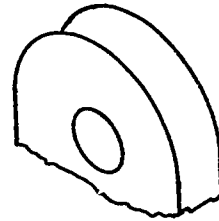

- E. Isometric lines missing

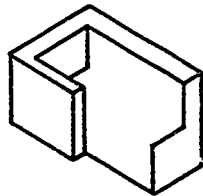

- F. Angles not measured correctly

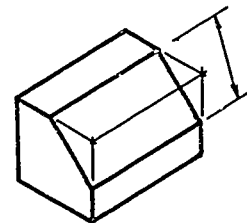

INFORMATION SHEET

- G. Dimensions not measured parallel to isometric axis lines

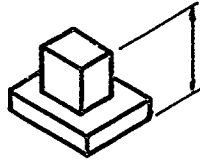

VII. Advantages and disadvantages of isometric drawing

A. Advantages

1. Easy to construct
2. Three sides of an object may be shown in one view
3. Circles are not very distorted

B. Disadvantages

1. Long objects appear distorted
2. Symmetrical type drawing causes some lines to meet or overlap, confusing the viewer

VIII. Types of three-dimensional drawings created on CADD

A. Simulated three-dimensional (2 1/2 D)

1. Perspective views
2. Isometric views
3. Oblique views

B. Three-dimensional (model mode) (Transparency 2)

1. Wire frame models
2. Surface models
3. Solid models

INFORMATION SHEET

IX. Difference between model mode and draw (drawing) mode (Transparency 3)

A. Difference in spaces

1. Model mode space

- a. Is three-dimensional and has three axes — X-Horizontal, Y-Vertical, and Z-Back and forth (moves in and out of the CRT).
- b. Origin of the three axes is user-defined.

2. Draw mode space

- a. Is two-dimensional and has two axes — X-Horizontal and Y-Vertical.
- b. Origin of the two axes is located at the lower left corner of the drawing.

(NOTE: The illusion of depth can be created using a two-dimensional coordinate system.)

B. Difference in uses

1. Model mode uses

- a. Used to create the 3 D model of a part.
- b. Used to generate NC (numerical control) data.

2. Draw mode uses

- a. Used to create drawing representations of the model.

(NOTE: This uses the model database for pictorial information of the part. However, the model database cannot be altered.)

- b. Used to create dimensions, text, and notes.

(NOTE: A drawing is a collection of parts which depict the [model] part.)

INFORMATION SHEET

Example:

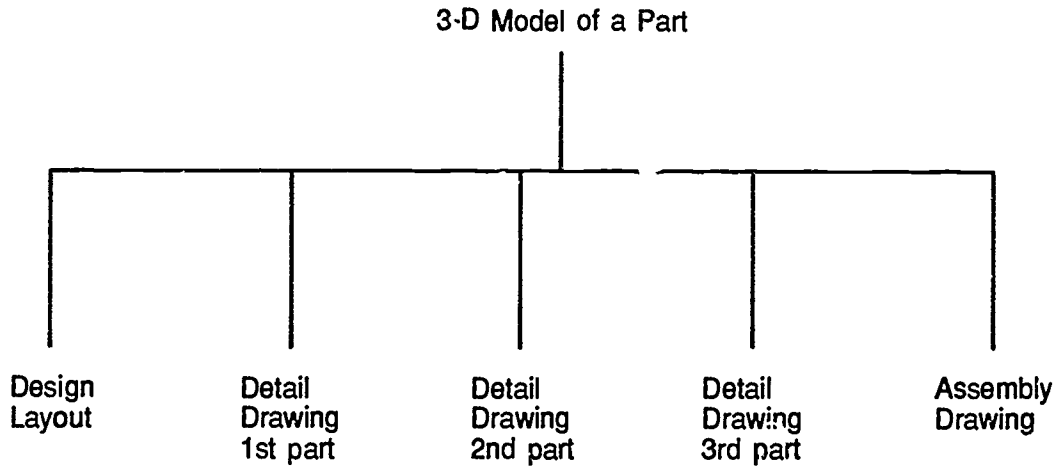

X. Applications for three-dimensional part model building

(NOTE: This supports all engineering design and manufacturing groups involved with the design through manufacturing cycle.)

- A. Manufacturing simulation
- B. Assembly analysis
- C. Mechanism analysis
- D. Mesh generation (finite element analysis of solid models)
- E. Automatic drawings
- F. Illustrations

XI. Definition of automatic drawings — Fully-dimensioned drawings that are automatically created from the solid model rather than creating a special two-dimensional picture; the dimension and tolerance information is carried with the model.

Types of Axonometric Drawings

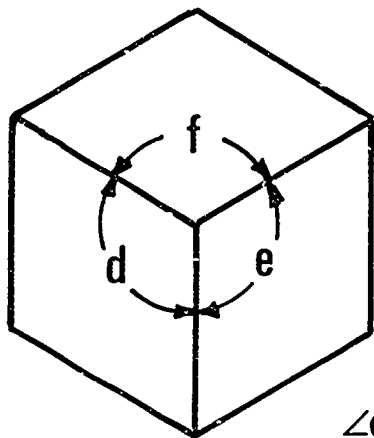

$$\angle d = \angle e = \angle f$$

Isometric

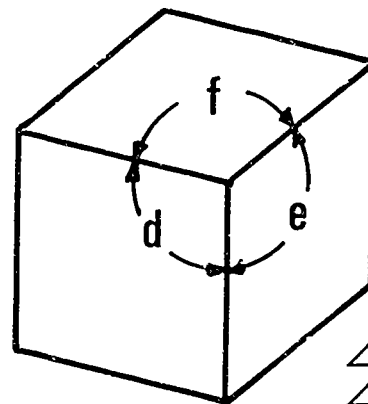

$$\angle e = \angle f \\ \angle d \text{ not } =$$

Dimetric

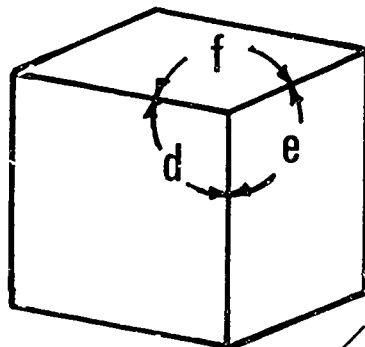

$$\angle d, \angle e, \angle f \text{ are not } =$$

Trimetric

Three-Dimensional CADD Drawings (Model Mode)

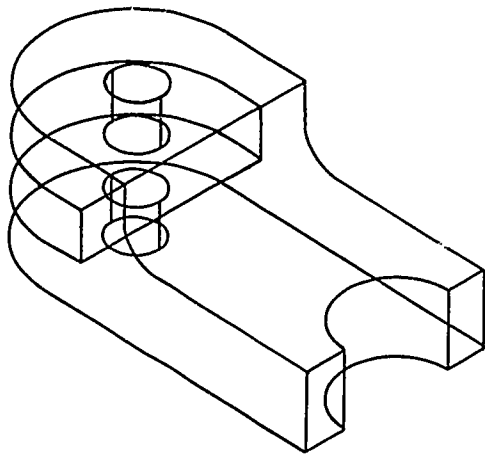

Wire Frame Model

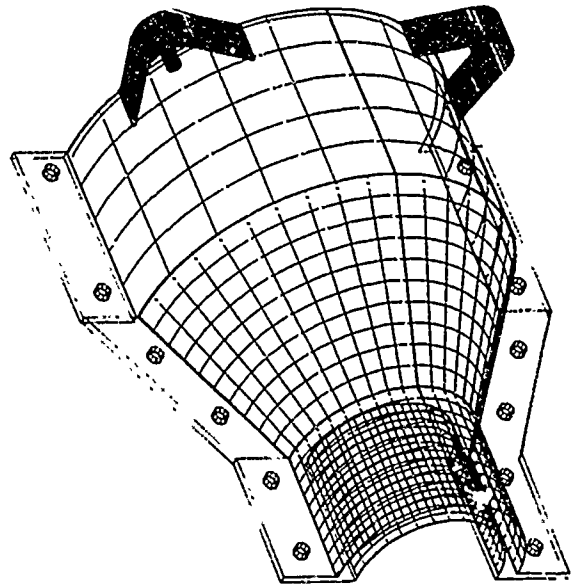

Surface Model

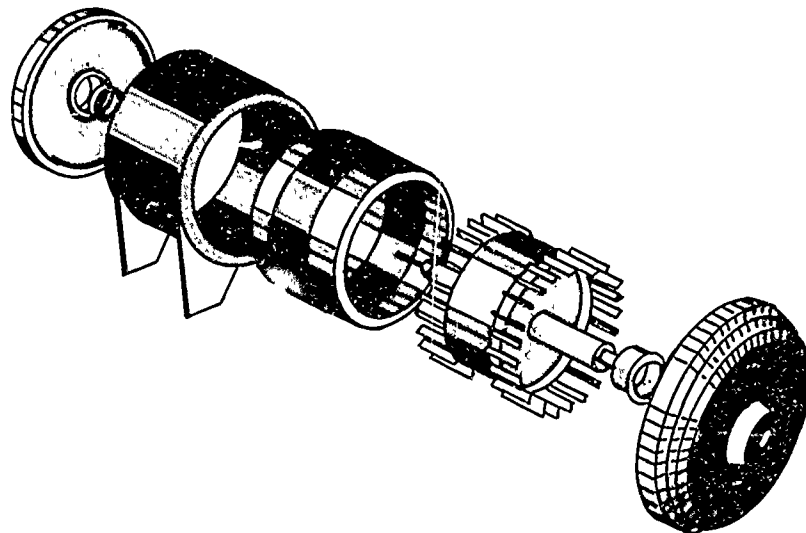

Solid Model

Courtesy of VersaCAD.

Three-Dimensional CADD Drawings (Model Mode and Draw Mode)

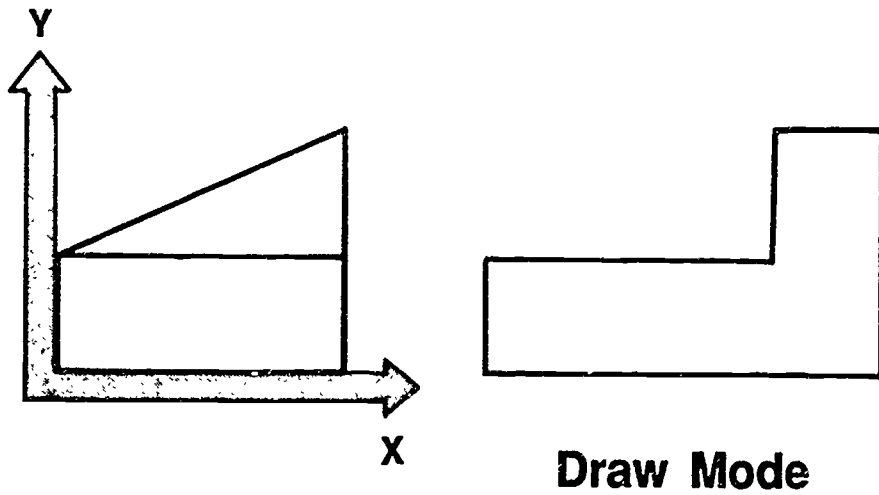
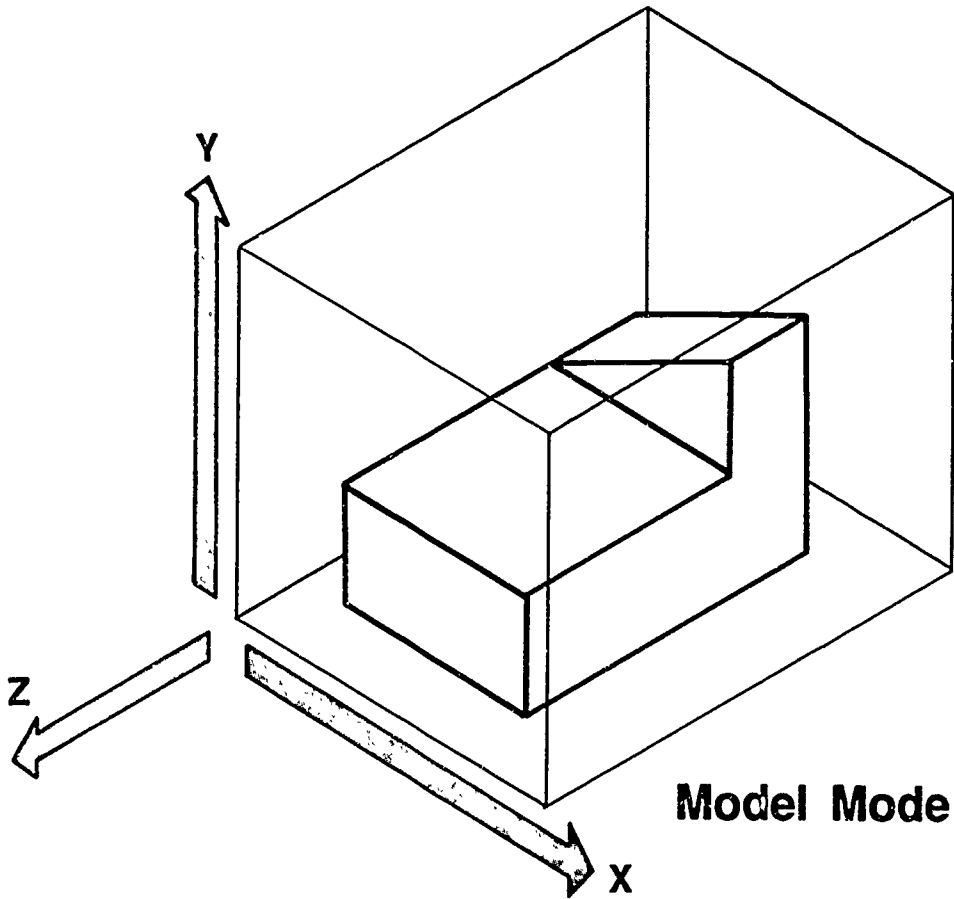

AXONOMETRICS UNIT XIV

ASSIGNMENT SHEET #1 — SKETCH AN ISOMETRIC DRAWING

NAME _____ SCORE _____

Introduction: This type of sketching can be drawn from an actual object or from any multiview type drawing. An isometric sketch is drawn with both sides slanting back at approximately a 30° angle.

Directions: Study the following example and then complete the assigned problem.

Example:

1. Use given actual object or multiview drawing and determine height, width, and depth.

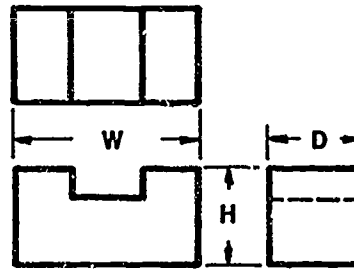

2. Lay off height, width, and depth as shown.

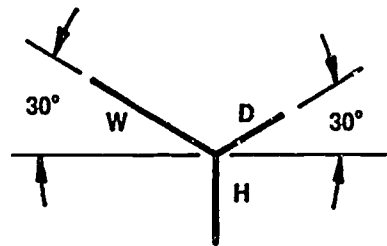

3. Box in the outline of the object.

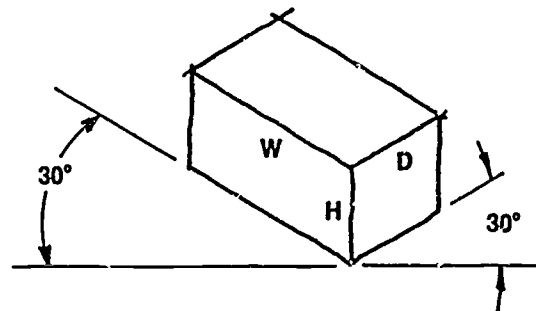

777

ASSIGNMENT SHEET #1

4. Locate object features such as slots, holes, and grooves.

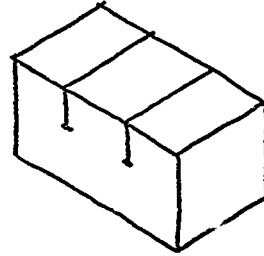

5. Complete shape of object.

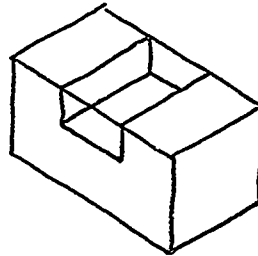

6. Erase construction lines and darken outline.

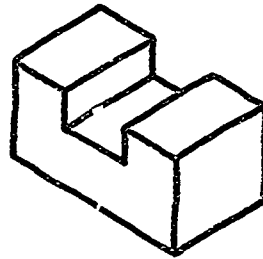

Problem: Sketch an enlarged isometric of the object below.

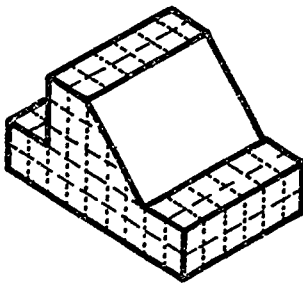

AXONOMETRICS UNIT XIV

ASSIGNMENT SHEET #2 — SKETCH ISOMETRIC CIRCLES

NAME _____ SCORE _____

Introduction: An isometric circle can be in the top, right side, or left side. In any case the circle should always be boxed in and then its individual arcs sketched to make the complete isometric circle.

Directions: Study the following example and then complete the assigned problems.

Example:

1. Lay out center lines.

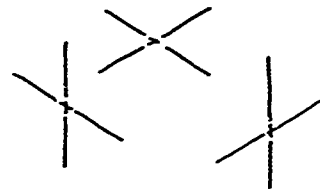

2. Mark off radius points.

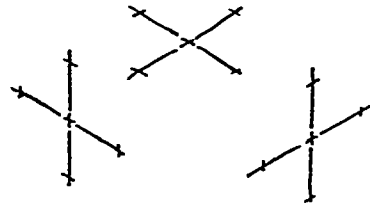

3. Box in circle outlines.

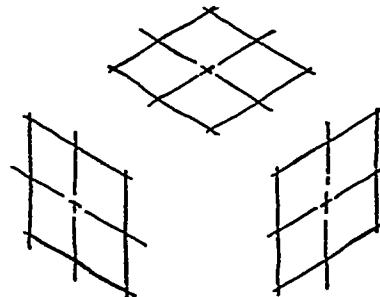

ASSIGNMENT SHEET #2

4. Sketch in arcs lightly.

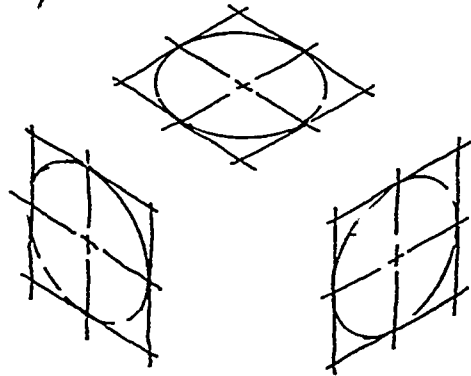

5. Erase construction lines and darken circles.

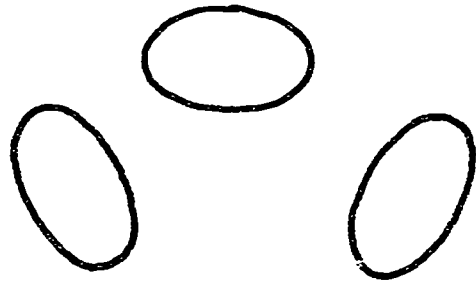

Directions: Make enlarged isometric sketches of the objects below.

Problem A:

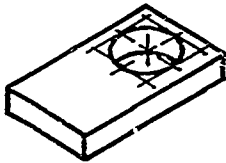

Problem B:

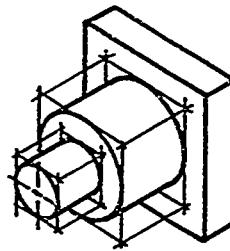

**AXONOMETRICS
UNIT XIV**

**ASSIGNMENT SHEET #3 — CONSTRUCT AXONOMETRIC
DRAWINGS BY BOX METHOD**

NAME _____ SCORE _____

Directions: Study the following example and then complete the assigned problems.

1. Select position of isometric axis lines.



Top

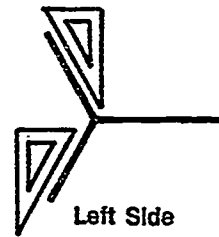

Left Side

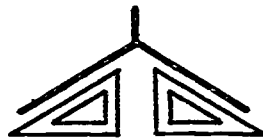

Bottom

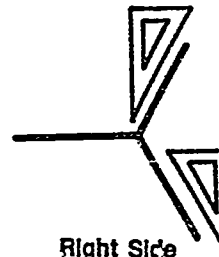

Right Side

2. Locate axis lines on drawing media for the type of axonometric to be drawn.

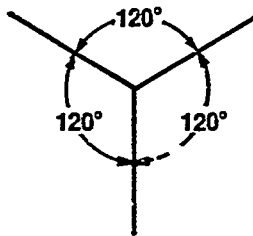

Isometric
(All angles are equal)

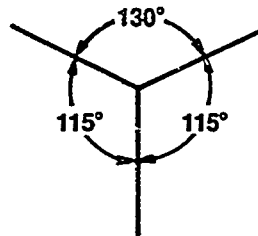

Dimetric
(Angles vary — Two angles are equal)

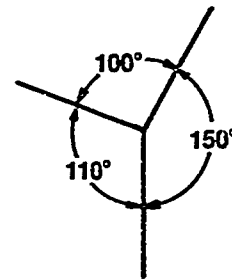

Trimetric
(Angles vary — No angles are equal)

ASSIGNMENT SHEET #3

3. Extend lines from these axis lines with 30°60° triangle or drafting machine.

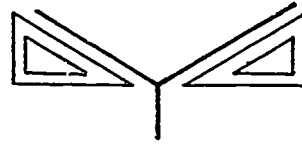

4. Measure overall width, depth, and height on these projected axis lines and mark point.

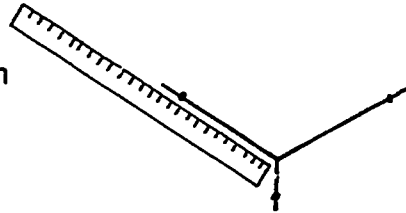

5. Complete box with 30°60° triangle or drafting machine making sure lines are parallel to main axis lines.

(NOTE: This drawing is isometric. Dimetric and trimetric axis lines will be parallel at different angles.)

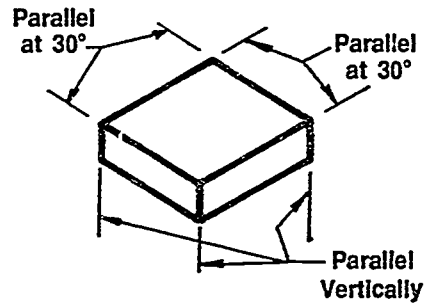

6. Add details to object by removing parts of box not needed.

Problem A: Construct an isometric drawing of the following object. Use top axis position.

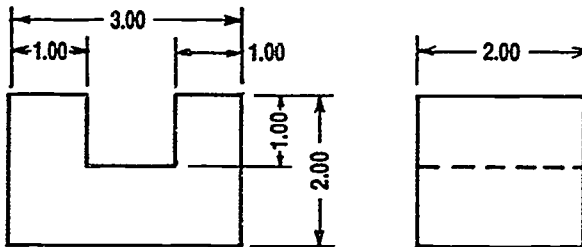

ASSIGNMENT SHEET #3

Problem B: Construct a dimetric drawing of the following object. Use top axis position and 20° angles from horizontal.

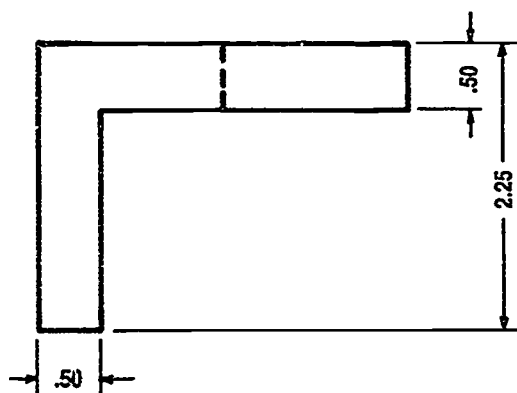
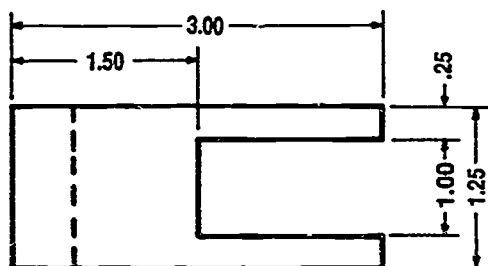

Problem C: Construct a trimetric drawing of the following object. Use top axis position and 20° and 50° angles from horizontal.

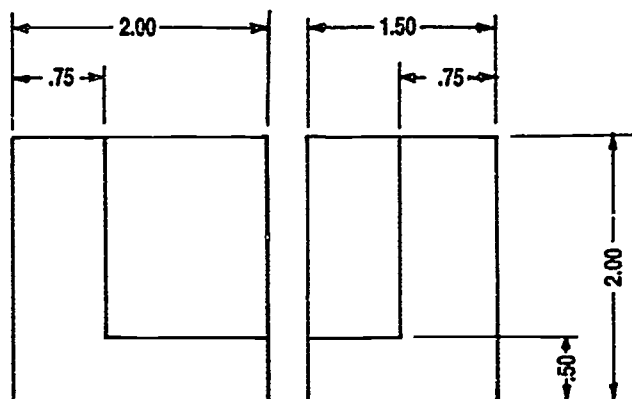

AXONOMETRICS UNIT XIV

ASSIGNMENT SHEET #4 — CONSTRUCT ANGLES ON AN ISOMETRIC

NAME _____ SCORE _____

Directions: Study the following example and then complete the assigned problem.

(NOTE: The example will use the dimensions of the object on the left to construct the object on the right.)

Example:

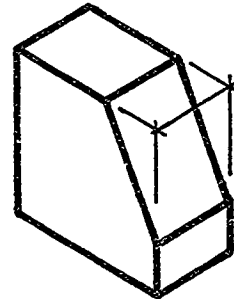
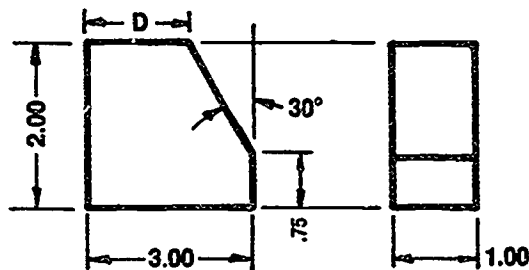

1. Box in overall dimensions of the object in isometric.

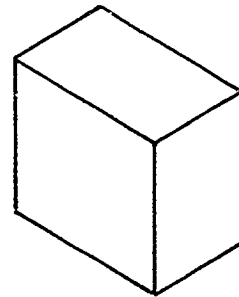

2. Use dividers to lay out offset dimensions of angle and connect points.

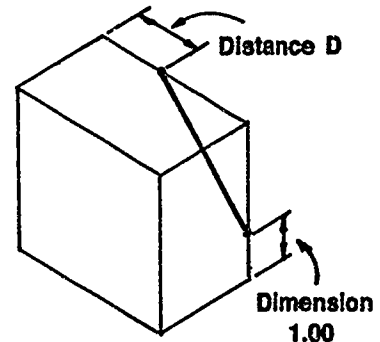

ASSIGNMENT SHEET #4

3. Complete the other side after extending lines across with 30°60° triangle or drafting machine.

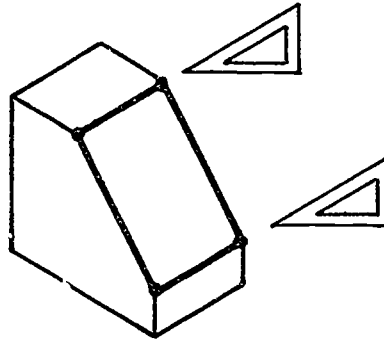

Problem: Construct the following object in isometric using the correct method to construct angles. Use top axis position and construct long dimension to left.

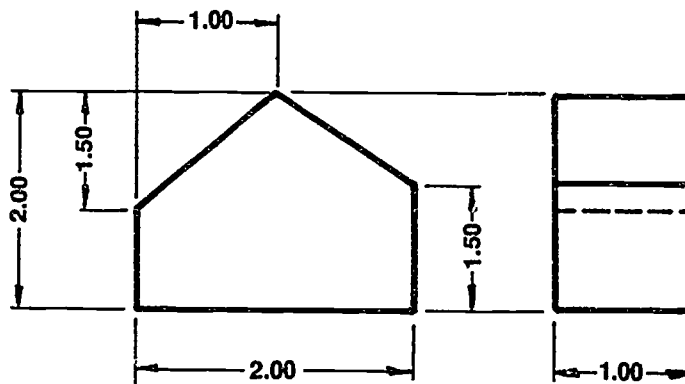

785

AXONOMETRICS
UNIT XIV

ASSIGNMENT SHEET #5 — CONSTRUCT ISOMETRIC CIRCLES AND ARCS

NAME _____ SCORE _____

Directions: Study the following examples and then complete the assigned problems.

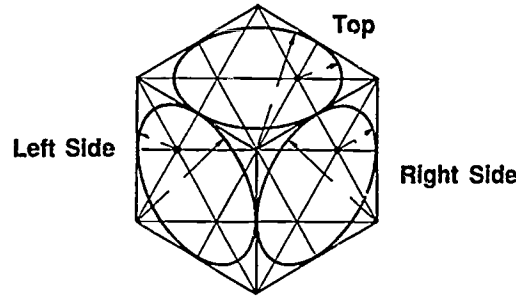

Example A: Circle in top plane

1. Locate center of circle and lay out centerlines with a 30°60° triangle or drafting machine.

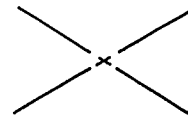

2. Locate diameter of circle by measuring its radius from the center point along the centerlines.

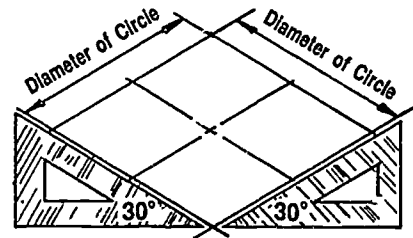

3. Erect perpendicular bisectors to each side using the 30°60° triangle or drafting machine as shown. These perpendiculars will intersect at four points, which will be centers for the four circular arcs.

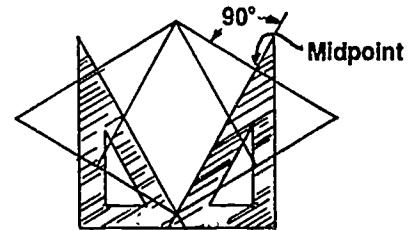

4. Draw the two large arcs, with radius R, from the intersections of the perpendiculars in the two closest corners of the parallelogram as shown.

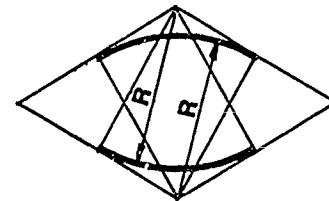

ASSIGNMENT SHEET #5

5. Draw the two small arcs, with radius r , from the intersections of the perpendiculars within the parallelogram, to complete the ellipse.

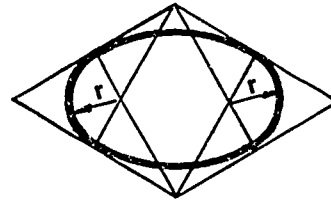

Example B: Circle in side plane

(NOTE: The method for constructing isometric circles is the same for both sides of the box. In this example the right side plane will be used.)

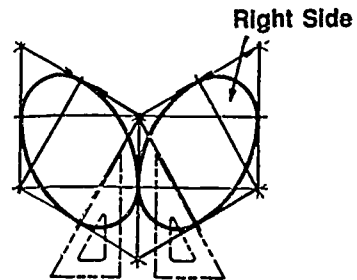

1. Locate center of circle and lay out centerlines with $30^{\circ}60^{\circ}$ triangle or drafting machine.

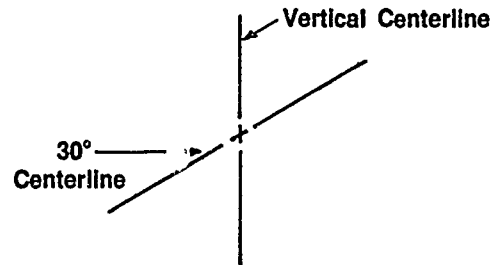

2. Locate diameter of circle by measuring its radius from the center point along the center lines.

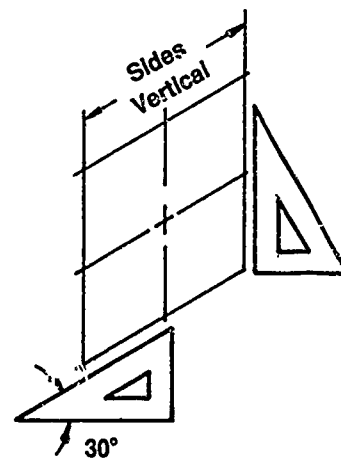

ASSIGNMENT SHEET #5

3. Erect perpendicular bisectors to each side as shown. Use the intersecting points as centers for the arcs.

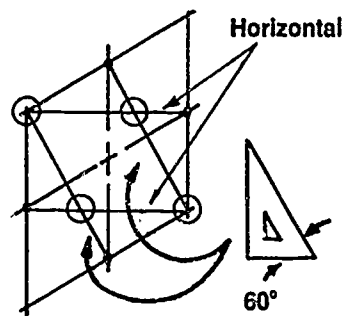

4. Draw the two large arcs, with radius R from the intersection of the perpendiculars from the two closest corners.

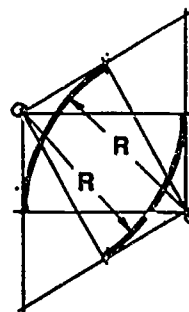

5. Draw the two small arcs, with radius r , from the intersection of the perpendicular lines within the parallelogram to complete the figure.

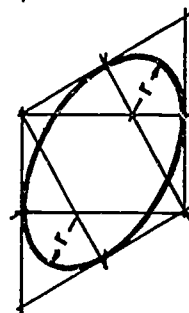

ASSIGNMENT SHEET #5

Example C: Circles with ellipse template

(NOTE: For convenience and time saving, isometric ellipse templates [35°16'] should be used. These ellipses have centerline marks that are parallel to two of three major axis lines on the isometric drawing.)

1. Construct isometric centerlines that are parallel to two axis lines.
2. Select template marked isometric ellipses.
3. Select correct diameter marked on template.
4. Position template so that the four line-up marks are at a 30° angle from horizontal.
5. Line up ellipse template marks on centerlines.
6. Construct ellipse.
7. To position the ellipse on the centerlines in the other planes, use the same marks. Place two of them vertically and the other two marks at a 30° angle from horizontal.

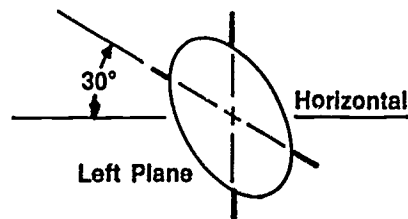
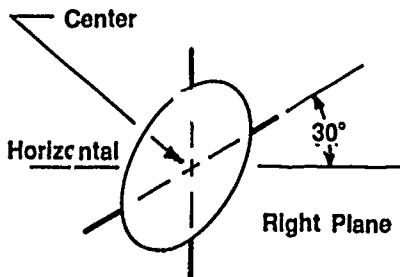
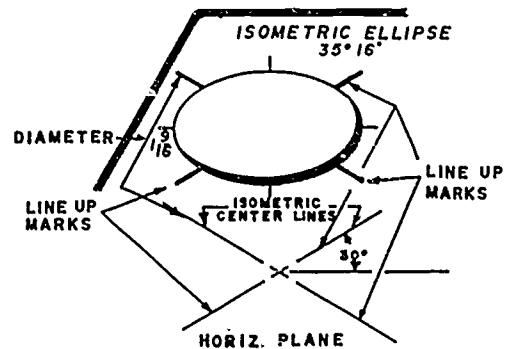

ASSIGNMENT SHEET #5

Example D: Arcs

(NOTE: Arcs in isometric pose another problem in determining which plane to lay out the isometric box and which part of the elliptical circle to use. The required radius R is measured equally and in each case is measured from the corner where the arc is to be located as shown in the following illustrations.)

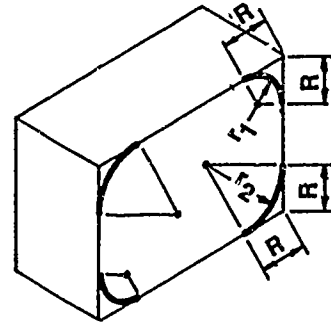
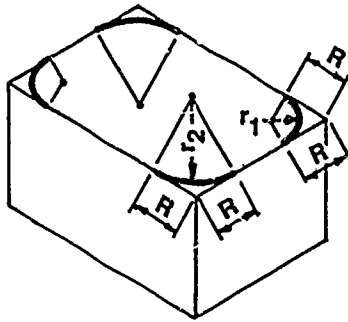

1. Mark off radius points from the corners along the box lines.

(NOTE: In this example 1/4" R arcs will be constructed.)

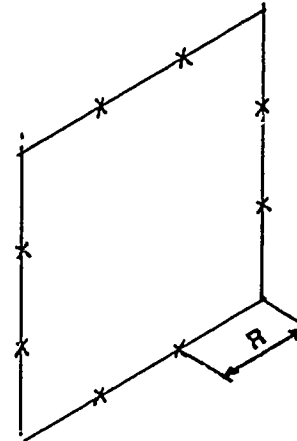

2. Erect construction lines inside the circle perpendicular to each of the lines on which the radius points are marked.

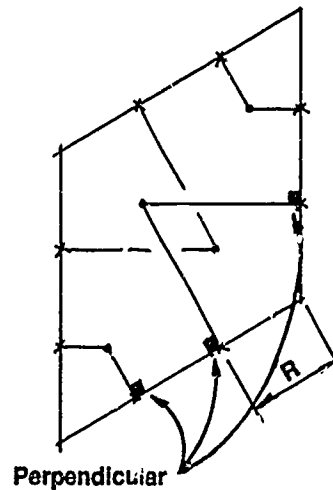

ASSIGNMENT SHEET #5

3. Set compass at radius of line intersections and put in arcs as shown on all four corners.

(NOTE: Heavy dots inside box are line intersections and are used for radius points.)

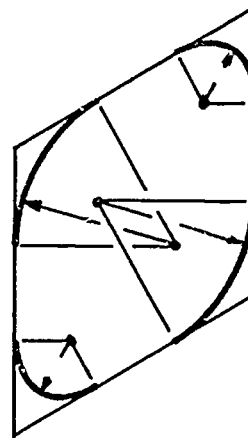

4. If plane where arcs are needed should be in the top, the procedure is the same. After points are located, swing arcs from intersecting lines as shown.

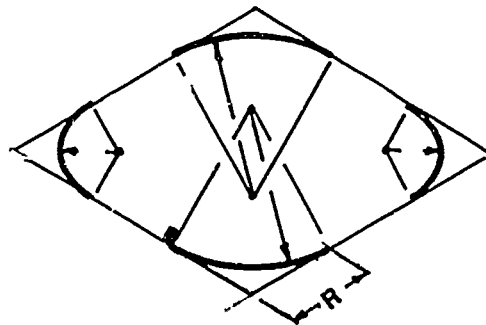

791

ASSIGNMENT SHEET #5

Example E: Arcs with ellipse template

(NOTE: The principle for constructing arcs is the same as circles, but only 1/4 of an ellipse is used.)

1. Mark off radius points from comers along the box lines.
2. Construct isometric centerlines parallel to box lines.
3. Select correct ellipse size for radius.
4. Position template line-up marks on centerlines.
5. Construct required arc.

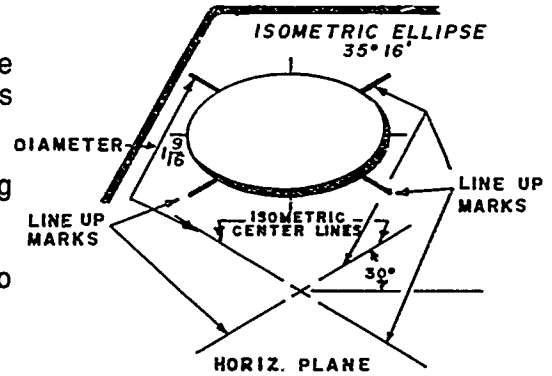

(NOTE: Arc lengths greater than or less than one-fourth circle are determined by marking tangent points.)

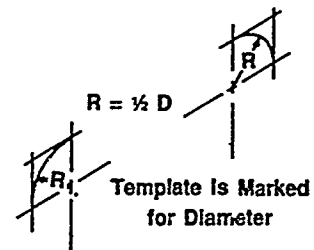

Problem A: Construct an isometric circle with a diameter of 2" using the procedure outlined in Example A.

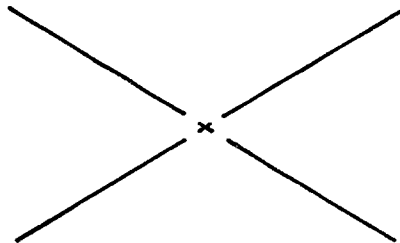

ASSIGNMENT SHEET #5

Problem B: Construct isometric circles in right and left planes in the boxes below using the procedure outlined in Example B.

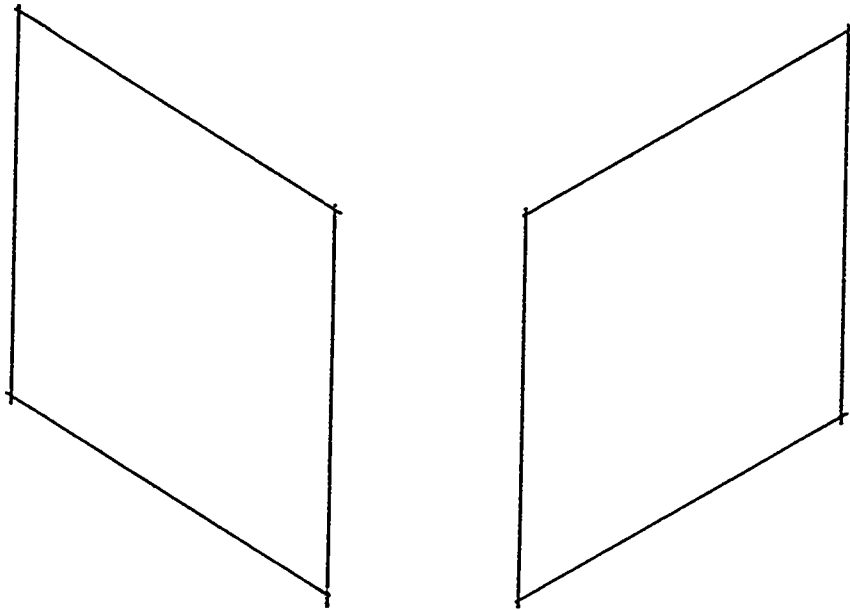

Problem C: Construct isometric circles on the following centerlines using isometric ellipse template and procedure outlined in Example C.

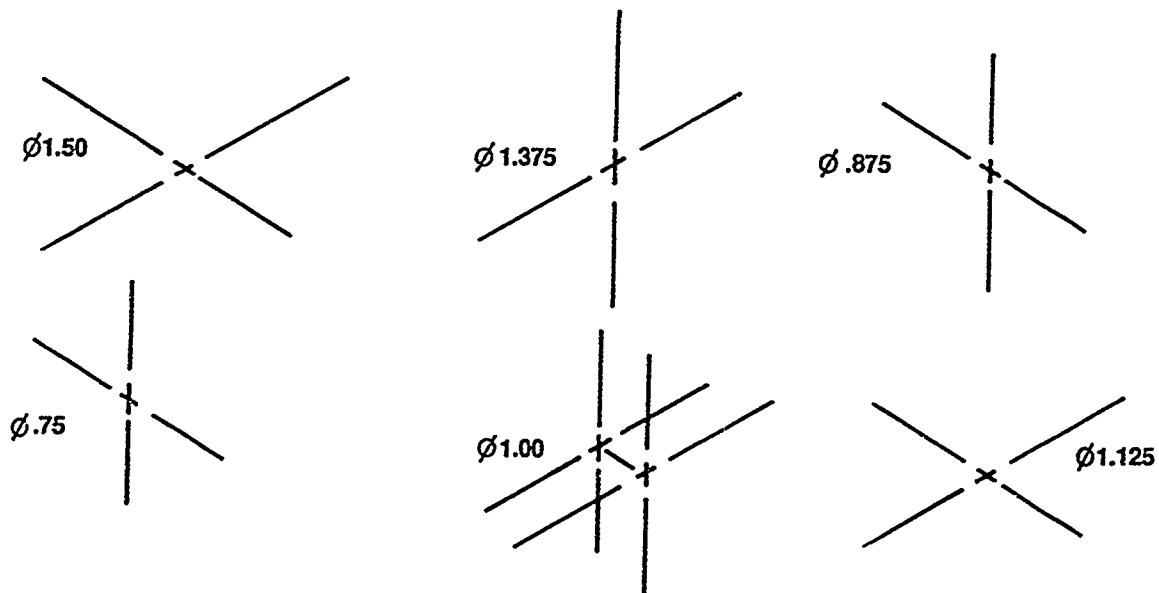

ASSIGNMENT SHEET #5

Problem D: Construct $1/2$ " radius arcs in the corners of the following boxes using procedure outlined in Example D.

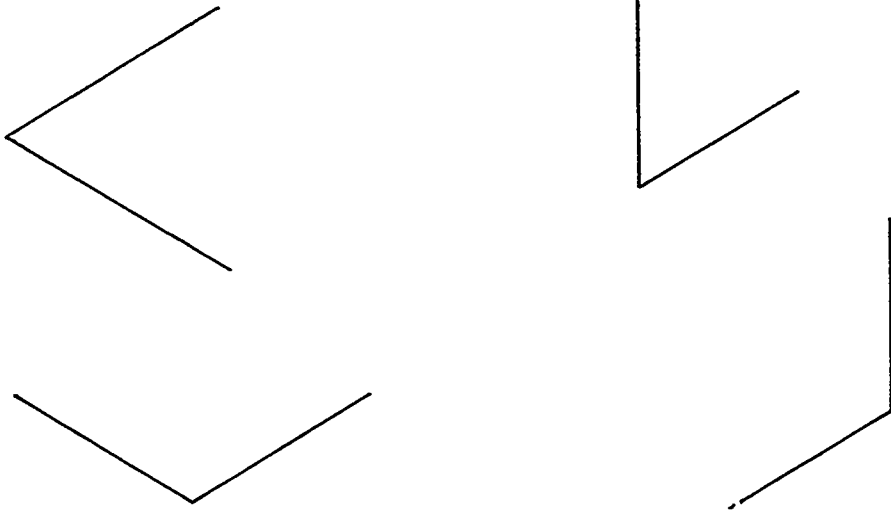

Problem E: Construct $1/2$ " radius arcs in the corners of the following boxes using circle template and procedure outlined in Example E.

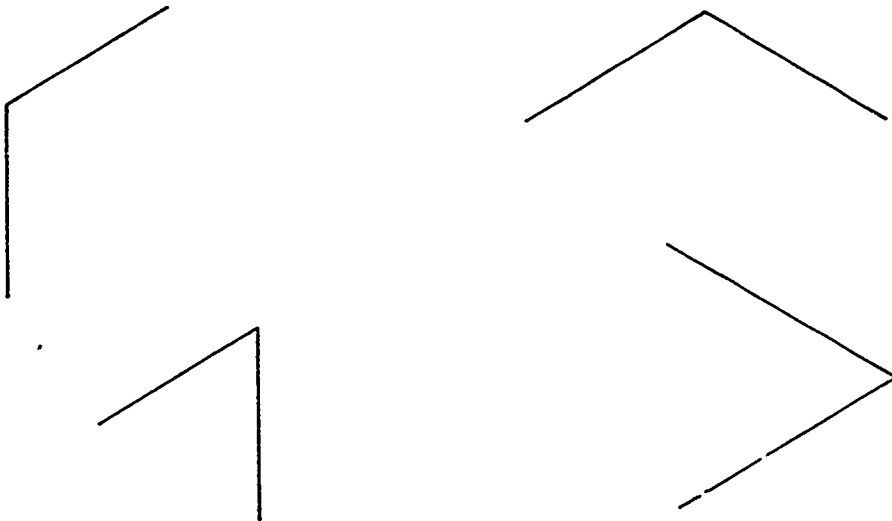

**AXONOMETRICS
UNIT XIV**

**ASSIGNMENT SHEET #6 — CONSTRUCT ISOMETRIC CURVES
BY COORDINATES**

NAME _____ SCORE _____

Directions: Circles and arcs that are not regular make it necessary to use points to lay out the curve. Isometric curves such as in the following illustration can be constructed by coordinates. Study the following example and then complete the assigned problem.

Example:

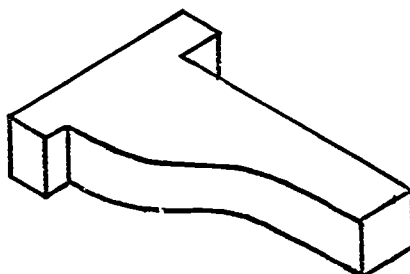

1. Locate coordinate points along the curve as at A, B, C, and D.
2. Mark distance a and b as shown on top view of orthographic.

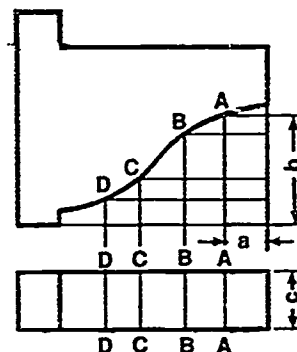

3. Draw isometric box in position desired to illustrate object.

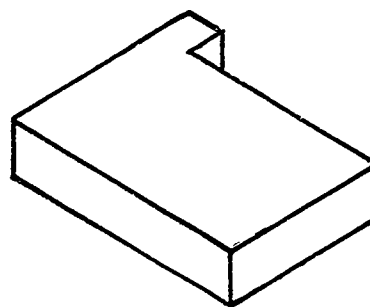

ASSIGNMENT SHEET #6

4. Along right and left edges lay out coordinate distances a and b from orthographic view in step #2. This locates point A.

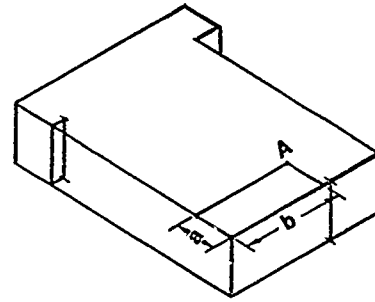

5. Locate points B, C, and D in the same manner as point A was located.

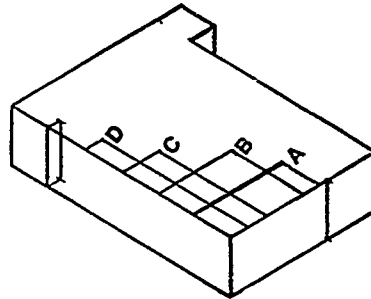

6. Use irregular curve to connect points.

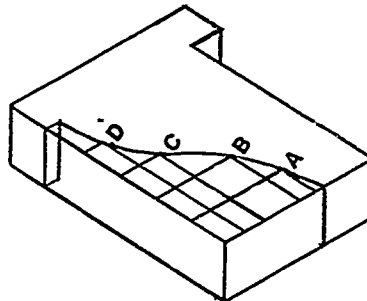

7. Locate curve points at bottom edge by dropping them down the thickness of the object.

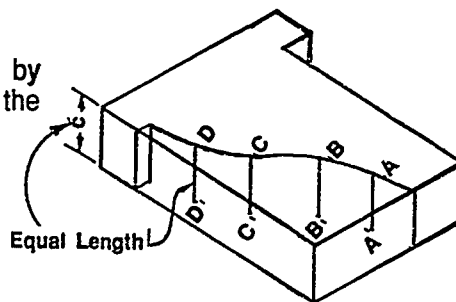

8. Use irregular curve to put in bottom edge; darken visible lines.

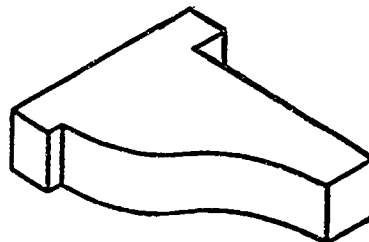

ASSIGNMENT SHEET #6

Problem: Construct an isometric drawing of the following object beginning with point A.

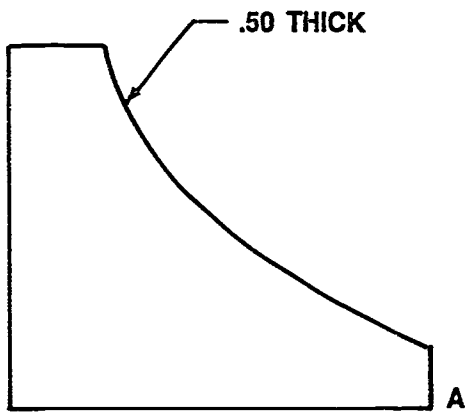

**AXONOMETRICS
UNIT XIV**

ASSIGNMENT SHEET #7 — MEASURE IN ISOMETRIC BY OFFSETS

NAME _____ SCORE _____

Directions: Study the following example and then complete the assigned problem.

Example:

1. Box in outline of top and front view.

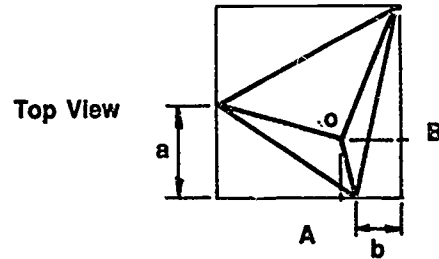

2. Locate points on outline of box as at a and b.

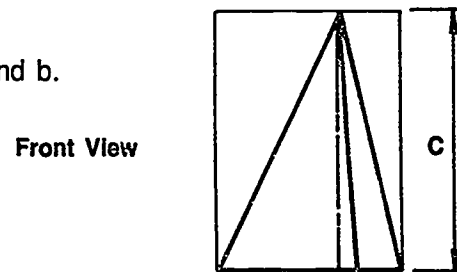

3. Lay out isometric box with same height, width, and depth of object.

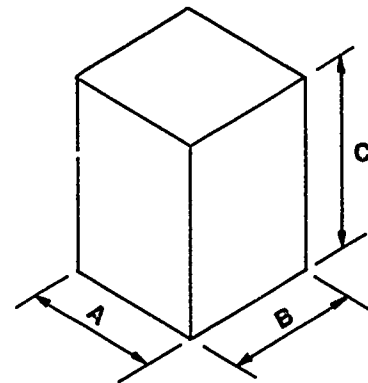

ASSIGNMENT SHEET #7

4. Locate points on isometric box by locating them on their correct plane. All measurements must be made parallel to isometric lines, such as the outline of the box.

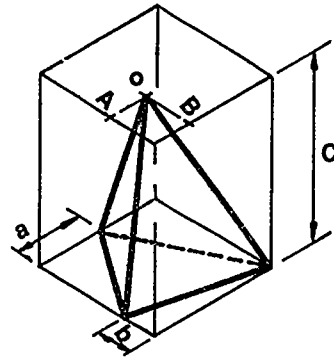

5. Erase construction lines and darken outline of the object.

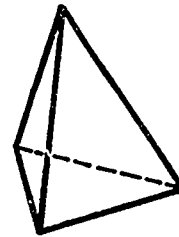

Problem: Construct the two views as an isometric.

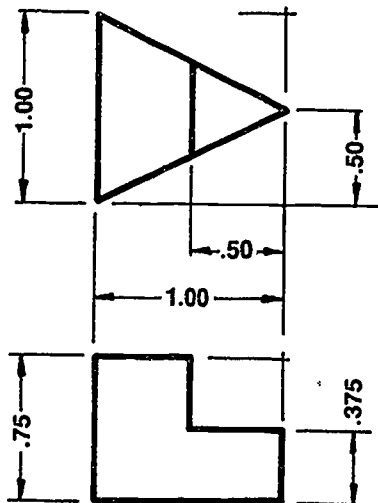

**AXONOMETRICS
UNIT XIV**

**ASSIGNMENT SHEET #8 — CONSTRUCT AN ISOMETRIC
IN THE CENTER OF A DRAWING MEDIA**

NAME _____ SCORE _____

Introduction: It is important that isometric drawings be located somewhere near the center of the drawing media to allow room for dimensions, notes, and to add to the appearance of the drawing.

Directions: Study the following example and then complete the assigned problems.

Example:

1. Make an isometric box sketch of the overall dimensions of the object to be drawn.

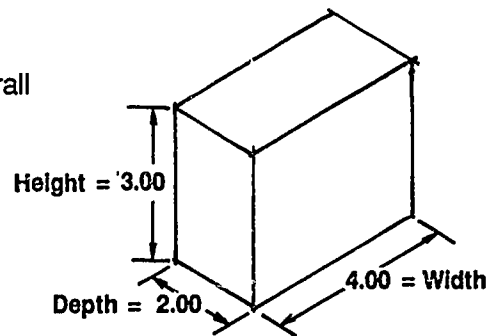

2. Find center of drawing media by using diagonals from corners.

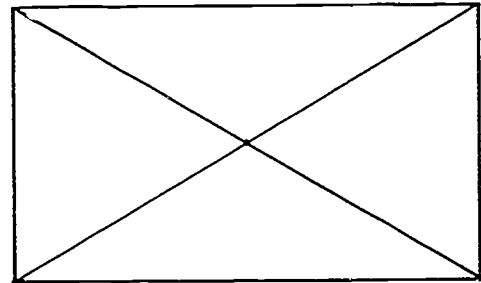

3. From the center of the work area, measure vertically $\frac{1}{2}$ the height of the object. (1.50 in this example)
4. At a 30° angle down and to the left, measure $\frac{1}{2}$ the width of the object. (2.00 in this example)
5. At a 30° angle to the right and down, measure $\frac{1}{2}$ the depth of the object. (1.00 in this example). This point is the front corner of the object to be drawn.

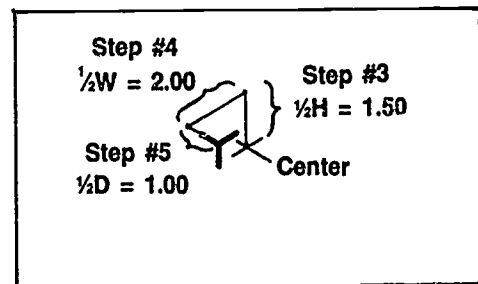

ASSIGNMENT SHEET #8

6. From this point, complete the object as an ordinary isometric by boxing in the outline, adding features, and erasing construction lines.

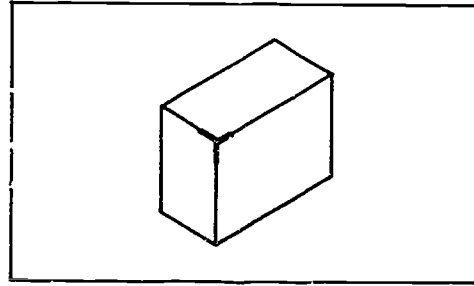

Problem A: Center the isometric object in the space below with longest dimension to left.

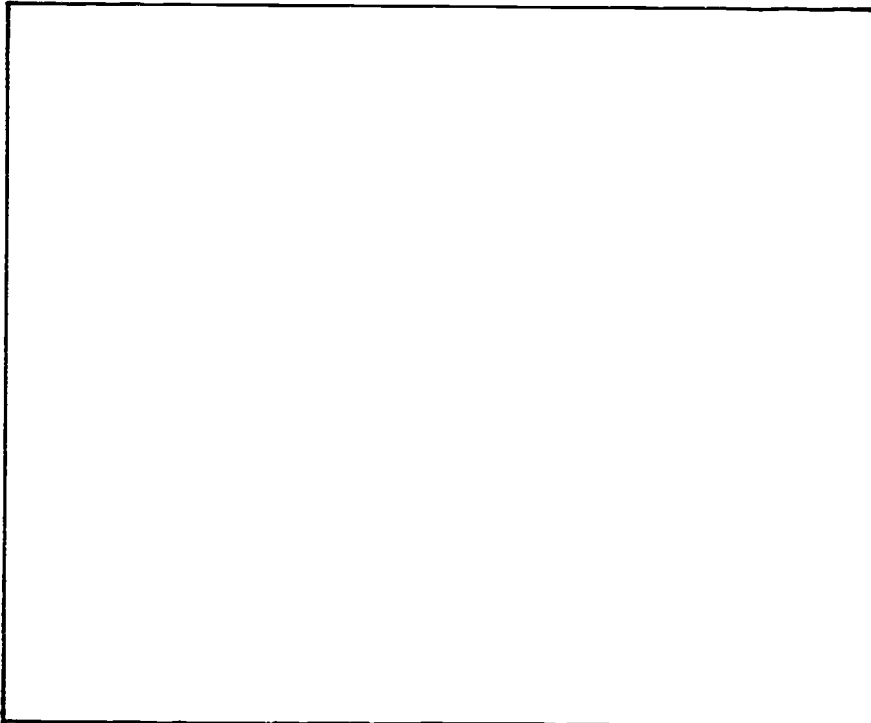
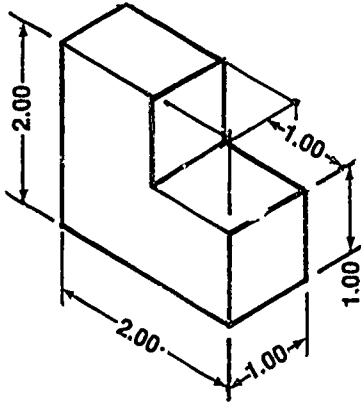

ASSIGNMENT SHEET #8

Directions: Center and construct isometrics for the following problems on "A" size vellum. Use standard borders and title block. Omit dimensions and erase construction lines. Start with point A.

Problem B:

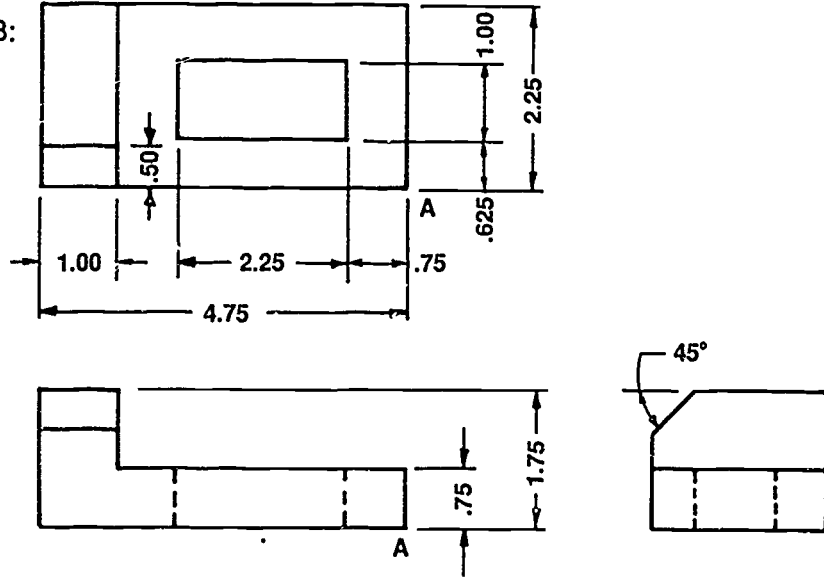

Problem C:

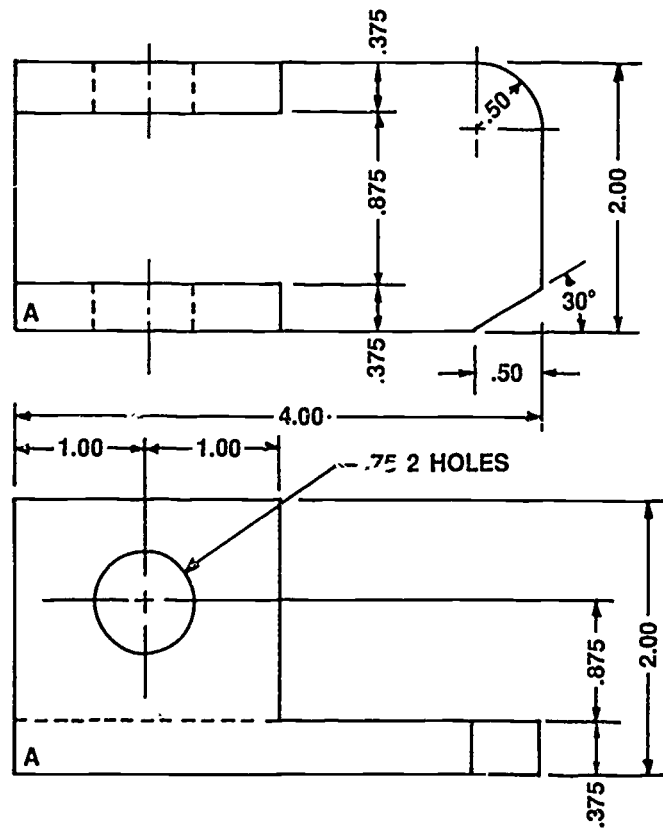

ASSIGNMENT SHEET #8

Problem D: Center and construct an isometric of the following object on "A" size vellum. Use standard borders and title block.

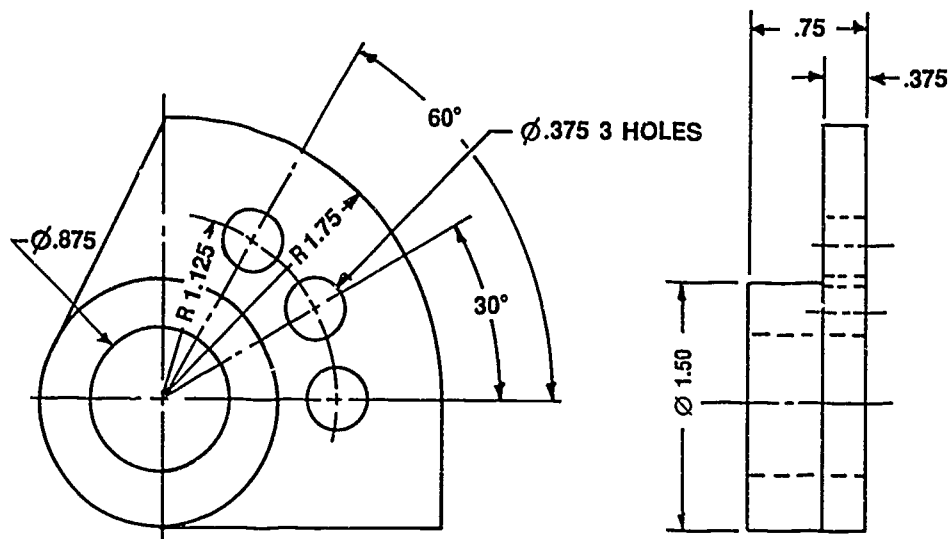

803

AXONOMETRICS
UNIT XIV

ANSWERS TO ASSIGNMENT SHEETS

Assignment Sheets #1-#2 — Evaluated to the satisfaction of the instructor

Assignment Sheet #3

A.

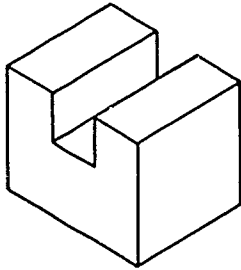

B.

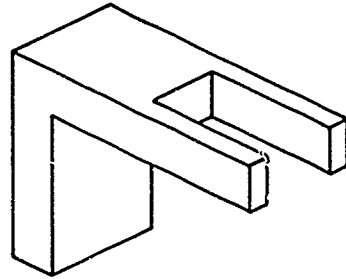

C.

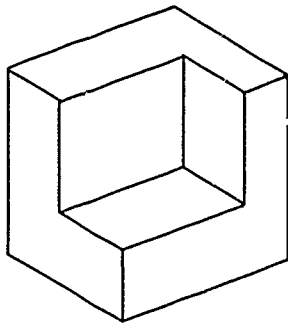

Assignment Sheet #4

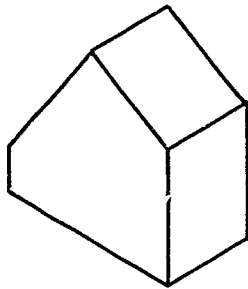

ANSWERS TO ASSIGNMENT SHEETS

Assignment Sheet #5

C.

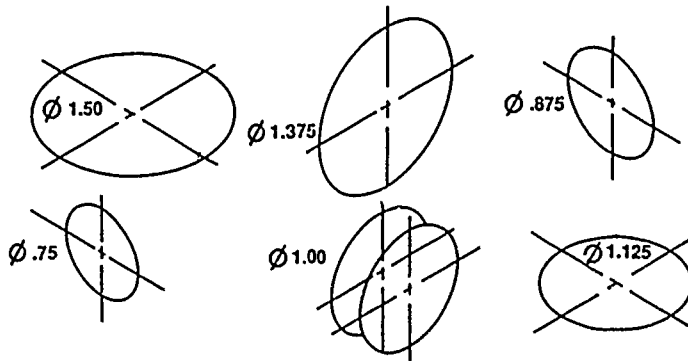

Assignment Sheet #6

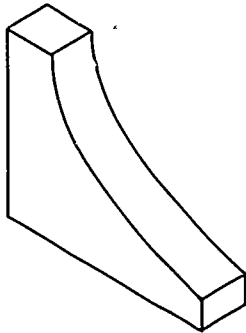

Assignment Sheet #7

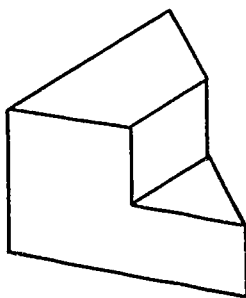

ANSWERS TO ASSIGNMENT SHEETS

Assignment Sheet #8

B.

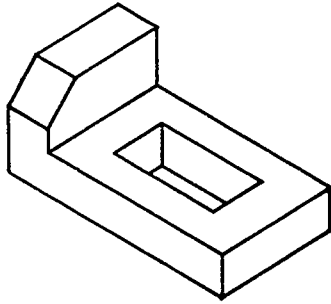

C.

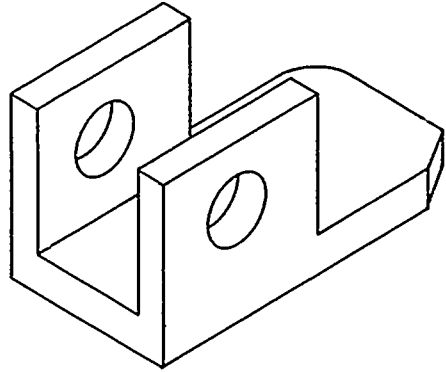

D.

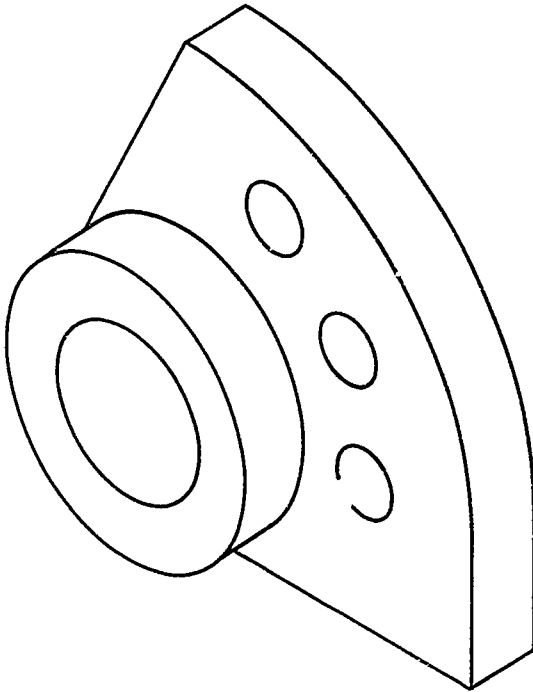

**AXONOMETRICS
UNIT XIV**

**JOB SHEET #1 — CREATE AN ISOMETRIC VIEW
OF A MECHANICAL PART ON CADD**

A. Tools and equipment

1. CADD system
2. CADD systems manual
3. CADD software for 2 1/2 D-view creation

Evaluation Criteria	
Criteria	Rating
Created orthographic views of parts	_____
Created isometric views of parts	_____

B. Procedure: Read the following procedure and then complete the assigned problems as appropriate for your CADD system.

(NOTE: The following procedure has been provided by VersaCAD Design Corporation. Since the system and software may be different in your training institution, refer to your CADD system manual for the proper procedure to create an isometric view. Compare the differences between this method and the method provided in your CADD manual.)

Example: VersaCAD

In this exercise, you will create an isometric view of a sample mechanical block. The front, right, and top orthographic views have been drawn for you. An orthographic view is a two-dimensional drawing of an object.

To construct an isometric view, you have to build each orthographic view into a group and "iso" it. When you construct an isometric drawing, you are creating a three-dimensional view of a two-dimensional drawing. After you have completed the isometric view of the mechanical block, you will have to remove the extra lines to perfect the drawing.

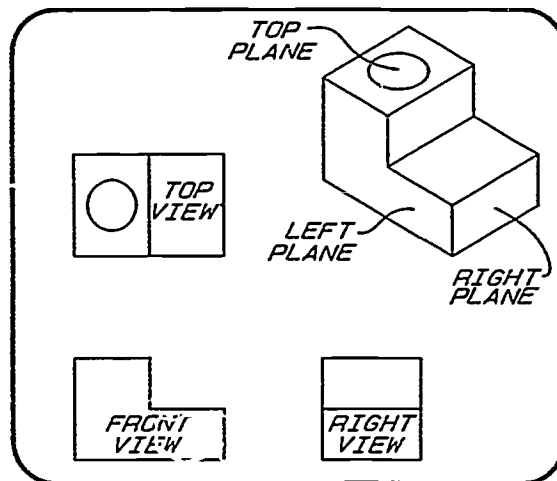

JOB SHEET #1

Step 1: Getting Started

At the drafting menu, select **Filer/Gst** and enter the file name "iso". The three orthographic views will appear on the screen.

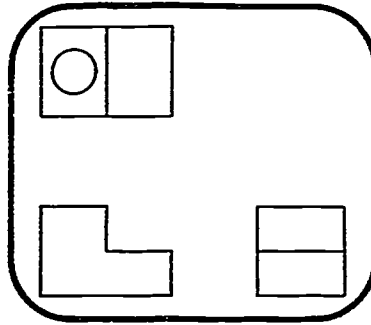

To construct an isometric view of the mechanical box, you have to group and then "iso" each orthographic view separately. The right orthographic view becomes the right isometric plane, the front orthographic view becomes the left isometric plane, and the top orthographic view becomes the top isometric plane.

First you will construct the right plane of the isometric view, then the left plane, and last the top plane. Since the same procedure is used to "iso" each of the three views, you should be comfortable with the procedure by the end of this exercise.

Step 2: Constructing the Right Isometric Plane

1. First you will build a group that consists of the right orthographic view and then "iso" it. Before you build the group, you have to clear out any previous working groups. To do this, select **GROUP/Build/New/Yes**.
2. Now you are ready to build a new group. From the **BUILD** menu, select **Fence**.
3. Quit back to the **GROUP** menu and select **View**. Your current working group (the right orthographic view) will become the right plane of the isometric view. **RIGHT** is the default on the **VIEW** menu so it is already selected for you. Select **Copy** to keep the original orthographic view in place while you build the isometric view.
4. The prompt at the bottom of the screen asks you to define the handle point of the object. The handle point is the lower lefthand corner of the right orthographic view.

To indicate the handle point's new position, place the cursor somewhere in the upper righthand portion of the screen and accept the location. An isometric representation of the right plane appears.

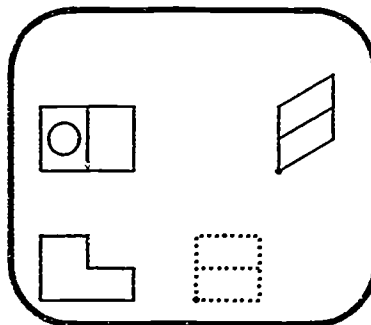

JOB SHEET #1

Step 3: Constructing the Left Isometric Plane

1. The front orthographic view represents the left plane of the isometric view. The group you build will include the front orthographic view. Before you build the group, you have to clear out the previous working group. To do this, you select GROUP/Build/New/Yes.
2. Now you are ready to build the group. From the BUILD menu, select Fence. Draw a rectangular fence around the front orthographic view.
3. Quit back to the GROUP menu and select View. Your current working group (the front orthographic view) will become the left plane of the isometric view. From the VIEW menu, select Left. Also select Copy to keep the original orthographic view in place while you build the isometric view.
4. The prompt at the bottom of the screen asks you to define the handle point of the object. The hand point is the lower righthand corner of the front orthographic view.

The prompt then asks you to define the handle point's new position. In this case, you will define two positions because the front orthographic view is used to construct both the left plane and back surface of the isometric view.

First place the cursor on the lower lefthand corner of the right isometric plane and accept the location. The left plane appears.

Then place the cursor on the lower right hand corner of the right isometric plane and accept this location also. The back surface of the isometric view appears.

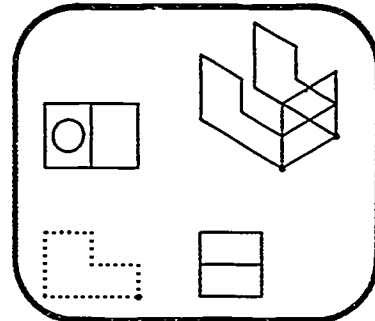
**Step 4: Constructing the Top Isometric Plane**

1. Build a group consisting of the top orthographic view. Select GROUP/Build/New/Yes to clear the previous working group.
2. From the BUILD menu, select Fence. Draw a rectangular fence around the top view.
3. Quit back to the GROUP menu and select View. Your current working group (the top orthographic view) will become the top plane of the isometric view. From the VIEW menu, select Top. Also select Copy to keep the original orthographic view in place while you build the isometric view.
4. The prompt at the bottom of the screen asks you to define the handle point of the object. The handle point is the lower righthand corner of the top orthographic view.

To define the handle point's new position, place the cursor on the upper lefthand corner of the right isometric plane and accept the location (this will be easier if you turn Object snap on using function key [F2]). The top plane is added to the isometric view.

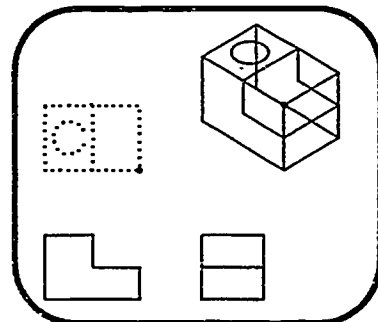

JOB SHEET #1

Step 5: Completing the Isometric View

The isometric function is a tool for constructing isometric views. To perfect the final isometric view, you may have to remove, add, or move some lines. The mechanical box drawing gives you practice removing and moving lines.

1. All of the dotted lines in the illustration are extra lines and must be deleted. To delete the extra lines, select **MODIFY/Find**. Pick each of the dotted lines one at a time as the find object and select **Delete** to delete it.

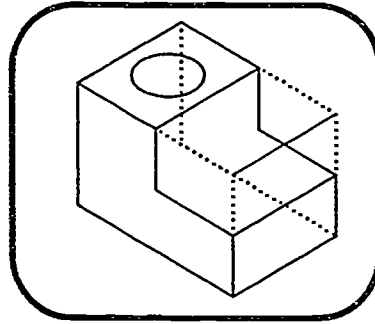

2. Line #1 must be moved. To move line #1, select **Find** and pick line #1 as the target object. Then select **Move** and move line #1 to the correct position.

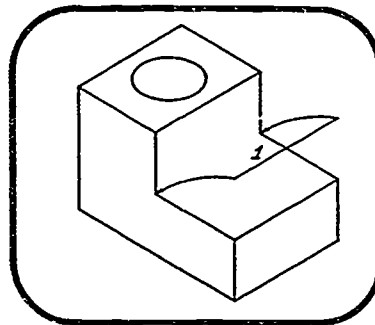

3. Select **sKetch** to resketch the isometric drawing.

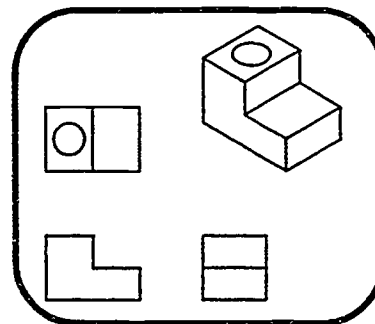

Courtesy of VersaCAD.

JOB SHEET #1

Directions: Create an isometric view of the problems provided here on your CADD system. Refer to the system's manual for proper procedure.

Problem A:

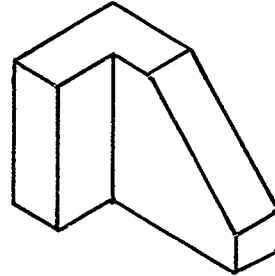
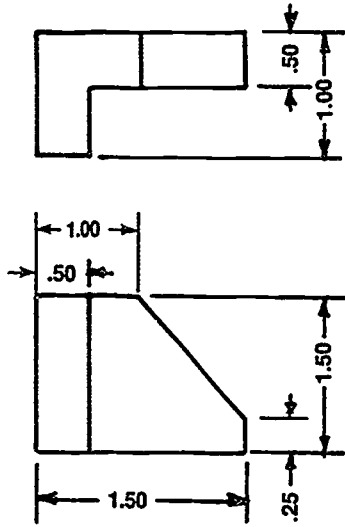

JOB SHEET #1

Problem B:

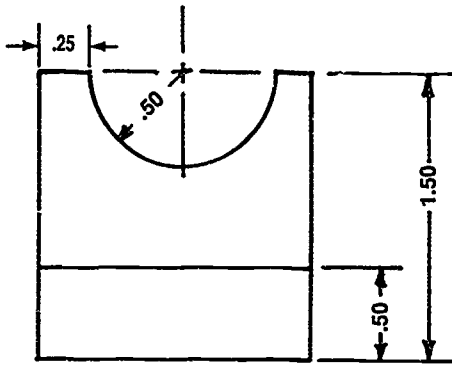
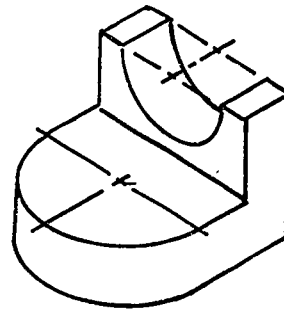
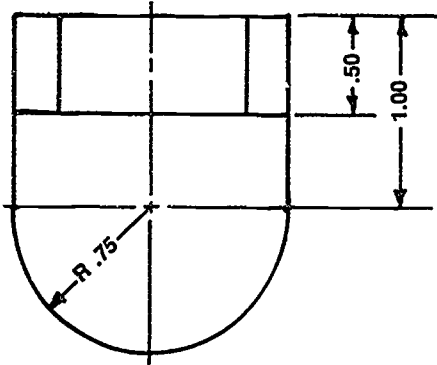

AXONOMETRICS UNIT XIV

TEST

NAME _____ SCORE _____

1. Match the terms on the right with their correct definitions.

- | | | | |
|---------|--|-----|---------------------|
| _____a. | Suggesting a picture or mental image | 1. | Axis lines |
| _____b. | To appear shorter to the eye than it actually is | 2. | Axonometric |
| _____c. | The lines used to represent surfaces or planes coming together | 3. | Construction plane |
| _____d. | To extend from one point to another | 4. | Ellipse |
| _____e. | The lines that run parallel to the isometric axis lines | 5. | Foreshortened |
| _____f. | A foreshortened circle with a major and minor axis | 6. | Isometric lines |
| _____g. | A type of pictorial with each of the three planes and axes at any angle and not equal to 90° | 7. | Model |
| _____h. | An accurate three-dimensional representation of a part, assembly, or plant designed on a CADD system and stored in the database | 8. | Non-isometric lines |
| _____i. | A picture of a three-dimensional object displayed on the screen as a series of lines that represent the edges of its surfaces; this picture looks as if it were made from coat hangers | 9. | Offset coordinates |
| _____j. | Depicts the face of an object and defines the contours of the geometry between edges of a part, providing a "skin" for wire frame models with lines, arcs, and other curves | 10. | Pictorial |
| | | 11. | Project (CADD) |
| | | 12. | Projection |
| | | 13. | Surface |
| | | 14. | Wire frame |

TEST

2. Distinguish between the types of axonometric drawings by placing the following letters next to the correct descriptions:

- D — Dimetric
- I — Isometric
- T — Trimetric

- ___ a. Has three planes and axes equal to each other
- ___ b. Has three planes and axes that are not equal to each other
- ___ c. Has two planes on equal axes to each other and a third plane at a different angle

3. Identify the positions used as axis lines for isometric drawings.

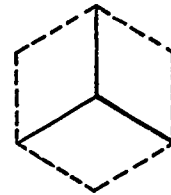
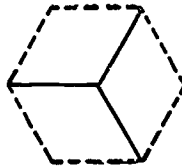
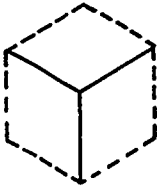

a. _____

b. _____

c. _____

4. Identify plane surfaces on isometrics below:

- a. _____
- b. _____
- c. _____
- d. _____
- e. _____
- f. _____

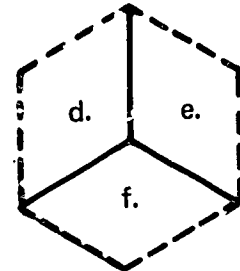
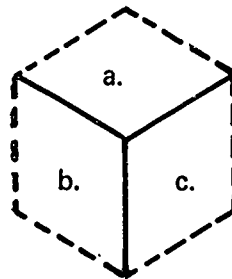

5. Select true statements concerning rules in constructing an isometric drawing by placing an "X" next to the true statements.

- ___ a. All measurements are made parallel to the main edges of the isometric axis lines.
- ___ b. Angles are measured with a protractor in isometrics.
- ___ c. Hidden lines are always shown on isometric drawings.
- ___ d. Isometric drawings are detailed and then centered in their space.
- ___ e. Always block in a circle before constructing its arcs.

TEST

- ___f. The sight direction that best represents the object should be used for the isometric position.
- ___g. If lines are parallel in two successive orthographic views, they are perpendicular in isometric views.

6. Match common errors made in isometric drawing below with their correct drawings.

- ___a. Isometric lines missing
- ___b. Ellipses not in proper plane
- ___c. Angles not measured correctly
- ___d. Tangent lines missing from circles and arcs, and rear ellipse of a hole missing
- ___e. Circle arcs not tangent to each other
- ___f. Dimensions not measured parallel to isometric axis lines

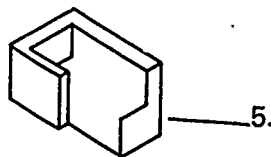
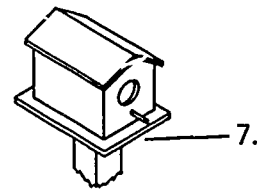
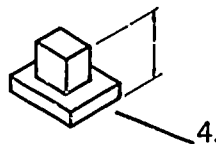
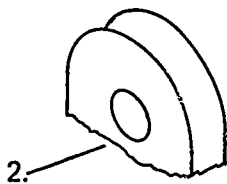
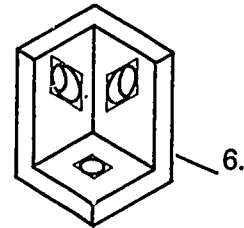
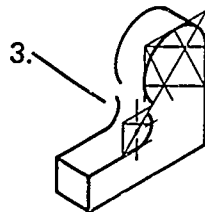
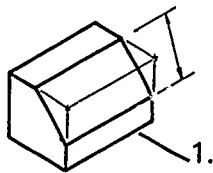

TEST

7. Distinguish between the advantages and disadvantages of isometric drawing by placing an "A" for advantage and a "D" for disadvantage in the appropriate blanks.

- ___ a. Easy to construct
 ___ b. Long objects appear distorted
 ___ c. Symmetrical type drawing causes some lines to meet or overlap, confusing the viewer
 ___ d. Three sides of an object may be shown in one view

8. Distinguish between the types of three-dimensional drawings created on CADD by placing the following letters next to the correct descriptions:

- S — Simulated three-dimensional
- M — Three-dimensional (model mode)

- ___ a. Solid models
 ___ b. Isometric views
 ___ c. Perspective views
 ___ d. Surface models
 ___ e. Wire frame models

9. Distinguish between model mode and draw (drawing) mode by placing the following letters next to the correct descriptions or illustrations:

- D — Draw mode
- M — Model mode

___ a.

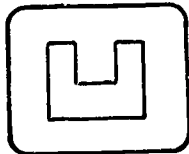

___ b.

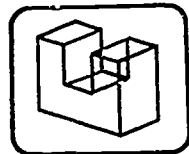

- ___ c. Origin of axes is user defined
 ___ d. Used to create the 3D model of a part
 ___ e. Used to create dimensions, text, and notes

TEST

10. List four applications for three-dimensional part model building.

- a. _____
- b. _____
- c. _____
- d. _____

11. Define the term "automatic drawings."

(NOTE: If the following activities have not been accomplished prior to the test, ask your instructor when they should be completed.)

- 12. Sketch an isometric drawing. (Assignment Sheet #1)
- 13. Sketch isometric circles. (Assignment Sheet #2)
- 14. Construct axonometric drawings by box method. (Assignment Sheet #3)
- 15. Construct angles on an isometric. (Assignment Sheet #4)
- 16. Construct isometric circles and arcs. (Assignment Sheet #5)
- 17. Construct isometric curves by coordinates. (Assignment Sheet #6)
- 18. Measure in isometric by offsets. (Assignment Sheet #7)
- 19. Construct an isometric in the center of a drawing media. (Assignment Sheet #8)
- 20. Demonstrate the ability to create an isometric view of a mechanical part on CADD. (Job Sheet #1)

**AXONOMETRICS
UNIT XIV**

ANSWERS TO TEST

- | | | | | | |
|----|---------|------------|--|----|------------|
| 1. | a. | 10 | | f. | 4 |
| | b. | 5 | | g. | 2 |
| | c. | 1 | | h. | 7 |
| | d. | 12 | | i. | 14 |
| | e. | 6 | | j. | 13 |
| | | | | | |
| 2. | a. | I | | | |
| | b. | T | | | |
| | c. | D | | | |
| | | | | | |
| 3. | a. | Top | | | |
| | b. | Right side | | | |
| | c. | Bottom | | | |
| | | | | | |
| 4. | a. | Top | | d. | Left side |
| | b. | Left side | | e. | Right side |
| | c. | Right side | | f. | Bottom |
| | | | | | |
| 5. | a, e, f | | | | |
| | | | | | |
| 6. | a. | 5 | | d. | 2 |
| | b. | 6 | | e. | 3 |
| | c. | 1 | | f. | 4 |
| | | | | | |
| 7. | a. | A | | | |
| | b. | D | | | |
| | c. | D | | | |
| | d. | A | | | |
| | | | | | |
| 8. | a. | M | | | |
| | b. | S | | | |
| | c. | S | | | |
| | d. | M | | | |
| | e. | M | | | |
| | | | | | |
| 9. | a. | D | | | |
| | b. | M | | | |
| | c. | M | | | |
| | d. | M | | | |
| | e. | D | | | |

ANSWERS TO TEST

10. Any four of the following:
 - a. Manufacturing simulation
 - b. Assembly analysis
 - c. Mechanism analysis
 - d. Mesh generation
 - e. Automatic drawings
 - f. Illustrations

11. They are fully-dimensioned drawings that are automatically created from the solid model rather than creating a special two-dimensional picture. The dimension and tolerance information is carried with the model.

- 12-19. Evaluated to the satisfaction of the instructor.

20. Performance skills evaluated to the satisfaction of the instructor.

**OBLIQUES
UNIT XV****UNIT OBJECTIVE**

After completion of this unit, the student should be able to construct angles, circles, and various objects as each type of oblique drawing. Competencies will be demonstrated by completing the assignment sheets, job sheet, and the unit test with a minimum score of 85 percent.

SPECIFIC OBJECTIVES

After completion of this unit, the student should be able to:

1. Match terms related to obliques with their correct definitions.
2. Distinguish between the types of oblique drawings.
3. Identify the positions used as axis lines on oblique drawings.
4. Name the two most common positions used as axis lines.
5. Select true statements concerning rules in constructing an oblique drawing.
6. Match common errors made in oblique drawing with their correct drawings.
7. List types of analysis information capabilities available to the CADD operator.
8. Match basic options that are retrievable by the LIST command with their descriptions.
9. Distinguish between other CADD commands.
10. Sketch an oblique. (Assignment Sheet #1)
11. Construct each type of oblique drawing by box method. (Assignment Sheet #2)
12. Measure in oblique. (Assignment Sheet #3)
13. Construct angles on an oblique object. (Assignment Sheet #4)
14. Construct oblique circles. (Assignment Sheet #5)
15. Construct oblique drawings in the centers of drawing spaces. (Assignment Sheet #6)
16. Demonstrate the ability to measure and verify a line on a CADD drawing. (Job Sheet #1)

OBLIQUES UNIT XV

SUGGESTED ACTIVITIES

- A. Provide student with objective sheet.
- B. Provide student with information, assignment, and job sheets.
- C. Make transparency.
- D. Discuss unit and specific objectives.
- E. Discuss information, assignment, and job sheets.
- F. Discuss the uses of oblique drawings and how the student decides when to make an oblique drawing.
- G. Set up a series of geometry on different layers and sizes on the CADD for student to measure, verify, and court.
- H. Show filmstrips or films which cover the fundamentals of oblique drawings.
- I. Give test.

REFERENCES USED IN DEVELOPING THIS UNIT

- A. Brown, Walter C. *Drafting for Industry*. South Holland, IL 60473: Goodheart-Willcox Co., Inc., 1984.
- B. Giesecke, Frederick E., et al. *Technical Drawing*, 8th ed. New York: Macmillan Publishing Co., Inc., 1986.
- C. Jensen, Cecil and Jay Helsel. *Engineering Drawing and Design*, 3rd ed. New York: Gregg Division/McGraw-Hill Book Co., 1985.
- D. *Pictorial Drawing, ANSI Y14.4-1957, R 1987*. New York: American Society of Mechanical Engineers.
- E. Lamit, Gary Louis and Vernon Paige. *Computer-Aided Drafting and Design — CADD*. Columbus, OH 43216: Merrill Publishing Co., 1987.

**OBLIQUES
UNIT XV****INFORMATION SHEET****I. Terms and definitions**

- A. Axis lines — The lines used to represent where planes come together
- B. Ellipse — A foreshortened circle with a major and minor axis
- C. Foreshortened — To appear shorter to the eye than it actually is
- D. Non-oblique lines — The lines that do not run parallel to one of the oblique axis lines
- E. Oblique — A type of pictorial drawing with front plane true size and parallel to frontal plane, the other two at any angle to the front
- F. Oblique lines — The lines that run parallel with one of the oblique axis lines
- G. Pictorial — Suggesting a picture or mental image
(NOTE: The types of pictorials are axonometrics, obliques, and perspectives.)
- H. Project — To extend from one point to another

II. Types of oblique drawings (Transparency 1)

- A. Cavalier — A type of oblique drawing with all axis lines drawn at the same scale.

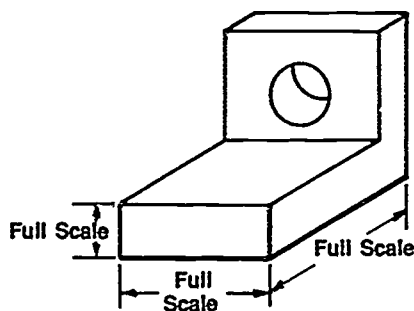

INFORMATION SHEET

- B. Cabinet — A type of oblique drawing with the depth (receding) axis drawn half scale and the other axis lines drawn full scale.

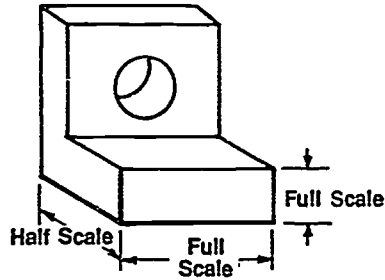

- C. General — A type of oblique drawing with the depth (receding) axis drawn at a varying scale from half to full.

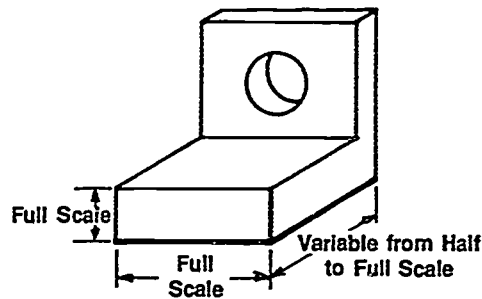

iii. Positions used as axis lines on oblique drawings

(NOTE: Depth [receding] angle can be at any angle but usually a 30°, 45°, or 60° angle is used.)

- A. Up to right

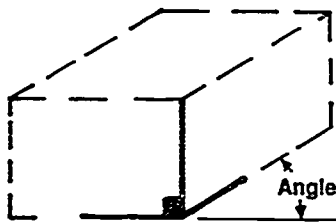

- B. Down to right

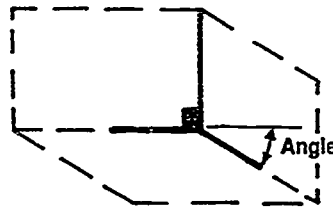

- C. Up to left

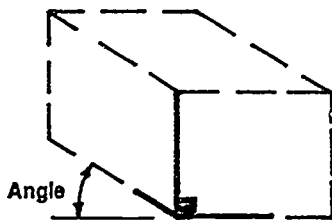

- D. Down to left

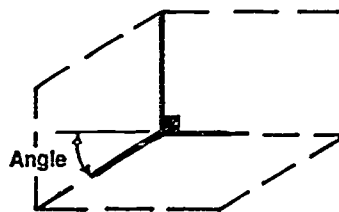

INFORMATION SHEET

IV. Most common positions used as axis lines

- A. Up to left
- B. Up to right

V. Rules in constructing an oblique drawing

- A. Make all measurements parallel to the main axis edges of the oblique axis lines.
- B. Measure angles by coordinate offsets.
- C. Omit hidden lines in oblique drawings if possible.
- D. Center a drawing in the work space and box in before adding details.
- E. Use the approximate ellipse method on circles that cannot be drawn as regular circles or if no templates are available.
- F. Always box in a circle before constructing its arcs.
- G. Always face contours toward the frontal plane where they will appear in true size and shape and can be drawn with compass.
- H. Draw long objects with the long axis perpendicular to the line of sight (parallel to frontal plane).
- I. Keep all arcs and lines tangent to each other.
- J. Include the rear ellipse or circle of a hole if it is visible.

VI. Common errors made in oblique drawing

- A. Wrong axis selected

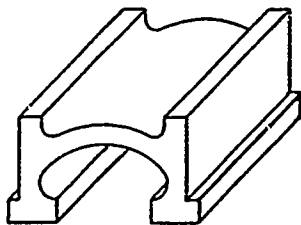

Correct

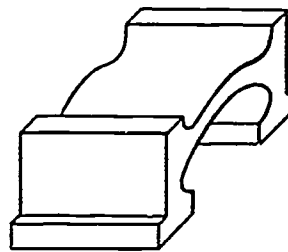

Incorrect (Descriptive feature should be placed parallel to frontal plane.)

INFORMATION SHEET

- B. Arcs not tangent, or tangent lines omitted

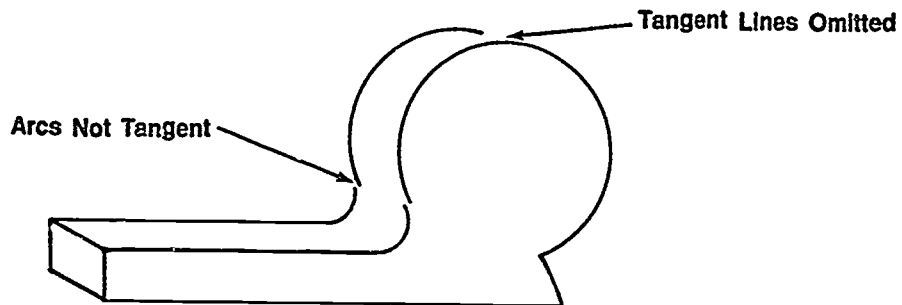

- C. Rear circles or ellipses omitted, or lines missing

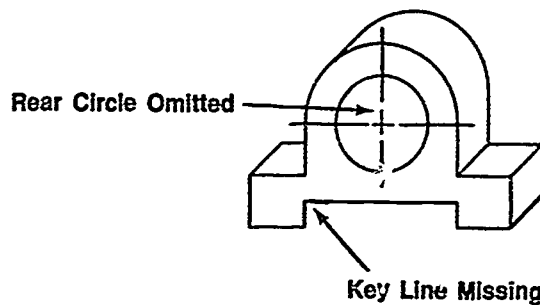

- D. Plane with the longest dimension not in frontal plane

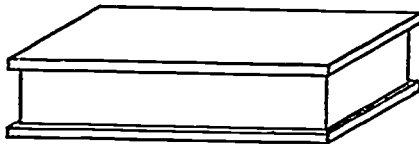

Correct

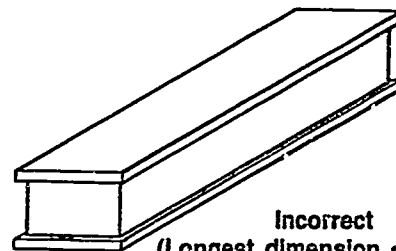

Incorrect
(Longest dimension on depth
axis causes more distortion.)

VII. Analysis information available to the CADD operator

- A. Displaying capabilities
 - 1. LIST command
 - 2. HELP command
- B. Verification of geometry
- C. Counting capabilities
- D. Measuring capabilities

INFORMATION SHEET**VIII. Basic options retrievable by the LIST command**

- A. LIST PART — Lists information on a part
- B. LIST DRAWING — Lists status information on specified drawings
- C. LIST VIEW — Lists status of views
- D. LIST CPL — Lists construction planes
- E. LIST IMAGE — Lists information on specified views
- F. LIST LAYER — Lists layer
- G. LIST TEXT — Lists text parameters
- H. LIST DIMENSION — Lists current dimension parameters

IX. Other CADD commands and their definitions

- A. MEASURE command — Allows the operator to determine distances, areas, and angles
- B. COUNT command — Provides statistical information on a drawing including the following:
 - 1. Types of geometry and number of each type
 - 2. Number of operator-defined views
 - 3. Number of extents
 - 4. Number of erased items of geometry
 - 5. Size of the part
- C. VERIFY command — Used to confirm (verify) information about a piece of geometry such as the type of geometry, coordinate location, length, and layer of geometry

Types of Oblique Drawings

Front surface is parallel to frontal plane and is shown in its true size and shape

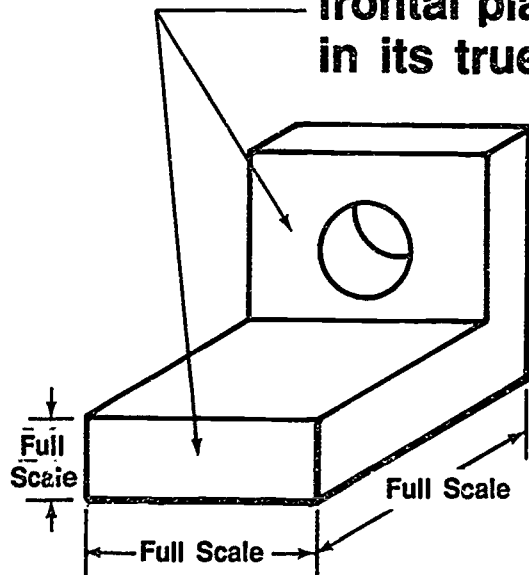

Cavalier

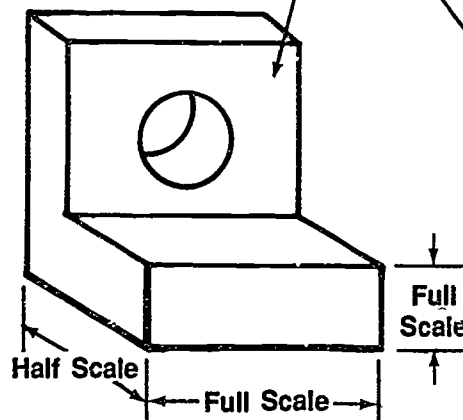

Cabinet

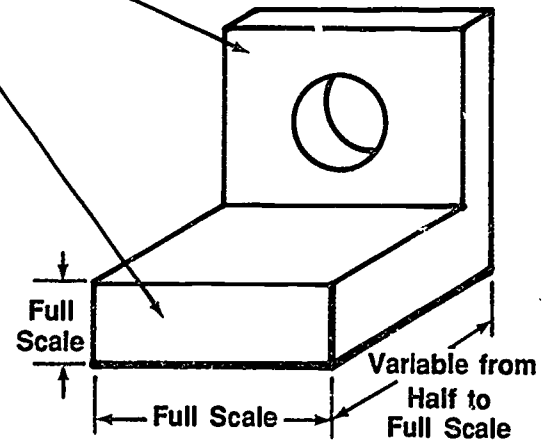

General

OBLIQUES
UNIT XV

ASSIGNMENT SHEET #1 — SKETCH AN OBLIQUE

NAME _____ SCORE _____

Directions: Study the following example and then complete the assigned problem.

Example:

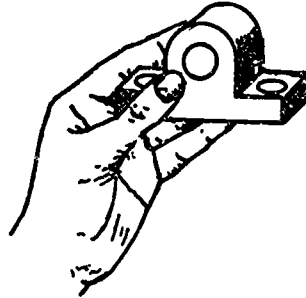

1. Take the object and block in a front view.
2. Draw the receding (depth) lines parallel to each other at a 45° angle or any convenient angle and at a length so the depth looks correct.
 - a. If receding lines are half their full length, the sketch is a cabinet sketch.
 - b. If receding lines are full length, the sketch is a cavalier sketch.
 - c. If receding lines are between half and full length, the sketch is a general sketch.
3. Use an artgum eraser to dim construction lines and darken in visible lines.

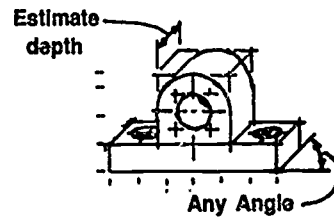
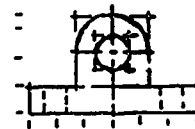

ASSIGNMENT SHEET #1

Problem: Make a full size oblique sketch of the following object.

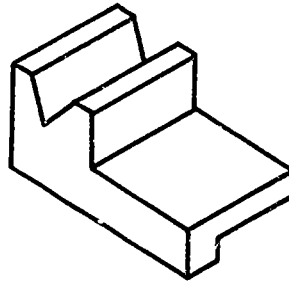

830

OBLIQUES UNIT XV

ASSIGNMENT SHEET #2 — CONSTRUCT EACH TYPE OF OBLIQUE DRAWING BY BOX METHOD

NAME _____ SCORE _____

Directions: Study the following example and then complete the assigned problems.

Example:

1. Attach sheet to drawing surface in alignment with working edge using a parallel bar or drafting machine.
2. Determine the appropriate position of oblique axis lines (up or down to left or right) and the correct depth angle. Common positions and angles are as follows:

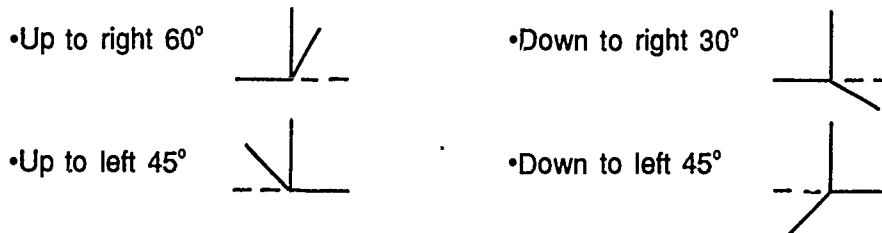

3. Locate axis lines on drawing media so that contours and circles of object will show best.

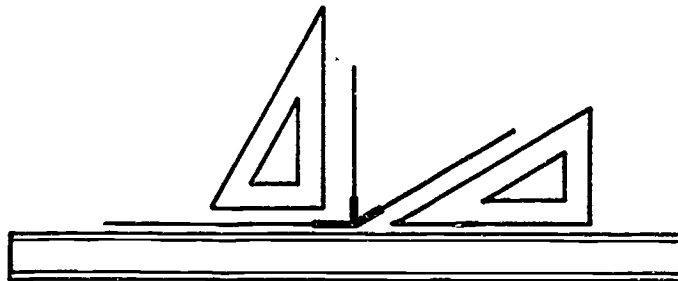

4. Measure overall width, depth, and height of object on these projected axis lines.

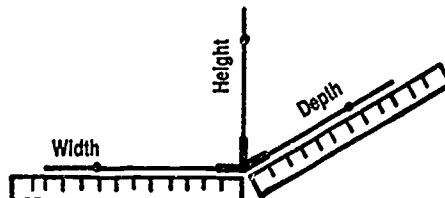

ASSIGNMENT SHEET #2

5. Complete box parallel to main axis lines.

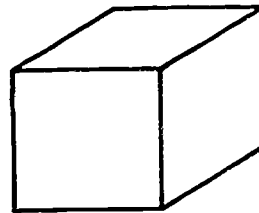

6. At this point details can be added to complete shape of object.

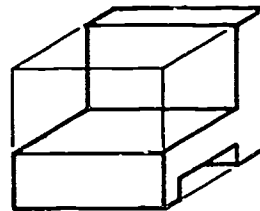

Problem A: Construct a cavalier oblique drawing of a box with the following dimensions: $H = 1"$, $D = 2"$, $W = 3"$. Make depth axis up to left 30° .

Problem B: Construct a cabinet oblique drawing of the following object. Make depth axis up to right 45° .

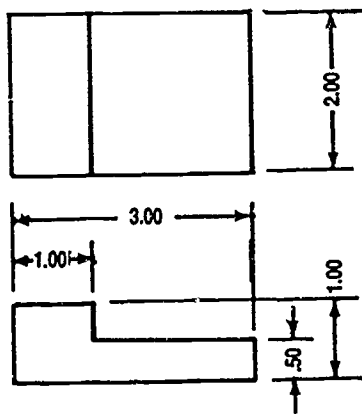

832

ASSIGNMENT SHEET #2

Problem C: Construct a general oblique drawing of the following object. Make depth axis up to left 45° and $3/8"$ scale.

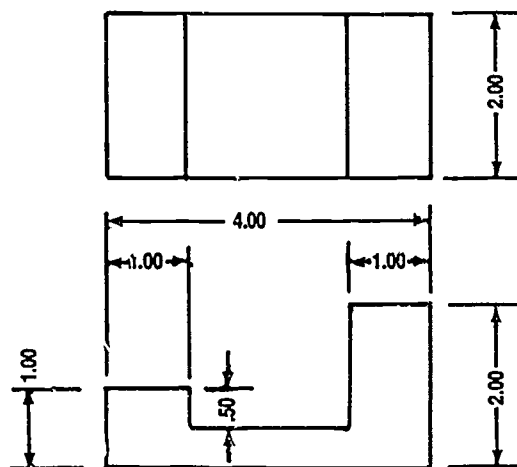

OBLIQUES
UNIT XV

ASSIGNMENT SHEET #3 — MEASURE IN OBLIQUE

NAME _____ SCORE _____

Directions: Study the following example and then complete the assigned problem.

Example:

1. Sketch necessary views of object to be drawn.

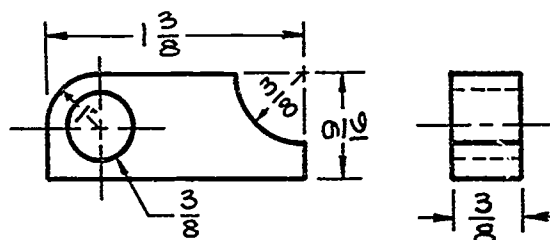

2. Lay out axis lines selecting axis best for object.

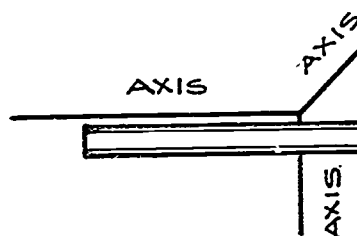

3. Measure dimensions on axis lines.

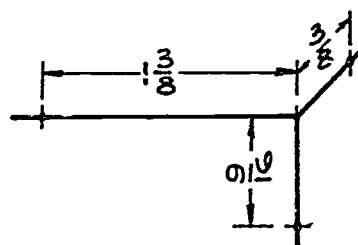

4. Box in object.

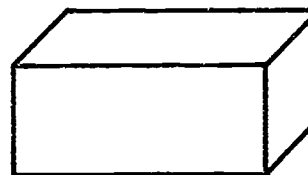

ASSIGNMENT SHEET #3

5. Add arc at right side of box.

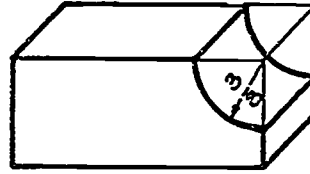

6. Add arcs at left side of box.

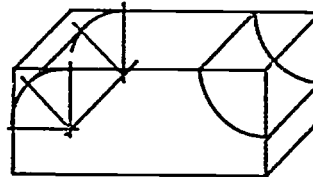

7. Add circle in object.

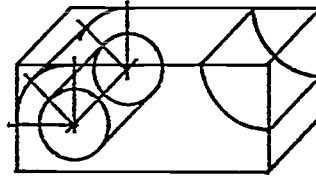

8. Darken visible lines.

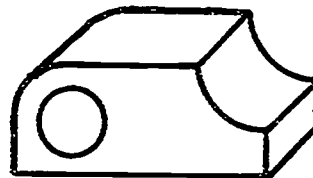

Problem: Construct the object below in cavalier. Depth axis is up to right 45°.

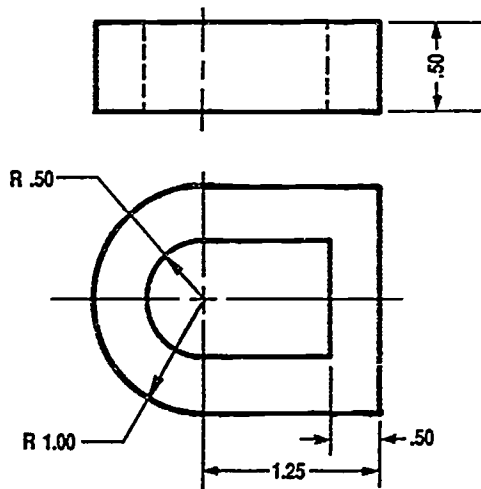

835

OBLIQUES
UNIT XV

ASSIGNMENT SHEET #4 — CONSTRUCT ANGLES ON AN OBLIQUE OBJECT

NAME _____ SCORE _____

Directions: Study the following example and then complete the assigned problem.

Example:

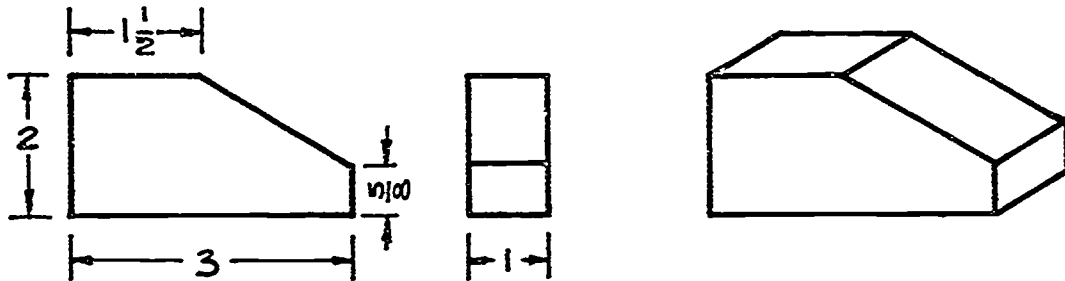

1. Box in overall dimensions of the object in oblique.

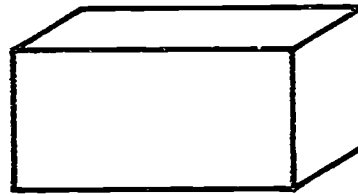

2. Use dividers or scale to lay out offset dimensions of angle.

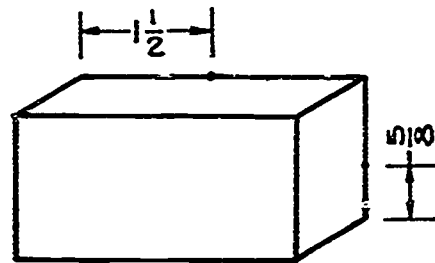

ASSIGNMENT SHEET #4

3. Connect points and complete the shape of the object.

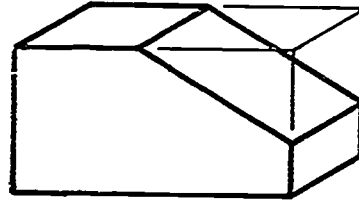

Problem: Draw the following object in cavalier. Depth axis is up to left 45° .

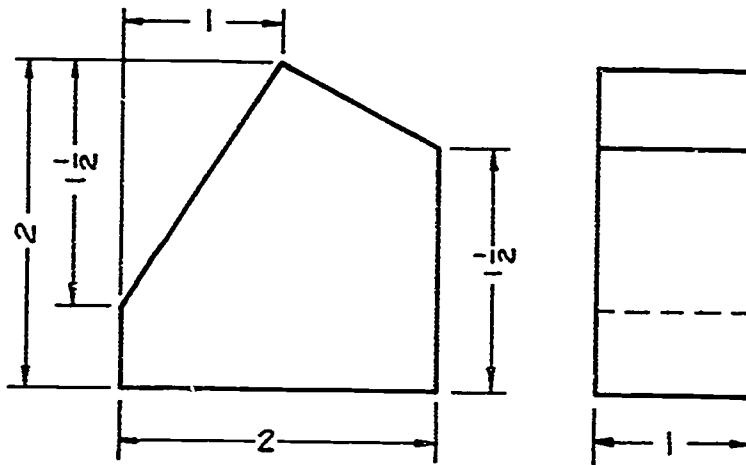

OBLIQUES UNIT XV

ASSIGNMENT SHEET #5 — CONSTRUCT OBLIQUE CIRCLES

NAME _____ SCORE _____

Introduction: A circle can appear in any one of the three planes shown at right. In the front plane the circle is drawn as a true circle with the compass. The other two planes are drawn using the four-center ellipse method which makes drawing easier and more legible.

Directions: Study the following example and then complete the assigned problem.

Example:

1. With this object all circles can be drawn from the front plane. Determine depths, heights, and diameters of circles and arcs.

(NOTE: All circles are either in the front plane or parallel to the front plane.)

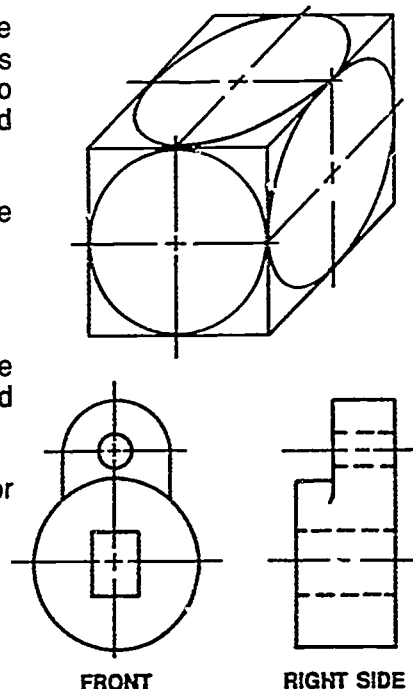

2. Box in overall shape.

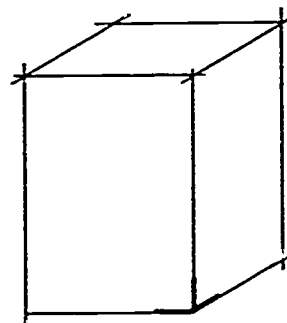

ASSIGNMENT SHEET #5

3. Locate center point of circle in front surface.

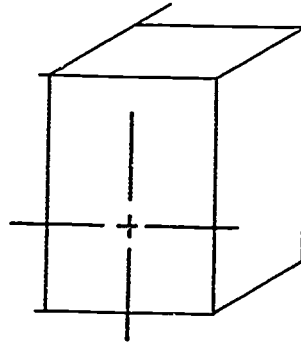

4. Lay out skeleton framework of object by locating circle center points.

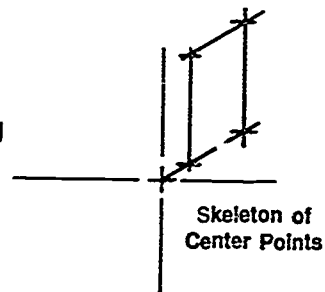

5. Use center points to draw in circles and arcs using circle template or compass.

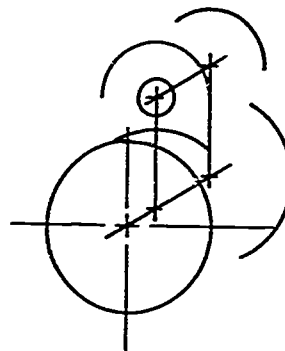

6. Put in lines tangent to circle arcs.
7. Add other features and darken lines.

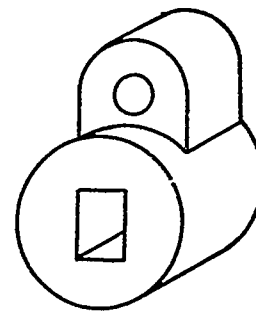

ASSIGNMENT SHEET #5

Problem: Construct a cavalier drawing of the following object. Depth axis is up to left 45°.

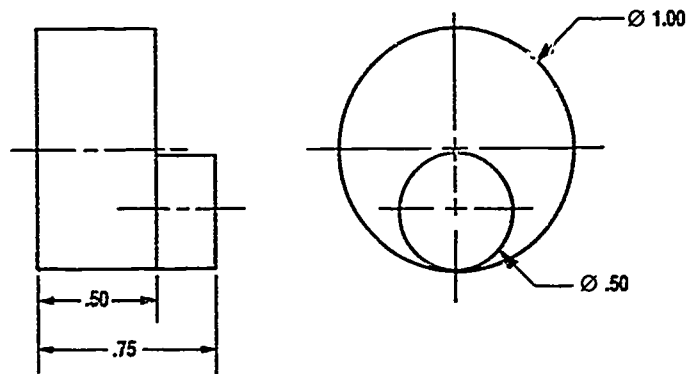

**OBLIQUES
UNIT XV****ASSIGNMENT SHEET #6 — CONSTRUCT OBLIQUE DRAWINGS IN THE
CENTER OF DRAWING SPACES**

NAME _____ SCORE _____

Introduction: It is important that oblique drawings be located somewhere near the center of the drawing space that is available to allow room for dimensions, notes, and to add to the appearance of the drawing.

Directions: Study the following example and then complete the assigned problem.

Example:

1. Box in an oblique sketch of the overall dimensions of the object to be drawn.

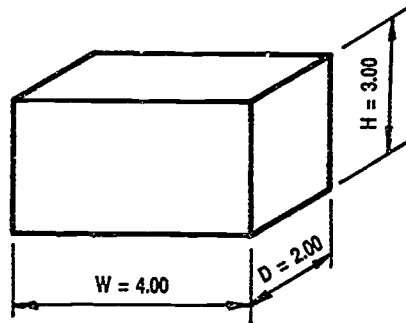

2. Find center of drawing space by using diagonals from corners.

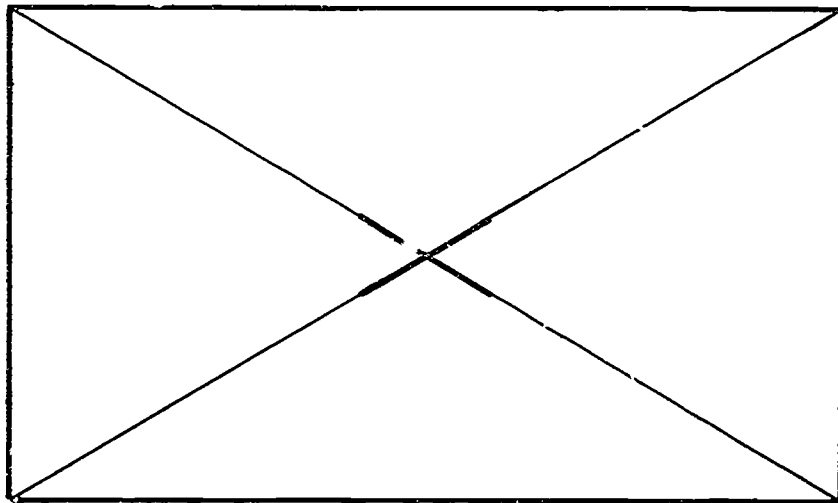

841

ASSIGNMENT SHEET #6

3. From the center of the work area, measure up vertically 1/2 the height of the object. (1.50 in this example)
4. At some angle down and to the left, measure 1/2 the depth of the object. (1.00 in this example)
5. In a horizontal direction to the right, measure 1/2 the width of the object. (2.00 in this example)

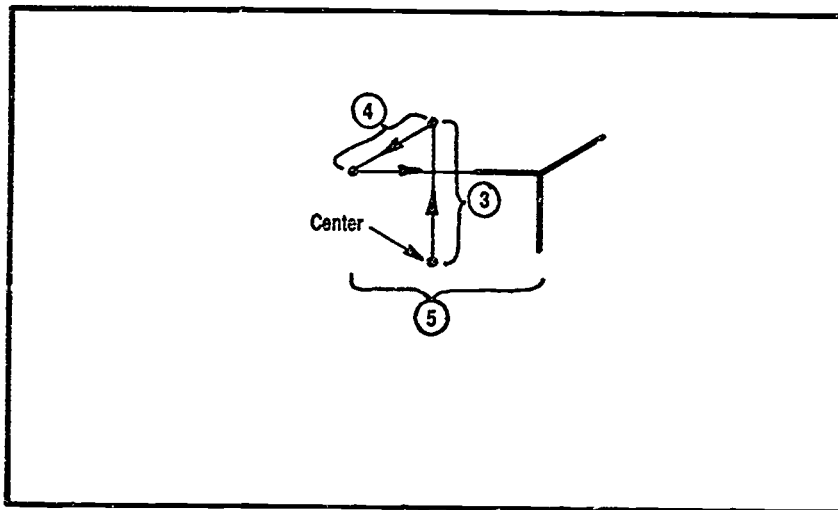

6. Complete the shape of the box.

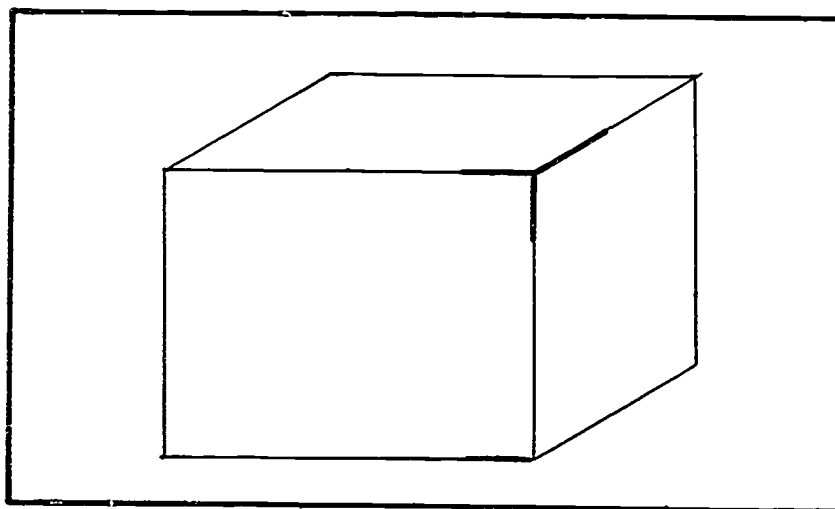

ASSIGNMENT SHEET #6

Problem A: Center and construct the following oblique in the space below. Use dividers and drafting machine to transfer dimensions.

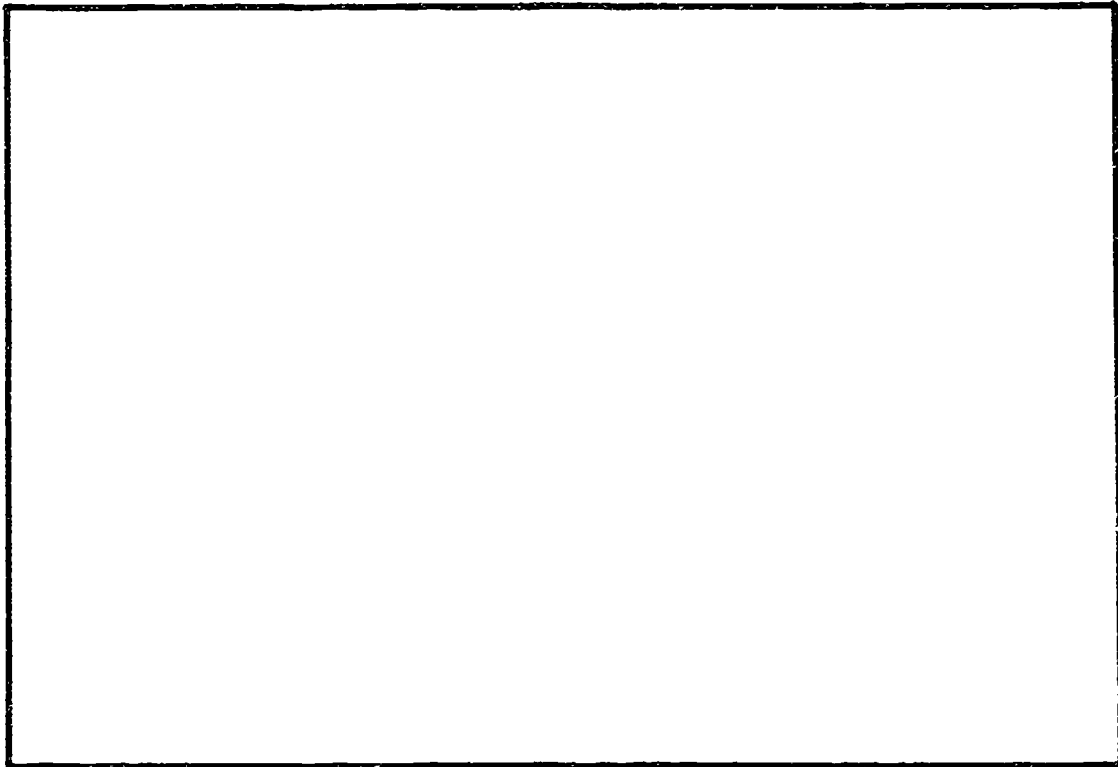
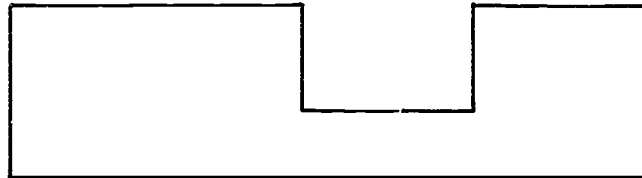
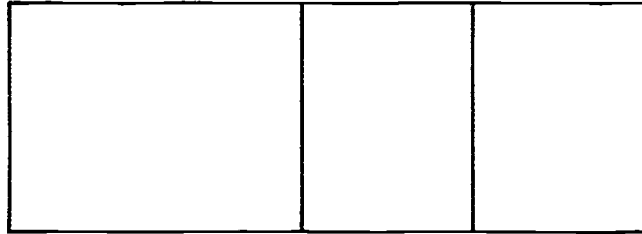

ASSIGNMENT SHEET #6

Problem B: Center and construct a cavalier drawing of the following object on "A" size vellum with standard border and title block. Construct down to right 45°. Omit dimensions and erase construction lines.

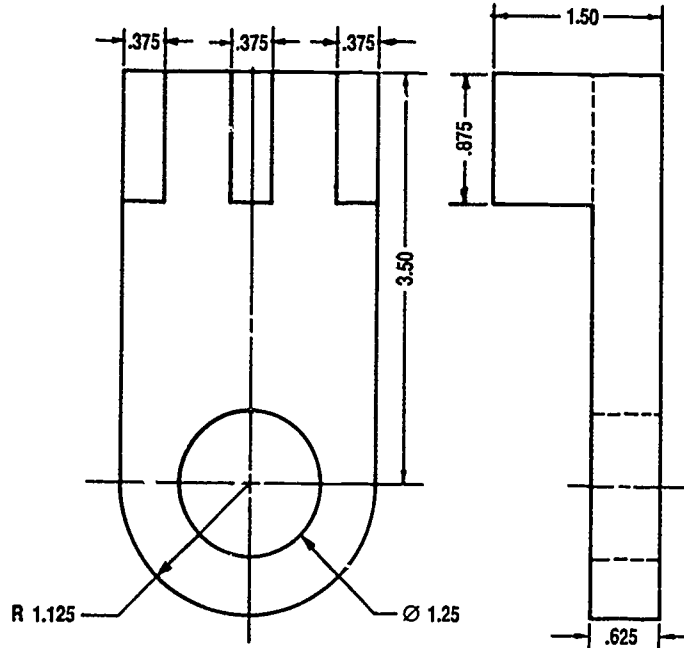

Problem C: Center and construct a cabinet drawing of the following object on "A" size vellum with standard border and title block. Construct up to right 45°. Omit dimensions and erase construction lines.

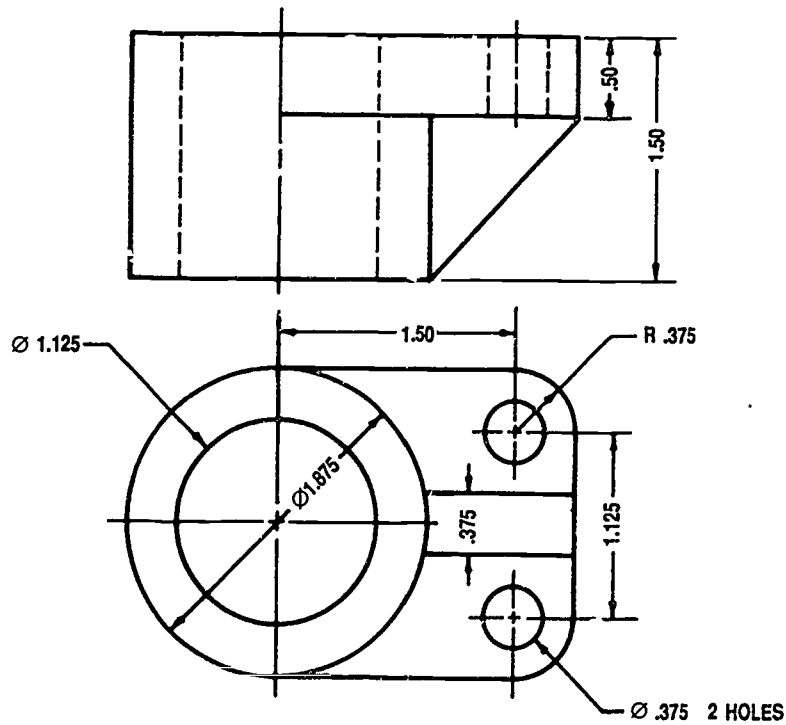

OBLIQUES
UNIT XV

ANSWERS TO ASSIGNMENT SHEETS

Assignment Sheet #1

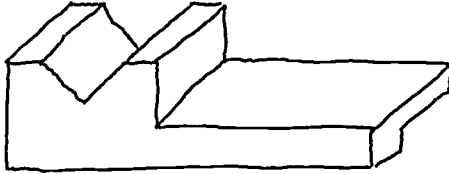

Assignment Sheet #2

A.

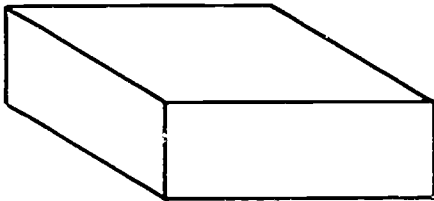

B.

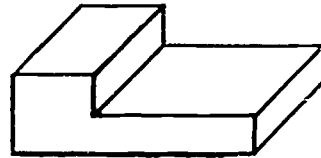

C.

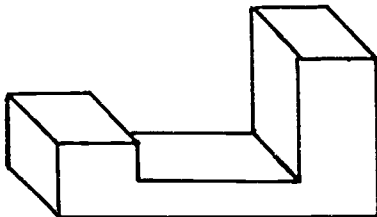

Assignment Sheet #3

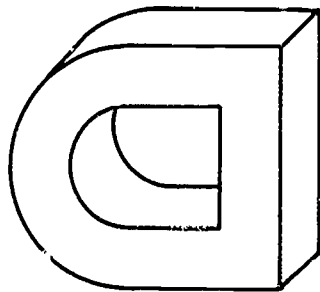

ANSWERS TO ASSIGNMENT SHEETS

Assignment Sheet #4

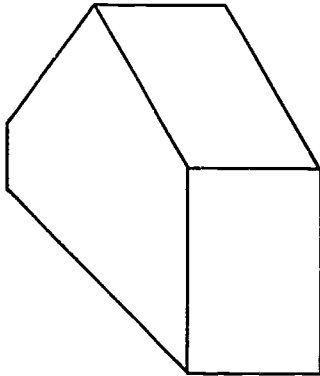

Assignment Sheet #5

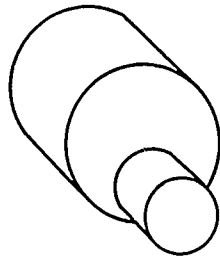

Assignment Sheet #6

A.

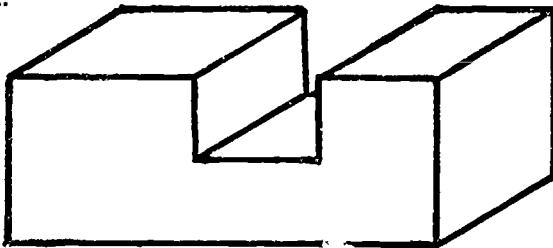

B.

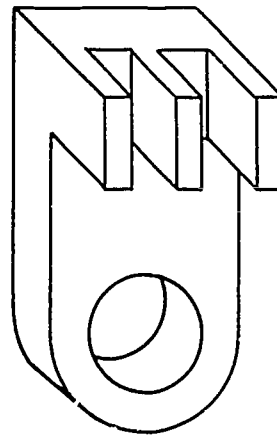

ANSWERS TO ASSIGNMENT SHEETS

C.

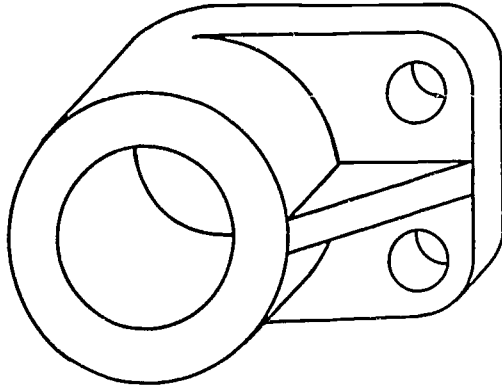

**OBLIQUES
UNIT XV**

**JOB SHEET #1 — MEASURE AND VERIFY A LINE
ON A CADD DRAWING**

- A. Materials and equipment
1. Computer hardware
 2. Appropriate CADD software
 3. Instruction manual for CADD system
- B. Procedure: The following procedure is only an example. Discuss with your instructor the exact procedure for your CADD system or refer to your system manual.

Evaluation Criteria	
Criteria	Rating
Activated correct drawing	_____
Correctly digitized the lines to be verified	_____
Properly digitized the lines to be measured	_____

Example: From the MATC-CAD graphics system package:

1. VERIFY COMMAND

VERIFY ENTITY: D1

LINE = ENTITY TYPE

DRAW: COORDINATE OUTPUT

X1 = 4.0523 Y1 = 2.0612 Z1 = 0.0

X2 = 4.5012 Y2 = 3.0123 ZZ = 0.0

LENGTH = 4.9123

LAYER = 5

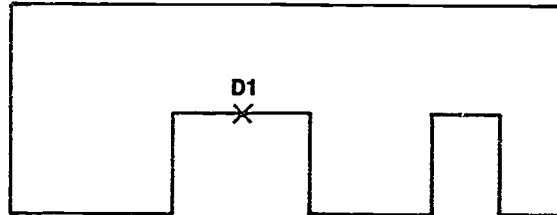

2. MEASURE COMMAND

MEASURE DISTANCE: D1 D2

IN MODEL SPACE

NORMAL DISTANCE = 3.1251

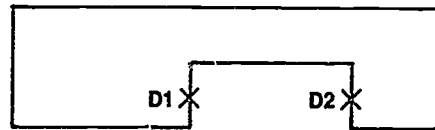

From *MATC CAD Operations and Training Manual*. © Milwaukee Area Technical College.

Reprinted with permission.

C. Problem:

1. Log on to your CADD system.
2. Call up a previously constructed drawing from Unit XI, such as Assignment Sheet #14, Problem A.

JOB SHEET #1

3. Verify 2 or 3 lines.
4. Measure the distance between two lines.
5. Review your findings with the instructor.

849

**OBLIQUES
UNIT XV**

TEST

NAME _____ SCORE _____

1. Match the terms on the right with their correct definitions.

- | | | | |
|----------|---|----|-------------------|
| _____ a. | To extend from one point to another | 1. | Axis lines |
| _____ b. | The lines used to represent where planes come together | 2. | Ellipse |
| _____ c. | A type of pictorial drawing with front plane true size and parallel to frontal plane, the other two at any angle to the front | 3. | Foreshortened |
| _____ d. | The lines that run parallel with one of the oblique axis lines | 4. | Non-oblique lines |
| _____ e. | The lines that do not run parallel to one of the oblique axis lines | 5. | Oblique |
| _____ f. | A foreshortened circle with a major and minor axis | 6. | Oblique lines |
| | | 7. | Pictorial |
| | | 8. | Project |

2. Distinguish between the types of oblique drawings by placing the following letters next to the correct descriptions:

- X — Cabinet
- Y — Cavalier
- Z — General

- _____ a. All axis lines are drawn at the same scale
- _____ b. Depth axis is drawn at a varying scale from half to full
- _____ c. Depth axis is drawn at half scale

3. Identify the positions used as axis lines on oblique drawings.

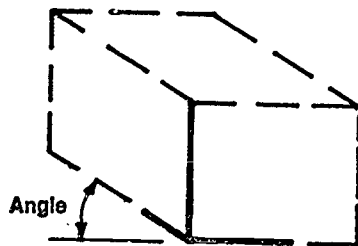

a. _____

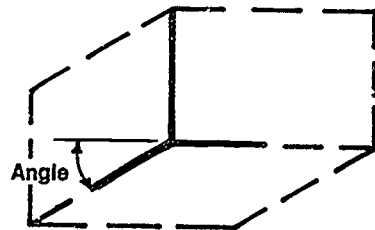

b. _____

TEST

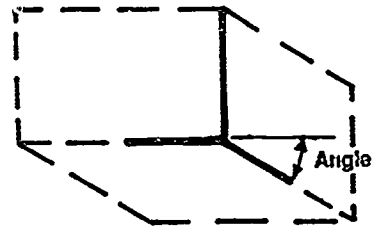
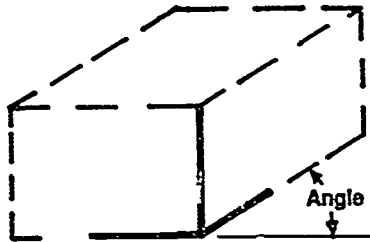

c. _____

c. _____

4. Name the two most common positions used as axis lines.

a. _____

b. _____

5. Select true statements concerning rules in constructing an oblique drawing by placing an "X" next to the true statements.

____ a. Make all measurements parallel to the main axis edges of the oblique axis lines.

____ b. Measure angles by coordinate offsets.

____ c. Show all hidden lines on oblique drawings.

____ d. Center an oblique drawing in the work space before adding details.

____ e. Use the concentric circle method for drawing oblique circles.

____ f. Construct arcs before boxing in a circle.

____ g. Face circles and contours toward the top plane of an oblique drawing, rather than the front.

____ h. Draw long objects with the long axis perpendicular to the line of sight.

____ i. Keep all arcs and lines tangent to each other.

____ j. Include the real ellipse or circle of a hole if it is visible.

TEST

6. Match common errors made in oblique drawing below with their correct drawings.

- ___ a. Wrong axis selected
- ___ b. Arcs not tangent
- ___ c. Line missing
- ___ d. Rear circle or ellipse omitted
- ___ e. Tangent lines omitted
- ___ f. Plane with the longest dimension not in frontal plane

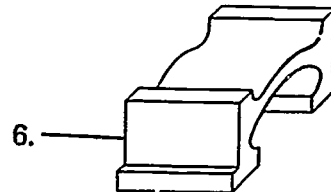
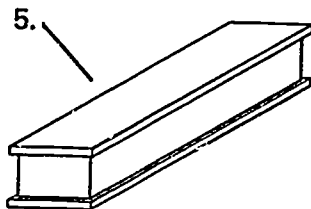
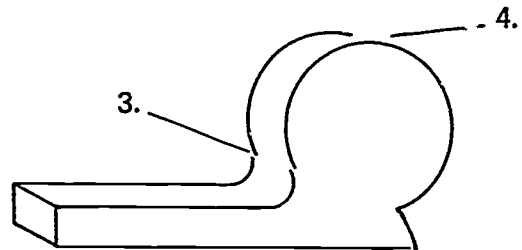
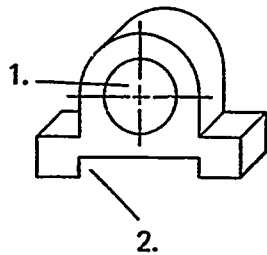

7. List two types of analysis information capabilities available to the CAD operator.

a. _____

b. _____

TEST

8. Match basic options that are retrievable by the LIST command with the correct descriptions.

_____ a.	Lists current dimension parameters	1.	LIST PART
_____ b.	Lists status information on specified drawings	2.	LIST CPL
_____ c.	Lists construction planes	3.	LIST DIMENSION
_____ d.	Lists information on a part	4.	LIST TEXT
		5.	LIST DRAWING
		6.	LIST VIEW

9. Distinguish between the following CADD commands by placing an "X" next to the description of the COUNT command.

_____ a.	Provides statistical information on a drawing such as number of extents, operator-defined views, and erased items of geometry
_____ b.	Allows the operator to determine distances, areas, and angles.
_____ c.	Used to confirm information about a piece of geometry such as type of geometry, coordinate location, length, and layer of geometry.

(NOTE: If the following activities have not been accomplished prior to the test, ask your instructor when they should be completed.)

10. Sketch an oblique. (Assignment Sheet #1)
11. Construct each type of oblique drawing by box method. (Assignment Sheet #2)
12. Measure in oblique. (Assignment Sheet #3)
13. Construct angles on an oblique object. (Assignment Sheet #4)
14. Construct oblique circles. (Assignment Sheet #5)
15. Construct oblique drawings in the centers of drawing spaces. (Assignment Sheet #6)
16. Demonstrate the ability to measure and verify a line on a CADD drawing. (Job Sheet #1)

**OBLIQUES
UNIT XV****ANSWERS TO TEST**

1. a. 8 d. 6
 b. 1 e. 4
 c. 5 f. 2

2. a. Y
 b. Z
 c. X

3. a. Up to left
 b. Down to left
 c. Up to right
 d. Down to right

4. a. Up to left
 b. Up to right

5. a, b, d, h, i, j

6. a. 6 d. 1
 b. 3 e. 4
 c. 2 f. 5

7. Any two of the following:
 a. Displaying capabilities (LIST command and HELP command)
 b. Verification of geometry
 c. Counting capabilities
 d. Measuring capabilities

8. a. 3
 b. 5
 c. 2
 d. 1

9. a

- 10.-15. Evaluated to the satisfaction of the instructor

16. Performance skills evaluated to the satisfaction of the instructor

PERSPECTIVES UNIT XVI

UNIT OBJECTIVE

After completion of this unit, the student should be able to identify perspective types and views and sketch and construct various perspectives. Competencies will be demonstrated by completing the assignment sheets and the unit test with a minimum score of 85 percent.

SPECIFIC OBJECTIVES

After completion of this unit, the student should be able to:

1. Match terms related to perspectives with their correct definitions.
2. Identify the three types of perspectives.
3. Distinguish between perspectives and isometrics.
4. Identify the types of perspective views.
5. List types of perspective equipment.
6. Distinguish between the types of perspectives and their uses.
7. Identify the lines and points in a two-point perspective.
8. Match perspective terms with their correct letter designations.
9. Select true statements concerning perspective projection on CADD.
10. List types of CADD drawings created from library parts.
11. Select true statements concerning CADD library parts and symbols.
12. Sketch a one-point perspective. (Assignment Sheet #1)
13. Sketch a two-point perspective. (Assignment Sheet #2)
14. Construct a one-point perspective. (Assignment Sheet #3)
15. Construct a two-point perspective. (Assignment Sheet #4)
16. Construct curves in a perspective. (Assignment Sheet #5)

**PERSPECTIVES
UNIT XVI**

SUGGESTED ACTIVITIES

- A. Provide student with objective sheet.
- B. Provide student with information and assignment sheets.
- C. Make transparencies.
- D. Discuss unit and specific objectives.
- E. Discuss information and assignment sheets.
- F. Demonstrate the setup for a two-point perspective drawing.
- G. Have students do a perspective for a building trades program.
- H. Visit architectural delineator's office.
- I. Give test.

REFERENCES USED IN DEVELOPING THIS UNIT

- A. Brown, Walter C. *Drafting for Industry*. South Holland, IL: Goodheart-Willcox Co., Inc., 1984.
- B. Goodhan, Jack J. and Jack J. Haysleft. *Architectural Drawing and Planning*. St. Louis, MO: Gregg Division/McGraw-Hill Book Co.
- C. Jensen, Cecil and Jay Helsel. *Engineering Drawing and Design*, 3rd ed. New York: Gregg Division/McGraw-Hill Book Co., 1985.
- D. Lamit, Louis and Paige Vernon. *Computer-Aided Design and Drafting-CADD*. Columbus, OH: Merrill Publishing Company — A Bell & Howell Information Company, 1987.

**PERSPECTIVES
UNIT XVI**

INFORMATION SHEET

I. Terms and definitions

- A. Delineation — The act of representing or describing a structure or part graphically
- B. Diagram (CADD) — A collection of library symbols that are stored and used together in a group
Example: Electronic circuit
- C. Figure (CADD) — A symbol or a part that may contain other figures, attributes, and associations
- D. Ground line — Bottom of the object being drawn
- E. Horizon line — Eye level of the person viewing the drawing and the line on which the vanishing points are located
- F. Perspective — Pictorial drawing made by the intersection of the picture plane with lines of sight meeting from points on the object to the point of sight
- G. Perspective board — Has variety of scales and permits direct reading for layout of perspectives
- H. Perspective grid — Graph oriented method for making accurate perspectives without having to establish vanishing points and measure lines
- I. Picture plane — Projection plane of the plan view of the object being drawn
- J. Station point — Assumed plan view point representing the observer's eye
- K. Symbols (CADD) — Geometry items grouped together in a two-dimensional construction
- L. Symbol library (CADD) — A collection of stored symbols
- M. Vanishing lines — Lines of the object which meet on the vanishing points
- N. Vanishing point — A point on the horizon at which receding parallel lines seem to meet
- O. Vertical measuring line — Part of the object closest to the person viewing the object on which true heights are measured
- P. Visual ray lines — Lines of sight from selected points on the object which pierce the picture plane on their way to the station point

INFORMATION SHEET

II. Types of perspectives (Transparency 1)

- A. One-point perspective — Has only one vanishing point and the frontal plane of the object is parallel to the picture plane

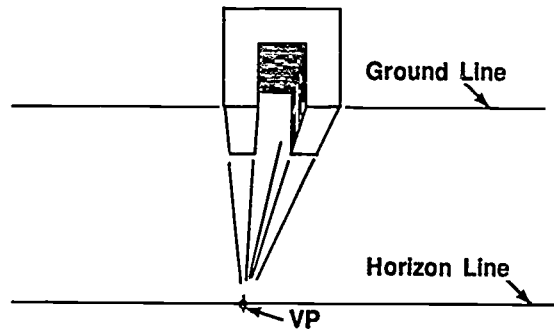

- B. Two-point perspective — Has two vanishing points

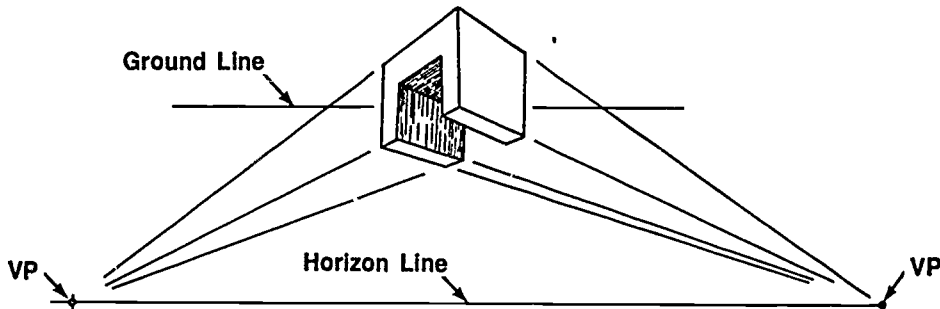

- C. Three-point perspective — Has three vanishing points

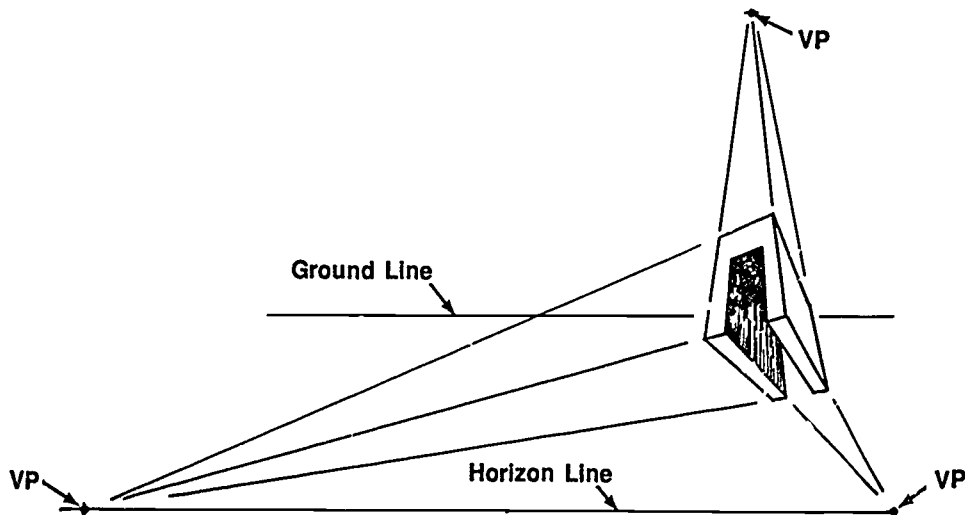

INFORMATION SHEET

III. Difference between perspectives and isometrics

A. Perspectives

1. Method of representing a three-dimensional object as it would appear to the eye.
2. Lines are not in true measure.

B. Isometrics

1. Method of representing a three-dimensional object to show three sides of a part as it appears to sit in space.
2. Lines are drawn to true measurements.
3. Sometimes appear distorted to the human eye.

IV. Types of perspective views (Transparency 2)

A. Above horizon (Worm's eye view)

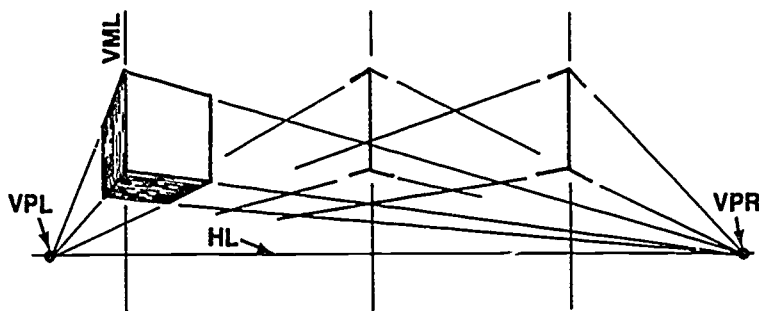

B. Horizon (Man's eye view)

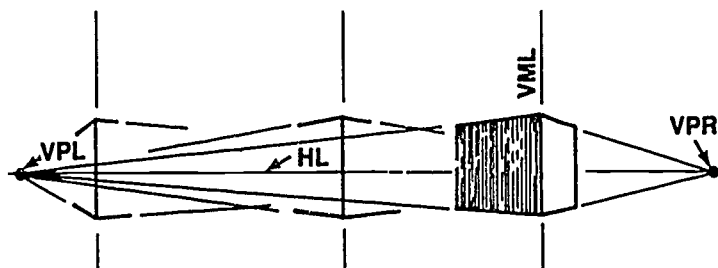

INFORMATION SHEET

C. Below horizon (Bird's eye view)

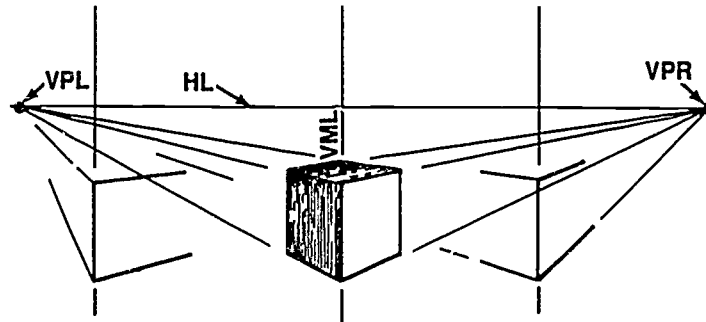

V. Types of perspective equipment

- A. Grids
- B. Board
- C. CADD machine and software

VI. Uses of each type of perspective

- A. One-point — Used to represent the interior of an object
- B. Two-point — Used to represent the exterior of an object
- C. Three-point — Used to represent the exterior of an object

VII. Lines and points in a two-point perspective (Transparency 3)

- A. Picture plane
- B. Horizon, line
- C. Ground line
- D. Visual ray lines
- E. Station point
- F. Vanishing point left
- G. Vanishing point right
- H. Vertical measuring line
- I. Vanishing lines

INFORMATION SHEET

VIII. Perspective terms and their designations (Transparency 3)

- Ground line — GL
- Vanishing points — VP
- Horizon line — HL
- Vanishing point left — VPL
- Picture plane — PP
- Vanishing point right — VPR
- Station point — SP
- Vertical measuring line — VML
- Vanishing lines — VL
- Visual ray lines — VRL

IX. Perspective projection on CADD

- A. Creating a perspective view on CADD is limited to three-dimensional systems with modeling capabilities.

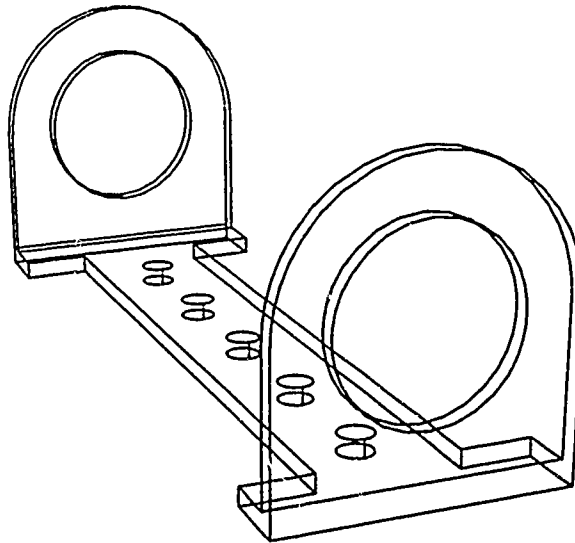

- B. A typical CADD command is "SELECT PERSPECTIVE."
- C. The perspective command on CADD temporarily distorts the part so that it can be viewed in perspective.
- D. The part is scaled in proportion to its distance to the viewer.
- E. The default station point assumes the part to be in the center of the CRT, but may be user-specified.
- F. The distance between the station point and the picture plane may be specified.

INFORMATION SHEET

- X. Types of CADD drawings created from library parts**
- A. Schematics
 - B. Charts
 - C. Flow diagrams
 - D. Other types of pictorial representation
- XI. CADD library parts and symbols**
- A. Library parts are made as a part and stored in a parts library by a copy command.
 - B. Library parts may be repeated on a drawing.
 - C. Library parts may be user-created or come with the original CADD software.
 - D. Library symbols may be called up as a part or selected from a menu of library parts.
 - E. Library parts increase productivity in the creation of a CADD drawing.

862

Types of Perspectives

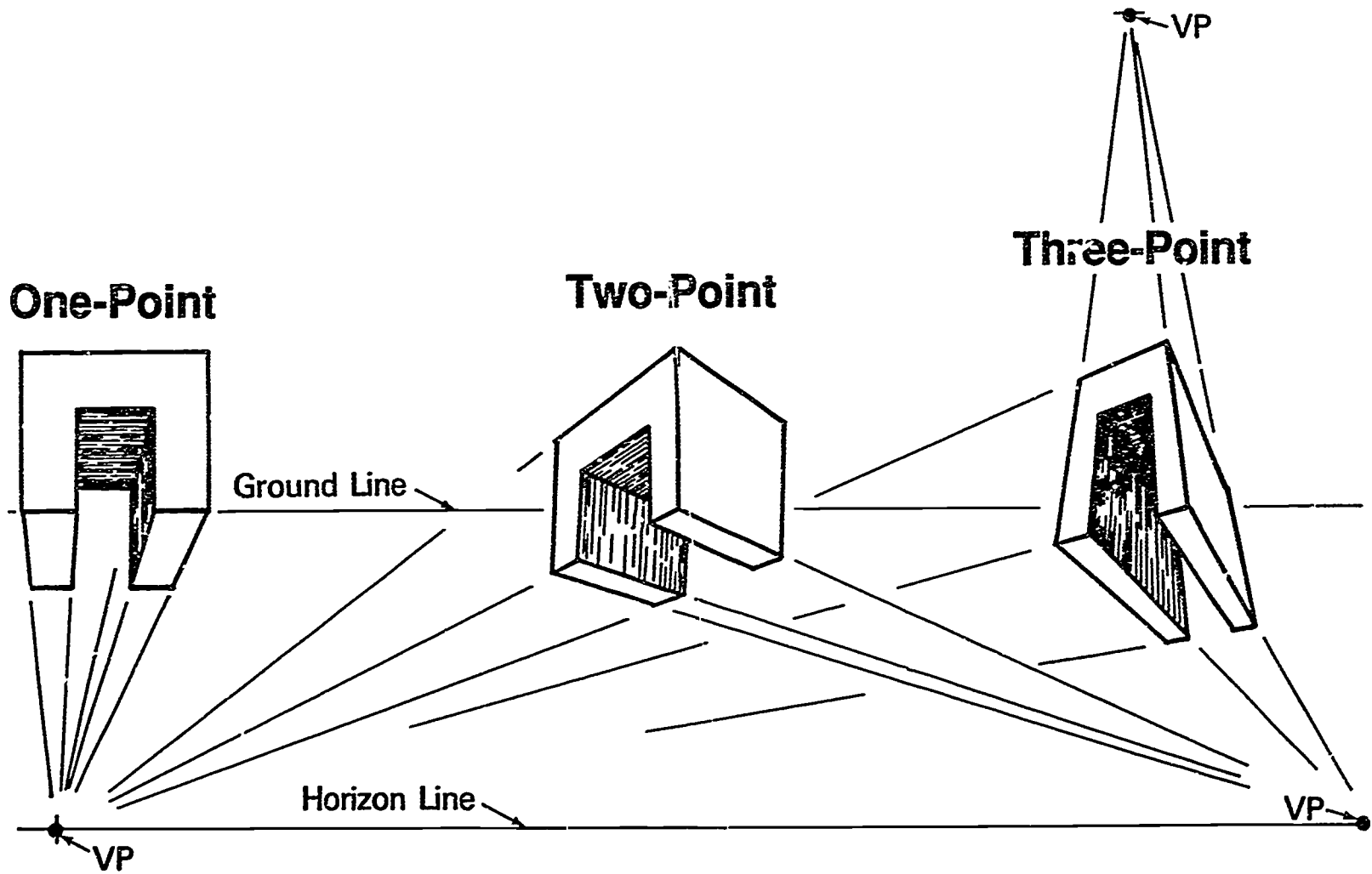

863

864

Perspective Views

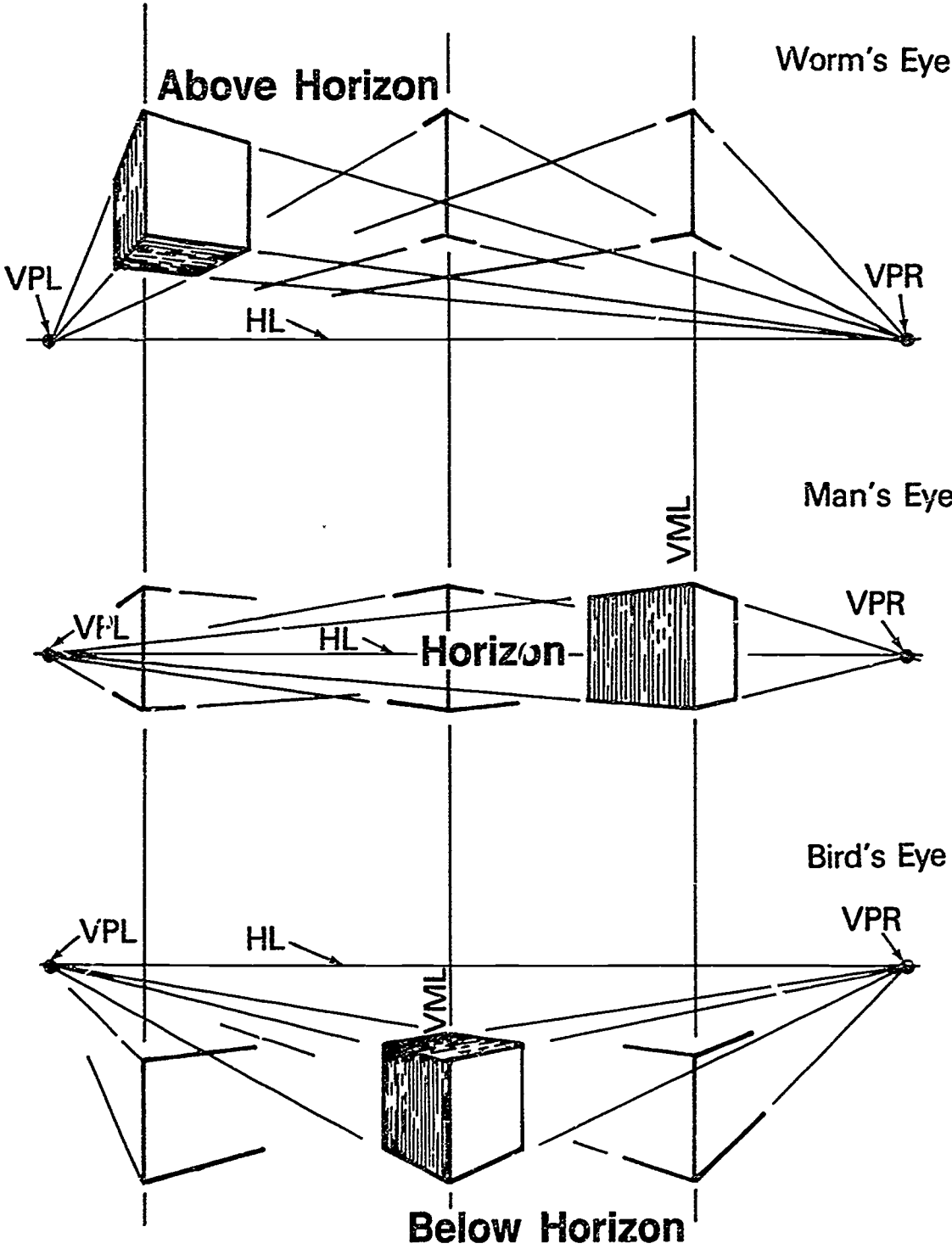

Two-Point Perspective

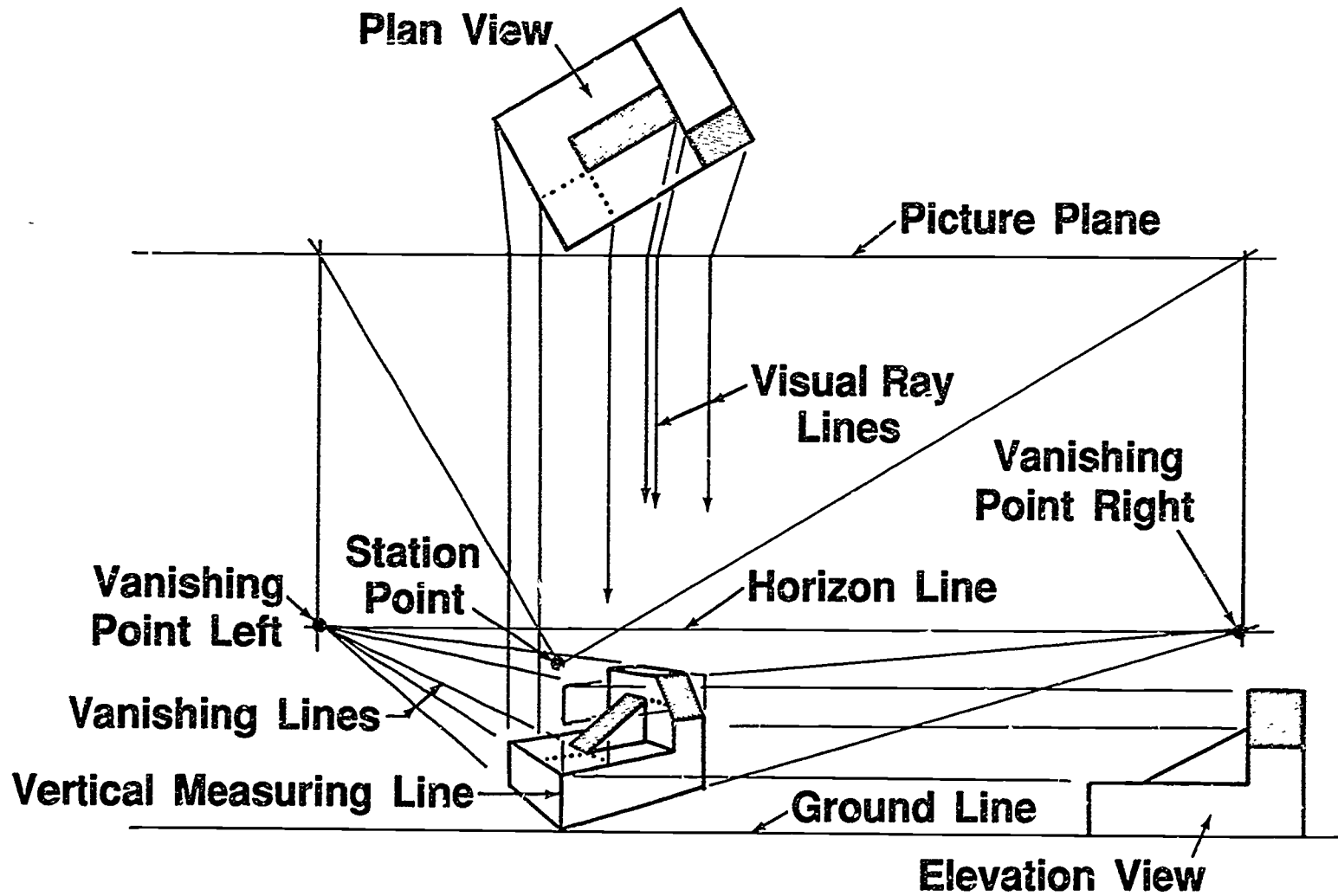

PERSPECTIVES UNIT XVI

ASSIGNMENT SHEET #1 — SKETCH A ONE-POINT PERSPECTIVE

NAME _____ SCORE _____

Directions: Study the following example and then complete the assigned problem.

VP
+

Example:

1. Take the object, block in a front view, and select a vanishing point.

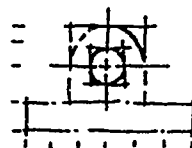

2. Sketch all the receding lines to the vanishing point.

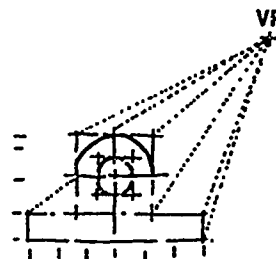

3. Estimate the depth of the object and sketch in the back portion of the object.

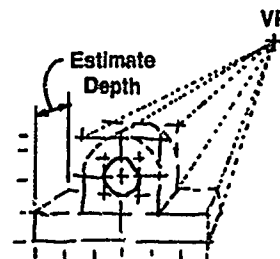

4. Use an artgum eraser to dim construction lines and darken in visible lines.



ASSIGNMENT SHEET #1

Problem: Sketch a one-point perspective of the following object.

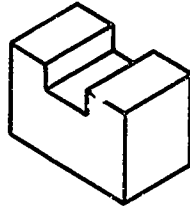

859

**PERSPECTIVES
UNIT XVI**

ASSIGNMENT SHEET #2 — SKETCH A TWO-POINT PERSPECTIVE

NAME _____ SCORE _____

Directions: Study the following example and then complete the assigned problem.

Example:

1. Sketch the front corner of the object in the true height.

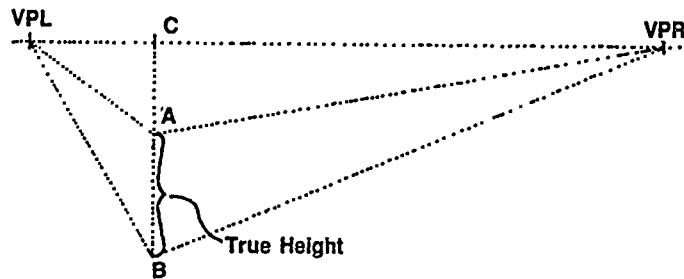

2. Locate the VPL and VPR on the horizon line.
(NOTE: The distance to the horizon line may vary.)
3. Estimate the depth and width of the object.

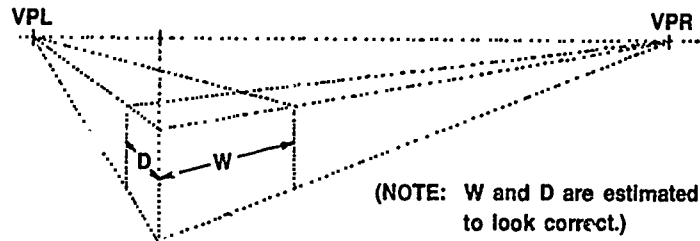

4. Block in all detail of remaining items.
(NOTE: Most lines will go to either the VPL or VPR.)

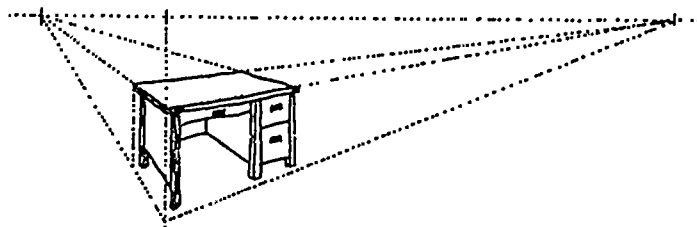

ASSIGNMENT SHEET #2

5. Use an artgum eraser to dim construction lines and darken in visible line.

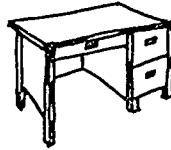

Problem: Sketch a two-point perspective of the following object.

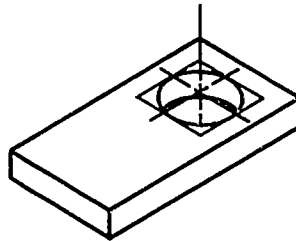

**PERSPECTIVES
UNIT XVI****ASSIGNMENT SHEET #3 — CONSTRUCT A ONE-POINT PERSPECTIVE**

NAME _____ SCORE _____

Directions: Study the following example and the accompanying illustration on the next page, and then complete the assigned problems.

Example:

1. Construct the picture plane near the top of the vellum.
(NOTE: Provide space for the plan view.)
2. Construct one plane of the object on the picture plane so it will be drawn in its true size and shape. Then complete the plan view.
3. Locate the station point far below to the left or right of the plan view.
(NOTE: The visual ray lines that will enclose the object on an angle should not be greater than 30° .)
4. Construct the horizon line near the station point.
5. Construct the ground line below the horizon line.
(NOTE: Provide enough distance between ground line and horizon line for elevation view.)
6. Construct the bottom of the elevation view on the ground line at the left or right side of vellum.
7. Project a line from station point above to intersect horizon line.
(NOTE: This will provide the vanishing point.)
8. Construct lines from station to the corners of the plan view.
9. Construct vertical lines downward where these lines intersect the picture plane.
10. Project horizontal lines from the elevation view to intersect the vertical lines from plan view.
11. Connect all points of intersection.
(NOTE: Corners and the required shape of the one-point perspective will now be formed.)

ASSIGNMENT SHEET #3

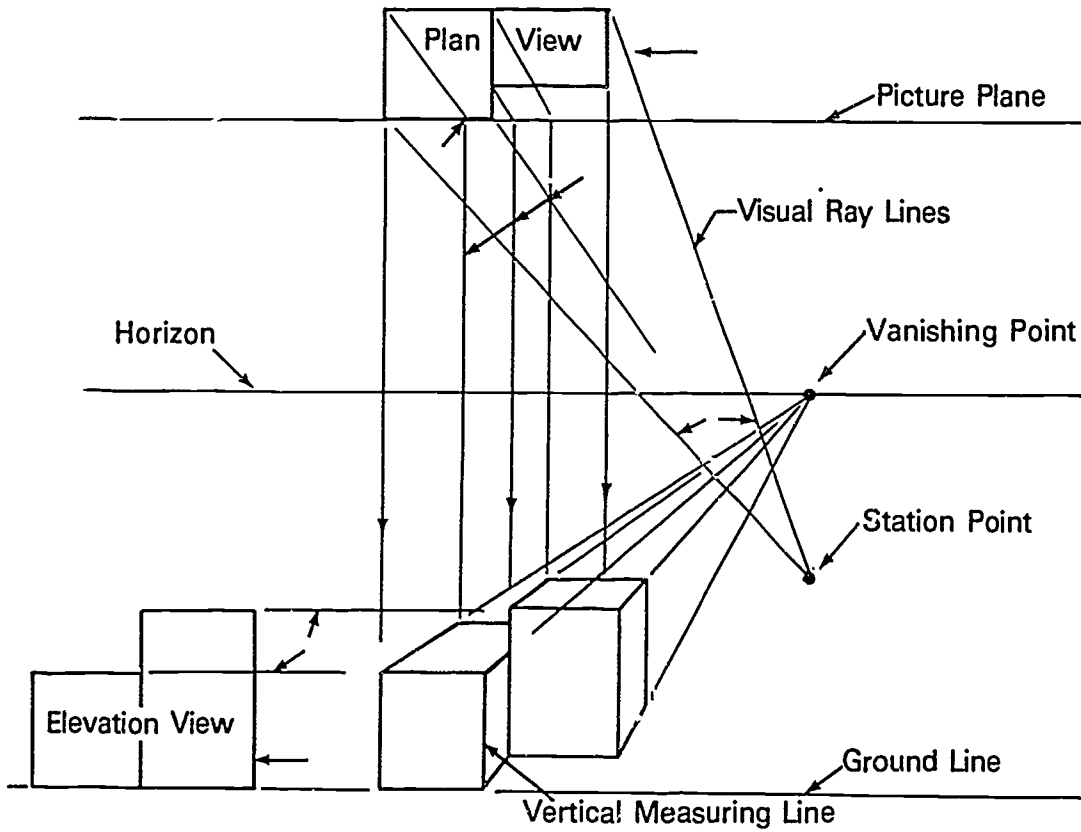

873

ASSIGNMENT SHEET #3

Directions: Construct a one-point perspective on media recommended by instructor with standard borders and title block for the following problems.

Problem A:

Problem B:

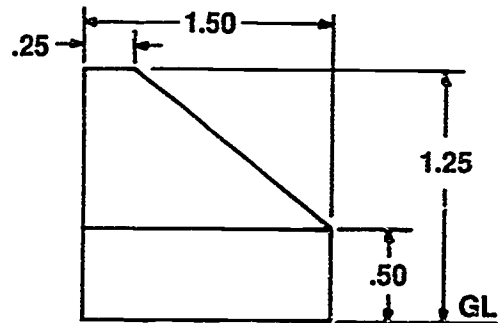
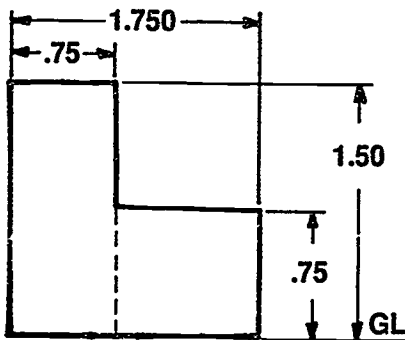
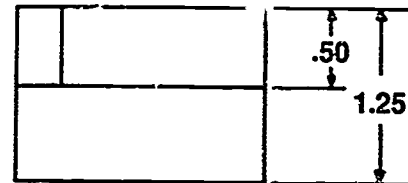
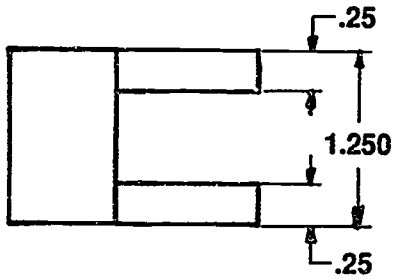

**PERSPECTIVES
UNIT XVI**

ASSIGNMENT SHEET #4 — CONSTRUCT A TWO-POINT PERSPECTIVE

NAME _____ SCORE _____

Directions: Study the following example and then complete the assigned problems.

Example:

1. Construct the picture plane near the top of the vellum.
(NOTE: Provide space for the plan view.)
2. Construct the plan view of the object so that the corner touches the picture plane.
(NOTE: Rotation should not be more than 30° .)
3. Locate the station point below and far enough in front of the picture plane.
(NOTE: A short distance will give a distorted view. It should be above the elevation view.)
4. Construct the horizon line near the station point.
5. Construct the ground line below the horizon line.
(NOTE: Provide enough distance between ground line and horizon line for elevation view.)
6. Construct the bottom of the elevation view on the ground line.
7. Construct parallel lines parallel to edges of plan view from station point to intersect picture plane.
(NOTE: The included angle between these lines is 90° .)
8. Construct perpendicular lines from picture plane intersection to horizontal line.
(NOTE: This will locate the two vanishing points for the perspective.)
9. Construct lines from corners of the object to station point piercing with picture plane.
10. Construct horizontal lines from corners of elevation view to vertical measuring line; from these intersections construct lines to vanishing points.
(NOTE: These lines are the heights of the perspective.)
11. Construct vertical lines from picture plane to intersect vanishing lines.
(NOTE: This represents the perspective box of the object.)

ASSIGNMENT SHEET #4

12. Proceed in the following order to cut out the box or find a point in the object:
- Construct heights of the object in the perspective and then project to vanishing points to form edges of a plan in the box.
 - Construct a line from a point or cut to near edges of the plan view. Then project picture plane to the lines just drawn on the perspective, and then to the vanishing points.

(NOTE: Their intersection is the end of cut or point.)

13. Proceed in the following order to find any true height not in the picture plane:
- Construct a line from a point not on the picture plane parallel to plan view lines to the picture plane.
 - Project this line to the ground line.
 - Project the height of the point from elevation view to intersect this line; from these intersections project to vanishing point.

(NOTE: This is the true height of the point in the perspective.)

14. Connect all points of intersection.

(NOTE: The corners and required shape of the two-point perspective will then be formed.)

Problems: Construct two-point perspectives for the following problems.

Problem A:

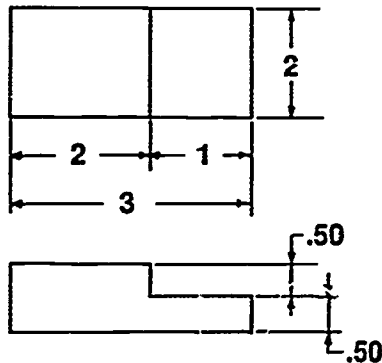

Problem B:

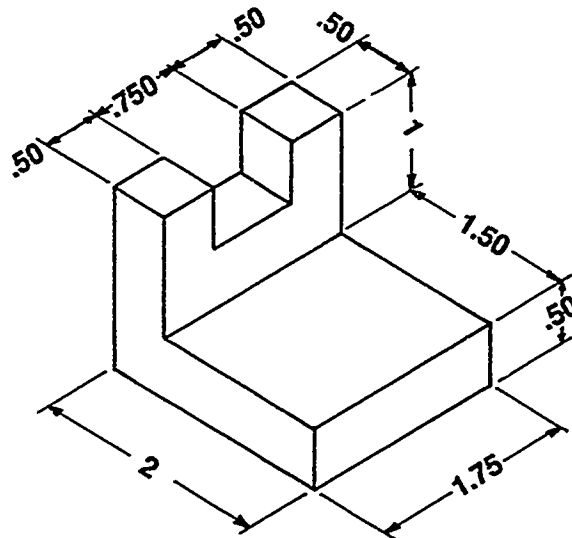

ASSIGNMENT SHEET #4

Problem C:

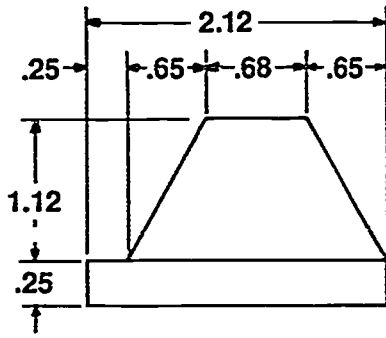
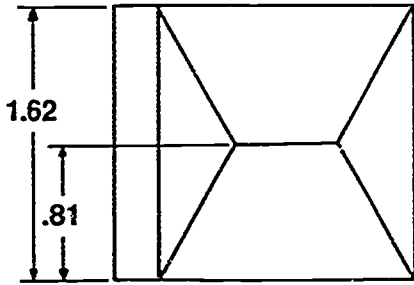

PERSPECTIVES UNIT XVI

ASSIGNMENT SHEET #5 — CONSTRUCT CURVES IN A PERSPECTIVE

NAME _____ SCORE _____

Directions: Study the following example and the accompanying illustration, and then complete the assigned problems.

Example:

1. Construct a perspective of an object. Refer to previous assignment sheets for help in constructing perspectives.
2. Construct a square grid on the elevation and plan views.
3. Construct a grid in perspective for perspective view.
4. Project horizontal lines to intersect in perspective from common points in plan and elevation views.
5. Connect the intersecting of lines in perspective with irregular curve or template to form curve.

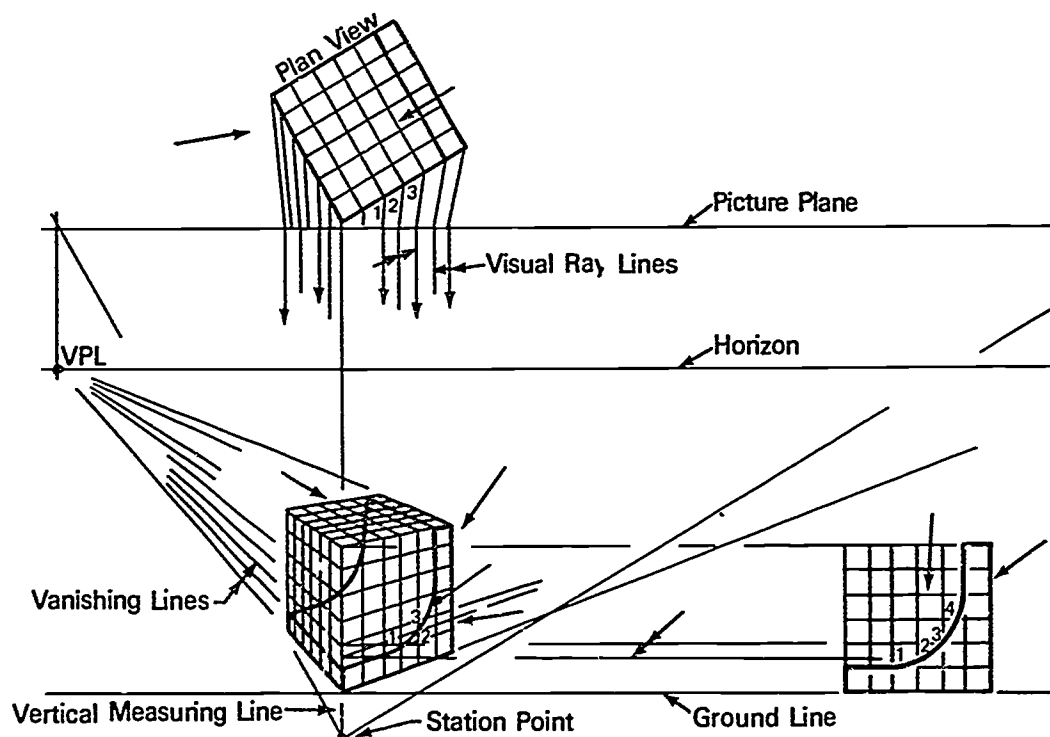

ASSIGNMENT SHEET #5

Problems: Construct curves in perspectives for the following problems.

Problem A:

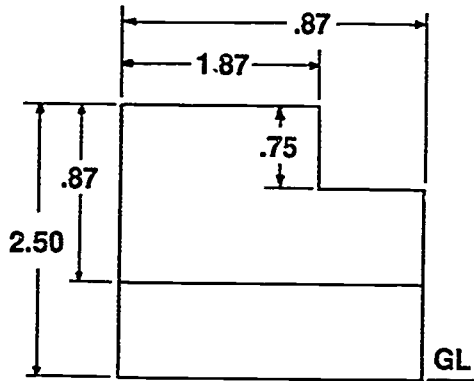
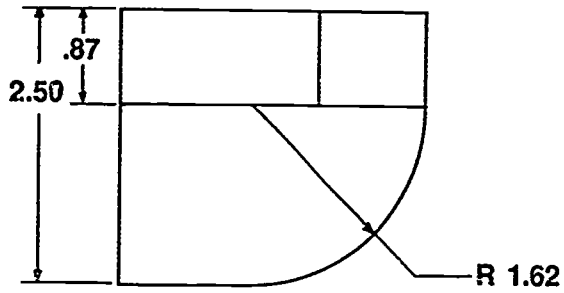

Problem B:

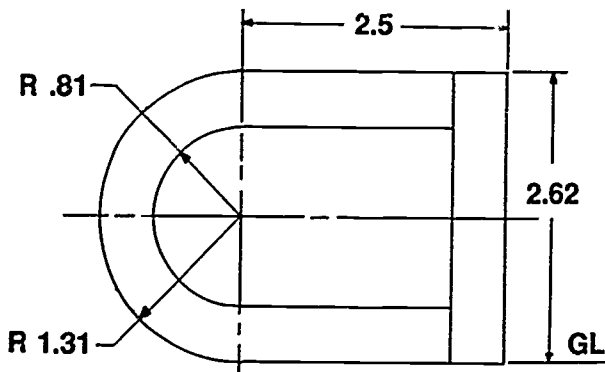

879

**PERSPECTIVES
UNIT XVI**

TEST

NAME _____ SCORE _____

1. Match the terms on the right with their correct definitions.

- | | | | |
|----------|---|-----|-------------------------|
| _____ a. | Part of the object closest to the person viewing the object on which true heights are measured | 1. | Delineation |
| _____ b. | Eye level of the person viewing the drawing and the line on which the vanishing points are located | 2. | Diagram (CADD) |
| _____ c. | Bottom of the object being drawn | 3. | Figure (CADD) |
| _____ d. | Has variety of scales and permits direct reading for layout of perspectives | 4. | Ground line |
| _____ e. | Projection plane of the plan view of the object being drawn | 5. | Horizon line |
| _____ f. | Assumed plan view point representing the observer's eye | 6. | Perspective |
| _____ g. | Lines of the object which meet on the vanishing points | 7. | Perspective board |
| _____ h. | Pictorial drawing made by the intersection of the picture plane with lines of sight meeting from points on the object to the point of sight | 8. | Perspective grid |
| _____ i. | Lines of sight from selected points on the object which pierce the picture plane on their way to the station point | 9. | Picture plane |
| _____ j. | A collection of CADD library symbols that are stored and used together in a group | 10. | Station point |
| _____ k. | A point on the horizon at which receding parallel lines seem to meet | 11. | Vanishing lines |
| | | 12. | Vanishing point |
| | | 13. | Vertical measuring line |
| | | 14. | Visual ray lines |

TEST

2. Identify the types of perspectives shown below.

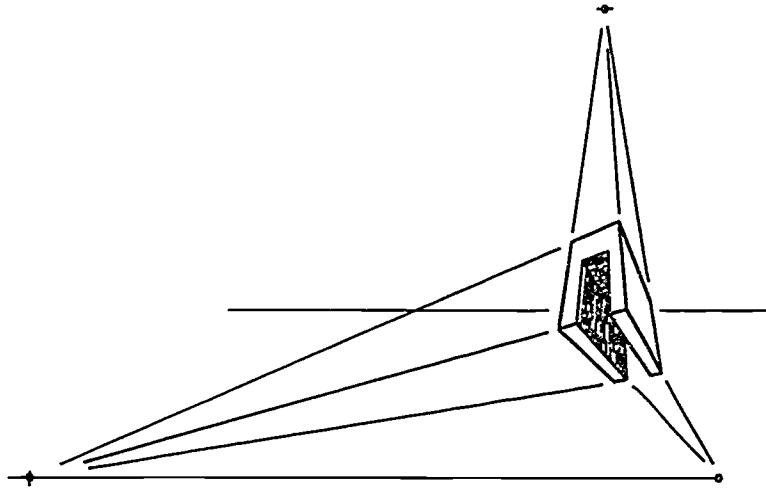

a. _____

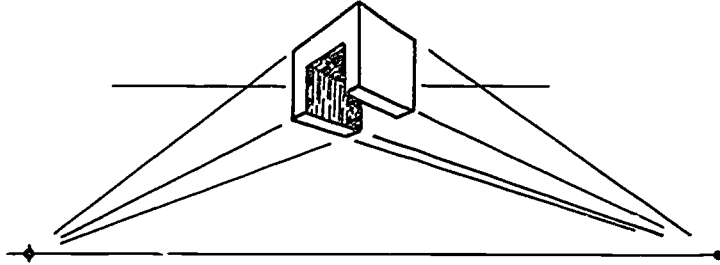
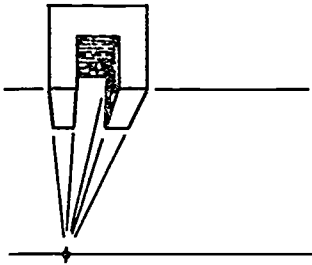

b. _____

c. _____

3. Distinguish between perspectives and isometrics by placing a "P" next to the description(s) of perspectives and an "I" next to those for isometric(s).

- ____ a. Lines are drawn to true measurements.
- ____ b. Lines are not in true measure.
- ____ c. Show three sides of a part as it appears to sit in space.
- ____ d. Show three-dimensional object as it would appear to the eye.

TEST

4. Identify the types of perspective views.

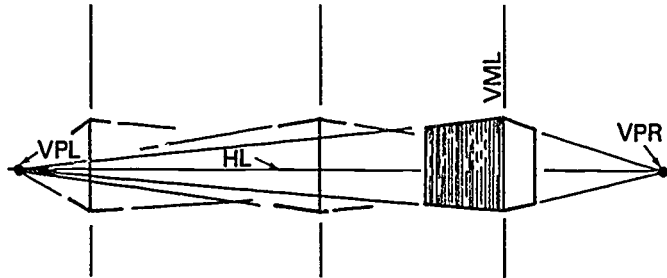

a. _____

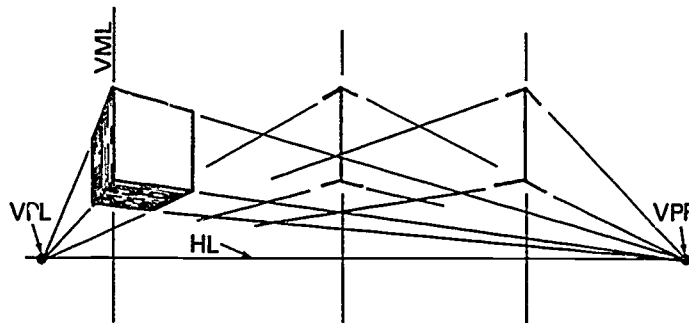

b. _____

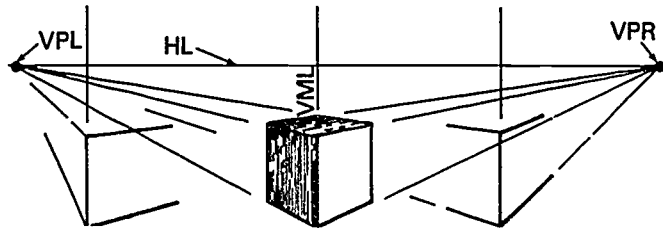

c. _____

5. List three types of perspective equipment.

a. _____

b. _____

c. _____

TEST

6. Distinguish between the types of perspectives and their uses by placing the correct numbers next to the appropriate uses:

- 1 — One-point perspective
- 2 — Two-point perspective
- 3 — Three-point perspective

____ a. Used to represent the exterior of an object

____ b. Used to represent the interior of an object

7. Identify the lines and points in the following two-point perspective.

a. _____

f. _____

b. _____

g. _____

c. _____

h. _____

d. _____

i. _____

e. _____

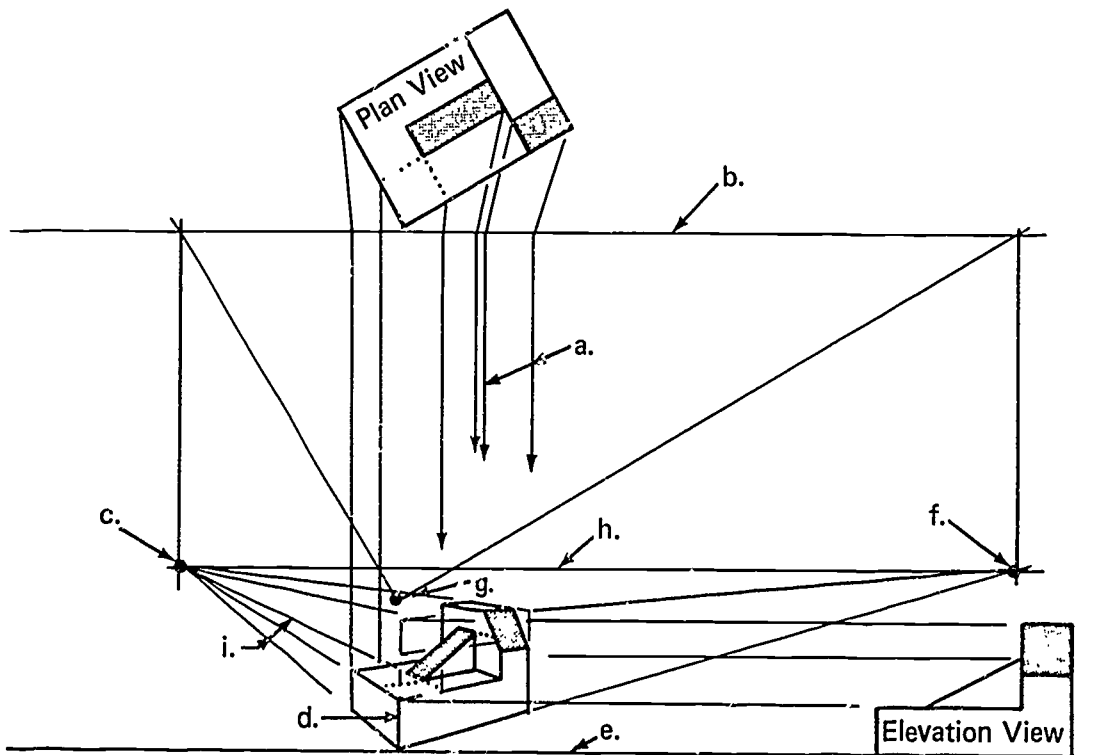

TEST

8. Match the perspective terms on the right with their correct letter designations.

___ a.	PP	1. Horizon line
___ b.	HL	2. Ground line
___ c.	VPL	3. Vanishing point left
___ d.	VL	4. Station point
___ e.	VPR	5. Visual ray lines
___ f.	SP	6. Picture plane
___ g.	VML	7. Vanishing lines
___ h.	VRL	8. Vertical measuring line
___ i.	GL	9. Vanishing point right
___ j.	VP	10. Vanishing points

9. Select true statements concerning perspective projection on CADD by placing a "T" or "F" in the appropriate blanks.

- ___ a. A typical CADD command is "SELECT PERSPECTIVE."
- ___ b. The default station point assumes the part to be in the upper right hand corner of the CRT.
- ___ c. Creating a part in perspective on CADD is limited to three-dimensional systems with modeling capabilities.
- ___ d. The distance between the station point and the picture plane is always a fixed distance on CADD and cannot be changed.

10. List two types of CADD drawings created from library parts.

- a. _____
- b. _____

TEST

11. Select true statements about CADD library parts and symbols by placing a "T" or "F" in the appropriate blanks.
- a. Library parts slow down the production of a CADD drawing.
 - b. Library parts may be created by the user.
 - c. Library parts can only be used off of a menu.
 - d. Library parts are made as a part and stored in a parts library by a delete command.

(NOTE: If the following activities have not been accomplished prior to the test, ask your instructor when they should be completed.)

- 12. Sketch a one-point perspective. (Assignment Sheet #1)
- 13. Sketch a two-point perspective. (Assignment Sheet #2)
- 14. Construct a one-point perspective. (Assignment Sheet #3)
- 15. Construct a two-point perspective. (Assignment Sheet #4)
- 16. Construct curves in a perspective. (Assignment Sheet #5)

PERSPECTIVES
UNIT XVI

ANSWERS TO TEST

- | | | | | |
|----|----|---------------------------|----|-----------------------|
| 1. | a. | 13 | g. | 11 |
| | b. | 5 | h. | 6 |
| | c. | 4 | i. | 14 |
| | d. | 7 | j. | 2 |
| | e. | 9 | k. | 12 |
| | f. | 10 | | |
| 2. | a. | Three-point | | |
| | b. | One-point | | |
| | c. | Two-point | | |
| 3. | a. | I | | |
| | b. | P | | |
| | c. | I | | |
| | d. | P | | |
| 4. | a. | Horizon | | |
| | b. | Above horizon | | |
| | c. | Below horizon | | |
| 5. | a. | Grids | | |
| | b. | Board | | |
| | c. | CADD machine and software | | |
| 6. | a. | 2 or 3 | | |
| | b. | 1 | | |
| 7. | a. | Visual ray lines | f. | Vanishing point right |
| | b. | Picture plane | g. | Station point |
| | c. | Vanishing point left | h. | Horizon line |
| | d. | Vertical measuring line | i. | Vanishing lines |
| | e. | Ground line | | |
| 8. | a. | 6 | f. | 4 |
| | b. | 1 | g. | 8 |
| | c. | 3 | h. | 5 |
| | d. | 7 | i. | 2 |
| | e. | 9 | j. | 10 |

ANSWERS TO TEST

9. a. T
b. F
c. T
d. F
10. Any two of the following:
a. Schematics
b. Chart
c. Flow diagrams
d. Other types of pictorial representation
11. a. F
b. T
c. F
d. F
- 12.-16. Evaluated to the satisfaction of the instructor

**DIMENSIONING
UNIT XVII****UNIT OBJECTIVE**

After completion of this unit, the student should be able to correctly dimension various objects and features on standard and CADD drawings. Competencies will be demonstrated by completing the assignment sheets, job sheet, and the unit test with a minimum score of 85 percent.

SPECIFIC OBJECTIVES

After completion of this unit, the student should be able to:

1. Match terms related to dimensioning with the correct definitions.
2. Distinguish between size description and shape description.
3. Differentiate between the types of dimensions.
4. Identify the systems of placing dimensions.
5. State the meanings for common abbreviations used in dimensioning.
6. Match common symbols used in dimensioning with their names.
7. Identify four basic types of lines used in dimensioning.
8. Differentiate between correct and incorrect placement of leader lines.
9. Select true statements concerning the proper techniques for drawing arrowheads.
10. Distinguish between the two systems for writing dimensional values.
11. Select true statements concerning rules for dimensional figures.
12. Select true statements concerning rules for placement of dimensions.
13. Arrange in order the steps in applying dimensions to an object.
14. Select types of finish marks.
15. Select true statements concerning rules for finish marks.
16. Distinguish between the types of notes used on a drawing.
17. Select true statements concerning rules for notations.
18. List ways to avoid superfluous dimensions.

SPECIFIC OBJECTIVES

19. Identify common machine manufactured features.
20. Select true statements concerning rules for dimensioning common machine manufactured features.
21. Distinguish between two typical CADD commands used to change linetypes.
22. Select true statements concerning dimensioning on a CADD system.
23. List the two steps for inserting dimensions on CADD.
24. Construct arrowheads. (Assignment Sheet #1)
25. Dimension arcs. (Assignment Sheet #2)
26. Dimension angles. (Assignment Sheet #3)
27. Dimension curves. (Assignment Sheet #4)
28. Dimension rounded end shapes and slotted holes. (Assignment Sheet #5)
29. Dimension spherical objects. (Assignment Sheet #6)
30. Dimension cylindrical objects. (Assignment Sheet #7)
31. Dimension cones, pyramids, and prisms. (Assignment Sheet #8)
32. Dimension features on a circular center line. (Assignment Sheet #9)
33. Dimension theoretical points of intersection. (Assignment Sheet #10)
34. Dimension an object using a rectangular coordinate system. (Assignment Sheet #11)
35. Dimension an object using a polar coordinate system. (Assignment Sheet #12)
36. Dimension an object using a tabular coordinate system. (Assignment Sheet #13)
37. Dimension an object using an ordinate dimensioning system. (Assignment Sheet #14)
38. Dimension common machine manufactured features. (Assignment Sheet #15)
39. Demonstrate the ability to apply dimensions to CADD drawings. (Job Sheet #1)

**DIMENSIONING
UNIT XVII****SUGGESTED ACTIVITIES**

- A. Provide student with objective sheet.
- B. Provide student with information and assignment sheets.
- C. Make transparencies.
- D. Discuss unit and specific objectives.
- E. Discuss information and assignment sheets.
- F. Arrange for the test to be presented one half at a time to facilitate its length.
- G. Have file drawings or working drawings available to demonstrate dimensioning to the class.
- H. Display and have readily available for students a copy of *ANSI Y14.5M-1982* specifications for dimensioning.
- I. Demonstrate the dimensioning procedure for your CADD system.
- J. Display samples of the line fonts available on your CADD system.
- K. Give test.

REFERENCES USED IN DEVELOPING THIS UNIT

- A. Brown, Walter C. *Drafting for Industry*. South Holland, IL: Goodheart-Willcox Co., Inc., 1984.
- B. Spencer, Henry C., et al. *Technical Drawing Problems*. New York: Macmillan Publishing Co., 1980.
- C. Giesecke, Frederick E., et al. *Technical Drawing*, 8th ed. New York: Macmillan Publishing Co., Inc., 1986.
- D. Jensen, Cecil and Jay Helsel. *Engineering Drawing and Design*, 3rd ed. New York: Gregg Division/McGraw-Hill Book Co., 1985.
- E. Oberg, Erik, et al. *Machinery's Handbook*, 23rd ed. New York: Industrial Press, 1988.
- F. *ANSI Y14.5M-1982 — Dimensioning and Tolerancing*. New York: American Society of Mechanical Engineers.
- G. Lamit, Louis & Vernon Paige. *Computer-Aided Design and Drafting*. Columbus, OH: Merrill Publishing Co., 1987.

**DIMENSIONING
UNIT XVII****INFORMATION SHEET****I. Terms and definitions**

- A. Actual size — Measured size of an object
- B. Associative dimensioning — The means by which a CADD dimensioning program automatically updates the dimensions as the geometry changes
- C. Automatic dimensioning — The CADD system computes the dimensions and automatically places dimensions, extension lines, and arrowheads where required
- D. Bevel — A slanted fiat surface not at 90° to another surface
- E. Blind hole — A hole not drilled all the way through
- F. Bore — To enlarge a hole with a boring bar or tool in a lathe, drill press, or boring mill
- G. Boss — A raised flat, cylindrical surface providing a flat surface for bolts
- H. Chamfer — A slight bevel removed from an edge
- I. Counterbore — An enlargement of the end of a hole to a specified diameter and depth
- J. Counterdrill — A second, larger drill along the same center line as a first drill, but not as deep
- K. Countersink — A funnel-like bevel at the surface end of a drilled hole; standard included angle is 82°
- L. Datum — Points, lines, or other geometric shapes assumed to be exact from which the location or geometric features of a part may be established
- M. Die — A tool used to cut external threads
- N. Drill — A tool with a pointed cutting edge used to make a hole in hard surfaces
- O. Finish mark — A symbol used to indicate a surface to be machined
- P. Knurl — The process of rolling depressions in the surface of an object
- Q. Nominal — Designated or theoretical size that may vary from the actual size
- R. Radial — Moving along a radius

INFORMATION SHEET

- S. Ream — To enlarge a finished hole slightly to a very precise diameter with a reamer
- T. Relief groove — A shallow groove that allows for a thread relief
- U. Reference dimension — A dimension used for information purposes only; does not govern production or inspection operations
- V. Spot face — A machined circular spot on the surface of a part to provide a flat bearing surface for a bolt head
- W. Superfluous — Exceeding what is sufficient or necessary
- X. Tabular — Set up in rows and columns, by means of a table
- Y. Tap — A tool used to cut internal threads
- Z. Taper — A gradual decrease or change of diameter from one end to the other

II. Size and shape descriptions (Transparency 1)

- A. Size description — Notes and dimensions that tell the size of an object
- B. Shape description — Views that illustrate the shape of an object

III. Types of dimensions (Transparency 1)

- A. Size dimension — Tells how large or small an object is
- B. Location dimension — Locates a feature on an object

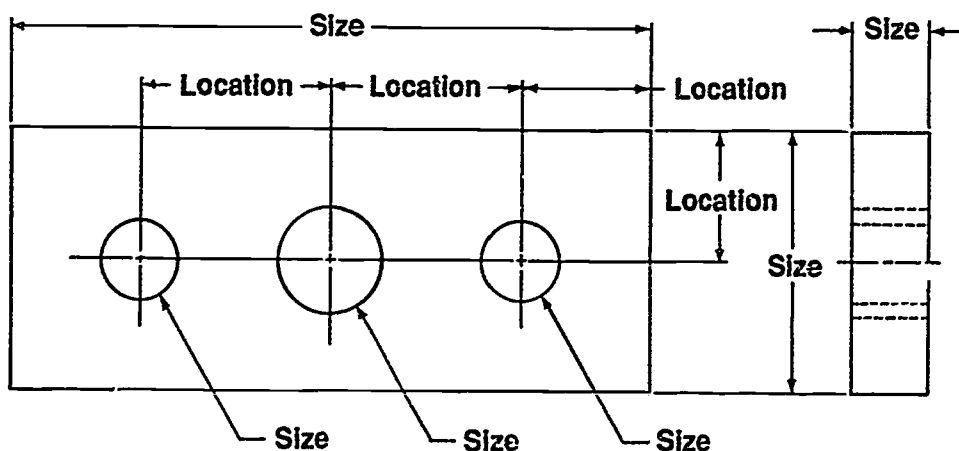

INFORMATION SHEET

IV. Systems of placing dimensions (Transparency 2)

- A. Aligned system — All dimension figures are aligned with the dimension lines so that they may be read from the bottom or from the right side of the sheet.

(NOTE: Dimensions and notes shown with leader lines are aligned with the bottom of the page.)

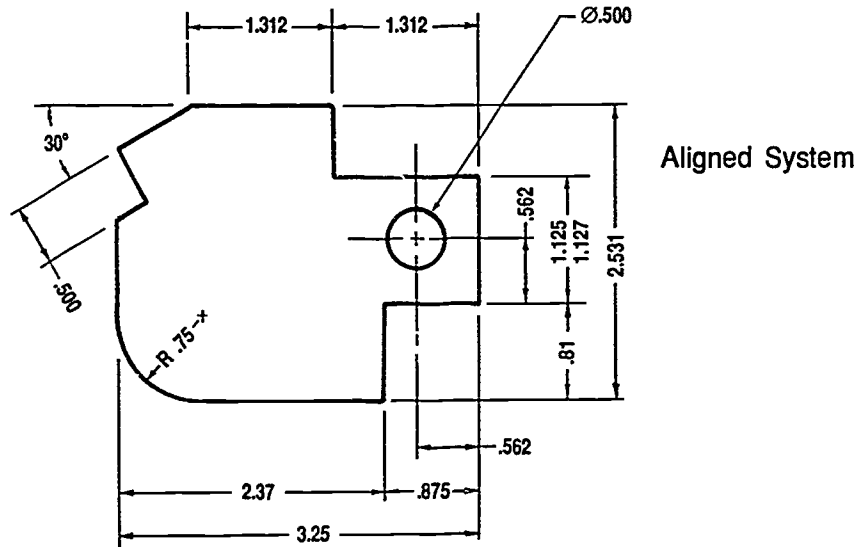

- B. Unidirectional system — All dimension figures and notes are lettered horizontally on the sheet and read from the bottom of the drawing.

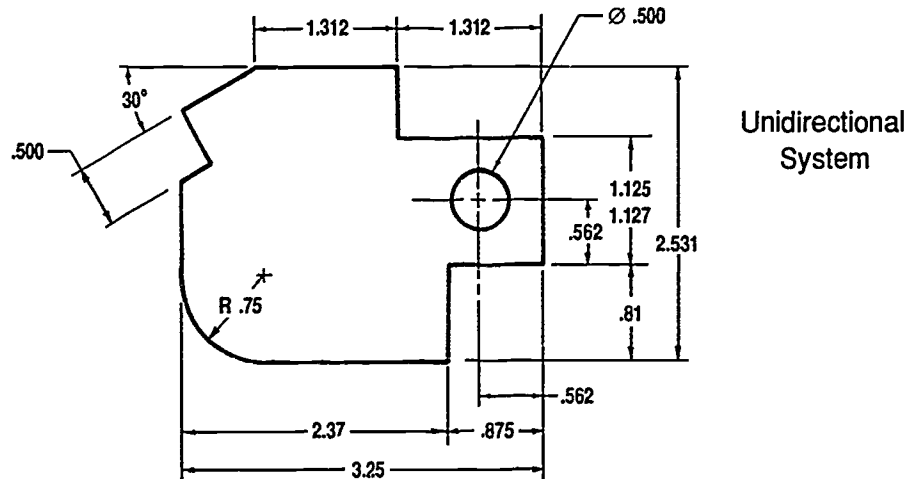

INFORMATION SHEET

V. Common abbreviations used in dimensioning (Handout #1)

- ANSI — American National Standards Institute
- ASSY — Assembly
- BEV — Bevel
- B/M — Bill of materials
- BC — Bolt circle
- CI — Cast iron
- CS — Cast steel
- CL — Center line
- C to C — Center to center
- CHAM — Chamfer
- CRS — Cold-rolled steel
- CBORE — Counterbore
- CDRILL — Counterdrill
- CSK — Countersink
- DEG — Degree
- DIA — Diameter
- DIM — Dimension
- DWG — Drawing
- FAO — Finish all over
- ID — Inside diameter
- KST — Keyseat
- KWY — Keyway
- LH — Left hand
- MATL — Material
- MIL-STD — Military standard
- OD — Outside diameter
- RAD — Radius
- SAE — Society of Automotive Engineers
- SF — Spot-face
- THD — Thread
- TOL — Tolerance

(NOTE: Refer to Handout #1 and *ANSI Y1.1-1972, R1984* for other standard abbreviations.)

INFORMATION SHEET

VI. Common symbols used in dimensioning

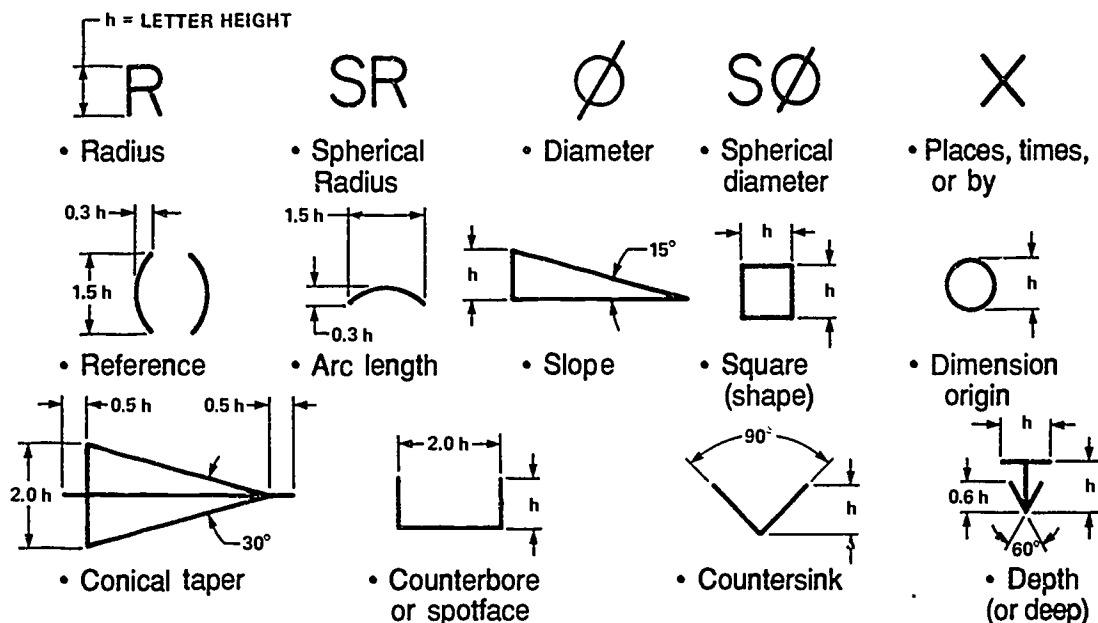

From ANSI Y14.5M-1992(R1988). Reprinted with permission of ASME.

VII. Basic types of lines used in dimensioning

- A. Dimension line — A line, with arrowheads, that shows the direction and length of what is being measured

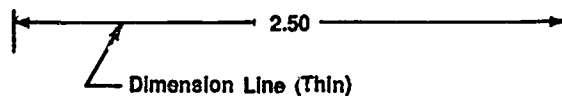

- B. Extension line — A line used to indicate the extension of a surface or a point to a location outside the part outline

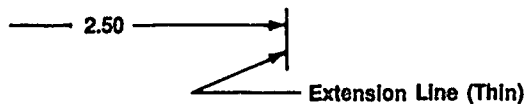

- C. Center line — A line used to indicate the center of a cylindrical feature

(NOTE: Center lines are used as extension lines but never as dimension lines.)

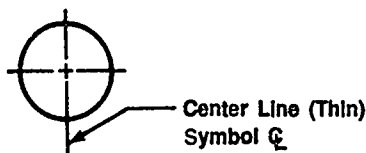

INFORMATION SHEET

- D. Leader line — A thin solid line that "leads" from a note or dimension and is terminated by an arrowhead touching the part to which attention is directed.

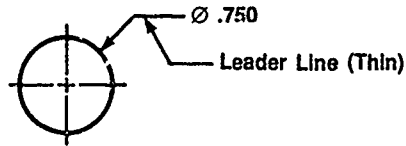

VIII. Placement of leader lines

- A. Leader lines are always inclined lines from the feature at an angle of 60° or 45° from the horizontal.

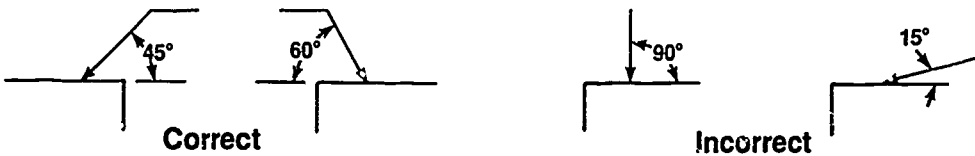

- B. Leader lines should end with a short shoulder preceding the note or dimension.

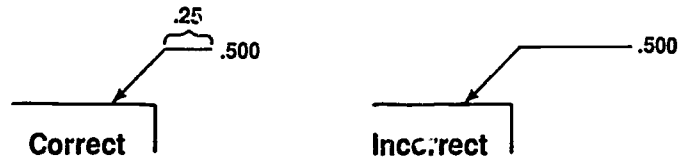

- C. Dimensions are specified individually to avoid complicated leaders.

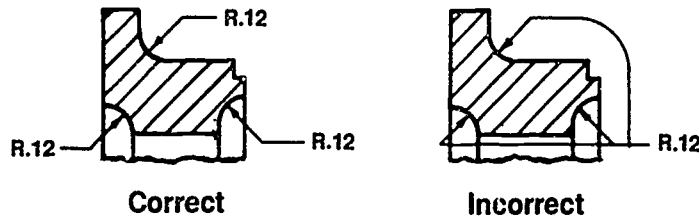

INFORMATION SHEET

- D. If too many leaders would impair the legibility of the drawing, letter symbols should be used to identify features.

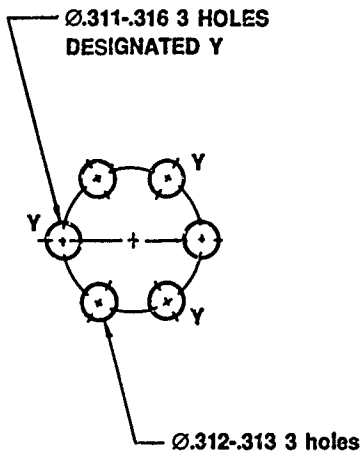

Correct

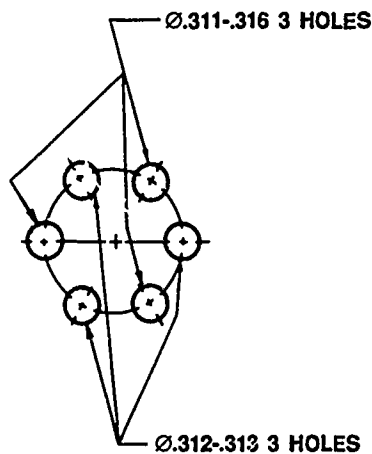

Incorrect

- E. Where a leader is directed to a circle or arc, its direction should be toward the center.

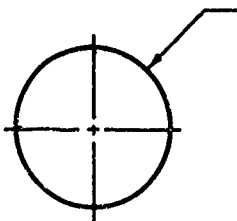

Correct

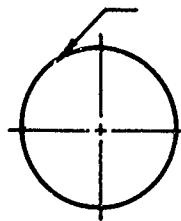

Incorrect

INFORMATION SHEET

IX. Drawing arrowheads (Transparency 3)

- A. Arrowheads are drawn with two sharp strokes toward or away from the point.
- B. Length will vary depending on size of drawing, but width should always be 1/3 of the length.

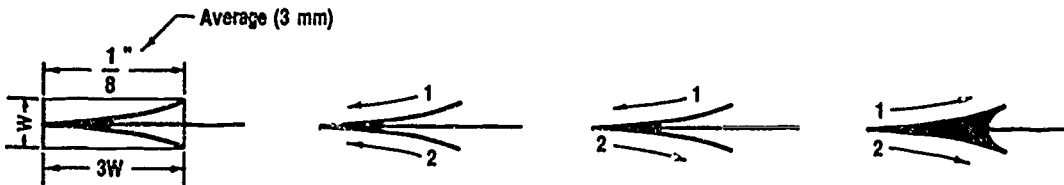

(NOTE: Arrowhead templates are available to aid in consistent applications of arrowheads.)

- C. Arrowheads always touch extension lines.
- D. Arrowheads are reversed and placed outside the extension lines when space for the dimension is too small.

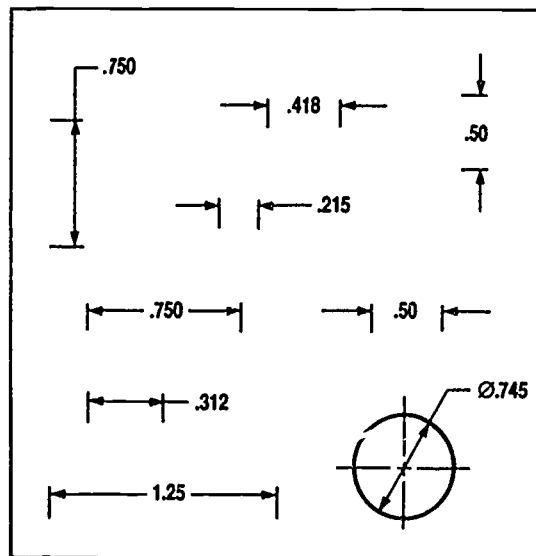

From ANSI Y14.5M-1982(R1988). Reprinted with permission of ASME.

INFORMATION SHEET

X. Systems of writing dimensional values

- A. U.S. Customary — Uses the inch as the basic unit
1. Fractional — Uses inches and fractions of an inch ($\frac{1}{4}$, $\frac{1}{2}$, etc.)
 2. Decimal — Uses inches and decimal inches (1.25, .75, etc.)
- (NOTE: The decimal inches are compatible with the calibrations of many machine tool controls and numerically-controlled machines.)
- B. Metric — Based on "The International System of Units" where the millimeter is the basic linear unit of measure

XI. Rules for dimensional figures

(NOTE: Decimal dimensioning shall be used on drawings except where certain commercial commodities are identified.)

- A. All lettering, letters, and numerals must be perfectly legible.
- B. Numerals should be large enough to be easily read; standard height is $\frac{5}{32}$ ".
- C. Inch marks (") are omitted unless a dimension may be misunderstood; thus, \varnothing 1" should be written \varnothing 1.00.
- D. Fractions are two times the height of whole numbers.
- E. The fraction bar is always in line with the dimension line. The fraction bar is never drawn at an angle.

(NOTE: An exception to this may be made in crowded places, such as parts lists, but never in dimensioning on a view.)

- F. The numerator and denominator of a fraction should never touch the fraction bar.
- G. Never letter a dimension figure over any line on the drawing. Break the line if necessary.
- H. Make all decimal points bold.
- I. In a group of parallel dimension lines, the numerals should be staggered, not stacked one above the other.

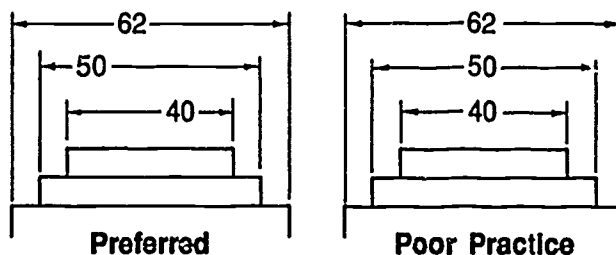

INFORMATION SHEET

- J. A zero is not used before the decimal point for values less than one inch.
- K. A dimension is expressed to the same number of decimal places as its tolerance.

XII Rules for placement of dimensions (Transparency 4)

- A. Each dimension should be given clearly so that it can be interpreted in only one way.
- B. Dimensions should not be duplicated or the same information be given in two different ways. No dimensions should be given except those needed to produce or inspect the part.
- C. Dimensions should be given between points or surfaces that have a functional relation to each other or that control the location of mating parts.
- D. Dimensions should be given to finished surfaces or important center lines in preference to rough surfaces whenever possible.
- E. Dimensions should be so given that it will not be necessary for the machinist to calculate, scale, or assume any dimension.
- F. Dimensions should be attached to the view where the shape is best shown (contour rule).
- G. Dimensions should be placed in the views where the features dimensioned are shown true shape.
- H. Avoid dimensioning to hidden lines wherever possible.
- I. Dimensions should not be placed upon a view unless clearness is promoted and long extension lines are avoided.
- J. Dimensions applying to two adjacent views should be placed between views unless clearness is promoted by placing some of them outside.
- K. The longer dimensions should be placed outside all intermediate dimensions so that dimension lines will not cross extension lines.
- L. Locate all interior features in relation to an outside edge of the part.
- M. Horizontal and vertical center lines may be used as reference datum lines for dimensions.

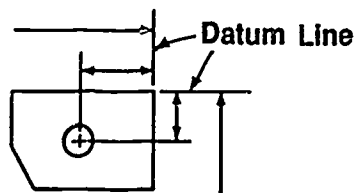

INFORMATION SHEET

- N. Keep dimensions in line and grouped as much as possible.
- O. The space between the first dimension line and the part outline should not be less than .40 (10 mm).
- P. The space between succeeding parallel dimensions should not be less than .25 (6 mm).

(NOTE: These are intended as guidelines.)

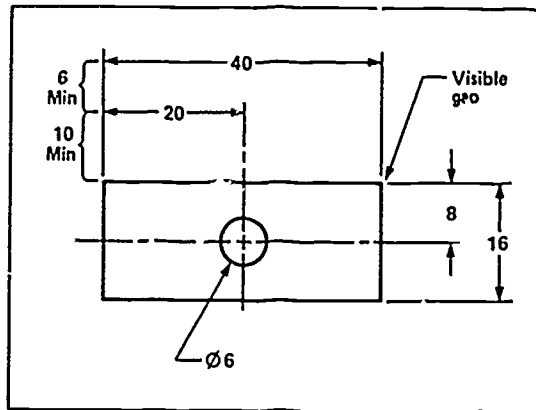

From ANSI Y14.5M-1982(R1989). Reprinted with permission of ASME.

- Q. Extension lines should extend past the dimension lines by a minimum of .125 of an inch.

XIII. Steps in applying dimensions to an object

- A. Draw extension lines and extend the center lines of the hole to be used in the same manner as extension lines.
- B. Use scale to measure dimension line locations with adequate space between each and gaps for dimension figures.
- C. Draw in arrowheads.
- D. Draw in guidelines for figures.
- E. Letter in dimensions.

XIV. Types of finish marks

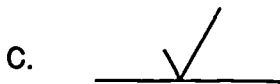
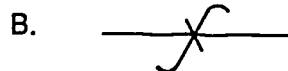
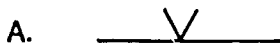

INFORMATION SHEET

Examples:

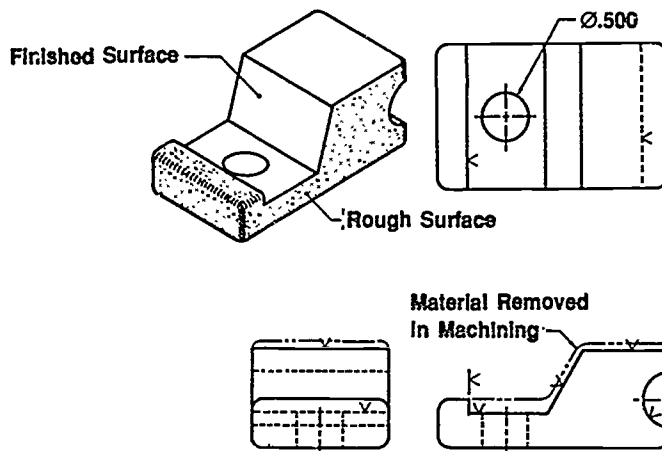

XV. Rules for finish marks

- A. Finish marks should be placed on the edge views of all finished surfaces, including hidden edges and the contour and circular views of cylindrical surfaces.
- B. Finish marks should be omitted on holes or other features where a note specifies a machining operation.
- C. Finish marks should be omitted on parts made from rolled stock.
- D. If a part is finished all over, omit all finish marks, and use the following general note: FINISH ALL OVER, or FAO.

XVI. Types of notes used on a drawing

- A. General note—Consists of information which applies to the entire drawing
 Example: ALL FILLETS AND ROUND R.12 UNLESS OTHERWISE SPECIFIED
- B. Local (specific) note—Refers to one particular feature and requires the use of a leader
 Example:

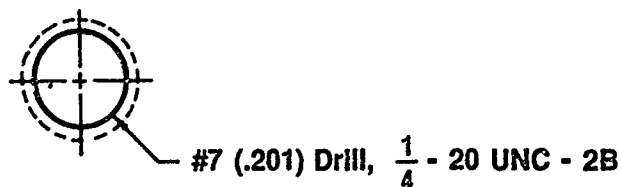

INFORMATION SHEET

XVII. Rules for notations

- A. Notes are always placed parallel to the bottom of the drawing.
- B. Notes should be brief and clear and contain only pertinent data.
- C. General notes should be placed in the upper left hand corner of the drawing plate.
- D. Notes should always be composed so that the various shop operations are listed in the order in which they should be performed.
- E. Local notes should be placed far enough from the views not to crowd, but still close enough to eliminate the need for long leaders.
- F. Use upper case letters for all notes on machine drawings.

XVIII. Ways to avoid superfluous dimensions (Transparency 5)

- A. Always dimension to shop operation requirements.
(NOTE: Remember that the worker should never have to do any calculations from a drawing to find a necessary dimension.)
- B. Never give a dimension more than once in the same view or in different views.

XIX. Common machine manufactured features

A. Hole operations (Transparency 6)

1. Drill, bore, ream

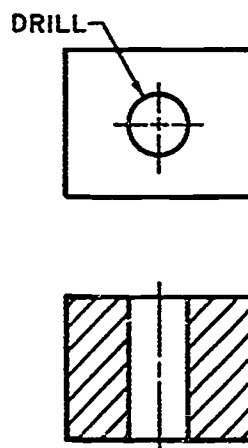

2. Counterdrill

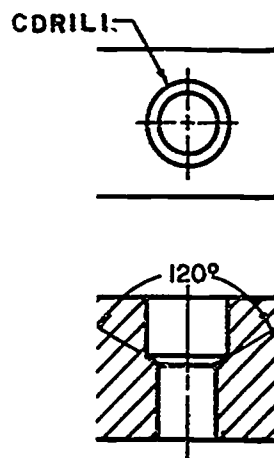

INFORMATION SHEET

3. Countersink

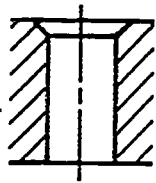
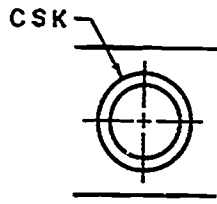

4. Counterbore

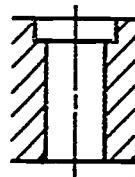
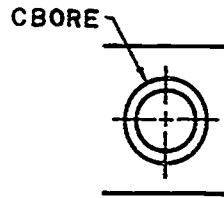

5. Spot faced

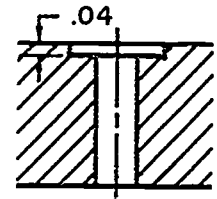
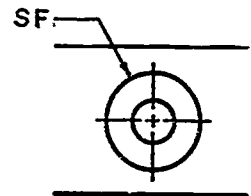

B. Taper

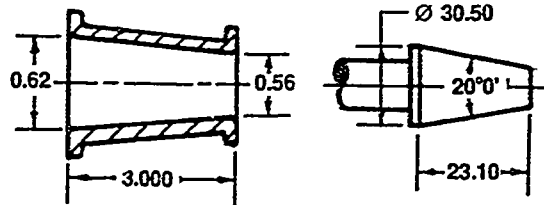

C. Knurl

1. Diamond pattern

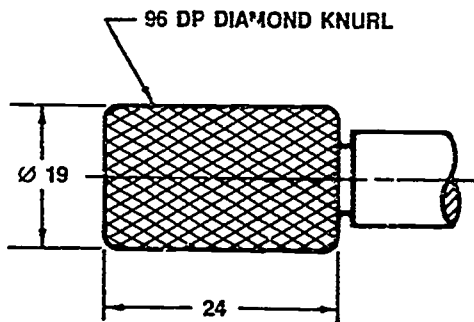

2. Straight line

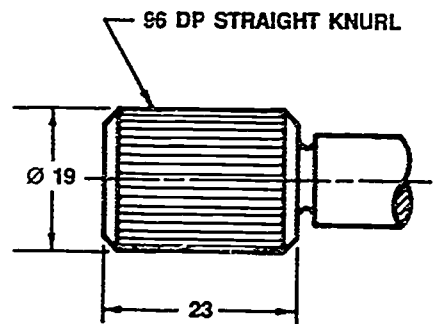

INFORMATION SHEET

D. Chamfer

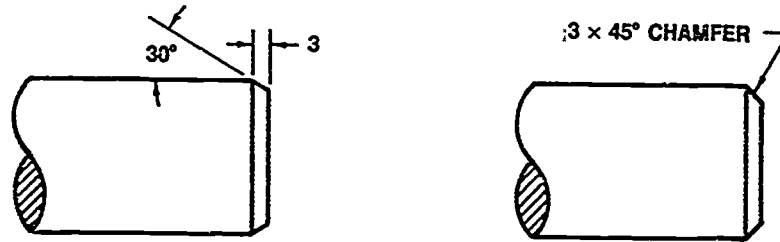

E. Threads

1. Internal
2. External

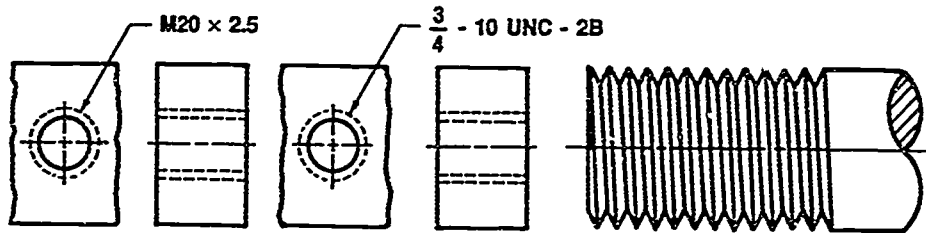

F. Keyways and keyseats

1. Square

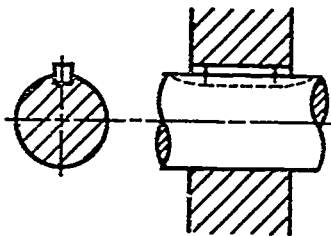

Square Key

2. Flat

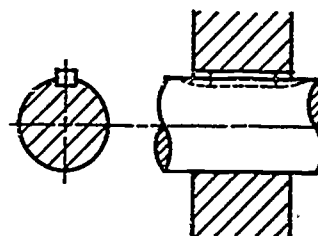

Flat Key

3. Gib head

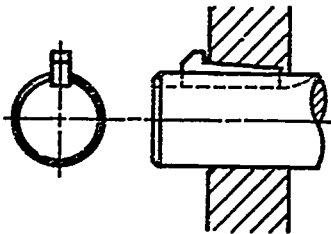

Gib Head Key

4. Pratt and Whitney

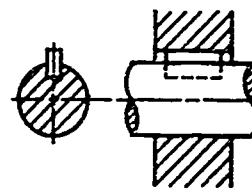

Pratt & Whitney Key

INFORMATION SHEET

5. Woodruff

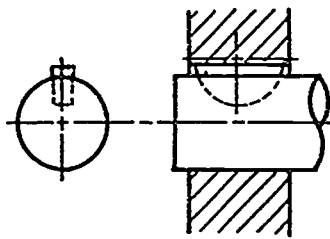

Woodruff Key

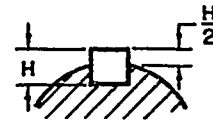

(Size Proportion for Key)

G. Relief groove

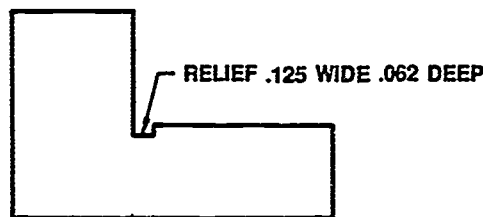

H. Neck

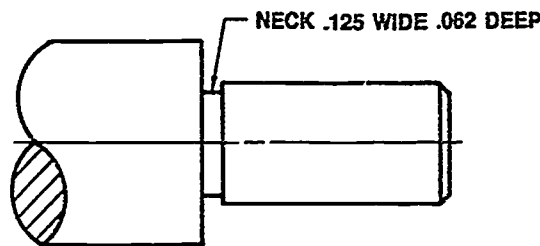

XX. Rules for dimensioning common machine manufactured features

- A. "R" precedes all radii dimensions. The center is shown by a cross and only one arrowhead is used. Available space determines whether the dimension figure goes inside or outside the arc.
- B. In general, a circle is dimensioned by its diameter, an arc by its radius.
- C. Avoid diagonal diameters, except for very large holes and for circles of centers. They may be used on positive cylinders when clearness is gained thereby.
- D. The diameter symbol (\varnothing) precedes all diameter values.
- E. The method for identifying a reference dimension on a drawing is to enclose the dimension with parentheses.
- F. Cylinders should be located by their center lines.

INFORMATION SHEET

- G. Drill sizes are preferably expressed in decimals. For drills designated by number or letter, the decimal size must also be given.
- H. Cylinders should be located in the circular views, if possible.
- I. Cylinders should be located by coordinate dimensions in preference to angular dimensions where accuracy is important.
- J. When there are several rough noncritical features obviously the same size such as fillets or rounds, it is necessary to indicate the number of places the dimension applies.

(NOTE: The word "TYPICAL" or the abbreviation "TYP" is not used.)

- K. When a dimension is not to scale, it should be underscored with a straight thick line or marked NTS or NOT TO SCALE.

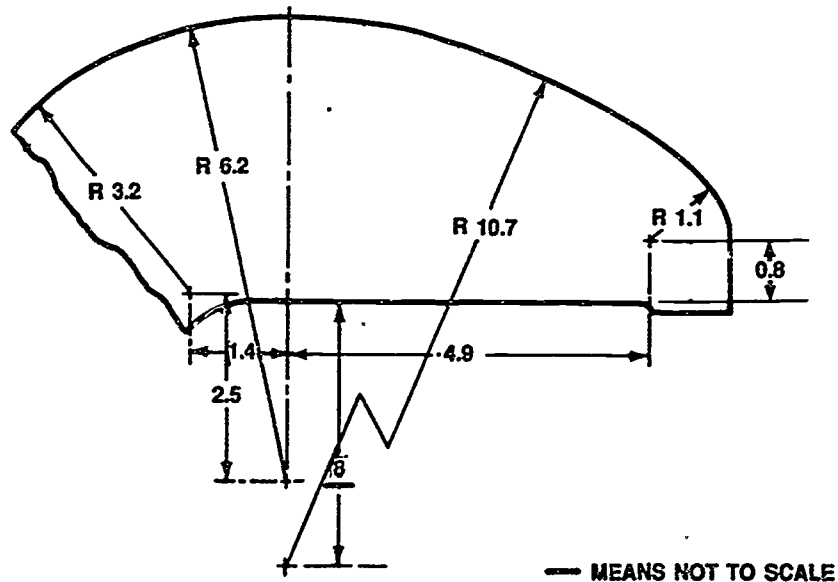

- L. Mating dimensions should be given correspondingly on drawings of mating parts.
- M. Pattern dimensions should be given in two-place decimals.
- N. Decimal dimensions are required on a machine dimension.

INFORMATION SHEET

XXI. Typical commands to change linetypes on CADD

(NOTE: Default linetype on CADD is a solid line.)

- A. "SELECT LINE FONT" will change a solid line to dashed when used with a linetype such as a dash.

Example:

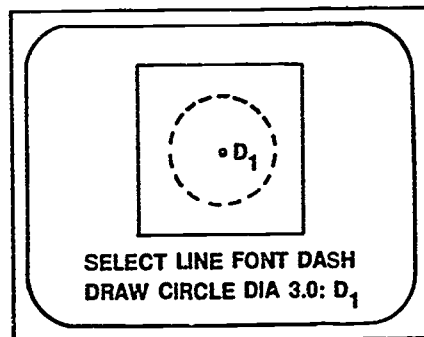

- B. "CHANGE LINE FONT" will change the line to whatever linetype is requested. To initiate, digitize the line to change after command is entered with the new linetype selected.

XXII. General Information concerning dimensioning on a CADD system

(NOTE: Dimensioning procedures will vary between systems.)

- A. CADD systems provide five basic types of dimensioning.
1. Linear
 2. Angular
 3. Diameter
 4. Radius
 5. Labels
- B. Most CADD dimensioning is based on ANSI standard *Y14.5M-1982*.
- C. The operator may select dimensions in the following units of measure:
1. Decimal
 2. Fractional
 3. English or metric
 4. Bilateral or unilateral tolerances

INFORMATION SHEET

5. Feature control symbols
 6. Datum blocks
- D. Dimensioning on CADD is a Draw Mode activity.
- (NOTE: Dimensions are text; therefore, they are two-dimensional.)
- E. Text fonts and arrowheads are available in many styles.
- F. Dimensions created by the operator will reflect the true size of the part regardless of viewing size.

XXIII. Typical CADD procedure to insert dimensions

- A. Step 1: Identify two locations to be measured and dimensioned. (D_1 and D_2)
- B. Step 2: Identify third location to place the dimensioning text and associated values. (D_3)

(NOTE: The system automatically creates extension lines, dimension lines, leader lines, arrowheads, and text.)

Example:

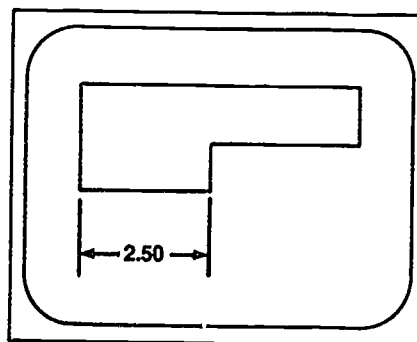
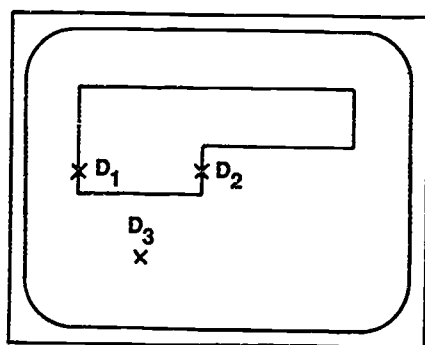

Descriptions and Dimensions

Size Dimension

Location Dimension

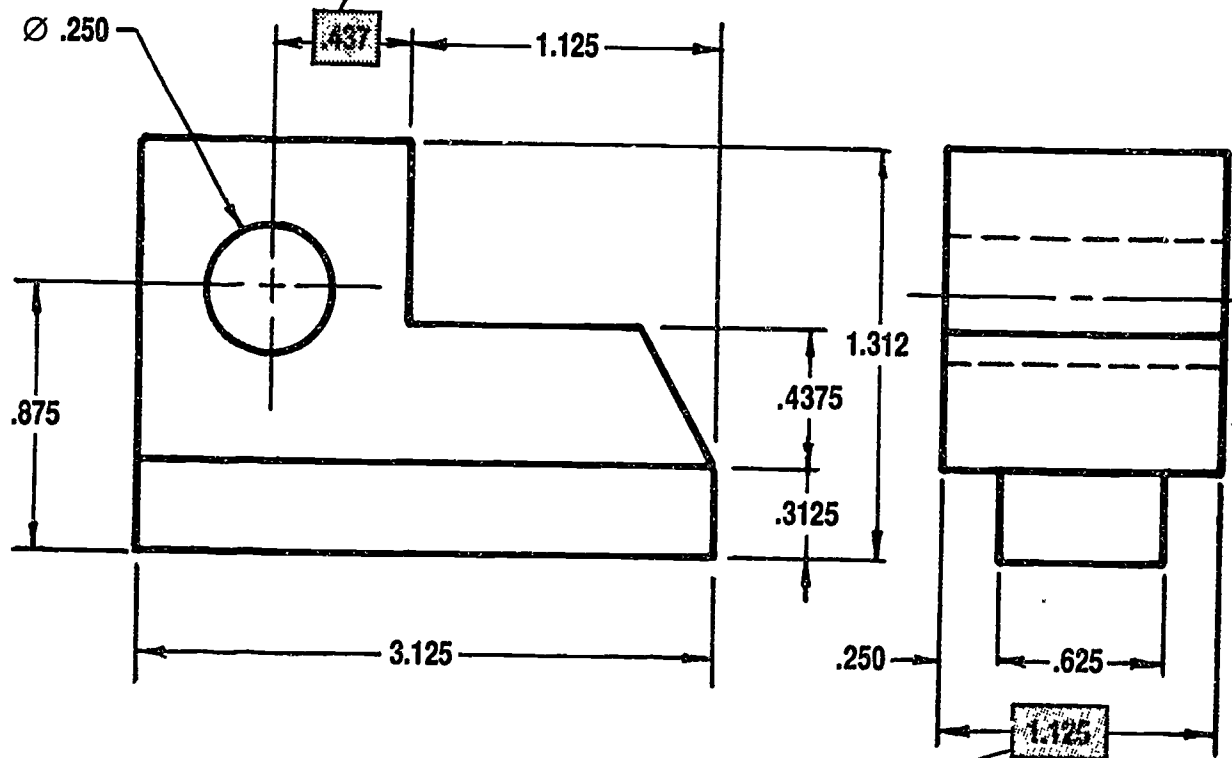

Size Description

Systems of Placing Dimensions

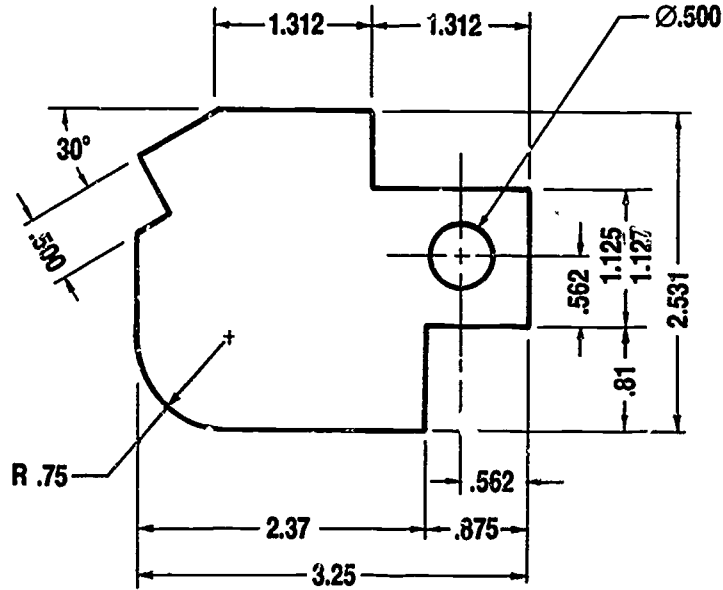

Aligned System

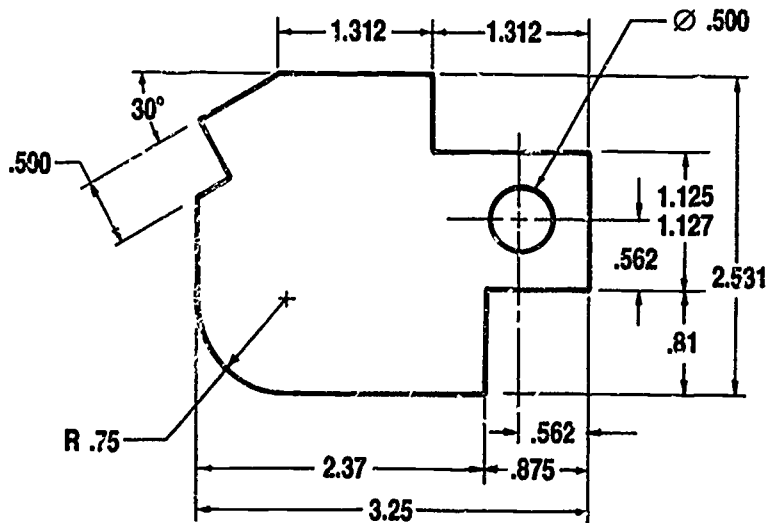

Unidirectional System

Arrowheads

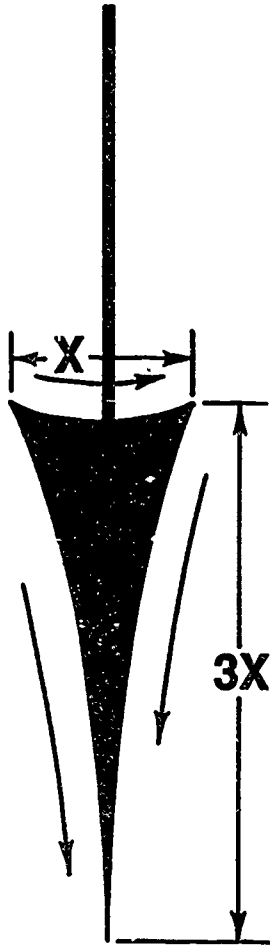

Correct

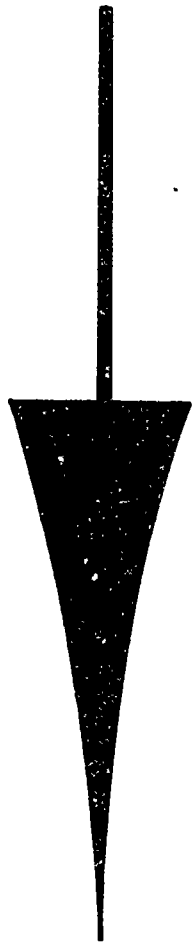

Incorrect



Correct
(In Some Fields)

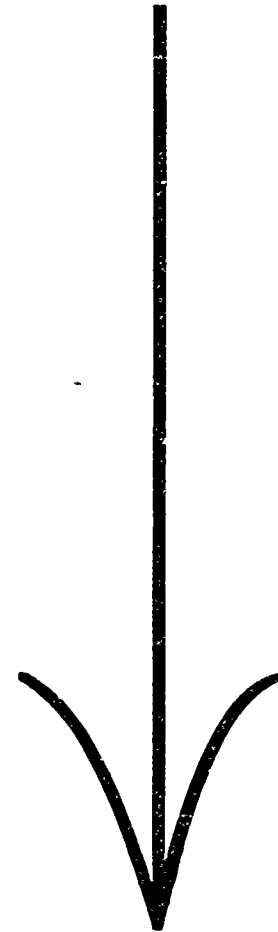

Incorrect

Placement of Dimensions

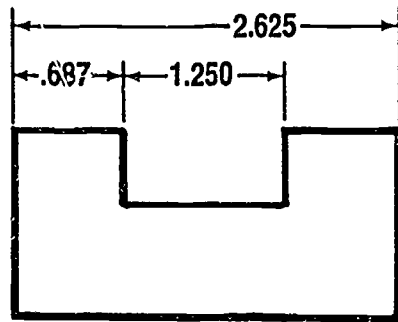

Correct

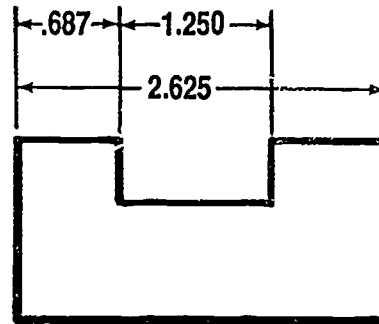

Incorrect

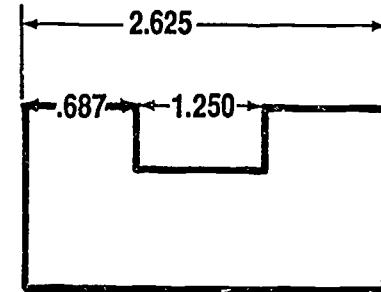

Incorrect

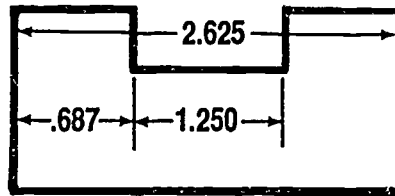

Incorrect

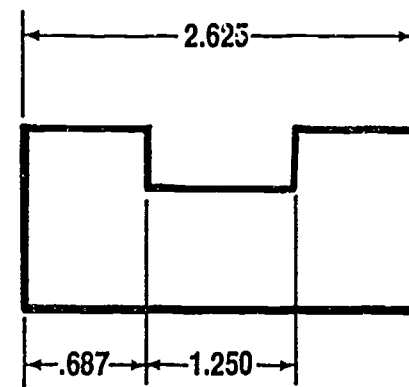

Incorrect

Superfluous Dimensions

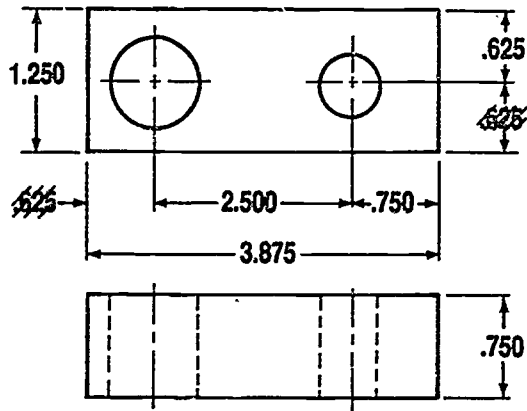

Omit One Dimension in a Chain

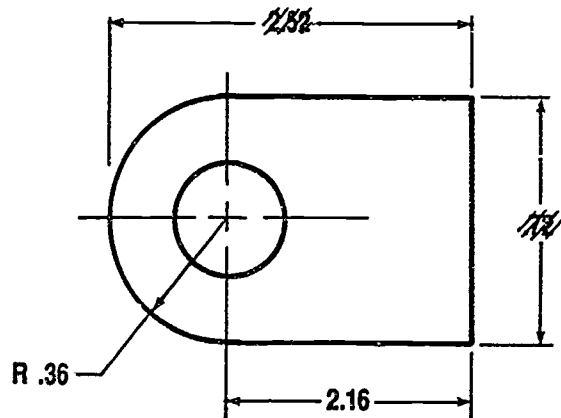

Omit Width and Overall Length

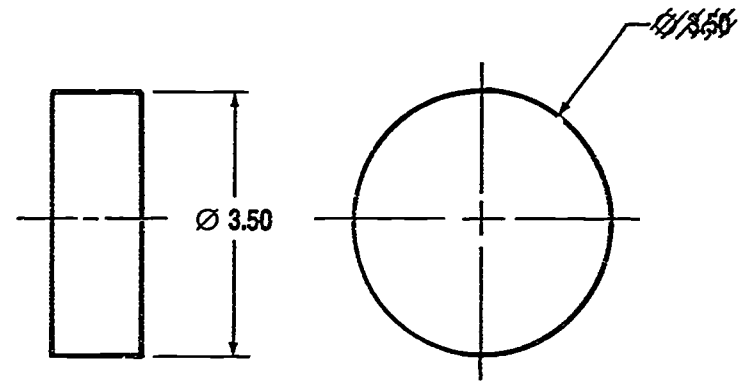

Omit Diagonal Diameter

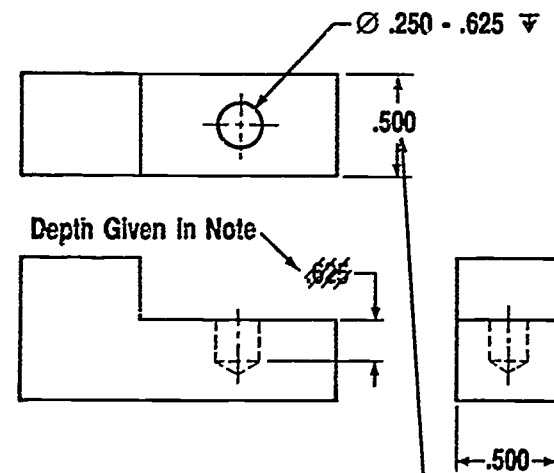

Both Not Needed

Avoid Duplicate Dimensions

Hole Operations



Drill

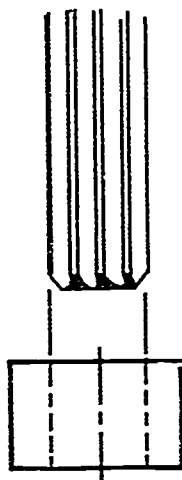

**Chucking
Reamer**



**Hand
Reamer**



**Hand Taper
Reamer**

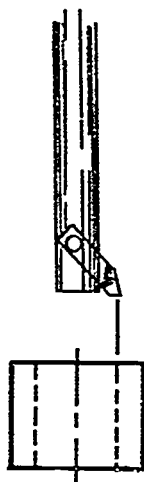

**Boring
Bar**

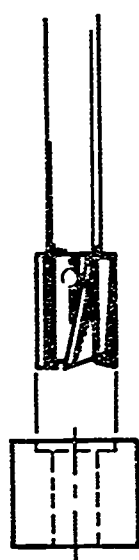

**Counter-
Bore**

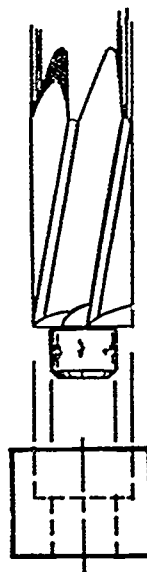

Spotfacer



Countersink

DIMENSIONING UNIT XVII

HANDOUT #1 — ABBREVIATIONS

<p>A</p> <p>Absolute ABS</p> <p>Accelerate ACCEL</p> <p>Accessory ACCESS.</p> <p>Account ACCT</p> <p>Accumulate ACCUM</p> <p>Actual ACT.</p> <p>Adapter ADPT</p> <p>Addendum ADD.</p> <p>Addition ADD.</p> <p>Adjust ADJ</p> <p>Advance ADV</p> <p>After AFT.</p> <p>Aggregate AGGR</p> <p>Air Condition AIR COND</p> <p>Airplane APL</p> <p>Allowance ALLOW</p> <p>Alloy ALY</p> <p>Alteration ALT</p> <p>Alternate ALT</p> <p>Alternating Current AC</p> <p>Altitude ALT</p> <p>Aluminum AL</p> <p>American National Standard AMER NATL STD</p> <p>American Wire Gage AWG</p> <p>Amount AMT</p> <p>Ampere AMP</p> <p>Amplifier AMPL</p> <p>Anneal ANL</p> <p>Antenna ANT.</p> <p>Apartment APT.</p> <p>Apparatus APP</p> <p>Appendix APPX</p> <p>Approved APPD</p> <p>Approximate APPROX</p> <p>Arc Weld ARC/W</p> <p>Area A</p> <p>Armature ARM.</p> <p>Armor Plate ARM-PL</p> <p>Army Navy AN</p> <p>Arrange ARR.</p> <p>Artificial ART.</p> <p>Asbestos ASB</p> <p>Asphalt ASPH</p> <p>Assemble ASSEM</p> <p>Assembly ASSY</p> <p>Assistant ASST</p> <p>Associate ASSOC</p> <p>Association ASSN</p> <p>Atomic AT</p> <p>Audible AUD</p> <p>Audio Frequency AF</p> <p>Authorized AUTH</p> <p>Automatic AUTO</p> <p>Auto-Transformer AUTO TR</p> <p>Auxiliary AUX</p> <p>Avenue AVE</p> <p>Average AVG</p> <p>Aviation AVI</p> <p>Azimuth AZ</p> <p>B</p> <p>Babbitt BAB</p> <p>Back Feed BF</p> <p>Back Pressure BP</p> <p>Back to Back B to B</p> <p>Backface BF</p> <p>Balance BAL</p>	<p>Ball Bearing BB</p> <p>Barometer BAR</p> <p>Base Line BL</p> <p>Base Plat. BP</p> <p>Bearing BRG</p> <p>Bench Mark BM</p> <p>Bending Moment M</p> <p>Bent BT</p> <p>Bessemer BESS</p> <p>Between BET.</p> <p>Between Centers BC</p> <p>Between Perpendiculars BP</p> <p>Bevel BEV</p> <p>Bill of Material B/M</p> <p>Birmingham Wire Gage BWG</p> <p>Blank BLK</p> <p>Block BLK</p> <p>Blueprint BP</p> <p>Board BD</p> <p>Boiler BLR</p> <p>Boiler Feed BF</p> <p>Boiler Horsepower BHP</p> <p>Boiling Point BP</p> <p>Bolt Circle BC</p> <p>Both Faces BF</p> <p>Both Sides BS</p> <p>Both Ways BW</p> <p>Bottom BOT</p> <p>Bottom Chord BC</p> <p>Bottom Face BF</p> <p>Bracket BRKT</p> <p>Brake BK</p> <p>Brake Horsepower BHP</p> <p>Brass BRS</p> <p>Brazing BRZG</p> <p>Break BRK</p> <p>Brinell Hardness BH</p> <p>British Standard BR STD</p> <p>British Thermal Units BTU</p> <p>Broach BRO</p> <p>Bronze BRZ</p> <p>Brown & Sharpe (Wire Gage, same as AWG) B&S</p> <p>Building BLDG</p> <p>Bulkhead BHD</p> <p>Burnish BNH</p> <p>Bushing BUSH.</p> <p>Button BUT.</p> <p>C</p> <p>Cabinet CAB.</p> <p>Calculate CALC</p> <p>Calibrate CAL</p> <p>Cap Screw CAP SCR</p> <p>Capacity CAP</p> <p>Carburetor CARB</p> <p>Carburize CARB</p> <p>Carriage CRG</p> <p>Case Harden CH</p> <p>Cast Iron CI</p> <p>Cast Steel CS</p> <p>Casting CSTG</p> <p>Castle Nut CAS NUT</p> <p>Catalogue CAT.</p> <p>Cement CEM</p> <p>Center CTR</p> <p>Center Line CL</p> <p>Center of Gravity CG</p> <p>Center of Pressure CP</p> <p>Center to Center C to C</p> <p>Centering CTR</p>	<p>Chamfer CHAM</p> <p>Change CHG</p> <p>Channel CHAN</p> <p>Check CHK</p> <p>Check Valve CV</p> <p>Chord CHD</p> <p>Circle CIR</p> <p>Circular CIR</p> <p>Circular Pitch CP</p> <p>Circumference CIRC</p> <p>Clear CLR</p> <p>Clearance CL</p> <p>Clockwise CW</p> <p>Coated CTD</p> <p>Cold Drawn CD</p> <p>Cold Drawn Steel CDS</p> <p>Cold Finish CF</p> <p>Cold Punched CP</p> <p>Cold Rolled CR</p> <p>Cold Rolled Steel CRS</p> <p>Combination COMB.</p> <p>Combustion COMB</p> <p>Commercial COML</p> <p>Company CO</p> <p>Complete COMPL</p> <p>Compress COMP</p> <p>Concentric CONC</p> <p>Concrete CONC</p> <p>Condition COND</p> <p>Connect CONN</p> <p>Constant CONST</p> <p>Construction CONST</p> <p>Contact CONT</p> <p>Continue CONT</p> <p>Copper COP.</p> <p>Corner COR</p> <p>Corporation CORP</p> <p>Correct CORR</p> <p>Corrugate CORR</p> <p>Cotter COT</p> <p>Counter CTR</p> <p>Counter Clockwise CCW</p> <p>Counterbore CBORE</p> <p>Counterdrill CDRILL</p> <p>Counterpunch CPUNCH</p> <p>Countersink CSK</p> <p>Coupling CPLG</p> <p>Cover COV</p> <p>Cross Section XSECT</p> <p>Cubic CU</p> <p>Cubic Foot CU FT</p> <p>Cubic Inch CU IN.</p> <p>Current CUR</p> <p>Customer CUST</p> <p>Cyanide CYN</p> <p>D</p> <p>Decimal DEC</p> <p>Dedendum DED</p> <p>Deflect DEFL</p> <p>Degree (°) DEG</p> <p>Density D</p> <p>Department DEPT</p> <p>Design DSGN</p> <p>Detail DET</p> <p>Develop DEV</p> <p>Diagonal DIAG</p> <p>Diagram DIAG</p> <p>Diameter DIA</p> <p>Diametral Pitch DP</p> <p>Dimension DIM.</p> <p>Discharge DISCH</p> <p>Distance DIST</p> <p>Division DIV</p>	<p>Double DBL</p> <p>Dovetail DVTL</p> <p>Dowel DWL</p> <p>Down DN</p> <p>Dozen DOZ</p> <p>Drafting DFTG</p> <p>Draftsman DFTSMN</p> <p>Drawing DWG</p> <p>Drill or Drill Rod DR</p> <p>Drive DR</p> <p>Drive Fit DF</p> <p>Drop D</p> <p>Drop Forge DF</p> <p>Duplicate DUP</p> <p>E</p> <p>Each EA</p> <p>East E</p> <p>Eccentric ECC</p> <p>Effective EFF</p> <p>Elbow ELL</p> <p>Electric ELEC</p> <p>Elementary ELEM</p> <p>Elevate ELEV</p> <p>Elevation EL</p> <p>Engine ENG</p> <p>Engineer ENGR</p> <p>Engineering ENGRG</p> <p>Entrance ENT</p> <p>Equal EQ</p> <p>Equation EQ</p> <p>Equipment EQUIP</p> <p>Equivalent EQUIV</p> <p>Estimate EST</p> <p>Exchange EXCH</p> <p>Exhaust EXH</p> <p>Existing EXIST.</p> <p>Exterior EXT</p> <p>Extra Heavy X HVY</p> <p>Extra Strong X STR</p> <p>Extrude EXTR</p> <p>F</p> <p>Fabricate FAB</p> <p>Face to Face F to F</p> <p>Fahrenheit F</p> <p>Far Side FS</p> <p>Federal FED.</p> <p>Feed FD</p> <p>Feet (') FT</p> <p>Figure FIG.</p> <p>Fillet FIL</p> <p>Filister FIL</p> <p>Finish FIN.</p> <p>Finish All Over FAO</p> <p>Flange FLG</p> <p>Flat F</p> <p>Flat Head FH</p> <p>Flour FL</p> <p>Fluid FL</p> <p>Focus FOC</p> <p>Foot (') FT</p> <p>Force F</p> <p>Forged Steel FST</p> <p>Forging FORG</p> <p>Forward FWD</p> <p>Foundry FDRY</p> <p>Frequency FREQ</p> <p>Front FR</p> <p>Furnish FURN</p>
--	---	---	--

HANDOUT #1

G		Locate	LOC	Pitch Circle	PC	Sleeve	SLV
Gage or Gauge	GA	Logarithm	LOG.	Pitch Diameter	PD	Slide	SL
Gallon	GAL	Long	LG	Plastic	PLSTC	Slotted	SLOT.
Galvanize	GALV	Lubricate	LUB	Plate	PL	Small	SM
Galvanized Iron	GI	Lumber	LBR	Plumbing	PLMB	Socket	SOC
Galvanized Steel	GS			Point	PT	Space	SP
Gasket	GSKT	M		Point of Curve	PC	Special	SPL
General	GEN	Machine	MACH	Point of Intersection	PI	Specific	SP
Glass	GL	Machine Steel	MS	Point of Tangent	PT	Spot Faced	SPF
Government	GOVT	Maintenance	MAINT	Polish	POL	Spring	SPG
Governor	GOV	Malleable	MALL	Position	POS	Square	SQ
Grade	GR	Malleable Iron	MI	Potential	POT.	Standard	STD
Graduation	GRAD	Manual	MAN.	Pound	LB	Station	STA
Graphite	GPH	Manufacture	MFR	Pounds per Square Inch	PSI	Stationary	STA
Grind	GRD	Manufactured	MFD	Power	PWR	Steel	STL
Groove	GRV	Manufacturing	MFG	Prefabricated	PREFAB	Sock	STK
Ground	GRD	Material	MATL	Preferred	PFD	Straight	STR
		Maximum	MAX	Prepare	PREP	Street	ST
H		Mechanical	MECH	Pressure	PRESS.	Structural	STR
Half-Round	HRD	Mechanism	MECH	Process	PROC	Substitute	SUB
Handle	HDL	Median	MED	Production	PROD	Summary	SUM.
Hanger	HGR	Metai	MET.	Profile	PF	Support	SUP.
Hard	H	Meter	M	Propeller	PROP	Surface	SUR
Harden	HDN	Miles	MI	Publication	PUB	Symbol	SYM
Hardware	HDW	Miles per Hour	MPH	Push Button	PB	System	SYS
Head	HD	Millimeter	MM				
Headless	HDLS	Minimum	MIN	Q			
Heat	HT	Minute	(^o) MIN	Quadrant	QUAD	T	
Heat Treat	HT TR	Miscellaneous	MISC	Quality	QUAL	Tangent	TAN.
Heavy	HVY	Month	MO	Quarter	QTR	Taper	TPR
Hexagon	HEX	Morse Taper	MOR T			Technical	TECH
High-Pressure	HP	Motor	MOT	R		Template	TEMP
High-Speed	HS	Mounted	MTD	Radial	RDL	Tension	TENS.
Horizontal	HOR	Mounting	MTG	Radius	RAD	Terminal	TERM.
Horsepower	HP	Multiple	MULT	Railroad	RR	Thick	THK
Hot Rolled	HR	Music Wire Gage	MWG	Ream	RM	Thousand	M
Hot Rolled Steel	HRS			Received	RECD	Thread	THD
Hour	HR	N		Record	REC	Threads per Inch	TPI
Housing	HSG	National	NATL	Rectangle	RECT	Through	THRU
Hydraulic	HYD	Natural	NAT	Reduce	RED.	Time	T
		Near Face	NF	Reference Line	REF L	Tolerance	TOL
I		Near Side	NS	Reinforce	REINF	Tongue & Groove	T & G
Illustrate	ILLUS	Negative	NEG	Release	REL	Tool Steel	TS
Inboard	INBD	Neutral	NEUT	Relief	REL	Tooth	T
Inch	(^o) IN.	Nominal	NOM	Remove	REM	Total	TOT
Inches per Second	IPS	Normal	NOR	Require	REQ	Transfer	TRANS
Inclosure	INCL	North	N	Required	REQD	Typical	TYP
Include	INCL	Not to Scale	NTS	Return	RET.		
Inside Diameter	ID	Number	NO.	Reverse	REV	U	
Instrument	INST			Revolution	REV	Ultimate	ULT
Interior	INT	O		Revolutions per		Unit	U
Internal	INT	Obsolete	OBS	Minute	RPM	Universal	UNIV
Intersect	INT	Octagon	OCT	Right	R		
Iron	I	Office	OFF.	Right Hand	RH	V	
Irregular	IRREG	On Center	OC	Rivet	RIV	Vacuum	VAC
		Opposite	OPP	Rockwell Hardness	RH	Valve	V
J		Optical	OPT	Roller Bearing	RB	Variable	VAR
Joint	JT	Original	ORIG	Room	RM	Versus	VS
Joint Army-Navy	JAN	Outlet	OUT.	Root Diameter	RD	Vertical	VERT
Journal	JNL	Outside Diameter	OD	Root Mean Square	RMS	Volt	V
Junction	JCT	Outside Face	OF	Rough	RGH	Volume	VOL
		Outside Radius	OR	Round	RD	W	
K		Overall	OA	S		Wall	W
Key	K			Schedule	SCH	Washer	WASH.
Keypad	KST	P		Schematic	SCHEM	Watt	W
Keyway	KWY	Pack	PK	Scleroscope Hardness	SH	Week	WK
		Packing	PKG	Screw	SCR	Weight	WT
L		Page	P	Second	SEC	West	W
Laboratory	LAB	Paragraph	PAR.	Section	SECT	Width	W
Laminate	LAM	Part	PT	Semi-Steel	SS	Wood	WD
Lateral	LAT	Patent	PAT.	Separate	SEP	Woodruff	WDF
Left	L	Pattern	PATT	Set Screw	SS	Working Point	WP
Left Hand	LH	Permanent	PERM	Sheet	SFT	Working Pressure	WP
Length	LG	Perpendicular	PERP	Sheet	SH	Wrought	WRT
Length Over All	LOA	Piece	PC	Shoulder	SHLD	Wrought Iron	WI
Letter	LTR	Piece Mark	PC MK	Side	S	X, Y, Z	
Light	LT	Pint	PT	Single	S	Yard	YD
Line	L	Pitch	P	Sketch	SK	Year	YR

**DIMENSIONING
UNIT XVII**

ASSIGNMENT SHEET #1 — CONSTRUCT ARROWHEADS

NAME _____ SCORE _____

Introduction: Arrowheads add much to a drawing if constructed correctly. They must be uniform in size and shape and the drafter must be able to construct them with speed, neatness, and accuracy.

Directions: Study the two examples below and then complete the assigned problems.

Examples:

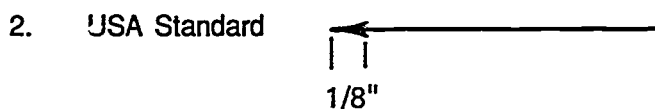
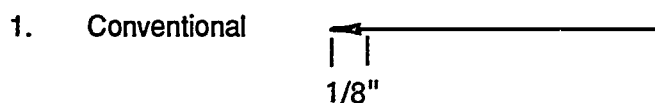

Problems: Place arrowheads at all intersecting lines below.

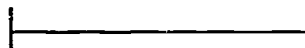
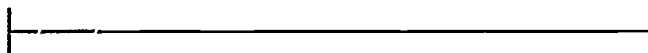
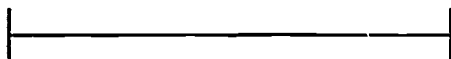

**DIMENSIONING PROCEDURES
UNIT XVII**

ASSIGNMENT SHEET #2 — DIMENSION ARCS

NAME _____ SCORE _____

Directions: Study the following guidelines and examples and then complete the assigned problems.

GUIDELINES

- A. Dimension an arc in the view in which its true shape is shown.
- B. Indicate the center by a small cross to locate exact center point.
(NOTE: Center cross may be omitted for small or unimportant radii.)
- C. Keep figure and arrowhead inside if possible.
- D. In limited space, move figure outside.
- E. In most limited space, move figure and arrowhead outside.

Examples:



**Keep Figure Inside
if Possible**

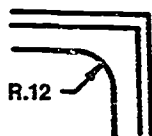

**Move Figure Outside
if Necessary**

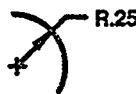

**Move Both Arrow
and Figure Outside
if Necessary**

ASSIGNMENT SHEET #2

PROBLEMS: Dimension the following arcs and radii using correct dimensioning procedures. Determine measurements with a scale.

Problem A:

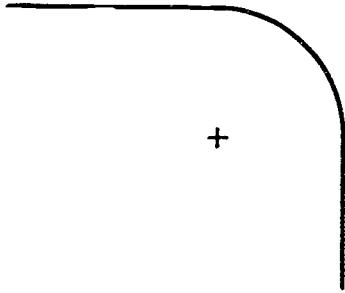

Problem B:

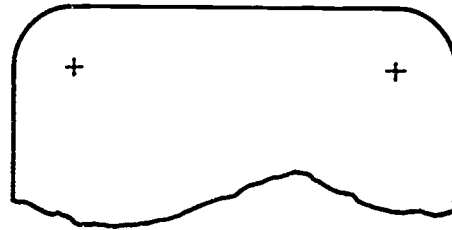

Problem C:

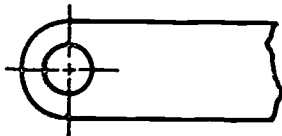

Problem D:

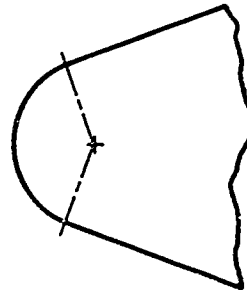

923

ASSIGNMENT SHEET #2

Problem E: 20" Radius

+



Problem F:

+

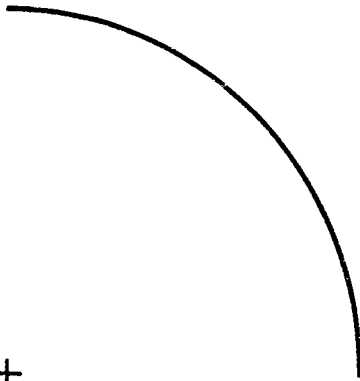

ASSIGNMENT SHEET #2

Problem G:

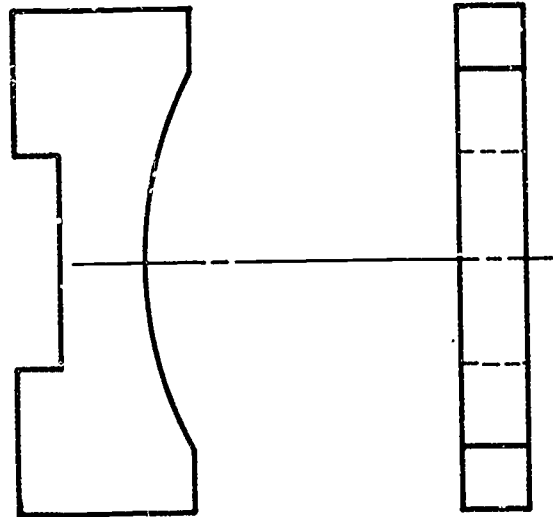

Problem H:

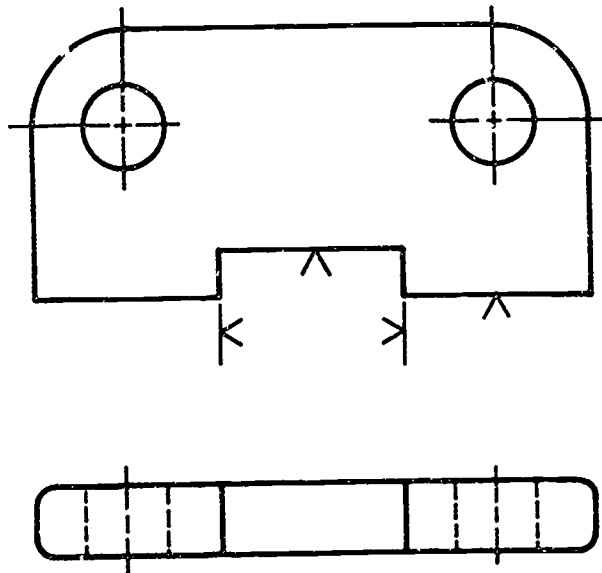

NOTE: .XX ±.010 (UNMACHINED SURFACES USE 2 PLACE DECIMAL FIGURES)

.XXX ±.005 (FINISHED SURFACES USE 3 PLACE DECIMAL FIGURES)

DIMENSIONING UNIT XVII

ASSIGNMENT SHEET #3 — DIMENSION ANGL

NAME _____ SCORE _____

Directions: Study the following guidelines and examples and then complete the assigned problems.

GUIDELINES

A. Angle may be shown by two methods:

1. Coordinate dimensions of the two legs of a right triangle

(NOTE: Coordinate dimensions are preferred when a high degree of accuracy is required.)

Example:

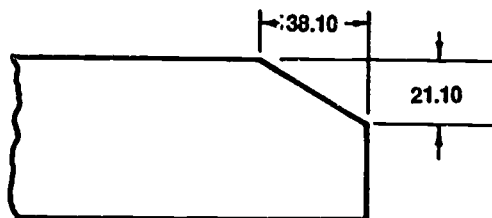

2. Linear dimension and an angle in degrees

Example:

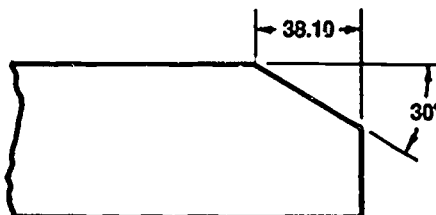

B. Variations of degrees and arrowhead placements should be as follows:

Examples:

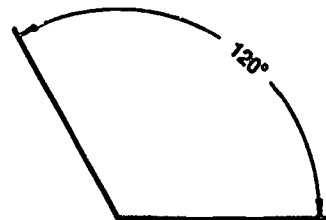
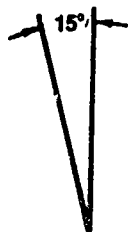

(NOTE: The circular dimension lines are always drawn with the compass center at the vertex of the angle.)

ASSIGNMENT SHEET #3

- C. For a long radius with center point outside available space, the dimension leader is drawn toward the actual center, but a false center is indicated and the dimension line is jogged to it.

Example:

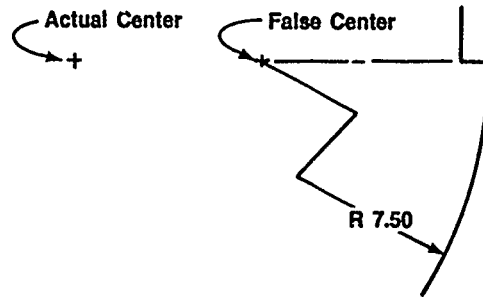

PROBLEMS: Dimension the following objects using correct dimensioning procedures. Pay particular attention to dimensioning the angles. Measure with a scale and protractor. Use decimal figures for all dimensions.

Problem A:

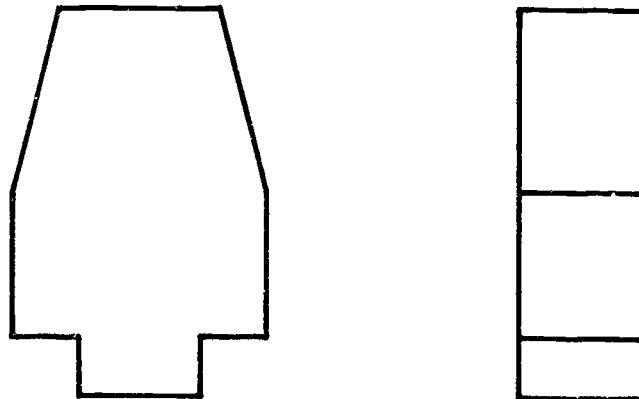

ASSIGNMENT SHEET #3

Problem B:

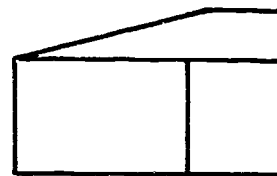
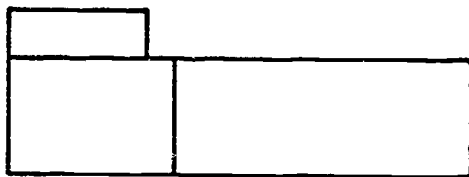
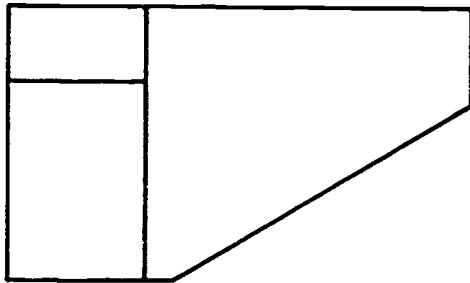

Problem C: Dimension all inside angles in degrees and minutes.

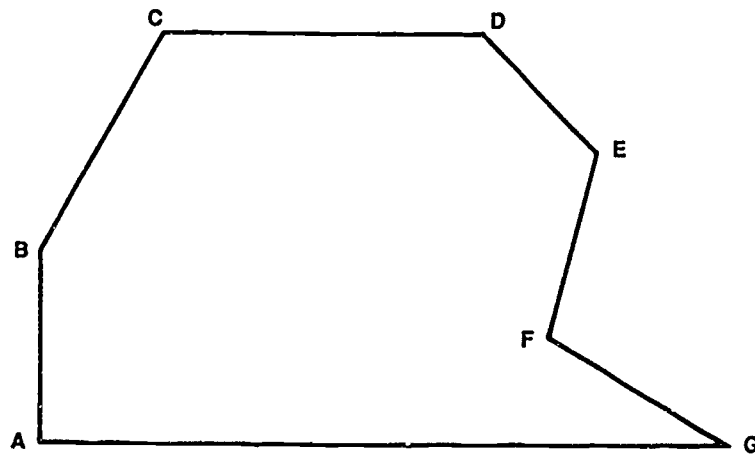

DIMENSIONING UNIT XVII

ASSIGNMENT SHEET #4 — DIMENSION CURVES

NAME _____ SCORE _____

Directions: Study the following guidelines and examples and then complete the assigned problems.

GUIDELINES

- A. For continuous curves made up of a series of circular arcs with known center points,
1. Dimension all arcs with leader lines.
 2. Locate all center points from each other and from some common datum point.

Example:

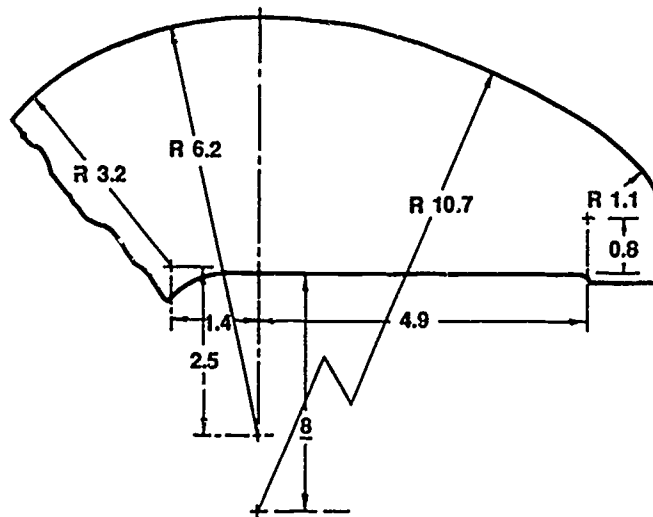

(NOTE: For extremely large radii, such as the 10.7" radius in the example above, the center may be drawn closer to the arc than actual size. The actual location dimension is still given even though it is not to scale.)

ASSIGNMENT SHEET #4

- B. Irregular curves with unknown center points can be dimensioned by means of coordinate dimensions or from two datum base lines, a method which will provide a series of points which can be connected with an irregular curve.

(NOTE: Values in upper line in example are not accumulative although they are all in one line.)

Example:

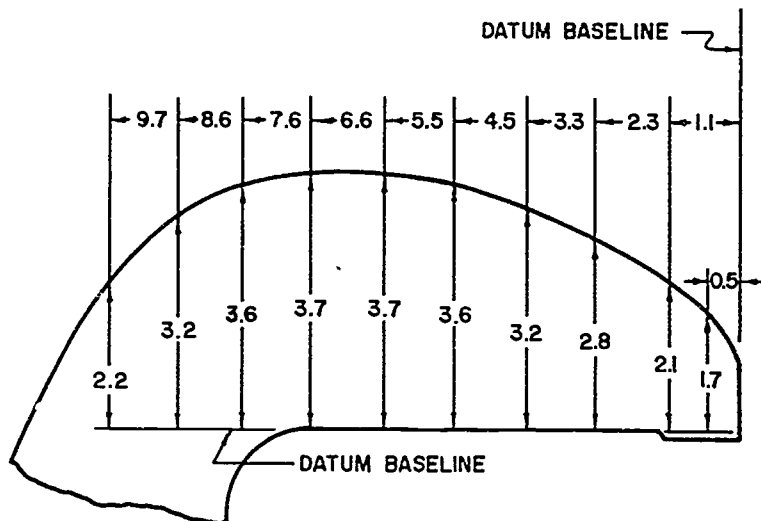

PROBLEMS: Dimension the following objects using correct dimensioning procedures. Substitute "x"s for actual numbers when placing dimension figures.

Problem A:

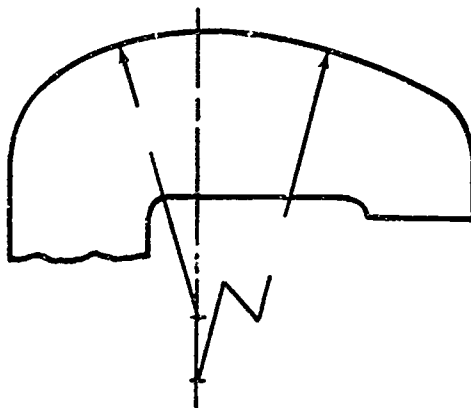

930

ASSIGNMENT SHEET #4

Problem B:



Problem C:

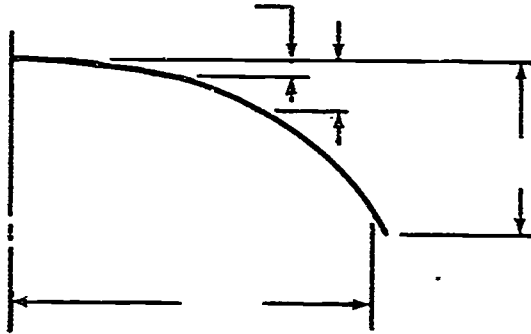

**DIMENSIONING
UNIT XVII**

**ASSIGNMENT SHEET #5 — DIMENSION ROUNDED END SHAPES
AND SLOTTED HOLES**

NAME _____ SCORE _____

Directions: Study the following guidelines and examples and then complete the assigned problems.

GUIDELINES

- A. For fully rounded ends, the overall dimensions are used and the radii are indicated but not dimensioned.

Example:

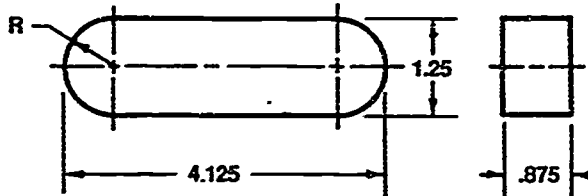

- B. For slotted holes dimensioned as shown, the radii are indicated but not dimensioned.

Example:

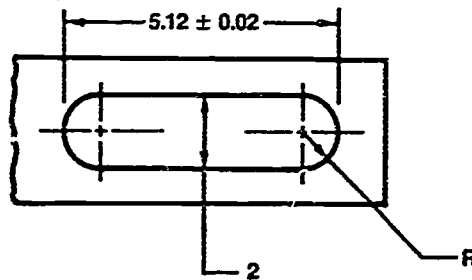

ASSIGNMENT SHEET #5

PROBLEMS: Dimension the following objects using correct dimensioning procedures.
Measure with a scale.

Problem A:

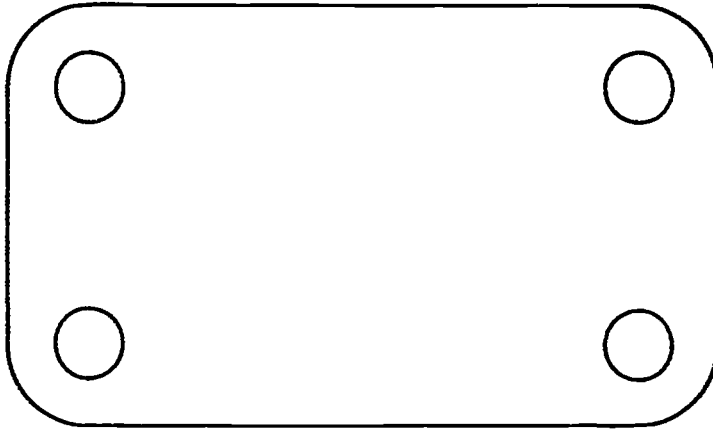

Problem B:

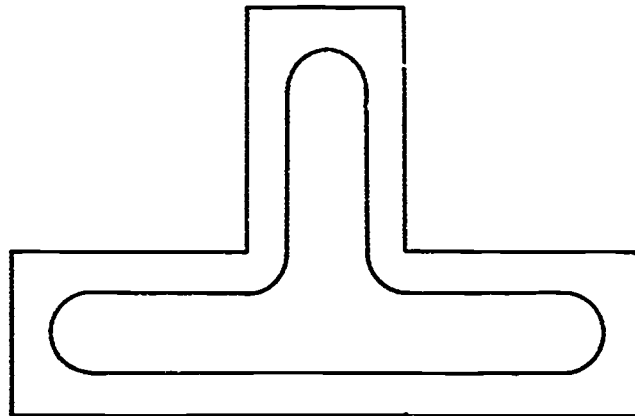

**DIMENSIONING
UNIT XVII**

ASSIGNMENT SHEET #6 — DIMENSION SPHERICAL OBJECTS

NAME _____ SCORE _____

Directions: Study the following guidelines and examples and then complete the assigned problems.

GUIDELINES

- A. A spherical end is dimensioned by a radius, preceded by SR.

Example:

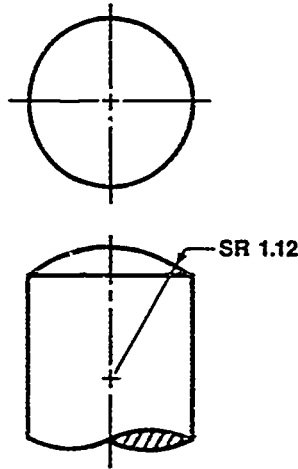

- B. A sphere is dimensioned by giving its diameter.

Example:

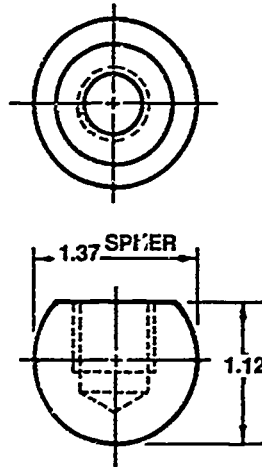

ASSIGNMENT SHEET #6

PROBLEMS: Dimension the following objects using correct dimensioning procedures.
Measure with a scale.

Problem A:

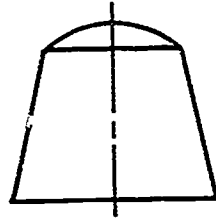
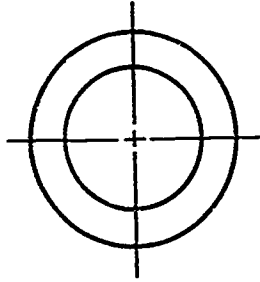

Problem B:

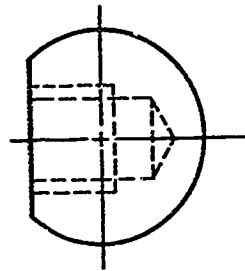
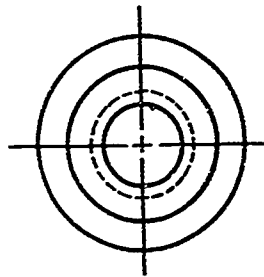

**DIMENSIONING
UNIT XVII**

ASSIGNMENT SHEET #7 — DIMENSION CYLINDRICAL OBJECTS

NAME _____ SCORE _____

Directions: Study the following guidelines and examples and then complete the assigned problem.

GUIDELINES

- A. Give both the diameter and the length in the rectangular view.
- B. The radius of a cylinder should never be given.

Example:

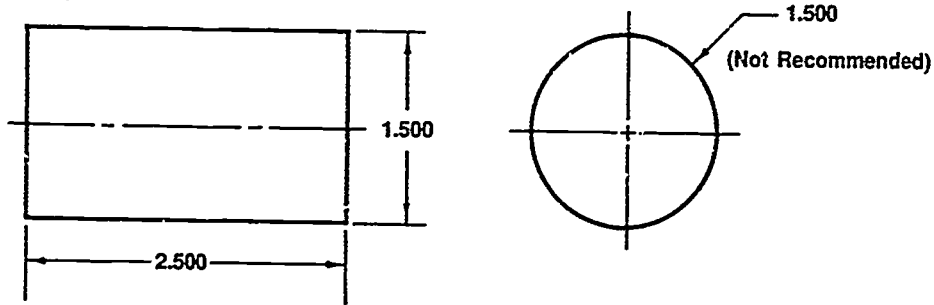

PROBLEM: Dimension the following object using correct dimensioning procedures. Measure with a scale.

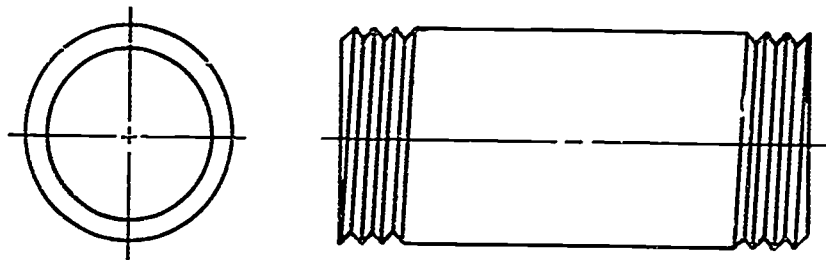

**DIMENSIONING
UNIT XVII**

**ASSIGNMENT SHEET #8 -- DIMENSION CONES, PYRAMIDS,
AND PRISMS**

NAME _____ SCORE _____

Directions: Study the following guidelines and examples and then complete the assigned problems.

GUIDELINES

- A. Show cones and truncated cones in one of the following methods:

(NOTE: The appropriate method to use depends on the accuracy required and the process that will be used to make the cone.)

1. Diameter and height in triangular view

Example:

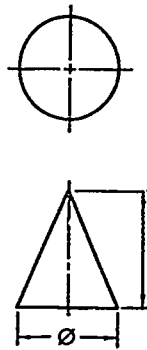

2. Diameter and angle

Example:

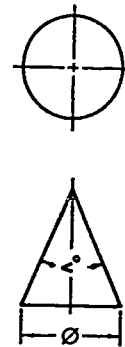

3. Two diameters and height

Example:

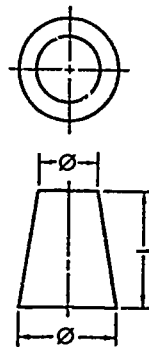

4. Diameter of large end, height, and taper

Example:

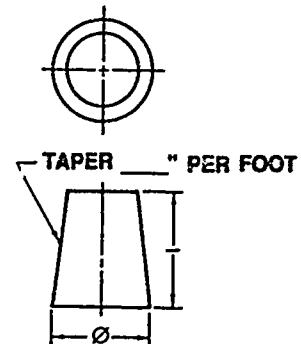

ASSIGNMENT SHEET #8

B. Show pyramids and truncated pyramids in one of the following methods:

1. Dimensions of base in top view and height in front view

Example:

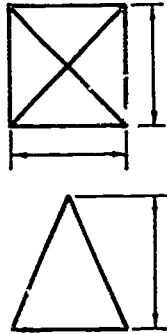

2. Dimensions of base and frustum in top view (or front view for square pyramids) and height in front view

Examples:

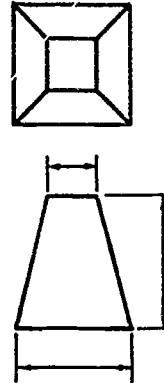

C. For prisms, give the height, width, and depth. Two of the dimensions will be in one view and the third dimension will always be in the next view. Additional dimensions may be needed depending on the type of prism.

Examples:

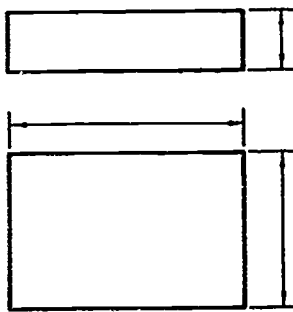

Rectangular Prism

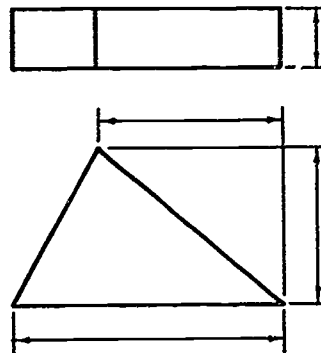

Triangular Prism

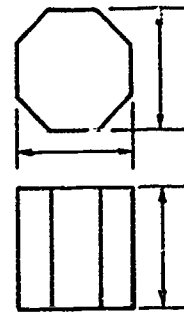

Octagonal Prism

ASSIGNMENT SHEET #8

PROBLEMS: Dimension the following objects using correct dimensioning procedures.
Measure with a scale.

Problem A: Cones

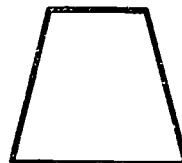
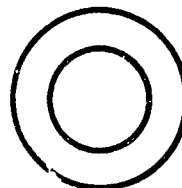
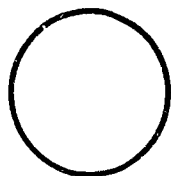

Problem B: Pyramids

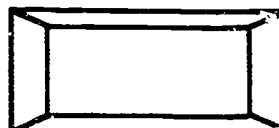

ASSIGNMENT SHEET #8

Problem C: Prisms

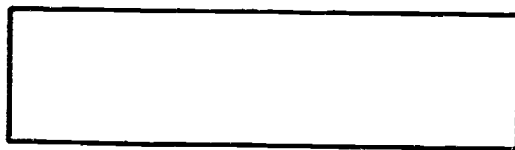
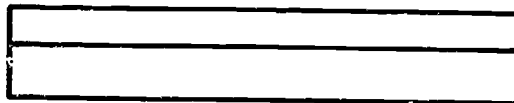
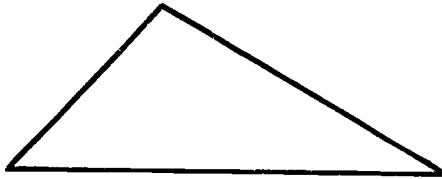

**DIMENSIONING
UNIT XVII**

**ASSIGNMENT SHEET #9 — DIMENSION FEATURES ON A
CIRCULAR CENTER LINE**

NAME _____ SCORE _____

Directions: Study the following guidelines and examples and then complete the assigned problems.

GUIDELINES

- A. Holes equally spaced are dimensioned by giving the diameter of the center line or bolt circle and specifying "equally spaced" in a note.

Example:

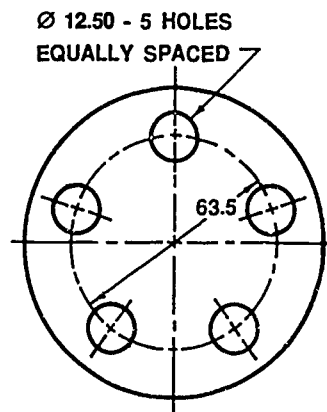

- B. Holes unequally spaced are dimensioned by giving the diameter of the center line plus angular measurements with reference to one of the center lines.

Example:

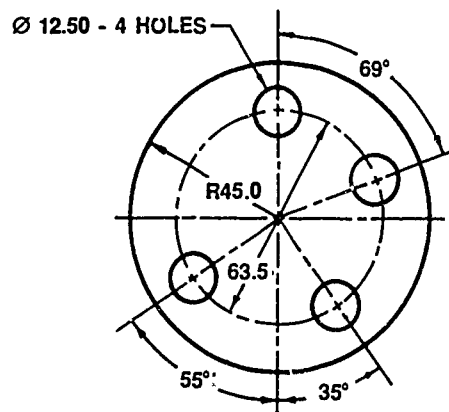

ASSIGNMENT SHEET #9

- C. When precise accuracy is required, coordinate dimensions should be given using the center lines as datum lines.

Example:

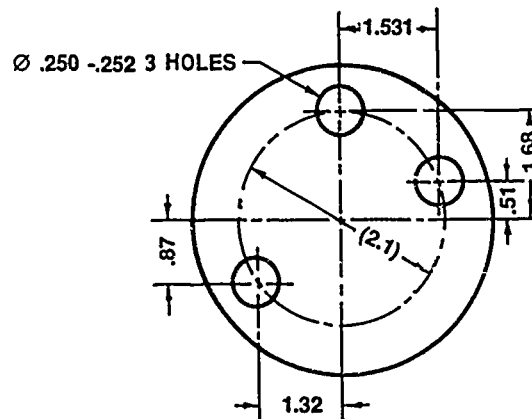

PROBLEMS: Dimension the following objects using correct dimensioning procedures. Measure with a scale.

Problem A: Holes equally spaced

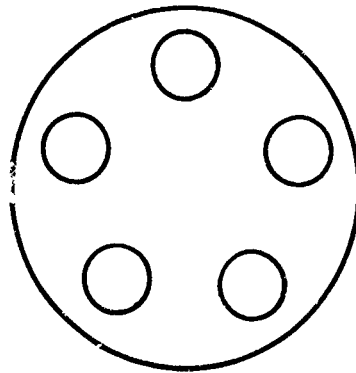

ASSIGNMENT SHEET #9

Problem B: Holes unequally spaced; use angular measurements

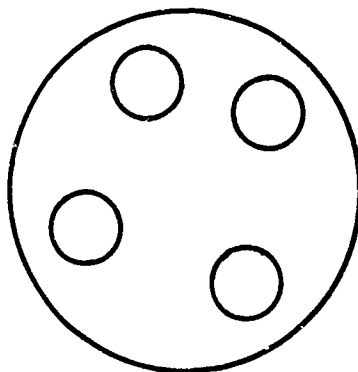

Problem C: Holes unequally spaced; use coordinate dimensions

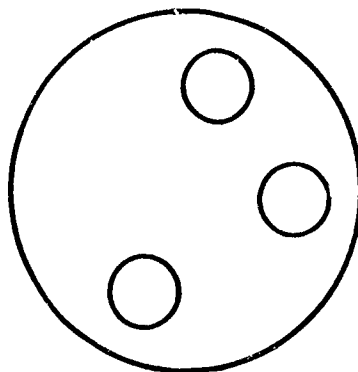

**DIMENSIONING
UNIT XVI!**

**ASSIGNMENT SHEET #10 — DIMENSION THEORETICAL POINTS
OF INTERSECTION**

NAME _____ SCORE _____

Directions: Study the following guideline and examples and then complete the assigned problems.

GUIDELINE

Project extension lines until they cross, forming a point that can be dimensioned.

Examples:

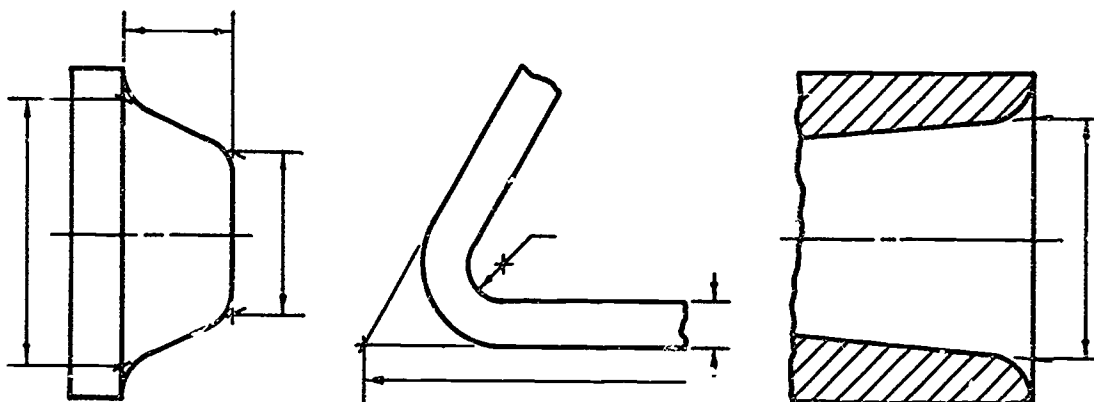

PROBLEMS: Dimension the following objects using correct dimensioning procedures. Measure with a scale.

Problem A:

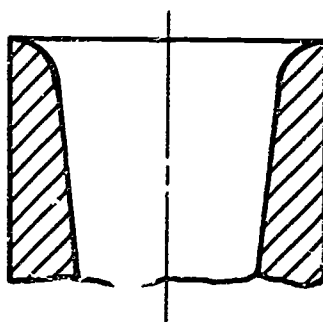

ASSIGNMENT SHEET #10

Problem B:



Problem C:

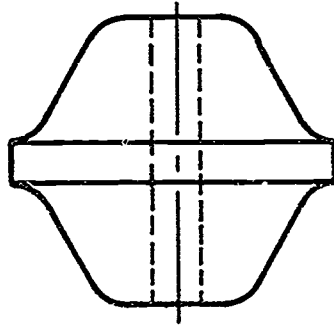

DIMENSIONING UNIT XVII

ASSIGNMENT SHEET #11 — DIMENSION AN OBJECT USING A RECTANGULAR COORDINATE SYSTEM

NAME _____ SCORE _____

Directions: Study the following guidelines and examples and then complete the assigned problems.

GUIDELINES

- A. All horizontal dimensions are from a common datum line.
- B. All vertical dimensions are from a common datum line.

(NOTE: This method is used to draw parts that are to be numerically machined.)

Examples:

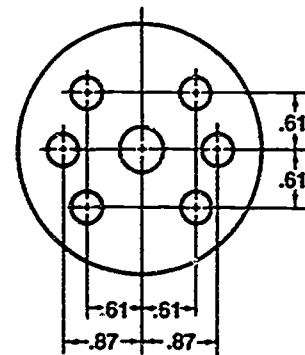
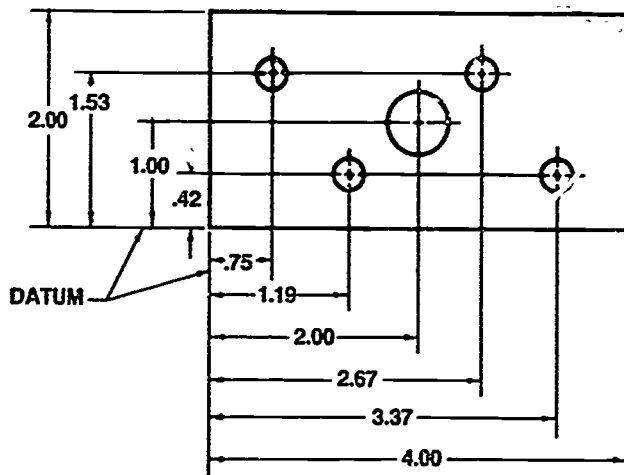

ASSIGNMENT SHEET #11

PROBLEMS: Dimension the following objects using correct dimensioning procedures. Measure with a scale.

Problem A:

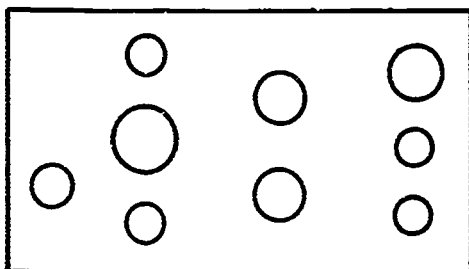

Problem B:

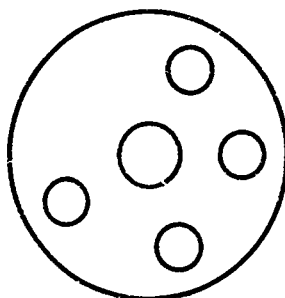

DIMENSIONING
UNIT XVIIASSIGNMENT SHEET #12 — DIMENSION AN OBJECT USING A
POLAR COORDINATE SYSTEM

NAME _____ SCORE _____

Directions: Study the following guidelines and example and then complete the assigned problem.

GUIDELINES

- A. Give a radial dimension from the center of the pattern in the form of a diameter.
- B. Give angular dimensions from a datum.

(NOTE: This is used when holes or other features to be located lie in a circular or radial pattern.)

Example:

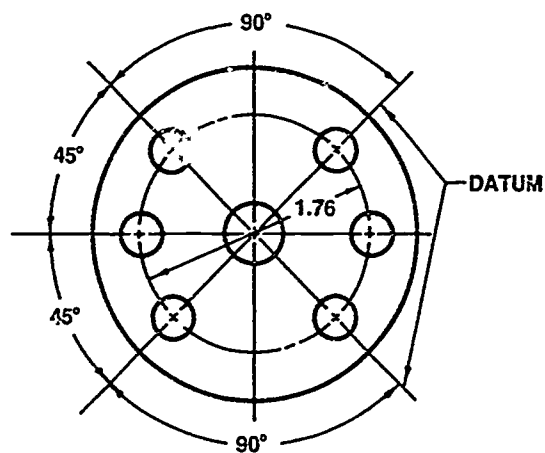

ASSIGNMENT SHEET #12

Problem: Dimension the following object using correct dimensioning procedures. Measure with a scale.

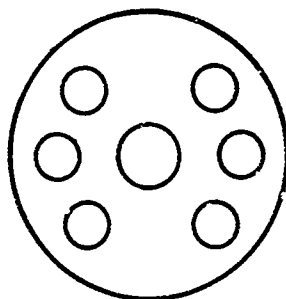

**DIMENSIONING
UNIT XVII**

**ASSIGNMENT SHEET #13 — DIMENSION AN OBJECT USING
A TABULAR COORDINATE SYSTEM**

NAME _____ SCORE _____

Directions: Study the following guidelines and example and then complete the assigned problem.

GUIDELINES

- A. Dimension placement is the same as for rectangular coordinate dimensioning, using horizontal and vertical datum planes.
- B. Dimension figures are not applied directly to the views but are placed in a table and the holes are labeled with a code letter.

Example:

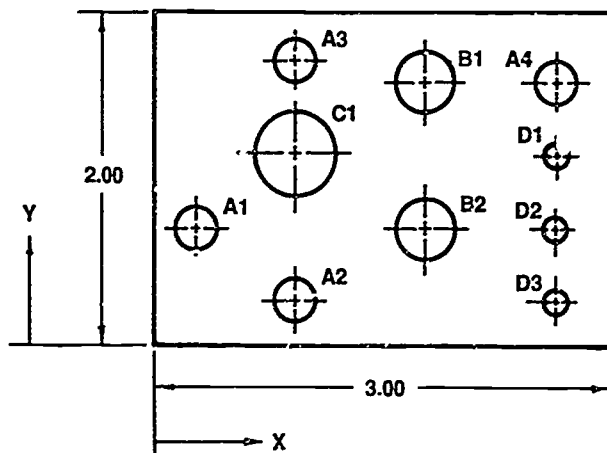

		REQ'D	4	2	1	3
		HOLE DIA	.250	.312	.500	.125
POSITION		HOLE SYMBOL				
X	Y	A	B	C	D	
.250	.625	A1				
1.000	.250	A2				
1.000	1.750	A3				
2.750	1.500	A4				
1.750	1.500		B1			
1.750	.625		B2			
1.000	1.000			C1		
2.750	1.000					D1
2.750	.625					D2
2.750	.250					D3

ASSIGNMENT SHEET #13

PROBLEM: Dimension the following object using correct dimensioning procedures and properly make a chart. Measure with a scale.

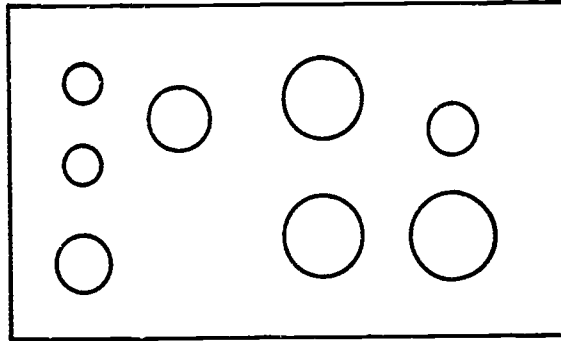

DIMENSIONING UNIT XVII

ASSIGNMENT SHEET #14 — DIMENSION AN OBJECT USING AN ORDINATE DIMENSIONING SYSTEM

NAME _____ SCORE _____

Directions: Study the following guidelines and example and then complete the assigned problem.

GUIDELINES

(NOTE: Other names for the ordinate dimensioning system are zero plane or arrowless dimensioning.)

- A. Dimension placement is the same as for rectangular coordinates in that it uses perpendicular datum planes.
- B. The datum planes are indicated as zero coordinates.
- C. Dimensions from these planes are shown on extension lines without the use of dimension lines or arrowheads.

Example:

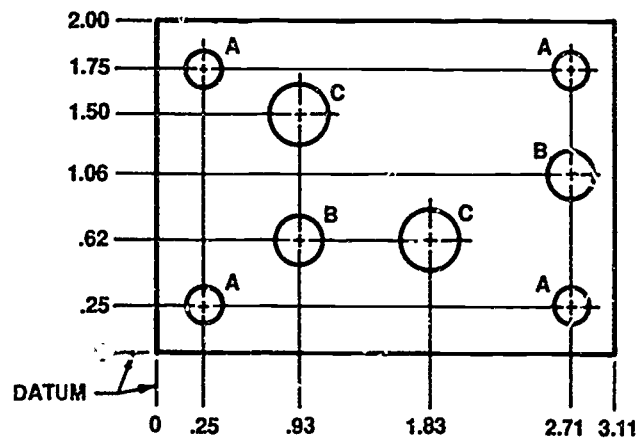

SIZE SYMBOL	A	B	C
HOLE DIA	.250	.312	.375

ASSIGNMENT SHEET #14

PROBLEM: Dimension the following object using correct dimensioning procedures.
Measure with a scale.

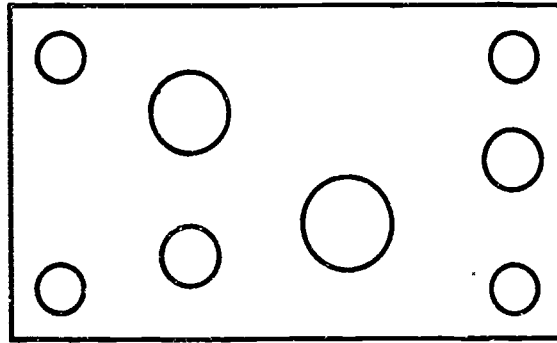

**DIMENSIONING
UNIT XVII****ASSIGNMENT SHEET #15 — DIMENSION COMMON MACHINE
MANUFACTURED FEATURES**

NAME _____ SCORE _____

Directions: Study the following guidelines and examples and then complete the assigned problems.

GUIDELINES

A. Hole operations — Holes are always dimensioned on the view in which they appear as a circle.

1. Drill — Hole sizes are always specified by diameter, never by radius. The diameter is given in a common fraction or in decimal form.

(NOTE: For drills designated by number or letter, the decimal size must be given. A drill that does not go all the way through is a blind drill and depth must be included.)

Example:

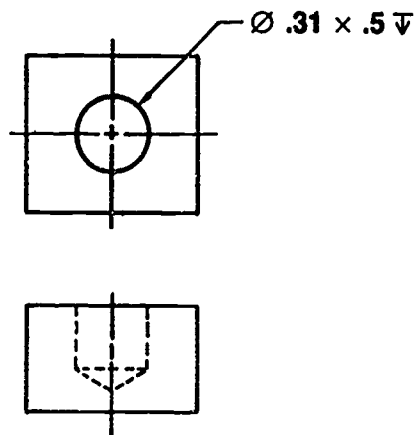

ASSIGNMENT SHEET #15

2. Bore — Hole diameter is specified in decimal form and the word BORE follows the size.

Example:

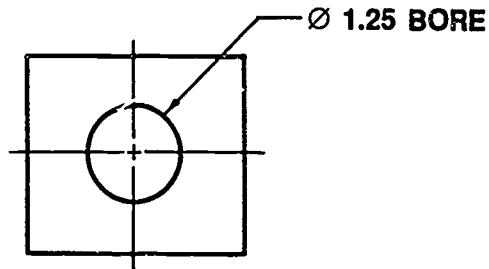

3. Ream — Pre-drill size is specified first, then the ream size in decimal form, followed by the word REAM.

Example:

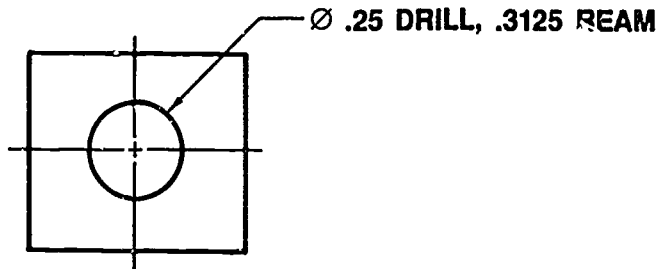

(NOTE: It is not always necessary to indicate drill or ream. The number of decimal places will indicate process.)

- B. Counterdrill — Diameter of first drill is given first, then the diameter of the second drill and the depth.

Example:

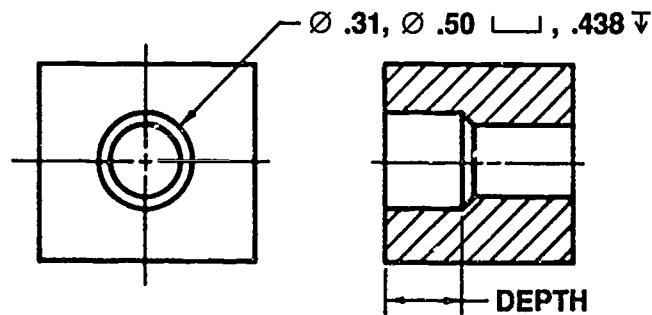

ASSIGNMENT SHEET #15

- C. Counterbore — Diameter of the drill is given first, then the diameter of the bore and the depth it is to be cut.

Example:

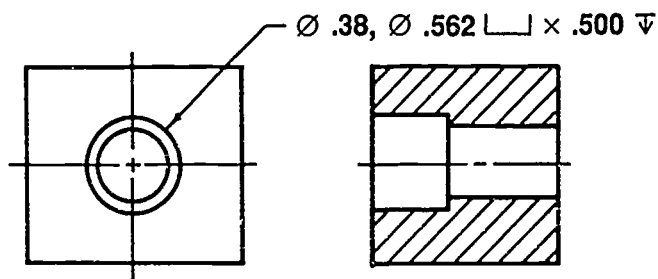

- D. Countersink — Diameter of the drill is given first, then the diameter of the top of countersink by the included angle of the countersink.

(NOTE: The standard countersink for manufacturing is 82° .)

Example:

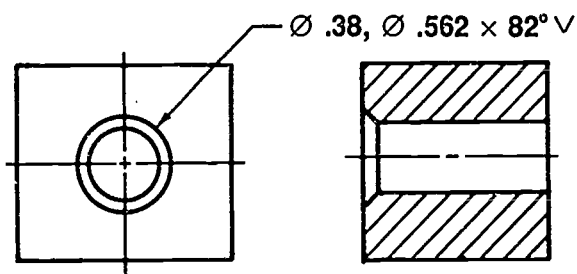

- E. Spot faced — Diameter of the drill is given first, then the diameter of the spot face is given. The depth is not normally given for a spot face.

(NOTE: Common practice is for a spot face to be cut $1/16$ " deep.)

Example:

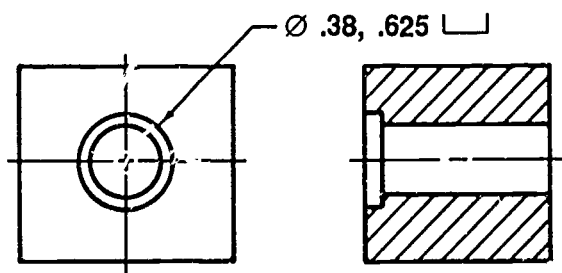

ASSIGNMENT SHEET #15

F. Tapers — There are three methods of dimensioning a taper. The accuracy required and the machine process available to cut the taper will determine the method to use.

1. Standard machine tapers — The diameter, usually at the large end, and the length are applied to the view in the form of dimensions. The actual taper is given as a note such as "NO. 4 AMER NATL STD TAPER."

Example:

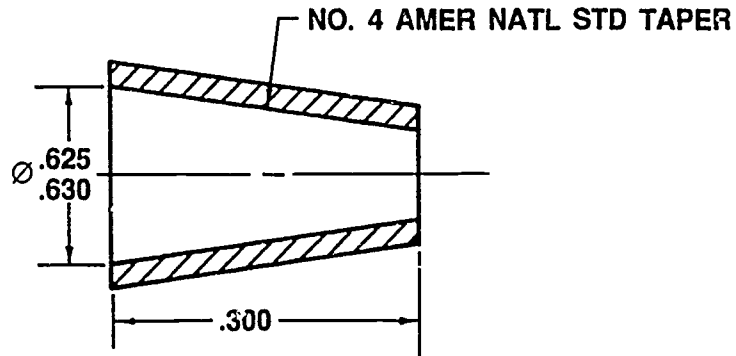

2. Non-critical tapers — The diameter at the large end, the length, and the included angle are applied to the view in the form of dimensions.

Example:

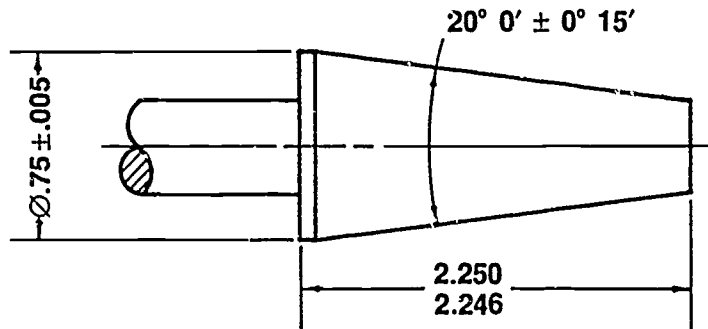

ASSIGNMENT SHEET #15

3. Critical tapers — The diameter of the large end and the length are applied to the view as dimensions and the "taper per unit on diameter" is indicated in a note.

(NOTE: Taper on diameter means the difference in diameter per unit of length.)

Example:

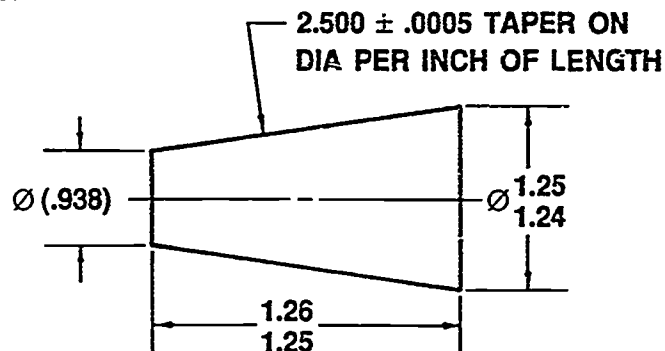

G. Knurl

1. Diamond pattern

- a. Coarse knurl (33 pitch)

(NOTE: Pitch is the distance between two points per inch.)

- b. Medium knurl (21 pitch)
- c. Fine knurl (14 pitch)

2. Straight pattern

- a. Coarse knurl (33 pitch)
- b. Medium knurl (21 pitch)
- c. Fine knurl (14 pitch)

ASSIGNMENT SHEET #15

3. The pitch, type of knurl, and the minimum diameter after knurling are applied to the view in the form of a note.

Examples:

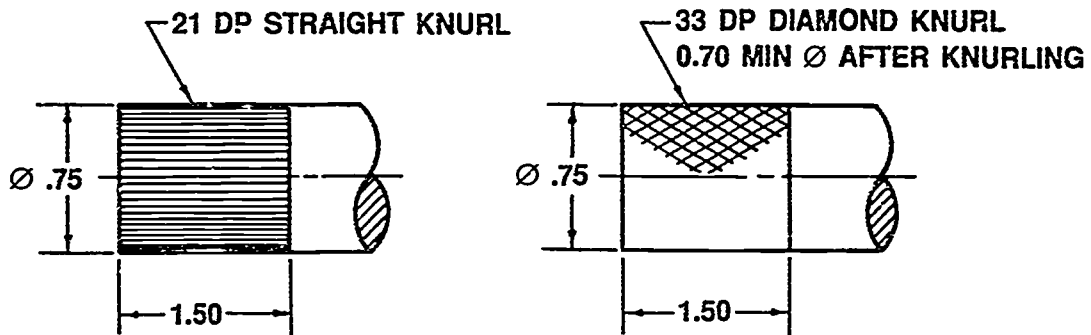

- H. Chamfer — The length of the offset and the angle are applied to the view. A note may be used to specify 45° chamfers only.

Example:

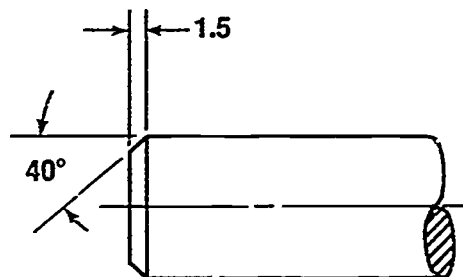

I. Threads

1. Internal thread

- a. Through-drill — The following items are applied to the view in the form of a note: Nominal diameter, threads per inch, thread form and series, class of thread, letter A (for internal), and LH (if it is left-handed).

(NOTE: Tap drill size is determined by referring to American National Standard Thread tables, (ANSI Y14.6-1978), Machinery Handbook, or various textbook appendixes. Thread callouts may be designated by a fraction or a decimal figure.)

ASSIGNMENT SHEET #15

Example:

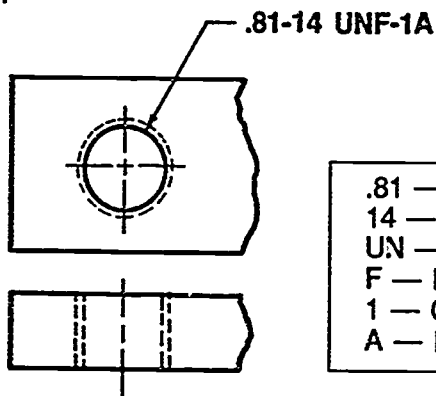

.81 — Nominal diameter
 14 — Threads per inch
 UN — Unified thread form
 F — Fine thread series
 1 — Class 1 thread fit
 A — Internal thread

- b. Blind drill — The following items are applied to the view in the form of a note: Tap drill size, depth of tap drill, nominal thread diameter, threads per inch, thread form and series, class of thread fit, A (for internal), LH (if it is left handed), and depth of thread.

Example:

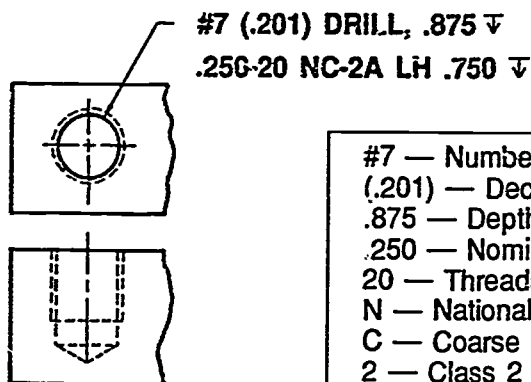

#7 — Number size of tap drill
 (.201) — Decimal size of tap drill
 .875 — Depth of tap drill
 .250 — Nominal thread diameter
 20 — Threads per inch
 N — National thread form
 C — Coarse thread series
 2 — Class 2 thread fit
 A — Internal thread
 LH — Left hand threads
 .750 — Depth of thread

ASSIGNMENT SHEET #15

2. External thread — The following items are added to the view in the form of a note: nominal thread diameter, threads per inch, thread form and series, class of thread fit, B (for external), and LH (if it is left handed).

Example:

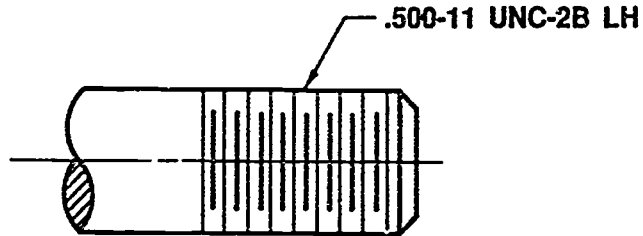

- J. Keyways — The size and number of the required key is given in the form of a note and the location on the shaft of the keyway is given in the form of dimensions on the two views showing the keyway.

(NOTE: Notice the use of a dimension to center the keyway in the shaft.)

Example:

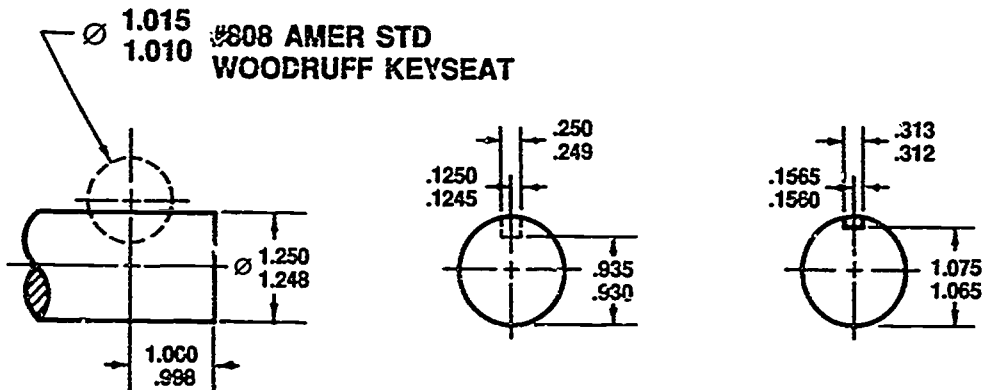

981

ASSIGNMENT SHEET #15

- K. Keyseats — The size and location of the slot is given in the form of dimensions applied to the view.

(NOTE: The proper clearance for various keys can be obtained from a machinists' handbook.)

Example:

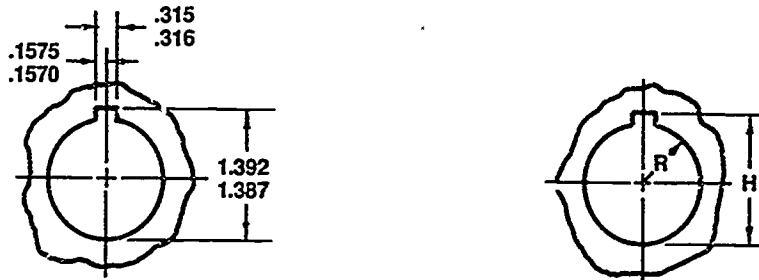

- L. Relief groove — The width and depth of a relief can be given by placing dimensions on the view or in the form of a note.

Example:

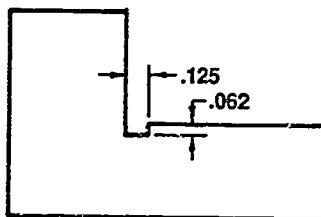

Using Dimensions

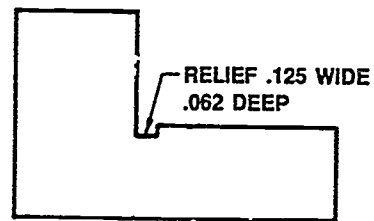

Using a Note

ASSIGNMENT SHEET #15

- M. Neck — The width and depth of a neck can be given by placing dimensions on the view or in the form of a note.

Example:

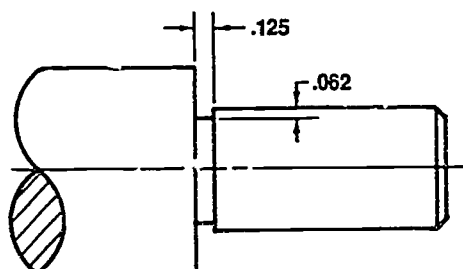

Using Dimensions

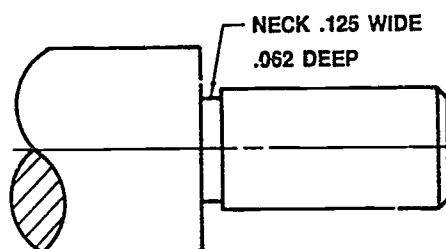

Using a Note

PROBLEMS: Dimension the following standard features correctly by adding all necessary notes and dimensions to the views. Measure with a scale unless given.

Problem A: Blind drill \varnothing .51-.50

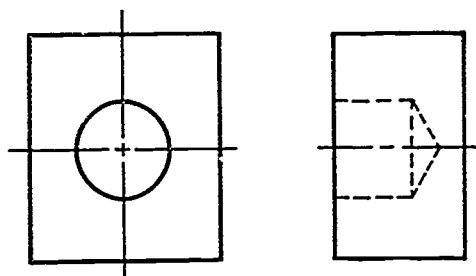

ASSIGNMENT SHEET #15

Problem B: 1.500 Ø bore

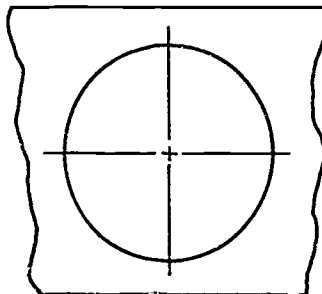

Problem C: .50 Ø drill and .562 Ø ream

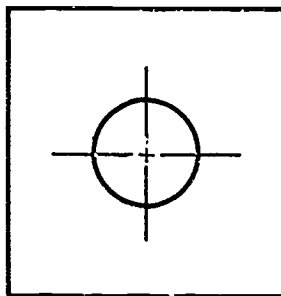

Problem D: Size of counterdrill

Problem E: Size of counterbore

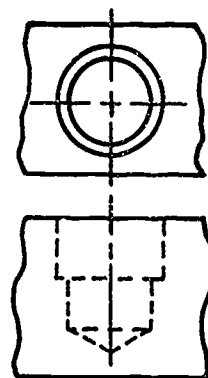
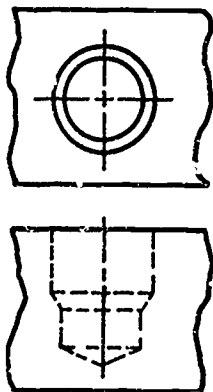

ASSIGNMENT SHEET #15

Problem F: Size of countersink

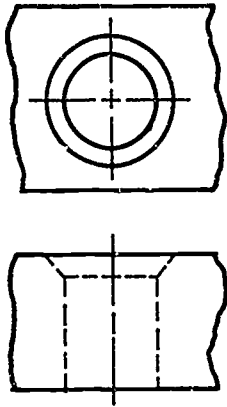

Problem G: Size of spot face

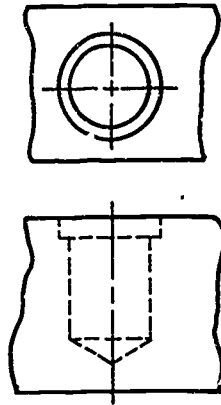

Problem H: Tapers

1. Standard machine taper labeled with an American National Standard taper #4

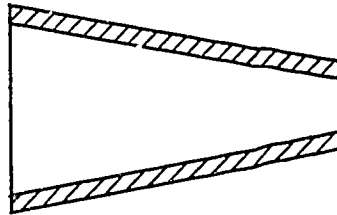

2. Size of non-critical taper

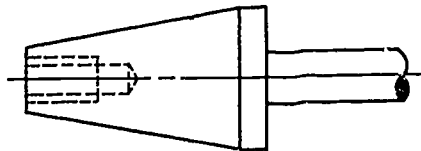

ASSIGNMENT SHEET #15

3. Size of critical taper

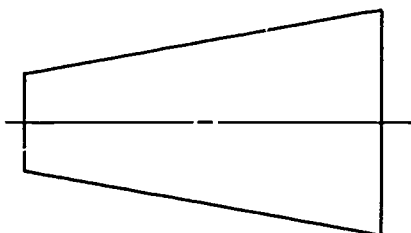

Problem I: Size and type of coarse knurl

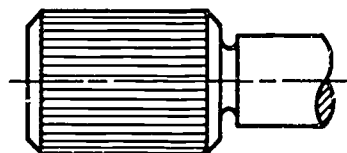
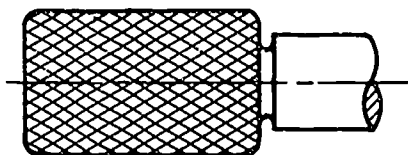

Problem J: Size of metric chamfers



ASSIGNMENT SHEET #15

Problem K: Threads

1. Internal through drill

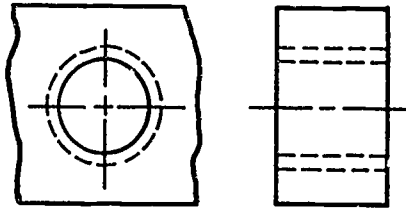

2. Internal blind drill

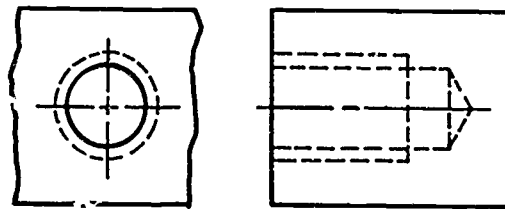

3. External left-handed thread

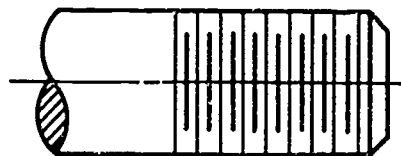

ASSIGNMENT SHEET #15

Problem L: Size of keyseat

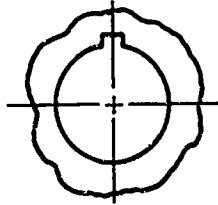

Problem M: Size of relief groove

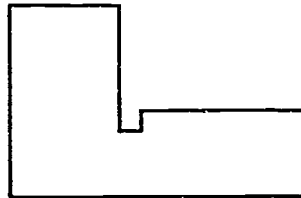

Problem N: Size of neck

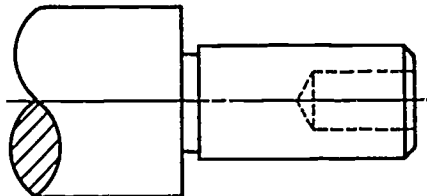

**DIMENSIONING
UNIT XVII****ANSWERS TO ASSIGNMENT SHEETS**

The following criteria should be used to evaluate each assignment sheet.

1. Placement of dimensions
2. Lettering
3. Neatness
4. Placement of extension lines, leader lines, and center lines
5. Symbols
6. Notations

DIMENSIONING UNIT XVII

JOB SHEET #1 -- APPLY DIMENSIONS TO CADD DRAWINGS

A. Tools and materials

1. CADD system
2. Operator's manual
3. Parts file storage diskette

B. Procedure

1. Log on to the CADD system and load your parts file storage diskette.

(NOTE: If parts are loaded on a hard disk, enter system's level and pull up a list of your parts file.)

2. Pull up on screen a list of all your parts that are on file.
3. With your instructor's help, determine which parts should be dimensioned.
4. Review with your instructor the proper procedure for dimensioning on your CADD system. Refer to the operator's manual for specific instruction.

(NOTE: Some systems may have a help file that will show the dimensioning procedures.)

5. Proceed to add dimensions and necessary text to the different drawings.
6. File completed drawings for future use.
7. Print or plot a hardcopy of the dimensioned drawings for evaluation by your instructor.

Evaluation Criteria	
Criteria	Rating
Parts are correctly dimensioned	_____
Updated drawings are correctly filed	_____

DIMENSIONING UNIT XVII

TEST

NAME _____ SCORE _____

1. Match the terms on the right with their correct definitions.

- | | | | |
|----------|---|-----|--------------------------|
| _____ a. | A slanted flat surface not a 90° to another surface | 1. | Actual size |
| _____ b. | A symbol used to indicate a surface to be machined | 2. | Associative dimensioning |
| _____ c. | Points, lines, or other geometric shapes assumed to be exact from which the location or geometric features of a part may be established | 3. | Automatic dimensioning |
| _____ d. | Measured size of an object | 4. | Bevel |
| _____ e. | A slight bevel removed from an edge | 5. | Blind hole |
| _____ f. | A tool with a pointed cutting edge used to make a hole in hard surfaces | 6. | Bore |
| _____ g. | The means by which a CADD dimensioning program automatically updates the dimensions as the geometry changes | 7. | Boss |
| _____ h. | A second, larger drill along the same center line as a first drill, but not as deep | 8. | Chamfer |
| _____ i. | An enlargement of the end of a hole to a specified diameter and depth | 9. | Counterbore |
| _____ j. | A gradual decrease or change of diameter from one end to the other | 10. | Counterdrill |
| _____ k. | A dimension used for information purposes only; does not govern production or inspection operations | 11. | Countersink |
| _____ l. | Exceeding what is sufficient or necessary | 12. | Datum |
| _____ m. | A funnel-like bevel at the surface end of a drilled hole; standard included angle is 82° | 13. | Die |
| | | 14. | Drill |
| | | 15. | Finish mark |
| | | 16. | Knurl |
| | | 17. | Nominal |
| | | 18. | Radial |
| | | 19. | Ream |
| | | 20. | Relief groove |
| | | 21. | Reference dimension |

TEST

- _____n. The process of rolling depressions in the surface of an object
- _____o. A hole not drilled all the way through
- _____p. A tool used to cut internal threads
- _____q. A tool used to cut external threads
- _____r. A raised flat, cylindrical surface providing a flat surface for bolts
- _____s. Designated or theoretical size that may vary from the actual
- 22. Spot face
- 23. Superfluous
- 24. Tabular
- 25. Tap
- 26. Taper

2. Distinguish between size description and shape description by placing an "X" next to the size description.

- _____a. Views that illustrate the shape of an object
- _____b. Notes and dimensions that tell the size of an object

3. Differentiate between the types of dimensions in the accompanying illustration by placing an "L" next to the location dimensions and an "S" next to the size dimensions.

- _____a. Dim. A
- _____b. Dim. B
- _____c. Dim. C
- _____d. Dim. D
- _____e. Dim. E
- _____f. Dim. F

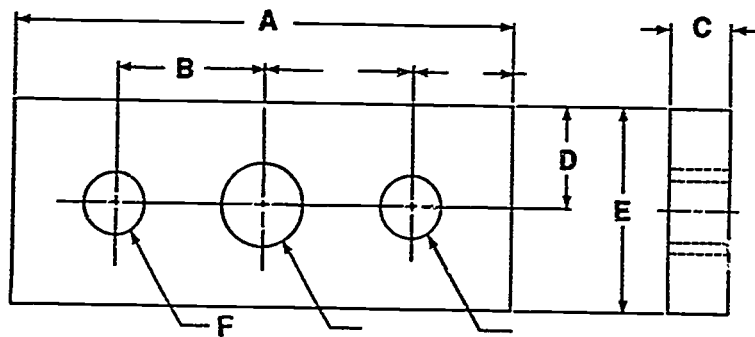

TEST

4. Identify the following systems of placing dimensions.

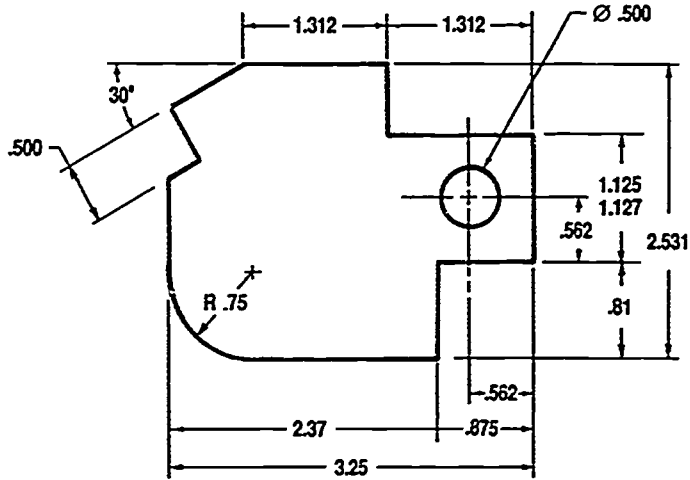

a. _____

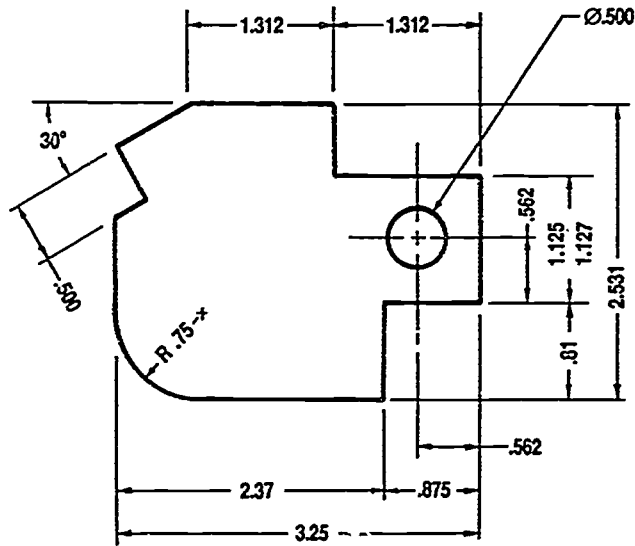

b. _____

TEST

5. State the meanings for the following common abbreviations used in dimensioning.

- | | |
|---------------|----------------|
| a. SF _____ | i. THD _____ |
| b. ANSI _____ | j. DWG _____ |
| c. CHAM _____ | k. CBORE _____ |
| d. TOL _____ | l. MATL _____ |
| e. BEV _____ | m. FAO _____ |
| f. ID _____ | n. LH _____ |
| g. OD _____ | o. KWY _____ |
| h. ASSY _____ | |

6. Match common symbols used in dimensioning with their correct names.

- | | |
|-----------------------|-----------------------------|
| _____ a. R | 1. Arc length |
| _____ b. \square | 2. Conical taper |
| _____ c. ∇ | 3. Counterbore or spot face |
| _____ d. () | 4. Countersink |
| _____ e. \checkmark | 5. Depth (or deep) |
| _____ f. \square | 6. Diameter |
| _____ g. \emptyset | 7. Places, times, or by |
| _____ h. X | 8. Radius |
| | 9. Reference |
| | 10. Square |

7. Identify the basic types of lines used in dimensioning.

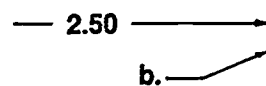
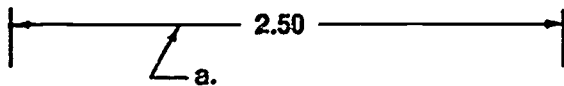

- a. _____ b. _____

TEST

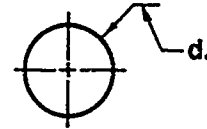
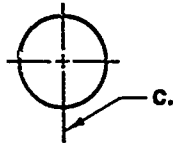

c. _____

d. _____

8. Differentiate between the correct and incorrect placement of leader lines by placing an "X" next to the leaders that are placed correctly.

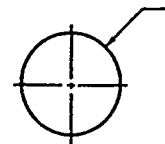
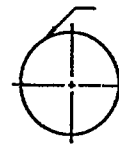
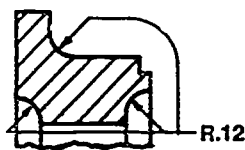
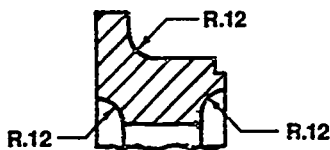

a. _____

b. _____

c. _____

d. _____

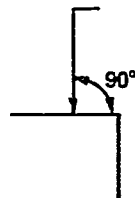
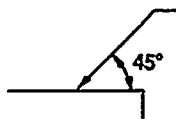

e. _____

f. _____







9. Select true statements concerning the proper techniques for drawing arrowheads by placing a T or F next to the true or false statements.

- _____ a. Arrowheads are drawn with two sharp strokes toward or away from the point.
- _____ b. Length of arrowheads should always be 1/4" long.
- _____ c. Arrowheads always touch extension lines.
- _____ d. Arrowheads are reversed and placed outside the extension lines when space for the dimension is too small.

TEST

10. Distinguish between the two systems for writing dimensional values by placing an "M" next to the description of the metric system.
- _____ a. Millimeter is the basic linear unit.
 - _____ b. Inch is the basic linear unit.
11. Select true statements concerning rules for dimensional figures by placing a T or F next to the true or false statements.
- _____ a. All lettering and numerals must be perfectly legible.
 - _____ b. Standard height of numerals is 1".
 - _____ c. Fractions are four times the height of whole numbers.
 - _____ d. The fraction bar is always drawn at an angle on a view.
 - _____ e. The numerator and denominator of a fraction should touch the fraction bar.
 - _____ f. Never letter a dimension figure over any line on the drawing. Break the line if necessary.
 - _____ g. Make all decimal points bold.
 - _____ h. In a group of parallel dimension lines, the numerals should be stacked one above the other.
12. Select true statements concerning rules for placement of dimensions by placing a T or F next to the true or false statements.
- _____ a. Each dimension should be given clearly so that it can be interpreted in only one way.
 - _____ b. Dimensions may be duplicated at any time.
 - _____ c. Dimensions should be given between points or surfaces that have a functional relation to each other or that control the location of mating parts.
 - _____ d. Dimensions should be given to finished surfaces or important center lines in preference to rough surfaces wherever possible.
 - _____ e. Dimensions need to be complete enough for the machinist.
 - _____ f. Dimensions should be drawn to hidden lines wherever possible.
 - _____ g. Locate all interior features in relation to an outside edge of the part.
 - _____ h. Horizontal and vertical center lines should not be used as reference lines for dimensions.

TEST

- _____ i. Extension lines should end exactly at the arrowhead.
- _____ j. The space between the first dimension line and the part outline should not be less than .40 (10 mm).
13. Arrange in order the steps in applying dimensions to an object by placing the correct sequence numbers (1-5) in the appropriate blanks.
- _____ a. Draw in arrowheads.
- _____ b. Draw extension lines and extend the center lines of the hole to be used in the same manner as extension lines.
- _____ c. Draw in guidelines for figures.
- _____ d. Letter in dimensions.
- _____ e. Use scale to measure dimension line locations with adequate space between each and gaps for dimension figures.
14. Select the correct types of finish marks from the following list.
- _____ a. 
- _____ b. 
- _____ c. 
- _____ d. 
- _____ e. 
- _____ f. 
15. Select true statements concerning rules for finish marks by placing an "X" next to the true statements.
- _____ a. Finish marks should be placed on the edge views of all finished surfaces, including hidden edges and the contour and circular views of cylindrical surfaces.
- _____ b. Finish marks should be used on holes and other features where a note specifies a machining operation.
- _____ c. Finish marks should always be used on parts made from rolled stock.
- _____ d. If a part is finished all over, omit all finish marks, and use the following general note: FINISH ALL OVER or its abbreviation.

TEST

16. Distinguish between the types of notes used on a drawing by placing a "G" next to the description of general note and an "L" next to the local (specific) note description.

- _____ a. Refers to one particular feature and requires the use of a leader
- _____ b. Consists of information which applies to the entire drawing

17. Select true statements concerning rules for notations by placing a T or F next to the true or false statements.

- _____ a. Notes are always placed parallel to the right side of the drawing.
- _____ b. Notes should be brief and clear and contain only pertinent data.
- _____ c. Notes should be spaced far enough from the views not to crowd, but still close enough to eliminate the need for a long leader.
- _____ d. Notes should always be composed so that the various shop operations are listed in the order in which they should be performed.
- _____ e. Use lower case letters for all notes on machine drawings.

18. List one way to avoid superfluous dimensions.

19. Identify the following common machine manufactured features.

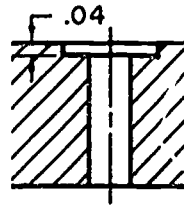
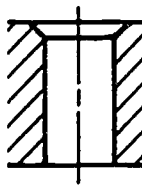
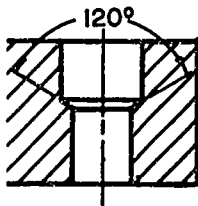
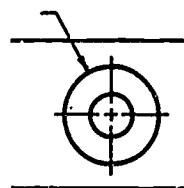
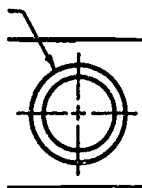
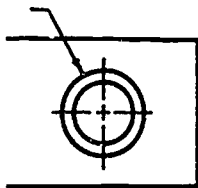

a. _____

b. _____

c. _____

TEST

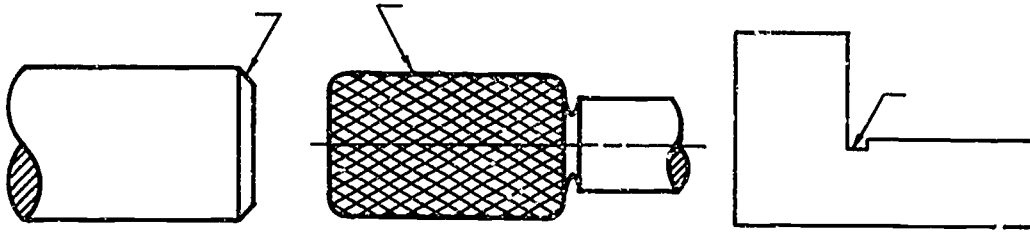

d. _____ e. _____ f. _____

20. Select true statements concerning rules for dimensioning common machine manufactured features by placing a T or F next to the true or false statements.

- _____ a. "R" precedes all radii dimensions
- _____ b. The center of a radius is shown by a dot and only one arrowhead is used.
- _____ c. Available space determines whether the dimension figure goes inside or outside the arc.
- _____ d. A circle is always dimensioned by its radius.
- _____ e. The diameter symbol follows all diameter values.
- _____ f. Cylinders should be located by their radius.
- _____ g. Drill sizes are preferably expressed in fractions.
- _____ h. Cylinders should be located in the circular views, if possible.
- _____ i. Cylinders should always be located by angular dimensions where accuracy is important.
- _____ j. When a dimension is not to scale, it should be placed in parentheses.

21. Distinguish between the typical CADD commands for changing linetypes by placing the following letters next to the correct descriptions:

- C — Change line font
- S — Select line font

- _____ a. Will change the line to whatever linetype is requested
- _____ b. Will change a solid line to dashed when used with a linetype such as a dash

TEST

22. Select true statements concerning dimensioning on a CADD system by placing a T or F next to the true or false statements.
- _____ a. Dimensioning on CADD is a model mode activity.
 - _____ b. Dimensions created on CADD will reflect true size of the part regardless of viewing size.
 - _____ c. Most CADD dimensioning is based on ANSI standard Y14.5M-1982.

23. List the two steps for inserting dimensions on CADD.

- a. _____
- b. _____

(NOTE: If the following activities have not been accomplished prior to the test, ask your instructor when they should be completed.)

- 24. Construct arrowheads. (Assignment Sheet #1)
- 25. Dimension arcs. (Assignment Sheet #2)
- 26. Dimension angles. (Assignment Sheet #3)
- 27. Dimension curves. (Assignment Sheet #4)
- 28. Dimension rounded end shapes and slotted holes. (Assignment Sheet #5)
- 29. Dimension spherical objects. (Assignment Sheet #6)
- 30. Dimension cylindrical objects. (Assignment Sheet #7)
- 31. Dimension cones, pyramids, and prisms. (Assignment Sheet #8)
- 32. Dimension features on a circular center line. (Assignment Sheet #9)
- 33. Dimension theoretical points of intersection. (Assignment Sheet #10)
- 34. Dimension an object using a rectangular coordinate system. (Assignment Sheet #11)
- 35. Dimension an object using a polar coordinate system. (Assignment Sheet #12)
- 36. Dimension an object using a tabular coordinate system. (Assignment Sheet #13)
- 37. Dimension an object using an ordinate dimensioning system. (Assignment Sheet #14)
- 38. Dimension common machine manufactured features. (Assignment Sheet #15)
- 39. Demonstrate the ability to apply dimensions to CADD drawings. (Job Sheet #1)

**DIMENSIONING
UNIT XVII**

ANSWERS TO TEST

- | | | | | |
|----|-------|-------|-------|-------|
| 1. | a. 4 | f. 14 | k. 21 | p. 25 |
| | b. 15 | g. 2 | l. 23 | q. 13 |
| | c. 12 | h. 10 | m. 11 | r. 7 |
| | d. 1 | i. 9 | n. 16 | s. 17 |
| | e. 8 | j. 26 | o. 5 | |
-
2. b
-
3. a. S
b. L
c. S
d. L
e. S
f. S
-
4. a. Unidirectional
b. Aligned
-
5. a. Spot face
b. Chamfer
c. American National Standards Institute
d. Tolerance
e. Bevel
f. Inside diameter
g. Outside diameter
h. Assembly
- | | |
|--|--------------------|
| | i. Thread |
| | j. Drawing |
| | k. Counterbore |
| | l. Material |
| | m. Finish all over |
| | n. Left hand |
-
- | | | |
|----|------|-------|
| 6. | a. 8 | e. 4 |
| | b. 3 | f. 10 |
| | c. 5 | g. 6 |
| | d. 9 | h. 7 |
-
7. a. Dimension line
b. Extension line
c. Center line
d. Leader line
-
8. a, d, e

ANSWERS TO TEST

9. a. T
b. F
c. T
d. T
10. a
11. a. T
b. F
c. F
d. F
- e. F
f. T
g. T
h. F
12. a. T
b. F
c. T
d. T
e. T
- f. F
g. T
h. F
i. F
j. T
13. a. 3
b. 1
c. 4
d. 5
e. 2
14. b, d, e, f
15. a, d
16. a. L
b. G
17. a. F
b. T
c. T
d. T
e. F
18. Either one of the following:
- a. Always dimension to shop operation requirements.
b. Never give a dimension more than once in the same view or in different views.

TOLERANCING UNIT XVIII

UNIT OBJECTIVE

After completion of this unit, the student should be able to calculate and dimension fit tolerances and determine tolerances from standard fit tables. Competencies will be demonstrated by completing the assignment sheets and the unit test with a minimum score of 85 percent.

SPECIFIC OBJECTIVES

After completion of this unit, the student should be able to:

1. Match terms related to tolerancing with their correct definitions.
2. Complete statements concerning mating dimensions.
3. Identify the types of tolerances.
4. Distinguish among the general types of fits.
5. Match the standard classes of fits with the correct descriptions.
6. Distinguish between the basic shaft system and the basic hole system.
7. Identify the types of dimensioning systems for tolerances.
8. Illustrate the three ways to show toleranced dimensions on drawings.
9. Select true statements concerning layers on CADD.
10. Distinguish among the three layer commands on CADD.
11. Interpret decimal tolerance dimensions. (Assignment Sheet #1)
12. Calculate and dimension clearance fit tolerances of mating parts. (Assignment Sheet #2)
13. Calculate and dimension interference fit tolerances of mating parts. (Assignment Sheet #3)
14. Calculate and assign tolerances to mating parts using standard fit tables. (Assignment Sheet #4)
15. Construct a drawing using datum dimensioning. (Assignment Sheet #5)

**TOLERANCING
UNIT XVIII****SUGGESTED ACTIVITIES**

- A. Provide student with objective sheet.
- B. Provide student with information and assignment sheets.
- C. Make transparency.
- D. Discuss unit and specific objectives.
- E. Discuss information and assignment sheets.
- F. Show standard fit tables from *USAS (ANSI) B4.1-1967, R1997*, and discuss how to use the tables.
- G. Show part drawings which include specified tolerances.
- H. Contact a local engineering firm and obtain a copy of their CADD layering scheme.
- I. Demonstrate the layering capabilities on your CADD system.
- J. Display a layering scheme to be used in your CADD lab.
- K. Give test.

REFERENCES USED IN DEVELOPING THIS UNIT

- A. Giesecke, Frederick E., et al. *Technical Drawing*, 8th ed. New York: Macmillan Publishing Co., Inc., 1986.
- B. Brown, Walter C. *Drafting for Industry*. South Holland, IL: Goodheart-Willcox Co., Inc., 1984.
- C. Oberg, Erik, et. al. *Machinery's Handbook*, 23rd ed. New York: Industrial Press, Inc., 1988.
- D. American Society of Mechanical Engineers. *Preferred Limits and Fits for Cylindrical Parts*, USAS B4.1-1967, reaffirmed 1987.

**TOLERANCING
UNIT XVIII**

INFORMATION SHEET

I. Terms and definitions

- A. Actual size — The measured size of the finished part
- B. Allowance — The minimum clearance space (or maximum interference) intended between the maximum material condition (MMC) of mating parts

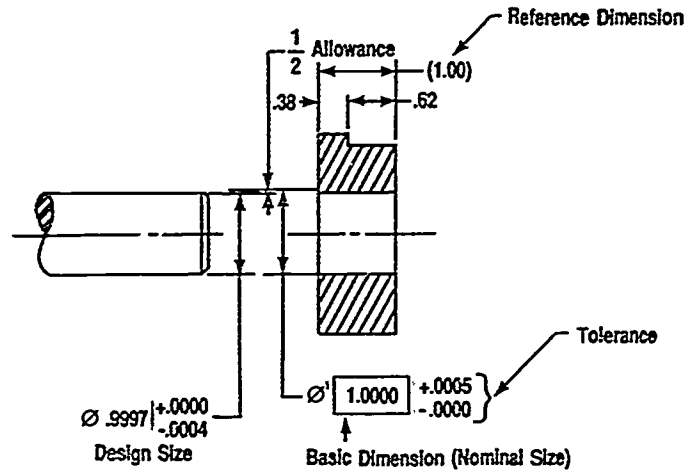

- C. Basic size or dimension — A numerical value used to describe the theoretically exact size, profile, orientation, or location of a feature or datum target; basis from which permissible variations are established

(NOTE: Basic dimensions are indicated on the drawing either by the word BASIC, the abbreviation BSC, or a box around the dimension.)

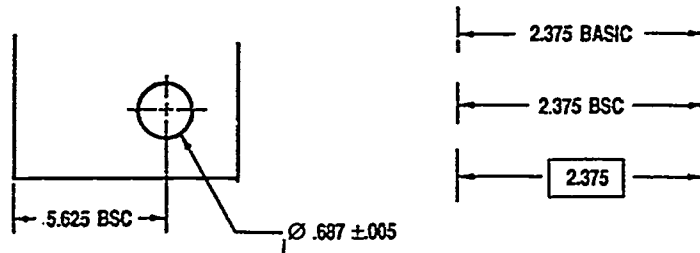

- D. Datums — Points, lines, or other geometric shapes assumed to be exact from which the location or geometric form of features of a part may be established
- E. Datum target — A specific point, line, or area on a part used to establish a datum

INFORMATION SHEET

- F. Design size — The size of a feature after an allowance for clearance has been applied and tolerances have been assigned
- G. Dimension — A numerical value expressed in appropriate units of measurements that define the size, geometric characteristic, or both of a part
- H. Feature — A portion of a part, such as a diameter, hole, keyway, or flat surface
- I. Fit — Degree of tightness or looseness between mating parts
- J. Interchangeability — The condition that refers to a part made to limit dimensions so that it will fit any part similarly manufactured
- K. Limits — The extreme permissible dimensions of a part resulting from the application of a tolerance

Example: 1.002 Maximum (Upper) Limit
 1.000 Minimum (Lower) Limit

- L. Line fit — Unit of size so specified that clearance or interference may result when mating parts are assembled
- M. Nominal size — Designation used for general identification
 (NOTE: Nominal and basic size are often the same. Nominal size may or may not indicate exact size of the product.)
- N. Maximum material condition (MMC) — The condition where the feature size contains the maximum amount of material within the stated limits
 Example: Minimum hole diameter, maximum shaft diameter
- O. Reference dimension — A dimension usually without tolerance used for information purpose only; does not govern production or inspection operations
 (NOTE: Reference dimensions are enclosed in parentheses.)

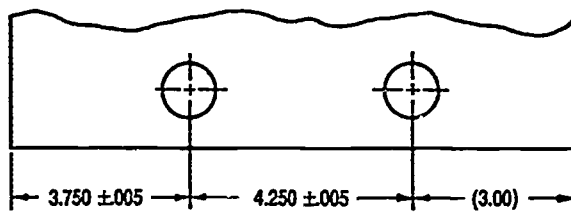

INFORMATION SHEET

- P. Tolerance — The total amount by which a specific dimension is permitted to vary; difference between the maximum and minimum limits

Example: $1.50 \pm .02$
 1.52 Max. Limit
 1.48 Min. Limit $1.52 - 1.48 = .04$ Tolerance

- Q. Tolerancing — System designed to control dimensions to allow interchangeability in manufacturing

- R. Variation — The extent (range) to which a dimension or size varies

ii. Mating dimensions

- A. On two mating parts, certain dimensions must correspond to make the parts fit together. These are mating dimensions.
- B. While the base size will remain the same, the actual values of two corresponding mating dimensions may not be exactly the same because the difference will depend on the accuracy of fit required.

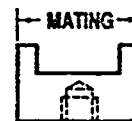
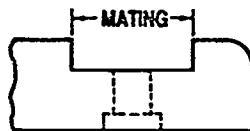
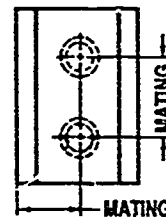
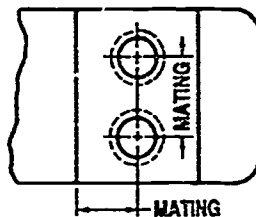
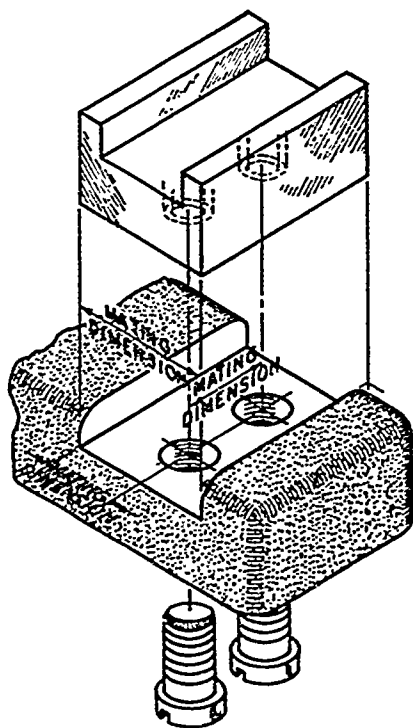

INFORMATION SHEET

III. Type of tolerances

- A. Unilateral tolerance — Variation is permitted in only one direction from the specified dimensions

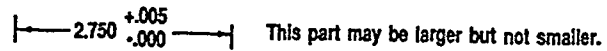

- B. Bilateral tolerance — Variations are permitted in both directions from the specified dimensions

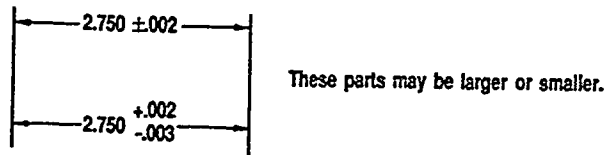

IV. General types of fits (Transparency 1)

- A. Clearance fit — Has limits of size so prescribed that a clearance (space) always results when mating parts are assembled
- B. Interference fit — Has limits of size so prescribed that an interference (contact) always results when mating parts are assembled
- C. Transition fit — Has limits of size so prescribed that an interference (contact) or clearance (space) may result where mating parts are assembled

INFORMATION SHEET

V. Standard classes of fits

- A. Running or sliding fits (RC) — Provide a similar running performance, with suitable lubrication allowance, through all range of sizes

RC1	Close sliding fit	For parts that must assemble without perceptible play
RC2	Sliding fit	Greater clearance than RC1
RC3	Precision running fit	Close fits for precision work at slow speeds and light shaft pressure
RC4	Close running fit	For accurate machinery with moderate surface speeds and pressures
RC5 & RC6	Medium running fit	For high running speeds or heavy shaft pressures
RC7	Free running fit	For use where accuracy is not essential or where large temperature variations exist
RC8 & RC9	Loose running fit	Where wide commercial tolerance may be needed on the external member

INFORMATION SHEET

- B. Locational fits (LC, LT, and LN) — Determine only the location of the mating parts; are divided into three groups

LC1 thru LC11	Locational clearance fits	For parts which are normally stationary, but which can be freely assembled or disassembled; range from snug to loose
LT1 thru LT6	Locational transition fits	Compromise between clearance and interference fits; for use where location is important but small clearance or interference is permissible
LN1 thru LN3	Locational interference fits	Provides accuracy of location for parts requiring rigidity and alignment with no special requirements for bore pressure

- C. Force or shrink fits (FN) — Special type of interference fit normally characterized by constant bore pressures throughout the range of sizes

FN1	Light drive fits	For parts requiring light assembly pressures
FN2	Medium drive fits	For ordinary steel parts or shrink fits on light sections
FN3	Heavy drive fits	For heavier steel parts or shrink fits in medium sections
FN4 &FN5	Force fits	For parts which can be highly stressed

(NOTE: The class symbol and number [ex: FN3] correspond to limit and fit tables developed by USAS(ANSI) in B4.1-1967,R1987. The tables are based on the basic hole system.)

INFORMATION SHEET

VI. Difference between basic shaft system and basic hole system

- A. Basic shaft system — The basic size of the shaft is the design size and the allowance is applied to the hole
- B. Basic hole system — The basic size of the hole is the design size and the allowance is applied to the shaft

VII. Types of dimensioning systems for tolerances

- A. Chain — Features are dimensioned from point to point, such as holes, and may accumulate tolerances that exceed specifications

(NOTE: This is not normally used.)

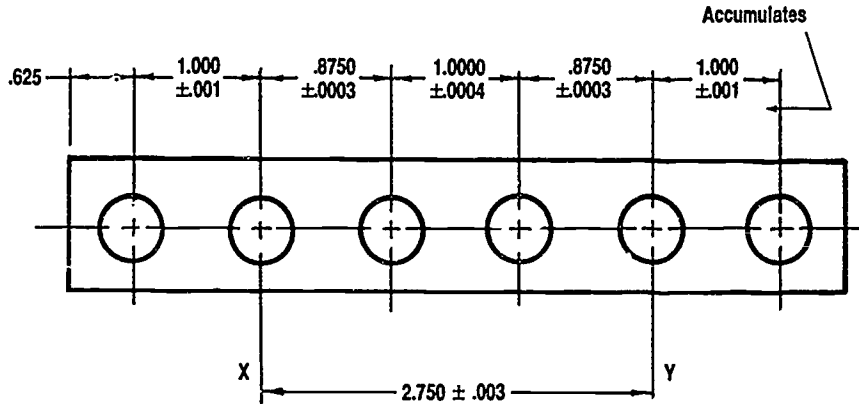

- B. Datum — Features are dimensioned individually from a datum or zero line and avoids accumulation of tolerances

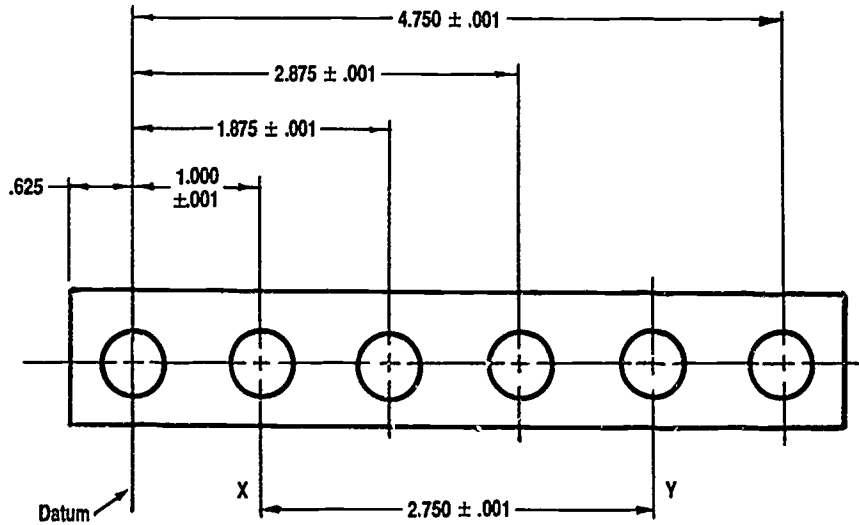

INFORMATION SHEET

VIII. Ways to show toleranced dimensions on drawings

A. Maximum and minimum limits

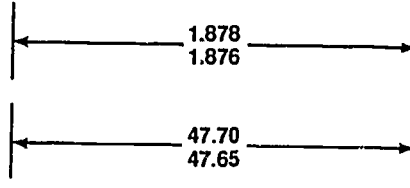

B. Size plus or minus tolerances

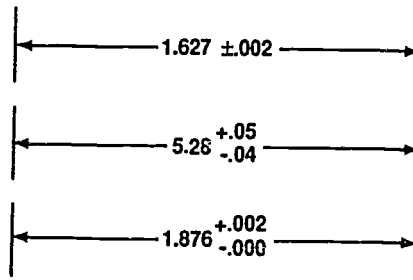

- C. Notes — Separated with a hyphen when part of a note or in cases where all tolerances are the same, it is more convenient to list the information in a note than to list the tolerances separately. Low limit is stated before the high limit.

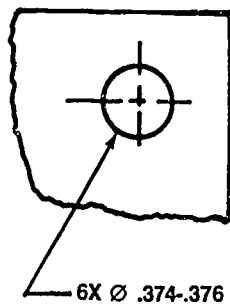

NOTE: TOLERANCES ARE $\pm .002$
UNLESS OTHERWISE SPECIFIED

INFORMATION SHEET**IX. Layers on CADD**

- A. Most systems have the capability to provide multiple layers.
- B. Working on layers is similar to working on a stack of transparent overlays.
- C. Layers are numbered.
- D. Layers are always perfectly registered.
- E. The same drawing limits, coordinate system, and zoom factor apply to all layers.
- F. Layers may be named.
- G. Active work takes place on the selected layer but all layers may be viewed at once.
- H. Most companies develop standard layering schemes.

Example: Layer 0 — Layer index, table of contents
Layer 1-50 — Drawings (all geometry)
Layer 51-100 — Manufacturing information
Layer 101-145 — Dimensions, labels, text
Layer 146-175 — Illustrations

X. Layer commands on CADD

- A. Select layer — Defines the layer on which the system places new geometry
- B. Echo layer — Shows the specific layers that are requested
(NOTE: All or only some layers may be viewed at once.)
- C. Change layer — Used to change the layer of existing geometry by digitizing the geometry to be changed to a different layer

Types of Fits

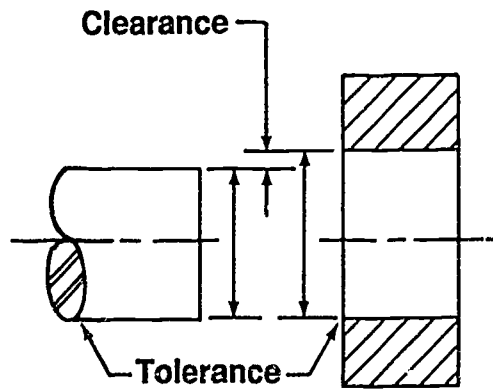

Clearance Fit

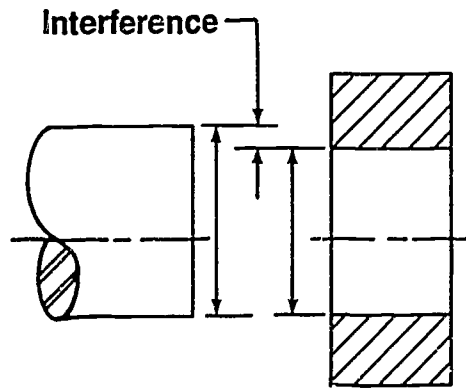

Interference Fit

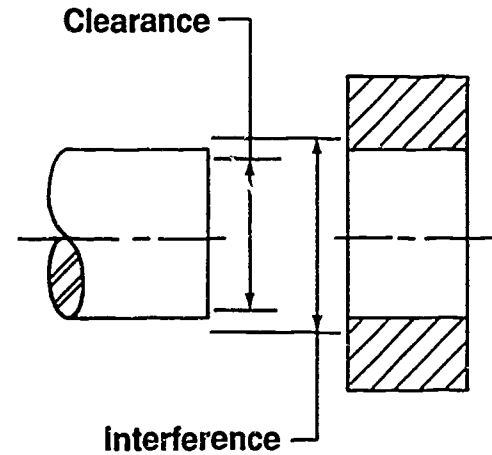

Transition Fit

**TOLERANCING
UNIT XVIII**

**ASSIGNMENT SHEET #1 — INTERPRET DECIMAL
TOLERANCE DIMENSIONS**

NAME _____ SCORE _____

Introduction: Limit dimensioning with decimals is used so that parts that require extreme accuracy can be held between very close maximum and minimum limits. Limits are also used when parts can fit very loosely and still function properly. The dimension is called out as liberally as possible leaving the machinist a margin which increases production and lowers cost. Decimal tolerance dimensions can be expressed by any one of the methods in the following examples.

Examples:

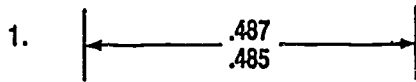

.487 Maximum limit
.485 Minimum limit
.002 Tolerance

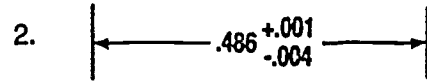

.487 Maximum limit
.482 Minimum limit
.005 Tolerance

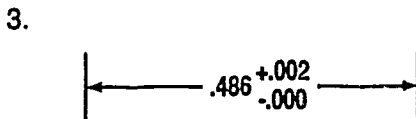

.488 Maximum limit
.486 Minimum limit
.002 Tolerance

4. Shaft basic size 0.750

NOTE: Tolerances $\pm .002$ unless otherwise specified

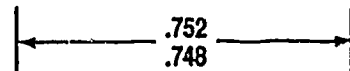

.004 = Tolerance

5. Basic diameter 0.625

Shaft + .000
- .002

Hole +.002
- .000

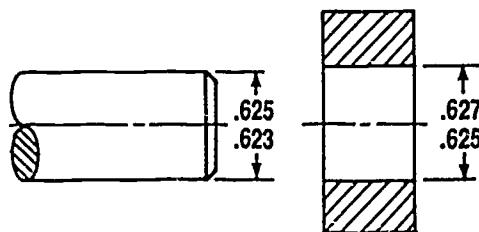

ASSIGNMENT SHEET #1

Directions: Determine decimal tolerance dimensions for the following problems.

Problem A:

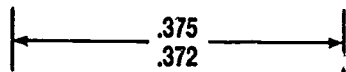

Maximum limit = _____

Minimum limit = _____

Tolerance = _____

Problem B:

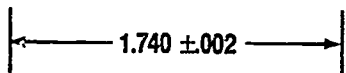

Maximum limit = _____

Minimum limit = _____

Tolerance = _____

Problem C:

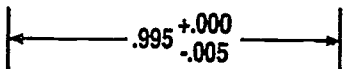

Maximum limit = _____

Minimum limit = _____

Tolerance = _____

**TOLERANCING
UNIT XVIII**

**ASSIGNMENT SHEET #2 — CALCULATE AND DIMENSION CLEARANCE
FIT TOLERANCES OF MATING PARTS**

NAME _____ SCORE _____

Directions: Study the following example and then complete the assigned problems.

Example:

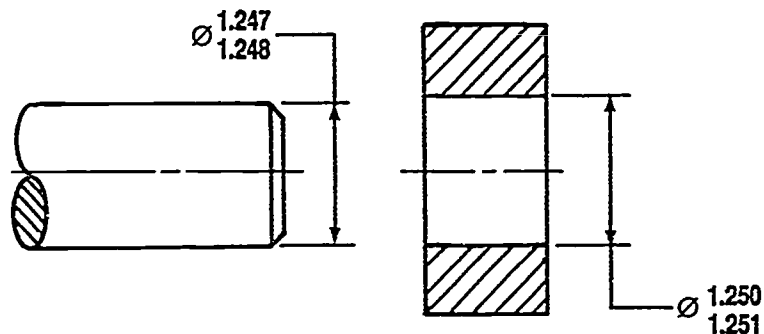

Steps to determine the clearance fit tolerance of mating parts

1. Determine tolerance for shaft.
2. Determine tolerance for hole.
3. Determine allowance.
(NOTE: Allowance is the minimum clearance of mating parts.)
4. Determine maximum clearance.

Example Problem

$1.248 - 1.247 = .001$	Tolerance for shaft
$1.251 - 1.250 = .001$	Tolerance for hole
1.250	Smallest hole diameter limit
1.248	Largest shaft diameter limit
$.002$	Allowance
1.251	Largest hole diameter limit
1.247	Smallest shaft diameter limit
$.004$	Maximum clearance

ASSIGNMENT SHEET #2

Directions: Calculate the tolerances and dimension the following problems.

Problem A:

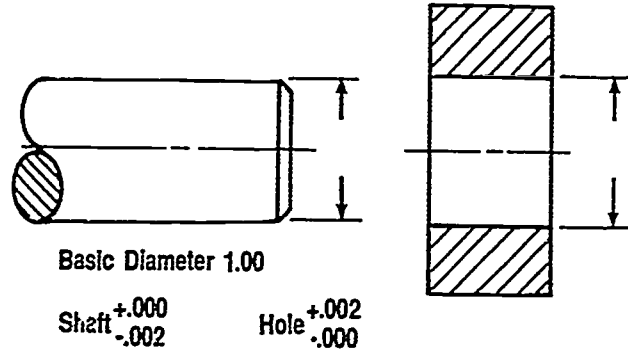

- Tolerance for shaft = _____
- Tolerance for hole = _____
- Allowance = _____
- Maximum clearance = _____

Problem B:

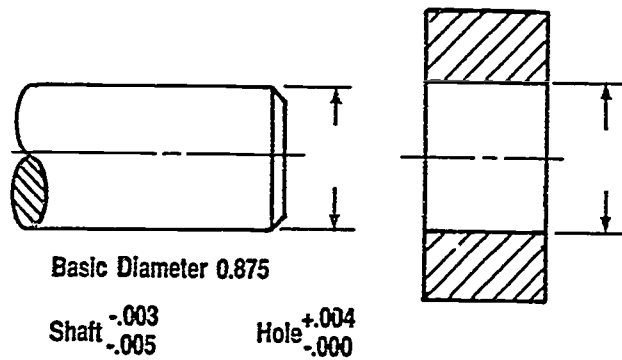

- Tolerance for shaft = _____
- Tolerance for hole = _____
- Allowance = _____
- Maximum clearance = _____

2000

ASSIGNMENT SHEET #2

Problem C: Dimension the shaft to have a tolerance of .004 and a clearance fit with an allowance of .006.

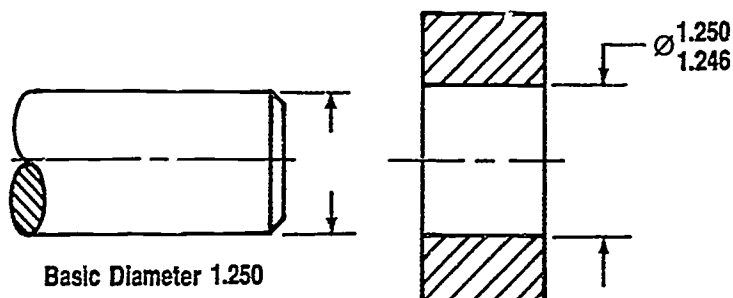

Tolerance for shaft = .004
 Tolerance for hole = _____
 Allowance = .006

Problem D: Dimension the hole to have a tolerance of .010 and a clearance fit with an allowance of .012.

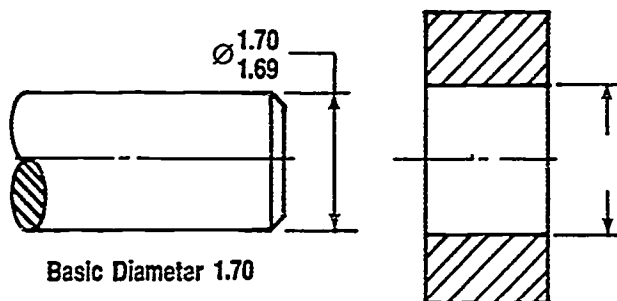

Tolerance for shaft = _____
 Tolerance for hole = .010
 Allowance = .012

1001

TOLERANCING UNIT XVIII

ASSIGNMENT SHEET #3 — CALCULATE AND DIMENSION INTERFERENCE FIT TOLERANCES OF MATING PARTS

NAME _____ SCORE _____

Directions: Study the following example and then complete the assigned problems.

Example:

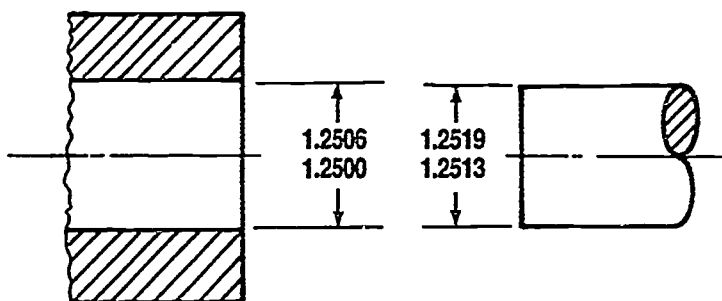

Steps to determine the interference fit tolerance of mating parts

1. Determine tolerance for shaft.
2. Determine tolerance for hole.
3. Determine interference.
4. Determine maximum interference.

Example Problem

$$1.2519 - 1.2513 = .0006 \text{ Tolerance for shaft}$$

$$1.2506 - 1.2500 = .0006 \text{ Tolerance for hole}$$

1.2513	Smallest shaft diameter limit
<u>-1.2506</u>	Largest hole diameter limit
.0007	Interference

1.2519	Largest shaft diameter limit
<u>1.2500</u>	Smallest hole diameter limit
.0019	Maximum interference

ASSIGNMENT SHEET #3

Directions: Calculate the tolerances and dimension the following problems.

Problem A:

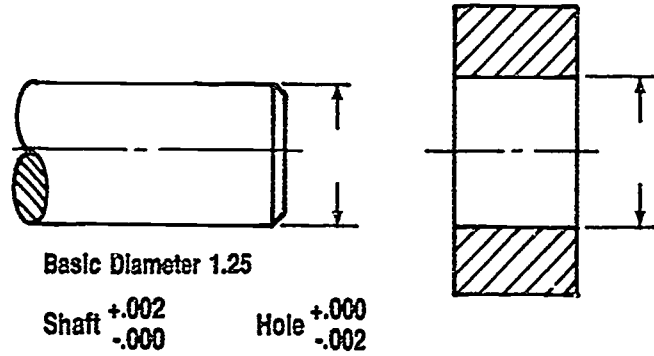

Tolerance for shaft = _____

Tolerance for hole = _____

Interference = _____

Problem B:

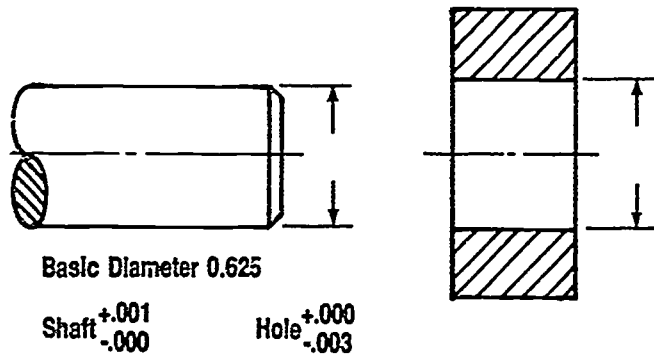

Tolerance for shaft = _____

Tolerance for hole = _____

Interference = _____

ASSIGNMENT SHEET #3

Problem C: Dimension the hole to have a tolerance of .006 and an interference of .007.

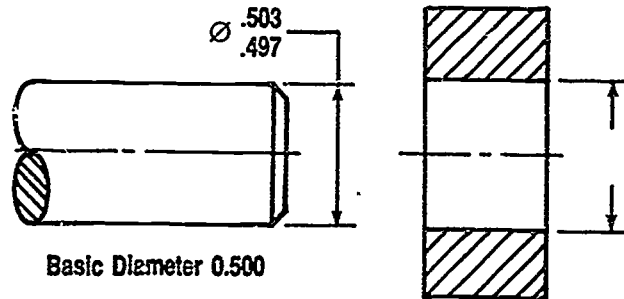

Tolerance for shaft = _____

Tolerance for hole = .006

Interference = .007

Problem D: Dimension the shaft to have a tolerance of .006 and an interference of .009.

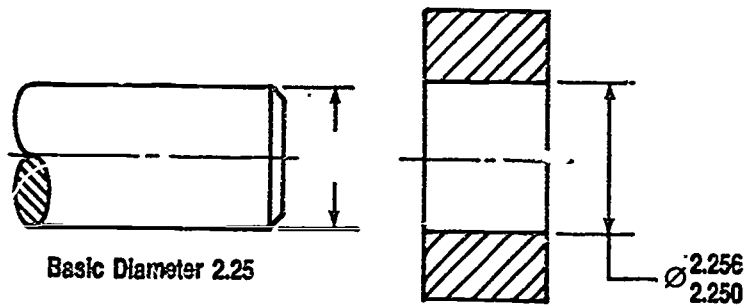

Tolerance for shaft = .006

Tolerance for hole = _____

Interference = .009

TOLERANCING UNIT XVIII

ASSIGNMENT SHEET #4 — CALCULATE AND ASSIGN TOLERANCES TO MATING PARTS USING STANDARD FIT TABLES

NAME _____ SCORE _____

Directions: Study the following example and then complete the assigned problems

Example: Find the limits if an RC2 fit is required for 1 $\frac{3}{4}$ " nominal size.

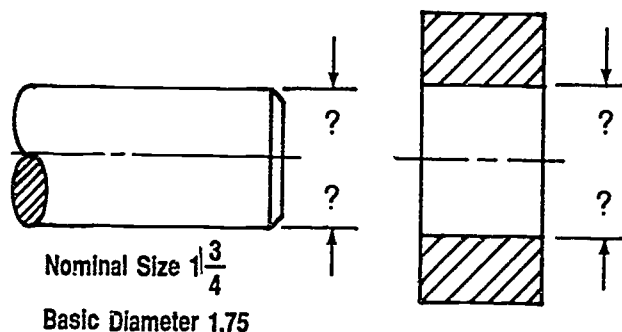

Steps to determine the limit dimensions of mating parts from standard fit tables

1. Locate the RC2 fit column in *USAS B4.1 - 1967, H1987*, Table 5 for Running and Sliding Fits. Part of the table is as follows:

Nominal Size Range inches		Class RC 1			Class RC 2			Class RC 3		
		Limits of Clearance	Standard Limits		Limits of Clearance	Standard Limits		Limits of Clearance	Standard Limits	
			Hole H5	Shaft g4		Hole H6	Shaft g5		Hole H7	Shaft f6
Over	To									
0	0.12	0.1 0.45	+0.2 0	-0.1 -0.25	0.1 0.55	+0.25 0	-0.1 -0.3	0.3 0.95	+0.4 0	-0.3 -0.55
0.12	0.24	0.15 0.5	+0.2 0	-0.15 -0.3	0.15 0.65	+0.3 0	-0.15 -0.35	0.4 1.12	+0.5 0	-0.4 -0.7
0.24	0.40	0.2 0.6	+0.25 0	-0.2 -0.35	0.2 0.85	+0.4 0	-0.2 -0.45	0.5 1.5	+0.6 0	-0.5 -0.9
0.40	0.71	0.25 0.75	+0.3 0	-0.25 -0.45	0.25 0.95	+0.4 0	-0.25 -0.55	0.6 1.7	+0.7 0	-0.6 -1.0
0.71	1.19	0.3 0.95	+0.4 0	-0.3 -0.55	0.3 1.2	+0.5 0	-0.3 -0.7	0.8 2.1	+0.8 0	-0.8 -1.3
1.19	1.97	0.4 1.1	+0.4 0	-0.4 -0.7	0.4 1.4	+0.6 0	-0.4 -0.8	1.0 2.6	+1.0 0	-1.0 -1.6
1.97	3.15	0.4 1.2	+0.5 0	-0.4 -0.7	0.4 1.6	+0.7 0	-0.4 -0.9	1.2 3.1	+1.2 0	-1.2 -1.9

From *USAS B4.1-1967(H1987)*. Reprinted with permission of ASME.

ASSIGNMENT SHEET #4

2. Find the nominal size range of the hole and shaft. 1.750 falls between 1.19 - 1.97.
3. Move across to the RC2 column and read the limits given for the hole (+0.6 and 0) and shaft (-0.4 and -0.8).

(NOTE: To conserve space, all values for limits of holes and shafts in standard fit tables are expressed in thousandths of an inch.)

4. Convert the values in the table to thousandths of an inch by multiplying by one-thousandth (.001).

$$\begin{aligned} +0.6 \times .001 &= +.0006 \\ -0.4 \times .001 &= -.0004 \\ -0.8 \times .001 &= -.0008 \end{aligned}$$

5. Add (or subtract) these to the basic size.

SHAFT		HOLE	
1.7500	1.7500	1.7500	1.7500
<u>-.0004</u>	<u>-.0008</u>	<u>± .0006</u>	<u>-.0000</u>
1.7496	1.7492	1.7506	1.7500

6. Assign limit dimensions to drawings.

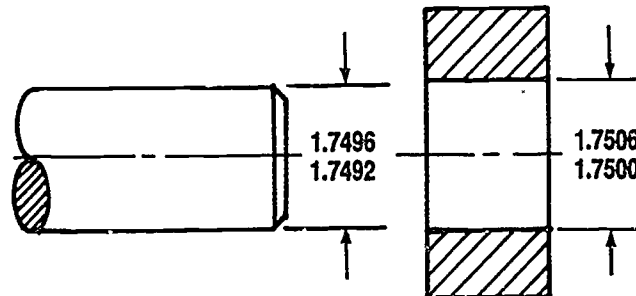

7. Check limits of clearance or interference of fits after calculations have been made.
 - a. Allowance = $1.7500 - 1.7496 = .0004 = 0.4$
 - b. Maximum clearance = $1.7506 - 1.7492 = .0014 = 1.4$
 - c. Read from RC2 limits of clearance table; 0.4 and 1.4.
 - d. Calculations are correct.

ASSIGNMENT SHEET #4

Directions: Calculate and assign tolerances for the following problems. Standard fit tables are on the last page of this assignment or use the tables from *USAS B4.1—1967, R1987*.

Problem A:

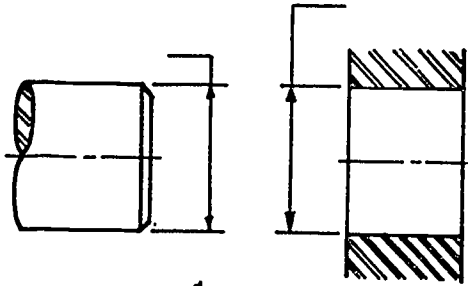

Nominal Size is $\frac{1}{2}$ DIA

Tolerance for FN 2

Problem B:

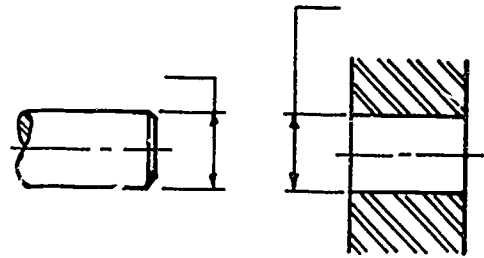

Nominal Size is $\frac{3}{4}$ DIA

Tolerance for LT 2

Problem C:

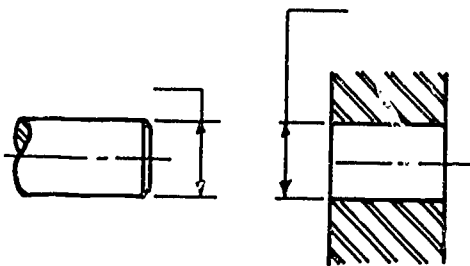

Nominal Size is $\frac{5}{8}$ DIA

Tolerance for LC 2

Problem D:

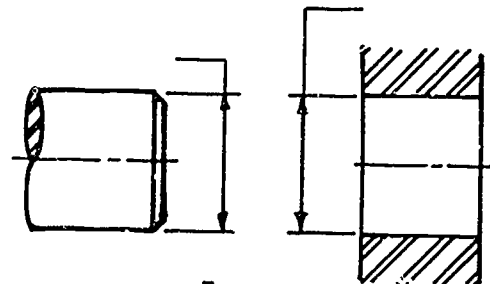

Nominal Size is $\frac{7}{8}$ DIA

Tolerance for RC 1

ASSIGNMENT SHEET #4

Problem E:

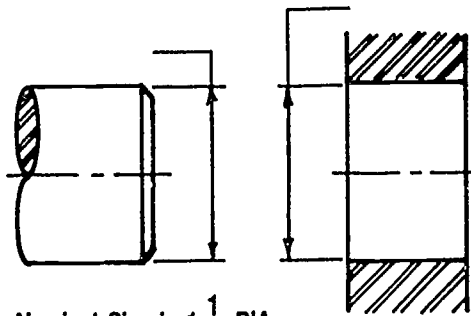

Nominal Size is $1\frac{1}{8}$ DIA

Tolerance for LN 2

Problem F:

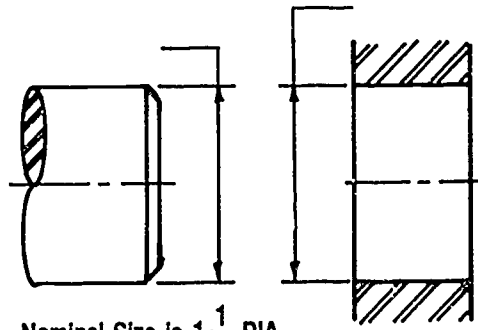

Nominal Size is $1\frac{1}{4}$ DIA

Tolerance for FN 2

Nominal Size Range Inches		Class RC 2		
		Limits of Clearance	Standard Limits	
Over	To		Hole H6	Shaft g5
0	— 0.12	0.1 0.55	+0.25 0	-0.1 -0.3
0.12	— 0.24	0.15 0.65	+0.3 0	-0.15 -0.35
0.24	— 0.40	0.2 0.85	+0.4 0	-0.2 -0.45
0.40	— 0.71	0.25 0.95	+0.4 0	-0.25 -0.55
0.71	— 1.19	0.3 1.2	+0.5 0	-0.3 -0.7
1.19	— 1.97	0.4 1.4	+0.6 0	-0.4 -0.8

Nominal Size Range Inches		Class LC 2		
		Limits of Clearance	Standard Limits	
Over	To		Hole H7	Shaft h6
0	— 0.12	0 0.65	+0.4 -0	+0 -0.25
0.12	— 0.24	0 0.8	+0.5 0	+0 -0.3
0.24	— 0.40	0 1.0	+0.6 0	+0 -0.4
0.40	— 0.71	0 1.1	+0.7 0	+0 -0.4
0.71	— 1.19	0 1.3	+0.8 -0	+0 -0.5
1.19	— 1.97	0 1.6	+1.0 -0	+0 -0.6

Nominal Size Range Inches		Class LN 2		
		Limits of Interference	Standard Limits	
Over	To		Hole H7	Shaft p6
0	— 0.12	0 0.65	+0.4 -0	+0.65 +0.4
0.12	— 0.24	0 0.8	+0.5 -0	+0.8 +0.5
0.24	— 0.40	0 1.0	+0.6 -0	+1.0 +0.5
0.40	— 0.71	0 1.1	+0.7 -0	+1.1 +0.7
0.71	— 1.19	0 1.3	+0.8 -0	+1.3 +0.8

Nominal Size Range Inches		Class FN 1		Class FN 2			
		Limits of Interference	Standard Limits		Limits of Interference	Standard Limits	
Over	To		Hole H6	Shaft		Hole H7	Shaft s6
0	— 0.12	0.05 0.5	+0.25 -0	+0.5 +0.3	0.2 0.85	+0.4 -0	+0.85 +0.6
0.12	— 0.24	0.1 0.6	+0.3 -0	+0.6 +0.4	0.2 1.0	+0.5 -0	+1.0 +0.7
0.24	— 0.40	0.1 0.75	+0.4 -0	+0.75 +0.5	0.4 1.4	+0.6 -0	+1.4 +1.0
0.40	— 0.56	0.1 0.8	+0.4 -0	+0.8 +0.5	0.5 1.6	+0.7 -0	+1.6 +1.2
0.56	— 0.71	0.2 0.9	+0.4 -0	+0.9 +0.6	0.5 1.6	+0.7 -0	+1.6 +1.2
0.71	— 0.95	0.2 1.1	+0.5 -0	+1.1 +0.7	0.6 1.9	+0.8 -0	+1.9 +1.4
0.95	— 1.19	0.3 1.2	+0.5 -0	+1.2 +0.8	0.6 1.9	+0.8 -0	+1.9 +1.4
1.19	— 1.58	0.3 1.3	+0.6 -0	+1.3 +0.9	0.8 2.4	+1.0 -0	+2.4 +1.3

Nominal Size Range Inches		Class LT 2		
		Fit	Standard Limits	
Over	To		Hole H8	Shaft js7
0	— 0.12	-0.2 +0.8	+0.6 -0	+0.2 -0.2
0.12	— 0.24	-0.25 +0.95	+0.7 -0	+0.25 -0.25
0.24	— 0.40	-0.3 +1.2	+0.9 -0	+0.3 -0.3
0.40	— 0.71	-0.35 +1.35	+1.0 -0	+0.35 -0.35
0.71	— 1.19	-0.4 +1.6	+1.2 -0	+0.4 -0.4
1.19	— 1.97	-0.5 +2	+1.6 -0	+0.5 -0.5

From USAS B4.1-1967(R1987).
Reprinted with permission of ASME.

**TOLERANCING
UNIT XVIII**

**ASSIGNMENT SHEET #5 — CONSTRUCT A DRAWING
USING DATUM DIMENSIONING**

NAME _____ SCORE _____

Directions: Construct and dimension the following problem on the back of this page or on "A" size vellum. Each hole distance from datum is $\pm .001$. Change fractions to decimal dimensions and use datum system.

HOLES

A $\varnothing 1 \frac{1}{8}$

B $\varnothing 1$

C $\varnothing \frac{7}{8}$

D $\varnothing \frac{3}{4}$

E $\varnothing \frac{1}{4}$

F $\varnothing \frac{3}{8}$

G $\varnothing \frac{1}{2}$

H $\varnothing \frac{5}{8}$

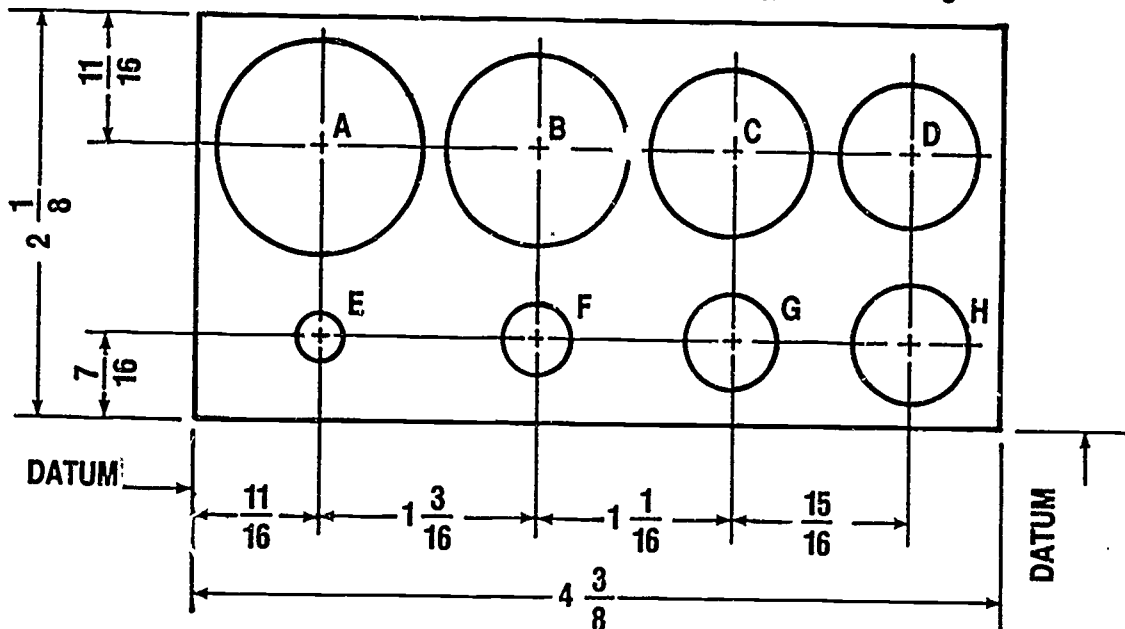

$\frac{1}{8}$ THICK MAT'L

SCALE: FULL

**TOLERANCING
UNIT XVIII**

ANSWERS TO ASSIGNMENT SHEETS

Assignment Sheet #1

A.	Maximum limit	=	.375
	Minimum limit	=	.372
	Tolerance	=	.003
B.	Maximum limit	=	1.742
	Minimum limit	=	1.738
	Tolerance	=	.004
C.	Maximum limit	=	0.995
	Minimum limit	=	0.990
	Tolerance	+	.005

Assignment Sheet #2

A.	Tolerance for shaft	=	.002	shaft dimensions =	1.000
	Tolerance for hole	=	.002		0.998
	Allowance	=	.000	hole dimensions =	1.002
	Maximum clearance	=	.004		1.000
B.	Tolerance for shaft	=	.002	shaft dimension =	.872
	Tolerance for hole	=	.004		.870
	Allowance	=	.003	hole dimensions =	.879
	Maximum clearance	=	.009		.875
C.	Tolerance for hole	=	.004	shaft dimensions =	1.252
					1.248
D.	Tolerance for shaft	=	0.010	hole dimensions =	1.698
					1.688

Assignment Sheet #3

A.	Tolerance for shaft	=	.002	hole dimensions =	1.250
	Tolerance for hole	=	.002		1.248
	Interference	=	.002	shaft dimensions =	1.252
					1.250
B.	Tolerance for shaft	=	.001	hole dimensions =	0.625
	Tolerance for hole	=	.002		0.622
	Interference	=	.004	shaft dimensions =	0.626
					0.625
C.	Tolerance for shaft	=	.006	hole dimensions =	0.496
					0.503

ANSWERS TO ASSIGNMENT SHEETS

D. Tolerance for hole = .006 shaft dimensions = 2.259
2.253

Assignment Sheet #4

A. Shaft = .5016
.5012
Hole = .5007
.5000

B. Shaft = .7504
.7496
Hole = .7512
.7500

C. Shaft = .6250
.6243
Hole = .6257
.6250

D. Shaft = .8747
.8743
Hole = .8750
.8755

E. Shaft = 1.1263
1.1258
Hole = 1.1258
1.1250

F. Shaft = 1.2513
1.2509
Hole = 1.2506
1.2500

Assignment Sheet #5

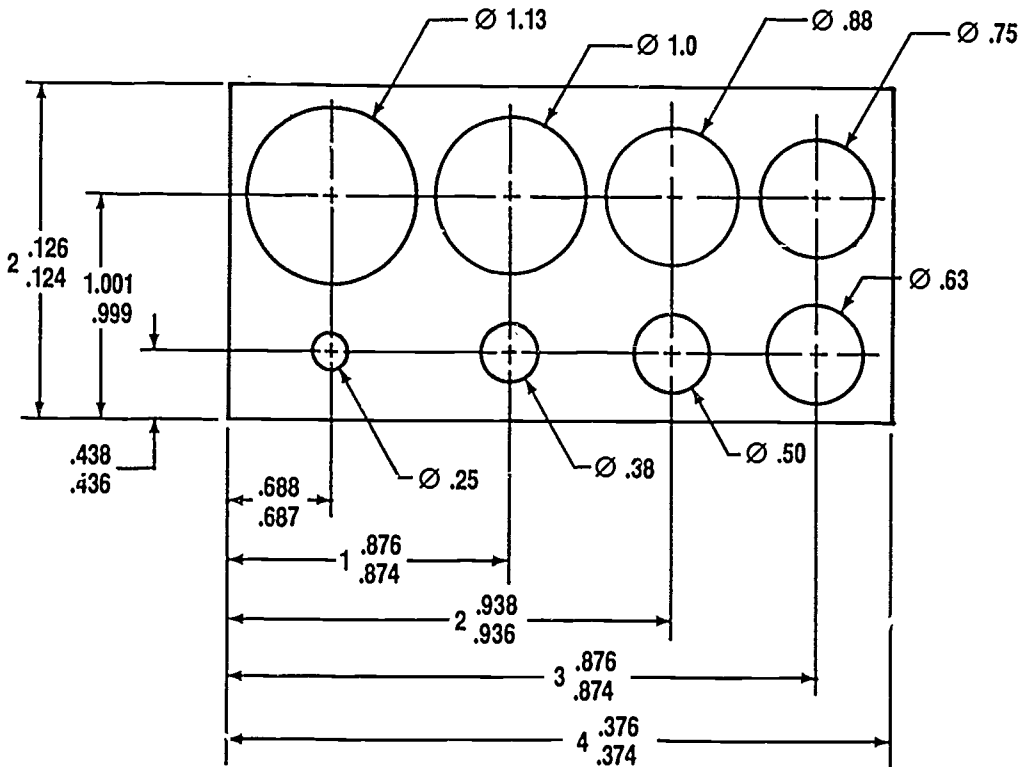

**TOLERANCING
UNIT XVIII**

TEST

NAME _____ SCORE _____

1. Match the terms on the right with their correct definitions.

- | | | | |
|----------|---|-----|----------------------------------|
| _____ a. | System designed to control dimensions to allow interchangeability in manufacturing | 1. | Actual size |
| _____ b. | The condition that refers to a part made to limit dimensions so that it will fit any part similarly manufactured | 2. | Allowance |
| _____ c. | A numerical value used to describe the theoretically exact size, profile, orientation, or location of a feature or datum target | 3. | Basic size or dimension |
| _____ d. | A portion of a part, such as a diameter, hole, keyway, or flat surface | 4. | Datums |
| _____ e. | A dimension usually without tolerance, used for information purpose only; does not govern production or inspection operation | 5. | Design size |
| _____ f. | Points, lines, or other geometric shapes assumed to be exact from which the location or geometric form of features of a part may be established | 6. | Dimension |
| _____ g. | Designation used for general identification | 7. | Feature |
| _____ h. | A numerical value expressed in appropriate units of measurement that define the size, geometric characteristic, or both of a part | 8. | Fit |
| _____ i. | The measured size of the finished part | 9. | Interchangeability |
| _____ j. | The minimum clearance space (or maximum interference) intended between the maximum material condition of mating parts | 10. | Limits |
| _____ k. | Degree of tightness or looseness between mating parts | 11. | Nominal size |
| | | 12. | Maximum material condition (MMC) |
| | | 13. | Reference dimension |
| | | 14. | Tolerance |
| | | 15. | Tolerancing |
| | | 16. | Variation |

TEST

- _____ l. The size of a feature after an allowance for clearance has been applied and tolerances have been assigned
- _____ m. The extreme permissible dimensions of a part resulting from the application of a tolerance
- _____ n. The total amount by which a specific dimension is permitted to vary; difference between the maximum and minimum limit
2. Complete the following statements concerning mating dimensions by circling the correct words.
- a. On two mating parts, certain dimensions must correspond to make the parts (look good, fit together). These are the mating dimensions.
- b. The actual values of two corresponding mating dimensions (must be, may not be) exactly the same, depending on the fit required.
3. Identify the following types of tolerances.

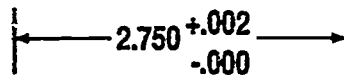
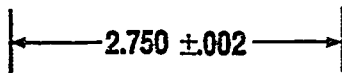

- a. _____ b. _____
4. Distinguish among the general types of fits by placing the following letters next to the correct descriptions:
- C — Clearance fit
 - I — Interference fit
 - T — Transition fit
- _____ a. Has limits of size so prescribed that contact always results when mating parts are assembled
- _____ b. Has limits of size so prescribed that space always results when mating parts are assembled
- _____ c. Has limits of size so prescribed that contact or space may result when mating parts are assembled

TEST

5. Match the standard classes of fits on the right with the correct descriptions.

- | | |
|--|---|
| <p>_____ a. Provide a similar running performance, with suitable lubrication allowance, through all range of sizes</p> <p>_____ b. Determine only the location of the mating parts; are divided into three groups</p> <p>_____ c. Special type of interference fit normally characterized by constant bore pressures throughout the range of sizes</p> | <p>1. Force or shrink fits (FN)</p> <p>2. Locational fits (LC, LT, LN)</p> <p>3. Running or sliding fits (RC)</p> |
|--|---|

6. Distinguish between the basic shaft system and the basic hole system by placing an "X" next to the descriptions of the basic hole system.

- _____ a. The basic size of the shaft is the design size
- _____ b. The basic size of the hole is the design size
- _____ c. Allowance is applied to the shaft
- _____ d. Allowance is applied to the hole

7. Identify the following types of dimensioning systems for tolerances.

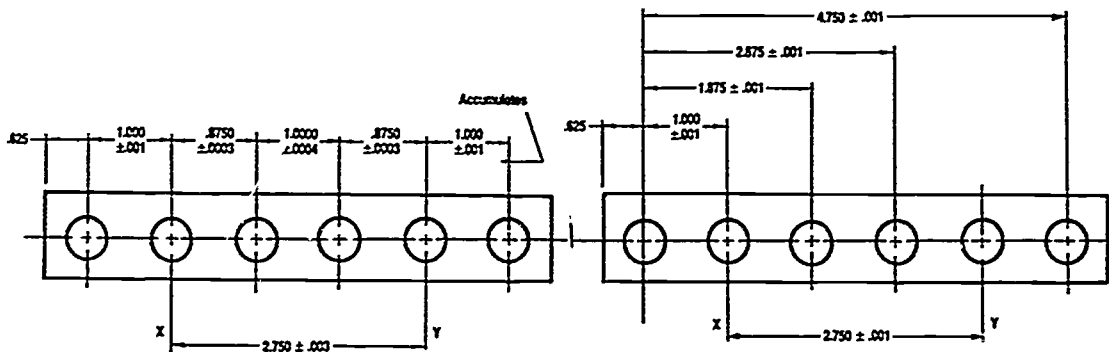

- a. _____
- b. _____

8. Illustrate the three ways to show toleranced dimensions on drawings.

- a. Maximum and minimum limits

TEST

- b. Size plus or minus tolerances
- c. Notes
9. Select true statements concerning layers on CADD by placing a "T" or "F" next to the true or false statements.
- _____ a. Different drawings limits are used on each layer.
 - _____ b. Layers are numbered.
 - _____ c. Active work takes place on the selected layer.
 - _____ d. Layers are always in perfect register.
10. Distinguish among the three layer commands on CADD by placing the following letters next to the correct descriptions:
- C — Change layer
E — Echo layer
S — Select layer
- _____ a. Defines the layer on which the system places new geometry
 - _____ b. Used to change the layer of existing geometry by digitizing geometry to be changed to a different layer
 - _____ c. Shows the specific layers that are replaced

1015

TEST

(NOTE: If the following activities have not been accomplished prior to the test, ask your instructor when they should be completed.)

11. Interpret decimal tolerance dimensions. (Assignment Sheet #1)
12. Calculate and dimension clearance fit tolerances of mating parts. (Assignment Sheet #2)
13. Calculate and dimension interference fit tolerances of mating parts. (Assignment Sheet #3)
14. Calculate and assign tolerances to mating parts using standard fit tables. (Assignment Sheet #4)
15. Construct a drawing using datum dimensioning. (Assignment Sheet #5)

**TOLERANCING
UNIT XVIII**

ANSWERS TO TEST

- | | | | |
|----|-------|-------|-------|
| 1. | a. 15 | f. 4 | k. 8 |
| | b. 9 | g. 11 | l. 5 |
| | c. 3 | h. 6 | m. 10 |
| | d. 7 | i. 1 | n. 14 |
| | e. 13 | j. 2 | |
-
2. a. Fit together
b. May not be
3. a. Bilateral
b. Unilateral
4. a. I
b. C
c. T
5. a. 3
b. 2
c. 1
6. b, c
7. a. Chain
b. Datum
8. Evaluated to the satisfaction of the instructor
9. a. F
b. T
c. T
d. T
10. a. S
b. C
c. E
- 11.-15. Evaluated to the satisfaction of the instructor