

## DOCUMENT RESUME

ED 319 914

CE 054 856

AUTHOR Smreker, Eugene  
 TITLE Microwave Oven Repair. Teacher Edition.  
 INSTITUTION Mid-America Vocational Curriculum Consortium,  
 Stillwater, Okla.  
 PUB DATE 87  
 NOTE 176p.  
 AVAILABLE FROM Mid-America Vocational Curriculum Consortium, 1500  
 West Seventh Avenue, Stillwater, OK 74074 (order no.  
 601301, \$10.50).  
 PUB TYPE Guides - Classroom Use - Guides (For Teachers) (052)  
 EDRS PRICE MF01 Plus Postage. PC Not Available from EDRS.  
 DESCRIPTORS \*Appliance Repair; Competency Based Education;  
 \*Electrical Appliances; \*Electrical Occupations; High  
 Schools; \*Occupational Information; Postsecondary  
 Education; Skilled Occupations; Trade and Industrial  
 Education; Troubleshooting  
 IDENTIFIERS \*Microwave Ovens

## ABSTRACT

This competency-based curriculum guide for teachers addresses the skills a technician will need to service microwave ovens and to provide customer relations to help retain the customer's confidence in the product and trust in the service company that performs the repair. The guide begins with a task analysis, listing 20 cognitive tasks and 5 psychomotor tasks for microwave oven orientation and 14 cognitive tasks and 28 psychomotor tasks for microwave oven troubleshooting and repair. A listing of needed tools, equipment, and materials is provided. Six references are listed. The guide contains two units: microwave oven orientation and microwave oven troubleshooting and repair. Each instructional unit includes performance objectives, suggested activities for teachers and students, information sheets, assignment sheets, job sheets, transparency masters, tests, and answers to the tests. Units are planned for more than one lesson or class period of instruction.  
 (CML)

\*\*\*\*\*  
 \* Reproductions supplied by EDRS are the best that can be made \*  
 \* from the original document. \*  
 \*\*\*\*\*

# Microwave Oven Repair

ED319914

- Theory

U.S. DEPARTMENT OF EDUCATION  
Office of Educational Research and Improvement  
EDUCATIONAL RESOURCES INFORMATION  
CENTER (ERIC)  
 This document has been reproduced as received from the person or organization originating it.  
 Minor changes have been made to improve reproduction quality.  
  
• Points of view or opinions stated in this document do not necessarily represent official OERI position or policy.



- Components

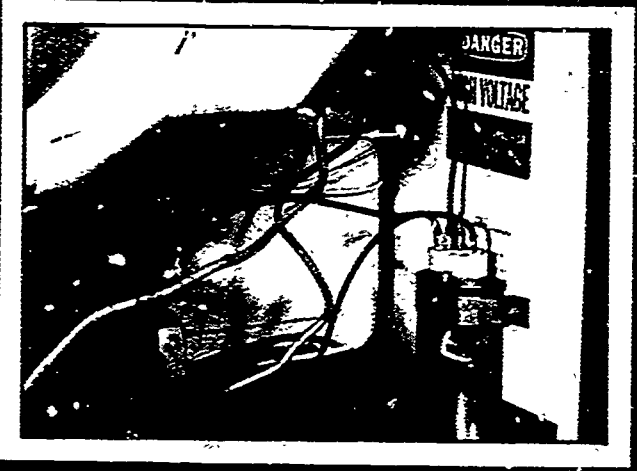

- Operation

"PERMISSION TO REPRODUCE THIS MATERIAL IN MICROFICHE ONLY HAS BEEN GRANTED BY  
  
*RL Bremson*  
  
TO THE EDUCATIONAL RESOURCES INFORMATION CENTER (ERIC)."

- Troubleshooting



- Repair

**MAVCC MID-AMERICA VOCATIONAL CURRICULUM CONSORTIUM** **Teacher Edition**

BEST COPY AVAILABLE



# MICROWAVE OVEN REPAIR

Written by

Eugene Smreker

Edited by

Dan Fulkerson

Developed by

The Mid-America Vocational Curriculum Consortium, Inc.

## Board of Directors

Bob Patton, Oklahoma, Chairman

Larry Lyngstad, South Dakota, Vice Chairman

Harley Schlichting, Missouri, Parliamentarian

James Dasher, Arkansas

Bob Wilmoth, Colorado

John Van Ast, Iowa

David Poston, Louisiana

Merle Rudebusch, Nebraska

Ron Mehrer, North Dakota

Robert Patterson, Texas

Greg Pierce, Executive Director

© 1987 by the Mid-America Vocational Curriculum Consortium, Inc.

All rights reserved. No part of this book  
may be reproduced in any form or by any  
means without written permission from the publisher.

Printed in the United States of America by the  
Oklahoma State Department of Vocational-Technical Education  
Stillwater, Oklahoma 74074

Mid-America Vocational Curriculum Consortium, Inc.  
1500 West Seventh  
Stillwater, Oklahoma 74074-4364

# MICROWAVE OVEN REPAIR

## TABLE OF CONTENTS

Unit I:	Microwave Oven Orientation .....	1
Unit II:	Microwave Oven Troubleshooting and Repair .....	63

## FOREWORD

No pun intended, but microwave ovens are the hottest appliances around. They seem to be made to order for the fast-paced American life style, and as technological advances continue to make microwave ovens more affordable, they will continue to grow in popularity.

As the number of microwave ovens increase in both home and restaurant use, the need for microwave oven repair technicians will increase accordingly. *Microwave Oven Repair* addresses the skills that a good microwave oven repair technician will need to succeed in this relatively new area of appliance repair.

There are a host of technical skills required to service microwave ovens, and those are addressed in this text. The text also addresses another set of skills vital to success in microwave oven service. Microwave oven technicians also need to know how to cook food in a microwave oven, the keys to good microwave oven maintenance, and other significant information about microwave oven use that can help a homemaker better enjoy the full capabilities of a microwave oven.

In short, this text address all the skills a technician will need to service microwave ovens and to accomplish that other significant part of the job—the customer relations that help retain the customer's confidence in the product and trust in the service company that performs the repair.

These competency-based materials will add a vital new dimension to any appliance repair program, and provide students with an opportunity to expand their potential for getting a good job.

Bob Patton, Chairman  
Board of Directors  
Mid-America Vocational  
Curriculum Consortium

## PREFACE

Although it is a relatively short text, *Microwave Oven Repair* is one of the most comprehensive books that MAVCC has ever published. It touches upon every area of microwave oven service in two well illustrated units, and constantly directs the student toward the extra attention to safety that microwave oven repairs demand.

We naturally recommend *Microwave Oven Repair* for appliance repair programs. We feel that instructors will find that teaching from a competency-based text a pleasure, and we're sure that the graphic impact of MAVCC's well illustrated materials will make learning an easier task for students.

For instructors who may not know about it, we also recommend MAVCC's *Major Appliance Repair* which presents materials on laundry equipment, gas and electric ranges, garbage disposers, and trash compactors.

In short, when it comes to major appliance repair, MAVCC's got the major materials you need to build a successful program.

Greg Pierce  
Executive Director  
Mid-America Vocational  
Curriculum Consortium



## ACKNOWLEDGEMENTS

Appreciation is extended to the many individuals who contributed their time and expertise to the successful development of *Microwave Oven Repair*. The Resource Committee which planned and approved the text included outstanding appliance repair instructors from MAVCC member states, curriculum specialists, and a regional service director for a major appliance manufacturer. A special thank you goes out to the Resource Committee:

<b>James Bledsoe</b>	Houston Community College	Houston, Texas
<b>King Calvert</b>	Crowley's Ridge Vocational School	Forrest City, Arkansas
<b>Nels Clang</b>	Mid-Plains Community College	North Platte, Nebraska
<b>Duan McBeth</b>	Indian Hills Community College	Ottumwa, Iowa
<b>Terry Newcomer</b>	Southeast Vo-Tech Institute	Sioux Falls, South Dakota
<b>Lee Veronie</b>	Kaw Area Vo-Tech School	Topeka, Kansas
<b>Eugene Smreker</b>	Tulsa County AVTS, Peoria Campus	Tulsa, Oklahoma
<b>Huey P. Sonnier</b>	Vocational Curriculum Development and Research Center	Natchitoches, Louisiana
<b>Charles Losh</b>	State Department of Education	Bismarck, North Dakota
<b>Brent Clever</b>	Whirlpool Corporation	Denver, Colorado

Another special thank you goes to Eugene Smreker of the Tulsa County AVTS for writing an excellent text and for his contributions as a committee member.

Another special thank you goes to Litton Systems, Inc., for permission to reprint the many procedures and illustrations that give the text an invaluable authenticity. Among those at Litton Systems, Inc., that we wish to thank are Gary L. Brisbine, Assistant Division Counsel, and Tom Lillihi of Technical and Field Service for his help with the many job sheets in the final unit.

Appreciation is also extended to Dan Fulkerson, MAVCC's Publications Coordinator, for his contributions as editor of the project, and to Mary Kellum and Jane Huston of MAVCC for editing assistance.

The text was phototypeset in the Oklahoma State Vo-Tech Communications Center, and for her dedicated contribution, appreciation is extended to the phototypesetter Leslie Mathis.

Another vote of thanks goes to the personnel of the Oklahoma State Vo-Tech Print Shop for their excellent work in printing the text.

## USE OF THIS PUBLICATION

### Instructional Units

*Microwave Oven Repair* contains two units. Each instructional unit includes some or all of the basic components of a unit of instruction; performance objectives, suggested activities for teachers and students, information sheets, assignment sheets, job sheets, visual aids, tests, and answers to the tests. Units are planned for more than one lesson or class period of instruction.

Careful study of each instructional unit by the teacher will help to determine:

- A. The amount of material that can be covered in each class period
- B. The skills which must be demonstrated
  - 1. Supplies needed
  - 2. Equipment needed
  - 3. Amount of practice needed
  - 4. Amount of class time needed for demonstrations
- C. Supplementary materials such as pamphlets or filmstrips that must be ordered
- D. Resource people who must be contacted

### Objectives

Each unit of instruction is based on performance objectives. These objectives state the goals of the course, thus providing a sense of direction and accomplishment for the student.

Performance objectives are stated in two forms: unit objectives, stating the subject matter to be covered in a unit of instruction; and specific objectives, stating the student performance necessary to reach the unit objective.

Since the objectives of the unit provide direction for the teaching-learning process, it is important for the teacher and students to have a common understanding of the intent of the objectives. A limited number of performance terms have been used in the objectives for this curriculum to assist in promoting the effectiveness of the communication among all individuals using the materials.

Reading of the objectives by the student should be followed by a class discussion to answer any questions concerning performance requirements for each instructional unit.

Teachers should feel free to add objectives which will fit the material to the needs of the students and community. When teachers add objectives, they should remember to supply the needed information, assignment and/or job sheets, and criterion tests.

## **Suggested Activities for the Instructor**

Each unit of instruction has a suggested activities sheet outlining steps to follow in accomplishing specific objectives. Duties of instructors will vary according to the particular unit; however, for best use of the material they should include the following: provide students with objective sheet, information sheet, assignment sheets, and job sheets; preview filmstrips, make transparencies, and arrange for resource materials and people; discuss unit and specific objectives and information sheet; give test. Teachers are encouraged to use any additional instructional activities and teaching methods to aid students in accomplishing the objectives.

## **Information Sheets**

Information sheets provide content essential for meeting the cognitive (knowledge) objectives in the unit. The teacher will find that the information sheets serve as an excellent guide for presenting the background knowledge necessary to develop the skill specified in the unit objective.

Students should read the information sheets before the information is discussed in class. Students may take additional notes on the information sheets.

## **Transparency Masters**

Transparency masters provide information in a special way. The students may see as well as hear the material being presented, thus reinforcing the learning process. Transparencies may present new information or they may reinforce information presented in the information sheets. They are particularly effective when identification is necessary.

Transparencies should be made and placed in the notebook where they will be immediately available for use. Transparencies direct the class's attention to the topic of discussion. They should be left on the screen only when topics shown are under discussion.

## **Assignment Sheets**

Assignment sheets give direction to study and furnish practice for paper and pencil activities to develop the knowledge which is a necessary prerequisite to skill development. These may be given to the student for completion in class or used for homework assignments. Answer sheets are provided which may be used by the student and/or teacher for checking student progress.

## **Job Sheets**

Job sheets are an important segment of each unit. The instructor should be able to demonstrate the skills outlined in the job sheets. Procedures outlined in the job sheets give direction to the skill being taught and allow both student and teacher to check student progress toward the accomplishment of the skill. Job sheets provide a ready outline for students to follow if they have missed a demonstration. Job sheets also furnish potential employers with a picture of the skills being taught and the performances which might reasonably be expected from a person who has had this training.

## Test and Evaluation

Paper-pencil and performance tests have been constructed to measure student achievement of each objective listed in the unit of instruction. Individual test items may be pulled out and used as a short test to determine student achievement of a particular objective. This kind of testing may be used as a daily quiz and will help the teacher spot difficulties being encountered by students in their efforts to accomplish the unit objective. Test items for objectives added by the teacher should be constructed and added to the test.

## Test Answers

Test answers are provided for each unit. These may be used by the teacher and/or student for checking student achievement of the objectives.

# MICROWAVE OVEN REPAIR

## INSTRUCTIONAL/TASK ANALYSIS

**JOB TRAINING: What the Worker Should Be Able to Do (Psychomotor)**

**RELATED INFORMATION: What the Worker Should Know (Cognitive)**

### UNIT I: MICROWAVE OVEN ORIENTATION

1. Terms and definitions
2. Microwaves and microwave ovens
3. Ionizing and non-ionizing forms of RF energy
4. Safety standards and their controlling agencies
5. The performance standard for microwave ovens
6. The FCC microwave standards
7. Major components and their components in a microwave oven
8. Magnetron structure and operation
9. Characteristics of microwaves
10. Microwave reflection
11. Microwave transmission
12. Microwave absorption
13. Steps in microwave cooking
14. Advantages of microwave cooking and their benefits
15. Steps in installing a microwave oven
16. General rules for preventive maintenance
17. Guidelines for effective in-shop repairs
18. Guidelines for effective on-site service calls

**JOB TRAINING: What the Worker Should Be Able to Do (Psychomotor)**

21. Test the interlock system on a microwave oven for safe performance
22. Check an RF leakage test meter
23. Conduct an RF leakage test on microwave oven door seals, door glass, cabinet vents, and power cord to assure that the oven complies with the performance standard for microwave ovens
24. Clean and deodorize a microwave oven
25. Determine if selected utensils are microwave safe

**RELATED INFORMATION: What the Worker Should Know (Cognitive)**

19. Requirements for RF leakage test instruments
20. Requirements for spacer cones

**UNIT II: MICROWAVE OVEN TROUBLESHOOTING AND REPAIR**

1. Terms and definitions
2. Microwave oven components and their functions
3. Operating controls and their functions
4. Motors in microwave ovens
5. Door seals and their importance in microwave oven construction
6. Technical materials required for microwave oven service
7. Advantages of using wiring schematics in circuit diagnosis
8. How to use schematics for system diagnosis
9. Typical circuit diagnosis for an oven in the COOK condition
10. Typical circuit diagnosis for an oven in the VARI-COOK condition

**JOB TRAINING: What the  
Worker Should Be Able to Do  
(Psychomotor)**

15. Diagnose a circuit for problems when an oven is in a CAVITY LIGHT ON condition
16. Diagnose a circuit for problems when an oven is in a COOK condition
17. Diagnose a circuit for problems when an oven is in a VARI-COOK condition
18. Discharge a capacitor
19. Check stirrer blade rotation
20. Prepare a microwave oven for component testing
21. Replace and adjust a microwave oven door assembly
22. Troubleshoot microwave oven problems with circuit diagnosis
23. Conduct power tests on a microwave oven to check for temperature rise under full power
24. Conduct tests on high-voltage components when little or no heat is produced by the oven but all other operations appear normal
25. Make interlock switch module tests on a microwave oven
26. Test magnetron and cavity thermal protectors
27. Test a low voltage transformer

**RELATED INFORMATION: What  
the Worker Should Know  
(Cognitive)**

11. Pre-service inspection requirements for microwave ovens
12. Safety requirements for microwave oven service
13. Post-service safety requirements for microwave ovens
14. Steps in troubleshooting a microwave oven

**JOB TRAINING: What the  
Worker Should Be Able to Do  
(Psychomotor)**

**RELATED INFORMATION: What  
the Worker Should Know  
(Cognitive)**

28. Test a temperature probe and probe jack
29. Test an oven timer
30. Test a controller
31. Remove and test a control panel
32. Test a control circuit board
33. Test a triac module
34. Test a cook relay
35. Remove a blower motor and transformer
36. Remove and reinstall a magnetron
37. Remove a timer and a controller
38. Remove a low voltage transformer and a triac
39. Remove and disassemble a stirrer system
40. Remove magnetron and cavity thermal protectors
41. Remove, disassemble, and reassemble a microwave oven door
42. Replace a door hook on a microwave oven



# MICROWAVE OVEN REPAIR

## TOOLS, EQUIPMENT, AND MATERIALS LIST

Sixteen-ounce beaker  
Nine-volt battery  
RF leakage detection meter  
Fresh lemon  
Cleaning cloth  
Pan  
Tablespoon  
Standard hand tools  
Screwdriver with insulated handle  
Needle nose pliers with insulated handles  
20K $\Omega$  resistor  
Crows-foot type wrench (Litton)  
Centrigrade thermometer  
Stop watch or watch with a second hand  
Ohmmeter with R $\times$ 10,000 range or greater  
VOM  
Jumper wire  
Utility knife (X-Acto type)  
Electrical tape  
Pencil and paper  
Safety glasses

**ALPHABETICAL LIST OF REFERENCES USED  
IN DEVELOPING THIS TEXT**

- A. *Commercial Service Information Manual, Systems 70 Microwave Ovens.* Minneapolis, MN 55440: Litton Systems, Inc., 1984.
- B. *Litton Microwave Service Training Manual, Commercial Basics.* Minneapolis, MN 55440: Litton Systems, Inc., 1984.
- C. *Microwave Oven Service Manual (1300 and 1400 Series).* Minneapolis, MN 44550: Litton Systems, Inc., 1984.
- D. *Microwave Oven Service Manual (Generation II, All Models).* Minneapolis, MN 55440: Litton Systems, Inc., 1984.
- E. *Procedures for Field Testing Microwave Ovens.* Rockville, MD 20857: U.S. Department of Health, Education, and Welfare, 1977.
- F. *Service Information Manual, The 1500 Series, Model 1510.000.* Minneapolis, MN 55440: Litton Systems, Inc., 1979.

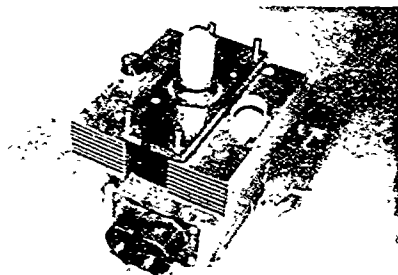

## MICROWAVE OVEN ORIENTATION UNIT I

### UNIT OBJECTIVE

After completion of this unit, the student should be able to discuss microwave generation and the structure of a magnetron as well as the characteristics of microwaves and how those characteristics function in microwave cooking. The student should also be able to list safety precautions required for microwave oven service, prepare an RF leakage test instrument, and conduct an RF leakage test on a microwave oven. These competencies will be evidenced by correctly performing the procedures outlined in the assignment and job sheets and by scoring 85 percent on the unit test.

### SPECIFIC OBJECTIVES

After completion of this unit, the student should be able to:

1. Match terms related to microwave oven orientation with their correct definitions.
2. Complete statements concerning microwaves and microwave ovens.
3. Complete statements concerning ionizing and non-ionizing forms of RF energy.
4. Match microwave oven safety standards with their controlling agencies.
5. Select true statements concerning the performance standard for microwave ovens.
6. Select true statements concerning the FCC microwave standards.
7. Match major components with their functions in a microwave oven.
8. Complete statements concerning magnetron structure and operation.
9. Identify three characteristics of microwaves.
10. Complete statements concerning microwave reflection.
11. Complete statements concerning microwave transmission.
12. Complete statements concerning microwave absorption.
13. Arrange in order the steps in microwave cooking.

**OBJECTIVE SHEET**

14. Match advantages of microwave cooking with their benefits.
15. Arrange in order the steps in installing a microwave oven.
16. Select true statements concerning general rules for preventive maintenance.
17. Complete statements concerning guidelines for effective in-shop repairs.
18. Complete statements concerning guidelines for effective on-site service calls.
19. Select true statements concerning requirements for RF leakage test instruments.
20. Select true statements concerning requirements for spacer cones.
21. Demonstrate the ability to:
  - a. Test the interlock system on a microwave oven for safe performance. (Job Sheet #1)
  - b. Check an RF leakage test meter. (Job Sheet #2)
  - c. Conduct an RF leakage test on microwave oven door seals, door glass, cabinet vents, and power cord to assure that the oven complies with the performance standard for microwave ovens. (Job Sheet #3)
  - d. Clean and deodorize a microwave oven. (Job Sheet #4)
  - e. Determine if selected utensils are microwave safe. (Job Sheet #5)

## MICROWAVE OVEN ORIENTATION UNIT I

### SUGGESTED ACTIVITIES

- A. Provide students with objective sheet.
- B. Provide students with information and job sheets.
- C. Make transparencies.
- D. Discuss unit and specific objectives.
- E. Discuss information sheet.
- F. Discuss and demonstrate the procedures in the job sheets.
- G. Discuss rumors and unfounded fears about microwave ovens

(NOTE: There is no need to stand at arm's length when operating a microwave oven; microwave ovens did affect early-demand type pacemakers that were unshielded, but unshielded pacemakers were also affected by fluorescent lights and even by electric shavers, and unshielded pacemakers are no longer made.)

- H. Have an inspector from a local or area health inspection unit talk about and demonstrate the use of an RF leakage detector, and especially demonstrate the proper use of a spacer cone around handles, controls, and along door discontinuities.
- I. Invite a microwave oven repair technician to talk to the class about typical microwave oven problems and the importance of using correct manuals, updates, and schematics in troubleshooting.
- J. Impress upon students the importance of proper microwave oven installation and preventive maintenance, and why preventive maintenance should be stressed as a part of good customer service.
- K. Place a small fluorescent tube in a microwave oven and demonstrate to students how it lights up when the oven is turned on; discuss how a fluorescent tube can be used to check RF energy emission in cases where a meter is not available.
- L. Give test.

### CONTENTS OF THIS UNIT

- A. Objective sheet
- B. Information sheet
- C. Transparency masters
  - 1. TM 1 — Electromagnetic Frequency Spectrum
  - 2. TM 2 — Microwave Oven Labels

## CONTENTS OF THIS UNIT

3. TM 3 — Microwave Dissipation
  4. TM 4 — Revision Literature
  5. TM 5 — Exploded View for Parts Identification
  6. TM 6 — Wiring Schematic
  7. TM 7 — Spacer Cone Requirements
- D. Job sheets
1. Job Sheet #1 — Test the Interlock System on a Microwave Oven for Safe Performance
  2. Job Sheet #2 — Check an RF Leakage Test Meter to Assure it Complies with Manufacturer's Specifications
  3. Job Sheet #3 — Conduct an RF leakage test on Microwave Oven Door Seals, Door Glass, Cabinet Vents, and Power Cord to Assure the Oven Complies with the Performance Standard for Microwave Ovens
  4. Job Sheet #4 — Clean and Deodorize a Microwave Oven
  5. Job Sheet #5 — Determine if Selected Utensils are Microwave Safe
- F. Test
- G. Answers to test

### REFERENCES USED IN DEVELOPING THIS UNIT

- A. *Procedures for Field Testing Microwave Ovens*. Rockville, MD 20857: U.S. Department of Health, Education, and Welfare, 1977.
- B. *Litton Microwave Service Training Manual, Commercial Basics*. Minneapolis, MN 55440: Litton Systems, Inc., 1984.
- C. *Service Information Manual, The 1500 Series, Model 1510.000*. Minneapolis, MN 55440: Litton Systems, Inc., 1979.
- D. *Commercial Service Information Manual, Systems 70 Microwave Ovens*. Minneapolis, MN 55440: Litton Systems, Inc., 1984.
- E. *Microwave Oven Service Manual (1300 and 1400 Series)*. Minneapolis, MN 44550: Litton Systems, Inc., 1984.
- F. *Microwave Oven Service Manual (Generation II, All Models)*. Minneapolis, MN 55440: Litton Systems, Inc., 1984.

# MICROWAVE OVEN ORIENTATION

## UNIT I

### INFORMATION SHEET

#### I. Terms and definitions

- A. CFR (Code of Federal Regulations) — A government document published at required intervals to provide the general public with printed copies of new federal regulations or changes in existing regulations
- B. FCC (Federal Communications Commission) — A government agency which assigns and controls the use of electromagnetic frequencies
- C. RF (radio frequency) energy — A general reference to all forms of electromagnetic wavelengths, but used in this unit to specifically reference microwaves at a frequency of 2450 MHz
- D. Condition — A way of stating whether a microwave oven is idle or going through a cycle that will defrost, warm, or cook food
- E. Cycle — Sometimes used synonymously with condition, but is also a reference to a complete performance of a command to defrost, warm, or cook food
- F. The standard — A shortened reference to the Federal Performance Standard for Microwave Ovens contained in 21 CFR, Subchapter J
- G. Load — The food or liquid placed into a microwave oven to assure microwaves will be absorbed instead of reflected back into the oven components

#### II. Microwaves and microwave ovens

- A. Microwave ovens are so named because they generate microwaves in a controlled process that permits the ovens to rapidly thaw, warm, or cook food
- B. Microwave are waves of energy that are 4.8 inches long and as thick as a pencil (Figure 1)

FIGURE 1

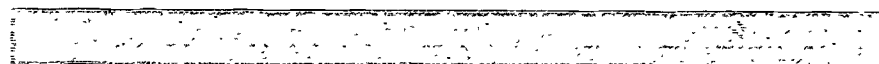

## INFORMATION SHEET

- C. Microwaves are part of the electromagnetic spectrum that includes several forms of RF energy (Transparency 1)
  - D. Microwaves are non-ionizing forms of RF energy
  - E. Understanding microwaves will help a technician better understand the entire field of microwave cooking and microwave oven service and repair
- III. **Ionizing and non-ionizing forms of RF energy (Transparency 1)**
- A. Ionizing RF energy forms have short waves packed with tremendous energy, but cannot produce heat
  - B. Ionizing RF energy forms have a cumulative effect on the human body and can cause permanent chemical and biological changes in body cells
  - C. Gamma rays, cosmic rays, X-rays, and ultra-violet rays are all ionizing RF energy forms
- (NOTE: Because they can damage body cells does not mean that ionizing RF energy forms can't be safely put to use; X-rays are a good example of ionizing energy that is properly controlled for beneficial applications.)
- IV. **Microwave oven safety standards and their controlling agencies**
- A. Federal Communications Commission — Limits the frequencies available for microwave oven operations so that they can operate without interfering with communications devices
  - B. Department of Health and Human Services — Limits the acceptable amount of radiation that a microwave oven may emit and specifies door locks and monitoring system
  - C. Underwriters Laboratories — Requires that microwave ovens subscribe to safety standards for operation as an electrical device
- (NOTE: The FCC and HHS regulations require specific labels be placed on a microwave oven at the time of manufacture, but the UL approval that appears on most labels is a voluntary option of the manufacturer.)
- V. **The Performance Standard for Microwave Ovens**
- A. The Performance Standard for Microwave Ovens applies to all microwave ovens manufactured after October 6, 1971
- (NOTE: The standard is presented in detail by the Department of Health and Human Services, 21 CFR, Subchapter J, and the following materials cover the main parts of the standard only.)



## INFORMATION SHEET

- B. Microwave emission shall not exceed 1 milliwatt per square centimeter at 5 cm (2") from the external surface of the oven prior to acquisition by the purchaser
- C. Microwave emission shall not exceed 5 milliwatts per square centimeter at anytime during the life of the oven

(NOTE: RF leakage checks that should follow all microwave oven repair should adhere to that part of the standard listed in item C.)

- D. Microwave ovens must have at least two safety interlocks, and one of the interlocks must be concealed

(NOTE: Most ovens designate these safety interlocks as primary or bottom interlock and secondary or upper interlock.)

- E. The interlock system must include a monitor which will cause the oven to become inoperative if either interlock fails

- F. RF leakage tests to determine microwave emission must be made with approved test instruments only

(NOTE: This will be treated in a later objective and also in a following job sheet.)

- G. Precaution labels concerning use and service must be attached to a microwave oven (Transparency 2)

- H. The label on a microwave oven must have the name and address of the manufacturer and the place of manufacturer (Transparency 2)

(NOTE: Some of these items may be coded.)

### VI. FCC microwave standards

- A. Microwave ovens are assigned operating frequencies by the FCC so they will not interfere with other frequencies

(NOTE: Because microwaves are reflected by metal objects they could easily cause interference; the fact that metals do reflect microwaves was put to good use in England during World War II when microwaves were discovered and first used in radar devices.)

- B. Microwave frequencies include 915 MHz and 2450 MHz, but almost all modern countertop microwave ovens use the 2450 MHz frequency

(NOTE: The 915 MHz frequency was used in early microwaves, but it is rare to find a modern microwave oven that operates at 915 MHz.)

## INFORMATION SHEET

- C. Other microwave frequencies do have specific FCC assignments, but these frequencies are reserved for ISM (industrial, scientific, and medical) applications

(NOTE: These frequencies include 5,800 MHz and 22,125 MHz as well as the more common 915 MHz and 2450 MHz.)

- D. The label on a microwave oven must list the operating frequency of the oven and indicate FCC approval (Transparency 2)

### **VII. Major components and their functions in a microwave oven**

- A. A microwave source — This is usually a magnetron which generates microwaves and directs them from an antenna into a transmission device or an oven cavity
- B. Transmission device — This is usually a waveguide which acts as a chute through which the microwaves are directed into the oven cavity
- C. Distribution device — This is usually a fan-like device called a stirrer which spreads the microwaves in a random pattern to assure even distribution of the microwaves into the oven cavity
- D. Oven cavity — A resonant chamber into which food is placed for thawing, heating, or cooking
- E. Interlock system — Primary and secondary safety devices on a microwave oven door to assure that microwave transmission will stop immediately when the door is opened

(NOTE: Specific microwave oven components will be discussed in the next unit of instruction.)

### **VIII. Magnetron structure and operation (Figure 2)**

- A. Most magnetrons are constructed as a series of cylinders:
1. The outer cylinder is a permanent magnet
  2. The middle cylinder is an anode with vanes or ridges in it that create "resonant cavities"
  3. The inner cylinder is a cathode with a heating filament in the center
- B. As high voltage is supplied to the magnetron from a transformer, the filament heats the cathode
- C. As the cathode is heated, it gives off electrons whose negative charges are attracted to the anode which operates at a positive potential

## INFORMATION SHEET

- D. The magnetic field around the anode repels the electrons so that they travel in a circular path to reach the anode instead of traveling in a straight line as electrons normally would
- E. As the electrons move in a rapid orbit from cathode to anode, they travel past the resonant cavities in the anode and cause the cavities to vibrate at a high frequency
- F. The pulsating 2450 MHz frequency generated by the magnetron is picked up by the antenna and directed into a waveguide and on to a stirrer which distributes the microwaves into the oven cavity

FIGURE 2

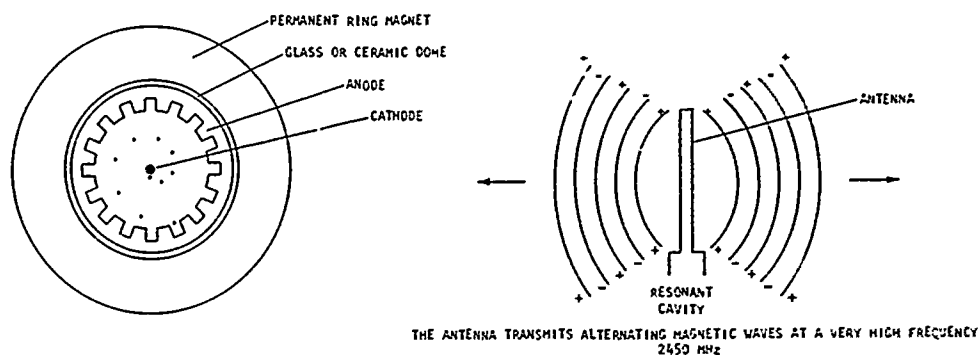

© Litton Systems, Inc., reprinted with permission

### IX. Characteristics of microwaves

- A. Reflection — Microwaves are reflected by metal
- B. Transmission — Microwaves are transmitted through glass, plastic, and paper
- C. Absorption — Microwaves are absorbed by food and water

### X. The significance of microwave reflection (Figure 3)

- A. The walls inside a microwave oven never get hot because metal reflects microwaves, and for that same reason, a microwave oven should never be operated without a load
- B. Metal utensils cannot be used in a microwave because they cause arcing that can damage components

## INFORMATION SHEET

- C. Aluminum foil can be used in limited quantity to shield parts of food to assure even cooking

Example: When cooking a turkey, putting foil over the legs will shield them from overcooking

FIGURE 3

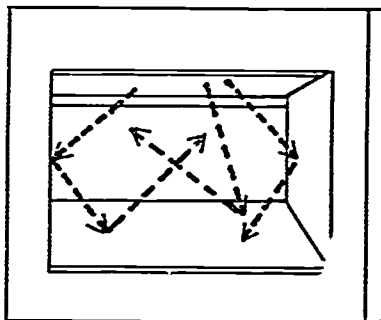

XI. The significance of microwave transmission (Figure 4)

- A. Since microwaves easily penetrate glass, paper, and plastic, most utensils made from these materials are safe for use in a microwave oven
- B. Glass utensils are best for foods high in fat or sugar content because such foods can distort certain plastics
- C. Paper towels can be used beneath foods to help keep the oven clean or placed over bacon to avoid splatter

FIGURE 4

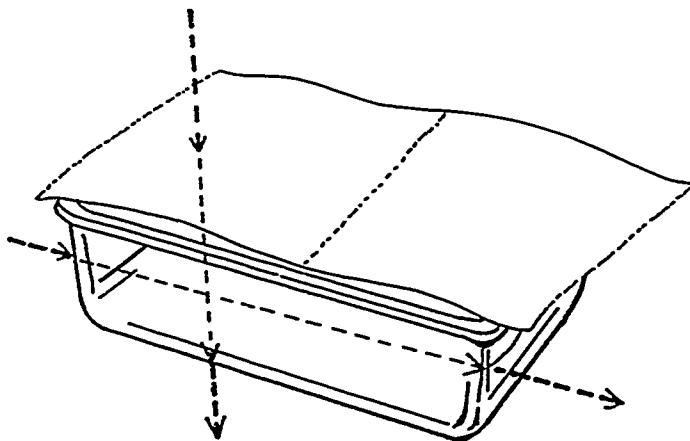

## INFORMATION SHEET

### XII. The significance of microwave absorption (Figure 5)

- A. The fact that foods absorb microwaves is the key to microwave cooking
- B. The process of absorption is also used to defrost frozen foods or to keep foods warm by employing a timed sequence in which the magnetron is on for awhile, then off for awhile

(NOTE: This variable defrost or warming control is an attractive feature of microwave ovens, but it does not mean that magnetron power is ever reduced; it is accomplished, as outlined, by controlling the on/off time of the magnetron.)

- C. How fast foods absorb microwaves depends on the amount of food, temperature of the food when cooking starts, and even the shape of food

(NOTE: Placing food properly is one of the secrets of good microwave cooking because it avoids problems with food that can literally be partly overcooked and partly undercooked; encouraging a customer to reference a microwave cook book is a good thing to do.)

FIGURE 5

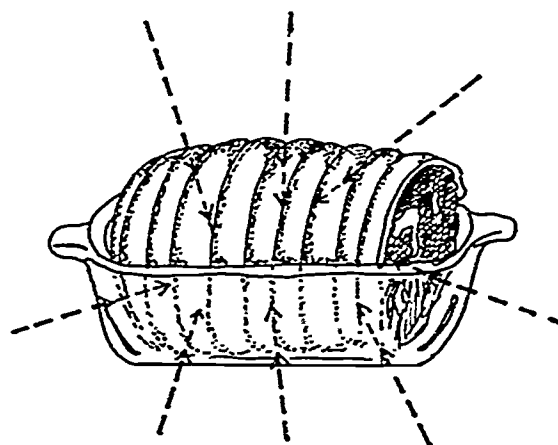

### XIII. Steps in microwave cooking

- A. As microwaves enter food, they set up electrical fields that change polarity every half cycle
- B. Molecules in the food, especially water and fat molecules, start moving back and forth and changing directions every half cycle just as the microwaves do
- C. Food molecules oscillate back and forth four billion, nine hundred million times every second

## INFORMATION SHEET

- D. The ultra high-speed oscillation produces friction between the molecules which converts the microwave energy to instant heat
- E. Microwaves penetrate food up to a depth of 2 inches and accelerate the conduction of heat, but microwaves do not cook food from the inside out

### XIV. Advantages of microwave cooking

- A. Speed — Microwave ovens cook about ten times faster than conventional methods and better serve the fast-paced American life style
- B. Conservation — Microwave ovens actually consume less energy than conventional cooking devices
- C. Space — Microwave ovens require far less space than conventional ranges and ovens  
  
(NOTE: The space saving feature has made microwave ovens popular in campers, trailers, boats with galleys, and airplanes.)
- D. Health — Microwave ovens require less water to cook vegetables and other foods and help preserve valuable vitamins and minerals that are lost with other cooking methods
- E. Comfort — Microwave ovens do not heat up the kitchen and increase the need for summer air conditioning
- F. Cleanliness — Microwave ovens do not cook food on to oven walls or other components and cleanup is faster and easier than with conventional ovens
- G. Safety — Microwave ovens are proving to be one of the safest appliances in a home, and burns on hands and fingers are unheard of with microwave cooking

(NOTE: Microwaves dissipate rapidly in relation to the square of the distance from the oven; see Transparency 3.)

### XV. Steps in properly installing a microwave oven

- A. Check the oven thoroughly to assure there is no damage
- B. Remove all material from the oven interior
- C. Place the oven in location and check for:
  1. One inch of clearance at the top and back
  2. Two to three inches clearance on each side
  3. Sufficient clearance to assure air flow at the bottom of the oven

(CAUTION: Clearances should never be less than specified by the manufacturer.)

## INFORMATION SHEET

- D. Plug oven into a 120 volt three-prong or four-prong grounded outlet only
- E. Check for at least a 15 amp circuit and make sure the microwave is the only appliance on that circuit

(NOTE: It is the customer's responsibility to contact an electrician, if required, to assure a proper circuit for a microwave oven; otherwise, there may be oven problems or problems with other appliances or services on the circuit.)

- F. If oven has been stored in a cold location, let it warm to room temperature before operating
- G. Place a cup of water in the oven cavity and close the door
- H. Push the start button to put the oven in a COOK cycle for 30 seconds
- I. Open oven door, remove water, and check water to make sure it has been heated
- J. Heated water indicates oven is ready for operation

### XVI. General rules for preventive maintenance

- A. Clean the stirrer cover and the oven with a damp cloth after each use
- B. Wipe out excess moisture after every use
- C. Use a plastic scrub pad with a mild detergent to clean up stubborn soils, but do not use steel wool or abrasive pads or cleaners that could scratch the door and interior surface
- D. Use a damp cloth to clean a temperature probe after each use, and dry the probe after cleaning, but do not put the probe into dishwasher or a dishwasher
- E. Do not use a knife to scrape the stirrer cover clean because it could easily damage the cover and affect oven performance
- F. Remember that caked-on food buildup on oven or door surfaces affects oven performance
- G. A clean oven looks better, smells better, and cooks better
- H. Inspect air intakes and outlets weekly to make sure someone has not blocked them

## INFORMATION SHEET

### XVII. Guidelines for effective in-shop repairs

- A. Know the brand name, model, and serial number of the oven to be serviced
- B. Have revisions and updates for service manuals available for reference (Transparency 4)

(NOTE: Revisions and updates are critical because they may affect both service and parts requirements.)

- C. Rely on the manufacturer's part catalog for proper parts identification (Transparency 5)

(NOTE: A good parts catalog will normally have a well referenced exploded view that makes parts identification quick and sure.)

- D. Use wiring schematics to assure cost-effective troubleshooting (Transparency 6)
- E. Begin with the customer's complaint and troubleshoot in a systematic sequence to avoid wasting time testing components that have nothing to do with the problem

- F. Ask a supervisor for assistance with problems you can't handle, or call the national service number for technical assistance from the manufacturer hot-line

(NOTE: Several microwave oven manufacturers do have service hot lines, and the numbers are usually listed in both the service manual and in service bulletins and technical update literature.)

### XVIII. Guidelines for effective on-site service calls

- A. Introduce yourself and explain the reason for your call
- B. Ask the customer to define the problem

(NOTE: Asking intelligent questions at this point in the service call can save you time and save the customer money.)

- C. Place a drop cloth on the counter area where tools or materials will be placed
- D. Inspect the power supply for proper 120V three-pronged or four-pronged grounded outlet
- E. Never make quick evaluations of a problem that may cause the customer to anticipate a speedy repair or a minimal bill

(NOTE: Fast, low-cost service is the best way to impress customers, but preparing the customer for good news too early can be upsetting if the problem turns out to be a major one.)



## INFORMATION SHEET

- F. Keep the area free of children and pets, and follow all safety rules when working with oven components
- G. Don't waste time on the service call if it is obvious the oven will require major repair that cannot be accomplished on-site
- H. Reference service materials and schematics as required to assure cost-effective service
- I. Complete a door inspection and an RF leakage inspection, and tag the oven with an inspection tag after repairs are complete
- J. Present the bill to the customer, explain charges for parts and labor, and collect the amount due
- K. Reacquaint the customer with proper oven use and review preventive maintenance requirements

### **XIX. Requirements for RF leakage test instruments**

- A. Leakage test instruments must always be set at a frequency of 2450 MHz
- B. Leakage test instruments must have a response time that permits them to reach 90% of their response capacity in only three seconds

(NOTE: This requirement assures that the test can be almost instantly discontinued if there is immediate evidence of RF leakage, and provides added protection for service people.)

- C. Batteries in test instruments should be checked prior to every use and replaced as required
- D. Spacer cones and probes should be checked prior to each use to assure they are clean and undamaged

### **XX. Requirements for spacer cones (Transparency 7)**

- A. Spacer cones are fitted onto detector probes to assure that the center of the probe is kept 5 cm (2") from any external surface of the oven
- B. Although most spacer cones have conical shapes, it is good for a service technician to think of them as being shaped as spheres and remember to keep them a proper distance from latches and control knobs
- C. Spacer cones should not be forced into door seams, but held so that they barely intrude into the surface discontinuity

# Electromagnetic Frequency Spectrum

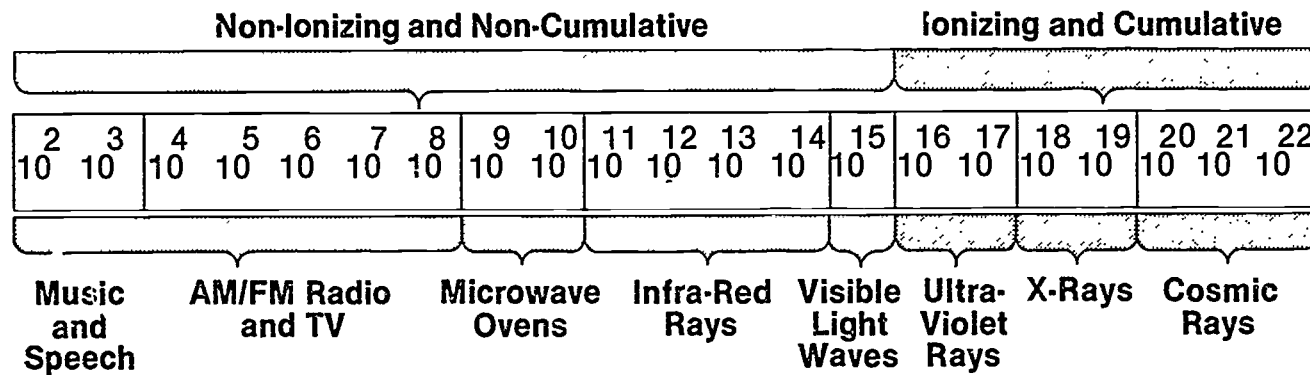

# Microwave Oven Labels

THIS MICROWAVE OVEN HAS BEEN DESIGNED AND TESTED FOR COMPLIANCE TO THE U.S. GOVERNMENT DEPARTMENT OF HEALTH, EDUCATION AND WELFARE FEDERAL REGULATION 21 CFR SUBCHAPTER J PERFORMANCE STANDARD FOR MICROWAVE OVENS

HOUSE HOLD



LISTED

293H

MADE IN JAPAN FOR  
**SEARS, ROEBUCK  
AND CO., U.S.A.**  
HOUSEHOLD MICROWAVE OVEN

MODEL NO. 564.991761G  
SERIAL NO. 5K 400238  
AC ONLY SINGLE PHASE 120V 60Hz  
MICROWAVE FREQUENCY 2450 MHz  
POWER CONSUMPTION 1.3 KW  
U.S. PATENT 3396342

Courtesy U.S. Department of Health, Education, and Welfare

# Microwave Dissipation

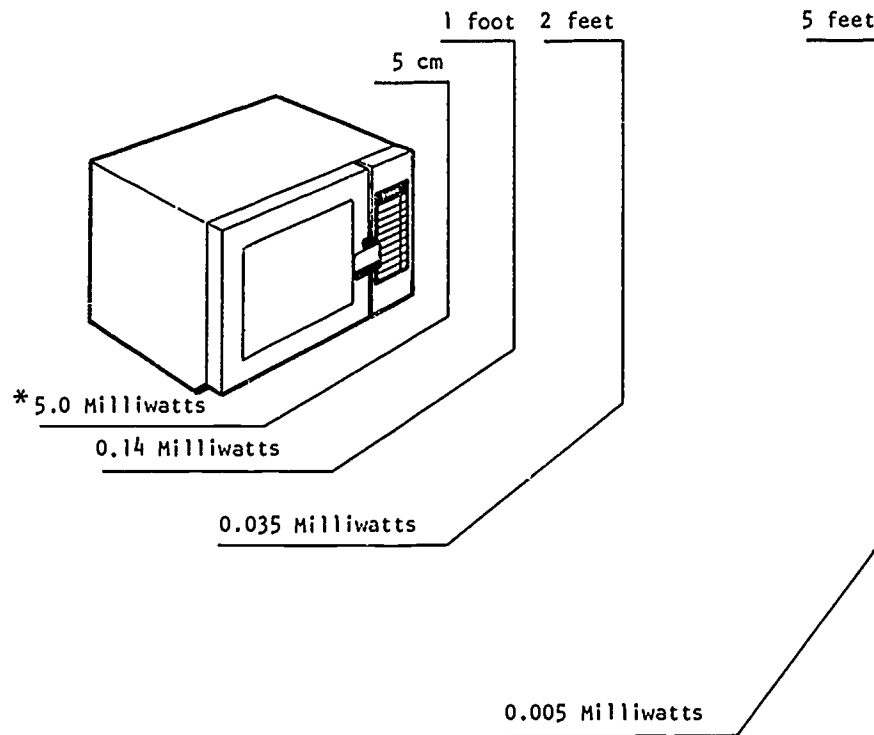

\* 5.0 MILLIWATTS PER SQUARE CENTIMETER MEASURED 5 CM FROM THE OVEN IS THE U.S. PERFORMANCE STANDARD FOR THE LIFE OF A MICROWAVE OVEN.

NOTE: 1.0 MILLIWATTS IS EQUAL TO 1/1000 OF A WATT OF ELECTRICITY.

©Litton Systems, Inc.; reprinted with permission

# Revision Literature

# Service Bulletin

from the LITTON SERVICE DEPARTMENT

November 1981

Door Adjustment

C-TB053

### Models Affected

80/30.000, 80/30.001, 80/30.002  
 80/40.000, 80/40.001, 80/40.002  
 80/42.000, 80/42.001, 80/42.002, 80/42.003  
 80/50.000, 80/50.001, 80/50.002  
 80/52.000, 80/52.001, 80/52.002, 80/52.003

### Problem:

The door hinges move changing the alignment of the door.

### Cause:

Loose hinge mounting screws and insufficient friction between the hinges and hinge mounting bracket.

### Correction:

Install hinge gaskets M25D65 to increase friction between the hinge and hinge bracket.  
 Tighten hinge mounting screws securely.

NOTE: M25D65 contains 2 each hinge gaskets.

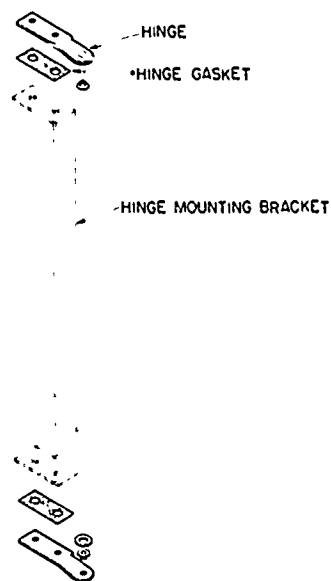

"The cost of repairs made pursuant to this Service Bulletin will be borne by the appropriate party as determined in accordance with Litton's standard warranty provisions. This Service Bulletin is not intended as an indication that Litton will pay for any repairs made outside of Litton's standard warranty coverage."

**LITTON**  
 Microwave Cooking

P.O. Box 9465

Minneapolis, Minnesota 55440

612-553-2600

© Litton Systems, Inc.; reprinted with permission

TM 4



# Wiring Schematic

WIRING SCHEMATIC

MODEL 1444.001

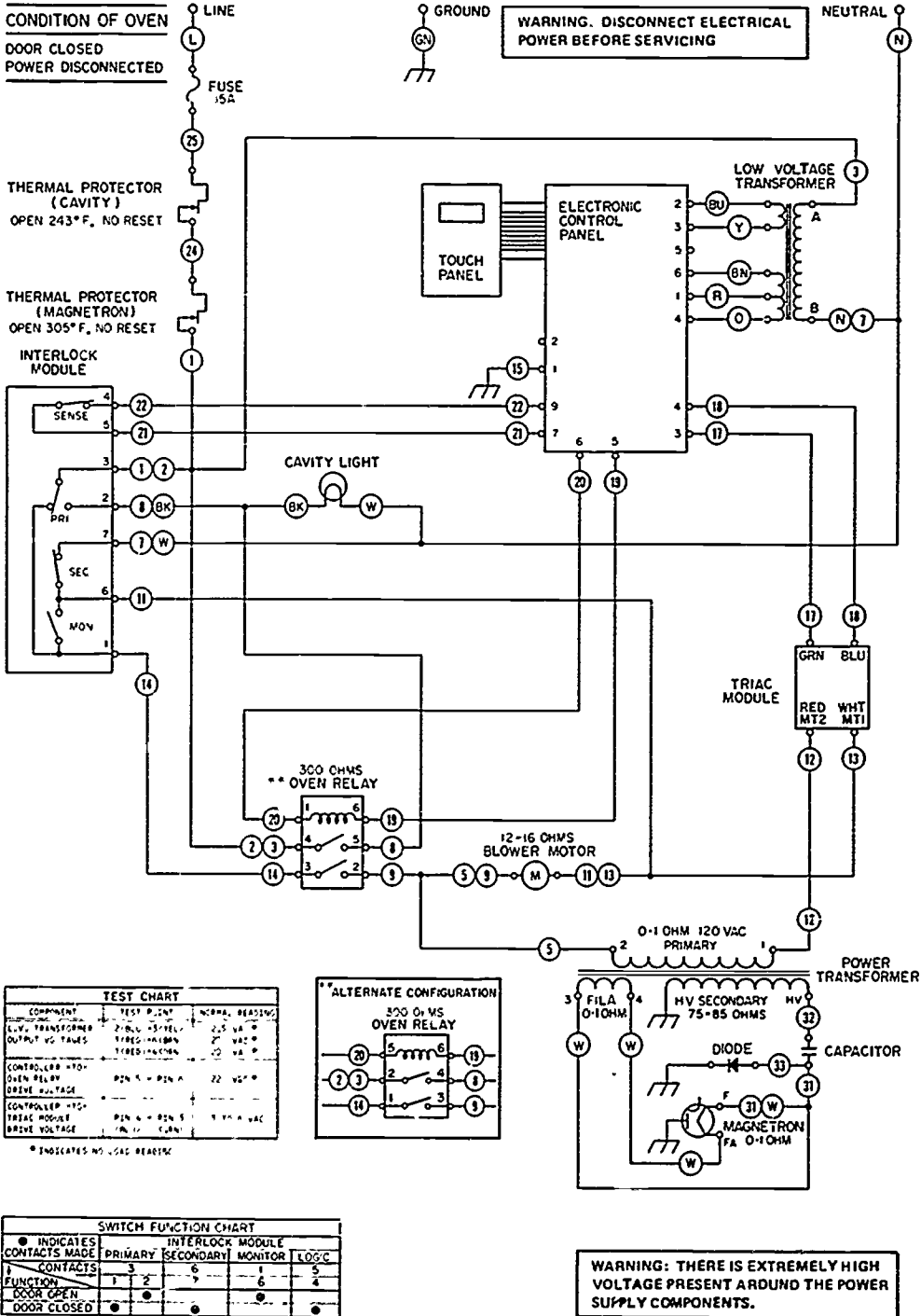

© Litton Systems, Inc.; reprinted with permission

# Spacer Cone Requirements

INCORRECT

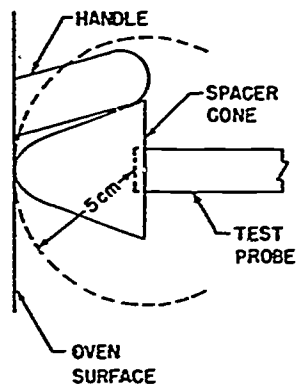

CORRECT

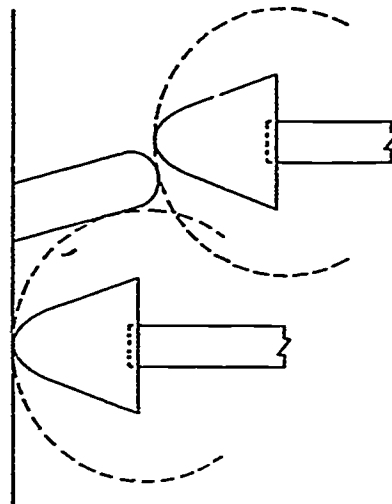

TESTING IN CLOSE PROXIMITY TO  
HANDLE OR OTHER PROTRUSION

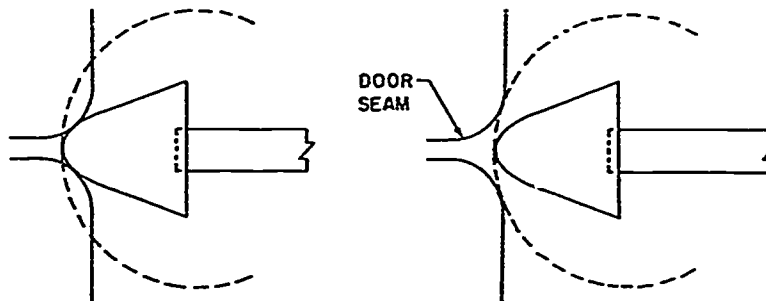

TESTING IN VICINITY OF  
SURFACE DISCONTINUITY



## MICROWAVE OVEN ORIENTATION UNIT I

### JOB SHEET #1 — TEST THE INTERLOCK SYSTEM ON A MICROWAVE OVEN FOR SAFE PERFORMANCE

- A. Tools and materials
1. Microwave oven as selected by instructor
  2. Operating manual for selected microwave
  3. Sixteen-ounce measuring beaker
  4. Cool water supply
  5. Paper and pencil
  6. Safety glasses
- B. Routine #1 — Gathering preliminary information
1. Put on safety glasses
  2. Unplug the microwave oven from its power source
  3. Position the oven so that the metal tag on the rear panel can easily be read
  4. Complete the following information concerning the oven specifications:
    - a. Manufacturer's Name: \_\_\_\_\_
    - b. Serial Number: \_\_\_\_\_
    - c. Model Number: \_\_\_\_\_
    - d. Operating frequency: \_\_\_\_\_ MHz

(NOTE: If the operating frequency is not listed, it should be in the operating manual, and if it isn't in the manual, it will have to be obtained by contacting the manufacturer.)
  5. Check as best you can the major electronic components located between the cabinet and the cavity walls:
    - a. Is the cavity free of odors that would indicate a component may have burned? \_\_\_\_\_
    - b. Does the magnetron appear to be okay? \_\_\_\_\_

## JOB SHEET #1

- c. Does the waveguide appear to be okay? \_\_\_\_\_
- d. Do the stirrer and stirrer blades appear to be okay? \_\_\_\_\_
- 6. Check the door, door gasket, and oven surfaces:
  - a. Are the door seals in place? \_\_\_\_\_
  - b. Are the door seals free of cracks or separations? \_\_\_\_\_
  - c. Is the glass in the door free of cracks or other visible damage? \_\_\_\_\_
  - d. Are outside oven surfaces free of dents or scratches that would indicate the oven has been dropped or abused? \_\_\_\_\_
  - e. Are door hinges free of sag and excessive play? \_\_\_\_\_

Have your instructor check your work

(NOTE: If you answered NO to any of the preliminary inspection questions, your instructor may request you to stop your inspection at this point and complete needed repairs before starting the next routine.)

### C. Routine #2 — Checking the interlock system

1. Fill the measuring beaker with nine ounces of cool water and place the beaker in the center of the oven cavity (Figure 1)

FIGURE 1

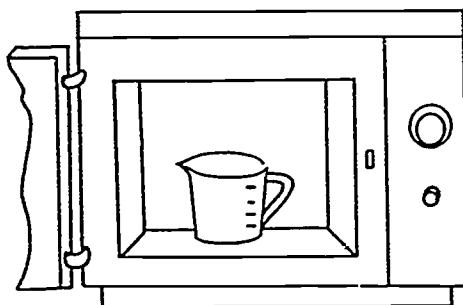

2. Close the oven door and plug the power cord in
3. Set the power control at the highest available level

**JOB SHEET #1**

4. Set the timer for three to five minutes
5. Press the start button
6. Permit the water to come to a boil and quickly open the oven door just a bit less than one inch
  - a. If the interlock system is functioning properly, the water will stop boiling as soon as the door latch is released
  - b. If the interlock system is not functioning properly, the water will continue to boil as the door latch is released
  - c. If the water does continue to boil, close the oven door quickly and unplug the power supply to the oven
- Have your instructor check your work
7. Continue with a formal leak test as directed or clean up area and return tools and materials to proper storage

## MICROWAVE OVEN ORIENTATION UNIT I

### JOB SHEET #2 — CHECK AN RF LEAKAGE TEST METER

#### A. Tools and materials

1. RF leakage detection meter as selected by instructor (Narda Model 8200 or equivalent)
2. Detection probe for selected meter
3. Nine-volt battery
4. Operator's manual for meter and probe
5. Safety glasses

#### B. Procedure

1. Put on safety glasses
2. Remove the radiation meter and other components from the carrying case
3. Read the operator's manual carefully to make sure the meter is made for a 2450 MHz frequency and a maximum operating power density of 20 mW/cm<sup>2</sup>

(NOTE: The following steps in this procedure assume that a Narda 8200 detection meter is being used; if you are using another type, follow the operator's manual carefully.)

4. Check to make sure the equipment includes (Figure 1):
  - a. The radiation detection meter
  - b. A detachable probe
  - c. A spacer cone
  - d. A 9-volt battery

FIGURE 1

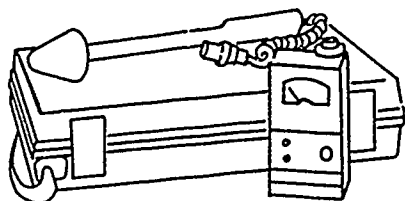

## JOB SHEET #2

5. Check the operator's manual, if required, to make sure that the meter is made for a frequency of 2450 MHz and that its maximum operating power density is 20 mW/cm
6. Set the meter on a clean work area where it can be clearly seen
7. Turn the range multiplier switch to the X1 setting (Figure 2)

FIGURE 2

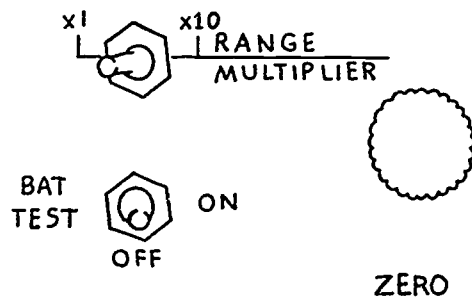

8. Turn the BAT TEST (battery test) switch to the BAT TEST position (Figure 2)
9. Look for the TEST MIN (test minimum) mark at the bottom of the meter scales and make sure the needle settles to the right of the TEST MIN mark (Figure 3)
  - a. If the battery test needle settles anywhere to the left of the TEST MIN mark, turn the switch to the OFF position, check the operator's manual for the procedure, and replace the battery
  - b. Check the replacement battery with the procedure outlined in Steps 8 and 9

FIGURE 3

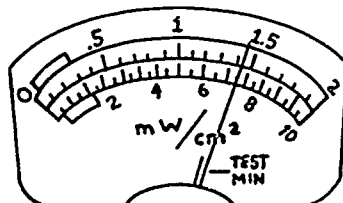

**JOB SHEET #2**

10. Attach the probe to the meter by grasping the connector at the end of the coiled probe cord and pushing it into the fitting on top of the meter (Figure 4)
11. Turn the connector onto the fitting clockwise until it is hand tight (Figure 4)

FIGURE 4

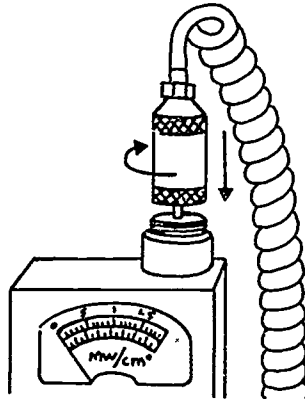

12. Examine the spacer cone to make sure it is not damaged, and then place it on the free end of the probe (Figure 5)

FIGURE 5

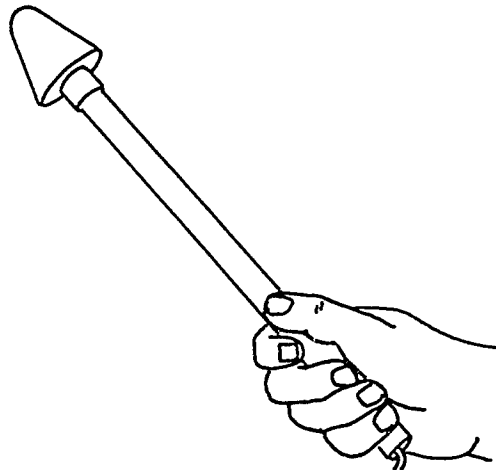

## JOB SHEET #2

13. Check the operator's manual for warmup requirements, and turn the meter on and wait until warmup time is over
14. Turn the zero adjust knob as required to align the the indicator needle with the zero line to the left of the scales (Figure 6)

FIGURE 6

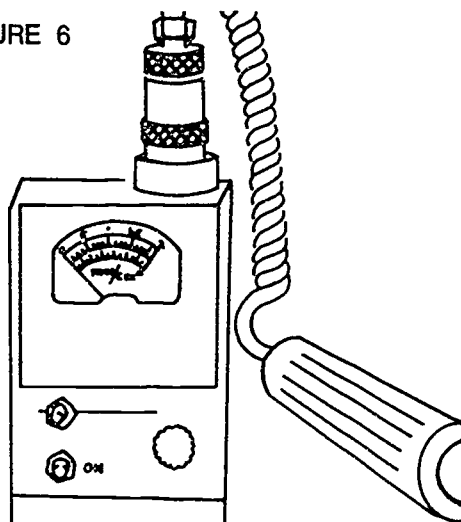

- Have your instructor check your work
15. Turn the unit off and return it to proper storage or continue with leak testing as directed by your instructor

## MICROWAVE OVEN ORIENTATION UNIT I

### JOB SHEET #3 — CONDUCT AN RF LEAKAGE TEST ON MICROWAVE OVEN DOOR SEALS, DOOR GLASS, CABINET VENTS, AND POWER CORD TO ASSURE THE OVEN IS IN COMPLIANCE WITH THE PERFORMANCE STANDARD FOR MICROWAVE OVENS

#### A. Tools and materials

1. Microwave oven as selected by instructor
2. Microwave radiation detection meter as selected by instructor
3. Microwave radiation detection probe for selected radiation detection meter
4. Nine-volt battery
5. Operator's manual for selected meter and probe
6. Sixteen-ounce measuring beaker
7. Pencil and paper
8. Safety glasses

#### B. Procedure

1. Put on safety glasses
2. Fill a beaker with 9 ounces of water that is about room temperature
3. Place the load (the water) into the oven cavity and close the oven door
4. Prepare your RF meter as outlined in a previous job sheet
5. Turn the range selector switch on the RF meter to the correct position  
  
(NOTE: On a Narda 8200, the meter should be set at the X10 position for this and following routines.)
6. Turn the microwave oven ON
7. Pick up the meter in one hand and the test probe with the spacer cone in the other
8. Start at the upper left hand corner of the door seal with the tip of the spacer cone slightly touching the door edge (Figure 1)

**(CAUTION: Should any reading reach 100 mW/cm<sup>2</sup> quickly, turn the oven off immediately and check with your instructor!)**



### JOB SHEET #3

9. Move the tip of the probe slowly across the top edge of the door until you reach a point where you get a reading (Figure 1)

FIGURE 1

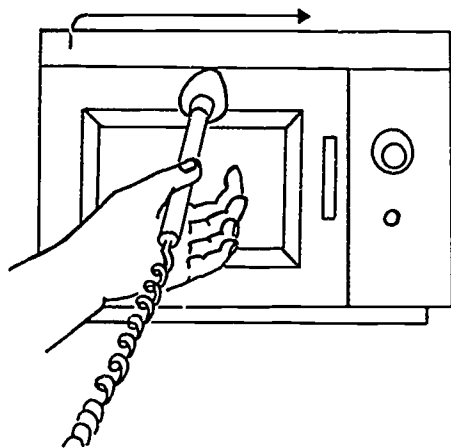

10. Stop at any point where you get a reading and turn the shaft of the probe to obtain the highest reading possible
11. Continue slowly left to right across the top edge, down the right edge, right to left across the bottom edge, and up the left edge until all edges have been completely checked
- (NOTE: Monitor the beaker every now and then to make sure it has plenty of water in it, and if it needs refilling, turn the oven off, refill the beaker, and start again where you left off.)
12. Record your readings as you go and enter them in the appropriate chart in Figure 2 at the end of the job sheet
13. Turn the range multiplier switch to position X1 if you cannot get readings from the X10 position
14. Repeat the door edge measurements at the X1 position and enter your readings in the appropriate chart
15. Hold the tip of the probe to the upper top edge of the door glass
16. Move the probe slowly back and forth on the oven window until you reach the bottom of the door
17. Stop at any point where you get a reading and turn the shaft of the probe to obtain the highest reading possible

(NOTE: Unless there is reason to suspect the glass is loose, this reading should be made at the X1 position when using the Narda 8200 meter.)

## JOB SHEET #3

18. Record your readings in the appropriate chart in Figure 2 at the end of this job sheet
19. Set the multiplier range at X10 and check the power cord at the point where it enters the oven cabinet  
**(CAUTION: Should any reading reach 10 mW/cm<sup>2</sup> quickly, turn the oven off immediately and check with your instructor!)**
20. Check all vents, air ducts, or any other openings in the oven cabinet at the X10 range, and if you don't get a reading, switch to the X1 range
21. Record all readings in the appropriate chart in Figure 2 that accompanies this job sheet
22. Turn the RF meter OFF
23. Turn the microwave oven OFF and unplug the power cord to the oven
24. Have your instructor check your charts in Figure 2
24. Remove the spacer cone from the probe and the probe from the meter and replace everything in the meter carrying case
25. Return the RF meter to proper storage and doublecheck the work area to make certain everything is in order

### JOB SHEET #3

FIGURE 2

### RF Leakage

Door Edge Measurements:			
Top Edge	Right Edge	Bottom Edge	Left Edge
_____	_____	_____	_____
_____	_____	_____	_____
_____	_____	_____	_____
_____	_____	_____	_____
_____	_____	_____	_____
Highest Reading _____			

Door Glass Measurements:	
Upper	_____
Middle	_____
Lower	_____
Left Side	_____ Right Side _____

Power Cord Measurement:	_____
Cabinet Opening Measurements:	_____
	_____

Date of Survey	_____
Technician's Signature	_____

## MICROWAVE OVEN ORIENTATION UNIT I

### JOB SHEET #4 — CLEAN AND DEODORIZE A MICROWAVE OVEN

A. Tools and materials

1. Microwave oven as selected by instructor
2. One-cup container (microwave-safe)
3. Tablespoon
4. Fresh lemon
5. Cleaning cloth and pan
6. Safety glasses

B. Procedure

(NOTE: This is a good procedure to show to a customer at the time a new oven is set up, or when on-site repairs are completed.)

1. Put on safety glasses
2. Place three tablespoons of lemon juice in the cup
3. Fill the cup with water
4. Place the lemon/water in the oven cavity and close the door
5. Set the timer for six minutes
6. Set the oven for HIGH cook cycle
7. Press START
8. Allow lemon/water to boil for six minutes
9. Permit oven to shut off
10. Remove the cup of lemon/water
11. Wipe the oven clean with a damp cloth
12. Have your instructor check your work
12. Clean up area and return tools and materials to proper storage

## MICROWAVE OVEN ORIENTATION UNIT I

### JOB SHEET #5 — DETERMINE IF SELECTED UTENSILS ARE MICROWAVE SAFE

#### A. Tools and materials

1. Microwave as selected by instructor
2. Utensils as selected by instructor
3. One-cup container
4. Safety glasses

#### B. Procedure

(NOTE: This is a good procedure to show to a customer at the time a new oven is set up, or when on-site repairs are completed.)

1. Put on safety glasses
2. Fill the cup with half a cup of water
3. Place the cup in the oven and set the oven for HIGH
4. Set the timer for one minute
5. Place the first selected utensil in the oven beside the cup
6. Close the oven door and press the START button
7. Allow oven to complete the one-minute cycle
8. Determine results according to the following:
  - a. If the water is hot and the utensil is cool, the utensil is safe for use in a microwave oven
  - b. If the water is only warm and the utensil is hot, the utensil is not safe for use in a microwave oven
9. Report your findings to your instructor
10. Repeat the procedure for other utensils as selected by your instructor, and report all findings
11. Clean up area and return tools and materials to proper storage

# MICROWAVE OVEN ORIENTATION UNIT I

NAME \_\_\_\_\_

## TEST

1. Match the terms on the right with their correct definitions.

- |         |   |                 |
|---------|---|-----------------|
| _____a. | A government document published at required intervals to provide the general public with printed copies of new federal regulations or changes in existing regulations | 1. Cycle        |
| _____b. | A government agency which assigns and controls the use of electromagnetic frequencies   | 2. RF energy    |
| _____c. | A general reference to all forms of electromagnetic wavelengths, but used in this unit to specifically reference microwaves at a frequency of 2450 MHz                | 3. Load         |
| _____d. | A way of stating whether a microwave oven is idle or going through a cycle that will defrost, warm, or cook food  | 4. CFR          |
| _____e. | Sometimes used synonymously with condition, but is also a reference to a complete performance of a command to defrost, warm, or cook food                             | 5. The standard |
| _____f. | A shortened reference to the Federal Performance Standard for Microwave Ovens contained in 21 CFR, Subchapter J   | 6. FCC          |
| _____g. | The food or liquid placed into a microwave oven to assure microwaves will be absorbed instead of reflected back into the oven components                              | 7. Condition    |

2. Complete statements concerning microwaves and microwave ovens by inserting the word(s) that best completes each statement.

- a. Microwave ovens are so named because they generate \_\_\_\_\_ in a controlled process that permits the ovens to rapidly thaw, warm, or cook food.
- b. Microwaves are waves of energy that are 4.8 inches long and as thick as a \_\_\_\_\_.

## TEST

- c. Microwaves are part of the electromagnetic \_\_\_\_\_ that includes several forms of RF energy.
- d. Microwaves are \_\_\_\_\_ forms of RF energy.
- e. Understanding microwaves will help a technician better understand the entire field of microwave \_\_\_\_\_ and microwave oven service and repair.
3. Complete statements concerning ionizing and non-ionizing forms of RF energy by inserting the word(s) that best completes each statement.
- a. Ionizing RF energy forms have short waves packed with tremendous energy, but cannot produce \_\_\_\_\_.
- b. Ionizing RF energy forms have a cumulative effect on the human body and can cause permanent chemical and biological changes in body \_\_\_\_\_.
- c. Gamma rays, cosmic rays, X-rays, and ultra-violet rays are all \_\_\_\_\_ RF energy forms.
4. Match microwave oven safety standards with their controlling agencies.
- |          |   |  |
|----------|---|--|
| _____ a. | Limits the frequencies available for microwave oven operations so that they can operate without interfering with communications devices | 1. Department of Health and Human Services |
| _____ b. | Limits the acceptable amount of radiation that a microwave oven may emit and specifies door locks and monitoring system                 | 2. Underwriters Laboratories               |
| _____ c. | Requires that microwave ovens subscribe to safety standards for operation as an electrical device                                       | 3. Federal Communications Commission       |
5. Select true statements concerning the performance standard for microwave ovens by placing an "X" beside each statement that is true.
- \_\_\_\_\_ a. The Performance Standard for Microwave Ovens applies to all microwave ovens manufactured after October 6, 1980.
- \_\_\_\_\_ b. Microwave emission shall not exceed 1 milliwatt per square centimeter at 5 cm from the external surface of the oven prior to acquisition by the purchaser.
- \_\_\_\_\_ c. Microwave emission shall not exceed 5 milliwatts per square centimeter at anytime during the life of the oven.
- \_\_\_\_\_ d. Microwave ovens must have at least one safety interlock.
- \_\_\_\_\_ e. The interlock system must include a monitor which will cause the oven to become inoperative if either interlock fails.

## TEST

- \_\_\_\_\_f. RF leakage tests to determine microwave emission must be made with approved test instruments only.
- \_\_\_\_\_g. Precaution labels concerning use and service must be attached to a microwave oven.
- \_\_\_\_\_h. The label on a microwave oven must have only the name of the manufacturer.
6. Select true statements concerning FCC microwave standards by placing an "X" beside each statement that is true.
- \_\_\_\_\_a. Microwave ovens are assigned operating frequencies by the FCC so they will not interfere with other frequencies.
- \_\_\_\_\_b. Microwave frequencies include 915 MHz and 2450 MHz, but almost all modern countertop microwave ovens use the 915 MHz frequency.
- \_\_\_\_\_c. Other microwave frequencies do have specific FCC assignments, but these frequencies are reserved for TV stations.
- \_\_\_\_\_d. The label on a microwave oven must list the operating frequency of the oven and indicate FCC approval.
7. Match major components with their functions in a microwave oven.
- |  |                        |
|--|------------------------|
| _____a. This is usually a magnetron which generates microwaves and directs them from an antenna into a transmission device or an oven cavity                                   | 1. Transmission device |
| _____b. This is usually a waveguide which acts as a chute through which microwaves are directed into the oven cavity   | 2. Oven cavity         |
| _____c. This is usually a fan-like device called a stirrer which spreads the microwaves in a random pattern to assure even distribution of the microwaves into the oven cavity | 3. A microwave source  |
| _____d. A resonant chamber into which food is placed for thawing, heating, or cooking  | 4. Interlock system    |
| _____e. Primary and secondary safety devices on a microwave oven door to assure that microwave transmission will stop immediately when the door is opened                      | 5. Distribution device |



## TEST

8. Complete statements concerning magnetron structure and operation by inserting the word(s) that best completes each statement.
- a. Most magnetrons are constructed as a series of cylinders:
    - 1) The outer cylinder is a permanent \_\_\_\_\_
    - 2) The middle cylinder is an \_\_\_\_\_ with vanes or ridges in it that create "resonant cavities"
    - 3) The inner cylinder is a \_\_\_\_\_ with a heating filament in the center
  - b. As high voltage is supplied to the magnetron from a \_\_\_\_\_, the filament heats the cathode
  - c. As the cathode is heated, it gives off electrons whose \_\_\_\_\_ charges are attracted to the anode which operates at a positive potential
  - d. The magnetic field around the anode \_\_\_\_\_ the electrons so that they travel in a circular path to reach the anode instead of traveling in a straight line as electrons normally would
  - e. As the electrons move in a rapid orbit from cathode to anode, they travel past the resonant cavities in the anode and cause the cavities to \_\_\_\_\_ at a high frequency
  - f. The pulsating 2450 MHz frequency generated by the magnetron is picked up by the \_\_\_\_\_ and directed into a waveguide and on to a stirrer which distributes the microwaves into the oven cavity
9. Define three characteristics of microwaves.
- a. Reflection — \_\_\_\_\_
  - b. Transmission — \_\_\_\_\_
  - c. Absorption — \_\_\_\_\_
10. Complete statements concerning the significance of microwave reflection by circling the word(s) that best completes each statement.
- a. The walls inside a microwave (**always, never**) get hot because metal reflects microwaves, and for that same reason, a microwave oven should never be operated without a load.
  - b. Metal utensils cannot be used in a microwave because they cause (**arcing, melting**) that can damage components.
  - c. Aluminum foil (**can, cannot**) be used in limited quantity to shield parts of food to assure even cooking.

## TEST

11. Complete statements concerning the significance of microwave transmission by circling the word(s) that best completes each statement.
- Since microwaves easily (**penetrate, heat**) glass, paper, and plastic, most utensils made from these materials are safe for use in a microwave oven.
  - Glass utensils are best for foods high in (**fat or sugar, acid**) content because such foods can distort certain plastics.
  - Paper towels can be used (**beneath, over**) foods to help keep the oven clean or placed (**over, beneath**) bacon to avoid splatter.
12. Complete statements concerning the significance of microwave absorption by circling the word(s) that best completes each statement.
- The fact that foods (**absorb, reflect**) microwaves is the key to microwave cooking.
  - The process of absorption is also used to defrost frozen foods or to keep foods warm by employing a timed sequence in which the magnetron is (**on for awhile then off for awhile, put on low power**).
  - How fast foods absorb microwaves depends on the amount of food, temperature of the food when cooking starts, and even the (**shape, weight**) of food.
13. Arrange in order the steps in microwave cooking by placing the correct sequence number in the appropriate blank.
- \_\_\_\_\_a. Food molecules oscillate back and forth four billion, nine hundred million times every second.
  - \_\_\_\_\_b. The ultra high-speed oscillation produces friction between the molecules which converts the microwave energy to instant heat.
  - \_\_\_\_\_c. Microwaves penetrate food up to a depth of 2 inches and accelerate the conduction of heat, but microwaves do not cook food from the inside out.
  - \_\_\_\_\_d. As microwaves enter food, they set up electrical fields that change polarity every half cycle.
  - \_\_\_\_\_e. Molecules in the food, especially water and fat molecules, start moving back and forth and changing directions every half cycle just as the microwaves do.

## TEST

14. Match advantages of microwave cooking with their benefits.

- |         |   |                 |
|---------|---|-----------------|
| _____a. | Microwave ovens cook about ten times faster than conventional methods and better serve the fast-paced American life style                                       | 1. Health       |
| _____b. | Microwave ovens actually consume less energy than conventional cooking devices  | 2. Safety       |
| _____c. | Microwave ovens require far less space than conventional ranges and ovens   | 3. Speed        |
| _____d. | Microwave ovens require less water to cook vegetables and other foods and help preserve valuable vitamins and minerals that are lost with other cooking methods | 4. Cleanliness  |
| _____e. | Microwave ovens do not heat up the kitchen and increase the need for summer air conditioning  | 5. Conservation |
| _____f. | Microwave ovens do not cook food on to oven walls or other components and cleanup is faster and easier than with conventional ovens                             | 6. Comfort      |
| _____g. | Microwave ovens are proving to be one of the safest appliances in a home, and burns on hands and fingers are unheard of with microwave cooking                  | 7. Space        |

15. Arrange in order the steps in installing a microwave oven by placing the correct sequence number in the appropriate blank.

- \_\_\_\_\_a. Push the button to put the oven in a COOK cycle for 30 seconds
- \_\_\_\_\_b. Open oven door, remove water, and check water to make sure it has been heated
- \_\_\_\_\_c. Place the oven in location and check for:
- 1) One inch of clearance at the top and back
  - 2) Two to three inches clearance on each side
  - 3) Sufficient clearance to assure air flow at the bottom of the oven
- \_\_\_\_\_d. Heated water indicates oven is ready for operation
- \_\_\_\_\_e. If oven has been stored in a cold location, let it warm to room temperature before operating

## TEST

- f. Place a cup of water in the oven cavity and close the door  
 g. Check the oven thoroughly to assure there is no damage  
 h. Plug oven into a 120 volt three-prong or four-prong grounded outlet only  
 i. Check for at least a 15 amp circuit and make sure the microwave is the only appliance on that circuit  
 j. Remove all material from the oven interior
16. Select true statements concerning general rules for preventive maintenance by placing an "X" beside each statement that is true.
- a. Clean the stirrer cover and the oven with a damp cloth after each use  
 b. Wipe out excess moisture after every use  
 c. Use steel wool to clean up stubborn soils  
 d. Use a damp cloth to clean a temperature probe after each use, and dry the probe after cleaning, but do not put the probe into dishwasher or a dishwasher  
 e. Use a knife to scrape the stirrer cover clean  
 f. Remember that caked-on food buildup on oven or door surfaces affects oven performance  
 g. A clean oven looks better, smells better, and cooks better  
 h. Inspect air intakes and outlets weekly to make sure someone has not blocked them
17. Complete statements concerning guidelines for effective in-shop repairs by inserting the word(s) that best completes each statement.
- a. Know the brand name, model, and \_\_\_\_\_ number of the oven to be serviced.  
 b. Have revisions and \_\_\_\_\_ for service manuals available for reference.  
 c. Rely on the manufacturer's \_\_\_\_\_ catalog for proper parts identification.  
 d. Use wiring \_\_\_\_\_ to assure cost-effective troubleshooting.  
 e. Begin with the customer's complaint and troubleshoot in a \_\_\_\_\_ sequence to avoid wasting time testing components that have nothing to do with the problem.  
 f. Ask a supervisor for assistance with problems you can't handle, or call the national service number for technical assistance from the manufacturer \_\_\_\_\_

## TEST

18. Complete statements concerning guidelines for effective on-site service calls by inserting the word(s) that best completes each statement.
- a. Introduce yourself and explain the reason \_\_\_\_\_.
  - b. Ask the customer to \_\_\_\_\_ the problem.
  - c. Place a \_\_\_\_\_ on the counter area where tools or materials will be placed.
  - d. Inspect the power supply for proper 120V three-pronged or four-pronged \_\_\_\_\_ outlet.
  - e. Never make quick \_\_\_\_\_ of a problem that may cause the customer to anticipate a speedy repair or a minimal bill.
  - f. Keep the area free of \_\_\_\_\_ and \_\_\_\_\_, and follow all safety rules when working with oven components.
  - g. Don't waste time on the service call if it is \_\_\_\_\_ the oven will require major repair that cannot be accomplished on-site.
  - h. Reference \_\_\_\_\_ materials and schematics as required to assure cost-effective service.
  - i. Complete a door inspection and an RF leakage inspection, and tag the oven with an \_\_\_\_\_ tag after repairs are complete.
  - j. Present the bill to the customer, explain charges for parts and labor, and \_\_\_\_\_ the amount due.
  - k. Reacquaint the customer with proper oven use and review \_\_\_\_\_ requirements.
19. Select true statements concerning requirements for RF leakage test instruments by placing an "X" beside each statement that is true.
- \_\_\_\_a. Leakage test instruments must always be set at a frequency of 918 MHz.
  - \_\_\_\_b. Leakage test instruments must have a response time that permits them to reach 90% of their response capacity in only three seconds.
  - \_\_\_\_c. Batteries in test instruments should be checked once a year.
  - \_\_\_\_d. Spacer cones and probes should be checked prior to each use to assure they are clean and undamaged.

## TEST

20. Select true statements concerning requirements for spacer cones by placing an "X" beside each statement that is true.
- \_\_\_\_\_a. Spacer cones are fitted onto detector probes to assure that the center of the probe is kept 5 cm from any external surface of the oven
  - \_\_\_\_\_b. Although most spacer cones have conical shapes, it is good for a service technician to think of them as being shaped as spheres and remember to keep them a proper distance from latches and control knobs
  - \_\_\_\_\_c. Spacer cones should not be forced into door seams, but held so that they barely intrude into the surface discontinuity

(NOTE: If the following activities have not been accomplished prior to the test, ask your instructor when they should be completed.)

21. Demonstrate the ability to:
- a. Test the interlock system on a microwave oven for safe performance. (Job Sheet #1)
  - b. Check an RF leakage test meter. (Job Sheet #2)
  - c. Conduct an RF leakage test on microwave oven door seals, door glass, cabinet vents, and power cord to assure that the oven complies with the performance standard for microwave ovens. (Job Sheet #3)
  - d. Clean and deodorize a microwave oven. (Job Sheet #4)
  - e. Determine if selected utensils are microwave safe. (Job Sheet #5)

# MICROWAVE OVEN ORIENTATION UNIT I

## ANSWERS TO TEST

1.
  - a. 4
  - b. 6
  - c. 2
  - d. 7
  - e. 1
  - f. 5
  - g. 3
  
2.
  - a. Microwaves
  - b. Pencil
  - c. Spectrum
  - d. Non-ionizing
  - e. Cooking
  
3.
  - a. Heat
  - b. Cells
  - c. Ionizing
  
4.
  - a. 3
  - b. 1
  - c. 2
  
5. b, c, e, f, g
  
6. a, d
  
7.
  - a. 3
  - b. 1
  - c. 5
  - d. 2
  - e. 4
  
8.
  - a.
    - 1) Magnet
    - 2) Anode
    - 3) Cathode
  - b. Transformer
  - c. Negative
  - d. Repels
  - e. Vibrate
  - f. Antenna
  
9.
  - a. Microwaves are reflected by metal
  - b. Microwaves are transmitted through glass, plastic, and paper
  - c. Microwaves are absorbed by food and water

## ANSWERS TO TEST

10. a. Never  
b. Arcing  
c. Can
11. a. Penetrate  
b. Fat or sugar  
c. Beneath, over
12. a. Absorb  
b. On for awhile, then off for awhile  
c. Shape
13. a. 3  
b. 4  
c. 5  
d. 1  
e. 2
14. a. 3  
b. 5  
c. 7  
d. 1  
e. 6  
f. 4  
g. 2
15. a. 8  
b. 9  
c. 3  
d. 10  
e. 6  
f. 7  
g. 1  
h. 4  
i. 5  
j. 2
16. a, b, d, f, g, h
17. a. Serial  
b. Updates  
c. Parts  
d. Schematics  
e. Systematic  
f. Hot-line



## ANSWERS TO TEST

18. a. For your call  
b. Define  
c. Drop cloth  
d. Grounded  
e. Evaluations  
f. Children, pets  
g. Obvious  
h. Service  
i. Inspection  
j. Collect  
k. Preventive maintenance
19. b, d
20. a, b, c
21. Performance skills evaluated according to procedures written in the job sheets

## MICROWAVE OVEN TROUBLESHOOTING AND REPAIR UNIT II



### UNIT OBJECTIVE

After completion of this unit, the student should be able to discuss microwave oven components and explain their functions in oven operation. The student should also be able to relate wiring schematics to their uses in circuit diagnostics, and arrange safety requirements according to troubleshooting procedures. The student should also be able to spot component malfunctions through circuit diagnosis, test suspect components for malfunctions, and remove and replace malfunctioning components. These competencies will be evidenced by correctly performing the procedures outlined in the assignment and job sheets and by scoring 85 percent on the unit test.

### SPECIFIC OBJECTIVES

After completion of this unit, the student should be able to:

1. Match terms related to microwave oven troubleshooting with their correct definitions.
2. Match major microwave oven components with their functions.
3. Match operating controls with their functions.
4. Complete statements concerning motors in microwave ovens.
5. Select true statements concerning door seals and their importance in microwave oven construction.
6. Complete statements concerning technical materials required for microwave oven service.
7. Select true statements concerning advantages of using wiring schematics in circuit diagnosis.
8. Solve problems concerning how to use schematics for system diagnosis.
9. Solve problems concerning typical circuit diagnosis for an oven in the COOK condition.
10. Solve problems concerning typical circuit diagnosis for an oven in the VARI-COOK condition.

**OBJECTIVE SHEET**

11. Complete statements concerning pre-service inspection requirements for microwave ovens.
12. Complete statements concerning safety requirements for microwave oven service.
13. Complete statements concerning post-service safety requirements for microwave ovens.
14. Arrange in order the steps in troubleshooting a microwave oven.
15. Diagnose a circuit for problems when an oven is in a CAVITY LIGHT ON condition. (Assignment Sheet #1)
16. Diagnose a circuit for problems when an oven is in a COOK condition. (Assignment Sheet #2)
17. Diagnose a circuit for problems when an oven is in a VARI-COOK condition. (Assignment Sheet #3)
18. Demonstrate the ability to:
  - a. Discharge a capacitor. (Job Sheet #1)
  - b. Check stirrer blade rotation. (Job Sheet #2)
  - c. Prepare a microwave oven for component testing. (Job Sheet #3)
  - d. Replace and adjust a microwave oven door assembly. (Job Sheet #4)
  - e. Troubleshoot microwave oven problems with circuit diagnosis (Job Sheet #5)
  - f. Conduct power tests on a microwave oven to check for temperature rise under full power. (Job Sheet #6)
  - g. Conduct tests on high-voltage components when little or no heat is produced by the oven but all other operations appear normal. (Job Sheet #7)
  - h. Make interlock switch module tests on a microwave oven. (Job Sheet #8)
  - i. Test magnetron and cavity thermal protectors. (Job Sheet #9)
  - j. Test a low voltage transformer. (Job Sheet #10)
  - k. Test a temperature probe and probe jack. (Job Sheet #11)
  - l. Test an oven timer. (Job Sheet #12)
  - m. Test a controller. (Job Sheet #13)

**OBJECTIVE SHEET**

- n. Remove and test a control panel. (Job Sheet #14)
- o. Test a control circuit board. (Job Sheet #15)
- p. Test a triac module. (Job Sheet #16)
- q. Test a cook relay. (Job Sheet #17)
- r. Remove a blower motor and transformer. (Job Sheet #18)
- s. Remove and reinstall a magnetron. (Job Sheet #19)
- t. Remove a timer and a controller. (Job Sheet #20)
- u. Remove a low voltage transformer and a triac. (Job Sheet #21)
- v. Remove and disassemble a stirrer system. (Job Sheet #22)
- w. Remove magnetron and cavity thermal protectors. (Job Sheet #23)
- x. Remove, disassemble, and reassemble a microwave oven door. (Job Sheet #24)
- y. Replace a door hook on a microwave oven. (Job Sheet #25)

## MICROWAVE OVEN TROUBLESHOOTING AND REPAIR UNIT II

### SUGGESTED ACTIVITIES

- A. Provide students with objective sheet.
- B. Provide students with information, assignment, and job sheets.
- C. Make transparencies.
- D. Discuss information and assignment sheets.
- E. Discuss and demonstrate the procedures in the job sheets.

(NOTE: The job sheets are dedicated to specific models of Litton microwave ovens. If the Litton models specified are available, the job sheets should be followed as written. If another brand and model of oven is selected, the job sheets will have to be modified as required by the service manual.)

- F. Demonstrate to the class the procedure for discharging a capacitor by bleeding off the charge through a resistor, and impress upon the students the need to master the procedure for the sake of personal safety and to protect the capacitor itself.
- G. Impress upon students the need to have a load in the oven cavity anytime a microwave oven is operating under any condition.
- H. Invite a local or area technician who repairs microwave ovens to talk to the class about the job market, matters concerning customer relations, and problems peculiar to servicing and repairing microwave ovens.
- I. Invite a manufacturer's representative to demonstrate his/her brand of oven and talk about service and repair procedures that may vary slightly from the procedures in the job sheets that accompany this unit.
- J. Explain to students that the job sheets are all dedicated to a specific model of Litton microwave ovens because Litton service and repair procedures are typical of microwave oven service and repair in general. The materials were made available for reproduction by Litton Systems, Inc., and their use does not constitute an institutional endorsement by MAVCC or any school.
- K. Have available for student examination a magnetron, power transformer, starter assembly, and other major components from a microwave oven.
- L. Invite an electronics instructor to talk to the class about microprocessors and chips that are part of the digital control panels on some microwaves, how static electricity can damage these devices, and how they can be safely handled.
- M. Give test.

### CONTENTS OF THIS UNIT

- A. Objective sheet
- B. Information sheet

## CONTENTS OF THIS UNIT

### C. Transparency masters

1. TM 1 — Microwave Oven Components
2. TM 2 — Microwave Oven in CAVITY LIGHT ON Condition
3. TM 3 — Microwave Oven in COOK Condition
4. TM 4 — Microwave Oven in VARI-COOK Condition
5. TM 5 — Microwave Oven in IDLE Condition

### D. Assignment sheets

1. Assignment Sheet #1 — Diagnose a Circuit for Problems When an Oven is in CAVITY LIGHT ON Condition
2. Assignment Sheet #2 — Diagnose a Circuit for Problems When an Oven is in a COOK Condition
3. Assignment Sheet #3 — Diagnose a Circuit for Problems When an Oven is in a VARI-COOK Condition

### E. Job sheets

1. Job Sheet #1 — Discharge a Capacitor
2. Job Sheet #2 — Check Stirrer Blade Rotation
3. Job Sheet #3 — Prepare a Microwave Oven for Component Testing
4. Job Sheet #4 — Replace and Adjust a Microwave Oven Door Assembly
5. Job Sheet #5 — Troubleshoot Microwave Oven Problems with Circuit Diagnosis
6. Job Sheet #6 — Conduct Power Tests on a Microwave Oven to Check for Temperature Rise Under Full Power
7. Job Sheet #7 — Conduct Tests on High-Voltage Components When Little or No Heat is Produced by the Oven But All Other Operations Appear Normal
8. Job Sheet #8 — Make Interlock Switch Module Tests on a Microwave Oven
9. Job Sheet #9 — Test Magnetron and Cavity Thermal Protectors
10. Job Sheet #10 — Test a Low Voltage Transformer
11. Job Sheet #11 — Test a Temperature Probe and Probe Jack
12. Job Sheet #12 — Test an Oven Timer
13. Job Sheet #13 — Test a Controller
14. Job Sheet #14 — Remove and Test a Control Panel
15. Job Sheet #15 — Test a Control Circuit Board
16. Job Sheet #16 — Test a Triac Module

**CONTENTS OF THIS UNIT**

17. Job Sheet #17 — Test a Cook Relay
  18. Job Sheet #18 — Remove a Blower Motor and Transformer
  19. Job Sheet #19 — Remove and Reinstall a Magnetron
  20. Job Sheet #20 — Remove a Timer and a Controller
  21. Job Sheet #21 — Remove a Low Voltage Transformer and a Triac
  22. Job Sheet #22 — Remove and Disassemble a Stirrer System
  23. Job Sheet #23 — Remove Magnetron and Cavity Thermal Protectors
  24. Job Sheet #24 — Remove, Disassemble, and Reassemble a Microwave Oven Door
  25. Job Sheet #25 — Replace a Door Hook on a Microwave Oven
- F. Test
- G. Answers to test

**REFERENCES USED IN DEVELOPING THIS UNIT**

- A. *Litton Microwave Service Training Manual, Commercial Basics*. Minneapolis, MN 55440: Litton Systems, Inc., 1984.
- B. *Service Information Manual, The 1500 Series, Model 1510.000*. Minneapolis, MN 55440: Litton Systems, Inc., 1979.
- C. *Commercial Service Information Manual, Systems 70 Microwave Ovens*. Minneapolis, MN 55440: Litton Systems, Inc., 1984.
- D. *Microwave Oven Service Manual (1300 and 1400 Series)*. Minneapolis, MN 44550: Litton Systems, Inc., 1984.
- E. *Microwave Oven Service Manual (Generation II, All Models)*. Minneapolis, MN 55440: Litton Systems, Inc., 1984.

# MICROWAVE OVEN TROUBLESHOOTING AND REPAIR

## UNIT II

### INFORMATION SHEET

#### I. Terms and definitions

- A. Arcing — The generation of visible electric sparks caused by microwaves striking and bouncing off metal objects or objects with too much metallic content
- B. Capacitor — A device capable of storing and discharging electricity
- C. Diode — A device that permits electrical current to flow in only one direction
- D. N.C. (Normally Closed) — A switch that is normally closed when it is not activated
- E. N.O. (Normally Open) — A switch that is normally open when it is not activated
- F. Rectifier — A device that converts normal household AC current into pulsating DC current

#### II. Major microwave oven components and their functions (Transparency 1)

- A. Power transformer — A transformer that converts 120V AC current into low voltage (about 3.2V AC) that is fed to the magnetron filaments, and into high voltage (about 1900V AC) that is fed into the voltage-doubler circuit
- B. Voltage-doubler circuit — A diode/rectifier/capacitor combination that converts the high voltage AC feed from the transformer into approximately 3900V pulsating DC current that is fed into the magnetron
- C. Magnetron — A cylinder-shaped cathode/anode in a magnetic field that converts applied low voltage AC and high voltage DC current into microwaves
- D. Antenna — The part of the magnetron tube that directs generated microwaves into a waveguide
- E. Waveguide — A duct-like channel through which the microwaves travel in controlled transmission to the stirrer assembly
- F. Stirrer assembly — A device with fan-like blades that scatter the microwaves at random into the oven cavity to assure even heat distribution in the cavity



## INFORMATION SHEET

### III. Operating controls and their functions (Transparency 1)

- A. Interlock switches — These switches are activated by the opening or closing of the oven door to assure that microwave generation does not start until the door is properly closed and stops the moment the door is opened
- B. Interlock monitor — A device that instantly shuts off microwave transmission in the event any interlock switch fails
- C. Timer — May be a rotary, digital, pushbutton, or touchpad device, and is designed to stop microwave generation at the end of a specified period
- D. Start/stop controls — Permits selection of COOK, DEFROST or other conditions of a particular oven, and some oven doors cannot be opened until STOP has been pressed
- E. Thermal protectors — Devices which stop oven operations in the event a blower obstruction causes a magnetron to overheat or the oven cavity to overheat
- F. Cook relay — Activated by depressing the COOK switch to generate a current path to the stirrer assembly, transformer, and cook light
- G. Controller — Used on microwave ovens to start and stop microwave transmission for thawing food or keeping food warm during a variable heat cycle  
  
(NOTE: Keeping food warm or thawing food is not accomplished by reducing the power output of the magnetron; the warm or thaw mode simply means the magnetron turns on and shuts off at intervals determined by the controller.)
- H. Triac — A switching relay used for controlling circuits in a microwave oven

### IV. Motors in microwave ovens

- A. Blower motor — A motor that drives a fan which directs air around the vanes of the magnetron to help keep it cool and also directs some air through the oven cavity to remove steam and vapors from cooking food  
  
(NOTE: Some ovens equipped with turn trays use a stepdown winding on the blower motor to turn the tray.)
- B. Stirrer motor — A motor that drives a fan which deflects microwaves from the waveguide into the oven cavity  
  
(NOTE: Some ovens have two stirrer motors and two stirrer fans in the stirrer assembly.)

## INFORMATION SHEET

### V. Door seals and their importance in microwave oven construction

- A. Door seals must be so designed that they prevent the escape of microwaves from the oven
- B. Door seals must be so designed that they can limit RF leakage from the oven door to a maximum level of  $5\text{mw}/\text{cm}^2$
- C. A "capacitive seal" is a flexible metal plate with a thin insulated coating to break metal-to-metal contact and prevent arcing when the oven door is closed

(NOTE: Capacitive seals are so called because they create a very low resistance path, like a capacitor, between the oven door and the cavity.)

- D. A "choke seal" is so structured that the dimensions are related to the wavelength of microwaves, and will actually reflect stray microwaves back into the oven cavity
- E. "Absorbent seals" are made of plastic or synthetic rubber and may have a ferritic content to help them absorb harmonic energy that might get by the other seals
- F. Door seals are critical to safe microwave oven operation and should be carefully inspected anytime an oven is first delivered or later serviced

### VI. Technical materials required for microwave oven service

- A. The nameplate on the oven should always be checked for the proper model number and serial number
- B. The service manual for the specific oven being worked on must be available to assure proper references for circuitry and parts
- C. Service bulletins, technical updates, or literature that lists engineering changes that affect component or parts modifications for the oven must be available
- D. Replacement parts should be ordered by number from the parts catalog for the specific oven being serviced
- E. Circuit diagnosis and troubleshooting should not begin without a proper wiring schematic for the specific oven being serviced

(NOTE: Schematics are usually included in service manuals and revised schematics sometimes appear in service bulletins, but be sure to read legends that appear with schematics or wiring diagrams.)

## INFORMATION SHEET

### VII. Advantages of using wiring schematics in circuit diagnosis

- A. Using a schematic is the quickest way to locate a malfunctioning component so it can be tested
- B. Using a schematic eliminates the bad habit of wasting the time testing components that could not possibly have anything to do with the problem
- C. Using a schematic promotes cost-effective repairs and saves customers money
- D. Using a schematic promotes professional attitudes and builds confidence in service technicians who learn to use schematics effectively

### VIII. How to use schematics for system diagnosis

(NOTE: Items in this objective are adapted from materials copyrighted © by Litton Systems, Inc., and are reprinted with permission. Terminology is applicable to the Litton product line, but is representative of microwave oven operation in general.)

- A. To use a schematic for troubleshooting requires knowing (Transparency 2):

1. What oven set-up the schematic shows

Example: Is the oven OFF with the door open, in a COOK cycle, or at some other setting?

2. What the normal condition of the oven should be

Example: With the timer set to the OFF position and the oven door open (set-up), the cavity light should be on (normal condition)

3. The problem

Example: The cavity light does not light

- B. Troubleshooting should begin at the circuit breaker and proceed through the circuitry identifying components or conditions that could be causing the problem(s)

Example: Possible causes for the cavity light not lighting in the above example include:

- A blown wall fuse or tripped circuit breaker
- A blown 15-amp oven fuse
- A defective cavity thermal protector
- A defective lower door interlock switch
- A defective cavity light
- A defective cavity light socket
- A broken or loose connection

(NOTE: All component tests should be made in order to assure effective systematic troubleshooting.)

## INFORMATION SHEET

### IX. Typical circuit diagnosis for an oven in the COOK condition (Transparency 3)

(NOTE: Items in this objective are adapted from materials copyrighted © by Litton Systems, Inc., and are reprinted with permission. Terminology is applicable to the Litton product line, but is representative of microwave oven operation in general.)

- A. Oven set-up includes:
  - 1. Open oven door
  - 2. Place container of water in oven cavity
  - 3. Set vari-cook dial to HIGH
  - 4. Set timer dial to two minutes
  - 5. Close oven door
- B. Normal operation includes:
  - 1. Cavity light on
  - 2. Cook light on
  - 3. Stirrer motors operate
  - 4. Blower motor operates
  - 5. Timer motor operates
  - 6. Oven heats load placed in cavity
  - 7. Timer shuts off oven at end of selected time setting
- C. First problem:
  - 1. Cavity light illuminates with door open, but when door is closed, cavity light goes off *and* no components operate
  - 2. Possible cause:
    - a. Defective timer switch
    - b. Broken or loose wire connection
- D. Second problem:
  - 1. Cavity light illuminates, but timer *and* other components do not operate

**INFORMATION SHEET**

2. Possible causes:
  - a. Defective primary (lower door) interlock switch
  - b. Defective secondary (upper door) interlock switch
  - c. Broken or loose wire connection
- E. Third problem:
  1. Timer does not advance, but other operations normal
  2. Possible causes:
    - a. Defective timer assembly
    - b. Binding timer assembly
    - c. Broken or loose wire connection
- F. Fourth problem:
  1. Cook indicator light does not illuminate, but other operations are normal
  2. Possible causes:
    - a. Defective cook indicator light
    - b. Broken or loose wire connection
- G. Fifth problem:
  1. Stirrer blade does not rotate, but other operations are normal
  2. Possible causes:
    - a. Defective stirrer motor
    - b. Stirrer blade binding
    - c. Broken or loose wire connection
- H. Sixth problem:
  1. Blower motor does not operate, but other operation normal
  2. Possible causes
    - a. Defective blower motor
    - b. Blower fan binding
    - c. Broken or loose wire connection

**INFORMATION SHEET****I. Seventh problem:**

1. Cavity light stays on at the end of cook cycle
2. Possible cause — Defective primary (lower door) interlock switch

**J. Eighth problem:**

1. Oven appears to operate normally, but heats very slowly
2. Possible causes:

- a. Vari-cook control not set to appropriate power level
- b. Low line voltage

(NOTE: Line voltage should be 120V, and during operation, line voltage should never drop below 105V.)

- c. Defective electro-mechanical controller
- d. Overheat condition causing thermal protector to open
- e. Defective magnetron
- f. Defective capacitor
- g. Defective power transformer

**K. Ninth problem:**

1. Oven appears to operate normally, but does not heat at all
2. Possible causes:

- a. Defective electro-mechanical controller
- b. Defective magnetron thermal protector
- c. Defective diode
- d. Defective capacitor
- e. Defective transformer
- f. Defective magnetron
- g. Broken or loose wire connection

## INFORMATION SHEET

### X. Typical circuit diagnosis for an oven in the VARI-COOK condition (Transparency 3)

(NOTE: Items in this objective are adapted from materials copyrighted © by Litton Systems, Inc., and are reprinted with permission. Terminology is applicable to the Litton product line, but is representative of microwave oven operation in general.)

#### A. Oven set-up includes:

1. Open oven door
2. Place container of water in oven cavity
3. Set vari-cook dial to setting other than HIGH
4. Set timer dial to two minutes
5. Close oven door

#### B. Normal operation includes:

1. Cavity light on
2. Cook light on
3. Stirrer motors operate
4. Blower motor operates
5. Timer motor operates
6. Controller operates
7. Oven heats load placed in cooking cavity at selected vari-cook power level
8. Timer shuts off oven at end of selected time setting

#### C. First problem:

1. Oven appears to operate normally, but continues to heat on HIGH (full power)
2. Possible causes:
  - a. Defective electro-mechanical controller assembly
  - b. Broken or loose wire connection

## INFORMATION SHEET

- D. Second problem:
  - 1. Oven appears to operate normally, but does not heat at all
  - 2. Possible causes:
    - a. Defective electro-mechanical controller assembly
    - b. Broken or loose wire connection
- E. Special conditions for the VARI-COOK diagnosis
  - 1. Test the COOK CONDITION first to make sure it is operating normally
  - 2. Knowing why the controller works as it does will help you better understand its functions and the functions of the surge resistor
    - a. During vari-cook operation, the controller motor alternately opens and closes the controller contacts 4, 1, and 2, and the "ON" time is dependent upon the vari-cook dial setting
    - b. When contact 4 and 1 closes, power is applied through the surge resistor to the primary of the power transformer
    - c. A moment later, contact 4 and 2 closes, bypassing the surge resistor
    - d. The contact closure sequence limits start-up current surges to protect the controller contacts

### XI. Pre-service inspection requirements for microwave ovens

- A. Check interlock operations and proper door closing
- B. Examine the seals and door surfaces for signs of arcing, wear, or damage that could endanger the integrity of the door
- C. Check the door hinges to make sure they are not loose or damaged
- D. Examine the oven wrap and all exterior surfaces for evidence of misuse or abusive use such as dropping
- E. Check the magnetron and waveguide for proper alignment
- F. Check the stirrer assembly
- G. If there is evidence of abuse or doubts about the microwave generating components, the oven should not be serviced



## INFORMATION SHEET

### XII. Safety requirements for microwave oven service

- A. Always inspect the oven before starting any tests or service
- B. Unplug the power cord to the oven before removing access panels or oven wraps
- C. DISCHARGE THE CAPACITOR by shorting across the capacitor terminals with a screwdriver that has an insulated handle  
  
(CAUTION: If a capacitor is at full charge, it can be damaged by shorting across the terminals; the best way to discharge a full or partially charged capacitor is to bleed the charge through a 20K $\Omega$  resistor; that procedure is outlined in Job Sheet #1.)
- D. When a test routine calls for operating the oven for a "live" test, make all test connections BEFORE YOU PLUG THE UNIT INTO THE POWER RECEPTACLE
- E. Use alligator clips when making "live" tests so you won't have to hold VOM leads near areas of dangerous high voltages
- F. Operate the unit only from a three-prong or four-prong grounded outlet on a 15-amp circuit that services the microwave only
- G. When using an extension cord for testing, use a three-wire grounded cord of at least 16-gauge copper, but do not use a two-wire extension cord
- H. NEVER take high voltage readings around the transformer or the magnetron

### XIII. Post-service safety requirements for microwave ovens

- A. Attach a note to the oven to indicate what the customer can do to avoid further problems if the problem resulted from any form of misuse or lack of proper maintenance
- B. Conduct an RF leakage test to assure that oven microwave emissions are at or below the 5mw/cm<sup>2</sup> maximum level set by the Department of Health and Human Services
- C. Fill out a leakage test tag listing the type of leakage test instrument used, the serial and model numbers of the oven, the date the test was made, and the signature of the technician that made the test

## INFORMATION SHEET

### XIV. Steps in troubleshooting a microwave oven

- A. Complete pre-service inspection and make sure you have the model and serial number for reference
- B. Check troubleshooting procedures in service manual
- C. Make sure your technical materials reflect engineering changes and are otherwise up to date
- D. Start with a proper wiring schematic and a circuit diagnosis (Transparency 5)

(NOTE: The wiring schematic in Transparency 5 is the conditional schematic for Litton microwave ovens, model 1304, 1305, 1420, and 1422, and Transparency 5 should be referenced as required for the job sheets that follow.)

- E. Perform components tests in order
- F. Use a parts catalog that specifically lists parts and components for the oven being repaired
- G. Make an RF leakage test after repairs are complete
- H. Run the oven through a complete operating cycle to insure everything is in order

# Microwave Oven Components

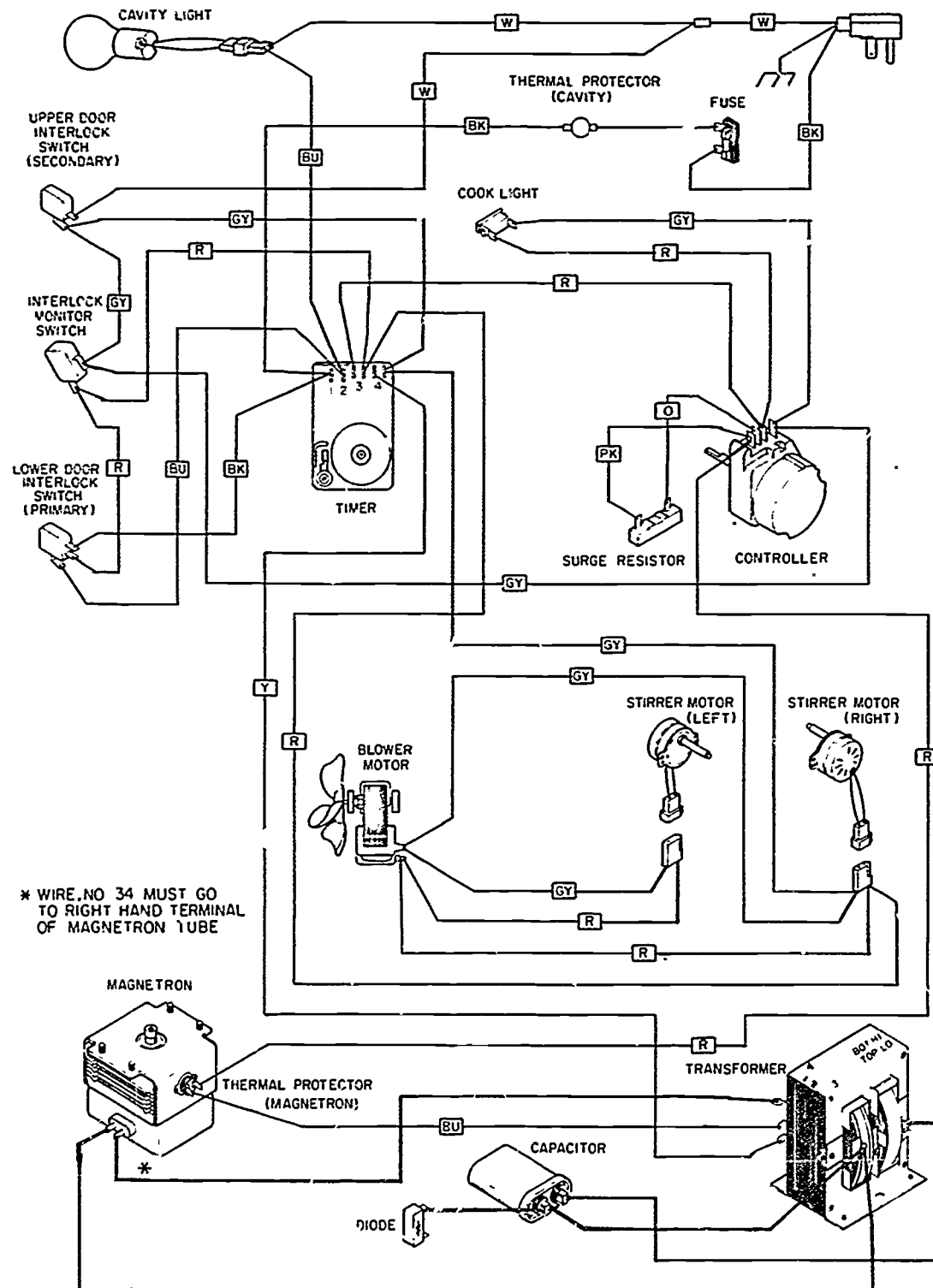

© Litton Systems, Inc.; reprinted with permission

# Microwave Oven in CAVITY LIGHT ON Condition

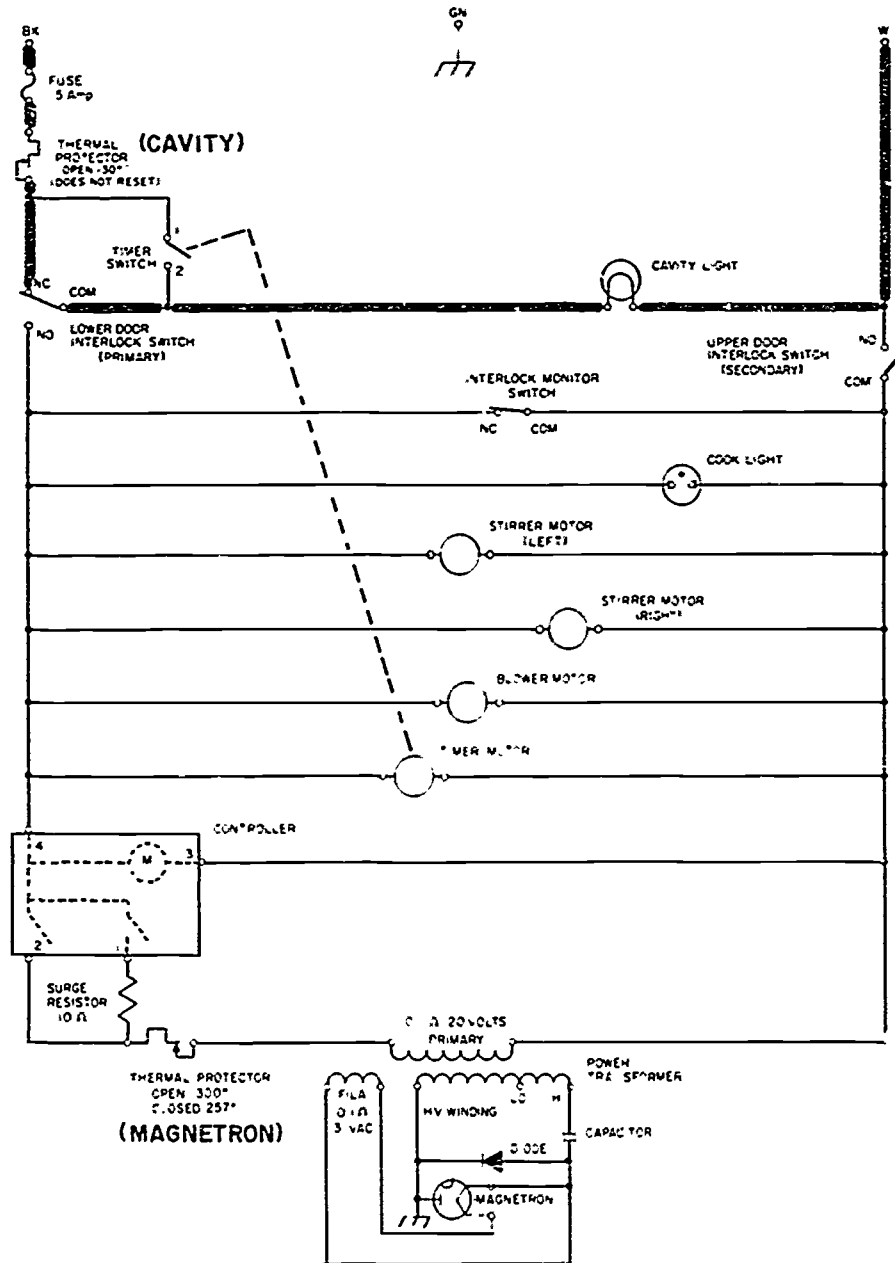

© Litton Systems, Inc.; reprinted with permission

# Microwave Oven in COOK Condition

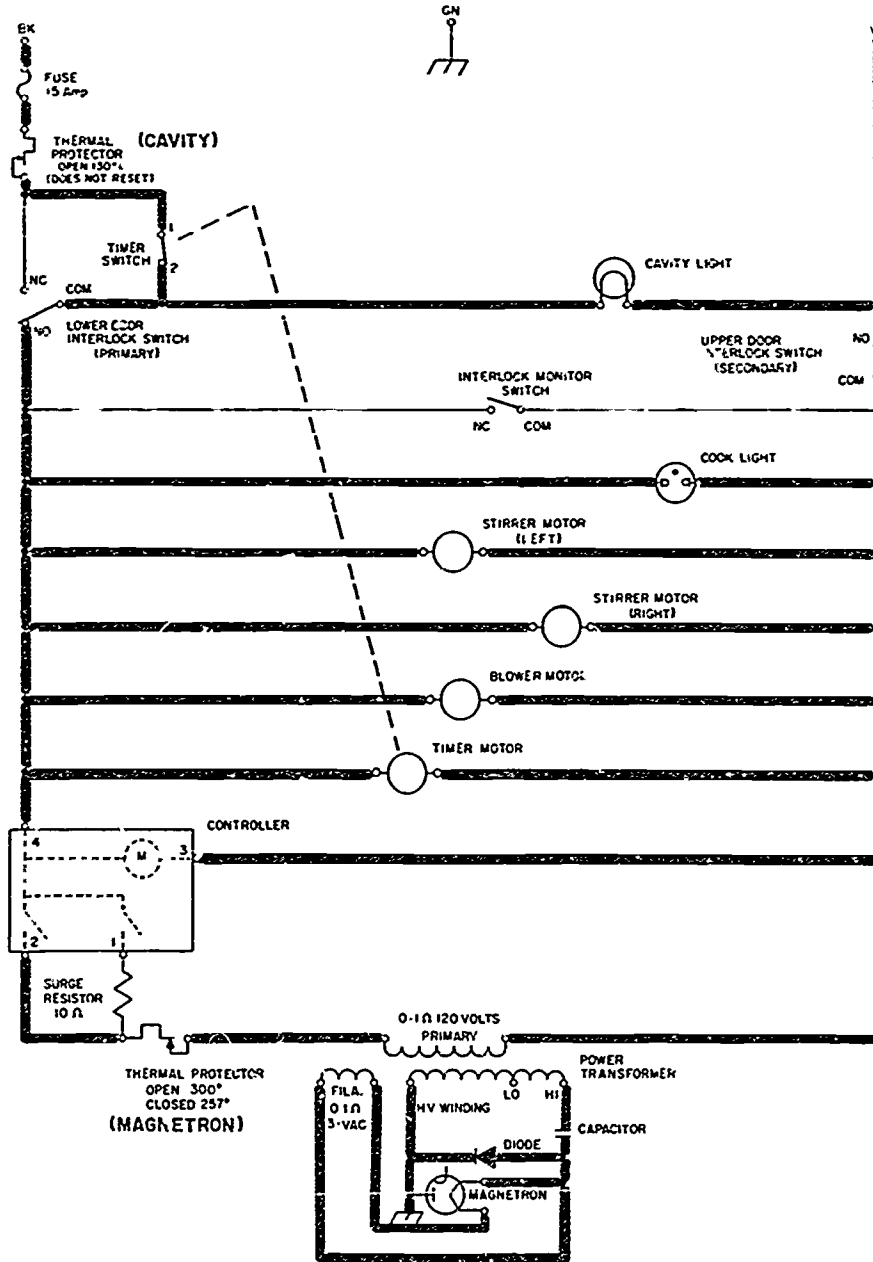

©Litton Systems, Inc.; reprinted with permission

# Microwave Oven in VARI-COOK Condition

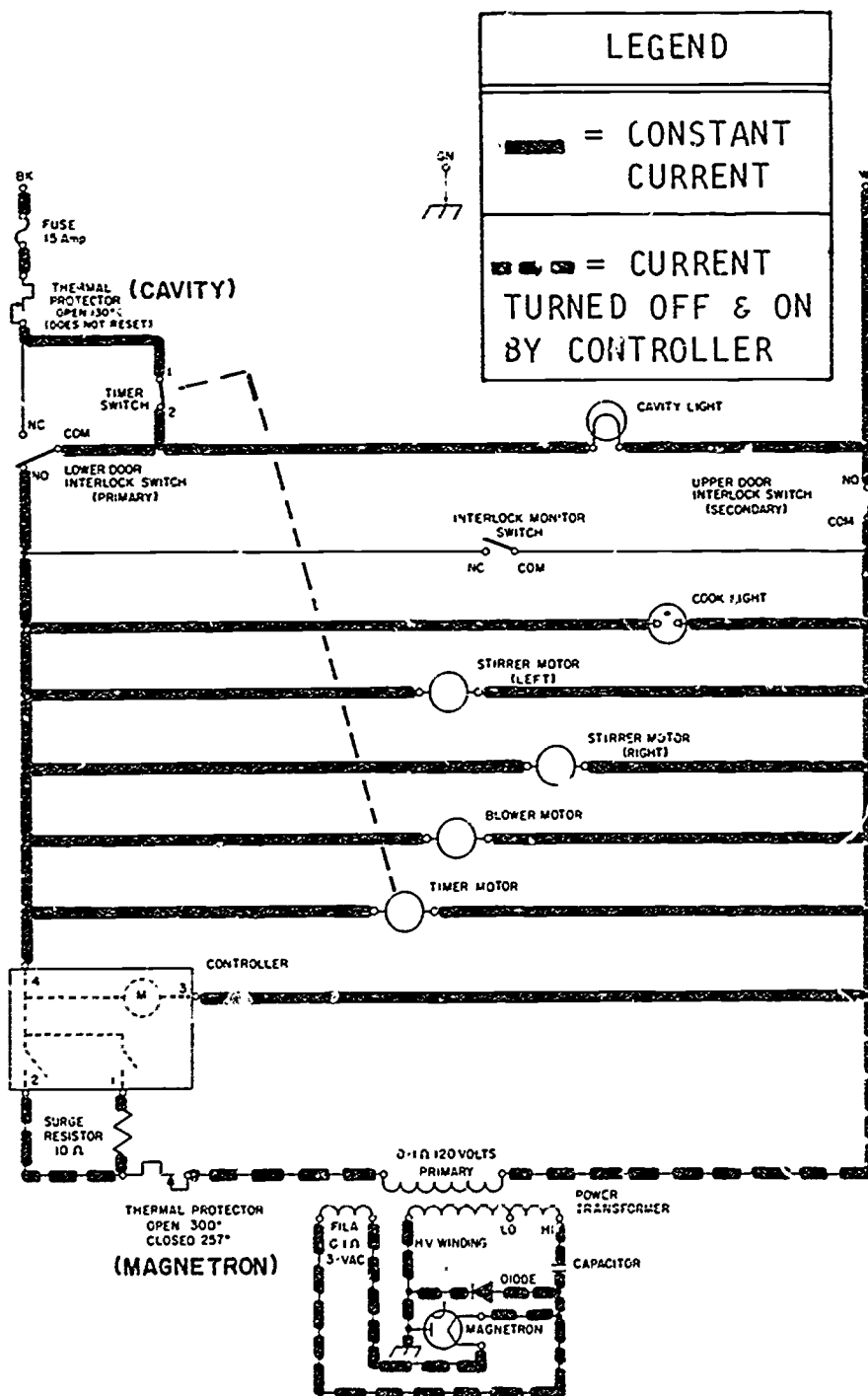

©Litton Systems, inc.; reprinted with permission

# Microwave Oven in IDLE Condition

**CONDITION OF OVEN**  
**DOOR CLOSED**  
**TIMER OFF**

**WARNING: DISCONNECT ELECTRICAL POWER BEFORE SERVICING**

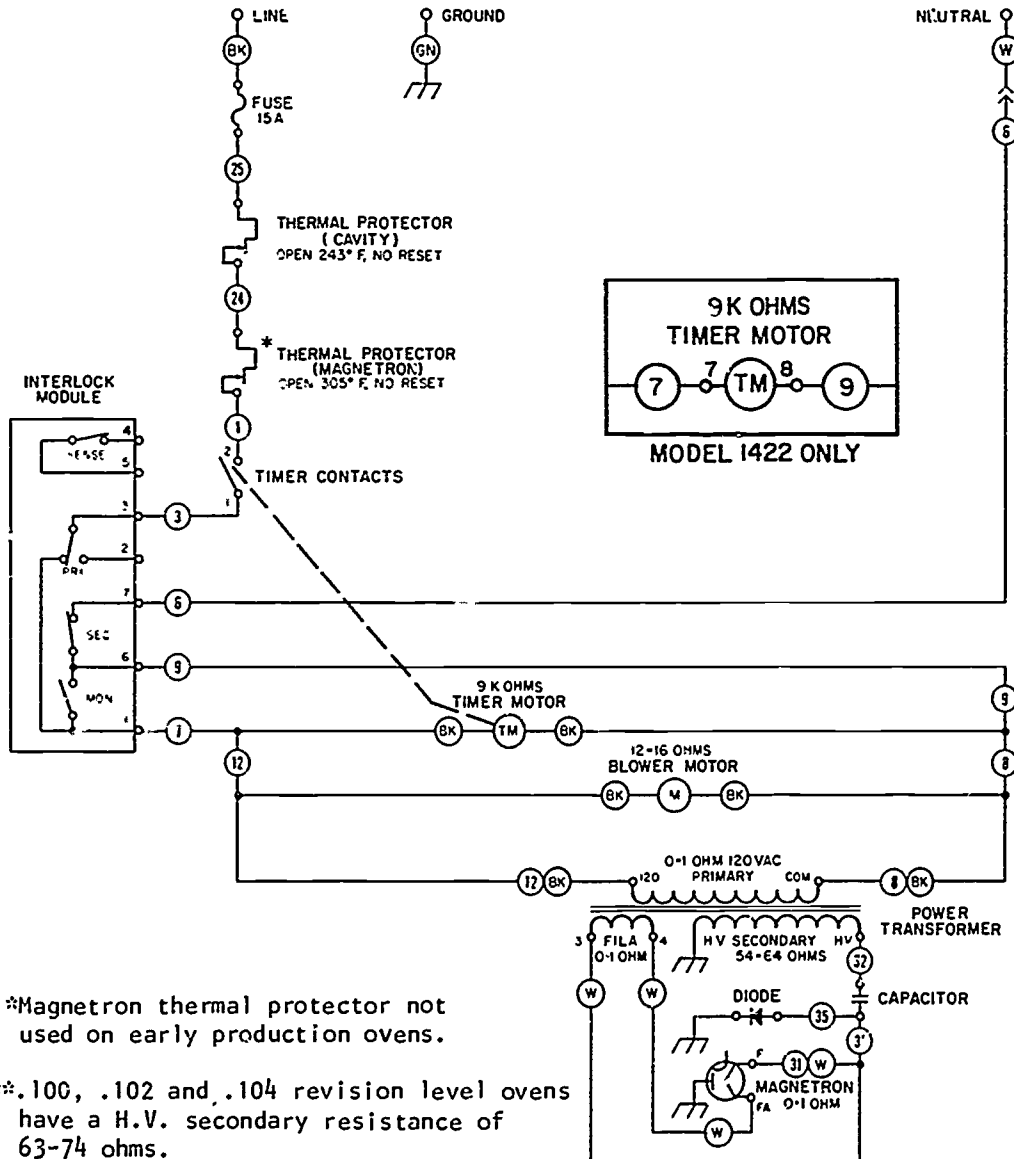

\*Magnetron thermal protector not used on early production ovens.

\*\* .100, .102 and .104 revision level ovens have a H.V. secondary resistance of 63-74 ohms.

FUNCTION	INTERLOCK MODULE				TIMER
	PRIMARY	SECONDARY	MONITOR	1	
DOOR OPEN					
DOOR CLOSED	●	●	●	●	
TIMER OFF					
TIMER ON					●

**WARNING: THERE IS EXTREMELY HIGH VOLTAGE PRESENT AROUND THE POWER SUPPLY COMPONENTS.**

©Litton Systems, Inc.; reprinted with permission

# MICROWAVE OVEN TROUBLESHOOTING AND REPAIR UNIT II

## ASSIGNMENT SHEET #1 — DIAGNOSE A CIRCUIT FOR PROBLEMS WHEN THE OVEN IS IN A CAVITY LIGHT ON CONDITION

Situation: Refer to Transparency 2, assume a set-up that includes the timer set in the OFF position and the oven door open. Under normal conditions, the cavity light would come on.

Problem: The cavity light does not come on. What are at least four causes of the problem?

- a. \_\_\_\_\_  
\_\_\_\_\_
- b. \_\_\_\_\_  
\_\_\_\_\_
- c. \_\_\_\_\_  
\_\_\_\_\_
- d. \_\_\_\_\_  
\_\_\_\_\_



## MICROWAVE OVEN TROUBLESHOOTING AND REPAIR UNIT II

### ASSIGNMENT SHEET #2 — DIAGNOSE A CIRCUIT FOR PROBLEMS WHEN AN OVEN IS IN THE COOK CONDITION

**Situation:** Refer to Transparency 3, and assume a set-up that includes:

- Open oven door
- Place container of water in oven cavity
- Set vari-cook dial to HIGH
- Set timer dial to two minutes
- Close oven door

Normal operation includes:

- Cavity light on
- Cook light on
- Stirrer motors operate
- Blower motor operates
- Timer motor operates
- Oven heats load placed in cavity
- Timer shuts off oven at end of selected time setting

**Problem 1:** The cavity light illuminates with door open, but when door is closed, cavity light goes off *and* no components operate. What are two possible causes?

a. \_\_\_\_\_

b. \_\_\_\_\_

**Problem 2:** Cavity light illuminates, but timer *and* other components do not operate. What are two possible causes?

a. \_\_\_\_\_

b. \_\_\_\_\_

**Problem 3:** Timer does not advance, but other operations normal. What are two possible causes?

a. \_\_\_\_\_

b. \_\_\_\_\_

**Problem 4:** Cook indicator light does not illuminate, but other operation normal. What are two possible causes?

a. \_\_\_\_\_

b. \_\_\_\_\_

**ASSIGNMENT SHEET #2**

**Problem 5:** Stirrer blade does not rotate at one side (left or right) of oven cavity, but other operation normal. What are two possible causes?

a. \_\_\_\_\_

b. \_\_\_\_\_

**Problem 6:** Blower motor does not operate, but other operation normal. What are two possible causes?

a. \_\_\_\_\_

b. \_\_\_\_\_

**Problem 7:** Cavity light stays on at end of cook cycle. What is the most obvious cause?

\_\_\_\_\_

**Problem 8:** Oven appears to operate normally, but heats very slowly. What are five possible causes?

a. \_\_\_\_\_

b. \_\_\_\_\_

c. \_\_\_\_\_

d. \_\_\_\_\_

e. \_\_\_\_\_

**Problem 9:** Oven appears to operate normally, but does not heat at all. What are five possible causes?

a. \_\_\_\_\_

b. \_\_\_\_\_

c. \_\_\_\_\_

d. \_\_\_\_\_

e. \_\_\_\_\_

## MICROWAVE OVEN TROUBLESHOOTING AND REPAIR UNIT II

### ASSIGNMENT SHEET #3 — DIAGNOSE A CIRCUIT FOR PROBLEMS WHEN A MICROWAVE OVEN IS IN THE VARI-COOK CONDITION

Situation: Refer to Transparency 4, and assume a set-up that includes:

- Open oven door
- Place container of water in oven cavity
- Set vari-cook dial to setting other than HIGH
- Set timer dial to two minutes
- Close oven door

Normal operation includes:

- Cavity light on
- Cook light on
- Stirrer motors operate
- Blower motor operates
- Timer motor operates
- Controller operates
- Oven heats product placed in cooking cavity at selected vari-cook power level
- Timer shuts off at end of selected time setting

Problem: Oven appears to operate normally, but continues to heat on HIGH (full power) or does not heat at all. Assuming there is no broken wire or connection, what is the most obvious cause?

---

# MICROWAVE OVEN TROUBLESHOOTING AND REPAIR UNIT II

## ANSWERS TO ASSIGNMENT SHEETS

### Assignment Sheet #1

Answer should include five of the following:

- a. Blown fuse or tripped circuit breaker
- b. Blown 15-amp oven fuse
- c. Defective cavity thermal protector
- d. Defective lower door interlock switch
- e. Defective cavity light
- f. Defective cavity light socket
- g. Broken or loose wire connection

### Assignment Sheet #2

- Problem 1:
- a. Defective timer switch
  - b. Broken or loose wire connection

- Problem 2: Any two of the following:
- a. Defective primary (lower door) interlock switch
  - b. Defective secondary (upper door) interlock switch
  - c. Broken or loose wire connection

- Problem 3: Any two of the following:
- a. Defective timer assembly
  - b. Binding timer assembly
  - c. Broken or loose wire connection

- Problem 4:
- a. Defective cook indicator light
  - b. Broken or loose wire connection

**ANSWERS TO ASSIGNMENT SHEETS**

Problem 5: Any two of the following:

- a. Defective stirrer motor
- b. Stirrer blade binding
- c. Broken or loose wire connection

Problem 6: Any two of the following:

- a. Defective blower motor
- b. Blower fan binding
- c. Broken or loose wire connection

Problem 7: Defective primary (lower door) interlock switch

Problem 8: Any five of the following:

- a. Vari-cook control not set to appropriate power level
- b. Low line voltage (should be at least 110V AC)
- c. Defective electro-mechanical controller
- d. Overheat condition causing thermal protector to open
- e. Defective magnetron
- f. Defective capacitor
- g. Defective power transformer

Problem 9: Any five of the following:

- a. Defective electro-mechanical controller
- b. Defective magnetron thermal protector
- c. Defective diode
- d. Defective capacitor
- e. Defective transformer
- f. Defective magnetron
- g. Broken or loose wire connection

**Assignment Sheet #3**

Answer: A defective electro-mechanical controller assembly

# MICROWAVE OVEN TROUBLESHOOTING AND REPAIR

## UNIT II

### JOB SHEET #1 — DISCHARGE A CAPACITOR

#### A. Tools and materials

1. Microwave oven as selected by instructor
2. Service manual for selected oven
3. Screwdriver with insulated handle
4. 20K $\Omega$  resistor with jumper-type leads
5. Needlenose pliers with insulated handles
6. Safety glasses

#### B. Procedure (Figure 1)

1. Put on safety glasses
2. Unplug the oven power cord

**(CAUTION: Perform the rest of this procedure ONLY IN THE PRESENCE OF AND UNDER THE DIRECT SUPERVISION OF YOUR INSTRUCTOR.)**

3. Remove the oven wrap or access panels as required to reach the capacitor
4. Position the resistor leads so that they are equal to the distance between the capacitor terminals
5. Hold the resistor at mid-point with a pair of pliers with insulated handles

## JOB SHEET #1

6. Move the resistor and leads to a point where the leads contact the capacitor terminals and discharge the capacitor (Figure 1)

FIGURE 1

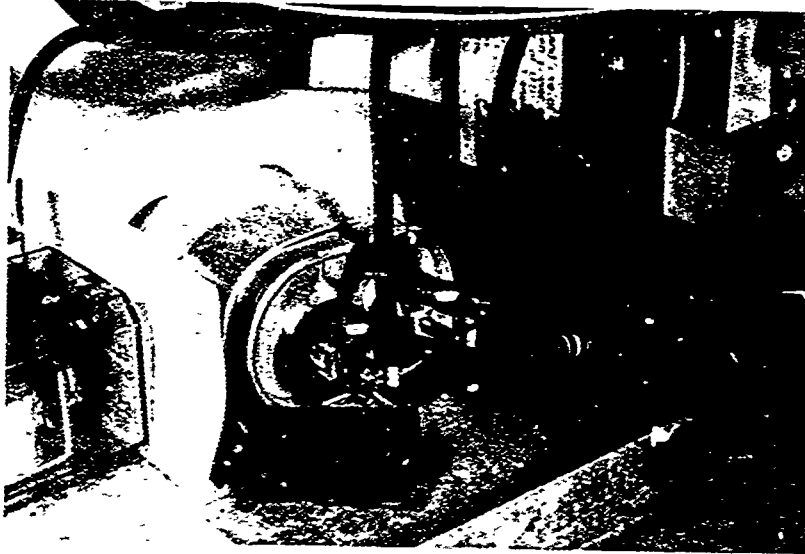

- Have your instructor check your work

(NOTE: A capacitor can also be discharged by barring across the two capacitor terminals with a screwdriver that has an insulated handle, and you should ask your instructor whether or not to practice that procedure.)

7. Clean up area and return tools and materials to proper storage, or prepare for next job sheet as directed by your instructor

## MICROWAVE OVEN TROUBLESHOOTING AND REPAIR UNIT II

### JOB SHEET #2 — CHECK STIRRER BLADE ROTATION

#### A. Tools and materials

1. Microwave oven: Litton model 1304, 1305, 1420, or 1422
2. Service manual for selected oven
3. Microwave safe container
4. Water supply
5. Paper and pencil
6. Safety glasses

#### B. Procedure (Figure 1)

The following procedure and illustrations are adapted from materials copyrighted © by Litton Systems, Inc., and are reprinted with permission. Any other use is prohibited.

1. Put on safety glasses
2. Place a cup of cool water in the oven cavity and close the oven door
3. Program the oven for a 20-second COOK cycle
4. After 10 seconds of operation, open the oven door and verify stirrer rotation with the following procedure:
  - a. Position yourself below the oven so that your angle of sight permits a good view of the stirrer cover (Figure 1)

FIGURE 1

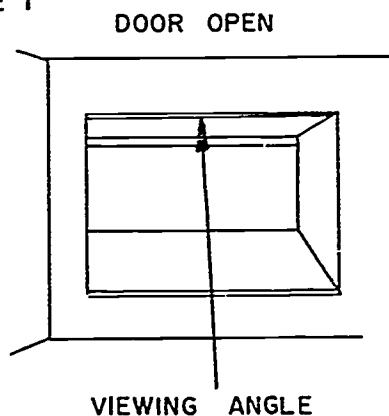



**JOB SHEET #2**

- b. Look for the reflection or shadows of the stirrer blade through the semi-transparent stirrer blade cover
  - c. If the shadows of the blade are turning, it indicates the stirrer is operating properly
  - d. If the stirrer blade does not appear to be turning, run the test again, and if required, check the stirrer as outlined in Job Sheet #22
4. Record your findings
- Have your instructor check your work
5. Clean up area and return tools and materials to proper storage, or prepare for next job sheet as directed by your instructor

## MICROWAVE OVEN TROUBLESHOOTING AND REPAIR UNIT II

### JOB SHEET #3 — PREPARE A MICROWAVE OVEN FOR COMPONENT TESTING

#### A. Tools and materials

1. Microwave oven: Litton model 1304, 1305, 1420, or 1422
2. Service manual for selected oven
3. Crows-foot type wrench
4. Screwdriver with insulated handle
5. Safety glasses

#### B. Procedure (Figure 1)

The following procedure and illustrations are adapted from materials copyrighted © by Litton Systems, Inc., and are reprinted with permission. Any other use is prohibited.

1. Put on safety glasses
  2. Unplug the oven power cord and remove the access panel screws with a crows-foot type wrench (Figure 1)
  3. Remove the access panel and set it aside  
**(CAUTION: Discharge the capacitor with the following procedure only if the oven has not been operated in at least 24 hours; if you are not sure how much of a charge the capacitor has or if you suspect it has a full charge, USE THE PROCEDURE FOR CAPACITOR DISCHARGE OUTLINED IN JOB SHEET #1.)**
  4. **DISCHARGE THE CAPACITOR** by shorting the two capacitor terminals together with the blade of a screwdriver with an insulated handle (Figure 1)  
**(CAUTION: If you have not been instructed how to make a safe capacitor discharge, have your instructor demonstrate the procedure.)**
  5. Make certain the capacitor has properly discharged by shorting from either terminal to the case with the blade of a screwdriver with an insulated handle  
**(NOTE: The words DISCHARGE THE CAPACITOR appear in capital letters in many of the following job sheets, and in each instance, it means to complete the procedure according to how much of a charge the capacitor has.)**
- Have your instructor check your work

## JOB SHEET #3

6. Clean up area and return tools and materials to proper storage, or prepare for next job sheet as directed by your instructor

FIGURE 1

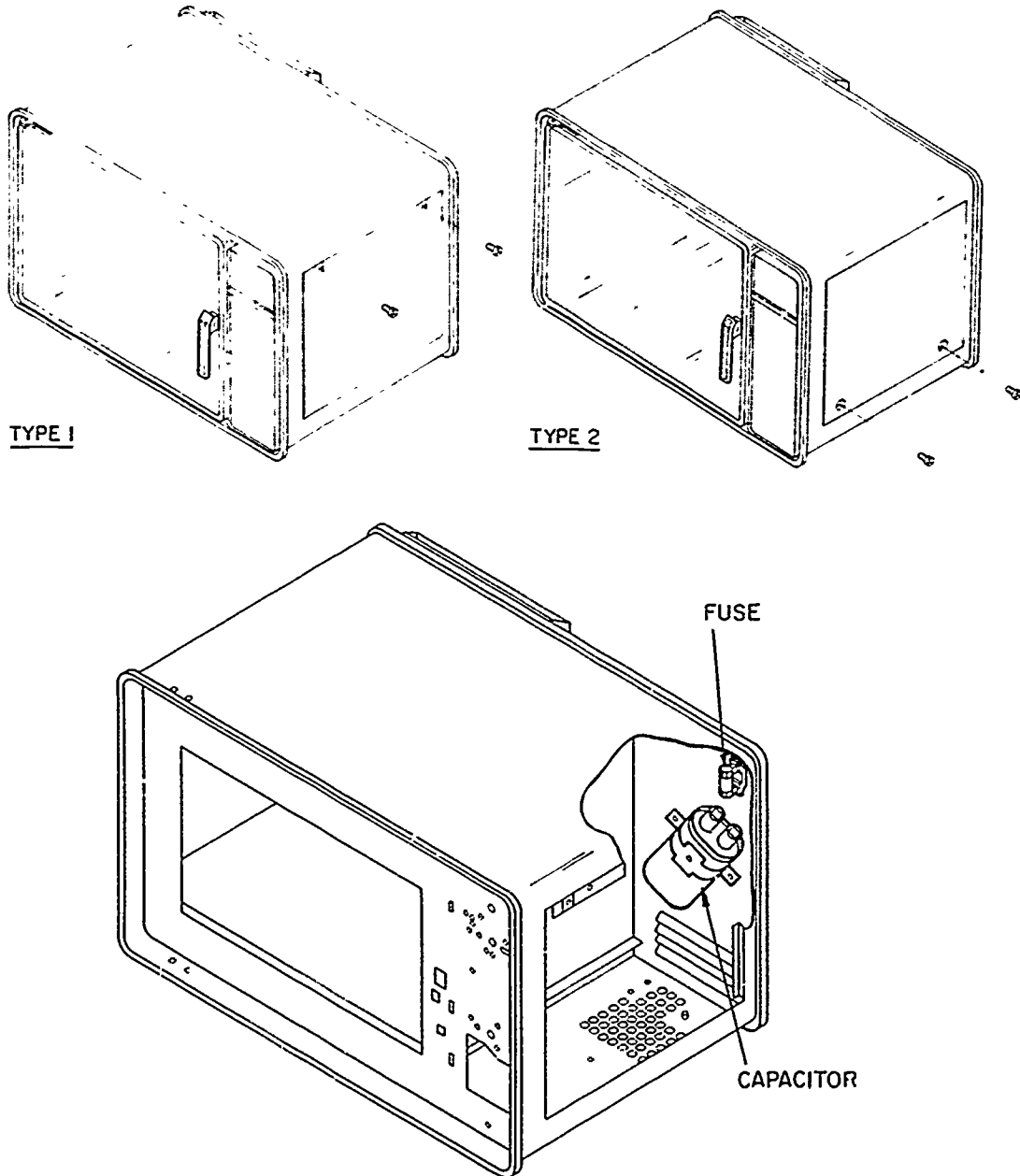

© Litton Systems, Inc.; reprinted with permission

## MICROWAVE OVEN TROUBLESHOOTING AND REPAIR UNIT II

### JOB SHEET #4 — REPLACE AND ADJUST A MICROWAVE OVEN DOOR ASSEMBLY

#### A. Tools and materials

1. Microwave oven: Litton model 1304, 1305, 1420, or 1422
2. Service manual for selected oven
3. Crows-foot type wrench
4. Screwdriver with insulated handle
5. RF test instrument and materials
6. Replacement door
7. Safety glasses

#### B. Procedure (Figure 1)

The following procedure and illustrations are adapted from materials copyrighted © by Litton Systems, Inc., and are reprinted with permission. Any other use is prohibited.

1. Put on safety glasses
2. Unplug the power cord and remove the access panel
3. DISCHARGE THE CAPACITOR
4. Remove the two upper hinge mounting screws
5. Tilt the top of the door away from the oven and remove the door from the oven
6. Remove the lower hinge washer and wave washer from the old door and install them onto the new door
7. Install the upper hinge onto the new door
8. Install the new door into the lower hinge, leaving the door half way open
9. Install the upper hinge mounting screws, but leave the screws loose
10. Close the oven door

**JOB SHEET #4**

11. Press the door against the cavity faceplate near the hinges and tighten the upper hinge mounting screws
12. Adjust the Interlock Switch Module as required
13. Check once more for proper door fit
14. Replace the access panel
15. Plug the power cord in
- Have your instructor check your work
16. Conduct an RF leakage test and record your findings
- Have your instructor check your work
17. Clean up area and return tools and materials to proper storage, or prepare for next job sheet as directed by your instructor

JOB SHEET #4

FIGURE 1

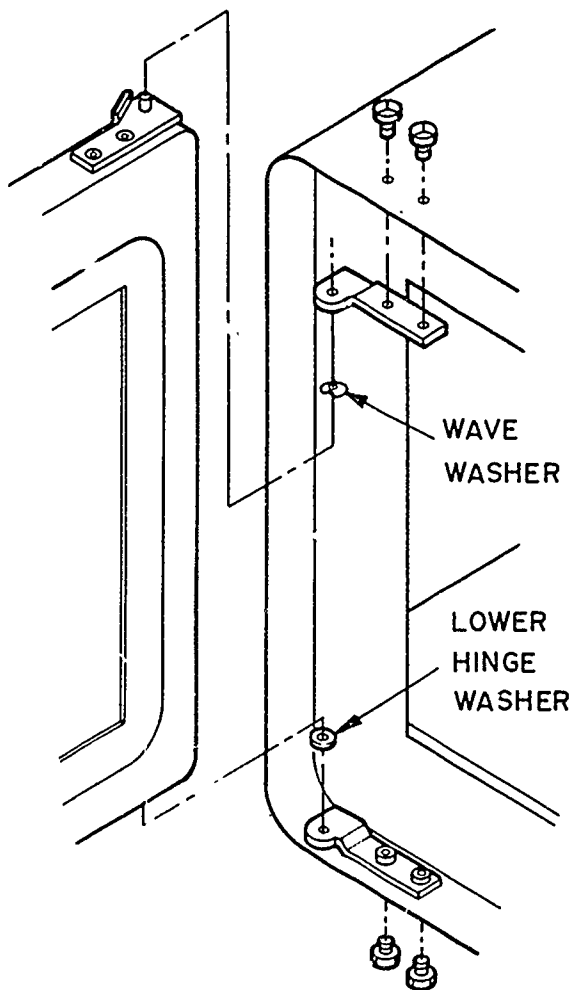

© Litton Systems, inc.; reprinted with permission

## MICROWAVE OVEN TROUBLESHOOTING AND REPAIR UNIT II

### JOB SHEET #5 — TROUBLESHOOT MICROWAVE OVEN PROBLEMS WITH CIRCUIT DIAGNOSIS

A. Tools and materials

1. Microwave oven: Litton model 1304, 1305, 1420, or 1422
2. Service manual for selected oven
3. Microwave safe container with two-cup capacity
4. Pencil and paper
5. Safety glasses

B. Procedure (Figure 1)

The following procedure and illustrations are adapted from materials copyrighted © by Litton Systems, Inc., and are reprinted with permission. Any other use is prohibited.

1. Put on safety glasses
2. Conduct a preliminary inspection of the oven to assure that it is safe to service
3. Place a little less than two cups of water in a container, place it in the oven, and set the oven for full power (cook condition) as shown in the schematic in Figure 1
4. Close the oven door, set the timer for two minutes, and start the oven
5. Check to see if the blower motor is operating, and if it is, move on to Step 7
6. Establish that the blower motor is not working and complete the following procedures in order:
  - a. Check for a bad fuse; see Job Sheet #3 for fuse location
  - b. Check for an open thermal protector for the magnetron or the cavity as outlined in Job Sheet #9
  - c. Check for a defective timer assembly as outlined in Job Sheet #12
  - d. Check for a defective or out of adjustment Interlock Switch Module
  - e. Check for a defective or binding motor with standard troubleshooting procedures

**JOB SHEET #5**

7. Check to see if the stirrer blades rotate, and if they do, move on to Step 8
8. Establish that the stirrer blades are not rotating and correct the defective stirrer system with the procedures outlined in Job Sheet #22
9. Check to make sure timer is advancing properly, and if it is, move on to Step 11
10. Establish that the timer is not advancing properly and troubleshoot for a defective or binding timer assembly as outlined in Job Sheet #20
11. Open the oven door
12. Check to see if the water you placed in the cavity has heated, and if it has, the cook operation is normal and you should move on to Step 15
13. Establish whether or not the water is heating slowly by performing the power tests outlined in Job Sheet #6 that covers:
  - a. Problems with line voltage less than 120V AC
  - b. Problems with a defective power transformer, a defective capacitor, or a defective magnetron
14. Establish that the water is not heating at all by performing the no heat tests outlined in Job Sheet #7 that covers:
  - a. Defective diode
  - b. Defective capacitor
  - c. Defective power transformer
  - d. Defective magnetron
15. Write a brief summary of your findings complete with the date and the model and serial numbers of the microwave oven
- Have your instructor check your work
16. Clean up area and return tools and materials to proper storage, or prepare for next job sheet as directed by your instructor

(NOTE: Be sure to save the schematic in Figure 1 for use with Job Sheet #9.)



JOB SHEET #5

FIGURE 1

CONDITIONAL SCHEMATIC - COOK CONDITION

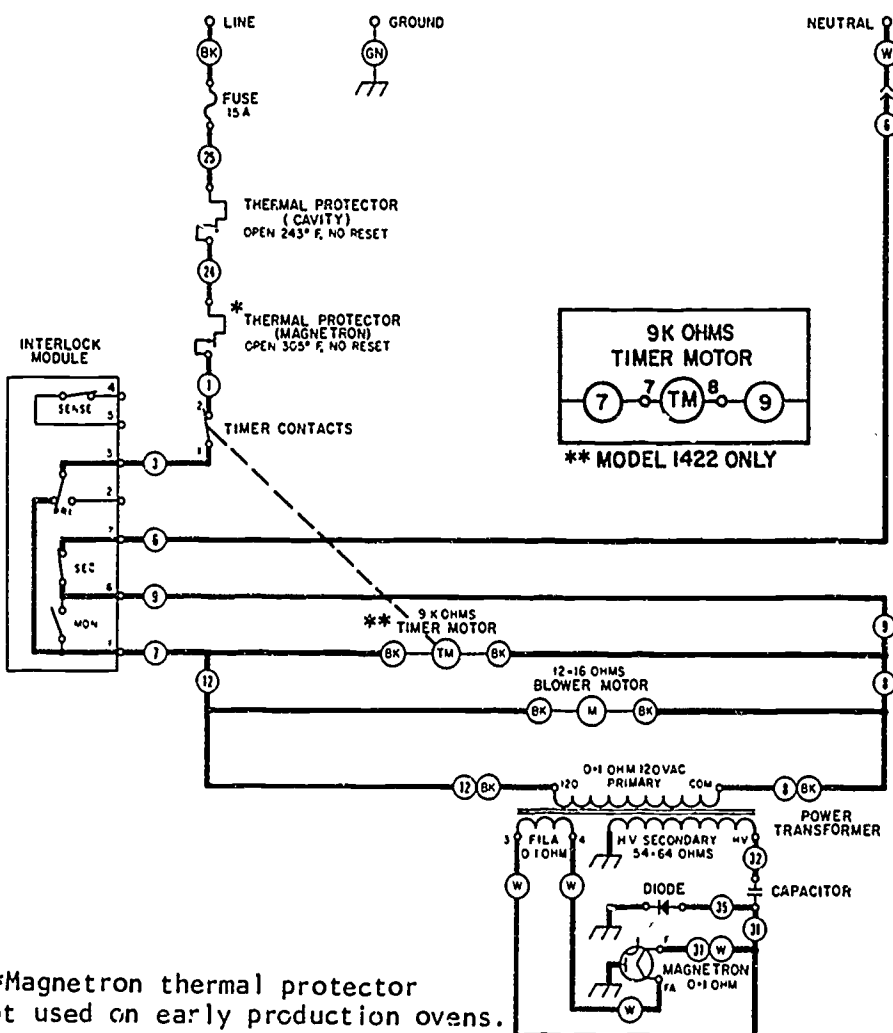

\*Magnetron thermal protector not used on early production ovens.

© Litton Systems, Inc.; reprinted with permission

## MICROWAVE OVEN TROUBLESHOOTING AND REPAIR UNIT II

### JOB SHEET #6 — CONDUCT POWER TESTS ON A MICROWAVE OVEN TO CHECK FOR TEMPERATURE RISE UNDER FULL POWER

#### A. Tools and materials

1. Microwave oven: Litton model 1304, 1305, 1420, or 1422
2. Service manual for selected oven
3. Litton Power Test Kit M95D5 or equivalent plastic container and centigrade thermometer
4. Pencil and paper
5. Stop watch or watch with second hand
6. Safety glasses

#### B. Procedure

The following procedure and illustrations are adapted from materials copyrighted © by Litton Systems, Inc., and are reprinted with permission. Any other use is prohibited.

1. Put on safety glasses
2. Fill the plastic container with 1000 ml of cool tap water
3. Place the centigrade thermometer in the water and record the initial temperature  
  
(NOTE: It is important that initial water temperature be between 17°C and 27°C or 62.6°F to 80.6°F)
4. Adjust water temperature as required by briefly heating if too cold or running more tap water until water cools off
5. Open oven door and place container on the center of the oven shelf
6. Set the oven to operate at full power in the COOK condition and close the oven door
7. Energize the oven and start timing simultaneously
8. Heat the water for exactly 63 seconds as timed by a stop watch

**JOB SHEET #6**

9. Measure and record the temperature of the heated water immediately
10. Subtract the initial water temperature recorded in Step 3 from the heated water temperature recorded in Step 9
11. Check for a temperature rise between  $6^{\circ}\text{C}$  and  $7.5^{\circ}\text{C}$  ( $10.8^{\circ}\text{F}$  to  $13.5^{\circ}\text{F}$ ), and if it is above the minimum, move on to Step 13
12. Establish that the temperature rise is less than minimum and:
  - a. Make additional tests to assure that variations or errors in the test procedure did not account for the unacceptable reading
  - b. Use standard test procedures to assure that supply voltage is a minimum 115V AC
13. Multiply the temperature rise recorded in Step 9 by a factor of 70 to determine the power output in watts
- Have your instructor check your work
14. Continue troubleshooting as directed by your instructor if temperature rise is less than the minimum of  $6^{\circ}\text{C}$
15. Clean up area and return tools and materials to proper storage, or prepare for next job sheet as directed by your instructor

## MICROWAVE OVEN TROUBLESHOOTING AND REPAIR UNIT II

### JOB SHEET #7 — CONDUCT TESTS OF HIGH-VOLTAGE COMPONENTS WHEN LITTLE OR NO HEAT IS PRODUCED BY AN OVEN BUT ALL OTHER OPERATIONS APPEAR NORMAL

#### A. Tools and materials

1. Microwave oven: Litton model 1304, 1305, 1420, or 1422
2. Service manual for selected oven
3. Ohmmeter with a range of  $R \times 10,000$  or greater
4. 9-V battery
5. Screwdriver with and insulated handle
6. Pencil and paper
7. Safety glasses

#### B. Routine #1 — Testing the capacitor

The following procedure and illustrations are adapted from materials copyrighted © by Litton Systems, Inc., and are reprinted with permission. Any other use is prohibited.

1. Put on safety glasses
2. DISCHARGE THE CAPACITOR

FIGURE 1

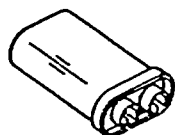

3. Set the ohmmeter on its highest resistance scale

(NOTE: The following test will not work with a capacitor that has a built-in bleed resistor, so that type of capacitor should be checked with a capacitor analyzer.)

4. Remove wires from the capacitor terminals and connect ohmmeter leads to the capacitor terminals

## JOB SHEET #7

5. Check the meter to make sure it momentarily deflects toward zero and then returns to infinite
  - a. If no deflection occurs, replace the capacitor
  - b. If continuous deflection occurs, replace the capacitor
6. Check between each terminal to the capacitor case for infinite resistance, and if it is not present, replace the capacitor

Have your instructor check your work

### C. Routine #2 — Testing the diode (Figure 2)

1. DISCHARGE THE CAPACITOR

FIGURE 2

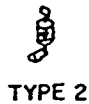

2. Set the ohmmeter to the highest resistance scale
3. Remove the leads that come from the capacitor and connect with the diode terminals
4. Place the ohmmeter leads on the diode terminals
5. Check for an infinite resistance of either 50,000 or 200,000 ohms and record your finding

(NOTE: Diodes on other model ovens may not give these readings.)

6. Reverse the ohmmeter leads on the diode terminals and check for either 50,000 or 200,000 ohms on the second testing and record your finding

(NOTE: If the first reading was 50,000, the second reading should be 200,000, or the reverse.)

7. Replace the diode if it fails to pass the infinite resistance tests

Have your instructor check your work

## JOB SHEET #7

## D. Routine #3 — Testing the magnetron (Figure 3)

## 1. DISCHARGE THE CAPACITOR

FIGURE 3

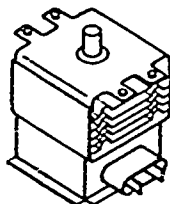

2. Remove wires from the magnetron and connect ohmmeter to its terminals

3. Check for a reading of less than 1 ohm between terminals

(CAUTION: Set your VOM at highest scale for the following check.)

4. Check for infinite resistance between each magnetron terminal and ground

(NOTE: This test is not conclusive, and if all other components test good and the oven still does not heat, replace the magnetron as outlined in Job Sheet #19 and retest.)

Have your instructor check your work

## E. Routine #4 — Testing the power transformer (Figure 4)

## 1. DISCHARGE THE CAPACITOR

FIGURE 4

POWER TRANSFORMER

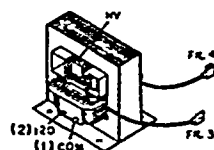

TYPE 1

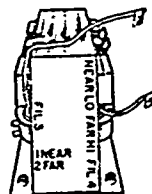

TYPE 2

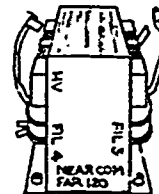

TYPE 3

2. Check primary winding first by removing wires from the terminals marked 1 and 2 and connecting the ohmmeter leads to those terminals and recording your findings

3. Check between each terminal and ground

a. On all three types of power transformers, the primary winding check should read less than 1 ohm

b. On all three types of power transformers, the terminal to ground should read infinite resistance

**JOB SHEET #7**

4. Check high voltage winding next by removing the wire from the secondary terminal marked HV
5. Connect ohmmeter between the HV terminal and the oven chassis
  - a. HV to ground on a Type 1 transformer should read 54 to 64 ohms
  - b. HI to ground on a Type 2 transformer should read 66 to 74 ohms, and LO to ground on a Type 2 transformer should read 63 to 71 ohms
6. Record all findings
7. Check the filament winding next by removing the wires 3 and 4 on the transformer and connecting the ohmmeter between these terminals
8. Check between each filament terminal and ground
  - a. Step 7 should give a reading of less than 1 ohm
  - b. Step 8 should show infinite resistance
9. Record all findings
10. Replace power transformer if findings indicate problems  
(NOTE: Power transformer replacement is outlined in Job Sheet #18.)
- Have your instructor check your work
11. Clean up area and return tools and materials to proper storage, or prepare for next job sheet as directed by your instructor

## MICROWAVE OVEN TROUBLESHOOTING AND REPAIR UNIT II

### JOB SHEET #8 — MAKE INTERLOCK SWITCH MODULE TESTS ON A MICROWAVE OVEN

#### A. Tools and materials

1. Microwave oven: Litton model 1304, 1305, 1420, or 1422
2. Service manual for selected oven
3. Screwdriver with insulated handle
4. Ohmmeter
5. Pencil and paper
6. Safety glasses

#### B. Procedure

The following procedure and illustrations are adapted from materials copyrighted © by Litton Systems, Inc., and are reprinted with permission. Any other use is prohibited.

1. Put on safety glasses
2. Unplug the power cord and remove the access panel as outlined in a previous job sheet
3. DISCHARGE THE CAPACITOR
4. Check continuity between terminals with an ohmmeter, using the Function Test Chart in Figure 1 as a guide

FIGURE 1

FUNCTION TEST CHART

● Indicates Contacts Made	Primary Interlock		Secondary Interlock	Interlock Monitor	Door Sense
<div style="display: flex; align-items: center; justify-content: center;"> <div style="text-align: right; margin-right: 10px;">↓ Function</div> <div style="text-align: left; margin-left: 10px;">→ Terminals</div> </div>	2-3	1-3	6-7	1-6	4-5
Door Open	●			●	
Door Closed		●	●		●



## JOB SHEET #8

5. Use the reference points shown in Figure 2 to assure that your ohmmeter probes are on the proper terminals

FIGURE 2

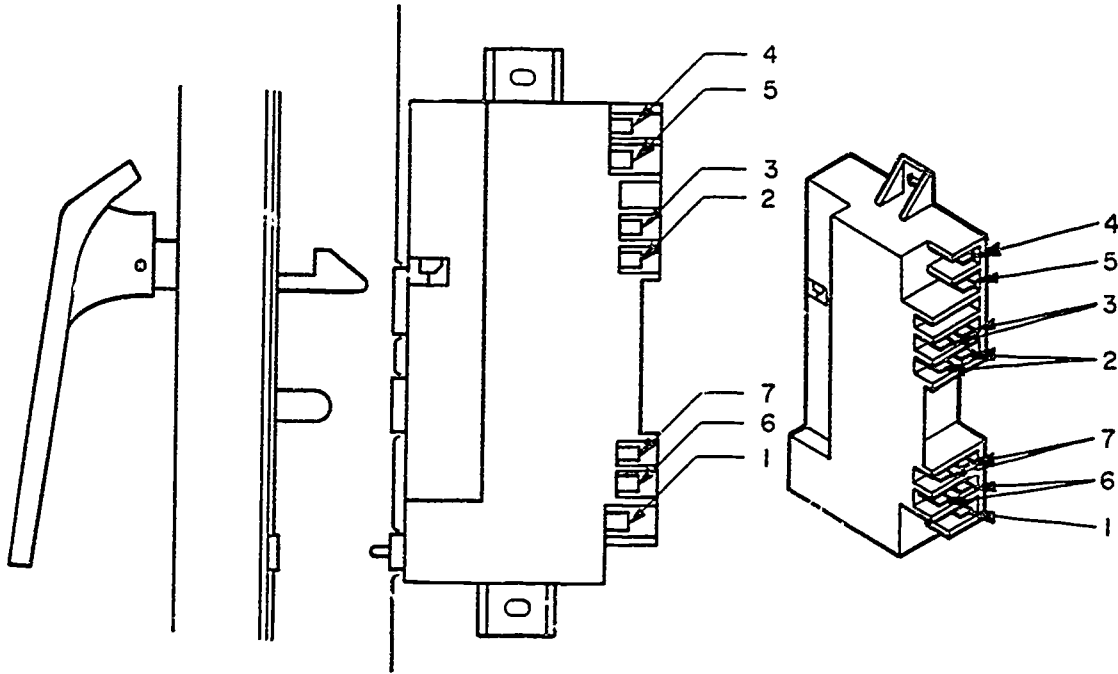

6. Record your findings
- a. If improper indications are given, check the door latch for proper activation of switches  
  
If door latch is okay, but switching is not okay, replace the Interlock Switch Module
- Your instructor check your work
7. Clean up area and return tools and materials to proper storage, or prepare for next job sheet as directed by your instructor

## MICROWAVE OVEN TROUBLESHOOTING AND REPAIR UNIT II

### JOB SHEET #9 — TEST MAGNETRON AND CAVITY THERMAL PROTECTORS

#### A. Tools and materials

1. Microwave oven: Litton model 1304, 1305, 1420, or 1422
2. Service manual for selected oven
3. Screwdriver with insulated handle
4. Ohmmeter
5. Pencil and paper
6. Safety glasses

#### B. Procedure

The following procedure and illustrations are adapted from materials copyrighted © by Litton Systems, Inc., and are reprinted with permission. Any other use is prohibited.

1. Put on safety glasses
2. Unplug the power cord and remove the access panel as outlined in a previous job sheet
3. DISCHARGE THE CAPACITOR
4. Refer to Figure 2 as you complete this procedure as well as the schematic in Figure 1 with Job Sheet #5
5. Disconnect #25 wire from the fuse block
6. Perform a continuity test from #25 wire to #1 wire
  - a. If continuity test indicates a closed circuit, both thermal protectors are okay and no further testing is necessary
  - b. If continuity test indicates an open circuit, complete the procedure to determine which thermal protector is open

## JOB SHEET #9

7. Cut #24 wire between the cavity thermal protector and the magnetron thermal protector
8. Perform a continuity test using the chart in Figure 1 as a guide

FIGURE 1

TEST POINTS	
* Magnetron T.P.	Wire #1 - Wire #24 (Magnetron side)
Cavity T.P.	Wire #25 - Wire #24 (Cavity side)

- a. If continuity test indicates an open circuit, replace the defective thermal protector as outlined in Job Sheet #23
  - b. Also check for a stalled blower or an obstruction in the magnetron cooling air flow, or an overheat condition in the oven cavity
9. Record your findings
    - Have your instructor check your work
  10. Clean up area and return tools and materials to proper storage, or prepare for next job sheet as directed by your instructor

JOB SHEET #9

FIGURE 2

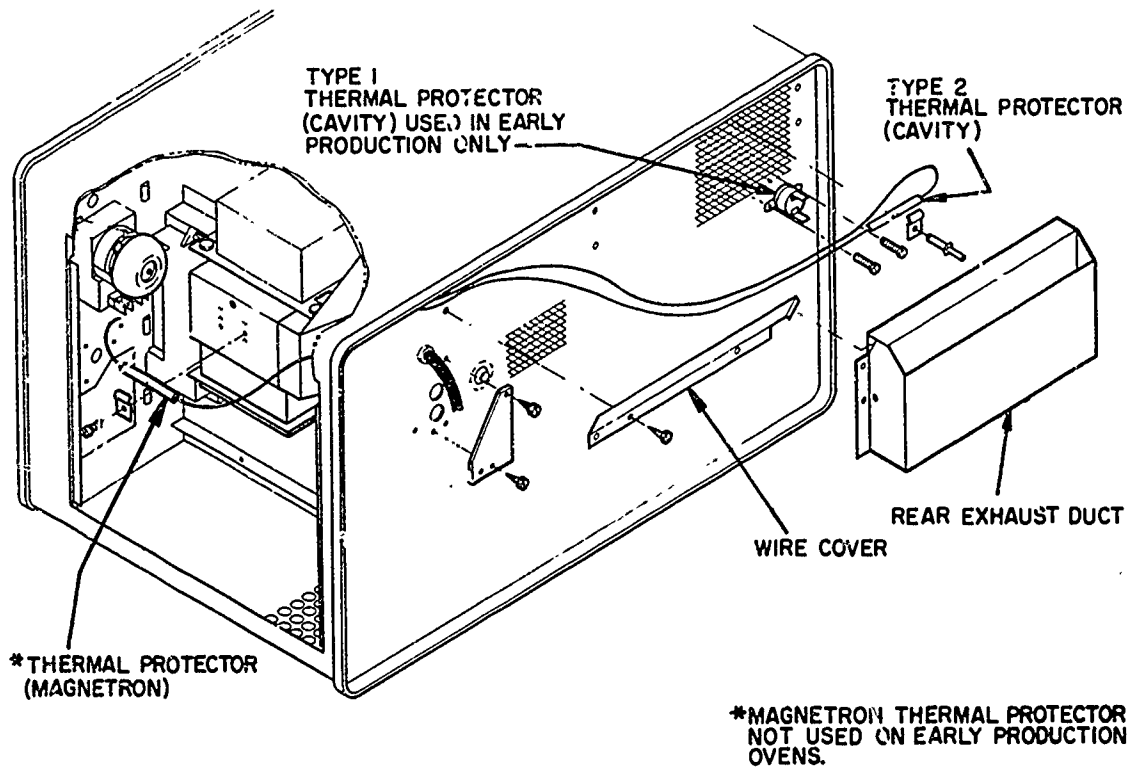

© Litton Systems, Inc.; reprinted with permission

## MICROWAVE OVEN TROUBLESHOOTING AND REPAIR UNIT II

### JOB SHEET #10 — TEST A LOW VOLTAGE TRANSFORMER

#### A. Tools and materials

1. Microwave oven: Litton model 1320, 1325, 1335, or 1442
2. Service manual for selected oven
3. Screwdriver with insulated handle
4. VOM
5. Pencil and paper
6. Safety glasses

#### B. Procedure

The following procedure and illustrations are adapted from materials copyrighted © by Litton Systems, Inc., and are reprinted with permission. Any other use is prohibited.

1. Put on safety glasses
2. Unplug the power cord and remove the access panel as outlined in a previous job sheet
3. DISCHARGE THE CAPACITOR
4. Set your voltmeter for the appropriate VAC scale and perform the test set-ups indicated in the chart in Figure 2

## JOB SHEET #10

5. Use the illustration in Figure 1 to make sure your leads are connected to the proper terminals

FIGURE 1

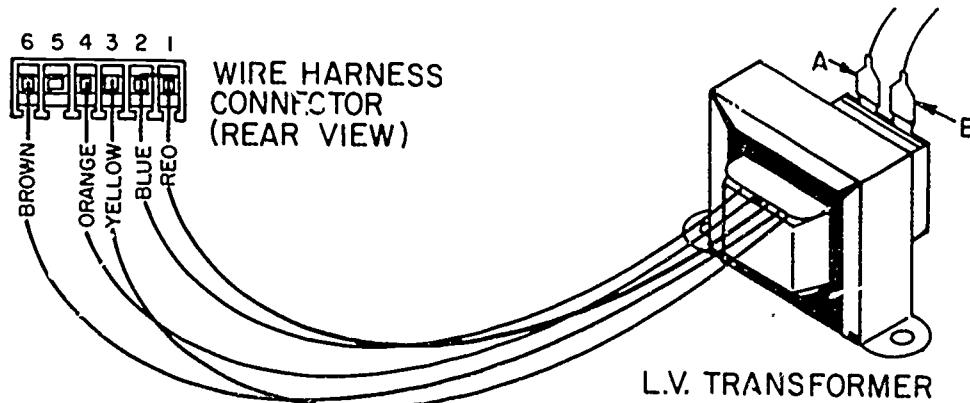

6. Record your findings
- If the proper AC voltages were measured as shown on the test chart, the low voltage transformer operation is normal
  - If an abnormal reading was measured at test points 2-3, 1-6, and 1-4 as indicated on the text chart, but the normal voltage was measured at test points A-B, replace the low voltage transformer
  - If no voltage was measured at test points A-B, check wire connections and perform circuit diagnosis for other possible causes
- Have your instructor check your work
7. Clean up area and return tools and materials to proper storage, or prepare for next job sheet as directed by your instructor

## JOB SHEET #10

FIGURE 2

WARNING: DO NOT TOUCH ANY OVEN COMPONENTS OR WIRING DURING OVEN OPERATION.

TEST SET-UPS	TEST POINTS	NORMAL VOLTAGE (Approximate)
Attach meter leads to wire harness test points A-B, apply power to oven and open oven door.	A & B	120 VAC (Line Voltage)
Disconnect power and remove L.V. transformer connector attached to the control circuit board and attach meter leads into harness side of connector at test points shown in chart. Apply power to oven and open oven door.	2(Blue)-3(Yellow)	2.5 VAC
	1(Red)-6(Brown)	20 VAC
	1(Red)-4(Orange)	20 VAC

© Litton Systems, Inc.; reprinted with permission

## MICROWAVE OVEN TROUBLESHOOTING AND REPAIR UNIT II

### JOB SHEET #11 — TEST A TEMPERATURE PROBE AND PROBE JACK

#### A. Tools and materials

1. Microwave oven: Litton model 1320, 1325, 1335, or 1450
2. Service manual for selected oven
3. Screwdriver with insulated handle
4. VOM
5. Beaker or container
6. Hot water supply
7. Pencil and paper
8. Safety glasses

#### B. Routine #1 — Testing the temperature probe

The following procedure and illustrations are adapted from materials copyrighted © by Litton Systems, Inc., and are reprinted with permission. Any other use is prohibited.

1. Put on safety glasses
2. Set the VOM to a scale capable of reading 100,000 ohms
3. Connect the meter leads to the temperature probe as shown in Figure 1

FIGURE 1



- a. If resistance indicated on the meter approximately 30,000 to 75,000 ohms at room temperature, go on to Step 4
- b. If infinite resistance or extremely low resistance is indicated on the meter, replace the temperature probe and check the oven for proper operation



## JOB SHEET #11

4. Leave the leads connected to the temperature probe and immerse the tip of the probe into a container of hot water (Figure 2)

FIGURE 2

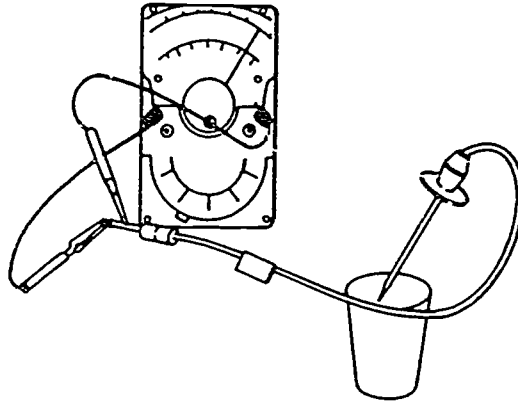

- a. If the resistance increased with the probe immersed in hot water, go on to the next probe jack test in Routine #2
  - b. If the resistance did not decrease with the probe placed in hot water, replace the temperature probe
5. Record your findings
- Have your instructor check your work
- C. Routine #2 — Testing the probe jack
1. Unplug the power cord and remove the access panel as outlined in a previous job sheet
  2. DISCHARGE THE CAPACITOR
  3. Locate the probe jack at the rear of the oven cavity, and the point where it connects to the circuit board connector (Figure 3)

FIGURE 3

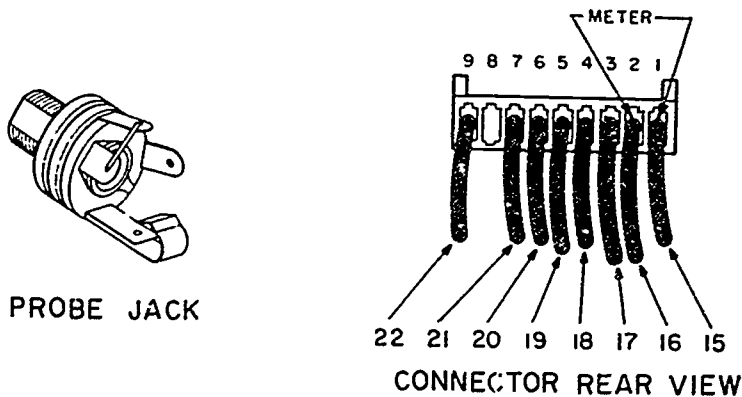

## JOB SHEET #11

4. Remove the harness from the electronic control circuit board assembly
5. Set the VOM to the  $R \times 1$  scale and connect the meter leads into the harness side of the connector contacts as shown in Figure 1
  - a. With the probe removed from the probe jack, the meter should read approximately zero ohms
  - b. With the VOM set to the highest resistance scale and the probe plugged into the probe jack, the meter should read approximately 30,000 to 75,000 ohms at room temperature
  - c. If either reading is significantly off, replace the probe jack by removing the light cover, oven light, and the component cover (Figure 4)

FIGURE 4

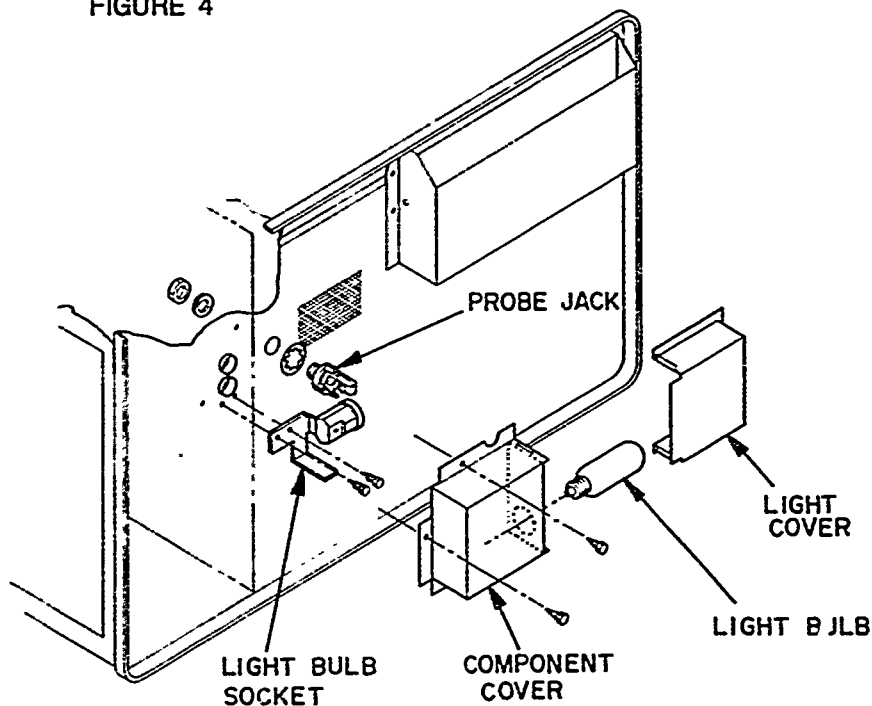

**JOB SHEET #11**

6. Record your findings
- Have your instructor check your work
7. Clean up area and return tools and materials to proper storage, or prepare for next job sheet as directed by your instructor

## MICROWAVE OVEN TROUBLESHOOTING AND REPAIR UNIT II

### JOB SHEET #12 — TEST AN OVEN TIMER

#### A. Tools and materials

1. Microwave oven: Litton model 1304, 1305, 1420, or 1422
2. Service manual for selected oven
3. Screwdriver with insulated handle
4. VOM
5. Pencil and paper
6. Safety glasses

#### B. Procedure

The following procedure and illustrations are adapted from materials copyrighted © by Litton Systems, Inc., and are reprinted with permission. Any other use is prohibited.

1. Put on safety glasses
2. Unplug the power cord and remove the access panel as outlined in a previous job sheet
3. DISCHARGE THE CAPACITOR
4. Disconnect wire leads from timer switch terminals according to type (Figure 1)

FIGURE 1

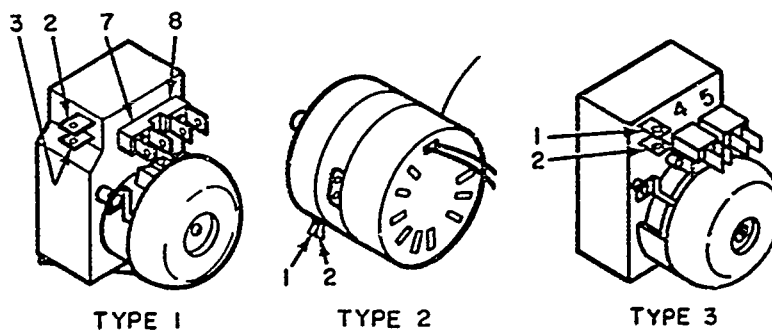

## JOB SHEET #12

5. Check continuity between terminals according to the chart in Figure 2

FIGURE 2

● INDICATES CONTACTS MADE	OVEN TIMER TYPE 1	OVEN TIMER TYPE 2 & 3
CONTACTS FUNCTION →	2-3	1-2
TIMER OFF		
TIMER ON	●	●

6. Replace the timer if it does not operate with 120 volts AC applied to the motor terminals
- a. Terminals 7 and 8 on Type 1 timers
  - b. Motor terminals on Type 2 timers
  - c. Terminals 4 and 5 on Type 3 timers
7. Record your findings
- Have your instructor check your work
8. Clean up area and return tools and materials to proper storage, or prepare for next job sheet as directed by your instructor

# MICROWAVE OVEN TROUBLESHOOTING AND REPAIR

## UNIT II

### JOB SHEET #13 — TEST A CONTROLLER

#### A. Tools and materials

1. Microwave oven: Litton model 1315, 1320, 1430, or 1450
2. Service manual for selected oven
3. Screwdriver with insulated handle
4. In-line connector or jumper wire
5. Pencil and paper
6. Safety glasses

#### B. Procedure

The following procedure and illustrations are adapted from materials copyrighted © by Litton Systems, Inc., and are reprinted with permission. Any other use is prohibited.

1. Put on safety glasses
2. Unplug the power cord and remove the access panel as outlined in a previous job sheet
3. DISCHARGE THE CAPACITOR
4. Disconnect the wire leads from the controller terminals #2 and #4 (Figure 1)

FIGURE 1

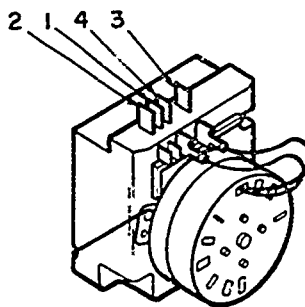

**(CAUTION: High voltage up to 610v volts AC can be present at the high voltage terminal of the power transformer during a cook cycle, so CONDUCT THE NEXT PROCEDURE ONLY IN THE PRESENCE OF THE INSTRUCTOR.)**

**JOB SHEET #13**

5. Connect terminals #2 and #4 together with an in-line connector or a jumper wire
6. Set the oven at full power and conduct an operation test to determine if the oven is operating normally
  - a. If the oven operates normally, replace the controller and test oven operation again
  - b. If an abnormal condition still exists with the controller bypassed, conduct a circuit diagnosis for other possible causes
7. Record your findings
- Have your instructor check your work
8. Unplug microwave and remove the jumper wire and replace leads to the #2 and #4 terminals
9. Clean up area and return tools and materials to proper storage, or prepare for next job sheet as directed by your instructor

## MICROWAVE OVEN TROUBLESHOOTING AND REPAIR UNIT II

### JOB SHEET #14 — REMOVE AND TEST A CONTROL PANEL

#### A. Tools and materials

1. Microwave oven: Litton model 1320, 1325, 1440, or 1450
2. Service manual for selected oven
3. VOM
4. Screwdriver with insulated handle
5. Utility knife (X-Acto or similar)
6. Pencil and paper
7. Safety glasses

#### B. Routine #1 — Removing the control panel (Figure 1)

The following procedure and illustrations are adapted from materials copyrighted © by Litton Systems, Inc., and are reprinted with permission. Any other use is prohibited.

1. Put on safety glasses
2. Unplug the power cord and remove the access panel as outlined in a previous job sheet
3. DISCHARGE THE CAPACITOR
4. Insert a flat-blade screwdriver between oven side and control panel mounting tabs and push tabs inward to disengage them  
  
(NOTE: If this is an early production model Litton oven, there will be a nylon spacer that should be squeezed together and pulled away from the cavity; refer to Figure 1 as required.)
5. Swing the control panel away from the oven using the left side tabs as pivots, then disengage the left side tabs
6. Pull the control panel about 2 inches forward and disconnect the component wires
7. Remove the control panel for testing (and replacement, if required)  
 Have your instructor check your work



**JOB SHEET #14****C. Routine #2 — Testing the touch panel (Figure 2)**

1. **DISCHARGE THE CAPACITOR**
2. Read the following **CAUTIONS** carefully before continuing with this routine:
  - a. Over-flexing the ribbon cable will damage the silver circuit
  - b. Pointed test leads cannot be used on ribbon cable silver because the silver circuit will be damaged
  - c. Scratching the ribbon cable will also damage the silver circuit
  - d. Avoid touching any part of the circuitry on the back of the electronic control circuit board assembly because static discharge can damage the circuit board
  - e. Do not bend the ribbon cable forward
  - f. Refer to Figure 2 that accompanies this job sheet as you need to
3. Disconnect the ribbon cable from the circuit board by applying even pressure to both sides of the ribbon cable and pulling outward from the ribbon cable connector
4. Touch ohmmeter test leads to ribbon cable test points indicated in Figure 2
5. Check for a reading of 1 Meg ohms between the ribbon cable test points while no touch panel pad is depressed
6. Depress any touch panel pad and check for a resistance reading of less than 100 ohms between the connecting test points
  - a. If improper readings appear, run the test again
  - b. If improper readings still appear, replace the defective touch panel assembly
7. Inspect the ribbon cable silver circuit, and if any silver circuit is missing from the connector end of the ribbon cable, even trim  $\frac{1}{16}$  inch off the end of the cable as shown in Figure 2
8. Reinsert the cable into the connector by applying even pressure to both sides of the ribbon cable and pressing gently down
- Have your instructor check your work
9. Clean up area and return tools and materials to proper storage, or prepare for next job sheet as directed by your instructor

# JOB SHEET #14

FIGURE 1

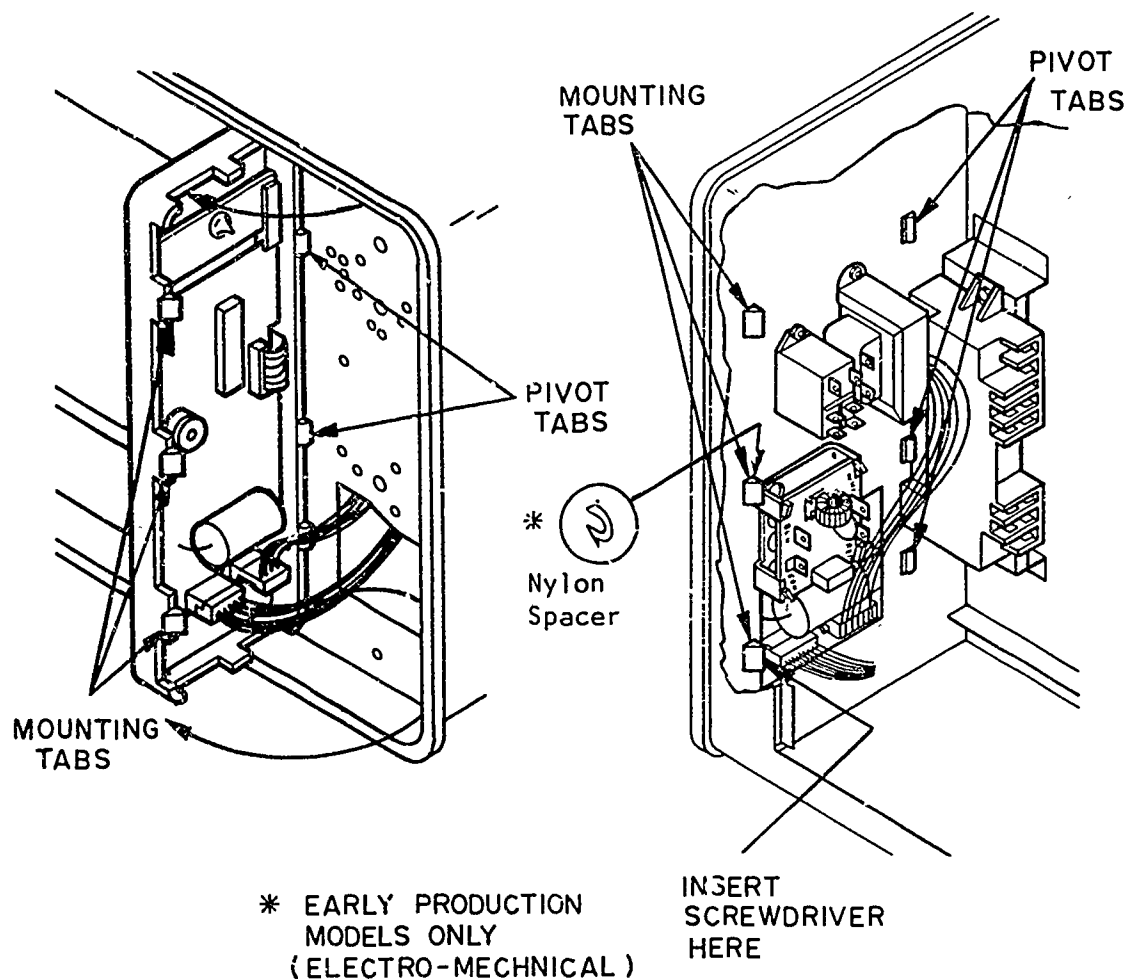

© Litton Systems, Inc.; reprinted with permission

**JOB SHEET #14**

FIGURE 2

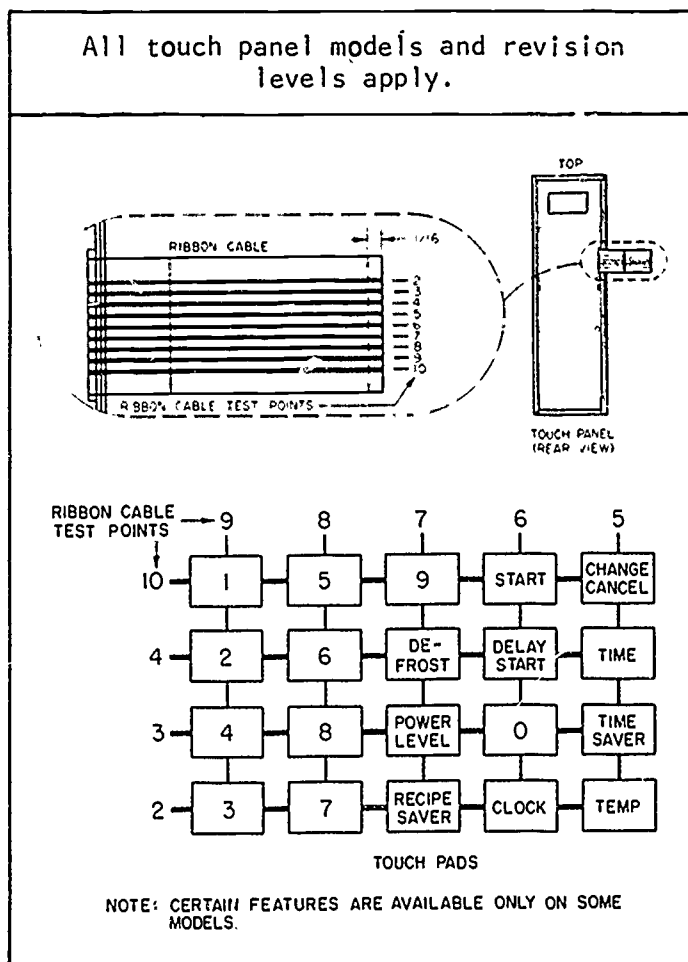

© Litton Systems, Inc.; reprinted with permission

## MICROWAVE OVEN TROUBLESHOOTING AND REPAIR UNIT II

### JOB SHEET #15 — TEST A CONTROL CIRCUIT BOARD

A. Tools and materials

1. Microwave oven: Litton model 1320, 1325, 1440, or 1450
2. Service manual for selected oven
3. VOM
4. Screwdriver with insulated handle
5. Pencil and paper
6. Watch with a second hand
7. Safety glasses

B. Routine #1 — Running the self diagnostic test sequence (Figure 1)

The following procedure and illustrations are adapted from materials copyrighted © by Litton Systems, Inc., and are reprinted with permission. Any other use is prohibited.

1. Put on safety glasses
  2. Use the circuit diagnosis flow chart for troubleshooting prior to running the self diagnosis test sequence
  3. Follow all the procedures outlined in the troubleshooting tree in Figure 1
  4. Make notes as required at points in the self diagnostic test that indicate trouble areas
  5. Record your findings
- Have your instructor check your work

**JOB SHEET #15****C. Routine #2 — Verifying oven relay operation or triac operation (Figure 2)**

(NOTE: The following tests are provided for reference only. The self diagnostic test is normally all that is required to verify normal operation of the Electronic Control Circuit Board. If a specific controller output is needed to verify oven relay operation or triac module operation, the following tests may be performed.)

1. Unplug the power cord and remove the access panel as outlined in a previous job sheet
  2. DISCHARGE THE CAPACITOR
  3. Perform test set-ups and testing as indicated in the chart in Figure 3 at test points illustrated in Figure 2
  4. Record your findings
- Have your instructor check your work
5. Clean up area and return tools and materials to proper storage, or prepare for next job sheet as directed by your instructor

## JOB SHEET #15

FIGURE 1

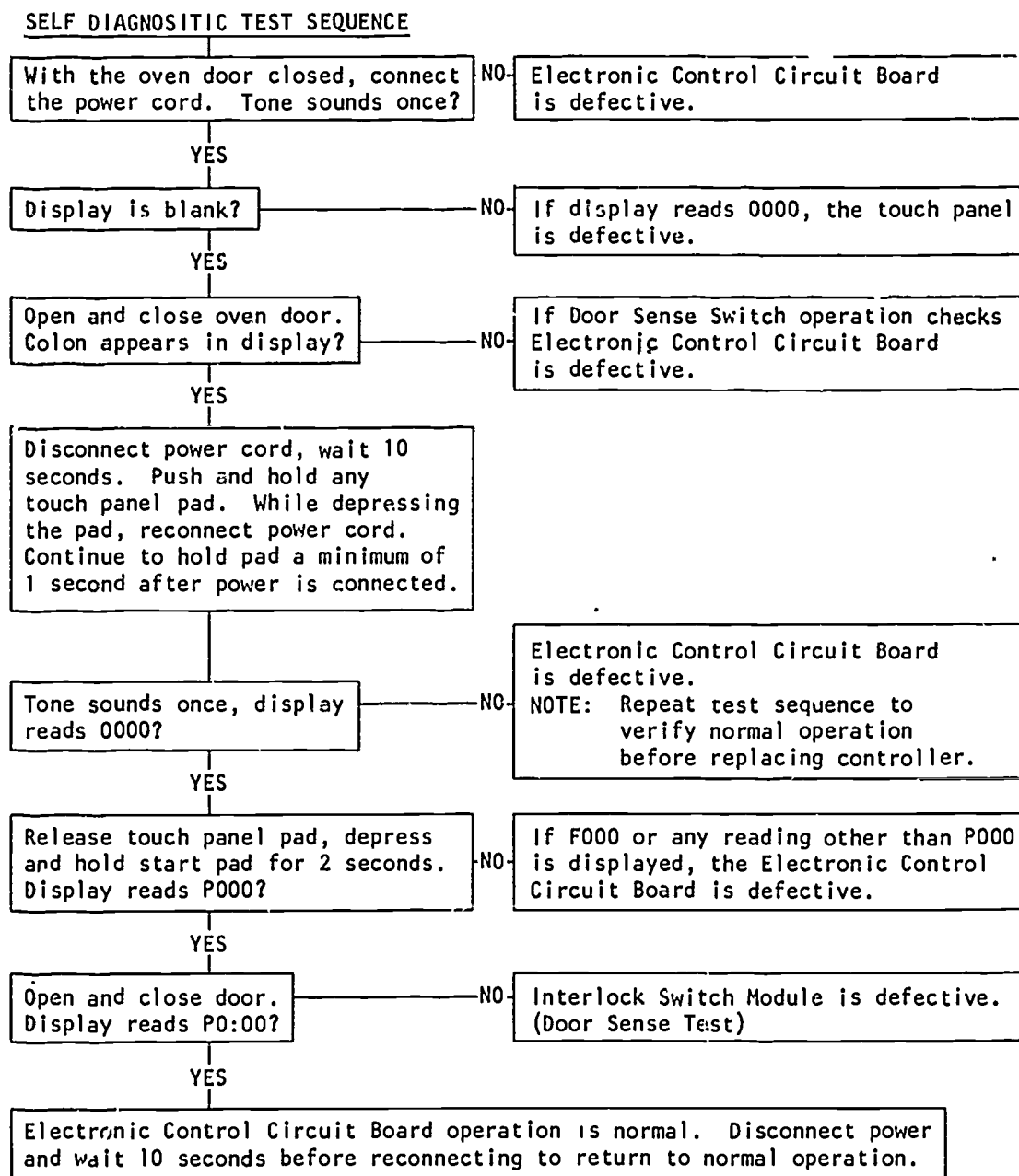

© Litton Systems, Inc.; reprinted with permission

JOB SHEET #15

FIGURE 2

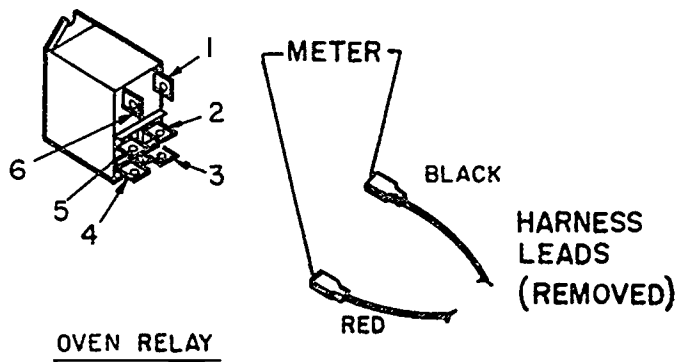
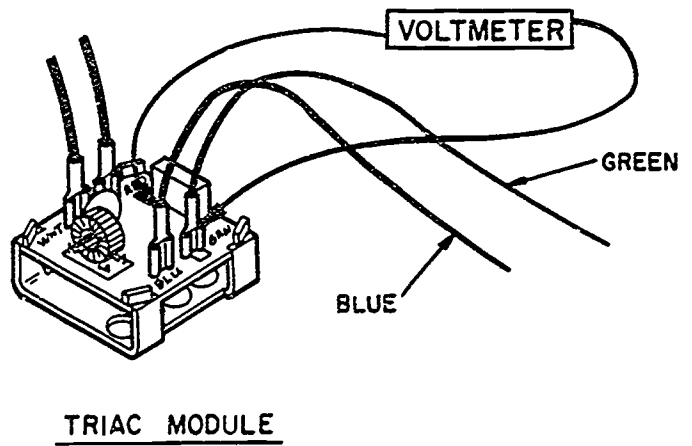

FIGURE 1



© Litton Systems, Inc.; reprinted with permission

FIGURE 3

ELECTRONIC CONTROL CIRCUIT BOARD TEST CHART

TEST SET-UP	TEST POINTS	NORMAL READINGS (Approximate)	CORRECTIVE ACTION
<p><b>OVEN RELAY DRIVE OUTPUT</b></p> <ol style="list-style-type: none"> <li>1. Disconnect harness leads from relay terminals 1 &amp; 6.</li> <li>2. Apply power to the oven and close the oven door.</li> <li>3. Put oven into a TIME cook cycle.</li> </ol>	<p>Wire from terminal 1 (Black meter lead) Wire from terminal 6 (Red meter lead) (Reference Figure 1)</p>	<p>22 VDC (during cook cycle) 0 VDC (after completion of cook cycle)</p>	<p><u>Procedure A:</u> If voltage <u>was not</u> present during cook cycle, <u>or</u> if voltage was present after completion of cook cycle replace the electronic control circuit board and retest.</p> <p><u>Procedure B:</u> If voltages were correct, see circuit diagnosis for other possible causes.</p>
<p><b>TRIAC MODULE DRIVE OUTPUT</b></p> <ol style="list-style-type: none"> <li>1. With power disconnected, connect voltmeter to triac module terminals marked GRN and BLU.</li> <li>2. Apply power to the oven and put the oven into a TIME cook cycle on HIGH setting.</li> </ol>	<p>Triac Module Terminals GRN to BLU (Reference Figure 2)</p>	<p>1 to 6 VAC (during cook cycle)</p>	<p><u>Procedure A:</u> If voltage <u>was not</u> present during cook cycle, <u>or</u> if voltage was present after completion of cook cycle replace the electronic control circuit board and retest.</p> <p><u>Procedure B:</u> If voltages were correct, see circuit diagnosis for other possible causes.</p>

JOB SHEET #15



# MICROWAVE OVEN TROUBLESHOOTING AND REPAIR UNIT II

## JOB SHEET #16 — TEST A TRIAC MODULE

### A. Tools and materials

1. Microwave oven: Litton model 1320, 1325, 1440, or 1450
2. Service manual for selected oven
3. VOM
4. Screwdriver with insulated handle
5. Pencil and paper
6. Safety glasses

### B. Routine #1 — Testing for a shorted triac module on an oven that only heats on high

The following procedure and illustrations are adapted from materials copyrighted © by Litton Systems, Inc., and are reprinted with permission. Any other use is prohibited.

1. Put on safety glasses
2. Unplug the power cord and remove the access panel as outlined in a previous job sheet
3. DISCHARGE THE CAPACITOR
4. Remove harness leads from the triac module  
**(NOTE: Remember that this test is for a shorted triac module and should be performed when an oven heats only in the HIGH condition.)**
5. Set the ohmmeter on the  $R \times 1$  scale and attach the test leads across the WHT (MT1) and RED (MT2) terminals (Figure 1)

FIGURE 1

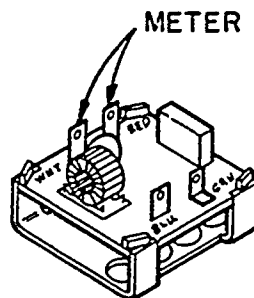

## JOB SHEET #16

6. Record your findings
    - a. The ohmmeter should indicate a normal reading of infinity (open)
    - b. If an abnormal reading is indicated, replace the triac module and retest
  7. Repeat Step 5 with the test leads reversed
  8. Record your findings
- Have your instructor check your work

C. Routine #2 — Testing for an open triac module on an oven that doesn't heat at all

1. DISCHARGE THE CAPACITOR
2. Remove completely the high voltage lead marked HV that connects the capacitor to one of the transformer high voltage terminals
3. Make sure VOM is capable of measuring 120V AC
4. Attach the meter leads to triac terminals WHT (MT1) and RED (MT2) and use alligator clips (Figure 2)

(NOTE: The triac harness leads should remain connected.)

FIGURE 2

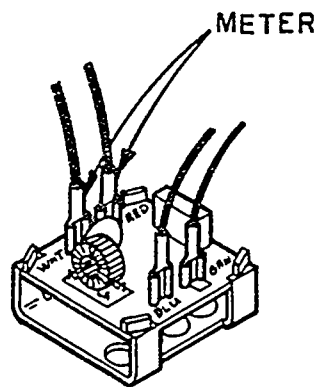

**(CAUTION: The alligator clips are required for making the operational checks that follow!)**

5. Pay careful attention to the following as you complete this procedure:
  - a. DANGEROUS HIGH VOLTAGES ARE PRESENT AT THE HIGH VOLTAGE SECONDARY TERMINALS DURING A COOK CYCLE
  - b. DO NOT TOUCH ANY OVEN COMPONENTS OR WIRING WHEN THE OVEN IS OPERATING

**JOB SHEET #16**

**(CAUTION: Complete the remainder of this procedure only in the presence of and with the supervision of your instructor.)**

6. Plug the power cord in and energize the oven in a COOK cycle
7. Measure and record the voltage indicated on the meter
8. Disconnect power to the oven
9. Evaluate your findings
  - a. If a normal indication of less than 5V AC was indicated, the triac module operation is normal
  - b. If an abnormal reading is indicated and the electronic control circuit board triac drive test was okay, replace the triac module and retest
  - c. If abnormal condition still exists, reinstall the old triac module, replace electronic control circuit board, and retest
10. Record retest findings
- Have your instructor check your work
11. Clean up area and return tools and materials to proper storage, or prepare for next job sheet as directed by your instructor

## MICROWAVE OVEN TROUBLESHOOTING AND REPAIR UNIT II

### JOB SHEET #17 — TEST A COOK RELAY

#### A. Tools and materials

1. Microwave oven: Litton model 1320, 1325, 1440, or 1450
2. Service manual for selected oven
3. VOM
4. Screwdriver with insulated handle
5. Pencil and paper
6. Electrical tape
7. Safety glasses

#### B. Procedure

The following procedure and illustrations are adapted from materials copyrighted © by Litton Systems, Inc., and are reprinted with permission. Any other use is prohibited.

1. Put on safety glasses
2. Unplug the power cord and remove the access panel as outlined in a previous job sheet
3. DISCHARGE THE CAPACITOR  
**(CAUTION: Complete the remainder of this procedure only in the presence of and with the supervision of your instructor.)**
4. Perform test set-ups as indicated in the chart in Figure 1 that accompanies this job sheet
5. Pay special attention to the following while completing the test procedures:
  - a. DO NOT TOUCH COMPONENTS OR WIRING DURING OPERATIONAL TESTS
  - b. BEFORE TOUCHING OVEN COMPONENTS OR WIRING, ALWAYS DISCHARGE THE CAPACITOR

**JOB SHEET #17**

6. Record your findings
- Have your instructor check your work
7. Clean up area and return tools and materials to proper storage, or prepare for next job sheet as directed by your instructor

144

FIGURE 1

TEST CHART

TEST SET-UP	TERMINAL TEST POINT	NORMAL READING	CORRECTIVE ACTION For Abnormal Reading
Disconnect power. Remove harness leads from relay terminals 1 & 6. Set meter to R x 1 ohm scale.	1 to 6	250 to 350 ohms	If abnormal reading is measured, replace the relay and retest.
Reconnect harness leads to terminals 1 & 6. Remove harness leads from terminals 2, 3, 4 and 5, and insulate to prevent electrical short.	2 to 3 4 to 5	Infinite Infinite	If wire connections and incoming line voltage check OK, replace relay and retest.
Reconnect power. Program oven for 15 seconds and put oven into a COOK cycle.	2 to 3 4 to 5	Less than 1 ohm during cook, then infinite at the end of the COOK cycle.	If electronic controller oven relay drive checks OK, replace relay and retest.

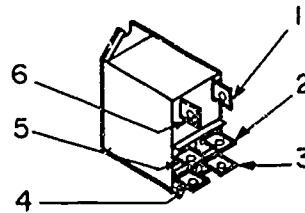

OVEN RELAY

JOB SHEET #17

## MICROWAVE OVEN TROUBLESHOOTING AND REPAIR UNIT II

### JOB SHEET #18 — REMOVE A BLOWER MOTOR AND TRANSFORMER

#### A. Tools and materials

1. Microwave oven: Litton model 1304, 1305, 1420, or 1422
2. Service manual for selected oven
3. Standard tool set
4. Screwdriver with insulated handle
5. Pencil and paper
6. Safety glasses

#### B. Routine #1 — Removing the blower motor (Figure 1)

The following procedure and illustrations are adapted from materials copyrighted © by Litton Systems, Inc., and are reprinted with permission. Any other use is prohibited.

1. Put on safety glasses
2. Unplug the power cord and remove the access panel as outlined in a previous job sheet
3. DISCHARGE THE CAPACITOR
4. Remove the magnetron support bracket
5. Remove the blower housing duct
6. Remove the blower motor mounting screw
7. Disconnect leads and remove blower

(NOTE: Blower is now ready for inspection, and the procedure may also be required to make the oven ready for other component testing.)

- Have your instructor check your work

**JOB SHEET #18****C. Routine #2 — Removing the transformer (Figure 1)**

1. DISCHARGE THE CAPACITOR
2. Disconnect wires and remove capacitor
3. Disconnect transformer leads
4. Remove transformer mounting hardware
5. Lift transformer up to clear base and remove it

(NOTE: The transformer should be replaced by reversing the procedure outlined.)

Have your instructor check your work

6. Clean up area and return tools and materials to proper storage, or prepare for next job sheet as directed by your instructor



JOB SHEET #18

FIGURE 1

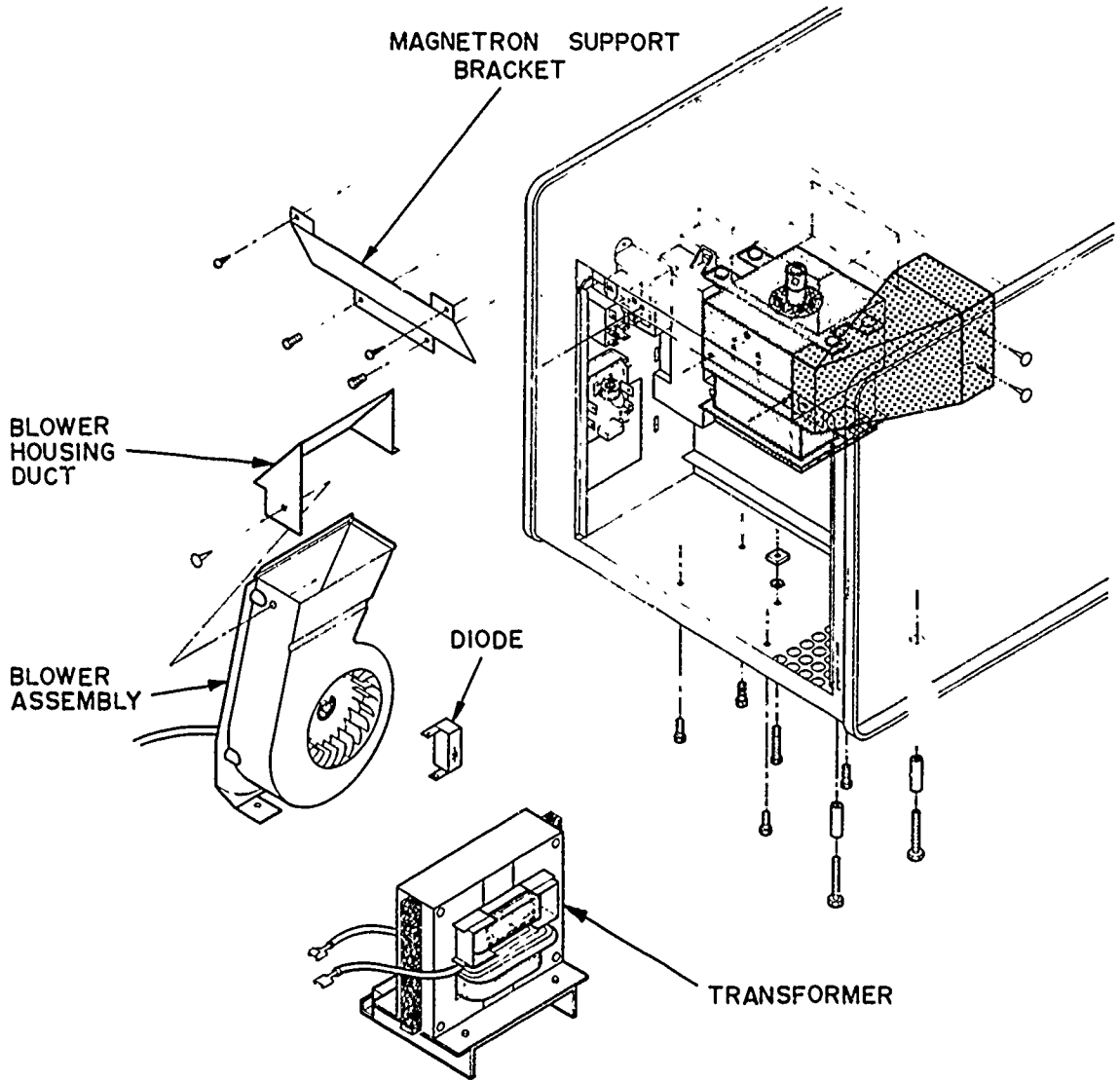

© Litton Systems, Inc.; reprinted with permission

## MICROWAVE OVEN TROUBLESHOOTING AND REPAIR UNIT II

### JOB SHEET #19 — REMOVE AND REINSTALL A MAGNETRON

#### A. Tools and materials

1. Microwave oven: Litton model 1304, 1305, 1420, or 1422
2. Service manual for selected oven
3. Standard tool set
4. Screwdriver with insulated handle
5. Pencil and paper
6. Safety glasses

#### B. Procedure (Figure 1)

The following procedure and illustrations are adapted from materials copyrighted © by Litton Systems, Inc., and are reprinted with permission. Any other use is prohibited.

1. Put on safety glasses
2. Unplug the power cord and remove the access panel
3. DISCHARGE THE CAPACITOR
4. Remove the blower motor as previously outlined
5. Remove the diode
6. Remove the magnetron mounting nuts and lower the magnetron to remove it
7. Check magnetron RF gasket to make sure it is in good shape and properly placed before reinstalling the magnetron
8. Reinstall magnetron, tighten mounting nuts, and check for secure and even alignment of the magnetron
9. Install the magnetron air duct and thermo protector
10. Install the high voltage transformer and reconnect magnetron filament leads and transformer leads

**JOB SHEET #19**

11. Install diode
12. Install blower, blower housing duct, and magnetron support bracket
- Have your instructor check your work
13. Place a container of cool water in the cavity and check the oven for proper operation
14. Check the oven for RF leakage with an approved RF test meter and procedure as outlined in a previous job sheet
15. Record your findings
- Have your instructor check your work
16. Clean up area and return tools and materials to proper storage, or prepare for next job sheet as directed by your instructor

# JOB SHEET #19

FIGURE 1

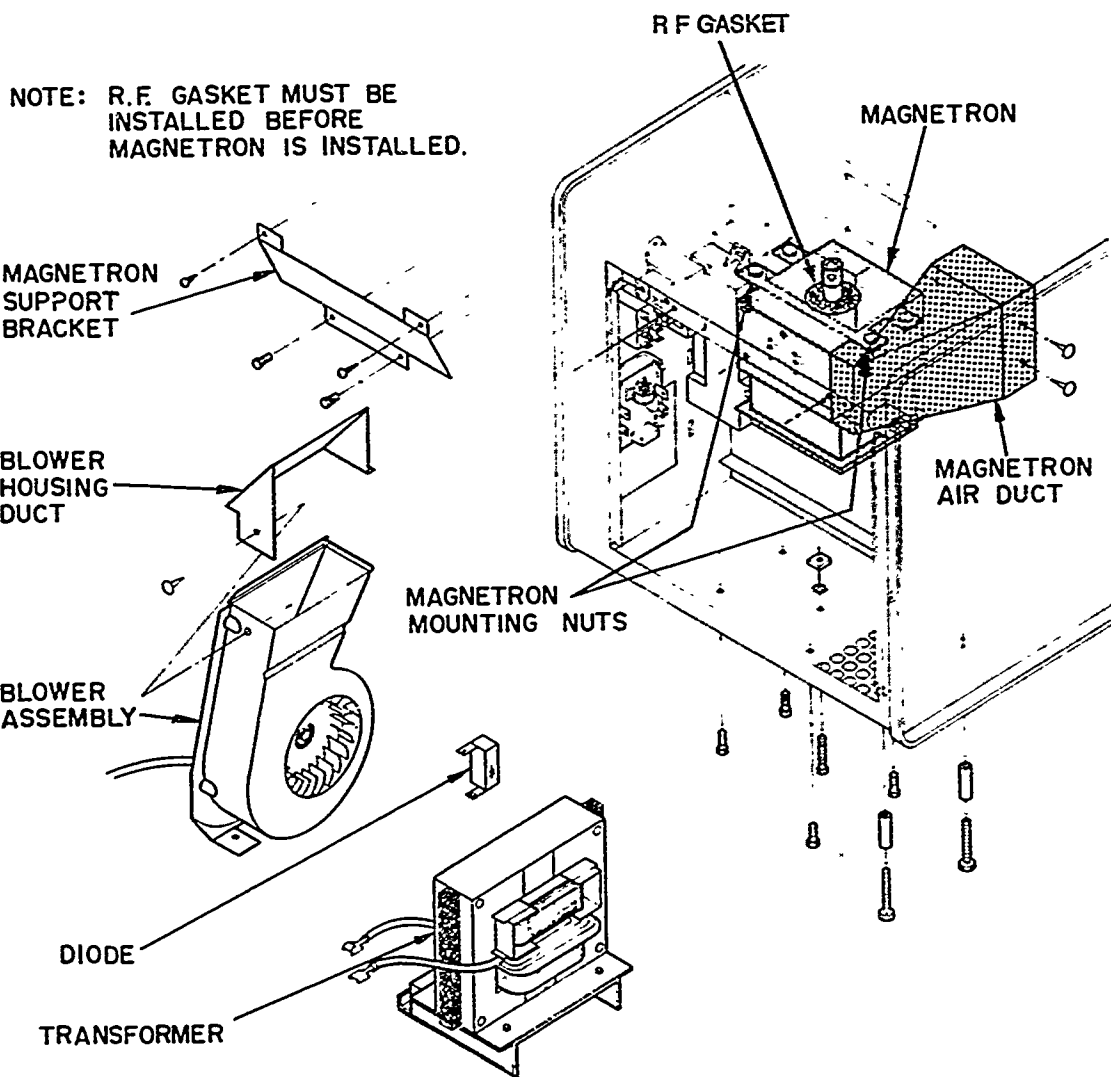

© Litton Systems, Inc.; reprinted with permission

## MICROWAVE OVEN TROUBLESHOOTING AND REPAIR UNIT II

### JOB SHEET #20 — REMOVE A TIMER AND A CONTROLLER

A. Tools and materials

1. Microwave oven: Litton model 1320, 1325, 1440, or 1450
2. Service manual for selected oven
3. Screwdriver with insulated handle
4. Safety glasses

B. Procedure (Figure 1)

The following procedure and illustrations are adapted from materials copyrighted © by Litton Systems, Inc., and are reprinted with permission. Any other use is prohibited.

1. Put on safety glasses
  2. Unplug the power cord and remove the access panel
  3. DISCHARGE THE CAPACITOR
  4. Remove the blower motor as previously outlined
  5. Remove the control panel as previously outlined
  6. Remove the mounting screws or bolts for the timer, and remove the timer for inspection
  7. Remove the mounting screws or bolts for the controller, and remove the controller for inspection
- Have your instructor check your work
8. Replace timer and controller as directed
  9. Clean up area and return tools and materials to proper storage, or prepare for next job sheet as directed by your instructor

JOB SHEET #20

FIGURE 1

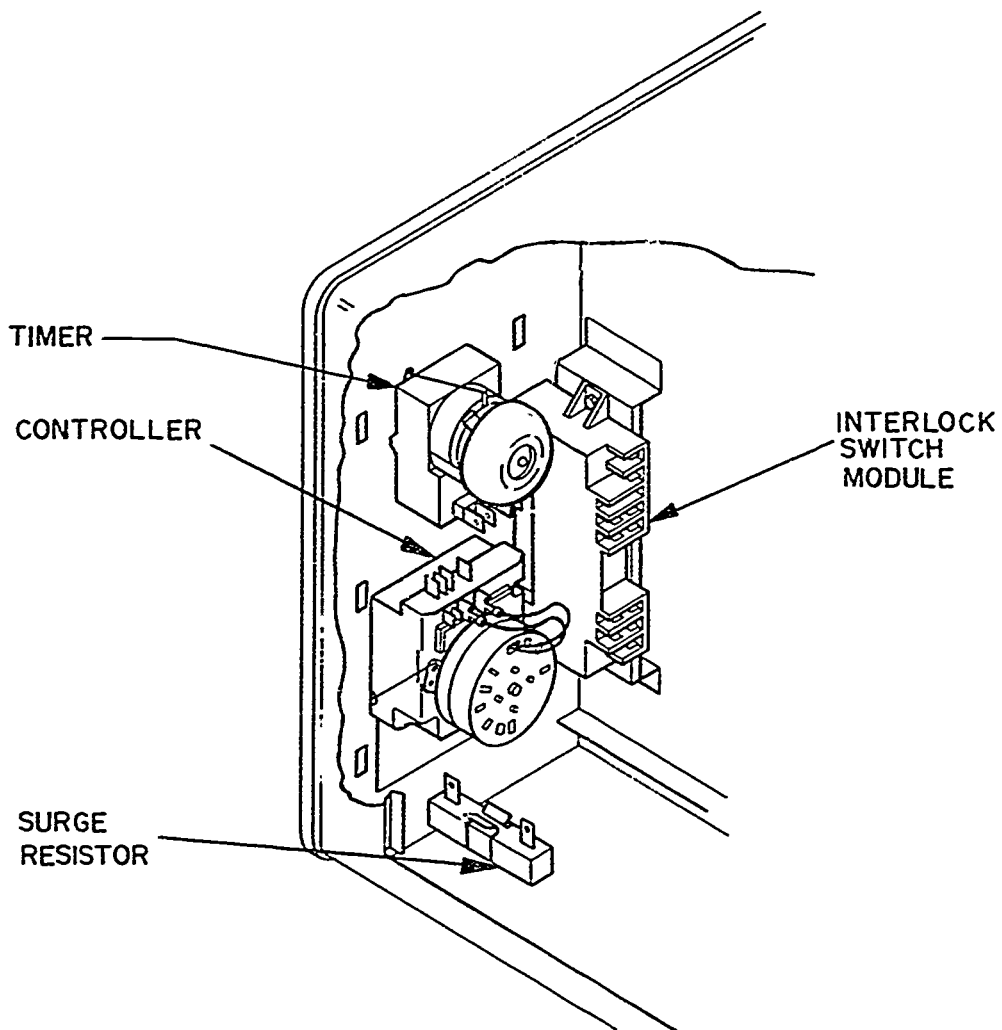

© Litton Systems, Inc.; reprinted with permission

## MICROWAVE OVEN TROUBLESHOOTING AND REPAIR UNIT II

### JOB SHEET #21 — REMOVE A LOW VOLTAGE TRANSFORMER AND A TRIAC

#### A. Tools and materials

1. Microwave oven: Litton model 1320, 1325, 1440, or 1450
2. Service manual for selected oven
3. Screwdriver with insulated handle
4. Safety glasses

#### B. Procedure (Figure 1)

The following procedure and illustrations are adapted from materials copyrighted © by Litton Systems, Inc., and are reprinted with permission. Any other use is prohibited.

1. Put on safety glasses
  2. Unplug the power cord and remove the access panel
  3. DISCHARGE THE CAPACITOR
  4. Remove the blower motor as previously outlined
  5. Remove the control panel as previously outlined
  6. Remove the mounting screws or bolts for the transformer, remove transformer leads, and remove the transformer
  7. Remove the mounting screws or bolts for the triac, remove the triac leads, and remove the triac
- Have your instructor check your work
8. Replace low voltage transformer and triac as directed
  9. Clean up area and return tools and materials to proper storage, or prepare for next job sheet as directed by your instructor

JOB SHEET #21

FIGURE 1

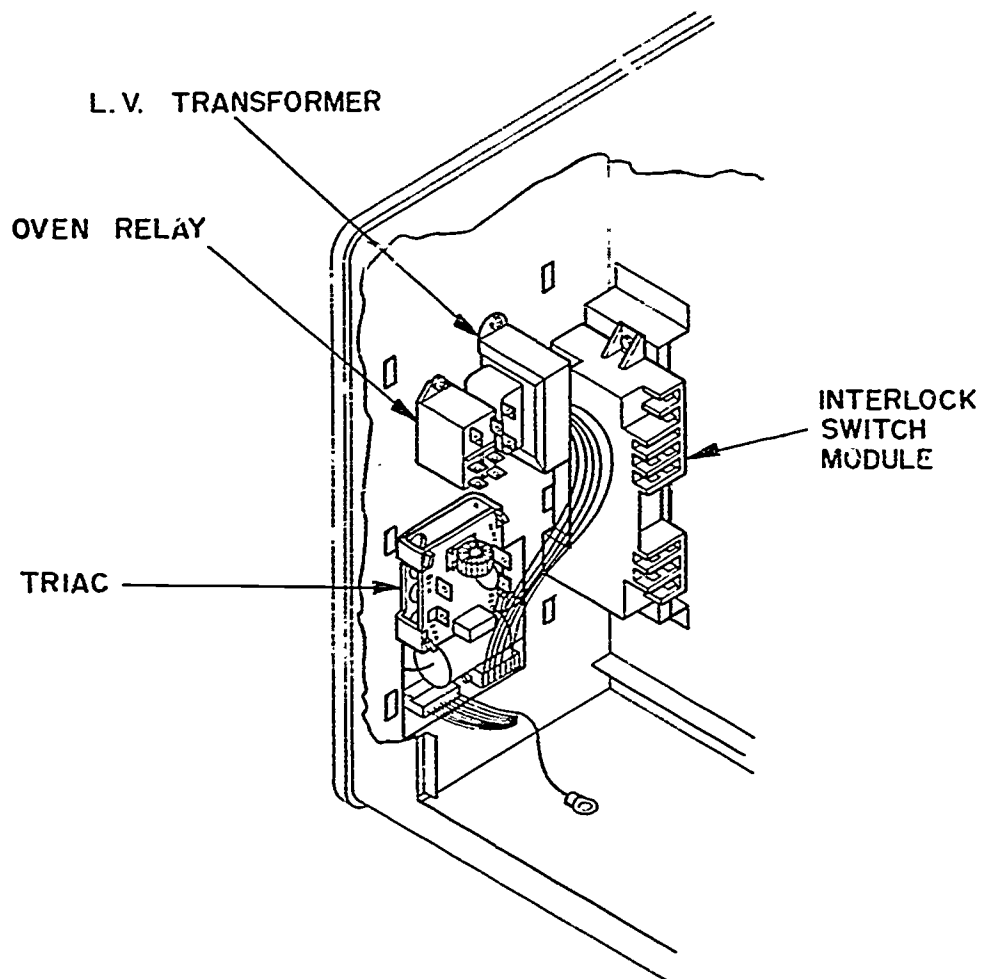

© Litton Systems, Inc.; reprinted with permission



## MICROWAVE OVEN TROUBLESHOOTING AND REPAIR UNIT II

### JOB SHEET #22 — REMOVE AND DISASSEMBLE A STIRRER SYSTEM

#### A. Tools and materials

1. Microwave oven: Litton model 1320, 1325, 1440, or 1450
2. Service manual for selected oven
3. Screwdriver with insulated handle
4. Standard tools
5. Sealant: M13D2 as required
6. Safety glasses

#### B. Procedure (Figure 1)

The following procedure and illustrations are adapted from materials copyrighted © by Litton Systems, Inc., and are reprinted with permission. Any other use is prohibited.

1. Put on safety glasses
2. Unplug the power cord and remove the access panel
3. DISCHARGE THE CAPACITOR
4. Remove the access panel
5. Remove the stirrer cover by pulling forward to release the molded-in button that hold it in place  
  
(NOTE: On early production ovens the rear poly buttons have to be removed.)
6. Remove the stirrer bracket support and lower the support assembly and stirrer blade
7. Remove left and right hand air baffles as required
8. Keep the stirrer insert intact with bearing and set it aside
9. Inspect stirrer blade and baffles for evidence of damage

**JOB SHEET #22**

10. Inspect stirrer insert and bearing for excessive wear
- Have your instructor check your work
11. Reassemble as directed and use sealant as indicated in Figure 1
12. Clean up area and return tools and materials to proper storage, or prepare for next job sheet as directed by your instructor

JOB SHEET #22

FIGURE 1

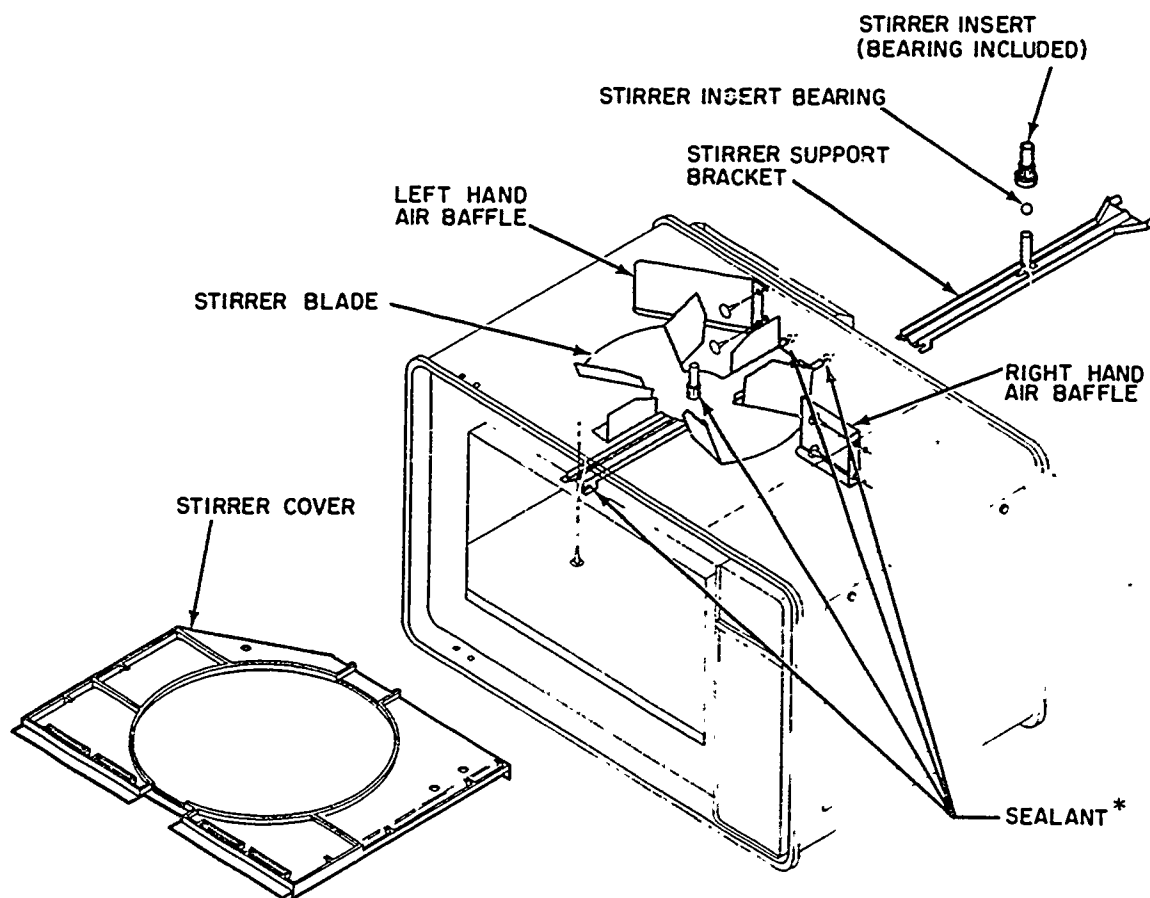

© Litton Systems, Inc.; reprinted with permission

## MICROWAVE OVEN TROUBLESHOOTING AND REPAIR UNIT II

### JOB SHEET #23 — REMOVE MAGNETRON AND CAVITY THERMAL PROTECTORS

A. Tools and materials

1. Microwave oven: Litton model 1320, 1325, 1440, or 1450
2. Service manual for selected oven
3. Screwdriver with insulated handle
4. Standard tools
5. Safety glasses

B. Procedure (Figure 1)

The following procedure and illustrations are adapted from materials copyrighted © by Litton Systems, Inc., and are reprinted with permission. Any other use is prohibited.

1. Put on safety glasses
2. Unplug the power cord and remove the access panel
3. DISCHARGE THE CAPACITOR
4. Remove the wire cover and rear exhaust duct on the back of the oven to expose the cavity thermal protector  
  
(NOTE: Thermal protector styles may vary with model, but the protector should be easy to remove at this point.)
5. Remove the clamp holding the magnetron thermal protector
6. Inspect both protectors, check for continuity, and replace as required
- Have your instructor check your work
7. Clean up area and return tools and materials to proper storage, or prepare for next job sheet as directed by your instructor

JOB SHEET #23

FIGURE 1

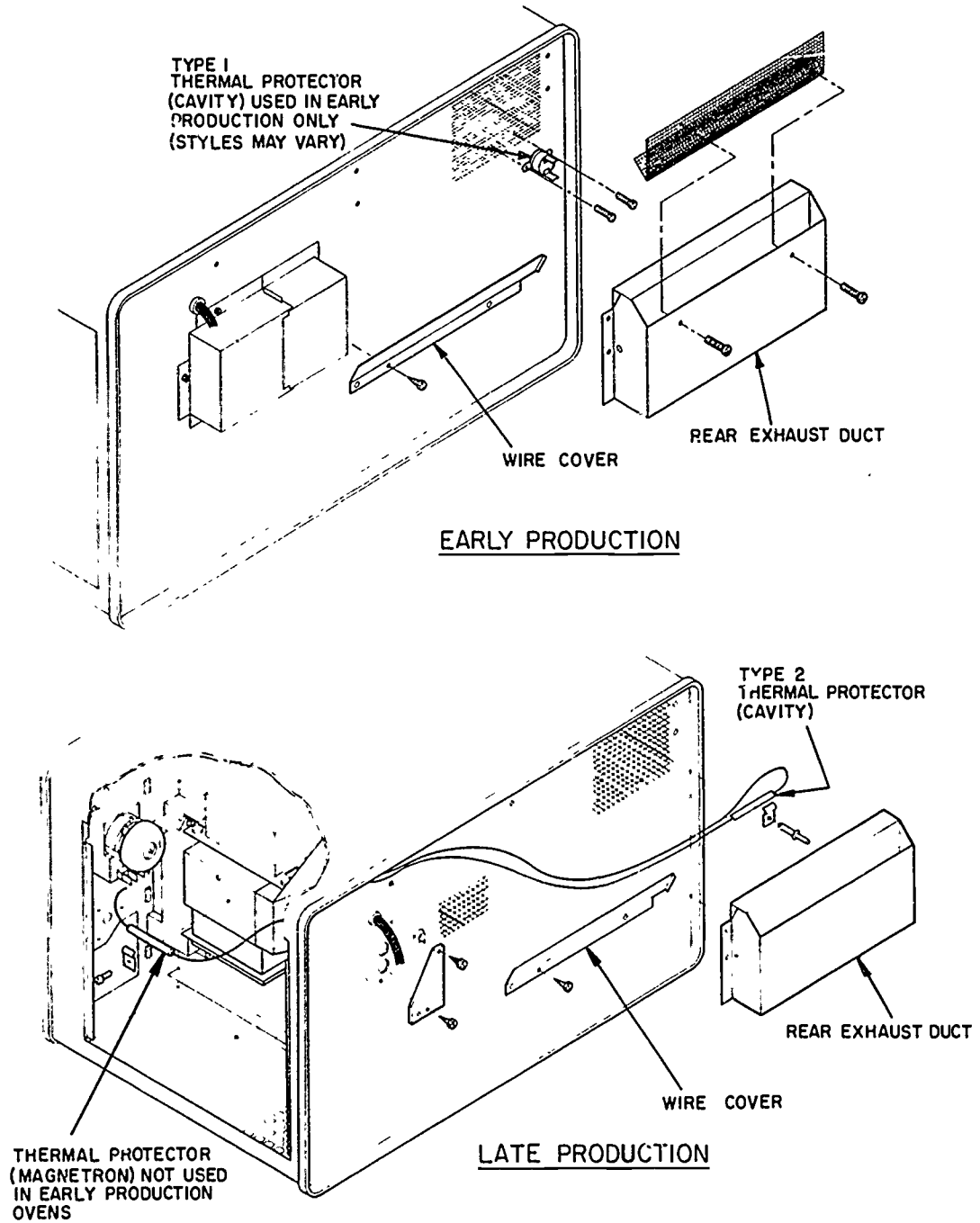

© Litton Systems, Inc.; reprinted with permission

## MICROWAVE OVEN TROUBLESHOOTING AND REPAIR UNIT II

### JOB SHEET #24 — REMOVE, DISASSEMBLE, AND REASSEMBLE A MICROWAVE OVEN DOOR

#### A. Tools and materials

1. Microwave oven: Litton model 1320, 1325, 1440, or 1450
2. Service manual for selected oven
3. Screwdriver with insulated handle
4. Standard tools
5. RF leakage test meter and materials
6. Safety glasses

#### B. Routine #1 — Removing and disassembling the door

The following procedure and illustrations are adapted from materials copyrighted © by Litton Systems, Inc., and are reprinted with permission. Any other use is prohibited.

1. Put on safety glasses
2. Unplug the power cord and remove the access panel
3. DISCHARGE THE CAPACITOR
4. Remove the door from the oven as outlined in Job Sheet #4
5. Place the door front down on a flat, protected surface with the door handle extending over the edge of the surface
6. Peel off the adhesive mounted inner window if it is a Type 2 door (Figure 1)
7. Remove inner door mounting screws
8. Separate inner door from outer door and door filler
9. inspect all door components for signs of wear or damage and replace components as required

Have your instructor check your work

**JOB SHEET #24****C. Routine #2 — Reassembling the door**

1. Place door front down on a flat, protected surface with the door handle extending out over the edge of the surface
2. Mount Inner door and door filler onto outer door
3. Install inner door mounting screws while keeping outer door as flat as possible
4. Install new adhesive mounted inner window if it is a Type 2 door
5. Install door hinges as outlined in Job Sheet #4
6. Check the door for proper fit

Have your instructor check your work

**D. Routine #3 — Checking the oven for safe operation**

1. Replace the access panel
2. Plug the oven power cord in
3. Fill a container with water and place it in the oven cavity
4. Prepare a test meter and conduct an RF leakage test as previously outlined
5. Record your findings

Have your instructor check your work

6. Unplug the power cord
7. Clean up area and return tools and materials to proper storage, or prepare for next job sheet as directed by your instructor

# JOB SHEET #24

FIGURE 1

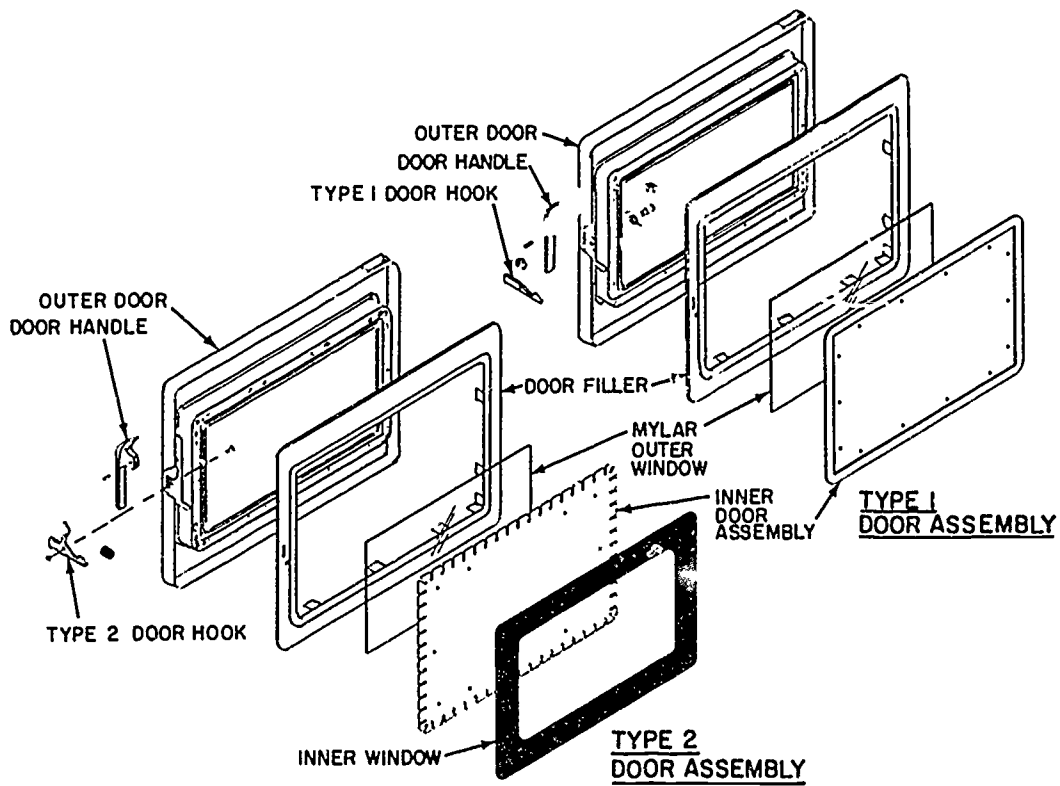

© Litton Systems, Inc.; reprinted with permission



## MICROWAVE OVEN TROUBLESHOOTING AND REPAIR UNIT II

### JOB SHEET #25 — REPLACE A DOOR HOOK ON A MICROWAVE OVEN

#### A. Tools and materials

1. Microwave oven: Litton model 1320, 1325, 1440, or 1450
2. Service manual for selected oven
3. Screwdriver with insulated handle
4. Standard tools
5. RF leakage test meter and materials
6. Safety glasses

#### B. Procedure (Figure 1)

The following procedure and illustrations are adapted from materials copyrighted © by Litton Systems, Inc., and are reprinted with permission. Any other use is prohibited.

1. Put on safety glasses
2. Unplug the power cord and remove the access panel
3. DISCHARGE THE CAPACITOR
4. Remove the door from the oven as outlined in Job Sheet #4
5. Disassemble the door as outlined in Job Sheet #4
6. Remove door hook according to the following:
  - a. On a Type 1 Door, remove the snap ring, pivot pin, and torsion bar; remove the door hook and door handle; push out the guide pin to remove the hook from the handle
  - b. On a Type 2 Door, remove the compression spring, push out the guide pin, and remove the door handle; remove snap ring and pivot pin to remove hook

**JOB SHEET #25**

7. Replace as required and reassemble hook mechanism and door
8. Install door as previously outlined
- Have your instructor check your work
- . Conduct an RF leakage test and record your findings
- Have your instructor check your work
10. Clean up area and return tools and materials to proper storage, or prepare for next job sheet as directed by your instructor

JOB SHEET #25

FIGURE 1

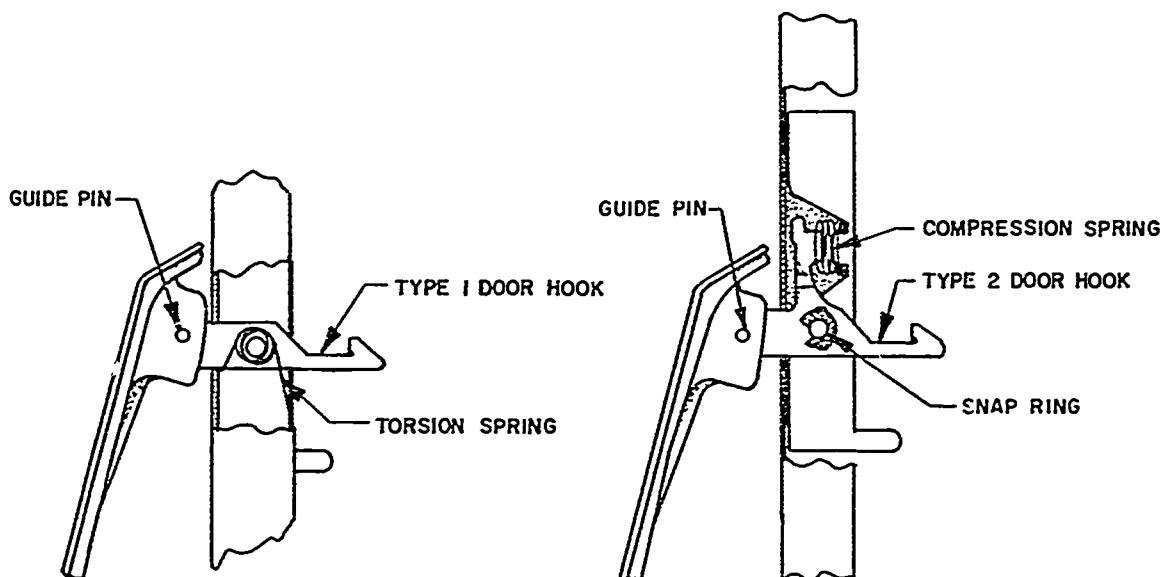

© Litton Systems, Inc.; reprinted with permission

## MICROWAVE OVEN TROUBLESHOOTING AND REPAIR UNIT II

NAME \_\_\_\_\_

### TEST

1. Match the terms on the right with their correct definitions.

- |         |  |              |
|---------|--|--------------|
| _____a. | The generation of visible electric sparks caused by microwaves striking and bouncing off metal objects or objects with too much metallic content | 1. N.C.      |
| _____b. | A device capable of storing and discharging electricity  | 2. Rectifier |
| _____c. | A device that permits electrical current to flow in only one direction   | 3. Diode     |
| _____d. | A switch that is normally closed when it is not activated  | 4. N.O.      |
| _____e. | A switch that is normally open when it is not activated  | 5. Arcing    |
| _____f. | A device that converts normal household AC current into pulsating DC current   | 6. Capacitor |

2. Match major microwave oven components with their functions.

- |         |  |                            |
|---------|--|----------------------------|
| _____a. | A transformer that converts 120V AC current into low voltage that is fed to the magnetron filaments, and into high voltage that is fed into the voltage-doubler circuit          | 1. Waveguide               |
| _____b. | A diode/rectifier/capacitor combination that converts the high voltage AC feed from the transformer into approximately 3900V pulsating DC current that is fed into the magnetron | 2. Antenna                 |
| _____c. | A cylinder-shaped cathode/anode in a magnetic field that converts applied low voltage AC and high voltage DC current into microwaves   | 3. Power transformer       |
| _____d. | The part of the magnetron tube that directs generated microwaves into a waveguide  | 4. Stirrer assembly        |
|         |  | 5. Voltage-doubler circuit |
|         |  | 6. Magnetron               |

## TEST

- \_\_\_\_e. A duct-like channel through which the microwaves travel in controlled transmission to the stirrer assembly
- \_\_\_\_f. A device with fan-like blades that scatter the microwaves at random into the oven cavity to assure even heat distribution in the cavity

## 3. Match operating controls with their functions.

- |   |                        |
|---|------------------------|
| ____a. These switches are activated by the opening or closing of the oven door to assure that microwave generation does not start until the door is properly closed and stops the moment the door is opened | 1. Timer               |
| ____b. A device that instantly shuts off microwave transmission in the event any interlock switch fails   | 2. Interlock monitor   |
| ____c. May be a rotary, digital, pushbutton, or touchpad device, and is designed to stop microwave generation at the end of a specified period  | 3. Cook relay          |
| ____d. Permits selection of COOK, DEFROST or other conditions of a particular oven, and some oven doors cannot be opened until STOP has been pressed  | 4. Triac               |
| ____e. Devices which stop oven operations in the event a blower obstruction causes a magnetron to overheat or the oven cavity to overheat   | 5. Interlock switches  |
| ____f. Activated by depressing the COOK switch to generate a current path to the stirrer assembly, transformer, and cook light  | 6. Controller          |
| ____g. Used on microwave ovens to start and stop microwave transmission for thawing food or keeping food warm during a variable heat cycle  | 7. Thermal protectors  |
| ____h. A switching relay used for controlling circuits in a microwave oven  | 8. Start/stop controls |

## TEST

4. Complete statements concerning motors in microwave ovens by inserting the word(s) that best completes each statement.
- Blower motor — A motor that drives a fan which directs air around the vanes of the magnetron to help keep it cool and also directs some air through the oven cavity to remove \_\_\_\_\_ and vapors from cooking food
  - Stirrer motor — A motor that drives a fan which deflects microwaves from the waveguide into the \_\_\_\_\_
5. Select true statements concerning door seals and their importance in microwave oven construction by placing an "X" beside each statement that is true.
- Door seals must be so designed that they prevent the escape of microwaves from the oven
  - Door seals must be so designed that they can limit RF leakage from the oven door to a maximum level of  $5\text{mw}/\text{cm}^2$
  - A "capacitive seal" is a flexible metal plate with a thin insulated coating to break metal-to-metal contact and prevent arcing when the oven door is closed
  - A "choke seal" is so structured that the dimensions are related to the wavelengths of microwaves, and will actually reflect stray microwaves back into the oven cavity
  - "Absorbent seals" are made of plastic or synthetic rubber and may have a ferritic content to help them absorb harmonic energy that might get by the other seals
  - Door seals are critical to safe microwave oven operation and should be inspected every year
6. Complete statements concerning technical materials required for microwave oven service by inserting the word(s) that best completes each statement.
- The nameplate on the oven should always be checked for the proper model number and \_\_\_\_\_ number
  - The \_\_\_\_\_ manual for the specific oven being worked on must be available to assure proper references for circuitry and parts
  - Service bulletins, technical updates, or literature that lists \_\_\_\_\_ changes that affect component or parts modifications for the oven must be available
  - Replacement parts should be ordered by \_\_\_\_\_ from the parts catalog for the specific oven being serviced
  - Circuit diagnosis and troubleshooting should not begin without a proper \_\_\_\_\_ schematic for the specific oven being serviced

## TEST

7. Select true statements concerning advantages of using wiring schematics in circuit diagnosis by placing an "X" beside each statement that is true.
- \_\_\_\_\_a. Using a schematic is the slowest way to locate a malfunctioning component so it can be tested
  - \_\_\_\_\_b. Using a schematic eliminates the bad habit of wasting the time testing components that could not possibly have anything to do with the problem
  - \_\_\_\_\_c. Using a schematic promotes higher repair costs to customers
  - \_\_\_\_\_d. Using a schematic promotes professional attitudes and builds confidence in service technicians who learn to use schematics effectively
8. Solve problems concerning how to use schematics for system diagnosis by answering the following questions.
- a. What three things do you have to know to use a schematic for troubleshooting?  
Answer \_\_\_\_\_  
\_\_\_\_\_
  - b. Where should troubleshooting begin?  
Answer \_\_\_\_\_
9. Solve problems concerning typical circuit diagnosis for an oven in the COOK condition by answering the following questions.
- a. What safety devices might be malfunctioning when a cavity light illuminates but the timer and other components do not operate?  
Answer \_\_\_\_\_  
\_\_\_\_\_
  - b. What could be a possible cause to almost all oven problems?  
Answer \_\_\_\_\_
10. Solve problems concerning typical circuit diagnosis for an oven in the VARI-COOK condition by answering the following questions.
- a. If the VARI-COOK condition is not working properly, what test should you make first?  
Answer \_\_\_\_\_
  - b. What component would probably be malfunctioning if the oven was having a problem in the VARI-COOK condition?  
Answer \_\_\_\_\_

## TEST

11. Complete statements concerning pre-service inspection requirements for microwave ovens by inserting the word(s) that best completes each statement.
- a. Check \_\_\_\_\_ operations and proper door closing
  - b. Examine the seals and \_\_\_\_\_ surfaces for signs of arcing, wear, or damage that could endanger the integrity of the \_\_\_\_\_
  - c. Check the door \_\_\_\_\_ to make sure they are not loose or damaged
  - d. Examine the oven wrap and all exterior surfaces for evidence of misuse or abusive use such as \_\_\_\_\_
  - e. Check the magnetron and \_\_\_\_\_ for proper alignment
  - f. Check the \_\_\_\_\_ assembly
  - g. If there is evidence of \_\_\_\_\_ or doubts about the microwave generating components, the oven should not be serviced
12. Complete statements concerning safety requirements for microwave oven service by inserting the word(s) that best completes each statement.
- a. Always \_\_\_\_\_ the oven before starting any tests or service
  - b. Unplug the \_\_\_\_\_ to the oven before removing access panels or oven wraps
  - c. DISCHARGE THE CAPACITOR by shorting across the capacitor terminals with a screwdriver that has an \_\_\_\_\_ handle
  - d. When a test routine calls for operating the oven for a \_\_\_\_\_ test, make all test connections BEFORE YOU PLUG THE UNIT INTO THE POWER RECEPTACLE
  - e. Use \_\_\_\_\_ when making "live" tests so you won't have to hold VOM leads near areas of dangerous high voltages
  - f. Operate the unit only from a three-prong or four-prong \_\_\_\_\_ outlet on a 15-amp circuit that services the microwave only
  - g. When using an extension cord for testing, use a three-wire grounded cord of at least 16-gauge copper, but do not use a \_\_\_\_\_ extension cord
  - h. \_\_\_\_\_ take high voltage readings around the transformer or the magnetron



## TEST

13. Complete statements concerning post-service safety requirements for microwave ovens by inserting the word(s) that best completes each statement.
- a. Attach a note to the oven to indicate what the customer can do to avoid further problems if the problem resulted from any form of misuse or lack of proper \_\_\_\_\_
  - b. Conduct an \_\_\_\_\_ to assure that oven microwave emissions are at or below the  $5\text{mw}/\text{cm}^2$  maximum level set by the Department of Health and Human Services
  - c. Fill out a leakage test tag listing the type of leakage test instrument used, the serial and model numbers of the oven, the \_\_\_\_\_ the test was made, and the signature of the technician that made the test

14. Arrange in order the steps in troubleshooting a microwave oven by placing the correct sequence number in the appropriate blank.

- \_\_\_\_a. Make an RF leakage test after repairs are complete
- \_\_\_\_b. Run the oven through a complete operating cycle to insure everything is in order
- \_\_\_\_c. Make sure your technical materials reflect engineering changes and are otherwise up to date
- \_\_\_\_d. Start with a proper wiring schematic and a circuit diagnosis
- \_\_\_\_e. Complete pre-service inspection and make sure you have the model and serial number for reference
- \_\_\_\_f. Check troubleshooting procedures in service manual
- \_\_\_\_g. Perform components tests in order
- \_\_\_\_h. Use a parts catalog that specifically lists parts and components for the oven being repaired

(NOTE: If the following activities have not yet been accomplished prior to the test, ask your instructor when they should be completed.)

15. Diagnose a circuit for problems when an oven is in a CAVITY LIGHT ON condition. (Assignment Sheet #1)
16. Diagnose a circuit for problems when an oven is in a COOK condition. (Assignment Sheet #2)
17. Diagnose a circuit for problems when an oven is in a VARI-COOK condition. (Assignment Sheet #3)

**TEST**

18. Demonstrate the ability to:
- a. Discharge a capacitor. (Job Sheet #1)
  - b. Check stirrer blade rotation. (Job Sheet #2)
  - c. Prepare a microwave oven for component testing. (Job Sheet #3)
  - d. Replace and adjust a microwave oven door assembly. (Job Sheet #4)
  - e. Troubleshoot microwave oven problems with circuit diagnosis. (Job Sheet #5)
  - f. Conduct power tests on a microwave oven to check for temperature rise under full power. (Job Sheet #6)
  - g. Conduct tests on high-voltage components when little or no heat is produced by the oven but all other operations appear normal. (Job Sheet #7)
  - h. Make interlock switch module tests on a microwave oven. (Job Sheet #8)
  - i. Test magnetron and cavity thermal protectors. (Job Sheet #9)
  - j. Test a low voltage transformer. (Job Sheet #10)
  - k. Test a temperature probe and probe jack. (Job Sheet #11)
  - l. Test an oven timer. (Job Sheet #12)
  - m. Test a controller. (Job Sheet #13)
  - n. Remove and test a control panel. (Job Sheet #14)
  - o. Test a control circuit board. (Job Sheet #15)
  - p. Test a triac module. (Job Sheet #16)
  - q. Test a cook relay. (Job Sheet #17)
  - r. Remove a blower motor and transformer. (Job Sheet #18)
  - s. Remove and reinstall a magnetron. (Job Sheet #19)
  - t. Remove a timer and a controller. (Job Sheet #20)
  - u. Remove a low voltage transformer and a triac. (Job Sheet #21)
  - v. Remove and disassemble a stirrer system. (Job Sheet #22)
  - w. Remove magnetron and cavity thermal protectors. (Job Sheet #23)
  - x. Remove, disassemble, and reassemble a microwave oven door. (Job Sheet #24)
  - y. Replace a door hook on a microwave oven. (Job Sheet #25)

## MICROWAVE OVEN TROUBLESHOOTING AND REPAIR UNIT II

### ANSWERS TO TEST

1.
  - a. 5
  - b. 6
  - c. 3
  - d. 1
  - e. 4
  - f. 2
  
2.
  - a. 3
  - b. 5
  - c. 6
  - d. 2
  - e. 1
  - f. 4
  
3.
  - a. 5
  - b. 2
  - c. 1
  - d. 8
  - e. 7
  - f. 3
  - g. 6
  - h. 4
  
4.
  - a. Steam
  - b. Oven cavity
  
5. a, b, c, d, e
  
6.
  - a. Serial
  - b. Service
  - c. Engineering
  - d. Number
  - e. Wiring
  
7. b, d
  
8.
  - a. What oven set-up the schematic shows, what the normal condition of the oven should be, and the problem
  - b. At the circuit breaker
  
9.
  - a. The primary or lower interlock switch and the secondary or upper interlock switch
  - b. A broken or loose wire connection

## ANSWERS TO TEST

10.
  - a. Test the oven in the COOK condition
  - b. The controller
  
11.
  - a. Interlock
  - b. Door, door
  - c. Hinges
  - d. Dropping
  - e. Waveguide
  - f. Stirrer
  - g. Abuse
  
12.
  - a. Inspect
  - b. Power cord
  - c. Insulated
  - d. Live
  - e. Alligator clips
  - f. Grounded
  - g. Two-wire
  - h. NEVER
  
13.
  - a. Maintenance
  - b. RF leakage test
  - c. Date
  
14.
  - a. 7
  - b. 8
  - c. 3
  - d. 4
  - e. 1
  - f. 2
  - g. 5
  - h. 6
  
15. Evaluated to the satisfaction of the instructor
  
16. Evaluated to the satisfaction of the instructor
  
17. Evaluated to the satisfaction of the instructor
  
18. Performance skills evaluated according to procedures written in the job sheets