

DOCUMENT RESUME

ED 318 920

CE 054 855

AUTHOR Smreker, Eugene; Calvert, King
 TITLE Major Appliance Repair. Teacher Edition.
 INSTITUTION Mid-America Vocational Curriculum Consortium,
 Stillwater, Okla.
 PUB DATE 87
 NOTE 662p.; Edited by Dan Fulkerson.
 AVAILABLE FROM Mid-America Vocational Curriculum Consortium, 1500
 West Seventh Avenue, Stillwater, OK 74074-4364 (order
 no. 601201: \$18.50).
 PUB TYPE Guides - Classroom Use - Guides (For Teachers) (052)

EDRS PRICE MF03 Plus Postage. PC Not Available from EDRS.
 DESCRIPTORS *Appliance Repair; Classroom Techniques; Course
 Content; Curriculum Guides; *Electrical Appliances;
 Electrical Systems; *Electricity; *Entry Workers;
 First Aid; *Job Skills; Learning Activities; Learning
 Modules; Lesson Plans; Occupational Safety and
 Health; Postsecondary Education; Power Technology;
 Secondary Education; Skill Development; *Small Engine
 Mechanics; Teaching Methods; Test Items; Units of
 Study

ABSTRACT

This module is a comprehensive text on basic appliance repair, designed to prepare students for entry-level jobs in this growing field. Ensuring a firm grounding in electrical knowledge, the module contains 13 instructional units that cover the following topics: (1) major appliance repair orientation; (2) safety and first aid; (3) fundamentals of electricity; (4) AC induction motors; (5) diagrams and schematics; (6) tools, materials, and test equipment; (7) automatic washers; (8) automatic dryers; (9) automatic dishwashers; (10) garbage disposers; (11) trash compactors; (12) gas ranges and ovens; and (13) electric ranges and ovens. Each instructional unit follows a standard format that includes some or all of these eight basic components: performance objectives, suggested activities for teachers and students, information sheets, assignment sheets, job sheets, visual aids, tests, and answers to tests and assignment sheets. All of the unit components focus on measurable and observable learning outcomes and are designed for use for more than one lesson or class period. Instructional task analyses; a list of tools, equipment, and materials; and 31 references are also included. (KC)

 * Reproductions supplied by EDRS are the best that can be made *
 * from the original document. *

Major Appliance Repair

EDRS 18920

- Automatic Washers



- Automatic Dryers

- Automatic Dishwashers

- Garbage Disposers

U.S. DEPARTMENT OF EDUCATION
Office of Educational Research and Improvement
EDUCATIONAL RESOURCES INFORMATION
CENTER (ERIC)
 This document has been reproduced as
received from the person or organization
originating it.
 Minor changes have been made to improve
reproduction quality.
• Points of view or opinions stated in this docu-
ment do not necessarily represent official
OERI position or policy.

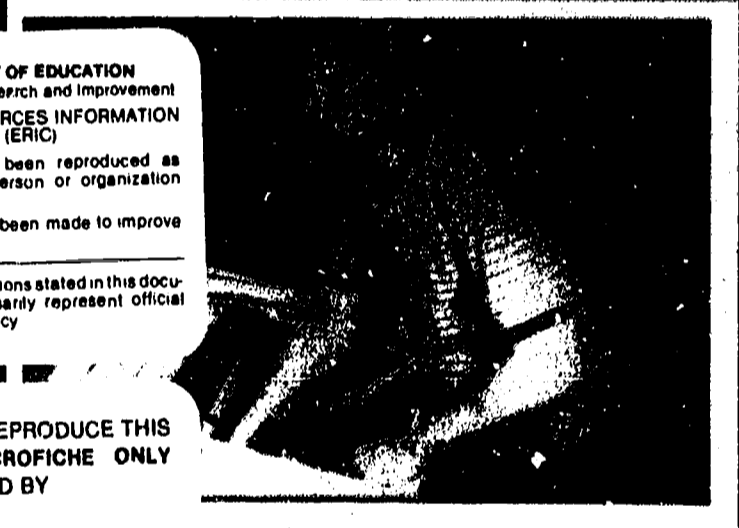

- Trash Compactors

"PERMISSION TO REPRODUCE THIS
MATERIAL IN MICROFICHE ONLY
HAS BEEN GRANTED BY
R. L. Brannon
TO THE EDUCATIONAL RESOURCES
INFORMATION CENTER (ERIC)."

- Gas Ranges and Ovens



- Electric Ranges and Ovens

MAVCC
MAVCC
MAVCC
MAVCC
MID-AMERICA
VOCATIONAL
CURRICULUM
CONSORTIUM

Teacher Edition

BEST COPY AVAILABLE



MAJOR APPLIANCE REPAIR

Written by
Eugene Smreker
and
King Calvert

Edited by
Dan Fulkerson

Developed by
The Mid-America Vocational Curriculum Consortium, Inc.

Board of Directors

Bob Patton, Oklahoma, Chairman
Larry Lyngstad, South Dakota, Vice Chairman
Harley Schlichting, Missouri, Parliamentarian
James Dasher, Arkansas
Bob Wilmoth, Colorado
John Van Ast, Iowa
David Poston, Louisiana
Merle Rudebusch, Nebraska
Ron Mehrer, North Dakota
Robert Patterson, Texas
Greg Pierce, Executive Director

© 1987 by the Mid-America Vocational Curriculum Consortium, Inc.

All rights reserved. No part of this book
may be reproduced in any form or by any
means without written permission from the publisher.

Printed in the United States of America by the
Oklahoma State Department of Vocational-Technical Education
Stillwater, Oklahoma 74074

Mid-America Vocational Curriculum Consortium, Inc.
1500 West Seventh
Stillwater, Oklahoma 74074-4364

MAJOR APPLIANCE REPAIR

TABLE OF CONTENTS

Unit I:	Major Appliance Repair Orientation	1
Unit II:	Safety and First Aid	25
Unit III:	Fundamentals of Electricity	69
Unit IV:	AC Induction Motors	151
Unit V:	Diagrams and Schematics	207
Unit VI:	Tools, Materials, and Test Equipment	255
Unit VII:	Automatic Washers	329
Unit VIII:	Automatic Dryers	401
Unit IX:	Automatic Dishwashers	451
Unit X:	Garbage Disposers	503
Unit XI:	Trash Compactors	533
Unit XII:	Gas Ranges and Ovens	581
Unit XIII:	Electric Ranges and Ovens	701

FOREWORD

Let's face it; major appliance repair technicians make good money, and the really good ones make excellent money. What's more, the work is mostly inside modern repair facilities that are warm in the winter and cool in the summer. As the number of households in America increases, the demand for appliances will also increase and create a continued demand for well-trained technicians who can get the job done.

And getting the job done is what *Major Appliance Repair* is all about. Basically, getting the job done means learning electrical skills such as properly using test meters and properly reading wiring schematics. Other parts of getting the job done include mastering the concept of "systematic" troubleshooting, because cost-effective repairs impress customers and keep a business alive. And still another part of getting the job done is knowing how to work with people, how to soothe feathers that get ruffled when an appliance quits working, and how to win back customer confidence with top-notch service.

What we're saying is that a successful appliance repair technician has to wear many hats, and all of those hats are presented here in what is probably the most comprehensive major appliance repair text available. The good jobs are waiting, and here is the curriculum that will guide students toward a productive future and a full life.

Bob Patton, Chairman
Board of Directors
Mid-America Vocational
Curriculum Consortium

PREFACE

To the best of my knowledge, *Major Appliance Repair* is the only competency-based curriculum now available in the appliance field. But more than that, it is a book that spends enough time on the basics of electricity and AC induction motors to really give a student the kind of background required to become a versatile, well-paid repair technician.

Like all MAVCC texts, *Major Appliance Repair* is profusely illustrated for the sake of clarifying complex materials and retaining student interest. We would also say the same for *Microwave Oven Repair*, another MAVCC text that belongs in every appliance repair program.

MAVCC has the materials to make every appliance repair program a success. To order materials or to discuss the contents of individual texts, call toll free at 1-800-654-3988. Let us help you make your appliance repair program a success.

Greg Pierce
Executive Director
Mid-America Vocational
Curriculum Consortium

ACKNOWLEDGEMENTS

Appreciation is extended to the many individuals who contributed their time and expertise to the successful development of *Major Appliance Repair*. The Resource Committee which planned and approved the text included outstanding appliance repair instructors from MAVCC member states, curriculum specialists, and a regional service director for a major appliance manufacturer. A special thank you goes out to the Resource Committee:

James Bledsoe	Houston Community College	Houston, Texas
King Calvert	Crowley's Ridge Vocational School	Forrest City, Arkansas
Nels Clang	Mid-Plains Community College	North Platte, Nebraska
Duan McBeth	Indian Hills Community College	Ottumwa, Iowa
Terry Newcomer	Southeast Vo-Tech Institute	Sioux Falls, South Dakota
Lee Veronie	Kaw Area Vo-Tech School	Topeka, Kansas
Eugene Smreker	Tulsa County AVTS, Peoria Campus	Tulsa, Oklahoma
Huey P. Sonnier	Vocational Curriculum Development and Research Center	Natchitoches, Louisiana
Charles Losh	State Department of Education	Bismarck, North Dakota
Brent Clever	Whirlpool Corporation	Denver, Colorado

Another special thank you goes to Eugene Smreker of the Tulsa County AVTS and to King Calvert of Crowley's Ridge Vocational School for writing an excellent text and for their contributions as committee members.

Another special thank you goes to the Frigidaire Parts and Service Company, one of the White Consolidated Industries, for their kind permission to reprint certain materials from their *Tech-Talk* series and other service information.

Appreciation is also extended to Dan Fulkerson, MAVCC's Publications Coordinator, for his contributions as editor of the project, and to Mary Kellum and Jane Huston of MAVCC for editing assistance.

The text was phototypeset in the Oklahoma State Vo-Tech Communications Center, and for their dedicated contribution, appreciation is extended to the phototypesetters Leslie Mathis and Rose Primeaux.

Another vote of thanks goes to the personnel of the Oklahoma State Vo-Tech Print Shop for their excellent work in printing the text.

USE OF THIS PUBLICATION

Instructional Units

Major Appliance Repair contains thirteen units. Each instructional unit includes some or all of the basic components of a unit of instruction; performance objectives, suggested activities for teachers and students, information sheets, assignment sheets, job sheets, visual aids, tests, and answers to the tests. Units are planned for more than one lesson or class period of instruction.

Careful study of each instructional unit by the teacher will help to determine:

- A. The amount of material that can be covered in each class period
- B. The skills which must be demonstrated
 - 1. Supplies needed
 - 2. Equipment needed
 - 3. Amount of practice needed
 - 4. Amount of class time needed for demonstrations
- C. Supplementary materials such as pamphlets or filmstrips that must be ordered
- D. Resource people who must be contacted

Objectives

Each unit of instruction is based on performance objectives. These objectives state the goals of the course, thus providing a sense of direction and accomplishment for the student.

Performance objectives are stated in two forms: unit objectives, stating the subject matter to be covered in a unit of instruction; and specific objectives, stating the student performance necessary to reach the unit objective.

Since the objectives of the unit provide direction for the teaching-learning process, it is important for the teacher and students to have a common understanding of the intent of the objectives. A limited number of performance terms have been used in the objectives for this curriculum to assist in promoting the effectiveness of the communication among all individuals using the materials.

Reading of the objectives by the student should be followed by a class discussion to answer any questions concerning performance requirements for each instructional unit.

Teachers should feel free to add objectives which will fit the material to the needs of the students and community. When teachers add objectives, they should remember to supply the needed information, assignment and/or job sheets, and criterion tests.

Suggested Activities for the Instructor

Each unit of instruction has a suggested activities sheet outlining steps to follow in accomplishing specific objectives. Duties of instructors will vary according to the particular unit; however, for best use of the material they should include the following: provide students with objective sheet, information sheet, assignment sheets, and job sheets; preview filmstrips, make transparencies, and arrange for resource materials and people; discuss unit and specific objectives and information sheet; give test. Teachers are encouraged to use any additional instructional activities and teaching methods to aid students in accomplishing the objectives.

Information Sheets

Information sheets provide content essential for meeting the cognitive (knowledge) objectives in the unit. The teacher will find that the information sheets serve as an excellent guide for presenting the background knowledge necessary to develop the skill specified in the unit objective.

Students should read the information sheets before the information is discussed in class. Students may take additional notes on the information sheets.

Transparency Masters

Transparency masters provide information in a special way. The students may see as well as hear the material being presented, thus reinforcing the learning process. Transparencies may present new information or they may reinforce information presented in the information sheets. They are particularly effective when identification is necessary.

Transparencies should be made and placed in the notebook where they will be immediately available for use. Transparencies direct the class's attention to the topic of discussion. They should be left on the screen only when topics shown are under discussion.

Assignment Sheets

Assignment sheets give direction to study and furnish practice for paper and pencil activities to develop the knowledge which is a necessary prerequisite to skill development. These may be given to the student for completion in class or used for homework assignments. Answer sheets are provided which may be used by the student and/or teacher for checking student progress.

Job Sheets

Job sheets are an important segment of each unit. The instructor should be able to demonstrate the skills outlined in the job sheets. Procedures outlined in the job sheets give direction to the skill being taught and allow both student and teacher to check student progress toward the accomplishment of the skill. Job sheets provide a ready outline for students to follow if they have missed a demonstration. Job sheets also furnish potential employers with a picture of the skills being taught and the performances which might reasonably be expected from a person who has had this training.

Test and Evaluation

Paper-pencil and performance tests have been constructed to measure student achievement of each objective listed in the unit of instruction. Individual test items may be pulled out and used as a short test to determine student achievement of a particular objective. This kind of testing may be used as a daily quiz and will help the teacher spot difficulties being encountered by students in their efforts to accomplish the unit objective. Test items for objectives added by the teacher should be constructed and added to the test.

Test Answers

Test answers are provided for each unit. These may be used by the teacher and/or student for checking student achievement of the objectives.

MAJOR APPLIANCE REPAIR

INSTRUCTIONAL/TASK ANALYSIS

**JOB TRAINING: What the
Worker Should Be Able to Do
(Psychomotor)**

**RELATED INFORMATION: What
the Worker Should Know
(Cognitive)**

UNIT I: MAJOR APPLIANCE REPAIR ORIENTATION

- i. Terms and definitions
2. The job outlook for appliance repair technicians
3. Advancement opportunities for appliance repair technicians
4. Where appliance repair technicians work
5. Working conditions
6. Training requirements for appliance repair work
7. Physical requirements for successful appliance repair technicians
8. Personal habits that promote success on the job
9. Repair technicians and customer relations
10. Warranties and their importance
11. Cautions about warranties
12. Guidelines for service calls

UNIT II: SAFETY AND FIRST AID

1. Terms and definitions
2. Benefits of safe working practices
3. Major causes of accidents
4. Guidelines for good housekeeping
5. Basic rules for safe use of tools and equipment

**JOB TRAINING: What the
Worker Should Be Able to Do
(Psychomotor)**

**RELATED INFORMATION: What
the Worker Should Know
(Cognitive)**

6. Steps In lifting safely
 7. Special lifting rules for appliance repair
 8. Fire safety rules
 9. Classes of fires and their causes
 10. Types of fire extinguishers and their recommended uses
 11. Types of fire extinguishers and their recommended operations
 12. Special safety requirements for appliance repair
 13. Special rules for eye protection
 14. Ways to recognize shock
 15. Steps In treating shock
 16. First aid for victims of electrical shock
 17. First aid guidelines for common workplace injuries
 18. First aid guidelines for workplace burns
 19. Steps in controlling bleeding
 20. Pressure points for checking bleeding
 21. First aid for eye injuries
 22. General guidelines for first aid emergencies
-
23. Complete a student safety pledge (Assignment Sheet #1)
 24. Select proper first aid procedure (Assignment Sheet #2)

**JOB TRAINING: What the
Worker Should Be Able to Do
(Psychomotor)**

**RELATED INFORMATION: What
the Worker Should Know
(Cognitive)**

UNIT III: FUNDAMENTALS OF ELECTRICITY

1. Terms and definitions
2. What electricity is
3. Sources of electricity
4. The electron theory
5. The importance of electrical charges
6. How electron flow is created in a conductor
7. Conductors, insulators, and semiconductors
8. Direct current
9. Alternating current
10. Basic Electrical symbols
11. Types of circuits
12. Elements of a basic circuit
13. Circuit applications
14. Circuit grounding
15. Electrical measurements
16. Abbreviations in ohm's law
17. Ohm's law for electrical circuits
18. Using ohm's law to find unknown values in a circuit
19. Characteristics of electrical power
20. Ways ohm's law is used
21. Kirchhoff's laws for voltage and current
22. Working with resistors
23. Steps in using the color code to determine resistor value

JOB TRAINING: What the Worker Should Be Able to Do (Psychomotor)

24. Solve problems for an unknown voltage (Assignment Sheet #1)
25. Solve problems for an unknown amperage (Assignment Sheet #2)
26. Solve problems for an unknown resistance (Assignment Sheet #3)
27. Identify resistor values using a standard color code (Assignment Sheet #4)

RELATED INFORMATION: What the Worker Should Know (Cognitive)

UNIT IV: AC INDUCTION MOTORS

1. Terms and definitions
2. Principles of magnetism
3. The left hand rule for conductors
4. Electromagnets and coils
5. Other principles of magnetism
6. Types of transformers
7. DC motor components
8. DC motor operation
9. AC induction motors
10. AC induction motor components and their functions
11. Types of AC induction motors
12. Operations of an induction start, induction run motor
13. Operations of a capacitor start, induction run motor
14. Motor housings
15. Motor speeds
16. Types of motor bearings and their characteristics

JOB TRAINING: What the Worker Should Be Able to Do (Psychomotor)

24. Troubleshoot an AC induction motor for thermal overload problems (Job Sheet #1)
25. Troubleshoot an AC induction motor to determine whether the start mechanism or the start windings are bad, and replace a centrifugal switch (Job Sheet #2)
26. Bench test a single-speed motor with a test cord (Job Sheet #3)

RELATED INFORMATION: What the Worker Should Know (Cognitive)

17. Motor thermal protection
18. Other motor problems
19. Using compressor test cords in motor testing
20. Guidelines for servicing throw-away motors
21. Motor nameplate information
22. Motor safety
23. Steps in systematically troubleshooting an induction motor

UNIT V: DIAGRAMS AND SCHEMATICS

1. Terms and definitions
2. Block diagrams
3. Schematic diagrams
4. Wiring diagrams
5. Other graphic aids and their functions
6. Where to find helpful graphic aids
7. Timer sequence charts
8. What legends do
9. Common color code abbreviations

**JOB TRAINING: What the
Worker Should Be Able to Do
(Psychomotor)**

13. Interpret a timer sequence chart and wiring diagram for an automatic dishwasher (Assignment Sheet #1)

**RELATED INFORMATION: What
the Worker Should Know
(Cognitive)**

10. Basic electrical symbols
11. Symbols for solid state devices
12. Guidelines for using diagrams and schematics

UNIT VI: TOOLS, MATERIALS, AND TEST INSTRUMENTS

1. Terms and definitions
2. Basic hand tools
3. Shop tools
4. Miscellaneous supplies
5. Appliance repair literature and its uses
6. VOM's and their uses
7. Clamp-on ammeters and their uses
8. Digital multimeters and their uses
9. Temperature testers and their uses
10. Capacitor analyzers and their uses
11. Wattmeters and their uses
12. Shunts and their functions in ammeters
13. Electrical measurements and ways to make them
14. Appliance wiring
15. Soldering tools
16. Resin-core solder and its characteristics
17. Procedure for using solid wire solder

JOB TRAINING: What the Worker Should Be Able to Do (Psychomotor)

RELATED INFORMATION: What the Worker Should Know (Cognitive)

26. Identify selected tools (Assignment Sheet #1)
 27. Test electrical receptacles for proper voltages (Job Sheet #1)
 28. Use a clamp-on ammeter to test for high and low amperages on a fan motor and a light bulb (Job Sheet #2)
 29. Make a continuity check of a magnetic control assembly from an automatic washer (Job Sheet #3)
 30. Splice electrical conductors to acceptable service standards (Job Sheet #4)
 31. Use a VOM for a quick capacitor check (Job Sheet #5)
18. Steps in wire stripping
 19. Types of splices
 20. Guidelines for connections at screw terminals
 21. Guidelines for good soldered splices
 22. Guidelines for using solderless connectors and terminals
 23. Proper care and use of hand tools
 24. Guidelines for using other tools and equipment
 25. Eye protection

UNIT VII: AUTOMATIC WASHERS

1. Terms and definitions
2. Major components and their functions in an automatic washer
3. Steps in a typical automatic washer cycle

**JOB TRAINING: What the
Worker Should Be Able to Do
(Psychomotor)**

**RELATED INFORMATION: What
the Worker Should Know
(Cognitive)**

4. Fill functions in a normal cycle
 5. Agitation functions in a normal cycle
 6. Pumpout and spin functions in a normal cycle
 7. Guidelines for evaluating automatic washer malfunctions
 8. Steps for validating repairs
 9. Troubleshooting a washer that will not fill with water
 10. Troubleshooting a washer for improper water level or water temperature
 11. Troubleshooting a washer when water will not shut off
 12. Troubleshooting a washer that leaks water
 13. Troubleshooting when water will not drain from a washer
 14. Troubleshooting a washer with a motor that will not run
 15. Troubleshooting a washer that will not agitate
 16. Troubleshooting a washer that will not spin
 17. Troubleshooting a washer that will not advance or shut off
 18. Troubleshooting a washer that leaks oil
 19. Troubleshooting a washer that tears clothing
 20. Other washer problems and ways to correct them
21. Install an automatic washer (Job Sheet #1)

**JOB TRAINING: What the
Worker Should Be Able to Do
(Psychomotor)**

22. Troubleshoot a Whirlpool/Kenmore automatic washer for typical malfunctions (Job Sheet #2)
23. Troubleshoot a GE/Hotpoint automatic washer for typical malfunctions (Job Sheet #3)

**RELATED INFORMATION: What
the Worker Should Know
(Cognitive)**

UNIT VIII: AUTOMATIC DRYERS

1. Terms and definitions
 2. Major components and their functions in an automatic dryer
 3. Steps in automatic dryer operation
 4. Thermostats and their functions in a dryer
 5. Troubleshooting a dryer that will not run
 6. Troubleshooting a dryer that will run but not heat
 7. Troubleshooting a dryer when the motor runs but the drum will not turn
 8. Troubleshooting a dryer that runs but will not shut off
 9. Troubleshooting dryer that runs and heats but will not dry clothes
 10. Other dryer problems and their solutions
 11. Troubleshooting gas valves and igniters on gas dryers
 12. Special dryer problems and their solutions
-
13. Install an automatic dryer (Job Sheet #1)

**JOB TRAINING: What the
Worker Should Be Able to Do
(Psychomotor)**

14. Troubleshoot a Whirlpool/Kenmore automatic dryer for typical malfunctions (Job Sheet #2)
15. Troubleshoot a GE/Hotpoint automatic dryer for typical malfunctions (Job Sheet #3)

**RELATED INFORMATION: What
the Worker Should Know
(Cognitive)**

UNIT IX: AUTOMATIC DISHWASHERS

1. Terms and definitions
 2. Major components of a dishwasher and their functions
 3. Steps in an automatic dishwasher cycle
 4. Special considerations for dishwasher installation
 5. Water problems with dishwashers
 6. Loading order in dishwasher operation
 7. Dishwasher misuses and their causes
 8. Guidelines for better dishwasher service
 9. Guidelines for troubleshooting automatic dishwashers
 10. Ways to prevent mineral build-up in an automatic dishwasher
 11. Troubleshooting redeposit problems
-
12. Install an automatic dishwasher under a counter (Job Sheet #1)
 13. Troubleshoot malfunctions on an automatic dishwasher (Job Sheet #2)
 14. Inspect the seal on an automatic dishwasher (Job Sheet #3)

**JOB TRAINING: What the
Worker Should Be Able to Do
(Psychomotor)**

**RELATED INFORMATION: What
the Worker Should Know
(Cognitive)**

UNIT X: GARBAGE DISPOSERS

1. Terms and definitions
 2. First consideration for garbage disposers
 3. Safety rules for disposer operation
 4. Major components of a garbage disposer and their functions
 5. Steps in garbage disposer operation
 6. The importance of cold water flow in a disposer
 7. Common misuses that cause disposer problems
 8. Items that can be placed into a garbage disposer
 9. Guidelines for handling a jammed garbage disposer
 10. Guidelines for installing a garbage disposer
 11. Guidelines for troubleshooting disposer malfunctions
-
12. Install a garbage disposer
 13. Free a jammed garbage disposer

UNIT XI: TRASH COMPACTORS

1. Terms and definitions
2. Trash compactor characteristics
3. Steps in a typical compactor cycle
4. Compactor electrical components and their characteristics
5. Trash compactor operating safety

**JOB TRAINING: What the
Worker Should Be Able to Do
(Psychomotor)**

16. Use schematics to determine operating conditions on a trash compactor (Assignment Sheet #1)
17. Install an undercounter trash compactor to specifications (Job Sheet #1)
18. Test the drive motor on a trash compactor to determine its operational condition (Job Sheet #2)
19. Troubleshoot common trash compactor problems (Job Sheet #3)

**RELATED INFORMATION: What
the Worker Should Know
(Cognitive)**

6. Trash compactor service safety
7. Guidelines for properly loading a compactor
8. Common causes for failure to compact
9. Major wear problems with compactors
10. Lubrication requirements for compactors
11. Chain and belt adjustments
12. Troubleshooting guidelines for trash compactor problems
13. Guidelines for troubleshooting a noisy compactor
14. Troubleshooting other compactor problems
15. Items that should not be placed in a trash compactor

UNIT XII: GAS RANGES AND OVENS

1. Terms and definitions
2. Basics of gas heating
3. Natural and bottled gases
4. How a gas range top burner works

**JOB TRAINING: What the
Worker Should Be Able to Do
(Psychomotor)**

**RELATED INFORMATION: What
the Worker Should Know
(Cognitive)**

5. Orifice settings
6. Primary and secondary air
7. Byproducts of combustion
8. Burner combustion problems
9. Gas burner types and their applications
10. Ignition systems and their characteristics
11. How a gas oven works
12. Types of oven thermostats and their characteristics
13. Safety valves
14. Common misuses of gas ovens
15. Considerations for ovens with upper and lower burners
16. How self-cleaning ovens work
17. Special safety features of self-cleaning ovens
18. Safety requirements for gases
19. Flexible connectors
20. Requirements for gas supply lines
21. Functions of electrical circuits on gas ovens
22. Typical circuit functions in a gas oven
23. Range complaints and recommended troubleshooting
24. Gas pressure drops
25. Manometer selection and use
26. Guidelines for roasting

**JOB TRAINING: What the
Worker Should Be Able to Do
(Psychomotor)**

31. Use a wiring schematic to determine voltage and resistance readings on a self-cleaning gas oven set for a bake operation (Assignment Sheet #1)
32. Use a wiring schematic to determine voltage and resistance readings on a self-cleaning gas oven set for a timed bake operation (Assignment Sheet #2)
33. Use a wiring schematic to determine voltage and resistance readings on a self-cleaning gas oven set for a cleaning operation (Assignment Sheet #3)
34. Use a wiring schematic to determine voltage and resistance readings on a self-cleaning gas oven during lock and unlock (Assignment Sheet #4)
35. Install a gas range level and leak free with all burners properly adjusted (Job Sheet #1)
36. Use a temperature tester to check gas oven temperature for proper oven thermostat settings (Job Sheet #2)
37. Recalibrate a gas oven thermostat to correct settings (Job Sheet #3)
38. Remove, disassemble, clean, lubricate, and reassemble a standard gas burner valve (Job Sheet #4)

**RELATED INFORMATION: What
the Worker Should Know
(Cognitive)**

27. Guidelines for broiling
28. Guidelines for baking
29. Baking problems and their solutions
30. Guidelines for service calls

UNIT XIII: ELECTRIC RANGES AND OVENS

1. Terms and definitions
2. Basics of electric cooking
3. Electrical requirements for hooking up an electric range

**JOB TRAINING: What the
Worker Should Be Able to Do
(Psychomotor)**

11. Remove a surface unit from an electric range and check for proper resistance (Job Sheet #1)
12. Check the self-cleaning function on an electric oven (Job Sheet #2)
13. Make continuity checks on step-type and infinite electric range switches (Job Sheet #3)

**RELATED INFORMATION: What
the Worker Should Know
(Cognitive)**

4. Electric surface and oven heating elements
5. Types of heat controls for surface heating elements
6. Types of electric oven thermostats
7. Recalibrating electric oven thermostats
8. Typical electric oven self-cleaning operation
9. Components and their functions in a self-clean cycle
10. Troubleshooting electric ranges

MAJOR APPLIANCE REPAIR

TOOLS, EQUIPMENT, AND MATERIALS LIST

Hand tools

Tool chest and lock
Standard screwdriver set
Phillips screwdriver set
Offset standard and Phillips screwdrivers
Stubby standard and Phillips screwdrivers
Allen wrench set
Nutdriver set
Combination wrench set
Adjustable wrenches
Standard and Phillips screw starters
Slip-joint pliers
Locking jaw (vise-grip) pliers
Needlenose pliers
Diagonal (sidecutting) pliers
Lineman's pliers
Hose-clamp pliers
Internal and external snap-ring pliers
Electrical terminal pliers
Ball peen hammer
Soft-faced hammer
Chisel set
Punch set
Drive socket set
Ratchet socket set
Pipe wrenches
Tape measure

Test Equipment

Volt-Ohmmeter (multimeter)
Digital VOM
Clamp-on ammeter
Wattmeter
Capacitor analyzer
Temperature tester

Shop tools

Appliance dolly
Appliance flipper
Compressed air supply
Wet/dry shop vacuum
File set
Keyhole saw
Hacksaw and extra blades
Pry bar
Heavy duty drill
Drill bit set (steel)
Drill bit set (wood)
Masonry drill
Pry bar
Soldering gun and solder
Test cord
Aviation snips
Level
Drill press
Bench grinder
Oxyacetylene cutting equipment

Miscellaneous tools and supplies

Drop cloth
Inspection light
Electrical tape
Pipe dope
Clean shop towels

Safety and First Aid Equipment

Fire extinguishers
First aid kit
Eye wash station

ALPHABETICAL LIST OF REFERENCES USED IN DEVELOPING THIS TEXT

- A. Anderson, Edwin P. *Home Appliance Servicing*. Indianapolis, IN 46268: Howard W. Sams & Co., Inc., 1974.
- B. Bacon, Bill and Mark Sutton. *Major Appliance Repairer*. Austin, TX 78712: The University of Texas at Austin, 1983.
- C. Baker, Gus E., and Leonard R. Crow. *Electricity Fundamentals*. Indianapolis, IN 46206: Howard W. Sams & Co., Inc., 1971.
- D. *Cooking Equipment Course*. Chicago, IL: Sears Training Center, undated.
- E. *Do-it-Yourself Repair Manual for Your Whirlpool Automatic Washer (Belt Driven)*. Benton Harbor, MI 49022: Whirlpool Corporation, 1984.
- F. *Do-it-Yourself Repair Manual for Your Whirlpool Gas/Electric Dryer*. Benton Harbor, MI 49022: Whirlpool Corporation, 1983.
- G. *Guide for Occupational Exploration*. Washington, DC 20402: U.S. Department of Labor, 1979.
- H. Henderson, John, M.D. *Emergency Medical Guide*. New York, NY: McGraw-Hill, 1963.
- I. Kaiser, Joe. *Electrical Power*. South Holland, IL: The Goodheart-Willcox Company, Inc., 1982.
- J. *Kansas Safety Education Handbook, Volume III*. Wichita, KS: Kansas State Department of Education in Cooperation with the Wichita Public Schools, U.S.D. 259, 1981.
- K. *Kidde Portable Extinguishers, The ABC's of Fire Prevention*. Bellevue, NJ: Walter Kidde & Co., Inc., 1978.
- L. Lieder, Larry. *Really Basic Electricity*. Honeywell, Inc., 1982.
- M. McClain, Gerald R. and Neal A. Wilson. *Electronic Drafting*. Stillwater, OK 74074: Mid-America Vocational Curriculum Consortium, 1983.
- N. Milaf, Harry. *Electricity One-Seven*. New York, NY: Hayden Book Company, 1966.
- O. *Occupational Outlook Handbook*. Washington, DC 20212: U.S. Department of Labor, Bureau of Labor Statistics, April 1982.
- P. Pipe, Ted. *Basic Electricity Training Manual*. Indianapolis, IN 46263: Howard W. Sams & Co., Inc., 1973.
- Q. *Repair-Master for Electric Ranges and Controls*. Santa Monica, CA 90404: Master Publications, Inc., 1980.
- R. *Repair-Master for General Electric Automatic Washers*. Garden Grove, CA 92642: Master Publications, a Gem Products, Inc. Company, 1985.

- S. *Repair-Master for General Electric Gas & Electric Dryers*. Santa Monica, CA 90404: Master Publications, Inc., 1980.
- T. *Repair-Master for Gas Ranges and Controls*. Santa Monica, CA 90404: Master Publications, Inc., 1980.
- U. *Repair-Master for Hamilton Gas & Electric Dryers*. Santa Monica, CA 90404: Master Publications, Inc., 1980.
- V. *Repair-Master of Norge Gas & Electric Dryers*, Santa Monica, CA 90404: Master Publications, Inc., 1980.
- W. *Repair-Master for Speed Queen Automatic Washers*. Santa Monica, CA: 90404: Master Publications, Inc., 1980.
- X. *Step-by-Step Repair Manual Plus Preventive Maintenance for General Electric/Hotpoint Dishwashers*. Louisville, KY 40225: General Electric Co., 1985.
- Y. *Step-by-Step Repair Manual Plus Preventive Maintenance for General Electric/Hotpoint Dryers*. Louisville, KY 40225: General Electric Co., 1985.
- Z. *Step-by-Step Repair Manual Plus Preventive Maintenance for General Electric/Hotpoint Ranges*. Louisville, KY 40225: General Electric Co., 1985.
- AA. *Step-by-Step Repair Manual Plus Preventive Maintenance for General Electric/Hotpoint Washers*. Louisville, KY 40225: General Electric Co., 1985.
- BB. Teague, Cash and Garner Pewewardy. *Industrial Electricity Motors*. Stillwater, OK 74074: Curriculum and Instructional Materials Center, Oklahoma State Department of Vocational and Technical Education, 1984.
- CC. *Tech-Talk "M" Clothes Washers*. Dayton, OH 45449: Frigidaire Parts and Service Company, 1983.
- DD. *Tech-Talk "M" Dryers*. Dayton, OH 45449: Frigidaire Parts and Service Company, 1983.
- EE. *Tech-Talk "J" Dishwashers*. Dayton, OH 45449: Frigidaire Parts and Service Company, 1981.

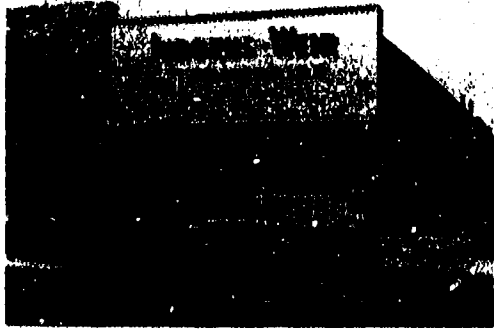

MAJOR APPLIANCE REPAIR ORIENTATION UNIT I

UNIT OBJECTIVE

After completion of this unit, the student should be able to discuss training requirements and job opportunities for appliance repair technicians. The student should also be able to discuss the importance of good customer relations and critical elements in warranties. These competencies will be evidenced by scoring 85 percent on the unit test.

SPECIFIC OBJECTIVES

After completion of this unit, the student will be able to:

1. Match terms related to major appliance repair orientation with their correct definitions.
2. Complete statements concerning the job outlook for appliance repair technicians.
3. Select true statements concerning advancement opportunities for appliance repair technicians.
4. Complete a list of places where appliance repair technicians work.
5. Select true statements concerning working conditions.
6. Complete statements concerning training requirements for appliance repair work.
7. Complete a list of physical requirements for successful appliance repair technicians.
8. Select true statements concerning personal habits that promote success on the job.
9. Complete statements concerning repair technicians and customer relations.
10. Complete statements concerning warranties and their importance.
11. Complete statements concerning cautions about warranties.
12. Solve problems concerning guidelines for service calls.

MAJOR APPLIANCE REPAIR ORIENTATION UNIT I

SUGGESTED ACTIVITIES

- A. Provide students with objective sheet.
- B. Provide students with information sheet.
- C. Discuss unit and specific objectives.
- D. Discuss information sheet.
- E. Invite a local or area appliance store owner to talk to the students about appliance repair in general and what sort of job opportunities there are for entry-level technicians; have the owner also discuss the importance of recordkeeping and customer relations.
- F. Discuss the importance of proper attitudes about the workplace, and the personal habits that promote success in a job.
- G. Arrange with a local appliance repair firm for individual students to spend part of a day on a service truck and go on a service call with a working appliance repair technician; have students make brief reports to the class.
- H. Give test.

CONTENTS OF THIS UNIT

- A. Objective sheet
- B. Information sheet
- C. Transparency masters
 - 1. TM 1 — Warranty Service Invoice
 - 2. TM 2 — Warranty
- D. Test
- E. Answers to test

REFERENCES USED IN DEVELOPING THIS UNIT

- A. *Occupational Outlook Handbook*. Washington, DC 20212: U.S. Department of Labor, Bureau of Labor Statistics, April 1982.
- B. *Guide for Occupational Exploration*. Washington, DC 20402: U.S. Department of Labor, 1979.

AVAILABLE INSTRUCTIONAL MATERIALS

- A. **CALLTAKER**, a 19-minute video cassette showing how to take service calls over a phone. LIT677484 is the cassette number, and the accompanying test booklet is LIT677485.
- B. **CUSTOMER RELATIONS FOR APPLIANCE TECHNICIANS**, a 23-minute video cassette presenting customer/technician situations including how to handle difficult customers and how to collect the bill. LIT 787045 is the cassette number and the accompanying student study guide is LIT787046.
- C. **QUALITY — PASS IT ON**, a 20-minute video cassette showing effective customer relations techniques. LIT 787195 is the cassette number, the accompanying meeting leader's guide is LIT787196, and the accompanying discussion guide for students is LIT787197.
- D. Video cassettes are available in 1/2" VHS or Beta formats and should be ordered from:
- Whirlpool Corporation
ATTN: General Accounting
1900 Whirlpool Drive
La Porte, IN 46350-0927
- E. For information about Whirlpool training materials, call:
- (219) 325-2359
or
(219) 325-2230

MAJOR APPLIANCE REPAIR ORIENTATION UNIT I

INFORMATION SHEET

I. Terms and definitions

- A. Small appliances — Labor saving devices such as can openers or toasters that are generally portable and relatively inexpensive
- B. Major appliances — Labor saving devices such as automatic washers and dryers that are generally stationary and relatively expensive

(NOTE: This unit and the ones that follow are dedicated to major appliance repair.)

- C. Electromechanical — A mechanical part such as a solenoid that is started or stopped by an electrical control device
- D. Habit — An act repeated so often that it becomes an automatic and unconscious personal trait

II. Job outlook for appliance repair technicians

- A. The demand for appliance repair technicians will grow at an average rate into the 1990's
- B. Current technicians who advance to other jobs or retire will have to be replaced
- C. As the number of new households increases in America, the number of appliances will increase rapidly and help increase the demand for repair technicians
- D. Most people consider major appliances essential, and available work should continue even during periods of economic recession
- E. Pay varies with geographical area, but experienced technicians in the early 1980's made from \$10 to \$12 an hour and wages should increase with each passing year.

III. Advancement opportunities for appliance repair technicians

- A. After two to three years experience and a good work record, repair technicians may be promoted to:
 - 1. Supervisor
 - 2. Assistant service manager
 - 3. Service manager

INFORMATION SHEET

- B. Highly skilled technicians with good people skills may advance to regional service manager or regional parts manager for a major manufacturer
- C. A technician with a wide range of skills, experience, and sufficient financial support may open his/her own appliance store or repair shop

IV. Where appliance repair technicians work

- A. Most appliance repair technicians work in independent appliance stores and repair shops
- B. Many more appliance repair technicians work for manufacturers' service centers, department stores, wholesalers, or utility companies
- C. Some appliance repair technicians run their own businesses full or part time, and contract their services to service centers or appliance dealers
- D. Appliance repair technicians work in communities of all sizes, but most of them work in highly populated metropolitan areas

V. Working conditions

- A. Appliance repair shops are generally quiet, well lighted and ventilated, and comfortable places to work in
- B. Most technicians work with little or no direct supervision, and most technicians enjoy this aspect of the occupation
- C. The work is generally safe as long as safety procedures are observed around electrical elements of equipment and as long as lifting and moving of heavy appliances is accomplished properly
- D. Technicians who repair appliances in customers' homes may sometimes have to drive a portion of the day and be responsible for the care of a company vehicle
- E. Technicians who repair appliances in customers' homes also have to explain to the customer what repair work was done, the cost of parts and labor, and then collect the bill

VI. Training requirements for appliance repair work

- A. Although some repair technicians are trained on the job, formal training in appliance repair is the more common route into the industry

(NOTE: Formal training is available at some high schools, in many vocational-technical schools, in many community colleges, and in a variety of training programs from appliance manufacturers.)

INFORMATION SHEET

- B. Training should stress both the mechanical and electrical aspects of the repair industry and the electromechanical
- C. Modern appliances use more and more electronic parts, and technicians with good electronics skills have the best job prospects (Figure 1)

FIGURE 1



- D. Entry-level technicians frequently start out repairing one type of appliance until they master it and then learn other appliances one at a time
 - E. Large department stores and service centers have training programs of their own to help technicians master advanced areas of repair
 - F. Technicians who make service calls in customer homes generally go through a period of on-the-job training with a more experienced technician
 - G. Changes in appliance design demand that a technician keep up to date, and this usually means attending manufacturers' seminars where new models and service procedures are demonstrated
 - H. Service manuals provide a wealth of information, and a good repair technician should read all manuals available and maintain a personal library of service manuals
- VII. Physical requirements for successful appliance repair technicians**
- A. The occupation requires some heavy lifting which requires a person to be in generally good physical condition
 - B. The ability to identify wires of several different colors is essential for some electrical elements of the occupation, and good eyesight is required
 - C. Areas of the occupation require articulate skills in soldering and tinning, and the technician needs to have a steady hand

INFORMATION SHEET

- D. Much of the work is repetitive and requires an ability to tolerate doing the same thing over and over
- E. Technicians selected to service appliances in customer's home must have the verbal skills required to talk with customers

VIII. Personal habits that promote success on the job

- A. Take a bath or shower daily and generally keep yourself neat and clean
(NOTE: Body odors irritate customers, and are not especially popular with fellow workers.)
- B. Get to work on time, and if you know you're going to be late or if you're too ill to go to work, try to call in far enough in advance so arrangements can be made for others to cover your job
- C. Respect all company property and use tools and equipment only for their intended purposes
- D. Think of yourself as an advertisement for the company anytime you're on a service call or using a company vehicle in public, and conduct yourself properly
- E. Avoid drugs or alcohol because their use can impair your ability to work safely or to work at all
- F. Be honest in all your relations with supervisors, fellow-workers, and customers
- G. Put in a day's work for your day's pay

IX. Repair technicians and customer relations

- A. Appliance repair technicians mostly work for dealers who sell and service appliances and whose business depends on good customer relations
- B. Repair technicians need basic business skills in reading and interpreting work/service orders so they can approach customers with confidence
- C. Repair technicians need basic math skills to total bills properly and avoid errors that could lose the company money or irritate a customer
- D. Repair technicians must be diplomatic on service calls that take them into a customer's home
- E. Repair technicians should assume they are part of the company image at all times and conduct themselves accordingly

(NOTE: Word of mouth is the most powerful form of advertising, and if you say bad things about the company you work for, it's bad advertising; if you don't like the place, quit and go to work someplace else.)

INFORMATION SHEET

X. Warranties and their Importance

A. Warranty

1. Usually for one full year
2. Covers all defective workmanship and materials
3. Pays for both parts and labor

B. Limited warranty:

1. Usually runs from the second through the fifth year

(NOTE: Time periods vary with appliance and manufacturer, and some trash compactors and garbage disposers have no warranty past the first year.)

2. Usually cover only specific components such as the transmission on an automatic washer
3. Pays for parts, but customer pays for labor which includes travel costs

C. Warranties should not be confused with dealer service contracts that provide special services beyond what the manufacturer warranties

(NOTE: Some dealer service contracts run up to ten years or more and may be limited or unlimited, but knowing if an appliance is under a warranty or a service contract is an important piece of information.)

XI. Cautions about warranties (Transparency 2)

A. Warranties are void if an appliance has been:

1. Improperly installed or modified
2. Subjected to improper voltage supply
3. Subjected to unreasonable use

Example: If an automatic washer designed for household use is used in a commercial laundry, that is unreasonable use

B. Service or repair work performed by an unauthorized technician voids most warranties

C. Payment for warranty work is made by manufacturers to authorized dealers and requires careful attention to paperwork (Transparency 1)

INFORMATION SHEET

XII. Guidelines for service calls

A. Prepare for the service call

1. Read the work order in advance
2. Know the brand name, serial number, and model number of the appliance
3. Examine the customer's description of the problem, and call the customer to clarify anything not clear
4. Anticipate any special tools you may need and take them with you because trips back to the shop are expensive
5. Take a service manual and parts catalog along just in case
6. Check with the person who took the call if the order is incomplete or confusing

B. Begin the service call tactfully

1. Show up on time in clean work clothes or company uniform
2. Park your car or service vehicle so it doesn't block a driveway, a sidewalk, or a mailbox
3. Introduce yourself and explain who you represent and why you are there

(NOTE: Most people are very tentative about opening their door to strangers, and an intelligent self-introduction can help put the customer at ease.)

4. Address the customer by his/her proper name, and ask how the name should be pronounced in case you're not sure

(NOTE: Do not hesitate to ask the customer how the name should be properly pronounced; if you're going to be in the home for awhile, the customer will not appreciate being addressed improperly.)

5. Invite the customer to talk about the trouble in his/her own words because service order notes are sometimes very brief

(NOTE: Many service calls are taken over the telephone and many customers are not articulate in describing funny noises, unpleasant smells, or the many things that just can't be said without hand gestures.)

INFORMATION SHEET**C. Keep the service call businesslike**

1. Refrain from accepting invitations to coffee or refreshments
2. Request the customer to keep children and pets away from the work area for safety reasons
3. Make no hasty statements about the problem or the cost of repairs
4. Use a drop cloth around an appliance when you work, and if you use an appliance surface for a work area, cover it with a drop cloth too

D. Keep the service call customer oriented

1. Give the customer an explanation of the problem and what work you did you correct the malfunction
2. Save any parts that were replaced so the customer can inspect them, but take faulty parts back to the shop if they must be returned to the manufacturer

3. Explain the bill to the customer and have the customer sign the bill

(NOTE: For warranty service where the customer will not be charged, it is still a good idea to review the bill so the customer will appreciate the savings.)

4. For other than warranty work, collect for the amount of the bill before you leave

(NOTE: If the customer has made previous arrangements for payment, it should have been noted on the service order or work order.)

E. Leave the customer on a positive note

1. Thank the customer for his/her help
2. Assure the customer that the appliance is in working order
3. Compliment the customer for making an intelligent appliance selection

(NOTE: Part of the repair work is to also repair the customer's confidence in the product, the manufacturer, and the dealer for whom the service person works, and prompt, courteous repair is the best way to restore that confidence.)

4. Always offer tips the customer can use to improve appliance service

INFORMATION SHEET

5. In cases where an appliance has simply had it, be smart enough to interest the customer in a replacement

(NOTE: The prospects that a worn out appliance may still have trade in value may be enough to sell a new appliance.)

6. Leave the area clean

Warranty Service Invoice

PRESS HARD - YOU ARE MAKING 5 COPIES

13L2490A

FORM 306-2 (REV. 2-79)

MAGIC CHEF WARRANTY SERVICE INVOICE

NO. A043374-S

CUSTOMER PHONE NUMBER: _____

CUSTOMER CALL DATE: _____

SERVICE AGENCY NAME ADDRESS PHONE		CUSTOMER OR TENANTS NAME ADDRESS ZIP CODE		DEALER NAME ADDRESS ZIP CODE PHONE	
SIGNATURE		SIGNATURE			
NOTE TO TECHNICIAN : REFER TO REVERSE SIDE OF FORM FOR SERVICE CODE AND INDICATE HERE →					
APPLIANCE DATA →		POWER SOURCE LP. NAT ELEC.	APPLIANCE PURCHASE DATE MO. DAY YEAR	MODEL #	SERIAL #
SERVICE DATA →	DATE SERVICE CALL ARR. DEP. TOTAL MINUTES		2ND SERVICE CALL DATE ARR. DEP. TOTAL MINUTES		
TYPE APPLIANCE (CHECK ONE)		DISHWASHER		VENDOR CODE	
) GAS RANGE		REFRIGERATOR		MAGIC CHEF USE ONLY ACCOUNT DISTRIBUTION	
) ELECTRIC RANGE		SINK DISPOSAL		5 9 9 7 5 4 1	
) COUNTER TOP		VENT HOOD		PART CODE QUANTITY	
) BUILT-IN OVEN		OTHER		GROSS AMT. DISCOUNT	
) EYE LEVEL CHATEAU		MICROWAVE OVEN		APPVD. BY DATE	
) COMPACTOR		R.F. LEAKAGE LEVEL		00-00-00	
) LAUNDRY		MW/CM2		MAGIC CHEF APPROVAL	
) FREEZER				DM DATE RM DATE	
PARTS INSTALLED		SERVICE CHARGE			
PART #	QTY	DESCRIPTION		TOTAL LABOR CHARGE	
A.				1 1/2 30 MIN. RATE \$	
B.				% HR. RATE \$	
C.				OR	
D.				FLAT RATE \$	
E.					
F.					
G.					
CUSTOMER INITIAL DESCRIPTION OF SERVICE PROBLEM:					
DESCRIPTION OF SERVICE WORK PERFORMED:					
DATE WORK COMPLETED					

THIS FORM MUST BE COMPLETE AND INFORMATION MUST BE LISTED ON MONTHLY STATEMENT FORM 306-2 BEFORE PAYMENT BY MAGIC CHEF. COMPLETED INVOICES WITH COPIES OF 306-2 SHOULD BE SENT TO WARRANTY SERVICE CO-ORDINATOR, MAGIC CHEF, INC., CLEVELAND, TENN. 37311

ORIGINAL (FACTORY COPY)

Courtesy Magic Chef Inc.

Warranty

Frigidaire Dishwasher Warranty

FULL ONE-YEAR WARRANTY (Excluding Alaska)

Frigidaire Company warrants that Frigidaire will repair, without charge, any defect or malfunction occurring in this Dishwasher during the first year after original date of delivery to the consumer.

THIS WARRANTY DOES NOT APPLY:

1. To conditions resulting from (A) improper installation, or (B) incorrect electric current.
2. To conditions resulting from consumer damage, such as: (A) improper maintenance, or (B) misuse, abuse, accident, alteration.
3. If the original serial number cannot be readily determined.
4. To service calls not involving malfunction or defects in materials or workmanship, and naturally the consumer shall pay for such calls.
5. To Dishwashers installed outside the continental United States and Hawaii.
6. If used in any commercial application.
7. To Dishwashers installed in the State of Alaska.

LIMITED WARRANTY

Applicable to the State of Alaska

In the State of Alaska, all of the provisions of the full warranty and the exclusions thereunder listed on this form are unchanged, except that Frigidaire does not pay for the cost of the technician's travel to your home nor for the cost of transporting the product to his shop. You are responsible for these charges.

This warranty gives you specific legal rights, and you may also have other rights which vary from state to state.

This is the only written warranty applicable to Frigidaire Dishwashers and Frigidaire neither assumes nor authorizes anyone to assume for it any other obligation or liability in connection with such Dishwashers. **FRIGIDAIRE SHALL NOT BE LIABLE FOR CONSEQUENTIAL DAMAGES, SUCH AS PROPERTY DAMAGE AND INCIDENTAL EXPENSES RESULTING FROM BREACH OF THIS WRITTEN WARRANTY OR ANY IMPLIED WARRANTY.**

Some states do not allow the exclusion or limitation of incidental or consequential damages, so this limitation or exclusion may not apply to you.

FOR SERVICE UNDER THIS WARRANTY contact any authorized Frigidaire servicing dealer, or if there is a question as to where to obtain warranty service, write our Customer Relations Department at this address.

FRIGIDAIRE COMPANY
P.O. Box WC4900
3555 S. Kettering Blvd.
Dayton, Ohio 45449

Courtesy Frigidaire

MAJOR APPLIANCE REPAIR ORIENTATION UNIT I

NAME _____

TEST

1. Match terms on the right with their correct definitions.

<p>_____a. Labor saving devices such as can openers or toasters that are generally portable and relatively inexpensive</p>	<p>1. Electromechanical</p>
<p>_____b. Labor saving devices such as automatic washers and dryers that are generally stationary and relatively expensive</p>	<p>2. Major appliances</p>
<p>_____c. A mechanical part such as a solenoid that is started or stopped by an electrical control device</p>	<p>3. Habit</p>
<p>_____d. An act repeated so often that it becomes an automatic and unconscious personal trait</p>	<p>4. Small appliances</p>

2. Complete statements concerning the job outlook for appliance repair technicians by circling the word(s) that best completes each statement.
 - a. The demand for appliance repair technicians will grow at an **(average rate, rapid rate)** into the 1990's
 - b. Current technicians who advance to other jobs or retire will **(have to be replaced, be replaced with automated processes)**
 - c. As the number of new households increases in America, the number of appliances will increase **(rapidly, slowly)** and help increase the demand for repair technicians
 - d. Most people consider major appliances essential, and available work should continue **(even during periods of economic recession, except for periods of economic depression)**
 - e. Pay varies with geographical areas, but experienced technicians in the early 1980's made from \$10 to \$12 an hour and wages should **(increase, hold steady)** with each passing year

TEST

3. Select true statements concerning advancement opportunities for appliance repair technicians by placing an "X" in the appropriate blanks.

(NOTE: For a statement to be true, all parts of the statement must be true.)

_____a. After two to three years experience and a good work record, repair technicians may be promoted to:

- 1) Supervisor
- 2) Assistant service manager
- 3) Service manager
- 4) President of the company

_____b. Highly skilled technicians with good people skills may advance to regional service manager or regional parts manager for a major manufacturer

_____c. A technician with a wide range of skills, experience, and sufficient financial support may open his/her own appliance store or repair shop

4. Complete a list of places where appliance repair technicians work by inserting the word(s) that best completes each statement.

a. Most appliance repair technicians work in _____ appliance stores and repair shops

b. Many more appliance repair technicians work for manufacturers' service centers, department stores, wholesalers, or _____ companies

c. Some appliance repair technicians run their own businesses full or part time, and _____ their services to service centers or appliance dealers

d. Appliance repair technicians work in communities of all sizes, but most of them work in _____ areas

5. Select true statements concerning working conditions by placing an "X" in the appropriate blanks.

_____a. Appliance repair shops are generally noisy, poorly lighted, and not comfortable places to work in

_____b. Most technicians work with strict supervision

_____c. The work is generally safe as long as safety procedures are observed around electrical elements of equipment and as long as lifting and moving of heavy appliances is accomplished properly

TEST

- _____d. Technicians who repair appliances in customers' homes may sometimes have to drive a portion of the day and be responsible for the care of a company vehicle
- _____e. Technicians who repair appliances in customers' homes also have to explain to the customer what repair work was done, the cost of parts and labor, and then collect the bill
6. Complete statements concerning training requirements for appliance repair work by inserting the word(s) that best completes each statement.
- a. Although some repair technicians are trained _____, formal training in appliance repair is the more common route into the industry
- b. Training should stress both the mechanical and electrical aspects of the repair industry and the _____
- c. Modern appliances use more and more electronic parts, and technicians with good _____ skills have the best job prospects
- d. Entry-level technicians frequently start out repairing _____ of appliance until they master it and then learn other appliances one at a time
- e. Large department stores and service centers have _____ of their own to help technicians master advanced areas of repair
- f. Technicians who make service calls in customer homes generally go through a period of on-the-job training with a _____ technician
- g. Changes in appliance design demand that a technician keep up to date, and this usually means attending manufacturers' _____ where new models and service procedures are demonstrated
- h. _____ manuals provide a wealth of information, and a good repair technician should read all manuals available and maintain a personal library of _____ manuals
7. Complete a list of physical requirements for successful repair technicians by circling the word(s) that best completes each statement.
- a. The occupation requires some (**moderate, heavy**) lifting which requires a person to be in generally good physical condition
- b. The ability to identify (**wires, schematics**) of several different colors is essential for some electrical elements of the occupation, and good eyesight is required

TEST

- c. Areas of the occupation require articulate skills in **(splicing, soldering and tinning)**, and the technician needs to have a steady hand
- d. Much of the work is repetitive and requires an ability to tolerate **(doing the same thing over and over, absolute boredom)**
- e. Technicians selected to service appliances in customer's home must have the **(verbal skills, glib style)** required to talk with customers
8. Select true statements concerning personal habits that promote success on the job by placing an "X" in the appropriate blanks.
- a. Take a bath or shower weekly
- b. Get to work on time, and if you know you're going to be late or if you're too ill to go to work, try to call in far enough in advance so arrangements can be made for others to cover your job
- c. Respect all company property and use tools and equipment any way so long as you get the job done
- d. Think of yourself as an advertisement for the company anytime you're on a service call or using a company vehicle in public, and conduct yourself properly
- e. Avoid drugs or alcohol because their use can impair your ability to work safely or to work at all
- f. Be honest in all your relations with supervisors, fellow-workers, and customers
- g. Put in a day's work for your day's pay
9. Complete statements concerning repair technicians and customer relations by circling the word(s) that best completes each statement.
- a. Appliance repair technicians mostly work for dealers who sell and service appliances and whose business **(depends, only partly depends)** on good customer relations
- b. Repair technicians need basic **(math, business)** skills in reading and interpreting work/service orders so they can approach customers with confidence
- c. Repair technicians need basic **(math, business)** skills to total bills properly and avoid errors that could lose the company money or irritate a customer
- d. Repair technicians must be **(quiet, diplomatic)** on service calls that take them into a customer's home
- e. Repair technicians should assume they **(are, may be)** part of the company image at all times and conduct themselves accordingly

TEST

10. Complete statements concerning warranties and their importance by inserting the word(s) that best completes each statement.

a. Warranty

- 1) Usually for _____ full year
- 2) Covers all defective workmanship and _____
- 3) Pays for both parts and _____

b. Limited warranty:

- 1) Usually runs from the second through the _____ year
- 2) Usually cover only _____ components such as the transmission on an automatic washer
- 3) Pays for parts, but customer pays for labor which includes _____ costs

c. Warranties should not be confused with dealer _____ that provide special services beyond what the manufacturer warranties

11. Complete statements concerning cautions about warranties by inserting the word(s) that best completes each statement.

a. Warranties are void if an appliance has been:

- 1) Improperly _____ or modified
- 2) Subjected to improper _____ supply
- 3) Subjected to unreasonable _____

b. Service or repair work performed by an _____ technician voids most warranties

c. Payment for warranty work is made by manufacturers to authorized dealers and requires careful attention to _____

TEST

12. Solve problems concerning service calls by providing the correct answer for each of the following situations.

a. A service order is not clear. What are two things that can be done to clarify it?

1) _____

2) _____

b. What are the first things you would do after a customer opens the door?

c. What would you do if the customer asked you to make a quick estimate of what the repairs will cost?

d. What would you do if the customer says a check will be mailed later to cover the bill?

e. What are two things you can do to leave the customer on a positive note?

1) _____

2) _____

MAJOR APPLIANCE REPAIR ORIENTATION UNIT I

ANSWERS TO TEST

1. a. 4
b. 2
c. 1
d. 3
2. a. Average rate
b. Have to be replaced
c. Rapidly
d. Even during periods of economic recession
e. Increase
3. b, c
4. a. Independent
b. Utility
c. Contract
d. Highly populated metropolitan
5. c, d, e
6. a. On the job
b. Electromechanical
c. Electronics
d. One type
e. Training programs
f. More experienced
g. Seminars
h. Service, service
7. a. Heavy
b. Wires
c. Soldering and tinning
d. Doing the same thing over and over
e. Verbal skills
8. b, d, e, f, g
9. a. Depends
b. Business
c. Math
d. Diplomatic
e. Are

ANSWERS TO TEST

10. a. 1) One
2) Materials
3) Labor
b. 1) Fifth
2) Specific
3) Travel
c. Service contracts
11. a. 1) Installed
2) Voltage
3) Use
b. Unauthorized
c. Paperwork
12. a. 1) Talk to the person who took the order
2) Call the customer
b. Introduce yourself, explain whom you represent, and why you are there
c. Refuse politely
d. Explain that you have to collect at the time service is completed
e. 1) Assure the customer the appliance is working well
2) Compliment the customer on a wise appliance selection
(NOTE: Item may also include offering tips for ways to improve appliance service, and leaving the area clean.)



SAFETY AND FIRST AID UNIT II

UNIT OBJECTIVE

After completion of this unit, the student should be able to discuss the rules of good housekeeping, guidelines for electrical safety, and special safety requirements for appliance repair technicians. The student should also be able to list fire safety rules, identify fire evacuation exits, discuss first aid for workplace accidents, complete a safety pledge, and select proper first aid applications for given accidents. These competencies will be evidenced by correctly performing the procedures outlined in the assignment sheets and by scoring 100 percent on the unit test.

SPECIFIC OBJECTIVES

After completion of this unit, the student should be able to:

1. Match terms related to safety and first aid with their correct definitions.
2. Complete a list of benefits of safe working practices.
3. Select true statements concerning the major causes of accidents.
4. State the motto for good housekeeping.
5. Complete statements concerning basic rules for safe use of tools and equipment.
6. Arrange in order the steps in lifting safely.
7. Select true statements concerning special lifting rules for appliance repair.
8. Complete statements concerning fire safety rules.
9. Match classes of fires with their causes.
10. Match types of fire extinguishers with their recommended uses.
11. Match types of fire extinguishers with their recommended operations.
12. Complete statements concerning special safety requirements for appliance repair.
13. Complete statements concerning special rules for eye protection.
14. Select true statements concerning ways to recognize shock.

OBJECTIVE SHEET

15. Arrange in order the steps in treating shock.
16. Complete statements concerning first aid for victims of electrical shock.
17. Select true statements concerning first aid guidelines for common workplace injuries.
18. Select true statements concerning first aid guidelines for workplace burns.
19. Arrange in order the steps in controlling bleeding.
20. Complete statements concerning pressure points for checking bleeding.
21. Select true statements concerning first aid for eye injuries.
22. Complete statements concerning general guidelines for first aid emergencies.
23. Complete a student safety pledge. (Assignment Sheet #1)
24. Select proper first aid procedures. (Assignment Sheet #2)

SAFETY AND FIRST AID UNIT II

SUGGESTED ACTIVITIES

- A. Provide students with objective sheet.
- B. Provide students with information, assignment, and job sheets.
- C. Make transparencies.
- D. Discuss information and assignment sheets.
- E. Arrange for a talk about fire safety with your local fire department, and back it up with a fire drill, identification of reassembly points, and a demonstration of proper use of all fire extinguishers in the class/shop area.
- F. Arrange for qualified medical personnel to talk about first aid and give demonstrations of dressing common cuts, punctures, and burns, and also demonstrations of resuscitation methods.
- G. Stress the importance of eye safety, the importance of wearing eye protection when using striking tools, drill presses, and grinding tools, and demonstrate the use of available eye flushing equipment.
- H. Review any special safety rules of the school, and impress upon students the importance of signing the safety pledge in Assignment Sheet #1.
- I. Review the accident/first aid situations presented in Assignment Sheet #2 and add other situations you feel need to be stressed with your students or problems peculiar to your class/shop area.
- J. Contact your state Safety Council or equivalent agency for good safety films, or check with your local Red Cross; show safety films at monthly intervals as they are available to impress upon students the need for thinking "safety" all the time.
- K. Give test.

CONTENTS OF THIS UNIT

- A. Objective sheet
- B. Information sheet
- C. Transparency masters
 - 1. TM 1 — Fire Safety
 - 2. TM 2 — Rescue Procedures

CONTENTS OF THIS UNIT

3. TM 3 — Pressure Points
 4. TM 4 — Accident Report Form
- D. Assignment sheets
1. Assignment Sheet #1 — Complete a Student Safety Pledge
 2. Assignment Sheet #2 — Select Proper First Aid Procedures
- E. Test
- F. Answers to test

REFERENCES USED IN DEVELOPING THIS UNIT

- A. The American Red Cross. *Standard First Aid and Personal Safety*. Garden City, NJ: Doubleday and Co., Inc., 1978.
- B. Henderson, John, M.D. *Emergency Medical Guide*. New York, NY: McGraw-Hill, 1963.
- C. *Kansas Safety Education Handbook, Volume III*. Wichita, KS: Kansas State Department of Education in Cooperation with the Wichita Public Schools, U.S.D. 259, 1981.
- D. *Kidde Portable Extinguishers, The ABC's of Fire Prevention*. Belleville, NJ: Walter Kidde & Co., Inc., 1978.

SAFETY AND FIRST AID UNIT II

INFORMATION SHEET

I. Terms and definitions

- A. **Safety** — State or condition of being safe; freedom from danger, risk, or injury
- B. **Accident** — Any suddenly occurring, unintentional event which causes personal injury or property damage
- C. **First aid** — Immediate, temporary care given the victim of an accident or sudden illness until the service of a physician can be obtained
- D. **Pressure points** — Points on the body where arteries pass close to the surface of the skin and in front of bone structure so that pressure forcing the artery against the bone can check the flow of blood to a specific part of the body
- E. **Combustible** — Materials or liquids that catch fire easily
- F. **Hygiene** — The science of good health and its maintenance, including sanitary practices and cleanliness
- G. **Tetanus** — An acute, infectious disease that usually enters the body through cuts or wounds; characterized by spasmodic contractions or rigidity of some voluntary muscles and frequently referred to as lockjaw
- H. **Tourniquet** — A bandage or strap twisted around a limb to compress the flow of blood through arteries and check severe bleeding; previously a recommended first aid procedure, but now recommended not at all or only in life-threatening situations

II. Benefits of safe working practices

- A. Eliminates the pain or discomfort of personal injury
- B. Eliminates the loss of equipment or the expense of repair
- C. Eliminates lost time and lost wages
- D. Contributes to the psychological well being of all employees
- E. Contributes to productivity and job security
- F. Fulfills the moral obligation a worker has to employer and fellow employees

INFORMATION SHEET

III. The major causes of accidents

- A. Unsafe condition — May be caused by improper design, improper installation, or improper maintenance of a tool, machine, or any piece of equipment

Example: Unguarded machinery, mushroomed heads on striking tools, poor housekeeping, and poor lighting are all unsafe conditions

- B. Unsafe act — The violation of a commonly accepted safe practice

Example: Removing machinery guards, throwing material instead of carrying it, improper lifting, and horseplay are all unsafe acts

- C. Combination causes — An unsafe condition combined with an unsafe act causes the majority of accidents

Example: Firmly grasping a wrench being pushed toward an open metal edge can severely injure knuckles and fingers if the wrench slips or the nut loosens sooner than expected

IV. Rules for good housekeeping

- A. Keep tools and materials out of passageways
- B. Stack materials neatly away from passageways, walkways, electrical outlets, and work areas
- C. Place scraps that can't be used in a trash can; return materials that can still be used to stock
- D. Immediately wipe up any oil or water that you or anyone else may have spilled on the floor
- E. Store all rags in a fire-proof metal container with a tight lid
- F. Dispose of oily rags that will not be used again, and be sure to place them in a proper receptacle
- G. Practice good housekeeping at all times because it is one of the most important parts of accident prevention
- H. Inspect electrical cords and plugs before using them, and do not carelessly pull or drag an electrical cord when using it
- I. Return tools and unused materials to proper storage when you're through with a job, and make sure the tools are clean and dry
- J. Remember the motto for good housekeeping: a place for everything and everything in its place

INFORMATION SHEET

V. Basic rules for safe use of tools and equipment

- A. When using a screwdriver, support the work on a bench or against a solid surface
- B. When using a wrench, pull it toward the body to prevent smashing your hand if the wrench should slip
- C. Do not strike a mushroomed punch or chisel, pieces of it may strike you in the eye or the hammer may slip and injure your hand
- D. Wear safety goggles when using striking tools
- E. Be especially careful of burrs and fish hooks which are left on the edge of sheet metal; they can cause severe cuts
- F. Never use a file without a handle; the tang could easily pierce your hand and cause a serious injury
- G. When working with a drill press, remove the chuck and clamp the work in place
- H. When grinding or polishing, always wear safety goggles
- I. Never operate a machine from which the guards have been removed
- J. Do not let molten solder come in contact with wet metal because the solder will blow up in your face and eyes
(NOTE: Only fools solder without wearing safety glasses.)
- K. Do not let soldering acid get on your skin or in your eyes because it can cause serious injury
- L. NEVER NEVER use oil near oxyacetylene welding equipment; the interaction of oxygen and oil can cause a violent explosion
- M. Wear cutting goggles when working with oxyacetylene cutting equipment

VI. Steps in lifting safely

- A. Size up the load to make sure you can safely handle it alone, and then place your feet close to the object and about 12" apart (Figure 1)

FIGURE 1

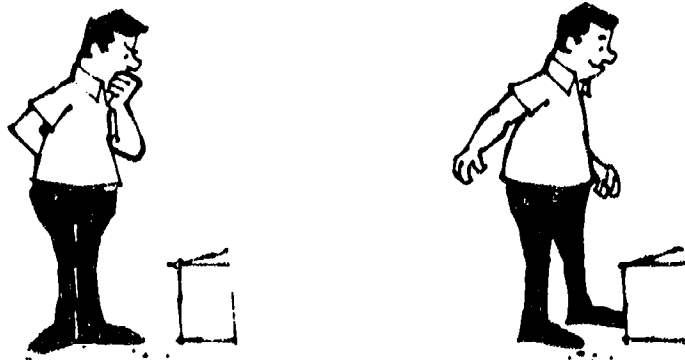

INFORMATION SHEET

- B. Bend your knees, get a good hand hold, then use both legs and back muscles to lift the load straight up as you push with your legs and keep the load close to your body (Figure 2)

FIGURE 2

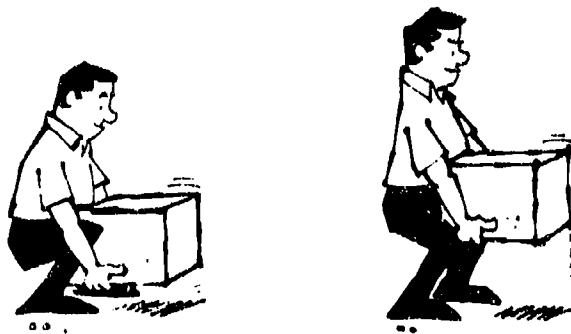

- C. Do not turn or twist until you have the load lifted into a carrying position, and then move your feet to turn your body as you check your path of travel to make sure it's clear (Figure 3)

FIGURE 3

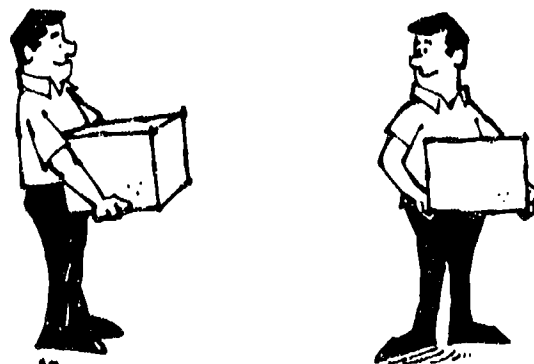

- D. Lower the load by bending your knees, and remember to store heavy objects at least 12" off the floor (Figure 4)

FIGURE 4



INFORMATION SHEET

VII. Special lifting rules for appliance repair

- A. Heavy appliances such as washers and dryers should always be transported on an appliance dollie and securely tied with a restraining strap

(CAUTION: Side rails on a good appliance dollie should be padded, and if they aren't, portable padding should be used to avoid scarring the finish on the cabinet.)

- B. An appliance flipper should always be used to turn heavy appliances because it will protect your back, avoid damage to the appliance, and protect a customer's floor
- C. In cases where heavy appliances have to be loaded on a truck, always work with a helper unless the truck is equipped with a hydraulic tail gate lift such as a Tommy Lift

VIII. Fire safety rules

- A. Report immediately anything that might be a potential fire hazard
- B. Know the location and the proper operation of fire extinguishers and make sure they have been recently checked
- C. Know where the nearest telephone is and make sure the number of the nearest fire department is listed on the phone
- D. Know the procedure for evacuating the building and the location of all fire exits in case one or more exits may be blocked
- E. Smoke only at authorized times and in authorized areas and make sure cigarette butts are completely extinguished and properly discarded
- F. Examine materials and equipment around the workplace to determine what types of fires might occur, then make sure available fire extinguishers are correct for the classes of fires that might occur
- G. Isolate combustible materials in fire-resistant areas
- H. Dispose of rubbish regularly
- I. Conduct fire drills at regular intervals to make sure the alarm can be heard over shop noises, and that everyone knows evacuation routes, exits, and reassembly points
- J. Don't stack anything in front of a fire extinguisher
- K. Know where electrical and gas cut-offs are located so you can reach them quickly if an emergency demands

INFORMATION SHEET

IX. Classes of fires and their causes (Transparency 1)

- A. Class A fires — Result from ordinary combustibles such as wood, paper, and cloth
- B. Class B fires — Result from flammable liquids such as gasoline, oil, paint, solvents, and grease
- C. Class C fires — Result from electrical wires, switches, and motors

X. Types of fire extinguishers and their recommended uses (Transparency 1)

- A. Foam — Recommended only for Class A and Class B fires
- B. Soda acid — Recommended only for Class A fires
- C. Pump tank — Recommended only for Class A fires
- D. Multi-purpose dry chemical — Recommended for all classes of fires
- E. Ordinary dry chemical — Recommended for only Class B and Class C fires
- F. Halon — Recommended for only Class B and Class C fires

(NOTE: Because of its expense, Halon should not be used on a Class A fire, and although it can be used on a Class B fire, it is usually reserved for Class C use around computer rooms or high-density electronic installations because it leaves no residue to damage sensitive parts or components.)

XI. Types of fire extinguishers and their recommended operations

- A. Foam — Allow foam to fall lightly onto the fire, not directly into the fire, especially a burning liquid (Figure 5)

FIGURE 5

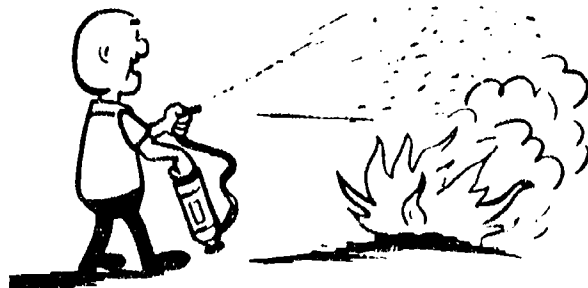

INFORMATION SHEET

- B. Carbon dioxide — Get as close to the fire as possible, and direct the discharge at the edge of the flames and work gradually forward and upward (Figure 6)

(NOTE: A Halon fire extinguisher should be used in the same way as a carbon dioxide extinguisher.)

FIGURE 6

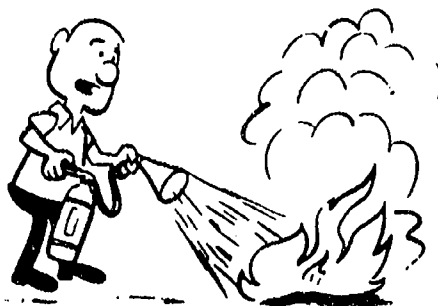

- C. Soda acid and pump tank — Direct the stream at the base of the flames (Figure 7)

FIGURE 7

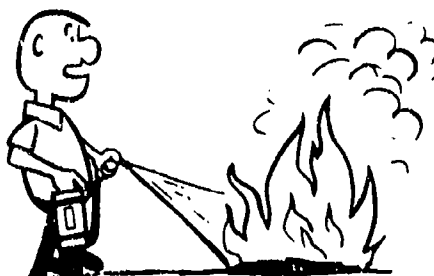

- D. Dry chemical — Direct the stream at the base of the flames, and then directly at material left burning (Figure 8)

FIGURE 8

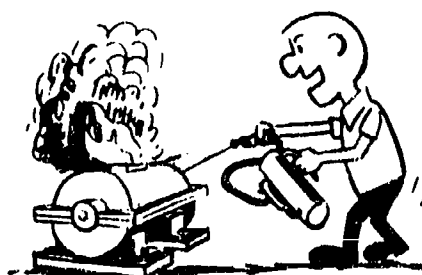

INFORMATION SHEET

XII. Special safety requirements for appliance repair

A. Working with washers, dishwashers, and garbage disposers exposes technicians to electrical/water hazards that demand special attention

B. Always make sure the appliance is unplugged or removed from its power source before working with water lines or hoses

(NOTE: Undercounter dishwashers, garbage disposers, and many ranges usually require tripping a breaker or removing a fuse.)

C. When loosening water-carrying connections, hold a shop towel around the connection so water won't spray onto adjacent electrical components

D. Drain water into a pan, but do not permit water to drain onto a floor, especially in a customer's home

(NOTE: Some shop areas have direct drain facilities, but on a house call, water on a floor is unsightly and dangerous.)

E. When testing a water-carrying connection that has just been made up, hold a shop towel around it until you know it doesn't leak

F. Tools exposed to water should be thoroughly dried and lubricated before putting them away

G. Never set electrical test instruments on a wet surface

H. Make sure all equipment that you install or work on is properly grounded

I. Use compressed gases with care

J. Never direct a compressed air hose in the direction of another worker

XIII. Special rules for eye protection

A. Safety glasses should be worn at all times in the shop

B. Safety goggles with proper shaded lenses must be worn when working with oxyacetylene cutting equipment

C. Safety goggles should be worn when soldering

D. A face shield should be worn when grinding

E. Any form of eye protection worn should be kept clean so it will not impair the view of materials or the work area

INFORMATION SHEET

XIV. Ways to recognize shock

- A. Skin is pale or bluish
- B. Skin may be moist and clammy, even cold to the touch
- C. Victim feels weak
- D. Pulse is rapid and weak
- E. Breathing rate is fast and irregular
- F. Victim may be confused or incoherent

XV. Steps in treating shock

- A. Notify supervisor or instructor IMMEDIATELY
- B. DO NOT DELAY immediate first aid treatment; it can be life saving
- C. Eliminate the causes of shock, control bleeding, or administer artificial respiration if the victim is not breathing
- D. Keep victim lying down with feet slightly elevated

(CAUTION: If the victim has sustained a head or chest injury, do not elevate the feet. Leave the victim lying flat, and when in doubt about the nature of the wound, leave the victim lying flat.)
- E. Cover the victim to retain body heat, but do not make the victim sweat
- F. Give no liquids or food to a shock victim

XVI. First aid for victims of electrical shock (Transparency 2)

- A. Remove the victim from the electrical source or cut off the electrical source as quickly as possible
 - 1. In a shop area where electrical breakers can be reached quickly, shut off power before touching the victim
 - 2. In any situation where the power cannot be shut off, use a dry stick, a rope or leather belt, or a coat or blanket to separate the victim from the source of electricity
- B. Have someone call for medical assistance immediately

INFORMATION SHEET

- C. Check victim's breathing and heartbeat:
 - 1. If pulse is present, but breathing has stopped, administer mouth to mouth resuscitation
 - 2. If heartbeat has stopped, administer cardiopulmonary resuscitation, but only if you have been properly trained
- D. Treat for shock by keeping the victim warm with legs raised slightly above the level of the head
- E. Treat for electrical burns by wrapping the burned area with sterile gauze, and as you treat for burns, cover your mouth with a handkerchief to keep germs away from the burns
- F. Continue treatment until medical help arrives

XVII. First aid guidelines for common workplace injuries

- A. Minor cuts should be cleaned with soap and water, rinsed, and covered with a dry, sterile dressing
- B. Puncture wounds should be cleaned with soap and water, rinsed, then cleaned and rinsed again before covering with a dry, sterile dressing
- C. Slivers and splinters that do not penetrate deeply should be treated as puncture wounds, but splinters that penetrate deeply should be removed by a doctor
- D. Regardless of severity, all cuts, punctures, and splinter injuries should be treated immediately to avoid infection
- E. Depending on the cause of the cut, puncture, or splinter wound, it is usually wise to consider tetanus a hazard
- F. Report all cuts, punctures, splinter wounds, and abrasions to your supervisor or instructor

XVIII. First aid guidelines for workplace burns

- A. Always treat the victim for shock
- B. In the case of a chemical burn, wash off the chemical with large quantities of running water and cut clothing off the affected area
- C. In the case of thermal burns, cut away clothing from the area of the burn, but do not try to remove material that adheres to the burn
- D. With all burns, apply a thick, sterile dressing to prohibit air from reaching the burn

INFORMATION SHEET

XIX. Steps in controlling bleeding

- A. Place a compress of sterile gauze or the cleanest available material directly over the bleeding site
- B. Press firmly with fingers or palm of one hand
- C. Elevate the bleeding parts above the heart level unless there is evidence of a fracture
- D. If blood soaks through the first compress, place another compress on it, but do not remove the first compress
- E. Secure compress with a pressure bandage
- F. Treat for shock
- G. If there is a severe life-threatening hemorrhage, AND ONLY AS A LAST RESORT, APPLY A TOURNIQUET

(CAUTION: There is an enormous pressure build-up at the point of tourniquet application. Premature loosening of the tourniquet could cause an excessive loss of blood, and that is why a tourniquet, once applied, should not be loosened except by a physician or on the advice of a physician.)

XX. Pressure points for checking bleeding (Transparency 3)

- A. Bleeding from the front of the face can often be controlled by pressing the facial artery
- B. Bleeding from the armpit, or sometimes the entire arm, can often be controlled by pressure on the subclavian artery
- C. Bleeding from an arm can often be controlled by pressure on the brachial artery
- D. Bleeding from a leg can often be controlled by deep pressure on the femoral artery

(CAUTION: The pressure point selected must be between the heart and the wound. Instruction by a qualified first aid instructor is the best way to learn where pressure points are and how to be sure the right one is selected.)

XXI. First aid for eye injuries

- A. Every eye injury should receive immediate first aid attention
- B. Notify your supervisor or instructor immediately



























INFORMATION SHEET

- C. For an apparent minor object in the eye, have the person wink several times. If the tears produced by winking do not remove the object, assume that the object is embedded and use the following procedure:
 1. Have the victim close his or her eyes
 2. Put a piece of moist cotton over the closed lid
 3. Place a bandage over the cotton
 4. Get the victim to a doctor as soon as possible
- D. When the eyeball has been obviously scratched or penetrated, apply a sterile dressing, bandage *loosely*, and get medical help immediately
- E. Never permit the victim of an eye injury to rub his or her eye
- F. When in doubt about any eye injury, seek the most immediate medical attention whether it's on the job or in the classroom
- G. Even though damage may be confined to one eye, it is sometimes best to bandage both eyes with a sterile dressing so the victim will not have a tendency to move the damaged eye
- H. For chemical or acid splashes, flush the eyes repeatedly at an eye-flushing station or use a bottled, portable flushing solution, then seek immediate medical assistance

XXII. General guidelines for first aid emergencies

- A. Never hesitate to administer first aid when it is needed
 (CAUTION: Resuscitation procedures require special training and should not be practiced by untrained persons.)
- B. Always have a reason for what you do
- C. Reassure the injured person that everything possible is being done
 (NOTE: Hearing the concerned voice of a co-worker is psychologically comforting to an injured person and can actually lessen the degree of shock.)
- D. Make accurate notes about the accident including name of victim, time, place, cause or nature of the accident, and any first aid that was administered
- E. Do not notify the victim's family because this is the responsibility of the school, the jobsite supervisor, or the medical facility
- F. Report all accidents and injuries to your instructor or jobsite supervisor, no matter how minor they may seem to be
- G. File a complete accident report and submit a copy to the proper persons (Transparency 4)
 (NOTE: Follow emergency procedures that have been adopted by local school board.)

Fire Safety

KIND OF FIRE DECIDE THE CLASS OF FIRE YOU ARE FIGHTING... ↓ ... THEN CHECK THE COLUMNS TO THE RIGHT OF THAT CLASS →		APPROVED TYPE OF EXTINGUISHER MATCH UP PROPER EXTINGUISHER WITH CLASS OF FIRE SHOWN AT LEFT						
		FOAM Solution of Aluminum Sulphate and Bicarbonate of Soda	CARBON DIOXIDE Carbon Dioxide Gas Under Pressure	SODA ACID Bicarbonate of Soda Solution and Sulphuric Acid	PUMP TANK Plain Water	GAS CART-RIDGE Water Expelled by Carbon Dioxide Gas	MULTI-PURPOSE DRY CHEMICAL	ORDINARY DRY CHEMICAL HALON
 <p>CLASS A FIRES</p> <p>USE THESE EXTINGUISHERS →</p> <p>ORDINARY COMBUSTIBLES</p> <ul style="list-style-type: none"> • WOOD • PAPER • CLOTH ETC. 								
 <p>CLASS B FIRES</p> <p>USE THESE EXTINGUISHERS →</p> <p>FLAMMABLE LIQUIDS, GREASE</p> <ul style="list-style-type: none"> • GASOLINE • PAINTS • OILS, ETC. 								
 <p>CLASS C FIRES</p> <p>USE THESE EXTINGUISHERS →</p> <p>ELECTRICAL EQUIPMENT</p> <ul style="list-style-type: none"> • MOTORS • SWITCHES ETC. 								

Rescue Procedure

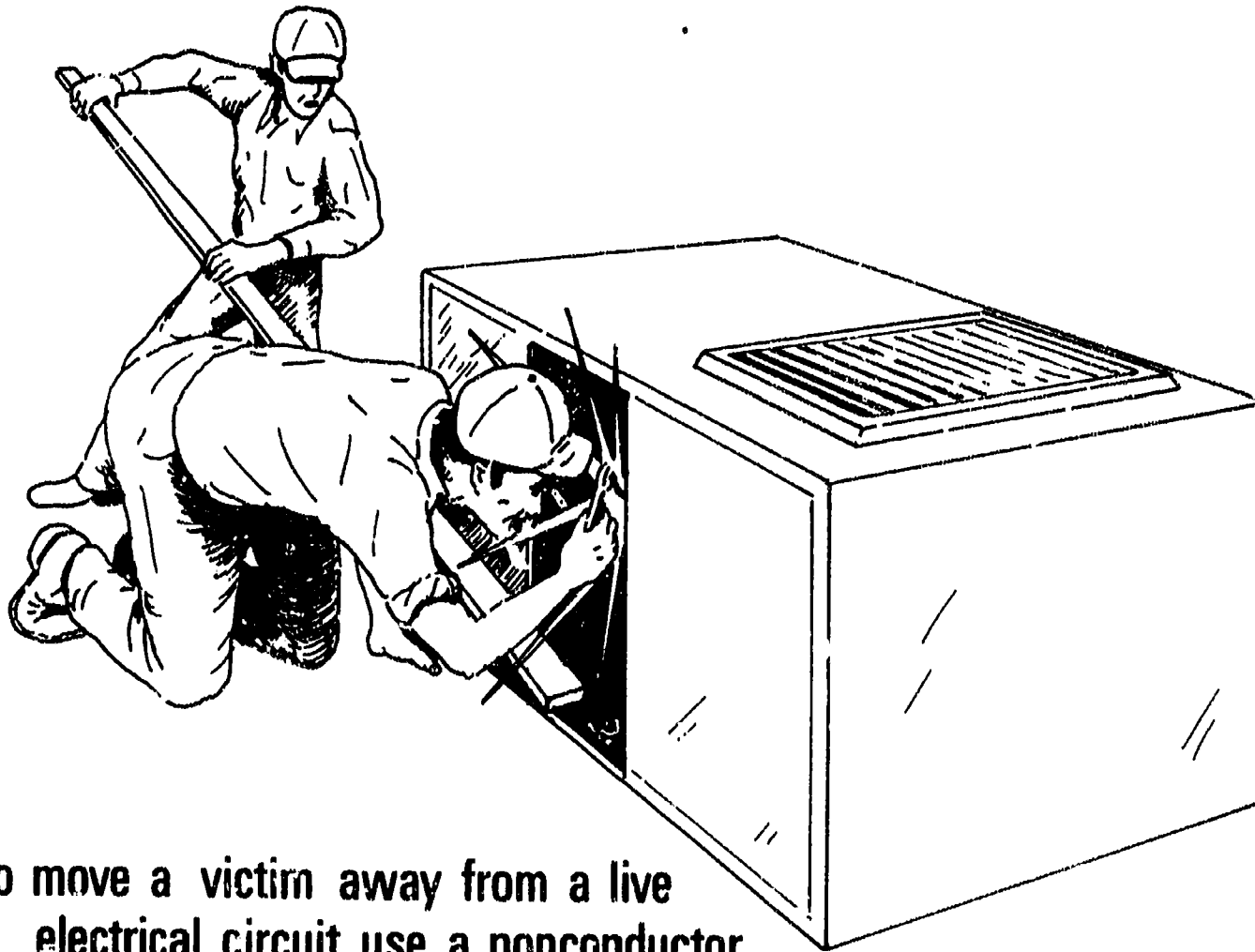

To move a victim away from a live electrical circuit use a nonconductor such as a long dry wooden or plastic pole.

Pressure Points

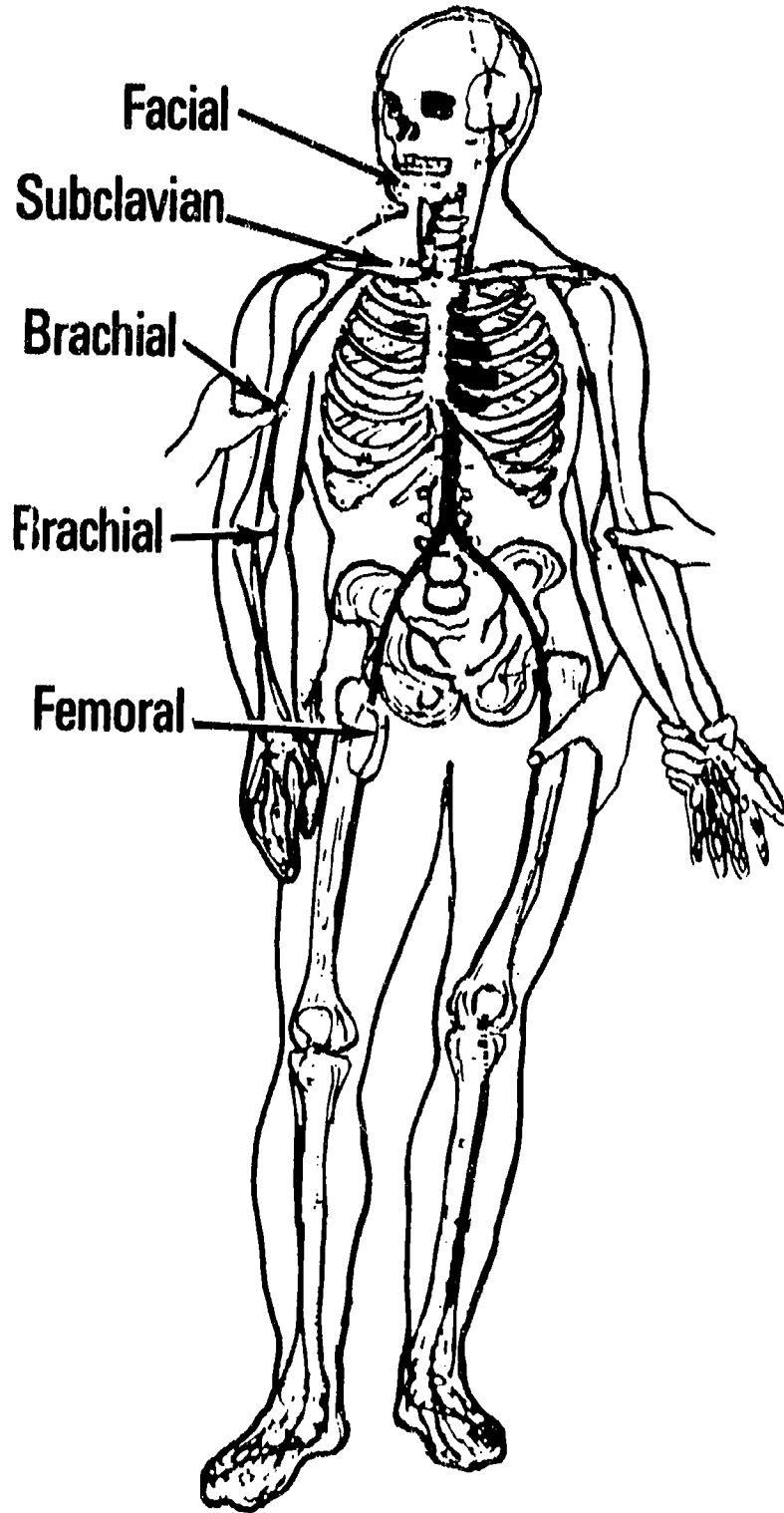

SAFETY AND FIRST AID UNIT II

ASSIGNMENT SHEET #1 — COMPLETE A STUDENT SAFETY PLEDGE

STUDENT SAFETY PLEDGE FOR VOCATIONAL APPLIANCE REPAIR

_____, who is enrolled in vocational appliance repair studies at _____, will, as a part of the training program, operate machines and equipment. This activity requires the written permission of parent(s) or guardian.

It is understood that each student will be given proper instruction in the safe use of machines and equipment before being allowed to operate the machines or equipment alone. Further, the student will be instructed in rules and regulations and safety requirements for classroom and shop activities. The student must assume responsibility for conducting him/herself in a safe manner, and it is requested that the student sign the following student safety pledge:

1. I PROMISE TO ABIDE BY ALL SAFETY RULES FOR THE SHOP AS FOLLOWS:
 - a. To wear eye protection at all times in the shop area
 - b. To use hand tools, bench tools, and floor tools only after proper instruction and only with the instructor's permission
 - c. To use all tools and equipment only for their intended purpose
 - d. To exhibit a concern for tools and equipment by returning them to proper storage areas after use
 - e. To contribute to good housekeeping requirements and to keep the shop area clean and safe
 - f. To abide by all fire regulations and to respect smoking rules
 - g. To avoid horseplay at all times
 - h. To follow all rules and regulations of the school
2. I WILL REPORT ALL ACCIDENTS TO THE INSTRUCTOR IMMEDIATELY

Date _____ STUDENT'S SIGNATURE _____

As parent(s) or guardian of _____, I hereby give consent for my son/daughter to operate all machines and equipment necessary for carrying out the requirements of the appliance repair course in which he/she is enrolled (parent or guardian signature not required for students of legal age).

DATE _____

PARENT(S) OR GUARDIAN SIGNATURE _____

(NOTE: Parents are cordially invited to visit the school and inspect the appliance repair program at any convenient time.)

SAFETY AND FIRST AID UNIT II

ASSIGNMENT SHEET #2 — SELECT PROPER FIRST AID PROCEDURES

Directions: The following statements present situations in which first aid is required; read the statements carefully and provide answers as indicated.

- A. A fellow student has suffered a minor cut working with a washer; you have cleaned the cut with mild soap and water and rinsed the cut off, but the cut still looks as if it might have dirt on it.
1. What would you do next? _____
 2. What would you do after that? _____
- B. A fellow student complains of a splinter in her wrist; you examine it and find that the splinter is deeply embedded.
1. What would you use to remove the splinter? _____

 2. What would you do next? _____
- C. A fellow student has just had a hard bump on the head; a few moments later he complains of feeling weak; you reach over to help him to a chair and notice that his skin feels moist and almost cold to touch.
1. What is probably wrong? _____
 2. What would you do? _____
- D. A fellow student has suffered a bad cut; you have cleaned the cut and applied a compress to it, but in a few minutes the compress is bloody and messy.
1. Should you remove the blood-soaked compress? _____
 2. What would you do next? _____
- E. A fellow student has suffered an eye injury, and it appears that a small piece of metal may be embedded in the eyeball.
1. What would you do first? _____
 2. What would you do next? _____

ASSIGNMENT SHEET #2

F. A fellow student has suffered an eye injury, nothing appears to be embedded in the eye-ball and the rest of the eye appears to be free of any foreign matter, but the student complains of great pain.

1. What would you do if this happens in the school shop? _____

2. What should you do if this happens on the job? _____

G. You have just assisted in administering first aid to a fellow worker with a bad cut; the cut has been cleaned, the compress that was applied is doing a good job, and everything is under control.

1. What should you do next? _____

2. What should you do after that? _____

SAFETY AND FIRST AID UNIT II

ANSWERS TO ASSIGNMENT SHEETS

Assignment Sheet #1 — Evaluated to the satisfaction of the instructor

Assignment Sheet #2

- A.
 - 1. Clean the cut again
 - 2. Cover with a dry sterile dressing
- B.
 - 1. Nothing; deeply imbedded splinters should not be removed
 - 2. Notify supervisor or instructor
- C.
 - 1. The student is probably suffering from shock
 - 2. Treat for shock
- D.
 - 1. No
 - 2. Apply another compress over the first one
- E.
 - 1. Apply a sterile dressing
 - 2. Bandage loosely and get medical help immediately
- F.
 - 1. Seek the most immediate medical attention
 - 2. Seek the most immediate medical attention
- G.
 - 1. Make notes about the accident: name of victim, time, place, cause, or nature of the accident, and any first aid that was administered
 - 2. Report the accident to your instructor or supervisor

SAFETY AND FIRST AID UNIT II

NAME _____

TEST

1. Match the terms on the right with their correct definitions.

- | | | |
|---------|--|--------------------|
| _____a. | State or condition of being safe; freedom from danger, risk, or injury | 1. First aid |
| _____b. | Any suddenly occurring, unintentional event which causes personal injury or property damage | 2. Tetanus |
| _____c. | Immediate, temporary care given the victim of an accident or sudden illness until the service of a physician can be obtained | 3. Pressure points |
| _____d. | Points on the body where arteries pass close to the surface of the skin and in front of bone structure so that pressure forcing the artery against the bone can check the flow of blood to a specific part of the body | 4. Hygiene |
| _____e. | Materials or liquids that catch fire easily | 5. Tourniquet |
| _____f. | The science of good health and its maintenance, including sanitary practices and cleanliness | 6. Safety |
| _____g. | An acute, infectious disease that usually enters the body through cuts or wounds; characterized by spasmodic contractions or rigidity of some voluntary muscles and frequently referred to as lockjaw | 7. Combustible |
| _____h. | A bandage or strap twisted around a limb to compress the flow of blood through arteries and check severe bleeding; previously a recommended first aid procedure, but now recommended not at all or only in life-threatening situations | 8. Accident |

2. Complete the list of benefits of safe working practices by circling the word(s) that best completes each statement.

- a. Eliminates the pain or discomfort or personal (**injury, embarrassment**)
- b. Eliminates the loss of equipment or the expense of (**repair, cleanup**)

TEST

- c. Eliminates lost time and lost (wages, esteem)
 - d. Contributes to the psychological well being of (only the boss, all employees)
 - e. Contributes to productivity and job (security, promotions)
 - f. Fulfills the (social, moral) obligation a worker has to employer and fellow employees
3. Select true statements concerning the major causes of accidents by placing an "X" in the appropriate blanks.

(NOTE: For a statement to be true, all parts of the statement must be true.)

- _____a. Unsafe condition — May be caused by improper design, improper installation, or improper maintenance of a tool, machine, or any piece of equipment
 - _____b. Unsafe act — The violation of a commonly accepted safe practice
 - _____c. Combination causes — An unsafe condition combined with an unsafe act causes the fewest accidents
4. State the motto for good housekeeping.
- _____

5. Complete statements concerning basic rules for safe use of tools and equipment by inserting the word(s) that best completes each statement.
- a. When using a screwdriver, _____ the work on a bench or against a solid surface
 - b. When using a wrench, pull it _____ the body to prevent smashing your hand if the wrench should slip
 - c. Do not strike a mushroomed punch or chisel, pieces of it may strike you in the _____ or the hammer may slip and injure your _____
 - d. Wear safety _____ when using striking tools
 - e. Be especially careful of burrs and fish hooks which are left on the edge of _____; they can cause severe cuts
 - f. Never use a file without a _____; the tang could easily pierce your hand and cause a serious injury
 - g. When working with a drill press, remove the chuck and _____ the work in place

TEST

- h. When grinding or polishing, always wear safety _____
- i. Never operate a machine from which the _____ have been removed
- j. Do not let molten solder come in contact with _____ metal because the solder will blow up in your face and eyes
- k. Do not let soldering _____ get on your skin or in your eyes because it can cause serious injury
- l. NEVER NEVER use _____ near oxyacetylene welding equipment; the interaction of oxygen and _____ can cause a violent explosion
- m. Wear _____ goggles when working with oxyacetylene cutting equipment
6. Arrange in order the steps in lifting safely by inserting the correct sequence number in the appropriate blank.
- _____a. Bend your knees, get a good hand hold, then use both legs and back muscles to lift the load straight up as you push with your legs and keep the load close to your body
- _____b. Lower the load by bending your knees, and remember to store heavy objects at least 12" off the floor
- _____c. Size up the load to make sure you can safely handle it alone and then place your feet close to the object and about 12" apart
- _____d. Do not turn or twist until you have the load lifted into a carrying position, and then move your feet to turn your body as you check your path of travel to make sure it's clear
7. Select true statements concerning special lifting rules for appliance repair by placing an "X" in the appropriate blanks.
- _____a. Heavy appliances such as washers and dryers should always be transported on an appliance dolly and securely tied with a restraining strap
- _____b. An appliance flipper should always be used to turn heavy appliances because it will protect your back, avoid damage to the appliance, and protect a customer's floor
- _____c. In cases where heavy appliances have to be loaded on a truck, always work with a helper unless the truck is equipped with a hydraulic tail gate lift such as a Tommy Lift

TEST

8. Complete statements concerning fire safety rules by inserting the word(s) that best completes each statement.
- a. Report immediately anything that might be a _____ fire hazard
 - b. Know the location and the proper _____ of fire extinguishers and make sure they have been recently checked
 - c. Know where the nearest _____ is and make sure the _____ of the nearest fire department is listed on the _____
 - d. Know the procedure for _____ the building and the location of all fire exits in case one or more exits may be blocked
 - e. Smoke only at _____ times and in _____ areas and make sure cigarette butts are completely extinguished and properly discarded
 - f. Examine materials and equipment around the workplace to determine what _____ of fires might occur, then make sure available fire extinguishers are correct for the _____ of fires that might occur
 - g. Isolate _____ materials in fire-resistant areas
 - h. Dispose of _____ regularly
 - i. Conduct fire _____ at regular intervals + make sure the alarm can be heard over shop noises, and that everyone knows evacuation routes, exits, and reassembly points
 - j. Don't _____ anything in _____ of a fire extinguisher
 - k. Know where _____ and _____ cut-offs are located so you can reach them quickly if an emergency demands
9. Match classes of fires with their causes.
- | | |
|---|-------------------------|
| <p>_____a. Result from ordinary combustibles such as wood, paper, and cloth</p> | <p>1. Class B fires</p> |
| <p>_____b. Result from flammable liquids such as gasoline, oil, paint, solvents, and grease</p> | <p>2. Class C fires</p> |
| <p>_____c. Result from electrical wires, switches, and motors</p> | <p>3. Class A fires</p> |

TEST

10. Match types of fire extinguishers with their recommended uses.

- | | | |
|---------|--|-------------------------------|
| _____a. | Recommended only for Class A and Class B fires | 1. Pump tank |
| _____b. | Recommended only for Class A fires | 2. Soda acid |
| _____c. | Recommended only for Class A fires | 3. Halon |
| _____d. | Recommended for all classes of fires | 4. Foam |
| _____e. | Recommended for only Class B and Class C fires | 5. Multi-purpose dry chemical |
| _____f. | Recommended for only Class B and Class C fires | 6. Ordinary dry chemical |

11. Match types of fire extinguishers with their recommended operations.

- | | | |
|---------|--|----------------------------|
| _____a. | Allow foam to fall lightly onto the fire, not directly into the fire, especially a burning liquid | 1. Carbon dioxide |
| _____b. | Get as close to the fire as possible, and direct the discharge at the edge of the flames and work gradually forward and upward | 2. Dry chemical |
| _____c. | Direct the steam at the base of the flames | 3. Foam |
| _____d. | Direct the steam at the base of the flames, and then directly at material left burning | 4. Soda acid and pump tank |

12. Complete statements concerning special safety requirements for appliance repair by inserting the word(s) that best completes each statement.

- Working with washers, dishwashers, and garbage disposers exposes technicians to _____ hazards that demand special attention
- Always make sure the appliance is _____ or _____ from its _____ source before working with water lines or hoses
- When loosening water-carrying connections, hold a shop towel around the connection so water won't spray onto adjacent _____ components
- Drain water into a pan, but do not permit water to drain onto a floor, especially in a _____

TEST

- e. When testing a water-carrying connection that has just been made up, hold a _____ around it until you know it doesn't leak
- f. Tools exposed to water should be thoroughly dried and _____ before putting them away
- g. Never set electrical test instruments on a _____ surface
- h. Make sure all equipment that you install or work on is properly _____
- i. Use _____ gases with care
- j. Never direct a _____ in the direction of another worker
13. Complete statements concerning special rules for eye protection by inserting the word(s) that best completes each statement.
- a. Safety _____ should be worn at all times in the shop
- b. Safety _____ with proper shaded lenses must be worn when working with oxyacetylene cutting equipment
- c. Safety _____ should be worn when soldering
- d. A _____ should be worn when grinding
- e. Any form of eye protection worn should be kept _____ so it will not impair the view of materials or the work area
14. Select true statements concerning ways to recognize shock by placing an "X" in the appropriate blanks.
- _____a. Skin looks flushed and reddish
- _____b. Skin may be moist and clammy, even cold to the touch
- _____c. Victim feels weak
- _____d. Pulse is rapid and strong
- _____e. Breathing rate is fast and irregular
- _____f. Victim may be confused or incoherent

TEST

15. Arrange in order the steps in treating shock by placing the correct sequence number in the appropriate blank.
- _____a. Eliminate the causes of shock, control bleeding, or administer artificial respiration if the victim is not breathing
 - _____b. Notify supervisor or instructor IMMEDIATELY
 - _____c. DO NOT DELAY immediate first aid treatment; it can be life saving
 - _____d. Cover the victim to retain body heat, but do not make the victim sweat
 - _____e. Give no liquids or food to a shock victim
 - _____f. Keep victim lying down with feet slightly elevated
16. Complete statements concerning first aid for victims of electrical shock by inserting the word(s) that best completes each statement.
- a. Remove the victim from the electrical source or cut off the electrical source as quickly as possible
 - 1) In a shop area where electrical breakers can be reached quickly, _____ before touching victim
 - 2) In any situation where the power _____ be shut off, use a dry stick, a rope or leather belt, or a coat or blanket to separate the victim from the source of electricity
 - b. Have someone call for medical assistance _____
 - c. Check victim's breathing and heartbeat:
 - 1) If pulse is present, but _____ has stopped, administer mouth to mouth resuscitation
 - 2) If _____ has stopped, administer cardiopulmonary resuscitation, but only if you have been properly trained
 - d. Treat for shock by keeping the victim _____ with legs raised slightly above the level of the head
 - e. Treat for electrical burns by wrapping the burned area with _____ gauze, and as you treat for burns, cover your mouth with a handkerchief to keep germs away from the burns
 - f. Continue treatment until _____ help arrives

TEST

17. Select true statements concerning first aid guidelines for common workplace injuries by placing an "X" in the appropriate blanks.
- _____a. Minor cuts should be cleaned with soap and water, rinsed, and covered with a dry, sterile dressing
 - _____b. Puncture wounds should be immediately bandaged
 - _____c. Slivers and splinters that do not penetrate deeply should be treated as puncture wounds, but splinters that penetrate deeply should be taken out with tweezers
 - _____d. Regardless of severity, all cuts, punctures, and splinter injuries should be treated immediately to avoid infection
 - _____e. Depending on the cause of the cut, puncture, or splinter wound, it is usually wise to consider tetanus a hazard
 - _____f. Report all cuts, punctures, splinter wounds, and abrasions to your supervisor or instructor
18. Select true statements concerning first aid guidelines for workplace burns by placing an "X" in the appropriate blanks.
- _____a. Always treat the victim for shock
 - _____b. In the case of a chemical burn, wash off the chemical with large quantities of running water and cut clothing off the affected area
 - _____c. In the case of thermal burns, cut away clothing from the area of the burn, but do not try to remove material that adheres to the burn
 - _____d. With all burns, leave uncovered so air can reach the burn
19. Arrange in order the steps in controlling bleeding by placing the correct sequence number in the appropriate blank.
- _____a. Treat for shock
 - _____b. If there is a severe life-threatening hemorrhage, AND ONLY AS A LAST RESORT, APPLY A TOURNIQUET
 - _____c. Elevate the bleeding parts above the heart level unless there is evidence of a fracture
 - _____d. Place a compress of sterile gauze or the cleanest available material directly over the bleeding site
 - _____e. Secure compress with a pressure bandage
 - _____f. If blood soaks through the first compress, place another compress on it, but do not remove the first compress
 - _____g. Press firmly with fingers or palm of one hand

TEST

20. Complete statements concerning pressure points for checking bleeding by circling the word(s) that best completes each statement.
- Bleeding from the front of the face can often be controlled by pressing the (**femoral, facial**) artery
 - Bleeding from the armpit, or sometimes the entire arm, can often be controlled by pressure on the (**subclavian, femoral**) artery
 - Bleeding from an arm can often be controlled by pressure on the (**brachial, facial**) artery
 - Bleeding from a leg can often be controlled by deep pressure on the (**femoral, brachial**) artery

21. Select true statements concerning first aid for eye injuries by placing an "X" in the appropriate blanks.

(NOTE: For a statement to be true, all parts of the statement must be true.)

- ___ a. Every eye injury should receive immediate first aid attention
- ___ b. Notify your supervisor or instructor immediately
- ___ c. For an apparent minor object in the eye, have the person wink several times. If the tears produced by winking do not remove the object, assume that the object is imbedded and use the following procedure:
- 1) Have the victim close his or her eyes
 - 2) Put a piece of moist cotton over the closed lid
 - 3) Place a bandage over the cotton
 - 4) Get the victim to a doctor as soon as possible
- ___ d. When the eyeball has been obviously scratched or penetrated, apply a sterile dressing, bandage *loosely*, and get medical help immediately
- ___ e. Never permit the victim of an eye injury to rub his or her eye
- ___ f. When in doubt about any eye injury, seek the most immediate medical attention whether it's on the job or in the classroom

TEST

- _____g. Even though damage may be confined to one eye, it is sometimes best to bandage both eyes with a sterile dressing so the victim will not have a tendency to move the damaged eye
- _____h. For chemical or acid splashes, flush the eyes repeatedly at an eye-flushing station or use a bottled, portable flushing solution, then seek immediate medical assistance

22. Complete statements concerning general guidelines for first aid emergencies by inserting the word(s) that best completes each statement.
- a. Never _____ to administer first aid when it is needed
 - b. Always have a _____ for what you do
 - c. _____ the injured person that everything possible is being done
 - d. Make accurate _____ about the accident including name of victim, time, place, cause or nature of the accident, and any _____ that was administered
 - e. Do not notify the victim's _____ because this is the responsibility of the school, the jobsite supervisor, or the medical facility
 - f. Report all accidents and injuries to your instructor or jobsite supervisor, no matter how _____ they may seem to be
 - g. File a complete _____ report and submit a copy to the proper persons

(NOTE: If the following activities have not been accomplished prior to the test, ask your instructor when they should be completed.)

- 23. Complete a student safety pledge.
- 24. Select proper first aid procedures.

SAFETY AND FIRST AID UNIT II

ANSWERS TO TEST

1. a. 6 e. 7
 b. 8 f. 4
 c. 1 g. 2
 d. 3 h. 5

2. a. Injury
 b. Repair
 c. Wages
 d. All employees
 e. Security
 f. Moral

3. a, b

4. A place for everything and everything in its place

5. a. Support
 b. Toward
 c. Eye, hand
 d. Goggles
 e. Sheet metal
 f. Handle
 g. Clamp
 h. Goggles
 i. Guards
 j. Wet
 k. Acid
 l. Oil, oil
 m. Cutting

6. a. 2
 b. 4
 c. 1
 d. 3

7. a, b, c

8. a. Potential
 b. Operation
 c. Telephone, number, phone
 d. Evacuating
 e. Authorized, authorized
 f. Types, classes
 g. Combustible
 h. Rubbish
 i. Drills
 j. Stack, front
 k. Electrical, gas

ANSWERS TO TEST

9. a. 3
b. 1
c. 2
10. a. 4
b. 1 or 2
c. 1 or 2
d. 5
e. 3 or 6
f. 3 or 6
11. a. 3
b. 1
c. 4
d. 2
12. a. Electrical/water
b. Unplugged, removed, power
c. Electrical
d. Customer's home
e. Shop towel
f. Lubricated
g. Wet
h. Grounded
i. Compressed
j. Compressed air hose
13. a. Glasses
b. Goggles
c. Goggles
d. Face shield
e. Clean
14. b, c, e, f
15. a. 3
b. 1
c. 2
d. 5
e. 6
f. 4
16. a. 1) Shut off power
2) Cannot
b. Immediately
c. 1) Breathing
2) Heartbeat
d. Warm
e. Sterile
f. Medical
17. a, d, e, f

ANSWERS TO TEST

18. a, b, c
19. a. 6
b. 7
c. 3
d. 1
e. 5
f. 4
g. 2
20. a. Facial
b. Subclavian
c. Brachial
d. Femoral
21. a, b, c, d, e, f, g, h
22. a. Hesitate
b. Reason
c. Reassure
d. Notes, first aid
e. Family
f. Minor
g. Accident
23. Evaluated to the satisfaction of the instructor
24. Evaluated to the satisfaction of the instructor



FUNDAMENTALS OF ELECTRICITY UNIT III

UNIT OBJECTIVE

After completion of this unit, the student should be able to discuss the electron theory, sources of electricity, and the difference between direct and alternating current. The student should also be able to identify different types of circuits, and use ohm's law to solve for unknown voltage, amperage, and current values in selected circuits. These competencies will be evidenced by correctly completing the procedures outlined in the assignment sheets and by scoring 85 percent on the unit test.

SPECIFIC OBJECTIVES

After completion of this unit, the student will be able to:

1. Match terms related to fundamentals of electricity with their correct definitions.
2. Complete statements concerning electricity.
3. Match sources of electricity with their characteristics.
4. Select true statements concerning the electron theory.
5. Complete statements concerning the importance of electrical charges.
6. Complete statements concerning how electron flow is created in a conductor.
7. Solve problems concerning conductors, insulators, and semiconductors.
8. Complete statements concerning direct current.
9. Complete statements concerning alternating current.
10. Identify basic electrical symbols.
11. Identify types of circuits.
12. Complete a list of elements of a basic circuit.
13. Complete statements concerning circuit applications.

OBJECTIVE SHEET

14. Select true statements concerning circuit grounding.
15. Select true statements concerning electrical measurements.
16. Match abbreviations with their meanings in ohm's law.
17. Solve problems concerning ohm's law for electrical circuits.
18. Solve problems using ohm's law to find unknown values in a circuit.
19. Solve problems concerning characteristics of electrical power.
20. Complete a list of ways ohm's law is used.
21. Differentiate between Kirchhoff's laws for voltage and current.
22. Complete statements concerning working with resistors.
23. Arrange in order the steps in using the color code to determine resistor value.
24. Solve problems for an unknown voltage. (Assignment Sheet #1)
25. Solve problems for an unknown amperage. (Assignment Sheet #2)
26. Solve problems for an unknown resistance. (Assignment Sheet #3)
27. Identify resistor values using a standard color code. (Assignment Sheet #4)

FUNDAMENTALS OF ELECTRICITY

UNIT III

SUGGESTED ACTIVITIES

- A. Provide students with objective sheet.
- B. Provide students with information and assignment sheets.
- C. Make transparencies.
- D. Discuss unit and specific objectives.
- E. Discuss information sheet.
- F. Invite a representative of a local or area electric company or co-op to talk to the students about electrical service in the area, where local electricity is generated, how it is transmitted to the area, and other particulars about cost and general service.
- G. Select appropriate appliances to demonstrate how series, parallel, and series-parallel circuits are effectively put to practical use.
- H. Select appropriate appliances for use in demonstrating to the class how conductors, insulators, and semiconductors are put to use in practical applications.
- I. Use an oscilloscope to demonstrate to the class what alternating and direct current look like on a scope.
- J. Discuss the concept of grounding as a necessary part of a circuit function, and impress upon students the hazards of improperly grounded circuits and components.
- K. Give test.

CONTENTS OF THIS UNIT

- A. Objective sheet
- B. Information sheet
- C. Transparency masters
 - 1. TM 1 — Electrical Transmission
 - 2. TM 2 — Electricity From Friction
 - 3. TM 3 — Electricity From Chemical Action
 - 4. TM 4 — Electricity From Magnetism
 - 5. TM 5 — Electricity From Light

CONTENTS OF THIS UNIT

6. TM 6 — Electricity From Heat
 7. TM 7 — Electricity From Pressure
 8. TM 8 — Structure of an Atom
 9. TM 9 — Insulators, Semiconductors, and Conductors
 10. TM 10 — Types of Direct Current
 11. TM 11 — Basic Circuit
 12. TM 12 — Ohm's Law—Computing Voltage
 13. TM 13 — Ohm's Law—Computing Current
 14. TM 14 — Ohm's Law—Computing Resistance
 15. TM 15 — Kirchoff's Law of Voltage
 16. TM 16 — Voltage Drops in a Circuit
 17. TM 17 — Resistor Color/Value Chart
- D. Assignment sheets
1. Assignment Sheet #1 — Solve Problems for an Unknown Voltage
 2. Assignment Sheet #2 — Solve Problems for an Unknown Amperage
 3. Assignment Sheet #3 — Solve Problems for an Unknown Resistance
 4. Assignment Sheet #4 — Identify Resistor Values Using a Standard Color Code
- E. Test
- F. Answers to test

REFERENCES USED IN DEVELOPING THIS UNIT

- A. Vorderstrasse, Ron. *General Electronic Technician*. Stillwater, OK 74074: Mid-America Vocational Curriculum Consortium, 1986.
- B. Lieder, Larry. *Really Basic Electricity*. Honeywell, Inc., 1982.
- C. Baker, Gus E., and Leonard R. Crow. *Electricity Fundamentals*. Indianapolis, IN 46206: Howard W. Sams & Co., Inc., 1971.

CONTENTS OF THIS UNIT

- D. Buban, Peter, and Marshall L. Schmitt. *Understanding Electricity and Electronics*. New York, NY: McGraw-Hill, Inc., 1975.
- E. Lister, Eugene C., *Electric Circuits and Machines*. New York, NY: McGraw-Hill, Inc., 1975.
- F. Bacon, Bill and Mack Sutton. *Major Appliance Repairer*. Austin, TX 78712: The University of Texas at Austin, 1983.

FUNDAMENTALS OF ELECTRICITY

UNIT III

INFORMATION SHEET

I. Terms and definitions

- A. Closed circuit — A circuit in which there is a complete and unbroken path for current to flow
- B. Open circuit — A circuit in which the path for current has been broken
- C. Short circuit — A circuit in which the current has been diverted from its intended path into a side current of lower resistance
- D. Load — A device to which electrical energy is being supplied and used
- E. LED (light-emitting diode) — A low voltage bulb used to illuminate numbers on control panels and other displays

II. Electricity (Transparency 1)

- A. Electricity is a form of energy that can be converted to light, heat, or mechanical energy to perform useful work
- B. Electricity exists in nature as static electricity and as lightning, but these forms of electricity do not perform useful work
- C. Electricity used for domestic and industrial purposes is generated at power plants and transmitted by high voltage power lines to towns and cities
- D. High voltage electricity from a generating plant usually has to go through a transformer that steps it down to a lower voltage for home and industry use
- E. Electricity is put to work in the average home in an arrangement of parallel circuits to supply electricity for lighting, heating, air conditioning, and appliance use
- F. To benefit people, electricity has to be controlled, and switches, solenoids, transformers and other control devices are what make major appliances useful tools for modern living

III. Sources of electricity and their characteristics

- A. Friction — Produces static electricity when two materials are rubbed together (Transparency 2)

Example: Sliding your feet across a wool or nylon carpet develops a static charge that is transferred from your shoes to your body

INFORMATION SHEET

- B. Chemical reaction — Produces direct current electricity in batteries and cells when dissimilar elements are placed in a chemical which acts upon them (Transparency 3)**

Example: Flashlight batteries and car batteries both use chemical reaction to create electricity

- C. Magnetism — Produces direct current or alternating current electricity by moving a conductor through a magnetic field (Transparency 4)**

Example: Both DC and AC motors use magnetism to produce electricity, and AC induction motors are the ones most used with major appliances

- D. Photoelectric surfaces — Produce electricity when light strikes them (Transparency 5)**

Example: Solar cells in space crafts and photovoltaic cells in generating plants both produce electricity from sunlight

- E. Heat — Produces electricity when it is applied to two dissimilar metals that are next to each other (Transparency 6)**

Example: Bimetallic switches in many oven controls and thermocouples of all kinds operate from electricity produced by heat

- F. Mechanical pressure — Produces electricity when applied to certain crystalline substances (Transparency 7)**

Example: The crystal in the needle on a record player produces an electrical signal as a result of pressure between the record and the needle

IV. The electron theory (Transparency 8)

- A. Understanding electricity requires basic knowledge of the structure of an atom**
- B. Neutrons with no charges and protons with positive charges make up the nucleus of an atom**
- C. Electrons with negative charges orbit the nucleus in paths that are called shells**
- D. Electrons that orbit in inner shells are attracted to the nucleus, but electrons in the outer shell or "valence" shell can be set free**
- E. When energy is applied to the centrifugal force in an electron, the electron leaves its previous orbit and moves to a higher orbit**

INFORMATION SHEET

- F. Since a valence electron has no higher orbit, it will leave the parent atom and move to another atom
- G. The negative charge of an electron freed from the valence shell is the basic unit of electricity

V. The importance of electrical charges

- A. A man named Coulomb experimented with electrical charges and formulated a law that governs the interaction of negative and positive charges
- B. The two most important electrical relationships established by Coulomb's law are that:
 - 1. Like charges repel
Example: A negative charge repels another negative charge
 - 2. Unlike charges attract
Example: A positive charge attracts a negative charge
- C. The fact that positive charges attract negative charges is extremely important to the movement of electrons required to create current flow in a conductor
- D. The attraction and repulsion principles help make DC and AC motors work

VI. How electron flow is created in a conductor

- A. To create electron flow requires a source of already energized electrons like those found in a battery
- B. The wire or medium that serves as a conductor must have one end connected to the negative side of the power source and the other end connected to the positive side of the power source
- C. The negative charges from the power source energize the negative charges in the conductor and cause them to start moving

(NOTE: Remember that Coulomb's law says that electrons will repel other electrons.)
- D. The positive charges at the other end of the power source attract the electrons from the negative side and reinforce electron flow
- E. The presence of negative charges at one end of the conductor and the absence of negative charges at the other end of the conductor sets up a situation called a potential difference

INFORMATION SHEET

- F. The potential difference must be present before electrons will flow in a conductor to create electric current that can be put to work
- VII. Conductors, Insulators, and semiconductors (Transparency 9)**
- A. Materials whose atoms have one or very few valence electrons have little resistance to electron flow and make good conductors
- Example: Gold, silver, and copper
- B. Materials whose atoms have valence electrons strongly attached to the parent atom have high resistance to electron flow and make good insulators
- Example: Mica, glass, porcelain, and ceramic
- C. Materials whose atoms have valence electrons that are only moderately attached to the parent atom can have their resistance manipulated to be high or low, and these materials are semiconductors
- Example: Silicon and germanium
- VIII. Direct current**
- A. The most common source of direct current electricity is the battery
- B. Both wet and dry cell batteries operate on the same principle of two dissimilar metals placed in a chemical that reacts upon them
- (NOTE: A liquid electrolyte is used in the wet cell battery, and a chemical paste is used in the dry cell battery.)
- C. Chemical reaction in a battery creates a potential difference between the dissimilar elements and creates a condition for electron flow
- D. Potential difference is also called "voltage" and can be tapped into with wires and directed to an electrical device or "load"
- E. The essential characteristic of direct current is that the strength of the current may rise or fall, but it never becomes negative
- F. When plotted graphically to depict its movement in time, direct current may be (Transparency 10):
1. Nonfluctuating
 2. Pulsating
 3. Fluctuating

INFORMATION SHEET

- G. Direct current is seldom used with major appliances, but batteries are an excellent source of power for the study of electrical circuits and electrical measurements

IX. Alternating current

- A. The essential characteristic of alternating current is that it constantly reverses itself above and below a zero base line
- B. When alternating current is depicted graphically in time, it creates a wave form that starts at zero, rises to a maximum level, returns to zero, then reaches another maximum level below zero base line, and then repeats the alternation (Figure 1)

FIGURE 1

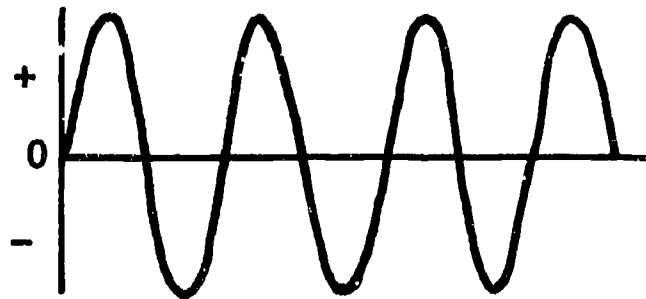

- C. One complete reversal of alternating current is called a cycle, and one cycle contains two different current directions (Figure 1)
- D. Most household current reverses itself 120 times per second, so there are 60 cycles per second or 60 hertz per second

(NOTE: Hertz is usually abbreviated to Hz and when 60 Hz appears on an appliance or a motor, it means the device is designed to run on normal household current.)

- E. Alternating current can be transmitted from generating sources over long distances without excessive power loss, and it is preferred over direct current

(NOTE: In some countries, AC is less than 60 Hz, and major appliances have to be modified to operate at the lower frequency.)

INFORMATION SHEET

X. Basic electrical symbols

(NOTE: The following symbols are designed to make it easier for you to work with circuit diagrams; symbols used in wiring diagrams and schematics will be treated in detail in a later unit.)

A. The symbol for an AC power source may be shown as:

1.



or 2.

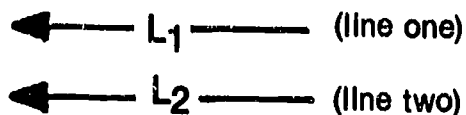

B. The symbol for a DC power source may be shown as:

1.

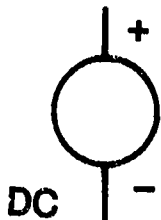

or 2.



(NOTE: The symbol for a dry cell or battery in B-2 should have a small plate to indicate negative and a large plate to indicate positive.)

C. The symbol for electrical wires are straight lines:

1. Connected

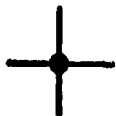

or 2. Not connected

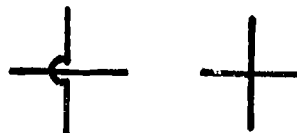

D. The symbols for a switch should indicate whether the contacts are:

1. Open

or 2. Closed

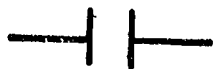

E. The symbol for a resistor is:



INFORMATION SHEET

F. The symbol for a light or lamp may be:



G. The symbol for a fuse is:



H. The symbol for ohms is the Greek letter Omega:



I. The symbols for switches show how switches work internally:

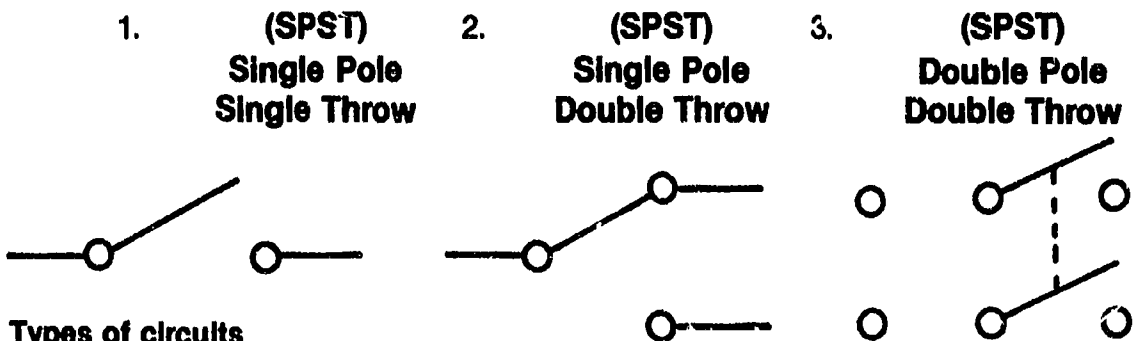

XI. Types of circuits

A. A circuit arranged so that all the current flowing in the circuit will pass through all the components in a circuit is called a series circuit (Figure 2)

FIGURE 2

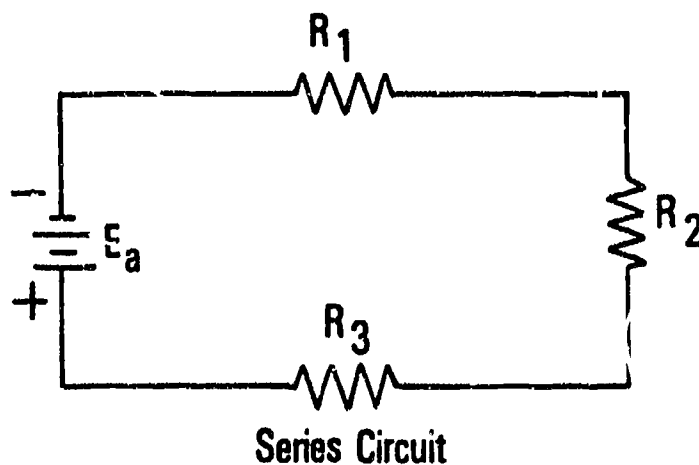

INFORMATION SHEET

- B. A circuit with components connected to the same power source but located side-by-side so that a division of current occurs is called a parallel circuit (Figure 3)

FIGURE 3

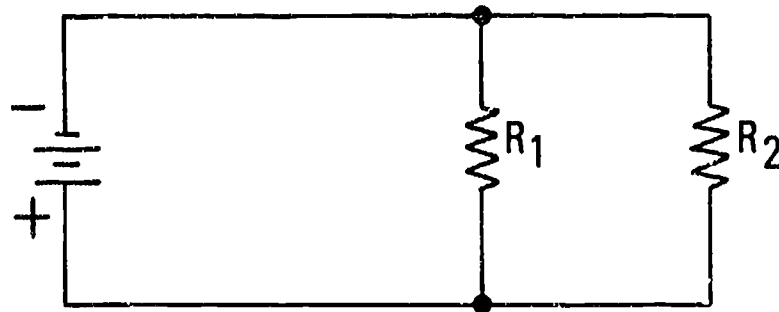

Parallel Circuit

- C. When a circuit has components that are connected in series and components that are connected in parallel, the circuit is a series-parallel circuit (Figure 4)

FIGURE 4

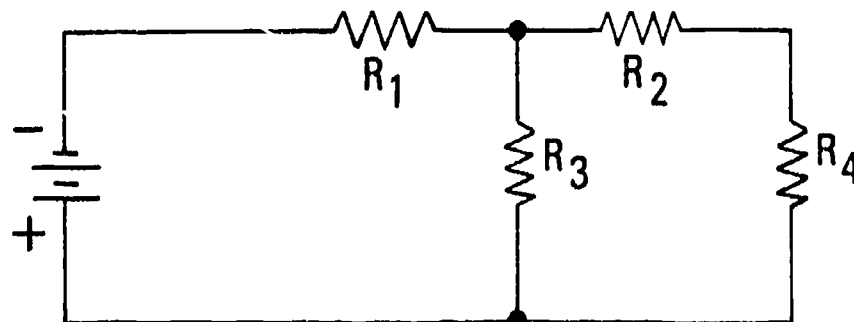

Series-Parallel Circuit

XII. Elements of a basic circuit (Transparency 11)

- A. A complete circuit must have:
1. A power source such as a battery
 2. A conductor such as an electric wire
 3. A load such as a light bulb
- B. To be of practical use, a circuit should also have:
1. A switch
 2. A protection device such as a fuse or a circuit breaker

INFORMATION SHEET

XIII. Circuit applications

- A. Switches are always wired in series with the circuits they control
- B. Series circuits are used in several appliances such as automatic dryers where the door switch is in series with the motor circuit so the appliance will not start if the door is open

(NOTE: The series circuit is also used with microwave ovens to make sure microwave generation doesn't happen if the door is open.)

- C. Parallel circuits are most common in house wiring, but are also common in refrigerators and ranges
- D. In an automatic washer, the fill valve is in series with the water level switch so water will cut off at the predetermined level, but the fill valve is in parallel with the timer so the dishwasher will go into a wash cycle after filling

(NOTE: Modern appliances using solid state controls also use series-parallel circuits for odd jobs such as lighting LED's.)

XIV. Circuit grounding

- A. A ground in a circuit serves to protect operators and technicians against hazardous static electrical shock
- B. All circuits should be grounded with a ground wire from the power source to a point on the appliance chassis
- C. In cases where a circuit cannot be grounded to chassis, the ground wire should be secured to a cold water pipe or to a grounding rod driven into the ground
- D. Loose grounds create static in radio and television sets and contribute to heat build-up in appliances

XV. Electrical measurements

- A. Being able to measure the electrical characteristics in a circuit is the basis of all electrical troubleshooting
- B. Electrical measurements permit duplication of previous conditions
- C. Electrical measurements permit the comparison of a present electrical condition with a specified normal condition
- D. Electrical measurements are made with specialized instruments, and knowing how to use test instruments properly is a basic requirement for appliance repair technicians

INFORMATION SHEET

XVI. Abbreviations and their meanings in ohm's law

- A. E = Electromotive in volts
- B. I = Intensity of the current in amps
- C. R = Resistance in ohms
- D. P = Power in watts

XVII. Ohm's law for electrical circuits

- A. Ohm's law for electrical circuits concerns itself with the mathematical relationship between voltage, current, and resistance in a DC circuit
- B. The law may be expressed in three ways:
 - 1. The voltage required to force a given amount of current through a circuit is equal to the current times the resistance ($E = I \times R$)
 - 2. The current in a circuit is equal to the voltage divided by the resistance ($I = E/R$)
 - 3. The resistance of a circuit is equal to the voltage divided by the current ($R = E/I$)
- C. For reference and easier figuring, the law is frequently presented graphically in a triangle or a circle divided into three parts that represent the three elements in a circuit (Figure 5)

FIGURE 5

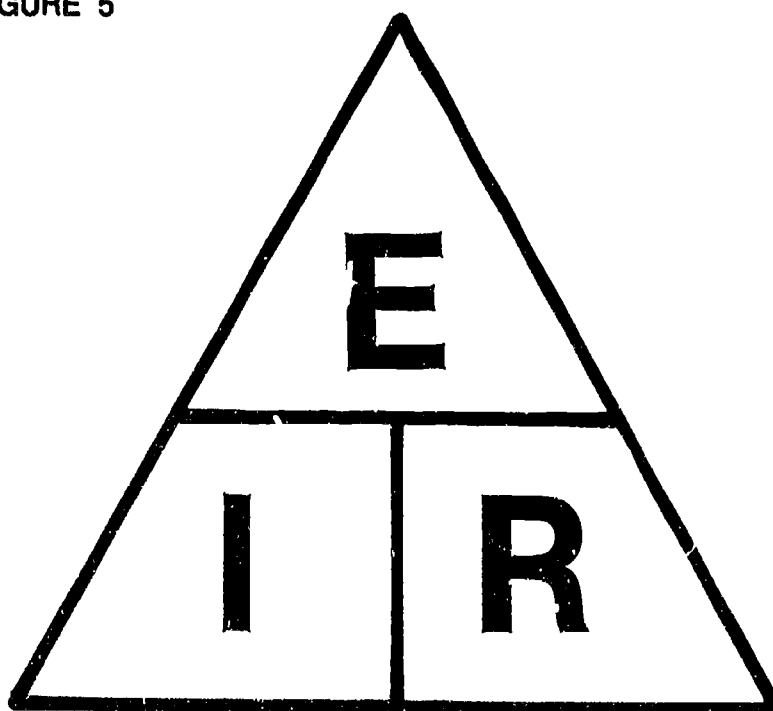

INFORMATION SHEET

XVIII. Using ohm's law to find unknown values in a circuit

- A. Sketch a triangle (or a circle), divide it in three parts, and insert E, I, and R as shown in Figure 6

(NOTE: Remember that E is volts, I is amps, and R is resistance.)

FIGURE 6

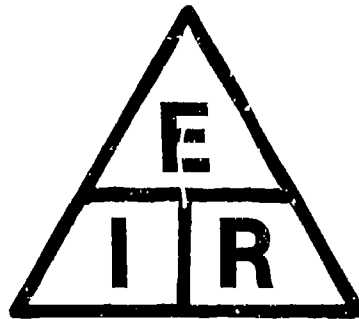

- B. To determine an unknown voltage, cover the E (the unknown value), and multiply the I (amps) times the R (ohms) (Figure 7 and Transparency 12)

FIGURE 7

$$E = \begin{array}{c} \triangle \\ \hline I \quad R \end{array} \text{ or } E = I \times R$$

or Volts = Amps \times Ohms

INFORMATION SHEET

- C. To determine an unknown current, cover the I (the unknown value), and divide the E (volts) by R (ohms) (Figure 8 and Transparency 13)

FIGURE 8

$$I = \begin{array}{c} \triangle \\ \hline E \\ \hline \\ \hline R \\ \hline \end{array} \quad \text{or } I = E/R$$

or Amps = Volts ÷ Ohms

- D. To determine an unknown resistance, cover the R (the unknown value), and divide E (volts) by I (amps) (Figure 9 and Transparency 14)

FIGURE 9

$$R = \begin{array}{c} \triangle \\ \hline E \\ \hline I \\ \hline \\ \hline \\ \hline \end{array} \quad \text{or } R = E/I$$

or Ohms = Volts ÷ Amps

INFORMATION SHEET

XIX. Characteristics of electrical power

- A. The fundamental unit of measure for electrical power is the watt (W) and may be measured with an instrument called a wattmeter
1. Electrical power is the time rate at which a charge is moved by voltage
 2. One watt equals the work accomplished in one second by one volt of potential difference in moving one coulomb of charge

(NOTE: 746 watts = 1 horsepower.)

- B. Power (P) in an electrical circuit may be calculated by using Watt's law, expressed by three basic formulas:

$$P \text{ (in watts)} = E \text{ (volts)} \times I \text{ (amperes)}$$

$$P \text{ (in watts)} = I^2 \text{ (amperes)} \times R \text{ (ohms)}$$

$$P \text{ (in watts)} = \frac{E^2 \text{ (volts)}}{R \text{ (ohms)}}$$

- C. Power is dissipated in resistance in the form of heat and is made evident by a voltage drop across the resistance
- D. The law is often presented graphically in a triangle or circle divided into three parts that represent the three elements in power relationships (Figure 10)

FIGURE 10

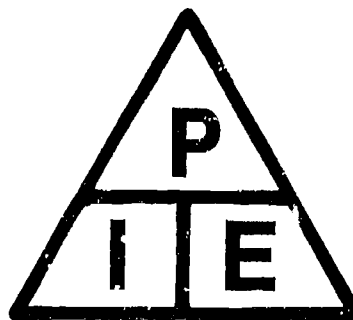

INFORMATION SHEET**XX. Ways ohm's law is used**

- A. To calculate circuit resistance
- B. To calculate circuit amperage
- C. To calculate circuit voltage
- D. To calculate circuit wattage
- E. To calculate voltage drop

XXI. Kirchhoff's law for voltage and current (Transparencies 15 and 16)

- A. Kirchhoff's voltage law — The sum of the voltage drops in a closed loop circuit (series circuit) is equal to the applied voltage
- B. Kirchhoff's current law — The algebraic sum of currents into any point in a circuit is equal to the algebraic sum of currents out of that point

XXII. Working with resistors

- A. Resistors are used in some major appliance circuitry to limit current or provide a load to establish proper circuit voltage
- B. Knowing how to read the value of resistors is essential in troubleshooting circuit problems
- C. Some wire-wound resistors have their value stamped on the body and are easy to determine
- D. Most carbon-composition and film-type resistors can only be evaluated by use of a color code, and understanding the code is essential to resistor troubleshooting (Transparency 17)

INFORMATION SHEET

XXIII. Steps in using the color code to determine resistor value (Transparency 17)

- A. Always begin with the color band nearest the end of the resistor (Figure 11)

FIGURE 11

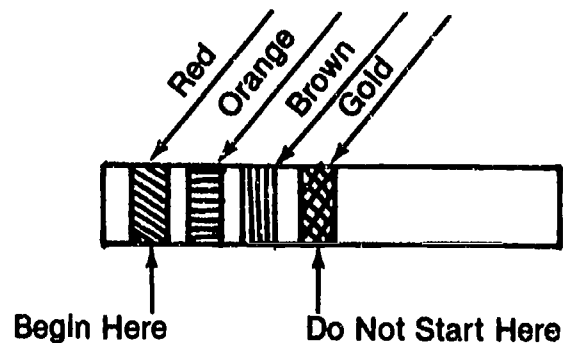

- B. List the first color band as the first number of the resistance value

Example: Red has a value of 2, so the resistor in Figure 11 has 2 as the first resistance value

- C. List the second color band as the second number of the resistance value

Example: Orange has a value of 3, so it should be listed to the right of the red 2 to give a value of 23

- D. Use the third color band as the multiplier

(NOTE: Gold as a multiplier has a value of 0.1, so divide by 10 and silver as a multiplier has a value of 0.01, so divide by 100.)

Example: Since brown has a value of 10 when used as a multiplier, the resistor in Figure 11 would have a value of 23×10 or 230 ohms

- E. Use the fourth color band to determine the tolerance of the resistor

Example: Since gold has a plus or minus tolerance of 5%, the resistor in Figure 11 with a resistance of 230 ohms would have a plus or minus tolerance of $230 \times .05$, an 11.5 tolerance, or the resistor would be serviceable at any range from 218.5 ohms to 241.5 ohms

Electrical Transmission

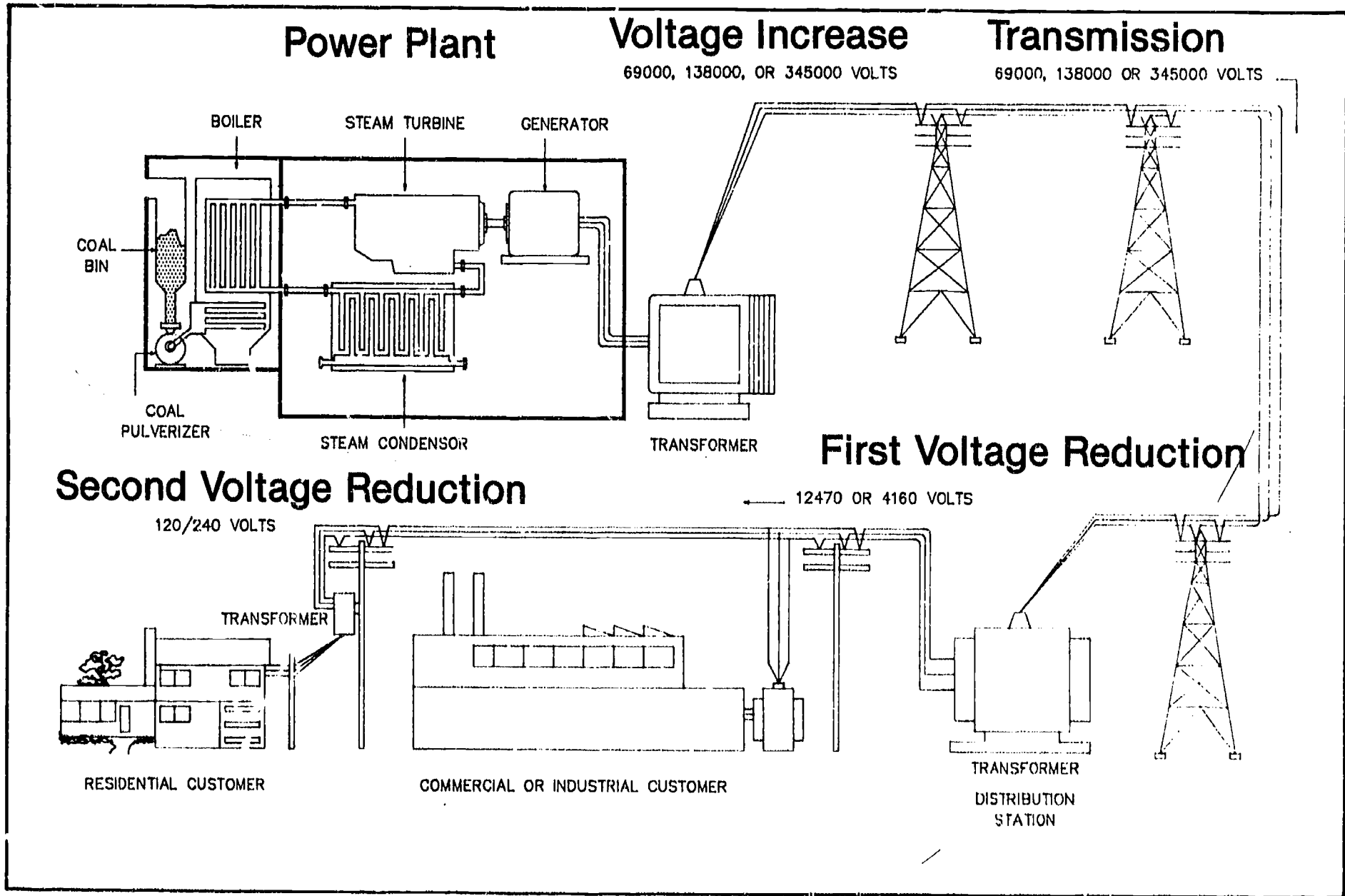

Electricity From Friction

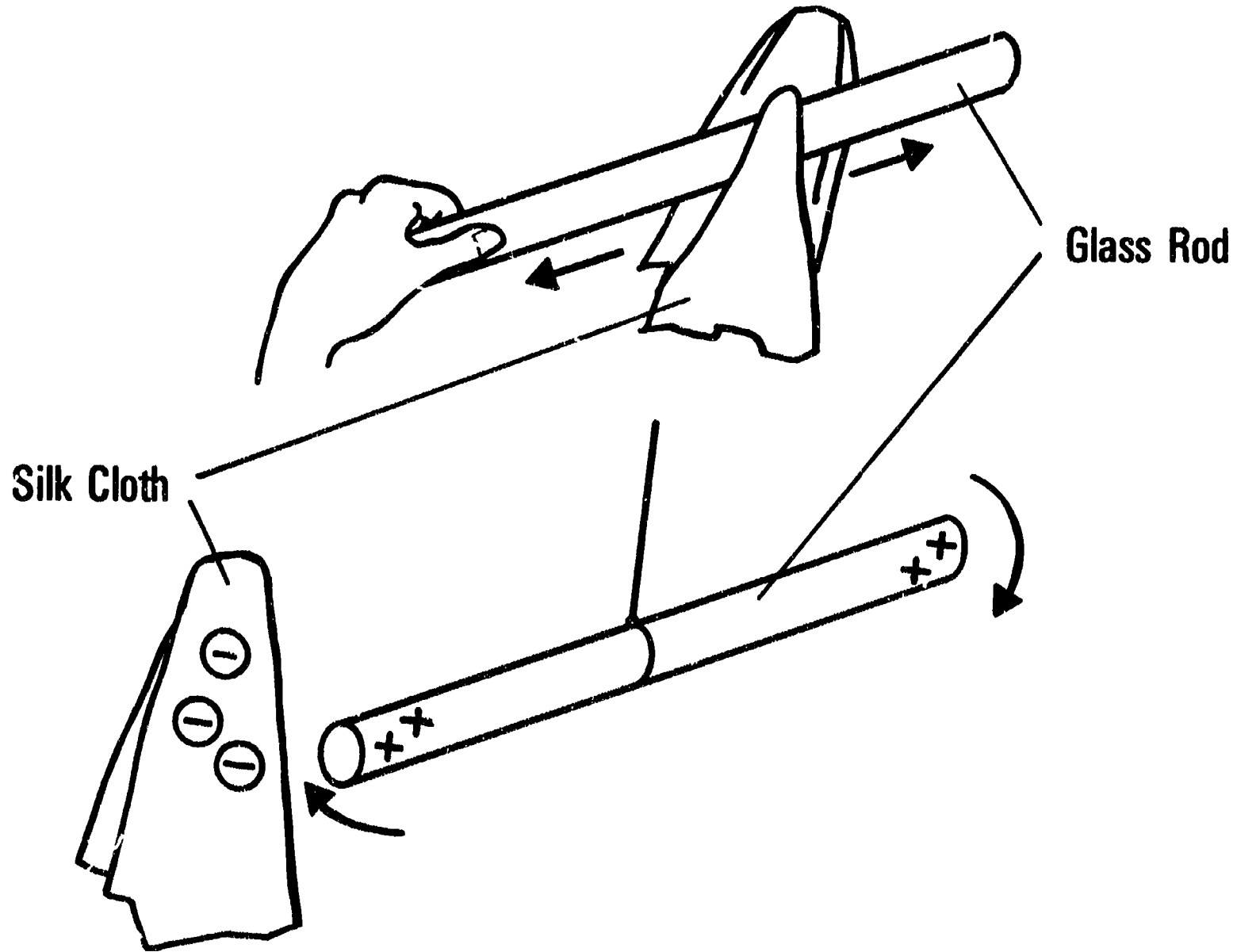

Electricity From Chemical Action

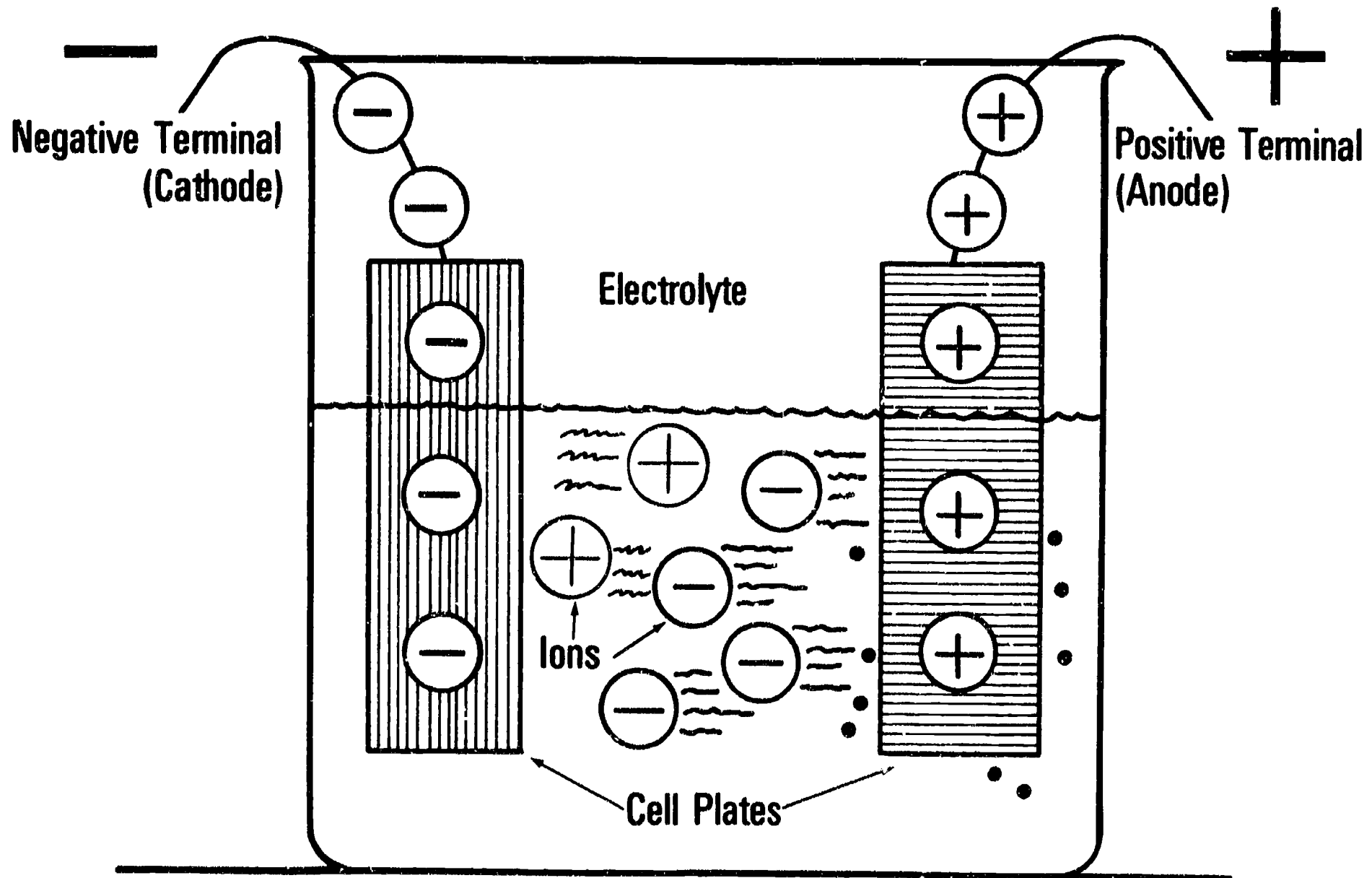

Electricity From Magnetism

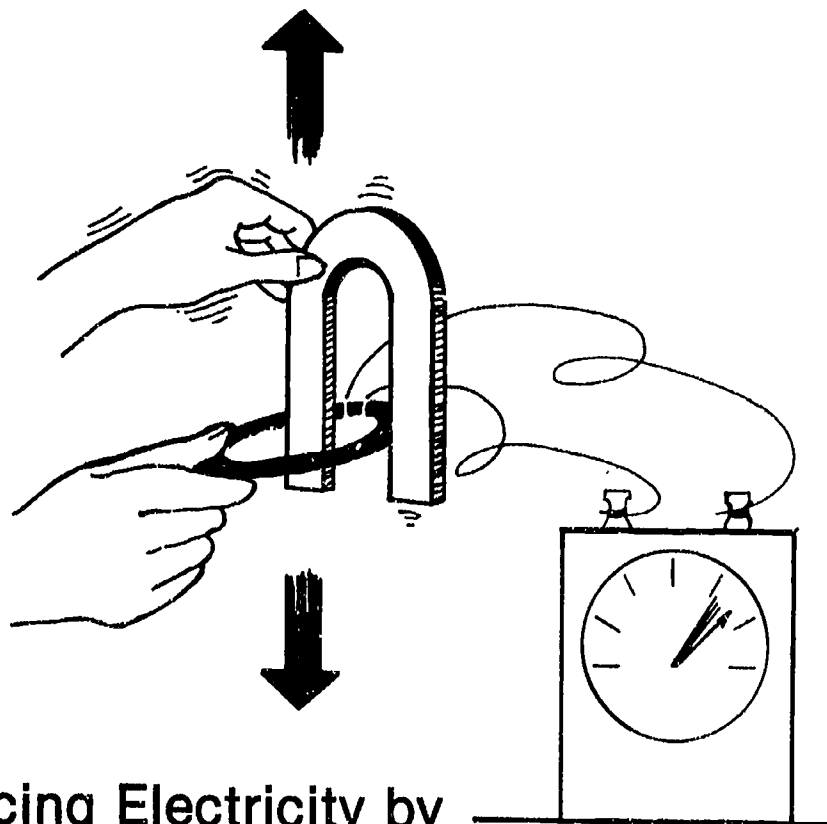

Producing Electricity by Moving a Horseshoe Magnet Through a Coil of Wire

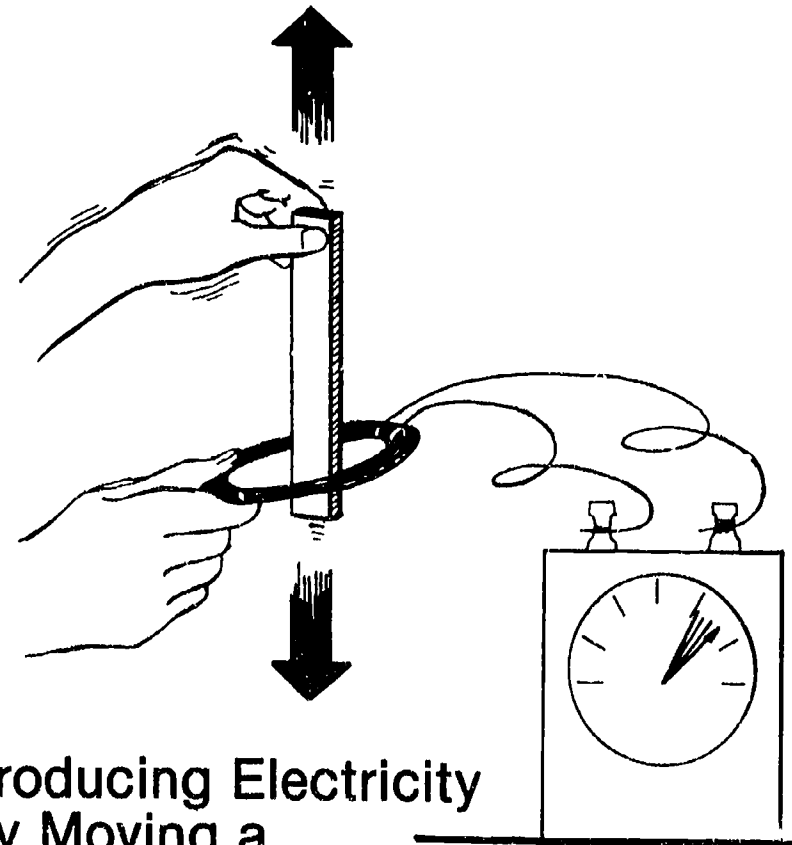

Producing Electricity by Moving a Bar Magnet Through a Coil of Wire

This Principle is used in generators.

Electricity From Light

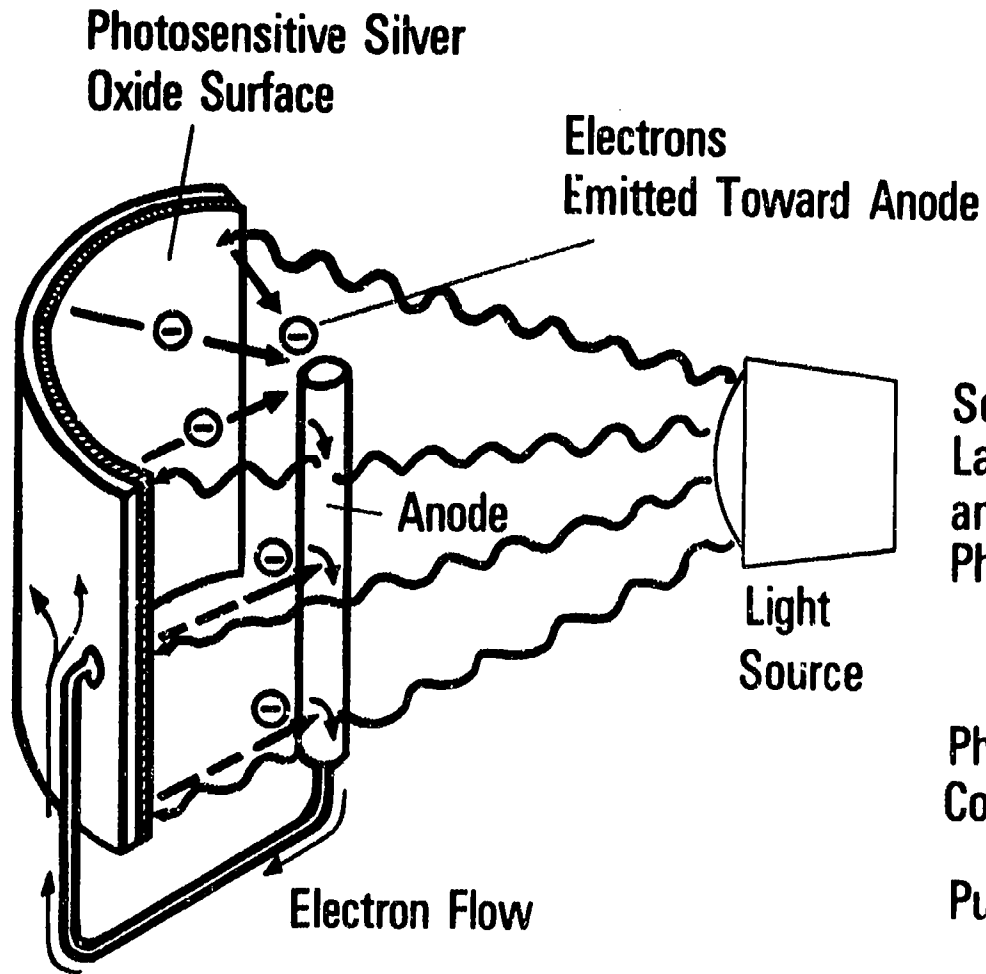

119

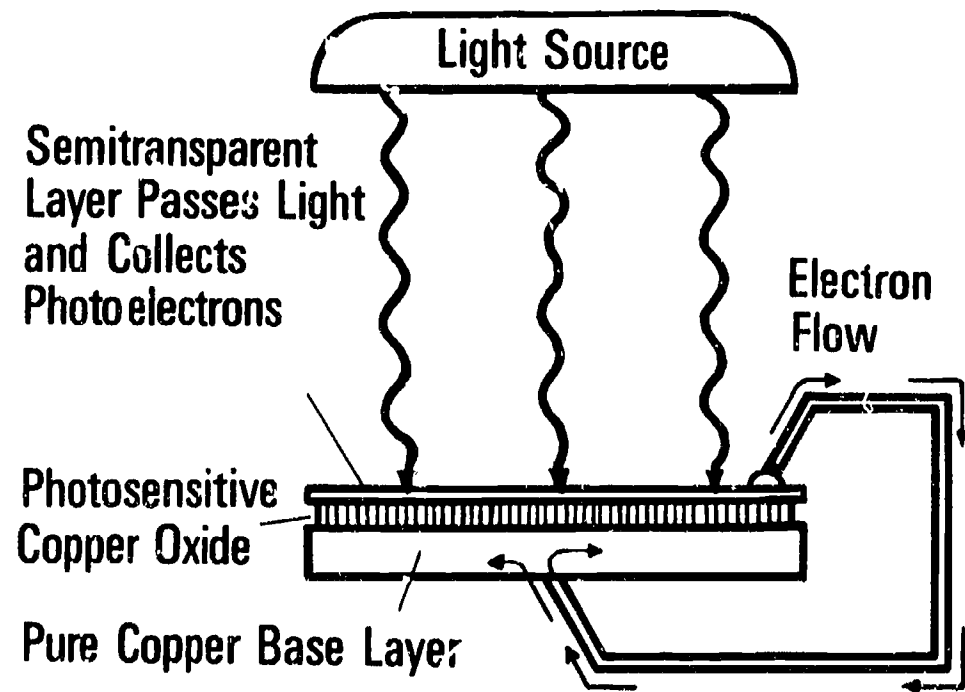

120

Electricity From Heat

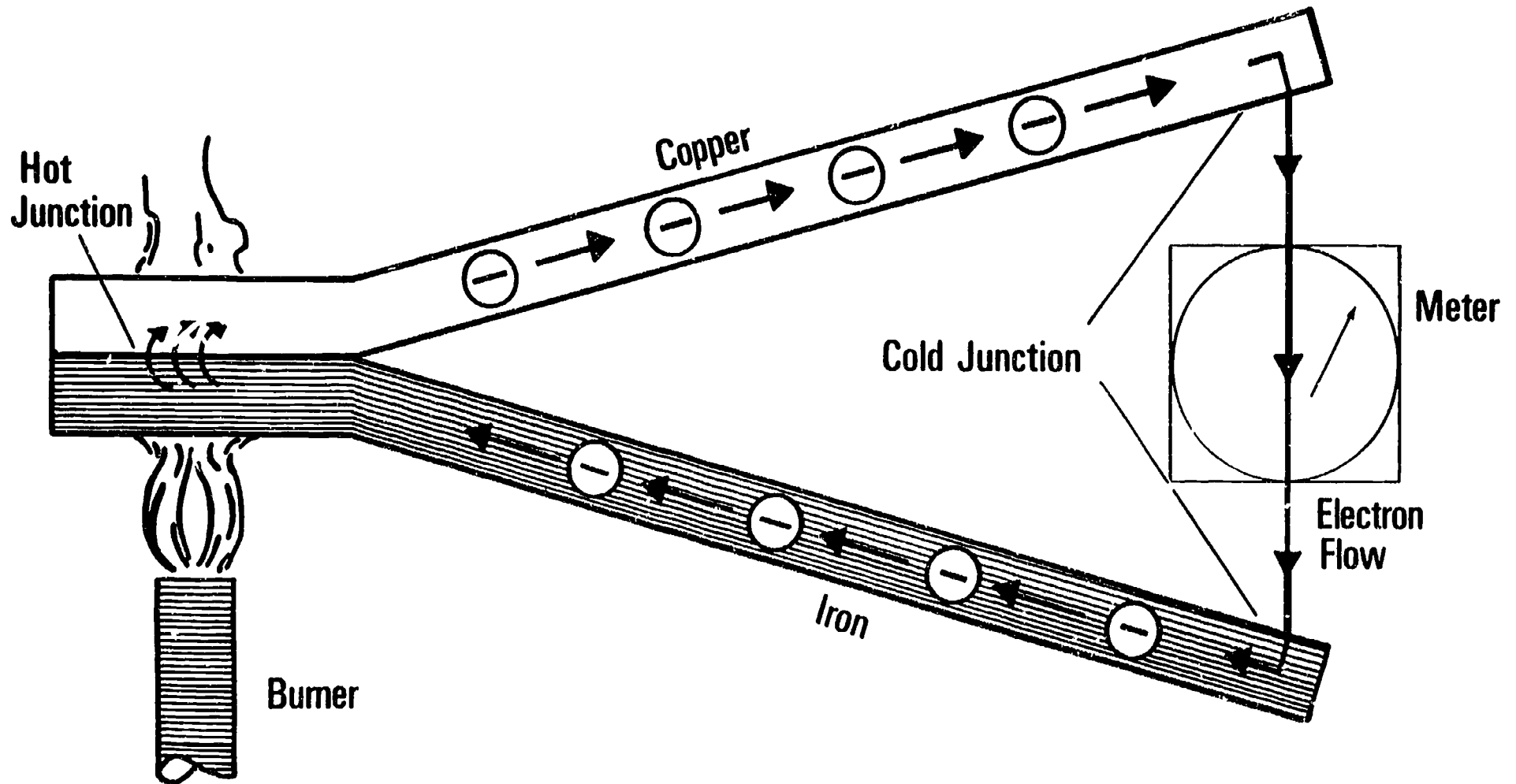

Electricity From Pressure

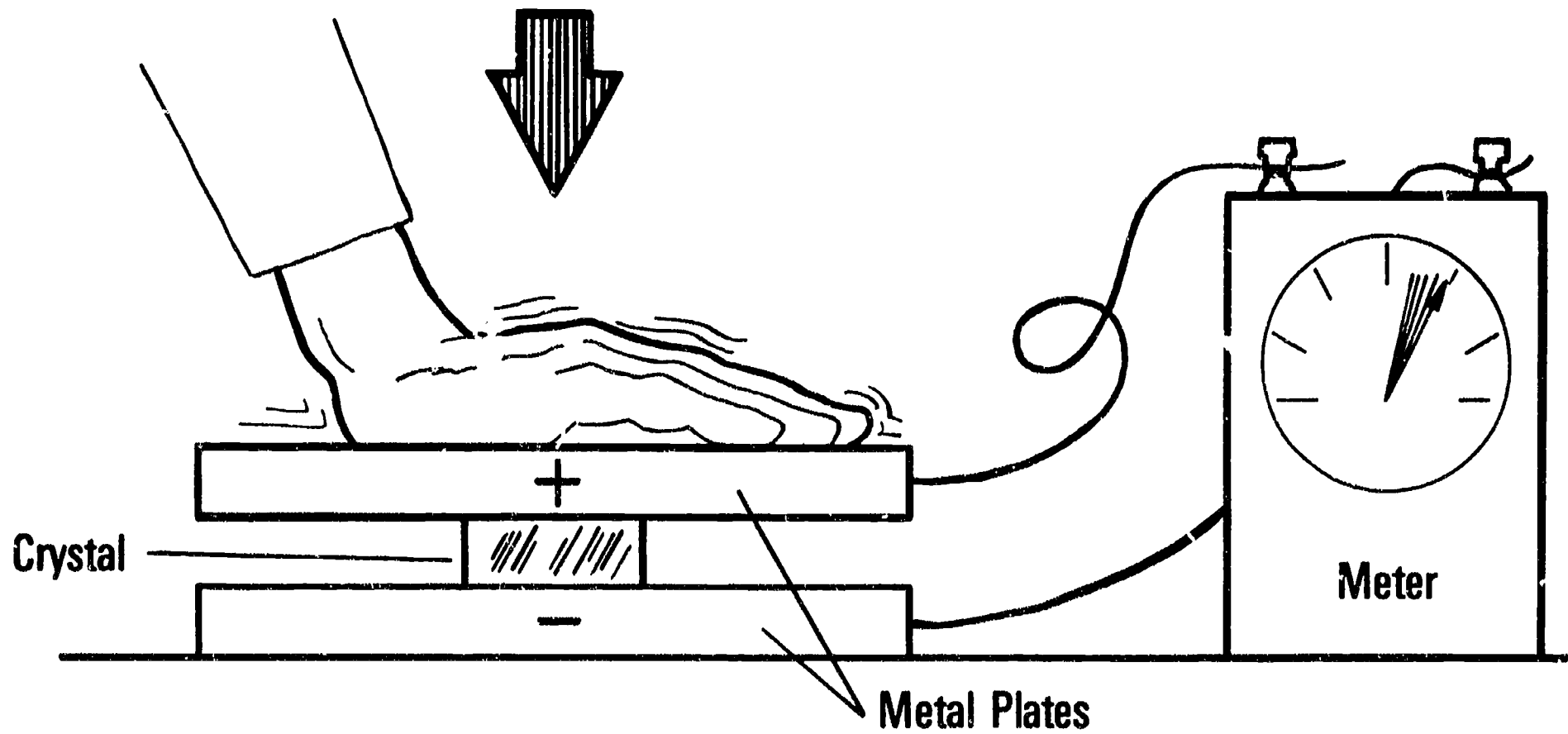

Structure of an Atom

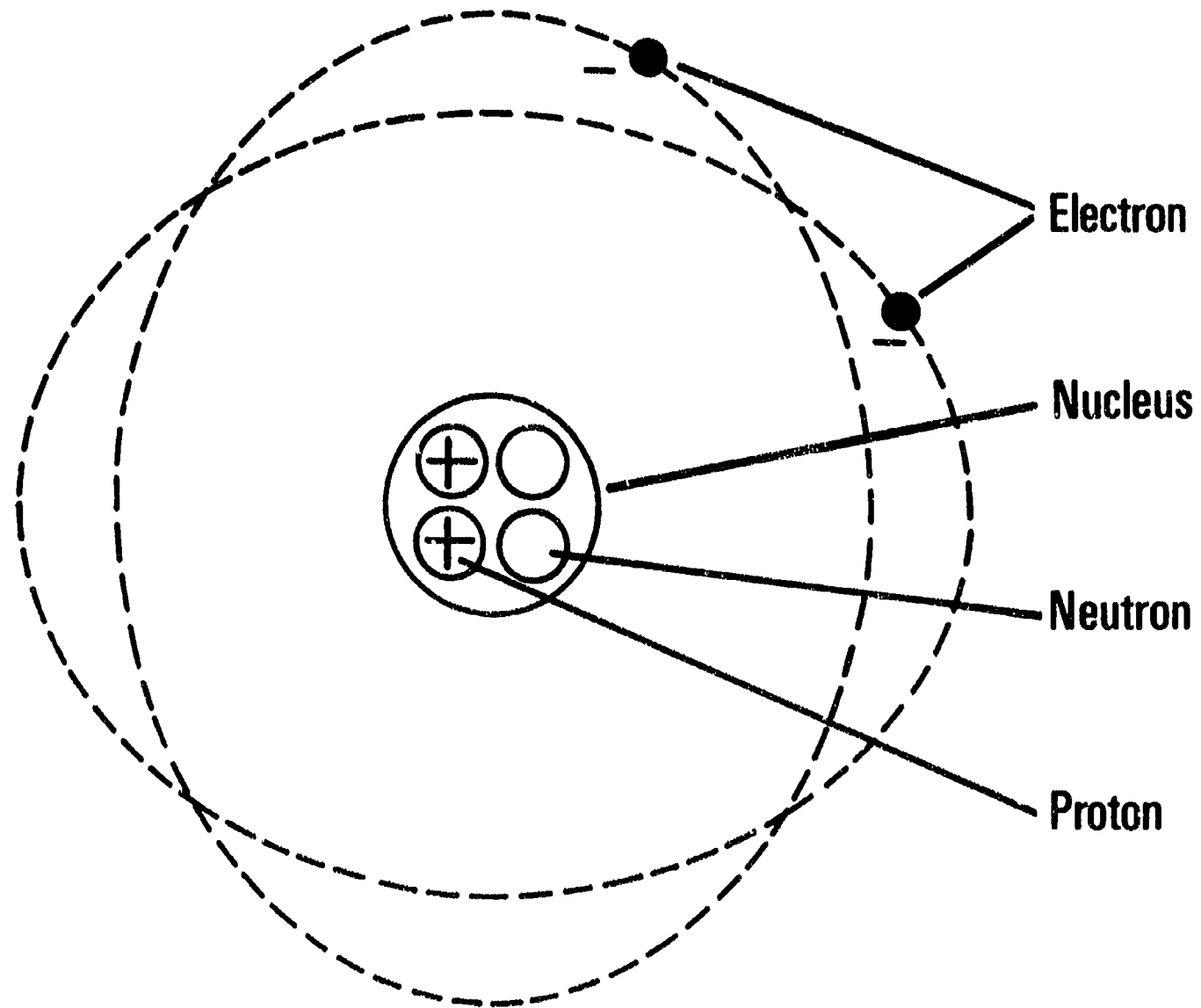

Insulators, Semiconductors, and Conductors

Increasing Resistance

Insulators

Mica
Glass
Shellac
Paper
Rubber
Bakelite
Fiber
Air or Vacuum

Semiconductors

Germanium
Silicon

Conductors

Iron
Nickel
Tungsten
Aluminum
Gold
Copper
Silver

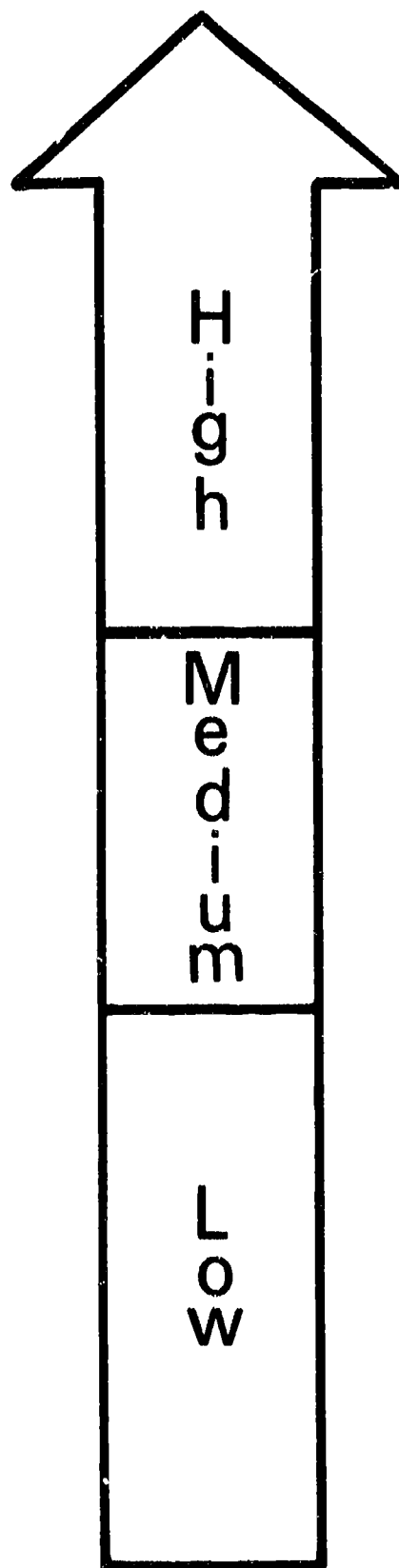

Types of Direct Current

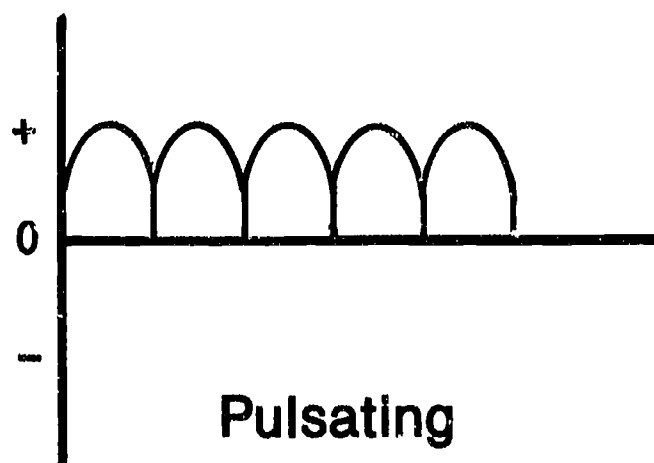
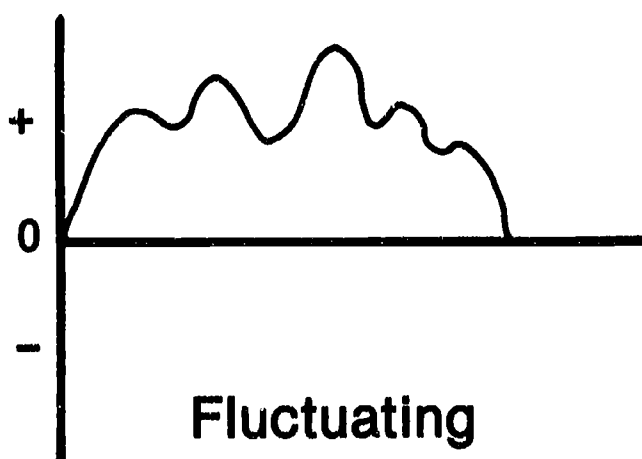
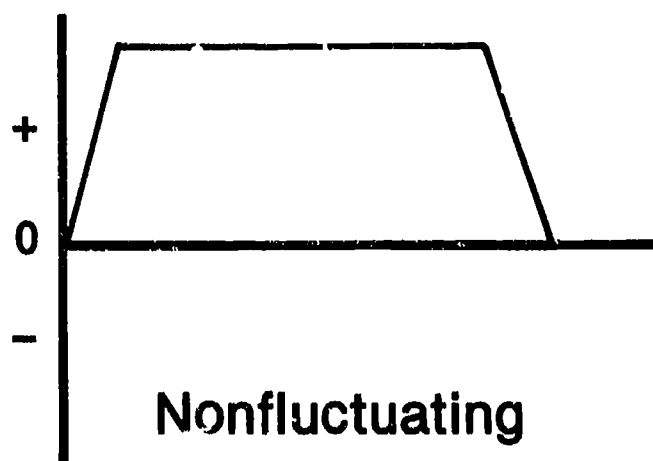

Basic Circuit

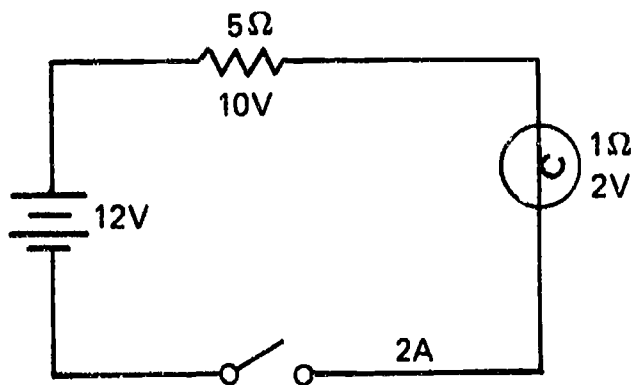
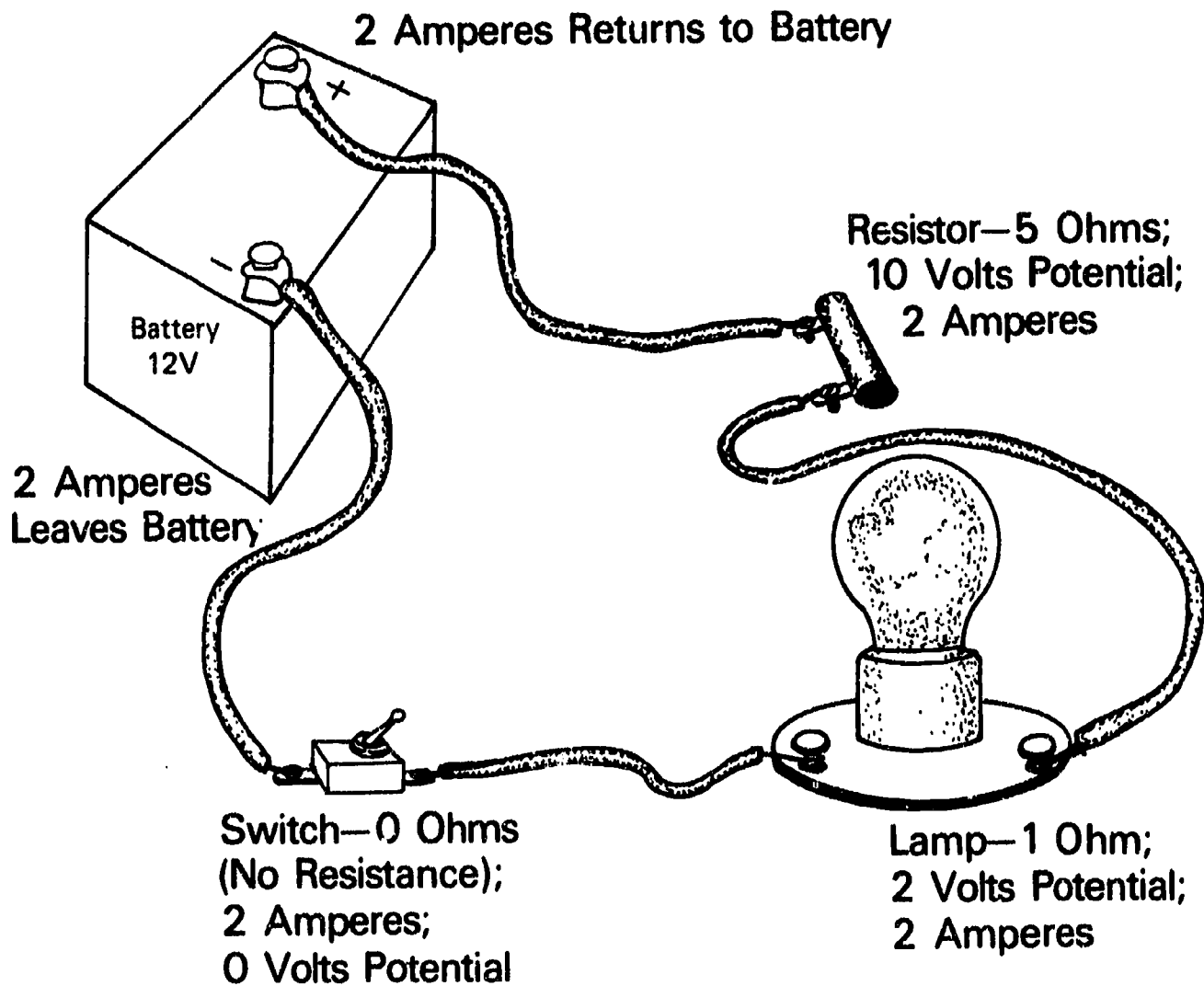

Ohm's Law--Computing Voltage

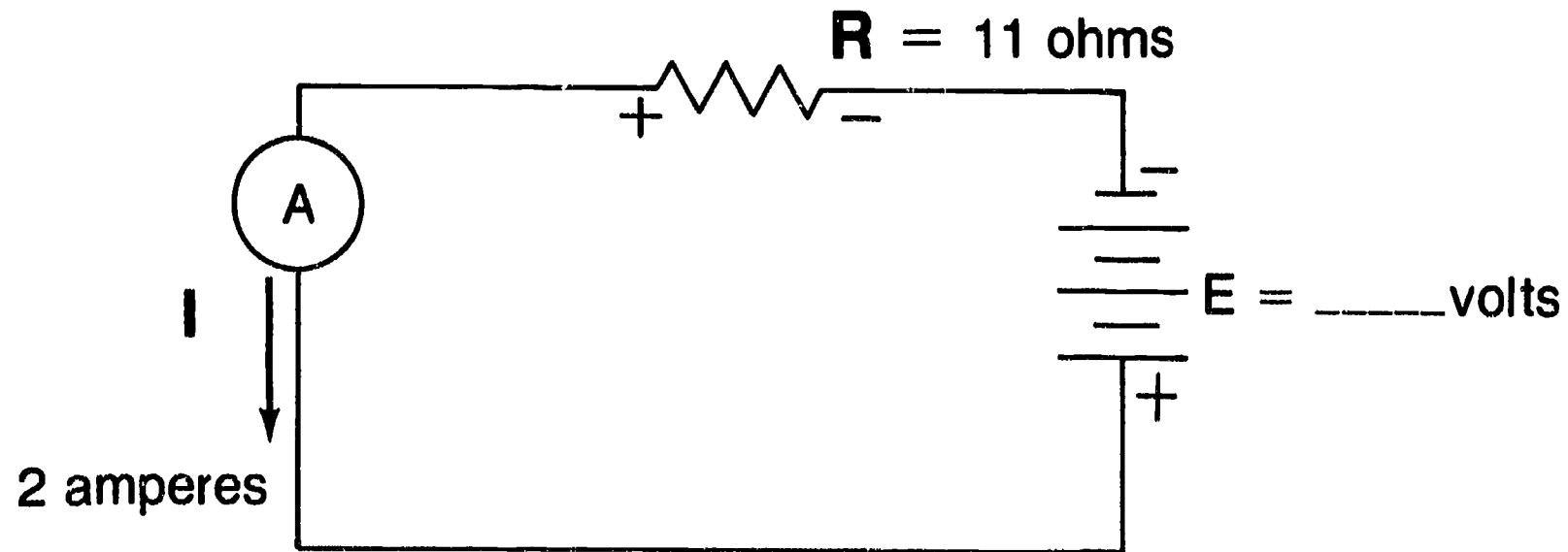

What voltage is being supplied by the battery?

$$E = IR \quad E = 2 \text{ amperes} \times 11 \text{ ohms}, E = 22 \text{ volts}$$

The value of the voltage being supplied by the battery is 22.

Ohm's Law--Computing Current

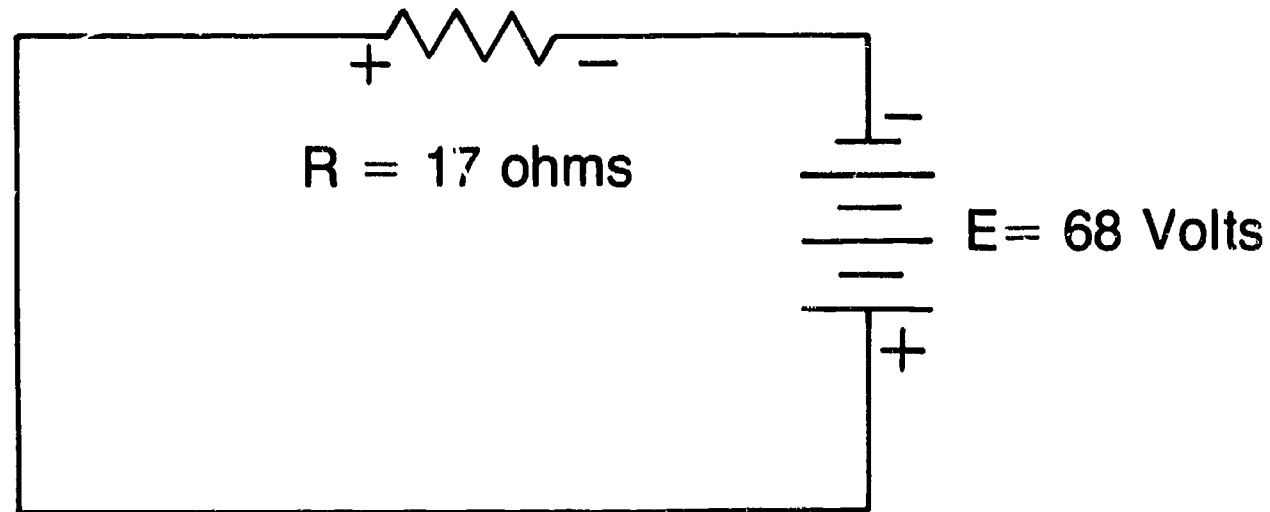

I = _____ amps

How many amperes of current are flowing in this circuit?

$$E = IR$$

$$I = \frac{E}{R}$$

$$I = \frac{68 \text{ volts}}{17 \text{ ohms}} = 4 \text{ amperes}$$

Ohm's Law--Computing Resistance

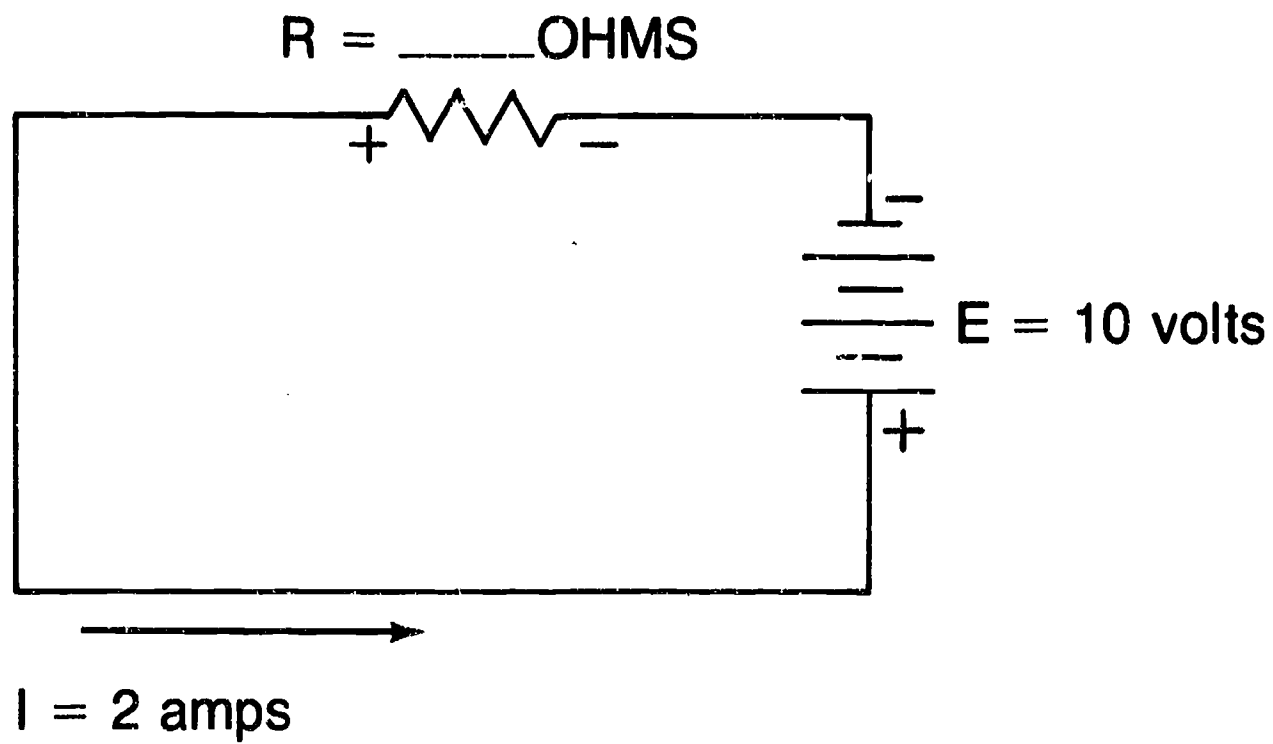

What is the resistance value of the resistor in this circuit?

$$E = IR \qquad R = \frac{E}{I} \qquad R = \frac{10 \text{ volts}}{2 \text{ amperes}} = 5 \text{ ohms}$$

Kirchhoff's Law of Voltage

**The algebraic sum of the voltages around
a closed loop must equal the applied
voltage.**

Voltage Drops in a Circuit

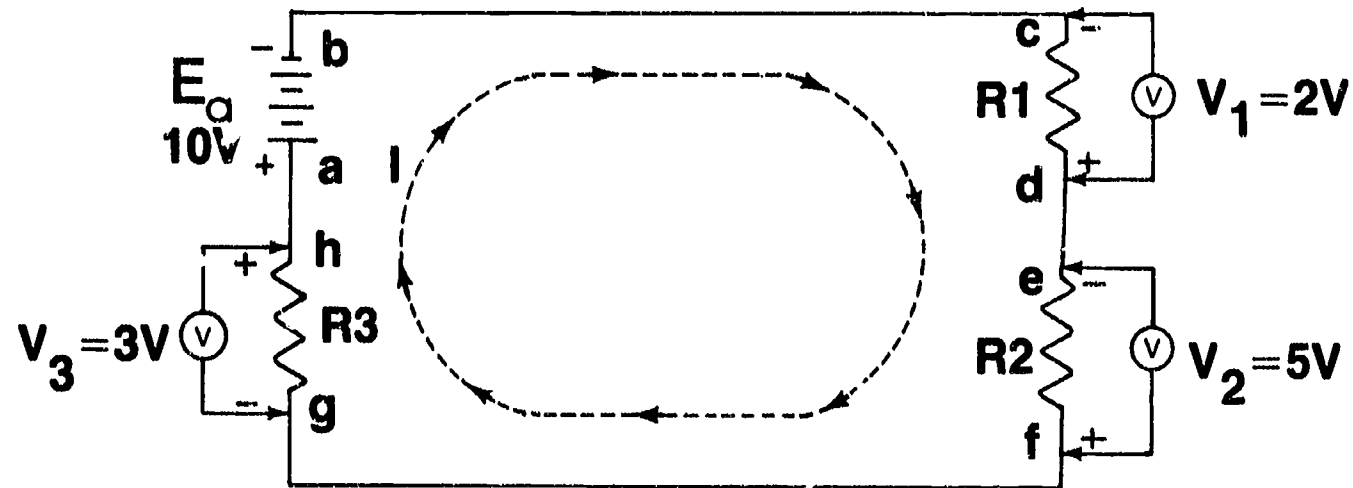

Applied Voltage (E) = 10V

Direction of Electron Flow: Negative (b) to Positive (a)

Application of Kirchhoff's Law of Voltage:

$$V_1 + V_2 + V_3 = E$$

$$2V + 5V + 3V = 10V$$

Resistor Color/Value Chart



Color	Band 1	Band 2	Band 3		Band 4	Band 5
	1st Digit (Number)	2nd Digit (Number)	Multiplier		Tolerance (percent)	Reliability (percent)
Black	0	0	10^0	1		
Brown	1	1	10^1	10	1	1.0
Red	2	2	10^2	100	2	0.1
Orange	3	3	10^3	1,000	3	0.01
Yellow	4	4	10^4	10,000	4	0.001
Green	5	5	10^5	100,000		
Blue	6	6	10^6	1,000,000		
Violet	7	7	10^7	10,000,000		
Gray	8	8	10^8	100,000,000		
White	9	9	10^9	1,000,000,000		
Gold			10^{-1}	0.1	5	
Silver			10^{-2}	0.01	10	
none					20	Not tested

Use the following to remember the resistor color code:

Bad Boys Race Our Young Girls, But Violet Generally Wins.

0 1 2 3 4 5 6 7 8 9

FUNDAMENTALS OF ELECTRICITY UNIT III

ASSIGNMENT SHEET #1 — SOLVE PROBLEMS FOR AN UNKNOWN VOLTAGE

Directions: Apply the appropriate formula from Ohm's law to find the voltage in the following problems.

Example: 2 amps, 60 ohms = _____ volts

Answer: $E = IR = 2 \times 60 = 120$ volts

Problems:

	<i>Amps</i>	<i>Ohms</i>	<i>Volts</i>
1.	20	6	_____
2.	4	60	_____
3.	9.6	2.5	_____
4.	5	3	_____
5.	75	0.16	_____

FUNDAMENTALS OF ELECTRICITY UNIT III

ASSIGNMENT SHEET #2 — SOLVE PROBLEMS FOR AN UNKNOWN AMPERAGE

Directions: Apply the appropriate formula to find the amperage in the following problems.

Example: 120 volts, 40 ohms = _____ amps

Answer: $I = E/R = 120/40 = 3$ amps

Problems:

	<i>Volts</i>	<i>Ohms</i>	<i>Amps</i>
1.	240	12	_____
2.	110	11	_____
3.	440	20	_____
4.	120	30	_____
5.	24	3	_____

FUNDAMENTALS OF ELECTRICITY UNIT III

ASSIGNMENT SHEET #3 — SOLVE PROBLEMS FOR AN UNKNOWN RESISTANCE

Directions: Apply the appropriate formula to find resistance.

Example: 440 volts, 10 amps = _____ ohms

Answer: $R = E/I = 440/10 = 44$ ohms

Problems:

	<i>Volts</i>	<i>Amps</i>	<i>Ohms</i>
1.	240	4	_____
2.	24	9.6	_____
3.	12	5	_____
4.	230	5	_____
5.	24	8	_____

FUNDAMENTALS OF ELECTRICITY UNIT III

ASSIGNMENT SHEET #4 — IDENTIFY RESISTOR VALUES USING A STANDARD COLOR CODE

Directions: Using the color code chart provided in this assignment sheet, identify the value of each resistor provided by your instructor, and record the value in the appropriate blank on the Resistor Value Chart that accompanies this job sheet.

Color	Band 1	Band 2	Band 3		Band 4	Band 5
	1st Digit (Number)	2nd Digit (Number)	Multiplier		Tolerance (percent)	Reliability (percent)
Black	0	0	10^0	1		
Brown	1	1	10^1	10	1	1.0
Red	2	2	10^2	100	2	0.1
Orange	3	3	10^3	1,000	3	0.01
Yellow	4	4	10^4	10,000	4	0.001
Green	5	5	10^5	100,000		
Blue	6	6	10^6	1,000,000		
Violet	7	7	10^7	10,000,000		
Gray	8	8	10^8	100,000,000		
White	9	9	10^9	1,000,000,000		
Gold			10^{-1}	0.1	5	
Silver			10^{-2}	0.01	10	
none					20	Not tested

FUNDAMENTALS OF ELECTRICITY UNIT III

ASSIGNMENT SHEET #4

Resistor Value Chart

1. _____
2. _____
3. _____
4. _____
5. _____
6. _____
7. _____
8. _____
9. _____
10. _____

You Name _____ Date _____

FUNDAMENTALS OF ELECTRICITY UNIT III

ANSWERS TO ASSIGNMENT SHEETS

Assignment Sheet #1

1. 120V
2. 240V
3. 24V
4. 15V
5. 12V

Assignment Sheet #2

1. 20A
2. 10A
3. 22A
4. 4A
5. 8A

Assignment Sheet #3

1. 60 Ω
2. 2.5 Ω
3. 2.4 Ω
4. 46 Ω
5. 3 Ω

Assignment Sheet #4

Evaluated to the satisfaction of the instructor

FUNDAMENTALS OF ELECTRICITY

UNIT III

NAME _____

TEST

1. Match the terms on the right with their correct definitions.

- | | | |
|---------|---|-------------------|
| _____a. | A circuit in which there is a complete and unbroken path for current to flow | 1. Short circuit |
| _____b. | A circuit in which the path for current has been broken | 2. Closed circuit |
| _____c. | A circuit in which the current has been diverted from its intended path into a side current of lower resistance | 3. LED |
| _____d. | A device to which electrical energy is being supplied and used | 4. Open circuit |
| _____e. | A low voltage bulb used to illuminate numbers on control panels and other displays | 5. Load |

2. Complete statements concerning electricity by inserting the word(s) that best completes each statement.

- a. Electricity is a form of energy that can be converted to light, heat, or mechanical energy to perform useful _____
- b. Electricity exists in nature as _____ electricity and as _____, but these forms of electricity do not perform useful work
- c. Electricity used for domestic and industrial purposes is generated at power plants and transmitted by high voltage _____ to towns and cities
- d. High voltage electricity from a generating plant usually has to go through a _____ that steps it down to a lower voltage for home and industry use
- e. Electricity is put to work in the average home in an arrangement of _____ circuits to supply electricity for lighting, heating, air conditioning, and appliance use
- f. To benefit people, electricity has to be _____, and switches, solenoids, transformers and other control devices are what make major appliances useful tools for modern living

TEST

3. Match sources of electricity with their characteristics.

- | | |
|---|--|
| <p>_____a. Produces static electricity when two materials are rubbed together</p> <p>_____b. Produces direct current electricity in batteries and cells when dissimilar elements are placed in a chemical which acts upon them</p> <p>_____c. Produces direct current or alternating current electricity by moving a conductor through a magnetic field</p> <p>_____d. Produce electricity when light strikes them</p> <p>_____e. Produces electricity when it is applied to two dissimilar metals that are next to each other</p> <p>_____f. Produces electricity when applied to certain crystalline substances</p> | <p>1. Magnetism</p> <p>2. Mechanical pressure</p> <p>3. Friction</p> <p>4. Heat</p> <p>5. Chemical reaction</p> <p>6. Photoelectric surfaces</p> |
|---|--|

4. Select true statements concerning the electron theory by placing an "X" beside each statement that is true.

- _____a. Understanding electricity requires basic knowledge of the structure of an atom
- _____b. Neutrons with no charges and ions with positive charges make up the nucleus of an atom
- _____c. Electrons with negative charges orbit the nucleus in paths that are called shells
- _____d. Electrons that orbit in inner shells are attracted to the nucleus, but electrons in the outer shell or "valence" shell can be set free
- _____e. When energy is applied to the centrifugal force in an electron, the electron leaves its previous orbit and moves to a lower orbit
- _____f. Since a valence electron has no higher orbit, it will leave the parent atom and move to another atom
- _____g. The positive charge of an electron freed from the valence shell is the basic unit of electricity

5. Complete statements concerning the importance of electrical charges by inserting the word(s) that best completes each statement.

- a. A man named Coulomb experimented with electrical charges and formulated a law that governs the interaction of _____ and _____ charges

TEST

- b. The two most important electrical relationships established by Coulomb's law are that:
- 1) Like charges _____
 - 2) Unlike charges _____
- c. The fact that positive charges attract negative charges is extremely important to the movement of _____ required to create current flow in a conductor
- d. The attraction and repulsion principles help make DC and AC _____ work
6. Complete statements concerning how electron flow is created in a conductor by circling the word(s) that best completes each statement.
- a. To create electron flow requires a source of already energized electrons like those found in (a battery) (silicon)
 - b. The wire or medium that serves as a (conductor) (transmitter) must have one end connected to the negative side of the power source and the other end connected to the positive side of the power source
 - c. The (positive) (negative) charges from the power source energize the negative charges in the conductor and cause them to start moving
 - d. The (positive) (negative) charges at the other end of the power source attract the electrons from the negative side and reinforce electron flow
 - e. The presence of negative charges at one end of the conductor and the absence of negative charges at the other end of the conductor sets up a situation called a (potential difference) (inductance)
 - f. The (potential difference) (inductance) must be present before electrons will flow in a conductor to create electric current that can be put to work
7. Solve problems concerning conductors, insulators, and semiconductors.
- a. Would a piece of copper wire be considered a conductor, an insulator, or a semiconductor?
Answer _____
 - b. Would a silicon disc be considered a conductor or a semiconductor?
Answer _____
 - c. Would gold or silver make good insulators?
Answer _____

TEST

- d. Would glass make a good insulator?

Answer _____

8. Complete statements concerning direct current by circling the word(s) that best completes each statement.

- a. The (strongest) (most common) source of direct current electricity is the battery
- b. Both wet and dry cell batteries operate on the same principle of two (similar) (dissimilar) metals placed in a chemical that reacts upon them
- c. Chemical reaction in a battery creates (a potential difference) (an inductance) between the dissimilar elements and creates a condition for electron flow
- d. Potential difference is also called ("amperage") ("voltage") and can be tapped into with wires and directed to an electrical device or "load"
- e. The essential characteristic of direct current is that the strength of the current may rise or fall, but it never becomes (negative) (positive)
- f. When plotted graphically to depict its movement in time, direct current may be
- 1) (Nonfluctuating) (Slanted)
 - 2) (Pulsating) (Intermittent)
 - 3) (Fluctuating) (Sporadic)
- g. Direct current is (often) (seldom) used with major appliances, (but) (and) batteries are an excellent source of power for the study of electrical circuits and electrical measurements

9. Complete statements concerning alternating current by inserting the word(s) or figure(s) that best complete each statement.

- a. The essential characteristic of alternating current is that it constantly _____ itself above and below a zero base line
- b. When alternating current is depicted graphically in time, it creates a wave form that starts at _____, rises to a maximum level, returns to _____, then reaches another maximum level below _____ base line, and then repeats the alternation
- c. One complete reversal of alternating current is called a _____, and one _____ contains two different current directions
- d. Most household current reverses itself _____ times per second, so there are 60 cycles per second or 60 hertz per second

TEST

e. Alternating current can be transmitted from generating sources over _____ distances without excessive power loss, and it is preferred over direct current

10. Identify the following basic electrical symbols by placing the correct number in the appropriate blank.

____ a.



____ b.



____ c.



____ d.

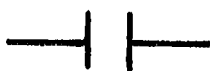

____ e.



____ f.



____ g.



____ h.



____ i.



1. Resistor

2. Ohms

3. An AC power source

4. An open switch

5. A single pole, single throw switch

6. Connected electrical wires

7. Fuse

8. Light or lamp

9. DC power source

TEST

11. Identify types of circuits by writing the appropriate name beside each of the following circuit diagrams.

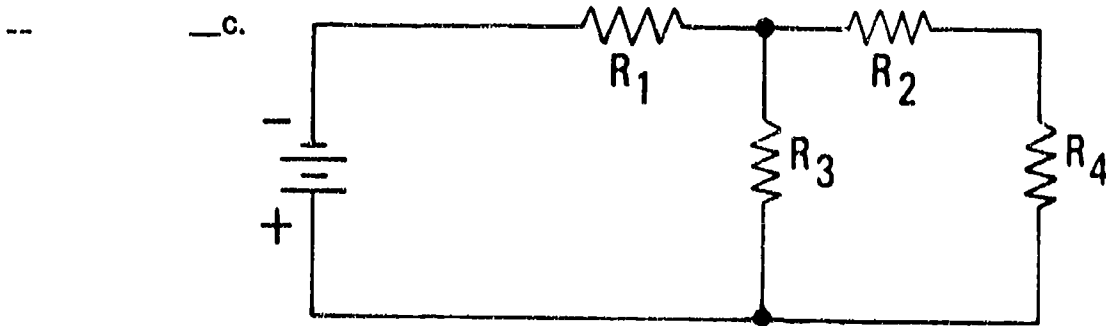
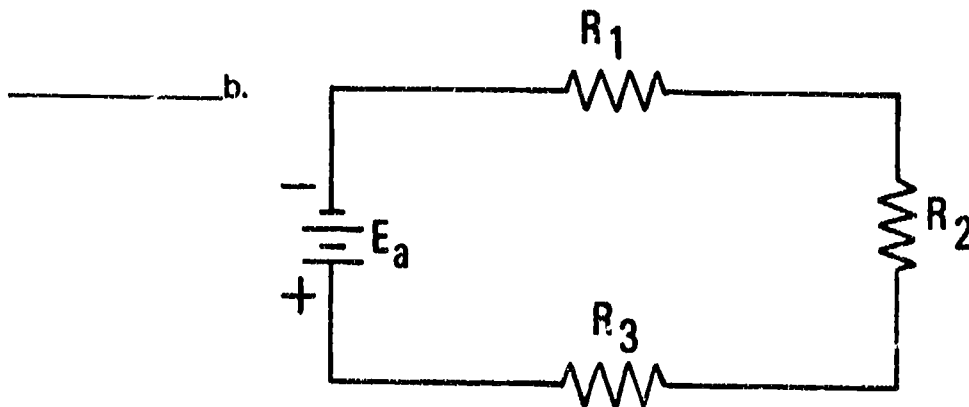
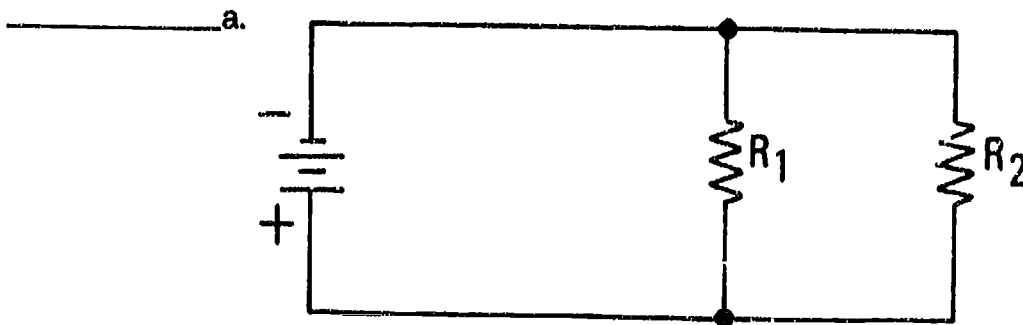

12. Complete a list of elements of a basic circuit by inserting the word(s) that best complete each statement.

a. A complete circuit must have:

- 1) A _____ such as a battery
- 2) A _____ such as an electric wire
- 3) A _____ such as a light bulb

TEST

- b. To be of practical use, a circuit should also have:
- 1) A _____
 - 2) A _____ device such as a fuse or a circuit breaker
13. Complete statements concerning circuit applications by circling the word(s) that best complete each statement.
- a. Switches are always wired in (series) (parallel) with the circuits they control
 - b. Series circuits are used in several appliances such as automatic dryers where the door switch is in series with the motor circuit so the appliance will not start if the (door is open) (fuse is blown)
 - c. Parallel circuits are most common in (washers) (house wiring), but are also common in refrigerators and ranges
 - d. In an automatic washer, the fill valve is in (parallel) (series) with the water level switch so water will cut off at the predetermined level, but the fill valve is in (parallel) (series) with the timer so the dishwasher will go into a wash cycle after filling
14. Select true statements concerning circuit grounding by placing an "X" beside each statement that is true.
- _____a. A ground in a circuit serves to protect operators and technicians against hazardous static electrical shock
 - _____b. All circuits should be grounded with a ground wire from the power source to a point on the appliance chassis
 - _____c. In cases where a circuit cannot be grounded to chassis, the ground wire should be secured to a cold water pipe or to a grounding rod driven into the ground
 - _____d. Loose grounds create static in radio and television sets and contribute to heat build-up in appliances
15. Select true statements concerning electrical measurements by placing an "X" beside each statement that is true.
- _____a. Being able to measure the electrical characteristics in a circuit is the basis of all electrical troubleshooting
 - _____b. Electrical measurements permit duplication of previous conditions
 - _____c. Electrical measurements permit the comparison of a present electrical condition with a past condition

TEST

- _____d. Electrical measurements are made with specialized instruments, and knowing how to use test instruments properly is a basic requirement for appliance repair technicians
16. Match abbreviations with their meanings in ohm's law.
- | | | |
|---------|----------------------------------|------|
| _____a. | Electromotive in volts | 1. R |
| _____b. | Intensity of the current in amps | 2. E |
| _____c. | Resistance in ohms | 3. P |
| _____d. | Power in watts | 4. I |
17. Solve problems concerning ohm's law for electrical circuits by properly completing each of the following statements:
- a. The voltage required to force a given amount of current through a circuit is equal to the current times the _____
 - b. The current in a circuit is equal to the voltage divided by the _____
 - c. The resistance of a circuit is equal to the voltage divided by the _____
18. Solve problems using ohm's law to find unknown values in a circuit.
- a. Since $E = IR$, a circuit with 20 amps and 6 ohms resistance would have how many volts?
Answer _____
 - b. Since $I = E/R$, a circuit with 240 volts and 12 ohms resistance would have how many amps?
Answer _____
 - c. Since $R = E/I$, a circuit with 240 volts and 4 amps would have how many ohms resistance?
Answer _____
19. Solve problems concerning characteristics of electrical power by answering the following questions.
- a. Name the fundamental unit of measure for electrical power, and also name the instrument used to measure power.
Answer _____

TEST

- b. How is power made evident?

Answer _____

20. Complete a list of ways ohm's law is used by inserting the word(s) that best complete each statement.

- a. To calculate circuit _____
- b. To calculate circuit _____
- c. To calculate circuit _____
- d. To calculate circuit _____
- e. To calculate _____

21. Differentiate between Kirchoff's laws for voltage and current by placing an "X" beside the statements that describes the law for voltage.

- _____a. The sum of the voltage drops in a closed loop circuit is equal to the applied voltage
- _____b. The algebraic sum of currents into any point in a circuit is equal to the algebraic sum of currents out of that point

22. Complete statements concerning working with resistors by inserting the word(s) that best completes each statement.

- a. Resistors are used in some major appliance circuitry to limit current or provide a _____ to establish proper circuit voltage
- b. Knowing how to read the value of resistors is essential in _____ circuit problems
- c. Some wire-wound resistors have their value _____ on the body and are easy to determine
- d. Most carbon-composition and film-type resistors can only be evaluated by use of a _____, and understanding the _____ is essential to resistor troubleshooting

23. Arrange in order the steps in using the color code to determine resistor value by inserting the correct sequence number in the appropriate blank.

- _____a. List the first color band as the first number of the resistance value
- _____b. Use the fourth color band to determine the tolerance of the resistor

TEST

- _____c. Always begin with the color band nearest the end of the resistor
- _____d. Use the third color band as the multiplier
- _____e. List the second color band as the second number of the resistance value

(NOTE: If the following activities have not been accomplished prior to the test, ask your instructor when they should be completed.)

- 24. Solve problems for an unknown voltage. (Assignment Sheet #1)
- 25. Solve problems for an unknown amperage. (Assignment Sheet #2)
- 26. Solve problems for an unknown resistance. (Assignment Sheet #3)
- 27. Identify resistor values using a standard color code. (Assignment Sheet #4)

FUNDAMENTALS OF ELECTRICITY

UNIT III

ANSWERS TO TEST

1.
 - a. 2
 - b. 4
 - c. 1
 - d. 5
 - e. 3

2.
 - a. Work
 - b. Static, lightning
 - c. Power lines
 - d. Transformer
 - e. Parallel
 - f. Controlled

3.
 - a. 3
 - b. 5
 - c. 1
 - d. 6
 - e. 4
 - f. 2

4. a, c, d, f

5.
 - a. Negative, positive
 - b.
 - 1) Repel
 - 2) Attract
 - c. Electrons
 - d. Motors

6.
 - a. A battery
 - b. Conductor
 - c. Negative
 - d. Positive
 - e. Potential difference
 - f. Potential difference

7.
 - a. A conductor
 - b. A semiconductor
 - c. No
 - d. Yes

8.
 - a. Most common
 - b. Dissimilar
 - c. A potential difference
 - d. "Voltage"
 - e. Negative

ANSWERS TO TEST

- f. 1) Nonfluctuating
2) Pulsating
3) Fluctuating
- g. Seldom, but
9. a. Reverses
b. Zero, zero, zero
c. Cycle, cycle
d. 120
e. Long
10. a. 3 f. 8
b. 9 g. 7
c. 6 h. 2
d. 4 i. 5
e. 1
11. a. Parallel
b. Series
c. Series-parallel
12. a. 1) Power source
2) Conductor
3) Load
b. 1) Switch
2) Protection
13. a. Series
b. Door is open
c. House wiring
d. Series, parallel
14. a, b, c, d
15. a, b, d
16. a. 2
b. 4
c. 1
d. 3
17. a. Resistance
b. Resistance
c. Current
18. a. 120V
b. 20 amps
c. 60 ohms

ANSWERS TO TEST

19. a. The watt, a wattmeter
b. A voltage drop across the resistance
20. a. Resistance
b. Amperage
c. Voltage
d. Wattage
- (NOTE: A through d may be in any order.)
- e. Voltage drop
21. a
22. a. Load
b. Troubleshooting
c. Stamped
d. Color code, code
23. a. 2
b. 5
c. 1
d. 4
e. 3

24 through 27. Evaluated to the satisfaction of the instructor



AC INDUCTION MOTORS UNIT IV

UNIT OBJECTIVE

After completion of this unit, the student should be able to discuss the principles of magnetism and how those principles apply to electromagnets, coils, transformers, DC motors, and AC induction motors. The student should also be able to name components of an AC induction motor, list types of motors, and discuss guidelines for servicing throw-away motors. The student should also be able to troubleshoot an AC induction motor for thermal overload problems, determine whether a start mechanism or start windings are bad, replace a centrifugal switch, and bench-test a single-speed motor with a test cord. These competencies will be evidenced by correctly completing the procedures outlined in the job sheets and by scoring 85 percent on the unit test.

SPECIFIC OBJECTIVES

After completion of this unit, the student will be able to:

1. Match terms related to AC induction motors with their correct definitions.
2. Solve problems concerning principles of magnetism.
3. Apply the left hand rule for conductors.
4. Complete statements concerning electromagnets and coils.
5. Solve problems concerning other principles of magnetism.
6. Identify types of transformers.
7. Complete statements concerning DC motor components.
8. Select true statements concerning DC motor operation.
9. Complete statements concerning AC induction motors.
10. Match components of an AC induction motor with their functions.
11. Solve problems concerning types of AC induction motors.

OBJECTIVE SHEET

12. **Select true statements concerning operations of an Induction start, Induction run motor.**
13. **Select true statements concerning operations of a capacitor start, Induction run motor.**
14. **Complete statements concerning motor housings.**
15. **Solve problems concerning motor speeds.**
16. **Match types of motor bearings with their characteristics.**
17. **Solve problems concerning motor thermal protection.**
18. **Complete statements concerning other motor problems.**
19. **Select true statements concerning using compressor test cords in motor testing.**
20. **Complete a list of guidelines for servicing throw-away motors.**
21. **Solve problems concerning motor nameplate information.**
22. **Complete statements concerning motor safety.**
23. **Arrange in order the steps in systematically troubleshooting an Induction motor.**
24. **Demonstrate the ability to:**
 - a. **Troubleshoot an AC Induction motor for thermal overload problems. (Job Sheet #1)**
 - b. **Troubleshoot an AC Induction motor to determine whether the start mechanism or the start windings are bad, and replace a centrifugal switch. (Job Sheet #2)**
 - c. **Bench test a single-speed motor with a test cord. (Job Sheet #3)**

AC INDUCTION MOTORS UNIT IV

SUGGESTED ACTIVITIES

- A. Provide students with objective sheet.
- B. Provide students with information sheet.
- C. Make transparencies.
- D. Demonstrate and discuss the procedures outlined in the job sheets.
- E. Have samples of different types of AC induction motors on hand so students can examine the components and learn to identify them.
- F. Show good samples of run and start windings and how they are wired onto the poles in the stator.
- G. Discuss the concepts of the reversible motor and its application in modern appliances.
- H. Show the class different types of centrifugal switches and how they work.
- I. Discuss safety as related to motor service and impress upon students the importance of safe grounding.
- J. Invite a local or area appliance service store owner to talk to the class about the importance of being able to efficiently troubleshoot an appliance motor.
- K. Demonstrate use of a compressor test cord and explain its value in verifying electrical problems and identifying mechanical problems.
- M. Give test.

CONTENTS OF THIS UNIT

- A. Objective sheet
- B. Information sheet
- C. Transparency masters
 - 1. TM 1 — Start and Run Windings
 - 2. TM 2 — Components of an AC Induction Motor
 - 3. TM 3 — Compressor Test Cord
 - 4. TM 4 — Motor Nameplate

CONTENTS OF THIS UNIT

- D. Job sheets
 - 1. Job Sheet #1 — Troubleshoot an AC Induction Motor for Thermal Overload Problems.
 - 2. Job Sheet #2 — Troubleshoot an AC Induction Motor to Determine Whether the Start Mechanism or Start Windings Are Bad, and Replace a Centrifugal Switch.
 - 3. Job Sheet #3 — Bench Test a Single-Speed Motor With a Test Cord.
- E. Test
- F. Answers to test

REFERENCES USED IN DEVELOPING THIS UNIT

- A. Vorderstrasse, Ron. *General Electronic Technician*. Stillwater, OK 74074: Mid-America Vocational Curriculum Consortium, 1986.
- B. Bacon, Bill and Mack Sutton. *Major Appliance Repairer*. Austin, TX 78712: The University of Texas at Austin, 1983.
- C. Lieder, Larry. *Really Basic Electricity*. Honeywell, Inc., 1982.
- D. Teague, Cash and Garner Pewewardy. *Industrial Electricity Motors*. Stillwater, OK 74074: Curriculum and Instructional Materials Center, Oklahoma State Department of Vocational and Technical Education, 1984.
- E. Milaf, Harry. *Electricity One-Seven*. New York, NY: Hayden Book Company, 1966.
- F. Kaiser, Joe. *Electrical Power*, South Holland, IL: The Goodheart Willcox Company, Inc., 1982.

AC INDUCTION MOTORS UNIT IV

INFORMATION SHEET

I. Terms and definitions

- A. Centrifugal switch — A mechanical switch used to disconnect starting mechanisms in induction motors by taking advantage of the force created by a rotating motor shaft
- B. Electromagnet — A soft iron core that temporarily becomes a magnet when electrical current flows through wires coiled around it
- C. Induction — The process of magnetizing an object by bringing it into the magnetic field of an electromagnet or a permanent magnet
- D. Magnet — Any device or material that has the properties of magnetism
- E. Momentary switch — A mechanical device that has to be manually pressed down to complete a circuit
- F. Motor test cord — A device used to direct start an induction motor
- G. Overload — A load on a circuit or system greater than the load for which it was designed
- H. Split-phase — A reference to a motor type that has both start and run windings
- I. SPST (single pole, single throw) — A single lever that operates a single set of contacts
- J. SPDT (single pole, double throw) — A single lever that operates two sets of contacts
- K. Reversible motor — A motor wired in a manner that permits external control of polarity so the direction of motor rotation can be reversed
- L. Pole — The soft, laminated iron portion of a stator around which wire is wound
- M. SF (service factor) — The degree to which a motor can be loaded beyond its rated horsepower
- N. Duty rating — The length of time a motor can be safely operated, expressed as continuous or intermittent
- O. Rotor — The iron core cylinder that rotates within the stator of an AC induction motor

INFORMATION SHEET

- P. Stator — The component in an AC induction motor that contains the stationary parts of the magnetic circuit and their associated windings.

II. Principles of magnetism

- A. A magnet is a piece of metal that exerts an invisible force of attraction on other similar metals

(NOTE: Iron oxide makes the best magnets, but nickel and cobalt are also used in the permanent magnets that are used in electrical devices and motors.)

- B. Molecules in a magnet are arranged with their N(orth) and S(outh) poles together (Figure 1)

FIGURE 1

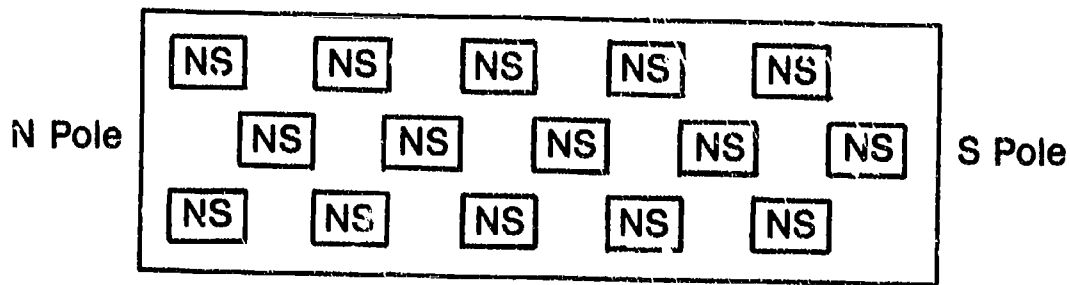

- C. Magnets are surrounded with lines of magnetic force or "flux" that form a field around the magnet (Figure 2)

FIGURE 2

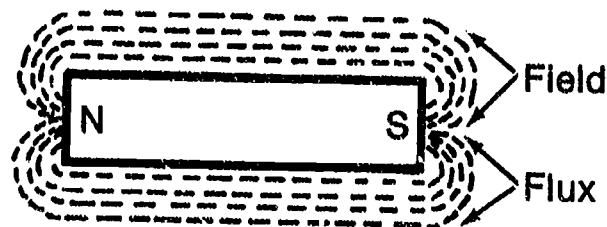

INFORMATION SHEET

D. Converting magnetic energy into electrical energy requires application of two basic principles of magnetism:

1. Like charges repel and unlike charges attract (Figure 3)

FIGURE 3

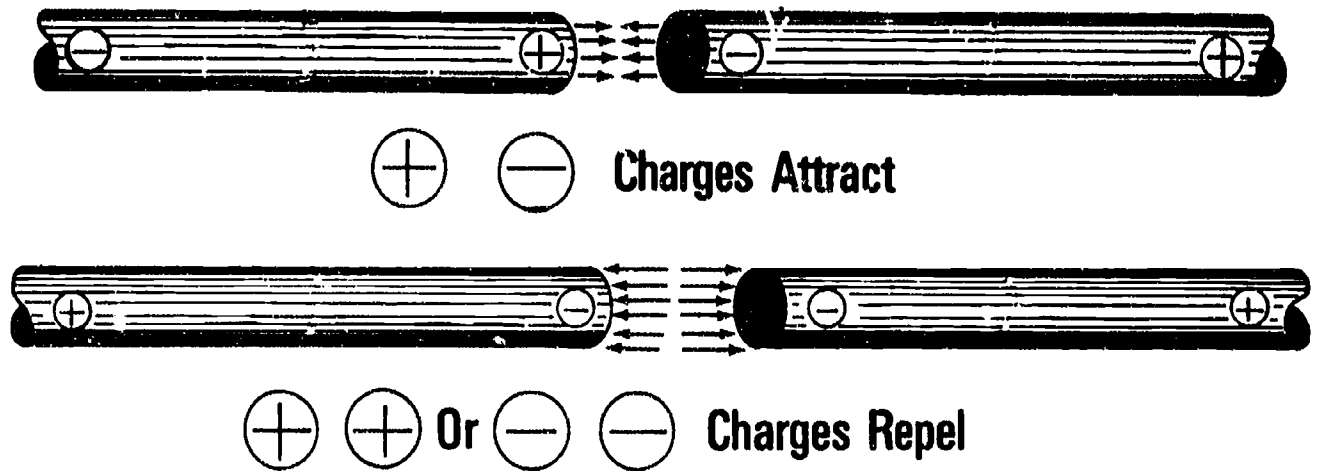

2. The magnetic force moves through the magnetic flux in a definite N to S direction (Figure 4)

FIGURE 4

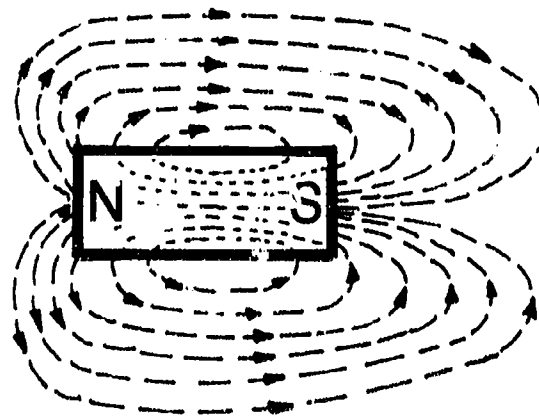

INFORMATION SHEET

III. The left hand rule for conductors

- A. Current flowing through a conductor wire produces a magnetic field around the wire
- B. The direction of the magnetic field around the conductor is determined by the direction of electron flow
- C. Using the left hand rule for conductors is the best way to determine the direction of the lines of magnetic flux:
 1. Grasp the conductor with the left hand with the thumb pointing in the direction of the electron flow (Figure 5)
 2. Your four fingers will point in the direction of the magnetic field (Figure 5)

FIGURE 5

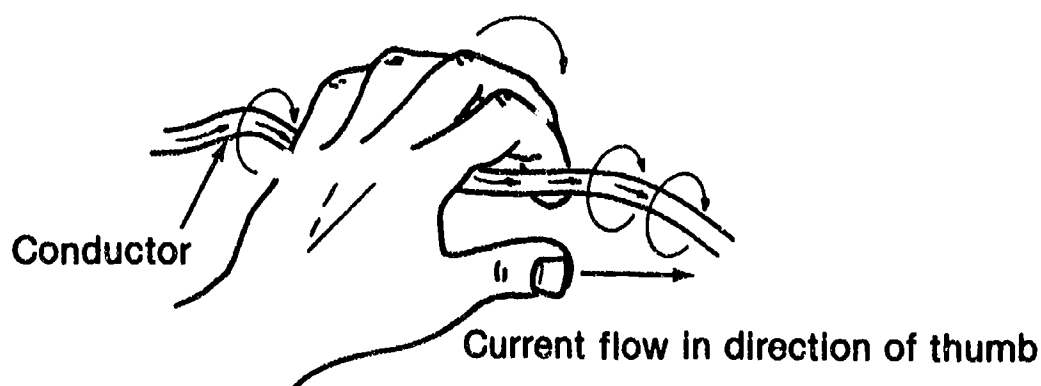

IV. Electromagnets and coils

- A. The field of force around a conductor can be strengthened by forming the conductor into a coil
- B. The strength of the magnetic field depends on the number of coils in the conductor and the amount of voltage applied to the conductor
- C. The strength of the magnetic field can be made much stronger by placing an iron core inside the coiled conductor

INFORMATION SHEET

- D. When electricity flows through the conductor coils, the iron core becomes an electromagnet (Figure 6)

FIGURE 6

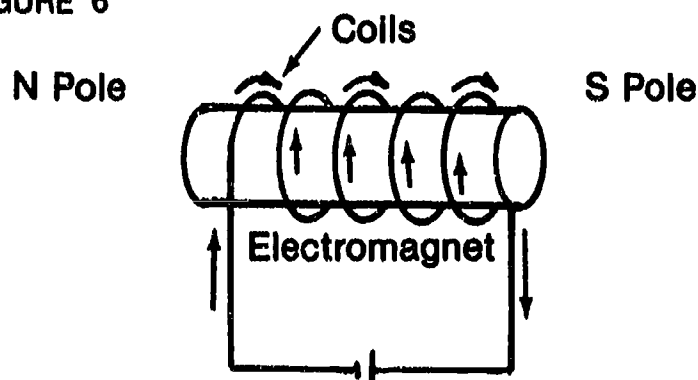

- E. The polarity of the electromagnetic field can be determined by using the left hand rule for coils:

1. Grasp the coil in such a way that your fingers point in the direction of current flow (Figure 7)
2. Your thumb will point to the N pole of the electromagnet (Figure 7)

FIGURE 7

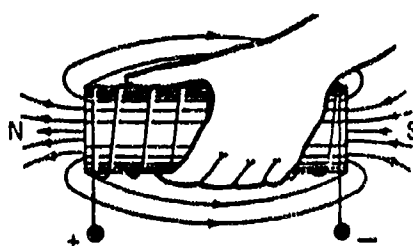

- F. Reversing the direction of current flow in an electromagnet reverses the N and S poles of the electromagnet (Figure 8)

FIGURE 8

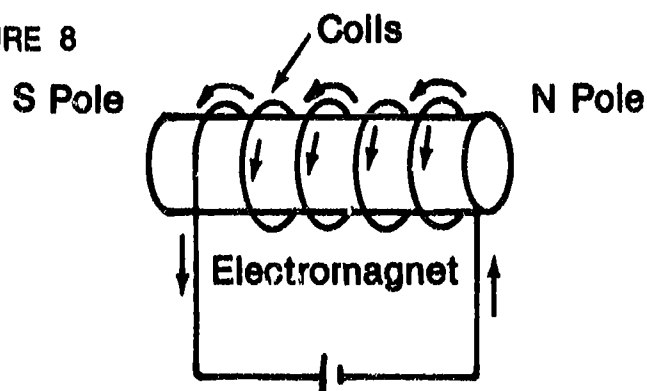

INFORMATION SHEET

- G. Electromagnets can be turned on or off by simple controls and made to do useful work
- H. A metal conductor can be so constructed that when electric current flows through it, the magnetic force created will pull a metal plunger into the coil (Figure 9)
- I. The metal plunger moving into the coil when the coil is energized and moving out of the coil when the current is shut off is the principle that makes solenoids work, the same kind of solenoids used in many major appliances (Figure 9)

FIGURE 9

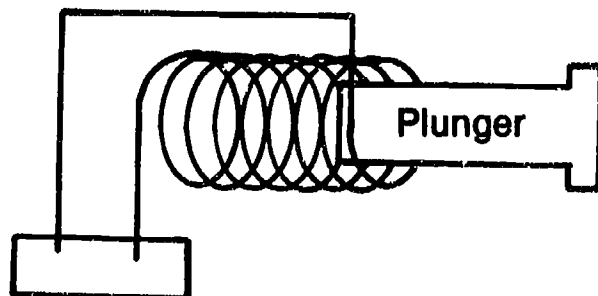

V. Other principles of magnetism

- A. Transformers like those used in microwave ovens and many other electrical and electronic devices function on another principle of magnetism
- B. When a magnetic field cuts across a wire, it induces electricity into the wire
- C. Making a transformer requires that iron cores wrapped with wire be placed alongside each other:
 1. The wire around the first core will carry electricity from a power source and back to the power source (Figure 10)
 2. As electricity flows through the wire around the first core, the core becomes an electromagnet (Figure 10)
 3. As the first core becomes an electromagnet, it sets up lines of magnetic flux that cut across the wires in the second core (Figure 10)

INFORMATION SHEET

4. Induced electricity flows into the second set of coils, and the electrical energy can be tapped and put to work (Figure 10)

FIGURE 10

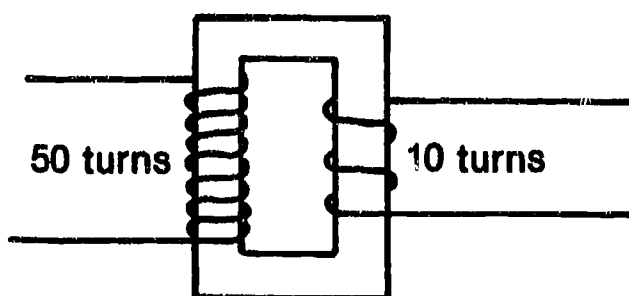

- D. In order for induced voltage to continue to flow in the second coil, the lines of force must continually start and stop, so that is why AC current is usually used as a power supply
- E. The first coil in a transformer is called the primary, and it receives the electrical input
- F. The second coil in a transformer is the secondary, and it becomes the source of electrical output

VI. Types of transformers

- A. There are three types of transformers:
1. Step-up transformers that increase voltage
 2. Step-down transformers that decrease voltage
 3. Isolation transformers have equal windings on each side

(NOTE: Isolation transformers are used as filtering devices and for technician protection.)

INFORMATION SHEET

- B. The ratio of the number of the wire wraps in the primary coil to the number of wraps in the secondary coil is what determines whether it is a step-up or step-down transformer (Figure 11)

FIGURE 11

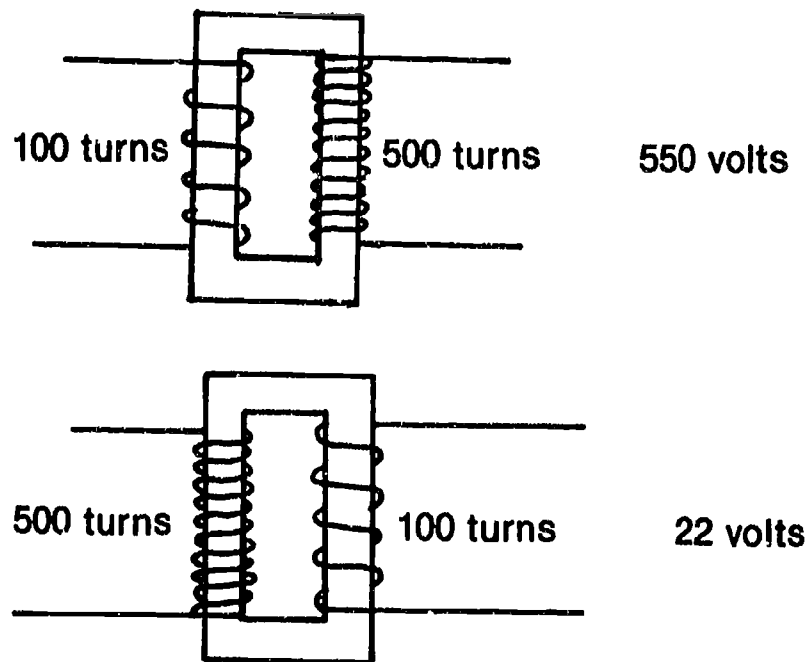

- C. The formula for determining voltage in a transformer is easy to apply:
1. The number of turns in the primary coil equals the voltage applied to the primary coil
 Example: A primary with 100 turns with 110 volts applied to it would have a voltage of 110 volts
 2. The number of turns in the secondary coil equals the voltage in the secondary coil
 Example: If a primary coil with 100 turns has had 110V applied to it and the secondary coil beside it has 500 turns, then the voltage in the secondary coil would be 500×110 or 550 volts and it would be a step-up transformer; however, if the primary had 110 turns and the secondary had only 50 turns, the voltage in the secondary would be $110 \times .50$ or 55 volts and it would be a step-down transformer
- D. AC induction motors used with most major appliances work with the same electromagnetic principles that make transformers work

INFORMATION SHEET

VII. DC motor components

- A. DC motors are not in common use around major appliances, but knowing how they work will help a technician better understand AC induction motors that are used with major appliances
- B. The basic DC motor has four major components:
1. An armature which is an electromagnet mounted on a shaft so it can turn (Figure 12)

FIGURE 12

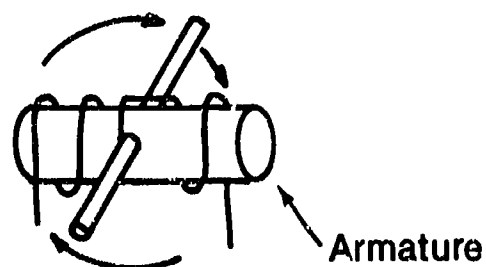

2. A split-ring commutator (Figure 13)
3. Brushes that the commutator makes contact with (Figure 13)

FIGURE 13

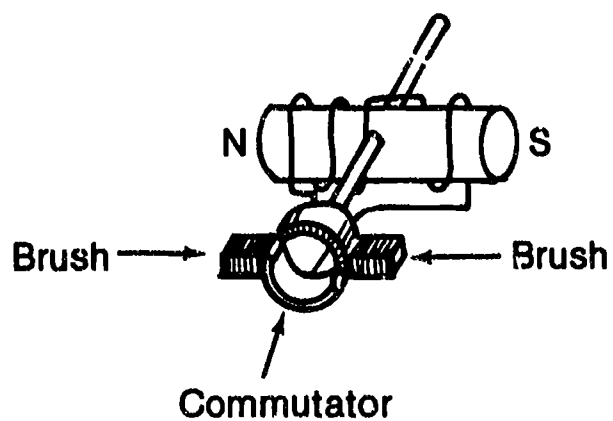

INFORMATION SHEET

4. A magnetic field so that the armature will spin (Figure 14)

FIGURE 14

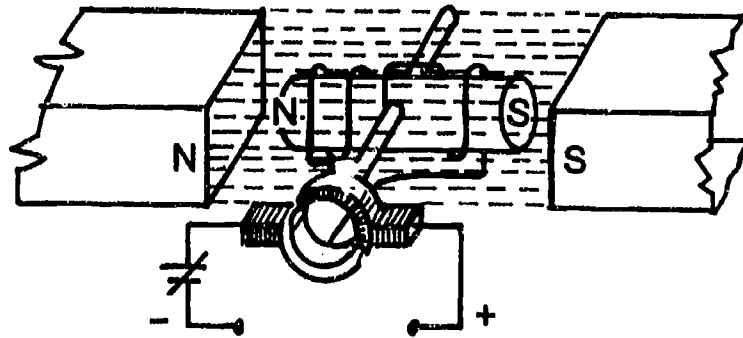

VIII. DC motor operation

- A. The arrangement of the commutator and brushes causes the electricity that flows through the armature to reverse its direction each time the armature rotates half a revolution
- B. Turning a switch to ON turns the armature into an electromagnet, and since like magnetic poles repel each other, the armature's N and S poles spin away from the N and S poles of the field magnet (Figure 15)

FIGURE 15

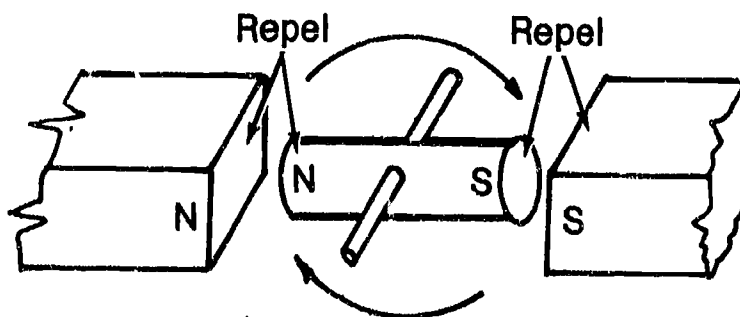

INFORMATION SHEET

- C. Since opposite magnetic poles attract, the N and S poles of the field magnet attract the opposite poles of the armature as the armature turns (Figure 16)

FIGURE 16

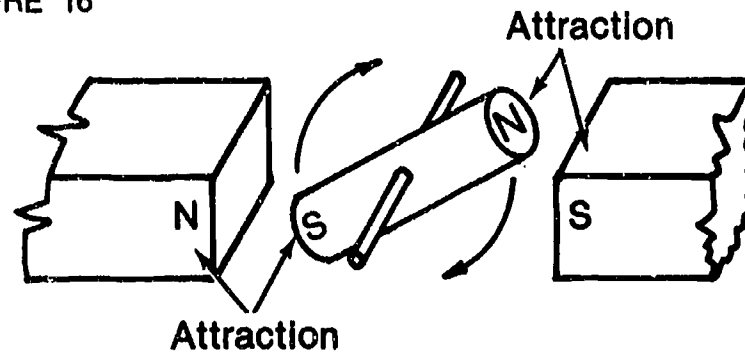

- D. Just as the N and S armature poles align themselves with the opposite S and N poles in the field magnet, the commutator/brush arrangement reverses the flow of electricity in the armature
- E. Since the poles on the armature are reversed electrically, the armature and field magnets repel each other once again and the armature continues to spin and produce direct current (Figure 17)

FIGURE 17

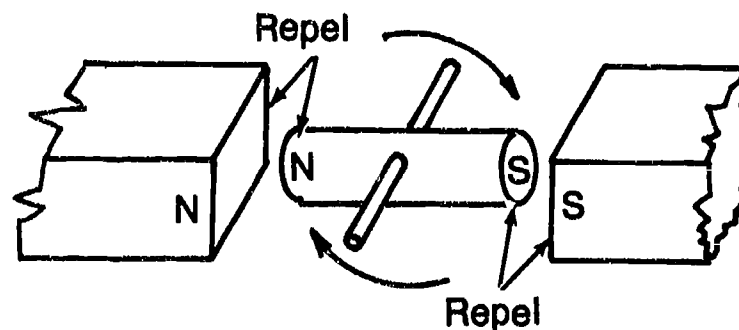

IX. AC Induction motors

- A. The AC induction motor is the one most frequently used with major appliances because its rugged construction is especially suited to constant speed applications, and it has a long, trouble-free service life
- B. AC induction motors have several advantages over DC motors:
1. AC current is more readily available
 2. Induction motors have no commutator or brushes to wear out
 3. Induction motors are spark free and can be used in applications where a DC motor might create a hazard

INFORMATION SHEET

- C. AC induction motors use a rotating magnetic field to produce torque, a field created by winding wires of different size and resistance onto poles within a stator
- D. The windings in an induction motor are either high resistance start windings or low resistance run windings (Transparency 1)
- E. When an induction motor is started, a normally closed centrifugal switch connects both the start and run windings in parallel across the line
- F. When the motor reaches 75% to 80% of its designed operating speed, the centrifugal switch opens to disconnect itself from the circuit as the motor continues to operate with only the run windings

(NOTE: Run windings are sometimes called main or field windings, and start windings are sometimes called auxiliary windings.)

X. Components of an AC induction motor (Transparency 2)

- A. Motor housing — The outer protective covering designed for specific service applications
- B. Stator — The stationary laminated iron casing containing the poles that start and run windings are wound onto to form a magnetic field

(NOTE: The stator works on the same principle of the primary windings in a transformer.)

- C. Rotor — A cylinder with laminations of soft iron that rotates within the stator on a shaft that may have the centrifugal switch attached to it

(NOTE: The rotor works on the same principle as the secondary winding in a transformer because current is induced into the rotor.)

- D. Centrifugal switch — A control device that disconnects the start windings after a motor reaches 75% to 80% of its normal operating speed so the motor will continue operation on the run windings only
- E. Thermal overload — A protection device that shuts the motor off to keep it from overheating
- F. End bells — The flange-like caps on each end of the motor that contain bearings which support the shaft, usually have open slots for ventilation, and one end bell may contain the centrifugal switch

(NOTE: The location of a centrifugal switch varies with the type of motor and the manufacturer.)

- G. Assembly bolts — Bolts that go through the motor housing and hold the end bells in place

INFORMATION SHEET

XI. Types of AC Induction motors

- A. When an induction motor starts, it draws 6 to 8 times its normal running current, so almost all induction motors require a starting device, and motors are usually typed according to their start/run characteristics
- B. Induction start, induction run motors have low starting torque and were once in common use in many appliances
- C. Present day appliances require higher starting torque and use a capacitor start, induction run motor
- D. Another type of induction motor is the capacitor start, capacitor run motor which is used frequently in air conditioning applications

XII. Operations of an induction start, induction run motor

- A. An induction start, induction run motor has no external starting mechanism
- B. The induction start, induction run motor has a start and run winding, and when voltage is applied to the start winding, it starts the rotor turning
- C. When the motor reaches a speed of approximately 1150 rpm, a centrifugal switch in the motor disconnects the start winding and engages the run winding
- D. The motor continues to run on the run winding only

XIII. Operations of a capacitor start, induction run motor

- A. A capacitor start, induction run motor has an external starting mechanism in the form of a capacitor which is capable of temporarily storing electrical energy
- B. As the motor is energized, the line voltage decreases 20 to 25 percent, and the voltage that is stored in the capacitor is now at a higher potential than the line voltage, so the capacitor discharges an electrical surge that increases starting torque
- C. As the motor reaches a speed of approximately 1150 rpm, a centrifugal switch disconnects the starting capacitor and engages the run winding
- D. The motor continues to run on the run winding only as the capacitor circuit is recharged

XIV. Motor housings

- A. Motor housings are designed for special applications and often determine the nature of motor service

INFORMATION SHEET

- B. For some special applications such as fan motors or certain automatic dishwashers, motors use a vapor-proof or dust-proof housing that totally encases the motor
- C. Totally enclosed motors run hotter and generally have a shorter service life than vented motors
- D. Totally enclosed motors generally have to be replaced when they go bad because there is little service that can be performed on them
- E. The trend in modern appliance motors is to use an open-frame housing which promotes cooler operation
- F. Motors in open-frame housings are called "throw-away" motors because it is not cost effective to work on them, and the open-frame housings are almost impossible to reassemble because they are welded together or glued together with epoxy
- G. Motors with open-frame housings are the most common type confronted in major appliance service, and such motors will be found on almost all major appliances designed for normal use
- H. Motors with open-frame housing cost less, but they do collect lint and dirt readily, and part of every service call should be to vacuum the open-frame motor if the appliance has one

(NOTE: If you're servicing an appliance in the shop, use compressed air to clean the motor.)

XV. Motor speeds

- A. Single-speed motors are found on many automatic dryers and dishwashers
- B. Two-speed motors are found on many automatic washers where service demands require both a normal and a gentle cycle
- C. Three-speed motors are found on some automatic washers that have normal, gentle, and delicate cycles
- D. The standard single-speed motor turns at a speed of 1725 rpm or 1750 rpm
- E. The standard two-speed motor turns at speeds of 1150 rpm and 1725 rpm
- F. The standard three-speed motor turns at speeds of 1150 rpm and 1725 rpm, and the third speed will vary depending on manufacturer and application

XVI. Types of motor bearings and their characteristics

- A. Sleeve bearings — Commonly found in induction motors on washers and dryers because they are least expensive and have good service life, but are prone to get noisy as they wear out

INFORMATION SHEET

- B. Roller bearings — Commonly found in induction motors on appliances where less noise is preferred and where cooler operation is desired for increased performance and motor life
- C. Ball bearings — More expensive than other types of bearings, but less friction makes for a quieter running motor that is preferred for special applications

Example: Motors with ball bearings are usually found in precision applications such as medical equipment and precision measuring devices

XVII. Motor thermal protection

- A. All AC induction motors are equipped with thermal overload devices which open when an overheating condition occurs in the motor
- B. The thermal overload device will stay open and keep power from reaching the motor until the motor cools down
- C. In cases where motor overheating is frequent, the thermal overload will sometimes remain permanently open and the motor cannot be started
- D. In other cases where motor overheating is frequent, the thermal overload will open soon after the motor starts and runs
- E. The thermal overload cannot be repaired, but on almost all AC induction motors it can be replaced
- F. Always permit a hot or overheated motor to cool down before attempting to start it or troubleshoot a motor problem

XVIII. Other motor problems

- A. Motors function best within a 10% range above or below their rated nameplate voltage
- B. Low voltage reduces starting torque, increases full load temperature, and shortens motor life
- C. High voltage increases starting torque, produces increased heat, and shortens motor life
- D. Excess voltage variations up or down will increase heat, cause noise and vibration, and shorten motor life
- E. Modern appliance motors have a lifetime lubrication system built in, but some motors still have an oiler tube so oil can be added as required by specifications

INFORMATION SHEET

- F. Never over lubricate a motor; in fact, most specifications call for only two or three drops of oil every six months
- G. Oiler tubes have flip caps and these should always be checked to make sure they are in place so dirt will not get into the bearing directly below the tube
- H. Never replace a motor with a smaller motor, and never overload a motor
- I. Belts on motor pulleys should be properly adjusted, and the rule of thumb is that the belt under normal pressure should deflect no more than a distance equal to the width of the belt

XIX. Using compressor test cords in motor testing (Transparency 3)

- A. Compressor test cords are useful for checking a motor for mechanical problems such as being locked up or having bad bearings, and these problems may exist even though the motor checks okay on all electrical tests
- B. A bench test with a test cord is the best way to assure that the motor is sound mechanically as well as electrically, but electrical tests should always be made before test cord use to avoid blowing the fuse in the test cord
- C. A test cord bypasses all control circuits so that the motor can be tested at normal rpm
- D. A test cord can be used in conjunction with a wattmeter to see if the motor is drawing too much amperage
- E. For safety, a good test cord will have 3 wire power cords and a ground cord to attach to the motor housing

(NOTE: The Roblnair Test Cord #12476 is a popular test cord with appliance repair technicians, and it is built with technician safety in mind.)

- F. Test cords are available from parts supply stores or can be assembled in a shop from readily available components

XX. Guidelines for servicing throw-away motors

- A. A centrifugal switch on a throw-away motor is always located outside the motor on the opposite end of the drive pulley
- B. The centrifugal switch can be tested for continuity with an ohmmeter (VOM), and replaced as required
- C. On a capacitor start, induction run motor, the capacitor can be tested for capacitance with a VOM or a capacity checker, and replaced as required

INFORMATION SHEET

- D. The thermal overload on all motors with open-frame housings can be tested for continuity with an ohmmeter (VOM), and replaced as required
- E. All start windings and run windings in an induction motor are internal and it is not cost effective to attempt to service them by rewinding

XXI. Motor nameplate information (Transparency 4)

- A. The motor nameplate should be attached to the motor housing, and is the only source of information available for selecting a replacement motor of the proper size and electrical characteristics or for ordering a replacement part
- B. The model number, serial number, type, and horsepower rating must be known in order to select the proper service application
- C. The Hertz (cycles), voltage, FLA (full load amperage), LRA (locked rotor amperage), and SF (service factor) need to be known in order to select a motor with proper electrical characteristics
- D. Other elements on the nameplate include RPM, FR (frame type), TEMP RISE (temperature rise), and duty rating, and need to be referenced to assure proper motor replacement
- E. Whether replacing an entire motor or a single component, the safest rule to follow is: copy down all of the nameplate information

XXII. Motor safety

- A. Always unplug a motor from its power source before starting any electrical checks
- B. Always allow a hot or overheated motor to cool down before attempting to restart it or performing any tests
- C. When installing a motor, always make sure the ground wire to the appliance chassis is securely fastened

(CAUTION: Touching a running motor that is not properly grounded can cause hazardous static shock.)

- D. Roll up your sleeves or wear tight fitting cuffs when you're working around any kind of rotating equipment because loose clothing can be easily caught on a motor shaft

XXIII. Steps in systematically troubleshooting an induction motor

- A. Unplug the motor from the power source

INFORMATION SHEET

- B. Check with a VOM for power at the outlet into which the motor was plugged
- C. If there is no power at the outlet, check the breaker box or fuse panel
- D. If the breaker is tripped, reset it; if a fuse is blown, replace it
- E. Plug the motor into the outlet again and attempt to start the motor
- F. If the motor again trips the breaker or blows a fuse, the problem is in the motor
- G. Once the problem is established as being in the motor, check for loose connections or broken wires around the motor
- H. Make all the electrical checks you can make with your VOM
 1. The capacitor on a capacitor start motor is always accessible and can be checked with a capacitor analyzer and replaced as required
 2. The thermal overload on a throw-away motor can be checked with a VOM and replaced as required
 3. If a centrifugal switch is located outside the motor on a throw-away motor, the switch can be checked with a VOM and replaced as required, but if the centrifugal switch is inside the motor, the motor will have to be replaced
- I. Hook the motor up to a test cord and check it for mechanical problems such as loose bearings
- J. If electrical or mechanical checks indicate a problem that would not be cost effective to repair, replace the motor according to information on the old motor nameplate

181

Start and Run Windings

Run

Start

Low Resistance



High Resistance



Heavier Wire



Lighter Wire



Few Turns



More Turns



Wound in Bottom of Slots

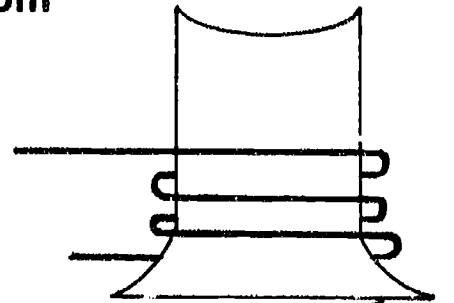

Wound on Top of Main Winding

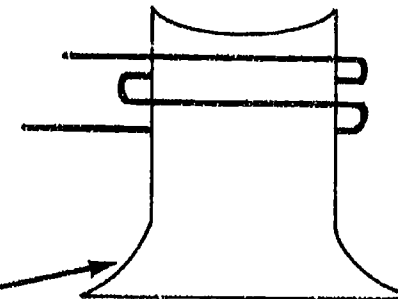

Laminated Poles

Components of an AC Induction Motor

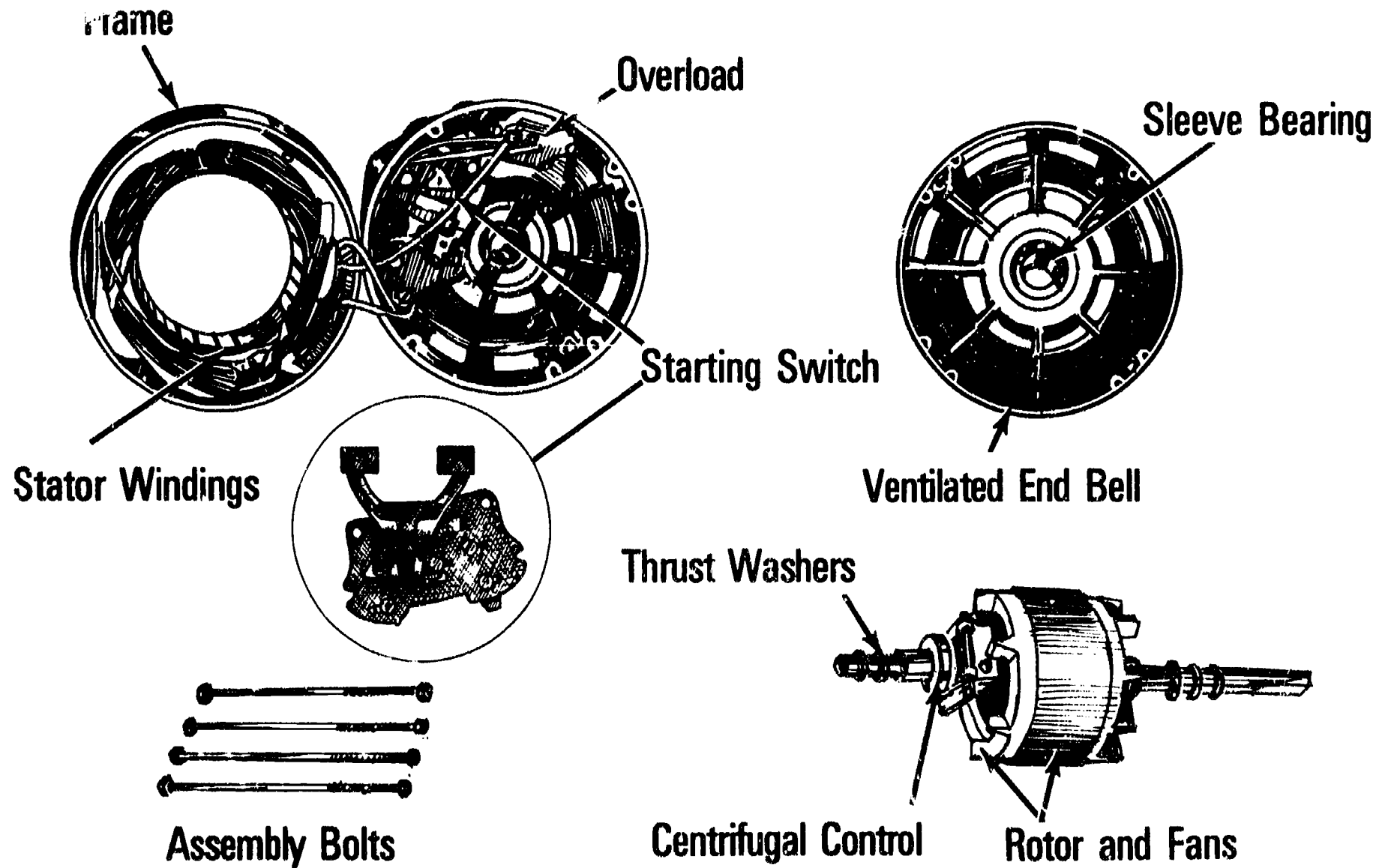

Compressor Test Cord

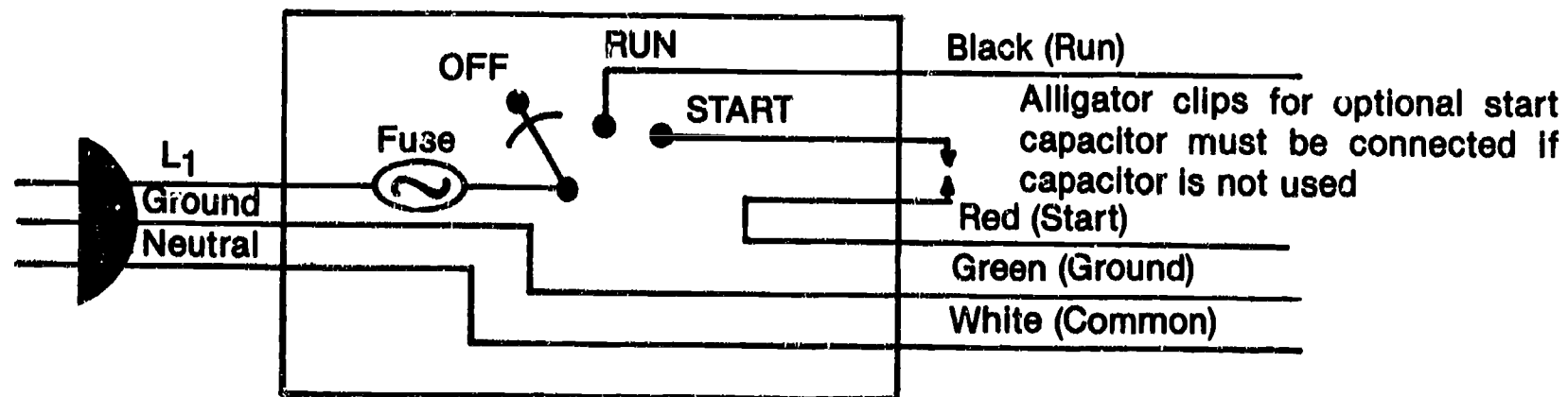

Motor Nameplate

POWER				ELECTRIC	
A. C. MOTOR					
MODEL	500	TYPE	KC	PHASE	1
HP	1½	HERTZ (CYCLES)	60	F.L.A.	15/7.5
VOLTS	120/240	RPM	1725		
TEMP RISE	40° C	L.R.A.	80/40		
DUTY RATING	CONTINUOUS		SERIAL NO.	25803	
CODE		S.F.	1.25	FR	66

188

189

AC INDUCTION MOTORS UNIT IV

JOB SHEET #1 — TROUBLESHOOT AN AC INDUCTION MOTOR FOR THERMAL OVERLOAD

A. Tools and materials

1. Appliance with AC Induction motor
2. VOM
3. Schematic for appliance
4. Pencil and paper
5. Safety glasses

B. Procedure

1. Put on safety glasses
2. Check the appliance schematic to determine where to locate the two thermal overload conductors coming out of the motor

(NOTE: On some open-face motors, the thermal overload housing is exposed and the leads are easy to remove, but on some motors the thermal overload leads may be plugged onto the external centrifugal switch.)

3. Set your VOM to measure resistance on the R \times 1 scale
4. Place the red VOM lead on one terminal and the black VOM lead on the other terminal
 - a. If there is no reading and you have an open-face motor with the thermal overload exposed, replace the thermal overload
 - b. If there is no reading and you have an open-face motor with the thermal overload in the motor, replace the entire motor
 - c. If there is a full scale deflection on the meter, the thermal overload is probably okay and the windings will require further testing
5. Write your findings down on paper

JOB SHEET #1

6. Have your instructor evaluate your procedure for
- Proper use of the schematic
 - Proper use of the VOM
 - Proper evaluation of the thermal overload condition
7. Clean up area and return tools and equipment to proper storage, or prepare for next job sheet as directed by your instructor

AC INDUCTION MOTORS UNIT IV

JOB SHEET #2 — TROUBLESHOOT AN AC INDUCTION MOTOR TO DETERMINE WHETHER THE START MECHANISM OR THE START WINDINGS ARE BAD, AND REPLACE A CENTRIFUGAL SWITCH

- A. Tools and materials
1. Appliance with AC Induction motor
 2. VOM
 3. Schematic for appliance
 4. Basic hand tools
 5. Pencil and paper
 6. Safety glasses
 7. Motor test cord
- B. Routine #1 — Making preliminary tests
1. Put on safety glasses
 2. Plug motor into power source and start the motor:
 - a. If motor starts, runs for only a short time and stops, unplug the appliance and remove the motor
 - b. If motor starts and hums but will not start or run, unplug the appliance and remove the motor
 3. Place the motor on a safe, solid work area
 4. Hook the motor up to a test cord
 5. Plug the test cord into a power source and start the motor
 6. Listen for the motor hum
 7. Grasp the motor shaft between your thumb and fingers and give the shaft a sharp twist clockwise
 - a. If the motor does not run, the problem is the run windings and the motor should be replaced

JOB SHEET #2

- b. If the motor does run, let it run a moment and then unplug the test cord
- 8. Grasp the motor shaft again between your thumb and fingers, but this time give the shaft a sharp twist counterclockwise
 - a. If the motor does not run, the problem is in the run windings and the motor should be replaced
 - b. If the motor does run, and if it also ran when you twisted the shaft clockwise, the problem is either in the start windings or in the start mechanism
 - c. If the starting mechanism is internal, it is not cost effective to fool with the problem any longer, and the motor should be replaced
 - d. If the starting mechanism is external, continue troubleshooting to determine if the problem is in the starting mechanism or in the start windings

Have your instructor check your work

C. Routine #2 — Checking the start and run windings

1. Check the wiring diagram again to determine the type of centrifugal switch the motor has, and where the terminals for the run and start windings are located
(NOTE: Make a sketch if you need to.)
2. Set your VOM on the R \times 1 scale
3. Put on your safety glasses
4. Remove the leads from the run winding terminals and note where they come from so you can return them to the proper terminals
5. Place the red VOM lead on one terminal and the black VOM lead on the other terminal
6. Look for a resistance reading close to zero but less than 2 ohms
 - a. If there is no reading, it means the run windings are open and the motor should be replaced
 - b. If the reading is okay, go on to the next step
7. Place the red VOM lead on one of the start winding leads coming out of the motor
8. Place the black VOM lead against the motor case and make sure you get good contact

JOB SHEET #2

9. Repeat the procedure for the other start winding lead from the motor
 - a. If there is any kind of reading, it means the start windings are shorted to the motor housing and the motor should be replaced
 - b. If there is no reading, the start windings are okay, but the centrifugal switch needs to be replaced

Have your instructor check your work

D. Routine #3 — Replacing the centrifugal switch

1. Make a sketch of the conductor leads to the centrifugal switch
2. Remove the two screws holding the centrifugal switch to the motor housing
3. Check the part number on the centrifugal switch, and be sure the replacement switch is the exact part number as the old switch
4. Install the new centrifugal switch exactly as the old switch was removed so you'll be certain the spring-loaded plunger in the motor fits into the switch properly
5. Secure the new switch with the two screws that were removed
6. Replace conductor leads according to the sketch you made previously
7. Plug motor into a test cord and start the motor

Have your instructor check your work

8. Clean up area and return tools and materials to proper storage

AC INDUCTION MOTORS UNIT IV

JOB SHEET #3 — BENCH TEST A SINGLE-SPEED MOTOR WITH A TEST CORD

A. Tools and materials

1. Single-speed motor as selected by instructor
2. Test cord
3. VOM
4. Wattmeter
5. Clean shop towels
6. Capacitor analyzer
7. Safety glasses

B. Procedure

1. Put on safety glasses
2. Secure the motor to be tested in a vice, but don't damage the motor by tightening the vice too tight
3. Set your VOM to measure resistance on the R x 1 scale
4. Check resistance between the terminals on the centrifugal switch, BU to W
 - a. If the resistance reading is between 1 to 3 ohms, go on to step 5
 - b. If the resistance reading is 0 ohms, the motor windings are shorted and the defective motor should be replaced

(CAUTION: Do not apply power to this motor.)

5. Set the VOM to measure resistance on the R x 1,000 scale
6. Measure resistance from all motor terminals to the motor case
 - a. If the reading is infinity, go on to step 7
 - b. If you obtain any resistance reading, the motor windings are shorted to ground and the defective motor should be replaced

(CAUTION: Do not apply power to this motor.)

JOB SHEET #3

7. Connect the test cord leads as follows:
 - a. Connect the black test cord lead to the BU motor switch terminal
 - b. Connect the white test cord lead to the W motor switch terminal
 - c. Connect the green test cord lead to the motor case and be sure it makes a good ground
 - d. Leave the red test cord lead unconnected
8. Plug the test cord into a wattmeter set at the 500 watt scale
9. Plug the wattmeter into a 120V 3-prong grounded outlet

(NOTE: If you're working with a capacitor start motor, it would be good at this point to check the capacitor with a capacitor analyzer.)
10. Turn the test cord start switch to RUN and observe the reading on the wattmeter
 - a. If the wattage reading is between the normal range of 165W to 225W, the motor is okay, but continue with your procedure
 - b. If the wattage reading is above 250W, turn the start switch to the OFF position and go on to the next step
11. Record your wattage reading here: _____
12. Disconnect the test cord and wattmeter
13. Check the colors of the wires to the start switch and make a note of which color goes to which terminal so you can later put the wires back on their correct terminals

(NOTE: If any wires have the same color, use colored tape to identify them.)
14. Disconnect the wires from the start switch (there should be 3 of them) and measure resistance between all three wires with your VOM set to measure resistance on the R x 1 scale

JOB SHEET #3

15. Record wire colors and resistance readings on the diagram that follows:

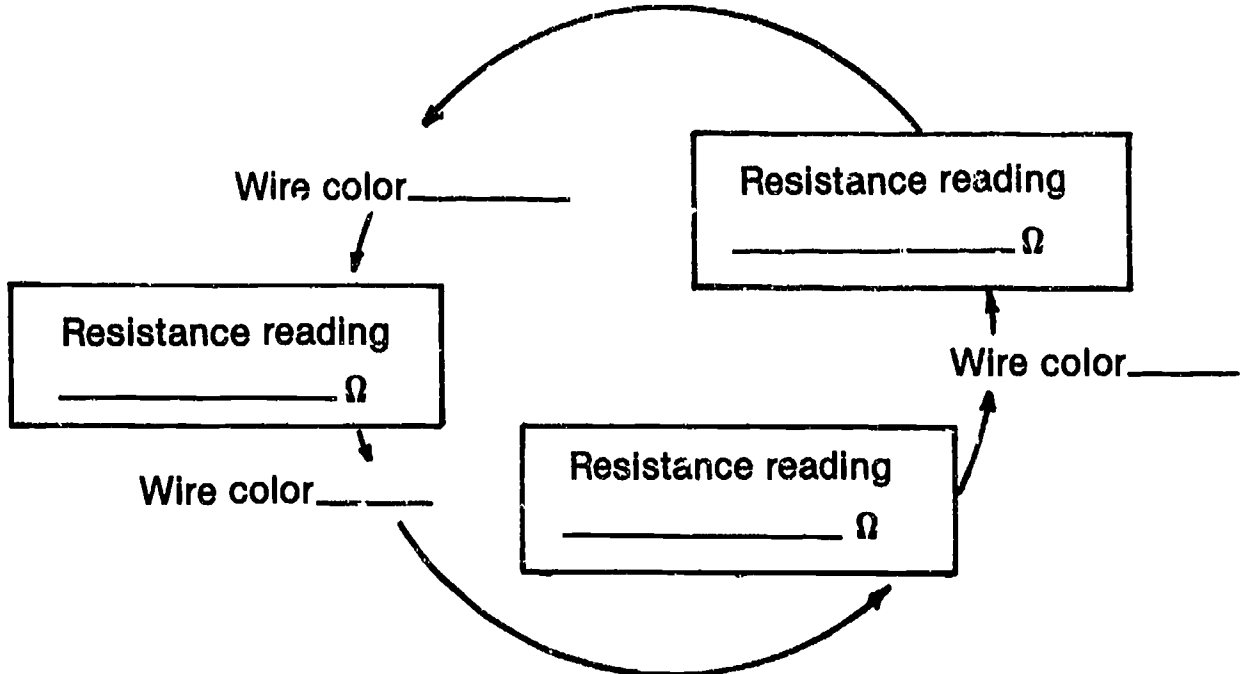

16. Take the highest resistance reading between 2 wires and mark the other wire that is left over as "common"
17. Take the next highest resistance reading between the 2 wires remaining and mark that wire as "start"
18. Mark the remaining wire as "run"
19. Connect the test cord leads as follows:
- Connect the black test cord lead to the run wire
 - Connect the white test cord lead to the common wire
 - Connect the red test cord lead to the start wire
 - Connect the green test cord lead to the motor case and be sure it makes a good ground
20. Plug the test cord into a wattmeter set for the 500 watt scale
21. Plug the wattmeter into a 120 V 3-prong grounded outlet
22. Turn the test cord switch to the START position and observe the wattage reading as you release the switch
23. Record your wattage reading here: _____
- If the wattage reading is between the normal range of 165W to 225W, the motor is okay

JOB SHEET #3

- b. If the wattage reading is above 250W, the defective motor should be replaced
 - c. If the motor did not start, or started and drained high wattage in Step 10, but started and ran normal wattage in Step 22, then the start switch is defective and should be replaced
24. Complete the following evaluation:
- a. Motor is okay _____
 - b. Motor is okay, but start switch must be replaced _____
 - Have your instructor check your work
25. Clean up area and return tools and materials to proper storage

AC INDUCTION MOTORS UNIT IV

NAME _____

TEST

1. Match the terms on the right with their correct definitions.

- | | | |
|---------|---|-----------------------|
| _____a. | A mechanical switch used to disconnect starting mechanisms in induction motors by taking advantage of the force created by a rotating motor shaft | 1. Magnet |
| _____b. | A soft iron core that temporarily becomes a magnet when electrical current flows through wires coiled around it | 2. SPST |
| _____c. | The process of magnetizing an object by bringing it into the magnetic field of an electromagnet or a permanent magnet | 3. Rotor |
| _____d. | Any device or material that has the properties of magnetism | 4. Reversible motor |
| _____e. | A mechanical device that has to be manually pressed down to complete a circuit | 5. Centrifugal switch |
| _____f. | A device used to direct start an induction motor | 6. Momentary switch |
| _____g. | A load on a circuit or system greater than the load for which it was designed | 7. SF |
| _____h. | A reference to a motor type that has both start and run windings | 8. Motor test cord |
| _____i. | A single lever that operates a single set of contacts | 9. Electromagnet |
| _____j. | A single lever that operates two sets of contacts | 10. Stator |
| _____k. | A motor wired in a manner that permits external control of polarity so the direction of motor rotation can be reversed | 11. Induction |
| _____l. | The soft, laminated iron portion of a stator around which wire is wound | 12. Duty rating |

TEST

- _____m. The degree to which a motor can be loaded beyond its rated horsepower
- _____n. The length of time a motor can be safely operated, expressed as continuous or intermittent
- _____o. The iron core cylinder that rotates within the stator of an AC induction motor
- _____p. The component in an AC induction motor that contains the stationary parts of the magnetic circuit and their associated windings

2. Solve the following problems concerning the principles of magnetism.

- a. What is the name of the magnetic force that forms a field around a magnet?

Answer _____

- b. What do like charges do?

Answer _____

- c. What do unlike charges do?

Answer _____

3. Apply the left hand rule for conductors by completing the following statements.

- a. Using the left hand rule for conductors is the best way to determine the direction of the lines of _____

- b. When the conductor is grasped with the left hand and the thumb is pointing in the direction of electron flow, the four fingers will point in the direction of the _____

4. Complete statements concerning electromagnets and coils by inserting the word(s) that best completes each statement.

- a. The field of force around a conductor can be strengthened by forming the conductor into a _____

- b. The strength of the magnetic field depends on the number of coils in the conductor and the amount of _____ applied to the conductor

- c. The strength of the magnetic field can be made much stronger by placing an _____ core inside the coiled conductor

TEST

- d. When electricity flows through the conductor coils, the iron core becomes an _____
- e. The polarity of the electromagnetic field can be determined by using the left hand rule for coils:
- 1) Grasp the coil in such a way that your _____ point in the direction of current flow
 - 2) Your _____ will point to the N pole of the electromagnet
- f. Reversing the direction of _____ in an electromagnet reverses the N and S poles of the electromagnet
- g. Electromagnets can be turned on or off by simple controls and made to do useful _____
- h. A metal conductor can be so constructed that when electric current flows through it, the magnetic force created will pull a metal _____ into the coil
- i. The metal _____ moving into the coil when the coil is energized and moving out of the coil when the current is shut off is the principle that makes _____ work, the same kind of _____ used in many major appliances
5. Solve problems concerning other principles of magnetism by answering the following questions.
- a. What happens when a magnetic field cuts across the wire?
Answer _____
 - b. What does making a transformer require?
Answer _____
 - c. Electricity directly from a power source flows through the primary coil in a transformer, but what kind of electricity flows through the secondary coil in a transformer?
Answer _____
 - d. The primary coil receives electrical input, but what does a secondary coil in a transformer become?
Answer _____

TEST

6. Identify types of transformers by placing the correct name of the transformer under the appropriate illustration.

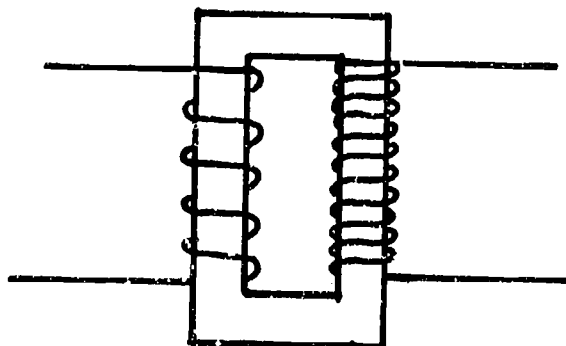

a. _____

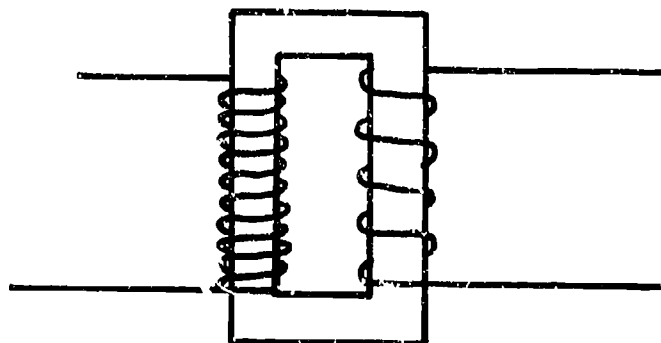

b. _____

7. Complete statements concerning DC motor components by inserting the word(s) that best completes each statement.

- a. DC motors are not in common use around major appliances, but knowing how they work will help a technician better understand AC _____ motors that are used with major appliances
- b. The basic DC motor has four major components:
- 1) An _____ which is an electromagnet mounted on a shaft so it can turn
 - 2) A split-ring _____
 - 3) _____ that the _____ makes contact with
 - 4) A _____ field so that the armature will _____

TEST

8. Select true statements concerning DC motor operation by placing an "X" beside each statement that is true.
- _____a. The arrangement of the commutator and brushes causes the electricity that flows through the armature to reverse its direction each time the armature rotates half a revolution
 - _____b. Turning a switch to ON turns the armature into an electromagnet, and since like magnetic poles repel each other, the armature's N and S poles spin away from the N and S poles of the field magnet
 - _____c. Since opposite magnetic poles attract, the N and S poles of the field magnet attract the opposite poles of the armature as the armature turns
 - _____d. Just as the N and S armature poles align themselves with the opposite S and N poles in the field magnet, the commutator/brush arrangement reverses the flow of electricity in the armature
 - _____e. Since the poles on the armature are reversed electrically, the armature and field magnets repel each other once again and the armature continues to spin and produce direct current
9. Complete statements concerning AC Induction motors by inserting the word(s) that best completes each statement.
- a. The AC induction motor is the one most frequently used with major appliances because its rugged construction is especially suited to _____ speed applications and it has a long, trouble-free service life
 - b. AC induction motors have several advantages over DC motors:
 - 1) AC current is more readily _____
 - 2) Induction motors have no _____ or _____ to wear out
 - 3) Induction motors are _____ and can be used in applications where a DC motor might create a hazard
 - c. AC induction motors use a rotating magnetic field to produce torque, a field created by winding wires of different size and resistance onto _____ within a stator
 - d. The windings in an induction motor are either _____ resistance start windings or _____ resistance run windings
 - e. When an induction motor is started, a normally closed _____ switch connects both the start and run windings in parallel across the line
 - f. When the motor reaches 75% to 80% of its designed operating speed, the _____ switch opens to disconnect itself from the circuit as the motor continues to operate with only the _____ windings

TEST

10. Match the components of an AC Induction motor with their functions.

- | | | |
|---------|---|-----------------------|
| _____a. | The outer protective covering designed for specific service application | 1. End bells |
| _____b. | The stationary laminated iron casing containing the poles that start and run windings are wound onto to form a magnetic field | 2. Centrifugal switch |
| _____c. | A cylinder with laminations of soft iron that rotates within the stator on a shaft that may have the centrifugal switch attached to it | 3. Motor housing |
| _____d. | A control device that disconnects the start windings after a motor reaches 75% to 80% of its normal operating speed so the motor will continue operation on the run windings only | 4. Stator |
| _____e. | A protection device that shuts the motor off to keep it from overheating | 5. Assembly bolts |
| _____f. | The flange-like caps on each end of the motor that contain bearings which support the shaft, usually have open slots for ventilation, and one of these may contain the centrifugal switch | 6. Rotor |
| _____g. | Blots that go through the motor housing and hold the end bells in place | 7. Thermal overload |

11. Solve problems concerning types of AC Induction motors by answering the following questions.

a. Why do induction motors require starting devices?

Answer _____

b. How are induction motors usually typed?

Answer _____

c. What type of induction motor do present day appliances require, and why?

Answer _____

TEST

12. Select true statements concerning operations of an induction start, induction run motor by placing an "X" beside each statement that is true.
- a. An induction start, induction run motor has an external starting mechanism
 - b. The induction start, induction run motor has a start and run winding, and when voltage is applied to the start winding, it starts the rotor turning
 - c. When the motor reaches a speed of approximately 1150 rpm, a centrifugal switch in the motor disconnects the start winding and engages the run winding
 - d. The motor continues to run on the run winding only
13. Select true statements concerning the capacitor start, induction run motors by placing an "X" beside each statement that is true.
- a. A capacitor start, induction run motor has no external starting mechanism
 - b. As the motor is energized, the line voltage decreases 20 to 25 percent, and the voltage that is stored in the capacitor is now at a higher potential than the line voltage, so the capacitor discharges an electrical surge that increases starting torque
 - c. As the motor reaches a speed of approximately 1150 rpm, a centrifugal switch disconnects the starting capacitor and engages the run winding
 - d. The motor continues to run on the run winding only as the capacitor circuit is recharged
14. Complete the following statements concerning motor housings by inserting the word(s) that best completes each statement.
- a. For some special applications such as _____ motors or certain automatic dishwashers, motors use a vapor-proof or dust-proof housing that totally encases the motor
 - b. Totally enclosed motors run _____ and generally have a shorter service life than vented motors
 - c. Totally enclosed motors generally have to be replaced when they go bad because there is _____ that can be performed on them
 - d. The trend in modern appliance motors is to use an open-frame housing which promotes _____ operation
 - e. Motors in open-frame housings are called _____ motors because it is not cost effective to work on them, and the open-frame housings are almost impossible to reassemble because they are welded together or glued together with epoxy

TEST

- f. Motors with open-frame housings are the most _____ type confronted in major appliance service, and such motors will be found on almost all major appliances designed for normal use
- g. Motors with open-frame housing cost less, but they do collect lint and dirt readily, and part of every service call should be to _____ the open-frame motor if the appliance has one
- h. Motor housings are designed for special applications and often determine the nature of motor _____
15. Solve problems concerning motor speeds by answering the following questions.
- a. If an automatic washer has a normal and a gentle cycle, will it have a single-speed, two-speed, or three-speed motor?
Answer _____
- b. If an automatic washer has a normal, wash and wear, and a delicate cycle, will it have a single-speed, a two-speed, or a three-speed motor?
Answer _____
16. Match types of motor bearings with their characteristics.
- | | |
|--|---|
| <p>_____a. Commonly found in induction motors on washers and dryers because they are least expensive and have good service life, but are prone to get noisy as they wear out</p> <p>_____b. Commonly found in induction motors on appliances where less noise is preferred and where cooler operation is desired for increased performance and motor life</p> <p>_____c. More expensive than other types of bearings, but less friction makes for a quieter running motor that is preferred for special applications</p> | <p>1. Roller bearings</p> <p>2. Ball bearings</p> <p>3. Sleeve bearings</p> |
|--|---|
17. Solve problems concerning motor thermal protection by answering the following questions.
- a. If a thermal overload on an AC induction motor goes bad, does the motor have to be replaced?
Answer _____
- b. What should be done before attempting to start or troubleshoot a hot or overheated motor?
Answer _____

TEST

18. Complete statements concerning other motor problems by inserting the word(s) that best completes each statement.
- a. Motors function best within a 10% range above or below their rated nameplate _____
 - b. Low voltage reduces starting torque, increase full load temperature, and _____ motor life
 - c. High voltage increases starting torque, produces increased heat, and _____ motor life
 - d. Excess voltage variations up or down will increase heat, cause _____ and vibration, and shorten motor life
 - e. Modern appliance motors have a lifetime _____ system built in, but some motors still have an oiler tube so oil can be added as required by specifications
 - f. Never over lubricate a motor; in fact, most specifications call for only two or three _____ of oil every six months
 - g. Oiler tubes have _____ and these should always be checked to make sure they are in place so dirt will not get into the bearing directly below the tube
 - h. Never replace a motor with a _____ motor, and never overload a motor
 - i. Belts on motor pulleys should be properly adjusted, and the rule of thumb is that the belt under normal pressure should deflect no more than a distance equal to the _____ of the belt
19. Select true statements concerning using compressor test cords in motor testing by placing an "X" beside each statement that is true.
- _____a. Compressor test cords are useful for checking a motor for mechanical problems such as being locked up or having bad bearings, and these problems may exist even though the motor checks okay on all electrical tests
 - _____b. A bench test with a test cord is the best way to assure that the motor is sound mechanically as well as electrically, but electrical tests should always be made before test cord use to avoid blowing the fuse in the test cord
 - _____c. A test cord bypasses all control circuits so that the motor can be tested at normal rpm
 - _____d. A test cord can be used in conjunction with a wattmeter to see if the motor is drawing too much amperage

TEST

- _____e. For safety, a good test cord will have 3 wire power cords and a ground cord to attach to the motor housing
- _____f. Test cords are available from parts supply stores or can be assembled in a shop from readily available components
20. Complete a list of guidelines for servicing throw-away motors by inserting the word(s) that best completes each statement.
- a. A centrifugal switch on a throw-away motor is always located _____ the motor on the opposite end of the drive pulley
 - b. The centrifugal switch can be tested for _____ with an ohmmeter, and replaced as required
 - c. On a capacitor start, induction run motor, the capacitor can be tested for capacitance with a VOM or a _____, and replaced as required
 - d. The thermal overload on all motors with open-frame _____ can be tested for continuity with an ohmmeter, and replaced as required
 - e. All start windings and run windings in an induction motor are _____ and it is not cost effective to attempt to service them by rewinding
21. Solve problems concerning motor nameplate information by answering the following questions.
- a. Name at least five items of importance that will be found on a motor nameplate.
 - 1) _____
 - 2) _____
 - 3) _____
 - 4) _____
 - 5) _____
 - b. What is the safest rule to follow when ordering an entire replacement motor or a single component?
 Answer _____
22. Complete the following statements concerning motor safety by inserting the word(s) that best completes each statement.
- a. Always unplug a motor from its _____ before starting any electrical checks

TEST

- b. Always allow a hot or overheated motor to _____ before attempting to restart it or performing any tests
- c. When installing a motor, always make sure the _____ to the appliance chassis is securely fastened
- d. Roll up your sleeves or wear tight fitting cuffs when you're working around any kind of _____ equipment because loose clothing can be easily caught on a motor shaft
23. Arrange in order the steps in systematically troubleshooting an induction motor by placing the correct sequence number in the appropriate blank.
- _____a. Check with a VOM for power at the outlet into which the motor was plugged
- _____b. If there is no power at the outlet, check the breaker box or fuse panel
- _____c. If the breaker is tripped, reset it; if a fuse is blown, replace it
- _____d. Make all the electrical checks you can make with your VOM
- 1) The capacitor on a capacitor start motor is always accessible and can be checked with a capacitor analyzer and replaced as required
 - 2) The thermal overload on a throw-away motor can be checked with a VOM and replaced as required
 - 3) If a centrifugal switch is located outside the motor on a throw-away motor, the switch can be checked with a VOM and replaced as required, but if the centrifugal switch is inside the motor, the motor will have to be replaced
- _____e. Plug the motor into the outlet again and attempt to start the motor
- _____f. If the motor again trips the breaker or blows a fuse, the problem is in the motor
- _____g. Once the problem is established as being in the motor, check for loose connections or broken wires around the motor
- _____h. Hook the motor up to a test cord and check it for mechanical problems such as loose bearings
- _____i. If electrical or mechanical checks indicate a problem that would not be cost effective to repair, replace the motor according to information on the old motor nameplate
- _____j. Unplug the motor from the power source

TEST

(NOTE: If the following activities have not been accomplished prior to the test, ask your instructor when they should be completed.)

24. Demonstrate the ability to:
 - a. Troubleshoot an AC induction motor for thermal overload problems. (Job Sheet #1)
 - b. Troubleshoot an AC induction motor to determine whether the start mechanism or the start windings are bad, and replace a centrifugal switch. (Job Sheet #2)
 - c. Bench test a single-speed motor with a test cord. (Job Sheet #3)

AC INDUCTION MOTORS UNIT IV

ANSWERS TO TEST

- | | | | | |
|----|----|----|----|----|
| i. | a. | 5 | i. | 2 |
| | b. | 9 | j. | 13 |
| | c. | 11 | k. | 4 |
| | d. | 1 | l. | 15 |
| | e. | 6 | m. | 7 |
| | f. | 8 | n. | 12 |
| | g. | 14 | o. | 3 |
| | h. | 16 | p. | 10 |
-
2. a. Flux
b. Repel
c. Attract
3. a. Magnetic flux
b. Magnetic field
4. a. Coil
b. Voltage
c. Iron
d. Electromagnet
e. 1) Fingers
2) Thumb
f. Current flow
g. Work
h. Plunger
i. Plunger, solenoids, solenoids
5. a. It induces electricity into the wire
b. Two iron cores wrapped with wire be placed alongside each other
c. Induced electricity
d. A source of electrical output
6. a. Step-up transformer
b. Step-down transformer
7. a. Induction
b. 1) Armature
2) Commutator
3) Brushes, commutator
4) Magnetic, spin
8. a, b, c, d, e
9. a. Constant
b. 1) Available
2) Commutator, brushes
3) Spark free

ANSWERS TO TEST

- c. Poles
 d. High, low
 e. Centrifugal
 f. Centrifugal, run
10. a. 3 e. 7
 b. 4 f. 1
 c. 6 g. 5
 d. 2
11. a. When they start, they draw 6 to 8 times their normal running current
 b. According to their start/run characteristics
 c. Capacitor start, induction run motor because it has higher starting torque
12. b, c, d
13. b, c, d
14. a. Fan
 b. Hotter
 c. Little service
 d. Cooler
 e. Throw-away
 f. Common
 g. Vacuum
 h. Service
15. a. Two-speed
 b. Three-speed
16. a. 3
 b. 1
 c. 2
17. a. No
 b. Allow the motor to cool down
18. a. Voltage
 b. Shortens
 c. Shortens
 d. Noise
 e. Lubrication
 f. Drops
 g. Flip caps
 h. Smaller
 i. Width
19. a, b, c, d, e, f

ANSWERS TO TEST

20. a. Outside
b. Continuity
c. Capacity checker
d. Housings
e. Internal
21. a. Any five of the following:
1) Model number
2) Serial number
3) Type
4) Horsepower
5) Hertz
6) Voltage
7) Full load amperage
8) Locked rotor amperage
9) Service factor
10) RPM
11) Frame type
12) TEMP RISE
13) Duty rating
b. Copy down all of the nameplate information
22. a. Power source
b. Cool down
c. Ground wire
d. Rotating
23. a. 2 f. 6
b. 3 g. 7
c. 4 h. 9
d. 8 i. 10
e. 5 j. 1
24. Performance skills evaluated according to procedures written in the job sheets



DIAGRAMS AND SCHEMATICS UNIT V

UNIT OBJECTIVE

After completion of this unit, the student should be able to discuss how to use block diagrams, schematic diagrams, and wiring diagrams as troubleshooting tools. The student should also be able to list other graphic aids used in service literature and identify basic electrical symbols. The student should also be able to use a wiring diagram to troubleshoot customer complaints, and use a timer sequence chart to isolate a malfunctioning component. These competencies will be evidenced by correctly performing the procedures outlined in the assignment sheet and by scoring 85 percent on the unit test.

SPECIFIC OBJECTIVES

After completion of this unit, the student will be able to:

1. Match terms related to diagrams and schematics with their correct definitions.
2. Select true statements concerning block diagrams.
3. Complete statements concerning schematic diagrams.
4. Solve problems concerning wiring diagrams.
5. Match other graphic aids with their functions.
6. Complete statements concerning where to find helpful graphic aids.
7. Select true statements concerning timer sequence charts.
8. Complete a list of what legends do.
9. Complete a chart of common color code abbreviations.
10. Identify basic electrical symbols.
11. Identify symbols for solid state devices.
12. Complete statements concerning guidelines for using diagrams and schematics.
13. Interpret a timer sequence chart and wiring diagram for an automatic dishwasher. (Assignment Sheet #1)

DIAGRAMS AND SCHEMATICS UNIT V

SUGGESTED ACTIVITIES

- A. Provide students with objective sheet.
- B. Provide students with information sheet.
- C. Make transparencies.
- D. Discuss unit and specific objectives.
- E. Discuss information sheet.
- F. Discuss and demonstrate the procedures outlined in the assignment sheet.
- G. Remove the service panel from an appliance and show students where the service information is located and identify it by type.
- H. Use a selected wiring diagram or wiring schematic to demonstrate to the class how service literature is applied in the actual process of troubleshooting.
- I. Use TM 2 and TM 3 to demonstrate to the class the functional differences between a schematic diagram and a wiring diagram, and point out the reasons why a wiring diagram is more effective for troubleshooting.
- J. Discuss symbols in general, the lack of formal standards for the use of symbols, and the importance of legends and notes on diagrams and schematics.
- K. Give test.

CONTENTS OF THIS UNIT

- A. Objective sheet
- B. Information sheet
- C. Transparency masters
 1. TM 1 — Block Diagram
 2. TM 2 — Schematic Diagram
 3. TM 3 — Wiring Diagram
 4. TM 4 — Other Graphic Aids
 5. TM 5 — Wiring Harness

CONTENTS OF THIS UNIT

6. TM 6 — Timer Sequence Chart and Schematic Diagram
 7. TM 7 — Electrical Symbols
 8. TM 8 — Electrical Symbols (Continued)
 9. TM 9 — Solid State Symbols
- D. Assignment Sheet #1 — Interpret a Timer Sequence Chart and Wiring Diagram for an Automatic Washer
- E. Answers to assignment sheets
- F. Test
- G. Answers to test

REFERENCES USED IN DEVELOPING THIS UNIT

- A. *Tech-Talk "J" Dishwashers*. Dayton, OH 45449: Frigidaire Parts and Service Company, 1981.
- B. *Tech-Talk "M" Dryers*. Dayton, OH 45449: Frigidaire Parts and Service Company, 1983.
- C. *Tech-Talk "M" Clothes Washers*. Dayton OH 45449: Frigidaire Parts and Service Company, 1983.
- D. Kaiser, Joe. *Electrical Power*. South Holland, IL: The Goodheart-Willcox Company, Inc., 1982.
- E. Pipe, Ted. *Basic Electricity Training Manual*. Indianapolis, IN 46263: Howard W. Sams & Co., Inc., 1973.
- F. McClain, Gerald R. and Neal A. Wilson. *Electronic Drafting*. Stillwater, OK 74074: Mid-America Vocational Curriculum Consortium, 1983.

DIAGRAMS AND SCHEMATICS

UNIT V

INFORMATION SHEET

I. Terms and definitions

- A. Cabinet — The frame and lower covering of an appliance where the operating components and their associated wiring are housed
- B. Console — The upper panel of an appliance that houses control devices such as timers and switches and is frequently lighted to enhance the appearance of the appliance
- C. Color coding — The use of colored insulation around conductor wires to identify different circuits in an appliance, and the marking of terminals with appropriate colors to assure proper assembly and facilitate more efficient troubleshooting
- D. Graphic aids — Diagrams, schematics, line drawings, views, and photographs available for a given product to assure proper assembly and efficient service
- E. Line drawing — A hand drawn or computer drawn pictorial as opposed to a photograph
- F. Perspective — A view of an object from a given angle such as the top, bottom, end, or side
- G. Pictorial — A drawing or other graphic representation of an object made in such a way that it helps a viewer visualize how the object is made or how it works
- H. Tracer — A second color of narrow width molded into the basic color of the insulation around a wire
- I. View — A portion of an object presented in a perspective which helps to clarify its assembly or its function

II. Block diagrams (Transparency 1)

- A. Block diagrams are simple illustrations showing the relationship of components in a circuit.
- B. Block diagrams use boxes or circles to indicate relative component location and often have the name of the component written near the box or circle.
- C. Block diagrams sometimes use switch symbols, but other symbols are seldom found on a block diagram.

INFORMATION SHEET

- D. Block diagrams sometimes use arrows to indicate the direction of current flow.
- E. Block diagrams are often used to illustrate in a general way how an appliance circuit and components are related, but they are not specific enough to be used for actual troubleshooting activity.
- F. Block diagrams seldom have legends like wiring diagrams and schematic diagrams do.

III. Schematic diagrams (Transparency 2)

- A. Schematic diagrams do not show wiring detail, but are used to show how a circuit is structured to serve the components in an appliance.
- B. Schematic diagrams serve to illustrate general operations, but do not show actual detail of wires, terminals, and connectors.
- C. If you know electrical symbols, schematics are relatively easy to read.
- D. The limitation of a schematic is that its lack of detail makes it difficult to use in situations where wire by wire troubleshooting is required.
- E. Schematic diagrams frequently have legends to clarify circuit structure and component relationships to the circuit and control devices.

IV. Wiring diagrams (Transparency 3)

- A. Wiring diagrams are a troubleshooter's best friend because they are more complete than any other type of diagram.
- B. A good wiring diagram will show, in some way, every wire, terminal, connector, and component in an appliance.
- C. One of the conventions of a wiring diagram is that phantom lines or other techniques may be used to express relationships of components and switches or control devices.
- D. Wiring diagrams use symbols profusely, but the size, shape, and relationships are not necessarily shown to any scale because distances have to fit within the diagram.
- E. Wiring diagrams are effective troubleshooting tools because wires have their color codes listed, and some wiring diagrams show the wires in their actual colors.
- F. Wiring diagrams almost always have legends for clarification, and some legends list components names and part numbers as an added aid for the service technician.

INFORMATION SHEET

V. Other graphic aids and their functions

- A. Phantom views — Use dashes to create a window to expose an object that would otherwise be hidden or to represent an object that is hidden (Transparency 4)
- B. Cutaway views — Use irregular lines to create a window that permits a viewer to better visualize an assembly or a troubleshooting activity (Transparency 4)
- C. Detail views — Used to clarify other pictorials by enlarging and spotlighting parts of a component that would be otherwise difficult to visualize (Transparency 4)
- D. Section views — Slice through the plane of an object to display internal component relationships and operations (Transparency 4)
- E. Exploded views — Depict components separated and suspended in the order in which they fit together (Transparency 4)
- F. Wiring harness diagrams — Show how wires are actually connected to terminals or to other wires (Transparency 5)

VI. Where to find helpful graphic aids

- A. Repair manuals, service manuals, and installation guides are usually well illustrated with schematics, diagrams, timer charts, and photographs or line drawings to depict proper assembly and service.
- B. A wiring diagram or a schematic is usually attached to an appliance behind a service panel so that a service technician can readily find it. (Figure 1)

FIGURE 1



INFORMATION SHEET

- C. Wiring diagrams or schematics should always be returned to the appliance after use so that the next technician who works on the appliance will not have to waste time finding a proper diagram.
- D. Repair manuals, service manuals, and installation guides use cutaways, phantom lines, and detail views to help clarify difficult assemblies or service routines.
- E. Exploded views are used frequently in service literature, but are also common in parts catalogs because the detail is most effective for helping relate parts to their part numbers. (Figure 2)

FIGURE 2

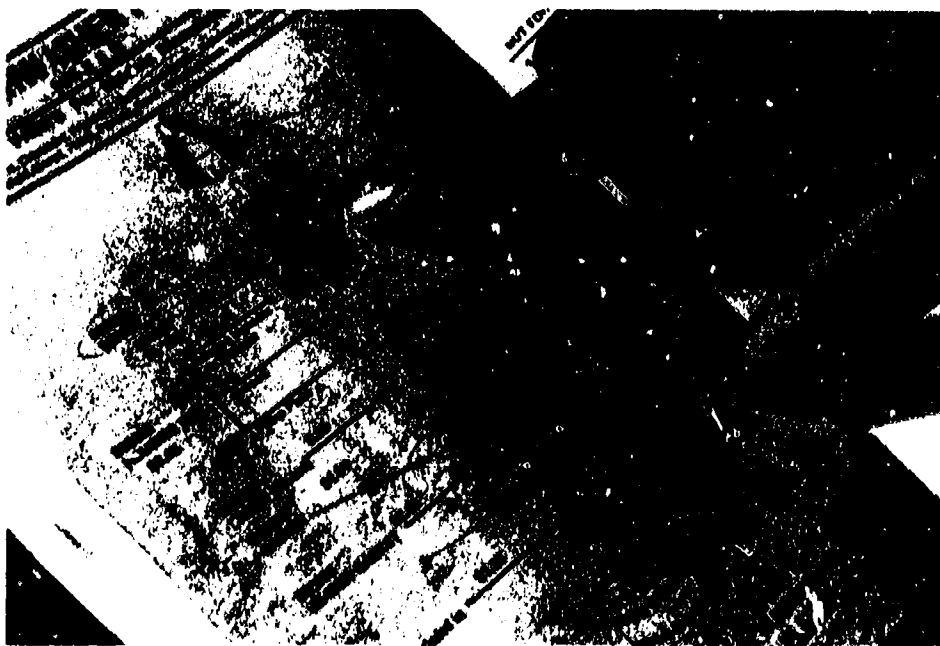

- F. Wiring harness diagrams are used mostly at the point where an appliance is actually assembled in the factory, but every now and then they show up in service literature when wiring needs to be detailed.

VII. Timer sequence charts (Transparency 6)

- A. Timer sequence charts are almost always included with an appliance that has a timer, and they frequently are shown with a wiring diagram or schematic because the two should be used together.
- B. The timer sequence chart is a valuable troubleshooting tool because it depicts what is happening at any given point in an operating cycle.
- C. Timer sequence charts number the timer switches and list the functions of each switch.
- D. Each timer switch number indicates the color code or the terminal and the wiring that connects components controlled by each of the timer switches.
- E. When used with a wiring diagram or schematic, a timer sequence chart can be used to quickly isolate a problem component or a bad switch.

INFORMATION SHEET

VIII. Legends

- A. Legends accompany diagrams, schematics, and other pictorials to provide a key for properly interpreting the material.
- B. Legends are typically used to:
 - 1. Indicate color code meanings. (Figure 3)

FIGURE 3

B = BLACK	R = RED
BU = BLUE	W = WHITE
BR = BROWN	Y = YELLOW
G = GREEN	 INSULATED CONNECTOR
OR = ORANGE	
PJ = PURPLE	

Courtesy Frigidaire

- 2. Indicate special circuitry. (Figure 4)

FIGURE 4

TEMPERATURE SELECTOR CHART

FUNCTION	CIRCUIT		
	R to Y	OR+TR to Y	BU to BU
HOT/COLD			X
WARM/WARM	X	X	X
WARM/COLD		X	X
COLD/COLD		X	

OPTIONS CHART

FUNCTION	CIRCUIT			
	G to T+TR	G to OR	P+TR to Y+TR	P+TR to OR
NORMAL/FAST				
NORMAL/SLOW				
GENTLE/SLOW				

Courtesy Frigidaire

- 3. Provide notations needed to interpret abbreviations and special symbols. (Figure 5)

FIGURE 5

CONTACTS CLOSED
 ELECTRICALLY CONNECTED

 2.27" ROTATION = 1 MINUTE
 TM-TIMER MOTOR
 "X" DENOTES CONTACT CLOSED

Courtesy Frigidaire

IX. Color codes

- A. Because there are many circuits in a single appliance, wires and terminals are color coded to assure proper assembly and make troubleshooting more efficient.

INFORMATION SHEET

- B. Color codes vary with manufacturer and sometimes from appliance to appliance, but single colors are usually indicated with obvious abbreviations, and colors with tracers lists the tracer color second or sometimes simply indicate it is a basic color with a tracer.

Example: T-B = Tan with a black tracer

T-TR = Tan with a tracer

- C. There are no standards for color abbreviations, but some that are fairly common are shown in Figure 5.

FIGURE 6

B or BK = Black	G = Green	PU = Purple	W = White
BR = Brown	GY = Gray	R = Red	Y = Yellow
BU = Blue	O or OR = Orange	T = Tan	TR = Tracer
LBU = Light blue	P or PK = Pink	V = Violet	

- D. Color codes are always indicated on timer sequence charts, but in some cases color codes vary significantly, and proper interpretation requires careful reference to the legend that accompanies the material. (Figure 7)

Example: The following color code from a Frigidaire dishwasher schematic varies from standard abbreviations.

FIGURE 7

<u>COLOR CODE</u>	
A•GRAY	PK•PINK
B•BLACK	R•RED
G•GREEN	T•TAN
K•BROWN	U•BLUE
N•ORANGE	W•WHITE
P•PURPLE	Y•YELLOW
U-W•BLUE/WHITE TRACER	
T-B•TAN/BLACK TRACER	
Y-B•YELLOW/BLACK TRACER	
K-W•BROWN/WHITE TRACER	
N-W•ORANGE/WHITE TRACER	
R-B•RED/BLACK TRACER	
P-W•PURPLE/WHITE TRACER	
<u>TERMINAL</u>	
<u>CONNECTIONS CODE</u>	
—•INTERNAL BUSS BAR	
—•INTERCONNECTING WIRES	
<u>SWITCH CIRCUIT CODE</u>	
X•CLOSED O•OPEN	

Courtesy Frigidaire

INFORMATION SHEET

- X. Basic electrical symbols (Transparency 7 and 8)**
- A. The heart of a circuit is wiring, and the symbol for wiring is a straight line with special symbols for points where wires join, cross, or join with connectors.
 - B. To be safe, a circuit must be grounded, and there are separate symbols to indicate whether the circuit has an earth ground or a ground to chassis.
 - C. Fuses, circuit breakers, and overloads are protection devices that frequently require troubleshooting.
 - D. Switches are probably the most common parts of an appliance circuit, and their symbols indicate their functions.
 - E. When an operator pushes a button to start an appliance, a momentary switch does the work of getting things started.
 - F. Water level switches are found in automatic washers and dishwashers.
 - G. Centrifugal switches are usually found in motors.
 - H. Relays and solenoids activate other components, and their symbols may vary slightly.
 - I. Motors are important components of many major appliances, and their symbols indicate their type and service application.
 - J. Capacitors are used with some motors and for other applications, and their symbols indicate whether they are fixed or variable.
 - K. Resistors in a circuit may have the ohmic value indicated, and the resistor symbol is also used to indicate a resistance heater.
 - L. Thermostats and thermocouples are both control and protective devices.
 - M. Lights generally function to alert an appliance operator to a proper or improper operating condition, and each type of light has its own symbol.
 - N. Terminals where wires are attached to devices are usually blocked out and individual terminals are lettered or numbered.
- XI. Symbols for solid state devices (Transparency 9)**
- A. Since more and more modern appliances are using solid state devices for controls, repair technicians need to know solid state symbols
 - B. Solid state controls usually include transistors, diodes, triacs, rectifiers, and silicon controlled rectifiers (SCR's)
 - C. Solid state controls may include electronic devices such as resistors and capacitors

INFORMATION SHEET

- D. Solid state devices promise to grow in popularity because they are compact, lightweight, and operate faster than other types of components

XII. Guidelines for using diagrams and schematics

- A. Check for the hot side or ungrounded line of the power source so you'll have a logical starting point.
- B. Trace the current flow from the source through any control devices to the malfunctioning component so you can identify components that you will physically have to check on the appliance.
- C. A hot wire passing through several in-line components indicates a series circuit.
- D. Look for places where a hot wire goes into a point, but two or more wires come out; this indicates a branch or parallel circuit, and each branch has to be traced individually back to the source.
- E. When there are two or more current sources, the sources will be confined to their own circuits, but they will never be joined.
- F. Remember two important rules for electrical troubleshooting:
 - 1. Current never vanishes; if current flows into a device, it must flow out again and back to the power source for the circuit.
 - 2. If the current flow divides, it must come together again at a point before the power source or at the power source.
- G. Read the legend to be certain you know what incidental symbols mean, and take all notations into consideration.
- H. Make sure you interpret symbols correctly, and consult a reliable reference when you're not sure.
- I. Remember that schematics and diagrams show switches and control devices in the condition they are in just before appliance operation starts and that a manual or automatic event must take place to change a switch position.

Block Diagram

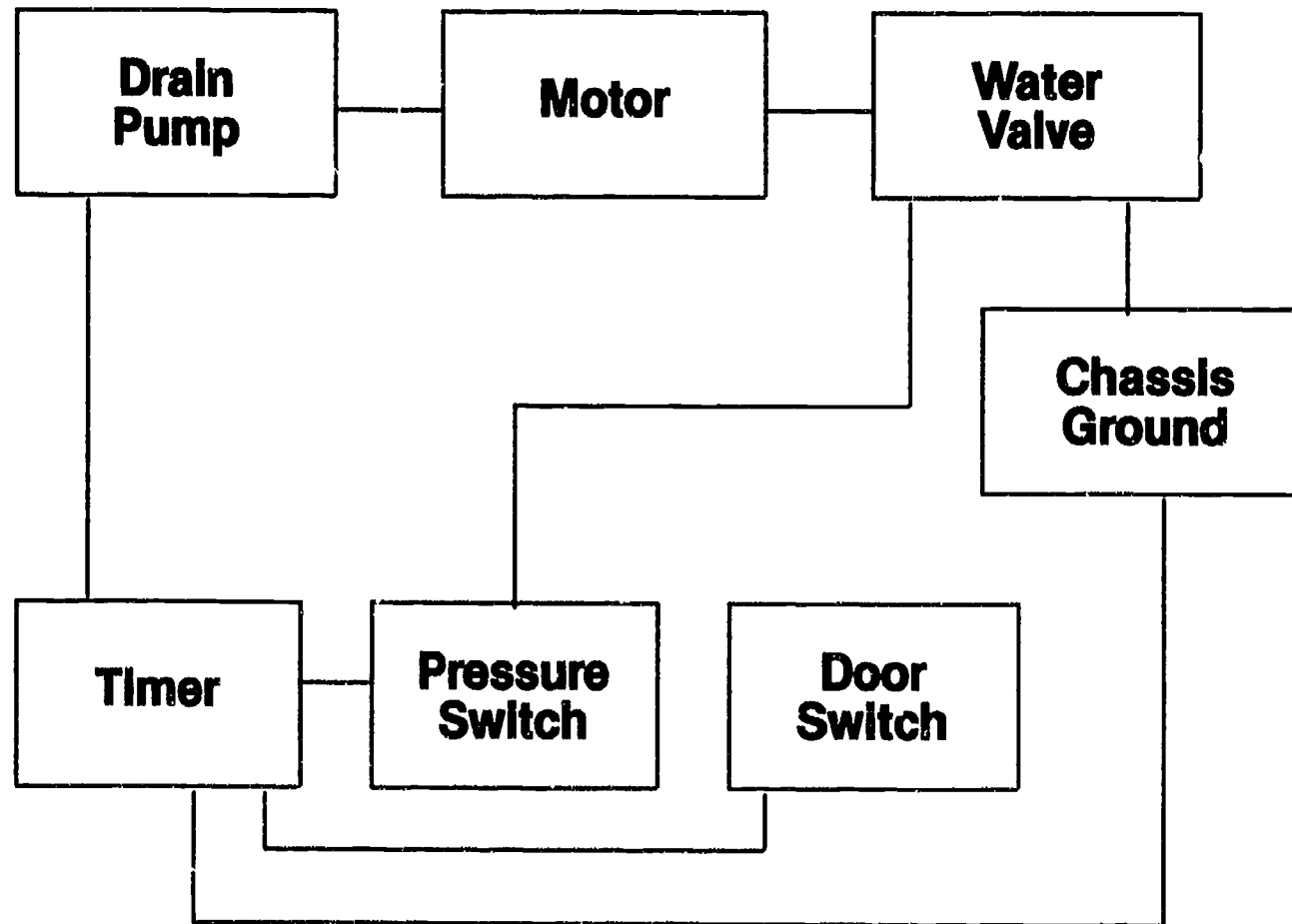

Schematic Diagram

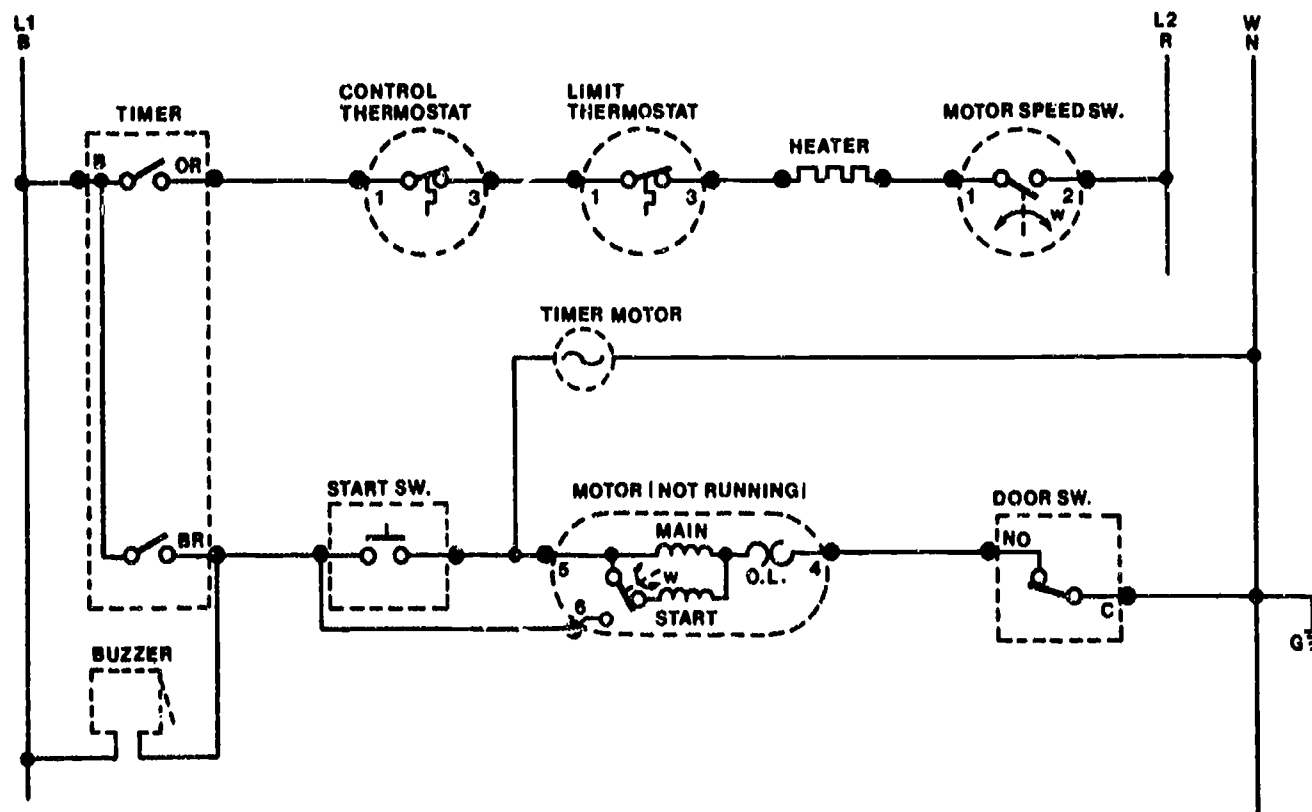

B = BLACK OR = ORANGE
 BR = BROWN R = RED
 G = GREEN W = WHITE

TIME SCHEDULE IN MINUTES				
SWITCH CLOSED	CYCLES			
	TIME DRY	OFF	NO HEAT	OFF
HEATER B-OR	[Hatched]			
MOTOR B-BR	[Hatched]		[Hatched]	
	84-86		70	
	90			

Automatic Dryer

Courtesy Frigidaire

Wiring Diagram

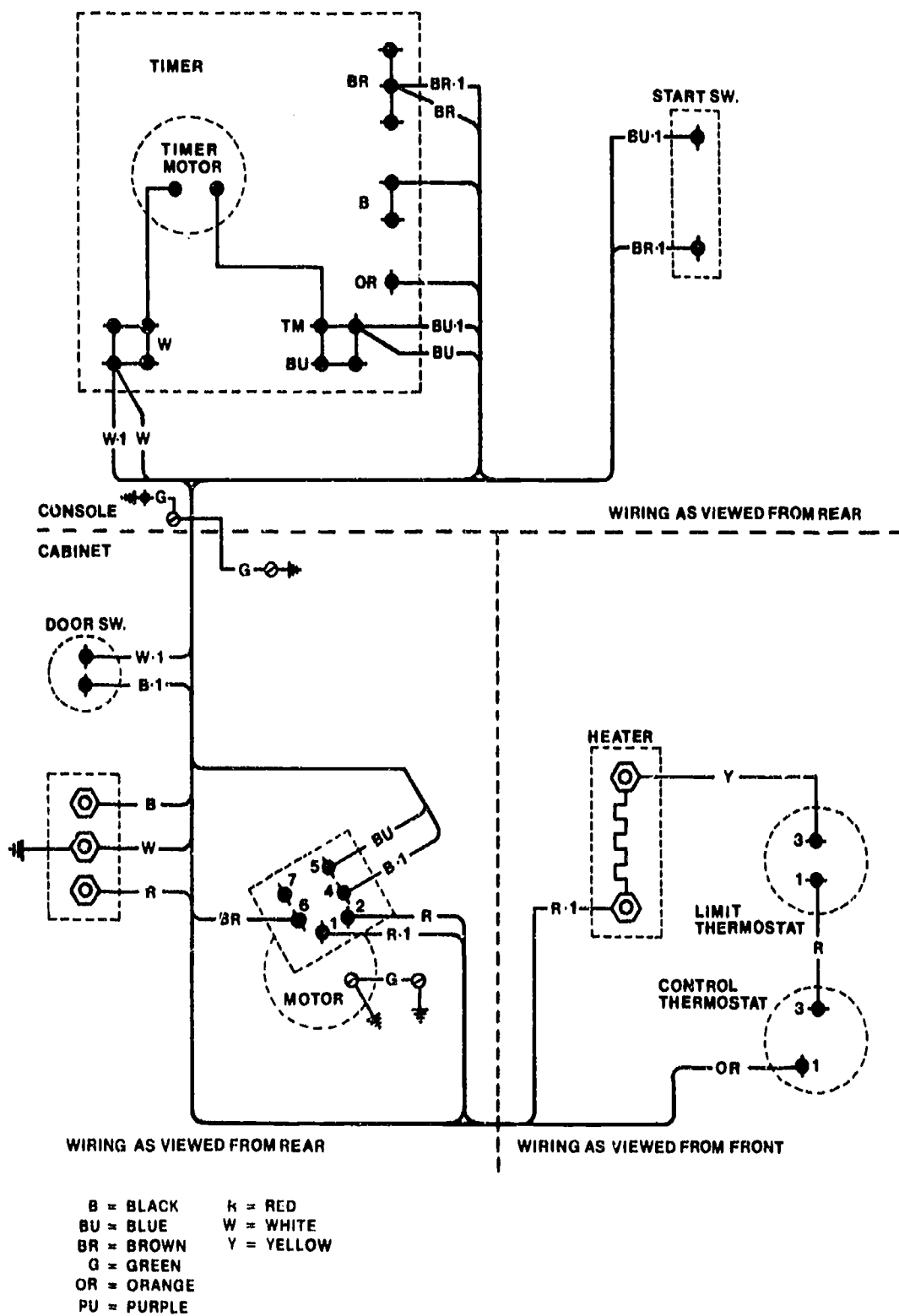

Automatic Dryer

Courtesy Frigidaire

Other Graphic Aids

Cutaway View with Detail

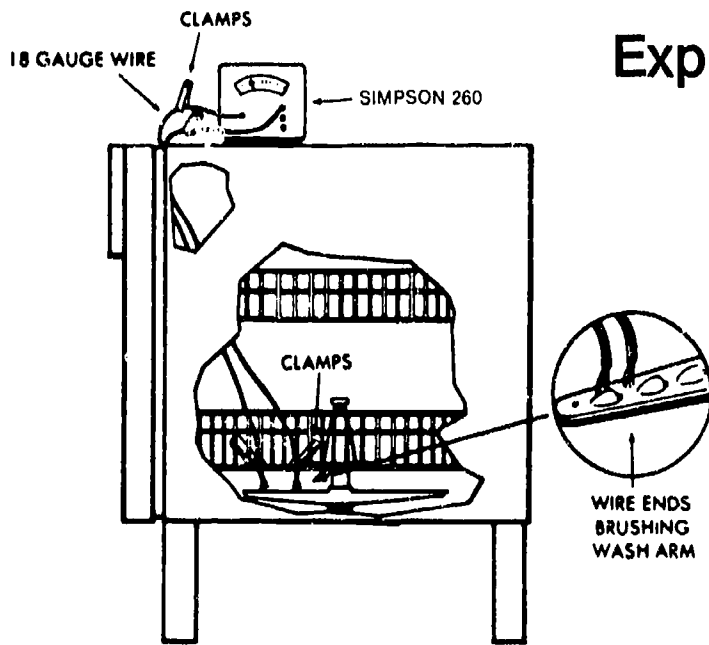

Exploded View of Float and Switch Assembly

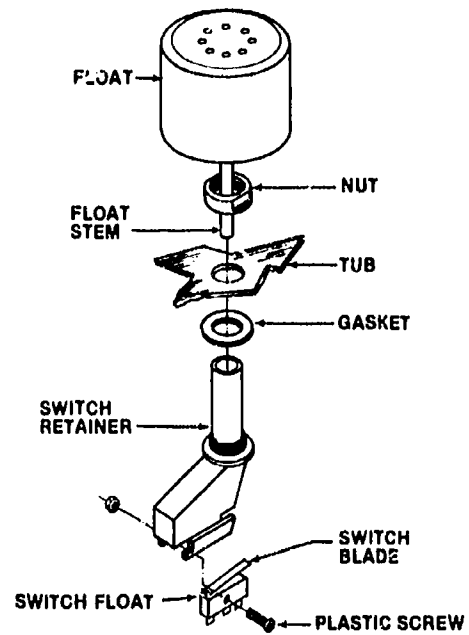

Section View of Water Valve

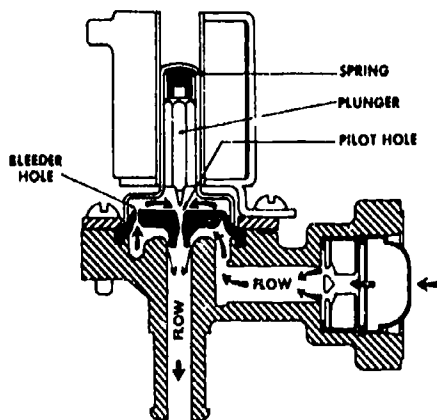

Phantom View

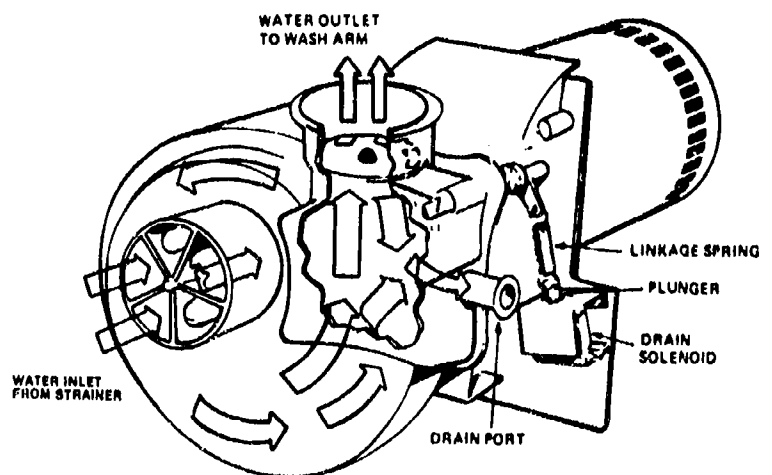

Courtesy Frigidaire

Wiring Harness

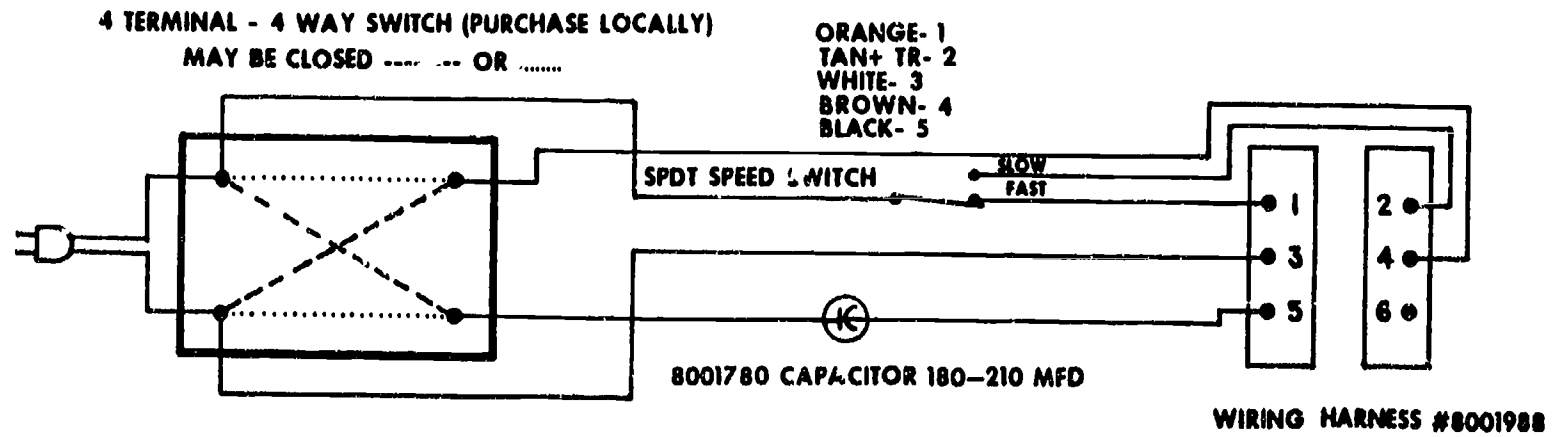

Courtesy Frigidaire

230

231

Timer Sequence Chart and Schematic Diagram

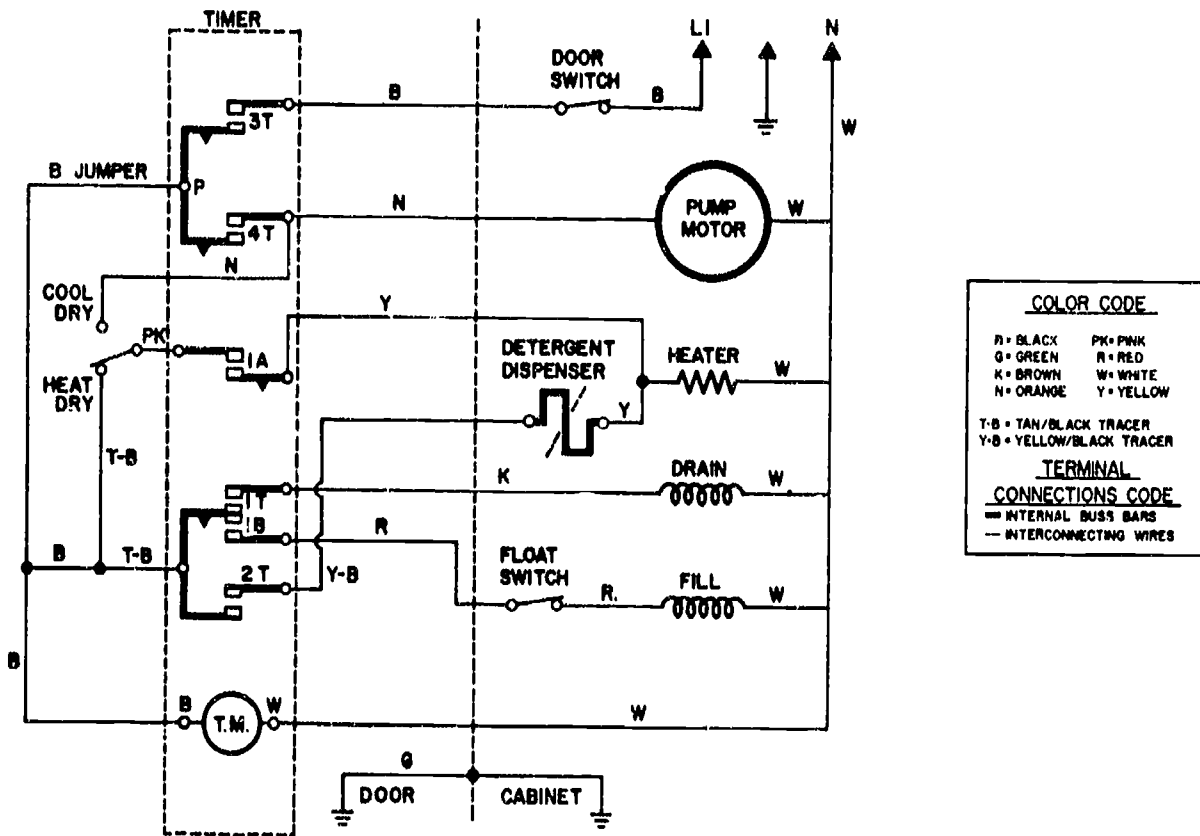

SCHEMATIC DIAGRAM

TIMER CHART

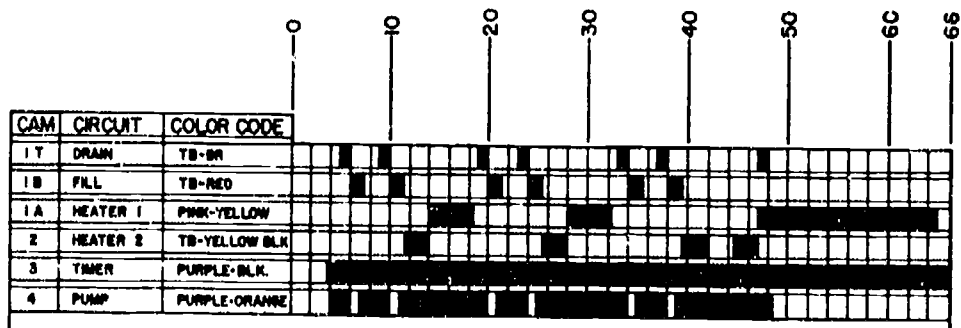

CYCLE CHART

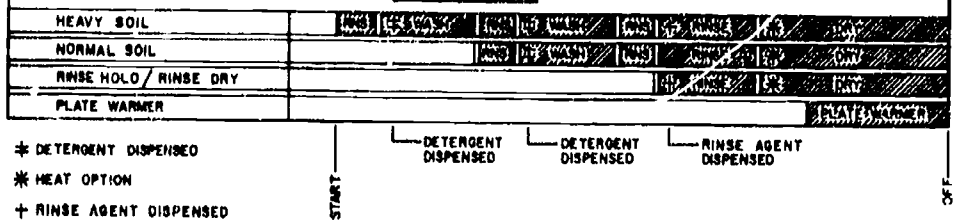

Courtesy Frigidaire

Electrical Symbols



Circuit Wire

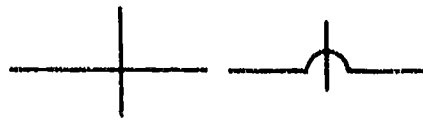

Crossing Wires

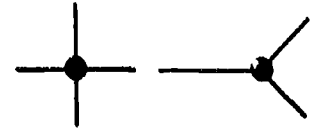

Junctions



Connectors



Earth Ground

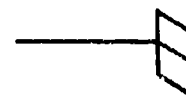

Chassis Ground



Fuse



Circuit Breaker



Overload



Single Pole,
Single Throw Switch

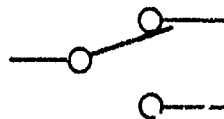

Single Pole,
Double Throw Switch

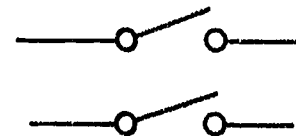

Double Pole,
Single Throw Switch

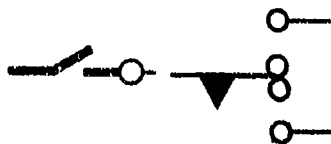

Timer Switches

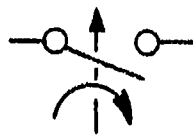

Centrifugal Switch

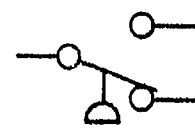

Water Level Switch

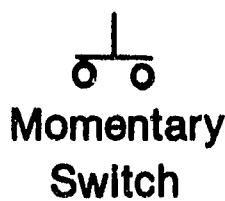

Momentary
Switch



Coil

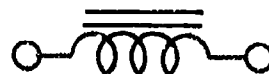

Solenoid



Transformer

Electrical Symbols

(Continued)



Timer Motor

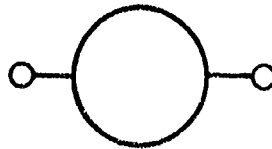

Single-Speed Motor

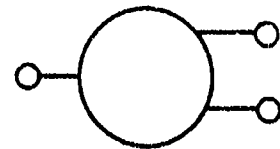

Multi-Speed Motor

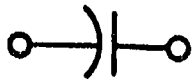

Fixed Capacitor



Variable Capacitor



Resistor or
Resistance Heater



Thermostat

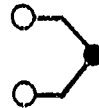

Thermocouple



Fluorescent Light



Incandescent Light

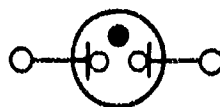

Neon Light



Single Terminal

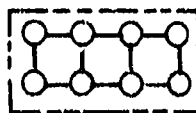

Block Terminal

Solid State Symbols

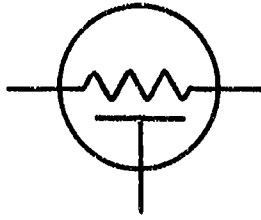

Thermistor

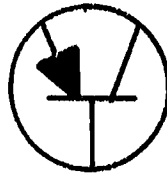

Transistor

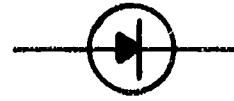

Diode

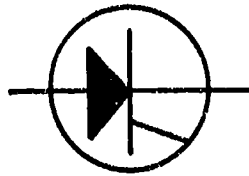

SCR (Silicon Controlled Rectifier)



Zener Diode

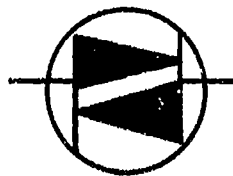

Triac

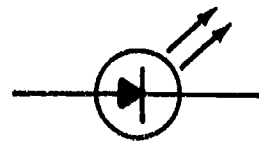

Light Emitting Diode

DIAGRAMS AND SCHEMATICS UNIT V

ASSIGNMENT SHEET #1 — INTERPRET A TIMER SEQUENCE CHART AND WIRING DIAGRAM FOR AN AUTOMATIC DISHWASHER

A. Tools and materials

1. Wiring diagram (Figure 1)
2. Timer sequence chart (Figure 1)
3. Pencil and paper

B. Procedure

1. Remember that the solid lines in the timer sequence chart indicate at what points and for how long voltage is applied to a given timer contact
2. Remember that the timer sequence chart functions for the sake of clarity, and that the time increments across the chart which appear to be one minute increments are actually half-minute increments, and the complete cycle takes about 33 minutes, not 66 minutes as the chart seems to indicate
3. Start troubleshooting by finding the hot side of the incoming power supply on the wiring diagram

(NOTE: On Figure 1 that accompanies this assignment sheet, the hot side is shown at the top of the diagram as L1.)

4. Trace the circuit through the door switch which is in series with the timer
5. Trace the circuit into the timer and out of the timer into the black jumper

(NOTE: Check the legend to the right of the wiring diagram if you have questions about what abbreviations mean.)

6. Trace the black jumper into its connection with a tan with black tracer conductor which takes the circuit through the 1B timer cam which comes out on a red wire and carries the current on to the float switch which is in series with the fill valve

(NOTE: On this particular Frigidaire dishwasher, the timer motor starts as the ON switch is activated and stays on until the end of the full cycle, but notice that the water pump is ON and OFF Intermittently for rinse and wash operations.)

7. Note the many things that happen when the ON switch is actuated:
 - a. The door switch is in series with the timer and closes to permit current to reach the timer and begin the cycle

ASSIGNMENT SHEET #1

- b. The first activity is a heavy soil rinse which begins early in the cycle and involves activation of the 4T timer cam to the pump motor, activation of the 1T timer cam to the drain, and activation of the 1B timer cam to the fill valve
 - c. The rinse/drain function for heavy soil starts the first 6 minutes (actually 3 minutes) of the cycle, and both the pump/drain activities are intermittent as is the fill activity throughout the remainder of the wash/rinse operations
 - d. Heater 2 is first activated at about 11 minutes (actually 5½ minutes) into the cycle and then alternates with heater 1 through the first two wash cycles to help maintain proper water temperature
 - e. After the final rinse, only heater 1 stays on during the drying part of the cycle
 - f. All pump and drain alternations end at about 48 (24) minutes into the cycle, and only the timer and heat 1 remain activated until the 66 (33) minute cycle is complete
8. Use the preceding information, reference the wiring diagram and timer chart in Figure 1, and answer the following questions:

- a. At what points in the cycle is detergent dispensed?

Answer _____

- b. At what point in the cycle is the rinse agent dispensed?

Answer _____

- c. Can timer cam 1B and 1T both be activated at the same time?

Answer _____

- d. What do timer cams 1B and 1T control?

Answer _____

- e. What drying options does this dishwasher offer?

Answer _____

ASSIGNMENT SHEET #1

f. What timer cam controls the drying options?

Answer _____

g. The timer chart in Figure 1 shows Heater 1 and Heater 2, but there is only one heating element indicated on the wiring diagram. What does this mean?

Answer _____

h. Use the wiring diagram and timer chart in Figure 1, list at least three components that might be causing the common complaint that the dishwasher will not fill with water.

Answer _____

i. What timer cams would you check to see if the fill circuit is complete through the timer?

Answer _____

j. If you have continuity through the timer contacts in a given circuit, what does that mean?

Answer _____

k. What component is most likely to be causing a complaint that dishes do not dry properly?

Answer _____

l. If the dishwasher has a complaint of improper cleaning because the detergent is not being properly dispensed, but a check of the detergent dispenser solenoid proves the solenoid is okay, what color wire would you trace back to the timer, and what timer cam would you trace it to?

Answer _____

ASSIGNMENT SHEET #1

FIGURE 1

WIRING DIAGRAM

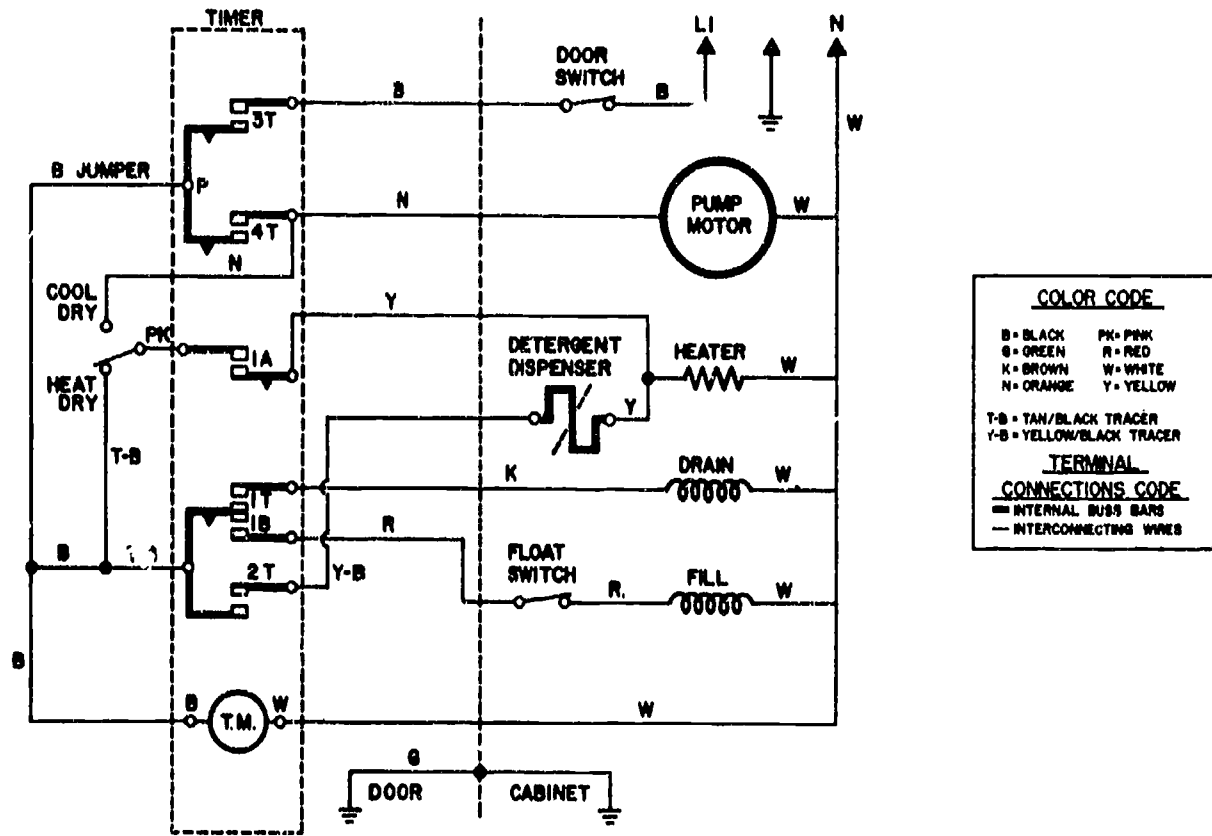

COLOR CODE

B = BLACK PK = PINK
 G = GREEN R = RED
 K = BROWN W = WHITE
 N = ORANGE Y = YELLOW

T-B = TAN/BLACK TRACER
 Y-B = YELLOW/BLACK TRACER

TERMINAL CONNECTIONS CODE

— INTERNAL BUS BARS
 - INTERCONNECTING WIRES

SCHEMATIC DIAGRAM

TIMER CHART

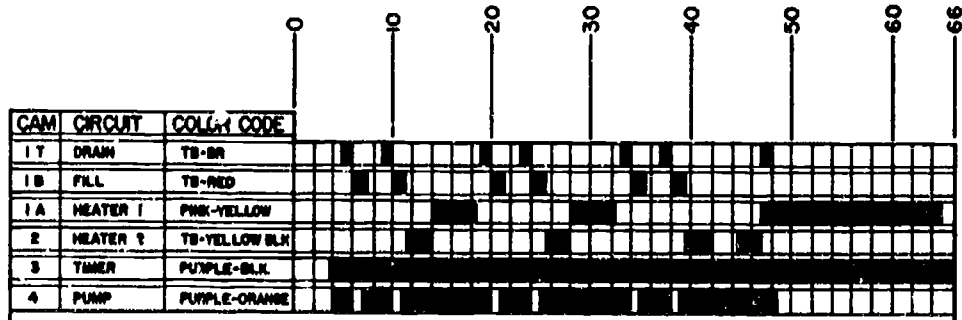

CYCLE CHART

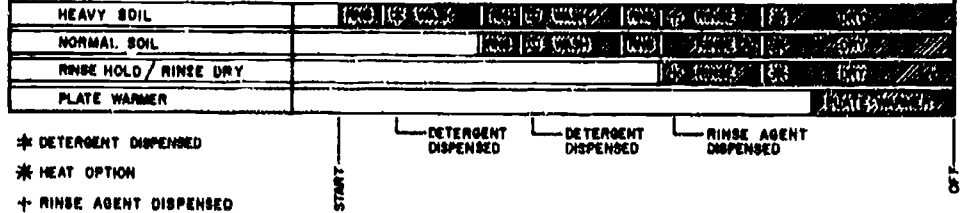

DIAGRAMS AND SCHEMATICS UNIT V

ANSWERS TO ASSIGNMENT SHEETS

- a. At about 10 (5) minutes into the cycle at the beginning of the first wash operation, and at about 14 (7) minutes into the cycle at the beginning of the second wash operation
- b. At about 38 (19) minutes into cycle at the beginning of the final rinse
- c. No
- d. 1B controls the fill function, and 1T controls the drain function
- e. Cool dry and heat dry
- f. 1A
- g. It means there are two heater circuits, one to maintain water temperature and the other for drying
- h. The door switch, the float switch, and the fill valve
- i. 3T and 1B
- j. That the circuit is complete through the timer
- k. The heating element
- l. Yellow with a black tracer should be traced back to timer cam 2T

DIAGRAMS AND SCHEMATICS UNIT V

NAME _____

TEST

1. Match the terms on the right with their correct definitions.

- | | | |
|---------|--|-----------------|
| _____a. | The frame and lower covering of an appliance where the operating components and their associated wiring are housed | 1. Line drawing |
| _____b. | The upper panel of an appliance that houses control devices such as timers and switches and is frequently lighted to enhance the appearance of the appliance | 2. Tracer |
| _____c. | The use of colored insulation around conductor wires to identify different circuits in an appliance, and the marking of terminals with appropriate colors to assure assembly and facilitate more efficient troubleshooting | 3. Graphic aids |
| _____d. | Diagrams, schematics, line drawings, views, and photographs available for a given product to assure proper assembly and efficient service | 4. Cabinet |
| _____e. | A hand drawn or computer drawn pictorial as opposed to a photograph | 5. Perspective |
| _____f. | A view of an object from a given angle such as the top, bottom, end, or side | 6. Color coding |
| _____g. | A drawing or other graphic representation of an object made in such a way that it helps a viewer visualize how the object is made or how it works | 7. View |
| _____h. | A second color of narrow width molded into the basic color of the insulation around a wire | 8. Console |
| _____i. | A portion of an object presented in a perspective which helps to clarify its assembly or its function | 9. Pictorial |

TEST

2. Select true statements concerning block diagrams by placing an "X" beside each statement that is true.
- _____a. Block diagrams are simple illustrations showing the relationship of components in a circuit
 - _____b. Block diagrams use boxes or circles to indicate relative component location and often have the name of the component written near the box or circle
 - _____c. Block diagrams sometimes use switch symbols, but other symbols are seldom found on a block diagram
 - _____d. Block diagrams sometimes use arrows to indicate the direction of current flow
 - _____e. Block diagrams are often used to illustrate in a general way how an appliance circuit and components are related, and are good for actual troubleshooting activity
 - _____f. Block diagrams usually have legends like wiring diagrams and schematic diagrams to
3. Complete statements concerning schematic diagrams by inserting the word(s) that best completes each statement.
- a. Schematic diagrams do not show _____ detail, but are used to show how a circuit is structured to serve the components in an appliance.
 - b. Schematic diagrams serve to illustrate _____ operations, but do not show actual detail of wires, terminals, and connectors.
 - c. If you know electrical _____, schematics are relatively easy to read.
 - d. The limitation of a schematic is that its lack of detail makes it difficult to use in situations where _____ by _____ troubleshooting is required.
 - e. Schematic diagrams frequently have _____ to clarify circuit structure and component relationships to the circuit and control devices.
4. Solve problems concerning wiring diagrams by answering the following questions.
- a. Why are wiring diagrams a troubleshooter's best friend?
Answer _____
 - b. Why are sizes and shapes in a wiring diagram not to scale?
Answer _____

TEST

- c. Why do wiring diagrams help make circuit troubleshooting easier?

Answer _____

5. Match other graphic aids with their functions.

- | | | |
|---------|--|----------------------------|
| _____a. | Use dashes to create a window to expose an object that would otherwise be hidden or to represent an object that is hidden | 1. Section views |
| _____b. | Use irregular lines to create a window that permits a viewer to better visualize an assembly or a troubleshooting activity | 2. Wiring harness diagrams |
| _____c. | Used to clarify other pictorials by enlarging and spotlighting parts of a component that would be otherwise difficult to visualize | 3. Detail views |
| _____d. | Slice through the plane of an object to display internal component relationships and operations | 4. Exploded views |
| _____e. | Depict components separated and suspended in the order in which they fit together | 5. Phantom views |
| _____f. | Show how wires are actually connected to terminals or to other wires | 6. Cutaway views |

6. Complete statements concerning where to find helpful graphic aids by inserting the word(s) that best completes each statement.

- a. Repair manuals, service manuals, and installation guides are usually well illustrated with schematics, diagrams, timer charts, and photographs or line drawings to depict proper assembly and _____.
- b. A wiring diagram or a schematic is usually attached to an appliance _____ a service panel so that a service technician can readily find it.
- c. Wiring diagrams or schematics should always be returned to the _____ after use so that the next technician who works on the appliance will not have to waste time finding a proper diagram.
- d. Repair manuals, service manuals, and installation guides use cutaways, phantom lines, and detail views to help clarify difficult _____ or service routines.
- e. Exploded views are used frequently in service literature, but are also common in parts catalogs because the detail is most effective for helping relate parts to their _____.

TEST

- f. Wiring harness diagrams are used mostly at the point where an appliance is actually _____ in the factory, but every now and then they show up in service literature when wiring needs to be detailed.
7. Select true statements concerning timer sequence charts by placing an "X" beside each statement that is true.
- _____a. Timer sequence charts are almost always included with an appliance that has a timer, and they frequently are shown with a wiring diagram or schematic because the two should be used together.
- _____b. The timer sequence chart is a valuable troubleshooting tool because it depicts what is happening at any given point in an operating cycle.
- _____c. Timer sequence charts number the timer switches and list the functions of each switch.
- _____d. Each timer switch number indicates the color code of the terminal and the wiring that connects components controlled by each of the timer switches.
- _____e. When used with a wiring diagram or schematic, a timer sequence chart can be used to quickly isolate a problem component or a bad switch.
8. Complete a list of what legends do by circling the word(s) that best completes each statement.
- a. Legends accompany diagrams, schematics, and other pictorials to provide a key for properly (interpreting) (applying) the material.
- b. Legends are typically used to
- 1) Indicate (color) (assembly) code meanings.
 - 2) Indicate (normal) (special) circuitry.
 - 3) Provide (notations) (hints) needed to interpret abbreviations and special symbols.
9. Complete the following chart of common color code abbreviations by inserting the correct name in the appropriate blank.

B or BK = Black	G = b. _____	PU = d. _____	W = f. _____
BR = Brown	GY = Gray	R = Red	Y = Yellow
BU = a. _____	O or OR = Orange	T = e. _____	TR = g. _____
LBU = Light blue	P or PK = c. _____	V = Violet	

TEST

10. Identify basic electrical symbols by matching the correct term with the appropriate symbol.

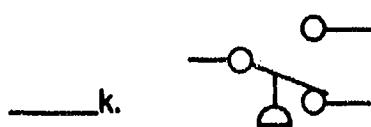
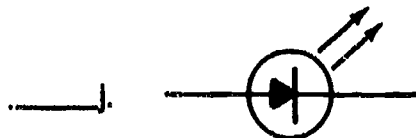
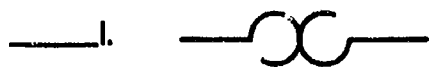
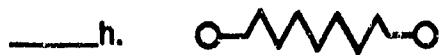
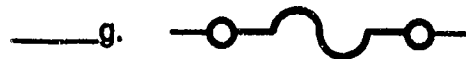
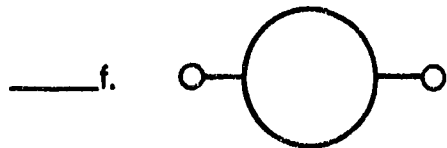
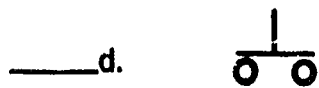
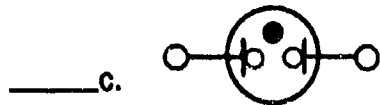
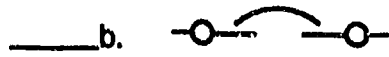
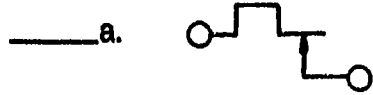

1. Chassis ground
2. Fuse
3. Circuit breaker
4. Overload
5. Water level switch
6. Single-speed motor
7. Light emitting diode
8. Thermostat
9. Momentary switch
10. Resistor
11. Neon light

TEST

11. Complete statements concerning solid state devices by inserting the word(s) that best completes each statement.
- a. Since more and more modern appliances are using solid state devices for _____, repair technicians need to know solid state symbols.
 - b. Solid state controls usually include _____, diodes, triacs, rectifiers, and silicon controlled rectifiers.
 - c. Solid state controls may include electronic devices such as resistors and _____.
 - d. Solid state devices promise to grow in popularity because they are compact, lightweight, and operate _____ than other types of components.
12. Complete guidelines for using diagrams and schematics by inserting the word(s) that best complete each statement.
- a. Check for the _____ side or ungrounded line of the power source so you'll have a logical starting point.
 - b. Trace the current flow from the source through any _____ devices to the malfunctioning component so you can identify components that you will physically have to check on the appliance.
 - c. A hot wire passing through several in-line components indicates a _____ circuit.
 - d. Look for places where a hot wire goes into a point, but two or more wires come out; this indicates a branch or _____ circuit, and each branch has to be traced individually back to the source.
 - e. When there are two or more current sources, the sources will be confined to their own circuits, but they will never be _____.
 - f. Remember two important rules for electrical troubleshooting:
 - 1) Current never _____; if current flows into a device, it must flow out again and back to the power source for the circuit.
 - 2) If the current flow divides, it must come _____ again at a point before the power source or at the power source.
 - g. Read the _____ to be certain you know what incidental symbols mean, and take all notations into consideration.
 - h. Make sure you interpret symbols correctly, and consult a reliable reference when you're _____.

TEST

1. Remember that schematics and diagrams show switches and control devices in the condition they are in just before appliance operation _____ and that a manual or automatic event must take place to change a switch position.

(NOTE: If the following activity has not been accomplished prior to the test, ask your instructor when it should be completed.)

13. Interpret a timer sequence chart and wiring diagram for an automatic dishwasher. (Assignment Sheet #1)

DIAGRAMS AND SCHEMATICS UNIT V

ANSWERS TO TEST

1.
 - a. 4
 - b. 8
 - c. 6
 - d. 3
 - e. 1
 - f. 5
 - g. 9
 - h. 2
 - i. 7

2. a, b, c, d

3.
 - a. Wiring
 - b. General
 - c. Symbols
 - d. Wire, wire
 - e. Legends

4.
 - a. Because wiring diagrams are more complete than schematics
 - b. Because things have to fit within a limited space
 - c. Because all wiring is color coded

5.
 - a. 5
 - b. 6
 - c. 3
 - d. 1
 - e. 4
 - f. 2

6.
 - a. Service
 - b. Behind
 - c. Appliance
 - d. Assembly
 - e. Part numbers
 - f. Assembled

7. a, b, c, d, e

ANSWERS TO TEST

8. a. Interpreting
b. 1) Color
2) Special
3) Notations
9. a. Blue
b. Green
c. Pink
d. Purple
e. Tan
f. White
g. Tracer
10. a. 8
b. 3
c. 11
d. 9
e. 1
f. 6
g. 2
h. 10
i. 4
j. 7
k. 5
11. a. Controls
b. Transistors
c. Capacitors
d. Faster
12. a. Hot
b. Control
c. Series
d. Parallel
e. Joined
f. 1) Vanishes
2) Together
g. Legend
h. Not sure
i. Starts
13. Evaluated to the satisfaction of the instructor



TOOLS, MATERIALS, AND TEST INSTRUMENTS UNIT VI

UNIT OBJECTIVE

After completion of this unit, the student should be able to identify hand tools and shop tools, AWG conductor sizes, and types of splices used on appliance conductors. The student should also be able to use test instruments to check for proper voltages, to measure amperages, and to make continuity checks. These competencies will be evidenced by correctly performing the procedures outlined in the assignment and job sheets and by scoring 85 percent on the unit test.

SPECIFIC OBJECTIVES

After completion of this unit, the student will be able to:

1. Match terms related to tools, materials, and test instruments with their correct definitions.
2. Identify selected basic hand tools.
3. Identify selected shop tools.
4. Complete a list of miscellaneous supplies.
5. Match required appliance repair literature with its uses.
6. Solve problems concerning VOM's and their uses.
7. Select true statements concerning clamp-on ammeters and their uses.
8. Complete statements concerning digital multimeters and their uses.
9. Select true statements concerning temperature testers and their uses.
10. Complete statements concerning capacitor analyzers and their uses.
11. Select true statements concerning wattmeters and their uses.
12. Complete statements concerning shunts and their functions in ammeters.
13. Match electrical measurements with ways to make them.
14. Complete statements concerning appliance wiring.

OBJECTIVE SHEET

15. Solve problems concerning soldering tools.
16. Complete statements concerning resin-core solder and its characteristics.
17. Arrange in order the procedure for using solid wire solder.
18. Arrange in order the steps in wire stripping.
19. Identify selected types of splices.
20. Complete statements concerning guidelines for connections at screw terminals.
21. Complete statements concerning guidelines for good soldered splices.
22. Complete statements concerning guidelines for using solderless connectors and terminals.
23. Complete statements concerning proper care and use of hand tools.
24. Complete a list of guidelines for using other tools and equipment.
25. Select true statements concerning eye protection.
26. Identify selected tools. (Assignment Sheet #1)
27. Demonstrate the ability to:
 - a. Test electrical receptacles for proper voltages. (Job Sheet #1)
 - b. Use a clamp-on ammeter to test for high and low amperages on a fan motor and a light bulb. (Job Sheet #2)
 - c. Make a continuity check of a magnetic control assembly from an automatic washer. (Job Sheet #3)
 - d. Splice electrical conductors to acceptable service standards. (Job Sheet #4)
 - e. Use a VOM for a quick capacitor check. (Job Sheet #5)

TOOLS, MATERIALS, AND TEST INSTRUMENTS UNIT VI

SUGGESTED ACTIVITIES

- A. Provide students with objective sheet.
- B. Provide students with information sheet.
- C. Make transparencies.
- D. Discuss unit and specific objectives.
- E. Discuss information sheet.
- F. Discuss and demonstrate the procedures outlined in the job sheets.
- G. Demonstrate the use of a VOM, a clamp-on ammeter, a wattmeter, a temperature analyzer, and a capacitor analyzer.
- H. Invite the manager of a local or area appliance repair facility to talk to the students about the need for safe and proper use of tools and test instruments, and the importance of gaining basic skills in the use of electrical test instruments.
- I. Invite a local plumber to show students some of the basics of pipefitting and how to use adjustable and pipe wrenches in tandem to make secure connections.
- J. Select receptacles for students to check for proper voltage, and prepare some so they will indicate improper voltage or no voltage at all.
- K. Examine Assignment Sheet #1 carefully and tag selected tools as required for students to complete the assignment.
- L. Give test.

CONTENTS OF THIS UNIT

- A. Objective sheet
- B. Information sheet
- C. Transparency masters
 1. TM 1 — Basic Hand Tools
 2. TM 2 — Basic Hand Tools (Continued)
 3. TM 3 — Measuring Voltage at a Receptacle
 4. TM 4 — Measuring Voltage in a Parallel Circuit
 5. TM 5 — Measuring Amperage in a Circuit
 6. TM 6 — Measuring Resistance in a Coil

CONTENTS OF THIS UNIT

- D. Assignment Sheet #1 — Identify Selected Tools
- E. Job sheets
 - 1. Job Sheet #1 — Test Electrical Receptacles for Proper Voltages
 - 2. Job Sheet #2 — Use a Clamp-On Ammeter to Test for High and Low Amperages on a Fan Motor and a Light Bulb
 - 3. Job Sheet #3 — Make a Continuity Check of a Magnetic Control Assembly From an Automatic Washer
 - 4. Job Sheet #4 — Splice Electrical Conductors to Acceptable Service Standards
 - 5. Job Sheet #5 — Use a VOM for a Quick Capacitor Check
- F. Test
- G. Answers to test

REFERENCES USED IN DEVELOPING THIS UNIT

- A. *National Electric Code 1987*. Quincy, MA 02269: National Fire Protection Association, 1986.
- B. *Armstrong Value Parts Catalog, Spring and Summer, 1985*. Willoughby, OH 44094: W.D. Armstrong Corp., 1985.
- C. Anderson, Edwin P. *Home Appliance Servicing*. Indianapolis, IN 46268: Howard W. Sams & Co., Inc., 1979.

TOOLS, MATERIALS, AND TEST INSTRUMENTS

UNIT VI

INFORMATION SHEET

I. Terms and definitions

- A. **AWG (American Wire Gauge)** — A classification system for identifying wire conductors by diameter and number
- B. **Chassis ground** — A ground tied to the appliance cabinet or frame
- C. **Common** — A conductor (usually white) that serves as a return to complete an electrical circuit
- D. **Hand tools** — Frequently used portable tools that can be readily carried in a tool box
- E. **Shop tools** — Large tools, infrequently used tools, or expensive tools that would be difficult to replace
- F. **NEC (National Electric Code)** — Guidelines dedicated to the protection of life and property in the use of electrical materials and their functions in residential and commercial applications
- G. **Short** — A disruption in a higher resistance circuit that diverts current from its intended path into a side current of lower resistance and often blows a fuse or trips a breaker
- H. **Open** — A circuit through which no current flows

II. Basic hand tools (Transparencies 1 and 2)

- A. Set of standard screwdrivers with short to long shafts and insulated handles
- B. Set of Phillips screwdrivers, #1, #2, #3, and #4 with insulated handles
- C. Nut driver set, 7-piece
(NOTE: Nut driver set should include $\frac{3}{16}$ " , $\frac{7}{32}$ " , $\frac{1}{4}$ " , $\frac{9}{32}$ " , $\frac{5}{16}$ " , $\frac{11}{32}$ " , and $\frac{3}{8}$ " nut drivers.)
- D. Adjustable slip-joint pliers large enough to remove washer hoses
- E. Longnose (needlenose) pliers for working with cotter keys, retainer clips, and wire terminals
- F. Slip joint pliers to hold parts and double as wire cutters
- G. Wire strippers/terminal pliers
- H. Diagonal cutting pliers/lineman's pliers

INFORMATION SHEET

- I. Locking pliers for general use
 - J. Internal and external snap-ring pliers
 - K. Side-cutting and straight-cutting aviation snips
 - L. Set of open end wrenches, 5-piece
 - M. $\frac{3}{8}$ " and $\frac{1}{4}$ " ratchet/socket sets for working with cabinet screws
 - N. Hand-held drills/bit sets, $\frac{1}{4}$ " through $\frac{1}{2}$ "
 - O. Set of cold chisels, drift punches, and center punches
 - P. Files, fine to coarse
 - Q. Hex key set
 - R. Ball peen hammer
 - S. Soft-face hammer for working with bronze and brass bushings and pins
- (NOTE: A good pocket knife is always handy, a putty knife is useful too, and as work demands, there may be other hand tools required, but the basic hand tools are those listed.)
- T. Adjustable wrenches, 6", 12"
 - U. Pipe wrenches, 12", 18"

III. Shop tools

- A. Dollies for transporting appliances safely (Figure 1)

FIGURE 1

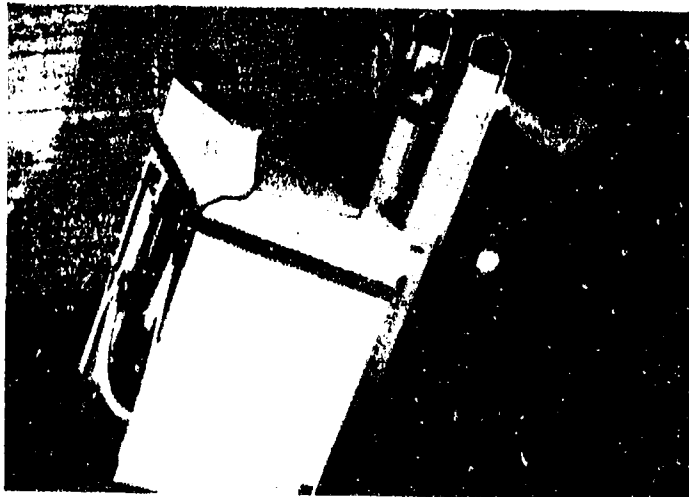

INFORMATION SHEET

B. Appliance flippers (Figure 2)

FIGURE 2

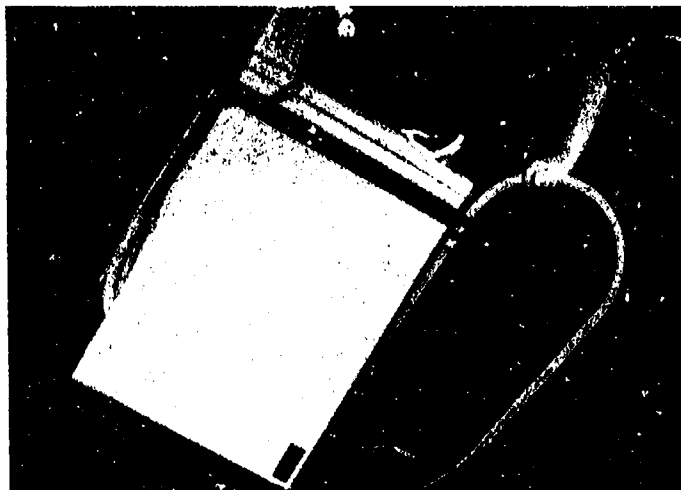

C. Compressed air supply and good hose for cleaning (Figure 3)

FIGURE 3

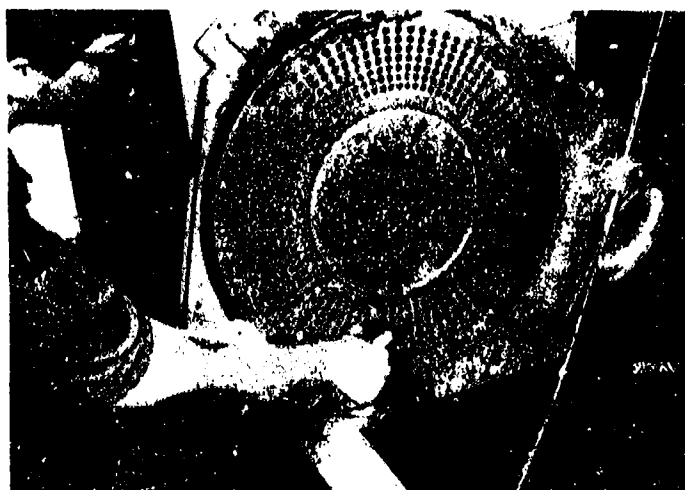

D. Bearing remover and installer (Figure 4)

FIGURE 4

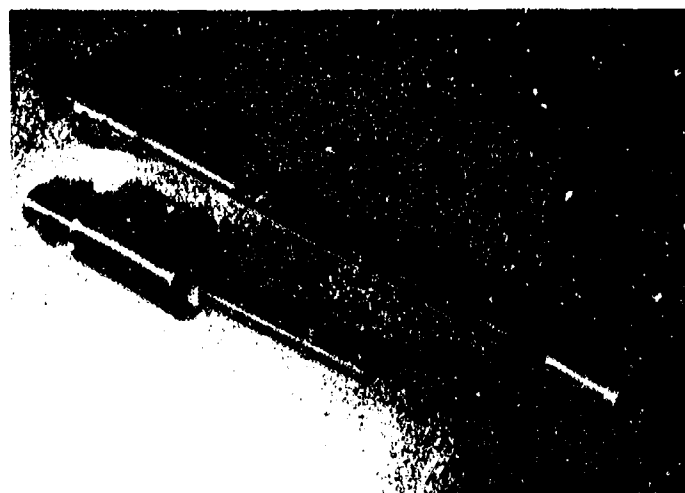

INFORMATION SHEET

E. Spanner wrench (Figure 5)

(NOTE: Certain appliances require special tools that will be mentioned as they are required in job sheets in the units that follow.)

FIGURE 5



F. Wet/dry shop vacuum (Figure 6)

FIGURE 6

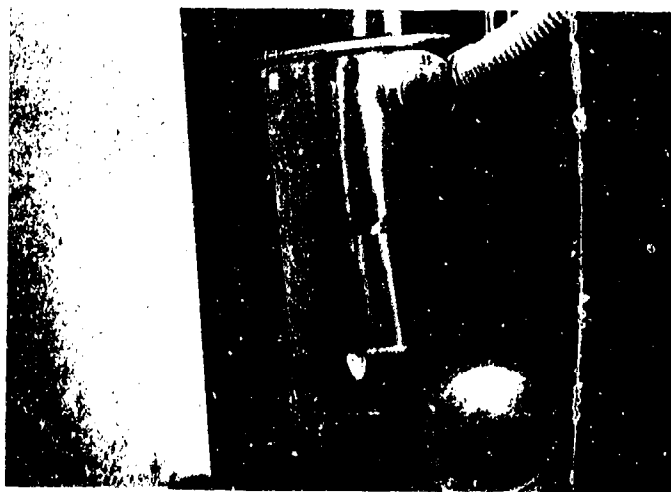

IV. Miscellaneous supplies

- A. Electrical, masking, and friction tape
- B. High temperature lubricant and adhesive
- C. Rubber adhesive

INFORMATION SHEET

- D. Multipurpose lubricant such as WD-40
- E. Degreasers and detergent
- F. Leak-testing liquid and brush
- G. Lint-free shop towels
- H. Emery cloth and sandpaper
- I. Shrink tubing
- J. Assortment of nuts, bolts, screws, and washers
- K. Assortment of wire terminals, wire nuts, and connecting devices

V. Required appliance repair literature and its uses

- A. Service manuals — Relate service and repair routines to specific models of appliances
- B. Schematics - Provide visual guides to electrical circuits and to component circuitry
- C. Parts catalog — Uses exploded views and numbered references for positive parts identification
- D. Technical updates — Keep service people informed of important part changes or changes in service requirements

VI. VOM's and their uses (Figure 7)

- A. Volt-ohm-milliamper meters are the most frequently used meters in appliance repair and knowing how to use one properly is a basic requirement for all service people
- B. VOM's have three major functions:
 - 1. Checking voltage

(NOTE: This is very important because most warranties are void if the appliance is hooked up to an improper voltage supply.)
 - 2. Checking amperage (rate of flow)

(NOTE: Motors that are drawing too much amperage cause all sorts of problems and amperage checks are the only way to find the problem; the same applies to surface elements on electric ranges.)

INFORMATION SHEET

3. Checking continuity (resistance)

(NOTE: This may be the most frequently used VOM test because it can be used on everything from triacs to solenoids and will quickly determine if the component is shorted or open.)

- C. VOM's can quickly differentiate between a short and an open because a short will always show some reading and an open will always show no reading at all
- D. Proper scales should be selected for the function being measured
- E. When a VOM is used to measure resistance (ohms), the power to the appliance should **ALWAYS BE TURNED OFF** or the meter might be destroyed
(CAUTION: Discharge capacitors before working around them.)
- F. A VOM should always be zeroed before use, and this is accomplished by simply crossing the test leads and adjusting the zero ohms control knob
- G. If a meter will not zero, the battery is probably bad
- H. Care should be taken when reading a VOM to assure that there is no parallax error caused by the viewing angle

(NOTE: Some VOM's have mirrors behind the meter face so the reflection of the pointer gives a precise reading and eliminates the parallax error.)

FIGURE 7

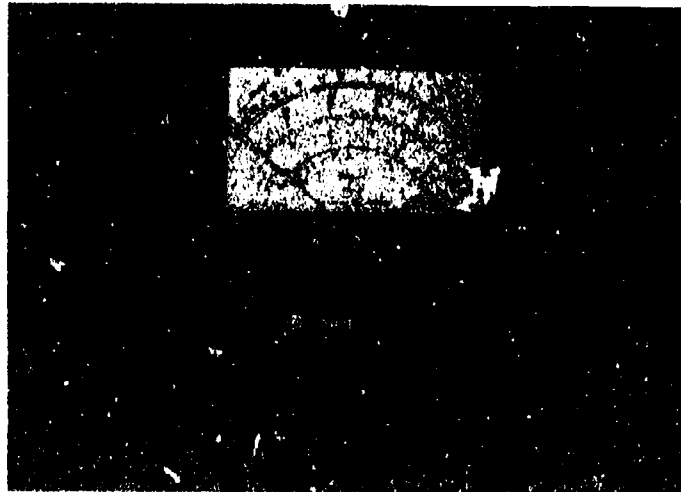

INFORMATION SHEET

VII. Clamp-on ammeters and their uses (Figure 8)

- A. Clamp-on ammeters are used to measure amperage in an AC current carrying conductor without having to cut into or probe the conductor itself
- B. Clamp-on ammeters can also be used to perform VOM functions with voltage and resistance with special test leads that fit into the bottoms of the meters, and scales for each function
- C. Reading resistance with a clamp-on ammeter requires inserting an in-line fuse adapter into the hot lead

(NOTE: The in-line fuse adapter includes a penlite battery and a fuse, and this permits the meter to be used as an ohmmeter.)
- D. A special internal fuse system eliminates the prospect that a clamp-on ammeter could accidentally be destroyed while measuring resistance
- E. Small amperages can be measured with a clamp-on ammeter by looping the conductor lead around one jaw of the clamp two, three, or four times and then dividing the reading by the number of loops
- F. Clamp-on ammeters are favored by service people because they are easy to carry, versatile, and rugged

FIGURE 8

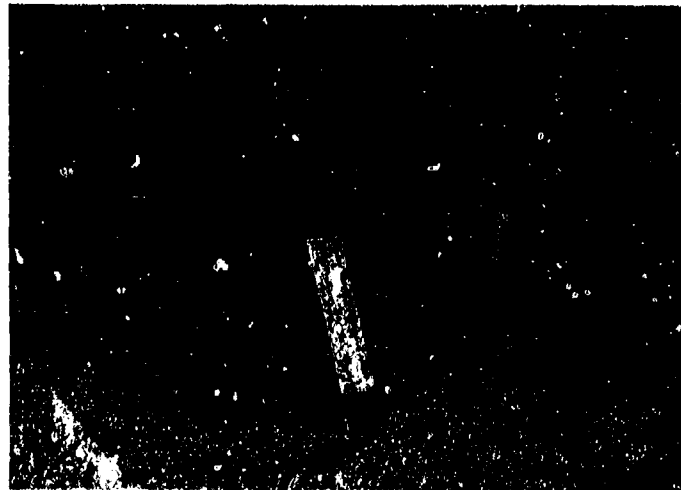

VIII. Digital multimeters and their uses (Figure 9)

- A. Digital multimeters do everything that VOM's can do, but have a numbered readout instead of a scale
- B. Digital multimeters are more accurate than VOM's for measuring small voltages or resistances

Example: When crossing leads to zero a VOM, it will indicate zero while a digital multimeter will indicate three zeros

INFORMATION SHEET

- C. Digital multimeters have special selectors for checking transistors in washers, dryers, and appliances that have solid state controls

FIGURE 9

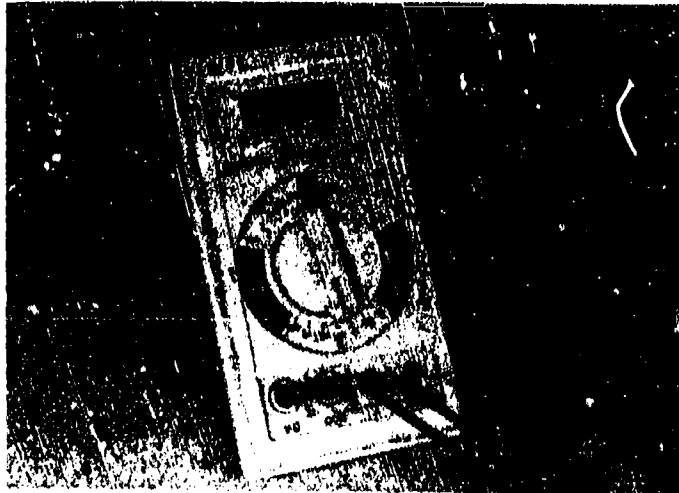

IX. Temperature testers and their uses (Figure 10)

- A. Temperature testers are used to measure:
1. Ambient temperature in ovens and refrigerators
 2. Griddle and surface temperature
(NOTE: There is a special feature for this function.)
 3. Exhaust vent temperature on gas and electric dryers
- B. Because temperature testers measure in millivolts converted to a Fahrenheit scale, they are more accurate than hang-in thermometers
- C. A temperature tester is remote from the sensing element and is much more convenient to use than a hang-in thermometer which requires opening the oven door to read

INFORMATION SHEET

- D. Because of their accuracy, temperature testers are a "must" piece of equipment for recalibrating oven controls

FIGURE 10

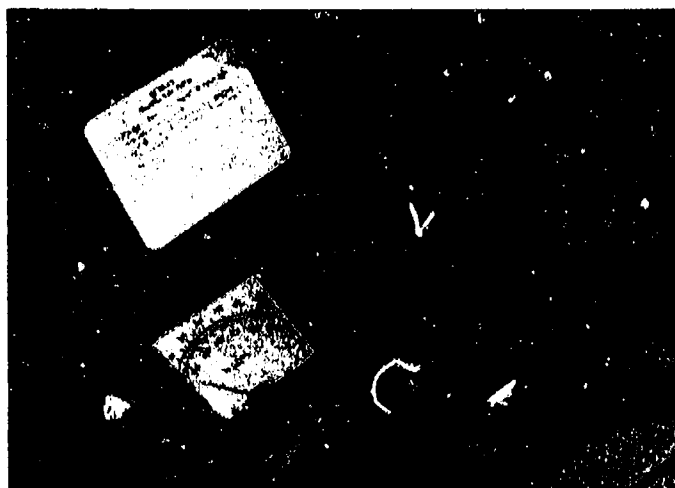

X. Capacitor analyzers and their uses (Figure 11)

- A. Capacitor analyzers are used strictly for checking capacitors on capacitor start motors on washers
- B. A capacitor analyzer is a much better test instrument than a VOM for determining if a capacitor is still in working condition because it will show if the capacitor is shorted or open, or read the capacitor in microfarads
- C. A good capacitor analyzer should be able to determine power factor tolerance and general capacitance tolerance
- D. A good capacitor analyzer should also be able to isolate shorted capacitors and capacitors with intermittent problems

FIGURE 11

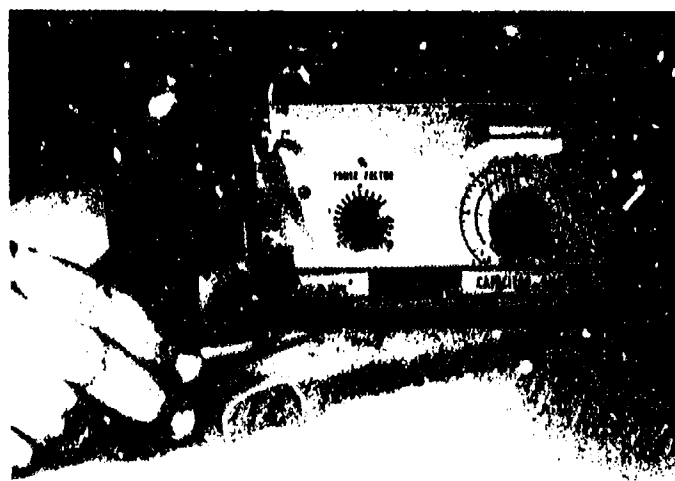

INFORMATION SHEET

XI. **Wattmeters and their uses (Figure 12)**

- A. Wattmeters are used to measure the amount of energy consumed by a motor, an appliance, or a component
- B. Measuring wattage will help determine if an appliance or component is drawing too much current
- C. Conversion factors for determining watt consumption are built into wattmeters, so they're much easier to use than VOM's or clamp-on ammeters whose readings must be converted
- D. Wattmeters can be used to measure wattages on electrical appliances in the range of 130V to 260V
- E. Wattmeters are used for checking other meters for proper calibration

FIGURE 12

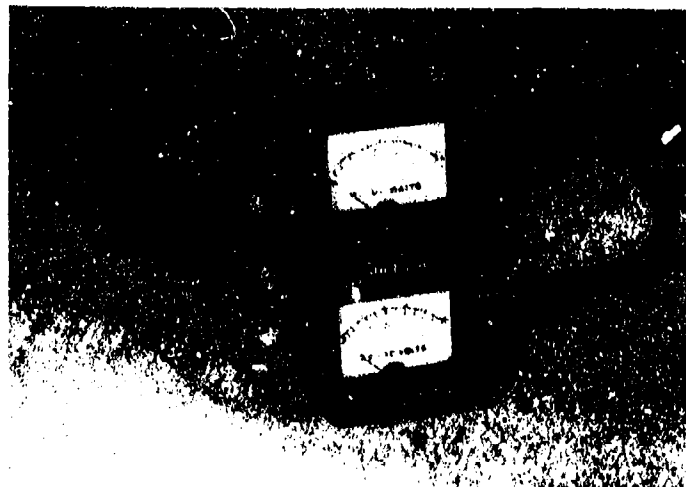

XII. **Shunts and their functions in ammeters (Figure 13)**

- A. A shunt is designed to allow only a small percentage of a total current to pass through an ammeter so the meter can be used to measure a wide range of currents
- B. Shunts eliminate the need for heavier coils which would increase the cost and weight of ammeters and decrease sensitivity

INFORMATION SHEET

- C. Shunts are built into many ammeters and are so indicated on selector scales that permit a technician to select the shunt most suitable to the measurement

FIGURE 13

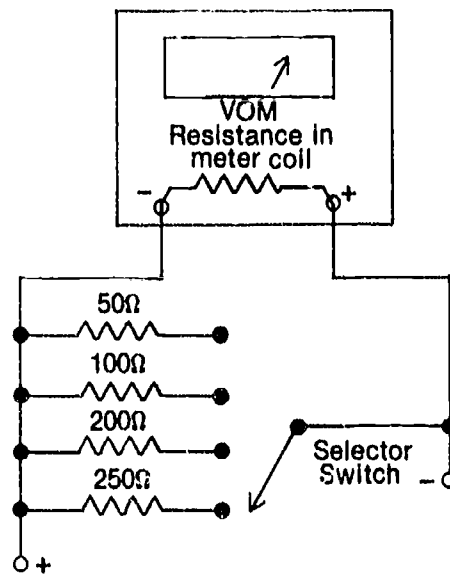

XIII. Electrical measurements and ways to make them

- A. Voltage — Must be measured **ACROSS** the circuit or source being tested (Transparencies 4 and 5)
- B. Amperage — Must be measured **In series** with the circuit being tested (Transparency 6)
- C. Resistance — Must be measured from one point to another **In a component** or a circuit (Transparency 7)

XIV. Appliance wiring

- A. Appliance wiring is selected according to an **AWG** number to identify its diameter and an **Insulation type** to identify its service qualities

INFORMATION SHEET

- B. The AWG number grows smaller as the size of the wire increases (Figure 14)

FIGURE 14

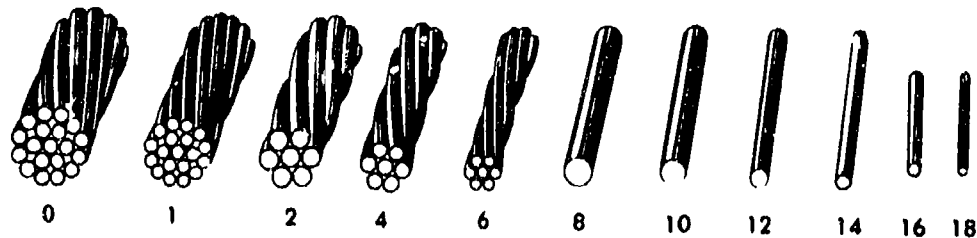

- C. The major insulation types required around major appliances are:
1. RHW — Moisture and heat-resistant rubber for dry and wet locations where operating temperatures do not exceed 167°F
 2. THW — Moisture and heat-resistant thermoplastic for dry and wet locations where operating temperatures do not exceed 194°F
 3. AA — A special wire for electric ranges because it has a braided asbestos covering and can operate at temperatures up to 392°F
- D. When reading wire sizes, the first number is the AWG size and the second number indicates how many conductors are in the wire

Example: 10/3 is a 10-gauge wire with 3 conductors

INFORMATION SHEET

- E. The maximum amperage a wire can safely carry is known as ampacity, and low ampacity wires should never be used for high ampacity applications (Figure 15)

FIGURE 15

AWG#	Ampacity
14	15
12	20
10	30
8	45
6	65
4	85
2	115
1	130
0	150
00	175
000	200

- F. Never replace an AWG wire with a smaller wire because it could cause a malfunction and create a fire hazard

Example: A receptacle for an electric range has a #8 AWG wire for ground and #6 AWG wires for both the hot leads; using #10 wire for the connection would not meet the NEC code, but #10 AWG wire is acceptable on a dryer receptacle because of the lower amperage a dryer demands

INFORMATION SHEET

XV. Soldering tools

- A. A 150 to 250 watt soldering gun is recommended for connectors and circuits rated 30 to 50 amps or greater (Figure 16)

FIGURE 16

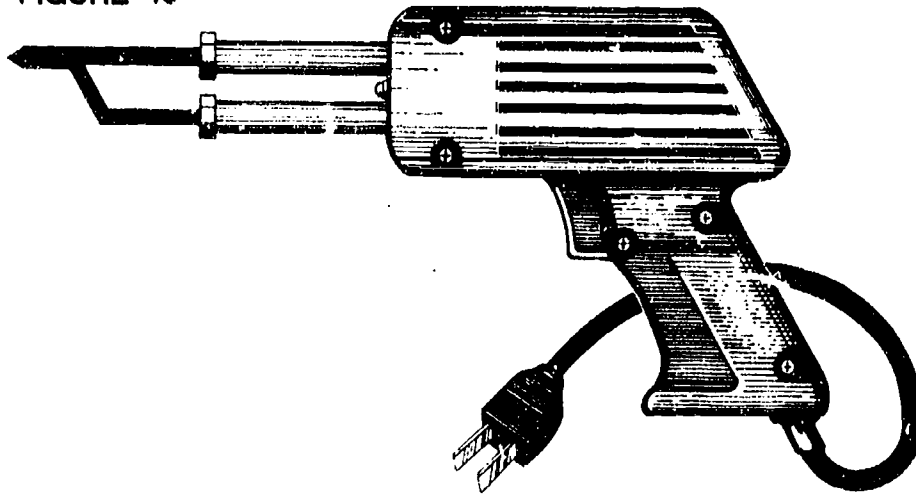

- B. Large soldering irons of 40 to 150 watts are suitable for connectors and circuits rated 10 to 30 amps (Figure 17)

FIGURE 17

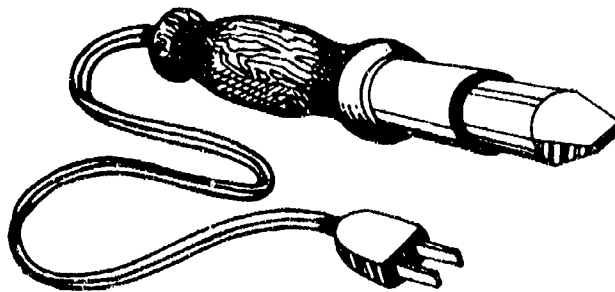

- C. A pencil iron rated 20 watts or less may be required for special applications such as printed circuit boards or where space will not permit a larger iron (Figure 18)

FIGURE 18

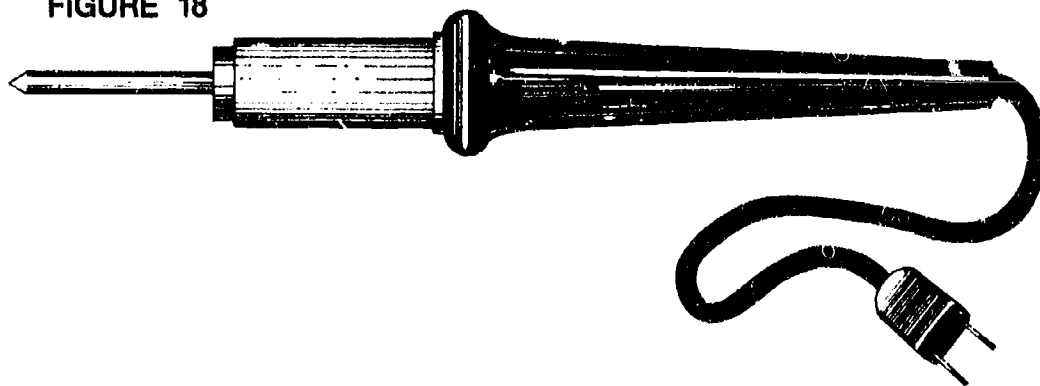

- D. Soldering poses burn hazards, but the greater danger is potential eye damage, so always wear safety glasses when soldering

INFORMATION SHEET

XVI. Resin-core solder and its characteristics

- A. The type of solder used most often around electrical connections is 40/60 resin-core solder
- B. The 40/60 means the solder is an alloy of 40% tin and 60% lead
- C. The flux required to clean metal and promote fusion is placed inside the core of resin-cored solder
- D. Resin-core solder comes in handy rolls that are convenient to store and carry (Figure 19)

FIGURE 19

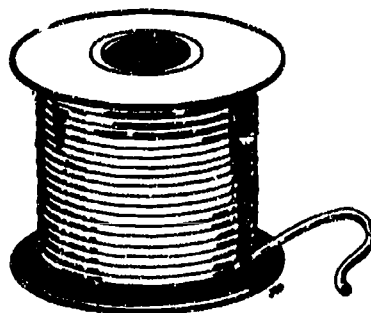

- E. Resin-core solder is noncorrosive and suitable for almost all work around major appliances
- F. When using resin-core solder, clean surface(s) to be soldered, apply heat to the surfaces, and then run the strand of solder over the heated surface(s)

XVII. Solid wire solder and its characteristics

- A. Solid wire solder is a popular 40/60 alloy for use in sweating or swaging joints of tubing
- B. Because solid wire solder has no flux core, a paste flux must be used with it
- C. The procedure for using solid wire solder is:
 - 1. Clean surfaces to be soldered
 - 2. Apply soldering flux to both surfaces
 - 3. Apply heat to the parts to be soldered, not to the solder itself
 - 4. Apply the solder to the heated parts and allow it to melt onto the parts

INFORMATION SHEET

XVIII. Steps In wire stripping

- A. Place the wire in the proper slot in the wire stripper and work the stripper back and forth until a cut is made around the entire insulation (Figure 20)

FIGURE 20

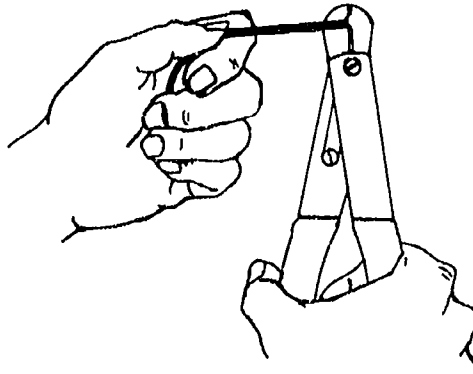

- B. Hold the wire tight with one hand and use the other hand to gently move the insulation back and forth until the cut breaks clean and unwanted insulation can be pulled off (Figure 21)

FIGURE 21

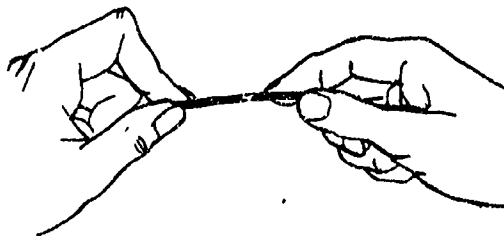

- C. Taper the insulation with a knife to increase the wire's flexibility because straight cut insulation creates a force point that can cause a wire to break (Figure 22)

FIGURE 22



Right

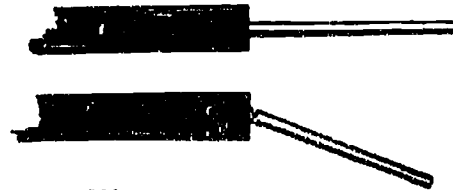

Wrong

INFORMATION SHEET

XIX. Types of splices

A. Simple splice (Figure 23)

FIGURE 23

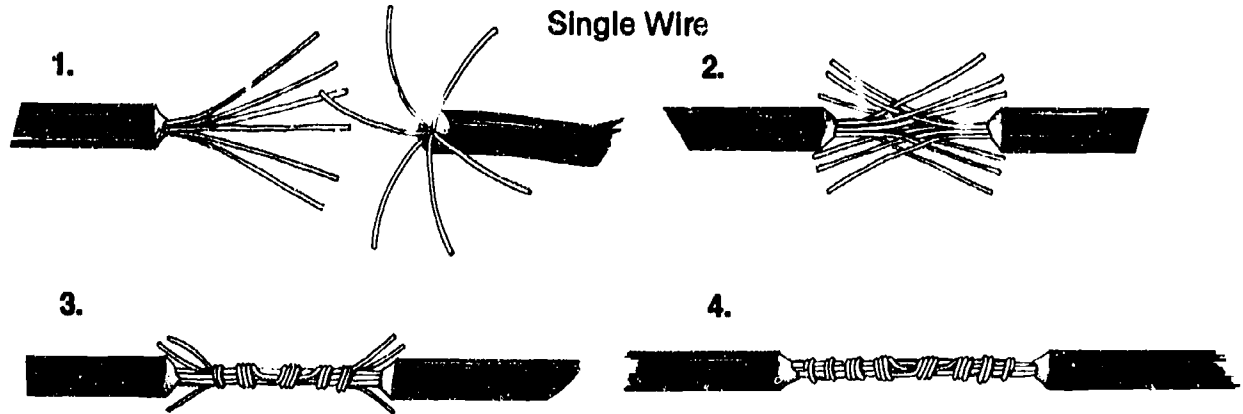
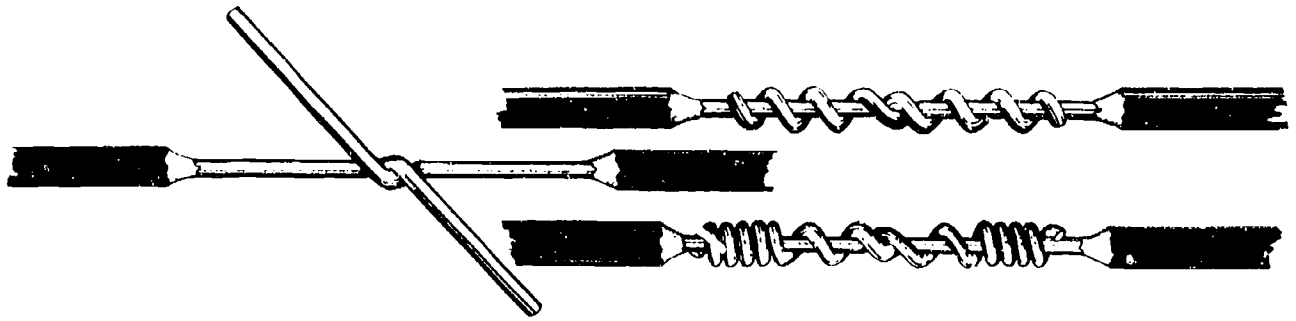

Single Wire

Stranded Wire

B. Simple tap (Figure 24)

FIGURE 24

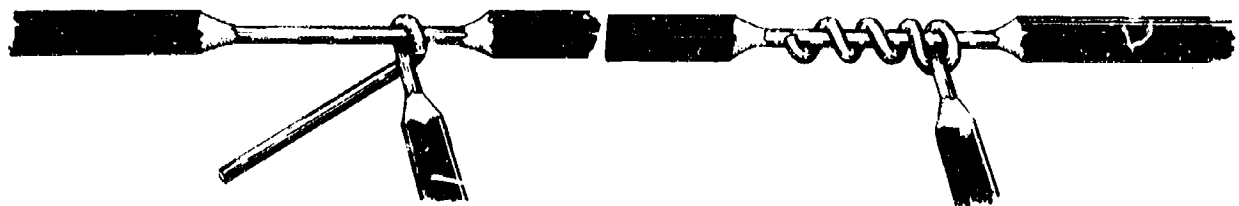

Single Wire

INFORMATION SHEET

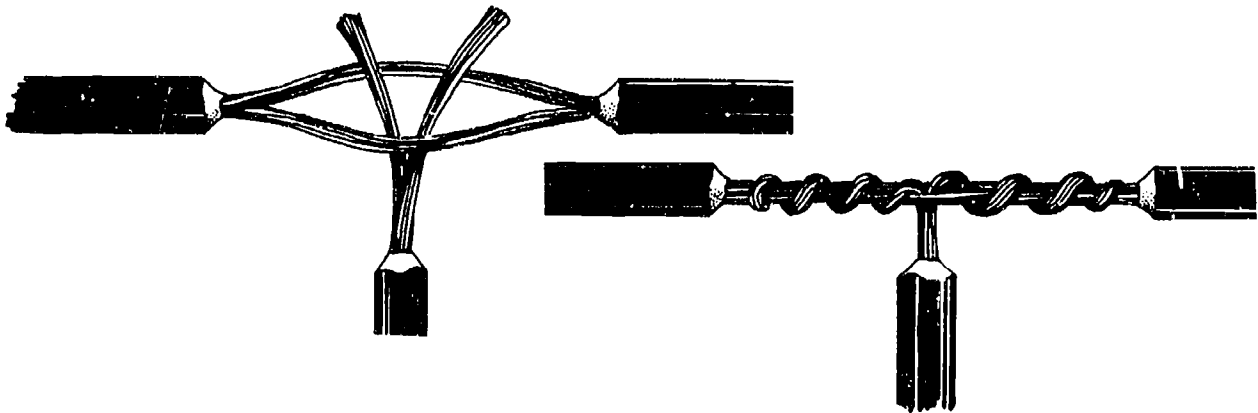

Stranded Wire

C. Pigtail splice (Figure 25)

FIGURE 25

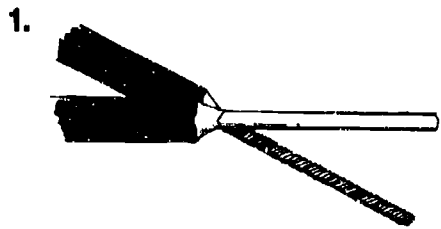
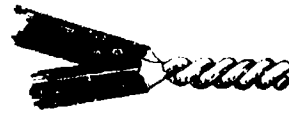
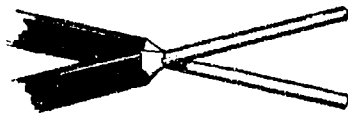

Single Wire

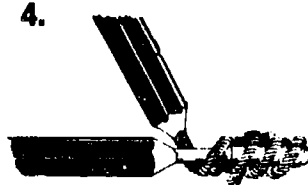
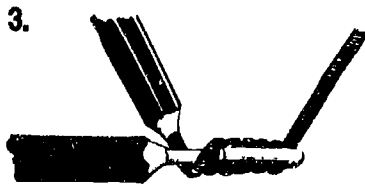
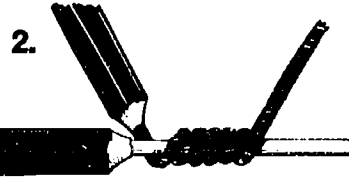

Single Wire to Stranded Wire

D. Hook splice (Figure 26)

FIGURE 26



INFORMATION SHEET

XX. Guidelines for connections at screw terminals

- A. Wire should be attached at a screw terminal so that the loop lies in the direction the screw turns (Figure 27)

FIGURE 27



Right



Wrong

- B. Wire should loop the screw a little less than one full turn, but excessive loops are not recommended (Figure 28)

XXI. Guidelines for good soldered splices

- A. Wires to be spliced must be bright and clean at the point of connection
- B. Connecting points must be tight so solder will solidify without wire movement (Figure 28)

FIGURE 28



Right



Wrong

- C. Wire should be coated with electric soldering paste, and then soldered so that solder melts and flows into every crevice of the splice (Figure 29)

FIGURE 29

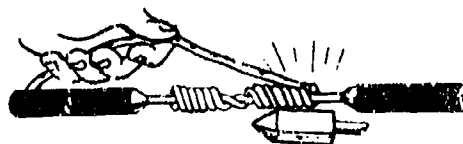

- D. Entire splice area should be covered with water-proof plastic tape (Figure 30)

FIGURE 30



INFORMATION SHEET

XXII. Guidelines for using solderless connectors and terminals

- A. Solderless connectors should be used according to their color codes, and a connector for a lighter gauge should never be used on a wire of a heavier gauge
- B. Screw-on connectors work well on pigtail splices, and they require no taping because they're made of insulating materials (Figure 31)

FIGURE 31



- C. Crimp-on terminal lugs should not leave a gap between the insulation and the lug, and if there is a gap, a plastic sleeve should be added to cover the bare wire (Figure 32)

FIGURE 32



XXIII. Proper care and use of hand tools

- A. Screwdrivers (Figure 33)
 1. Do not hammer or pry with screwdrivers
 2. Worn Phillips screwdrivers should be discarded, but flat blade screwdrivers can be useful as long as the tip can be reground square

FIGURE 33

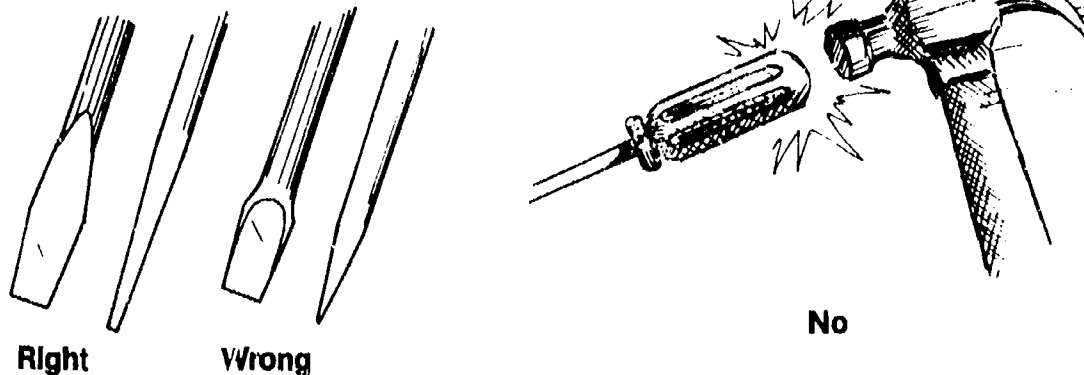

INFORMATION SHEET

B. Wrenches and pliers (Figure 34)

1. Do not hammer on wrenches or hammer with wrenches
2. Use adjustable wrenches so that the large jaw is opposite the direction of force
3. When pulling on an adjustable wrench, be careful not to hit yourself in the chest or head, and when pushing on an adjustable wrench, hold your hand palm-flat on the handle so you won't accidentally scar your knuckles
4. Do not use pliers in place of a wrench, especially on brass fittings
5. Use pliers with insulated handles when working around electrical circuits and components

FIGURE 34

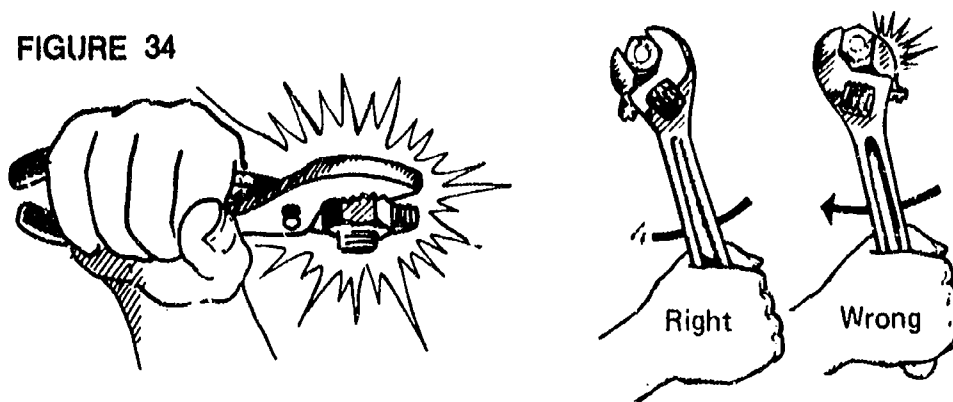

C. Hammers (Figure 35)

1. Never use a hammer with a loose handle
2. Use all hammers for their intended purpose

FIGURE 35

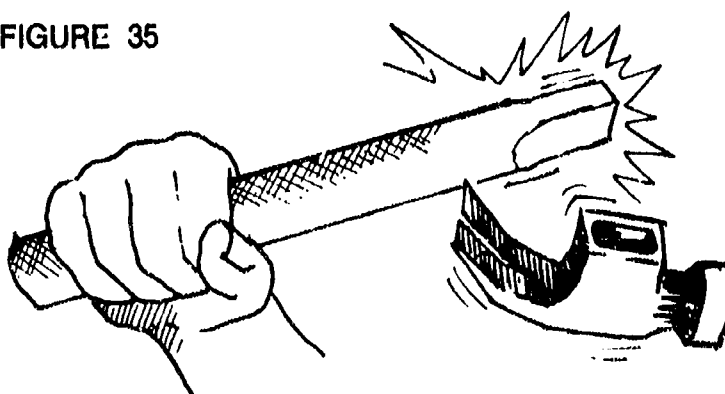

D. Punches, chisels, and files (Figure 36)

1. Keep chisel cutting edges sharp
2. Keep chisel heads properly dressed, and never strike a chisel that has a mushroomed head

INFORMATION SHEET

3. Files become dull if stacked in a drawer, so hang them up
4. Do not hammer or pry with a file because they are brittle and break easily

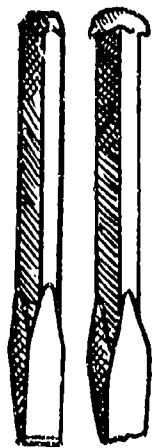
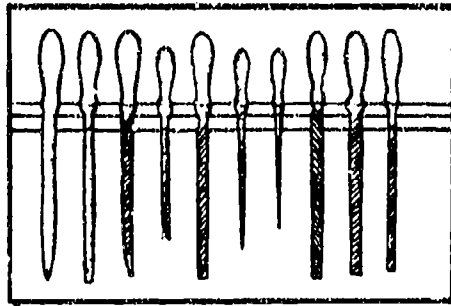

FIGURE 36



E. Socket sets and nut drivers (Figure 37)

1. Do not use a cheater bar to gain greater leverage on the handle of a ratchet because it will strip the ratchet gears
2. Do not use a cheater bar on a thin wall socket because the socket will break
3. Nut drivers should be used for hand-tight nuts, bolts, and screws, but do not use pliers to increase leverage

FIGURE 37

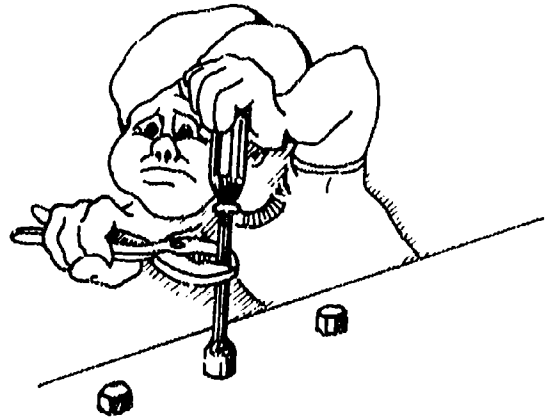
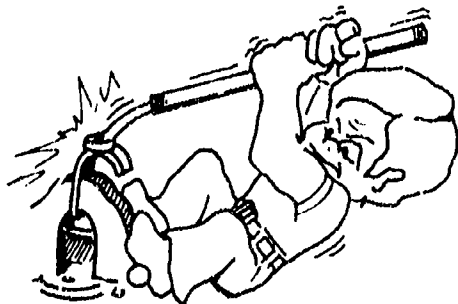

XXIV. Guidelines for using other tools and equipment

- A. Cords for drop lights should not be run over by appliance dollies or placed where objects with metal edges may be placed on them
- B. Handle levels with care because once they're dropped they're usually inaccurate
- C. Do not apply too much pressure on a hex key wrench or it may break or round out the socket in the set screw

INFORMATION SHEET

- D. Never use oxyacetylene equipment without proper instruction or without permission
- E. Keep safety glasses in a case when they're not in use so they'll stay clean

(NOTE: If someone had to take time to clean a pair of safety glasses, they might have a tendency just to forget them.)
- F. Never point a compressed air nozzle at another person, and never use compressed air when it might spray dirt or metal particles at someone nearby

XXV. Eye protection

- A. Wear safety glasses at all times in the shop area
- B. Blow compressed air away from you when using it for cleaning
- C. Wear a face shield when working with grinding tools
- D. If you get cleaning solvent on your hands, wash them with soap and water to avoid the possibility of accidentally rubbing your eyes
- E. Know the location of the nearest eye flush station

Basic Hand Tools



Adjustable Pliers



Standard Screwdriver Set

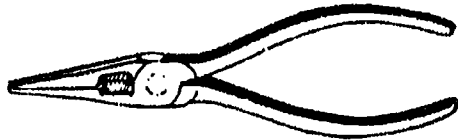

Needlenose Pliers



Phillips Screwdriver Set



Lineman's (sidecutting) Pliers

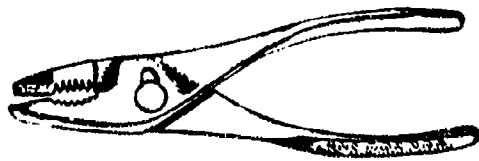

Slip-Joint Pliers



Nut Driver



Wire Strippers
(Electrician's 6-in-1 tool)

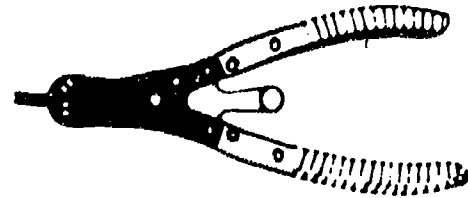

Internal Snap-Ring Pliers



Locking Pliers

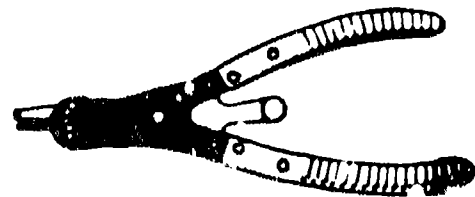

External Snap-Ring Pliers

Basic Hand Tools

(Continued)



Aviation Snips

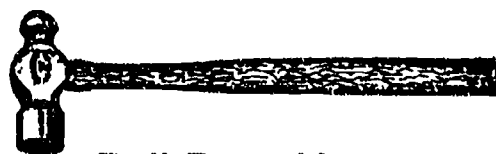

Ball Peen Hammer

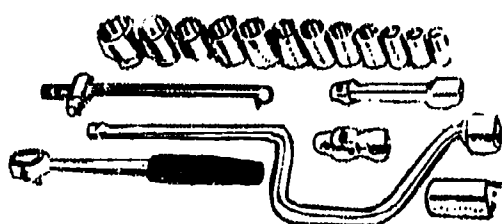

Socket Set and Ratchet



Pipe Wrench

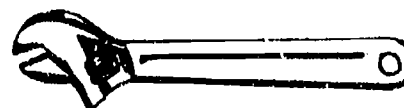

Adjustable Wrench

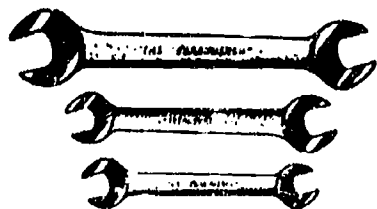

Open End Wrenches



Drill Bits

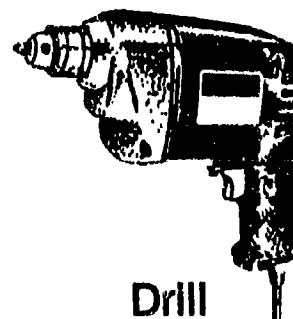

Drill



Chisel



Punch

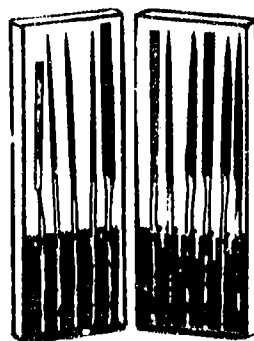

Files

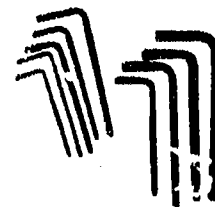

Hex Wrenches

Measuring Voltage at a Receptacle

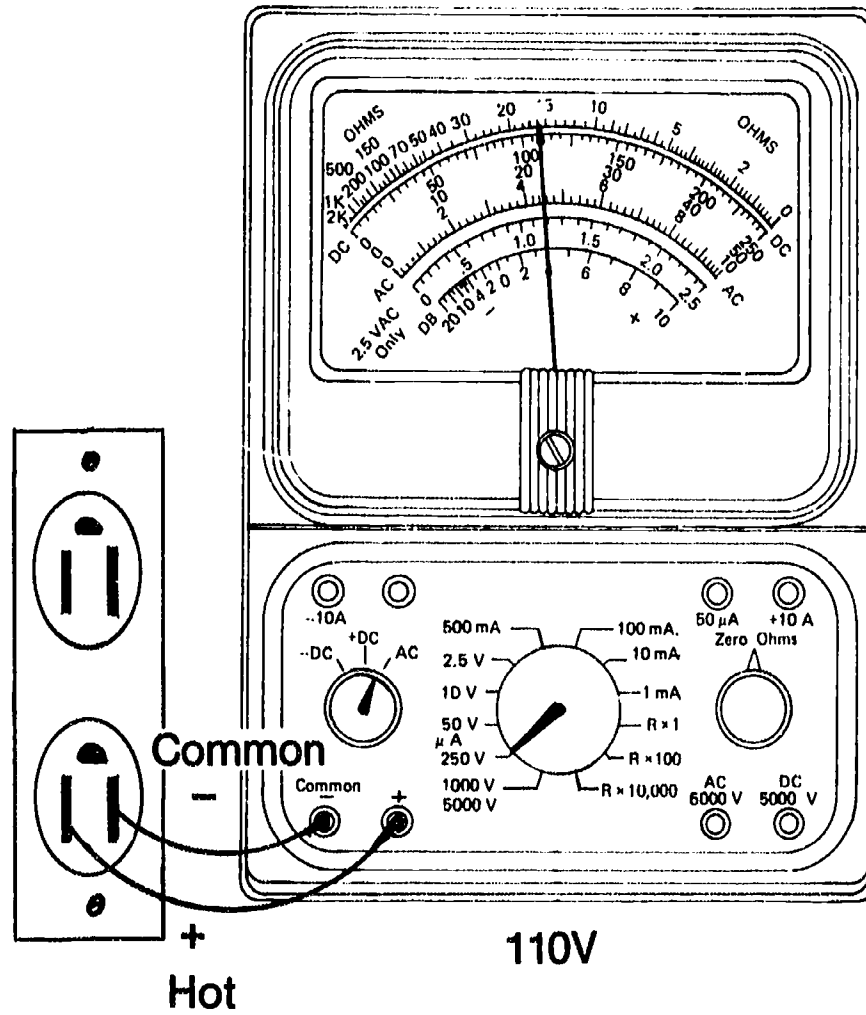

Measuring Voltage in a Parallel Circuit

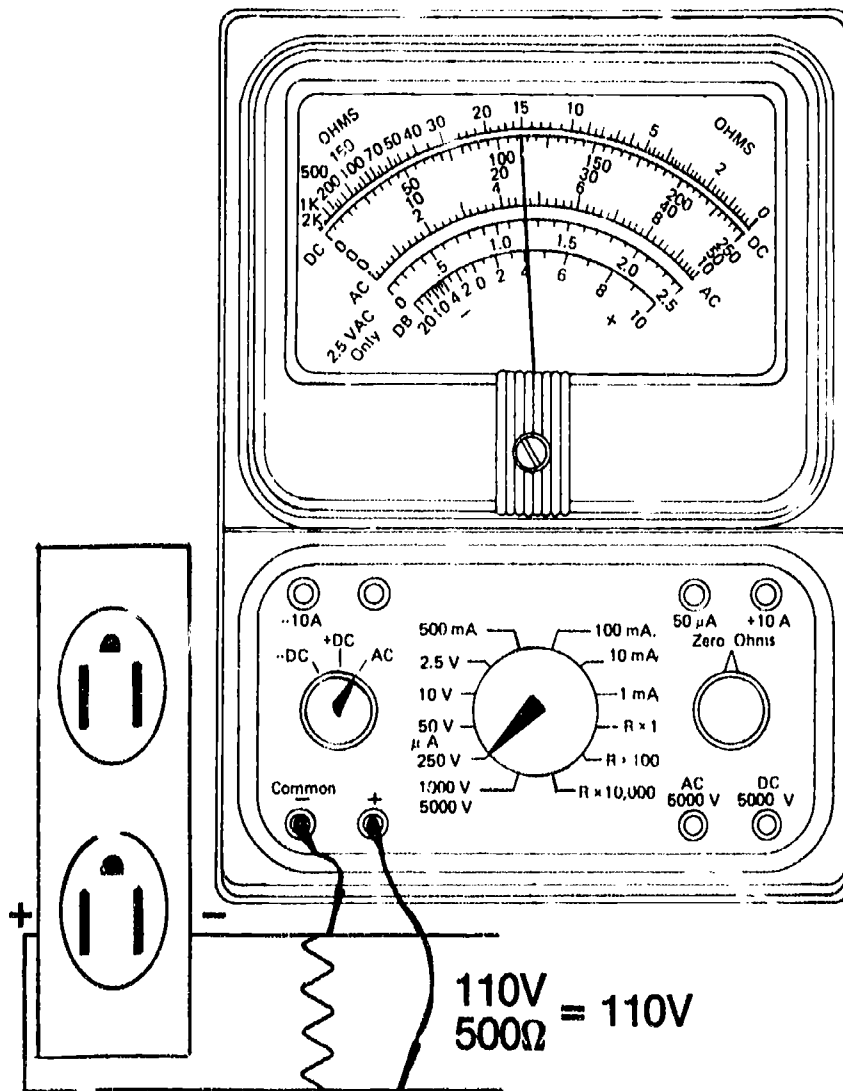

Measuring Amperage in a Circuit

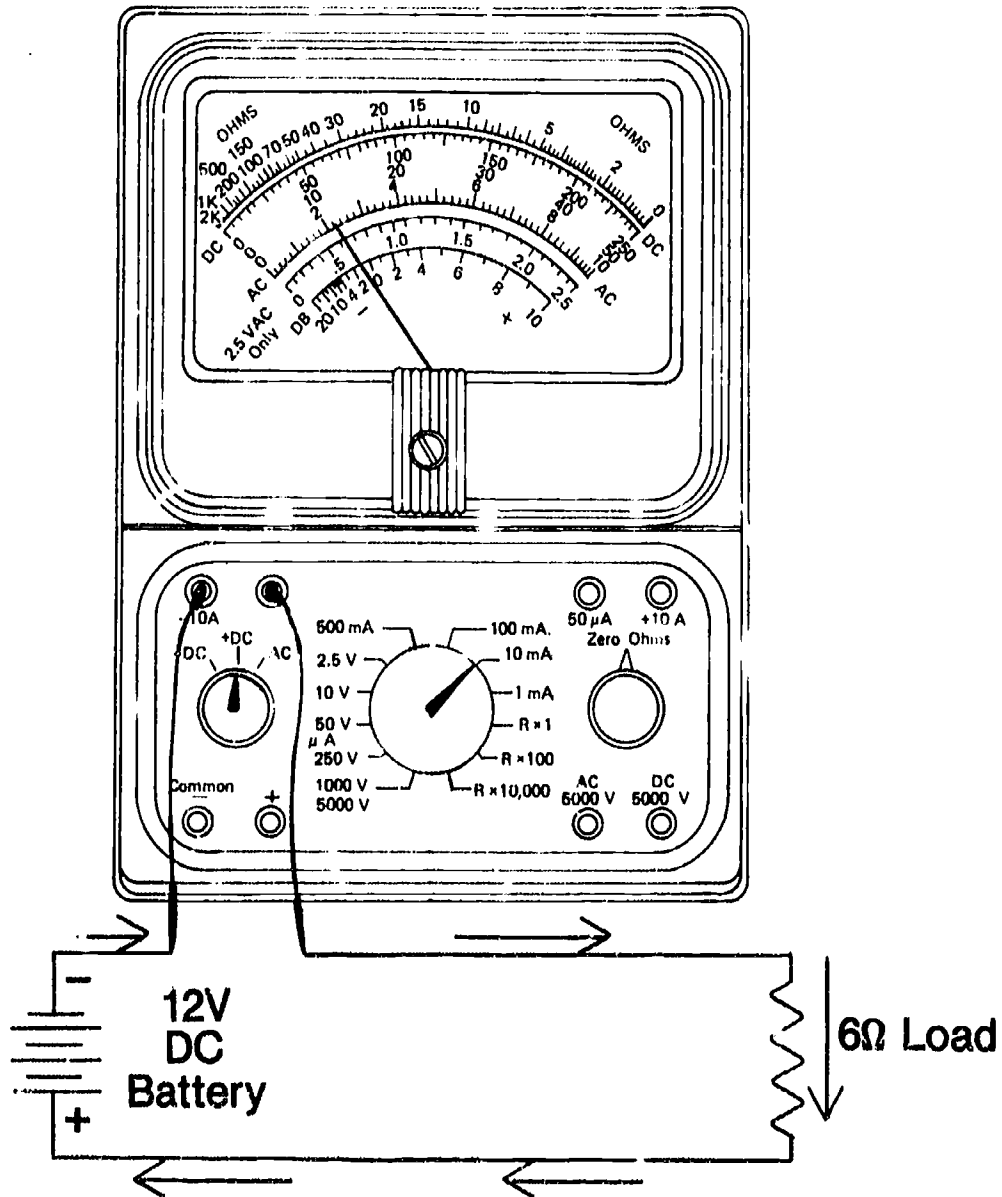

$$\begin{matrix} \text{E} \\ \hline \text{I} / \text{R} \end{matrix} \quad \begin{matrix} \text{E} = 12\text{V} \\ \text{R} = 6\Omega \end{matrix} \quad \text{So } I = \frac{12}{6} \quad (12 \div 6) = 2 \text{ Amps}$$

Measuring Resistance in a Coil

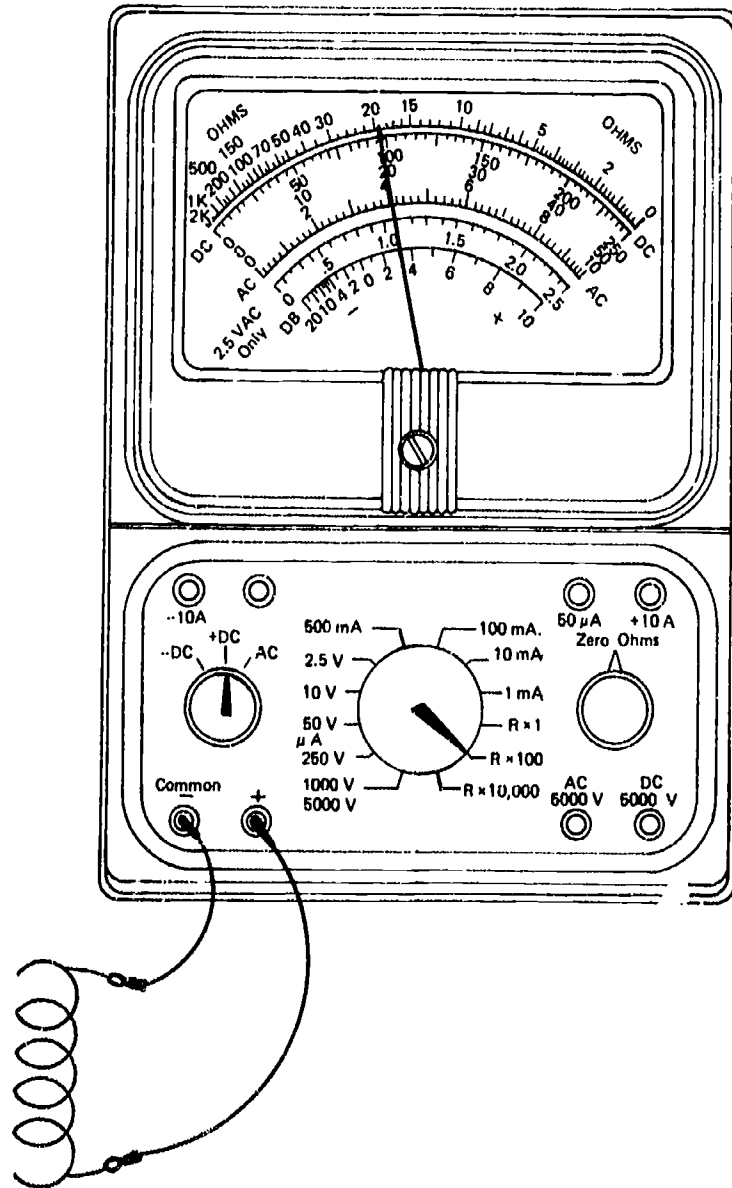

TOOLS, MATERIALS, AND TEST INSTRUMENTS

UNIT VI

ASSIGNMENT SHEET #1 — IDENTIFY SELECTED TOOLS

Directions: Your instructor has prepared a display of tools that are each tagged with a number. Examine the tools and write the name of each tool beside the appropriate number. Add more numbers as needed.

- | | | | |
|-----|-------|-----|-------|
| 1. | _____ | 16. | _____ |
| 2. | _____ | 17. | _____ |
| 3. | _____ | 18. | _____ |
| 4. | _____ | 19. | _____ |
| 5. | _____ | 20. | _____ |
| 6. | _____ | 21. | _____ |
| 7. | _____ | 22. | _____ |
| 8. | _____ | 23. | _____ |
| 9. | _____ | 24. | _____ |
| 10. | _____ | 25. | _____ |
| 11. | _____ | 26. | _____ |
| 12. | _____ | 27. | _____ |
| 13. | _____ | 28. | _____ |
| 14. | _____ | 29. | _____ |
| 15. | _____ | 30. | _____ |

Your Name _____ Date _____

TOOLS, MATERIALS, AND TEST INSTRUMENTS UNIT VI

JOB SHEET #1 — TEST ELECTRICAL RECEPTACLES FOR PROPER VOLTAGES

A. Tools and materials

1. Wall receptacle for 120V supply
2. Wall receptacle for 240V range supply
3. Wall receptacle for 240V dryer supply
4. VOM
5. Pencil and paper
6. Safety glasses

B. Routine #1 — Checking a 120V receptacle

1. Put on safety glasses and set the VOM to measure voltage at 250V
2. Make sure the selector switch is set for AC
3. Place one VOM test lead into each of the slotted openings in the receptacle (Figure 1)

FIGURE 1

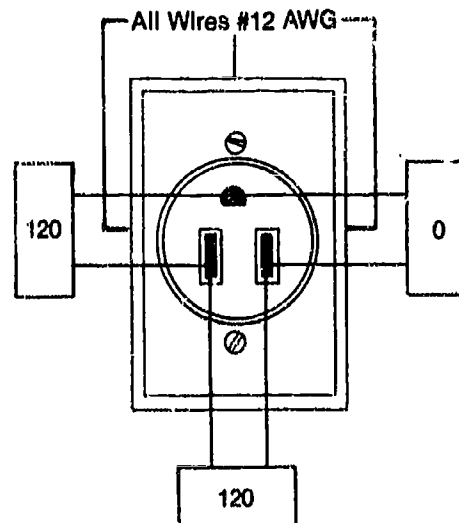

4. Check your meter and record the reading _____
5. Place one VOM lead in the left slotted opening and the other VOM lead in the round hole at the top of the receptacle
6. Check your meter and record the reading _____

JOB SHEET #1

7. Place one VOM lead in the right slotted opening and the other VOM lead in the round hole at the top of the receptacle
8. Check your meter and record the reading _____
9. Compare the reading in Step 8 with the reading from Step 6
- Have your instructor check your findings
10. Make all voltage checks again if your findings vary at all from the values shown in Figure 1

C. Routine #2 — Checking a 240V range receptacle

1. Leave the VOM set to measure 250V and the range selector set at AC
2. Place one VOM test lead into each of the outside slotted openings in the receptacle (Figure 2)

FIGURE 2

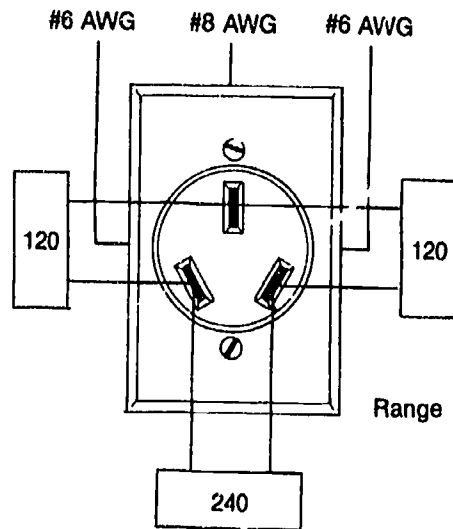

3. Check your meter and record the reading _____
4. Place one VOM lead into the left slotted opening and the other VOM lead in the center slotted opening
5. Check your meter and record the reading _____
6. Place one VOM lead into the right slotted opening and the other VOM lead in the center slotted opening
7. Check your meter and record the reading _____
8. Compare the reading in Step 7 with the reading from Step 5
- Have your instructor check your findings
9. Make all voltage checks again if your findings vary at all from the values shown in Figure 2

JOB SHEET #1

D. Routine #3 — Checking a 240V dryer receptacle

1. Leave the VOM set to measure 250V and the range selector set at AC
2. Place one VOM lead into each of the outside slotted openings in the receptacle (Figure 3)

FIGURE 3

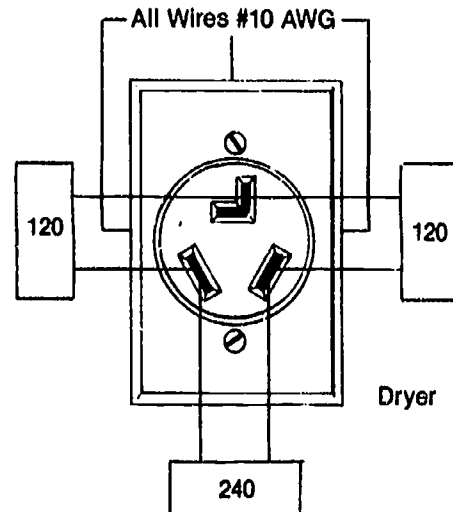

3. Check your meter and record the reading _____
4. Place one VOM lead into the left slotted opening and the other VOM lead in the center L-shaped slot
5. Check your meter and record the reading _____
6. Place one VOM lead into the right slotted opening and the other VOM lead into the center L-shaped slot
7. Check your meter and record the reading _____
8. Compare the reading in Step 7 with the reading from Step 5
- Have your Instructor check your findings
9. Make all voltage checks again if your findings vary at all from the values shown in Figure 3
10. Discuss with your Instructor the differences in the wire gauges used for each of the receptacles checked
11. Clean up area and return tools and materials to proper storage

TOOLS, MATERIALS, AND TEST INSTRUMENTS UNIT VI

JOB SHEET #2 — USE A CLAMP-ON AMMETER TO TEST FOR HIGH AND LOW AMPERAGES ON A FAN MOTOR AND A LIGHT BULB

A. Tools and materials

1. Fan motor (or equivalent)
2. 100-watt light bulb
3. Clamp-on probe
4. Pencil and paper
5. Safety glasses

B. Routine #1 — Checking high amperage

1. Put on safety glasses and plug motor into power source

2. Determine current-carrying conductor

(NOTE: Check schematic if you have to.)

3. Clamp ammeter probes over current-carrying conductor

(NOTE: Don't clamp probes over two or three wires, make certain they're clamped over only one conductor.)

4. Set the rotary scale for the highest amperage scale first, then move down as necessary to make your reading

5. Determine amp reading from proper scale and record the reading

Have your instructor check your work

C. Routine #2 — Checking low amperage

1. Plug 100-watt light bulb into power source

(NOTE: Conductor lead to load should have enough play that it can be wrapped around one of the meter clamps.)

2. Clamp ammeter probes over current-carrying conductor

3. Set the rotary scale for the highest amperage scale first, then move down as necessary to make your reading

JOB SHEET #2

4. **Unclamp the probe and loop the conductor three times around one of the meter clamps**
5. **Determine amp reading from the proper scale and record your reading**
6. **Divide reading by the number of loops (three) you made in the conductor**
- Have your instructor check your work**
7. **Clean up area and return tools and materials to proper storage**

TOOLS, MATERIALS, AND TEST INSTRUMENTS UNIT VI

JOB SHEET #3 — MAKE A CONTINUITY CHECK OF A MAGNETIC CONTROL ASSEMBLY FROM AN AUTOMATIC WASHER

A. Tools and materials

1. Magnetic control assembly from a Whirlpool/Kenmore automatic washer
2. VOM
3. Pencil and paper
4. Safety glasses

B. Procedure

1. Put on safety glasses and place the magnetic control assembly on a work bench
2. Set the VOM to the R \times 1 scale
3. Place the VOM probes on the terminals of the left or right solenoid
4. Note the meter deflection and write your observation on a piece of paper
(NOTE: If the deflection is too small to read, write none.)
5. Set the VOM to the R \times 100 scale
6. Note the meter deflection and write your observation on a piece of paper
7. Check your finding to see how close it is to 525 ohms
8. Repeat the procedure for the other solenoid, but start with the R \times 100 scale
9. Record your finding
- Have your instructor check your work
10. Clean up area and return tools and materials to proper storage

TOOLS, MATERIALS, AND TEST INSTRUMENTS UNIT VI

JOB SHEET #4 — SPLICE ELECTRICAL CONDUCTORS TO ACCEPTABLE SERVICE STANDARDS

A. Tools and materials

1. Soldering gun
2. 60/40 rosin-core solder
3. Wire strippers
4. Utility knife
5. Needle nose pliers
6. Slip-joint pliers
7. Diagonal cutters
8. Supply of single wire and stranded wire conductor
9. Sponge
10. Plastic tape
11. Safety glasses

B. Routine #1 — Splicing and soldering simple splices

1. Select two pieces of single wire conductor
2. Put on safety glasses and strip 2" of insulation from the end of each conductor
3. Bevel the end of each insulation cut (Figure 1)

FIGURE 1

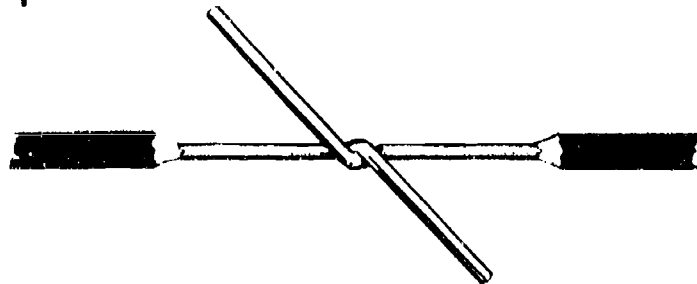

JOB SHEET #4

4. Twist conductors around each other with enough turns to insure a sturdy splice (Figure 2)

FIGURE 2

5. Place the spliced wires on a work bench
6. Heat the soldering gun tip
7. Clean the tip of the soldering gun with a sponge
8. Apply a small amount of solder to the tip
9. Begin at one end of the splice and apply solder from the top as you move the tip of the soldering gun slowly along the underside of the splice (Figure 3)

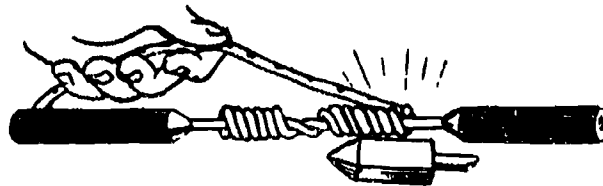
FIGURE 3

10. Move the soldering tip slowly enough that the solder melts evenly onto the splice and runs down so that it fills all crevices where conductors meet
 11. Permit soldered splice to cool
- Have your Instructor check your work

JOB SHEET #4

12. Tape complete splice with plastic tape in a spiral wrap that slightly overlaps to assure a complete covering (Figure 4)

FIGURE 4



13. Repeat the procedure as required to make a simple splice on stranded wire (Figure 5)

FIGURE 5

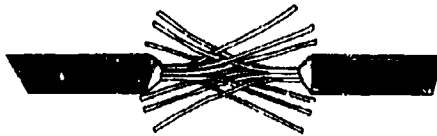

- Have your instructor check your work

C. Routine #2 — Making pigtail splices

1. Select two more pieces of single wire conductor
2. Strip and bevel conductors as previously outlined
3. Place conductors side by side and start a twist on the end with your fingers or pliers, if required
4. Place a screw-on cap of the proper size over the end of the two conductors and screw it clockwise down until it completely covers the bare conductors (Figure 6)

FIGURE 6



JOB SHEET #4

- Have your instructor check your work
5. Select two more pieces of single wire conductor and strip and bevel as previously outlined
 6. Prepare another pigtail splice, but this time, twist the wires out from the bevel around each other to form the pigtail (Figure 7)

FIGURE 7



7. Heat the soldering tip again, clean it, tin it and solder the pigtail with the same procedure used to solder the simple splice
 8. Permit the pigtail to cool
- Have your instructor check your work
9. Tape the pigtail as previously outlined
 10. Repeat the procedure for splicing and soldering a single wire conductor and a stranded wire conductor into a pigtail
- Have your instructor check your work
11. Tape the pigtail as previously outlined

D. Routine #3 — Making tap splices

1. Select two more pieces of single wire conductor
2. Strip about 1 1/2" from the center of one conductor and bevel the insulation edges on both sides
3. Strip one end of the other conductor and bevel as previously outlined
4. Place the free end of the last conductor prepared at about the center of the first conductor and wrap the tap onto the bare space in the first conductor (Figure 8)

FIGURE 8

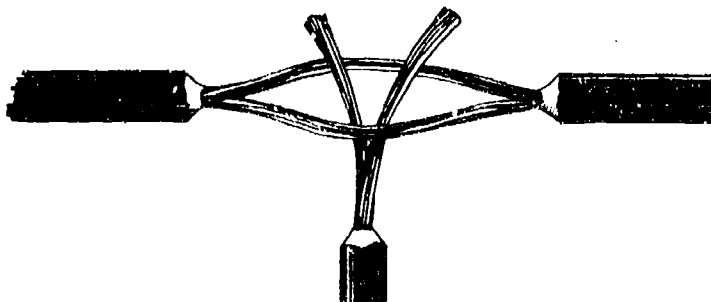

JOB SHEET #4

5. Heat the soldering tip again, clean it, tin it, and solder the tap with the same procedure previously used
6. Permit the splice to cool
- Have your instructor check your work
7. Tape the tap splice as previously outlined
8. Repeat the procedures for splicing and soldering a stranded wire tap (Figure 9)

FIGURE 9

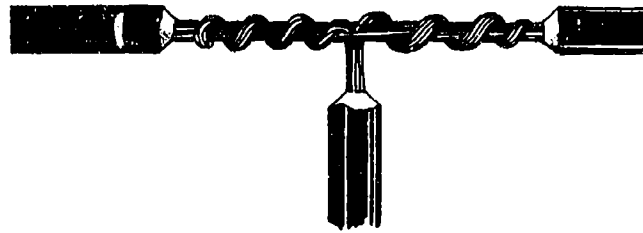

9. Permit the soldered splice to cool
- Have your instructor check your work
10. Tape the tap splices as previously outlined
11. Clean up area and return tools and equipment to proper storage, or continue practice with splicing and soldering as directed by your instructor

TOOLS, MATERIALS, AND TEST INSTRUMENTS UNIT VI

JOB SHEET #5 — USE A VOM FOR A QUICK CAPACITOR CHECK

A. Tools and materials

1. Capacitor(s) as selected by Instructor
2. VOM
3. Pencil and paper
4. Safety glasses

B. Procedure

1. Put on safety glasses and make sure the capacitor has been discharged if it has been recently energized

(NOTE: Check with your instructor for a safe discharging procedure.)
2. Connect VOM leads in any order to the capacitor terminals (Figure 1)

FIGURE 1

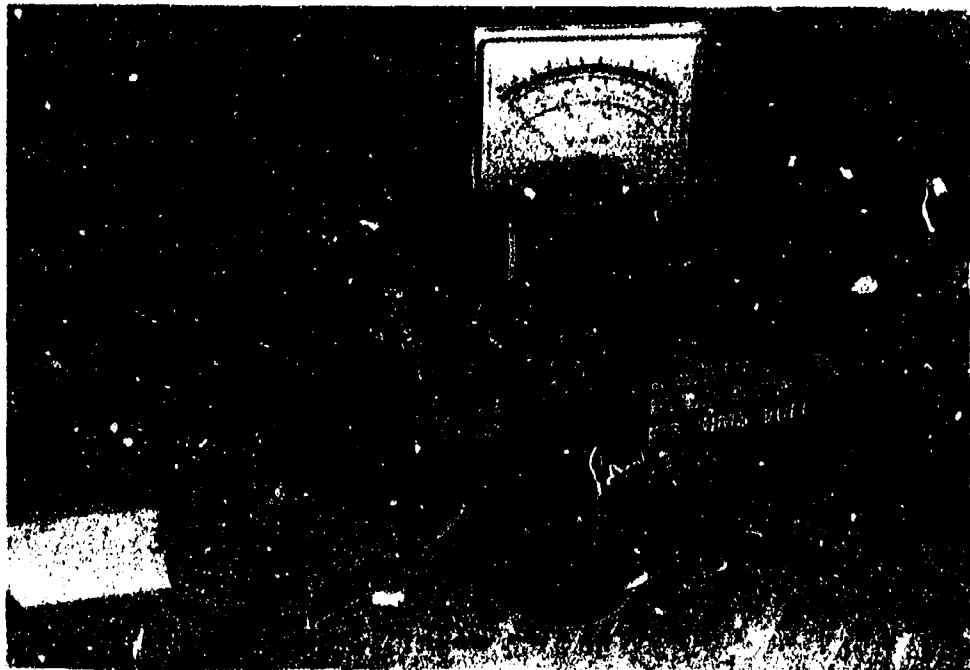

JOB SHEET #5

3. Check the indicator needle for movement about halfway across the scale and then a drop back to zero
4. Reverse the VOM leads on the capacitor terminals
 - a. If switching the meter leads back and forth continues to show a noticeable deflection and then a fall back to zero, the capacitor is okay
 - b. If there is more than a half-scale deflection and the needle will not return to zero, the capacitor is shorted
 - c. If there is no reading at all, the capacitor is open
5. Record your findings for the first capacitor and repeat the procedure for other capacitors that your instructor may supply
6. Record all findings
- Have your instructor check your work
7. Clean up area and return tools and materials to proper storage

TOOLS, MATERIALS, AND TEST INSTRUMENTS UNIT VI

NAME _____

TEST

1. Match the terms on the right with their correct definitions.

- | | | |
|---------|---|-------------------|
| _____a. | A classification system for identifying wire conductors by diameter and number | 1. Short |
| _____b. | A ground tied to the appliance cabinet or frame | 2. Hand tools |
| _____c. | A conductor that serves as a return to complete an electrical circuit | 3. NEC |
| _____d. | Frequently used portable tools that can be readily carried in a tool box | 4. AWG |
| _____e. | Large tools, infrequently used tools, or expensive tools that would be difficult to replace | 5. Open |
| _____f. | Guidelines dedicated to the protection of life and property in the use of electrical materials and their functions in residential and commercial applications | 6. Shop tools |
| _____g. | A disruption in a higher resistance circuit that diverts current from its intended path into a side current of lower resistance and often blows a fuse or trips a breaker | 7. Chassis ground |
| _____h. | A circuit through which no current flows | 8. Common |

2. Identify the following basic hand tools by placing the correct tools name with the appropriate illustration.

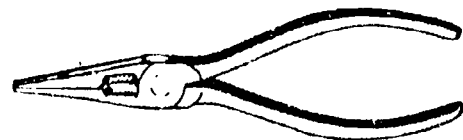
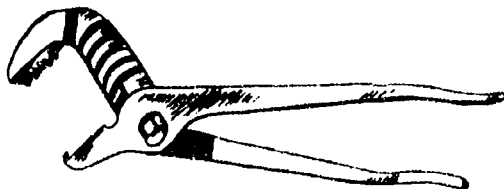

a. _____

b. _____

TEST



c. _____

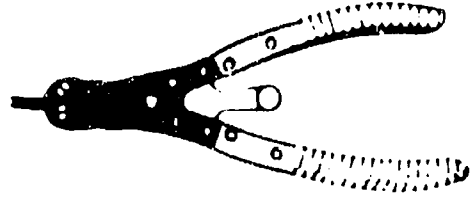

d. _____

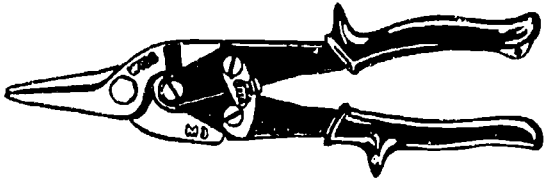

e. _____

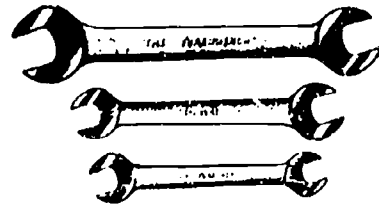

f. _____

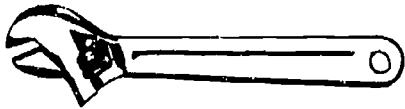

g. _____



h. _____



i. _____

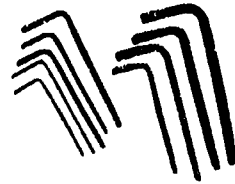

j. _____

TEST

3. Identify selected shop tools by placing the correct tool name with the appropriate illustration.



a. _____

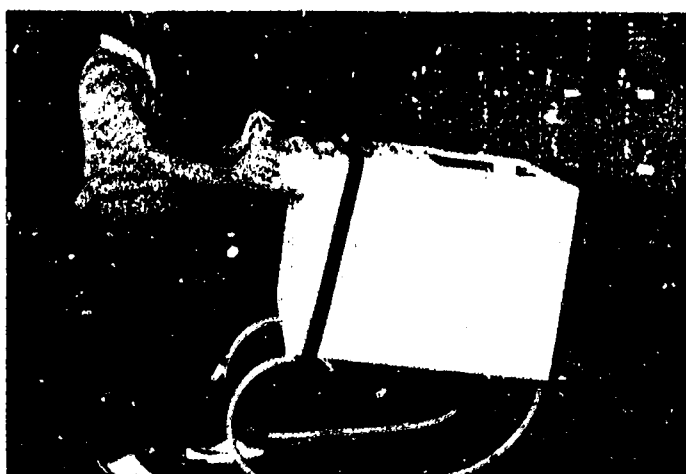

b. _____

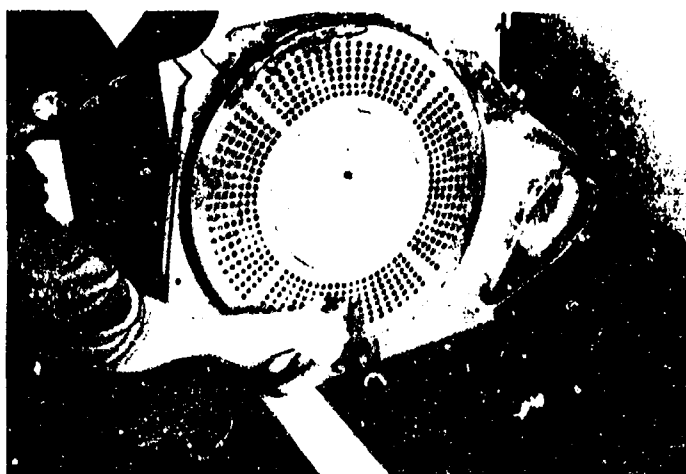

c. _____

TEST

4. Complete the following list of miscellaneous supplies by circling the word(s) that best completes each statement.
- Electrical, masking and (~~friction~~, ~~scotch~~) tape
 - (~~High~~, ~~Low~~) temperature lubricant and adhesive
 - Rubber (~~adhesive~~, ~~seals~~)
 - Multipurpose (~~cleaner~~, ~~lubricant~~) such as WD-40
 - Degreasers and (~~detergent~~, ~~etching agent~~)
 - Leak-testing liquid and (~~brush~~, ~~match~~)
 - Lint-free shop (~~towels~~, ~~rags~~)
 - Emery cloth and (~~sandpaper~~, ~~file~~)
 - (~~Shrink~~, ~~Insulated~~) tubing
 - Assortment of nuts, bolts, screws, and (~~wire~~, ~~washers~~)
 - Assortment of wire terminals, wire nuts, and (~~splicing~~, ~~connecting~~) devices
5. Match required repair literature with its uses.
- | | |
|--|----------------------|
| _____ a. Relate service and repair routines to specific models of appliances | 1. Parts catalog |
| _____ b. Provide visual guides to electrical circuits and to component circuitry | 2. Service manuals |
| _____ c. Uses exploded views and numbered references for positive parts identification | 3. Technical updates |
| _____ d. Keep service people informed of important part changes or changes in service requirements | 4. Schematics |
6. Solve the following problems concerning VOM's and their uses.
- How do you quickly differentiate between a short and an open by using a VOM?
Answer _____

 - How do you zero a VOM?
Answer _____
 - When a VOM will not properly zero, what does it usually mean?
Answer _____

TEST

7. Select true statements concerning clamp-on ammeters and their uses by placing an "X" beside each statement that is true.
- _____a. Clamp-on ammeters are used to measure amperage in a DC current carrying conductor without having to cut into or probe the conductor itself.
 - _____b. Clamp-on ammeters can also be used to perform VOM functions with voltage and resistance with special test leads that fit into the bottoms of the meters, and scales for each function.
 - _____c. Reading resistance with a clamp-on ammeter requires inserting an in-line fuse adapter into the hot lead.
 - _____d. A special internal fuse system eliminates the prospect that a clamp-on ammeter could accidentally be destroyed while measuring resistance.
 - _____e. Small amperages can be measured with a clamp-on ammeter by looping the conductor lead around one jaw of the clamp two, three, or four times and then dividing the reading by the number of loops.
 - _____f. Clamp-on ammeters are favored by service people because they are easy to carry, versatile, and rugged.
8. Complete statements concerning digital multimeters and their uses by inserting the word(s) that best completes each statement.
- a. Digital multimeters do everything that VOM's can do, but have a _____ readout instead of a scale.
 - b. Digital multimeters are _____ accurate than VOM's for measuring small voltages or resistances.
 - c. Digital multimeters have special selectors for checking transistors in washers, dryers, and appliances that have _____ controls.
9. Select true statements concerning temperature testers by placing an "X" beside each statement that is true.

(NOTE: For a statement to be true, all parts of the statement must be true.)

- _____a. Temperature testers are used to measure:
 - 1) Ambient temperature in ovens and refrigerators
 - 2) Griddle and surface temperature
 - 3) Exhaust vent temperature on gas and electric dryers
- _____b. Because temperature testers measure in millivolts converted to a Fahrenheit scale, they are less accurate than hang-in thermometers.

TEST

- _____c. A temperature tester is remote from the sensing element and is much more convenient to use than a hang-in thermometer which requires opening the oven door to read.
- _____d. Because of their accuracy, temperature testers are a "must" piece of equipment for recalibrating oven controls.
10. Complete statements concerning capacitor analyzers and their uses by circling the word(s) that best completes each statement.
- a. Capacitor analyzers are used (**mostly, strictly**) for checking capacitors on capacitor start motors on washers.
- b. A capacitor analyzer is a much better test instrument than a VOM for determining if a capacitor is still in working condition because it will show if the capacitor is (**burned out, shorted or open**), or read the capacitor in microfarads.
- c. A good capacitor analyzer should be able to determine power factor tolerance and general capacitance (**tolerance, characteristics**).
- d. A good capacitor analyzer should also be able to isolate shorted capacitors and capacitors with (**overheating, intermittent**) problems.
11. Select true statements concerning wattmeters and their uses by placing an "X" beside each statement that is true.
- _____a. Wattmeters are used to measure the amount of energy consumed by a motor, an appliance, or a component.
- _____b. Measuring wattage will help determine if an appliance or component is drawing too much current.
- _____c. Conversion factors for determining watt consumption are built into wattmeters, so they're much easier to use than VOM's or clamp-on ammeters whose readings must be converted.
- _____d. Wattmeters can be used to measure wattages on electrical appliances in the range of 130V to 260V.
- _____e. Wattmeters are used for checking other meters for proper calibration.
12. Complete statements concerning shunts and their functions in ammeters by inserting the word(s) that best completes each statement.
- a. A shunt is designed to allow only a _____ percentage of a total current to pass through an ammeter so the meter can be used to measure a wide range of currents.
- b. Shunts eliminate the need for heavier _____ which would increase the cost and weight of ammeters and decrease sensitivity.
- c. Shunts are built into many ammeters and are so indicated on selector scales that permit a technician to select the shunt most _____ to the measurement.

TEST

13. Match electrical measurements with ways to make them.
- | | | |
|---------|--|---------------|
| _____a. | Must be measured ACROSS the circuit or source being tested | 1. Amperage |
| _____b. | Must be measured in series with the circuit being tested | 2. Resistance |
| _____c. | Must be measured from one point to another in a component or a circuit | 3. Voltage |
14. Complete statements concerning appliance wiring by circling the word(s) that best completes each statement.
- Appliance wiring is selected according to an AWG number to identify its diameter and an insulation type to identify its **(service qualities, relative cost)**.
 - The AWG number grows **(larger, smaller)** as the size of the wire increases.
 - The major **(insulation, AWG)** types required around major appliances are:
 - RHW — Moisture and heat-resistant rubber for dry and wet locations where operating temperatures do not exceed 167°F
 - THW — Moisture and heat-resistant thermoplastic for dry and wet locations where operating temperatures do not exceed 194°F
 - AA — A special wire for electric ranges because it has a braided asbestos covering and can operate at temperatures up to 392°F
 - When reading wire sizes, the **(first, second)** number is the AWG size and the **(first, second)** number indicates how many conductors are in the wire.
 - The maximum amperage a wire can safely carry is known as ampacity, and low ampacity wires should **(be used carefully, never be used)** for high ampacity applications.
 - Never replace an AWG wire with a **(smaller, larger)** wire because it could cause a malfunction and create a fire hazard.
15. Solve the following problems concerning soldering tools.
- A pencil soldering iron is recommended for use on printed circuit boards, but where else is a pencil iron a useful tool?
Answer _____
 - Soldering poses burn hazards, but what is the greater danger that soldering poses and what should be done to avoid the danger?
Answer _____

TEST

16. Complete statements concerning resin-core solder and its characteristics by circling the word(s) or figure(s) that best completes each statement.
- The type of solder used most often around electrical connections is **(40/60, 60/40)** resin-core solder.
 - The 40/60 means the solder is an alloy of **(60%, 40%)** tin and **(60%, 40%)** lead.
 - The flux required to clean metal and promote fusion is placed **(inside, outside)** the core of resin-cored solder.
 - Resin-core solder comes in handy **(cartons, rolls)** that are convenient to store and carry.
 - Resin-core solder is **(noncorrosive, nontoxic)** and suitable for almost all work around major appliances.
 - When using resin-core solder, clean surface(s) to be soldered, apply **(heat, flux)** to the surfaces, and then run the strand of solder over the heated surface(s).
17. Arrange in order the procedure for using solid wire solder by placing the correct sequence number in the appropriate blank.
- _____a. Apply heat to the parts to be soldered, not to the solder itself.
 - _____b. Apply the solder to the heated parts and allow it to melt onto the parts.
 - _____c. Clean surfaces to be soldered.
 - _____d. Apply soldering flux to both surfaces.
18. Arrange in order the steps in wire stripping by placing the correct sequence number in the appropriate blank.
- _____a. Place the wire in the proper slot in the wire stripper and work the stripper back and forth until a cut is made around the entire insulation.
 - _____b. Hold the wire tight with one hand and use the other hand to gently move the insulation back and forth until the cut breaks clean and unwanted insulation can be pulled off.
 - _____c. Taper the insulation with a knife to increase the wire's flexibility because straight cut insulation creates a force point that can cause a wire to break.

TEST

19. Identify the following types of splices by placing the correct name of the splice below the appropriate illustration.



a. _____

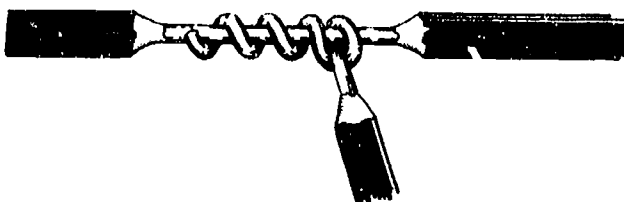

b. _____

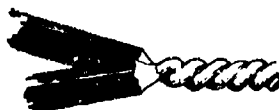

c. _____



d. _____

TEST

20. Complete statements concerning guidelines for connections at screw terminals by circling the word(s) that best completes each statement.
- a. Wire should be attached at a screw terminal so that the loop lies in the (**direction, opposite direction**) the screw turns.
 - b. Wire should loop the screw a little less than (**one full turn, two full turns**), but excessive loops are not recommended.
21. Complete statements concerning guidelines for good soldered splices by inserting the word(s) that best completes each statement.
- a. Wires to be spliced must be bright and _____ at the point of connection.
 - b. Connecting points must be _____ so solder will solidify without wire movement.
 - c. Wire should be coated with electric soldering paste, and then soldered so that solder melts and flows into every _____ of the splice.
 - d. Entire splice area should be covered with water-proof _____.
22. Complete statements concerning guidelines for using solderless connectors and terminals by inserting the word(s) that best completes each statement.
- a. Solderless connectors should be used according to their _____, and a connector for a lighter gauge should never be used on a wire of a heavier gauge.
 - b. Screw-on connectors work well on _____ splices, and they require no taping because they're made of insulating materials.
 - c. Crimp-on terminal lugs should not leave a _____ between the insulation and the lug, and if there is a _____, a plastic sleeve should be added to cover the bare wire.
23. Complete statements concerning proper care and use of hand tools by inserting the word(s) that best completes each statement.
- a. Screwdrivers
 - 1) Do not hammer or _____ with screwdrivers.
 - 2) Worn Phillips screwdrivers should be _____, but flat blade screwdrivers can be useful as long as the tip can be reground _____.

TEST

b. Wrenches and pliers

- 1) Do not _____ on wrenches or _____ with wrenches.
- 2) Use adjustable wrenches so that the large jaw is _____ the direction of force.
- 3) When pulling on an adjustable wrench, be careful not to hit yourself in the chest or head, and when pushing on an adjustable wrench, hold your hand _____ on the handle so you won't accidentally scar your knuckles.
- 4) Do not use pliers in place of a wrench, especially on _____ fittings.
- 5) Use pliers with _____ handles when working around electrical circuits and components.

c. Hammers

- 1) Never use a hammer with a _____ handle.
- 2) Use all hammers for their _____ purpose.

d. Punches, chisels, and files

- 1) Keep chisel cutting edges _____.
- 2) Keep chisel heads properly dressed, and never strike a chisel that has a _____ head.
- 3) Files become dull if stacked in a drawer, so _____ them up.
- 4) Do not hammer or pry with a file because they are _____ and break easily.

e. Socket sets and nut drivers

- 1) Do not use a _____ to gain greater leverage on the handle of a ratchet because it will strip the ratchet gears.
- 2) Do not use a _____ on a thin wall socket because the socket will break.
- 3) Nut drivers should be used for _____ nuts, bolts, and screws, but do not use pliers to increase leverage.

TEST

24. Complete a list of guidelines for using other tools and equipment by inserting the word(s) that best completes each statement.
- a. Cords for drop lights should not be run over by appliance _____ or placed where objects with metal edges may be placed on them.
 - b. Handle levels with care because once they're _____ they're usually inaccurate.
 - c. Do not apply too much pressure on a _____ key wrench or it may break or round out the socket in the set screw.
 - d. Never use _____ equipment without proper instruction or without permission.
 - e. Keep _____ in a case when they're not in use so they'll stay clean.
 - f. Never point a _____ at another person, and never use _____ when it might spray dirt or metal particles at someone nearby.
25. Select true statements concerning eye protection by placing an "X" beside each statement that is true.
- _____a. Wear safety glasses at all times in the shop area.
 - _____b. Blow compressed air away from you when using it for cleaning.
 - _____c. Wear safety glasses when working with grinding tools.
 - _____d. If you get cleaning solvent on your hands, wash them with soap and water to avoid the possibility of accidentally rubbing your eyes.
 - _____e. Know the location of the nearest eye flush station.

(NOTE: If the following activities have not been accomplished prior to the test, ask your instructor when they should be completed.)

26. Identify selected tools. (Assignment Sheet #1)
27. Demonstrate the ability to:
- a. Test electrical receptacles for proper voltages. (Job Sheet #1)
 - b. Use a clamp-on ammeter to test for high and low amperages on a fan motor and a light bulb. (Job Sheet #2)
 - c. Make a continuity check of a magnetic control assembly from an automatic washer. (Job Sheet #3)
 - d. Splice electrical conductors to acceptable service standards. (Job Sheet #4)
 - e. Use a VOM for a quick capacitor check. (Job Sheet #5)

TOOLS, MATERIALS, AND TEST INSTRUMENTS UNIT VI

ANSWERS TO TEST

1.
 - a. 4
 - b. 7
 - c. 8
 - d. 2
 - e. 6
 - f. 3
 - g. 1
 - h. 5

2.
 - a.
 - b.
 - c.
 - d.
 - e.
 - f.
 - g.
 - h.
 - i.
 - j.

3.
 - a. Dolly
 - b. Appliance flipper
 - c. Compressed air supply

4.
 - a. Friction
 - b. High
 - c. Adhesive
 - d. Lubricant
 - e. Detergent
 - f. Brush
 - g. Towels
 - h. Sandpaper
 - i. Shrink
 - j. Washers
 - k. Connecting

5.
 - a. 2
 - b. 4
 - c. 1
 - d. 3

6.
 - a. A short always shows some reading, and an open shows no reading at all
 - b. Cross the test leads and zero the ohms control knob
 - c. The battery is probably bad

ANSWERS TO TEST

7. b, c, d, e, f
8. a. Numbered
b. More
c. Solid state
9. a, c, d
10. a. Strictly
b. Shorted or open
c. Tolerance
d. Intermittent
11. a, b, c, d, e
12. a. Small
b. Coils
c. Suitable
13. a. 3
b. 1
c. 2
14. a. Service qualities
b. Smaller
c. Insulation
d. First, second
e. Never be used
f. Smaller
15. a. When space will not permit use of a larger iron
b. Eye damage, so always wear safety glasses when soldering
16. a. 40/60
b. 40%, 60%
c. Inside
d. Rolls
e. Noncorrosive
f. Heat
17. a. 3
b. 4
c. 1
d. 2
18. a. 1
b. 2
c. 3

310

ANSWERS TO TEST

19. a. Simple splice
b. Simple tap
c. Pigtail splice
d. Hook splice
20. a. Direction
b. One full turn
21. a. Clean
b. Tight
c. Crevice
d. Plastic tape
22. a. Color codes
b. Pigtail
c. Gap, gap
23. a. 1) Pry
2) Discarded, square
b. 1) Hammer, hammer
2) Opposite
3) Palm-flat
4) Brass
5) Insulated
c. 1) Loose
2) Intended
d. 1) Sharp
2) Mushroomed
3) Hang
4) Brittle
e. 1) Cheater bar
2) Cheater bar
3) Hand-tight
24. a. Dollies
b. Dropped
c. Hex
d. Oxyacetylene
e. Safety glasses
f. Compressed air nozzle, compressed air
25. a, b, d, e
26. Evaluated to the satisfaction of the instructor
27. Performance skills evaluated according to instructions written in the job sheets



AUTOMATIC WASHERS UNIT VII

UNIT OBJECTIVE

After completion of this unit, the student should be able to discuss the major components of an automatic washer in relation to their functions in a typical cycle. The student should also be able to list problems common to automatic washers and discuss systematic troubleshooting routines. These competencies will be evidenced by correctly performing the procedures outlined in the job sheets and by scoring 85 percent on the unit test.

SPECIFIC OBJECTIVES

After completion of this unit, the student will be able to:

1. Match terms related to automatic washers with their correct definitions.
2. Match major components with their functions in an automatic washer.
3. Arrange in order the steps in a typical automatic washer cycle.
4. Complete statements concerning fill functions in a normal cycle.
5. Complete statements concerning agitation functions in a normal cycle.
6. Complete statements concerning pumpout and spin functions in a normal cycle.
7. Select true statements concerning guidelines for evaluating automatic washer malfunctions.
8. Arrange in order the steps for validating repairs.
9. Complete statements concerning troubleshooting a washer that will not fill with water.
10. Select true statements concerning troubleshooting a washer for improper water level or water temperature.
11. Select true statements concerning troubleshooting a washer when water will not shut off.
12. Complete statements concerning troubleshooting a washer that leaks water.
13. Complete statements concerning troubleshooting when water will not drain from a washer.

OBJECTIVE SHEET

14. Select true statements concerning troubleshooting a washer with a motor that will not run.
15. Complete statements concerning troubleshooting a washer that will not agitate.
16. Complete statements concerning troubleshooting a washer that will not spin.
17. Select true statements concerning troubleshooting a washer that will not advance or shut off.
18. Select true statements concerning troubleshooting a washer that leaks oil.
19. Select true statements concerning troubleshooting a washer that tears clothing.
20. Match other washer problems with ways to correct them.
21. Demonstrate the ability to:
 - a. Install an automatic washer. (Job Sheet #1)
 - b. Troubleshoot a Whirlpool/Kenmore automatic washer for typical malfunctions. (Job Sheet #2)
 - c. Troubleshoot a GE/Hotpoint automatic washer for typical malfunctions. (Job Sheet #3)

AUTOMATIC WASHERS UNIT VII

SUGGESTED ACTIVITIES

- A. Provide students with objective sheet.
- B. Provide students with information sheet.
- C. Provide students with job sheets.
- D. Discuss unit and specific objectives.
- E. Discuss information sheet.
- F. Discuss and demonstrate the procedures outlined in the job sheets.
- G. Discuss the special tools required for working with Whirlpool/Kenmore washers; and demonstrate how to properly pull and replace a bearing.
- H. Have available a brake/clutch assembly from a GE washer so students can inspect the assembly and its components.
- I. Impress students with the importance of starting repairs by verifying the complaint, and also discuss the importance of systematic troubleshooting for cost-effective repairs.
- J. Have students save their troubleshooting logs and use them again with the same routines at a later date to see if their speed has improved.
- K. Give test.

CONTENTS OF THIS UNIT

- A. Objective sheet
- B. Information sheet
- C. Job sheets
 - 1. Job Sheet #1 — Install an Automatic Washer
 - 2. Job Sheet #2 — Troubleshoot a Whirlpool/Kenmore Automatic Washer for Typical Malfunctions
 - 3. Job Sheet #3 — Troubleshoot a GE/Hotpoint Automatic Washer for Typical Malfunctions
- D. Test

CONTENTS OF THIS UNIT

- E. Answers to test

REFERENCES USED IN DEVELOPING THIS UNIT

- A. *Tech-Talk "M" Clothes Washers*. Dayton, OH 45449: Frigidaire Parts and Service Company, 1983.
- B. *Repair Manual for Your Whirlpool Automatic Washer (Belt Driven)*. Benton Harbor, MI 49022: Whirlpool Corporation, 1984.
- C. *Repair Master for General Electric Automatic Washers*. Garden Grove, CA 92642: Master Publications, a Gem Products, Inc. Company, 1985.
- D. Anderson, Edwin P. *Home Appliance Servicing*. Indianapolis, IN 46268: Howard W. Sams & Co., Inc., 1979.

AUTOMATIC WASHERS UNIT VII

INFORMATION SHEET

I. Terms and definitions

- A. Automatic washer — An appliance designed to clean dirty clothes in a wash, rinse, and spin-dry sequence controlled by a timer
- B. Centrifugal — The force that impels something outward from a rotating center
- C. Cycle — One complete performance of a series of events that completes a procedure
- D. Glazing — The highly-polished look of hydrocarbon build-up resulting from heat produced by friction between brake shoes and their metal housings
- E. Reciprocating — Moving back and forth in an alternating motion

II. Major components and their functions in an automatic washer

- A. Timer — An electromechanical device referred to as the "brain" of the automatic washer because it controls all switch operations for all functions except start-up

(NOTE: Automatic washers have to be started by the user.)

- B. Motor — Drives or turns the transmission or power train to provide power for agitation and spin motion
- C. Transmission — Converts motor power into directional control of agitate and spin functions including reciprocating back and forth motion for agitation

(NOTE: Early model Frigidaire transmissions also provide pulsating or up and down motion.)

- D. Water pump — Pumps water from the tub and may also recirculate the water in the tub by pulling it from the bottom of the tub and dumping it back in at the top

(NOTE: Single-stage water pumps only extract water from a tub, and two-stage or multi-stage water pumps extract water and recirculate water in a recirculating compartment that is separate from the pumpout compartment.)

- E. Water pressure/water level switch — Controls the water level in the tub

(NOTE: A water pressure switch is activated by air pressure created in a tube as water in the tub rises, and a water level switch is activated in the agitator by a float-type device that rises as the water rises much like the float in the water tank on a stool.)

INFORMATION SHEET

III. Steps in a typical automatic washer cycle

- A. First fill
- B. Wash agitation
- C. First pumpout and spin
- D. Second fill
- E. Rinse agitation
- F. Final pumpout and spin

IV. Fill functions in a normal cycle

- A. Machine usually fills twice during one cycle
- B. The first fill is a wash fill with hot, warm, or cold water selected manually or predetermined by timer setting
- C. The second fill is a rinse fill with warm or cold water only (no hot water) determined by timer setting
- D. Timer is usually set to automatically direct cold water to the tub during the rinse fill portion of the cycle

V. Agitation functions in a normal cycle

- A. Machine usually agitates twice during one cycle
- B. Agitation may be accomplished with reciprocating motion or by rotating a drum
- C. The first agitation is a wash agitation which may vary from 6 to 18 minutes and is usually accomplished with a high-speed motor setting
- D. The second agitation is a rinse agitation which may vary from 2 to 6 minutes and is usually accomplished with a high-speed motor setting
- E. The wash agitation mixes detergent with water and creates action to dislodge and separate soil from clothes
- F. The rinse agitation separates detergent residue and dislodges separated particles so that they will be removed with pumpout and not settle back onto the clothes

VI. Pumpout and spin functions in a normal cycle

- A. Machine usually pumps out and spins twice in one cycle
- B. Pumpout is initiated by the timer and regulated by either the water level or water pressure switch

INFORMATION SHEET

- C. In most washers, the water pressure switch will not allow the timer to advance until the water has been pumped out to assure that the first spin will last 2 to 4 minutes
- D. The spin action creates a centrifugal force which literally throws water from the clothes
- E. The final spin usually lasts at least 4 minutes or longer and is always a high-speed motor function
- F. On some machines, spray rinse is an added feature of the spin function so that any residue that collects on the clothes during the spin function will be rinsed off and pumped out

(NOTE: Spray action is usually intermittent, lasts only a few seconds, and may be repeated up to half a dozen times.)

VII. Guidelines for evaluating automatic washer malfunctions

- A. Identify the washer brand and model number

(NOTE: Automatic washers from each manufacturer have problems that are peculiar to that brand, and recognizing the similarities or problems within a brand line can save troubleshooting time.)

- B. Ask the customer to explain what the machine is not doing or what the machine is doing wrong
- C. Take notes as required so you will remember what has been said if the customer should have to leave
- D. Verify the problem with a physical inspection or run the washer in an attempt to duplicate the problem if running the washer is still practical

VIII. Steps for validating repairs

- A. Run the washer through one full normal cycle
- B. Do not manually advance the timer
- C. Make sure the washer:
 1. Fills properly
 2. Agitates effectively
 3. Pumps out and spins properly
 4. Shuts itself off

INFORMATION SHEET

- D. Doublecheck for leaks
- E. Check the machine for level

IX. Troubleshooting a washer that will not fill with water

- A. Check the obvious first:
 - 1. Washer may not be properly turned on
 - 2. Hoses may be kinked
 - 3. Screens in the fill hoses may be clogged
- B. Make sure a proper water supply is available to the machine
- C. Check for proper voltage at the mixing valve with a VOM

(NOTE: An alternate check is to put the washer on a "fill" setting, turn the timer on, and feel the valve to see if it vibrates or listen for a humming noise; if the valve vibrates or makes a humming noise, this indicates proper voltage at the mixing valve, but be sure to exercise caution when working with live circuits.)

- D. When a mixing valve is energized but still won't admit water, check for obstructions in the valve and remove them
- E. Run a continuity check on the fill switch and replace as required
- F. Check the temperature selection switch
- G. Make sure it is not a timer problem
- H. Check the lid switch to make sure it is making proper contact

X. Troubleshooting a washer for improper water level or water temperature

- A. Check for reversed hot and cold water hoses
- B. Check for the quality of the hot water supply
- C. Check for a faulty water level switch
- D. Check for a faulty thermal element in the mixing valve if it is a thermal type mixing valve
- E. Check for a faulty temperature selection switch in the control panel or timer
- F. Check for faulty timer

INFORMATION SHEET

G. If the washer has a spray rinse in the spin portion of the rinse cycle, and this doesn't work:

1. Check for no cold water supply or a kinked cold water hose
2. Check for a clogged inlet screen
3. Check for a defective cold water solenoid in the mixing valve
4. Check for a defective timer

(NOTE: The contacts for the spray rinse action are usually separate from the other contacts in a timer, and although the spray rinse doesn't work, the washer may work well except for that feature.)

XI. Troubleshooting a washer when water will not shut off

A. On time-fill washers, the failure of water to shut off may indicate a timer malfunction

(NOTE: A time-fill machine is one where water fill volume is controlled by setting the timer for the washer to fill for a given period of time.)

B. Check the water level/water pressure switch and replace it if it is defective

C. Check for foreign particles in the mixing valve, and if that is suspected, take the valve apart and remove them

(NOTE: Cleaning a mixing valve can be accomplished in the field, but if it doesn't correct the problem, the valve should be replaced.)

D. On pressure-filled models check for a break or pinhole in the air chamber or connecting tubing, and replace either or both as required

(NOTE: If water gets in the air chamber or pressure tube, it will have the same effect as a pinhole, and this sometimes happens when a washer is tilted for cleaning or for moving.)

XII. Troubleshooting a washer that leaks water

A. Check for loose or cracked supply hoses and tighten or replace as required

B. Check for a loose drain hose and tighten or replace the clamp as required

C. Run the washer through a normal cycle and replace any hose that is broken or appears to be damaged

D. Check for worn or damaged supply hose washers

INFORMATION SHEET

- E. Check for leaky gaskets:
 1. Around the water pump
 2. Where the transmission enters the outer tub
 3. Seals between the inner and outer tub
 4. Outer tub gasket
- F. Check for cracked housing:
 1. Outer tub, especially tubs made of plastic
 2. Water pump housing
 3. Mixing valve housing
- G. Replace any component with cracked housing

XIII. Troubleshooting when water will not drain from a washer

- A. Check for a kinked or clogged drain hose and correct as required
- B. Check for a water pump problem, and readjust the pump and tighten the pump drive

(NOTE: On models with a drain-before-spin feature, suds lock sometimes occurs, but this can usually be corrected by dumping cold water into the tub to break up the suds.)
- C. Check for a loose belt at the water pump and adjust as required
- D. Check for a faulty transfer or solenoid valve and replace as required
- E. Check for a defective water pump and replace as required
- F. Check for a faulty timer and replace as required

XIV. Troubleshooting a washer with a motor that will not run

- A. Make sure there is power to the machine
- B. Check for a faulty door/lid switch and replace as required
- C. Check for an overload device or other protective device in the circuit and replace as required
- D. Check for a faulty timer and replace as required
- E. Check for a faulty motor and replace as required

INFORMATION SHEET**XV. Troubleshooting a washer that will not agitate**

- A. Check for a motor malfunction and replace as required
- B. Check timer for bad contacts and correct or replace as required
- C. Check for a faulty transmission and repair or replace as required
- D. Check for broken linkage or other agitation control mechanism

Examples: The agitate drive roller on a Frigidaire, the agitate solenoid on the Kenmore, and the eccentric linkage connection of the Speed Queen are potential trouble spots

- E. Check for a broken wire in circuitry and splice, tin, and insulate as required
- F. Check for stripped splines in the agitator

XVI. Troubleshooting a washer that will not spin

- A. If the washer will agitate but not spin, the motor is probably okay
- B. Check timer for defective contacts and replace as required
- C. Check the door or lid switch and replace as required
- D. Check for a faulty transmission and repair or replace as required
- E. Check for broken linkage or other spin control mechanisms

Examples: The spin roller on a Frigidaire, the spin control solenoid on a Kenmore, and the fluid drive unit on a Speed Queen are spin control mechanisms

- F. Check for a faulty water level switch and replace as required
- G. Check for a broken wire in circuitry and splice, tin, and insulate as required

XVII. Troubleshooting a washer that will not advance or shut off

- A. If the timer will not advance, check the timer contacts
- B. Check for a defective timer and replace the timer if required or replace the timer motor if that is the problem
- C. Replace a timer motor only with the exact type of motor removed or the timed cycles will all be wrong
- D. Check for a break in the circuitry wiring and splice, tin, and insulate as required

INFORMATION SHEET

XVIII. Troubleshooting a washer that leaks oil

- A. If oil leaks on the floor, check for a leak in the gearcase caused by a faulty gasket, damage to the gearcase housing, or a bad transmission seal
- B. If oil leaks onto clothes in the tub, check for a faulty gearcase or transmission seal and replace seal or transmission as required

(NOTE: On Norge and GE washers, it is recommended that the transmission be replaced, but on Kenmore/Whirlpool washers, both the tub and transmission seals can be replaced.)

XIX. Troubleshooting a washer that tears clothing

- A. Caution the user to use bleach wisely
 - 1. Do not use too much bleach
 - 2. Do not add bleach at the wrong time
 - 3. Add bleach to water before loading clothes in the tub, or dilute bleach with water before putting it in the tub
- B. Check for a broken agitator and replace if required because chips and cracks in the agitator can tear clothes
- C. Check for a defective inner tub or basket and replace as required

XX. Other washer problems and ways to correct them

- A. Machine spins slowly — Adjust belt to clutch or replace clutch if it is faulty
- B. Water does not recirculate during agitation — Clean out clogged water pump
- C. Defective pump drive — Tighten as needed or replace the coupling
- D. Defective distribution valve — Clean out or replace valve, or replace solenoid as required
- E. Timer will not advance to next cycle — Replace timer motor, or replace entire timer as required
- F. Frozen timer shaft or knob — Check for obstructions and free the shaft or replace the timer as required
- G. Faulty water level switch — Replace the control

INFORMATION SHEET

- H. **Washer vibrates excessively — Reinforce weak floor or move washer, check for level, caution user not to overload or create unbalanced loads, or replace rubber cups on leveling feet**

(NOTE: Single large, heavy items such as beach towels or denim jeans will create an unbalanced condition and cause more than normal vibration.)

- I. **Tub vibrates excessively — Check for a damaged snubber and replace as required, or adjust or replace suspension bolts**

(NOTE: Vibration may indicate a faulty transmission or worn bearings.)

AUTOMATIC WASHERS UNIT VII

JOB SHEET #1 — INSTALL AN AUTOMATIC WASHER

A. Tools and materials

1. Washer as selected by instructor
2. Standard hand tools and tool box
3. VOM
4. Level
5. Dolly
6. Safety glasses

B. Procedure

1. Put on safety glasses
2. Uncrate the washer carefully
3. Visually inspect the washer to make sure it is not damaged
4. Secure washer on a proper dolly if it must be moved any distance to the installation site
5. Inspect the location where the washer will be installed for:
 - a. Level, sturdy floor

(NOTE: If the floor is not level and sturdy, point out to the customer that the condition could impair performance and eventually damage the washer; if the customer insists the floor remain as it is, have the customer sign a release.)
 - b. Adequate supplies of hot and cold water
 - c. Adequate drainage
 - d. Adequate clearance and ventilation
6. Remove ties, blocks, tape, and any other retaining devices installed to protect the washer during shipment
7. Check inside the washer for the owner's manual, installation kit, or any other materials that should be removed and saved

JOB SHEET #1

8. Set the washer in place
9. Connect hot and cold water hoses
10. Install grounding kit
(NOTE: Grounding kit installation varies from washer to washer, but the instructions should be with the washer and they should be carefully followed.)
11. Level the machine side to side and front to back
12. Check the receptacle for proper voltage
13. Plug the washer power cord into a three-hole grounded receptacle only
(CAUTION: Never use an adapter or an extension cord that defeats the ground connection on a washer power receptacle because it will void the warranty and damage the washer.)
14. Operate the machine through one normal cycle
(NOTE: Do not manually advance the timer; permit the washer to complete a full cycle on its own.)
15. Explain operating procedures to the customer, and encourage the customer to follow recommended procedures for washer care and preventive maintenance
16. Check the installation order and make sure you have recorded all serial numbers and any other information required to assure a correct warranty
17. Clean up the installation area and make sure all crating materials or blocks and ties are removed from the customer's home
18. Remind the customer that your company should be called for any questions about the washer or its performance
19. Compliment the customer on making a wise decision in washer selection, and leave the customer on a positive note
- Have your instructor check your work
20. Return tools and materials to proper storage

AUTOMATIC WASHERS UNIT VII

JOB SHEET #2 — TROUBLESHOOT A WHIRLPOOL/KENMORE AUTOMATIC WASHER FOR TYPICAL MALFUNCTIONS

A. Tools and materials

1. Washer as selected by Instructor
2. Appropriate service information
3. Standard hand tools and tool box
4. Motor test cord
5. Drop cord/inspection light
6. Drop cloth
7. VOM
8. Pressure bulb
9. Special Whirlpool/Kenmore tools
 - a. Spanner wrench #12393
 - b. Agitator drive block remover tool
10. Repair log
11. Safety glasses

B. Routine #1 — Troubleshooting the control panel

1. Sign on the repair log that accompanies this job sheet and save the log for use in later job sheets, and be sure to put on safety glasses
2. Place drop cloth down, set the tool box on it, and generally prepare a safe, uncluttered work area (Figure 1)

FIGURE 1



JOB SHEET #2

3. Unplug the washer
4. Turn off water supply to hoses and disconnect fill hoses with channel-lock pliers (Figure 2)

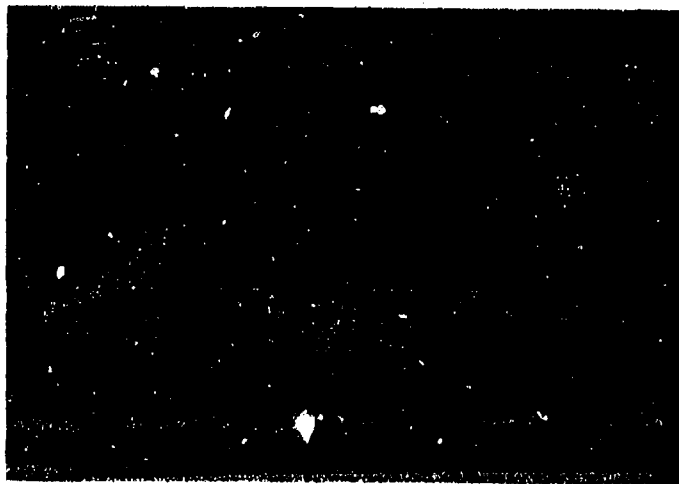
FIGURE 2

5. Remove the timer knob by holding the timer dial and turning the knob in a counter clockwise direction
6. Remove the timer dial by first removing any retaining screws or lock nuts and lift slightly to remove the timer dial (Figure 3)

FIGURE 3

7. Remove the screws that retain the control panel (console)
8. Move the control panel forward far enough to expose all electrical connections

JOB SHEET #2

9. **Unplug the electrical connection to the control panel (it plugs into the machine) and remove the fill hose from the water pressure switch (Figure 4)**

FIGURE 4

10. **Place a drop cloth on top of the washer and set the control panel out on top of the lid for easy access**
11. **Disconnect the harness or individual leads to the timer and be sure to sketch or make notes of the location of each individual connector so you will know how to put them back**

(NOTE: Failure to note the locations could cause you trouble later, and codes on schematics are not always reliable; even your knowledge of a particular appliance may not be counted on if you're dealing with a part some other technician has previously replaced.)
12. **Remove the inspection plate from the open-type timer and inspect the condition of the switch contacts**
13. **Remove the timer motor and inspect the drive gear for frayed or worn spots that indicate wear**
14. **Replace timer motor if wear is evident**

JOB SHEET #2

15. Test run the timer motor using a motor test cord:
- a. Scratch a mark at a point on the motor body and the gear to provide a reference point for checking timer motor rotation (Figure 5)

(CAUTION: Be sure to make the mark clear because the motor advances so slowly that it cannot be seen by the naked eye.)

FIGURE 5



- b. Connect motor test cord to timer motor (Robinaire Test Cord #12476). Use the black and white motor test leads.
- c. Turn the test cord on to the RUN position and allow it to run for at least ten minutes (Figure 6)

FIGURE 6



- d. If there is no noticeable timer motor advancement in a ten minute test period, the timer motor is defective and must be replaced

JOB SHEET #2

16. Replace the old timer motor or install a new timer motor as test indicates

Have your instructor check your timer removal

17. Reinstall entire existing timer if it appears to be in good shape or replace the timer if it is obviously defective

(NOTE: Timer problems usually are obvious, but ask your instructor for help in your evaluation of the timer's condition.)

Have your instructor check your timer installation

(NOTE: On a normal service call, the control panel would probably be reinstalled at this point, but leave it off for now.)

18. Note on your repair log the length of time it took for you to accomplish Routine #1, and add five minutes to that figure to have a realistic assessment of the time it would have taken to remove, troubleshoot, and replace the timer

C. Routine #2 — Troubleshooting the water level switch

1. Remove the knob from the water level switch

2. Remove the retaining screw(s) that hold the switch

3. Disconnect the individual leads to the water level switch and be sure to sketch the location of each individual lead so you can get each lead back in the proper location

4. Inspect the switch visually for any physical damage such as breaks or cracks in the housing or loose or corroded terminals

(NOTE: With water level switches in washers where the water level is selected by the user, the switch should be worked back and forth between high and low, or turned left and right, to make sure it is unobstructed.)

5. Perform a continuity test on the water level switch contacts with the following procedure:

a. Sketch two pictorial diagrams of the three water level switch terminals and label the terminals V, P, or T to indicate they are violet, pink, or tan

Example: 1. V P T

 2. V P T

JOB SHEET #2

- b. Make the continuity test across the three switch terminals from V to T, from V to P, and from T to P
 - c. When the reading between any two terminals is zero Ohms, connect those two terminals with a straight line (V_____T) (V_____P)
 - d. When the reading between any two terminals is infinite ohms, which generally indicates an open circuit, leave the space between the terminals blank (T P)
6. Evaluate your first continuity test according to the following:
- a. If there is no line between the tan and violet terminals and there is a line between the violet and pink terminals, it indicates the switch is in the empty position and is probably okay
 - b. If the lines and open space are reversed, it indicates the switch is stuck in the full position and should be replaced
7. Perform another continuity test on the water level switch with the following procedure:
- a. Attach a pressure bulb to the water level switch at the opening to the diaphragm (Figure 7)

FIGURE 7

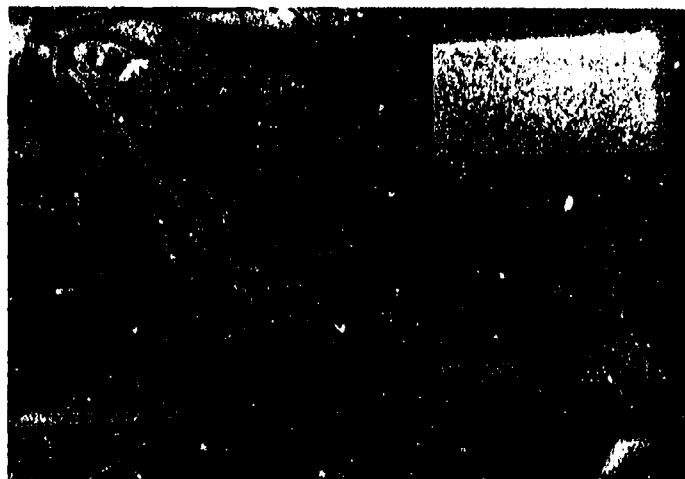

- b. Apply pressure to the bulb, listen for a clicking sound which indicates the diaphragm has moved to shift switch contacts, and at the same time take a continuity reading between terminals V and T
- c. With no pressure, continuity between V and T should be infinite
- d. When pressure is applied, continuity between V and T should be zero ohms

JOB SHEET #2

- e. Use your second diagram to indicate your final continuity reading
 - f. If there is an infinite reading between V and T with no pressure and a zero Ohms reading between V and T when pressure is applied, the switch is shifting from the empty to the full position properly and should be a good switch
8. Evaluate your continuity test and replace water level switch if required or put the old switch back in place
 9. Replace the entire control panel
 10. Note on your repair log the length of time it took to accomplish Routine #2
 - Have your instructor check your work
 11. Clean up area and return tools and materials to proper storage or proceed to next routine as directed by your instructor
- D. Routine #3 — Troubleshooting the mixing valve
1. Sign on your troubleshooting log
 2. Raise the lid and secure it, and then locate the mixing valve
- (NOTE: Refer to manufacturer's technical manual or ask your instructor if you have any questions about this procedure.)
3. Make a pictorial sketch of all conductors that lead to the mixing valve solenoids and note their identifying markings (Figure 8)
- (NOTE: This is to avoid the prospects that the cold water conductors won't be hooked up to the hot water solenoid, or vice versa, when the mixing valve is reinstalled.)

FIGURE 8

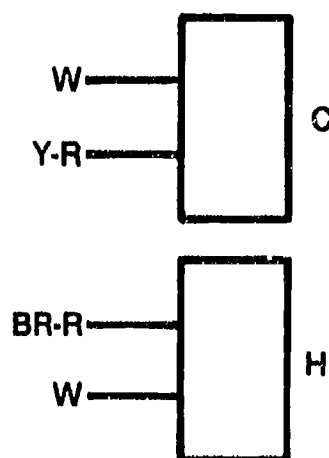

JOB SHEET #2

4. Remove the mixing valve
5. Remove the solenoids from the mixing valve and make a continuity check with the following procedure:
 - a. Check the cold water solenoid for continuity across the terminals and record the reading
 - b. Check the hot water solenoid for continuity across the terminals and record the reading
 - c. If it is a three-solenoid valve, check the warm water solenoid for continuity across the terminals and record the reading

(NOTE: The continuity reading should indicate a resistance reading of around 500-2000 ohms on the ohmmeter scale.)

6. Conduct an electrical test on the solenoids with the following procedure:
 - a. You will need the Robinalre 1246 motor test cord and a paper clip
 - b. Connect the motor test cord to the cold water solenoid (use the black and white leads on the test cord)
 - c. Turn the test cord to RUN and listen for a humming sound in the solenoid
 - d. Place the paper clip near the solenoid opening and note whether or not the solenoid pulls the paper clip inside the solenoid (Figure 9)

FIGURE 9



- e. If the solenoid attracts the paper clip, it is probably good, and if there is no magnetic attraction present, the solenoid is probably defective

JOB SHEET #2

7. Repeat the electrical test for the hot water solenoid and for the warm water solenoid, if there is one
 - Have your instructor check your work
 8. Dismantle the mixing valve
 9. Inspect the mixing valve diaphragm and other mixing valve parts and look for foreign particles and wear
 - a. If foreign particles are present, remove them
 - b. If valve parts evidence extensive wear, replace the mixing valve
 10. Replace the mixing valve if the valve itself is worn or if any of the solenoids are defective because it is more cost-effective to replace than to repair
 11. Put the valve back together and reinstall it or install a new mixing valve
 - Have your instructor check your work
 12. Note on your repair log the length of time it took for you to accomplish Routine #3
- E. Routine #4 -- Troubleshooting the water pump
1. Sign on your troubleshooting log
 2. Assemble special tools required for the routine:
 - a. An appliance flipper to get the washer over on its side or front as needed (Figure 10)

FIGURE 10

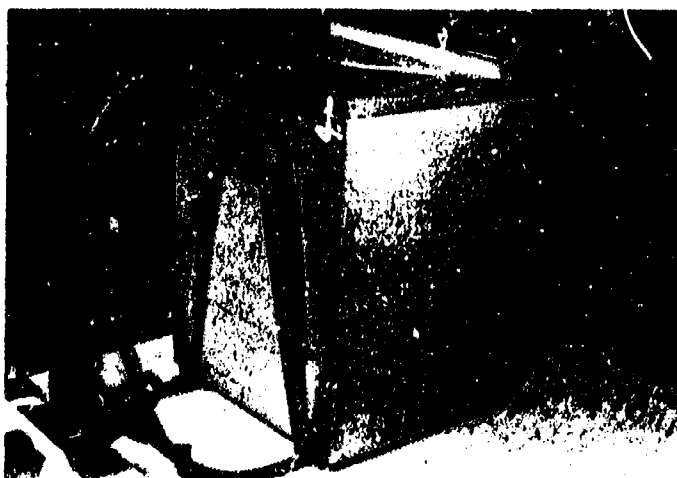

JOB SHEET #2

3. Insert the flipper under the front of the machine and turn the machine over on its front so that the underside of the washer is readily accessible
4. Place drop cloth down and arrange tool box to one side
5. Use hose-clamp pliers to remove the hoses from the water pump and note their locations so you'll get them back in the right place
6. Loosen motor mounting bolts enough to provide enough slack in the drive belt that the belt can be removed
7. Remove the two water pump retaining bolts
8. Slip the pump away from the bolt and out of the washer
9. Clean the pump as required and then inspect it for obstructions, and make sure it turns freely
10. Dismantle the pump and clean the impeller if it is a two-piece pump connected with retaining clips or screws (Figure 11)

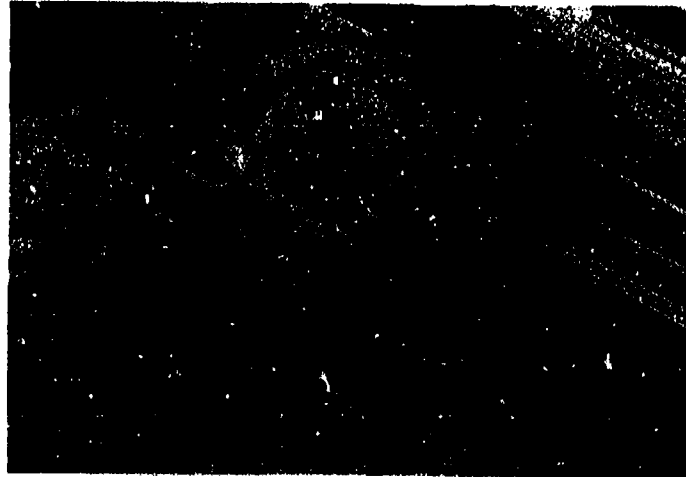
FIGURE 11

11. Put pump back together

JOB SHEET #2

12. Shift the directional lever on the pump to make sure the direction control baffle inside the pump moves back and forth (Figure 12)

FIGURE 12

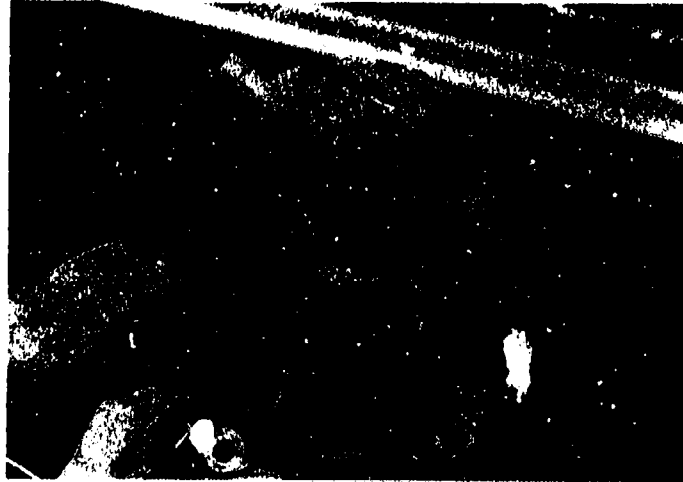

13. Reinstall the old pump if it's okay, or install a replacement pump if required
- Have your instructor check your work
14. Note on your repair log the length of time it took for you to accomplish Routine #4
- F. Routine #5 — Troubleshooting the motor
1. Sign on your troubleshooting log
 2. Disconnect all electrical conductors to the motor and note where they go and their identifying colors and markings
 - a. Single-speed motors should have two conductors, one blue and one white
 - b. Two-speed motors should have three conductors, one blue, one orange, and one white
 - c. Three-speed motors should have four conductors, one blue, one orange, one gray/pink, and one white
 3. Remove the two motor retaining bolts
 4. Remove the motor and place it on the drop cloth

JOB SHEET #2

5. Conduct a continuity test on the motor with the following procedure:
- a. Sketch two pictorial diagrams of the motor switch terminals and their identifying markings (Figure 13)

FIGURE 13

- b. Make a continuity check on the motor control terminals
- c. Write meter readings on the first diagram, and this will probably be a reading of less than two ohms

(NOTE: If the motor is equipped with a capacitor, discharge the capacitor with a 2,000 ohm 2-watt resistor and short capacitor leads together.)
- d. Record the resistance across the terminals
- e. Using a pencil or some other wooden object, depress the centrifugal mechanism
- f. Record the resistance across the terminal with the centrifugal mechanism depressed (Figure 14)

FIGURE 14

JOB SHEET #2

6. Evaluate your continuity check according to the following:
- a. On a single speed (two terminal) motor, two things should happen:
 - 1) The first resistance reading should be a relatively low reading, approximately 2 ohms or less
 - 2) The second reading with the centrifugal mechanism depressed should increase slightly to about 2 ohms
 - b. If the first reading was a resistance of 2 ohms or more, the starting switch is defective, and depending on the application, replace the switch or the entire motor

(NOTE: On the throw-away motor, the starting switch can be replaced, and on the conventional motor it is not cost-effective to attempt internal motor repair.)
 - c. If a resistance reading of zero ohms, infinite continuity, or a high resistance greater than 3 ohms comes up in your continuity check, either the starting switch or the motor itself is defective and should be repaired or replaced as previously indicated

(NOTE: For directions on continuity checks for two and three-speed motors, check the manufacturer's service material.)
7. Conduct continuity check and evaluations for two-speed and three-speed motors with the same general procedure outlined for single-speed motors
8. Test run the motor using a test cord with the following procedure:
- a. Connect the test cord to the motor

(NOTE: This procedure is for a single-speed motor only; check service manual for two- or three-speed motor procedures.)
 - b. Use the black and white leads from the test cord and connect the black lead to the blue motor terminal and the white lead to the white motor terminal

JOB SHEET #2

- c. Turn motor test switch to RUN (Figure 15)

FIGURE 15



- d. If the motor starts and runs, it's okay
- e. If the motor does not start, or starts and runs erratically, the motor is defective and should be replaced

(NOTE: A current or amperage check should be made on the motor, but it can only be made with the motor under a real or simulated load.)

9. Reinstall the motor and adjust the drive belt, but do not reconnect motor conductors yet
10. Turn the appliance flipper so that the washer is upright again
11. Connect the motor test cord to the motor as previously outlined
12. Connect a clamparound ammeter to the white motor test lead
13. Set the ammeter on high scale and turn test cord to RUN
14. Check amperage reading and compare your reading with the amperage specified on the motor identification plate

(NOTE: The amount of current actually drawn by the motor under load should never be equal to or more than the full load amperage listed on the motor identification plate because the FLA reflects maximum capability and a washer motor should never function to its maximum potential.)

- Have your instructor check your amperage reading
15. Replace the motor if amperage check indicates it is bad, but otherwise, make conductor connections and replace the old motor if all checks indicate it is probably okay

JOB SHEET #2

16. Note on your repair log the length of time it took for you to accomplish Routine #5

G. Routine #6 — Troubleshooting the transmission/spin tube assembly

1. Sign on your troubleshooting log
2. Raise the top according to directions in the service manual (Figure 16)

(NOTE: On some models this may mean removing the recirculating hose first, but other models simply raise up; in all cases, it's a good idea to tape the lid down before moving the top.)

FIGURE 16

3. Remove the snubber by lifting up on the snubber retaining spring and lifting the snubber out of its spring support (Figure 17)

FIGURE 17

JOB SHEET #2

4. Remove the snubber retaining spring by removing the retaining nut and pulling the spring toward the front of the washer while pushing down on the back of the spring
5. Remove the water Inlet from the tub ring (Figure 18)

(NOTE: On some models the Inlet snaps in and out, and on other models it is held by a retaining screw that has to be removed.)

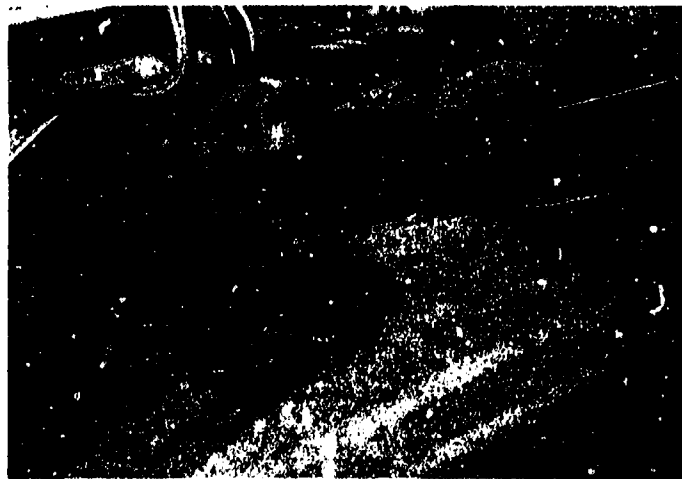
FIGURE 18

6. Remove the tub ring and gasket with the following procedure (Figure 19)
 - a. Remove the clips or fasteners that hold the tub ring and be sure to note colors and sizes of clips by location
 - b. Lift up on the tub ring to remove it
 - c. Remove the tub ring gasket

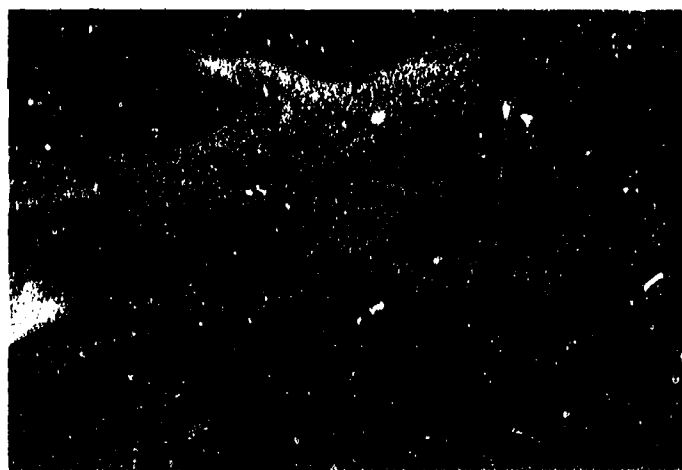
FIGURE 19

JOB SHEET #2

7. Remove the agitator

(NOTE: Check the service manual for the procedure because agitator removal varies significantly from model to model.)

8. Remove the agitator drive block (if there is one) with the following procedure:

- a. Insert the forks of a tie rod separator tool between the agitator drive block and the spin drive block
- b. Drive the tool forward with a ball peen hammer and pry upward to remove the agitator drive block

(NOTE: If there is a stud that still retains the agitator drive block, it has to be removed before the block can be removed.)

9. Remove the spanner lock nut with the following procedure:

- a. Place the spanner wrench over the nut so that it catches the grooves in the nut
- b. Tap the spanner wrench with a ball peen hammer in a counterclockwise direction to loosen it (Figure 20)

FIGURE 20



JOB SHEET #2

- c. Remove the spanner nut
10. Remove the inner tub by lifting it up and out (Figure 21)

FIGURE 21

11. Remove the basket drive block (Figure 22)

(NOTE: The basket drive block may have come out with the basket, and if so, just take the wooden end of your hammer and push the drive block out.)

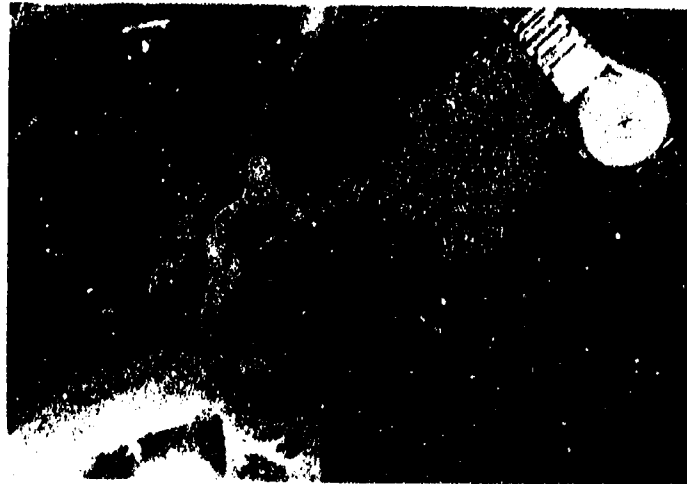
FIGURE 22

12. Insert the flipper under the front of the machine and flip it over once again
13. Remove all hoses from the water pump and get them out of the way
14. Remove the water pump as previously outlined

JOB SHEET #2

15. Remove all retaining or support braces (there may be as many as three) from the transmission and spin tube assembly/basket drive assembly (Figure 23)

FIGURE 23

16. Disconnect all electrical conductors from the spin/agitate solenoids mounted on the transmission and be sure to note the identifying colors and locations
17. Remove the three transmission mounting bolts (Figure 24)

(NOTE: The transmission bolt mounted on the underside has a spacer between the transmission and the frame, so be sure to keep track of the spacer for proper reinstallation.)

FIGURE 24

18. Remove the belt from motor drive pulley

JOB SHEET #2

19. Remove transmission and spin tube assembly by pulling on the spin tube assembly, not the transmission, so that the two will come out together (Figure 25)

(NOTE: Pulling on the spin tube helps prevent damage to the retainer and spring at the top of the spin tube assembly, but do not lift the transmission from the agitator shaft because it will dislodge the thrust washer under the shaft.)

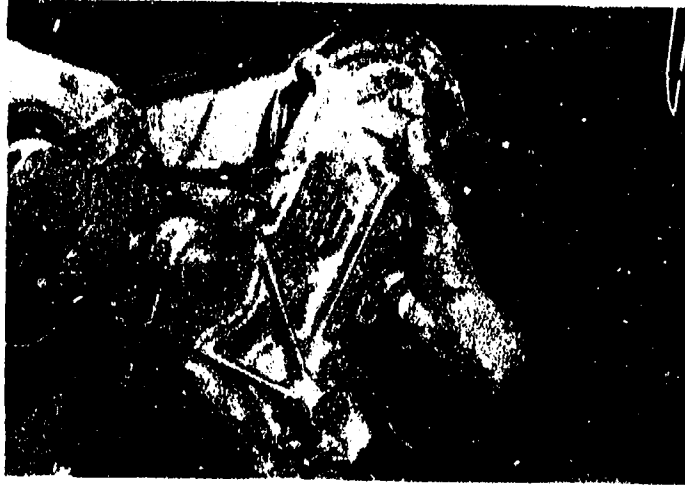
FIGURE 25

20. Remove spin tube assembly from transmission with the following procedure:
- Remove the spring and retaining clip that hold the top of the spin tube assembly
 - Lift the spin tube assembly up and off and inspect it (Figure 26)

FIGURE 26

JOB SHEET #2

- c. Look for worn areas on the brake and on the clutch pad, and also broken or missing springs
- d. Check your service manual to see what components in the spin tube assembly can be replaced in the field

(NOTE: Generally, if any components in the spin tube assembly are damaged, it is more cost-effective to replace the entire spin tube assembly.)

- 21. Remove the thrust bearing (called a T-bearing) by slipping it off the agitator shaft
(CAUTION: Some models have ball bearings, and they are easy to lose if you're not careful.)
- 22. Inspect the T-bearing for frayed or broken edges, and if it is a plastic bearing, it may have swelled from excessive wear
- 23. Replace the T-bearing as required
- 24. Check the agitate/spin solenoids with the following procedure:
 - a. Remove the solenoid mounting screw, and lift the solenoid out (Figure 27)

FIGURE 27



- b. Conduct a continuity test on the agitate solenoid and record the resistance reading
- c. Conduct a continuity test on the spin solenoid and record the resistance reading

(NOTE: Refer to the procedure outlined for checking the mixer valve solenoids if you have questions about this procedure.)

- d. The resistance reading should be 200-700 ohms in each solenoid to indicate that the solenoid is working okay

JOB SHEET #2

25. Conduct an electrical test on the agitate/spin solenoids with the same procedure outlined for the electrical tests for the mixer valve outlined in Routine #3
 26. Replace the agitate/spin solenoids if they are defective, or reinstall them if they appear to be okay
 27. Inspect the transmission with the following procedure:
 - a. Check the spin cam bar to make sure it is not warped or that it has damaged edges
 - b. Check the agitator cam bar to make sure it is not warped or that it has damaged edges
 - c. Check the agitate and spin drive plungers to make sure the hardened pin is in good shape and that the plunger itself has no rough edges

(NOTE: Work the plungers up and down so you can make a good evaluation.)
 - d. Check the operation of the transmission by manually shifting it from agitate to spin and rotating the drive pulley
 - e. If no damage or wear is noted, reassemble the transmission

(NOTE: Should there be evidence that the transmission requires internal repair, check your service manual for procedure, and continue with transmission repair or replace the transmission as directed by your instructor.)
 28. Replace the transmission and spin tube assembly by reversing the disassembly procedure

(NOTE: Be sure to replace solenoid wiring through the hole in the control magnet assembly.)
- Have your instructor check your work
29. Reinstall all hoses
 30. Make all necessary electrical and water connections
 31. Level the machine
 32. Plug washer in and run it through a normal cycle to check it
 - a. if the washer will not pull a fairly heavy load, go on to Routine #7 and adjust the clutch
 - b. If you can keep the agitator from moving back and forth by holding it with your hand, that means the clutch needs adjustment and you should go on to Routine #7

JOB SHEET #2

33. Note on your repair log the length of time it took you to complete Routine #6

Have your instructor check your work

H. Routine #7 -- Adjusting the clutch

1. Sign on your troubleshooting log
2. Make tests as outlined in Routine #6 to confirm that the clutch needs adjusting
3. Position yourself so you can reach the adjustment nut at the top of the basket clutch shaft (Figure 28)

FIGURE 28



4. Put a $\frac{3}{4}$ ' open-end wrench on the nut and move the adjustment nut according to the following:
 - a. If the agitator has no torque, run the adjustment nut down about $\frac{1}{8}$ th of a turn
 - b. If the agitator has too much torque, run the adjustment nut up about $\frac{1}{8}$ th of a turn
5. Place the machine level and run a test load to check for proper torque and good agitation
6. Drain the washer, unplug it from its power source, and make further adjustments as required

Have your instructor check your work

JOB SHEET #2

7. Sign off your troubleshooting log and be sure to note any special problems you've had with any of the routines in this job sheet
8. Clean up area and return tools and equipment to proper storage

350

AUTOMATIC WASHERS UNIT VII

JOB SHEET #2

REPAIR LOG

	Date	Time On	Time Off
Routine #1 — Troubleshooting the Control Panel			
Routine #2 — Troubleshooting the Water Level Switch			
Routine #3 — Troubleshooting the Mixing Valve			
Routine #4 — Troubleshooting the Water Pump			
Routine #5 — Troubleshooting the Motor			
Routine #6 — Troubleshooting the Transmission/ Spin Tube Assembly			
Routine #7 — Adjusting the Clutch			

Your name: _____ Date _____

Note below any special problems you encountered in any of your troubleshooting routines:

AUTOMATIC WASHERS UNIT VII

JOB SHEET #3 — TROUBLESHOOT A GE/HOTPOINT AUTOMATIC WASHER FOR TYPICAL MALFUNCTIONS

A. Tools and materials

1. Washer as selected by Instructor
2. Appropriate service information
3. Basic hand tools
4. Motor test cord
5. Drop cord/inspection light
6. Drop cloth
7. VOM
8. Repair log
9. Pencil and paper
10. Safety glasses

B. Routine #1 — Troubleshooting a washer that will not pump out

1. Sign on your troubleshooting log and put on safety glasses
2. Verify the complaint by attempting to run the washer through a normal cycle
 - a. If the washer goes through a complete cycle but will not pull a load, or if agitate action is sluggish, the timer is probably okay and the trouble is probably in the brake and clutch assembly
 - b. If the timer will not advance, or if other functions won't work automatically, the timer or part of the timer are bad and will have to be repaired

(NOTE: A distinctive feature of the GE/Hotpoint washer is that the timer does not have to be replaced as a unit; it can be repaired.)
 - c. If the complaint indicates problems with the clutch and brake assembly, continue with Routine #1, and if it is a timer problem, go on to Routine #2
3. Drain the washer and unplug it from its power source

JOB SHEET #3

4. Strap the washer to an appliance flipper and turn it over on its face or turn the washer over onto a blanket or comforter
5. Disconnect the web coupling between the pump and the clutch drive assembly, and be sure to save the clamp (Figure 1)

FIGURE 1

6. Mark the leads to the motor terminals so you'll know how to put them back, and then remove the leads to the motor

(NOTE: Some units will have plug that is easy to unplug.)

7. Remove the motor and clutch/brake assembly as a unit, and place it on a workbench
8. Use a ball peen hammer and a punch to remove the dowel pin at the bottom of the web coupling (Figure 2)

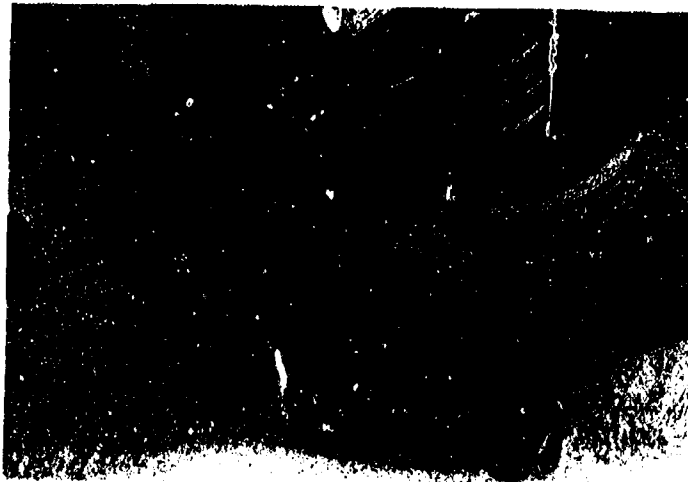
FIGURE 2

JOB SHEET #3

9. Put nails or pieces or wire through the small holes of the slip shoes where the shoes extend through the outer drum assembly (Figure 3)

FIGURE 3

10. Remove the outer drum assembly
11. Inspect the primary shoes and the inner lock-in and outer lock-in shoes for glazing or excessive wear, and continue with disassembly as required to remove worn brake shoes
12. Remove the U-bolt and plate clamp from the shaft extension assembly (Figure 4)

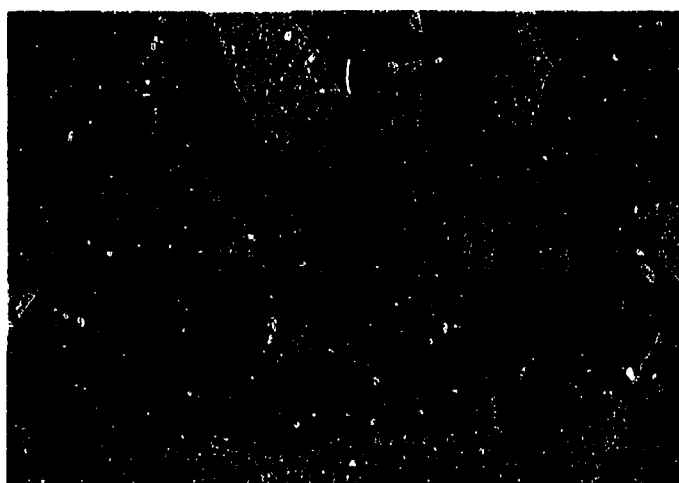
FIGURE 4

13. Remove the washer, clutch leaf spring, and the primary shoe assembly, and be sure to keep everything in order so you can reassemble everything properly

JOB SHEET #3

14. Remove the shaft extension assembly from the motor shaft; this may require using some spray lubricant and working the assembly back and forth, or even using a small pry bar (Figure 5)

FIGURE 5

15. Remove the outer and inner lock-in shoes, and be sure to keep all washers and springs in order (Figure 6)

FIGURE 6

16. Replace the outer and inner lock-in shoes as required, and be sure to get all springs and washers in their proper places
17. Replace the shaft extension assembly and secure the U-bolt and plate clamp in place on the motor shaft
18. Replace the primary shoes as required, and be sure to get all washers and springs back in their correct places

JOB SHEET #3

19. Inspect the inner surfaces of the slip shoes for excessive wear and glazing, and replace as required
 20. Replace the clutch leaf spring and washer over the primary shoe assembly
 21. Replace the outer drum assembly
 22. Replace the retaining rings and bearings in proper order
 23. Replace the lower drive plate and drive the dowel pin back into place with a punch and a ball peen hammer
 - Have your instructor check your work
 24. Fit the motor and clutch/brake assembly back into place, and secure the motor loosely to its mountings
 25. Attach the drive belt by moving the motor out until the belt has a deflection equal to the width of the belt when a moderate amount of pressure is applied, and then tighten the motor in place
 26. Reattach the web coupling to the lower drive with the clamp that was previously removed
 27. Place washer upright and check all hoses
 28. Plug washer into properly grounded power supply
 29. Run the washer through a complete cycle and check for proper operation
 - Have your instructor check your work
- C. Routine #2 — Troubleshooting the timer
1. Sign on your troubleshooting log
 2. Unplug the washer from its power source

JOB SHEET #3

3. Remove the screws on each end of the console and turn the console over onto the lid so you can conveniently get to the timer and to the service information stored inside the console (Figure 7)

FIGURE 7

4. Start your troubleshooting based on the complaint that the washer will not fill, and since this involves checking the timer cams that control the fill functions, you will have to remove the timer
 - a. If there is a timer schematic attached to the back of the console panel, look it over to make sure you understand how to replace all leads or plugs before you remove them
 - b. If there is no schematic attached, sketch the wiring harness, and label the color codes for every terminal (Figure 8)

FIGURE 8

JOB SHEET #3

5. Remove the four Phillips screws that hold the top half of the timer in place, but hold the timer in place with your other hand as you take the screws out
6. Remove the top half of the timer, making sure that any springs or small gears that are part of the assembly
7. Make sure the metal inserts in the cam follower stay in place, and if the dowel-like inserts should come out of the cam follower, check the service information for proper replacement
8. Take the top half of the timer to a workbench, turn it over carefully, and set it down in a clean work space
9. Inspect all contacts on the timer switches for evidence of discoloration which indicates burned contacts, or for spots where contacts obviously burned (Figure 9)

FIGURE 9



10. Replace switch assemblies as required according to the following:
 - a. The switch assembly with 2 terminals is part #WH12X94
 - b. The switch assembly with 3 terminals is part #WH12X195, or it may be the 3 terminal switch used with the long silver plunger, and that is part #WH12X395
 - c. The switch assembly with 4 terminals is part #WH12X410
 - d. The switch assembly with 5 terminals is part #WH12X97

(NOTE: If you have any doubts about which switch to use, check the service information and the inserts in the cam follower.)

JOB SHEET #3

11. Use a $\frac{1}{4}$ " nut driver to remove the old switches and to tighten the new switches in place, but don't overtighten the studs or you will break the plastic housing
 12. Double-check the inserts in the cam follower to make sure they are in the proper places, and then reassemble the timer
 13. Replace the timer in the console, and put the four Phillips screws back in place
 14. Put all the leads back in place on the proper timer switch terminals
 - Have your instructor check your work
 15. Put the console back in place and secure it
 16. Plug the washer into a properly grounded receptacle and run it through a complete cycle
 - a. If the washer goes through the cycle properly, the new switch or switches have corrected the problem
 - b. If the washer does not fill properly, go on to the next routine for checking the water pressure switch
 - Have your instructor check your work
- D. Routine #3 — Checking the water pressure switch
1. Sign on your troubleshooting log
 2. Unplug the washer from its power source
 3. Remove the screws that hold the console in place, and turn the console over onto the washer lid
 4. Disconnect the three leads to the pressure switch (Figure 10)

FIGURE 10



JOB SHEET #3

5. Set your VOM to measure ohms on the Rx1 scale
6. Remove the air hose from the pressure switch and visually inspect it to make sure it isn't damaged
7. Find another piece of hose the same size as the pressure switch hose and install it onto the pressure switch with one end clear so you can blow through it
8. Set your VOM to measure ohms on the Rx1 scale
9. Place one VOM lead on the violet terminal and the other VOM lead on the purple or red terminal
10. Verify that there is a full scale deflection on the VOM, which will indicate little or no resistance
11. Leave the first lead on the violet terminal, remove the second lead from the purple or red terminal, and place it on the tan terminal
12. Verify that there is no reading on the VOM
13. Blow into the tube, listen for a clicking sound, and verify a full scale deflection on the VOM to verify that the pressure switch is okay (Figure 11)

FIGURE 11



- Have your instructor check your work
14. Inspect all wires and terminals associated with the pressure switch, and repair or replace as needed
- Have your instructor check your work

JOB SHEET #3

15. Replace the leads to the pressure switch, the pressure switch hose, and then replace the console
16. Plug the washer into a grounded receptacle and run it through a complete cycle
 - a. If the washer fills properly, you've solved the problem
 - b. If the washer still has fill problems, go on to the next routine

Have your instructor check your work

E. Routine #4 — Checking the water fill valves

1. Sign on your troubleshooting log
2. Unplug the washer from its power source
3. Turn off the hot and cold water supplies and remove the hoses from the washer
4. Remove the mounting screws that hold the water valve mounting bracket on the back of the washer (Figure 12)

FIGURE 12

5. Pull the water valve solenoids out so you can conveniently check them
6. Make a sketch of the leads to the solenoids so you'll get them back in the proper places, and then remove the leads
7. Set your VOM to measure ohms on the R x 100 scale

JOB SHEET #3

8. Place the VOM leads on the two terminals of one of the solenoids (Figure 13)

FIGURE 13



9. Look for a reading of approximately 52 Ω ohms
- a. If the reading is too high, it means the solenoid should be replaced
 - b. If there is no reading, it means the solenoid has an opening and should be replaced
10. Repeat the procedure for the other solenoid
11. Replace solenoids as required
- Have your instructor check your work
12. Secure the solenoid support bracket
13. Replace the hot and cold water hoses
14. Turn the hot and cold water supplies on
15. Plug the washer into a grounded receptacle and run it through a complete cycle
- Have your instructor check your work
- F. Routine #5 — Checking the water pump
1. Sign on your troubleshooting log
- (NOTE: Failure to pump out water is a common washer complaint, and it almost always means trouble with the water pump.)
2. Unplug the washer from its power source and turn off and disconnect the hot and cold water supplies
 3. Secure the washer to an appliance flipper and turn it over on its front side

JOB SHEET #3

4. Use snap-ring pliers to remove the clamps from the hoses on the pump, and then remove the hoses
5. Inspect the two pump openings to make sure there are no small or delicate pieces of clothing clogging the openings

(NOTE: Since GE/Hotpoint washers have no holes in the tub except at the top of the rim, the washers have to spin water out over the top of the tub, and small or delicate articles of clothing sometimes get past the clothes guard and are drawn into the water pump.)

6. Remove the top half of the web coupling to free the water pump
7. Remove the three screws holding the pump to the tub bracket (Figure 14)

FIGURE 14

8. Remove the pump, take it to a workbench, and remove the six screws that hold the pump together (Figure 15)

FIGURE 15

JOB SHEET #3

9. Scrape off detergent build-up inside the pump, and be careful not to damage the gasket (Figure 16)

FIGURE 16

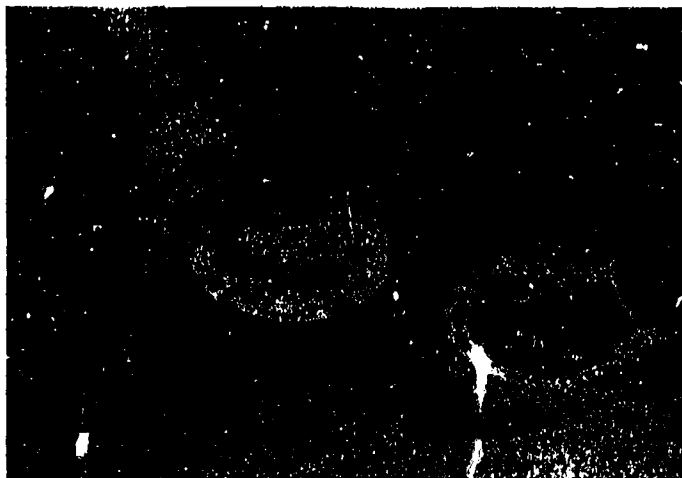

10. Inspect the impeller and pump valve for worn or broken vanes
11. Replace broken or worn pump parts as they are available
- (NOTE: Pump kits are available, but broken or worn parts usually mean the entire pump assembly has to be replaced.)
12. Reassemble the pump
13. Remount the pump on the tub bracket and replace the pump hoses
14. Reconnect the web coupling
- Have your instructor check your work
15. Set the washer upright, reconnect the hot and cold water hoses, and plug the washer into a grounded receptacle
16. Run the washer through a complete cycle to verify that the pump is working properly
- Have your instructor check your work
17. Sign off your troubleshooting log, and be sure to note any special problems you had with any of the routines in this job sheet
18. Clean up area and return tools and materials to proper storage

AUTOMATIC WASHERS UNIT VII

JOB SHEET #3

REPAIR LOG

	Date	Time On	Time Off
Routine #1 — Troubleshooting a Washer That Will Not Pump Out			
Routine #2 — Troubleshooting the Timer			
Routine #3 — Check the Water Pressure Switch			
Routine #4 — Checking the Water Fill Valves			
Routine #5 — Checking the Water Pump			

Your name _____ Date _____

Note below any special problems you encountered in any of your troubleshooting routines:

AUTOMATIC WASHERS UNIT VII

NAME _____

TEST

1. Match the terms on the right with their correct definitions.

- | | | |
|---------|--|---------------------|
| _____a. | An appliance designed to clean dirty clothes in a wash, rinse, and spin-dry sequence controlled by a timer | 1. Centrifugal |
| _____b. | The force that impels something outward from a rotating center | 2. Cycle |
| _____c. | One complete performance of a series of events that completes a procedure | 3. Reciprocating |
| _____d. | The highly-polished look of hydrocarbon build-up resulting from heat produced by friction between brake shoes and metal surfaces | 4. Automatic washer |
| _____e. | Moving back and forth in an alternating motion | 5. Glazing |

2. Match major components with their functions in an automatic washer.

- | | | |
|---------|--|--------------------------------------|
| _____a. | An electromechanical device referred to as the "brain" of the automatic washer because it controls all switch operations for all functions except start-up | 1. Water pump |
| _____b. | Drives or turns the transmission or power train to provide power for agitation and spin motion | 2. Transmission |
| _____c. | Converts motor power into directional control of agitate and spin functions including reciprocating back and forth motion for agitation | 3. Motor |
| _____d. | Pumps water from the tub and may also recirculate the water in the tub by pulling it from the bottom of the tub and dumping it back in at the top | 4. Water pressure/water level switch |
| _____e. | Controls the water level in the tub | 5. Timer |

TEST

3. Arrange in order the steps in a typical automatic washer cycle by placing the correct sequence number in the appropriate blank.

- _____a. Second fill
- _____b. Rinse agitation
- _____c. Final pumpout and spin
- _____d. First fill
- _____e. Wash agitation
- _____f. First pumpout and spin

4. Complete statements concerning fill functions in a normal cycle by inserting the word(s) that best completes each statement.

- a. Machine usually fills _____ during one cycle
- b. The first fill is a _____ fill with hot, warm, or cold water selected manually or predetermined by timer setting
- c. The second fill is a _____ fill with warm or cold water only (no hot water) determined by timer setting
- d. Timer is usually set to automatically direct cold water to the tub during the _____ fill portion of the cycle

5. Complete statements concerning agitation functions in a normal cycle by inserting the word(s) that best completes each statement.

- a. Machine usually agitates _____ during one cycle
- b. Agitation may be accomplished with reciprocating motion or by _____ a drum
- c. The first agitation is a _____ agitation which may vary from 6 to 18 minutes and is usually accomplished with a high-speed motor setting
- d. The second agitation is a _____ agitation which may vary from 2 to 6 minutes and is usually accomplished with a high-speed motor setting
- e. The _____ agitation mixes detergent with water and creates action to dislodge and separate soil from clothes
- f. The _____ agitation separates detergent residue and dislodges separated particles so that they will be removed with pumpout and not settle back onto the clothes

TEST

6. Complete statements concerning pumpout and spin functions in a normal cycle by inserting the word(s) that best completes each statement.

- a. Machine usually pumps out and spins _____ in one cycle
- b. Pumpout is initiated by the _____ and regulated by either the water level or water pressure switch
- c. In most washers, the water pressure switch will not allow the _____ to advance until the water has been pumped out to assure that the first spin will last 2 to 4 minutes
- d. The spin action creates a centrifugal force which literally _____ water from the clothes
- e. The final spin usually lasts at least 4 minutes or longer and is always a high-speed _____ function
- f. On some machines, _____ rinse is an added feature of the spin function so that any residue that collects on the clothes during the spin function will be rinsed off and pumped out

7. Select true statements concerning guidelines for evaluating automatic washer malfunctions by placing an "X" beside each statement that is true.

- _____ a. Identify the washer model number only
- _____ b. Ask the customer to explain what the machine is not doing or what the machine is doing wrong
- _____ c. Take notes as required so you will remember what has been said if the customer should have to leave
- _____ d. Verify the problem with a physical inspection or run the washer in an attempt to duplicate the problem if running the washer is still practical

8. Arrange in order the steps for validating repairs by placing the correct sequence number in the appropriate blank.

- _____ a. Doublecheck for leaks
- _____ b. Check the machine for level
- _____ c. Make sure the washer:
 - 1) Fills properly
 - 2) Agitates effectively
 - 3) Pumps out and spins properly
 - 4) Shuts itself off

TEST

- _____d. Run the washer through one full normal cycle
- _____e. Do not manually advance the timer
9. Complete statements concerning troubleshooting a washer that will not fill with water by inserting the word(s) that best completes each statement.
- a. Check the obvious first:
- 1) Washer may not be properly _____
 - 2) Hoses may be _____
 - 3) Screens in the fill hoses may be _____
- b. Make sure a proper _____ supply is available to the machine
- c. Check for proper _____ at the mixing valve with a VOM
- d. When a mixing valve is energized but still won't admit water, check for _____ in the valve and remove them
- e. Run a continuity check on the _____ switch and replace as required
- f. Check the _____ selection switch
- g. Make sure it is not a _____ problem
- h. Check the _____ switch to make sure it is making proper contact
10. Select true statements concerning troubleshooting a washer for improper water level or water temperature by placing an "X" beside each statement that is true.

(NOTE: For a statement to be true, all parts of the statement must be true.)

- _____a. Check for reversed hot and cold water hoses
- _____b. Check for the quality of the hot water supply
- _____c. Check for a faulty water level switch
- _____d. Check for a faulty thermal element in the mixing valve if it is a thermal type mixing valve
- _____e. Check for a faulty temperature selection switch in the control panel or timer
- _____f. Check for faulty timer

TEST

- _____g. If the washer has a spray rinse in the spin portion of the rinse cycle, and this doesn't work:
- 1) Check for no cold water supply or a kinked cold water hose
 - 2) Check for a clogged Inlet screen
 - 3) Check for a defective cold water solenoid in the mixing valve
 - 4) Check for a defective lid switch
11. Select true statements concerning troubleshooting a washer when water will not shut off by placing an "X" beside each statement that is true.
- _____a. On time-fill washers, the failure of water to shut off may indicate a lid switch malfunction
- _____b. Check the lid switch and replace it if it is defective
- _____c. Check for foreign particles in the timer, and if present, take the timer apart and repair it
- _____d. On pressure-filled models check for a bad transmission
12. Complete statements concerning troubleshooting a washer that leaks water by inserting the word(s) that best completes each statement.
- a. Check for loose or cracked supply _____ and tighten or replace as required
 - b. Check for a loose _____ hose and tighten or replace the clamp as required
 - c. Run the washer through a normal cycle and replace any _____ that is broken or appears to be damaged
 - d. Check for worn or damaged supply hose _____
 - e. Check for leaky gaskets:
 - 1) Around the _____ pump
 - 2) Where the transmission enters the _____ tub
 - 3) _____ between the inner and outer tub
 - 4) Outer tub _____

TEST

- f. Check for cracked housing:
- 1) Outer tub, especially tubs made of _____
 - 2) Water pump _____
 - 3) Mixing valve _____
- g. Replace any component with _____ housing
13. Complete statements concerning troubleshooting when water will not drain from the washer by inserting the word(s) that best completes each statement.
- a. Check for a kinked or clogged _____ hose and correct as required
 - b. Check for a water _____ problem, and readjust the _____ and tighten the _____ drive
 - c. Check for a loose _____ at the water pump and adjust as required
 - d. Check for a faulty transfer or _____ valve and replace as required
 - e. Check for a defective _____ and replace as required
 - f. Check for a faulty _____ and replace as required
14. Select true statements concerning troubleshooting a washer with a motor that will not run by placing an "X" beside each statement that is true.
- _____ a. Make sure there is power to the machine
 - _____ b. Check for a faulty door/lid switch and replace as required
 - _____ c. Check for an overload device or other protective device in the circuit and replace as required
 - _____ d. Check for a faulty timer and replace as required
 - _____ e. Check for a faulty motor and replace as required
15. Complete statements concerning troubleshooting a washer that will not agitate by inserting the word(s) that best completes each statement.
- a. Check for a _____ malfunction and replace as required
 - b. Check _____ for bad contacts and correct or replace as required
 - c. Check for a faulty _____ and repair or replace as required

TEST

- d. Check for broken _____ or other agitation control mechanism
- e. Check for a broken _____ in circuitry and splice, tin, and insulate as required
- f. Check for stripped _____ in the agitator
16. Complete statements concerning troubleshooting a washer that will not spin by inserting the word(s) that best completes each statement.
- a. If the washer will agitate but not spin, the motor is probably _____
- b. Check _____ for defective contacts and replace as required
- c. Check the _____ or _____ switch and replace as required
- d. Check for a faulty _____ and repair or replace as required
- e. Check for broken _____ or other spin control mechanisms
- f. Check for a faulty _____ level switch and replace as required
- g. Check for a broken _____ in circuitry and splice, tin, and insulate as required
17. Select true statements concerning troubleshooting a washer that will not advance or shut off by placing an "X" beside each statement that is true.
- ____a. If the timer will not advance, check the lid switch
- ____b. Check for a defective timer and replace the timer if required or replace the timer motor if that is the problem
- ____c. Replace the timer motor with a motor similar to the one removed
- ____d. Check for a break in the circuitry wiring and splice, tin, and insulate as required
18. Select true statements concerning troubleshooting a washer that leaks oil by placing an "X" beside each statement that is true.
- ____a. If oil leaks on the floor, check for a leak in the gearcase caused by a faulty gasket, damage to the gearcase housing, or a bad transmission seal
- ____b. If oil leaks onto clothes in the tub, check for a faulty gearcase or transmission seal and replace seal or transmission as required

TEST

19. Select true statements concerning troubleshooting a washer that tears clothing by placing an "X" beside each statement that is true.

(NOTE: For a statement to be true, all parts of the statement must be true.)

- ____a. Caution the user to use bleach wisely
- 1) Do not use too much bleach
 - 2) Do not add bleach at the wrong time
 - 3) Add bleach to water after loading clothes in the tub, or dilute bleach with water after putting it in the tub
- ____b. Check for a broken agitator and replace if required because chips and cracks in the agitator can tear clothes
- ____c. Check for a defective inner tub or basket and replace as required

20. Match other washer problems with ways to correct them.

- | | |
|---|--|
| ____a. Adjust belt to clutch or replace clutch if it is faulty | 1. Faulty water level switch |
| ____b. Clean out clogged water pump | 2. Defective pump drive |
| ____c. Tighten as needed or replace the coupling | 3. Washer vibrates excessively |
| ____d. Clean out or replace valve, or replace solenoid as required | 4. Machine spins slowly |
| ____e. Replace timer motor, or replace entire timer as required | 5. Timer will not advance to next cycle |
| ____f. Check for obstructions and free the shaft or replace the timer as required | 6. Water does not recirculate during agitation |
| ____g. Replace the control | 7. Tub vibrates excessively |
| ____h. Reinforce weak floor or move washer, check for level, caution user not to overload or create unbalanced loads, or replace rubber cups on leveling feet | 8. Frozen timer shaft or knob |
| ____i. Check for a damaged snubber and replace as required, or adjust or replace suspension bolts | 9. Defective distribution valve |

TEST

(NOTE: If the following activities have not been completed prior to the test, ask your instructor when they should be completed.)

21. Demonstrate the ability to:
 - a. Install an automatic washer. (Job Sheet #1)
 - b. Troubleshoot a Whirlpool/Kenmore automatic washer for typical malfunctions. (Job Sheet #2)
 - c. Troubleshoot a GE/Hotpoint automatic washer for typical malfunctions. (Job Sheet #3)

AUTOMATIC WASHERS UNIT VII

ANSWERS TO TEST

1.
 - a. 4
 - b. 1
 - c. 2
 - d. 5
 - e. 3

2.
 - a. 5
 - b. 3
 - c. 2
 - d. 1
 - e. 4

3.

a. 4	d. 1
b. 5	e. 2
c. 6	f. 3

4.
 - a. Twice
 - b. Wash
 - c. Rinse
 - d. Rinse

5.
 - a. Twice
 - b. Rotating
 - c. Wash
 - d. Rinse
 - e. Wash
 - f. Rinse

6.
 - a. Twice
 - b. Timer
 - c. Timer
 - d. Throws
 - e. Motor
 - f. Spray

7. b, c, d

8.
 - a. 4
 - b. 5
 - c. 3
 - d. 1
 - e. 2

9.
 - a.
 - 1) Turned on
 - 2) Kinked
 - 3) Clogged

ANSWERS TO TEST

- b. Water
 - Voltage
 - u. Obstructions
 - e. Fill
 - f. Temperature
 - g. Timer
 - h. Lid
10. a, b, c, d, e, f
11. None of the statements are true
12. a. Hoses
- b. Drain
 - c. Hose
 - d. Washers
 - e.
 - 1) Water
 - 2) Outer
 - 3) Seals
 - 4) Gasket
 - f.
 - 1) Plastic
 - 2) Housing
 - 3) Housing
 - g. Cracked
13. a. Drain
- b. Pump, pump, pump
 - c. Belt
 - d. Solenoid
 - e. Water pump
 - f. Timer
14. a, b, c, d, e
15. a. Motor
- b. Timer
 - c. Transmission
 - d. Linkage
 - e. Wire
 - f. Splines
16. a. Okay
- b. Timer
 - c. Door, lid
 - d. Transmission
 - e. Linkage
 - f. Water
 - g. Wire

ANSWERS TO TEST

17. b, d

18. a, b

19. b, c

20.	a.	4	f.	8
	b.	6	g.	1
	c.	2	h.	3
	d.	9	i.	7
	e.	5		

21. Performance skills evaluated according to procedures written in the job sheets

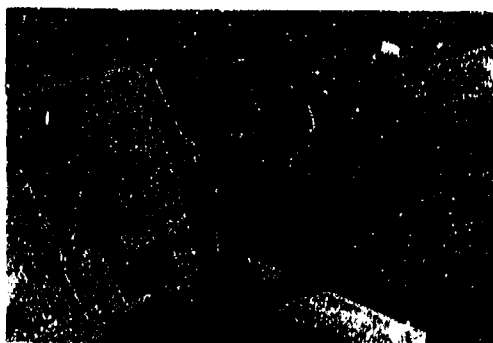

AUTOMATIC DRYERS

UNIT VIII

UNIT OBJECTIVE

After completion of this unit, the student should be able to define the functions of major components in an automatic gas or electric dryer and discuss operating principles and troubleshooting techniques. The student should also be able to properly install an automatic dryer and troubleshoot various brand name dryers for typical problems. These competencies will be evidenced by correctly performing the procedures outlined in the job sheets and by scoring 85 percent on the unit test.

SPECIFIC OBJECTIVES

After completion of this unit, the student will be able to:

1. Match terms related to automatic dryers with their correct definitions.
2. Match major components with their functions in an automatic dryer.
3. Arrange in order the steps in automatic dryer operation.
4. Complete statements concerning thermostats and their functions in a dryer.
5. Complete statements concerning troubleshooting a dryer that will not run.
6. Select true statements concerning troubleshooting a dryer that will run but not heat.
7. Complete statements concerning troubleshooting a dryer when the motor runs but the drum will not rotate.
8. Complete statements concerning troubleshooting a dryer that runs but will not shut off.
9. Select true statements concerning troubleshooting a dryer that runs and heats but won't dry clothes.
10. Match other dryer problems with their solutions.
11. Complete statements concerning troubleshooting gas valves and igniters on gas dryers.
12. Match special gas dryer problems with their solutions.

OBJECTIVE SHEET

13. Demonstrate the ability to:
 - a. Install an automatic dryer. (Job Sheet #1)
 - b. Troubleshoot a Whirlpool/Kenmore automatic dryer for typical malfunctions. (Job Sheet #2)
 - c. Troubleshoot a GE/Hotpoint automatic dryer for typical malfunctions. (Job Sheet #3)

AUTOMATIC DRYERS UNIT VIII

SUGGESTED ACTIVITIES

- A. Provide students with objective sheet.
- B. Provide students with information sheet.
- C. Provide students with job sheets.
- D. Discuss unit and specific objectives.
- E. Discuss information sheet.
- F. Discuss and demonstrate the procedures in the job sheets.
- G. Have available operating and high-limit thermostats for students to examine and test.
- H. Invite a service technician to talk to the class about troubleshooting and repairing gas dryers and the importance of safety when working with a gas dryer.
- I. Demonstrate to the class how to install a restring kit properly so that hot spots will be eliminated.
- J. Give test.

CONTENTS OF THIS UNIT

- A. Objective sheet
- B. Information sheet
- C. Job sheets
 - 1. Job Sheet #1 — Install an Automatic Dryer
 - 2. Job Sheet #2 — Troubleshoot a Whirlpool/Kenmore Automatic Dryer for Typical Malfunctions
 - 3. Job Sheet #3 — Troubleshoot a GE/Hotpoint Automatic Dryer for Typical Malfunctions
- D. Test
- E. Answers to test

REFERENCES USED IN DEVELOPING THIS UNIT

- A. *Do-it-Yourself Repair Manual for Your Whirlpool Gas/Electric Dryer*. Benton Harbor, MI 49022: Whirlpool Corporation, 1983.
- B. *Repair-Master of Norge Gas & Electric Dryers*, Santa Monica, CA 90404: Master Publications, Inc., 1980.
- C. *Repair-Master for Hamilton Gas & Electric Dryers*. Santa Monica, CA 90404: Master Publications, Inc., 1980.
- D. *Repair-Master for General Electric Gas & Electric Dryers*. Santa Monica, CA 90404: Master Publications, Inc., 1980.

AUTOMATIC DRYERS UNIT VIII

INFORMATION SHEET

I. Terms and definitions

- A. **Automatic Dryer** — An appliance designed to dry wet clothes in a heat, air flow sequence in a drum that tumbles clothes as it rotates under control of a timer
- B. **Centrifugal** — The force that impels something outward from a rotating center
- C. **Cycle** — One complete series of events that completes a procedure
- D. **Pilot burner** — A continuous small flame used in gas appliances to ignite the gas burner (also called a pilot light)
- E. **Purging** — Any procedure that cleans or removes obstructions such as removing air from a gas line

II. Major components and their functions in an automatic dryer

- A. **Timer** — The electromechanical brain of an automatic dryer that controls the sequence of functions
- B. **Motor** — Turns the drum, controls the heat circuit, and drives the blower
- C. **Heat source** — An electric dryer uses an electric heating element and a gas dryer uses a gas valve and burner assembly
- D. **Thermostats** — Devices that sense temperature and open or close to energize or de-energize the heat circuit

III. Steps in automatic dryer operation

- A. When the dryer starts, timer contacts energize the drive motor circuits
- B. Through a series of motors or belts, the drive motor rotates the drum and causes clothes inside to tumble
- C. As the drum rotates, air is circulated into the drum to provide proper heat
(NOTE: Some dryers have a fan to provide proper air flow.)
- D. In a normal cycle, after the motor circuits are energized, another set of contacts in the timer energize the dryer heat circuit

INFORMATION SHEET

- E. The drying cycle runs for a selected length of time and is controlled by the drive motor

(NOTE: Having the dryer heat circuit controlled by the drive motor starting switch is a safety feature that insures that air flow and drum rotation should start before the heat circuit is energized, and this prevents overheating on both gas and electric dryers.)

- F. During the last five minutes, the starting switch circuit opens, heat stops and dissipates, and cooler air flows through the clothes as the tumbling action continues until the cycle is complete

(NOTE: Most models refer to this final part of the cycle as "cool down.")

IV. Thermostats and their functions in a dryer

- A. Cycling thermostats in a dryer help maintain a constant heat level inside the drum when clothes are tumbling
- B. The safety or limiting thermostat shuts the dryer heat circuit off when there is evidence the dryer may overheat
- C. Cycling thermostats are mounted in or on the air exhaust duct so they can sense both the temperature and moisture level of the air in the drum
- D. As the temperature in the drum reaches the limits of a cycling thermostat setting, the thermostat de-energizes the heat circuit and will remain open until the air cools sufficiently, and then close to energize the circuit again

(NOTE: This may also complete a circuit to the timer.)

- E. The number of cycling thermostats in a dryer may vary, but many have low heat, medium heat, and high heat thermostats to provide the user with temperatures for a variety of fabrics

V. Troubleshooting a dryer that will not run

- A. Make sure the dryer is plugged into a proper power source, and then check the branch circuit control
- B. Check for loose wires at terminals and run a continuity check on the circuitry to make sure there are not broken wires
- C. Check for a faulty door switch by first making sure the door is properly shut and then running a continuity check on the door switch, and replace as required
- D. Check motor wiring and motor centrifugal switch, and replace motor or switch as required

INFORMATION SHEET

- E. Check the timer and timer circuitry and replace the timer motor or the timer as required

VI. Troubleshooting a dryer that will run but not heat

- A. Check for loose wires on terminals and run a continuity check to make sure there are no broken wires
- B. On an electric dryer, check for a proper 240V power supply
- C. Check for defective thermostats and replace as required
- D. Check for a wrong setting on the heat switch or check the heat switch itself and replace as required

(NOTE: This check applies only to dryer models with temperature selector switches.)

- E. Check timer and timer wiring and replace timer motor or entire timer as required
- F. Check the centrifugal switch, if it is the type of motor that has one, and replace as required
- G. Check for an open heater element and replace heater element as required
- H. On gas model, check the gas supply and make sure the gas supply valve is open
- I. If the gas model has pilot light that is out, purge the line as indicated on the dryer plate directions and relight the pilot
- J. Check for a defective solenoid coil in the gas valve by testing the coil for an open circuit, and replace the solenoid, if required, or the entire gas valve

(NOTE: On some models solenoids can be replaced, and the voltage reading at the valve should be indicated on the dryer plate, but this voltage is usually 120V.)

- K. Check for a defective flame switch
- L. Check for a malfunctioning igniter

VII. Troubleshooting a drying when the motor runs but the drum will not rotate

- A. Check for a slipping or broken belt and adjust or replace as required
- B. Check for a loose pulley and tighten the pulley on the motor shaft

INFORMATION SHEET

- C. Check for foreign objects that may be obstructing drum movement and remove them
- D. Check for a frozen bearing and replace as required
- E. Check for tension and adjust or replace

VIII. Troubleshooting a dryer that runs but will not shut off

- A. Check to see if one side of the branch circuit control is tripped open
 (NOTE: When a circuit overload occurs and the motor side or L₁ side of the line control fuse or breaker trips open, the motor will continue to run through L₂ or in series with the motor heating circuit.)
- B. Check for a defective timer and replace timer motor or timer as required

IX. Troubleshooting a dryer that runs and heats but won't dry clothes

- A. Check for a clogged lint screen and clean or replace as required
- B. Check for a clogged exhaust vent
- C. Check for incorrect heat or timer setting and reset as required
- D. Check for a leaky door seal and if the door seal leaks air, replace it
- E. Check for leaky drum seals and replace as required
- F. Check for a fan or pulley loose on its shaft and tighten as required to restore good air motion in the drum
- G. Check for defective operating thermostats, and if any of the thermostats are cycling too soon or too late, replace them
 (NOTE: Checking thermostats requires using a temperature tester as outlined in Job Sheet #2.)
- H. Find out if clothes were too wet when placed into the drum, and encourage customer to make sure clothes are properly wrung out before placing them in the dryer

(NOTE: Excessively wet clothes indicates the customer may also have a problem with an automatic washer, and a sharp repair technician will suggest that the washer may also need repair.)

X. Other dryer problems and their solutions

- A. Dryer repeatedly blows fuses or trips breaker
 - 1. Check wiring for bare spots that may be touching the frame
 - 2. Check for a sagging drum that may be causing the heater element to touch its housing

INFORMATION SHEET

3. Check heater element for foreign matter
- B. Motor runs when door is open and timer fails to advance
1. Check for a defective door switch and replace as required
 2. Check for a dial that binds because it is too far out from the control panel, and relocate the dial on the timer shaft to eliminate binding
- C. Drum inspection light is burned out — Replace the bulb
- (NOTE: If the drum inspection light is burned out, always replace it because it is something a customer can immediately see and respond to positively.)
- D. Dryer heats with door open or in OFF cycle
1. Check centrifugal switch
 2. Check for a malfunctioning heating element

XI. Troubleshooting gas valves and igniters on gas dryers

- A. Make sure gas is turned off
- B. When a test shows that there is voltage to a gas valve but there is no flame, the problem is in the gas valve circuitry and the entire valve should be replaced
- (NOTE: Some models have replaceable solenoids.)
- C. The igniter is serviceable in the field, but a continuity test should indicate a resistance between 50 to 400 ohms, and if continuity is otherwise, the igniter also should be replaced
- (NOTE: Dryers with manually-lit pilot lights are no longer manufactured.)
- D. When installing a gas dryer or when relighting one that has been repaired, purge the gas line with the following procedure:
1. Turn the gas off
 2. Loosen the connection between the shut-off valve and the burner
 3. Turn gas on until you hear or smell gas at the loose connection, turn the gas off, and tighten the connection
- (NOTE: Purging clears air from the line and saves time relighting the pilot burner.)

INFORMATION SHEET

XII. Special gas dryer problems and their solutions

A. Pilot burner goes out (only models with manually-lit pilots)

1. Check for insufficient gas supply, low gas pressure, a clogged pilot filter, or a closed or partially closed gas supply valve
2. Check for excessive carbon build-up on the thermocouple and clean as required
3. Check for a faulty thermocouple and replace as required
4. Readjust pilot flame until a faint yellow tip appears
5. Check for a faulty ignition or reset valve and replace as required
6. Check for excessive back drafts

B. Pilot burner does not light

1. Check for a closed or partially closed gas supply valve, a clogged pilot filter, or an obstruction in the gas supply line
2. Check setting on pilot switch and reset as instructions direct

C. Pilot burner is okay but main burner does not light

1. Check for insufficient gas supply, a partially closed gas supply valve, or an obstruction in the gas supply line

(NOTE: Gas pressure may be enough to keep the pilot burner lit, but not enough to keep the main burner going.)

2. Check for a defective safety thermostat and replace as required

(NOTE: The service manual should have instruction for testing the thermostat.)

3. Check for incorrect air supply and readjust the air shutter on the gas burner until a bright blue flame appears
4. Check gas valve solenoid and replace solenoid as required or replace gas valve

D. Main burner cycles (comes on and goes off) too fast

1. Check for loose connections at wiring terminals and tighten as required

INFORMATION SHEET

2. Check for a faulty timer and replace timer motor or timer as required
 3. Check for a faulty operating thermostat and replace as required
 4. Check safety thermostat for erratic cycling because of restricted air flow, and clean lint or obstructions from the dryer as required
 5. Check safety thermostat for proper operation and replace as required
- E. Main burner goes out after lighting**
1. Check for low gas pressure, partially closed gas supply valve, or an obstruction in the gas supply line
 2. Check the primary air adjustment and adjust the air shutter until a bright blue flame appears at the main burner
 3. Check for loose connections at terminals and tighten as required

AUTOMATIC DRYERS UNIT VIII

JOB SHEET #1 — INSTALL AN AUTOMATIC DRYER

A. Tools and materials

1. Standard hand tools and tool box
2. VOM
3. Level
4. Safety glasses
5. Dolly

B. Procedure

1. Put on safety glasses
2. Uncrate the dryer carefully
3. Inspect the dryer visually to make sure it has not been damaged in shipment
4. Secure dryer on a proper dolly if it must be moved any distance to the installation site
5. Inspect the location where the dryer will be for:

a. Level, sturdy floor

(NOTE: If the floor is not level and sturdy, point out to the customer that the condition could impair performance and eventually damage the dryer; if the customer insists the floor remain as it is, have the customer sign a release.)

b. Check the electrical supply to make sure:

- 1) There is a 240-volt three-wire single-phase outlet for an electric dryer

(NOTE: The power wiring from the fuse panel (circuit breaker) must be a minimum of #10 AWG, three-wired cable fused with a 30-amp or larger slow-blow or time-delay fuse or breaker.)

- 2) That a three-hole grounded 120V receptacle is available for a gas dryer
- 3) That outlet meets local code requirements

JOB SHEET #1

- 4) That an adequate gas supply is available for the gas dryer and that it is a minimum 1/2" line if it is no more than 20 feet from the gas meter

(NOTE: On runs of pipe longer than 20 feet, 1/2" pipe is not large enough so check with local codes, and in cases where LP gas instead of natural gas is used, 3/8" copper tubing may be used.)

- 5) That the gas supply line has a shut-off valve near the dryer and readily accessible

c. Adequate air supply must be present for both electric and gas dryers

6. Remove ties, blocks, tape, and any other retaining devices installed to protect the dryer during shipment
7. Check inside the dryer for the owner's manual and any other materials that should be saved
8. Set the dryer in place
9. Vent the dryer according to the service manual recommendations
10. Level the dryer side to side and front to back
11. Use the following procedure for an electric dryer:
 - a. Plug the power cord into the 240V receptacle
 - b. Place enough clothes in the drum to test tumbling action
 - c. Operate the dryer through one timed cycle, and take care to note undue heat build-up that may indicate ventilation or venting are improper
12. Use the following procedure for a gas dryer:
 - a. Plug the power cord into the 120V receptacle
 - b. Connect gas supply line, open the shut-off valve, and use a soap and water solution to test for leaks

(CAUTION: Never use a match or other open flame to test for leaks; bubble action from a soap and water solution is safe and dependable.)
 - c. Turn the gas off
 - d. Begin purging by loosening the connection between the shut-off valve and burner assembly
 - e. Turn gas on and let it flow until you hear or smell gas escaping through the loosened connection, and then turn gas off

JOB SHEET #1

- f. Tighten the loose connection and turn the gas back on
- g. Start dryer until ignition occurs

(NOTE: You may have to start the pilotless dryer several times, and there may also be an erratic clicking sound until ignition occurs.)

- h. Place enough clothes in the drum to test tumbling action
 - i. Operate the dryer through one normal cycle, and take care to note undue heat build-up that would indicate ventilation or venting are improper
- 13. Explain operating procedures to the customer, and encourage the customer to follow recommended procedures for dryer care and maintenance
 - 14. Clean up installation area and make sure all crating materials or blocks and ties are removed from the customer's home
 - 15. Remind the customer that your company should be called for any questions about the dryer or its performance
 - 16. Check the work order to make sure you have recorded the serial number and other needed warranty information including the date
 - 17. Compliment the customer on making a wise decision in dryer selection, and leave the customer on a positive note
 - Have your instructor check your work
 - 18. Return tools and materials to proper storage

AUTOMATIC DRYERS UNIT VIII

JOB SHEET #2 — TROUBLESHOOT A WHIRLPOOL/KENMORE AUTOMATIC DRYER FOR TYPICAL MALFUNCTIONS

A. Tools and materials

1. Automatic dryer as selected by Instructor
2. Service manual
3. Standard hand tools
4. Motor test cord
5. Drop cord/Inspection light
6. Temperature tester
7. VOM
8. Wattmeter
9. Drop cloth
10. Safety glasses
11. Pencil and paper
12. Troubleshooting log

B. Routine #1 — Troubleshooting the timer

1. Sign on your troubleshooting log
2. Place drop cloth down, set the tool box on it, and arrange the tools and test equipment you will be using
3. Put your safety glasses on

(NOTE: Safety glasses should be worn during all activities in a repair shop, and even on a residential service call, safety glasses are still recommended.)

4. Transfer all nameplate information on the dryer nameplate to your troubleshooting log (Figure 1)

JOB SHEET #2**FIGURE 1**

5. Unplug the power supply cord to the dryer

(NOTE: In the case of a gas dryer, also shut off main gas supply and disconnect gas line to the dryer.)

6. Disconnect the dryer vent duct and be careful not to damage it
7. Remove the timer knob by pulling it straight off and note the location of the flat section on the knob and on the timer shaft so you can put the timer knob back on properly (Figure 2)

FIGURE 2

8. Remove the console rear panel retaining screws and remove the rear panel
9. Remove the console front panel retaining screws, but do not remove the front panel unless you cannot get the timer out through the open back panel

JOB SHEET #2

10. Disconnect all conductor leads to the timer but be sure to note where they go by sketching a pictorial diagram to help you remember
11. Remove the timer
12. Check the timer motor with the following procedure:
 - a) Remove the motor from the timer
 - b) Make a continuity test of the timer motor and record your reading
 - Have your instructor check your reading
 - c) Conduct an electrical test of the timer motor by making a reference mark on the motor shaft and housing and then using a test cord to run the motor for at least ten minutes
 - Have your instructor check your electrical test
13. Replace the entire timer if the timer motor is bad
14. Remount the timer but do not reconnect the conductors
15. Replace the timer dial and knob
16. Test the timer switch contacts with the following procedure:

(NOTE: Before attempting any checks on the timer, refer to a timer sequence chart, make sure you understand it, and that the wiring diagram is with it.)

 - a) Move the timer dial to any heat cycle, preferably the time dry cycle about midway in the cycle, but not on the first five minutes
 - b) Zero your VOM, touch one probe in terminal Y and the other probe to terminal R on the timer
 - c) The VOM should read zero ohms resistance, and if not, the timer is bad and should be replaced
 - d) Check remaining timer contacts according to timer sequence chart
17. Replace the old timer or install a new timer as test indicates
18. Put all conductors back in place and reinstall the control panel
- Have your instructor check your work
17. Note on your troubleshooting log how long it took you to accomplish Routine #1

JOB SHEET #2**C. Routine #2 — Troubleshooting the door switch**

(NOTE: The door switch functions to stop the dryer when the door is opened, and, depending on the model, it may also turn on the inspection light in the drum.)

1. Sign on your troubleshooting log
2. Check your service manual to see how the door switch is mounted on the dryer model you're working on
3. Raise the top of the dryer and secure it
4. Check your service manual for the correct way to remove the top on the model you're working on (Figure 3)

(NOTE: Generally, on dryers with the lint filter mounted in the top of the lid, there are two mounting screws securing the top to the vent housing, and these mounting screws are located underneath the lint screen cover; remove the screws.)

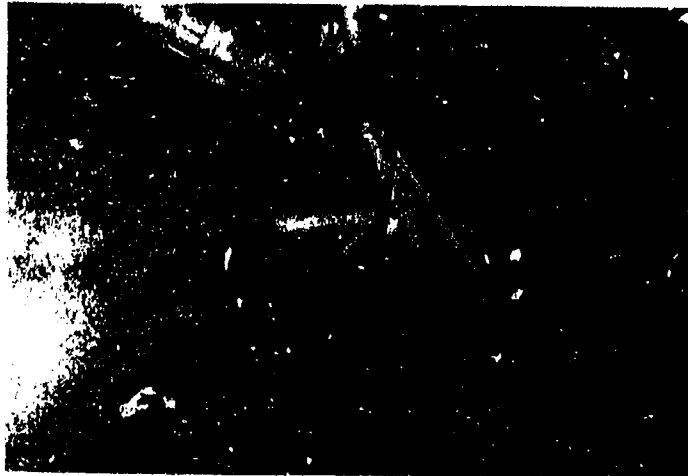
FIGURE 3

5. Use a putty knife and place the blade between the top and the front of the cabinet at a corner about two inches from the edge
6. Push in on the putty knife to release the retaining clip while lifting up on the corner of the top, and then repeat the procedure on the opposite corner (Figure 4)

JOB SHEET #2

FIGURE 4

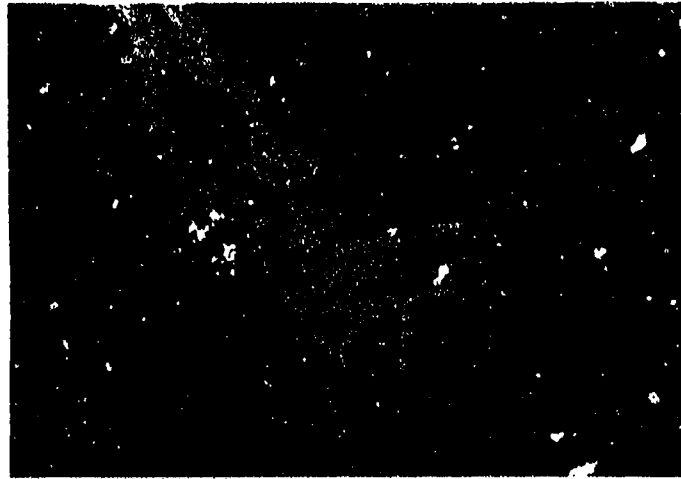

7. Make a pictorial sketch of the conductors to the door switch and label each one according to the terminal markings on the door switch (Figure 5)

FIGURE 5

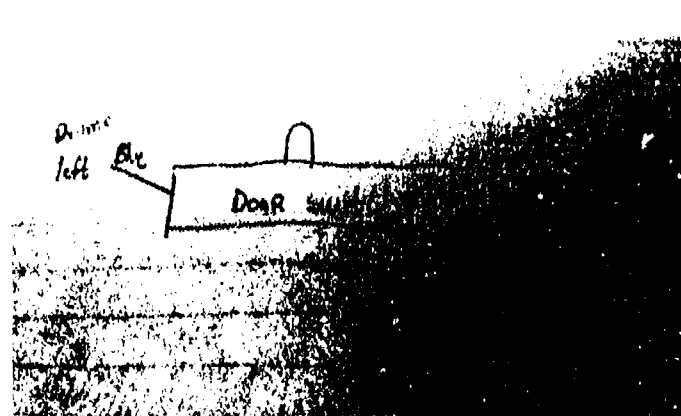

8. Remove all conductors
9. Remove the switch (check the service manual)
10. Make a continuity check of the switch
 - a) With door switch in the closed position, test for continuity across the COM (common) terminal and the NO (normally open) terminal
 - b) VOM should read zero ohms
 - c) If reading is not zero ohms, the door switch is bad and should be replaced

JOB SHEET #2

- d) If door switch is a three-terminal switch (COM, NO, AND NC) with no pressure applied to the switch, this should be the NC of door switch
 - e) Test across terminals COM and NC for a resistance reading of zero ohms
 - f) If reading is not zero ohms, switch is faulty and should be replaced
11. Inspect switch mounting bracket and lever assembly for breaks or signs of wear, and if there is evident wear, replace the bracket (Figure 6)

FIGURE 6

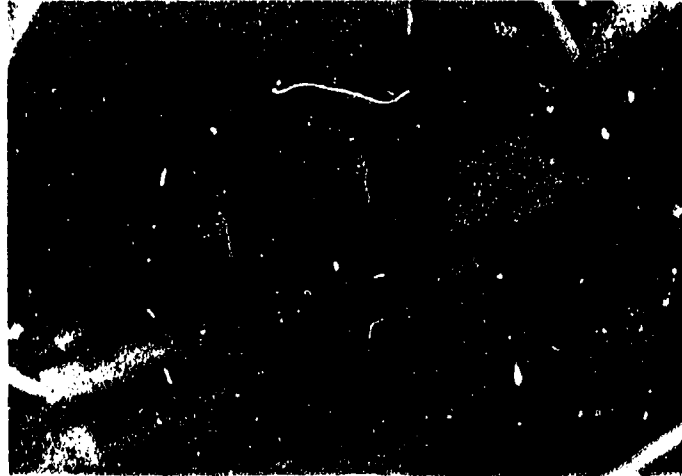

- Have your instructor check your work
- 12. Reinstall the old switch or install a new switch as test indicates
 - 13. Replace conductors properly
 - 14. Note on your troubleshooting log how long it took you to accomplish Routine #2
- Have your instructor check your work
- D. Routine #3 — Troubleshooting the motor
- 1. Sign on your troubleshooting log
 - 2. Raise and secure the top of the dryer
 - 3. Remove the lower front inspection panel
- (NOTE: Some models are different; check your service manual.)
- 4. Remove the drum with the following procedure:

JOB SHEET #2

- a) Remove the drive belt by using one hand to push the idler pulley toward the motor shaft (Figure 7)
- b) Use the other hand to remove the drive belt off the motor pulley (Figure 7)

FIGURE 7

- c) Slip the drive belt under the idler pulley and remove it from the drum
- d) Lift and pull forward to remove the drum (Figure 8)

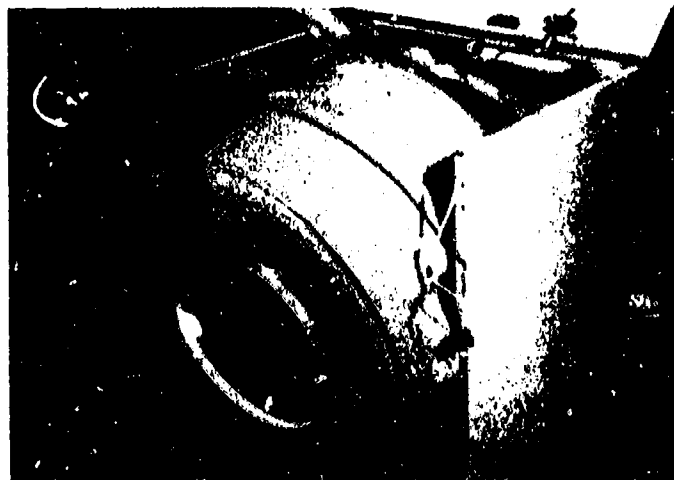
FIGURE 8

(NOTE: This procedure is only for models without a drum bearing; if you're working on a model with a drum bearing, check your service manual.)

JOB SHEET #2

5. Inspect the motor for lint and debris, and clean motor with compressed air if it needs it (Figure 9)

FIGURE 9

6. Remove the conductors coming from the main wiring harness to the motor and sketch a pictorial diagram labeling each conductor according to its terminal marking (color code/numbers), and verify connections on a wiring diagram
7. Make a continuity test of the motor/start switch with the following procedure:
- a) Disconnect internal motor conductor leads from start switch and identify their locations
 - b) Using VOM, check continuity between the yellow and blue conductor leads
 - c) The VOM should show 1 to 5 ohms on the ohm scale
 - d) If you get any other reading, the motor is faulty and should be replaced
 - e) Make a continuity test between the black and blue conductor leads
 - f) The VOM should show 1 to 5 ohms on the ohm scale
 - g) If you get any other reading, the motor is faulty and should be replaced
 - h) Remove start switch from front of motor with a standard screwdriver

(CAUTION: When replacing a start switch be sure to use the correct switch for the motor because different motors require different start switches.)

JOB SHEET #2

- l) Using VOM, make the following continuity checks
 - j) Check continuity between terminals 1 and 2 on the start switch with the start switch button in the "out" position or no pressure applied
 - k) The VOM should indicate zero ohms, and if not, the switch is bad and should be replaced
 - l) Check continuity between terminals 5 and 6 on the start switch with the start switch button in the "out" position or no pressure applied
 - m) The VOM should indicate zero ohms, and if not, the switch is bad and should be replaced
 - n) Check continuity between terminals 5 and BK with the start switch button in the "out" position and no pressure applied
 - o) The VOM should indicate infinite resistance or an open circuit, and if not, the switch is bad and should be replaced
 - p) Repeat steps j, l, and n with the start switch button in the "in" position or pressure applied
 - q) Look for continuity readings as follows: between 1 and 2 should be infinite ohms or an open circuit, between 5 and 6 should be infinite ohms or an open circuit, and between 5 and BK should show zero ohms
 - r) If all or any of one of the readings is not correct, the switch is faulty and should be replaced
- Have your instructor check your work
8. Reinstall motor switch and internal motor leads if the tests indicate everything is okay
9. Test run the motor using 115V motor test cord
- a) Connect the black test motor lead to #5 start switch terminal
 - b) Connect the white test motor lead to #4 start switch terminal (Figure 10)
 - c) Place a clamp around ammeter around the white motor test cord lead, and set the ammeter scale (Figure 10)
 - d) Turn motor test cord to the RUN position (Figure 10)

JOB SHEET #2

FIGURE 10



- e) If the motor fails to start and run or draws too much current, shut off test cord
 - f) Motor probably has mechanical problems and should be replaced
 - Have your instructor check your work and recommend repair or replacement
 - g) If motor starts and runs, check amperage for a reading less than the amperage on the motor nameplate, and if it is otherwise, the motor is faulty and should be replaced
 - Have your instructor check your work and recommend repair or replacement
10. Reinstall old motor or install new motor and start switch as directed
 11. Note on your troubleshooting log how long it took you to complete Routine #3
- E. Routine #4 — Troubleshooting the thermostats
1. Sign on your troubleshooting log
 2. Remove the rear service panel so the thermostats will be accessible
 3. Locate the operating or cycling thermostats in or on the blower housing (Figure 11)

JOB SHEET #2

FIGURE 11

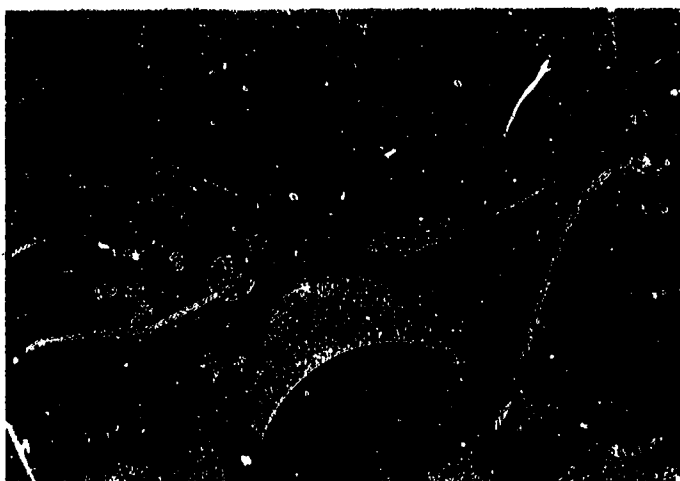

4. Locate the high limit or safety thermostat in or on the heater box itself (Figure 12)

FIGURE 12



5. Isolate the thermostat you plan to check with the following procedure:
 - a) Sketch a pictorial diagram of each thermostat, its location, and note the color markings of each conductor and terminal on each thermostat
 - b) Remove the conductors, but leave the thermostats in place
6. Make continuity test with the following procedure:
 - a) Check continuity across the two terminals of the high-heat (regular heat) cycling thermostat and record the reading

JOB SHEET #2

- b) VOM should indicate zero ohms, and if not, thermostat is faulty and should be replaced
- c) Repeat the procedure for the medium-heat and low-heat cycling thermostats (if machine has two or more cycling thermostats)
- d) If any reading is other than zero ohms, the thermostat is faulty and should be replaced

(NOTE: A continuity reading may indicate a good thermostat, but the dryer still may cycle erratically because of thermostat problems, and a temperature check will sometimes be required to completely isolate the problem.)

- e) Repeat the procedure for the high limit or safety thermostat
- f) If the reading is other than zero ohms, the thermostat is faulty and should be replaced

(NOTE: Most thermostats have a fixed temperature setting, and in the case of the safety thermostat, that limit should be between 220°F and 325°F, and the thermostat range should be stamped somewhere on the body of the thermostat.)

Have your instructor check your work

- 7. Reinstall old thermostats or new ones as required, and replace conductors
- 8. Reinstall the rear panel, plug the dryer into a power source, and cycle check the dryer

Have your instructor check your work

- 9. Note on your troubleshooting log how long it took you to accomplish Routine #4

(NOTE: In the event thermostats checked out okay but the cycling test indicates erratic cycling or improper drying, there is probably a faulty thermostat that can only be identified with a temperature check.)

F. Routine #5 — Troubleshooting the thermostat cycling temperatures

- 1. Sign on your troubleshooting log
- 2. Remove the rear panel
- 3. Clamp the ammeter around the conductor between the high-limit thermostat and the heating element, and select the proper amperage scale

JOB SHEET #2

(NOTE: The ammeter will indicate amperage as the heating element cycles on and will indicate no amperage as the heating element cycles off, and these two points are the points where temperature checks should be made.)

4. Insert temperature tester lead into the dryer exhaust duct, and place it as near the cycling thermostat as possible (Figure 13)

FIGURE 13



5. Check the high-heat cycling thermostat with the following procedure:
 - a) Select time-dry cycle approximately 25-30 minutes of drying time
 - b) Make appropriate temperature selector switch setting for high-heat
 - c) Start dryer
 - d) Watch the ammeter scale to note when the heating element cycles off
 - e) Record the temperature indicated at that exact moment by the temperature tester
 - f) Wait until the ammeter indicates the heating element has cycled on again
 - g) Record the temperature indicated at that exact moment by the temperature tester
 - h) Repeat the procedure until you have at least three readings. Add your two temperature readings and divide the total by two to obtain an average cycling temperature
 - i) Add all temperature readings and divide by the number of temperature readings made (in this case, six) to obtain an average cycling temperature

JOB SHEET #2

- j) Check your average cycling temperature with the temperature listed on the high-heat cycling thermostat
 - k) If the average temperature you obtained exceeds recommended tolerances, thermostat is faulty and should be replaced
6. Repeat the previous procedure for all other thermostats
- Have your instructor check your work
7. Replace the thermostats, if required, and reinstall the rear service panel, and cycle test the machine
8. Note on your troubleshooting log how long it took you to accomplish Routine #5
- (NOTE: The total time dedicated to thermostat troubleshooting should be the times listed for both Routines #4 and #5.)

G. Routine #6 — Troubleshooting the heating element

- 1. Sign on your troubleshooting log
- 2. Unplug the dryer and remove the rear service panel
- 3. Sketch a pictorial diagram of the heating element terminals and conductors
- 4. Remove one or both conductors from the heating element terminals
- 5. Make a continuity check with the following procedure:
 - a) Take a reading across the two heating element terminals

(NOTE: In case of a three terminal element, check with your instructor or check your service manual.)
 - b) VOM reading should indicate between 5 and 50 ohms of resistance
 - c) If reading is otherwise, element is faulty and should be replaced
 - d) Place one VOM probe on either terminal of the heater element
 - e) Arc the other probe against the heater element housing and be sure you make good metal-to-metal contact
 - f) The VOM should indicate infinite resistance or an open circuit, and if it doesn't, the heating element is faulty and should be replaced
 - g) Check the other terminal as outlined in steps d, e, and f and evaluate reading as outlined

JOB SHEET #2

Have your instructor check your work

6. Replace the heating element, if required, with the following procedure:

- a) Raise and secure the top
- b) Use a stubby screwdriver to remove the screw holding the clip that secures the heater housing to the bulkhead
- c) Remove the hex head screws that secure the high-limit thermostat to the heater housing
- d) Lift the heater housing upward from the bulkhead bracket to free it
- e) Pull down and out the rear of the dryer to remove the heater housing
- f) Remove the screw holding the heater element in the heater housing
- g) Remove the heating element carefully from the heater housing
- h) Install the new heating element by sliding it into the heater housing
- i) Secure the heating element to the heater housing with the screw that was removed
- j) Reinstall heater housing by reversing the previous procedure

(NOTE: It's recommended that anytime a heating element is replaced that the high-limit thermostat also be replaced.)

- k) Install new high-limit thermostat
- l) Replace conductor wires, close the top, and reinstall the rear service panel
- m) Reconnect the exhaust duct to the dryer
- n) Check to make sure dryer is level
- o) Plug dryer in and cycle test it

Have your instructor check your work

7. Note on your troubleshooting log how long it took you to accomplish Routine #6

8. Clean up area, and return tools and equipment to proper storage

AUTOMATIC DRYERS UNIT VIII

JOB SHEET #3 — TROUBLESHOOT A GE/HOTPOINT AUTOMATIC DRYER FOR TYPICAL MALFUNCTIONS

A. Tools and materials

1. Dryer as selected by instructor
2. Appropriate service literature
3. Hand tools
4. VOM
5. Drop cloth
6. Appliance flipper
7. Pencil and paper
8. Troubleshooting log
9. Safety glasses

B. Routine #1 — Troubleshooting a no heat complaint

1. Put on safety glasses
2. Sign on your troubleshooting log
3. Verify the complaint by attempting to run the dryer through a normal cycle
4. Check the circuit breakers first, if there is a no heat problem, and make sure they are both properly set
5. Unplug the dryer and open the dryer door
6. Set your VOM on the R \times 1 scale
7. Pull the lint filter out of the bottom of the door opening and remove one of the leads to the thermostat at the bottom of the filter assembly (Figure 1)

FIGURE 1



JOB SHEET #3

8. Place one VOM lead on each terminal of the thermostat and look for a reading of little or no resistance
 - a. If there is a full scale deflection followed by a measurement of little or no resistance, the thermostat is okay
 - b. If there is no full scale deflection and no reading at all, the thermostat should be replaced
9. Check the number of terminals on the thermostat and the L number which indicates the operating temperature limit and refer to the good parts catalog to get the correct GE/Hotpoint replacement thermostat
10. Remove the old thermostat and replace it with the new one, and put the leads onto the correct terminals
11. Use a putty knife to release the springs on each side and then turn the lid back, or newer models may have screws that have to be removed in order to raise the lid (Figure 2)

FIGURE 2



12. Look for the upper limit thermostat mounted on the top of the heater element housing
13. Make a continuity check on the upper limit thermostat with the same procedure used for the operating thermostat (Figure 3)

FIGURE 3



JOB SHEET #3

14. Replace the upper limit thermostat as required

Have your Instructor check your work

15. Replace the lid, close the door, plug the dryer in to a grounded receptacle and run the dryer through a normal cycle

a. If the dryer performs properly, the new thermostat(s) has solved the problem

b. If the dryer still does not heat, check the heating element as outlined in the next routine

C. Routine #2 — Troubleshooting the heating element

1. Sign on your troubleshooting log

2. Unplug the dryer from its power source

3. Release the lid and fold it back

4. Reach down behind the right hand side of the door and remove the leads from the door switch, making sure you note the color coding so you can properly replace the leads (Figure 4)

FIGURE 4

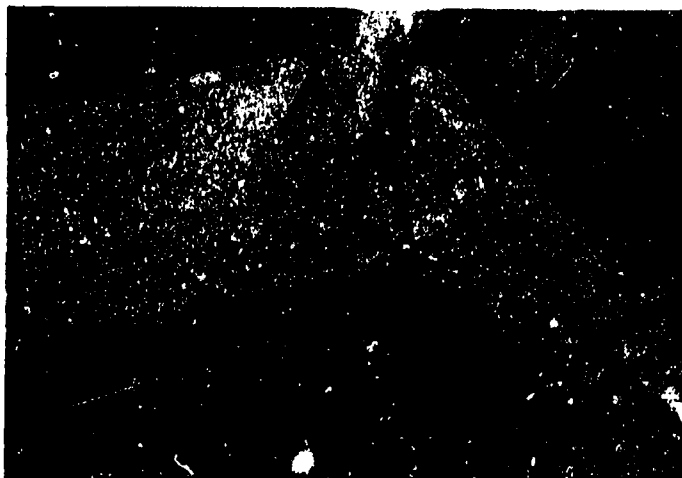

5. Remove the top inside screws that secure the front panel to the cabinet

6. Lift the front panel up a bit to free it, and then set it aside

7. Go to the back of the dryer and use a nut driver to remove the cover plate that protects the drum spindle

JOB SHEET #3

8. Reach in with a small screwdriver and remove the snap ring that secures the drum spindle (Figure 5)

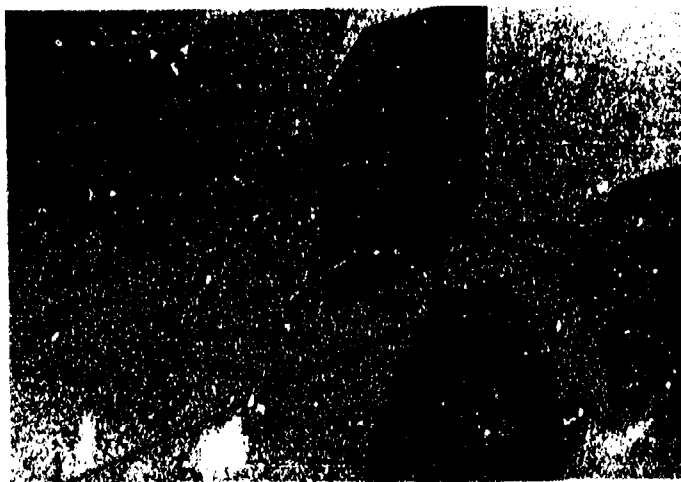
FIGURE 5

9. Reach in at the bottom of the drum at the end of the motor shaft and depress the tension spring, and then remove the belt while you have the spring depressed (Figure 6)

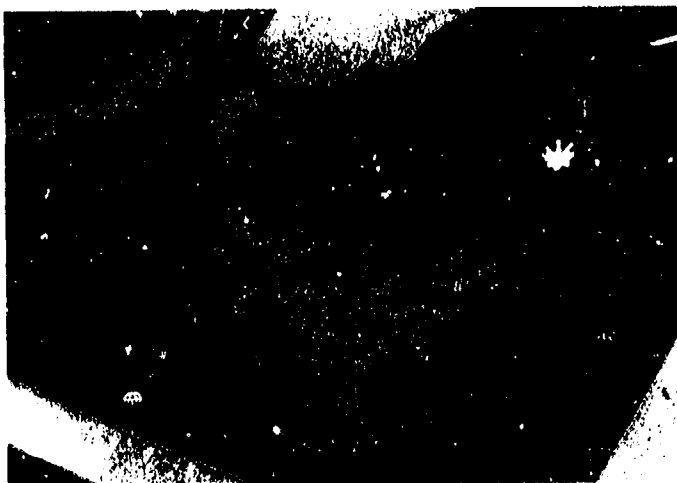
FIGURE 6

JOB SHEET #3

10. Pull out and lift up to remove the drum, and set it safely aside (Figure 7)

FIGURE 7

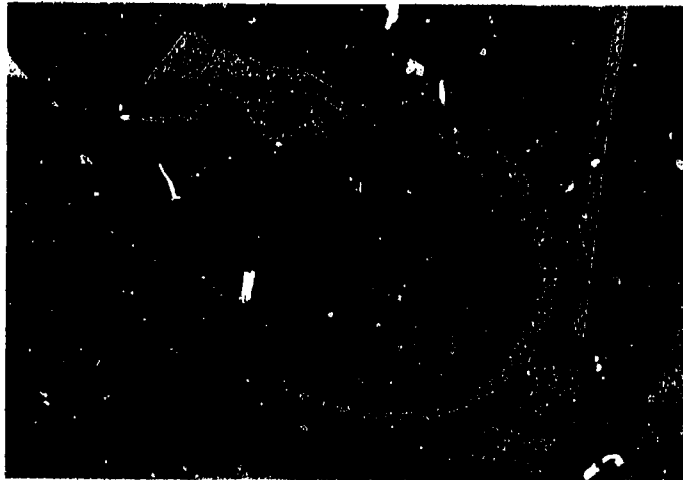

11. Inspect the heating elements, the two nichrome coils, for breaks where they may have burned in two
12. Check the heating elements with the VOM set at $R \times 1$ if there are no evident breaks in the elements
 - a. If the heating elements register a full scale deflection, it means they are okay
 - b. If there is no meter movement, the heating elements are bad and should be replaced
13. Replace bad elements with a restring kit

(NOTE: Restring kits are much less expensive than complete replacement elements, but restringing requires even spacing of the coils through the insulators, and you should ask your instructor to demonstrate the procedure.)
14. Replace the drum, the snap-ring that secures the drum spindle at the back of the dryer, and replace cover plate (Figure 8)

(NOTE: Make sure the brass leaf ground is making contact with the end of the drum spindle because this serves to not only ground that part of the dryer, it also serves to eliminate static electricity which might cause interference with radios.)

JOB SHEET #3**FIGURE 8**

15. Replace the front panel, replace the leads to the door switch, and put the lid back in place
- Have your instructor check your work
16. Plug the dryer in to a grounded receptacle and start it through a normal cycle
17. Place a temperature probe into the dryer exhaust and monitor the temperature throughout the normal cycle (Figure 9)

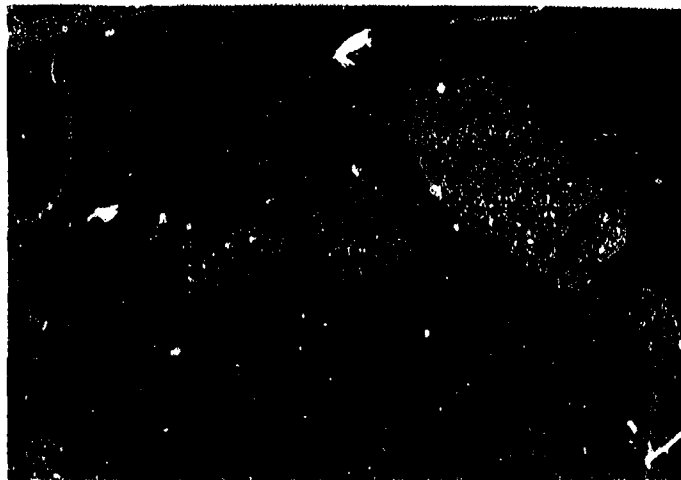
FIGURE 9

18. Run the dryer through whatever other cycles are available (wash and wear, delicate) and check the temperature
19. Check with your instructor for manufacturer's temperature requirements and compare your temperature findings to verify correct temperature ranges
- Have your instructor check your work

JOB SHEET #3**D. Routine #3 — Checking the timer**

1. Sign on your troubleshooting log
2. Unplug the dryer from its power source

(NOTE: This procedure should be used for complaints that the timer will not advance or not turn on at all.)

3. Remove the screws on each end of the console and fold the console down over the lid
4. Plug the dryer back in to a grounded receptacle
5. Make a check of the voltage going into the timer, and the voltage coming out of the timer (Figure 10)

FIGURE 10

- a. If the voltage coming out of the timer is the same as the voltage going into the timer, the timer is okay
- b. If there is not voltage coming out of the timer, the contacts are burned and the timer will have to be replaced with a new timer

(NOTE: Unlike the GE/Hotpoint washer timer which can be repaired, the dryer timer is an integrated unit and has to be replaced as a unit.)

6. Unplug the dryer and replace the timer as required
7. Put the console back in place
8. Plug the dryer in and run it through a complete cycle
- Have your instructor check your work
9. Clean up the area and return tools and materials to proper storage

AUTOMATIC DRYERS UNIT VIII

NAME _____

TEST

1. Match the terms on the right with their correct definitions.

- | | | |
|---------|---|--------------------|
| _____a. | An appliance designed to dry wet clothes in a heat, air flow sequence in a drum that tumbles clothes as it rotates under control of a timer | 1. Cycle |
| _____b. | The force that impels something outward from a rotating center | 2. Purging |
| _____c. | One complete series of events that completes a procedure | 3. Automatic dryer |
| _____d. | A continuous small flame used in gas appliances to ignite the gas burner (also called a pilot light) | 4. Pilot burner |
| _____e. | Any procedure that cleans or removes obstructions such as removing air from a gas line | 5. Centrifugal |

2. Match major components with their functions in an automatic dryer.

- | | | |
|---------|---|----------------|
| _____a. | The electromechanical brain of an automatic dryer that controls the sequence of functions | 1. Timer |
| _____b. | Turns the drum, controls the heat circuit, and drives the blower | 2. Thermostats |
| _____c. | An electric dryer uses an electric heating element and a gas dryer uses a gas valve and burner assembly | 3. Heat source |
| _____d. | Devices that sense temperature and open or close to energize or de-energize the heat circuit | 4. Motor |

TEST

3. Arrange in order the steps in automatic dryer operation by placing the correct sequence number in the appropriate blank.
- _____a. The drying cycle runs for a selected length of time and is controlled by the drive motor
 - _____b. As the drum rotates, air is circulated into the drum to provide proper heat
 - _____c. During the last five minutes, the starting switch circuit opens, heat stops and dissipates, and cooler air flows through the clothes as the tumbling action continues until the cycle is complete
 - _____d. When the dryer starts, timer contacts energize the drive motor circuits
 - _____e. Through a series of motors or belts, the drive motor rotates the drum and causes clothes inside to tumble
 - _____f. In a normal cycle, after the motor circuits are energized, another set of contacts in the timer energize the dryer heat circuit
4. Complete statements concerning thermostats and their functions in a dryer by inserting the word(s) that best completes each statement.
- a. Cycling thermostats in a dryer help maintain a _____ heat level inside the drum when clothes are tumbling
 - b. The safety or _____ thermostat shuts the dryer heat circuit off when there is evidence the dryer may overheat
 - c. Cycling thermostats are mounted in or on the air _____ so they can sense both the temperature and moisture level of the air in the drum
 - d. As the temperature in the drum reaches the limits of a cycling thermostat setting, the thermostat de-energizes the heat circuit and will remain open until the air cools sufficiently, and then close to _____ the circuit again
 - e. The number of _____ thermostats in a dryer may vary, but many have low heat, medium heat, and high heat thermostats to provide the user with temperatures for a variety of fabrics
5. Complete statements concerning troubleshooting a dryer that will not run by inserting the word(s) that best completes each statement.
- a. Make sure the dryer is plugged into a proper _____ source, and then check the branch circuit control
 - b. Check for _____ wires at terminals and run a continuity check on the circuitry to make sure there are no broken wires

TEST

- c. Check for a faulty door switch by first making sure the door is properly shut and then running a _____ check on the door switch, and replace as required
- d. Check motor wiring and motor _____ switch, and replace motor or switch as required
- e. Check the timer and timer circuitry and replace the timer _____ or the timer as required
6. Select true statements concerning troubleshooting a dryer that will run but not heat by placing an "X" beside each statement that is true.
- _____a. Check for loose wires on terminals and run a continuity check to make sure there are no broken wires
- _____b. On an electric dryer, check for a proper 120V power supply
- _____c. Check for defective thermostats and replace as required
- _____d. Check for a wrong setting on the heat switch or check the heat switch itself and replace as required
- _____e. Check timer and timer wiring and replace timer motor or entire timer as required
- _____f. Check the centrifugal switch, if it is the type of motor that has one, and replace as required
- _____g. Check for an open heater element and replace heater element as required
- _____h. On gas model, check the gas supply and make sure the gas supply valve is open
- _____i. If the gas model has pilot light that is out, replace the gas valve
- _____j. Check for a defective solenoid coil in the gas valve by testing the coil for an open circuit, and replace the solenoid, if required, or the entire gas valve
- _____k. Check for a defective flame switch
- _____l. Check for a malfunctioning igniter
7. Complete statements concerning troubleshooting a dryer when the motor runs but the drum will not rotate by inserting the word(s) that best completes each statement.
- a. Check for a slipping or broken _____ and adjust or replace as required
- b. Check for a loose _____ and tighten the _____ on the motor shaft
- c. Check for _____ objects that may be obstructing drum movement and remove them

TEST

- d. Check for a frozen _____ and replace as required
 - e. Check for _____ and adjust or replace
8. Complete statements concerning troubleshooting a dryer that runs but will not shut off by inserting the word(s) that best completes each statement.
- a. Check to see if one side of the _____ circuit control is tripped open
 - b. Check for a defective timer and replace timer _____ or timer as required
9. Select true statements concerning troubleshooting a dryer that runs and heats but won't dry clothes by placing an "X" beside each statement that is true.
- _____ a. Check for a clogged lint screen and clean or replace as required
 - _____ b. Check for a bad door switch
 - _____ c. Check for incorrect heat or timer setting and reset as required
 - _____ d. Check for a leaky door seal and if the door seal leaks air, replace it
 - _____ e. Check for a bad centrifugal switch
 - _____ f. Check for a fan or pulley loose on its shaft and tighten as required to restore good air motion in the drum
 - _____ g. Check for defective operating thermostats, and if any of the thermostats are cycling too soon or too late, replace them
 - _____ h. Find out if clothes were too wet when placed into the drum, and encourage customer to make sure clothes are properly wrung out before placing them in the dryer

TEST

10. Match other dryer problems with their solutions.

- | | | |
|---------|--|--|
| _____a. | 1) Check wiring for bare spots that may be touching the frame | 1. Motor runs when door is open and timer fails to advance |
| | 2) Check for a sagging drum that may be causing the heater element to touch its housing | 2. Dryer heats with door open or in OFF cycle |
| | 3) Check heater element for foreign matter | 3. Dryer repeatedly blows fuses or trips breaker |
| _____b. | 1) Check for a defective door switch and replace as required | 4. Drum inspection light is burned out |
| | 2) Check for a dial that binds because it is too out far out from the control panel, and relocate the dial on the timer shaft to eliminate binding | |
| _____c. | Replace the bulb | |
| _____d. | 1) Check centrifugal switch | |
| | 2) Check for malfunctioning heating element | |

11. Complete statements concerning troubleshooting gas valves and igniters on gas dryers by inserting the word(s) that best completes each statement.

- a. Make sure _____ is turned off
- b. When a test shows that there is voltage to a gas valve but there is no flame, the problem is in the gas valve circuitry and the _____ valve should be replaced
- c. The igniter is _____ in the field, but a continuity test should indicate a resistance between 50 to 400 ohms, and if continuity is otherwise, the igniter also should be replaced
- d. When installing a gas dryer or when relighting one that has been repaired, purge the gas line with the following procedure:
- 1) Turn the _____ off
 - 2) _____ the connection between the shut-off valve and the burner
 - 3) Turn gas on until you _____ or _____ gas at the loose connection, turn the gas off, and tighten the connection

TEST

12. Match special gas dryer problems with their solutions.

- | | | |
|---------|---|--|
| _____a. | <ol style="list-style-type: none"> 1) Check for Insufficient gas supply, low gas pressure, a clogged pilot filter, or a closed or partially closed gas supply valve 2) Check for excessive carbon build-up on the thermocouple and clean as required 3) Check for a faulty thermocouple and replace as required 4) Readjust pilot flame until a faint yellow tip appears 5) Check for a faulty ignition or reset valve and replace as required 6) Check for excessive back drafts | <ol style="list-style-type: none"> 1. Pilot burner is okay but main burner does not light 2. Main burner goes out after lighting 3. Pilot burner goes out 4. Main burner cycles too fast 5. Pilot burner does not light |
| _____b. | <ol style="list-style-type: none"> 1) Check for a closed or partially closed gas supply valve, a clogged pilot filter, or an obstruction in the gas supply line 2) Check setting on pilot switch and reset as instructions direct | |
| _____c. | <ol style="list-style-type: none"> 1) Check for insufficient gas supply, a partially closed gas supply valve, or an obstruction in the gas supply line 2) Check for a defective safety thermostat and replace as required 3) Check for incorrect air supply and readjust the air shutter on the gas burner until a bright blue flame appears 4) Check gas valve solenoid and replace solenoid as required or replace gas valve | |
| _____d. | <ol style="list-style-type: none"> 1) Check for loose connections at wiring terminals and tighten as required 2) Check for a faulty timer and replace timer motor or timer as required | |

TEST

- 3) Check for a faulty operating thermostat and replace as required
 - 4) Check safety thermostat for erratic cycling because of restricted air flow, and clean lint or obstructions from the dryer as required
 - 5) Check safety thermostat for proper operation and replace as required
- _____e.
- 1) Check for low gas pressure, partially closed gas supply valve, or an obstruction in the gas supply line
 - 2) Check the primary air adjustment and adjust the air shutter until a bright blue flame appears at the main burner
 - 3) Check for loose connections at terminals and tighten as required

(NOTE: If the following activities have not been accomplished prior to the test, ask your instructor when they should be completed.)

13. Demonstrate the ability to:

- a. Install an automatic dryer. (Job Sheet #1)
- b. Troubleshoot a Whirlpool/Kenmore automatic dryer for typical malfunctions. (Job Sheet #2)
- c. Troubleshoot a GE/Hotpoint automatic dryer for typical malfunctions. (Job Sheet #3)

AUTOMATIC DRYERS UNIT VIII

ANSWERS TO TEST

1.
 - a. 3
 - b. 5
 - c. 1
 - d. 4
 - e. 2

2.
 - a. 1
 - b. 4
 - c. 3
 - d. 2

3.

a.	5	d.	1
b.	3	e.	2
c.	6	f.	4

4.
 - a. Constant
 - b. Limiting
 - c. Exhaust duct
 - d. Energize
 - e. Cycling

5.
 - a. Power
 - b. Loose
 - c. Continuity
 - d. Centrifugal
 - e. Motor

6. a, c, d, f, g, h, j, k, l

7.
 - a. Belt
 - b. Pulley, pulley
 - c. Foreign
 - d. Bearing
 - e. Tension

8.
 - a. Branch
 - b. Motor

9. a, c, d, f, g, h

10.
 - a. 3
 - b. 1
 - c. 4
 - d. 2

ANSWERS TO TEST

11. a. Gas
b. Entire
c. Serviceable
d. 1) Gas
2) Loosen
3) Hear, smell
12. a. 3
b. 5
c. 1
d. 4
e. 2
13. Performance skills evaluated according to procedures written in the job sheets



AUTOMATIC DISHWASHERS UNIT IX

UNIT OBJECTIVE

After completion of this unit, the student should be able to identify major components of an automatic dishwasher and discuss component functions in dishwasher operation. The student should also be able to list common dishwasher misuses, installation and troubleshooting guidelines, and install, troubleshoot, and repair an automatic dishwasher. These competencies will be evidenced by correctly performing the procedures outlined in the job sheets and by scoring 85 percent on the unit test.

SPECIFIC OBJECTIVES

After completion of this unit, the student will be able to:

1. Match terms related to automatic dishwashers with their correct definitions.
2. Match major components of a dishwasher with their functions.
3. Arrange in order typical steps in an automatic dishwasher cycle.
4. Complete statements concerning special considerations for dishwasher installation.
5. Select true statements concerning water problems with dishwashers.
6. Complete statements concerning loading order in dishwasher operation.
7. Match common dishwasher misuses with their causes.
8. Select true statements concerning guidelines for better dishwasher service.
9. Complete statements concerning guidelines for troubleshooting automatic dishwashers.
10. Complete a list of ways to prevent mineral build-up in an automatic dishwasher.
11. Complete statements concerning troubleshooting redeposit problems.
12. Demonstrate the ability to:
 - a. Install an automatic dishwasher under a counter. (Job Sheet #1)
 - b. Troubleshoot malfunctions on an automatic dishwasher. (Job Sheet #2)
 - c. Inspect the seal on an automatic dishwasher. (Job Sheet #3)

AUTOMATIC DISHWASHERS UNIT IX

SUGGESTED ACTIVITIES

- A. Provide students with objective sheet.
- B. Provide students with information and job sheets.
- C. Make transparencies.
- D. Discuss unit and specific objectives.
- E. Discuss and demonstrate the procedures outlined in the job sheets.
- F. Invite an automatic dishwasher manufacturer's representative to talk to the class about dishwasher design and operation.
- G. Invite a local or area appliance repair technician to talk to the class about typical automatic dishwasher problems and how to troubleshoot them most effectively.
- H. Invite an extension specialist to talk to the class about water quality in your area, and arrange for a demonstration of how to use a hard water test kit.
- I. Give test.

CONTENTS OF THIS UNIT

- A. Objective sheet
- B. Information sheet
- C. Transparency masters
 - 1. TM 1 — Automatic Dishwasher Components
 - 2. TM 2 — Automatic Dishwasher Timer Sequence Chart
- D. Job sheets
 - 1. Job Sheet #1 — Install an Automatic Dishwasher Under a Counter
 - 2. Job Sheet #2 — Troubleshoot Malfunctions on an Automatic Dishwasher
 - 3. Job Sheet #3 — Inspect the Seal on an Automatic Dishwasher
- E. Test
- F. Answers to test

REFERENCES USED IN DEVELOPING THIS UNIT

- A. Meyerink, George. *Appliance Service Handbook*. Englewood Cliffs, NJ: Prentice-Hall, Inc., 1973.
- B. Anderson, Edwin P. *Home Appliance Servicing*. Indianapolis, IN 46268: Howard W. Sams & Co., Inc., 1974.

AUTOMATIC DISHWASHERS UNIT IX

INFORMATION SHEET

I. Terms and definitions

- A. Hard water — Water containing mineral salts in quantities enough to interfere with lathering, sudsing, or cleaning properties of soaps and detergents**
- B. Soft water — Water such as rainwater that contains none or few mineral salts**
- C. Lime build-up — A mineral deposit that remains after a substance containing calcium carbonate is subjected to heat**

Example: Water heaters, automatic washers, and automatic dishwashers all use hot water and are subject to lime build-up in areas with hard water

- D. Water softener — Any chemical that removes mineral salts from water or a filtering device that uses chemicals to remove minerals from water**
- E. Purge — The process of running cold water out of a hot water supply line to assure that only hot water of a desired temperature will be available**
- F. Rinsing agent — Chemicals added to water during a rinse cycle to enhance the ability of the water to remove other chemical or detergent residue from dishes**

II. Major components of a dishwasher and their functions (Transparency 1)

- A. Timer — The electromechanical "brain" of an automatic dishwasher because it controls the operations of other components in a predetermined sequence**
- B. Inlet valve — Controls water flow through the inlet hose into the tub**
- C. Motor — The source of power for driving the impeller that spins to complete the washing cycle**
- D. Heating element — The device that maintains water temperature and provides heat for the hot air used during the drying cycle**
- E. Pump — Forces water through the spray arms during the wash and rinse cycles and forces water and food particles out of the dishwasher during pumpout**
- F. Spray arms — Perforated extensions that reach out horizontally below and above the dishracks to provide a route for the revolving pressurized hot water that is sprayed onto the dishes**

INFORMATION SHEET

- G. **Filter** — The device that separates food particles from the water so they won't be sprayed back onto the dishes
- H. **Drain valve** — Directs dirty water and food particles away from the dishwasher into a drain system
- I. **Door/lid switch** — Keeps the tub from filling until the door is closed to eliminate the prospects that water will spray out of an open door or lid into the kitchen
- J. **Dispensers** — Devices for releasing detergent and rinsing agent
- K. **Float switch** — Safety device to prevent overfilling

III. **Typical steps in a automatic dishwasher cycle (Transparency 2)**

- A. **Dirt** dishes should be properly arranged in the dishracks.
- B. **Detergent** as recommended by the manufacturer, and in the proper quantity, should be placed in the detergent dispenser.
- C. **Rinse conditioner** should be added as recommended or as local water conditions demand.
- D. **Water** enters the tub through the inlet hose and inlet valve until there is approximately two gallons of water in the tub.
- E. **The heating element** is energized to assure that the water will be at least 140°F.
- F. **The motor** is energized and pumps hot water through the lower spray arm in a jet stream and over the dishes to the upper spray arm.
- G. **The upper spray arm** deflects the water back down over the dishes and the washing action between the lower and upper spray arms is repeated over and over again.
- H. **As water** runs off the dishes, it flows through a filtering system to keep food particles from being sprayed back onto the dishes.
- I. **As each wash or rinse cycle** ends, water is pumped out of the dishwasher and small food particles are flushed away with it.
- J. **As the drying cycle** starts, the heating element comes on so that hot air can be circulated over and around the dishes to help dry them.

IV. **Special considerations for dishwasher installation**

- A. **There must be a proper 120V power supply**, and it is recommended that the circuit be equipped with a 15-amp time delay fuse.
- B. **Dishwasher must be properly grounded**

INFORMATION SHEET

- C. Extension cords should not be used to extend the power supply because they usually result in low line voltage.
- D. Low line voltage does not permit the motor to operate at its rated capacity and results in poor washing action and water circulation.
- E. A dishwasher should be installed only on a sturdy, level floor in a well ventilated area.
- F. Dishwasher drain hookups must be near the equipment and free of obstructions that might impair proper drainage.
- G. The water supply must have a minimum flow rate of three gallons per minute and a minimum pressure of 15 psi.

(NOTE: Pressure too high needs to be moderated with a pressure regulator in the water line so that the inlet hose and fill valve won't be damaged, and low water pressure usually demands an analysis of the water supply system.)

- H. Water supply must also be in the range of 140°F to 160°F because some detergents will not dissolve and work at lower temperatures, and the higher temperature also helps in the drying cycle.

V. Water problems with dishwashers

- A. Loading patterns vary with design, so follow operator's manual carefully
- B. Stains on dishes result from minerals found in "hard" water or rust that comes from the metal piping.

(NOTE: More than 75% of the water supplies in America are classified as hard water.)

- C. When piping is so old that rust cannot be controlled, it should be replaced.
- D. Minerals in the water not only cause stains, they lead to lime build-up even in cases where the detergent recommended is designed to fight lime build-up.
- E. Cleaning the dishwasher with vinegar or citric acid will help control lime build-up.
- F. The best way to control stains, spots, and lime build-up is to install a water softener/filter in the water supply line.

(NOTE: In cases where the water is extremely hard, the filtering water softener is the only means of controlling the situation, and specific types of hard water may require an iron or manganese filter.)

INFORMATION SHEET

VI. Loading order in dishwasher operation

- A. Each model dishwasher has its own spray or splash pattern for water action and the order in which dishes are loaded must facilitate dishwasher design.
- B. Common sense is the best aid to proper placement, but generally, nothing should be placed on one rack that would block the flow of water to another rack.
- C. Cups and glasses and any containers that will retain water should always be placed upside down so water will drain from them and they will dry.
- D. Keep flatware and other utensils in their proper baskets because they can puncture seals and create problems if they're in the wrong place.

VII. Common dishwasher misuses and their causes

- A. Improper dishrack loading — Results from care'ess neglect of instructions or when dishes are loaded by a child or other pe 'son unfamiliar with loading order
- B. Improper dish preparation — Results when dishes or utensils with dried food caked on them are not wetted and scraped before loading
- C. Careless dish preparation — Results when small bones or large seeds are carelessly left on dishes

(NOTE: Bones and seeds inevitably reach the pump and clog it or damage it.)

- D. Improper detergent use — Results when soap flakes or soap powders are used instead of the recommended detergent

(NOTE: Soap flakes or powders form so much suds that they actually form a barrier that keeps the water spray away from the dishes.)

VIII. Guidelines for better dishwasher service

- A. When a dishwasher is hooked up with a garbage disposer, the disposer should be completely empty so water will drain freely through the disposer.
- B. Before starting the dishwasher, run hot water at the sink to purge cold water out of the line and assure that only hot water enters the dishwasher.

(NOTE: Remembering to run the cold water off can help solve problems with spotting and general dishwasher performance.)

INFORMATION SHEET

- C. The same amount of water goes through a dishwasher each time it is used, so even when washing half a load, enough detergent for a full load should be placed in the dishwasher.

IX. Guidelines for troubleshooting automatic dishwashers

- A. Before assuming anything about a malfunctioning dishwasher, remember that almost 75% of dishwasher problems are not related to component failures.
- B. Check for a proper 120V electrical power source.
- C. Check for a hot water supply of 140°F to 160°F and for a minimum water pressure of 15 psi.
- D. Check for a faulty floor that may be causing the dishwasher to vibrate or a poor installation that does not provide ventilation.
- E. Make sure the dishwasher is not being operated with improper detergent, loaded improperly, or subjected to other forms of abuse.
- F. Check the removable panel at the back or front of the machine for a schematic wiring diagram and compare it with the operating sequence of the timer to systematically track down other problems. (Transparencies 1 and 2)
- G. Refer to the manufacturer's service chart for specific problems.
- H. Look for leaks or broken parts, listen for parts that are binding, and generally use your senses and your common sense to diagnose the problem properly.

(NOTE: If you can't find the problem, you can't repair it, and when you don't proceed in an orderly manner, you stand a good risk of creating another problem or a bigger problem.)

- I. Check with customer to see if shower or laundry use is depleting the hot water supply

X. Ways to prevent mineral build-up in an automatic washer

- A. Check the washer at regular intervals for the presence of a white, brown, or yellow build-up in the tub.

(NOTE: The color of the deposit is a good clue to the type of water filter that would solve the problem; white indicates an excess of manganese in the water, brown indicates an excess of iron, and yellow indicates an excess of sulphur.)

INFORMATION SHEET

- B. When build-up is enough that it can be readily detected, Whirlpool recommends the following procedure:
1. Empty the dishwasher and set it for a one wash cycle.
 2. Start dishwasher, and then open the door so it will stop when it has filled enough for the wash cycle.
 3. Add half a cup of citric acid crystals to the tub.
 4. Close the door latch and allow the dishwasher to complete the cycle.
 5. Run another complete wash and rinse cycle to clean remaining residue from the tub and the drain system.
- C. An alternate method of controlling lime build-up is to add two cups of distilled white vinegar to the tub instead of citric acid crystals.
- D. In areas where a brown stain is deposited on dishes, a quarter of a teaspoon of oxalic acid crystals used after dishes are washed should remove the iron deposits from the dishes.
- (NOTE: Do not use the crystals and the detergent together, and follow the cycle using crystals with another cycle using detergent.)
- E. Build-ups of tea stains on cups and saucers usually have to be removed by hand with a wash cloth saturated with baking soda.

XI. Troubleshooting redeposit problems

- A. Because redeposits leave white spots on dishes, everyone assumes the spots are undissolved detergent, but they may be undissolved starch from foods.
- B. To isolate the problem, place a glass or dish under hot water:
1. If the spots dissolve quickly in hot water, it is a detergent problem.
 2. If the spots stick to the glass or dish, they are food starches.
- C. Detergent problems can be corrected by changing to a different detergent or mixing detergent with water conditioner.
- D. Food starch problems require better precleaning, especially with containers used for mashed potatoes, cooked cereals, cream soups, and any pudding or dessert that has a cornstarch base.
- E. Both problems may be related to improper water temperature and require adjustment of the hot water supply control.

(NOTE: Water under 140°F will not dissolve detergent nor hold food soil in suspension, and water over 160° will bake food particles onto dishes.)

Automatic Dishwasher Components

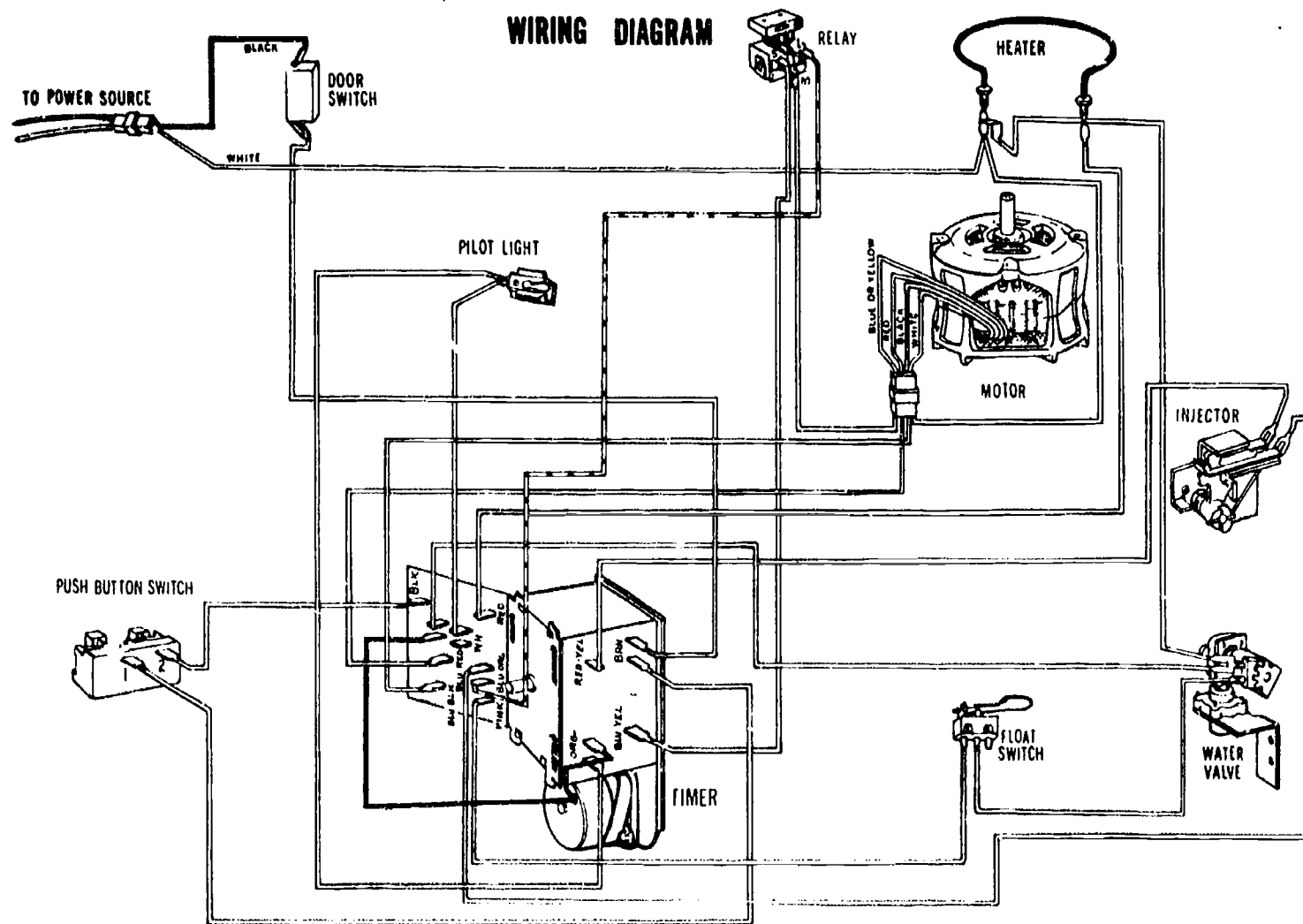

432

433

Automatic Dishwasher Timer Sequence Chart

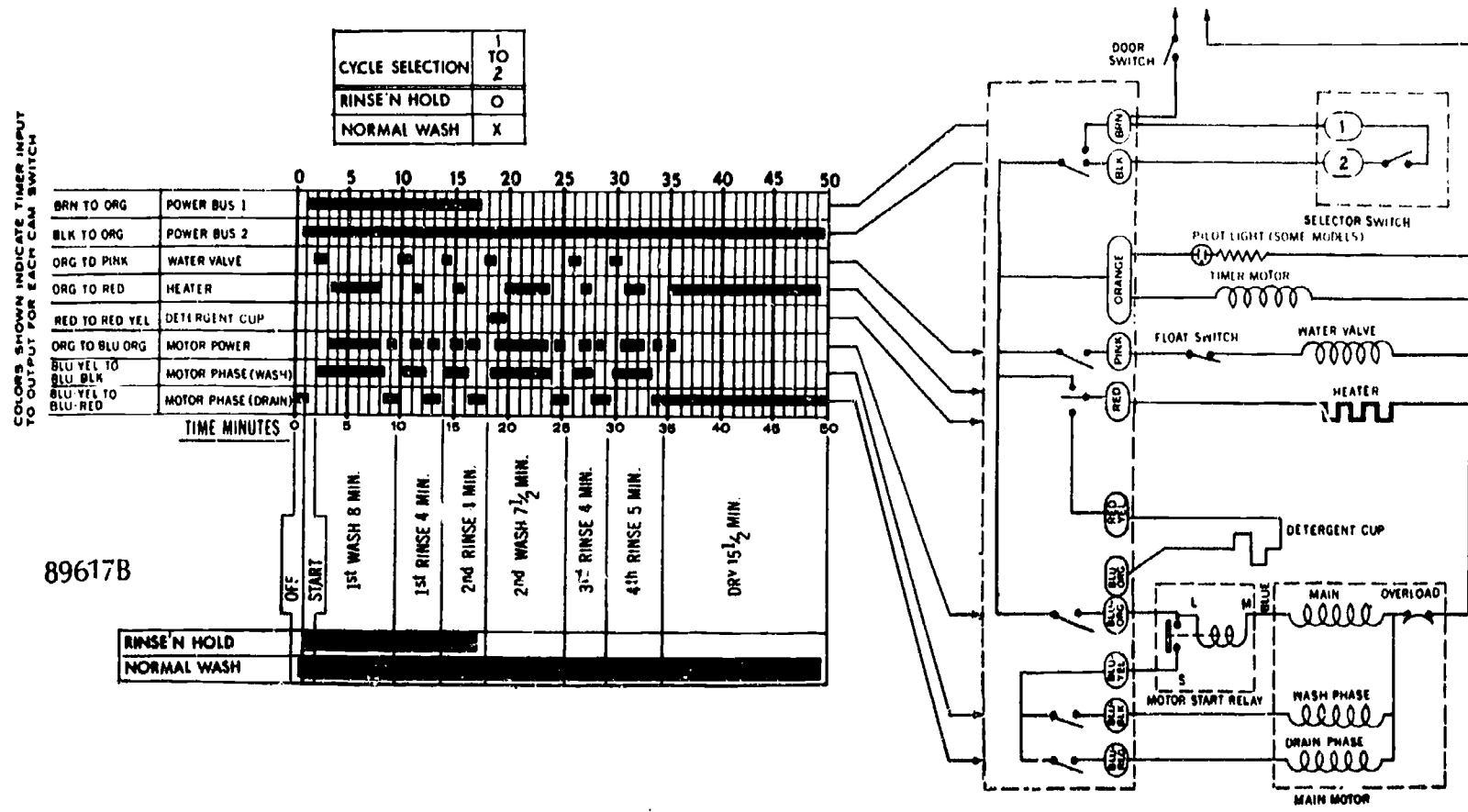

434

435

AUTOMATIC DISHWASHERS UNIT IX

JOB SHEET #1 — INSTALL AN AUTOMATIC DISHWASHER UNDER A COUNTER

A. Tools and materials

1. Automatic dishwasher as selected by Instructor
2. Available cabinet enclosure rough-in
3. Basic hand tools
4. Level
5. Safety glasses

B. Routine #1 — Checking plumbing and electric service

1. Make sure circuit breaker for electric service is turned off, and put on your safety glasses.
2. Check enclosure distances with a tape measure to make sure they meet manufacturer's specifications. (Figure 1)

FIGURE 1

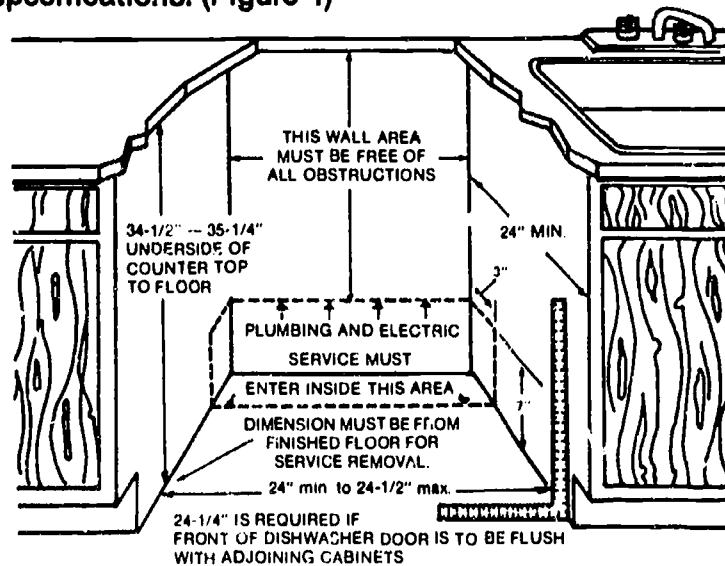

Courtesy Frigidaire

3. Check to make sure that the waste connection hookup is no more than 10 feet away from the dishwasher drain.

(NOTE: Although rough-in for electric and water may have been completed by others, it's your responsibility to check each item because improper installation will void a warranty.)

4. Check to make sure that the hot water service line is not less than 1/2" OD copper tubing or 3/8" ID NPT pipe (Figure 2)

(CAUTION: Hose of any type is not acceptable for this installation.)

JOB SHEET #1

5. Make sure the hot water line has a shut-off valve that can be conveniently shut off for service or emergencies. (Figure 2)
6. Be certain the hot water supply line enters in the proper space at the back of the enclosure and that the line is 2½" from the floor at the point where it hooks onto the fill valve. (Figure 2)

(NOTE: Figure 2 shows a few options that can be used for the hot water supply.)

FIGURE 2

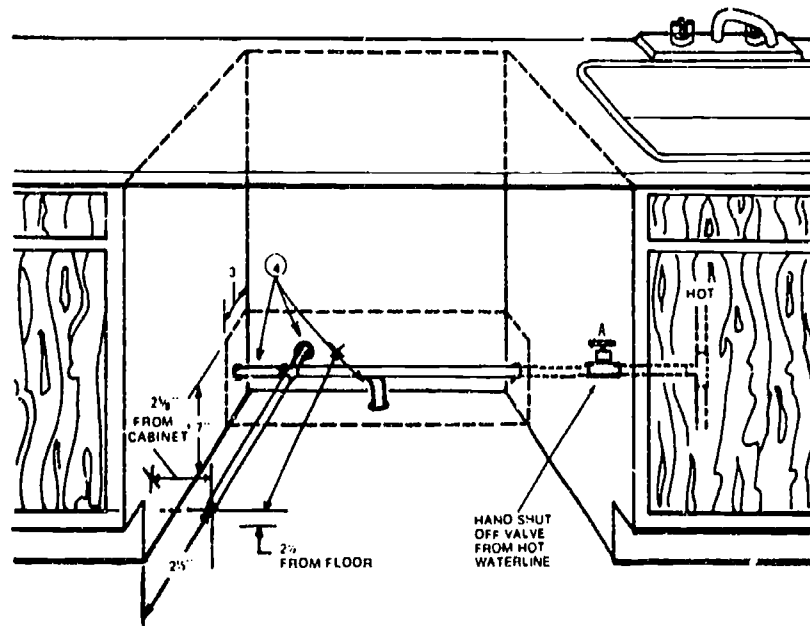

Courtesy Frigidaire

7. Check to see that the electrical rough-in comes in on a proper 15 amp circuit protected by a breaker device.

(NOTE: If the same circuit will service a garbage disposer, it should be 20 amps, and in all cases, the electrical service must conform to local codes.)

JOB SHEET #1

8. Make sure the electrical service enters in the proper space at the back of the enclosure. (Figure 3)

(NOTE: Figure 3 shows some options that can be used for the electrical service.)

FIGURE 3

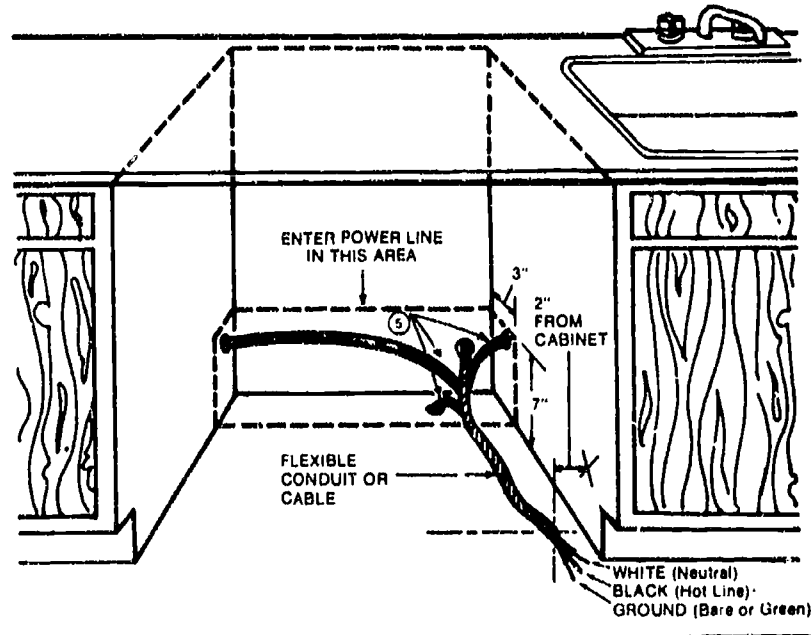

Courtesy Fridglaire

9. Check the rough-in drain line to the garbage disposer or to the waste tee to make sure. (Figure 4)
- Drain line is $\frac{5}{8}$ " OD copper tubing or $\frac{5}{8}$ " ID braided rubber hose
 - Hopper plug has been removed from the garbage disposer for proper installation (if disposer is present)
 - Drain line connection into waste tee is at least 8" off the floor (if waste tee is used)

JOB SHEET #1

10. Make sure a high loop or an air gap is properly installed at countertop level between the dishwasher drain and the disposer or the waste tee. (Figure 4)

FIGURE 4

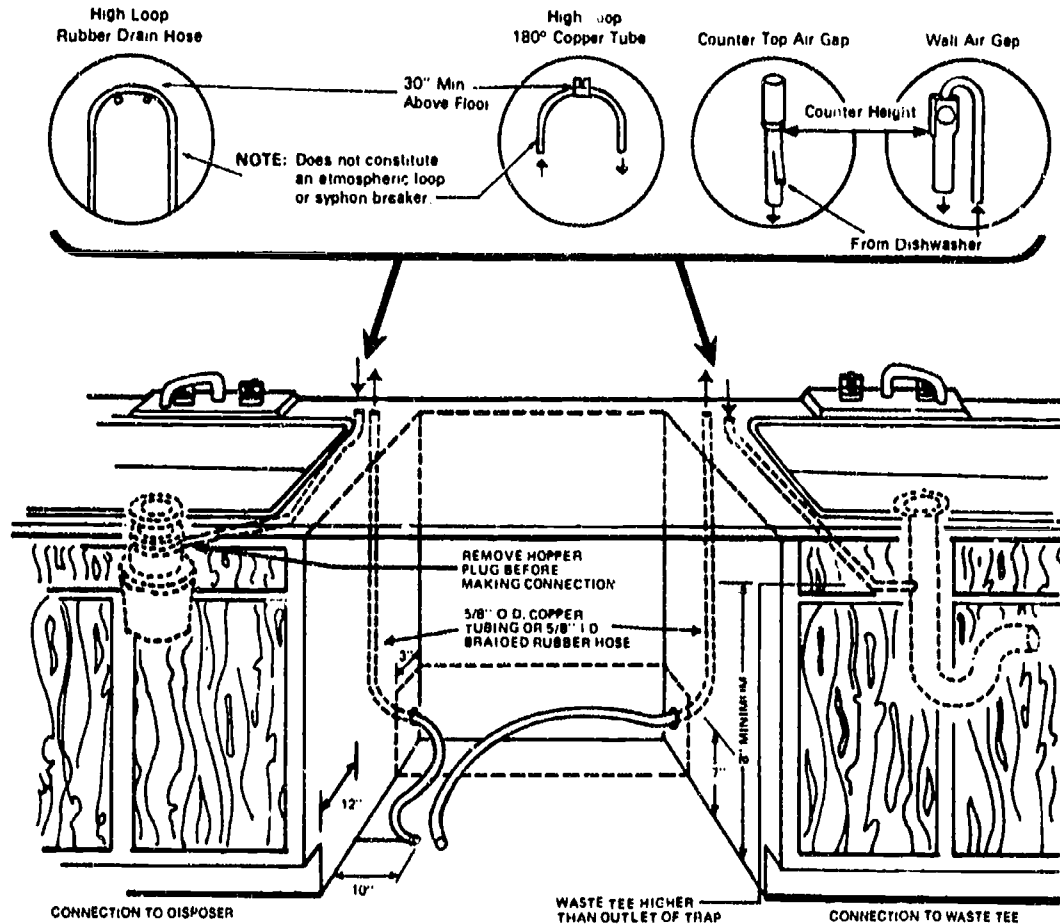

Courtesy Frigidaire

(NOTE: Air gaps are available locally and are easy to install through the sink spray hole or through a 1 $\frac{1}{4}$ " hole in an adjacent counter top. The air gaps tighten down with a locknut and can be used with compression fittings or solder joints depending on local codes. An air gap made by the Frost Co. of Kenosha, Wisconsin is shown in Figure 4.)

C. Routine #2 — Installing a dishwasher

1. Use the dolly to place the dishwasher near the enclosure, and remove padding.
2. Remove the toe/service panel by removing the two screws at the bottom and lifting up. (Figure 5)
3. Adjust leveling screws so that the dishwasher is level with the counter top.
4. Slide dishwasher into enclosure being careful not to hit the switch at the top of the tub.

(CAUTION: If the screw heads on the front trim will scar the cabinets, leave the dishwasher about $\frac{3}{4}$ " out from the rest of the cabinets and make appropriate adjustments for the hot water line.)

JOB SHEET #1

5. Fasten the brackets at the front of the dishwasher to the underside of the counter top with two #8 x 3/4" flat-head wood screws from the envelope that came with the dishwasher. (Figure 5)

(NOTE: The brackets may extend out a bit and require trimming.)

FIGURE 5

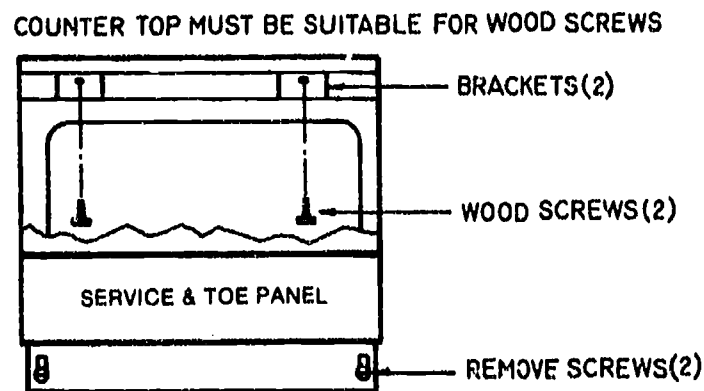

Courtesy Frigidaire

6. Assemble the 5/8" OD copper tubing drain line to the pump by clamping it to the short rubber hose with clamp provided. (Figure 6)

(NOTE: A long or short 5/8" ID rubber hose may be used if required.)

FIGURE 6

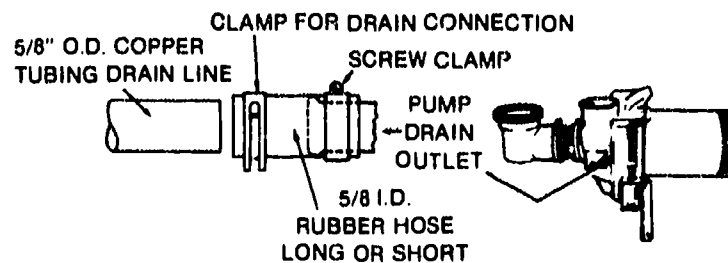

Courtesy Frigidaire

7. Remove the brass adapter assembly from the dishwasher fill valve.

JOB SHEET #1

8. Assemble a $\frac{1}{2}$ " OD sweat fitting or compression fitting to the incoming hot water supply line. (Figure 7)

(NOTE: Soft copper may be used with compression fitting, but the chances of leaks are less if you sweat the fitting with solder, and complete any soldering before installing the adapter assembly in the next step.)

FIGURE 7

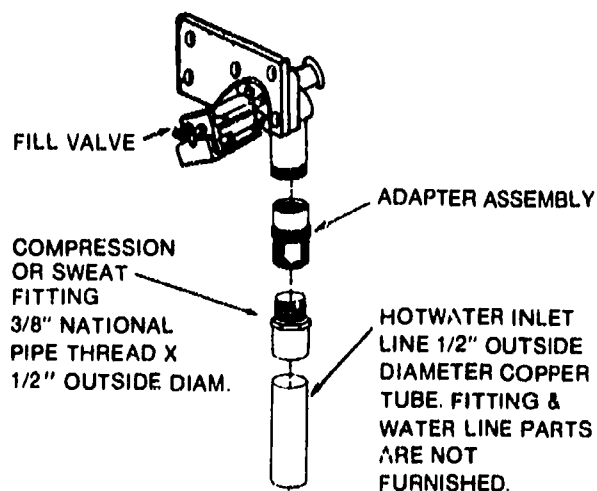

Courtesy Frigidaire

9. Apply pipe dope or Teflon tape to the sweat fitting threads and tighten the fitting onto the adapter assembly.
10. Tighten the adapter assembly to the fill valve as tight as you can get it by hand, then give it another quarter turn with a pair of pliers.
11. Turn on shut-off valve and check for water leaks at the adapter assembly and fill valve.
12. Tighten as needed and shut off water.
13. Doublecheck to make sure power is shut off to the electrical supply.
14. Connect the incoming black wire to black wire on dishwasher. (Figure 8)
15. Connect the incoming white wire to the white wire on dishwasher. (Figure 8)

JOB SHEET #1

16. Connect the incoming ground wire to the green ground screw. (Figure 8)

FIGURE 8

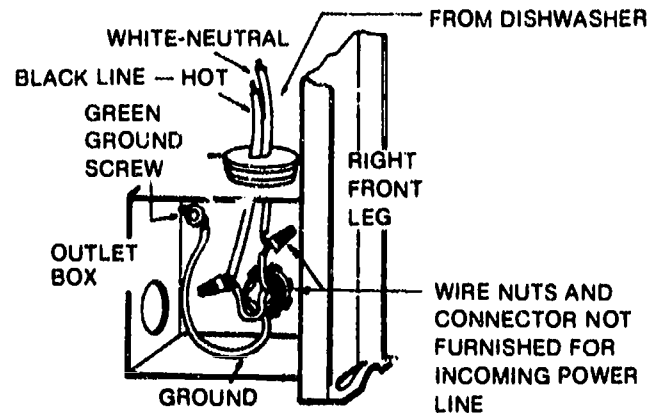

Courtesy Frigidaire

(CAUTION: Use UL approved wiring connectors to connect wiring, and if the connection calls for joining aluminum wiring to copper wiring, it should only be done with special materials and the work should be done by a licensed electrician.)

D. Routine #3 — Making final checks

1. Check to make sure that the dishwasher is properly lined up with adjacent cabinets and that the door opens and closes freely.

(NOTE: Sometimes the counter balance springs rub against adjacent cabinets and the dishwasher still requires a clearance adjustment.)

2. Reassemble toe/service panel by hooking the panel over the top hooks and then securing it with the two screws that were removed earlier. (Figure 9)

(NOTE: The toe panel provides the front cover for the electrical box, so make sure it is securely screwed on.)

FIGURE 9

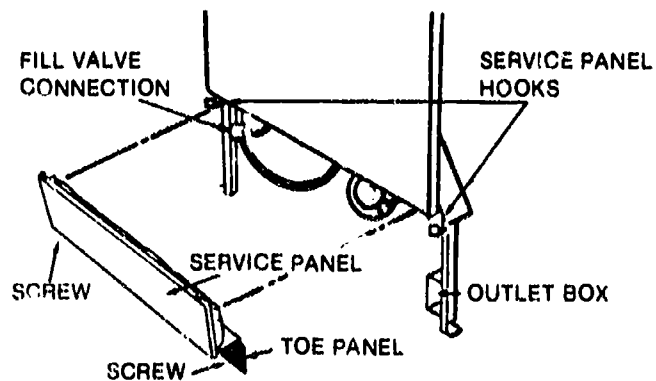

Courtesy Frigidaire

JOB SHEET #1

3. Remove all packing materials in the tub.
4. Remove literature package and place it safely aside.
5. Check plastic screen behind center post to make sure it is firmly in place. (Figure 10)
6. Place wash arm over pin in center post and turn it to make sure it has free spinning action. (Figure 10)
7. Check float to make sure it is free to operate. (Figure 10)

FIGURE 10

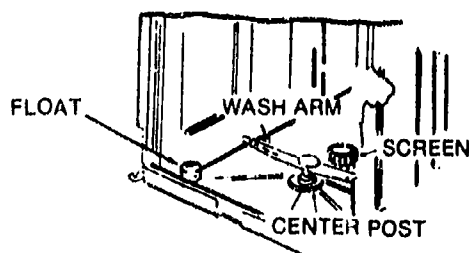

Courtesy Frigidaire

8. Check the water heater to make sure it is set no lower than 140°F and no higher than 160°F, and that it delivers minimum 140°F water to the dishwasher.
9. Check the dishwasher for level.
10. Turn hot water supply on.
11. Request some glasses and dishes from the customer and load them properly into the dishwasher.
12. Run the dishwasher through a complete cycle and watch for leaks and listen for unusual noises that might indicate a problem.
13. Use the time the dishwasher is completing its first complete cycle to offer the customer tips about using the dishwasher for maximum convenience and minimum trouble.
14. Check work order to make sure you have recorded the serial number, delivery date, and all needed warranty information.
15. Check dishes after first complete cycle.
(NOTE: It's normal for a little water to be left in the tub at the end of a cycle.)
16. Deliver the owner's manual to the customer and congratulate the customer on making an excellent dishwasher selection.
17. Clean up area as required and be on your way.

AUTOMATIC DISHWASHERS UNIT IX

JOB SHEET #2 — TROUBLESHOOT MALFUNCTIONS ON AN AUTOMATIC DISHWASHER

A. Tools and materials

1. Automatic dishwasher as selected by instructor
2. Service manual for dishwasher
3. Wiring diagram and timer sequence chart for dishwasher
4. VOM
5. Basic hand tools
6. Lint-free shop towels
7. Safety glasses

B. Routine #1 — Checking continuity on a door switch

1. Put on safety glasses and sign on your troubleshooting log.
2. Disconnect the dishwasher from power source or trip the breaker switch.
3. Remove the top panel on the door.
4. Remove the latch handle so it can slide through the front panel opening and be removed.
5. Open the door and remove the screws on either side so you can gain access to the door switch.

JOB SHEET #2

6. Check behind the panel for the wiring diagram and the timer sequence chart, and place them aside for troubleshooting reference and later replacement. (Figure 1)

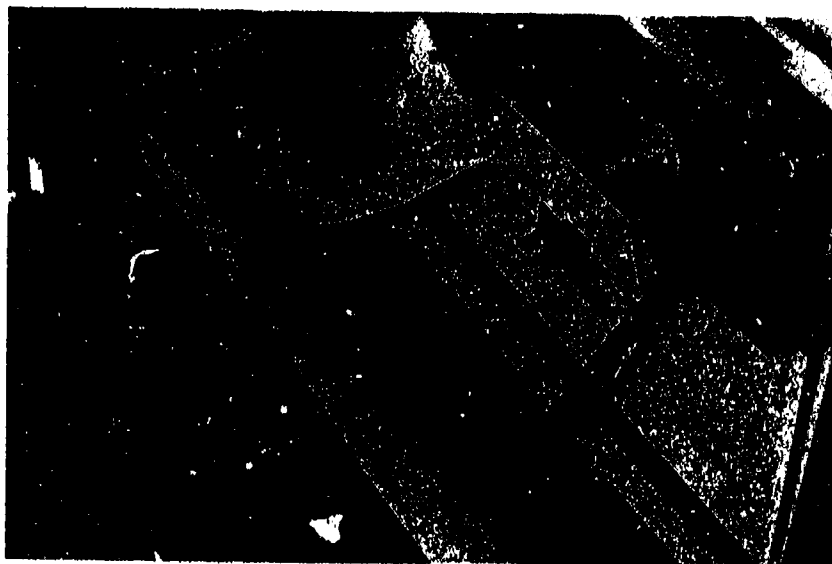
FIGURE 1

7. Remove the conductor lead from either door switch terminal.

(NOTE: The door switch is wired in series with the 120V power supply so that when the door is opened all power to the unit is shut off.)
8. Place the VOM leads in any order on the terminals of the door switch. (Figure 2)

FIGURE 2

- a. If there is a reading of zero when the switch is depressed to duplicate the door being locked and latched, and if there is a reading of infinity when the switch is released, the switch is okay
- b. Any other reading indicates the switch is bad and should be replaced

JOB SHEET #2

9. Record your findings and make replacement as required.
- Have your instructor check your work.
- C. Routine #2 — Checking continuity on a float switch
1. Remove the bottom panel from the dishwasher.
(CAUTION: Make sure power is off.)
 2. Set the VOM to R \times 1.
 3. Remove at least one conductor lead to the first switch.
(NOTE: This is a simple off/on switch that is a water overflow protection device.)
 4. Place the VOM leads in any order on the terminals of the float switch.
 5. Check and record your meter reading.
 - a. With dishwasher upright and flat in position, the reading should be zero to indicate the float switch is okay
 - b. If the reading is not zero, the float switch is bad and should be replaced
 6. Open the door, raise the float, and check your meter reading. (Figure 3)

FIGURE 3

- a. If the meter reading goes to infinity, the float switch is okay
- b. If the meter reading does not go to infinity, it means that the switch is stuck and the machine will overflow

JOB SHEET #2

- c. If the meter reading does not go to infinity, clean the float and area around it that the float fits into
 - 7. Open the door, raise the float, and check your meter reading again.
 - a. If the reading is now infinity, the float switch is okay
 - b. If the reading is other than infinity after cleaning the float, the float switch should be replaced.
 - 8. Record your findings.
 - Have your instructor check your work.
- D. Routine #3 — Checking continuity on a water fill valve solenoid
- 1. Remove the bottom panel on the dishwasher.
(CAUTION: Make sure the power is off.)
 - 2. Set the VOM to R \times 1.
 - 3. Remove at least one conductor lead to the water fill valve solenoid.
(NOTE: This is to eliminate the prospects that you will read back through the circuit and get an improper reading.)
 - 4. Place VOM leads in any order on the solenoid terminals. (Figure 4)

FIGURE 4

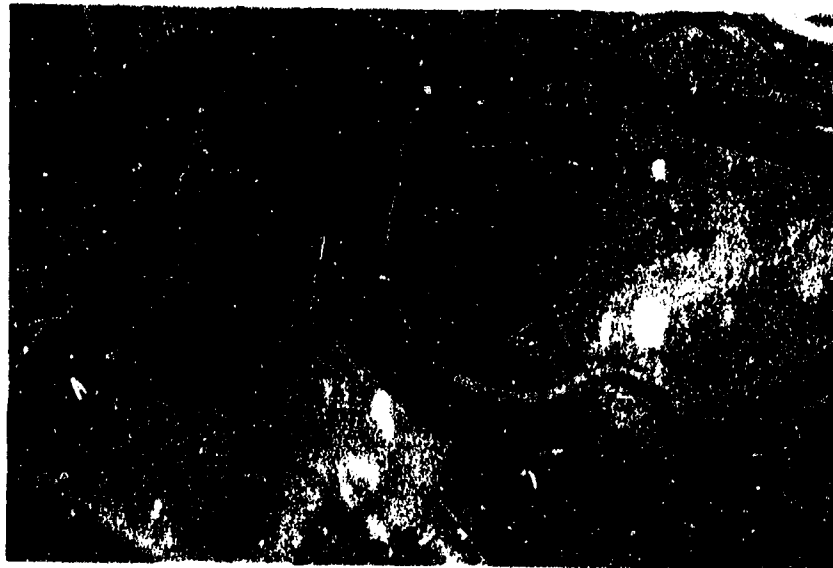

- a. If the reading is about 500 to 600 ohms, the water fill valve solenoid is okay
- b. If the reading is zero, the water fill valve should be replaced

JOB SHEET #2

- c. If the reading is too high, there are bad connections within the solenoid and the water fill valve solenoid should be replaced

(NOTE: If another solenoid of the exact type is available, the solenoid can be replaced instead of having to replace the entire water fill valve.)

- d. If electrical checks appear to be okay but the water fill valve still doesn't work, go on to the next routine for cleaning the filter screen on the water fill valve.

5. Record your findings.

Have your instructor check your work.

E. Routine #4 — Cleaning the water fill valve filter screen

1. Shut the water off to the dishwasher.
2. Disconnect the hose that feeds the water from the valve into the dishwasher.
3. Remove the water fill valve from its mounting and save the mounting screws.

(NOTE: On brass body valves with tube-screen filters, the valve does not have to be removed.)

4. Place the valve on a clean working surface.
5. Disconnect the $\frac{3}{8}$ " inlet water line to the valve.
6. Remove the flange that holds the filter screen to the plastic body.

(NOTE: Plastic body fill valves all have filter screens like the screens in washing machine water supply lines, but sized to fit the fill valve.)

7. Remove the screen and clean it if it can be cleaned, or replace it if it's rusted or otherwise unserviceable. (Figure 5)

(NOTE: The same applies to tube-screen filters on brass body fill valves.)

FIGURE 5

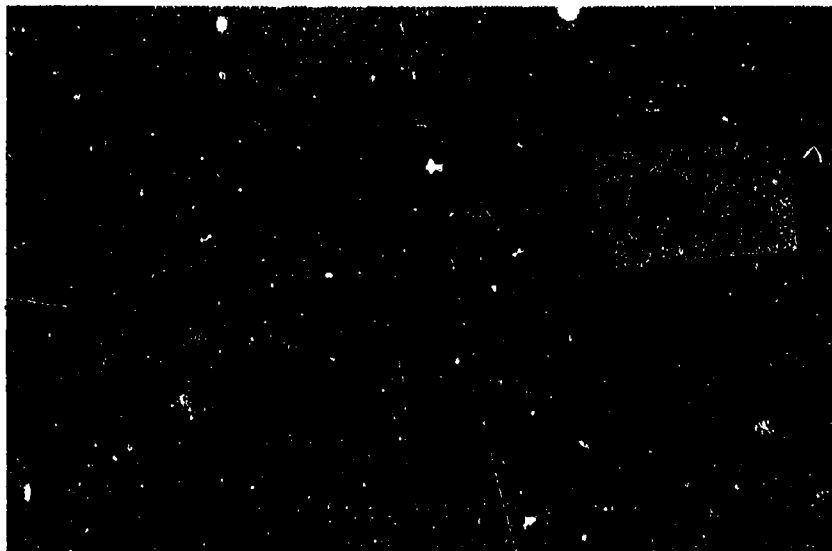

JOB SHEET #2

8. Secure the new filter, reassemble fill valve, and remount, if required.

Have your instructor check your work.

F. Routine #5 — Checking continuity on a start relay

1. Remove the bottom panel on the dishwasher.

(CAUTION: Make sure power is off.)

2. Remove the start relay from its mounting and be sure to save the mounting screws.

3. Look for the arrow on the bottom edge of the start relay and hold the relay so that the arrow points up. (Figure 6)

FIGURE 6

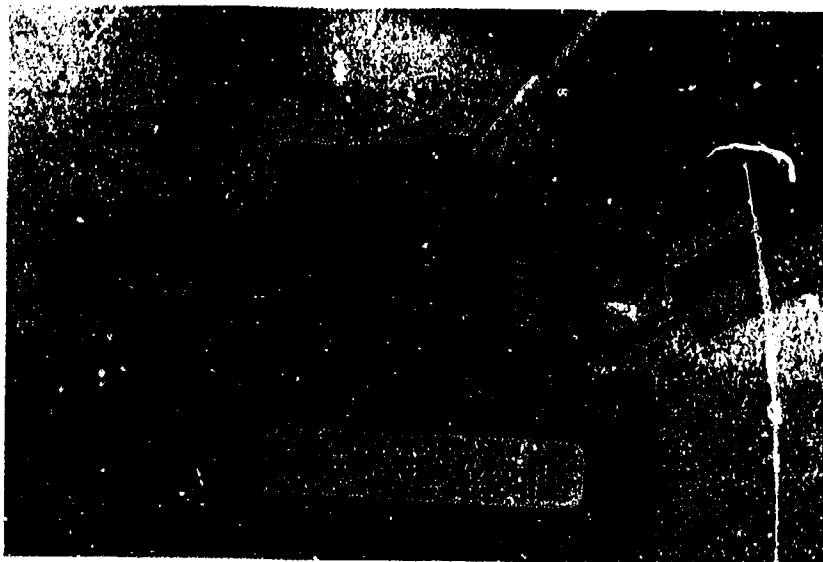

4. Place one VOM lead on the M terminal and the other VOM lead on the L terminal of the start relay.

5. Check for a continuity of zero ohms.

(NOTE: If you're using a digital VOM, you may get a reading of 1/2 to 1 ohm, but this should indicate the relay is okay.)

6. Place the VOM leads on terminals S and L of the relay.

7. Check to make sure there is no reading, and if there is a reading it means the plunger in the relay is stuck and the relay should be replaced.

8. Keep the VOM leads held securely to terminals S and L and physically turn the start relay upside down so that the arrow points downward.

JOB SHEET #2

9. Note the meter reading; it should be zero ohms.

(CAUTION: What you have just accomplished in Steps 8 and 9 is to show how the start relay is activated; if the dishwasher is started while it is on its back or side, the start relay cannot engage, improper voltage reaches the motor, and THE MOTOR BURNS UP; in other words, never start an automatic dishwasher in any position other than UPRIGHT!)

10. Record your findings.

Have your instructor check your work.

G. Routine #6 — Checking continuity on a heating element

1. Set the VOM for R \times 1.
2. Make sure power is off.
3. Remove the bottom panel from the dishwasher.
4. Remove either lead (red or white) from the heater unit.
5. Place one VOM lead on each of the terminals to the heater element. (Figure 7)

FIGURE 7



6. Record the reading.

(NOTE: Reading should be in the range of 10 to 20 ohms; check with your instructor if it is different.)

JOB SHEET #2

7. Remove one VOM lead from either heater element terminals and place the VOM lead on any green ground wire.

(NOTE: This will let you know if the heating element is shorted to the cabinet.)

8. Check for a reading of infinity on the VOM, and if the reading is other than infinity, the heating element is bad and should be replaced.
9. Switch VOM/terminal leads and make the ground check on the opposite terminal.
10. Check for a reading of zero on the VOM, and if the reading is other than zero, the heating element is bad and should be replaced.
11. Record your findings.

Have your instructor check your work.

H. Routine #7 — Checking continuity on detergent dispenser

1. Remove the bottom front panel on the dishwasher.

(CAUTION: Make sure power is off.)

2. Remove at least one lead from the dispenser solenoid.

(NOTE: Some detergent dispensers are spring-loaded, solenoid-actuated components which in turn are actuated by a signal from the timer, so essentially, the problem is either with the solenoid or the spring.)

3. Place the VOM leads in any order on the terminals of the solenoid. (Figure 8)

FIGURE 8



JOB SHEET #2

- a. If there is a reading of 500 to 600 ohms, the solenoid is okay and the spring-loaded mechanism needs to be checked and cleaned.
- b. Calcium deposits build up so heavily on the spring mechanism that a knife or screwdriver blade may have to be used to clean them off.
- c. If the solenoid reading is too high or too low, replace the solenoid

4. Record your findings.

Have your instructor check your work.

I. Routine #8 -- Checking a dishwasher timer

(NOTE: Timers on automatic dishwashers are mostly sealed units that simply have to be replaced if they're not advancing properly, but the following routine will be helpful if a timer is misaligned or a timer motor is burned out; a disconnect timer would be an exception to this routine.)

1. Make sure power is off, and remove the timer from the control panel.
2. Make a diagram of all conductor/terminal connections before removing any wires.
3. Remove conductors from timer with care because the terminals break easily.
4. Make a visual inspection of the timer terminal board to see if any terminals indicate charring that would indicate a short has destroyed internal connections. (Figure 9)

FIGURE 9



- a. If the terminal board is burned, the timer will have to be replaced.

JOB SHEET #2

- b. If the terminal board is okay, then the timer sequences chart should be checked and all timer functions should be traced and checked with a VOM.
5. Complete circuit checks and identify sequence malfunction.
 - a. If there appears to be a major problem with any sequence function, the timer should be replaced.
 - b. If the sequence appears to be either too slow or too fast, check the timer motor.
6. Remove the motor assembly and disconnect the two leads from the terminal block that lead to the motor.
7. Remove the motor, place it on a flat surface, and hook up a test cord for power.
8. Mark a point on the motor gear and a point on the motor housing to use as a reference. (Figure 10)

(NOTE: A timer runs so slowly that it can't be timed by looking at it.)

FIGURE 10



9. Permit the motor to run ten or fifteen minutes.
10. Determine whether or not the motor has moved a significant distance.
 - a. If the motor has not moved, replace it.
 - b. If the motor has moved, the motor is probably okay and the problem is in the timer itself, and the timer should be replaced.

JOB SHEET #2

11. Inspect the gears for evidence that a ring has worn around the drive gear on the motor shaft, and if so, replace the motor.
12. Record your findings.
- Have your instructor check your work.
13. Sign off your troubleshooting log and make a note of any problems you had with the routines in this job sheet.
14. Clean up area and return tools and materials to proper storage, or prepare for next job sheet as directed by your instructor.

AUTOMATIC DISHWASHERS UNIT IX

JOB SHEET #2

TROUBLESHOOTING LOG

	Date	Time On	Time Off
Routine #1 — Checking Continuity on a Door Switch			
Routine #2 — Checking Continuity on a Float Switch			
Routine #3 — Checking Continuity on a Water Fill Valve Solenoid			
Routine #4 — Cleaning the Water Fill Valve Filter Screen			
Routine #5 — Checking Continuity on a Start Relay			
Routine #6 — Checking Continuity on a Heating Element			
Routine #7 — Checking Continuity on a Detergent Dispenser			
Routine #8 — Checking a Dishwasher Timer			

Your name _____ Date _____

Note below any special problems you encountered in any of your troubleshooting routines:

AUTOMATIC DISHWASHERS UNIT IX

JOB SHEET #3 — INSPECT THE SEAL ON AN AUTOMATIC DISHWASHER

A. Tools and materials

1. Automatic dishwasher manufactured by D&M
2. Appropriate service literature
3. Basic hand tools
4. Replacement seal kit as required
5. Troubleshooting log
6. Clean shop towels
7. Pencil
8. Safety glasses

B. Procedure

1. Put on your safety glasses
2. Sign on your troubleshooting log
3. Make sure the dishwasher is unplugged from its power source
4. Wipe the seal area dry with a clean shop towel
5. Remove the nut that secures the spray arm to the diffuser housing (Figure 1)

FIGURE 1



JOB SHEET #3

6. Remove the nut and washer that hold the housing over the diffuser; then remove the housing and inspect the diffuser for chipped or broken vanes (Figure 2)

FIGURE 2



7. Remove the upper impeller and inspect the O-ring that seals the impeller to its shaft, and replace the O-ring if it's bad (Figure 3)

FIGURE 3



8. Remove the two remaining screws holding the pump plate in place, and then remove the pump plate and blade (Figure 4)

FIGURE 4



JOB SHEET #3

9. Remove the lower impeller and inspect it for chipped or broken vanes (Figure 5)

FIGURE 5



10. Remove the lower seal and shim from off the motor shaft, and this may require working it out with the blade of a screwdriver (Figure 6)

FIGURE 6



11. Inspect the shim on top of the seal and replace if it is worn or cracked (Figure 7)

FIGURE 7



JOB SHEET #3

12. Inspect the lower seal that fits around the motor shaft, and replace it if it shows any signs of wear at all because this is the seal that keeps water from flowing down onto the motor (Figure 8)

FIGURE 8

- Have your instructor check your work
13. Reassemble the seal by reversing the disassembly procedure, and replace the spray arm (Figure 9)

FIGURE 9

14. Attach water hoses as required, plug the dishwasher in, and run it through a complete cycle as you check for leaks
- Have your instructor check your work
15. Sign off your troubleshooting log
16. Clean up area and return tools and equipment to proper storage

AUTOMATIC DISHWASHERS UNIT IX

JOB SHEET #3

TROUBLESHOOTING LOG

Date _____ Time On _____ Time Off _____

Condition of upper diffuser _____

Condition of Impeller O-ring _____

Condition of lower Impeller _____

Condition of shlm _____

Your Name _____ Date _____

Note below any problems you had with this procedure:

AUTOMATIC DISHWASHERS UNIT IX

NAME _____

TEST

1. Match the terms on the right with their correct definitions.

- | | | |
|---------|---|-------------------|
| _____a. | Water containing mineral salts in quantities enough to interfere with lathering, sudsing, or cleaning properties of soaps and detergents | 1. Water softener |
| _____b. | Water such as rainwater that contains none or few mineral salts | 2. Soft water |
| _____c. | A mineral deposit that remains after a substance containing calcium carbonate is subjected to heat | 3. Rinsing agent |
| _____d. | Any chemical that removes mineral salts from water or a filtering device that uses chemicals to remove minerals from water | 4. Hard water |
| _____e. | The process of running cold water out of a hot water supply line to assure that only hot water of a desired temperature will be available | 5. Lime build-up |
| _____f. | Chemicals added to water during a rinse cycle to enhance the ability of the water to remove other chemical or detergent residue from dishes | 6. Purge |

TEST

2. Match major components of a dishwasher with their functions.

- | | | |
|---------|--|--------------------|
| _____a. | The electromechanical "brain" of an automatic dishwasher because it controls the operations of other components in a predetermined sequence | 1. Drain valve |
| _____b. | Controls water flow through the inlet hose into the tub | 2. Inlet valve |
| _____c. | The source of power for driving the impeller that spins to complete the washing cycle | 3. Door/lid switch |
| _____d. | The device that maintains water temperature and provides heat for the hot air used during the drying cycle | 4. Timer |
| _____e. | Forces water through the spray arms during the wash and rinse cycles and forces water and food particles out of the dishwasher during pumpout | 5. Dispensers |
| _____f. | Perforated extensions that reach out horizontally below and above the dishracks to provide a route for the revolving pressurized hot water that is sprayed onto the dishes | 6. Motor |
| _____g. | The device that separates food particles from the water so they won't be sprayed back onto the dishes | 7. Float switch |
| _____h. | Directs dirty water and food particles away from the dishwasher into a drain system | 8. Heating element |
| _____i. | Keeps the tub from filling until the door is closed to eliminate the prospects that water will spray out of an open door or lid into the kitchen | 9. Filter |
| _____j. | Devices for releasing detergent and rinsing agent | 10. Spray arms |
| _____k. | Safety device to prevent overfilling | 11. Pump |

3. Arrange in order the typical steps in an automatic dishwasher cycle by placing the correct sequence number in the appropriate blank.

- _____a. The upper spray arm deflects the water back down over the dishes and the washing action between the lower and upper spray arms is repeated over and over again

TEST

- _____b. As water runs off the dishes, it flows through a filtering system to keep food particles from being sprayed back onto the dishes
 - _____c. Rinse conditioner should be added as recommended or as local water conditions demand
 - _____d. Water enters the tub through the inlet hose and inlet valve until there is approximately two gallons of water in the tub
 - _____e. Dirty dishes should be properly arranged in the dishracks
 - _____f. Detergent as recommended by the manufacturer, and in the proper quantity, should be placed in the detergent dispenser
 - _____g. As each wash or rinse cycle ends, water is pumped out of the dishwasher and small food particles are flushed away with it
 - _____h. As the drying cycle starts, the heating element comes on so that hot air can be circulated over and around the dishes to help dry them
 - _____i. The heating element is energized to assure that the water will be at least 140°F
 - _____j. The motor is energized and pumps hot water through the lower spray arm in a jet stream and over the dishes to the upper spray arm
4. Complete statements concerning special considerations for dishwasher installation by inserting the word(s) or figure(s) that best completes each statement.
- a. There must be a proper _____ power supply, and it is recommended that the circuit be equipped with a 15-amp time delay fuse
 - b. Dishwasher must be properly _____
 - c. _____ cords should not be used to extend the power supply because they usually result in low line voltage
 - d. _____ line voltage does not permit the motor to operate at its rated capacity and results in poor washing action and water circulation
 - e. A dishwasher should be installed only on a sturdy, level floor in a well _____ area
 - f. Dishwasher drain hookups must be _____ the equipment and free of obstructions that might impair proper drainage
 - g. The water supply must have a minimum flow rate of three gallons per minute and a minimum pressure of _____ psi
 - h. Water supply must also be in the range of _____ °F to _____ °F because some detergents will not dissolve and work at lower temperatures, and the higher temperature also helps in the drying cycle

TEST

5. Select true statements concerning water problems with dishwashers by placing an "X" beside each statement that is true.

- ____a. Loading patterns vary with design, so follow operator's manual carefully
- ____b. Stains on dishes result from poor detergent
- ____c. When piping is so old that rust cannot be controlled, it should be replaced
- ____d. Minerals in the water not only cause stains, they lead to lime build-up even in cases where the detergent recommended is designed to fight lime build-up
- ____e. Cleaning the dishwasher with a good detergent will help control lime build-up
- ____f. The best way to control stains, spots, and lime build-up is to install a new water line

6. Complete statements concerning loading order in dishwasher operation by inserting the word(s) that best completes each statement.

- a. Each model dishwasher has its own spray or splash pattern for water action and the order in which dishes are loaded must facilitate dishwasher _____
- b. _____ is the best aid to proper placement, but generally, nothing should be placed on one rack that would block the flow of water to another rack
- c. Cups and glasses and any containers that will retain water should always be placed _____ so water will drain from them and they will dry
- d. Keep flatware and other utensils in their proper baskets because they can _____ seals and create problems if they're in the wrong place

7. Match common dishwasher misuses with their causes.

- | | |
|---|------------------------------|
| ____a. Results from careless neglect of instructions or when dishes are loaded by a child or other person unfamiliar with loading order | 1. Careless dish preparation |
| ____b. Results when dishes or utensils with dried food caked on them are not wetted and scraped before loading | 2. Improper dishrack loading |
| ____c. Results when small bones or large seeds are carelessly left on dishes | 3. Improper detergent use |
| ____d. Results when soap flakes or soap powders are used instead of the recommended detergent | 4. Improper dish preparation |

TEST

8. Select true statements concerning guidelines for better dishwasher service by placing an "X" beside each statement that is true.

- _____a. When a dishwasher is hooked up with a garbage disposer, the disposer should be completely empty so water will drain freely through the disposer
- _____b. Before starting the dishwasher, run hot water at the sink to purge cold water out of the line and assure that only hot water enters the dishwasher
- _____c. The same amount of water goes through a dishwasher each time it is used, so even when washing half a load, enough detergent for a full load should be placed in the dishwasher

9. Complete statements concerning guidelines for troubleshooting automatic dishwashers by inserting the word(s) or figure(s) that best completes each statement.

- a. Before assuming anything about a malfunctioning dishwasher, remember that almost _____% of dishwasher problems are not related to component failures
- b. Check for a proper _____V electrical power source
- c. Check for a hot water supply of _____°F to _____°F and for a minimum water pressure of 15 psi
- d. Check for a faulty floor that may be causing the dishwasher to _____ or a poor installation that does not provide ventilation
- e. Make sure the dishwasher is not being operated with improper _____, loaded improperly, or subjected to other forms of abuse
- f. Check the removable panel at the back or front of the machine for a schematic _____ and compare it with the operating sequence of the timer to systematically track down other problems
- g. Refer to the manufacturer's _____ chart for specific problems
- h. Look for leaks or broken parts, listen for parts that are binding, and generally use your senses and your _____ to diagnose the problem properly
- i. Check with customer to see if _____ or _____ use is depleting the hot water supply

10. Complete a list of ways to prevent mineral build-up in an automatic dishwasher by inserting the word(s) that best complete each statement.

- a. Check the washer at regular intervals for the presence of a white, brown, or yellow build-up in _____

TEST

- b. When build-up is enough that it can be readily detected, Whirlpool recommends the following procedure:
- 1) Empty the dishwasher and set it for a _____ wash cycle
 - 2) Start dishwasher, and then _____ the door so it will _____ when it has filled enough for the wash cycle
 - 3) Add half a cup of _____ acid crystals to the tub
 - 4) Close the door latch and allow the dishwasher to _____ the cycle
 - 5) Run another complete _____ and _____ cycle to clean remaining residue from the tub and the drain system
- c. An alternate method of controlling lime build-up is to add two cups of distilled _____ to the tub instead of citric acid crystals
- d. In areas where a _____ stain is deposited on dishes, a quarter of a teaspoon of oxalic acid crystals used after dishes are washed should remove the iron deposits from the dishes
- e. Build-ups of tea stains on cups and saucers usually have to be removed by hand with a wash cloth saturated with _____
11. Complete statements concerning troubleshooting redeposit problems by inserting the word(s) that best completes each statement.
- a. Because redeposits leave white spots on dishes, everyone assumes the spots are undissolved detergent, but they may be undissolved _____ from foods
 - b. To isolate the problem, place a glass or dish under hot water:
 - 1) If the spots dissolve quickly in hot water, it is a _____ problem
 - 2) If the spots stick to the glass or dish, they are food _____
 - c. Detergent problems can be corrected by changing to a different detergent or mixing detergent with _____
 - d. Food starch problems require better precleaning, especially with containers used for mashed potatoes, cooked cereals, cream soups, and any pudding or dessert that has a _____ base
 - e. Both problems may be related to improper _____ and require adjustment of the _____ water supply control

TEST

(NOTE: If the following activities have not been accomplished prior to the test, ask your instructor when they should be completed.)

12. Demonstrate the ability to:
 - a. Install an automatic dishwasher under a counter. (Job Sheet #1)
 - b. Troubleshoot malfunctions on an automatic dishwasher. (Job Sheet #2)
 - c. Inspect the seal on an automatic dishwasher. (Job Sheet #3)

AUTOMATIC DISHWASHERS UNIT IX

ANSWERS TO TEST

- | | | | | |
|----|------------|--------------|----|----|
| 1. | a. | 4 | d. | 1 |
| | b. | 2 | e. | 6 |
| | c. | 5 | f. | 3 |
| 2. | a. | 4 | g. | 9 |
| | b. | 2 | h. | 1 |
| | c. | 6 | i. | 3 |
| | d. | 8 | j. | 5 |
| | e. | 11 | k. | 7 |
| | f. | 10 | | |
| 3. | a. | 7 | f. | 2 |
| | b. | 8 | g. | 9 |
| | c. | 3 | h. | 10 |
| | d. | 4 | i. | 5 |
| | e. | 1 | j. | 6 |
| 4. | a. | 120V | | |
| | b. | Grounded | | |
| | c. | Extension | | |
| | d. | Low | | |
| | e. | Ventilated | | |
| | f. | Near | | |
| | g. | 15 | | |
| | h. | 140, 160 | | |
| 5. | a, c, d, f | | | |
| 6. | a. | Design | | |
| | b. | Common sense | | |
| | c. | Upside down | | |
| | d. | Puncture | | |
| 7. | a. | 2 | | |
| | b. | 4 | | |
| | c. | 1 | | |
| | d. | 3 | | |
| 8. | a, b, c | | | |
| 9. | a. | 75 | | |
| | b. | 120 | | |
| | c. | 140,160 | | |
| | d. | Vibrate | | |
| | e. | Detergent | | |

ANSWERS TO TEST

- f. Wiring diagram
 - g. Service
 - h. Common sense
 - i. Shower, laundry
10. a. The tub
- b. 1) One
 - 2) Open, stop
 - 3) Citric
 - 4) Complete
 - 5) Wash, rinse
- c. White vinegar
 - d. Brown
 - e. Baking soda
11. a. Starch
- b. 1) Detergent
 - 2) Starches
- c. Water conditioner
 - d. Cornstarch
 - e. Water temperature, hot
12. Performance skills evaluated according to procedures written in the job sheets



GARBAGE DISPOSERS UNIT X

UNIT OBJECTIVE

After completion of this unit, the student should be able to discuss the major components of a garbage disposer and their functions in disposer operation. The student should also be able to outline guidelines for safe disposer operation, install a garbage disposer, and troubleshoot and repair a malfunctioning garbage disposer. These competencies will be evidenced by correctly performing the procedures outlined in the job sheets and by scoring 85 percent on the unit test.

SPECIFIC OBJECTIVES

After completion of this unit, the student will be able to:

1. Match terms related to garbage disposers with their correct definitions.
2. Complete statements concerning first considerations for garbage disposers.
3. Complete a list of safety rules for disposer operation.
4. Match major components of a garbage disposer with their functions.
5. Arrange in order the steps in garbage disposer operation.
6. Complete statements concerning the importance of cold water flow in a disposer.
7. Complete a list of common misuses that cause disposer problems.
8. Select true statements concerning items that can be placed into a garbage disposer.
9. Complete statements concerning guidelines for handling a jammed garbage disposer.
10. Select true statements about guidelines for installing a garbage disposer.
11. Complete statements concerning guidelines for troubleshooting disposer malfunctions.
12. Demonstrate the ability to:
 - a. Install a garbage disposer.
 - b. Free a jammed garbage disposer.

GARBAGE DISPOSERS UNIT X

SUGGESTED ACTIVITIES

- A. Provide students with objective sheet.
- B. Provide students with information and assignment sheets.
- C. Make transparencies.
- D. Discuss unit and specific objectives.
- E. Discuss Information sheet.
- F. Discuss and demonstrate the procedures in the job sheets.
- G. Invite a garbage disposer manufacturer's representative to talk to the class about garbage disposer design and operation.
- H. Invite a local or area appliance repair technician to talk to the class about typical disposer problems and how to best troubleshoot them.
- I. Give test.

CONTENTS OF THIS UNIT

- A. Objective sheet
- B. Information sheet
- C. Job sheets
 - 1. Job Sheet #1 — Install a Garbage Disposer
 - 2. Job Sheet #2 — Free a Jammed Garbage Disposer
- D. Test
- E. Answers to test

REFERENCES USED IN DEVELOPING THIS UNIT

- A. Meyerink, George. *Appliance Service Handbook*. Englewood Cliffs, NJ: Prentice-Hall, Inc., 1973.
- B. Anderson, Edwin P. *Home Appliance Servicing*. Indianapolis, IN 46268: Howard W. Sams & Co., Inc., 1974.

GARBAGE DISPOSERS UNIT X

INFORMATION SHEET

I. Terms and definitions

- A. **Batch feed** — A disposer type that uses a lid that locks in place to start the motor or unlocks to stop the motor so that waste cannot be fed into the disposer while it is running
- B. **Continuous feed** — A disposer type that uses an ON/OFF switch and appropriate safeguards so that waste can be fed into the disposer while it is running
- C. **Biodegradable** — That which can be readily decomposed through natural biological processes

Example: Biodegradable detergents are safe for septic systems because they can be broken down through bacterial action in the system

- D. **Local codes** — Legal guidelines for electrical and plumbing installations in a specific town, city, or geographic area where local geography may impose special needs on such installations

Example: In high risk earthquake zones, all kinds of transport lines must be buried in sand, and in cold climates, water lines must be buried below the frost line

- E. **Septic tank** — A holding facility for waste matter that is directed into lateral pipes placed in a sand/gravel bed to accomplish waste disposal in areas where waste cannot be fed into a sewer line

- F. **Trap** — That part of a drain pipe so shaped that water will stand in it to help seal off offensive odors that could otherwise return from a sewer or septic system

Example: U-traps, S-traps, and P-traps are all plumbing devices that hold standing water and get their names from their shapes

II. First considerations for garbage disposers

- A. Automatic garbage disposers and automatic dishwashers are the two appliances most subject to failure because of improper use or outright abuse by their operators.
- B. Customers having a new disposer installed should be carefully instructed in its proper use and the dangers improper use can pose to both the equipment and the customer.

INFORMATION SHEET

III. Safety rules for disposer operation

- A. NEVER place your bare hand into a garbage disposal even when the disposer is disconnected.
- B. ALWAYS run cold water when the disposer is operating.

(NOTE: Cold water is vital for clearing the impeller and cutters of food particles that may clog the disposer itself or the drain line.)

- C. NEVER use any kind of silverware to attempt to unjam a clogged garbage disposer

IV. Major components of a garbage disposer and their functions

- A. Lower housing — Contains the drive motor, the stationary shredding ring, and the flywheel
- B. Upper housing — Contains the starting controls, the impeller, and serves as the hopper into which wastes are placed
- C. Drive motor — The principle part of the disposer that provides the high torque required to drive the impeller
- D. Flywheel — A circular device driven by the motor shaft to provide inertia and to compensate for fluctuations in operating speeds
- E. Shredding ring — A stationary device circling the interior of the housing and so positioned that the impeller forces waste matter against its cutting edges

(NOTE: Cutters on a shredding ring are sometimes called vanes because of their shape or spurs because of the gouging action they cause.)

- F. Impeller — A rotating disk with projections that force waste against the shredding ring
- G. Mounting flange — The top lip of a disposer that is secured over a gasket and tightened to a support ring so that the disposer can be easily installed in a kitchen sink

(NOTE: The mounting flange is an easy installation feature that makes garbage disposers attractive appliances because modification to an existing sink is seldom required.)

- H. Tailpiece — The drain outlet of the disposer that permits easy hookup to existing plumbing with a slip-joint plumbing connection

(NOTE: Another attractive aspect of garbage disposers is that they seldom require modification of existing plumbing.)

INFORMATION SHEET

- I. Insulation — Surrounds lower housing and helps to keep down the noise of the motor and grinding sounds

V. Steps in garbage disposer operation

- A. Garbage is placed into the disposer
- B. The cold water is turned on
- C. The disposer cover is put in place and turned clockwise to activate the starting control switch, if it is a batch feed model
- D. The drive motor starts rotating
- E. Centrifugal force impels garbage outward from the rotating flywheel
- F. Garbage is shredded into small pieces as it is forced into the cutting edges of the shredding ring by the action of the impeller
- G. The shredded garbage is washed down through holes in the flywheel strainer plate and on out into the plumbing drain

(NOTE: A few models have a cold-water interlock that prevents the motor from starting unless there is a sufficient supply of cold water flowing into the disposer; this is usually an electrical connection on the cold water line just before the cold water faucet.)

VI. Importance of cold water flow in a disposer

- A. Cold water is required as a transporting agent to carry ground-up waste away.
- B. Cold water is required to solidify grease that may be placed into the disposer so that grease can be shredded and washed away like other waste.

(NOTE: When hot grease is washed down a drain, it almost always solidifies quickly in cold water and will eventually clog a drain.)

- C. Cold water also cools the motor shaft that turns the impeller so it won't overheat.
- D. Cold water should be allowed to continue to flow about 30 seconds after all wastes have been completely shredded so that the drain line will be completely flushed of wastes.

VII. Common misuses that cause disposer problems

- A. Overloading with waste is probably the biggest cause of disposer problems.

INFORMATION SHEET

- B. Failure to run sufficient water during disposer operation is probably the second biggest cause of disposer problems.

(NOTE: These two items should be emphasized when instructing a customer about proper disposer use.)

- C. Injecting inorganic materials such as glass or metallic items such as silverware cause a disposer to jam and lead to other major problems.
- D. Cloth, paper, and even string can cause a disposer to jam and lead to other major problems.
- E. Chemicals used to clean clogged drains should never be placed in a disposer because they will damage rubber and fiber seals and corrode metal parts.

VIII. Items that can be placed into a garbage disposer

- A. Waste vegetables and meat scraps
- B. Waste scraps of bread, potato and fruit peelings, and fruit seeds
- C. Bones that are not too large

(NOTE: Sticking part of a large bone into a disposer in hopes that it will shred it up little at a time is dangerous to the equipment and the user.)

- D. Waste grease and fats

(NOTE: Hot grease or fat should never be placed in a disposer because it may later clog up the plumbing line when it resolidifies; the cold water running into a disposer actually solidifies grease so it can be cut just like other waste and that is one reason a disposer requires cold instead of hot water.)

- E. All other soluble food wastes

IX. Guidelines for handling a jammed garbage disposer

- A. The most common problem with garbage disposers is that they get jammed (clogged) with food waste and have to be unjammed.
- B. When a disposer jams, always turn the disposer off, allow the motor to cool, and then press the reset button.

(NOTE: ON models with automatic reset, letting the motor cool will permit the automatic reset to work.)

- C. Turn on the motor-reversing switch, if the disposer has that feature, and permit the impeller to run in reverse until it is unjammed.

INFORMATION SHEET

- D. On models without a motor-reversing switch, turn the machine off, insert an unjamming tool, and manually turn the impeller backwards.

(NOTE: Check the owner's manual for proper use of the "unjamming tool," and if there is no tool, use a broom handle, a long-bladed screwdriver, or a T-handle wrench.)

- E. Attempt to run the motor forward to complete shredding of the obstacle that caused the jamming.
- F. If the obstacle jams the disposer again, turn the disposer off, repeat the procedure for freeing the impeller, but this time, reach in with a pair of tongs and remove the obstruction.

X. Guidelines for installing a garbage disposer

- A. Check the power supply to make sure it agrees with the voltage and frequency listed on the motor nameplate.

(NOTE: Some models may have a motor-reversing switch, but this is wired at the factory and requires no special attention at installation.)

- B. Make sure the disposer is properly grounded.
- C. Existing plumbing should be carefully examined to make sure it is suitable for the installation, and make sure local codes do not prohibit a disposer installation.

(NOTE: In areas where there are drainage problems, disposers may be prohibited.)

- D. The disposer should be hooked up to its own trap and not to a trap that serves another piece of equipment such as a washing machine.
- E. Unless codes require them, remove old grease traps, and if they are required, advise the customer to clean the trap every 90 days.
- F. Septic systems must have a minimum capacity of 500 gallons before a garbage disposer can function properly.

(NOTE: An old rule of thumb is that 500 gallons will serve a two-bedroom home and that 250 gallons should be added for each additional bedroom, but in all cases, local codes dictate whether or not a garbage disposer can be used with a septic system.)

- G. Encourage customers with septic systems to avoid placing anything into the disposer that is not biodegradable.

(NOTE: This includes items such as oyster and clam shells, cigar and cigarette butts, and many other inorganic items that clog a septic system.)

INFORMATION SHEET

XI. Guidelines for troubleshooting disposer malfunctions

- A. Always disconnect the power before inserting any kind of tool into the disposer.
- B. Check first to see that the impeller is free to turn and unjam it if it is obstructed.

(NOTE: If the impeller will not turn, the motor will not start.)
- C. Permit the motor to cool off if it has been running and then push the reset button.

(NOTE: On models with automatic resets, the reset will activate only after the motor cools off.)
- D. Make sure a proper 120V power supply is reaching the motor because low line voltage will cause a motor to overheat and stop.
- E. Check for a blown fuse.
- F. Check for loose wires at terminals.
- G. If all else seems to be in order, check all switches by disconnecting the power supply and making continuity checks.
- H. If switches appear to be okay, the motor itself will have to be checked.
- J. Continue with troubleshooting as the problem demands.
- I. Make sure the power supply and disposer are safely grounded.

GARBAGE DISPOSERS UNIT X

JOB SHEET #1 — INSTALL A DISPOSER TO MANUFACTURER'S SPECIFICATIONS

A. Tools and materials

1. Garbage disposer as selected by instructor
2. Installation and user's guide
3. Sink and installation area and electrical supply
4. Basic hand tools
5. Oil-base putty
6. Putty knife
7. Plumbing router for cleaning lines
8. Clean shop towels
9. Trash bag
10. Safety glasses

B. Routine #1 — Preparing sink and drain lines

(NOTE: The following procedure and illustrations are adapted from materials published by Frigidaire and are reprinted with permission; any other use is prohibited.)

1. Put on safety glasses.
2. Remove sink fittings, trap, and drain line from old sink are required.
3. Clean off old putty, caulking, or gasket material from the bottom and top of the sink drain hole.
4. Place trash into a garbage bag and keep the area as clean as possible as you work.
5. Clean the old kitchen drains thoroughly with a flexible plumber's cleaning router.

(NOTE: In a new home, this step is not required, but older drain lines are usually coated with hardened grease that will retard the flow of food waste; once the old lines have been cleaned, granulated food waste from the disposer will keep them clean in the future.)

6. Remove all written materials attached to the disposer and any special tools that come with the disposer.

JOB SHEET #1

C. Routine #2 — Installing the sink mounting assembly

1. Remove the sink mounting assembly from the dispose; by turning the mounting lugs to the left. (Figure 1)

FIGURE 1



2. Unscrew the mounting screws on the mounting ring surface. (Figure 1)
3. Take a good look at the entire sink mounting assembly so you'll know how it should look when it's back together, and then pry out the snap ring holding the sink sleeve. (Figure 2)
4. Separate all the parts and lay them aside. (Figure 2)

FIGURE 2



JOB SHEET #1

5. Use the putty knife to apply a liberal amount of oil-base putty around the top of the sink drain opening. (Figure 3)

FIGURE 3

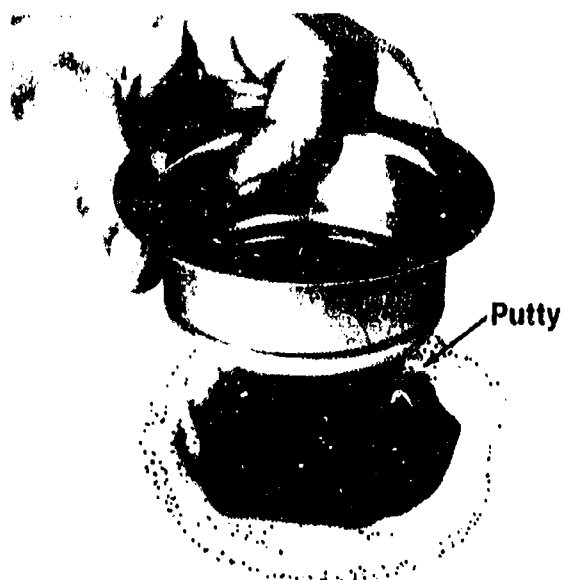

6. Place the sink sleeve into the sink drain opening. (Figure 3)
7. Get underneath the sink and place the fiber sleeve gasket over the sink sleeve. (Figure 4)
8. Install the back-up ring flat side up. (Figure 4)

FIGURE 4

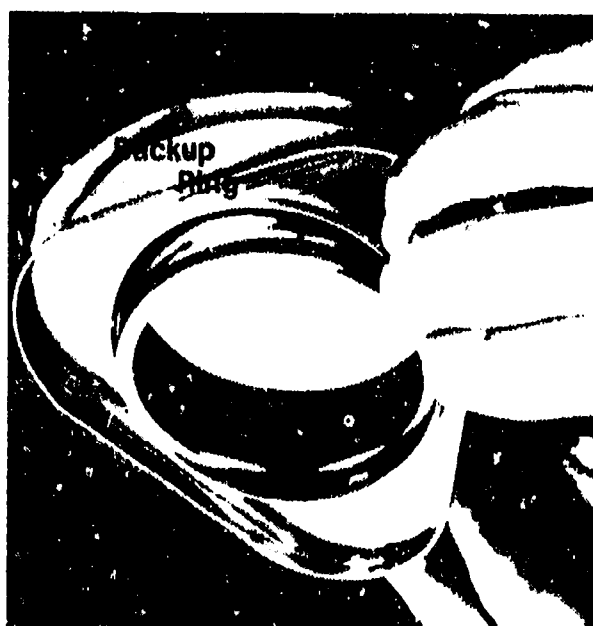

JOB SHEET #1

9. Take the mounting ring that contains the three screws and slip it onto the sink sleeve, and slide all the parts above the groove in the sleeve. (Figure 5)
10. Insert the snap ring into the groove in the sleeve. (Figure 5)

FIGURE 5

11. Tighten the three mounting screws evenly, and make sure they all fit into the back-up ring. (Figure 6)
12. Tighten the three mounting screws until the fiber sleeve gasket and back-up ring draw up tightly against the sink. (Figure 6)

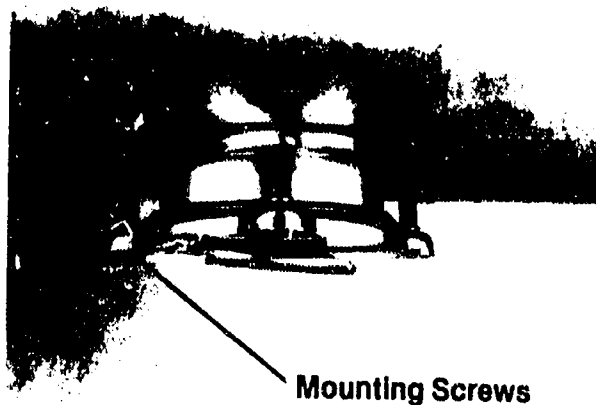
FIGURE 6

- Check your work (or have your instructor check your work) to make sure the sink mounting assembly is properly installed.

JOB SHEET #1**D. Routine #3 — Attaching the disposer to the sink**

1. Raise the disposer up to the sink mounting assembly so that the mounting lugs on the flange of the disposer are positioned to the right of the mounting screws on the mounting ring. (Figure 7)
2. Hold unit tightly in place and turn the body flange to the right until the three tabs on the body are engaged in the mounting assembly and the unit becomes self-supported. (Figure 7)

FIGURE 7

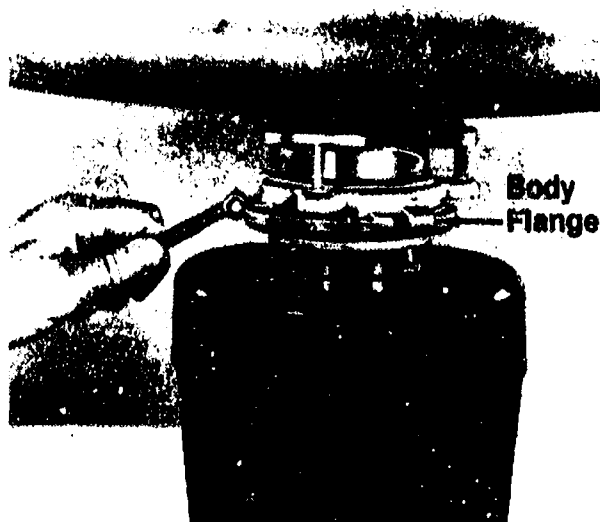

3. Tighten the body onto the mounting assembly, but do not tighten securely at this time. (Figure 7)
- Check your work (or have your instructor check your work) to make sure the body of the disposer is properly installed on the mounting flange.

E. Routine #4 — Making the plumbing connections

1. Install the discharge tube gasket into the disposer waste outlet opening. (Figure 8)

JOB SHEET #1

2. Place the discharge tube flange over the discharge tube and secure the tube in place over the tube gasket with two flange screws. (Figure 8)

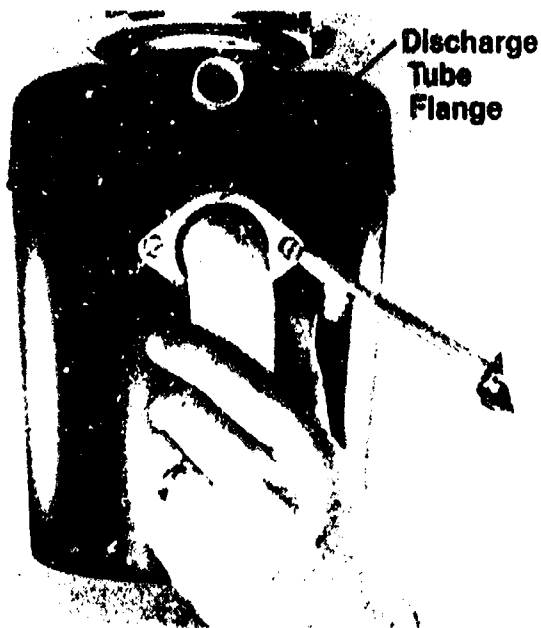
FIGURE 8

3. Rotate the disposer as required to align the discharge tube with the trap. (Figure 9)
4. Tighten the slip nut on the trap for connection to the discharge tube and secure the tube to the trap. (Figure 9)

FIGURE 9

JOB SHEET #1

5. Insert the special wrench or screwdriver from the LEFT side into a mounting lug. (Figure 10)
6. Turn the body flange right until all three locking tabs pass over the three lock ridges into position. (Figure 10)

FIGURE 10



7. Place the stopper in the "seal" position and fill the sink with water.
 8. Remove the stopper and permit water to flow as you check for leaks.
- Check your work (or have your instructor check your work) and correct leaks as required.

F. Routine #5 — Making a disposer/dishwasher connection

1. Remove the knockout plug in the dishwasher inlet by inserting a cold chisel into the dishwasher inlet at an angle, but do not center the chisel.
2. Tap the chisel sharply with a hammer to remove the knock-out plug.
3. Reach inside with tongs and remove the knock-out plug from the disposer.
4. Make all connections to comply with local plumbing codes.

(NOTE: Generally, flexible connections from the dishwasher into a counter-level air gap and then down to the disposer dishwasher inlet are acceptable, but in all cases, the installation must meet local codes which may require compression fittings or soldered joints.)

JOB SHEET #1

5. Use a dishwasher connector kit if one is available, and keep all trap connections to manufacturer's specifications. (Figure 11)

(NOTE: Connector kits for the Frigidaire food waste disposer are available from a Frigidaire dealer or an authorized Frigidaire service center.)

FIGURE 11

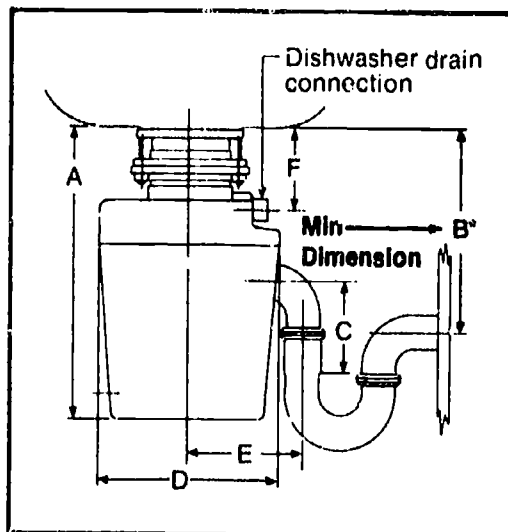

- Check your work (or have your instructor check your work) to see that all fittings are tight.

G. Routine #8 — Making disposer electrical connections

1. Turn the OFF-ON switch to the OFF position, and disconnect electric power at the breaker box or remove the fuse before starting this routine.

(NOTE: This routine assumes that electrical connections are already present, and if the connections are not present, check with your instructor.)

JOB SHEET #1

- Remove the electrical cover from the bottom of the disposer and pull out the two electrical wires there. (Figure 12)

FIGURE 12

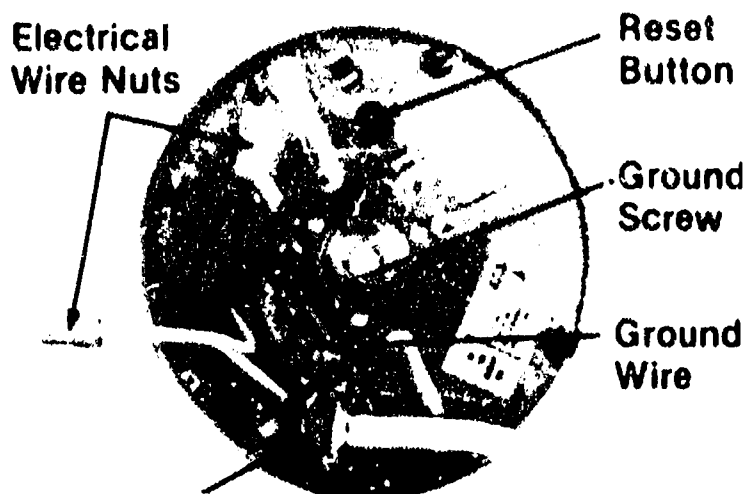

Place locknut backward on connector before threading connector into end bell. Then secure locknut against end bell.

- Install an appropriate electrical connector in the opening on the bottom of the unit, and secure the connector with a lock nut.

(NOTE: The installation can use BX, Greenfield, or a Romex connector.)

- Insert the three-wire lead into the connector and tighten the clamp.
- Connect the ground wire to the grounding screw on the disposer.

(CAUTION: Grounding properly is extremely important for a disposer, so make sure the disposer is properly connected to a grounded, metal, permanent wiring system; if needed, an equipment-grounding conductor must be run with the circuit conductor and connected to the grounding terminal lead on the disposer.)

- Connect the white wire from the disposer to the neutral wire of the power supply.
- Connect the black wire from the disposer to the black wire of the power supply.
- Plug cord-connected disposer, if it is one, into a properly grounded receptacle designed for a three-prong plug.
- Replace the electrical cover on the bottom of the disposer.

- Check all connections (or have your instructor check them).

JOB SHEET #1**H. Routine #7 — Making an Initial test run**

1. Remove the drain cover from the disposer and turn on a medium flow of cold water and leave the water on during the entire disposer operation.
 2. Check for leaks once again.
 3. Turn the breaker on or replace fuse as required to start the disposer, then turn the wall switch ON.
 4. Feed food waste into the disposer while it is operating.
 5. Permit disposer to operate until waste has been properly ground up (you can tell by the sound), and then let the disposer continue to run with cold water running for about another 30 seconds so all waste will be completely flushed down the drain.
 6. Turn the wall switch OFF and turn the cold water off.
 7. Deliver warranty and operating instructions to customer.
 8. Explain warranty and advise customer on proper use.
 9. Congratulate the customer on a wise disposer selection.
 10. Clean area as required, thank the customer, and leave on a positive note.
- Have your instructor evaluate your installation.

GARBAGE DISPOSERS UNIT X

JOB SHEET #2 — FREE A JAMMED GARBAGE DISPOSER

A. Tools and materials

1. Garbage disposer as selected by instructor
2. Special unjamming wrench, if available
3. Pair of tongs
4. Broom handle, if unjamming tool not available
5. Trash bag or box
6. Safety glasses

B. Procedure

(NOTE: The following procedure and illustration are adapted from materials copyrighted by Frigidaire and are reprinted with permission; any other use is prohibited.)

1. Put on safety glasses
2. Make sure the electrical power to the disposer is turned OFF at the breaker, or remove the fuse.
3. Use a pair of tongs to remove as much food waste from the disposer as possible and place the waste in a trash bag or box for later disposal.
4. Insert the special wrench that came with the disposer into the center hole at the bottom of the disposer. (Figure 1)

(NOTE: This is a special Frigidaire wrench, and other manufacturer's may supply a different type of wrench.)

FIGURE 1

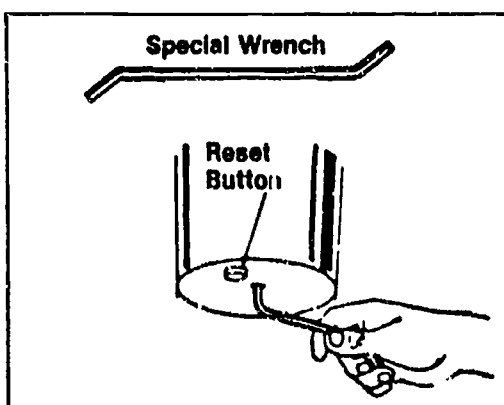

JOB SHEET #2

5. Work the wrench back and forth until you can turn the flywheel freely for at least one complete revolution.

(NOTE: In case you do not have a special unjamming tool, your instructor may direct you to insert a broom handle into the top of the disposer and attempt to turn the flywheel to unjam the unit.)

6. Use a pair of tongs to remove the foreign object that caused the disposer to jam.
7. Wait 5 minutes to allow the motor to cool.
8. Push the red restart button at the bottom of the disposer.
9. Turn on the cold water and restore power to the disposer.
10. Allow the disposer to run until it has been thoroughly flushed.
11. Place food waste removed in Step 2 into the disposer and allow the disposer to run until all waste has been disposed of and the disposer is thoroughly flushed.
12. Turn off disposer and cold water (in that order).
- Have your instructor check your work.
13. Clean up area and return tools and materials to proper storage.

GARBAGE DISPOSERS UNIT X

NAME _____

TEST

1. Match the terms on the right with their correct definitions.

- | | | |
|---------|---|--------------------|
| _____a. | A disposer type that uses a lid that locks in place to start the motor or unlocks to stop the motor so that waste cannot be fed into the disposer while it is running | 1. Septic tank |
| _____b. | A disposer type that uses an ON/OFF switch and appropriate safeguards so that waste can be fed into the disposer while it is running | 2. Continuous feed |
| _____c. | That which can be readily decomposed through natural biological processes | 3. Local codes |
| _____d. | Legal guidelines for electrical and plumbing installations in a specific town, city, or geographic area where local geography may impose special needs on such installations | 4. Trap |
| _____e. | A holding facility for waste matter that is directed into lateral pipes placed in a sand/gravel bed to accomplish waste disposal in areas where waste cannot be fed into a sewer line | 5. Batch feed |
| _____f. | That part of a drain pipe so shaped that water will stand in it to help seal off offensive odors that could otherwise return from a sewer or septic system | 6. Biodegradable |

2. Complete statements concerning first considerations for garbage disposers by inserting the word(s) that best completes each statement.

- a. Automatic garbage disposers and automatic dishwashers are the two appliances most subject to failure because of _____ use or outright _____ by their operators.
- b. Customers having a new disposer installed should be carefully instructed in its proper use and the _____ improper use can pose to both the equipment and the customer.

TEST

3. Complete the list of safety rules for disposer operation by inserting the word(s) that best completes each statement.

- a. NEVER place your bare hand into a garbage disposal even when the disposer is _____.
- b. ALWAYS run _____ water when the disposer is operating.
- c. NEVER use any kind of _____ to attempt to unjam a clogged garbage disposer.

4. Match major components of a garbage disposer with their functions.

- | | |
|--|--------------------|
| _____a. Contains the drive motor, the stationary shredding ring, and the flywheel | 1. Mounting flange |
| _____b. Contains the starting controls, the impeller, and serves as the hopper into which wastes are placed | 2. Insulation |
| _____c. The principle part of the disposer that provides the high torque required to drive the impeller | 3. Impeller |
| _____d. A circular device driven by the motor shaft to provide inertia and to compensate for fluctuations in operating speeds | 4. Lower housing |
| _____e. A stationary device circling the interior of the housing and so positioned that the impeller forces waste matter against its cutting edges | 5. Tailpiece |
| _____f. A rotating disk with projections that force waste against the shredding ring | 6. Drive motor |
| _____g. The top lip of a disposer that is secured over a gasket and tightened to a support ring so that the disposer can be easily installed in a kitchen sink | 7. Upper housing |
| _____h. The drain outlet of the disposer that permits easy hookup to existing plumbing with a slip-joint plumbing connection | 8. Flywheel |
| _____i. Surrounds lower housing and helps to keep down the noise of the motor and grinding sounds | 9. Shredding ring |

TEST

5. Arrange in order the steps in garbage disposer operation by placing the correct sequence number in the appropriate blank.
- _____a. The drive motor starts rotating
 - _____b. Centrifugal force impels garbage outward from the rotating flywheel
 - _____c. Garbage is placed into the disposer
 - _____d. Garbage is shredded into small pieces as it is forced into the cutting edges of the shredding ring by the action of the impeller
 - _____e. The shredded garbage is washed down through holes in the flywheel strainer plate and on out into the plumbing drain
 - _____f. The cold water is turned on
 - _____g. The disposer cover is put in place and turned clockwise to activate the starting control switch, if it is a batch feed model
6. Complete statements concerning the importance of cold water flow in a disposer by inserting the word(s) or figure(s) that best completes each statement.
- a. Cold water is required as a _____ agent to carry ground-up waste away.
 - b. Cold water is required to _____ grease that may be placed into the disposer so that grease can be shredded and washed away like other waste.
 - c. Cold water also _____ the motor shaft that turns the impeller so it won't overheat.
 - d. Cold water should be allowed to continue to flow about _____ after all wastes have been completely shredded so that the drain line will be completely flushed of wastes.
7. Complete a list of common misuses that cause disposer problems by inserting the word(s) that best completes each statement.
- a. _____ with waste is probably the biggest cause of disposer problems.
 - b. Failure to run sufficient _____ during disposer operation is probably the second biggest cause of disposer problems.
 - c. Injecting inorganic materials such as glass or _____ items such as silverware cause a disposer to jam and lead to other major problems.
 - d. Cloth, paper, and even _____ can cause a disposer to jam and lead to other major problems.

TEST

- e. Chemicals used to clean clogged drains should never be placed in a disposer because they will damage _____ and _____ seals and corrode metal parts.
8. Select true statements concerning items that can be placed into a garbage disposer by placing an "X" beside each statement that is true.
- _____a. Waste vegetables and meat scraps
- _____b. Waste scraps of bread, potato and fruit peelings, and fruit seeds
- _____c. Bones of all sizes
- _____d. Waste grease and fats
- _____e. All other soluble food wastes
9. Complete statements concerning guidelines for handling a jammed garbage disposer by inserting the word(s) that best completes each statement.
- a. The most _____ problem with garbage disposers is that they get jammed with food waste and have to be unjammed.
- b. When a disposer jams, always turn the disposer off, allow the motor to cool, and then press the _____.
- c. Turn on the motor-reversing switch, if the disposer has that feature, and permit the impeller to run in _____ until it is unjammed.
- d. On models without a motor-reversing switch, turn the machine off, insert an unjamming tool, and _____ turn the impeller backwards.
- e. Attempt to run the motor _____ to complete shredding of the obstacle that caused the jamming.
- f. If the obstacle jams the disposer again, turn the disposer off, repeat the procedure for freeing the impeller, but this time, reach in with a _____ _____ and remove the obstruction.
10. Select true statements concerning guidelines for installing a garbage disposer by placing an "X" beside each statement that is true.
- _____a. Check the power supply to make sure it agrees with the voltage and frequency listed on the motor nameplate.
- _____b. Make sure the disposer is properly grounded
- _____c. Existing plumbing should be carefully examined to make sure it is suitable for the installation, and make sure local codes do not prohibit a disposer installation.

TEST

- _____d. The disposer should be hooked up to a trap that serves another piece of equipment such as a washing machine.
 - _____e. Unless codes require them, remove old grease traps, and if they are required, advise the customer to clean the trap every 90 days.
 - _____f. Septic systems must have a minimum capacity of 100 gallons before a garbage disposer can function properly.
 - _____g. Encourage customers with septic systems to avoid placing anything into the disposer that is not biodegradable.
11. Complete statements concerning guidelines for troubleshooting disposer malfunctions by inserting the word(s) that best completes each statement.
- a. Always _____ the power before inserting any kind of tool into the disposer.
 - b. Check first to see that the _____ is free to turn and unjam it if it is obstructed.
 - c. Permit the motor to _____ if it has been running and then push the reset button.
 - d. Make sure a proper 120V power supply is reaching the motor because _____ line voltage will cause a motor to overheat and stop.
 - e. Check for a blown _____.
 - f. Check for loose wires at _____.
 - g. If all else seems to be in order, check all _____ by disconnecting the power supply and making continuity checks.
 - h. If _____ appear to be okay, the _____ itself will have to be checked.
 - i. Continue with _____ as the problem demands.
 - j. Make sure the power supply and disposer are safely _____.

(NOTE: If the following activities have not been accomplished prior to the test, ask your instructor when they should be completed.)

12. Demonstrate the ability to:
- a. Install a garbage disposer. (Job Sheet #1)
 - b. Free a jammed garbage disposer. (Job Sheet #2)

GARBAGE DISPOSERS UNIT X

ANSWERS TO TEST

1. a. 5 d. 3
 b. 2 e. 1
 c. 6 f. 4

2. a. Improper, abuse
 b. Dangers

3. a. Disconnected
 b. Cold
 c. Silverware

4. a. 4 f. 3
 b. 7 g. 1
 c. 6 h. 5
 d. 8 i. 2
 e. 9

5. a. 4 e. 7
 b. 5 f. 2
 c. 1 g. 3
 d. 6

6. a. Transporting
 b. Solidify
 c. Cools
 d. 30 seconds

7. a. Overloading
 b. Water
 c. Metallic
 d. String
 e. Rubber, fiber

8. a, b, d, e

9. a. Common
 b. Reset button
 c. Reverse
 d. Manually
 e. Forward
 f. Pair of tongs

10. a, b, d, e, g

ANSWERS TO TEST

11.
 - a. Disconnect
 - b. Impeller
 - c. Cool off
 - d. Low
 - e. Fuse
 - f. Terminals
 - g. Switches
 - h. Switches, motor
 - i. Troubleshooting
 - j. Grounded

12. Performance skills evaluated according to procedures written in the job sheets

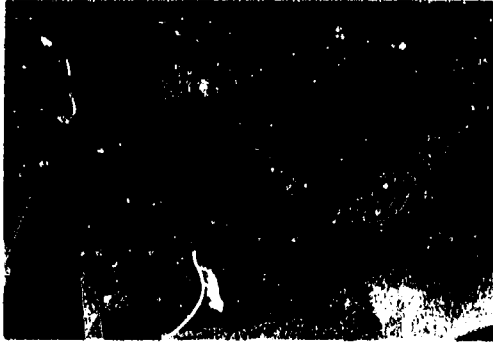

TRASH COMPACTORS UNIT XI

UNIT OBJECTIVE

After completion of this unit, the student should be able to discuss trash compactor design and operational characteristics including all electrical controls and safety devices. The student should also be able to list common causes for failure to compact, major wear problems, and be able to install an undercounter trash compactor and troubleshoot compactor electrical and mechanical problems. These competencies will be evidenced by correctly performing the procedures outlined in the assignment and job sheets and by scoring 85 percent on the unit test.

SPECIFIC OBJECTIVES

After completion of this unit, the student will be able to:

1. Match terms related to trash compactors with their correct definitions.
2. Complete statements concerning trash compactor characteristics.
3. Arrange in order steps in a typical compactor cycle.
4. Match compactor electrical components with their characteristics.
5. Select true statements concerning trash compactor operating safety.
6. Complete statements concerning trash compactor service safety.
7. List guidelines for properly loading a compactor.
8. Complete statements concerning common causes for failure to compact.
9. Select true statements concerning major wear problems with compactors.
10. Complete statements concerning lubrication requirements for compactors.
11. Complete statements concerning chain and belt adjustments.
12. Match troubleshooting guidelines with trash compactor problems.
13. Complete statements concerning guidelines for troubleshooting a noisy compactor.

OBJECTIVE SHEET

14. Complete statements concerning guidelines for troubleshooting other compactor problems.
15. Select true statements concerning items that should not be placed in a trash compactor.
16. Use schematics to determine operating conditions on a trash compactor. (Assignment Sheet #1)
17. Demonstrate the ability to:
 - a. Install an undercounter trash compactor to specifications. (Job Sheet #1)
 - b. Test the drive motor on a trash compactor to determine its operational condition. (Job Sheet #2)
 - c. Troubleshoot common trash compactor problems. (Job Sheet #3)

TRASH COMPACTORS UNIT XI

SUGGESTED ACTIVITIES

- A. Provide students with objective sheet.
- B. Provide students with information sheet.
- C. Make transparency.
- D. Provide students with job sheets.
- E. Discuss unit and specific objectives.
- F. Discuss information sheet.
- G. Demonstrate and discuss the procedure outlined in the job sheets.
- H. Invite a technician who has worked on trash compactors to talk to the class about compactor repairs and problems that are peculiar to trash compactors.
- I. Impress upon students the importance of blocking up the ram when working on a trash compactor, and other dangers such as bits of glass that may still be in the trash drawer.
- J. Show a sample of multi-purpose molybdenum grease and explain how its high pressure service characteristics make it a vital lubricant for proper trash compactor maintenance.
- K. Show the class samples of worn power screws and demonstrate how they can be replaced.
- L. Give test.

CONTENTS OF THIS UNIT

- A. Objective sheet
- B. Information sheet
- C. Transparency Master #1 — Compactor Wiring Schematic
- D. Job sheets
 - 1. Job Sheet #1 — Install an Undercounter Trash Compactor to Specifications
 - 2. Job Sheet #2 — Test the Drive Motor on a Trash Compactor to Determine its Operational Condition
 - 3. Job Sheet #3 — Troubleshoot a Trash Compactor for Typical Malfunctions
- E. Test
- F. Answers to test

REFERENCES USED IN DEVELOPING THIS UNIT

- A. *Tech Talk Trash Compactor*. Dayton, OH 45449: Frigidaire Parts and Service Company, 1980.
- B. *Do-It-Yourself Repair Manual for Your Whirlpool Trash Masher Compactor*. Benton Harbor, MI 49022: Whirlpool Corporation, 1984.
- C. Anderson, Edwin P. *Home Appliance Servicing*. Indianapolis, IN 46268: Howard W. Sams & Co., Inc., 1979.

TRASH COMPACTORS UNIT XI

INFORMATION SHEET

I. Terms and definitions

- A. **Bumpers** — Stops so placed that the ram will strike them as it nears the bottom of the trash drawer and complete a full cycle even when there is less than a minimum load of trash
- B. **Power screws** — Sprocketed rotating shafts that are chain or belt driven to build up the high torque required to power the ram
- C. **Ram** — A round or box-shaped welded steel component that is driven into the trash drawer to compact trash
- D. **Ram wiper** — A gasket-like attachment extending from all sides of the ram so that the walls of the trash drawer will be wiped clean during compaction
- E. **Trash drawer** — A welded steel drawer at the bottom of the compactor where trash bags are placed and from which full trash bags are removed

II. Trash compactor characteristics

- A. Trash compactors are designed to reduce trash to approximately one-fourth its original size and contain it in a leak resistant bag.
- B. Trash compactors also have built-in components to hold and disperse deodorant to eliminate unpleasant odors.
- C. As a safety factor, almost all trash compactors must be turned on with a key.
- D. Compactors also have built-in safety devices to protect the trash drawer from being damaged by the ram.
- E. Most trash compactors use special Kraft/polyethylene bags and substitute bags will not work properly.
- F. Compactors are built with straight rams or scissor-type rams, but both types operate with power screws and have similar service characteristics.

III. Steps in a typical compactor cycle

- A. The trash drawer must be closed and the ram in home position.
- B. The key lock switch must be turned ON.
- C. The start switch must be depressed and held down until the ram travels $\frac{3}{4}$ ".
- D. The motor runs clockwise (CW) to engage the drive sprocket and chain to the power screws which in turn start the ram traveling downward.

INFORMATION SHEET

- E. The ram will travel downward until the motor is stalled by the action of compacting trash or by striking the four bumpers located on the frame channel.
- F. The motor stall stops the clockwise motor starting switch and energizes the counterclockwise (CCW) motor starting switch.
- G. As the motor reverses, the ram travels upward until it returns to the normal OFF or home position.

IV. Compactor electrical components and their functions (Trans. Agency 1)

- A. Start switch — Key operated so that when turned to ON it energizes the motor and starts downward ram travel

(NOTE: The start switch must be held in position until the ram has traveled at least $\frac{3}{4}$ " downward; if it is released prior to required ram movement, the ram will stop.)

- B. Top limit and ram directional switch — Mounted on the front frame so that it is activated by ram movement to control motor direction which in turn controls the down/up ram movement

(NOTE: When the unit is OFF, the top limit switch is open, but when the unit is turned ON, the switch closes and causes the motor to turn in a clockwise direction to move the ram downward; when ram stops for any reason, the switch causes the motor to move counterclockwise and move the ram upward.)

- C. Drawer safety switch — Is energized anytime the drawer is improperly loaded or improperly closed to indicate a problem

- D. Drawer tilt switch — Is energized anytime the load shifts forward in the drawer to stop the ram and prevent damage to both the drawer and the ram

(NOTE: On some compactors, the drawer tilt switch is tied in with a restart light that will alert the customer to the problem.)

- E. Drive motor — Usually a $\frac{1}{3}$ HP that operates on 120V AC at 60 Hz

(NOTE: Technically, drive motors are split phase, four pole, reversible, open type motors with two start windings, a replaceable starting switch, and a nonreplaceable motor protector.)

V. Trash compactor operating safety

- A. All trash compactors should be properly grounded at the time of installation and checked for proper grounding after any repairs.
- B. Children should never be allowed to operate a trash compactor or load or unload a bag in the trash drawer.
- C. Always wear gloves when unloading a trash bag because fragments of glass may be sticking through the bag.

INFORMATION SHEET

- D. Clean the trash drawer at regular intervals to keep down odors and maintain a sanitary appliance.
- E. Provide as much ventilation space as possible around the compactor because compactor motors get demanding service and overheat easily.
- F. Do not overload the trash drawer because the unit will not compact and it will cause excessive motor and power screw wear.
- G. NEVER place aerosol cans in a trash compactor.

VI. Trash compactor service safety

- A. Always unplug the compactor from its power source before making electrical tests.
- B. Block the ram up to assure that it won't accidentally fall on your hand.
- C. Tape the switch arms of the top limit and directional switches when removing or reinstalling the ram because the switch arms can be damaged. (Figure 1)

FIGURE 1

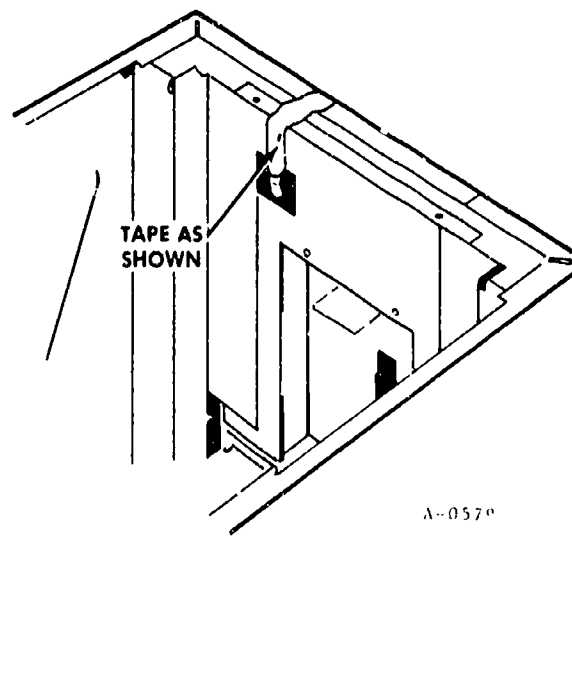

Courtesy Frigidaire

- D. Never bypass or otherwise disable a safety device for any reason.
- E. Always disconnect at least one terminal lead when checking continuity on electrical switches.

(NOTE: Leaving both terminals connected could cause you to read back through the circuit and get an improper reading.)

INFORMATION SHEET

VII. Guidelines for properly loading a compactor

- A. Make sure the ram is in the home position.

(CAUTION: On some models, trash can be loaded with the ram in the down position, and doing so would cause extensive damage to the switching mechanism.)

- B. Place folded newspapers in the bottom of the trash drawer to help minimize tears in the bag caused by glass or metal fragments.
- C. Place paper over bottles or light bulbs to keep broken glass within the trash bag.
- D. Lay bottles lengthwise in the center and slightly to the rear of the trash drawer.

VIII. Common causes for failure to compact

- A. The compact force developed by the ram is directly related to the voltage supplied to a unit while compacting action is in progress.
- B. Since force/voltage are directly related, low voltage while compacting is taking place will impair performance. (Figure 2)

FIGURE 2

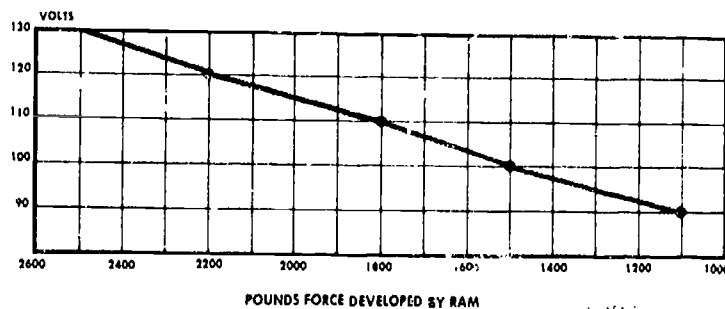

Courtesy Frigidaire

- C. Customer may be trying to compact too small a load because maximum ram travel is 5" less than the depth of the trash drawer and compaction cannot take place until drawer is at least $\frac{1}{3}$ full.
- D. Customer may have bottles mixed in with a spongy load that prevents the bottles from breaking.

(NOTE: Most, but not all, bottles in a load will be broken.)

INFORMATION SHEET

- E. Customer may be overloading the compactor to the point that the crushing resistance of the load is greater than the crushing force of the ram. (Figure 3)

FIGURE 3

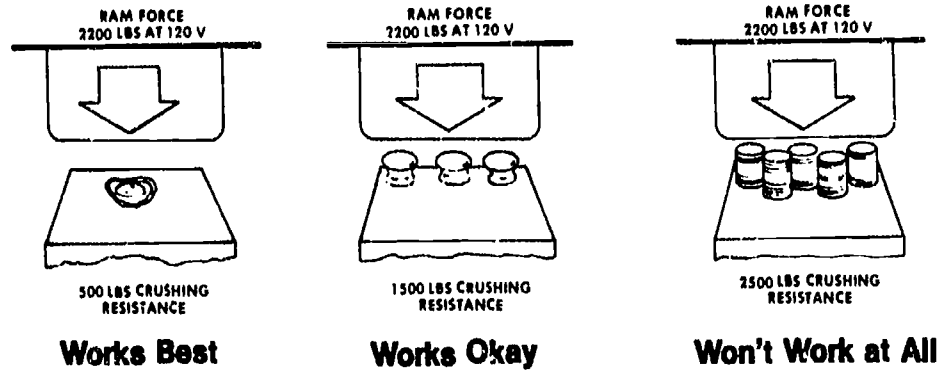

Courtesy Frigidaire

IX. Major wear problems with compactors

- A. Motor burnout may be a problem with trash compactors, and it can be caused by overloading or by overheating in poorly ventilated locations.
- B. Power screws are subject to high torque stress and threads may strip.
- C. Chains and belts break or go out of adjustment because they are subject to high torque stress.
- D. Motors should be checked carefully before replacement.

(NOTE: See Job Sheet #2.)

- E. Power screws and their associated bearings, washers, sprockets, and nuts can be ordered from supply houses and replaced. (Figure 4)

FIGURE 4

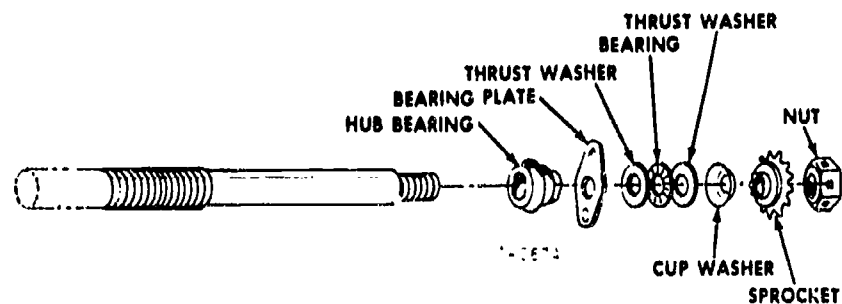

Courtesy Frigidaire

INFORMATION SHEET

- F. Chains and belts are both replaceable or can be adjusted by loosening the motor mounting and moving the motor one way or the other.

(NOTE: Chains go together with a master link.)

X. Lubrication requirements for compactors

- A. Power screws should be lubricated with a multi-purpose molybdenum grease designed especially for high pressure applications.
- B. Slide rollers on the trash drawer should be lubricated with SAE 30W oil.

XI. Chain and belt adjustments

- A. Tightening loose belts or chains is best done by loosening the motor mount screws and moving the motor as required.
- B. Chains and belts should normally have a deflection of $\frac{3}{16}$ " to $\frac{1}{2}$ " at mid-point between sprockets, but in all cases, check specifications.

XII. Troubleshooting guidelines for trash compactor problems

- A. When the compactor will not start, troubleshoot for:
1. No power to the unit (breaker or fuse, or not plugged in)
 2. Start switch not held to START, or not held in position long enough
(NOTE: Switch must be depressed until motor is energized and ram travels at least $\frac{3}{4}$ ".)
 3. Defective start switch
 4. Drawer not properly closed
 5. Defective drawer safety switch
 6. Motor protector open
 7. Motor windings open
 8. Top limit and ram directional switch defective
 9. A loose connection or a broken wire
- B. When the compactor will not stop, troubleshoot for:
1. A drive nut that has run off the top of the power drive screws
 2. Top limit and ram directional switch not properly adjusted or defective

INFORMATION SHEET

3. Start switch defective or momentary contact stuck closed
 4. Stripped threads on the power drive nuts, or stripped threads on the power drive screws
- C. When the compactor stops before the end of a cycle, troubleshoot for:
1. Top limit and ram directional switch not properly adjusted or defective
 2. Drawer tilt switch open, usually indicated when the restart light comes on
 3. Drawer tilt switch open because the drawer has tilted because of an unbalanced load
 4. Motor protector open
 5. A loose connection or broken wire
 6. If the problem occurs at the reversing point, troubleshoot for a defective ram directional switch, a motor start switch stuck open, or a start winding open
- D. When the compactor reverses too soon, troubleshoot for:
1. Motor speed being dragged down by insufficient lubrication on power drive screws, nuts, and bearings
 2. Ram binding because of worn or missing glides
 3. Unusually dense load of too many cans or odd-shaped bottles
 4. Low voltage causing insufficient torque
- E. When the drive screw runs the wrong way, troubleshoot for:
1. if it begins at the start of the cycle, the top limit ram directional switch is probably bad.
 2. If it happens during any part of the cycle, the top limit and directional switch may be wired improperly or the start windings may be reversed on the motor.
- XIII. **Guidelines for troubleshooting a noisy compactor**
- A. If the problem is at the start of the cycle and is accompanied by a thumping sound, the power drive screw nuts are probably off the top of the threads.

INFORMATION SHEET

- B. If the noise occurs during ram travel, troubleshoot for:
1. Chain too tight or too loose
 2. Insufficient lubrication
 3. Worn power screw drive bearings
 4. Worn drive gear assembly
 5. Worn motor drive gear
 6. Worn thrust bearings
 7. Loose or worn power drive screw nuts
- C. If the noise occurs during the bottom of the cycle, troubleshoot for:
1. Worn bumpers
 2. Loading down

XIV. Guidelines for troubleshooting other compactor problems

- A. When the complaint is unpleasant odor in or around the compactor, troubleshoot for:
1. Garbage outside the container
 2. Inside of drawer needs cleaning
 3. Inside of cabinet needs cleaning
 4. Deodorizer needs to be replaced
 5. Garbage has been left standing too long
- B. When trash bags get tangled in the ram, troubleshoot for:
1. Improperly installed trash bag
 2. Wrong type of trash bag used

(NOTE: Customer should always buy and use the bags recommended in the owner's or operator's guide.)

INFORMATION SHEET

XV. Items that should not be placed in a trash compactor

- A. Soft food wastes should be disposed of in a garbage disposer because in a compactor they dirty the ram head.

(NOTE: Covering soft food wastes with newspapers or towels will help, but it is still better not to put such items in the compactor.)

- B. Fish and meat trimmings and citrus rinds quickly build up strong odors in a compactor and are best handled in a garbage disposer.
- C. Aerosol cans should not be compacted, and especially aerosol cans that contained insecticides or any material considered toxic or hazardous.

Compactor Wiring Schematic

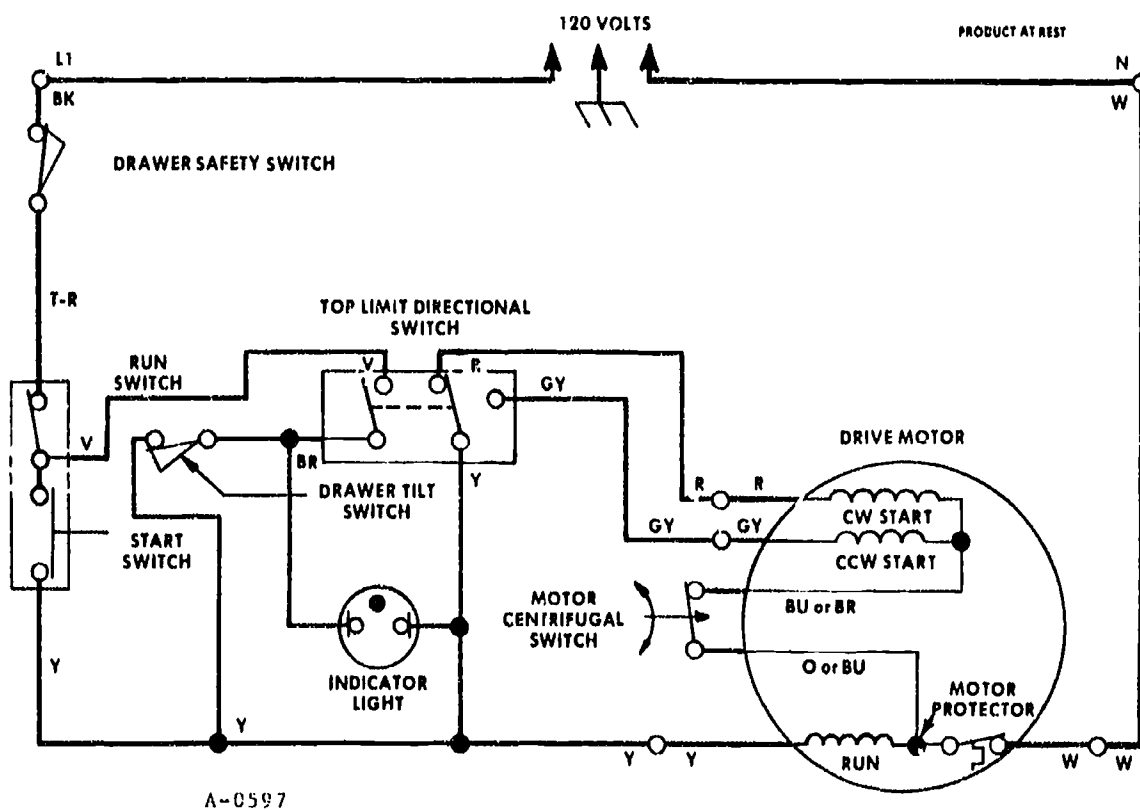
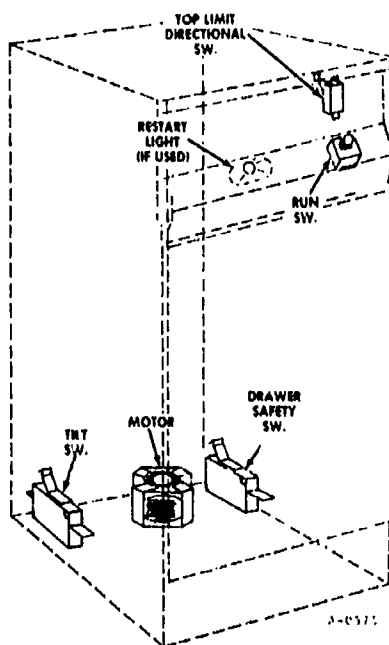

Courtesy Frigidaire

TRASH COMPACTORS UNIT XI

ASSIGNMENT SHEET #1 — USE SCHEMATICS TO DETERMINE OPERATING CONDITIONS ON A TRASH COMPACTOR

- A. The following schematic shows a compactor just after the motor has started and the ram has traveled downward at least $\frac{3}{4}$ ". Examine the schematic in Figure 1 and answer the questions that follow.

FIGURE 1

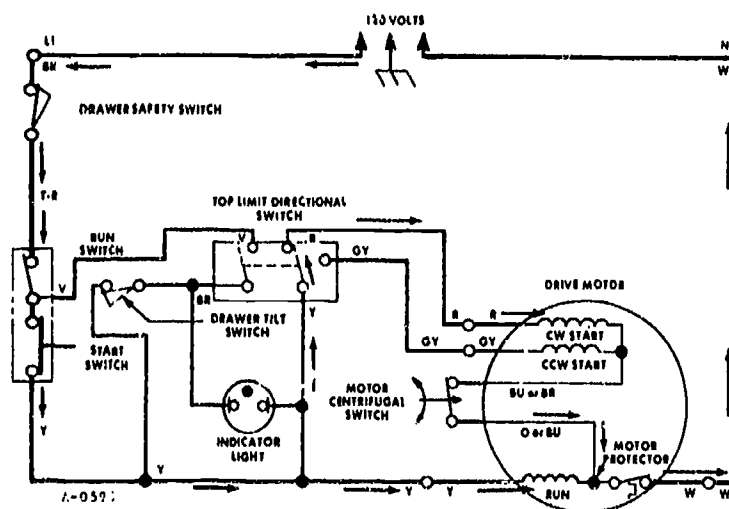

1. Which start windings have been energized, CW or CCW?

2. The start switch was released after the ram traveled $\frac{3}{4}$ "; Is the start switch now open or closed?

3. Is the run switch open or closed at this point in the cycle?

4. What is the condition of the drawer tilt switch?

5. Is the Indicator light ON at this point in the cycle?

ASSIGNMENT SHEET #1

- B. The following schematic shows a compactor at a specific point in a compacting cycle. Examine the schematic in Figure 2 and answer the questions that follow.

FIGURE 2

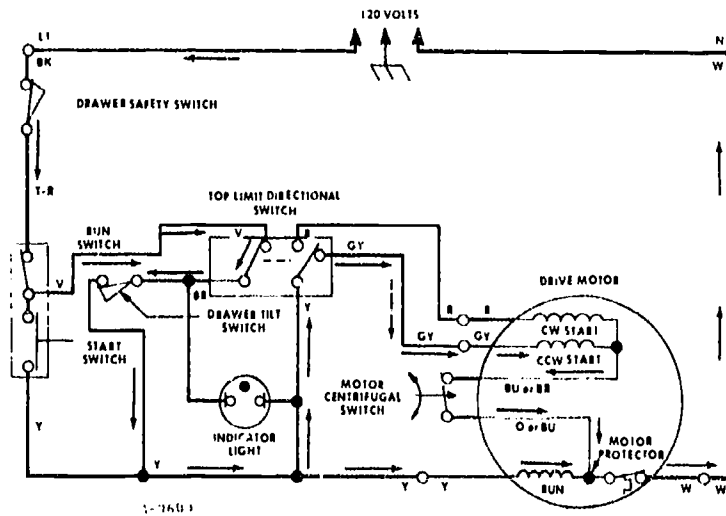

1. Since the schematic indicates that the CCW start windings have been energized, what is happening at this point in the cycle?

2. If the schematic indicated that the drawer tilt switch were open, would the cycle continue or stop?

3. Is the Indicator light ON at this point?

4. Is there anything in the schematic to indicate there is anything wrong with the compactor at this point?

ASSIGNMENT SHEET #1

- C. The following schematic shows a compactor with safety devices at work. Examine the schematic in Figure 3 and answer the questions that follow.

FIGURE 3

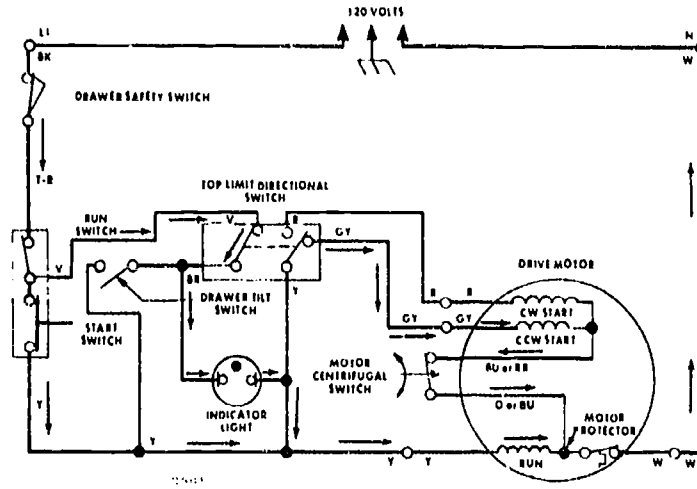

1. What safety device is working and what is its condition?

2. What has happened to the indicator light?

3. What is the current condition of the compactor?

TRASH COMPACTORS UNIT XI

ANSWERS TO ASSIGNMENT SHEETS

- A.
1. CW
 2. Closed
 3. Closed
 4. Closed
 5. No
- B.
1. The ram has compacted trash or hit the bumpers and the motor start switch has reversed
 2. Stop
 3. No
 4. No
- C.
1. The drawer tilt switch is open
 2. It is ON
 3. Bottles or other hard objects were loaded off center and forced the drawer forward enough that it could be damaged by the ram, and the cycle has stopped to protect the appliance

TRASH COMPACTORS UNIT XI

JOB SHEET #1 — INSTALL AN UNDERCOUNTER TRASH COMPACTOR TO SPECIFICATIONS

A. Tools and materials

1. Trash compactor as selected by instructor
2. Service manual for trash compactor
3. Manufacturer's installation directions
4. Basic hand tools
5. VOM
6. Lint-free shop towels
7. Household cleaner
8. Level
9. Safety glasses

B. Routine #1 — Checking out electrical requirements

(NOTE: The following procedures and illustrations are adapted from materials copyrighted by Frigidaire and are reprinted with permission; any other use is prohibited.)

1. Put on safety glasses.
2. Check the electrical service available for the trash compactor for:
 - a. 120V 60 Hz, AC power only
 - b. 15 amp fused electrical supply is required with a time-delay fuse or a circuit breaker
 - c. Separate circuit serving only the trash compactor is recommended
3. Check for proper electrical grounding because a trash compactor must be properly grounded:
 - a. The 3-prong power supply cord on the unit must be plugged into a mating 3-prong, grounded wall receptacle.

JOB SHEET #1

- b. Grounded wall receptacle should be about 18" off the floor and about center of the recess where the compactor will be installed (Figure 1).

FIGURE 1

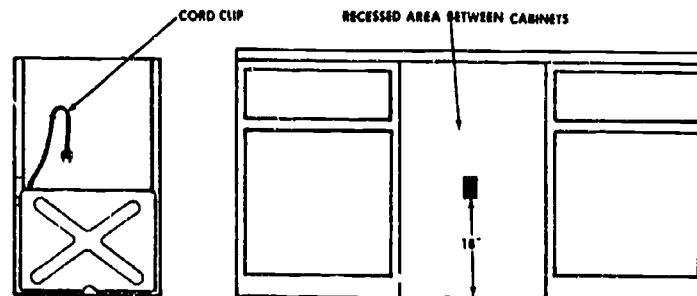

- c. Never cut the grounding prong off a plug to defeat the ground, and never use an extension cord as a power supply to the compactor.

(NOTE: If a proper, grounded receptacle is not available, the customer should be informed that one should be installed by a licensed electrician.)

C. Routine #2 -- Installing the compactor

1. Remove the shipping carton and protective packaging materials such as tape and shipping pads.

(NOTE: Keep these materials out of the way and be sure to remove them when you leave.)

2. Remove the package taped to the top cover; it contains the stabilizer catch and mounting catch that will be installed later.
3. Check compactor for any waxy residue left by protective shipping material, and if required, use household cleaner and water to clean the cabinet.
4. Open the drawer and remove and save the materials and literature shipped with the compactor.
5. Remove the drawer as follows (Figure 2):
 - a. Grip the handle and raise the front of the drawer until it clears the stops.

JOB SHEET #1

- b. Grasp the ridges of the door front and lift the drawer out.

(NOTE: Remember the procedure for you will have to reverse it when you replace the drawer.)

FIGURE 2

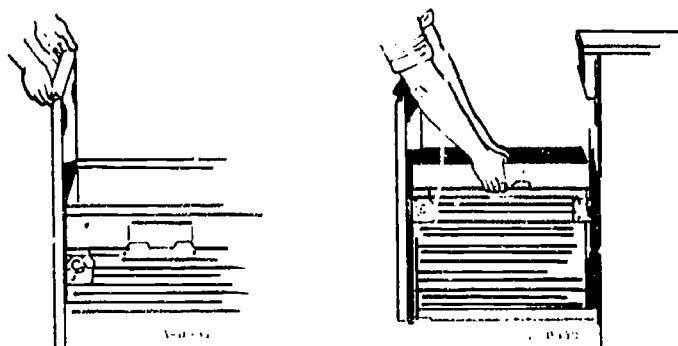

6. Lay two corner posts from the shipping carton onto the floor so positioned that the unit can rest on them without marring the cabinet finish.
7. Lay the unit over on one side on the corner posts. (Figure 3)

FIGURE 3

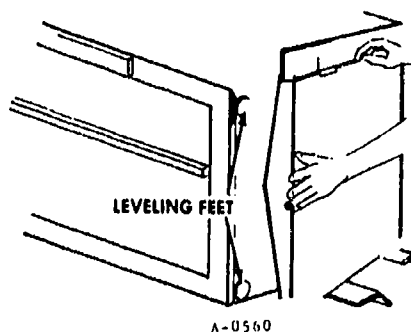

8. Remove the cardboard shipping pad from the bottom of the unit.
9. Turn all four leveling feet out the same distance so they will be preadjusted.
10. Stand the compactor upright with care and move it to the area in front of the recess.
11. Move the compactor into location, and be careful not to pinch your fingers between the adjacent cabinets.

JOB SHEET #1

12. Check the compactor for level, and make sure it is high enough that the stabilizer bracket contacts the underside of the countertop.
13. Remove the compactor from the recess and raise the four leveling feet as required to get the compactor high enough while still keeping it level. (Figure 4)

(CAUTION: Use the level on the bottom panel, but be careful that the compactor does not drop on your hand.)

FIGURE 4

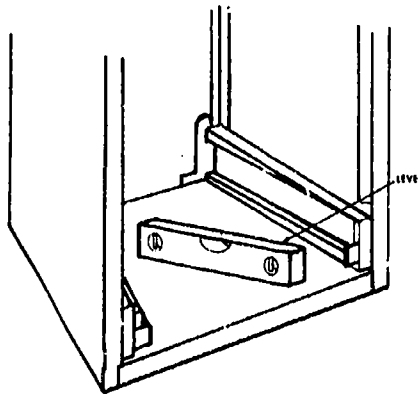

14. Work compactor into recess, make a final check for level, then pull the compactor out far enough to plug the power cord into the grounded receptacle at the back of the recess.
15. Work the compactor back into place and flex the stabilizer bracket downward so that the stabilizer catch will slide over it and the parts will latch together. (Figure 5)

FIGURE 5

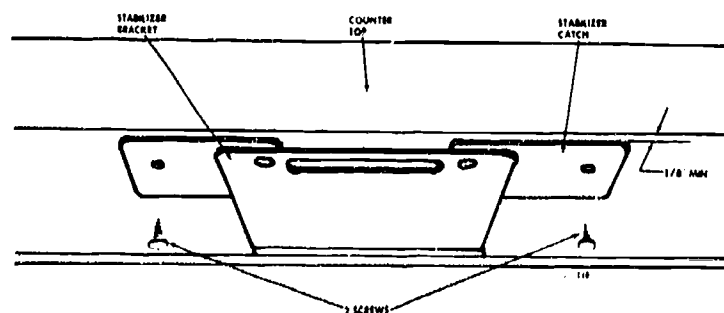

16. Make sure there is at least $\frac{1}{8}$ " between the front edge of the countertop and the front edge of the stabilizer bracket, and, if necessary, move the compactor back until the $\frac{1}{8}$ " clearance is attained. (See Figure 5)

JOB SHEET #1

17. Screw the stabilizer catch securely to the underside of the countertop with the screws that came with it.
18. Use your fingers to release the stabilizer bracket from the stabilizer catch and pull the compactor far enough out of the recess to replace the drawer. (Figure 6)

FIGURE 6

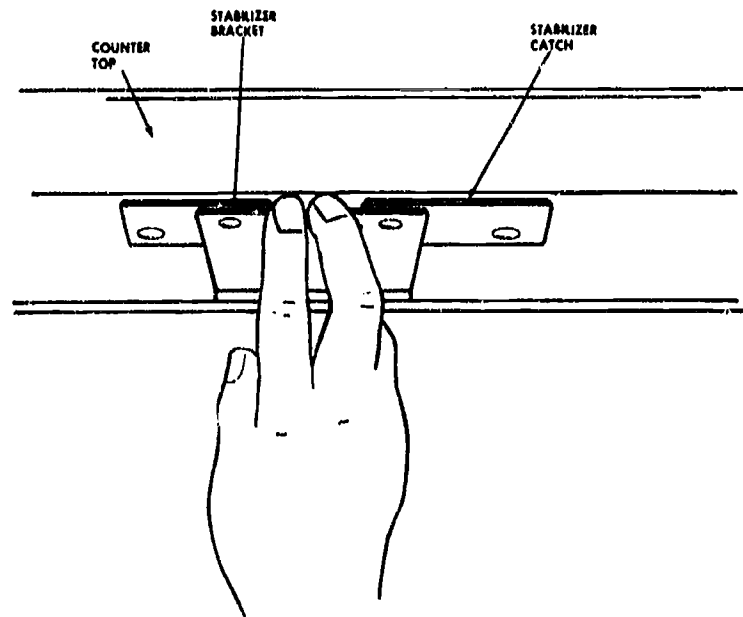

19. Replace the drawer by grasping the side ridges and placing it onto the tracks while being careful to lift so the front will clear the stops.
20. Close the door, and note that the flexible vinyl toe panel returns to its original shape as the drawer is replaced.
21. Work compactor into recess, and if the toe plate should rub the floor at the front of the compactor, trim it in the following manner:
 - a. Measure the amount that will need to be trimmed from the toe plate.
 - b. Slide the drawer from the unit, and lay the drawer so that the front panel faces upward.
 - c. Use the level as a straightedge and mark a straight line across the toe plate.
 - d. Cut excess toe plate off with scissors, and replace the panel and the drawer.
22. Deliver operator's manual, extra bag, and warranty to customer.

(CAUTION: It's carefully outlined in the operator's manual, but remind the customer that children should never be allowed to operate the compactor and that the keys should be kept in a place where children cannot reach them.)

JOB SHEET #1

23. Review safe compactor loading, operation, and maintenance with the customer.

(NOTE: In the event the compactor has alternate color options for the front panel, and the customer wants a different color panel, go on to the next routine.)

24. Congratulate the customer on a wise choice of compactor, pick up left over packing materials, and be on your way.

D. Routine #3 — Changing front panel colors

1. Remove the drawer from the unit as previously outlined.
2. Remove the handle by removing the screws at the top inside the drawer.
3. Remove the corrugated filler strip from behind the front panels.
4. Remove only the inner front panel by carefully pulling it up between the drawer trim. (Figure 7)

(CAUTION: The panels have cut metal edges so handle them with care to avoid injury or damage to the panels.)

FIGURE 7

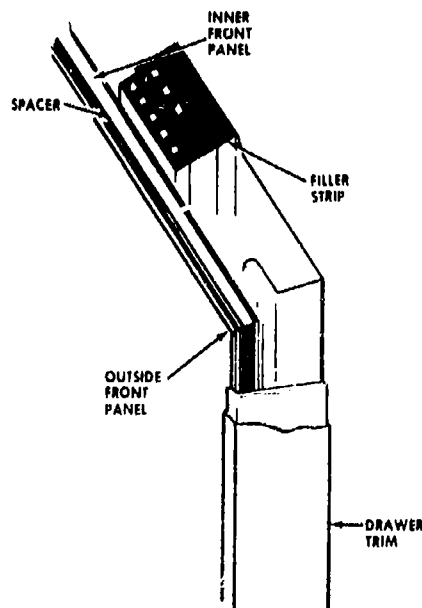

5. Remove the spacer which fits between the panels.
6. Remove the outside panel by carefully pulling it up.
7. Remove the panel color selected by the customer and carefully place it in the front of the door trim.

(NOTE: Typical color selections are wheat, white, almond, or avocado.)

8. Replace the spacer.

JOB SHEET #1

9. Replace the other panel carefully and put the corrugated filler back in place.
(NOTE: The flat section of the handle may be used to push the panel in the last couple of inches, but work with care.)
10. Replace the handle with the screws removed previously.
(CAUTION: Never attempt to operate a compactor with the handle removed because it would be possible to accidentally enter the ram.)
11. Slide the drawer back into the unit.
12. Clean up area as required and invite the customer to inspect the new color panel.

TRASH COMPACTORS UNIT XI

JOB SHEET #2 — TEST THE DRIVE MOTOR ON A TRASH COMPACTOR TO DETERMINE ITS OPERATIONAL CONDITION

A. Tools and materials

1. Compactor as selected by Instructor
2. Repair guide or service manual for selected compactor
3. VOM
4. Pencil and paper
5. Basic hand tools
6. Test cord
7. Safety glasses

B. Routine #1 — Testing the motor run winding

(NOTE: The following routines and illustrations are adapted from materials copyrighted by Frigidaire and are reprinted with permission; any other use is prohibited.)

1. Put on safety glasses.
2. Make sure unit is unplugged from its power supply.
3. Remove the Y wire from the start switch.
4. Remove the Y wire from the directional switch.
5. Set the VOM for $R \times 1$ and zero the meter.
6. Connect one test lead to the neutral side of the compactor's power cord and the other lead alternately to each Y wire. (Figure 1)

FIGURE 1

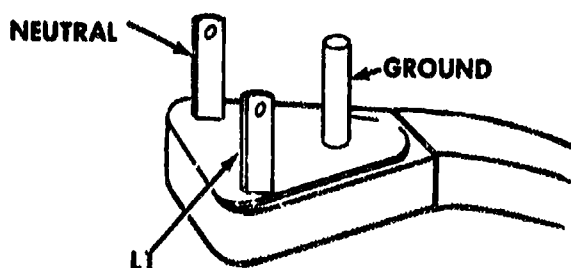

JOB SHEET #2

7. Check meter reading and record your finding.
 - a. If each reading is 3 to 5 ohms, the motor run winding is okay.
 - b. If the readings are other than 3 to 5 ohms, continue with other tests.
- Have your instructor check your finding.
- C. Routine #2 — Testing the motor start windings**
1. Make sure motor is unplugged from its power supply.
 2. Remove the GY and R wires from the directional switch.
 3. Set the VOM for R \times 1 and zero the meter.
 4. Connect one test lead to the GY wire and the other test lead to the R wire.
 5. Check meter reading and record your finding.
 - a. If the VOM shows an open circuit, check to make sure the GY or R wires are not broken or disconnected at the motor.
 - b. If wires are okay and meter still indicates an open circuit, the start windings are open and the motor will have to be replaced.
 - c. If the meter readings is 4 to 10 ohms, the start windings are okay.
- Have your instructor check your finding.
- D. Routine #3 — Testing the motor centrifugal switch**
1. Make sure motor is unplugged from its power source.
 2. Disconnect the BU and O or BU and BR wires from the motor switch (wire color will vary with motor).
 3. Set the VOM for R \times 1 and zero the meter.
 4. Connect one test lead to the BU or O wire and the other lead to the BU or BR wire.
 5. Check meter reading and record your finding.
 - a. If the reading indicates an open, the motor centrifugal switch is stuck or burned and should be replaced.
 - b. If the meter reading is zero ohms, the switch is okay.
- Have your instructor check your finding.

JOB SHEET #2

E. Routine #4 — Testing motor functions

1. Make sure unit is unplugged from its power source.
2. Disconnect all motor leads from the centrifugal switch.

(NOTE: The blue and orange or blue and brown leads do not have to be disconnected.)

3. Connect the test cord as indicated in Figure 2.

FIGURE 2

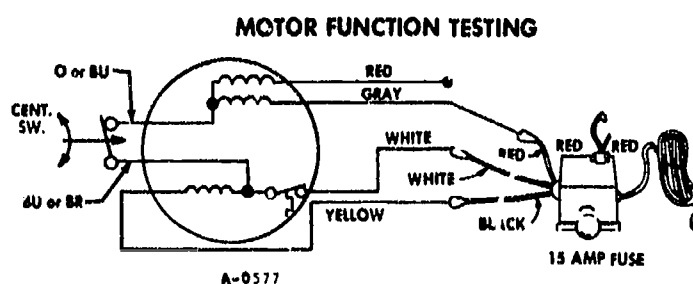

4. Make sure that no leads are touching each other or any part of the cabinet or frame.
5. Plug in test cord, turn the tester switch to the start position for 2 or 3 seconds, and then release the switch.

(NOTE: The switch will return to the run position.)

6. Check to make sure that the motor runs in the COUNTERCLOCKWISE direction.
7. Turn the tester off and unplug it from the power supply.
8. Remove the red tester lead from the gray motor lead and connect the red motor lead to the red tester lead.
9. Plug in test cord, turn the tester switch to the start position for 2 or 3 seconds, and then release the switch.
10. Check to make sure the motor runs in the CLOCKWISE direction.
 - a. If the motor now runs clockwise and previously ran counterclockwise, it is okay.

JOB SHEET #2

- b. If the motor does not run in both directions or in only one direction, it should be replaced.
11. Record your findings.
 - Have your instructor check your work.
 12. Clean up area and return tools and materials to proper storage.

TRASH COMPACTORS UNIT XI

JOB SHEET #3 -- TROUBLESHOOT A TRASH COMPACTOR FOR TYPICAL MALFUNCTIONS

- A. Tools and materials
1. Trash compactor as selected by Instructor
 2. Appropriate service manual
 3. VOM
 4. Basic hand tools
 5. Clean shop towels
 6. Multi-purpose molybdenum grease and SAE 30W oil
 7. Pencil and paper
 8. Safety glasses
- B. Routine #1 — Troubleshooting a compactor that will not run
1. Put on safety glasses
 2. Remove the service panel that provides access to the motor (Figure 1)

FIGURE 1

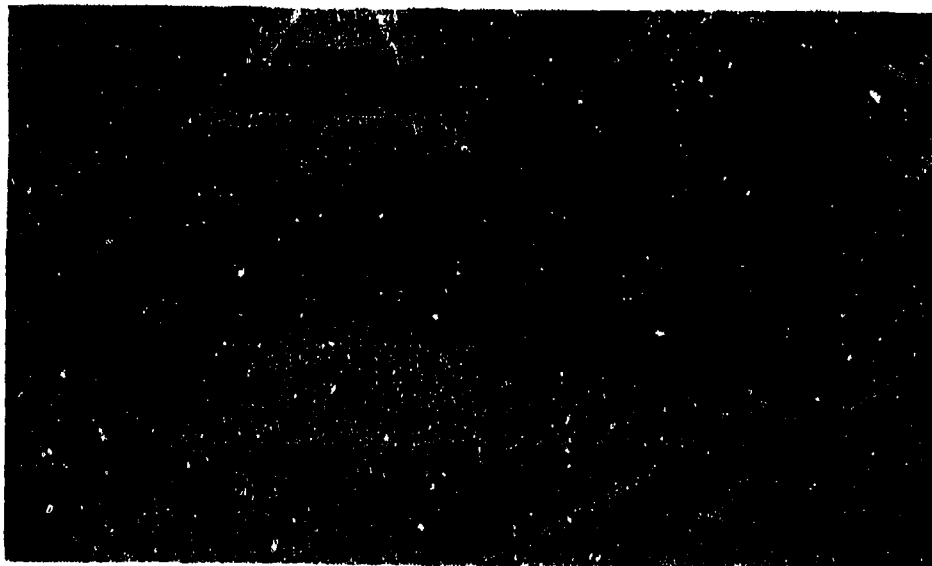

JOB SHEET #3

3. Inspect the motor visually for any signs that it has burned out or the smell of burned components
 4. Check the motor for shorts or opens
 - a. If the motor has an open, the motor must be replaced
 - b. If the motor windings are shorted, the motor must be replaced
 - c. If the motor is okay, continue with troubleshooting
 5. Remove service panels as required to reach the ON/OFF switch and the key-actuated safety switch
 6. Check the ON/OFF switch for continuity and replace as required
 7. Check the key-actuated safety switch for continuity and replace as required
- Have your instructor check your work

C. Routine #2 — Troubleshooting a ram that will not return to home position

1. Leave your safety glasses on
2. Unplug the compactor and remove the back or front panel as needed to gain access to the wiring schematic (Figure 2)

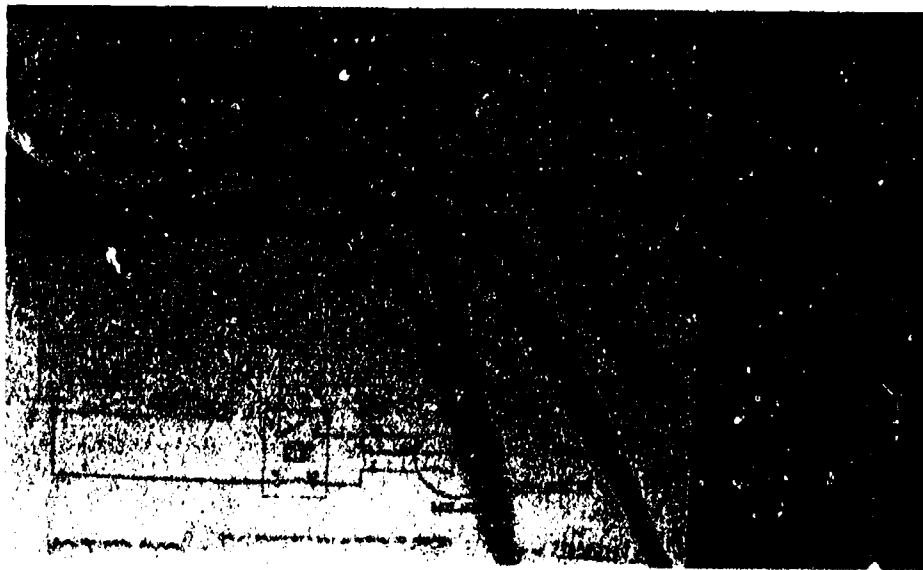
FIGURE 2

3. Inspect the power screws for obstructions that might be keeping the ram from returning home

JOB SHEET #3

4. Determine the location of the bottom and top limit switches that control ram travel (Figure 3)

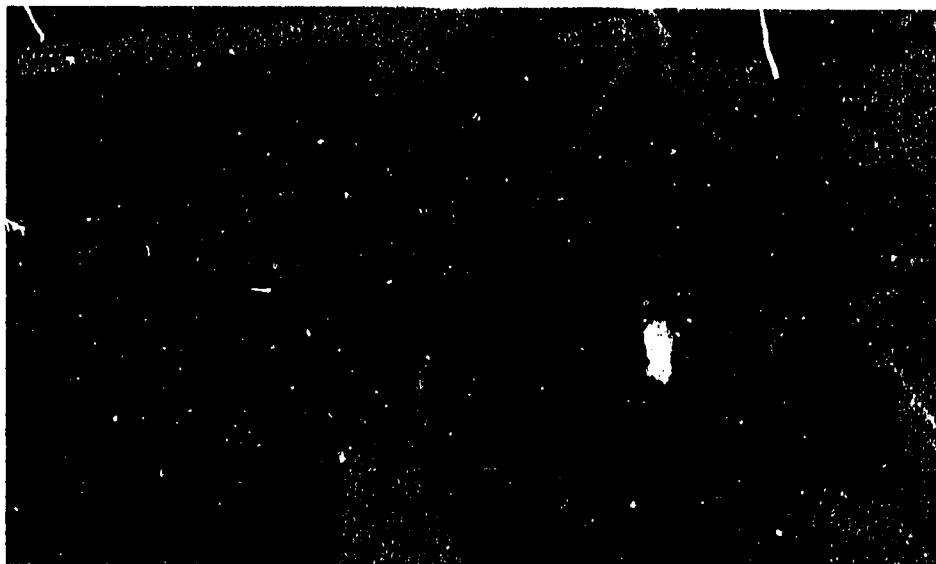
FIGURE 3

5. Remove one of the leads to the upper limit switch and make a continuity check on the upper limit switch
6. Set the VOM on Rx1, zero the meter, and then place the two VOM leads onto the terminals of the upper limit switch
7. Press the actuator switch on the upper limit switch and look for a full scale deflection
 - a. If there is no full scale deflection, the upper limit switch is bad and should be replaced
 - b. If there is a full scale deflection, the upper limit switch is okay, but may require adjustment

JOB SHEET #3

- c. If adjustment is required, it usually involves no more than loosening the screw that secures the switch, moving the switch up or down as required, and then retightening the screw, but be sure to check the service manual for the compactor you're working with (Figure 4)

FIGURE 4



8. Repeat the continuity check for the lower limit switch and adjust or replace as required
 9. Plug the compactor in and test for proper ram movement into the home position
 - Have your instructor check your work
- D. Routine #3 — Complete preventive maintenance on a trash compactor
1. Leave your safety glasses on
 2. Lubricate the power screws with a multi-purpose high-pressure grease
 3. Lubricate the side rollers with SAE 30W oil
 4. Check tension on the drive belt and adjust to specifications in the service manual
 5. Test run the compactor to make sure all operations are proper
 - Have your instructor check your work
 6. Replace all panels that were removed
 7. Clean up area and return tools and materials to proper storage

TRASH COMPACTORS UNIT XI

NAME _____

TEST

1. Match the terms on the right with their correct definitions.

- | | |
|--|------------------------|
| <p>_____a. Stops so placed that the ram will strike them as it nears the bottom of the trash drawer and complete a full cycle even when there is less than a minimum load of trash</p> | <p>1. Ram</p> |
| <p>_____b. Sprocketed rotating shafts that are chain or belt driven to build up the high torque required to power the ram</p> | <p>2. Bumpers</p> |
| <p>_____c. A round or box-shaped welded steel component that is driven into the trash drawer to compactor trash</p> | <p>3. Trash drawer</p> |
| <p>_____d. A gasket-like attachment extending from all sides of the ram so that the walls of the trash drawer will be wiped clean during compaction</p> | <p>4. Power screws</p> |
| <p>_____e. A welded steel drawer at the bottom of the compactor where trash bags are placed and from which full trash bags are removed</p> | <p>5. Ram wiper</p> |

2. Complete statements concerning trash compactor characteristics by inserting the word(s) that best completes each statement.

- a. Trash compactors are designed to reduce trash to approximately _____ its original size and contain it in a leak resistant bag.
- b. Trash compactors also have built-in components to hold and disperse _____ to eliminate unpleasant odors.
- c. As a safety factor, almost all trash compactors must be turned on with a _____.
- d. Compactors also have built-in safety devices to protect the _____ from being damaged by the ram.
- e. Most trash compactors use special Kraft/polyethylene bags and _____ bags will not work properly.

TEST

- f. Compactors are built with straight rams or scissor-type rams, but both types operate with _____ and have similar service characteristics.
3. Arrange in order steps in a typical compactor cycle by placing the correct sequence number in the appropriate blank.
- _____a. As the motor reverses, the ram travels upward until it returns to the normal OFF or home position.
- _____b. The start switch must be depressed and held down until the ram travels $\frac{3}{4}$ ".
- _____c. The ram will travel downward until the motor is stalled by the action of compacting trash or by striking the four bumpers located in the frame channel.
- _____d. The trash drawer must be closed and the ram in home position.
- _____e. The key lock switch must be turned ON.
- _____f. The motor stall stops the clockwise motor starting switch and energizes the counterclockwise motor starting switch.
- _____g. The motor runs clockwise to engage the drive sprocket and chain to the power screws which in turn start the ram traveling downward.
4. Match compactor electrical components with their characteristics.
- | | |
|---|---|
| _____a. Key operated so that when turned to ON it energizes the motor and starts downward ram travel | 1. Drawer safety switch |
| _____b. Mounted on the front frame so that it is activated by ram movement to control motor direction which in turn controls the down/up ram movement | 2. Drive motor |
| _____c. Is energized anytime the drawer is improperly loaded or improperly closed to indicate a problem | 3. Start switch |
| _____d. Is energized anytime the load shifts forward in the drawer to stop the ram and prevent damage to both the drawer and the ram | 4. Drawer tilt switch |
| _____e. Usually a $\frac{1}{3}$ HP that operates on 120V AC at 60 Hz | 5. Top limit and ram directional switch |

TEST

5. Select true statements concerning trash compactor operating safety by placing an "X" beside each statement that is true.
- _____ a. All trash compactors should be properly grounded at the time of installation and checked for proper grounding after any repairs.
 - _____ b. Children should be allowed to operate a trash compactor only after careful instruction.
 - _____ c. Always wear gloves when unloading a trash bag because fragments of glass may be sticking through the bag.
 - _____ d. Clean the trash drawer at regular intervals to keep down odors and maintain a sanitary appliance.
 - _____ e. Provide as much ventilation space as possible around the compactor because compactor motors get demanding service and overheat easily.
 - _____ f. Do not overload the trash drawer because the unit will not compact and it will cause excessive motor and power screw wear.
 - _____ g. NEVER place aerosol cans in a trash compactor unless you know they are completely empty.
6. Complete statements concerning trash compactor service safety by inserting the word(s) that best completes each statement.
- a. Always _____ the compactor from its _____ before making electrical tests.
 - b. Block the _____ to assure that it won't accidentally fall on your hand.
 - c. Tape the _____ of the top limit and directional switches when removing or reinstalling the ram because the _____ can be damaged.
 - d. Never bypass or otherwise disable a _____ device for any reason.
 - e. Always disconnect at least _____ when checking continuity on electrical switches.
7. List guidelines for properly loading a compactor by inserting the word(s) that best completes each statement.
- a. Make sure the ram is in the _____ position.
 - b. Place folded _____ in the bottom of the trash drawer to help minimize tears in the bag caused by glass or metal fragments.
 - c. Place _____ over bottles or light bulbs to keep broken glass within the trash bag.
 - d. Lay large bottles _____ in the center and slightly to the rear of the trash drawer.

TEST

8. Complete statements concerning common causes for failure to compact by inserting the word(s) that best completes each statement.
- a. The compact force developed by the ram is directly related to the _____ supplied to a unit while compacting action is in progress.
 - b. Since force/voltage are directly related, _____ voltage while compacting is taking place will impair performance.
 - c. Customer may be trying to compact too small a load because maximum ram travel is 5" less than the depth of the trash drawer and compaction cannot take place until drawer is at least _____ full.
 - d. Customer may have bottles mixed in with a _____ load that prevents the bottles from breaking.
 - e. Customer may be overloading the compactor to the point that the crushing resistance of the load is _____ than the crushing force of the ram.
9. Select true statements concerning major wear problems with compactors by placing an "X" beside each statement that is true.
- _____ a. Motor burnout may be a problem with trash compactors, and it can be caused by overloading or by overheating in poorly ventilated locations.
 - _____ b. Power screws are subject to high torque stress and threads may strip.
 - _____ c. Chains and belts break or go out of adjustment because they are subject to high torque stress.
 - _____ d. Motors should be checked carefully before replacement.
 - _____ e. Power screws and their associated bearings, washers, sprockets, and nuts can be ordered from supply houses and replaced.
 - _____ f. Chains and belts cannot be adjusted so they should always be replaced.
10. Complete statements concerning lubrication requirements for compactors by inserting the word(s) that best completes each statement.
- a. _____ should be lubricated with a multi-purpose moly-lithium grease designed especially for high pressure applications.
 - b. _____ on the trash drawer should be lubricated with SAE 30W oil.

TEST

11. Complete statements concerning chain and belt adjustments by inserting the word(s) the best completes each statement.
- Tightening loose belts or chains is best done by loosening the motor mount screws and _____ the motor as required.
 - Chains and belts should normally have a deflection of $\frac{3}{8}$ " to $\frac{1}{2}$ " at _____ between sprockets, but in all cases, check specifications.
12. Match compactor problems with troubleshooting guidelines.
- | | | |
|---------|---|---|
| _____a. | <ol style="list-style-type: none"> No power to the unit Start switch not held to START, or not held in position long enough Defective start switch Drawer not properly closed Defective drawer safety switch Motor protector open Motor windings open Top limit and ram directional switch defective A loose connection or a broken wire | <ol style="list-style-type: none"> When the compactor stops before the end of a cycle, troubleshoot for: When the drive screw runs the wrong way, troubleshoot for: When the compactor will not stop, troubleshoot for: When the compactor reverses too soon, troubleshoot for: When the compactor will not start, troubleshoot for: |
| _____b. | <ol style="list-style-type: none"> A drive nut that has run off the top of the power drive screws Top limit and ram directional switch not properly adjusted or defective Start switch defective or momentary contact stuck closed Stripped threads on the power drive nuts, or stripped threads on the power drive screws | |
| _____c. | <ol style="list-style-type: none"> Top limit and ram directional switch not properly adjusted or defective Drawer tilt switch open, usually indicated when the restart light comes on Drawer tilt switch open because the drawer has tilted because of an unbalanced load | |

TEST

- 4) Motor protector open
 - 5) A loosen connection or broken wire
 - 6) If the problem occurs at the reversing point, troubleshoot for a defective ram directional switch, a motor start switch stuck open, or a start winding open
- _____d.
- 1) Motor speed being dragged down by insufficient lubrication on power drive screws, nuts, and bearings
 - 2) Ram binding because of worn or missing glides
 - 3) Unusually dense load of too many cans or odd-shaped bottles
 - 4) Low voltage causing insufficient torque
- _____e.
- 1) If it begins at the start of the cycle, the top limit ram directional switch is probably bad.
 - 2) If it happens during any part of the cycle, the top limit and directional switch may be wired improperly or the start windings may be reversed on the motor
13. Complete statements concerning guidelines for troubleshooting a noisy compactor by inserting the word(s) that best completes each statement.
- a. If the problem is at the start of the cycle and is accompanied by a thumping sound, the power drive screw nuts are probably _____ of the threads.
 - b. If the noise occurs during ram travel, troubleshoot for:
 - 1) _____ too tight or too loose
 - 2) Insufficient _____
 - 3) Worn power screw drive _____
 - 4) Worn _____ gear assembly
 - 5) Worn motor drive _____
 - 6) Worn thrust _____
 - 7) Loose or worn power drive _____

TEST

- c. If the noise occurs during the bottom of the cycle, troubleshoot for:
- 1) Worn _____
 - 2) Loading _____
14. Complete statements concerning guidelines for troubleshooting other compactor problems by inserting the word(s) that best completes each statement.
- a. When the complaint is unpleasant odor in or around the compactor, troubleshoot for:
- 1) Garbage _____ the container
 - 2) Inside of _____ needs cleaning
 - 3) _____ of cabinet needs cleaning
 - 4) _____ needs to be replaced
 - 5) Garbage has been left standing _____
- b. When trash bags get tangled in the ram, troubleshoot for:
- 1) Improperly _____ trash bag
 - 2) _____ type of trash bag used
15. Select true statements concerning items that should not be placed in a trash compactor by placing an "X" beside each statement that is true.
- _____ a. Soft food wastes should be disposed of in a garbage disposer because in a compactor they dirty the ram head.
- _____ b. Fish and meat trimmings and citrus rinds quickly build up strong odors in a compactor and are best handled in a garbage disposer.
- _____ c. Aerosol cans should be compacted only if they are completely empty.
- (NOTE: If the following activities have not been accomplished prior to the test, ask your instructor when they should be completed.)
16. Use schematics to determine operating conditions on a trash compactor. (Assignment Sheet #1)
17. Demonstrate the ability to:
- a. Install an undercounter trash compactor to specifications. (Job Sheet #1)
 - b. Test the drive motor on a trash compactor to determine its operational condition. (Job Sheet #2)
 - c. Troubleshoot common trash compactor problems (Job Sheet #3)

TRASH COMPACTORS UNIT XI

ANSWERS TO TEST

1.
 - a. 2
 - b. 4
 - c. 1
 - d. 5
 - e. 3

2.
 - a. One-fourth
 - b. Deodorant
 - c. Key
 - d. Trash drawer
 - e. Substitute
 - f. Power screws

3.
 - a. 7
 - b. 3
 - c. 5
 - d. 1
 - e. 2
 - f. 6
 - g. 4

4.
 - a. 3
 - b. 5
 - c. 1
 - d. 4
 - e. 2

5. a, c, d, e, f

6.
 - a. Unplug, power source
 - b. Ram up
 - c. Switch arms, switch arms
 - d. Safety
 - e. One terminal lead

7.
 - a. Home
 - b. Newspapers
 - c. Paper
 - d. Lengthwise

8.
 - a. Voltage
 - b. Low
 - c. $\frac{1}{3}$
 - d. Spongy
 - e. Greater

ANSWERS TO TEST

9. a, b, c, d, e
10. a. Power screws
b. Slide rollers
11. a. Moving
b. Midpoint
12. a. 5
b. 3
c. 1
d. 4
e. 2
13. a. Off the top
b. 1) Chain
2) Lubrication
3) Bearings
4) Drive
5) Gear
6) Bearings
7) Screw nuts
c. 1) Bumpers
2) Down
14. a. 1) Outside
2) Drawer
3) Inside
4) Deodorizer
5) Too long
b. 1) Installed
2) Wrong
15. a, b
16. Evaluated to the satisfaction of the instructor
17. Performance skills evaluated according to procedures written in the job sheets.



GAS RANGES AND OVENS UNIT XII

UNIT OBJECTIVE

After completion of this unit, the student should be able to discuss the functions of components on a gas range and the procedures for troubleshooting common complaints for surface and oven burners. The student should also be able to install a gas range, run an oven temperature test, recalibrate an oven thermostat, and check gas regulator pressure with a manometer. These competencies will be evidenced by correctly performing the procedures outlined in the assignment and job sheets and by scoring 85 percent on the unit test.

SPECIFIC OBJECTIVES

After completion of this unit, the student will be able to:

1. Match terms related to gas ranges and ovens with their correct definitions.
2. Complete statements concerning basics of gas heating.
3. Select true statements concerning natural and bottled gases.
4. Complete statements concerning how a gas range top burner works.
5. Select true statements concerning orifice settings.
6. Select true statements concerning primary and secondary air.
7. Complete statements concerning byproducts of combustion.
8. Recommend solutions for burner combustion problems.
9. Complete a chart of gas burner types and their applications.
10. Match types of oven ignition systems with their characteristics.
11. Complete statements concerning how a gas oven works.
12. Match types of oven thermostats with their characteristics.

OBJECTIVE SHEET

13. Complete statements concerning safety valves.
14. Complete statements concerning common misuses of gas ovens.
15. Select true statements concerning special considerations for ovens with upper and lower burners.
16. Complete statements concerning how self-cleaning ovens work.
17. Select true statements concerning special safety features of self-cleaning ovens.
18. Complete a list of safety requirements for gases.
19. Complete statements concerning flexible connectors.
20. Select true statements concerning requirements for gas supply lines.
21. Complete statements concerning functions of electrical circuits on gas ovens.
22. Solve problems concerning typical circuit functions in a gas oven.
23. Match gas range complaints with recommended troubleshooting.
24. Select true statements concerning gas pressure drops.
25. Solve problems concerning manometer selection and use.
26. Complete statements concerning guidelines for roasting.
27. Complete statements concerning guidelines for broiling.
28. Complete statements concerning guidelines for baking.
29. Match baking problems with their solutions.
30. Select true statements concerning guidelines for service calls.
31. Use a wiring schematic to determine voltage and resistance readings on a self-cleaning gas oven set for a bake operation. (Assignment Sheet #1)
32. Use a wiring schematic to determine voltage and resistance readings on a self-cleaning gas oven set for a timed bake operation. (Assignment Sheet #2)
33. Use a wiring schematic to determine voltage and resistance readings on a self-cleaning gas oven set for a cleaning operation. (Assignment Sheet #3)
34. Use a wiring schematic to determine voltage and resistance readings on a self-cleaning gas oven during lock and unlock. (Assignment Sheet #4)

OBJECTIVE SHEET

35. Demonstrate the ability to:
- a. Install a gas range level and leak free with all burners properly adjusted. (Job Sheet #1)
 - b. Use a temperature tester to check gas oven temperature for proper oven thermostat settings. (Job Sheet #2)
 - c. Recalibrate a gas oven thermostat to correct settings. (Job Sheet #3)
 - d. Remove, disassemble, clean, lubricate, and reassemble a standard gas burner valve. (Job Sheet #4)

GAS RANGES AND OVENS UNIT XII

SUGGESTED ACTIVITIES

- A. Provide students with objective sheet.
- B. Provide students with information and assignment sheets.
- C. Make transparencies.
- D. Discuss unit and specific objectives.
- E. Discuss information sheet.
- F. Discuss the wiring schematics presented in the assignment sheets and prepare an appropriate demonstration on either a gas or electric range to show how a VOM can be used in circuit analysis, and provide the students with typical readings taken from an actual circuit.
- G. Discuss and demonstrate the procedures outlined in the job sheets.
- H. Invite a representative from the local gas company to talk about local gas supplies and safety around gas appliances.
- I. Invite a local gas company service person to demonstrate how a manometer is used to check pressure on a gas regulator valve.
- J. Have individual components from gas ranges and ovens available for demonstration as they are discussed in the information sheet.
- K. Give test.

CONTENTS OF THIS UNIT

- A. Objective sheet
- B. Information sheet
- C. Transparency masters
 - 1. TM 1 — Types and Characteristics of Gases
 - 2. TM 2 — Nameplate Information
 - 3. TM 3 — Top Burner Operation
 - 4. TM 4 — Burner Types
 - 5. TM 5 — Automatic Oven Ignition System

CONTENTS OF THIS UNIT

6. TM 6 — Semi-Automatic Oven Ignition System
 7. TM 7 — Manual Oven Ignition System
 8. TM 8 — Hydraulic Thermostat
 9. TM 9 — Electric-Hydraulic Thermostat
 10. TM 10 — Pneumatic Thermostat
 11. TM 11 — Circuit Operations During a Bake Operation (Self-Cleaning Gas Oven)
 12. TM 12 — Circuit Operations During a Timed Bake Operation (Self-Cleaning Gas Oven)
 13. TM 13 — Circuit Operations During a Clean Operation (Self-Cleaning Gas Oven)
 14. TM 14 — Circuit Operations During Lock and Unlock Operations (Self-Cleaning Gas Oven)
 15. TM 15 — Manometer Pressure Equivalent Table
- D. Assignment sheets
1. Assignment Sheet #1 — Use a Wiring Schematic to Determine Voltage and Resistance Readings on a Self-Cleaning Gas Oven Set for a Bake Operation
 2. Assignment Sheet #2 — Use a Wiring Schematic to Determine Voltage and Resistance Readings on a Self-Cleaning Gas Oven Set for a Timed Bake Operation
 3. Assignment Sheet #3 — Use a Wiring Schematic to Determine Voltage and Resistance Readings on a Self-Cleaning Gas Oven Set for a Cleaning Operation
 4. Assignment Sheet #4 — Use a Wiring Schematic to Determine Voltage and Resistance Readings on a Self-Cleaning Gas Oven During Lock and Unlock
- E. Answers to assignment sheets
- F. Job sheets
1. Job Sheet #1 — Install a Gas Range Level and Leak Free With All Burners Properly Adjusted
 2. Job Sheet #2 — Use a Temperature Tester to Check Gas Oven Temperature for Proper Oven Thermostat Settings
 3. Job Sheet #3 — Recalibrate a Gas Oven Thermostat to Correct Settings
 4. Job Sheet #4 — Remove, Disassemble, Clean, Lubricate, and Reassemble a Standard Gas Burner Valve

CONTENTS OF THIS UNIT

- G. Test
- H. Answers to test

REFERENCES USED IN DEVELOPING THIS UNIT

- A. *Cooking Equipment Course*. Chicago, IL: Sears Training Center, undated.
- B. Bacon, Bill and Mark Sutton. *Major Appliance Repairer*. Austin, TX 78712: The University of Texas at Austin, 1983.
- C. Anderson, Edwin P. *Home Appliance Servicing*. Indianapolis, IN 46208: Howard W. Sams & Co., Inc., 1974.

GAS RANGES AND OVENS

UNIT XII

INFORMATION SHEET

I. Terms and definitions

- A. **AGA (American Gas Association)** — A national organization that sets design and performance standards for gas appliances, and conducts laboratory and on-site checks for compliance
- B. **Baffle** — A metal sheet (flat or slightly V-shaped) placed over an oven burner to divert heat to both sides of a gas oven and to keep direct flame off the oven bottom to prevent burnout
- C. **Burner valves** — Valves that screw into a gas manifold to control gas flow to the top burners
- D. **Charge port** — A small fitting mounted on the side of a burner where it directs gas through a flash tube to a pilot light to cause the burner to ignite
- E. **Gas regulator** — Controls gas pressure and gas flow into the manifold and to other gas range components
- F. **LP (liquid propane) gas** — A general reference to both propane and butane gases used for heating and cooking purposes when natural gas is unavailable
- G. **Manifold** — A pipe which receives gas from the gas supply and distributes that gas to the burner valves and the oven thermostat on a gas range
- H. **Manometer** — An instrument, usually a U-shaped glass tube, for measuring the pressure of gases or vapors
- I. **Thermostat** — A device mounted onto a manifold to control gas flow to an oven much like burner valves control gas flow to top burners on a gas range
- J. **Venturi** — A tube-like connection where air and gas are mixed and transported to a top burner on a gas range

II. Basics of gas heating

- A. Gas heating and cooking devices are rated according to a unit of heat known as a BTU (British Thermal Unit).
- B. A BTU is equal to the amount of heat required to raise one pound of water one degree Fahrenheit.

(NOTE: A common wood match will release about 1 BTU as it completely burns up.)

INFORMATION SHEET

- C. Gases are rated in BTU's. (Transparency 1)
1. Natural gas may range from 300 to 3,000 BTU per cubic foot.
 2. The standard for natural gas in American is almost always 1,000 BTU per cubic foot, and most heating and cooking appliances are designed with that standard in mind.
 3. A gas range should list the BTU rating of every burner and the oven on the name plate. (Transparency 2)
- D. Gas burners are designed according to their intended use.
1. A standard size surface burner for household use is usually rated about 9,000 BTU/hr.
 2. A jumbo size burner for commercial use is usually rated about 12,000 BTU/hr.
 3. Oven burners for household use are usually rated about 23,000 BTU/hr.
- E. Burner ratings should never be surpassed.

III. Natural and bottled gases

- A. Natural gas comes from wells and is usually piped from a central supply point to homes and businesses in an area.
- B. Propane and butane are extracts from crude petroleum and are stored in bottles and tanks as a liquid, and then changed to gas when they are used.
- C. Because of its convenience, natural gas is the most common gas used for gas appliances, but in areas remote from a central natural gas supply, propane and butane are used.
- D. Natural gas is lighter than air and will rise in the atmosphere, but propane and butane are heavier than air and will collect in low spots.

(NOTE: These characteristics can cause problems with wrongly positioned pilot lights.)
- E. Natural gas, propane, and butane are all odorless and colorless and have mercaptan added to them to provide color and a pungent odor so leaking gas can be quickly detected.

(NOTE: Mercaptan has a high sulphur content and smells like rotten eggs.)

INFORMATION SHEET

IV. How a gas range top burner works (Transparency 3)

- A. The main gas supply goes through a gas regulator valve which assures gas will be delivered to the range at a constant, proper pressure.
- B. The gas regulator valve feeds gas into a manifold which serves as a gas transmission line to the top burners, oven pilot, and oven burner.
- C. For a top burner, a gas control valve is screwed into the manifold so that it can be manually operated to turn gas on or off.
- D. From the gas control valve, gas goes through a spud which is screwed into the valve, and from the spud through an orifice with a hood that holds it in place.
- E. Gas from the orifice is fed into a venturi where an air shutter allows air in to mix with the gas.
- F. As gas is mixing in the venturi and being carried to the burner, another constant gas flow is going down a separate tube to the pilot.
- G. As gas from the venturi reaches the burner, part of it passes out a flash port on the side of the burner, and is directed down a flash tube to the pilot flame.
- H. As the pilot flame ignites gas from the flash port, gas at the burner itself is ignited, combustion is complete, and burning begins.

V. Orifice settings

- A. Depending on geographical location, a range will come from the manufacturer with the orifice preset for either natural gas or LP gas.
- B. An orifice for LP gas cannot be used with natural gas because the opening is too small, and an orifice for natural gas cannot be used with LP gas because the opening is too large and would create a fire hazard.
- C. If the orifice in the range is improper for the local gas supply it must be replaced with the proper orifice.

INFORMATION SHEET

- D. If the orifice is a universal orifice, it can be adjusted for LP gas by tightening the hood until it is against the needle. (Figure 1)

(NOTE: The hollow needle will permit sufficient gas flow for LP gas burning.)

FIGURE 1

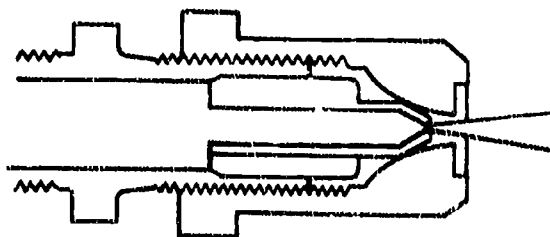

L.P. Setting

- E. The universal orifice can also be adjusted for natural gas by screwing the orifice hood out to achieve proper flame size. (Figure 2)

FIGURE 2

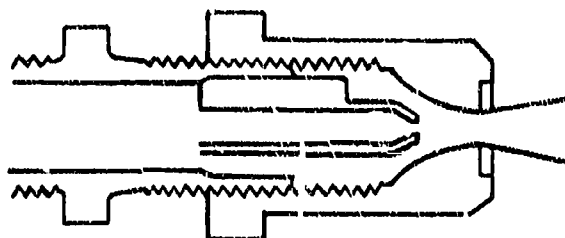

Natural Setting

- F. If the needle is solid, no hole in the center, the orifice opening can only be adjusted by changing to another hood with an opening sized either for LP gas or natural gas.
- G. When connecting the hood to a venturi, it may be necessary to use an extension called a spud to reach into the venturi the proper distance. (Figure 3)

FIGURE 3

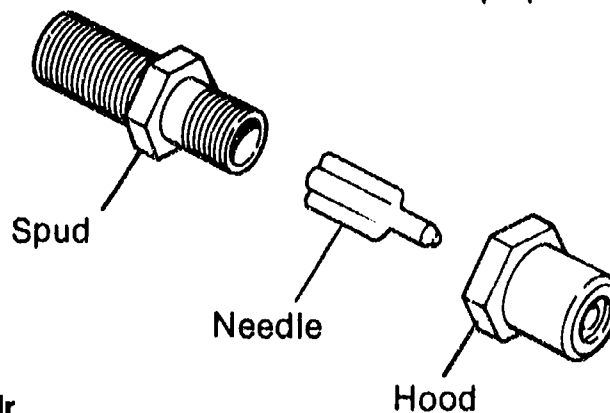

VI. Primary and secondary air

- A. Primary air enters the gas supply through an air shutter located at the front of the venturi.
- B. Primary air is mixed with gas in the throat of the venturi and enters the burner combustion area as an air/gas mixture which is ignited.

INFORMATION SHEET

- C. Secondary air comes from the entire area around the burner and mixes with the flame as it comes from the burner.
- D. Secondary air stabilizes the flame, completes combustion, and carries off the byproducts of combustion.

VII. Byproducts of combustion

- A. When gas burns it gives off water vapor which is usually absorbed by the atmosphere around the range area.
- B. When a home or kitchen area is improperly ventilated, water vapor may condense on walls or other surfaces.

(NOTE: This is more of a problem in winter weather when outside walls are cold.)

- C. Improper combustion that leaves part of the gas unburned will produce CO (carbon monoxide) which is extremely dangerous to humans.
- D. Although CO is odorless and colorless, it can usually be quickly detected because it is accompanied by other gases called aldehydes which do have a pungent odor and irritate the nose and eyes.
- E. When there is an indication that CO is present, the appliance should be shut down and not used until it has been properly adjusted.

(NOTE: Properly adjusted gas appliances pose no CO danger.)

VIII. Burner combustion problems and their solutions

- A. If a flame is literally leaping off a burner, there is too much primary air and the air shutter should be closed down as required. (Figure 4)

FIGURE 4

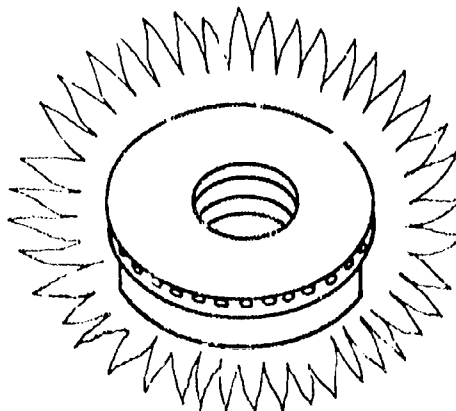

INFORMATION SHEET

- B. If a flame burns yellow and produces soot, there is not enough primary air and the air shutter should be opened up as required. (Figure 5)

FIGURE 5

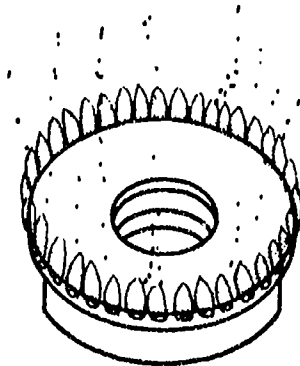

- C. If the flame looks lazy and seems to float away from the burner, the secondary air supply is insufficient, and this may require cleaning out a blocked flue or dirty air vents. (Figure 6)

FIGURE 6

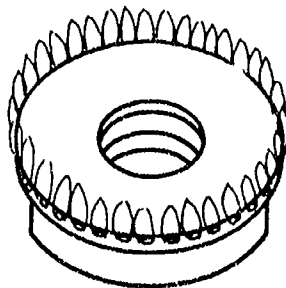

- D. In addition to flue or vent blockage, secondary air problems may be caused by:
1. Overrating the burner and sending more gas than a limited air supply can handle
 2. Bad location of the range so that there is insufficient draft for secondary air, and not enough air to carry off the byproducts of combustion
- E. When there is a problem with primary air, always start the adjustment with the shutter completely open and close it slowly until the flame is correct.

INFORMATION SHEET

- F. When properly adjusted with the gas valve wide open, natural gas should give a bluish flame with a well defined center cone with a flame about $\frac{3}{4}$ " high. (Figure 7)

FIGURE 7

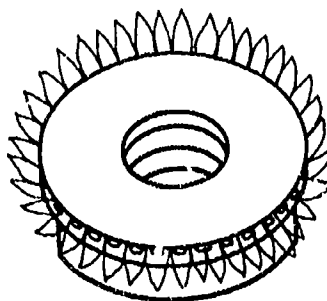

- G. A proper LP gas flame should be colored like a natural gas flame, but should be about $\frac{1}{2}$ " high with the gas valve wide open.

IX. Gas burner types and applications (Transparency 4)

Type of Burner	Shape	Application	Performance
Drilled-Ring	Circular	Top surface burners	Is most efficient burner because it provides a better supply of secondary air to all parts of the flame
Drilled-Pipe	Star	Top surface burners	Permits more drilled holes to provide better heat distribution and greater capacity for large pots and pans used commercially
Drilled-Pipe	Oval, Straight line, or special configuration	Ovens, trays, tanks, and special application	Permits even distribution of heat over surfaces of large oven, tray, or tank areas in cases where circular or star burners could heat only a part of the surface

INFORMATION SHEET

X. Types of oven ignition systems and their characteristics

A. Automatic Ignition (Transparency 5)

1. Most popular type
2. Has no standing pilot
3. Goes through ignition process each time the oven calls for heat
4. May use sparking points, a glow coil, or a silicon carbide combustion

B. Semi-automatic Ignition (Transparency 6)

1. Gas supply controlled by a thermostat in the manifold
2. Uses same gas regulator and manifold as top burners
3. As gas reaches the oven burner, it is ignited by a standing pilot
4. A thermostat senses ambient temperature in the oven and shuts off gas supply when oven heats to a specified temperature
5. Thermostat also turns gas supply back on when oven cools below specified temperature

C. Manual Ignition (Transparency 7)

1. Gas enters oven burner when thermostat is turned on
2. Burner must be lit with a match placed at the entrance to a flash tube
3. Precautionary pilot comes on only after oven burner has ignited
4. Thermostat bypasses enough gas to maintain a minimum flame
5. Precautionary pilot goes out when thermostat is turned off
6. Oven must be manually lit each time it is used
7. These type ovens are no longer manufactured, but some are still around

INFORMATION SHEET

XI. How a gas oven works (Figure 8)

- A. After the oven burner is ignited, heat from the burner enters the oven cavity through a row of holes along each side of the oven bottom. (Figure 8)
- B. Hot air circulates through the oven and around food placed into the oven.
- C. There are byproducts of combustion that are carried along with the hot circulating air out of the oven and into the oven flue.
- D. Hot air also circulates around the thermostat capillary tube so oven temperature can be controlled.
- E. Oven may be shut off manually or shut off by a timer control or a temperature-probe control.

FIGURE 8

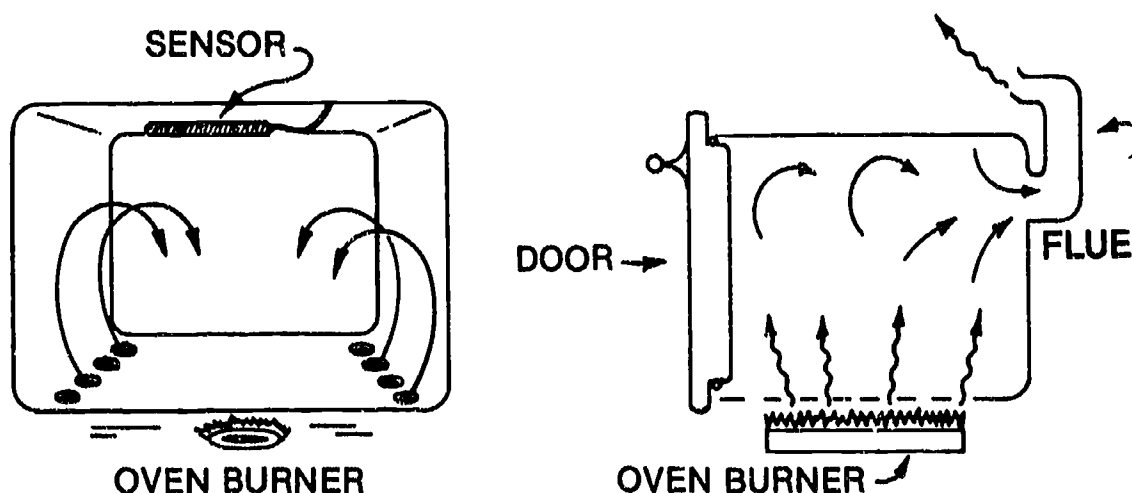

XII. Types of oven thermostats and their characteristics

- A. Hydraulic thermostat (Transparency 8)
 1. Usually filled with oil
 2. As oil is heated or cooled it activates or deactivates a bellows
 3. The bellows move or close a disc valve to start or stop gas flow
- B. Electric hydraulic thermostat (Transparency 9)
 1. Used only in electrically controlled gas ranges or in electric ranges
 2. Uses a liquid filled sensing bulb to activate or deactivate a bellows
 3. Instead of moving a disc valve, the bellows opens or closes a set of contact switches to start or stop gas flow

INFORMATION SHEET

C. Pneumatic thermostat (Transparency 10)

1. Used in self-cleaning gas ovens because a thermostat with liquid in the design would not operate at the 850° to 900° temperatures needed to clean an oven
2. Works with a C-shaped Bourdon tube, a thermostat tube, and a sensing bulb all filled with helium
3. Heat creates vapor pressure which causes the Bourdon tube to straighten out
4. Cooling causes the Bourdon tube to return to its original position
5. The action of the Bourdon tube controls the temperature control contacts to keep the burner cycling on and off as needed
6. The action of the Bourdon tube also controls the door lock contacts so the oven door is locked shut during the self-clean cycle

XIII. Safety valves

A. Safety valves on gas ranges serve two valuable safety purposes:

1. Gas from the main gas supply will not flow if the pilot light is out when the gas is turned on.
2. Gas from the main gas supply will be shut off if the pilot goes out while the oven is in operation.

B. One common safety valve works with a mercury sensing bulb that has to be heated by the oven pilot before it will open, and will close immediately if the pilot goes out. (Figure 9)

FIGURE 9

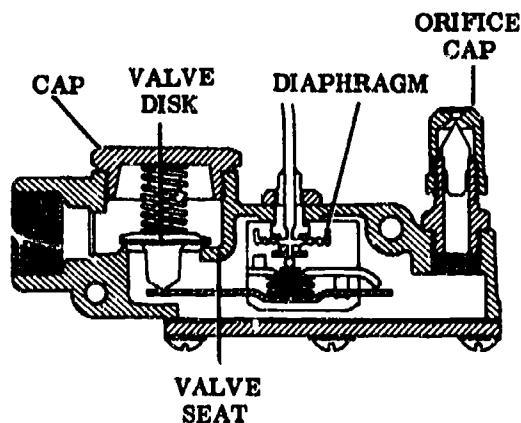

INFORMATION SHEET

- C. Another type safety valve uses a bi-metal actuating device with a wrap-around heater, and this valve works in conjunction with a flame switch which senses whether the pilot is lit or not lit. (Figure 10)

FIGURE 10

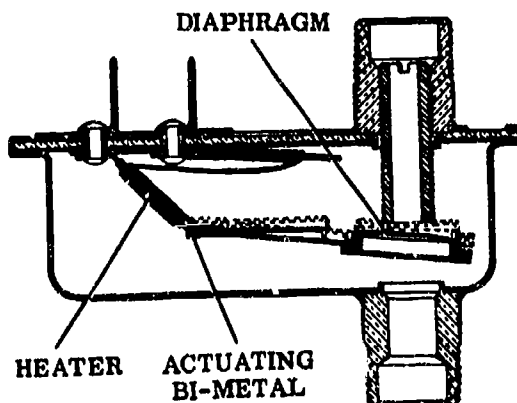

XIV. Common misuses of gas ovens (Figure 11)

- A. Covering the holes at the bottom of the oven will cause baking problems and damage the oven.
- B. Using large pieces of foil to catch spills will literally divide the oven into improperly heated parts and cause baking problems.
- C. Placing utensils too close to the oven wall will also impair circulation and jamming too many pans on one shelf will impair circulation.

FIGURE 11

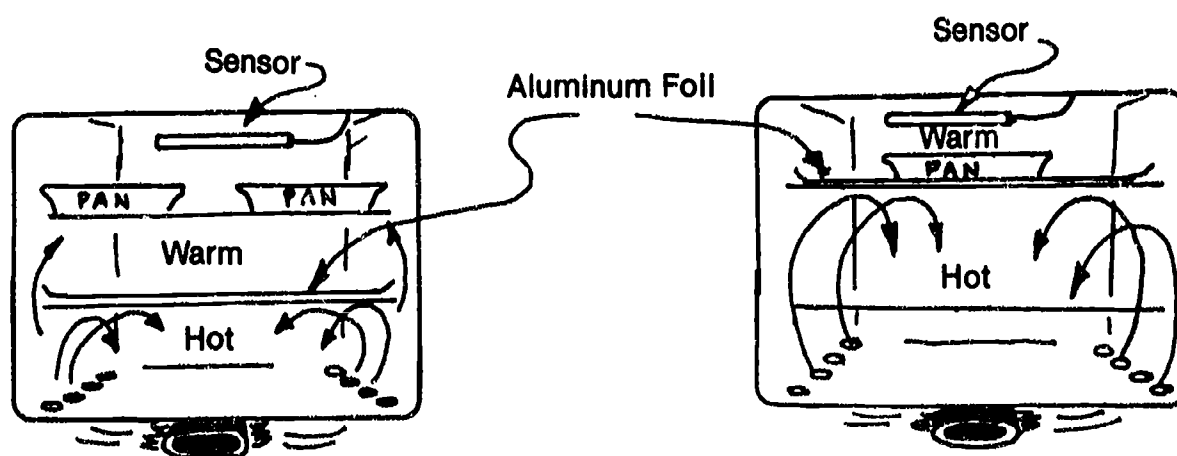

INFORMATION SHEET

XV. Special considerations for ovens with upper and lower burners (Figure 12)

- A. In a two-burner oven, the upper burner pilot requires a separate fresh air supply because the upper pilot cannot burn in the byproducts of combustion from the lower burner.
- B. To assure the upper burner pilot will have a proper fresh air supply requires a separate tube to bring fresh air to the upper pilot.
- C. Fresh air supply to an upper burner is usually accomplished with a snorkle-like tube that brings fresh air from outside the oven and also senses pressure changes inside the oven.

FIGURE 12

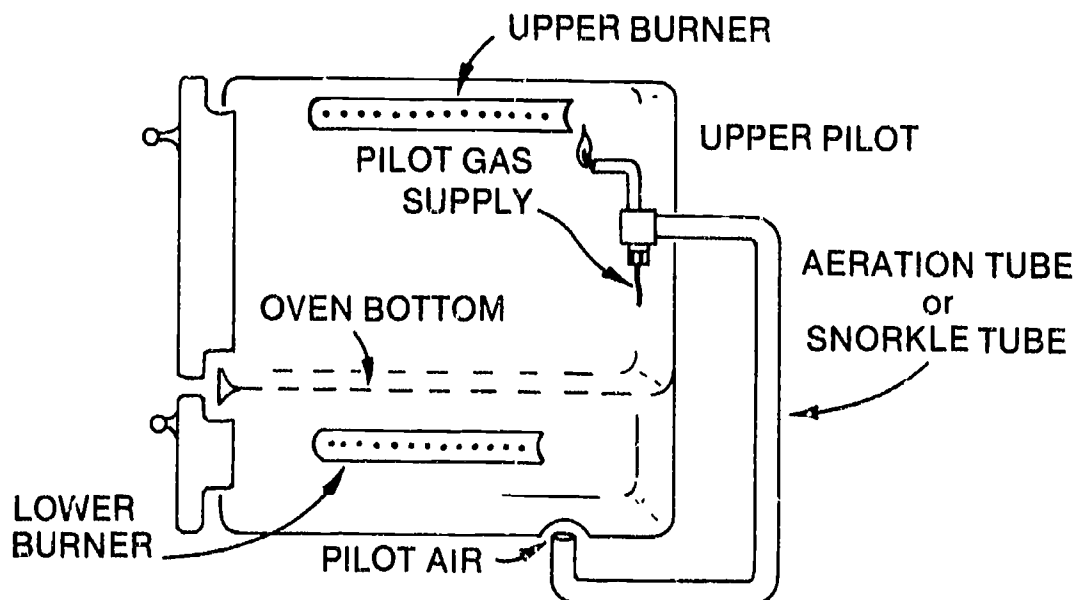

XVI. How self-cleaning ovens work

- A. Most oven spills are forms of hydrocarbons that break down into water and gases when burned in a temperature above 850°F.
- B. The intense heat causes a decomposition process called pyrolysis and leaves a white ash that can be easily wiped off.
- C. In most gas ovens, smoke and other byproducts of self-cleaning are directed out of the oven flue.

XVII. Special safety features of self-cleaning ovens

- A. Since the high temperatures in the self-cleaning function pose a fire danger and danger to the operator, special safety features are built into self-cleaning ovens.

INFORMATION SHEET

- B. A metal-mesh protection screen must be manually pulled into place over the glass in the oven door before the oven door can be manually latched for self-cleaning.

(NOTE: Because the cleaning process is accomplished through use of a special coating on the oven liner, a continuous-cleaning oven does not require the high temperature of a self-cleaning oven and the metal-mesh screen and other safety devices are not required on a continuous-cleaning oven.)

- C. As another safety feature, an inside thermometer activates an inside door lock when the oven reaches 550°F.
- D. The inside door latch stays in place until the oven cools back down to less than 550°F.

(CAUTION: Attempting to open an oven door while the self-cleaning function is in progress could cause serious burns and introduce enough oxygen into the oven to cause an explosion, and operators are encouraged to stay away from ovens during self-cleaning and never attempt to look in through the glass of the oven door.)

XVIII. Safety requirements for gases

- A. Be sure to shut off all gas appliances before turning off the main gas supply.
- B. Smoking while working around gas appliances is **ABSOLUTELY FORBIDDEN**.
- C. Never use a match or any open flame to test for gas leaks.
- D. Test for leaks by brushing on a soap-water mixture and watching for bubbles which would indicate a leak.

(NOTE: Liquid detergent mixed with water until it has a syrupy quality is good for leak testing, and there are commercial leak testing fluids such as LeakTec which are available at supply houses.)

- E. Use pipe dope, Teflon tape, or Teflon dope when making up connections on supply lines that are made of steel.
- F. Do not use pipe dope on any brass fitting except when mating a brass fitting to a steel supply line.
- G. Propane and butane will dissolve some pipe dope, so be sure you use dope that is LP gas resistant.
- H. Do not expose your bare hands or skin to propane or butane because they absorb heat so fast that escaping gas can cause frostbite.

INFORMATION SHEET

- I. Keep propane and butane tanks away from excessive heat.
- J. Never fill a propane or butane tank completely full because both gases require expansion space.
- K. Never use rubber gaskets or washers around propane or butane because both gases will dissolve rubber.

XIX. Flexible connectors

- A. Flexible connectors make hooking up a range much easier, but be sure local codes permit the use of flexible connectors before installing one.

(NOTE: Some local codes still require rigid pipe hookups, and this is almost always true for gas appliances in mobile homes.)

- B. Bend or shape flexible connectors with care because they are made of copper and are fairly easy to break.
- C. Plastic-coated (epoxy) flexible connectors are preferred because bare copper connectors readily corrode in situations where propellants from canned aerosol cooking aids can reach them.

(NOTE: Spray butter substitutes such as Pam contain such propellants.)

- D. Use no pipe dope on brass fittings except the connector fitting from a steel pipe inlet.
- E. Use only connectors that have dielectric qualities and the AGA seal of approval that indicates the connector meets AGA requirements.
- F. Limit flexible connections to no more than six feet.
- G. Make sure the connector is properly sized to match the gas branch line to which it is connected.

XX. Requirements for gas supply lines

- A. Most incoming gas supply lines have a diameter of 1".
- B. Most feeder lines off the main gas supply lines have a diameter of 1/2".

(NOTE: A branch line to a gas clothes dryer may have a 3/8" line because the BTU requirements for a gas dryer are less than for a range or water heater, but piping sizing should be increased in situations where several gas appliances may be in use at one time.)

- C. Piping used for gas transport must be made of black iron or galvanized iron.
- D. Pipe dope, Teflon dope, or Teflon tape should be used when making up all joints and connections on black iron or galvanized iron.

INFORMATION SHEET

XXI. Functions of electrical circuits on gas ovens

- A. Electrical circuits on self-cleaning gas ovens operate oven lights, clocks, and timing devices.
- B. Electrical circuits on gas ovens also operate the door lock switch and other elements of the self-cleaning function.

XXII. Typical circuit functions in a gas oven

- A. When circuits are energized for a simple BAKE function, oven burner operation is controlled through the selector switch and thermostat. (Transparency 11)
- B. When circuits are energized for a TIMED BAKE function, the length of the oven burner operation is controlled through a clock. (Transparency 12)
- C. When circuits are energized for the CLEAN operation in a self-cleaning oven, the cleaning temperatures are controlled by the opening and closing of the thermostatic contacts of the oven control. (Transparency 13)

(NOTE: During opening and closing of the thermostatic contacts, the heating element in the smoke eliminator is energized, and the smoke eliminator fan blows the byproducts of combustion into the flue.)

- D. When circuits are energized for the LOCK operation in a self-cleaning oven, terminals in the oven control cause the lock indicator light to come on, and the unlocking mechanism cannot be energized. (Transparencies 13 and 14)
- E. When circuits are energized for the UNLOCK operation, oven control contacts close as the oven cools down to 550°F and cause a selector switch to activate the unlock solenoid which withdraws the safety rod so the door can be unlocked. (Transparency 14)

XXIII. Gas range complaints and recommended troubleshooting

- A. When the complaint is that the pilot light is out and will not light or will not stay lit, check for:
 - 1. A poorly adjusted pilot light.
 - 2. A poorly adjusted burner flame so high that it puts the pilot out
 - 3. Bad safety valve or thermocouple

INFORMATION SHEET

- B. When the complaint is that the top burner will not light or that the flame is too high or too low, check for:**
1. Top burner pilot light out
 2. Flash tube to pilot clogged or out of position
 3. Burner itself out of position
 4. Flash port clogged
 5. Burner itself clogged
- (NOTE: This problem could produce smoke residue on utensils, and is a sure sign that the user needs to be encouraged to clean food spills from the burner as soon as possible after they happen.)
6. Improper primary air
 7. Wrong size orifice
- C. When the complaint is that the flame jumps off the burner or that the flame is smoky, check for:**
1. Too much primary air through the shutter
 2. Too little primary air through the shutter
- D. When the complaint is that the oven is not heating properly, check for:**
1. Oven thermostat problems
 2. Bypass gas supply problems
 3. Improper calibration of oven thermostat
 4. Improper burner adjustment
 5. Improper gas pressure
- E. When the complaint is that the oven is sweating, check for:**
1. Improper preheating (oven door may need to be left open)
 2. Oven thermostat temperatures incorrect (recalibration)
 3. Clogged oven vent

INFORMATION SHEET

- F. When there is a complaint that there is an odor of gas around the range, check for:
1. Gas leak in connections along supply lines
 2. Oven burners not getting enough primary air
 3. Oven pilot touching burner (needs relocating)

XXIV. Gas pressure drops

- A. No gas appliance will operate properly at a gas pressure less than the appliance is rated for.
- B. Gas ranges have gas pressure ratings expressed in ounces of gas pressure per square inch (PSI).
- C. An average gas rating for natural gas is 4 oz. PSI, and for LP gas, 10 oz. PSI.
- D. With natural gas, a pressure drop can be regulated at the appliance, but with an LP gas pressure drop, the adjustment has to be made at the LP supply tank.
- E. The two most common causes of pressure drops are:
1. An obstruction in the main gas supply line, usually water
 2. Undersized piping that will not serve multi-appliance demands
- F. Water problems are frequent with gas lines in high-acidity soils because acid attacks and corrodes the iron pipe.
- (NOTE: Water can easily penetrate pinholes in the pipe because the water pressure will be much greater than the normal 4 oz. PSI inside the pipe.)
- G. Pilot lights that keep going out, and erratic burner operation are signs of water problems.
- H. In situations where several gas appliances are in use at one time, undersized piping will cause pressure drop.
- I. The handiest tool for troubleshooting a complaint of gas pressure drop is a water or a mercury manometer, and since the water manometer is easier to work with and easier to read, it is a useful tool.

(NOTE: The mercury manometer must be read in pounds per square inch and then converted to ounces per square inch, but the reading with a water manometer is direct and no conversion is required, and because of this, many technicians feel the water manometer is the more accurate of the two.)

INFORMATION SHEET

XXV. Manometer selection and use (Transparency 15)

- A. A water manometer is probably easier to work with than a mercury manometer and the conversion from inches of water column to ounces of pressure is easier to take.
- B. When a gas pressure problem is suspected, it is always best to have the local gas utility check for proper gas pressure at the meter (Figure 13)

FIGURE 13



- C. The next check should be at the range itself:
 - 1. Fill the manometer with enough water that the water level is zero on each side of the scale.

INFORMATION SHEET

2. Remove the venturi from a surface burner and place the manometer tube over the orifice spud. (Figure 14)

(NOTE: Some manifolds have a special plug that can be removed and the manometer tube can be fitted to the manifold with a special connector, but simply putting the tube over the orifice will provide an accurate measurement.)

FIGURE 14



3. Turn the gas valve full ON and read the inches of water column on the right side of the manometer glass.
 4. Write down your manometer reading in inches and tenths of an inch.
 5. Convert inches of water column to ounces per square inch according to the table in Transparency 15.
 6. Check the nameplate for the pressure specified for the range.

Example: A common pressure rating for a natural gas range is 4 oz. PSI or 7 inches water column, and a common rating for an LP range is 10 oz. PSI or 18 inches of water column
 7. Compare your finding with the nameplate information and adjust the gas valve as required.
- D. When gas valve adjustment will not correct the problem, make the following check:
1. Leave the manometer hooked up to the range with the test burner turned to full ON.

INFORMATION SHEET

2. If the home has a gas furnace, start the furnace and look for a pressure drop on the manometer.
3. If there is a noticeable pressure drop, it is an indication that the gas supply line is undersized, and the customer should be advised to have the piping changed by a licensed plumber.

XXVI. Guidelines for roasting

A. Factors that increase roasting time

1. Roasts that are boned and tied take more time to cook than standing roasts

(NOTE: The ties on the roast actually increase the density of the meat and increased density requires more cooking time.)

2. Small roasts require more cooking time per pound than do large roasts.
3. Wrapping meat or poultry in foil increases roasting time.

B. Factors that decrease roasting time

1. A thick coating of fat decreases roasting time.
2. Selecting aged meat decreases roasting time.
3. Selecting standing roasts (not boned and tied) decreases roasting time.

C. Using a thermometer for roasting

1. A thermometer should be inserted into the center of the thickest part of the meat.
2. The tip of the thermometer probe should not be allowed to contact areas of gristle, fat, or bone.

(NOTE: Bone and fat register higher temperatures than the meat adjacent to them and can give deceptive readings.)

3. Generally, a probe should be inserted 3 1/2" into the meat, and if it is a thin roast, the probe should be inserted from an angle that will give it a 3 1/2" penetration.
4. For poultry, a thermometer should be inserted into the center of the breast above the wing or into the inside of the thigh muscle.

INFORMATION SHEET**XXVII. Guidelines for broiling**

- A. Broiling is popular because it reduces fat content and enhances taste.
- B. Broiling is also popular because it is about the only way to please people who like their steaks browned on the outside and rare in the middle.

(NOTE: Remember that the oven door should be left slightly open when broiling.)

C. Selecting steaks for broiling:

- 1. For outside browning and a rare inside, the steak must be at least 1" thick, and it is better if it is slightly thicker.
- 2. The steak should be kept at refrigerator temperature until broiling begins.
- 3. The best way to assure the brown/rare combination is to broil a frozen steak directly from the freezer.
- 4. Place the steak as close to the broiler unit as possible.
- 5. Preheating the oven also helps to control the brown/rare combination.

D. Ways to promote browning

- 1. As fat content in a steak increases, browning increases.
- 2. Brushing any meat with butter or oil will increase browning.
- 3. Seasoning meats after broiling will increase browning because salt added prior to broiling produces moisture which delays browning.
- 4. Handle aged steak with care because the outside cooks rapidly and the inside may be too rare.

(NOTE: Moving the steak farther away from the broiling element will sometimes solve the problem with aged beef.)

XXVIII. Guidelines for baking**A. Placement of shelves and pans**

- 1. Use the middle shelf when baking on only one shelf, and space shelves so that they divide the oven in thirds when using more than one shelf.
- 2. Do not impair heat circulation by placing a pan too close to the oven wall, and with two or three pans, stagger them so that there is a good heat combination around each one.

INFORMATION SHEET

B. Preheating

1. Cakes, pies, and other delicate foods require preheating, so follow the recipe.
2. Preheating is not usually required for meat and poultry.

C. Using foil

1. If oven shelves are completely covered with foil, heat circulation in the oven will be improper.
2. Foil placed directly under a pie may interfere with bottom browning.

D. Selecting pans and bakeware

1. Shiny aluminum is best for cakes, but glass can be used if oven temperature is lowered 25 degrees.
2. Glass pie plates are best for pies, but dark tin or anodized aluminum can also give satisfactory results.
3. Shiny baking sheets are best for biscuits and cookies.
4. Anodized aluminum or glass are best for yeast breads because they help make the crust thick.
5. A dull cookie sheet is best for frozen pies because it helps browning of the bottom crust.

XXIX. Baking problems and their solutions

(NOTE: Some of the following items apply only to gas ovens, but most items apply to both electric and gas ovens.)

A. When baked goods burn on the top

1. Oven flame may be too hard and primary air should be decreased.
2. Baffle may be out of position or upside down, so position baffle properly.
3. Flue may be blocked and it should be cleaned.

B. When baked goods burn on one side

1. Cookware is blocking heat circulation, so position cookware away from sides of oven.
2. Pan may be unlevel or the range may be unlevel, so level the range or replace the utensil as required.

INFORMATION SHEET

- C. When baked goods burn on the bottom**
1. Oven flame may be too soft and primary air should be increased.
 2. Baffle may be out of position or upside down, so position baffle properly.
 3. Dark cookware should be exchanged for a brighter utensil.
 4. Flue may be blocked and it should be cleaned.
- D. When baked goods crack open**
1. Oven is too hot and thermostat should be checked, or a lower temperature should be used.
 2. Batter may be improperly prepared or recipe may be wrong and require correction.
- E. When baked goods are soggy**
1. Oven is not hot enough and thermostat should be checked, or a higher temperature should be used.
 2. Batter may have wrong ingredients, so check the recipe.
 3. Baked item may have been left in the pan too long, and it should be removed immediately.

XXX. Guidelines for service calls

- A. Introduce yourself to the customer, identify your company, and confirm that you are there to answer to the customer's request for service.
- B. Ask the customer to explain in his/her own words what the problem is.
- C. Check to see if baking problems provide a clue to the trouble before looking for mechanical problems.
- D. Place a drop cloth around the range area before starting any work.
- E. Request the customer to keep the area free of children and pets.

Types and Characteristics of Gases

	TYPE OF GAS				
	Manufactured	Natural	Mixed	Propane	Butane
Specific Gravity (Air = 1)	0.40-0.70	0.60-0.70	0.60	1.52	2.00
Heating Value, Btu/cu.ft.	520-600	925-1200	800	2570	3260
Explosive Limits, % Gas in Air					
Lower	5.6	4.8		2.4	1.9
Upper	31.7	14.0		9.5	8.4
Main Constituents, %					
Hydrogen	50		25		
Carbon Monoxide	10		5		
Methane	25	90	60		
Ethane		5	3	3	
Propane				91	6
Butane					94
Cu. Ft. of air required for complete combustion of one cu.ft. of gas	5	10	8	24	31

Courtesy Sears

569

570

MAR-613

Nameplate Information

HOURLY B.T.U. RATINGS FOR NATURAL, MANUFACTURED, MIXED AND L.P. GAS: OVEN		RANGE TOP ROTISS	IN ALL CORRESPONDENCE REGARDING THIS ARTICLE MENTION THIS KENMORE MODEL NO. REG. TRADE MARK						
23,000	8,000 EACH								
HOURLY B.T.U. RATINGS FOR NATURAL, MANUFACTURED OR MIXED GAS: RIGHT AND LEFT REAR TOP BURNER		RIGHT AND LEFT FRONT TOP BURNER	<p>THIS RANGE IS SHIPPED FROM THE FACTORY EQUIPPED FOR USE WITH L.P. GAS (BOTTLED OR TANK GAS).</p> <p>ALL ORIFICE HOODS MUST BE LEFT SCREWED TIGHT WHEN L.P. GAS IS USED.</p> <p>THIS RANGE CAN ALSO BE USED WITH NATURAL OR MIXED GAS AFTER THE FOLLOWING ADJUSTMENTS ARE MADE:</p> <ol style="list-style-type: none"> 1. MAIN BURNER ORIFICE HOODS: UNSCREW HOODS UNTIL SPECIFIED INPUT RATE TO EACH BURNER IS OBTAINED. 2. ON RANGES WITH SIDE TOWER BURNER, REMOVE THE BRASS TOWER BURNER SPUD AND REPLACE WITH A NICKEL SPUD WHICH MAY BE FOUND BEHIND THIS PLATE. 3. ON RANGES WITH LO-TEMP OVEN, REMOVE THE RED HEATER PILOT ORIFICE AND REPLACE WITH A BLACK ORIFICE WHICH MAY BE FOUND BEHIND THIS PLATE. <p>THIS RANGE CAN ALSO BE USED WITH MANUFACTURED GAS BY INSTALLING CONVERSION PARTS (WHICH MAY BE ORDERED THROUGH SEARS, ROEBUCK AND CO.'S MAIL ORDER HOUSES OR RETAIL STORED).</p> <p>ANY INFORMATION ON THIS PLATE REFERRING TO EQUIPMENT NOT FOUND ON YOUR RANGE MAY BE DISREGARDED</p> <p style="text-align: right;">FLUSH TO WALL</p> <p>SEE OWNERS GUIDE FOR MORE DETAILED INFORMATION</p> <p>COVERED BY ONE OR MORE OF THE FOLLOWING U.S. PATENTS:</p> <table> <tr> <td>2,490,885</td> <td>2,787,948</td> </tr> <tr> <td>2,524,210</td> <td>2,862,667</td> </tr> <tr> <td>2,560,777</td> <td>RE.23,299</td> </tr> </table> <p>OTHER PATENTS PENDING</p> 	2,490,885	2,787,948	2,524,210	2,862,667	2,560,777	RE.23,299
2,490,885	2,787,948								
2,524,210	2,862,667								
2,560,777	RE.23,299								
9,000	12,000								
		GRIDDLE							
		12,000							
HOURLY B.T.U. RATINGS FOR L.P. GAS: RIGHT AND LEFT REAR TOP BURNER		RIGHT AND LEFT FRONT TOP BURNER							
8,000	10,000								
		GRIDDLE							
		10,000							
MINIMUM HORIZONTAL DISTANCE FROM SIDES OF RANGE TO ADJACENT COMBUSTIBLE VERTICAL SURFACES EXTENDING ABOVE COOK TOP:									
4"									
115 AMPS	60 CYCLES	15 AMPS							
SERIAL NO.									
<p>MANUFACTURED IN U.S.A. FOR SEARS, ROEBUCK AND CO., U.S.A. ORDER REPLACEMENT PARTS THRU ANY OF OUR MAIL ORDER HOUSES OR RETAIL STORES</p>									

Top Burner Operation

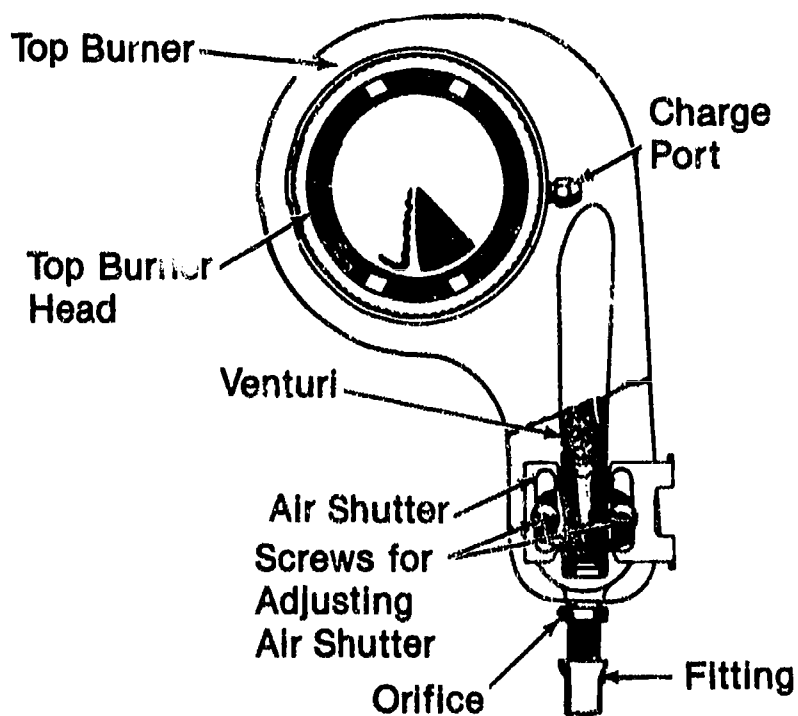
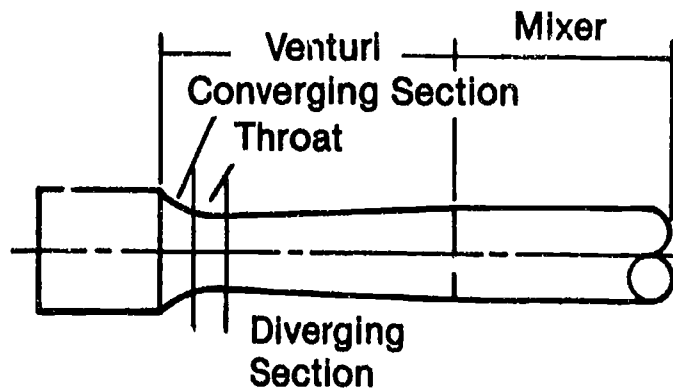

Courtesy Sears
572

Burner Types

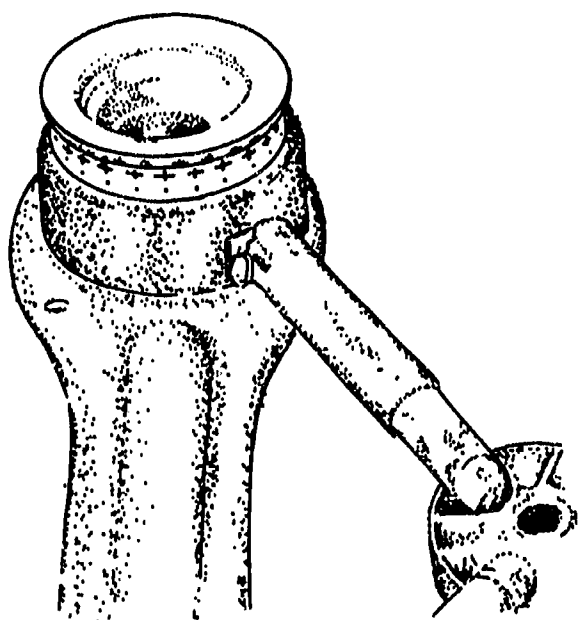

Circular

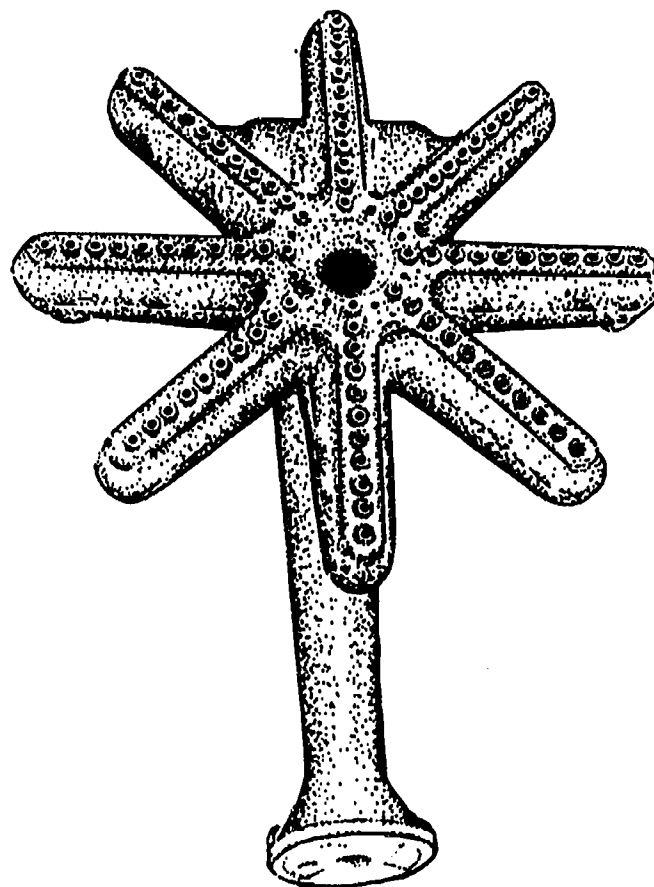

Star

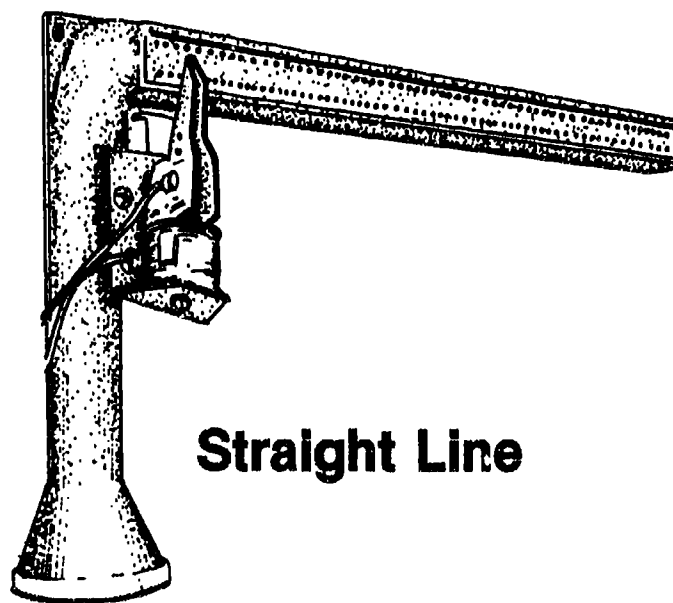

Straight Line

Automatic Oven Ignition System

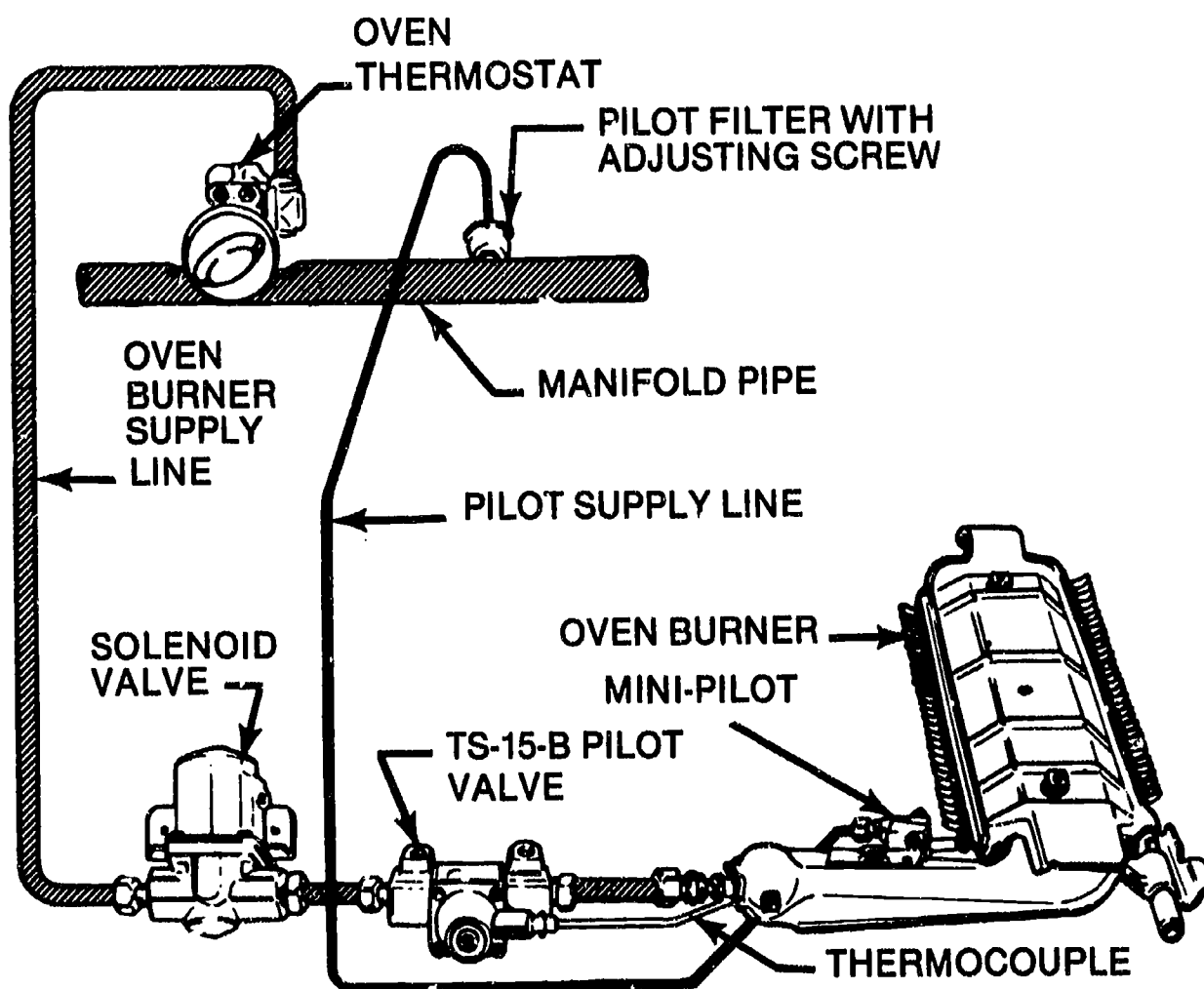

Semi-Automatic Oven Ignition System

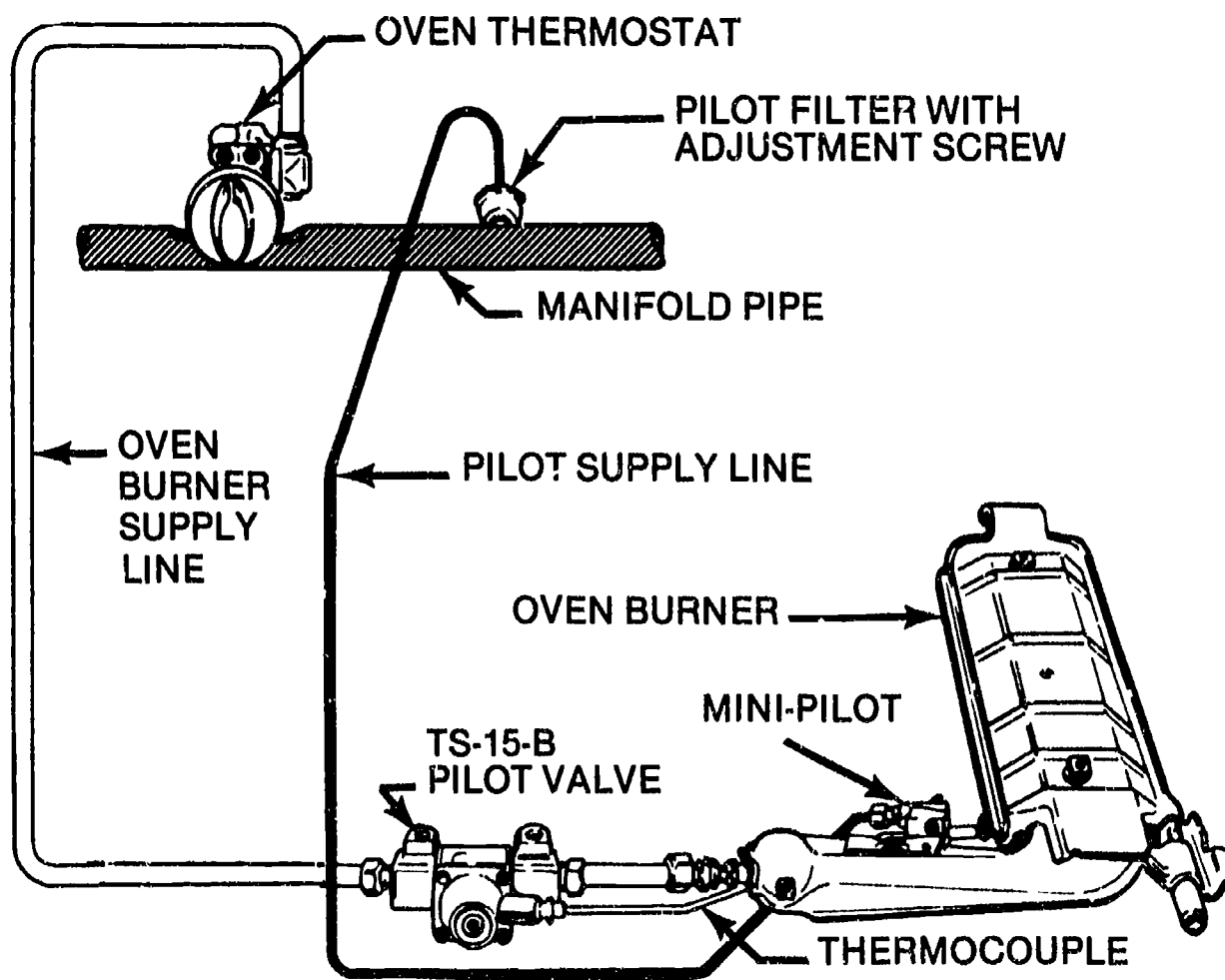

Manual Oven Ignition System

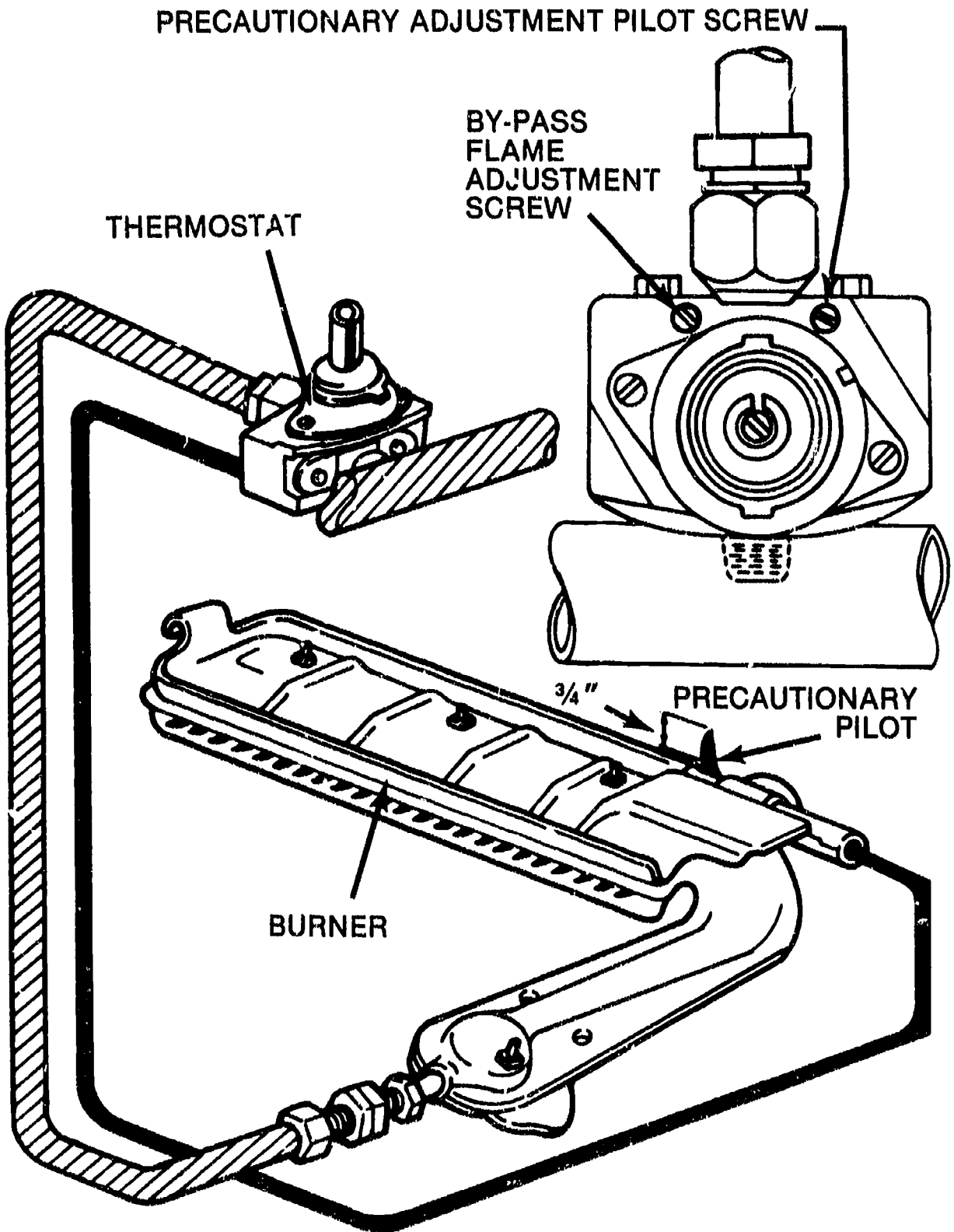

Hydraulic Thermostat

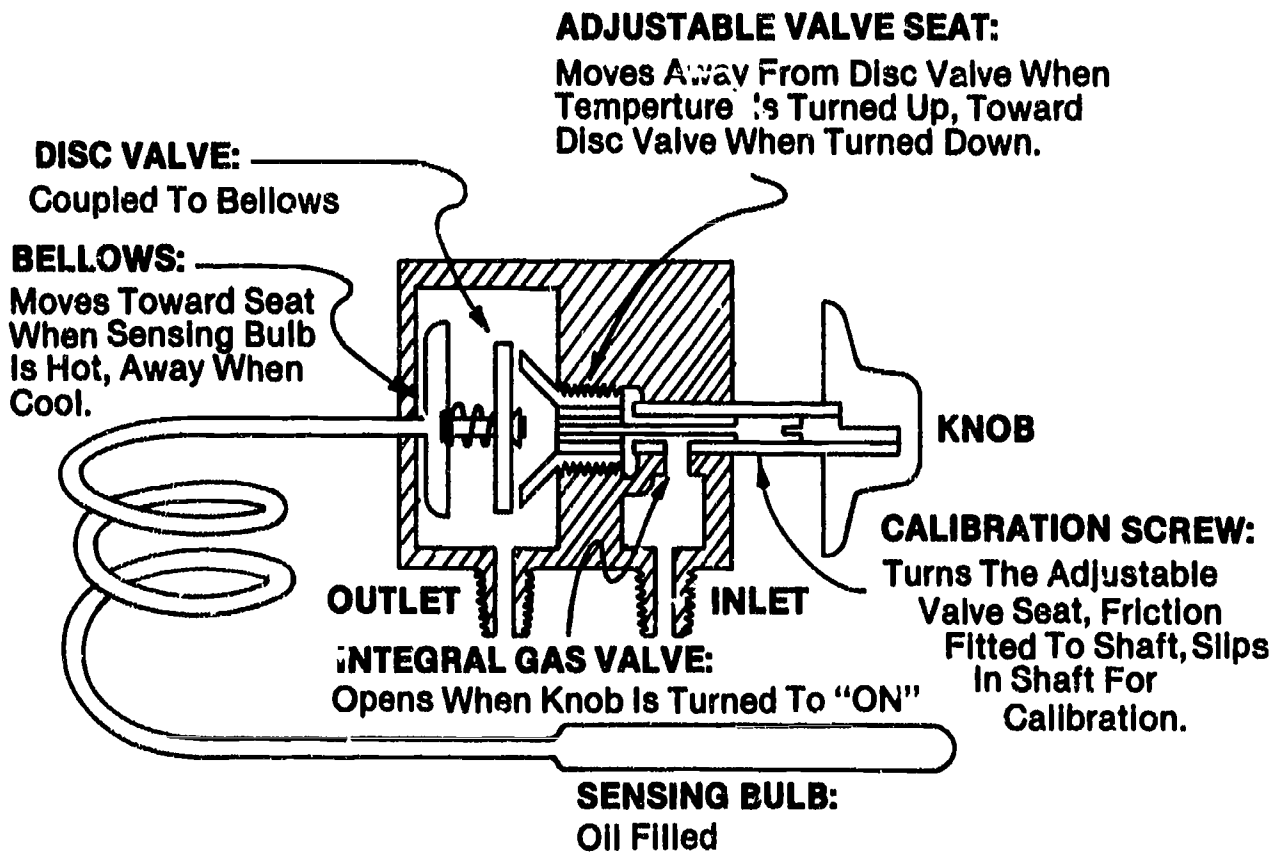

Electric-Hydraulic Thermostat

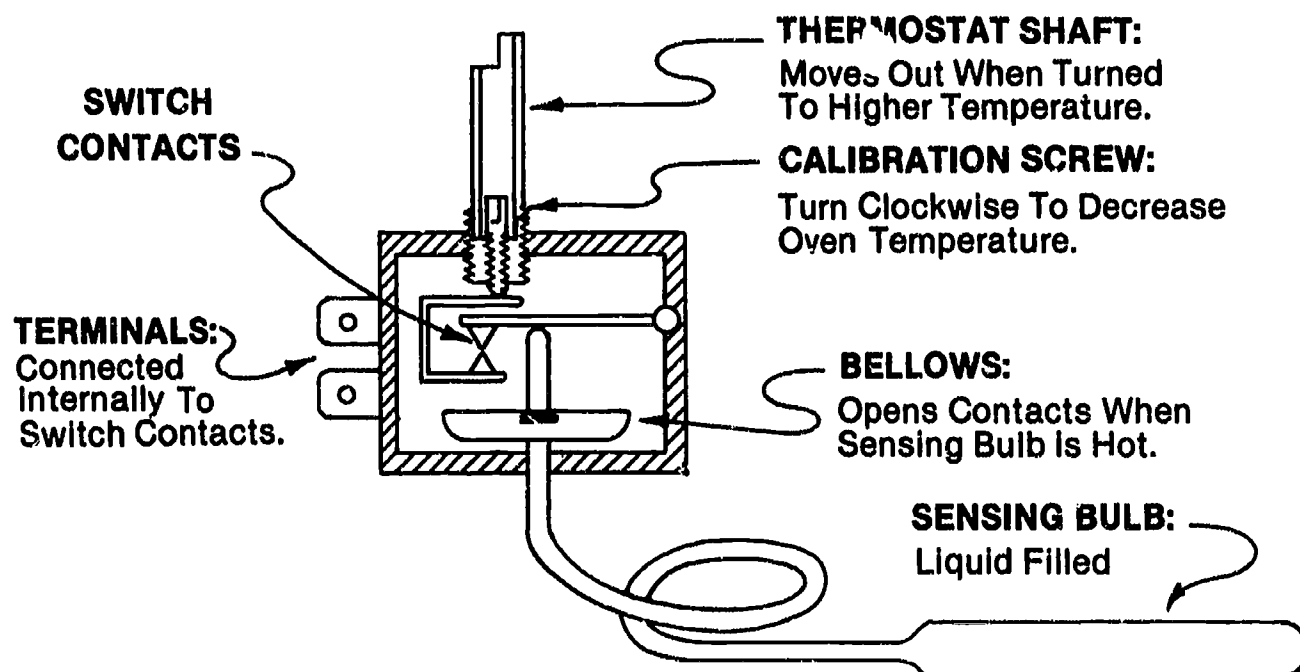

Pneumatic Thermostat

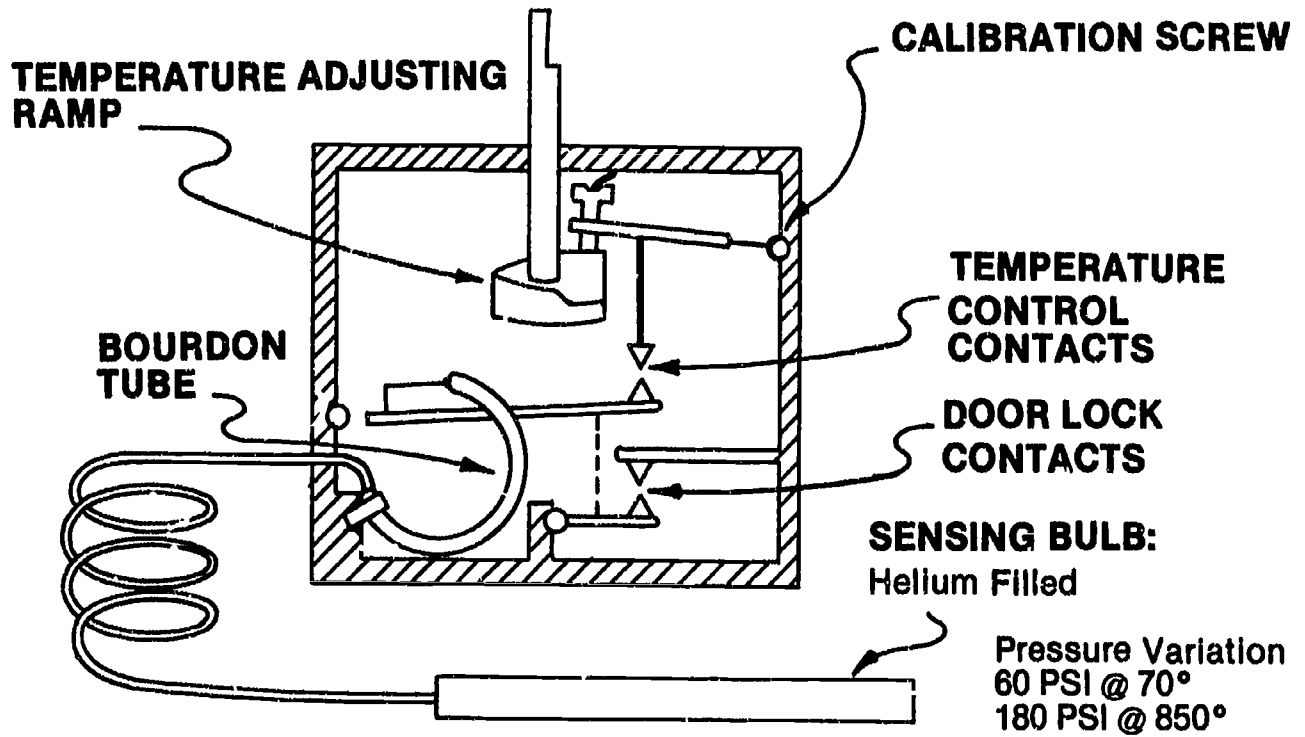

Circuit Operations During a Bake Operation

(Self-Cleaning Gas Oven)

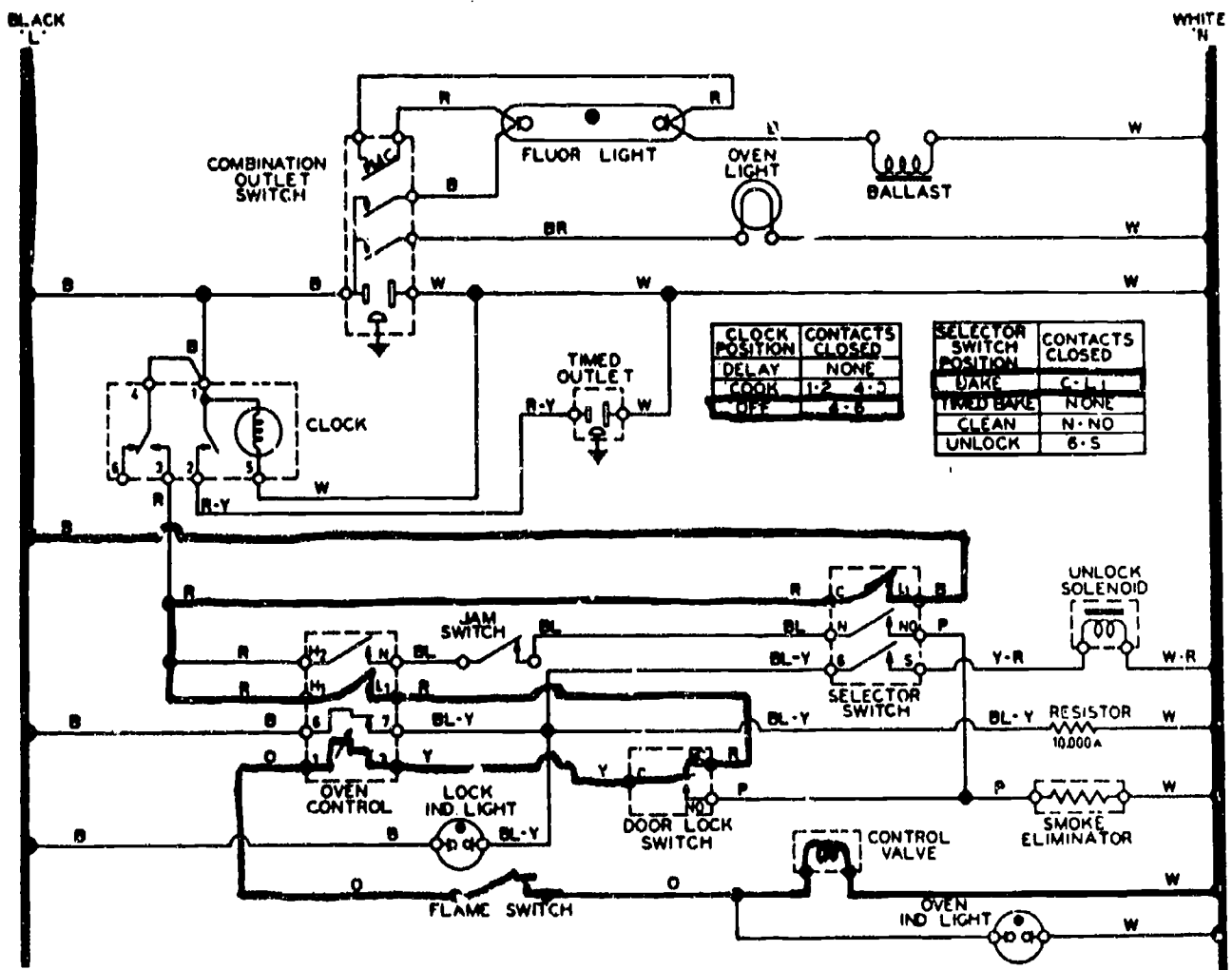

Courtesy Sears

Circuit Operations During a Timed Bake Operation (Self-Cleaning Gas Oven)

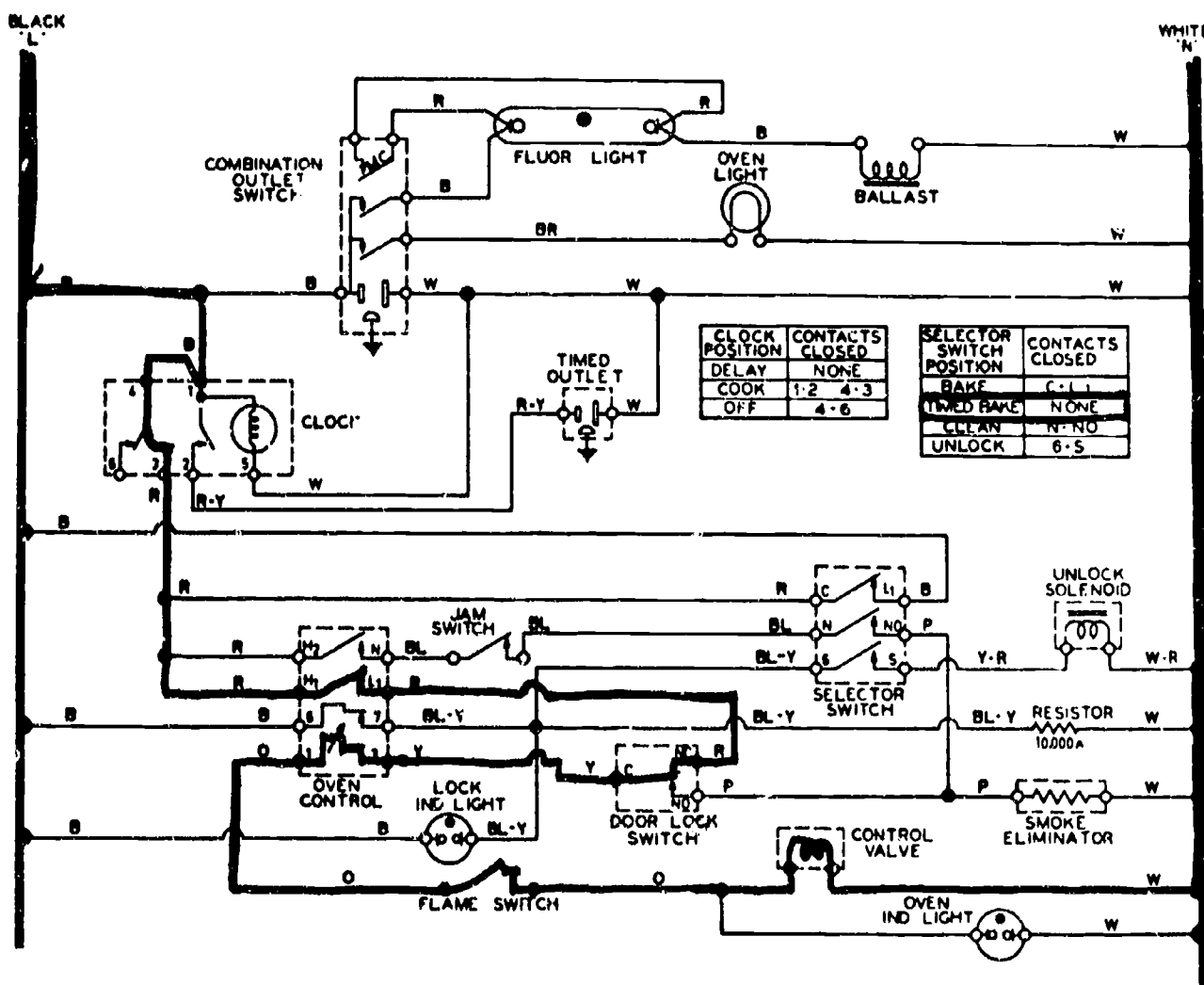

Courtesy Sears

Circuit Operations During a Clean Operation (Self-Cleaning Gas Oven)

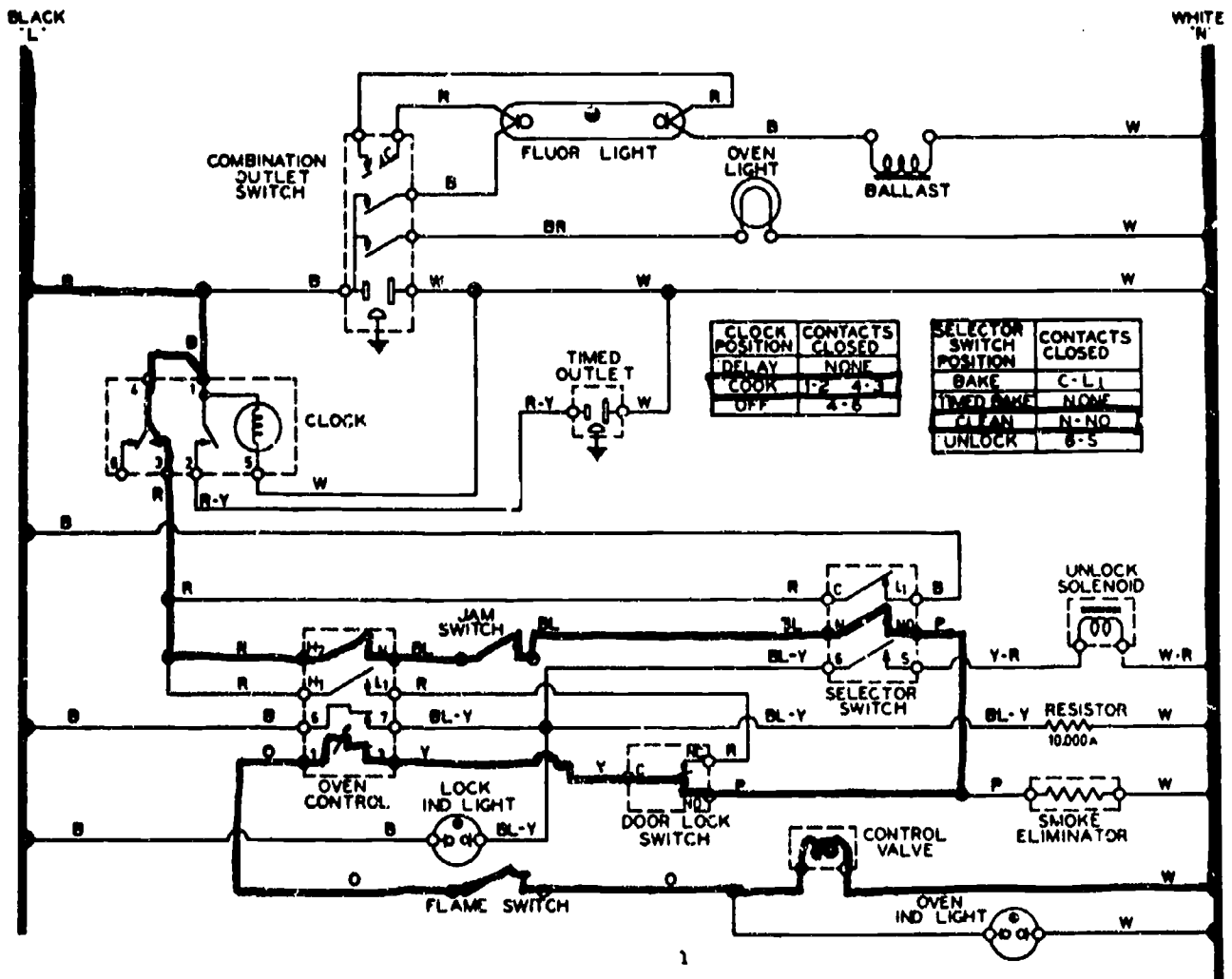

Courtesy Sears

Circuit Operations During Lock and Unlock Operations

(Self-Cleaning Gas Oven)

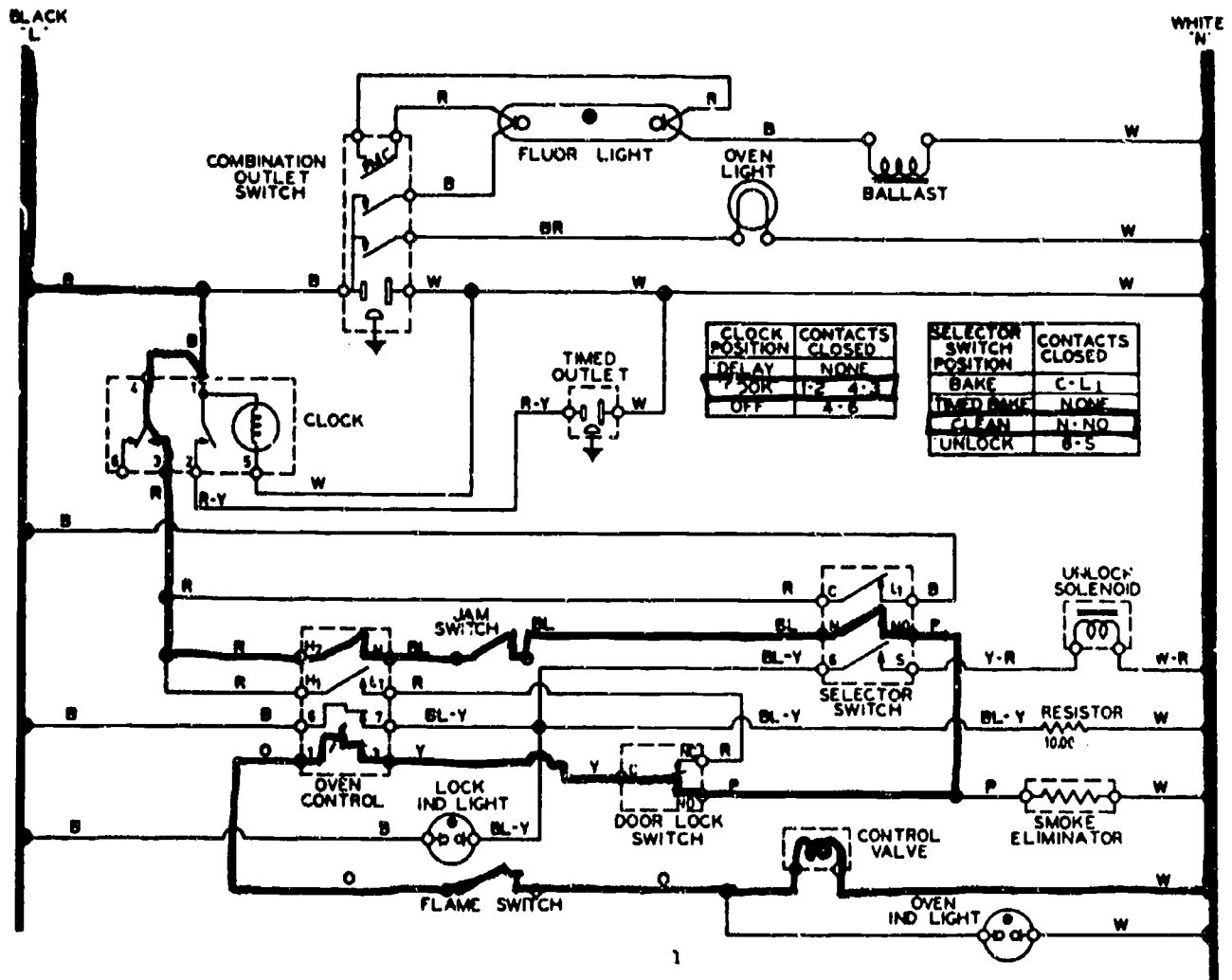

Courtesy Sears

Manometer Pressure Equivalent Table

INCHES OF WATER	INCHES OF MERCURY	OUNCES PER SQ. IN.	POUNDS PER SQ. IN.
.5	0.037	0.289	.0181
1	0.074	0.578	.0361
2	0.148	1.156	.0723
3	0.222	1.734	.1084
4	0.296	2.312	.1445
5	0.370	2.890	.1807
6	0.454	3.468	.2168
7	0.518	4.046	.2529
8	0.592	4.624	.2890
9	0.666	5.202	.3252
10	0.740	5.780	.3613
11	0.814	6.538	.3974
12	0.888	6.936	.4336
13	0.962	7.514	.4697
14	1.036	8.092	.5058
15	1.110	8.670	.5420
16	1.184	9.246	.5781
17	1.258	9.826	.6142
18	1.332	10.404	.6503
19	1.406	10.982	.6865
20	1.480	11.560	.7226
21	1.554	12.138	.7587
22	1.628	12.716	.7949
23	1.702	13.294	.8310
24	1.776	13.872	.8671
25	1.850	14.450	.9032
26	1.924	15.028	.9394
27	1.998	15.606	.9755
28	2.072	16.184	1.0116

GAS RANGES AND OVENS UNIT XII

ASSIGNMENT SHEET #1 — DETERMINE VOLTAGES AND RESISTANCE READINGS ON A SELF-CLEANING OVEN SET FOR A BAKE OPERATION

Directions: Refer to the wiring schematic in Figure 1 and assume that you are working with a VOM. Circle the correct answer to each of the following problems.

- A. If your VOM is set to read voltage and the meter leads are on Terminal 1 of the oven control and Terminal 5 of the selector switch, what voltage would the meter indicate?

Answer: 0 volts 120 volts 240 volts

- B. With the VOM still set to read voltage and the meter leads on Terminal 1 of the oven control and L₁ of the selector switch, what voltage would the meter indicate?

Answer: 0 volts 120 volts 240 volts

- C. With the VOM still set to read voltage and the meter leads on Terminal 1 of the oven control and Terminal C of the selector switch, what voltage would the meter indicate?

Answer: 0 volts 120 volts 240 volts

- D. With the VOM still set to read voltage and the meter leads still on Terminal 1 of the oven control and L₁ of the selector switch, what voltage would the meter indicate if you were to open the oven door?

Answer: 0 volts 120 volts 240 volts

- E. With the electric supply unplugged, the VOM set to read resistance, and the meter leads on Terminal 6 of the selector switch and the white wire to the right of the smoke eliminator, what will the resistance reading be?

Answer: 10 Ω 100 Ω 10,000 Ω

- F. With the electric supply unplugged, the VOM set to read resistance, and the meter leads on Terminal 6 of the selector switch and the BL-Y on the lock indicator light, what will the resistance reading be?

Answer: 10 Ω 100 Ω 0 Ω (Infinity)

ASSIGNMENT SHEET #1

FIGURE 1

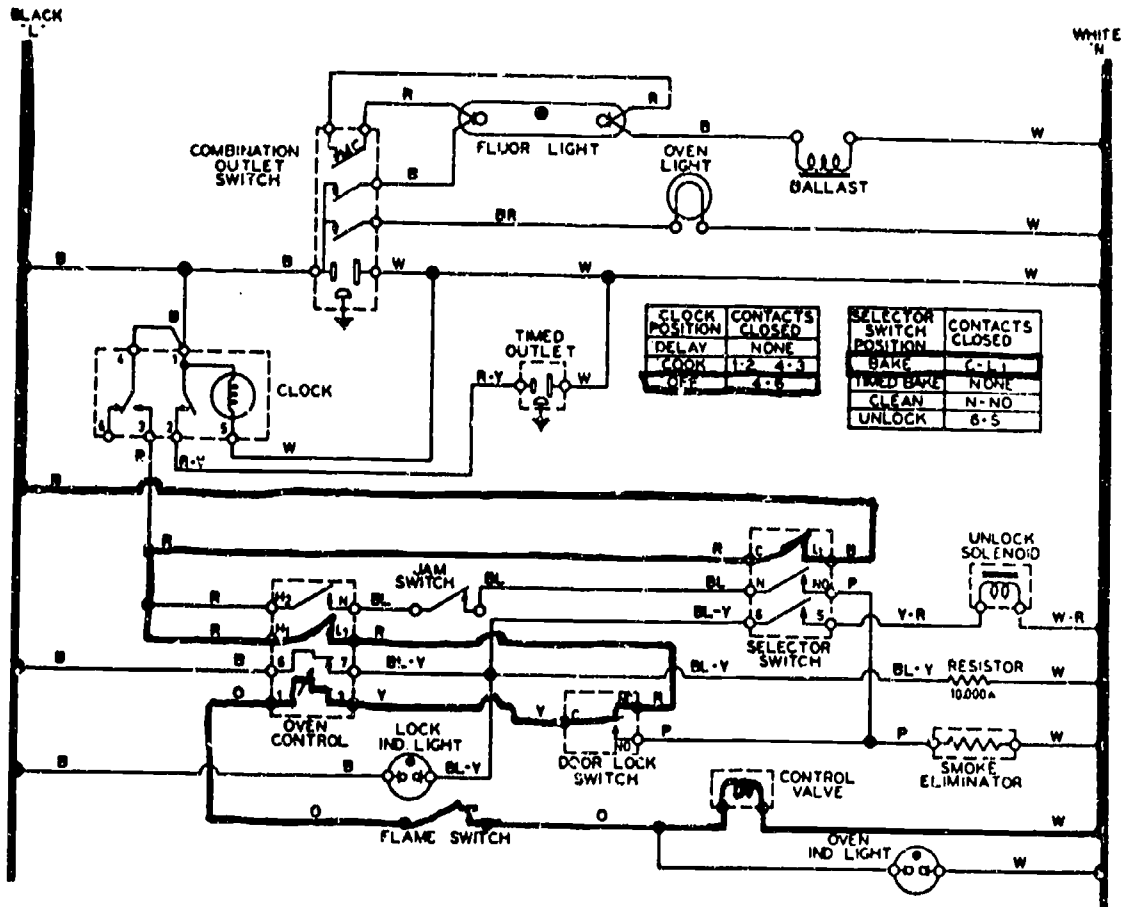

Courtesy Sears

586

GAS RANGES AND OVENS UNIT XII

ASSIGNMENT SHEET #2 — USE A WIRING SCHEMATIC TO DETERMINE VOLTAGE AND RESISTANCE READINGS ON A SELF-CLEANING GAS OVEN SET FOR A TIMED BAKE OPERATION

Directions: Refer to the wiring schematic in Figure 1 and assume that you are working with a VOM. Circle the correct answer to each of the following problems.

- A. If your VOM is set to read voltage and the meter leads are on Terminal 1 of the clock and on the white wire to the right of the control valve, what voltage would the meter indicate?

Answer: 0 volts 120 volts 240 volts

- B. With the VOM still set to read voltage and the meter leads on Terminal 2 of the clock and on the white wire to the right of the control valve, what voltage would the meter indicate?

Answer: 0 volts 120 volts 240 volts

- C. With the VOM still set to read voltage and the meter leads on Terminal H, on the oven control and pin S of the selector switch, what voltage would the meter indicate?

Answer: 0 volts 120 volts 240 volts

- D. With the electric supply unplugged, the VOM set to read resistance, and the meter leads on Terminal 1 on the clock and Terminal 1 on the oven control, what will the resistance reading be?

Answer: 10 Ω 100 Ω 10,000 Ω

- E. With the electric supply unplugged, the VOM set to read resistance, and the meter leads on Terminal 3 of the oven control and the white wire just to the right of the control valve, what will the resistance reading be?

Answer: 10 Ω 100 Ω 10,000 Ω

ASSIGNMENT SHEET #2

FIGURE 1

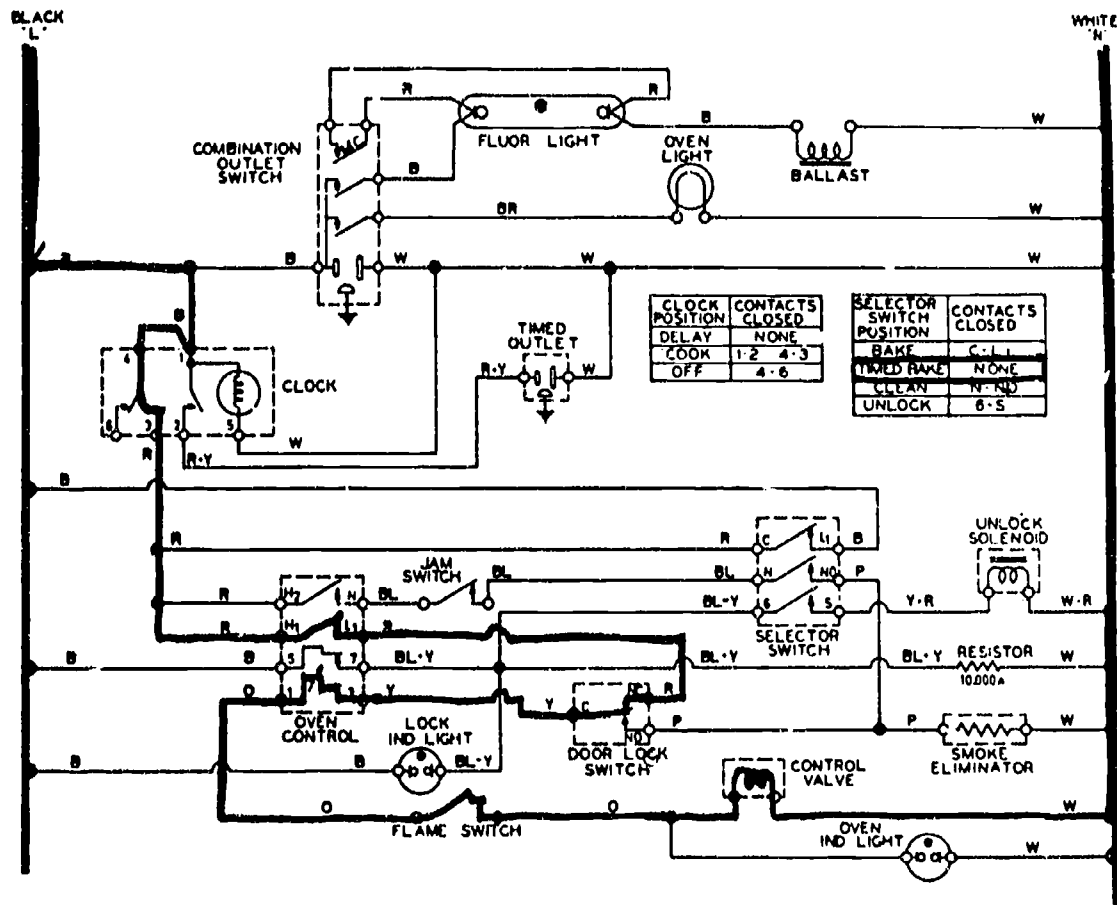

Courtesy Sears

GAS RANGES AND OVENS UNIT XII

ASSIGNMENT SHEET #3 — USE A WIRING SCHEMATIC TO DETERMINE VOLTAGE AND RESISTANCE READINGS ON A SELF-CLEANING GAS OVEN SET FOR A CLEANING OPERATION

Directions: Refer to the wiring schematic in Figure 1 and assume that you are working with a VOM. Circle the correct answer to each of the following problems.

- A. If your VOM is set to read voltage and the meter leads are on Terminal 6 of the oven control and the white wire just to the right of the unlocking solenoid, what voltage would the meter indicate?

Answer: 0 volts 120 volts 240 volts

- B. With the VOM still set to read voltage and the meter leads on Terminal 1 of the clock and Terminal L, on the selector switch, what voltage would the meter indicate?

Answer: 0 volts 120 volts 240 volts

- C. With the VOM still set to read voltage and the meter leads on Terminal 1 on the oven control and the white wire just to the right of the smoke eliminator, what voltage would the meter indicate?

Answer: About 0 volts About 120 volts About 240 volts

- D. With the electric supply unplugged, the VOM set to read resistance, and the meter leads on the left hand terminal of the timed outlet and Terminal C on the selector switch, what will the resistance reading be?

Answer: About 100 Ω About 600 Ω About 1,000 Ω

- E. With the electric supply unplugged, the VOM set to read resistance, and the meter leads on Terminal 1 of the oven control and the purple wire to the left of the smoke eliminator, what will the resistance reading be?

Answer: About 150 Ω About 600 Ω About 900 Ω

ASSIGNMENT SHEET #3

FIGURE 1

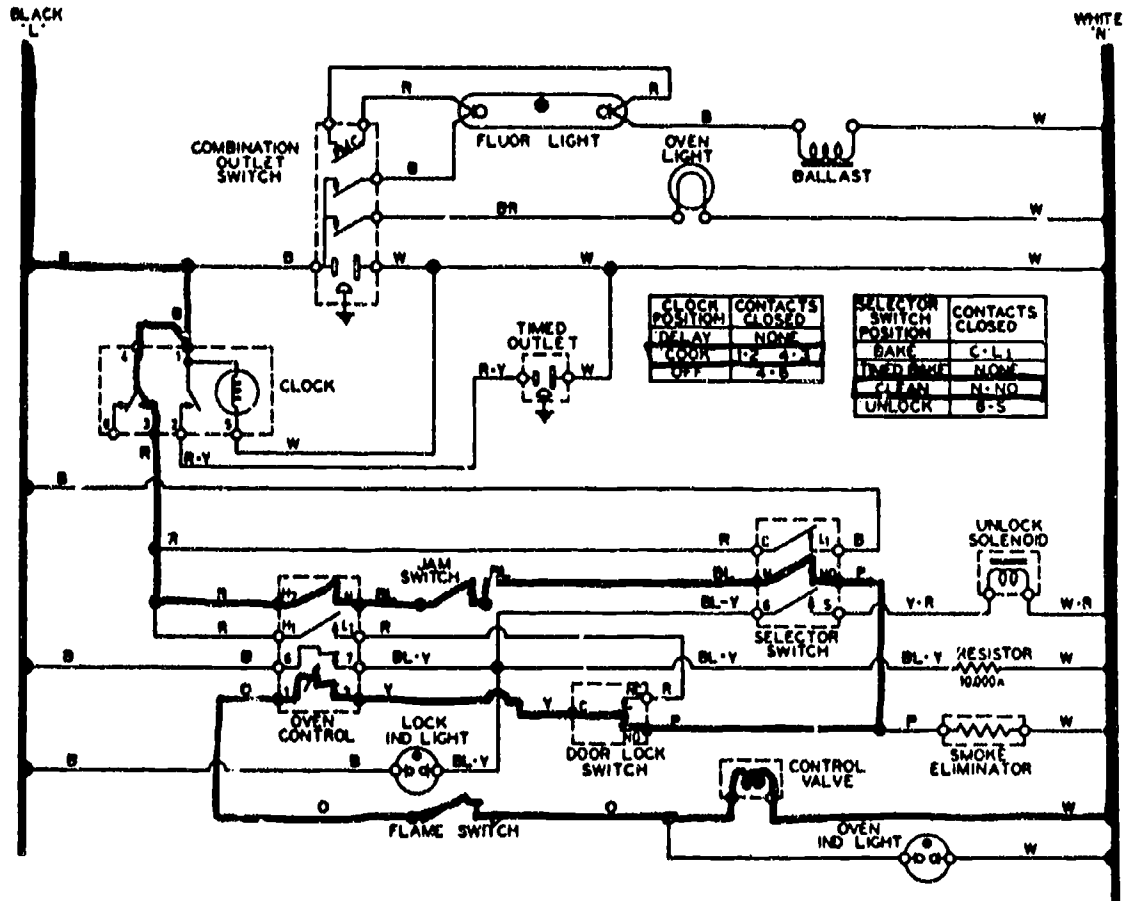

Courtesy Sears

GAS RANGES AND OVENS UNIT XII

ASSIGNMENT SHEET #4 — USE A WIRING SCHEMATIC TO DETERMINE VOLTAGE AND RESISTANCE READINGS ON A SELF-CLEANING GAS OVEN DURING LOCK AND UNLOCK

Directions: Refer to the wiring schematic in Figure 1 and assume that you are working with a VOM. Circle the correct answer to each of the following problems.

- A. If your VOM is set to read voltage and the meter leads are on Terminal 1 of the clock and the white wire to the right of the unlock solenoid, what voltage would the meter indicate?

Answer: 0 volts 120 volts 240 volts

- B. With the VOM still set to read voltage and the meter leads on Terminal 1 of the clock and Terminal 6 of the selector switch, and assuming oven temperature has reached 540°F, what voltage would the meter indicate?

Answer: 0 volts 120 volts 240 volts

- C. With the electric supply unplugged, the VOM set to read resistance, and the meter leads on Terminal 3 on the clock and the white wire, what will the resistance reading be?

Answer: 0 Ω 50 Ω 100 Ω

- D. With the electric supply unplugged, the VOM set to read resistance, and the meter leads on Terminal 3 of the oven control and Terminal L₁ of the oven control, what will the resistance reading be?

Answer: 0 to 5 Ω 10 to 20 Ω 100 to 110 Ω

ASSIGNMENT SHEET #4

FIGURE 1

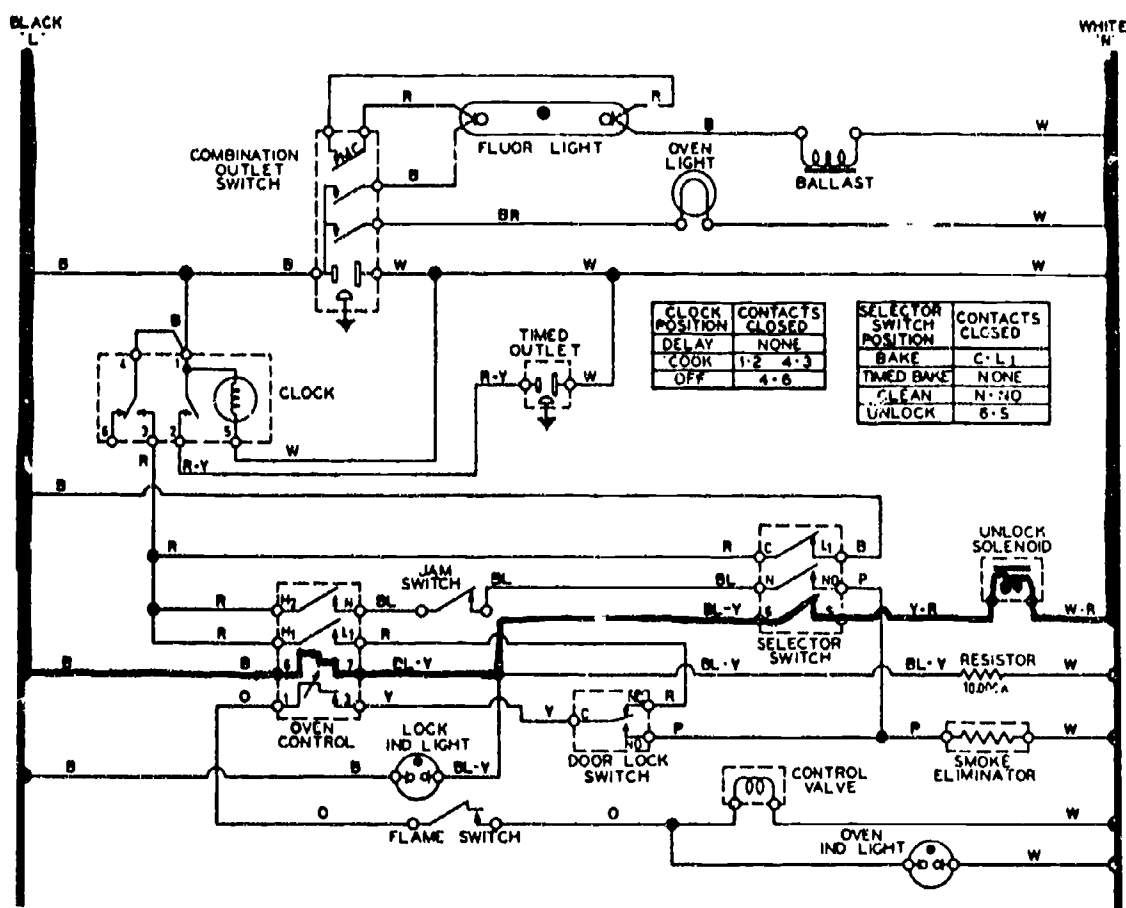

Courtesy Sears

GAS RANGES AND OVENS

UNIT XII

ANSWERS TO ASSIGNMENT SHEETS

Assignment Sheet #1

- A. 120 volts
- B. 0 volts
- C. 0 volts
- D. 120 volts
- E. 10,000 volts
- F. 0 Ω

Assignment Sheet #2

- A. 120 volts
- B. 0 volts
- C. 120 volts
- D. 0 Ω
- E. About 100 Ω

Assignment Sheet #3

- A. 120 volts
- B. 120 volts
- C. About 120 volts
- D. About 600 Ω
- E. About 150 Ω

Assignment Sheet #4

- A. 120 volts
- B. 0 volts
- C. 0 Ω
- D. 0 to 5 Ω

GAS RANGES AND OVENS UNIT XII

JOB SHEET #1 — INSTALL A GAS RANGE LEVEL AND LEAK FREE WITH ALL BURNERS PROPERLY ADJUSTED

A. Tools and materials

1. Range as selected by Instructor
2. Flexible connector (plastic coated, AGA approved)
3. Adjustable wrench (12")
4. Pipe wrench for backup (12" or 14")
5. Leak test liquid and a small brush
6. Pipe dope or tape
7. Cut-off valve
8. Level
9. Safety glasses

B. Procedure

1. Put on safety glasses and turn off main gas supply

(CAUTION: If turning off the main gas supply will also cut off gas to other appliances, turn off the pilots to those other appliances BEFORE turning off the main gas supply.)

2. Inspect area where range will be installed to make sure it will have sufficient air supply and not be near combustible materials
3. Position range in approximate area of installation, but leave room enough behind to install connection
4. Dope the threads on the gas inlet line
5. Install cut-off valve using an adjustable wrench on the cut-off valve and using a pipe wrench as a backup on the inlet line

(NOTE: Apply dope only to the threads on the inlet line, not to the interior threads of the brass cut-off fitting.)

6. Make up the fitting between the cut-off valve and the flexible hose with an adjustable wrench on the flex hose connector and an open end wrench as a backup on the cut-off valve

(NOTE: Remember that on a residential installation, a flexible connector may not meet local codes, so be sure to check with the local building inspector.)

JOB SHEET #1

7. Determine if the fitting on the range manifold requires a reducer or an expander from the flex hose and select the appropriate fitting as required
8. Make up the fitting between the flex hose and the range manifold with an adjustable wrench

(NOTE: The manifold should be securely bolted down and not require a backup wrench.)
9. Check to make sure the range is level

(NOTE: If you're ever caught without a level, a dish or container with a ring around it can be filled with water and used as a level.)
10. Turn on the main gas supply

(CAUTION: Make sure there is not open flame around the range area, and remember that smoking while working around gas appliances is STRICTLY FORBIDDEN.)
11. Purge the line by turning on an upper burner control until you detect the odor of gas, and then turning it off

(NOTE: This will bleed all air out of the gas line.)
12. Brush leak detector on each fitting that you made up and watch for bubbles that would indicate a leak
13. Tighten any connection that shows evidence of leaking, and test again
14. Make sure there are no leaks, and then test each top burner for a proper gas supply
15. Test the oven burner for a proper gas supply
16. Observe flame at each burner, and adjust air shutter as required to produce a blue flame with a well defined inner cone of about 1/2" and a total flame height of about 1 1/2"
17. Turn off all burners after adjustment
18. Make a final check for each burner to make sure it ignites when turned on and that the flame is properly adjusted
- Have your instructor check your work
19. Relight all pilot lights that were turned off
20. Clean up area and return tools and equipment to proper storage

5.95

GAS RANGES AND OVENS UNIT XII

JOB SHEET #2 — CHECK GAS OVEN TEMPERATURE FOR PROPER OVEN THERMOSTAT SETTINGS

A. Tools and materials

1. Range as selected by Instructor
2. Temperature tester (Roblnaire, Universal Instruments, or equivalent)
3. Pencil and paper
4. Safety glasses

B. Procedure

1. Put on safety glasses.
2. Clip the tester probe to the center portion of the center rack in the oven
3. Set the oven thermostat and preheat to 250°F so the oven liner will be properly heated

(NOTE: Always start a temperature check at a low oven setting because starting with a high setting would waste time while the oven cools off.)

3. Position yourself so you can observe the oven flame
4. Compare the temperature on the tester with the temperature on the oven thermostat at the moment the oven flame cuts back to the pilot
 - a. If the two readings are within 15°F high or low, the oven temperature is okay
 - b. If the two readings are beyond the 15°F limit, recalibrate the oven thermostat as outlined in a later job sheet

(NOTE: The temperature differential in some ovens may be higher than the 15°F listed above, so always check manufacturer's specifications.

5. Advance oven thermostat to 300°F and make temperature/thermostat checks as previously outlined
6. Advance oven thermostat to 400°F and make temperature/thermostat checks as previously outlined
- Have your instructor check your findings
7. Turn oven off and leave the door open so the oven will cool faster
8. Prepare for recalibration of the oven thermostat or clean up area as directed by your instructor

GAS RANGES AND OVENS UNIT XII

JOB SHEET #3 — RECALIBRATE A GAS OVEN THERMOSTAT TO CORRECT SETTINGS

A. Tools and materials

1. Range as selected by instructor
2. Temperature tester (Robinar, Universal Instruments, or equivalent)
3. Longshank, extra-slender screwdriver
4. Needlenose pliers
5. Inspection light
6. Safety glasses

B. Routine #1 — Setting up equipment

1. Put on safety glasses
2. Complete oven temperature test as previously outlined to make sure recalibration is required
3. Permit oven to cool
4. Clip the tester probe to the center portion of the center rack in the oven
5. Set the oven thermostat to 250°F
6. Position yourself so you can observe the oven flame
7. Compare the tester temperature with the temperature of the oven thermostat setting the moment the oven flame cuts back to pilot
8. Record your finding: _____
9. Determine if the thermostat needs to be increased to raise oven temperature or decreased to lower oven temperature
10. Determine type of thermostat and adjustment required
 - a. If the thermostat has a D-stem with a pin that has to be removed, follow instructions in Routine #2
 - b. If the thermostat has a recessed calibration screw, follow instructions in Routine #3
 - c. If the thermostat has a dial shaft adjustment, follow instructions in Routine #4

JOB SHEET #3

- C. Routine #2 — Adjusting a thermostat with a D-stem and pin (Figure 1)**
1. Remove the control knob by pulling out
 2. Remove the bezel
 3. Make sure the D-stem does not move in either direction
 4. Use the needlenose pliers to remove the holding pin at the face of the calibration plate
 5. Insert a pocket screwdriver blade into the D-stem adjustment screw
 6. Follow instructions on the calibration plate to raise or lower temperature as required
 - a. To increase temperature follow arrow direction counterclockwise to raise to a higher (H) temperature
 - b. To decrease temperature follow arrow direction clockwise to a lower (L) temperature
 - c. Each notch on the calibration plate indicates an increment of 25°F
 7. Complete recalibration for oven thermostat at 250°F
 8. Put D-stem pin back in place and return the bezel and thermostat control knob
 9. Open oven door and permit oven to cool down a bit
 10. Make a second oven temperature check and record your findings
 - a. If the reading is a bit low, don't recalibrate until you make temperature checks at 300°F and 400°F
 - b. If the reading is a bit high, wait until other temperature checks are made before recalibrating
 11. Take temperature checks at 300°F and at 400°F and record your findings
 - a. If the 400°F thermostat setting is within 25°F of the oven temperature test, the thermostat is okay
 - b. If the 400°F thermostat setting is beyond or below the 25°F limit, then recalibrate as outlined previously

(NOTE: Exact calibration is seldom possible, but if the lower and upper temperature settings are relatively close, the mid-range temperature will probably be okay and a recalibration at 300°F will not be required.)
 12. Put the D-stem pin, bezel, and control knob back in place
- Have your instructor check your work

JOB SHEET #3**D. Routine #3 — Adjusting a thermostat with a recessed calibration screw (Figure 2)**

1. Make a 250°F temperature test as previously outlined
2. Remove thermostat knob
3. Insert a longshank, slender screwdriver down the D-stem shaft until the blade engages the calibration screw
4. Turn the calibration screw counterclockwise to increase temperature or clockwise to decrease temperature

(NOTE: The basic difference between this type of control and the previous one is that there is no bezel and no D-stem pin to remove and replace.)

5. Replace thermostat knob and recheck thermostat setting at 250°F as previously outlined
6. Make a temperature check at 400°F and recalibrate as required
7. Record your findings

Have your Instructor check your work

E. Routine #4 — Adjusting a thermostat with a dial shaft adjustment (Figure 3)

1. Make sure the standby pilot is lit
2. Turn dial counterclockwise to 550°F
3. Permit oven burner to stay on for five minutes
4. Turn dial back until it is mid-way between LO and OFF, and turn dial slightly either way until you observe a full heater pilot flame
5. Use a screwdriver to turn the by-pass adjustor until flames over the entire burner are approximately 1/8" high

(NOTE: The by-pass flame adjustment should be made before recalibration is attempted.)

6. Clip the temperature tester onto the center rack in the center of the oven
7. Set dial to the LO mark and light the oven burner

(NOTE: The oven will snap on and off between LO and 325°F, and there should be no by-pass flame on the burner.)

JOB SHEET #3

8. Watch as burner snaps on and off, and when it snaps on and stays on, make an oven temperature check
9. Record your finding: _____
10. Recalibrate only if the temperature check is more than 150° above/below the dial marking of 140°F
11. Insert a screwdriver in the screw of the calibration stem, and push the stem inward
12. Hold the stem firmly in and turn the stem clockwise to obtain a lower temperature or counterclockwise to obtain a higher temperature

(NOTE: Calibration marks are in increments of 25°F)
13. Replace dial assembly
14. Turn oven off, open door, and let oven cool about ten minutes
15. Make another temperature check as previously outlined to make sure recalibration is proper
16. Record your findings
- Have your instructor check your work
17. Clean up area and return tools to proper storage

600

JOB SHEET #3

FIGURE 1

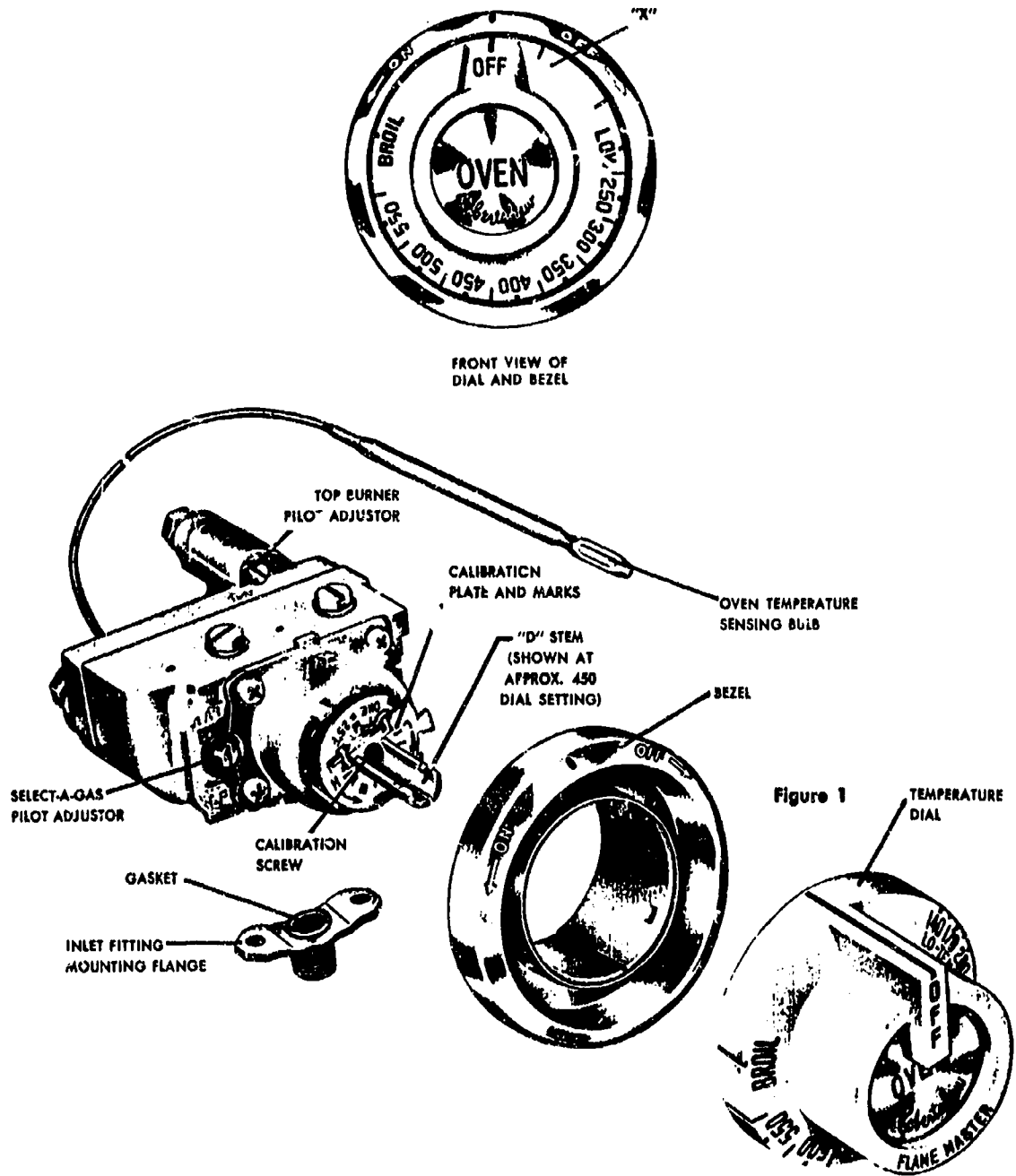

Courtesy Robertshaw

JOB SHEET #3

FIGURE 2

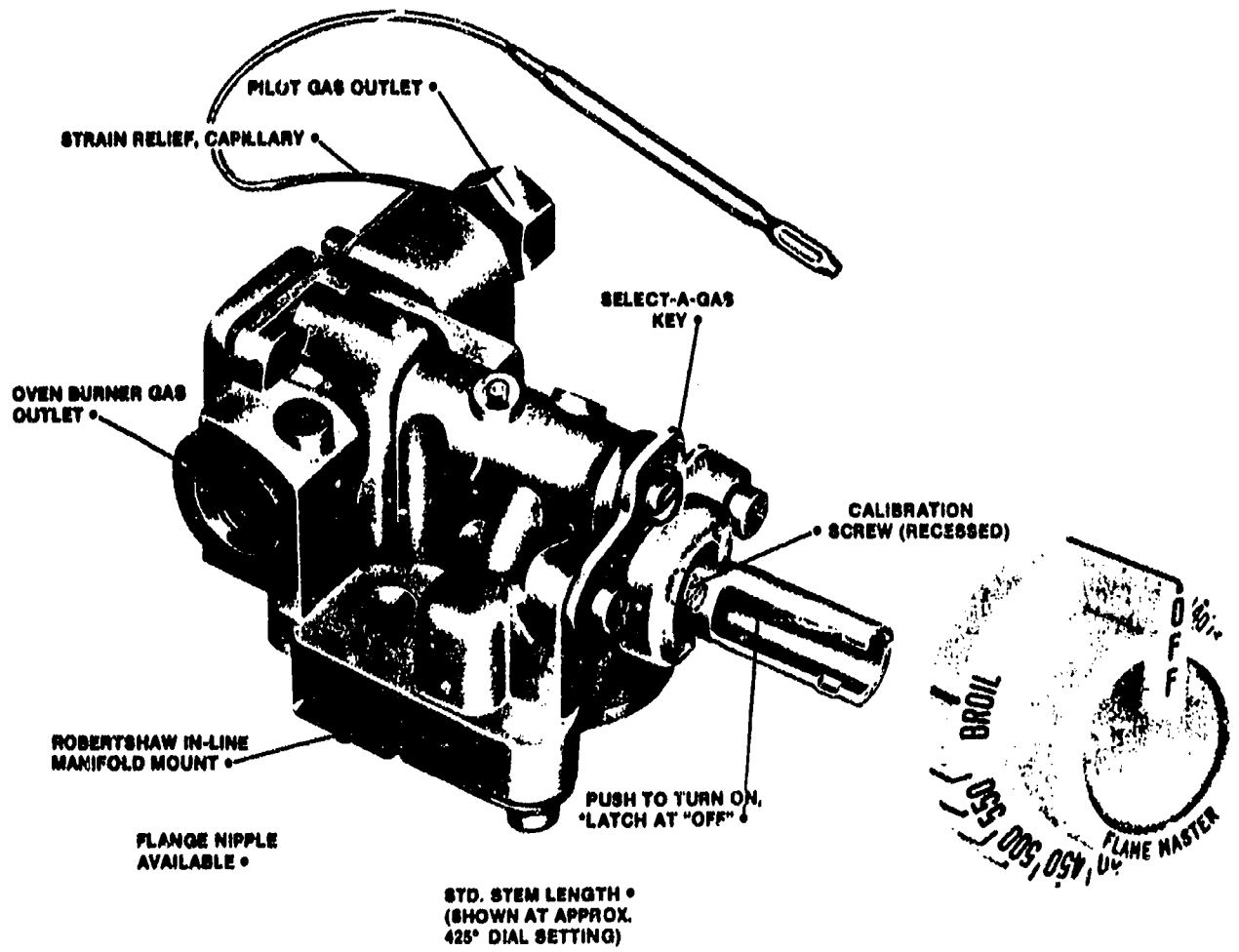

Courtesy Robertshaw

JOB SHEET #3

FIGURE 3

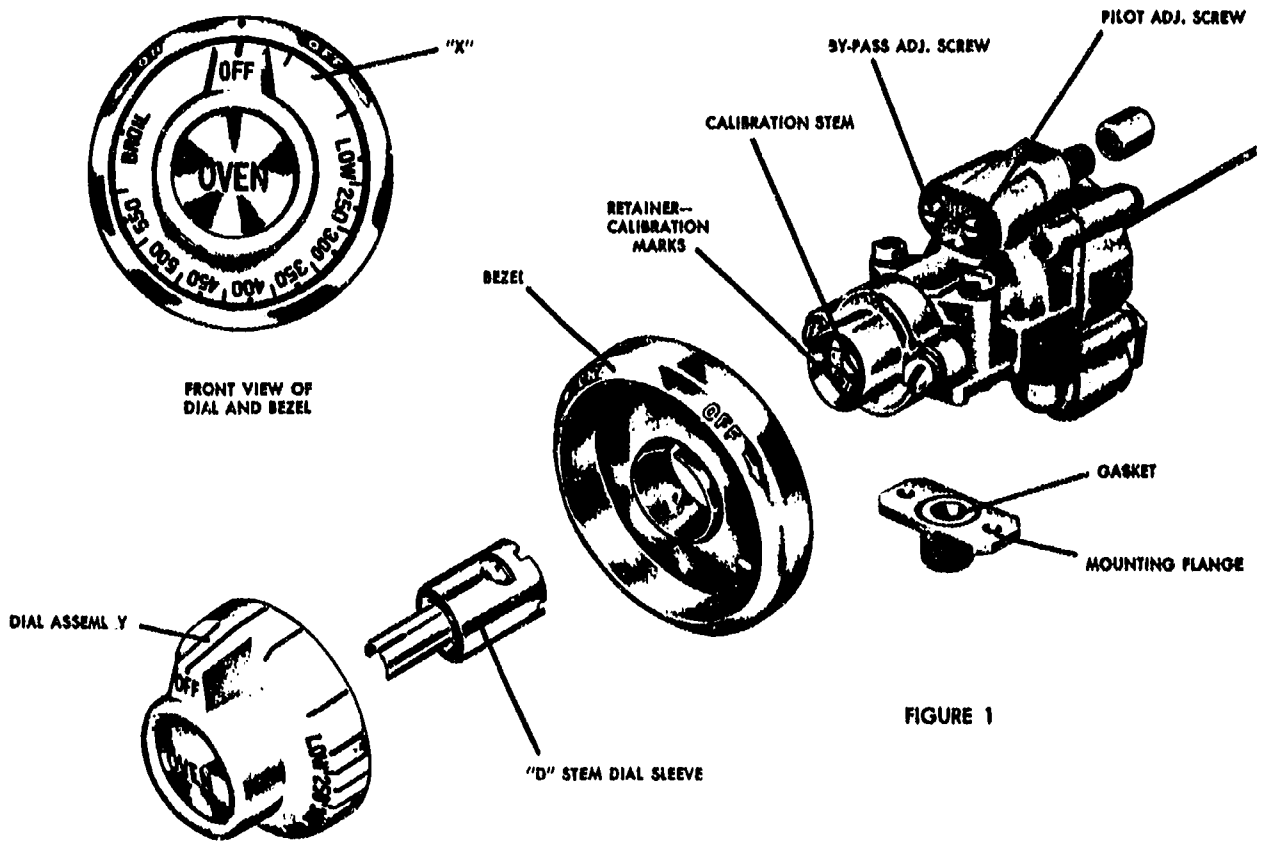

FIGURE 1

Courtesy Robertshaw

GAS RANGES AND OVENS UNIT XII

JOB SHEET #4 — REMOVE, DISASSEMBLE, CLEAN, LUBRICATE, AND REASSEMBLE A STANDARD GAS BURNER VALVE

A. Tools and materials

1. Range with standard gas burner valves
2. Pliers
3. Open-end or adjustable wrench
4. Shop cloths
5. Graphite grease

B. Routine #1 — Disassembling the burner valve

1. Turn off gas supply to the oven
2. Remove control knob from the burner valve
3. Remove front panel to gain access to the burner valve

(NOTE: On some ranges, the burners have to be removed in order to gain access to the burner valves.)

JOB SHEET #4

4. Use pliers to remove the knurled nut from the end of the valve body (Figure 1)
(CAUTION: Watch for the spring behind the nut because it may fly out as you remove the nut.)

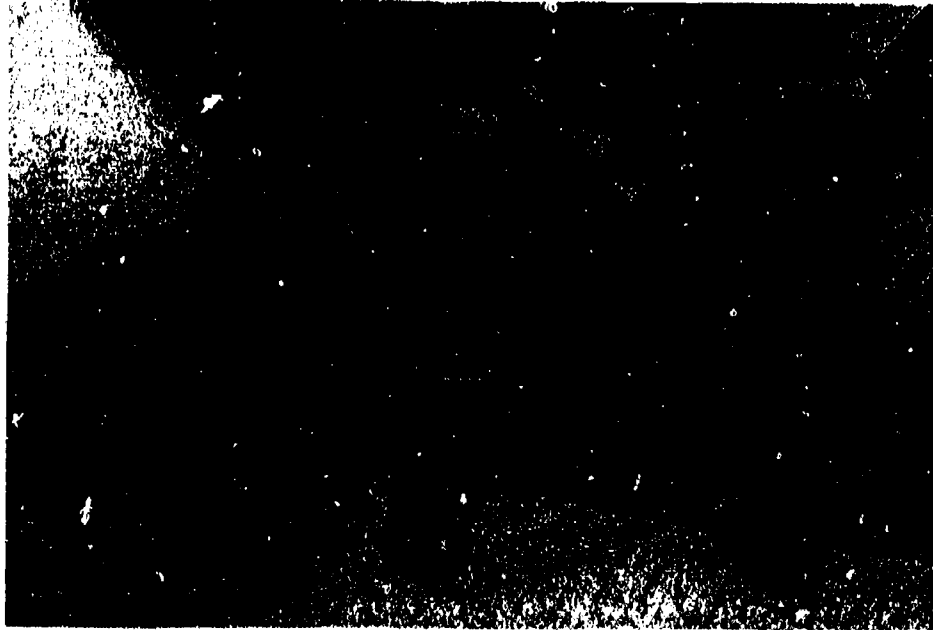
FIGURE 1

5. Place the pliers on the valve control stem and work it back and forth gently until it comes out (Figure 2)

FIGURE 2

JOB SHEET #4

6. Clean the cone-shaped stem with a clean shop cloth
7. Clean the interior of the stem housing with a clean shop cloth
8. Place graphite lubricant on the outside of the control stem and work it all around the stem with your finger (Figure 3)

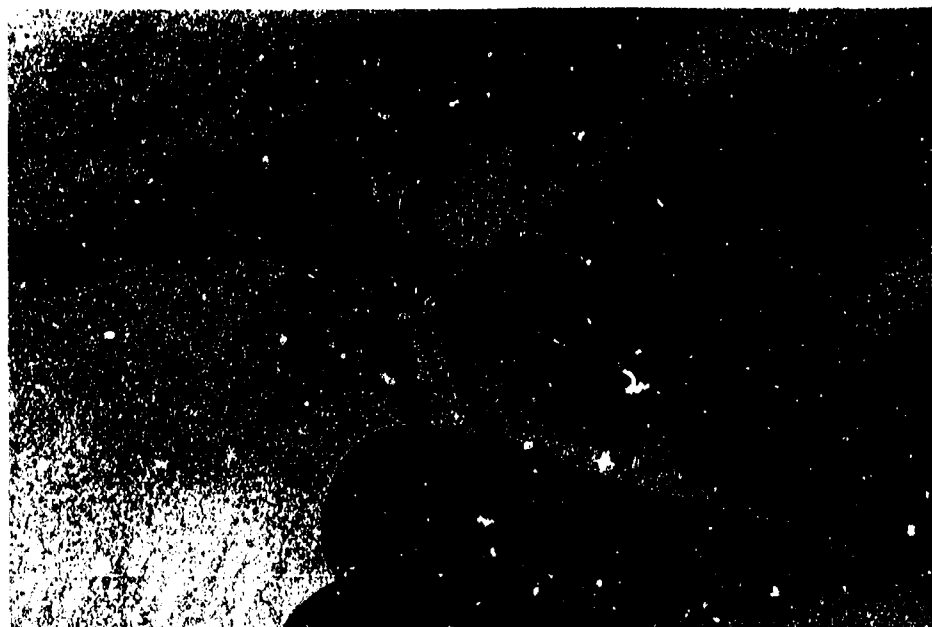
FIGURE 3

606

JOB SHEET #4

9. Place the control stem back into the housing, and make sure the pin in the control stem fits into the cutout in the valve body (Figure 4)

FIGURE 4

10. Put the spring back onto the end of the control stem
11. Replace the knurled nut on the end of the control stem
12. Work stem back and forth to make sure it's free and moving properly
13. Repeat the same procedure for the other gas burner valves on the range
14. Replace the front panel as required
15. Replace all control knobs and burners
16. Turn the gas supply on
17. Check each valve for proper operation
18. Have your instructor check your work
18. Clean up the area and return tools and materials to proper storage

GAS RANGES AND OVENS UNIT XII

NAME _____

TEST

1. Match the terms on the right with their correct definitions.

- | | | |
|---------|--|-------------------|
| _____a. | A national organization that sets design and performance standards for gas appliances, and conducts laboratory and on-site checks for compliance | 1. LP gas |
| _____b. | A metal sheet (flat or slightly V-shaped) placed over an oven burner to divert heat to both sides of a gas oven and to keep direct flame off the oven bottom to prevent burn-out | 2. Manometer |
| _____c. | Valves that screw into a gas manifold to control gas flow to the top burners | 3. Charge port |
| _____d. | A small fitting mounted on the side of a burner where it directs gas through a flash tube to a pilot light to cause the burner to ignite | 4. Venturi |
| _____e. | Controls gas pressure and gas flow into the manifold and to other gas range components | 5. AGA |
| _____f. | A general reference to both propane and butane gases used for heating and cooking purposes when natural gas is unavailable | 6. Thermostat |
| _____g. | A pipe which receives gas from the gas supply and distributes that gas to the burner valves and the oven thermostat on a gas range | 7. Baffle |
| _____h. | An instrument, usually a U-shaped glass tube, for measuring the pressure of gases or vapors | 8. Manifold |
| _____i. | A device mounted onto a manifold to control gas flow to an oven much like burner valves control gas flow to top burners on a gas range | 9. Burner valves |
| _____j. | A tube-like connection where air and gas are mixed and transported to a top burner on a gas range | 10. Gas regulator |

TEST

2. Complete statements concerning the basics of gas heating by inserting the word(s) or figure(s) that best completes each statement.

- a. Gas heating and cooking devices are rated according to a unit of _____ known as a BTU.
- b. A BTU is equal to the amount of heat required to raise one pound of _____ one degree fahrenheit.
- c. Gases are rated in BTU's.
 - 1) _____ gas may range from 300 to 3,000 BTU per cubic foot.
 - 2) The standard for natural gas in America is almost always _____ BTU per cubic foot, and most heating and cooking appliances are designed with that standard in mind.
 - 3) A gas range should list the BTU rating of every burner and the _____ on the name plate.
- d. Gas burners are designed according to their intended use.
 - 1) A standard size surface burner for _____ use is usually rated about 9,000 BTU/hr.
 - 2) A jumbo size burner for _____ use is usually rated about 12,000 BTU/hr.
 - 3) Oven burners for _____ use are usually rated about 23,000 BTU/hr.
- e. Burner ratings should never be _____.

3. Select true statements concerning natural and bottled gas by placing an "X" beside each statement that is true.

- ____a. Natural gas comes from wells and is usually piped from a central supply point to homes and businesses in an area.
- ____b. Propane and butane are extracts from crude petroleum and are stored in bottles and tanks as a liquid, and then changed to gas when they are used.
- ____c. Because of its convenience, natural gas is the most common gas used for gas appliances, but in areas remote from a central natural gas supply, propane and butane are used.
- ____d. Natural gas is heavier than air and will collect in low spots, but propane and butane are lighter than air and will rise in the atmosphere.
- ____e. Natural gas, propane, and butane are all odorless and colorless and have mercaptan added to them to provide color and a pungent odor so leaking gas can be quickly detected.

TEST

4. Complete statements concerning how a gas range top burner works by inserting the word(s) that best completes each statement.
- a. The main gas supply goes through a gas regulator valve which assures gas will be delivered to the range at a _____ proper pressure.
 - b. The gas regulator valve feeds gas into a _____ which serves as a gas transmission line to the top burners, oven pilot, and oven burner.
 - c. For a top burner, a gas control valve is screwed into the _____ so that it can be manually operated to turn gas on or off.
 - d. From the gas control valve, gas goes through a spud which is screwed into the valve, and from the spud through an _____ with a hood that holds it in place.
 - e. Gas from the _____ is fed into a venturi where an air shutter allows air in to mix with the gas.
 - f. As gas is mixing in the venturi and being carried to the burner, another constant gas flow is going down a separate tube to the _____.
 - g. As gas from the venturi reaches the burner, part of it passes out a flash port on the side of the burner, and is directed down a flash tube to the _____ flame.
 - h. As the _____ flame ignites gas from the flash port, gas at the burner itself is ignited, combustion is complete, and burning begins.
5. Select true statements concerning orifice settings by placing an "X" beside each statement that is true.
- ____ a. A range will come from the manufacturer with the orifice preset for natural gas.
 - ____ b. An orifice for LP gas can be used with natural gas because the opening is the same.
 - ____ c. If the orifice in the range is improper for the local gas supply it must be replaced with the proper orifice.
 - ____ d. If the orifice is a universal orifice, it cannot be adjusted for LP gas.
 - ____ e. The universal orifice can be adjusted for natural gas by screwing the orifice hood out to achieve proper flame size.
 - ____ f. If the needle is solid, no hole in the center, the orifice opening can only be adjusted by changing to another hood with an opening sized either for LP gas or natural gas.
 - ____ g. When connecting the hood to a venturi, it may be necessary to use an extension called an extender to reach into the venturi the proper distance.

TEST

6. Select true statements concerning primary and secondary air by placing an "X" beside each statement that is true.
- ____ a. Primary air enters the gas supply through an air shutter located at the front of the venturi.
- ____ b. Primary air is mixed with gas in the throat of the venturi and enters the burner combustion area as an air/gas mixture which is ignited.
- ____ c. Secondary air comes from the entire area around the burner and mixes with the flame as it comes from the burner.
- ____ d. Secondary air stabilizes the flame, completes combustion, and carries off the byproducts of combustion.
7. Complete statements concerning byproducts of combustion by circling the word(s) that best completes each statement.
- a. When gas burns it gives off (water, gas) vapor which is usually absorbed by the atmosphere around the range area.
- b. When a home or kitchen area is improperly ventilated, (water vapor, soot) may condense on walls or other surfaces.
- c. Improper combustion that leaves part of the gas unburned will produce CO which is (mildly, extremely) dangerous to humans.
- d. Although CO is odorless and colorless, it can usually be quickly detected because it is accompanied by other gases called (aldehydes, sulfides) which do have a pungent odor and irritate the nose and eyes.
- e. When there is an indication that (water vapor, CO) is present, the appliance should be shut down and not used until it has been properly adjusted.
8. Recommend solutions for the following burner combustion problems.
- a. The problem: Flame is literally leaping off the burner
Solution: _____

- b. The problem: Flame burns yellow and produces soot
Solution: _____

- c. The problem: Flame looks lazy and seems to float away from the burner
Solution _____

TEST

9. Complete the following chart of gas burner types and applications by filling the blanks with the appropriate information.

Type of Burner	Shape	Application	Performance
Drilled-Ring	a. _____	Top surface burners	Is most efficient burner because it provides a better supply of secondary air to all parts of the flame
Drilled-Pipe	Star	b. _____	Permits more drilled holes to provide better heat distribution and greater capacity for large pots and pans used commercially
c. _____	Oval, Straight line or special configuration	Ovens, trays, tanks, and special application	Permits even distribution of heat over surfaces of large oven, tray, or tank areas in cases where circular or star burners could heat only a part of the surface

10. Match types of oven ignition systems with their characteristics.

- _____a.
- 1) Most popular type
 - 2) Has no standing pilot
 - 3) Goes through ignition process each time the oven calls for heat
 - 4) May use sparking points, a glow coil, or a silicon carbide coil for ignitions
- _____b.
- 1) Gas supply controlled by a thermostat in the manifold
 - 2) Uses same gas regulator and manifold as top burners
 - 3) As gas reaches the oven burner, it is ignited by a standing pilot
1. Manual Ignition
 2. Automatic Ignition
 3. Semi-automatic Ignition

TEST

- 4) A thermostat senses ambient temperature in the oven and shuts off gas supply when oven heats to a specified temperature
 - 5) Thermostat also turns gas supply back on when oven cools below specified temperature
- _____c.
- 1) Gas enters oven burner when thermostat is turned on
 - 2) Burner must be lit with a match placed at the entrance to a flash tube
 - 3) Precautionary pilot comes on only after oven burner has ignited
 - 4) Thermostat bypasses enough gas to maintain a minimum flame
 - 5) Precautionary pilot goes out when thermostat is turned off
 - 6) Oven must be manually lit each time it is used
 - 7) These type ovens are no longer manufactured, but some are still around
11. Complete statements concerning how a gas oven works by inserting the word(s) that best completes each statement.
- a. After the oven burner is ignited, heat from the burner enters the oven cavity through a row of _____ along each side of the oven bottom.
 - b. _____ circulates through the oven and around food placed into the oven.
 - c. There are byproducts of combustion that are carried along with the hot circulating air out of the oven and into the oven _____.
 - d. Hot air also circulates around the thermostat capillary tube so oven temperature can be _____.
 - e. Oven may be shut off _____ or shut off by a timer control or a temperature-probe control.

TEST

12. Match types of oven thermostats with their characteristics.

- | | | |
|----------------|--|---|
| <p>_____a.</p> | <p>1) Usually filled with oil</p> <p>2) As oil is heated or cooled it activates or deactivates a bellows</p> <p>3) The bellows move or close a disc valve to start to stop gas flow</p> | <p>1. Electric hydraulic thermostat</p> <p>2. Pneumatic thermostat</p> <p>3. Hydraulic thermostat</p> |
| <p>_____b.</p> | <p>1) Used only in electrically controlled gas ranges or in electric ranges</p> <p>2) Uses a liquid filled sensing bulb to activate or deactivate a bellows</p> <p>3) Instead of moving a disc valve, the bellows opens or closes a set of contact switches to start or stop gas flow</p> | |
| <p>_____c.</p> | <p>1) Used in self-cleaning gas ovens because a thermostat with liquid in the design would not operate at the 850° to 900° temperatures needed to clean an oven</p> <p>2) Works with a C-shaped Bourdon tube, a thermostat tube, and a sensing bulb all filled with helium</p> <p>3) Heat creates vapor pressure which causes the Bourdon tube to straighten out</p> <p>4) Cooling causes the Bourdon tube to return to its original position</p> <p>5) The action of the Bourdon tube controls the temperature control contacts to keep the burner cycling on and off as needed</p> <p>6) The action of the Bourdon tube also controls the door lock contacts so the oven door is locked shut during the self-clean cycle</p> | |

TEST

13. Complete statements concerning safety valves by circling the word(s) that best completes each statement.
- a. Safety valves on gas ranges serve two valuable safety purposes:
 - 1) Gas from the main gas supply (**will, will not**) flow if the pilot light is out when the gas is turned on.
 - 2) Gas from the main gas supply will be shut off if the (**pilot goes out, gas pressure decreases**) while the oven is in operation.
 - b. One common safety valve works with a mercury sensing bulb that has to be heated by the oven (**pilot, thermostat**) before it will open, and will close immediately if the (**thermostat, pilot**) goes out.
 - c. Another type safety valve uses a bi-metal actuating device with a wrap-around heater, and this valve works in conjunction with a (**flame switch, thermostat**) which senses whether the pilot is lit or not lit.
14. Complete statements concerning common misuses of gas ovens by inserting the word(s) that best completes each statement.
- a. Covering the _____ at the bottom of the oven will cause baking problems and damage the oven.
 - b. Using large pieces of _____ to catch spills will literally divide the oven into improperly heated parts and cause baking problems.
 - c. Placing _____ too close to the oven wall will also impair circulation and jamming too many pans on one shelf will impair circulation.
15. Select true statements concerning special considerations for ovens with upper and lower burners by placing an "X" beside each statement that is true.
- _____ a. In a two-burner oven, the upper burner pilot requires a separate fresh air supply because the upper pilot cannot burn in the byproducts of combustion from the lower burner.
 - _____ b. To assure the upper burner pilot will have a proper fresh air supply requires a separate tube to bring fresh air to the upper pilot.
 - _____ c. Fresh air supply to an upper burner is usually accomplished with a snorkle-like tube that brings fresh air from outside the oven and serves no other function.

TEST

16. Complete statements concerning how self-cleaning ovens work by circling the word(s) that best completes each statement.
- Most oven spills are forms of **(calcium, hydrocarbons)** that break down into water and gases when burned in a temperature above 850°F.
 - The intense heat causes a decomposition process called **(thermalysis, pyrolysis)** and leaves a white ash that can be easily wiped off.
 - In most gas ovens, smoke and other byproducts of self-cleaning are directed out of the oven **(flue, side panel)**.
17. Select true statements concerning special safety features of self-cleaning ovens by placing an "X" beside each statement that is true.
- Since the high temperatures in the self-cleaning function pose a fire danger and danger to the operator, special safety features are built into self-cleaning ovens.
 - A metal-mesh protection screen must be manually pulled into place over the glass in the oven door before the oven door can be manually latched for self-cleaning.
 - As another safety feature, an inside thermometer activates an inside door lock when the oven reaches 550°F.
 - The inside door latch stays in place until the oven cools back down to less than 800°F.
18. Complete a list of safety requirements for gases by inserting the word(s) that best completes each statement.
- Be sure to shut off all gas appliances before turning off the _____ gas supply.
 - _____ while working around gas appliances is ABSOLUTELY FORBIDDEN.
 - Never use a _____ or any open flame to test for gas leaks.
 - Test for leaks by brushing on a soap-water mixture and watching for _____ which would indicate a leak.
 - Use pipe dope, Teflon tape, or Teflon dope when making up connections on supply lines that are made of _____.
 - Do not use pipe dope on any _____ fitting except when mating a _____ fitting to a steel supply line.

TEST

- g. Propane and butane will _____ some pipe dope, so be sure you use dope that is LP gas resistant.
- h. Do not expose your bare hands or skin to propane or butane because they absorb heat so fast that escaping gas can cause _____.
- i. Keep propane and butane tanks away from _____ heat.
- j. Never fill a propane or butane tank completely full because both gases require _____ space.
- k. Never use _____ gaskets or washers around propane or butane because both gases will dissolve _____.
19. Complete statements concerning flexible connectors by inserting the word(s) that best completes each statement.
- a. Flexible connectors make hooking up a range much easier, but be sure _____ permit the use of flexible connectors before installing one.
- b. Bend or shape flexible connectors with care because they are made of _____ and are fairly easy to break.
- c. _____ flexible connectors are preferred because bare copper connectors readily corrode in situations where propellants from canned aerosol cooking aids can reach them.
- d. Use no pipe dope on _____ fittings except the connector fitting from 1/4 steel pipe inlet.
- e. Use only connectors that have dielectric qualities and the _____ seal of approval that indicates the connector meets _____ requirements.
- f. Limit flexible connections to no more than _____ feet.
- g. Make sure the connector is properly sized to _____ the gas branch line to which it is connected.
20. Select true statements concerning requirements for gas supply lines by placing an "X" beside each statement that is true.
- _____ a. Most incoming gas supply lines have a diameter of 1".
- _____ b. Most feeder lines off the main gas supply lines have a diameter of 3/4".
- _____ c. Piping used for gas transport must be made only of black iron.
- _____ d. Pipe dope, Teflon dope, or Teflon tape should be used when making up all joints and connections on black iron or galvanized iron.

TEST

21. Complete statements concerning functions of electrical circuits on gas ovens by inserting the word(s) that best completes each statement.

- a. Electrical circuits on self-cleaning gas ovens operate oven lights, clocks, and _____ devices.
- b. Electrical circuits on gas ovens also operate the door lock switch and other elements of the _____ function.

22. Solve the following problems concerning typical circuit functions in a gas oven.

- a. In a simple BAKE function, how is oven burner operation controlled?

Answer _____

- b. What controls the length of a TIMED BAKE function?

Answer _____

- c. What controls temperatures in the CLEAN operation of a self-cleaning oven?

Answer _____

TEST

23. Match gas range complaints with recommended troubleshooting.

- | | | |
|---------|---|--|
| _____a. | 1) A poorly adjusted pilot light
2) A poorly adjusted burner flame so high that it puts the pilot out
3) Bad safety valve or thermocouple | 1. When the flame jumps off the burner or the flame is smoky, check for:
2. When the oven is sweating, check for: |
| _____b. | 1) Top burner pilot light out
2) Flash tube to pilot clogged or out of position
3) Burner itself out of position
4) Flash port clogged
5) Burner itself clogged
6) Improper primary air
7) Wrong size orifice | 3. When the pilot light is out and will not light or will not stay lit, check for:
4. When there is an odor of gas around the range, check for:
5. When the oven is not heating properly, check for: |
| _____c. | 1) Too much primary air through the shutter
2) Too little primary air through the shutter | 6. When the top burner will not light or the flame is too high or too low, check for: |
| _____d. | 1) Oven thermostat problems
2) Bypass gas supply problems
3) Improper calibration of oven thermostat
4) Improper burner adjustment
5) Improper gas pressure | |
| _____e. | 1) Improper preheating
2) Oven thermostat temperatures incorrect
3) Clogged oven vent | |
| _____f. | 1) Gas leak in connections along supply lines
2) Oven burners not getting enough primary air
3) Oven pilot touching burner | |

TEST

24. Select true statements concerning gas pressure drops by placing an "X" beside each statement that is true.

(NOTE: For a statement to be true, all parts of the statement must be true.)

- ____a. No gas appliance will operate properly at a gas pressure less than the appliance is rated for.
- ____b. Gas ranges have gas pressure ratings expressed in ounces of gas pressure per square inch.
- ____c. An average gas rating for natural gas is 4 oz. PSI, and for LP gas, 10 oz. PSI.
- ____d. With natural gas, a pressure drop can be regulated at the meter, but with an LP gas pressure drop, the adjustment has to be made at the appliance.
- ____e. The two most common causes of pressure drops are:
- 1) An obstruction in the main gas supply line, usually water
 - 2) Undersized piping that will not serve multi-appliance demands
- ____f. Water problems are frequent with gas lines in high-acidity soils because acid attacks and corrodes the iron pipe.
- ____g. Pilot lights that keep going out, and erratic burner operation are signs of water problems.
- ____h. In situations where several gas appliances are in use at one time, undersized piping will cause pressure drop.
- ____i. The handiest tool for troubleshooting a complaint of gas pressure drop is a pressure gauge.

25. Solve problems concerning manometer selection and use.

- a. When a gas pressure drop is suspected, what is the first thing to do?

Answer _____

- b. How full of water should a manometer be filled?

Answer _____

TEST

- c. What is the advantage of working with a manometer that has a tube and does not require a special manifold fitting?

Answer _____

- d. What is a good check for undersized piping?

Answer _____

26. Complete statements concerning guidelines for roasting by inserting the word(s) that best completes each statement.

- a. Factors that increase roasting time

- 1) Roasts that are _____ and _____ take more time to cook than standing roasts.
- 2) Small roasts require more cooking time per _____ than do large roasts.
- 3) Wrapping meat or poultry in _____ increases roasting time.

- b. Factors that decrease roasting time

- 1) A thick coating of _____ decreases roasting time.
- 2) Selecting _____ meat decreases roasting time.
- 3) Selecting _____ roasts decreases roasting time.

- c. Using a thermometer for roasting

- 1) A thermometer should be inserted into the center of the _____ part of the meat.
- 2) The tip of the thermometer probe should not be allowed to contact areas of gristle, fat, or _____.
- 3) Generally, a probe should be inserted 3 1/2" into the meat, and if it is a thin roast, the probe should be inserted from an _____ that will give it a 3 1/2" penetration.
- 4) For poultry, a thermometer should be inserted into the center of the _____ above the wing or into the inside of the thigh muscle.

TEST

27. Complete statements concerning guidelines for broiling by inserting the word(s) or figure(s) that best completes each statement.
- a. Broiling is popular because it reduces _____ content and enhances taste.
 - b. Broiling is also popular because it is about the only way to please people who like their steaks browned on the outside and _____ in the middle.
 - c. Selecting steaks for broiling:
 - 1) For outside browning and a rare inside, the steak must be at least _____ thick, and it is better if it is slightly thicker.
 - 2) The steak should be kept at _____ temperature until broiling begins.
 - 3) The best way to assure the brown/rare combination is to broil a _____ steak directly from the _____.
 - 4) Place the steak as close to the _____ unit as possible.
 - 5) _____ the oven also helps to control the brown/rare combination.
 - d. Ways to promote browning
 - 1) As fat content in a steak increases, _____ increases.
 - 2) Brushing any meat with _____ or _____ will increase browning.
 - 3) Seasoning meats _____ broiling will increase browning because salt added prior to broiling produces moisture which delays browning.
 - 4) Handle aged steak with care because the outside cooks _____ and the inside may be too _____.
28. Complete statements concerning guidelines for baking by inserting the word(s) that best completes each statement.
- a. Placement of shelves and pans
 - 1) Use the _____ shelf when baking on only one shelf, and space shelves so that they divide the oven in thirds when using more than one shelf.
 - 2) Do not impair heat circulation by placing a pan too close to the _____ and with two or three pans, stagger them so that there is a good heat circulation around each one.

TEST

b. Preheating

- 1) Cakes, pies, and other delicate foods require preheating, so follow the _____.
- 2) Preheating is not usually required for _____ and _____.

c. Using foil

- 1) If oven shelves are completely covered with foil, heat circulation in the oven will be _____.
- 2) Foil placed directly under a pie may interfere with _____ browning.

d. Selecting pans and bakeware

- 1) Shiny _____ is best for cakes, but glass can be used if oven temperature is lowered 25 degrees.
- 2) _____ are best for pies, but dark tin or anodized aluminum can also give satisfactory results.
- 3) Shiny baking sheets are best for biscuits and _____.
- 4) Anodized aluminum or glass are best for _____ breads because they help make the crust thick.
- 5) A dull cook's sheet is best for _____ pies because it helps browning of the bottom crust.

29. Match baking problems with their solutions.

- | | | |
|---------|---|---|
| _____a. | <ol style="list-style-type: none"> 1) Oven flame may be too hard and primary air should be decreased. 2) Baffle may be out of position or upside down, so position baffle properly. 3) Flue may be blocked and it should be cleaned. | <ol style="list-style-type: none"> 1. When baked goods burn on one side 2. When baked goods are soggy 3. When baked goods crack open |
| _____b. | <ol style="list-style-type: none"> 1) Cookware is blocking heat circulation, so position cookware away from sides of oven. 2) Pan may be unlevel or the range may be unlevel, so level the range or replace the utensil as required. | <ol style="list-style-type: none"> 4. When baked goods burn on the top 5. When baked goods burn on the bottom |

TEST

- _____c. 1) Oven flame may be too soft and primary air should be increased.
- 2) Baffle may be out of position or upside down, so position baffle properly.
- 3) Dark cookware should be exchanged for a brighter utensil.
- 4) Flue may be blocked and it should be cleaned.
- _____d. 1) Oven is too hot and thermostat should be checked, or a lower temperature should be used.
- 2) Batter may be improperly prepared or recipe may be wrong and require correction.
- _____e. 1) Oven is not hot enough and thermostat should be checked, or a higher temperature should be used.
- 2) Batter may have wrong ingredients, so check the recipe.
- 3) Baked item may have been left in the pan too long, and it should be removed immediately.

30. Select true statements concerning guidelines for service calls by placing an "X" beside each statement that is true.

- _____a. Introduce yourself to the customer, identify your company, and confirm that you are there to answer to the customer's request for service.
- _____b. Ask the customer to explain in his/her own words what the problem is.
- _____c. Check to see if baking problems provide a clue to the trouble before looking for mechanical problems.
- _____d. Place a drop cloth around the range area before starting any work.
- _____e. Request the customer to keep the area free of children and pets.

TEST

(NOTE: If the following activities have not been completed prior to the test, ask your instructor when they should be completed.)

31. Use a wiring schematic to determine voltage and resistance readings on a self-cleaning gas oven set for a bake operation. (Assignment Sheet #1)
32. Use a wiring schematic to determine voltage and resistance readings on a self-cleaning oven set for a timed bake operation. (Assignment Sheet #3)
33. Use a wiring schematic to determine voltage and resistance readings on a self-cleaning gas oven set for a cleaning operation. (Assignment Sheet #3)
34. Use a wiring schematic to determine voltage and resistance readings on a self-cleaning gas oven during lock and unlock. (Assignment Sheet #4)
35. Demonstrate the ability to:
 - a. Install a gas range level and leak free with all burners properly adjusted. (Job Sheet #1)
 - b. Use a temperature tester to check gas oven temperature for proper oven thermostat settings. (Job Sheet #2)
 - c. Recalibrate a gas oven thermostat to correct settings. (Job Sheet #3)
 - d. Remove, disassemble, clean, lubricate, and reassemble a standard gas burner valve. (Job Sheet #4)

625

GAS RANGES AND OVENS UNIT XII

ANSWERS TO TEST

1.

a.	5	f.	1
b.	7	g.	8
c.	9	h.	2
d.	3	i.	6
e.	10	j.	4

2.
 - a. Heat
 - b. Water
 - c.
 - 1) Natural
 - 2) 1,000
 - 3) Oven
 - d.
 - 1) Household
 - 2) Commercial
 - 3) Household
 - e. Surpassed

3. a, b, c, e

4.
 - a. Constant
 - b. Manifold
 - c. Manifold
 - d. Orifice
 - e. Orifice
 - f. Pilot
 - g. Pilot
 - h. Pilot

5. c, e, f

6. a, b, c, d

7.
 - a. Water
 - b. Water vapor
 - c. Extremely
 - d. Aldehydes
 - e. CO

8.
 - a. Too much primary air, so close the air shutter as required
 - b. No enough primary air, so open the air shutter as required
 - c. Insufficient secondary air, so check for dirty vents or blocked flue

9.
 - a. Circular
 - b. Top surface burners
 - c. Drilled-Pipe

ANSWERS TO TEST

10. a. 2
b. 3
c. 1
11. a. Holes
b. Hot air
c. Flue
d. Controlled
e. Manually
12. a. 3
b. 1
c. 2
13. a. 1) Will not
2) Pilot goes out
b. Pilot, pilot
c. Flame switch
14. a. Holes
b. Foil
c. Utensils
15. a, b
16. a. Hydrocarbons
b. Pyrolysis
c. Flue
17. a, b, c
18. a. Main
b. Smoking
c. Match
d. Bubbles
e. Steel
f. Brass, brass
g. Dissolve
h. Frostbite
i. Excessive
j. Expansion
k. Rubber, rubber
19. a. Local codes
b. Copper
c. Plastic-coated
d. Brass
e. AGA, AGA
f. Six
g. Match

627

ANSWERS TO TEST

20. a, d
21. a. Timing
b. Self-cleaning
22. a. Through the selector switch and thermostat
b. A clock
c. The opening and closing of thermostatic contacts in the oven control
23. a. 3
b. 6
c. 1
d. 5
e. 2
f. 4
24. a, b, c, e, f, g, h
25. a. Have the gas company check for proper pressure at the main meter
b. Until the water levels out at zero on each side of the scale
c. The tube can be quickly slipped over an orifice spud
d. Leave the manometer hooked up and turn on the range and all other gas appliances in the home
26. a. 1) Boned, tied
2) Pound
3) Foil
b. 1) Fat
2) Aged
3) Standing
c. 1) Thickest
2) Bone
3) Angle
4) Breast
27. a. Fat
b. Rare
c. 1) 1"
2) Refrigerator
3) Frozen, freezer
4) Broiler
5) Preheating
- d. 1) Browning
2) Butter, oil
3) After
4) Rapidly, rare

ANSWERS TO TEST

28. a. 1) Middle
2) Oven wall
b. 1) Recipe
2) Meat, poultry
c. 1) Improper
2) Bottom
d. 1) Aluminum
2) Glass pie plates
3) Cookies
4) Yeast
5) Frozen
29. a. 4
b. 1
c. 5
d. 3
e. 2
30. a, b, c, d, e
31. Evaluated to the satisfaction of the instructor
32. Evaluated to the satisfaction of the instructor
33. Evaluated to the satisfaction of the instructor
34. Evaluated to the satisfaction of the instructor
35. Performance skills evaluated according to procedures written in the job sheets



ELECTRIC RANGES AND OVENS UNIT XIII

UNIT OBJECTIVE

After completion of this unit, the student should be able to discuss the different types of heating elements for electric surface units and ovens, and problems with recalibrating oven thermostats. The student should also be able to troubleshoot electric range problems including removing a surface unit and checking for proper resistance, and making continuity checks on step-type and infinite electric range switches. These competencies will be evidenced by correctly performing the procedures outlined in the job sheets and by scoring 85 percent on the unit test.

SPECIFIC OBJECTIVES

After completion of this unit, the student will be able to:

1. Match terms related to electric ranges and ovens with their correct definitions.
2. Complete statements concerning electrical requirements for hooking up an electric range.
3. Select true statements concerning basics of electric cooking.
4. Solve problems concerning servicing electric surface and oven heating elements.
5. Differentiate between types of heat controls for surface heating elements.
6. Complete statements concerning types of electric oven thermostats.
7. Solve problems concerning recalibrating electric oven thermostats.
8. Solve problems concerning a typical electric oven self-cleaning operation.
9. Match other components with their functions in a self-clean cycle.
10. Complete statements concerning troubleshooting electric ranges.
11. Demonstrate the ability to:
 - a. Remove a surface unit from an electric range and check for proper resistance. (Job Sheet #1)
 - b. Check the self-cleaning function on an electric oven. (Job Sheet #2)
 - c. Make continuity checks on step-type and infinite electric range switches. (Job Sheet #3)

ELECTRIC RANGES AND OVENS UNIT XIII

SUGGESTED ACTIVITIES

- A. Provide students with objective sheet.
- B. Provide students with Information sheet.
- C. Make transparencies.
- D. Discuss unit and specific objectives.
- E. Discuss information sheet.
- F. Discuss and demonstrate the procedures outlined in the job sheets.
- G. Review guidelines for roasting, broiling, and baking from Unit XII, "Gas Ranges and Ovens," and discuss how improper baking or cooking can serve as clues to problems with electric ovens.
- H. Review safety procedures for testing self-cleaning ovens.
- I. Have samples of step-type and infinite control switches available for students to examine, and discuss the nature of their operations.
- J. Give test.

CONTENTS OF THIS UNIT

- A. Objective sheet
- B. Information sheet
- C. Transparency masters
 - 1. TM 1 — Electric Heating Elements
 - 2. TM 2 — Self-Cleaning Cycle Schematic
 - 3. TM 3 — Electric Range Wiring Diagram
- D. Job sheets
 - 1. Job Sheet #1 — Remove a Surface Unit From an Electric Range and Check for Proper Resistance
 - 2. Job Sheet #2 — Check the Self-Cleaning Function on an Electric Oven
 - 3. Job Sheet #3 — Make Continuity Checks on Step-Type and Infinite Electric Range Switches

CONTENTS OF THIS UNIT

- E. Test
- F. Answers to test

REFERENCES USED IN DEVELOPING THIS UNIT

- A. *Cooking Equipment Course*. Chicago, IL: Sears Training Center, undated.
- B. Bacon, Bill and Mark Sutton. *Major Appliance Repairer*. Austin, TX 78712: The University of Texas at Austin, 1983.
- C. Anderson, Edwin P. *Home Appliance Servicing*. Indianapolis, IN 46268: Howard W. Sams & Co., Inc., 1974.

ELECTRIC RANGES AND OVENS

UNIT XIII

INFORMATION SHEET

I. Terms and definitions

- A. **Catalyst** — A chemical or other substance used to speed up or slow down a process such as the platinum/paladium screens that cause smoke to burn at lower temperatures in self-cleaning ovens
- B. **Infinite controls** — Electric range switches that provide a user with limited heat selections by cycling voltage on and off
- C. **Step-type controls** — Electric range switches that provide a user heat selections in limited increments such as low, medium, and high by controlling voltage input only
- D. **Recalibrate** -- The procedure of adjusting a switch or control device so that it will perform to a specified standard

II. Electrical requirements for hooking up an electric range

- A. To operate properly, electric ranges require 240V at 50 amps.
- B. Receptacles for electric ranges will accept only a three-prong or four-prong, straight-bladed plug.
- C. A dryer plug with an L-shaped blade should never be modified for use on an electric range because a dryer plug is designed for only 30 amps and has smaller conductor wires. (Figure 1)

(CAUTION: A modified dryer connection used on an electric range is a fire hazard, and any service person who runs into such a hookup should immediately inform the customer of the danger and advise that the hookup be changed.)

FIGURE 1

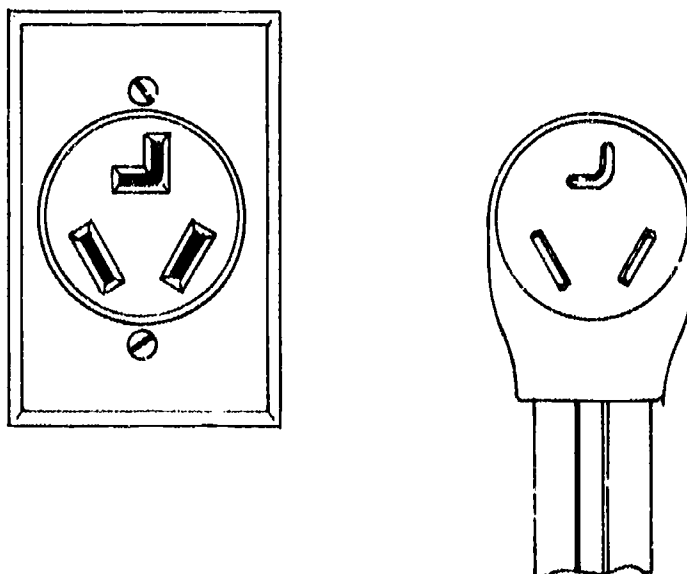

INFORMATION SHEET

- D. Anything less than the proper 3-prong or 4-prong range hookup is in violation of the National Electric Code and state and local codes. (Figure 2)

FIGURE 2

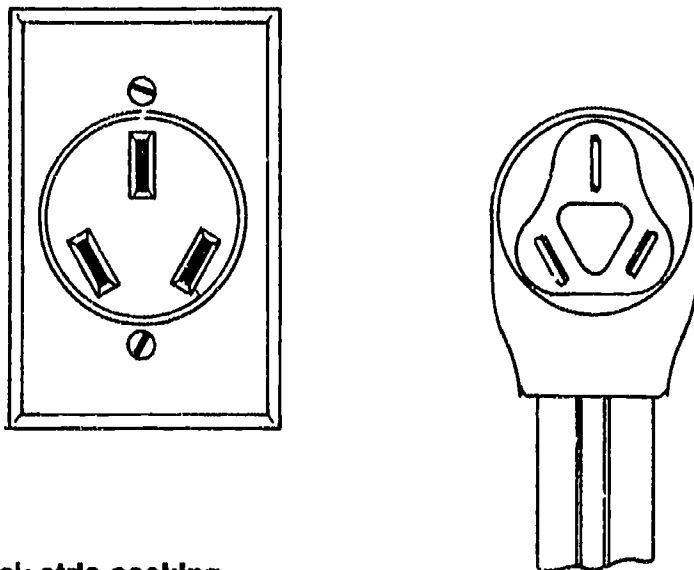

III. Basics of electric cooking

- A. Instead of being rated in BTU's, electric range heating elements are rated in watts.
- B. Both surface heating elements and oven heating elements are made from an alloy of nickel and chromium called nichrome.
- C. Heating elements have nichrome coils embedded in an insulated sheath, then covered with stainless steel tubing, a design that produces efficiency.

(NOTE: Top surface heating elements have the tubing flattened on one side to provide a level surface for pots and pans, but oven elements are almost always tube-shaped.)

- D. Electric ranges produce no byproducts of combustion.

(NOTE: Electric ranges with self-cleaning features are exceptions to the rule about byproducts; they usually have filtering devices to consume smoke produced in self-cleaning.)

- E. Electric ranges are preferred appliances in areas where the cost of electricity is lower than the cost of gas.

(NOTE: Arguments about the advantages of electric cooking over gas cooking or vice-versa, usually boil down to which energy supply is least expensive because when preheat recommendations are followed, both types of ranges perform equally well.)

INFORMATION SHEET

IV. Servicing electric surface and oven heating elements (Transparency 1)

- A. The power supply reaches heating elements through connections in ceramic housings mounted near the element opening.
- B. Surface and oven elements may plug directly into the ceramic connections, may be connected with screw connectors, or may have spade connectors.
- C. When there is a complaint of poor surface or oven heating, always check the connectors first.
- D. On any service call, it is always good to check all connections to make sure none of them are loose.

(CAUTION: A loose connection not only impairs element performance, it will eventually burn up and create a fire hazard.)

- E. Surface elements are coil-shaped and may have single elements or double elements.
- F. Oven heating elements come in a variety of shapes, but almost all oven elements have a single two-lead connection.
- G. A simple continuity test can determine whether or not an element needs to be replaced, and replacement elements should always be of the same wattage as the original.

V. Types of heat controls for surface heating elements

- A. Step-type heat controls (Figure 3)
 - 1. Step type controls work by controlling voltage input only.
 - 2. Controls permit use of both 240V and 120V in such a way that the two voltages may work individually or together for precise heat control.
 - 3. Some step-type controls have as few as three heat settings: high, medium, and low.

INFORMATION SHEET

4. Other step-type controls may have 5 or even 7 heat settings for temperature ranges that include high, medium-high, medium, low, medium-low, extra-low, and simmer.

FIGURE 3



B. Infinite heat controls (Figure 4)

1. Infinite heat controls work by controlling voltage input timed in an on/off cycling pattern.
2. Most infinite controls have 240V connected to the dual element, but some infinite controls use 120V too.
3. Infinite controls may have unlimited heat settings or be limited to five or seven heat settings.

(NOTE: Control selection varies with manufacturer, but replacement controls should always be of the type with the original equipment.)

FIGURE 4

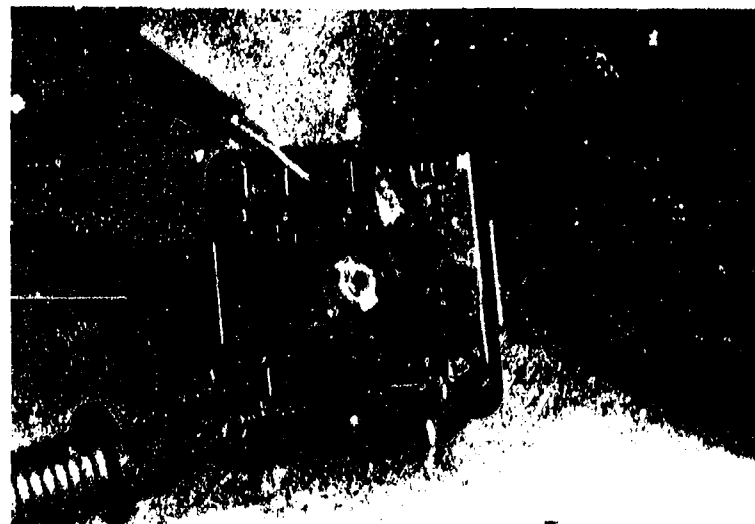

INFORMATION SHEET

VI. Types of electric oven thermostats

A. Bellows type (Figure 5)

1. A bellows expands or contracts as silicon oil in a capillary tube expands or contracts.
2. As the bellows expands or contracts it opens or closes switch contacts which turn the oven heating element on or off.

FIGURE 5

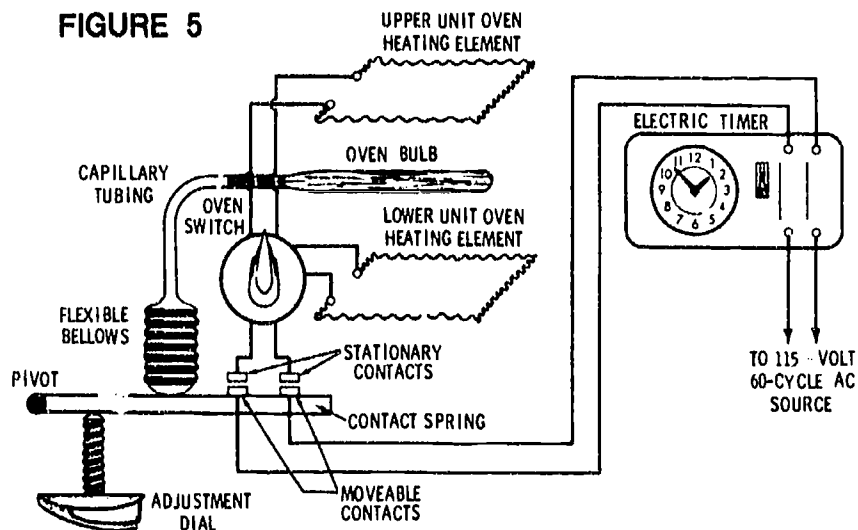

Reprinted with permission of Macmillan Publishing Company from *Home Appliance Servicing* by Edwin P. Anderson. Copyright © 1963, 1974, 1979 by Howard W. Sams & Co., Inc.

B. Bimetallic type (Figure 6)

1. A strip made of two dissimilar metals flattens or arches in response to temperature changes, and opens and closes switch contacts.
2. As the switch contacts open and close, the oven heating element is turned on or off.

FIGURE 6

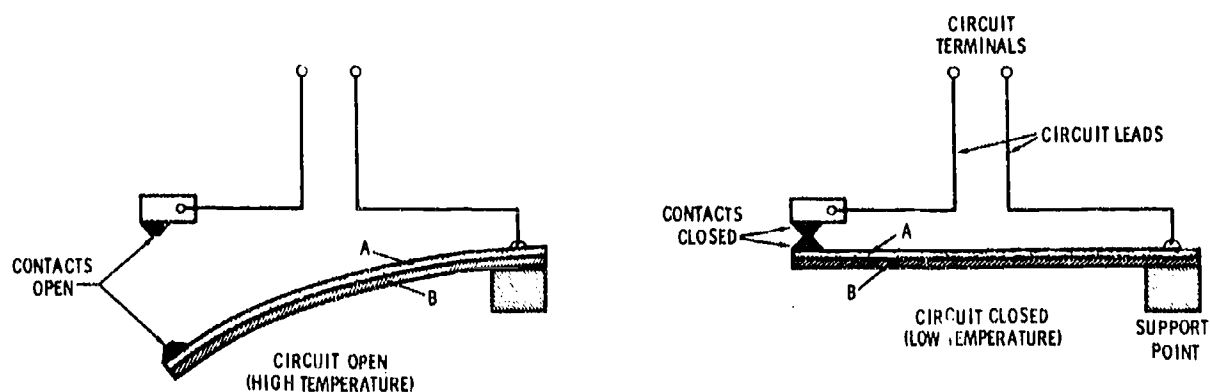

Reprinted with permission of Macmillan Publishing Company from *Home Appliance Servicing* by Edwin P. Anderson. Copyright © 1963, 1974, 1979 by Howard W. Sams & Co., Inc.

INFORMATION SHEET

C. Diaphragm type (Figure 7)

1. A diaphragm expands or contracts in response to pressure from a capillary tube.
2. The diaphragm activates or deactivates a click-action switch that turns the oven heating element on or off.

FIGURE 7

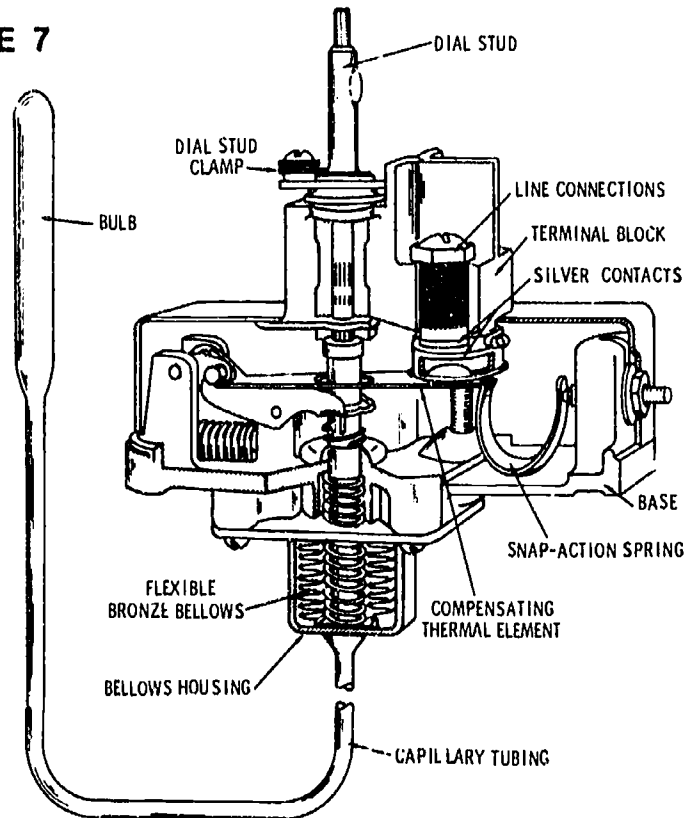

Reprinted with permission of Macmillan Publishing Company from *Home Appliance Servicing* by Edwin P. Anderson. Copyright © 1963, 1974, 1979 by Howard W. Sams & Co., Inc.

VII. Recalibrating electric oven thermostats

- A. Electric oven thermostats are calibrated at the factory and should not be tampered with unless a careful check of oven temperature indicates recalibration is required.

(NOTE: For oven temperature testing, see Job Sheet #2, Unit XII.)

- B. Recalibration on most electric oven thermostats is accomplished by turning a small screw in the face of the thermostat to the left to increase oven temperature or to the right to decrease oven temperature.

(NOTE: Recalibration for electric oven thermostats is basically the same procedure used for recalibrating gas oven thermostats; see Job Sheet #3, Unit XII, for the procedure.)

INFORMATION SHEET

- C. Recallbration should always be followed with a second oven temperature test to assure the new settings are correct.
- D. Newer ovens require only a simple knob adjustment.

VIII. Typical electric oven self-cleaning operation

(NOTE: The wiring schematics in Transparencies 2 and 3 should be referenced as needed to relate circuit operations to steps in the clean cycle.)

- A. The operation starts when the CLEAN button on the selector switch is pushed:
 - 1. The internal heat element is placed in series with the broil element through switch contacts "BR" and "EX1" which close.
 - 2. At the same time, "BK" and "EX2" contacts close completing a circuit between the external front frame element and the bake element, and this places the bake element in parallel with the broil element and internal heat element.
 - 3. As all of the above takes place, the switch contacts close from "P1" to "CL" and from "HL" to "NO".
- B. Setting the control knob on the clock timer to LIGHT CLEAN or HEAVY CLEAN:
 - 1. Closes the contacts between terminals "1" and "3" on the clock timer switch
 - 2. Breaks the circuit at terminal "2"
 - 3. Prevents operation of the right rear surface unit and oven light during the clean cycle
- C. Pushing the LOCK lever all the way to the right:
 - 1. Closes the switch contacts "C" to "NO" on the Door Latch Switch
 - 2. This completes the low voltage circuit through the secondary windings of the transformer across terminals "HL" and "NO" on the selector switch, and through the Hi Limit Switch and across terminals "S" and "A" on the oven thermostat.
- D. Applying 12-volt current to the "Hot Wire Relay" on the back of the oven thermostat:
 - 1. Causes the relay switch contacts between terminals "L" and "H" in the Hi-Voltage side of the relay to close
 - 2. This completes a circuit across all heat elements.
 - 3. The "OVEN ON" Indicator light comes on.

INFORMATION SHEET

- E. As oven temperature rises to approximately 550°F:
- (NOTE: Be sure to reference Transparencies 16 and 17 so you'll have a complete understanding of what control circuitry takes over as oven heat increases.)
1. The bimetallic thermal unit in the door lock switch raises the locking screw into position so that the lock lever cannot be moved.
 2. At the same time, contacts in the switch are closed to complete a circuit to the lock indicator light.
- F. As oven temperature increases to 825°F to 1100°F:
1. The HI LIMIT SWITCH opens.
 2. The low voltage circuit to the Oven Thermostat is now broken causing the Hot Wire Relay to cool.
 3. This causes the relay switch contacts in the high voltage circuit to open.
- G. As oven temperature decreases to about 825°F:
1. The HI LIMIT SWITCH closes.
 2. The oven goes through a temperature rise once again until the HI LIMIT SWITCH opens at somewhere beyond 825°F.
 3. The cycle is repeated until the Clock Timer runs through the programmed CLEAN time.
- H. As programmed time expires:
1. The Clock Timer Switch contacts break at terminal "Z" and the oven starts cooling.
 2. As the oven cools, the right rear surface unit can be used.
- I. As the oven cools to 250°F to 325°F:
1. The thermal unit in the Door Lock Lever cools.
 2. This permits the Door Lock Lever to be moved manually to the left.
 3. At the same time the lock light goes out, the clean cycle is complete, and the oven door may be opened.

INFORMATION SHEET

IX. Other components and their function in a self-clean cycle

- A. Metal-mesh oven window screen — Must be pulled in place over the oven window before the oven door can be latched shut
- B. Lock latch — A mechanical latch that must be pushed to the far right in order for the self-cleaning function to be started.

(NOTE: Do not confuse this mechanical lock with the interior lock that snaps into place after the oven reaches about 550°F; the interior lock backs up the mechanical lock for added safety.)

- C. Smoke eliminator — A filter-type screen coated with a platinum/palladium combination and then oxidized to act as a catalyst which causes smoke to burn at a lower temperature.

(NOTE: Smoke eliminators are usually mounted to the oven top directly under the right rear surface unit.)

X. Troubleshooting electric ranges

- A. When the oven will not heat or when the oven will not turn off, check for:
 - 1. A blown fuse
 - 2. Loose wire(s)
 - 3. Selector switch problems
 - 4. Timer problems
 - 5. Defective thermostat
 - 6. Defective bake element
 - 7. Control circuitry problems
- B. When a surface unit will not heat, is always on high, or has too much heat on a low setting, check for:
 - 1. A blown fuse
 - 2. Loose or incorrect connection
 - 3. An open in the element itself
 - 4. Bad surface unit switch

INFORMATION SHEET

- C. When a timer appears to be malfunctioning, check for:
1. Loose connections or wrong connections (check wiring schematic)
 2. Bad timer motor
 3. Bad timer
- D. When an oven door does not close properly, check for:
1. Worn pins or hinge brackets
(NOTE: As heat pressure builds up, oven liner expansion could cause the door to come open while the oven is baking.)
 2. Problems with the oven door seal or misalignment
(NOTE: This might actually cause the oven to sweat, and could also suggest a clogged vent or the need for recalibrating the oven thermostat.)
- E. When a self-cleaning function does not operate, check for:
1. Problems with bake and broil circuitry
(NOTE: This requires a wiring schematic.)
 2. Problems with selector switch or oven thermostat
 3. Blown fuse
 4. Problems with the safety interlock system

Electric Heating Elements

WIRE IN

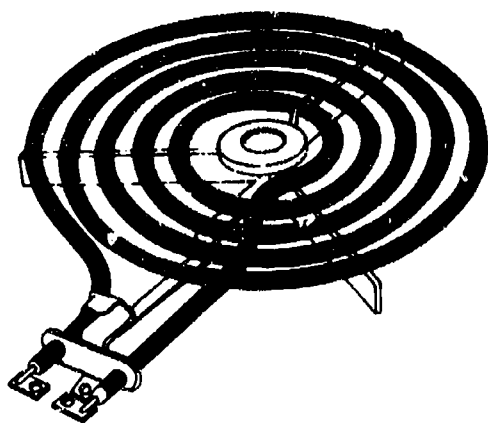

PLUG IN

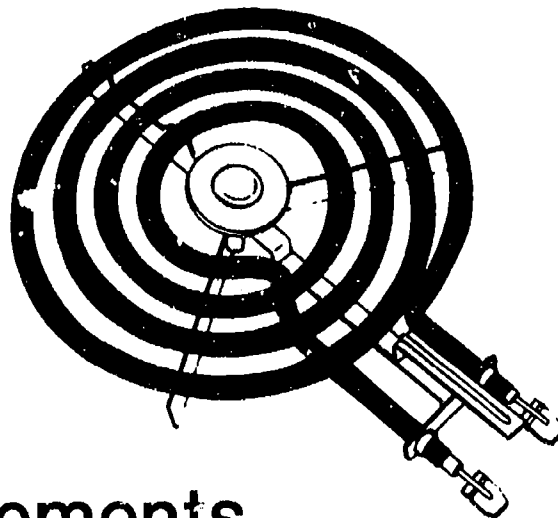

Surface Elements

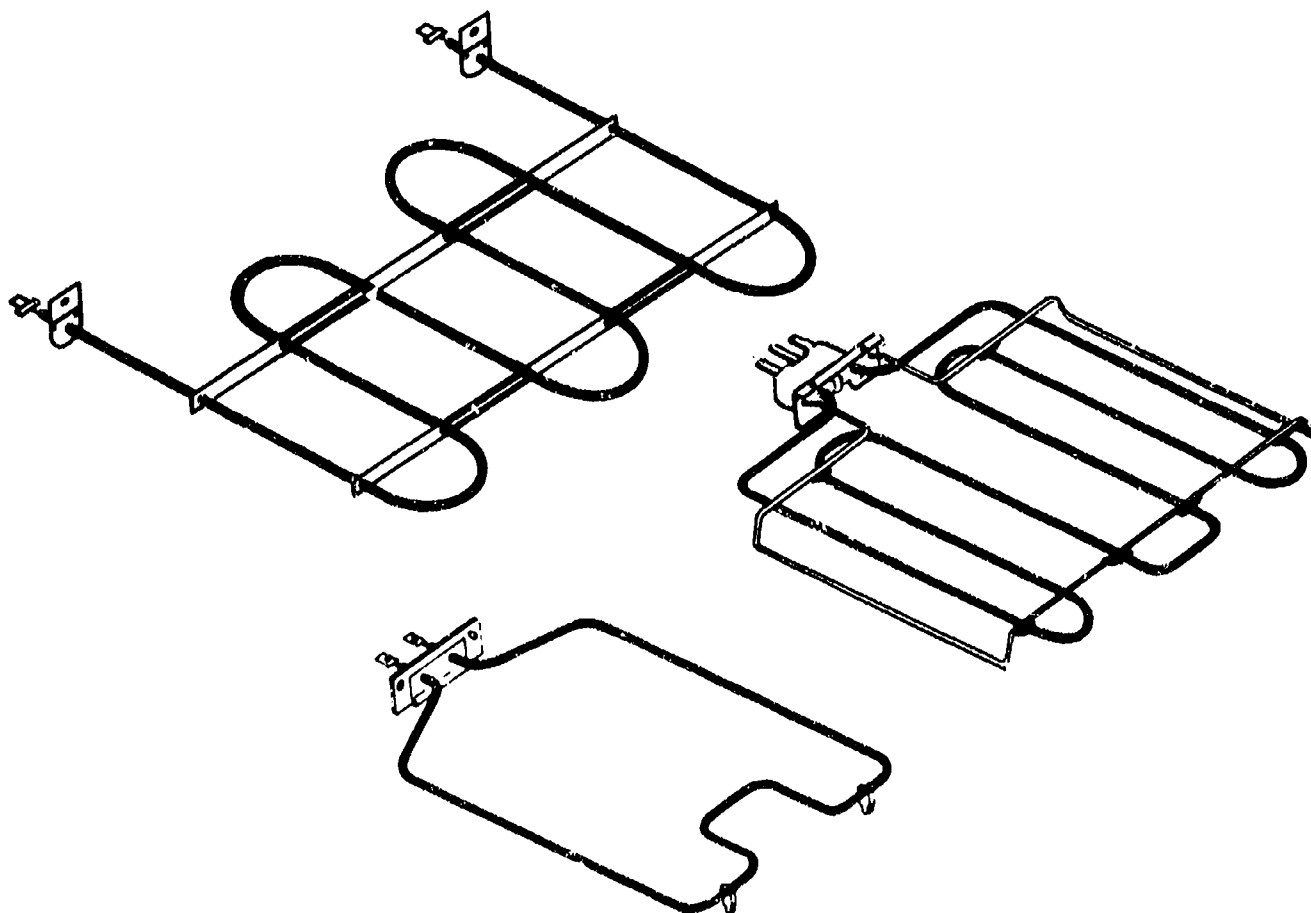

Bake and Broil Elements

Self-Cleaning Cycle Schematic

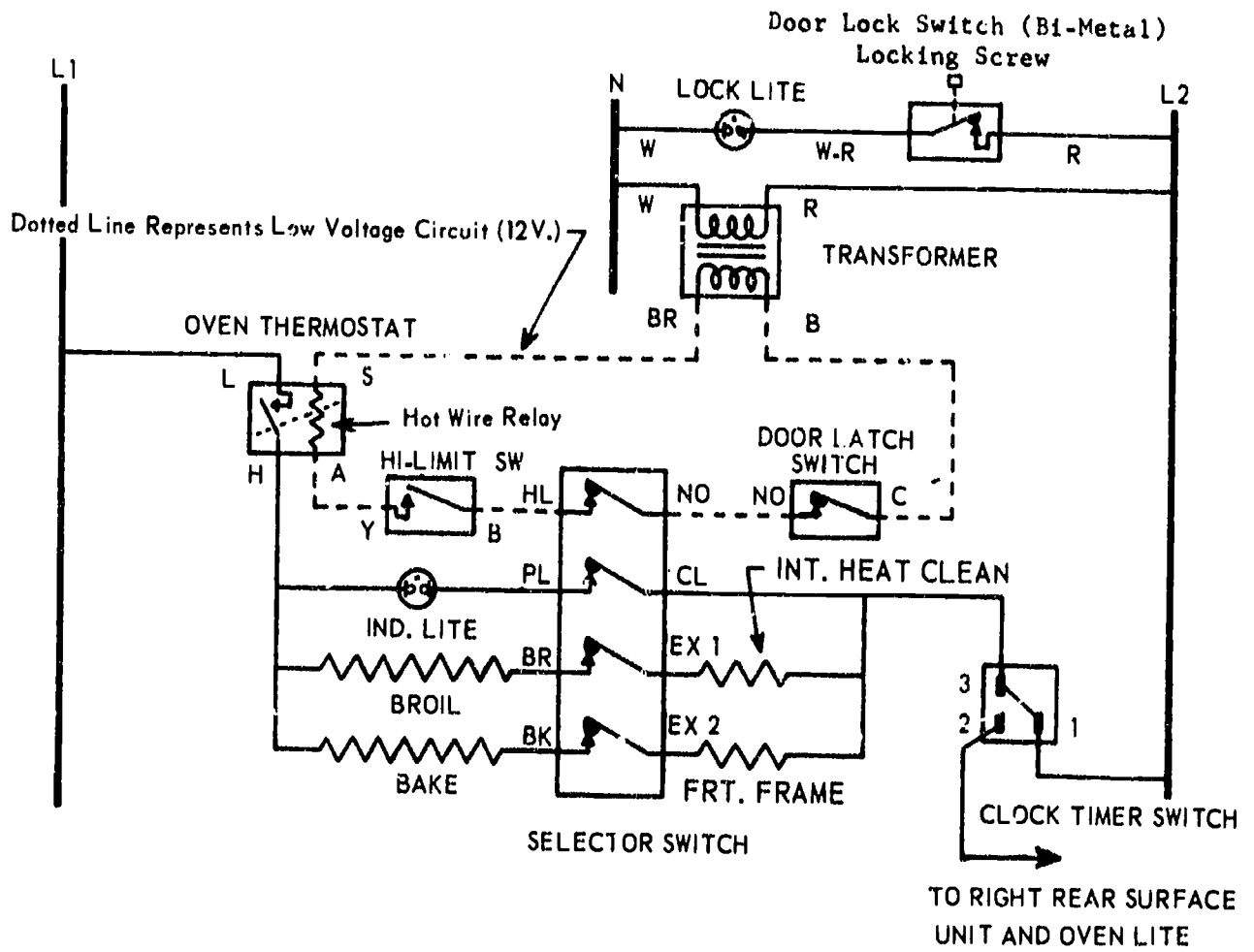

Courtesy Sears

Electric Range Wiring Diagram

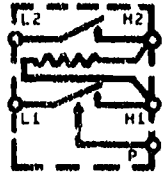

OPTIONAL INFINITE SWITCH

SELECTOR SW SETTINGS	CLOSED CONTACTS
OFF	A-1
BROIL	A1, B-4, D-6
TIME BAKE	A1, B-3, C-5, D-6, E-7
BAKE	A1, B-4, C-5, D-6, E-7
PRE-HEAT	A1, B-4, C-5, D-6
CLEAN	A-2, B-3, C-5

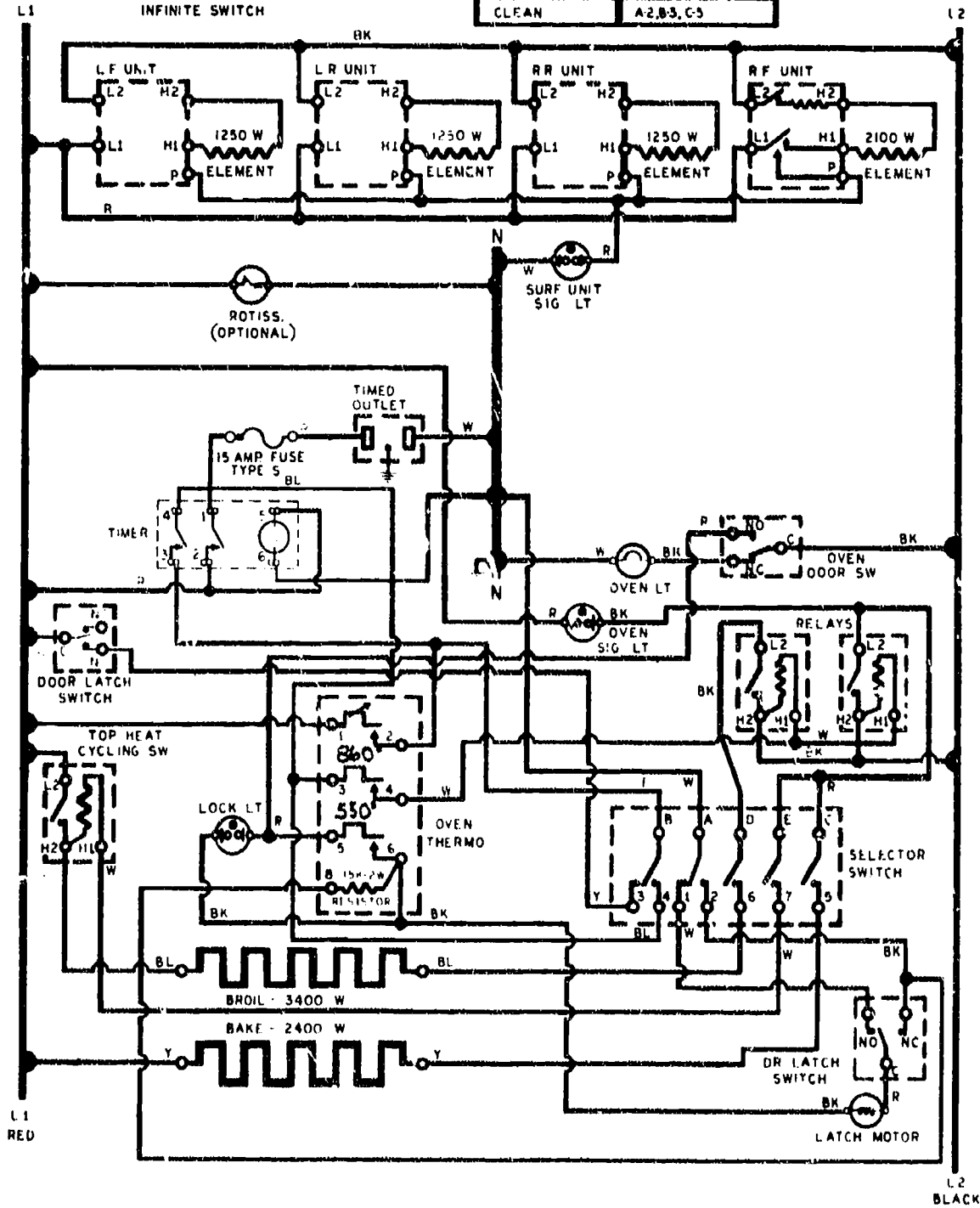

Courtesy Sears

ELECTRIC RANGES AND OVENS UNIT XIII

JOB SHEET #1 — REMOVE A SURFACE UNIT FROM AN ELECTRIC RANGE AND CHECK FOR PROPER RESISTANCE

A. Tools and materials

1. Electric range as selected by instructor
2. VOM
3. Standard and Phillips screwdrivers
4. Shop cloth
5. Pencil and paper
6. Wire brush and sandpaper
7. Safety glasses

B. Procedure

1. Put on safety glasses.
2. Unplug the range from the power supply.
3. Permit top elements to cool if recently used.
4. Make a visual inspection of the ceramic receptacles the top heating elements are plugged into or wired into.

(NOTE: If it appears that there may be connector problems, check with your instructor for appropriate modifications to this procedure.)

5. Set VOM to lowest resistance reading scale and cross leads to zero the meter.
6. Place one lead on each terminal of the heating element.
7. Record the reading on the worksheet that accompanies this job sheet.

(NOTE: If you're working with an element that has two heating coils, both coil terminals should be checked.)

8. Repeat the procedure for the remaining top heating elements.

Have your instructor check your readings.

9. Clean up area and return tools and materials to proper storage.

JOB SHEET #1

Surface Unit Resistance Check

Right front surface unit: _____

Left front surface unit: _____

Right rear surface unit: _____

Left rear surface unit: _____

Your Name _____

Date _____

ELECTRIC RANGES AND OVENS UNIT XIII

JOB SHEET #2 — CHECK THE SELF-CLEANING FUNCTION OF AN ELECTRIC OVEN

A. Tools and materials

1. Electric range with self-cleaning oven function as selected by instructor
2. Shop cloth
3. Pencil and paper
4. Watch or clock for timing
5. Safety glasses

B. Procedure

1. Put on safety glasses.
2. Check to make sure the range is plugged into a proper power supply.
3. Check oven door or oven console face for self-cleaning procedure (Figure 1).

FIGURE 1



JOB SHEET #2

4. Open oven door and manually raise the mesh screen protector over the oven door (Figure 2).

FIGURE 2

5. Close oven door and manually lock it into place (Figure 3).

FIGURE 3

JOB SHEET #2

6. Set the oven for the self-clean cycle as directions indicate (Figure 4).

FIGURE 4



7. Write down the time as the cycle begins. _____
8. Monitor heat on the outside of the oven door by placing your hand close to the door surface.

(CAUTION: Do not put your face near the glass in the oven door or attempt to look inside the oven.)
9. Continue to monitor the oven for indication that the smoke eliminator is functioning.
 - a. In some ranges, a fan will come on and a lock switch light will go on to indicate the smoke eliminator has been activated.

JOB SHEET #2

- b. In some ranges, the only evidence that the smoke eliminator is working will be hot air rising from the right rear burner (Figure 5).

FIGURE 5



- c. If smoke comes out of the right rear burner along with the hot air, it means the platinum/palladium screen filter is not working and needs to be replaced.

(CAUTION: Do not attempt to open the door on an oven that has just completed a self-clean cycle until you are certain that the oven has cooled down.)

10. Permit oven to complete self-clean cycle and record the ending time.

11. Compare your recorded time with the predetermined time set on the self-clean clock mechanism.

(NOTE: If the two times are off, it may indicate a malfunction in the self-clean clock mechanism.)
12. Permit oven to cool.
13. Check the results of the self-clean cycle.
14. Wipe away any ash residue with a shop cloth.
- Have your instructor check your work.
15. Clean up area and return tools and materials to proper storage.

ELECTRIC RANGES AND OVENS UNIT XIII

JOB SHEET #3 — MAKE CONTINUITY CHECKS ON STEP-TYPE AND INFINITE ELECTRIC RANGE SWITCHES

A. Tools and materials

1. Electric range as selected by instructor
2. VOM
3. Pencil and paper
4. Phillips and standard screwdrivers
5. Open-end wrenches
6. Inspection light
7. Temperature tester with griddle probe
8. Safety glasses

B. Routine #1 — Checking an infinite switch

1. Unplug range from power source.
2. Remove front console or access panel so you can reach the switches.
3. Draw a sketch of the switch if there is no schematic diagram available and note the position of each wire and the terminal it goes to on the switch.
4. Remove the leads from the switch terminals.
5. Unbolt or unscrew the switch and remove it from the range.
6. Place the switch on a clean working surface.
7. Inspect the switch to make sure the bus bar running diagonally from the H1 terminal has not burned out

(NOTE: If the bus bar is burned out it will be dislodged from its normal position and easy to detect.)

- a. If the bus bar is bad, replace the entire switch
- b. If the bus bar is okay, continue troubleshooting

JOB SHEET #3

8. Set the VOM on the R \times 1 scale for measuring resistance.

(NOTE: 120V and 240V infinite switches will check the same, and service technicians usually carry a few of each kind to assure prompt service.)

9. Place one VOM probe on the L1 terminal of the switch and the other probe on H1 (Figure 1).

FIGURE 1

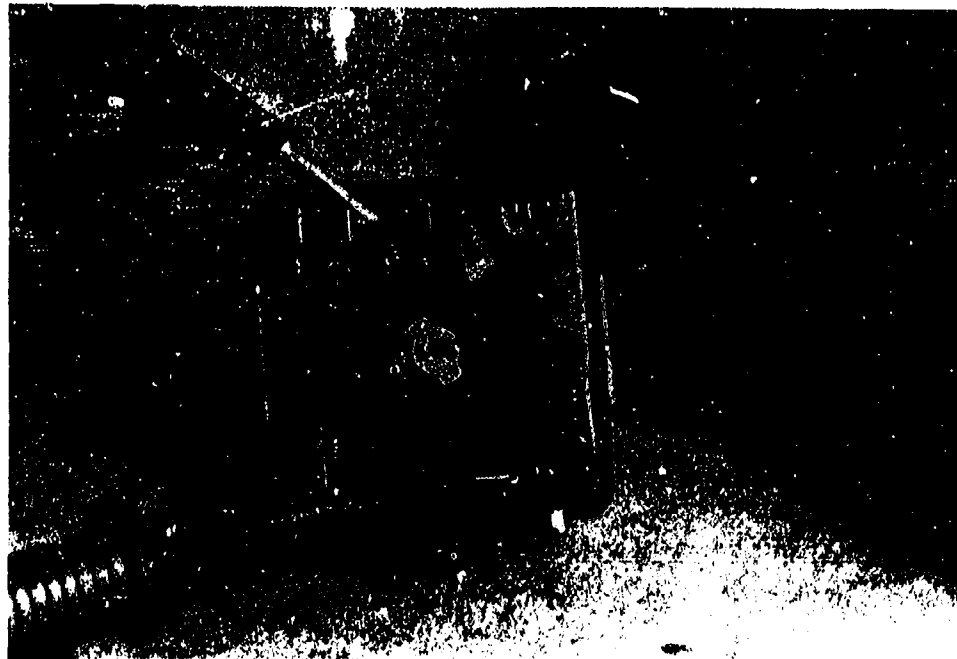

10. Rotate the switch control stem a full 360 degrees and record the readings on the VOM each time the switch clicks.
- If no readings are evident, the switch is no good and should be replaced.
 - If the readings range from 2 to 5 ohms, the switch is okay.
11. Use a temperature tester with a griddle probe to conduct a cycling test to make sure the switch is cycling the surface unit off and on
12. Replace the switch in the range, if you removed it, and turn the range on
13. Hold the sensor of the griddle probe onto the surface unit, and turn the infinite switch to its first setting
- If the meter indicates a low temperature reading, and if the reading then drops off, the surface unit is cycling on low heat
 - If there is no temperature reading the switch is not cycling the surface unit and the switch should be replaced

JOB SHEET #3

c. If the temperature reading goes beyond a low reading, and does not cycle off, the switch is bad and should be replaced

14. Repeat the procedure for medium and high heat positions, and replace the switch if any of the readings are improper

(NOTE: Although it takes a bit longer, a cycling check can also be made by using a pan of water and a regular thermometer.)

15. Repeat the procedure for all switches on the range.

Have your instructor check your work.

C. Routine #2 — Checking a step-type switch

1. Make sure range is unplugged from power source.
2. Remove front console or access panel so you can reach the switches.
3. Draw a sketch of the switch you plan to check and note the position of each wire and the terminal it goes to on the switch.
4. Remove the leads from the switch terminals.
5. Unbolt or unscrew the switch and remove it from the range.
6. Place the switch on a clean working surface.
7. Set the VOM on the $R \times 1$ scale for measuring resistance.
8. Place one VOM probe on the power input terminal.

(NOTE: This will probably require a schematic, so check with your instructor.)

JOB SHEET #3

9. Place the other probe on any other terminal and keep moving the probe from one terminal to another until you get a reading on the VOM (Figure 2).

FIGURE 2

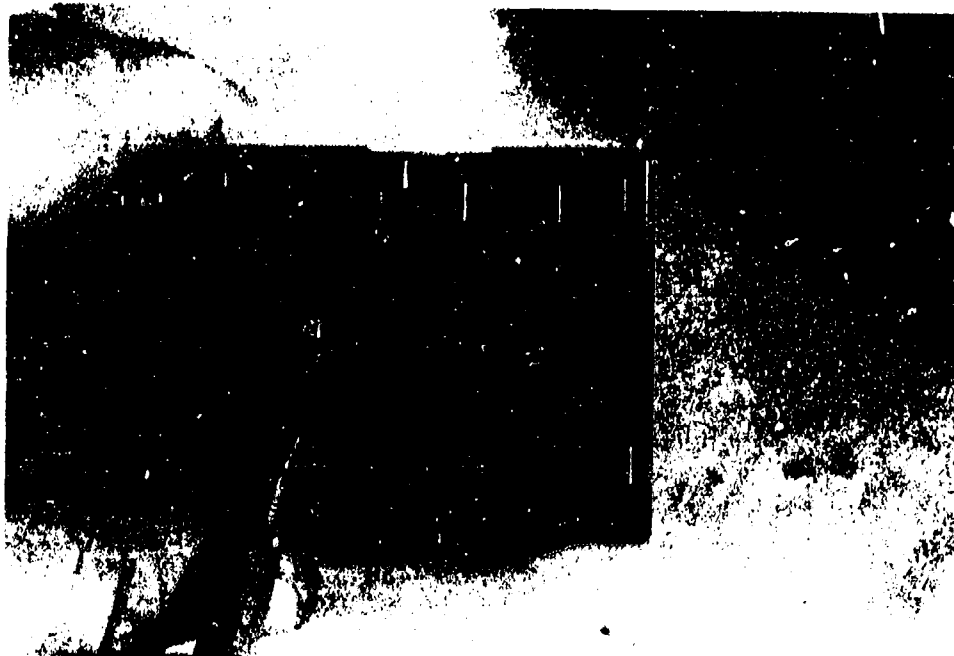

10. Rotate the switch control stem a full 360 degrees and record the readings on the VOM each time the switch clicks.
 - a. If no readings are evident, the switch is no good and should be replaced.
 - b. If the readings are as low as infinity or range from 2 to 5 ohms, the switch is okay and should be reinstalled on the range.
11. Repeat the procedure for all step-type switches on the range.
- Have your instructor check your work.
12. Clean up area and return tools and materials to proper storage.

ELECTRIC RANGES AND OVENS UNIT XIII

NAME _____

TEST

1. Match the terms on the right with their correct definitions.

- | | | |
|----------|--|-----------------------|
| _____ a. | A chemical or other substances used to speed up or slow down a process such as the platinum/paladium screens that cause smoke to burn at lower temperatures in self-cleaning ovens | 1. Recalibrate |
| _____ b. | Electric range switches that provide a user with limited heat selections by cycling voltage on and off | 2. Step-type controls |
| _____ c. | Electric range switches that provide a user heat selections in limited increments such as low, medium, and high by controlling voltage input only | 3. Catalyst |
| _____ d. | The procedure of adjusting a switch or control device so that it will perform to a specified standard | 4. Infinite controls |

2. Complete statements concerning electrical requirements for hooking up an electric range by circling the word(s) or figure(s) that best complete each statement.

- a. To operate properly, electric ranges require (120V, 240V) at 50 amps.
- b. Receptacles for electric ranges will accept only a three-prong or four-prong, (straight-bladed, single-ground) plug.
- c. A dryer plug with an L-shaped blade should never be modified for use on an electric range because a dryer plug is designed for only (30, 15) amps and has smaller conductor wires.
- d. Anything less than the proper 3-prong or 4-prong range hook-up is in (violation of, agreement with) the National Electric Code and state and local codes.

TEST

3. Select true statements concerning the basics of electric cooking by placing an "X" beside each statement that is true.

- a. Instead of being rated in BTU's, electric range heating elements are rated in amps.
- b. Both surface heating elements and oven heating elements are made from an alloy of nickel and chromium called nichrome.
- c. Heating elements have nichrome coils embedded in an insulated sheath, then covered with stainless steel tubing, a design that produces efficiency.
- d. Electric ranges produce no byproducts of combustion.
- e. Electric ranges are preferred appliances in almost all areas.

4. Solve the following problems concerning servicing electric surface and oven heating element.

- a. What's the first thing that should be checked to troubleshoot a complaint of poor surface or oven heating?

Answer _____

- b. What simple test can determine whether or not an element needs to be replaced?

Answer _____

5. Differentiate between types of heat controls for surface heating elements by placing an "X" beside the definition of step-type controls.

- a.
 - 1) Work by controlling voltage input only
 - 2) Controls permit use of both 240V and 120V in such a way that the two voltage may work individually or together for precise heat control
 - 3) Some controls have as few as three heat settings: high, medium, and low.
 - 4) Other controls may have 5 or even 7 heat settings for temperature ranges that include high, medium-high, medium, low, medium-low, extra-low, and simmer.
- b.
 - 1) Work by controlling voltage input in an on/off cycling pattern
 - 2) Most controls have 240V control to the dual element, but some controls use 120V too.
 - 3) Controls may have unlimited heat settings or be limited to five or seven heat settings.

TEST

6. Complete statements concerning types of electric oven thermostats by inserting the word(s) that best completes each statement.

a. Bellows type

- 1) A bellows expands or contracts as _____ oil in a capillary tube expands or contracts.
- 2) As the bellows expands or contracts it _____ or _____ switch contacts which turn the oven heating element on or off.

b. Bimetallic type

- 1) A strip made of two _____ metals flattens or arches in response to temperature changes, and opens and closes switch contacts.
- 2) As the switch contacts _____ and _____, the oven heating element is turned on or off.

c. Diaphragm type

- 1) A diaphragm expands or contracts in response to _____ from a capillary tube.
- 2) The diaphragm activates or deactivates a click-action _____ that turns the oven heating element on or off.

7. Solve problems concerning recalibrating electric oven thermostats.

a. What sort of check is required to determine if an oven thermostat needs to be recalibrated?

Answer _____

b. What should follow recalibration?

Answer _____

8. Solve problems concerning typical electric oven self-cleaning operation.

a. Can the right rear surface element be used during a self-cleaning operation?

Answer _____

b. What happens in a self-cleaning cycle when an oven reaches a temperature of about 550°F?

Answer _____

TEST

c. At about 825°F, what happens to the HI LIMIT SWITCH?

Answer _____

d. At what point may the oven door be opened again?

Answer _____

9. Match other components with their functions in a self-clean cycle.

- | | | |
|---------|--|----------------------------------|
| _____a. | Must be pulled in place over the oven window before the oven door can be latched shut | 1. Smoke eliminator |
| _____b. | A mechanical latch that must be pushed to the far right in order for the self-cleaning function to be started | 2. Metal-mesh oven window screen |
| _____c. | A filter-type screen coated with a platinum/palladium combination and then oxidized to act as a catalyst which causes smoke to burn at a lower temperature | 3. Lock latch |

10. Complete statements concerning troubleshooting electric ranges by inserting the word(s) that best completes each statement.

a. When the oven will not heat or when the oven will not turn off, check for:

- 1) A blown _____
- 2) Loose _____
- 3) Selector _____ problems
- 4) Timer _____
- 5) _____ thermostat
- 6) _____ bake element
- 7) Control _____ problems

TEST

- b. When a surface unit will not heat, is always on high, or has too much heat on a low setting, check for:
- 1) A blown _____
 - 2) Loose or _____ connection
 - 3) An _____ in the element itself
 - 4) Bad surface unit _____
- c. When a timer appears to be malfunctioning, check for:
- 1) Loose connections or _____ connections
 - 2) Bad timer _____
 - 3) Bad _____
- d. When an oven door does not close properly, check for:
- 1) Worn pins or _____ brackets
 - 2) Problems with the oven door _____ or misalignment
- e. When a self-cleaning function does not operate, check for:
- 1) Problems with _____ and broil circuitry
 - 2) Problems with selector switch or oven _____
 - 3) Blown _____
 - 4) Problems with the safety _____ system

(NOTE: If the following activities have not been accomplished prior to the test, ask your instructor when they should be completed.)

11. Demonstrate the ability to:
- a. Remove a surface unit from an electric range and check for proper resistance. (Job Sheet #1)
 - b. Check the self-cleaning function on an electric oven. (Job Sheet #2)
 - c. Make continuity checks on step-type and infinite electric range switches. (Job Sheet #3)

ELECTRIC RANGES AND OVENS UNIT XIII

ANSWERS TO TEST

1. a. 3
b. 4
c. 2
d. 1
2. a. 240V
b. Straight-bladed
c. 30
d. Violation of
3. b, c, d
4. a. Check all connectors
b. A continuity test
5. a
6. a. 1) Silicon
2) Opens, closes
b. 1) Dissimilar
2) Open, closes
c. 1) Pressure
2) Switch
7. a. An oven temperature check
b. An oven temperature check
8. a. No
b. The door lock switch activates a locking screw into position so that the lock lever cannot be removed
c. It cycles on and off to maintain required heat until the clock timer runs through the programmed clean time
d. When the oven cools to between 325°F and 250°F and the door lock lever can be moved manually to the left
9. a. 2
b. 3
c. 1
10. a. 1) Fuse
2) Wire or wires
3) Switch
4) Problems
5) Defective
6) Defective
7) Circuitry

ANSWERS TO TEST

- b.
 - 1) Fuse
 - 2) Incorrect
 - 3) Open
 - 4) Switch
 - c.
 - 1) Wrong
 - 2) Motor
 - 3) Timer
 - d.
 - 1) Hinge
 - 2) Seal
 - e.
 - 1) Bake
 - 2) Thermostat
 - 3) Fuse
 - 4) Interlock
11. Performance skills evaluated according to procedures written in the job sheets