

DOCUMENT RESUME

ED 312 133

SE 050 902

TITLE Launching a Dream. A Teachers Guide to a Simulated Space Shuttle Mission.

INSTITUTION National Aeronautics and Space Administration, Cleveland, Ohio. Lewis Research Center.

PUB DATE Jun 88

NOTE 109p.; Photographs may not reproduce well.

PUB TYPE Guides - Classroom Use - Guides (For Teachers) (052)

EDRS PRICE MF01/PC05 Plus Postage.

DESCRIPTORS *Aerospace Education; *Elementary School Science; Elementary Secondary Education; Satellites (Aerospace); *Science Activities; *Science Careers; Science Education; Science Experiments; *Science Projects; Scientific Enterprise; Secondary School Science; *Simulation

IDENTIFIERS National Aeronautics and Space Administration

ABSTRACT

This publication is about imagination, teamwork, creativity, and a host of other ingredients required to carry out a dream. It is about going into space--going into space as part of a simulated space shuttle mission. The publication highlights two simulated shuttle missions cosponsored by the National Aeronautics and Space Administration (NASA) Lewis Research Center and Cleveland, Ohio, area schools: the first in 1985 and the more recent in 1987. Sections include: (1) "Getting Started" (summarizing the organization of the mission project); (2) "Preflight Preparation" (describing the shuttle preparation, devising of the flight plan, selecting and training of the astronauts, payload experiments, building preparation, handling public relations, and 'Living in Space'); (3) "Flight Day" (conducting the preflight inspection, writing a launch schedule, space center activities, and scheduling rendezvous and stops); (4) "Postflight Activities" (debriefing; press conference, and school and community activities; a recognition program; and letters of commendation); and (5) "Further Suggestions" (from the faculty and staff). The purpose, materials needed, and procedures are provided for each of the 13 payload experiments covering geology, biology, and physics. Lists of participating schools, materials used, related publicity, and NASA and Regional Teacher Resource Centers are appended. (YP)

 * Reproductions supplied by EDRS are the best that can be made *
 * from the original document. *

ED 312 133

LAUNCHING A DREAM

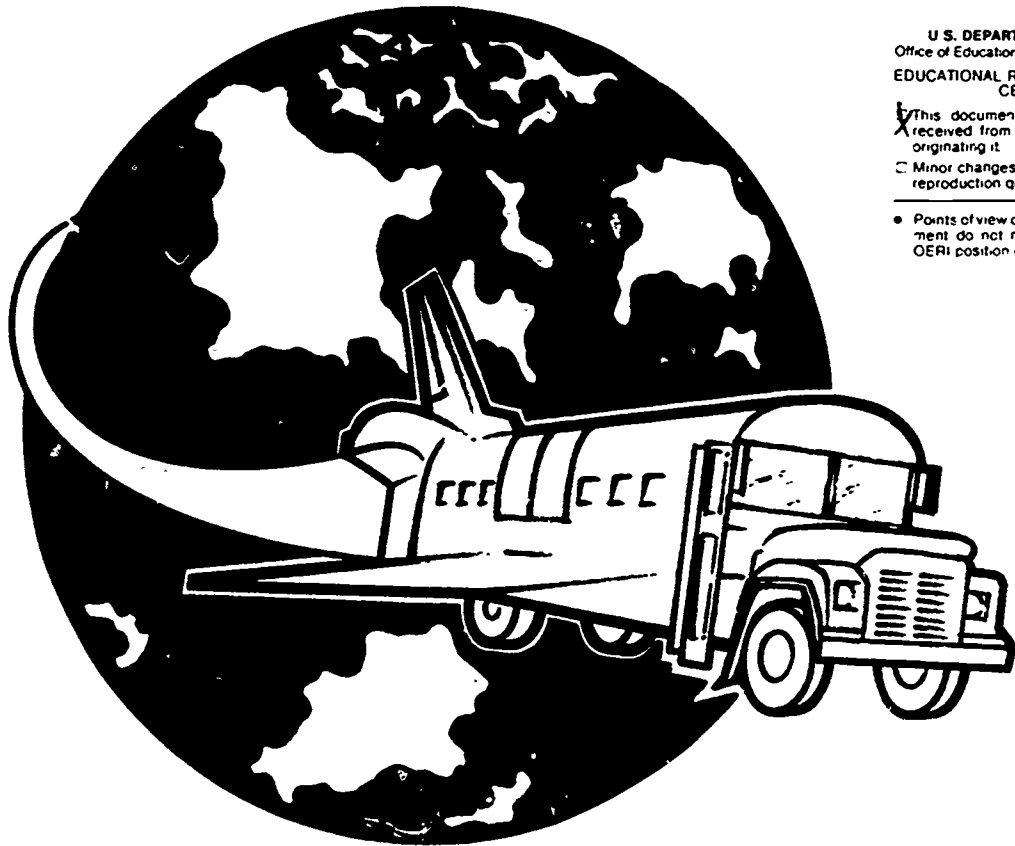

U.S. DEPARTMENT OF EDUCATION
Office of Educational Research and Improvement
EDUCATIONAL RESOURCES INFORMATION
CENTER (ERIC)

This document has been reproduced as received from the person or organization originating it.

Minor changes have been made to improve reproduction quality.

• Points of view or opinions stated in this document do not necessarily represent official OERI position or policy.

**A Teachers Guide to a
Simulated Space Shuttle Mission**

SE 050 902

LAUNCHING A DREAM

A Teachers Guide to a Simulated Space Shuttle Mission

NASA

National Aeronautics and
Space Administration

Lewis Research Center
Cleveland, Ohio 44135

Foreword

This publication is about imagination, teamwork, creativity, and a host of other ingredients required to carry out a dream, a dream that will permit young people to touch and "live" the future for a moment in their young lives. It is about going into space—going into space as part of a simulated space shuttle mission.

The publication highlights two simulated shuttle missions cosponsored by the NASA Lewis Research Center and Cleveland, Ohio, area schools: the first in 1985 and the more recent in 1987. The story is an exciting one.

A simulated space shuttle mission is an opportunity for students of all ages to plan, train for, and conduct a shuttle mission. Some students are selected to be astronauts, flight planners, and flight controllers. Other students build and test the experiments that the "astronauts" will conduct. Some set up mission control, while others design the mission patch. Students also serve as security officers or carry out public relations activities. For the simulated shuttle mission school buses or recreation vehicles are converted to represent shuttle orbiters.

All aspects of a shuttle mission are included. During preflight activities the shuttle is prepared, and experiments and a flight plan are made ready for launch day. The flight itself includes lifting off, conducting experiments "on orbit," and rendezvousing with the crew from the sister school. After landing back at the home school the student astronauts are debriefed and hold press conferences. The astronauts celebrate their successful missions with their fellow students at school and with the community at an evening postflight recognition program.

To date, approximately 6,000 students have been involved in simulated shuttle missions with the Lewis Research Center. A list of the participating schools, along with the names of their space shuttles, is included in appendix A.

Educational outcomes for the students are many. The students are able to learn about the space shuttle itself, as well as become aware of the many tasks and activities associated with a shuttle flight. Throughout their involvement in the projects students learn about the extensive variety of career choices involved in the space program. Students also have the opportunity to participate in a "team" effort, culminating in an event that they will remember all their lives.

The effect of the simulated shuttle mission on students is extraordinary! Unmotivated and underachieving students begin doing library research. Attendance improves. Students express their appreciation for the opportunity to work with students in other classrooms. Students demonstrate school pride.



Looking skyward to a dream.

The communities get equally as excited about the project, as demonstrated by their active support throughout all stages. Community members provide time and technical expertise and donate equipment, materials, and money. The flights are covered on television and in the press.

This publication is intended to assist educators who might desire to have their students become involved in simulated space shuttle missions. Included in the publication are the various aspects to consider when planning for a mission. The information included was provided by the many people involved in the projects.

The publication is organized chronologically by mission activity. Teachers can refer to the different components of the flight to find necessary information and suggestions for completing the project. Reference checklists are provided in each section to assist educators in planning their own missions.

This project, like so many others before it, began with a dream—a dream of going into space—but this time carried out on the ground. This dream was first shared with the superintendents of two of our Partnership in Education schools—Jack Thomas of the North Royalton City Schools and Terrance Furin of the Midview Local Schools. Both school districts are located near the Lewis Research Center and had sponsored teachers to attend a two-week Lewis Aerospace Education Workshop during the summer of 1984.

Both superintendents were enthusiastic about the possible project. They each selected a school from their districts to participate in this “first-ever” project. A meeting was held with the principals from each of the elementary schools, Belden and Royal View, to elicit their support. Their enthusiastic endorsement was soon followed by early morning meetings with selected teachers from each school to gain their support as well. Once this was achieved, Lewis provided assistance in the planning and training necessary to carry out the project.

The teachers, students, and community volunteers of the Belden Elementary School in Grafton, Ohio, and the Royal View Elementary School in North Royalton, Ohio, were the pioneers in simulated shuttle missions. Theirs was the first: on May 30, 1985, they made history and paved the way for others to participate in similar missions.

The project in 1987 was much more extensive. The 1987 simulated shuttle missions involved nine elementary schools from the Berea, Cleveland, Lorain City, North Olmsted, and Strongsville school districts. In addition, selected students from two high schools in the Diocese of Cleveland participated.

After several preparatory meetings with me, administrators and staffs of the schools involved agreed to “Go for launch!” In November of 1986 selected staff members from the participating schools attended a one-day training program at Lewis to begin the 1987 project.

I appreciate the dedication and commitment of the teachers who carried out the projects. Congratulations also for a job well done to all of the students who enthusiastically participated and completed their simulated shuttle missions. A special thanks to the administrations, boards of education, parents, and community volunteers who supported the project. I am especially grateful to the members of the Educational Services Office and other members of the Lewis team who became so actively involved in the project and to Joe Nervi and Jane Warner, who organized and coordinated this publication.

Robert Goddard, the father of the liquid fuel rocket, said:

The dreams of yesterday
become the hopes of today
and the realities of tomorrow.

Indeed, a simulated shuttle mission is a great way to launch a dream. It is a way to demonstrate to students that there is hope for tomorrow and that they will be the ones to sail the oceans of space, for the future belongs to them.

I hope you will share the results of your simulated shuttle missions as well. Please send your comments or questions to me:

R. Lynn Bondurant, Jr.
Chief, Educational Services Office
Project Director, Simulated Shuttle Missions
NASA Lewis Research Center
Cleveland, Ohio 44135

May your mission be as successful as ours have been!

Contents

FOREWORD

1. GETTING STARTED	
Organizing the Project	3
Soliciting Support and Volunteers	3
Involving the Whole School	4
Adapting to Grade Level	5
Involving the Entire Curriculum	5
2. PREFLIGHT PREPARATION	
Preparing the Shuttle	11
Devising the Flight Plan	16
Selecting the Astronauts	20
Training the Astronauts	21
Planning Payload Experiments	23
Preparing the Building	32
Handling Public Relations	38
"Living in Space"	41
3. FLIGHT DAY	
Conducting Preflight Inspection	45
Writing Launch Schedule	46
Planning Space Center Activities	48
Scheduling Rendezvous and Stops	50
4. POSTFLIGHT ACTIVITIES	
Debriefing, Press Conference, and School and Community Activities	55
Recognition Program	57
Letters of Commendation	58
5. FURTHER SUGGESTIONS	65
6. APPENDIXES	
A—Simulated Shuttle Mission School Participants	69
B—Astronaut Selection Forms and Letters	70
C—Astronaut Training Documents	78
D—Mission Patches	80
E—Mission Control Data	82
F—Press Kit Outline and Materials	86
G—Related Publicity	90
H—Recognition Certificates	103
I—NASA and Regional Teacher Resource Centers	104
J—Acknowledgments	109



1. GETTING STARTED

"It's just so amazing what we can do by cooperating with each other."

Tracy

Organizing the Project

Once a decision has been made to embark on a simulated shuttle mission, careful organization is essential. Completing a simulated shuttle mission will require a major effort by faculty, staff, students, and parent and community volunteers. Careful planning and cooperation are key to a successful mission and will have an impact not only on the students who are selected as astronauts, but on the entire student body and much of the community as well.

Organize a Core Team

The initial organizational step involves recruiting faculty members to serve as core mission planners. These core team members will be responsible for developing an outline of mission components. The list below notes committees formed for previous simulated shuttle missions. Subcommittees may be set up within each to further delegate tasks.

Shuttle preparation	Mission control
Flight plan	Space center preparation
Astronaut selection	and activities
and training	Public relations
Payload experiments	Living in space
Launch and landing	Postflight activities

Establish Mission Component Committees

Teachers are invited to work on the mission component committee of their choice. From this group of volunteers committee chairpersons are chosen who will take responsibility for the completion of tasks assigned to their committee. Student volunteers are recruited for each committee, and their ideas and input become an integral part of every mission component.

Establish a Broad Timetable

It is necessary to establish a timetable for the completion of tasks and a mechanism for reporting progress to the core planning committee. This helps to ensure that all components of the mission are moving forward. Work on one component of the mission often depends on completion of tasks by other committees. For example, if payload experiments are not selected and planned early, bus modifications to accommodate these experiments are delayed. The mechanism for reporting progress to the core planning committee can be informal, but reporting must take place at regularly scheduled intervals and highlight specific progress. This provides the core team members with information to assess progress in each area and permits them to alter the schedule or make recommendations to committees for changes. Problem areas can be identified early and solutions found that will not impede progress on the mission.

Soliciting Support and Volunteers

Identify Needs and Available Resources

Completing a simulated shuttle mission without the assistance of volunteers would be virtually impossible. Whether the assistance is in the form of time, technical expertise, donation of equipment and materials, or monetary contributions, it is essential to the success of the mission. The support needed can be found in your community. The task is to identify the resources available and to solicit and encourage interest and involvement. There is no single way to do this; each community is unique. Your effort and creativity will pay off in soliciting volunteers.

Recruit Volunteers From School and Community

A broad base of support is very beneficial. The more components of the community recruited for the project, the greater your chances for success. Begin your volunteer recruitment drive at your school. The faculty and staff of your school, as well as the parents of your students, can provide invaluable resources. You may find within this group a tremendous amount of time available

to be given to each aspect of the project. In addition, these people may be able to donate materials, equipment, and supplies or be willing to contribute money. The importance of this involvement from your school community cannot be overstated.

An area for initial support is the central office of your school district for the acquisition of a school bus to be converted to a shuttle. Other areas where district level expertise can provide support are bus modification and maintenance, astronaut selection, and public relations.

Obtaining the support of community resources may require letters, phone calls, or visits to the appropriate persons, organizations, agencies, or businesses. Because of the variety of activities involved in a simulated shuttle mission a wide variety of resources for services and materials will be needed. Ask for assistance from as many available resources as possible. Experience has taught us that the results will be more fruitful if you deal with the person or persons in a decision-making role within the organization. This may be the mayor, city council person, owner of a business, or president of a service organization, for example.

Maintain Ongoing Communication With Supporters

Regardless of who your resource people are or how they were recruited, it is important to keep them informed about the progress of the project. They will want to know how their support and the support of others is being used to help the project progress. As the project progresses, you will continue to pick up additional support as people learn about the project.

Publicity from local newspapers and radio and television stations can encourage the participation of new volunteers as well as inform present ones. Publicized interviews with teachers or student astronauts will encourage support. The experience of schools involved in previous simulated shuttle missions indicates that successful volunteer recruiting is a result of asking and

letting people know exactly how they can help. These schools found the support of their communities overwhelming. At the end of the mission some recognition for the efforts of the individuals is recommended.

Success in this endeavor requires not only dedication from those directly involved at the school, but the support of numerous volunteers as well. As you can see, that support can be defined in many ways. No single area of support is more important than another. Because the entire project requires the time, materials, and resources of many, it is possible to allow persons or groups to choose where they wish to contribute. This will permit the most efficient use of the available resources. Soliciting support and volunteers requires attention early in the project to ensure the success of the simulated shuttle mission.

Involving the Whole School

Making everyone feel a part of the simulated shuttle mission is an essential ingredient to the total success of the project. Whatever tasks or positions students are assigned, it is necessary that they see the relationship of their jobs to the mission and recognize their significance. It is important that they feel that the mission would not be as successful without their involvement. This task becomes especially difficult in a very large school, but efforts must be made to see that it happens. Previous missions have demonstrated that this often makes the difference between a good and a great experience.

Recognize the Contributions of Everyone

Make sure that all students, in addition to the astronauts, receive recognition. Although there are obvious occasions within the project when the astronauts will be highlighted, it is important to keep their roles in perspective. All jobs in the project are necessary and play an integral part. Instilling the feeling in students that each is a working member of the team should be a goal of the project. As can be seen from other sections of this publication, there are numerous opportunities for all students to be involved in some aspect of a simulated shuttle mission.

In addition to the number of special jobs such as mission control personnel, ground crew, medical officers, public relations workers, or nutritional specialists, for example, there is a tremendous amount of work to be done in the school building. The art committee will need people to assist with the transformation of the school to a "Space

Center." Patches, flags, and uniforms must be designed. A song, skit, or poem can be written and performed. Each of these takes the dedication of students and teachers in the school.

Find Ways for Continued Involvement

As launch day approaches, students will continue to be involved in a number of ways. They will be "aliens" when their school is visited by another school's shuttle and provide messages on computer disks to be shared or included in satellite balloon launches. Students at the school can perform the same experiments as the astronauts and compare results. Through the use of computers and radios students at the school can know at any moment the location of the shuttle and its astronauts. In addition, it is possible for all students in the school to eat the same or similar lunch as the astronauts on mission day. These activities encourage all students to feel an integral part of what is going on.

Decide on Mechanics

The mechanics for involving everyone in the building in the project is an individual school decision. One design might permit students to sign up for the committee or committees on which they would most like to serve. At a regularly designated time committee meetings take place in school and work proceeds. Another design might have groups of students involved only on selected components of the project. In many instances when space and space travel are integrated into the curriculum, students will feel a part of the project. Anything done to increase

involvement will enhance feelings of being a part of a very special project and contribute to its success. It is easy to get caught up in the excitement of the astronauts in the limelight and overlook or minimize the many

contributions of so many others. However, when you experience the electric atmosphere at a school totally involved in a simulated shuttle mission, you readily sense the full potential of this project.

Adapting to Grade Level

Although the simulated shuttle mission project was originally conceived as an elementary level activity, it can be easily modified to accommodate students of any grade level. A simulated shuttle mission can be an exciting project for primary students as well as high school math and science students. It is the role of the teachers involved in designing the mission to make sure that each component of the mission is adapted to be appropriate for the age and developmental level of the students involved.

Every aspect of the mission can be adjusted. Bus modifications, astronaut selection and training, and experiment development, for example, can reflect the sophistication of the group involved in the mission. Each aspect can be as simple or as complex as necessary. It is important that the complexity of the mission components be appropriate to the capabilities of the participants.

A word of caution is in order if your school is a K-3 building. Participants from a recent mission reported the difficulty they had working with very young students. Although they believed the project was extremely worthwhile, they felt somewhat limited. Most of the activities were totally teacher originated and centered. In such a case the success of the project becomes dependent upon the interest, enthusiasm, and commitment of the

teacher or teachers involved. This may result in an uneven distribution of the work load to complete the project. Careful thought given to these potential problems might minimize or eliminate them.

In working with older students there are many exciting possibilities for astronaut training and experiments. In a recent mission involving high school students the astronauts underwent underwater training to simulate weightlessness. Another mission permitted astronauts to experience a flight simulator as part of their training. A simulated shuttle mission involving older students may also permit the length of the mission to be extended. For example, a recent high school mission lasted 24 hours. An illustration of the types of activities involved in a longer mission can be found under "Devising the Flight Plan." As with each component of the mission the efforts and creativity of the participants can encourage unique experiences.

A simulated shuttle mission is possible with students of any grade level. Again, the goals and objectives for the project should be appropriate to the level of the students participating. When a project is carefully conceived and organized, it can be a rewarding educational experience.

Involving the Entire Curriculum

The components of a simulated shuttle mission project are diverse enough to involve all disciplines of the curriculum, in addition to stimulating excitement for learning in general. At first glance one might think that such a project involves only math and science, but closer scrutiny reveals that every discipline can contribute to and enrich the project. It is an ideal chance for interdisciplinary learning. Students experience firsthand that learning science or any other subject does not take place in a vacuum. Involving students in this interdisciplinary approach permits them to draw on their existing strengths from different disciplines, as well as providing a unique opportunity for enriching their skills in other areas. Educators often look for new ways to teach and excite students about math, English, and social

studies, for example, and a simulated shuttle mission is an ideal vehicle.

Science and Math Involvement

The role of science and math in such a project is obvious. Learning about the space shuttle, space travel, and aeronautics is an essential first step in preparation. Inclusion of astronomy lessons is appropriate. Other science-related activity and learning is centered around developing scientific experiments for the payload. In designing the experiments students learn about the scientific method and proper laboratory equipment, procedures, and reporting. Mathematical calculations and problem solving are an integral part of the shuttle project. Students use math in devising the flight plan, in

modifying the shuttle, and in designing and carrying out payload experiments and meal menu preparation—to highlight a few areas. Computer use is suggested throughout all phases of the mission. Students could develop and use their computer skills by working in mission control as well as on the shuttle itself. Specific computer use is discussed in a later section of this publication.

English and Language Arts Involvement

English and associated skills can be used and enhanced in a simulated shuttle mission. From the inception of the project through its conclusion, students will constantly be using language arts skills. Whether it is in completing the application form and interview for an astronaut position, participating on a shuttle committee, publicizing the event, reporting each step, or reflecting upon the outcome, students must use reading, writing, and speaking skills to be successful. There are numerous opportunities for students to document, report, and respond at every step in the mission project. Social studies lessons can easily be incorporated into this project. Conducting research, exploring the history of aeronautics and space travel, studying the biographies of space travelers, and examining the reasons for space travel are examples of topics that relate to social studies and can be readily integrated into any simulated shuttle mission. The sophistication and variety of activities are limited only by the desired outcomes and creativity of the teacher.

Fine Arts Involvement

The possibilities for involving the arts in a project of this nature are unlimited. There are numerous opportunities for students to express their ideas and creativity. Modifying and decorating the interior and exterior of the shuttle, converting a school building to a "space center," and designing the mission patch, flag, and uniforms, breakfast placemats, "alien" mementos, and pre- and postlaunch festivities will require the expertise of the arts. There will be opportunities through dramatic interpretation, dance, and song for creative expression about the mission. Videotaping and photographing each aspect of the project combines the skills of the arts and technology. The potential for input is extensive and adds to the excitement and enthusiasm of the students and staff.

Additional Involvement

Other subjects and disciplines can be involved as well. The physical fitness of all students and the training of the astronauts can involve instruction in physical education class. Planning and preparation of the menu on launch day can be assigned to a home economics class. Bus

modifications for the shuttle can be a project for an industrial arts class. These limited examples highlight the fact that there is a place for each class or discipline in this project.

Career Education Involvement

One final area of the curriculum that can be addressed through a simulated shuttle mission is career education. Most states outline a specific program to foster career development and education in their schools. In Ohio the components of career education, as defined by the Ohio Department of Career Education, can be included because of the comprehensive and diverse nature of a simulated shuttle mission. Depending on the grade level of the students participating in the project, the different goals of the Ohio career components can be met.

Career motivation is the career education component for students in grades K-6. The goals of this component are to encourage students to develop a better awareness of self and the world of work and to motivate them to become a part of the work force. Through this project students may become more aware of their interests and abilities and how they relate to school subjects. In addition, this project can heighten their awareness about work and encourage an appreciation for it. Certainly a simulated shuttle mission is an ideal project for helping students develop motivation toward task completion.

If the students to be involved in the project are in grades 7-8, career orientation is the career education component. Students quickly learn about the wide variety of careers essential to a simulated shuttle mission. In addition to becoming familiar with their titles the students actually have the opportunity to learn firsthand what the worker would do to carry out his or her job, as well as what is needed in preparation and training to adequately perform the job. Students can further assess their interests and abilities in relation to the careers being studied.

Career exploration is the component for students in grades 9-10. Students are encouraged to explore career choices in depth and to participate in actual or simulated work experiences. Students at this level would choose their jobs in the shuttle project because of a sincere interest in a particular career. It is important that the students have as close to an actual experience as possible so that they have a realistic concept of the career.

Finally students in grades 11-12 are in the career preparation phase. By this time students have chosen and are enrolled in classes they believe will assist them in preparing for their career choices. Participation in a simulated shuttle mission at this point in their educations provides the opportunity for involvement in a project designed to enhance their skills and preparation.

It should be obvious that undertaking a simulated shuttle mission can provide students the opportunity for remediation, new learning, and enrichment of skills in all areas of the curriculum. As discussed earlier, there are

numerous other educational, social, and personal outcomes, as well. Although undertaking a project of this magnitude will require many sacrifices, the rewards will be many, and we believe, lasting.

GETTING STARTED CHECKLIST

Organizing the Project

- Organize core team to develop mission component outline.
- Establish mission component committees.
- Establish broad timetable for completion of tasks.

Soliciting Support and Volunteers

- Identify needs and available resources.
- Recruit volunteers from school and community.
- Maintain ongoing communication with supporters.

Involving the Whole School

- Recognize contributions of everyone.
- Find ways for continued involvement of students through all phases of mission.
- Decide on mechanics for involving whole school in project early.

Adapting to Grade Level

- Adjust mission components to reflect age and developmental level of students involved.

Involving the Entire Curriculum

- Identify how all curriculum disciplines can be involved in project.
 - Science and math
 - English and language arts
 - Fine arts
 - Other disciplines
 - Career education



2. PREFLIGHT PREPARATION

"May 30, blast-off day. The day that 18 astronauts made a dream become reality. This shuttle was the most magnificent sight."

Meredith

Preparing the Shuttle

"Creative use of materials" might well be an appropriate slogan for anyone converting an ordinary school bus into a simulated space shuttle. The key to the successful transformation of a yellow school bus into a believable space shuttle is the imaginative use of paint, plywood, and household items such as garbage cans and lampshades coupled with the energy, enthusiasm, and time of dedicated volunteers. Described below are the steps necessary to bring about this physical transformation.

Establish a Committee

Establishing a committee to oversee the preparation of the shuttle is the first step in the process. Both students and teachers should be members of this committee. Their major task is to see that the preparation runs smoothly and to function as troubleshooters for the project.

Students submit shuttle designs to the committee, which is responsible for selecting the design that will "fly." Many ideas will be combined to design the final product.

Obtain Guidelines

Before actual construction can begin, it is necessary to obtain guidelines from both the school transportation department and the central office administration as to what modifications can be made to the school bus. At this time liability insurance should be checked to verify that students would be covered in a venture of this nature. School bus and vehicle regulations and route clearance must be obtained from the state and local departments of transportation. It is necessary to consider such things as budget and regulations regarding changing bus color and dimensions as well as other safety regulations.

Acquire Materials

Simulating a space shuttle requires external and internal changes, and many services and materials are needed. Solicit area businesses, local service organizations, parents, and volunteers to obtain free or reduced-cost materials, monetary contributions, and labor. Supplies needed include paint, plywood, cardboard, nuts, bolts, duct and electrical tape, nails, crates, rolls of paper, plastic tubing, chicken wire, framing, garbage cans, lampshades, stretch straps, fabric, standard school supplies, and many other household items.

Modify Interior of Bus

Inside the bus, seats may be removed to create laboratory and work space. Desk-like workstations can be

constructed on both sides of the bus where astronauts can perform experiments enroute to a destination. Interior modifications should be made with experiment activity and payload in mind. Materials can be stored in crates and boxes, on pegboards, and in pockets on the seat covers. Students can add their own personal touches to their storage areas.

To complete the interior, paint the walls white or design paper panels to cover walls and ceiling. Simulated control panels, constructed of cardboard, can be attached to the bus walls. Any additional equipment should be properly secured to prevent extensive movement or damage during the "flight."



Interior modifications are designed to facilitate payload experiments.



An astronaut workstation is fabricated to house electronic equipment inside a shuttle.

Modify Exterior of Bus

The bus exterior should be designed to resemble an actual shuttle. Ideally, paint the bus white. Individual touches can be added with lettering, foil, and tape. Garbage cans, lampshades, and barrels can be used to simulate engine nozzles. A plywood fin can be attached to the roof, keeping height restrictions in mind. A nose cone, designed to allow air to reach the engine, can be

built with chicken wire, fabric, and duct tape. Previous shuttle designers also fabricated folding "wings" that could be secured in the open or closed position, as road conditions dictated. Windows, making certain to allow for ventilation, can be painted or partially covered with cardboard. Creative additions and modifications enhance the finished shuttle.



Volunteers use cardboard and foil tape to modify the exterior of a shuttle.



Movable wings are tested before launch.

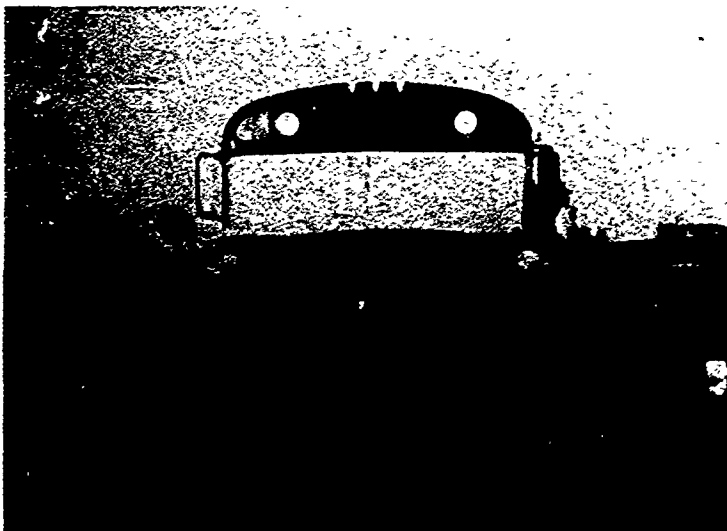

Nose cone and fin are attached to shuttle.



Add Technical Equipment

In addition to the construction materials technical items can be acquired to enhance the realism of the simulated spacecraft. Computers, two-way radios, and other devices require electric power. The electric power can be provided by using battery-powered equipment, by installing a portable generator at the rear of or under the bus, taking care to provide adequate venting for heat and engine exhaust, or by drawing power from the bus electrical system. The latter two alternatives are especially

attractive if the payload will include extensive electrical equipment. Recruit volunteers from the transportation department to make these modifications.

For special effects fire extinguishers mounted inside the rear of the bus can be discharged to simulate the firing of engines at blast-off. A parachute, attached to the rear of the shuttle immediately before "touchdown," can be deployed as the shuttle lands. Both of these add to the excitement and contribute to the realism of the mission.



Testing fire extinguisher "engines" in preparation for launch.



Testing the parachute to be used during shuttle landing.



Computer workstation inside a shuttle.

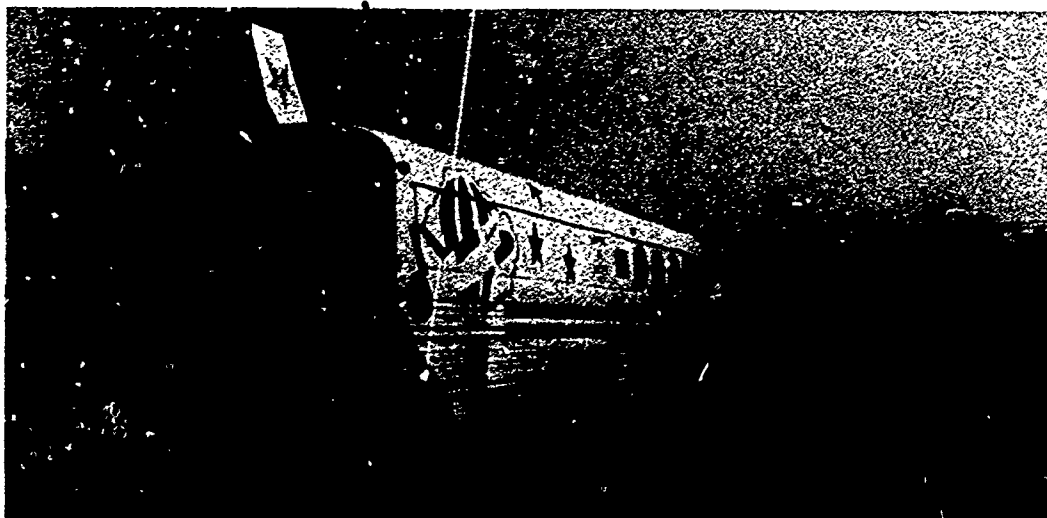

Completed shuttle is ready for launch.

Exterior Drawing of Galaxy City Kids Shuttle

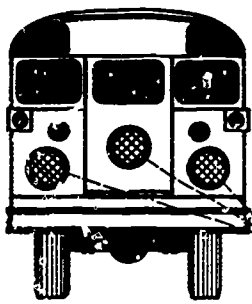

Three metal wastebasket-like paper baskets (paint top black and middle one red)

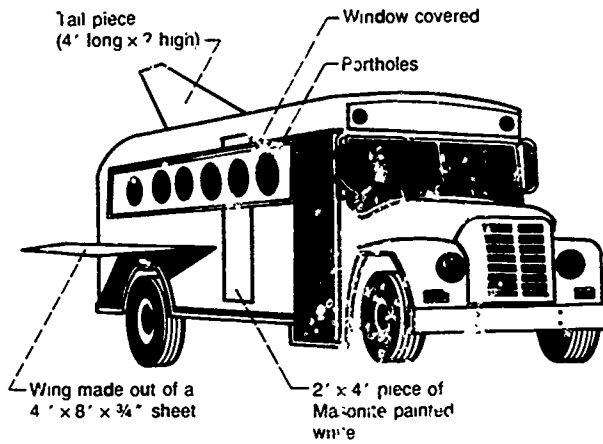

Tail piece (4' long x 2' high)

Window covered

Portholes

Wing made out of a 4' x 8' x 3/4" sheet

2' x 4' piece of Masonite painted white

Bee Stinger Wing Mechanism

Wing up (handle held up with bolt through two supports)

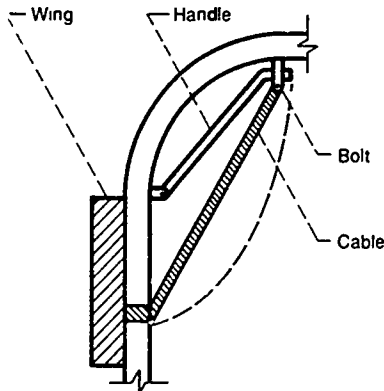

Wing down (to lower wing, pull bolt out and push handle down)

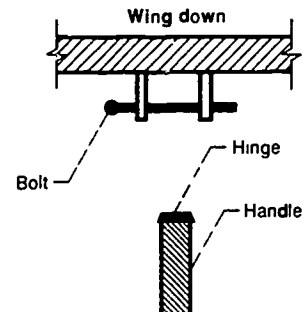
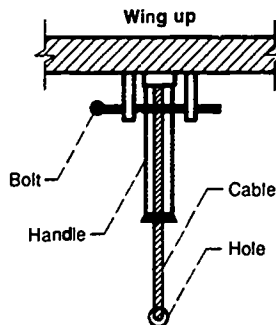
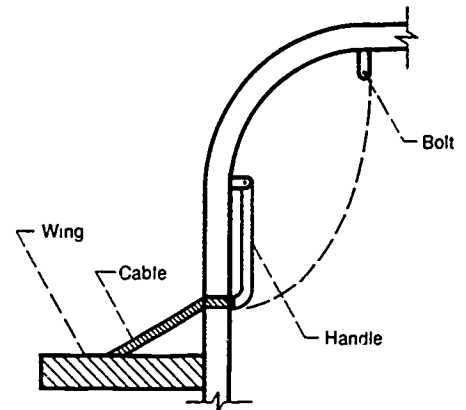

Design by Roy Dennison

Floor Plan of Bee Stinger Space Shuttle

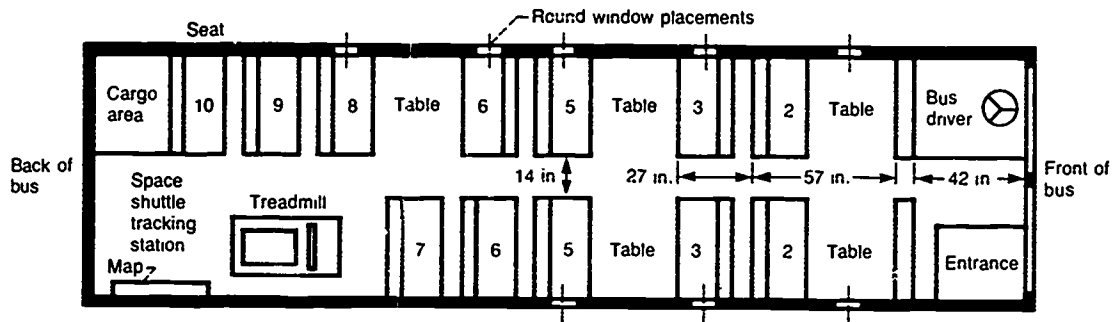
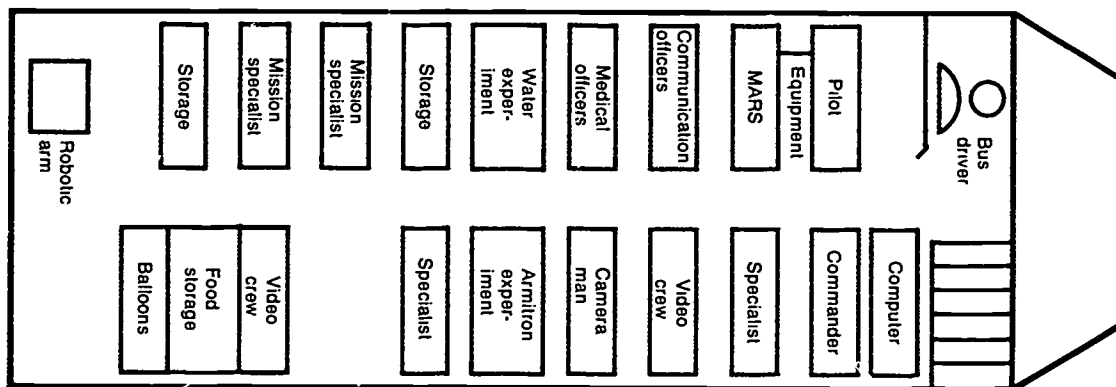

Table measurements (inches):
 36 x 31 x 3/4 (three of these)
 30 x 31 x 3/4 (two of these)

Window filler (inches)
 22 x 82 1/2 x 3/8 CDX (six of these)
 22 x 55 3/8 x 3/8 CDX (two of these)

Legs:
 31 in 2 x 4's

Floor Plan of U.S.S. Belden Starship



PREPARING THE SHUTTLE CHECKLIST

- ___ Establish committee to oversee preparation of shuttle.
- ___ Select shuttle design
- ___ Obtain guidelines from administration and transportation department to guide bus modifications.
- ___ Check liability insurance to ensure that students are covered.
- ___ Obtain clearance for vehicle and route from state and local departments of transportation.
- ___ Acquire materials for construction (also personnel, time, and monetary resources).
- ___ Acquire technical equipment and devices (computer, radio, etc.).
- ___ Execute external and internal modifications of bus.

Devising the Flight Plan

A detailed flight plan answers the who, what, when, where, and how of a space shuttle mission. Launch date and time, flight route, rendezvous, and landing and checkpoint sites are all items that should be included in a complete flight plan. The flight plan then becomes the framework around which the entire mission is built.

Map Flight Route

Devising the flight plan is the responsibility of the flight plan committee. This group of students and teachers maps out several possible flight routes and identifies any midflight "landing" sites. In mapping the flight route the flight plan committee members must consider bridge clearances and weight limits, low-hanging tree branches, and telephone or power lines, as well as other road conditions. Include the most interesting landmarks and terrain possible. Distance traveled from mission control may also be determined by the range of any radio communications system being used. Rendezvous and landing sites are selected on the basis of safety,

environmental interest, adequate area for experiment deployment, and room for bus parking and media coverage. Arrange with local law enforcement officials for clearance and escort service. Permission to use rendezvous and experiment deployment sites is necessary and should be obtained as early as possible.

Complete Test Flights

The flight plan committee should make a series of "test flights," keeping a log of time, mileage, and speed. Take photographs for navigational purposes. Previous mission planners completed three flights before making final flight plans.

- Flight 1: Check route for road conditions, clearances, and problem areas. Check communications system.
- Flight 2: Log time, mileage, and speed. Identify landmarks.
- Flight 3: Conduct final preflight runthrough.

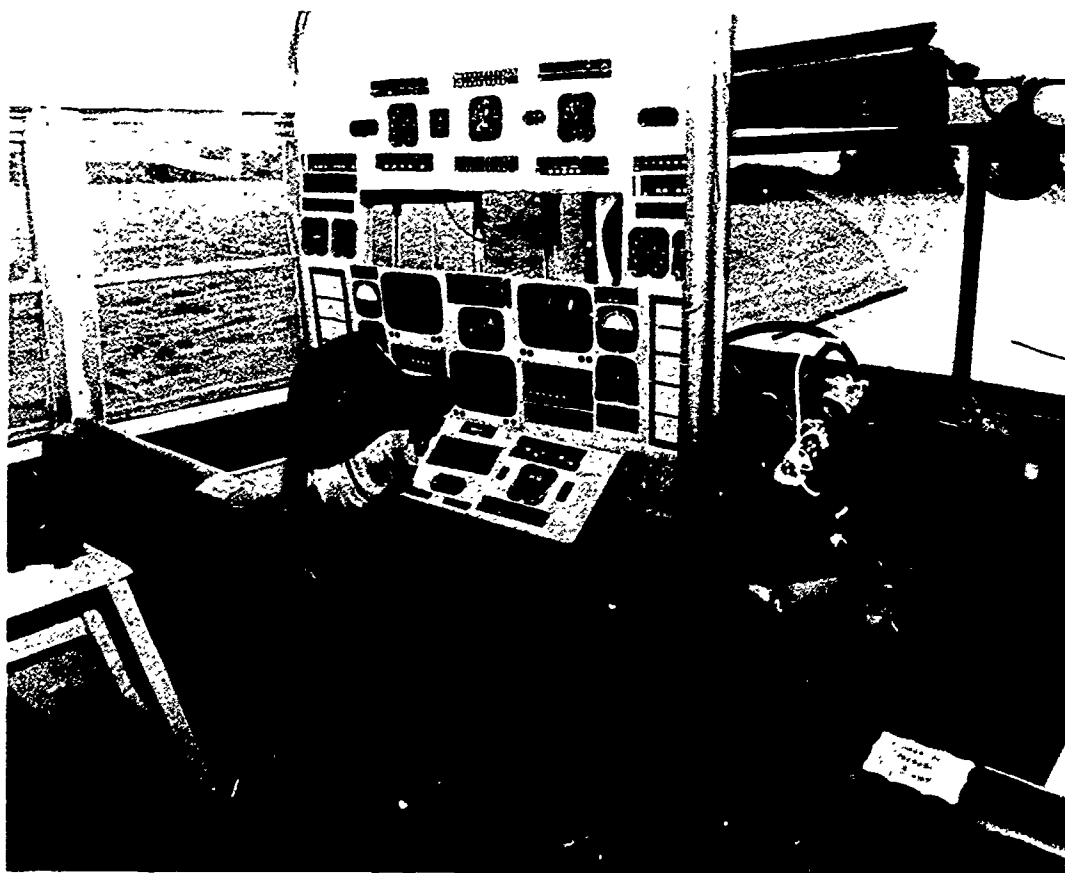

Student astronauts participate in test flight to make final flight plan.

Devise Flight Schedule

With route planning completed, the flight plan committee members use the time, mileage, and speed data gathered during test flights to devise an accurate flight schedule. The schedule should include time for rendezvous or landing activities and for any experiment stops to be made. Committee members also plan for loading and unloading, experiment deployment, greeting ceremonies, meals, debriefing, and media coverage, including a press

conference at the completion of the mission. By using the data described above, a detailed, written flight plan can be developed for use by mission control and local officials and placement in press kits. Once a final flight plan has been made, the public relations committee may want to notify the media to enable them to publicize the route.

The following pages are examples of previous mission flight plans.

U.S.S. BELDEN/MIDVIEW STARSHIP FLIGHT PLAN

May 29	7:00-9:30 p.m.	Shuttle open house; arrive for sleepover
May 30	7:30 a.m.	Wake up and suit up
	8:00 a.m.	Astronaut breakfast
	8:30 a.m.	Load payload
	9:00 a.m.	Last-minute astronaut briefing and preflight inspection; launch area cleared; spectators gather for lift-off
	9:15 a.m.	Astronauts board transfer van, ride van to shuttle, and board shuttle; countdown begins
	9:30 a.m.	Lift-off
	9:47 a.m.	Arrive Valley City Depot—satellite launch
	10:10 a.m.	Arrive at Whipp's Ledges
	10:15 a.m.	Rendezvous with Royal View shuttle; greetings, toasts, and experiments
	10:55 a.m.	Proceed to Royal View "planet"
	11:10 a.m.	Landing at Royal View; greetings and exploration of planet
	11:55 a.m.	Depart Royal View
	12:15 p.m.	Arrive Elizabeth Ann Seaton Church yard, lunch; experiments; stowing of gear, preparation for landing
	12:55 p.m.	Depart church yard
	1:15 p.m.	Land at Belden "Control"

KIDS VII FLIGHT PLAN

April 7	7:30-8:30 p.m.	Arrive at Parknoll for sleepover Astronomy activities (outside/indoors)—Mr. Bud Linderman
	8:30-9:00 p.m.	Ablutions and preparation for bed
April 8	7:00 a.m.	Wake up, wash up, and clean up
	8:00 a.m.	Flag raising, pledge, and silence
	8:10 a.m.	Astronaut breakfast
	8:35 a.m.	Experiments
	9:00 a.m.	Astronauts suit up
	9:30 a.m.	Assembly—Guest speakers: Superintendent Andrisek, Mayor Whipple, Principal Irma Bartlett, honor guard of planet flags; band
	10:30 a.m.	Astronauts enter shuttle for countdown; honor guard of flags and red carpet

10:45 a.m. Blast off—begin orbit for shuttle

10:48 a.m. Backup bus leaves for NASA (takes VHS tape)

10:50 a.m. Shuttle reaches Water St. and Columbia

11:00 a.m. Shuttle arrives I-480

11:10 a.m. Shuttle followed by bus arrives at NASA

11:15 a.m. Rendezvous at NASA; picture taking, greetings, experiments, bathroom break

11:45 a.m. Shuttle and bus leave for Fullerton and Benesch schools

11:50 a.m. Arrive I-480, proceed on I-480 to I-71; astronauts eat lunch aboard ship

12:00 m. Shuttle and bus proceed on I-71 North

12:30 p.m. Shuttle and bus proceed to I-77 South

12:40 p.m. Shuttle and bus take I-77 South to Fleet Avenue

12:42 p.m. Shuttle and bus proceed down Fleet Ave

12:45 p.m. Shuttle and bus arrive at Fullerton Elementary

12:50 p.m. Astronauts exit shuttle; greet aliens of Fullerton;
astronauts from bus enter shuttle and proceed to Benesch Elementary

12:55 p.m. Shuttle leaves for Benesch

12:58 p.m. Shuttle arrives at Benesch

1:00 p.m. Greetings and presentations—both schools

1:15 p.m. Astronauts explore alien planets and gather materials for experiments and return trip

1:30 p.m. Interaction with aliens of Fullerton and Benesch

1:45 p.m. Shuttle returns to Fullerton

1:55 p.m. Astronauts reenter shuttle and bus and bid farewell to aliens of Fullerton

2:00 p.m. Shuttle blasts off on return trip

2:05 p.m. Shuttle enters I-77 North

2:15 p.m. Shuttle and bus arrive I-71 South

2:30 p.m. Shuttle and bus arrive I-480 West

2:35 p.m. Shuttle exits I-480 at 252 South—Olmsted Falls exit

2:40 p.m. Shuttle arrives at 252 and Water St.;
astronauts disembark for experiments

3:10 p.m. Astronauts board vehicles and return to Parknoll Galaxy

3:15 p.m. Shuttle greeted by student and guest inhabitants

3:16 p.m. Astronauts exit shuttle for medical examination

3:25 p.m. Astronauts greet natives and prepare to debrief

3:30 p.m. Parknoll Galaxy dismissal

PHOENIX FLIGHT PLAN

Astronaut crew 1	Astronaut crew 2
1:00 p.m. Lunch	1:00 p.m. Lift-off
2:00 p.m. Experiments	1:15 p.m. Lunch
3:00 p.m. Exercise	1:30 p.m. Systems test
4:00 p.m. Experiments	2:15 p.m. Experiments
4:30 p.m. Math problems	4:15 p.m. Housekeeping
5:00 p.m. Exercise	4:45 p.m. Exercise
5:30 p.m. Dinner	5:00 p.m. Dinner
6:30 p.m. Experiments	6:00 p.m. Personal hygiene
7:00 p.m. Off duty	6:30 p.m. Math problems
9:00 p.m. Experiments	7:00 p.m. Off duty
10:00 p.m. Sleep	8:30 p.m. Systems check
7:00 a.m. Wake up	9:00 p.m. Exercise
7:15 a.m. Breakfast	9:45 p.m. Personal hygiene
7:30 a.m. Personal hygiene	10:15 p.m. Sleep
8:00 a.m. Experiments	7:00 a.m. Personal hygiene
9:00 a.m. Exercise	7:30 a.m. Breakfast
9:30 a.m. Experiments	8:15 a.m. Experiments
10:30 a.m. Off duty	9:00 a.m. Math problems
11:00 a.m. Exercise	9:30 a.m. Exercise
11:30 a.m. Experiments	10:00 a.m. Housekeeping
12:15 p.m. Lunch	10:30 a.m. Off duty
1:00 p.m. Landing	11:30 a.m. Lunch
1:15 p.m. Debriefing	12:15 p.m. Systems check
1:30 p.m. Telecall	1:00 p.m. Landing
	1:15 p.m. Debriefing
	1:30 p.m. Telecall

DEVISING A FLIGHT PLAN CHECKLIST

- ___ Devise flight plan early in project.
- ___ Map out possible flight routes (consider bridge clearance, weight limits, low-hanging tree branches, telephone or power lines, and road conditions).
- ___ Identify suitable midflight rendezvous sites (consider safety, environmental interest, space for experiments, parking, and media coverage).
- ___ Contact local law enforcement officials for necessary clearances and assistance (do this early). Arrange for police escort on flight day.
- ___ Complete series of test flights before making final flight plans.
- ___ Devise accurate flight schedule (include time for loading and unloading shuttle, experiment deployment, ceremonies, meals, debriefing, and media coverage).

Selecting the Astronauts

The selection and training of the student astronauts and their alternates is the responsibility of the astronaut selection and training committee. Teachers involved in the pioneer simulated shuttle missions felt that every student, regardless of grade level, should have the opportunity to be selected as an astronaut.

Devise Standardized Selection Procedure

In order to select the relatively small number of student astronauts, the committee will need to devise an equitable, standardized selection procedure. It is not necessary for the astronauts to represent only one segment of the school population. Efforts should be made to open the field for potential candidates. In previous missions astronauts were members of all grades and all academic levels and equally represented the sexes. To help promote a strong sense of involvement throughout the student body, crew selectors involved in previous missions chose at least one astronaut and one alternate from each grade level at the school. Crew size depends on the size of the school and the size of the shuttle, as well as on specific mission objectives.

Distribute Parent Consent Forms

Components of the selection criteria differed in previous missions, though there were some consistent components. (See appendix B for samples of astronaut selection forms.) In each instance a parental consent form was sent home with all students. This form provided an introductory explanation of the simulated shuttle mission project, an outline of the criteria to be used for astronaut selection, and a statement of parental consent for participation in all aspects of the mission.

Evaluate Applicants

In some instances the physical condition of the students was assessed by the physical education staff with assistance from students. Applicants were scored on endurance and dexterity. Vision and hearing were checked by the school nurse and speech therapist.

Academic achievement was based on grade averages for the school year. Grade averages required for selection differed from school to school. Working to potential was a consideration when assessing the academic achievement of a candidate. Input on social behavior and work habits was provided by the student applicants' classroom teachers. In one high school project students applying to be astronauts were administered a science exam.

The selection process may also involve an essay competition. Each astronaut candidate submits an essay explaining why he or she should be selected. Younger students might dictate their responses. All schools incorporated a personal interview as one component of the selection process.

Select Astronauts

The committee responsible for interviewing the candidates and perhaps making the selection should involve a cross section of the school and community population. Teachers, principals, superintendents, local government officials, and local businesspersons make excellent members of the interview and selection committees.

In some instances a numerical rating system was devised to determine the most-qualified candidates. Each component of the selection criteria would be rated numerically. The top applicants were selected on the basis of this numerical rating and then interviewed by an astronaut screening committee and eventually selected to be astronauts and alternates. All astronauts and alternates received the same rigorous training.



Student astronauts.

SELECTING THE ASTRONAUTS CHECKLIST

- ___ Form selection, interview, and training committees.
- ___ Determine applicant pool and standardized selection procedure.
- ___ Distribute parent consent forms.
- ___ Evaluate applicants on selection criteria.
- ___ Select astronauts and alternates.

Training the Astronauts

Assign Crew Positions

After the astronauts are selected, their crew positions are assigned. When a rating system is used, the commander is often the student having the highest overall rating and the pilot, the student having the second highest rating. In previous missions many of these positions were held by older students. Two student-teacher committees may be formed to complete the training process: the experiment-payload specialist committee, responsible for the design of experiments for the flight; and the astronaut training committee, responsible for crew training.

Train Astronauts

Because they will be responsible for keeping the shuttle and all aboard on schedule, the commander and pilot require intensive training with respect to speed, odometer reading, time, and checkpoints. The flight plan committee may provide valuable assistance in this area of training. Other astronauts should be trained in accordance with their assigned duties aboard the shuttle. (See appendix C for a sample training document.)



Astronauts receive rigorous classroom training to prepare for their mission.



Student astronaut is training in flight simulator provided by local flight school.

The following is a list of possible crew positions and duties:

Commander and pilot: As mission leaders the commander and pilot organize the crew and direct the shuttle flight route. This team is also responsible for time, mileage, and speed data records. The commander and pilot may operate computers, a portable radar gun, or other equipment to gather and record data.

Communicator: The communicator teams with an adult volunteer radio operator to maintain communication between shuttle and mission control.

Aerial technicians: The aerial technicians are responsible for launching helium balloon "satellites." In addition, these crew members may fly kite models to test the aerodynamics of varying flight structures.

Biologists: The biology team collects plant and insect specimens from any landing sites. They analyze the specimens and make scientific hypotheses regarding the landing sites. Each biology team may plant a specimen at the sister school as a gesture of friendship.

Geologists: The geology team is responsible for collecting rock and soil specimens from each landing site. Samples are analyzed and the geologists compare results from the landing sites. The geology team uses metal detectors to search for foreign or man-made metal objects.

Medical team: The medical team records the astronauts' vital signs and observes crew behavior during preflight, flight, and postflight activities. Team members, trained by the school nurse, use the onboard computer to develop a medical profile for each crew member.

Meteorologists: The meteorology team uses standard and student-made instruments to record vital weather statistics at predetermined sites during the flight. The data are recorded in a weather log.

Photographer: This mission specialist photographs all in-flight activities.

Physics engineers: This team is responsible for the execution of physics experiments related to the effects of motion aboard the shuttle. They may re-create the "Toys in Space" experiments performed on NASA Mission 51-E in March 1985, recording the effects of flight on a top, a paddleball, a gyroscope, ball and jacks, and a yo-yo. Other experiments may be devised to test the effect of a moving environment on human dexterity, liquid behavior, and mechanical manipulation.

Scientists: These mission specialists conduct various experiments during flight. The experiments are also performed at home base as a control. The results are compared upon the return of the shuttle.

Specific training may be required by the astronauts to perform the duties and responsibilities of their positions. The following are examples of resources recruited by the training committees of previous missions:

- Flight instruction schools for experience in a flight simulator
- Local airports for flight operation and airfoil structure training
- NASA Teacher Resource Centers for technological information
- Local fire departments for workshops on fire extinguishers and fire safety
- Local college science department for training and use of a programmable robot arm
- MARS (Military Affiliated Radio Systems), Air Force Association, and local radio clubs for communications training and equipment
- Local computer store for use of a portable computer

Design Uniforms and Patch

Once astronauts are selected and are in training, crew uniforms should be designed. Each astronaut's position and duties should be considered. Mission planners may also wish to design a patch representing the mission. Patches from previous missions are included as examples. (See appendix D.) Volunteers and home economics departments will be especially helpful in completing these tasks.

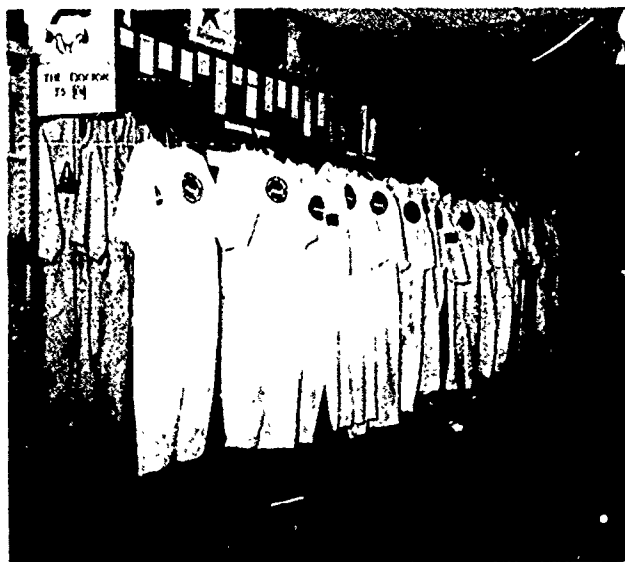

In anticipation . . . original design uniforms are ready for flight day.

TRAINING THE ASTRONAUTS CHECKLIST

- ___ Assign crew positions.
- ___ Train each astronaut to complete assigned duties.
- ___ Design crew uniforms.
- ___ Design mission patch.

Planning Payload Experiments

A space shuttle mission would be incomplete without a full schedule of experiments and test activities. Flight schedule, payload, interior shuttle construction, and crew training must be carefully planned so that these experiments can be properly performed.

Design Experiments and Activities

The design of the experiments and activities should reflect the goals and objectives of the mission. In

addition, the experiments and activities may be designed to complement what is taking place in the science classroom. The astronauts may be trained to perform a variety of experiments including biological specimen collection, geological sampling, meteorological data collection, medical data collection, aeronautics, satellite launching, environmental observation, and the effects of flight on body movement, crystal development, the motion of liquids, human dexterity, toys, and yeast growth.



Astronaut collects meteorological data.

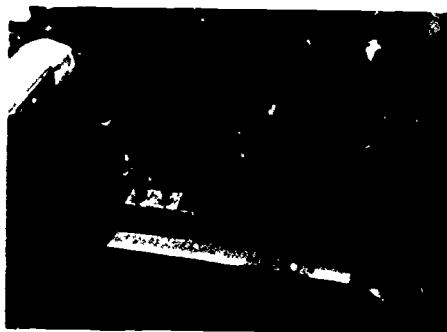

Robotic arm is used in experiment.



Mission specialists launch helium balloon.

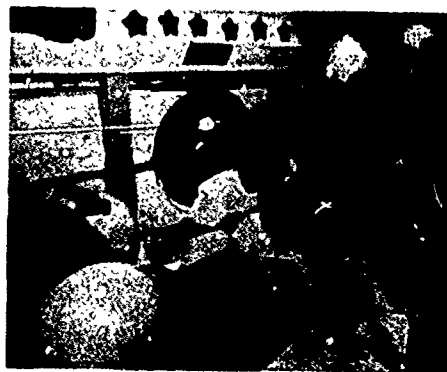

Commander and pilot record experiment data and make adjustments to flight plan on portable computer.



Mission specialists analyze water sample and record data.

Determine Schedule and Location of Experiments and Activities

The flight plan will dictate when experiments and activities can take place. Time will sometimes permit them to occur while the shuttle is enroute to a destination. Other times it may be practical for experiments or activities to take place only at designated stops. Special activities and exchanges between astronauts

at any rendezvous sites and at the partnership schools should be considered. For example, small trees or shrubs may be planted at each school as a remembrance of the event.

The following pages highlight some of the experiments used during previous simulated shuttle missions. They could be adapted to reflect the skills and abilities of the students participating.

Types of Experiments

GEOLOGY

Purpose. To provide data to compare and contrast rock environments at mission landing sites

Rock Group Classification

Materials needed: rock samples, classification pictures

Procedure:

1. Compare rock samples with the classification pictures.
2. General descriptions:
Sedimentary rocks—have a layered appearance, break easily, and feel gritty
Metamorphic rocks—are very hard; crystals are lined in layers
Igneous rocks—have a crystalline appearance, are not layered
3. Record results on record sheet.

Mineral Hardness

Materials needed: rock samples, penny, knife, glass

Procedure:

1. Use the Mohs hardness scale to determine hardness. The scale from soft to hard is

1—talc	6—feldspar
2—gypsum	7—quartz
3—calcite	8—topaz
4—fluorite	9—corundum
5—apatite	10—diamond

 - Any rock that can be scratched with a fingernail has the hardness of 1 or 2.
 - Minerals that can be scratched with a penny are 3 on the scale.
 - A knife will scratch minerals rated 4 or 5.
 - Minerals rated 6 or 7 will scratch glass
 - Number 8 on the scale will scratch quartz.
 - Number 9 will scratch topaz
 - Number 10 will cut glass.
2. Record results on record sheet.

Acid Test

Materials needed: rock samples, vinegar

Procedure:

1. Pour vinegar on each rock sample.
2. Hold the rock close to your ear and listen for fizzing. Rocks that contain calcite or lime will bubble or fizz when vinegar is poured on them.
3. Record results on record sheet.

Cleavage Test

Materials needed: rock samples, hammer, cloth

Procedure:

1. Place a cloth over the rock to contain flying chips. Hit the rock with a hammer to break it. The rock will either cleave (an easy, flat break) or fracture (split into many pieces).
2. Record results on record sheet.

Streak Sheet Test

Materials needed: samples, white porcelain tile, "Classifying Rocks" chart.

Procedure:

1. Scratch the rock over the back of the tile.
2. Identify your specimens by using the information above and the chart.
3. Record results on record sheet.

Observations: Analyze results from each test

Conclusions:

SOIL CLASSIFICATION

Purpose: To classify soil samples collected at landing sites

Soil Texture

Materials needed: soil sample, magnifying lens

Procedure:

1. Rub the soil through your fingers.
 - If the soil feels harsh and coarse grains are visible, it is classified as a *sandy soil*.
 - If moist soil (wet, if necessary) feels slippery but not really sticky, it is a *silty soil*.
 - If it is very sticky, it is a *clay soil*.
2. Record results on record sheet. Compare results from each site.

Particle Size Analysis

Materials needed: soil sample, distilled water and detergent mixture

Procedure:

1. Shake up a sample in the mixture. The mineral particles settle out at different rates: the *sand* falls to the bottom first, the *silt* next, and *clay* only after many hours.
2. Record results on record sheet. Compare results from each site.

Soil Color

Materials needed: soil sample, magnifying lens

Procedure:

1. Look at a sample under the lens.
 - If the sample is dark brown or black, soil contains much *humus*.
 - If the sample is red, soil contains *iron* that is *oxidized*.
 - If the sample is yellow, soil contains *iron* with *less oxidation*.
 - If sample is gray, chemical reduction has occurred due to lack of oxygen.
2. Record results on record sheet. Compare results from each site.

Observations: Analyze results from each test

Conclusions:

BELDEN EXPLORATION

Purpose: To explore environment of "alien planet"

Materials needed: Record sheets

Procedure: Complete sheet on interior and exterior of "alien planet."

Observations:

Building Exterior

1. Does the building show signs of weathering? Describe these signs.
2. Is there a cornerstone to tell how old the building is? How old is it?
3. Do you see any energy-saving techniques? Describe them.
4. Is the name of the school on the outside? If so, what is it?
5. What is the building made of?
6. Is there a playground? If so, what equipment is there?
7. Are there any fire escapes on the building? How many?

Describe the parking lot (location, material made of, size, shape).

Describe the surroundings (road, trees, farms, houses, flat land, hilly land).

Building Interior

Answer the following questions for all floors:

1. What grades are on each level?
2. How many children are in each classroom? Sample a certain number of classrooms.
3. What do you think each classroom is studying? Sample a certain number of classrooms.
4. What kind of materials are the floors, walls, and ceilings?
5. Describe how the rooms are different from or similar to those at your own school. (Include such things as lights, height of ceiling, chalkboards, bulletin boards, desks, etc.).
6. Are there restrooms on each floor?
7. Where is the office located?
8. Any special rooms on each level? If so, list them.
9. Are there lockers on each level?
10. Are there bulletin boards in the hallway? Describe them?
11. If possible, draw a floor plan.

Conclusions:

MECHANICAL MOVEMENT EXPERIMENT (ARMITRON ROBOT 2)

Purpose: To determine the effect of movement on an astronaut's manual dexterity. (Results used to develop techniques needed to deal with motions encountered when performing activities.)

Materials needed: Armitron robot arm, container, items to be picked up

Procedure:

1. During flight astronauts will pick up items with Armitron and place them in container.
2. Record data.
3. Compare results with those gathered from control experiment performed on ground.

Observations: Record data on chart and analyze results.

Astronaut	Time started	Time finished	Total time
-----------	--------------	---------------	------------

Conclusions:

VITAL MEDICAL STATISTICS

Purpose: To collect medical information for determining effects of flight on shuttle crew members

Materials needed: thermometer, timer, sphygmomanometer (blood pressure cuff)

Procedure:

1. Using instruments, record vital statistics of crew members at three times during mission: before flight, during flight, after flight.
2. Record results on record sheet.

Observations: Analyze results from tests.

Conclusions

ADDITIONAL EXPERIMENT: TREADMILL

Materials needed: Treadmill, sphygmomanometer (blood pressure cuff), timer

Procedure:

1. On the treadmill maintain a specified pace for 2 minutes.
2. Use instruments to measure blood pressure and pulse and record results
3. Compare results with statistics taken at start of mission.
4. Record results on record sheet.

Observations: Analyze results from tests.

Conclusions.

PHYSICS ENGINEERS' LOG

Purpose: To observe the performance of selected toys on the "shuttle"

Materials needed: top, paddle ball, slinky, ball and jacks, gyroscope, yo-yo, ball and cup

Procedure:

1. Use each toy during flight.
2. Record results on record chart.
3. Compare results with those gathered from control experiment performed on ground.

Observations: Analyze results for each toy.

Conclusions:

WEATHER EXPERIMENT

Purpose: To record weather conditions at various locations.

Materials needed: thermometer, wind speed instrument, wind direction instrument, barometer

Procedure:

1. Meteorologist measures the four weather conditions at each stopping point during flight and records results on record sheet
2. Weather conditions are measured at mission control. Results are recorded on record sheet.
3. Meteorologist gathers official weather forecast from mission control and records it on record sheet.

Observations: Analyze results from each location.

Conclusions:

EFFECT OF MOVEMENT ON JUMPING

Purpose: To determine the effect that shuttle movement has on a person jumping

Materials needed: Tape

Procedure:

1. Place a piece of tape on floor of shuttle.
2. Stand on the piece of tape and then jump up off the piece of tape.
3. Record where you land.
4. Repeat procedure at different times during flight.

Observations: Analyze results from each trial.

Conclusions:

EFFECT OF SHUTTLE MOVEMENT ON A WORM

Purpose: To determine the effect that shuttle movement has on a worm's movement

Materials needed: Glass jar, soil, sand, bits of carrot, lettuce, two worms, dark-colored paper, 2 Tbs. water

Procedure:

1. Arrange materials in glass jar.
2. Check layers and food before launch and record observations.
3. Observe jar during flight and record results
4. Observe jar after landing and record results

Observations: Analyze results

Conclusions.

ZERO GRAVITY DROP

Purpose: To determine if true weightlessness can be achieved in a free fall on Earth

Materials needed: 1-foot-long clear pipe, aluminum weight, two AA batteries, wire, one small red light bulb, one small green light bulb, nylon bushings, four equal-value springs, four long flathead screws, silicon sealant, bucket of sand

Procedure:

1. Construct capsule according to sketch
2. Place bucket of sand in target area.
3. Drop from highest available point.
4. Observe descent. Record results on record sheet
5. Repeat. Record results.

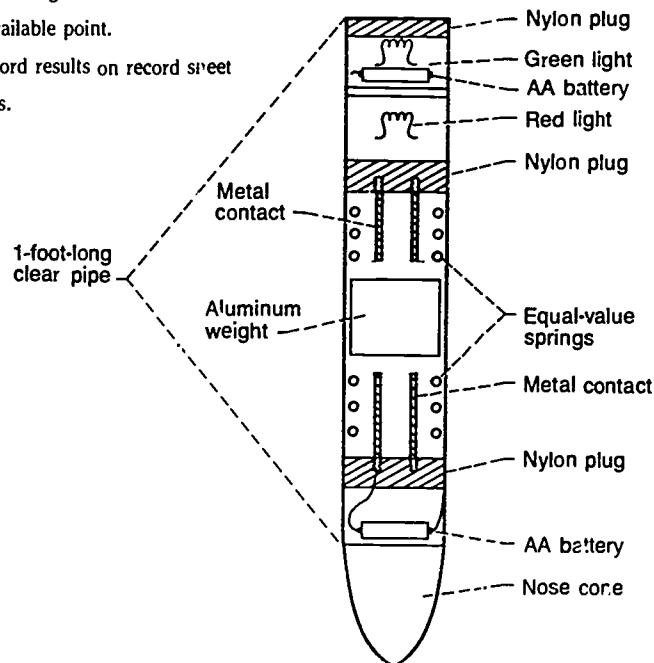

Observations: Analyze results from each drop. Consider these questions.

1. What will the difference be between weightlessness and Earth atmosphere for the liquids during descent?
2. What effect does a change in height have on the apparatus?

Conclusions:

**SIMULATED EXTRAVEHICULAR ACTIVITIES:
COMMUNICATIONS SATELLITE POSITIONING; CAPTURE AND REDEPLOYMENT
OF MALFUNCTIONING SATELLITE**

Purposes: Mission 1—to position mirrors on two “communications satellites” so that messages can be relayed by modulated laser transmission. Mission 2—to rendezvous, capture, and redeploy a “malfunctioning” satellite. To simulate an extravehicular activity (EVA) by using a wheelchair as a mobile maneuvering unit.

Materials needed: MMU (electric wheelchair), modulated laser and receiver, communications satellites with mirror-positioning devices, (one Radio Shack Armitron, one remote-controlled arm home-built using “robotics”), malfunctioning satellite (radio-controlled tank), remote-controlled capturing device (cherry picker gardening tool)

Procedure: Mission 1

1. An electric wheelchair is the MMU. The astronaut will maneuver the MMU to two communications satellites placed in courtyard.
2. Satellites consist of two wired remote-controlled mirrors. The first mirror must be remotely aimed to receive a laser beam and relay it to the next mirror. The second mirror must then be aimed back toward the shuttle and the receiving microphone.
3. When aiming is completed, the onboard crew will transmit and monitor predetermined messages by using a modulated laser and the communications satellites.
4. The astronaut will then return to the shuttle. Return aiming missions may be necessary.

Procedure: Mission 2

1. A second mission will be to intercept and retrieve a malfunctioning satellite (MS).
2. The astronaut will locate and visually track the MS and then maneuver the MMU to an intercept point in the path of the MS.
3. The MS will be retrieved by using a remote-controlled capturing device (RCCD). The MS and RCCD will be designed to interlock. The interlock needs to be done while the MMU and the MS are moving.
4. The astronaut will return to the shuttle and transfer the MS.
5. The MS will be “repaired.”
6. The repaired MS will then be launched from the shuttle. The payload specialist will direct mission control. Mission control will have actual radio control for the MS and will operate that control via instructions from the shuttle. The shuttle will have visual contact with the MS and can call out course directions.
7. The MS will be returned to proper “orbit” by the above method.

Observations: Record data on record sheet and analyze results.

Conclusions:

PLANNING PAYLOAD EXPERIMENTS CHECKLIST

- Design experiments and test activities.
- Determine schedule and location of experiments and activities.

Preparing the Building

Although much attention is directed toward shuttle preparation and astronaut selection and training, modifications of the school are necessary to enhance and support the mission. Activities at the school, during all three stages of the project, are equally important to the success of the mission. Three areas that need special attention are the space center itself, the launch and landing area, and mission control. Careful planning and preparation of these areas is important to the smooth operation of the mission.

Space Center

Each school building functions as both a "space center" for its own mission and an "alien planet" for its sister's mission. Each space center is named, and corresponding signs and flags are designed and constructed. The signs highlight the name of the space center as well as the

name of the planet. One flag flies at the space center; the other is placed at the sister school (alien planet) by the astronauts.

Identify areas: A well-equipped space center contains a press room, where the astronauts will meet the media, and a PTA-hosted hospitality room, for visitors throughout the day of the flight. A guest register book can be used to keep a record of visitors.

Decorate the space center: The decor of the space center can be enhanced with space- and mission-related student-designed bulletin boards, signs, banners, and painted murals on the windows. A large countdown calendar, listing daily activities to be accomplished, may be prominently displayed in the school. This helps inform everyone about the project and highlights the progress of the mission.

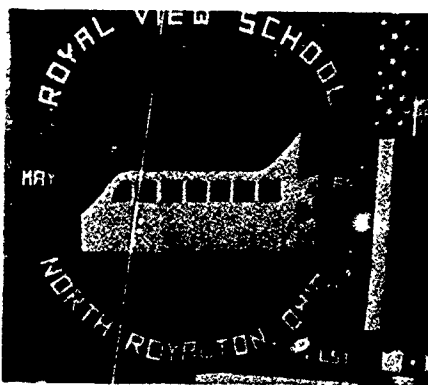

Mission flag designed by student.



Every available space was used by students to highlight the mission.

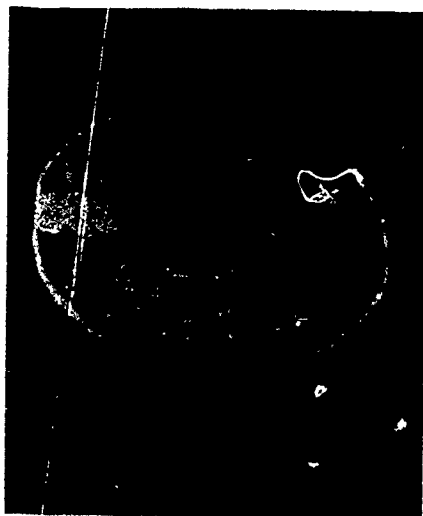

Playgrounds were decorated with larger-than-life mission patches.



Shuttle crew and medical team in front of space center decoration highlighting the shuttle and space center names.

Additional arrangements: A final consideration for the space center preparation is to arrange for additional parking and adult traffic controllers on launch day to accommodate visitors.

As an integral part of the project the space center and its preparation require creativity, time, and enthusiasm to ensure its smooth operation.

Launch and Landing

The launch and landing committee is responsible for a variety of important activities that take place throughout all stages of the mission. Initially committee members decide what is needed at the launch and landing area and where it is to be located.

Select a launch site: In choosing a suitable launch site considerations must include adequate space; viewing areas for the public, students, press, and VIP's; and consideration for the general safety and security of the area. The area immediately surrounding the launch site is designated "restricted."

Establish security procedure. To ensure safety, the following security precautions may be taken: install fences around the restricted area; use floodlights to illuminate the shuttle on the night before launch; and assign students, trained as security guards, to screen visitors, to patrol the area, and to maintain crowd control. Guardhouses constructed from refrigerator boxes can be strategically placed to secure the grounds on launch day. Students on the security team can wear armbands, caps with a special security emblem, and name tags for identification.

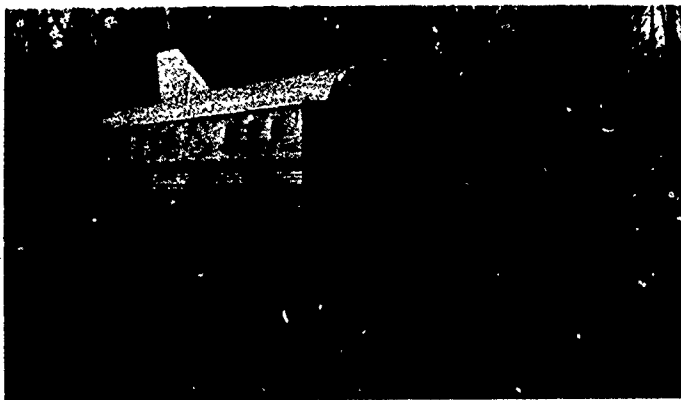

Security personnel guard a shuttle before launch.



Ground personnel provide security for visiting astronauts.

Additional preparations and responsibilities: The actual preparation of the launch and landing areas involves a number of tasks. Sign painting ("Restricted Area," "Authorized Personnel," "Welcome Astronauts," etc.), fence erection, and painting the mission emblem on the playground blacktop are all examples of activities that allow additional student participation.

Further preparations by the launch and landing committee involve operations inside the space center. The news conference room ("press room") must be set up. The mission emblem and a nameplate for each astronaut should be displayed in the press room.

Additional responsibilities of the committee are divided between launch and landing activities. Launch responsibilities include loading the shuttle with supplies; securing the vehicle and launch area; inspecting the shuttle before launch with the copilot (bus driver); escorting the astronauts to a transfer vehicle and then to the launch area; and conducting the blast-off sequence. Landing responsibilities include assisting in reentry, which involves instructions for the checking of flight systems, stowing gear, etc; securing the landing area; preparing for welcome, including a red carpet; greeting the crew; escorting debriefing personnel and astronauts; and unloading the shuttle.

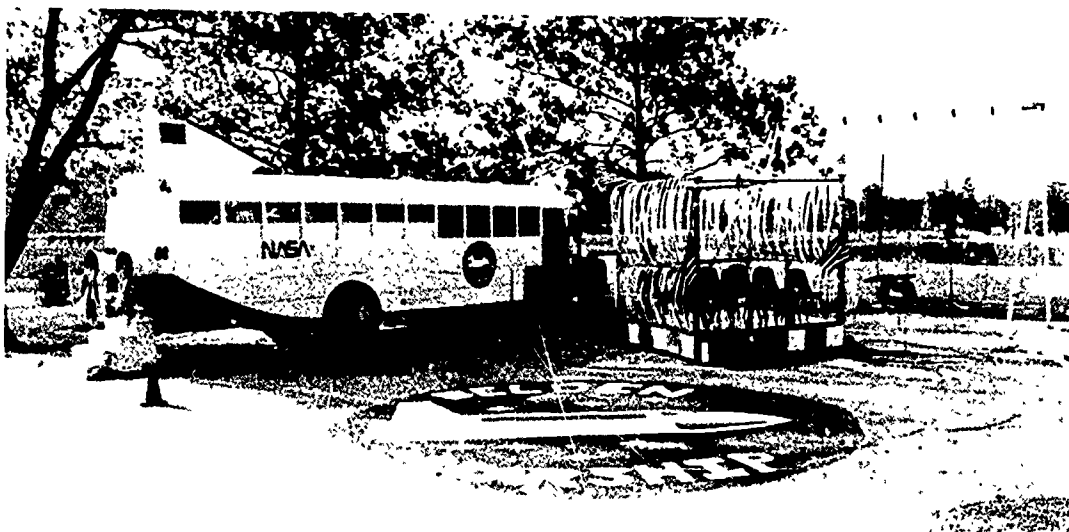

Shuttle and reviewing stand await postflight activities.



Technicians load the support and scientific equipment into waiting shuttle.

Mission Control

Mission control is the nerve center of the mission, where information is gathered and analyzed and through which all communications pass. Accessibility to the launch site and communications systems (including two-way radio, telephone, and school public address system) as well as security must be considered when choosing a site for mission control.

The mission control staff consists of students and adults working together to maintain a communications link between the crew of the shuttle and the school space center. Just as in an actual space shuttle flight, communication between shuttle and mission control is critical to the success of the mission.



High school mission control.

A clear, functional line of communication allows in-flight route and schedule adjustment, providing a degree of mission flexibility. Experiment data can be instantaneously transmitted back to mission control. Perhaps most importantly, communication between the shuttle and mission control provides an important safety measure as the staff at mission control has the capability



Mission control contains computers, radio equipment, and an electronic map for tracking shuttle.

of knowing the shuttle location and status at all times. A communications system also creates additional astronaut and mission control positions, as well as maintaining an important link between the shuttle crew and the student body remaining at the school through the school's public address system.



Lighted map permits students at space center to track shuttle.

Equip and train for communications system:

Setting up an effective communications system requires the installation of radio equipment on each shuttle involved in the mission, as well as at each mission control center. Radio equipment is expensive and complex, and its use is regulated and closely monitored by the Federal Communications Commission. Radio communication is one aspect of the mission that will require expert volunteers to set up and supervise.

Amateur radio clubs, the Military Affiliated Radio System, National Guard or Reserve units, and the Air Force Association are examples of groups that may be able to provide volunteers and equipment. Volunteers can provide specific information concerning the range and other capabilities of the available equipment (radio range will determine maximum "orbit" distance, for example), as well as requirements for power supply and installation at mission control and on the shuttle.

Training sessions with volunteer instructors can be set up to make student communications officers familiar with the equipment and the Federal regulations governing its use. On previous missions students were able to operate the equipment and talk on the air, under close supervision by licensed operators at mission control and on the shuttles. Student communicators should keep a log of all communications. (Portions of a sample log are included in appendix E.)

Contact the following organizations to help find radio resources in your area:

Amateur Radio Relay League, 224 Main St., Newington, CN 06111

Ohio DRCM, Air Force Association, 9046 Cedar Rd., Chesterland, OH 44026



Mission control personnel, supervised by amateur radio operator, keep track of shuttle during mission.

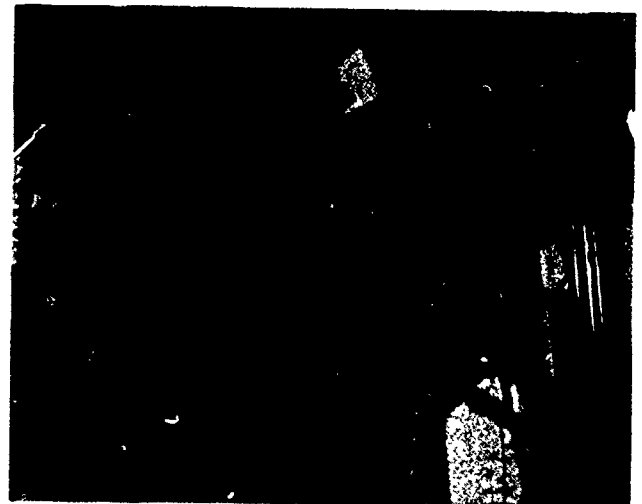

Crew members maintain radio communication throughout mission.

Equip and train for computer equipment: Another important responsibility of the mission control staff is the use of computers to provide support for the mission. Mission control personnel use computer equipment to display mission maps, flight plan information, experiment data, and shuttle instrument data, including fuel gage readings, tire pressure, and engine oil pressure. This information can be relayed from the shuttle to mission control, where student "information officers" use word processing software to write "mission updates," which are then printed and posted or read over the school public address system. Using graphics software, students can translate information into graphs for display. Examples of these graphs can be found in appendix E.



Trajectory program helps mission control keep track of shuttle's location and estimated time of arrival at next stop.

Aboard the shuttle, crew members use computers for displaying programmed flight plan data to aid navigation and for recording experiment and crew medical data. It may be possible for the computers at mission control and aboard the shuttle to be linked directly by using a "packet radio," which uses radio equipment much like a telephone modem to transmit data. Ask your volunteer radio operator if this equipment is available.

Training on use of the computer and its potential is important. This training may be provided by the classroom teacher, the computer instructor at the school or district, or by a representative of the computer store if the equipment is on loan. Proper training will facilitate computer utilization and further enhance the educational value of the mission.

On previous missions battery-powered portable computers were used in one instance and a portable generator was used to provide power to the computer in another. It may be possible for the bus maintenance personnel to connect computer equipment to the bus electrical system.



Astronaut uses portable computer and radio equipment to transmit data to mission control.

PREPARING THE BUILDING CHECKLIST

Space Center

- ___ Name space center.
- ___ Design signs and flags.
- ___ Identify areas in space center (press room, hospitality room).
- ___ Decorate space center.
- ___ Arrange for additional parking and traffic controllers for launch day.

Launch and Landing

- ___ Select launch and landing area (considerations include adequate space, safety, and security).
- ___ Establish shuttle and ground security procedures.
- ___ Establish crowd control procedures.
- ___ Prepare launch and landing area (signs, painting, construction).
- ___ Prepare press rooms.
- ___ Complete launch responsibilities (load shuttle, secure vehicle and launch area, conduct preflight inspection, escort astronauts, conduct blast-off sequence).
- ___ Complete landing responsibilities (advise astronauts to prepare for reentry, secure landing area, prepare for welcome, escort personnel, unload shuttle).

Mission Control

- ___ Select mission control site (consider access to launch site, communications access, and security).
- ___ Equip mission control.
- ___ Train for correct operation of equipment.
- ___ Keep log of all communications.

Handling Public Relations

Public relations is an essential ingredient of any project. A public relations committee made up of students and adults may be established early in the project to process requests for publicity and information. A public relations committee is necessary to document activities as they happen and to publicize this information in the school and in the community at large. It is essential to obtain signed parent release-of-information forms from all

participating students early to permit release of photographs and information to the media.

Design Public Relations Activities

The tasks of the public relations committee are numerous and diverse. An excellent starting point is to photograph each step in the project, using student photographers

whenever possible. Solicit film donations from local businesses. A systematic method to keep track of the photographs is needed to allow easy and accurate retrieval of photographs and negatives for media release and other public relations activities. A video camera crew can further document the project. Once again, use student videographers whenever possible.

A major responsibility of the public relations committee is to release information to the public about the project.

Student reporters can be assigned to interview committee members and workers and record the work in progress on the space shuttle project. These reporters, with adult guidance, can then use interview notes to write mission update bulletins for release to the media. Another way information is provided to the public, especially the media, is through the distribution of a press kit. A press kit can be prepared by using the outline provided in appendix F. Examples of a mission summary and press releases are also included in appendix F.

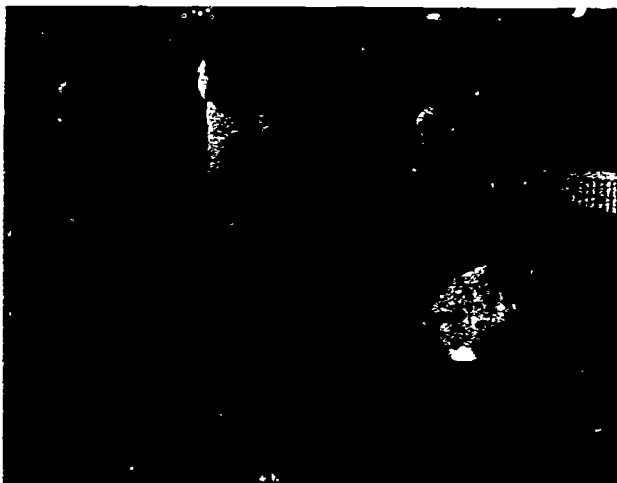

Student videographer documents experiment.



Rendezvous is recorded for posterity.



Local television reporter interviews astronaut at rendezvous site.



Rendezvous is recorded for posterity.

Plan Open House

An example of an effective public relations activity is an open house, held at the school the evening before the launch to give parents, children, and the general public the opportunity to view the shuttle. The astronauts may guide visitors through the shuttle and answer questions about equipment and experiments. Student tour guides escort visitors through the school space center.

On launch day public relations committee members are busy reporting on the mission. If your district audiovisual department has the equipment, televise the launch of the shuttle and other activities "live" throughout the day to other schools in the district. This will help spread the excitement of the project. Through the live broadcast students have an additional opportunity to practice their communications skills with on-the-spot reporting.

Design Followup Activities

The landing of the shuttle and completion of any postflight recognition activities does not necessarily mark the end of the duties of the public relations committee. There is the potential for numerous meaningful followup activities that can be coordinated by the committee.

The shuttle, astronauts, and support personnel can participate in parades sponsored by the community. This includes parades immediately following the mission, later in the school year, or during the summer. Shuttles from previous missions participated in Memorial Day, Labor Day, and summer "Hometown" parades. This participation provides an opportunity for the community to feel proud of their support for a significant educational activity.

Another way in which the shuttle can be used after the mission is completed is for tours by students at other schools. The shuttle can be on display for students to

tour and get the feel of being an astronaut. It is also possible to use the shuttle as a science laboratory on wheels. Experiments related to the flight can be performed at different locations. This experience can generate excitement in other students who were not directly involved in the initial project. It should be quite obvious that the benefits of a simulated shuttle mission go beyond the actual flight.

Quality public relations is an essential ingredient in the success of the project. In addition to providing high project visibility, the public relations effort contributes to a positive image for your school. Increased community awareness of the project may make contributions of time, materials, and funds easier to obtain as people become aware of what you are doing. Perhaps most importantly, the efforts and achievements of the public relations committee will provide many fond memories for the participants of the project as well as the community.



Local television station covers landing of shuttle for evening news.

HANDLING PUBLIC RELATIONS CHECKLIST

- ___ Establish committee to process demands for publicity and information.
- ___ Obtain signed parent release-of-information forms.
- ___ Design public relations activities to document project and disseminate information to public.
Reporters and photographers are needed.
- ___ Prepare press kit.
- ___ Plan and execute community open house.
- ___ Design followup activities.

"Living in Space"

Although elementary student astronauts will not actually live in the shuttle overnight, it is the goal of the project to attempt to simulate actual spaceflight living conditions aboard the shuttle throughout all stages of the mission.

Determine Procedure for Astronaut Sleepover

To prevent the possibility of a late-arriving astronaut delaying lift-off, a sleepover, hosted by teacher and parent volunteers, may be held at school for the shuttle crew members and other essential personnel. A sleepover also provides time for final briefing, payload preparation, and comradeship.

Plan and Implement Food Preparation

On the morning of the flight the student astronauts eat a breakfast resembling that prepared for real astronauts. Possible menus include

Pancakes	Sandwich steak
Scrambled eggs	Eggs
Bacon	Rolls
Juice and milk	Juice and milk



Astronauts eat a well-balanced breakfast the morning of launch.

Assisting in the preparation and serving of breakfast provides additional student participation opportunities. In addition, placemats, placecards, and other decorations can be designed and constructed by individuals or classrooms.

In flight the astronauts' meal is eaten on board the shuttle. A number of designs are possible for the meal trays. In one instance "space trays" were designed. Mission planners used soft drink boxes turned upside down and painted silver, with painted knobs and dials and cut to hold plastic food containers and utensils. It is important that the meal container be designed to withstand movement, as meals may be eaten enroute to a destination. Water needed to rehydrate foods can be carried in vacuum bottles. The menu for lunch can be determined by the nutrition specialist for the mission in conjunction with cafeteria personnel from the school.

Arrangements can be made for the same lunch to be served to all students, whether they are astronauts, mission control personnel, ground crew members or space center inhabitants. Eating a "space lunch" will help reinforce the sense of participation in all students.



Launch support personnel prepare and load space lunches on shuttle for in-flight meal.

Plan Waste Management Stops

Especially when the mission involves elementary age students, it is necessary to plan for "waste management" stops. When selecting a rendezvous site consider the availability of appropriate facilities.

Variations for Older Students

When a simulated shuttle mission involves older students, there are other possibilities for "living in space." In a recent mission that involved high school students a recreational vehicle became their shuttle and crew

members remained in "space" for 24 hours. Although this required some additional planning and arrangements, it posed no real problems. In addition, meal preparation can be more complex with older students. Food can be prepared onboard instead of before the launch. Spending a longer period of time aboard the shuttle enhances the experience—more realistically simulating an actual

mission. Issues resulting from confinement, experienced as the students spend an extended period of time in a relatively small area, would need to be addressed.

Whatever the arrangements, experiences should be incorporated into the mission that simulate living in space.

"LIVING IN SPACE" CHECKLIST

- Determine procedure for sleepover or night-before-launch activities.
- Plan and implement food preparation.
- Plan waste management stops.
- Adapt arrangements for age group involved.



3. FLIGHT DAY

"I felt spectacular as the countdown began for the Fantasy I blast-off."

Nehal

Conducting Preflight Inspection

The importance of safety cannot be overemphasized. On flight day a representative from the launch committee and the copilot (bus driver) are responsible for the preflight inspection of the shuttle. The general condition of the shuttle should be visually checked during a walkaround inspection, followed by a more detailed mechanical inspection. A sample outline of the inspection follows:

Cabin

1. Ignition switch—off
2. Fuel level (quantity)
3. Horn

Nose

1. Nose cone structure
2. Under hood inspection with bus driver
3. Front lights

Left side

1. Left front tire
2. Running lights

Empennage (tail section)

1. Back tires
2. Back lights
3. Rear door
4. Fins
5. Blast-off fire extinguishers

Right side

1. Right front tire
2. Running lights
3. Front door

Final preparation prior to lift-off includes the following inspections and procedures:

Before engine start

1. Preflight inspection—complete
2. Seatbelts—on
3. Radios and electrical equipment—off
4. Brakes—test and set

Starting engine

1. Launch area—CLEAR
2. Ignition switch—start engine
3. Oil pressure—check
4. Brakes—check

Before lift-off

1. Doors—closed and latched
2. Flight controls—free and correct (check steering)
3. Radios—set
4. Release brake; taxi to launch area.



Student conducts preflight inspection.

CONDUCTING PREFLIGHT INSPECTION CHECKLIST

- ___ Design inspection checklist.
- ___ Conduct preflight inspection.
- ___ Prepare for lift-off.

Writing Launch Schedule

A detailed schedule for the launch helps to ensure that lift-off will take place on time and to permit the flight plan to be executed according to schedule. The launch schedule includes specific times for all activities of the

astronauts and other significant personnel from the time of wakeup until the actual lift-off of the shuttle. Samples of launch schedules follow.

U.S.S. BELDEN/MIDVIEW STARSHIP LAUNCH SCHEDULE

- 7:30 a.m. Wakeup call—reveille (record)
Get dressed/wash up
- 8:00 a.m. Breakfast—astronauts, teachers, students, and parents who slept over
- 8:30 a.m. Launch crews load payload; astronauts suit up
Township firefighters supervise parking at fire station
Students arrive at school
- 9:00 a.m. Last minute briefing of astronauts
Launch crew 1 conducts preflight inspection of vehicle
Launch crew 2 and township firemen clear launch area
Students gather by playground bench for lift-off
Spectators gather on grassy area of playground for lift-off
- 9:15 a.m. Astronauts load transfer van at basement door
Astronauts ride by van to shuttle located in restricted area
Astronauts, bus driver, MARS personnel and video crews load shuttle
Launch crew 1 completes checklist
- 9:30 a.m. Countdown—mission control
Song
Lift-off



Astronauts suit up.



Astronauts leave transfer van and board waiting shuttle.

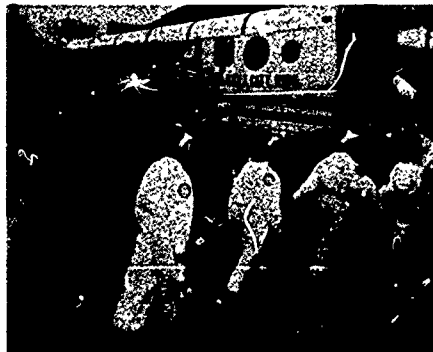

Pomp and circumstance as astronauts board shuttle.

BEE STINGER LAUNCH SCHEDULE

8:00 a.m.	Wakeup call for all Buzz Stop personnel
8:10 a.m.	Wash and dress for preflight
8:20 a.m.	Astronaut and ground crew medical check. blood pressure, pulse, temperature
8:30 a.m.	Exercise routine for all launch personnel
8:45 a.m.	Preflight briefing Buzz Stop staff
9:00 a.m.	Breakfast
9:45 a.m.	Astronauts suit up in flight gear Ground crew assemble payload on shuttle All personnel and visitors proceed to launch area (homerooms to designated areas) Lincoln West High School Band playing
9:55 a.m.	Band plays "America the Beautiful" Astronauts arrive Ground crew performs radio and computer check
10:00 a.m.	Astronauts and ground crew introduced "Star Spangled Banner" "Pledge of Allegiance"
10:08 a.m.	Remarks from local dignitaries
10:13 a.m.	Remarks from principal
10:18 a.m.	Remarks from supporters (PTA president)
10:22 a.m.	Astronauts board shuttle Ground crew go to stations
10:23 a.m.	Cheerleaders lead cheer
10:26 a.m.	Presentation by supporters
10:28 a.m.	Astronauts take positions on shuttle Security moves crowd back
10:29 a.m.	Drum roll Countdown
10:30 a.m.	Bee Stinger blast-off! Balloon release Band plays "This Land Is Our Land"



Countdown to launch.



Crowd looks on as shuttle is launched.

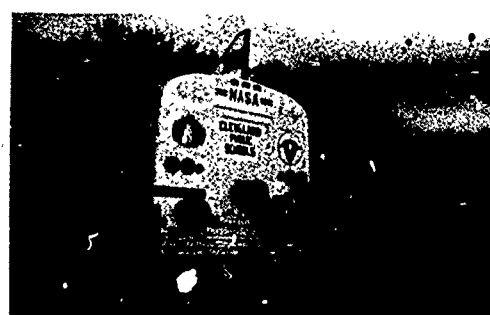

Lift-off!

WRITING LAUNCH SCHEDULE CHECKLIST

___ Write launch schedule.

Planning Space Center Activities

Activities at school space centers should be planned with the goal of making the day as exciting as possible for all students. Although only a limited number of students will be chosen to be astronauts or ground crew members, every student should be able to participate in space center activities.

In previous missions many classrooms were transformed into alien planets in new solar systems by using posters and other decorations created by students. Students constructed alien masks to wear while greeting visiting astronauts and played space games such as "Meteor Toss" (a tennis ball in a sock), "Going Through Orbit" (throwing a frisbee through a hula hoop), and "Moon-Walk Race" (crab walk). At one school students made visors silkscreened with the school emblem. A number of

schools arranged for bands from the local school district to perform on school grounds to entertain guests and later to help welcome back the astronauts.

Pioneer mission schools also held radio-controlled model airplane demonstrations, gave space center facility tours, and made presentations on aerospace careers and NASA space shuttle glider kit building.

Visits to the school from local emergency service personnel and equipment, including police, fire, and paramedic units are also possible. Mission planners at a number of schools arranged for the on-grounds landing of the local emergency helicopter ambulance. The number and variety of space center activities is limited only by the imagination of planners. Examples of space center activities follow.



Students track progress of mission on wall map at space center.



"Aliens" await landing of space shuttle.

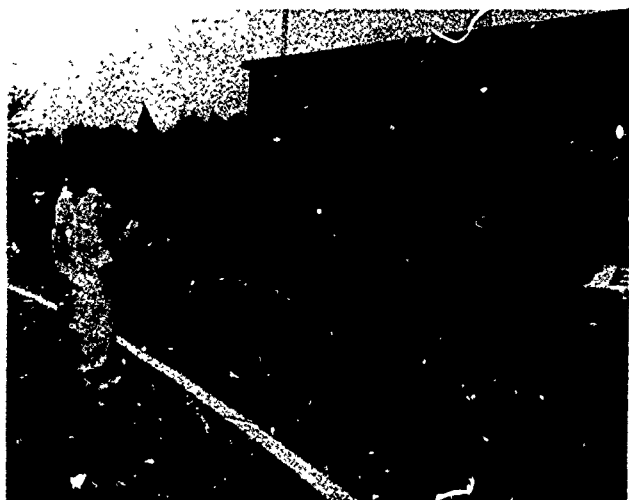

Visiting astronauts are welcomed to "alien" space center.



Shrub planted by astronauts at "alien" planet will provide a lasting remembrance of an unforgettable experience.

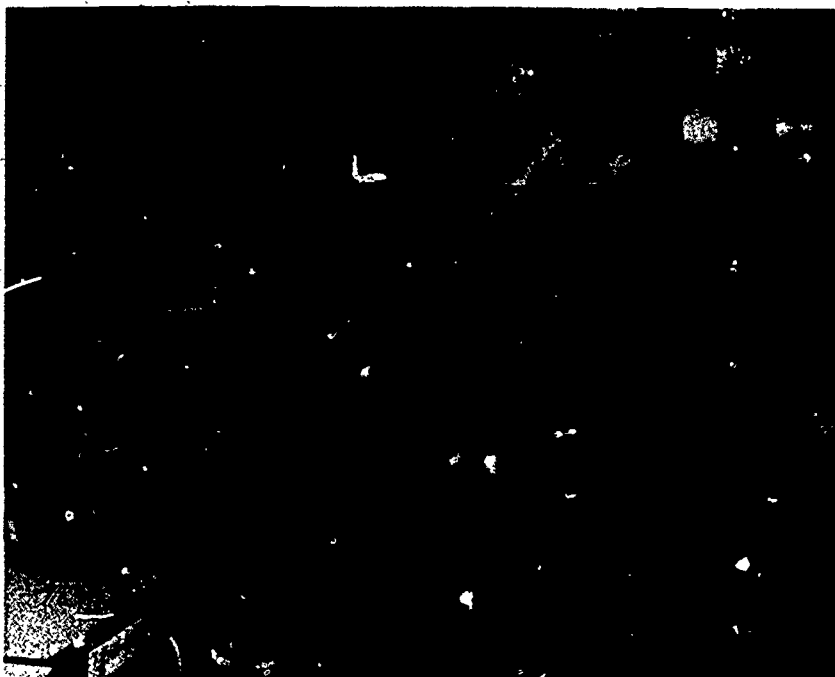

Space center activities include guest presentations on aerospace topics.

LAUNCH DAY ACTIVITIES: A.A. BENESCH

Launch day will be treated as a field day at Alfred A. Benesch. Students will be given a special schedule to follow. The activities will be space related. By the close of the day, students will have taken part in at least seven activities.

The activities that will take place on launch day are as follows:

1. Space Stories—Teacher will read an adventures-in-space story and lead a discussion of the story. Students will illustrate story.
2. Space Puzzle Worksheets—Teacher will introduce and review vocabulary that is space related. Students will work with vocabulary through crosswords and wordsearch puzzles.
3. Reading Space Worksheets—Students will read short space stories written by teachers and practice reading comprehension skills.
4. Math Fun Worksheets—Students will perform math problems at the appropriate level and solve space messages through their correct answers.
5. Careers in Space—Teacher will lead a discussion of possibilities of future careers in space. A creative writing activity will be provided.
6. Toys in Space—Teacher and students will view and experiment with several motion toys. Students will discuss the effect of zero gravity on the functioning of the toy. Videotape of "Toys in Space" will be viewed to show the actual toy in space.
7. Experiments—Teacher will lead and provide information as well as demonstrate experiments that are space related. Students will perform some of the experiments that the student astronauts will be performing on the shuttle.
8. Astronaut Training: Fitness aspect—Teacher leads discussion about the training that an astronaut goes through. Students will also perform simple exercises and learn about heart and pulse rate.
9. Astronaut Space Suits—Students will learn about the different parts and functions of the space suit. Students will create simple space suits out of brown paper bags.
10. Space Games—Students will play games related to space travel.
11. Music—Students will learn several space songs.
12. "Mighty Mouse in Space"—Videotape. Students will view various cartoon characters' adventures in space.

During the day there will also be several all-school gatherings:

1. Launching: City Kids shuttle students will gather to cheer astronauts on their journey.
2. Greeting of Shuttle from Parknoll: Preschool and kindergarten students will greet landing shuttle. Astronauts will be invited into Galaxy 1 and treated to alien dance.
3. Landing: Astronauts will be debriefed. Students will listen to prerecorded message from a NASA astronaut.

LAUNCH DAY ACTIVITIES: PARKNOLL SPACE CENTER

- 9:00 a.m. Regular activities Students arrive, attendance is taken, etc
- 9:30 a.m. Assembly—Parknoll Elementary School Band, flag bearers, astronauts Speakers include local school and community dignitaries. Special presentations
- 10:15 a.m. Parknoll students prepare to go outside for the launch
- 10:45 a.m. Launch—Red carpet treatment for blast-off at exactly 10:45 a.m., students return to homerooms
- 11:00 a.m. All students eat "space" lunch in homerooms.
- 11:20 a.m. Recess in designated areas
- 11:50 a.m. Return to homerooms
- 12:00 p.m. Greet aliens—Grade 5 students line up outside to greet aliens. All band members, flag bearers, student council members go outside.
- 12:10 p.m. Greet aliens—All Parknoll students go to the blacktop with masks, etc., to greet aliens. Red carpet treatment outside. All students then go to gym.
- 12:20 p.m. Assembly—Astronauts are interviewed and gifts presented.
- 12:45 p.m. Return to homerooms. Begin planned activities—kite making, games, puzzles, parachute time, etc.
- 1:30 p.m. Aliens leave—All students assemble outside to bid farewell to aliens. Return to homeroom.
- 1:40 p.m. Activity time—Continue activities planned
- 3:15 p.m. Parknoll Kids VII splashdown—As the Parknoll astronauts arrive all students, flag bearers, band members, etc., get in place.
- 6:30 p.m. Bus loading—Bus leaves Parknoll for recognition program
- 7:30 p.m. Recognition program

PLANNING SPACE CENTER ACTIVITIES CHECKLIST

Design activities to take place during the "flight" of the shuttle for students at the school who do not directly participate as astronauts, ground crew personnel, etc.

Scheduling Rendezvous and Stops

A midflight rendezvous with a sister school's simulated shuttle mission is an integral component of many simulated space shuttle missions. A rendezvous is an opportunity for space shuttles from participating schools to meet one another at a common location. A rendezvous can consist of as few as two schools to as many as are involved, provided that the chosen site can accommodate shuttles, crews, and spectators. In one instance in Cleveland a mission rendezvous involved 11 schools. At

the rendezvous crews from partner schools greet each other and often exchange mementos. This meeting provides an opportunity for valuable information about the flight, its payload and experiments, or the "spacecraft" to be exchanged. In addition, because youth share a common bond with each other through this unique adventure, they can readily relate their personal thoughts and feelings about their missions.

Astronauts greet one another at rendezvous site.



Astronauts exchange mementos with sister school at rendezvous site.

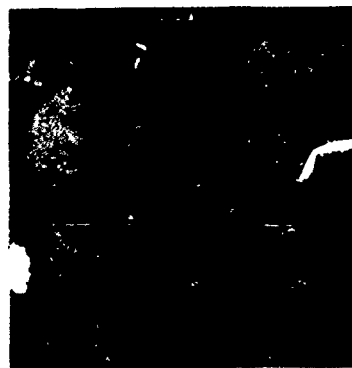

Select a Rendezvous Site

In planning for a rendezvous, select a site that provides easy access for the participants, as well as being an interesting location. Interesting could be defined as historic, prestigious, or a place that lends itself to completing mission experiments. As soon as a site for the rendezvous is selected, include it in the flight plan. In

addition, adequate parking, safety, and radio communications with mission control must be considered in choosing the rendezvous site. If the crew includes younger students, planners may wish to consider the availability of restroom facilities at the chosen site. When all these factors are accounted for and activities are well planned, the rendezvous can enhance the mission.

Solo Mission

For schools planning a mission without a partner school, another activity can have many of the same outcomes as the rendezvous. It may be possible for the shuttle to make planned stops at "alien" planets (other schools within the district or neighboring districts, for example). These stops would offer the astronauts a chance to meet other students, present mementos, and complete experiments. The same criteria of interesting location,

adequate parking, safety, and ability to remain in radio communication apply at the "alien" planets.

The inclusion of a rendezvous or other planned stops as part of a mission is an individual school decision. It is important that this decision be consistent with the overall goals and objectives of the mission. If the decision to proceed with a rendezvous or other stop is made, adequate time for planning is necessary to ensure that it is a successful component of the mission.



Astronauts assemble in front of their docked shuttles.



SCHEDULING RENDEZVOUS AND STOPS CHECKLIST

- Select a rendezvous site that offers easy access and interest and meets the other requirements for parking, safety, and radio communications.
- Plan the activities of the rendezvous in detail.
- Plan alternative activity if mission is solo.



4. POSTFLIGHT ACTIVITIES

"I'm glad this happened to our school and I will remember this for the rest of my life."

Lisa

Debriefing, Press Conference, and School and Community Activities

Mission activities need not end with the landing of the shuttle at the school space center. It is possible for the entire student body to join parents and community spectators and form an enthusiastic welcoming entourage

for the returning shuttle. This welcome home may include local officials, a marching band performing patriotic music, and "red carpet treatment" as the astronauts disembark and enter the school space center.



Space center personnel await landing of space shuttle.



Commander and crew return triumphantly from mission.

Arrange Debriefing and Press Conference

Upon completion of an actual NASA space shuttle mission, crew members attend a debriefing session with mission planners to discuss the flight and answer questions about the various components of the mission. The debriefing session can be an important simulated shuttle mission activity as well and should be included in your plan. The debriefing session would be held at the school space center, possibly before students actually disembark from the shuttle. Conducted by an official dignitary or a team of student and adult interviewers, the debriefing provides an opportunity for the student crew members to share their observations of the mission and adds another level of realism to the day's activities. If this session is declared "classified" and therefore closed to the media, the student astronauts will also be able to meet briefly with faculty planners to prepare for a press conference held for the local media, assembled through the efforts of the public relations committee. Student security personnel can be used to maintain "order" during these sessions.

The following are examples of topics for the debriefing session and the press conference questions posed to the commander and crew:

1. The commander is asked to comment on the success of the mission.

2. The crew is asked to comment on the completion of the flight plan.
3. Details are requested if plan was not completed.
4. Student astronauts are asked about the success and results of the experiments completed.
5. The details of any course or schedule adjustments completed in-flight are requested
6. Comments about observations made at rendezvous and landing sites are requested.



Crew members attend debriefing session immediately following landing.

Arrange for Followup Activities

Additional postflight activities may include an assembly at the school where the astronauts and other student participants are asked to talk briefly about the mission. After previous missions students received congratulatory telephone calls from NASA officials at these assemblies. These calls were taken over speaker phones set up especially for this purpose. Although it may not be possible to contact NASA for these calls, local or state officials should be available, as well as the NASA space ambassadors from your state. If it is not possible to install a speaker phone, messages may be prerecorded and

replayed on a tape machine. The school assembly also offers an opportunity for enhancing school pride. It provides a chance for the whole school to pat itself on the back for a "job well done."

Mission planners, with the assistance of the public relations committee, may arrange for a community parade in which the astronauts ride in cars or the shuttle itself. Astronauts may be able to visit other local schools, where students then have the opportunity to inspect the shuttle and question the astronauts. Other activities designed to "keep the dream alive" are encouraged.



Commander speaks to the crowd after a successful mission.



Festivities take place at home school after shuttle landing.



Enthusiastic crowds greet returning astronauts.

DEBRIEFING, PRESS CONFERENCE, AND SCHOOL AND COMMUNITY ACTIVITIES CHECKLIST

- ___ Arrange for and conduct official debriefing session.
- ___ Arrange for and conduct press conference to meet media representatives.
- ___ Arrange followup activities with school and community.

Recognition Program

The successful completion of a simulated shuttle mission will require an extraordinary effort by faculty, staff, students, and community volunteers. It is an accomplishment worthy of a special program to highlight the day's activities and provides an opportunity to recognize and reward all of the mission participants and supporters.

Schedule Evening Program

By scheduling an evening program planners make it possible for working parents, civic leaders, and community supporters to participate. Encourage local officials to attend and invite them to speak, offering congratulations to all mission participants. Student astronauts and key mission personnel may be introduced and asked to briefly present their reactions to the mission. Volunteers and representatives of organizations that provided resources should be introduced as well; it may be possible to present certificates or other awards to

them at this time. An objective of the evening recognition program is to acknowledge the contributions of as many people as possible.

Provide Opportunity for Student Participation

A recognition program may also provide an opportunity for the participation of additional students. Through the presentation of student songs or skits, feelings and thoughts about the mission can be conveyed. In addition, it may be possible to present videotape footage shot by student videographers. At programs held after previous missions, video highlights proved very popular, eliciting cheers and applause from students and adults.

The content and format of the recognition program should be designed to meet your individual needs. The important component is that it provide the appropriate finale to a very exciting and successful day.

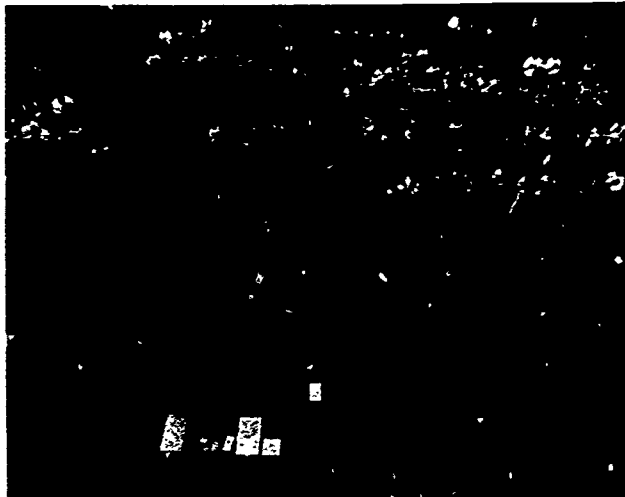

Evening recognition program.



Astronauts perform at evening recognition program.

RECOGNITION PROGRAM CHECKLIST

- Schedule an evening recognition program.
- Provide opportunity for student participation in the program.

Letters of Commendation

Letters of commendation or congratulatory messages were received by each of the schools following the simulated shuttle mission from significant persons in its school district and community. Arranging for these letters or congratulatory messages requires considerable followup after the initial request is made. Examples of persons

from whom you might want to request letters of commendation or congratulatory messages include, but are not limited to the school superintendent; the mayor; state senators and representatives; and other prominent city or state officials. Copies of sample letters received following the 1985 and 1987 missions are included here.

THE WHITE HOUSE
WASHINGTON

March 31, 1987

I am pleased to send congratulations to all of the young people who participated in the 1987 Cleveland Area Simulated Shuttle Mission in conjunction with the NASA Lewis Research Center. Each of you can take pride in the part you have played in the completion of this innovative and worthwhile project.

The education of America's young people is vital to our continued progress in the space sciences. The members of this mission, from the "astronauts" and "flight controllers" to the designers of its experiment packages and logo, have had a unique opportunity to see firsthand the detailed planning and teamwork successful space exploration requires. I am sure you've found that it's hard work, but that it's also exciting and rewarding. The infinite reaches of space have always made us dream of discovery and adventure, and some of you may find your own dreams leading you on to careers in space.

This year we mark completion of the third decade of space exploration. In those 30 short years, mankind has received images from the outer reaches of the solar system, sampled the climate of Mars, learned new and unimagined facts about our own planet, and landed men on the Moon. In the next three decades, you, America's young people, will carry these achievements on to new heights. The future belongs to the bold and the brave. America is counting on you, and if your work on this mission is any indication, we can look to the future with confidence and hope.

Congratulations, again, to all of you and to the fine people from NASA who conceived this project and saw it through to touchdown. God bless you.

Ronald Reagan



RICHARD F. CELESTE
GOVERNOR

STATE OF OHIO
OFFICE OF THE GOVERNOR

COLUMBUS 43266-0601

March 18, 1987

To: The Participants of the 1987 Cleveland Area Simulated Shuttle Mission

As Governor of the great State of Ohio, I welcome the opportunity on this special occasion to congratulate each of you on your participation in the 1987 Cleveland Area Simulated Shuttle Mission. The impressive cooperation between Lewis Research Center, nine elementary schools, two high schools, staff members, parents, community friends, and approximately five thousand students resulted in an outstanding and exciting educational experience.

I am very proud of the citizens of this state--especially Ohio's students. I urge you to continue your pursuit of knowledge and academic excellence. It is a process that must be ongoing for our nation to advance economically and scientifically. We recognize that many of the state's future leaders are currently students meeting challenges in Ohio's classrooms.

Congratulations on planning, training for, and conducting the successful Shuttle Mission. By serving as astronauts, flight planners or controllers, builders, testers, designers, security office and public relations personnel, you had a unique opportunity to experience extraordinary effort and the tremendous teamwork required to launch successful space flight. I heartily congratulate you for your interest and efforts in the area of aeronautical and space education.

Sincerely,

Richard F. Celeste
Governor

RFC/1a

WILLIAM V. ROTH, JR., DELAWARE, CHAIRMAN
TED STEVENS, ALASKA
CHARLES MCC. MATHIAS, JR., MARYLAND
WILLIAM S. COHEN, MAINE
DAVID DURENBERGER, MINNESOTA
WARREN B. RUDDMAN, NEW HAMPSHIRE
THAD COCHRAN, MISSISSIPPI
THOMAS F. EAGLETON, MISSOURI
LAWTON CHILES, FLORIDA
SAS? NUNN, GEORGIA
JOHN GLENN, OHIO
CARL LEVIN, MICHIGAN
ALBERT GOR, JR., TENNESSEE

JOHN M. DUNCAN, STAFF DIRECTOR
MARGARET P. CRENSHAW, MINORITY STAFF DIRECTOR

United States Senate

COMMITTEE ON
GOVERNMENTAL AFFAIRS

WASHINGTON, DC 20510

May 20, 1985

Mr. L. Jack Thomas
Superintendent
North Royalton City Schools
6579 Royalton Road
North Royalton, Ohio 44133

Dear Mr. Thomas:

Although I will be unable to participate in the Royal View/Belden Elementary schools simulated space shuttle launch, I would appreciate if you would share my thoughts with your students.

Man's exploration of outer space is the greatest human adventure of the 20th century -- perhaps of all time. Being able to participate in America's space program was one of the greatest honors and thrills of my life.

I encourage each of you to continue in your quest for a spirit of discovery. We cannot permit ourselves to fall behind other nations in the pursuit of scientific discoveries that can add so much to the well being of Americans and all of humanity. If America is to keep pace with the changing times, we must start producing more scientists, engineers and other highly skilled people to meet the challenges of the future.

I commend all of those participating in this innovative exercise in learning. If I can be of any assistance in the future, please do not hesitate to contact me.

Best regards.

Sincerely,

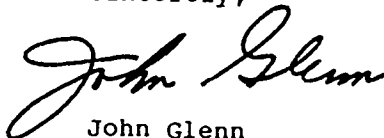

John Glenn
United States Senator

JG:rg

Howard M. Metzenbaum
Ohio

United States Senate
Washington, D. C.

May 30, 1985

Fantasy I
C/O Jefferey Lampert,
Commander In Chief
Royal View School
North Royalton, Ohio

Dear Friends:

Welcome Home All! My congratulations to all the students and teachers of Belden and Royal View Schools on your excellent mission. This was a difficult and ambitious program that could only have been brought off with large amounts of creativity, ingenuity and hard work.

You have not only explored new horizons in space, you have opened up vast new horizons here on earth. American education has taken a giant leap forward with your successful completion of this mission. We are all very proud of you.

Best regards,

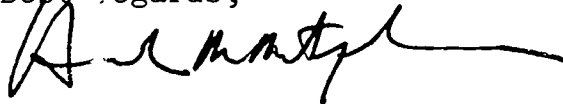

Howard M. Metzenbaum
United States Senator

HMM:clk



National Aeronautics and
Space Administration
Washington D C
20546
Office of the Administrator

Dear Students:

Although I cannot be with you on the occasion of your Post Flight Recognition Program on April 8, I want to congratulate each of you who participates in the 1987 Cleveland Area Simulated Mission.

I am pleased to know about your program and I support the endeavor to stimulate student interest and activities in the study of science and engineering. Our students of today must be bold and imaginative in their pursuit of careers and particularly in science and technology. I challenge each of you to continue the good work with a goal toward lifelong learning to accommodate increased competition in an ever changing society.

Best wishes to each of you.

Sincerely,

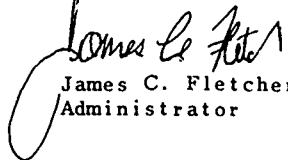

James C. Fletcher
Administrator

National Aeronautics and
Space Administration
Lewis Research Center
Cleveland Ohio
44135



March 18, 1987

Dear Mission Participants:

On behalf of the entire Lewis Research Center staff, I extend congratulations to all of the students, school personnel, parents, and volunteers whose time and effort contributed to the success of the '87 Greater Cleveland Simulated Mission. Your efforts serve to demonstrate the exciting educational possibilities that exist when committed individuals throughout a community work together.

The NASA Lewis Research Center is proud and pleased to be a part of this educational endeavor. Projects like the Simulated Shuttle Mission are important to all of us because of their impact on our most important national resource, our children. Today's "astronauts" are tomorrow's leaders, and activities like this mission help prepare them for that role.

Sincerely,



John M. Klineberg
Acting Director



5. FURTHER SUGGESTIONS

"I changed a lot after that day. I hope to be an astronaut when I grow up. I hope many other schools and kids get to enjoy that experience that I was so lucky to have."

Juliann

Faculty and staff from schools completing successful simulated shuttle missions submitted the following suggestions for future mission planners:

- Consider carefully the time of year in relation to academics as well as to the weather in your area.
- Select a core group to establish an outline of the program. Develop a time line early in the school year to provide time for long-range planning and implementation.
- Communication and cooperation are vital to a project of this nature. Keep notes. Update parents and community regularly to keep everyone involved.
- School personnel must make a commitment to the total program.
- Emphasize *all* student contributions to the project rather than focusing only on the astronauts. Make the experience enjoyable as well as educational for *all* students.
- Use imagination and creativity. This project can touch all areas of the curriculum.
- Community resources should be used to the fullest extent. Follow up on promises for assistance with a letter confirming the details and time line.
- Raise money for the project before beginning. If possible, actually budget for it.
- Public relations and demands for detailed information can be handled by the development of a press kit.
- Keep the project flexible. Think of alternatives. Working with another school or schools is an asset, but certainly not a requirement.
- Release time should be built into the teachers' schedules. Arrange for the board of education to make an amount of professional leave available to teachers in the core group and to committee chairpersons.
- A uniform parent permission slip that permits release of information to the media for publication should be filled out early in the project for all participants.

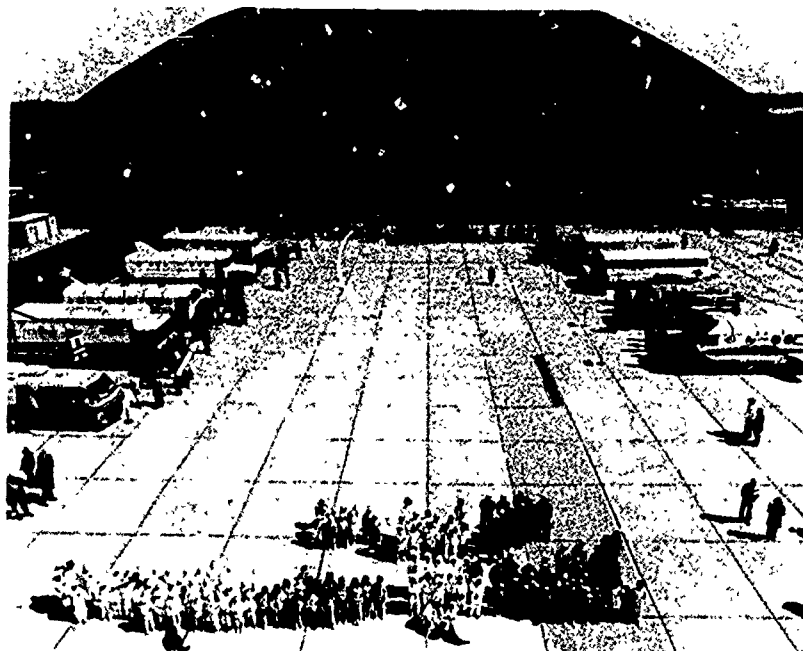

SIMULATED SHUTTLE MISSION



6. APPENDIXES

"You will find out anything is possible. Such as making our dreams come true. Iowa Maple reached for the stars and caught them."

Heather

Appendix A

Simulated Shuttle Mission School Participants

1985	
School	Shuttle Name
Belden Elementary School Midview Local Schools Grafton, Ohio	U.S.S. Belden- Midview Starship
Royal View Elementary School North Royalton City Schools North Royalton, Ohio	Fantasy I
1987	
School	Shuttle Name
Alfred E. Benesch Elementary School Cleveland Public Schools Cleveland, Ohio	Galaxy I City Kids
Daniel C. Morgan Elementary School Cleveland Public Schools Cleveland, Ohio	Morgan Express
Fullerton Elementary School Cleveland Public Schools Cleveland, Ohio	Cosmic Connection
Iowa Maple Elementary School Cleveland Public Schools Cleveland, Ohio	Victory II
Walton Elementary School Cleveland Public Schools Cleveland, Ohio	Bee Stinger
Helen Muraski Elementary School Strongsville City Schools Strongsville, Ohio	Muraski Conqueror
Lowell Academy Lorain City Schools Lorain, Ohio	Leopard Express
Parknoll Elementary School Berea City Schools Berea Ohio	Kids VII
Pine Elementary School North Olmsted City Schools North Olmsted, Ohio	Lunar Limo
St. Vincent-St. Mary High School Akron, Ohio	Phoenix
Walsh Jesuit High School Stow, Ohio	Phoenix

Appendix B

Astronaut Selection Forms and Letters

St. Vincent-St. Mary High School—Walsh Jesuit High School

SPACE SHUTTLE SIMULATION PROJECT

Please read the following description of the environment in the space shuttle and write two pages describing what kind of special project you would like to conduct while on the simulation. This project should demonstrate originality and creativity. Please include the objective, the research background, a description of the procedure that has been adapted to be performed in space, a sketch of the setup, and questions that will be answered by performing the experiment.

Past projects proposed by students for the SkyLab are on closed reserve in the school LRC. Other suggested references are listed below. Proposed projects should not require any time of other crew members, as they will have their own mission responsibilities during the flight. Experimentation should not require extreme equipment in size or weight or caustic chemicals. No experiments should involve extravehicular activities (space walks). The advisors of the SSS reserve the right to alter parts of the proposed project. All projects should be workable during the SSS and should simulate as closely as possible the special conditions present onboard an actual shuttle.

Space Shuttle Description

The space shuttle has been designed to support an extensive range of operations that make use of one of the special properties of space - weightlessness. In the weightless environment it is necessary to restrain oneself in order to work. Managing equipment or tools in space requires procedures that are drastically opposed to managing such activities on Earth. Moving things around is easy, but keeping them in a particular location is not!

Suggested References

Information for Teachers/SkyLab Student Project - in LRC on closed reserve, copies can be purchased.

SkyLab Guidebook - in LRC on closed reserve - copies of individual pages can be purchased. Guidebook contains brief descriptions of SkyLab student projects and detailed descriptions of SkyLab program, missions, and equipment

First to Fly: Moulton, Robert, Lerner Publications, Mpls, 1983. The story of the high school student experiment to fly on the space shuttle Colt in 1982.

Entering Space: An Astronaut's Odyssey: Allen, Stewart, Tabor, and Chang. New York, 1984. The most recent account of travel aboard the space shuttle written from the perspective of an astronaut.

Please check with the school LRC specialist for other available books on the space shuttle SkyLab.

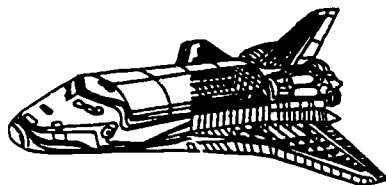

Selection Criteria

Selection of the students (four from each high school) will be based on the following standards. Each school will select at least one freshman or sophomore to represent their team.

1. Recommendations of one teacher and one community member (adult) not associated with the school
2. Ability to pass adequately a general math and science test
3. Satisfactory approval of present teaching staff based on a checklist
4. Ability to successfully undergo an interview and general physical fitness test

All applicants will be judged by a team of teachers from both schools involved. Applications will be evaluated on the following criteria:

1. Creativity and originality - as shown in the essays as well as the project
2. Communication skills - both written and oral formats of the application mechanism
3. Academic background - as shown in the student's dedication to learning
4. Commitment to space research - student shows and shares his/her enthusiasm for the future possibilities of space research and travel.

Student Responsibilities

The primary role of the SSS is to show the present students' future commitment to space. Each participant will be expected to follow the prescribed space mission. Only experiments designed for the simulation may be performed during the simulation.

Each student astronaut is representing many students that applied. For this reason each student will be asked to be available for assemblies and lectures before and after the simulation. At this time questions that were answered in your experiment should be explained by participants. Each student should be willing to help publicize any space shuttle activities to promote the simulation in the future. All participants will be subject to the authority of the administrators and advisors of the schools involved in the activity.

- | | |
|--------------------------|--|
| 5 December | Preliminary application form DEADLINE; essays due to the science department heads |
| 9 December | Announcement of semifinalists |
| 11 December | Test for semifinalists in general mathematics and science |
| 16 December | Endurance/physical fitness tests |
| 5 January | Announcement of command center officials and four astronaut finalists from each school |
| 17 January
(Saturday) | Space shuttle made and outfitted |
| 20-22 January | Training for the four astronauts |
| 23-24 January | Space shuttle flight simulation (24 hours) |

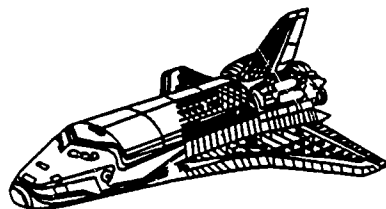

Space Shuttle Special Project
Description

Why would you want to be a United States astronaut?
Express your feelings about the future of space exploration.

Community Member Recommendation

_____ is applying to participate in the St. Vincent-St. Mary/Walsh Jesuit STUDENT SPACE SIMULATION. The student selected will represent his/her school onboard a 24-hour planned simulation of a space shuttle flight. Please comment in particular on the applicant's ability to communicate effectively, creativity, learning ability, and involvement in school/community activities. Does this applicant have the ability to be a team member?

Please type this form, single spaced. It must not exceed the space provided. When completed please return to the applicant.

Thank you for taking the time to complete this form.

Signature of Reference _____
Name of Reference _____
Title/Subject of Reference _____
Address _____
Telephone _____
Date _____

Daniel E. Morgan Elementary School

ASTRONAUT SELECTION PARENT LETTER

Dear Parents:

This is to inform you that your child has chosen to compete in our search for the astronauts for the Morgan Express Simulated Space Shuttle Program. This is a very special project that the Daniel E. Morgan School is participating in with the NASA Lewis Research Center. We will be transforming a standard school bus into a model space shuttle that, in reality, will NOT leave the ground. It will be driven by a school bus driver and will be supervised by a Daniel E. Morgan teacher at all times.

In order for your child to qualify for further consideration, the attached application must be signed and returned by March 4, 1987. You and your child must sign the bottom of the astronaut pledge. Below is a list of the required qualifications:

1. An average of C or better
2. All citizenship grades S or better
3. The recommendations of three teachers from Daniel E. Morgan

Please remember that many students will be applying for a seat on our shuttle, and only a few can be selected. All children at the Daniel E. Morgan school will take an active part in our shuttle program whether or not they are selected as astronauts.

Sincerely,

The Simulated Space Shuttle Committee

ASTRONAUT PLEDGE

If selected as a Morganaut, I pledge that I will do my best to make Daniel E. Morgan and his students, principal, teachers, and staff proud that I am representing them on this important mission.

I will take my training very seriously, will learn my individual duties, and will learn to work as a team member. The success of our shuttle mission depends on these three things.

Candidate's Signature

I give my child, if selected, permission to be an astronaut on the Morgan Express.

I give my child permission to be photographed and or interviewed by anyone, including the press.

Parent's Signature

TEACHER RECOMMENDATIONS

Three teachers must sign below in order for your application to be valid. One teacher must be your homeroom teacher; one must be any teacher you take special classes with (music, gym, library etc.). In order for any teacher to sign, they must feel you are qualified to be an astronaut on the Morgan Express simulated space shuttle.

Homeroom Teacher

Special Class Teacher

Any Teacher

Belden Elementary School

April 22, 1985

Dear Parents,

Belden Elementary School in cooperation with Royal View School (North Royalton) and NASA will be staging a simulated shuttle launch on May 29, 1985. This will include all of the activities associated with preflight/flight/and postflight of a space shuttle experience. All of the students at Belden will participate in some aspect of this space shuttle activity. Additionally, fourteen students will be selected as astronauts or backup astronauts. These astronauts will be selected by a screening committee. The following is a brief outline of the criteria that will be used for selection of the astronauts:

- I Physical requirements
 - A. Vision
 - B. Hearing
 - C. Dexterity
 - D. Weight
 - E. Endurance

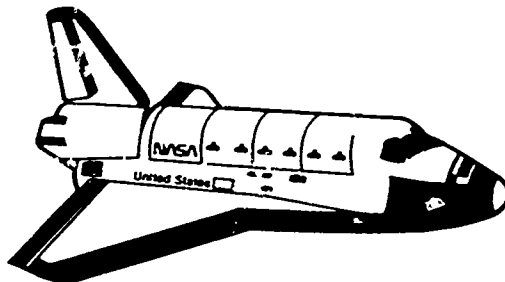

- II Background information
- III Academic skills
- IV Communication skills
- V Social skills and citizenship
- VI Personal - a paragraph or two explaining why this child feels that he or she should be picked as an astronaut
- VII Interview - prospective astronauts will be interviewed by the screening committee
- VIII References - child will supply the names and phone numbers of two people, not relatives or teachers, who know the child well, such as a troop leader, minister, or 4-H advisor
- IX Parental consent

Please fill in the following form and return by tomorrow, Tuesday, April 23, 1985.

Sincerely,
Belden Staff

*****cut*****cut*****cut*****cut*****cut*****cut*****

REFERENCES

1. _____
 name position address phone #

2. _____
 name position address phone #

PARENTAL CONSENT

I understand that if my child is selected as an astronaut for the simulated space shuttle launch, he or she will be traveling by school bus from Belden to Royal View School in North Royalton and back again. I hereby give my permission for _____ to take this trip if he/she is selected as an astronaut.

(parent's signature)

72

PERSONAL INTERVIEW FOR ASTRONAUT CANDIDATES

NAME _____

GRADE _____

DATE _____

4 3 2 1 0

Eye Contact					
English Grammar					
Enunciation - Clarity					
Ability to Express Oneself					
Appearance					
Mannerisms					

- 4 - Excellent
- 3 - Very Good
- 2 - Good
- 1 - Average
- 0 - Below Average

1. Why do you want to be an astronaut?
2. What is an astronaut?
3. What do you think an astronaut does?
4. What would you do if a friend dared you to do something you knew was wrong?
5. Who do you admire? Why?
6. What do you do when things don't go your way?
7. If you saw a friend cheating or stealing, what would you do?
8. If you had the power to change one thing in the world, what would you change?



Total

Average (divide by 14)

Fullerton Elementary School

Astronaut Training Program Application

Name _____
Address _____
City _____ State & Zip _____
Parent or Guardian _____
Home Phone _____ Emergency _____

Part I - Academic Evaluation

Grade-level performance required in reading, mathematics, and science with satisfactory performance in study habits. Attach transcript.

Essay

On a separate page, in 150 words or less, tell why you want to be an astronaut. Include what you expect to learn and how you will use that knowledge to benefit others.

Part II - Teacher Section

Would you recommend this child for the astronaut training program?

_____ Yes _____ No

(If you answered "yes," please complete this form.)

1 - lowest 10 - highest

Indicate applicant's rating

Trustworthy _____

Dependable _____

Cooperative _____

What are the applicant's greatest strengths?

Socially _____

Academically _____

Appendix C

Astronaut Training Documents

WEIGHTLESSNESS TRAINING - UNDERWATER TRAINING:

EXPERIMENT DESCRIPTIONS

- A. SPACESHIP NAVIGATION - LARGE RUBBER INNER TUBE WAS OUTFITTED WITH A SMALL MOTOR. STUDENTS SAT ON WOODEN FLOOR AND NAVIGATED BETWEEN WEIGHTED PLASTIC CONTAINERS.
- B. SPACE CONSTRUCTION - STUDENTS WITH THE AID OF SCUBA DIVERS PLACED A SERIES OF PVC PIPES TOGETHER TO FORM A WORKBENCH-STYLE APPARATUS BELOW WATER. STUDENTS WERE USING SNORKELING MASKS. STUDENTS WERE ALSO ASKED TO HAMMER BELOW WATER.
- C. COORDINATION - STUDENTS WERE ASKED TO PLACE SMALL, DIFFERENT-SHAPED OBJECTS IN A BABY TOY BELOW WATER. THE APPARATUS COULD NOT BE HELD.
- D. TORQUES - STUDENTS WERE ASKED TO SUSPEND THEMSELVES IN THE DEEP END OF THE POOL AND TRY TO TURN TWO DIFFERENT LENGTHS OF OPEN-END PVC PIPE (10 AND 6 FOOT) WITHOUT MOVING OUT OF POSITION.
- E. BEACH BALL - STUDENTS FILLED BALL WITH WATER AND THREW IT TO PARTNER WHILE IN THE DEEP END, OBSERVING VIBRATION OF THE BALL.
- F. INSTRUMENT NAVIGATION - STUDENTS PLACED A COMPASS ON A RUBBER RAFT. PARTNER WAS NOT TO OBSERVE THE PATH TO BE FOLLOWED. OTHER PARTNER COULD ONLY OBSERVE COMPASS WHILE BEING MOVED IN THE WATER.
- G. MASS EXPERIMENTS - SMALL VIALS WERE FILLED WITH DIFFERING WEIGHTS OF LEAD SHOT. VIALS WERE LETTERED, AND STUDENTS ATTEMPTED TO DISCERN DIFFERENCES BELOW WATER.

SPACE SHUTTLE SIMULATION: Weightlessness Training

NAME:

PARTNER:

- | | | |
|------------------------------------|----------------|---------------|
| 1) Spaceship navigation: | yes: | no: |
| 2) Space construction: | yes | no: |
| 3) Coordination (baby toy): | yes: | no: |
| 4) Torques: | | |
| a) 10' pole: | yes: | no: |
| b) 6' pole: | yes: | no: |
| c) turning valve: | yes: | no: |
| d) hammering nail: | yes: | no: |
| 5) Third law physics (beach ball): | yes: | no: |
| 6) Instrument navigation: | yes: | no: |
| 7) Mass experiment: | yes: | no: |

Appendix D

Mission Patches

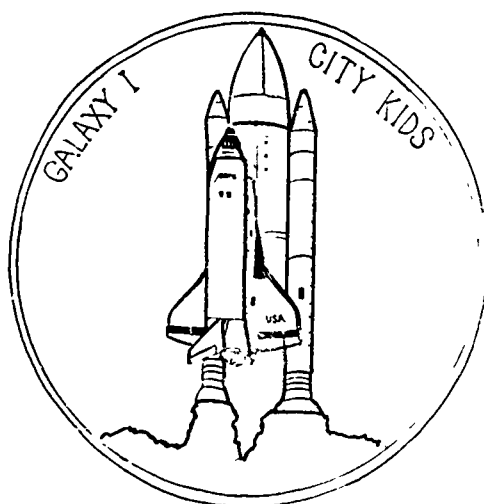

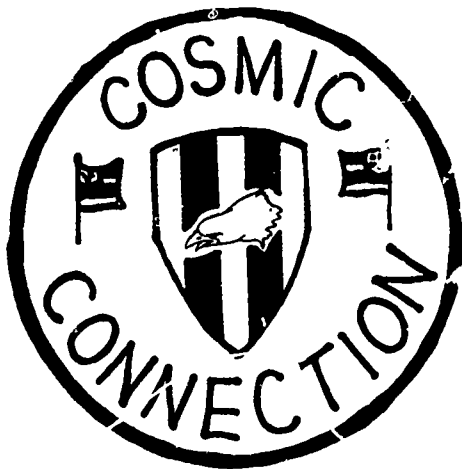
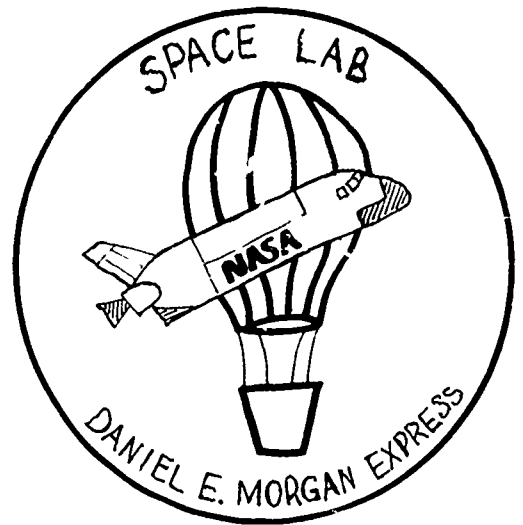
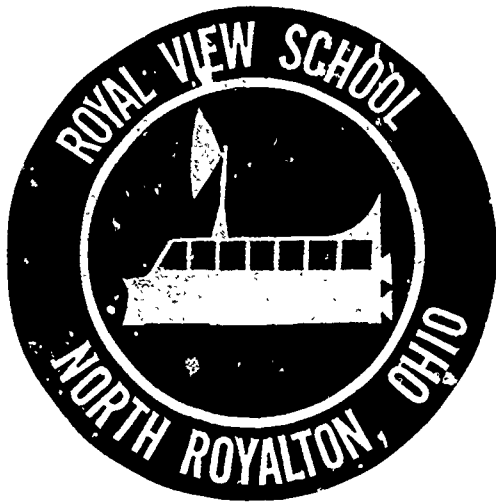

KIDS VII

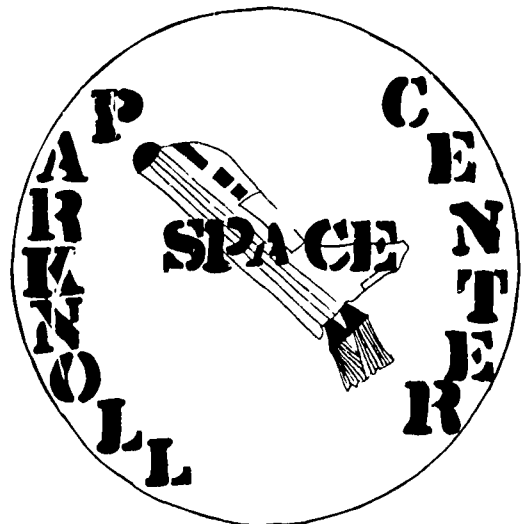
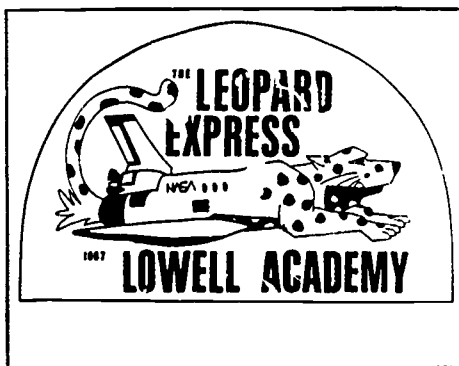

Appendix E

Mission Control Data

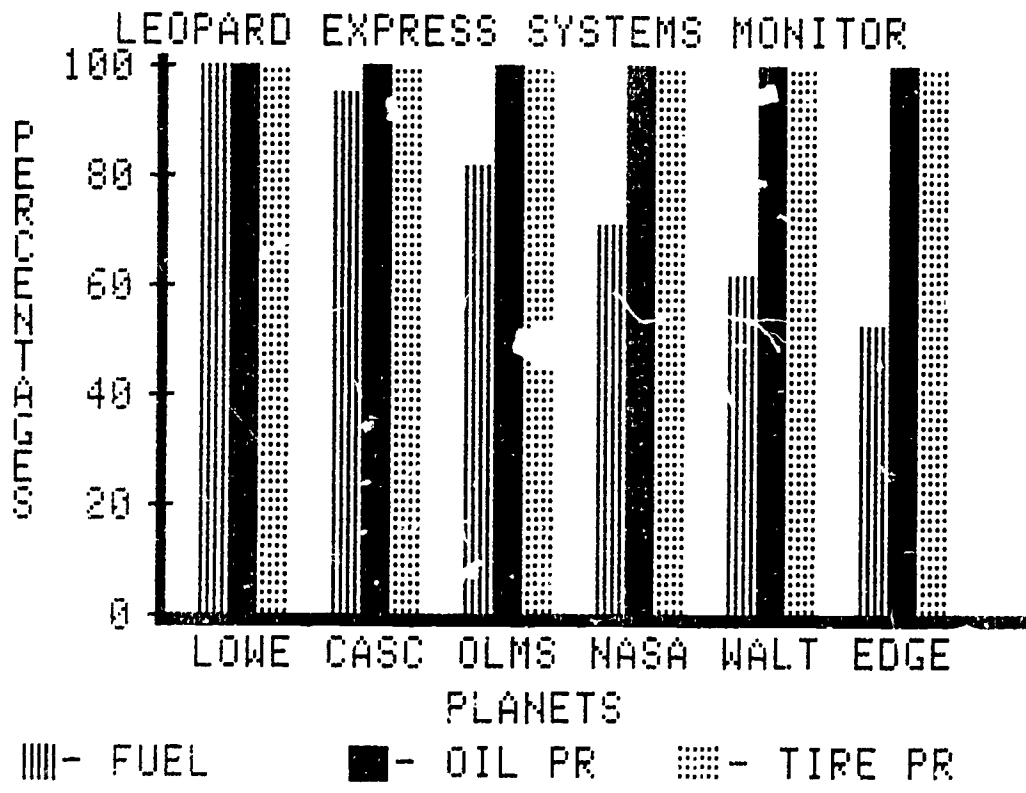
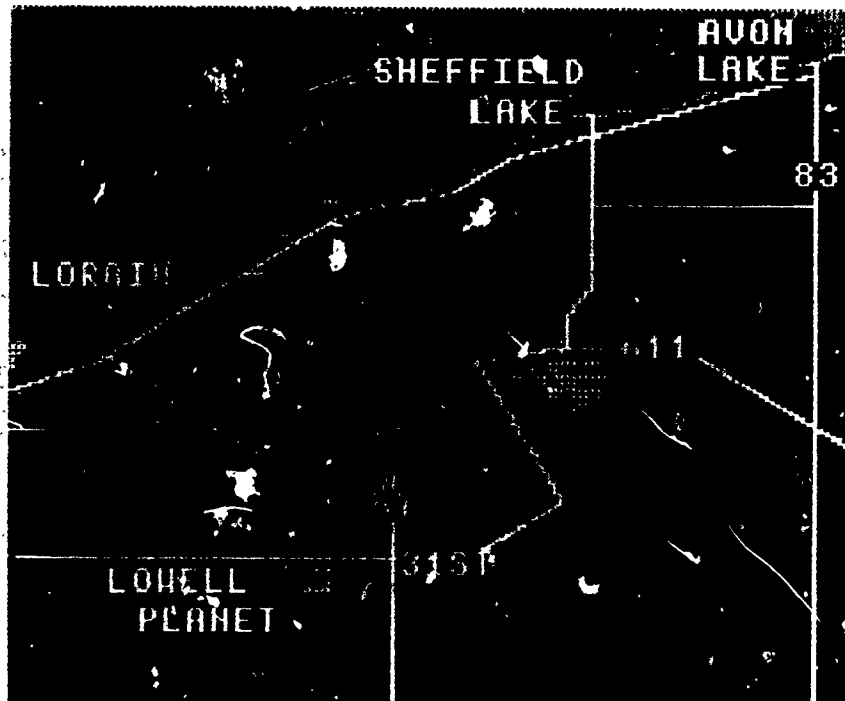

PARTIAL MISSION CONTROL LOG

TIME
Proj. Update

ODOMETER
Proj. Update

Launch Control: ON BEHALF OF THE STUDENTS AND STAFF OF ROYAL VIEW SCHOOL, THIS IS FANTASY I SHUTTLE CONTROL WELCOMING YOU TO THE LAUNCH OF ROYAL VIEW'S FANTASY I.

WE ARE AT T - 30 MINUTES AND COUNTING.

Launch Control: THE SHUTTLE INSPECTION TEAM IS NOW MOVING TO THE LAUNCH SITE WHERE THEY WILL MAKE THE FINAL INSPECTION.

Launch Control: THE WEATHER CONDITIONS FOR THIS MAY 30, 1985 BLAST-OFF ARE _____

THE TIME TO BLAST-OFF IS _____ MINUTES AND COUNTING.

Launch Control: THE CREW MEMBERS OF FANTASY I ARE AS FOLLOWS:

Launch Control: FANTASY I WILL BE TRAVELING 60 MILES AT A SPEED OF 35 MILES PER HOUR DURING THE 3 1/2 HOUR MISSION.

TIME
Proj. Update

ODOMETER
Proj. Update

Launch Control: FANTASY I WILL RENDEZVOUS WITH THE
U.S.S. BELDEN/MIDVIEW STARSHIP AT WHIPPS
LEDGES IN HINKLEY, OHIO.

THEY WILL LATER DOCK AT THE HOME OF THE
U.S.S. BELDEN/MIDVIEW STARSHIP WHERE THE
ASTRONAUTS WILL COLLECT DATA AND PERFORM
EXPERIMENTS.

Launch Control: WE ARE AT T - 15 MINUTES AND COUNTING.

THE CREW OF FANTASY I IS NOW APPROACHING
THE LAUNCH SITE FOR PICTURES AND
BOARDING.

Launch Control: THE SHUTTLE INSPECTION IS COMPLETE.

Launch Control: FANTASY I, THIS IS LAUNCH CONTROL.
RADIO CHECK, OVER.

Fantasy I: Roger, out.

Fantasy I: Launch Control, this is Fantasy I.
Radio Check complete, over.

Launch Control: ROGER, OUT.

Commander: This is Fantasy I. Commander Voice
Check, over.

Launch Control: ROGER, OUT.

Pilot: Control, this is the pilot. Voice
Check, over.

Launch Control: ROGER, OUT.

Fantasy I: Control, this is Fantasy I. Flight Plan
is loaded into the computer, over.

Launch Control: ROGER, OUT.

TIME
Proj. Update

ODOMETER
Proj. Update

Launch Control: FANTASY I, THIS IS LAUNCH CONTROL.
READY ABORT ADVISORY CHECK, OVER.

FANTASY I: Roger. Check is satisfactory, out.

Launch Control: FANTASY I, THIS IS CONTROL. SIDE HATCH
IS SECURE, OVER.

FANTASY I: Roger, we copy. Out.

Launch Control: FANTASY I, THIS IS CONTROL. REAR HATCH
IS SECURE, OVER.

Fantasy I: Roger, copy. Out.

Launch Control: FANTASY I, SECURE PAYLOAD. OVER.

Fantasy I: Roger, out.

FANTASY I: Launch Control, this is Fantasy I.
Payload is secure, over.

Launch Control: ROGER, FANTASY I, OUT.

Launch Control: FANTASY I, THIS IS LAUNCH CONTROL.
SECURE ALL SEAT BELTS, OVER.

Fantasy I: Roger. Securing now.

Seatbelts secure, over.

Launch Control: ROGER, CUT.

Launch Control: FANTASY I, THIS IS CONTROL. GROUND CREW
IS SECURE, OVER.

Fantasy I: Roger, out.

84

Appendix F

Press Kit Outline and Materials

Press Kit Outline

The following items would generally be included in a press kit prepared and distributed by the public relations committee. Additional items could be added at the discretion of the committee.

- Contacts, committees, and resources
- Description of mission
- Press release
- Mission summary
- Crew biographies
- Payload experiment descriptions
- Flight plan
- Flight route
- Launch and landing schedules
- Launch day activities
- Space center activities

Mission Summary

Below is an example of a mission summary that was included in a press kit.

SHUTTLE MISSION FANTASY I

Crew:

Astronauts	Alternates
Brian Basinet, Commander	Chris Raiter
Angie Ceo, Pilot	Michelle Hicho
Larry Zajac, Photographer	Julie Johnson
Katie Kupec, Communicator	Susan Ray
Emily Swiatek, Medical Team Member	Raabia Halim
Juliann Mitchell, Medical Team Member	Deryk Thompson
Alicia Angey, Scientist	Cindy Ulrich
Leah Coyne, Scientist	Jenny Lingafelter
Jeff Harhay, Meteorologist	Erica Gurewicz
Jerry Corbo, Meteorologist	Heather Breyley
Andrew Martinson, Physics Engineer	Walter Noss
Dan Fox, Physics Engineer	Jason Lundy
Karla Lingafelter, Biologist	Billy Janson
Shana Burns, Biologist	Kim Craig
Nick Yurkiw, Geologist	Tim Martin
Sara Kudasick, Geologist	Brian Dempsey
Erin Fabish, Aerial Technician	Michael Delia
Bea Valentine, Aerial Technician	Christine Brown

Orbiter:	Fantasy I
Launch site:	Royal View Space Center, North Royalton, Ohio
Launch date and time:	May 30, 1985, 10:00 a.m. est
Orbital miles:	60 miles, 35 mph
Mission duration:	3½ hours
Landing date and time:	May 30, 1985; 1:30 p.m. est
Primary landing site:	Royal View School, North Royalton, Ohio (Runway 1)
Rendezvous site:	Whipp's Ledges, Hinckley, Ohio
Secondary landing site:	Belden School, Midview, Ohio (Runway 1—Alternate Runway 2)
Cargo and payloads:	18 astronauts, 3 adults, computers, equipment, maps, barometers, soil samples, metal detector

Press Releases

GENERAL PRESS RELEASE

Launching Pine School into its third decade is an exciting event happening on April 8th, 1987! The "Lunar Limo," a simulated space shuttle, will blast off with 12 expert elementary astronauts bound for planet Daniel E. Morgan, our Cleveland "partner in space" school on East 92nd Street.

The 12 trained astronauts will be fortified for their mission with a specially prepared nutritious breakfast prior to boarding. Countdown at 9:39:50 will ready the shuttle for "blast off" as well as the launching of 350 balloons—all on 4/8 at 9:40!

The Lunar Limo will follow a flight plan that takes the astronauts past the six other North Olmsted Schools. Rendezvous will occur at NASA. There astronauts from six other Cleveland area schools will join Pine's and Daniel E. Morgan's crews for welcoming ceremonies, exchange of payload, and photos. Lunar Limo will continue on to its destination, where Pine's crew will be greeted by their partner school aliens (of Planet Rolyat), conduct additional experiments on this foreign territory, and present their gift to Daniel E. Morgan recipients. Upon return to Pine the Lunar Limo will be met with red carpet treatment as North Olmsted band welcomes the crew. Community and school officials, staff, students, families, and friends will be on hand to applaud this great undertaking.

Following debriefing, a school-wide assembly will be held in Pine School's All Purpose Room. North Olmsted's mayor and school dignitaries will congratulate the crew on their successful mission.

The history of the simulated space shuttle project is noteworthy. In the spring of 1986, successful partnership launches had already occurred in two nearby schools, under the able guidance of Dr. Lynn Eondurant, Educational Director of NASA Lewis Research Center. The Career Educational Department, located in North Olmsted, contacted NASA Lewis and the Cleveland City Schools to get the ball rolling for partnership launches between suburban North Olmsted, Berea, and Strongsville schools and Cleveland City Schools, thereby promoting not only the study of space but a sense of greater community togetherness.

Pine's students were informed of the space shuttle adventure late in November. All children had an opportunity to enter the contests. The shuttle name, Lunar Limo, was submitted by third grader Mike Zeager. The logo, featuring a characterized astronaut with the duo pine cones on his space suit, was designed by fifth grader Beth Kelly.

The thoughtful and detailed process of astronaut selection began in February. The return of parent consent forms afforded student astronaut hopefuls, grades 1-5, an application to fill out during school time. Wellness tests, including vision, hearing, balance, flexibility, reflex, vertigo, and strength were conducted. Quality points 0-4 were recorded on applications, along with academic and team/cooperative spirit for each applicant. Interviews were conducted with four or five qualifiers in each classroom. Twelve astronauts and 12 alternates will receive a month of thorough training before launching the "Lunar Limo" on April 8th.

Following the announcement of astronauts, committees were described to the students and committee selection commenced in each classroom. Committees include launching, landing, mission control, flight plan, shuttle preparation—exterior and interior, public relations, experiments, payload, health and nutrition, the arts, and security.

Each committee is composed of students from grades 1-5. As they work in these committees students will wear T-shirts with a specific logo depicting Planet ENIP.



The first event in beginning work toward the completion of the "Lunar Limo" was to view and board bus #19, the basis for Pine's shuttle. The school bus was driven to Pine's playground and parked there for the whole school day. Each class boarded, sat in the seats, and envisioned what the interior might be like if it were a space shuttle. As they left they imagined how the exterior could be altered to resemble a space shuttle. Those who join the shuttle preparation committees will have an opportunity to bring these visions to reality.

Committees worked long and hard through March, designing panels for the shuttle and mission control, making flight plans, hearing from the paramedics and school nurse, studying our universe and planets. The halls and rooms were filled with space-related reports, murals, space monsters, displays, stars, rockets, ENIP National Park (97% recycled materials), lunar rovers, and student astronaut boards. Interviews were conducted; the shuttle was designed and decorated; seat covers and equipment was secured aboard the shuttle; placemats were made in assembly line fashion; many pictures were taken! Staff and parents planned and assisted students in these and many other endeavors.

At Planet ENIP students made Eniptian masks before the blast-off. Following the launch four space stations were set up for Eniptians to visit on a rotating basis: the helicopter from WMMS (Pat Baron), a weather man (Tom Tasselmeyer), a pilot (Tom Hurst), and an experiment room, which included seven equipment stations, a planetarium, and a lunar rock. The Eniptians greeted the crew from the Morgan express "en maske" and ushered them through the Eniptian Lands.

GENERAL PRESS RELEASE

On April 8, 1987, twenty-four Parknoll students will blast off in a renovated school van, followed by a school bus, in a simulated space shuttle program. After an overnight stay at school and an astronaut breakfast, the crew will board the shuttle, KIDS VII, to the sounds of the school band and the flare of a flag group. Outfitted in white and blue uniforms and head gear and displaying a student-designed logo, they will assume their posts for a 22-mile roundtrip "spaceflight."

The first stop of the orbiting shuttle will be NASA, where KIDS VII will rendezvous with its sister ships, Galaxy I City Kids and The Cosmic Connection. After handshakes and picture taking, each shuttle will head toward its anticipated destination.

Around 12:45 p.m. KIDS VII will arrive at Fullerton Elementary School. A team of 12 astronauts will stay at Fullerton School while 12 other astronauts go to Benesch Elementary School. Each crew will perform specific experiments and log their findings. Then it will be homeward bound to the Parknoll Space Center.

Touchdown is anticipated at 3:15 p.m. Before disembarking each crew member of KIDS VII will be checked by a medical team. All students of the Parknoll Space Center will greet them with red carpet treatment. Following the welcome home festivities, the astronauts will be debriefed by NASA officials. Afterward, they will be ready to meet the press, receive a congratulatory message from NASA and attend an evening reception at Cleveland State University.

Every kid's dream is to meet the stars in the sky, and for 24 student astronauts this will become almost a reality on April 8, 1987.

NASA News

National Aeronautics and
Space Administration

Levis Research Center
21000 Brookpark Road, Cleveland, Ohio 44135
AC (216) 433-2901

87-12

For Release: IMMEDIATE

Linda S. Ellis
(res: 215/779-1266)

5000 CLEVELAND AREA SCHOOLS CHILDREN

STAGE APRIL 8 SIMULATED SHUTTLE LAUNCH

CLEVELAND, OH -- The metamorphosis of school buses into space shuttles, classrooms and entire schools changed into planets and galaxies, elementary school students turned into astronauts. No, this is not a stage set for "Star Trek." Rather, it is thousands of Cleveland area school students preparing for a simulated space shuttle launch.

Each of nine schools has redesigned a school bus in the image of a space shuttle. Onboard each shuttle, each appropriately named by the students, will be a team of astronauts, computers, experiments, and two-way radios. The event will get under way at the nine schools the morning of April 8 with "lift-off" from each site.

In addition, students from St. Vincent-St. Mary High School, Akron, and Walsh Jesuit High School, Stow, will be participating in the simulated shuttle flight program. These students will spend 24 hours onboard a simulated shuttle on April 3-4. Their shuttle will be located at the St. Vincent-St. Mary High School orbit (parking lot). To prepare for their mission the students will participate in underwater training and flight simulator training and prepare experiments.

'Space' for learning



By Mark Duncan, AP
MISSION ACCOMPLISHED: Students from Cleveland's Royal View Elementary return to earth after a journey aboard bus made to look like a NASA space shuttle.

Kids high on lessons

By Ken Myers
Special for USA TODAY

CLEVELAND — They never left the ground Thursday, but two "space shuttles" launched from area elementary schools returned home to a heroes' welcome.

The buses-turned-space shuttles — named Fantasy I and USS Belden-Midview Starship — successfully com-

pleted 3½ hour missions with rendezvous, experiments and real space suits.

"I've seen kids who wouldn't normally go to a library in a million years do research and write things for this project," said Royal View Elementary Principal Jeff Lampert. "We wanted to give the kids a moment they wouldn't forget, and I think we accomplished that."

Twenty-six "astronauts" were chosen from 250 applicants at Royal View and Belden elementary schools. Other pupils monitored the trips — sponsored by NASA — on radio and TV equipment at "Mission Control."

"I learned that it's not easy being an astronaut," said fourth-grader Andrew Mardinson, 10. "It takes a lot of training."

Giant leap

Astrotots' flight A-OK

By **TED WENDLING**

STAFF WRITER

Amid cheers, tears and clouds of carbon dioxide smoke, Belden and Royal View elementary schools yesterday successfully launched what NASA called the nation's first school-based, simulated space shuttle.

Call it one small step for the schools, one giant leap for primary education.

"Wow. Seriously, what can you say? It was bigger and better than we hoped for," Terrance L. Furin, Midview schools superintendent, said after an ROTC color guard and more than 100 cheering people greeted the USS Belden/Midview Starship's return to the tiny southern Lorain County school.

"It almost brings tears to my eyes," he said. "We don't know what will happen; maybe one of these kids will one day be an astronaut, a scientist, a humanitarian. We don't know...but this is a thrill they'll remember for a long time."

Belden's eight and Royal View's 18 astrotots blasted off precisely at 9:30 and 10 a.m., respectively, and, according to seasoned space-launch observers, the sendoffs lacked almost nothing in pageantry compared to those given the big boys and girls in their departures from Cape Canaveral.

"This was beyond our expectations," said R. Lynn Boudurant Jr., chief of educational services at NASA's Lewis Research Center in Cleveland and the man principally responsible for the twin, maiden voyages. "From the people I've talked to who've seen a real shuttle launch, there was as much or more excitement here."

Both journeys were recorded by a seven-man team of NASA video and still photographers, as well as nearly a dozen news photographers. NASA said it expected to make a documentary of the trips.

Belden's blastoff was cheered by the largest throng ever to gather at the 150-pupil school. As a Grafton Township fire truck blared its horns and kindergarteners released dozens of orange balloons, a black-and-white school bus, fitted with nose cone, tail fin and two main rockets and crammed with the instruments and expectations of eight schoolchildren, left the launching pad to explore vaguely known worlds in North Royalton.

Trailing a convoy of NASA and press cars, the Belden Starship rocketed through pungent farmland on Ohio 308 before touching down at the Liverpool Township Office Building to release the first of three helium-balloon satellites with the aid of a robotic arm. Along the way, their passage was cheered by dozens of aliens from C.R. Townslee Elementary School, who held a banner reading "Planet Brunswick Welcomes You!"

Belden's shuttle was scheduled to meet Royal View's Fantasy I at Whipp's Ledges in Hinckley at 10:15 a.m., but the rendezvous was delayed by 10 minutes when a Lorain County deputy sheriff, piloting the escort/chase plane (his car), fell behind. The starship's pilot subsequently took a wrong turn and Belden crew members found themselves temporarily lost in space.

If the detour dampened the spirits of Belden's astronauts, Royal View's commander, Brian Basinet, endeared himself to Belden's crew at Hinckley by descending from Fantasy I with that most thirst-quenching of peace offerings — a half-gallon jug of cola. And you thought astronauts only drank Tang.

After shyly exchanging greetings, the shuttle crews performed experiments in their simulated weightless environment, took vital signs and collected soil, rock and water samples. Alas, none of Hinckley's famed space buzzards could be found, so Belden's astronauts settled for an animal specimen discovered by mission specialist April Klinec. "Dad, guess what I found?" the third-grader yelled to her father, Larry, who was taking photographs. "A worm I put it in my knapsack."

Belden's trip to the Royal View alien planet was delayed a second

time when the starship failed to start at Whipp's Ledges. It fired up five minutes later when a kindly Metro-parks ranger jumped the bus' solenoid with a car key.

Wearing cut-paper masks, Royal View's 550 pupils greeted the Belden shuttle's landing. After politely shaking hands with the ground crew, the Belden eight scurried to a place of privacy where they could relieve themselves of an excess of cola.

After planting a shrub, viewing Royal View's remarkable mission control room and planting a flag, the Belden crew departed, stopping in Columbia Station to eat lunch. Their return was met by a red carpet and a delirium of confetti.

"This is an example of how two schools can accept the challenge of educational excellence," said L. Jack Thomas, superintendent of North Royalton schools. "It was an opportunity for the schools and communities to really work together."

Pupils from both schools, along with their parents, were feted last night by NASA. Pupils gave speeches and heard congratulatory tape recordings by Defense Secretary Caspar Weinberger and astronaut Sally Ride.

Astrotots going out of world to learn . . . by bus

By **TED WENDLING**

STAFF WRITER

The time was 1500 hours. Commander Shannon Brewer and her 13 crew members were getting fidgety.

Blastoff was still more than a week away. Besides, school was about to let out.

"April, Brian, pay attention," said Tom Steigerwald, a teacher at Belden Elementary School in Grafton Township. "We don't know what we're going to find on that planet. We don't know what to expect. Maybe they're going to do something, Brian, that will detain us."

Even so, Belden's anxious astrotots were ready to demonstrate the skills and knowledge they had accumulated as a result of an unprecedented partnership among Belden, Royal View Elementary School in North Royalton and NASA.

Thursday, the USS Belden/Midview Starship and Royal View's Fantasy I, two made over school buses, will be launched at their respective schools, beginning a 60-mile, simulated space shuttle that NASA officials said would explore uncharted territory in the federal "Partnerships in Education" program. School officials have invited the public to attend.

"I really think, in today's educa-

tional system, kids are not given an opportunity to dream enough," said R. Lynn Bondurant Jr., chief of the educational services office at NASA Lewis Research Center, 21000 Brookpark Rd. "In doing this, I think the kids are painting a memory they'll remember for the rest of their lives.

"As far as I know, this is a first in the United States."

Belden has 150 pupils in grades kindergarten through five; Royal View has 550 pupils in grades three through five. For many of the youngsters, all of whom will participate, exposure to the wonders of space travel has been limited to watching "Star Wars" and "The Jetsons" and amassing collections of "Masters of the Universe" dolls. Consequently, administrators and teachers at both schools have emphasized that they wanted the shuttle to be a fun learning experience.

Still, the many people who have participated in two months of pre-flight planning will tell you to expect much more than cute kids doing cute things.

"This is absolutely the most fascinating thing I've ever experienced in my 30 years in education," said L. Jack Thomas, superintendent of North Royalton schools. "It's unbelievable that third-, fourth- and fifth-graders can so accurately replicate a space mission."

Added Terrance L. Furin, Midview Local Schools superintendent and a former assistant superintendent at North Royalton, "Before this, some of our kids wouldn't write a paragraph. They wrote pages about this." Belden is in the Midview school district.

Flight plans call for the two shuttles - each to be packed with such equipment as an on-board computer and generator, Military Affiliated Radio System (MARS) and robotic arm for the release of helium-balloon satellites - to rendezvous at Vespers

Ledges in Hinckley. There, they will be taken to each others' leaders, eat a space snack, collect rock, soil, vegetation and water samples and (what else?) perform experiments.

The shuttles then will proceed to the alien school, where they will plant flags and make suitably momentous speeches.

Much of the four-hour exercise will consist of play-acting, but the schools have shown ingenuity with relatively few resources. That is particularly true of Belden, which is in a school district that spent just \$2,359 a year per pupil during the 1983-84 school year, well below the state average of \$2,741.

Using knowledge culled primarily from a two-week "The Sky Is Your Classroom" workshop that NASA sponsored last summer for 15 Belden and Royal View teachers, teacher-coordinated committees have pupils' minds racing with even the minutiae of Thursday's launch.

Food is one such consideration, and committees at both schools have tried to provide the kind of compressed, dehydrated and thermo-stabilized meals fed to astronauts during the Apollo and Skylab programs.

At Belden, teacher Pat Filipiak's health and nutrition committee will serve astronauts, who will spend Wednesday night at the school a lunch consisting of dehydrated soup, ham-and-cheese sandwiches, carrot and celery sticks, pudding and Tang. Meals will be served on cardboard trays pupils made to resemble NASA's food warmer/retainer trays.

Experiments, however, will be the focus of the two maiden voyages, and last week Steigerwald had his astronauts testing some of the experiments they would conduct aboard the starship. One consisted of balancing a glass of water while walking a straight line, partly to see how water reacted to movement and partly to

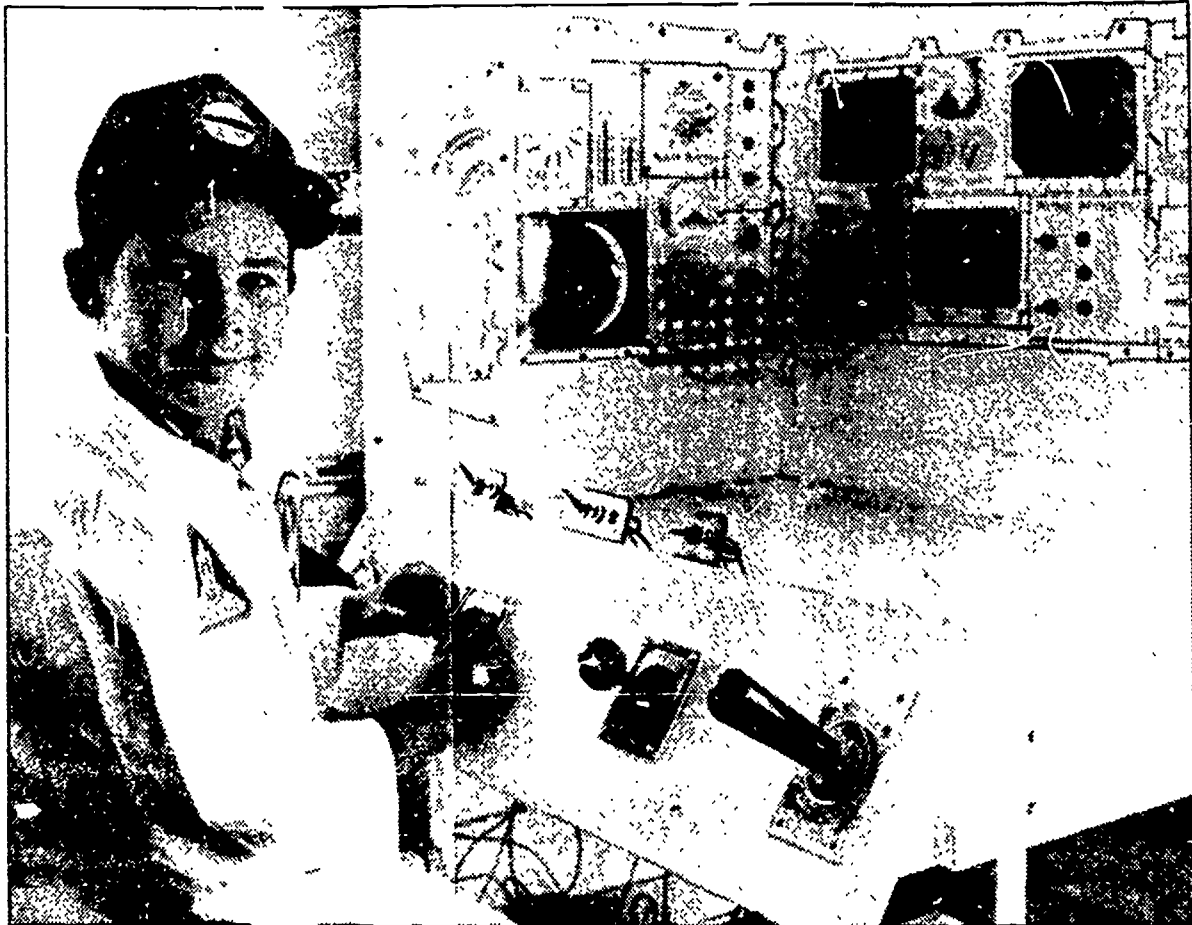

PD/RALPH J. MEYERS

Nick Yurkiw, third-grader at Royal View Elementary School, at the instrument panel of Fantasy I, ready for a simulated space flight.

practice coordination, Steigerwald said.

All of this is pretty heady stuff for the eight pupils from Belden and 18 from Royal View who will actually make the voyage. Unsurprisingly, some pupils who scored lower on the battery of qualifying tests sulked at not being chosen as astronauts. Royal View had 250 pupils apply for its 18 slots.

"My alternate hopes I get sick," said Larry Zajac, 11, a Royal View fifth-grader who will sport a 35mm Canon as the crew's photographer. "I've never had chicken pox, and she hopes I get 'em."

Belden Principal Donna Lynch said a few parents and pupils complained to her.

"I told them that not everyone can be an astronaut, that many other people are important because the astronauts couldn't go anywhere if it wasn't for them," Lynch said. "These are things kids need to learn about life. You can't always have everything you want."

Officials at both schools have gone to great lengths to include all of their pupils. Belden's kindergartners and first-graders will play satellite Frisbee and comet throw, while the older pupils are exploring other worlds.

Others will act as security guards, reporters and mission control specialists.

Ham radio operators Clair Vellenoweth and Henry Garrison will assist Belden pupils assigned to mission control.

"We'll probably have to guide them on what they say," said Vellenoweth. "If they're going to get on there (the radio) and laugh and giggle, we'll have to step in."

NASA has been filming pre-flight preparation with the intention of making a documentary. At 7 p.m. Thursday, it will cap the day's activities by hosting a reception for pupils and their parents. Congratulatory letters will be read, and NASA has been trying to arrange a conference call from astronaut Sally Ride.

"To me, this is what education ought to be like," said NASA's Bondurant. "You can learn so much by doing things this way."



ROYALTON RECORDER

45th YEAR

PUBLISHED BY THE NORTH ROYALTON CHAMBER OF COMMERCE, INC.

JUNE 5, 1985
ISSUE NO. 11

The Flight of Fantasy I

At 10 a.m. on May 30, the Royal View space shuttle, the Fantasy I, took flight on the wings of imagination and education. It was fueled by weeks of enthusiastic work by the staff, students and volunteers whose efforts made this simulated space launch possible.

Flags waved and cameras clicked as an exuberant crowd chanted along with the countdown clock as it flashed out the seconds to blast off. And the air, thick with the cheers of the young astronauts in a school bus that had been transformed into a space shuttle.

Their mission was to explore new worlds, to boldly go where no Royal View school bus had ever gone before - to the planet of Belden, located in the Cuyahoga county galaxy beyond the known edge of our county.

Fantasy I was truly a fantasy come true. From an old school bus of lumbering yellow and black was fashioned a vision of a gleaming white space shuttle. The transformation was created by hours of volunteer work and the use of lots of wood, paint, fabric, nuts, bolts, tape and glue. The result was a sleek white and black space shuttle; outside its shape resembled that of a shuttle with tapered and rounded

nose section, the curve of the tail piece on top and a cluster of engine cones in the back; inside the shuttle had been modified to include working and storage areas, control panels covered the ceiling and re-covered seats held equipment for the astronauts. Driver of the Fantasy I was Tom Luech, who usually gets to drive only school buses.

After they left Royal View aboard Fantasy I, the astronauts rendezvoused with astronauts from Belden School at Whipp's Ledges and, after official greetings were exchanged and scientific experiments were done, the Fantasy I traveled on to Belden while the Belden astronauts proceeded to Royal View and to explore the environment here.

Meanwhile, back at Royal View mission control, the communications team was in constant radio contact with Fantasy I as it traveled on its journey. A large map showed the route of the shuttle and as it passed each checkpoint, a light was lit on the map to chart the flight.

On board Fantasy I, the medical team checked temperature, blood pressure and heart rates of the astronauts, the photographer recorded the flight and the commander and pilot fed coordinates into the computer to determine

speed and distance traveled in flight.

Other specialists on board were the aerial technicians who released satellites disguised as helium filled balloons; biologists who collected plant and insect samples and planted a bush on planet Belden to mark the exploration; meteorologists who sampled the different environments with standard and student-devised equipment; geologists who collected and tested soil and rock samples; and physics engineers who tested the effects of flight on various toys.

Each astronaut represented a classroom at Royal View and was responsible for performing a scientific experiment created by the astronaut's classmates. The same test was done at Royal View and the students were able to compare the results.

Astronauts for the mission we chosen through a process designed to simulate actual astronaut selection, but on a third, fourth and fifth grade level. The astronauts aboard Fantasy I were: Alicia Angrey, Brian Basinet, Shana Burns, Angie Cro, Jerry Corbo, Leah Coyne, Erin Fabish, Dan Fox, Jeff Harbar, Sara Kudack, Katie Kupec, K. La Lingaleiter, Andy Martinson, Julian Mitchell, Emily Swiatek, Nick Yurkiw, Bea Valentine

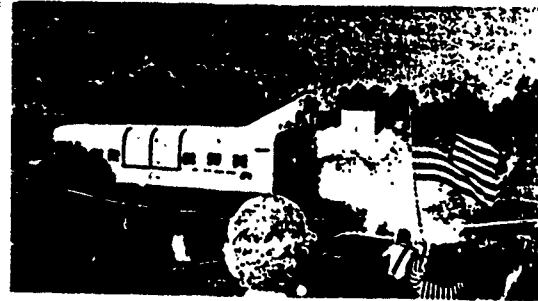

and Larry Zajac.

After the experiments were done and the lunches eaten, it was time for Fantasy I to return home. Back at Royal View, the excitement mounted as mission control announced that Fantasy I was making its approach. The students poured into the viewing area, flags were flying, the band got its music ready, the security team cordoned off the landing area and the red carpet was put in place, while parents and observers checked their cameras.

At the runway approach, the bright red and white drogue parachute billowed behind to brake the shuttle's landing. As the shuttle systems were shut down, the astronauts emerged to the cheers of classmates and spectators.

A reception line of parents and teachers greeted the returning explorers who received applause for a job well done. Jeff Lampert, principal of Royal View School, congratulated the astronauts and expressed his sincere thanks to everyone who had made this special experience possible for the students.

Mission complete, the astronauts went to a debriefing and an assembly with their classmates, where they received a call from Jess Moore, head of the space shuttle program. Congratulating the students on behalf of the school system was L. Jack Thomas, superintendent of schools, and a proclamation, was read by Mayor John Halak, who expressed congratulations on behalf of the city of North Royalton.

Now at rest on its landing strip, Fantasy I was visited by all the

BLAST OFF!!!



TRANSFORMATION OF A SCHOOL BUS



BELDEN ASTRONAUTS LAUNCH SATELLIT'S

clases for a post-flight inspection before returning to its hangar. The classes also enjoyed a display of radio controlled aircraft by Paul Brown, who teaches at CVJVS.

Their gear stowed

away and the experiments complete, the students of Royal View returned home tired but carrying the memory of a very special event in their lives - the flight of Fantasy I.

by Barbara Wright

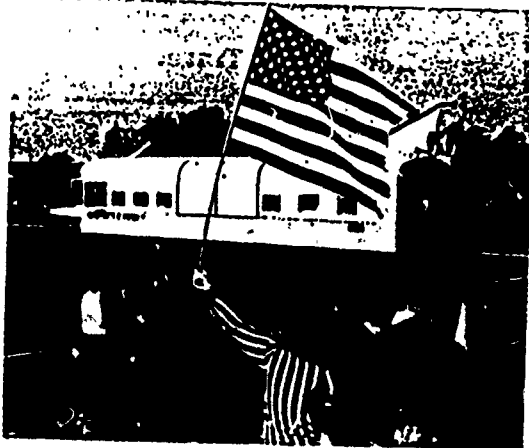

MISSION SUCCESS! *Simulated shuttle flight is no child's play*



Astrotot flight crew ...



... pilot and controls ...



... blastoff of shuttle ...

Leading to successful blastoffs at 0930 and 1000 hours on May 31, 18 brave astronauts boarded two specially equipped shuttle crafts and embarked on unprecedented space flights that left both participants and observers starry-eyed. The mission to explore uncharted territories in the "Partnerships in Education" program sponsored by the Center's Educational Services Office.

"This is absolutely the most fascinating thing I've experienced in my 30 years of education," said L. Jack Thomas, superintendent of North Royalton schools.

The four-hour, 60-mile simulated space shuttle mission was part of a NASA Lewis-sponsored space science awareness program conducted with Midview (Southern Lorain County) and North Royalton School (Cuyahoga County) districts involving some 600 elementary students.

The simulated launch, first conceptualized by Educational Services Chief Lynn Bondurant, Jr., was an outgrowth of the two-week "The Sky Is Your

Classroom" workshop which Lewis sponsored last summer for 15 Belden and Royal View Elementary teachers.

And before the much-awaited blastoff, two months of flight preparations were conducted. From the 249 third-, fourth- and fifth-graders who applied for the simulated flight, 36 astronauts (18 as alternates) were chosen by teacher-directed selection committees to train for a variety of simulated mission roles: commander, pilot, photographer, communicator, medical team member, scientist, meteorologist, engineer, biologist, geologist and aerial technician.

The selected 18 "astrotots," emerging in crisp white fitted paper uniforms, boarded two repainted and outfitted buses-turned-shuttles—Fantasy I and USS Belden Midview Starship—each carrying a payload that included communications gear, computer, maps and metal detector.

In addition to collecting rock, soil, vegetation and water samples along their 35-mph trek on Routes 82 Royalton Rd. and 303 Richfield Rd., the crews con-

ducted pupil-designed experiments. For example, one Belden flight experiment involved balancing a glass of water while walking in a straight line to test water reaction to movement as well as crew coordination.

Mission control operations were handled by MARS (Military Affiliated Radio Systems). Four MARS representatives conducted workshops to familiarize assigned students with the set up and dismantling of mission control and operational procedures. On launch day, four students per communication group worked as recorder, page, radio operator and P.A. announcer, each rotating in half-hour shifts. The communications teams were in direct contact with the shuttles and relayed messages of mission progress to students and guests.

When the shuttles reached the village green (city offices) at North Royalton, student aerial technicians, using a homemade robotic arm, released several helium balloon "satellites." And at the rendezvous (Whipp's Ledges, Huxley Park) and the landing (Royal View

School) sites, three types of kites, each differing in size and shape, were tested.

Following successful completion of their simulated shuttle flights, recorded by a dozen area news photographers and by a NASA video team for the making of a documentary, the astronauts were checked out by a mission medical team and received a post-flight NASA debriefing.

Then an enthusiastic throng of students, guests and supporters cheered the victorious astrotots with a red-carpet welcome and a confetti-tossing parade and celebration. Pupils gave speeches and heard tape-recorded congratulations from Defense Secretary Casper Weinberger and astronaut Sally Ride.

"I really think, in today's educational system, kids are not given an opportunity to dream enough," said Lynn Bondurant. "In doing this, I think the kids are painting a memory they'll remember for the rest of their lives. And as far as I know, this is a first in the United States." □

Photos by Don Huebner



... taking soil samples ...



... hero's welcome ...

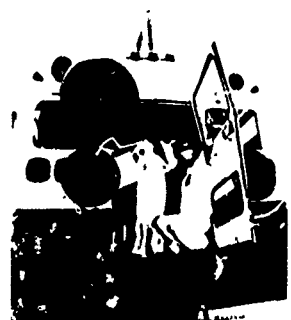

... satellite deployment.

10-9-8-7-6-5-4-3 . . .

. . . 2 more days until 'liftoff' at Belden School

By SUSAN GOFORTH
C-T Staff Writer

GRAFTON TWP. — Amid whistles, firecrackers and sirens, a new "shuttle" will lift off at 9:30 a.m. Thursday at Belden Elementary School.

For a day, the school parking lot will be a Cape Canaveral as a school bus outfitted with a nose cone becomes the students' USS Belden-Midview Starship.

The ambitious project is being undertaken in cooperation with the National Aeronautics and Space Administration's Lewis Research Center in Cleveland.

Midview and North Royalton school districts are "partnerships in education" schools, which encourage contact between students and the worlds of business and government.

As the USS Belden lifts off, Royalview School's shuttle, Fantasy I — another schoolbus — will be "lifting off" from North Royalton.

Complete with nose cone and on-board computers, the two buses will spend the entire day trekking through "space," landing on "alien planets" — the other school — collecting soil and rock samples, and returning home.

DR. R. LYNN Bondurant, chief of educational services at the Lewis Center, said: "The simulated shuttle launch will enable all of the participants to experience firsthand all of the details associated with a real launch as they relate to preflight, flight and post flight activities."

Belden's eight "astronauts" have already been through valuable learning experiences. Beginning with interviews that resulted in their selection from among 139 pupils, the astronauts of the USS Belden experienced a simulated flight in the cockpit of a plane May 14 at Sundorph Corp. in Brook Park.

The Belden shuttle boasts the first woman commander in the United States, Shannon Brewer. The rest of the crew includes Sean Wuensch, William Grime, Brian Sitz, Jennie Noble, John Sloan, April Klinecct and Shawn Beres.

Shortly after liftoff at 9:30 a.m., the shuttle will orbit the Valley City train depot and use its "mechanical arm" to launch a satellite, or to release a weather balloon. The shuttle will rendezvous with the aliens in Fantasy I at Whipps Ledges

where they will exchange greetings and gather rock, soil and water samples before continuing to Royalview.

THE REST of Belden School has not been left behind to just wonder how their shuttle is doing in an alien world. They will be preparing to greet the aliens of the Fantasy I. The people of the "Planet of the Middies" have set each room as a different planet and will greet their alien visitors in masks of each world.

When they're not conversing with the visiting creatures, the Middies will enjoy a robot demonstration, helicopter landings and space games.

When the USS Belden lands back at Belden Control at 2 p.m., they will be greeted by a rousing band fanfare and paraded about the area in convertibles.

The launching pad will be illuminated the night before liftoff and open for viewing at 7-8 p.m.

A reception for the returning astronauts will be at Lewis Center. An astronaut and state and school dignitaries will attend.

A chance to learn and to dream

The NASA Junior Shuttle Program creates student interest in the sciences.

On a bright, sunny day in April, 1987, a group of twenty elementary school students from the Lowell Academy of Lorain, Ohio, embarked on a simulated space shuttle mission aboard the Leopard Express to the farthest reaches of the greater Cleveland, Ohio, area. Joining the Lowell Academy students in this extra-terrestrial curriculum were students from eight other area schools. Students from each school had designed their own custom space shuttles which were equipped with Tandy 102 portable computers.

While the space shuttles were partially a fantasy—they were converted school buses—their missions, and the activities on-board, were serious matters. This one day was the culmination of seven months of preparation and coordination between the schools and the Cleveland-based NASA Lewis Research Center.

"We realize the importance of the sciences in education," said Dr. Lynn Bondurant, Chief of the NASA Educational Services Office at the Lewis Research Center. "To couple the study of science with something as exciting as the shuttle program adds an extra incentive for students to become involved. What's more, the shuttle program gives students the opportunity to dream about their futures."

Early in the Junior Shuttle Program, mission planners recognized the need for a data-keeping device that was portable enough to be carried on the mission. Maintaining its commitment to education and technology, Radio Shack loaned the participating schools eight Tandy 102 portable computers for use during the shuttle missions.

Months before the mission, preparations began for the shuttle flight. Crew members were selected on the basis of interviews conducted by a community interviewing committee. While only a few students from each school were selected to actually take the flight, each student from every grade had a duty whether it was in Mission Control, security or escorting proud parents through the school/home base during a pre-flight open house.

Throughout the school year, the students worked on the shuttle mission as a part of their daily curriculum. They spent time learning about outer space, the history of space flight, and the space program as it exists today. In addition, each class was assigned a specific planet or NASA facility on which to conduct research and prepare presentations for the open house.

The evening before the mission, with the school transformed into Mission Control, an open house was held for parents at Lowell Academy. Early the next morning, as final preparations for liftoff were made, the astronauts donned their uniforms and headed to the front lawn of the school for a pre-flight ceremony, hosted by the mayor of Lorain, Alex Olejko.

With the ceremony completed, the astronauts were whisked away to the launch pad in a special van for shuttle boarding. Liftoff was achieved at 9:00 a.m. with the Leopard Express making its way from the "Lowell Galaxy" in a cloud of smoke.

On the flight agenda, stored in the Tandy 102 TEXT mode, were a variety of stops for scientific experiments such as the release of fifteen balloons containing postcards to be returned by the finder, the collection of organic samples and the planting of a shrub in a local park. Throughout the mission, results from experiments and a flight log were entered into the Tandy 102 by the mission computer specialist.

To keep the shuttles on course, and on schedule, the computers were programmed with vital flight information concerning routes and timetables.

Midway through the voyage, all eight shuttles converged at the NASA Lewis Research Center for friendly interaction between alien crews, a group picture and, of course, lunch. The remainder of the mission was carried out flawlessly with final touchdown at the "Lowell Galaxy" at 2:30 p.m. A weary, but excited, crew departed the shuttle and was met by the Superintendent of Lorain Schools, John W. Pavic, who congratulated the returning astronauts on their successful mission. □

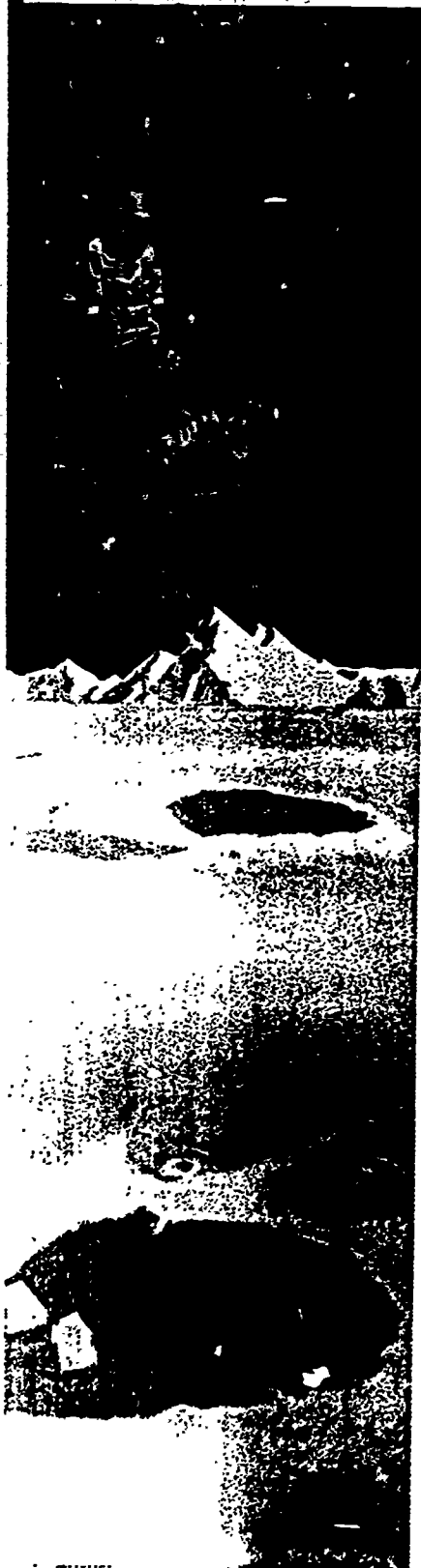

THE SIGNAL

APRIL 1987

From Your Strongsville City Schools

Vol. XXVI, No. 8

MURASKI SET TO BLAST OFF



Police Officer Mike Filicko trains the security team.

There's a rumor going around Strongsville that the students, staff, and parents at Muraski have been acting "spacey" this year!

Well, it's true. Everyone associated with Muraski this year has been very busy preparing for an exciting program being sponsored by NASA. Muraski is one of only nine schools in the Greater Cleveland area to be selected for this opportunity.

Known as a "Simulated Shuttle Mission", the program is an opportunity for students to plan, train for, and conduct a shuttle trip. Some students have been selected to be astronauts, flight planners, or flight controllers. Others have



ASTRONAUTS

From left: Row 1: Lisa Bobula, Amy Knoblock, Row 2: Sharda Desai, Joshua Pavluk, Scott Havlice, Bryan Klink, Holly Viebranz, Row 3: Tracie Galla, Jennifer Pines, Tara Pines, Adrian Flakes, Helen Jankura, Amy Volz, Row 4: Commander, Ryan Niro, Captain, Stefanie Camm

been busy building and testing experiments that the astronauts will conduct during their flight. Still others serve as security officers or carry out publicity activities.

For the mission, a Strongsville school bus will be converted to represent a shuttle orbiter. This is one of many tasks being

completed by parent volunteers. Other parent projects have included exercise classes to make the astronauts fit for their mission, and making the space suits to be worn on the big day.

Wednesday, April 8 is launch day! The flight itself includes lift-off, conducting experiments "on orbit", rendezvousing with the crew from the sister school at the NASA Lewis Research Center, and visiting the sister school. After "landing" back at Muraski, the student-astronauts will be debriefed by NASA engineers and hold press conferences.

In the weeks following the flight the astronauts and shuttle will visit the other schools in Strongsville to share their experiences.



TEACHERS PREPARE FOR NEXT PHASE.

In foreground: Left, Mrs. Korosi, Mrs. Moore. In background: Left, Mrs. Mazzone, Mrs. Hudacko.

"It has been an awesome undertaking to get everything ready," said Mrs. Hudacko, the teacher-coordinator of the project. "It would not have been possible without the cooperation of everyone, but it shows again that when we all work together anything is possible," Hudacko continued.

Indeed! The pride of the entire school district and community goes with the whole "crew" at Muraski for being a part of this exciting program.

Confirm the rumor! They are acting spacey!



Mrs. Juli Ogella gets students in shape for the flight.

Leprechaun Gold

St. Vincent-St. Mary High School 15 North Maple St., Akron, Ohio 44303 March 13, 1987 Volume Vol. 16, No. 5

St. V-M and Walsh students practice for simulation

by Joe Noase
STAFF REPORTER

With the appointments of the astronauts and the command center officials completed, the simulation participants could begin their extensive training.

Once each week, the simulation teams from both Walsh and St. Vincent-St. Mary meet and condition under the supervision of Mrs. Chionchio. After these exercise sessions, videotapes are usually shown describing life and conditions in space. The astronauts received a special treat when a NASA agent came and fielded questions about space exploration and the shuttle program.

On Monday, February 16, the astronauts underwent their training in a weightless environment. In order to simulate the weightless experience, the students traveled to Old Trail School in Bath, where a series of seven experiments would be preformed under water.

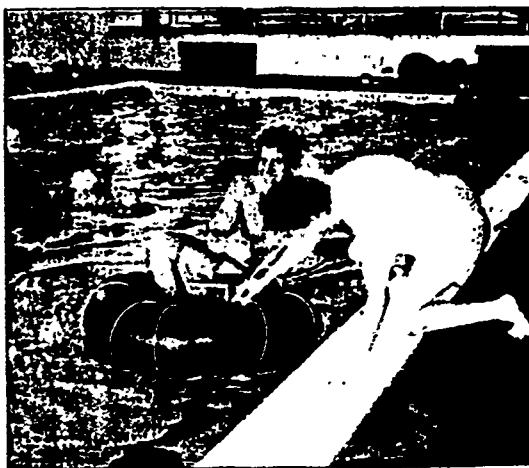

SENIOR SUE SUNKIN and a participant from Walsh practice navigation skills

The astronauts were outfitted with masks and snorkels, to make the experiments move smoothly. The first exercise was in space ship navigation. This involved maneuvering a rotor propelled innertube around a series

of buoys to the other side of the pool and back again to home base.

The second and most difficult exercise was space construction. In this experiment, the astronaut and his command center partner had to swim to the bottom of the

pool and assemble a small cubicle from a series of plastic poles and joints. This proved to be the most challenging and time consuming

The coordination experiment simulated the weightless environment the most. It demonstrated the mobility of objects in space and how difficult it is to keep ahold of things.

The torove experiments were used to illustrate the difficulty in staying in a stationary place. The astronauts had to rotate 10' and 6' foot poles while rotating themselves. Also included in this series of tests was another segment of construction. Nail hammering proved difficult in the fact that the object to be hammered would float away and many times the hammer would fall on fingers instead of the wood.

Exercises in third law physics, instrument navigation, and mass-density experiments were also preformed.

Before the experimentation, crew members were given their assignments

April 17, 1987

LEWIS NEWS



ABOVE: Each of the crew members on board the simulated Shuttle had specific research assignments as part of his or her individual flight plan. The ten-member crew included a co-commander from each school, a pilot, a medical officer, two communications officers, two mission specialists, and two payload specialists.

RIGHT: The ground crew in the command center in St. Vincent-Mary High School had complete audio/visual coverage of the flight which lasted from 1:00 p.m. Fri., April 3 until 1:00 p.m. Sat., April 4

Simulated Launch Held At High Schools

On April 3 and 4, St. Vincent-Mary and Walsh Jesuit High Schools in Akron conducted a 24-hour simulated Shuttle flight aboard "the Phoenix"—a converted recreational vehicle. They were the first high schools to participate in the Simulated Shuttle Mission program developed by Lewis' Educational Services Office.

The simulation included using a "mobile maneuvering unit"

(electric wheelchair) to position mirrors on two "communications satellites" to allow messages to be relayed by modulated laser transmission. Other experiments involved observing the effects of gravity and mapping the changing positions of the stars.

As part of their preflight training, the crews learned about working in a weightless environment by performing a series of tasks, such as building a cubicle

with PVC pipes underwater in a swimming pool.

"As our technologies develop and become more refined I am delighted to see our students taking such an active interest in educational programs of this kind," wrote Rev. John Murphy, Superintendent of Education, Diocese of Cleveland in one of the many congratulatory messages the students received.

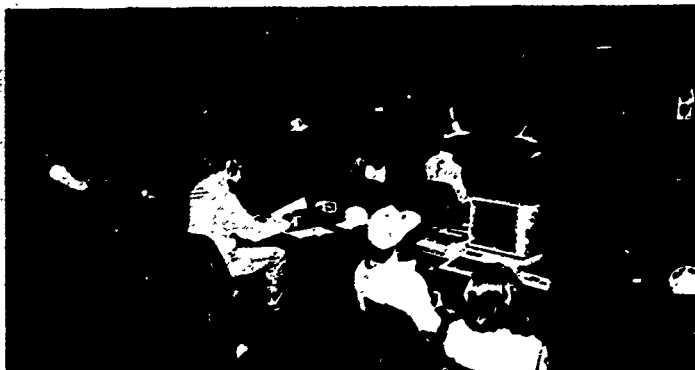

Yellow space shuttles make learning a trip

By Mary-Beth McLaughlin
Journal Staff Writer

Space shuttles that look amazingly like school buses, pint-size crews that need permission to travel, a Mission Control room that smells like chalk and a mission to visit four planets in the land of Cleve?

It may sound like a twisted science-fiction tale but is instead a hands-on attempt to teach grade-schoolers the wonders and joy of space exploration.

The actual "launch" isn't until April 8, but students at Pine Elementary in North Olmsted and at Lowell Academy in Lorain, along with students from elementary schools in Strongsville and Berea, have already started the arduous task of mounting a simulated shuttle launch.

Their mission? To visit and report back on life at four Cleveland grade schools.

Preblast-off preparations will keep both adults and children busy — choosing a shuttle crew, converting yellow school buses into sophisticated space machines and transforming brick school buildings into Mission Control, planets and launching pads.

"This takes as much energy as to put a real shuttle in orbit," said William Lange, principal at Lowell Academy, one of Lorain's magnet schools.

An exchange mission between two Ohio schools was held in 1985 but this is the first with eight schools — and the first since the shuttle Challenger exploded. The 1985 mission was between Belden Elementary School in Grafton and a North Royalton school.

"It is a chance for young people to dream about a future," said Dr. Lynn Bondurant,

chief of education services at NASA's Lewis Research Center. NASA put together a short film of the first exchange and showed it at interested schools, but the actual shuttle design, astronaut selection and course of study are up to the schools involved.

While the real shuttle program is on hold, it is important to keep children interested in space exploration, said Bondurant, especially because students in first grade today will be the space explorers of tomorrow.

"Out of this pool of people will be the first expedition to Mars," Bondurant said.

Linda Ward, principal at Pine Elementary, said astronaut selection will get under way next week, when about 50 candidates will be interviewed by community residents other than school staff. More than 200 students initially showed interest in being part of the crew.

Those to be interviewed have already survived wellness training, when they were tested for such things as vision, balance, strength and risk of vertigo, and have been selected partly on academics and their ability to get along with others.

During the interviews, the students will be judged on eye contact, appearance and manners as well as their ability to express their answers to seven questions, including their reasons for wanting to be an astronaut, and what one thing they might change in the world.

An astronaut and an alternate will be chosen from each class, kindergarten through fifth grade.

And then the serious work begins.

While the astronauts prepare

for their mission, the rest of the student body will be involved in mission control, building the shuttle and launching and landing techniques, not to mention studying the planets and conducting scientific experiments.

"This is an opportunity for them to do many things and to learn what can be accomplished through team effort to make sure the flight is successful," Bondurant said.

At Lowell, astronaut selection is not as far along, but there are already 14 designated building committees for the shuttle construction — which will be tricky, considering the bus is on loan and must be returned intact, yellow paint and all. Each class from kindergarten through fifth grade has been assigned to study either one of the planets in our solar system or one of the NASA installations across the country.

"This is the kind of experience that they will remember all the rest of their lives. It is a real learning process," Lange said.

That is precisely what Bondurant is aiming for. "I don't think the schools do enough to teach about hope," he said.

Bondurant said the simulated shuttle mission will not ignore the dangers of such missions but will show that "we're ready to go on, so risks will be reduced."

Blast-off at each school will be at 10 a.m. as each shuttle travels to its designated Cleveland "planet." The Pine shuttle will head for Cleveland's Daniel E. Morgan School, while Lowell will head to Walton School.

In return, when the Cleveland shuttles reach the suburban "planets," they will receive gifts and exchange experiments.

Parknoll pupils to get a lift from simulated space flight

By R. David Heileman

BEREA — Parknoll Elementary School has been transformed into "Parknoll Space Center" where student astronauts, ground crew members, youthful scientists and "logistics experts" will join in a simulated shuttle blastoff next Wednesday.

Parknoll's 490 pupils have joined with thousands of students from five elementary schools and three other suburban school districts for a trek to NASA's Lewis Research Center where their shuttles will be "launched" toward "alien" planets.

Parknoll's seven astronauts will leave NASA in a former mobile classroom converted by a group of parents, to look like a shuttle — right down to the presence of an on-board computer.

THEY'LL BE HEADED toward Fullerton and Benesch elementary schools in Cleveland, where they'll break bread with the "aliens" on those "planets."

The students at Parknoll will participate in every aspect of a shuttle launch, including countdown, liftoff, planning and conducting onboard experiments and debriefing after landing, according to Dr. Lynn Bondurant, chief of educational services at NASA's Lewis Research Center.

Bondurant is the virtual creator of the simulated shuttle experiment which was tried back in '85 when Royalview Elementary School in North Royalton and Belden Elementary School in Grafton took part in the very first program.

"I had talked to teachers to see if they would be interested in carrying out a project that would be a lot of fun for kids to do. It started growing from there," said Bondurant.

Since that time, elementary schools in Birmingham, Mich., have their own simulated shuttle launch program "and hopefully, after this it will spread across the U.S.," said Bondurant.

He said that two schools in the Palmdale, Calif., area are planning to have their students participate in a simulated shuttle launch this spring.

Preparations for the launch began last October when Parknoll faculty members Joseph Fortunato and Mary Ann Theodosian attended a meeting at NASA. "We got staff commitment then and we really got involved in January and it has really grown ever since," said Irma Bartlett, Parknoll principal.

Since the first of the year, pupils, parents, teachers and others have jumped into the program "feet first" as the saying goes.

A TEAM OF mothers got together to design and sew the astronauts' uniforms. "They look like the real thing," said Bartlett.

Another crew of parents, headed by David Robinson, got together to begin transforming the old mobile classroom into something suitable for simulated space travel.

Even classrooms at Parknoll have been renamed for planets in the galaxy. Teacher Jill Smith's third-grade classroom is known as the planet "Smithsonian" and the kids in the homeroom are known as "Smithsonians."

Barbara Nimon's first-grade classroom is now known as "The Candy Planet," or more formally, "Nimyummia." The pupils who "reside" there are known as "Nimyummians." They live in a world where it rains gumdrops and snows coconut and where all the continents are fashioned from candy bars.

BUT THERE'S A serious side to the simulated shuttle program. The astronauts, who were chosen from among the Parknoll students after an interview, will have a "payload" which will include about 80 experiments such as keeping track of weather and analyzing samples taken from where the craft landed.

Last Monday, Richard Heckathorn, physics teacher at Midpark High School, visited Parknoll for the day and helped students conduct experiments in motion, movement, chance and probability and in deciphering equations used to figure shuttle speed, etc.

Parknoll pupils have also participated in experiments showing them

how to test the properties of soil and water, how to develop barometers and the use of gyroscopes.

Teachers at Parknoll have also tied in creative writing and reading as a part of the simulated shuttle launch project.

The whole purpose of the project is "for children to share a simulated shuttle launch to learn more about science and math," said Bartlett.

EVEN COMMUNITY institutions and businesses outside the Berea schools got involved in the project.

Ralph-Wallace College officials let Parknoll students use the college gymnasium for jogging and other physical training.

Instructors at Nautilus Fitness Centers gave pupils tips on building up their bodies and Thom, Ohio Gymnastics in Olmsted Township put student astronauts through aerobic exercises and took their blood pressure to help them get in shape for their arduous "outer-space" journey.

Parknoll kids will spend the night of April 7 at the school. They'll be watched over by a student security crew. A cereal and Tang breakfast will be served just prior to the early Wednesday morning launch.

After that, the young astronauts will be up at 7 a.m. for washup, jogging, a cereal-and-Tang breakfast and last minute pre-launch instructions and experiments.

On April 8, 1987, the Kid Next Door Will Roar into Orbit.

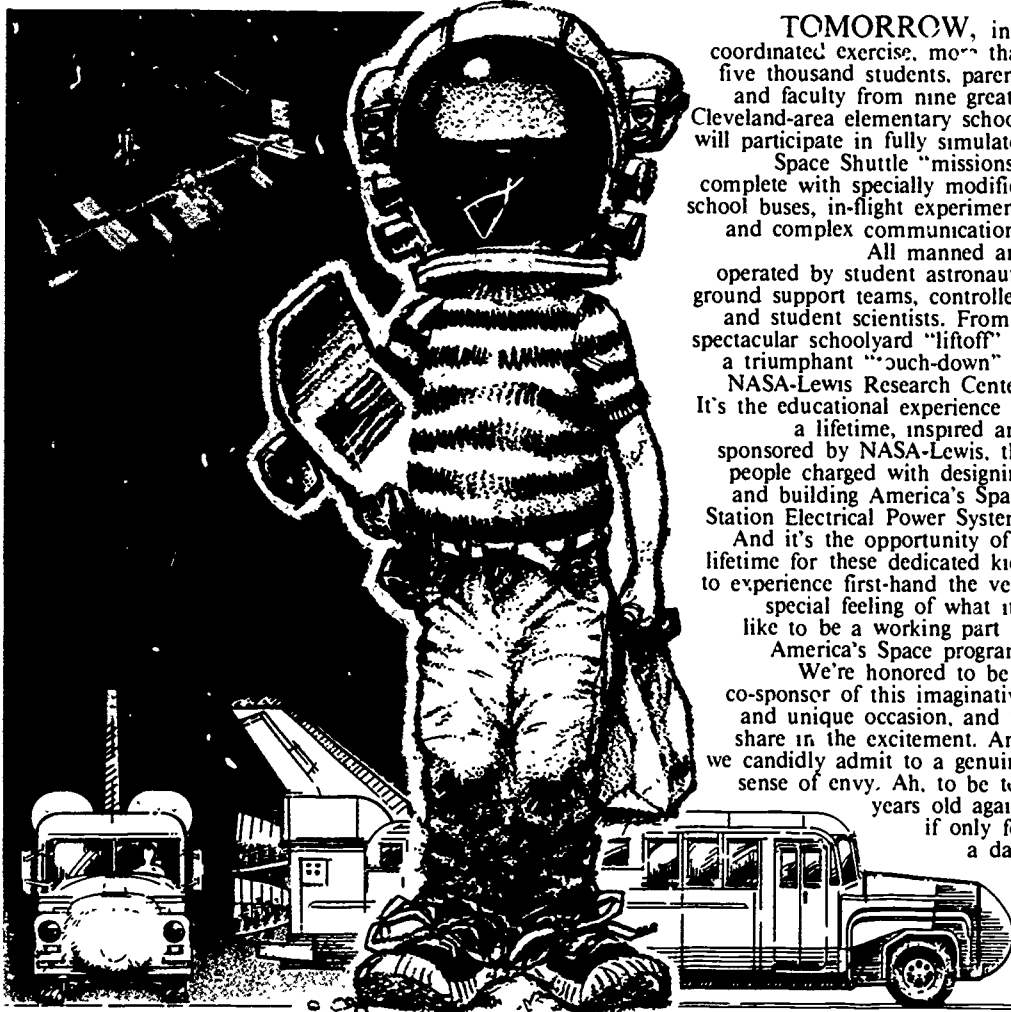

TOMORROW, in a coordinated exercise, more than five thousand students, parents and faculty from nine greater Cleveland-area elementary schools will participate in fully simulated Space Shuttle "missions," complete with specially modified school buses, in-flight experiments and complex communications.

All manned and operated by student astronauts, ground support teams, controllers and student scientists. From a spectacular schoolyard "liftoff" to a triumphant "touch-down" at NASA-Lewis Research Center.

It's the educational experience of a lifetime, inspired and sponsored by NASA-Lewis, the people charged with designing and building America's Space Station Electrical Power System. And it's the opportunity of a lifetime for these dedicated kids to experience first-hand the very special feeling of what it's like to be a working part of America's Space program.

We're honored to be a co-sponsor of this imaginative and unique occasion, and to share in the excitement. And we candidly admit to a genuine sense of envy. Ah, to be ten years old again, if only for a day.

Parknoll Elementary School • Fullerton School • Alfred A. Benesch School • Pine Elementary School • Lowell Academy
Helen Muraski Elementary School • Daniel E. Morgan School • Walton School • Iowa Maple School

On a School Bus.

The Rocketdyne Division of Rockwell International is honored to lend a helping hand.



Rockwell International

where science gets down to business

Aerospace / Electronics / Automotive
General Industries / A-B Industrial Automation

As seen in the April 7, 1987 issue of the CLEVELAND PLAIN DEALER

Appendix H Recognition Certificates



BE IT KNOWN THAT



**Participated in the
First Simulated Shuttle Launch
May 30, 1985**

Cosponsored by

Midview Local Schools	North Royalton City Schools	NASA Lewis Research Center
<i>Terrance L. Furin</i> Terrance L. Furin, Superintendent	<i>L. Jack Thomas</i> L. Jack Thomas, Superintendent	<i>R. Lynn Bondurant</i> R. Lynn Bondurant Chief, Educational Services

BELDEN ROYAL VIEW

NASA Lewis Research Center
is privileged to present this certificate
to
ASTRONAUT

of

In recognition of participation in the
**Greater Cleveland
Simulated Shuttle Mission
April 8, 1987**



R. Lynn Bondurant, Jr.
Educational Programs Officer

NASA Lewis Research Center
is privileged to present this certificate
to

of

In recognition of participation in the
**Greater Cleveland
Simulated Shuttle Mission
April 8, 1987**



R. Lynn Bondurant, Jr.
R. Lynn Bondurant, Jr.
Educational Programs Officer

Appendix I

NASA and Regional Teacher Resource Centers

The NASA teacher resource centers and the NASA regional teacher resource centers provide educators with a source of aerospace materials for use in the classroom. In preparing to do a simulated shuttle mission, teachers will need technical information about the shuttle and mission components. Audiovisual and printed materials on these topics, as well as on a number of other aerospace and related topics, are available at the teacher resource centers. In addition, you may want to contact the teacher resource center nearest you to request a copy of "Launching a Dream," a 15-minute videotape highlighting the 1985 simulated shuttle mission. An additional videotape on the 1987 mission, entitled "Simulated Shuttle Launch, April 8, 1987," is available from the Lewis Research Center Teacher Resource Center in Cleveland, Ohio. Addresses of the NASA and regional teacher resource centers and a listing of other sources for materials follow.

NASA Teacher Resource Centers

Teacher Resource Center
Alabama Space and Rocket Center
Tranquility Base
Huntsville, AL 35807
FTS/824-5812
205/544-5812

Teacher Resource Center
NASA Ames Research Center
Mail Stop 204-7
Moffett Field, CA 94035
FTS/464-6077
415/694-6077

Teacher Resource Center
Jet Propulsion Laboratory
Mail Stop CS 530
4747 New York Avenue
La Crescenta, CA 91214
FTS/792-6916
818/354-6916

Teacher Resource Center
NASA John F. Kennedy Space Center
Mail Code ERL
John F. Kennedy Space Center, FL 32899
FTS/823-4090
407/867-4090

Teacher Resource Center
NASA Goddard Space Flight Center
Mail Code 130.3
Greenbelt, MD 20771
FTS/888-8570
301/280-2570

Teacher Resource Center
NASA John C. Stennis Space Center
Building 1200
Stennis Space Center, MS 39529
FTS/494-3338
601/688-3338

Teacher Resource Center
NASA Lewis Research Center
Mail Stop 8-1
21000 Brookpark Road
Cleveland, OH 44135
FTS/297-2016/2017
216/433-2016/2017

Teacher Resource Center
NASA Lyndon B. Johnson Space Center
Mail Code AP-4
Houston, TX 77058
FTS/525-8696
713/483-8696

Teacher Resource Center
NASA Langley Research Center
Mail Stop 146
Hampton, VA 23665
FTS/928-4468
804/865-4468

NASA Regional Teacher Resource Centers

NASA Teacher Resource Center
U.S. Space Foundation
P.O. Box 1838
Colorado Springs, CO 80901
303/550-1000

Education Resource Center P-700
National Air and Space Museum
Smithsonian Institution
Washington, DC 20560
202/357-1838

NASA Teacher Resource Center
Parks College of St. Louis University
400 Falling Springs Road
Cahokia, IL 62206
618/337-7500

NASA Teacher Resource Center
Museum of Science & Industry
57th Street & Lakeshore Drive
Chicago, IL 60637
312/684-1414, Ext. 429/449

NASA Teacher Resource Center
University of Evansville
1800 Lincoln Avenue
Evansville, IN 47714
812/479-2393

NASA Teacher Resource Center
The Children's Museum
P.O. Box 3000
Indianapolis, IN 46206
317/924-5431

NASA Teacher Resource Center
Bossier Parish Community College
2719 Airline Drive
Bossier City, LA 71111
318/746-7754

NASA Teacher Resource Center
Olson Library Media Center
Northern Michigan University
Marquette, MI 49855
906/227-2270

NASA Teacher Resource Center
Central Michigan University
101 Ronan Hall
Mount Pleasant, MI 48859
517/774-4387

NASA Teacher Resource Center
Oakland University
O'Dowd Hall, Room 115
Rochester, MI 48063
313/370-3079

NASA Teacher Resource Center
Dept. of Curriculum Instruction
Mankato State University
P.O. Box 52
Mankato, MN 56001
507/389-1516

NASA Teacher Resource Center
Center for Information Media
St. Cloud University
St. Cloud, MN 56201
612/255-2062

NASA Teacher Resource Center
University of North Carolina at Charlotte
J. Murrey Atkins Library
Charlotte, NC 28223
704/547-2559

The City College
NAC 5/208
Convent Avenue at 138th Street
New York, NY 10031
212/690-6678

Christa McAuliffe Teacher Resource Institute
NASA Industrial Applications Center
University of Pittsburgh
823 William Pitt Union
Pittsburgh, PA 15260
412/624-5212

NASA Teacher Technology Resource Center
Champlain College
174 South Willard Street
Burlington, VT 05402-0670
802/658-0800, Ext. 430

NASA Teacher Resource Center
University of Wisconsin at LaCrosse
Morris Hall, Room 200
LaCrosse, WI 54601
608/785-8650

NASA Teacher Resource Center
818 West Wisconsin Avenue
Milwaukee, WI 53233
414/765-9966

NASA Information Summaries

National Aeronautics and
Space Administration

Washington, D.C.
20546

PMS-006/5-86

Source List

This list represents possible sources of items from independent concessionaires and entrepreneurs, not available from the National Aeronautics and Space Administration, and is offered without recommendation or endorsement by NASA. Inquiry should be made directly to the appropriate source to determine availability, price, and time required to fill orders before sending money.

Scientific and Technical Information (Mission Reports):

National Technical Information Services, 5285 Port Royal Road, Springfield, VA 22151
Scientific and Technical Information Facility, 800 Elkridge Landing Road, Linthicum Heights, MD 21090

Spacecraft and Airplane Models:

Models of spacecraft and aircraft may be purchased at hobby shops and toy departments of your local department stores, and also at some of the companies listed below. The following firms are model-rocket manufacturers:

Estes Industries, PO Box 227, Penrose, CO 81240
Revell, Inc., 4288 Glencoe Avenue, Venice, CA 90291
Flight Systems, Inc., 9300 East 68th Street, Raytown, MO 64133
Pacific Miniatures, Inc., 817 South Palm Avenue, Alhambra, CA 91803
Monogram Models, Inc., Morton Grove, IL 60053
Custom Graphics, PO Box 2176, Altamonte Springs, FL 32715
Toys and Models Corporation, 222 River Street, Hackensack, NJ 07601
Wesco Models, Inc., 1453 J Virginia Avenue, Baldwin Park, CA 91706
Scale Models, Inc., 111 Independence Drive, Menlo Park, CA 94025
Movie Miniatures, 5115 Douglas Fir Drive, Suite F, Calabasas, CA 91302

Souvenirs and memorabilia commemorating space, such as Cameras, Text Books, Photograph Albums, Emblems, Patches, Decals, Commemorative Medals, Flight Jackets, T-Shirts, Caps, Buttons, etc.:

AW/JSC Exchange Store, Johnson Space Center, Houston, TX 77058
Alabama Space and Rocket Center, Tranquility Base, Huntsville, AL 35807
Space Age Enterprises, PO Box 58127, Houston, TX 77058
National Medallion Company, Inc., PO Box 58127, Houston, TX 77058
KSC Tours, TWA Services, Inc., TWA-810, Kennedy Space Center, FL 32899
Communications Association Corporation, 250 Babcock Street, Melbourne, FL 32935
Smithsonian Institution Museum Shops, 900 Jefferson Drive SW, Washington, DC 20560
NASA Headquarters Exchange Store, 600 Maryland Avenue SW, Washington, DC 20546
Action Packets, Inc., 344 Cypress Road, Ocala, FL 32672
International Space Hall of Fame Gift Shop, PO Box 25, Alamogordo, NM 88310
GEWA Visitor Center Gift Shop, Goddard Space Flight Center, Greenbelt, MD 20771
Space Art, Original Paintings & Prints, Blatch Museum, PO Box 584, Rockledge, FL 32955-0584
Johnson and Associates, PO Box 46251, Pentagon, Washington, DC 20050

Space Suits:

ILC-Dover, Box 266, Frederica, DE 19946
Hamilton Standard, Windsor Locks, CT 06096

Stamps:

JSC Stamp Club, PO Box 58328, Houston, TX 77058
Houston Hobby Center, PO Box 10791, Houston, TX 77018
GEWA Visitor Center Gift Shop, Goddard Space Flight Center, Greenbelt, MD 20771

Maps: Moon, Mars, etc.:

Superintendent of Documents, U.S. Government Printing Office, Washington, DC 20402
National Geographic Society, PO Box 2806, Washington, DC 20036
U.S. Geological Survey, Department of the Interior, 1200 South Eads Street, Arlington, VA 22202
GEWA Visitor Center Gift Shop, Goddard Space Flight Center, Greenbelt, MD 20771

Photographs, Slides, etc.:

AW/JSC Exchange Store, Johnson Space Center, Houston, TX 77058
Astronomical Society of the Pacific, 1290 24th Avenue, San Francisco, CA 94122
Woodstock Products, Inc., PO Box 2519, Beverly Hills, CA 90213
GEWA Visitor Center Gift Shop, Goddard Space Flight Center, Greenbelt, MD 20771

8mm and 16mm NASA Films:

National Audio Visual Center (GSA), Washington, DC 20409

Space-Type Freeze-Dehydrated Foods:

Oregon Freeze-Dry Foods, Inc., PO Box 1048, Albany, OR 97321
Sam-Andy Foods, PO Box 1120, Colton, CA 92324
Freeze Dry Products, 321 Eighth Street, NW, Evansville, IN 47708
G. Armanino & Sons, Inc., 1970 Carroll Avenue, San Francisco, CA 94124
Right-A-Way Foods, PO Box 184, Edgington, TX 78539
Spaceland Enterprises, PO Box 775, Merritt Island, FL 32952
Sky-Lab Foods, Inc., 177 Lake Street, White Plains, NY 10604
GEWA Visitor Center Gift Shop, Goddard Space Flight Center, Greenbelt, MD 20771

Solar System Information, Charts, etc.:

The Hansen Planetarium, Department F, 1098 South 200 West, Salt Lake City, UT 84101
Smithsonian Astrophysical Observatory, 60 Garden Street, Cambridge, MA 02138
Astronomical Society of the Pacific, 1290 24th Avenue, San Francisco, CA 94122
GEWA Visitor Center Gift Shop, Goddard Space Flight Center, Greenbelt, MD 20771

Special Sources:

Abstracts of technical reports on imagery from Earth Resources Satellites (LANDSAT) funded by NASA, prepared and distributed by National Technical Service of Department of Commerce as a weekly bulletin, abstracts on NASA-owned inventions available for licensing

U.S. Department of Commerce
National Technical Information Services
Springfield, VA 22161

LANDSAT photographs and digital products are available from

Technology Applications Center
University of New Mexico
Albuquerque, NM 87106

specializes in remote sensing
technology

EOSAT
c/o EROS Data Center
Sioux Falls, SD 57198

LANDSAT

National Climatic Center
NOAA Environmental Data Services
Federal Building
Asheville, NC 28801

data in oceanographic, hydrologic, and
atmospheric sciences

Western Aerial Photograph Laboratory
Agricultural Stabilization & Conservation Service
U.S. Department of Agriculture
2502 Parley's Way
Salt Lake City, UT 84109

agriculture imagery and data

Space Camp Information

Alabama Space & Rocket Center
Space Camp Application
Tranquility Base
Huntsville, AL 35807

Power Factor Controller Distributor

Energy Vent. Inc
915 Valley Street
Dayton, OH 45404

The Teacher In Space Foundation is a private non-profit foundation established by the 112 NASA Teacher In Space Finalists to foster the pioneer space-age spirit in American education

Teacher In Space Foundation
1110 Vermont Avenue NW
Suite 717
Washington DC 20005

The Young Astronaut Council is a private sector educational program created by the President which focuses on improving the math and science skills of elementary and junior high school students

Young Astronaut Council
1211 Connecticut Avenue NW
Washington DC 20036

Appendix J

Acknowledgments

We wish to thank these persons and organizations for contributing to the 1987 Lewis simulated shuttle mission.

Admiral Richard Truly, Associate Administrator for Space Science, NASA Headquarters

Dr. Robert W. Brown, Director, Educational Affairs Division, NASA Headquarters

Dr. John M. Klineberg, Director, NASA Lewis Research Center

Americo F. Forestieri, Director, Office of External Affairs, NASA Lewis Research Center

Astronaut David Walker, NASA

Barbara Morgan, Teacher in Space, NASA

Dr. Franklin Walter, Superintendent of Instruction, State of Ohio

Dr. Walter B. Waetjun, President, Cleveland State University

Anthony B. Potter, Dean, College of Engineering, Cleveland State University

George C. Chang, Associate Dean, College of Engineering, Cleveland State University

T. Wendell Butler, Executive Director, Young Astronauts Foundation

NASA Lewis Research Center

NASA Aerospace Education Services Project

Cleveland Area Amateur Radio Enthusiasts

Cleveland Metro Area Zonta International Association

Radio Shack-Tandy Corporation

Rocketdyne Division of Rockwell International Corporation

U.S. Air Force Association