

DOCUMENT RESUME

ED 309 066

SE 050 719

TITLE Educational Materials Linking Technology Teaching with Science Education: Technology in Life. Science and Technology Education Document Series No. 31.

INSTITUTION Curtin Univ. of Technology, Perth (Australia). Science and Mathematics Education Centre.

SPONS AGENCY United Nations Educational, Scientific, and Cultural Organization, Paris (France). Div. of Science, Technical and Environmental Education.

REPORT NO ED/88/WS/52

PUB DATE 88

NOTE 226p.

AVAILABLE FROM United Nations Educational, Scientific, and Cultural Organization, 7 place de Fontenoy, 75700 Paris, France (price not available).

PUB TYPE Guides - Classroom Use - Guides (For Teachers) (052)

EDRS PRICE MF01 Plus Postage. PC Not Available from EDRS.

DESCRIPTORS Electricity; Energy; Energy Conservation; *Energy Education; Heat; *Instructional Materials; Science Instruction; Scientific and Technical Information; Scientific Literacy; Secondary Education; *Secondary School Science; *Solar Energy; Teaching Guides; Teaching Methods; Technological Literacy; Technology

ABSTRACT

This publication addresses the ways in which energy can be harnessed to improve the quality of human life. Seven units are included: (1) sundials; (2) solar houses; (3) greenhouse; (4) solar heaters; (5) windmills; (6) biomasses; and (7) photovoltaic cells. Each unit contains six subheadings: objectives; introduction; presentation and investigation; association and systematization; application; and bibliography. Presentation and investigation, which form the main part of each unit, consist of a series of investigations to be carried out with the design and development of functional products of technology. The section on application addresses general problems to be solved within the community. All units involve the students in decision-making as well as in the design and production processes of a wide range of solar collection devices. Evaluation of each unit has been left to the individual teacher. (MVL)

 * Reproductions supplied by EDRS are the best that can be made *
 * from the original document. *

This document has been reproduced as received from the person or organization originating it.

Minor changes have been made to improve reproduction quality.

• Points of view or opinions stated in this document do not necessarily represent official OERI position or policy.

Susanne Adlung

TO THE EDUCATIONAL RESOURCES
INFORMATION CENTER (ERIC)."

Educational Materials Linking Technology Teaching with Science Education: Technology in Life



BEST COPY AVAILABLE

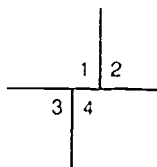

Cover photos

- 1 Photo Unesco/Paul Almasy
- 2 Photo UNATIONS
- 3 Photo Unesco/D Bahrman
- 4 Photo rights reserved

Science and Technology Education

Document Series No. 31

Educational Materials Linking Technology Teaching with Science Education: Technology in Life

by the Science and Mathematics Education Centre,
Curtin University of Technology,
Perth, Australia

Division of Science
Technical and
Environmental Education

UNESCO

ED-88/WS/52

Paris, 1988

P R E F A C E

The document series was initiated as part of UNESCO's Programme on the Teaching of Science and Technology to encourage an international exchange of ideas and information on science and technology education.

The present volume under the theme of "Technology in Life" addresses the ways in which energy can be harnessed to improve the quality of human life. It comprises seven units:

- Sundials: Solar Timing Devices
- The Solar House: A Passive Solar Structure
- The Green House: A Passive Solar Structure
- Solar Hot Water Heater, Solar Oven, Solar Still;
Solar Thermal Systems
- The Windmill: Using the Wind's Energy
- Biomass: Energy from Plant and Animal Materials
- Photovoltaic Cells: Solar Energy in the Future.

Each unit has been treated under six sub-headings: Objectives, Introduction, Presentation and Investigation, Association and Systematization, Application, and Bibliography. "Presentation and Investigation", forming the main part of each unit, consists of a series of investigations to be carried out with the design and development of functional products of technology.

The section on "Application" addresses general problems to be solved within the community. Since it is not possible to describe all possible communities, this part of the unit will require additional input from the teacher to specify the actual environment's concern, for example, reducing heat gain to a house, or building a greenhouse.

All units involve the students in decision-making as well as in the design and production processes of a wide range of solar collection devices. Evaluation of each unit has been left to the individual teacher. It could, however, take the form of a pencil and paper test and the decision-making/design/production processes involved in each case.

The materials have been prepared under the auspices of the Science and Mathematics Education Centre of the Curtin University of Technology, Perth, Australia, under contract with UNESCO. They were developed by Dr David Treagust as the Project Director. He was assisted by Ms Marjorie Beckingham and Ms Dorit Maor (Project Writers) and Ms Trudy Tanner (Word Processing). Their services are gratefully acknowledged.

The opinions expressed in the text are those of the authors and not necessarily those of UNESCO.

UNITS

1. SUNDIALS: SOLAR TIMING DEVICES
2. THE SOLAR HOUSE: A PASSIVE SOLAR STRUCTURE
3. THE GREENHOUSE: A PASSIVE SOLAR STRUCTURE
4. SOLAR HOT WATER HEATER, SOLAR OVEN AND SOLAR STILL: SOLAR THERMAL SYSTEMS
5. THE WINDMILL: USING THE WIND'S ENERGY
6. BIOMASS: ENERGY FROM PLANT AND ANIMAL MATERIAL
7. PHOTOVOLTAIC CELLS: SOLAR ENERGY IN THE FUTURE

CONTENTS

UNIT 1

	<u>Page</u>
(i) Topic: Sundials: Solar Timing Devices	
(ii) Objectives	1
(iii) Introduction	2
(iv) Presentation	3
Investigation	3
(v) Association and Systematization	13
(vi) Application	18
Bibliography	19

- (i) THEME: TECHNOLOGY IN LIFE
TOPIC: SUNDIALS: SOLAR TIMING DEVICES

(ii) OBJECTIVES

Upon completion of this unit students will be able to:

1. Construct sundials of various types.
2. Compare the accuracy of different sundial designs.
3. Demonstrate an understanding of how the sun can be used to tell the time of day.
4. Demonstrate an understanding of how the sun can be used to tell the time of the season.
5. Examine ancient and modern technological devices used to keep track of the time of the day and the seasons prior to the use of calendars and clocks.

(iii) INTRODUCTION

Humans have always attempted to keep track of time. They followed the seasons and learned when to plant crops. They also developed simple technology devices to help trace the apparent movement of the sun across the daily sky. These simple technological devices are called sundials.

In Egypt as early as 15th century BC they used a time reckoning device. It consisted of a slate block marked along its length with five equal divisions. At one end a raised projection cast a shadow upon the scale when the block was placed upon a flat surface in the sun.

Knowledge of the sundial came to the Romans from the Greeks about 290 BC. Generally though the dials produced in the time before Christ were astronomical models for demonstrating the annual cycle of the sun, while those produced in the time after Christ became diurnal time keeping devices.

An early form of sundial used by the church was the "scratch dial", a type peculiar to England as early as the seventh century.

The mechanical clock appeared in the late 14th century AD. The appearance of this clock did not stop the fascination with sundials which continued to be made in great variety and numbers from the 15th century onwards.

In the traditional sundial a shadow is cast by a gnomon or shadow stick located at the dial centre, and the time is indicated by the position of the shadow on a graduated plate or surface.

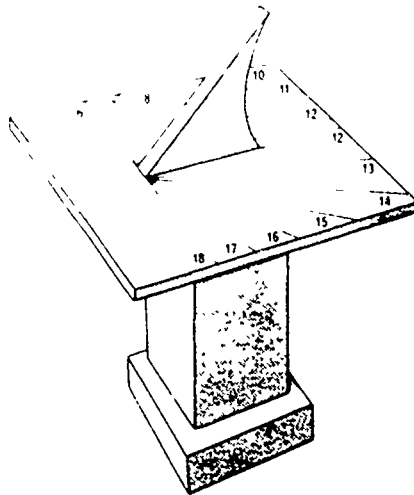

Traditional Sundial

(iv) PRESENTATION

This is the main section of the topic and consists of an investigation into the construction of three designs of sundials.

INVESTIGATION

A. Question: How can you develop simple sundials that can tell you the time of day?

I. SHADOW STICK SUNDIAL

B. Materials

A stick or length of dowel approximately 30 cms long

Corrugated cardboard approximately 30 x 30 cms

Pen

Watch

Plasticene

C. What you do: Setting up the materials

1. Push stick or length of dowelling through a piece of corrugated cardboard. Plasticene can be used to keep stick in an upright position.
2. Place shadow stick in a position that will see full sunlight all day. It should not be moved from this original position.
3. Make a mark on the cardboard every hour that corresponds to the position of the shadow. Label each shadow mark with the time at which it was taken.

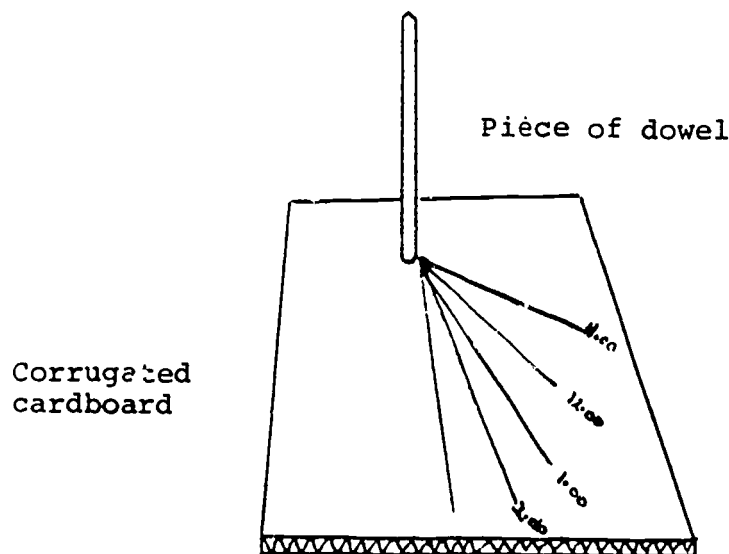

Shadow Stick Sundial

II. PAPER SUNDIAL

B. Materials

Construction paper

Compass

Ruler

Pen

Scissors

Template of model

C. What you do: Setting up the materials

1. Take template of the model, place on construction paper and cut exactly the same size and shape.

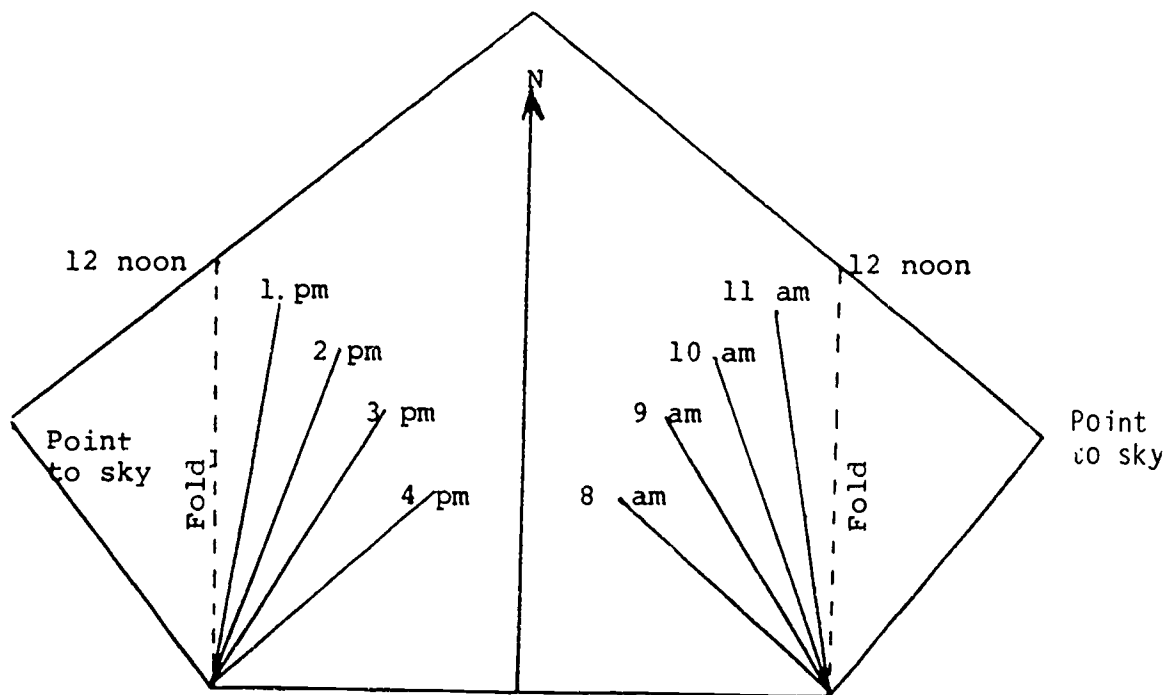

Template of Paper Sundial

2. Fold the sides so that they point to the sky when the sundial is laid on the ground.
3. Use your compass so that the arrow pointing North on your sundial is positioned correctly.
4. The folded sides will cast a shadow on the paper to indicate the time of day.
5. At hourly intervals throughout the day draw in lines as indicated and mark them with the appropriate time. The calibrated paper sundial can now be used on subsequent days to tell the time.

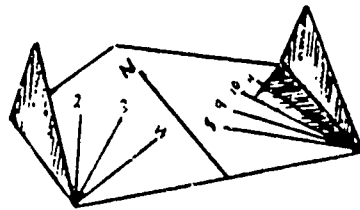

The paper sundial above shows a time of 10.00 am.

III. TRADITIONAL SUNDIAL

B. Materials

Glue

2 pieces of corrugated cardboard

Pen

Protractor

Scissors

C. What you do: Setting up the materials

1. On the cardboard base, use a protractor to mark off equal divisions as shown below.

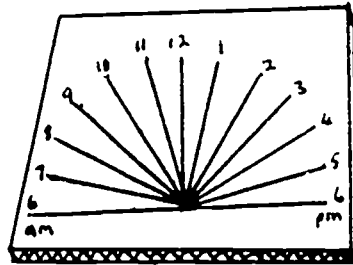

2. Cut out a triangular shape to fit onto the cardboard base. This piece called the gnomon will probably need modification. Initially the acute angle of the gnomon should be the same or a little larger than the latitude of the location in which it is to be located.

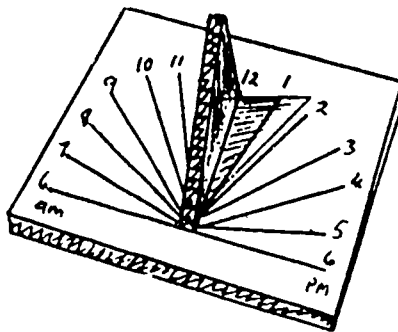

3. Attach gnomon to base with glue.
4. Place sundial outdoors at solar noon with the 12 marker pointing to North (in the Southern hemisphere) to the South (in the Northern hemisphere).
5. Check the shadow at 1 o'clock. If the shadow of the gnomon does not coincide with the 1 o'clock mark it will require modification and either a smaller or larger acute angle of the gnomon is needed.

D. What do you predict will happen?

Which of the three designs do you predict will be the most accurate?

E. Interpretation of Data

1. Using your watch, at a given time, compare the accuracy of the three model sundials.
2. Which model is the most accurate?

F. Conclusions

1. Explain why you think sundials do not remain accurate all the year round.

2. Did your prediction agree with your results? Explain any differences between your prediction and your results.

3. How does the sundial in this photograph work?



4. In the space below sketch sundials which are to be found in your environment

5. Design a sundial that is different to those described in this module. Draw it and explain your ideas.

G. Further Information

Today, with standardized time zones, the common traditional sundials are often in error as the local sun time at a particular place may vary up to half an hour from the local standard time. However, it is possible to construct a sundial that is accurate for all days of the year by designing a dial face which includes built in compensation for the equation of time, which is the difference between sundial time and the given standard time for a particular location.

In sundials the hour indicators are marked in straight lines. A pointer which will cast a shadow is placed at the centre of the lines and parallel to the Earth's axis of rotation. Then each 15° displacement of the shadow marks the passing of one hour.

Examples of Sundial Designs

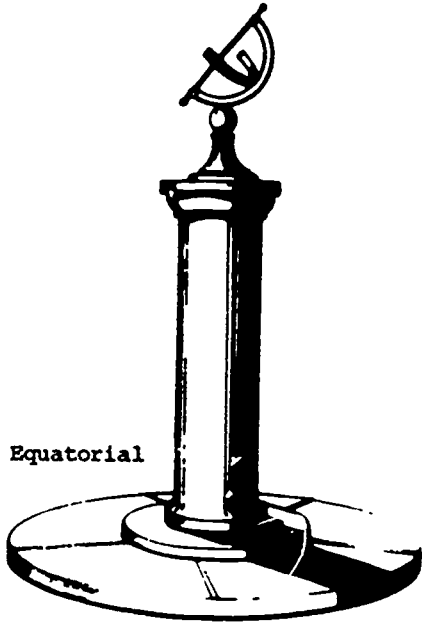

Equatorial

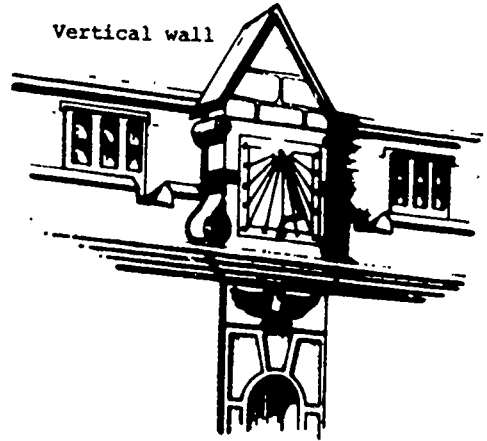

Vertical wall

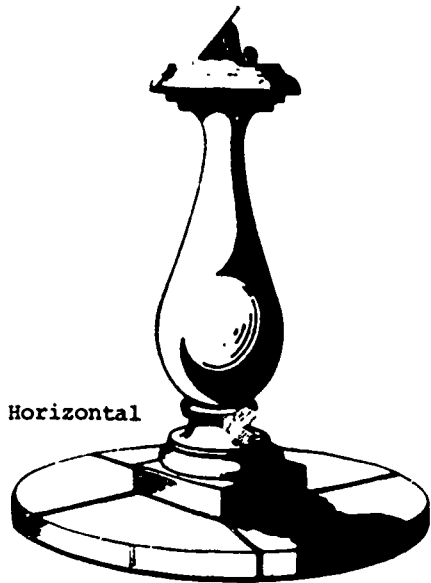

Horizontal

(v) ASSOCIATION AND SYSTEMATIZATION

In earlier centuries civilizations in a variety of countries developed their own systems for "telling the time" and for knowing the time of the summer and winter solstice. The solstice is one of two points at which the sun appears to be at its furthest position north or south. In the northern hemisphere the summer solstice occurs on about June 21st and the winter solstice occurs on about December 22nd. These correspond to the longest and shortest days respectively. In the southern hemisphere the seasons are reversed for these dates.

There are some famous examples of human invention and ingenuity to construct a technological device to tell the time of the season. Perhaps the most famous in the English speaking world is Stonehenge in Southern England. Stonehenge was built and rebuilt on the same spot several times over a span of at least seven centuries starting about 2800 BC. If a person stands at the centre of the ring of huge stones which is Stonehenge and looks to the northeast, through the middle of the three great arches can be seen the Heel Stone about 50 metres away. Here is the famous spot where the sun appears to rise on the longest day of the year. This event draws curious onlookers by the hundreds to view the midsummer dawn.

There are many more examples of ingenious devices, carved out of rock, mounted in the side of cliff faces, and stones erected with delicate precision to show the time of winter and summer solstice and indeed the times of the year. In the southwest of the United

States are many of these examples created and designed by the Indian people who lived there before European settlement.

Why were the inventors of these solar calendars interested in designing and constructing such devices?

It is possible for you to make a simple solar calendar to keep track of the sun's path and to mark especially the winter and summer soltices.

Find a location where you can see the horizon. Since this may not be possible, find a location where you can at least see the sun close to the horizon.

Using the horizon that you can see make a daily record of where the sun first and last appears in the east and west respectively. Do this on a weekly basis for a period long enough to observe the winter and summer soltice. Also observe the sun's rising and setting on a daily basis for a few weeks. In both occasions, record your observations of the position of the sun with respect to the horizon.

Position of the rising sun on the east horizon on a weekly basis

Position of the setting sun on the west horizon on a weekly basis.

Position of sun on a daily basis for two weeks (Choose either sunrise or sunset).

How could you use this information to develop a technological device which will help tell the seasons. Make a sketch of your design.

Make such a device and see if your plans and predictions work as well as you expect. Keep a record of your results.

In your locality or in your country find out how the seasons were recorded before calendars and clocks were invented. Describe your findings and draw sketches of the devices.

(vi) APPLICATION

Assume you became lost and had no contact with other people for several weeks or even months. Also assume that you could find enough food to eat to sustain you and that you had no clock or wrist watch. Describe how you would go about keeping track of

the days

the time of the day

the time of the year.

Draw sketches of any device you would use and explain how you would use it.

BIBLIOGRAPHY

Bedini, S.A. (1981). *Fire of Life, The Book of the Sun*. Australia and New Zealand Book Company.

Golding, P. (1981). An Unusual Sundial for the Southern Hemisphere. *Sunworld, International Solar Energy Society*, 5(2), 53-56.

CONTENTS

UNIT 2

Page

(i)	Topic: The Solar House: A Passive Solar Structure	
(ii)	Objectives	1
(iii)	Introduction	2
(iv)	Presentation	3
	The Problem	3
	Investigation 1	3
	Investigation 2	9
	Investigation 3	14
(v)	Association and Systematization	28
(vi)	Application	34
	Bibliography	35

(i) THEME: TECHNOLOGY IN LIFE

TOPIC: THE SOLAR HOUSE: A PASSIVE SOLAR STRUCTURE

(ii) OBJECTIVES

Upon completion of this unit, students will be able to:

1. Describe the technological elements in an efficient solar house design.
2. Describe the importance of landscape design in an efficient solar house.
3. Design an energy efficient house.
4. Build an energy efficient house.
5. Analyse a given system for use of solar energy.
6. Gain an appreciation of how efficient solar house design can affect energy conservation.

(iii) INTRODUCTION

Humans have always been seeking to make their living conditions as comfortable as possible. As long ago as 2,000 years in the Middle Eastern countries they developed an efficient method to keep the air temperature down. Underneath their buildings they built a long tunnel partly filled with water. Into this water dipped screens made of jute which hung from underneath the floorboards. Water moved up through the jute screens and air moving past the screens caused the water to evaporate. This process cooled the air around the screens. Natural convection currents circulated this cool air through the various rooms of the house.

The Egyptians found ways to keep their houses warm by using solar energy to give them heat. With the advent of glass around the first century AD expensive homes were built by Romans using glass windows to trap solar heat. In the past, because of apparent abundance of coal and oil and low energy prices, the design of energy efficient houses was only rarely considered. Coal gas was widely used in Europe and America for heating in the 19th century. Around the middle of the 19th century oil began to be used on a large scale to replace coal as a fuel. In the late 1920's the development of high pressure pipes and the ability to lay pipes at a reasonable cost made the delivery of gas to cities economical. Natural gas is a clean burning fuel that can be used to provide heat in furnaces in conjunction with coal and oil. Nowadays energy issues have made it necessary to plan correct orientation and good design so that solar energy can be utilized to save these fossil fuels and money.

A building using solar energy is carefully planned to take advantage of local sun position and weather conditions. Making use of day-time sun for night time heating and cooling itself in the summer, in order to get comfort as well as energy efficiency. A passive solar building is one that is designed to use its architectural and structural elements (floor, walls, windows and roofs) to collect, store and distribute some of the heat required by the building and an active solar design would incorporate devices that would discharge unwanted heat to the environment.

(iv) PRESENTATION

This is the main section of the topic and consists of a series of problems to be solved, and the design and development of a functional product of technology.

THE PROBLEM

A family wants to build a house using solar energy taking into account the sun's position and weather conditions. What advice would you give the family in order to design such a house and what solar devices would you suggest they incorporate?

INVESTIGATION 1

- A. Question: Which direction should a house face (North, South, East or West) to make maximum use of solar energy?

B. Materials

2 cardboard boxes approximately 60 x 30 x 30 cms

Masking tape

Glass or clear cellophane

2 thermometers

A directional compass

C. What you do: Setting up the materials

1. Paint the two boxes both white.
2. In one end of each box cut a large window 25 x 25 cms square. See diagram 1.
3. In the centre of the opposite end of each box make a hole and push the bulb end of the thermometer through. Use tape to fix the thermometer firmly but make sure that it can be easily read.
4. Seal each box shut at the top.
5. Over the cut out window attach glass or clear cellophane.

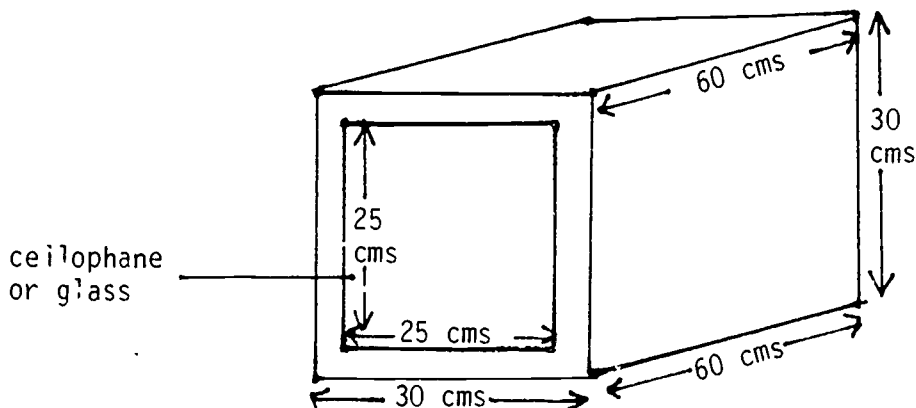

Diagram 1

6. Using the compass place one box with the window facing north and the other box with the window facing south. Make sure both boxes are in full sun.

D. What do you predict will happen?

In the following space give your reasons for which direction will give the higher temperature gain in the two houses.

7. Every 5 minutes, read the temperature in the box. Record on the table below.
8. Continue to read and record the temperatures until it reaches a constant reading. (If it is a very hot day take readings every 2 minutes instead of 5 minutes.)

RESULTS TABLE

Temperature

Time	North facing window	South facing window
5 mins		
10 mins		
15 mins		
20 mins		

E. Interpretation of Data

1. How long did it take for the box with the north facing window to reach maximum temperature?

2. How long did it take for the box with the south facing window to reach maximum temperature?

F. Conclusion

1. Did the results agree with your prediction? Explain any differences between your results and your prediction.

2. In which direction do you think the window in the house should face in order to make maximum use of warm winter sun?

3. How would you minimize the heating effect of the sun through the window in the summer?

G. Further Information

To make maximum use of warming winter sun there should be maximum window areas on the north wall (in the southern hemisphere). In the northern hemisphere south facing windows would be used for maximum warming.

Windows in the north wall should allow the low angle winter sun to enter the house but exclude the high angle summer sun from doing so.

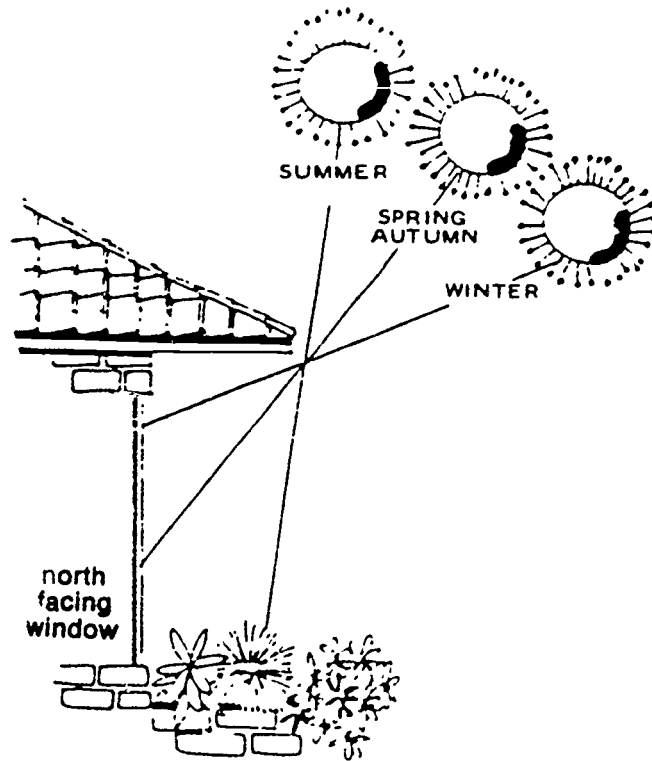

Seasonal Midday Sun Angles in the Southern Hemisphere

A house should have a sufficient roof overhang on the north side to minimize the amount of summer sun from entering the house. In winter the sun is low enough to shine into the windows providing warmth.

White curtains, blinds and awnings can help reflect heat in summer. Also if windows in the east and west walls are avoided or kept to a minimum the substantial unwanted early morning and late afternoon summer sun can be prevented from entering the house. The colour of the house and the roof can also affect the temperature in the house. In hot climates, houses are often painted white to reflect the sun's rays.

INVESTIGATION 2

A. Question: Does the shape of the roof effect the temperature inside the house?

B. Materials

2 boxes constructed in Investigation 1

2 thermometers

Cardboard, one piece 80 x 60 cms, one piece 30 x 30 cms

Scissors

Tape

Paint

C. What you do: Setting up the materials

1. Take one of the boxes used in Investigation 1 making sure that the thermometer is still firmly attached and the top is taped flat. This will represent a flat roofed house. Be sure this surface is painted white.
2. Take both pieces of cardboard and paint them white.
3. Make a fold along the longer side of the piece of cardboard. See diagram.
4. Fold the smaller piece of cardboard in half diagonally. Cut along this fold to make two triangles. See diagram.

5. Tape the two triangles into either end of the roof shape.
6. Place roof on the top of the second box.

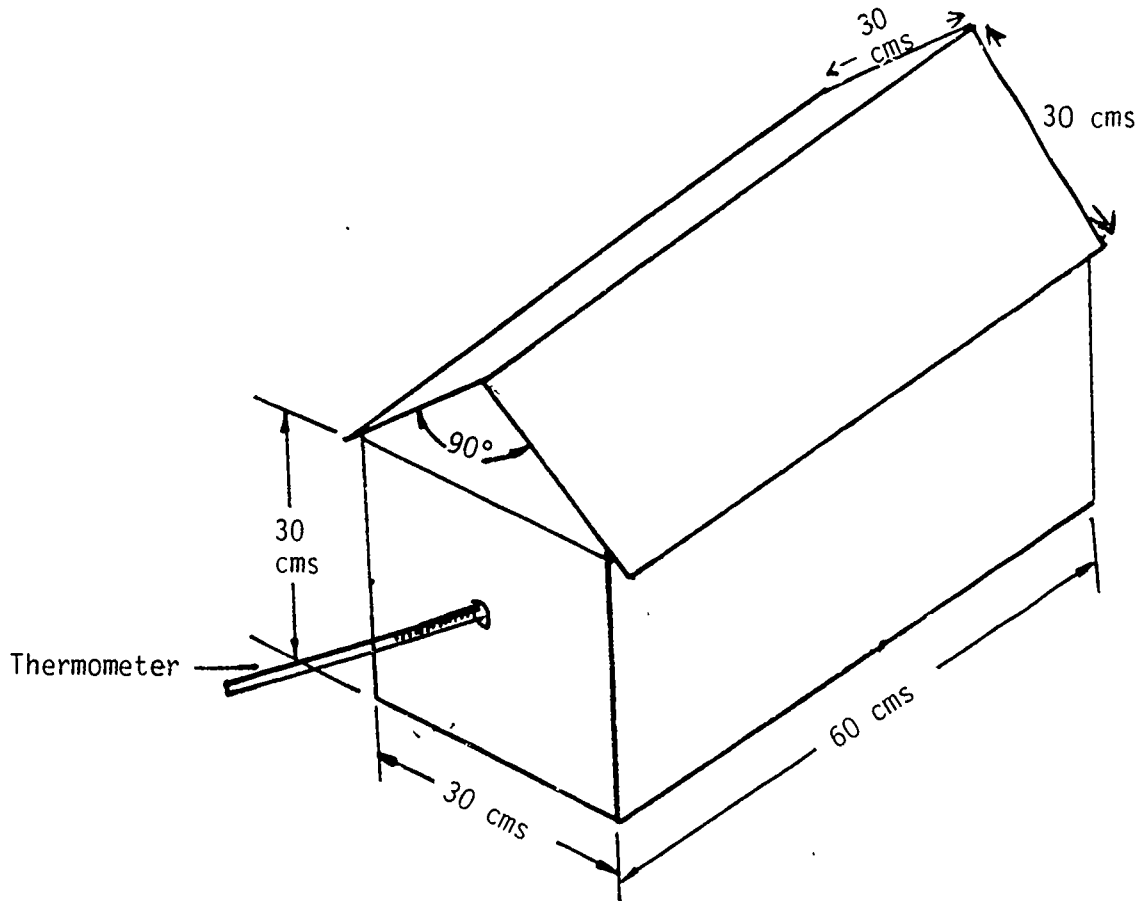

7. Put the two boxes into the sun with the window ends facing the same direction.

D. What do you predict will happen?

In the following space describe your prediction for the reading of the thermometer in the two houses.

8. After 5 minutes read the temperatures and record on table.

9. Continue to read and record the temperatures every 5 minutes for 20 minutes or until a constant temperature is reached.

RESULTS TABLE

Temperature

Time	Flat roof	Folded roof
5 mins		
10 mins		
15 mins		
20 mins		

10. Plot the data from the results table on the graph using two different colours for the two different roofs results.

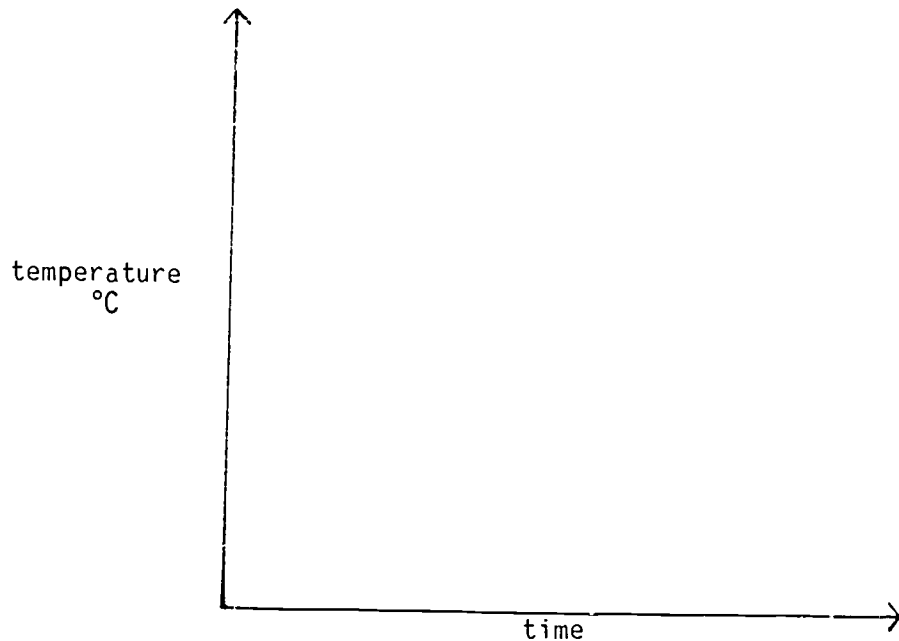

E. Interpretation of Data

1. How long did it take for the box with the flat roof to reach maximum temperature?

2. How long did it take for the box with the folded roof to reach maximum temperature?

F. Conclusion

1. Did the results agree with your prediction? Explain any differences between the results and your prediction.

2. Which roof design would you use to make maximum use of warm winter sun?

3. Which roof design would you use to minimize the effect of the hot summer sun?

4. What do you think would happen if we painted the roofs black instead of white? Give reasons for your answer.

INVESTIGATION 3

- A. Question: How can we help to reduce heat loss or heat gained between the interior of a building and the surroundings?

B. Materials

2 houses as constructed for Investigation 1 with thermometer still inserted (both with flat tops)

4 thermometers (2 for each house)

Tape

Insulation materials (corrugated cardboard, styrofoam or paper)

C. What you do: Setting up of materials

1. On box 1 tape a thermometer along one of the long sides.
2. Remove sealing tape from top of box 2 carefully.

3. Place chosen insulation material over all walls and top of box but exclude the window area. Tape where necessary. Arrange carefully around thermometer that is inserted through the box.
4. Close lid of box and tape.
5. Tape second thermometer on the outside of the box 2 in the same position as box 1.

D. What do you predict will happen?

Do you predict there will be the least temperature gain in the insulated house or non insulated house? Explain your answer.

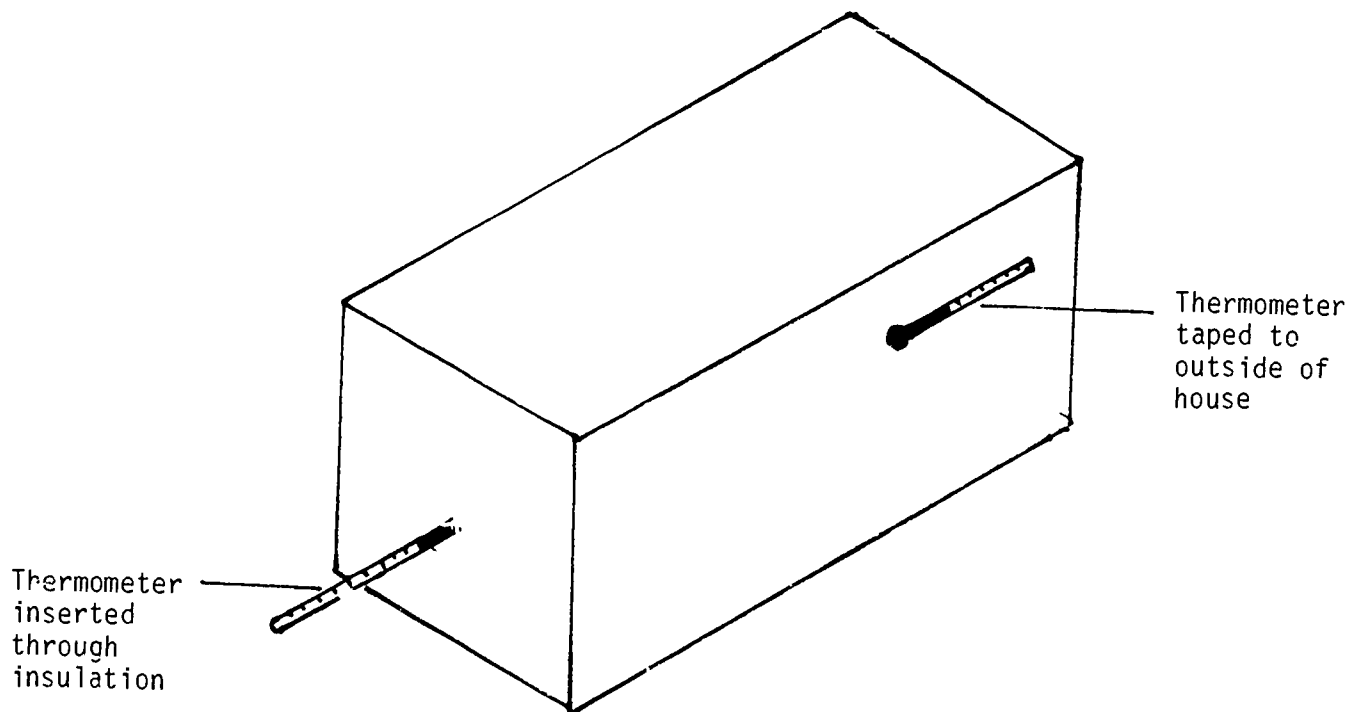

6. Place the two model houses in the sun. Be sure that the side of the box where the thermometer is attached is facing away from direct sunshine.
7. Read the thermometers every 2 minutes for up to 20 minutes or until no further change and record results on table.

RESULTS TABLE

Time Minutes	Box without insulation		Box with insulation	
	Inside temp. (°C)	Outside temp. (°C)	Inside temp. (°C)	Outside temp. (°C)
2				
4				
6				
8				
10				
12				
14				
16				
18				
20				

8. Plot the inside temperatures of the two houses on a graph, using two different colours for the two models.

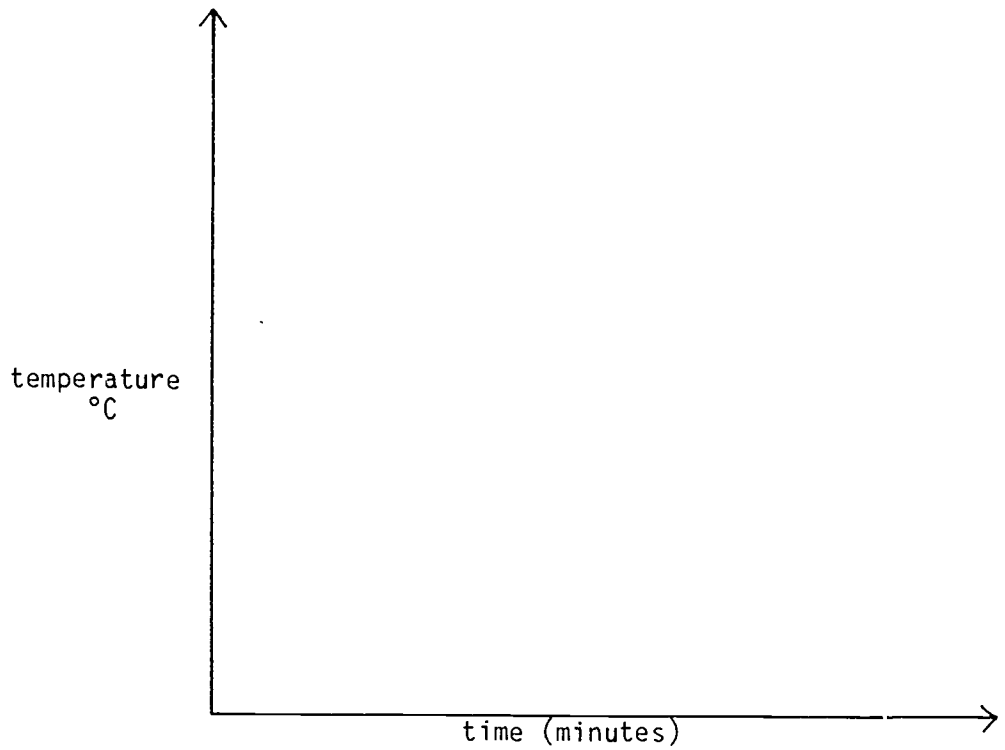

E. Interpretation of Data

1. How long did it take to reach the highest temperature in each house?

House with insulation _____ min.

House without insulation _____ min.

2. What was the maximum temperature gain for each house?

House with insulation _____

House without insulation _____

3. What was the median temperature rise for each house model?

House with insulation _____

House without insulation _____

F. Conclusion

1. Did your results agree with your prediction? Explain any differences between your results and your prediction.

2. Which house from this investigation would you build to prevent heat gained in summer or to keep heat in the house in winter? Explain your answer.

G. Further Information

Insulation works in two ways. If cool air is trapped inside a house then insulation can keep out the heat (Diagram 1). In winter the heat from fires can be kept in by insulation (Diagram 2). The arrows on the diagrams represent reflected heat.

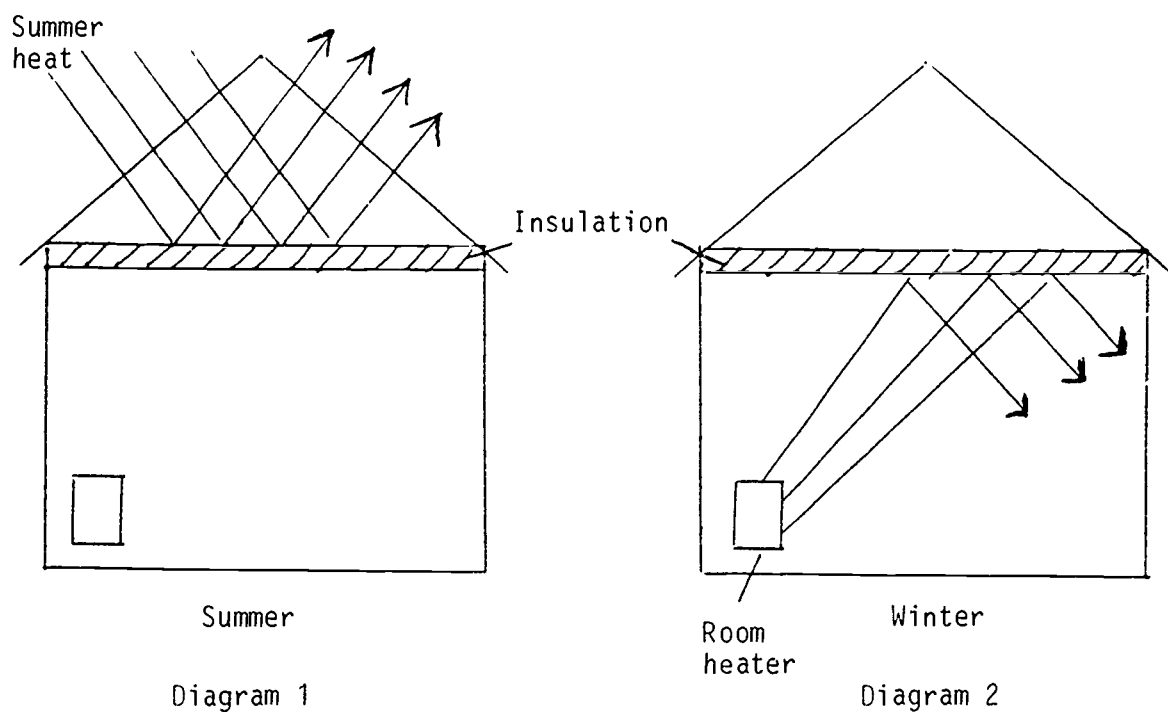

In this way home owners can reduce their use of energy for heating in winter and cooling in summer. As well as insulation in the ceiling, insulation between walls can be utilized to increase effectiveness. Heating and cooling costs can also be reduced by up to 80% by building houses in the ground or partially covered by earth. This is because the

temperature of the earth two metres below ground level is fairly constant. The earth only changes about 5°C between night and day, and summer and winter. Underground houses have been built for up to 2,000 years. Nowadays partially underground houses are becoming increasingly popular.

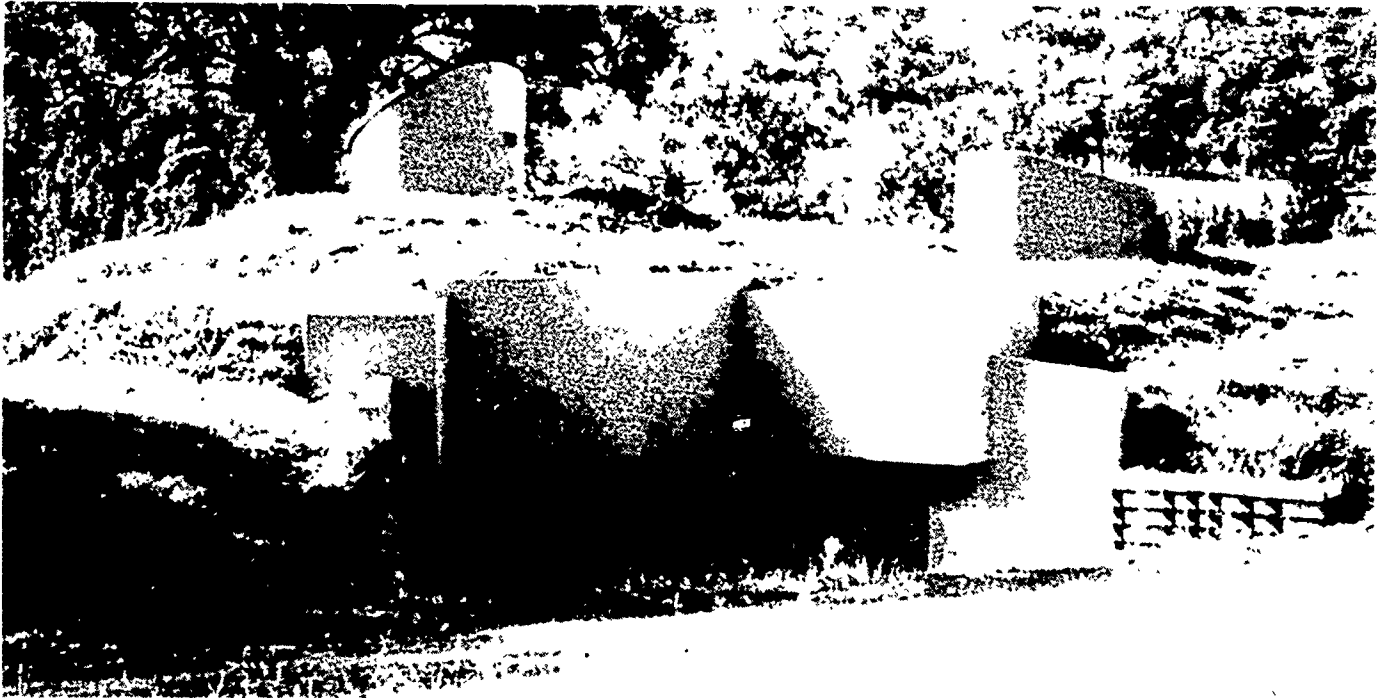

Prize winning design for underground house in Australia

As technology changes and develops means of insulation have been improved. Materials such as fibreglass and metal foil are used together with double brick walls which trap air in between the two layers of bricks.

You can obtain information about which materials to use for designing a house with the correct insulation from a consulting engineer. To design an effective cooling system for a building an engineer will carry out a "heat load analysis" of that building. This involves calculating the total energy flow (in watts) through the walls, windows, floor and roof of the building. The smaller the energy flow the more effective is the insulation of the building which means less expense to make it cool in the summer and warm in the winter.

This energy flow can be calculated by using the formula

$$\text{ENERGY FLOW} = \text{AREA} \times u \times k$$

where

1. area = the expanse through which the heat energy will flow (in m^2)
2. u = the heat transfer coefficient of the particular material for which you are calculating the heat flow (in $\text{w}/\text{m}^2.\text{k}$)
3. k = the temperature difference between the outside temperature and the desired inside temperature (in degrees Celsius).

Example: To calculate the energy flow through an outside cavity brick wall 10 m long x 3 m high when the temperature outside is 37°C and the preferred inside temperature is 25°C .

$$\begin{aligned} \text{ENERGY FLOW} &= \text{area} \times u \times k \\ &= (10 \times 3)\text{m}^2 \times 1.9\text{w}/\text{m}^2.\text{k} \times (37-25) \\ &= 30\text{m}^2 \times 1.9\text{w}/\text{m}^2.\text{k} \times 12 \\ \text{ENERGY FLOW} &= 684 \text{ watts} \end{aligned}$$

You will see from the following list that the energy flow depends on the materials used and the construction type used in the building (ie. the "u" value varies).

Examples of Heat Transfer coefficients, u

cavity brick with indoor plaster	1.9 w/m ² .k
concrete, dense, with indoor plaster	3.8 w/m ² .k
concrete with ceramic tiles	3.1 w/m ² .k
concrete block indoor plaster	2.6 w/m ² .k
cavity concrete block, indoor plaster	1.6 w/m ² .k

In the above examples note that the two cavity construction types, which means they incorporate air spaces in their design, have low heat transfer coefficients (1.9 w/m².k, 1.6 w/m².k) and therefore they are more efficient insulating materials.

EXERCISES

1. You have a house which is 12 m long x 3 m high. It is made out of concrete blocks with indoor plaster. The outside temperature is 35°C and the preferred inside temperature is 24°C. Calculate the energy flow for this house.

2. Which kind of building material would you choose in order to have the least energy flow? Explain your answer.

Indirect heating and direct cooling in the design of a house

In the following diagrams explain how indirect heating is occurring.

(a) Roof pond.

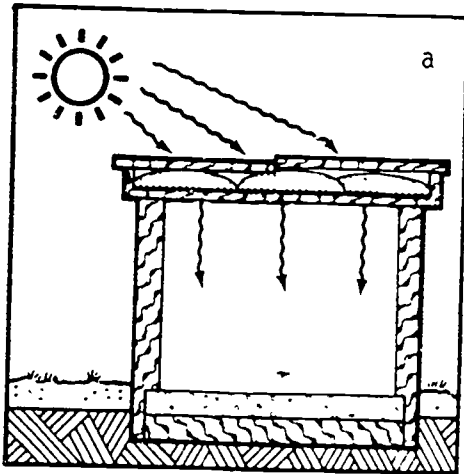

(b) Thermal mass wall.

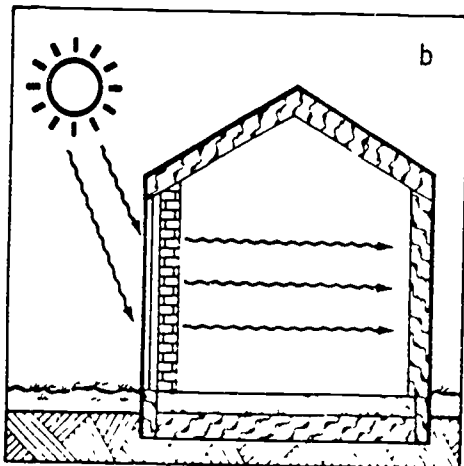

In the following diagrams explain how direct cooling is occurring.

(c) By natural ventilation.

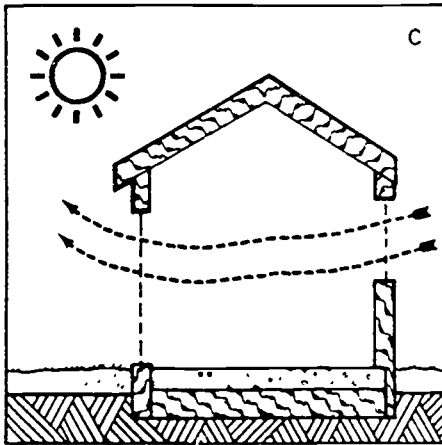

(d) By radiation to the night sky.

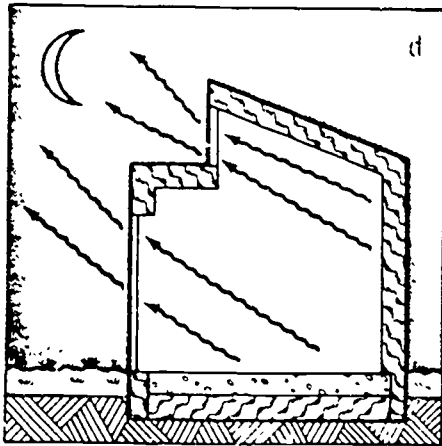

Conserving energy and increasing the level of comfort in the house is mostly achieved by the structural features of the house and the landscaping of the building site.

- (e) The long axis of the house should lie on an east-west orientation.
- (f) The main living daytime areas should face north in the southern hemisphere and south in the northern hemisphere.

Landscaping

Some of the landscaping features that should be considered are:

- (a) Trees and shrubs can significantly lower air and ground temperatures in summer.

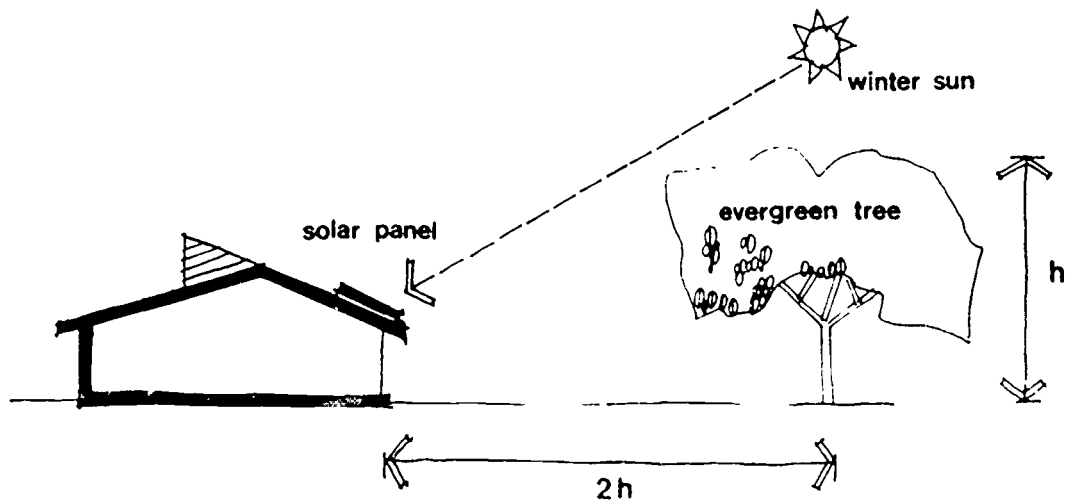

- (b) Ground cover can lower ground temperature, reduce glare and reduce reflected heat in summer.

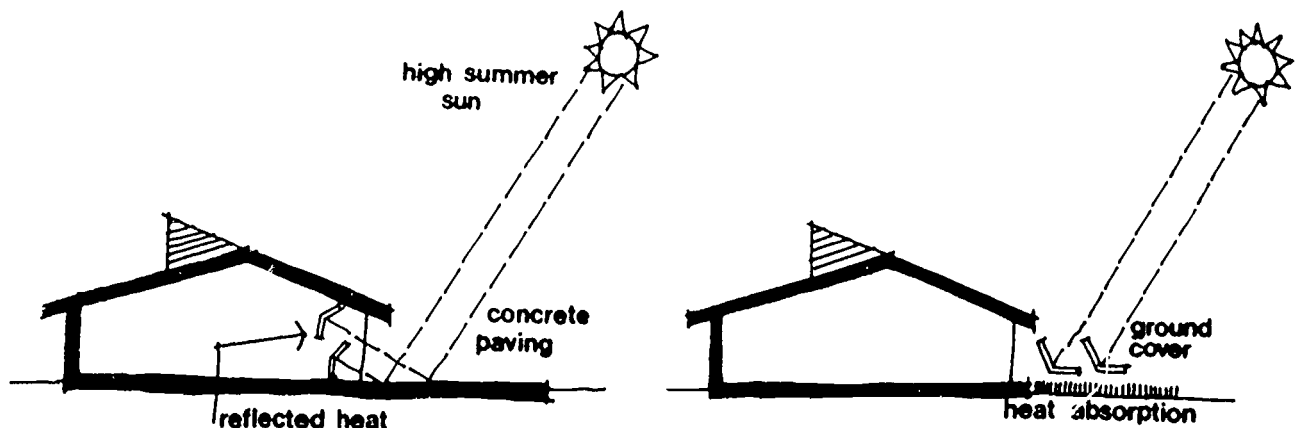

- (c) Windbreak planting assists wind and dust control and reduce heat loss in a building in winter.

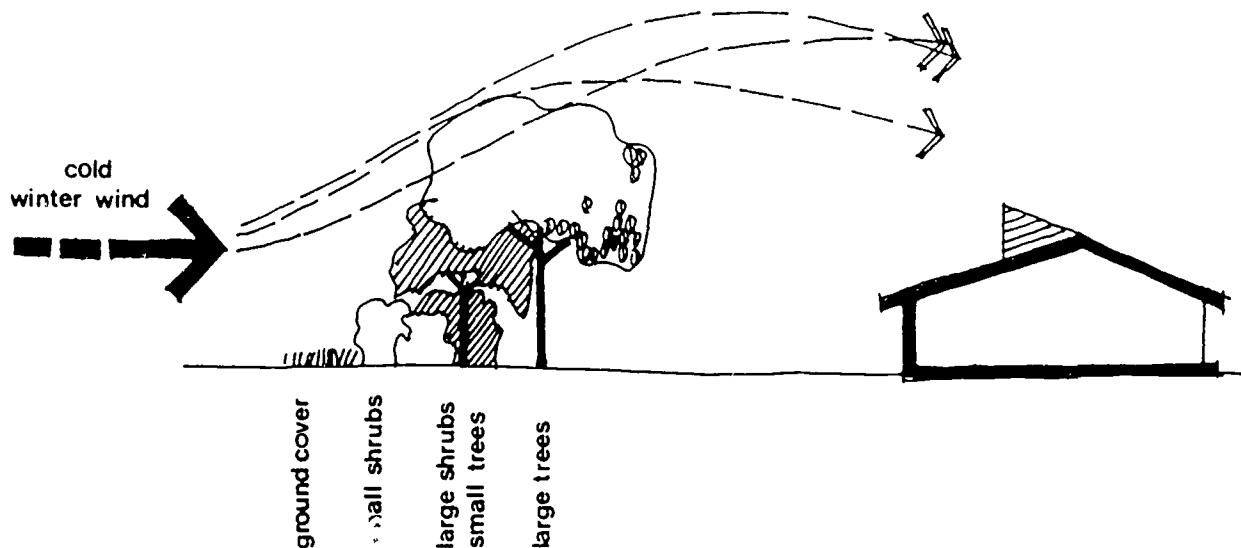

- (d) Deciduous trees and creepers provide shade in summer and allow warming winter sun to enter the house.

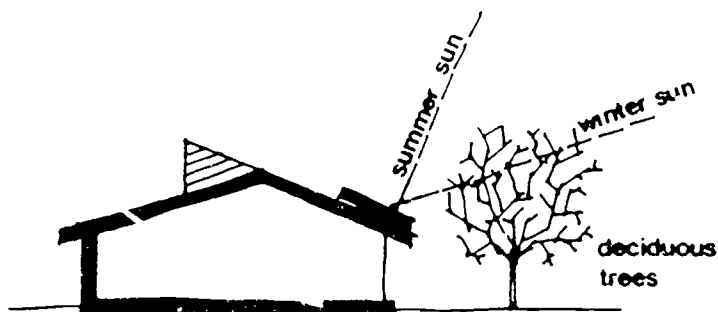

- (e) Evergreen trees should be planted reasonably close to the west wall to block summer heat in the afternoon.

(v) ASSOCIATION OR SYSTEMATIZATION

In order to answer the original problem concerning the family and their solar house now: DESIGN A LOW ENERGY SOLAR HOUSE.

The house should have:

1. Minimum heat gain in summer.
2. Maximum heat gain in winter.
3. Minimum heat loss in winter.

A. Draw a plan of your design that indicates:

1. The orientation of the house.
2. Day-time and night-time areas.
3. The positioning and size of the windows.
4. The placing of insulation.
5. The ventilation in the house.
6. Roof shape and colour.
7. Landscaping details.

My Design of a Low Energy Solar House

B. List the materials you will require.

C. Build the house and create the landscape.

D. In addition to the structure and landscaping of the solar house, list other solar devices that could be incorporated into the house design.

E. An Environmental Conservation System

We have been discussing the elements in an efficient solar house design which also incorporates the correct use of landscaping. Now we consider an environmental conservation system which has the ability to exist totally on solar energy.

Here is an example of an environmental conservation system in the country sustained by sun, wind and rain. On the picture you will find marked numbers 1 to 5 which indicate an area where energy is being used. Refer to each number and give a full explanation as to how you feel energy is being used at that area.

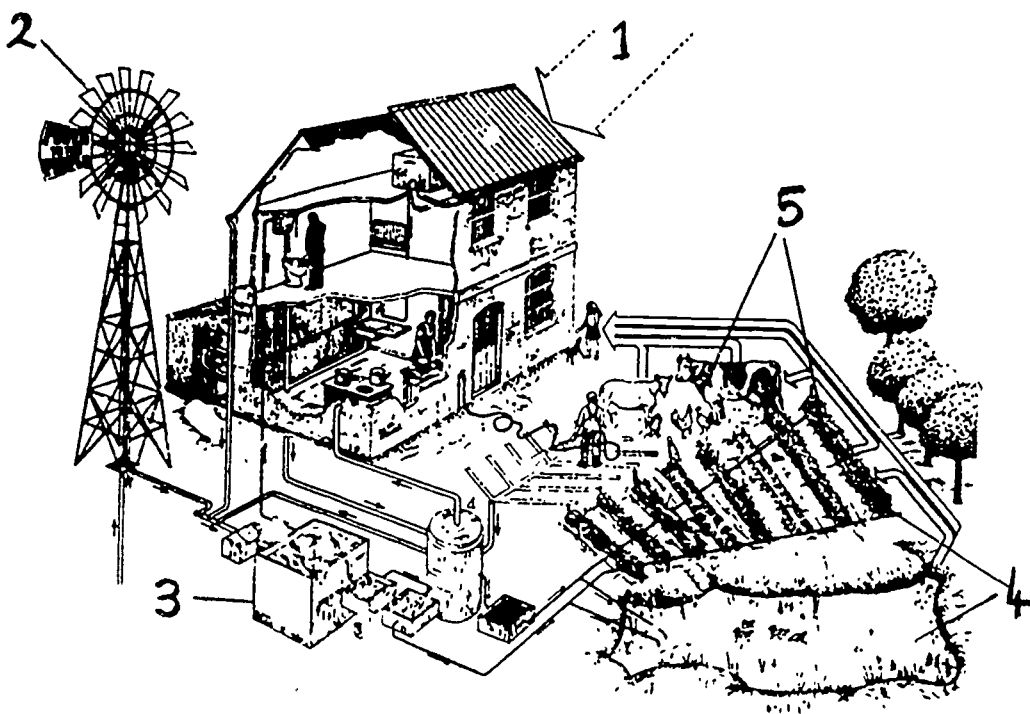

Environmental Conservation System

1. Solar roof

2. Windmill

3. Rain water collection.

4. Water use to fish pond and vegetable garden.

5. Vegetable and animal production.

Not all houses are built with energy conservation in mind but it is sometimes possible to make adaptations to make use of the sun's energy.

Below is an example which has not taken into account efficient use of solar energy. However, the inhabitants of the houses have added attached glass conservatories to collect heat for use in their homes. In this way they have improved their living condition and in the long term will save money by making use of solar energy.

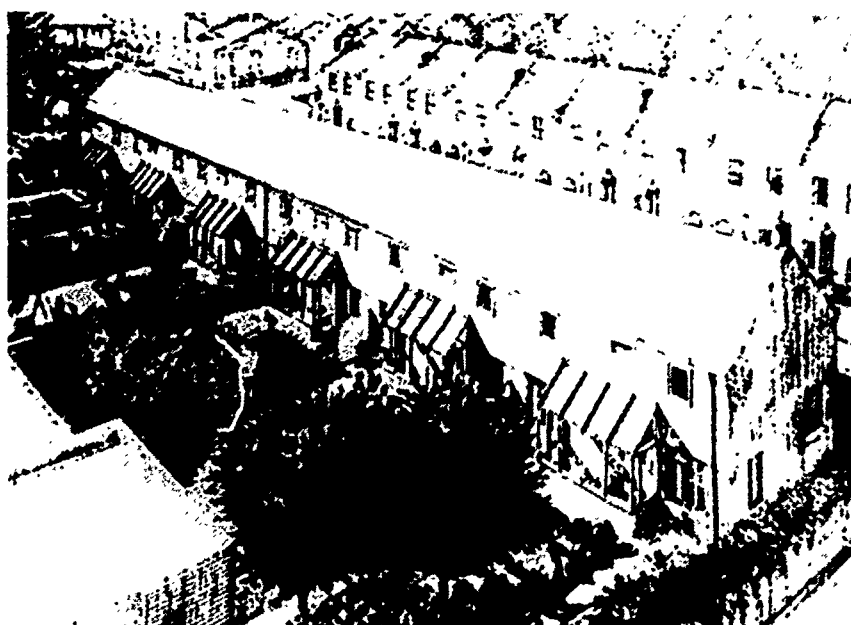

(vi) APPLICATION

Examine your own house or those of your neighbours and determine whether or not they meet the solar principles for efficient house design which you have learned in this topic.

Prepare a plan of action (which could reasonably be accomplished) to redesign aspects of your house (or your neighbours) which would help make it more energy efficient in terms of following the solar principles used in this topic.

Is it feasible to carry out any of these plans? If so, contact persons who are knowledgeable about building design and landscaping and make any possible and permissible change to help improve the energy efficiency of the house.

BIBLIOGRAPHY

Baggs, D.W. (1983). Australia's first passive-solar earth covered dwelling. Solar Progress, 4(3).

Conservation of heated and cooler air. (1976). Energy Conservation Resources for Education.

Dekkers, J., O'Loughlin, M., Treagust, D., Vlahov, S. (1985). Energy from the Sun. Solar Energy Education Project, W.A.

Den-Juden, H. (1980). Low Energy Housing in South Australia. Department of Mines and Energy.

Energy, Lower secondary science. (1983). Curriculum Branch, Education Department of Western Australia.

Heffernan, D.A., Learmonth, M.S. (1981). The world of science. Longman, Cheshire, England.

Miller, H. (1981). Passive Solar Principles. Sun World, 5(6).

Science and Society, Teacher's Guide. (1978). Curriculum Branch, Education Department of Western Australia.

W.A. Gould League. Fun with Solar Energy. Education Department of Western Australia.

CONTENTS

UNIT 3

Page

(i)	Topic: The Greenhouse: A Passive Solar Structure	
(ii)	Objectives	1
(iii)	Introduction	2
(iv)	Presentation	3
	The Problem	3
	Investigation 1	4
	Investigation 2	13
	Investigation 3	20
	Investigation 4	29
(v)	Association and Systematization	35
(vi)	Application	36
	Bibliography	39

(i) THEME: TECHNOLOGY IN LIFE

TOPIC: THE GREENHOUSE: A PASSIVE SOLAR STRUCTURE

(ii) OBJECTIVES

Upon completion of this unit, students will be able to:

1. Identify that solar energy is essential for plants to grow.
2. Know that the greenhouse is a product of technology that has been invented to meet the particular need of growing plants in colder climates and in the winter time.
3. Solve a given problem by carrying out investigations with passive solar structures.
4. Comprehend the effectiveness of the greenhouse by understanding the use of technology including its interdependence and inter-relationship with science.
5. Develop the ability to design and construct a functioning greenhouse as a technological product.
6. Show an appreciation of the use of passive solar structures through history and by examples illustrate the direct influence technology has on our own lives in general.
7. Be introduced to the organization and sociology of the work of a gardener.

(iii) INTRODUCTION

Cultivating plants under cover has been practised by gardeners from the earliest times. Since Roman times when they used glass to protect their fruit trees from the wind, humans have been constantly using technology to meet particular needs. In the middle ages the enormous popularity of citrus fruits in Europe caused the development of plant houses to overcome the problems of winter. By the 1500's buildings where citrus fruits could be raised began to appear in Europe. In the early 17th century the first glass version appeared in Germany which was heated by four furnaces. Later in the 18th century they began to look at making a more efficient structure rather than one just to be a protection against low temperatures and wind.

By the early 1800's work was developed on the best forms of structures and angles of glass to make the most of the sun's rays on the building which had become known as a conservatory or a greenhouse.

Cast iron played an important role in Victorian greenhouses. Hot water pipes heated both air and a deep soil bed.

The great greenhouse revolution came with the use of steam and hot water heating. In recent times big changes have occurred in greenhouse technology through electronics, materials and new manufacturing processes all to improve plant growth.

(iv) PRESENTATION!

This is the main section of the topic and consists of a series of problems to be solved, and the design and development of a functional product of technology.

THE PROBLEM!

A group of students want to enter an agricultural competition and to surprise other students by producing a food not typical for the winter season. They decide to grow tomatoes which usually grow in the summer.

At their disposal they have the following materials: sheets of plastic, glass, pieces of wood, hammers, nails.

1. How would you advise students to grow their tomatoes in the winter season? Describe the type of construction which is needed for the plants to grow.

Your ideas

Your sketch

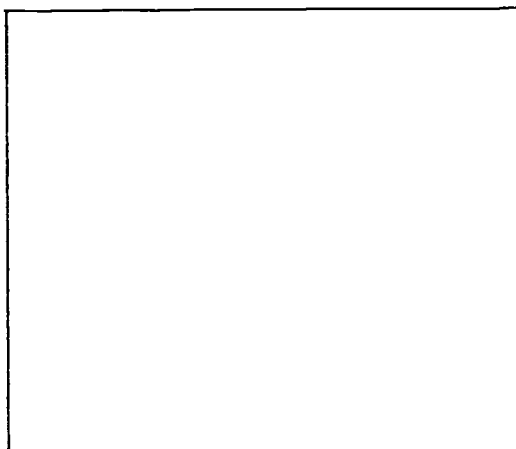

2. Describe the conditions that you think will enable the students to grow tomatoes successfully in winter.

The following experiments will help you to discover the best conditions in which to grow plants successfully.

INVESTIGATION 1

- A. Question: How do different materials affect the rise in temperature of the enclosed space?

To answer this question you will need the following materials and will need to set up the materials as shown as you do this investigation.

- B. Materials

3 identical cardboard boxes (e.g. shoe boxes approximately
30 x 20 x 15 cms)

3 thermometers

Tape

Scissors

Piece of glass

Clear plastic sheet

C. What you do: Setting up the materials

1. Cut a hole in all boxes as shown.

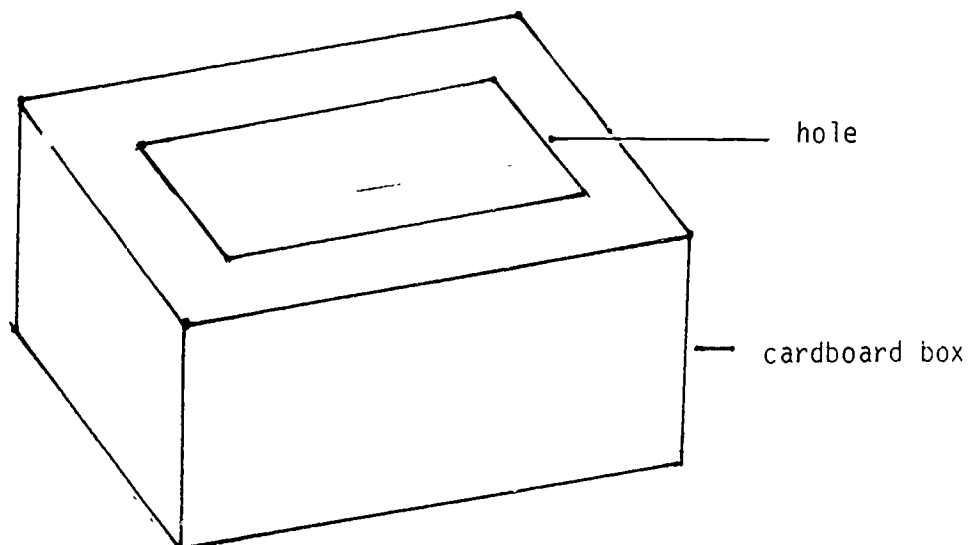

2. Punch a hole in one end of each box and insert a thermometer in each box.

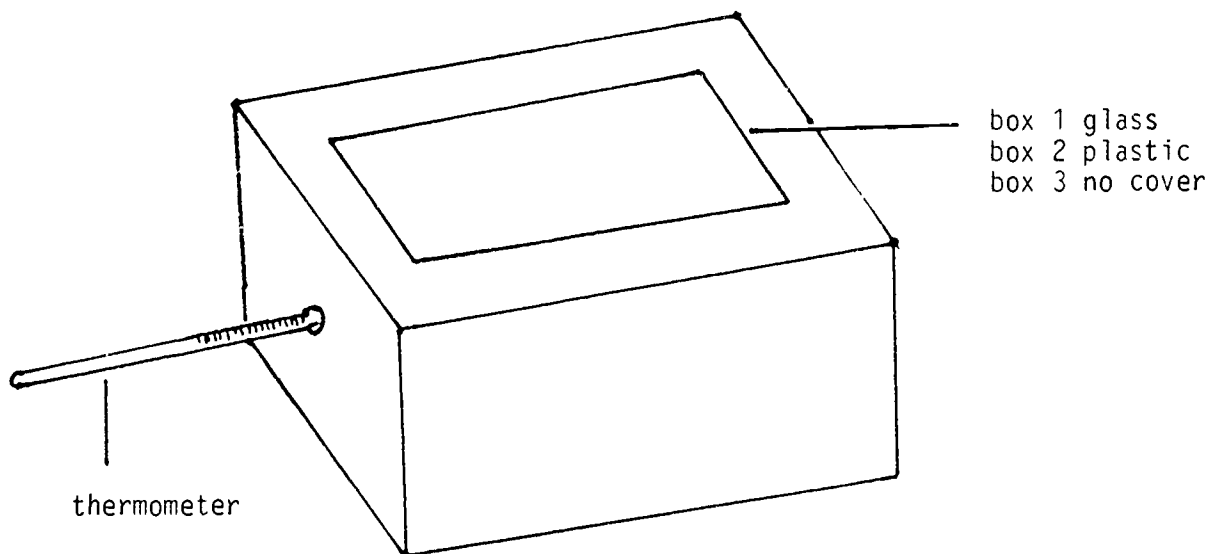

3. Place a glass cover on the top of one box.
4. Place some plastic sheeting on top of the second box.
5. Leave the third box uncovered.

D. What do you predict will happen?

In the following space describe your predictions for the reading of the thermometers in the three boxes after 3, 5, 10, 15, 20 minutes.

6. Use the table shown below to collect your data.

Time \ Box No.	Box 1	Box 2	Box 3
0 min			
3 min			
5 min			
10 min			
15 min			
20 min			

7. Record the temperature on each of the three thermometers before you take the prepared equipment out into the sun.
8. Leave the apparatus in the direct sunlight for 20 minutes.
9. Record in table form the temperature of each thermometer for the times indicated.

E. Interpretation of Data

1. What were the changes in temperature before and after placing each box in the sun?

Box 1 _____

Box 2 _____

Box 3 _____

2. In which box was the greater difference in temperature?

3. Is there a difference between the temperature changes in the boxes with the glass and plastic covers?

4. Why did we need box number 3?

F. Conclusions

1. What reason can you give for the differences in temperature gain from the uncovered box to the covered boxes?

To examine the effectiveness of glass or plastic as heat absorbers, it was necessary to compare the temperature inside the boxes with the covers with the temperature in the box without any cover. Box number 3 is called a "control" for your investigation.

2. Describe in your own words what is meant by a "control".

3. Did these results agree with your prediction? Explain any differences between your results and your prediction.

The greater the temperature gain the more effective the system will be. This difference that you observed in the temperature gain is called The Greenhouse Effect.

4. If the temperature gain is too great, this will damage the plants. How can we avoid this problem?

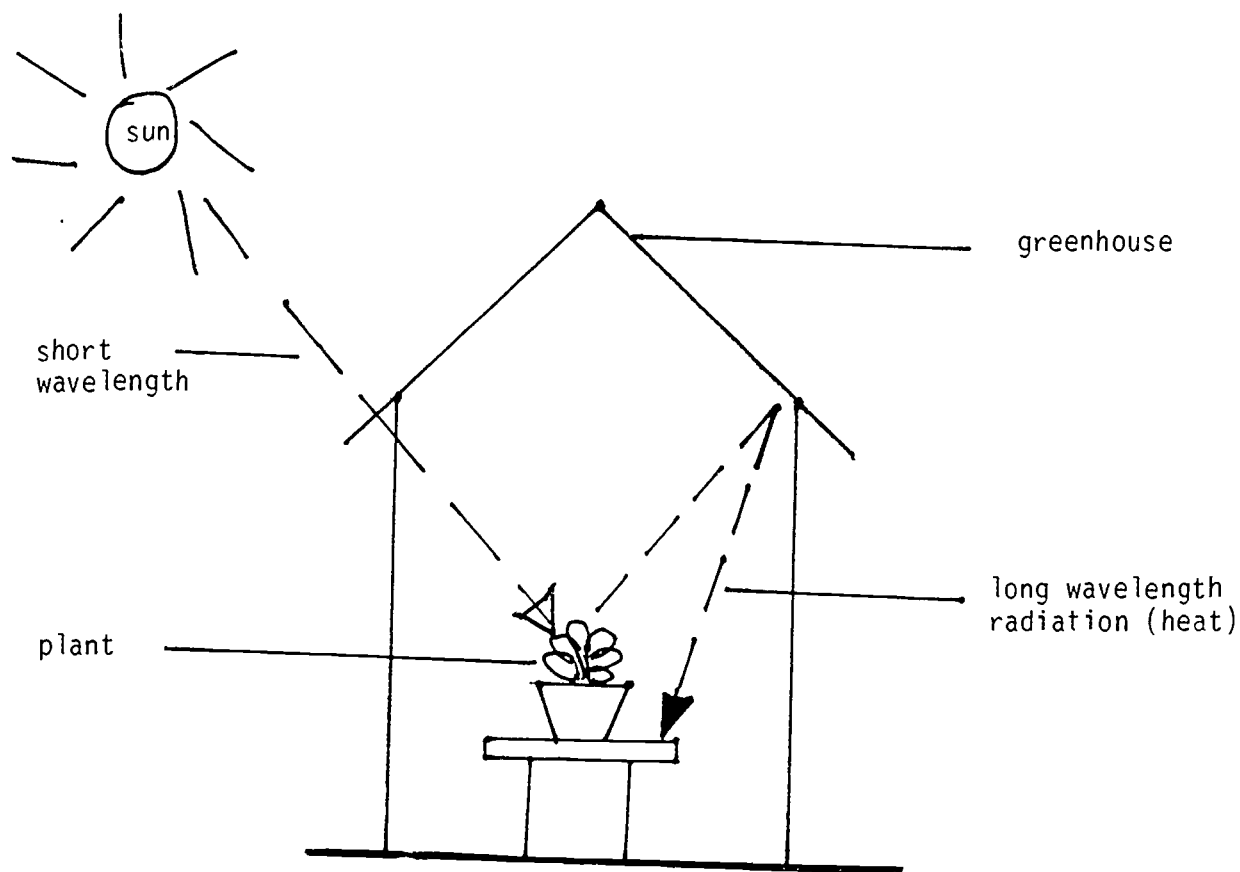
G. Further InformationThe Greenhouse Effect

In the greenhouse the glass or plastic covering lets the light inside. This is short wave radiation. Inside the greenhouse the ground and plants absorb the radiation and heat up. Heat is later radiated from everything in the greenhouse. However, this radiation is longer wavelength infra red radiation which cannot pass through glass or plastic. It is trapped inside. Hence the temperature inside a greenhouse can be quite high even on a cold day which will help our group of children towards the solution to their problem.

Plants are solar radiation collectors. Solar radiation provides the energy that plants need in order to grow and produce the organic material. This process is called photosynthesis. Through photosynthesis the sun's energy is converted into the chemical energy of the plant material. This plant material is the basic energy source for all men and animals.

Carbon and water are the raw materials of photosynthesis, organic compounds are built up from this and oxygen is a byproduct.

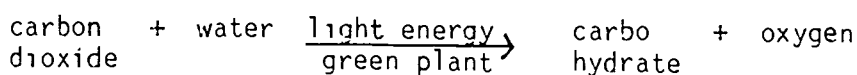

We now know that the usual colour of leaves is due to several pigments. Some are green, some are yellow. Research tells us that the green pigments, the chlorophylls, are the ones that convert light energy to chemical energy in photosynthesis. In the dark there is no photosynthesis. As soon as there is some light photosynthesis begins.

The photosynthetic parts of land plants can be recognised by their green colour. All green cells can carry out photosynthesis but most photosynthetic tissue occurs in the leaves whose purpose is to absorb the sun's energy.

Now let's investigate further the greenhouse effect.

INVESTIGATION 2

A. Question: How does the angle of the collector affect the temperature inside the container?

B. Materials

3 identical cardboard boxes (e.g. shoe boxes approximately
30 x 20 x 15 cms)

3 thermometers

Tape

Scissors

Piece of glass

Clear plastic sheet

C. What you do: Setting up the materials

1. Using the conclusions you reached from Investigation 1 construct each of your three cardboard boxes with the same most effective heat absorbing material.

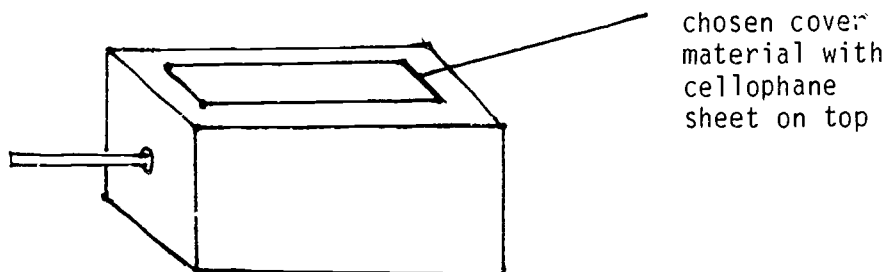

2. What data will you need to collect and record? Make up a table to collect these data.

3. Measure and record in table form the temperature of each box.
4. Place each box in direct sunlight with box 1 flat on the surface (See diagram).
5. Place books under one edge of box 2 to create an angle of about 30° (See diagram).
6. Place books under one edge of box 3 to create an angle of about 60° (See diagram).

D. What do you predict will happen?

In the following space describe your prediction for which box will reach the maximum temperature in the shortest time.

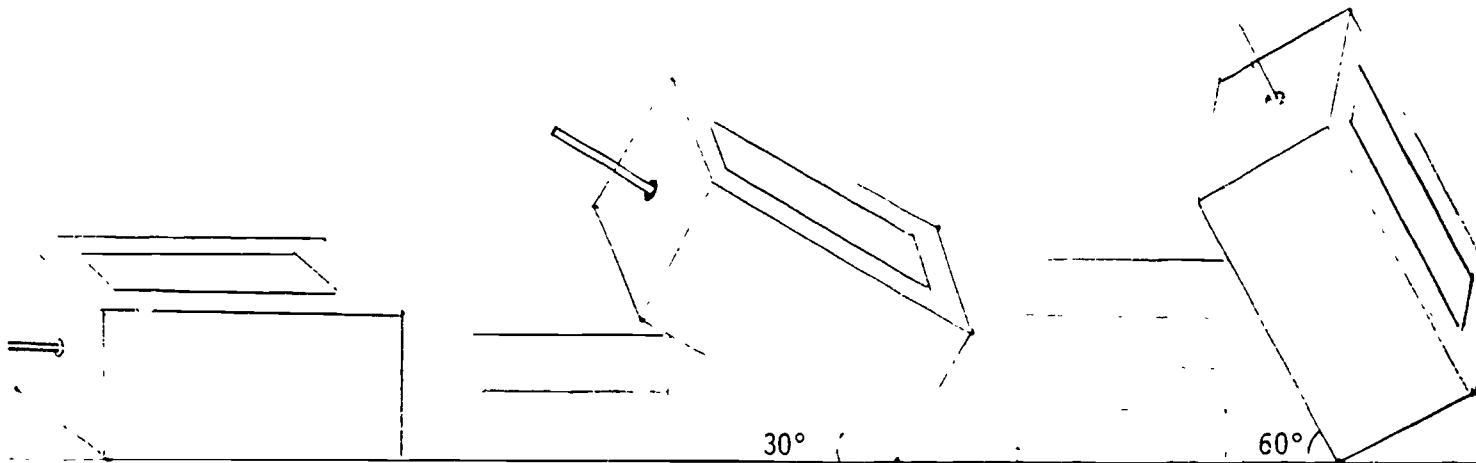
Box 1Box 2Box 3

7. Leave the boxes in the sun or facing where the sun would be if there is cloud cover. Read and record the temperature in the boxes for every 2 minutes until there is no change in temperature.
8. Measure and record the temperature of each box in the table you previously prepared.
9. Plot a graph of temperature (or the vertical axis) and time (or the horizontal axis) for the 3 boxes.

E. Interpretation of Data

1. In which box is the greatest difference in temperature during each two-minute interval?

2. Which box has the greatest temperature after 20 minutes?

3. How can you explain any differences in temperature of the boxes?

F. Conclusion

1. Which angle is the most effective to make a solar collector?

2. Did these results agree with your predictions? Explain any differences between your results and your predictions.

G. Further Information

Angles

Passive solar heating is dependent on the climate, the latitude, and the sun angle. Because the sun is not directly overhead, it is best to tilt the surface of the collector towards the sun facing north in the southern hemisphere countries, and to the south in the northern hemisphere countries.

You should tilt the solar system to the angle equal to the latitude of your location, and then add 10° so that maximum energy will be received during the winter months when it is most needed.

1. What will be the optimum angle to tilt the collector in your location?

Optional activity

1. Set up apparatus using the angle determined for your particular location.

2. Develop a table and record your data as before.

3. Compare the results.

4. Has using a specific degree measurement made any difference to the temperature gain?

INVESTIGATION 3

A. Question: How does the colour of the collector surface affect the temperature gain?

B. Materials needed

Boxes used in Investigations 1 and 2

Coloured cellophane papers - red, blue, green and clear - or
painted glass or plastic

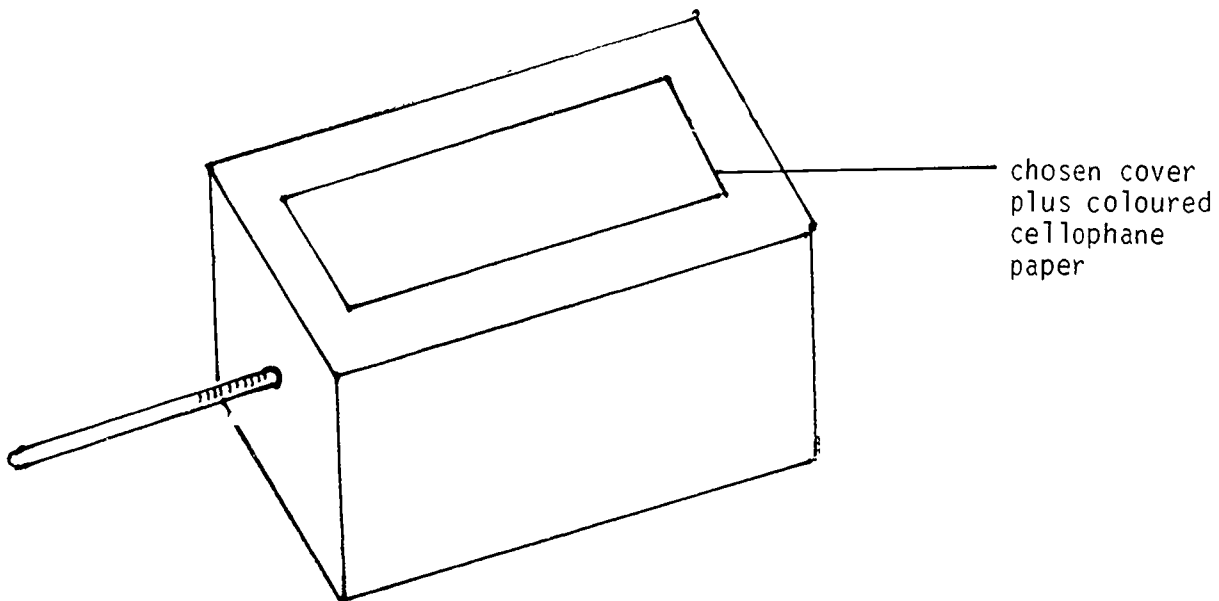

C. What you do: Setting up the materials

1. Place blue cellophane on top of box number 1.
Place red cellophane on box number 2.
Place green cellophane on box number 3.
Also set up one box with either glass or plastic cover
but with no coloured cellophane. This is your control.

2. Measure and record on the result table the temperature of each box.

RESULT TABLE

Box No. / Time	Box 1	Box 2	Box 3	Box 4
0 min				
4 min				
8 min				
12 min				
16 min				
20 min				

3. Using information obtained from Investigations 1 and 2 set up boxes to receive the maximum temperature gain.

- D. What do you predict will happen?

In the following space describe your predictions for the effects the different colours will have on temperature gain.

- 4. Leave the investigation in the sun for 20 minutes.
- 5. Record the temperature on the result table of each box over each 4-minute period.

E. Interpretation of Data

- 1. What were the changes in temperature for each box during the 4-minute intervals?

Box 1 _____

Box 2 _____

Box 3 _____

Box 4 _____

2. What were the changes in the temperature for each box after 20 minutes in the sun?

Box 1 _____
Box 2 _____
Box 3 _____
Box 4 _____

3. Which box had the greatest gain in temperature?

4. What is the colour of this box?

F. Conclusion

- i. How can you explain the greater temperature gain as stated in the Interpretation of Data section?

2. Did these results agree with your predictions? Explain any differences between your results and your predictions.

G. Further Information

The gain in temperature that you observed came from the heat energy from the sun. The heat radiated from the sun heats the surfaces of the earth.

Some of the surfaces reflect the radiation while other surfaces absorb a lot of the radiation.

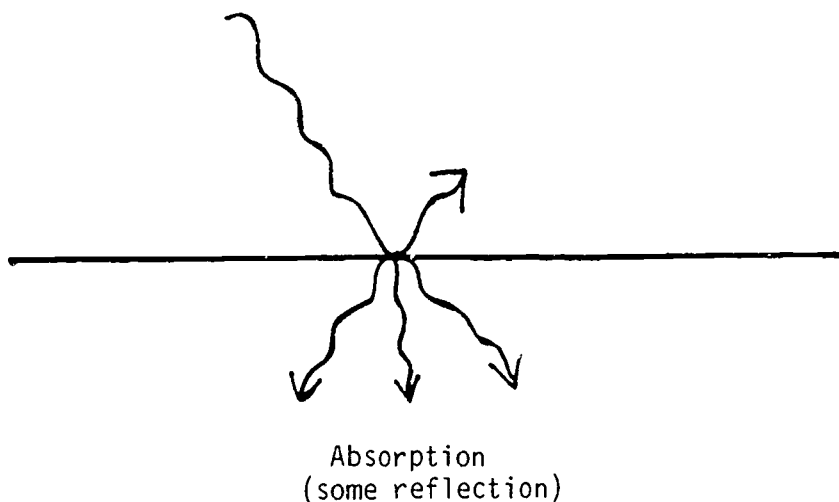

The sun's radiation consists of many waves of different wave length. Heat is called Infra red radiation. It is a long wave length radiation (See diagram Wave A).

Visible light is another form of radiation. It has a shorter wave length than the heat waves (See diagram Wave B).

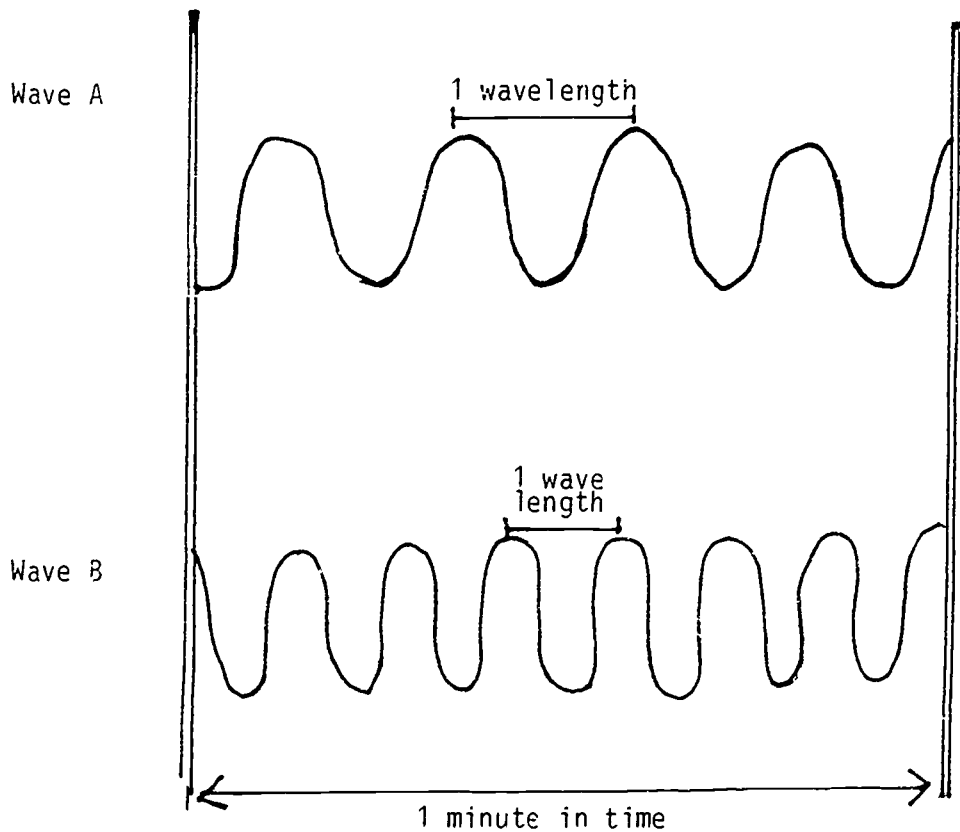

All the different types of solar wave radiation together form the radiation spectrum.

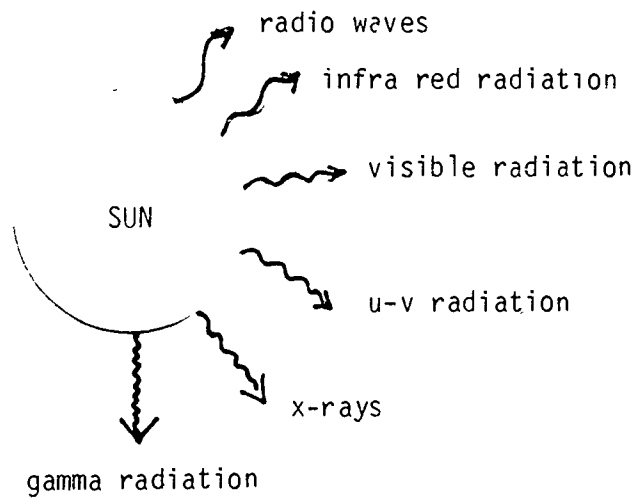

We can draw the radiation spectrum ranging from the short wave lengths that have most energy, to the long wave lengths that have least energy.

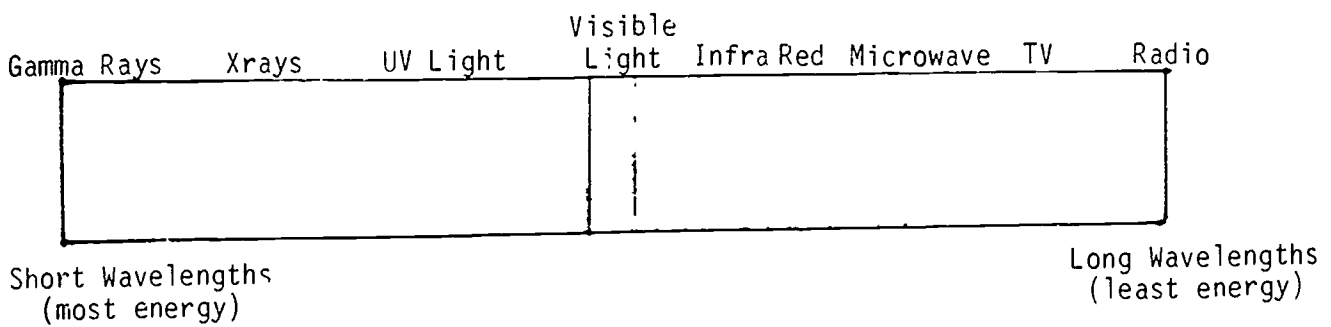

Let us see how these affect the temperature gains that you measured in Investigation 3. The earth reflects and absorbs some of the solar radiation and gets hot. Solar radiation does not contain equal amounts of each type of radiation. Most of the Ultra Violet radiation coming from the sun is absorbed by gases in the earth's atmosphere. These UV rays could cause permanent blindness and skin burning if they were not absorbed by the atmosphere.

Above earth between 16 km and 48 km (stratosphere) there is an ozone layer which screens out excessive amounts of ultraviolet radiation coming from the sun and helps protect the troposphere which extends from the earth's surface to 16 km.

The Greenhouse Effect is the result of an input of gases into the troposphere where most of it remains retaining heat in the same way as a greenhouse roof keeps the warmth over the plants.

On the earth's surface the Greenhouse Effect is expected to set in motion major climatic changes possibly within 30 years.

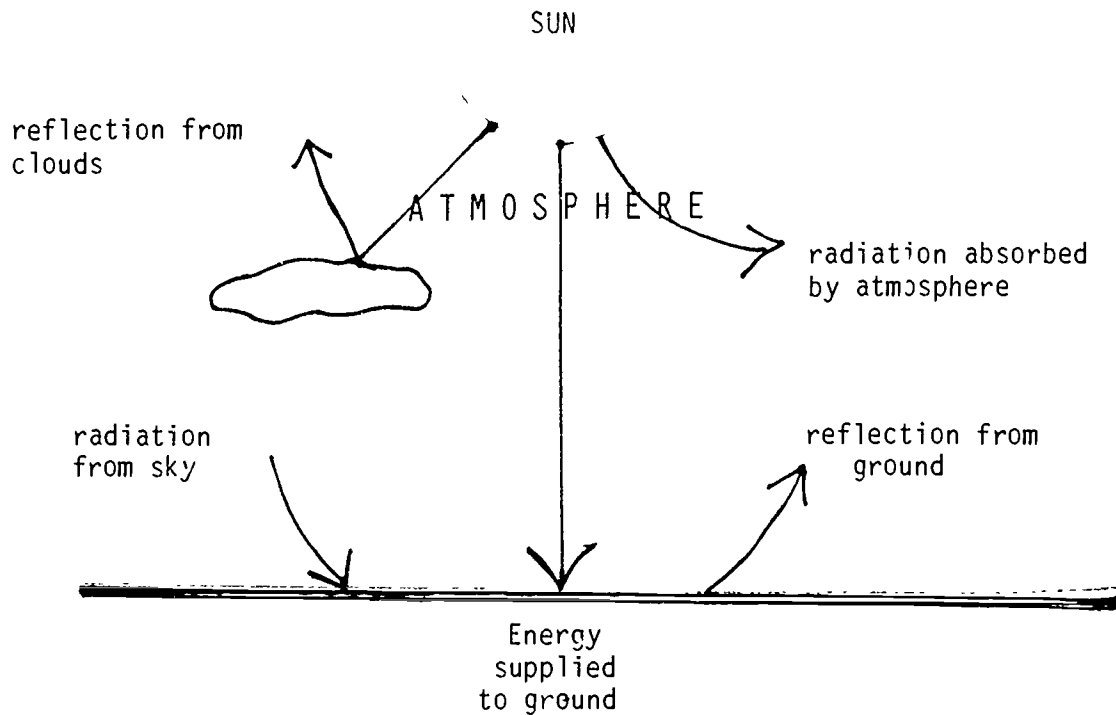

The radiation waves that effect your investigation results are those of Visible Light. This visible light is also called White Light. White Light can be broken up into a number of colours. We call this the Spectrum of White Light.

INVESTIGATION 4

- A. Question: What colours make up the spectrum?

B. Materials

Dark area

Flashlight

Small mirror

Full clear glass of water

White surface

C. What you do: Setting up the materials

In a dark room place a small mirror into a full clear glass of water. Ask a friend to shine a bright flashlight beam through the glass and water at the mirror. Change the position of the mirror so that the light hits at an angle and makes a number of colours appear on the white surface.

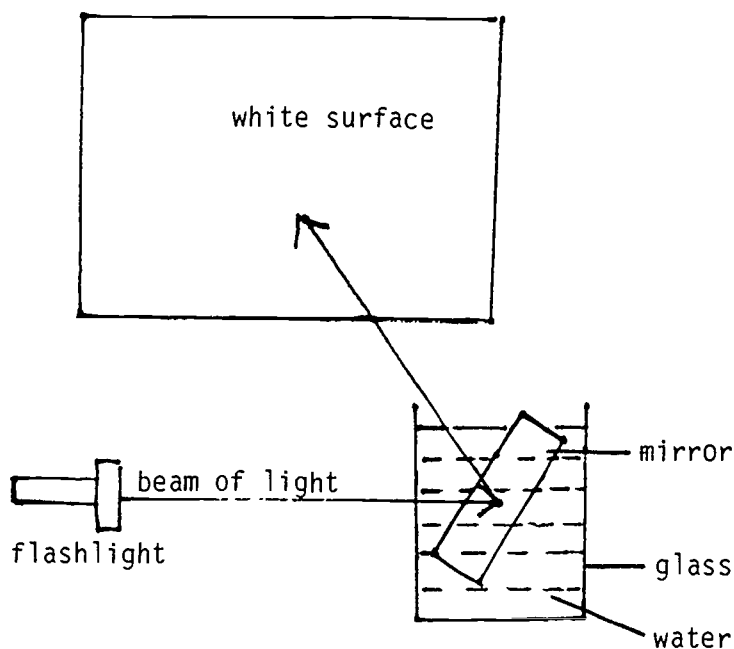

D. What do you predict will happen?

E. Interpretation of Data

1. What colours do you see?

2. Draw the order in which they appear.

3. Are they spread out?

F. Conclusion

1. Where did the colours come from?

2. Do you think they came from the incoming light?

3. Did the results agree with your predictions?

4. As the red colour proved to create the maximum temperature gain can you figure out why we do not see red "greenhouses"?

G. Further Information

Your arrangement made the spectrum from the ordinary White Light. The same spectrum will appear if you use a special kind of glass object called a prism.

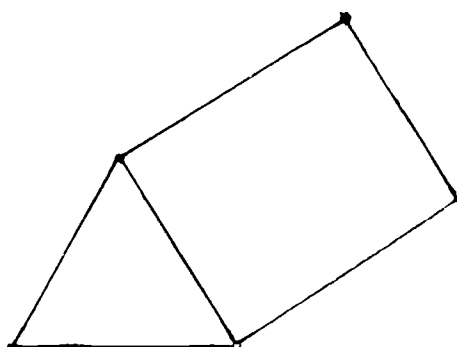

a prism

If you have a prism and a beam of light in a dark room you should be able to make observations like those Isaac Newton made in 1666. He was the first person to discover that ordinary light could be broken up into colour.

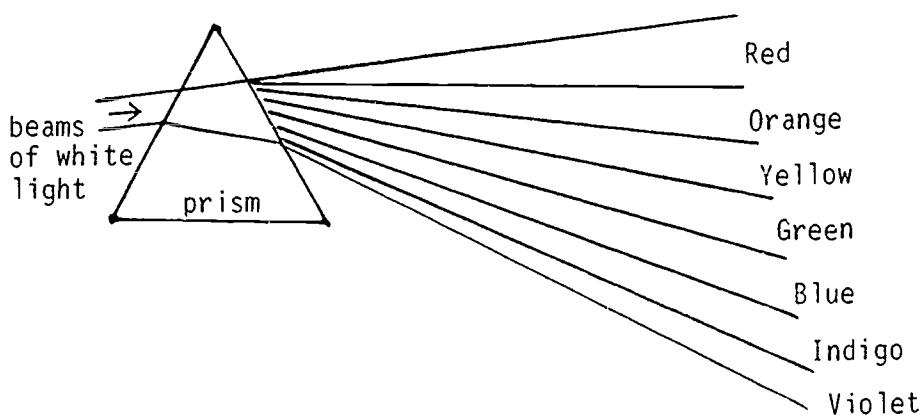

In Investigation 3 where you were discovering the most effective colour for maximum temperature gain you found that the red cellophane was the most successful. The red cellophane allows only the red component of the white light to pass through the cellophane while absorbing all the other colours.

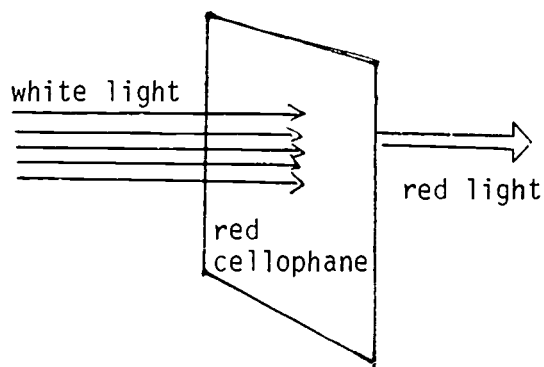

When a substance takes in radiation, as in the case of the red cellophane, it is said to absorb the radiation and create heat. We use clear glass or clear plastic to build greenhouses because only the white light with the whole colour spectrum can be absorbed by the plants and enable them to carry out the process of photosynthesis.

(v) ASSOCIATION & SYSTEMATIZATION

The best conditions to build a greenhouse that will grow plants successfully even in the winter will be:

1. Use of clear glass or clear plastic cover to absorb the solar heat.
2. Building the greenhouse using appropriate angles.
3. Red colour is the most efficient for temperature gain but white light is needed for photosynthesis.

Now go to your local gardener, look at any greenhouses that he uses. Draw a picture, and describe in writing, the greenhouse. Be specific about the angles, the materials and the colours used.

(v1) APPLICATION

1. Ask the gardener about other essential elements to make a greenhouse successful. List them here.

2. What other technological developments are used in the greenhouse? Draw a picture and describe in writing (eg. ventilation system, water system, insulation).

3. If in your area a computer is used in the running of a greenhouse find out and describe how it is utilized.

4. What advantages has the use of a computerised greenhouse over an ordinary greenhouse?

5. Now let's return to our group of students and their problem of wanting to grow tomatoes in the winter. What were the problems to be overcome?

Design and build from materials available to you, a greenhouse to grow tomatoes. Take into consideration all the elements previously discussed.

The design of your greenhouse:

This greenhouse shows an efficient passive solar system

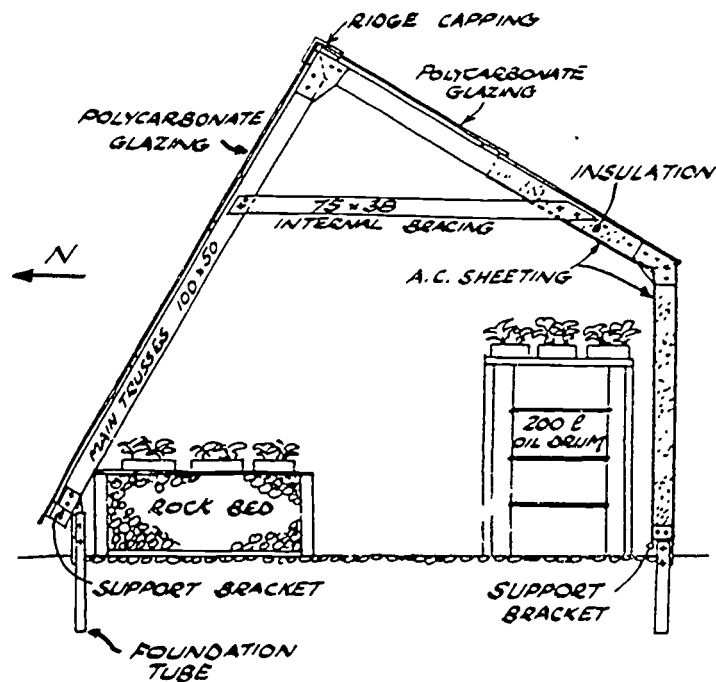

FIG. 1 CROSS SECTION THROUGH GREENHOUSE

BIBLIOGRAPHY

Dekkers, J., O'Loughlin, M., Treagust, D., Vlahov, S. (1985). Energy from the Sun. Solar Energy Education Project. Western Australia

Fischler, A. (1971). Modern Elementary Science. Holt Rinehart & Winston Inc.

Morgan, D. (1983). Biological science, the web of life. Australian Academy of Science, Canberra, A.C.T.

Pierson, H.O., Nahui, A. (1981). Passive solar heating in the Andes. Sunworld, International Solar Energy Society, 5(6), 169-171.

Robbins, T. (Ed.). (1984). Solar leads the greenhouse revolution. Solar progress. Journal of the Australian and New Zealand International Solar Energy, 5(4), 13-17.

Stannard P. (1975). The Sun on the Earth. MacMillan & Co.

CONTENTS

UNIT 4

Page

(i)	Topic: Solar Hot Water Heater, Solar Oven, Solar Still: Solar Thermal Systems	
(ii)	Objectives	1
(iii)	Introduction	2
(iv)	Presentation	3
	Problem Number 1	3
	Investigation 1	3
	Investigation 2	10
	Problem Number 2	21
	Investigation	21
	Problem Number 3	28
	Investigation	28
(v)	Association and Systematization	38
(vi)	Application	40
	Bibliography	42

(i) THEME: TECHNOLOGY IN LIFE

TOPIC: SOLAR HOT WATER HEATER, SOLAR OVEN, SOLAR STILL: SOLAR
THERMAL SYSTEMS

(ii) OBJECTIVES

Upon completion of this unit students will be able to:

1. Identify the applications of solar energy in the development of technological products to enhance everyday living.
2. Solve a given problem by carrying out investigations.
3. Develop skills in building solar thermal system.
4. Demonstrate knowledge of the heat transfer in solar thermal systems.
5. Draw graphs to analyse and interpret data.
6. Apply the technological knowledge of insulation to improve the performance of other solar energy devices.

(iii) INTRODUCTION

Since the discovery of fire by primitive peoples, heat energy has always played an important role in society. Heat is used for cooking, heating and in certain industries. The first major source of heat was wood but even in early times this was not always easy to come by. For example the Romans had to import their wood from overseas. In the 18th century coal mining became a large industry and began to replace wood as a fuel which was becoming increasingly scarce. Around 1850 the oil industry developed not because of a shortage of coal but because oil was a more convenient fuel. About the same time natural gas was also being used as a heat source. Nowadays we are looking toward an alternative energy source as those energy resources mentioned above are non-renewable. Therefore we turn to Solar Energy which is a renewable and constant source of heat energy. Energy from the sun can be used directly. Solar radiation can be converted directly into heat energy by a solar collector. An additional advantage of solar energy is that it produces no wastes to pollute the atmosphere.

For solar energy to gain widespread public acceptance it must be shown to be economically competitive with other forms of energy. In estimating the cost of energy for a solar heating system, most of the expense is for construction and installation of the system, and for energy storage facilities. This initial cost, plus the small amount needed for maintenance and operation must then be averaged over the useful lifetime of the system.

(iv) PRESENTATION

This is the main section of the topic and consists of a series of problems to be solved and the design and development of a functional product of technology.

PROBLEM NUMBER 1

You are going with your family for a long vacation to a remote area where there is no electricity. Your father suggests taking a variety of materials and you wonder why he considers them necessary. After your arrival at the site everyone feels the need for a shower to freshen up. You discover the only available water is very cold. Your father poses you the problem of how can you produce hot water so that you will not have to take a cold shower again. The following investigations will help you decide what materials you will need.

INVESTIGATION 1

A. Question: How does change in temperature affect movements in water?

B. Materials

1 test tube (preferably 4 cm diameter)

1 glass tube (preferably same diameter as test tube)

2 two-hole stoppers to fit test tube and glass tube

2 narrow gauge glass tubes

Water

Colouring (food dye, ink)

Thermometer

C. What you do: Setting up the materials

Assemble apparatus as shown in diagram.

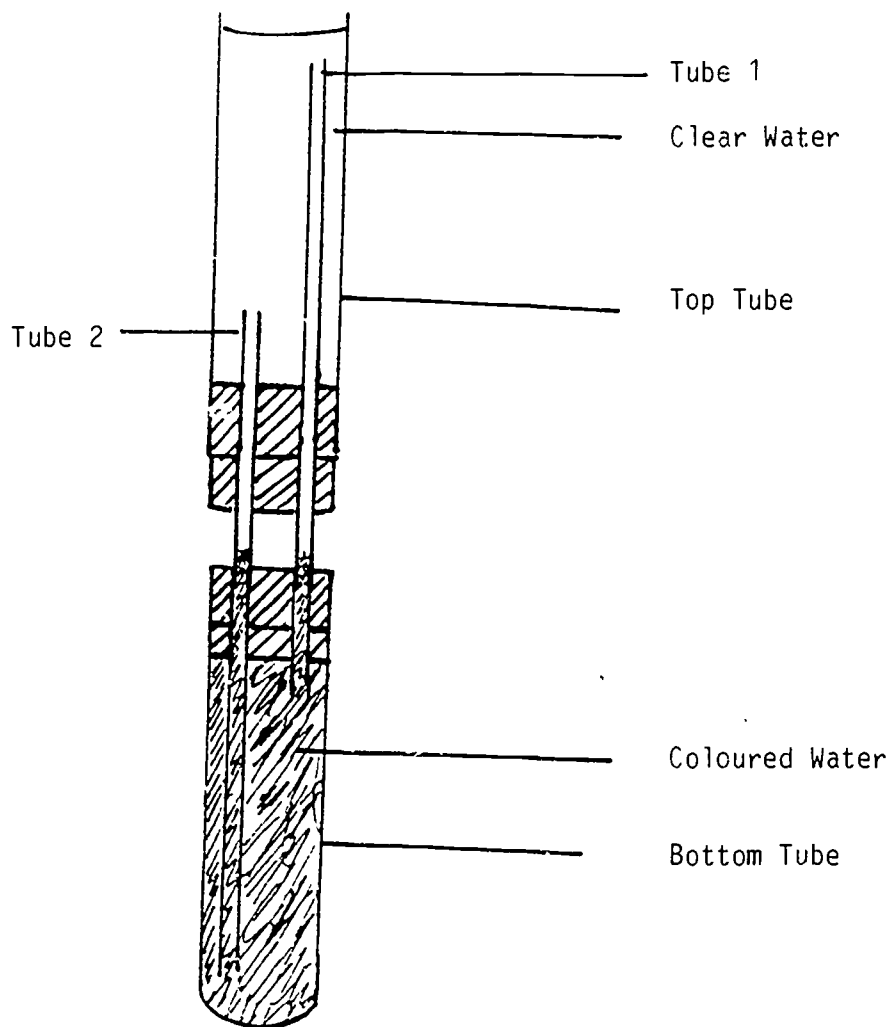

1. Fill the test tube with coloured water.
2. Carefully slide the stopper and tubing into the test tube, avoiding air bubbles. (When placing glass tubes through stoppers be very careful.)
3. Place the top tube into position and fill with cold tap water.

4. Place set up apparatus in direct sunlight, supporting it as necessary.
5. Record the temperature of the water in the top tube.

D. What do you predict will happen?

In the following space describe your prediction for the effect of temperature on the movement of the water.

6. Continue to record the temperature of the water every 2 minutes for a total of 20 minutes in the table below.

Time (Minutes)	0	2	4	6	8	10	12	14	16	18	20
Temperature (°C)											

E. Interpretation of Data

1. What happened to the temperature of the water in the top tube?

2. Describe how the coloured water moved through the system.

F. Conclusion

Attempt to answer these questions. If you are unable to answer these questions read Further Information which follows and try again.

1. What caused the change in temperature in the top tube?

2. What made the water in the system move?

3. Why is the level of tube 1 higher than tube 2?

4. Did the results agree with your prediction? Explain any differences between your results and your prediction.

G. Further Information

The apparatus that you just made is a simple solar water heater. The temperature of the water increases as heat is transferred to it from the sun. The warm water rises upwards through tube 1. Colder water flows into the lower test tube down tube 2. This flow continues until all the water in the system is the same temperature. This can be observed when the colour of the water is equal in both large tubes. The flow of water within the solar hot water system is called the thermosyphon effect.

Most materials expand when heated and contract when cold. As a fluid absorbs heat energy the particles collide more often and more violently than before. At higher temperatures the particles rebound greater distances after collisions. The space between particles increases which causes the fluid to expand when heated.

There is a second reason for the expansion of fluids. A force of attraction exists between the particles. When the temperature of a fluid is raised the particles move faster and the force of attraction between them is less effective which causes the fluid to expand. When the temperature is lowered the particles move more slowly and the force of attraction between the particles becomes more effective and the fluid contracts.

1. Can you suggest any improvements to your model solar hot water heater which might enable the water to warm up more quickly?

2. Make a sketch of this solar hot water system and explain why it is likely to be better.

INVESTIGATION 2

- A. Question: How do we build a solar heater which will heat up a greater quantity of water in less time than the solar heater in Investigation 1?

B. Materials

Large cardboard box (approximately 60 x 30 x 30 cms)

Sheet of black plastic to fit bottom of the box or black paint

About 5-7 metres of plastic tubing

Large clean container (plastic bottle or tin) (approximately 2 litres)

Cardboard box to fit around container

Cotton wool, sawdust, old clothing

Thermometer

Plasticene

Glass sheet or clear plastic sheet

C. What you do: Setting up the materials.Part 1

1. Cut large cardboard box down so that the sides are about 10 cm high.
2. Place a hole at each end so that the tubing will just fit through the holes.
3. Cover the inside of the box with black plastic (or paint with black paint).
4. Insert the tubing into the box and position it as shown.
The tubing can be kept in position by using wire.

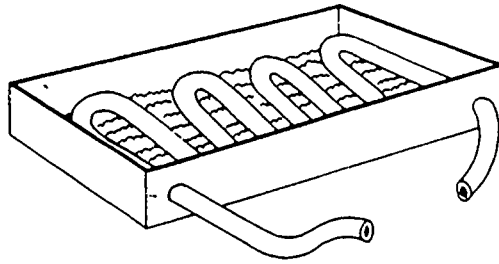

5. Cover the top of the box with a glass sheet or clear plastic. Tape firmly. This completes the construction of the solar plate collector.

Next we will construct the water storage tank which will later be connected to the solar collector.

6. Punch two holes into the sides of the large clear container. One near the base and one near the top.
7. Put the container into the cardboard box and insert the tubes from the plate collector through this box into the holes prepared in the container.
8. Seal these tubes with plasticene.
9. Fill the container with water.
10. Place the thermometer in the top of the container and seal in place with plasticene.

11. Pack cotton wool, sawdust or old clothing around the container.

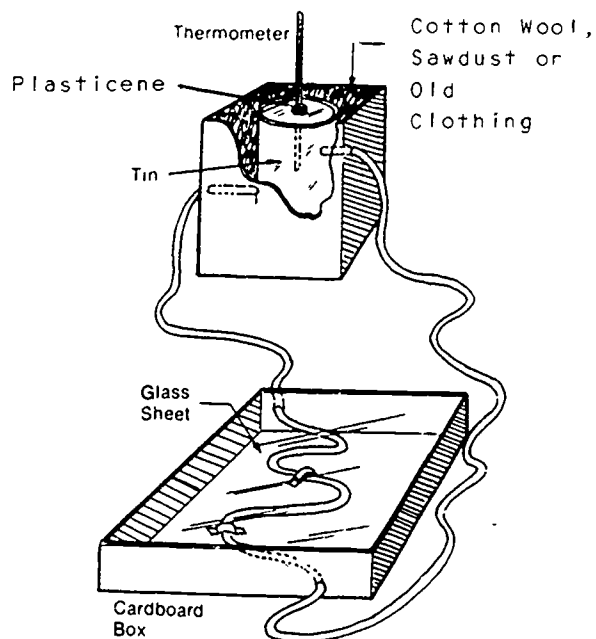

Part 2

1. Record the temperature of the water.

2. Place the apparatus into direct sunlight.
3. Tilt the apparatus to the angle which you found most effective for the Greenhouse Effect as investigated in Module 1.

D. What do you predict will happen?

In the following space describe your prediction for the temperature changes in the water tank.

4. Continue to take temperature readings every two minutes for the next 20 minutes. Record on the following table:

Time (Minutes)	2	4	6	8	10	12	14	16	18	20
Temperature ($^{\circ}\text{C}$)										

E. Interpretation of Data

1. Plot the information from the table on a line graph

2. Describe the temperature changes observed.

3. How long did it take for the temperature of the water to rise 10°C, 20°C, 40°C?

F. Conclusions

1. Would the water heat up as much if the tubing was not in a solar collector? Explain your answer

2. What purpose did the cotton wool, sawdust or old clothing serve?

3. Why did we make the inside of the box black?

4. Did the results agree with your prediction?

Explain any differences between your results and your prediction.

G. Further Information

A simple solar hot water system consists of a solar plate collector and a storage tank. Water is heated in the solar plate collector by the sun's radiation and then flows into the storage tank. This storage tank is usually positioned above the collector. This allows the water to circulate by natural

convection currents. The hot water produced in the system can be used from the storage tank when it is required (see diagram).

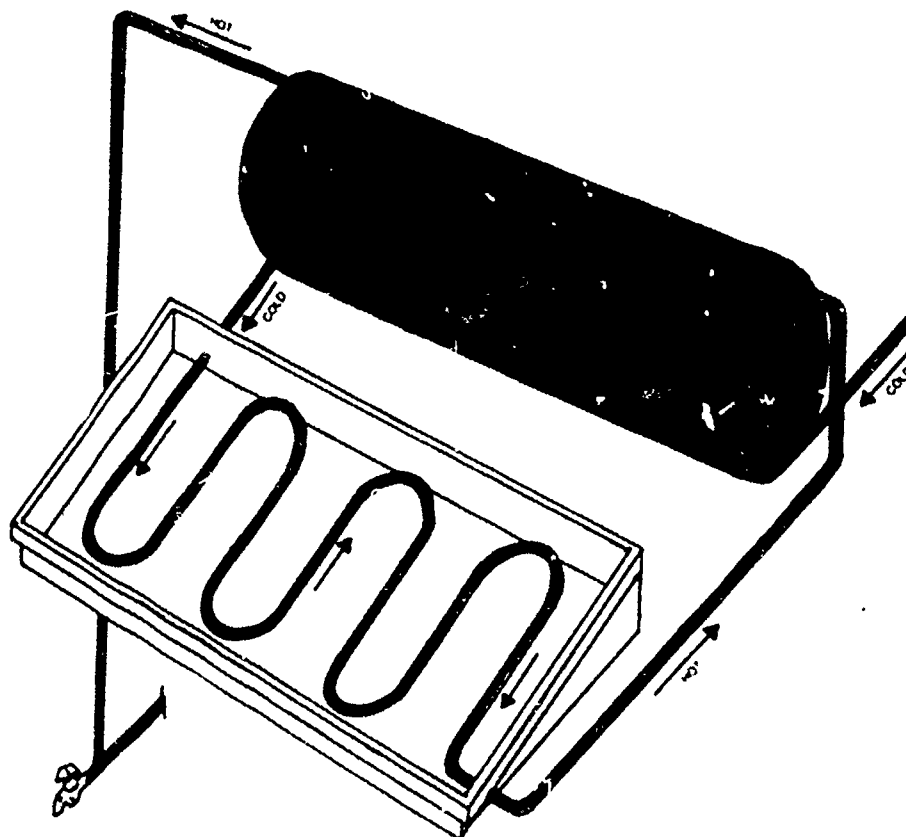

In order not to lose any of the heat stored in the tank in your experiment you used cotton wool, sawdust or old clothes around the container. This is insulation material which is also used in commercial apparatus around the tank and pipes. Insulation stops the heat escaping. The black surface increases the heat absorption from the sun and in commercial solar heaters they use a black metal absorber. Throughout the world solar hot water systems are used to provide hot water for houses, offices and factories.

Commercial solar hot water systems have changed design over the years but still consist of two basic major parts which are:

a flat plate collector which converts solar radiation into heat energy. This heat energy is then transferred in the collector.

a storage tank which holds the hot water until it is required.

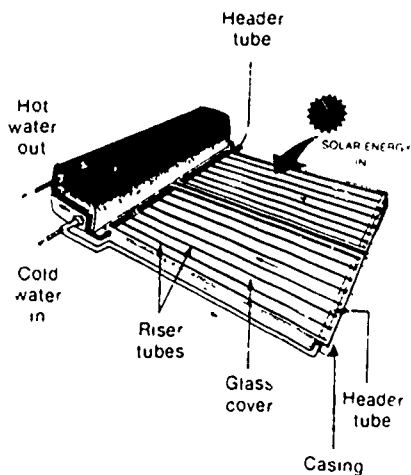

A typical solar hot water system

A glass cover is placed over the absorber plate to reduce heat loss. The cover acts in the same way as the glass in a greenhouse. Metal casing encloses the absorber and the glass cover. Heat loss through the back of the collector is reduced by insulation being placed between the absorber plate and the casing. The storage tank is placed above the absorber plate and is connected to it by insulated pipes.

1. Now is the time to consider the hot water problem of your family on vacation in the remote area. With the information that you now have obtained from Investigations 1 and 2 describe how you could solve your family's problem.

PROBLEM NUMBER 2

The next day your family wanted a cooked meal. Unfortunately they found the stove and matches had been left behind. You suggested they could make use of the sun's energy as they did in the solar water system to build a solar cooking device. How do you suggest the family goes about preparing their cooked meal?

INVESTIGATION

A. Question: How can we build a cooking device using the sun's energy?

B. Materials

Large cardboard box (approximately 60 x 60 x 60 cms)

Aluminium foil

Black plastic or black paint

Tape

Sheet of clear glass or clear thick plastic

Scissors

C. What to do: Setting up the materials

1. Take the cardboard box and cut it to the shape shown in the diagram.
2. Bend back the top and bottom panels.
3. Attach 2 side panels.
4. Cover each of the 4 panels with aluminium foil.
5. Make the inside of the box black with either black plastic covering or black paint.
6. After placing the food in the box place the clear glass or clear thick plastic over the opening to the box.
7. Place apparatus in the sun.
8. Move the aluminium covered panels until spots of light appear on the clear glass or clear plastic covering.
9. For the purpose of insulation, insulate back and sides of the box with insulating materials.

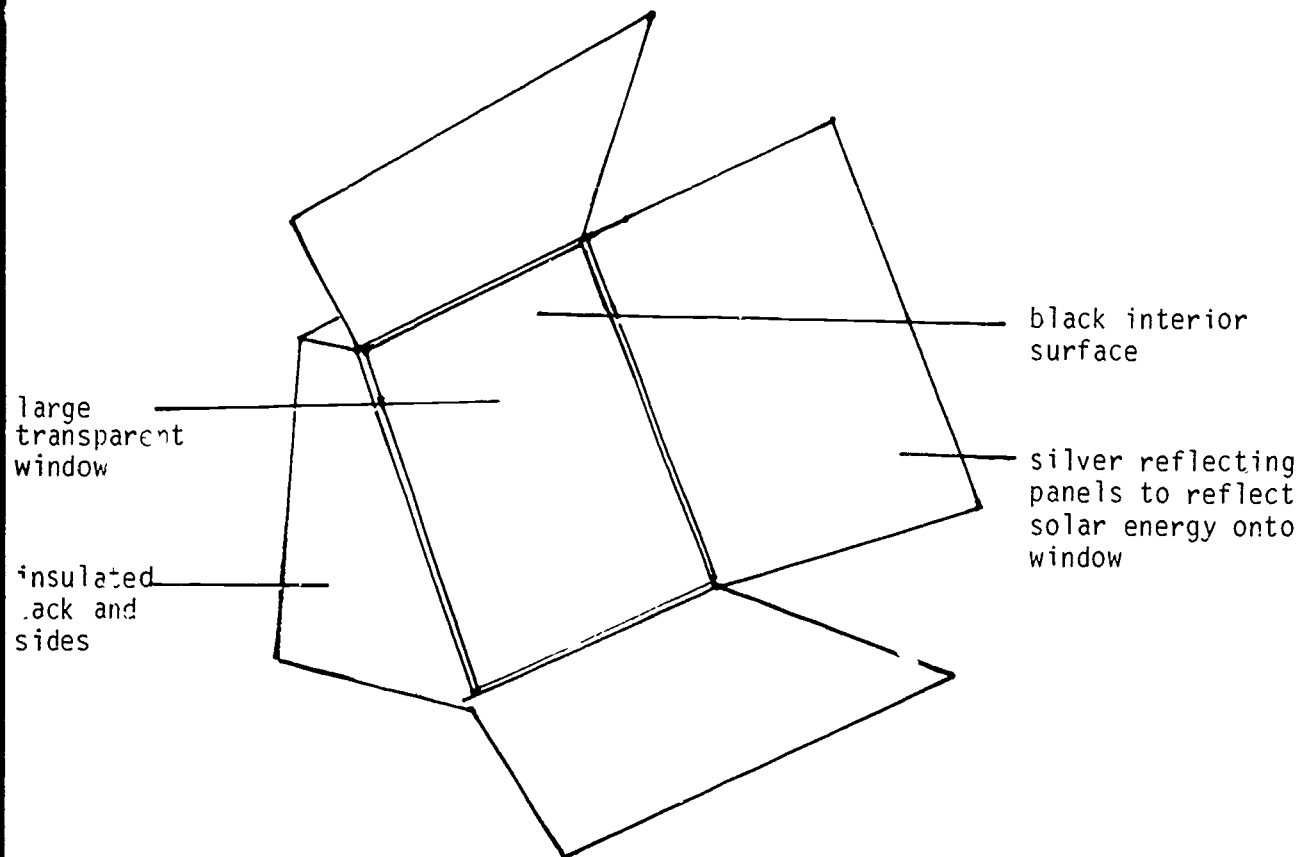

- D. What do you predict will happen to an egg broken into a dish if it is placed in the solar oven in the sun?

10. To find the effectiveness of your new solar cooking device break an egg into a small dish. Put it in your oven and measure the time it takes to cook in the sun.

11. Try various other items (potato, cup of water, etc.) and measure the time it takes to cook them. Since cooking maybe slow it is not advisable to use meats which require long cooking times which could develop harmful bacteria.

E. Interpretation of Data

1. How long did it take for the egg to be cooked?

2. Compare the times taken to cook the various items you tried in the solar oven to the time it takes to cook in a conventional oven.

F. Conclusion

1. Did your results agree with your prediction? Explain any differences between your results and your prediction.

2. In the solar oven that you constructed how was the absorption of solar energy enhanced?

3. How could you make the oven absorb more heat?

4. List the advantages and disadvantages to the use of a solar oven.

5. Can you expect to get the same cooking results almost everyday? Explain your answer.

6. If you had only a solar oven for cooking would your eating habits change? Explain your answer.

G. Further Information

By building your solar oven you will have discovered how your family can use simple materials and take advantage of solar energy to cook their meals.

Cooking with sunshine is a way that solar radiation can be converted into useful heat energy. Solar radiation can be used effectively for slow cooking of food.

In developed nations solar cooking is not so common. One of the reasons for this is that cooking can extend over a considerable period of time and the device must be adjusted to keep the radiation focused on the cooker. Another difficulty is that cooking can only occur when direct radiation is available.

In developing nations solar cookers are potentially more useful as fuel for cooking can be scarce. A simple solar cooker using the same elements as the one you built is shown below.

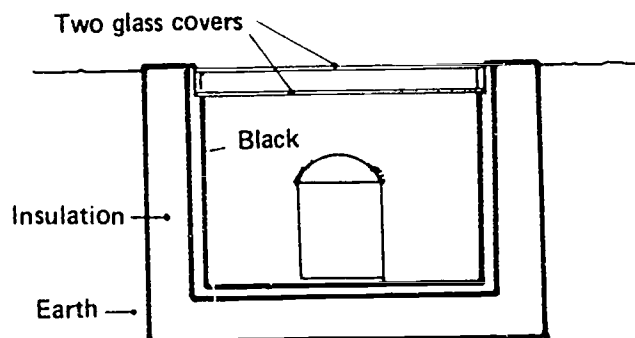

A Simple Solar Cooker

This solar cooker consists of a well insulated box with two glass covers. The cooking utensils and the interior of the cooker are painted black. If extra insulation is needed the box can be placed in a hole in the ground.

PROBLEM NUMBER 3

Your family discovered that the water available was suitable for taking a shower but not very good for drinking. They want to create a device, which makes use of the sun's energy, to produce water that can be safely drunk.

INVESTIGATION

A. Question: How can we make a water collecting arrangement to produce drinkable water using available plants?

B. Materials

Spade

Cup or any other collecting container

Sheet of clear plastic

Rocks

Plants (or parts of plants)

C. What to do: Setting up the materials

1. Dig a hole about 40 cms deep and 1 metre in diameter.
2. Place cup in centre of hole and the plants and leaves around the cup.
3. Cover the hole with the clear sheet of plastic and place rocks on one side to hold firm, and on the other side to hold loosely.
4. Place small rock in the centre of clear plastic sheet directly over the cup and allow the plastic to dip about 45° from the horizontal (see diagram).
5. Make sure all edges of the plastic around the hole are sealed firmly with rocks and sand but be sure to keep the dip in the plastic sheet as shown in the diagram.

D. What do you predict will happen?

What do you expect to find in the cup?

6. Check the device regularly and see how much water you collect in the cup.
7. Check appearance of plants and put fresh plants in the hole as required.
8. When device is no longer needed dismantle and fill in the hole.

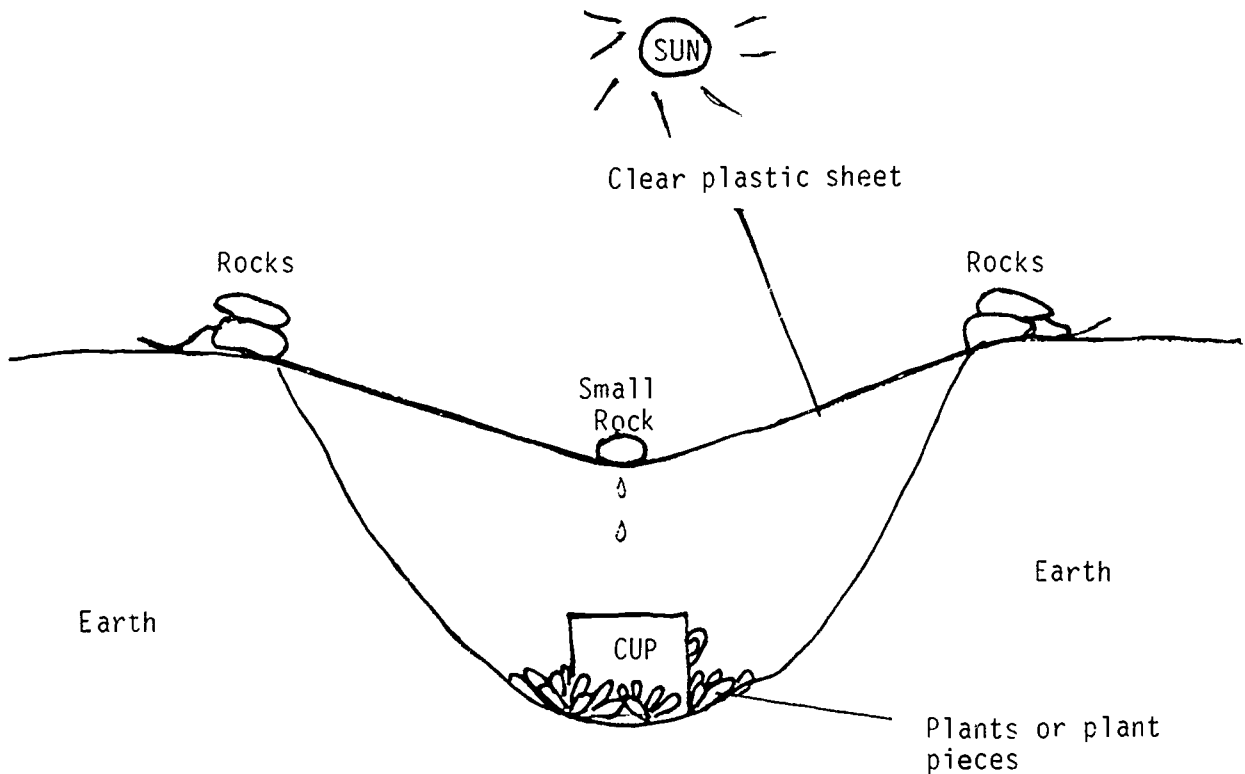

E. INTERPRETATION OF DATA

1. Where on the device did you observe water droplets appearing?

2. How long did it take to fill a quarter of the cup with water? How long did it take to collect half a cup of water?

3. How did the appearance of the plants look after an hour, two hours of the investigation?

F. Conclusion

1. Did the results agree with your predictions?

2. Where did the water come from?

3. Why did the water collect on the innerside of the plastic sheet?

4. Why did it drip into the cup?

5. What is the role of the plants, or parts of plants, in the device?

6. What was the cause of the change in appearance in the plants during the investigation?

7. Why is it necessary to replace the old plants with new plants regularly?

8. Do you think we would collect any water if no plants were used in the device at all? Explain your answer.

9. What part did solar energy play in the formation of the water?

10. List 3 factors that could affect the amount of water collected in the cup? Explain your answers.

G. Further Information

The device that you built is called an EARTH STILL. It uses solar radiation to heat moisture contained in the earth or plants. This moisture evaporates and rises as water vapour until it hits the cooler surface of the clear plastic sheet. Here it condenses to water droplets. These droplets run down the slope formed by the plastic sheet and collect at the lowest point of the dip under the small rock. When a large enough droplet of water is created its weight causes it to fall into the cup positioned underneath. Plants, or parts of plants, placed in the hole lose water by transpiration. The effectiveness of the earth still can be greatly influenced by the addition of plant life in the design. The water collected is safe to drink. The earth still you have just made is one way to collect water in order to survive in the desert. Commercial use of solar stills can involve the conversion of salty water to fresh water. In this case the solar radiation is used to complete this process.

The simplest type of commercial solar still is the basin type still shown below.

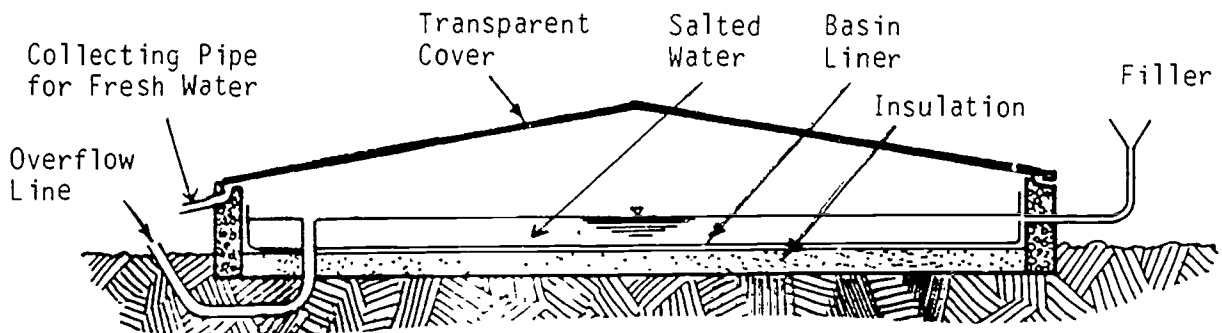

In this still the solar radiation passes through the transparent cover and is absorbed by the water in the dark coloured basin liner. Evaporation occurs as the water heats up and this warmer less dense air rises. Because the cover is cooler than the water the cooler denser air sinks. This flow of cool and warm air causes convection currents to occur. Some of the water vapour condenses on the inside of the cover. It flows down this cover surface to collecting troughs and then on out of the still via the collecting pipe. The salt remains on the bottom of the still and more salted water can be added through the filler in order to get more fresh water.

Many different designs of solar stills have been tried. The largest commercial still built was in Chile in 1872. This still covered 4,700 square metres and was built in the desert to supply fresh water for a salt petre mine. The still was operational for 40 years during the entire life span of the mine and produced 22,000 litres of fresh water per day.

Passive and active solar thermal systems

Solar thermal systems are generally classified as either passive or active according to the way in which the heat energy from the solar collector is transferred to the heat storage system. Passive thermal systems usually have the collector located close to the heat storage system. Examples of passive solar systems are solar hot water devices, solar ovens and greenhouses.

Active thermal devices are more complicated than passive thermal devices. In addition to the solar collector and heat storage tank, active devices have a heat transfer control unit. This unit controls the flow of heat from the collector to the heat storage system. Two uses of active thermal devices are solar air conditioning and solar ponds.

For any solar system to be economically viable the equipment must require minimal maintenance and be as long lasting as possible.

Other examples of solar systems.



Installed on top of existing roof to desired size and shape to blend into existing architectural design.

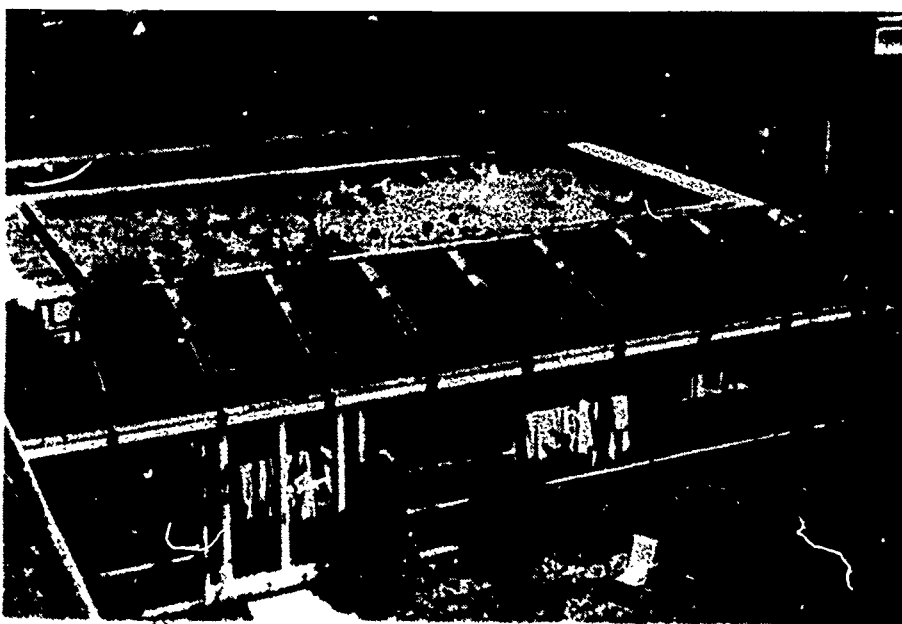

Open-air swimming pool at Howlands School in Welwyn Garden City has been heated by solar energy for the last three seasons.

Building costs are reduced incorporating

- Industrial
- Domestic Water
- Air Heater

in one system including



(v) ASSOCIATION AND SYSTEMATIZATION

1. From people in your community find out who has used a solar hot water system. Determine and describe the features which make the solar hot water system a success.

2. Describe how you could improve the design of the solar hot water system. If possible make these improvements and test the results.

3. From people in your community find out who has used a solar oven. Determine and describe the features which make this solar oven a success.

4. Describe how you could improve the design of the solar oven. If possible make these improvements and test the results.

5. Find out if anyone in your community has used a solar still. Find out how it worked and describe any differences to the one made in this topic.

6. Describe how you could improve the design of the solar still.
If possible make these improvements and test the results.

(vi) APPLICATION

Contact a manufacturer of solar hot water systems and ask for information about his product.

1. Find the optimum size and weight of the system for an average family of four people.

2. What materials are used in the manufacture of the system?

3. Describe the different types of solar hot water systems available.

4. Find out and describe different installation techniques.

BIBLIOGRAPHY

Charters, W., Pryor, T.L. (1981). Solar Energy. Beatrice Publishing.

Dekkers, J., O'Loughlin, M., Treagust, D., Vlahov, S. (1985). Energy from the Sun. Solar Energy Education Project, Western Australia.

Hastwell, P. (1978). Energy and Solar Energy. Applied Research of Australia Pty Ltd.

Murphy, J.T., Smoot, R.C. (1982). Physics, principles and problem. Charles E. Merril Publishing Co., U.S.A.

Stannard, P. (1975). The Sun on the Earth. MacMillan & Co.

Szokolay, S.V. (ed.). (1982). Solar Progress. International Solar Energy Society, 3(2).

Tabor, Z. (1984). Why Solar Energy? Sun World. International Solar Energy Society, 8(1).

CONTENTS

UNIT 5

Page

(i) Topic: The Windmill: Using the Wind's Energy

(ii) Objectives	1
(iii) Introduction	2
(iv) Presentation	3
The Problem	3
Investigation 1	9
Investigation 2	17
(v) Association and Systematization	24
(vi) Application	25
Bibliography	27

(i) THEME: TECHNOLOGY IN LIFE

TOPIC: THE WINDMILL: USING THE WIND'S ENERGY

(ii) OBJECTIVES

Upon completion of this unit, students will be able to:

1. Understand that wind is another form of solar energy.
2. Gain an appreciation of how the use of wind energy has developed through the ages.
3. Construct two different wind machine devices.
4. Investigate the efficiency of two different wind machine designs.
5. Make conclusions from a graph showing two sets of data.
6. Carry out an investigation to convert wind energy into electricity.

(iii) INTRODUCTION

Humans have attempted to harness the wind's energy from their early existence. To do this they had to invent and construct machines which would collect the wind and convert the wind energy to do tasks or work for them. Over five thousand years ago the Egyptians were using wind energy to sail barges along the Nile. About four thousand years ago the Chinese developed simple windmills to pump irrigation water.

Around the first century A.D. the Persians constructed the first large windmills which did not become common in Europe until the 12th Century. The use of windmills became a common sight in the 14th-16th centuries. In Holland in the 17th century people were using the windmill for purposes such as grinding corn and pumping water. This technological use of wind energy helped them become one of the world's most industrialised nations by the 18th century.

When the steam engine was developed in the 17th century it decreased the use of wind as a source of energy. Windmills still remained in use in situations where it was not practical to use steam energy.

Since the 1920's a number of large windmill systems have been used to generate electricity. Some are still in use but in developed countries, the cheap cost of oil in the 1950's resulted in a decline in the use of wind energy.

Human interest in harnessing the wind's energy has been renewed as fossil fuel costs have increased since the mid 1970's. In recent years there has been an increase in the technological development of devices using wind energy. New windmills which are more reliable and efficient have been developed and constructed to make use of wind energy to pump water, grind grain, and produce electricity.

(iv) PRESENTATION

This is the main section of the topic and consists of a series of investigations to be solved and the design of a functional product of technology.

THE PROBLEM

A family is settling on a remote island for a few months and decided to use natural resources as much as possible to provide their needs. How would you advise them to use the wind for their energy needs?

- A. Question: How can you build a device to collect the wind's energy?

To answer this question you will need the following materials as shown to construct Design 1 and Design 2. You will then use these designs in the investigations that follow

Design 1

- B. Materials

Stiff cardboard 20 cms x 20 cms

40 cms length of strong wire (like a wire coat hanger)

2 small corks

Large knob of plasticene

Scissors

Template design

Paint

- C. What you do: Setting up the materials

1. Place the template of the wind machine propeller on a square of stiff cardboard.
2. Draw around edges and cut out the propeller.

3. Paint one blade with any available colour. This will be your marker blade.
4. Bend each blade at the dotted line to an angle of about 45° . Make sure each blade is folded in the same direction.
5. Make a right angle bend in the wire about 10 cms in length from the propellor.
6. Place a cork (1) onto one end of the piece of wire and place as shown in the diagram.
7. Push one end of the piece of wire through the centre of the propellor.
8. Place a second cork (2) on one end of the wire against the propellor as shown in the diagram.
9. Move the two corks so that the propellor is free to rotate between them.
10. Push the free end of the length of wire into the knob of plasticene making sure that the wind machine stands firm. If you don't have any plasticene use something to hold the length of wire firm.

TEMPLATE FOR DESIGN 1

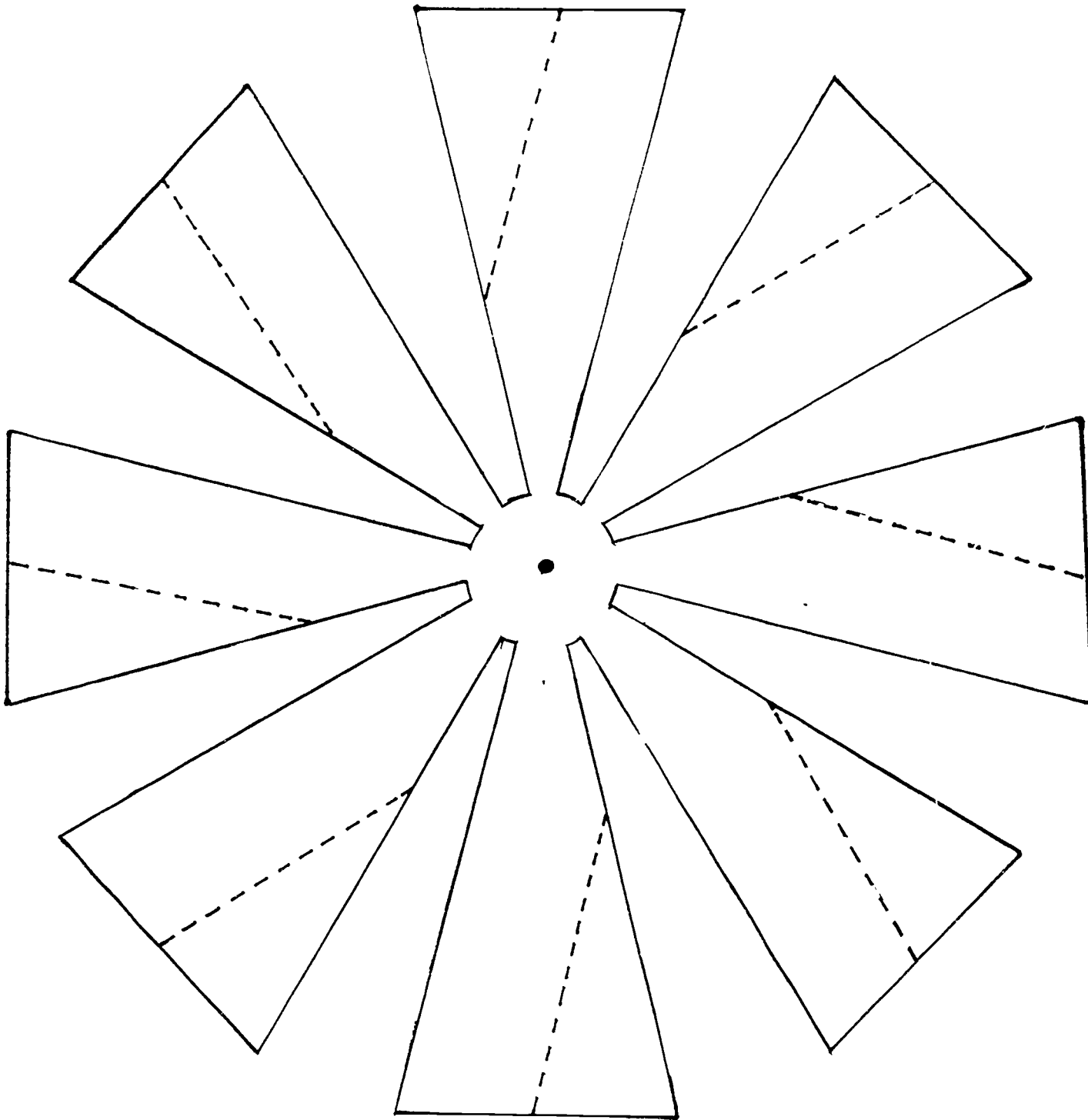

11. Stand the wind machine in the wind and observe that it spins freely.

You have now constructed a Horizontal Axis wind machine.

Place this to one side for use later on.

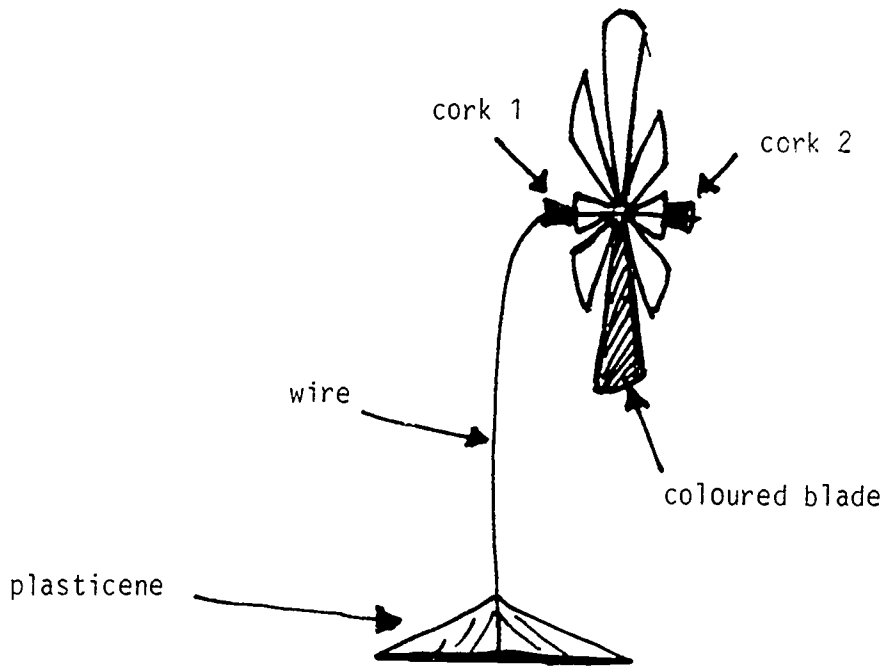

Design 2

B. Materials

1 cylindrical cardboard tube (eg. from a role of toilet paper, paper towel, Gladwrap, Alfoil)

Tape

1 knitting needle or piece of doweling rod

2 cotton reels or spools

Scissors

Paint

C. What you do: Setting up the materials

1. Cut the cylindrical cardboard tube in half lengthways and tape it together securely as shown in the diagram.
2. Secure the knitting needle or piece of doweling to the two half cylinders with tape.
3. Place the cotton reels (spools) on each end of the knitting needle so that the device is free to rotate.
4. Paint a stripe of colour on one of the cylinders. This will be your marker blade.
5. To see if the wind machine works, hold the spools and let the rotor spin in the wind.

You have now constructed a Vertical Axis wind machine.

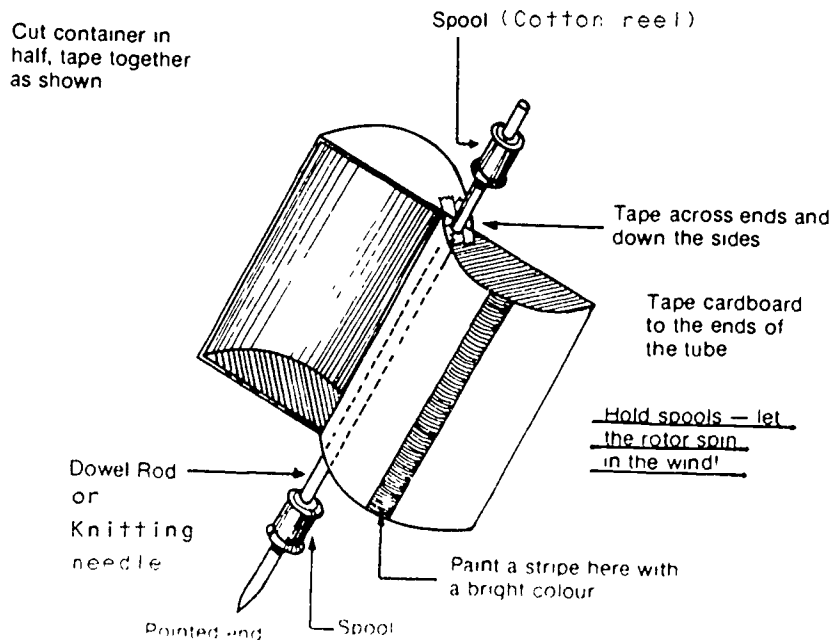

INVESTIGATION 1

A. Question: Which of the constructed wind machines is the most efficient, eg. produces the most turns per minute?

B. Materials

2 constructed wind machines

A fan (or natural breeze).

C. What you do: Setting up the materials

Note: This investigation is designed for use with a fan with variable speed. If you do not have a fan, choose two or three days with varying wind strengths.

1. Set the electric fan on low speed. Position Horizontal Axis wind machine so that the propellor is just turning.
2. Keep the distance between the wind machine and the fan constant for the rest of the investigation.
3. Count the number of turns of the propellor per minute by watching the coloured blade.
4. Take three readings and calculate the average. Record results on the table.

5. Now set the fan on medium speed and repeat the above steps. Record the results on the table.
6. Now set the fan on high speed, repeat the above steps and record the results on the table.

D. What do you predict will happen?

When you compare the performance of the two wind devices which do you predict will produce the most turns per minute?

Explain your answer.

Results Table
Horizontal Axis Wind Machine

Fan speed	Number of Turns Per Minute			Average of Turns Per Minute
	Test 1	Test 2	Test 3	
Low Medium High				

Repeat the above procedure using the Vertical Axis wind machine holding the spools so that the propellor can spin freely. Record the results in the following table.

Results Table
Vertical Axis Wind Machine

Fan speed	Number of Turns Per Minute			Average of Turns Per Minute
	Test 1	Test 2	Test 3	
Low Medium High				

E. Interpretation of Data

1. Why was it necessary to keep a constant distance between the wind machine and the fan throughout the investigation?

2. Which wind machine produced the greatest number of turns at low fan speed?

3. Which wind machine produced the greatest number of turns at medium speed?

4. Which wind machine produced the greatest number of turns at high speed?

5. Graph the results of fan speeds and average number of turns per minute for each of the two wind machines using the same set of axes. Plot the data using different colours for the two devices.

Average
Number of
Turns
Per Minute

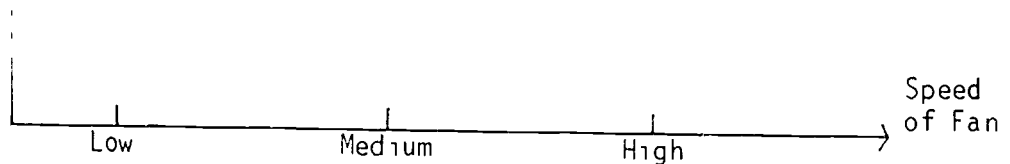
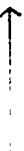

6. Which wind machine was the most efficient for each speed of fan, eg. produced the most turns per minute?

Low

Medium

High

F. CONCLUSION

1. Did the results agree with your prediction? Explain any differences between your results and your prediction

2. Which would be the best design of wind machine to build in very strong wind conditions? Explain your answer.

150

3. Which wind machine design would be most efficient to use for year round performance? Use the data on your graph to explain your answer.

G. Further Information

As you saw in your investigation there are two types of wind machines with either a Horizontal Axis or a Vertical Axis.

Commercial wind machines, also called windmills, consist of three basic parts

- (i) the wind propellor
- (ii) the energy transfer system
- (iii) a support structure.

These three parts are present in both vertical and horizontal axis machines as shown in the following two figures.

The wind propeller is made up of a set of blades attached to a rotating shaft. The wind causes the propeller to turn which then causes the shaft to rotate. Then the motion of the shaft is converted into the desired type of motion by the energy transfer system. In a water pumping wind machine the circular movement of the propeller is converted into an up and down movement to pump the water.

In the Horizontal Axis windmill the number, size and shape of the blades can vary from one windmill to another. All of these factors have an effect on the efficiency of the windmill. This type of windmill is the one most used on farms for pumping water. The blades are designed so that as the air flows past them a force is produced that turns the propeller. Horizontal Axis windmills must be mounted on towers to raise the propeller above the ground level. The propeller must face into the wind, therefore it must be free to rotate as the wind direction changes.

Vertical Axis windmills respond to wind from any direction. As they do not have to face the wind in order to work this is an important advantage over the horizontal design windmill. Another advantage they have is that their energy transfer system can be located on the ground as they do not require tall support structures.

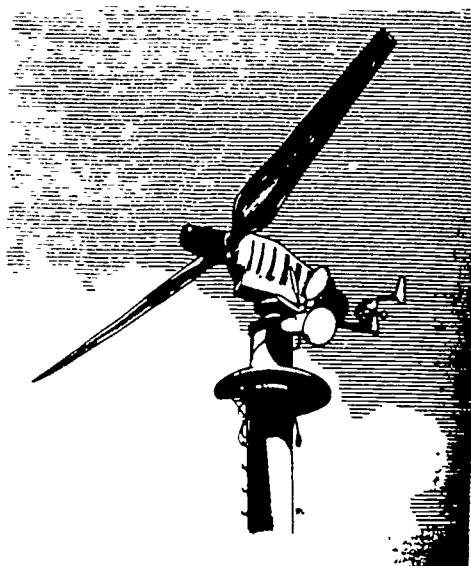

Horizontal Axis Windmill

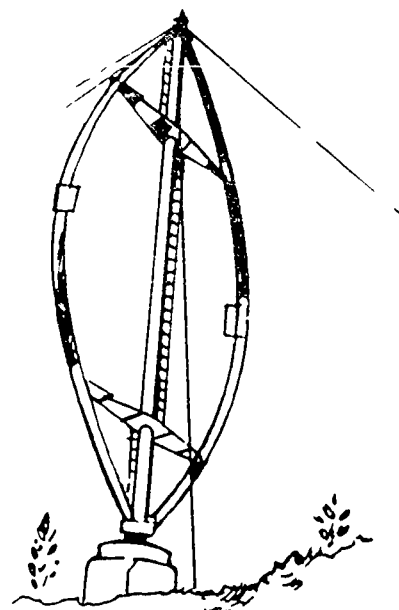

Vertical Axis Windmill

Wind energy can be thought of as an indirect application of solar energy. The different surfaces of the earth heat up at various rates when exposed to solar radiation. A water surface for example heats up more slowly than a land surface. Near hot surfaces the air rises and produces areas of low pressure. Air flows from high pressure areas to low pressure areas. These differences in air pressure caused by the heating effect of solar radiation on the earth's surface create air movements we call winds.

Windmills are a technological development to enable us to extract the energy from the wind.

INVESTIGATION 2 (if materials available)

A. Question: Can you convert wind energy to electricity?

B. Materials

Horizontal Axis wind machine model (Investigation 1)

DC motor (0.5 volt)

Support stand

2 pieces insulated wire for circuit about 20 cms in length each

Bulb (2.5 volt)

Bulb holder

Electric fan with varying speeds

C. What you do: Setting up the materials

1. Take the Horizontal Axis wind machine. Cut the wire at the bend (about 10 cms from the propellor).

2. Attach this cut end of the wire securely to the spindle on the DC Motor by winding around and using electrical tape.

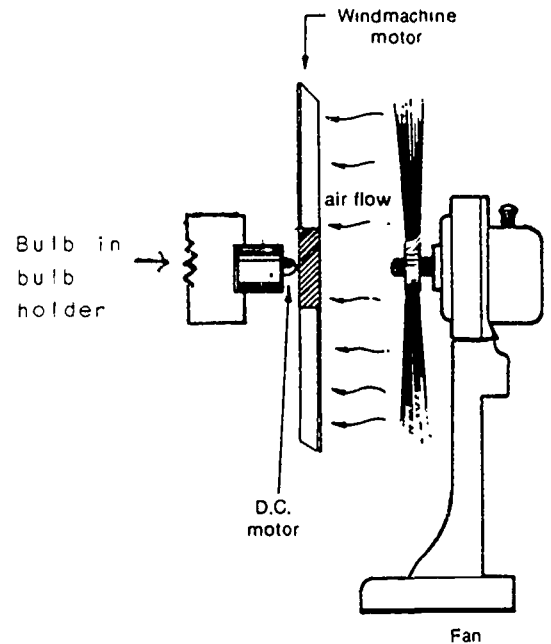

3. Place bulb in bulb holder and attach the two pieces of wire, one to each terminal.
4. Next attach the two free ends of wire to the terminals on the DC motor.
5. Clamp the motor in the support stand and adjust to the same level as the fan.

D. What will you predict will happen?

Do you think light will appear in the bulb? Explain your answer.

6. Turn the fan on low and observe if light is produced in the bulb.

7. Change the fan speed to medium and then high and observe if light is produced in the bulb.

E. Interpretation of Data

1. On which speed of the fan did the bulb glow the brightest?

F. Conclusion

1. Did the results agree with your prediction? Explain any differences between your results and your prediction.

2. Can a wind machine be used to generate electricity?
Explain your answer.

3. What is the condition necessary to generate electricity?

G. Further Information

Wind machines can be used to generate electricity. This production is affected by

- wind speed
- size of propellor blades
- number of propellor blades
- land surface over which the wind blows.

Windmills that produce electricity are called wind generators. In most wind generators an electrical generator is connected to the wind propellor by mechanical linkages. As the propellor spins an electric current is produced by the generator. This electricity, if not used directly, can be stored in a accumulator for use later on. If the location where the electricity is required is not suitable for the wind generator then it can be located elsewhere and the electrical energy produced can be transferred by transmission lines.

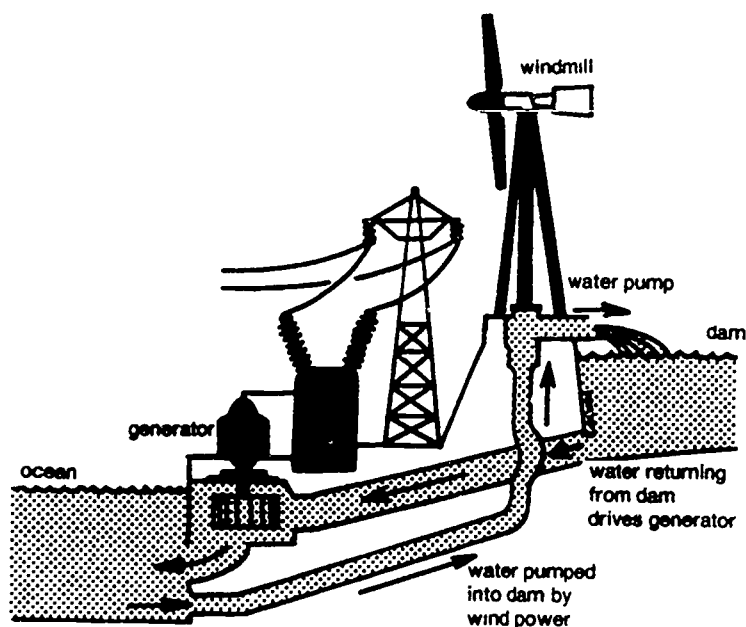

Use of a windmill to generate electricity and to pump water.

There are some limitations with the use of windmill power. The size of the blades has to be very large in order to generate even moderate amounts of electricity. The efficiency of the windmill depends on the wind so the wind speed has to reach a certain level before the blades even start to turn. On the other hand if the wind speed exceeds a certain level the wind generator must be shut down for safety reasons. As the wind doesn't blow consistently all year round that means that wind power does not supply a continuous source of power. Thus if wind generated electricity was used in the home for lighting, the lights would dim when the wind speed decreased.

Technology has been developed to overcome some of these limitations. A high technology wind generator that senses out the most power effective wind has been developed in Australia. The nerve centre of the generator is a computer which not only senses the best direction for maximum effect of the wind but also switches on the electric motor as required. It is able to decide when the generator needs to be shut down because the wind is too strong for safe operation. Also it can start an alternative back up motor any time the station is shut down or the wind is too light for operation.

With this kind of computerized windmill a family can rely on wind power to give them a consistent supply of electricity.

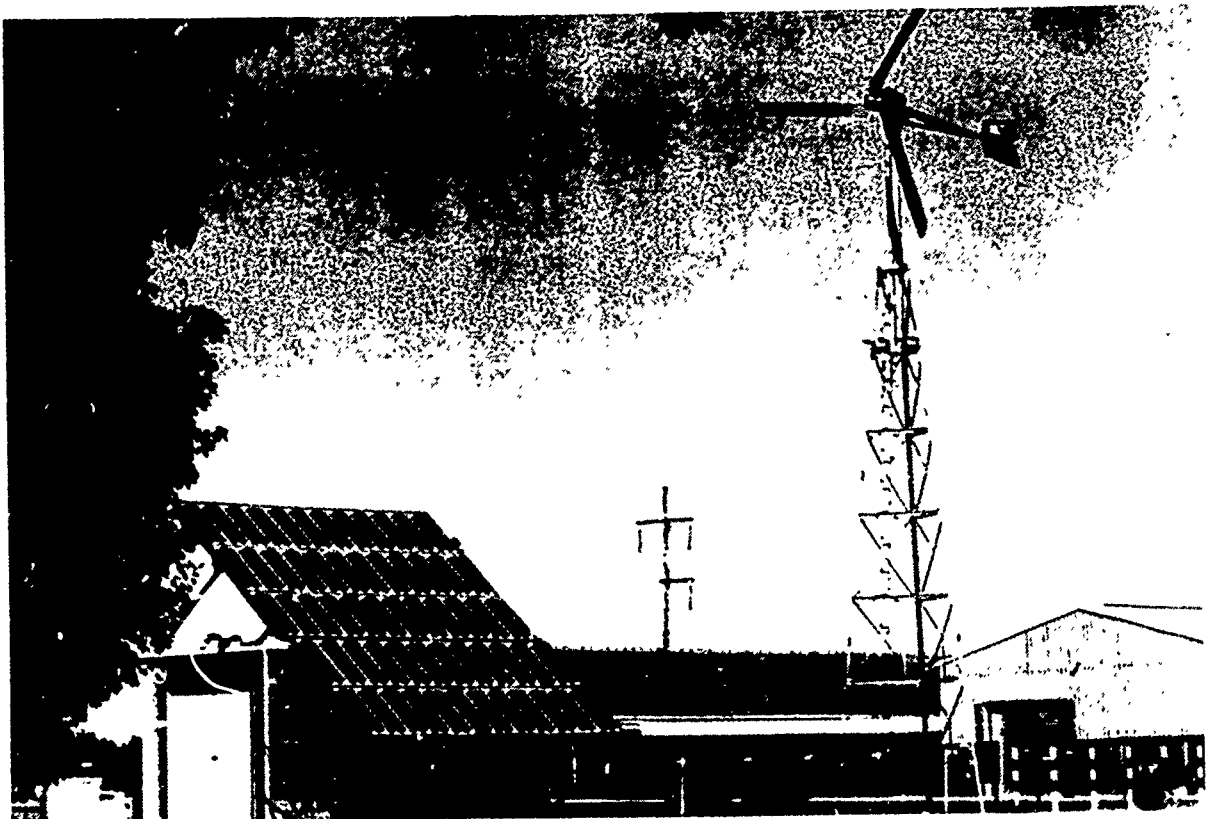

Windmill with a computer brain

(v) ASSOCIATION AND SYSTEMATIZATION

1. Using the windmachines designed in the previous sections of the topic determine the effects of the wind blowing in different directions. What are some of the problems you foresee in using the wind to generate electricity in your location? Which machine is most consistent for collecting the wind's energy?

2. Over a short time span, the wind seems very fickle. However, the average character of the wind at a given spot over months and years is much more regular. Obtain a map of your country and your locality which shows either the average wind speed at fixed times (9 am and 3 pm) or the speed integrated over a day called the daily wind-run. The wind-run maps closely parallel the wind-speed maps. However, although wind-run is a good indicator of potential power output of a windpower generator, the data on the maps are not sufficient for any detailed calculation of the wind energy potential of particular sites. Nevertheless, the maps will aid in identifying those generally windy regions where prospecting for windy sites should be focussed.

Based on the data you collect propose where a wind farm may be developed in your country and in your own locality. What problems do you foresee in your proposal? How would you recommend overcoming these problems?

(v1) APPLICATION

1. The Vertical Axis Wind Machine you developed in Design 1 uses a Savonius rotor. Using the same principles of construction in developing this small rotor, build a larger Savonius rotor using buckets or 5-litre plastic cans. Make sure the support structure is strong enough to hold up the rotor. You will need to have the axis free to rotate using bearings. Roller skate wheels may be useful as bearings.
2. Having built the larger Vertical Axis Wind Machine, erect it in a location where you can experiment with its efficiency in a similar way as the investigations for this topic. To maintain the wind machine in an upright position you will need to make a suitable framework that will allow you to mount the

rotor in a vertical position supported by its bearings and tree to turn in the wind. Make a sketch of your wind machine and framework and discuss it with your teacher prior to building.

3. Once you have the larger Savonius rotor in working order, develop a gear system for doing different forms of work.

BIBLIOGRAPHY

Charters, W. & Pryor, L. (1981). Solar Energy. Beatrice Publishing.

Dekkers, J., O'Loughlin, M., Treagust, D. & Vlahov, S. (1985). Energy from the Sun. Solar Energy Education Project, Western Australia.

Energy, Lower Secondary Science. (1983). Curriculum Branch, Education Department of WA.

Energy Transformations. (1984). Curriculum Branch, Education Department of WA.

Lacy, T., Dekkers, J., O'Loughlin, M., Treagust, D. & Vlahov, S. (1983). Sunshine Science. Solar Energy Education Project, Western Australia.

Robbins, T. (Ed.). (1984). The Windmill with a computer brain. Solar Progress. Journal of the Australian and New Zealand International Solar Energy, 5(2), 1.4

CONTENTS

<u>UNIT 6</u>	<u>Page</u>
(i) Topic: Biomass: Energy from Plant and Animal Material	
(ii) Objectives	1
(iii) Introduction	2
Activity	3
(iv) Presentation	7
Investigation 1	7
Investigation 2	15
(v) Association and Systematization	21
(vi) Application	27
Bibliography	29

(1) THEME: TECHNOLOGY IN LIFE

TOPIC: BIOMASS: ENERGY FROM PLANT AND ANIMAL MATERIAL

(ii) OBJECTIVES

Upon completion of this unit, students will be able to:

1. Comprehend that biomass, created by solar energy, is the basis for all life.
2. Identify that biomass is a source of energy and give examples to illustrate this.
3. Describe different technological methods to obtain energy from biomass.
4. Solve given problems and form valid conclusions by carrying out investigations.
5. Discover how waste material can be recycled.
6. Show an appreciation of how recycling can conserve valuable energy resources.
7. Be introduced to the procedure involved in the commercial production of paper.

(111) INTRODUCTION

In the process of photosynthesis solar energy is converted to chemical energy and stored in a variety of organic materials which are called BIOMASS. The term "biomass" is used to describe plant and animal materials and substances derived from plants and animals such as wood, wheat, sugar and animal fats. There are two main sources of biomass:

- . Left over material from industry, agriculture and households. Some of these left over materials can be used to produce other materials.
- . Plant material that is grown specifically for its energy content such as sugar cane from which alcohol can be used as a fuel.

Plant material that has absorbed solar energy is a vital energy source for animals. Animals that eat only plants are called HERBIVORES and they obtain their energy for living processes by eating plant material. In turn the herbivores are eaten by meat eating animals called CARNIVORES who get their energy by eating the stored energy in the herbivores.

Thus the basis for life is the solar energy that is collected by the plants. This energy is stored in plants as chemical energy during the process of photosynthesis. Eventually all the chemical energy stored in plants and animals is converted by RESPIRATION and

used in the processes of movement and growth which occur in all plant and animal matter.

Biomass can be converted to usable energy in a variety of ways. For example, sugar cane can be fermented to produce alcohols which can be used as a fuel and animal waste can be digested by bacteria to produce methane gas. All types of biomass can be burned directly and are used by man for many purposes. By burning biomass material, especially wood, heat and light energy can be produced for man to use.

Millions of years ago plants growing in swamps were buried when changes happened in the earth's crust. Slowly this plant material was changed into coal by the high pressure and temperatures deep in the earth. Thus coal is formed from plant material.

Other natural resources as petroleum and natural gas are formed when marine plants and animals decay on the sea floor and become covered by sediment. This material changes into petroleum and eventually into natural gas after millions of years have passed. After man refines the petroleum he can use it as petrol, kerosene and lubricants.

ACTIVITY

In the diagram on the following page you will see the energy flow from the sun to the car.

1. In the 4 empty boxes describe the energy form that is being illustrated by the picture along side the box.

Flow of Solar Energy From Sun to Car

WHERE DOES IT ALL COME FROM?

1

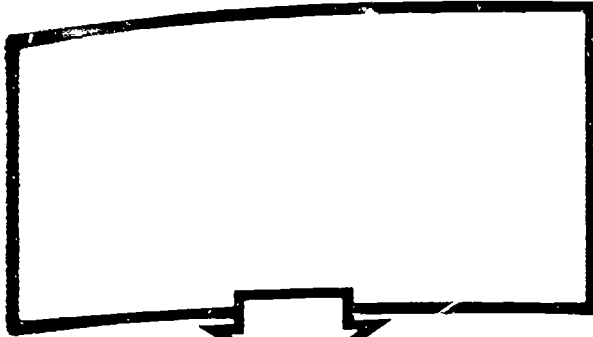

2

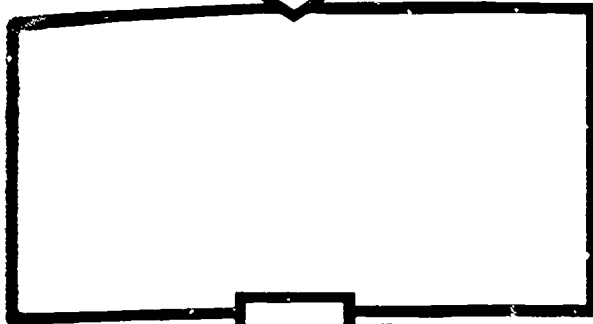

3

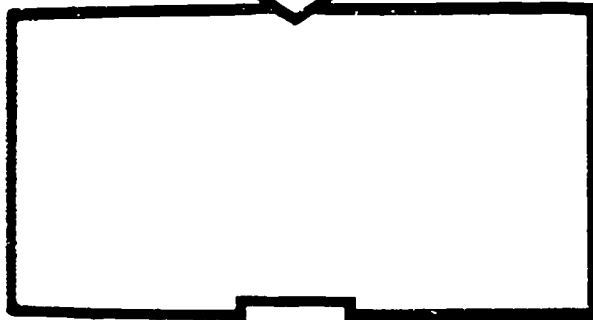

4

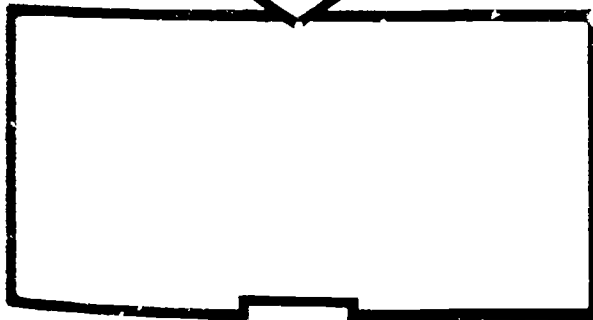

Petroleum stores solar energy. When it is burnt it produces heat that can be used.

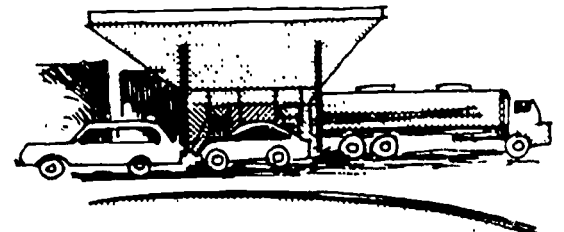
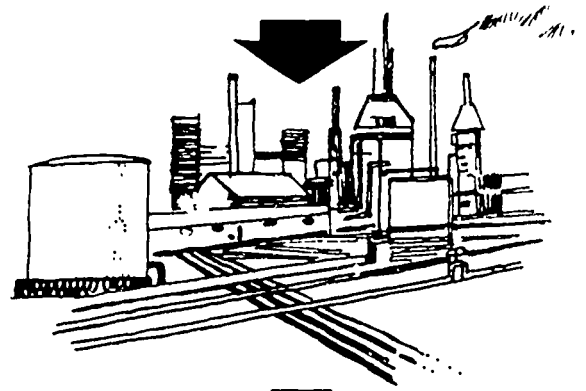
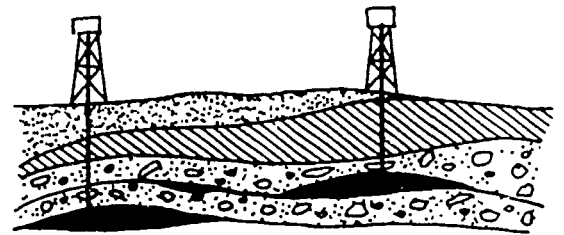
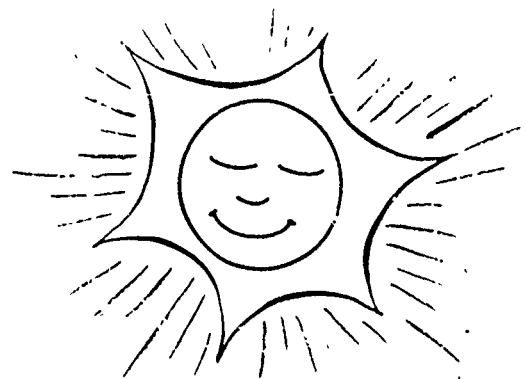

2. Explain how energy is being used in each stage of the chart.

Box 1

Box 2

Box 3

Box 4

3. What do you notice about the size of the black arrows? What do you think is the reason for this change in size?

4. What can you say about the efficiency of the solar energy flow? Is all the energy being absorbed by the plants being used to produce the petroleum?

PRODUCTION OF BIOMASS

Many crops are grown specifically for the production of energy. Such crops can produce energy directly by burning or indirectly by producing alcohol which is used as a fuel.

Oil from seeds can also be used to produce energy by being added to distillate for diesel engines. This might become a more common fuel resource if the long term cost of petroleum continues to rise. Solid animal food is produced from the material which remains after the oil is removed from the seeds. Thus the biomass material is used completely and nothing is wasted.

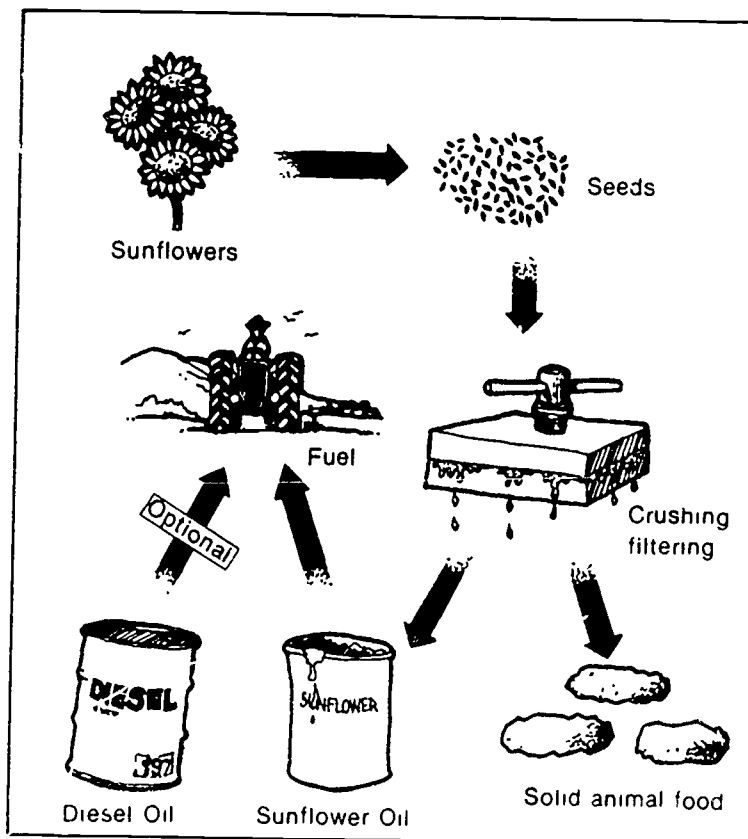

The above diagram shows the stages of the production of solid animal food and diesel oil from sunflowers.

Another way of producing energy from biomass is by alcohol production. This would mean less dependence on fossil fuels and also could reduce the need to import oil. However, alcohol production from biomass is more expensive than petroleum production. Also a large area of land would be needed to grow crops just for the production of energy instead of being used to grow food. Another limitation to the production of alcohol is that other energy resources become cheaper and more convenient to produce. Some car engines need modifications in order to use alcohol as a fuel. One of the most suitable materials for alcohol production is sugar cane.

Another method of obtaining energy from biomass is the collection of methane gas. In the absence of oxygen bacteria break down biomass into methane gas. This gas has several uses such as providing heat for cooking and driving electrical machinery.

(iv) PRESENTATION

This is the main section of the topic and consists of a series of investigations to be solved and the design and development of a functional product of technology.

INVESTIGATION 1

- A. Question: How can we produce methane gas from biomass material?

B. Materials

Aquarium heater

Calcium chloride and hydrochloric acid to produce carbon dioxide

Clamp

Rubber tubing

Flask 250 ml

Plastic bag

Elastic bands

Glass beaker 1 litre

Stirrer rod

Round bottom flask 500 ml

Water trough

Biomass, eg. chicken manure, lawn clippings, potato peel

C. What you do: Setting up the materials

1. Stir the mixture of biomass material of chicken manure, grass clippings and potato peel. Add water until the mixture has a creamy consistency.
2. Place the mixture in a round bottom flask approximately half full.
3. Place the flask in a waterbath with a temperature of 30-35°C.

4. Connect the flask to the deflated plastic bag firmly by placing elastic bands as shown in the diagram.
5. Connect the exit tube to a conical flask (see diagram).
6. Pass carbon dioxide gas through the system to remove any oxygen.
7. Leave apparatus for several days.

D. What do you predict will happen?

Describe any changes you predict will occur in the apparatus.

8. Squeeze the inflated plastic bag to discard the collected gas as it will be mainly air and carbon dioxide.
9. Gently shake the round bottomed flask to prevent settling.
10. When the plastic bag has inflated again release the clamp to allow the gas to flow to the gas nozzle.

11. Squeeze the plastic bag gently to maintain a steady flow of gas. Place a lighted match at the gas nozzle.

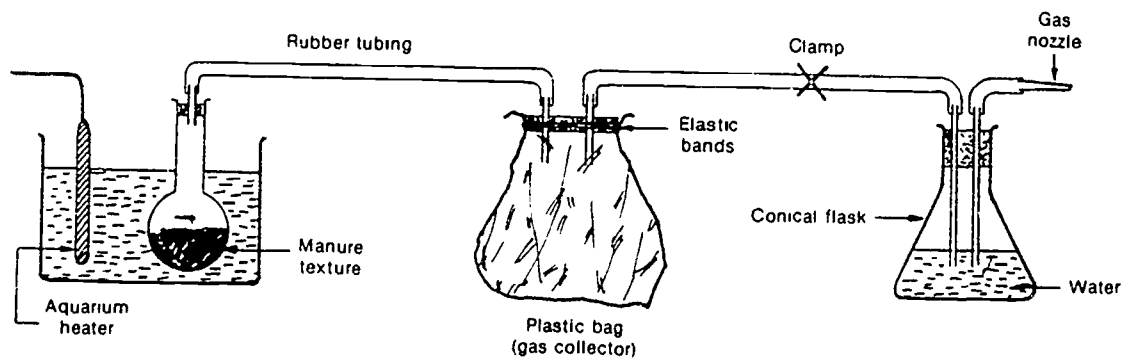

E. Interpretation of Data

1. How long did it take for the plastic bag to inflate for the first time?

2. How long did it take for the plastic bag to inflate for the second time?

3. Describe the appearance of the biomass mixture?

4. Does the biomass mixture have any smell?

5. List characteristics of the gas before it was ignited.

F. Conclusions

1. Did the results agree with your predictions? Explain any differences between your results and your predictions.

2. Why did the plastic bag inflate?

3. Why did the temperature of the water need to be kept between 30°C and 35°C?

4. What changes did you notice in the round bottom flask?

5. Describe the flame as the methane gas is burnt.

6. Comment on the efficiency of production of methane gas from biomass by this method?

7. What do you think about producing methane gas commercially by this method? What would be necessary to produce methane gas on a large scale? What equipment can you design that can be used for commercial production of methane?

G. Further Information

The production of methane gas using biomass has been used for many years in rural areas. In rural India, villagers use animal manure to generate methane gas and the material left over is used as a fertilizer for their gardens.

The following diagram shows a simple device for generating methane gas.

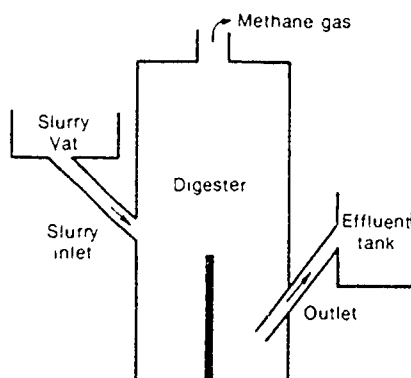

The mixture of manure and water in the slurry vat enters the digester by the slurry inlet. In the digester bacteria breaks down the mixture and methane gas is produced which is collected at the top of the digester. Biomass residues are removed through the outlet pipe to the effluent tank. These residues are used as fertilizer.

Energy from Trash

All countries produce huge amounts of trash which needs to be disposed of constantly. As it is necessary to burn this trash the heat of combustion that is produced can be utilized as an energy source.

In order to produce fuel from trash it is necessary to sort combustible materials from non-combustible materials.

Trash containing carbon compounds such as paper and wood, and petroleum based materials such as plastic can be converted at very high temperatures to combustible gases or liquids. The gas has a low energy content therefore liquid fuel is more valuable. Even so the rapidly rising cost of fossil fuels can make trash a more attractive source of future energy.

INVESTIGATION 2

A. Question: How trash can be used to save energy?

B. Materials

4 large plastic garbage bags

Balance

One week's trash collection

C. What you do: Setting up of materials

1. Label the four plastic garbage bags with one each of the following waste materials

- . aluminium
- . paper
- . plastics
- . glass

2. Each day for a week sort the family trash and place materials into the appropriate bag.

D. What do you predict will happen?

Which one of the four garbage bags will contain the most waste material by the end of the week? Which bag do you think will be the heaviest? Explain your answers.

3. Weigh each bag and record the totals on the given table.
4. From Information Table obtain the energy needed to produce one kilogram of aluminium and enter the value in the Results Table.
5. Determine the amount of energy needed to produce the aluminium products thrown away each week by completing the results for aluminium on the table.
6. Repeat procedures 4 and 5 for the other waste materials collected.

RESULTS TABLE

Energy in a week's household trash

Waste Materials	Mass of Waste (Kg)	Energy Needed for Production (MJ/Kg)	Energy in Trash
Aluminium			
Paper			
Plastics			
Glass			

INFORMATION TABLE

Energy requirements for the manufacture of some common materials

Material	Energy Requirements (MJ/kg)
Aluminium	284
Copper	130
Steel	28
Glass	20
Concrete	1
Bricks	5
Paper	25
Plastic (Polystyrene)	74

Source: CHEMTECH September, 1980, p. 550 (converted to metric measurements to nearest whole unit)

E. Interpretation of Data

1. What was the total mass of household trash that you collected in the week?

2. List the four types of materials collected from highest to lowest amounts.

3. What do you think are the reasons for the differences in the amounts collected of each material?

4. Did the results agree with your predictions? What do you think are the reasons for the differences between your results and your predictions?

5. Calculate the average amount of waste for each member of your family.

F. Conclusion

1. Discuss the advantages of using household trash in order to save energy.

2. Discuss the limitations of using household trash in order to save energy.

3. Describe any recycling programmes for trash that are organised in your neighbourhood.

G. Further Information

Energy and Papermaking

About half the fibrous raw material used for paper making is waste paper and cardboard. This means that a paper product which has already served a worthwhile function can be made to perform a task over and over again. Newspapers, books, magazines and cardboard cartons are a few of the everyday items which are available and collected for recycling.

The general aim of energy conservation is to use less energy and natural resources to produce the same end product. Conservation strategies in industry are also aimed at reducing energy waste and improving the efficiency of energy usage.

With the concern for the preservation of forests, which are biomass material, technology has developed recycling processes which can help to conserve the trees.

(v) ASSOCIATION AND SYSTEMATIZATION

A. Question: How can paper trash materials be recycled for a new use?

B. Materials

Variety of used paper such as used envelopes, computer paper, newspaper,

Bags

Large container, eg. old baby bath

Frame: see diagram for construction

Blender

Sieve

Flywire

Metal coat hangers

Pegs

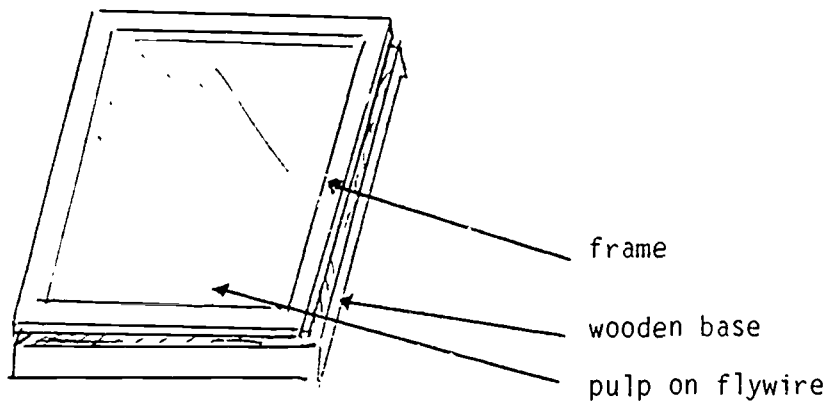

C. What you do: Setting up materials

Step 1: Making the pulp

1. Tear up used paper and leave to soak in water for several days.
2. Blend in a blender till lump free (Do this in bursts only blending a small amount of pulp in a large amount of

water each time.). If you do not have a blender stir vigorously until paper and water have formed a smooth pulp.

3. Drain through sieve and store if necessary.

Step 2: Making paper sheets

4. Stir pulp to suspend evenly in the water.
5. Take frame, wooden base and flywire and dip into pulp. Lift out so that a fine pulp suspension is deposited on the flywire. If suspension is too thick or thin wash it off and try again.
6. Place coated flywire, frame and base into sun to dry. Peel off the paper sheet when dry.

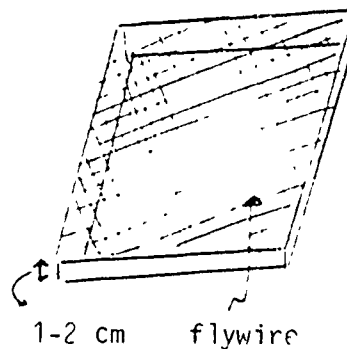
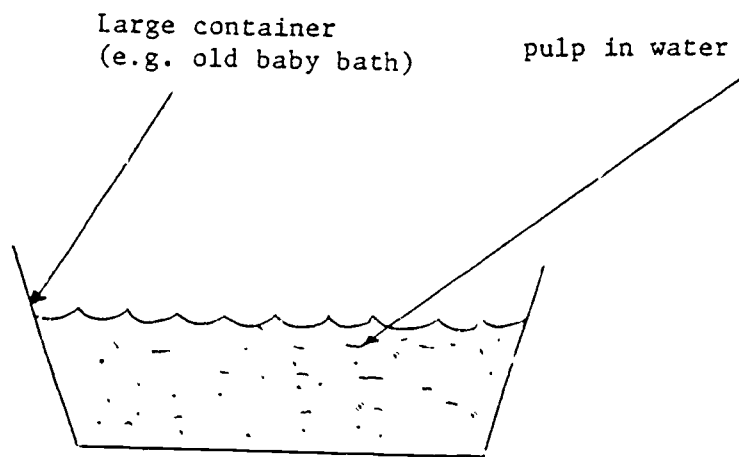

Step 3: Pressing the Paper - an alternative to drying on the frame. Extra materials required: newspaper, piece of blanket, piece of cotton material, top and base boards, bricks, wire coat hanger, pegs.

Set up pressing pan as follows:

1. Take a metal or plastic pan as a base. Place on base board 5 sheets of newspaper. On newspaper place a piece of blanket or sheeting or foam.
2. Next place a piece of cotton sheeting onto other layers (see diagram).
3. Drain paper on frame until it stops dripping.
4. Stand frame on edge of cotton sheet. Tip frame slightly so it can be grasped securely on 2 sides. Using a rolling motion press so as to leave pulp paper onto cotton sheet.
5. Place a board on the top of water absorbing materials and press paper sheet overnight using bricks as weights.

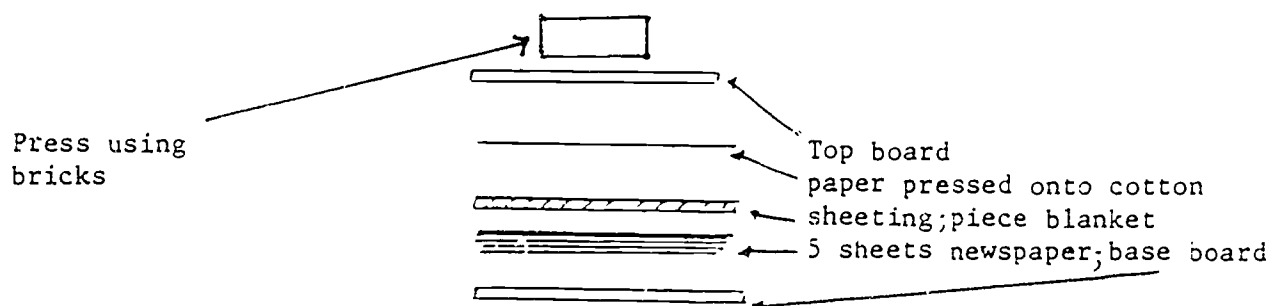

6. After pressing hang up to dry on cotton sheeting and peel off when dry.

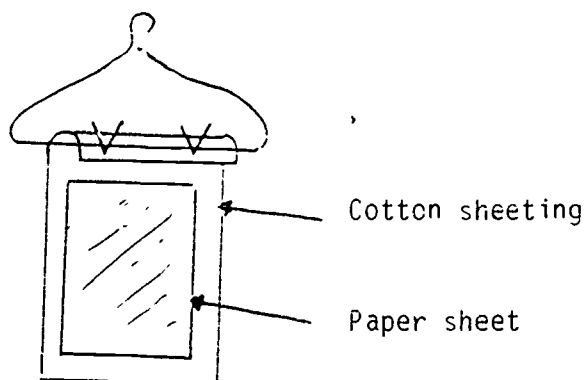

7. Describe the appearance of the paper you have made. How does it compare to the paper you are writing on now?

Interesting Variations

Add colour: Mix white pulp with handfuls of pulp from coloured material such as paper napkins (not crepe paper).

Change texture: Replace cotton sheeting with a textured material, eg. linen to give the paper a patterned surface.

Use natural plant fibres: Choose plant such as bamboo leaves, grasses or leaves of native plants. These plants need to be boiled in caustic soda till material is soft and broken up.

WASH WELL. You need rubber gloves to handle it and break it

up. Then make pulp as with paper materials. Also you can add various amounts of this natural plant pulp to paper pulp to vary texture and colour.

Further Information

The activity you have just done is an example of recycling of waste material in order to save energy resources. Paper is an important and useful item in everyday life. It was first made about 2,000 years ago in China using the fibres of hemp rope, old rags and fishing nets. The ingredients were beaten into a pulp, mixed with water and poured over grass strainers. When the water drained away the pulp was left to dry in the sun, rubbed smooth with a stone and there it was - paper. However at the time China was unknown to the Western World and paper making remained a secret for centuries until the year 751 when Muslims captured a Chinese paper mill and discovered the paper making process. By the 12th century paper had reached Spain. By the 16th century it was being made by hand in England. In 1719 a French scientist saw a wasp chewing wood to pulp to build its nest and concluded that paper could be made the same way. A hundred years later two Germans designed a machine for grinding wood into fibre. A few years later two Englishmen developed a machine that was to be the prototype of the modern paper making process. Using straw and rags as the ingredients and a fine wire mesh as a strainer, the machine produced paper in a continuous length.

Paper could now be made in quantity but raw materials were scarce. However, the new technique of grinding wood into pulp was only a few years away and various chemical methods of reducing wood to fibre were also being discovered. By the later half of the nineteenth century the pulping industry was getting into full swing and the world of ready made paper was born.

The process of making paper depends on the amount of biomass that is available to man. When paper manufacturers use forests effectively they can help healthy regeneration by allowing more sunlight to reach the forest floor.

Biomass means materials or substances all having an origin in some living form which constitute now, or could in the future, a source of energy. Examples of biomass can be wood and wood waste; agriculture products and waste such as stalks, shells, husks, etc; algae; animal wastes and home trash. Some of these materials are already sources of energy, as in the use of firewood. Other forms of biomass can be fermented to produce alcohol and many botanical materials can produce burnable gas and liquid fuel. Sugar cane for example, after the juice has been squeezed out, can be used directly as a burnable residue or be fermented, or serve as a raw material in paper making.

3. Compare their process with the process we used in Investigation 3 and comment on any differences.

4. Find out and comment on what factories are doing about conserving the forest areas from which they get their raw materials.

BIBLIOGRAPHY

Braunstein, H.M., Kasciruk, P., Dickinson, R., Sharples, F.E., Tatum, J.S., Oakes K.M. (1981). Biomass Energy Systems and the Environment. Pergamon Press.

Dekkers, J., O'Loughlin, M.J., Treagust, D.F., Vlahov, S. (1985). Energy from the Sun. Solar Energy Education Project, W.A..

Energy Perspectives - Energy from Biomass. (1977). Battle Memorial Institute, Columbus, Ohio.

Energy Perspectives - Energy from Trash. (1975). Battle Memorial Institute, Columbus, Ohio.

How We Make Paper - Australian Manufacturers Limited. Last printed on APMIL MG Litho.

CONTENTS

<u>UNIT 7</u>	<u>Page</u>
(i) <u>Topic: Photovoltaic Cells: Solar Energy in the Future</u>	
(ii) Objectives	1
(iii) Introduction	2
(iv) Presentation	6
Activity 1	7
Investigation	9
(v) Association and Systematization	15
(vi) Application	18
Bibliography	22

(i) THEME: TECHNOLOGY IN LIFE

TOPIC: PHOTOVOLTAIC CELLS: SOLAR ENERGY IN THE FUTURE

(ii) OBJECTIVES

Upon completion of this unit, students will be able to:

1. Be familiar with the uses of photovoltaic cells and apply this knowledge to designing a solar powered device.
2. Carry out an investigation and calculate the power produced by solar cells.
3. Be aware of possible technological developments in the future that could be developed to use the sun's energy.

(iii) INTRODUCTION

The term "solar energy" means the direct usage of the sun's rays by collectors or photovoltaic cells and the indirect source of energy generated by wind, water and the breakdown of biomass materials.

The sun constantly delivers more energy than the world could ever use. It has been estimated that the incoming solar energy reaching the surface of the earth in one year is ten times greater than total fossil resources. However the main problem is that the collection and storage of the sun's energy in reasonable quantities and cost is currently too expensive compared to conventional fossil fuels.

PHOTOVOLTAIC CELLS

In the early 1950's in the USA the first silicon solar cells were developed which enabled solar radiation to be converted directly into electrical energy. Photovoltaic cells are made of thin wafers of specially treated semi-conductor materials. Materials that are neither conductors or insulators of electricity are called semi-conductors, for example silicon and germanium.

The amount of electricity produced by a photovoltaic cell depends on the intensity of light falling on the cell and not on the amount of heat absorbed. Photovoltaic cells work most efficiently at very low temperatures where there is intense light; thus they are very efficient in Antarctica in the summer when there is less cloud cover but it is still a very cold place.

As a single photovoltaic cell only produces a small amount of electricity it is necessary to join several together to produce large amounts of electricity. This construction is called a SOLAR PANEL. Solar panels can only operate during day light hours. So, in order to supply electricity during the night time electrical accumulators are used to store the energy produced during the day. Therefore, a constant supply of electricity can be maintained from the sun's energy.

USES OF SOLAR PANELS

The main advantages of photovoltaic cells are that running costs are very small, they require little maintenance, they operate silently and do not emit pollutants. The major disadvantages of the cells are the high cost of manufacture, they do not operate at night and their efficiency is still only between 10% and 15%.

We see the use of photovoltaic cells in fairly isolated areas where the cost of fuel delivery and maintenance of equipment would be very high. They can be combined with diesel and wind generators to generate electricity or used on their own when only small amounts of electricity are needed.

In remote areas photovoltaic cells are used to run telephone systems capable of covering large areas. Isolated farming communities use photovoltaic cells to power their water pumps and electric fences. Small towns can receive their lighting and

weather recording stations can receive their power from solar panels. Railway crossing signals and airport lighting are other examples of photovoltaic cell use in remote places.

Photovoltaic cells can be used in transportation. At sea they can supply the power to recharge ship's batteries, operate signal buoys, lighthouses and warning lights. Lightweight aircraft and cars have also been developed which use photovoltaic cells to generate their power.

A solar-cell
powered navigation
buoy

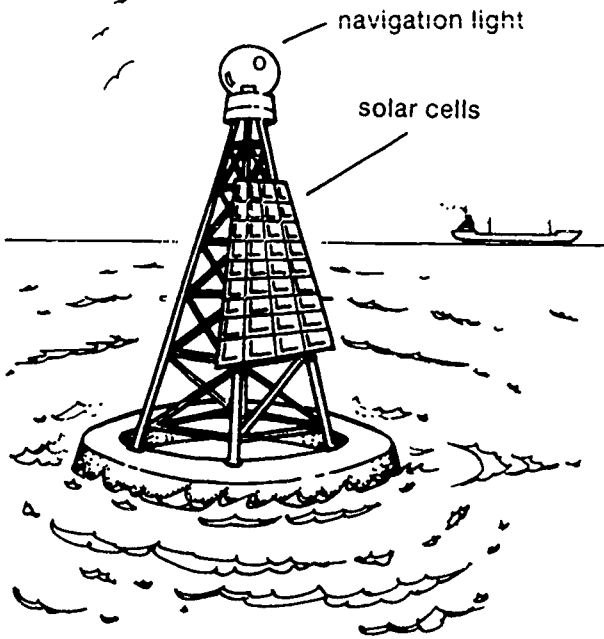

solar cells

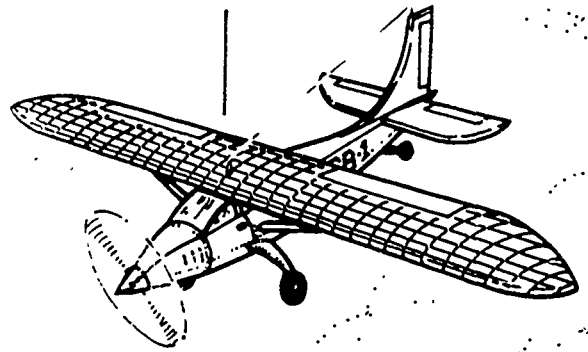

A solar-cell
powered plane

solar cells

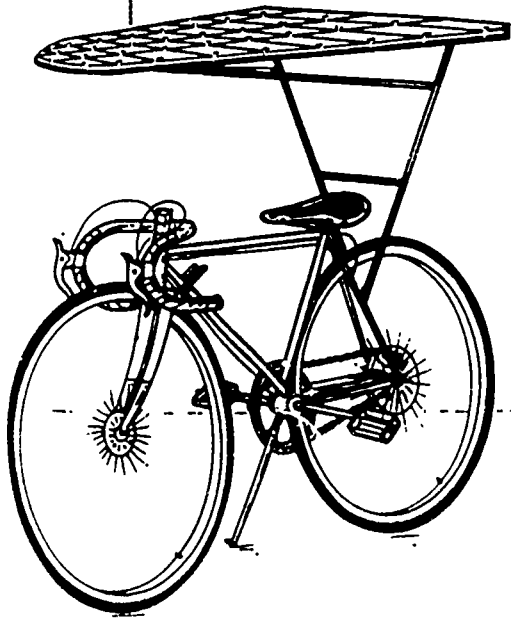

A solar-cell
powered bicycle

Smaller technological devices that use solar cells for power include calculators, watches, toys and other microelectronic products.

Small satellites orbiting the earth were the first practical users of solar cells in space. Because solar cells are very light and do not operate on fuel that would need to be carried by the satellite, they are now used in larger satellites to generate the electric power that the satellite needs to operate.

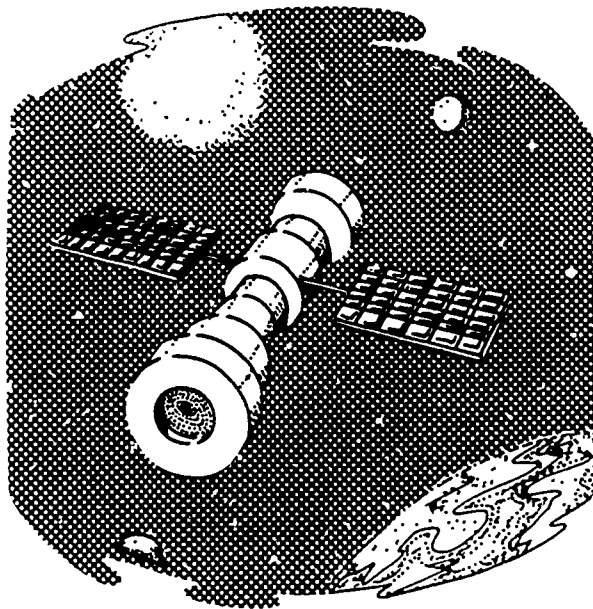

Solar-powered
satellite

(iv) PRESENTATION

This is the main section of the topic and consists of several activities to be carried out to see possible technological developments of energy in the future.

3. Describe how your community can make use of your device.

HOW SOLAR CELLS ARE CONSTRUCTED

Solar cells are made by a manufacturing process that takes very pure silicon (the basic component of rock and sand), adds slight amounts of other elements such as boron and phosphorus and eventually produces the wafer thin photovoltaic cell. The individual cells are usually circular with diameters between 5 and 8 cms. Groups of these cells are connected in series-parallel arrangements to provide the required voltage and current for the particular application being considered. The cells are usually sealed in a protective casing to guard against atmospheric interference.

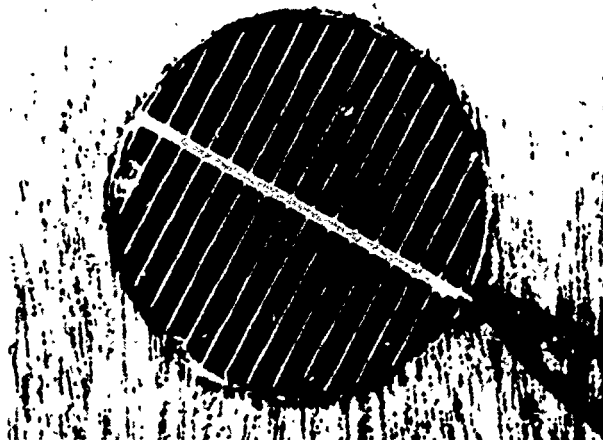

Single Photovoltaic Cell. Approximately Full Size

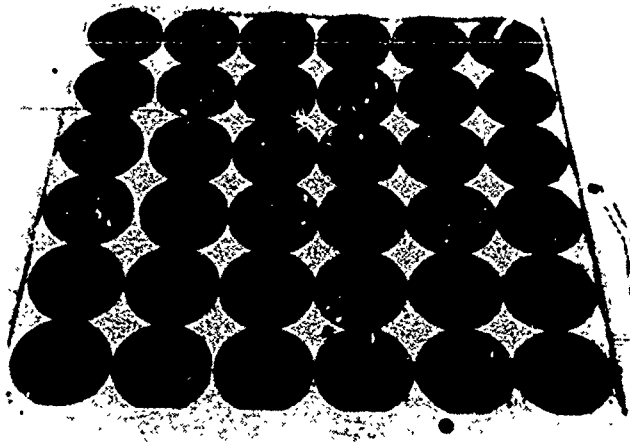

Sealed Unit Containing 36 Photovoltaic Cells

INVESTIGATION

A. Question: How much power can be produced by a single solar cell and a solar panel?

B. Materials

Solar cell

Solar panel (a collection of solar cells)

Ammeter

Electrical leads

Voltmeter

C. What to do: Setting up materials

- Using the solar panel set up the circuit as shown in the diagram.

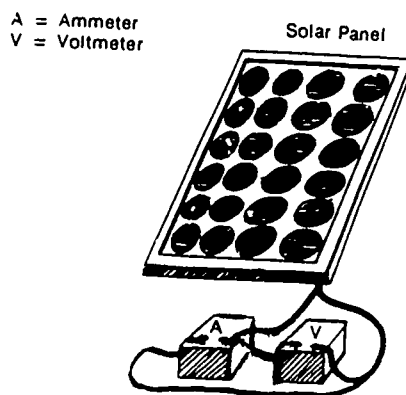

- Place the apparatus in direct sunlight.
- D. Describe what you predict will happen when you complete the circuit.

- Record the readings on the ammeter and the voltmeter in the results table.
- Repeat stages 1-3 using the single solar cell in place of the solar panel.

RESULTS TABLE

Solar Panel

Current A	
Voltage V	

Solar Cell

Current A	
Voltage V	

E. Interpretation of Data

1. Did your solar cell generate any electricity? Did the result agree with your prediction?

2. Using the following equation calculate the power produced by the cell.

POWER	=	VOLTAGE	x	CURRENT
(watts)		(volts)		(amperes)

3. Did your solar panel generate any electricity?

4. Calculate the power produced by the solar panel using the given equation.

5. Count the number of solar cells making up the solar panel. Calculate the power output from each of these cells by dividing the total power produced by the solar panel by the number of cells.

$$\text{POWER PER CELL} = \frac{\text{TOTAL POWER}}{\text{NUMBER OF CELLS}}$$

6. Compare the power produced by the single solar cell to the average power produced by a single cell from the solar panel.

F. Conclusion

1. Did your results agree with your prediction?

2. Does the placing of solar cells into a solar panel construction increase the power generated by the single cell?
-
-

G. Further Information

View to the Future

In the future we can foresee an energy crisis because conventional known fuel sources such as fossil fuels can only last for a few more decades before they run out. But there is plenty of energy available for use on earth if we look at the sun as an energy resource although as we have stated the sun's energy can be expensive to collect. Solar energy can be converted to useful energy as heat or electricity from 5-15% efficiency. If only 1% of the land area was utilized as a solar collector it could supply all of the energy needs even of a large country such as United States of America. In the same way you covered your roof with solar cells you could supply all of your energy needs. This way we can build a self reliant city which will probably also raise a portion of its food within its city limits to make it even more energy efficient. Organic waste left over after the production of methane and alcohol fuels will be used to fertilize the soil or to supply animal feed. Recycling of waste material can conserve energy resources.

Most solar technologies can be built rapidly to match demand and can be relocated to support changing needs. In the 1960's solar energy technology and space technology led to the concept of the solar power satellite. The satellite would be placed into earth's orbit and there it would convert solar energy into electricity and pass it to microwave generators forming part of a transmitting antenna. The antenna would precisely direct a microwave beam of very low power to one or more receiving antennas at desired locations on earth. On the ground the microwave energy would be safely and efficiently reconverted to electricity and then transmitted to users.

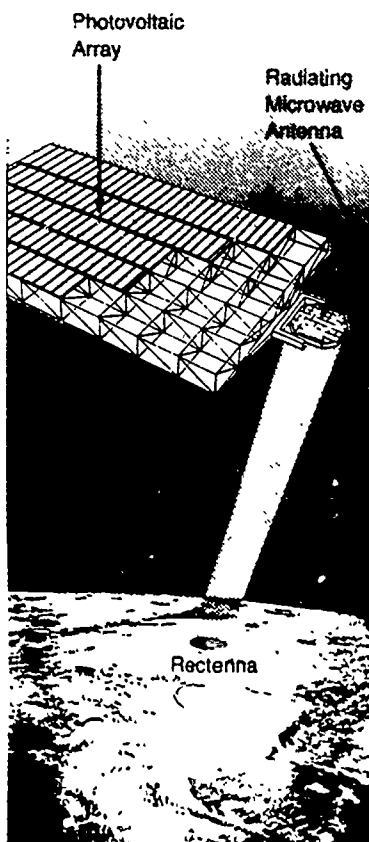

Solar Power Satellite Generator

The solar power satellite generator is a development of the future because consideration is still needed on its environmental effects, comparative economic factors, impacts on existing institutions as well as programme risks and uncertainties.

Up to now we have tended to look for solutions of our immediate problems only, and we have often failed to see the future except as a continuation of the present. Society has to bear the responsibility to build a livable future for succeeding generations and sun power represents the ultimate energy resource.

(v) ASSOCIATION AND SYSTEMATIZATION

By the year 2050 the earth's conventional fuel resources are not sufficient to support the population.

You have been appointed to lead a small group of twenty people to start an alternative community in space.

You are able to take with you any materials you will need except energy fuels.

Your only energy source will be the sun.

The newly discovered planet that you are being sent to has the same atmospheric conditions as earth.

3. Plan the food production for the group.

4. Devise means of transportation.

(vi) APPLICATION

Current market applications of photovoltaics are in areas where the use of conventional sources of electric power is prohibitively expensive. Examples are communication system signal repeaters on mountain tops, spacecraft, satellites, lights on ocean rigs, remote weather stations and cathodic protection (passing currents through metal to prevent rust) of bridges and other metal structures. As the cost of solar electric power declines, the number and variety of applications will significantly increase. The market potential in the industrial, military and residential markets is unlimited.

In some areas of the world trial houses have now been constructed using an array of photovoltaic cells on the roof to generate the necessary power to run all of the electrical appliances. When more power is generated than is needed by the house, the excess power is banked with the local electrical company for use elsewhere and credited to the house's account. At night and on cloudy days, when the power needs of the house exceed the power output of the array the electric company provides the needed electricity.

(a) You have now experienced different applications using solar energy.

1. Find out if there are any solar energy systems used to generate power in your capital city.

2. What other types of energy resources are used in your country?

3. Has the technological development in your area been affected by the available energy resources? Explain your answer.

(b) Mankind's Use of Energy (see diagram on next page)

1. What were the main sources of energy that were used in each of the time periods shown?

A _____
B _____
C _____
D _____
E _____

2. How has the use of energy resources affected the development of industry and technology?

3. In the spaces given on the diagrams write what you think each of the characters might be saying about the way they use energy.

Mankind's Use of Energy

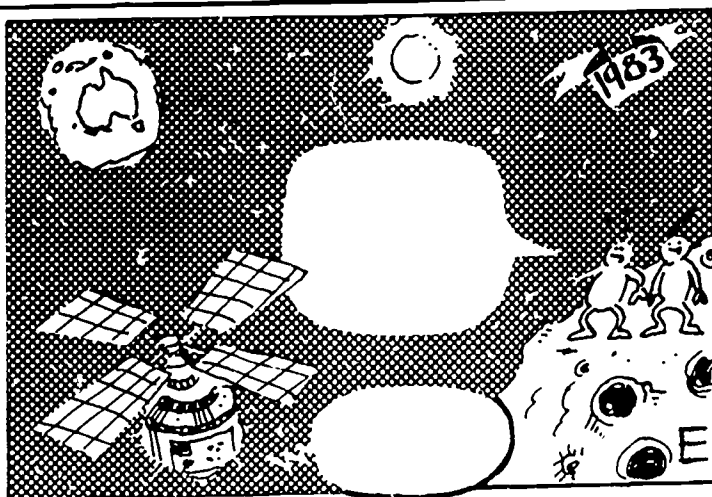
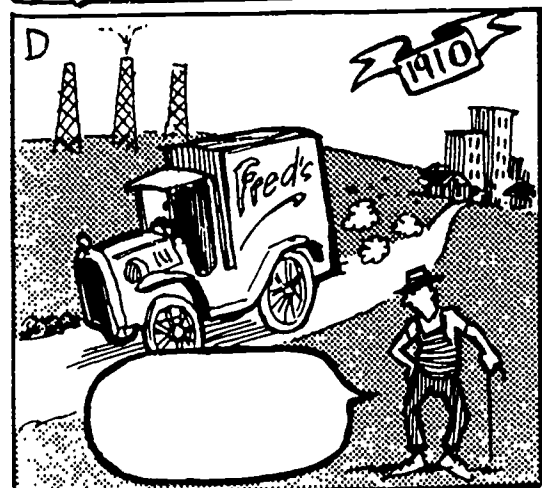
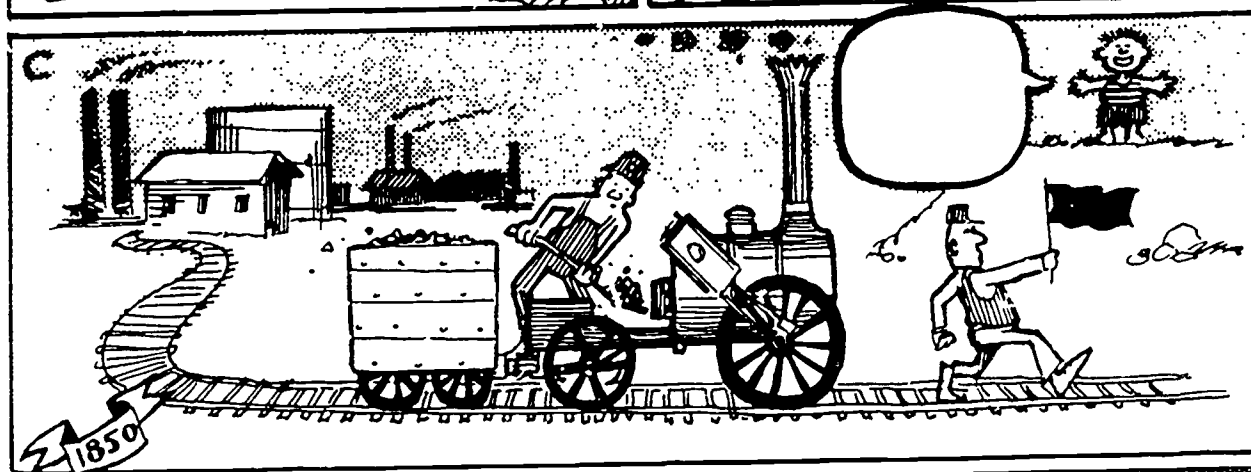
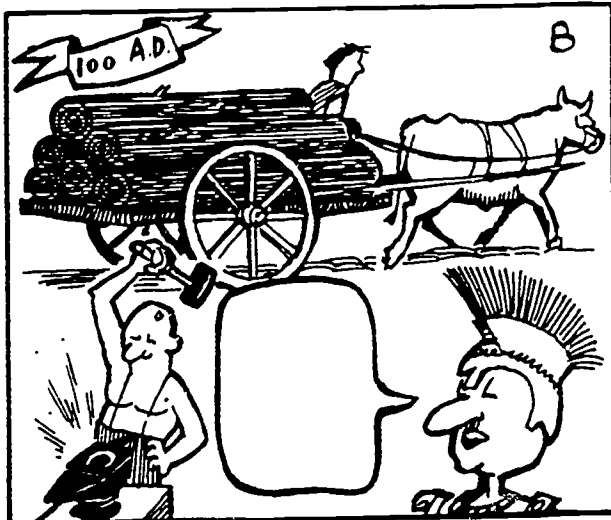
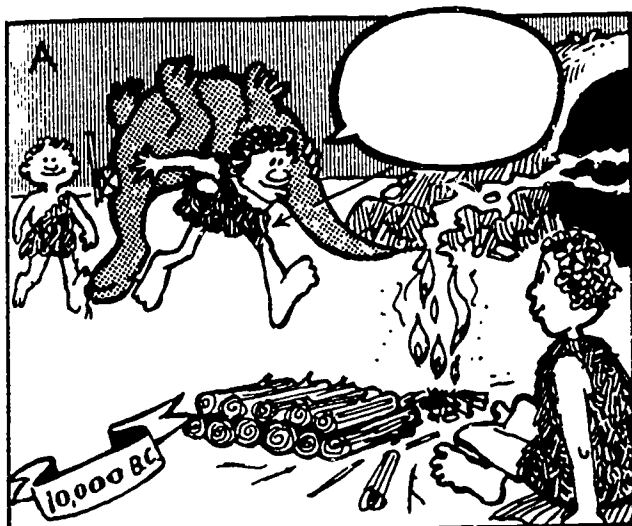

REFERENCES

Charters, W.S., Pryor, T. (1981). Solar Energy - An Introduction to the Principles and Applications. Beatrice Publishing.

Dekkers, J., O'Loughlin, M.J., Treagust, D.F., Vlahovs, S. (1985). Energy from the Sun. Solar Energy Education Project, W.A.

Energy, lower second, science. (1983). Curriculum Branch, Education Department of W.A..

Glaser, P.R. (1981). Power from earth orbit, Fire of life, the book of the sun. Australia and New Zealand Book Company, 236-243.

Kiss, Z.J. (1982). Economics of thin film photovoltaics. Sunworld, 6(3), 63-66.

Lampert, S., Nulf, K. and Yanour, G. (1979). Solar energy curriculum for elementary schools. U.S. Department of Energy.

Photovoltaics: The solar promise. (1984). Solar Energy Research Institute, Western Australia.