

DOCUMENT RESUME

ED 305 075

IR 052 687

AUTHOR Estes, Bettie, Ed.  
 TITLE Stacks of Ideas. Activities for the Library Media Center and Classroom, K-8.  
 INSTITUTION Oklahoma State Dept. of Education, Oklahoma City.  
 PUB DATE 88  
 NOTE 352p.; For Stacks of Ideas 7-12. see IR 052 688.  
 PUB TYPE Guides - Classroom Use - Guides (For Teachers) (052)

EDRS PRICE MF01/PC15 Plus Postage.  
 DESCRIPTORS \*Cooperative Planning; \*Course Integrated Library Instruction; Curriculum Guides; Elementary Education; \*Elementary School Teachers; Information Needs; Learning Resources Centers; \*Library Skills; \*Media Specialists; School Libraries; Teaching Methods; \*Units of Study

ABSTRACT

Designed to encourage cooperative program planning between the library media specialist and the classroom teacher, this guide consists of 26 teaching units in all elementary (K-8) curriculum areas. At least one teaching unit with learner outcomes and related information skills is included in each content area with an indication of the particular grade level at which that unit should be emphasized. It is noted that these units can be adapted for other grade levels or to different methods of instruction, and that they can be integrated into an existing school curriculum. Also provided are other units that emphasize pure enjoyment and pleasure in reading. Supplementary materials for use with the units are appended. A 23-item bibliography of sources of information on authors of materials for elementary school children is also provided. (CGD)

\*\*\*\*\*  
 \* Reproductions supplied by EDRS are the best that can be made \*  
 \* from the original document. \*  
 \*\*\*\*\*

ED305075

**U.S. DEPARTMENT OF EDUCATION**  
Office of Educational Research and Improvement  
**EDUCATIONAL RESOURCES INFORMATION**  
**CENTER (ERIC)**

- This document has been reproduced as received from the person or organization originating it.
- Minor changes have been made to improve reproduction quality

• Points of view or opinions stated in this document do not necessarily represent official OERI position or policy



052687

**"PERMISSION TO REPRODUCE THIS  
MATERIAL HAS BEEN GRANTED BY**

**J. Craddock**

---

---

**TO THE EDUCATIONAL RESOURCES  
INFORMATION CENTER (ERIC)."**



# Stacks Of Ideas

Activities for the  
library media center  
and classroom

K-8

**Oklahoma**  
**State Department of Education**  
John M. Folks  
State Superintendent Of Public Instruction

Oklahoma City, Oklahoma

1988

This publication, printed by the Graphics Division of the Oklahoma State Department of Vocational and Technical Education, is issued by the Oklahoma State Department of Education, as authorized by John M. Folks, State Superintendent of Public Instruction. 6,000 copies have been prepared and distributed at a cost of \$17,270.03. Date 3-2-88. Copies have been deposited with the Publications Clearinghouse of the Oklahoma Department of Libraries. — 88-005509

## FOREWORD

The primary function of the school library media specialist is to teach how to find and use information. It is recognized that the best way to teach these skills and have students retain them is within the scope of the classroom curriculum.

*Stacks of Ideas* consists of units in all elementary curriculum areas designed to encourage cooperative program planning between the library media specialist and the classroom teacher. It is hoped that this guide will strengthen and improve education through effective utilization of library media and educational technology programs.

  
John M. Folks  
State Superintendent

## ACKNOWLEDGMENTS

This edition of *Stacks of Ideas K-8* was compiled and edited by Bettie Estes with the leadership, assistance, and support of many individuals.

### LEADERSHIP

#### Library Resources Section Oklahoma State Department of Education

Barbara Spriestersbach, Administrator  
John McGrath, Assistant Administrator  
Betty Riley, Coordinator  
Bettie Estes, Coordinator  
Linda Chapman, Coordinator  
Kathleen Curran, Secretary  
Cindy Hawkins, Secretary

### ASSISTANCE

Clarice Roads  
Linda Cowen, Norman Public Schools  
Paula Krivanek, Word Processing  
Nita West, Cover Design  
Kathleen Curran, Proofing  
Jo Garrett, Proofing

### CONTRIBUTIONS

Special thanks to the many school library media specialists and classroom teachers who were willing to contribute their successful teaching practices, ideas, and materials, and also to take time to fieldtest many of the units

### SUPPORT

Curriculum Section  
Oklahoma State Department of Education  
Mary Reid, Administrator

## TABLE OF CONTENTS

GRADE	TITLE	PAGE
K-3	Orientation	1
4-6	Orientation	5
3-6	Introduction/Review of the Card Catalog	23
K-4	Mouse Tales	29
K-1-2	Bears in Literature	49
1	Dinosaurs	65
1	Clever Counting	79
1-2	Focus on Roger Duvoison	103
1-3	I Wrote the Story--I Drew the Pictures	109
2-3-4	Frog Fact-Frog Fiction	121
3	Let It Snow!	139
3	Fairy Tales	151
3	Folktales	161
4	Pigfest	165
4-6	Science Fair Projects	179
5	Drugs	201
5	Biography	209
5	The Fabulous 50	225
5	Where in the World	231
5	Something About the Author	239
5-6	Literature Letters	243
6	Building the Great Wall	247
6	Sequoyah Children's Book Award Multi-Media Project	259
6	How Much Fact in Science Fiction	267
6	Fantasy Themes	279
7	Read Your Way Across the U S A	291
	APPENDIX	303



## INTRODUCTION

The greatest challenge facing educators today is to make education relevant to students' needs both for today and for the future. It is important that we meet this challenge by teaching students to "think" and to locate information. Integration of research and information skills into regular classroom units of instruction is now recognized as the most effective method for teaching these skills. This integration is achieved through cooperative planning and teaching between the teacher and the library media specialist. The acquisition of library and information skills should be planned sequentially across the curriculum by the total school staff, with skills being introduced at appropriate grade levels.

In this guide, at least one teaching unit with learner outcomes has been included in each content area, with emphasis at a particular grade level. These units can be adapted to other grade levels as well. Other units related to pure enjoyment and pleasure in reading have also been included. Information skills are provided in all content areas rather than being taught in isolation.

It is our hope that this guide will be adapted to your own methods of instruction and integrated into your existing school curriculum.

## ORIENTATION

Emphasis Grade Level: K-3

**GOAL:** The student will be able to locate the library media center in the school, and materials within the center. He/she will demonstrate acceptable media center behavior and show responsibility for borrowing and returning materials.

### LEARNER OUTCOMES

Content Area	Information Skills
The student will	The student will:
1. Locate specific places in the school setting.	1. Know the location of the library media center
2. Identify the roles of the people who work at school.	2. Become familiar with the library media center staff
3. Distinguish between fiction and nonfiction	3. Realize the library media center is a source of information
4. Identify and locate areas, with the focus on making and reading maps.	4. Learn the rules of conduct expected
5. Be introduced to the use of the glossary and encyclopedia.	5. Learn circulation routines for borrowing and returning materials
6. Use parts of a book correctly	6. Learn the following terms: <i>end paper, author, illustrator, borrower's card</i>
7. Use the encyclopedias and other reference books	7. Sign a borrower's card
	8. Borrow materials without assistance
	9. Distinguish the front from the back of a book
	10. Turn pages correctly

### Information Skills (cont.)

11 Learn to remove a book properly from a shelf	20. Locate and distinguish between fiction and nonfiction
12 Understand the significance of the call number	21. Become familiar with the arrangement of fiction books on the shelf
13 Learn how to care for books	22 Locate magazines, encyclopedias, dictionaries, and a newspaper
14 Use a bookmark.	23. Locate the pamphlet/vertical file
15. Understand the following terms: <i>picture book, title, spine</i>	24 Locate biographies.
16 Locate picture books, easy-reading books, nursery-rhyme books, fairy tales, and picture dictionaries	25 Select materials for enjoyment
17 Learn the difference between storybooks and true or information books and locate each type.	26 Learn the following terms: <i>table of contents, book pocket, date due slips, glossary and catalog</i>
18 Learn the meaning of "E" (easy) on the spine label.	27. Construct a simple floor plan map of the library media center
19 Learn that easy-reading books are arranged alphabetically by the author's last name	28. Be introduced to appropriate pieces of audiovisual equipment and learn their location

#### ACTIVITIES/SUGGESTIONS:

1. Tour the media center with the students, reviewing location of various materials and books appropriate to group involved
- 2 Introduce/review circulation system using transparency or large tag board borrower's cards. Student samples are included Terms *borrower's card, book pocket, date due slip*
- 3 Share with kindergarten students a book about a visit to the library Suggested source. *Quiet! There's a Canary in the Library* by Don Freeman
4. Draw a floor plan of the library
- 5 Review library procedures with first graders by sharing a filmstrip about what is an appropriate response to a series of problems or situations Suggested source *What Do You Do Dear?* by Sesyle Joslin available from Weston Woods

Afterwards ask questions like

- a What do you do, dear, when you check out a book?
  - b What do you do, dear, when you need a bookmark?
  - c What do you do, dear, when you aren't through reading a book and it is due?
6. Share with second and third grade students a filmstrip or videocassette on appropriate library behavior. Suggested source: *School Library Adventure of the Lollipop Dragon*, SVE, 1986.
  7. Share Virginia Poulet's *Blue Bug Goes to the Library* with young students to make them aware of the different kinds of media to be found in a library.
  8. Timed Orientation Game. Write questions and numbers on cards, for example
    - a Where is the circulation desk?
    - b. Where do you return books?
    - c Where are the magazines?

Give students a number, pull questions out of the bowl. Student with that number has 30 seconds to answer the question

9. Prepare \_\_\_\_\_ Bookworm, inserting name of school mascot to involve some school spirit in a citizenship activity. For example: "The Tuttle Tiger Bookworm" and use tiger colors. Make signs for each section stating a desirable behavior. Use as a bulletin board display.
10. Introduce alphabet books. Prepare a bibliography of alphabet books. Have kindergarten or first grade students prepare Alphabet Footprints and place in order.
11. Introduce/review the following terms:

"easy" books	table of contents
end paper	book pocket
author	date due slip
illustrator	glossary
borrower's card	catalog
picture book	fiction
title	nonfiction
spine	biography
call number	
12. Primary students will enjoy playing "Simon Sez" to locate parts of a book. The teacher or media specialist can give directives to locate each of the terms listed in Activity 11 (example: Simon Sez, "Put your finger on the book's spine." "Find the borrower's card and hold it up")

**EVALUATION:** Orientation activities will be evaluated by observing the degree of accuracy demonstrated by students on a daily basis in locating media center materials. Student behavior in the center will also be observed on an on-going basis. Additional learning activities will be provided as needed.

**RESOURCES:**

*School Library Adventures of the Lollipop Dragon.* (videocassette), Society for Visual Education, 1986.

Society for Visual Education  
Department BK  
1345 Diversey Parkway  
Chicago, Illinois 60614-1299

*What Do You Do, Dear?* (sound filmstrip), Weston Woods

Weston Woods  
Weston, CT 06883-9989

Freeman, Don. *Quiet! There's a Canary in the Library*, Childrens Press, 1969

Poulet, Virginia. *Blue Bug Goes to the Library*, Childrens Press, 1979.

## ORIENTATION

**Emphasis Grade Level: 4-6**

**GOAL:** The student will be exposed to a review of media center behavior, circulation procedures and the location of different kinds of library materials. Students will further refine those skills learned previously regarding interpretation and application of important terminology appropriate for the intermediate-grade learner.

### LEARNER OUTCOMES

Content Area	Information Skills
<p>The student will:</p> <ol style="list-style-type: none"> <li>1 Locate and interpret information by selecting appropriate materials.</li> <li>2. Be able to use reference material skills with emphasis on encyclopedias, card catalog, atlases and maps, charts and graphs, newspapers and magazines.</li> <li>3 Use a bibliography to find information</li> <li>4 Read to locate information with emphasis on understanding the table of contents, title page, pictures, map and chart keys, guide words, publisher, and copyright date</li> <li>5 Use a dictionary, encyclopedia, thesaurus, atlas, and almanac</li> </ol>	<p>The student will:</p> <ol style="list-style-type: none"> <li>1 Understand the concept of the Dewey Decimal classification system as an organizational tool</li> <li>2 Use the library catalog to locate specific sources by author, title, and subject.</li> <li>3 Learn circulation procedures for pamphlet/vertical file</li> <li>4 Learn the following terms <i>copyright, publisher, bibliography, periodical</i></li> <li>5 Locate the periodical index (e.g., <i>Children's Magazine Guide</i>)</li> <li>6 Recognize electronic programs as a source of information</li> <li>7. Use call numbers to locate print and nonprint resources</li> <li>8. Find different categories of books according to the classification system</li> <li>9. Learn the following terms. <i>subtitle, foreword, chapter headings</i></li> <li>10 Locate special tools (e.g., biographical dictionaries, thesauri, etc.)</li> <li>11 Learn the following terms <i>appendix, cross-reference, preface</i></li> <li>12 Be introduced to the use of appropriate pieces of audiovisual equipment and their use</li> </ol>

## ACTIVITIES/SUGGESTIONS:

- 1 Tour the media center with the students, reviewing location of various materials and books appropriate to group involved
- 2 Introduce/review circulation system, using transparency or large tagboard borrower's cards. Student samples are included.
- 3 Prepare slide series or videocassette of library arrangement. Involve students in the production
4. For fourth grade classes, place in a bag, questions on cards concerning parts of a book, library terms, etc. Also include *borrower's card*, *bookmark*, *catalog cards*, *book pockets* and any other appropriate items. In small groups have one student at a time select one item or card from the bag and answer the question or explain the object
- 5 Have students take pictures/slides of library media center activities. Use for orientation and/or PTA, open house, etc
- 6 Draw unlabeled floor plan of library media center on an old bed sheet. Have students walk around and label location of various media by placing paper labels on the floor.
- 7 Show a filmstrip about how to make a book. Suggested sources
  - a "Story of a Book," *Literature for Children, Series 1*, Pied Piper Productions
  - b *How a Picture Book Is Made. The Island of the Skog*, Weston Woods
- 8 Introduce/review the following terms

copyright	chapter headings
publisher	appendix
bibliography	cross-reference
periodical	preface
subtitle	annotation
foreword	

## EVALUATION:

Orientation activities will be evaluated by observing the degree of accuracy demonstrated by students on a daily basis in locating media center materials. Student behavior in the center will also be observed on an ongoing basis. Additional learning activities will be provided as needed.

## RESOURCES:

*How a Picture Book Is Made. The Island of the Skog* (sound filmstrip), Weston Woods

Weston Woods  
Weston, CT 06883-9989

"Story of a Book," *Literature for Children, Series 1* (sound filmstrip) Pied Piper Productions, 1983.

Pied Piper Productions  
P O Box 320  
Verdugo City, CA 91046

## GLOSSARY

- almanac--book containing up-to-date statistical information
- annotation--a short summary or note, telling what a book is about or what it contains
- appendix--a supplement or addition to a book that is added at the end; tables, lists, abbreviations, etc.
- atlas--a collection of maps
- autobiography--story of a person's life written by himself/herself
- author--the original writer of a book
- bibliography--a list of writings related to the subject of a book, or on a particular subject
- biography--story of a person's life written by someone else
- borrower's card--the card used to sign the name of the person who is checking out library materials
- book packet--pocket which holds the borrower's card, usually located at the front or back of a book
- call number--address of a book, used to give books a special place (or home) on the shelf of a media center
- catalog--recording of the holdings of a library either in card form or in an automated system
- catalog card--3" x 5" card which records all information about each item in a library collection
- chapter headings--titles indicating content of a portion of a book
- circulation desk--area where materials and books are checked out and returned
- copyright date--the date on which the right to produce, publish or sell a literary or artistic work is granted by law
- cross-reference--a reference telling where to find additional information on a subject
- date due slip--records the stamped date when an item is to be returned to the library
- dictionary--selection of words arranged alphabetically with definitions
- "easy" books--books with many pictures and large print, written especially for younger children
- encyclopedia--book or set of books usually arranged alphabetically on different subjects
- end papers--first and last pages of a book, not part of the text



fiction--a made up story

foreword--a prefatory statement preceding the text of a book

gazetteer--dictionary of geography

glossary--a partial dictionary that explains the terms or words in a book

illustrator--an artist who creates the pictures in a book

index--an alphabetical list at the end of a book that helps to locate information

media center--a place where students and teachers can find books, software and equipment to use in subject planning and study, and also for enjoyment

media clerk or aide--a person who helps the media specialist with routine, everyday tasks and clerical duties

media specialist--a certified person who helps children and teachers learn to use and enjoy the media center

nonfiction--a writing based on fact

pamphlet--short writing on some subject of interest

periodical--a magazine that is published regularly

preface--something written as an introduction to the body of a book

publisher--the company that prints a work after it is written by the author

reference book--book used to find facts and background information, etc

spine--the point where a book is bound together (the book's backbone), usually inscribed with the book's title, author and call number

subtitle--a subordinate or explanatory title in a book, play or document

table of contents--a list in the front of a book which breaks down the sections of a book, usually by page number

thesaurus--the opposite of a dictionary; usually synonyms and antonyms arranged in categories

title--the name of a book

title page--one of the first pages in a book which shows the title, author, and publisher of the book

tracings--the record on the main entry card, of the additional headings under which the publication is represented in the catalog

verso--the reverse, or back of the title page

vertical file--a file of ephemeral materials (articles, pamphlets, pictures, maps, overlays, etc ) usually housed in a legal sized steel filing cabinet

## MEDIA CENTER RULES

Directions Fill in the blanks with one of the following words

nice          book          ask          listen          room          leaving  
 walk          quietly          chairs          date due          two

- 1  \_ \_ \_ , instead of run, when visiting the library
- 2 You do not have to be silent in the library but speak \_ \_ \_  \_ \_ \_
- 3 When the library teacher is talking during library class, please  \_ \_ \_ \_ \_ and raise your hand when you want a turn to talk
- 4 Only one student at a time sits on our special orange  \_ \_ \_ \_ \_ Places cannot be saved
- 5 Kindergartners and first graders check out one book Second through fifth graders can check out \_ \_
- 6 When checking out books, please sign both your name and \_ \_ \_  number
- 7 Please do not lose your \_ \_ \_  \_ \_ \_ slip. If it accidentally happens, please write your name on a piece of paper and put it in the book pocket
- 8 Please use  \_ \_ \_ marks when reading Only take one for each book from our special bookmark holder
- 9 Only one door in the library is used for entering and \_  \_ \_ \_ \_ \_
- 10 Please be \_ \_  \_ to other boys and girls who are using the library Keep your hands to yourself and say only kind things
- 11 If you haven't finished reading your book before it is due, please \_ \_  to have it renewed

Directions Copy in the circles the letters that are in the circles

Mystery Message

I pledge to follow these media center rules \_\_\_\_\_  
Your Name

(Adapt rules to match your own media center situation )

ANSWER W E L C O M E B A C K

(Adapted and reprinted with permission from the *School Librarian's Workshop*,  
September 1981 issue, Vol 2, No. 1 Copyright 1981 by Hilda K Weisburg and Ruth  
Toor. Published by Library Learning Resources, Inc , 61 Greenbriar Drive, Berkeley  
Heights, NJ 07922 )

AUTHOR	
TITLE	
Date Due	Borrower's Name

AUTHOR	
TITLE	
Date Due	Borrower's Name

# WELCOME TO THE MEDIA CENTER

## OBJECTIVE

After taking an audio-cassette tape tour of the library media center and completing the task card, the learner will be able to identify correctly eight out of eleven areas in the library media center.

## MATERIALS FOR CONSTRUCTION

- Script describing important areas in media center
- 3 blank cassette tapes
- Cassette recorder with shoulder strap
- Recorded music
- Earphones
- Numbered tagboard circles
- Mimeographed maps of the media center
- Laminated task cards
- Trifold tagboard screen

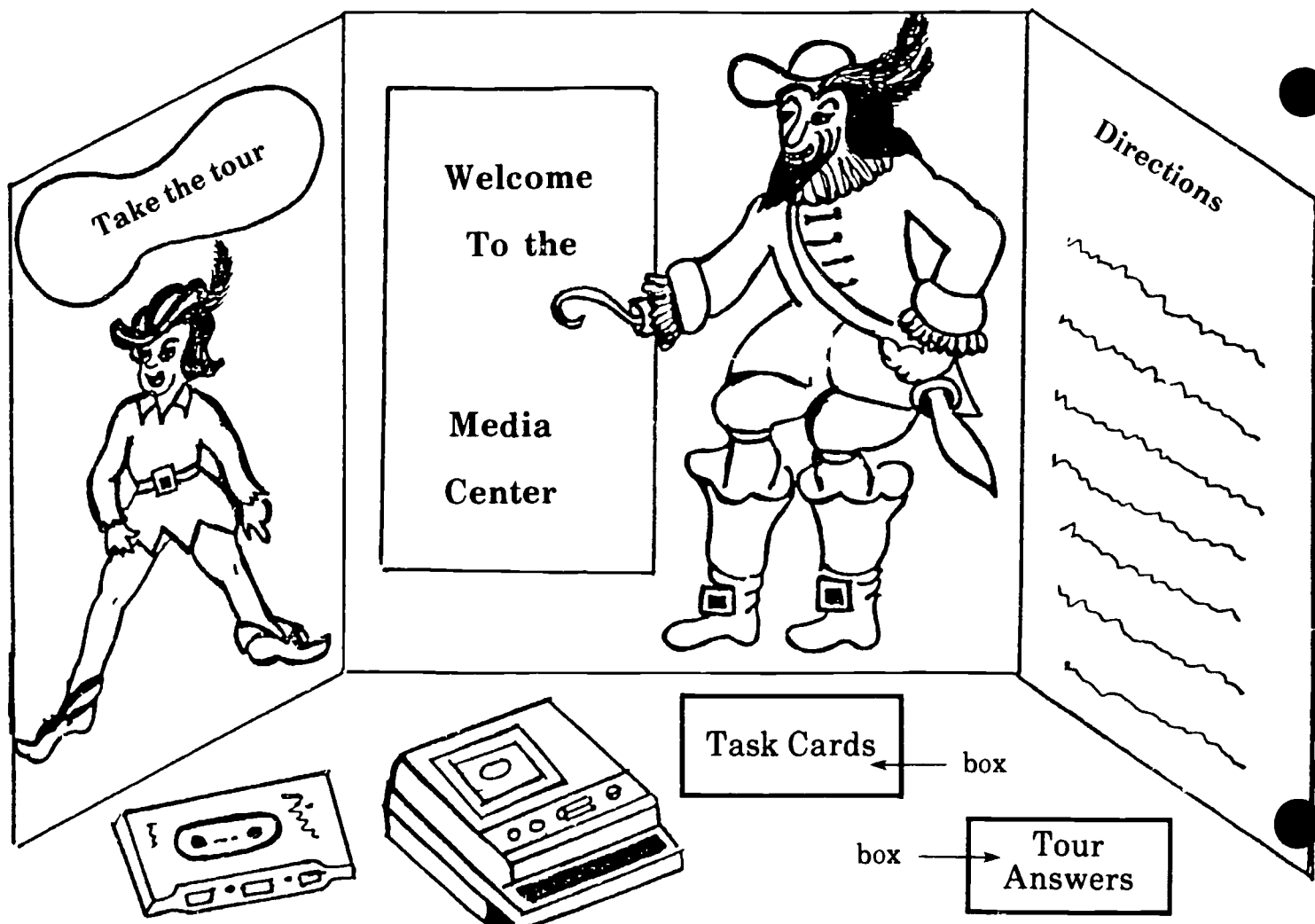

## DIRECTIONS FOR CONSTRUCTION

Write script describing important areas in the media center. Select music popular with students to use as interlude while students are moving from area to area. Record tape. Use tape yourself to tour center. Make adjustments if necessary. Record tour on two additional blank tapes. Create and laminate tagboard task cards that involve students during tour. Create and mimeograph maps of the media center for students to keep. Mimeographed maps should have areas labeled and numbered to correspond with numbered tagboard circles to be hung over appropriate areas. Create attractive trifold display from tagboard. At the top write "Welcome To The Media Center." Under this write "Take The Tour" and student directions.

## NOTES TO TEACHER/MEDIA SPECIALIST

This activity is especially helpful for transfer students who come to the school in the middle of the year. Three tapes are recorded to increase the availability of the activity. You may wish to record on the back of each tape so that students will not have to rewind tape.

## DIRECTIONS

- 1 Obtain tour tape, cassette player, earphones, task card, and media center map from circulation desk.
- 2 The circulation desk is the starting place for your tour.
- 3 Listen to the tape. The map and circles hanging above areas will help you to move in the correct direction.
- 4 Answer the questions written on the task card on your own paper. Write your full name and language arts teacher's name at the top of your paper. You may answer the questions as you take the tour by stopping the tape, or you may answer the questions after you finish the tour.
- 5 Return all equipment, task card, and tape to circulation desk. Place your answers in the box marked "Tour Answers" located at the circulation desk.
- 6 If you have any difficulty with equipment or procedure, please obtain help from the media specialist, media aide or student assistants.
- 7 You may keep media center map for your own use.
- 8 Within the next week, you will receive a blank map from your language arts teacher. You will be expected to label at least eight of the eleven areas toured on this map.

## ASSESSMENT

The media specialist will evaluate responses to task card questions. A learner who has difficulty with four of the ten questions will be called in for individual help before he takes the final evaluation. Learners who misplace more than three areas on final evaluation will be given additional individual help and have an opportunity to redo the evaluation.

### EXAMPLE OF TASK CARD

- 1 At the circulation desk, stamp your paper with the date due stamp beside No. 1
- 2 In the audiovisual materials section, locate a filmstrip you would like to review or a record to which you would like to listen. Write the title on your paper beside No. 2
- 3 In the fiction section, find a book with the call number F Ker Write the title
- 4 In the story collection, find a book with the call number SC Hit Write the title
- 5 In the Oklahoma section, select a book you would like to read. Write the title
- 6 In the reference area, locate a reference book with the call number R 031 New  
Write the title
- 7 In the production area, locate the laminating machine and introduce yourself to the teacher's aide. Have her sign your paper beside No. 7
- 8 In the nonfiction area, locate the 600's section. Write the title of a book you would like to read.
- 9 In the biography section, find the call number B Ken Write the title of a book  
with this call number
- 10 In the browsing area, write the title of a magazine you would like to read

SOURCE *Eureka--Ideas and Activities for Personalizing Media Skills* Wake County Public Schools, Raleigh, North Carolina, 1977, pp. 27-29 (Used with permission)

## BOOK HOSPITAL

### OBJECTIVE

The learner will demonstrate his understanding of the proper treatment of books by taking care of his books

### MATERIALS FOR CONSTRUCTION

Cardboard box (use a box in which books have been packed)

Tempera paint

Books which have been discarded because of damage by water, dog, scissors, crayons, etc -- any "sick" book.

### DIRECTIONS FOR CONSTRUCTION

Paint the box with tempera paint. Do not forget the windows and chimney. Cut a door large enough to open to show your "sick" books. Place damaged books in the Book Hospital and close the door. Print the words BOOK HOSPITAL above the door. Make a sign, BOOK DOCTOR, to hang around your neck. Obtain a play doctor's kit from the dime store and put repair materials in it.

### DIRECTIONS

- 1 Sit around the Book Hospital and visit the "sick" books
- 2 Discuss why they are in the hospital and if they can be made well again
- 3 Make a list of how books get "sick."

### ASSESSMENT

Evaluation will be by observation of the decrease in damage and mutilation of books

**SOURCE:** *Eureka--Ideas and Activities for Personalizing Media Skills*. Wake County Public Schools, Raleigh, North Carolina, 1977, pp 11-12. (Used with permission.)



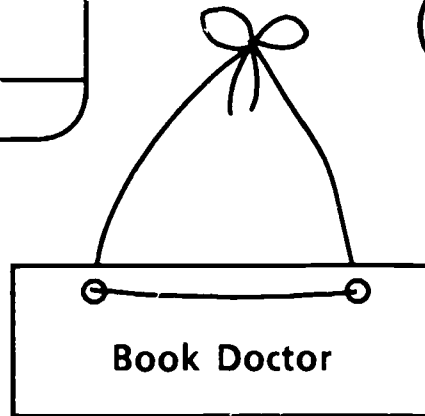
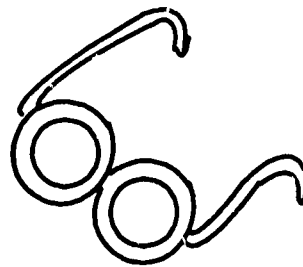
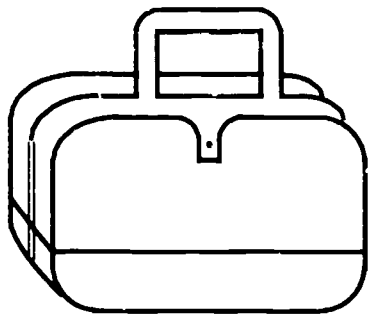

Open the door to  
find the "sick" books

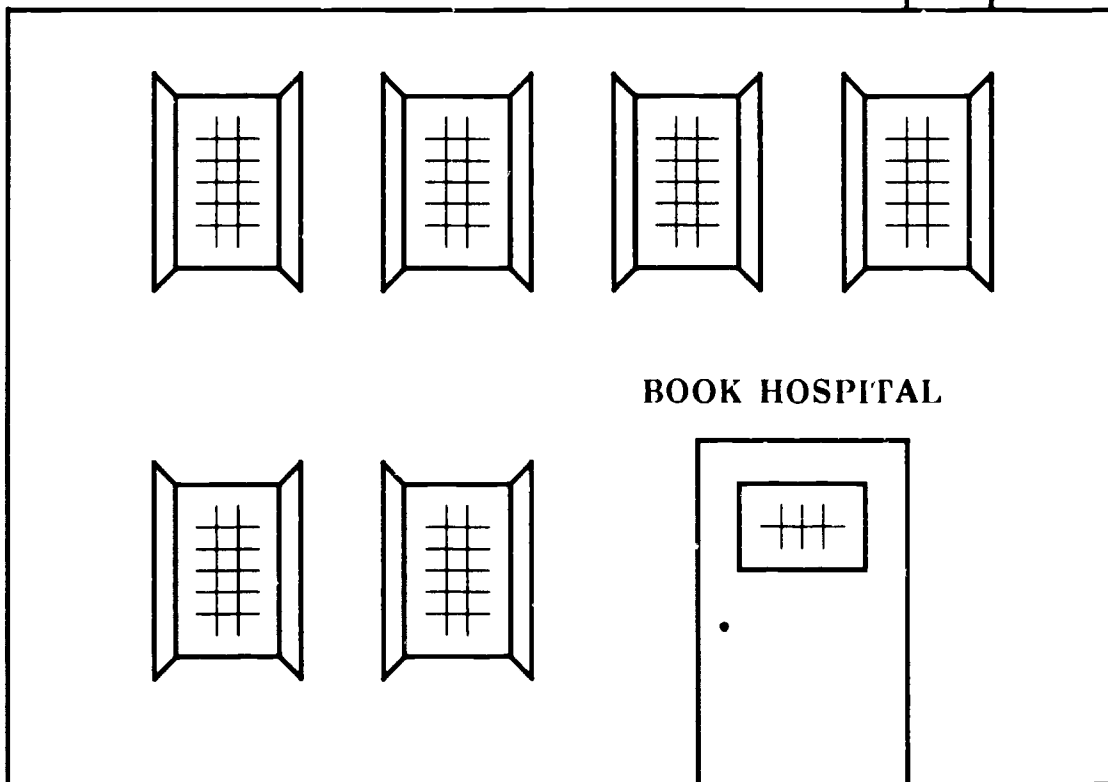

Door

## SCAVENGER HUNT

### OBJECTIVE

The learner, given a map of the media center, will identify and locate the different types of materials and indicate them on his map with symbols

### MATERIALS FOR CONSTRUCTION

Decorated file folder  
Duplicated maps of media center  
Duplicated list of symbols  
Laminating film  
Construction paper to make pockets to hold maps and symbols inside folder

### DIRECTIONS

Print on inside of folder

- 1 Take a media center map from the folder.
- 2 Study your media center and the location of all materials
- 3 Study the list of symbols
- 4 Place the correct symbol on your media center map where each type of material is located
- 5 Take your map to the media specialist.

### SYMBOLS.

E--Easy Books	000--Encyclopedia
B--Biography	100--Behavior and Haunted Houses
F--Fiction	200 -Mythology Book
R--Reference	300--Social Sciences Books--Fairy Tales--Holidays
K--Kits	400--Language Books
CC--Card Catalog	500--Science Books--Snakes--Dinosaurs
SFS--Sound Filmstrips	600--Technology and Pet Books
BR--Book/Record	700--Art Books
Fa--Fairy Tales	800--Literature Books
SP--Study Prints	900--History and Geography Books
REC--Records	SC -Story Collection
M--Magazines	

### ASSESSMENT.

Evaluation of the correct placement of symbols on the map will be made by the media specialist

SOURCE: *Eureka--Ideas and Activities for Personalizing Media Skills* Wake County Public Schools, Raleigh, North Carolina, 1977, p 23 (Used with permission)

## BOOK CARE

This activity helps children to take proper care of books by drawing attention to situations that might damage books

### MATERIALS

Oaktag  
Marking pens  
Opaque projector

### PREPARATION:

Use the opaque projector to enlarge each illustration. Those that do not show proper book care are marked with an "X" (Do not trace "X" onto oaktag while enlarging)

### ACTIVITY DIRECTIONS:

Ask the children if they have books at home. Hold up each illustration asking children to tell whether or not the picture indicates proper book care. Point to each picture and have the children explain what would happen to the books in each instance.

Explain that many children read the books in the library media center and that it is important to keep these books in good condition for others to read. Hold up each picture again and have children give examples of times when they did these things

### FOLLOW-UP:

Hang the pictures in a prominent place in the easy section of the library media center

SOURCE. Carol Collier Kuhlthau, *School Librarian's Grade-by-Grade Activities Program* (West Nyack, New York, The Center for Applied Research in Education, Inc , 1981)

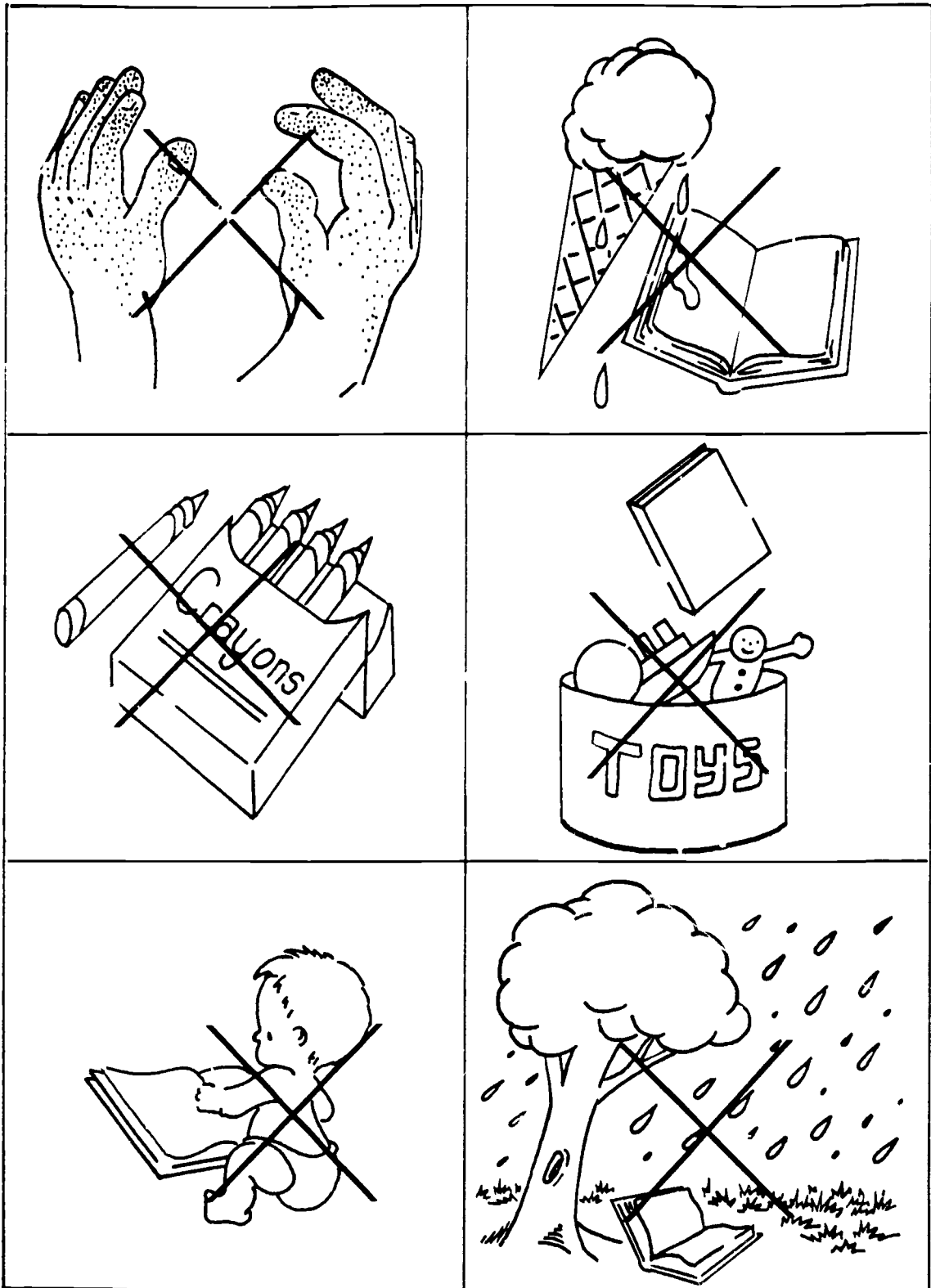

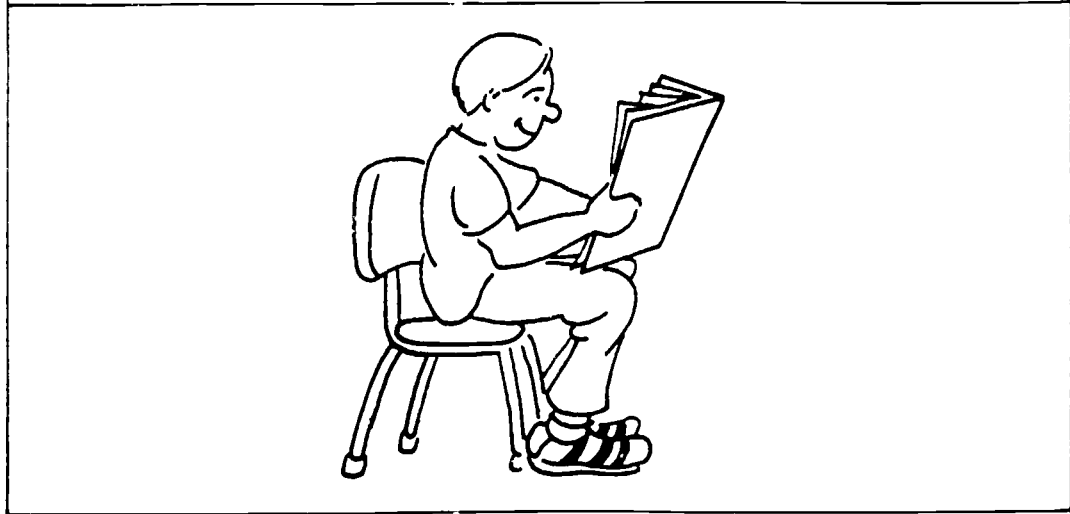
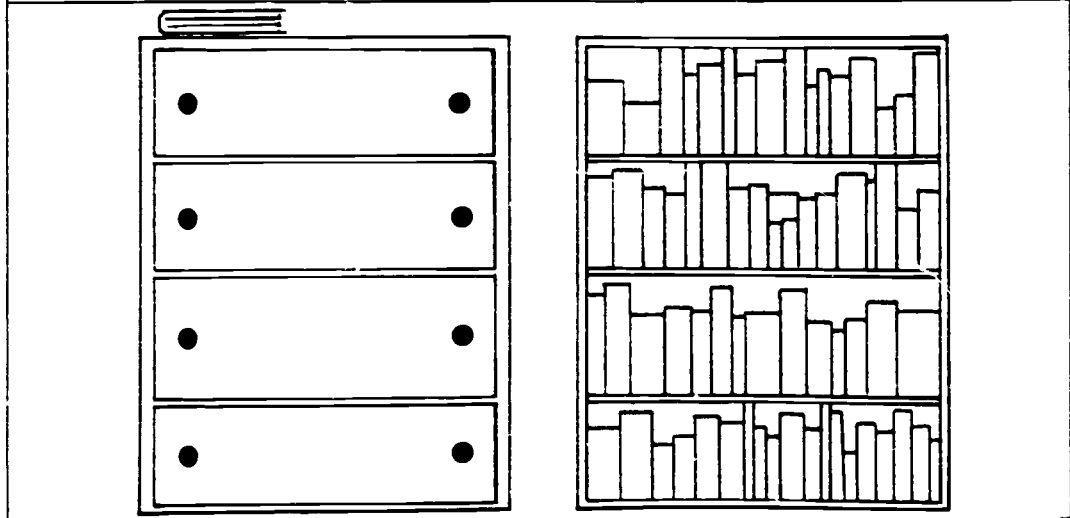
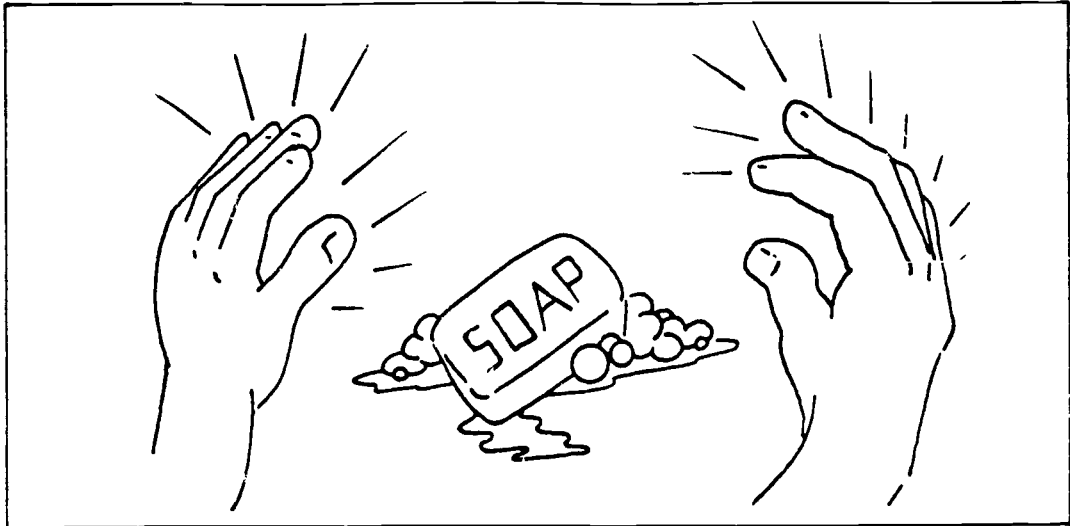

## AMAZE YOURSELF

As an eye-catcher for the opening of the media center, a puzzle bulletin board is highly effective. It can serve to remind students of basic library terminology and be a fun activity at the same time

### Materials.

- Poster board or oaktag
- Wide-tip felt marker
- Narrow-tip felt marker of another color
- One 10" x 13" manila envelope
- One sheet of graph paper
- Opaque projector

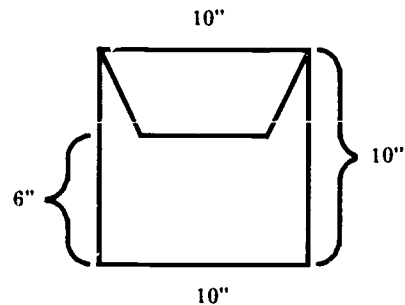

### Preparation.

- 1 Design a maze or use the one shown. Use graph paper to keep your lines straight if you design your own
- 2 Use an opaque projector to enlarge the maze, by tracing onto posterboard
- 3 Use the wide-tip marker to outline the maze
- 4 Use the narrow-tip marker to label the boxes within the maze
- 5 Use the wide-tip marker to copy the title "Amaze Yourself "
- 6 Copy the directions using the narrow-tip marker
- 7 Cut the manila envelope down to 10" x 10"
- 8 Cut the front of the envelope so that it measures 6" x 10" (See Illustration )
- 9 Use the narrow-tip marker to write "Have fun, take one" on the manila envelope.
10. Make copies of the maze for individual students and put them in the manila envelope.

**SOURCE:** Hilda K Weisburg and Ruth Toor, *Elementary School Librarian's Almanac* (West Nyack, New York, The Center for Applied Research in Education, Inc., 1979)

# AMAZE YOURSELF

START

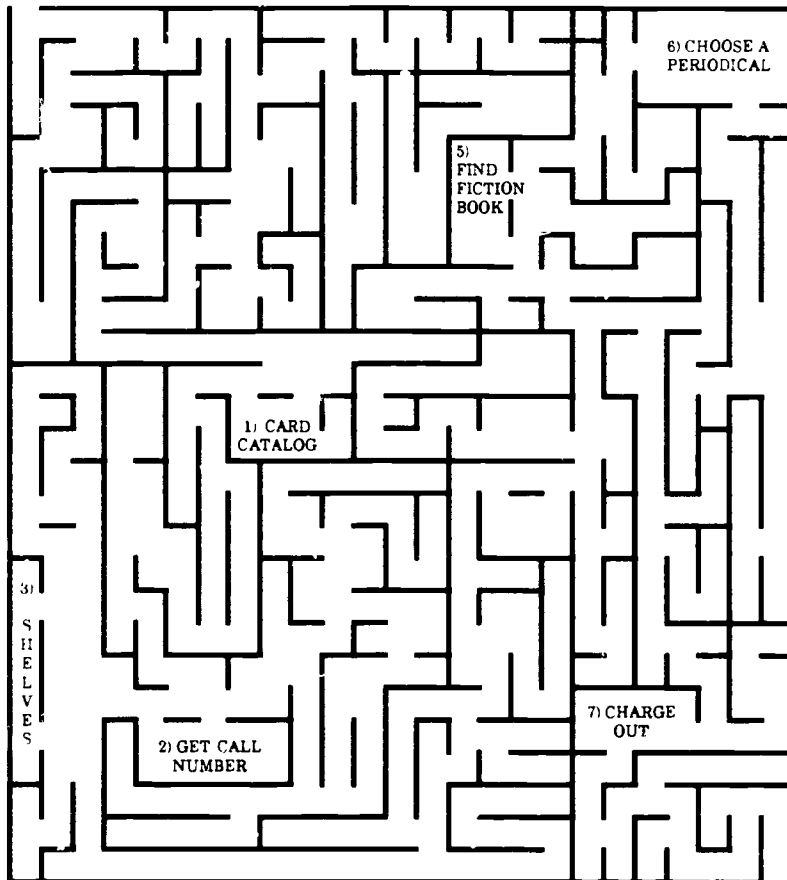

FINISH

Know your  
Media Center

1. Enter all Boxes  
in Numerical Order.
2. Do NOT Retrace  
Your Steps.

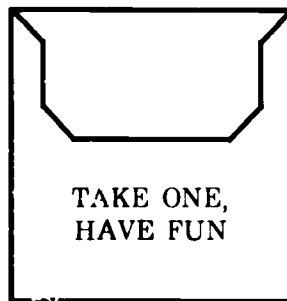

## INTRODUCTION/REVIEW OF THE CARD CATALOG

Emphasis Grade Level: 3-6

**GOAL:** The student will understand the importance of the card catalog and demonstrate how the information in the card catalog is used. The student will also be able to distinguish between fiction and nonfiction and be introduced to the online card catalog system.

### LEARNER OUTCOMES

Content Area	Information Skills
<p>The student will:</p> <ol style="list-style-type: none"><li>1. Distinguish between fictional and factual reading materials.</li><li>2. Be able to use reference material skills with emphasis on the card catalog</li></ol>	<p>The student will</p> <ol style="list-style-type: none"><li>1. Be introduced to the library catalog</li><li>2. Use the library catalog to locate specific sources by author, title and subject</li><li>3. Identify and state the purpose of the basic information in the library catalog.</li><li>4. Understand the significance of the call number.</li><li>5. Use call numbers to locate print and nonprint resources</li><li>6. Find different categories of books according to the classification system</li><li>7. Locate and distinguish between fiction and nonfiction.</li><li>8. Locate some specific nonfiction areas (e.g., 591--animals)</li></ol>



## ACTIVITIES/SUGGESTIONS:

### Session 1

- 1 To set students down in front of the card catalog and say, "this is the card catalog to the library" is too abstract. They first need to know what it is and why it is used in the library. Each student is given a store catalog (Sears', Ward's, Penney's, etc.)
- 2 They note how "like" things are grouped together. Therefore, if they are only interested in bicycles, they would only have to look in one section. It is pointed out that by looking in the catalog, they can determine what items are offered for sale by that particular store. If it's not in the catalog, they wouldn't need to look in the store.
- 3 Students will then look at the index to the catalog. They are asked why the index might be helpful in using that catalog. They will find that if they are looking for bicycles, the catalog index provides them with page numbers to that section which is clearly a much quicker way of looking rather than "thumbing" through the catalog. Students are then asked how they can relate what they have learned about the store catalog to a card catalog found in the library.
- 4 The session is concluded with the viewing of the sound filmstrip, "Using the Card Catalog," *The Elementary School Library*, SVE, 1977.

### Session 2

- 1 Students are introduced to two concepts:
  - A. Searching by author, title, and subject.
  - B. Arrangement according to fiction and nonfiction.
- 2 Give each student sample author, title and subject cards. Go over who is the author, what is the title, what is the subject.
- 3 Show students pictures of the fruit/vegetable aisle of a grocery store. Point out how all the oranges are together, all the apples are together, all the potatoes are together, etc. This prompts them to talk about how other items within a store are arranged.
- 4 Discuss the arrangement in the library of factual and non-factual items.
- 5 Give them sample nonfiction catalog cards of several in each group and discuss why those within a major category are grouped together.
- 6 Then go to the shelves so they can see the actual groupings.

### Session 3.

- 1 Demonstrate the use of the computer-based catalog.
- 2 Explain the various symbols used in the computer program.
- 3 Formulate some search questions, type them on pieces of paper, and put them in a box. Each student picks a slip of paper from the box and performs a search of the card catalog based on that particular question. Each student has to read their question aloud so that all the other students can help determine whether this search will be by author, title, or subject.

- 4 After typing the search question in under the appropriate mode, the students have to rely on what they remember from the teacher's demonstration and/or follow the instructions on the screen
- 5 Once the item is "found," each student tells whether it is fiction or nonfiction

#### **EVALUATION:**

This activity will be evaluated after Step 5 above. The student writes the call number of the item found on a slip of paper and goes to the shelf and finds the book.

#### **MATERIALS NEEDED:**

1. Sample author, title, subject cards.
2. Sample nonfiction cards
3. Search questions.
4. Store catalogs (Sears', Ward's, etc.)

#### **DISCUSSION QUESTIONS:** (to be covered at some point during the sessions)

1. What is a card catalog? (Compare card catalog to store catalog.)
2. What is an index? (Compare store catalog index and index of a book to the card catalog in the library.)
3. Why are like "things" grouped together in a store? Why are like "things" grouped together in a library?
4. What is an author? Title? Subject?
5. What three ways can a search be conducted using the card catalog? (Point out this similarity between a traditional card catalog and an online card catalog.)
6. What is the difference between fiction and nonfiction?
7. What is the purpose of the call number?
8. Where is the call number located in the card catalog entry?
9. Where is the call number located on a book?

#### **RESOURCES:**

"Using the Card Catalog," *The Elementary School Library* (sound filmstrip), Society for Visual Education, 1986.

Society for Visual Education  
Department BK  
1345 Diversey Parkway  
Chicago, Illinois 60614-1299

**SOURCE:** This unit was developed by Jeannie Moss, John Ross Elementary School, Edmond, Oklahoma.

## GLOSSARY

almanac--book containing up-to-date statistical information

annotation--a short summary or note, telling what a book is about or what it contains

appendix--a supplement or addition to a book that is added at the end, tables, lists, abbreviations, etc.

atlas--a collection of maps

autobiography--story of a person's life written by himself/herself

author--the original writer of a book

bibliography--a list of writings related to the subject of a book, or on a particular subject

biography--story of a person's life written by someone else

borrower's card--the card used to sign the name of the person who is checking out library materials

book packet--pocket which holds the borrower's card; usually located at the front or back of a book

call number--address of a book; used to give books a special place (or home) on the shelf of a media center

catalog--recording of the holdings of a library either in card form or in an automated system

catalog card--3" x 5" card which records all information about each item in a library collection

chapter headings--titles indicating content of a portion of a book

circulation desk--area where materials and books are checked out and returned

copyright date--the date on which the right to produce, publish or sell a literary or artistic work is granted by law

cross-reference--a reference telling where to find additional information on a subject

date due slip--records the stamped date when an item is to be returned to the library

dictionary--selection of words arranged alphabetically with definitions

"easy" books--books with many pictures and large print, written especially for younger children

encyclopedia--book or set of books usually arranged alphabetically on different subjects

end papers--first and last pages of a book, not part of the text

fiction--a made-up story

foreword--a prefatory statement preceding the text of a book

gazetteer--dictionary of geography

glossary--a partial dictionary that explains the terms or words in a book

illustrator--an artist who creates the pictures in a book

index--an alphabetical list at the end of a book that helps to locate information

media center--a place where students and teachers can find books, software and equipment to use in subject planning and study, and also for enjoyment

media clerk or aide--a person who helps the media specialist with routine, everyday tasks and clerical duties

media specialist--a certified person who helps children and teachers learn to use and enjoy the media center

nonfiction--a writing based on fact

pamphlet--short writing on some subject of interest

periodical--a magazine that is published regularly

preface--something written as an introduction to the body of a book

publisher--the company that prints a work after it is written by the author

reference book--book used to find facts and background information, etc.

spine--the point where a book is bound together (the book's backbone), usually inscribed with the book's title, author and call number

subtitle--a subordinate or explanatory title in a book, play or document

table of contents--a list in the front of a book which breaks down the sections of a book, usually by page number

thesaurus--the opposite of a dictionary, usually synonyms and antonyms arranged in categories

title--the name of a book

title page--one of the first pages in a book which shows the title, author, and publisher of the book

tracings--the record on the main entry card, of the additional headings under which the publication is represented in the catalog

verso--the reverse, or back of the title page

vertical file--a file of ephemeral materials (articles, pamphlets, pictures, maps, overlays, etc ) usually housed in a legal sized steel filing cabinet

## MOUSE TALES

Emphasis Grade Level: Adaptable for K-4

**CURRICULUM APPLICATION(S):** Reading, Language Arts

**GOAL:** Students will become familiar with mice and their physical characteristics, habits, etc. They will enjoy literature about mice in various formats and participate in a variety of "mousetivities"

### COOPERATIVE PLANNING/TEACHING

This theme can be initiated from either the classroom or library, but is most effective when pursued as a joint effort between teacher and library media specialist. It also works well as an all school activity with the add-on "Mouse Tales" bulletin board planned for the whole school (Be prepared for overwhelming participation!) The "Mouse Party" could be planned to take place in the library.

### LEARNER OUTCOMES

Content Area	Information Skills
<p>The student will:</p> <ol style="list-style-type: none"><li>1. Differentiate between fiction and nonfiction</li><li>2. Be able to enjoy many forms of reading materials for a variety of purposes</li><li>3. Develop an interest in reading for appreciation</li><li>4. Read and appreciate poems, plays, and nursery rhymes</li><li>5. Participate in role playing activities.</li><li>6. Develop an appreciation of good literature through listening, viewing, and reading</li><li>7. Develop an appreciation for short stories, novels, prose, and poetry</li></ol>	<p>The student will:</p> <ol style="list-style-type: none"><li>1. Locate and distinguish between fiction and nonfiction</li><li>2. Locate some specific nonfiction areas (e.g., 591-animals)</li><li>3. Locate reference material related to specific subject areas</li><li>4. Watch stories on film, filmstrips or video.</li><li>5. Find and enjoy a variety of literature</li><li>6. Develop recreational reading habits</li></ol>

## ACTIVITIES/SUGGESTIONS:

1. Plan a month-long theme highlighting mouse books. January is a good month because of a lack of other scheduled activities. Prepare a "Mouse Tales" bulletin board. Father Mouse on the cover of Arnold Lobel's *Mouse Tales* is a good one to enlarge with the opaque projector. As each student reads a mouse book, let him/her add a section to Father Mouse's tail. The tail can be made of construction paper and can include a place for the book title and the student's name. (See pattern.) See how long the tail can grow.
2. Introduce authors who have written several books about mice: Arnold Lobel, Robert Kraus, Leo Lionni, Beverly Cleary, Beatrix Potter.
3. Students of all ages will enjoy the sound filmstrip *Meet the Newbery Author Arnold Lobel* (revised edition). Source: Random House. Show other pictures of Lobel if they are available and have children look at the similarities between Arnold Lobel and Father Mouse.
4. Display "mouse books" in the classroom or library in a cardboard box covered with yellow craft paper to look like a chunk of cheese. (Idea contributed by Martha Nickles, Enid Public Schools.)
5. Many mice books are excellent for reading aloud. Older students will enjoy these.  
**Conly, Jane Leslie**--*Roscoe and the Rats of NIMH*, Harper, 1986  
**Lawson, Robert**--*Ben and Me*, Little, 1939  
**O'Brien, Robert**--*Mrs. Frisby and the Rats of NIMH*, Atheneum, 1971.  
**Winthrop, Elizabeth**--*Journey to the Bright Kingdom*, Holiday, 1979.  
  
\* (Jane Conly is the daughter of Robert O'Brien )
6. Have students collect "mice" poems. Make copies of each and let each student make a booklet. See cheese pattern for booklet cover.
7. *The Maid and the Mouse and the Odd-Shaped House* by Paul O. Zelinsky is a good mouse book to share during a study of geometric shapes. Children (even older ones) will enjoy drawing the story on a chart tablet, one page at a time, as it is read aloud. Some will be surprised to find out what the odd-shaped house really is.
8. Many children are familiar only with basic varieties of cheese such as cheddar, Swiss, and American. Have a tasting party and serve small squares of cheese on toothpicks. Serve Brie, Camembert, Edam and Limburger served with crackers and something to drink. It's a fun way to expose students to a new taste.
9. Have a child bring in a "pet" mouse and explain about its habits, care, etc. If possible, weigh the mouse and measure its length.
10. Research activities about mice and cheese are included in *Cheese Anyone?* and *Mice Ring Thing* in this guide.
11. Write a list of "mouse" words for use in story writing.

12. Intermediate students will enjoy creative dramatics with scenes from such books as Beverly Cleary's *Runaway Ralph*, *Ralph S Mouse* and *The Mouse and the Motorcycle*. Joseph Low's *Mice Twice* and Kenneth Grahame's *The Wind in the Willows* are also excellent for this type of creative expression.
13. Students of all ages will enjoy creating their own mice after reading Leo Lionni's *Frederick*. The technique of tearing black or gray construction paper will allow the artwork to appear as it does in the book.
14. Introduce children to limericks; write them about mice--excellent language arts activity for older students.
15. Try shape poetry--words written in the shape of a mouse
16. The teacher or librarian can motivate children to write mice stories by writing the first part of a story and having the children write sequels
17. Using the autoharp for accompaniment, teach songs such as "Hickory Dickory Dock" and "Three Blind Mice"--use as a round Share the book, *Complete Version of Ye Three Blind Mice* by John W Ivimey.
18. Review the meaning of "fiction" and "nonfiction" and introduce the students to the Dewey section containing information on mice. Several non-fiction books about mice have been included on the "Mouse Tales" bibliography
19. Introduce the encyclopedia for research purposes Use the *Mice Ring Thing* with this activity.
20. Oral storytime. tell how people act when they see a mouse, why people are frightened
21. Talk about why elephants are afraid of mice; check the validity of this statement.
22. Share Leo Lionni's *Greentail Mouse* with students. Discuss why Greentail Mouse's tail was green. Then have students talk about other creatures and why a particular part of their body is a certain color. For example, why do fish have scales or why is a cardinal red? As a writing assignment have them write an explanation for the color. It can be conjecture or actual research can be done.
23. Fingerprint mice are easy for children to make. Using a well-inked stamp pad and fine-point markers, the possibilities are limitless.
24. Provide a variety of materials such as toothpicks, rubber bands, craft sticks, glue, and a selection of boxes of different sizes. Let students design and build a mouse trap.
25. At the conclusion of the theme the librarian can invite the children to a "Mouse Party" in the library (see attached invitation). The format for the "Mouse Party" could be as follows:

## MOUSE PARTY

- A Students make their own costume for the party, i.e., headbands with ears, whiskers, and tails pinned on
- B Begin party by reading a story about mice or perhaps one you have written yourself for the occasion. Students will love this. (Create a story about two mice who come to live in your library. Let the students act it out.)
- C Mouse songs can be sung
- D Mouse games can include "Pin the Tail on the Mouse" and a "Cheese Hunt" in the library. Use pieces of yellow paper for cheese, scattered throughout the library, and give students a few minutes to see who can collect the most. Prizes can be real pieces of cheese
- E Have a drawing contest to see who can draw.
  - the strangest looking mouse
  - the smallest mouse
  - the thinnest mouse, etc
- F During the party, plan to have a live "cat" pay a visit, or have your principal "growl" like a cat over the intercom. (The reaction is priceless.)
- G At the conclusion of the party, serve cheese and crackers to all the mice and send them off happily on all fours



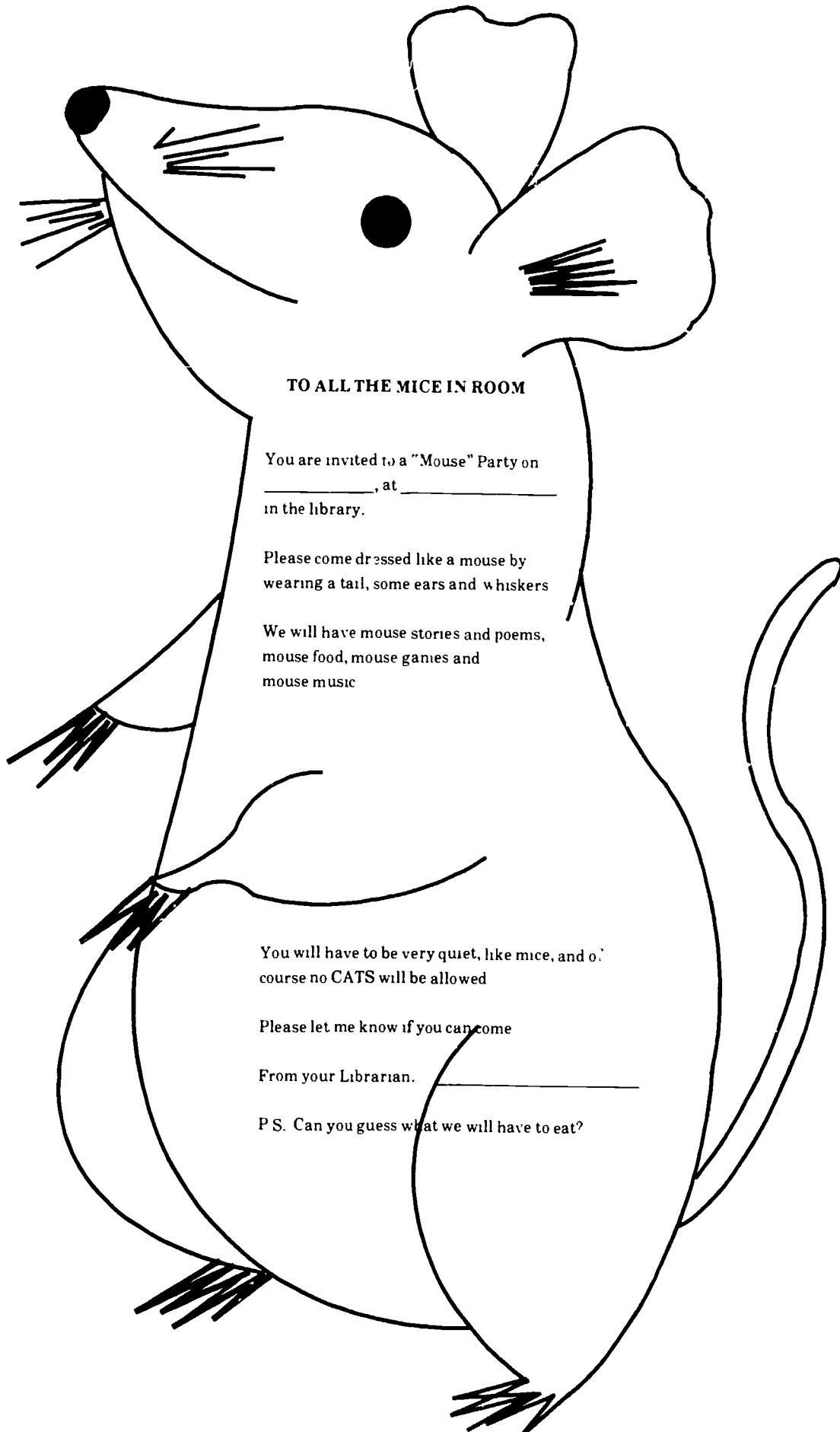

**TO ALL THE MICE IN ROOM**

You are invited to a "Mouse" Party on \_\_\_\_\_, at \_\_\_\_\_ in the library.

Please come dressed like a mouse by wearing a tail, some ears and whiskers

We will have mouse stories and poems, mouse food, mouse games and mouse music

You will have to be very quiet, like mice, and of course no CATS will be allowed

Please let me know if you can come

From your Librarian. \_\_\_\_\_

P.S. Can you guess what we will have to eat?

## EVALUATION:

Allow students to give a written evaluation of the month-long Mouse Tales activities. Sample questions might include:

- 1 Which book did you like best?
- 2 Which art activity did you like best?
- 3 Approximately how many tails did you add to Father Mouse on the bulletin board?
- 4 Of the filmstrips and videos, which was your favorite?
- 5 Of all the "Mouse Tails" activities, which one did you enjoy most?

## RESOURCES:

Laughlin, Mildred Knight and Letty Watt. *Developing Learning Skills Through Children's Literature*, Oryx Press, 1986, pp. 47-50.

"Mice Are Nice!" *Kidstuff* Periodical, A Treasury of Early Childhood Enrichment Materials, Volume 11, Number 1, 1982, Guidelines Press.

Guidelines Press  
1307 S. Killian Drive  
Lake Park, FL 33403

*Mailbox Idea Magazine for Teachers--Primary Edition* May/June, 1987

Olson, Margaret J. "How Mouse Became Small and Gray." *More Tell and Draw Stories*. Minneapolis, Minnesota: Arts and Crafts Unlimited, 1969, pp. 43-47.

Paulin, Mary Ann. *Creative Use of Children's Literature*. Shoe String Press, 1982. pp. 64-68.

Sitarz, Paula Gaj. *Picture Book Story Hours*. Libraries Unlimited, 1987. pp.145-151.

## MOUSE TALES

- Allen, Laura Jean. *Where Is Freddy?* Harper, 1986 1-3
- Balian, Lorna. *Humbug Rabbit*. Abingdon, 1974 K-2
- Barry, Robert. *Mr. Willowby's Christmas Tree*. McGraw, 1963 K-3
- Boegehold, Betty. *Pippa Mouse*. Knopf, 1973. K-2
- Brandenburg, Franz *Six New Students*. Greenwillow, 1978 1-4
- Brown, Marcia. *Once a Mouse* Scribner, 1961. P-5
- Brown, Michael *Santa Mouse*. Putnam, 1966. K-3
- Brown, Palmer *Hickory*. Harper, 1978 P-3
- Brown, Ruth. *A Dark, Dark Tale*. Dial, 1984. P-3
- Carle, Eric. *Do You Want to Be My Friend?* Crowell, 1971. K-3
- Cauley, Lorinda. *Town Mouse and the Country Mouse*. Putnam, 1984. 3-6
- Cleary, Beverly. *The Mouse and the Motorcycle*. Morrow, 1965. 2-6
- Cleary, Beverly. *Ralph S. Mouse*. Morrow, 1982. 4-6
- Cleary, Beverly. *Runaway Ralph*. Morrow, 1970. 3-7
- Clifford, Sandy. *The Roquefort Gang* Houghton, 1981 2-6
- Conly, Jane Leslie. *Rosco and the Rats of NIMH*. Harper, 1986 5-8
- Dauer, Rosamond. *Bullfrog Grows Up* Greenwillow, 1976. 1-4
- Drury, Roger. *Champion of Merrimack County*. Little, 1976. 4-6
- Flack, Marjorie. *Walter the Lazy Mouse*. Doubleday. 2-5
- Freeman, Don. *The Guard Mouse*. Viking, 1967. P-2
- Gackenbach, Dick. *The Perfect Mouse*. Macmillan, 1984. K-3
- Goodall, John S. *Naughty Nancy*. Atheneum, 1975. K-1
- Gordon, Margaret. *The Supermarket Mice* Dutton, 1984. K-1
- Gounauet, Karen. *A Very Mice Joke Book*. Houghton, 1981. All ages
- Grahame, Kenneth *The Wind in The Willows* Holt, 1980. 2-7
- Greaves, Margaret. *The Mice of Nibbling Village*. Dutton, 1986. K-2

- Gurney, Nancy. *The King, the Mice and the Cheese* Beginner, 1965 K-3
- Haley, Gail. *The Post Office Cat* Scribner, 1976. 2-4
- Hoban, Lillian. *The Sugar Snow Spring* Harper, 1973. P-3
- Hoban, Russell. *A Sorely Trying Day* Harper, 1964 K-3
- Holabird, Katharine. *Angelina and the Princess* Crown, 1984 K-2
- Holabird, Katharine. *Angelina at the Fair*. Crown, 1985 K-2
- Hurd, Thacher. *The Pea Patch Jig*. Crown, 1986. P-2
- Ivimey, John W. *Complete Version of Ye Three Blind Mice* Warne, 1979 1-3
- Kelley, True. *The Mouses' Terrible Christmas*. Lothrop, 1978 1-4
- Kellogg, Steven. *The Island of the Skog*. Dial, 1973. P-3
- Kraus, Robert. *Another Mouse to Feed*. Windmill, 1980. P-3
- Kraus, Robert. *Whose Mouse Are You?* Macmillan, 1970. K-3
- Lawson, Robert. *Ben and Me* Little, 1939. 1-7
- LeSieg, Theo. *In a People House* Random House, 1972. P-1
- Lillian, Hoban. *It's Really Christmas* Greenwillow, 1982 1-5
- Lionni, Leo. *Alexander and the Wind-Up Mouse* Pantheon, 1969. K-3
- Lionni, Leo. *Frederick*. Pantheon, 1966. 1-3
- Lionni, Leo. *Geraldine, the Music Mouse*. Pantheon, 1979 P-3
- Lobel, Arnold. *Martha, the Movie Mouse*. Harper, 1966. K-3
- Lobel, Arnold. *Mouse Soup* Harper, 1977. K-3
- Lobel, Arnold. *Mouse Tales*. Harper, 1982. K-3
- Low, Joseph. *The Christmas Grump*. Atheneum, 1977 P-3
- Low, Joseph. *Mice Twice*. Atheneum, 1980. P-3
- Miller, Edna. *Mousekin's Christmas Eve*. Prentice-Hall, 1965 K-3
- Miller, Edna. *Mousekin's Woodland Sleepers*. Prentice-Hall, 1970. K-3
- Miller, Moira. *Oscar Mouse Finds a Home*. Dial, 1985. K-2
- O'Brien, Robert C. *Mrs. Frisby and the Rats of NIMH*. Atheneum, 1971. 3-7

- Oakley, Graham *The Church Mice at Christmas* Atheneum, 1980 K-up
- Oechsli, Kelly. *Mice at Bat* Harper, 1986. 1-2
- Ormondroyd, Edward. *Broderick* Houghton, 1984. K-3
- Peppe, Rodney *The Mice and the Clockwork Bus* Lothrop, 1986 1-3
- Potter, Beatrix. *Tale of Johnny Townmouse* Warne, 1918 P-2
- Potter, Beatrix. *Tale of Mrs. Tittlemouse* Warne, P-3
- Potter, Beatrix *Tale of Two Bad Mice* Warne, P-2
- Sharp, Margery. *Rescuers* Dell, 1974 4-6
- Steig, William. *Abel's Island*. Farrar, 1976 ALL
- Steig, William *Doctor DeSoto* Farrar, 1982. P-3
- Stephoe, John. *The Story of Jumping Mouse* Lothrop, 1984. K-3
- Titus, Eve. *Anatole and the Pied Piper* McGraw, 1979. 2-4
- Vincent, Gabrielle. *Bravo, Ernest & Celestine!* Greenwillow, 1982. K-3
- Vincent, Gabrielle *Ernest & Celestine's Picnic* Greenwillow, 1982 K-3
- Watson, Clyde. *How Brown Mouse Kept Christmas*. Farrar, 1980 P-3
- Wells, Rosemary. *Noisy Nora* Dial, 1973. P-2
- White, E B. *Stuart Little*. Harper, 1945. P-4
- Winthrop, Elizabeth *Journey to the Bright Kingdom*. Holiday, 1979. 4-6
- Yamoshita, Haruo *Mice at the Beach* Morrow, 1987 K-2
- Yolen, Jane. *Mice on Ice*. Dutton, 1980. 1-2
- Zelinsky, Paul O *Maid, Mice and the Odd-Shaped House* Dodd, 1981 P-3

Audiovisual materials to accompany MOUSE TALES

*The Mouse and the Motorcycle.* (sound filmstrip or 16mm), Pied Piper.

Pied Piper  
P O Box 320  
Verdugo, CA 91046

*Alexander and the Wind-Up Mouse.* (sound filmstrip), Random House

*Frederick.* (sound filmstrip), Random House

*Greentail Mouse.* (sound filmstrip), Random House

*The King, the Mice and the Cheese.* (sound filmstrip), Random House

*Meet the Newbery Author: Arnold Lobel* (revised edition). (sound filmstrip), Random House.

*Mice Twice.* (sound filmstrip), Random House.

*The Story of Jumping Mouse.* (sound filmstrip), Random House.

Random House School Division  
Department 9278  
400 Hahn Road  
Westminster, MD 21157

*Doctor DeSoto.* (sound filmstrip, 16mm, or video), Weston Woods

*Ernest & Celestine.* (sound filmstrip), Weston Woods.

*Island of the Skog.* (sound filmstrip, 16mm, or video), Weston Woods

*The Mouse and the Motorcycle.* (sound filmstrip or 16mm), Weston Woods.

*Noisy Nora.* (sound filmstrip), Weston Woods.

*Norman the Doorman.* (sound filmstrip), Weston Woods.

*Whose Mouse Are You?* (sound filmstrip), Weston Woods.

Weston Woods  
Weston, Connecticut 06883

## CHEESE ANYONE?

Cut eight cheese patterns from yellow construction paper. Type a question from those listed below on each, or make your own questions. Clamp the cheese in a large mouse trap for a learning center

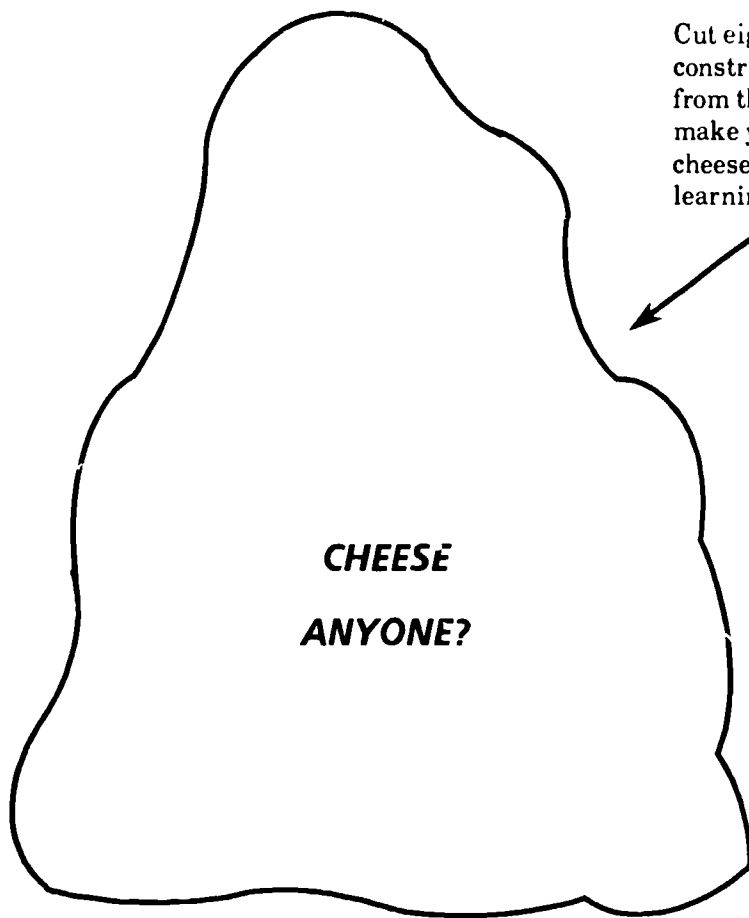

### QUESTIONS FOR CHEESE ANYONE?

What kind of cheese has holes in it?

How many states can you find that produce cheese?

How is cheese made?

How many foods can you list that use cheese?

List as many kinds of cheese as you can find.

Where is cheese produced in Oklahoma?

Which country leads the world in cheese production?

**SOURCE:** Letty Watt, Jefferson School, Norman, Oklahoma

## MICE RING THING

Sample questions for research activity

List four physical characteristics of a mouse.

Draw an illustration of how mouse tracks would look if a mouse walked on a floor lightly covered with flour

Choose three kinds of mice. List their common name. On a map of the Western Hemisphere locate where each can be found.

Locate the word "mouse" in the dictionary. What are the guide words on that page.

Write a newspaper want ad advertising a place for mice to live. Make the description of the residence appealing where a mouse might choose it to live

Compare the house mouse and the deer mouse as to body size, coloring, and fur

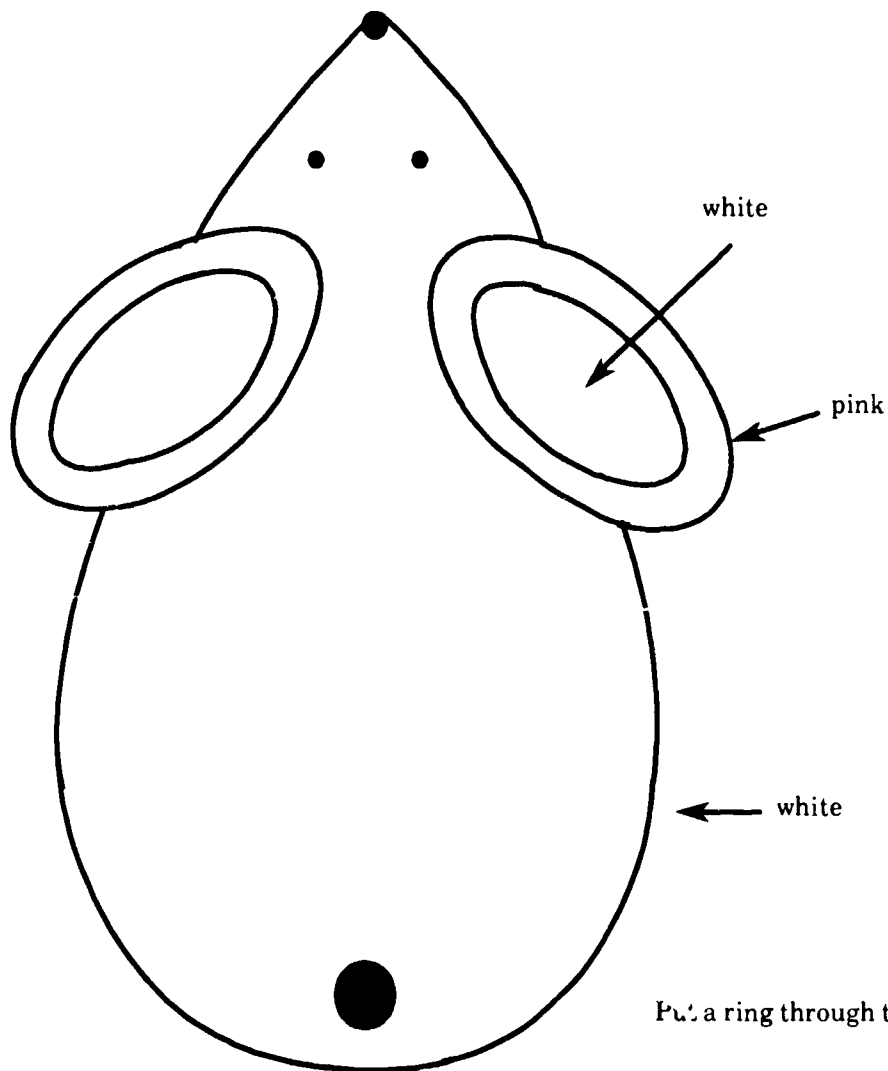



MOUSE PUPPET PATTERNS

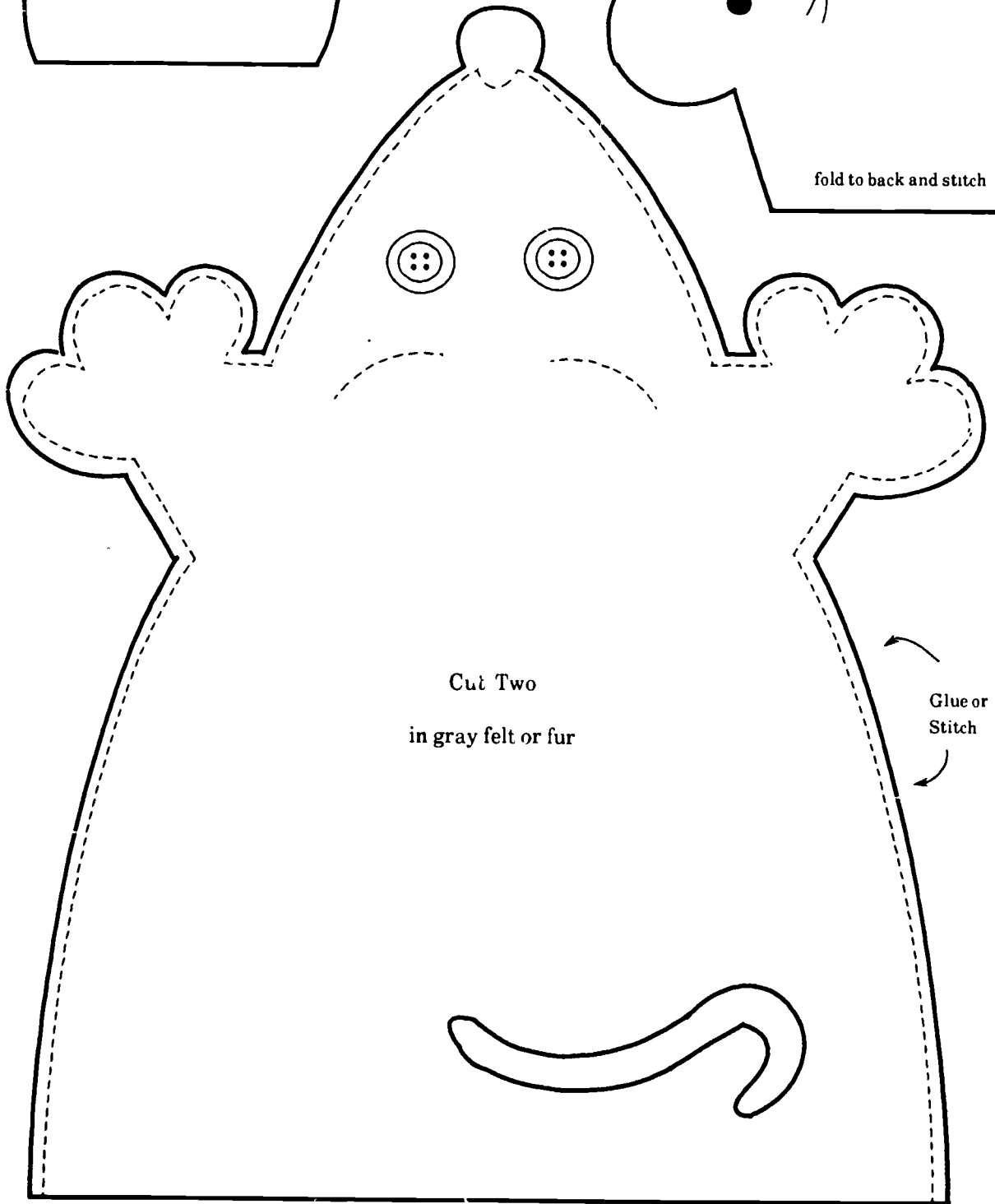
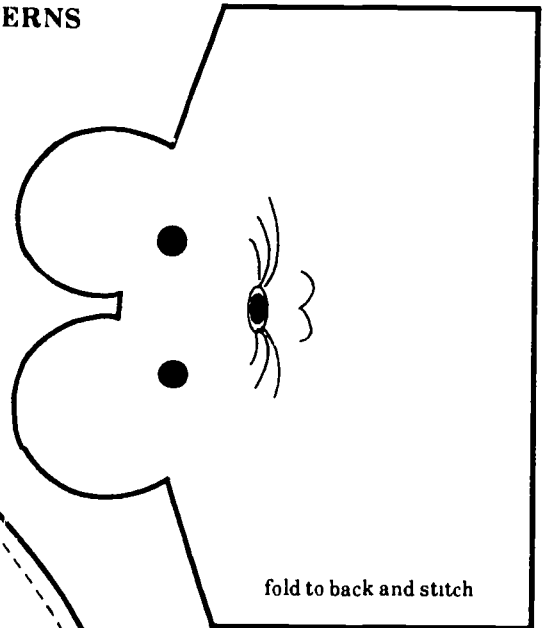
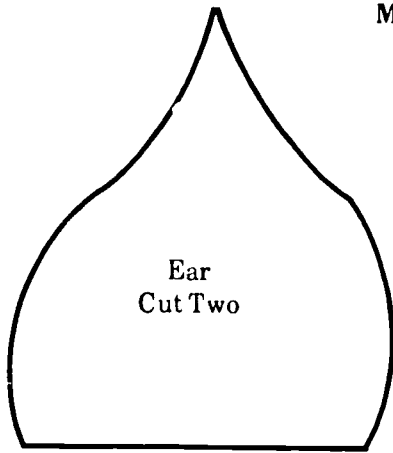

SOURCE: Letty Watt, Jefferson School, Norman, Oklahoma

BOOK MARKERS

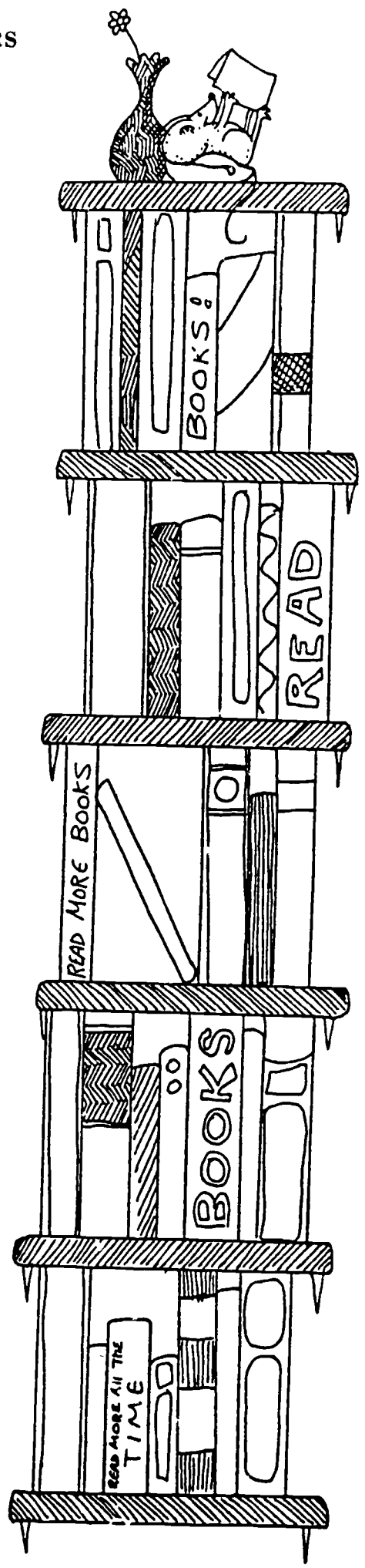
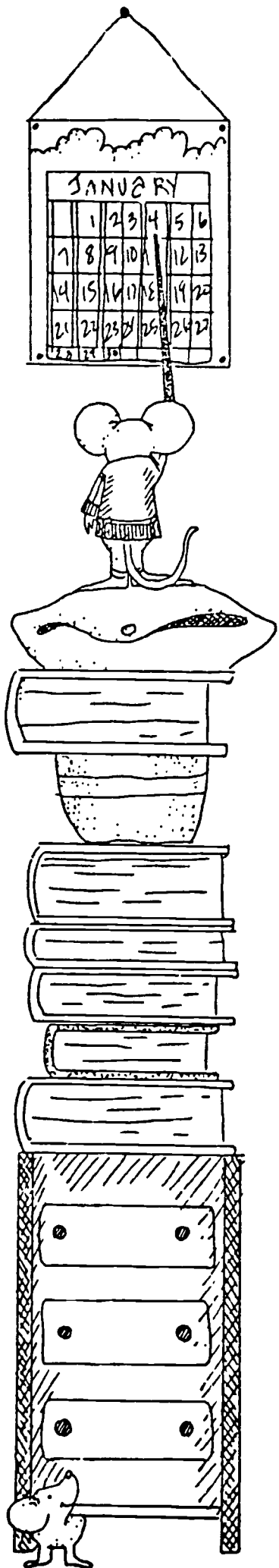

Drawings by  
Lynn Gates Bredeson

# MOUSE TALES

Title \_\_\_\_\_

Author \_\_\_\_\_



Lynn Gates Bredeson

Make a picture of something that happened in this story

Find three new words you learned in reading this story.	Find the names of three animals or two people you read about in this story.

# SONGS TO SING AND DO

## THREE BLIND MICE

Traditional Tune

Three blind mice.  
(Cover eyes)  
Three blind mice.

See how they run,  
(shade eyes)  
See how they run.

They all ran after the farmer's wife  
(Run in place)  
She cut off their tails with a carving knife.  
(Swooping, cutting motion)  
Did you ever see such a sight in your life,  
(Raise hands)  
As three blind mice!  
(Cover eyes)

## HICKORY DICKORY DOCK

Traditional Tune

Hickory Dickory Dock  
(Swing arm back and forth like pendulum)  
The mouse ran up the clock.  
(Wiggle fingers, raise arm above head)  
The clock struck one,  
(Clap)  
The mouse ran down,  
(Wiggle fingers, lower hand)  
Hickory Dickory Dock.  
(Repeat first motion)

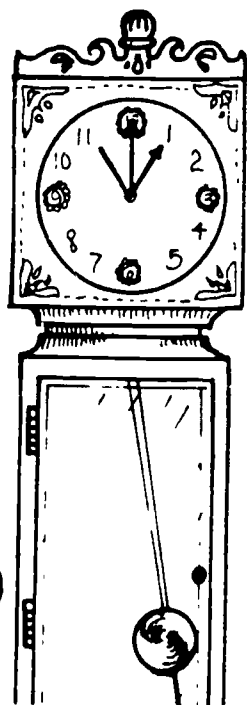
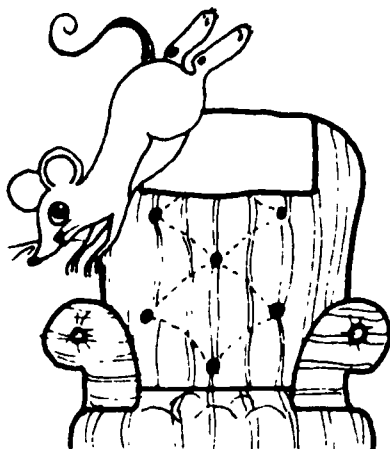

# FINGER PLAYS

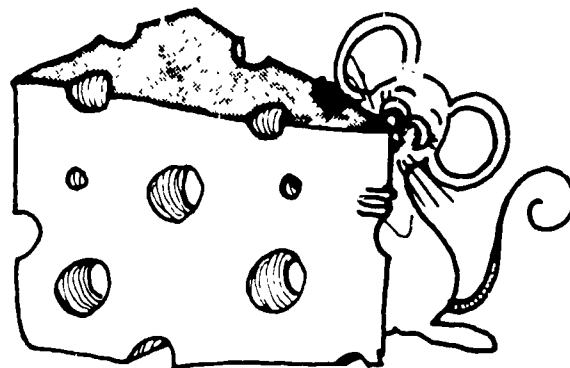

## THIS LITTLE MOUSE

Five little mice on the pantry floor,  
(Hold up five fingers of left hand)  
This little mouse peeked behind the door,  
(Bend down left little finger, shade eyes with right hand)  
This little mouse nibbled at some cake,  
(Bend down left ring finger, make nibbling movements with right hand)  
This little mouse not a sound did make,  
(Bend down left middle finger, hold right forefinger to lips)  
This little mouse took a bite of cheese,  
(Bend down left pointer finger, right hand "take a bite")  
This little mouse heard the kitten sneeze.  
(Bend down left thumb, cup right hand to ear)  
"Ah-choo!" sneezed the kitten  
(Finger under nose, pretend to sneeze)  
And "Squeak!" the mice cried  
(Hands up in the air in fright)  
And they found a hole and ran inside  
(Make running motion with fingers and hide hands behind back)

Unknown

## A MOUSE LIVED IN A HOLE

A mouse lived in a little hole,  
(one hand curled inside the other)  
Lived softly in a little hole.  
  
When all was quiet as can be (Sh! Sh!)  
(Forefinger to lips)  
When all was quiet as can be (Sh! Sh!)  
(Replace hand inside the other)  
Out popped HE!  
(Right hand jumps out of left)

Unknown

Used by permission of KIDSTUFF Periodical, A Treasury of Early Childhood Enrichment Materials, c 1982, Guidelines Press

# A TELL-AND-DRAW STORY

This story can be presented on a chalkboard with colored chalk, on piece of poster board or on a large pad of paper using crayons or broad tip markers. Just draw each feature (in a larger size, of course!) as you tell the corresponding part of the story. The charm of this method of storytelling is the wonderful sense of anticipation which is built up on the part of the audience.

## THE LION, THE TIGER AND THE MOUSE

A NEW VERSION OF AN OLD FABLE

1. One day a lion and a tiger were walking through the jungle.



2. When their paths met, they walked on together.

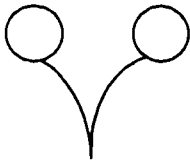

3. They wandered around, admiring the flowers and talking.

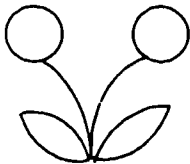

4. Suddenly, they stepped into a path of stinging nettles. Ouch! Did they hurt!

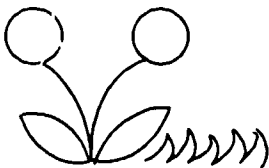

5. The lion and the tiger hopped up and down, moaning and groaning and holding their paws in pain.

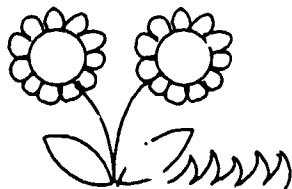

6. All the jungle creatures came rushing to see what was the matter.

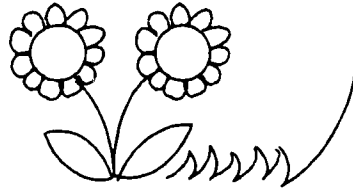

7. "Help us! Help us!" cried the lion and tiger. But the other creatures shook their heads. They were afraid.

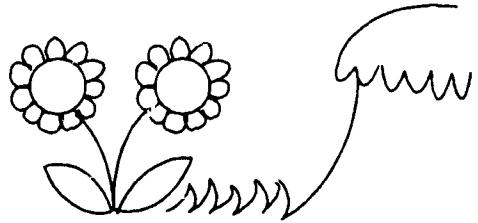

8. At last, a little tiny mouse crept forth out of his hidey hole.

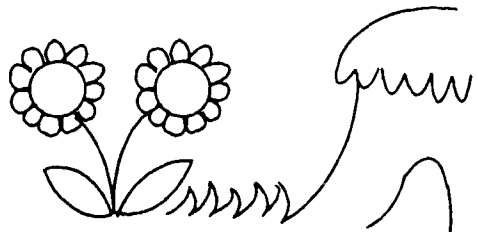

9. Slowly he approached the lion and the tiger and very carefully pulled each and every nettle out of their paws.

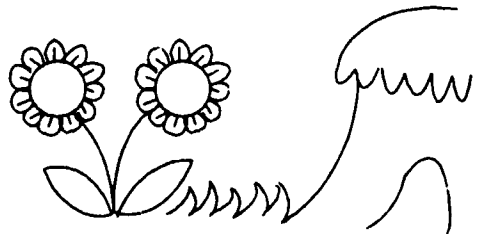

10. The lion and tiger were very grateful, but the mouse didn't want to take any chances. So, he quickly ran back to his hole.

Better to be safe than sorry!

J.S.H.

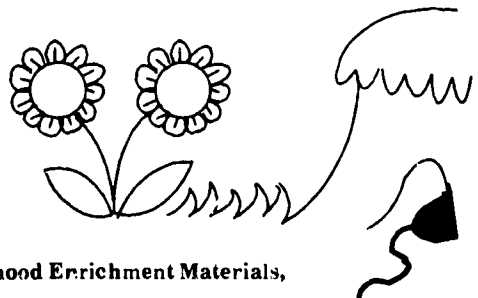

Used by permission of KIDSTUFF Periodical, A Treasury of Early Childhood Enrichment Materials, c 1982, Guidelines Press

PATTERN FOR COVER OF  
"MICE" POEMS BOOKLET

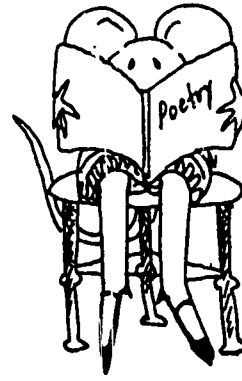

Lynn Gates  
Bredeson

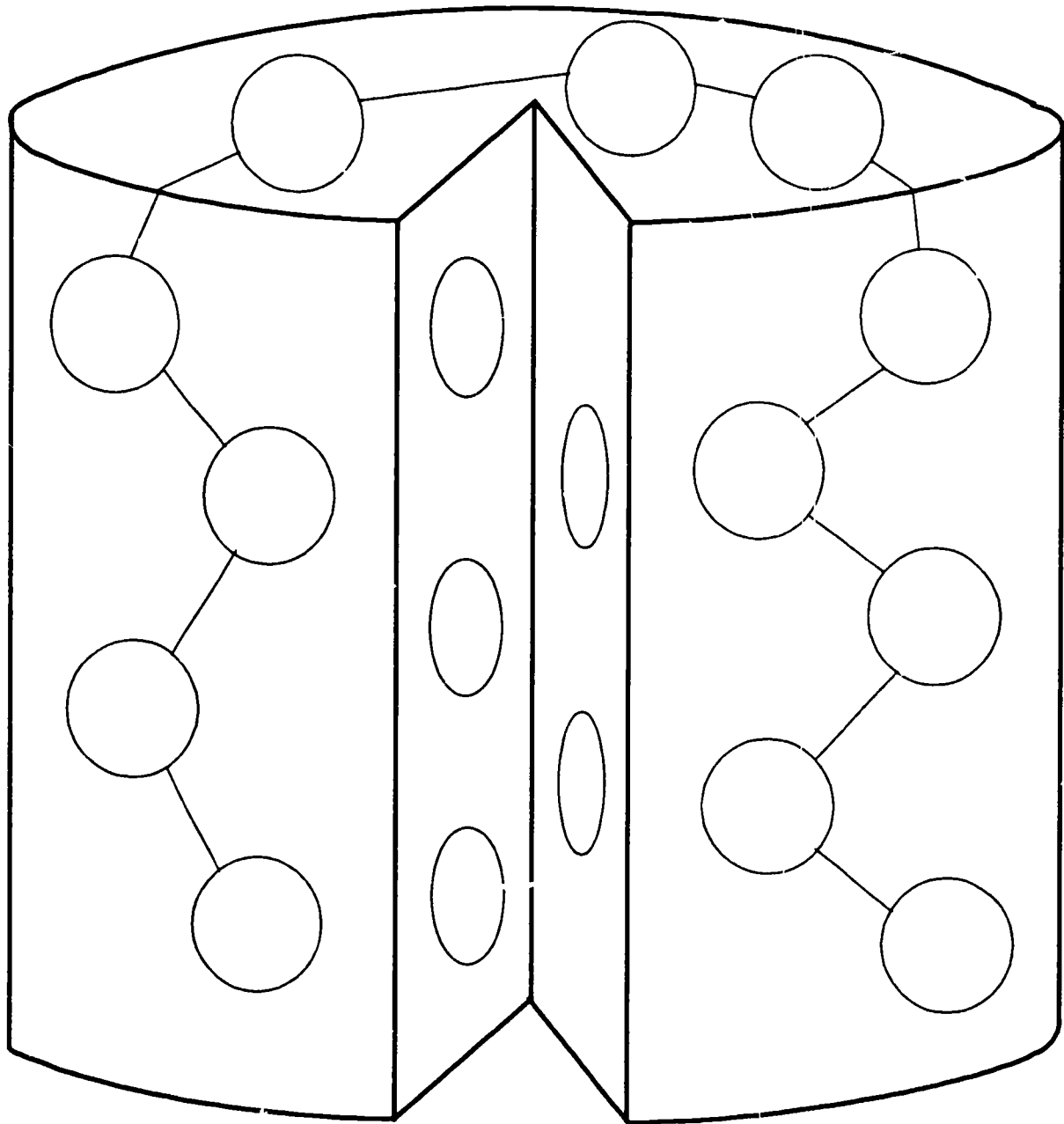

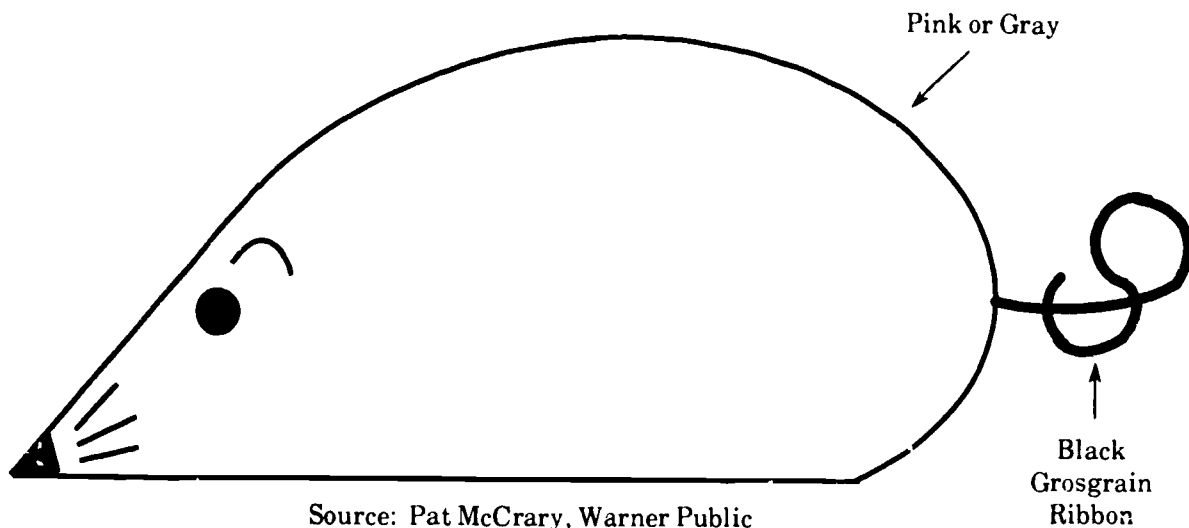
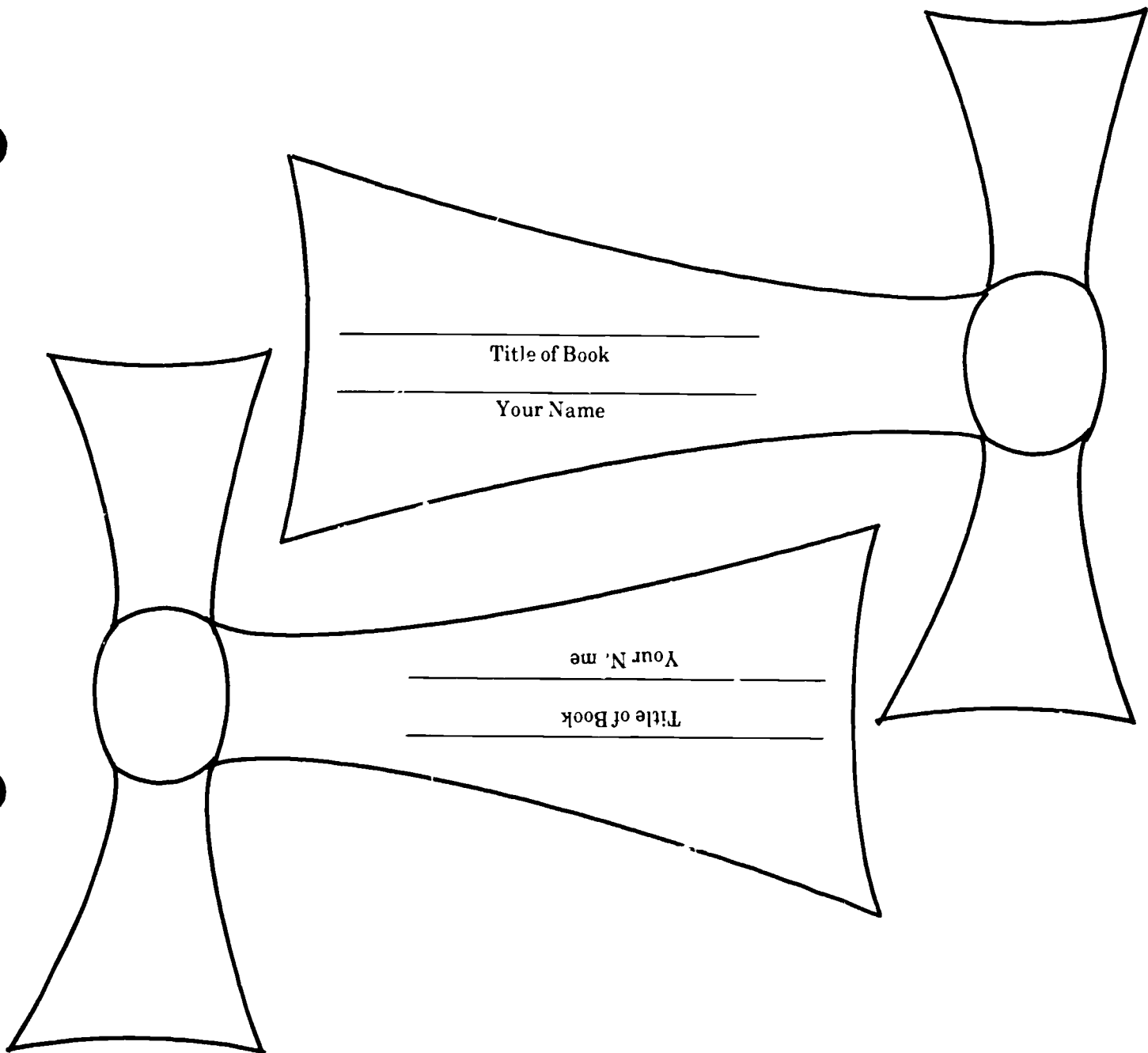

Source: Pat McCrary, Warner Public Schools

## BEARS IN LITERATURE

Emphasis Grade Level: K-1-2

**CURRICULUM APPLICATION(S):** Reading

**GOAL:** Students will become familiar with bears in literature, and enjoy a variety of bear stories in various formats.

### COOPERATIVE PLANNING/TEACHING

These activities will be most successful when planned jointly by the classroom teacher and the library media specialist, with appropriate activities scheduled for the library and the classroom.

### LEARNER OUTCOMES

Content Area	Information Skills
The student will: <ol style="list-style-type: none"><li>1. Be introduced to literature</li><li>2. Say and act out nursery rhymes and stories.</li><li>3. Participate in role playing activities.</li></ol>	The student will: <ol style="list-style-type: none"><li>1. Listen to stories read or told.</li><li>2. Watch stories on film, filmstrips or video.</li><li>3. Enjoy reading simple stories and poetry</li><li>4. Identify characters in selections viewed, listened to or read.</li></ol>

### ACTIVITIES/SUGGESTIONS:

1. "Let's Go on a Bear Hunt" and other bear fingerplays are included in *Ring a Ring O'Roses*--available from the Flint, Michigan, Public Library. (See resource list )
2. *Moon Bear* by Frank Asch is easily adapted to a flannel board story.
3. After sharing Anthony Browne's *Bear Hunt* divide the class into pairs. Each bear has a piece of drawing paper and a pencil. The hunter thinks of a way to catch the bear and acts this out. The bear then draws something that will help with an escape. Each child should have the opportunity to be the bear and the hunter.
4. Compare Brinton Turkle's *Deep in the Forest* with several other versions of the *The Three Bears*.



5. Designate "Bear Day" for your class. Have children bring bears to school for display. Let each child tell why his/her bear is special.
6. Share samples of different types of honey with children. Purchase small jars of orange blossom, sunflower, or clover honey. Dip small chunks of apple or small pieces of bread into the honey. Talk about the different flavor of each. Provide washcloths or paper towels to wipe sticky fingers.
7. Teach children the traditional tune "The Bear Went Over the Mountain"
8. Many children have never tasted marmalade. After introducing Paddington, serve tiny marmalade sandwiches.

#### EVALUATION:

The student will be able to identify five out of the ten Book Bears on the Ring Thing activity in this unit.

#### RESOURCES:

"BEAR-TIVITIE ~" Kidstuff Periodical, A Treasury of Early Childhood Enrichment Materials, Volume 2, Number 8, 1983. Guidelines Press.

Guidelines Press  
1307 S. Killian Drive  
Lake Park, FL 33403

Bialosky, Peggy and Alan. *The Teddy Bear Catalog*. Workman, 1980

Workman Publishing Co., Inc.  
One West 39th Street  
New York, New York 10018

Catalog of stuffed bears, bear totes, books, ceramics, toys and miniatures available from

Bear-in-Mind, Inc.  
73 Indian Pipe Lane  
Concord, MA 01742

Hutchins, Margaret. *Teddy Bears and How to Make Them*. Dover, 1978

Dover Publications, Inc.  
31 E. Second Street  
Mineola, New York 11501

*Reading Beyond the Basal* offers the following programs about "Bears" for use in reading, writing, and other learning activities.

*Ira Sleeps Over*  
*Blueberries for Sal*  
*Corduroy*

Perfection Form Company  
1000 North Second Avenue  
Logan, Iowa 51546

*Ring a Ring O'Roses.* (revised edition) Flint, Michigan, Public Library, 1981

Flint Public Library  
1020 E. Kearsy  
Flint, Michigan 48502

Wendelin, Karla Hawkins and M Jean Greenlaw *Storybook Classrooms--Using Children's Literature in the Learning Center* Humanics Limited, Atlanta, Georgia.

Humanics, Limited  
P.O. Box 7447  
Atlanta, Georgia 30309

"Corduroy" rubberstamp #593. Kidstamps

"Flower Panda" rubberstamp #331 Kidstamps

"Blackboard Bear and Anthony" rubberstamp #446 Kidstamps

Kidstamps  
P.O. Box 18699  
Cleveland Heights, Ohio 44118



Lynn Gates Bredeson

## BEARS IN LITERATURE BIBLIOGRAPHY

- Alexander, Martha.** *Blackboard Bear.* Dial, 1969.
- Alexander, Martha.** *And My Mean Old Mother Will Be Sorry.* Dial, 1977
- Alexander, Martha.** *I Sure Am Glad to See You, Blackboard Bear* Dial, 1976.
- Alexander, Martha.** *We're in Big Trouble, Blackboard Bear.* Dial, 1980.
- Allen, Pamela.** *Bertie and the Bear.* Putnam, 1984.
- Asch, Frank.** *Happy Birthday, Moon.* Prentice Hall, 1982
- Asch, Frank.** *Popcorn.* Prentice Hall, 1982.
- Asch, Frank.** *Mooncake.* Prentice Hall, 1983.
- Asch, Frank.** *Bear Shadow* Prentice Hall, 1985.
- Asch, Frank.** *Bear's Bargain* Prentice Hall, 1985
- Asch, Frank.** *Moongame.* Prentice Hall, 1985
- Asch, Frank.** *Skyfire* Prentice Hall, 1984
- Asch, Frank.** *Sandcake.* Parents, 1979.
- Berenstain, Stan & Jan.** Numerous Titles. Random House
- Bond, Michael.** Numerous Paddington Titles.
- Browne, Anthony.** *Bear Hunt.* Atheneum, 1980
- Craft, Ruth.** *Winter Bear.* Atheneum, 1975.
- Delton, Judy.** *Brimhall Turns Detective.* Carolrhoda, 1983
- Delton, Judy** *Bear and Duck on the Run* Whitman. 1984
- Douglass, Barbara.** *Good as New.* Lothrop, 1982
- Duvoisin, Roger.** *Snowy and Woody.* Knopf, 1979
- Flack, Marjorie.** *Ask Mr. Bear.* Macmillan, 1932.
- Freeman, Don.** *Corduroy.* Viking, 1968.
- Freeman, Don.** *A Pocket for Corduroy.* Viking, 1978.
- Freeman, Don.** *Beady Bear.* Viking, 1954.
- Gackenbach, Dick.** *Hourd and Rear.* Houghton, 1976

- Galdone, Joanna.** *Little Girl and the Big Bear.* Houghton, 1980.
- Ginsburg, Mirra.** *Two Greedy Bears* MacMillan, 1976
- Gretz, Susanne.** *Teddy Bears 1 to 10.* Follett, 1969.
- Gretz, Susanne.** *Teddy Bears Cure a Cold.* MacMillan, 1985.
- Haas, Dorothy.** *Bears Upstairs.* Dell, 1981
- Hague, Kathleen.** *Alphabears: An ABC Book* Holt, 1984
- Holl, Adelaide.** *Bedtime for Bears.* Garrard, 1973.
- Janice.** *Little Bear Marches in the St. Patrick's Day Parade.* Lothrop, 1967
- Janice.** *Little Bear's Christmas.* Lothrop, 1964.
- Janice** *Little Bear's Thanksgiving.* Lothrop, 1967.
- Jonas, Ann.** *Two Bear Cubs* Morrow, 1982
- Lapp, Eleanor.** *Blueberry Bears.* Whitman, 1983.
- Lemieux, Michele** *What's That Noise?* Morrow, 1985.
- Mack, Stanley.** *10 Bears in My Bed.* Pantheon, 1974
- Marshall, James.** *What's the Matter with Carruthers?* Houghton, 1972
- Martin, Bill.** *Brown Bear, Brown Bear, What Do You See?* Holt, 1983
- McCloskey, Robert.** *Blueberries for Sal* Viking, 1948.
- McLeod, Emilie.** *Bear's Bicycle.*
- McPhail, David.** *Bear's Toothache* Little, 1972
- McPhail, David.** *Emma's Pet.* Dutton, 1985
- Milne, A.A.** *Pooh's Bedtime Book* Dutton, 1980.
- Milne, A A.** *Pooh Story Book* Dutton, 1965
- Milne, A A.** *Pooh's Birthday Book* Dutton, 1963
- Milne, A A** *Pooh's Counting Book* Dutton, 1983
- Minarik, Else** *Father Bear Comes Home.* Harper, 1959.
- Minarik, Else.** *Kiss for Little Bear.* Harper, 1968
- Minarik, Else.** *Little Bear.* Harper, 1957

**Minarik, Else.** *Little Bear's Friend*. Harper, 1960.

**Minarik, Else.** *Little Bear's Visit*. Harper, 1961.

**Murphy, Jill.** *Peace at Last*. Dial, 1980.

**Murphy, Jill.** *What Next, Baby Bear?* Dial, 1984.

**Parker, Nancy.** *Ordeal of Byron B. Blackbear*. Dodd, 1979.

**Peet, Bill.** *Big Bad Bruce*. Houghton, 1978.

**Steiner, Jorg.** *The Bear Who Wanted to Be a Bear*. Atheneum, 1977.

**Stevenson, James.** *Bear Who Had No Place to Go*. Harper, 1972.

**Turkle, Brinton.** *Deep in the Forest*. Dutton, 1976.

**Vincent, Gabrielle.** *Ernest and Celestine*. Morrow, 1982.

**Vincent, Gabrielle.** *Ernest & Celestine's Patchwork Quilt*. Greenwillow, 1985.

**Vincent, Gabrielle.** *Ernest & Celestine's Picnic*. Morrow, 1982.

**Vincent, Gabrielle.** *Merry Christmas, Ernest & Celestine*. Greenwillow, 1984.

**Waber, Bernard.** *Ira Sleeps Over*. Houghton, 1975.

**Ward, Lynn.** *The Biggest Bear*. Houghton, 1952.

**Watanabe, Shiego.** *How Do I Put It On? Getting Dressed*. Philomel, 1979.

**Winter, Paula.** *Bear and the Fly*. Crown, 1976.

**Audiovisual materials to accompany BEARS IN LITERATURE:**

Beady Bear. (read-along), Live Oaks Media.

The Bear's Toothache. (read-along), Live Oaks Media.

Blueberries for Sal. (read-along), Live Oaks Media.

Bear Party. (sound filmstrip), Live Oaks Media.

The Bear's Bicycle. (sound filmstrip), Live Oaks Media.

Beady Bear. (read-along), Random House.

Corduroy. (read-along), Random House.

Who Wants an Old Teddy Bear? (read-along), Random House.

Blueberries for Sal. (read-along), Random House.

Bear's Toothache. (read-along), Random House.

A Kiss for Little Bear. (read-along), Random House.

Ira Sleeps Over. (read-along), Random House.

Corduroy. (sound filmstrip), Random House.

A Pocket for Corduroy. (sound filmstrip), Random House.

Beady Bear (sound filmstrip), Random House.

Blueberries for Sal. (sound filmstrip), Random House.

Ira Sleeps Over. (sound filmstrip), Random House.

Random House  
Department 9278  
400 Hahn Road  
Westminster, MD 21157

Biggest Bear. (sound filmstrip), Weston Woods.

Blueberries for Sal. (16mm, video, sound filmstrip), Weston Woods.

A Kiss for Little Bear. (sound filmstrip), Weston Woods.

Corduroy. (16mm and video), Weston Woods.

Happy Birthday, Moon. (16mm and video), Weston Woods.

Weston Woods  
Weston, CT 06883

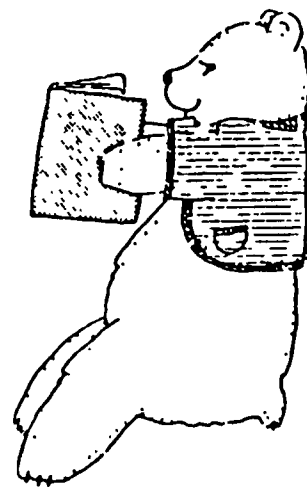
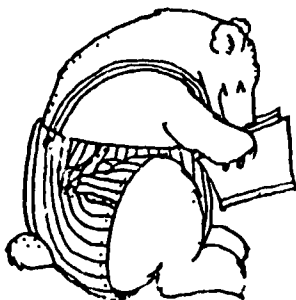

drawings by  
Lynn Gates Bredeson

**"CORDUROY"**

**Bear Pattern**

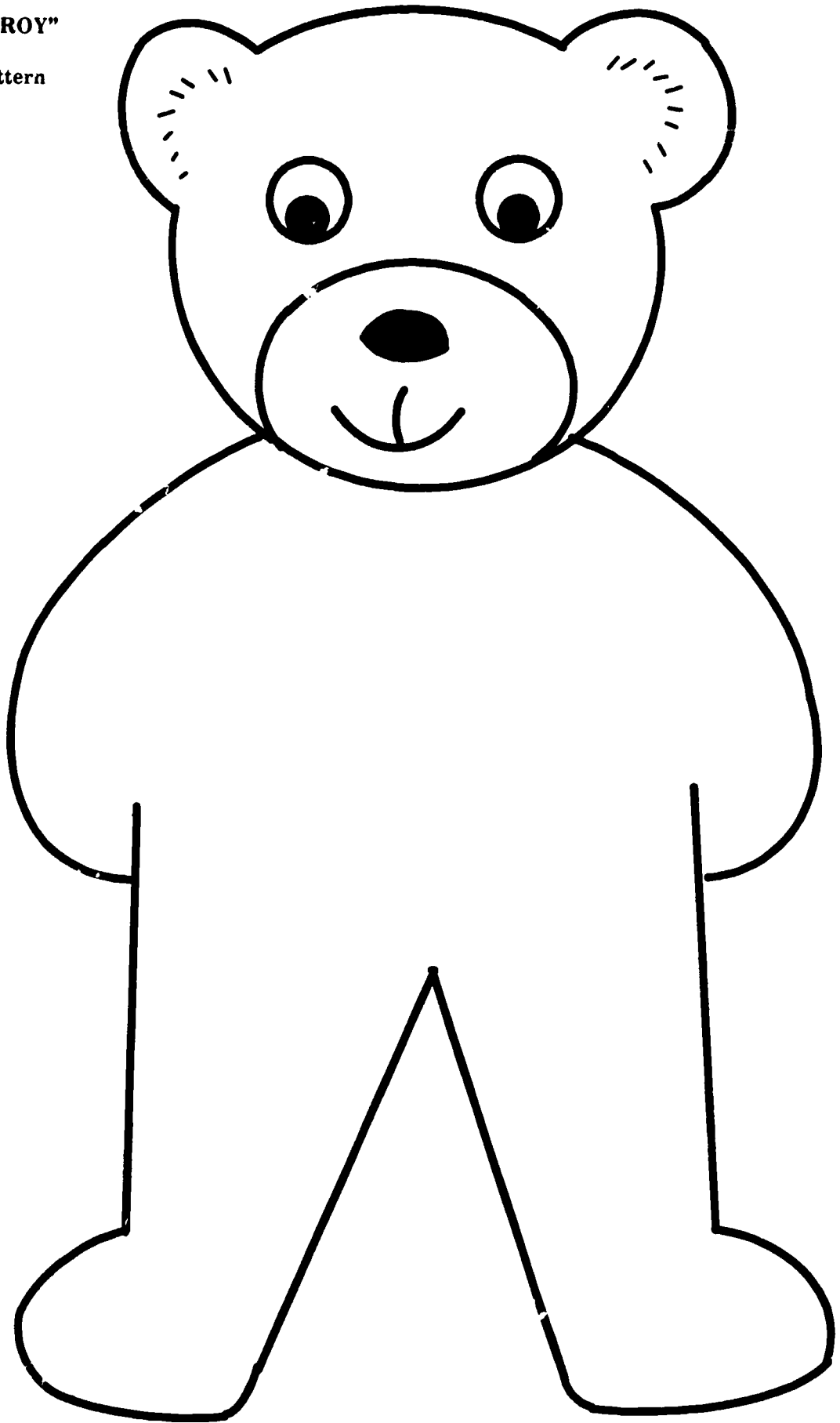

Corduroy's Overalls

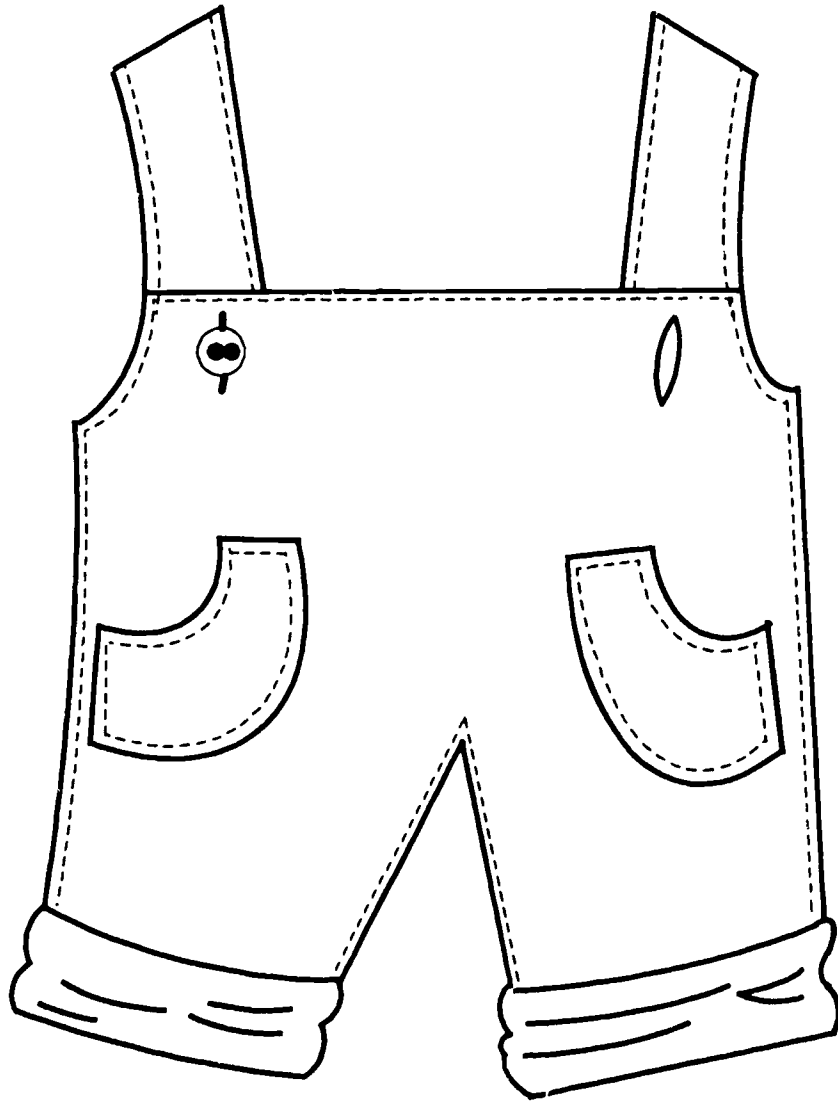



## THREE BEARS STICK PUPPETS

### Materials Needed:

Chinet or other paper plates in three sizes:

- 2-small
- 4-medium
- 2-large

Brown Spray Paint

Flesh-colored Spray Paint or Tempera

Ribbon

Red Felt

Blue Felt

Black Felt

Brown Corduroy

Yellow Doll Hair (available at Walmart)

4 Paint Sticks (available at most lumber companies)

1. Spray brown paint on two paper plates of each size, and three paint sticks.
2. Spray flesh-colored paint on the other medium-sized plates and one paint stick.
3. Glue all plates together, two at a time, with paint stick extending from bottom.
4. Cut black felt eyes, nose and mouth for bears.
5. Cut red felt for Goldilock's nose.
6. Cut blue felt for Goldilock's eyes.
7. Cut brown corduroy for bears' ears. Cut four pieces for each bear and glue two together for each ear.
8. Glue ears to front of bears' faces at the top.
9. Cut brown corduroy to go under black felt nose and mouth of bears.
10. Glue yellow hair around Goldilocks at the top and side. Let it extend out about 4", turn it up and tie ribbon around it.

Children will enjoy using these stick puppets to tell and act out *The Three Bears*.

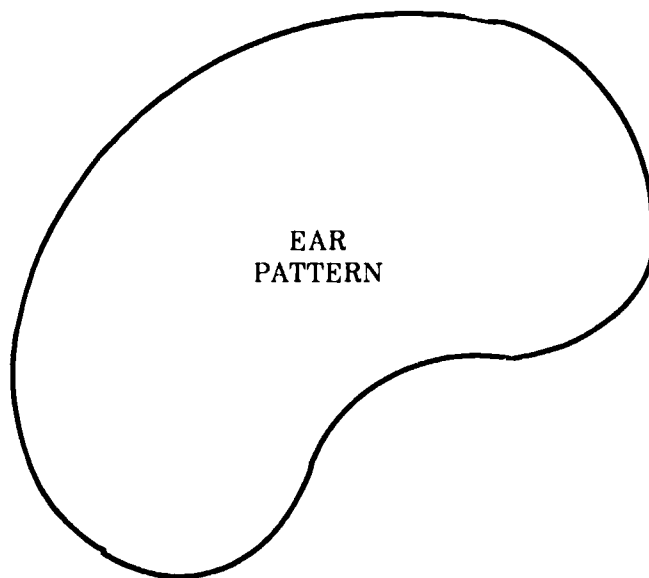

SAMPLE BEAR FACE

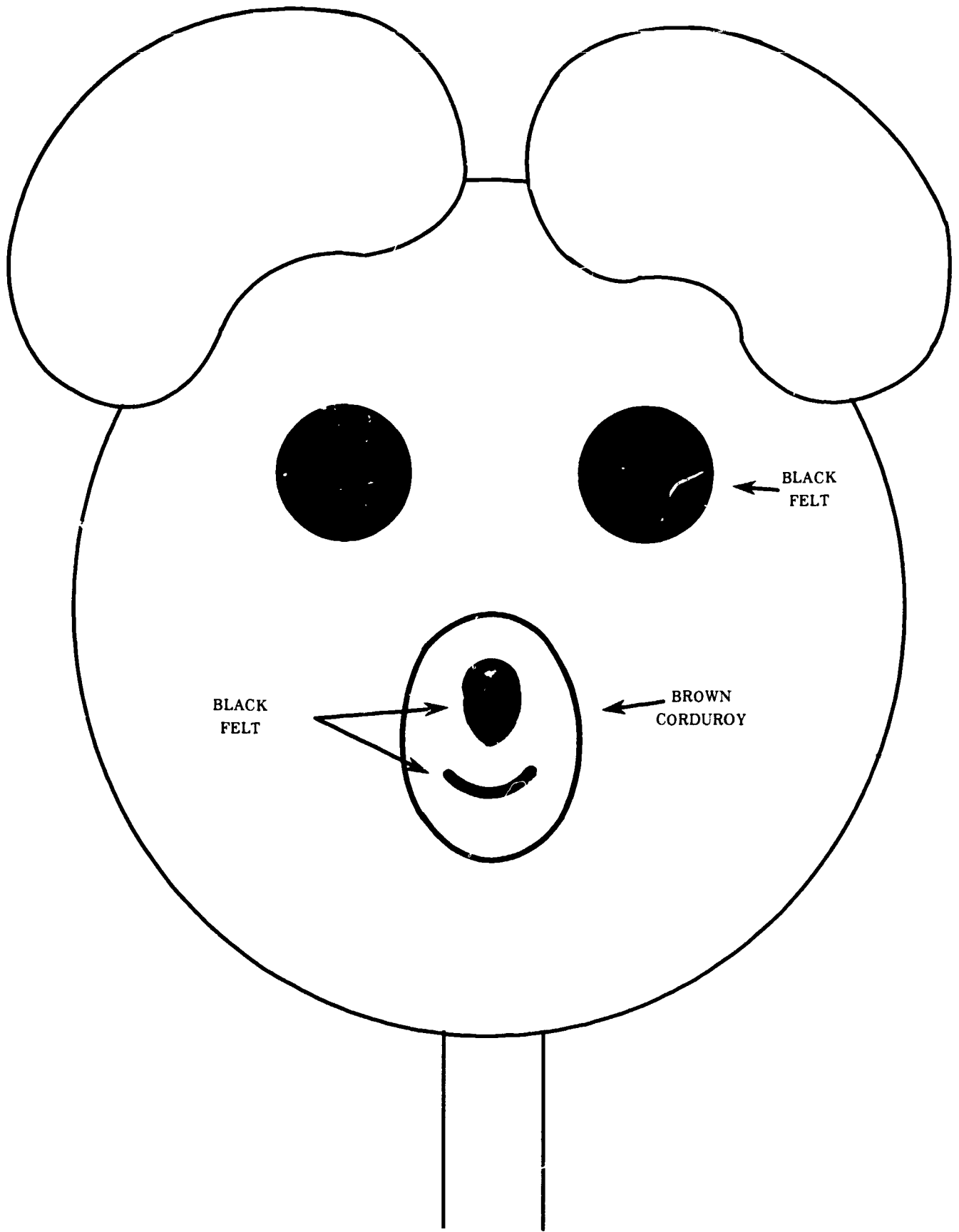

BLACK  
FELT

BLACK  
FELT

BROWN  
CORDUROY

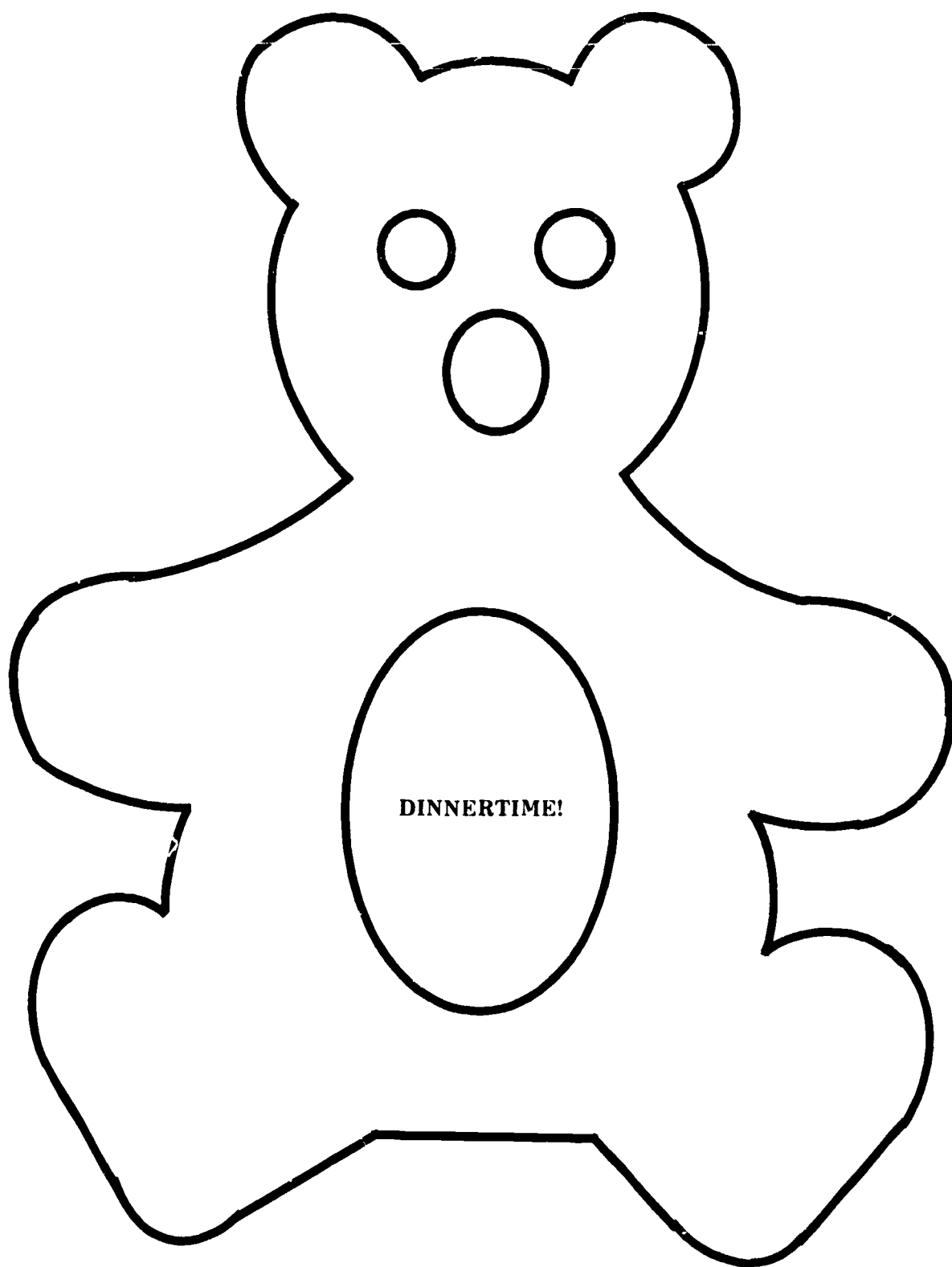

What has this little bear stuffed his tummy with this time? Have students cut out this bear and the one on the next page to use for a writing assignment. The basic four food groups can be used to plan the menu, or the writing can be purely fictional. Glue back and front together.

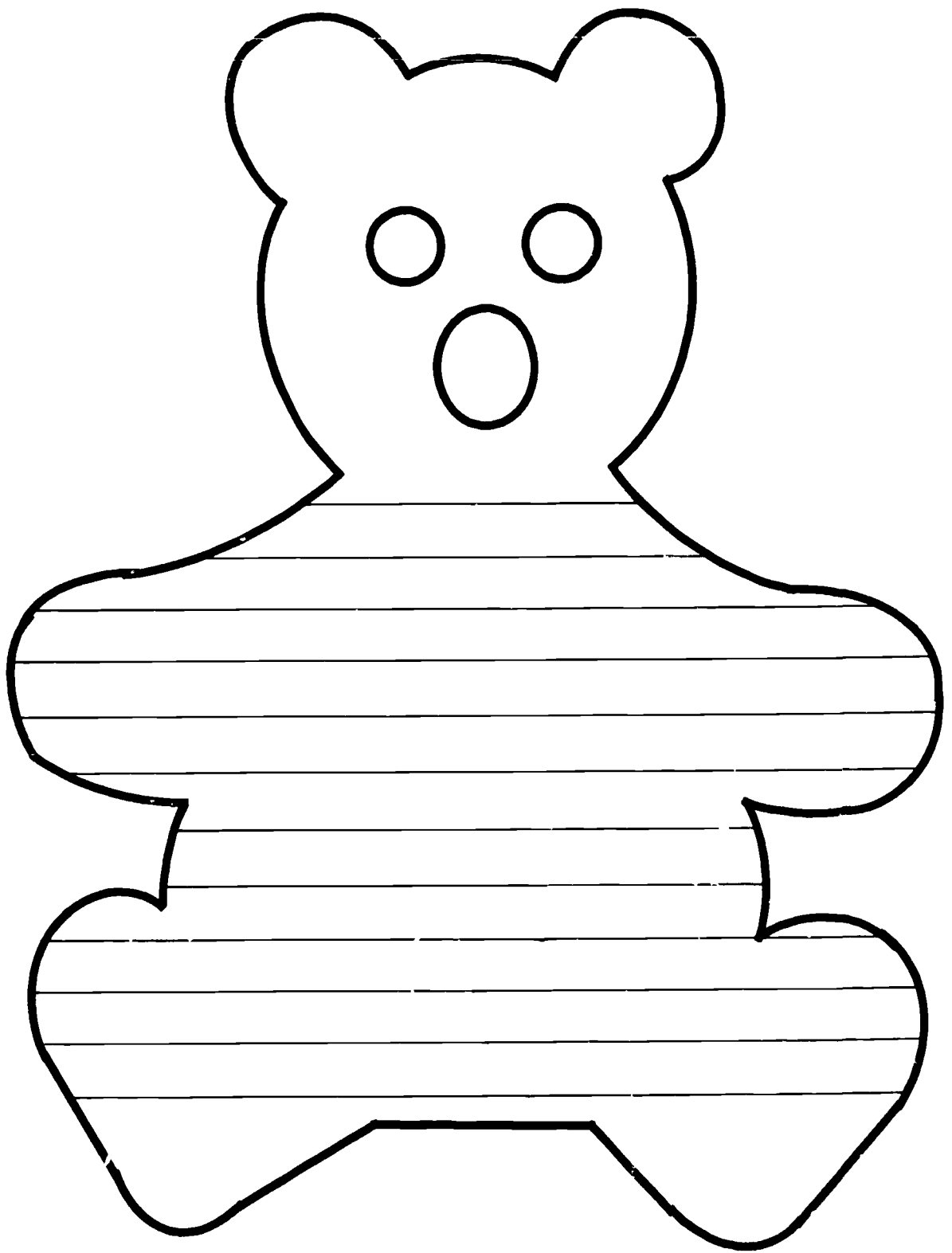

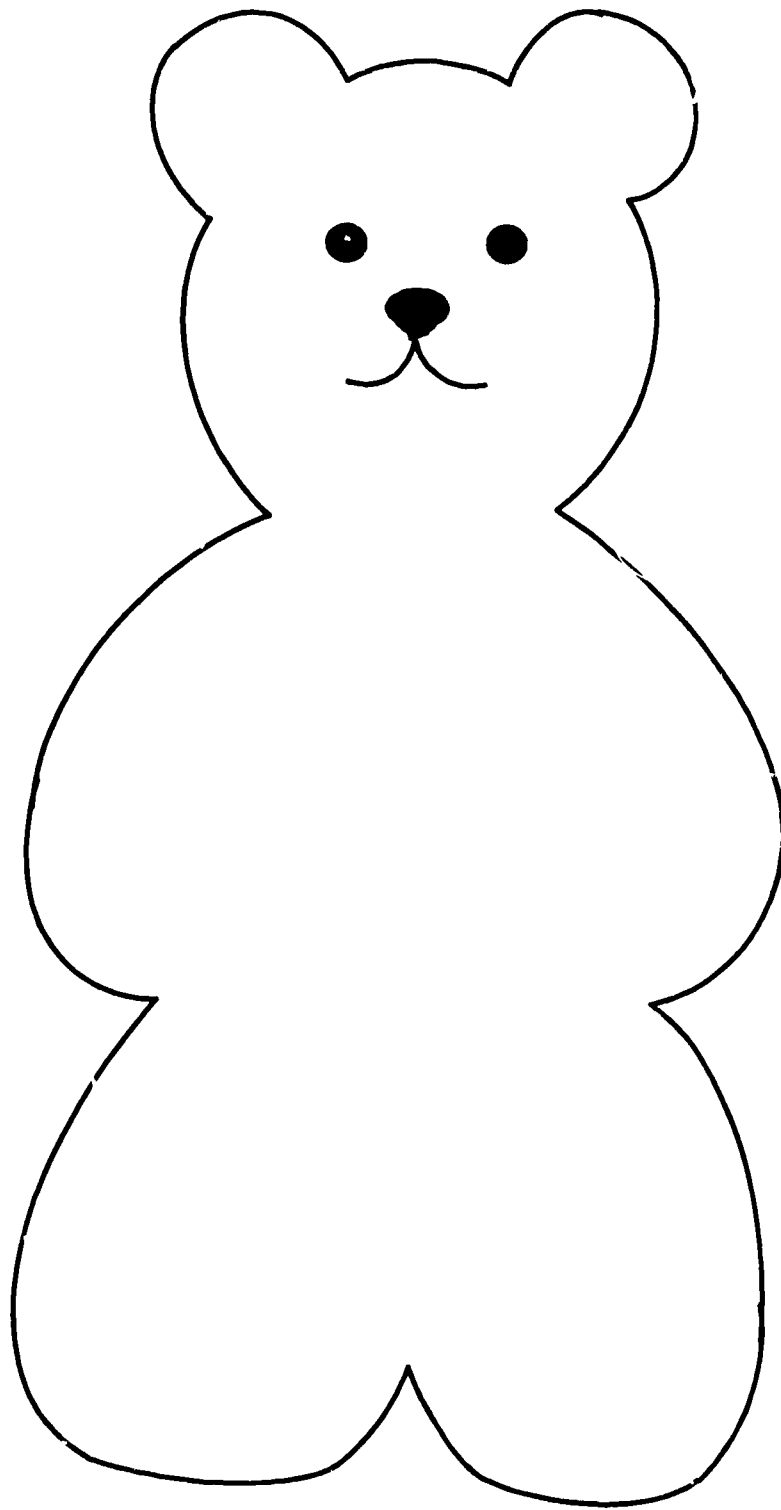

**BOOK BEAR Ring Thing**

Use this pattern to construct a Ring Thing about **BOOK BEARS**. Make ten copies and type one question on each.

1. Which bear was created when a little boy drew a great, big, fuzzy bear on his blackboard? **Blackboard Bear**
2. What is the name of the bear family where Small Bear always ends up teaching his pop a lesson? **Berenstain**
3. Which group of bears introduces each letter of the alphabet? **Alphabears**
4. What is the name of the bear who always gets into trouble and lives in London? **Paddington**
5. Which bear book tells about the adventures of a little girl and her mother as they pick blueberries? **Blueberries for Sal**
6. Who is the large bully bear who thinks it is great fun to roll boulders down the hill to frighten small creatures who live in Forevergreen Forest? **Big Bad Bruce**
7. What is the name of the picture book where Johnny wants a bearskin for his barn, but gets a live bear instead? **The Biggest Bear**
8. In which book does a little boy try, for the first time, to sleep over at a friend's house without his teddy bear? **Timmy Sleeps Over**
9. Which bear searches a department store for a lost button? **Corduroy**
10. Which bear is a friend of Christopher Robin, Piglet, Rabbit and Owl? **Winnie-the-Pooh**

## DINOSAURS

**Emphasis Grade Level: 1**

**CURRICULUM APPLICATION(S):** Language Arts, Reading, Math, Science, Physical Movement, Music

**GOAL:** The students will develop a better understanding of when, how and where dinosaurs lived. Their enthusiasm and interest in dinosaurs will carry into all areas of the curriculum

### COOPERATIVE PLANNING/TEACHING

<p>The teacher will:</p> <ol style="list-style-type: none"> <li>1. Plan with the library media specialist.</li> <li>2. Introduce concepts using books, tape, , sound filmstrips, etc.</li> <li>3. Guide students in the related curriculum area activities.</li> </ol>	<p>The library media specialist will</p> <ol style="list-style-type: none"> <li>1. Plan with the teacher.</li> <li>2. Locate available resources.</li> <li>3. Direct students where they can find "true" books, and "storybooks" and discuss the difference.</li> <li>4. Share books, poems, etc about dinosaurs and plan follow-up activities with the teacher</li> </ol>
--	--

### LEARNER OUTCOMES

Content Area	Information Skills
<p>The student will:</p> <ol style="list-style-type: none"> <li>1. Arrange words in alphabetical order with the first letter.</li> <li>2. Dictate sentences for the teacher to write.</li> <li>3. Copy sentences from charts or board.</li> <li>4. Begin to write creative stories and poetry.</li> <li>5. Develop an appreciation of stories read or told.</li> <li>6. Identify triangles, rectangles, square and circles</li> </ol>	<p>The student will:</p> <ol style="list-style-type: none"> <li>1. Learn the difference between storybooks and true or informational books and locate each type.</li> <li>2. Alphabetize words by the first letter.</li> <li>3. Record information with word or phrase answers.</li> <li>4. Use their own pictures to communicate with others.</li> </ol>

**Content Area (cont.)**

7. Count by fives from zero to one hundred.
8. Compare lengths
9. Identify the part of a region which represents one-half, one-third, and one-fourth
10. Do simple alphabetizing
11. Use materials and complete tasks in a safe manner
12. Measure objects using English units of measure.
13. Describe the characteristics of living things and identify familiar objects as living or nonliving
14. Tell the basic needs of animals and describe some characteristics

**ACTIVITIES/SUGGESTIONS:**

1. Introduce the students to the following concepts:
  - A. Dinosaurs lived millions of years ago
  - B. Dinosaurs are extinct.
  - C. There were many kinds of dinosaurs.
2. View a filmstrip which covers these concepts. Suggested source: 'When the Dinosaurs Were Alive' available from National Geographic.
3. Review the filmstrip and discuss some of the different kinds of dinosaurs and some ideas on why they became extinct.
4. As a group activity, prepare a chart listing different dinosaurs and information about each. Include space for dinosaur's name, height and weight. Add column for checking either "meat eater" or "plant-eater." As the students read more about dinosaurs add information to the chart. This can be done as a class project on a large chart or individually by each student. A sample chart is included in the unit
5. Set up a listening center using a read-aloud book about dinosaurs. Suggested source: "Amazing World of Dinosaurs." (available from Troll)
6. Read "The Wonderful Egg;" discuss the story. What else hatches from eggs? Have children dictate a language experience story about the life cycle of a dinosaur.
7. As a group activity, use the study prints "Animals of the Primeval World" to discuss the differences in plant eaters and meat eaters. Write a list of characteristics of each. Suggested Source: Walt Disney



8. Read "Digging Up Dinosaurs" by Alikei. Discuss, emphasizing the meaning of the following paleontologis/geologist-fossils
9. Use large cardboard model of a dinosaur, place several pieces at a time between sheets to demonstrate how the bones or fossils are discovered in layers of earth, then assembled in a museum. Assemble and display in library. Suggested Source: Brodart.
10. Have students create their own fossils. Using clean chicken bones press them into wet, packed sand to make an imprint. Pour wet plaster of paris into the mold and remove when it is hardened.
11. As a group activity compose a poem about dinosaurs. Teacher could start the first line, then let students compose as teacher writes it on chart paper.
12. Talk about Dinosaurland in Utah and the Smithsonian Institute in Washington, D.C. Explain letter form; then in a writing center or as a group activity, write letters to Dinosaurland and the Smithsonian Institute for dinosaur information and pictures.
13. As a group activity use the overhead projector, list a group of dinosaur words and arrange them in alphabetical order.
14. Draw the outline of a dinosaur to be used as a shape book and have students write their own dinosaur stories.
15. Discuss different shapes, (circles, squares, rectangles, ovals). Cut these shapes and use to create pictures of dinosaurs. Scraps of colored paper can be used for shapes then pasted onto newsprint.
16. Read "Mary's Monster," selected from *Where the Sidewalk Ends*, or other poems about dinosaurs
17. Read the *Zoo Book* magazine on extinct animals to the class. Discuss what extinct is and some causes as to why it happens to animals.
18. Use a map of the United States to show where dinosaurs are thought to have lived and what the weather was probably like when they lived there. Suggested Source: Stoval Museum of Science and History, Norman, OK.
19. Have students shape their favorite dinosaur from baker's clay

#### BAKER'S CLAY

1 cup salt  
 1½ cup warm water  
 4 cups flour.

Stir salt into water. Add flour and mix to form dough. Knead until smooth. Add food coloring to water if color is desired (If you use tempera, add paint to flour before mixing )

20. Sing dinosaur songs, as you are talking about a particular dinosaur. Suggested source: American Teaching Aids, for record or cassette, *Our Dinosaur Friends: The Early Years* Words to the dinosaur songs are included in unit.

21. When unit is completed award each student with his/her **Dinosaur Hunting License**, available from Dinosaurland Travel Board, Inc., 500 East Main Street, Vernal, Utah 84078. Send \$1.45 to cover the postage when ordering 100.

**DINOSAUR HUNTING LICENSE**

# DINOSAUR HUNTING LICENSE

## SPECIAL PERMIT

\*No. 181 - U022



**ISSUED TO:**

NAME \_\_\_\_\_

ADDRESS \_\_\_\_\_

CITY \_\_\_\_\_ STATE \_\_\_\_\_ ZIP \_\_\_\_\_

**ISSUED BY AUTHORITY**  
**U.S. REPTILE CONTROL COMMISSION**  
**Restricted to Uintah County, Utah, Only**

This license entitles holder to hunt for, pursue, shoot, kill and remove from that area known as Dinosaur Control Area of Uintah County, Utah, which is in the vicinity of Dinosaur National Monument the following types of reptilian wild game:

- A. TYRANNOSAURUS REX - 1 Only (adult male)
- B. DIPLODOCUS GIGANTICUS - 1 Only (either sex) and not less than 5000 lbs. live weight
- C. STEGOSAURS - 2 Only (males) any size
- D. PTERODACTYL - 4 Only (without young)

The holder of this license agrees to remove all such game, legally bagged by him under the proper restriction, properly preserved and in sanitary condition within 5 days of time of reptiles' death, and further agrees to have said game inspected by the Utah Game Warden before removal.





Signed \_\_\_\_\_

ISSUED BY ALE OUP  
Deputy Lizard Warden, Vernal, Utah

**ALTERATIONS ERASURES OR OBLITERATIONS VOID THIS CERTIFICATE**

- 22 During this unit take the attendance role by cutting out baby dinosaurs and writing each child's name on one. Place egg shells on bulletin board. Each child locates the dinosaur with his name on it and puts it in an egg shell. A child fills out absentee slip and takes it to the office.

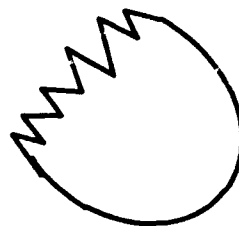
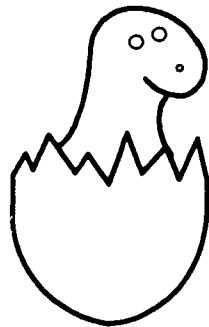

- 23 Children make skeletal models of dinosaurs from packing pieces and toothpicks.
24. Cut up vegetables and hot dogs to learn fractions  $\frac{1}{2}$ ,  $\frac{1}{4}$ ,  $\frac{1}{3}$ . Hot dogs can be called "dinosaur toes" and served with a sauce to guests when they come for the open house at the end of the unit.
- 25 Create a "dinosaur museum" with the creations the students have made and things you have collected. Invite other classes to share what your students have learned.
26. For a learning center activity, take a long piece of yarn, measure every five feet and tie a knot. Select five dinosaurs that were thought to have been at least five feet long, or longer. Write names and their lengths on a file folder, or poster board. Child uses yarn counting by fives--measure length of each dinosaur and stretch it out on the floor to get an idea of just how long the dinosaurs are thought to have been. Store yarn in "Leggs egg."
27. Locate pictures of the following animals:

lizard	brontosaurus
snake	turtle
allosaurus	crocodile
triceratops	pteranodon

On a file folder or a piece of poster board write the words "Living" and "Extinct." Take one picture at a time and decide if that animal is living or extinct. Place the picture under the appropriate heading. This can be done as a group activity or used as a learning center. If used as a learning center you may want to make it self-checking by color coding the back of the card with the picture of the animal to match the color of the card of the appropriate heading.

28. In the "Dinosaur Dig" unit, each student picks his/her favorite dinosaur to research or learn about. They may use various types of sources. Use form included in unit "Dinosaur Dig." They will find out about its physical description, habitat, and adaptations. Older students may use form "Animal Data Chart" for more detailed research (included in Appendix)

29. For gifted or older students, after a lot of information on dinosaurs has been covered, or as a research activity, use the worksheet "Dinosaur Chronology" (included in unit) It will help them to have a better understanding of when the dinosaurs lived

**RESOURCES:**

"Days of the Dinosaurs," *Frank Schaffner's School Days*, Feb-Mar 1986.

Smithsonian Institution  
Office of Elementary and Secondary Education  
Washington, DC 20560

Dinosaurland Travel Board, Inc  
50 East Main Street  
Vernal, UT 84078

Stoval Museum  
1335 Asp  
Norman, OK 73019

**SOURCE:** Mary Legan, Muskogee Public Schools

## DINOSAUR BIBLIOGRAPHY

### Grades K-3

- Aliki.** *Digging Up Dinosaurs* Crowell, 1981. Grades 2-4.
- Aliki.** *My Visit to the Dinosaurs* Crowell, 1985. Grades PreS-3.
- Bolognese, Don.** *Drawing Dinosaurs and Other Prehistoric Animals.* Watts, 1982 Grades 2-up
- Carrick, Carol.** *Patrick's Dinosaurs* Clarion, 1983 Grades K-2.
- Davidson, Rosalie.** *Dinosaurs From A to Z* Childrens, 1983. Grades 3-5.
- Dinosaur Alphabet Book* (ABC Adventures read-alongs) Troll Assoc. 1986 Grades PreS-3.
- Emberley, Michael.** *Dinosaurs, a Drawing Book.* Little, 1983. Grades 2-4.
- Freedman, Russell** *Dinosaurs and Their Young.* Holiday, 1983. Grades 1-3.
- Glovach, Linda.** *The Little Witch's Dinosaur Book.* Prentice Hall, 1984. Grades 1-4.
- Hall, Derek** *Prehistoric Mammals.* Watts, 1984. Grades 2-3
- Hoff, Syd.** *Danny and the Dinosaur.* Harper Row, 1958. Grades K-2.
- Kaufman, John.** *Flying Giants of Long Ago.* Crowell, 1984. Grades K-3.
- Kroll, Steve.** *Tyrannosaurus Game.* Holiday House, 1976. Grades K-2.
- McGowen, Tom** *Album of Dinosaurs.* Rand McNally, 1972 Grades 3-5
- Moseley, Keith** *Dinosaurs: A Lost World* Putnam, 1984. Grades 1-4.
- Most, Bernard.** *Dinosaur Cousins?* Harcourt Brace, 1987. Grades 1-3.
- Most, Bernard.** *If the Dinosaurs Came Back.* Harcourt Brace, 1978 Grades 1-3
- Most, Bernard** *Whatever Happened to the Dinosaurs?* Harcourt Brace, 1984. Grades PreS-1.
- Parrish, Peggy** *Dinosaur Tme.* Harper Row, 1974. Grades PreS-1.
- Petty, Kate** *Dinosaurs* Watts, 1984 Grades K-3.
- Sattier, Helen R.** *Baby Dinosaurs* Lothrop, 1984 Grades 2-4.
- Sattier, Helen R** *Pterosaurs, the Flying Reptiles* Lothrop, 1985 Grades 2-5.
- Selsam, Millicent E.** *First Look at Dinosaurs.* Walker, 1982 Grades K-2.

**Selsam, Millicent E.** *Sea Monsters of Long Ago* Four Winds/Macmillan. Grades K-3

**Simon, Seymour** *Dinosaur Is the Biggest Animal That Ever Lived, and Other Wrong Ideas You Thought Were True.* Harper, 1986, c1984 Grades 3-6.

**Simon, Seymour** *The Smallest Dinosaur.* Crown, 1982. Grades K-3.

**Thomson, Peggy.** *Auks, Rocks and the Odd Dinosaur. Inside Stories From the Smithsonian's Museum of Natural History.* Crowell, 1985. Grades 3-up.

Complete bibliography available from Library Resources Section of the State Department of Education.

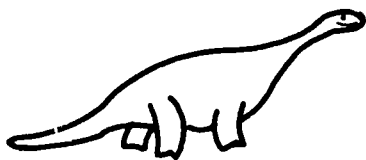

3 3 3

# DINOSAURS

## WHAT WERE THEY LIKE?

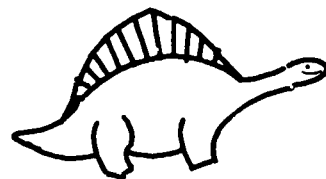

DINOSAUR	HEIGHT	WEIGHT	PLANT EATER	MEAT EATER

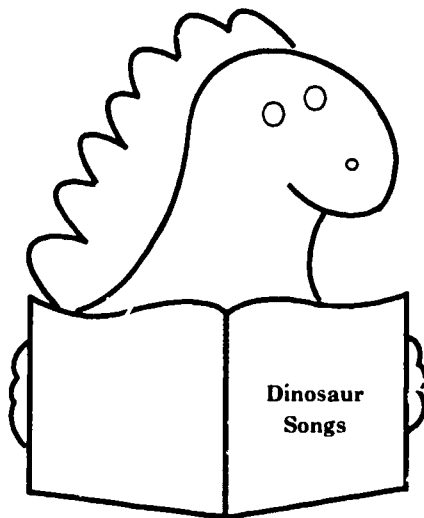

## OUR DINOSAUR FRIENDS

My Name is Stegosaurus

Chorus:

My name is Stegosaurus. I'm a funny-looking dinosaur.

For on my back are many bony plates and on my tail there's more.

Verse 1:

My front two legs are very short.

My back two legs are long.

My body's big, my head is very small.

I'm put together wrong

(Repeat Chorus)

## BRONTOSAURUS

Chorus:

Not very smart, not very quick,  
Not nearly as wise as Moby Dick.

Verse 1:

Brontosaurus means Thunder Lizard

So big and slow that on land soon grew tired

Doesn't eat meat, doesn't eat fish.

Leaves and plants are her favorite dish.

(Repeat Chorus)

## PTERODACTYL

Chorus:

I'd like to be the biggest dinosaur  
I'm not but can fly and I like that more

Verse 1:

Pterodactyl, pterodactyl, where are you?

Where are you?

Flying over treetops, flying over treetops.

Why oh why don't you? Why oh why don't you?

(Repeat Chorus)

## TYRANNOSAURUS REX

Verse 1:

Every story seems to have a villain

Ours will be the reptile they call T Rex

Chorus:

Boom, boom, boom, boom, boom, boom, boom,

Tyrannosaurus Rex means tyrant king

He terrorized the countryside.

And made the giant reptiles hide.

Boom, boom, boom, boom, boom, boom, boom.

Tyrannosaurus Rex was a very mean king

If it wasn't for him we'd have a happy ending

Boom, boom, boom, boom, boom, boom, boom,



## TRICERATOPS

Verse 1.

How many horns do you have?

None of course.

How many horns does a bull have?

Two, of course.

But me, but me, I have three.

I'm very special you can see

Chorus:

Triceratops with three long horns, a beak like a parrot,

And a frill where his neck is

Triceratops with four big legs and a tail in back.

## DINOSAUR FRIENDS

Verse:

Now we know our dinosaur friends,

Who were so tall they'd make teacher look small

They're not here so there's nothing to fear.

So sing their song and be of good cheer.

Chorus:

Terri Pterodactyl, Bertha Brontosaurus

Trini the Triceratops, Stanley Stegosaurus,

Tom Tyrannosaurus, he is carnivorous.

Try it once again and sing another chorus.

Terri Pterodactyl, Bertha Brontosaurus

Trini the Triceratops, Stanley Stegosaurus,

Tom Tyrannosaurus, he is carnivorous

Try it once again and sing another chorus

Terri Pterodactyl, Bertha Brontosaurus

Tom Tyrannosaurus, he is carnivorous.

That was lots of fun

Though these are big words for us.

Reprinted with permission of American  
Teaching Aids, Inc.

NAME \_\_\_\_\_

### DINOSAUR DIG

1. Physical Description

A. Size \_\_\_\_\_

\_\_\_\_\_

B. Shape \_\_\_\_\_

\_\_\_\_\_

C. Color \_\_\_\_\_

\_\_\_\_\_

D. Skin \_\_\_\_\_

\_\_\_\_\_

2. Habitat

A. Home \_\_\_\_\_

\_\_\_\_\_

B. Food \_\_\_\_\_

\_\_\_\_\_

C. Family \_\_\_\_\_

\_\_\_\_\_

3. Adaptations

A. Enemies \_\_\_\_\_  
\_\_\_\_\_  
\_\_\_\_\_

B. How the animal protected itself \_\_\_\_\_  
\_\_\_\_\_  
\_\_\_\_\_

4. Bibliography

A. Regular book \_\_\_\_\_  
\_\_\_\_\_

B. Science encyclopedia \_\_\_\_\_  
\_\_\_\_\_

C. General encyclopedia \_\_\_\_\_  
\_\_\_\_\_

## DINOSAUR CHRONOLOGY

Directions: Cut out dinosaurs. Arrange the dinosaurs on a blank sheet of paper in order according to the time period in which they lived. Paste dinosaurs on paper and prepare a title.



Name: Brontosaurus  
Period: \_\_\_\_\_

Name: Dimetrodon  
Period: \_\_\_\_\_

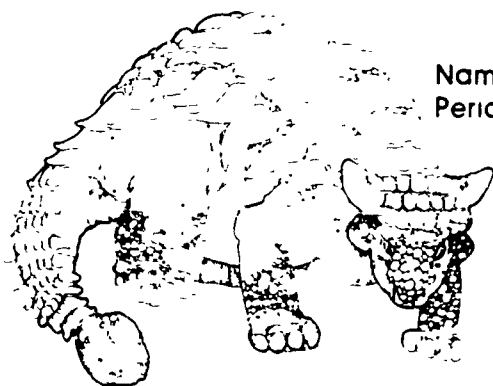
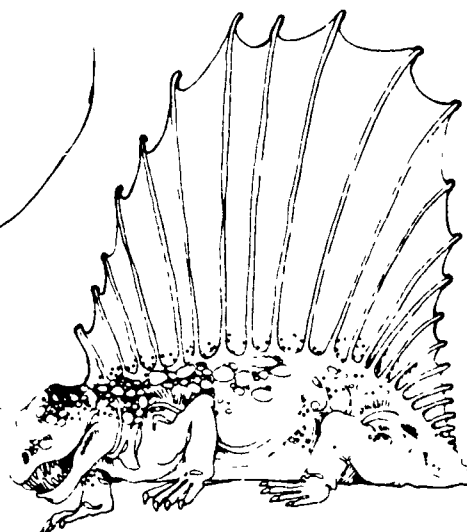

Name: Ankylosaurus  
Period: \_\_\_\_\_

Name: Plateosaurus  
Period: \_\_\_\_\_



Hint: You will need to determine the order of the time periods by using an encyclopedia or science reference book.

Reprinted from Vol. II, No. 8 April 1936.  
School Library Media Activities Monthly

**CLEVER COUNTING:  
Number Concepts in Children's Books**

**Emphasis Grade Level: 1**

**CURRICULUM AREA(S):** Math, Reading

**GOAL:** To use media center resources to reinforce primary counting and number skills

**COOPERATIVE PLANNING/TEACHING:**

This unit works best when activities are jointly planned and scheduled by the classroom teacher and media specialist. Activities presented are suggestions only and should serve as a catalyst for additional ideas. Alternative resources available in each school's collection can be substituted for those suggested here. This unit may also be used with kindergarten or transitional classes.

**LEARNER OUTCOMES**

Content Area	Information Skills
<p>The student will:</p> <ol style="list-style-type: none"> <li>1. Match numerals 0-10 with a given number of objects</li> <li>2. Count by 1, 5, and 10 from 0 to 100.</li> <li>3. Identify triangles, rectangles, circles and squares.</li> <li>4. Use concrete objects to demonstrate the concept of addition as the joining of two sets</li> <li>5. Identify and write the numerals 0 to 99.</li> <li>6. Given an ordered set of objects, name the positions first through fifth.</li> <li>7. Name the sum for addition facts whose answer is 10 or less.</li> <li>8. Identify days, weeks and months using a calendar</li> <li>9. Identify pennies, nickels, dimes and quarters and name their value</li> </ol>	<p>The student will</p> <ol style="list-style-type: none"> <li>1. Read a picture (identify)</li> <li>2. Create a picture record of what has been learned</li> <li>3. Become familiar with a book's cover and title.</li> <li>4. Tell a story about a picture</li> <li>5. Say and act out nursery rhymes and stories.</li> <li>6. Listen to stories read and told</li> </ol>

## ACTIVITIES/SUGGESTIONS:

A page follows for each numeral. The page for zero may be used first or with the page for ten. Space has been provided for students to practice the word, the numeral and to draw a given number objects of their choice. By completing each page and then producing a cover, each child will have a number book. Resource lists and activity suggestions are on the reverse side of each numeral page for teacher/media specialist use. Following the page for ten, sources and numbers are given for twelve and for larger numbers.

First lines of some nursery rhymes which have numbers or counting

One I love, two I love

Elizabeth, Elsbeth, Betsy and Bess

There once were two cats of Kilkenny

One, two, three, four, five, I caught a hare alive

The first day of Christmas

One, two, buckle my shoe

Three young rats with black felt hats

One to make ready

One, two, three, four, five, six, seven, All good children go to Heaven

Sing a song of sixpence

First in a carriage, Second in a gig

Chook, chook, chook, chook, Good morning Mrs. Hen

1,2,3,4,5 Once I caught a fish alive

Find these and other counting rhymes in "Mother Goose" books

**Resources other than books useful for this unit:**

Puppets

Flannel board with numerals, object sets, etc.

Manipulative objects beads, pennies, match sticks, popsicle sticks, beans, unifix cubes, etc

Dominoes

Boxes

Blocks

Egg cartons and/or muffin tins.

Picture files

Arts and crafts materials' paper, glue, scissors, crayons, paper plates, brads, yarn

**EVALUATION:**

In planning, the teacher and library media specialist should decide what and how the evaluation of the unit is to be accomplished. The media specialist might evaluate completed booklets and both might observe students demonstrate counting of objects, ordering of sets or grade accuracy of math facts, or listen to students recite rhymes.

**SOURCE:**

Special thanks to

Sue McAlister, Jackson Elementary School, Norman  
Dr. Judi Ford, Eisenhower Elementary School, Norman  
Sharon Young, Louisiana State University  
Aloma Cline, Franklin Elementary School, Shawnee

0	Z	e	r	o

Sources for ZERO

Alexander, Martha *No Ducks in Our Bathtub* Dial, 1977  
 Anno, Mitsumasa *Anno's Counting Book*. Crowell, 1977.  
 Gag, Wanda. *Nothing at All*. Putnam, 1941  
 Harada, Joyce. *It's the 0-1-2-3 Book*. Heian, 1985  
 Hoban, Russell. *Nothing to Do*. Harper, 1964  
 Howe, Caroline *Counting Penguins 0 to 9* Harper 1983  
 Payne, Emmy *Katy No-Pocket* Houghton, 1944

Activities for Zero:

- Brainstorm what is not in the library media center or classroom
- Make an animal picture beginning with a zero
- Use empty containers to discuss concept
- Blow soap bubbles
- Use a blank flannel board and pictures to establish when the board has nothing on it
- Introduce circles.

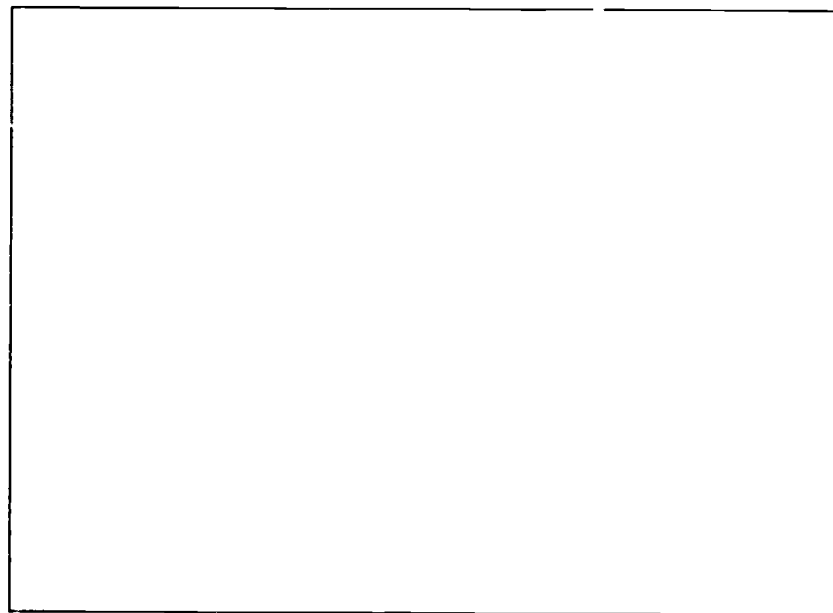

How could you show nothing?



1 One



2 Two

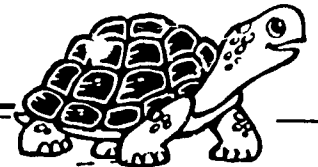
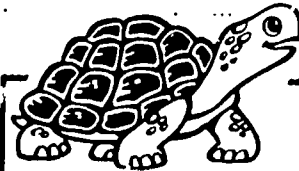

### Sources for: TWO

- Aliki.** *Two of Them.* Greenwillow, 1979.  
**Beim, Lorraine.** *Two Is a Team.* Harper, 1974.  
**Cleary, Beverly.** *Two Dog Biscuits.* Morrow, 1986.  
**Ginsburg, Mirra.** *Two Greedy Bears.* Macmillan, 1976.  
**Jonas, Ann.** *Two Bear Cubs.* Greenwillow, 1982.  
**Schuchman, Joan.** *Two Places to Sleep.* Carolrhoda, 1979.  
**Sharmat, Marjorie.** *Two Ghosts on a Bench.* Harper, 1982.  
**Spier, Peter.** *Noah's Ark.* Doubleday, 1977.  
**Ylla.** *Two Little Bears.* Harper, 1954.

### Activities for Two:

- Practice writing 2 and two.
- Introduce pairs. Line up in pairs.
- Brainstorm to find pairs in the library media center.
- Find pairs on the body.
- Discuss twins as pairs.
- Complete two page for the booklet
- Use a basket of objects in sets of two to create sets.
- Learn "Jack and Jill."
- Learn and act out finger play "Two Little Blackbirds Sitting On a Hill."

### Sources for: ONE

- Barry, Robert.** *Mr. Willowby's Christmas Tree.* McGraw, 1963  
**Hoban, Tana.** *One Little Kitten.* Greenwillow, 1979  
**Hogrogian, Nonny.** *One Fine Day.* Macmillan, 1971.  
**Hutchins, Pat.** *1 Hunter.* Greenwillow, 1982  
**Nic Leodhas, Sorche.** *Always Room for One More.* Holt, 1965.  
**Pomerantz, Charlotte.** *One Duck, Another Duck.* Greenwillow, 1984.  
**Seuss, Dr.** *One Fish, Two Fish, Red Fish, Blue Fish.* Random, 1960  
**Wildsmith, Brian.** *Briar Wildsmith One Two Three.* Watts, 1962  
**Williams, Jay.** *One Big Wish.* Macmillan, 1980.

### Activities for One:

- Practice writing 1 and one
- Make a "one" mobile. Arrange pictures of a favorite animal, food and toy along with a picture or self-portrait of each child.
- Play "I Spy" looking for single objects
- Begin a number book using the practice sheets and the box for drawing a picture of one object.
- Discuss words me and I, draw a self-portrait
- Learn "Little Miss Muffet"
- Learn and act out "Little Jack Horner"
- Introduce a penny as one cent

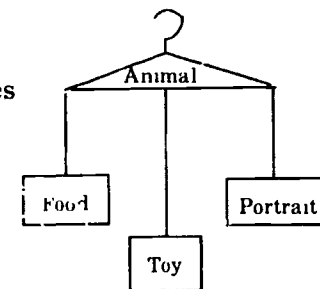

3 Three



4 Four



### Sources for: FOUR

**Arnosky, Jim.** *Watching Foxes* Lothrop, 1984  
**Godden, Rumer.** *Kindle of Kittens*. Viking, 1979  
**Grimm, Jacob.** *Bremen Town Musicians* Doubleday, 1980  
**Fisher, Edward Everett.** *Boxes, Boxes!* Viking, 1984.  
**Hoban, Tana.** *Count & See*. Macmillan, 1972.  
**Josse, Barbara** *Fourth of July*. Knopf, 1985.  
**Lasky, Kathryn.** *I Have Four Names for My Grandfather*. Little, 1976  
**Peet, Bill.** *No Such Things*. Houghton, 1983.  
**Slobodkina, Esphyr.** *Caps for Sale* Scholastic, 1984

### Activities for Four:

Brainstorm to find objects with four legs or four wheels  
Introduce squares and rectangles  
Play "I Spy" looking for these shapes in the media center.  
Introduce seasons.  
Play rummy card games where sets of four must be collected.  
Complete the four page for the booklet.

### Sources for: THREE

**Berenstain, Stan and Jan** All Berenstain Bears Books  
Random House,  
**Brown, Marcia** *Three Billy Goats Gruff* Harcourt, 1957  
**Cauley, Lorinda** *Three Little Kittens*. Putnam, 1982  
**Galdone, Paul.** *Three Bears*. Houghton, 1972  
**Galdone, Paul.** *Three Little Pigs* Houghton, 1970  
**Marshall, Edward** *Three by the Sea* Dial, 1981  
**Perrault, Charles.** *Three Wishes*. Troll, 1979.

### Activities for Three:

Act out favorite folktales having threes using puppets, flannel boards or creative dramatics. You may divide class into groups of three for this.  
Introduce triangles. Cut out paper triangles Use flannel board and triangles.  
Practice simple addition of sets using 1, 2, and 3 using small manipulative objects.  
Sing "3 Blind Mice." Accompany singing with triangle instrument  
Complete three page for the booklet.  
Learn "Baa Baa Black Sheep" and "Rub-a-Dub Dub"  
Make newspaper tricorn hats



5 Five

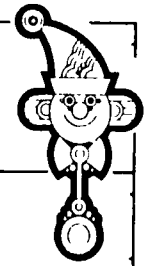
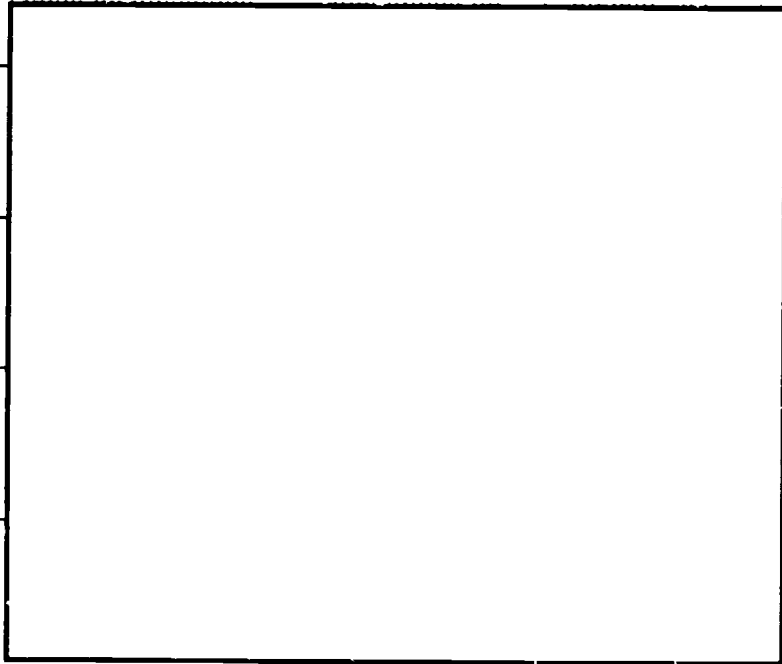

6 Six

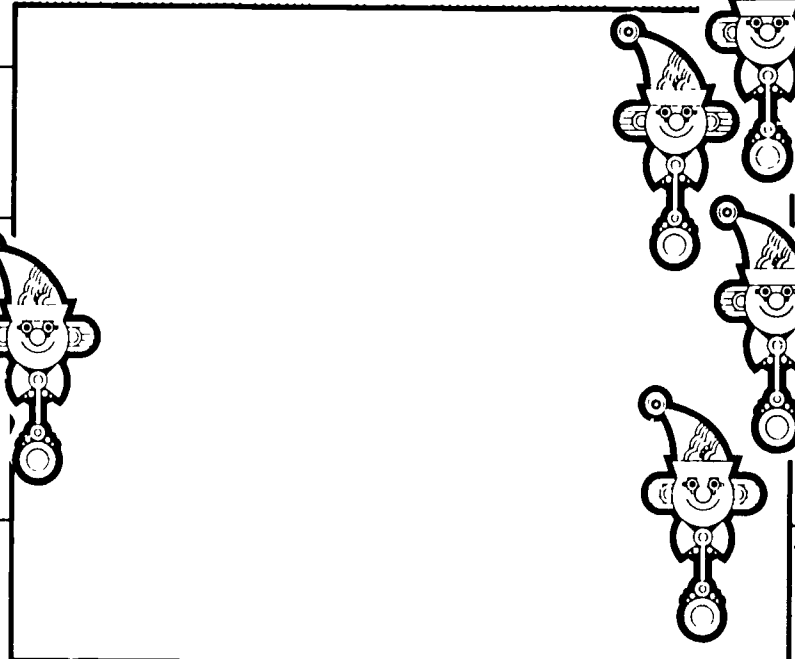
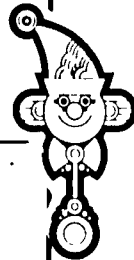
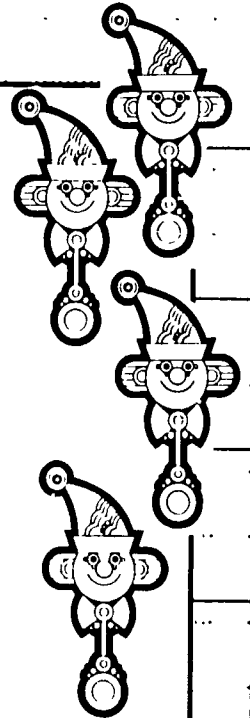

**Sources for: SIX**

**Brandenberg, Franz** *Six New Students* Greenwillow, 1978  
**Cheng, Hou-Tien.** *Six Chinese Brothers.* Holt, 1979  
**Conover, Chris** *Six Little Ducks* Crowell, 1976  
**Elkin, Benjamin.** *Six Foolish Fishermen* Scholastic, 1968  
**Gag, Wanda** *Wanda Gag's The Six Swans* Coward, 1982  
**Lowrey, Janette.** *Six Silver Spoons.* Harper, 1971.  
**Milne, A. A.** *Now We Are Six* Dutton, 1961  
**Punnett, Richard.** *Count the Possums* Childs' World, 1982.

**Activities for Six:**

Complete the six page for the booklet

Play dominoes

Share pictures of insects Discuss how they are alike Make an insect from small paper plates and yarn.

Create math fact sets totaling six using a flannel board

Use muffin tins with six cups to sort objects into sets

Tell a story into a cassette recorder about being six years old

**Sources for: FIVE**

**Aliki.** *My Five Senses* Crowell, 1962  
**Bishop, Claire** *Five Chinese Brothers* Putnam, 1938  
**Emberley, Rebecca** *Drawing with Numbers and Letters* Little, 1981  
**Gretz, Susanna** *Teddy Bears' 1-10.* Four Winds, 1986  
**Hoban, Tana.** *Count and See* Macmillan, 1972  
**Hoban, Tana** *26 Letters and 99 Cents.* Greenwillow, 1987  
**Low, Joseph.** *Five Men Under One Umbrella* Macmillan, 1975  
**Newton, Patricia.** *Five Sparrows A Japanese Folktale* Atheneum, 1982  
**Seuss, Dr** *500 Hats of Bartholomew Cubbins* Vanguard, 1965

**Activities for Five:**

Complete the five page for the booklet.

Use stamp pads to make fingerprint drawings

Investigate the five senses Have a station to explore each sense

Count all the finger and toes in the room (by fives)

Count money--pennies, nickels, dimes, and quarters

Learn "This Little Pig Went to Market " Use the verse to create number fact problems

Learn "Simple Simon "

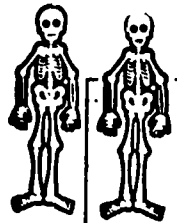

7 Seven

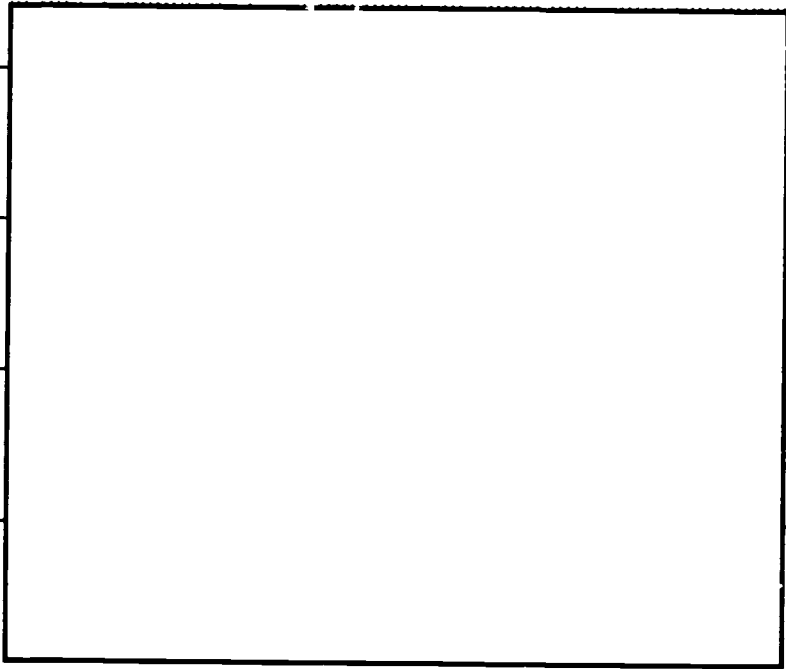

8 Eight

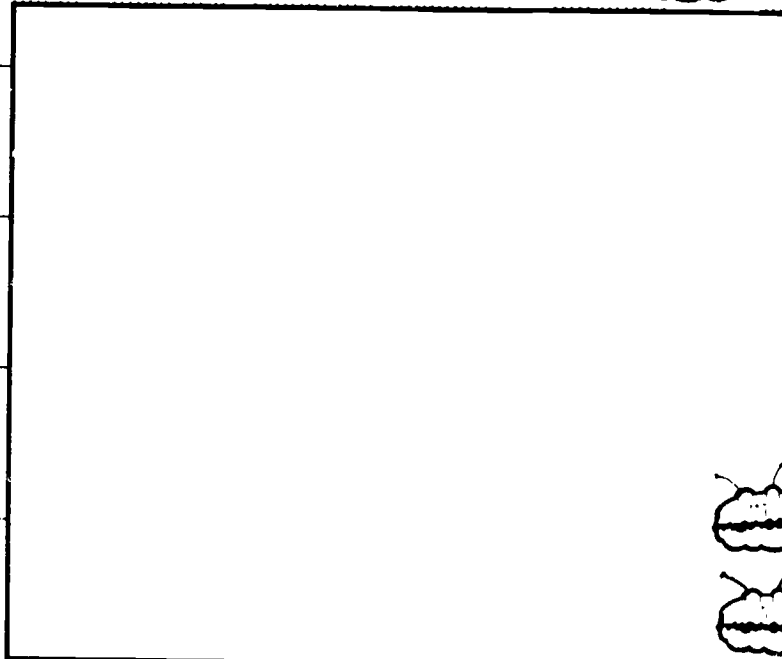

**Sources for: EIGHT**

- Carle, Eric. *Very Hungry Caterpillar* Putnam, 1981  
Dodd, Lynley. *Nickle Nackle Tree*. Macmillan, 1976  
McCloskey, Robert. *Make Way for Ducklings* Viking, 1941  
Moore, Clement. *The Night Before Christmas* Holiday House, 1980  
Podendorf, Ila. *Spiders*. Childrens Press, 1982  
Terban, Marvin. *Eight Ate. A Feast of Homonyms* Clarion, 1982

**Activities for Eight:**

- Complete the eight page for the booklet
- Create a drawing beginning with a number 8
- Use a magnifying lens and count the legs of spiders in photographs or terrariums
- Make a paper plate spider. Legs can be made from construction paper or yarn

**Sources for: SEVEN**

- Becker, John. *Seven Little Rabbits* Scholastic, 1985  
Bicknell, Trel. *Seven Is Heaven! The Great Big Book for Seven-Year-Olds* Gulliver, H B J., 1986  
Carle, Eric. *Very Hungry Caterpillar* Putnam, 1981  
DeRegniers, Beatrice. *May I Bring a Friend*. Atheneum, 1964  
Fisher, Leonard. *Seven Days of Creation* Holiday, 1981  
Friskey, Margaret. *Seven Diving Ducks*. Childrens, 1965  
Grimm, Jacob. *Seven Ravens*. Morrow, 1981  
Grimm, Jacob. *Snow White and the Seven Dwarfs* Four Winds, 1981  
Milne, A A. *Pooh's Counting Book* Dutton, 1982  
Schulevitz, Uri. *One Monday Morning*. Scribner's, 1967  
Sendak, Maurice. *Seven Little Monsters* Harper, 1977  
Weiss, Malcom. *Solomon Grundy, Born on One Day* Crowell, 1977

**Activities for Seven:**

- Complete the seven page for the booklet
- Learn or practice the days of the week. Make a week calendar
- Make a set of flash cards for math facts for seven



9

Nine



10

Ten

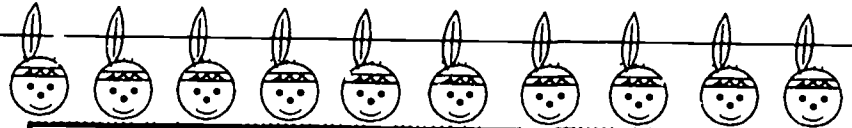

**Sources for: TEN**

- Bang, Molly.** *Ten, Nine, Eight* Greenwillow, 1983  
**Calmenson, Stephan** *Ten Items or Less A Counting Book* Golden, 1986  
**Crews, Donald** *Ten Black Dots* Greenwillow, 1986  
**Ernst, Lisa** *Up to Ten and Down Again.* Lothrop, 1986.  
**Frisky, Margaret.** *Chicken Little Count-To-Ten* Childrens, 1946  
**Keller, Holly.** *Ten Sleepy Sheep* Greenwillow, 1983  
**LeSieg, Theodore.** *Ten Apples up on Top* Beginner, 1961  
**Mack, Stan.** *Ten Bears In My Bed A Goodnight Countdown.* Pantheon, 1974.  
**Schwartz, Alvin.** *Ten Copycats in a Boat* Harper, 1980  
**Viorst, Judith.** *Tenth Good Thing About Barney* Atheneum, 1971.  
**Warren, Cathy** *Ten-Alarm Camp-Out.* Lothrop, 1983

**Activities for Ten:**

- Complete the ten page for the booklet
- Count by tens to one hundred
- Introduce book parts. cover, author, title.
- Make a cover for the booklet
- Learn "One, Two Buckle My Shoe "
- Sing "Ten Little Indians "

**Sources for: NINE**

- Branley, Franklyn** *The Planets in Our Solar System* Harper Trophy, 1987.  
**Downing, Joan** *Baseball Is Our Game* Childrens Press, 1982  
**Ets, Marie Hall** *Nine Days to Christmas* Viking, 1959  
**Gerstein, Mordcai** *Roll Over!* Crown, 1984  
**Howe, Caroline** *Counting Penguins 0 to 9* Harper, 1983

**Activities for Nine.**

- Complete the nine page for the booklet.
- Play baseball.
- Make a model of each planet, using styrofoam balls or paper plates  
Hang from the library media center or classroom ceiling
- Make nonagons by drawing or cutting paper (nine sides, nine angles)

12 Twelve

HOW MANY?

**Sources for: More Than 10**

- Anno** *Anno's Counting House*. Philomel, 1982.  
**Anno**, Masaichiro. *Anno's Mysterious Multiplying Jar*. Philomel, 1983.  
**Charlip**, Remy. *Thirteen*. Four Winds, 1975  
**Dubanevich**, Arlene. *Pigs in Hiding*. Four Winds, 1983  
**Gag**, Wanda. *Millions of Cats*. Putnam, 1977  
**Hoban**, Tana. *Count and See*. Macmillan, 1972.  
**Hoban**, Tana. *26 Letters and 99 Cents*. Greenwillow, 1987  
**Magee**, Doug. *Trucks You Can Count On*. Dodd, 1985  
**Mathews**, Louise. *Bunches and Bunches of Bunnies*. Dodd, 1978  
**Modell**, Frank. *One Zillion Valentines*. Greenwillow, 1981.  
**Nic Leodhas**, Sorche. *Always Room for One More*. Holt, 1965  
**Reiss**, John. *Numbers*. Bradbury, 1971  
**Schwartz**, David M. *How Much Is a Million?* Lothrop, 1985.  
**Seuss**, Dr. *Hunches in Bunches*. Random, 1982.  
**Suess**, Dr. *The 500 Hats of Bartholomew Cubbins*. Vanguard, 1965  
**Spier**, Peter. *Noah's Ark*. Doubleday, 1977.  
**Zaslavsky**. *Count on Your Fingers African Style*. Crowell, 1980

**Sources for: TWELVE**

- Aliki** *Twelve Months: A Greek Folktale*. Greenwillow, 1978  
**Brierley**. *Twelve Days of Christmas*. Holt, 1986  
**Carle**, Eric. *The Grouchy Lady Bug*. Crowell, 1977  
**Galdone**, Paul. *Over In the Meadow An Old Nursery Counting Rhyme*. Prentice-Hall, 1986  
**Hague**, Kathleen. *Numbears A Counting Book*. Holt, 1986  
**Maestro**, Betsy. *Around the Clock With Harriet*. Crown, 1984

**Activities for Twelve:**

Learn the word dozen

Use egg cartons to create dozens of manipulative objects

Learn "Hickory Dickory Dock." Make a paper plate clock. Punch a hole and thread with yarn. Staple a construction paper mouse to the bottom end. As you pull it the mouse can "run" up the clock

Sing "This Old Man"

Make a calendar for each month

## COUNTING BIBLIOGRAPHY

- Alexander, Martha. *No Ducks in Our Bathtub* Dial, 1977
- Anno, Mitsunasa. *Anno's Counting Book* Crowell, 1977
- Asch, Frank. *Sand Cake* Parents, 1975
- Bishop, Claire. *Five Chinese Brothers* Putnam, 1938
- Brown, Marc. *One, Two, Three: An Animal Counting Book* Little, 1976
- Carle, Eric. *Very Hungry Caterpillar* Putnam, 1981
- Carle, Eric. *My Very First Book of Numbers* Crowell, 1985
- Charlip, Remy. *Handtalk Birthday A Number and Story Book in Sign Language* Macmillan, 1987.
- Cleary, Beverly. *Two Dog Biscuits*. Morrow, 1961
- Demi. *Demi's Count the Animals 1 2 3* Putnam, 1986
- Dodd, Lynnly. *The Nickle Nackle Tree* Macmillan, 1978.
- Ehrlich, Amy. *The Everyday Train*. Dial, 1977
- Eichenberg, Fritz. *Dancing in the Moon Counting Rhymes* Harcourt, 1975
- Elkin, Benjamin. *Six Foolish Fishermen*. Scholastic, 1968
- Ernst, Lisa. *Up to Ten and Down Again*. Lothrop, 1986
- Ets, Marie Hall. *In the Forest*. Viking, 1944.
- Feelings, Muriel. *Moja Means One. A Swahili Counting Book*. Dial, 1971
- Friskey, Margaret. *Chicken Little Count-To-Ten*. Childrens, 1946
- Ginsburg, Mirra. *Two Greedy Bears*. Macmillan, 1976.
- Hague, Kathleen. *Numbears: A Counting Book* Holt, 1986
- Hoban, Tana. *Count & See* Macmillan, 1972.
- Howe, Caroline. *Counting Penguins, 0 to 9* Harper, 1983
- Hutchins, Pat. *1 Hunter*. Greenwillow, 1982.
- Hutchins, Pat. *The Doorbell Rang*. Greenwillow, 1986
- Kitamura, Satoshi. *When Sheep Cannot Sleep* Farrar, 1986
- Langstaff, John. *Over in the Meadow* Harcourt, 1973
- Leedy, Loreen. *A Number of Dragons* Holiday, 1985.
- LeSieg, Theo. *Wacky Wednesday*. Beginner, 1974
- LeSieg, Theo. *Ten Apples up on Top*. Beginner, 1961.
- Mack, Stan. *Ten Bears in My Bed. A Goodnight Countdown* Pantheon, 1974
- Maestro, Betsy. *Harriet Goes to the Circus A Number Concept Book*. Crown, 1977.
- Mathews, Louise. *Bunches and Bunches of Bunnies* Dodd, 1978
- McCloskey, Robert. *Make Way for Ducklings* Viking, 1941.

**McLoud, Emilie** *One Snail and Me* Little, 1981  
**McMillan, Bruce** *Counting Wild Flowers* Lothrop, 1986  
**Milne, A A** *Pooh's Counting Book* Dutton, 1982  
**Noll, Sally** *Off and Counting* Greenwillow, 1984  
**O'Connor, Vincent** *Mathematics in the Toy Store* Raintree, 1978  
**O'Connor, Vincent** *Mathematics in the Circus Ring* Raintree, 1978  
**Payne, Emmy** *Katy No-Pocket* Houghton, 1944  
**Peek, Merle** *Roll Over! A Counting Song* Houghton, 1981  
**Peet, Bill** *No Such Things*. Houghton, 1983  
**Peppé Rodney** *Circus Numbers*. Viking, 1985  
**Punnet, Dick** *Talk-Along-Count the Possums* Childrens, 1982  
**Reiss, John** *Numbers* Bradbury, 1971  
**Schwartz, David M.** *How Much Is a Million?* Lothrop, 1985  
**Sendak, Maurice.** *One Was Johnny* Harper, 1962  
**Seuss, Dr** *One Fish, Two Fish, Red Fish, Blue Fish* Random, 1960  
**Sitomer, Harry** *Zero Is Not Nothing*. Crowell, 1978  
**Slobodkina, Esphyr** *Caps for Sale* Scott, 1967  
**Srivastava, Jane.** *Statistics* Crowell, 1973  
**Tafari, Nancy** *Who's Counting* Greenwillow, 1986  
**Vogel, Ilse.** *One Is No Fun but Twenty Is Plenty* Atheneum, 1965  
**Wahl, John and Stacy** *I Can Count the Petals of a Flower* Atheneum, 1965  
**Wildsmith, Brian** *Brian Wildsmith One, Two Three* Watts, 1962  
**Ylla.** *Two Little Bears* Harper, 1954  
**Yolen, Jane** *An Invitation to the Butterfly Ball* Putnam, 1983

#### ADDITION/SUBTRACTION

**Burningham, John** *Count Up* Viking, 1983  
**Hawkins, Colin** *Adding Animals* Putnam, 1983  
**Mathews, Louise** *The Great Take-Away*. Dodd, 1980.

#### CARDINAL NUMBERS

**Maestro, Betty** *Harriet Goes to the Circus* Crown, 1977

## COUNTING WITH MISCOUNTING

Elkin, Benjamin *Six Foolish Fishermen* Scholastic, 1968

## FRACTIONS

Dennis, J. Richard *Fractions Are Parts of Things* Crowell, 1977

Lionni, Leo. *Pezzettino*. Pantheon, 1975

Mathews, Louise *Gator Pie*. Dodd, 1979

## GEOMETRY

Alder, David. *3D, 2D, 1D*. Crowell, 1975

Anno, Mitsumasa *Anno's Alphabet An Adventure in Imagination* Crowell, 1975

Fisher, Leonard *Symbol Art*. Macmillan, 1987

Hoban, Tana. *Circle, Triangles and Squares*. Macmillan, 1974

Hoban, Tana. *Round and Round and Round*. Greenwillow, 1983

Hoban, Tana. *Shapes and Things* Macmillan, 1970.

Keats, Ezra Jack. *Regards to The Man in the Moon*. Macmillan, 1985

Phillips, Jo *Exploring Triangles: Paper-Folding Geometry* Crowell, 1975

Testa, Fulvio. *If You Look Around*. Dial/Dutton, 1983

Wildsmith, Brian *Professor Noah's Spaceship*. Oxford University, 1980

Zelinsky, Paul *The Maid and the Mouse and the Odd-Shaped House* Dodd, 1981

## LARGE NUMBERS

Anno, Masaichiro. *Anno's Mysterious Multiplying Jar* Philomel, 1983

Dubanevich, Arlene. *Pigs in Hiding* Four Winds, 1983

Gag, Wanda. *Millions of Cats* Putnam, 1977.

Lord, John Vernon *The Giant Jam Sandwich* Houghton, 1972

Mathews, Louise. *Bunches and Bunches of Bunnies*. Dodd, 1978

Modell, Frank. *One Zillion Valentines* Greenwillow, 1981

Nic Leodhas, Sorche. *Always Room for One More* Holt, 1965

Schwartz, David M. *How Much Is a Million?* Lothrop, 1985

Seuss, Dr. *Hunches in Bunches* Random, 1982

Seuss, Dr. *The 500 Hats of Bartholomew Cubbins* Vanguard, 1965

Spier, Peter *Noah's Ark*. Doubleday, 1977

## LINEAR CONCEPTS

**Larranaga, Robert D.** *The King's Shadow* Carolrhoda, 1970

**Myller, Rolf.** *How Big Is a Foot?* Atheneum, 1962

## METRIC SYSTEM

**Barta, Ginevera.** *Metric Cooking for Beginners* Enslow, 1978.

**Behrens, June.** *True Book of Metric Measurement.* Childrens, 1975

**Branley, Franklyn.** *Think Metric!* Crowell, 1972.

**Leaf, Munro.** *Metric Can Be Fun!* Lippincott, 1976

## MONEY

**Elkin, Benjamin.** *Money (a New True book).* Childrens, 1983

**Hoban, Lillian.** *Arthur's Funny Money* Harper, 1981

**Hoban, Tana.** *26 Letters and 99¢.* Greenwillow, 1987

**Hutchins, Pat.** *You'll Soon Grow Into Them* Greenwillow, 1983

**Viorst, Judith.** *Alexander Who Used to Be Rich Last Sunday* Atheneum, 1978

## MULTIPLICATION/DIVISION

**Anno, Mitsumasa.** *Anno's Mysterious Multiplying Jar.* Putnam, 1983

**Sharmat, Marjorie.** *The 329th Friend.* Four Winds, 1979.

## OPERATIONS

**Bright, Robert.** *My Red Umbrella* Morrow, 1959.

**Burningham, John.** *Shopping Basket* Crowell, 1980

**Ets, Marie Hall.** *Play With Me.* Viking, 1955

**Hutchins, Pat.** *1 Hunter.* Greenwillow, 1982

**Mathews, Louise.** *Gator Pie.* Dodd, 1979

**Nozaki, Akihiro.** *Anno's Hat Tricks* Philomel, 1985.

## ORDINAL NUMBERS

**Bishop, Claire H.** *Five Chinese Brothers.* Putnam, 1938

**Coombs, Patricia.** *Dorrie and the Witch Doctor* Lothrop, 1967



- Davis, Alice V. *Timothy Turtle*. Harcourt, 1972  
 Emberley, Barbara *Drummer Hoff* Prentice-Hall, 1967  
 Potter, Beatrix. *The Tale of Squirrel Nutkin* Warne, 1903  
 Tresselt, Alvin. *The Mitten*. Lothrop, 1964  
 Viorst, Judith. *The Tenth Good Thing About Barney* Atheneum, 1971

#### PUZZLES/GAMES

- Burns, Marilyn *I Hate Mathematics! Book* Little, 1975.  
 Charosh, Mannis *Mathematical Games for One or Two*. Crowell, 1972  
 Weiss, Malcolm E. *Solomon Grundy, Born on Oneday* Crowell, 1977

#### REVERSE COUNTING

- Bang, Molly. *Ten, Nine, Eight* Greenwillow, 1983  
 Charlip, Remy. *Thirteen* Four Winds, 1975  
 Ernst, Lisa C. *Up to Ten and Down Again*. Lothrop, 1986.  
 Gerstein, Mordicai *Roll Over!* Crown, 1984.  
 Mack, Stan *Ten Bears in My Bed: A Goodnight Countdown* Pantheon, 1974  
 Sendak, Maurice *One Way Johnny* Harper, 1962.

#### ROMAN NUMERALS

- Adler, David A *Roman Numerals* Crowell, 1977  
 Fisher, Leonard Everett. *Number Art Thirteen 123s from Around the World*. Four Winds, 1982  
 Leighton, Ralph and Carl Feyman *How to Count Sheep Without Falling Asleep* Prentice-Hall,  
 1976

#### SHAPES

- Carle, Eric. *My Very First Book of Shapes* Crowell, 1985  
 Mayer, Mercer. *Bubble, Bubble*. Four Winds, 1980.  
 Emberley, I. d. *Wing on a Flea A Book About Shapes* Little, 1961.  
 Grifalconi, Ann *Village of Round and Square Houses* Little, 1986  
 Children's TV Workshop. *Sesame Street Book of Shapes*. NAL, 1971.  
 Lionni, Leo *Pezzettino* Pantheon, 1975  
 O'Connor, Vincent F *Mathematics in Buildings* Raintree, 1977.

- O'Connor, Vincent F. *Mathematics in the Kitchen* Raintree, 1977  
 O'Connor, Vincent F. *Mathematics on the Playground* Raintree, 1977  
 Wildsmith, Brian *Brian Wildsmith One, Two, Three* Watts, 1962

### SIZE COMPARISONS AND MEASUREMENT

- Anderson, Hans C. *Thumbelina* Dial, 1985  
 Bee, Lewi. Fritz, *The Too-Long Dog* Garrard, 1980  
 Brenner, Barbara *Mr Tall and Mr. Small* Young Scott, 1966.  
 Brown, Marcia. *Three Billy Goats Gruff*. Harcourt, 1957  
 Darling, Kathy. *Ants Have Pets*. Garrard, 1977.  
 Fisher, Leonard. *Boxes, Boxes!* Viking, 1984  
 Heide, Florence P. *Benjamin Budge and Barnaby Ball* Scholastic, 1970  
 Hutchins, Pat. *Titch*. Macmillan, 1971  
 Kuskin, Karla *Herbert Hated Being Small* Houghton, 1979  
 Lionni, Loe. *Biggest House in the World* Pantheon, 1968  
 Lionni, Loe. *Inch by Inch* Astor-Honor, 1962  
 Long, Earlene. *Gone Fishing* Houghton, 1984.  
 Peet, Bill. *Huge Harold*. Houghton, 1982  
 Peet, Bill. *Big Bad Bruce* Houghton, 1977  
 Provinsen, A. & M. *Our Animal Friends at Maple Hill* Random, 1984  
 Steig, William. *Doctor DeSoto*. Farrar, 1982  
 Ward, Lynn. *Biggest Bear*. Houghton, 1973.  
 Youldon, Gillian. *Sizes*. Watts, 1979.

### TIME

- Barrett, Judi *Benjamin's 365 Birthdays* Atheneum, 1974  
 Burns, Marilyn. *This Book Is About Time*. Little, 1978.  
 Carle, Eric. *The Grouchy Ladybug* Crowell, 1977.  
 Carison, Natalie. *Time for the White Egret* Scribner's, 1978.  
 Gibbons, Gail. *Clocks and How They Go*. Crowell, 1979

## Mathematics--Professional Materials

- Aten, Jerry.** *Prime Time Math Skills.* Good Apple, Inc. 1983
- Bell, Erick T.** *Men of Mathematics* Simon & Schuster, 1937
- Bendick, Jeanne** *Mathematics Illustrated Dictionary Facts, Figures and People, Including the New Math.* McGraw Hill, 1965
- Berman, Michelle and Linda Shevitz** *I Can Make It on My Own. Functional Reading Ideas and Activities for Daily Survival* Scott, Foresman, 1978
- Burns, Marilyn** *Math for Smarty Pants.* Little, 1982
- Burns, Marilyn** *A Collection of Math Lessons Form Grades 3 through 6* Math Solution Pubs , 1987
- Charlesworth, Rosalind and Deanna J Radeloff,** *Experiences in Math for Young Children* Delmar Publishers, 1978
- Fisher, Leonard Everett.** *Number Art Thirteen 123s From Around the World* Four Winds, 1982.
- Gersting, Judith L and Joseph E Kucakowski** *Yes-No, Stop-Go: Some Patterns in Mathematics.* Crowell, 1977
- Griesbach, Ellen and Jerry Taylor** *Prentice-Hall Encyclopedia of Mathematics* Prentice-Hall, 1982.
- Lamm, Joyce.** *Let's Talk About the Metric System.* Jonathan David, 1974
- Luce, Marnie** *Ten: Why Is It Important?* Lerner, 1969
- Luce, Marnie** *Zero Is Something* Lerner, 1969.
- Mathemagic--The 1978 Childcraft Annual* World Book--Childcraft International, 1978
- Matthias, Margaret and Diane Thiessen** *Children's Mathematics Books A Critical Bibliography.* American Library Association, 1979
- Meyer, Carol and Tom Sallee.** *Make It Simpler--A Practical Guide to Problem Solving in Mathematics.* Addison-Wesley, 1983
- Nursery Rhymes ana Numbers.* The Monkey Sisters, 1984
- Piercey, Dorothy.** *Reading Activities in Content Areas. An Idea Book for Middle and Secondary Schools* Allyn and Bacon, Inc , 1982.
- Product of Our Times: Mathematics Resource Book K-8.* Oklahoma State Department of Education, 1981.
- Radebaugh, Muriel Rogie,** "Using Children's Literature to Teach Mathematics " *The Reading Teacher.* May, 1981. pp 902-906.
- Shufelt, Gwen.** *Agenda in Action: Yearbook, 1983* National Council of Teachers of Mathematics, 1983
- Time, Money, Measurement and Metrics.* Macmillan Instant Activities Program Macmillan Educational Company, 1984

**FOCUS ON ROGER DUVOISIN  
AUTHOR/ILLUSTRATOR**

**Emphasis Grade Levels: 1-2**

**CURRICULUM APPLICATIONS:** Reading, Language Arts

**GOAL:** Children will get to know the style and technique of one author/illustrator

**COOPERATIVE PLANNING/TEACHING**

The classroom teacher and the library media specialist will plan materials to be covered, the length of time and number of sessions required for this unit. Responsibility roles will be discussed and agreed upon.

**LEARNER OUTCOMES**

Content Area	Information Skills
<p>The student will:</p> <ol style="list-style-type: none"><li>1. Demonstrate skills in the area of visual discrimination</li><li>2. Demonstrate ability in listening skills</li><li>3. Distinguish between fiction and nonfiction.</li><li>4. Make use of context clues and picture words</li><li>5. Develop a positive attitude toward reading</li></ol>	<p>The student will</p> <ol style="list-style-type: none"><li>1. Learn the following terms: <i>picture book, title, author, illustrator</i></li><li>2. Enjoy works of favorite authors and illustrators</li><li>3. Recognize that the author's background influences the content.</li><li>4. Identify characters in selections viewed, listened to, or read</li><li>5. Identify medium and style of illustrations</li><li>6. Locate picture books and easy reading books</li></ol>

**ACTIVITIES/SUGGESTIONS:**

1. Begin by sharing *A Writer* by M. B. Goffstein. Then share *Veronica* or *Petunia* by Roger Duvoisin. Many children are already familiar with these book characters. Some may recognize the name of the author/illustrator. They will observe that the style and techniques used are the same in both books. Compare the style and technique of these books to *The Happy Lion* to show contrast. Careful attention should be given to
  - a. Shapes and figures used by the illustrator
  - b. Colors used in the various pictures.

- c Media used (ink, paints, pastels, etc ) Students may be introduced to the various techniques in advance, i e , *A Picture Has a Special Look* by Helen Barter
  - d Subject matter
- 2 After listening to (or viewing) these two stories, ask children to compare the two story characters. Continue with questions which focus on the setting and its importance in a story.
  - 3 Children may be able to see the story line of "not belonging" and transfer this observation to personal experiences and feeling Many will be able to identify with Veronica as the "outsider" because they have been new to a neighborhood or school
  - 4 After reading *Petunia*, play "The Farmer in the Dell "
  - 5 Place other Duvoisin books on tables for independent reading and sharing
  6. The library media specialist may wish to assist the more able students in gathering biographical information about Duvoisin from the book jacket and/or reference books to share with the rest of the class If this is not feasible, the library media specialist may share this information with the group (including a recent photo)
  - 7 Record the childrens' comments about Duvoisin on a chart
  - 8 Identify Duvoisin and Louise Fatio as a married couple who assist each other with their books
  - 9 Identify books which Duvoisin has illustrated (for other authors) Compare style and techniques
  - 10 Let children share their independent reading experiences in the final session Note Pair those not yet able to read the books independently with someone who can read to them so that all can participate in the discussion
  - 11 Ask students to create situations from books involving Petunia or Veronica "Your name is Petunia and .." Then play out or pantomime
  - 12 You may wish to invite a local author to visit your class so students can enjoy learning about an author through first-hand experience as well as finding out more about how a book is made. (See *Guidelines* for an author visit) To expand on the book-making process, use Alike's *How a Book Is Made*
  - 13 Have a "Favorite Author Day " Each child can choose his favorite author and share a few of his/her books with the class (using the form in this unit) At the end of a given time period, vote on the favorite author of the class
  14. Set aside a permanent area in the classroom or library for displaying the works of favorite authors and illustrators Include a picture and a bit about the author's life. If classes have written to authors and received replies, they can be a part of the display. Share the book *Dear Miss Moshki* by Crescent Dragonwagon (a hilarious account of an author's classroom visit).

## EVALUATION:

The classroom teacher and the library media specialist will determine the students' understanding of these terms: author, illustrator, picture book, title

The library media specialist will observe children to determine if they can find Duvoisin's books on the library shelves

## RESOURCES:

### Duvoisin, Roger

- A for the Ark*. New York: Lothrop, Lee and Shepard Books, 1952
- All Aboard!*. New York: Grosset and Dunlap, 1935.
- Angelique*. New York: McGraw-Hill, 1960
- Chanticleer*. New York: Grosset and Dunlap, 1947
- The Christmas Cake in Search of Its Owner*. American Artists' Group, 1941
- The Christmas Whale*. New York: Alfred A. Knopf, 1945
- Day and Night*. New York: Alfred A. Knopf, 1960.
- Donkey-Donkey The Troubles of a Silly Little Donkey*. Chicago: Albert Whitman, 1933.
- Easter Treat*. New York: Alfred Knopf, 1954
- The Happy Hunter*. New York: Lothrop, Lee and Shepard Books, 1961
- The House of Four Seasons*. New York: Alfred A. Knopf, 1956
- Jasmine*. New York: Alfred A. Knopf, 1973.
- A Little Boy Was Drawing*. New York: Charles Scribner's Sons, 1932
- The Missing Milkman*. New York: Alfred A. Knopf, 1967.
- Periwinkle*. New York: Alfred A. Knopf, 1976.
- Petunia*. New York: Alfred A. Knopf, 1950.
- Petunia and the Song*. New York: Alfred A. Knopf, 1951.
- Petunia, Beware!*. New York: Alfred A. Knopf, 1958
- Petunia, I Love You*. New York: Alfred A. Knopf, 1965.
- Petunia's Christmas*. New York: Alfred A. Knopf, 1952
- Petunia's Treasure*. New York: Alfred A. Knopf, 1975
- Petunia Takes a Trip*. New York: Alfred A. Knopf, 1953
- Snowy and Woody*. New York: Alfred A. Knopf, 1979.
- Spring Snow*. New York: Alfred A. Knopf, 1963.
- Two Lonely Ducks: A Country Book*. New York: Alfred A. Knopf, 1955
- Veronica and the Birthday Present*. New York: Alfred A. Knopf, 1971
- What Is Right for Tulip*. New York: Alfred A. Knopf, 1969

Selected Books Illustrated by Roger Duvoisin

- Fatio, Louis.** *The Happy Lion*. New York: McGraw-Hill, 1954. (First in a series)
- Freschet, Berniece.** *The Old Bullfrog*. New York: Charles Scribner's Sons, 1968
- Freschet, Berniece.** *The Web in the Grass*. New York: Charles Scribner's Sons, 1972
- Haviland, Virginia.** *Favorite Fairy Tales Told in France*. New York: Little Brown, 1959
- Holl, Adelaide.** *The Rain Puddle*. New York: Lothrop, Lee and Shepard Books, 1965.
- Menotti, Gian-Carlo.** *Amahl and the Night Visitors*. New York: McGraw-Hill, 1952
- Miles, Patricia.** *The Pointed Brush*. New York: Lothrop, Lee and Shepard Books, 1959
- Schelein, Miriam.** *Little Red Nose*. New York: Abelard-Schuman, 1965.
- Tresselt, Alvin.** *The Beaver Pond*. New York: Lothrop, Lee and Shepard Books, 1970.
- Tresselt, Alvin.** *Follow the Wind*. New York: Lothrop, Lee and Shepard Books, 1950.
- Tresselt, Alvin.** *Hide and Seek Fog*. New York: Lothrop, Lee and Shepard Book, 1965
- Tresselt, Alvin.** *It's Time Now*. New York: Harper and Row, 1969
- Tresselt, Alvin.** *Sun Up*. New York: Lothrop, Lee and Shepard Books, 1949
- Tresselt, Alvin.** *Wake Up, City!*. New York: Lothrop, Lee and Shepard Books, 1957.
- Tresselt, Alvin.** *Wake Up, Farm!*. New York: Lothrop, Lee and Shepard Books, 1955
- Tresselt, Alvin.** *What Did You Leave Behind?*. New York: Lothrop, Lee and Shepard Books, 1978
- Tresselt, Alvin.** *White Snow, Bright Snow*. New York: Lothrop, Lee and Shepard Books, 1947.
- Tresselt, Alvin.** *The World of the Candy Egg*. New York: Lothrop, Lee and Shepard Books, 1967.
- Tworckov, Jack.** *The Camel Who Took a Walk*. New York: E. P. Dutton, 1951

**Other Books:**

- Aliki.** *How a Book Is Made*. Crowell, 1986. Information for the very young
- Barter, Helen.** *A Picture Has a Special Look*.
- Dragonwagon, Crescent.** *Dear Miss Moshki*. Illus. by Diane Pamisciano  
Macmillan, 1986.
- Goffstein, M. B.** *A Writer*. Harper, 1984
- Melton, David.** *How to Capture Live Authors and Bring Them to Your Schools*. Landmark  
Editions, Inc. (Kansas City, MO), 1986. pap
- Moss, Joy F.** *Focus Units in Literature. A Handbook for Elementary School Teachers*  
NCTE, 1984.

**Additional Resources:**

*Exploring the Art of the Picture Book #12*, Oklahoma State Department of Education  
Oklahoma State Department of Education  
Library Resources Section  
2500 North Lincoln Boulevard  
Oklahoma City, OK 73105

Petunia (sound filmstrip), Weston Woods  
Weston Woods  
Weston, CT 06883

Petunia, Beware! (sound filmstrip) Random House

Petunia Takes a Trip (sound filmstrip)  
Random House School Division  
Department 9278  
400 Hahn Road  
Westminster, MD 21157





## The Author

The author is the person who wrote your book

1. What is the name of your author?

---

2. Is the author a man or a woman?

---

3. What is the title of the book your author wrote?

---

4. List other books your author has written

---

---

---

---

---

5. Find out about your author

---

---

---

---

---

6. Briefly share an exciting or funny happening from a book by your author

---

---

---

---

---

## I WROTE THE STORY--I DREW THE PICTURES

Emphasis Grade Level: 1-3

CUI RICULUM APFLICATION(S): Reading, Language Arts, Art

**GOAL:** Children will learn the terms *author* and *illustrator* and what each does in producing a book. They will also appreciate and enjoy the works of favorite authors and illustrators.

### COOPERATIVE PLANNING/TEACHING

1. The classroom teacher and the library media specialist will plan together to develop a list of authors/illustrators to be introduced, and determine the amount of time that will be required for the activities.
2. Responsibilities for teaching and/or follow-up will be determined.

### LEARNER OUTCOMES

Content Area	Information Skills
The student will <ol style="list-style-type: none"><li>1. Be introduced to literature</li><li>2. Develop a positive attitude toward reading</li><li>3. Differentiate between fiction and nonfiction</li></ol>	The student will <ol style="list-style-type: none"><li>1. Enjoy works of favorite authors and illustrators</li><li>2. Be introduced to the Caldecott Medal books.</li><li>3. Understand the terms <i>picture book</i>, <i>title</i>, <i>spine</i></li><li>4. Learn the following terms. <i>author</i>, <i>illustrator</i>.</li><li>5. "Read" pictures (identify, describe).</li><li>6. Act out stories.</li><li>7. Retell a story</li><li>8. Recognize that the author's background influences the contents</li></ol>

### LEARNER OUTCOMES (cont.)

Content Area	Information Skills
<p>The student will</p> <p>4 Demonstrate skills in sequencing</p> <p>5. Demonstrate skills in the area of visual discrimination.</p>	<p>The student will</p> <p>9 Identify characters in selections viewed, listened to, or read</p> <p>10 Identify medium and style of illustrations</p>

### ACTIVITIES/SUGGESTIONS

1. Define the words *author, illustrator*. Point out that often the same person may write and illustrate the book.
2. Introduce picture books written and illustrated by husband and wife teams. Point out the contribution of each person. Show how they produce their books by working together (e.g., Ed and Barbara Emberly; Louise Fatio and Roger Duvoisin; Ingri and Edgar d'Aulaire, Berta and Elmer Hader; Alice and Martin Provenson, Ruth Kraus and Crockett Johnson, Arnold and Anita Lobel).
3. Show the filmstrip *A Picture Has a Special Look* to introduce children to the various media used by illustrators. Both the book and the filmstrip give an excellent introduction to the use of crayon, lead pencil, collage, pen and ink, poster paints and oils.
4. Following the filmstrip, discuss how artists use color and show how color qualities differ.
5. See *Exploring the Art of Picture Books*, pages 14-19, for additional ideas and ways to explore color with children.
6. Introduce students to the Caldecott Award. The following important facts about this award should be mentioned:

The award was named in honor of Randolph Caldecott  
 It was first awarded in 1938.  
 The winner is announced in January of each year  
 The award is for the most distinguished picture book.  
 It is awarded to the illustrator

View the sound filmstrip *Randolph Caldecott, The Man Behind the Medal*, Weston Woods.

Weston Woods  
 Weston, CT 06883

7. Introduce Brian Wildsmith's books. His illustrations are big and bold, using many shades of bright colors, which are easily recognized and generally liked by children.
8. Introduce books by illustrators who use the same style and techniques whenever possible (e.g., tempera--Bruno Munari, Ruth Robbins, Maurice Sendak, collage--Ezra Jack Keats, Leo Lionni, cartoons and comics--Raymond Briggs, William Steig, and charcoal--Clair Turley Newbery and Brinton Turkle).
9. Continue to introduce pertinent authors and artists and their works so that children can learn to identify illustrations created by the same artist.
10. Allow children to discover the difference between illustrations and photographs. Tana.
11. Show the filmstrip *Enjoying Illustrations, Literature for Children*, Series 3, Pied Piper Productions.
12. Introduce wordless picture books. Permit students to tell the story (visual discrimination, sequencing).
13. Using a variety of illustrations for the same book (e.g., *Three Billy Goats Gruff*, *Rumpelstiltskin*, *Little Red Riding Hood*, *Cinderella*, etc.), encourage children to study the illustrations and to tell what they see. They may then translate what they have learned in this visual mode into the verbal mode by stating which picture they prefer and why.

To develop verbal skills of describing, the teacher or library media specialist may wish to ask such questions as:

- a. What do you see in the picture?
  - b. What colors has the artist used?
  - c. Where did this event take place? How can you tell?
14. Second and third grade students will enjoy keeping an incentive chart of Caldecott books read. These charts can be purchased from school supply firms with a variety of stickers to indicate Caldecott books read by each child.
  15. Share several books illustrated by Leo Lionni. Compare his techniques and combinations of media (collage and watercolor with pencil or charcoal, torn paper, etc.).  
  
Read Lionni's *Let's Make Rabbits* (Pantheon, 1982) and use the patterns on page ??? of this guide to have children make their own rabbits using discarded wallpaper samples. See how many different ways the rabbits can be posed by arrangement of body parts. (Idea contributed by Jeanie Johnson, Iukfata School, and Diane Mauch, Calera Schools.)
  16. Culminate this unit by allowing students to make their own collage and/or woodcut using potatoes.

## EVALUATION:

Ninety percent of the students will

1. Be able to distinguish between author and illustrator
2. Be able to identify at least three artists' works by technique
3. Select illustrations which give them pleasure
4. Seek out specific works by selected illustrators
5. Define "collage."
6. Be able to interpret illustrations from three wordless picture books

## GLOSSARY:

Author--Person who writes a book (emphasize correct pronunciation).

Illustrator--Person who draws or creates pictures to go with a story. The pictures help words to tell the story. Sometimes books have no words and pictures are used to tell the story.

Title Page--A page at the beginning of a book which gives the name of the book, the author, and the illustrator. Other information may also be found on this page.

## RESOURCES:

**Lionni, Leo** *Let's Make Rabbits* Pantheon, 1982

**Mealy, Virginia T** *Happy Birthday Author* Book Lures

Book Lures, Inc.  
P.O. Box 9450  
O'Fallon, MO 63366

*The Caldecott Medal Books* #11, Oklahoma State Department of Education.

*Exploring the Art of the Picture Book* #12, Oklahoma State Department of Education

Oklahoma State Department of Education  
Library Resources Section  
2500 North Lincoln Boulevard  
Oklahoma City, OK 73105-4599

*A Picture Has a Special Look* (sound filmstrip) Weston Woods.

*Enjoying Illustrations* (sound filmstrip) Weston Woods.

*Randolph Caldecott, The Man Behind the Medal* (sound filmstrip). Weston Woods.

Weston Woods  
Weston, CT 06883



130

The following questions are designed to be used in a Caldecott Learning Center. The activities are based on Benjamin Bloom's Taxonomy of Learning. Copy each set of questions and apply to the back of the Caldecott Medal on the previous page of this guide. You may develop additional questions using other Caldecott winners.

### **The Snowy Day**

**Evaluation:** Find other books by Ezra Jack Keats in the library. Which book do you think is best? Be able to defend your choice.

**Synthesis:** Experiment with various ways of creating illustrations similar to the ones in this book. Techniques you might use: papercutting, watercolors, linoleum prints, and sand prints.

**Analysis:** Ask your parents or grandparents how to make snow ice cream. Share the recipe with your classmates.

**Synthesis:** Imagine a dog and a cat are walking with you in the snow. Draw a diagram of how your tracks would look in the snow.

### **Noah's Ark**

**Synthesis:** Imagine you are on the ark with all the animals, birds, reptiles, etc. What are some of the problems which might be encountered?

**Analysis:** Compare life outside the ark before and after the flood.

**Comprehension:** Which animals do you think might have trouble descending the boat as it sat on Mt. Ararat?

### **Drummer Hoff**

**Knowledge:** List all the parts of the cannon in the order they were assembled in the story.

**Evaluation:** Why do you think Drummer Hoff was chosen to fire off the cannon?

**Synthesis:** Imagine you are Drummer Hoff. Look at the page in the book after the command is given to "Fire!" How do you think Drummer Hoff feels at this moment?

### **Fables**

#### **The Hen and the Apple Tree**

**Knowledge:** Identify all the things Hen observed about the apple tree that caused her to suspect that the tree might be dangerous.

#### **The Crocodile in the Bedroom**

**Evaluation:** Why do you think that Crocodile turned a very pale and sickly shade of green?

## ILLUSTRATORS' STYLES/CHARACTERISTICS

ILLUSTRATORS	STYLES/CHARACTERISTICS
Anglund, Joan Walsh	Charm, quaintness, diminutive format
Bemelmans, Ludwig	<i>Madeline's Rescue</i> , the 1954 Caldecott medal winner, expresses action, wild exaggeration, humor.
Brown, Marcia	Has several styles <i>Dick Whittington and His Cat</i> --brown and black linoleum cuts, vigorous, full of movement, bold.
Ets, Marie Hall	<i>Play With Me</i> --subtle and exquisite pastel illustrations
Galdone, Paul	Humor, shows emotions in facial expressions
Goble, Paul	<i>The Girl Who Loved Wild Horses</i> , the 1979 Caldecott winner, is a book of exquisite, stylized illustrations. <i>Star Boy</i> --ALA Booklist says: "Goble uses intense, pure colors that add vibrancy to his delicate designs. His style combines simple geometric forms, stylized Indian motifs, and lacy details of landscape and apparel into masterfully coordinated spreads that are a visual delight. A considered, reverent, and eye-catching rendition of an important native American legend."
Hoff, Syd	Cartooning style
Keats, Ezra Jack	<i>Snowy Day</i> , the 1963 Caldecott winner, conveys freedom and freshness. The little boy expresses action and life.
Lawson, Robert	Humor, tenderness, appealing subjects.
Lionni, Leo	Deals with objects in nature, animals; never realistic Reactions of animals are those of human beings. Uses mixed media: collage and water color with pencil or charcoal <i>Swimmy and Frederick</i> --torn paper, mixed media
McCloskey, Robert	Humorous realism.
Potter, Beatrix	Got her inspiration from the natural world drawings and watercolors.
Schulz, Charles	Cartooning style.
Sendak, Maurice	<i>Where the Wild Things Are</i> , the 1964 Caldecott winner, expresses great originality. Its preposterous animals are delightful.
Seuss, Dr	Zany humor Outlandish animals.



Silverstein, Shel	Line drawings
Simont, Marc	<i>A Tree Is Nice</i> , the 1957 Caldecott winner, expresses warmth of color and feelings.
Spier, Peter	Expresses vitality. Shows great detail
Steig, William	Humor, tenderness, generally uses watercolors <i>Sylvester and the Magic Pebble</i> , the 1970 Caldecott winner, is an example of how Steig humanizes animals with clothing and facial expressions.
Ward, Lynd	Uses shading to create mood and character in the 1953 Caldecott medal winner, <i>The Biggest Bear</i> <i>America's Ethan Allen</i> --Ward uses brilliant, unexpected colors to highlight and enhance his illustrations.
Williams, Garth	Personifies animals. Often has full-color picture books.

**SOURCE:** Druce, Arden. *Library Skills: Lessons for Grades K-6* Dick Whittington Press, 1986, pp 322-3 Used with permission )

## CALDECOTT STORY PUZZLE

Find the 32 Caldecott Medal titles in the story below and underline each title in pencil  
Example. It was Nine Days to Christmas

IT WAS NINE DAYS TO CHRISTMAS WHEN MEI LI ASKED MADELINE, "MAY I BRING A FRIEND, CINDERELLA, ON OUR TRIP?" "YES", SAID MADELINE, "THERE'S ALWAYS ROOM FOR ONE MORE." THE GIRLS THEN SAILED FOR THE LITTLE ISLAND ON A BOAT WHICH HAD TO STOP ONCE TO MAKE WAY FOR DUCKLINGS

WHEN THE GIRLS ARRIVED, MEI LI SAID "WHEN THE ROOSTER CROWS WE WILL LOOK FOR A TREE TO DECORATE FOR CHRISTMAS." SO THEY EACH SAID A PRAYER FOR A CHILD AND WENT TO SLEEP. MEI LI DREAMED OF WHITE SNOW, BRIGHT SNOW. CINDERELLA DREAMED OF THE ANIMALS OF THE BIBLE, AND MADELINE DREAMED OF BABOUSHKA AND THE THREE KINGS, AND SAM BANGS AND MOONSHINE.

THE SONG OF THE SWALLOWS AND THE NOISE OF CHANTICLEER AND THE FOX WOKE THE GIRLS AND THEY RAN OUT OF THE LITTLE HOUSE INTO THE SNOW DAY. MADELINE FELL INTO THE BIG SNOW AND AFTER MADELINE'S RESCUE, THE GIRLS WENT EXPLORING. "THIS IS WHERE THE WILD THINGS ARE AND THE BIGGEST BEAR," SAID MEI LI, AS THEY WENT INTO THE FOREST. ONCE A MOUSE LOOKED AT THEM AND AS A FROG HOPPED BY, CINDERELLA SANG "FROG WENT A-COURTIN'."

THERE WERE MANY TREES. ONE WOULD HAVE BEEN PERFECT AT EASTER TIME FOR THE EGG TREE THE GIRLS LOOKED AT ALL THE TREES, THEY WERE STRONG AND GOOD. THE STRONGEST TREE THEY NAMED ABRAHAM LINCOLN AND DECIDED TO USE IT FOR CHRISTMAS. "FINDERS KEEPERS," CALLED MADELINE, WHEN THEY FOUND THE TREE. MEI LI HUNG MANY MOONS AND STARS CUT OUT OF PAPER ON THE TREE WHEN THE TREE WAS FINISHED THE CHILDREN LOOKED AT THE BEAUTIFUL SIGHT AND SAID, "A TREE IS NICE."

IT WAS A TIME OF WONDER, SAID DRUMMER HOFF TO SYLVESTER AND HIS MAGIC PEBBLE.

SOURCE: *Eureka--Ideas and Activities for Personalizing Media Skills*  
Wake County Public Schools, Raleigh, North Carolina, 1977, p 263.  
(Used with permission )

## CALDECOTT WINNERS

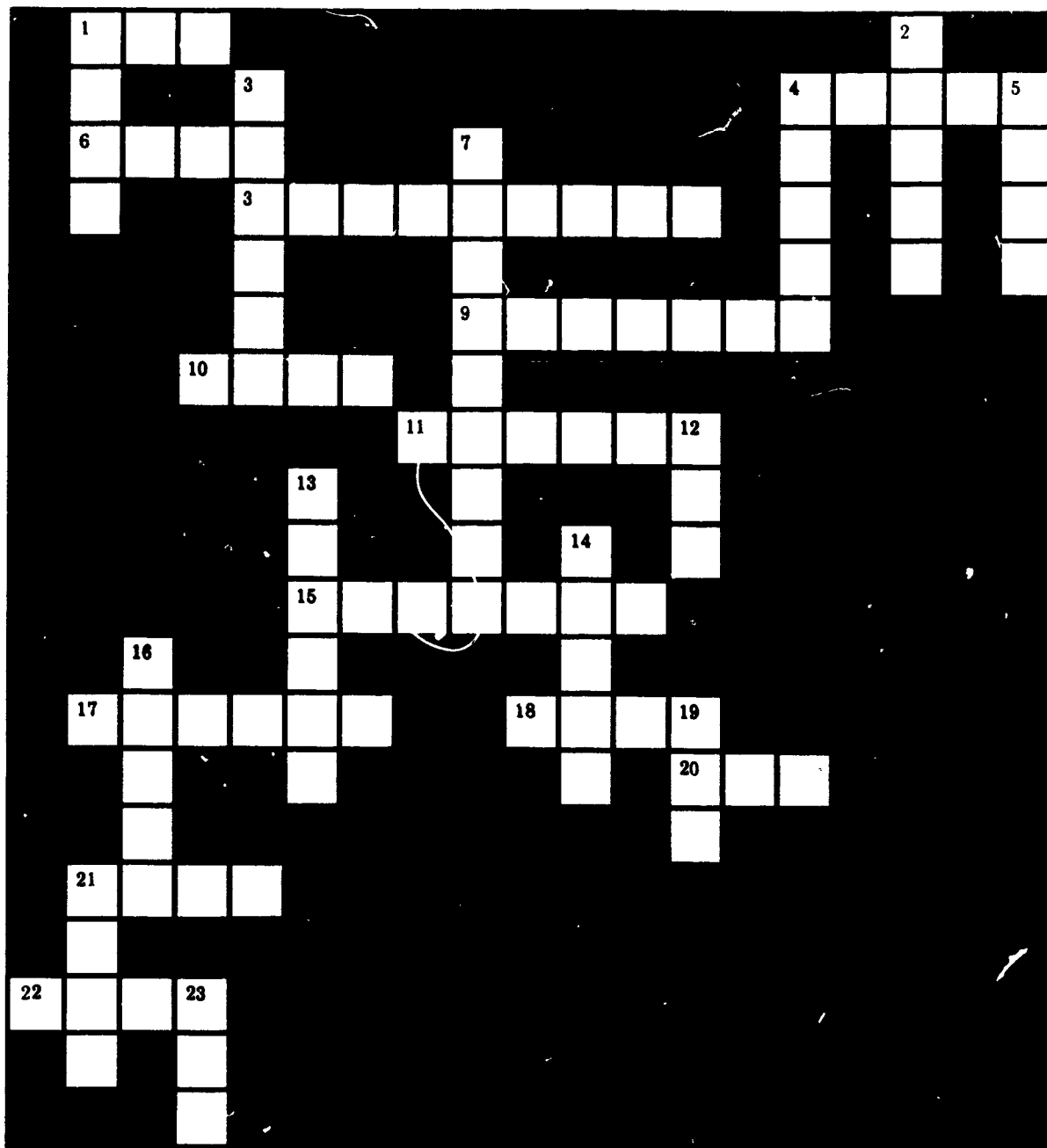

### ACROSS:

- 1 Arrow to the \_\_\_\_\_
- 4 Once a \_\_\_\_\_
- 6 A Tree Is \_\_\_\_\_
- 8 \_\_\_\_\_ and the Three Kings
- 9 Finders \_\_\_\_\_
- 10 The Biggest \_\_\_\_\_
- 11 The \_\_\_\_\_ Island
- 15 The \_\_\_\_\_ Crows
- 17 Time of \_\_\_\_\_
- 18 Where the \_\_\_\_\_ Things Are
- 20 Noah's \_\_\_\_\_
- 21 \_\_\_\_\_ Went A-Courtin'
- 22 Drummer \_\_\_\_\_

### DOWN:

- 1 \_\_\_\_\_ of the Swallows
- 2 The \_\_\_\_\_ Little Woman
- 3 Sylvester and the Magic \_\_\_\_\_
- 4 Many \_\_\_\_\_
- 5 Why Mosquitoes Buzz in People's \_\_\_\_\_
- 7 Make Way for \_\_\_\_\_
- 12 The \_\_\_\_\_ Tree
- 13 The Girl Who Loved Wild \_\_\_\_\_
- 14 Duffy and the \_\_\_\_\_
- 16 The \_\_\_\_\_ Express
- 19 The Snowy \_\_\_\_\_
- 21 The \_\_\_\_\_ of the World and the Flying Ship
- 23 Chanticleer and the \_\_\_\_\_

ANSWER KEY

ACROSS:

1. SUN
4. MOUSE
6. NICE
8. BABOUSHKA
9. KEEPERS
10. BEAR
11. LITTLE
15. ROOSTER
17. WONDER
18. WILD
20. ARK
21. FROG
22. HOFF

DOWN:

1. SONG
2. FUNNY
3. PEBBLE
4. MOONS
5. EARS
7. DUCKLINGS
12. EGG
13. EGG
14. DEVIL
16. POLAR
19. DAY
21. FOOL
23. FOX

PATTERNS FOR "LET'S MAKE RABBITS"

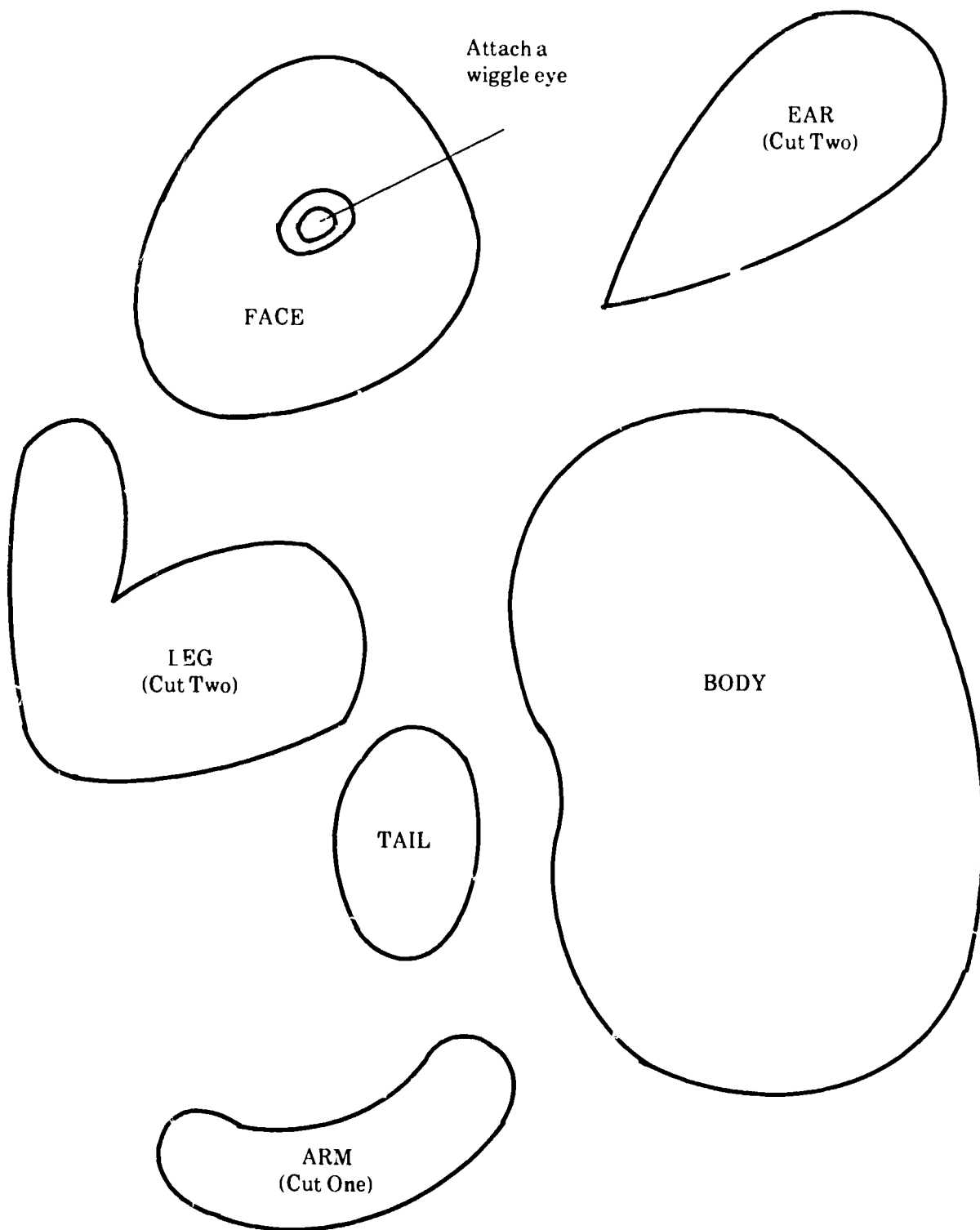

## FROG FACT--FROG FICTION

**Emphasis Grade Level: 2-3-4**

**CURRICULUM APPLICATION(S):** Science, Reading, Language Arts

**GOAL:** Students will identify and understand the stages in the life cycle of a frog. They will become familiar with some characteristics of frogs, and differentiate between frog facts and frog fiction. Each student will participate in a research activity and enjoy literature about frogs.

### COOPERATIVE PLANNING/TEACHING

<p>The teacher will:</p> <ol style="list-style-type: none"> <li>1. Guide students in the science curriculum activities.</li> <li>2. Help organize the interest groups</li> <li>3. Guide the writing process for the unit evaluation.</li> </ol>	<p>The library media specialist will:</p> <ol style="list-style-type: none"> <li>1. Guide students in the research process.</li> <li>2. Teach appropriate information skills.</li> <li>3. Gather audiovisual materials, periodicals, books and other resource materials for this study</li> </ol>
---	---

### LEARNER OUTCOMES

Content Area	Information Skills
<p>The student will:</p> <ol style="list-style-type: none"> <li>1. Know the different populations of plants and animals found in different environments.</li> <li>2. Study life cycles of animals</li> <li>3. Be able to identify major characteristics of living things.</li> <li>4. Distinguish between fictional and factual reading materials.</li> <li>5. Use the encyclopedias and other reference books.</li> <li>6. Develop an appreciation of good literature through listening, viewing, and reading.</li> <li>7. Write stories and reports.</li> </ol>	<p>The student will:</p> <ol style="list-style-type: none"> <li>1. Distinguish reality from fantasy.</li> <li>2. Find and enjoy a variety of literature.</li> <li>3. Use illustrations, charts, or photographs to present information.</li> <li>4. Locate and distinguish between fiction and nonfiction.</li> <li>5. Use the library catalog to locate specific sources by author, title, and subject.</li> <li>6. Use a cassette recorder.</li> <li>7. Write stories and reports.</li> <li>8. Make slides.</li> </ol>

## ACTIVITIES/SUGGESTIONS:

A frog theme to start off the school year in the fall offers many opportunities to expand on what students already know about this amphibian. This unit is designed to allow students to research certain aspects of frog life and to provide opportunities for writing experiences.

1. Talk about what is already known about frogs. Discuss the relationship between fact and fiction regarding frogs. Have reference books and encyclopedias ready to verify or discount information students may bring out.
2. Show a filmstrip which explains the frog's life cycle from egg, to tadpole and finally frog. Source: "From Tadpole to Frog," *Life Science Patterns*, (sound filmstrip for intermediate grades), SVE.
3. Share various books, stories and poems about frogs. Talk about frogs in literature--frogs that wore clothing, talked, or had human personalities. Have students search the 300's in the nonfiction section of the media center for frogs in fairy tales.
4. Allow the class to divide themselves into interest groups formed around these six categories: physical characteristics, habitat, food, life cycle, species, importance to humans.
5. Allow time on several successive days for students to go to the media center and compile a fact sheet for the category in which they are working. This information should then be shared orally with the entire class. Use the forms which follow for students to record information from the oral presentations in the other five categories.
6. Along with the oral presentations, an audiovisual aid for each category could be prepared by the interest group. Following are some examples, but students should be allowed to develop their own format for the audiovisual aid.

Physical characteristics--clay models used to demonstrate body parts

Habitat--mural of a swamp setting in which frogs live

Food--a picture collection that shows the variety of insects frogs consume

Life cycle--drawing to illustrate the stages in the development of a frog

Species--slides prepared with the Ektagraphic Visualmaker to show various species

Importance to humans--menu with frog legs as the main entrée

FROG FACTS

LIFE CYCLE	SPECIES	IMPORTANCE TO HUMANS
Resources Used:  - 140	Resources Used:  	Resources Used:  141



FROG FACTS

PHYSICAL CHARACTERISTICS	HABITAT	FOOD
<b>Resources Used:</b> 142	<b>Resources Used:</b>	<b>Resources Used:</b> 143

## ADDITIONAL ACTIVITIES WITH FROGS:

1. Share Henry L. Stephens' *Frog He Would A-Wooing Go*. This book is excellent used as a choral reading.
2. Alvin Tresselt's *Frog in the Well* adapts easily to a flannel board story. Use the animals in the book for patterns, or many patterns are included in Paul S. Anderson's *Storytelling With the Flannel Board, Book One*.
3. Mercer Mayer's wordless picture books about frogs provide an excellent opportunity for students to interpret the pictures in their own words. An additional activity would be to record the story as the child tells it.
4. Check your community resource file to see about borrowing a terrarium with live frogs or an aquarium with tadpoles. Have students record daily observations.
5. Have students list as many words as they can that rhyme with "frog" and "toad" (examples: dog, log, bog, hog, smog and load, road).
6. "Teeto, the Tadpole" grows into a grown-up frog in the flannel board story and activity included in *Storytelling With the Flannel Board, Book One* by Paul S. Anderson.
7. Green will become a much-used color during a frog theme study. Treat children to lime punch or Jello, or perhaps mint jelly on crackers. Lime Jello mixed with chilled pineapple juice and Sprite makes a quick punch.
8. When children need a break to burn off some energy, play Leap Frog. If your classroom is too small, take this activity to the playground or PE room.
9. Several frog fingerplays are included in *Ring a Ring O' Roses*--available from the Flint, Michigan, Public Library. (See resource list.)
10. The Grimm Brothers' *The Frog Prince* can easily be adapted to a reader's theater script, and all ages can enjoy this form of creative expression.
11. Make lily pads from green construction paper. Use these for math problems or spelling words during the frog study.
12. Use the Hungry Frog pattern for creative writing. Have students answer with alliterative phrases such as: THE HUNGRY FROG ATE--forty-five fruit flies, or warm, woolly worms.
13. Second grade students will enjoy the Frog and Toad Fan Club. Introduce them to this activity with the *Frog and Toad Skit* included in this guide.
14. Have students complete the *Frog Book* by drawing the stages in the life cycle of a frog in each box. Two booklets are provided on each page. Cut apart and fold accordion-style on the broken lines with the cover facing out.
15. At the end of the Frog and Toad Fan Club, serve "frog" cookies. Frog-shaped cookie cutters can be found in many variety stores and kitchen shops.

## FROG COOKIES

3/4 C. shortening (part butter)  
1 C. sugar  
2 eggs  
1/2 tsp lemon flavoring

2 1/2 C flour  
1 tsp. baking powder  
1 tsp salt  
green food coloring  
icing, if desired

Mix shortening, sugar, eggs and flavoring thoroughly. Add food coloring. Measure flour by dipping method or by sifting. Stir flour, baking powder, salt together, blend in. Chill at least one hour. Heat oven to 400 degrees. Roll dough 1/8" thick on lightly floured board. Cut with frog cookie cutter. Place on ungreased baking sheet. Bake 6-8 minutes or until cookies are starting to turn brown on edges. Makes approximately 30 cookies. (Recipe contributed by Sharon Burns, Charles Haskell Elementary School, Edmond, Oklahoma )

### EVALUATION:

The student will write a story with a frog as the main character. Have students give the frog a problem and have it act to solve the problem. Factual background information should be incorporated wherever appropriate by using the Frog Facts chart

### RESOURCES:

Anderson, Paul S. *Storytelling with the Flannel Board, Book One*  
T.S. Dennison, 1963.

T.S. Dennison & Co., Inc.  
9601 Newton Avenue South  
Minneapolis, Minnesota 55431

*Frog and Toad Are Friends*--Reading Beyond the Basal. Offers a wide variety of reading, writing and other learning activities.

Perfection Form Company  
1600 North Second Avenue  
Logan, Iowa 51546

*Frog and Fan Club Membership Cards*. Include mailing label and 60¢ in stamps

Harper, Row Publishers  
Junior Book Department 128  
10 East 53rd Street  
New York, New York 10022  
Attn: Frog and Toad Fan Club Cards

"Frog Fever": *Kidstuff* Periodical, A Treasury of Early Childhood Enrichment Materials,  
Volume 3, Number 5, 1984, Guidelines Press.

Guidelines Press  
1307 South Killian Drive  
Lake Park, FL 33403

Lobel, Arnold. *The Frog and Toad Coloring Book* Harper, 1981

Polette, Nancy. *The Frog and Toad Thinking Book* Book Lures. 1982

Book Lures, Inc.  
P O. Box 9450  
O'Fallon, Missouri 63366

*Ring a Ring O'Roses*. Flint, Michigan, Public Library, (revised edition) 1981

Flint Public Library  
1026 East Kearsley  
Flint, Michigan 48502

Sharp, Peggy Agostino. *An ABC of Children's Book Activities* Alleyside Press, 1983, p 17.

Alleyside Press  
P.O. Box 889  
Hagerstown, Maryland 21740

Shepard, Barbara, and Linda Wilbur. *The Ring Thing--Developing Projects in Social Science*.  
The Learning Factory, 1982, pp 52-54.

The Learning Factory  
Box 297  
Clearwater, KS 67026

"Toad" rubberstamp #176. Kidstamps.

Kidstamps  
P.O. Box 18699  
Cleveland Heights, Ohio 44118

## FROG FACT--FROG FICTION BIBLIOGRAPHY

- Berson, Harold** *Charles and Claudine*. Macmillan, 1980
- Blake, Quinton**. *Story of the Dancing Frog*. Knopf, 1985
- Chenery, Janet**. *Toad Hunt*. Harper, 1967.
- Cleveland, David**. *Frog on Robert's Head*. Putnam, 1981
- Coldrey, Jennifer** *The World of Frog*. Gareth Stevens, 1986
- Dallinger, Jane**. *Frogs and Toads*. Lerner, 1982.
- Dauer, Rosamond** *Bullfrog Grows Up*. Greenwillow, 1976.
- Dickerson, Mary**. *The Frog Book*. Dover. 1969
- Erickson, Russell**. *A Toad for Tuesday* Lothrop, 1974
- Erickson, Russell**. *Warton and Morton*. Lothrop, 1976.
- Erickson, Russell**. *Wart and the Contest* Lothrop, 1986.
- Flack, Marjorie**. *Walter, the Lazy Mouse*. Doubleday, 1983
- Grimm, Jacob**. *The Frog Prince* Troll, 1979.
- Hawes, Judy**. *Why Frogs Are Wet* Crowell, 1975.
- Isle, Elizabeth**. *Frog Princess A Russian Tale Retold*. Crowell, 1984.
- Kepes, Juliet**. *Frogs Merry*. Pantheon, 1961.
- Kimmel, Margaret M.** *Magic in the Mist*. Atheneum, 1975.
- Lane, Margaret** *Frog*. Dial, 1982.
- Langstaff, John**. *Frog Went A-Courtin'*. Harcourt, 1956
- Lobel, Arnold**. *Days With Frog and Toad* Harper, 1979
- Lobel, Arnold**. *Frog and Toad All Year*. Harper, 1976.
- Lobel, Arnold**. *Frog and Toad Are Friends* Harper, 1970.
- Lobel, Arnold**. *Frog and Toad Together*. Harper, 1972.
- Maris, Ron**. *Better Move on, Frog*. Watts, 1982.
- Mayer, Mercer**. *A Boy, a Dog, a Frog, a Friend*. Dial, 1971.
- Mayer, Mercer** *A Boy, a Dog, and a Frog* Dial, 1967

- Mayer, Mercer.** *Frog Goes to Dinner*. Dial, 1974
- Mayer, Mercer.** *Frog on His Own*. Dial, 1973.
- Mayer, Mercer.** *Frog, Where Are You?* Dial, 1969
- Mayer, Mercer.** *One Frog Too Many*. Dial, 1975
- McClung, Robert.** *Peeper, First Voice of Spring*. Morrow, 1977.
- Norton, Mary.** *Are All the Giants Dead?* Harcourt. 1975
- Paterson, Diane.** *If I Were a Toad*. Dial, 1977.
- Potter, Beatrix.** *Tale of Mr. Jeremy Fisher*. Warne, 1906.
- Seeger, Pete.** *Foolish Frog*. Macmillan, 1973.
- Selsam, Millicent.** *First Look at Frog, Toads, and Salamanders*. Walker, 1974
- Simon, Hilda.** *Frogs and Toads of the World*. Lippincott, 1975.
- Smith, Jim.** *Frog Band and the Onion Seller*. Little, 1980.
- Stephens, Henry L.** *Frog He Would A-Wooing Go*. Walker, 1967
- Tresselt, Alvin.** *Frog in the Well*. Lothrop, 1958.
- Twain, Mark.** *Celebrated Jumping Frog of Calaveras County*. Dover, 1971.
- Zemach, Harve.** *Princess and the Froggie*. Farrar, 1975.

Audiovisual materials to accompany FROG FACT--FROG FICTION

*Meet the Newbery Author Arnold Lobel* (revised edition). (sound filmstrip). Random House

*Days With Frog and Toad*. (read-along), Random House

*Frog and Toad All Year* (read-along), Random House

*Frog and Toad Are Friends* (read-along), Random House

*Frog and Toad Together* (read-along), Random House

*Frog and Toad Are Friends*. (set of five sound filmstrips), Random House

*A Boy, a Dog, and a Frog* (sound filmstrip), Random House.

*Frog Goes to Dinner* (sound filmstrip), Random House

*Frogs Merry*. (read-along), Random House

Random House  
Department 9278  
400 Hahn Road  
Westminster, MD 21157

"The Frog Prince," *Treasury of Fairy Tales*. (sound filmstrip), SVE

"From Tadpole to Frog," *Life Science Patterns*. (sound filmstrip for intermediate grades),  
SVE

Society for Visual Education, Inc  
Department BK  
1345 Diversey Parkway  
Chicago, IL 60614-1299

*The Foolish Frog*. (sound filmstrip), Weston Woods

*Frog Went A-Courtin'*. (sound filmstrip), Weston Woods

*The Tale of Mr. Jeremy Fisher* (sound filmstrip), Weston Woods

Weston Woods  
Weston, CT 06883

A Frog Book

by \_\_\_\_\_

A Frog Book

by \_\_\_\_\_

150

151



**Frog Eggs**

**Tadpole**

**Baby Frog**

**Big Frog**

**Frog Eggs**

**Tadpole**

**Baby Frog**

**Big Frog**

152

153

## FROG AND TOAD SKIT

- Frog: Ribbit, ribbit . . . .
- Librarian: Now Frog, you are going to have to speak in 2nd grade lingo today so the boys and girls will understand all the wonderful things you have to tell them.
- Frog: Ribbit. . . uh, croak. Hi ya tadpoles! My name is Frog. My friends, \_\_\_\_\_, \_\_\_\_\_, \_\_\_\_\_ and I want to tell you about the Frog and Toad Fan Club \_\_\_\_\_ tell these young tadpoles what the Frog and Toad Fan Club is all about.
- \_\_\_\_\_ : It is a special reading project for second graders at our school. It helps you learn to read better and practice reading out loud.
- Frog: \_\_\_\_\_, what do they have to do in order to join in on the fun?
- \_\_\_\_\_ : Take the Frog and Toad Fan Club letter home to Mom and Dad today Let them read it and help you decide if you will become a member.
- Frog: Ribbit . . . pardon me . . . Sounds simple to me, but there's bound to be some hidden work in there somewhere . . . and I hate work . . . yak, yak, yak .
- \_\_\_\_\_ : Frog, reading is fun! not work . . . and that's what you must do in order to join There are four books we want everyone to read out loud They are: (Show each book and title.)
- \_\_\_\_\_ : These books can be found in our media center here at school, the public library, or you may already have some of them at your home. They are usually available to purchase at our school book fair, too.
- Librarian: That's right \_\_\_\_\_ and \_\_\_\_\_ Students, don't forget that the important thing to do after you have read each book aloud is to have Mom, Dad, or your teacher sign your letter and bring it back to me. A frog with your name on it will be put on the bulletin board.
- Frog: Say, after these tadpoles do all this fun reading, what are they going to get?
- \_\_\_\_\_ : Membership cards like this one will be given by the principal at our Awards Assembly in the spring. Members will then attend a party, complete with cookies and Kool-Aid.
- Frog: Ribbit, Croak, Ribbit . . . I mean yeah! Come on boys and girls--start hopping (reading) those books so you can join the Frog and Toad Fan Club But before we go are there any questions?

Skit contributed by Sharon Burns, Charles Haskell Elementary School, Edmond.

## FROG AND TOAD FAN CLUB

\_\_\_\_\_ Elementary Library

Dear Parents of Second Graders:

Every school year I have a special project I like to do with our second graders. Harper Publishing Company has furnished free for us Frog and Toad Fan Club membership cards. Your child can earn one of these cards by reading all four of Arnold Lobel's books about Frog and Toad as listed below.

In library class this week we saw a filmstrip about Arnold Lobel and his life. Now your child needs to **READ TO YOU ALOUD** each of the titles listed below to earn a fan club membership card. Even if your child has read any of the four books before, please have him/her read them again for this project. Sign your name in each of the four places designated for you and have your child return this sheet to me with your signatures on it. I will then give your second grader the membership card.

Happy reading with your child! Thank you for your assistance. . . .

Your child's librarian,

My child has read to me *Days With Frog and Toad* by Arnold Lobel.

Signature \_\_\_\_\_

My child has read to me *Frog and Toad Together* by Arnold Lobel.

Signature \_\_\_\_\_

My child has read to me *Frog and Toad All Year* by Arnold Lobel.

Signature \_\_\_\_\_

My child has read to me *Frog and Toad Are Friends* by Arnold Lobel.

Signature \_\_\_\_\_

FROG PUPPET

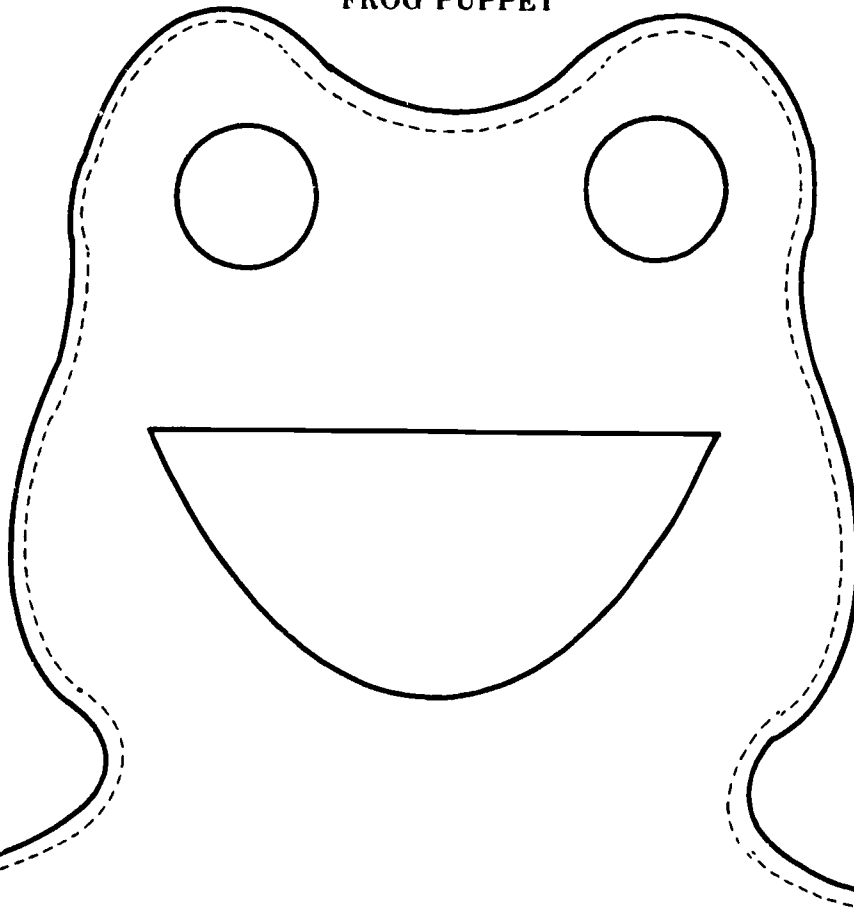

Attach  
A to C  
here

Attach  
A to C  
here

A

Cut 2

Green Felt

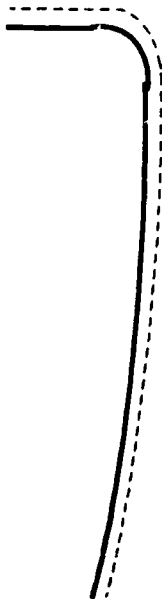

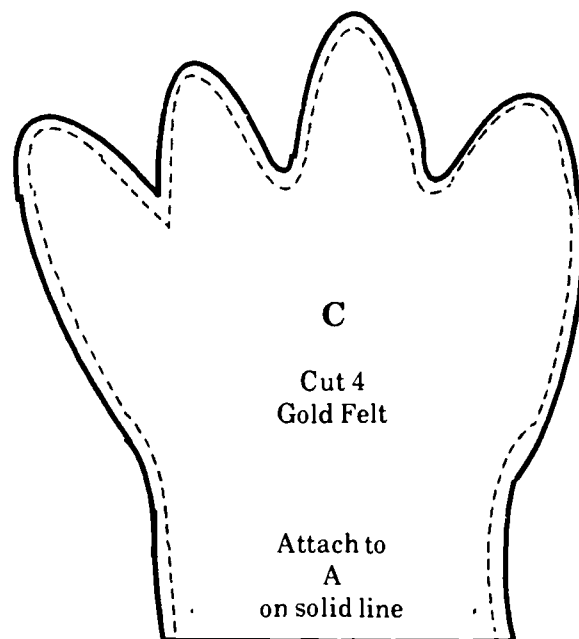
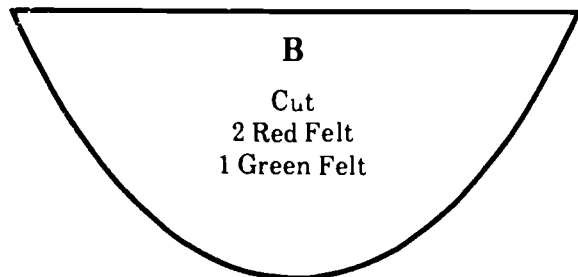

- A Body of the Frog
- B Used to Form the Mouth of the Frog
- C Hands of the Frog

**DIRECTIONS:**

1. Cut all pieces.
2. Sew one red B to A completely around mouth area as shown on the pattern
3. Sew the remaining red B to the green B. Attach to A, red side down, just across the top, forming a flap that creates the mouth.
4. Sew C to A, both sides, front and back
5. Sew the two A pieces together along stitch line.
6. Sew on plastic eyes (available at most craft stores).
7. Sew a small red pom pom on green side of flap.
8. Frog is now ready to reside on your hand and converse with your eager readers. Enjoy!

Puppet pattern provided by Virginia Lytle, Tushka School



The Hungry Frog

ATE

## LET IT SNOW!

Emphasis Grade Level: 3

**CURRICULUM APPLICATION(S):** Science, Math, Reading, Language Arts, Art

**GOAL:** Students will understand what happens to water that falls as precipitation and, through various activities, understand snow as a natural and valuable part of the world's water cycle.

### COOPERATIVE PLANNING/TEACHING

<p>The teacher will:</p> <ol style="list-style-type: none"><li>1. Teach scientific concepts regarding the water cycle.</li><li>2. Guide students in the related curriculum area activities.</li></ol>	<p>The library media specialist will:</p> <ol style="list-style-type: none"><li>1. Direct all research activities.</li><li>2. Make students aware of different sources of information, such as science magazines, television programs relating to science, newspapers, etc</li><li>3. Schedule the videocamera to be used in the science classroom to record activities such as the snowball melting, in order to observe the change in the snowball over a period of time.</li><li>4. Share some literature (books, poems, etc.) about snow, and plan follow-up activities with the classroom teacher.</li></ol>
---	---

## LEARNER OUTCOMES

Content Area	Information Skills
<p>The student will:</p> <ol style="list-style-type: none"> <li>1. Record and describe information gathered from first-hand experiences.</li> <li>2. Infer the possible cause and effect of an event.</li> <li>3. Understand the four natural factors which determine our weather: solar energy, atmosphere, movement of the earth, and water.</li> <li>4. Draw and label the basic stages of the water cycle.</li> </ol>	<p>The student will:</p> <ol style="list-style-type: none"> <li>1. Locate and distinguish between fiction and nonfiction.</li> <li>2. Be introduced to the library catalog.</li> <li>3. Use a simple index, a table of contents, and an encyclopedia.</li> <li>4. Read graphs, charts and tables.</li> <li>5. Obtain information from a filmstrip.</li> <li>6. Record impressions from listening to a story, watching a film</li> <li>7. Answer purposeful questions without copying from the text.</li> <li>8. Develop a chart to record information.</li> <li>9. Recall, summarize and paraphrase what is listened to and viewed.</li> <li>10. Develop an appreciation of good literature through listening, viewing, and reading.</li> </ol>

### ACTIVITIES/SUGGESTIONS:

1. Introduce the students to the following concepts:
  - A. Water from the earth's surface evaporates into the air.
  - B. Clouds form when warm, moist air cools.
  - C. Precipitation falls from clouds as snow, rain or sleet.
  - D. The water on the earth moves in a cycle.
2. As a group activity, prepare a chart listing interesting facts about water. Hang the chart for display in the classroom during this unit.
3. Share Janna Cole's book, *The Magic School Bus at the Waterworks*.



4. Referring to pages 38-39 in the above book, review the story with children, distinguishing between factual and fictional information.
5. View a filmstrip which relates the water cycle as an aspect of weather. Suggested Source: *Weather Changes* available from the Society for Visual Education.
6. Review the filmstrip by discussing how rain, snow, and sleet are formed.
7. Have students draw and label the basic stages of the water cycle.
8. Depending on the time of the year, choose rain (spring) or snow (winter) to provide extended interdisciplinary activities such as the following.
9. Keep thermometers both indoors and outdoors to be read at the same time every day. Have students keep track of both the Fahrenheit and Celsius readings every day for several weeks. For a math tie-in, students can make a graph and figure the average temperature for each week.
10. Talk about how the movie industry has used various materials to simulate snow (examples: bleached cornflakes, white sand, etc.). Have student try to think of other products which might be used for this purpose. Discuss more uses of artificial snow, other than to make movies.
11. For a creative writing exercise, have students write a short newspaper story about the effects of a major winter snowstorm in your area of the United States.
12. As a group activity, experiment with different ways to get an ice cube to melt. Try heating vents, radiators, fans, crushing the ice cubes, etc. Give each student a paper cup and an ice cube. Allow them to think of ways to get their ice cube to melt the fastest. **NO HOT WATER ALLOWED!**
13. For a short activity to fill five or ten minutes, give students a "snow" word such as SNOWBALL or SNOWFLAKE and see how many new words they can make in five minutes.
14. On a snowy day, make a tightly packed snowball. Stick it on the end of a pencil. Have students estimate how long it will take the snowball to melt. Record the guesses and see who was right. (This is an excellent activity to record with the video camera.)
15. Share Alvin Tresselt's *The Mitten* or the version recorded in the *Macmillan Early Skills Program* "Storytelling" section. Accompanying activities are included in this kit.
16. Discover the impurities in snow. Gather snow from different areas of the playground in clean jars. Allow the snow to melt. Examine the water under a microscope and using a magnifying glass. Allow students to draw conclusions.
17. During a heavy snowfall, the class can make a snow gauge. Mark every inch and half inch on a strip of masking tape. Put the tape on the outside of a clear jar. The jar should be placed outside in the open away from trees and other obstacles. Check every hour during the day to see how much snow is accumulating.

18 Make snow ice cream

- 4 C clean snow
- 2 T. sugar
- $\frac{1}{4}$  t. vanilla
- $\frac{1}{2}$  C. milk

Stir gently and eat quickly.

19. Give student a sheet of paper with a snowman outline on it. Have them write a snowman story.
20. Have students research facts about snow. For example: find the coldest, snowiest, iciest days in the area where you live or elsewhere.
21. Students will enjoy sharing snow stories orally. Even if you live in an area that has little snow, students' remembrances about snow at Grandma's or a ski trip will be enjoyable.
22. Develop a theme for winter recreational reading such as "Read the Winter Away." Motivational materials for this theme are available from Upstart, Box 889, Hagerstown, MD 21741.
23. Children can add a wintery effect to any picture. Have them draw and color winter scenes. Mix 16 ounces of Epsom salts in four ounces of very hot water. Paint over the entire picture with this mixture. As the picture dries, frosty crystals will appear. CAUTION. Epsom salts is poisonous, and the water is hot.
24. As one of your first activities of the morning, use the daily newspaper to obtain the weather forecast for your area. At the end of the day, record the actual weather on a chart using the following symbols.

	Sunny	T	Thunder
	Cloudy	Sn	Snow
W	Windy	Sl	Sleet
L	Lightning	Ha	Hail
R	Rain	Hu	Humidity

Some days may require more than one symbol. It is good to do this for a period of time so that each child can have the experience of observing and recording the weather.

25. Make a snowflake stamp with a potato. Cut it in half and on the flat portion draw a snowflake pattern. Cut the surface so that the snowflake is raised. Dip it in white paint and apply to a drawing for a snowy effect.
26. Share winter poetry and have children write their own.
27. Mitten math will provide a break from routine math lessons. Have students bring a pair of mittens from home. Label each pair and place them together. Review classifying, patterning, and matching skills using the mittens.

28. Children love a snowball fight. Make a collection to keep handy for snowy days. Tie medium weight white yarn loosely around a 4" cardboard about 100 times. Remove the yarn from the cardboard, gather at the center and tie with an additional piece of yarn. Clip the loop apart, and you're ready for a fun activity that will release lots of energy on those long winter days indoors.
29. BR-R-R-R-R! It's Cold When It Snows! Combine a cursive writing lesson on the joining of the "b" and "r" with some winter fun. Have students practice the joining of the "b." Write words that begin with this sound, then use these words to write winter-time sentences. (Example: Bruce broke his mother's broom when he brought it outside to build the snowman.)
30. Have a group of students research William Bentley (1865-1931) and the art of photomicrography. Class members will enjoy hearing how Bentley collected and studied snowflakes.
31. On a snowy day, give each child a piece of dark construction paper or felt to take outside to catch snowflakes. Observe their likenesses and differences. Return to the classroom to share findings and follow with an art activity in which children cut snowflakes to decorate the classroom.

**EVALUATION:** Students will receive a letter grade (A, B, C, D, F) at the end of the unit based on daily assignments and a teacher-made summative test.

**RESOURCES:**

"Storytelling," *Macmillan Early Skills Program*, 1982, pp. 15-16

Macmillan Educational Company  
Six Commercial Street  
Hicksville, NY 11801

"Weather Changes," *Slim Goodbody's World of Weather and Climate*. (sound filmstrip), Society for Visual Education, 1983.

Society for Visual Education  
Department BK  
1345 Diversey Parkway  
Chicago, IL 60614-1299

Cole, Joanna. *The Magic School Bus at the Waterworks*, Scholastic, 1986

Micallef, Mary. *Storms and Blizzards*, Good Apple, Inc., 1985.

Good Apple, Inc.  
Box 299  
Carthage, IL 62321-0299

Tresselt, Alvin. *The Mitten*, Lothrop, 1964.

*Young People's Science Encyclopedia*, (set of 20 volumes), Childrens Press, 1982.

Zinkgraf, Jane and Bauman, Tony. *Winter Wonders* Good Apple, Inc , 1978

*Celebrating Snow Web*, Volume IX, Number 2, Winter, 1985 Ohio State University, College of Education, 1985

The WEB  
Ohio State University  
Room 200 Ramseyer Hall  
29 West Woodruff  
Columbus, OH 43210

## "Let It Snow" BIBLIOGRAPHY

- Andersen, Hans Christian.** *The Snow Queen* Harper, 1985
- Beutley, W. A. and Humphreys, W. J.** *Snow Crystals*. Dover 1931
- Bodecker, N. M.** *Snowman Sniffles and Other Verse* Atheneum, 1985.
- Briggs, Raymond.** *The Snowman*. Random House, 1978.
- Brooks, Gwendolyn.** *Bronzeville Boys and Girls "Cynthia in the Snow"* Harper, 1956.
- Bunting, Eve.** *Winter's Coming*. Harcourt, 1977.
- Burningham, John.** *The Snow*. Crowell, 1975.
- Burton, Virginia Lee.** *Katy and the Big Snow* Houghton Mifflin, 1943.
- Busch, Phyllis S.** *Walk in the Snow*. Lippincott, 1971
- Calhoun, Mary** *Cross-Country Cat*. Morrow, 1979.
- Crompton, Anne Eliot** *The Winter Wife*. Atlantic-Little, Brown, 1975.
- dePaola, Tomie.** *Cat on the Dourefell A Christmas Tale* Putnam, 1979
- Delton, Judy.** *A Walk on a Snowy Night*. Harper, 1982
- Dodge, Mary Mapes.** *Hans Brinker, or The Silver Skates*. Grossett, 1978
- Duvoisin, Roger.** *Snowy and Woody*. Knopf, 1979.
- Fisher, Ron.** *Animals in Winter*. National Geographic, 1982.
- Frost, Robert.** *Stopping by Woods on a Snowy Evening*. Dutton, 1978.
- Goffstein, M. B.** *Our Snowman*. Harper & Row, 1986.
- Gundersheimer, Karen.** *Happy Winter*. Harper, 1982.
- Hader, Berta and Elmer.** *The Big Snow*. Macmillan, 1948.
- Hopkins, Lee Bennett.** *Moments Poems About the Seasons*. Harcourt, 1980.
- Keats, Ezra Jack.** *The Snowy Day* Viking, 1976.
- Kellogg, Steven.** *The Mystery of the Missing Red Mitten*. Dial, 1974
- Kurelek, William** *A Prairie Boy's Winter*. Houghton Mifflin, 1973
- Lindgren, Astrid** *The Tomten*. Coward, 1961.
- Lobe, Mira.** *Snowman Who Went for a Walk* Morrow, 1984.

- Mack, Gail.** *Yesterday's Snowman.* Pantheon, 1979.
- Markle, Sandra.** *Exploring Winter.* Atheneum, 1984
- Marshak, Samuel.** *The Month-Brothers. A Slavic Tale.* Morrow, 1983
- McCord, David.** *One at a Time.* "The Snowman." Little, Brown, 197.
- Milne, A. A.** *The House at Pooh Corner* "The More It Snows." Dutton, 1961
- Prelutsky, Jack** *It's Snowing! It's Snowing!* Greenwillow, 1984.
- Sasaki, Isao.** *Snow.* Viking, 1982.
- Schick, Eleanor.** *City in the Winter* Macmillan, 1970.
- Selsam, Millicent.** *How to Be a Nature Detective.* Harper, 1958.
- Selsam, Millicent.** *Where Do They Go? Insects in Winter* Four Winds, 1982.
- Sendak, Maurice.** *Chicken Soup With Rice.* "January." Harper, 1962.  
*Snowy Day: Stories and Poems.* Lippincott, 1986.  
*Time for Poetry.* "The Mitten Song" by Mary Louise Allen. Scott, Foresman, 1978.
- Tresselt, Alvin.** *White Snow, Bright Snow.* Lothrop, 1963.

## Snow Poems

MOMENTS: POEMS ABOUT THE SEASONS  
IT'S SNOWING!

STOPPING BY WOODS ON A SNOWY EVENING

- Make a favorite snow poem into an oversize class book or sequential mural, each child makes a picture for one line. "Cynthia in the Snow"
- Think of words to show how snow looks, tastes, feels, sounds; put some of them into a poem.

## Winter Magic

THE MONTH BROTHERS

THE WINTER CHILD

THE WINTER WIFE

- Find and share other folktales with snowy settings

THE TOMTEN

- Notice the many colors of snow in illustrations; watch how light and shadow make snow seem different colors in your neighborhood
- Create your own magical winter creature, make it out of scrap materials, name it, decide what its tracks look like in the snow, write or tell stories about its activities

## Snow People

THE SNOWMAN

- Compare with film of same title.

YESTERDAY'S SNOWMAN

THE RUNAWAY GIANT

THE SNOWMAN'S SECRET

SNOWMAN SNIFFLES

"The Snowman"

THE MYSTERY OF THE MISSING RED MITTEN

- Make snow people.
- Build your own models of snow people out of interesting materials at school; write stories and descriptions.
- Paint white snow-people pictures on black or navy blue paper.

Reprinted by permission of The WEB, The Ohio State University, From **CELEBRATING SNOW WEB**, Volume 9, No. 2 Winter 1995.

## Winter Walkers

A WALK ON A SNOWY NIGHT

"WINTER NIGHT"

THE SNOWMAN WHO WENT FOR A WALK

HOLD MY HAND

HAPPY WINTER

"The More It Snows"

Take a walk on a snowy day; write a description of your snow-covered school

HOW TO BE A NATURE DETECTIVE

- Who walks in the snow? Keep a record of tracks seen: animals, birds, people, model them in clay or plaster of Paris; see how many you can identify.

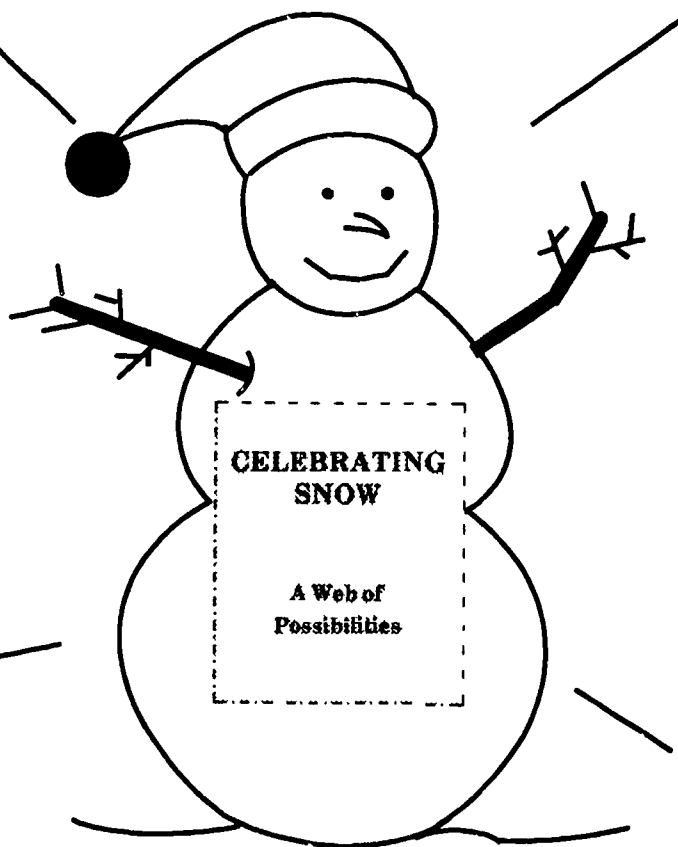

## Snow Fun

THE SNOW PARTY

A DAY OF WINTER

JOE AND THE SNOW

JOSIE AND THE SNOW

"January" from CHICKEN SOUP WITH RICE

- Explore different homemade or "found" objects for sliding.

IN THE FLAKY, FROSTY MORNING

A PRAIRIE BOY'S WINTER

- Plan a festival of snow events make snow angels, play fox and geese, make snow sculptures, eat snow ice cream

## Beautiful Snow

### SNOW

### THE SNOW

### WHITE SNOW, BRIGHT SNOW

### THE SNOWY DAY

### IT'S SNOW (film)

- Make paintings on the snow, using spray bottles filled with colored water
- Make cut-paper snowflakes.
- Describe the snow scene outside your window without using the word "snow"; write about snow for a friend or pen pal in a climate where no snow falls.

## Weather Trouble

### KATY AND THE BIG SNOW

### CITY IN THE WINTER

### MARY JO'S GRANDMOTHER

### CROSS-COUNTRY CAT

### THE BIG SNOW

### WE BE WARM 'TIL SPRINGTIME COMES

- Make a collection of news articles about people or animals in crises during winter weather.
- Make stories with illustrations about your own winter storm experiences, or imagine some--what would you do if you were snowed in at school?

## Waiting for Winter

### HAS WINTER COME?

### WINTER'S COMING

### THE MICE CAME IN EARLY THIS YEAR

### IT'S TIME NOW

### NOW THAT DAYS ARE COLDER

- Make a chart to show how different animals prepare for winter.
- What happens at your house to show that the snow season is coming? Make a picture chart; compare with classmates.

## Snow Gear

- Make surveys, graphs of the winter gear in your class. How many pairs of boots? What Kind? How many wear mittens? Gloves? Coats with hoods? Without? "Winter Clothes" "The Mitten Song"

## Winter Science

### SNOWY AND WOODY

- Make a list of animals that change color in winter.

### WHERE DO THEY GO? INSECTS IN WINTER

### ANIMALS IN WINTER

- Take a winter trip to a nearby zoo. Which animals are more active? Are they cared for differently than in the summer?

### ON SUNDAY THE WIND CAME

### SNOW IS FALLING

### THE SECRET LANGUAGE OF SNOW

### EXPLORING WINTER

- Keep a weather log; record daily temperatures and think of an interesting way to show your information.
- Freeze water, milk, orange juice, etc., in paper cups by putting them outside on a cold day. How long does it take for each? What happens if you add salt to the water? Sand?
- Bring a cup of snow into the classroom; make predictions about how soon it will melt, and time it to see how close you are.



## WINTER WORD FIND

T O X R E T E T H L F R F D V G D K M O N  
E I M D E P W C L I I V G C P M J H O Y N  
W T S Q W T I E V T L Q S N B M N Z F C Y  
R B A P L N N D T M F M W I J A T C U A U  
G P C K E L C I C I I L P R E E A I O A G  
U F R O S T Y L W Z B T A K L A V K F F S  
J A Q B L N A S S Q N T T K R T M S N V U  
M M B G E D O S M R O T S E E G E H Y Q D  
J I E A D A P W W N A M W O N S N O J T V  
V Z J C D D W H B L I Z Z A R D G V E Y A  
C G G G F X B I M A D C T B Q F R E E Z E  
D C F T P Y X T B K L O E K P D L L F F B  
N J O I X R M E J B P L X H B S M N V U O

Can you find these words?

FROSTBITE  
SNOWMAN  
FLAKES  
FROSTY  
SLIDE  
WHITE  
SKI

BLIZZARD  
FREEZE  
MITTEN  
WINTER  
STORM  
SLED  
ICE

SNOWBALL  
SHOVEL  
ICICLE  
SKATE  
SLEET  
COLD

Answer Key for: WINTER WORD FIND

. . . R . . . . .  
 E . . . E . . . . .  
 . T . . . T . E . . . . .  
 . . A . . . N D T M F . . . . .  
 . . C K E L C I C I I L . . . . . I . . . . .  
 . F R O S T Y L W . B T A . . . . . K . . . . .  
 . . . . . L N . S . . . . . T T K . . . . . S . . . . .  
 . . . . . E D O . M R O T S E E . . . . . H . . . . .  
 . . . . . D . . . W . N A M W O N S . O . T . . . . .  
 . . . . . . . . H B L I Z Z A R D . V E . . . . .  
 . . . . . . . . I . A . C . . . . . F R E E Z E  
 . . . . . . . . T . . . L . E . . . . . L L . . . . .  
 . . . . . . . . E . . . . . L . . . . . S . . . . .

## FAIRY TALES

Emphasis Grade Level: 3

**CURRICULUM APPLICATION(S):** Language Arts, Reading

**GOAL:** The students will be introduced to fairy tales and will gain a better understanding of the terminology and the different elements through listening, viewing, and reading.

### COOPERATIVE PLANNING/TEACHING

<p>The teacher will:</p> <ol style="list-style-type: none"> <li>1. Introduce fairy tales.</li> <li>2. Discuss story elements or ingredients</li> <li>3. Plan with library media specialist to work with students to complete the related activities.</li> </ol>	<p>The library media specialist will.</p> <ol style="list-style-type: none"> <li>1. Instruct students in 10 fairy tales.</li> <li>2. Discuss good storytelling techniques.</li> <li>3. Share fairy tales with students and plan follow-up activities with the teacher</li> </ol>
---	--

### LEARNER OUTCOMES

Content Area	Information Skills
<p>The student will:</p> <ol style="list-style-type: none"> <li>1. Develop basic sentences into interrogative, imperative and declarative forms</li> <li>2. Capitalize and punctuate properly.</li> <li>3. Develop an appreciation of good literature through listening, viewing, and reading</li> <li>4. Distinguish between fictional and factual reading materials</li> </ol>	<p>The student will.</p> <ol style="list-style-type: none"> <li>1. Understand the significance of the call number</li> <li>2. Locate some specific nonfiction area</li> <li>3. Be introduced to the card catalog</li> <li>4. Use a dictionary</li> <li>5. Be introduced to fairy tales.</li> <li>6. Develop a chart to record information</li> <li>7. Develop an appreciation of good literature through listening, viewing and reading.</li> </ol>

## ACTIVITIES/SUGGESTIONS:

1. Introduce the meaning of fairy tales using the filmstrip "Fairy Tales," Literature for Children, Series 2, sfs, Pied Piper Productions. Grades 3-6
2. Discuss "Ingredients of a Fairy Tale."
  - a. Tales usually begin--"Once upon a time" or "Long, long ago "
  - b. Both good and bad characters usually appear in the same story (Seven good dwarfs protected Snow White from the wicked queen )
  - c. Many fairy tales include some kind of command which, if broken will cause trouble. (Little Red Riding Hood was warned never to stop and talk to strangers )
  - d. One incident often occurs 3 times in a fairy tale. (The Three Bears came home 3 different times before they found Goldilocks in bed.)
  - e. Many fairy tales include some kind of magic. (The fairy Gounmother turned rats and mice into coachmen, a pumpkin into a coach, etc.).
  - f. Most tales end happily with--"and they all lived happily ever after."
3. The "Ingredients of a Fairy Tale" can be listed on a file folder and made into a learning center. The student would be instructed to read a fairy tale and see how many ingredients were in the story they read.
4. As a group activity prepare a large chart listing all the "ingredients" and identify each in fairy tales you have viewed or read.
5. Encourage children to help locate any fairy tale books and bring them to class
6. Read, view, and discuss different variations of fairy tales

Jim and the Beanstalk	Sidney Rella and the Glass Sneaker
Jack and the Beanstalk	Cinderella
7. Write an original fairy tale. Remember the characteristics of a fairy tale  
"Once upon a time . . .,"  
Good and bad characters,  
Command--if broken, trouble will result,  
Happenings in 3's,  
Magic , and  
Happy endings.
8. Let each student pick out a tale to tell to others. Be sure they read the story through several times, then practice telling it to small groups. They might want to try telling it into the tape recorder the first time

9. Share with the class the book *The Jolly Postman or Other People's Letters* by Janet and Allan Ahlberg. It contains letters to various folktale and Mother Goose characters, such as a letter to Baby Bear from Goldilocks apologizing for breaking his chair. As a follow-up activity have students write letters or design an advertisement concerning their favorite fairy tale characters.
10. As a group activity draw a large mural showing different scenes from various fairy tales.

#### RESOURCES:

"The World of Once Upon a Time," *Early Years*. November/December, 1985. pages 26-31

"Fairy Tales Learning Station," *Eureka. Ideas and Activities for Personalizing Media Skills*  
Wake County Public Schools.

Media Services  
Wake County Public Schools  
P.O. Box 28041  
601 Devereau Street  
Raleigh, NC 27611

*Folk and Fairy Tales II: A Second Web of Possibilities*. Volume X, No 2 Winter 1986.  
Ohio State University, College of Education, 1986

The WEB  
Ohio State University  
Room 200, Ramseyer Hall  
29 West Woodruff  
Columbus, OH 43210

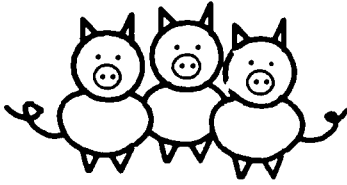

## FOLK AND FAIRY TALES II

### A Second Web of Possibilities

#### Celebrations

Have a folktale party

- Dress as folk characters.
- Cook and serve food based on stories  
(see bibliography for cook books.)
- Tell or dramatize stories, old and new.
- Play guessing games.
- Bring stuffed animals to represent a favorite character

Invite guests

- Ask storytellers to share stories.
- Ask grandparents to come tell about tales they love.
- Ask other teachers to come in and read their favorite tales

Investigate

- Take surveys to discover
  - favorite folktale characters
  - scariest folktale characters
  - funniest folktale characters
  - most disliked folk tale characters.

Create displays

- Make a folktale museum using real objects

Write descriptions

- Make folk characters' houses out of cardboard boxes.
- Make a mural of life-sized characters
- Make a folklore quilt

#### Pourquoi Tales

WHY THE TIDES EBB AND FLOW

MOON SONG

DEVIL'S TAIL

THE CAT'S PURR

- Write your own Pourquoi tale

#### Modern Variants

CHICKEN LITTLE

JIM AND THE BEANSTALK

JACK AND THE BEANSTALK (Ross)

THE THREE PIGS

SIDNEY RELLA

SLEEPING UGLY

MR. AND MRS. PIG'S EVENING OUT

- Compare these with the originals
- Discuss what makes these versions humorous
- Write a modern variant of another tale.

#### Stories to Compare

(Book titles vary; see author)

"Sleeping Beauty"

Hutton, Hyman, LeCain, Mayer

"Rapunzel"

Rogasky, Ash

"Little Red Riding Hood"

Crawford, deRegniers,

Hyman

"The Three Bears"

Cauley, Turkle

"The Three Little Pigs"

Blegvad, Galdone, Reinl

"Snow White"

Heins, Jarrell, Reeves

"The Bremen Town Musicians"

Plume, Diamond, Shub

- Chart the different versions noticing similarities and differences in language, characters, settings, story lines, illustrations and book design
- Hold an election to select class favorites preceded by campaign speeches, buttons, banners
- Write and illustrate versions of the books that combine the best elements

Reprinted by permission of The WEB, The Ohio State University  
From *Folk and Fairy Tales II A Second Web of Possibilities*,  
Volume X, No 2. Winter 1986.

## Motifs

### Magical Objects

THE MERMAID'S CAPE  
THE FIVE SPARROWS: A JAPANESE FOLKTALE  
BIG ANTHONY AND THE MAGIC RING

- Make a catalog of magical objects or bring real objects to school and make up the kind of magic they might do.

- Learn about and perform magic tricks.

JACK AND THE BEANSTALK

- Plant magic beans and predict what will happen

Magic Pot Stories

THE MAGIC PORRIDGE POT

THE MAGIC COOKING POT

STREGA NONA

- Chart the refrains

What starts the pot?

Stops it?

- Make pasta or bread dough figures.

### Trickery

GOING TO SQUINTUM'S

WHO'S IN RABBIT'S HOUSE?

THE TURTLE AND THE MONKEY

FIN M'COUL, THE GIANT OF KNOCKMANY HILL

MOLLY WHUPPIE

- Write descriptions of the tricksters

Try to "trick" others as they guess the identities

- Make a class book with portraits of tricksters and a description of their best trick. Invent some new ones.

- Retell a story from the point of view of the tricked character.

### Transformations

THE STORY OF JUMPING MOUSE

THE DONKEY PRINCE

THE FROG PRINCESS

CINDERELLA

- Make a list of characters who were transformed.

Illustrate them "before" and after

- Cook up some real transformations

(bread, gelatin, popsicles)

DAWN

THE CRANE WIFE

- Compare these versions

- Write

### Beast Tales

GOLDILOCKS AND THE THREE BEARS

- Continue the story of Goldilocks. What happened when she got home?

THE LITTLE RED HEN

THE COCK, THE MOUSE AND THE LITTLE RED HEN

- Bake Red Hen's bread.

THE BREMEN TOWN MUSICIANS

THE TOWN MOUSE AND THE COUNTRY MOUSE

THE THREE BILLY GOATS GRUFF

- Make story boxes filled with items to aid storytelling

- Make a collection of all the "threes" in beast tales

- Have a "beast party" Prepare foods the beasts might enjoy.

## Types of Tales

### Cumulative Tales Old and New

THE ROSE IN MY GARDEN

RUM PUM PUM

THE TROUBLESOME PIG

THE NAPPING HOUSE

- Make a chart of what accumulates

- Using the pattern, write or tell new tales

I KNOW AN OLD LADY

- Make an X-ray of the inside of the lady

### Noodlehead Tales

ALL OF OUR NOSES ARE HERE AND OTHER NOODLE TALES

THE MAN WHO KEPT HOUSE

THE THREE SILLIES

- Think of modern "noodleheads"

Tell or write about them

Books Mentioned in the FOLK AND FAIRY TALES II Web

- All of Our Noses Are Here and Other Noodle Tales* by Alvin Schwartz Illustrated by Weinhaus. Harper, 1985.
- Big Anthony and the Magic Ring* by Tomie dePaola. Harcourt, 1979
- The Bremen Town Musicians* from the Brothers Grimm Retold and illustrated by Donna Diamond. Delacorte, 1971.
- The Bremen Town Musicians* by Ilse Plume. Doubleday, 1980.
- The Bremen Town Musicians* by Elizabeth Shub Illustrated by Janina Domanska Greenwillow Books. 1980.
- The Cat's Purr* by Ashley Byran Atheneum, 1985.
- Cinderella* from the Brothers Grimm. Illustrated by Nanny Hogrigan. Greenwillow, 1981.
- Cinderella* retold from Charles Perrault by Amy Ehrlich. Illustrated by Susan Jeffers Dial, 1985.
- Cinderella* from the Brothers Grimm. Translated by Anne Rogers. Illustrated by Otto S Svend Larousse and Company, 1978.
- Chicken Little* retold and Illustrated by Steven Kellogg. Morrow, 1985.
- The Cock, the Mouse and the Little Red Hen* retold and illustrated by Lorinda Cauley. G.P. Putnam's Sons, 1982.
- The Crane Wife* by Sumiko Yagawa. Translated by Katherine Paterson Illustrated by Suekichi Akaba. Morrow, 1981
- Dawn* by Molly Bang. Morrow, 1983.
- Deep in the Forest* by Brinton Turkle Dutton, 1976
- Devil's Tail* by Nanine Valen. Illustrated by David McPhail. Scribner, 1978
- The Donkey Prince* by M. Jean Craig Illustrated by Barbara Cooney
- Fi, M'Coul and the Giant of Knockmany Hill* retold and illustrated by Tomie dePaola Holiday House, 1981.
- The Five Sparrows: A Japanese Folktale* by Patricia M Newton. Atheneum, 1982
- The Frog Princess* by Elizabeth Isele Illustrated by Michael Hague Crowell, 1984
- Going to Squintum's: A Foxy Folktale* by Jennifer Westwood. Illustrated by Fiona French. Dial, 1985.



Books Mentioned in the Folk and Fairy Tales Web (continued)

- Goldilocks and the Three Bears* by Lorrinda Cauley Putnam, 1981
- Goldilocks and the Three Bears* by Bernadette Watts. Harper, 1985
- I Know an Old Lady* by Nadine Westcott. Little Brown, 1980
- Jack and the Beanstalk* retold and illustrated by Lorinda Bryan Cauley G P Putnam's Sons, 1983.
- Jack and the Beanstalk* retold in verse for boys and girls to read themselves by Beatrice Schenk deRegniers. Illustrated by Anne Wilsdorf. Atheneum, 1985.
- Jack and the Beanstalk* by Tony Ross. Delacorte, 1981.
- Jim and the Beanstalk* by Raymond Briggs. Putnam, 1980.
- Little Red Cap* by the Brothers Grimm. Translated by Elizabeth Crawford Illustrated by Lisbeth Zwerger. Morrow, 1983.
- The Little Red Hen: An Old Story* by Margot Zemach Farrar, Straus and Giroux, 1983.
- Little Red Riding Hood* by the Brothers Grimm. Illustrated by Trina Schart Hyman Holiday House, 1983.
- The Magic Cooking Pot* by Faith Towle Houghton Mifflin, 1975
- The Magic Porridge Pot* by Paul Galdone. Houghton Mifflin, 1976.
- The Man Who Kept House* by Kathleen Hague. Illustrated by Michael Hague Harcourt Brace, 1981.
- The Mermaid's Cape* by Margaret K Wetterer. Atheneum, 1981
- Mr and Mrs. Pig's Evening Out* by Mary Rayner. Atheneum, 1976
- Molly Whuppie* retold by Walter de la Mare. Illustrated by Errol LeCain Farrar Straus & Giroux, 1983.
- Moon Song* by Byrd Baylor. Illustrated by Ronald Himler. Scribner, 1982.
- The Musicians of Bremen* by the Brothers Grimm. Translated by Anne Rogers. Illustrated by Otto S. Svend. Larousse and Company, 1974
- The Napping House* by Audrey Wood Harcourt Brace, 1984
- Rapunzel* retold and illustrated by Jutta Ash Holt, 1982
- Rapunzel* by Barbara Rogasky. Holiday House, 1982.

Books Mentioned in the FOLK AND FAIRY TALES II Web (continued)

- Red Riding Hood* by Beatrice Schenk deRegniers. Illustrated by Edward Gorey Atheneum, 1972
- The Rose in My Garden* by Arnold Lobel. Illustrated by Anita Lobel
- Rum Pum Pum* retold by Maggie Duff. Illustrated by Jose and Ariane Dewey Macmillan, 1978
- Sidney Rella and the Glass Sneaker* by Bernice Myers Macmillan, 1985
- Sleeping Beauty* from the Brothers Grimm Retold and illustrated by Warwick Hutton Atheneum, 1979.
- Sleeping Beauty* by the Brothers Grimm. Retold and illustrated by Trina Schart Hyman. Little Brown, 1977.
- Sleeping Beauty* from the Brothers Grimm. Illustrated by Errol LeCain Bradbury Press, 1975.
- Sleeping Beauty* by Mercer Mayer. Macmillan, 1984
- Sleeping Ugly* by Jane Yolen. Illustrated by Diane Stanley. Coward McCann, 1981.
- Snow White* by the Brothers Grimm. Translated by Paul Heins. Illustrated by Trina Schard Hyman. Little Brown, 1974
- Snow White and Red Rose* by James Reeves and Jenny Rodwell. England: Andersen-Hutchinson, 1981. (U.S.: State Mutual Book and Periodical Service).
- Snow White and the Seven Dwarfs* by the Brothers Grimm. Translated by Randall Jarrell Illustrated by Nancy Ekholm Burkert. Farrar, Straus, Giroux, 1972.
- The Story of Jumping Mouse* by John Steptoe. Lothrop, 1984.
- Strega Nona* by Tomie dePaola. Prentice Hall, 1975.
- The Three Billy Goats Gruff* by Paul Galdone. Houghton Mifflin, 1981.
- The Three Little Pigs* by Erik Blegvad. Atheneum, 1980.
- The Three Little Pigs* by Paul Galdone Houghton Mifflin, 1984.
- The Three Little Pigs* by Edda Reinl. Neugebauer, 1983.
- The Three Pigs* by Tony Ross. Pantheon. 1983.
- The Three Sillies* by Paul Galdone. Houghton Mifflin. 1981
- The Town Mouse and the Country Mouse* by Lorrinda Cauley Putnam, 1984

Books Mentioned in the Folk and Fairy Tales II Web (continued)

*The Troublesome Pig* by Priscilla Lamon. Crown, 1985

*The Turtle and the Monkey* by Paul Galdone. Houghton Mifflin, 1982

*Who's in Rabbit's House?* by Verna Aadema. Illustrated by Leo and Diane Dillon. Dial, 1977

*Why the Tides Ebb and Flow* by Joan Chase Bowden. Houghton Mifflin, 1979

**More for Reference**

**COOKBOOKS**

*The Fairy Tale Cookbook* by Carol MacGregor. Macmillan, 1983.

*Pease Porridge Hot: A Mother Goose Cookbook* by Lorrinda Cauley. Putnam, 1977.

*The Storybook Cookbook* by Carol MacGregor. Prentice-Hall.

**COLLECTIONS**

*Ardizzone's Hans Andersen's Fourteen Classic Tales* translated by Stephen Carrin. Illustrated by Edward Ardizzone. Andre Deutsch, 1985.

*The Baby's Story Book* by Kay Chora. Dutton, 1985.

*The Brocaded Slipper and Other Vietnamese Tales* by Lynette Dyer Wong. Illustrated by Vo Pink Mai. Addison-Wesley, 1982.

*The Helen Oxenbury Nursery Story Book* by Helen Oxenbury. Knopf, 1985

*The Larousse Book of Fairy Tales* compiled by Patricia Pierce. Larousse, 1985.

*The People Could Fly: American Black Folktales* by Virginia Hamilton. Illustrated by Leo and Diane Dillon. Knopf, 1985.

*The Random House Book of Fairy Tales* adapted by Amy Ehrlich. Illustrated by Diane Goode. Random House, 1985.

*Sweet and Sour: Tales From China* retold by Carol Kendall and Li Yao-wen. Houghton Mifflin, 1979

## FOLKTALES

**Emphasis Grade Level: 3**

**CURRICULUM APPLICATION(S):** Language Arts, Reading, Social Studies

**GOAL:** The student will gain a better understanding of folktales and their origins through reading, viewing and listening, and various activities.

### COOPERATIVE PLANNING/TEACHING

<p>The teacher will:</p> <ol style="list-style-type: none"> <li>1. Correlate unit with reading series.</li> <li>2. Guide students in related activities.</li> </ol>	<p>The library media specialist will.</p> <ol style="list-style-type: none"> <li>1. Discuss the origin of folktales</li> <li>2. Instruct and guide students in finding folktales</li> <li>3. Share folktales from different countries with students.</li> </ol>
---	---

### LEARNER OUTCOMES

Content Area	Information Skills
<p>The student will:</p> <ol style="list-style-type: none"> <li>1. Develop an appreciation of good literature through listening, viewing, and reading.</li> <li>2. Distinguish between realism and fantasy in print and nonprint medium.</li> <li>3. Use maps.</li> <li>4. Develop a variety of interests in independent library book selections.</li> </ol>	<p>The student will.</p> <ol style="list-style-type: none"> <li>1. Be introduced to the card catalog.</li> <li>2. Develop a chart to record information.</li> <li>3. Obtain information from a filmstrip.</li> <li>4. Recall, summarize, and paraphrase what is listened to and viewed.</li> <li>5. Be introduced to folktales</li> </ol>

## ACTIVITIES/SUGGESTIONS:

1. Introduce unit with "The Mitten," a Russian folktale by Alvin Gresselt.
2. View a filmstrip which tells about the characteristics and origins of folktales. Suggested source: "Folktales Then and Now," from the series 8, "Folktales: the Heritage, Traditions, Conventions and Themes" of *Literature for Children* by Pied Piper Media
3. Divide class into small groups of two or three. Locate and read all the folktales they can from a particular country. Record some of the basic things they found on a chart. Headings might include: Good Guys, Bad Guys, Country, Money or Riches, Plants, Animals, Food
4. Have students compare the strong differences as well as the strong similarities of the German and Irish folktales. Use the charts to compare and also read aloud to the class an example from each country and have students find the differences and the similarities
5. View filmstrip which shows folktales are a way of sharing the customs, values and feelings of people from cultures different from our own. Suggested source: "Folktales from Afar" from Series 8, "Folktales: The Heritage, Traditions, Conventions and Themes" of *Literature for Children* by Pied Piper Media.
6. Read a story about a spider. Suggested source: *Anansi the Spider* by Gerald McDermott. Make Anansi. For each spider
  - a. Cut one 3 inch circle from black construction paper
  - b. Cut eight "legs" 12 inches long,  $\frac{1}{4}$  inch wide from black paper
  - c. Fold legs accordion style, then straighten.
  - d. Use white crayon or chalk to draw Anansi's face on circle.
  - e. Glue legs to circle.
  - f. Attach piece of yarn or fishing line for hanging.
7. Read a North American folktale. Suggested source: *Arrow to the Sun* by Gerald McDermott. Use finger paints and a long strip of butcher paper to make a mural
8. Read *Stone Soup*. Suggested Sources. *Stone Soup* by Marcia Brown; *Stone Scup* by Ann McGovern; and *Stone Soup*, sfs by Weston Woods

Make stone soup using directions in the Elementary Level Oklahoma Nutrition Education Training Guide. pp. F-13 to F-15.
9. Have students nominate their favorite folktale character. Conduct a campaign with speeches and posters, let students vote to find the class favorite.
10. On a world map indicate the different countries the folktales are from, using map pins or some sort of markers.
11. As a final activity for the unit, students dress as a folk character they have read or heard about.

## EVALUATION:

Students will be given an identical pretest and a post test concerning the origins, names, and plots of various folk tales.

## RESOURCES:

"Storytelling," Macmillan Early Skills Program, 1982 pp 15-16

Macmillan Educational Company  
6 Commerce Street  
Hicksville, New York 11801

"Folktales From Afar" and "Folktales Then and Now" *Folktales: The Heritage, Traditions, Conventions and Themes*, Pied Piper Media (sound filmstrip)

"Stone Soup" Weston Woods. (soundfilmstrip)

Brown, Marcia. *Stone Soup*, Scribner, 1984

McDermott, Gerald. *Anansi the Spider*, Holt, Rinehart & Winston, 1972

McDermott, Gerald *Arrow to the Sun*. Viking, 1974

McGovern, Ann. *Stone Soup*. Scholastic, 1977

Tresselt, Alvin *The Mitten* Lothrop, 1964

"Folk Tales as Pictures Books: Visual Literacy or Oral Traditions" *School Library Journal*  
Volume 33, Number 10 (June-July 1987). pp. 46-47.

*Folk and Fairy Tales II: A Second Web of Possibilities*, Volume X, No. 2 Winter 1986  
Ohio State University, College of Education, 1986.

The WEB  
Ohio State University  
Room 200, Ramseyer Hall  
29 West Woodruff  
Columbus, Ohio 43210

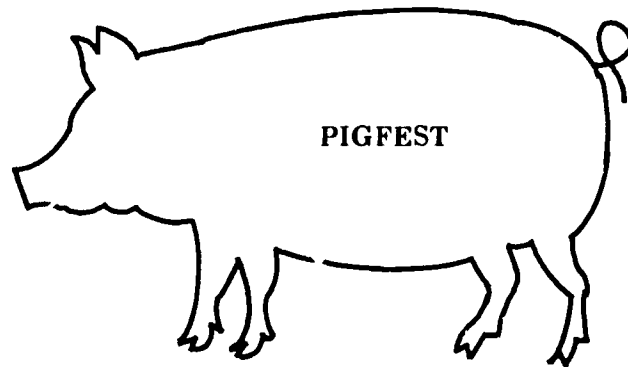

**Emphasis Grade Level: 4**

**CURRICULUM APPLICATION(S):** Reading, Language Arts

The following activities and teaching materials are only a sampling of many things which can be used in developing a "Pigfest" theme with students in the elementary school. This unit was used with a fourth grade class, but could be adapted for other grade levels. Activities have been included which are appropriate for younger children

**GOAL:** Students will become familiar with pigs, their habitat, physical characteristics and eating habits. They will also enjoy literature and related activities with pigs.

#### **COOPERATIVE PLANNING/TEACHING**

<p>The teacher will:</p> <ol style="list-style-type: none"><li>1. Carry out the curriculum-related activities</li></ol>	<p>The library media specialist will:</p> <ol style="list-style-type: none"><li>1. Teach/review the information skills.</li><li>2. Coordinate the research activities.</li><li>3. Work jointly with the classroom teacher to present the various books and audiovisual programs.</li><li>4. Work jointly with the classroom teacher to plan the Pigfest Party.</li></ol>
---	--

## LEARNER OUTCOMES

Content Area	Information Skills
<p>The student will:</p> <ol style="list-style-type: none"> <li>1 Use the encyclopedias and other reference books.</li> <li>2 Develop an appreciation of good literature through listening, viewing, and reading</li> <li>3 Write stories and reports.</li> <li>4 Differentiate between fiction and nonfiction.</li> <li>5 Develop the ability to create mental images</li> <li>6 Use a dictionary to find information.</li> <li>7 Use parts of a book correctly.</li> <li>8 Enjoy many forms of reading materials for a variety of purposes</li> <li>9 Be able to use reference material skills.</li> </ol>	<p>The student will</p> <ol style="list-style-type: none"> <li>1. Learn the following terms, <i>spine label, table of contents, index, glossary</i></li> <li>2. Distinguish between the use of an encyclopedia and a dictionary.</li> <li>3. Use an encyclopedia (guide words, index).</li> <li>4 Use a dictionary (guide words, entry words).</li> <li>5. Use the library catalog to locate specific sources by author, title and subject.</li> <li>6. Produce simple booklets.</li> <li>7. Record information on a cassette tape.</li> <li>8. Write stories and reports.</li> <li>9. Find and enjoy a variety of literature.</li> <li>10. Watch stories on film, filmstrips and video.</li> <li>11. Develop recreational reading habits.</li> </ol>

### ACTIVITIES/SUGGESTIONS:

- 1 Examine several different versions of *The Three Little Pigs*. Draw conclusions as to how the same story can change according to the different styles of illustrators.
- 2 March is a good month for "Pigfest" activities as March 1 is National Pig Day. This day was created "to accord the pig its rightful, though generally unrecognized, place as one of man's most useful domesticated animals."
3. People born in the years 1935, 1947, 1959, 1971, 1983, and 1995, are born under the sign of the boar in the Oriental zodiac. If you teach students born in one of these years, plan a pig program to celebrate birthdays.



4. Display piggy banks owned by students to create interest in pigs. Be sure they can be secured in a safe area.
  5. Share John Goodall's wordless picture books about Paddy Pork. Have students write a story to accompany the pictures.
  6. Share Arnold Lobel's *Book of Pigericks*. Use an atlas to locate where each of the pigs Lobel writes about live. Have students write their own pigericks.
  7. After introducing several nonfiction books about pigs and presenting the encyclopedia as an additional source of information, use the "Pigs at Play" pattern for a creative writing project. Students can write about how pigs have fun--rolling in the mud, grunting, etc.
  8. A lesson on nutrition fits in nicely with James Marshall's book *Yummers!* After reading the book, talk about a balanced diet and the four basic food groups. Give each student a sheet of drawing paper to fold into quarters and label. Provide old magazines to find pictures to be cut out and mounted in the right section. The collage should show foods that make up a balanced diet.
  9. After reading *Small Pig* by Arnold Lobel, have students make a "Lost" poster that would help in trying to locate Small Pig.
  10. Have students write a letter to a cousin who has just received a pet pig for his birthday. Give the cousin some suggestions to help him care for, train and enjoy his pig. (Source: Oklahoma State Department of Education: *Summer's Best to You--A Sampler of Reading Activities*)
  11. Involve students in a brainstorming session about "pigs." Categorize their ideas into headings such as appearance, habits, uses, etc.
  12. Encourage students to bring in pictures, poems, stories, drawings, and models of pigs for display. (Use the public library or neighboring schools as another source of books.)
  13. Teach pig songs such as "Sally the Pig," found in *Bananas in Pyjamas* by Carey Blyton.
  14. Have students make up their own crossword puzzles and wordfinds about pigs. Computer programs such as "Puzzles and Posters" by MECC are good for this activity.
- Minnesota Educational Computer Consortium (MECC)  
3490 Lexington Avenue North  
St. Paul, Minnesota 55112
15. "Pig" vocabulary--list words needed for writing poems and stories--display words in the shape of a pig.
  16. Teach the children how to conduct an interview. Have them prepare questions and then take them to visit a "piggery" where they can interview the owner. Other students could record the "sounds" of the animals at various times (during eating, etc.).
  17. Arrange a visit to the meat department of your local grocery store. Interview the butcher to find out about "pork" as sold in food stores.

18. Have students write stories such as

How Pigs Got Curly Tails  
Why Pigs Love Mud  
Why Pigs Are Fat

Compile all their stories into a pig anthology. Ask the librarian to catalog it as a permanent part of the library collection.

19. Do a novel study of *Charlotte's Web* by E. B. White or *Funch* by Larry Cullen. These titles are also suitable for reading aloud to the whole class.
20. Write to an author such as William Steig or Robert Newton Peck. Find out about their interest in pigs.
21. Allow the children to design and make their own "pigmarks" to be used as bookmarks. Then laminate them.
22. Discuss "greased pigs" contests as held at county fairs. See what information about this type of contest can be found in reference books.
23. Discuss "piggy banks"--possible origin, etc. Design one using old plastic containers and boxes.
24. Talk about expressions we use such as "dirty as a pig" or "fat as a pig".
25. Using encyclopedias or other sources of information, have students make an information book about pigs, including a title page, table of contents and index. Make the spine label as it would appear on a book in the library.
26. Read the story *Apple Pigs* by Ruth Orbach. Let students make the pigs from the instructions given on the last page of the book.
27. Have students make a "potato print" of a pig. Stamp it onto tissue paper to create perforated wrapping paper.
28. Older students can make a counting book for a kindergarten or first grade class using pigs and numbers one through ten.
29. Write a story about a pig. Some title suggestions might be

If I Were a Pig  
The Pig Who Oinked Too Much  
The Pig Who Was Afraid of Mud  
The Pig and the Wolf

30. Dictionary activities.

A. Words From Words--How many words can be made from letters in the words "Pig Out"? Some possibilities include gout, pout, tip, got, pit, tug, gut, put, pot, it, go, and pug. Using the words they can make from "Pig Out," have students compile their own PIGTIONARY. Students should list each word along with the pronunciation guide and definition. Have them use the word in a sentence. An illustrated PIGTIONARY would be simply "deswine."

- B Pig Vocabulary--After consulting the encyclopedia or other information source, ask students to list on a sheet of paper all the words associated with pigs (including food we get from pigs) Examples: hog, swine, piglet, sow, boar, farrow, gilt, herd, litter, pork, pork chops, spareribs, loin roast, ham, bacon, sausage, pickled pig's feet and knuckles, lard, etc Have students compile their own PIGTIONARY listing each word along with pronunciation guide and definition. Have them use the word in a sentence. They will go "hog wild" about an illustrated PIGTIONARY

(Numerous "pigfest" activities were contributed by Jeanne Moss, John Ross Elementary School, Edmond, Oklahoma.)

### PIGFEST PARTY

This theme may be concluded by the librarian inviting students to a "Pigfest" in the library (See sample invitation ) The format of the event could be as follows:

- a. Children can come dressed for the occasion by making a "snout" and a curly tail
- b. Use a movie or favorite pig story to start the celebration
- c. Have an "Apple Hunt" for all the pigs. Paper apples are hidden and students are given three minutes to see who can collect the most. Prizes can be real apples.
- d. Serve "pigcorn" (popcorn) to each pig in a plastic cup They must eat it without using their hands.

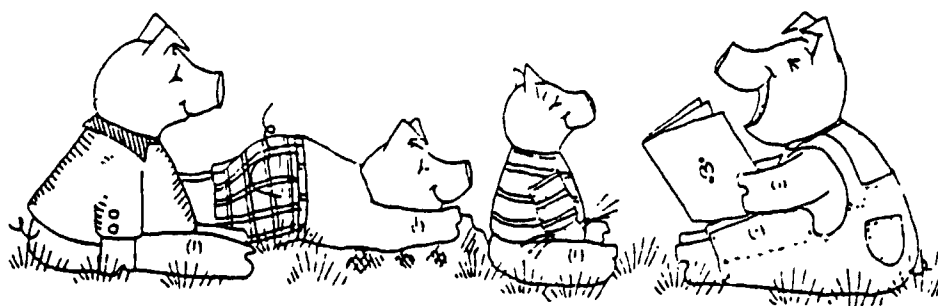

TO EVERYONE IN ROOM \_\_\_\_\_

FROM \_\_\_\_\_ YOUR LIBRARIAN

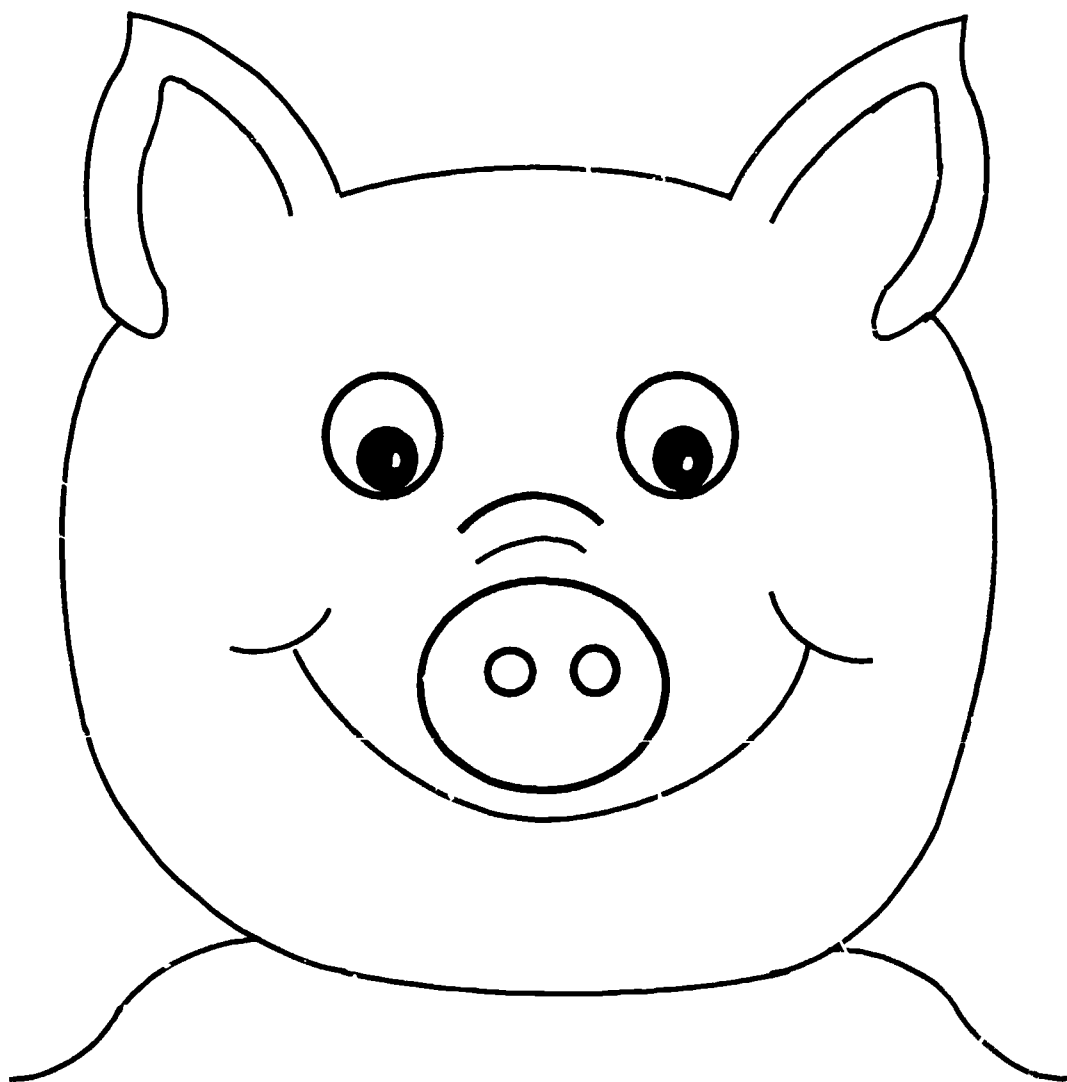

YOU ARE INVITED TO COME TO A "PIG FEST" IN THE  
LIBRARY ON \_\_\_\_\_ AT \_\_\_\_\_.

THERE WILL BE MUSIC, FILMS, STORIES, GAMES AND FOOD FIT  
FOR PIGS...

R.S.V.P

**EVALUATION:**

Allow students to evaluate "Pigfest" activities and make suggestions for improvements or additional activities.

**RESOURCES:**

**Bauer, Caroline Feller.** *This Way to Books.* H. W. Wilson, 1985. pp. 149-166

**Bauer, Caroline Feller.** *Celebrations.* H. W. Wilson, 1983. pp. 57-58.

**Paulin, Mary Ann.** *Creative Uses of Children's Literature.* Shoe String Press, 1982. pp. 42-43

**Sitarz, Paula Gaj.** *Picture Book Story Hours.* Libraries Unlimited, 1987. pp. 109-114.

**Watson, Clyde** *Father Fox's Feast of Songs* Philomel, 1983. pp. 8-9.



Lynn Gates Bredeson

## PIGFEST BIBLIOGRAPHY

- Ballaglia, Aurelius** *Three Little Pigs* Random, 1977.
- Bawden, Nina** *Peppermint Pig*. Penguin, 1977
- Blegvad, Erik** *Three Little Pigs*. Atheneum 1980
- Blegvard, Lenore.** *This Little Pig-a-Wig*. McElderry, 1978.
- Blyton, Care.** *Bananas in Pyjamas*. Faber, 1976.
- Bond, Felicia.** *Poinsettia and the Firefighters*. Crowell, 1984.
- Bowman, Sarah.** *Pigs: A Troughful of Treasures*. Macmillan, 1983
- Boynton, Sandra.** *Hester in the Wild* Harper, 1979.
- Brown, Marc.** *Perfect Pigs: An Introduction to Manners*. Little, 1983.
- Bucknall, Caroline** *The Three Little Pigs*. Dial, 1987
- Carroll, Lewis.** *Pig-Tale*. Little, 1975.
- Christelow, Eileen.** *Mr. Murphy's Marvelous Invention*. Houghton, 1983.
- Copeland, Colene.** *Priscilla*. Jordan Valley, 1981
- Cullen, Larry.** *Pinch*. Little, 1976
- DeJong, Meindert.** *House of the Sixty Fathers* Harper, 1956.
- Demong, Phyllis.** *It's a Pig World out There*. Avon, 1981.
- Dunn, Judy.** *The Little Pig* Random House, 1987.
- Fairless, Caroline.** *Hambone*. Tundra, 1980.
- Fleming, Susan.** *Pig at 37 Pinecrest Drive*. Westminster, 1981
- Gackenbach, Dick.** *Pig Who Saw Everything*. Houghton, 1978
- Galdone, Paul.** *The Three Little Pigs*. Houghton, 1970.
- Galdone, Paul.** *The Amazing Pig*. Houghton, 1981.
- Geisert, Arthur.** *Pigs From A-Z* Houghton, 1986.
- Geisert, Arthur** *Pa's Balloon and Other Pig Tales*. Houghton, 1984.
- Getz, Arthur.** *Fumphrey, the Dancing Pig* Dial, 1980.
- Gipson, Fred.** *Curly and the Wild Boar*. Harper, 1979
- Goodall, John S** *Adventures of Paddy Pork*. Harcourt, 1968.
- Goodall, John S** *Paddy Pork--Odd Jobs*. Atheneum, 1983.
- Goodall, John S.** *Paddy Pork's Holiday*. Atheneum, 1976.
- Gretz, Susanna.** *It's Your Turn, Roger!* Dial, 1985.
- Harrison, Harry.** *Men From P.I.G. and R.O.B.O.T.* Atheneum, 1978.
- Hauptmann, Tatjana.** *A Day in the Life of Petronella Pig*. Smith, 1980
- Heine, Helmet** *The Pigs' Wedding*. Atheneum, 1979.
- Hoban, Lillian.** *Mr. Pig and Family* Harper, 1980.

- Hopf, Alice. *Pigs Wild and Tame*. Holiday, 1979
- Jeschke, Susan. *Perfect the Pig*. Holt, 1981
- Johnston, Tony. *Farmer Mack Measures His Pig*. Harper, 1986
- Koller, Holly. *Geraldine's Blanket*. Greenwillow, 1984.
- King-Smith, Dick. *Babe. The Gallant Pig*. Crown, 1985
- King-Smith, Dick. *Pigs Might Fly*. Scholastic, 1984
- Lamont, Priscilla. *Troublesome Pig*. Crowell, 1984.
- Lavine, Sigmund. *Wonders of Pigs*. Dodd, 1981
- Lobel, Arnold. *Book of Pigericks*. Harper, 1983.
- Lobel, Arnold. *Small Pig*. Harper, 1969.
- Lobel, Arnold. *Treeful of Pigs*. Greenwillow, 1979
- MacLachlan, Patricia. *Arthur, for the Very First Time*. Harper, 1980.
- Marshall, James. *Yummers!* Houghton, 1973
- Marshall, James. *Yummers Too: The Second Course*. Houghton, 1986
- McClenathan, Louise. *Easter Pig*. Morrow, 1982
- McPhail, David. *Pig Pig and the Magic Photo Album*. Dutton, 1986
- McPhail, David. *Pig Pig Goes to Camp*. Dutton, 1983
- McPhail, David. *Pig Pig Grows Up*. Dutton, 1980
- McPhail, David. *Pig Pig Rides*. Dutton, 1982
- Orbach, Ruth. *Apple Pigs*. Putnam, 1981.
- Peck, Robert Newton. *A Day No Pigs Would Die*. Knopf, 1972
- Peet, Bill. *Chester the Worldly Pig*. Houghton, 1978.
- Pomerantz, Charlotte. *Piggy in the Puddle*. Macmillan, 1974
- Potter, Beatrix. *Tale of Pigling Bland*. Warne, 1913.
- Pryor, Bonnie. *Amanda and April*. Morrow, 1986.
- Rayner, Mary. *Garth Pig and the Ice-Cream Lady*. Atheneum, 1977
- Rayner, Mary. *Mr. and Mrs. Pig's Evening Out*. Atheneum, 1976.
- Rayner, Mary. *Mrs. Pig Gets Cross*. Dutton, 1986
- Rayner, Mary. *Mrs. Pig's Bulk Buy*. Atheneum, 1981.
- Ross, Tony. *The Three Pigs*. Pantheon, 1983.
- Sharmat, Michelle. *Seven Sloppy Days of Phineas Pig*. Harcourt, 1983
- Steig, William. *Amazing Bone*. Farrar, 1976.
- Steig, William. *Farmer Palmer's Wagon Ride*. Farrar, 1974.
- Steig, William. *Roland the Minstrel Pig*. Harper, 1968.
- Stevens, Carla. *Pig and the Blue Flag*. Houghton, 1976.
- Stine, Bob. *Pigs' Book of World Records*. Random, 1980.

**Stolz, Mary** *Emmett's Pig* Harper, 1959  
**Van Leeuwen, Jean** *Amanda Pig and Her Big Brother Oliver* Dial, 1982  
**Van Leeuwen, Jean** *Tales of Oliver Pig* Dial, 1973  
**Van Loon, Dirk** *Small-Scale Pig Raising* Garden Way, 1978  
**Watson, Pauline** *Wriggles, The Little Wishing Pig* Clarion, 1978  
**White, E. B.** *Charlotte's Web* Harper, 1952  
**Winthrop, Elizabeth** *Sloppy Kisses* Macmillan, 1980

Audiovisual materials to accompany PIGFEST

*Charlotte's Web.* (computer reading tutorial), Media Basics.

Media Basics  
Larchmont Plaza  
Larchmont, NY 10538

*The Amazing Bone* (sound filmstrip), Random House

Random House School Division  
Department 9278  
400 Hahn Road  
Westminster, MD 21157

*Mr and Mrs Pig's Evening Out* (sound filmstrip), Weston Woods

*The Three Little Pigs* (sound filmstrip), Weston Woods

Weston Woods  
Weston, CT 06883

*Pig Pig Grows Up.* (read-along), Live Oak Media

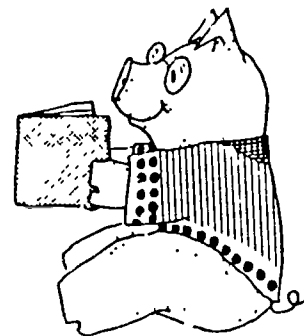

Lynn Gates Bredeson



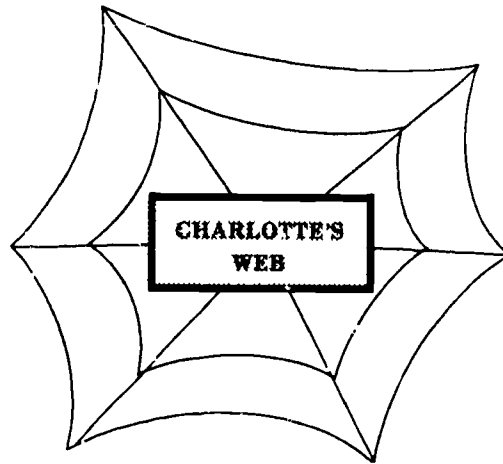

F G L T O J L S Y G W H B H  
 C Y U O Q Q J S R T N M E E  
 O T G L D J J G W E E J P T S  
 L A W Y M C V L V M S T N Q  
 J L X W U K G D A P O O Y C  
 I R T I I I R L N R E I T W C  
 Y D E L P Y A N R E F O D V  
 Z K I V D Z B A U T E K C X  
 D X T K W U H L B O M O O F  
 T T E E L C N U L N I B N G  
 N A C I O K I R I B M D H W  
 Q I S B O E U F W F E S Z J  
 A J W Y L R Z K I K O P F D  
 T E V B I M V E M R I I Y X  
 B Y A A R A Z Q T G R D B J  
 K R F M C N D W W X U E C L  
 A Q J U P V L E Y Z K R T

Can you find these words?

ZUCKERMAN  
 TERRIFIC  
 SPIDER  
 AVERY  
 FERN

CHARLOTTE  
 ARABLE  
 COBWEB  
 UNCLE  
 PIG

TEMPLETON  
 PIGLET  
 WILBUR  
 FAIR

Answer Key for: CHARLOTTE'S WEB

. . . . . Y  
 . . . . . R T E  
 . . . . . E M T E  
 . . . . . L V P O T  
 . . . . . G A P O  
 . . . . . I N R E F  
 . . . . . P Z H A U B O N  
 . . . . . E L C N U L N  
 . . . . . B O K I F W  
 . . . . . W B A  
 . . . . . E B A  
 . . . . . R A F  
 . . . . . A L I M A N  
 . . . . . N  
 . . . . . R I  
 . . . . . G R  
 . . . . . S P I D E R  
 . . . . . T

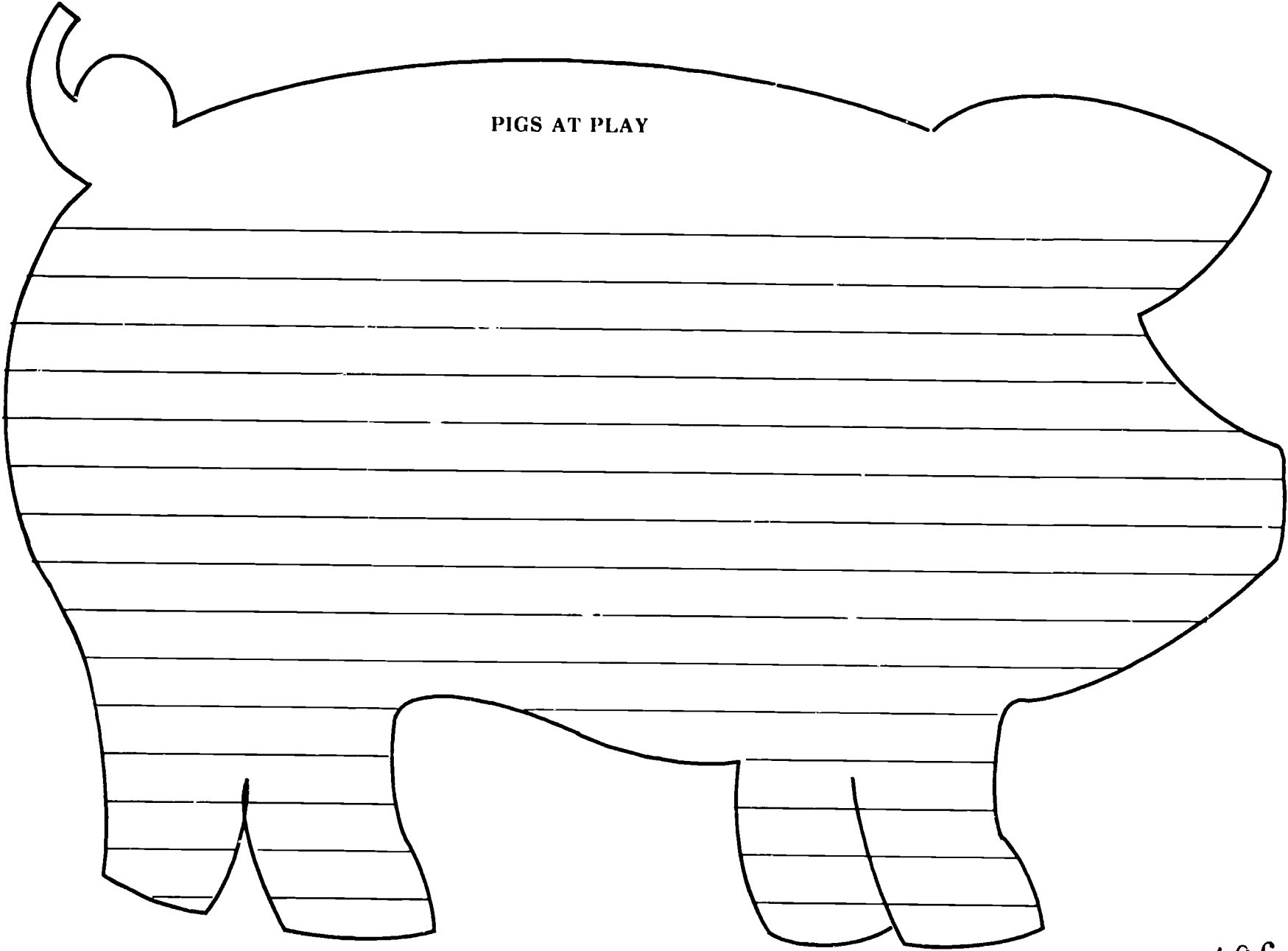

PIGS AT PLAY

## PIG TALES

Dear Parent.

Your child can help decorate our library this year by reading pig books. When a pig book is returned to the library, the reader will write their name on a pig sticker and add it to our display titled "A Treeful of Pigs" Please put a check by the style your child used to read his/her book. Students can read as many pig books as they desire! Thank you for sharing books with your child.

- \_\_\_\_\_ parent read book to child
- \_\_\_\_\_ child read book to parent
- \_\_\_\_\_ child and parent took turns reading book aloud
- \_\_\_\_\_ child read book by themselves and told parent about it

---

Parent's Signature



Lynn Gates Bredeson

The above activity was an all-school reading incentive program at Westwood Elementary School in Stillwater, Oklahoma. Under the direction of Lavonne Sanborn, library media specialist, students were introduced to the program with Arnold Lobel's *A Treeful of Pigs*. Pig spine labels were put on all pig stories so that volunteers would know to put them on the pig display table. As letters were returned to the library, the child's name was put on a pig sticker for the display. Stickers were obtained from the following source.

Mrs. Grossman's Paper Company  
1623 Fifth Avenue  
San Rafael, CA 94901

197

## SCIENCE FAIR PROJECTS

Emphasis Grade Level: 4-6

**CURRICULUM APPLICATION(S):** Science, Math, Reading, Language Arts, Art

What is a science fair project? Science fair projects are reports of research that has been done by an individual student or a team. The research and the display must be entirely the work of students, but this does not mean that students may not seek advice and technical assistance from qualified individuals.

**GOAL:** Students will use the scientific method to solve problems or find answers to questions by accessing a variety of resources. They will schedule time and organize resources to complete a project for the school science fair.

### COOPERATIVE PLANNING/TEACHING

The teacher will:	The library media specialist will
<ol style="list-style-type: none"><li>1. Introduce the science fair project to the students and give background information, as well as the timeframe for completion of the project.</li><li>2. Introduce/review the scientific method.</li><li>3. Help students choose appropriate topics.</li><li>4. Assist the class group in making an alphabetical listing of possible topics.</li><li>5. Notify parents about the science fair.</li><li>6. Prepare a list of rules and regulations.</li><li>7. Be available to give guidance, answer questions, and encourage students through the steps to the completion of the project.</li><li>8. Plan in depth, the day of the science fair. Enlist the help of teachers to serve in key roles during the fair. Obtain qualified judges.</li></ol>	<ol style="list-style-type: none"><li>1. Teach/review the information skills necessary to research the topics chosen by students.</li><li>2. Assist in helping students choose topics.</li><li>3. Help students locate pertinent information to set up the experiment and follow it through to completion.</li><li>4. Arrange for prizes and participation certificates for students.</li><li>5. Be available to further assist the science teacher as needed.</li></ol>

## LEARNER OUTCOMES

Content Areas Will vary according to the topic of the project See Science Section of *Suggested Learner Outcomes Grades 1-8* Oklahoma State Department of Education, 1984

### Information Skills

The student will

1. Understand the concept of the Dewey Decimal classification system as an organizational tool
2. Use the library catalog to locate specific sources by author, title, and subject
3. Use various sources to obtain information (e.g., encyclopedias, magazines, indexes, almanacs, etc.)
4. Use a periodical index (e.g., *Children's Magazine Guide*)
5. Scan material for relevant information.
6. Learn the following terms *index, table of contents*
7. Make concise notes from various types of media.
8. Write a composition on a selected topic after research.
9. Distinguish between relevant and irrelevant information
10. Examine material for validity and accuracy.
11. Prepare a bibliography.
12. Organize materials by classifying or summarizing
13. Design a visual to convey a message

## RELATED CURRICULUM ACTIVITIES

### MATH

- 1 Record findings on graphs or tables
2. Measurement--correct size or amount of materials/equipment to be used

### SCIENCE

1. Choose project which can be proven by experiment
2. Gather materials and equipment necessary to carry out experiment
3. Set up project

### READING

1. Read to gain needed information on how to do project.

### LANGUAGE ARTS

1. Take notes, record information, prepare bibliography.
- 2 Creative writing can be used as a break from working on projects. Nature poetry and science fiction stories are appropriate areas of literature

### ART

- 1 Make display board to show parts of project.
2. Set up display of project for the science fair.

**SOURCE:** Sharon Edmonds, Houchin Elementary School, Moore, Oklahoma

## Steps to Follow in Setting up a SCIENCE FAIR PROJECT

- Step 1:** A good science fair is a cooperative endeavor. To ensure maximum involvement from teachers, the seed should be planted early in the school year to give ample time for teachers to plan, ask questions and schedule other projects around the science fair. Talk to your principal and ask for a few minutes at staff meetings to share ideas and procedures. **COMMUNICATE!**
- Step 2:** Ask yourself:
- A. Who will be involved? Which grade levels? Several classes at the same grade level? All intermediate grades?
  - B. Is there an adequate facility to display the projects for judging? Can several classrooms be used? Is there an all-purpose room in the school? Would the media center be large enough?
  - C. Who will be invited? Other classes who are not involved? Parents? Newspapers? Local cable television stations? Could the science fair be jointly sponsored by the parent-teacher organization? Could the PTA furnish prizes? Could the fair be combined with an open house? A bake sale?
  - D. Will there be any restrictions on entries? Live animals? Electricity?
  - E. Can someone be available to take pictures? Will there be prizes or just participation certificates?
  - F. Who will be responsible for setting up and cleaning up?
  - G. **NOW!** Make a schedule and start planning.
- Step 3:** Present the idea to your students. Be enthusiastic! Expect numerous questions, some hesitation and doubts in the beginning. Have photographs from previous displays available. (Good photos, as well as other useful information, are included in *1987 Oklahoma Science & Engineering Fairs*, published by the Curriculum Section of the Oklahoma State Department of Education.) With patient explanations and answers to questions, students will begin to accept the challenge.
- Step 4:** Be prepared to help students think of subjects for their projects. Look through science textbooks, curriculum guides, encyclopedias, dictionaries, and other resource books. A good topic will inspire a question that can be answered only by experimenting.
- Step 5:** As a group project in the science class, make an alphabetical listing of science projects. List as many as students can think of for every letter of the alphabet. This will help students start to think of topics or experiments that could possibly be used for the science fair. (See page 188.)
- Step 6:** Establish the time, date and place of the fair. Make a chart for the classroom with a timeline for the completion of each part of the project. (See sample on page 189.)
- Step 7:** Notify parents of the science fair plans, date, rules and regulations. A form letter such as the one on page 190 can be used. Parents should acknowledge that they



understand their child's assignment by signing and returning the bottom portion of the page. A sample list of rules and regulations is included on page 191

**Step 8:** Before the day of the science display, each student should fill out an entry form (see page 192) and attach it to the project. If different grade levels are involved, duplicating the entry forms in different colors will facilitate arrangements and judging. After the class presentations, each student should fill out a critique such as the one on page 192.

**Step 9:** If possible, allow each student to stay with his or her project as the audience walks through. This kind of fair is a wonderful opportunity for students to take pride in their accomplishments and for parents and community members to see the positive learning experiences happening at school. As you walk through the fair, watch even your under-achievers beam as their projects are admired?

### ACTIVITIES/SUGGESTIONS:

1. Introduce/review the scientific method.
  - A. State the problem
  - B. Make a prediction
  - C. Design and carry out the experiment
  - D. Record observations
  - E. Draw a conclusion.
2. Have students write a paragraph describing their science project. They should explain the **purpose** of the project, and define what will need to be done to accomplish the goal. The purpose might be to determine the effects of pollution on the growth of roses, or to determine the reaction of meal worms to various environments.
3. Have students read the paragraphs aloud during science class. With input from the other students, make constructive suggestions to help make each proposal a potential success. Screen out or change any inappropriate proposals at this time. Make suggestions or add ideas as necessary.
4. Each student should give his project a title. He/she should form a hypothesis to predict the outcomes of the experiment. (Reinforce the use of the scientific method.) Science Project Plans on page 194 will help students to make definite plans for each phase in completing the project.
5. Allow some class time to work on the research paper and the construction of the display. Students' research papers should include:
  - A. Title page with name, school, grade and year
  - B. Table of contents.
  - C. Purpose.
  - D. Review of books and interviews
  - E. Materials and methods
  - F. Conclusion.
  - G. Bibliography.

## EVALUATION:

Students will be given a grade on the science project as a whole. The following things will be considered in grading the project: appropriateness of topic, use of the scientific method, accuracy in observing and recording results, neatness, and creativity.

The following criteria should be considered by the judges of the science fair competition:

1. Creative Ability--Was originality shown in solving the problem? Does the project have a purpose?
2. Scientific Thought--Does the problem illustrate completeness of observation and controlled experimentation? Are real study and effort represented?
3. Thoroughness--Does the exhibit tell a complete story?
4. Neatness and Dramatic Value--Are the labels large, attractive, neat, and easy to read? Is the exhibit attractive as compared to others in the same field?
5. Technical Skill--How skillfully was the mounting done? Is the exhibit of sound and durable construction?

## RESOURCES.

*Accent on Science* Charles E. Merrill Company, 1980. pp 41-43.

*1987 Oklahoma Science & Engineering Fairs*, Oklahoma State Department of Education, 1987.

"Science Fair With a Flair," *Frank Schaffer's CLASSMATE*, April/May/June, 1986. pp. 64-70.

Frank Schaffer Publications  
19771 Magellan Drive  
Torrance, CA 90502

"Steps to Follow in Setting up a Science Fair Project," *Creative Investigations*, The Learning Works, 1982 pp 45-48.

The Learning Works  
Santa Barbara, CA 93111

## SCIENCE FAIR PROJECT IDEAS

- Amery, Heather *The Know How Book of Experiments* EMC Publishing, 1978
- Arnold, Caroline *Sun Fun* Watts, 1981
- Arnov, Boris *Water Experiments to Understand It* Lothrop, 1980
- Beller, Joel *So You Want to Do a Science Project!* Arco, 1982
- Berenstain, Stan and Janice *Berenstain Bears' Science Fair* Random House, 1984
- Broekel, Ray *Experiments With Light*. Childrens Press, 1986.
- Broekel, Ray *Sound Experiments* Childrens Press, 1986
- Brown, Bob. *Science Treasures: Let's Repeat the Great Experiments* Fleet, 1978
- Brown, Marc. *Your First Garden Book*. Little, 1981
- Brown, Vinson. *Investigating Nature Through Outdoor Projects* Stackpole, 1983
- Challand, Helen J *Experiments With Electricity*. Childrens Press, 1986.
- Challand, Helen J. *Experiments With Magnets* Childrens Press, 1986.
- Cobb, Vicki. *More Science Experiments You Can Eat* Lippincott, 1979
- Cobb, Vicki *Science Experiments You Can Eat* Lippincott, 1972
- Cobb, Vicki and Kathy Darling *Bet You Can't--Science Impossibilities to Fool You* Avon, 1983
- DeVito, Alfred and Gerald H Krockover *Creative Sciencing Ideas and Activities for Teachers and Children*. Little, 1980.
- Filson, Brent. *Famous Experiments & How to Repeat Them* Messner, 1986
- Gardner, Martin. *Entertaining Science Experiments With Everyday Objects* Dover, 1981
- Gardner, Robert. *Ideas for Science Projects* Watts, 1986.
- Gardner, Robert. *Science Around the House*. Messner, 1985
- Goldstein-Jackson, Kevin *Experiments With Everyday Objects Science Activities for Children, Parents, and Teachers* Prentice-Hall, 1978.
- Gutnik, Martin J *Ecology. (Projects for Young Scientists)*. Watts, 1984
- Gutnik, Martin J *Genetics. (Projects for Young Scientists)*. Watts, 1985
- Herbert, Don. *Mister Wizard's Experiments for Young Scientists*. Doubleday, 1959.
- Herbert, Don. *Mister Wizard's Supermarket Science*. Random House, 1980.

- Herbert, Don and Hy Ruchlis** *Mister Wizard's Four Hundred Experiments in Science* Book-Lab, 1983.
- Keen, Martin L.** *Science Experiments Wonder*.
- Lehane, M. S.** *Science Tricks*. Watts, 1980.
- Math, Irwin** *Wires and Watts: Understanding and Using Electricity*. Scribner, 1981
- Moorman, Thomas.** *How to Make Your Science Project Scientific*. Atheneum, 1974.
- McKay, David.** *Space Science Projects for Young Scientists*. Watts, 1986
- Munson, Howard.** *Science Activities With Simple Things*. Science Man Press
- Nestor, William P.** *Into Winter: Discovering a Season* Houghton Mifflin, 1982.
- Olesky, Walter** *Experiments With Heat*. Childrens Press, 1986
- Reid, Robert.** *Science Experiments for the Primary Grades* Science Man Press
- Sattler, Helen R.** *Nature's Weather Forecasters* Lodestar, 1978.
- Schneider, Maxine Springer.** *Science Projects for the Intermediate Grades*. Science Man Press.  
*Science Fair Project Index. 1973-1980* Scarecrow Press, 1983.
- Selsam, Millicent.** *Eat the Fruit, Plant the Seed*. Morrow, 1980.
- Simon, Seymour** *Mirror Magic*. Lothrop, 1980
- Simon, Seymour.** *Science in a Vacant Lot* Viking, 1970.
- Stine, G. Harry.** *On the Frontiers of Science: Strange Machines You Can Build* Atheneum, 1985
- Stockman, Harry E.** *Scientific Models for Experimenters* Sercolab, 1976.
- Stokes, Donald.** *A Guide to Observing Insect Lives*. Little Brown, 1983.
- Stone, George K.** *More Science Projects You Can Do*. Prentice-Hall, 1981.
- Taylor, Ron.** *World of Science: Projects*. Facts on File, 1986.
- Tymony, Cy.** *99 Fun-to-Make Electronics Projects*. TAE Books, 1981
- VanDeman, Barry A.** *Nuts and Bolts: A Matter of Fact Guide to Science Fair Projects* Science Man Press, 1980.
- Webster, David.** *How to Do a Science Project*. Watts, 1974.
- Webster, Vera.** *Plant Experiments*. Childrens Press, 1982.
- Webster, Vera.** *Science Experiments*. Childrens Press, 1932.

Webster, Vera. *Weather Experiments* Childrens Press, 1982

Wyler, Rose *Science Fun With Peanuts and Popcorn* Messner, 1986.

*Young People's Science Encyclopedia* (set of 20 volumes) Childrens Press, 1982

#### FILMSTRIPS

*Berenstain Bears' Science Fair* (filmstrip), Random House.

Random House  
Department 9278  
400 Hahn Road  
Westminster, MD 21157

*Developing a Science Fair Project* (filmstrip), Science Man Press

Science Man Press  
4738 North Harlem Avenue  
Harwood Heights, Illinois 60656

**PERIODICALS** which may contain science experiments appropriate for science fair projects:

*Popular Electronics*  
*Popular Science*  
*Radio-Electronics*  
*Science and Children*  
*Science Teacher*  
*Scientific American*

## SCIENCE PROJECTS A TO Z

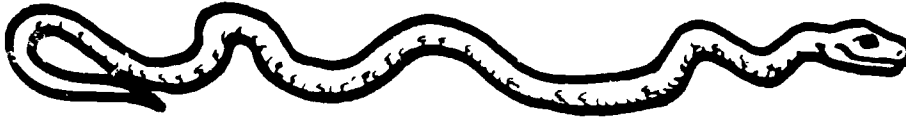

See how many ideas for science projects you can think of. Use your science textbook, encyclopedia, and resource people to find ideas from A to Z

A	_____
B	_____
C	_____
D	_____
E	_____
F	_____
G	_____
H	_____
I	_____
J	_____
K	_____
L	_____
M	_____
N	_____
O	_____
P	_____
Q	_____
R	_____
S	_____
T	_____
U	_____
V	_____
W	_____
X	_____
Y	_____
Z	_____

Adapted Frank Schaffer's CLASSMATE, April/May/June 1986

267

The following timeline should help you prepare your projects.



TASK	DEADLINE
1. <u>Choose a subject and a purpose</u>	_____
2. <u>Write a paragraph describing your project</u>	_____
3. <u>Give progress report</u>	_____
4. <u>Research, write first draft of report</u>	_____
5. <u>Revise report</u>	_____
6. <u>Set up display materials in class</u>	_____
7. <u>Give formal presentation to class</u>	_____
8. <u>Science Fair</u>	_____
9. <u>Take project home</u>	_____

Adapted from Frank Schaffer's CLASSMATE, April/May/June, 1986

## SCIENCE FAIR TIME

**TO:** Parents and Students of the Sixth Grade

Time is upon us to start preparing for the Parkland Science Fair. The fair will be for the **SIXTH GRADE STUDENTS ONLY**. Although the Science Fair will not be held until April, please encourage your child to make his or her Science Fair project selection as soon as possible as the projects must be approved by the science teacher. Attached are the rules and regulations. If you have any questions, please contact me at the school.

Your child has additional information on setting up a Science Fair project in his or her folder at school. He/she is free to bring this material home at any time.

### PARKLAND FAIR--APRIL 23--REQUIRED FOR ALL SIXTH GRADERS

Thank you for your time and cooperation.

---

Sixth Grade Science Teacher

(Clip and return to science teacher)

---

I have read the above information regarding the Parkland Sixth Grade Science Fair.  
My son/daughter will complete a project for the fair and for a part of their science grade.

---

Parent's Signature

**SOURCE:** Sandra Johnson, Science Teacher, Parkland Elementary School,  
Yukon, Oklahoma



## RULES AND REGULATIONS FOR THE SCIENCE FAIR

1. Write your project up on notebook paper. Be sure to include project title, short summary, your name (and partner, if any), homeroom teacher, and the equipment you will be needing. Your project must be approved by February 24
2. Keep project to a reasonable size. Use a space about 36" x 24".
3. **NO FIRE!!!** Be cautious of using water!!! If you are using electricity, please bring your own extension cord
4. You may have ONE partner. These projects will be judged separately
5. Projects must be labeled on a 3" x 5" notecard, as follows.

PROJECT TITLE:

NAME:

HOMEROOM TEACHER.

6. Everyone MUST participate as this will be a GRADE!!!
7. **THIS PROJECT IS TO BE MADE ENTIRELY BY THE STUDENT!!!** Parents may give advice.
8. Prizes will awarded. There will be: First Prize, Second Prize, Third Prize, and Honorable Mention. Certificates will be given to all students who participate

**SOURCE:** Sandra Johnson, Science Teacher, Parkland Elementary School,  
Yukon, Oklahoma



## SCIENCE FAIR ENTRY FORM

NAME \_\_\_\_\_ GRADE \_\_\_\_\_ ROOM \_\_\_\_\_

CATEGORY \_\_\_\_\_ TEACHER \_\_\_\_\_

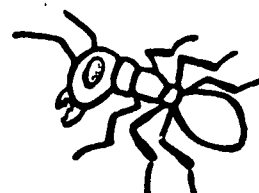
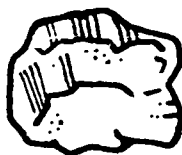
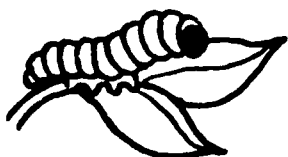

## SCIENCE FAIR CRITIQUE

Now that the Science Fair is over, think about what you have seen and learned.

1. What was your favorite exhibit? \_\_\_\_\_

2. What advice would you give to someone entering a science fair for the first time? \_\_\_\_\_

3. What project would you like to do next year? \_\_\_\_\_

What are your suggestions for making the Science Fair better?

5. Other comments \_\_\_\_\_

Date \_\_\_\_\_

Name \_\_\_\_\_

Adapted from Frank Schaffer's CLASSMATE, April/May/June 1986



# Achievement Award



To \_\_\_\_\_

For \_\_\_\_\_

\_\_\_\_\_  
Signature

\_\_\_\_\_  
Date

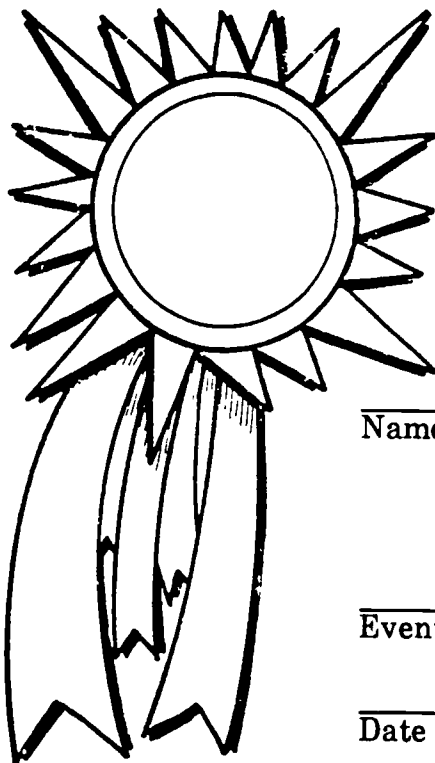

# PRIZE WINNER

Name \_\_\_\_\_

for

Event \_\_\_\_\_

Date \_\_\_\_\_

Signature \_\_\_\_\_

Adapted from Frank Schaffer's CLASSMATE, April/May/June 1986

# SCIENCE PROJECT PLANS

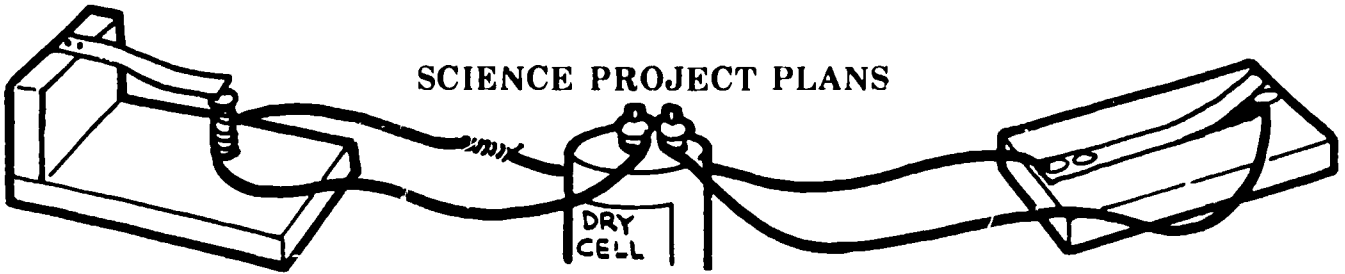

Write the purpose of your science project and what you're planning to do. Include the resources and materials you will need to complete it.

1. The purpose is \_\_\_\_\_  
\_\_\_\_\_
2. The title is. \_\_\_\_\_  
\_\_\_\_\_
3. My hypothesis is. \_\_\_\_\_  
\_\_\_\_\_
4. References I may use: \_\_\_\_\_  
\_\_\_\_\_
5. Experiment I plan \_\_\_\_\_  
\_\_\_\_\_
6. Materials I need. \_\_\_\_\_  
\_\_\_\_\_
7. How I will record results \_\_\_\_\_  
\_\_\_\_\_

Imagine what your project will look like when it's finished. Draw a picture of it and label the parts.

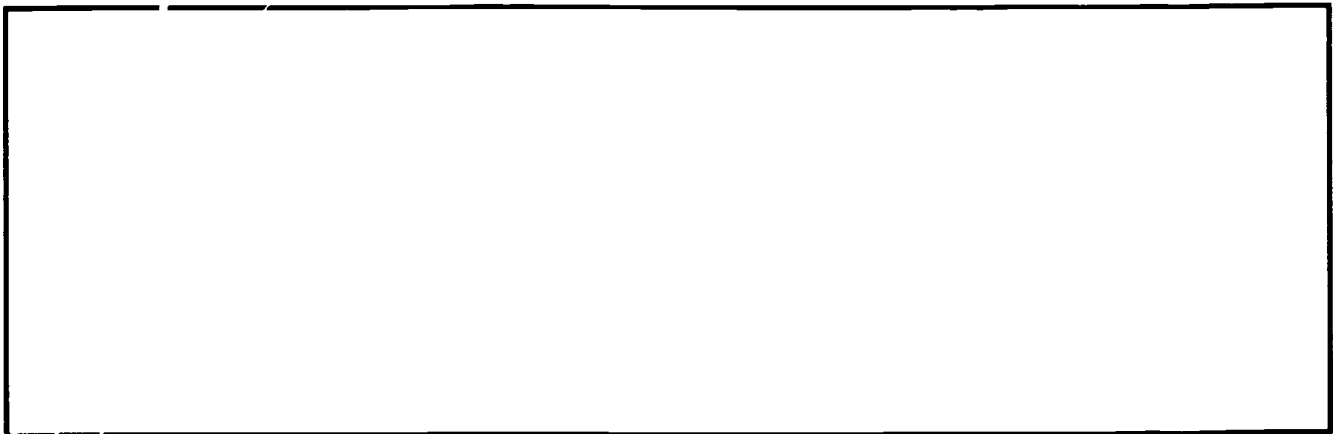

**Challenge!** Write a paragraph describing your project.

Adapted from Frank Schaffer's CLASSMATE, April/May/June 1986

## Science Reference Materials for Teachers and Students

### Periodicals for Teachers

*Audubon*  
*Discover*  
*Geo*  
*International Wildlife*  
*National Wildlife*  
*Science*  
*Science Activities*  
*Science and Children*  
*Science Books and Films*  
*Science Digest*  
*Science News*  
*The Science Teacher*

### Periodicals for Students

*3-2-1 Contact*  
*Cricket*  
*National Geographic WORLD*  
*Odyssey*  
*Ranger Rick's Nature Magazine*  
*Science World Magazine*  
*Scienceland*

### Books for Teachers

**Abruscato**, Joe and Jack Hassard. *Whole Cosmos Catalog of Science Activities for Kids*. Scott, Foresman, 1977.

**Crescimbeni**, Joseph B. *Science Enrichment Activities for the Elementary School*. Prentice-Hall, 1981.

**DeVito**, Alfred, and Gerald H. Krockover. *Creative Sciencing: A Practical Approach*. Little, Brown, 1980.

**DeVito**, Alfred and Gerald H. Krockover. *Creative Sciencing: Ideas and Activities for Teachers and Children*, 2nd edition. Little, Brown, 1980.

**Fowler**, John. *Energy-Environment Source Book: Energy, Society, and the Environment, Energy, Its Extraction, Conversion, and Use*, 2 Volumes. Washington, D.C.: National Science Teachers Association, 1980.

**Holfman**, Helenmarie H., and Kenneth S. Ricker. *Sourcebook: Science Education and the Physically Handicapped*. Washington, D.C.: National Science Teachers Association, 1979.

**Schmidt**, Victor, and Verne Rockcastle. *Teaching Science With Everyday Things*, 2nd edition. McGraw-Hill, 1982.

## RECENT OUTSTANDING SCIENCE BOOKS

**Black, David.** *Exploring the Sea Oceanography* Random, 1986 Grade 4-6.

Solid minicourse in oceanography--full-color illustrations and diagrams

**Black, David.** *Plants. Facts on File*, 1985 Grade 5-8.

Written in easy-to-read style, this book covers the plant kingdom. Illustrated and contains glossary

**Carle, Eric.** *Pupa, Please Get the Moon for Me.* Alphabet Press, 1986. Grade Preschool-1

Simple story briefly told, revolves around the waxing and waning of the moon

**Climo, Shirley** *Someone Saw a Spider: Spider Facts and Folktales.* Crowell, 1985. Grades 4-7

Retellings of Greek, Japanese, American Indian, and European spider folktales are given scientific legitimacy in a text that demonstrates the connection between science and the humanities.

**Cobb, Vicki.** *Chemically Active.* Lippincott, 1985 Grade 5-8

Experiments that can be performed at home with everyday household items

**Cole, Joanna.** *A Dog's Body.* Morrow, 1986. Grade 3-5.

Discusses physical attributes such as highly developed sense of hearing and smell.

**Curtis, Patricia** *All Wild Creature Welcome. The Story of a Wildlife Rehabilitation Center.* Lodestar, 1985. Grade 5-8.

A well-written, beautifully photographed, and often touching chronicle of the history and everyday operation of a wildlife rehabilitation center

**Dwiggins, Don** *Flying the Space Shuttles.* Dodd, 1985. Grade 4-8

Readers meet space shuttle astronauts through the informative, easy-to-read text and the color photographs from NASA and Rockwell International.

**Dingerkus, Guido.** *The Shark Watchers' Guide.* Messner, 1985. Grade 5-8.

Describes the characteristics, habits, and environments of various species and discusses their relationship to human beings

**Facklam, Margery.** *Changes in the Wind: Earth's Shifting Climate.* Harcourt, 1986. Grade 6-9.

Explanation of basic changes in global weather patterns

**Florian, Douglas.** *Discovering Butterflies.* Scribner, 1986. Grade 1-3

Features straightforward text that imparts a lot of information

**Frank, Julia** *Alzheimer's Disease The Silent Epidemic* Lerner, 1985 Grade 6-8

A timely introduction to a frightening, highly publicized disease. Case histories of victims and their families are discussed.

**Gilbreath, Alice** *The Great Barrier Reef: A Treasure in the Sea* Dillon, 1986 Grade 4-7

Clearly written presentation of oceanography and marine life. Informative and entertaining.

**Gardner, Beau** *Guess What?* Lothrop, 1985 Grade K-3

Readers guess which animal is represented by looking at a detail from the animal's silhouette. They then check their predictions by turning the page. Gardner's book will encourage children to observe, attend to details, think, and make predictions.

**Hiscock, Bruce** *Tundra The Arctic Land* Atheneum, 1986 Grade 5-8

Provides material for research papers on loons, caribou, tundra wolves, people, etc.

**Hoban, Tana** *A Children's Zoo*. Greenwillow, 1985 Grade K-2

Outstanding color photography and book design mark this collection of photographs of ten zoo animals.

**Haney, Jan P.** *A Look Inside Calculators*. Raintree, 1985. Grade 4-8

Through simple addition and multiplication problems, the inner workings of electronic calculators are examined.

**Johnston, Ginny and Judy Cutchins**. *Andy Bear: A Polar Cub Grows Up at the Zoo*. Morrow, 1985. Grade 2-5

The introduction to this factual account is full of information about polar bears, and it sets the stage for the compelling story of the first year in the life of Andrew Nicholas Polar Bear.

**Jacobs, Francine** *Breakthrough. The True Story of Penicillin* Dodd, 1985. Grade 6-8.

After briefly recounting the discoveries of Jenner, Pasteur, Lister and Koch, the author tells the complex story of penicillin's discovery.

**Krupp, E. C.** *The Comet and You*. Macmillan, 1985. Grade 2-5.

An imaginatively conceived look at comets, filled with up-to-date facts and historical data.

**Knight, David C.** *"Dinosaurs" That Swam and Flew* Prentice, 1985. Grade 3-6.

Profuse black-and-white drawings portray many of the lesser-known reptiles that "swam and flew."

**Lauber, Patricia.** *Volcano: The Eruption and Healing of Mount St Helens* Macmillan, 1986  
Grade 2-5

A spectacular book describing eruption, aftermath and gradual return of life

**McMillan, Bruce.** *Counting Wildflowers* Lothrop, 1986 Grade K-1.

A counting book listing wildflowers and their scientific names, blooming periods, etc

**Mori, Tuyosi.** *Socrates and the Three Little Pigs.* Putnam/Philomel, 1986. Grade 2-5

Promotes comprehension of mathematical concepts underlying computer literacy  
Excellent for gifted.

**Malnig, Anita.** *Where the Waves Break: Life at the Edge of the Sea* Carolrhoda, 1985  
Grade 3 and up.

Readers tour the ocean's edge to observe life in shallow waters, in tide pools, and elsewhere along the shore

**Nozaki, Akihiro.** *Anno's Hat Tricks.* Philomel, 1985. Grade 4 and up

An introduction to "if . . . then. " thinking for those who enjoy intellectual puzzles.

**Pringle, Laurence** *Animals at Play* Harcourt, 1985. Grade 4-7.

A fascinating look at the importance of animal play shown in such species as the cat, dog, wolf, bear, bat, and monkey

**Powzyk, Joyce.** *Wallaby Creek* Lothrop, 1985. Grade 3-6.

Observations of naturalists at work in the Australian bush are presented in carefully written text with superb watercolor illustrations.

**Ryden, Hope.** *America's Bald Eagle.* Putnam, 1985. Grade 4-8.

A naturalist-author-photographer observes the habits of the bald eagle, discusses conservation programs such as "hacking" and raptor rehabilitation centers, and stresses the importance of the 1973 Endangered Species Act.

**Sattler, Helen Roney.** *Sharks, the Super Fish.* Lothrop, 1986. Grade 4 and up.

Straightforward information on shark physiology and behavior with beautiful illustrations.

**Selsam, Millicent.** *Mushrooms.* Morrow 1986. Grade 2-5.

Superstitions, myths and history surrounding the mushroom plant, along with the growth cycle.

**Shapiro, Mary.** *How They Built the Statue of Liberty.* Random, 1985. Grade 5-up.

This handsome volume is an absorbing account of the conception and creation of the well-known statue, with emphasis on the engineering processes involved.



**Simon, Seymour** *101 Questions and Answers About Dangerous Animals* Macmillan, 1985  
Grade 3-7

In question-and-answer form, the book satisfies children's natural curiosity about dangerous animals. Includes little-known facts and an examination of myths that surround traditionally feared species.

**Simon, Seymour** *Saturn*. Morrow, 1985. Grade 1-4.

Concise, up-to-date information gathered by Voyager I about Saturn's surface, rings, and the nine largest of its twenty (so far) moons. A beautiful, first planet book for young readers.

**Sugarman, Joan**. *Snowflakes*. Little, 1985 Grade 4-6

Snowflake shapes--stars, needles, feathers, pyramids--are discussed and illustrated with pen-and-ink drawings. Clear explanations of how crystals are formed and a succinct summary of the study of snowflakes throughout history are presented. Readers also learn how to catch a snowflake. Glossary included.

**Taylor, Ron**. *The Invisible World*. Facts on File, 1985. Grade 4-8

Excellent science book, bright, large-sized format, readable text, profusely illustrated

**Wylar, Rose**. *Science Fun With Peanuts and Popcorn* Messner, 1986. Grade 2-4

Simply written experiment book aimed at explaining scientific principles and methods

## DRUGS AND YOUR HEALTH

**Emphasis Grade Level: 5**

**CURRICULUM APPLICATION(S):** Health, Science, Reading, Language Arts, Art.

**GOAL:** The student will learn the importance of using drugs safely and through this study will demonstrate an understanding of the dangers of drug abuse, use the decision-making process to make the most healthy decisions about drugs, and assume the responsibility for saying no to drugs.

### COOPERATIVE PLANNING/TEACHING

<p><b>The teacher will:</b></p> <ol style="list-style-type: none"> <li>1. Teach health concepts regarding the importance of drug safety and their responsibility in that safety</li> <li>2. Guide students in the related curriculum area activities.</li> </ol>	<p><b>The library media specialist will</b></p> <ol style="list-style-type: none"> <li>1. Direct all research activities</li> <li>2. Make students aware of different sources of information such as magazines, newspapers, reference books.</li> <li>3. Schedule filmstrips on drugs.</li> <li>4. Share some literature (books, pamphlets, etc.) about drugs and their effects and plan follow-up activities with the classroom teacher</li> </ol>
--	---

### LEARNER OUTCOMES

Content Area	Information Skills
<p><b>The student will:</b></p> <ol style="list-style-type: none"> <li>1. Record and describe information gathered from first-hand experiences.</li> <li>2. Infer the possible cause and effect of drug abuse.</li> <li>3. Label the parts of a prescription label.</li> <li>4. Design an anti-drug button.</li> </ol>	<p><b>The student will:</b></p> <ol style="list-style-type: none"> <li>1. Locate and distinguish between fiction and nonfiction.</li> <li>2. Use the card catalog</li> <li>3. Use index, table of contents, and an encyclopedia.</li> <li>4. Obtain information from a filmstrip</li> <li>5. Record impressions from listening to a story, watching a film.</li> <li>6. Answer purposeful questions without copying from a text</li> <li>7. Recall, summarize and paraphrase what is listened to and viewed.</li> </ol>

## ACTIVITIES/SUGGESTIONS:

1. Introduce the students to the following concepts
  - a. Drugs should not be taken except by the advice of a doctor
  - b. Drugs taken in excess are harmful to your body
  - c. Drugs taken by prescription of a doctor can be helpful to our bodies
  - d. Drugs are good or drugs are bad
2. As a drug activity make anti-drug buttons.
3. Have students label different parts of a medicine bottle label.
4. Complete worksheet on drug safety.
5. Do the drug safety search puzzle (included in unit).
6. Invite a drug officer from the police department to talk to the class.
7. Have students research facts about marijuana (e.g , What is it? Where can it be found? How is it used? and How does it affect the body?)
8. Have students cut articles about drugs and drug abuse from newspapers and magazines.
9. For a creative-writing exercise, have students write a newspaper story on some type of drug abuse and its effects.
10. Have students make posters that might prevent someone their age from using alcohol, tobacco, or some other drug.
11. Cut advertisements from magazines and newspapers advertising tobacco or alcohol and discuss them.
12. Cut advertisements of cigarettes from magazines that give the warnings from the Surgeon General. Discuss the warnings
13. Review and discuss the filmstrip, "Alcohol What Do You Know?"
14. Review and discuss the filmstrip "Drugs and You."
15. Share John S. Marr's book *Good Drugs and the Bad Drugs*.
16. Students will do an imaginary neighborhood activity program listing activities that young people might enjoy doing instead of wasting time and money on drugs

**SOURCE:** Irma Faulkenberry, Library Media Specialist  
Linda Hall, Teacher  
Howe School District

**EVALUATION:**

Students will receive a letter grade (A, B, C, D, F) at the end of the unit based on daily assignments and a teacher-made summative test.

**RESOURCES:**

*Childcraft*. World Book, Inc 15 vols.

"Drugs and Your Health," *Health for Life*. Scott, Foresman and Company, 1987 pp. 190-223

Scott, Foresman and Company  
1900 East Lake Avenue  
Glenview, IL 60025

*The New Book of Popular Science* Grolier, Inc , 1987 6 vols

*The New Book of Knowledge*. Grolier, Inc., 1985 21 vols

*World Book Encyclopedia* World Book, 1986. 22 vols.

*The World Book Encyclopedia of Science*. World Book, Inc. 6 vols.

## BIBLIOGRAPHY

*American Alliance for Health, Physical Education and Recreation.* American Alliance for Health, Physical Education and Recreation

**Berger, Melvin** *Mind Control.* Crowell, 1986 gr 5-up

**Dolan, Edward** *International Drug Traffic* Watts, 1985.

**Madison, Arnold.** *Drugs and You.* Messner, 1982. gr 3-6.

**Marr, John S.** *Good Drug and the Bad Drug* Evans, 1970 gr 3-up.

**Morey, Walt.** *Lemon Meringue Dog* Dutton, 1980. gr 4-7

**Seixas, Judith S** *Alcohol, What It Is, What It Does.* Greenwillow, 1981

**Seixas, Judith S.** *Tobacco, What It Is, What It Does* Greenwillow, 1981 gr 1-3

**Shreve, Susan.** *Nightmares of Geranium Street* Knopf, 1977. gr 4-7.

**Skurzynski, Gloria.** *Caught in the Moving Mountains.* Lothrop, Lee, & Shepard, 1984 gr 4-8

**Tobias, Ann.** *Pot, What It Is, What It Does.* Greenwillow, 1979. gr 3-4.

**Tessler, Diane Jane.** *Drugs Kids and Schools: Practical Strategies for Educators and Other Concerned Adults* Goodyear, 1980.

### Filmstrips:

*Alcohol. What Do You Know?* Sunburst, 1984

*Drugs and You* Learning Tree, 1983

*Marijuana: What Do You Know About It?* Sunburst, 1984

## DRUG SAFETY WORDSEARCH

Z	L	I	G	B	A	O	B	I	I	H	B	S	X	V	U	H	H	X	S	N
Z	N	N	U	X	Z	V	R	N	X	N	E	K	H	A	F	I	Q	E	O	Q
E	R	N	Q	R	X	Y	A	H	W	N	W	M	M	L	K	V	I	T	T	S
A	W	O	F	T	O	M	N	A	A	I	B	N	J	D	X	P	T	K	K	Y
T	M	N	E	S	U	B	A	L	R	L	Y	L	B	Q	N	P	P	V	L	Y
G	S	E	B	P	U	H	A	A	R	L	K	D	I	I	H	N	M	P	Q	C
I	L	K	S	X	S	M	J	N	R	G	Y	U	C	R	R	Y	N	Y	U	C
T	T	D	M	Y	I	D	I	T	S	Z	J	O	C	V	F	R	U	Y	A	N
U	S	N	M	T	H	T	R	S	S	I	T	S	C	I	T	O	C	R	A	N
V	O	S	N	S	P	A	W	M	I	E	X	M	J	N	G	N	Y	Q	C	E
J	L	Z	I	O	B	M	R	N	R	L	O	I	D	V	O	T	B	G	E	R
I	K	R	L	O	J	R	D	E	P	R	E	S	A	N	T	G	K	E	R	H
X	L	Q	O	G	K	X	K	V	S	N	D	E	B	A	W	O	Z	E	P	H
C	M	N	H	I	F	H	X	K	R	U	H	T	J	J	M	F	H	T	N	O
O	V	F	O	P	G	C	S	P	D	D	S	A	M	P	D	H	T	D	A	S
Z	F	B	C	H	D	I	O	L	B	J	E	I	E	V	K	I	F	N	E	V
G	L	B	L	T	K	T	D	B	X	Y	X	J	M	N	C	Q	B	O	B	U
N	Y	H	A	H	E	R	R	D	U	Q	R	O	Z	E	P	S	H	A	A	N

Can you find these words?

HALLUCINOGENS  
 STIMULANTS  
 MARIJUANA  
 NICOTINE  
 ABUSE

PRESCRIPTION  
 ALCOHOLISM  
 INHALANTS  
 CANCER  
 TAR

DEPRESSANT  
 EMPHYSEMA  
 NARCOTICS  
 MISUSE



## DESIGN A BUTTON

Design a button with a clever slogan or picture for an anti drug campaign

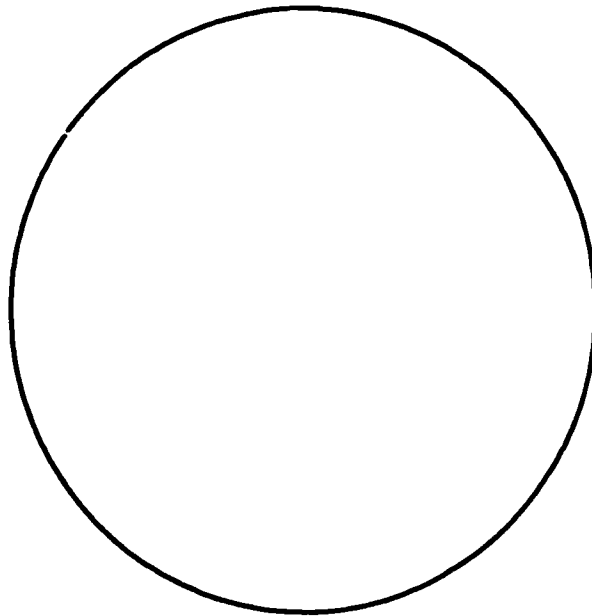



## READ MEDICINE LABELS CAREFULLY

Label the different parts of the two medicine bottle labels below

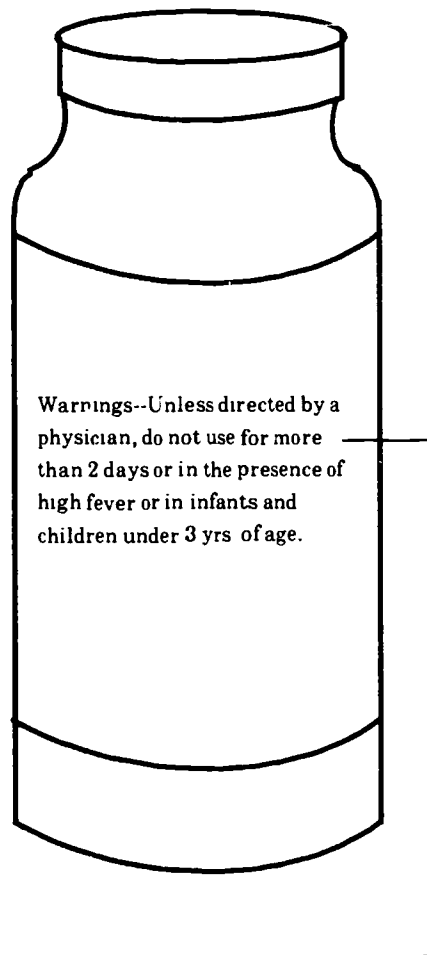
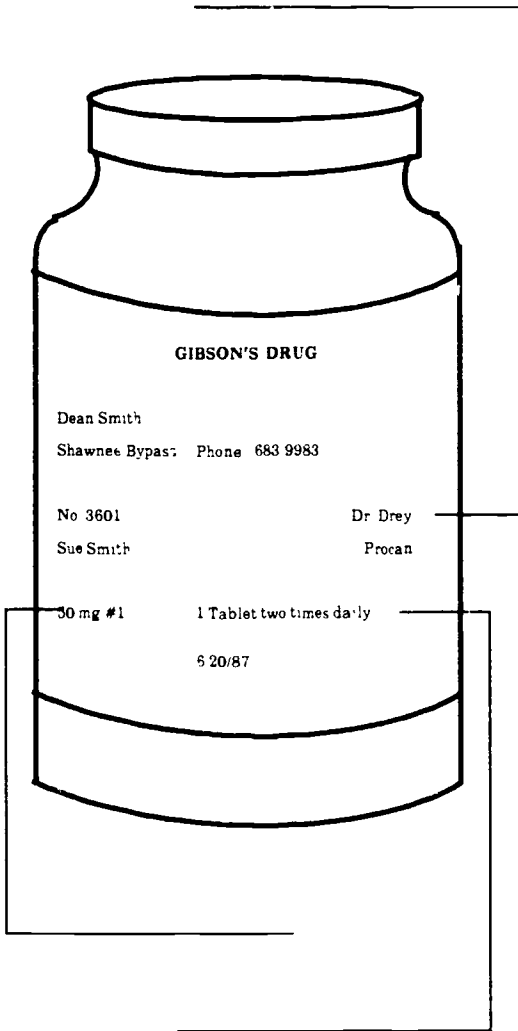

## BIOGRAPHY

### Emphasis Grade Level 5

**CURRICULUM APPLICATION(S):** Reading, Social Studies

**GOAL:** The student will learn to identify biography as a type of literature and be able to locate biographies and biographical data in the media center and will share information with the class.

### COOPERATIVE PLANNING/TEACHING

<p>The teacher will:</p> <ol style="list-style-type: none"> <li>1. Introduce the unit to the students and give an overview of the various activities they will be doing.</li> <li>2. Provide a list of people from history to research.</li> <li>3. Set a date for everyone to have their reading finished and schedule "Famous Person Masquerade."</li> <li>4. Assist library media specialist in going over the worksheets completed by students.</li> <li>5. Evaluate students' presentations.</li> </ol>	<p>The library media specialist will</p> <ol style="list-style-type: none"> <li>1. Collect and organize materials on Washington and Lincoln for learning center to be set up in the library or classroom</li> <li>2. Teach/review the information skills necessary to locate and use the biographical information they will need</li> <li>3. Assist students in finding suitable reading material and in planning their masquerade.</li> <li>4. Assist teacher in going over the worksheets completed by students.</li> </ol>
--	---

### LEARNER OUTCOMES

Content Area	Information Skills
<p>The student will:</p> <ol style="list-style-type: none"> <li>1. Read to locate information.</li> <li>2. Use a variety of reference materials to answer questions.</li> <li>3. Organize information for an oral report.</li> </ol>	<p>The student will:</p> <ol style="list-style-type: none"> <li>1. Find different categories of books.</li> <li>2. Use a biographical dictionary.</li> <li>3. Use a video-cassette to obtain information.</li> <li>4. Make concise notes from various types of media.</li> </ol>

## ACTIVITY/SUGGESTIONS:

1. Introduce unit by showing filmstrip which gives information about biography as a type of literature. "Biography" *Literature for Children*, Series 1, Piped Piper Productions.
2. Have students select a person from history they would like to find out more about.
3. Instruct the students in the use of the *Webster's Biographical Dictionary* and other available biographical sources. Complete the "Webster's Biographical Dictionary Worksheet," using the sample sheet to work from, pages 215-216
4. Develop a card game using the names of the people they are going to study. Give each student a set of two 3"x 5" cards, which they will use to record certain information. (See the sample cards on the next page ) Students may begin searching for the selected name in a biographical reference source such as *Webster's Biographical Dictionary* or *Concise Dictionary of American Biography*. Students may locate birth (and death) dates of the selected person and information about the major events of the person's life. This information may be recorded on Card 1. A biography of the person can be used to find out a specific detail about the person's life and recorded on Card 2. After students have recorded the information on both cards, pairs of cards on all selected names may be collected for the card game.
5. Each student in the class will complete the "Biography Center" on page 217. The products from the "Quest Activities" will be displayed in the library media center. This is not a required activity.

**RULES TO PLAY:** 2-4 players. Players shuffle cards. Deal out seven cards and try to assemble pairs by asking other players if they have the match for a particular card. If the other player has the requested card, it must be given to the player who asks for it. A player who completes a pair gets another turn. If the other player does not have the matching card, the player requesting the card must draw another card from the deck. The first person to complete pairs for all cards is the winner.

### SAMPLE CARDS

Card 1

<div data-bbox="310 740 740 1025" style="border: 1px solid black; height: 134px; width: 274px;"></div>
Person _____ _____
Date _____
Major Accomplishment _____ _____ _____

Card 2

Person _____ _____
Information Source _____ _____ _____
Details about Life _____ _____ _____ _____ _____ _____ _____ _____

**SOURCE:** *School Library Media Activities Monthly*. May 1985. pp 16-17.

## ADDITIONAL ACTIVITIES:

1. Have students prepare a time line, showing dates and events that happened in the biography.
2. Prepare a diary or journal (written in first person), expressing personal feelings about events taking place throughout a story. Assume the role of the subject of the biography or another character in the book.
3. Write a news article reporting key incidents from the biography including headlines, pictures and interviews with the subject of the biography. This is especially appropriate for action-type stories containing many interesting or exciting events. This activity may be extended to include other types of newspaper writing: editorial, feature, advertisements, etc.
4. Introduce beginning research. Suggested source: *Compton's Precyclopedia*. Prepare a series of research activities about famous people. Use large cards and list volume number, page, and three to four questions to answer. Decorate card with picture from magazines, etc. Good activity for second grade.
5. Make a shoe box filmstrip and a tape recording to tell the story of a person's life.
6. Book report idea: Have students prepare living biographies. Secretly research the person and write a short monologue about him/her in first person, containing clues to the identity of the person. Record the monologue on tape or dress and act out the script. When four to five monologues are ready, play them for the class. Guess identity of biography subjects.
7. Make a puppet or tin can dressed as the character from a selected biography. Have the puppet introduce and describe himself/herself to the class. Have class guess the identity of the puppet character.
8. Have Biography Day. Dress as a famous person and introduce yourself to the class.
9. Compile a "Who's Who." Collect class-written biographies and make a booklet. Have a group design a cover.
10. Encyclopedia Search. Have students do research on a specific person in encyclopedias. Before they begin their search, review.
  - a. The alphabetical arrangement of encyclopedias
  - b. The guide letter(s) on the spine of each volume to show the beginning letters of the main topics listed in the volume.
  - c. The numbers on the spine of each volume to help keep the volumes in order on the shelf.
  - d. The choice of key words to look for before using the encyclopedia (e.g., How are clouds formed? Key word is "clouds.")

Review the following information relating to key words:

- a. Topics having more than one word are usually alphabetized by the first word (e.g., Red Sea: look in "R" volume for Red Sea; Atlantic Ocean: look in "A" volume for Atlantic Ocean.)
- b. To find information in the encyclopedia about a person, use the person's last name as your key word (e.g., Abraham Lincoln: under "L" volume for Lincoln, Abraham).
- c. Guide words (compare to dictionary guide words), printed in heavy black type at the top of most of the pages of an encyclopedia, are used to help locate the topic quickly.

Give the following directions to students as they begin their encyclopedia search:

- a. Decide what name to look for (person's last name)
- b. Find the correct volume.
- c. Use guide words to locate the person's name.

Have students locate a long article in an encyclopedia volume. Note that long articles are divided into sections, with each section having its own title or heading in bold face type. This title or heading tells the reader what information is included in that section about the larger subject (name of main heading or title of article).

Review the steps for locating information quickly on a specific question or topic:

- a. Locate the correct encyclopedia article.
  - b. Skim the section headings until you find an appropriate heading that you think might have the information to answer your questions.
  - c. Read the first two or three sentences of each paragraph in the section and decide whether the information you need is likely to be in that paragraph.
  - d. If the information does not seem to be there, do not read the rest of the paragraph, but go on to the next one.
  - e. Only when you think the information you need will be located there should you read the whole paragraph slowly and carefully.
11. Remind students that information in an encyclopedia can be located quickly by knowing the exact volume and page it can be found; valuable information on a subject can often be found under other entries in the encyclopedia; the only way to find information on the subject under other entries is by using the index to an encyclopedia.

12. Pretend to be the main character in the biography and exchange letters with another student (pretending to be another character in the book) who has read the same book. Follow through to the end of the book, with discussion of events--expressing personal feelings, concerns and opinions of the action taking place. Stress the following:
- Proper letter form, including return address and date (setting).
  - Significant events from the story, taken from beginning, middle and end of the story.
  - Use of personal kind of writing one would use in a friendly letter.

**EVALUATION:** Students will be evaluated on the presentation of the information and characterization of their famous person and on the worksheets.

**RESOURCES:**

"Language Arts: Biography," *School Library Media Activities Monthly*. May 1985. pp. 16-17

School Library Media Activities Monthly  
17 East Henrietta Street  
Baltimore, MD 21230

"Biography," Literature for Children, Series 1, (sound cassette). Pied Piper Productions  
Grades 3-6.

Pied Piper Productions  
P. O. Box 320  
Verdugo City, CA 91046

*Compton's Encyclopedia.*

*Concise Dictionary of American Biography.*

*Webster's Biographical Dictionary.*

## WEBSTER'S BIOGRAPHICAL DICTIONARY \*

Includes over 40,000 names, in one alphabetical list, of persons from all eras, all fields, all parts of the world. Entries give the following types of information:

1. Full name of person
2. Pronunciation (given with the first entry with that last surname, sometimes in the appendix of prenames).
3. Birth and death date (where known; blank space instead of death date for persons still living).
4. Nationality.
5. Occupation, or other description.
6. Other information
  - a. Family relationships.
  - b. Education.
  - c. Occupational, business or professional career.
  - d. Other significant activities.
  - e. Scientific discoveries or inventions.
  - f. Names of literary, musical, artistic or architectural works.

### WEBSTER'S BIOGRAPHICAL DICTIONARY: SAMPLE ENTRY

born	name before marriage	birth date	death date

Stanton (stan' t'n), Elizabeth, *nee* Ca'dy (ka'di). 1815-1902.

American woman suffrage leader. b. Johnston, N.Y ; m. Henry Brewster Stanton (1805-87), a lawyer, journalist and abolitionist orator (1840). Organized first woman's rights convention, Seneca Falls, N.Y. (July 19-20, 1848), thus launching the woman's suffrage movement. Associated with Susan B. Anthony in the movement (from 1851). First president, National Woman Suffrage Association. Compiler, with Susan B. Anthony and Matilda Joslyn Gage, of *History of Woman Suffrage* (3 vols., 1881-86). See HARRIOT BLATCH

#### Abbreviations

b. = born  
m. = married



**WEBSTER'S BIOGRAPHICAL DICTIONARY \***  
(Worksheet)

Using the "Webster's Biographical Dictionary: Sample Entry," answer the following questions:

1. What is the pronunciation of Stanton? \_\_\_\_\_
2. With what name was Mrs Stanton born? \_\_\_\_\_
3. When was Mrs. Stanton born? \_\_\_\_\_
4. Where was Mrs. Stanton born? \_\_\_\_\_
5. When did she die? \_\_\_\_\_
6. What was her husband's name? \_\_\_\_\_
7. When was Mr. Stanton born? \_\_\_\_\_
8. When did he die? \_\_\_\_\_
9. Which convention did Mrs. Stanton organize? \_\_\_\_\_  
\_\_\_\_\_
10. What other woman suffrage leader did Mrs Stanton associate with beginning in 1851? \_\_\_\_\_
11. Where was the first woman's rights convention held? \_\_\_\_\_  
\_\_\_\_\_
12. What was Mr. Stanton's profession? \_\_\_\_\_
13. How would you find out why the name "Harriot Blatch" is related to Elizabeth Stanton? \_\_\_\_\_  
\_\_\_\_\_  
\_\_\_\_\_
14. For the "serious researchers" only Who was Harriot Blatch? \_\_\_\_\_  
\_\_\_\_\_  
\_\_\_\_\_  
\_\_\_\_\_

## BIOGRAPHY CENTER \*

The following biography center is designed to focus on George Washington and Abraham Lincoln. The center could be modified for use with other American history units. Allow three weeks for an entire class to complete the center. All of the material that follows should be posted at the center or should be in envelopes at the center.

This center has two purposes:

1. To give you experience in reading to find specific information
2. To give you an opportunity to read a biography on a person of your choice

When you complete this center:

1. You will be able to write three facts about both Washington and Lincoln.
2. You will be able to write a definition for the term biography.
3. You will have read one biography and will be able to write three facts about the person.
4. You will dress up like the person you read about and introduce that person to your classmates.

As you do this center, you will be practicing:

Dictionary skills.

Research skills.

Reading for information.

Speaking to a group.

Name \_\_\_\_\_

**BIOGRAPHY CENTER PRETEST\***

In February we celebrate the birth of two famous Americans, George Washington and Abraham Lincoln. What things do you know about these two men? Use the lines below to write as many things as you can about them.

---

---

---

---

---

NEXT, write the names of six famous real people.

---

---

---

---

NOW, tell what you think a biography is.

---

---

THEN, complete this sentence.

I wish I knew more about \_\_\_\_\_

---

Name \_\_\_\_\_

### PLAN FOR THE BIOGRAPHY CENTER \*

You may read the plan to yourself or you may listen to the tape in the recorder below. The tape will read the directions to you. You should follow along reading silently. If you choose to use the tape, be sure to rewind the tape and turn off the machine when you are finished listening.

Keep this sheet in your work folder. Read the whole thing before starting the center and then do each activity in order. Be sure to check with your teacher each time the directions tell you to.

1. Take a worksheet from envelope No. 3 and follow the directions on paper
2. Next, choose a biography that you would like to read. The media specialist will help you find a book that you will enjoy. Be sure to show your book to the teacher or the media specialist before you begin reading it.
3. Next, read your biography. Try to spend at least 30 minutes each day reading the biography. You may read it at home, too.
4. Next, make an appointment to discuss the biography with your teacher or the media specialist.
5. Each boy and girl in the class will dress up like the person he or she read about. We will have a special "Famous Person Masquerade" when everyone has finished their reading. At the masquerade you will have to introduce the person you read about.
6. The last part of this section is called "How Much Did You Learn?" Do it after the "Famous Person Masquerade." Place your paper in the completed work folder. Be sure your name is on the paper

Name \_\_\_\_\_

### BIOGRAPHY WORKSHEET \*

Two of the most famous men in the history of our country are George Washington and Abraham Lincoln. They were both born during the month of February. At this center there are many books about these two men. There are also some audiovisual materials and several dictionaries. For the next 15 minutes, explore the materials that interest you most.

#### NEXT

The books and filmstrips at this center are called biographies. Use one of the dictionaries at this center to find out what a biography is. Read what the dictionary says, think about it and then finish this sentence in your own words

A biography is \_\_\_\_\_  
\_\_\_\_\_

#### NOW

Find three facts about both Washington and Lincoln using the materials at this center. Write a sentence about each of the facts.

1. \_\_\_\_\_  
\_\_\_\_\_
2. \_\_\_\_\_  
\_\_\_\_\_
3. \_\_\_\_\_  
\_\_\_\_\_
4. \_\_\_\_\_  
\_\_\_\_\_
5. \_\_\_\_\_  
\_\_\_\_\_
6. \_\_\_\_\_  
\_\_\_\_\_

**SELF EVALUATION**

1. Did you understand the directions? \_\_\_\_\_ If you answered no, did you ask the teacher or a friend for help? \_\_\_\_\_
2. How well did you use your time? \_\_\_\_\_  
\_\_\_\_\_
3. Did you spend (all), (most), or (only part) of your time working at the center?  
\_\_\_\_\_

**When you have finished this paper put it in the completed work folder.**

Name \_\_\_\_\_

**BIOGRAPHY CENTER  
HOW MUCH DID YOU LEARN? \***

Do not begin this paper until the whole class has done the "Famous Person Masquerade "  
You must answer the following questions without help from the materials at the center and  
without the help of your classmates. If you have questions, ask the media specialist for help.

Write at least three things that you know about George Washington.

1. \_\_\_\_\_
2. \_\_\_\_\_
3. \_\_\_\_\_

Now write at least three things that you know about Abraham Lincoln.

1. \_\_\_\_\_
2. \_\_\_\_\_
3. \_\_\_\_\_

What famous person did you read a biography about? \_\_\_\_\_  
\_\_\_\_\_

Write three things that you remember about that person

1. \_\_\_\_\_
2. \_\_\_\_\_
3. \_\_\_\_\_

Finish this sentence. A biography is \_\_\_\_\_  
\_\_\_\_\_

Write the names of six famous, real people.

- |          |          |
|----------|----------|
| 1. _____ | 4 _____  |
| 2. _____ | 5. _____ |
| 3. _____ | 6. _____ |

### QUEST ACTIVITIES \*

(These are things you may do if you wish. They are not required of everyone.)

1. Choose a person you admire that you can interview. Take careful notes and write a short biography about the person.
2. Make a filmstrip or mobile to illustrate the book you read.
3. Write a poem describing the person you read about.
4. Make a box sculpture or poster to illustrate the book.
5. Write and present a play about the person you studied.
6. Has a poem been written about the person you studied? See if you can find one in the media center. Share it with the class.

\* "Permission to reprint granted by Montgomery County Public Schools, Rockville, Maryland."



## THE FABULOUS FIFTY

Emphasis Grade Level: 5

CURRICULUM APPLICATION (S): Social Studies, Reading, Language Arts

Goal: The student will become familiar with the geographical location, major land forms, natural resources as well as other information concerning the United States, through research using various sources of information.

### COOPERATIVE PLANNING/TEACHING

<p>The teacher will:</p> <ol style="list-style-type: none"><li>1. Introduce the unit to the students</li><li>2. Assist students in formulating questions to research.</li><li>3. Set guidelines and keep records of students working on various states.</li><li>4. Evaluate student activities.</li></ol>	<p>The library media specialist will:</p> <ol style="list-style-type: none"><li>1. Help students in locating different sources of information available in both print and nonprint.</li><li>2. Instruct students on keeping bibliographic information or sources used</li><li>3. Share literature that takes place in the state or region they are studying.</li></ol>
---	--

### LEARNER OUTCOMES

Content Areas	Information Skills
<p>The student will:</p> <ol style="list-style-type: none"><li>1. Locate and interpret information by selecting appropriate information from encyclopedias, atlases, periodicals, maps, globes, etc.</li><li>2. Demonstrate a knowledge of political boundaries within the United States.</li><li>3. The student will identify and/locate major topographical features such as water, landforms, and natural resources.</li></ol>	<p>The student will:</p> <ol style="list-style-type: none"><li>1. Make use of maps and graphs to record information.</li><li>2. Use an atlas.</li><li>3. Prepare a bibliography of books (in alphabetical order giving the author and title of each item).</li><li>4. Make notes from various media.</li></ol>

## ACTIVITIES/SUGGESTIONS:

1. Introduce the unit using a large map of the United States and a globe of the world to point out special geographical features of various states and their location to the rest of the world.
2. Students may choose the state they would like to find out more about, or the name of a state could be drawn from a box.
3. As a group activity, formulate questions the students may want to find out about their state. Encourage students to use at least three sources when completing their research. This could be presented as an oral report or in the form of a booklet.
4. During a visit to the library media center the librarian should point out and review various sources of information available on the United States. This could include books, encyclopedias, atlases, periodicals, filmstrips, etc.
5. Make available to the students outline maps of each state showing topographical areas, countries, county seats, major rivers, agricultural products, etc. (One source is STATE MAPS ON FILE. Permission is given to reproduce all maps for nonprofit education or private use.) The student may select at least three outline maps of the state, locate information in the resources, fill in the information on the outline maps and make a simple key for each map. These maps may be included in the booklet with the other information that has been obtained about the state.
6. Have students complete one or more of the following:
  - a. Design a map to show the birthplace of famous people of the state
  - b. Use an outline map to show the location of different universities and colleges.
  - c. Use an outline map to show the location of famous tourist attractions.
7. Have students write letters to the State Tourism Department of the state they are studying, asking for information about that state. This information could be placed in the vertical file in the library media center for use by other students. The addresses of the various state tourism departments are found on page 155 of the Oklahoma State Department Elementary Social Studies Curriculum Guide *Touching, Living, Growing*.
8. Using a map of the United States, students will plan a trip of at least 300 miles. Provide travel guides and road maps, if possible, and have students figure the cost and time to travel from their hometown to a point on the map and return. Include car expenses, motel bills and turnpike fees. List the places or things that would be of interest to see or visit during their journey. This is a good activity to do in small groups.
9. Using the pictorial map of the United States in this unit, have students list the places or things that would have been seen on the previous planned activity.
10. Divide the class into groups. Give each group a section of the pictorial. Each group reports back to the class on what the pictures in their section represent. Their resources could be family, friends or the library. The depth of the report would depend on the grade level and the ability of the students

11. Since the states are often studied in groups, or regions, the library media specialist may assist students in finding books taking place in that region, or in a particular state

Examples:

**NORTHEAST**

Fritz, Jean, *What's the Big Idea, Ben Franklin?* Coward, 1976  
George, Elizabeth, *The Sign of the Beaver* 1983.

**SOUTHEAST**

Armstrong, W., *Souder*. Harper, 1969  
Cleaver, Bill and Vera, *Where the Lilies Bloom*. Lippincott, 1969.

**PLAIN STATES**

MacLachlan, Patricia, *Sarah Plain and Tall*. Harper, 1985.  
Wilder, Laura Ingalls, *Little House on the Prairie*. Harper, 1953.

**PACIFIC STATES**

Gates, *Blue Willow*. Viking 1940.  
Odell, Scott, *Island of the Blue Dolphins*. Houghton, 1960.

**EVALUATION:** Students will receive a letter grade on the various written assignments and maps completed in the unit.

**RESOURCES:**

Carpenter, Allan, *The New Enchantment of America State Books*. Childrens Press, 1979.  
Childrens Press  
1224 West Van Buren Street  
Chicago, IL 60607

Ross, Wilma S., *Fabulous Facts About the 50 States*. Scholastic, 1986  
Scholastic, Inc.  
P.O. Box 7501  
2931 East McCarty Street  
Jefferson City, MO 65102

*Just Havin' Fun!* Spring Sampler, Vol. 5, 1986. Oklahoma State Department of Education.  
Oklahoma State Department of Education  
Reading Section  
2500 North Lincoln Boulevard  
Oklahoma City, OK 73105-4599

*New Book of Knowledge Encyclopedia*. Grolier Education Corporation.  
Grolier Education Corporation  
Sherman Turnpike  
Danbury, CT 06816

*School Library Media Activities Monthly*. Vol. III, No. 4, December 1986. p. 23.  
LMS Associates  
17 East Henrietta Street  
Baltimore, MD 21230

*State Maps on File.* Facts on File, Inc., 1984  
Facts on File  
460 Park Avenue South  
New York, NY 10016

*Touch, Living, Growing.* Elementary Social Studies Curriculum Guide.  
Oklahoma State Department of Education  
Curriculum Section  
2500 North Lincoln Boulevard  
Oklahoma City, OK 73105-4599

*Worldmark Encyclopedia of the States.* Worldmark Press, Ltd. 1981

Filmstrips and Computer Software:

*Geography of the United States Series.* National Geographic, 1979.  
National Geographic  
Educational Services  
Washington, DC 20036

*States and Traits* (computer program). Design Ware, Inc.

*Where in the USA is Carmen Sandiego?* (computer program). Follett Software Co.  
Follett Software Company  
4506 Northwest Highway  
Crystal Lake, IL 60014-7393

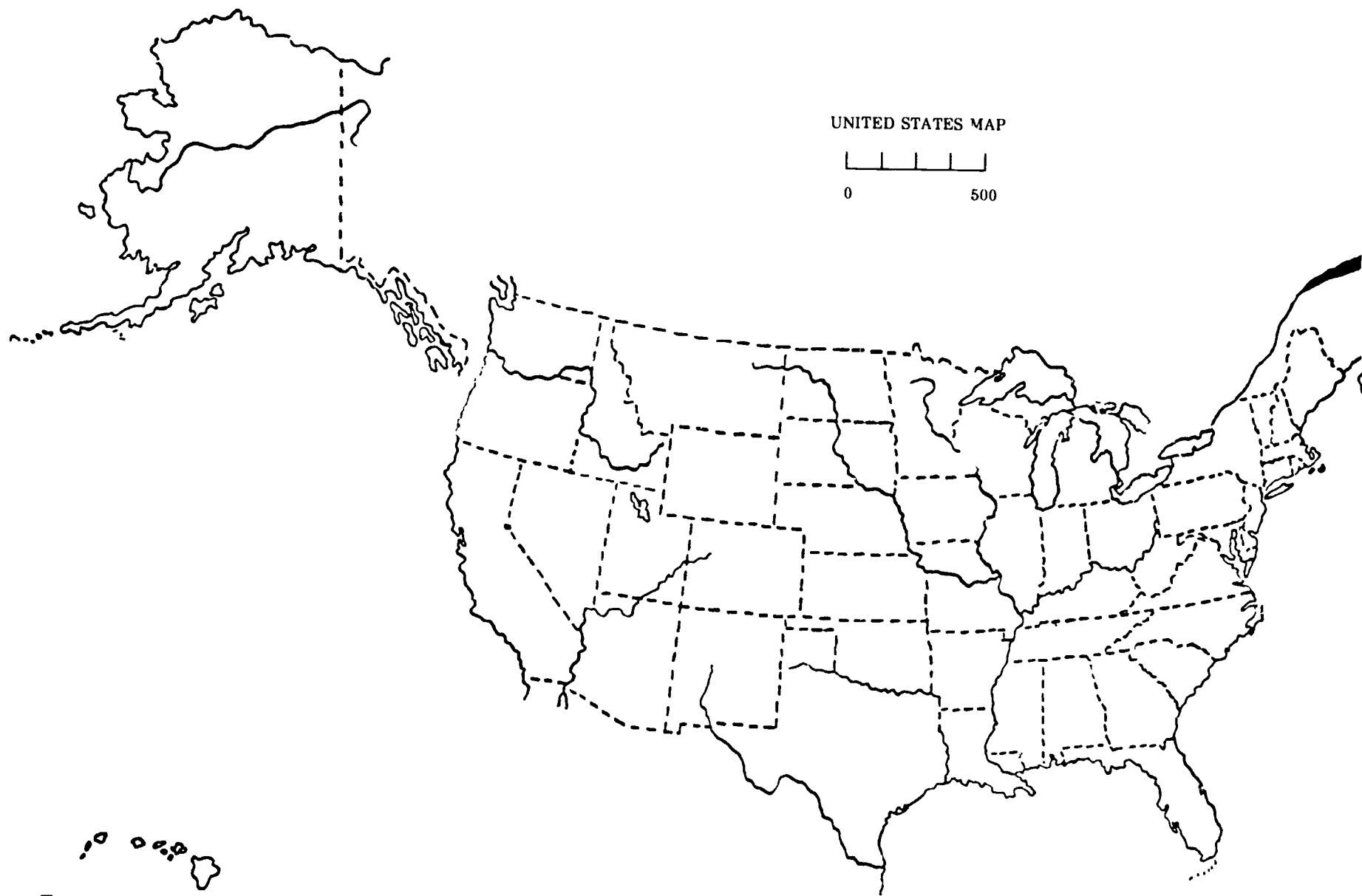

UNITED STATES MAP

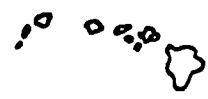
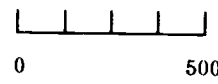

246

SOURCE: *Touching, Living, Growing*. Elementary Social Studies. Oklahoma State Department of Education, p. 157.

247



**"WHERE IN THE WORLD ARE WE"  
A Review of Map and Globe Skills**

**Emphasis Grade Level: 5**

**CURRICULUM APPLICATION(S):** Social Studies, Language Arts, Reading

**GOAL:** To review the use and purpose of maps and globes and to give the student a better understanding of how they can be useful tools in finding out about people and places.

**COOPERATIVE PLANNING/TEACHING**

<p>The teacher will:</p> <ol style="list-style-type: none"> <li>1. Introduce the importance of being able to use different types of maps and globes.</li> <li>2. Guide students in various activities</li> </ol>	<p>The library media specialist will.</p> <ol style="list-style-type: none"> <li>1. Make students aware of different sources and types of maps, globes, and atlases.</li> <li>2. Collect a number of different kinds of maps.</li> <li>3. Direct research activities.</li> </ol>
--	--

**LEARNER OUTCOMES**

<b>Content Area</b>	<b>Information Skills</b>
<p>The student will:</p> <ol style="list-style-type: none"> <li>1. Use a variety of reference materials to answer a question or solve a problem.</li> <li>2. Locate and interpret information by selecting appropriate material.</li> <li>3. Use an atlas.</li> </ol>	<p>The student will:</p> <ol style="list-style-type: none"> <li>1. Use an atlas.</li> <li>2. Make use of maps and graphs to record information.</li> </ol>

## ACTIVITIES/SUGGESTIONS:

1. View a filmstrip which relates the background information about maps and globes. Suggested source, "How To Use Maps and Globes" by Troll Associates.
2. Collect as many different globes and maps as possible for the students to use. Besides atlases and maps in various books, there are many free and inexpensive maps. Some sources are banks, chambers of commerce, state tourism departments, state highway departments, corps of engineers, and U.S. Government Printing Office Bookstore (address included in Resource history).
3. Have each student bring a map from home. Working in small groups, have the students share the following information about their maps
  - a. What type of map is it?
  - b. Point out and explain the key
  - c. What is the scale of measurement being used?
  - d. What was the source of the map?
4. Using your social studies text as a basis, introduce the vocabulary.

sphere	compass rose
hemisphere	cardinal directions
North Pole	intermediate directions
South Pole	map scale
equator	symbols
continents	insert
	grid

5. Using the vocabulary words, have each student compile an illustrated dictionary.
6. Use the worksheets "Where in the World" on pages 235-236 after completing the vocabulary dictionary.
7. Divide the class into small groups of three to four students. Each group would be responsible for finding information about one of the continents. After researching, using at least two sources--an atlas, encyclopedia, various types of maps, etc --they would develop oral reports.
8. Make a list of places to be located by latitude and longitude. This could be used as a competitive, small group activity.
9. Use a cantalope to represent the shape of the earth. The natural vertical lines can illustrate longitudes. Parallels of latitude can be added. It can also be used to demonstrate the poles, the hemispheres and the equator. Several can be used, then as the exercise is completed the models can be eaten. Fun!
10. Cut a map into sections. Mount each on a piece of posterboard leaving space to list questions that can be answered from reading the map. Be sure to indicate directions and scale of miles. This can be laminated and used as a learning center.

201



**EVALUATION:** Students will receive a letter grade on the worksheet and the research activity.

**RESOURCES:**

*Classroom Learning Activities for Social Studies*  
Oklahoma State Department of Education, 1982

*Touching, Living, Growing*  
Elementary Social Studies  
Oklahoma State Department of Education, 1981

Oklahoma State Department of Education  
Curriculum Section  
2500 North Lincoln Boulevard  
Oklahoma City, OK 73015

*The United States: Its History and Neighbors*  
Harcourt Brace Jovanovich.

For a list of inexpensive maps

U S. Government Printing Office Bookstore  
710 North Capital Street, NW  
Washington, DC 20401

## BIBLIOGRAPHY

### Atlases

*Doubleday Children's Atlas*. Doubleday, 1987. \$10.95.

*Hammond Ambassador World Atlas*. C. S. Hammond and Company, Inc. Hammond, 1982.

*Rand McNally Cosmopolitan World Atlas*. New Census Edition, 1981.

*Rand McNally Student's World Atlas*, 1984. Paperback.

*Viking Student World Atlas*. Viking Kestrel, 1986. \$9.95.

### Maps and Globes

**Arnold, Carline.** *Maps and Globes*. Illustrated by Lynn Sweat Watts, 1984. \$8.90.

**Berry, Marilyn.** *Help Is on the Way for Maps and Globes*. Illustrated by Bartholomew Childrens Press, 1985. \$8.95.

**Broekel, Ray.** *Maps and Globes*. Childrens Press, 1983. \$7.95.

**Knowlton, Jack.** *Maps and Globes*. Illustrated by Harriett Barton. Crowell, 1985. \$9.89.

# WHERE IN THE WORLD

Using the following terms label the globe shown below

- hemisphere
- North Pole
- South Pole
- equator
- continents

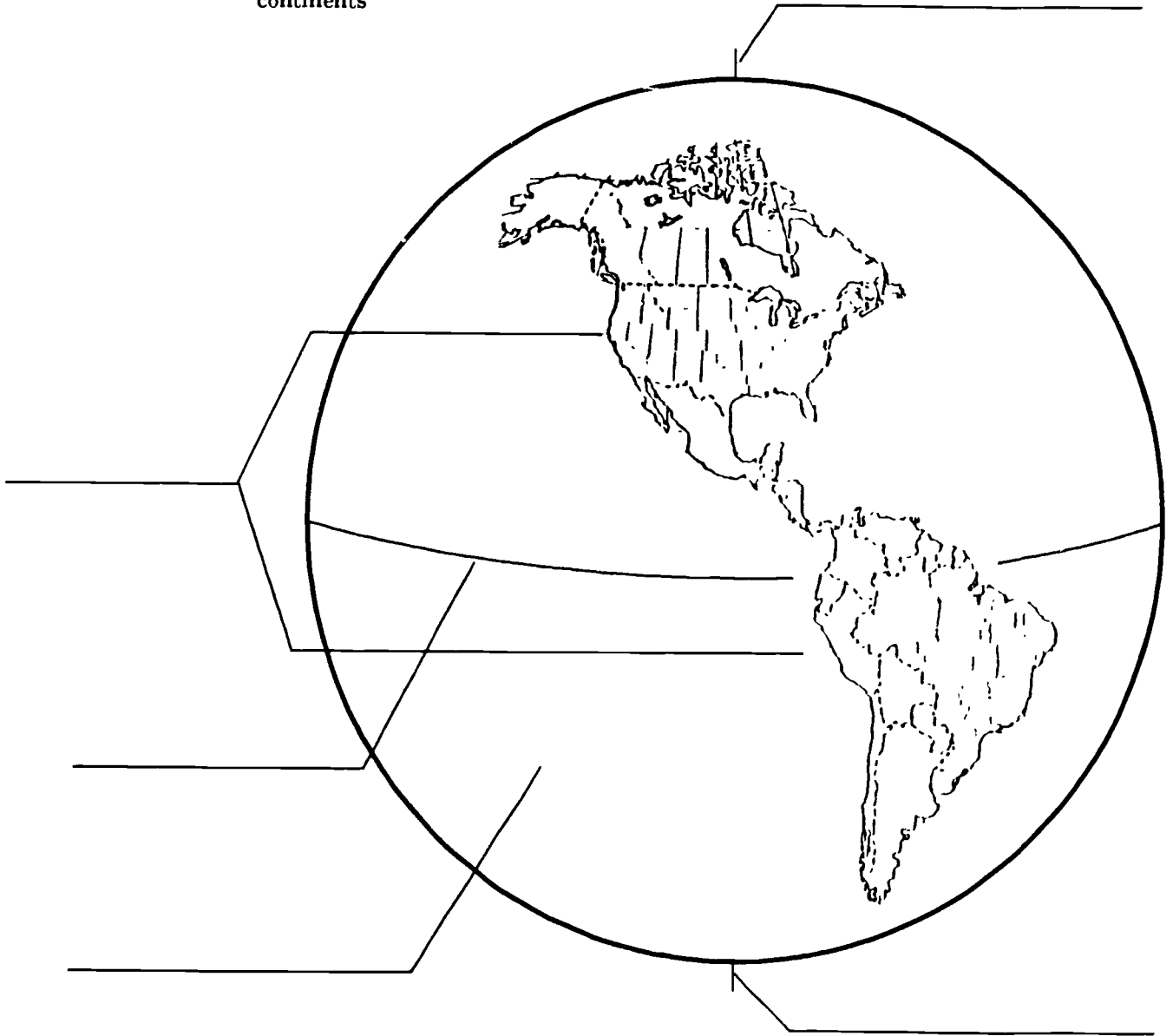

The cardinal directions or four main directions are labeled on this compass rose. Indicate the intermediate directions or the ones between the cardinal directions.

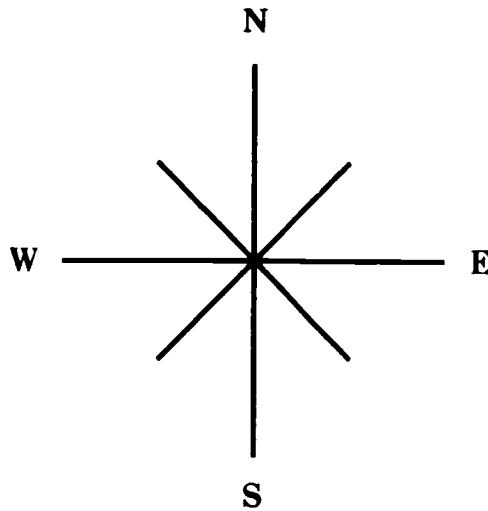

Answer the following questions after studying the map on the following page.

1. Give the map an appropriate title.

\_\_\_\_\_

2. What is the scale of measurement for the main part of the map? \_\_\_\_\_

3. Using the 40° parallel latitude, measure to see approximately how many miles you would travel from the west coast to the east coast of the United States.

4. Put a dot at the approximate place you live.

5. Why was an insert needed in this map of the world? \_\_\_\_\_

\_\_\_\_\_

6. What was the scale of measurement for this insert? \_\_\_\_\_

7. Using an atlas, label the seven continents and the oceans.

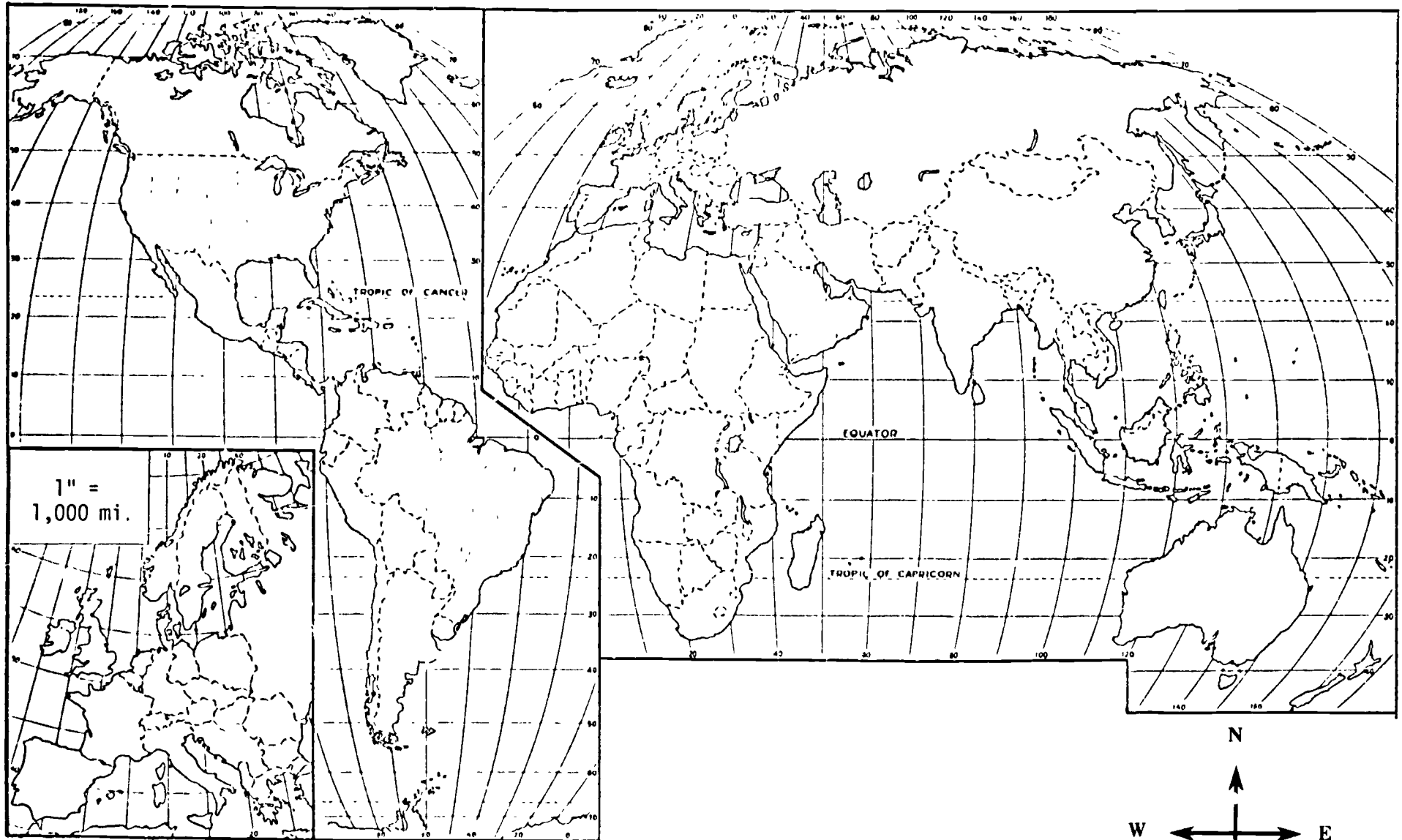

256

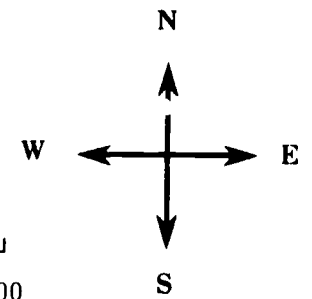
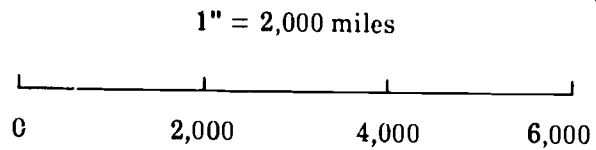

SOURCE: *Touching, Living, Growing*. Elementary Social Studies, 1981. Oklahoma State Department of Education. p. 164.



257



**Emphasis Grade Level: 5**

**CURRICULUM APPLICATION(S):** Reading

**GOAL:** Students will research specific information about authors and illustrators of books for young people using *Something About the Author*.

**COOPERATIVE PLANNING/TEACHING**

<p>The teacher will:</p> <ol style="list-style-type: none"> <li>1. Provide follow-up activities with authors and illustrators after students learn to access specific information in the biographical series.</li> </ol>	<p>The library media specialist will:</p> <ol style="list-style-type: none"> <li>1. Teach/review the research skills needed to use indexes of <i>Something About the Author</i> volumes to locate specific information.</li> </ol>
--	--

**LEARNER OUTCOMES**

Content Area	Information Skills
<p>The student will:</p> <ol style="list-style-type: none"> <li>1. Read to locate information.</li> <li>2. Use a variety of reference materials to answer a question or solve a problem.</li> <li>3. Learn to interpret the organization of material.</li> <li>4. Be able to read a selection and identify the main idea and details.</li> <li>5. Refine skills of locating and interpreting information on a specific topic.</li> </ol>	<p>The student will:</p> <ol style="list-style-type: none"> <li>1. Use an index.</li> <li>2. Formulate questions to be answered by research.</li> <li>3. Select appropriate learning resources.</li> <li>4. Distinguish between relevant and irrelevant information.</li> <li>5. Locate reference material related to specific subject areas or courses.</li> <li>6. Use appendixes, footnotes, almanacs, yearbooks, biographical dictionaries.</li> </ol>

### ACTIVITIES/SUGGESTIONS:

1. Use the enclosed activity sheet to develop research skills. Depending on the size and abilities of the class group, one to four days may be needed for all students to find all items of information asked for about each author/illustrator.

**NOTE:** Some information has been asked for which cannot be found in *Something About the Author*. Students should be aware of this before they start, so that they will be thorough in their research for specific information.

2. Have students develop a question or two about their favorite author to research in *Something About the Author*. These can be used by the teacher and library media specialist with other classes.

### EVALUATION:

The classroom teacher will provide opportunities for students to apply this particular type of research skill in regular assignments within the existing curriculum.

### RESOURCES:

*Something About the Author: Facts and Pictures About Contemporary Authors and Illustrators of Books for Young People*. Detroit, Michigan: Gale Research Company, 1971, Volumes 1-36.

Gale Research Company  
Book Tower  
Detroit, MI 48226

**SOURCE:** Lori Bradley, Skyview Elementary School, Yukon, Oklahoma

259

**Something About the Author**

Leo Politi Birthdate	Peter Spier current home town	Gerald McDermott one award he has won	Nonny Hogrogian title of a book she wrote
Marcia Brown Where was she born?	Evaline Ness one of her early jobs	Robert McCloskey parents' names	Ludwig Bemelmans first book published (give a date and title)
Janice Udry birthdate	Ezra Jack Keats current home town	Maurice Sendak one award he has won	Uri Shulevitz title of a book he wrote
Robert Lawson Where was he born?	Arnold Lobel one of his early jobs	Alvin Tresselt parents' names	Golden MacDonald real name
Jean George birthdate	Madeleine L'Engle current home town	Scott O'dell one award he has won	Harold Keith current home town
Betsy Byars title of a book she wrote	Marguerite Henry one of her early jobs	Lois Lenski parents' names	Rachel Field first book published (give date and title)
Judy Blume Where was she born?	Beverly Cleary current home town	Tomie De Paola parents' names	Bill Peet current age
Isaac Asimov birthdate	Brent Ashabranner Where was he born?	Dr. Seuss real name	Phyllis Whitney birth place
Fred Gipson one of his early jobs	Jean Fritz current home town	Robert Krauss parents' names	H A. Rey what the initials stand for
Charlotte Zolotow title of a book she wrote	Gene Zion home town	E. B. White what the initials stand for	Beatrix Potter one of her early jobs



## LITERATURE LETTERS

**Emphasis Grade Level: 5-6**

**CURRICULUM APPLICATION(3):** Reading, Language Arts

**GOAL:** Students will understand the different genres of literature and through creative expression, report on a book in a given genre.

### COOPERATIVE PLANNING/TEACHING

<p><b>The teacher will:</b></p> <ol style="list-style-type: none"> <li>1. Prepare the letters.</li> <li>2. Guide students in art activities as they interpret a book in a certain genre on the literature letter.</li> </ol>	<p><b>The library media specialist will.</b></p> <ol style="list-style-type: none"> <li>1. Review the genres of literature to be used for the project. Examples: P-Poetry, H-Historical Fiction, S-Science Fiction, B-Biography, M-Mystery, T-Tall Tales, R-Realistic Fiction, F-Folklore or others chosen by library media specialist and teacher.</li> <li>2. Show examples of books in each genre.</li> </ol>
--	--

### LEARNER OUTCOMES

Content Areas	Information Skills
<p><b>The student will:</b></p> <ol style="list-style-type: none"> <li>1. Identify the setting, characterization and plot of a book.</li> <li>2. Locate details from material read.</li> <li>3. Be able to enjoy many forms of reading materials for a variety of purposes.</li> <li>4. Be able to make a simple book report.</li> <li>5. Develop an interest in reading for appreciation.</li> </ol>	<p><b>The student will:</b></p> <ol style="list-style-type: none"> <li>1. Find and enjoy books in the different genres of literature</li> <li>2. Develop recreational reading habits.</li> </ol>

### **ACTIVITIES/SUGGESTIONS:**

1. Introduce and/or review the different genres of literature and characteristics of each
2. With the class, choose several genres to use for this project.
3. Enlarge letters to 36" using opaque projector.
4. After students have chosen and read books, divide each letter into sections (see sample). Each student will complete a section with a scene from the book depicting setting, characters or plot.
5. Display on walls throughout the school.

### **EVALUATION:**

Each student will briefly summarize the book orally and tell about the scene they have included on the letter.

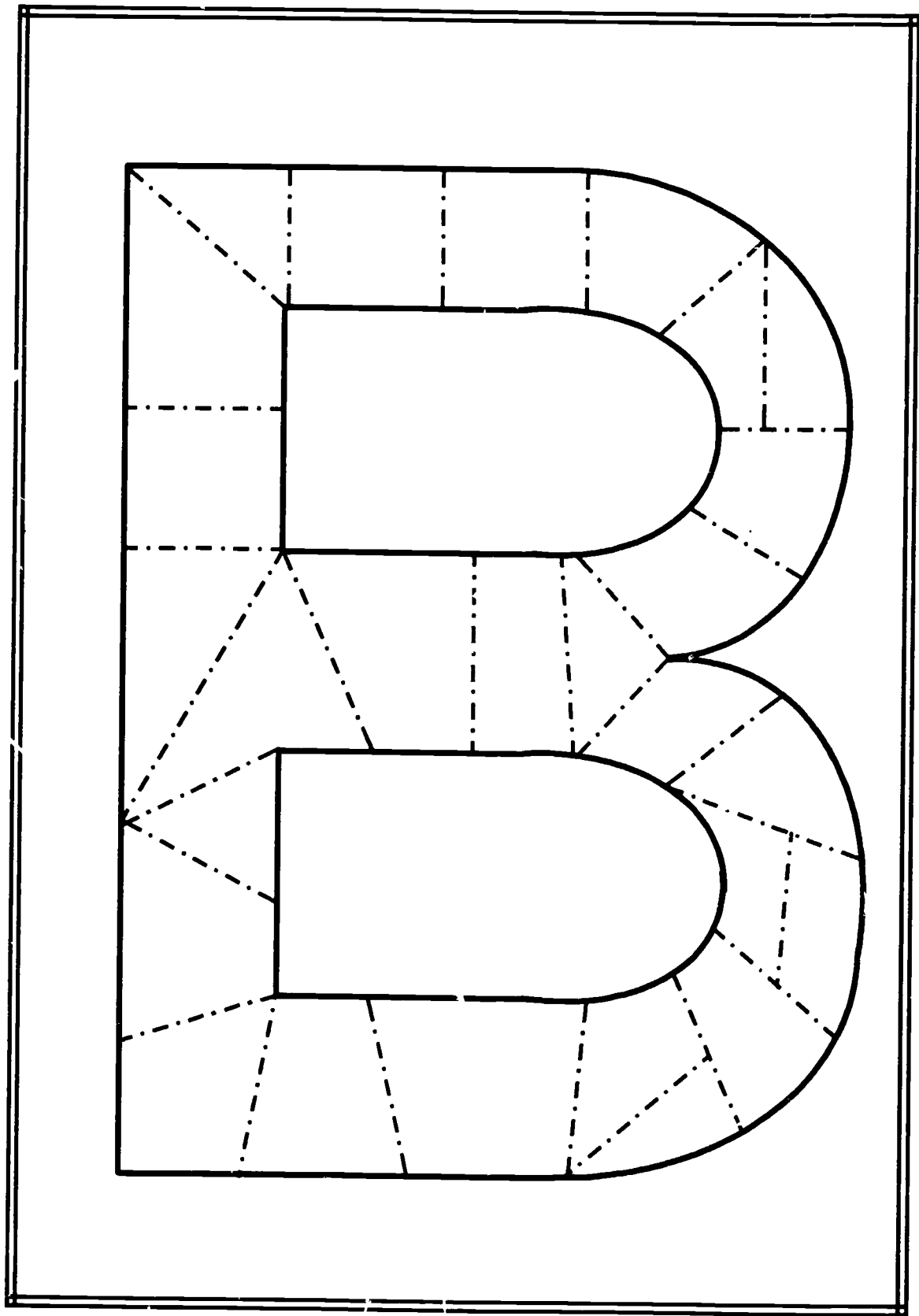

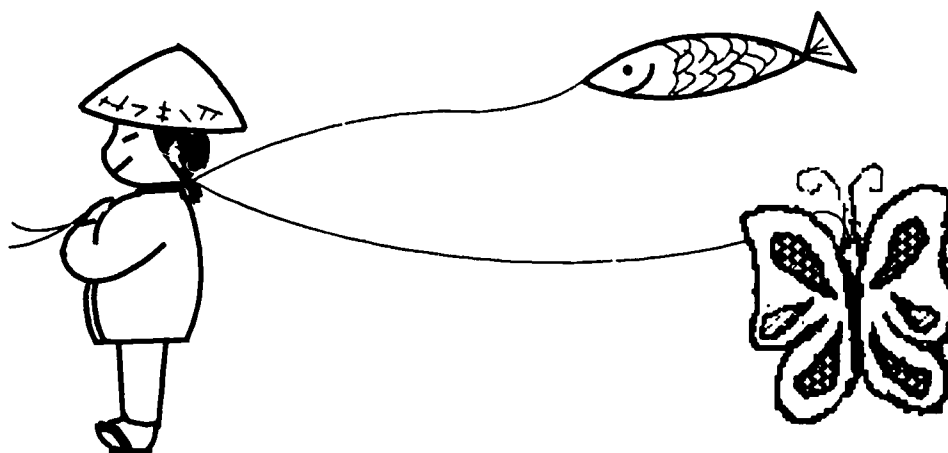

## BUILDING THE GREAT WALL

**Emphasis Grade Level; 6**

**CURRICULUM APPLICATIONS(S):** Reading, Language Arts, Math, Social Studies, Science, Art, Music, Physical Movement

**GOAL:** The students will develop a better understanding of the people, culture, and history of China through a variety of integrated curriculum activities

### COOPERATIVE PLANNING/TEACHING

The teacher will:	The library media specialist will
<ol style="list-style-type: none"> <li>1. Work with the library media specialist in developing a time line for the unit.</li> <li>2. Provide a list of subtopics on China to be researched</li> <li>3. Introduce the unit and give an overview of student activities and unit culmination.</li> <li>4. Assist the students in completing their worksheets and products.</li> <li>5. Coordinate the Chinese New Year culmination activity.</li> <li>6. Evaluate the students' research and products.</li> </ol>	<ol style="list-style-type: none"> <li>1. Work with the teacher in developing a time line for the unit.</li> <li>2. Provide a bibliography of related subject materials in the media center.</li> <li>3. Aid in selection and ordering of additional materials needed.</li> <li>4. Review proper use of reference books. (encyclopedias/dictionaries).</li> <li>5. Assist in completing worksheets and preparing any audiovisual materials.</li> <li>6. Assist the teacher in evaluation of students' research and products.</li> </ol>

## LEARNER OUTCOMES

Content Areas	Information Skills
<p>The student will:</p> <ol style="list-style-type: none"> <li>1. Demonstrate the ability to use reference materials and resources for investigating specific areas of geographical study.</li> <li>2. Identify cultural factors that influence the lives of the people within a nation</li> <li>3. Identify environmental factors that influence the lives of the people within a nation.</li> <li>4. Refine the skills of locating and interpreting information on a specific topic.</li> <li>5. Be able to determine the meaning of the word according to its usage.</li> <li>6. Construct a graph, read and interpret data from that graph</li> <li>7. Develop a report based on notetaking, outlining, and reference material.</li> <li>8. Develop an appreciation of good literature through listening, viewing, and reading.</li> </ol>	<p>The student will:</p> <ol style="list-style-type: none"> <li>1. Formulate questions to be answered by research.</li> <li>2. Select appropriate learning resources.</li> <li>3. Locate special tools (e.g. <i>geographical dictionaries</i>).</li> <li>4. Reinforce use of a dictionary. (<i>guide words, index</i>)</li> <li>5. Use a pronunciation key.</li> <li>6. Reinforce use of an encyclopedia. (<i>guide words, index</i>)</li> <li>7. Interpret graphs, charts, diagrams, maps, globes and atlases.</li> <li>8. Create and present a puppet presentation or dramatization to convey information.</li> <li>9. Present an oral report.</li> <li>10. Find and enjoy legends, fables, and mythology</li> <li>11. Enjoy drama, music, poetry, dances, stories, etc., in print and nonprint formats.</li> </ol>

## ACTIVITIES/SUGGESTIONS;

- 1 Introduce the unit on China with a bulletin board or wall depicting the famous Great Wall of China. Use the caption "Building the Great Wall." Additional pictures of China and other Chinese articles may be displayed around the room. Play a tape of oriental music for background atmosphere.

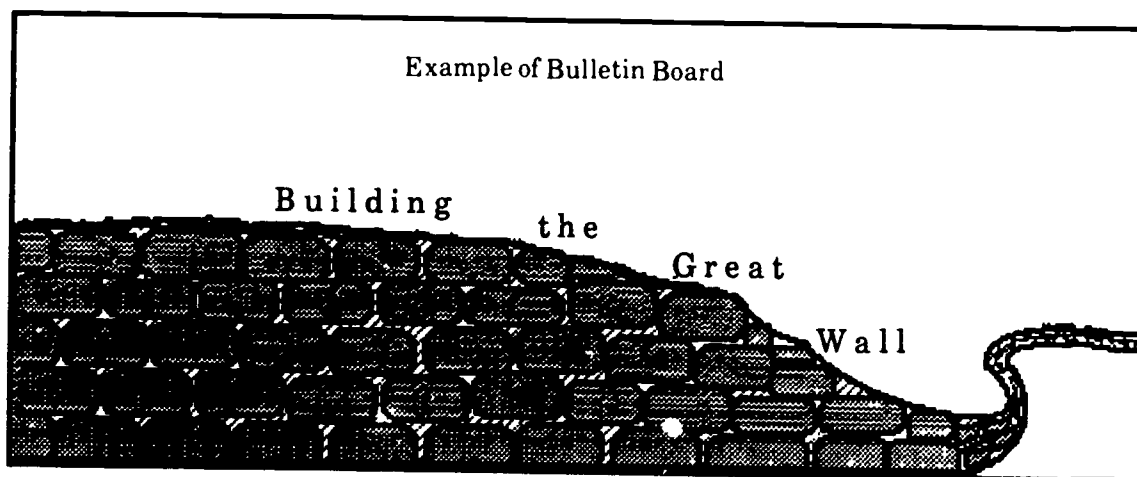

2. Focus students' attention to the bulletin board and generate interest by asking "where," "why," and "what" questions about the Great Wall and China.
3. Record student responses on the chalkboard or overhead projector.
4. Ask students what resources in the library media center could be used to validate and expand their knowledge of China. List resources.
5. Review the most commonly used resources (dictionary, encyclopedia) and have each student predict what type of information would be found in each source.
6. Review the use of guide words, entry words, and indexes, etc.
7. Tell students they will be building a "Great Wall of Information" from research they will collect and record about China.
8. Pass out homemade fortune cookies to the students. Each cookie should contain a fortune and some key words to be looked up in the dictionary. (Coolie hats with key words written on them could be substituted for cookies. Words might also be written on chopsticks.)
9. While students are munching on cookies instruct them to do the dictionary worksheet using their key words.
10. As these worksheets are completed, key words should be shared with the class and added to the bulletin board as blocks to extend the "Great Wall of Information."
11. View filmstrips or videos of China. (Suggested source: "Life in the People's Republic of China, SVE)
12. Brainstorm with students possible subtopics of interest to be researched (people, customs, government, education, industry, art, literature, drama, religion, philosophy).
13. Let students choose and narrow their topic. Research may be done individually or in small groups.

14. Give each student or group a worksheet on \_\_\_\_\_ to record their research. When these blocks are completed they should be shared with the class and added to the growing wall of information.
15. In addition to their research, each student/group should develop a product based on their interest in some aspect of China.

#### PRODUCT SUGGESTIONS.

\*Develop a time line on a chart or transparency identifying each Chinese dynasty and an important event that took place during that reign.

\*Construct a diorama of a Chinese fishing village or junks on the Grand Canal. Be prepared to describe a typical day in the life of a villager.

\*Dramatize the story of Buddha and the 12 animals of the Chinese Zodiac using puppets made by students

\*Write an article for your school or local newspaper describing your class activities involved in "Building the Great Wall." Include pictures and quotes from student interviews that tell what they learned from the unit.

\*Debate the advantages/disadvantages of life on the Yangtze River as opposed to life in a Chinese commune. This might be done orally, with one student being from the Yangtze River area and the other from a commune.

\*Design an oriental picture using a tangram

\*Organize a glossary of key words used in this unit and design a cover

\*Create a board game "Great Wall Trivia" Make questions based on all research topics covered in this unit.

\*Compile a book of Chinese proverbs. Make up a few of your own and add them to the collection.

\*Read the story of the *Five Chinese Brothers* Invent a sixth brother and tell of his unusual power.

\*Design and construct a Chinese kite. Give an oral report on how kites were used for purposes other than entertainment.

\*Analyze the curriculum of the Chinese school. Compare and contrast their curriculum to your school's curriculum.

\*Imagine yourself as a Chinese chef Prepare a cup of egg drop soup or demonstrate the art of using chopsticks The class may want to join you in compiling a cookbook of their favorite Chinese recipes

\*Create the Chinese musical instrument, the p'ip'a. Compose a melody and ask a friend to accompany your song with a Chinese dance

\*Develop a large map of China on a poster board. Construct the Great Wall on this map using bakers clay

\*Read a Chinese legend such as *Pie-biter* and retell it to the class

\*Act out a Chinese play such as "A Chinese Rip Van Winkle "

\*Read the Chinese version of "Cinderella" and compare it with an American version

\*Make a display and demonstrate the ancient art of origami. Enjoy the book *The Perfect Crane* and share it with the class.

16. Culminate the unit in January or February, if possible, with a Chinese New Year. Invite "honorable" father, mother, and possibly the whole school to celebrate. Guests may view the "Great Wall of Information" as well as student products on display. Students may wish to "dress" for the occasion.

17. Compile a folder containing plans, activities, etc., used in this unit. It's been so much fun you will want to do it again in the future!

**EVALUATION:** Students participating in "Building the Great Wall" will be evaluated on the basis of individual or group research and on the products developed.

**RESOURCES:**

*Chinese Tales.* (sound filmstrip) Clearvue, 1973. Grades 4-8.

Clearvue, Inc.  
5711 North Milwaukee Avenue.  
Chicago, IL. 60646

*Life in the Peoples Republic of China* (sound filmstrip) SVE, 1981. Grades 5-8

Society for Visual Education  
Dept. BK  
1345 Diversey Parkway  
Chicago, IL 60614-1299

*Treasury of Chinese Folk Tales* (sound filmstrip) Spoken Arts. Grades 5-6.

Spoken Arts  
310 North Avenue  
New Rochelle, NY. 10801



*Gung Hay Fat Choy.* (sound filmstrip) Long Filmslide Service, 1976

Long Filmslide Service  
7505 Fairmont Avenue  
El Cerrito, CA 94530

*Classroom Learning Activities for Social Studies.* Oklahoma State Department of Education,  
1982.

Oklahoma State Department of Education  
Curriculum Section  
2500 North Lincoln Boulevard  
Oklahoma City, OK 73105-4599

209

252

## "GREAT WALL" BIBLIOGRAPHY

- Andersen, Hans Christian** *Nightingale*. Harper & Row, 1965. Grades 4-6.
- Baron, Nancy**. *Getting Started in Calligraphy*. Sterling, 1979. Grades 5-6.
- Behrens, June**. *Gung Hay Fat Choy: Happy New Year*. Holt, Rinehart, & Winston, 1976  
Grades 4-7.
- Bishop, Claire H.** *Five Chinese Brothers*. Putnam, 1938. Grades K-3.
- Borja, Robert**. *Making Chinese Papercuts*. Whitman, 1980. Grades 5-6.
- Burack, A. S.** "A Chinese Rip Van Winkle," *One Hundred Plays for Children*. Plays Inc., 1970.  
Grades 1-6.
- Burack, A. S.** *Chinese Fairy Tales and Fantasies*. Pantheon, 1979. Grades 6-8.
- Burack, A. S.** *Chinese Mother Goose Rhymes*. Philomel, 1982. Grades 1-4.
- Cheng, Hou-Tien**. *Chinese New Year*. Holt, Rinehart, & Winston, 1976. Grades 4-7.
- Dejong, Meindert** *House of Sixty Fathers*. Harper & Row, 1956. Grades 4-6
- Fritz, Jean**. *Homesick: My Own Story*. Putnam, 1982. Grades 4-6.
- Fritz, Jean**. *China Homecoming*. Putnam, 1985. Grades 4-6.
- Kendall, Carol** *Sweet and Sour: Tales From China*. Houghton Mifflin/Clarion, 1979.  
Grades 4-6.
- Laurin, Anne**. *The Perfect Crane*. Harper & Row, 1981. Grades 1-4.
- Lawson, Don** *Long March: Red China Under Chairman Mao*. Crowell, 1983. Grades 5-8.
- Lee, Jeanne M.** *Legend of the Li River*. Holt, 1983. Grades 3-6.
- Lee, Jeanne M.** *Legend of the Milky Way*. Holt, Rinehart, & Wilson, 1982. Grades 2-6.
- Lewis, Elizabeth Forman** *Young Fu of the Upper Yangtze*. Holt, Rinehart, & Winston, 1960.  
Grades 5-6.
- Louie, Ai-Ling**. *Yeh-Shen, a Cinderella Story from China*. Philomel, 1982. Grades 3-6.
- Mason, Sally**. *China*. Watts, 1981. Grades 3-6.
- McCunn, Ruthanne Lum**. *Pie-biter*. Design Enterprises, 1983. Grades 3-5.
- McLennan, Valjean**. *China: A History to 1949*. Childrens Press, 1983.
- Mosel, Arlene**. *Tikki Tikki Tembo*. Holt, Rinehart, and Winston, 1967. Grades 2-5. (also sound  
filmstrip, Weston Woods)

- Takahama, Toshie.** *Origami for Fun.* Shufunotoma, 1973. Grades 3-6.
- Thompson, Brenda.** *Great Wall of China* Lerner, 1977. Grades 4-6.
- Van, Woerkom.** *The Rat, the Ox and the Zodiac--A Chinese Legend*
- Wallace, Ian.** *Chin Chiang and the Dragon Dance* Atheneum, 1984 Grades 1-5.
- Wiese, Kurt.** *You Can Write Chinese*
- Wilson, Barbara.** *Willow Pattern Story.* Angus & Robertson, 1981 Grades 4-6
- Wolkstein, Diane.** *White Wave: A Chinese Tale.* Crowell, 1979. Grades 4-6.
- Wu, Tinna Keh.** *Bo Po Mo Fo. Chinese-English Pictorial Dictionary.* Princeton Press, 1983. Grades K-6.
- Young & Beckett** *The Rooster's Horns. A Chinese Puppet Play to Make and Perform*

**"Great Wall of Information"  
Encyclopedia Skills**

Name/Group: \_\_\_\_\_ Class. \_\_\_\_\_ Date \_\_\_\_\_

\_\_\_\_\_

Topic: \_\_\_\_\_ Key words: \_\_\_\_\_

Subject headings. \_\_\_\_\_ Sou. ces. \_\_\_\_\_

Summary of facts:

**"Great Wall of Information"  
Dictionary Skills**

Name \_\_\_\_\_ Class \_\_\_\_\_ Date \_\_\_\_\_

Vocabulary	Guide Words	Pronunciation	Definition

Use in a sentence.

## Egg Drop Soup

1 Egg

1 T cornstarch

2 T cold water

3 Cups clear chicken broth (may use bouillon cubes or strained chicken noodle soup)

Optional: 1 t. chopped parsley or scallion to suggest leaves Pour broth into a metal saucepan, bring to a boil. Measure water and cornstarch into a baby food jar, cover with a lid and shake vigorously. Open jar, pour cornstarch mixture into the broth, stir with fork until smooth Break an egg into a small bowl and beat with fork.

Allow students to watch and take turns helping to pour egg into the broth. They can see the flowers formed when the egg cooks in shreds as it is dropped into the broth. It sinks and then rises to float on the surface in budlike pieces. Stir until all egg has been added and cooked, remove from heat and serve. Make sure each student gets some flowers. Spoon into his/her cup

**SOURCE:** *Classroom Learning Activities for Social Studies.* Oklahoma State Department of Education, 1982. p. 103.

## CHINESE TANGRAMS

To make a Chinese tangram, give each student a 4" x 4" square of construction paper and the following directions: (Step 1) Cut the square into two triangles. (Step 2) Cut one of the triangles into two more triangles to make pieces 1 and 2. (Step 3) Using the remaining large triangle, fold down the top point to touch the bottom of the base, then crease and cut off this small triangle to make piece 3 (Step 4) From the long piece left, cut pieces 4, 5, 6, and 7.

In making a picture, all seven pieces must be used and none are to overlap, but all pieces must connect to at least one other piece. The shapes of the pieces cannot be altered and no drawings can be added to the picture. The seven pieces must attach to form one object. Have students write a story or poem telling about their picture.

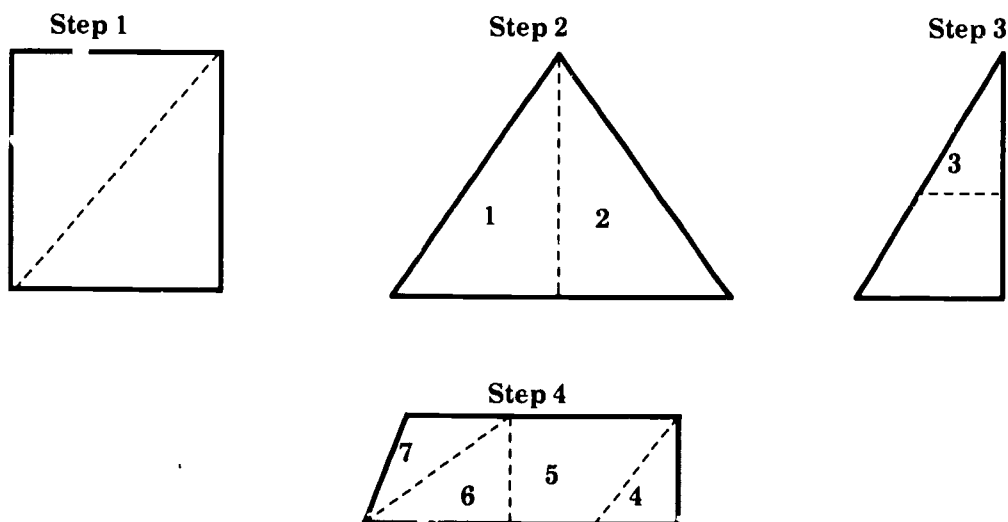

**SOURCE:** *Classroom Learning Activities for Social Studies.* Oklahoma State Department of Education, 1982. p. 86.

**SEQUOYAH CHILDREN'S BOOK AWARD  
MULTI-MEDIA PROJECT**

**Emphasis Grade Level: 6**

**CURRICULUM APPLICATION(S):** Reading, Language Arts

**GOAL:** Students will become familiar with the current "Sequoyah Masterlist" by creating a slide/tape production

**COOPERATIVE PLANNING/TEACHING**

<p>The teacher will:</p> <ol style="list-style-type: none"> <li>1. Assign each student a title on the current masterlist.</li> <li>2. Guide students in writing the script for slide/tape production.</li> <li>3. Work with librarian to assemble finished product</li> </ol>	<p>The library media specialist will:</p> <ol style="list-style-type: none"> <li>1. Introduce the current masterlist.</li> <li>2. Discuss the Sequoyah Children's Book Award Program.</li> <li>3. Instruct and assist students in making slides and tapes.</li> <li>4. Work with teacher to assemble finished product.</li> </ol>
---	---

**LEARNER OUTCOMES**

Content Area	Information Skills
<p>The student will</p> <ol style="list-style-type: none"> <li>1. Identify and dramatize the appropriate language and behavior for an oral presentation.</li> <li>2. Read selections aloud clearly, accurately, fluently, portraying characters, moods, and events through effective use of pause, rate volume, and pitch.</li> <li>3. Be able to follow a given set of directions.</li> </ol>	<p>The student will</p> <ol style="list-style-type: none"> <li>1. Design a visual to convey a message:</li> <li>2. Create and present a dramatization to convey information</li> <li>3. Present an oral report.</li> <li>4. Identify or infer main ideas, conclusions, and themes from literature</li> </ol>

## SEQUOYAH CHILDREN'S BOOK AWARD MASTERLIST MULTI-MEDIA PROJECT FOR GRADE SIX

**PURPOSE:** To introduce children to the current masterlist; to encourage the reading of books from this list; to have students practice writing skills, to be creative, and to learn simple techniques of slide/tape production.

**LENGTH:** Four to six class periods This does not include time to actually read the book This is done as they have time in school or at home.

**SESSION I--**Library media specialist will introduce Sequoyah program Review how books are selected, who Sequoyah was, voting procedures, etc. Teacher will assign each child a book from the current list to read. Give them time to read, tell them when they should have it all read.

**SESSION II--**Students should have books finished and with them for this class. Distribute report forms. Be sure everyone understands what needs to be done to complete this form (included in unit). As they work on these, have children take pictures of their book front or jacket. The librarian should demonstrate the use of the camera to the entire class first. Help them, one at a time, line up their book, mat if needed.

**SESSION III--**Report forms must be completed. Show them paper size for illustrations. Talk about various ways of making illustrations (crayon, markers, collage, use of other materials such as cotton, yarn, chalk, etc.). Have supplies assembled, assist where needed. Have students do ORIGINAL illustrations about their favorite part of the book, which they wrote about on their report forms Take pictures of these as soon as they are completed.

**SESSION IV--** student should use the information on the report forms to write a paragraph with vital information about the book for the narration of the book jacket slide frame. For picture books, include student's thoughts about the illustrations as well as a sentence or two about the plot Others should briefly tell what the book is about Narration for their illustration should come directly from what they wrote about their favorite part of the book

**SESSION V and VI--**Prior to this session, assemble all the slides in the proper order. (Each student's two slides should be together, but the order of the books is up to you ) Have a tape, a slide of introduction (picture of Sequoyah, etc.), a slide of the masterlist and appropriate narration ready for these. Each child should record his own narration for his slides Music may be added later, if desired. A practice recording session helps take away the jitters from the finished product.

**SOURCE:** Mary Alice McLeod, Helena-Goltry Schools

This slide presentation can be used in presenting the "Sequoyah Masterlist" to the other classes in grades 3 through 5. You might include a slide of the entire class that prepared the slide/tape presentation to better identify those students to the rest of the student body.



## **Background Information for the Sequoyah Children's Book Award Program**

The first Sequoyah Children's Book Award was given in April 1959. The program was designed to encourage the reading of books of literary quality.

A masterlist is compiled by the Sequoyah Children's Book Award Committee of the Oklahoma Library Association. The books reflect literary excellence and appropriateness of content to the ages of the designated reader. The masterlist is not intended to be an automatic recommendation because selection policies vary greatly across Oklahoma. One should apply specific selection guidelines.

The winning book is announced in February. The award is presented during the annual Oklahoma Library Association Conference. Children, representing the boys and girls of Oklahoma, present the winning author with the award. All children grades 3 through 6 are invited to attend the presentation.

Oklahoma honors Sequoyah for his unique achievement in creating the Cherokee alphabet, the 85 symbols representing the different sounds in the Cherokee language. Sequoyah was born in the Cherokee country east of the Mississippi River, sometime between 1760 and 1770. His mother was a Cherokee princess and his father is believed to have been a white trader. Sequoyah (Cherokee for "lame one") is also known by the English name George Guess. A cabin built by Sequoyah as part of a U.S. government grant still stands near Sallisaw, Oklahoma. This grant, in recognition of Sequoyah's outstanding contribution to his people, was the first literary award given in the United States. His statue is one of the two representing Oklahoma in the National Hall of Fame.

### **Who Can Vote?**

Any Oklahoma student in grades 3 through 6 may participate, but all students in a class do not have to vote. A student should have read or heard at least two books in order to cast a vote for his/her favorite. It is desirable to encourage the students to read as many of the titles as possible. A library need not purchase the entire masterlist.

### **How to Vote**

Each student meeting the above requirement may cast one vote for the book of his/her choice from the masterlist. The teacher or librarian will collect votes from those eligible to participate. *Each school must prepare a masterlist ballot by the author's last name to mail. This ballot containing all the votes for each title (not just your school's winner) should be sent (postmarked by January 31) to:*

The Sequoyah Children's Book Award  
Library Resources Section  
State Department of Education  
2500 North Lincoln Boulevard  
Oklahoma City, OK 73105-4599

The winning author is announced in February. The Sequoyah Children's Book Award presentation is held during the annual Oklahoma Library Association Conference in the spring. Two children, representing the girls and boys of Oklahoma, present the winning author with the award.

SEQUOYAH CHILDREN'S BOOK AWARD MASTER LIST  
MULTI-MEDIA PROJECT FOR GRADE SIX

Your Name: \_\_\_\_\_

Date: \_\_\_\_\_

Title of Book: \_\_\_\_\_

Author: \_\_\_\_\_

Illustrator: \_\_\_\_\_

What kind of story is in your book? (Mark one or more )

- Adventure
- Humor
- Legend or Folktale
- Animal
- A Long-Ago Story
- Cou'd Happen Now
- Fiction, but Sounds-Like It's Real
- Fiction, Could Never Really Happen
- Nonfiction

Write one or two sentences about the most important characters.

\_\_\_\_\_  
\_\_\_\_\_  
\_\_\_\_\_  
\_\_\_\_\_

SECTION A

Are there many illustrations in your book? If there are, answer these questions. If there are only a few illustrations, go right on to the next section

What are the illustrations like? Are they in color or black and white? \_\_\_\_\_

\_\_\_\_\_

Are they like real life or imaginary? \_\_\_\_\_

What do you think the illustrator used to make the pictures? Some choices might be paints, pencil, charcoal, chalk, cut-up paper, photos. \_\_\_\_\_

How do the pictures make you feel? \_\_\_\_\_

How do the pictures help tell the story? Could you "read" the story without the words?

\_\_\_\_\_  
\_\_\_\_\_

**SECTION B**

Briefly tell what happens in your book \_\_\_\_\_

\_\_\_\_\_  
\_\_\_\_\_  
\_\_\_\_\_  
\_\_\_\_\_  
\_\_\_\_\_  
\_\_\_\_\_  
\_\_\_\_\_

**SECTION C**

On the back of this paper, tell your favorite part of this book

**VIDEO**

**AUDIO**

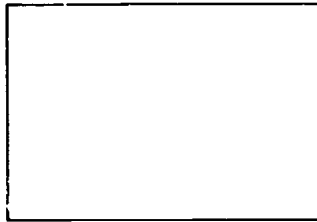
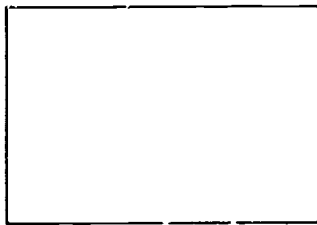
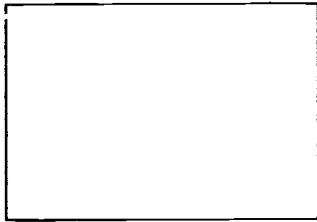
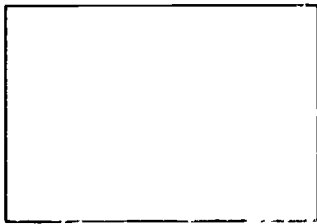
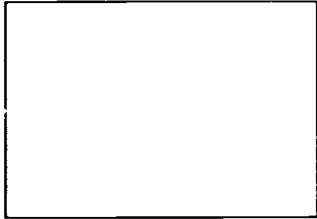

282

## GENERAL SEQUOYAH TRIVIA QUESTIONS

1. What book won the first Sequoyah Children's Book Award? (*Old Yeller*)
2. In what year was the first Sequoyah Children's Book Award given? (1959)
3. What year did *Bunnacula* win the Sequoyah Children's Book Award? (1982)
4. What does Sequoyah mean in the Cherokee Indian language? (Lame One)
5. In what famous city is there a statue of Sequoyah that represents Oklahoma? (Washington, D.C.)
6. What was Sequoyah's English name? (George Guess)
7. What book won the Sequoyah Children's Book Award last year?
8. How is the Sequoyah Children's Book Award winner selected year after year? (Children, grades 3-6, vote.)
9. Who sponsors the Sequoyah Children's Book Award? (Oklahoma Library Association)
10. What was Sequoyah famous for? (He wrote the Cherokee Indian alphabet )
11. How many books must a child read in order to get to vote in January? (2)
12. What Beverly Cleary book won the Sequoyah Children's Book Award in 1971? (*Ramona the Pest*)
13. In most pictures seen of Sequoyah, what does he have in his hand? (tablet)
14. In most pictures seen of Sequoyah, what does he have in his mouth? (a pipe)
15. Do we have a biography of Sequoyah in our library? (The student will have to check the card catalog in order to answer this question.)

**SOURCE:** Sequoyah Book Activities, Vicki Stewart, Bartlesville

## HOW MUCH FACT IN SCIENCE FICTION?

**Emphasis Grade Level: 6**

**CURRICULUM APPLICATION(S):** Reading, Science, Language Arts

**GOAL:** Students will become familiar with science fiction as a genre of literature and understand that believable science fiction is often based on factual science.

### COOPERATIVE PLANNING/TEACHING

<p>The teacher will:</p> <ol style="list-style-type: none"> <li>1. Introduce science fiction.</li> <li>2. Guide students in the related curriculum area activities</li> </ol>	<p>The library media specialist will.</p> <ol style="list-style-type: none"> <li>1. Provide a list of science fiction titles available in the media center.</li> <li>2. Compile a list of authors of science fiction.</li> <li>3. Instruct students in the use of the <i>Biographical Dictionary</i>, <i>Science Dictionary</i>, and the <i>Junior Book of Authors</i> series.</li> <li>4. Give book talks on several science fiction books</li> </ol>
---	--

### LEARNER OUTCOMES

Content Area	Information Skills
<p>The student will:</p> <ol style="list-style-type: none"> <li>1. Refine skills of locating and interpreting information on a specific topic.</li> <li>2. Study various aspects of science</li> <li>3. Distinguish between fact, opinion, and fantasy in print and nonprint medium, and read independently fiction and nonfiction.</li> <li>4. Express feelings and ideas by writing prose.</li> </ol>	<p>The student will:</p> <ol style="list-style-type: none"> <li>1. Locate special tools such as a <i>Biographical Dictionary</i>, <i>Science Dictionary</i>, <i>Junior Book of Authors</i> series.</li> <li>2. Examine material for validity and accuracy.</li> <li>3. Distinguish between fact and opinion.</li> <li>4. Become aware of the importance of research in the writing of fiction.</li> </ol>

## ACTIVITIES/SUGGESTIONS:

1. Introduce the students to two definitions of science fiction:
  - a. Science fiction is literature involving elements of science and technology as a basis or setting for the story.
  - b. Science fiction is the consideration of the "impossible" as possible
2. View filmstrip on science fiction. Suggested sources:
  - a. "Science Fiction," *Literature for Children*, Series 6, Pied Piper Productions.
  - b. "Reading for the Fun of It: Science Fiction", Guidance Associates.
3. Introduce several science fiction titles with book talks. Students may select and read science fiction titles. A group discussion of the topics of the various books may be held.
4. The classroom teacher may introduce a worksheet designed to help students concentrate on details in the book. A copy of "Where's the Science in Science Fiction?" worksheet is included in the unit.

After the classroom teacher explains the worksheet, the students may begin selecting appropriate details.

The library media specialist may help students use science and general reference sources to find more information about factual details, and determine if they are indeed based on factual scientific knowledge. Students may often select a detail which is partially factual and partially fiction, in which case they must separate fictional and factual aspects of the detail. Students should complete the form as required.

5. As a group activity compose a list of science fiction authors from books students are reading. Discuss Isaac Asimov's writing of both nonfiction science and science fiction. Asimov's education and experience qualify him to write accurate information about a subject. Refer to information in *Junior Authors* series.
6. Introduce or review the *Junior Authors* series

*Junior Book of Authors*. Wilson, 1951.

*More Junior Authors*. Wilson, 1963.

*Third Book of Junior Authors*. Wilson, 1972.

*Fourth Book of Junior Authors and Illustrators*. Wilson, 1978.

*Fifth Book of Junior Authors and Illustrators*. Wilson, 1983.

Explain that each book contains a list of authors who were well known when that book was published. The names of the authors are in alphabetical order as they would be in an encyclopedia. The index at the end of each book gives the names of authors found in **that book and also the other author books printed earlier in the series.**

7. Review meaning of science fiction, realistic fiction and science nonfiction. Discuss and give several examples of each.

## Fiction

- a. Characters--any unusual appearance, special powers.
- b. Setting--when and where the story took place.
- c. Plot--problems faced, how resolved
- d. What did you like most about the book?

## Nonfiction

- a. Tell something you learned that you did not know already.
  - b. What did you like most about the book?
8. Review the meaning of jargon (a specialized language used by people in a particular field of work). Note jargon used in different careers: football players (quarterback, punt, pass, first down); computer scientist (input, output, programmer, data, memory). Other fields of science; physics, chemistry, mathematics, etc , use special language (jargon) of science to write their books, either factual or science fiction.
  9. Remind students that they may find special language (jargon) in some of the science books they read. They may need to look in a dictionary to find the meaning of these words. The media centers have special dictionaries that include words related to science or technology (the application of scientific knowledge to practical purposes). One of these special dictionaries is *Compton's Illustrated Science Dictionary*. Introduce it with a transparency of "The Science Dictionary" page included in this unit. Have the students complete the "Science Dictionary Search" page.
  10. As a group activity students will plan a mural showing favorite characters, places, or scenes from various science fiction stories or books.
  11. Encourage students to write their own science fiction stories using diagrams you provide, using file folders, and pictures cut from catalogs or magazines or hand drawn. A sample diagram, or story line is illustrated below

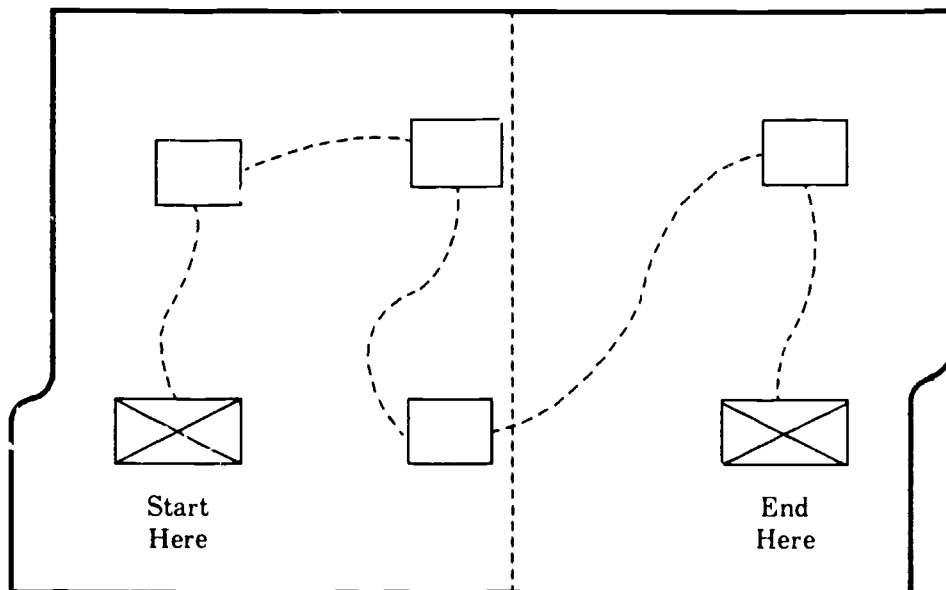



12. Try making a crossword puzzle of your own using words you have found in some of your reading.
13. Play "Science Fiction Sleuth" (included in unit).

#### **EVALUATION:**

The student will be given a grade for the various written assignments in the unit

#### **RESOURCES:**

Banks, Michael A. *Understanding Science Fiction*. Silver Burdett, 1982.

*Chambers Dictionary of Science and Technology*. Edinburgh, W & R Chambers, 1978

Junior Author series:

*Junior Book of Authors*. Wilson, 1951.

*More Junior Authors*. Wilson, 1963.

*Third Book of Junior Authors*, Wilson, 1952.

*Fourth Book of Junior Authors and Illustrators*. Wilson, 1978.

*Fifth Book of Junior Authors and Illustrators*. Wilson, 1983.

"Science Fiction." Literature for Children (sound filmstrip). Series 6, Pied Piper

Pied Piper Productions  
P.O. Box 320  
Verdugo City, CA 91046

"Reading for the Fun of It: Science Fiction" (sound filmstrip) Guidance Associates

Guidance Associates  
Communication Park  
Box 3000  
Mt. Kisco, NY 10549

**Where's the Science in Science Fiction?**

**Section 1**

Directions Find at least one factual detail and one fictional detail in at least two chapters of the selected science fiction book

Book Title: \_\_\_\_\_

Author: \_\_\_\_\_

Factual Detail		Fictional Detail	
Chapter _____	_____	Chapter _____	_____
_____	_____	_____	_____
_____	_____	_____	_____
_____	_____	_____	_____
_____	_____	_____	_____
Chapter _____	_____	Chapter _____	_____
_____	_____	_____	_____
_____	_____	_____	_____
_____	_____	_____	_____
_____	_____	_____	_____

**Section 2**

Directions Select one of the factual details and research it in another reference source. Write what you have learned.

\_\_\_\_\_  
\_\_\_\_\_  
\_\_\_\_\_  
\_\_\_\_\_

**Section 3**

Directions Which details made the book seem realistic and enjoyable? Explain why

\_\_\_\_\_  
\_\_\_\_\_  
\_\_\_\_\_  
\_\_\_\_\_

"Reading/Language Arts," *School Library Media Activities Monthly* Vol III, Number 2. October 1986 p 18.

### SCIENCE DICTIONARY SEARCH

Locate each of the following entries, list in the correct column to information requested. The first one is done for you.

Here is a sample entry top study. The numbers on the entry correspond to the explanation below.

- |                    |   |
|--------------------|---|
| 1 Entry word       | 4 Branch of science in which the word is used |
| 2 Special spelling | 5 Definition                                  |
| 3 Part of speech   | 6 Sentence using entry word                   |

solder

1    2    3

solderl 'sad-erl n

- 4 **CHEMISTRY and ENGINEERING.**  
An alloy of low melting point, used to join two pieces of metal or wire, usually, an alloy of lead and tin.
- 5 *Acid-core SOLDER is used on sheet metal, but rosin-core solder is used on copper wire.*

	Entry Word	Special Spelling	Branch of Science	Part of Speech	Illustration yes or no
1.	crust	sader	Earth Science	nour	no
2.	egg sac				
3.	pulse				
4.	solstice				
5.	tonsils				
6.	molting				
7.	watershed				
8.	locus				
9.	oscillating				
10.	filter				

## THE SCIENCE DICTIONARY

*Compton's Illustrated Science Dictionary* is a special dictionary listing only words related to science and technology. The entries are listed in alphabetical order according to the arrangement shown below.

- 1 Entry
- 2 Pronunciation or special spelling
- 3 Part of speech.
- 4 Branch of science in which the word is used (if no particular branch is indicated, this is omitted). These words appear in all capital letters
- 5 Definition.
- 6 Entry word is used in a sentence
- 7 Illustrations (for some of the entries)
- 8 Diagrams (for some of the entries).
- 9 Pronunciation key.

In the final pages are found.

- |            |                 |
|------------|-----------------|
| 1 Tables   | 4 Charts        |
| 2 Lists    | 5 Symbols       |
| 3 Diagrams | 6 Abbreviations |

Here is a sample page of *Compton's Illustrated Science Dictionary*

solid

- 1 **PHYSICS.** Any substance with definite shape and a nearly constant volume, that, unlike liquids and gases, resists forces tending to change its shape.
2. **MATHEMATICS.** A three-dimensional figure.

*The molecules in a SOLID are rather rigidly fixed in place, while liquid and gas molecules are relatively free to move.*

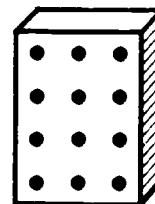

SOLID

solid geometry

**MATHEMATICS** That part of geometry dealing with the study of figures in three-dimensional space, and the logical investigation and study of the properties, characteristics and relationships of plane and solid

The study of **SOLID GEOMETRY** is of particular benefit to students in most branches of engineering.



LIQUID

solid propellant

**ASTRONAUTS.** A rocket propellant in solid form. It consists of one or more chemical compounds and usually contains both fuel and oxidizer; see liquid propellant

*Small rockets loaded with SOLID PROPELLANTS are often used as distress signals*

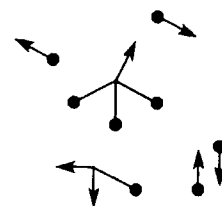

GAS

# "SCIENCE FICTION SLEUTH"

computer  
data  
outer space  
Martian  
warning  
U.F.O  
space ship  
space lab  
controls  
rocket

ray gun  
space station  
planet  
explore  
desolate  
crash course  
crew  
cue  
lunar  
comet

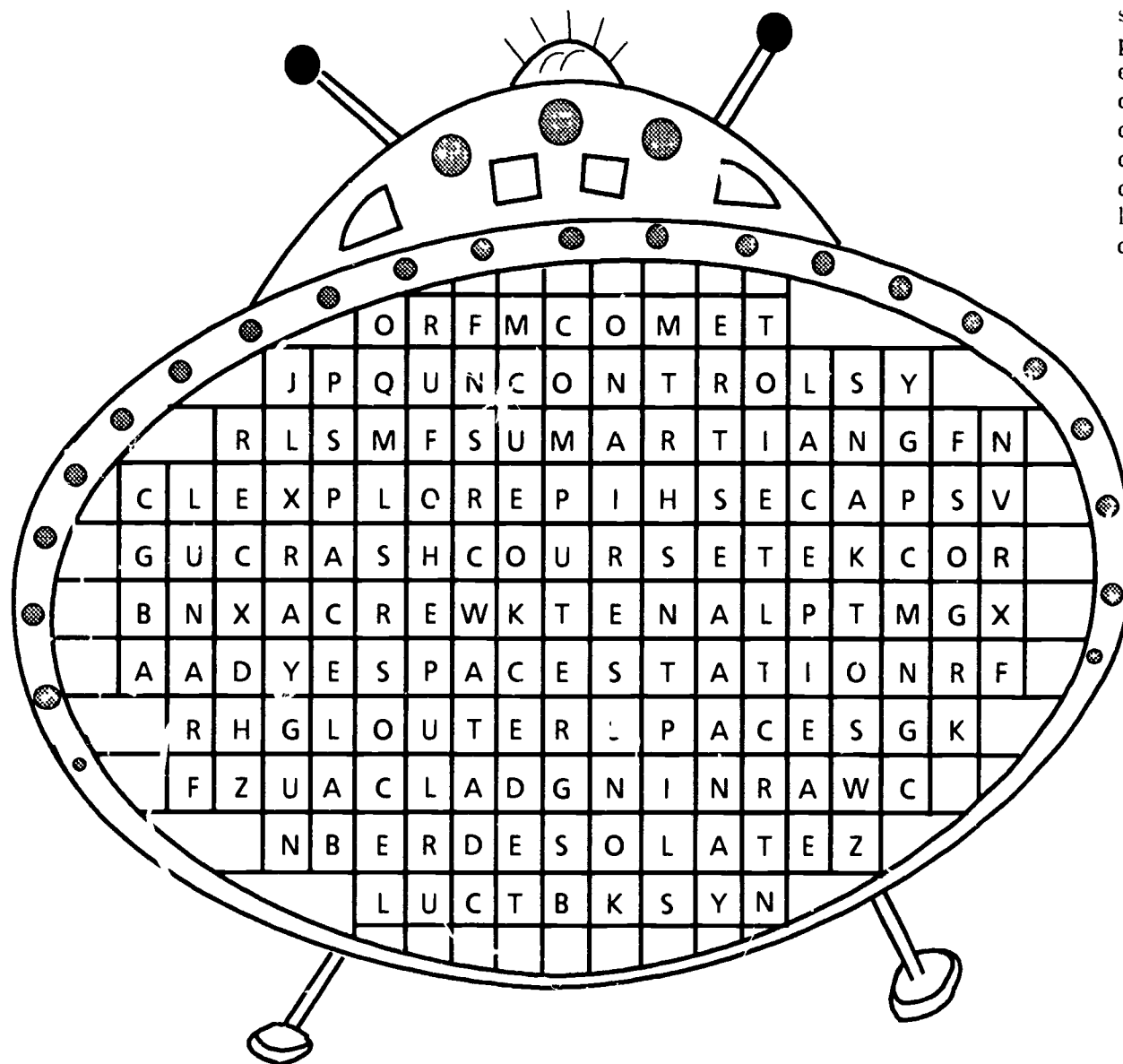

Directions Read up, down, forwards and backwards to find these science fiction words

"SCIENCE FICTION SLEUTH"  
Answer Key

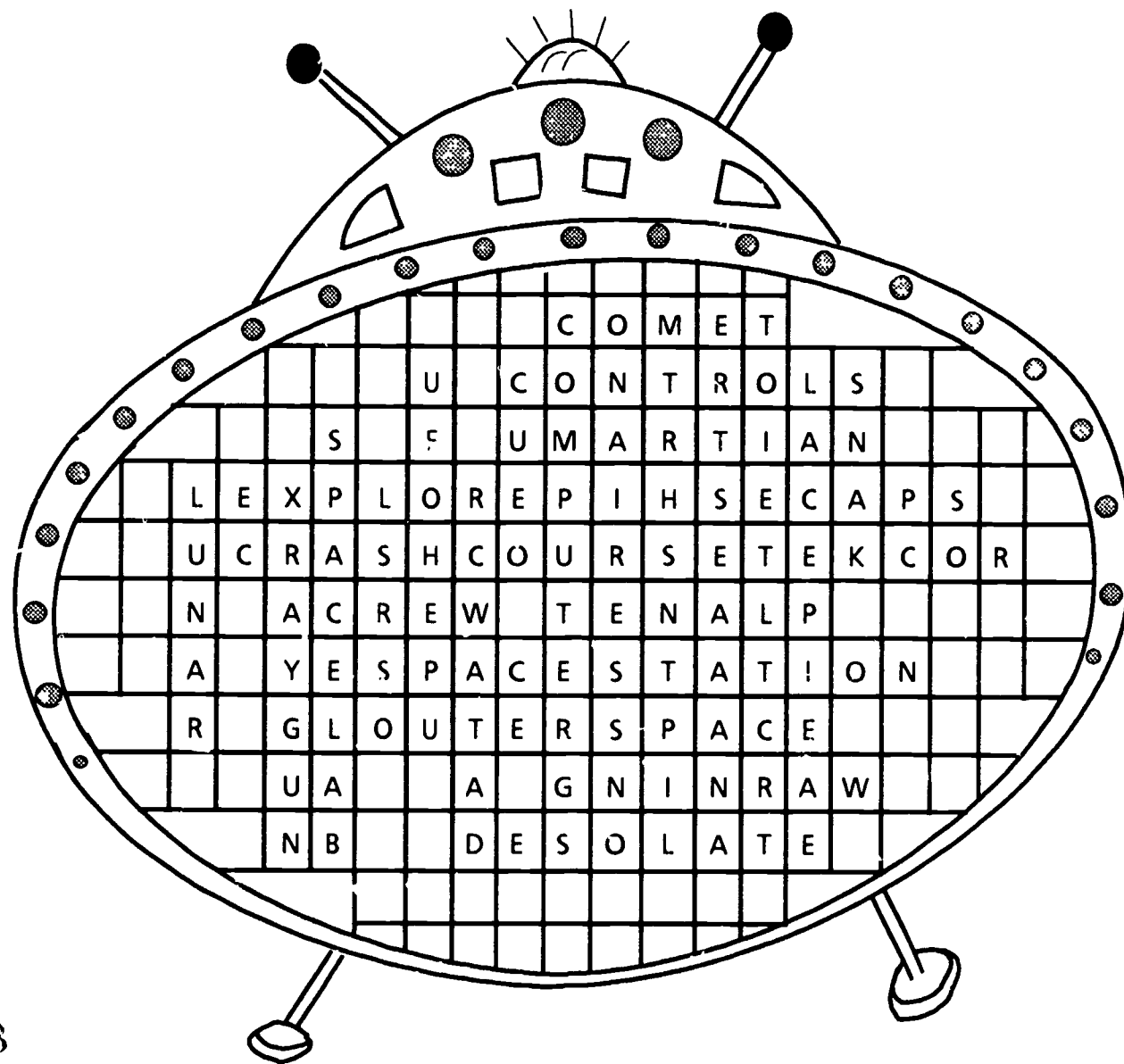

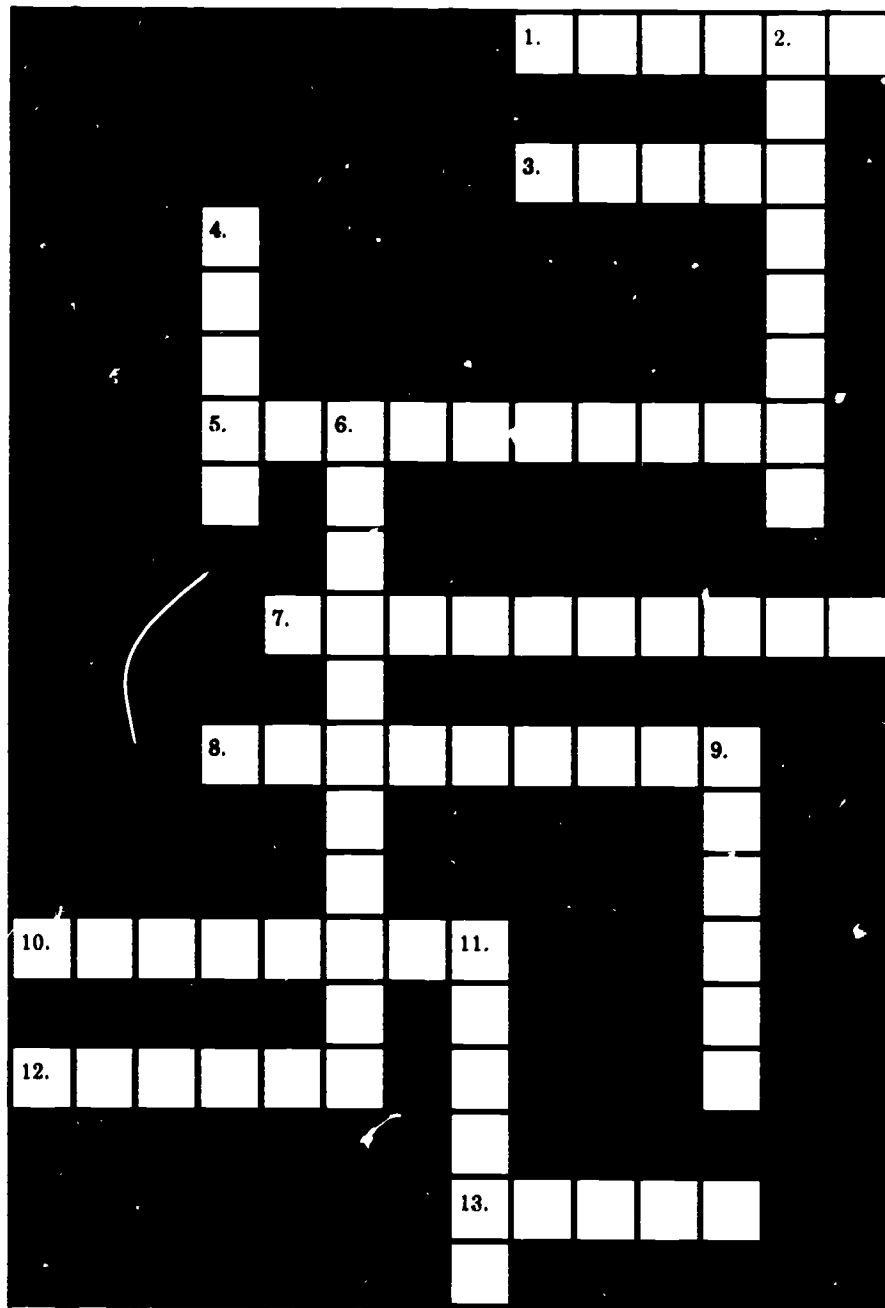

LUNAR LINGO

ACROSS

DOWN

- |                                   |   |
|-----------------------------------|---|
| 1. Used to fire a missile         | 2. Men from earth   |
| 3. Relating to the moon           | 4. Machine that looks and acts like a human being                   |
| 5. Outside the earth's atmosphere | 6. Container holding objects or records to be opened at a late date |
| 7. Without weight                 | 9. A heavenly body  |
| 8. Travels through space          | 11. To get away from something or someone                           |
| 10. Someone or something created  |   |
| 12. To trespass                   |   |
| 13. Planet farthest from the sun  |   |

# LUNAR LINGO

## Answer Key

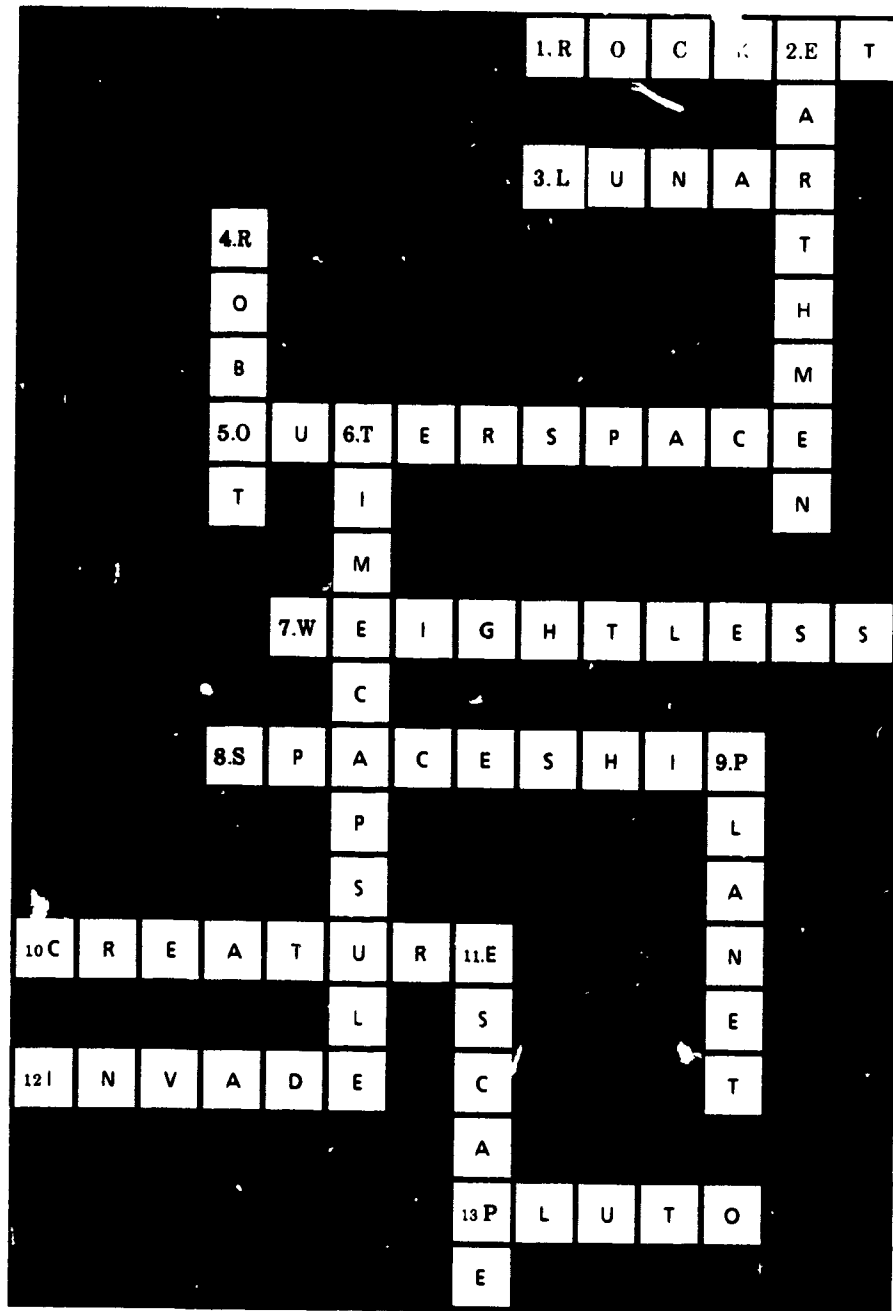



## FANTASY THEMES

Emphasis Grade Level: 6

**CURRICULUM APPLICATION(S):** Reading, Language Arts

**GOAL:** Students will understand "theme" in literature as the idea that holds the story together. They will identify and record examples of details that contribute to the theme of a book.

### COOPERATIVE PLANNING/TEACHING

The activity may be introduced and developed by the classroom teacher and supported by the library media specialist, with an entire class or a small group. If the activity is used as a complete unit, the teacher may divide the class into small groups so that the library media specialist may work with some of the groups.

### LEARNER OUTCOMES

Content Area	Information Skills
The student will:  1 Be able to read a selection and identify the main idea and details which support it.	The student will  1 Identify or infer main ideas, conclusions and themes from literature

### ACTIVITIES/SUGGESTIONS:

In an introductory session, the library media specialist or classroom teacher may use a book talk to motivate students to select fantasy books with a "good and evil" theme. Students may be told that they may select a book which they can study and discuss with others. After the book talk, the library media specialist or teacher may introduce a large web (see illustration) with the word "fantasy--good and evil," in the center. Students may be told that they may read books with just such a theme, and that as they read they must identify elements and details in the books which contribute to the development of the theme. The students may examine and discuss the strands which come from the center of the web.

As students read the selected books, they may use a worksheet which matches the web. They may record examples of the details as they identify them. During group sessions, the students may discuss the categories on the web and explain examples which they have found in the stories. The examples may be printed on strips of paper (book title, example, and student name). These examples may be placed on the bulletin board under the appropriate strand of the web. After the students have read the books, they may be asked to generalize about how an author develops a theme in fantasy books (e.g., good vs. evil) and how examples drawn from the books they read are elements of all fantasy novels.

## EVALUATION:

The student will read a novel to identify a major theme and locate details which support the development of the theme

## RESOURCES:

Multiple copies of books of fantasy which have as a theme "good versus evil" such as those listed below

- Alexander, Lloyd *The Black Cauldron* Holt, 1965
- Alexander, Lloyd *The Book of Three* Holt, 1964
- Alexander, Lloyd *The Castle of Llyr* Holt, 1966
- Alexander, Lloyd *The High King* Holt, 1968.
- Alexander, Lloyd *The Taran Wanderer* Holt, 1968
- Carlyon, Richard. *Dark Lord of Pengersick*. Farrar, 1980
- Cooper, Susan *The Dark Is Rising* Atheneum, 1973
- Cooper, Susan. *Greenwitch* Atheneum, 1974
- Cooper, Susan *The Grey King* Atheneum, 1975
- Cooper, Susan *Over Sea, Under Stone* Harcourt, 1966
- Cooper, Susan *Silver on the Tree* Atheneum, 1977
- Garner, Allan *Elidor* Ballantine, 1981
- Gripe, Maria *The Glassblower's Children* Delacorte, 1973
- Hunter, Mollie. *The Stranger Came Ashore* Harper, 1975
- Jones, Adrienne *The Mural Master*. Houghton, 1975
- L'Engle, Madeleine *Many Waters* Farrar, 1986.
- L'Engle, Madeleine. *Wind in the Door* Farrar, 1973
- L'Engle, Madeleine *A Wrinkle in Time* Farrar, 1962
- Lewis, C.S. *The Horse and His Boy* Macmillan, 1954
- Lewis, C.S *The Last Battle* Macmillan, 1956.
- Lewis, C S *The Lion, the Witch, and the Wardrobe* Macmillan, 1950
- Lewis, C S. *The Magician's Nephew* Macmillan, 1955.

Lewis, C S *Prince Caspian, the Return to Narnia* Macmillan, 1951

Lewis, C.S *The Silver Chair* Macmillan, 1953

Lewis, C S *The Voyage of the Dawn Treader* Macmillan, 1952

Norton, Andre *Lavender-Green Magic* Ace Books, 1982

Turnbull, Ann *Frightened Forest* Seabury Press, 1975

Wangerin, Walter *Book of the Dun Cow* Harper, 1978

**SOURCE:** *School Library Media Activities Monthly*, Volume III, Number 4, December, 1986,  
pp. 18-19. (Used with permission )

	silly or weak characters	
	_____	
	_____	
	_____	
	_____	
magic figures, potions, etc		mysterious setting or kingdom
_____		_____
_____		_____
_____		_____
	<b>FANTASY GOOD VERSUS EVIL</b>	
strange creatures		battle by hero against strong odds
_____		_____
_____		_____
_____		_____
	betrayal by good friends because of greed, etc	
	_____	
	_____	
	_____	
	_____	

**ADDITIONAL ACTIVITIES WITH FANTASY LITERATURE:**

1. Using the same process as outlined in the above unit, study a fantasy theme in a film or video format
2. Identify other elements in fantasy novels and locate supporting examples.
3. Show a filmstrip to initially introduce fantasy literature. Suggested source "Literature for Children," Series 1--*Fantasy*. Pied Piper.

Pied Piper  
P O Box 320  
Verdugo, CA 91046

4. Use booktalks to introduce fantasy titles to those who are reluctant to sample this genre of literature

5. Compile bibliographies of fantasy literature in your collection to share with students and teachers. Request Handout No 30 from the Available Materials List--*Fantasy--A Selected List of Titles: Grades 5-9*

Oklahoma State Department of Education  
Library Resources Section  
2500 North Lincoln Boulevard  
Oklahoma City, Oklahoma 73105-4599

- 6 Organize a display of fantasy books or prepare a bulletin board using a fantasy theme
- 7 Numerous fantasy books have been adapted to film, strip and video format and are available from companies such as

Random House  
Department 9278  
400 Hahn Road  
Westminster, MD 21157

Weston Woods  
Weston, CT 06883

8. Prepare a list of fantasy authors. Have students find three facts about each. Suggested list: Andre Norton, Natalie Babbitt, E.B. White, Roald Dahl, Ursula LeGuin, Chris Van Allsburg, Oliver Butterworth.
- 9 Discuss a fantasy book after having read it aloud to the whole class
  - a. Review the meaning of fantasy (a fanciful story that could not really happen)
  - b. Have students identify different types of fantasy (animal fantasy, personified toys, etc ) Refer to Types of Fantasy Literature on page 289 of this publication
  - c. Review the meaning of story elements: characters (people or animals in a story), setting (when and where a story takes place), and plot (the plan of action for a story)
  - d. Ask students to identify characters, setting and plot in the story
10. To reinforce students' understanding of personification, have them locate pictures of things or objects in old magazines. These may be mounted on tagboard or construction paper. Students will choose appropriate phrases using sensory words to describe the picture (example: a picture of palm trees with the caption: *The Palms Beckoned*, or a picture of a boat in a rough sea with the caption: *The Water Pitched*). A bulletin board or display could be made of the pictures. This activity could be extended to include similes, metaphors and other descriptive words.
11. Use the "Easy as Pie Mobile" on page 285 of this publication to reinforce students' understanding of similes.
12. Use the Fantasy Titles Crossword on page 287 at the end of this fantasy study. First have students answer as many clues as they can from memory. Then, they can complete the puzzle by using the card catalog, reinforcing that skill.

- 13 It has been observed that the characters in the *Star Wars* movies can be paralleled with characters in C.S. Lewis' *High King* and J.R.R. Tolkien's *The Hobbit*. As a group project, find parallel characters for: Luke Skywalker, Darth Vader, Princess Leia, R2D2 and C3PO, Chewbacca, and Hans Solo.
14. Read aloud to the class Lloyd Alexander's *The Marvelous Misadventures of Sebastian*. The Kingdom of Hamelin-Loring provides excellent material for discussion of a kingdom versus a dictatorship. Discuss the following questions: How was the Regent able to take over power in the country? How are the powers of a King and a Regent different? Would you like to live in a country governed by a dictator? Why? Can a dictatorship be good?
15. Have students compare and contrast the writings and lives of C.S. Lewis, J.R.R. Tolkien, and Lloyd Alexander. Some points of comparison are included on page \_\_\_\_\_. Students can think of others and research activities can be planned. Share findings with the class group.

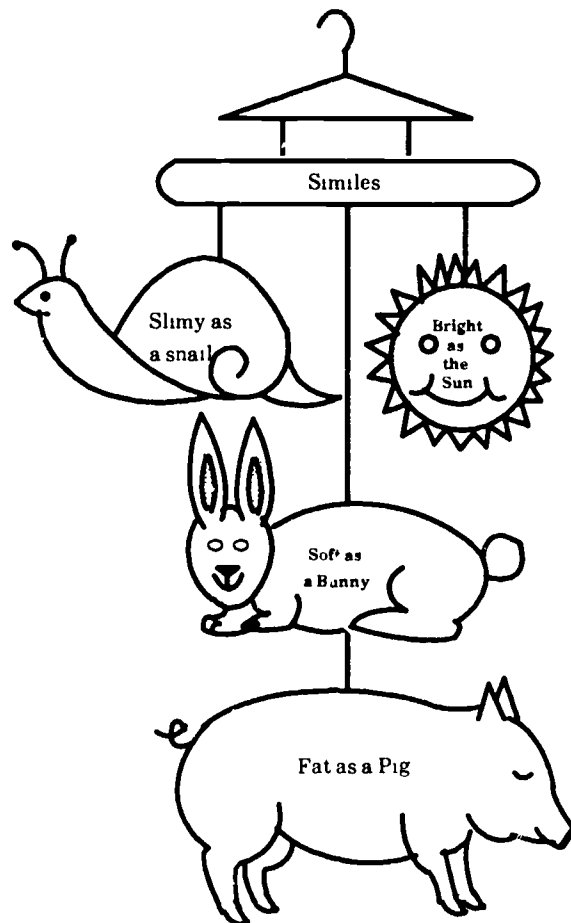

- I. Activity Easy as Pie Mobile
- II Purpose: To provide student with a "fun" introduction to a variety of similes
- III. Media Staff Preparation:
  - A. Materials
    1. Construction paper
    2. Poster board
    3. String
    4. Markers
- IV. Procedure.
  - A. Have each student select a simile from the selection sheet accompanying this unit.
  - B. Have them design an animal or object to illustrate the simile they select
  - C. Allow group to combine their completed figures to make one or more mobiles to display in the media center.

**SIMILES**  
(to be used for "Easy As Pie Mobile")

wise as an owl

sly as a fox

gentle as a lamb

slow as a turtle

stubborn as a mule

happy as a lark

busy as a bee

graceful as a swan

sings like a bird

quiet as a mouse

swift as a deer

proud as a peacock

brave as a lion

mad as a hornet

slippery as an eel

talkative as a parrot

majestic as an eagle

waddling like a duck

full as a tick

hard-headed as a goat

smart as a whip

sharp as a tack

easy as pie

stiff as a poker

snug as a bug

slick as a whistle

sour as a pickle

cold as ice

cool as a cucumber

hot as a firecracker

black as pitch

nutty as a fruitcake

light as a feather



## FANTASY TITLES CROSSWORD

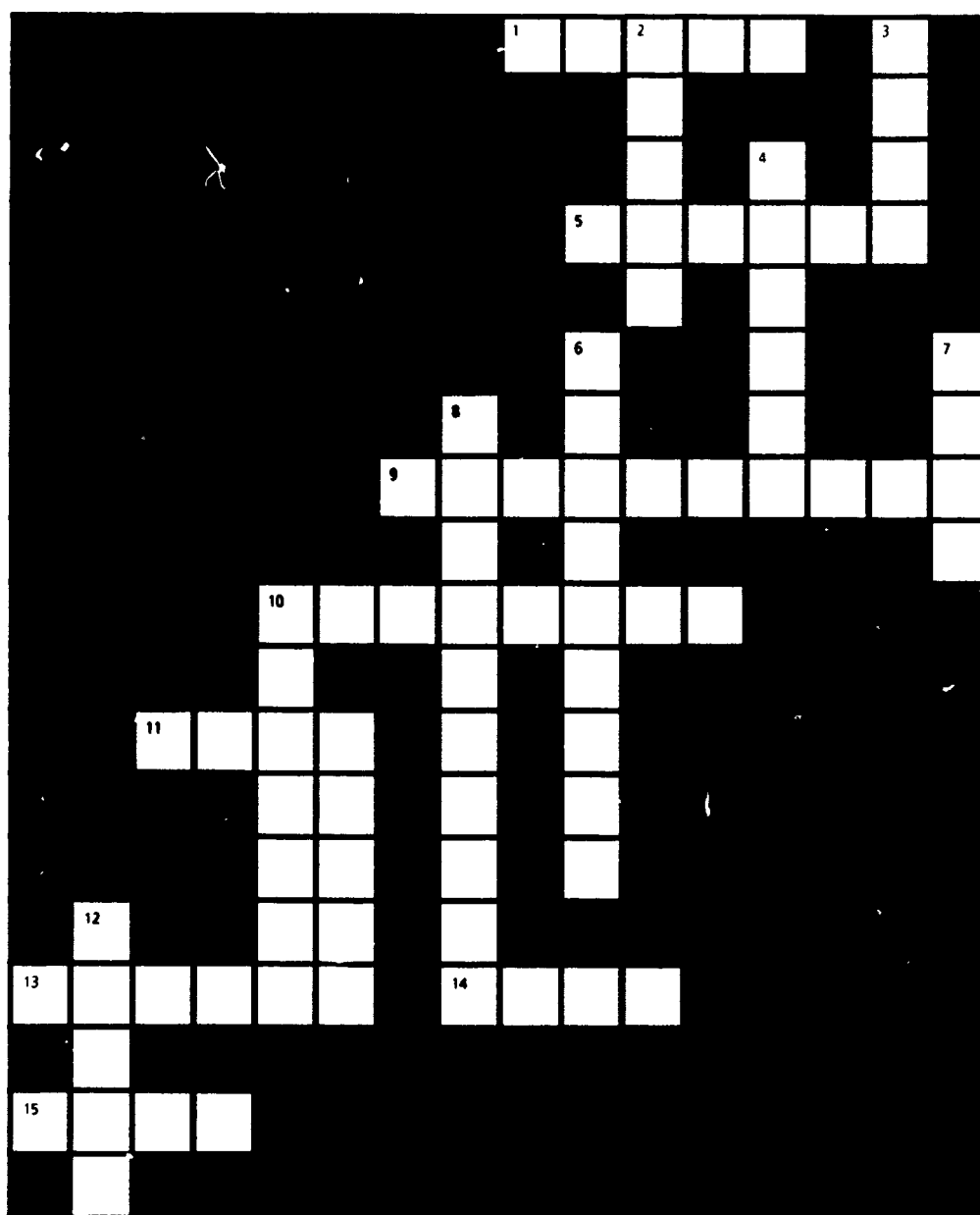

**ACROSS:**

1. Black and Blue ----- Zilpha Keatley Snyder
5. The ----- for Delicious. Natalie Babbitt
9. The Mouse and the ----- Beverly Cleary
10. The Lion, the Witch and the ---- C.S. Lewis.
13. Fellowship of the ----- J.R.R. Tolkien
14. Wind in the ----. Madeleine L'Engle
15. The ---- and the Crown. Robin McKinley

**DOWN:**

2. The Children of ----- Knowe Lucy Boston
3. The ---- King Lloyd Alexander
4. Mrs. ----- and the Rats of NIMH. Robert O'Brien
6. Charlie and the ----- Factory. Roald Dahl
7. The ---- King. Susan Cooper
8. Alice's Adventures in ----- Lewis Carroll
10. The Wind in the ----- Kenneth Grahame
12. The First Two ----- of Lukas Kasha. Lloyd Alexander

ANSWER KEY

Across

- 1 MAGIC
- 5 SEARCH
- 9 MOTORCYCLE
- 10 WARDROBE
- 11 HILL
- 13 RINGS
- 14 DOOR
- 15 HERO

Down

- 2 GREEN
- 3 HIGH
- 4 FRISBY
- 6 CHOCOLATE
- 7 GREY
- 8 WONDERLAND
- 10 WILLOWS
- 12 LIVES

```

                M A G I C      H
                  R           I
                    E         F   G
                      S E A R C H
                        N       I
                          C     S
                            W H B   G
                             O T O R C Y C L E Y
                              N   C
                                A R D R O B E
                                 I   L
                                  L   E
                                   W   E
                                    W   E
                                     L   O
                                      W   O
                                       V   S
                                        L   S
                                         R   I
                                          I   N
                                           V   G
                                            S   S
                                             H   R
                                              S   O
                                               S
    
```

## TYPES OF FANTASY LITERATURE (and examples)

### MINIATURES

Norton, Mary. *The Borrowers*.  
Kendall, Carol. *The Gamage Cup*

### TIME MANIPULATION

Boston, Lucy. *Children of Green Knowe*  
Davies, Andrew. *Conrad's War*.  
Park, Ruth. *Playing Beatie Bow*

### WORD PLAY

Carroll, Lewis. *Alice's Adventures in Wonderland*.  
Dahl, Roald. *Charlie and the Chocolate Factory*  
Juster, Norton. *The Phantom Tollbooth*

### WHOLE NEW WORLDS

Alexander, Lloyd. *The High King*  
Lewis, C.S. *Lion, the Witch and the Wardrobe*.  
Tolkien, J.R.R. *The Hobbit*.

### INVENTIONS

Du Bois, William. *Twenty-One Balloons*.

### ANIMAL FANTASY

White, E.B. *Charlotte's Web*  
Adams, Richard. *Watership Down*  
Grahame, Kenneth. *Wind in the Willows*.

### PERSONIFIED TOYS

Bond, Michael. *A Bear Called Paddington*.  
Milne, A.A. *Winnie-the-Pooh*.  
Williams, Margery. *The Velveteen Rabbit*

### HUMOROUS FANTASIES

Merrill, Jean. *Pushcart War*.  
Alexander, Lloyd. *The Marvelous Misadventures of Sebastian*.  
Butterworth, Oliver. *The Enormous Egg*.  
Seldon, George. *A Cricket in Times Square*

**A Comparison of the Lives and Works of  
Three Modern Fantasy Writers**

	<b>C. S. Lewis</b>	<b>J. R. R. Tolkien</b>	<b>Lloyd Alexander</b>
Born/Died	1898/1963	1892-1973	1924-
Background	Theologian, poet, scholar, teacher	Scholar, teacher	Writer
Age Appeal	8-11	10-12	9-14
Title of Fantasy Series	Narnia Chronicles	The Trilogy	Prydain Chronicles
Fantasy World of the Series	Narnia	Middle-earth	Prydain
Writings Based on	Norse legends, Arthurian romances, Andersen fairy tales	Norse folklore and mythology	Medieval Welsh legends, folk literature
Characteristics	Evil is on-going, religious theme, strong character descriptions, some humor	Good characterizations; no women, no religion; contain many folktale elements	Best character development of the three series; good humor and suspense
Awards	Lewis Carroll Shelf Award for <i>Lion, the Witch, and the Wardrobe</i>	<i>The Hobbit</i> --most widely read book by adolescents age 13-19 in the last generation	Newbery Award for <i>The High King</i> . National Book Award for <i>The Marvelous Misadventures of Sebastian</i>



**CURRICULUM APPLICATION(S):** Social Studies, Reading

**Emphasis Grade Level: 7**

**GOAL:** Students will read books with settings in the fifty United States and participate in a year- or semester-long reading theme by documenting each book read on the map. At the end of the activity, each student will do a book report on one book with an accompanying visual aid.

This unit can be used in conjunction with lessons in other curriculum areas, especially social studies. A variety of activities with states can be found in the materials listed in the resource list.

### COOPERATIVE PLANNING/TEACHING

The teacher will.	The library media specialist will
<ol style="list-style-type: none"><li>1. Introduce the theme, <b>READ YOUR WAY ACROSS THE U.S.A.</b></li><li>2. Help prepare the map.</li><li>3. Maintain the records kept for the activity.</li><li>4. Make periodic checks of books read.</li><li>5. Organize reports at the end of the activity so that each student in a class will report on a book from a different state.</li><li>6. Evaluate student activities.</li></ol>	<ol style="list-style-type: none"><li>1. Help prepare the map.</li><li>2. Print a bibliography of books in the school library media center which are appropriate for this activity.</li><li>3. Help students locate books and reserve them when necessary.</li><li>4. Encourage students to read books and place dots on every state.</li></ol>

## LEARNER OUTCOMES

Content Area	Information Skills
<p>The student will:</p> <ol style="list-style-type: none"> <li>1. Form concepts based on information or ideas encountered in literature</li> <li>2. Expand reading scope through various forms of literature</li> <li>3. Distinguish between fact, fiction, opinion, and inference in print and non-print media.</li> </ol>	<p>The student will:</p> <ol style="list-style-type: none"> <li>1. Identify or infer main ideas, conclusions and themes from literature</li> <li>2. Report and present information in a variety of ways (e.g., orally, using records, tapes, pictures, cassettes, charts, diagrams, maps, slides, transparencies).</li> </ol>

### ACTIVITIES/SUGGESTIONS:

1. Use a large commercially prepared map of the United States or make one by using the opaque projector. The boundaries of individual states should be outlined. A large map is preferable. An appropriate size would be 4' x 8' to fit a standard bulletin board. The map can also be mounted on a wall in the library, hallway or classroom.
2. Introduce students to the activity by booktalking several titles on the list. Indicate that they are to put a green (or any color) dot on the state where the story takes place. The goal is to get dots in every state
3. Students should be told that they will report on one book at the end of the activity, and that they will prepare a visual aid for the presentation
4. A check should be made periodically to encourage students to keep reading. Informal book-teasers throughout the activity are a good way to do this

### EVALUATION:

The book report and visual aid required at the end of the activity will serve as an evaluation.

### RESOURCES:

Anderson, Marcie. *Exploring the 50 States*. Willowisp Press, 1983

Willowisp Press  
401 East Wilson Bridge Road  
Worthington, Ohio 43085

Arnold, Pauline and Percival White. *How We Named Our States*. Criterion, 1965

*Know Your Own State* (duplicating masters) Milliken Publishing Company, 1981

Timesavers for Teachers  
Division of Milliken Publishing Co  
St Louis, Missouri 63132

Ross, Wilma S *Fabulous Facts About the 50 States* Scholastic, 1986

Scholastic, Inc  
P O. Box 7501  
2931 East McCarty Street  
Jefferson City, MO 65102

*Where in the USA Is Carmen Sandiego?* (computer program) Follett Software Co

Follett Software Co  
4506 Northwest Highway  
Crystal Lake, IL 60014-7393

**SOURCE:** Cindy Gateley, Hugo Junior High School

**BIBLIOGRAPHY**  
**READ YOUR WAY ACROSS THE U.S.A.**

- Alabama      Ellison, Lucile *Butter on Both Sides* Scribner, 1979
- Alaska      Rogers, Jean *The Secret Moose* Greenwillow, 1986.  
George, Jean. *Julie of the Wolves* Harper, 1972  
Osborne, Chester. *The Memory String* Atheneum, 1984  
Morey, Walt *Gentle Ben* Dutton, 1965  
Gray, Genevieve *Alaska Woman*. EMC, 1977  
London, Jack. *The Call of the Wild*. Macmillan, 1970  
St. George, Judith. *In the Shadow of the Bear* Putnam, 1983
- Arizona      Armer, Laura. *Waterless Mountain* McKay, 1931.  
Baker, Betty *The Spirit Is Willing*. Macmillan, 1974.  
Baylor, Byrd *Hawk, I'm Your Brother* Scribner, 1976.  
Fleishman, Sid *Me and the Man on the Moon-Eyed Horse* Little, 1977
- Arkansas      Greene, Bette *Philip Hall Likes Me, I Reckon Maybe* Dial, 1974  
Greene, Bette *Summer of My German Soldier* Dial, 1973
- California      Beatty, Patricia *Lacy Makes a Match* Morrow, 1979  
Cameron, Eleanor *Julia and 'he Hand of God* Morrow, 1979  
Cleary, Beverly *Luckiest Girl*. Morrow, 1958  
Beatty, Patricia *Eight Mules from Monterey*. Morrow, 1982.  
Gates, Doris. *Blue Willow*. Viking, 1940.  
Steinbeck, John *Of Mice and Men*. Viking, 1937.  
O'Dell, Scott. *Island of the Blue Dolphins*. Houghton Mifflin, 1960  
O'Dell, Scott. *Cruise of the Arctic Star*. Houghton Mifflin, 1973  
Snyder, Zilpha *Egypt Game* Atheneum, 1967.



- Colorado      **Beatty, Patricia** *Melinda Takes a Hand*. Morrow, 1983  
**Hunt, Irene** *Everlasting Hills* Scribner, 1985  
**Whitney, Phyllis** *Mystery of the Black Diamonds*. Westminster, 1954
- Connecticut      **Collier, James Lincoln** *My Brother Sam Is Dead* Four Winds, 1974  
**Dagliesh, Alice** *The Courage of Sarah Noble* Scribner, 1954  
**Esters, Eleanor** *The Moffats* Harcourt, 1941  
**Lawson, Robert**. *The Tough Winter*. Viking, 1954  
**Speare, Elizabeth** *The Witch of Blackbird Pond*. Houghton Mifflin, 1958.
- Delaware      **Richter, Conrad** *The Light in the Forest*. Knopf, 1966
- Florida      **Cleaver, Vera**. *Kissimmee Kid*. Lothrop, 1981.  
**Lenski, Lois**. *Strawberry Girl*. Lippincott, 1973.  
**Rawlings, Marjorie** *The Yearling* Scribner, 1967.
- Georgia      **Beatty, Patricia**. *Turn Homeward, Hannalee* Morrow, 1984  
**Burch, Robert** *Ida Early Comes Over the Mountain*. Viking, 1980  
**Burch, Robert** *Wilkin's Ghost* Viking, 1978  
**Burch, Robert** *Queenie Peavy* Viking, 1966
- Hawaii      **Bunting, Eve** *Yesterday's Island* Warne, 1979  
**Goodsell, Jane**. *Daniel Inouye* Crowell, 1977
- Idaho      **Johnson, R** *Chief Joseph*. Dillon, 1974.
- Illinois      **Hunt, Irene** *Across Five Aprils* Ace, 1984.  
**Sleator, William**. *Singularity*. Dutton, 1985.
- Indiana      **Chambers, Catherine**. *Indiana Days: Life in a Frontier Town*. Troll, 1984.  
**Reynolds, Quentin** *Wright Brothers: Pioneers of American Aviation*  
Random House, 1978  
**Stevenson, Augusta**. *Wilbur and Orville Wright, Young Flyers* Bobbs, 1951
- Iowa      **Hall, Lynn**. *Mystery of Pony Hollow*. Garrard, 1978.  
**Mills, Claudia** *The Secret Carousel*. Four Winds, 1983.

- Kansas      **Brown, Irene B** *Before the Lark* Atheneum, 1982  
**Talbot, Charlene.** *Sodbuster Venture.* Atheneum, 1983  
**Wilder, Laura Ingalls** *Little House on the Prairie* Harper, 1953
- Kentucky      **Chaffin, Little.** *Freeman* Macmillan, 1972  
**Henry, Marguerite** *Born to Trot* Random House, 1950  
**Stevenson, Augusta** *Daniel Boone. Young Hunter and Tracker* Bobbs, 1982
- Louisiana      **Carlson, Natalie** *Empty Schoolhouse* Harper, 1965  
**Field, Rachel.** *Hitty Her First Hundred Years.* Macmillan, 1957
- Maine      **McCloskey, Robert** *Blueberries for Sal.* Viking, 1948  
**McCloskey, Robert.** *Burt Dow, Deep-Water Man.* Viking, 1963  
**McCloskey, Robert.** *One Morning in Maine.* Viking, 1980.  
**McCloskey, Robert.** *Time of Wonder* Viking, 1977  
**Lasky, Kathryn.** *Jem's Island.* Scribner, 1982.  
**Ogilvie, Elisabeth.** *Becky's Island.* Amereon  
**Ogilvie, Elisabeth.** *Masquerade at Sea House* Amereon  
**Ogilvie, Elisabeth.** *Turn Around Twice* Amereon.
- Maryland      **Patterson, Lillian** *Benjamin Banneker. Genius of Early America*  
Abingdon, 1978.  
**Patterson, Lillian.** *Frederick Douglass Freedom Fighter.* Garrard, 1965.
- Massachusetts      **Fast, Howard.** *April Morning* Crown, 1961.  
**Forbes, Ester.** *Johnny Tramain.* Houghton Mifflin, 1971  
**Lawson, Robert.** *Mr. Revere and I.* Little, 1953.  
**Meigs, Cornelia.** *Invincible Louisa.* Little, 1968.  
**Voight, Cynthia.** *The Callendar Papers.* Atheneum, 1983.
- Michigan      **Hall, Lynn.** *Dragon Defiant.* Follett, 1977.  
**Holling, Holling C.** *Paddle-to-the-Sea.* Houghton Mifflin, 1969  
**Robertson, Keith.** *In Search of a Sandhill Crane* Viking, 1973.  
**Thayer, Marjorie.** *Christmas Strangers.* Childrens Press, 1976

- Minnesota      **Bellairs, John** *Dark Secret of Weatherend* Dial, 1984  
                          **Callaway, Kathy** *Bloodroot Flower* Knopf, 1982  
                          **Delton, Judy.** *Kitty in the Summer* Houghton Mifflin, 1980  
                          **Wilder, Laura Ingalls** *On the Banks of Plum Creek* Harper, 1965
- Mississippi      **Naylor, Phyllis Reynolds.** *Night Cry.* Atheneum, 1984  
                          **Taylor, Mildred.** *Let the Circle Be Unbroken* Dial, 1981  
                          **Taylor, Mildred.** *Roll of Thunder, Hear My Cry.* Dial, 1976  
                          **Taylor, Mildred.** *Song of the Trees* Dial, 1975
- Missouri          **Calhoun, Mary** *Honestly, Katie John!* Harper, 1963  
                          **Calhoun, Mary** *Katie John.* Harper, 1960  
                          **Keith, Harold.** *Rifles for Watie* Crowell, 1957.  
                          **Twain, Mark** *The Adventures of Huckleberry Finn.* University of California Press, 1985.  
                          **Twain, Mark.** *The Adventures of Tom Sawyer.* Messner, 1982  
                          **Wilder, Laura Ingalls** *On the Way Home.* Harper, 1962
- Montana          **Fleischman, Sid.** *Jim Bridger's Alarm Clock* Dutton, 1978.  
                          **Johnson, Annabel** *Grizzly* Harper, 1964.
- Nebraska          **Rock, Gail.** *House Without a Christmas Tree.* Knopf, 1974  
                          **Ruckman, Ivy** *Night of the Twisters.* Crowell, 1984.  
                          **Talbot, Charlene.** *Orphan for Nebraska.* Atheneum, 1982.
- Nevada            **Henry, Marguerite.** *Mustang: Wild Spirit of the West.* Random House, 1966
- New Hampshire **Bailey, Carolyn.** *Miss Hickory.* Viking, 1946.  
                          **Blos, Joan.** *A Gathering of Days.* Scribner, 1984.  
                          **Butterworth, O.** *The Enormous Egg.* Little Brown, 1956.  
                          **Cameron, Eleanor** *To the Green Mountains.* Little Brown, 1967  
                          **Yates, Elizabeth.** *Amos Fortune, Free Man* Dutton, 1950.

- New Jersey      **Blume, Judy.** *Are You There God? It's Me, Margaret* Bradbury, 1970
- Krumgold, Joseph** *Onion John* Crowell, 1959
- Robertson, Keith** *Henry Reed, Inc* Viking, 1958
- Robertson, Keith** *Henry Reed's Baby-Sitting Service* Viking, 1966
- New Mexico      **Krumgold, Joseph.** *And Now Miguel* Crowell, 1953
- Mayhar, Ardath** *Medicine Walk* Atheneum, 1985.
- Price, Joan** *Truth Is a Bright Start.* Celestial Arts, 1982.
- New York        **Gray, Genevieve.** *The Dark Side of Nowhere.* EMC, 1977
- Kerr, M.E** *Dinky Hocker Shoots Smack.* Harper, 1972.
- Levoy, Myron** *Alan and Naomi.* Harper, 1977
- Neville, Emily.** *It's Like This, Cat.* Harper, 1963
- Selden, George.** *Chester Cricket's Pigeon Ride.* Farrar, 1981
- Stevens, Carla.** *Anna, Grandpa, and the Big Storm* Houghton Mifflin, 1982.
- Konigsburg, Elaine.** *From the Mixed-Up Files of Mrs. Basil E Frankweiler.*  
   Atheneum, 1967.
- Sacks, Marilyn** *Call Me Ruth.* Doubleday, 1982.
- Sawyer, Ruth** *Roller Skates* Dell, 1969
- Stoltz, Mary.** *The Noonday Friends* Harper, 1965
- Wilder, Laura Ingalls** *Farmer Boy.* Harper, 1961.
- North Carolina      **Cleaver, Vera** *Where the Lillies Bloom.* Lippincott, 1969.
- Cleaver, Vera** *Trial Valley.* Lippincott, 1977.
- Taylor, Theodore.** *Teetoncey.* Doubleday, 1974
- Taylor, Theodore.** *Teetoncey and Ben O'Neal.* Doubleday, 1975
- North Dakota      **Wilder, Laura Ingalls.** *By the Shores of Silver Lake* Harper, 1953.

Ohio

- Cameron, Eleanor *To the Green Mountains*. Little, 1967.  
Chambers, Catherine. *Flatboats on the Ohio*. Troll, 1984  
Hamilton, Virginia *M C Higgins, the Great*. Macmillan, 1974  
Hamilton, Virginia *House of Dies Drear* Macmillan, 1968.  
McCloskey, Robert *Lentil* Viking, 1968  
McCloskey, Robert *Homer Price*. Viking, 1971.

Oklahoma

- Bauer, Marion *Shelter from the Wind*. Clarion, 1976.  
Henry, Marguerite *Black Gold*. Random House, 1957  
Hinton, S.E. *The Outsiders* Viking, 1967  
Hinton, S.E. *Tex*. Delacorte, 1979  
Keith, Harold *Rifles for Watie*. Crowell, 1957.  
Keith, Harold. *Obstinate Land*. Crowell, 1977.  
Keith, Harold. *Susy's Scoundrel*. Crowell, 1974.  
Sebestyen, Ouida. *Words by Heart*. Little, 1979  
Wallace, Bill. *A Dog Called Kitty* Holiday, 1980  
Wallace, Bill *Trapped in Death Cave*. Holiday, 1984.

Oregon

- McGraw, Eloise. *Really Weird Summer* Atheneum, 1977.  
Morey, Walt *Runaway Stallion*. Dutton, 1973  
Morey, Walt. *Year of the Black Pony* Dutton, 1976

Pennsylvania

- Avi. *Night Journeys*. Pantheon, 1979.  
DeAngeli, Marguerite. *Thee Hannah*. Doubleday.  
Fritz, Jean. *The Cabin Faced West*. Coward, 1958.  
Fritz, Jean. *What's the Big Idea, Ben Franklin?* Coward, 1976.  
Lawson, Robert. *Ben and Me*. Little, 1939.  
Richter, Conrad *The Light in the Forest* Knopf, 1953.  
Sorensen, Virginia *Miracles on Maple Hill*. Harcourt, 1956.

Rhode Island

- McCabe, John. *George M Cohan: The Man Who Owned Broadway*  
DeCapo, 1980.

- South Carolina    **Anderson, LaVere** *Mary McLeod Bethune Teacher With a Dream* Garrard, 1976.
- Greenfield, Eloise** *Mary McLeod Bethune* Crowell, 1975
- Hogrogrian, Nonny** *Francis Marion* January
- South Dakota    **Rounds, Glen** *Stolen Pony* Holiday, 1969
- Wilder, Laura Ingalls** *The First Four Years*. Harper, 1971
- Wilder, Laura Ingalls** *Little Town on the Prairie* Harper, 1953
- Wilder, Laura Ingalls** *The Long Winter* Harper, 1968
- Wilder, Laura Ingalls** *These Happy Golden Years*. Harper, 1971
- Tennessee        **Cross, Helen**. *Isabella Mine*. Lothrop, 1982
- Steele, W** *Man With the Silver Eyes* Harcourt, 1976.
- Texas                **DePaola, Tommie** *Legend of the Blue Bonnet*. Putnam, 1983
- Gipson, Fred** *Old Yeller*. Harper, 1956
- Gipson, Fred**. *Savage Sam* Harper, 1962.
- Jones, Weyman** *Edge of Two Worlds*. Dial, 1968
- Salassi, Otto**. *On the Ropes* Greenwillow, 1981
- Utah                 **Fitzgerald, John**. *The Great Brain* Dial, 1967
- Fitzgerald, John**. *The Great Brain Reforms* Dial, 1973.
- Fitzgerald, John**. *The Great Brain Does It Again* Dial, 1975.
- Vermont            **Henry, Marguerite**. *Justin Morgan Had a Horse*. Random House, 1954
- Peck, Robert Newton**. *Soup Series* Knopf.
- Peck, Robert Newton**. *A Day No Pigs Would Die*. Knopf, 1982.
- Peck, Robert Newton**. *Trig*. Little, 1977.
- Speare, Elizabeth**. *Calico Captive*. Houghton Mifflin, 1957
- Stolz, Mary** *Cider Days*. Harper, 1978
- Stolz, Mary** *Ferris Wheel*. Harper, 1985

Virginia

D'Aulaire, Ingri *George Washington* Doubleday, 1936

Fritz, Jean *Where Was Patrick Henry on the 29th of May?* Coward, 1982

Henry, Marguerite *Misty of Chincoteague*. Random House, 1975.

Henry, Marguerite *Sea Star Orphan of Chincoteague* Random House, 1949

Henry, Marguerite *Stormy, Misty's Foal* Random House, 1963.

Sargent, Sarah. *Secret Lies*. Crown, 1981.

Washington

Sabin. *Narcissa Whitman, Brave Pioneer*. Troll, 1982.

Sabin. *Lewis and Clark* Troll, 1985

West Virginia

Westervelt, Virginia. *Pearl Buck. A Biographical Novel*. Elsevier, 1979

Fritz, Jean *Stonewall* Putnam, 1979.

Wisconsin

Brink, Carol R. *Caddie Woodlawn*. Macmillan, 1973.

Epstein, Sam. *Dr. Beaumont and the Man with the Hole in His Stomach*  
Coward, 1978.

North, Sterling. *Rascal*. Dutton, 1963.

Pellowski, Anne. *Betsy's Story* Philomel, 1983

Raskin, Ellen. *Westling Game* Dutton, 1978.

Wyoming

Coren, Alan *Arthur the Kid*. Little, 1977.

Schaefer, Jack *Shane*. Houghton Mifflin, 1954

O'Hara, Mary. *My Friend Flicka*. Lippincott, 1973.

# APPENDIX

Clifford Pattern . . . . .	305
Make Way For Ducklings Pattern . . . . .	307
Critter Report Pattern . . . . .	309
Animal Safari . . . . .	311
Animal Data Chart . . . . .	313
My Research Project . . . . .	315
Conference Phoning . . . . .	317
It Starts with a Stamp . . . . .	325
Art, Prose and Poetry Contests . . . . .	333
Bibliography of Author Materials . . . . .	337

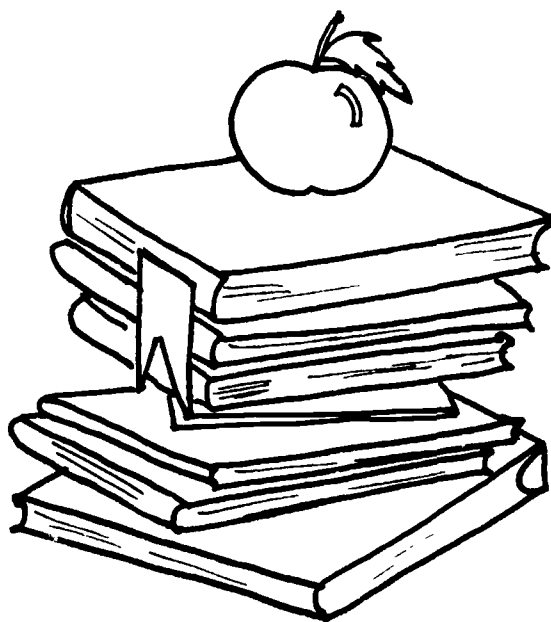



**Dog Pattern for  
Clifford.**

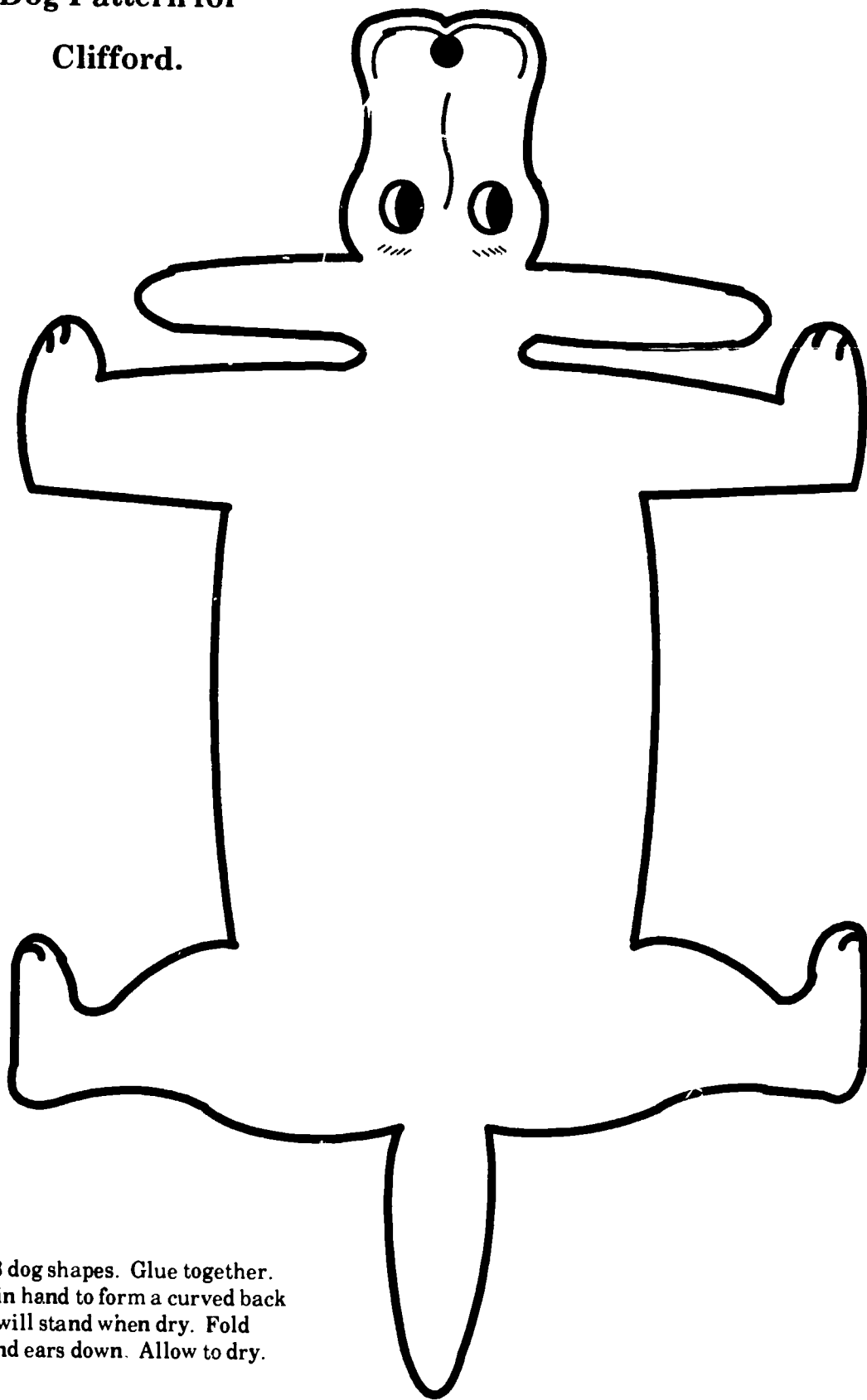

**Color.**  
Cut 2-3 dog shapes. Glue together.  
Shape in hand to form a curved back  
so dog will stand when dry. Fold  
head and ears down. Allow to dry.

Make Way for Ducklings Patterns.

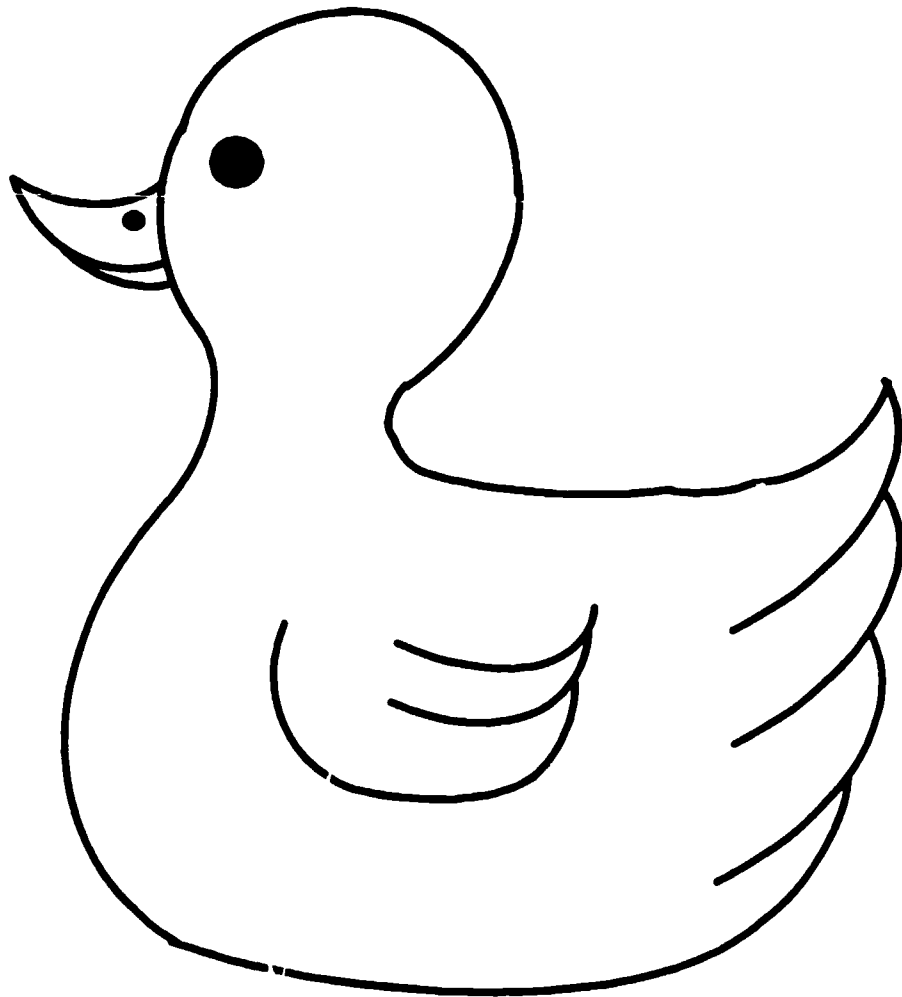

322

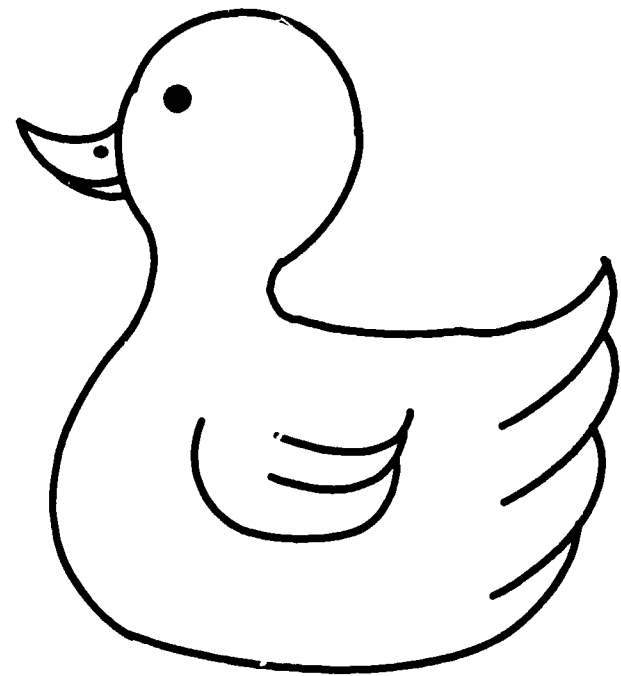

323



"Critter Report" Pattern.

324

325

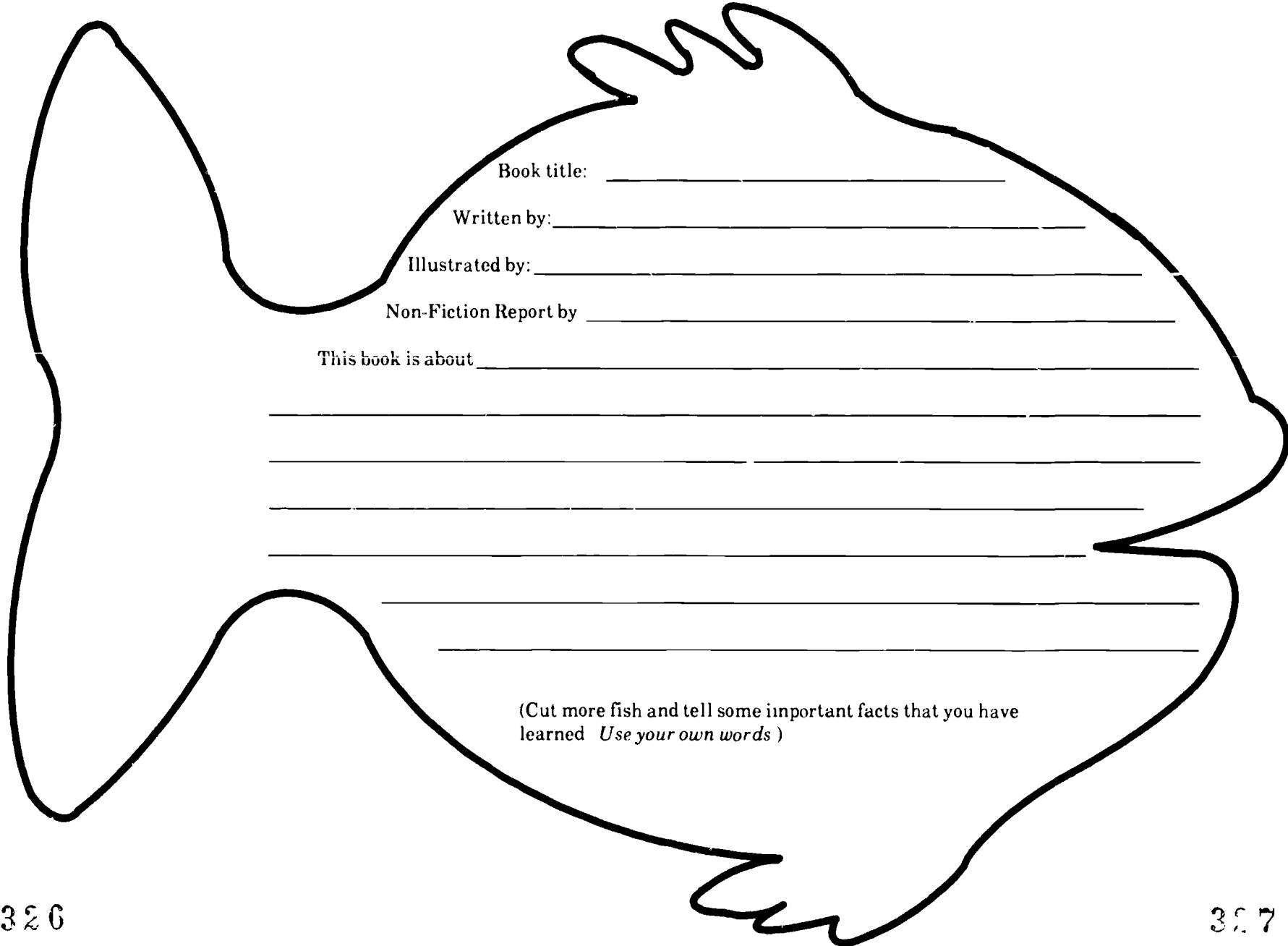

Book title: \_\_\_\_\_

Written by: \_\_\_\_\_

Illustrated by: \_\_\_\_\_

Non-Fiction Report by \_\_\_\_\_

This book is about \_\_\_\_\_

\_\_\_\_\_

\_\_\_\_\_

\_\_\_\_\_

\_\_\_\_\_

\_\_\_\_\_

\_\_\_\_\_

(Cut more fish and tell some important facts that you have learned *Use your own words*)



Name \_\_\_\_\_

## ANIMAL SAFARI

### 1. Physical Description

A. Size \_\_\_\_\_  
\_\_\_\_\_  
\_\_\_\_\_

B. Shape \_\_\_\_\_  
\_\_\_\_\_  
\_\_\_\_\_

C. Color \_\_\_\_\_  
\_\_\_\_\_  
\_\_\_\_\_

D. Skin \_\_\_\_\_  
\_\_\_\_\_  
\_\_\_\_\_

### 2. Habitat

A. Home \_\_\_\_\_  
\_\_\_\_\_  
\_\_\_\_\_

B. Food \_\_\_\_\_  
\_\_\_\_\_  
\_\_\_\_\_

C. Family \_\_\_\_\_  
\_\_\_\_\_  
\_\_\_\_\_

3. Adaptations

A. Enemies \_\_\_\_\_  
\_\_\_\_\_  
\_\_\_\_\_

B. How the animal protects itself \_\_\_\_\_  
\_\_\_\_\_  
\_\_\_\_\_

C. Use by man \_\_\_\_\_  
\_\_\_\_\_  
\_\_\_\_\_

4. Bibliography

A. Regular book \_\_\_\_\_  
\_\_\_\_\_

B. Science encyclopedia \_\_\_\_\_  
\_\_\_\_\_

C. General encyclopedia \_\_\_\_\_  
\_\_\_\_\_  
\_\_\_\_\_

# ANIMAL DATA CHART

Name: _____ Animal: _____	What does your animal look like? (size, shape, color, skin, etc.)	Where does your animal live in the world?
Author:  Title:  Publisher:  Date:		
Author:  Title:  Publisher:  Date:		
Author:  Title:  Publisher:  Date:		

### ANIMAL DATA CHART

What does your animal eat?	Who are your animal's enemies and how does your animal protect itself?	How do people use your animal?



NAME \_\_\_\_\_

**MY RESEARCH PROJECT**

I WENT TO MY SCHOOL LIBRARY TO FIND OUT ABOUT \_\_\_\_\_

\_\_\_\_\_

I SAW A \_\_\_\_\_

I LEARNED ABOUT \_\_\_\_\_

\_\_\_\_\_

\_\_\_\_\_

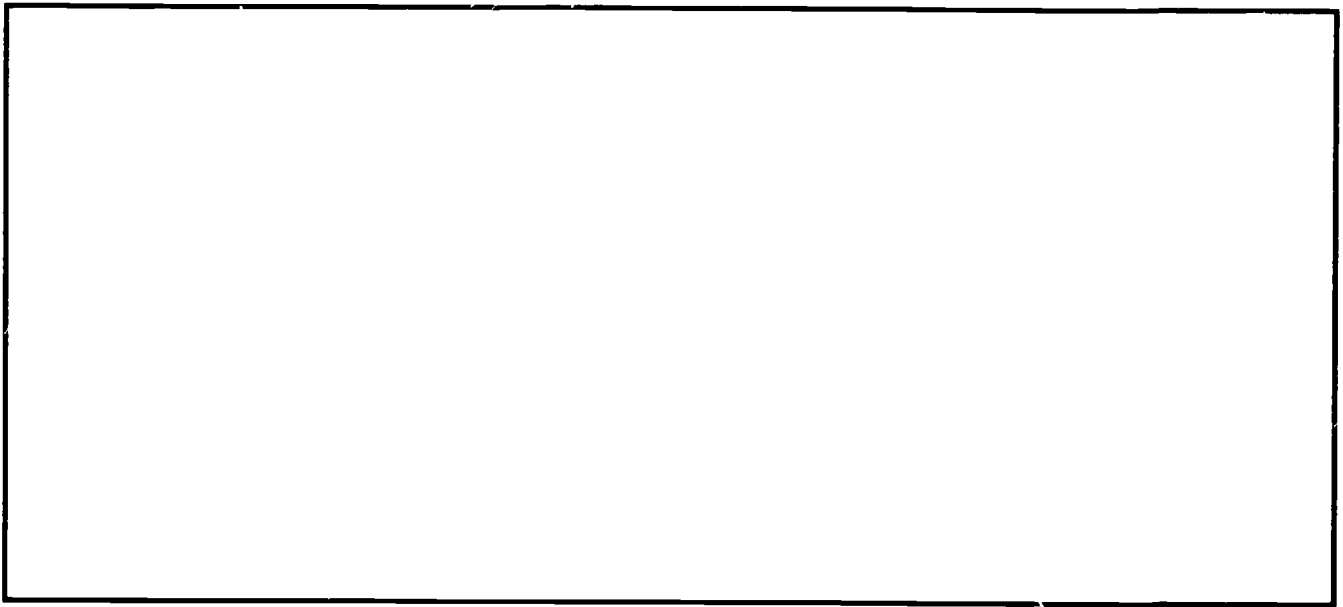

THIS IS A PICTURE OF \_\_\_\_\_

I THINK \_\_\_\_\_

\_\_\_\_\_

\_\_\_\_\_

## CONFERENCE PHONING WITH AUTHORS

Presented at OELMA Convention

by Bonnie Darrow

### BEFORE ORGANIZING A CONFERENCE PHONE CALL.

1. Recognize it will take planning, coordination, and enthusiasm.
2. Get administrative approval
3. Have equipment needed.
  - Base unit of dial telephone and loudspeaker with built-in microphones
  - Two extension microphones
  - Carrying case.
  - Electrical outlet.
  - Module jack outlet.
4. Determine financing of long-distance calls.

### STEPS IN ORGANIZING A CONFERENCE CALL:

1. Introduce the idea
2. Contact the author
3. Gather background information
4. Generate and prioritize questions.
5. Make the call.
6. Evaluate the call.
7. Thank the author in writing
8. Identify appropriate next steps.

#### STEP 1: INTRODUCE THE IDEA

- a. Present it to teachers.
- b. Decide which author will be called.
  - (1) Student decision?
  - (2) Teacher decision?

#### STEP 2: CONTACT THE AUTHOR

- a. Write letter (4-6 weeks).
- b. Include information about students.
  - (1) Age.
  - (2) Interests.
  - (3) Specific works liked.
- c. Mention general topics to be discussed
- d. Determine logistical arrangements of the call
  - (1) Date and time.
  - (2) Length.
- e. Alternative: Call the author to make arrangements.
- f. Reply to authors who say "yes" by sending letters stating definite dates and exact 15-minute times of the phone calls.

### STEP 3: GATHER BACKGROUND INFORMATION

- a. Require participating students to read at least one book by the author being called.
- b. Hold informational meetings
  - (1) Biographical data--SOMETHING ABOUT THE AUTHOR  
Picture, if possible.  
Books written.
  - (2) Examine style, plot development, and subjects written about
- c. Have available copies of the author's books.
  - (1) Buy paperbacks
  - (2) Check out from other libraries.
  - (3) Personal copies

### STEP 4: GENERATE AND PRIORITIZE QUESTIONS

- a. Brainstorm.
- b. Prioritize questions (10 to 20 in a 15-minute call)
- c. Arrange questions in a logical order
- d. Write out final list of questions.
  - (1) Include general questions.
  - (2) Include specific questions.
- e. Assign each question to a specific student.
  - (1) Have question on a card.
  - (2) Practice asking the question.
  - (3) Sit in order.
- f. Have master list of questions and substitute students.
- g. Ask a few students to take notes.

### STEP 5: MAKE THE CALL

- a. Demonstrate the use of the telexplorer conference phone.
- b. Test to see that all parts are working.
- c. Lift receiver and dial number.
- d. Identify yourself and briefly explain format when author answers.
- e. Ask permission, if taping.
- f. Press microphone button and hang up phone
- g. Have each student ask his/her specific question.
  - (1) First, introduce himself/her self
  - (2) Last, thank the author
- h. Ask author if he/she has any questions or comments
- i. Follow master list of questions; however, urge students to answer author's questions also.
- j. Thank the author and end the call at the time agreed upon
- k. Enjoy the smiles and reactions of the students!!!

### STEP 6: EVALUATE THE CALL

- a. Evaluate the call immediately, if at all possible
  - Sample discussion questions:  
What were the most enjoyable or interesting parts?  
What were the feelings or impressions of the author?  
How is the author reflected in the books written?  
What advice did the author give us?  
What did we learn from this call?

- b Have students evaluate their own performances  
Sample discussion questions:  
How did they feel?  
What did they learn?  
If they had to do it over, what would they ask?
- c Evaluate the experience from your own viewpoint

#### STEP 7 THANK THE AUTHOR IN WRITING

- a. Have individual students or student committees compose letters
- b. Add your own professional thank you.
- c. Send any reports or pictures taken to the author

#### STEP 8: IDENTIFY APPROPRIATE NEXT STEPS

- a. Have students suggest changes to improve next call.
- b Encourage students to follow up with creative activities
  - posters mapping
  - diaries drawing
  - writing
- c. Hold book discussion groups.
- d Compare the books of the author called with other books.
- e Organize the notes, tapes, and pictures for future use.

If your system does not have a telexplorer conference phone y u may obtain information by contacting:

Kip W. Kubbs  
Education Consultant  
AT&T Information System  
1-800-345-1477

HOW DO STUDENTS BENEFIT FROM THIS ACTIVITY?

They . . .

- a. Participate in a group project
- b. Achieve individual satisfaction.
- c. Expand educational experiences.
- d. Become enthusiastic about books, authors, and reading
  - (1) Reading in general
  - (2) Reading the work of a specific author
  - (3) Discussing books with more familiarity and interest.
  - (4) Appreciating the hard work and preparation that goes into writing a book.
- e. Make a new acquaintance!!!

-----  
Form sent with the letter when an author is first contacted. the author is expected to fill it out and return it in the stamped envelope provided

I AM INTERESTED IN HAVING A PHONE CONVERSATION WITH THOSE BARRINGTON FANS!

Yes \_\_\_\_\_

No \_\_\_\_\_

IF YES, THE FOLLOWING DATES AND TIMES WOULD BE THE MOST CONVENIENT FOR ME TO BE CALLED.

DATES	TIMES (You will be notified regarding the exact time later )
Tuesday, May 27 _____	Between 9 - 10 a.m. _____
Wednesday, May 28 _____	Between 10 - 11 a.m. _____
Thursday, May 29 _____	Between 1 - 2 p.m. _____
Friday, May 30 _____	Between 2 - 3 p.m. _____

PHONE NUMBER \_\_\_\_\_

NAME \_\_\_\_\_

## AUTHOR DISCUSSION GROUP

Select a group of five to six students (could be more or less) to do a group discussion for the class on a selected author. The following procedure may be followed:

### I. Preparation by each individual.

- A. Read and take notes on everything you can find about the author to be discussed
- B. Read as many books as possible written by the author. If your school library does not have all the author's books, check the public library for additional ones.

### II. Preparation by the group.

- A. Decide how the discussion will be presented. Examples.

The group may be talking informally at a friend's house; the group may be having cokes at a drugstore, they may be talking informally while waiting for scouts to begin, etc.

- B. Assign one or more of the author's books to each member of the group.

- C. Questions to discuss:

1. Who is your author?
2. Where was he/she born?
3. When did he/she get interested in writing?
4. How long has he/she been writing?
5. Has he/she won any awards? What are they?
6. Is he/she still living?
7. Where does he/she live?
8. Is he/she still writing?
9. Can you tell us anything about his/her family?
10. What is his/her latest book?
11. Do you know any other interesting facts about the author you'd like to tell?
12. Let's hear about some of his books: (each member of the group tells about one of the author's books. Give setting, part of plot, etc.).
13. Are all the author's books the same type?
14. Do you like the author's books?
15. Would you like to read some more of his/her books?
16. How many have you read?

## VIDEO INTERVIEWS WITH AUTHORS

If you discover that an author of children's or young adults' books will be in your area, use the opportunity to add to your author file with a student-conducted interview.

- I. Find an author (conventions, meetings, local residents)
- II. Select the students
  - A. Students can audition for the interview positions. We used a combination of written questions and individual interviews to evaluate them. They were judged by a panel of three staff members.
  - B. Be selective. You are taking the author's time and it should be well spent for all concerned. You need students who can competently and enthusiastically conduct an interview.
  - C. Three students is a workable number. It affords the best camera shots and a good distribution of questions.
  - D. Notify the parents and make sure each student selected can travel to the interview
- III. Planning
  - A. The students should have read as many of the author's books as possible.
  - B. Each student should prepare a list of questions on his/her own. Both general questions and specific ones about the individual books should be included.
  - C. Research the author. Students should (with your assistance) locate as much material as possible in order to base some questions on the author's personal life
  - D. Go over the questions in a group. Decide which ones to use. Help reword any that are awkward. Discuss possible follow-up questions for each.
  - E. Put questions in a logical sequence.
- IV. Practice
  - A. Let the students practice by asking you the questions. Make your replies test their ability to ask follow-up questions when appropriate
  - B. Emphasize flexibility. Make certain they understand not to ask a question that the author has already answered as part of another earlier question.
  - C. If available, video-tape a practice session and let them analyze it.
  - D. Don't overdo it, though. Too much practice can make them too rigid and will discourage ad-libbing. They are supposed to enjoy themselves, too.

V Go!!

A Allow plenty of time to get there

B Make certain all the equipment is arranged for and on time

C. Have fun!!! I guarantee the students will love it and you will have a valuable addition to your media center collection.

NOTE Be sure to get a release from the author to enable you to keep the tape in your collection. Some authors require that the tape only be used in your school or school district.



**"It Starts With a Stamp"  
Author and Student Workshop  
Putnam City Elementary Libraries**

It is generally recognized that having lots of good books available is the best way to encourage children to read. Students are fortunate to have libraries in their schools, as well as several public libraries in the area. Both school and public libraries are well stocked with books that encourage reading. Unfortunately, students seldom have opportunities to meet those responsible for the books--the authors.

Enthusiasm of students for books and reading overflows into intense curiosity about the authors and illustrators. Once children realize that books do not just fall out of the blue, they are even more curious about the people who are able to introduce them to worlds of dreams and ambitions. So there develops a desire to meet the people responsible for the books and to hear them tell how their works are created.<sup>1</sup>

Putnam City elementary librarians recognized the need to bring children's authors and their readers together. A search for information from those who had success in this area was extremely helpful. Much of the inspiration and many ideas came from Letty Watt, library media specialist at Jefferson Elementary School, Norman. Also of help was a handbook for planning a hassle-free visit entitled *Children and Young Adult Author Workshop*, developed by Beverly J. White, library supervisor, Shawnee Mission, Kansas.

Objectives for the author and student workshop were:

1. To introduce students to a nationally known author and/or illustrator of children's books.
2. To give students an understanding of how authors select topics for their work.
3. To give students an understanding of how authors select topics for their work.
3. To give students an opportunity to acquire autographed books for their personal libraries.
4. To help students develop writing skills.
5. To make students aware of careers in writing and illustrating books.
6. To teach interviewing skills.
7. To reinforce research skills by using biographical reference materials.
8. To stimulate greater interest in reading.

An invitation was extended to the nationally known children's poet Jack Prelutsky to come to Putnam City. Mr. Prelutsky accepted the invitation and spent four days in four elementary schools during the week of February 4, 1985. In addition to his visit and performances with the students, he conducted an inservice for the district elementary teachers on using poetry with students.

Response was overwhelming. Students have accepted poetry as a part of their daily language experience. The poetry section is a popular area of the library media center. Prelutsky books are in great demand. Teachers and students read poetry everyday, while more and more students are willing to try writing poetry.

Positive evaluations and popular requests have prompted the planning of a more extensive program for 1986. Plans are underway for noted children's author Mary Francis Shura to visit children in six buildings during the month of January. Gail E. Haley, illustrator and winner of

<sup>1</sup>Botham, Jane and Morris, William C. "Authors and Artists as Speakers: Suggestions for Hassle-Free Visits." *School Library Journal*, December 1977.

the prestigious Caldecott Medal for the most distinguished American picture book in 1971, will visit three schools in February. In addition, both Ms. Shura and Ms. Haley will conduct workshops for district teachers.

### GENERAL GUIDELINES FOR THE AUTHOR'S VISIT

1. Groups selected to see the author should fit the reading level and interest level of the author's works.
2. The size of audience should be limited to avoid the assembly concept.
3. Students need to read at least one book by the visiting author or have a book read to them.
4. To adequately serve students prior to the visit, the library should have adequate copies of the author's books. If not available, books should be borrowed from other libraries within the district, or from the public library.
5. The librarian should discuss with the students questions which are appropriate to ask and those that are not. The Pied Piper series *First Choice Authors and Books* has a taped interview with an author which gives students ideas for questions. This is a good series to use prior to the author's visit.
6. Work with students on proper behavior for asking questions. It is impolite and distracting to any speaker if students are waving hands in the air while the author is trying to answer another student's question.
7. If you wish to video- or audio-tape the author's presentation, get permission in advance from the author.
8. Send a tentative schedule for the author's approval well in advance. The schedule should contain the number of students, grade level, time of performance, location if other than the library media center.
9. Order books you plan to sell one month in advance.
10. There should be physical evidence displayed in the building and library media center that the author is coming and is welcome. This evidence can take the form of computer-made banners, posters, handicrafts made by students depicting the author's books, displays of books, etc. But make the author feel as though his/her arrival is a big event.
11. The building librarian is responsible for hosting the author while he/she is in the building; e.g., author should be given warm-up time before his/her presentation; beverage should be provided at break; check with the author prior to the presentation about the arrangement of the room--whether or not he/she wishes to sit or stand during his/her talk.
12. Consideration may be given to having name tags on the students. Authors may enjoy calling the students by name and it does facilitate questions and answers when the author does not have to call on "the student in the blue shirt." First name only should be printed clearly in large letters and worn high enough for the author to see the tag.

13. Plan for the seating arrangement of the students AND TEACHERS. Discuss with the teachers ahead of the visit how the students are to be seated and where the teachers should sit for best supervision. A program can be ruined for everyone if two or three students become clowns during the program and no teacher is nearby to settle the group down.
14. The librarian should sit near the author as he/she makes the presentation, ready to help or respond in any way. During the questioning session the librarian may be needed to repeat a question to the speaker if he/she has not heard the student.
15. The librarian should pay attention to the program schedule. It is easy to end the question-and-answer period by simply stating, "There is time for one last question" and selecting the student who is to ask the question.
16. Mementos given to the author during his/her visit are quite appropriate. Remember, however, that whatever is given to the author should be easy to pack for the return trip home. Do involve the art teachers with the program.
17. If an autographing session is planned, a table, pens, and water should be provided for the author.
18. Anyone seeking an autograph should write *only* his/her name on a slip of paper and put the paper in the book *prior* to the autographing session. This speeds up the autographing process and helps the author avoid misspelled names.
19. Do not ask authors to autograph slips of paper.
20. Students seeking the author's autograph should be handled in small groups of three to five students at one time. This permits time to personally talk with the author and get his/her autograph.
21. Following the author's visit, a thank-you note should be sent to the guest. Include comments which you have heard from the teachers, students, and parents.

SOURCE: Reprinted by permission of Putnam City Schools, Department of Elementary Libraries, Oklahoma City, Oklahoma. Gerry Willingham, Director.

**COUNTDOWN FOR AUTHOR VISIT  
FOUR WEEKS BEFORE THE BIG DAY**

Check When Completed		NOTES
	Identified students and teachers who will participate in the program and sent schedule for author's approval or comments.	
	Ordered books which will be offered for sale prior to the author's visit.	
	Coordinated program activities with students and teachers involved.	
	Presented biographical information about the author to students, teachers, and principal.	
	Read several of the author's books	
	Planned publicity for the PTA, school newsletter, district newsletter, community newspapers, etc.	
	Sent letter home explaining author's visit.	
	Made luncheon plans and notified those who will be going to lunch with the author.	
	Worked with students on appropriate questions to ask, proper questioning procedures.	
	Checked with art teacher and/or classroom teachers about special projects which might be done by the students and presented to the author	
	Sent notes to superintendent and other administrative personnel you would like to have attend	

## ONE WEEK BEFORE THE BIG DAY

Check When Completed		NOTES
	Offer books for sale to students, teachers, and parents. Students should write names on a slip of paper and have it inside the book purchased.	
	Make arrangements for lunch for your group.	
	Remind principal of luncheon plans and determine how bill will be handled.	
	Discuss seating arrangement of students with teachers and elicit their help with crowd control Provide teachers with schedule of events.	
	Make final plans with those responsible for coffee and refreshments to be available during author's visit	
	Check your camera--do you have film, batteries, flash, etc., ready for the day of the program?	
	Check video and audio equipment if it is to be used during the program.	
	Write down comments to be used when introducing the speaker.	
	Inform your custodian about the program and work with him/her if furniture is to be moved or rearranged	

## THE BIG DAY HAS ARRIVED

Check When Completed		NOTES
	Check room arrangement--microphone, water, chair, table for autographing, pens, tissues.	
	Welcoming signs, displays are up in the appropriate places.	
	Arrangements complete for coffee, etc.	
	Introduction is ready to be given.	
	Mementos are in the library ready to be given to the author.	
	Camera is ready--film, flash, batteries and in the library.	
	Video and audio equipment is ready and in the library.	
	Final memo to teachers has been sent reminding them of schedule, autographing.	
	Final check is made with volunteers to make certain that they are ready to handle book sales, reception, etc.	
	In case there is a lull in the program, you have several questions written out to ask the author.	
	Luncheon plans are checked one last time.	
	Check with custodian one final time about rearranging furniture, moving out/in chairs, etc.	
	Plug in coffee pot.	
	Set up book sales area.	
	Review notes of program, introduction.	
	Have your library copies of author's book signed	
	Have copies of author's books near where he/she will be speaking.	
	Final check on room arrangements.	
	<b>ENJOY THE DAY!</b>	

345

### THINGS TO DO AFTER THE AUTHOR'S VISIT

Check When Completed		NOTES
	Thank-you notes written to staff members, PTA people, the author, custodian.	
	Return books borrowed from other libraries.	
	Return unsold books and pay publisher.	
	Send any publicity articles, pictures, video tapes, etc., to author that might be enjoyed.	
	Evaluate the program with your teachers, students, and principal.	

SOURCE: Adapted with permission from: *Handbook of Shawnee Mission Public Schools*. Shawnee Mission, KS. Children's and YA's Author Workshop.

## ART, PROSE AND POETRY CONTESTS/PUBLISHING CHILDREN'S WORK

The following organizations and/or publishers accept children's written material and art work. Several sponsor contests, often concerning a specific theme. Each source should be consulted for specific instructions. All unsolicited materials (for which the publisher assumes no responsibility) must be accompanied by a self-addressed, stamped envelope if return of the material is desired.

### Boy's Life

1325 Walnut Hill Lane  
Irving, TX 75062

Publishes jokes sent on postcards with student's complete address given. Accepts stories about scouts or scouting, how-to hints, and news items. Magazine for ages 8-17 and especially Boy Scouts.

### Children's Art Foundation

Stone Soup  
Box 83  
Santa Cruz, CA 95063

Written entirely by children. Accepts all types of written material and art work. Dictated work will be accepted if acknowledged by note. (Send self-addressed, stamped envelope for return of material.) For ages 3-13.

### Children's Digest

1100 Waterway Blvd.  
P.O. Box 567  
Indianapolis, IN 46206

Monthly publication for ages 8-10. Accepts original fiction or nonfiction stories, original poetry, reader's favorite jokes and riddles. All material should be health-related.

### Children's Playmate

P.O. Box 567B  
Indianapolis, IN 46206

Sponsors annual contest for young artists, poets and writers. Magazine for ages 5-8.

### Contest, Youth Publications

P.O. Box 567B  
Indianapolis, IN 46206

Submit original poetry, short story or art work. Write for information

### Cricket, the Magazine for Children

P.O. Box 300  
Peru, IL 61354

Publishes stories, poetry, and art for children ages 5-14 only if it follows the rules of current Cricket League Contests.

### Ebony, Jr!

820 South Michigan Avenue  
Chicago, IL 60605

Regularly features art work, short stories, poems, and jokes. Magazine for ages 6-12.



Electric Company Magazine  
One Lincoln Place  
New York, NY 10023

Will accept students' jokes. Magazines for ages 8-12

Highlights for Children  
803 Church Street  
Honesdale, PA 18431

Features students' poems, stories and art work. Make black-and-white drawings on 8" x 11" white paper. Print name, age, street address, city, state, and zip code on the back. Enclose a note from parent or teacher stating that the drawings have not been traced or copied from pictures, and that the student has not read or heard the stories or poems anywhere else. No child's contribution will be paid for or returned. Read magazine for special contest information. Magazine for ages 4-11.

Humpty Dumpty's Magazine  
1100 Waterway Blvd.  
P.O. Box 567  
Indianapolis, IN 46206

Monthly publication for children ages 4-6. Publishes reader's art work or pictures drawn or colored by the readers themselves. Include self-addressed, stamped envelope if you wish material to be returned.

Jack and Jill  
P.O. Box 567BN  
Indianapolis, IN 46207

Features a "From Our Readers" column including drawings, poetry and letters, original stories, book reviews, jokes, and riddles. For ages 8-12. Send self-addressed, stamped envelope if you wish material to be returned.

Merlyn's Pen  
P.O. Box 1058  
East Greenwich, RI 02818

Offers a forum for writers, Grades 7-10. Send short stories, poems, plays, essays, illustrations, and word games.

National Geographic World  
17th and M Streets, NW  
Washington, DC 20036

Send games, letters, and pictures to "Mailbag" column. Magazine for ages 8-14.

Oklahoma Poetry Society  
Betty Becquart Sanders  
P.O. Box 26342  
Oklahoma City, OK 73126

Annual contest for children's poems. Deadline February 28

Ranger Rick's Nature Magazine  
National Wildlife Federation  
1412 16th Street, NW  
Washington, DC 20036

Will publish nature letters, poems, and art from members of Ranger Rick's Nature Club. Magazine for ages 4-12.

Spinoff  
Gifted Children Monthly  
P.O. Box 115  
Sewell, NJ 08080

Publishes original puzzles, tricks, mazes, challenges, stories, poems, essays, and word games. Also uses photos and art work.

Sesame Street  
One Lincoln Place  
New York, NY 10023

Submit children's original art. Magazine for ages 3-8

Stone Soup, the Magazine by Children  
Stone Soup  
P.O. Box 83  
Santa Cruz, CA 95063

Devoted exclusively to stories, poems, book reviews, and art by children ages 6-13. All work must be accompanied by self-addressed, stamped envelope.

"The Storyteller"  
Capper's Weekly  
Stauffer Publications, Inc.  
616 Jefferson Street  
Topeka, KS 66607

Submit jokes and true incidents.

Teenage  
P.O. Box 6H  
Holms, PA 19043

Offers readers the chance to be published.

Turtle Magazine for Preschool Kids  
1100 Waterbury Blvd.  
P.O. Box 567  
Indianapolis, IN 46206

Publishes art work or pictures drawn or colored by the readers themselves.

Wee Wisdom  
Unity Village, MO 64065

Send poems and stories of "character building" nature with a note attesting to originality and grade level in school.

**WOMBAT**  
P.O. Box 8088  
Athens, GA 30603

A journal of young people's (ages 6-16) writing and art. Submit short stories, poetry, nonfiction, art works, cartoons, illustrations, etc. Published authors and artists receive a badge imprinted "I've been published in WOMBAT."

NOTE. For additional information on preparing and submitting a manuscript for publication and more complete details on each publisher consult the following guide:

*Market Guide for Young Writers* by Kathy Henderson  
1986-87 Edition  
Savage Publishing Company  
ISBN 0-943194-23-7 \$12.95.

## BIBLIOGRAPHY OF AUTHOR MATERIALS

### Books

- Commire, Anne**, (ed.). *Something About the Author: Facts and Pictures About Contemporary Authors and Illustrators of Books for Young People*. Vol. 1-45. Gale Research Company.
- DeMontreville, Doris and Crawford, Elizabeth D** *Fourth Book of Junior Authors and Illustrators*. H. W. Wilson, 1978.
- DeMontreville, Doris and Hill, Donna** *Third Book of Junior Authors*. H. W. Wilson, 1972  
(Includes 255 autobiographical or biographical sketches of authors and illustrators of books for children and young people )
- Fuller, Muriel D.** *More Junior Authors* H. W. Wilson, 1963  
(Autobiographical sketches of 268 authors and illustrators of children's and young adult books.)
- Hoffman, Miriam and Samuels, Eva.** *Authors and Illustrators of Children's Books: Writings on Their Lives and Works*. R. R. Bowker, 1972.  
(An anthology of critical biographical articles about 50 persons who have made distinguished contributions to children's literature.)
- Hopkins, Lee Bennett.** *Books Are by People* Citation Press, 1969  
(Interviews with 104 authors and illustrators of books for young people.)
- Hopkins, Lee Bennett.** *More Books by More People*. Citation Press, 1969  
(Personal and warm glimpses of the working habits and life styles of 65 authors and illustrators of books for children.)
- Kingman, Lee.** (ed). "Newbery and Caldecott Medal Books: 1956-1965 " *Horn Book Magazine*, 1965.
- Kingman, Lee.** (ed.). "Newbery and Caldecott Medal Books: 1966-1975." *Horn Book Magazine*, 1975.  
(Acceptance papers, biographies, and related material chiefly from the magazine )
- Kirkpatrick, D. L.** (ed.) *Twentieth-Century Children's Writers*. St. Martins Press, 1978.
- Kunitz, Stanley J. and Haycraft, Howard.** *Junior Book of Authors*. 2nd ed. rev , H. W. Wilson, 1951.(This book covers 289 authors and illustrators of children's books.)
- Locher, Frances C.**, editor. *Contemporary Authors: A Bio-Biographical Guide to Current Writers in Fiction, General Nonfiction, Poetry, Journalism, Drama, Motion Pictures, Television, and Other Fields*. Gale Research, 1964 to present.
- Miller, Bertha Mahony and Field, Elinor Whitney** (eds.). "Newbery Medal Books: 1922-1955." *Horn Book Magazine*, 1957.  
(Acceptance papers, bibliographies, and related material chiefly from the *Horn Book Magazine*.)

**Smaridge, Norah.** *Famous Author-Illustrators for Young People.* Dodd, Mead, 1973  
(Readable accounts of the aims, achievements, art media, life styles, and personalities of 19 author-illustrators, many of whom are today's leaders in the field of children's literature.)

**Smaridge, Norah.** *Famous Modern Storytellers for Young People.* Dodd, Mead, 1969.  
(Warm interesting glimpses into the lives of 19 outstanding authors who have made distinguished and lasting contributions to the world of children's books.)

**Smaridge, Norah.** *Something About the Author.* Volumes 1-28. Gale Research, 1971.  
(Illustrated personal introductions to more than 200 authors per volume.)

**Ward, Martha E. and Marquardt, Dorothy A.** *Authors of Books for Young People.* 2nd edition. Scarecrow Press, 1971.  
Short biographies [75 to 100 words long] of 1,030 authors and illustrators of books for children and young people.)

*Illustration of Books for Young People.* 2nd edition. Scarecrow Press, 1975.  
(Brief biographies of 750 illustrators of children's books.)

### Indexes

**Commire, Anne, (ed.).** *Something About the Author: Facts and Pictures About Contemporary Authors and Illustrators of Books for Young People.* Vol. 1-48. Gale Research Company.

**Sarkissian, Adele.** *Children's Authors and Illustrators: An Index to Biographical Dictionaries.* Gale Research Company, 1978. (2nd ed.)

### Periodicals

*Language Arts* has monthly author feature.

### Audiovisuals

**First Choice: Authors and Books series.** Pied Piper Productions, Box 320, Verdugo City, California 91046.  
(Each set includes a sound filmstrip of a book. Also includes a cassette interview with the author of the book.)

**Meet the Newbery Author series.** Miller-Brody Productions.  
Sound filmstrips of authors such as Lloyd Alexander, William H. Armstrong, Natalie Babbitt, Carol Ryrie Brink, Betty Byars, Susan Cooper, Beverly Cleary, Eleanor Estes, Jean Craighead George, Bette Greene, Virginia Hamilton, Marguerite Henry, Jomake Highwater, Madeleine L'Engle, Arnold Lobel, Scott O'Dell, Isaac Bashevis Singer, Laura Ingalls Wilder, Elizabeth Yates, Laurence Yep.