

DOCUMENT RESUME

ED 300 899

EA 020 458

AUTHOR Constantinos, Fecadu
 TITLE Innovation in Management of Primary School
 Construction: Multi-Purpose Primary School Buildings
 in Bangladesh. Educational Building Report 18.
 INSTITUTION United Nations Educational, Scientific, and Cultural
 Organization, Bangkok (Thailand). Regional Office for
 Education in Asia and the Pacific.
 PUB DATE 88
 NOTE 54p.
 AVAILABLE FROM Customer Service, UNIPUB, 4611-F Assembly Drive,
 Lanham, MD 20706-4391 (Catalog No. UB385, \$11.50;
 quantity discounts).
 PUB TYPE Guides - Non-Classroom Use (055)
 EDRS PRICE MF01 Plus Postage. PC Not Available from EDRS.
 DESCRIPTORS blueprints; Building Design; Community Involvement;
 Construction Materials; Cost Effectiveness;
 *Educational Facilities Design; *Educational
 Facilities Planning; Elementary Education; Flexible
 Facilities; Foreign Countries; *School Buildings;
 *School Construction; Tables (Data)
 IDENTIFIERS *Bangladesh

ABSTRACT

This report deals with school building construction utilizing technology carried out by the Lutheran World Service/Rangpur Dinajpur Rehabilitation Service in Bangladesh. The purpose was to develop an alternative design for primary school constructions. The design, construction, and multipurpose use of the school buildings are described. Appended are the blueprints used for manufacturing the various elements, a detailed cost breakdown of three classroom multipurpose primary schools, and seven references. (SI)

 * Reproductions supplied by EDRS are the best that can be made *
 * from the original document. *

U.S. DEPARTMENT OF EDUCATION
Office of Educational Research and Improvement
EDUCATIONAL RESOURCES INFORMATION
CENTER (ERIC)

 This document has been reproduced as received from the person or organization originating it.

Minor changes have been made to improve
..... n quality

 ERIC

Full Text Provided by ERIC

.....w or opinions stated in this docu-
.....nt necessarily represent official
.....on or policy

PERMISSION TO REPRODUCE THIS
MATERIAL IN MICROFICHE ONLY
HAS BEEN GRANTED BY

E. Djaka

TO THE EDUCATIONAL RESOURCES
INFORMATION CENTER (ERIC)."

Unesco. Principal Regional Office for Asia and the Pacific.
*Innovation in management of primary school construction:
multi-purpose primary school buildings in Bangladesh*, by
Fecadu Constantinos. Bangkok, 1988.

43 p. (Educational Building Report 18)

1. EDUCATIONAL BUILDINGS – PRIMARY SCHOOLS
– BANGLADESH. 2. CONSTRUCTION TECHNOLOGY –
BANGLADESH. 3. BUILDING MATERIALS – BANGLADESH.
I. Constantinos, Fecadu. II. Title. III. Series.

727.1



INNOVATION IN MANAGEMENT OF PRIMARY SCHOOL CONSTRUCTION:

Multi-purpose Primary School Buildings in Bangladesh

by Fecadu Constantinos

Report printed under UNESCO-AGFUND Regional Project, Development of Educational Facilities in Asia and the Pacific

 **EDUCATIONAL BUILDING REPORT 18**
UNESCO Principal Regional Office for Asia and the Pacific
Bangkok, Thailand

© UNESCO 1988

Published by the
UNESCO Principal Regional Office for Asia and the Pacific
P.O. Box 1425, General Post Office
Bangkok 10501, Thailand

Printed in Thailand

The designations employed and the presentation of material throughout the publication do not imply the expression of any opinion whatsoever on the part of Unesco concerning the legal status of any country, territory, city or area or of its authorities, or concerning its frontiers or boundaries.

CONTENTS

PREFACE

INTRODUCTION	1
Chapter One : Design concept	3
Chapter Two : Prefabrication of building parts	23
Chapter Three : Construction	25
Chapter Four : Community participation	37
Annex	41
Bibliography	43
List of figures	
Figure 1. Two classroom primary school	7
2. Three classroom primary school	8
3. Four classroom primary school	9
4. Typical section	10
5. Steel structure	11
6. Steel structure — details	12
7. R.C.C. prefab panel/column fixing	13
8. Casting of R.C.C. prefab column	14
9. Casting of R.C.C. prefabs wall panels	15
10. Gable module	16
11. Door module	17
12. Window module	18
13. Steel door	19
14. Steel window	20
15. Removable partition	21
16. Removable partition — fixing details	22
17. Precasting of R.C.C. elements	29
18. Removing forms from precast R.C.C. elements	29
19. Precasting toilet pan units	30
20. Assembled water seal toilet pan units	30
21. Assembly of the steel structure	31
22. Structure detail	31
23. Precast panel in place	32
24. The assembled wall	32
25. Close-up of finished wall	33
26. Completed three classroom school exterior	33
27. Completed four classroom school exterior	34
28. Classroom interior	34
29. Large hall interior	35

PREFACE

In 1981 two Bangladesh fellows came to UNESCO Bangkok for one month of in-service training. The purpose: to develop alternative designs for the ambitious Universal Primary Education programme the country was launching with assistance from the World Bank. The resultant report has transformed primary school construction in Bangladesh.

The Facilities Department of the Ministry of Education oversees the improvement of some 36,000 primary schools under this project. Some schools are merely being repaired, in others classrooms are being added to existing buildings and in some new buildings are under construction. The majority of the work is done by the Department which has its own complete technical services.

Participation by non-governmental organizations is welcomed by the Ministry. This publication is a report on one such co-operative arrangement with the Lutheran World Service for the construction of 63 new school buildings.

The author, Mr. Fecadu Constantinos is also the designer of the buildings. Coming from a developing country himself, Mr. Constantinos holds degrees in engineering and educational administration. He worked on design and construction of low-cost schools in a number of African countries before coming to Bangladesh.

UNESCO has, since 1968, been working with governments in Asia and the Pacific on the improvement of primary schools. This EB report is one more in a series on Innovation in Primary School Construction which has included Afghanistan, India, Indonesia, Maldives and Sri Lanka.

The aims of the UNESCO-AGFUND project, 'Development of Educational Facilities in Asia and the Pacific' is to encourage experimentation in the design of educational buildings and furniture in the region and to disseminate the result of significant experiments. This EB Report, 'Multi-Purpose School in Bangladesh', incorporates many technical innovations and has come about through a cycle of research and development. For this reason it is being published under the UNESCO-AGFUND project.

INTRODUCTION

This is a report on one construction utilizing appropriate technology carried out by the Lutheran World Service/Rangpur Dinajpur Rehabilitation Service (LWS/RDRS) in Bangladesh. LWS is a voluntary, humanitarian, international organization with its Headquarter in Geneva, Switzerland assisting different third world countries in Africa, Asia and Latin America in development and relief work.

The idea of preparing an innovative primary schools design for joint projects between the Ministry of Education and the LWS/RDRS was first brought up in a meeting held at the Ministry of Education, Primary Education Directorate Office in Dhaka in October 1982. Among those who attended the meeting were: Mr. A.M.A. Rashid, Director of Facilities Department of the Ministry of Education (MOE), Mr. Charles J. Fluegel, Director of LWS/RDRS and Mr. John Beynon, Principal Architect, UNESCO Regional Office for Education in Asia and the Pacific, Bangkok. It was agreed in the meeting that RDRS would design and construct a Model School in Thakurgaon, Dinajpur District as a physical demonstration for a pilot project and to reach decision on final design details and specifications.

The Model School in Thakurgaon was completed in January 1983 and, after Mr. A.M.A. Rashid of the Ministry of Education inspected the school building, final design details and specifications were prepared. On the basis of the design of the Model School, an agreement between the Ministry of Education and RDRS was drawn up for the construction of 63 primary schools over a period of three years on an equal cost sharing basis. The agreement was signed in Dhaka in June 1983.

Construction of the 63 school buildings was started in October 1983 and by the end of 1984, in half the anticipated time, almost all the schools were completed. The completed schools were handed over to the local school committees and are presently being used. The design, construction and multi-purpose use of these schools is described in the following chapters.

The design of the multi-purpose primary school is based on the same dimensions as the floor plan of the Ministry of Education's design. It uses a 2,640 mm (8 feet 8 inches) bay and incorporates the architectural recommendations included in the report *Alternative Building Design for Universal Primary Education in Bangladesh* prepared at the UNESCO Regional Office for Education in Asia and the Pacific, Bangkok, by two staff members of the Educational Facilities Division, MOE.

The challenge was to design a school building that is structurally sound, durable, architecturally functional and attractive, yet economical considering the initial cost as well as the life span of the building. Construction of a large number of school buildings are required in order to implement the government's Universal Primary Education programme. There is also a demand from the communities to have facilities which can be used for community functions. As the funds available are extremely limited it was decided to design a single multi-purpose building which caters to all the educational and social needs of the school and the community at large.

It was considered from the outset that learning is a total life experience and the whole school environment is the educational arena of the pupils. They learn not only from textbooks and classroom lessons but also by observing the different forms and functions of the school building structure and from all other media they encounter in their daily experience. In the countryside, where these schools are constructed, the school building is usually the only high standard building and as such, is designed so as to inspire pride in each member of the community and attract them to this place where they may participate in social functions to improve their knowledge and to discuss and plan the development of their community.

The plans and elevation of two, three and four classroom schools are shown in Figures 1, 2 and 3 and a cross-section can be seen in Figure 4. A complete set of 'blue prints' for the buildings can be seen as pages 7 to 22.

Architectural considerations

Space. The building is designed with flexible and removable partitions, in order to provide space

suitable to the different functions such as class groups of 5 to 30 students, mass gatherings by the school or community of up to 200 persons; and for art and other displays.

The lower beam of the steel trusses which define the level of the ceiling is designed with split levels, to give greater floor to ceiling space in the central part of the room without increasing wall height. This results in an attractive interior space with a high ceiling while avoiding the extra cost of constructing high walls.

Aesthetics. In designing the forms and finishes of the school, consideration was taken to give the building a simple but attractive appearance. The design composition and finish of the exterior walls and the ventilation louvers give the building a distinct architectural character while serving structural and functional purpose.

The simple interior finish aims to create an enlightening learning atmosphere. The bamboo mat ceiling and the partition walls with chalkboards surrounded by paintings blend functionality with aesthetics. The National Flag in each classroom is intended to develop a sense of patriotism while the landscape paintings by local artists have been made to impart knowledge of the environment of Bangladesh. The bamboo mat ceiling adds a local organic material which contrasts pleasantly with the concrete and steel structure.

Acoustics. The bamboo mat ceiling, in addition to being an attractive and inexpensive finish, very substantially improves the sonic environment of the building. The sound absorption property of the bamboo mat ceiling and partition walls reduces noise reverberation to create an improved acoustic atmosphere.

Illumination. There is no electric supply in the rural area where the schools are constructed. Therefore, illumination of the interior of the rooms depends totally on natural light. For this reason, wide windows are provided which have a total opening area of about 15 per cent of the floor area. They let in plenty of natural light, and the interior walls are painted white to reflect on to the working surfaces the available natural light.

Ventilation. Human beings concentrate and perform best in a comfortable environment. In hot and humid climates such as Bangladesh it is important to provide adequate cross-ventilation in order to make the thermal environment of a building comfortable. In the school building this is achieved by providing cross-ventilation along the two lengths of the building at two levels; at sitting-level through louvers below the windows, and at

the top of the two long walls over the doors and windows. The high level ventilation opens into the rooms, and also into the attic space above the ceiling and below the roof. In this way the hot air which accumulates under the roof and under the ceiling is removed from the building.

Structural considerations:

The primary aim for the school building design was to achieve economical, appropriate, durable and functional structures requiring minimal maintenance. This was to be done by upgrading local traditional practices, and optimizing the use of indigenous building materials through the introduction of new ideas. From the outset of the planning stage, it was realized that in order to complete the large number of school buildings it would be necessary to develop a system of construction based on standard building parts which could be produced under an efficient operation with adequate quality control.

After careful study of the available local building materials, the choice for main walling material was biased in favour of concrete rather than the traditional and widely used brick masonry. The choice of concrete instead of brick as the primary building material was made considering the points listed below.

Availability of building material. Very good quality sand is abundantly available in most parts of Bangladesh either from the numerous rivers or mined from pits. In the northern part of Bangladesh, gravel is also found in large quantity from rivers and in pits. For reinforcement, mild steel rods or, for some uses, bamboo can be used. Locally manufactured and imported cement is readily available in all towns of Bangladesh, mild steel rods are also produced in Bangladesh while bamboo is abundant. Thus, reinforced concrete can be considered a local material.

Conservation. The quality of brick in Bangladesh is generally good but the soil required to produce good quality brick is also good agricultural soil. In recent years substantial farm lands have been taken over by brick fields because of the lucrative brick making business which is expanding to meet the ever increasing demand for bricks. The removal of the clay with which the bricks are made lowers the land below the water table. To preserve these rich farm lands it is essential to use alternative building materials. Moreover, firewood is still the main fuel used for burning brick. Forest wood in Bangladesh is already a scarce commodity and because of its use in the brickeries it is fast being

further depleted. If this practice is not immediately controlled it will not only exhaust the country's valuable timber resources but it will have dire consequences on the ecological balance and climate of the whole country.

Strength. Properly made concrete has much greater strength than brick. Furthermore concrete constructions are more durable and require less maintenance.

Prefabrication of building parts. Central production and prefabrication of building parts improves the quality of products and cuts down the time required for construction.

Economy. In the last three years the cost of brick has more than tripled and it is probable that this trend will continue in the future. To achieve the same strength, a concrete wall is much thinner in cross section and lighter in weight. By using the thinner concrete walls, lighter foundations can be used which further saves on building materials.

The resultant design

After study of different alternatives it was decided to use a light steel frame combined with prefabricated reinforced concrete (RCC) columns as the main load bearing structure of the building. By using angle iron and mild steel reinforcement bars it was possible to fabricate a steel frame that is reasonable in cost, and stable while being flexible enough to take any differential foundation settlement or minor earth tremors. It is well anchored and therefore cyclone proof. The steel structure frame of the building, is in fact a well advised investment since with suitable protective coatings it can be preserved to outlast the life of any building and could still be recovered for further future uses. For this reason, and for easy transportation, and the steel structure is joined and assembled using nuts and bolts which make for easy mounting and fixing. The steel structure which is mounted as the first step in the building erection process, consists of 35 x 35 mm angle iron columns with a 50 x 50 mm angle iron tie beam (or ring beam) running round the perimeter of the building, and steel trusses made of 40 x 40 mm angle iron and mild steel rod. The steel structure is fabricated in such a manner that it can be mounted and fixed in a very short time thus defining the form, character and shape of the building (Figures 5 and 6).

The most unusual aspect of the structural design of the school building is an innovative technology of using bamboo reinforced prefabricated concrete panels as the external walling material. The prefabricated concrete panels are fixed to the angle iron columns of the steel structure by pre-

fabricated reinforced concrete (RCC) columns which are added after the panels are in place. The angle iron and the prefabricated RCC columns, when assembled, act integrally as the load bearing structure of the building (Figures 7 and 8).

The bamboo reinforced concrete panels are manufactured by using a labour intensive technology with semi-skilled labour. The concrete is hand mixed and cast into steel moulds to get the desired shapes. The steel moulds are made of 75 x 75 mm angle iron which is rigid enough to give the concrete panels a true shape and uniform thickness. The bamboo reinforcement which is made of approximately 20 x 5 mm cross section split bamboo tied together with galvanized iron wire to form a mesh of 150 x 150 mm, is placed in the middle of the concrete panels. The steel moulds are placed on wooden plank slabs over which the ready mixed concrete is cast. The wooden planks give the concrete panels a slightly rough though plane surface. After the panels are fixed, very thin plaster is used to finish the panels and give a smooth wall surface (Figure 9).

The concrete proportion used was 1 : 2 : 4 (Cement : Fine Aggregate : Coarse Aggregate) with 0.5 Water : Cement ratio. This mix produces strong concrete with good workability though it is hand mixed. The mixed concrete is placed in the steel moulds and packed manually with a wooden trowel and levelled with a straight edge. After casting, the steel mould is removed by lifting it vertically and the panel is finished with the desired colouring using powder pigment. The concrete is then left for 24 hours for the cement to set. The concrete is cured for 24 hours by keeping it constantly damp then it is removed and placed in a basin to be completely immersed in water for 7 days. Compared to ordinary curing this simple curing technique can increase the strength of concrete by as much as 30 per cent.

The top of the concrete panel which forms the exterior facade of the building is finished with a wavy rough finish, with the help of a wooden float, to give it an appearance similar to timber cut along the grain. This finish is made by mixing the colouring pigment powder together with an amount of cement and is applied to the wet concrete panels when they are being finished. The cement finish gives the panels a hard and waterproof gloss surface and the selected colour of the pigment powder so applied becomes a permanent finish which does not fade with time.

Seven different standard sizes and forms of a uniform thickness of 75 mm prefabricated RCC

panels are assembled and mounted to enclose the building leaving openings for doors, windows and ventilation (Figures 10, 11, 12). The concrete floor slab is poured and effectively locks into place the prefabricated elements.

Finally, the panels with ventilation louvers, windows and doors are fixed in place in the exterior wall. Doors and windows are manufactured from steel following a simple design using angle iron, steel sheet and mild steel (M.S.) rod. All steel parts are painted (Figures 13, 14).

Interior partitions are of steel angle iron and plywood sheets (Figures 15, 16).

Advantages and disadvantages of the multi-purpose school building

The multi-purpose primary school has demonstrated the following advantages over traditional buildings:

Economy. The cost of the concrete panel wall is about 60 per cent of one brick 250 mm masonry wall. Moreover, the wall thickness (75 mm) being only 30 per cent of that of brick masonry it requires a much lighter foundation.

In 1985 the costs for one square metre of one brick (250 mm) masonry wall complete with external rule pointing and internal plastering cost around Tk. 260.00 (Tk. 235.00 for material and Tk. 25.00 for labour) while the cost of 1 M2 finished concrete panel walling (75 mm thick) was Tk. 155.00 (Tk. 105.00 for material and Tk. 50.00 for labour). Since the steel structure can be recovered even after the lifetime of the building it is a recoverable investment.

Optimum use of local building material. The bulk of the materials used in the building were local materials. Even manufactured products such as cement and mild steel are produced in Bangladesh.

Labour intensive technology. Labour intensive methods employing non-skilled labour are used for the production of the concrete panels while semi-skilled can mount and fix the wall panels. The technology is sufficiently simple to be suitable for easy training of the labour force.

Maintenance. The surface of concrete wall panels is waterproof and requires almost no maintenance from normal wear and tear and action of the elements.

Strength and longevity. The building is stable against minor earth tremors, and well anchored against damage by cyclones.

Precision and quality control. Precise shapes

and high quality concrete products could be attained by using strict but minimum supervision.

Efficiency. The technology is intended to be efficient and time saving. By carefully programming the operation following a time and motion study, it was possible to increase output and improve quality of work over traditional buildings. All the prefabricated components of the building including concrete panels, steel columns, trusses, doors, windows and removable partitions for 3-classroom building can be manufactured in one week by 25 workers using labour intensive technology, and the whole construction could be completed from foundation to assembling. The mounting, fixing and finishing of a school can be done in one month. The construction of the buildings was less than half the time it would have taken to build the same size of building with traditional materials and construction methods.

To illustrate how efficient and versatile the system is, one can study how it was used in Rowmari Upazila which is located in a remote area and is prone to flooding. There are very few roads, and each year, the embankment of these roads is washed away. Nine primary schools were constructed by RDRS in Rowmari Upazila in less than four months. This was possible because of good planning and the efficiency of the construction system. During the monsoon flood all the prefabricated building elements for the schools were produced at the central plant and transported by boat to the different school sites. Construction was carried out during the dry season when the water had receded.

Disadvantages are relatively few but the following points need to be kept in mind if a building programme involving prefabrication is going to be undertaken. In general, prefabrication is most suitable when mass production on a large scale is anticipated. As it requires more than normal care to construct a building with prefabricated RCC panels, the workforce needs to be trained to work accurately. For this reason in most situations it would be a disadvantage to use this technique for the construction of only a few buildings.

Another disadvantage is that in case of damage it is more difficult to repair RCC panel walls than those of traditional buildings.

The working drawings used for manufacturing the various elements used in the multi-purpose schools are given in the 'blueprints' which follow (Figures 1 through 16). The construction process can be seen in photographs which follow Chapter 3 (Figures 17 through 29).

FIGURE 1 TWO CLASSROOM PRIMARY SCHOOL

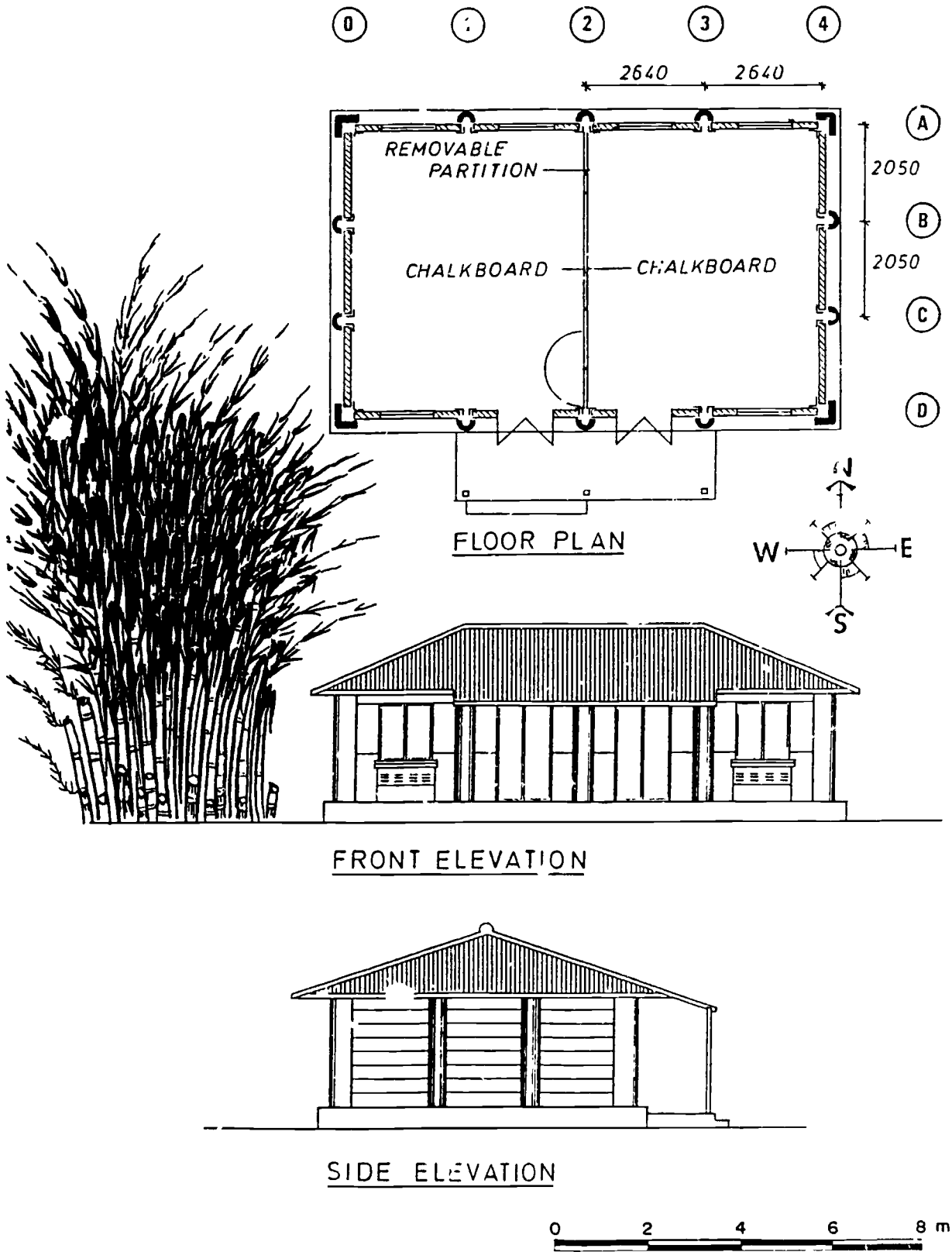
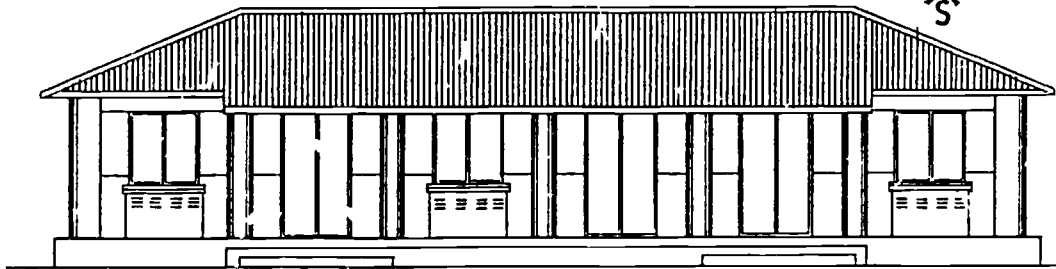
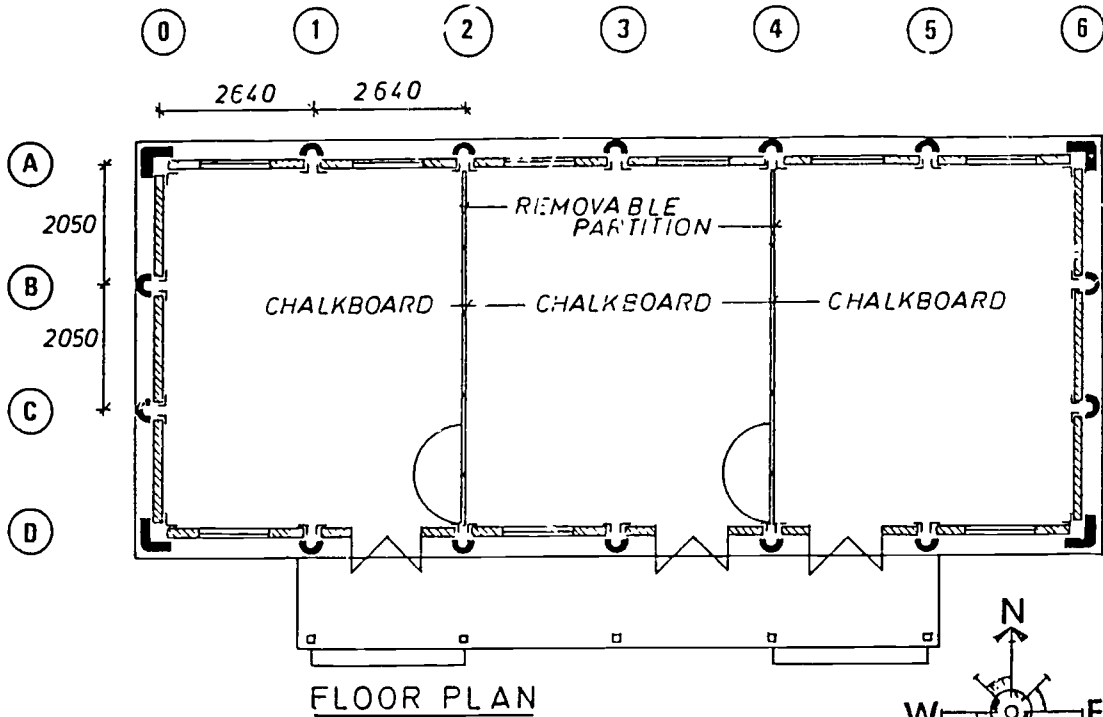
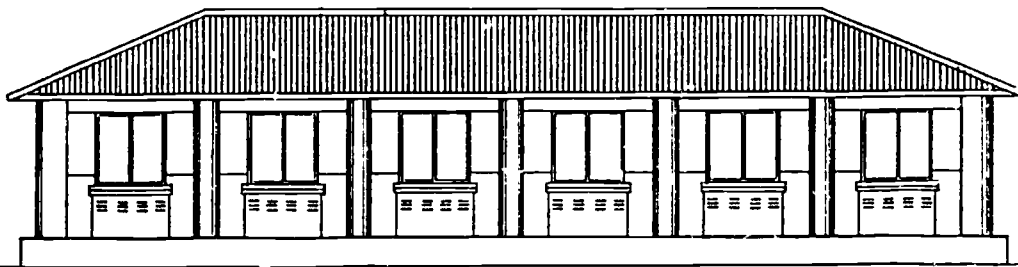

FIGURE 2 THREE CLASSROOM PRIMARY SCHOOL



FRONT ELEVATION



BACK ELEVATION



FIGURE 3 FOUR CLASSROOM PRIMARY SCHOOL

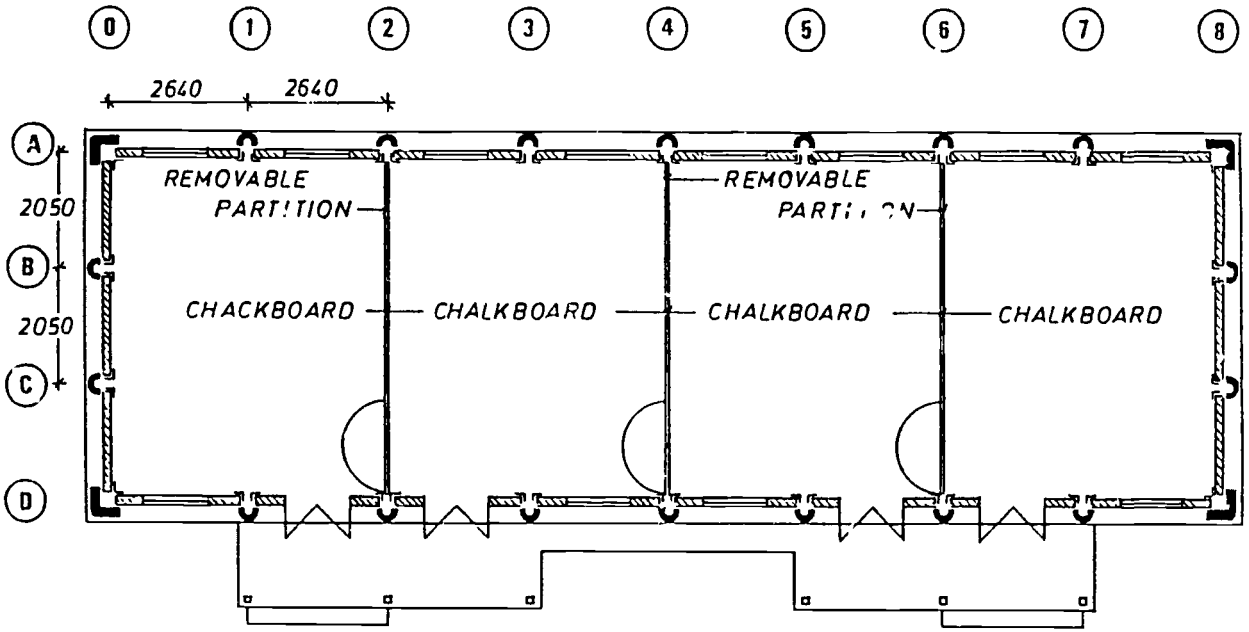

FLOOR PLAN

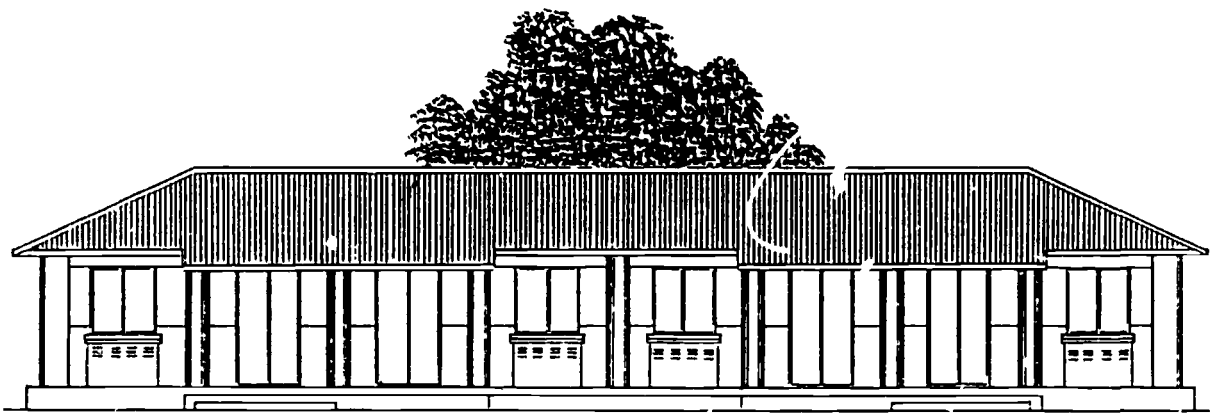

FRONT ELEVATION

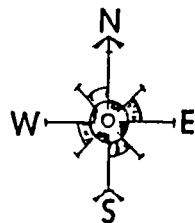

FIGURE 4 TYPICAL SECTION

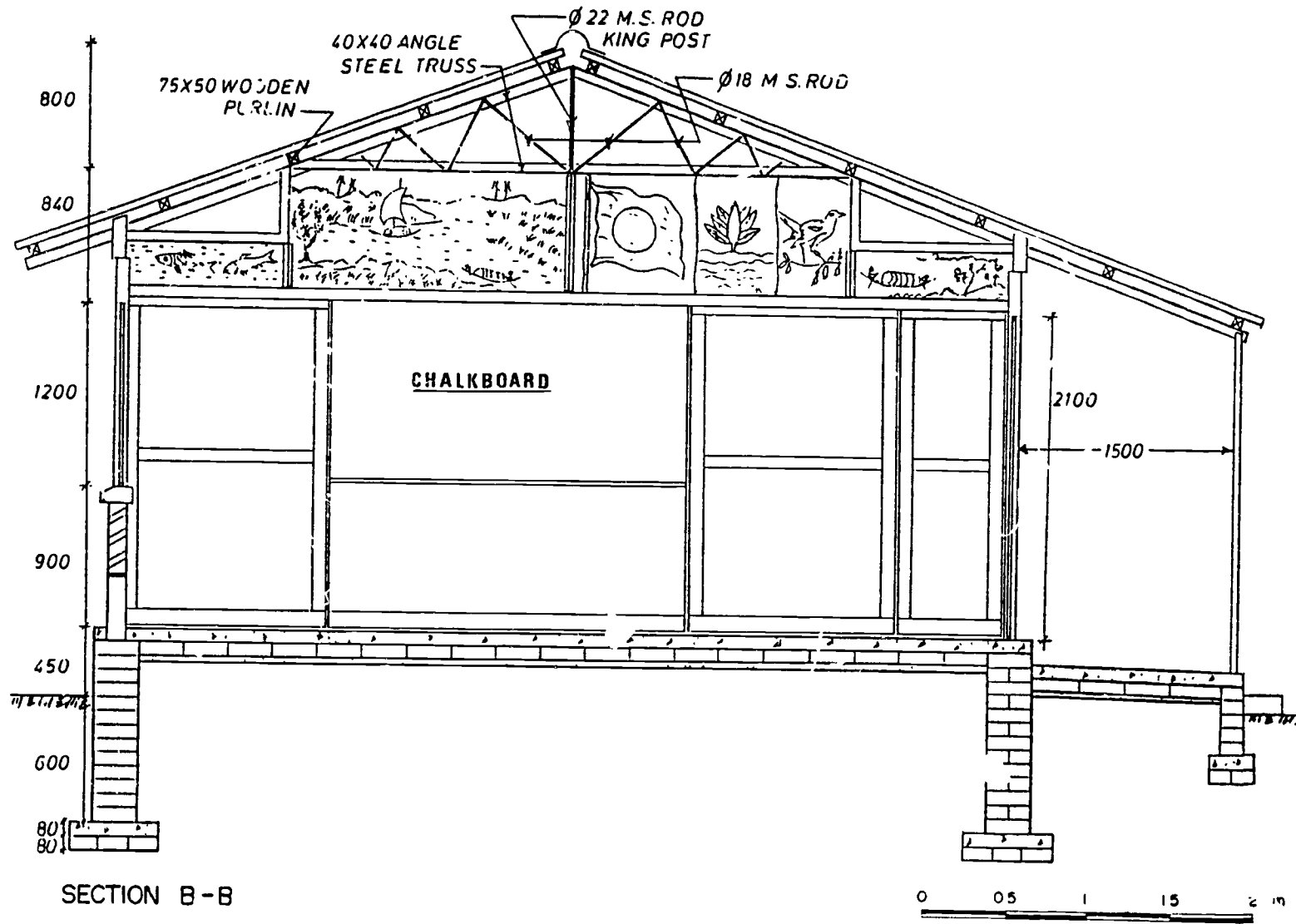
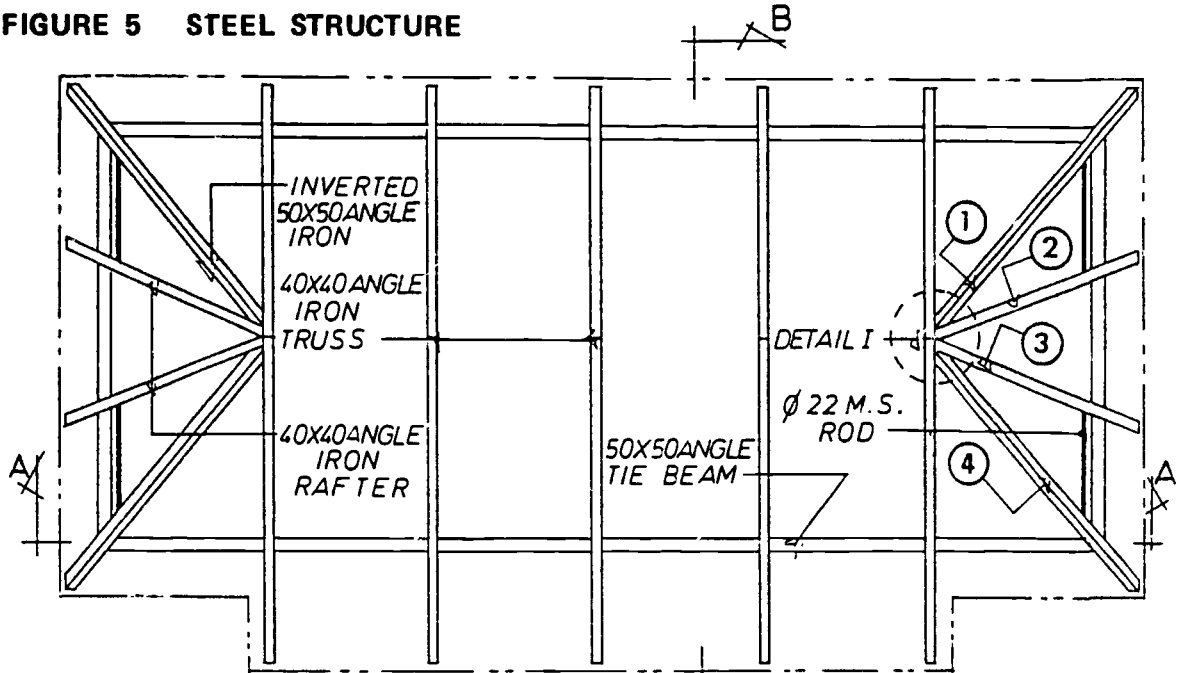
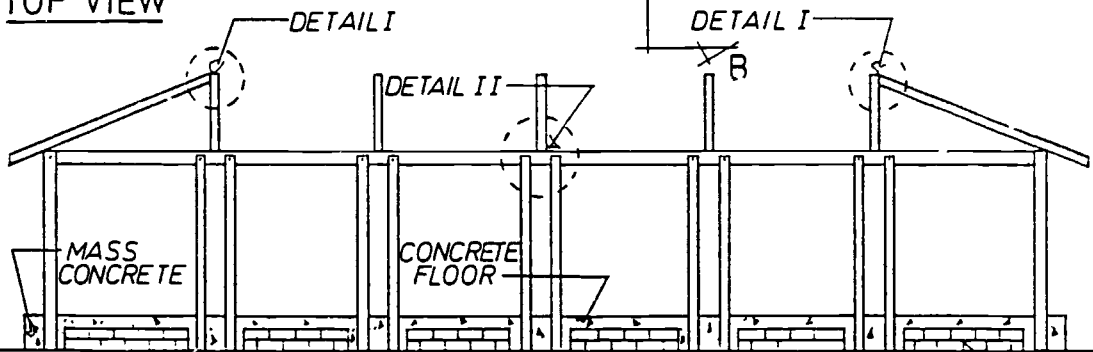

FIGURE 5 STEEL STRUCTURE



TOP VIEW



SECTION A-A

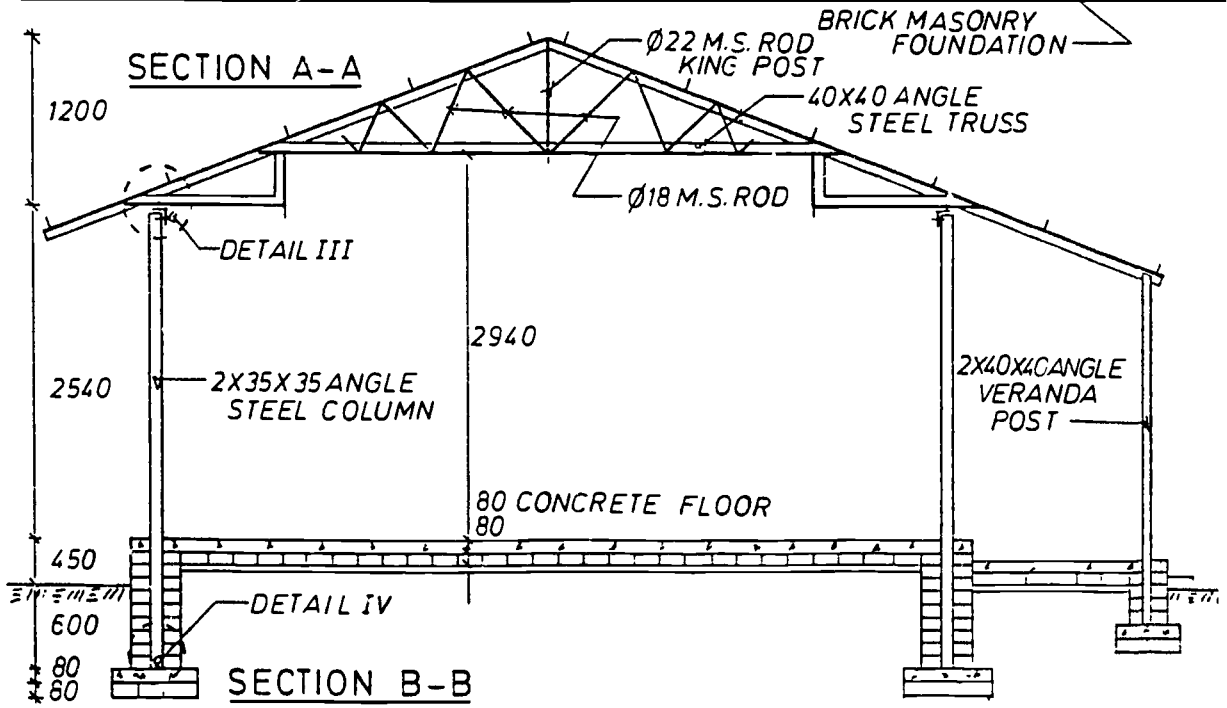

SECTION B-B

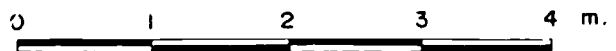

FIGURE 6 STEEL STRUCTURE - DETAILS

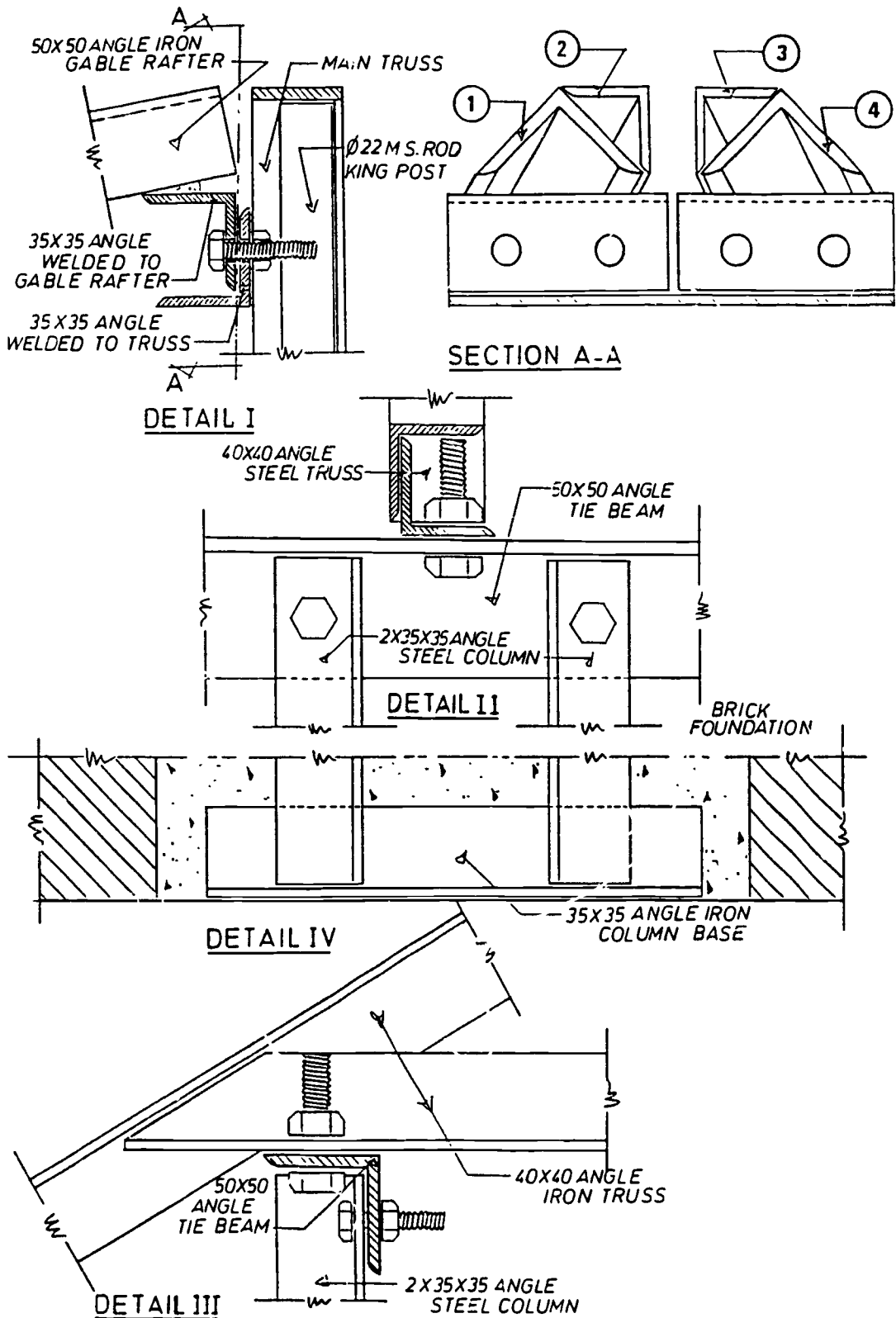

FIGURE 7 R.C.C. PREFAB PANEL/COLUMN FIXING

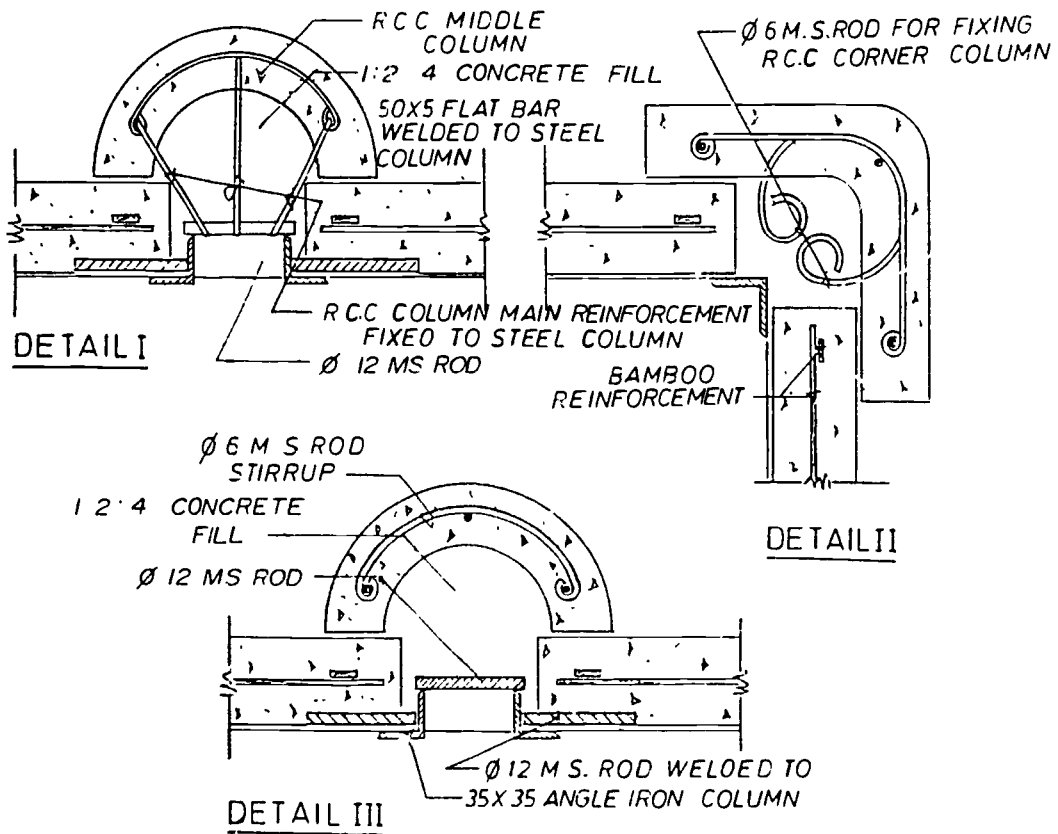
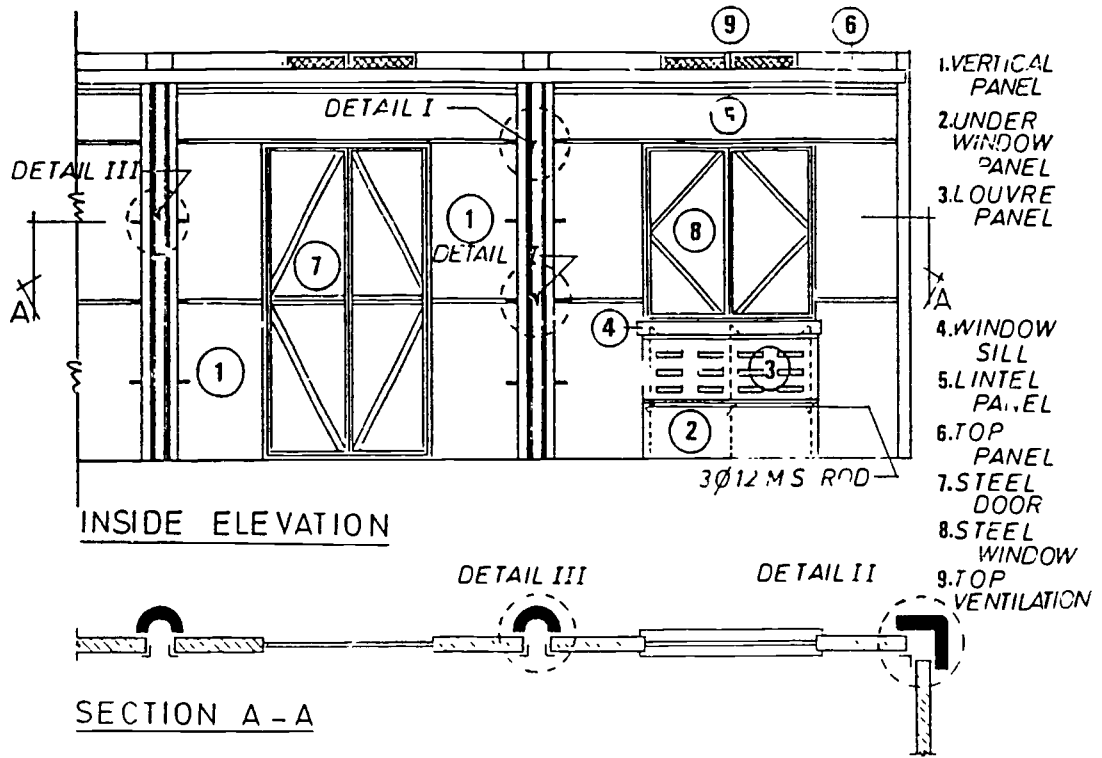

FIGURE 8 CASTING OF R.C.C. PREFAB COLUMNS

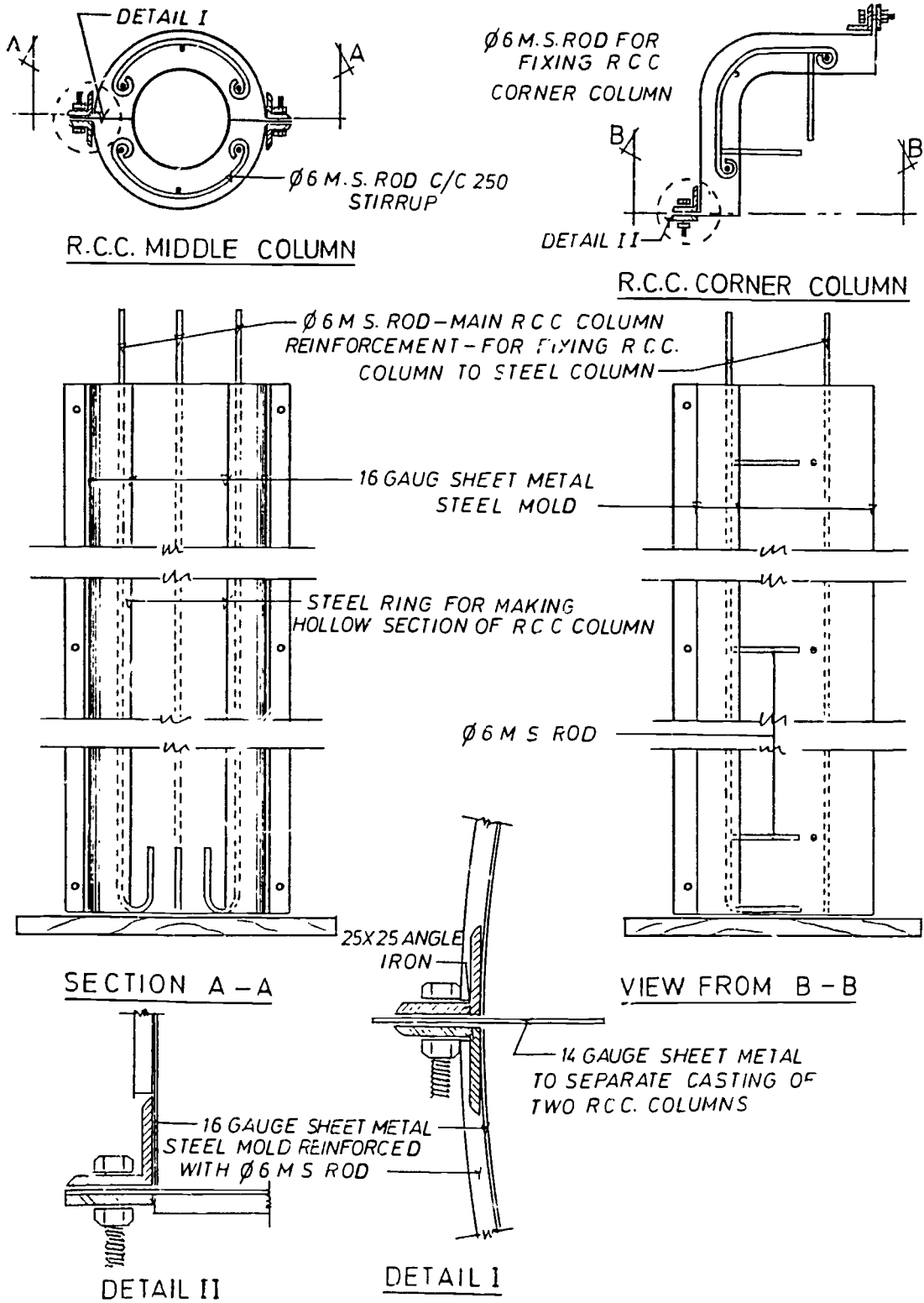

FIGURE 9 CASTING OF R.C.C. PREFABS WALL PANELS

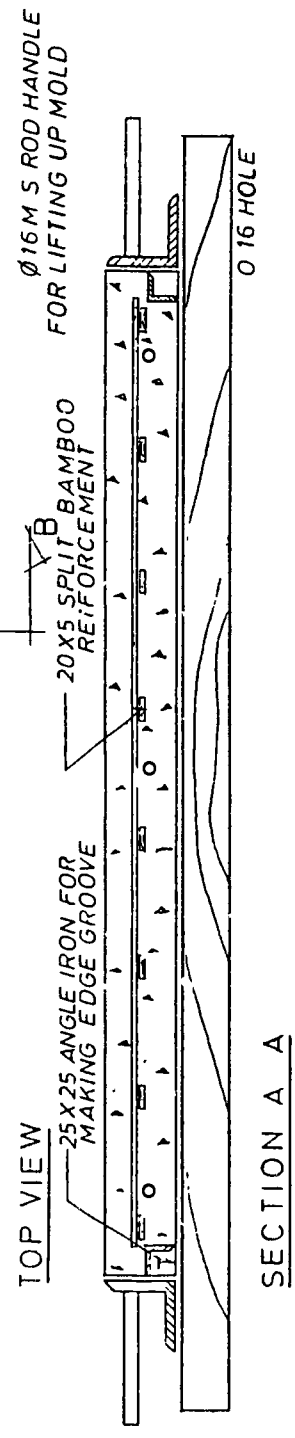
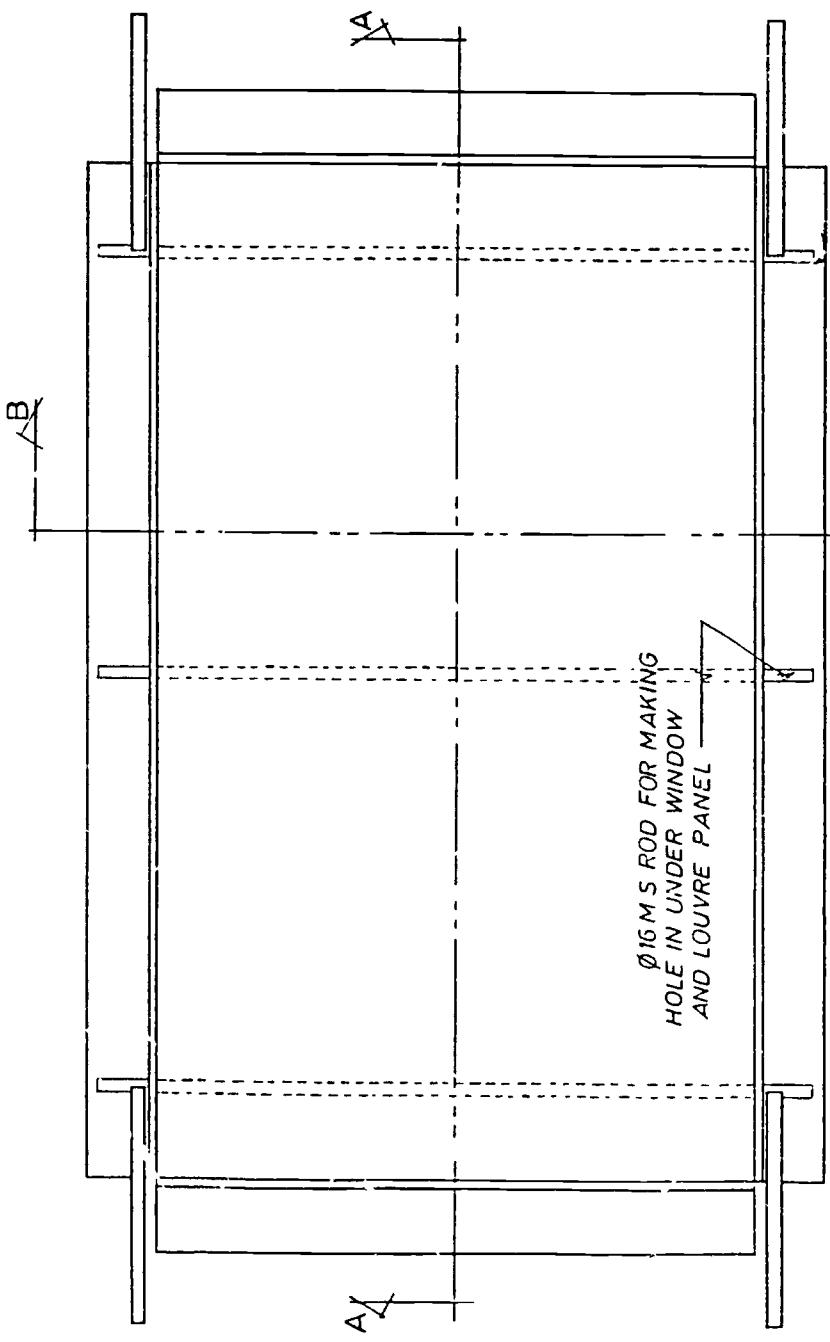
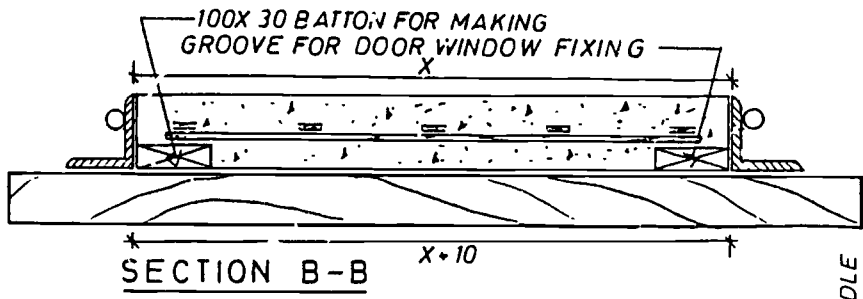
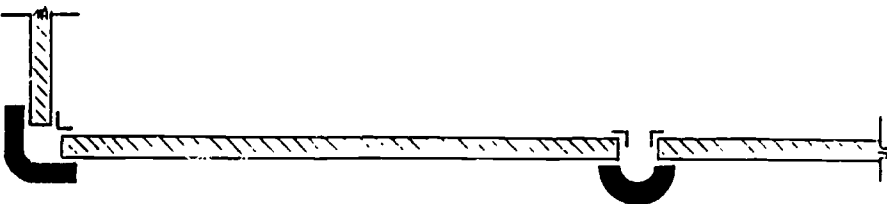
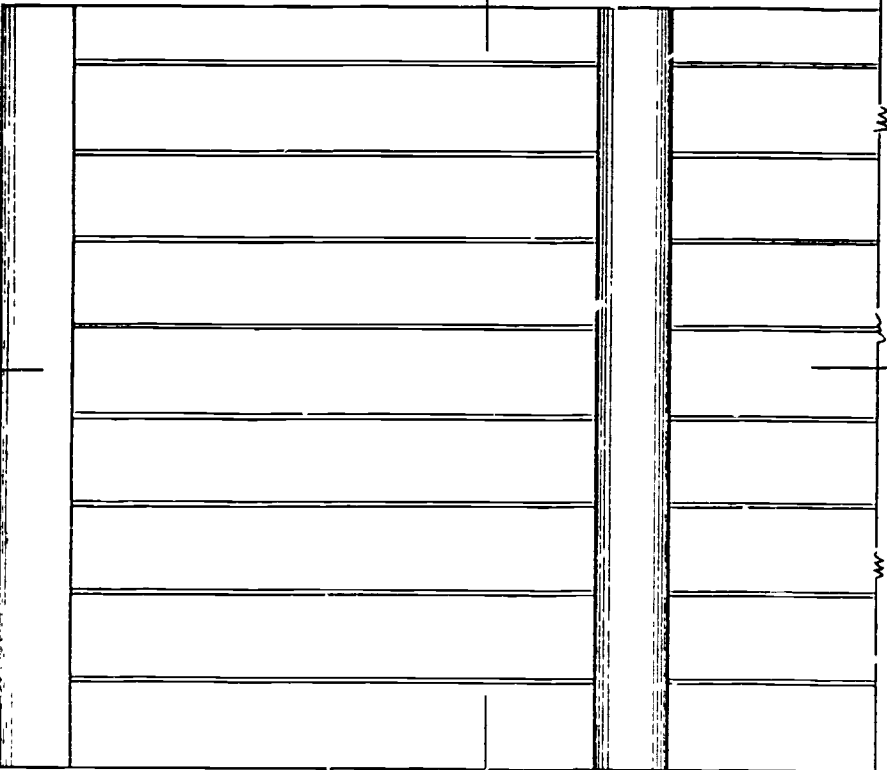

FIGURE 10 GABLE MODULE



SECTION A-A

B



ELEVATION

B

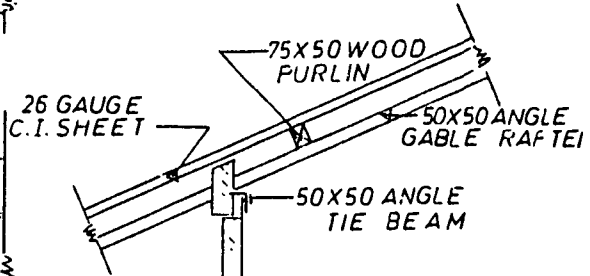

SECTION B-B

16

FIGURE 11 DOOR MODULE

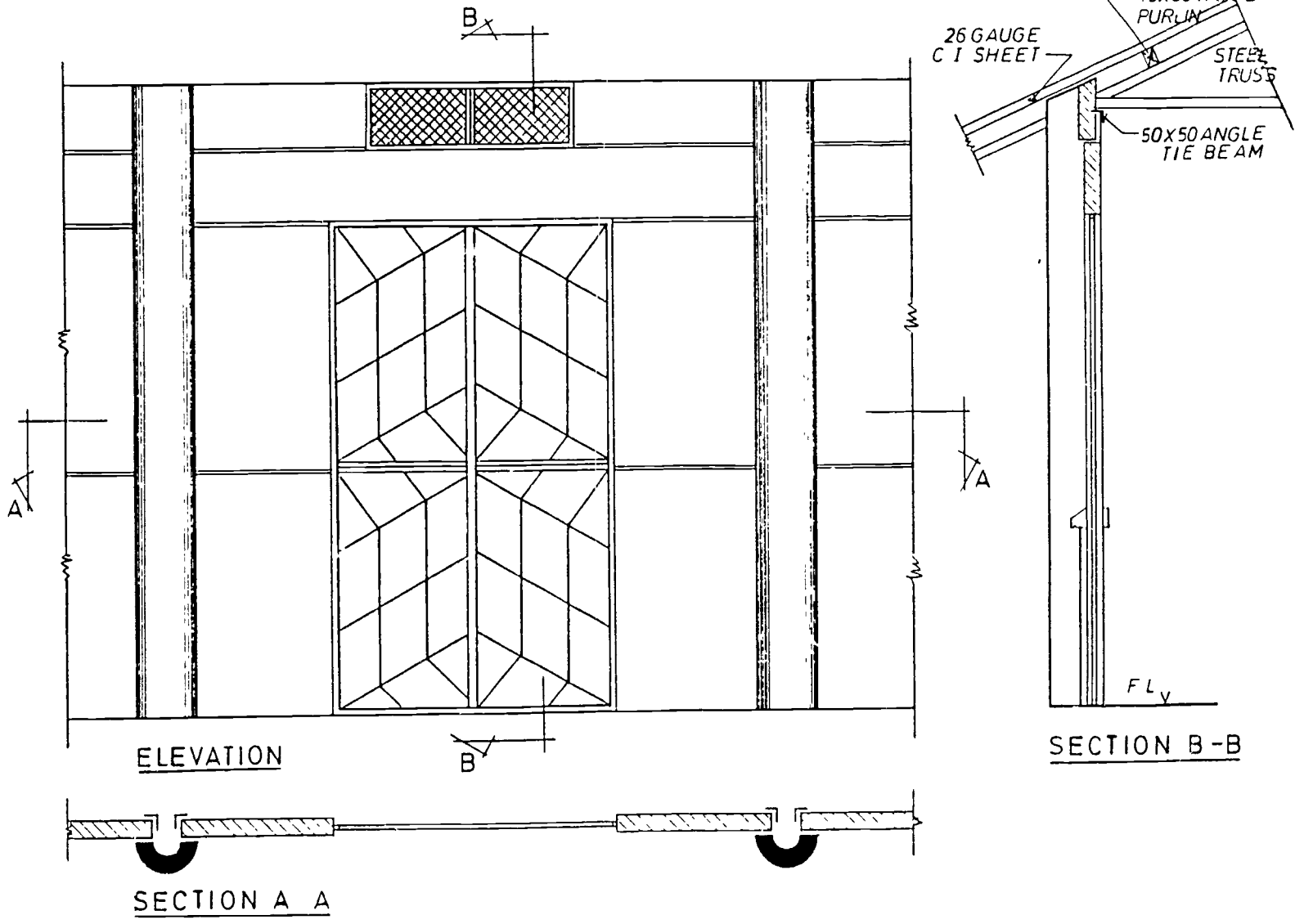
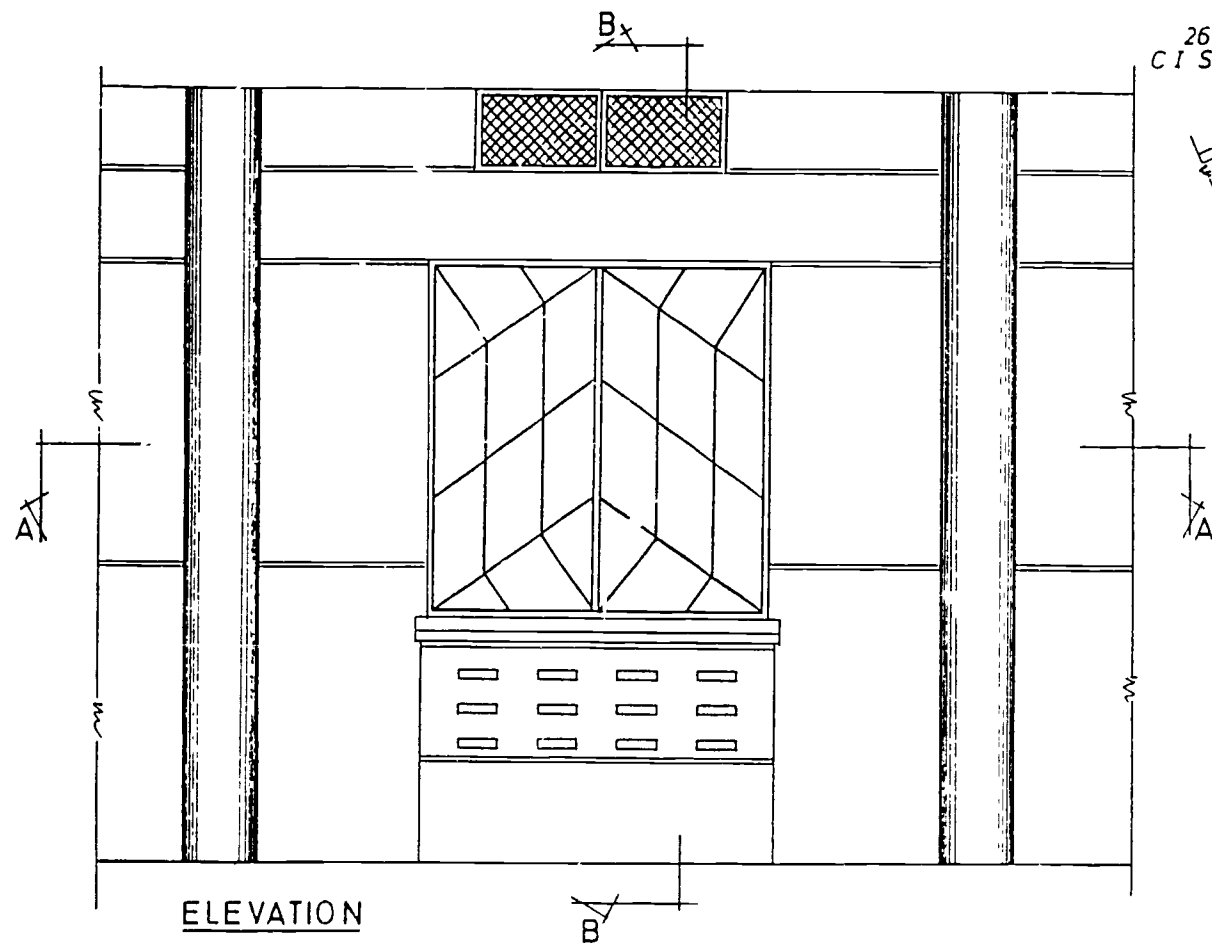
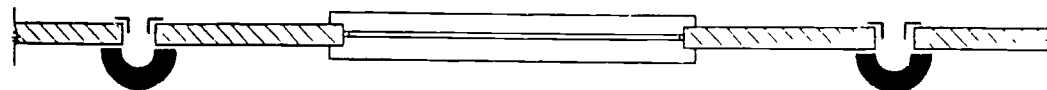

FIGURE 12 WINDOW MODULE



ELEVATION



SECTION A-A

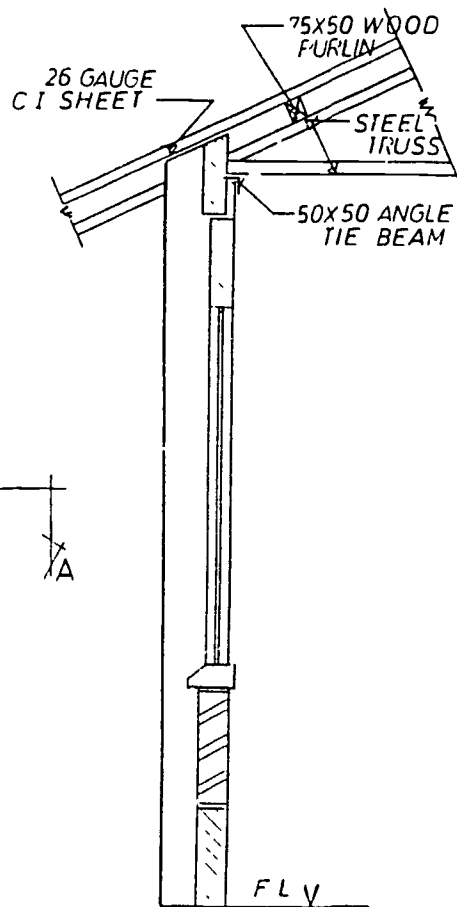

SECTION B - B

FIGURE 13 STEEL DOOR

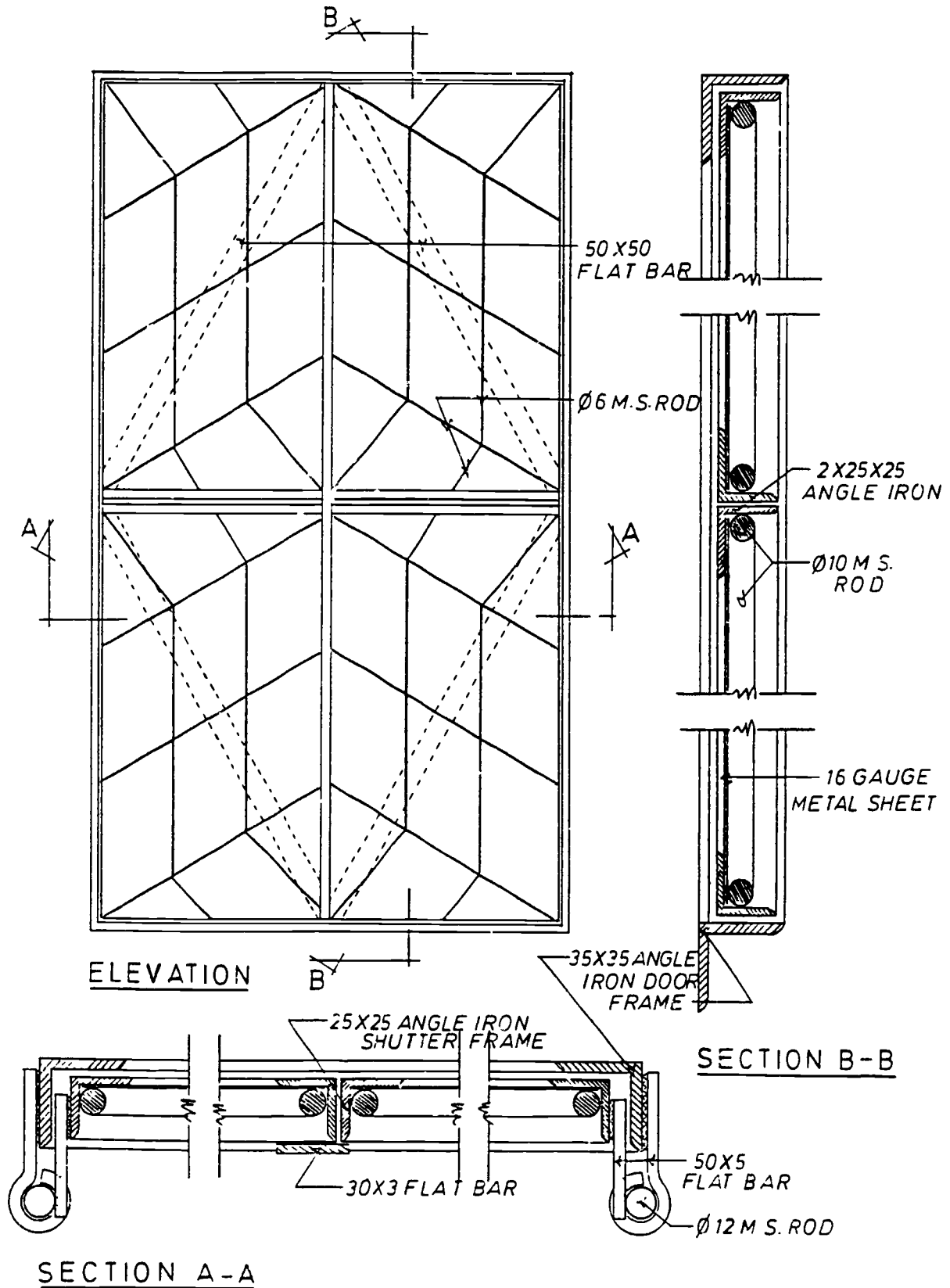

FIGURE 14 STEEL WINDOW

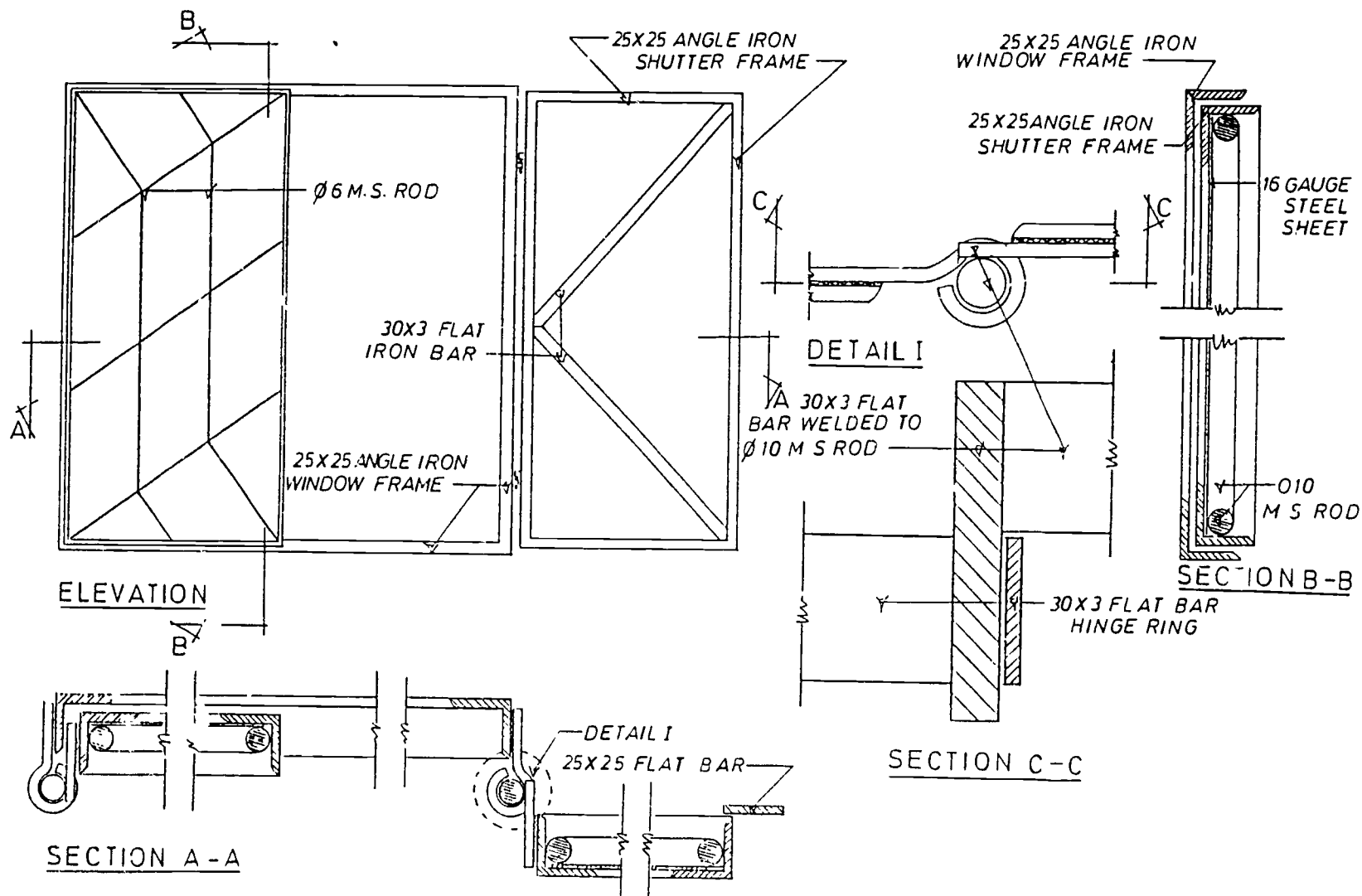
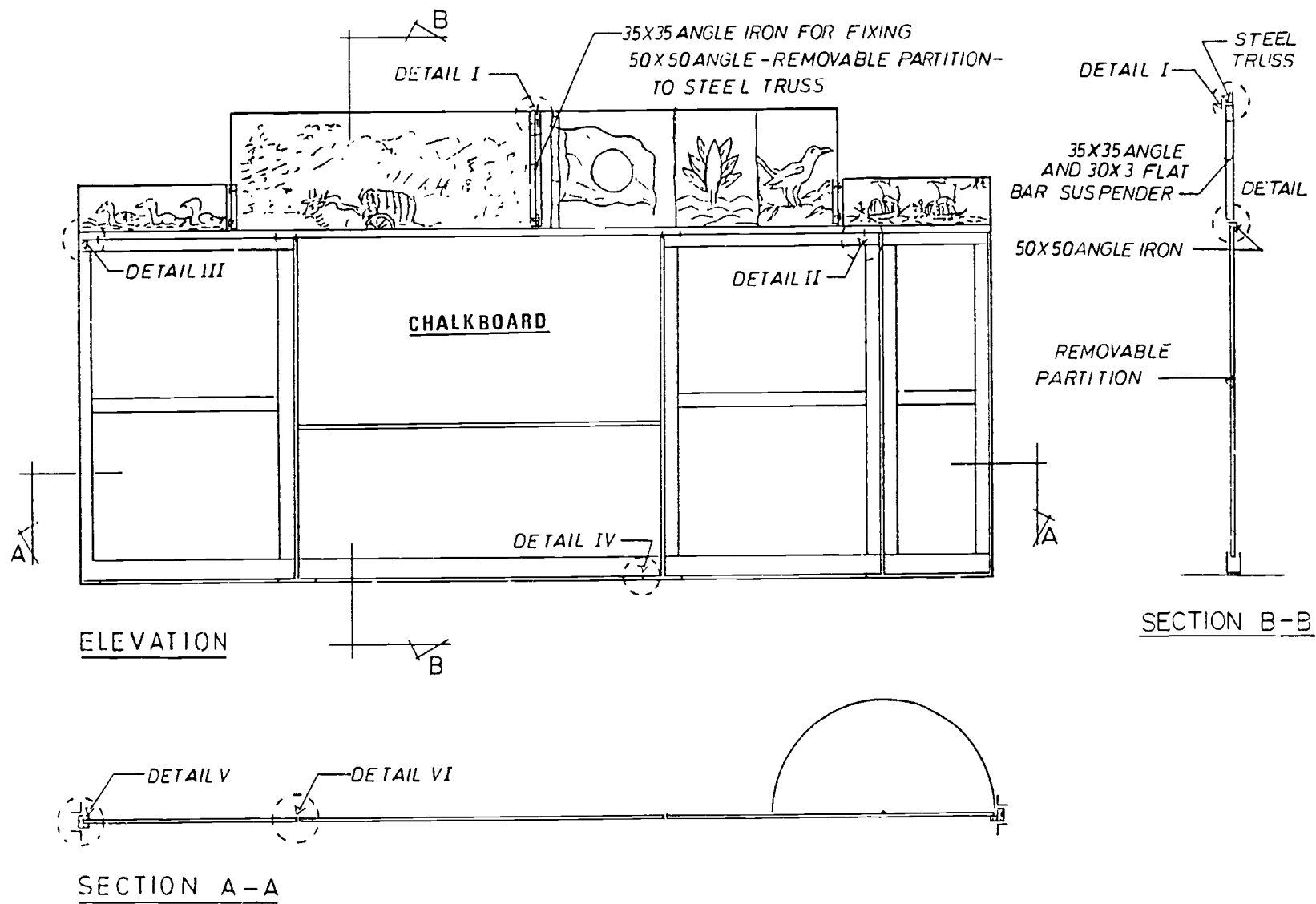

FIGURE 15 REMOVABLE PARTITION



ELEVATION

SECTION B-B

SECTION A-A

FIGURE 16 REMOVABLE PARTITION – FIXING DETAILS

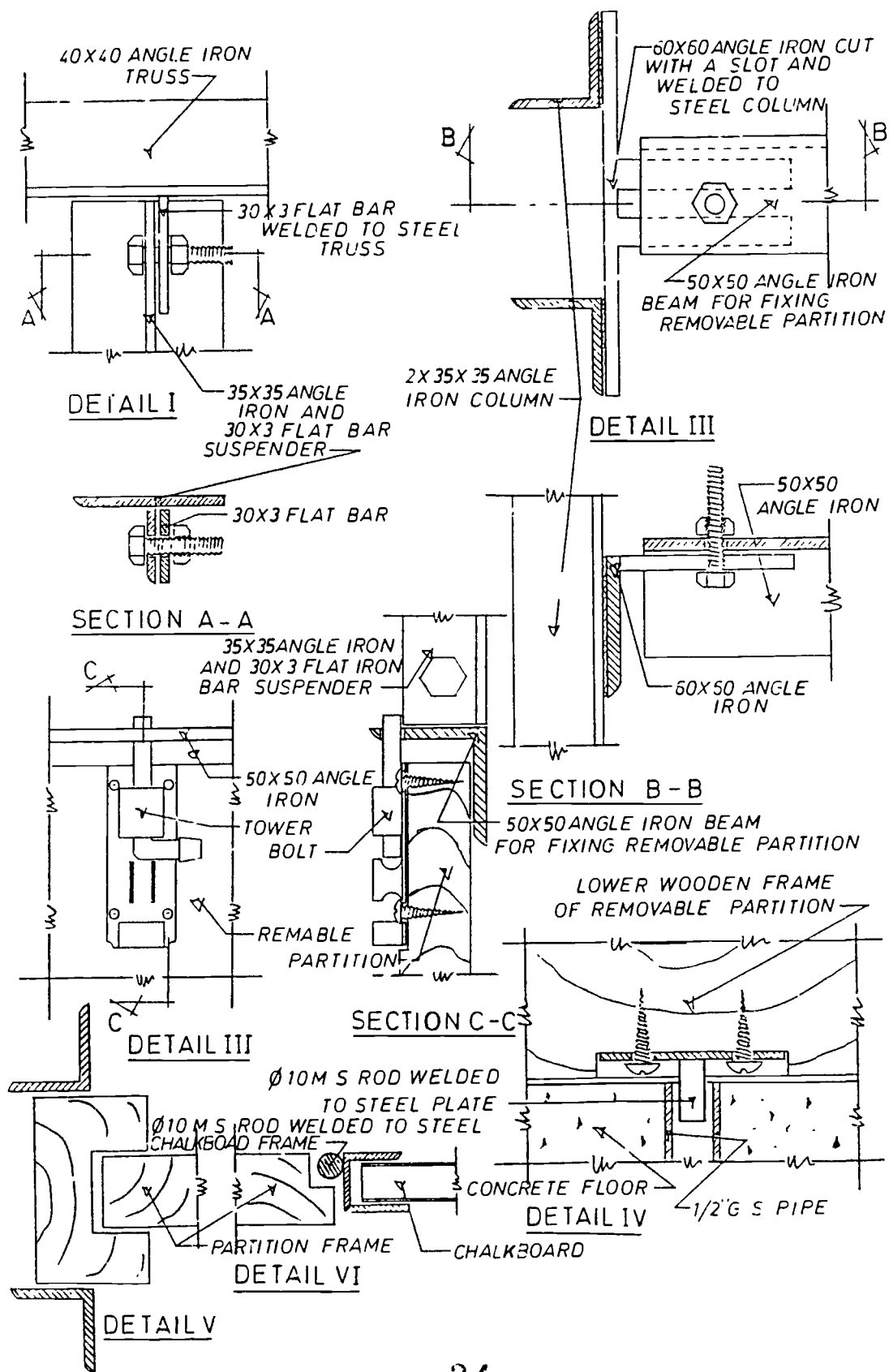

PREFABRICATION OF BUILDING PARTS

Small factories, using mainly very simple tools and light machinery operated largely by local manpower trained on the job, were set up to produce the prefabricated building components for the construction of the primary schools. The components were transported from the factory to the different building sites by trucks, tractors, bullock carts, boats and canoes to remote locations over rough earth roads or rivers. As the components were small no problem was encountered in their transport. Bamboo pole braces were used to avoid bending of the long and light steel trusses, which are made in one single piece of 40 mm x 40 mm angle iron and M.S. rod. RCC wall panels were carried to the building sites with minimal breakage.

Steel structure

Locally produced steel sections, plane steel sheets and M.S. rods are used to manufacture the light steel structure frame, and steel doors and windows of the school buildings. A steel mill in Chittagong produces mild steel billets and corrugated steel (C.I.) sheets using scrap and pig-iron. There are a number of re-rolling mills in Bangladesh which use the M.S. billets from Chittagong to produce steel products such as mild steel rods, flat bars, angles, tees and other sections.

Small local workshops that produce steel nuts and bolts are found in small towns throughout Bangladesh.

The machinery and tools that are used in the manufacture of the steel structure, steel doors and windows of the schools are; welding and drilling machine (with generator if there is no electricity supply), hack saws and different types and sizes of hammers. Welding rods and hack saw blades are found in the hardware shops of almost every town. Except for welding, unskilled labour with no previous experience was trained in a very short time. With a foreman in charge, one welder and eight helpers can manufacture the steel structure for a three-classroom primary school (including steel columns, trusses, doors and windows).

RCC wall panels and RCC columns

Similar to the manufacture of the steel structure, RCC panels and RCC columns for the external wall were designed to be produced by un-

skilled labour except for a masonry foreman to supervise and do some fine finishing work. The tools required for production of prefabricated concrete elements are angle iron molds, wooden boards, measuring batchbox for concrete, shovels, trowels and wooden floats. The angle iron moulds are tapered slightly with the lower sides larger to facilitate easy removal (Figures 9, 17, 18).

A split bamboo reinforcement of 20 x 5 mm cross section is tied together with G.I. wire to form a mesh of 150 x 150 mm and is used for RCC wall panels. A \emptyset 6 mm M.S. rod is used for RCC columns. When casting the panels, slots are introduced for fixing the steel doors and windows and for easy joining and plastering of panels.

All RCC columns are cast vertically in 1,500 mm high steel moulds with the Vertical Main \emptyset 6 mm M.S. rod reinforcement continuing outside the concrete and are used for fixing the prefabricated RCC columns to the angle iron columns of the steel structure. For the corner columns extra fixing is provided by 3 x \emptyset 6 mm M.S. rods coming out from the RCC column at the middle and near top and bottom of each prefabricated RCC column (Figure 8).

The middle columns are cast in circular moulds with 14 gauge plane steel sheet to produce two half-circular hollow section columns. In each type of steel mould one corner RCC column and two middle RCC columns can be cast every 24 hours. With one foreman and 10 labourers, RCC panels

and RCC columns for one three-classroom primary school can be produced in one week.

The external walling of the school building can be considered in three modules:

1. **Window Module** – 4 vertical panels, 1 under window panel, 1 window louver panel, 1 window sill, 1 lintel panel, 2 top panels, 1 steel window and 1 top ventilation grill.
2. **Door Module** – 4 vertical panels, 1 lintel panel, 2 top panels, 1 steel door and 1 top ventilation grill.
3. **Gable Module** – 7 gable panels and 1 top panel.

All prefabricated RCC panels, except the under window and the louver panels, are attached and fixed to the steel structure with prefabricated RCC middle or corner columns. The bottom parts of the under window panel are cast into the concrete floor. The window sill, louver and the under window panels, are vertically connected with three \emptyset 12 mm M.S. rods that are anchored in the concrete floor. To keep the vertical and lintel panels more firmly fixed to the 35 x 35 mm angle iron columns short pieces of \emptyset 12 mm M.S. rods and 50 x 50 mm flat bars are welded to the steel columns (Figure 7).

The number of different RCC elements used in any school is 10. These are given in Table 1. This excludes toilet pan units which can be seen in Figures 19, 20.

Table 1. Cost of RCC elements in 1984

No.	Description	Material cost		Labour cost	
		Taka	US\$	Taka	US\$
1.	Vertical RCC prefab panel (1,050 x 660 x 75)	77.00	3.08	38.00	1.52
2.	Under window panel (1,200 x 400 x 100) mm	59.00	2.36	26.00	1.04
3.	Louvre ventilation panel (1,200 x 400 x 100) mm	73.00	2.92	32.00	1.28
4.	Lintel panel (2 x \emptyset 10 M.S. rod) (2,520 x 300 x 75) mm	150.00	6.00	40.00	1.60
5.	Top panel (830 x 270 x 75) mm	33.25	1.33	11.75	0.47
6.	Gable panel (1,970 x 350 x 75) mm	82.00	3.28	38.00	1.52
7.	Gable top panel (1,970 x 150 x 75) mm	40.00	1.60	15.00	0.60
8.	Middle column (1,500 mm height)	87.00	2.48	28.00	1.12
9.	Corner column (1,500 mm height)	113.00	4.52	37.00	1.48
10.	Window sill	32.50	1.30	12.50	0.50

Orientation

The orientation of the school building is east to west with the front elevation having the long overhang of the veranda facing south to prevent sunlight entering the school building.

Foundation and concrete floor

The foundation is of brick masonry wall constructed on a concrete footing with an open space left for the columns. The RCC and steel column base is anchored in the foundation using 1 : 2 : 4 mix concrete. The floor is of 1 : 3 : 6 concrete with neat cement finish. The concrete floor rests over well compacted soil fill, a sandbed and flat brick soling. For some schools a concrete foundation and hard-core of gravel stone was used under the floor. The foundation could be made from natural stone, hollow block filled with concrete or another suitable building material. The deadload from the 75 mm section RCC panels is very small and requires only a very light foundation.

Steel structure frame

The steel frame is mounted and fixed with nuts and bolts. For the three-classroom building the steel structure can be erected in a single day. The base of the steel columns rests on a concrete footing which has been cast in place. After setting the four corner columns with a square and plumb bob, the rest of the columns are set by two string lines (Figures 21, 22).

External walls

The external facade is made up of seven types of prefabricated RCC panels, two types of prefabricated RCC columns, steel doors, and steel windows with prefabricated window sills. After placing the wall panels in position they are fixed to the steel structure of the building by means of the RCC columns. End hooks are made on the rods which extend outside the concrete before the prefabricated RCC columns are fixed to the 50 x 50 mm angle iron column. Two vertically connected 2 x 15,000 mm prefabricated RCC column sections make one complete column. After connecting the RCC columns to the angle iron columns the hollow section of the RCC columns is filled with 1 : 2 : 4 mix concrete (Figure 7). Figures 23, 24 and 25 show the assembly of a wall.

Roofing

The roof is covered with 26 gauge corrugated G.I. sheet fixed by screw nails with washers to 75 x 50 mm wooden purlins which are affixed to the steel trusses. The main trusses remade of 40 x 40 mm angle iron, \emptyset 22 and \emptyset 18 mm M.S. rods welded together. The gable rafters are made of inverted 50 x 50 mm and 40 x 40 mm angle iron welded together at the top and connected by \emptyset 18 mm M.S. rod. There are two such joined rafters at each gable end. The four inverted 50 x 50 mm rafters pass through grooves made in the RCC column at the four corners of the building. Similarly all main trusses and the remaining four gable rafters pass through grooves made in the RCC columns. These grooves are later filled up with concrete.

Steel doors and windows

The steel doors are made from 35 x 35 mm angle iron frame and shutters made of 25 x 25 mm angle iron and 16 gauge plane metal sheet with \emptyset 10 mm M.S. rod reinforcement welded all round the corners where the metal sheet is fixed to the angle iron. The external face of the door shutters are braced with patterned \emptyset 6 mm M.S. rod and the inside face with 50 x 5 mm flat bar. The windows are made similarly except their frames are of 25 x 25 mm angle iron and inside shutter bracing of 35 x 3.5 mm flat bar (Figures 13, 14).

All steel doors and windows are manufactured with hooks made of \emptyset 6 mm M.S. rod welded to the angle iron frames. The concrete wall panels are made with grooves where door/window fixing hooks are placed and the grooves are filled with 1 : 2 mix cement mortar. For extra strength to support the heavy steel doors, 80 mm brick wall pillars are built in the inside edge of door openings from floor to lintel level.

Hinges for doors and windows are manufactured from flat iron bars and M.S. rod. The windows are kept open at an angle parallel to the wall with 'hook and eye' latches. In this position, the RCC columns provide protection and prevent the window shutter from being caught by the wind. This minimizes the need for maintenance.

The ceiling is made of bamboo and straw mat fixed to bamboo poles which are secured to the steel trusses with G.I. wire. For longer life the bamboo is treated against insect attack.

Removable partition

The removable partition wall is made of partex (chipboard with plywood veneer) panels on a wooden frame and the chalkboard, which has

steel frame. The chalkboard and the two wings of the partition wall are fixed to a 50 x 50 mm angle iron beam with two towerbolts each. By operating these towerbolts the partition wall can be removed or fixed in a matter of a few minutes. The top of the partition wall consists of painted panels. Facing each classroom the middle right hand panel is painted with the national flag, the national flower, and the national bird, and the remaining panels with paintings depicting scenes from the Bangladesh countryside (Figures 15, 4).

Finishing

The external facade of the multi-purpose primary schools bears the colours of the Bangladesh flag – green and red. The concrete panels are of deep red colour while the RCC columns and the top panels are dark green. The red depicts the rising sun heralding the birth of a new nation and the green the lush fertile fields of Bangladesh.

The inside of the building is painted with lime wash while the partition walls are painted with oil paint to give them a protective surface. Mat chalkboard paint not being manufactured in Bangladesh the chalkboard is painted with green enamel paint. The partex chalkboard thus painted gives a satisfactory result with good contrast and no glare. All metal parts are initially painted with one coat of anti-rust paint after manufacturing and two coats of oil paint after mounting and fixing.

Each school has either a tubewell or well dug for water supply and a twin-latrines, one for girls, and one for boys. At least 10 saplings are planted along the boundary line of each school.

School furniture

The two faces of the middle portion of the partition walls are used as chalkboards. Each classroom is provided with a removable bookshelf which is fixed to the partition wall. The bookshelves are made from the left over materials of 25 x 25 mm angle iron and partex. On an experimental basis one school was provided with bamboo desks. The desks are entirely made of bamboo except the writing top which is made of wood. The wooden top is fixed by screws to wooden plugs placed inside the top of the hollow section of the vertical bamboo frames. Each plug, in turn, is attached to the bamboo frame with bamboo pins. Though the material cost of the desks was very low the actual cost was rather high since the desks were made by professional carpenters. The cost of the bamboo desk for two students in Tk. 150.00 (Tk. 50.00 for material and Tk. 100.00 for labour). The idea behind the experiment was to demonstrate the

possibility of making bamboo desks, and it has given fairly good results. To make the experiment viable in solving the acute shortage of school furniture, it might be possible to introduce the technology as vocational training in the school and let the students themselves produce the desks in handicraft class.

Construction costs

The total costs for classroom buildings of various sizes are given in Table 2. A detailed cost breakdown for a three classroom building is given in Annex 1. These do not include the cost of furniture.

Table 2. Cost of multi-purpose primary schools in 1984 (1 US\$ = 25.00 Tks)

School size	2 CR		3 CR		4 CR	
Total area M2	75.50		118.54		151.00	
Pupil capacity (1)	160		240		320	
Area per place M2	0.47		0.49		0.47	
Costs currencies	Tks	\$	Tks	\$	Tks	\$
Total cost	143,351.82	5,734.08	204,141.78	8,165.67	261,188.24	10,447.53
Cost/place	896	35.84	851	34.02	816	32.65
Cost/M2	1,899	75.95	1,722	68.89	1,730	69.19

- (1) Assumes 48 students in each room during the morning shift and 32 during the afternoon shift.
- (2) Costs based on exchange rate at time of construction.



Figure 17. *Precasting of RCC elements: Columns are cast in the two vertical elements at the rear. In front of them a wall panel with bamboo reinforcement is being cast. In the foreground, a labourer is compacting the dry concrete mix around the forms which define the louvre openings.*



Figure 18. *Removing forms from precast RCC elements. Two workmen are lifting the angle-iron frame from the wall panel while the man in the foreground is removing the louvre forms.*



Figure 19. *Precasting toilet pan units. Two separate units are used to create a water seal toilet pan. Unskilled workers compact the concrete into the moulds.*



Figure 20. *Assembled toilet pan units. The assembled units are at the right. To the left moulds are being removed from freshly cast units*

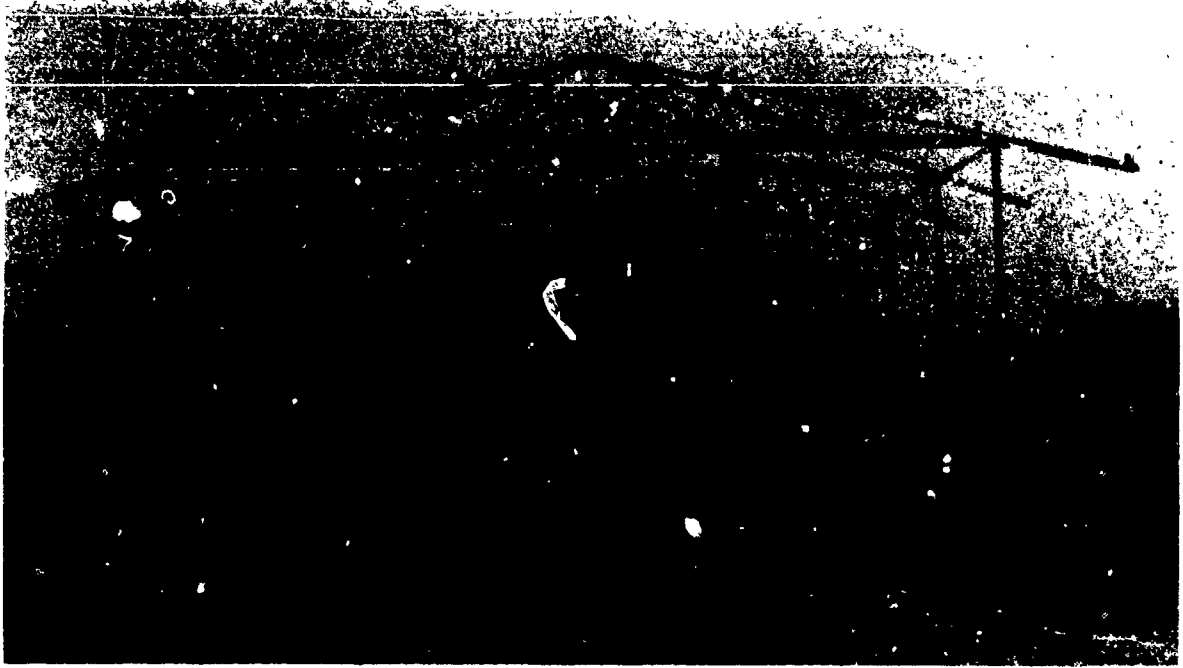

Figure 21. *Assembly of the steel structure. The light weight structure gives the initial shop of the building. An existing classroom block is behind.*

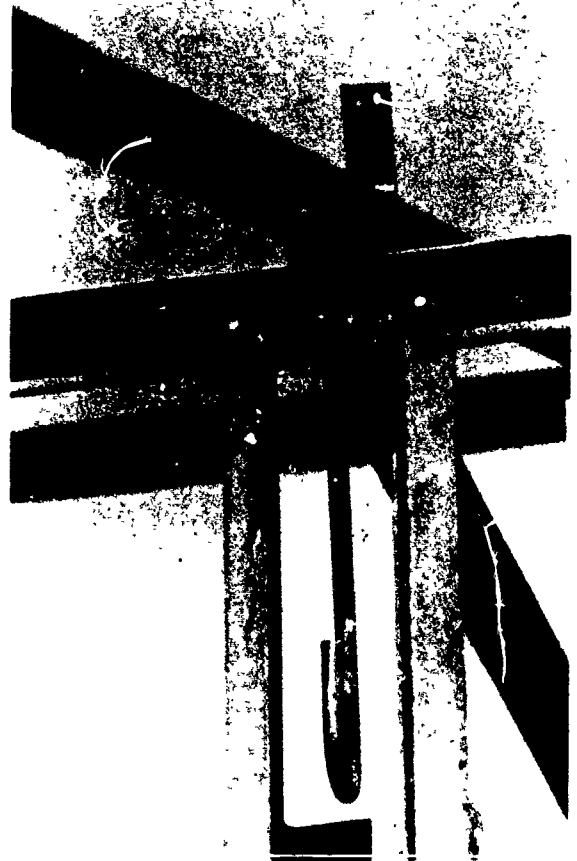

Figure 22.

Structure detail. The ring beam and truss cord are attached together by a 'J' bolt which is eventually cast into the concrete column. This ensures that strong winds will not carry away the roof.

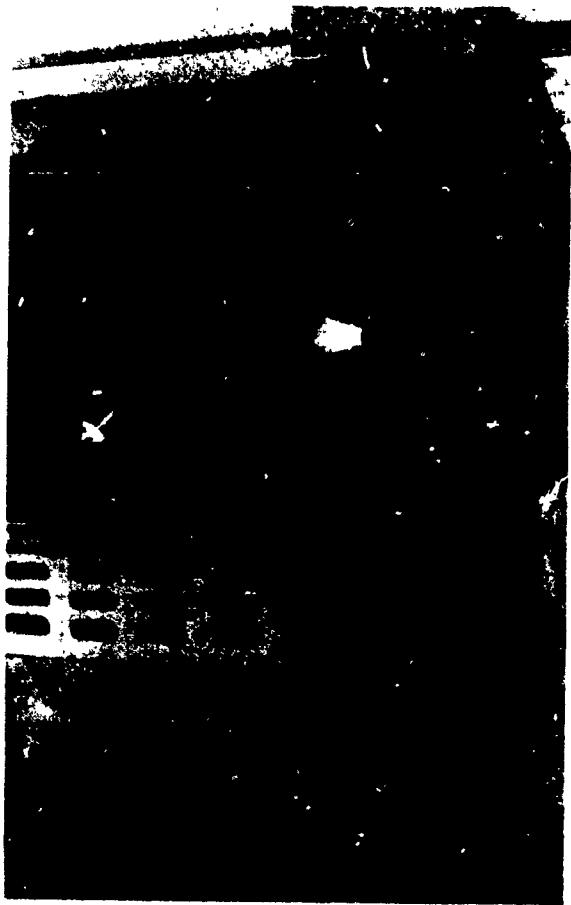

Figure 23. *Precast panels in place. A vertical wall panel, under-window panel, and lintel surround a prefabricated metal window unit. Note slots for grooving the window to the wall. The top panel is in place leaving a space for the mesh ventilation unit.*



Figure 24. *The assembled wall. A cement and dye mix is used to finish the panels with a texture.*

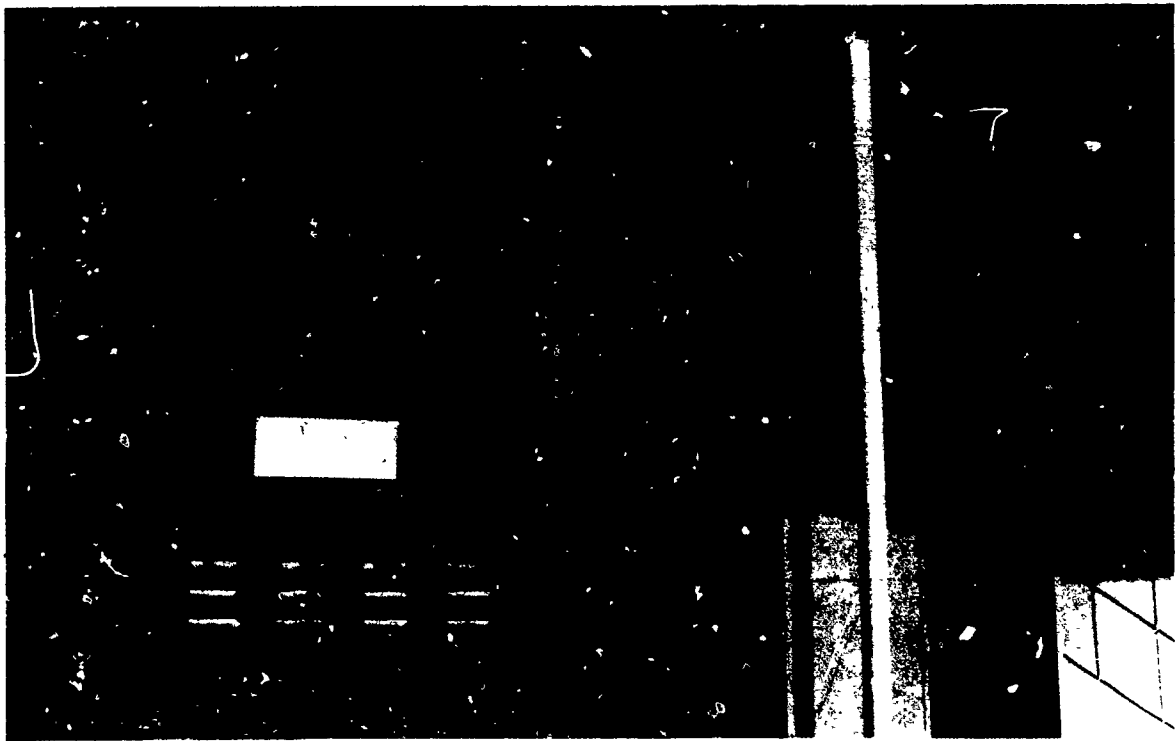

Figure 25. *Close-up of finished wall. The precast panels are finished in red colour while the structure is brown. The metal doors and shutters are painted blue.*

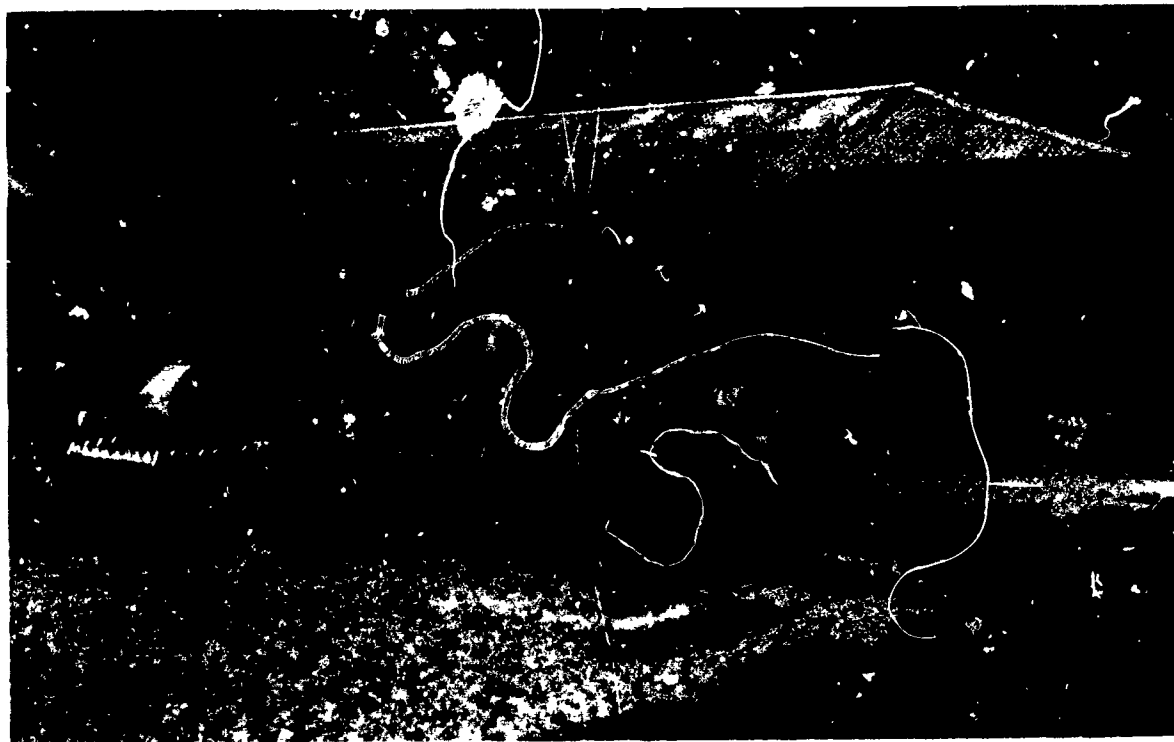

Figure 26. *Completed three classroom school exterior. A dedication plaque is placed in front of the flag pole while newly planted trees are protected with bamboo enclosures.*



Figure 27. *Completed four classroom school exterior. The small structure at the right is the school toilet block.*

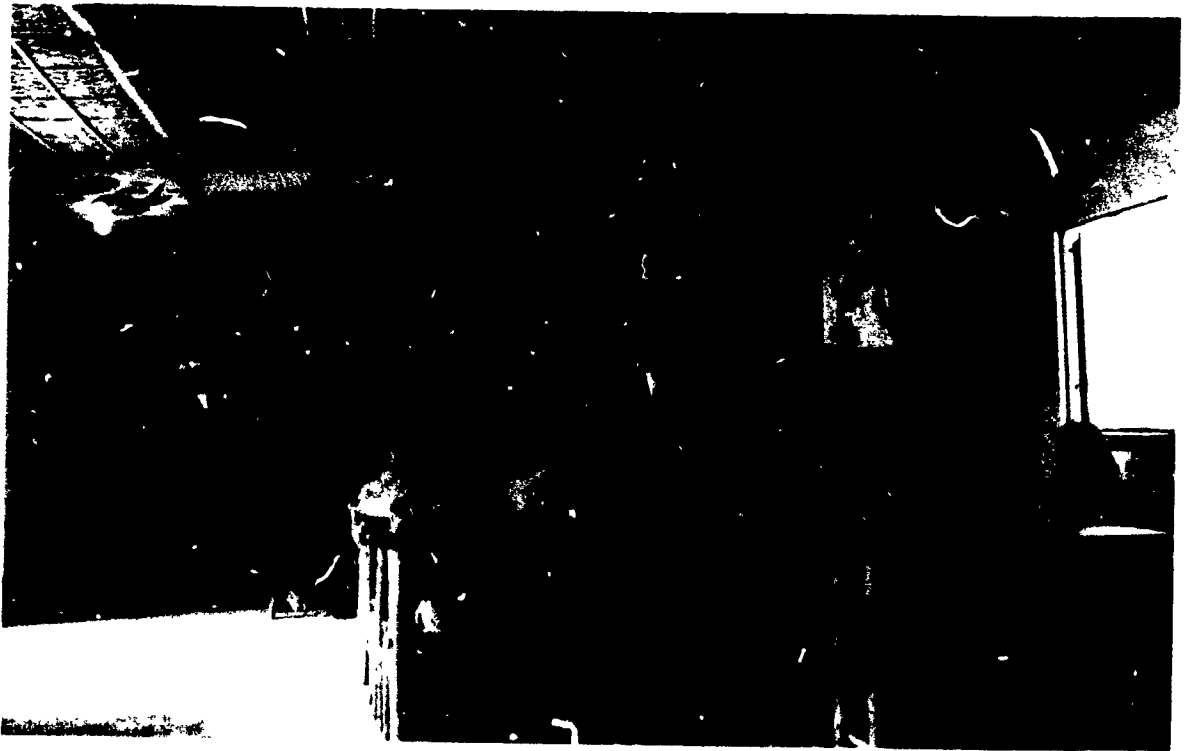

Figure 28. *Classroom interior. The panels in the wall with the chalkboard can be easily removed.*



Figure 29. *Large hall interior. Divider panels between the classrooms have been removed to create a large hall. This can be used for school functions or for community meetings.*

The construction of the multi-purpose primary schools is carried out with the active participation of the community as are all LWS/RDRS development projects. Some 50 per cent of the total construction cost is raised by local contribution. In the case of the primary schools the Ministry of Education contributes half the project cost.

The location and size (there are three types of primary schools; two-classrooms, three-classrooms and four-classrooms, of each school is centrally decided by the Ministry of Education in Dhaka and the information is transmitted to RDRS and the respective Upazila Education Offices. RDRS prepares its own plan and timetable for the construction of the school buildings. Following this plan the RDRS Zonal Engineer in charge of the construction of schools contacts the education office concerned and after receiving the land certificate, a document stating that the school committee has legal right of the land, he, together with the Sub-Assistant Engineer (SAE) of the Facilities Department, Ministry of Education, prepare the layout of the school building. Normally the school plot is purchased by the local school committee or, in some cases, it is donated by a local landlord. Once these formalities are fulfilled RDRS takes the full responsibility for the management and construction of the school building. Supervision of the projects is jointly done by RDRS and the S.A.E. of Facilities Department.

Administrative structures

The Bangladesh government has a policy to have one primary school in each 10 square kilometres.

The typical average student population of a primary school is between 150 to 200. Every school has five classes from class 1 to class 5. Classes are conducted in two shifts. The first shift is from 9 a.m. to 12 noon during the summer and from 10 a.m. to 12 noon during winter for classes 1 and 2. The second shift is from 1 p.m. to 4 p.m. for classes 3 to 5.

Each school has a managing committee which consists of 12 members. The Managing Committee is selected by the parents and local elders. The Upazila Education Officer approves the Committee which then serves for a period of three years. Its composition is as follows:

Chairman	Community Leader
Secretary	Headmaster of the School
Member	Teacher Representative
Member	Donor of the School Plot
Member	Local Educationalist
Member	Union Parishad Member
Member	Female Member
Member	Local High School Teacher
Member	Four Parents

As higher level Primary Education Committee deals with the overall development in primary education in the Upazila. At present it functions with nine members.

Chairman	The Upazila Nirbahi Officer
Secretary	The Upazila Education Officer
Member	Local Educationalist
Member	Primary School Teacher
Member	Chairman of a School Managing Committee
Member	One Union Parishad Chairman
Member	Headmaster of a High School
Member	Headmistress of a Girl's High School
Member	Upazila Engineer

School handing over ceremony

When the construction of a school building is completed the school committee prepares the school opening and handing over ceremony. For such occasions the movable partitions of the building are removed and the public assembles inside the school auditorium (Figure 29). Such functions

are attended by local government officials, community leaders, members of the school committee, parents and students, the building designers and the engineers who supervised the construction of the building. Speeches are made by the community leaders, the Administrator of RDRS Construction Programme and his senior staff. The different multi-purpose functions of the school building are explained to the public and mention is made that the partition walls of the building were removed, converting classroom space into an Assembly Hall. This is given as a practical example to demonstrate one of the many ways the building could be used. A leaflet, written in Bangla, which explains the different possible functions of the building and urges the community leaders to make the best use of their new school, is distributed to the people (reproduced at the end of this chapter in English and in Bengla). At this point the Administrator, on behalf of RDRS, gives the key of the building to the Upazila Nirbahi Officer as a gesture of handing over the school building to the community and passing to them the responsibility of its proper use and care. In return the Administrator receives the Completion Certificate to acknowledge the transfer of the building from RDRS to the school committee. The Certificate is signed by the Education Officer, the Chairman of the School Committee and the Headmaster of the school. After these official duties are concluded a cultural function of songs and folk dances is usually presented.

এই স্কুলর বিদ্যালয় ভবনটির পূর্ণ সদ্যবহার ও রক্ষণাবেক্ষণ

আগতার পবিত্র দায়িত্ব

গণপ্রজাতন্ত্রী বাংলাদেশ সরকারের শিক্ষা মন্ত্রণালয় ও রংপুর দিনাজপুর পূর্ববঙ্গ পুনর্বিধান সংস্থা (আর ডি আর এস) বোধভাবে এই মনোরম ও বহুমুখী প্রাথমিক বিদ্যালয় ভবনটি নির্মাণ করেছে। স্থাপত্য শিল্পের দিক দিয়ে এ ভবনটি যেমন আকর্ষণীয় সৌন্দর্যে মণ্ডিত, তেমনি এটি পল্লী এলাকার বহুমুখী প্রয়োজন পূরণেরও উপযোগী।

এ ভবনটির সুদৃঢ় নির্মাণ কৌশল, বিভিন্ন অংশের সুচিন্তিত স্থাপনা ও মিলিত রং কোমলমতি ছাত্র-ছাত্রীদের বিদ্যাশিক্ষার এক সুন্দর পরিবেশ সৃষ্টি করবে। পর্যাপ্ত দরজা জানালা ও ভেন্টিলেটর প্রয়োজনীয় আলোবাতাস নিশ্চিত করবে। পাটিশন দেয়ালের সঙ্গে সংযুক্ত রয়েছে সুন্দর চকবোর্ড। হালকা অথচ মজবুত পাটিশন দেয়ালগুলো অতি অল্প সময়ে ও সহজেই ধোলা ও লাগানো যায়। প্রয়োজনে এ-গুলো বিভিন্নভাবে স্থাপন করে ক্লাশরুম ছোট ও বড় করা যায়। এবং সম্পূর্ণ খুলে পুরো ভবনটিকে একটি হল ঘরেও রূপান্তরিত করা যায়। সুতরাং এ ভবনটিতে বিভিন্ন সামাজিক ও সাংস্কৃতিক অনুষ্ঠানও সম্পন্ন হতে পারবে।

বহুমুখী ব্যবস্থা সংযোজনের ফলে বিদ্যালয় ভবনটি :—

- (১) বিদ্যাশিক্ষার উৎকৃষ্ট পরিবেশে ছাত্র-ছাত্রীর শিক্ষাদানের বিশেষ উপযোগী।
- (২) গণশিক্ষামূলক কার্যক্রমের প্রশিক্ষণ কেন্দ্র হিসাবে ব্যবহারের উপযোগী।
- (৩) বয়স্কশিক্ষার জন্য নৈশ বিদ্যালয় পরিচালনার উপযোগী।
- (৪) সাহিত্যসভা, নাটক মঞ্চায়ন, সঙ্গীতানুষ্ঠান ইত্যাদি সাংস্কৃতিক অনুষ্ঠান আয়োজনের উপযোগী।
- (৫) গ্রামবাসীদের ঘরোয়া সভা-সমিতি ও বিচার-সালিশ অনুষ্ঠানের উপযোগী।

এলাকাবাসীর নেতৃবৃন্দের উচিত উপরোল্লিখিত জনকল্যাণমূলক কাজে এই বিদ্যালয় ভবনটিকে ব্যবহার করা এবং সেইসঙ্গে এর সুযোগ-সুবিধাসমূহের পূর্ণ সদ্যবহার নিশ্চিত করা। স্থানীয় জনসাধারণকে এই মর্মে উৎসাহিত করা উচিত যে, তারা যেন বিদ্যালয় ভবনটিকে তাদের নিজস্ব সম্পত্তি বলে বিবেচনা করেন এবং এর জিম্মাদার হিসেবে এলাকাবাসীর বৃহত্তর স্বার্থে একে টিকিয়ে রাখেন ও ব্যবহার করেন।

এ-ভবনটির সুযোগ-সুবিধা পরিপূর্ণভাবে ভোগ করতে হলে এর সুষ্ঠু রক্ষণাবেক্ষণও অত্যাৱশ্যক। এ-বিদ্যালয় ভবনটি জনসাধারণের সম্পত্তি। কাজেই এর রক্ষণাবেক্ষণ ও সৌন্দর্য রক্ষা করা সকলের পবিত্র দায়িত্ব। এ-ব্যাপারে বিদ্যালয়ের শিক্ষক-শিক্ষিকাগণ ও ছাত্র-ছাত্রীদের অভিভাবকগণ গুরুত্বপূর্ণ ভূমিকা পালন করতে পারেন। দেশের ও দেশের বৃহত্তর স্বার্থে এ বিদ্যালয় ভবনটির সুযোগ-সুবিধা পরিপূর্ণভাবে কাজে লাগাতে হবে এবং সময় পরিচয় এর সৌন্দর্য সংরক্ষণ করতে হবে।

OPTIMUM UTILIZATION AND MAINTENANCE OF THIS BEAUTIFUL SCHOOL BUILDING IS YOUR SACRED DUTY

The Education Ministry of the Government of the People's Republic of Bangladesh and Lutheran World Service/Rangpur Dinajpur Rehabilitation Service (LWS/RDRS) have jointly built this beautiful and multi-purpose primary school building. As this school building is endowed with attractive beauty from the architectural point of view it is also designed to fulfil the multi-purpose needs of the rural area.

The sturdy construction, thoughtful placement of various components and the soothing colours of this building will create a beautiful environment for learning to the students. All adequate and ventilation openings will ensure the necessary light and air. The attractive chalkboard is attached to the partition wall. This light but strong partition wall can easily be detached or fixed in place in a short time. The classroom space may be increased or decreased by shifting these partitions. And by removing them altogether the entire building can be turned into a large hall. Because of this multi-purpose feature of the building, various social and cultural functions can be held here when it is converted into an auditorium.

As a result of creating these multi-purpose facilities, this school building is appropriate for:

Imparting knowledge to the pupils in the most conducive educational environment.

Use as a training centre for the mass literacy programme.

Use as a night school for adult education.

Holding cultural functions such as literary discussions, drama and musical presentations.

Holding meetings, discussions and gatherings for community development planning, settlement of disputes, etc.

Community leaders should foster the above suggested and other public uses of the school building and ensure that the school facilities are put to the optimum service. The local people should be encouraged to view the school building as their community property and they, as the custodians, should use and preserve it to the best interest of the community at large.

In order to derive full benefits of this building its proper maintenance is very important. This school building is the property of the people. Therefore its maintenance and preservation of its beauty is everyone's sacred duty. The teachers and parents of the students can play a vital role in this regard. In the greater interest of the country and the people, the potential service of this school building should be realized fully and its beauty maintained with cherished care.

ANNEX

Detailed cost breakdown of three classroom multi-purpose primary school

Note: exchange rate used is that at time of construction

SL. No.	Description	Material cost		Labour cost	
		Taka	US\$	Taka	US\$
1. Foundation					
a)	Foundation excavation	—	—	100.00	4.00
b)	Brick flat soling	1,060.00	42.40	60.00	2.40
c)	Concrete footing	2,325.00	93.00	220.00	8.80
d)	Brick masonry	7,160.00	286.40	470.00	18.80
e)	1.2'4 concrete column base	1,660.00	66.40	200.00	8.00
f)	Cement plaster	145.00	5.80	50.00	2.00
g)	Rule pointing	130.00	5.20	110.00	4.40
Total		12,480.00	499.20	1,210.00	48.40
2. Cement concrete floor					
a)	Earth filling	—	—	225.00	9.00
b)	Sand filling	315.00	12.60	60.00	2.40
c)	Brick flat soling	4,405.00	176.20	235.00	9.40
d)	C.C. in floor	9,035.00	361.40	1,255.00	50.20
e)	Cement screed with neat cement finish	2,470.00	98.80	900.00	36.00
Total		16,225.00	649.00	2,675.00	107.00
3. Steel structure					
a)	Middle column (35 x 35 mm angle) — 14 Nos.	4,340.00	173.60	770.00	30.80
b)	Corner column (50 x 50 mm angle) — 4 Nos.	1,000.00	40.00	160.00	6.40
c)	Tee beam (50 x 50 mm angle)	3,000.00	120.00	250.00	10.00
d)	Veranda pole (2 x 35 x 35 mm angle) — 5 Nos.	2,055.00	82.20	220.00	8.80
Total		10,395.00	415.80	1,400.00	56.00
4. Pre-fab concrete walling					
a)	Vertical panel (1,050 x 6,000 x 75 mm) — 48 Nos.	3,700.00	148.00	1,825.00	73.00
b)	Gable panel (1,970 x 350 x 75 mm) — 42 Nos.	3,500.00	140.00	1,600.00	64.00
c)	Lintel panel (2,520 x 300 x 75 mm) — 12 Nos.	1,800.00	72.00	480.00	19.20
d)	Under window panel (1,200 x 400 x 80 mm) — 9 Nos.	530.00	21.20	235.00	9.40
e)	Window louvre vent (1,200 x 400 x 100 mm) — 9 Nos.	660.00	26.40	290.00	11.60
f)	Window sill (1,260 x 185 x 80 mm) — 9 Nos.	230.00	9.20	115.00	4.60
g)	Top panel (830 x 270 x 75 mm) — 24 Nos.	800.00	32.00	285.00	11.40
h)	Gable top panel (985 x 150 x 75 mm) — 12 Nos.	250.00	10.00	100.00	4.00
i)	Middle column (150 x 350 mm) — 28 Nos.	2,440.00	97.60	785.00	31.40
j)	Corner column (length 1,500 mm) — 8 Nos.	905.00	36.20	300.00	12.00
k)	Miscellaneous	2,450.00	98.00	1,460.00	58.40
Total		17,265.00	690.00	7,475.00	299.00

SL No.	Description	Material cost		Labour cost	
		Taka	US\$	Taka	US\$
5.	Roof ventilation (25 x 25 mm angle + mosquito net) – 12 Nos.	1,440.00	57.60	720.00	28.80
6.	Steel window (1,200 x 1,200 mm) – 9 Nos.	8,030.00	321.20	1,125.00	45.00
7.	Steel door (2,100 x 1,200 mm) – 3 Nos.	4,800.00	192.00	420.00	16.80
8.	Roofing				
	a) Main truss (40 x 40 mm angle) – 5 Nos.	5,830.00	233.20	970.00	38.80
	b) Gable truss (50 x 50 + 35 x 35 angle) – 4 Nos.	2,900.00	116.00	560.00	22.40
	c) Wooden purlin (75 x 50 mm)	3,250.00	130.00	-	-
	d) C.I. sheet (26 gauge) 2,000 mm – 64 Nos., 3,000 mm – 16 Nos.	28,860.00	1,154.00	-	-
	e) C.I. ridge cover (26 gauge)	1,430.00	57.20	-	-
	f) Miscellaneous (screwnail, washer, nail, etc.)	3,305.00	132.20	2,000.00	80.00
	Total	45,575.00	1,823.00	3,530.00	141.20
9.	Bamboo ceiling Bamboo poles, bamboo/strawmat, etc.	4,250.00	170.00	1,250.00	50.00
10.	Removable partition	11,470.00	458.80	2,890.00	115.60
11.	Painting and finishing	5,750.00	230.00	850.00	34.00
12.	Miscellaneous	2,810.00	112.40	380.00	15.20
	Grand total	140,490.00	5,619.60	23,925.00	957.00

Total estimate cost of three classroom multi-purpose primary school

SL No.	Description	Total cost estimate	
		Taka	US\$
1.	Material cost . . .	140,490.00	5,619.60
2.	Labour cost . . .	23,925.00	957.00
3.	Transport (7.5 per cent of material and labour)	12,331.13	493.24
4.	Overhead (10 per cent of material + labour + transport)	17,674.61	706.99
	Total	194,420.74	7,776.83
5.	Contingency 5 per cent of total . . .	9,721.04	388.84
	Grand total	204,141.78	8,165.67

BIBLIOGRAPHY

1. Constantinos, Fecadu. *Considerations behind school plant planning*. Bloomington, Indiana University, 1970.
2. Janssen, J.A. Jeles. *A series of articles on the use of bamboo in building construction*. 2nd ed. Eindhoven, University of Technology, 1982.
3. Punmia, B.C. *Reinforced concrete structures*. New Delhi, 1975.
4. Rangan, B.V. and R.F. Warner. *Reinforced concrete*. A.S. Hall, Pitman (Australia) 1977.
5. Reynolds, Charles E. and James C. Steedman. *Reinforced concrete designer's handbook*. 8th ed. London, 1976.
6. Unesco Regional Office for Education in Asia and the Pacific. *Alternative building designs for universal primary education in Bangladesh*. Bangkok, 1981.
7. United Nations. *The use of bamboo and reeds in building construction*. New York, 1972.

