

DOCUMENT RESUME

ED 296 881

SE 049 407

AUTHOR Lutz, Julie H.; Orlich, Donald C.
TITLE Astronomy Lectures and Laboratories. A Model to Improve Preservice Elementary Science Teacher Development. Volume I.
INSTITUTION Washington State Univ., Pullman.
SPONS AGENCY National Science Foundation, Washington, D.C.
PUB DATE 15 Jun 88
GRANT TEI-8470609
NOTE 251p.; Some drawings may not reproduce well. For other volumes in this series, see SE 049 408-412.
PUB TYPE Guides - Classroom Use - Materials (For Learner) (051)

EDRS PRICE MF01/PC11 Plus Postage.
DESCRIPTORS *Astronomy; *College Science; *Course Content; Course Descriptions; Curriculum Development; Elementary Education; Elementary School Science; Experiential Learning; Higher Education; *Preservice Teacher Education; Science Education; *Science Experiments; Science Teachers; Science Tests; *Teacher Education Curriculum; Teaching Methods

ABSTRACT

A group of scientists and science educators at Washington State University has developed and pilot tested an integrated physical science program designed for preservice elementary school teachers. This document includes the syllabus and class materials for the Astronomy block of the physical science courses developed by the group. Included are diagrams, lecture notes, laboratory exercises and evaluation materials to be used with the course. Topics include: (1) the night sky; (2) the sun and time; (3) seasons; (4) the moon; (5) eclipses; (6) planetary motion; (7) Greek astronomy; (8) the revolution in astronomy: Copernicus to Galileo; (9) light; (10) radiation; (11) astronomy tools; (12) space astronomy; (13) the planets; (14) comets, meteors, and asteroids; (15) stars; (16) galaxies; and (17) the universe. (CW)

* Reproductions supplied by EDRS are the best that can be made *
* from the original document. *

ASTRONOMY LECTURES AND LABORATORIES

MODEL TO IMPROVE PRESERVICE ELEMENTARY
SCIENCE TEACHER DEVELOPMENT

EDUCATION
Research and Improvement
SERVICES INFORMATION
ERIC

When reproduced in
any form or
on microfilm
ERIC
Full Text Provided by ERIC

as stated in this document

"PERMISSION TO REPRODUCE THIS
MATERIAL HAS BEEN GRANTED BY

Donald Orlich

TO THE EDUCATIONAL RESOURCES

FINAL REPORT

Submitted to the National Science Foundation

A MODEL TO IMPROVE PRESERVICE
ELEMENTARY SCIENCE TEACHER DEVELOPMENT

Julie H. Lutz, Principal Investigator
Donald C. Orlich, Principal Investigator

NSF Grant No. TEI-8470609
WSU 145 01 12V 2460 0102
Washington State University
Pullman, Washington 99164-2930
June 15, 1988

ASTRONOMY LECTURES AND LABORATORIES

A MODEL TO IMPROVE PRESERVICE
ELEMENTARY SCIENCE TEACHER DEVELOPMENT

Julie Lutz
Professor of Astronomy
Washington State University
Pullman, WA 99164-2930

NSF Grant No. TEI-8470609
Volume I

PHYSICAL SCIENCES 250, SPRING 1988

THE ASTRONOMY PART

Instructor: Dr. Julie Lutz
Sloan Hall 317
335-3136 or 335-8518 (message)
Office Hours: MWF 1:30-3:00, or by appointment

Teaching Assistant: Keith Wells
Sloan Hall 318
335-9137 or 335-8518 (message only)
Office Hours: or by appointment

Course Description: This is an eight week course in basic astronomy which has been designed for elementary education majors. No prior background in physical sciences is required. Very little mathematics is used in the course itself. The aim of the course is to familiarize prospective elementary school teachers with some of the subject matter, methods of investigation and current concepts of the science of astronomy.

Grading Policy: Two hour exams, laboratory work, Friday quizzes in lecture, homework assignments and lecture attendance and participation will determine the final grade for the Astronomy section of Physical Sciences 250. The hour exams and quizzes will be in a "short answer" format. The laboratory work will involve making various demonstration materials and filling in worksheets. Occasional homework assignments will be given.

Grading will be weighted approximately as follows:

Hour Exams:	45%
Laboratory:	40%
Quizzes:	5%
Assignments:	5%
Lecture Attendance and Participation	5%

Hour Exam Schedule:

Wednesday, February 10
Friday, March 4

Required Course Materials: Sky Challenger, Star Wheel, available in textbook section of Bookie.

Course Policy: No make-up exams will be given, no extra credit will be given and no late homework will be accepted. Students are expected to attend lectures and laboratories regularly and to participate in discussions.

ASTRONOMY LECTURES

<u>Lecture</u>	<u>Topics</u>
1.	Introduction - The Astronomy Part
2.	The Night Sky
3.	The Sun and Time
4.	Time and the Seasons
5.	The Moon, Lunar Eclipses
6.	Solar Eclipses, The Motions of the Planets
7.	Greek Astronomy
8.	Comes the Revolution; Copernicus to Galileo
9.	Light and Other Radiation
10.	Tools of the Astronomer
11.	Space Astronomy
12.	The Moon
13.	Mercury and Venus
14.	Hour Exam
15.	Mars
16.	Jupiter and Saturn
17.	The Outer Planets
18.	Comets, Meteors, Asteroids
19.	The Sun
20.	Stars
21.	Stellar Evolution
22.	Galaxies
23.	The Universe
24.	Hour Exam

ASTRONOMY LABORATORIES

1. Markers in the Sky, Star Frames, Constellation Postcards
2. Motion of the Sun, Equinoxes and Solstices, Seasons, the Zodiac, Sundials
3. Motion of the Moon, Times of Moonrise and Set, Precession
4. Sizes of Solar System Bodies, Student Presentations
5. Electromagnetic Radiation, Spectroscope, Lenses and Mirrors
6. Astronomy Materials - Magazines, Catalogues, Books, Software, Etc.
7. Making a Comet, Pinhole Camera, Student Presentations
8. Stars - Sizes and Distances, Galaxies, Student Presentations

PHYSICAL SCIENCES 250
BACKGROUND INFORMATION ON STUDENTS

Please fill out this form and return to the instructor.

Signature _____

Name (print) _____

Year in School _____

Major _____

List the courses you have had:

High School Math:

High School Science:

College Math:

College Science:

Why did you decide to take Physical Sciences 250?

LECTURE 1

THE NIGHT SKY

Constellations:

Constellations are groups of stars which lie in the same direction and which, viewed from the earth, seem to form patterns (squares, triangles, "stick figures"). Normally the individual stars within constellations are unrelated and lie at different distances out in space.

There are 88 "officially" recognized constellations and they all have Latin names (Ursa Major, Lyra, Orion). About half of the constellation names date back to the ancient Greeks or earlier (Taurus the Bull, Leo the Lion), while the other half are more modern (the air pump, the microscope). While we are most familiar with the constellation names and legends that have come down to us through western civilization, other cultures have their own sets of constellations.

Star Names:

Many of the individual star names are Arabic with a few others coming from other cultures such as the Greeks, and Phoenicians. Any star name that begins with the letters "al" is Arabic. Examples are the stars Aldebaran (the eye of the bull), Algol (the demon) and Alcor (the rider). Many star names are descriptive. For example, Deneb means "tail" and Regulus means "the little king."

In the 17th century, a systematic way was developed to designate the stars within an individual constellation in order of their brightnesses. The system is called "Bayer Letters". An individual star is designated with a Greek letter plus the Latin genitive of the constellation name, starting with the first letter of the Greek alphabet for the brightest star. For example, the brightest star in the constellation of Orion the Hunter is called Alpha Orionis and the second brightest star in the constellation of Cygnus the Swan is called Beta Cygni.

The Brightnesses of Stars:

When we look up in the sky, we notice immediately that some stars are brighter than others. The system that has been developed to express the relative brightnesses of stars with numbers is called the "magnitude system". The idea for the magnitude system came from the Greek astronomer Hipparchus. He divided stars into six classes according to

their apparent brightness in the sky. The "first class" stars were the brightest ones and the "sixth class" stars were the ones that were barely visible to the naked eye. Medieval astronomers continued with this system, but substituted the word "magnitude" for "class". We still call the brightest stars "first magnitude".

Note that the smaller the number, the brighter the object. Also, some astronomical objects are so bright that they exceed first magnitude and then their magnitudes are designated by negative numbers. For example, the full moon is -11 on the magnitude scale and Sirius, the brightest star in the night sky, has a magnitude of -1.4.

The magnitude scale is set up such that a factor of 100 in brightness corresponds to a magnitude difference of 5 magnitudes. In other words, a 1st magnitude star is really 100 times brighter than a 6th magnitude star.

Features on the Celestial Sphere:

The sky is called the "celestial sphere". This is where all the "action" takes place (day and night, the moon, planets). In order for observers to keep track of what is happening in the sky, a reference system is needed. (Question: Why would anyone want to keep track of what is going on in the sky?) The following reference points are used:

1. The basic directions: north, south, east, west.
2. Horizon: where the sky begins.
3. Zenith: the point directly overhead.
4. Meridian: an imaginary line from the north point, through the zenith and through the south point. It divides the sky into eastern and western halves.
5. North celestial pole: direction that the earth's rotation axis points to out on the celestial sphere (there is also a south celestial pole). Polaris, the North Star, is near this point.
6. Celestial equator: projection of earth's equator onto celestial sphere.

With these reference points observers can figure out how the stars are moving in their basic risings and settings, how any special objects are moving (moon, planets, the occasional comet), and how the sun is moving (timekeeping, calendar).

The basic rising and setting of the sun and stars is called the "daily motion" of the celestial sphere. This is due primarily to the rotation of the earth on its axis.

For each observer except somebody right on the earth's equator, there is a part of the celestial sphere that never appears above the horizon. Also, there are some parts of the celestial sphere that are always above the horizon. Constellations that never go below the horizon for a particular observer are called "circumpolar" (near the pole). For example, at the latitude of Pullman, the constellation of Ursa Major, the Great Bear, is circumpolar.

LECTURE 2

THE SUN AND TIME

The Annual Motion of the Sun, the Ecliptic:

From our earth-based point of view, the sun appears to move approximately 1 degree per day eastward with respect to the background stars. What is actually happening is that the earth is moving around the sun with an orbital period of 365.2422 days. So, from our point of view here on earth, the sun appears to move once around the sky, i.e. to trace out a 360 degree circle, in 365.2422 days. Thus, the sun appears to move 360 degrees/ 365.2422 days, i.e. about 1 degree per day.

If you did a thought experiment about this motion, it might look like this:

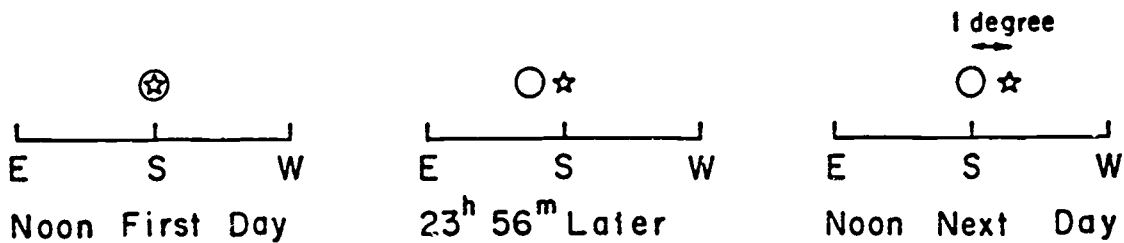

If we ask how much difference this eastward motion of the sun with respect to the star makes in terms of time (we do keep time primarily by the sun, right?), we would want to figure out sun time versus star time. The question boils down to what is 1 degree in terms of time rather than angle. One day = 24 hours = 360 degrees. Therefore, 1 degree = 24/360 hours = 1/15 hour. How many minutes is 1/15 of an hour? It is 4 minutes. Therefore, sun time is 4 minutes different than star time each day. Consider the following diagrams:

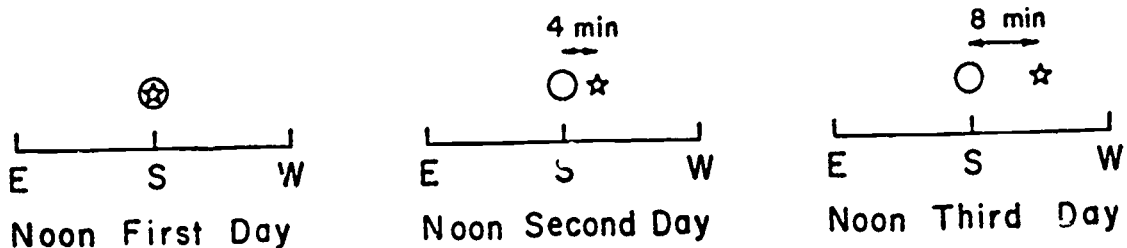

Thus, the sun is always changing its position. It does follow a certain path among the stars and the sun's motion repeats from year to year. The path of the sun around the celestial sphere is called the ecliptic. The motion of the sun around the ecliptic is the reason that we see different stars at different times of year.

The constellations that lie along the ecliptic are the ones that we call the Twelve Constellations of the Zodiac (Libra, Virgo, Sagittarius). By the way, because of long-term changes that we will discuss later, the "birthsigns" that are in use in astrology are over 2000 years out of date and no longer reflect correctly where the sun is during the particular period covered by each birthsign (so much for astrology).

Keeping Time:

There are many reasons for wanting to know the time (what are some of them?). If it is the time of day, the sun is a convenient marker when it is daytime (what did people do to keep time at night?). If it is the day of the month (month) or the time of the year, then entirely different markers are necessary.

Sun Time and Star Time:

We have discussed already the motion of the sun eastward along the ecliptic. Let us now consider a practical, earth-based issue. What is around that can be used conveniently as a timekeeper during the day when we are (more or less) active? Answer: the sun.

Is there something we can agree on to use as a standard for sun time? How about sunrise? Well, sunrise varies, doesn't it? How about what we now know as "noon"? What is noon, actually? Noon is defined as being the time when the sun crosses the observer's meridian. Great, that is a standard that I can use every day for my local time, but only for My Local Time. For my friend in Seattle, the sun actually crosses his or her meridian later than it crosses my meridian. For my friend in New York, it crosses earlier.

In fact, a.m. and p.m. come from the notion of using noon as a time marker. "a.m." is ante meridian (before the meridian) and "p.m." is post meridian (after the meridian).

Thus, some of the first timekeeping devices were sundials. The principle of a sundial is simple: you have some sort of a vertical pointer lined up with the meridian and it is calibrated in such a way that you can determine the local time. (Note: there is a sundial located on the southern side of Thompson Hall on the WSU campus if you want to have a look at one in action. Also, we will be making a sundial in the laboratory.) If you happen to teach in a classroom that has southern exposure, you can illustrate for

your students the notion of time passing by watching a patch of sunlight or shadows move across a wall or the floor.

If you see an actual large sundial, you may notice a "correction table" which gives a chart of so many minutes faster or slower than the sundial as a function of date during the year. In modern times we have adopted a day that is always exactly 24 hours in length. However, the sun does not move uniformly along the ecliptic during the year but sometimes moves a little faster than average and sometimes a little slower. Thus, telling time by the "actual sun" would sometimes give you times that are a few minutes off of "civil time". The correction between "actual sun time" and "civil sun time" can be as much as 17 minutes.

Time zones are a convenience that was devised to help people agree on what time it is. There are 24 time zones. The fundamental meridian for measuring time (and longitude) is the Greenwich Meridian which goes through the Royal Greenwich Observatory in England. The 180 degree meridian of longitude is known as the International Date Line. If you cross this meridian moving from west to east, you decrease your date by one day. If you cross it going from east to west, you increase your date by one day.

Star Time and the Earth's Rotation:

If you were to watch a star cross the meridian, you would find that it always does so at intervals of 23 hours and 56 minutes. The sidereal day is 23 hours and 56 minutes in length and this is the true rotation period of the earth. If you were a bug-eyed monster looking down upon the earth from a spaceship, you would find that planet earth rotates on its axis with a period of 23 hours and 56 minutes and revolves around the sun with a period of 365.2422 days.

LECTURE 3

TIME AND THE SEASONS

The Week and the Month:

The week is based loosely upon the phases of the moon. The interval between the major phases (say between first quarter moon and full moon) is just over seven days.

The month is based loosely upon the period of the phases of the moon (29.5 days from one full moon to the next) and attempts to fit appropriate numbers of months into one year.

Calendars:

The calendar that we use in civil life today came down to us from the Greek and Roman civilizations. By 70 B.C. the Romans had a calendar with 12 months and a basic year length of 355 days. An extra month would be thrown into the year every once in awhile to make the average year length come out to be about 365.25 days. The priests determined when this would happen and they tended to throw in extra months during years when politicians who were sympathetic to them were in office.

In 46 B.C., Julius Caesar decided that a calendar reform was necessary and the resulting calendar became known as the Julian Calendar. The features of this calendar were as follows:

1. Each year contained 12 months with a total of 365 days.
2. Every fourth year there would be one extra day added to February. The years with the extra day are called leap years. Thus, the length of the average year would be 365.25 days, pretty close to the actual length of 365.2422 days.
3. The date of the vernal equinox (the beginning of spring) had been slipping because of calendar errors. It was put back to its "traditional Roman date" of March 25. The year began on March 1.

The Julian Calendar is 11 minutes and 46 seconds too long per year compared to the actual length of the year. This doesn't make much difference over a few years, but when centuries pass the error accumulates. By 325 A.D. the vernal equinox was coming on March 21 and a special council of the Catholic church decreed that March 21 should be used in determining the date of Easter. Incidentally, Easter comes on the first Sunday after the first full moon after the vernal equinox.

No further calendar reforms were proposed until 1582. By that time, a 10 day error had accumulated, making the vernal equinox occur on March 11 instead of March 21. Pope Gregory XIII realized that if something wasn't done, Easter would be coming in the winter, etc.

The Gregorian Calendar reform consisted of two steps. First, 10 days were dropped out of the calendar to bring the vernal equinox back to March 21. By Papal decree, the day following October 4, 1582 was October 15. Second, the rule for leap year was changed to make the average length of the calendar year closer to the actual orbital period of the earth around the sun. The new rule was that only century years divisible by 400 would be leap years. Hence, 1700, 1800 and 1900 were not leap years, whereas the years 1600 and 2000 are leap years. This small reform makes the average length of the calendar year 365.2425 days. The Gregorian Calendar has an error of 1 day in 3300 years and this is the one we use in modern civil life.

Equinoxes and Solstices:

As the sun moves around the ecliptic, we here on earth experience seasons. We can imagine what is going on in the sky by using the following diagram:

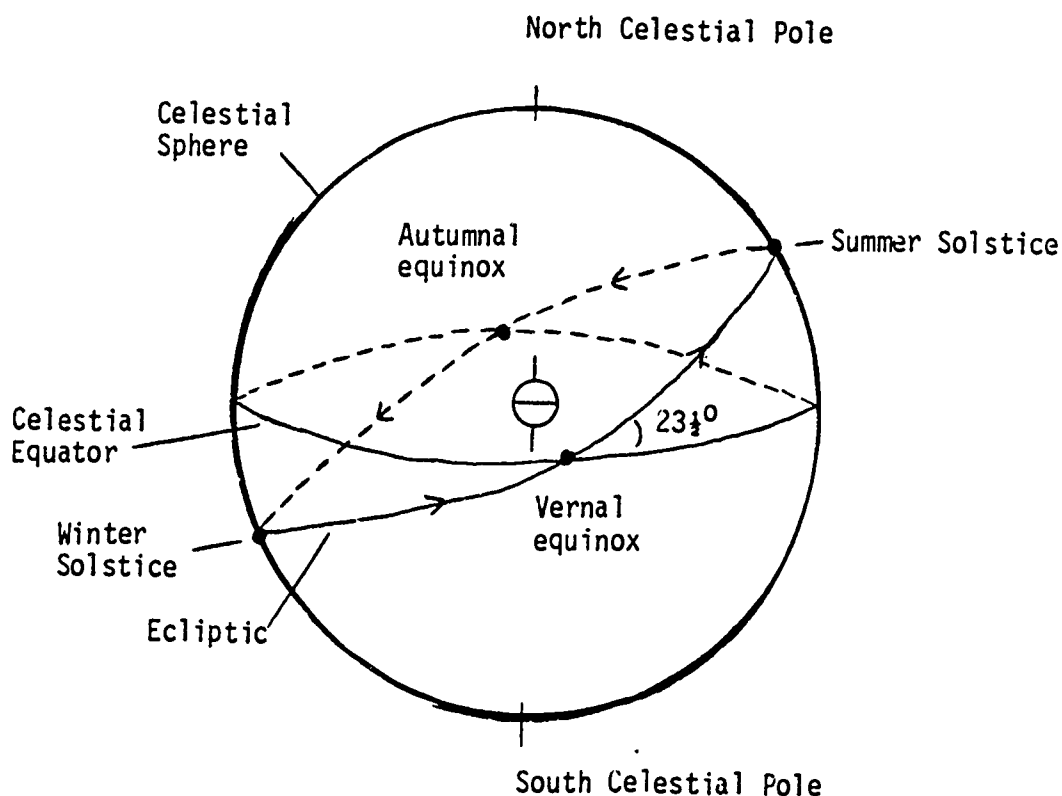

We mark the seasons by noting times that the sun is at particular extreme points:

1. Vernal Equinox - About March 21, begin spring in northern latitudes, equal length of day and night (approximately), sun rises due east and sets due west, sun overhead at noon on earth's equator.
2. Summer Solstice - About June 22, begin summer in northern latitudes, longest day and shortest night, sun rises and sets furthest north, sun overhead at noon on Tropic of Cancer (23.5 degrees north latitude).
3. Autumnal Equinox - About September 21, begin fall in northern latitudes, equal length of day and night (approximately), sun rises due east and sets due west, sun overhead at noon on earth's equator.
4. Winter Solstice - About December 22, begin winter in northern latitudes, shortest day and longest night, sun rises and sets furthest south, sun overhead at noon on Tropic of Capricorn (23.5 degrees south latitude).

Cause of the Seasons:

The seasons on the earth occur because of the 23.5 degree tilt between the ecliptic and the celestial equator.

LECTURE 4

THE MOON, LUNAR ECLIPSES

The Phases of the Moon

The Moon is such a bright and obvious astronomical object that it has played an important role in mythology and religion, as well as being the basis for the week and month. The Greeks identified the Moon as Artemis, goddess of the hunt, which is the same goddess as Diana in Roman mythology. Another name for the goddess of the moon is Luna and many words such as "lunar" and "lunacy" came from this name.

Because the moon does change its appearance, some human things that change are described by things that have to do with the moon. For example, a "lunatic" is somebody who is acting strange or crazy. In the past, stories were told about people becoming mad or creatures like werewolves coming out at the time of the full moon.

The phases of the moon result from the fact that the moon orbits around the earth. The diagram below shows the phases that result as the moon orbits the earth. For now we will neglect the fact that the earth-moon system is also orbiting around the sun.

When the moon is getting larger from night to night, we call it a waxing moon. When it is getting smaller from night to night, it is called a waning moon. In other words, as the moon goes from new to first quarter to full phase it is waxing. When it goes from full, through third (sometimes called last) quarter to new phase, it is called a waning moon. When it is less than a quarter phase, it is called a crescent moon; between quarter and full it is called a gibbous moon. We will talk about the times of moonrise and set in the laboratory.

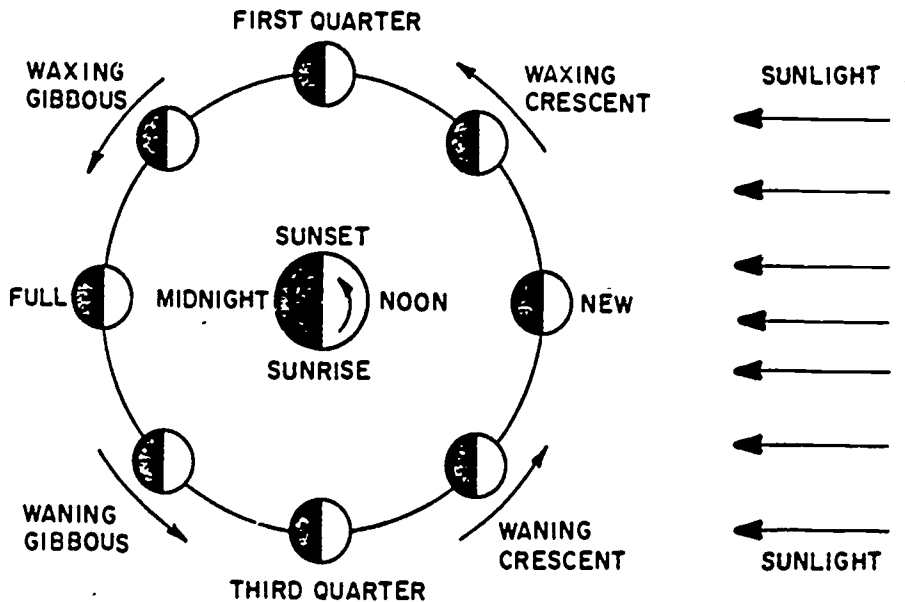

THE MOON AS SEEN FROM EARTH



NEW



WAXING
CRESCENT



FIRST
QUARTER



WAXING
GIBBOUS



FULL



WANING
GIBBOUS



THIRD
QUARTER



WANING
CRESCENT

Does the Moon Rotate?

You may have heard or have noticed from direct observation that the moon always keeps (approximately) the same face to the earth. You can see enough detail on the lunar surface with the naked eye to notice that this is the case.

Does this mean that the moon does not rotate on its axis? Not at all! Consider the following diagram:

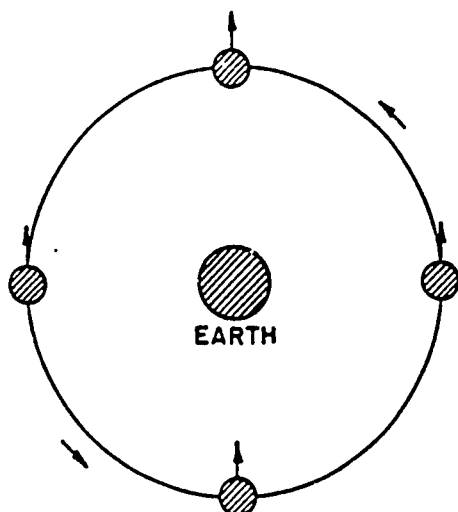

If the moon did not rotate, we would be able to see all its sides.

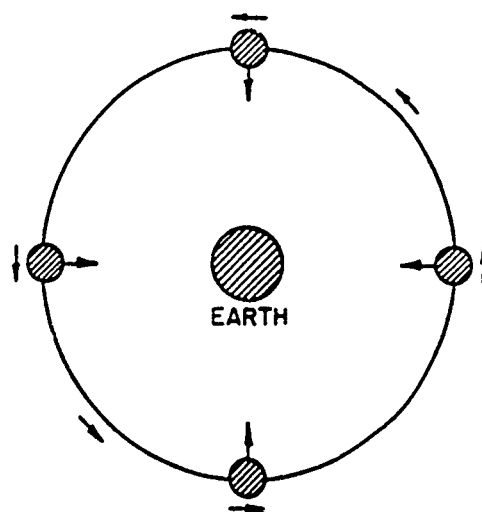

The moon actually rotates in the same period that it revolves so we always see the same side.

You can see from this that the moon rotates with the same period that it revolves around the earth. We see slightly more than half of the lunar surface from the earth (about 57%) for complex reasons that have to do with the fact that the moon's rate of revolution is not constant, while the rate of rotation is constant.

What Is the Length of the Month?

There are two possible ways to measure this. If you measure the position of the moon with respect to the background stars and then wait until it comes back to the same position, you find that it takes $27 \frac{1}{3}$ days. If you measure the interval from one full moon to the next, you get $29 \frac{1}{2}$ days. The former is called the sidereal period and is the more fundamental number. The $29 \frac{1}{2}$ day period is called the synodic period.

Why is there a difference? Consider the attached diagram. Basically, the reason for the difference between the synodic and the sidereal periods is the revolution of the earth-moon system around the sun. If all of this sounds reasonably complex, the great scientist Sir Isaac Newton agreed. He said, "The problem of the orbit of the moon doth cause my head to ache".

Lunar and Solar Eclipses

From the points of view of all ancient civilizations, lunar and solar eclipses were evidence that the gods and goddesses were angry, that something disasterous was happening (like the end of the world) or was going to happen later. There are all sorts of colorful stories about celestial goats eating the moon and other such things.

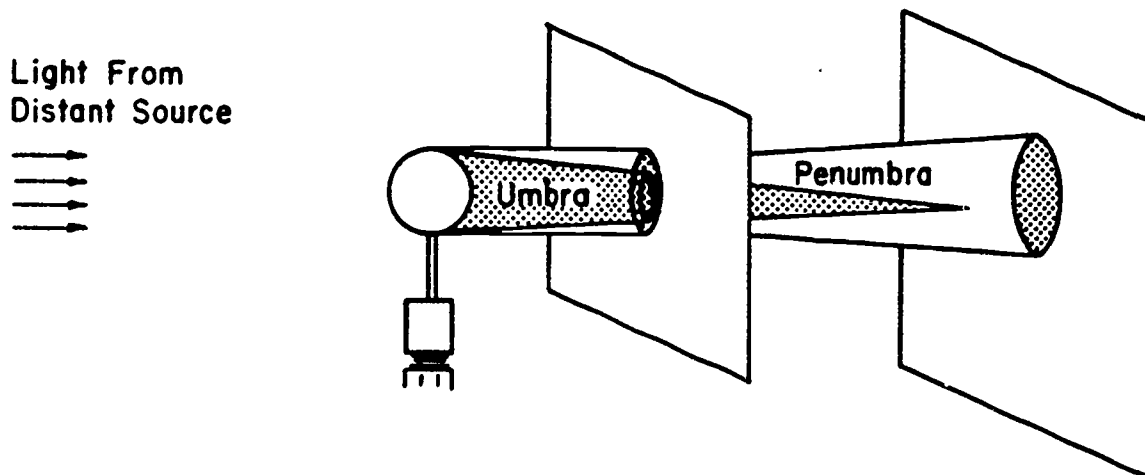

FULL MOON

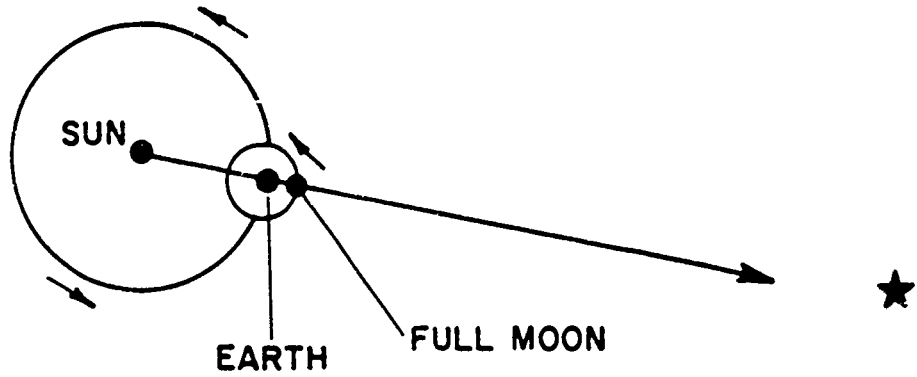

ONE SIDEREAL MONTH LATER

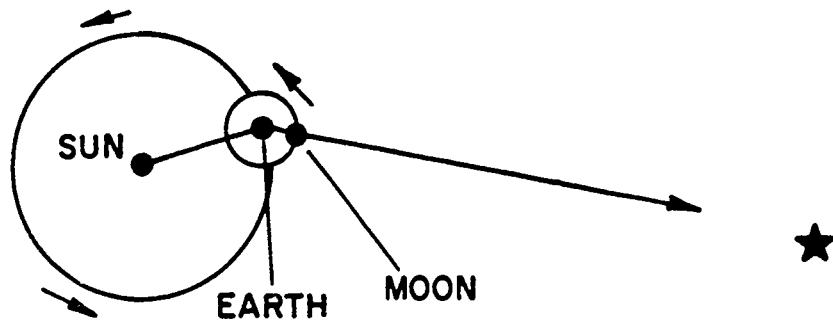

ONE SYNODIC MONTH LATER (next full moon)

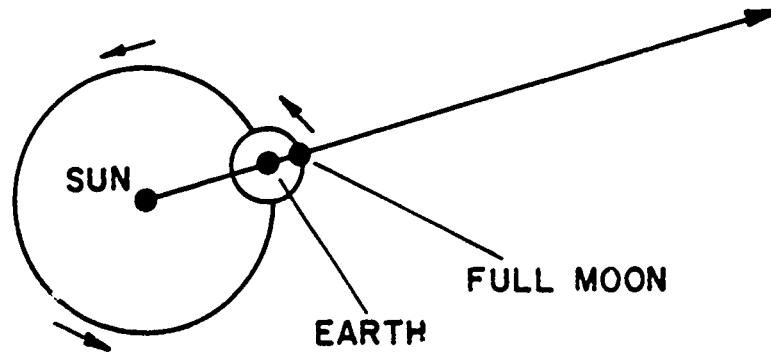

Lunar eclipses occur when the moon comes into the shadow of the earth. This occurs when the moon is near the full phase (but not every month). The earth's shadow has a very dark part and a lighter part. When the moon gets totally into the dark part we call it a total eclipse. It takes about an hour for the moon to get into the shadow, depending on circumstances it may spend anywhere from just a few minutes to over an hour moving through the shadow and then spend an hour moving out. Anybody who is on the nighttime side of the earth when this happens can see the lunar eclipse. When the moon gets into the lighter part of the earth's shadow, the dimming amounts to only a few percent of the normal amount of light and you hardly notice that anything is going on.

Total Lunar Eclipse

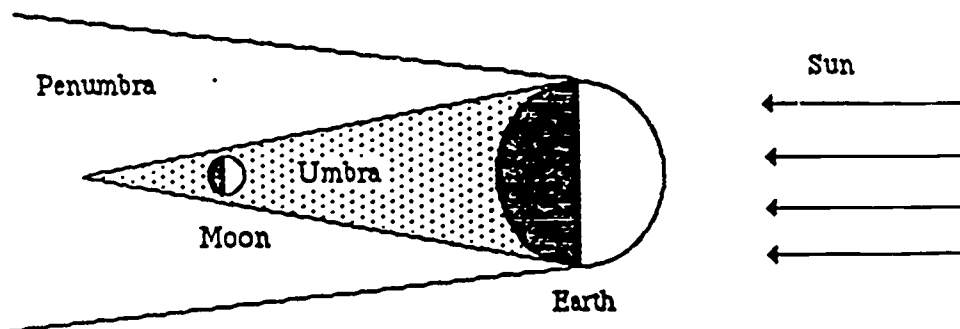

LECTURE 5

SOLAR ECLIPSES, THE MOTIONS OF THE PLANETS

Solar eclipses occur when the moon casts a shadow on the earth at a time near the new moon phase. Again, the moon's shadow has a dark and a light part. If you are in the dark part, you see a partial solar eclipse in which the moon covers only a part of the sun. The further away you are from the dark part, the less of the sun will be covered.

At best, a total solar eclipse lasts only about 7 1/2 minutes for an observer on the surface of the earth. The path of a total solar eclipse is only about 300 km wide but can be 1000's of km in length. In February of 1979 we had a total solar eclipse come through Pullman that lasted about 2 1/2 minutes (it was cloudy unfortunately). It was not total in Spokane. The next total solar eclipse that will come through the continental United States will be in 2017! But, if you like to plan ahead, there will be a nice total eclipse through the Hawaiian Islands in July of 1991.

Solar Eclipse

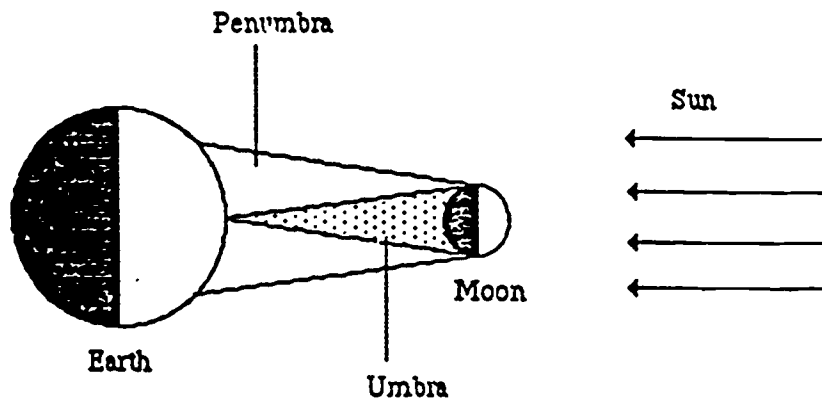

You may have read some things about people being blinded from looking at the sun during a solar eclipse. If the eclipse is total, it is ok to look right during totality. What you will see is the faint outer atmosphere of the sun (called the corona) and it is very beautiful. However, even if only a small fraction of the bright sun is visible, it can cause damage to vision. Sometimes people think that they have protected their vision by looking through layers of exposed film that look dark to them. The problem with doing something like that is that some films, while opaque (very dark) in the visible, are transmitting radiation in other regions of the spectrum and you can get your eyes zapped anyway. The safest way to look at the bright sun is to project an image, either with a telescope or with a "pinhole camera". That way you are not looking at the sun directly.

The reason that eclipses don't occur every month is that the orbit of the moon is tilted 5 degrees with respect to the ecliptic and the shadows don't line up right every month. Eclipses occur at times during two "eclipse seasons" that slowly change. From year to year the number and types of eclipses vary. For example, in one year there may be two lunar and two total solar eclipses while the next year there may be one lunar, two partial solar and one total solar eclipse. The total number of eclipses that might be squeezed into a particular calendar year under ideal circumstances is 7, but there might be as few as 2.

The Planets: Where, When and What

The word "planets" comes from a Greek word that meant "wanderer". The planets do not wander all over the sky. They are found in the constellations of the zodiac, but they do move about within those constellations (An exception is the planet Pluto which was not discovered until 1930. It is sometimes found a little bit outside the band of zodiac constellations--not by much, though).

The planets that can be observed easily with the naked eye are the following: Mercury, Venus, Mars, Jupiter and Saturn. The three outer planets (Uranus, Neptune and Pluto) were not discovered until relatively modern times.

Where and when the planets can be viewed is a relatively complex matter. Depending on the planet, you have to make observations for long times (at least months if not years) to figure out how the planet is moving and on what sort of timescales it will repeat its motions.

Mercury moves the fastest and was thought by the Greeks and Romans to be the messenger of the gods and goddesses. Mercury is faint and remains relatively close to the sun. You would hardly notice that it was around and was different from a star until you spotted that it moved significantly with respect to the background stars from night to night.

The planet Venus was named after the Goddess of Love and Beauty. Venus is a really bright object. It does get further from the sun than Mercury and is really hard to miss. When it is at its brightest, it is the third brightest astronomical object

Total and Annular Eclipses 1987 to 2000

Year	Date	Total or Annular	Best Observing Location
1987	March 29	A-T	South Atlantic, Africa
	Sept. 23	A	Asia, China, Pacific
1988	March 18	T	Indian Ocean, Indonesia
	Sept. 11	A	Indian Ocean
1990	Jan. 26	A	Antarctica, South Atlantic
	July 22	T	Finland, northern Siberia
1991	Jan. 15	A	Australia, New Zealand
	July 11	T	Hawaii, Mexico, South America
1992	Jan. 4	A	Pacific
	June 30	T	South America, Africa
1994	May 10	A	Pacific, central U.S.
	Nov. 3	T	South America, Atlantic
1995	April 29	A	South Pacific, South America
	Oct. 24	T	Iran, India, Southeast Asia
1997	March 9	T	Asia, Siberia, Arctic
1998	Feb. 26	T	Pacific, South America
	Aug. 22	A	Indian Ocean, Indonesia
1999	Feb. 16	A	Indian Ocean, Australia
	Aug. 11	A	Europe, Asia, India

Eclipses of the moon 1987 to 2000

Year	Date	Partial or Total	Best Observing Location
1987	Oct. 7*	P	South America
1988	Aug. 27*	P	South Pacific
1989	Feb. 20	T	Philippines
	Aug. 17*	T	Brazil
1990	Feb. 9	T	India
	Aug. 6	P	Australia
1991	Dec. 21.*	P	Hawaii
1992	June 15*	P	Chile
	Dec. 9*	T	North Africa
1993	June 4	T	South Pacific
	Nov. 29*	T	Mexico
1994	May 25*	P	Brazil
1995	April 15	P	South Pacific
1996	April 4*	T	South Atlantic
	Sept. 27*	T	Brazil
1997	March 24*	P	Brazil
	Sept. 16	T	Indian Ocean
1999	July 28*	P	South Pacific
2000	Jan. 21*	T	West Indies
	July 16	T	Australia

*Visible in at least part from the United States

after the sun and the moon. Under dark conditions on a moonless night, Venus can be bright enough to cast shadows. (Question: How many students have seen Mercury? Venus?)

Venus and Mercury are known as inferior planets because they are closer to the sun than the earth. The motion of an inferior planet is depicted in the diagram below.

Let's keep the earth fixed as indicated and examine how the inferior planet would look to us on earth at the four places indicated on the diagram. What we conclude from the diagram is that at times an inferior planet can be seen in the western part of the sky after sunset or in the eastern sky before sunrise. There will be times when the planet is between the sun and the earth (or near these positions) when the inferior planet cannot be seen at all.

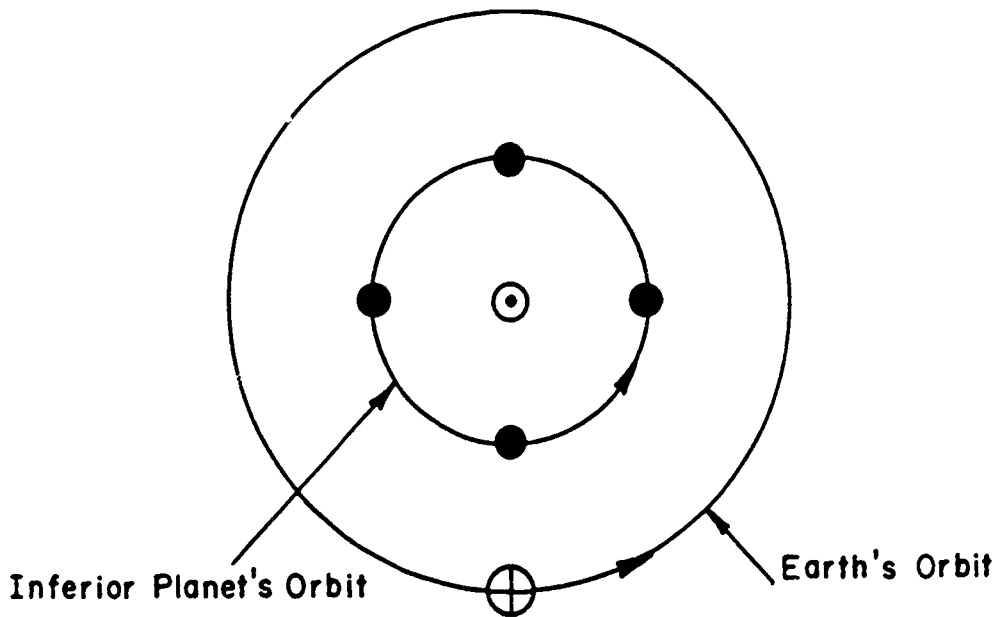

The planets that have orbits further from the sun than the earth are called superior planets. The orbit of a superior planet is shown in the following diagram:

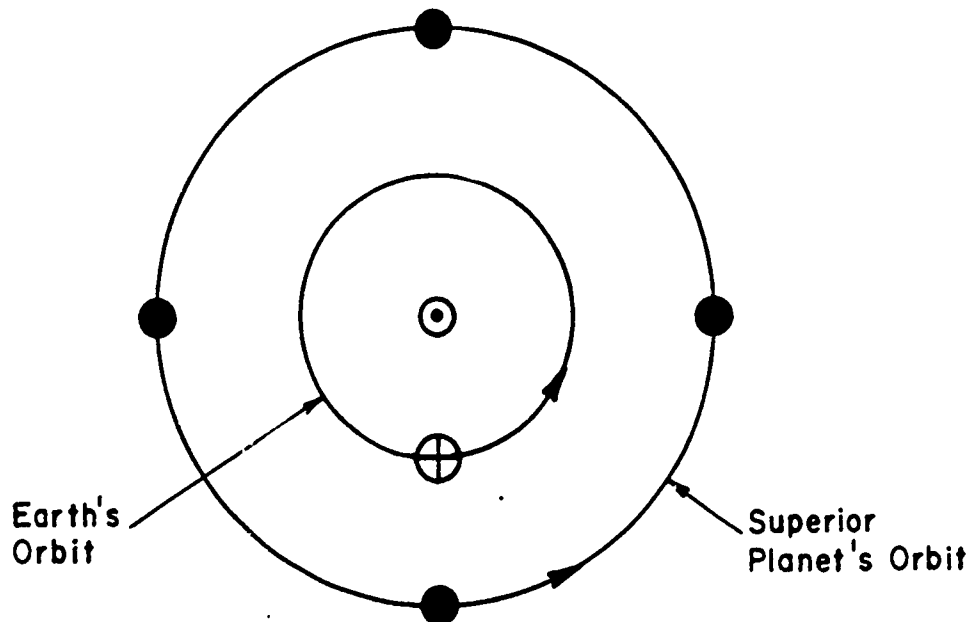

A superior planet may at one time or another be found in any constellation of the zodiac with respect to the sun. In other words, the superior planets can be observed at various times of night during their wanderings and are not constrained to stay within a certain number of degrees of the rising or setting sun.

The superior planets did something that was puzzling. Near the time that they were opposite in the sky from the sun, they would go through what the Greeks called "retrograde loops". To the Greeks, "direct" motion in the heavens was from west to east. The sun and the moon, two major deities to them, moved in this way with respect to the background stars.

For the most part, Mars, Jupiter and Saturn would move "direct" also. However, when they were coming up near the time that they were in opposition (i.e. when the planet would be rising in the east as the sun would be setting in the west), they would be doing the following sort of thing with respect to the background stars (you had to watch them for several weeks to notice this):

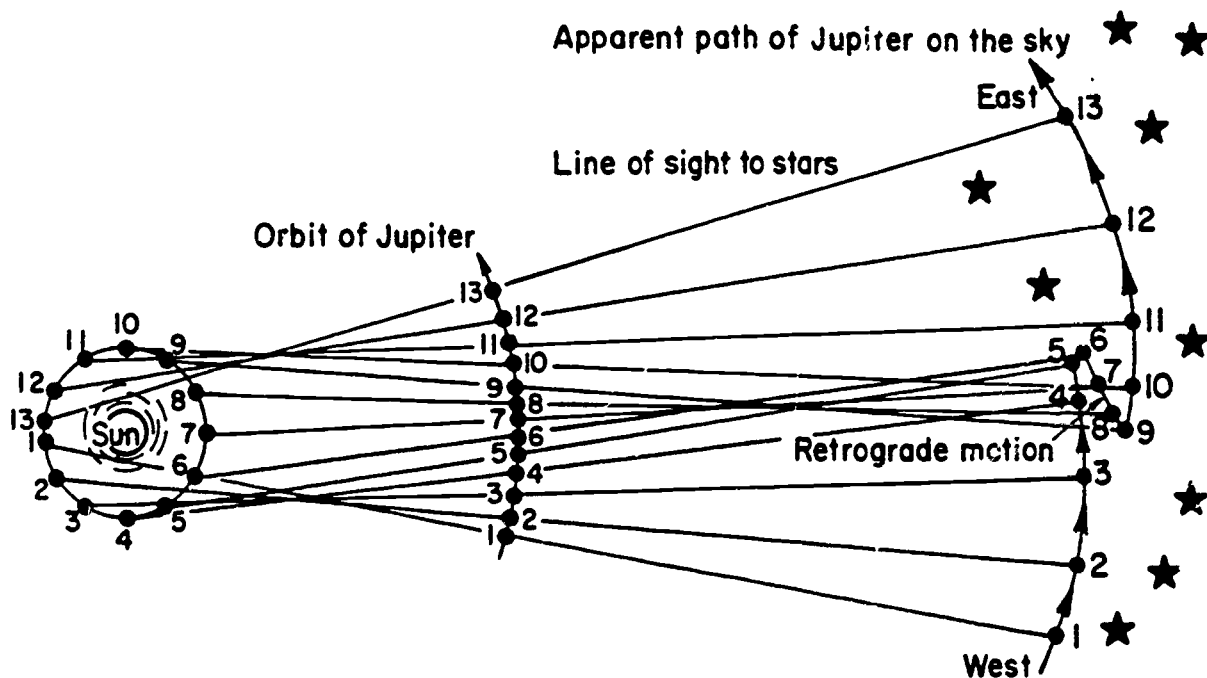

The Greeks were fascinated by these motions and wanted to explain them and other things about the heavens. We will discuss next time that they did develop an explanation of planetary motions based upon a geocentric (earth-centered) universe.

Incidentally, does anybody know how to tell the difference between a star and a planet if you go out and see a bright object and aren't quite sure about it? Space here for answer:

LECTURE 6

GREEK ASTRONOMY

As an example of the development of astronomy as a science, we will consider some aspects of Greek astronomy. However, don't get the idea that the Greeks were the only ones who made astronomical observations. From Stonehenge in England to Chichen Iza in Yucatan, people from many civilizations have been making systematic observations of the heavens for thousands of years.

The Greeks were the first ones to make serious attempts to use the observations for making what we would recognize as scientific hypotheses about the nature of bodies in the universe. A bare-bones summary of Greek astronomical discoveries appears in a table at the end of the lecture. There are too many things there for us to discuss in detail so we will concentrate upon only a couple of aspects of Greek astronomy.

First, let us consider in detail how Eratosthenes was able to make a measurement of the size of the earth. Eratosthenes, who lived from 276 to 195 BC, was a resident of Alexandria in what is now the northern part of Egypt, but was then a major Greek city and center of learning (it had a great library). Eratosthenes heard that in the small town of Syene further to the south, the sun was directly overhead at noon on the date of the summer solstice (approximately June 22). The evidence for this was that on that date the sunlight shone down directly into a well that was otherwise in darkness.

Eratosthenes knew that in his own city of Alexandria the sun was 7 degrees off of the overhead point at noon on June 22 (see diagram).

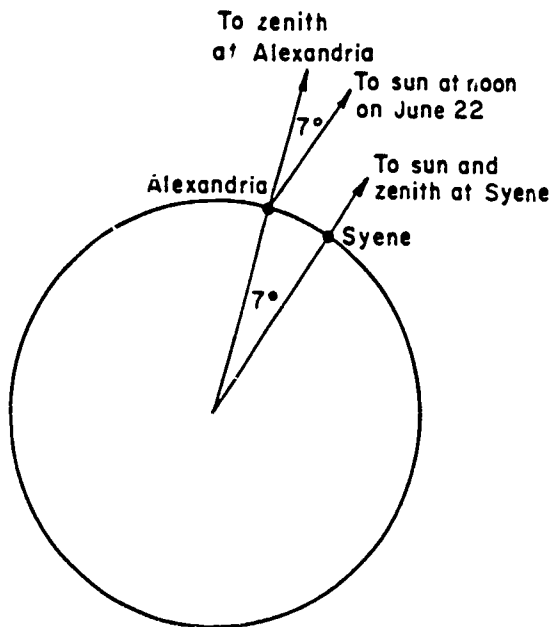

He realized that the earth was round (as did all educated people of his time) and that he could use a theorem in the new fangled math called geometry to make the first step in figuring out the size of the earth. The theorem is this: Two parallel lines that are crossed by a transversal have equal angles like shown in this diagram:

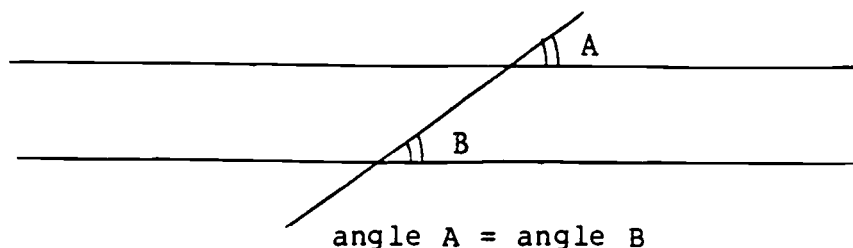

Can you see the application in the diagram of the earth above? Eratosthenes could make the following proportion:

$$\frac{7^{\circ}}{360^{\circ}} = \frac{\text{Distance from Alexandria to Syene}}{\text{Circumference of the Earth}}$$

So, what did he need to know in order to find the circumference (the distance around) of the earth? Answer:

The Greeks used a distance unit called the stadium (sound familiar?), but they kept changing the length of the "standard stadium" slightly. It is thought that Eratosthenes' measurement of the circumference of the earth (he estimated 252,000 stades) was correct to within about 2% of the modern value (24,900 miles). Not bad!

Now, let us turn to a second aspect of Greek astronomy that comes right at the end of the glory of Greece. It is a synthesis of many of the earlier discoveries into a comprehensive theory of the universe that was the standard until the 1500's. The theory was put forth by Cladius Ptolemy (c. 140 A.D.). To understand parts of his theory, you should understand the Greek attitude toward circles and spheres (as opposed to other curves and solids such as squares, ellipses, etc.). The Greeks considered the circle and the sphere to be the embodiment of perfection. Since the heavens were the abodes of the gods and goddesses, all the things up there (sun, moon, planets, stars) were perfect and thus would be spherical and move in circles.

In the Ptolemaic theory the stars were engraved on a crystalline sphere at some reasonably far distance from the last known planet (Saturn). The earth was at the center of the universe and it did not move. Everything went around the earth. The lunar and solar orbits were fairly simple circles with the moon being the closest body to the earth.

The planetary orbits were another thing entirely. The Greeks had watched the planets carefully and knew that simple circular orbits would not explain the observations. Ptolemy drew on earlier work to develop planetary orbits that were circles moving on circles (see diagram). He even put the earth off center of the big circle (called the deferent) to better explain the observations.

The bodies in the universe were arranged as follows (not to scale):

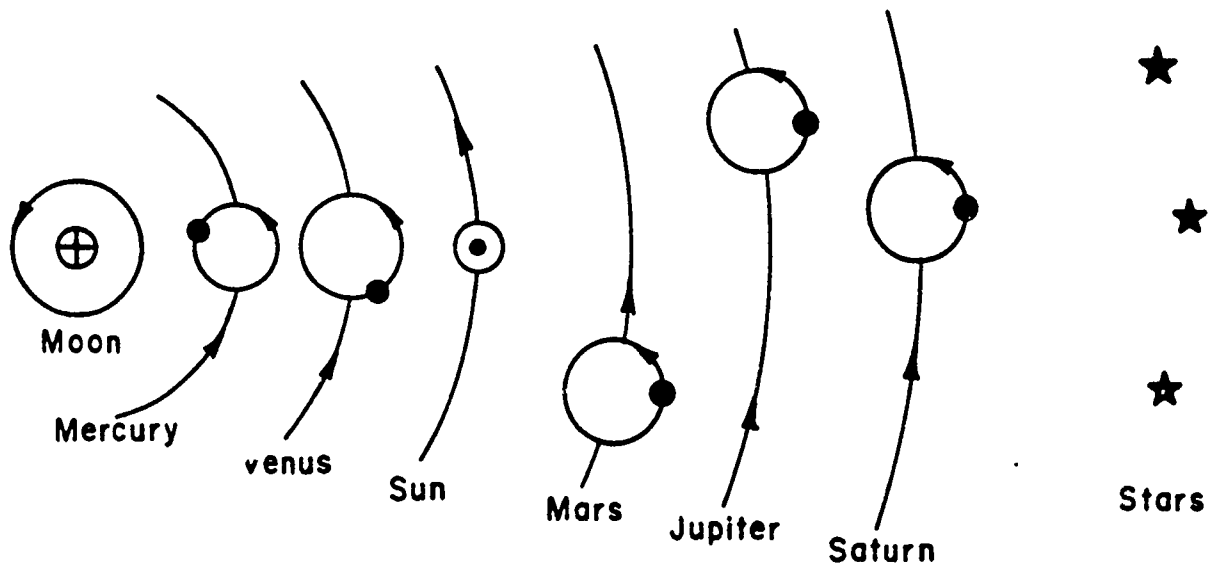

The center points of the orbits of Mercury and Venus were required to stay along a line between the earth and the sun so that they never wandered too far from the sun for an observer on earth. Day and night were produced by rotation of the whole shebang around the earth. The sun went around yearly so you would see different stars at different times of year.

Ptolemy had developed a great theory for the time. It explained the observations available up to that moment. As the Christian church ascended into power and influence, the Ptolemaic theory gradually became a part of the official doctrine of the church. No part of it could be questioned. For example, in 1600 A.D., a monk named Giordano Bruno was burned alive in Rome for suggesting that the stars themselves are suns. It was very difficult for science to make progress in an environment such as that.

SOME ASTRONOMICAL DISCOVERIES OF THE GREEKS

OBSERVATION	INFERENCE	OBSERVER COMMONLY QUOTED
CURVED LUNAR TERMINATOR (THE LINE BETWEEN LIGHT AND DARK AREAS)	THE MOON IS ROUND	PYTHAGOREANS
ROUND SHADOWS DURING LUNAR ECLIPSES	THE EARTH IS ROUND	PYTHAGOREANS
CRESCENT PHASES OF MOON	THE MOON IS BETWEEN THE EARTH AND SUN	ARISTOTLE
DIFFERENT STARS ARE OBSERVED AT THE ZENITH AT DIFFERENT LATITUDES	THE EARTH IS ROUND	ARISTOTLE
THE RELATIVE SIZES AND ANGLES OF MOON'S AND EARTH'S SHADOWS OBSERVED DURING ECLIPSES	THE MOON IS SMALLER THAN THE EARTH, AND THE SUN IS BIGGER THAN THE EARTH	ARISTARCHUS
RELATION BETWEEN ANGULAR SHIFT OF ZENITH POSITION AMONG SUN AND STARS AND DISTANCE TRAVELED ON EARTH	CAN CALCULATE THE CIRCUMFERENCE OF THE EARTH	ERATOSTHENES
NORTH CELESTIAL POLE'S SHIFT WITH RESPECT TO CONSTELLATIONS	PRECESSION	HIPPARCHUS

LECTURE 7

COMES THE REVOLUTION: COPERNICUS TO GALILEO

Medieval Astronomy

In medieval Europe, few new astronomical investigations were made. The Ptolemaic universe was accepted as part of the dogma of the Roman Catholic Church. Other cultures such as the Arabs contributed to knowledge of astronomy during this period.

The Theory of Nicolas Copernicus

Nicolas Copernicus (1473-1543) was born in Poland and trained in law and medicine. However, his main interests were in astronomy and mathematics. Copernicus did a mathematical evaluation of how well the Ptolemaic theory was explaining the observed motions of the astronomical bodies (sun, moon, planets--more accurate observations were possible) and concluded that the theory was failing.

Basically, he had three options once he discovered this. He could try to patch up the Ptolemaic theory somehow. Second, he could come up with a new theory. Third, he could go practice law or medicine and forget about the whole thing. He thought of a new theory in which the sun was the center of the universe and all of the planets went around the sun. In his theory the moon went around the earth. His scheme was called "heliocentric" or sun-centered theory.

While a manuscript describing the heliocentric theory was circulating among friends of Copernicus and other intellectuals by 1530, the formal publication of his work did not come until 1543, the year of his death. The title of the book is *De Revolutionibus* (Of Revolutions). In the book Copernicus had the planets going around the sun in circular orbits (This is not quite accurate; the orbits are ellipses). He even had a nice mathematical scheme for figuring out the distances of the planets from the sun in terms of the earth-sun distance. The book is an intellectual and mathematical marvel.

Tycho Brahe--Superobserver

The test of a theory is whether it can predict correctly what will happen when observations that it is supposed to deal with are made. In this respect, it was evident that the Copernican theory had flaws, as did the Ptolemaic theory. What was missing was the notion of elliptical orbits, but it took a long time to discover what was wrong.

The person who provided observations that made it possible to find the "missing link" was Tycho Brahe (1546-1601). Tycho

became court astronomer to Frederick II of Denmark and was allowed to build an observatory on the island of Hveen. For 20 years Tycho and his assistants made the most careful, systematic and accurate observations of stellar, lunar and planetary positions ever done.

Enter Johannes Kepler

Johannes Kepler (1571-1630) was a Protestant minister who taught mathematics in a high school in Gratz, Germany. He was fired from his job because the Catholic church was becoming increasingly powerful in Gratz and they didn't want Protestants teaching radical things (like the Copernican system) to innocent young minds.

Kepler got a job as an assistant to Tycho Brahe. Actually, there are various stories about the relationship between Tycho and Kepler and the development of a theory of planetary motions. Most of them involve a lot of screeching and fighting going on between the two of them. Tycho had developed a curious sort of theory that involved the sun and moon going around the earth and all of the other planets going around the sun. Kepler was a believer in the heliocentric theory, but he realized that it needed modifications. He realized that Tycho's observations could be used to help him find out what those modifications should be.

Tycho got out of Kepler's way in 1601 by dying. In 1609 Kepler published a book called *The New Astronomy, or Commentaries on the Motions of Mars*. To understand what Kepler did we should first back off and discuss the possible fundamental types of orbits that one body orbiting around another could have. These types of orbits are things that you have probably studied as mathematical curves.

In his book, Kepler spent many pages setting forth the justification for the following two "laws of planetary motion".

1. Kepler's First Law: Each planet moves about the sun in an orbit that is an ellipse, with the sun at one focus of the ellipse.
2. Kepler's Second Law (The Law of Areas): The straight line joining a planet and the sun sweeps out equal areas in space in equal intervals of time.

The First Law is illustrated by the following diagram:

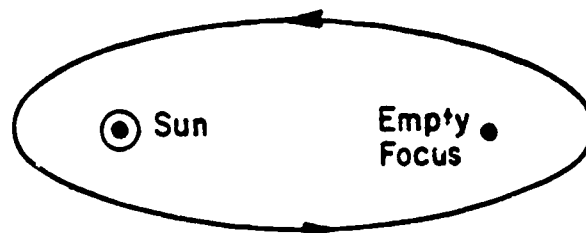

The Second Law is a bit more subtle. Consider the following diagram which illustrates the Second Law:

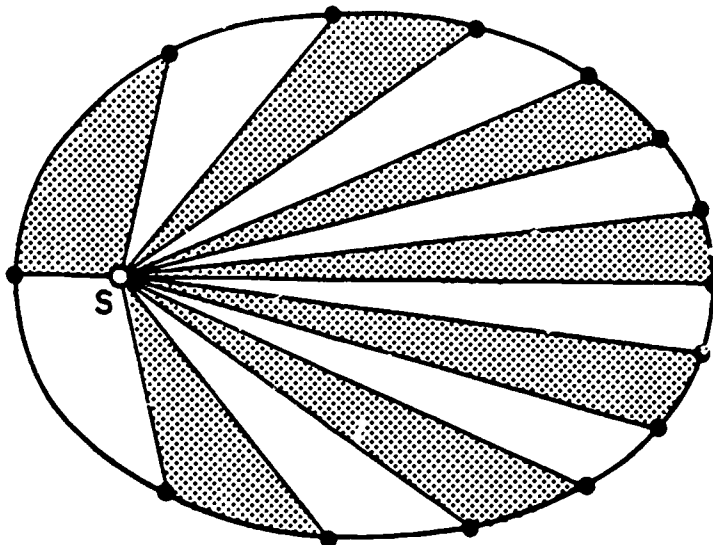

There is an implication to the Second Law. It will allow us to answer the following question: When is a planet traveling fastest (or slowest) in its orbit around the sun? Room here for answer:

We aren't done with Kepler quite yet. In 1618 Kepler published a book called Harmony of the Worlds, which contained his Third Law of planetary motions. The third law can be stated as a mathematical formula. It is

$$p^2 = a^3,$$

where "p" is equal to the orbit period of the planet around the sun in years and "a" is the size of the orbit in astronomical units. "a" needs further explanation. It is the quantity shown in the following diagram:

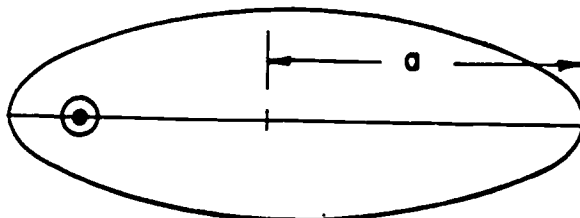

Mathematically this would be known as the semi-major axis of the elliptical orbit. An "astronomical unit" is simply the earth-sun distance. At the time it was not known how far this was in miles or kilometers or furlongs or any other distance unit used on the earth, so the astronomical unit (abbreviated a.u.) was something that was convenient to use.

The following table shows you that Kepler's Third Law does indeed work for the planets, especially out to Uranus.

Applying Kepler's Third Law to the Planets

Planet	a(AU)	P(YEARS)	a ³	p ²
Mercury	0.387	0.241	0.058	0.058
Venus	0.723	0.615	0.378	0.378
Earth	1.000	1.000	1.000	1.000
Mars	1.523	1.881	3.533	3.538
Jupiter	5.203	11.86	140.85	140.66
Saturn	9.539	29.46	867.98	867.89
Uranus	19.18	84.01	7055.79	7057.68
Neptune	30.06	164.8	27162.32	27159.04
Pluto	39.44	248.4	61349.46	61762.56

Actually, all of Kepler's Laws can be derived once you know about gravity. But Sir Isaac Newton didn't come along and develop the gravitational theory and the Laws of Motion until decades later. Hence, nobody quite knew exactly why Kepler's Laws worked. However, they did provide support for the Copernican theory. With the modification to elliptical orbits for planets about the sun, the Copernican theory predicted planetary phenomena much better than the Ptolemaic theory.

Kepler was a mystic and he believed in astrology and the occult. He called his Third Law the Harmonic Law and he believed that the planets were singing songs (he wrote music too). Most of Kepler's work was pure junk, but it contained the jewels of the Laws of Planetary Motion.

Galileo Galilei

Galileo Galilei (1564-1642) ranks as one of the greatest scientists of his time. He was Italian and was a professor of mathematics and astronomy at the University of Padua and later court mathematician to the Grand Duke of Tuscany. While we shall focus upon his contributions to the whole Ptolemaic-Copernican controversy, you should know that his experiments and calculations in mechanics (things rolling down inclined planes, dropping off the Leaning Tower of Pisa, etc.) laid the foundation for Sir Isaac Newton's work in developing the laws of motion and the theory of gravity.

Galileo heard about a Dutch optician who ground lenses such that they could magnify objects. He immediately figured out how to do it and built one of these devices for himself in 1608. We now call some of these devices telescopes.

Galileo discovered many new and wonderful things about the heavens (not in any particular order):

1. There were a lot more stars than just the ones that could be seen with the naked eye. Some of them appeared to be arranged in clusters and there were more of them in the Milky Way section of the sky than in other places.
2. There were craters on the moon.
3. There were spots on the sun and they moved around as if the sun were rotating.
4. Jupiter had four moons going around it.
5. Saturn was not round but looked like it had "ears".
6. Venus showed all phases like the moon-new, crescent, quarter, gibbous, full.

Galileo realized that some of these observations provided powerful arguments for preferring the Copernican theory over the Ptolemaic. For one thing, the presence of bodies orbiting around something other than the earth (the moons of Jupiter) was strictly prohibited according to the Ptolemaic theory. Also, the observation that Venus showed all phases contradicted directly the prediction of the Ptolemaic theory. In that theory Venus could show only the new and crescent phases. The Copernican theory made the correct prediction that Venus should show all phases.

Galileo was a Catholic and the Ptolemaic theory was a part of church doctrine. In 1616, he was forbidden to "hold or defend" belief in the Copernican theory. However, in 1632 he persuaded the Pope to let him publish a discussion of the Ptolemaic versus the Copernican theories. The book is called Dialogue on the Great World Systems and it was published in Italian rather than Latin so it could be read by a wider audience than just church scholars.

However, Galileo had enemies and after the book was published he was called before the Roman Inquisition and accused formally of believing and holding doctrines that were false and contrary to the Divine Scriptures. He was forced to plead guilty. His sentence was to be placed under house arrest, where he spent the last 10 years of his life.

All of the books mentioned in this lecture and the last one were placed on the Catholic Index of Prohibited Books where they remained until 1835.

PHYSICAL SCIENCE 250 -- SPRING 1988

LECTURE 8

LIGHT AND OTHER RADIATION

Introduction

Measuring the positions and motions of astronomical bodies will give you certain types of clues as to their physical nature, but only a part of what we know about the universe comes from such measurements. The rest comes from detailed analysis of the radiation that comes from astronomical bodies and using it to find out about the physical properties (sizes, masses, temperatures, chemical compositions, ages, etc.) of objects in the solar system and further out in the universe.

There has always been and there remain close ties between astronomy and the other branches of physical sciences. Astronomers rely heavily upon chemists, physicists and earth scientists for basic experimental data which astronomers use in studying the radiation from astronomical objects such as planets, stars and galaxies.

Physicists and chemists study the nature of light and other radiation (which is related also to atoms and molecules). Astronomers use this information. Let us take a look at some of the basic information and how it is applied.

The Nature of Light

We call "light" the radiation that we are able to detect with our human eye. You are probably aware of some other kinds of radiation. For now, let us concentrate upon what light does (and does not) do.

Light can be reflected. A mirror is an example of that. Light can be refracted (bent) as it passes through different types of substances. Take a look at a straw in a clear glass of water to see this. Light can be emitted and absorbed. You see the light bulbs in this room emitting light and some of the light is absorbed, particularly by dark objects in the room.

Light can be broken up into its component colors by passing it through a prism or by passing it through a grating, which is a bunch of lines ruled close together on a piece of glass. A grating works on a principle called interference. If you want to see interference, just hold two fingers close together so there is a small gap and then look at a light source. What do you see?

This represents some of the light waves adding together and others canceling each other out.

What is the fundamental nature of light, i.e. is it a wave or a particle? Light is a waveicle. In some experimental situations it behaves like a particle and in others like a wave. You will find out more about this in chemistry or physics. Astronomers are interested in collecting and analyzing light to find the physical properties of astronomical objects. Reflection, refraction, prisms, etc. help us to do this.

The Electromagnetic Spectrum

Light is only one small part of the radiation coming from most objects. The entire range of possibilities for such radiation is called "The Electromagnetic Spectrum". Such radiation ranges from low energy, long wavelength radiation to high energy, short wavelength radiation. We will not bother with the exact energies and wavelengths of the various regions. You should know that all of these regions exist and the order from shortest wavelength, highest energy to longest wavelength, lowest energy (see diagram below).

The earth's atmosphere does not allow much of this radiation that is coming from the universe to reach the surface of the earth. An excellent example of this is that most of the ultraviolet radiation is blocked by the ozone layer high in the earth's atmosphere. Only a tiny fraction of the ultraviolet radiation gets through (most of it from the sun since it is the closest hot body) and that is enough to give light-skinned people a good sunburn in a short time. The blocking of various regions of the electromagnetic spectrum by the earth's atmosphere is illustrated in the diagram:

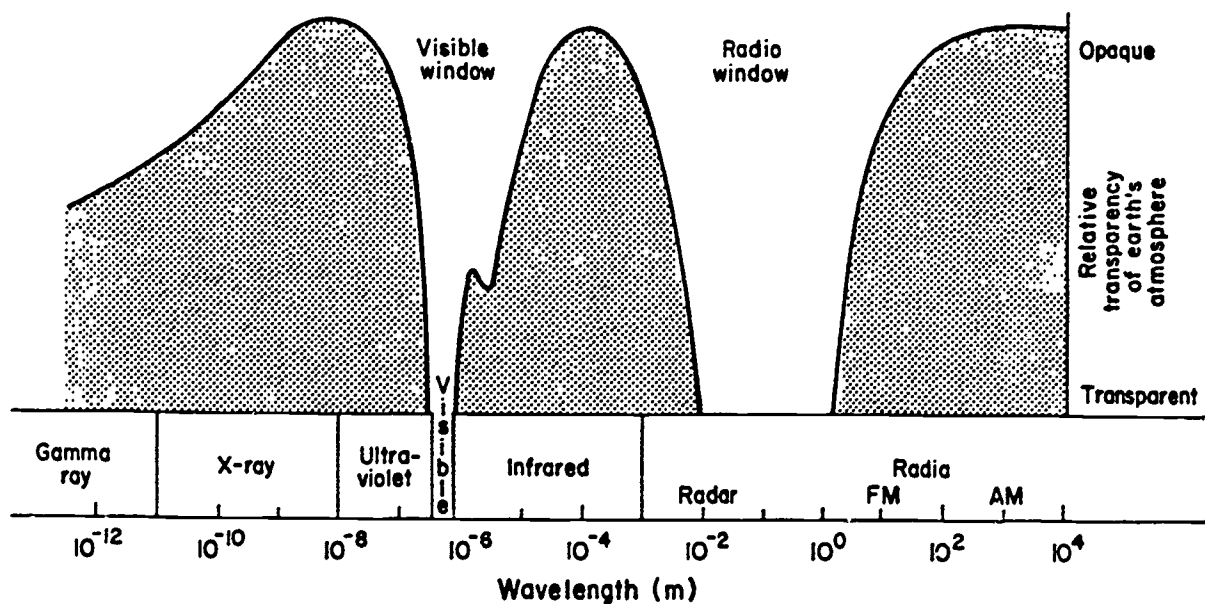

As a consequence, astronomers have not been able to study certain radiation at all until the advent of the space age.

Types of Spectra

Let's consider the optical (or visible) region again. What types of things are seen when you take a prism and spread light out into its component wavelengths (when you do this you look at the spectrum of the light)? There are three basic types of spectra. They can be tied to what the atoms or molecules that produce light are doing and what kinds of atoms or molecules there are in the source that is being studied. Hence, the analysis of spectra is a powerful method for analyzing what is going on with astronomical objects.

The three types of spectra are the following:

1. A glowing solid, liquid or gas under high pressure will emit a continuous spectrum.
2. A glowing gas under low pressure will emit a bright (or emission) line spectrum.
3. When a source of a continuous spectrum is seen through a cooler, lower pressure gas, the spectrum observed is called a dark (or absorption) line spectrum.

Spectra and Atoms

The nature of the spectrum that is observed from a particular object will depend upon the physical conditions such as temperature, density and the types of atoms or molecules in that object. In this section we will review some of the basic concepts about atoms and how spectra of various kinds are produced.

Atoms consist of protons, neutrons and electrons. Protons and neutrons are found in atomic nuclei and electrons orbit about the nuclei. The number of protons in the nucleus determines the type of atom. For example, a hydrogen atom has one proton and a helium atom has two protons.

Isotopes are forms of one type of atom that have different numbers of neutrons. For example, hydrogen has three isotopes. The most common by far is a hydrogen atom with just one proton in the nucleus. However, it is possible to have hydrogen atoms with one proton and one neutron (called deuterium) and hydrogen atoms with one proton and two neutrons (called tritium).

Some isotopes of atoms are "stable", i.e. they remain in the same form forever. Other isotopes are "unstable" and decay radioactively into something else--either other isotopes of the same atom or other atoms entirely. One of the most famous examples of this radioactive decay is some unstable isotopes of uranium changing (via several steps) to stable lead atoms. If an isotope is unstable it will have a certain characteristic "half-

life". The idea of a half-life is that if you have a sample of these unstable atoms (say, for example, 100 of them), half of the sample (50 in our example) will decay to a stable state in one half-life. Some unstable atoms have half-lives of only a few seconds; others have half-lives of billions of years.

Atoms which have equal numbers of protons and electrons are called neutral atoms. Atoms which have unequal numbers of protons and electrons are called ionized atoms.

Each type of atom gives off a distinctive spectrum, depending upon the number of electrons that surround the atomic nucleus. We see this spectrum when the atom gets excited due to the receipt of energy with a subsequent loss of the energy. We will illustrate what is going on by using the hydrogen atom as an example.

LECTURE 9

TOOLS OF THE ASTRONOMER

Introduction

Today we will talk about what sorts of things that astronomers use to study remote bodies in our solar system and beyond. Some types of instrumentation for making astronomical measurements were developed many centuries ago. What were the first observatories and what sorts of measurements were they interested in making? Space here for answer:

The Telescope

Galileo started the "modern era" in astronomical observations when he used the telescope to make observations of heavenly bodies in the early 1600's. The type of telescope that Galileo made is called a refracting telescope and it makes use of lenses in order to collect light and bring it to a focus. A sketch of a simple refracting telescope is shown below:

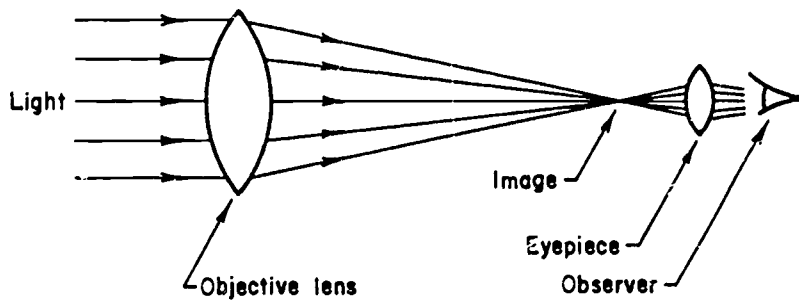

Sir Isaac Newton hit upon the idea of using mirrors instead of lenses to collect light and bring it to a focus. A reflecting telescope is shown in the diagram:

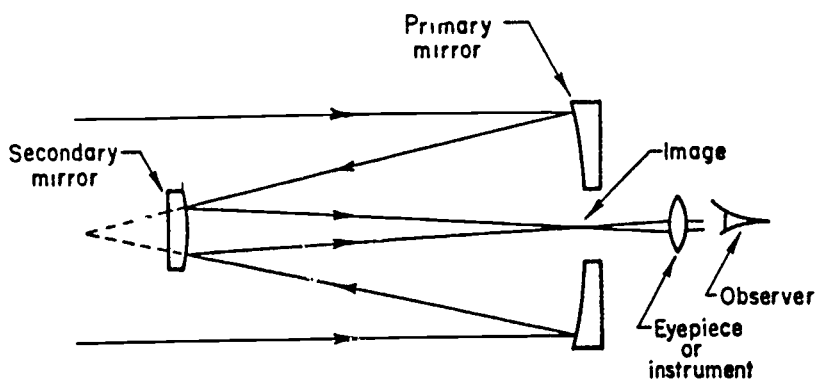

In a crude sense, telescopes should be thought of as "light buckets" or collectors. The bigger the collecting area, the more light you catch and the fainter the objects you will be able to see. However, you do care about the quality of the image and how much detail you are able to resolve in the planet, nebula, galaxy or whatever type of object you are observing. Hence, the lenses and mirrors that are used in astronomical telescopes must be of very high quality and purity.

To give you an example, the 200-inch reflecting (mirror) telescope at Mount Palomar required nine years of polishing the mirror surface to make it give good astronomical images. In fact, all large modern telescopes are reflectors rather than refractors because it is so much harder to optically figure and mechanically support a lens than a mirror. Mirrors can be supported on their entire backsides, whereas lenses can be supported only around their edges. Thus, the largest refracting telescope is the 40 inch at Yerkes Observatory in Williams Bay Wisconsin and the largest reflecting telescope is the 236 inch telescope in the Soviet Union.

Optical Instrumentation

Many people still have the stereotypical view of an astronomer bundled up against the cold nights, peering through his or her telescope and recording measurements on a piece of paper. Sorry Charlie, no tuna. That hasn't been true for over 100 years. Astronomers want to make some kind of a permanent record of their observations. They want to do this for several reasons.

1. There may be changes (motion, brightness) in the object over time.

2. There may be a need to compare one object with another or with a group of other objects (classifications, studies of physical properties such as temperature).
3. Different observatories may wish to observe the same objects (calibrations, motions, classifications).

The first device that provided a calibrated, permanent record was the photographic plate. Millions of photographic plates exist of star fields, galaxies, spectra, brightness measurements, planets, and other astronomical things. The photographic plate made possible great leaps forward in all branches of astronomy.

As time has passed, photographic plates have been replaced by electronic detectors which are much more sensitive. You can think of them as super-sophisticated television cameras. Most of these things have been developed for military applications and astronomers get them at the same time that they become available for use by business and industry in general. With the electronic detectors there are no more darkrooms or small pieces of glass that sometimes break. Instead, ground-based astronomers can be found lugging around large numbers of magnetic tapes and spending lots of time in front of computer terminals.

The "wave of the future" in optical astronomy seems to be going in two directions. The launch of the Hubble Space Telescope (HST), a 94 inch telescope in orbit is expected in 1988. At the same time, plans are being made to develop large ground-based telescopes (400 to 600 inches).

Tuning in to Radio Astronomy

Just prior to the outbreak of World War II, an electrical engineer got the bright idea of trying to detect radio emissions from the sun and other astronomical objects. He succeeded in doing so for a couple of cases (the sun and Jupiter), but further progress was stalled by the war effort. In the early 1950's, astronomers began in earnest to develop the field of radio astronomy. There are some big differences between radio and optical telescopes.

1. The type of collector is different. Certain types of metal or a combination of substances (asphalt and chicken wire, for example) will reflect radio waves. Radio waves can be collected and brought to a focus at a particular location, just like optical radiation.
2. The radio signals are weak so large collecting areas are required.
3. In order to resolve detail in sources, larger collecting areas are required for radio sources than for optical sources.

4. Radio astronomers must avoid wavelengths where there is interference from earth-based sources (radio stations, television, communications channels). Once they do this, there aren't many frequencies left for listening to the cosmos!

It turns out that many astronomical sources--from planets to galaxies have very interesting radio radiation. The trend in radio astronomy is towards large collecting arrays of radio receivers spread over large areas of the earth. For example, radio arrays in England and Denmark are used with antennae on the west coast of the United States to map radio sources in great detail.

The Infrared Heats Up

Beginning in the mid-1960's, detectors became available that astronomers could use to detect infrared astronomical sources. There are certain "windows" in the infrared where the molecules in the earth's atmosphere allow much of the radiation to get to the ground. However, high, dry sites where there is as little water vapor as possible provide the most desirable infrared sites (Mauna Kea on the island of Hawaii is one of the best sites). Also, in order to make the infrared detectors sensitive, they need to be cooled to very low temperatures, so special housings (called dewars) were developed so they could be kept at liquid nitrogen temperatures (very cold).

Again, when the new field of infrared astronomy was opened, there were tremendous advances. Many objects, particularly young stars and interstellar dust, radiate primarily at infrared wavelengths.

Since not all infrared wavelengths reach the ground, there are infrared telescopes that fly in high altitude aircraft and there was a major infrared satellite (IRAS-Infrared Astronomical Satellite) sent up to do a survey of the sky for nine months. There is an infrared telescope being built to fly occasionally on the Space Shuttle.

The Wavelengths Shortward of the Visible

Starting about 15 years ago, great progress was made in developing detectors for high energy, short wavelength electromagnetic radiation. In order to detect astronomical sources in these wavelength regions, it is necessary to get above the earth's atmosphere. Astronomical satellites have been developed to work in all the high energy wavelength regions and more are in progress. For example, the International Ultraviolet Explorer satellite has been working for over eight years taking spectra of astronomical sources. Other satellites such as the Einstein X-Ray Observatory lasted for just a couple of years.

Again, as these wavelength regions have opened, new discoveries and ideas have followed. Our views of the planets and the cosmos have changed remarkably and will continue to change as new observational techniques are developed and applied to astronomical observations.

Computers

Computers have played a crucial role in the acquisition and interpretation of astronomical observations. Some astronomers use computers to acquire and analyze data. Other astronomers use computers to make models of astronomical phenomena and to develop theoretical explanations. Some astronomers are high-level computer programmers, but most are not. Most of us are familiar with computers and can use them to acquire and reduce data with "canned" programs developed by other people, as well as write simple programs for our own use and do the inevitable work processing (writing up papers for publication, reports, grant applications).

LECTURE 10

SPACE ASTRONOMY

Introduction:

One of the exciting aspects of modern science is the ability of people on earth to study the earth itself and other bodies from vehicles that are in orbit around the earth or are sent out into the solar system. This lecture will set forth some of the basic principles of rockets and satellites and will discuss some highlights of the space programs of the United States and other countries.

Newton, Gravity, and the Laws of Motion:

In order to understand how rockets and vehicles such as satellites and the space shuttle can go up and stay in orbit, we must consider once again the work of Sir Isaac Newton on gravitation and the laws of motion. We have discussed the law of gravity,

$$F = G \frac{m_1 m_2}{r^2}$$

where G is the gravitation constant, m_1 and m_2 are the masses of the two bodies and r is the distance between the masses.

Newton's laws of motion are as follows:

1. A body continues at rest or in uniform motion in a straight line unless acted upon by some force.
2. The acceleration of a body is inversely proportional to its mass, directly proportional to the force, and in the same direction as the force.
3. To every action, there is an equal and opposite reaction.

The principles set forth in the laws are illustrated by what is happening in each of the diagrams below:

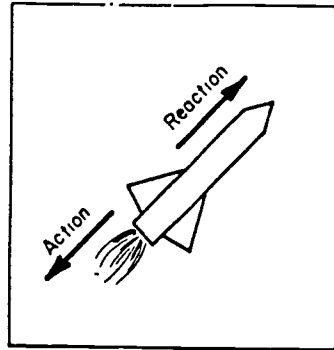
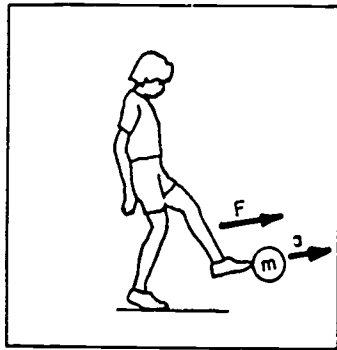

Now, let's look at the case of a "projectile" (could be a rocket) being fired.

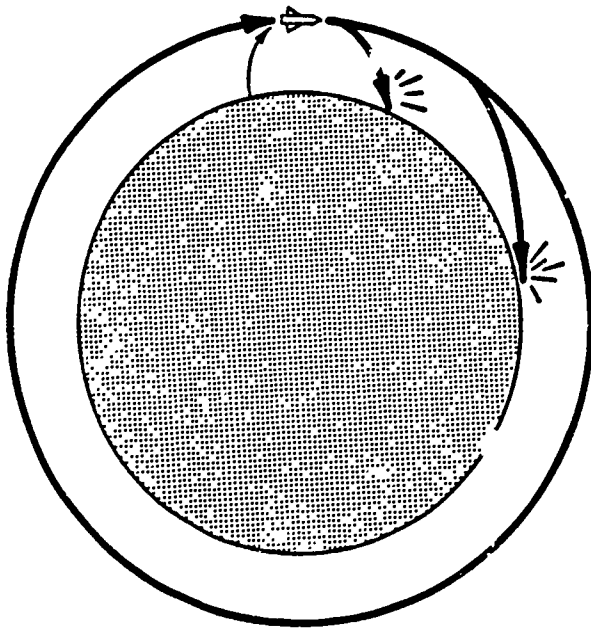

Questions:

1. What law of motion is operating to get the projectile fired in the first place?
2. Is acceleration involved in any way in this situation?

3. What force is making the projectile fall back to earth?

4. Suppose the earth weren't there? What would happen to the projectile?

5. Is a circle the only possibility for the orbit? What are the others (Hint: remember the work of Kepler)?

The diagram shows the possibilities for orbits:

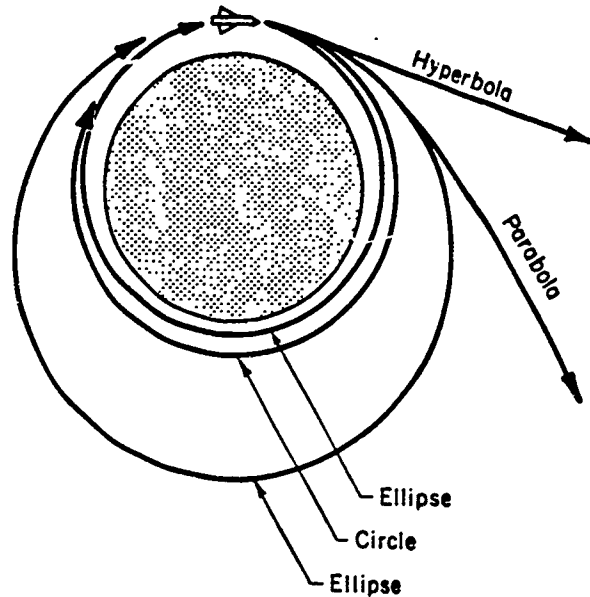

The velocity that it takes a rocket (or other small body) to escape from the gravitational field of a particular body is called the "escape velocity". It depends only upon the mass and the radius of the body. The formula for the escape velocity is

$$v_{\text{esc}} = \sqrt{\frac{2GM}{R}}$$

where G is the gravitational constant, M is the mass of the body from which the small body is escaping and R is the radius of the body. The escape velocity from the earth is about 25,000 mph (11.2 km/sec). Do you think that the escape velocity from the moon would be larger or smaller? Why?

Quite often interplanetary missions are first launched into "parking orbits" around the earth and are later fired off into interplanetary space at escape velocity. For reaching other bodies such as planets, Halley's Comet, etc. there are particular "launch windows", i.e. the mission can be accomplished only by doing the launch on particular dates. Why?

A Brief History of the Space Program:

Rockets were used in World War II, developed into lethal weapons by the Germans. Both the United States and Russia were very anxious to get their hands on this technology and some German rocket experts ended up in the USA after the war. The emphasis was on developing rockets as weapons. At the same time another interesting military project was underway. This was the Air Force project to develop high altitude, supersonic aircraft.

Early in 1957 the Russians launched the Sputnik satellite. The USA had been caught off guard. We didn't think that the Russians had the technology to do such a thing and we certainly didn't. The "space race" began. If you are interested in reading a popular book about the early history of the space program, *The Right Stuff* by Tom Wolff is pretty good.

The USA decided that rockets would be the way to go to get a satellite into orbit and we did it in 1958. Then the Russians were putting Cosmonauts into orbit and we followed with Astronauts. Then in the early 1960's President Kennedy declared that we should land Astronauts on the moon by the end of the decade. We did.

LECTURE 11

THE MOON

Introduction

Even with naked eye observations from the earth, two distinct areas can be observed on the lunar surface. The dark, smooth areas are called the maria (singular: mare), which is a Latin word for "seas". The lighter, rough areas are called the highlands. The maria turn out to be huge lava flow regions and the highlands have many impact craters from interplanetary debris hitting the moon long ago. We will consider some of the physical properties of the moon-- both what they are and how they are determined.

Moonfacts

The moon is a smaller, less massive body than the earth. It is roughly $1/4$ the size (diameter) of the earth, $1/81$ th the mass of the earth and has a surface gravity about $1/6$ th that of the earth. The moon has no atmosphere. Any ideas about how these things can be determined?

The Apollo Missions

In 1961 President Kennedy committed the United States to landing a human being on the moon by 1970. Why would he want to do this?

Prior to the actual lunar landings by humans, there were lunar orbiters which carefully mapped the surface of the moon and lunar landers to find out a little bit about the surface (for example, would the Apollo lander sink into a deep layer of dust on the lunar surface?).

The Apollo space vehicles had two parts. There was a vehicle which stayed in orbit around the moon with an astronaut aboard while the other part (the lunar landing module) went to the surface and returned with two astronauts aboard. The first lunar landing module, the Eagle, touched down on the lunar surface on July 20, 1969 and astronauts Neil Armstrong and Edwin Aldrin stepped out to start explorations. A list of the Apollo missions and a diagram of where the landings occurred are included in these notes (see attached sheets).

Lunar Geology

From the data gathered on the Apollo missions and by various lunar orbiters, it is possible to piece together an idea of the chemical composition and the history of the moon. For example, the Apollo missions returned a total of 840 pounds of lunar rocks and soils samples that can be studied directly in laboratories on the earth. The main thing that can be done with these samples are the following:

1. Determine the detailed composition (i.e., what types of minerals are present, what sorts of isotopes of various atoms).
2. Determine the ages of the rock and soil samples.

Doing each of these things requires years of detailed analysis, but such data will provide the most detailed information on lunar composition and history.

However, the data from the rock and soil samples come from only small parts of the lunar surface. In order to get the overall picture of how the moon formed and evolved, it is necessary to have more information on a more "gross" level.

Such data include the following:

1. Numbers of craters (and other features) on various parts of the lunar surface.
2. Information on moonquakes as gathered from seismographs installed on lunar surface during the various Apollo missions (this gives information mainly on the moons' interior).

The scenario that emerges is something like this:

1. There is some controversy about the first step in the formation of the earth-moon system approximately 4.6 billion years ago. The question is whether these bodies formed together or whether the moon happened to be "just passing by" and got captured by the earth. The "just passing by" hypothesis is unlikely because of the conditions necessary for such a capture. The "formed together" theories fall into two categories that can be pictured like this:
 2. Whatever happened initially, the moons' surface was molten until about 4.3 billion years ago. At that time the moon cooled fairly rapidly and the "heavy stuff" tended to settle to the center of the moon (geologists call this process differentiation). At that time there was lots of loose debris in the solar system that hadn't settled onto one body or another so the period between about 4.3 and 3.8 billion years ago was one of heavy cratering on the lunar surface. All of the rock samples from that era were fragmented (smashed to bits) by the impact of other solid bodies hitting the moon.
 3. During the era of heavy cratering some really big stuff hit parts of the lunar surface with sufficient energy that part of the crust temporarily became molten again. These events were responsible for creating the maria:

4. Since about 3.8 billion years ago nothing much has happened to the lunar surface. The occasional cratering event occurs, the sun bombards the moon with particles and radiation, but these are small changes. The moon is geologically dead--no crustal movements, no major sources of erosion, etc.

Table 1 Manned Apollo Missions.

Apollo Mission	Astronauts Commander LM Pilot CM Pilot	Date	Mission Goals	Sample Weight (kg)	Typical Samples	Ages (10 ⁹ y)
7	Schirra Eisele Cunningham	Oct. 1968	First test of command module in orbit			
8	Borman Lovell Anders	Dec. 1968	First manned orbit of moon in command module			
9	McDivitt Scott Schweickart	March 1969	First manned tests of lunar module in earth orbit			
10	Stafford Young Cernan	May 1969	Manned lunar module tests in lunar orbit. Descent to 17-km altitude.			
11	Armstrong Aldrin Collins	July 1969	First manned landing Mare Tranquillitatis	21.7	Mare basalts	3.48
12	Conrad Bean Gordon	Nov. 1969	Visit Surveyor 3 Sample Oceanus Procellarum (mare)	34.4	Mare basalts	3.15
13	Lovell Swigert Haise	April 1970	Destination Fra Mauro Explosion aborts landing			
14	Shepard Mitchell Roosa	Feb. 1971	Fra Mauro, Imbrium ejecta sheet	42.9	Brecchias	3.85
15	Scott Irwin Worden	July 1971	Edge of Mare Imbrium and Apennine Mts.; Hadley Rille	76.8	Mare basalts Highland anorthosite	3.28 4.05
16	Young Duke Mattingley	April 1972	Sample highland crust Cayley formation (ejecta) Descartes	94.7	Highland basalt Brecchia	3.86 3.95
17	Cernan Schmitt Evans	Dec. 1972	Sample highland crust Dark halo craters Taurus-Littrow	110.5	Mare basalt Highland brecchia Fractured dunite	3.77 3.86 4.48

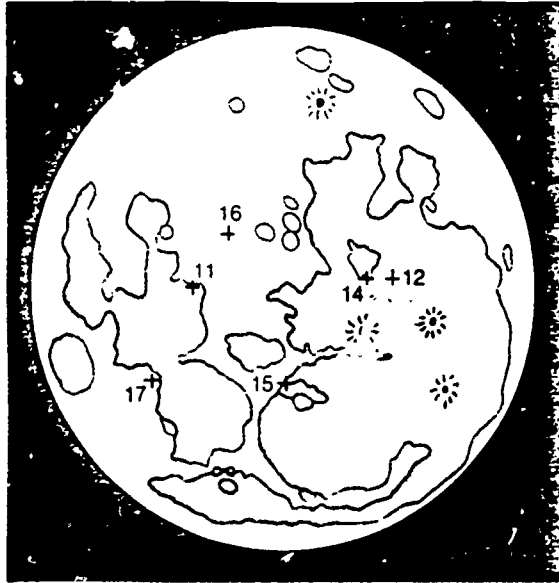

Figure 22-16 *The landing sites of the six Apollo missions that reached the moon.*

LECTURE 12

MERCURY AND VENUS

Mercury

In mythology Mercury was the messenger of the gods. The orbit period is 88 days and from our earth-based perspective we never see Mercury more than 28 degrees from the sun. Hence the planet is difficult to observe. In fact, it is only relatively recently (the 1960's) that the rotation period of Mercury (59 days) was determined. It is not a large planet. It has a diameter 40% larger than the moon and 38% smaller than the earth.

From the earth, the most detail you can see on Mercury with large telescopes looks like smudges. Therefore, our detailed information on the Mercurian terrain comes from the Mariner 10 spacecraft that swept by the planet three times during 1974/75.

Basically, the surface of Mercury shows many impact craters. The one striking difference between Mercury and the moon is that Mercury does not have the great dark lava plains (maria) like the moon. Mercury does have smaller areas of plains. The histories of Mercury and the moon are both basically those of solidification of the crust followed by heavy cratering which ceased long ago and no action since then. The differences can be understood in terms of Mercury's greater mass and size and the fact that it is made of heavier stuff than the moon.

Mercury has essentially no atmosphere. It does have just a little bit of hydrogen and helium that the planet captures from the solar wind (particles escaping from the sun) but it doesn't amount to much. The planet also has a very small magnetic field (about 1/100th as strong as that of the earth).

Venus

Venus was the goddess of love and beauty. Certainly this planet is a beautiful sight. It never gets more than 48 degrees from the sun, but it is so bright that it is easy to observe. However, observing it from earth doesn't do us that much good! We can learn some things--for example, the size of Venus is just a bit smaller than the earth (95%), the mass is less than that of earth (80%) and the average density of the earth and Venus is about the same. However, Venus is perpetually shrouded in opaque clouds that make it impossible for us to study the surface directly in the optical region of the spectrum.

A lot of what we know about Venus has been learned as a result of space probes, both from the USA and Russia. Two of the major American probes were called Mariner 10 (which also visited Mercury) and Pioneer Venus, which had both a Venus orbiter and atmospheric probes.

The Venusian atmosphere is very different than that of the earth. It is mostly carbon dioxide, with a little bit of nitrogen and some nasty things like sulfuric acid and hydrochloric acid (the earth's atmosphere is mostly nitrogen and a little bit of oxygen). In fact, the clouds that shroud the Venusian surface in mystery are made up mostly of sulfuric acid droplets.

Spacecraft that have reached the surface of the planet report a temperature of 745 K (880 F) and a surface pressure 90 times greater than that on the surface of the earth. The temperature on Venus is high at least in part because of the "greenhouse effect" in which heat from the sun gets trapped by the Venusian clouds. What is the greenhouse effect and can we think of other examples of such a phenomenon?

The temperature on the day and night side of Venus is pretty much the same. The rotation period of the planet is very slow, 243 days, which is even longer than the period of revolution around the sun (225 days).

We can study the surface of Venus indirectly via radar mapping from Venusian orbiters. The major type of terrain on Venus is a gentle, rolling plain. There are mountains and craters and valleys, but the spread from highest to lowest terrain on Venus is not so great as that on earth, as illustrated by the following diagram:

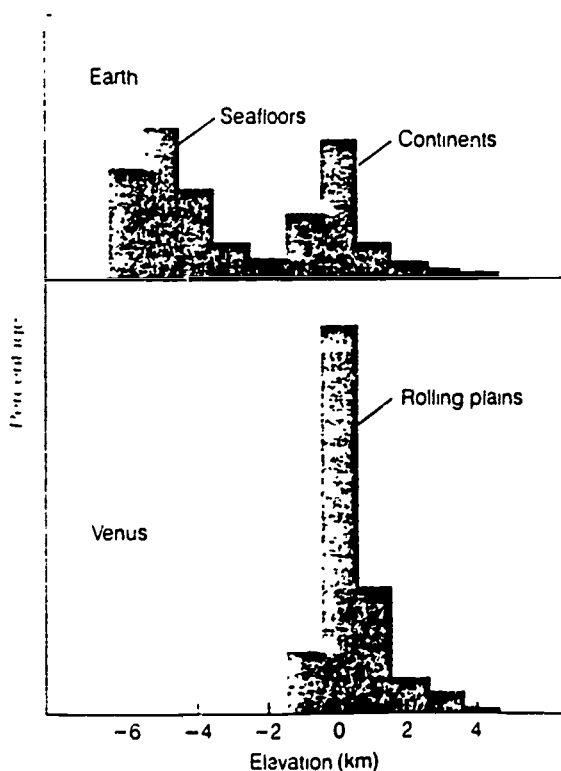

A map of some of the major features on Venus looks like this:

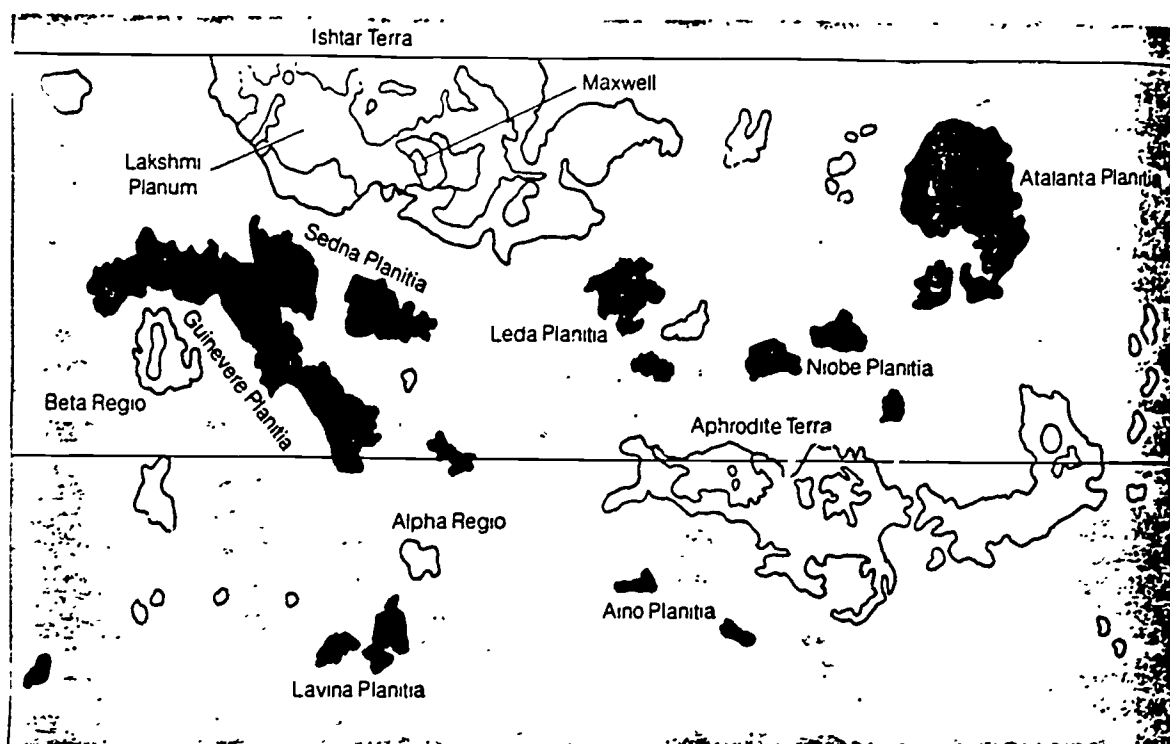

The reason for less height and depth in the features on Venus compared to earth may be that Venus does not have "plate tectonics" (continental drift), whereas the earth does have it. How does continental drift operate to change the crust of the earth?

There is evidence that the clouds of Venus hang out quite high in the atmosphere (10's of miles) and that there is a lot of lightning in the atmosphere. There is some tentative evidence that there may be active volcanoes on Venus, but more studies are needed. The latest "action" on Venus is that the Russians dropped off two probes into the Venusian atmosphere in June 1985, but the results of those probes have not been made public as yet. The USA hopes to send a very high resolution radar mapper to Venus in the 1990's.

The sketchy information that we have from the landers indicate basaltic (lava) rocks. Landers don't last long because of the unfavorable conditions on the Venusian surface.

LECTURE 13

MARS

Introduction

The reason that we devote an entire lecture to Mars is that it is a very interesting planet and we have managed to learn quite a bit about it. Mars was named after the god of war because of its distinctive red color. With even a small telescope features on Mars such as the polar caps and the distinctive "dark markings" which change with the Martian seasons can be seen. However, none of the amazing geological features of Mars can be seen with even the largest of earth-based telescopes.

Mars is a smaller planet than the earth (53% of the diameter and 11% of the mass of the earth). The rotation period happens to be similar, 24 hours and 40 minutes. The Martian atmosphere is mostly carbon dioxide with a little bit of nitrogen and the atmospheric pressure at the surface of the planet is only 1% as great as that at the surface of the earth. It is colder out at Mars. Temperatures occasionally reach 62 F during the day, but the night temperatures drop to about -126 F.

Canals and All That

Mars holds a little bit of a special place in the human imagination because of the early reports of "canals" on Mars. In 1877 an Italian astronomer named Schiaparelli reported the presence of very thin, straight lines on the Martian surface. He used the Italian word "canali", which means "channels" to describe these features, but "canali" was translated as "canals" by English-speakers, particularly the popular press. From then on many people thought that life on Mars was a foregone conclusion. Percival Lowell founded an observatory in Flagstaff, Arizona in 1894 to study Mars (as well as to look for a 9th planet) and he produced many maps of Martian canals. All of these things were figments of the imagination! With much larger telescopes than they had at the time, plus detailed mapping of the Martian surface by orbiters, there is absolutely no evidence for "canals". This is a classic example of scientists (and others) fooling themselves.

The Exploration of Mars

The space exploration of Mars began in the 1960's, but the most exhaustive explorations were done by the Mariner 9 (1971) and the Vikings 1 and 2 (1976) missions. Complete mappings of the Martian surface and the satellites of Mars have been done.

Vikings 1 and 2 each had a lander which was able to take photographs on the surface, measure temperatures, densities, wind velocities, atmospheric composition and other physical properties of the Martian surface. The landers had experiments to try and ascertain whether life exists or has existed on Mars.

The southern hemisphere of Mars has many impact craters and would remind you of many areas on the moon or Mercury. The northern hemisphere has fewer impact craters and some spectacular features. Mars has several volcanoes, including the largest volcano known in the solar system. Olympus Mons is comparable in size to the state of Texas. It towers 25 km (16 miles) above Martian plains. The largest volcano on earth, Mauna Loa, sticks up 10 km (6 miles) above its base on the Pacific Ocean floor. Olympus Mons and all the other Martian volcanoes are shield volcanoes (like Mauna Loa) and not cones like the Cascade volcanoes (Mount Rainier, Mount Hood, etc.). There is no evidence for current volcanic activity.

Another unique feature on the Martian surface is the Valles Marineris (Mariner Valley). This valley is 4000 km (2500 miles) long and, at its widest, 600 km (400 miles) wide and 6 km (4 miles) deep. That makes it longer than the distance from New York to Los Angeles and about four times deeper than the Grand Canyon.

On the surface of Mars there are a number of "dry channels" which look like they have been carved by some fluid, most likely water. They look like the winding river channels on the surface of the earth or the "channeled scablands" of Eastern Washington. Right now there is no evidence for any substantial quantities of liquid water on the Martian surface, but there may have been more in the past.

The polar caps of Mars are made of frozen carbon dioxide (dry ice) with some frozen water beneath. The seasonal changes in Martian dark markings turn out to be caused by winds shifting different colored soils around.

Life on Mars?

Each of the Viking landers carried three experiments to search for life on Mars. All of these experiments involved scooping up samples of Martian soil and looking for any signs of life like photosynthesis, respiration or reproduction. For example, in one experiment a sample of Martian soil was given a broth of nutrients and was monitored for changes that would indicate that living organisms were present. Some changes were found in one experiment, but they occurred too quick for living organisms to have caused them. The other two experiments didn't find anything at all.

Even more discouraging is that there were no organic molecules found in the Martian soils at either of the landing sites. Organic molecules are needed before you can even think of starting to make the "building blocks" of life. So it does not seem likely based on the present evidence that life exists or ever has existed on the surface of Mars.

What goes on beneath the Martian surface is another matter and one that is difficult to address with the present technology. There appears to be a possibility that there is quite a bit of water in frozen form beneath the porous Martian surface rocks (mostly basalts). If the Martian climate changes and warms up, Mars could be quite a different place than what we see at present. One has only to look at the earth, where we have evidence for dramatic climatic changes (ice ages, etc.) to see that Martian climatic changes are possible.

The Satellites of Mars

Mars has two small satellites, Phobos and Deimos (Fear and Dread, the attendants of the god of war). These are elongated bodies only a few miles in size. They are heavily cratered and are made of dark material that doesn't reflect much light. Phobos has one large crater from the impact of a body that was almost (but not quite) large enough to shatter that satellite into pieces.

LECTURE 14

JUPITER AND SATURN

Introduction--The Jovian Planets

The planets that we have studied so far (Mercury, Venus, Mars--and also the earth) are quite different in many respects than the planets further out in the solar system. They are called the terrestrial planets. The next four planets out (Jupiter, Saturn, Uranus and Neptune) are called the Jovian planets (we leave Pluto out of this discussion for now). Some differences between the terrestrial and Jovian planets are summarized in the following table:

	<u>Terrestrial</u>	<u>Jovian</u>
Diameter and Mass	small	large
Density	high	low
Number of Satellites	few	many

Thus, we now enter a different part of the solar system where the planets receive considerably less sunlight and are composed of a larger fraction of the lighter elements in the universe (such as hydrogen and helium).

Jupiter

Jupiter is the most massive planet in the solar system. It has a mass 318 times the mass of the earth and a diameter 11 times larger than that of the earth. The rotation period of Jupiter is approximately 9 hours and 50 minutes.

The interior structure of Jupiter is very different than that of a terrestrial planet. Models for the interiors of both Jupiter and Saturn are shown in the following diagram:

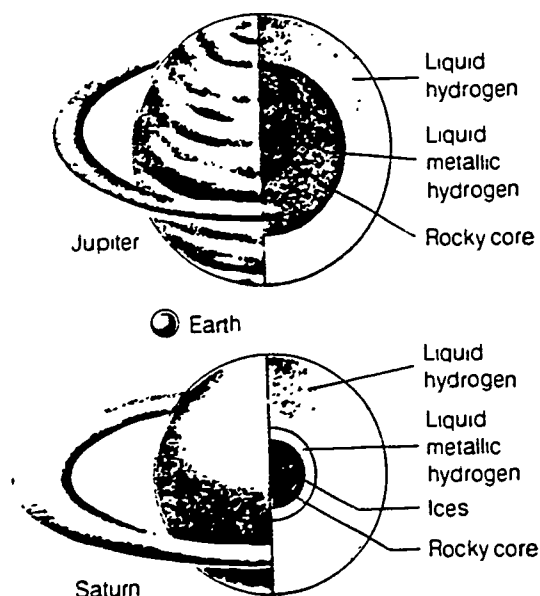

These models have been inferred from various kinds of observational data. Notice that these planets have only a relatively small rocky core. Most of the mass of the planet consists of liquids and a gaseous atmosphere.

In the visible region we can only observe the cloud tops of Jupiter. The temperature out there is cold--about 150 K (-190 F). The Jovian atmosphere shows many interesting features--bands of various colors and oval features such as the "Great Red Spot". The Great Red Spot is many times larger than the earth (about 14,000 km wide by 40,000 km long) and has been observed for over 300 years. Astronomers are still not clear about exactly how it operates, but it appears to be some sort of a gigantic cyclonic disturbance (high pressure area). Material circulates around it. Smaller spots come and go, but the Great Red Spot somehow resists breaking up.

Radiation Belts

Jupiter's magnetic field is about 20 times stronger than the earth's magnetic field. One consequence of a planet having a magnetic field is that it develops "radiation belts" where charged particles from the sun are trapped around the planet. In the case of the earth, we call our radiation belts the Van Allen belts. Jupiter's radiation belts are many times stronger than the Van Allen belts. The charged particles in the Jovian radiation belts emit a lot of radiation in the radio region of the electromagnetic

spectrum. To give you an idea of the size of Jupiter's radiation belts, if we could see them with the naked eye, they would cover 5 degrees in the sky (the full moon is half a degree so they would be ten times larger than the full moon).

The Galilean satellite Io has its orbit well within the radiation belts. There are some poorly-understood interactions taking place between Io and the particles in the radiation belts that cause occasional "radio noise storms" from these regions of the Jupiter environment.

The aurora (northern lights) on the earth is caused by the charged particles in the radiation belts. Jupiter has very strong aurorae.

Jupiter's Ring

Jupiter has a very thin ring that is nowhere near as elaborate as the ring system of Saturn. The Jovian ring was discovered during the Voyager 1 (1979) flyby of Jupiter and Voyager 2 took more detailed photographs a few months later. The ring is made up of dark, reddish material--probably a broken-up small moon of Jupiter.

The Satellites

Jupiter's satellites seem to fall into two distinct groups. At last count 17 moons had been discovered orbiting around Jupiter and most of them are small (only a few miles in size) and dark like the Martian moons Phobos and Deimos. However, the four Galilean satellites are each fascinating worlds in their own rights and say a lot about the history of the solar system. We will discuss each of them individually.

1.

Io--Io is just slightly larger than the earth's moon. It is orbiting close to a very massive planet so the tidal stresses on the interior of the satellite are great and cause it to have a hot interior. It is evident from the Voyager pictures what is taking place on Io. It is a satellite covered with volcanoes and lava flows. Eight active volcanoes were discovered by the Voyager missions. The surface of Io is being changed continually by volcanism. In addition, volcanic gases and some solid material is escaping from the satellite and being left behind in the Io orbit.

Actually, the tidal stresses cannot account for the entire story of what causes Io to have a hot interior and volcanic activity. Io moves through the Jovian

magnetic field and the satellite carries an electric charge. A huge electric current flows between Jupiter and this moon, so Io is really wired! This is the only place in the solar system besides the earth where active volcanoes are known for sure to exist.

2.

Europa--Europa is just a little bit smaller than the earth's moon. Europa is far enough away from Jupiter that it doesn't get involved in all the processes that make Io so unusual. Europa appears to be a rocky satellite that is covered by a thin crust of ice. The surface of Europa looks like a cracked egg. It doesn't have any craters. How could this be explained?

3.

Ganymede--Ganymede is slightly larger than the planet Mercury. It has a varied terrain. About 60% of the surface consists of a "grooved terrain" that consists of grooves that are about 100 km long, a few km apart, and a few 100 meters high. There are a few craters in these areas but not very many. The rest of the surface is a darker, more heavily cratered terrain.

4.

Callisto--Callisto is just about the same size as the planet Mercury. It is the most heavily cratered body in the solar system.

Relative sizes and models for the interiors of the Galilean satellites are shown below:

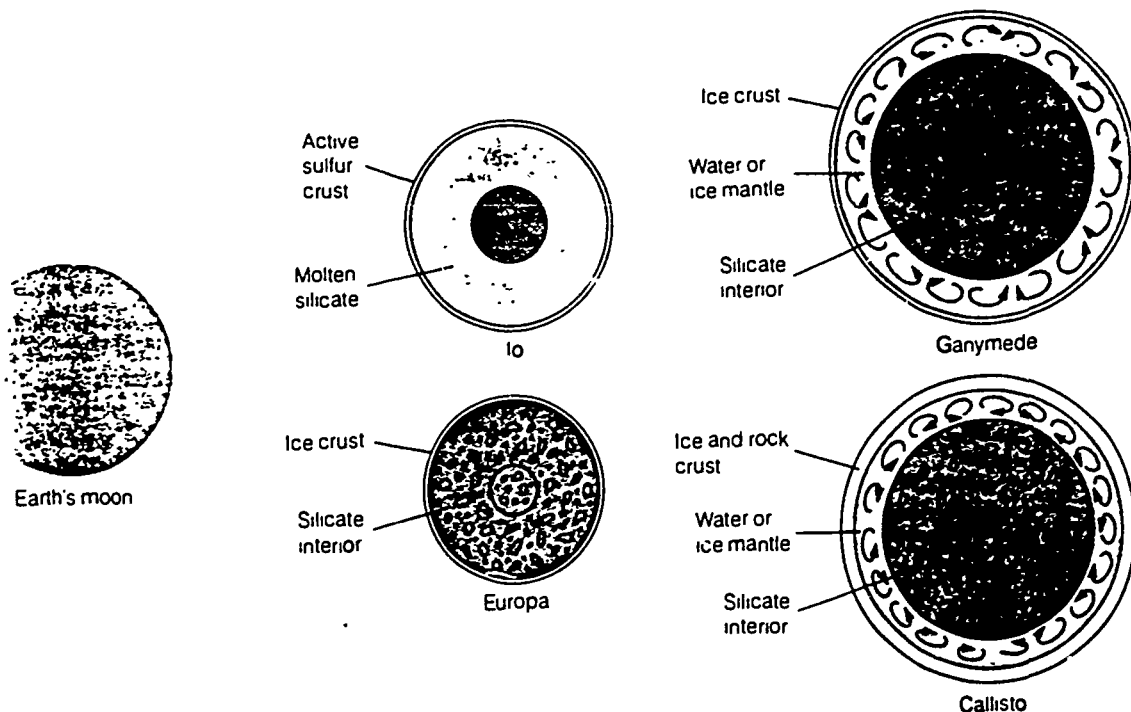

Saturn

Saturn consists of about the same sorts of things as Jupiter but it is colder where Saturn is so the cloud features are formed lower down in the atmosphere of Saturn. Some of the chemical reactions that produce colors in the Jovian cloud features don't operate at the lower temperatures on Saturn. Saturn has the lowest density of any of the planets (0.7 gm/cm^3 --less than the density of water). Saturn also has a magnetic field and strong radiation belts.

The Rings

A cross-section of the Saturnian rings are shown in the diagram:

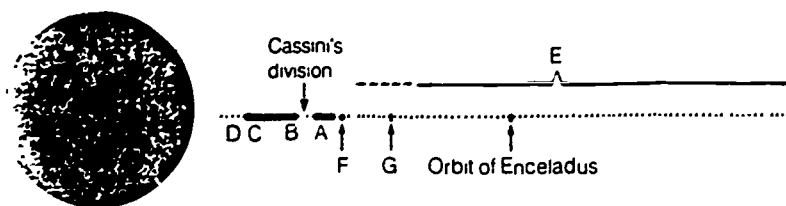

(Incidentally, if you were to fly from the inner edge of Saturn's rings to the outer edge in a commercial airplane, it would take over 5 days to make the journey.) The Voyager photographs have shown that there are actually several thousand individual ringlets that make up the ring system of Saturn. The particle sizes and densities vary in different parts of the ring system. Some sections are composed primarily of microscopic particles, while others are made up of larger material (rocky chunks, a few boulders). The ring system is very thin--only a few 100 meters thick. It is

still believed that the rings represent one or more broken-up satellites.

Satellites

Saturn has its share of small, dark satellites, just like Jupiter. However, the significant moons of Saturn are larger in number and different in character than the four large moons of Jupiter. Saturn is less massive than Jupiter by quite a lot and the satellite systems that formed around these two planets reflect in part the evolutionary histories of the planets themselves. A diagram of the relative sizes of the Saturnian satellites is as follows:

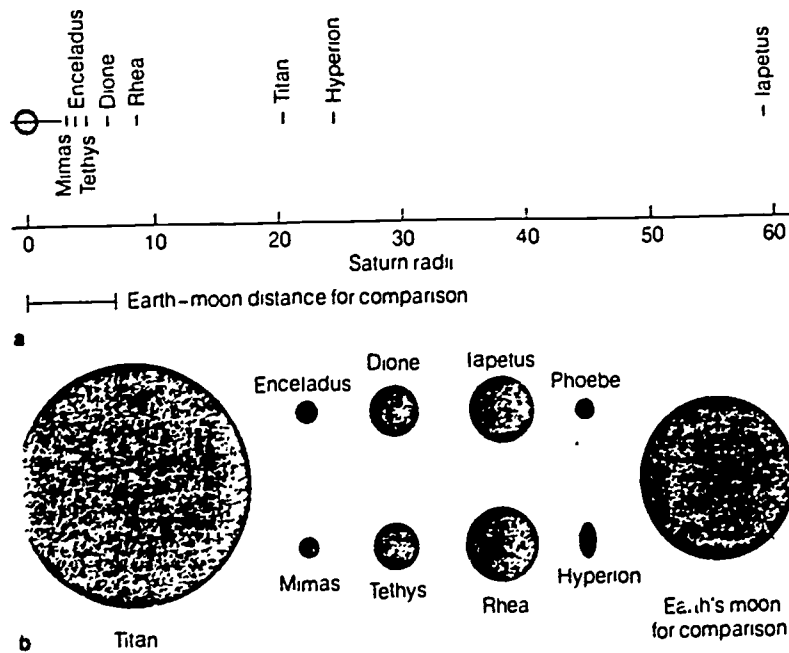

1. Titan--Titan is larger than the planet Mercury. It has a thick atmosphere made up primarily of nitrogen. Is this a surprise? Why?

2.

The rest of the moons--We could spend a week discussing the similarities and differences between the other moons. Studies of their surfaces represent real breakthroughs in comparative planetology. Some of them have old, cratered surfaces. Others have fresh, icy surfaces with few craters. Some are combinations. Iapetus is puzzling because it has dark material on one side but not the other.

From both the Jovian and Saturnian satellites astronomers have learned a lot about the history and evolution of the solar system. This investigation is being continued with the recent data from the planet Uranus with its ring and satellite systems.

LECTURE 15

THE OUTER PLANETS

Introduction

The planets out to Saturn were known to the ancients and can be observed easily with the naked eye. The three outer planets were discovered in more recent times. Comparatively little was known about these worlds until recently. The most notable event is the Voyager fly-by of Uranus in January 1986 which returned much new and surprising information about the seventh planet.

Uranus

Uranus was discovered by an English musician, William Herschel, who enjoyed astronomy as a hobby. The discovery was made totally by accident in the year 1781. Herschel thought at first that the object he was observing might be a comet (it was moving a little with respect to the background stars from night to night), but calculations of the orbit showed that it was a planet moving around out beyond the orbit of Saturn.

Herschel wanted to name the new planet Georgius Siderius (George's Star) after the reigning king of England, but was persuaded that a classical name would be more appropriate. King George rewarded Herschel by making him a lord with the title "Sir" and by giving him an observatory. Herschel loved to make telescopes and spent the rest of his life primarily making astronomical observations. Herschel's sister Caroline was also a musician and an enthusiastic astronomer. She was the first woman to be credited with the discovery of a comet.

Uranus--A "Post-Voyager" View

Prior to the Voyager fly-by of Uranus in January 1986, a few basic things like the size (4.1 times that of the earth) and mass (15 times that of the earth) of the planet were known. One very interesting thing is the inclination of the equator of Uranus to the orbit around the sun, which is shown in the diagram.

The planet was known to have five satellites. In 1977 a ring system was discovered from earth-based observations. Very few details were available on any of these things.

The Voyager 2 spacecraft was meant only for visits to Jupiter and Saturn. The experiments aboard the spacecraft were optimized for the relatively high light levels available at these planets. Both Voyagers 1 and 2 performed spectacularly on their missions to the gas planets. Voyager 1 was on an orbit that took it away from the plane of the planetary orbits after it went by Saturn. However, Voyager 2 happened to be on an orbit that could be modified to take it first to Uranus and then to Neptune.

The Voyager 2 swept by Uranus in a matter of a few hours on January 24, 1986. Pictures had to be taken and experiments had to be done QUICK. There was no choice in the matter. A lot of the information taken during the height of the fly-by was stored on tape recorders on board the spacecraft and was "played back" later as the spacecraft left the Uranian system. Results are just starting to come out. It will take years to analyze and interpret the data.

Some of the preliminary results are as follows:

1. Rotation Period--A simple thing like the rotation period of Uranus wasn't known very accurately. The rotation period was determined by measuring features in the Uranian cloud bands and by using the Uranian magnetic field. The rotation period is 17.24 hours.
2. Magnetic Field--Uranus has a magnetic field comparable in strength with that of Saturn. The interesting thing about the Uranian magnetic field is that the angle between the rotation axis and the magnetic field is 55 degrees. The other planets that are known to have magnetic fields (Mercury, Earth, Jupiter, Saturn) all have angles that are less than 20 degrees (see diagram).
3. The Uranian atmosphere is a mixture of ice and gaseous forms of molecules such as water, methane and ammonia. The temperature of the atmosphere is uniform over the whole planet, with the cloud tops having a temperature of about 52 K and warming to higher temperatures beneath.
4. The Uranian Ring System--From the earth-based observations it appeared that Uranus has a system of 9 rings. This was confirmed by the Voyager 2 observations. The rings are made of very dark material and are very thin - only 100's to 1000's of feet wide. On one frame taken after Voyager 2 had crossed the ring plane and the rings were backlit with sunlight, you could see some ringlets in addition to the 9 prominent rings.

and until March 14, 1999 Pluto will be closer to the sun than Neptune. Seen edge on, Pluto's orbit looks like this:

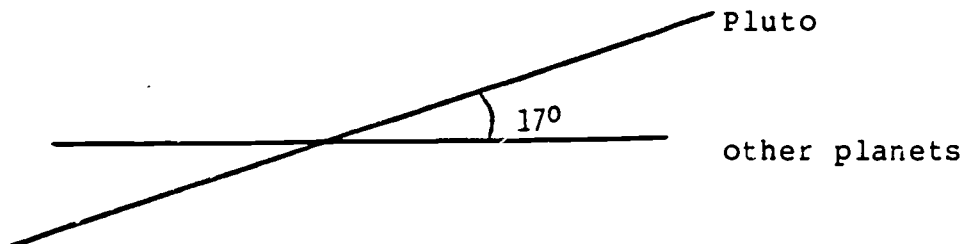

The orbital characteristics may be telling us something about the nature of Pluto. It is possible to make some general arguments for the hypothesis that Pluto may be an escaped satellite of Neptune.

However, the discovery made in 1978 that Pluto does itself have a satellite did quite a bit to deflate the "escaped satellite" notion. The satellite of Pluto is called Charon. Using the orbital characteristics of Charon, it is possible to determine the mass of Pluto. The planet is not very massive-- 0.002 times as massive as the earth. The density of Pluto is low--0.8 gm/cm³ (less than water).

A Tenth Planet?

Elaborate searches have been conducted for a trans-Plutonian planet with null results to date. If there were anything substantial out beyond Pluto, say larger than a few 100 km (Pluto's diameter is about 3000 km), we should have found it.

5. New satellites--Over a dozen new Uranian satellites have been discovered so far on the Voyager 2 images and nobody would be surprised to find a few more. These satellites are small (few km) and made of dark material.
6. Close-up images of the large satellites--Voyager got good images of the five large moons of Uranus. All of the satellites have dark, icy surfaces. Oberon is heavily cratered. Titania is heavily cratered and has fracture patterns. Umbriel is dark and relatively featureless. Ariel has diverse terrain, with valleys, craters and plains. By chance Voyager got especially high resolution images of Miranda. Miranda has a bizarre surface with few craters, indicating continuing activity of some sort that keeps changing the surface features. The satellite's surface is marked with some "grooved" features, one of which is roughly rectangular and has been dubbed the "racetrack". There are many channels and some of the highest, steepest cliffs on any body in the solar system. If you had asked planetary scientists in advance of the Voyager 2 fly-by, most of them would have predicted that the Uranian satellites would be simple cratered, icy surfaces. They are far more complex than that!

Neptune

Voyager 2 is now on its way to Neptune and should arrive in the summer of 1989. Neptune was discovered in 1846 by mathematical prediction. An Englishman (Adams) and a Frenchman (Leverrier) made predictions of the position of the eighth planet and they weren't aware of each other's work. Leverrier was the first of the pair to talk an observatory into looking at the predicted position (the Berlin Observatory). The planet was discovered immediately.

Neptune has a diameter about 4 times larger than the earth and a mass 17 times larger. The rotation period is thought to be about 18.5 hours. The planet may have a ring system. Neptune is known to have two satellites, including Triton, which is about the same size as the earth's moon and may have an atmosphere.

Pluto

The search for a 9th planet began practically the day after Neptune was discovered and ended early in 1930 when Clyde Tombaugh (he was a high school student) discovered Pluto at the Lowell Observatory. Pluto's orbit is much more elliptical than the orbits of the other planets. In fact, since January 21, 1979

LECTURE 16

COMETS, METEORS, ASTEROIDS

Introduction

Comets, meteors and asteroids are interesting bodies but they are not very massive. They are "small debris" in the solar system.

Comets--Names and Orbits

The Latin name for these bodies was "stella cometa" which translates as "hairy star". Comets were considered to be evil omens and they were thought to be part of the earth's atmosphere--some sort of poisonous vapor. Comets are named after their discoverer(s), with up to three people sharing the credit. For example, if people named Tomita, Gerber and Honda report the discovery of a new comet essentially simultaneously to the Central Bureau for Astronomical Telegrams at the Smithsonian Astrophysical Observatory, then the comet bears the name Comet Tomita-Gerber-Honda. An exception to this is Halley's Comet. Halley didn't discover the comet, but he did work out the characteristics of the orbit.

Most comets have orbits that carry them far beyond the sun (yet still attached to the solar system) with orbit periods of up to millions of years. There are a few "periodic comets" which have orbit periods of a few years. The comet with the shortest orbit period is Comet Encke with a period of 3.26 years. Halley's Comet is a member of the "periodic" family of comets (orbit period 76 years).

Most comets have orbits that are extremely elongated ellipses (orbit sizes of several 10's of thousands of astronomical units) and long orbit periods (millions of years). If you were to look at the orientations of these comet orbits with respect to the planes of the planetary orbits, you would get a picture that looks like this (not to scale):

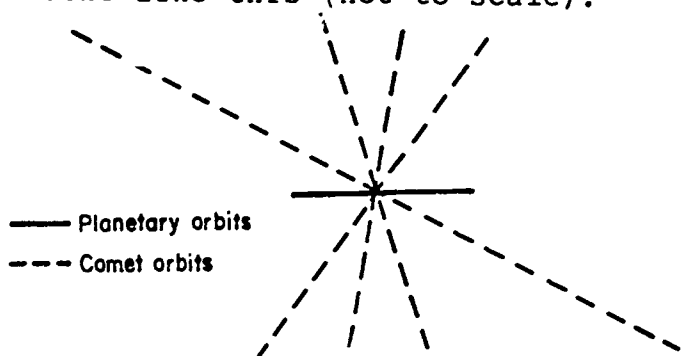

What do these observations suggest about where comets are located (where they come from)?

Occasionally, one of the long period comets happens to get close to one of the planets. In such a case, the orbit of the comet will be changed as a result of the comet getting close to the gravitational field of the planet. It will be the comet that experiences the change and not the planet. Why?

One of several things can happen as a result of such an encounter. The two most likely are

1. the comet orbit could be changed into a hyperbola and the comet would escape from the solar system, never to be seen again.
2. the comet orbit could be changed into an ellipse of a different eccentricity (amount of elongation), orientation in space and orbit period. It might, for example, become a shorter period, smaller orbit that is almost in the same plane as the planets of the solar system. We know that this has happened to a small number of comets such as Halley's-- they are the "periodic comets".

The Physical Nature of Comets

Comets are conglomerations of ices and small solid particles. A good way to think of them is to picture a "dirty snowball". Compared to planets and satellites, there isn't much material in a comet and they aren't very large. The masses are estimated to be one trillionth the mass of the earth and a typical comet nucleus is only a few miles in diameter.

The parts of a comet are shown in the diagram:

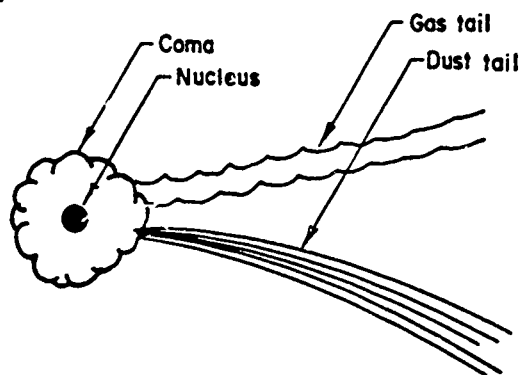

When a comet is far from the sun, it only has a nucleus--no coma and no tails. As a comet gets in close to the sun (typically within about 5 astronomical units) the radiation from the sun starts to heat up the material in the nucleus (it gets warmer as you get closer to the sun) and material starts to evaporate off of the comet nucleus into the coma and later gets pushed away

from the coma and into the tail. Another process that operates is that particles from the sun (mostly protons) hit the comet nucleus and knock material off of the nucleus and into the coma and tail regions.

Thus, as a comet gets closer to the sun it develops a coma and then one or more tails. The tails are composed of gas and dust that have been lost from the nucleus. At their best, comae can be several hundred thousand miles in diameter and tails can be up to millions of miles in length. Keep in mind that while their sizes are large, there is hardly any mass involved.

Each time a comet comes close to the sun it does lose some material. How much material it loses depends roughly on how close to the sun it comes. The point is that comets don't last forever. Some comets have been observed to break up. Also, some comets have been observed to strike the sun (believe me, the sun didn't feel anything).

Halley's Comet

We will reserve discussion of Halley's Comet for the laboratory. The return of Halley's Comet in 1985/86 provided a lot of new information on the nature of comets.

Meteors, Meteorites

Have you ever seen a "shooting star" or a "falling star"? These are popular terms for meteors. Meteors are small particles of interplanetary dust entering the earth's atmosphere. The vast majority of meteors are about the same size as a grain of sand. From the streak of light that you see, you might get the impression that the meteor is burning up in the earth's atmosphere. This is not happening. What does happen is that there is friction between the meteor and the molecules of gas in the earth's atmosphere. Some of the energy of motion of the meteor is transferred to the molecules of gas. The molecules of gas respond by getting excited and then radiating light. The meteor slows down as it loses energy. Eventually the meteor gently floats down to the surface of the earth. The earth accumulates a couple of tons of meteoric material per day over the whole surface of the earth (not much). If you go looking for meteoric "dust" in places where it would tend to not get disturbed (drag the ocean bottom, look in some places in Antarctica) you will find lots of it.

On a typical day, a couple of meteors that are large enough to be recognized as interplanetary rocks make it to the ground somewhere on the earth. These are called meteorites. There are a couple of basic types of meteorites:

1. Stones
2. Irons

The ages of meteorites are all about 4.6 billion years. They are fragments of bodies such as asteroids and (occasionally) other bodies such as the moon, Mars, etc.

Meteor Showers

Meteor showers occur at particular times of year and the meteors appear to come from a particular direction out in space.

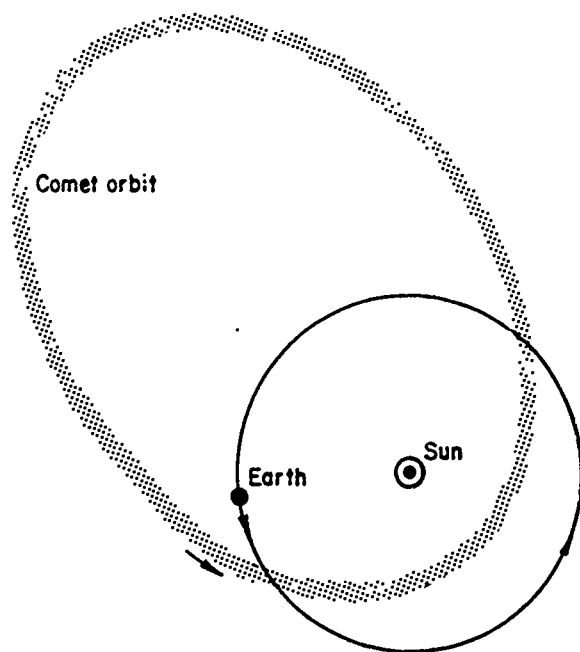
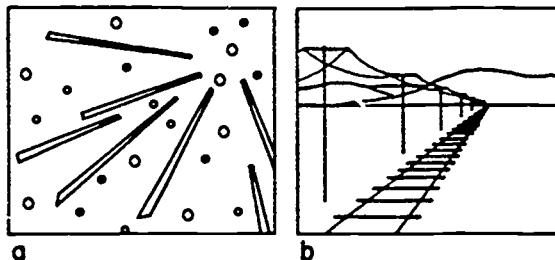

Meteor showers occur when the earth intersects the orbit of a comet. The shower meteors are some of the small, solid debris left behind in the orbit of a comet. A list of the major yearly meteor showers is as follows:

METEOR SHOWERS

Shower	Dates	Hourly Rate	Radiant		Associated Comet
			R.A.	Dec.	
Quadrantids	Jan. 2-4	30	15 ^h 24 ^m	50°	
Lyrids	April 20-22	8	18 ^h 4 ^m	33°	1861 I
η Aquarids	May 2-7	10	22 ^h 24 ^m	0°	Halley?
δ Aquarids	July 26-31	15	22 ^h 36 ^m	-10°	
Perseids	Aug. 10-14	40	3 ^h 4 ^m	58°	1982 III
Orionids	Oct. 18-23	15	6 ^h 20 ^m	15°	Halley?
Taurids	Nov. 1-7	8	3 ^h 40 ^m	17°	Encke
Leonids	Nov. 14-19	6	10 ^h 12 ^m	22°	1866 I
Geminids	Dec. 10-13	50	7 ^h 28 ^m	32°	

Asteroids

Asteroids are fairly small (a few km in size) rocky bodies with orbits located mostly between the orbits of Mars and Jupiter (the Asteroid Belt).

LECTURE 17

THE SUN

Introduction

The sun is a typical star. Most stars are large balls of hot gas held together by gravity and generating energy in their interiors by thermonuclear reactions. Because the sun is much closer to us than any other star, we can see and study a lot of details such as features on the solar exterior. The diameter of the sun is 860,000 miles (107 times that of the earth). The earth-moon system drawn to the same scale as the sun would look like this.

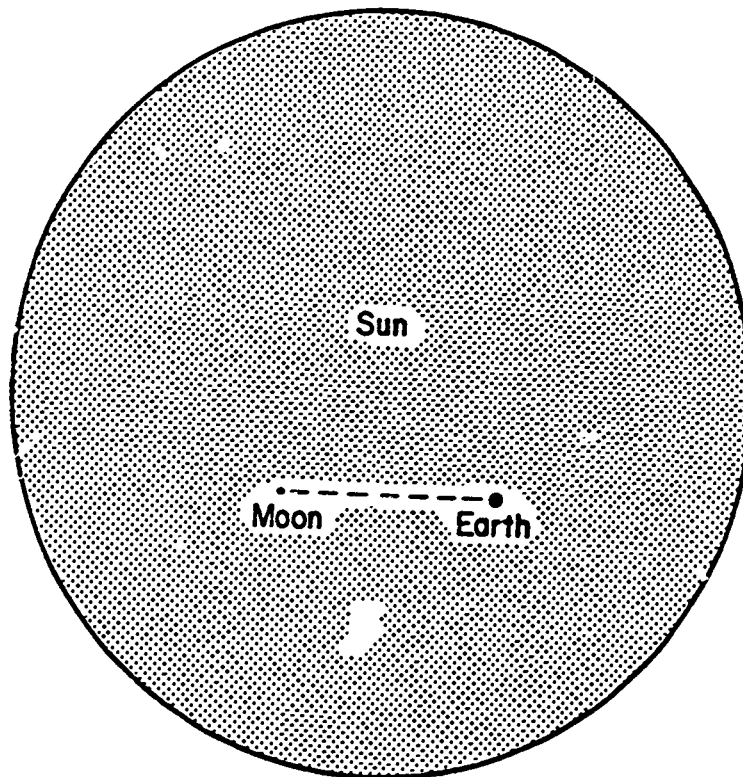

Solar Energy Generation

The surface temperature of the sun is 5800 K and the interior is much hotter. The sun gets its energy from the thermonuclear fusion of hydrogen into helium through a series of nuclear reactions. Have you ever heard of converting matter to energy (and vice versa)? Einstein developed the formula $E = mc^2$, where E is energy, m is mass and c is the velocity of light. Notice that a small amount of mass yields a large amount of energy.

Four hydrogen atoms are fused into one helium atom. The mass of four hydrogen atoms is slightly more than the mass of one helium atom.

$$\begin{array}{r}
 4 \text{ hydrogen atoms} = 6.693 \times 10^{-27} \text{ kg} \\
 1 \text{ helium atom} = 6.645 \times 10^{-27} \text{ kg} \\
 \hline
 \text{difference in mass} = 0.048 \times 10^{-27} \text{ kg}
 \end{array}$$

The extra mass is converted to energy.

$$\begin{aligned}
 E &= mc^2 \\
 &= (0.048 \times 10^{-27} \text{ kg}) (3 \times 10^8 \text{ m/sec})^2 \\
 &= 0.43 \times 10^{-11} \text{ joules}
 \end{aligned}$$

This is a small amount of energy, but since many of these reactions occur at the same time, a significant amount of energy is generated. The sun transforms 5 million tons of mass into energy every second.

The Interior of the Sun

Energy generation by thermonuclear reactions takes place only in the deep interior of the sun where temperatures and pressures are very high. The energy is transported to the surface through the rest of the gas. The solar surface is called the photosphere. A diagram of the interior would look something like this:

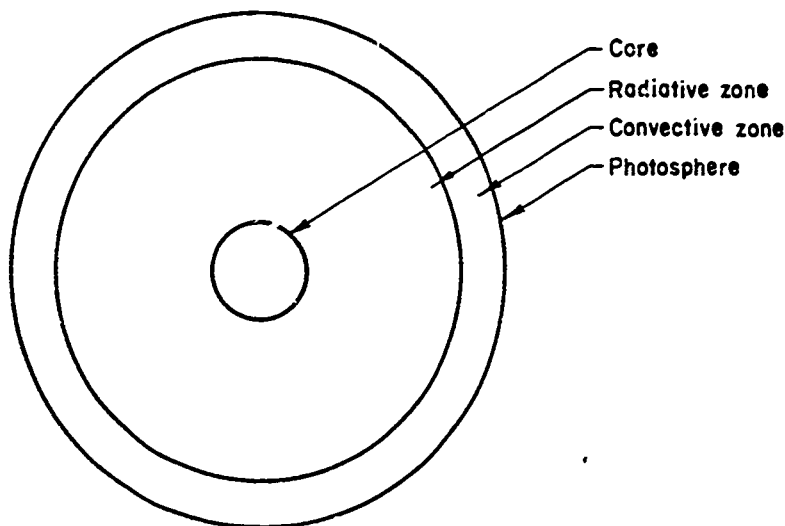

Energy generation takes place in the core. Energy is transported out of the core through first the radiative zone and then the convective zone to the photosphere where it is radiated out into the solar system. Examples of energy transport by radiation and convection are:

Can we think of a couple of other examples?

The Solar Atmosphere

The photosphere marks the boundary between the solar interior and the solar atmosphere. The photosphere has a mottled appearance with some areas being slightly brighter than others. This is because of the convection that is bringing energy (heat) up to the photosphere.

Above the photosphere are layers of the solar atmosphere called the chromosphere and the corona. Under normal circumstances these layers are difficult to observe, particularly from the surface of the earth because they are much fainter than the light from the photosphere. However, when a total eclipse occurs the chromosphere and corona look like this:

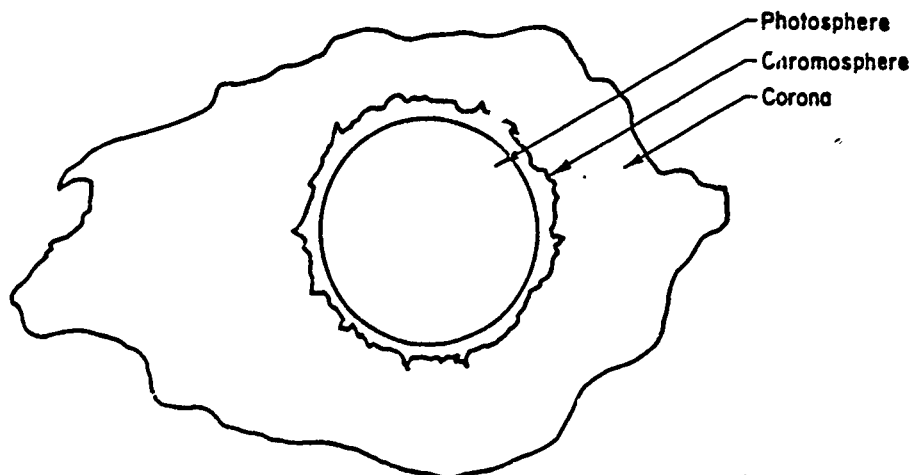

Solar Activity

The sun does undergo changes and some of them are cyclic. One of the most obvious involves sunspots. Sunspots appear to be dark because they are cooler than the rest of the photosphere by about 1500 K. The average sunspot is several times the size of the earth and lasts for a couple of weeks. Sunspots are associated with regions of strong magnetic fields on the photosphere. They seem to be one manifestation of a complicated magnetic cycle of variability on the sun. The numbers, locations and magnetic polarities of the spots varies cyclically.

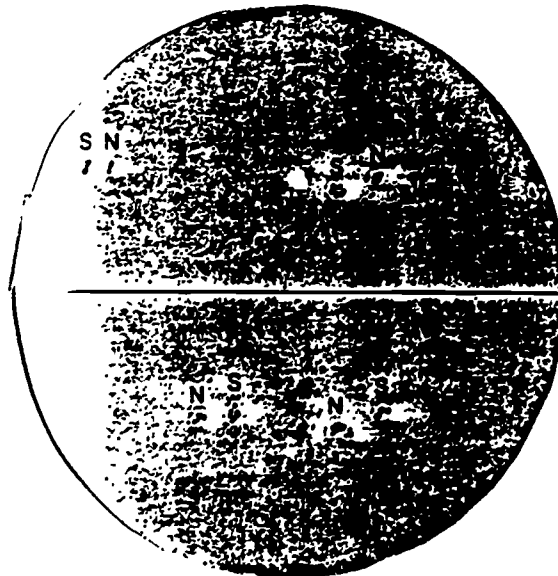
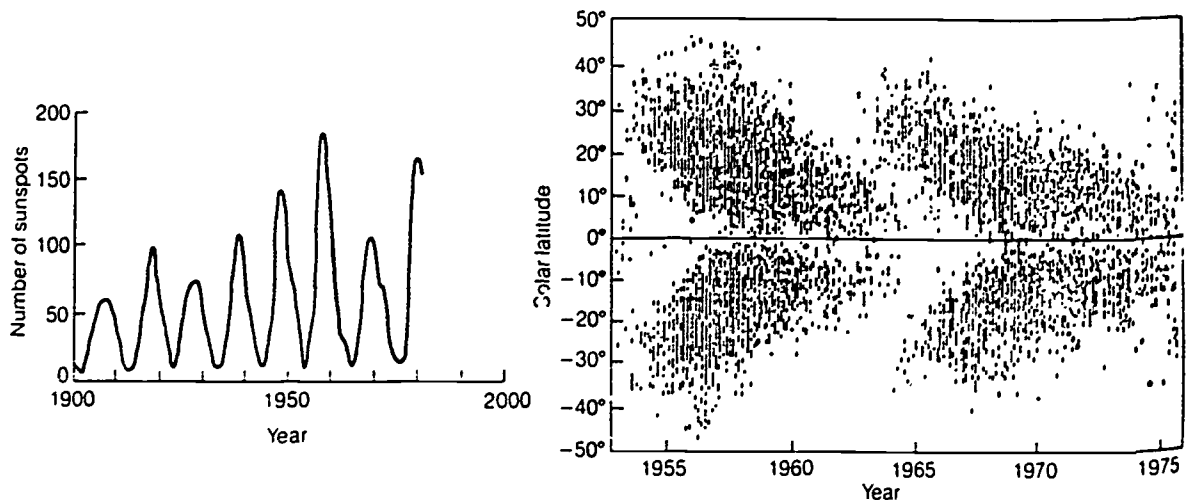

Other phenomena on and above the photosphere appear to be associated with the solar cycle. Eruptions of material from the solar surface (prominences and solar flares) seem to follow the solar cycle in terms of their numbers and severity and to happen in regions near sunspots.

Interestingly enough, there is reasonably solid evidence that the solar cycle that operates at present is not always there. Between 1645 and 1750 there were hardly any spots observed on the sun. This overlaps with a period of unusually cool weather on the earth known as the "little ice age". Some other "lapses" in the solar cycle over the last three thousand years appear to be correlated with cooling on the earth. It is clear that the sun does not provide absolutely constant amounts of radiation at all times. The climate on the earth is very sensitive to the amount of energy received from the sun. Even a small decrease in that energy can make a significant difference to our climate (not to even mention our lifestyles!).

LECTURE 18

STARS

Introduction

We only have time to say a few words about stars. We could spend weeks studying how stars generate energy, how they form and evolve, etc. We will cover just a few basic properties of stars and a little bit about how they go through their evolution.

Apparent magnitudes, distances and absolute magnitudes

We have talked previously about the magnitude scale for measuring the brightnesses of stars as seen in the sky. These are called apparent magnitudes. Whether one star is truly brighter than another star cannot be known unless we know the distances to the stars. The fundamental method for finding distances to some of the relatively nearby stars is called measuring the parallax. "Parallax" is a general term which refers to the apparent motion of an object which is due in reality to the motion of the observer. As applied to stars, it looks like this:

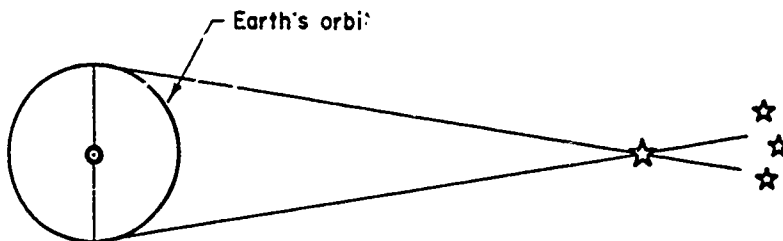

There is an apparent shift in the position of nearby stars with respect to very distant background stars as the earth goes around the sun. The closer the star, the larger the shift. However, the shifts are at best tiny. Measuring the parallax of the nearest star is like trying to determine the diameter of a dime located in Seattle with a measuring instrument located in Pullman, 300 miles away.

The distances to stars are very large and so we use special units to express distances. In the solar system we used the "astronomical unit" because it was convenient (for example, Pluto's average distance from the sun is 39 astronomical units). In dealing with stars, there are two (very large) distance units that are used.

1. light years (abbreviated ly)--This is the distance that light will travel in one year, approximately 6 trillion miles.
2. parsecs (abbreviated pc)--This is the distance that a star would have if it had a parallax (par) of one second of arc (sec). It is equal to 206265 astronomical units. One parsec is equal to 3.26 light years.

You will find light years used in many popular astronomy books. Professional astronomers use parsecs in research publications.

Once the apparent brightness and the distance of a star are known, it is possible to measure the true brightness. This is expressed on a magnitude scale and the numbers are called "absolute magnitudes". Absolute magnitudes are related to the luminosities (true energy outputs) of stars and to the sizes of stars. Some stars are small and do not put out much energy; others are very large and put out a lot of energy.

Surface Temperature of Stars

Temperatures of stars can be measured by several methods but one of the most convenient is to analyze the types of absorption lines observed in the spectra of stars. Cool stars will have quite different spectra (molecules, lots of neutral atoms) than hot stars (ionized atoms). It is possible to make "spectral classifications" of stars according to their temperatures. The spectral classes of stars are as follows:

O	B	A	F	G	K	M
hottest						coolest
30,000 k						3,000 k

The vast majority of stars fit into one of the spectral classes in this sequence, but not all of them. We will talk about some special objects such as protostars (stars just forming) and black holes later on.

The Hertzsprung-Russell Diagram.

If you determine absolute magnitudes and spectral types (temperatures) for many stars, you will find some patterns. A plot of absolute magnitude versus temperature is called the Hertzsprung-Russell (H-R) diagram.

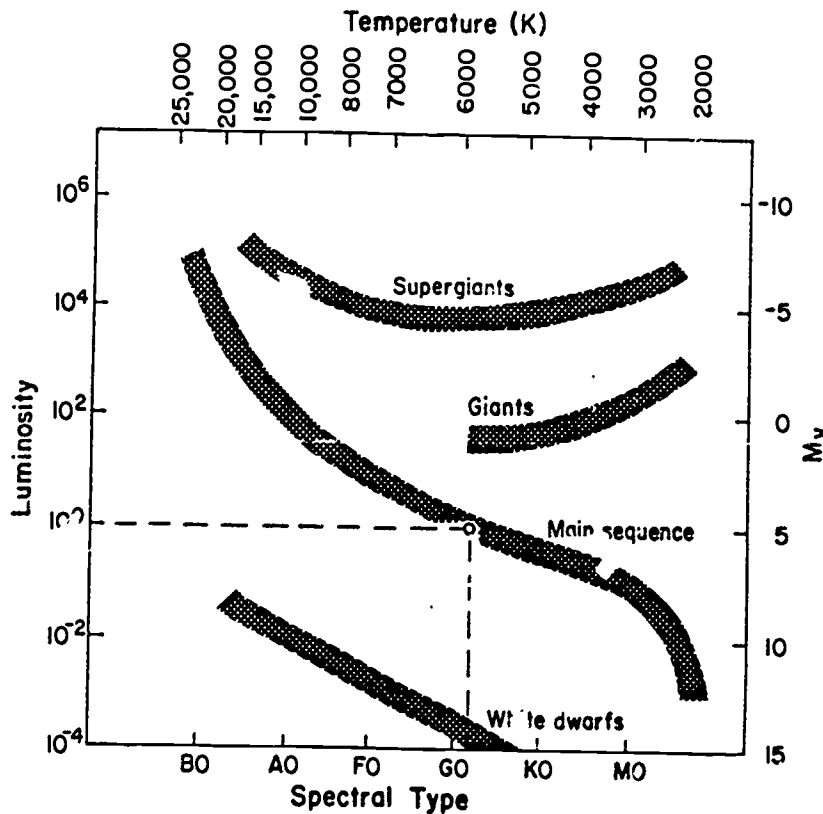

Most stars (roughly 90 percent) fall along the main sequence. There are a few so-called giant stars which have diameters a few 10's of times the diameters of main sequence stars like the sun. Even rarer are the supergiant stars which have diameters up to a few 100 times larger than main sequence stars. Then there are the "white dwarf" stars which are small, more like the sizes of planets.

The only way that we can understand why there are such dramatic differences in the sizes and temperatures of stars is to get more information. The really useful information comes from two sources. First, calculations of the masses of stars from binary systems (there is no way to determine directly the mass of a single star out in space) show that along the main sequence the masses of stars go like this:

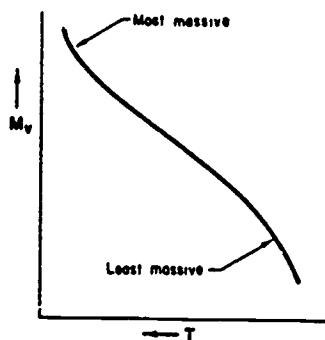

Second, studies of star clusters have been very revealing. There are different kinds of star clusters and their H-R diagrams are different. In star clusters all the stars were formed at roughly the same time. The positions of the cluster stars on the H-R diagrams must be saying something about what is important in stellar evolution.

It turns out that the key factor governing how fast a star will evolve and what stages it will go through is mass. The more massive stars evolve faster.

LECTURE 19

STELLAR EVOLUTION

How Stars Evolve

Stars do go through life cycles and how they behave is based in large part upon their masses. Some stars have masses smaller than the sun. Some stars have masses tens of times larger than the mass of the sun. Stars form from clouds of interstellar gas and dust called nebulae. The Orion Nebula is one example of a star forming region. Quite often a whole cluster of stars will form out of a nebula. Stars form by gravitational contraction until the temperatures and densities in their interiors are hot enough for thermonuclear reactions to start.

When thermonuclear fusion of hydrogen to helium begins, the energy released counteracts the inward push of gravity and the star settles down on the main sequence. Eventually the star ends up with a helium core. At that time there is temporarily no energy source in the interior. The star responds to this changed condition by the interior contracting and the outer layers expanding. The star (depending on its mass) moves to the giant or supergiant region of the H-R diagram. When it gets hot enough in the stellar core, a set of thermonuclear reactions which converts helium to carbon begins.

Depending on the mass of the star, it can build heavy elements in its interior up to a point. The more massive the star, the further it gets with thermonuclear reaction chains for the chemical elements up to iron. After a star is through with thermonuclear reactions in its core, it goes through some changes which will take it to one of three "end points" of stellar evolution. On the way to the appropriate "end point", a star may eject some matter in the form of a "planetary nebula" (sorry, these objects have nothing to do with the formation of planetary systems such as ours). The most massive stars undergo cataclysmic explosions called supernovae. The three possible end points of stellar evolution are:

1. White dwarfs--These stars have masses of up to 1.4 solar masses and are the most common end point of stellar evolution. There are a lot of white dwarfs observed. In white dwarfs the atoms are packed so close together that the electrons are free to move between atomic nuclei. White dwarfs are very dense. The more massive white dwarfs are smaller. A 1 solar mass white dwarf would be about the size of the earth.

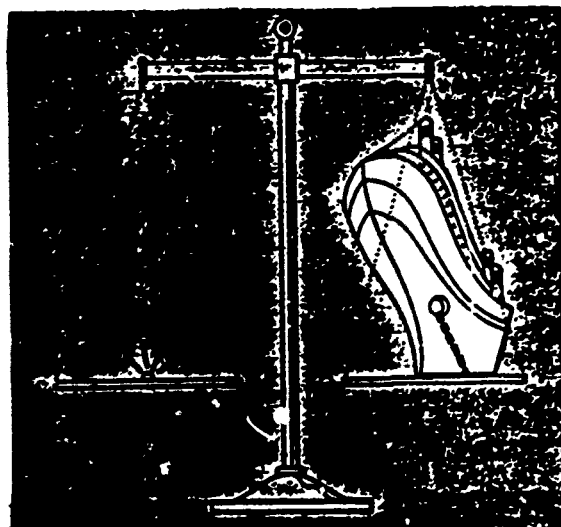

The degenerate matter from inside a white dwarf is so dense that a lump the size of a beach ball would, transported to earth, weigh more than an ocean liner.

2. Neutron stars--These stars have mass between 1.4 and 3 solar masses. These stars are much denser than white dwarfs. During the final stellar collapse to the neutron star configuration, the electrons that normally orbit the atomic nuclei were pushed into the nuclei where they combined with protons to form neutrons. Hence, a neutron star is a dense ball of neutrons only a few miles in size. Neutron stars should be rare but there is some observational evidence that they exist. Pulsars are sources of radio radiation that have very short periods (less than a few seconds). They can be explained as rapidly rotating neutron stars. A pulsar exists in the Crab Nebula, a supernova that was observed to explode in 1054 A.D. This pulsar varies 33 times a second in all wavelength regions.

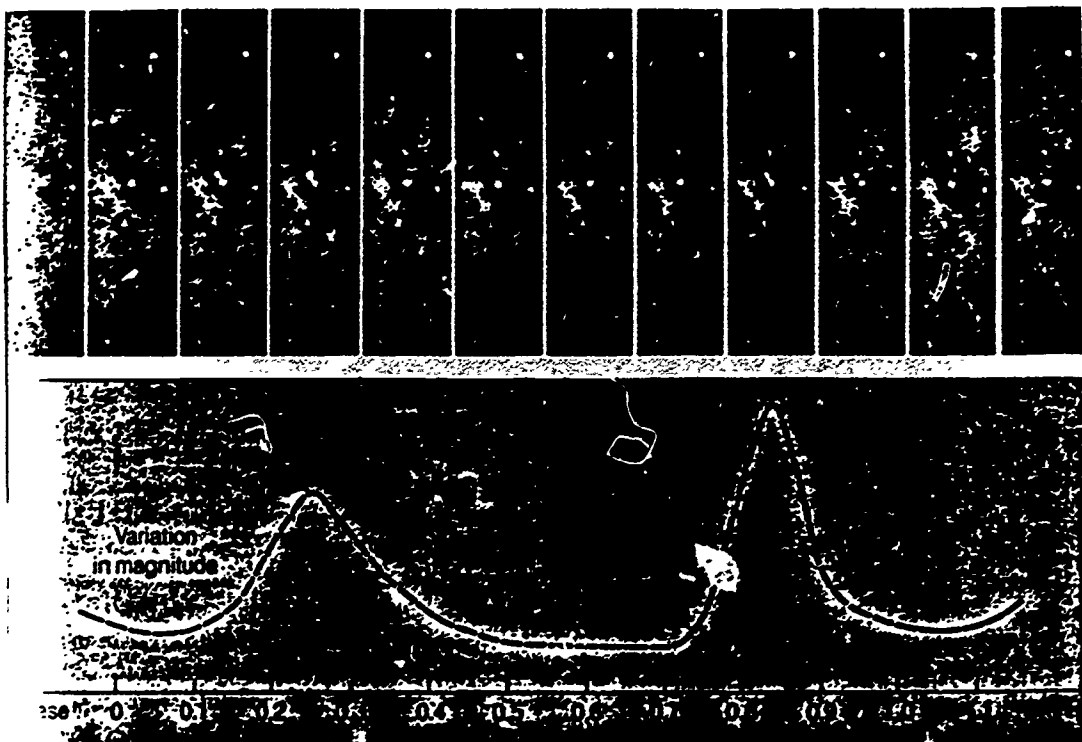

High-speed photographs show the Crab nebula pulsar blinking at visible wavelengths as it rotates. During each rotation lasting one-thirtieth of a second, the pulsar blinks twice as its two beams sweep over the earth. (Kitt Peak National Observatory.)

3. Black holes--Objects with masses greater than three solar masses collapse beyond the neutron star state to become what are called black holes. Black holes got their name because the escape velocity from the collapsed object is so great that no electromagnetic radiation can escape. Depending on the mass, stellar black holes can be a few miles in size. The state of matter inside a black hole is in the realm of theoretical high energy physics and a simple description is not possible. We can detect black holes indirectly by the gravitational influence that they have on other bodies. For example, if a black hole were a member of a binary system with an ordinary star, any

mass loss from the ordinary star will tend to flow towards the black hole and heat up to high temperatures as it flows into the black hole (the matter is accelerated by the increasing gravity as it gets closer to the black hole). There are a small number of likely black hole candidates among x-ray binary systems.

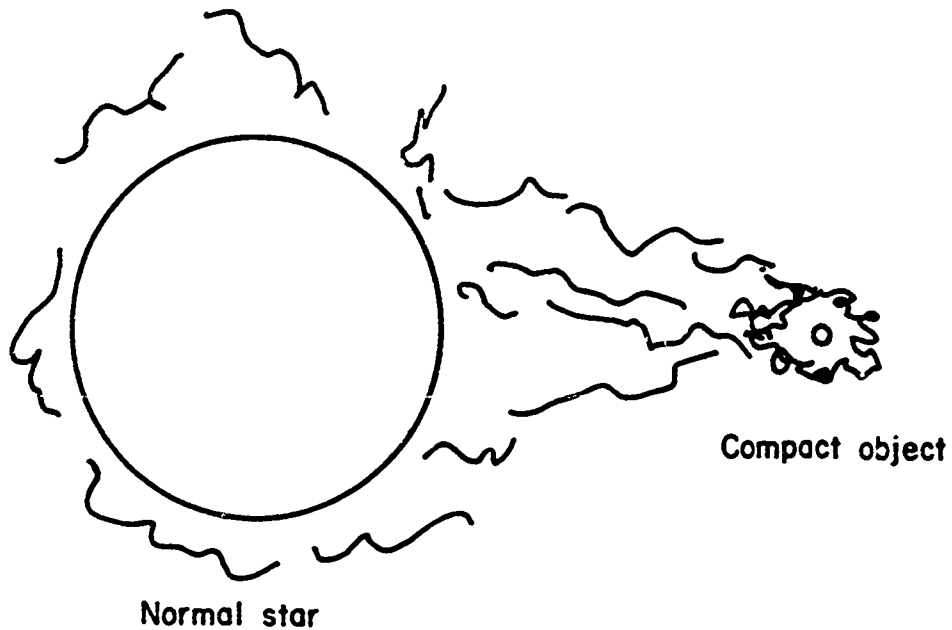

LECTURE 20

GALAXIES

The Milky Way Galaxy

Our sun is a part of the Milky Way Galaxy. In a way, it is difficult to study the structure of the Milky Way Galaxy because we live inside of it. However, by studying the motions of many stars, the distribution of hydrogen gas and other "large" issues, we have managed to piece together the following picture of the Milky Way Galaxy.

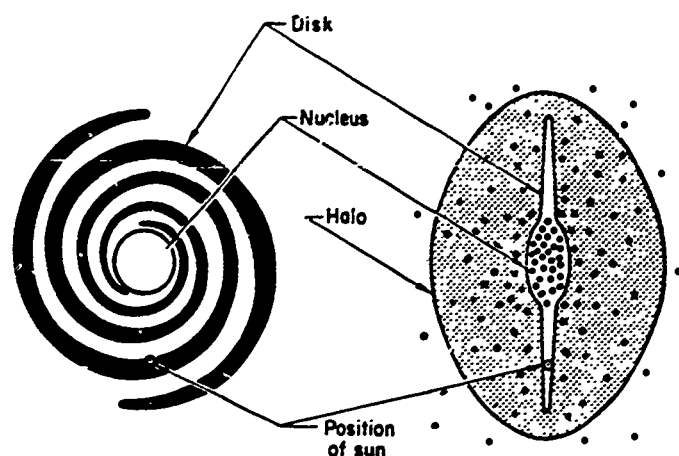

Our galaxy has roughly 200 billion stars. The sun is located about 2/3 of the way out from the nucleus along the inner edge of one of the spiral arms. The whole galaxy does rotate around; the sun's rotation period is about 250 million years.

The stars found in the halo of the Milky Way Galaxy are 10 to 15 billion years old, while the spiral arms contain young stars and star forming regions. The sun is located in the disk of the Galaxy, which has "middle-aged" stars (1 to 10 billion years old). The nucleus is also composed primarily of "middle-aged" stars.

The separation of stars in the Milky Way Galaxy by ages can be understood by considering the gravitational collapse of the Milky Way Galaxy from a huge primordial cloud of interstellar gas. As the cloud collapsed, stars formed in the outer regions first. The bulk of the material collapsed into the nucleus and disk regions. About 5% of the mass of the Milky Way Galaxy is in the form of free gas and dust that can form into new generations of stars now and in the future.

Other Normal Galaxies

When we look out into the universe we see many other galaxies. These galaxies come in just a limited number of shapes.



Spiral



Barred spiral

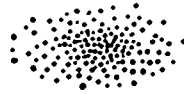

Elliptical



Irregular

Galaxies contain 100's of millions to 100's of billions of stars. They are the basic building blocks of luminous matter in the universe. By studying galaxies we can learn about the structure and evolution of the universe.

Galaxies are found generally in clusters. The Milky Way Galaxy is a part of the Local Group which contains about 35 galaxies, including naked eye objects called the Andromeda Galaxy and the Large and Small Magellanic Clouds. Some clusters contain 10's or 1000's of galaxies. Furthermore, there appear to be clusters of clusters (superclusters) of galaxies.

LECTURE 21

THE UNIVERSE

The study of the structure and evolution of the universe is called cosmology. Cosmologists have to deal with the problem of the velocity of light. The further away an object, the longer ago it was that the light (or other radiation) that we now observe from that object left the object. For a close-by galaxy like Andromeda, this amounts to a couple of million years. For the faint galaxies out in the universe, the "look-back" times are over a billion years.

Cosmology is a blend of theory and observations. Einstein's theory of general relativity is used to describe the shape and time-dependent behavior of a four dimensional space-time. The observations show that the universe appears to be expanding out from the so-called "big-bang" event approximately 15 billion years ago.

The observation that led to the proposal of the big bang theory is the following: Measure the Doppler shifts in galaxy spectra. You will find that galaxies have redshifts in their spectra that are larger in proportion to the distance of a particular galaxy from the Milky Way Galaxy. The further away a galaxy, the faster it appears to be receding. As a graph, the relationship between velocity of recession and distance looks like this:

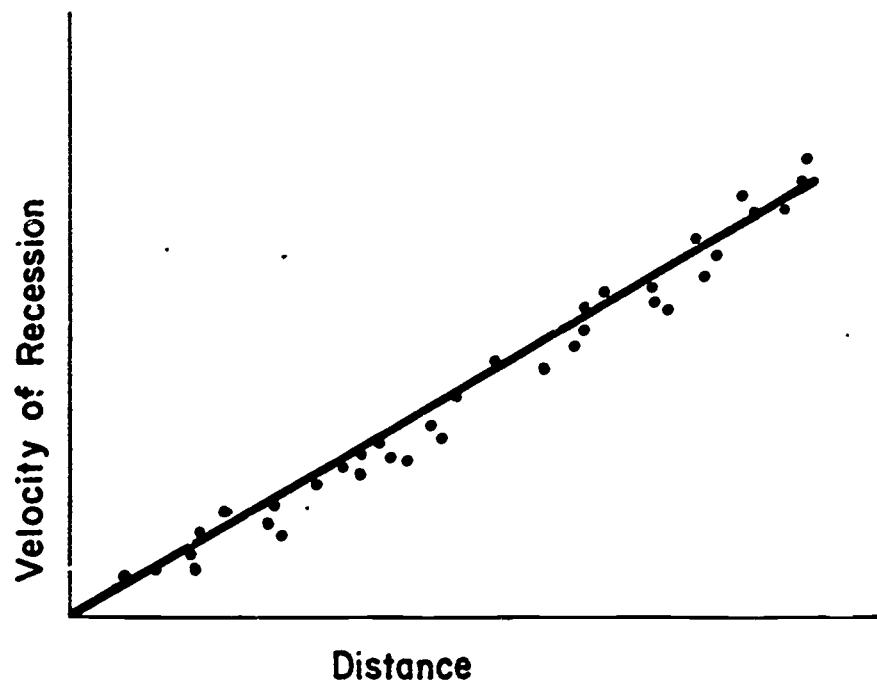

To picture the physical cause of the relationship between velocity of recession and distance, imagine that we are all raisins within a very large (transparent) loaf of raisin bread that is expanding. Imagine that you look around and measure the distances to other raisins as the whole loaf expands. What would you observe?

Just like the case of the raisin bread, the observable universe appears to be undergoing a uniform expansion. From the relationship between velocity and distance, the time interval that has passed since the expansion started can be estimated roughly to be 15 billion years.

The notion that the universe we observe at present was concentrated in a very hot, dense "fireball" that exploded approximately 15 billion years ago is called the Big Bang Theory. The Big Bang Theory has been confirmed by several other observations that confirm predictions made by the theory. First, the amount of helium in the universe (25% by mass) is far too great to be explained by nucleosynthesis in stars. Most of the helium that we observe was produced shortly after the expansion of the universe began when conditions were right for the fusion of hydrogen to helium. If the universe were too dense and hot, the helium atoms would get smashed apart soon after the fusion took place. If the universe were too cool, there wouldn't be sufficient energy for the fusion to take place. The Big Bang Theory predicts when conditions will be right and how much helium can be produced during that time. The prediction matches well with the observation. In addition, the universe has been cooling down since the start of the expansion and has reached a general temperature of about 3 degrees above absolute zero. Radiation at this low temperature is observed to be coming from the universe generally; it is called the Cosmic Background Radiation.

One interesting question is the following: Will the universe continue to expand forever or will the expansion stop eventually and contraction begin? No answer to this question is available at present. The answer depends upon the density of matter in the universe. Discoveries and theories in this area are very exciting and you are likely to hear more about this subject in the years to come.

Laboratory 1

The Night Sky I -- The Stars

Purpose

The goal of this laboratory is for you to become familiar with the stars and their configurations in the night sky.

Introduction

The laboratory will be in two parts. The first will be done in the WSU Planetarium and the second part in the laboratory room.

Laboratory Objectives

- I. Planetarium Session - As a result of this session you should be able to:
 1. describe the celestial sphere, north celestial pole, zenith and meridian.
 2. describe the effect of "light pollution" on the visibility of stars.
 3. describe the daily motion of stars.
 4. explain how changing latitude on the earth affects the appearance of the sky.
 5. use a Star Wheel to identify constellations.

- II. Starframes and Constellation postcards - As a result of this session, you would be able to:
 1. identify some of the prominent constellations.
 2. illustrate that stars vary in brightness (magnitude), and color.
 3. make tools to aid in constellation identification.

Part I -- The Planetarium

For the Planetarium Session you will need to bring your Star Wheel. After the session, your lab instructor will give you time to complete the worksheet.

Part II -- The Laboratory

Section A. Constellation Postcards

Introduction

In this part of the lab you will be making 'constellation postcards' --- drawings of constellations with the stars highlighted in glitter. These cards will be attached to your Constellation Information Sheets.

Materials

Per 2 Lab Stations (4 students)

Red, blue, orange, silver, and yellow glitter; bottle of glue; silver illuminating pen; blue construction paper; scissors; rulers

Sample 'postcards' (display at center table)

Per Student

Star Map from packet, star wheel, Constellation Information Pages.

Procedure

Your lab instructor will indicate the constellations you will be drawing today. The design of the constellations are found on the Star Map in your packet.

1. Cut out a piece of construction paper that is 8 centimeters by 10 centimeters.
2. Draw the stars of one of the assigned constellations on the card. Indicate magnitudes by star size.
3. Connect the pattern with the silver illuminating pen.
4. Glue glitter of the appropriate color to the bright stars. Those stars that have a distinguishable color other than white (silver glitter), are indicated in Appendix A of the Constellation Information Pages.

5. Use the silver illuminating pen to write the English and Latin name of the constellation across the top of the card. (See Figure 1)

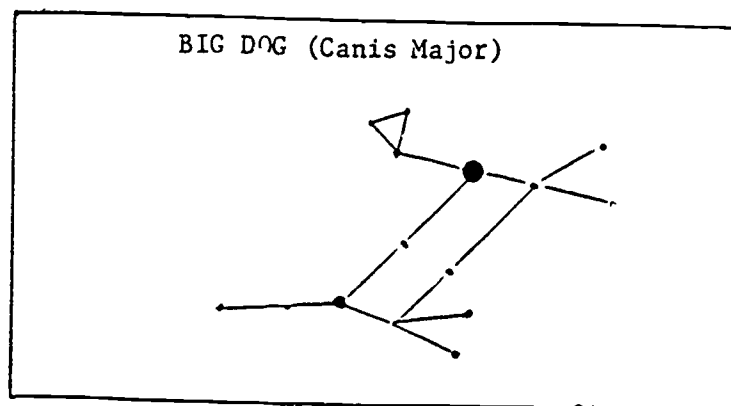

Figure 1. Constellation Postcard

6. Glue the postcard to the bottom of the appropriate Constellation Information Page.
7. Complete the other constellation postcards.

Section B. Starframes*

Introduction

In this section you will make Starframes, a tool to help find constellations in the night sky. Starframes were developed by Ben Mayer (see reference list for the original article).

Materials

Per 2 Lab Stations

Roll of plastic wrap, bottle of luminous paint, toothpicks, scissors, roll of scotch tape

Sample Starframes at center table

Per student

Star map from packet, star wheel from packet, wire coat hanger with plastic coating

Procedure

Your lab instructor will indicate the constellations for which you will be making Starframes. The patterns for the constellations are on your star map.

*Starframes is a registered trademark. Starframes were developed by astronomer Ben Mayer (see #4 on the list of references).

The steps for making a Starframe are shown below.

1. Take a wire coathanger and pull as shown in Fig. 1.

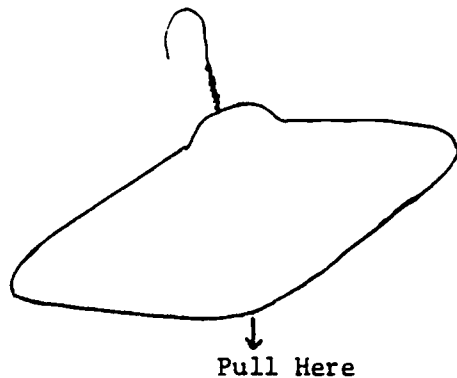

Figure 1. Start

2. Square off as shown in Fig. 2.

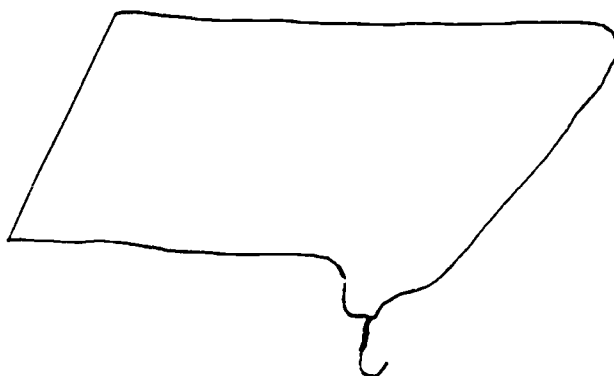

Figure 2. Push & pull

3. Beat into the shape shown in Fig. 3.

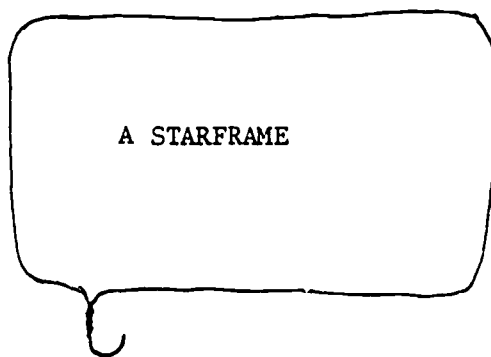

Figure 3. The Product

4. Place the plastic wrap on the starframe as shown in Fig. 4. Strips of tape will help hold plastic wrap in place.

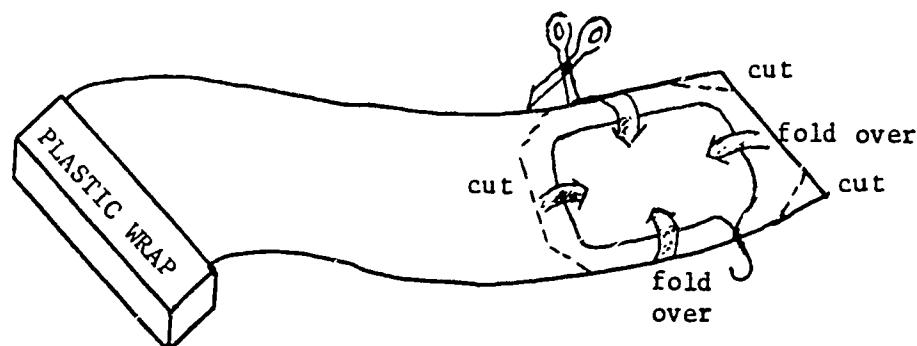

Figure 4. Putting the plastic in place

5. Place the starframe over the indicated constellation on your star map. Flow the luminous paint from the toothpick applicator onto the plastic wrap over the most prominent stars of the constellation. You may want to put a second layer of plastic wrap over the frame to help preserve it. You now have a completed starframe.
6. To use the Starframe for current observations, record today's month and date on masking tape strip attached to the Starframe. Next set your Star Wheel for the current date and a convenient time (say 9 p.m.). Record information on where the constellation can be viewed on the strip of tape attached to the Starframe.
7. To use the Starframe, 'activate' the luminous paint by shining a light on it. Take the starframe outside and face the directions indicated on the tape.

Optional: Astro-Tips: Alternative to Luminous Paint
Typewriter correction fluid can be used as a substitute for luminous paint. In this case use a dim red-filtered flashlight to illuminate the starframe observations.

References

1. Investigations in Observational Astronomy, Wayne D. Christiansen, et.al., Paladin House Publishers (Geneva, Illinois 60134: 1976).
A good lab book. Designed for high school or college use.
2. The Sky Observer's Guide, A Golden Handbook, Golden Press (New York: 1965).
An exceptionally good Golden Handbook. Also contains information on observing with a small telescope.
3. The Stars, A New Way to See Them, H.A. Rey, Houghton Mifflin Company, (Boston: 1976).
Excellent book! Provides a very clear explanation of sky motions.
4. "Finding Halley's Comet with Starframes", Ben Mayer, Sky & Telescope, (October, 1985), p. 324.

Lab Apparatus (based on 12 Lab set-ups)

- 6 pair of scissors
- 6 small bottles of Elmers glue
- 6 Calligraphic^R pens with silver illuminating ink
- 6 sheets of large dark blue construction paper
- 12 rulers
- 12 tubes of silver glitter
- 6 each of red, blue, orange and yellow glitter
- 6 (41 2/3 yd x 1 ft) rolls of plastic wrap
- 4 bottles of luminous paint (or typewriter correction fluid)
- 1 box of toothpicks
- 6 rolls of scotch tape
- 30 wire coat hangers with plastic coating (1 per student/
30 students)

Laboratory 1 - Planetarium Show

Lab Instructor Outline

Show Content

1. Constellation Identification (current season)
-- Star Wheel Usage
2. General notion of magnitude, light pollution
3. The Celestial Sphere
 - a. Pole Star (Latitude)
 - b. Zenith
 - c. Meridian
 - d. Celestial Poles
4. Effect of changing Latitude

Show Outline

- I. Introduction
 - A. Star study is an ancient source of legend and science
 - B. Stars important in timekeeping, agriculture, and religion
 - C. Modern Astronomy is the study of the past, present, and future of the universe.
- II. Statement of Objectives
-- To start this journey we need a road map of the stars. By the end of this session you should be able to....
 - A. Use a star wheel to identify constellations in the sky
 - B. Be able to identify some parts of the celestial sphere and state their purpose
 - C. Describe how a star appears to move across the sky.
 - D. Describe how the sky changes as we change latitude
- III. Overview of the Sky (Planetarium set for present evening, 9 pm. This will be reinforced during Part II of the Lab) (Night Sky up)
 - A. What you can see
 1. Planetarium shows more than can normally be seen from cities and towns.
 2. Briefly discuss Magnitude - Mention that "Light Pollution" washes out the dimmer stars
 3. Adjust Star Intensity to illustrate viewing conditions for city, small town, & country.
 - B. Stars are grouped in constellations (show cardinal points)
 1. Highlight/define circumpolar constellations Ursa Major and Ursa Minor.
 2. Highlight one other major visible constellation.

- IV. Star Wheel Usage (Use Constellation Outline Star Wheel)
(Lights up)
- A. Explain the Star Wheel and how to use
 - B. (Lights partway down) Allow Lab groups to practice identifying 3 major constellations of your choice (these are reinforced in Part II of the Lab). Check with each group to see how they are doing.
- V. The Celestial Sphere (Use overhead projector & overheads to develop the concepts. Then return to Planetarium projector.)
- A. How do we view the night sky from earth (Pullman, WA)?

Show overhead, note the following
 1. Polaris is the same # of degrees above the north horizon as our latitude (47° for Pullman). Check it!
 2. Meridian - define
 3. Zenith - point directly overhead
 4. Sky appears to rotate E→W about a line through observer to Polaris.
 - B. The celestial sphere (stars appear fixed to this)

Show overhead, note the following
 1. Axis through poles
 - C. How do stars appear to move?
Use questioning technique...

Show overhead, note the following
 1. E→W rotation of Celestial Sphere
 2. At highest altitude star crosses meridian
 3. All sky objects do this
 4. Star rotation is 4 min. short of a regular day; we will talk about in the next planetarium session.
 - D. What else is there to the Celestial Sphere?

Show overhead, note the following
 1. Celestial Equator splits it in half
Show overhead, note the following
 1. If we change latitude, we change the part of the sky we can see.
- VI. Summarize.
Ask for questions.

VII. Have students do and turn in worksheet. Dismiss to Part II of the lab.

Material

Overhead projector, overhead material

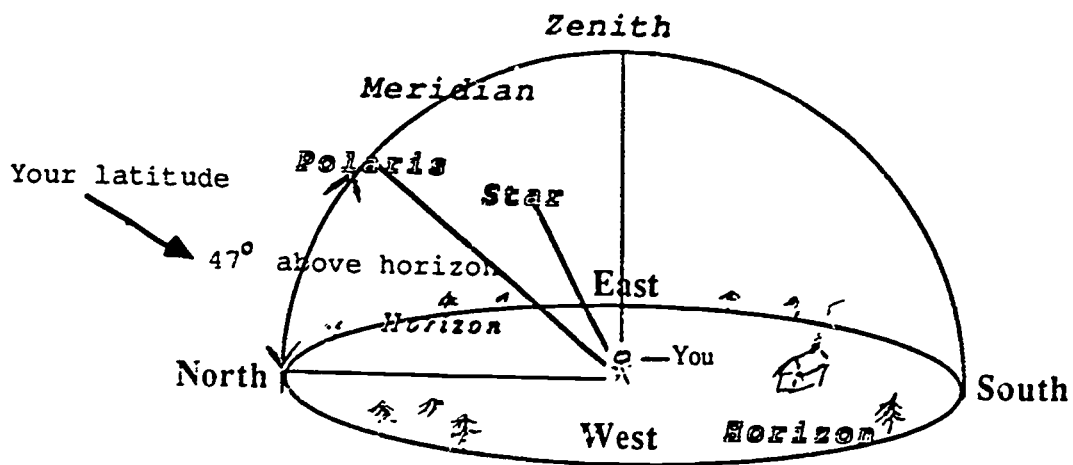

Celestial Equator as seen from Pullman

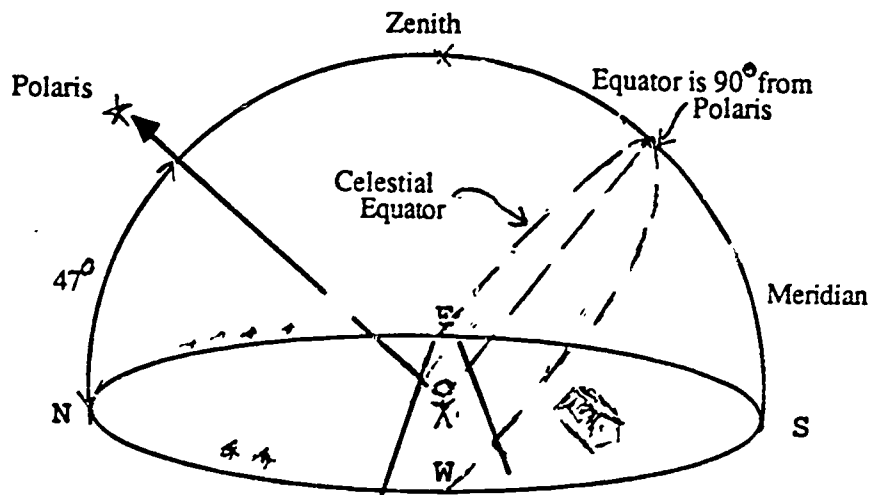

Another view of the Celestial Sphere

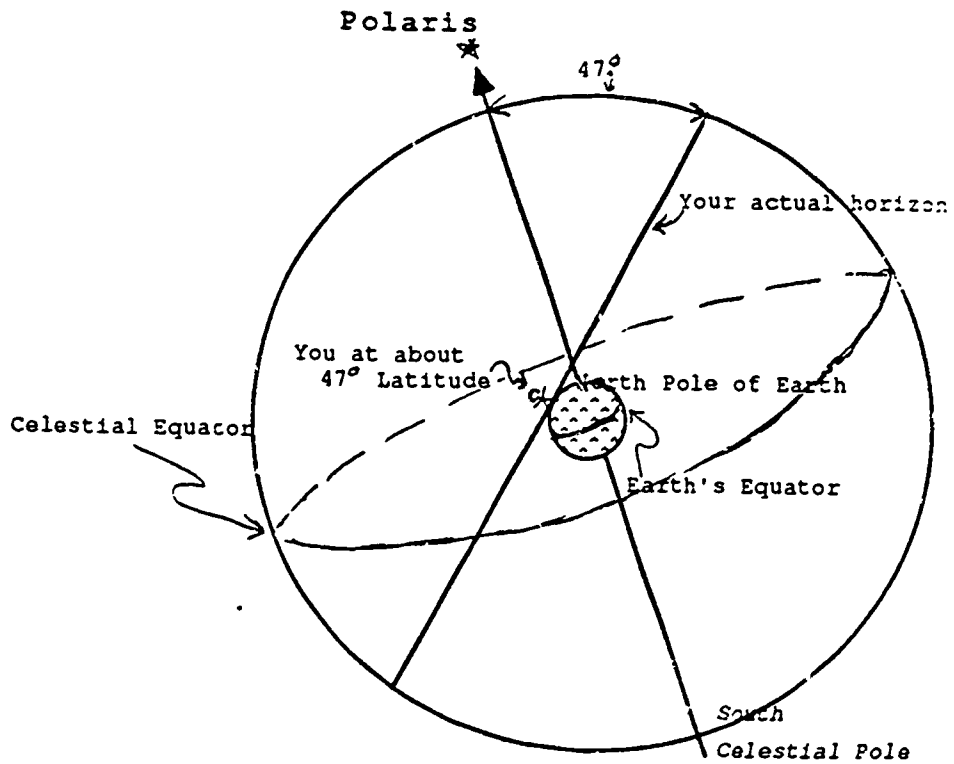

The Sky as seen from different latitudes

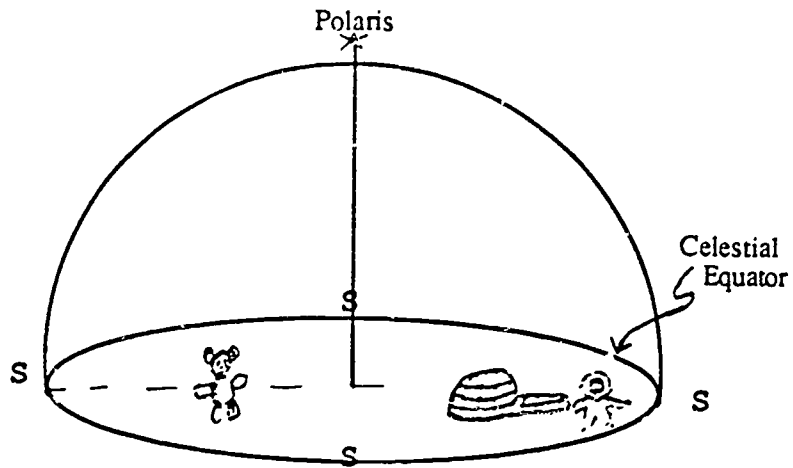

North Pole -- Latitude 90

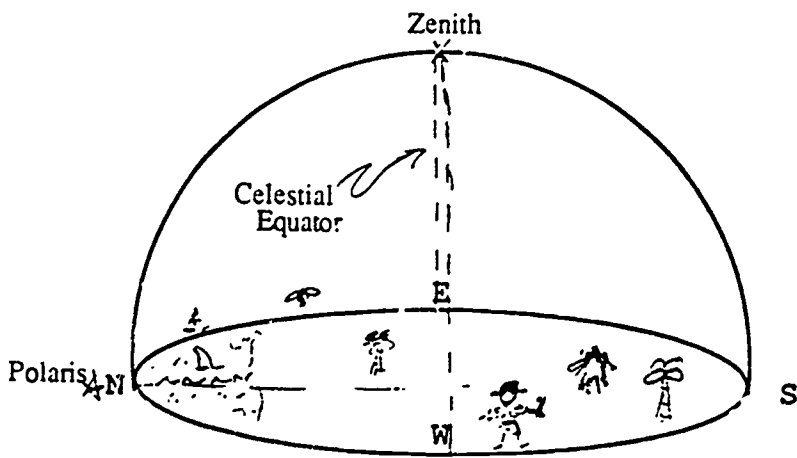

Equator -- Latitude 0

Apparent movement of a star

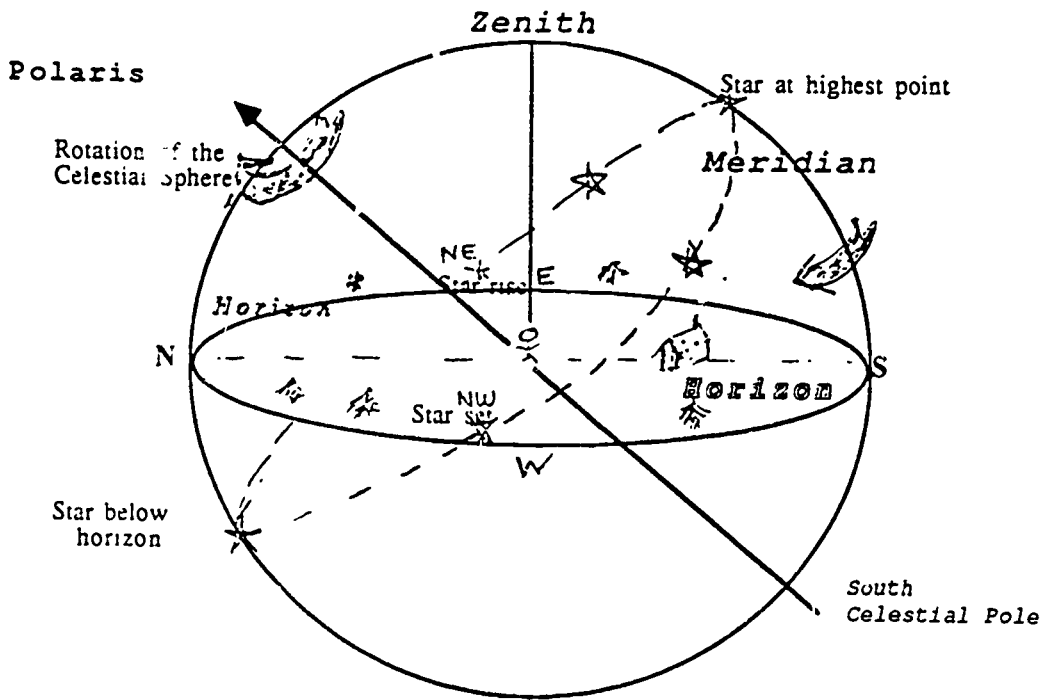

The Celestial Sphere

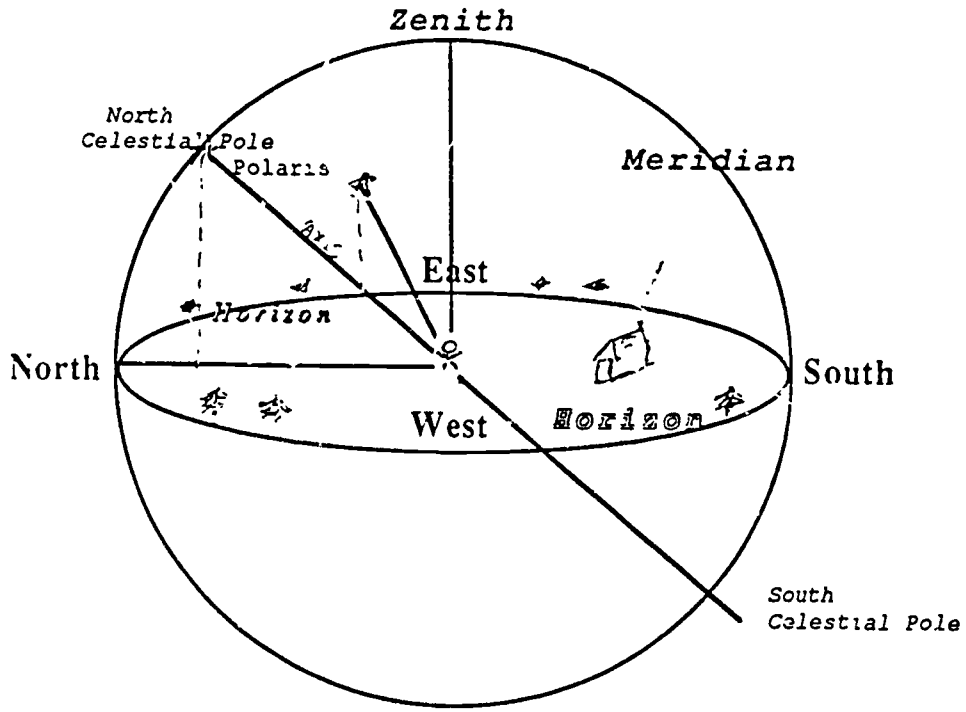

PHYSICAL SCIENCE 250, SPRING 1988

Lab Experience 1

Name _____

Introduction

The purpose of this exercise is to have you record observations of the moon and the sunset.

Procedure

1. Observe the moon on three different occasions over a period of four weeks. With each observation, sketch on the chart found on the worksheet, a small picture of the moon as it appeared in the sky. Be sure to include the date and time of the observation by each sketch.
2. Observe the sunset on four different occasions over a period of four weeks, following the instructions given on the attached sheet.

Worksheet

Moon Sketches

Date:

Time:

Date:

Time:

Date:

Time:

PHYSICAL SCIENCE 250, SPRING 1988

Lab Experience 2

You will be making a visit to the James Richard Jewett Observatory on a date and time designated by the instructor. Bring with you a flashlight, a pencil, some blank paper and something hard (such as a notebook) for steadying the paper on to make sketches.

Laboratory 2

The Sun, Seasons, and Stars

Purpose

The goal of this laboratory is for you to become familiar with the motions of the sun and stars and the explanation of the seasons on the earth. In addition, you will review and extend your knowledge of the constellations.

Laboratory Objectives

As a result of the planetarium session you should be able to:

1. Explain the apparent daily and annual motion of the sun.
2. Explain the apparent daily and annual motions of the stars.
3. Explain why there are seasons.
4. Describe the position of the Earth and Sun at the time of the solstices and equinoxes.

As a result of the laboratory session you will:

1. Learn demonstrations that reinforce the concepts mentioned above.
2. Learn to make a sundial.

Part I -- The Planetarium

For the planetarium session you will need to bring your star wheel. After the session your lab instructor will give you time to complete the worksheet.

Part II -- The Laboratory

Section A. The Seasons - part A

Introduction

Your lab instructor will demonstrate this section of the lab. You will complete worksheet questions dealing with the demonstration.

Materials

Globe of the earth (in stand with $23\frac{1}{2}^{\circ}$ tilt)
2 pins (one placed on globe through Pullman, WA,
the other placed through Sydney, Australia)
25w light bulb and fixture
Books or blocks to elevate fixture up to the middle
of the globe
Placard taped to the north wall with "North Star"
written on it
Masking tape

Procedure

(Note: This is the Lab Instructor's outline for an inquiry session on seasons)

1. On the center tables (2 placed side by side) elevate the lamp as indicated in the materials
2. Tape the "North Star" card on the wall.

- Place four strips of masking tape on the center table as shown in Figure B.1.

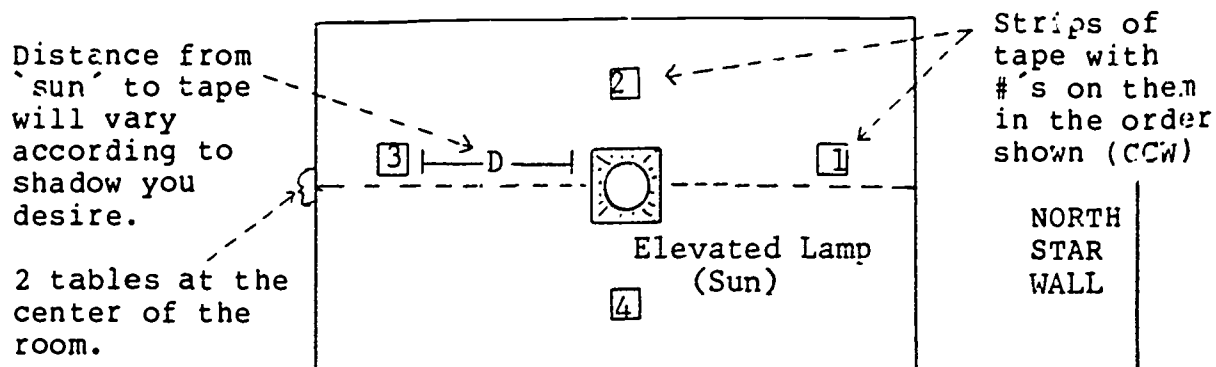

Figure B.1. Lab Set-up

Write the numbers 1 through 4 on the tape strips in a counter clockwise (ccw) order. Note that the #1 strip should be nearest the "North Star" wall.

- Turn on the lamp which represents the "sun". Darken the room. Have students gather around the center tables.
- Set the globe (referred to as the Earth) on the table at tape strip #1. Tilt the axis $23\frac{1}{2}^{\circ}$ if the globe stand is not constructed in this manner. This represents the actual tilt of the earth.
- Point the top of the axis (North Pole area of the globe) toward the North Star wall. This is the direction the earth's axis actually points. For this demonstration keep the globe's axis pointed at the North Star wall, just as earth's axis points to the North Star.

(NOTE: The Earth's axis appears to point to the North Star even as it moves in its orbit, because the North Star is so distant compared to the Earth's orbit. You have seen this in a moving car -- far objects appear fixed, near objects move quickly. Remember we are just modeling the Earth.)

- If you are at position 1, the season represented is winter for the northern hemisphere.
- Rotate the globe. Point out some of the features in a questioning manner. (You might have students pretend that they are the "pins" looking up at the sun).
 - ? How does the length of day compare between Pullman and Sydney, Australia.
 - ? How much sunlight does the north pole receive as compared to Pullman, the south pole.
 - ? What season is it in the Northern Hemisphere, Southern.

- ? How high in the sky might the sun appear to be in Pullman, Sydney.
- ? How might the length of day cause winter for us.

-- Ask the students these questions, generate correct responses from them.

9. Move the globe to position 3 (summer in the northern hemisphere) via position 2. Repeat the questions given in 8.

NOTE: In moving from 1 to 3 (as with any movements of the earth, as shown here) keep the top of the axis pointed to the North Star wall -- this is to model the Earth.

Section B. Making a sundial (See attached)

SUN WATCHING

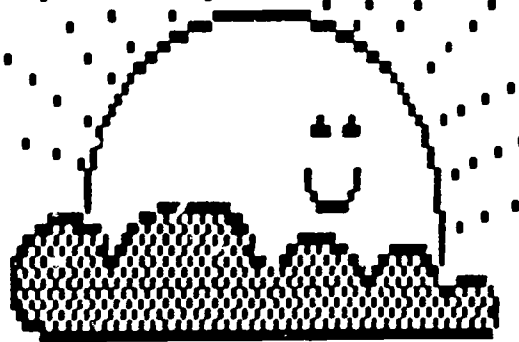

DEVELOPED BY:
DENNIS SCHATZ
PACIFIC SCIENCE CENTER, SEATTLE, WASHINGTON

Concept: To construct a pocket sun clock to understand how the sun's shadow can be used to tell time.

Materials: (one of each per student)

Pocket sun clock blueprint for latitude closest to yours
Tagboard slightly larger than the blueprint
String cut 20 cm long
Glue, chalk and scissors

Background

The pocket Sun clock is a sun dial that can fold to go in your pocket. It uses the sun's direction in the sky, indicated by the shadow of a piece of string, to tell the time.

Local noon is defined as when the sun is directly above the south point on the horizon. This is also when the sun reaches its highest point in the sky on that day. Since the sun is above the south point on the horizon at noon, we know that any shadow it produces will point north at that time. (Note: These directions are true north and south as determined by the stars, and not magnetic north. These can differ by as much as 30 degrees.)

Most sun dials are set up so they read correctly when the 12:00 noon line is pointing north. This can be accomplished by: 1) knowing which way is north each time you use it and aligning the noon line in that direction, or 2) when using the sun dial for the first time, go out in the sun and make it read the same time as the school clock. This will align the

noon line to the north. You should mark where you placed the sun clock so that when you can come back, you merely place the clock in the same spot and read the correct time.

Sun dials read local noon, whereas your school uses standard time. Standard time is used to minimize problems in communication between cities. The continental United States is divided into four standard time zones. It is agreed that the time is the same everywhere in that zone so the sun is not directly in the south at noon at all locations in the time zone. It is actually noon (local noon) first at the eastern edge of the time zone and then an hour or so later (depending on exactly where the time zone boundary is placed) at the western edge of the zone. If standard time were not in effect, it would be confusing and difficult to calculate time in another city when we needed to talk with someone there.

There are some other more minor factors which cause differences between local time measured on a sun dial and clock time. For more information, see Exploration of the Universe by George Abell.

You should be aware of the distinction between local and clock time; but when calculating your sun clocks, you can consider them to be the same. (Don't forget if daylight saving is in effect, subtract one hour from clock time to get standard time.)

Have the materials ready to go so you can do this activity on the next clear day.

Procedure

1. Glue the sun clock blueprint to the piece of tagboard. Cut tagboard to size of blueprint. Fold the tagboard along the dotted line. Cut short notches at each end as labeled. Take approximately 20 centimeters of string and place a knot in one end. Place the string in the other notch and tie a knot so fold makes right angle (90°). Check to see that each clock looks like the one shown.
2. Tell the students that you would like them to determine how their clocks work. Have them go out several times during the day to see if the sun clock must be in any special position to register the correct time. Have them draw an outline of the sun clock's position each time using a pencil or chalk. Have them use the time on the school clocks for this part of the activity. The students should find that they always have to place their clock facing the same way (south).
3. Emphasize the finding that the clock needs to face south and, if possible, have the students develop a set of directions for correctly using the clock. They can then take them home to tell their family. The directions they develop should contain these points:
 - a) Use the clock on a level spot that is away from buildings and trees which create shadows.

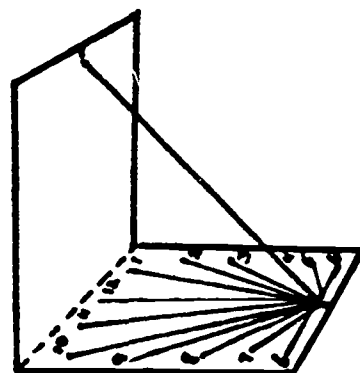

- b) Choose a spot that you can get to when you want to use the sun clock.
 - c) The first time the sun clock is used, line up the string's shadow to give the same time as a clock at school or home. (Don't forget that students will need to correct for daylight saving time if it is in effect - subtract one hour from clock time.)
 - d) Draw an outline of the sun clock on the surface where it is sitting.
 - e) The clock is now set. Place it in the "outline" to tell the time.
4. Once students are comfortable reading the time of their sun clock, ask them to think about how the clock could be used as a sun compass to find direction instead. Give them some time to explore with their clocks.
5. Write suggestions on the board, directing the discussion toward the following conclusion:
- a) You need to know the time to find direction.
 - b) Line up the clock so it reads the correct time. The clock then faces south and the rest of the directions can then be determined.
6. To get them familiar with using their sun compasses, have them solve the riddle below. Have two students work together. Mark enough X's on the playground for each pair to have an X.

Riddle: A treasure is buried where these directions lead you. Find out where you should dig.

- a) Take 5 steps north.
- b) Take 5 steps east.
- c) Take 5 steps north.
- d) Take 10 steps west.
- e) Take 5 steps south.
- f) Take 10 steps east.
- g) Take 5 steps south.
- h) Take 5 steps west

(Students should end up where they started. For more advanced students divide your own directions that have them move in other directions besides north, south, east and west.)

7. Many students will not like having to come back to the same place each time to use their clocks. To make the clock work anywhere (within a few hundred miles north or south of your latitude) it is only necessary to find the direction south, face the clock in that direction and read off the time. Follow these directions to make the sun clock work "anywhere":

- a) Attach a compass to clock with masking tape with north-south parallel to the noon line.
- b) Calibrate the clock by lining up the shadow of the string to give the same time as the school clock (don't forget to adjust for daylight saving time, if necessary).
- c) Let the compass needle stop moving.
- d) Mark on the tagboard the direction that one of the pointers on the compass points. (If magnetic south and true south were the same everywhere, the noon line and the compass needle would be parallel, but this is generally not true.)
- e) Whenever you want the time, just line up the same end of the compass pointer with the mark on the tagboard and read off the time.

Follow-up

1. After a few months, the student's sun clock time may not agree with clock time. Some students may want to research why.
2. As an art activity, students may want to make more elaborate sun clocks for their backyard. The essential design ingredients besides the direction it faces are:
 - a) Keeping the hour lines the same angle apart. (they can be longer or shorter).
 - b) The angle at which the string intersects the clock face must be kept the same (the size of the two clock faces must be kept in the same proportion. If you double the length of one you must double the length of the other).

SUN CLOCK BLUEPRINT

LATITUDE 45 degrees

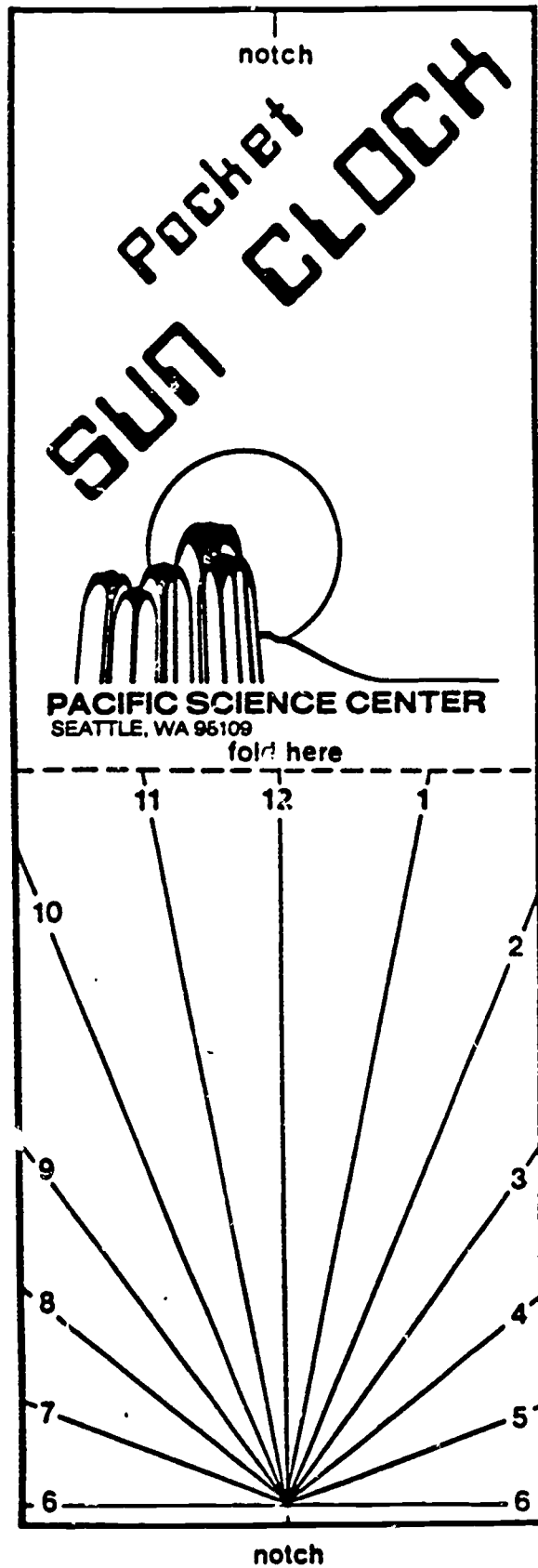

Section C. The Stars Through the Year

Introduction

Your lab instructor will demonstrate this section of the lab. You will complete worksheet questions dealing with the demonstration.

Materials

- Globe of the Earth with a pin marking Pullman
- Light bulb and fixture
- Books or blocks to elevate fixture up to the middle of the globe
- 12 placards (40cm x 25cm) made of white poster board with their zodiac constellation names written on them in fluorescent orange
- Masking tape

Procedure

(Lab instructor's outline for a demonstration of the ecliptic and the apparent yearly motion of the stars.)

Set-up

1. On the center tables (2 placed side by side) elevate the lamp as indicated in the materials.
2. Move the lab tables into the positions shown on the lab set-up section.
3. Tape the 12 placards around the room in the manner shown in Figure B.1. Place these at about the eye level of the students.
4. Turn out the lights.

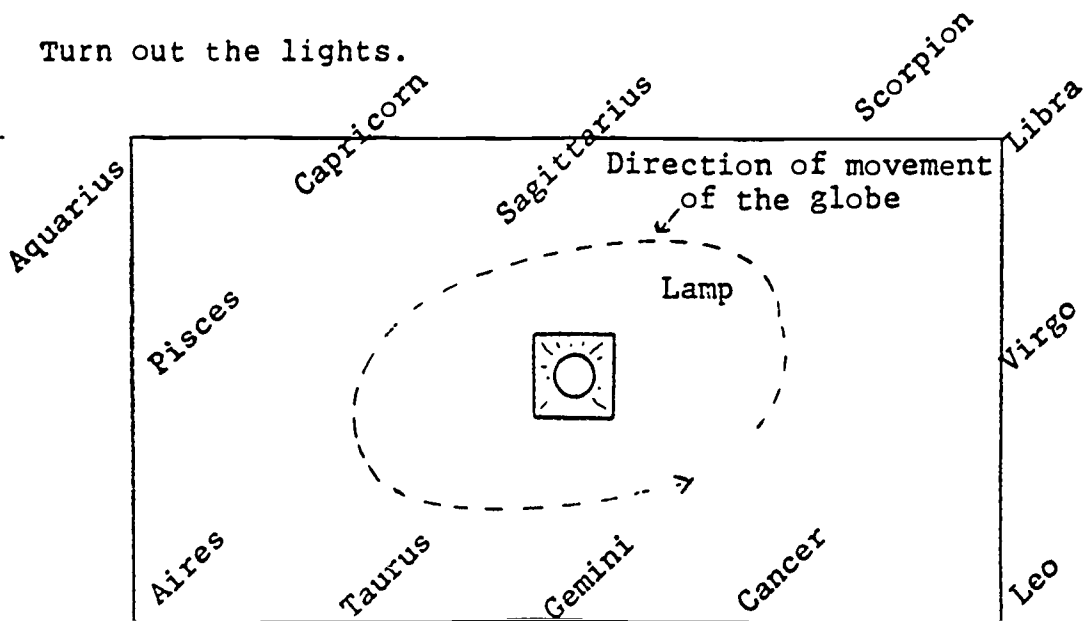

Figure B.1.

NORTH WALL

The Night Sky

3. Walk the globe to one side of the room. Point out that one part of the globe is in daylight the other part in darkness.
4. Rotate the globe through one day. Note that as viewed from the globe one can only see the constellations on the dark side of the earth -- but if we could "turn off" the sun we could see all the stars in one day.
5. Move to another section of the room and point this out again.

Ask questions which seem appropriate.

The Ecliptic

Point out how the position of the sun is referenced to being in a certain constellation.

6. To do this put the earth at the first day of winter for the northern hemisphere (Night Sky facing Gemini).
7. Point out that here the sun is on the meridian at noon, and Gemini is on the meridian at midnight (do this by pointing out where the pin is at noon and at midnight).
8. 6 months later (walk this out). (During the walk point out how the night sky changes).

We have completed one half the orbit. So here, at the first day of summer, with the sun on the meridian at noon we have Sagittarius on the meridian at midnight.

9. But 6 months ago Gemini was on the meridian at midnight so Gemini must be opposite Sagittarius on the Celestial Sphere.
10. So if we were to plot the path of the sun over the year we would say the sun, in December, was located in Sagittarius, since the sun is also opposite Gemini. NOTE: If we were in space we could actually see this -- since it is the brightness of the sky which doesn't allow us to see the stars -- not the sun as we'll see in eclipses.) In June the sun would be located in....(ask students).
11. Illustrate that it was in this manner that the apparent path of the sun (the ecliptic) was made by observations over the year. You can see this plotted on your star chart. NOTE: The sun moves eastward along the ecliptic by about one constellation per month.

Section C.

Complete the worksheet questions. Feel free to use the demonstration equipment or ask your lab instructor for assistance.

Some Useful Definitions

Celestial Equator = great circle on the celestial sphere midway between the north and south celestial pole.

Ecliptic = apparent path of the sun among the stars

Equinox, Equinoxes = the two points where the celestial equator crosses the ecliptic. This gives a time of approximately equal day and night.

Meridian = an imaginary north-south running line which passes through the observer's zenith

Noon = the time that the sun crosses the observer's meridian

Solar Day = the average time it takes from one noon to the next. (24 hours in duration)

Star Day = the time it takes from the vernal equinox position being on the meridian to the next. Very nearly equal to the time of the true rotation of the earth. (23 hours, 56 minutes in duration).

Solstice(s) = the two points on the ecliptic where the sun is at its greatest distance from the celestial equator. The highest displacement gives the longest day in the northern hemisphere, the lowest gives the shortest.

Zenith = point directly overhead

Materials List Lab 2

Light fixture with plug

25w bulb

Earth Globe (prefer one with $23\frac{1}{2}^{\circ}$ tilt)

2 pins (clay may also be needed if the pins cannot be placed in the globe)

1 30cm x 30cm square of cardboard (with North Star written boldly on it with orange marker)

Roll of masking tape

12 placards (40cm x 25cm of white poster board) -- write on each, the name of one of the zodiac constellations in fluorescent orange

1 fluorescent orange marker

Constellation postcard material

Names to be written on the placards (and the order in which they should be placed around the room)

Virgo the Virgin
Libra the Scales
Scorpius the Scorpion
Sagittarius the Archer
Capricorn the Goat
Aquarius the Water Carrier
Pisces the Fishes
Aries the Ram
Taurus the Bull
Gemini the Twins
Cancer the Crab
Leo the Lion

References

1. Elementary School Science, Book 6, Verne Rockcastle, et.al., Addison-Wesley (Menlo Park, Mass: 1973).
2. The Stars, A New Way to See Them, H.A. Rey, Houghton Mifflin Company (Boston:1976).

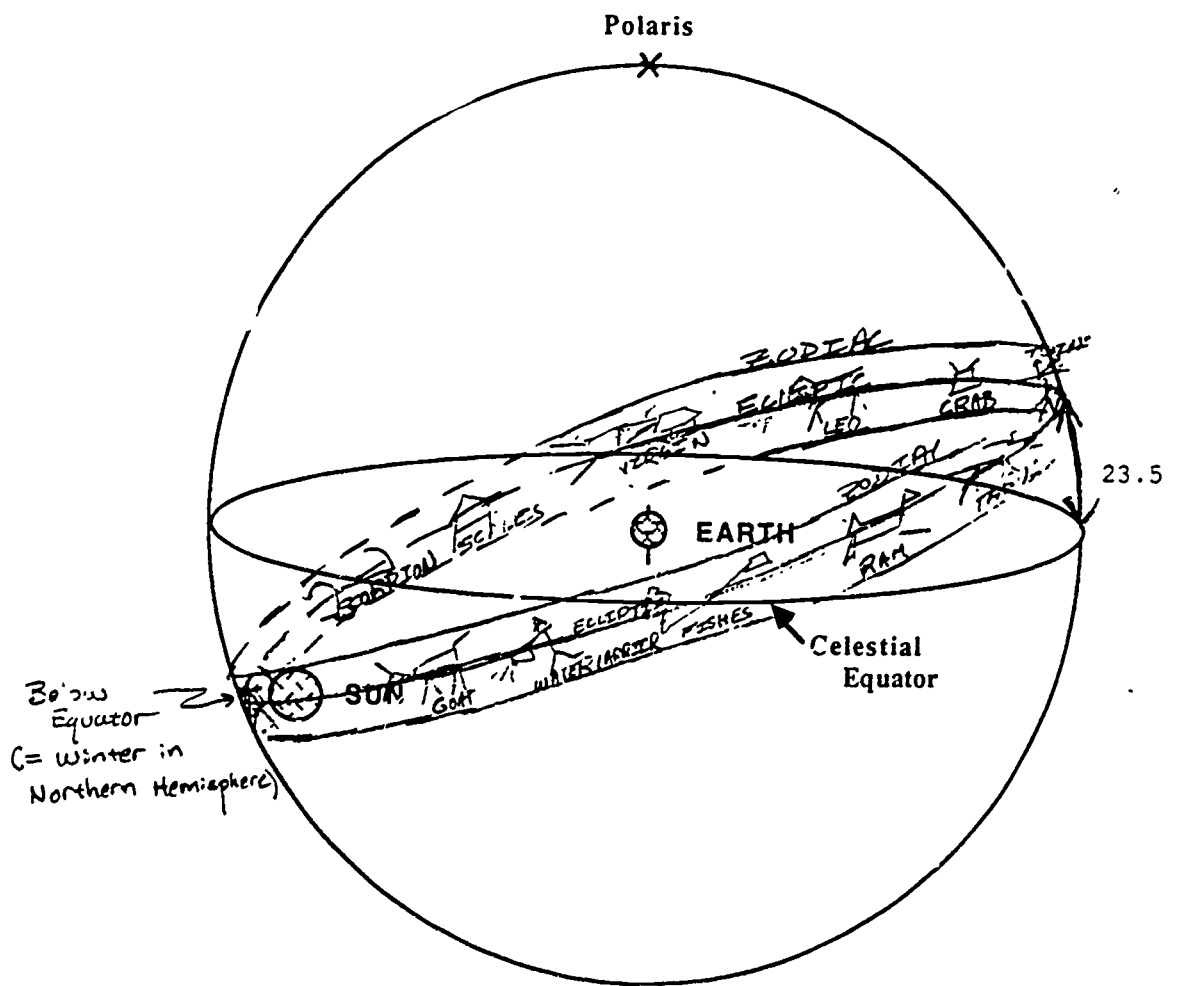

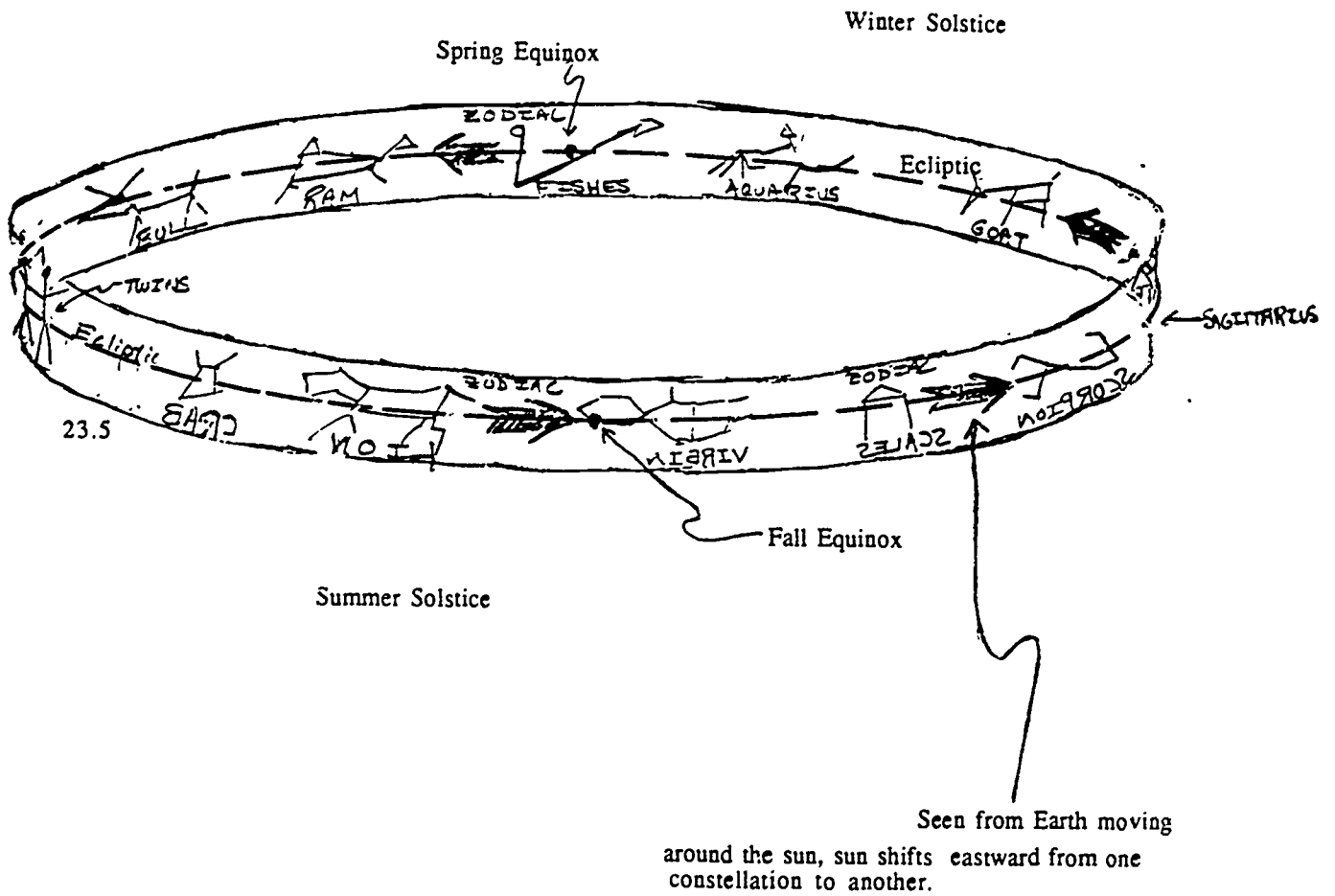

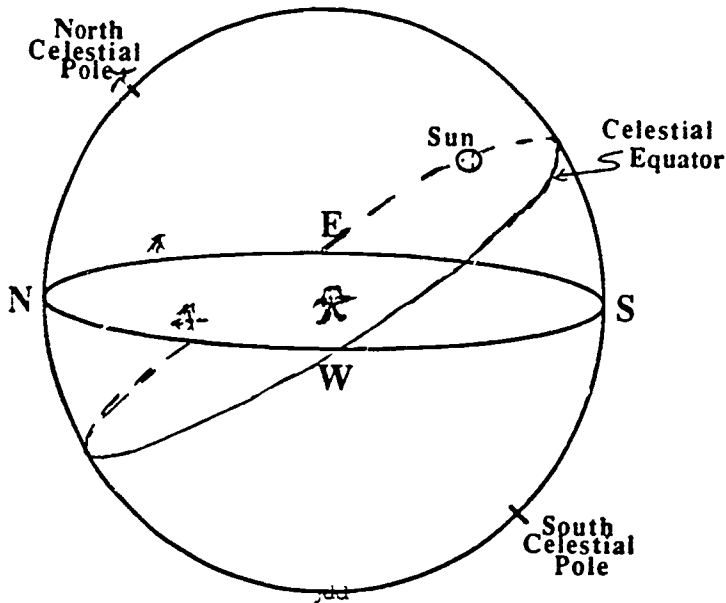

Sun's Path March 21 and September 23

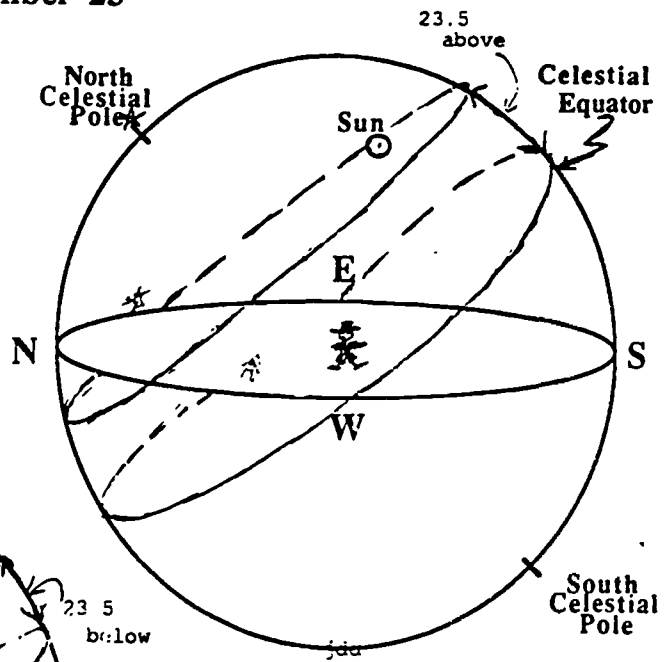

Sun's Path on June 21

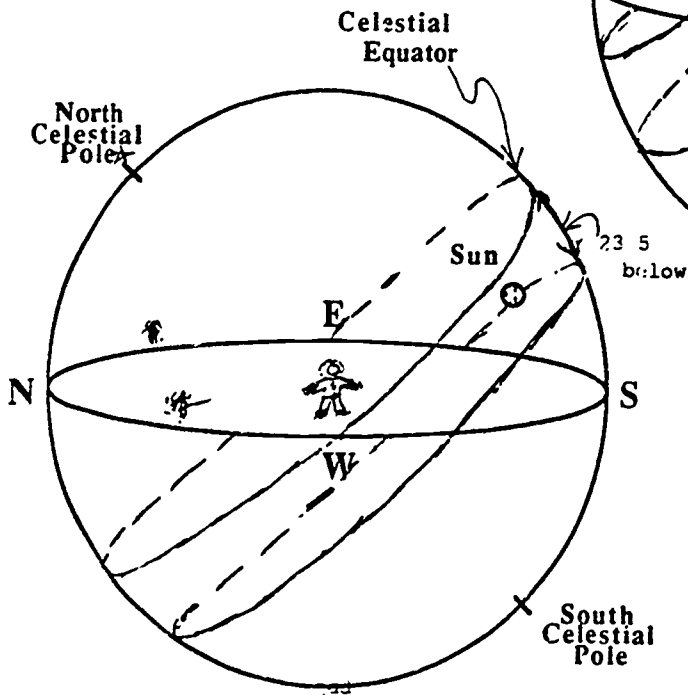

Sun's Path on December 22

The tilt of Earth's axis causes the seasons

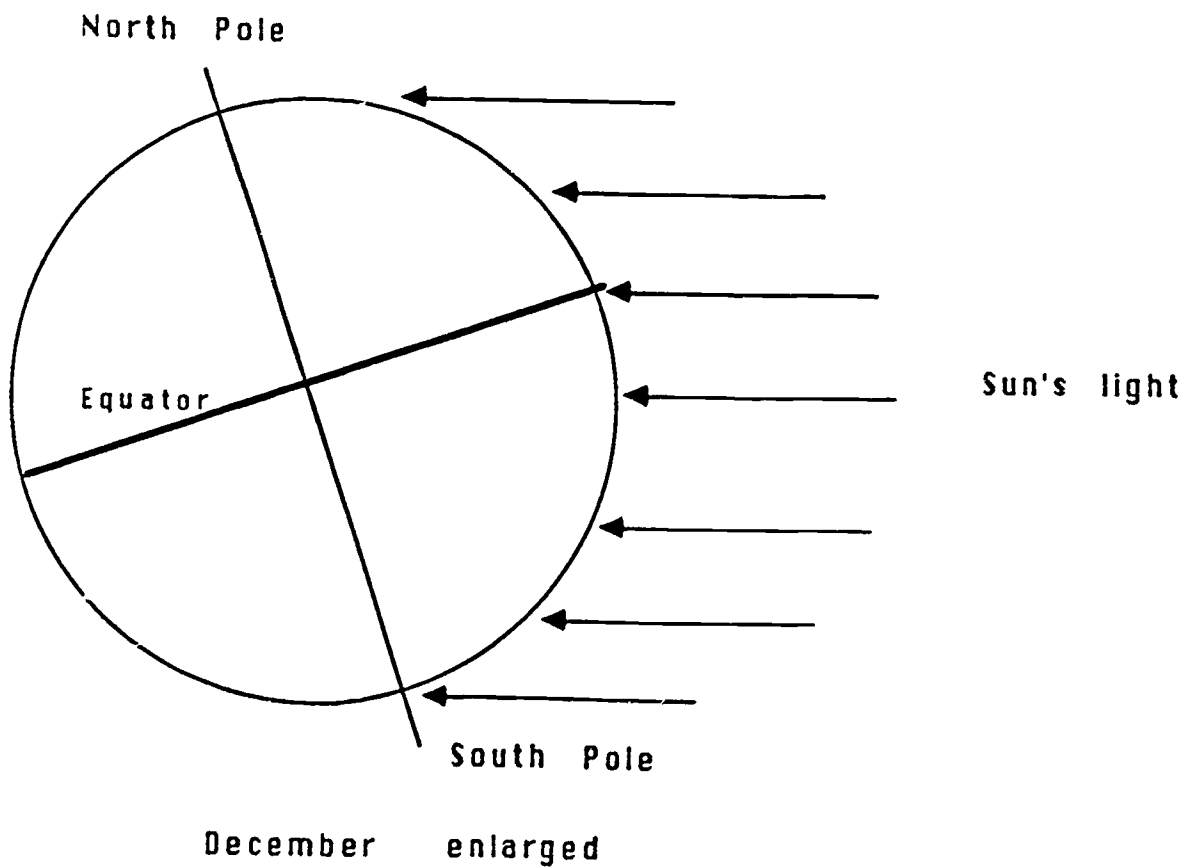
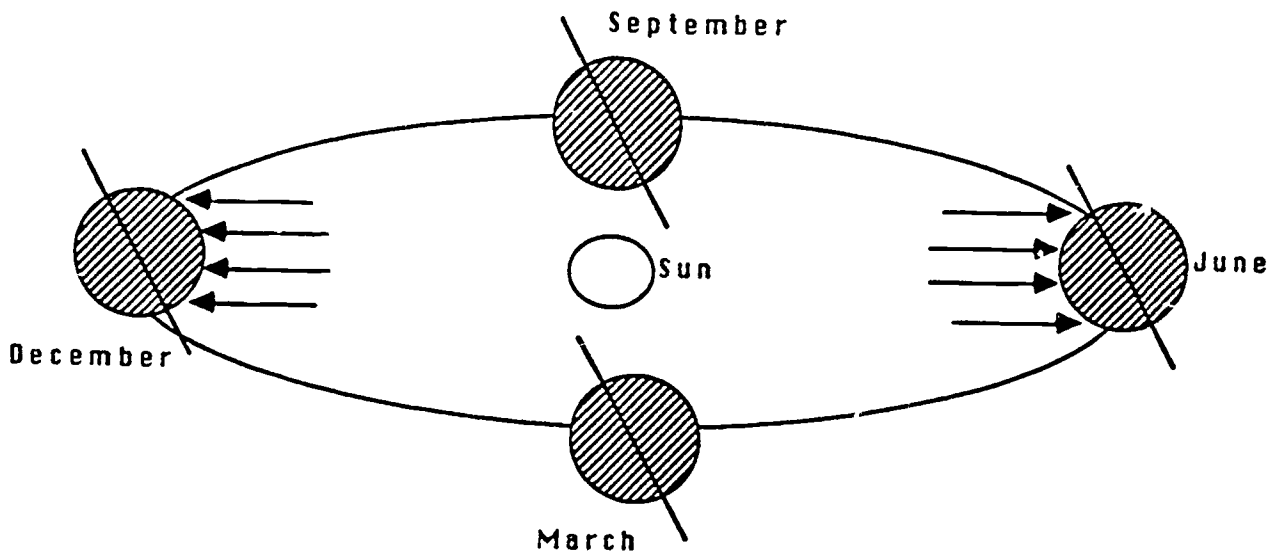

Laboratory 2 - Planetarium Show

Lab Instructor Outline

Show Content

1. Constellation Identification
----Review and new constellations
2. Celestial Sphere
 - a. Review
 - b. Celestial Equator
 - c. Ecliptic & Zodiac
3. Apparent Star Motion
 - a. Daily
 - b. Annual
 - c. Actual Movement
4. Apparent Sun Motion
 - a. Daily
 - b. Annual
 - c. Solstices and equinoxes
 - d. Position of Sun on Meridian for Different Seasons
 - e. Actual movement

Show Outline

- I. Opening event (Night sky set for the present evening)
 - A. Review celestial sphere (briefly)
 - B. Have students identify constellations they worked on in the last session.
 - C. Identify more constellations.
 - D. Break to Star Wheel practice (see notes from Lab. 1).
- II. Focus on today's lesson
 - A. The apparent yearly motion of the sun and stars has been of great importance to mankind
 - B. The position of the sun and stars in the sky has been used as an indicator of planting, hunting, coming of a new season, ancient rituals and worship
 - C. Today we will learn the reasons behind the motions
- III. Statement of objectives
As a result of today's instruction you should be able to...
 - A. Explain the apparent daily and annual motion of the stars
 - B. Explain the apparent annual motion of the sun
 - C. Explain why there are seasons
 - D. Describe the position of the Earth and Sun at the time of the solstices and equinoxes

IV. The sun and star movements

- A. Run the planetarium through one or two days.
Point out the following (flip on 'ecliptic').
1. In one sun day the stars do not go through a complete rotation --- they "rise" 4 minutes earlier. (We will come to reason in a bit). This implies that the stars are apparently travelling west! But, this actually means the earth travels counterclockwise around the sun.
 2. The sun travels along a special path called the 'ecliptic'.
 3. The celestial equator (flip on projector) is the projection of the earth's equator into celestial sphere. The celestial equator and the ecliptic are tilted by $23\ 1/2^\circ$ with respect to each other.
- B. Run the planetarium through a year.
Point out the following (stop at solstices & equinoxes - note dates on ecliptic).
1. The sun travels along the 'ecliptic'. Notice that the ecliptic cuts through twelve constellations. These constellations are zodiac constellations. The ecliptic is the center of the zodiac belt. Basically the ecliptic is the apparent path of the sun on the celestial sphere.
 2. The sun goes up and down in altitude in the sky. Point out that its highest point on the meridian corresponds to the summer solstice, lowest to the winter solstice, mid-points to the fall/spring equinoxes.
 3. Point out that the altitude change is $23\ 1/2^\circ$ from equinox to solstice.
 4. Note how the stars' visibility changes over the year.
- C. How does this come about?
(Brighten lights -- flip on overhead)
1. The celestial sphere as seen by the ancients (see overhead 1)
 2. The celestial sphere with the earth's orbit
(See overhead 2) Note on model: proportions are not to scale - if it were, the earth's orbit would be a pinpoint and the four separate axes would melt into one, as shown on the overhead, pointing at the North Star.

Notice the following:

- a. The earth is tilted $23\ 1/2^\circ$.
- b. This tilt applies to the celestial equator (remember it is the projection of earth's equator) and north pole celestial.

- c. Explain how the apparent path of the sun comes about
 - the sky is at 'rest'; the earth is moving
 - the sun appears against a background of stars
 - a plot of the sun's position over the year (as viewed from earth) gives the ecliptic - (so called because eclipses of the sun and moon occur along this line)
 - the ecliptic and earth's orbit are in the same plane
- 3. The longest and shortest day
 - a. Equinoxes = points of intersection of celestial equator and ecliptic; sun as seen from earth is on the equator.

Spring (Vernal) Equinox - Sun is in the Fishes (Mar. 21)

Fall (Autumnal) Equinox - Sun is in the Virgin (Sept. 23)

-- These correspond to equal days and nights

- b. Solstices (from Latin Sol = Sun and Stare = Stand still)
 - Summer and Winter = when sun is highest and lowest above and below the ecliptic. Give longest and shortest days. Longest (June 21)
 - Shortest (Dec. 22)
- c. Why does the length of day vary, ie why do these days have a special recognition?

Show Overhead 3

- 4. The seasons
 - a. Longer days and shorter nights explain why the summer is warm and winter is cold but another fact resulting from the tilt of the earth's axis makes the temperature change even greater - the angle of the sun's rays.

Show Overhead 4

V. Solar days and Star days

- A. We are now going to explain the daily gain of four minutes in the rising time of stars.
 - 1. A star day is the time it takes the celestial sphere to complete one rotation. (About 23 hours 56 minutes) A solar day is the average time between one noon to the next (about 24 hours)
 - 2. The star day starts with the time that the position of the spring equinox is overhead. It is done when it is again overhead.
 - 3. Solar and star days are not the same length because not only does the earth rotate about its axis it revolves about the sun.

Show Overhead 5

- B. Explaining the gain (use overhead and star wheel)
1. March 21 -
Pullman facing sun at noon
If stars could be seen, some would be directly overhead = pick Cas (have them do on star wheel)
After one full turn Earth will again face Cas, But not the sun since earth has moved in orbit.
Earth must turn a bit more to directly face the sun.
 2. To simplify let a year have 12 months of 30 days. So, 90 turns on the earth's axis later (90 star days)
 3. June 21
Pullman faces Cas for the 90th time but earth must make a 1/4 turn for Pullman to face the sun for the 90th time...! 90 solar days are not yet done. Noon is 6 hours off, the time to complete a quarter turn. It is 6 a.m. solar time; the star has gained 6 hours.
 4. Sept. 21
90 more rotations (180 star days total).
Pullman faces Cas for the 180th time, but not the sun. A half turn is needed to face the sun for the 180th time - noon is 12 hours off - it is midnight solar time - the stars have gained 12 hours.
 5. Dec. 21 - 90 more rotations - a gain of 18 hours 3/4 of a full turn
 6. Mar. 21 - 360 total rotations - a total gain of 24 hours (no more turning) - and we start over!
 7. 24 hours in 360 days = 2 hours a month - 4 mins./day. Really 365.24 solar days (366.24 star days) A daily gain of 3 minutes 55.91 seconds!

VI. Review - Tie-up

Run through aspects of star motion and sun's position again with the planetarium. Break to Lab.

Comments:

In addition to the overhead, the Sun-Earth-Moon Model can be used to illustrate the points. The technique in using this model is the same as outlined above. Pick a reference point on a far wall.

Materials

Overhead, overhead materials, Earth-Moon model, celestial sphere

References

The text and overhead were adapted from;

The Stars, A New Way to See Them, H.A. Ray, Houghton Mifflin Company (Boston: 1976).

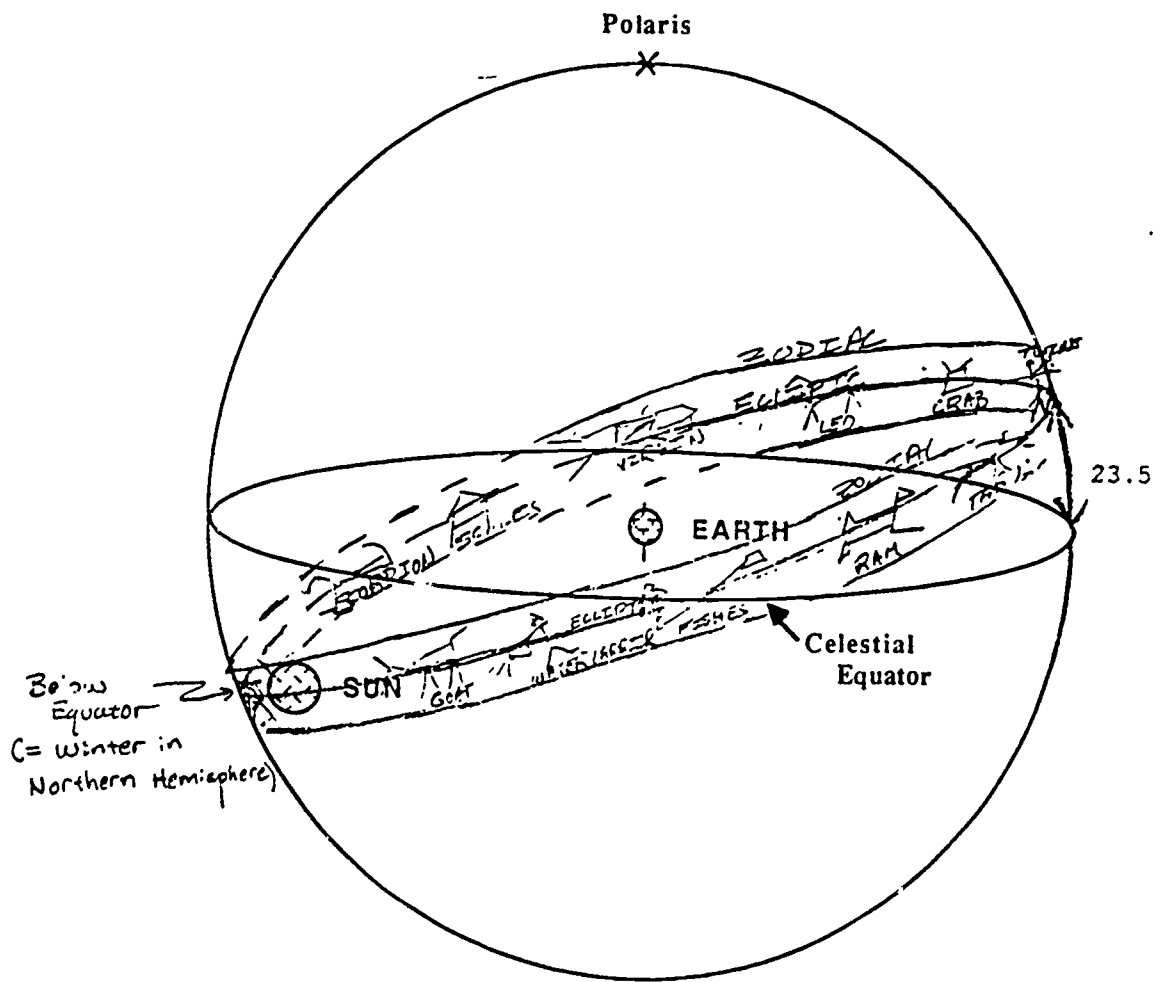

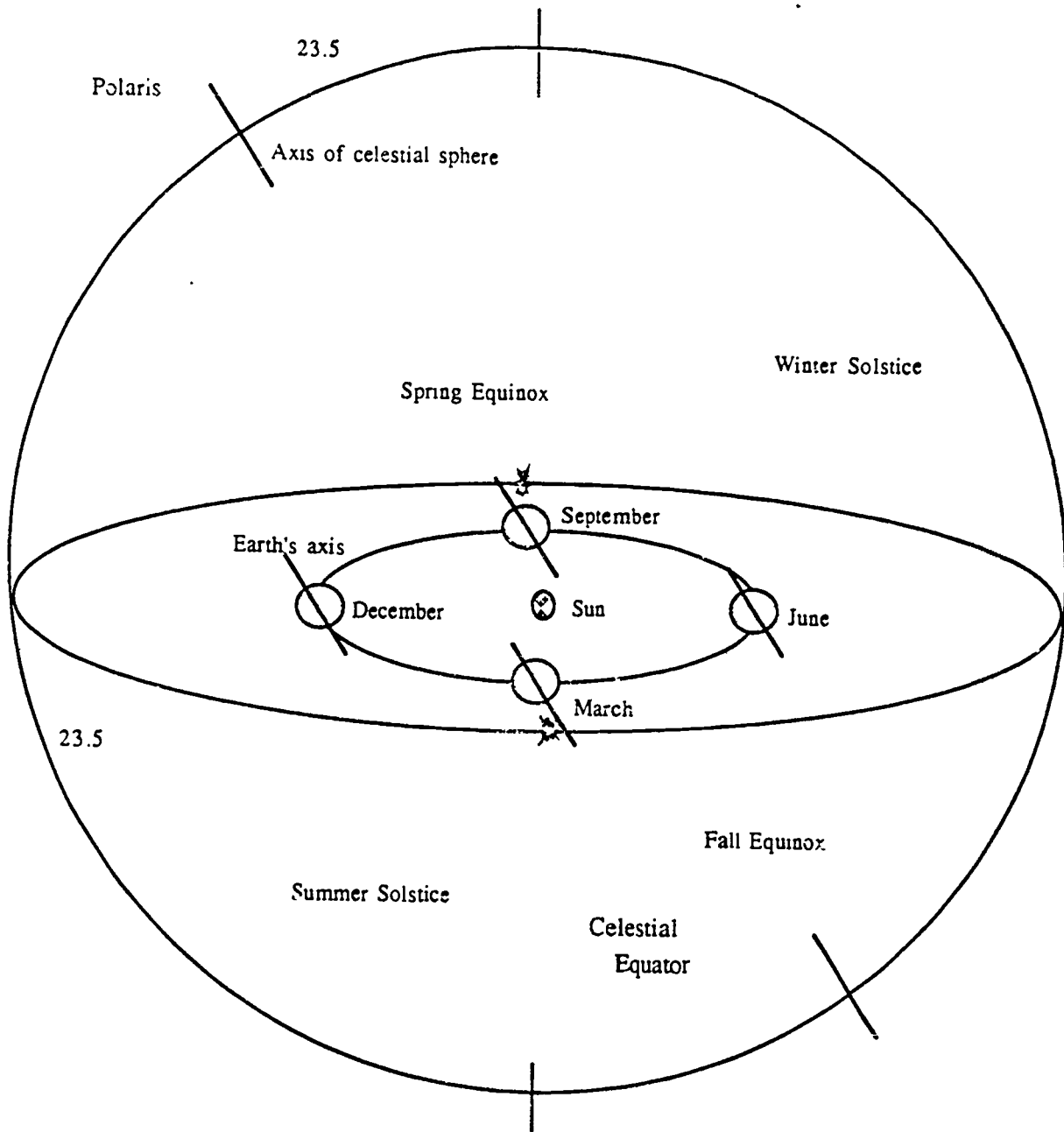

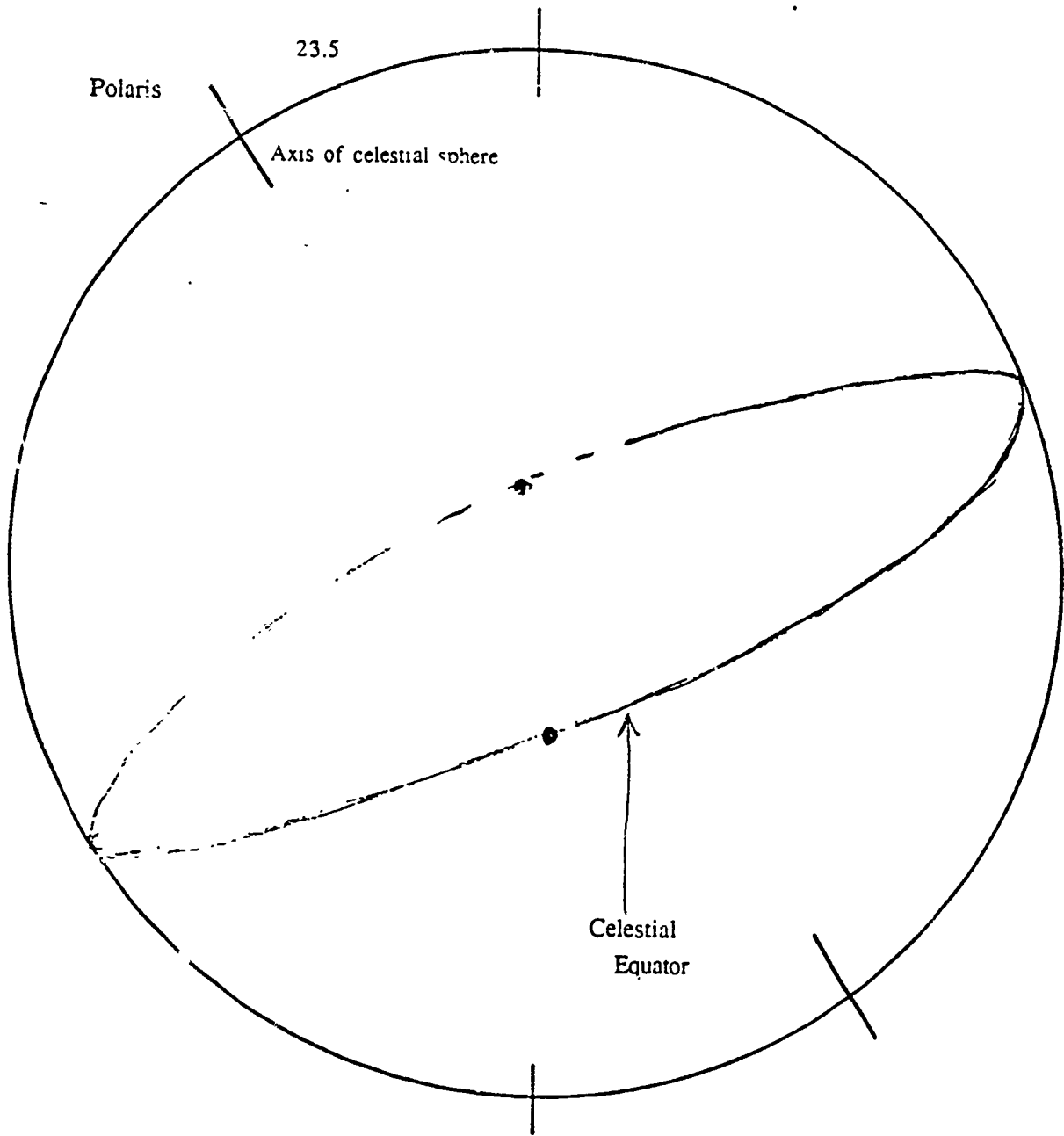

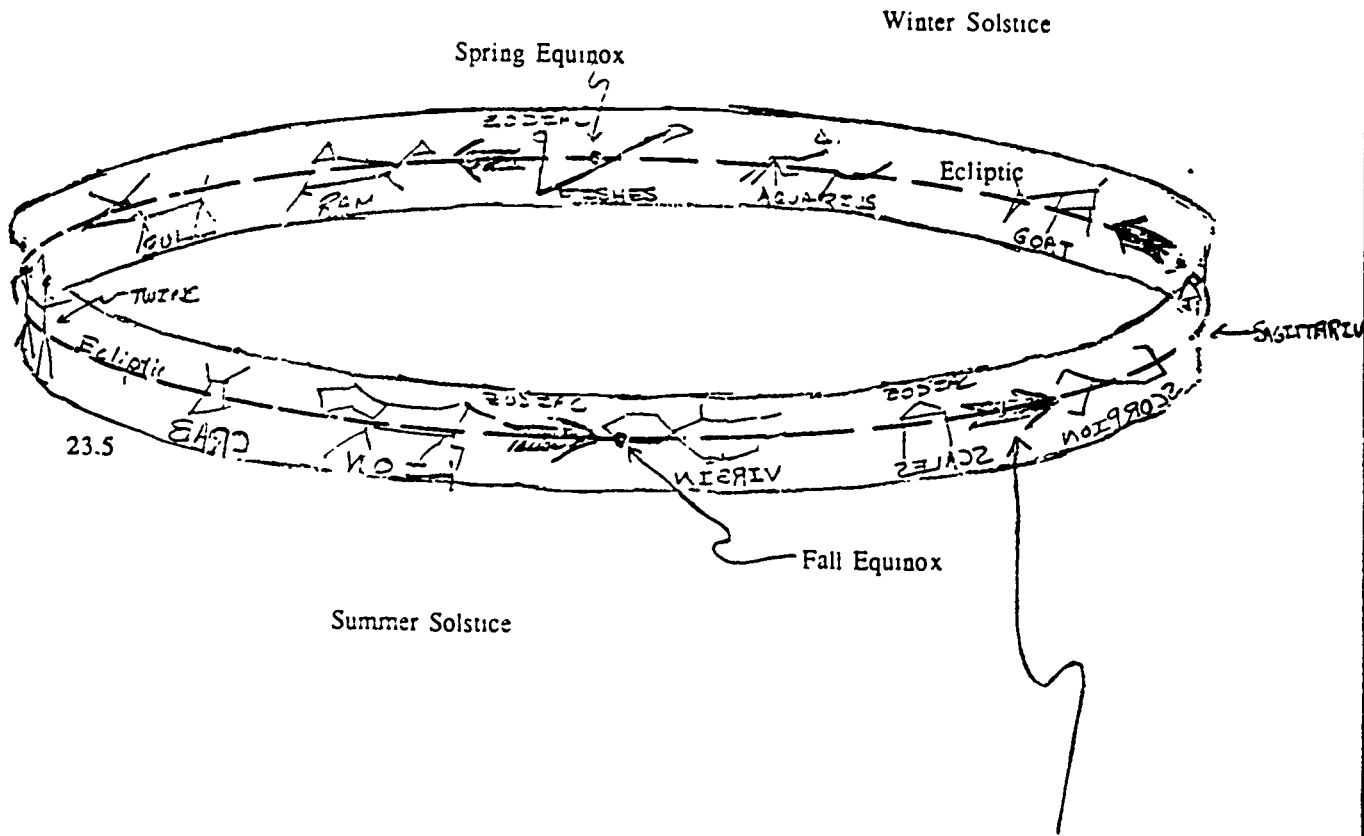

Seen from Earth moving around the sun, sun shifts eastward from one constellation to another.

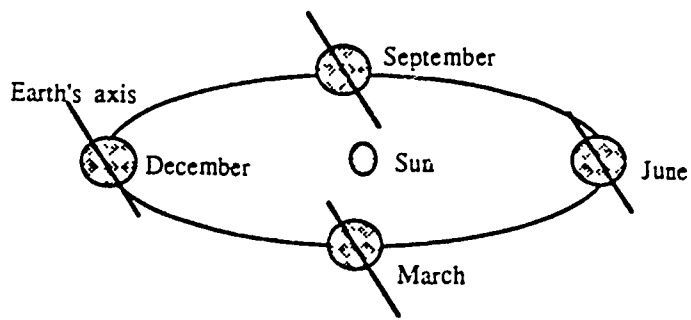

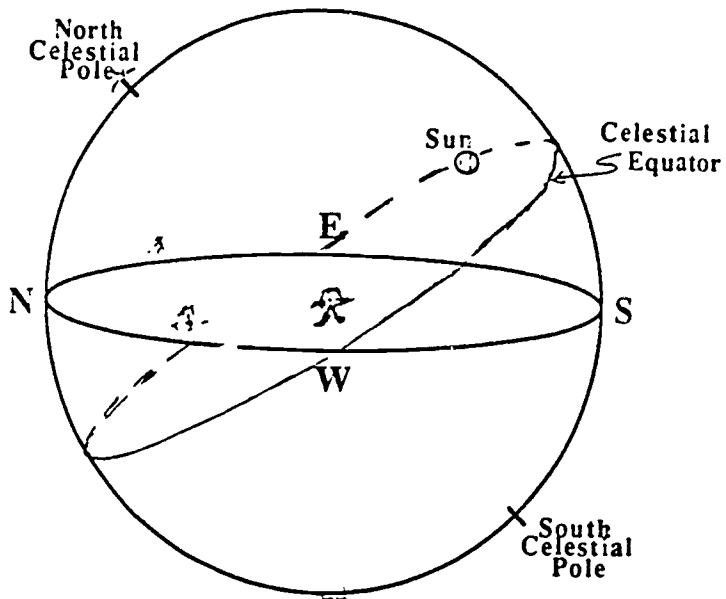

Sun's Path March 21 and September 23

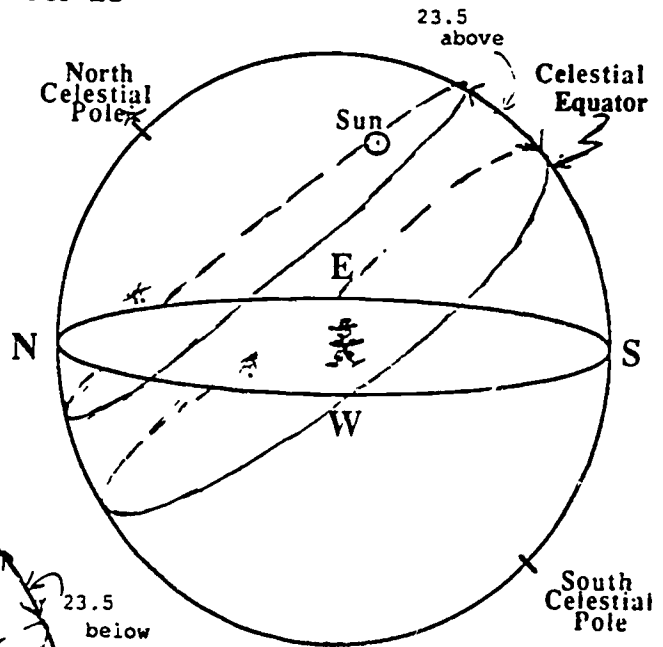

Sun's Path on June 21

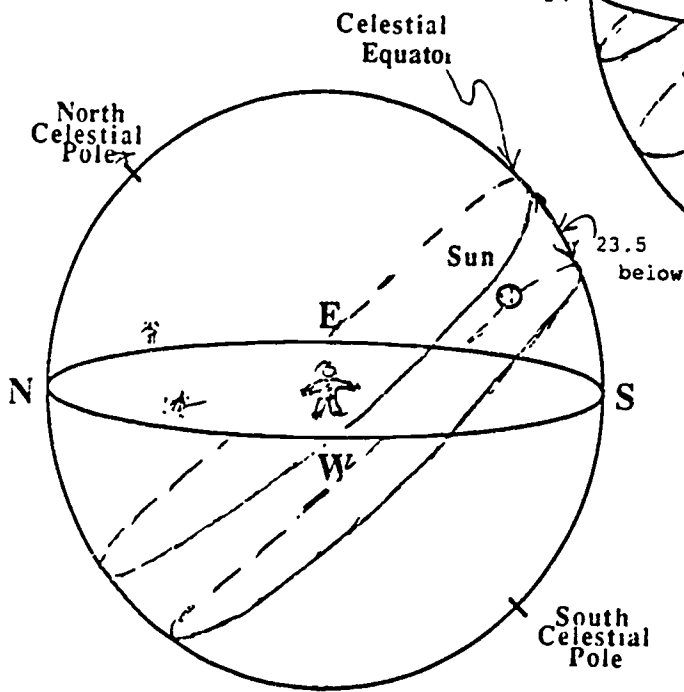

Sun's Path on December 22

The tilt of Earth's axis causes the seasons

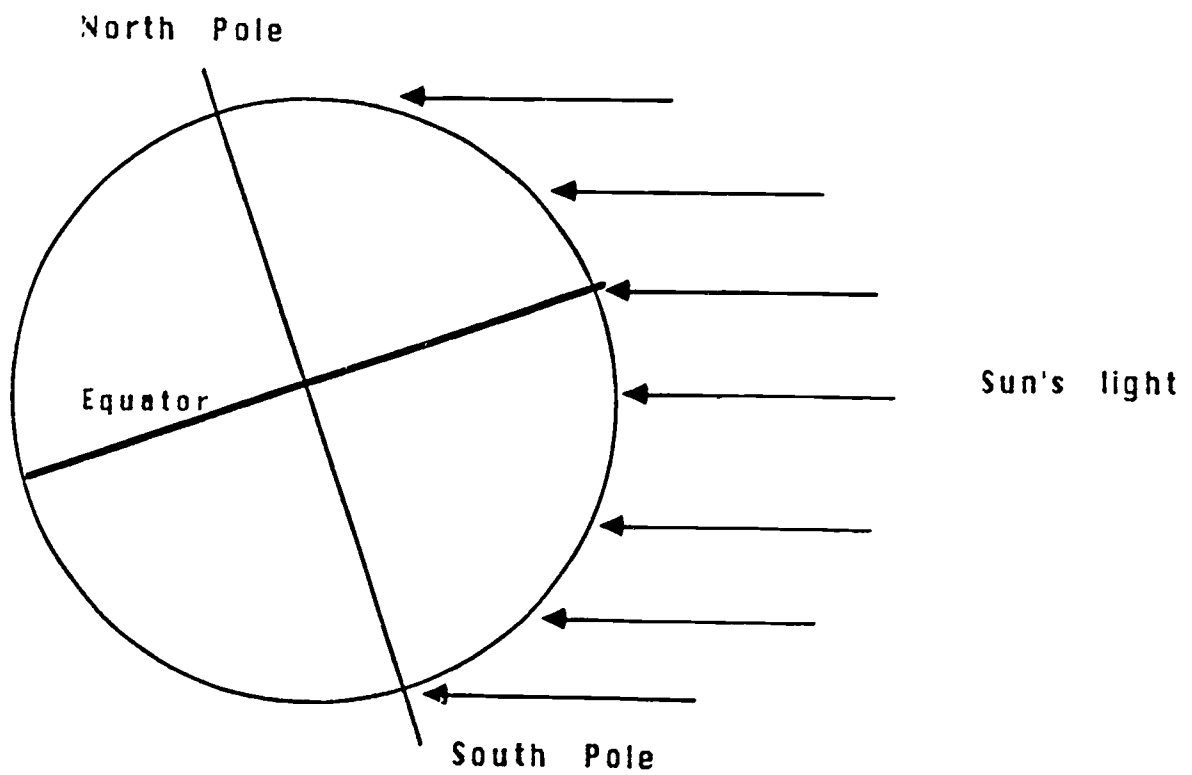
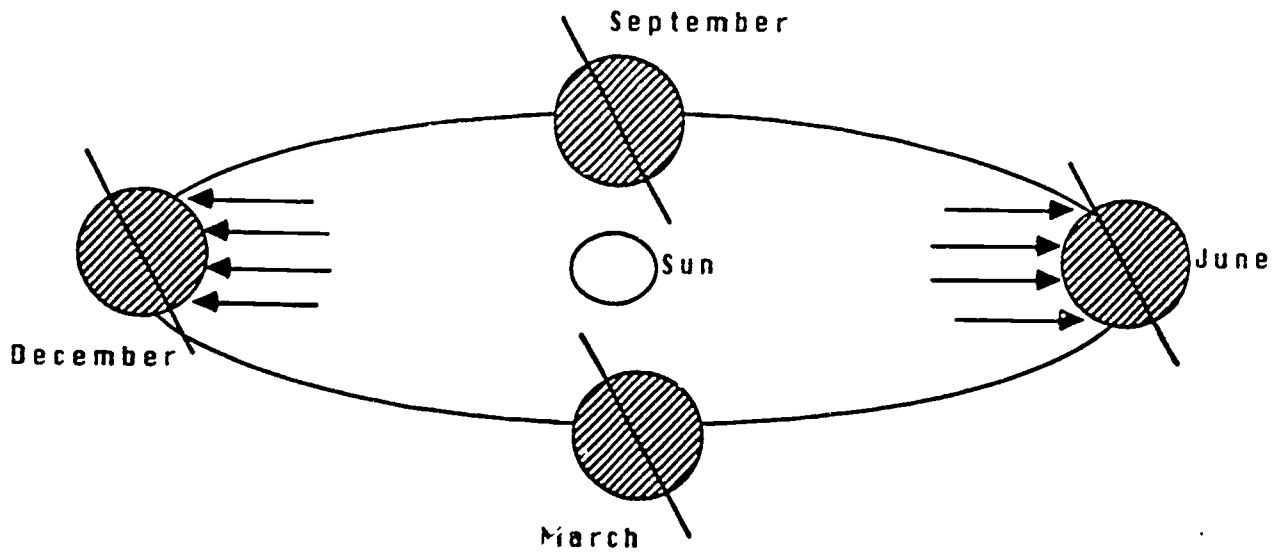

December enlarged

Solar day and Star day through the year

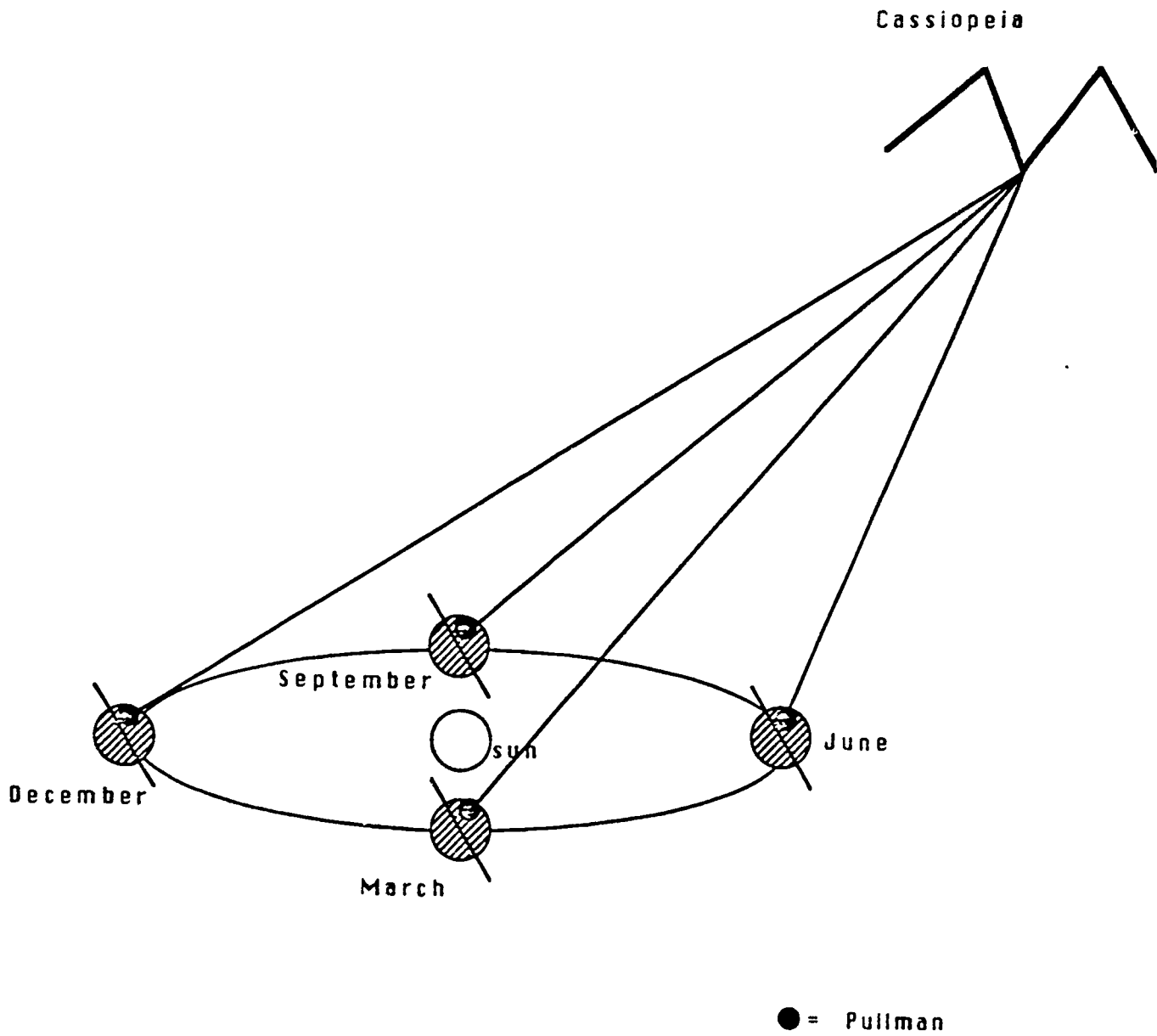

PHYSICAL SCIENCE 250 -- SPRING 1988

Laboratory 2 Worksheet

The Sun, Seasons, and Stars

Name _____ Date _____

Part I -- The Planetarium

1. For locations in the northern hemisphere, when during the year is the sun highest on the meridian at noon? Lowest?
2. When are the days that we have approximately equal lengths of day and night?
3. What day(s) of the year does the sun set due west?
4. Why is there difference between a star day and a solar day? What does this difference cause?

Part II -- The Laboratory

Section A. Globe at Position 1

1. Make a rough sketch of your observations of the sun and earth when the earth is at position 1.

2. What season in the Northern Hemisphere does this represent? the Southern Hemisphere?

3. How does the length of day in Pullman, WA compare to Sydney, Australia?

Globe at Position 3

1. Make a rough sketch of your observations of the sun and earth when the earth is at Position 3.

2. What season in the Northern Hemisphere does this represent? the Southern Hemisphere?

3. How does the length of day in Pullman, WA compare to Sydney, Australia?

4. How does the length of day help cause the seasons? Does this fully explain the change in temperatures with the seasons?

Globe at positions 2 and 4

1. Observations for 2 and 4. How much of the globe surface is illuminated when the Northern Hemisphere is tilted toward the light? Away? Identify the seasons in the Northern and Southern Hemispheres that these cases represent.

2. What type of seasons would the earth have if the earth's equator were in the plane of the ecliptic?

3. What type of seasons would the earth have if the earth's poles were in the plane of the ecliptic?

Section B

1. Make a diagram of the positions of the sun, earth, and zodiac to explain why we cannot see all the stars in one night. Include comments to clarify your work.

Laboratory 3

Precession, the Moon, Eclipses, Sundials

Purpose

The goal of this laboratory is for you to become familiar with the motions of the moon and the causes of eclipses. Also, to review and practice constellation identifications. The goal of the planetarium session is for you to become familiar with precession. In addition, you will review and extend your knowledge of the constellations.

Laboratory Objectives

As a result of the Planetarium session you should be able to:

1. Explain the cause of precession
2. Explain the effects of precession.
3. Identify more constellations.

As a result of the laboratory session you should be able to:

1. Explain the phases of the moon
2. Explain when the moon rises and sets for various phases
3. Describe the rotation of the moon
4. Explain the causes of solar and lunar eclipses in terms of the positions of the earth, moon, and sun.
5. Make a simple sundial.

Part I -- The Planetarium

For the planetarium session you will need to bring your star wheel and star charts. After the session your lab instructor will give you time to complete the worksheet.

Part II -- The Laboratory

Section A. The Moon - Background Information

Introduction

Your lab instructor will present a talk about the motions of the moon. Following the talk you will carry out demonstrations to illustrate the major points.

Material

overheads, marker for overhead (water-based)
moon observation worksheets (these were given to
students during the 1st week of class)
pencil with eraser
map tack
light

Laboratory 3 - Laboratory Session

Lab Instructor Outline

- I. Introduction - The moon is of great importance
 - A. 'Sky Clock' for daily and monthly cycles
 - B. Night light
 - C. Worship
 - D. Tides & Eclipses & Precession

- II. Statement of Objectives
As a result of this session....
 - A. Explain how and when the different phases of the moon occur
 - B. Describe why the moon must rotate
 - C. Explain how solar and lunar eclipses arise
 - D. Be able to use demonstrations to illustrate the motions of the moon

- III. The moon revolves around the earth
-- this is the starting point to explain what you have recorded on the 'moon worksheet' you have been working on...

Overhead 1 - Flip up

- A. Position of observer on earth is for when the moon is on the meridian
- B. Notice that the phases occur at certain positions in the orbit
- C. Notice the time of day when the moon rises and sets the different phases
- D. Notice earth & moon revolve and rotate in same direction (counterclockwise) (Use the overhead to point out these aspects)
 - because of earth's rotation the moon appears to rise in the east and set in the west
 - but if you watch the moon over a few hours you will see it travel a bit to the east (try it!)
 - this eastward travel (or counterclockwise revolution) of the moon causes the moon to rise later each day, since the earth must rotate a little bit further to catch up to the moon.....50 minutes.
- E. Notice that the plane of the moon's orbit is inclined 5° to the plane of the ecliptic (earth's orbit)
 - the moon's position in the sky is along the Zodiac (the band around the ecliptic) so you can locate it in this sky region
 - it is this tilt, as we shall see, that explains why we don't see a solar and lunar eclipse each new and full moon respectively

- IV. Why do we see phases of the moon over a month? As you can see it goes through phases -- but why do we see these?

Overhead 2 - Flip up

- A. We are looking at the moon for positions at sunrise and sunset -- You can picture the movement across the sky in your mind -- For simplicity sunrise is at 6 a.m., sunset at 6 p.m. Day and night are twelve hours.
- B. The observer on the earth sees along the sight lines shown
- C. The days around the outside are rough estimates -- the time varies by one or two days since the moon's orbit is not a true circle but an ellipse (oval)
- D. Notice there is a night and day side to the moon and earth -- since the sun is shining from one direction.
- E. Explain how the table at the bottom was arrived at (a matter of perspective), in terms of the sight lines.
- F. With phases, explain waxing (= growing), waning (= shrinking), gibbous (Latin for hump), crescent (as in outhouse), quarter
- G. Point out on the observations the students made that they saw these or intermediate phases. (If they saw a crescent with the dark side lit up this is called "the old moon in the new moon's arms." Light caused by reflections of earth's light {reflected sunlight}).
- H. Note relative positions of the sun, moon, and observer for different phases. Lead into....
Note that the moon can be seen during the day

- V. When can you see the moon....
We now know why we see phases, why the moon changes position, but when and where....

Overhead 3

- A. We have used a simplified day of 12 hours to show relative positions and time.
- B. Notice that if we know an object's position relative to the sun we can calculate when it rises by noting how many hours behind the sun it is.....so

Overhead 4 - (New to Full moon)

- A. See how the position of the moon changes during the month (just as in overhead 1)
- B. Notice position of moon at sunset (just as in overhead 2) (Due to eastward movement of moon - earth's takes more time) (Notice daily retardation)

- C. But when do these rise? (place overlay 1 on overhead)
 Explain how to arrive at these values. (Note it rises later each day)
 Example - on Day 4 the moon rises 3 hours behind the sun (see overhead 3) so to find rise time just add the 3 hours to sunrise - so 9 a.m. This is how this was found (Notice you can see later phases during the day!)
- D. When do these set? (Place overlay 2 in position)
 Explain how to arrive at these
 Example - (Notice 12 hour difference) The Full moon (rising 12 hours later) will take 12 hours to cross the sky to set -- so here it is about 6 a.m. the next day (sunrise). But what about the waning phases --

Overhead 5 - (Full to New Moon)

- A. See how the position of the moon changes during the month (just as in overhead 1)
- B. Notice position of moon at sunset (just as in overhead 2)
- C. But when do these rise? (place overlay 1 on the overhead) Explain how to arrive at these values. (Note that it rises later each day)
 Example - on Day 19 moon rises 3 hours behind the sun (see overhead 3) so to find rise time just add the 3 hours to sunrise - so 9 p.m.
- D. When do these set? (Place overlay 2 in position)

Five minute break

- VI. What are eclipses and why don't we see them all the time?
 -- Draw student response on the subject

Summarize with Overhead 6

- A. First, if you shine a light on an object it will cast a shadow. So we should expect the earth and moon to cast shadows because sunlight shines on them.
- B. Sometimes the moon passes through earth's shadow, or vice-versa. This gives eclipse.
- C. Notice solar eclipses can occur only near new moon (the only time it lines up right) and lunar eclipses near full moon.
- D. Because the moon's orbit is tilted we don't get an eclipse every month - we only get an eclipse when the moon passes through or near the plane of earth's orbit near the time of full or new moon.

What is the difference between a solar and lunar eclipse?

First some remarks about shadows

- Define umbra = total shadow, cannot see any light
- penumbra = partial shadow, can see part of the light

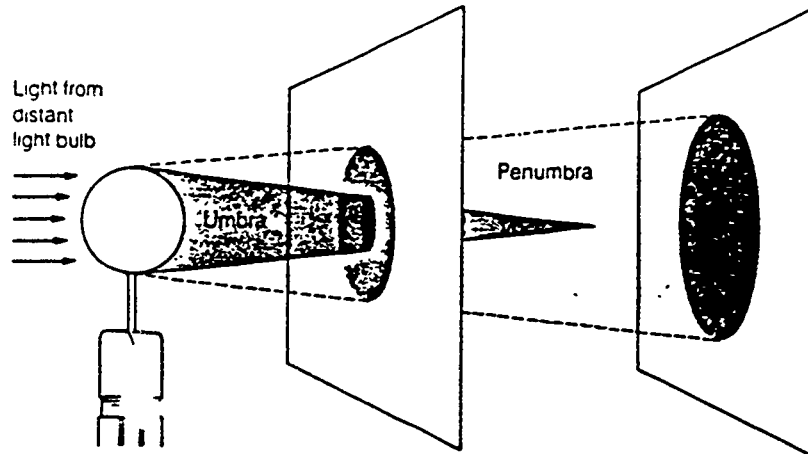

Figure VI.1. Illustration of Umbra and Penumbra

Point this out to the students...
Then draw questions on what difference is there
between solar and lunar eclipses.

Draw answers and summarize with Overhead 7

- A. Total Lunar Eclipse when moon goes through earth's umbra. Visible from entire dark side of earth.
- B. Partial Lunar Eclipse is when moon goes through lighter outer shadow (penumbra).
- C. Moon can block out the sun for only a small portion of the earth since the moon's shadow is smaller (Total Solar Eclipse)
- D. Partial Solar Eclipse can be seen over large area of the earth.

VII. Does the moon rotate?

Focus on the question by taking a show of hands then do the following demonstration.

1. Pick two volunteers. Have one sit on the middle table. The other should stand far enough away so that he/she can walk freely around the table. The sitter is the earth, the walker is the moon.
2. Have the "moon" face the chalkboard. Tell the class that if the moon does not rotate that it will keep itself facing a single direction. Have the moon walk around the earth while facing the chalkboard.

3. Have the earth describe what he/she saw. Draw out that he/she saw all sides of the moon. This disagrees with what we really see. In actuality we see approximately the same side of the moon at all times.
4. Repeat this with the moon facing the earth. As the moon walks around the earth have him/her turn so that he/she faces the earth at all times.
5. Have the class summarize what they observed. Draw out that the moon had to rotate to keep the same face toward the earth.

Point out that this is not just a lucky happening. The Earth's gravity has slowed the moon's rotation to where it is now -- about the same as its revolution. The moon is doing the same to earth through the tides. In a few billion years, one day on earth will last 700 hours!

*Also we can actually see about 57% of the moon because the moon is not in a perfectly circular orbit and the earth is moving.

VIII. A demonstration of the moon's revolution

Materials

Light, globe

1. Turn on the lamp, which represents the sun, located at the center table
2. Holding the globe, which represents the moon, at eye level in front of your face, turn toward the lamp. Your face is the earth.
3. Turn 1/4 of the way around to your left. Notice the phase of the moon. Notice the position of the sun and moon.
4. Repeat until you complete the circle.

Have students complete the worksheet

North stars throughout the ages due to Precession

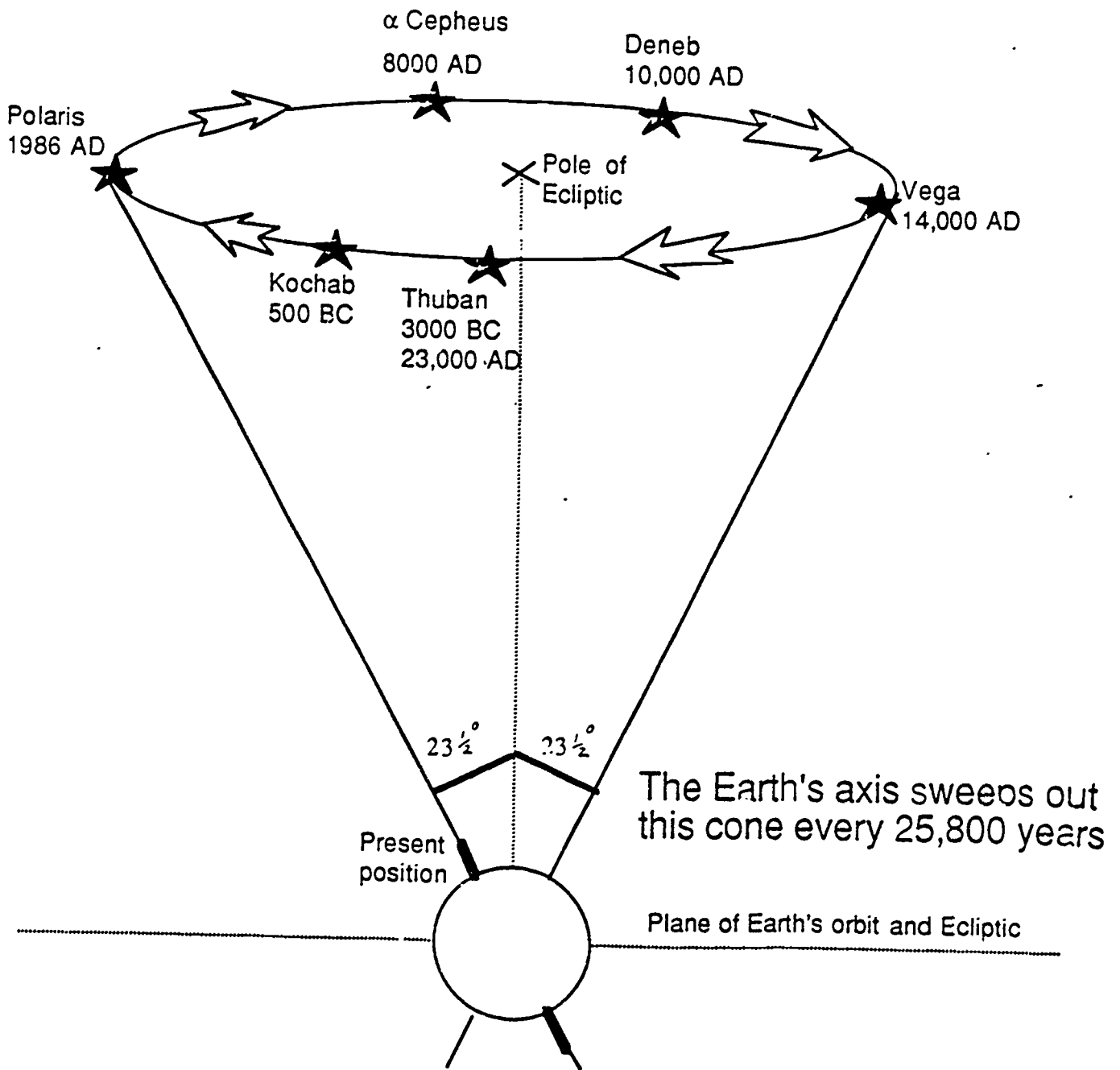

Phases of the moon

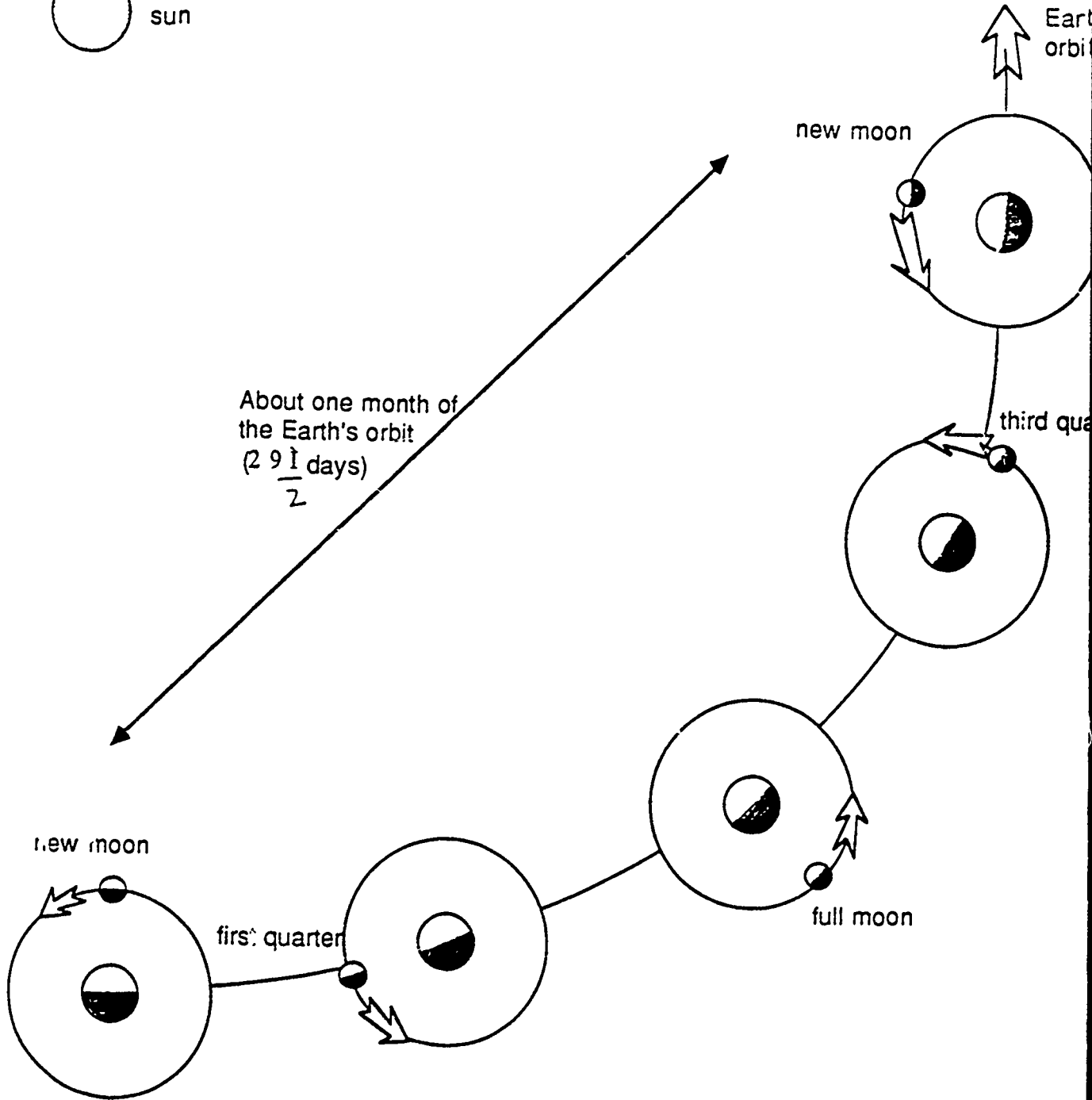
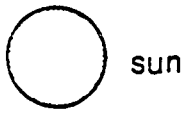

About one month of
the Earth's orbit
($29 \frac{1}{2}$ days)

new moon

first quarter

full moon

third quarter

Earth's orbit

Moon Phases seen on Earth

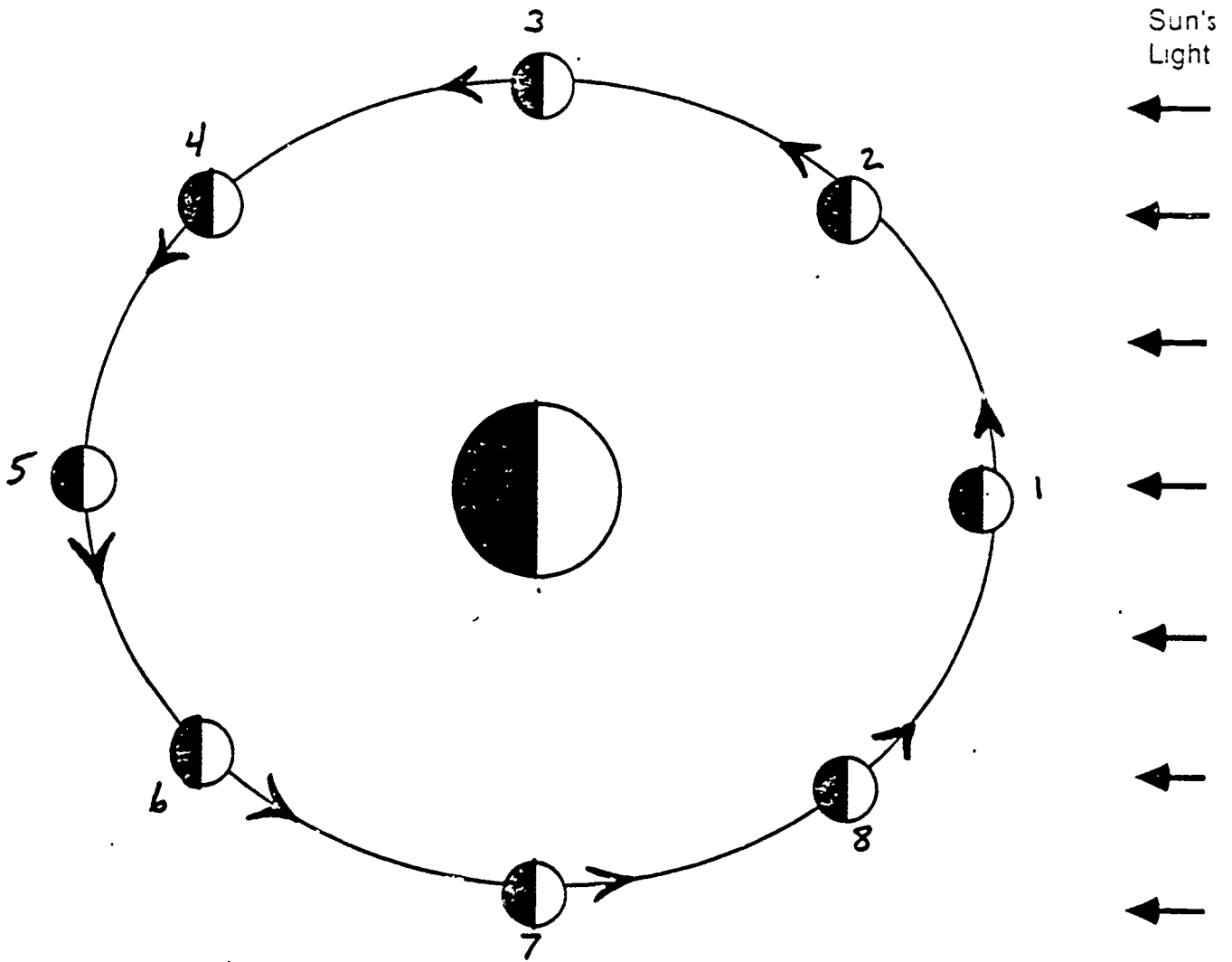

Phases	Shape seen in the sky	Phases	Shape seen in the sky
1) New Moon		5) Full Moon	
2) Waxing Crescent		6) Waning Gibbous	
3) First Quarter		7) Third Quarter	
4) Waxing Gibbous		8) Waning Crescent	

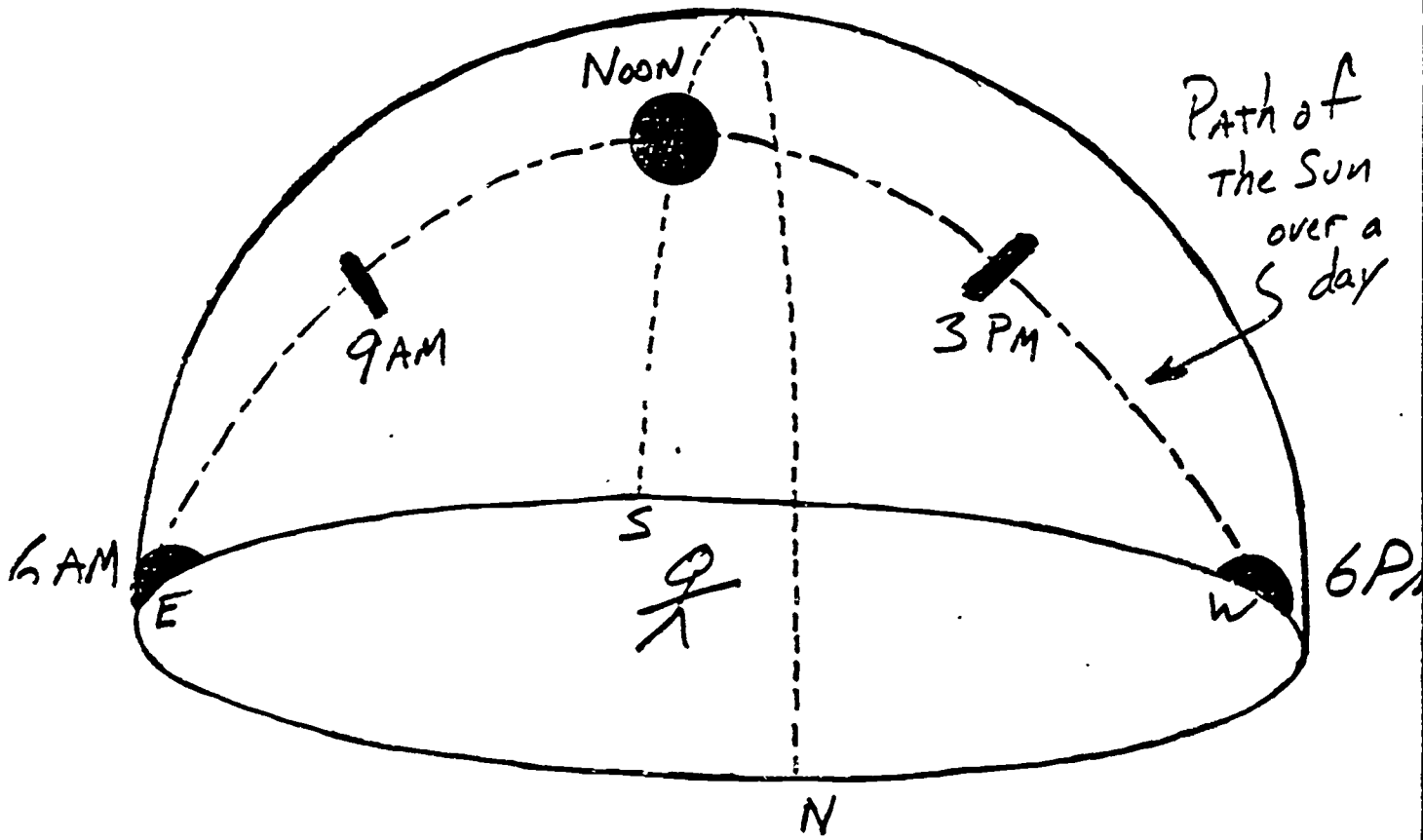

Laboratory 4

The Planets

Purpose

The goal of this laboratory is for you to become familiar with the motions of the planets in the night sky and to illustrate the relative sizes and distances of the planets.

Planetarium and Laboratory Objectives

As a result of the sessions you should be able to:

1. Explain why the planets are always located within the zodiac band.
2. Explain why Venus and Mercury exhibit phases.
3. Explain why we observe retrograde motion.
4. Relate Kepler's Laws to planetary motion.
5. Demonstrate the relative sizes of the planets using common material.
6. Demonstrate the relative distances of the planets from the sun.
7. Point out additional constellations.

Note: Students should bring a paper towel tube to lab next week. It will be used to construct a spectroscope.

Assignment: Students will use the blank star wheel to make up four constellations (complete with mythology and bright star names) of their own. Each student will discuss two constellations in class next week and will hand in the star wheel and a brief (2 pages or less) write-up on the constellations.

Part I -- The Planetarium

For the planetarium session you will need to bring your star wheel. After the session, your lab instructor will give you time to complete the worksheet.

Part II -- The Laboratory

Section A. Some Planet Facts

Introduction

In this section of the lab you will carry out demonstrations illustrating the relative sizes of planets and their distances from the sun.

Lab Introduction

Today we are going to learn a few facts about planets, which means "wanders" from the Greek. Again, we will be presenting some of the material in "lab instructor" format so you will be able to duplicate the demonstrations in your classrooms later.

Laboratory 4 - Laboratory Session

Lab Instructor Outline

A. How big are the planets?

Materials - see Appendix A.

The ratio scale and list of items to be used to illustrate the sizes can be found in Appendix A. This material can be set-up before the lab begins. As the instructor introduces this, he/she should point out the ratios as compared to earth. The idea is for the students to develop an appreciation of the variation in size.

B. How far away are the Planets?

Materials = overheads, adding machine tape

1. Use local maps such as the Campus map and Moscow/Pullman overheads with planet overlays to illustrate the distances. The scale distances in metric and English units can be found in Appendix A.
2. An additional tool to illustrate the distances between planets is to use adding machine tape with the planets marked out on it at the appropriate distances. Walk the tape out by starting in one corner of the room and then walking around the room and out the door. The scale and directions for set-up can be found in Appendix B.

C. Where do the planets appear in the sky?

Materials

Overhead

Procedure

1. Briefly sum up sizes and distances. Talk about how distances play an important role in the time it takes a planet to travel around the sun. This rule is Kepler's 2nd Law. Also, the greater the distance, the greater the orbital period.
2. Put up overhead 1. Point out the orbital periods. Have the students notice that these are the 'visible' planets. Also notice that all these planets orbit in about the same plane. Ask the students what this might mean for observations. Summarize that since these are about in same plane, all these must appear in the zodiac.
3. Point out Uranus, Neptune and Pluto are not identified since they are not visible to the naked eye. Also note that Pluto is an exception to the planets being near the zodiac. It is tilted 17° from the ecliptic.

Section B: Movie and/or Software Demonstration

Movie: "Planetary Motion and Kepler's Laws"
(Houghton Mifflin Company)

This movie highlights some of the important aspects of planetary motion. Appended to this lab is a glossary of the terms used. Following the movie you will learn some demonstrations to illustrate aspects of planetary motion. There are worksheet questions dealing with the movie.

Software demonstrations: "Orbital Motion" from the software package accompanying Michael Seeds book Foundations of Astronomy (Wadsworth Publishing Company).

This software can be used on Apple Computers. It demonstrates Kepler's second law and the effect of changing the relative masses of two bodies orbiting about each other. Also, "Elliptical Orbits" from the Astronomy Disk (Sheridan Simon).

Section C. Illustrations of Planetary Motion

Introduction

In this section of the lab you will do some demonstrations to reinforce planetary motions.

A. Why do Venus and Mercury show phases?

Materials

light fixture with bulb
ping pong ball (string attached to hold it up)
masking tape

Procedure

1. Place the lamp on the center demonstration table. It represents the sun. Tape masking tape to the table in the positions shown in Figure B.1. Write the numbers 1 through 4 on the tape.
2. Have the class split into two groups. Have them go to opposite ends of the table. The groups are done to prevent congestion on one side of the table. Each group is the "view" from earth. See Figure B.1.

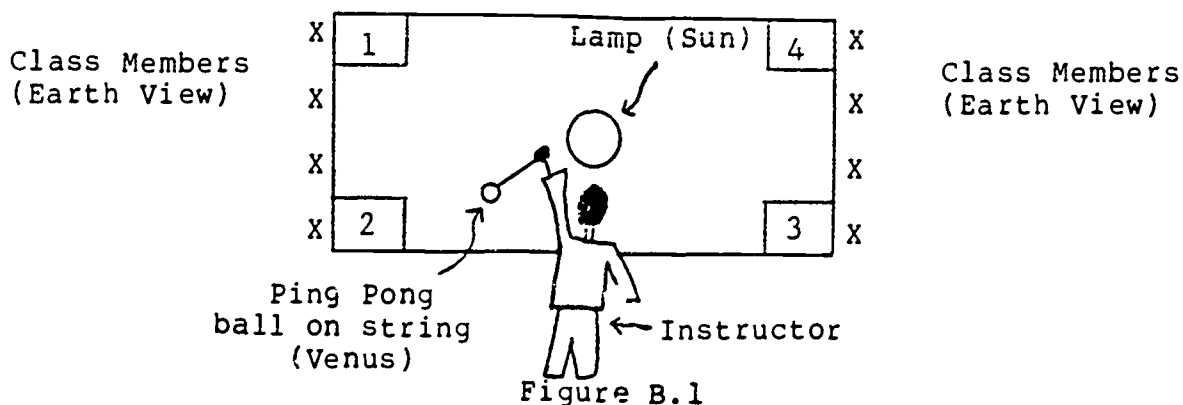

Figure B.1

3. Hold the ping pong ball which represents Mercury/Venus at position 2 at lamp level. Have the students look at ping pong ball level. Ask questions to summarize how much is lit in each case. Note each group will see something a bit different, however the principle is what is being sought.
4. Move from 2 -- 3. Have students generalize how Mercury/Venus has made a change of phase.
5. Move from 3 -- 4. Ask each half what they saw. Conclude that neither half can actually see Mercury/Venus. The far group loses the planet as it passes behind the sun. The near group loses it in the glare. For the near group it should be pointed out that this model does not show this, but it is apparent upon reflection.
6. Move from 4 -- 1. Note changes.
7. Move from 1 -- 2. Note that again we have the situation illustrated in 5. At this time also note that this transit across the sun -- corresponds to Venus/Mercury moving from an evening sky to a morning sky. It is due to the brightness of these objects, being close to the sun and for Venus being a good reflector, that these planets take on the title of evening and morning star. We'll look closely at this in the next part. Also note that these two don't show us a new or full phase because of their passage.
8. Point out that planets outside earth's orbit exhibit only full and gibbous phases. Ask the students why this happens.

B. Retrograde Motion II

1. Point out aspects of the movie. Then place up overhead 2.
2. Notice how observations give the varied path. It appears that the outer planet stops, reverses direction, and then resumes the "direct" motion.

Section E.

Complete the worksheet questions. Feel free to use the demonstration equipment.

APPENDIX A

Materials

25W bulb with fixture
ping pong ball
1m (3 ft.) of string
movie projector
movies = "Planetary Motion and Kepler's Laws"

Scale

1 cm = 2×10^3 km
1 m = 2×10^5 km
1/2 mi. = 745 m = 1 AU

	Actual Diam.	Ratio of diam. to earth's diam.	Actual Distance from Sun 10^6 km	Scaled Diam.	Scaled Distance from Sun
Sun	1.4×10^6 km	109.4		700cm	
Merc	4.9×10^3 km	.398	58	2.5cm	290m=.174mi=950ft= 319yd (Bryan)
V	12.1×10^3 km	.984	108	6.1cm	540m=.3mi=600yds (Fire station)
E	12.0×10^3 km	1	149	6.4cm	745m=.45mi=817yds (French Ad)
M	6.8×10^3 km	.523	228	3.4cm	1.14km=.68mi (gr. house, ball field, Ricos)
J	142.8×10^3 km	11.22	778	71.4cm	3.89km=2.33mi
S	120.6×10^3 km	9.42	1426	60.3cm	7.13km=4.3mi
U	51.8×10^3 km	4.17	2869	25.9cm	14.4km=8.6mi (Moscow)
N	49.5×10^3 km	3.88	4495	24.8cm	22.5km=13mi
Pl	4.0×10^3 km	.47	5900	2.0cm	29.5km=17.7mi (Colfax)
Moon	3.48×10^3 km	.272	38×10^4 km from earth	1.7cm	1.9m=6.3ft

Sun - 2 stories of a building
Mercury - grape
Venus - plum
Earth - apple
Mars - olive
Jupiter - weather balloon (garbage bags)
Saturn - beach ball (garbage bags)

Uranus - lettuce
Neptune - cabbage
Pluto - cherry
Moon - pea

APPENDIX B

Demonstration for planet distance -

Sun's radius	7×10^8 m
Mercury	6×10^8 m
Venus	1×10^8 m
Earth	1.5×10^8 m
Mars	2.3×10^8 m
Jupiter	7.8×10^8 m
Saturn	1.4×10^8 m
Uranus	2.9×10^8 m
Neptune	4.5×10^8 m
Pluto	5.9×10^8 m

--- if 10^9 m = .2 cm --- Sun 2 mm -- planets not present

Take roll of adding machine tape and put planetary position relative to the sun with an X.

Distance on scale

Mercury	12 mm
Venus	2 cm
Earth	3 cm
Mars	4.6 cm
Jupiter	1.56 m
Saturn	. 80 m
Uranus	5.80 m
Neptune	9.00 m
Pluto	11.80 m

NOTE: Walk it out in the classroom for the fun of it.

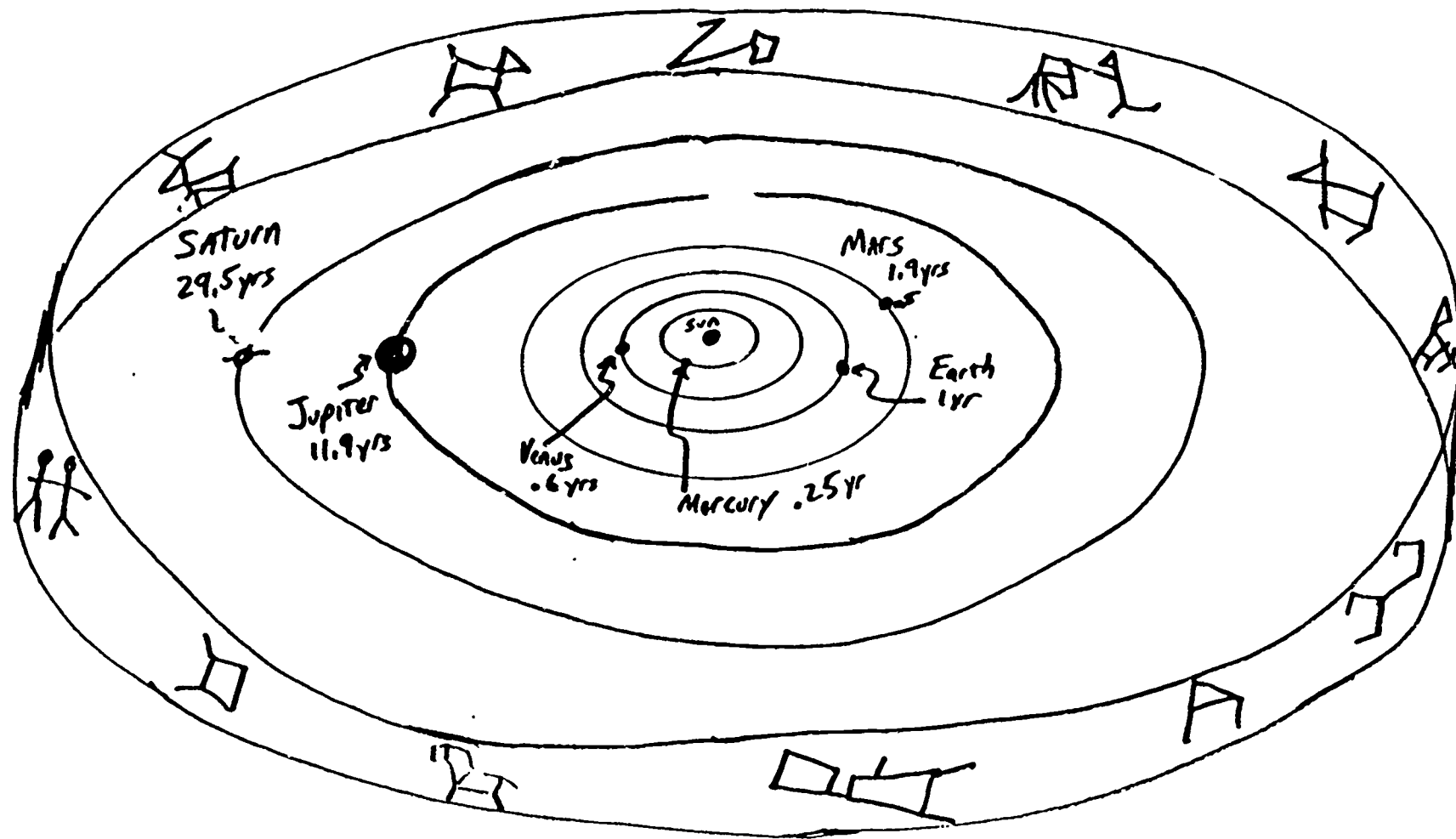

Periods of Revolution for The Visible Planets

Washington State University

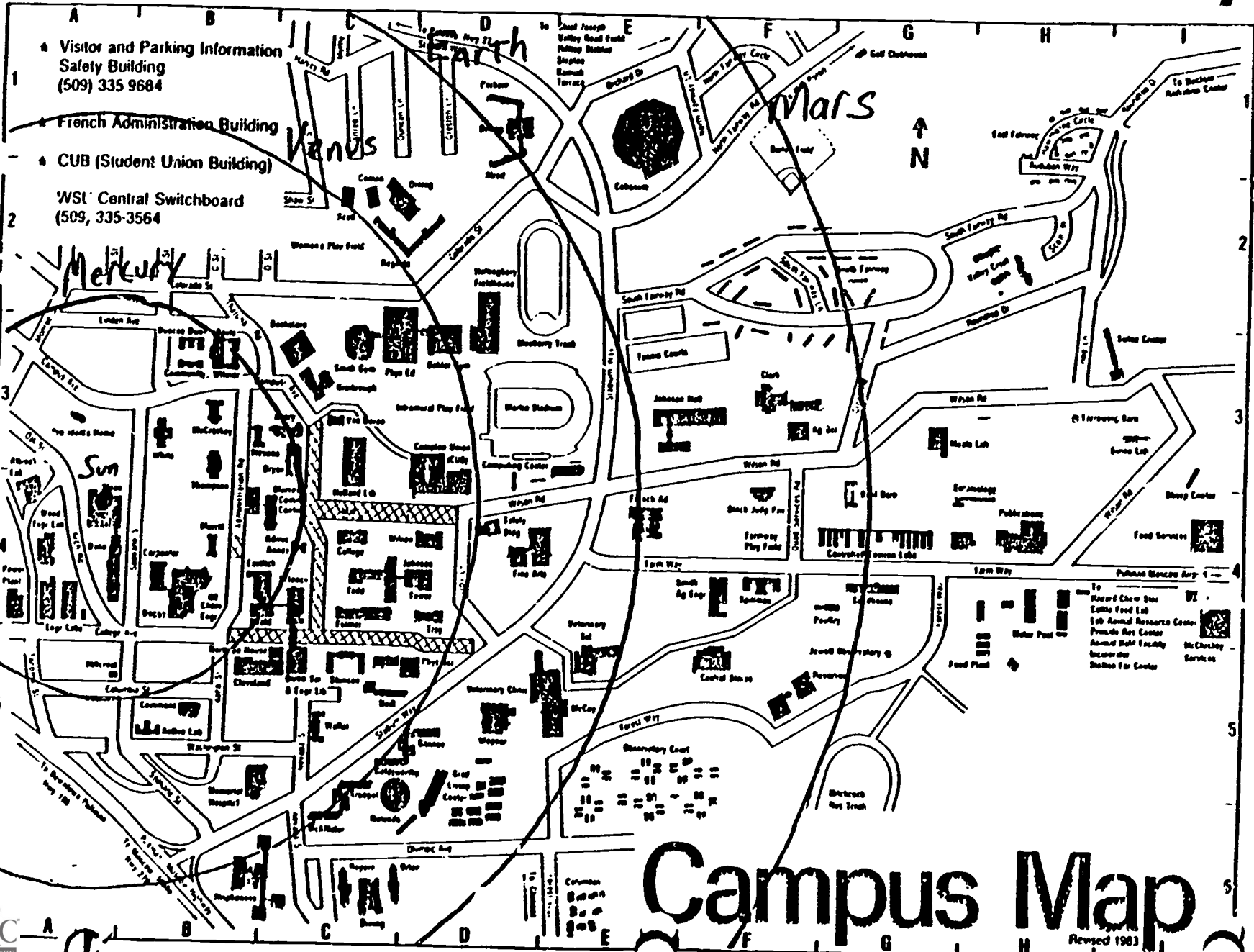

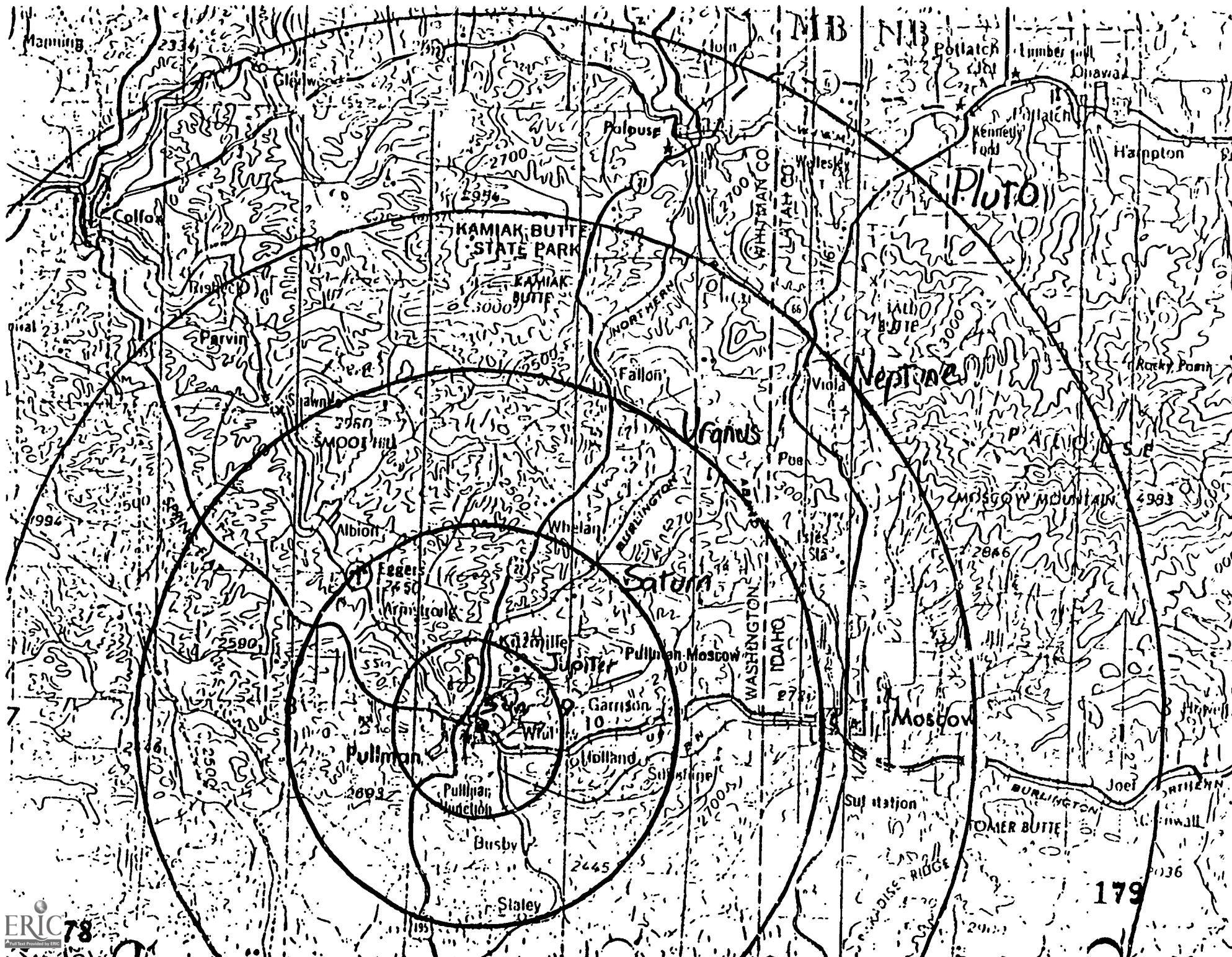

4. Why can't we see Venus and Mercury all night long?

5. Briefly explain retrograde motion. Feel free to use sketches. Try to develop an analogy in as part of your explanation.

6. In Appendix A, appropriate things to use for the relative sizes of the planets demonstration is given. Come up with a different list of things to use.

PHYSICAL SCIENCE 250 - SPRING 1988

Laboratory 5

Star Finding

Light and the Electromagnetic Spectrum

Purpose

The goals of this laboratory are for you to learn how to construct and use an inexpensive Star Finder and to construct and use an inexpensive spectroscope.

Planetarium and Laboratory Objectives

As a result of the sessions you should be able to:

1. Construct an inexpensive Star Finder and be able to explain how to use it.
2. Construct and use an inexpensive spectroscope.
3. Explain how and why different atoms have different types of spectra.
4. Explain the Doppler Effect.
5. Identify more constellations.

Other Activities

1. Students will give presentations on "do-it-yourself" constellations.
2. There will be a short quiz on material covered through Laboratory 4 (excluding constellations).

Assignment: Each student will pick a topic that is "pseudoscientific" and will read at least one reference which describes the phenomenon and one reference which debunks the phenomenon. A two page summary of the reading should be turned in during lab next week. Students will be expected to participate in discussion of these phenomena during the next lab.



STAR FINDING

DEVELOPED BY:
DENNIS SCHATZ
PACIFIC SCIENCE CENTER, SEATTLE, WASHINGTON

Concept: To construct a Star Finder and observe that:

- Some stars are always above the horizon while some rise and set.
- That different stars are visible at different times of night.
- That at the same time on different nights a different set of stars are visible.

Materials:

- Star Finder sheets (3 pages per student)
- Manila folder (1-1/2 per student)
- Star Finder worksheet for each student
- Scissors, X-Acto knives (plus scrap cardboard to protect table), glue, staplers
- Paper and pencil
- Sample of completed Star Finder

Background

The stars are continually changing their position as the earth rotates on its axis. A star finder has a rotating wheel which compensates for the motion of the sky. It can be set to show the sky for any date and time.

1981 © Dennis Schatz

If you are not familiar with star finders, you will find it helpful to construct one (using the instructions shown under "procedures") before you read further. It should look like the one shown.

The star finder can be used to analyze the motion of the stars. For example, set the sky for 10:00 pm tonight (line up today's date opposite 10:00 pm on the star finder). Note the constellations that are visible, and then move the dial until it shows the sky at 11:00 pm. Again note the constellations visible. If you do this at hourly intervals for an entire day, several observations can be made:

1. There are a set of stars centered around Polaris (the north star) which never go below the horizon. Ursa Major (the big dipper) and Cassiopeia are two of the brightest of such constellations.
2. A different set of stars are visible at different times of night.

If you keep the time the same, but look at what happens when you go out on different dates, you also find that a different set of stars is visible each night. These are observations the students should be able to make as they answer the questions on the Star Finder Worksheet.

Construction Procedure

- *Glue sheet 1 to the front of a manila folder with solid line along fold. Set aside.
- *Glue sheet 2 to half of another manila folder.
- *Cut out star field on sheet 2 along dotted line.
- *Glue sheet 3 to back of cut out circle so dotted line on sheet 3 is as close to edge of circle as possible (do not worry about matching up months, it can't be done).
- *Cut out manila folder as indicated on sheet 1. An X-acto knife is best for cutting out small areas next to direction indicators. If you do not wish students to use X-act knives, then you will need to attach and cut out appropriate parts of sheet 1 ahead of time.
- *You should have 2 pieces as shown below after all cutting is complete.



*Staple manila folder closed as indicated on front, and insert circular star map with simplified star field showing. After students are adept at using a simple map, they simply flip it over and use the sophisticated map.

*Have the students compare their results with your star finder and make any corrections.

*Tell them how to set the sky for a given date and time (see instructions on face of star finder). Encourage them to compare results.

*Give them several other times and/or dates until you feel they understand the process. Then let them work through the Worksheet, encouraging them to work together.

Have them compare their results to the Worksheet, discussing differences, until the class can agree on the observations discussed under background. Conclude the lesson by again looking at the last question of the Worksheet, developing a general description for the star's daily motion.

*Encourage students to use the star finder on the next clear night and discuss their observations the next day. If possible, arrange a class star party for everyone and their families.

Follow-up

1. Have interested students consider what kind of motion the stars would have at the north pole; at the equator.
2. Some students may wish to take photographs of star "trails" to show the motion of the stars in the sky. They will need a tripod and a camera that can have its lens left open. Have them pick a night without a moon up, and to go where there are no street lights nearby. Point the camera in the desired direction, focus to ∞ (infinity), use a F/5.6 aperture, and leave the shutter open for ten minutes to 30 minutes.

STAR FINDER WORKSHEET

Set your star finder for 9:00 p. m. today:

1. List the constellations you would be able to see if it were clear tonight.

Turn the dial until it is set for 11:00 p. m. today:

1. List the constellations you can see.

2. Which constellations were up at 9:00 p. m. but not at 11:00 p. m. ?

3. Which horizon are they closest to?

4. Which constellations were up at 11:00 p. m. but not at 9:00 p. m. ?

5. Which horizon are they closest to?

Turn the dial until it is set for 6:00 a. m. , just around sunrise.

1. What constellations are still visible that were up at 9:00 p. m. ?

2. For each of these constellations, describe the motion they follow from 9:00 p. m. to 6:00 a. m.

3. Follow each constellation, one at a time, as you turn the dial one complete turn (go through one day). List any constellations which never go below the "horizon".

Set your dial for 9:00 p. m. for two months from now.

1. List the constellations you can see. _____

2. Which constellations will be up one month from now at 9:00 p. m. that are not up tonight at 9:00 p. m. ? _____

Set your star finder for 9:00 p. m. 6 months from now.

1. What constellations are no longer up compared to tonight? _____

2. What new constellations are up? _____

3. What constellations are visible both times? _____

4. List any constellations that will always be visible at 9:00 p. m. no matter what the date is. _____

Find the constellation Canis Major. The brightest star is called Sirius. Circle Sirius.

1. What hour will Sirius rise today? _____
2. What hour will Sirius set today? _____
3. Three months from now, when will Sirius rise and set? _____

4. Six months from now, when will Sirius rise and set? _____

place along folded edge of folder - DO NOT CUT

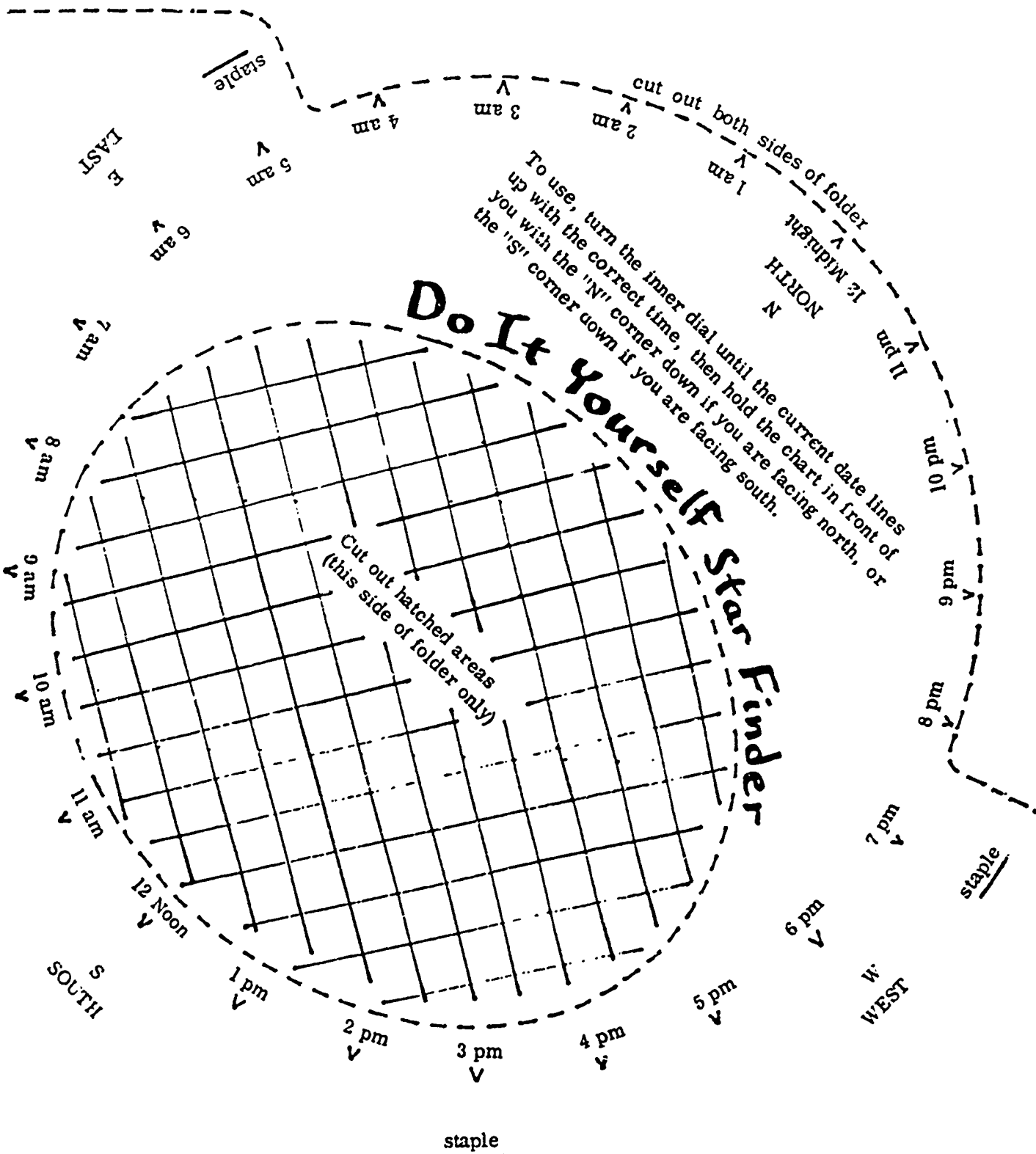

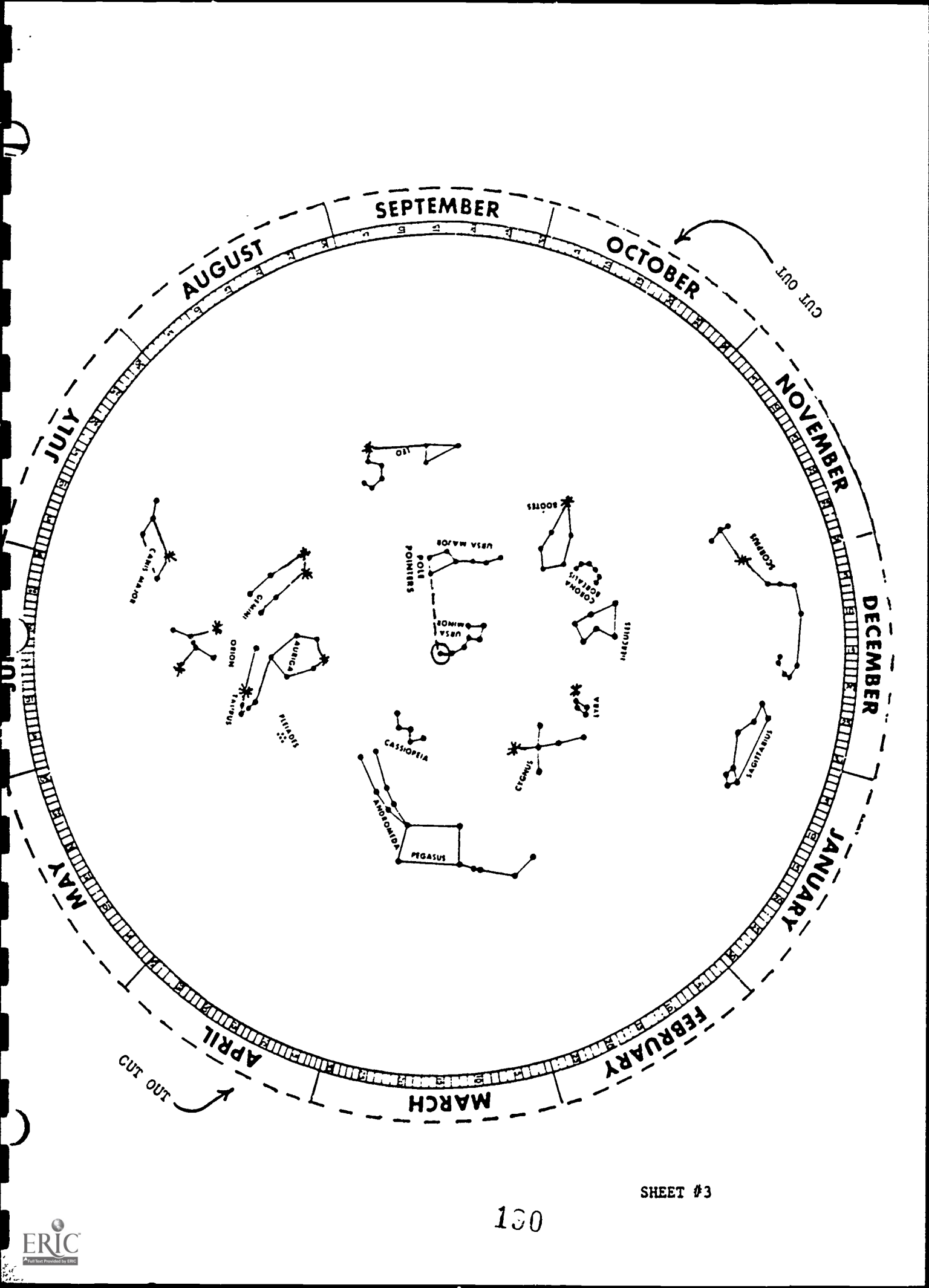

Light and the Electromagnetic Spectrum

Introduction

For most astronomical objects, the only way we can learn anything about them is to look at the radiation they give off. The atomic composition can be determined by breaking the light into its spectrum and examining the emission and absorption lines. These lines help indicate things like the temperature of the object. In today's lab we will look at the spectrum of various gases and sketch the spectral lines. Additional sources of light will be viewed outside of class. We will also learn how the Doppler Effect can be used to find the velocities of astronomical objects.

Materials

Diffraction grating (1 per student)
9-14 inch tube
cardboard for slit
light sources (such as neon, helium, mercury, sodium)
fluorescent lights

Section A. Doppler Effect

Movie: "Doppler Effect in Sound and Light"
Houghton Mifflin Company

This movie shows the effect that movement of a sound or light source has on the wavelength that reaches the observer.

Section B. Spectroscope

A spectroscope can be used to examine light sources. The diffraction grating is used to separate a beam of light into its spectral components. Light sources are continuous, bright line (emission) or dark line (absorption). The radiation laws that produce the three types of spectra were discussed in lecture. In this experiment you will view continuous and bright line sources of radiation. Cardmounted diffraction viewers are available from Edmund Scientific Company.

Procedure

1. Make a spectroscope (see instructions on following page)
2. Darken room and turn on light sources
3. Observe each light source through spectroscope and sketch the spectra on worksheet. (Neon has lots of lines so just sketch the strong ones).

4. Look at the fluorescent light through the spectroscope. Note there is an emission spectrum along with the continuous spectrum. Sketch the emission lines on the worksheet.

Spectrum of Different Sources (nm = nanometer = 10^{-9} m.)

Continuous	Mercury	Helium	Neon	Sodium
Violet (380-450nm)	Violet 405nm (dim)	Violet 389nm		
Blue (450-490nm)	Blue-violet 436nm	Blue-green 447nm (dim)		
Green (490-560nm)	Green 546nm	Green 492nm		
Yellow (560-590nm)	Yellow doublet 577 & 579nm	Yellow 587nm	Yellow 588nm	Yellow doublet 589 & 590nm
Orange (590-630nm)			Orange 603nm	
Red (630-760nm)		Red 668nm very dim	Red 626nm	

MAKING A SPECTROSCOPE

To make a spectroscope, you will need the following material:

1. Diffraction viewer
2. Cardboard tube, about 9 - 14 inches long, with opening about the same size as the viewer. The tube from inside a roll of paper towels is suitable. You can make a tube from some of the stiff paper available at the Bookie.
3. Tape. Masking tape is probably better than scotch tape.

The spectroscope consists of the viewer mounted at one end of the tube and a narrow slit at the other end. The slit is the critical part of the instrument. The edges should be sharp and clean. If the edges are jagged, the spectroscope will not work as well as if they are sharp and clean. It should be made of material which does not let light pass through (paper is not good unless it is black). The edges of the slit should be parallel.

If the slit is not straight or if the edges are not parallel, unusual results will be observed.

The viewer and slit are attached to opposite ends of the tube using masking tape. Be careful not to touch the plastic part of the viewer with your fingers or the tape. It is best to avoid touching it with anything.

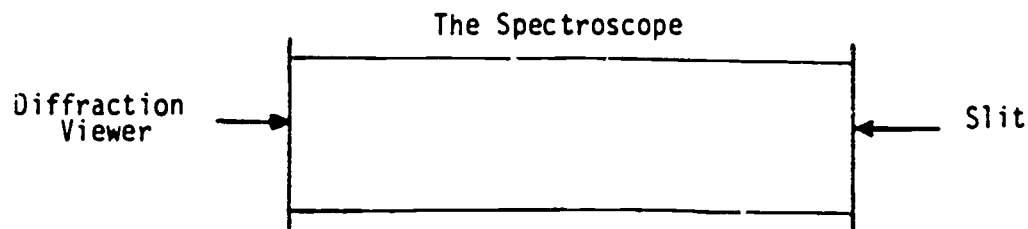
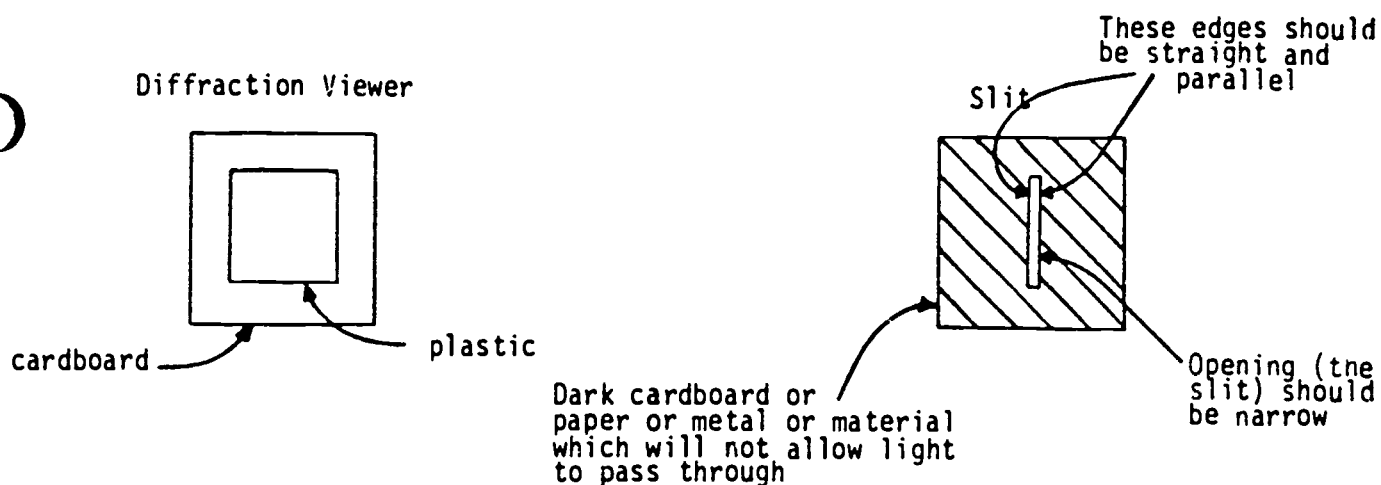

Laboratory 5

Lab Instructor Outline

1. Describe electromagnetic waves
 - use a slinky to demonstrate transverse and longitudinal waves (light is transverse; sound is longitudinal)
 - explain wavelength
2. Explain light
 - reflection - mirror
 - refraction - straw in glass
 - prism
 - diffraction (grating) and interference patterns
Use analogy of 2 stones dropped in water to help explain interference patterns.
3. Briefly describe electron shells and how specific wavelengths of EM waves are emitted or absorbed when electrons move from one shell to another.
4. Types of spectra (brief)
 - continuous
 - emission
 - absorption
5. Explain Doppler effect; show movie
6. Explain how spectroscopy is used in astronomy
 - can see different chemical elements in stars.
 - can determine temperature of stars.
 - can determine densities.
 - can determine chemical composition.
7. Activities
 - build a spectroscope
 - use it to look at known sources and various lights around campus. Sketch their spectra.
 - show movie on Doppler effect.

PHYSICAL SCIENCE 250 - SPRING 1988

Laboratory 5 Worksheet

Light and the Electromagnetic Spectrum

Name _____ Date _____

1. Sketch the Mercury emission lines

Violet Blue Green Yellow Orange Red

2. Sketch the Helium emission lines

Violet Blue Green Yellow Orange Red

3. Sketch the Neon emission lines

Violet Blue Green Yellow Orange Red

4. Sketch the Sodium emission lines

Violet Blue Green Yellow Orange Red

5. Sketch the spectrum of the fluorescent light.

Violet Blue Green Yellow Orange Red

6. The fluorescent emission spectrum is due to one of the previous gasses we've looked at. Which one do you think it is?

7. If a star was made of Mercury and Neon, sketch the probable spectrum of the starlight.

Violet Blue Green Yellow Orange Red

8. If this star was moving away from us, which way would the lines be shifted and why?

9. View the following sources of light and record what you observe in the table.

<u>Source</u>	<u>Type of Spectrum</u>	<u>Number Lines</u>	<u>Color Region</u>
---------------	-------------------------	---------------------	---------------------

Clouds

Television

Car headlights

High Pressure Sodium Lamps*

Low Pressure Sodium Lamps**

* the "yellow" street lamps on Stadium Way off campus, in Rosauer's parking lot, or on the viaduct leading to downtown Pullman

**the lights in the parking lot to the west of Pullman Memorial Hospital

Laboratory 6

Resource Materials in Astronomy

Astronomy, Astrology and Pseudoscience

Purpose

One goal of this laboratory is to familiarize you with what resource materials are available in astronomy and how to go about getting them. A second goal is to expose you to various areas of pseudoscience and to provide you with resources to get information on scientific work that has been done in these areas.

Laboratory Objectives

As a result of the laboratory session you should:

1. be familiar with some of the major sources of astronomy news and current events.
2. be familiar with some of the major sources of free information and materials (such as NASA and the Jet Propulsion Laboratory).
3. be familiar with some of the major sources of astronomy supplies (slides, posters, etc.) and general science supplies.
4. become familiar with astronomical names and symbols that are used in our everyday lives.
5. learn about the various areas of pseudoscience and how to get information on them.

Other Activities:

1. Discussion of pseudoscience topics.

Assignment: Each student will be given some astronomy resource materials and will make an oral report (5 minutes) during the next laboratory session on his/her materials. A one page written report will be collected.

Part I -- The Laboratory

Section A. Astronomy News and Current Events

The following are sources of information on current and upcoming events in astronomy, recent astronomical discoveries, etc.

1. Newspapers -- Newspapers often have news articles about astronomical discoveries and events. Often news articles on discoveries are so garbled that even professional astronomers have trouble figuring out what has transpired. The trouble is that a newspaper will take a press release from a university or an astronomical research agency (such as the National Optical Observatories) and shorten it without really having a sense of what can or cannot be omitted without robbing the story of all sense and content. So if your students (or their parents) or you read something in the Daily Rag and it doesn't make sense, you are not alone!

Newspapers sometimes have monthly columns on constellations and upcoming celestial events. For example, the Spokesman Review has such a column. These are often well-written and provide useful information.

2. General Magazines -- The reporting of astronomical news in magazines such as Newsweek and Time is generally pretty good. Occasional articles on astronomy appear in magazines like Natural History, Smithsonian World, National Geographic and similar publications.
3. Magazines on Science -- Scientific American is good for a high school or a college student who has a project to do for a class. The articles are specialized and increasingly often present one side of a controversial subject rather than a review of all sides. If you like science, you should run out and subscribe to Science News, a weekly publication which contains articles on recent discoveries and events in physical and biological sciences, mathematics, engineering and behavioral sciences. It is excellent.
4. Magazines on Astronomy -- Astronomy and Sky and Telescope are monthly magazines that contain all sorts of astronomical news, articles, etc. These magazines are often found in large book stores. Mercury magazine is published every alternate month by the Astronomical Society of the Pacific (see address below). The Planetary Report is a bimonthly magazine published by the Planetary Society; P.O. Box 91687, Pasadena, CA 91109. It gives the latest news of space exploration but doesn't cover the night skies.

Section B. Newsletters and Information Bulletins for Educators

1. AAS/ASP Bulletin for Educators:
Astronomical Society of the Pacific
Teacher's Newsletters Dept. N
1290 24th Ave.
San Francisco, CA 94122

This is a free classroom resource for grades 3-12. Each quarterly issue includes short, nontechnical articles on new developments, practical classroom activities, and specific suggestions for current written and audio-visual resources.

2. NASA Bulletin:
Elementary and Secondary Programs Branch
Educational Affairs Division
National Aeronautics and Space Administration
Washington, D.C. 20546

This is published 4 times a year. It gives the latest NASA developments along with regional addresses for NASA publications, films and other services.

3. Abrams Planetarium Newsletter:
Abrams Planetarium
Michigan State University
East Lansing, Michigan 48824

The Monthly Sky Calendar is \$5 per year and also available with a membership in The Astronomical Society of the Pacific. The Calendar shows the monthly night sky, gives planet locations, and informs you of interesting events that happen throughout the month.

Section C. Materials Available from NASA and JPL

1. For regional NASA center addresses, see attached page.

Being on their mailing list gets you some interesting materials as well as answers to questions you or your students may have about various NASA programs.

2. Jet Propulsion Labs:
Education Outreach
Jet Propulsion Laboratory
4800 Oak Grove Drive
Mail Stop 520-100
Pasadena, CA 91109

JPL deals mainly in planetary exploration. They are a good resource for slides and brochures on our solar system.

Section D. Sources of Astronomical Slides, Posters,...

1. ASP Selectory:
Selectory Sales
Astronomical Society of the Pacific
1290 24th Ave.
San Francisco, CA 94122

The ASP catalog contains many slides, posters, books, software, observing aids, bumper stickers and other astronomical items.

2. Hansen Planetarium:
Hansen Planetarium
15 South State Street
Salt Lake City, Utah 84111

The Hansen Planetarium puts out catalogs for slides, prints, posters and calendars. The complete set of catalogs costs \$2.00.

3. National Optical Astronomy Observations
Public Information Office
950 N. Cherry Avenue
P.O. Box 26732
Tucson, AZ 85726-6732

This catalog contains a very large selection of slides and prints of astronomical objects and observatory scenes.

4. MMI Space Science Corp.
2950 Wyman Parkway
P.O. Box 19907
Baltimore, Maryland 21211

MMI has a large selection of visual aids (slides, videos, posters) for astronomy along with some for physics and geology.

5. Sky Publications Catalogue
49 Bay State Rd.
Cambridge, MA 02238-1290

Sky Publications (they publish Sky and Telescope magazine) sells a wide variety of posters, star maps and wheels, books, catalogues, and laboratory exercises (for high school/college).

Section E. Information Packets on Astronomy

The following information packets are available for \$3 each from the Astronomical Society of the Pacific (address given above):

Interdisciplinary Approaches to Astronomy
Astronomy as a Hobby
Astronomy Versus Astrology
Selecting Your First Telescope
Introduction to Black Holes
Learning About Quasars

Section F. Catalogues of General Science Material

1. Edmund Scientific Catalog
101 E. Gloucester Pike
Barrington, NJ 08007

A very good general science supply catalog that has many basic general science supplies, especially optics. Materials such as diffraction viewers and luminous paint can be obtained from this company.

2. Carolina Biological Supply Company
2700 York Rd.
Burlington, NC 27215-3398

Despite the name, this company offers some materials for classroom use in physics, geology and astronomy.

3. Schoolmasters
745 State Circle
Box 1941
Ann Arbor, MI 48106

This company offers a variety of lab equipment and software for physical sciences. Good selection of planetaria.

Section G. Science Organizations

1. National Science Teachers Association (NSTA)
1742 Connecticut Ave. NW
Washington, D.C. 20009

The fastest-growing part of the membership of NSTA is elementary school teachers. They put on state meetings, regional meetings and national meetings, and publish practical journals for all levels of science teaching (Science and Children, Science Scope, The Science Teacher).

2. The Association for Women in Science
1346 Connecticut Ave. N.W.
Suite 1122
Washington, D.C. 20036

Information on careers in science for both women and men. They put out a good catalog for guidance resources containing books, pamphlets, films and posters.

Section H. Star Charts and Constellation Stories

There is a list referenced at the end of the Constellation Postcard Section of the Constellation Information Pages.

Section I. The Influence of Astronomical Names, Symbols and Concepts on Civilization

1. Flags

Alaska

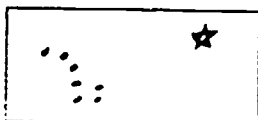

Western Samoa

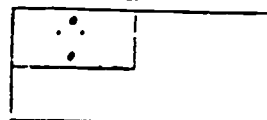

Brazil



Australia

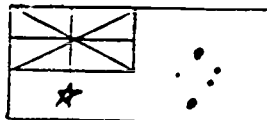

New Zealand

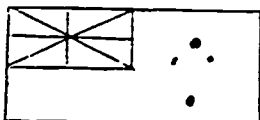

2. Consumer Products

Cars: Aries, Comet, Galaxy, Mercury, Nova, Taurus, Vega

Television: Quasar, Zenith

Comet Cleaner, Orion Films, Universal Films, Bill Halley and The Comets, Milky Way and Mars Candy Bars

3. Astronomy in Poetry, Literature and Music

Andrew Fraknoi's Interdisciplinary Approaches to Astronomy is a collection of articles on the connections between astronomy and other disciplines. It is available for \$3 from the Astronomical Society of the Pacific.

4. Everyday Expressions

"My stars!", "That's loony!", etc.

Section J. Science and Pseudoscience

Students picked various areas to investigate two weeks ago and read sources proclaiming the "truth" of the area and sources debunking the area. This section of the laboratory features free discussion of what the students found. The students also turn in a two page report summarizing their findings. Areas that are related to astronomy include astrology, Ancient Astronauts, flying saucers and "moon madness".

PHYSICAL SCIENCE 250, SPRING 1988
Using the Sky-Gazers
Almanac 1988

Name _____

1. On March 22, at what time of night will Regulus be on the meridian? _____
2. On what date and at what time of night will the Perseid meteor shower be at its best? _____
3. On what date in 1988 will Saturn rise about 9 pm?

4. On what date will the full moon occur in July 1988?
_____ At about what time would the moon rise on that date? _____
5. On what date in 1988 will Mars begin to set in the morning twilight? _____
6. On what date in 1988 will Jupiter be on the meridian at midnight? _____
7. If we don't catch Mercury in February 1988, when is the next period of time that it will be visible in the evening twilight? _____
8. If you want to see Deneb on your meridian at the end of evening twilight, on about what date would you look for them? _____
9. If you wanted your students to observe a crescent moon in the evening sky in October 1988, during what time period would you tell them to look for it? _____

Laboratory 7

Comets and Meteor Showers

Purpose

The goal of this laboratory is for you to become familiar with comets and meteors and to introduce you to the history and recent activities of Halley's Comet. In addition, you will learn some American Indian Constellations and their lore.

Laboratory Objectives

As a result of these sessions you should be able to:

1. Identify the different parts of a comet; Nucleus, Coma, Dust, Tail, Ion Tail.
2. Explain why comet tails always point away from the sun.
3. Explain why meteor showers occur in the paths of past comets.
4. Explain what happened with Halley's Comet in 1986.
5. Be able to make a "model comet".

Other Activities

1. Student presentations on astronomy resources
2. Quiz on major constellations.

Part I -- The Laboratory

Section A. Halley's Comet - History and Physical Characteristics

1. Comet slide show by Dr. Lutz
2. Discussion of meteors, meteor showers, meteorites and comets.

Section B. "Making a Comet" Activity

This activity came from the Fall 1985 AAS/A.S.P. University in the Classroom Newsletter (see attached page).

Dry ice can often be obtained from a local butcher. Check in advance if they have some on hand or can order some. Regular ice will also work but dry ice will keep the comet solid longer.

Section C. Quiz on Major Constellations

Students will identify major constellations and first magnitude stars on "blank" constellation sheets (available from Sky Publishing Corporation). They will also write about the legends associated with some of these constellations.

Section D. Discussion of Astronomy Resources

Last week each student was assigned a particular astronomy resource (books, catalogs, software, etc.) to consider in detail. Each student talks about his/her item with regard to its usefulness, what one might order, etc. Students turn in a one page report on their item.

Making A Comet in the Classroom

Dennis Schatz

Pacific Science Center, Seattle

A dramatic and effective way to begin a unit on Halley's Comet is to make your own comet right in front of the class. The ingredients for a comet are not difficult to find and watching a comet being "constructed" is something the students will remember for a long time.

The "ingredients" for a six-inch comet are:

- 2 cups water
- 2 cups dry ice (frozen carbon dioxide)
- 2 spoonfuls of sand or dirt
- a dash of ammonia
- a dash of organic material (dark corn syrup works well)

Other materials you should have on hand include:

- an ice chest
- a large mixing bowl (plastic if possible)
- 4 medium-size plastic garbage bags
- work gloves
- a hammer, meat pounder, or rubber mallet
- a large mixing spoon
- paper towels

Dry ice is available from ice companies in most cities (look under "ice" in the Yellow Pages for a local source.) Day-old dry ice works best, so you might want to buy it the afternoon before the day you do the activity. Keep the dry ice in an ice chest when transporting it and in your refrigerator's freezer compartment overnight. Most ice companies have a minimum on the amount of ice they will sell (usually 5 pounds). But having extra dry ice on hand will be useful because some will evaporate and also because it is advisable to practice this activity at least once before doing it with the class.

Here are the steps for making a 6-inch comet (students make good baker's assistants for this exercise):

- 1) Cut open one garbage bag and use it to line your mixing bowl.
- 2) Have all ingredients and utensils arranged in front of you.
- 3) Place water in mixing bowl.
- 4) Add sand or dirt, stirring well.
- 5) Add dash of ammonia.
- 6) Add dash of organic material (e.g. corn syrup), stirring until well mixed.
- 7) Place dry ice in 3 garbage bags that have been placed inside each other. (Be sure to wear gloves while handling dry ice to keep from being burned.)
- 8) Crush dry ice by pounding it with hammer.
- 9) Add the dry ice to the rest of the ingredients in the mixing bowl while stirring vigorously.
- 10) Continue stirring until mixture is almost totally frozen.
- 11) Lift the comet out of the bowl using the plastic liner and shape it as you would a snowball.
- 12) Unwrap the comet as soon as it is frozen sufficiently to hold its shape.

Now you can place the comet on display for the students to watch during the day as it begins to melt and *sublimate* (turn directly from a solid to gas — which is what carbon dioxide does at room temperature and comets do under the conditions of interplanetary space when they are heated by the Sun.)

The comet is reasonably safe to touch without getting burned by the dry ice, but it is still best to have a spoon or a stick for the students to use while examining it. As the comet begins to melt, the class may notice small jets of gas coming from it. These are locations where the gaseous carbon dioxide is escaping through small holes in the still-frozen water. This type of activity is also detected on real comets, where the jets can sometimes expel sufficient quantities of gas to make small changes in the orbit of the comet.

After several hours, the comet will become a crater-filled ice ball as the more volatile carbon dioxide sublimates before the water ice melts. Real comets are also depleted by sublimation each time they come near the Sun. Ultimately, old comets may break into several pieces or even completely disintegrate. In some cases, the comet may have a solid rocky core that is then left to travel around the comet's orbit as a dark barren asteroid.

Editor's note: Dennis Schatz is the author of a marvelous new student (and teacher) activity book about Halley's Comet discussed elsewhere in this issue.

Astronomical Society of the Pacific
1290 24th Ave.
San Francisco, CA 94122

Non-Profit Org.
U.S. POSTAGE
PAID
Permit No. 7438
San Francisco
California

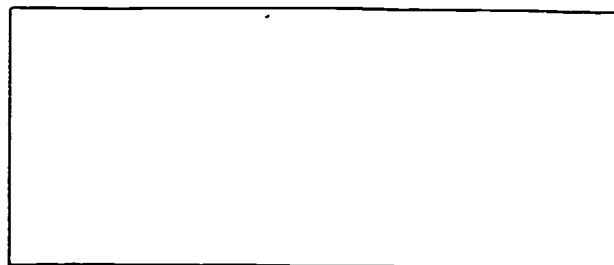

Laboratory 8

Stars

Computer Software for Astronomy

Purpose

The goal of this laboratory is for you to consider the distances of stars and how astronomical data are gathered. In addition, you will examine some examples of computer software for astronomy.

Laboratory Objectives

As a result of this laboratory you should be able to:

1. Discuss stellar distances in terms of parsecs and light years.
2. Go through the star cluster exercise, as an example of astronomical data collection.
3. Go through some astronomical software packages and evaluate them.

Section A. Stellar Distances

Table 1 gives the distances of various well known stars. To visually illustrate these distances, use the scale $1 \text{ pc} = 1 \text{ cm}$ and mark these distances on adding machine tape.

Section B. Speed of Light

Light traveling through space travels at a constant speed of 3×10^8 m/sec or 670 million miles/hr. Table 2 shows how long it takes light from the sun to reach the different planets and how long it takes light from the nearest star (alpha centauri) and the nearest galaxy (Andromeda) to reach us.

Section C. Astronomical Software

This section of the laboratory will be done in the microcomputer laboratory. Several software programs will be demonstrated and discussion is encouraged. For a comprehensive review of software that is available for astronomy see John Mosley and Andrew Fraknoi's article in Mercury Magazine (Volume XV, No. 5/September-October 1986).

Section D. Star Cluster Exercise

See attached handout. This section of the laboratory will be done on Apple II computers in the microcomputer laboratory. This assignment is adapted from the Cluster Photometry program on the Foundations of Astronomy Software by Michael Seeds (Wadsworth Publishing Company) with permission of the author and publisher.

Table 1 -- Distances of Various Stars

Alpha Centauri	1.3 parsec
Barnard's Star	1.8 pc
(Apparent visual mag. = 9.5)	
Sirius	2.7 pc
Vega	8.1 pc
Pollux	12 pc
Hyades Cluster	41 pc
Spica	80 pc
Pleiades	125 pc
Betelgeuse	150 pc
Rigel	250 pc
Deneb	430 pc

1 parsec = 3.26 light years

$$= 3.08 \times 10^{16} \text{m}$$

Table 2 -- Light Travel Time

	Distance from Sun	
Mercury	$58 \times 10^9 \text{m}$	3.2 minutes
Venus	$108 \times 10^9 \text{m}$	6 minutes
Earth	$149 \times 10^9 \text{m}$	8.3 minutes
Mars	$228 \times 10^9 \text{m}$	12.7 minutes
Jupiter	$778 \times 10^9 \text{m}$	43.2 minutes
Saturn	$1.43 \times 10^{12} \text{m}$	1.3 hours
Uranus	$2.87 \times 10^{12} \text{m}$	2.7 hours
Neptune	$4.5 \times 10^{12} \text{m}$	4 hours
Pluto	$5.9 \times 10^{12} \text{m}$	5.5 hours
Alpha Centauri	$4 \times 10^{16} \text{m}$	4.3 years
Andromeda Galaxy	$1.89 \times 10^{22} \text{m}$	2 million years

Speed of light in space = $3 \times 10^8 \text{m/sec}$ or
670 million miles/hour

PHYSICAL SCIENCE 250, SPRING 1988
Constellation Lab Quiz

Outline the constellations listed below on your starmaps. Label each constellation with its appropriate name, and also include the English translation. Be sure to indicate the names of any first magnitude stars in the constellation.

1. Aquila
2. Bootes
3. Canis Major
4. Cygnus
5. Gemini
6. Leo
7. Lyra
8. Orion
9. Scorpius
10. Taurus
11. Ursa Minor

PHYSICAL SCIENCE 250 -- SPRING 1988

Laboratory Assignment

HR DIAGRAM OF A STAR CLUSTER

Name _____

The purpose of this homework is for you to make an HR diagram of a star cluster. A sheet of graph paper is provided. You are to plot an HR diagram of your star cluster on this graph paper.

To do this homework you will have to go the Science Learning and Instruction Center (SLIC) on the third floor of Owen Science and Engineering Library, or to the Mathematics Department Microcomputer Laboratory in Sloan 327. There is a main counter in SLIC where reserve materials, computer diskettes and other course materials are kept. Ask the person at the counter for the ASTR 135 diskette and the key to one of the APPLE computers that are in SLIC. You will need your student ID card. Go to the computer, turn it on and insert the diskette in the disk drive. If you go to the Math Microcomputer Lab, there will be someone there to help you.

Type in your ID number when the computer asks for it. The TV monitor on the computer will show a star cluster. This is how the cluster would appear at a remote observing station.

You are to measure the magnitudes of the stars by observing each star through two filters, the B filter and the V filter. There is another filter in the system (the U filter). Ignore it. Warning: the sizes of the star images are not correlated with magnitude in this experiment. Also, there are different star clusters. You will be given credit only for the cluster which matches with your ID number. To observe a particular star, isolate it in the circular diaphragm. Move the circle by using the

I
J K keys. Hold a key down to make the circle move quickly.
M

Choose a filter using the F key. Type F several times and watch the filter information change at the lower right of the screen. When you are ready to observe with either the B or the V filter, type A.

The filter and magnitude information will appear at the bottom of the screen. Record the data on the blank table on the back of this sheet. Each star has a number in the table which corresponds to the numbers shown on the diagram of the screen below. Be sure to match up the star number with the number in the table.

There are 22 stars to be observed. When you are finished, type Q to quit. Remove the diskette from the APPLE and turn off the computer. Return the diskette and the computer key to the SLIC counter. At the Math Lab, return the diskette to the person in charge.

Plot V versus B - V for each star (an HR diagram) on the graph paper provided. The axes have been labeled for you.

BE SURE TO WRITE YOUR NAME AND ID NUMBER ON THE TABLE AND ON THE GRAPH.

Remote Telescope

1
2
3
4
5
6
7
8
9
10
11
12
13
14
15
16
17
18
19
20
21
22

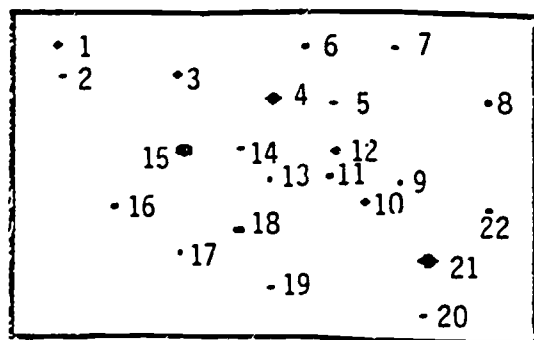

Commands
A..observe
F..step
filters
Q..quit.

Movement
I
J K
M

STAR CLUSTER DATA

B

V

B - V

1

2

3

4

5

6

7

8

9

10

11

12

13

14

15

16

17

18

19

20

21

22

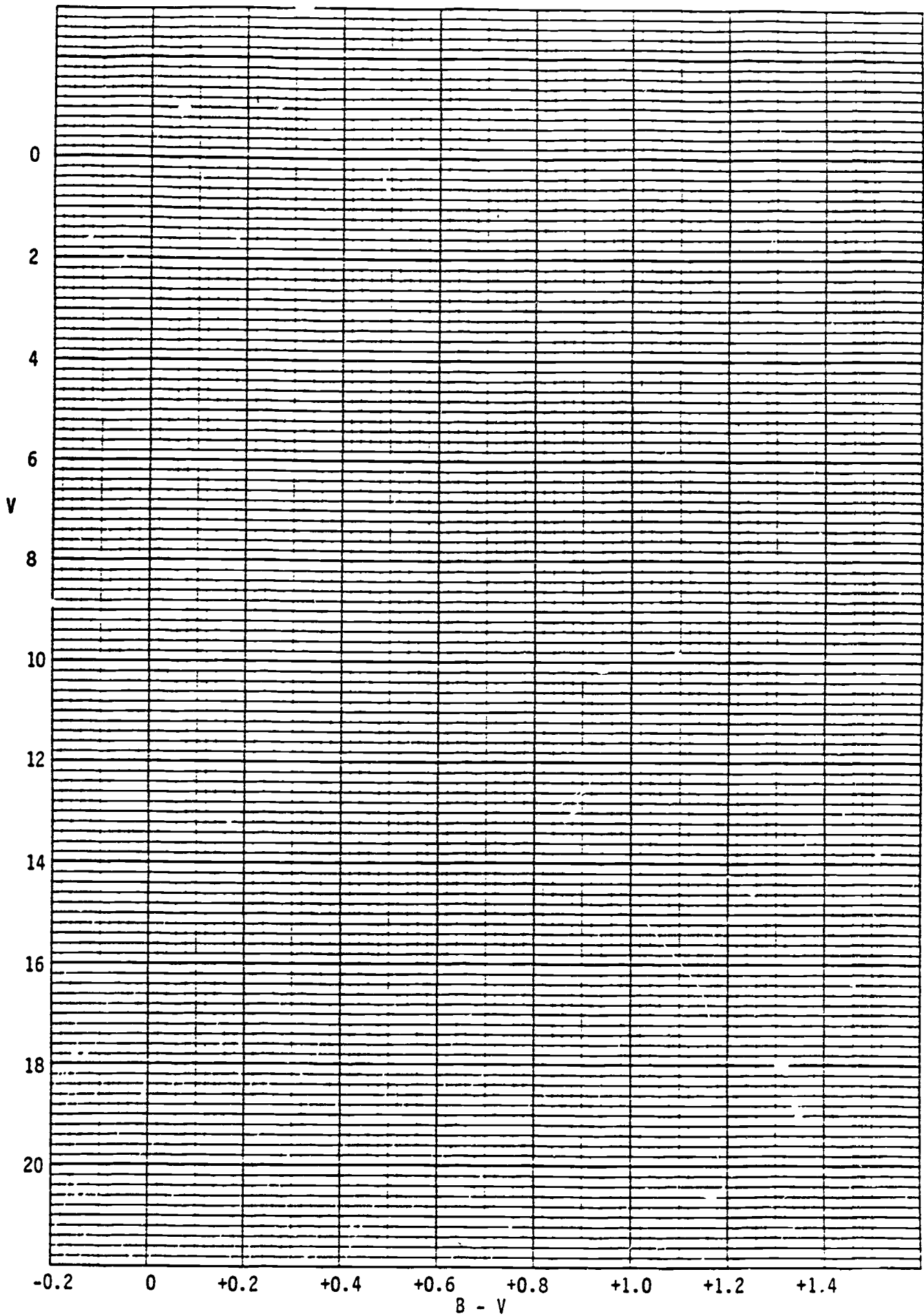

216

★ ∩

∩ ★

CONSTELLATION INFORMATION PAGES

★ ∩

∩ ★

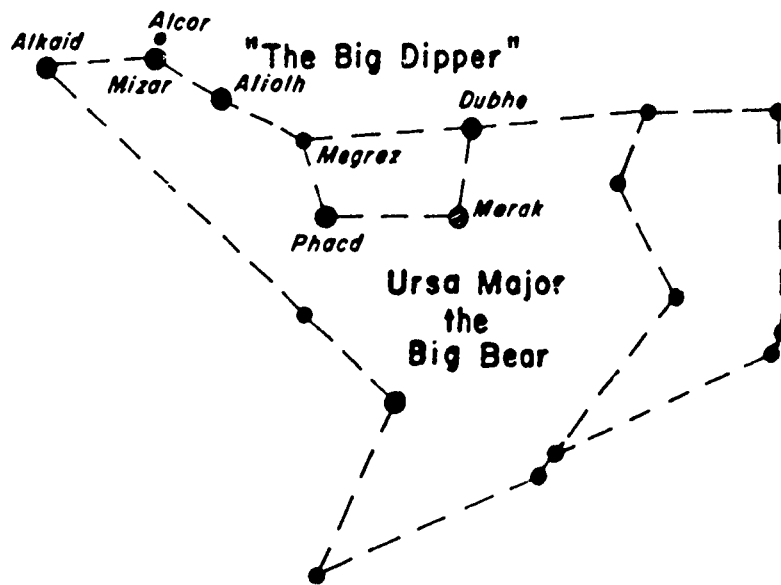

Notes on the Constellation Information Pages

The constellation information pages provide a brief description of the features, lore, and viewing of twelve prominent constellations seen in the northern latitudes. The material presented to you here is not a compendium of these constellations; it is an aid to start you on the road of descriptive astronomy.

Star and Constellation Names

As you read through the material, you will notice that the constellation and star names are not given in English (but a translation is provided!). The constellation names are Latin. Star names come from a mixture of cultural roots. For those stars with names, most are Arabic, with a majority of the rest coming from Greek or Latin. In Appendix A you will find a table that provides the pronunciation of the constellations and stars discussed in the information pages.

On some star charts you may find that the bright stars of a constellation are identified by Greek letters. The Greek letters are assigned to the stars by the approximate order of brightness. So, the brightest star is usually called α (alpha), the next brightest β (beta), and so on. The star is completely identified by its Greek letter followed by a three letter abbreviation of its Latin constellation name. For example, Vega, the brightest star in Lyra, is identified as α Lyr. Appendix B provides a list of the Greek alphabet.

Star Brightness (Magnitude)

The stars, as you have observed, are not all of the same brightness. Astronomers have developed a way of classifying relative brightness of stars called the magnitude scale. The scale is set up such that the brighter a sky object is, the lower its magnitude number. So, for example, the Sun has a magnitude of -26, while the brightest star, Sirius, has a magnitude of about -2.

A change of one magnitude corresponds to a brightness difference of about $2 \frac{1}{2}$ times. So, a change of three magnitudes gives a brightness difference of $2 \frac{1}{2} \times 2 \frac{1}{2} \times 2 \frac{1}{2}$ which is about 16 times as bright. As you can see, determining the change in brightness by the magnitude scale is not like a number line where you can find the difference by subtracting. Therefore, the Sun is not just 24 times as bright as Sirius, as you might expect from just subtracting their magnitudes, but actually over a billion times brighter!

The magnitudes just described are called the apparent visual magnitudes. The word apparent is used because of the distances from the Earth to the stars. For example, when you are close to a street light it appears very bright and large. As you go further away it appears very small and dim. This explains why there is such a diversity of star magnitudes, because the stars

are different sizes and distances away from the Earth. The absolute magnitude scale, a special scale used by astronomers, corrects for the differences in distance.

Figure 1 and Table 1 illustrate some of the features of the magnitude scale.

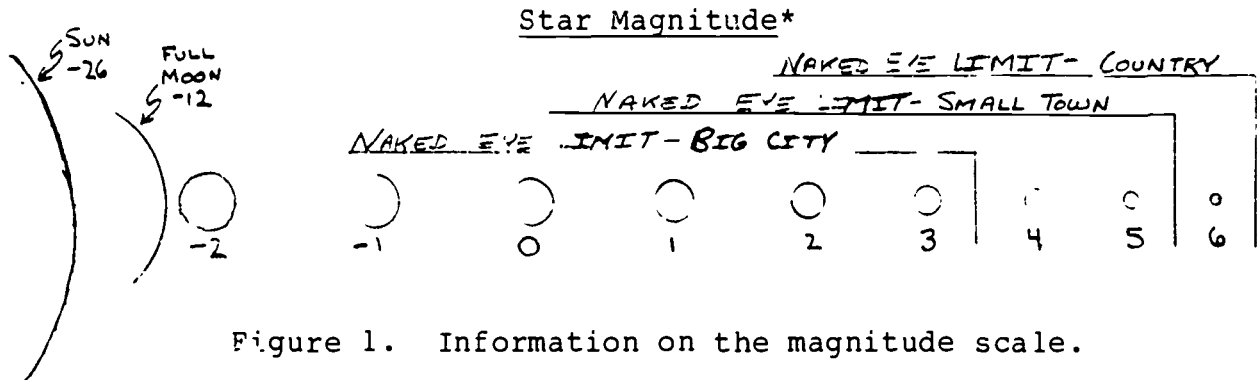

Figure 1. Information on the magnitude scale.

Table 1. Brightness Difference by Magnitudes*

One Magnitude	=	2.5 times	Five Magnitudes	=	100 times
Two Magnitudes	=	6.3 times	Six Magnitudes	=	250 times
Three Magnitudes	=	16 times	Seven Magnitudes	=	630 times
Four Magnitudes	=	40 times	Eight Magnitudes	=	1600 times

As an example -- The difference in brightness between a 1st magnitude star and a 3rd magnitude star is $3 - 1 = 2$ magnitudes difference, which from the table is a brightness difference of 6.3 times. Therefore a 3rd magnitude star is 6.3 times fainter than a 1st magnitude star.

*Adapted from: Edmund Mag 5 Star Atlas, Edmund Scientific Co.

The Ecliptic and the Zodiac

The ecliptic and Zodiac are important guideposts to understanding and following the motions of the Sun, Moon, planets, and stars. A brief description is given here to help guide you in use of the constellation information pages with a star chart.

The Ecliptic: The apparent path of the Sun among the stars throughout the year as seen from the Earth.

The Zodiac: An imaginary "belt" in the sky whose center is the ecliptic. It has a width of about twelve full moon diameters. The Zodiac contains the 12 zodiacal constellations, which are probably most familiar to you as the "birthsigns". The moon and planets travel within this zone.

APPENDIX A: Star Facts

<u>Constellation & Bright Star Names</u>	<u>Color</u>	<u>Magnitude</u>	<u>Identification</u>
1. Canis Major (KAY-miss MAY-ger)			
Sirius (SEER-ee-us)	white with tinge of blue	-2	α CMa
2. Cassiopeia (Kass-ee-oh-PEE-ya)			
Schedir (SHED-durr)	pale rose	2	α Cas
3. Cygnus (SIG-nuss)			
Deneb (DEN-ebb)	white	1.3	α Cyg
Albireo (Al-BURR-ee-oh)	gold and blue pair	3	β Cyg
4. Gemini (GEM-in-eye or GEM-in-knee)			
Castor (CASS-ter)	white	1.6	α Gem
Pollux (POLL-lux)	yellowish	1.1	β Gem
5. Leo (LEE-oh)			
Regulus (REG-you-luss)	bluish-white	1.4	α Leo
Denebola (de-NEB-oh-la)	blue	2.1	β Leo
6. Lyra (LYE-ruh)			
Vega (VEE-guh)	blue	0	α Lyr
Sheliak	white	3.5	β Lyr
Sulafat	yellow	3.2	γ Lyr
7. Orion (oh-RYE-un)			
Betelgeuse (BETT-el-jews)	orange	.5	α Ori
Rigel (RYE-jell)	blue-white	.1	β Ori
Bellatrix (bell-LAY-trix)	yellow	1.6	γ Ori

8. Taurus (TAW-russ)			
Aldebaran (al-DEB-oh-ran)	pale rose	.9	α Tau
Pleiades (PLEE-a-deez)	An open star cluster	3	

9. Sagittarius (saj-ih-TAY-rih-us)			
------------------------------------	--	--	--

10. Scorpius (SKOR-pih-uss)			
Antares (an-TAIR-ees)	red	1	α Sco

11. Ursa Major (URR-sah MAY-jer) (The dipper stars)			
Dubhe (DUBB-be)	yellow	1.9	α UMa
Merak (ME-rack)	greenish- white	2.4	β UMa
Phecda (FECK-dah)	yellow	2.5	UMa
Megrez (ME-grez)	pale yellow	3.4	δ UMa
Alioth (ALLEY-oth)	white	1.7	ϵ UMa
Mizar (MY-zar)	white	2.4	ζ UMa
Alkaid (al-KADE)	white	1.9	η UMa
Alcor (AL-cor)	white	4.0	---

12. Ursa Minor (URR-sah MY-ner)			
Polaris (pole-AIR-us)	yellow	2.1	α UMi
Kochab (KOE-kab)	reddish	2.2	β UMi

APPENDIX B: The Greek Alphabet*

α	Alpha	ν	Nu
β	Beta	ξ	Zi
γ	Gamma	\omicron	Omicron
δ	Delta	π	Pi
ϵ	Epsilon	ρ	Rho
ζ	Zeta	σ	Sigma
η	Eta	τ	Tau
θ	Theta	υ	Upsilon
ι	Iota	ϕ	Phi
κ	Kappa	χ	Chi
λ	Lambda	ψ	Psi
μ	Mu	ω	Omega

*Adapted from: Edmund Mag 5 Star Atlas, Edmund Scientific Co.
(1974)

Gemini (The Twins)

Description

Gemini, The Twins, is a Zodiac constellation. Gemini is distinguished by the two stars Castor (translation = The Horseman) and Pollux (translation = The Fighter) which represent the heads of the twins. Even though Castor and Pollux appear side by side Castor is actually 10 light years further away than Pollux. The stars which represent the arms and bodies of The Twins are faint: a dark clear night is needed to locate them. Since Gemini is in the Zodiac, the moon and planets will at times share the same sky region as Castor and Pollux, giving an impressive view.

Castor is actually a physical binary star with a period of about 400 years. The companion can be seen with a small telescope. Close to this pair is a third star that is moving with them. Spectroscopic analysis indicates that each of the three is a binary star!

On a clear dark night look toward the toe of the twin Castor; you will find the misty glow from the open star cluster M35. M35 is an excellent object in a small telescope, and is also viewed quite nicely with a pair of binoculars.

Legend

The identification of this constellation as a sky couple is present in many ancient cultures. Various identities have been assigned: The Twin Sons of Rebecca, Adam and Eve, Peacocks, Pair of young Goats, Two Gazelles, Two Sprouting Plants, The Yin and the Yang, and Two Angels just to name a few.

The Roman-Greek myth identifies The Twins as Castor, the horseman, the two brothers, and Pollux, the fighter. According to the story the brothers (actually half brothers) were the sons of Leda, the wife of Tyndarus, the King of Sparta. Castor, the son of Tyndarus, was mortal. Pollux, the son of Zeus, was immortal. After Castor's death Pollux was so distraught that he wanted to share his immortality with his twin. Finally, Zeus, as a reward for their brotherly love, reunited them by placing them together in the heavens.

Viewing

The best evening viewing for this constellation is December through May. To find the pair from the Big Dipper, picture a diagonal through the bowl and follow it to the pair Castor and Pollux.

Canis Major (The Big Dog)

Description

Canis Major is a fine constellation but is far to the south, making it difficult to see its fainter stars from northern latitudes. The brightest star in the constellation, and for that matter the brightest star in the night sky, is Sirius (translation- The Sparkling One), also called the Dog Star. The reason Sirius appears so bright, with a magnitude of -1, is not due to its size (1.8 times the diameter of the sun and 2.35 times as massive) but rather its nearness. Sirius is only 8 1/2 light years away. Sirius is actually a double star, but its companion is lost in the glare.

Sirius is deserving of its name because it appears to sparkle through all the colors of the rainbow as viewed from the northern skies. This is because it is low in the sky where the atmosphere is turbulent. Sirius is also one of the three stars in the winter triangle. The other two are Betelgeuse, in Orion, and Procyon, in Canis Minor. The Milky Way passes through the center of this configuration.

To the southeast of Sirius, on a clear night, you can see the faint glimmer of the open star cluster M41. It is a beautiful object in a small telescope and is seen quite well through binoculars.

Legend

According to Greek mythology, Canis Major is usually called the Dog of Orion. Orion loved to hunt wild animals such as Lepus, The Hare. Canis Major, at Orion's heels looks as if it is about to pounce on the Hare.

Another Greek myth about Canis Major is that it represents Cerberus, The Watchdog of Hades. Canis Major is said to be guarding the lower heavens, which according to myth is the abode of demons.

Sirius itself has been associated with legend. In Ancient Egypt, it was worshipped as the "Nile Star". The appearance of Sirius just before dawn on the summer solstice marked the rising of the Nile River. Sirius has also been connected with the "Dog Days" of summer during July and August. This time coincides with the time that Sirius and the Sun rise together. It was thought that Sirius added its heat to the Sun causing the hot days of middle summer.

Viewing

The best evening viewing time for this constellation is January through March. Sirius can be located by following Orion's belt down towards the southeast.

Taurus (The Bull)

Description

Taurus, The Bull, is one of the Zodiac constellations. The brightest stars in this constellation form the shape of a V. Aldebaran, the brightest star, aids in identifying the V. Except for Aldebaran, the V is made up of the Hyades, a loosely scattered cluster of stars. The Hyades is an attractive cluster through binoculars.

Aldebaran translates as "The Bright One That Follows" in reference to its rising after the Pleiades star cluster. The Pleiades is one of the best known star clusters. This misty group of stars is commonly called the Seven Sisters, although the naked eye can usually only detect 6 stars. The Pleiades is an attractive celestial object in a small telescope or binoculars.

Since this constellation is along the ecliptic, the planets and the moon are sometimes located here.

Legend

The association of this grouping with a bull has existed possibly longer than 15,000 years. The Greek legend is as follows: Zeus disguised himself as a snow-white Bull in order to attract the attention of the beautiful Europa, Princess of Phoenicia. She was drawn to the Bull by its beauty and climbed upon its back. Zeus then jumped into the sea and swam away with her to Crete. When they arrived he revealed his identity and won her love. If you look at the hindquarters of the Bull when it appears in the sky, you will notice that they are much dimmer than the head. The reason for this is that the Bull represents the disguised Zeus swimming, hence the hind parts are submerged in the water and cannot be seen. To the southeast Orion holds up a shield and club as he makes ready to face the charging beast.

According to Greek Myth the Hyades cluster represents the daughters of Atlas and Aethra, making them half sisters of the Pleiades.

Some of the names that have been identified with the Pleiades through history are: The Net of Stars, The Seven Atlantic Sisters, Children of Atlas, and The Hen and Her Chicks. In the Indian legend of the Kiowa and Cheyenne the Pleiades are seven Indian maidens who were being chased by giant bears. To save the maidens, Devil's Tower (located in Wyoming) was raised with them upon it. The marks of the bears' claws can be seen in the vertical striations on the tower as they tried to get the maidens. Later the maidens were placed in the sky as the Pleiades.

Viewing

The best evening viewing for this constellation is October through March. To locate it picture a line through Orion's belt to Aldebaran.

Orion (The Hunter)

Description

Orion is one of the most beautiful constellations in the sky. When Orion is up it dominates the southern sky. Four bright stars mark the corners of this pattern and three other bright stars lie diagonally across its center. Betelgeuse (translation = The Arm of the Giant) is in the northeast corner as Orion rises. It is a supergiant, 400 times the diameter of the sun, and 36,000 times as bright.

Diagonally across Orion to the southeast, is Rigel (translation = Left Leg of the Giant). Rigel is a giant star, 33 times the diameter of the sun and 2,000 times as bright.

The most striking feature of Orion is the belt made up of three stars in the center of the figure. The belt makes a good scale for measuring distances in the sky since it is about 3 degrees in length (6 full moon widths).

Hanging from the belt is a line of stars called the sword. On a dark night you will notice that the second star from the bottom of the line has a hazy appearance (binoculars will help you see this). This is the Great Orion Nebula. It is an extremely thin luminous gas cloud so large that it would take 10,000 Sun-sized stars to fill it.

Legend

The star pattern that is associated with Orion has in many ancient cultures been connected with national heroes, warriors, or demigods. Even J.R.R. Tolkien, author of The Hobbit, identified the constellation in the Third Age of Middle-Earth as Menelvagor, "The Swordsman of the Sky". The Greek legend is as follows: Apollo wanted to prevent his sister Artemis, goddess of the hunt and moon, from falling in love with Orion. He sent a Scorpion to kill Orion. Orion leaped into the sea to escape. Apollo tricked Artemis into shooting at a dark spot in the waves which was actually Orion. Artemis tried to have the great physician Asclepius revive Orion. The physician was struck by lightning from Zeus. Artemis placed Orion and the Scorpion in the heavens as far apart as possible to prevent further trouble between them. This is the Greek's explanation of why Orion and the Scorpion are never in the sky at the same time; they are exactly opposite each other in the sky.

Viewing

The best evening viewing for this constellation is December through March. The constellation rises at about 10:00pm in mid-November just a little south of east.

Scorpius (The Scorpion)

Description

Scorpius, The Scorpion, is a beautiful Zodiac constellation. Because it is located in the south, some of it is not seen in the northern latitudes. The brightest star in the constellation is Antares (translation = The Rival of Mars), which marks the heart of the Scorpion.

The meaning of Antares is well chosen. Referring to a star chart, one can see that Antares is well within the Zodiac, therefore the moon and planets pass close to it. Sometimes planets can be confused for Antares, particularly Mars since it is close to the same color and brightness as Antares. Antares is a supergiant, 6,300 times the diameter of the Sun and 300 times as bright. The density of its surface is less than that of the Earth's upper atmosphere. In effect, Antares is a glowing red-hot vacuum. It is also a double star.

If you are far enough south you will see a close pair of stars in the Scorpion's tail. They are nicknamed the Cat's Eyes.

Legend

Greek, Roman, Arabic, and Pre-Columbian cultures saw this group of stars as a scorpion. The Chinese saw the group as part of a constellation called Dragon of the East, identifying Antares as the Fire Star. One of the Greek legends related to this constellation is as follows: Orion the Hunter, said to be the tallest and most beautiful of men, was boastful. He was said to have claimed dominion over every living creature. Hera sent the Scorpion to punish his arrogance. The Scorpion stung Orion, thereby killing him. Nevertheless, Orion was honored in death by being placed in the heavens. The Scorpion was placed in the exact opposite side of the heavens so that the two will never meet again, thereby protecting Orion from further danger.

Viewing

The best evening viewing for this constellation is July through August. In the northern latitudes it may be obscured by haze since it will be low in the southern horizon. To locate this constellation, face south shortly after dark and let your eyes drift past Altair (one of the stars in the Summer Triangle [see Lyra]) and follow the Milky Way down toward the horizon until you come to the bright red star Antares.

Sagittarius (The Archer)

Description

Sagittarius, The Archer, is a Zodiac constellation. Because The Archer is to the south as viewed from northern latitudes, an observer can see only the stars that comprise the body and bow of the grouping. There are two common formations that can be identified from the constellation, depending on how you group the stars. One of these is called "the teapot". When you look at the constellation you can see a handle, lid, and spout. The other commonly recognized formation is "The Milk Dipper" (called The Temple in ancient China). The Milk Dipper appears as if it is about to dip into the "foaming surface of the Milky Way".

The Archer is distinguished by having the center of the Milky Way Galaxy located within its boundaries. If you look towards Sagittarius on a dark clear night you will see a vast swarm of millions of stars interspersed with rifts of dark interstellar dust that comprise the Milky Way Galaxy. The Center of the Milky Way is 30,000 light years away.

A little to the east of the bow of Sagittarius you will be able to detect the small faint globular star cluster M22 with a pair of binoculars. A little to the southeast of the top of the bow, you will be able to see the Lagoon Nebula (M8) through a small telescope or strong pair of binoculars.

At times you will find the moon and planets occupying this sky region.

Legend

In early India this constellation was identified at one time with a horse, another time with a horse's head, and finally as a horse with rider. The Chinese saw a tiger in this group of stars. The early Christians identified the group with the Apostle Matthew. The Egyptians saw a swan while the Hindus and Babylonians saw the group as "The Archer God". The Greek myth is as follows: Chiron, an educated, civilized centaur (a creature that is half man, half horse) placed the centaur Sagittarius, The Archer in the sky to help guide Jason and his Argonauts on their voyage to Thessaly. Part of The Archer's job is to avenge the death of Orion. For this reason the arrow of The Archer is aimed towards Antares, the heart of the Scorpion.

Viewing

The best evening viewing of this constellation is July through August. To locate it look directly south and follow the Milky Way to the horizon. The Archer is to the east of Scorpius.

Leo (The Lion)

Description

Leo the Lion, a Zodiac constellation, is readily identified by "The Sickle". The Sickle appears as a backwards questionmark in the sky. The star at the base of the Sickle is Regulus (translation = The Little King), the brightest star in Leo. The rising of the Sickle in early evening has traditionally been the herald of spring. The other bright star in the constellation is Denebola (translation = The Lion's tail).

The moon and planets will at times be located in Leo since it is a Zodiac constellation. On occasion the moon will pass in front of Regulus (this is called an occultation).

Legend

Many cultures have identified this grouping with a lion. The Egyptians identified this constellation as a lion, possibly because the Sun is in its sky region during the time that the lions would leave their desert haunts for the coolness of the Nile River. The Christians of the Middle Ages said that this grouping represented one of Daniel's lions from the den. Other Christians called it Doubting Thomas. The Greek myth is as follows: The Lion, originally from the moon, came to roam the earth to devour game and people. Hercules was sent to kill the Lion, as his first Labor of the Twelve Labors. He managed to strangle the Lion. The thick, tough skin of this fierce Lion was worn by Hercules and became his trademark. After its death, the Lion was returned to the heavens.

Viewing

The best evening viewing for this constellation is February through June. Regulus can be located by picturing a line extended downward from the two stars on the inside of the bowl of the Big Dipper.

Cygnus (The Swan)

Description

Cygnus, The Swan, is a large magnificent constellation. The Swan is also called the Northern Cross, the top of which is marked by Deneb (translation = The Hen's Tail), the bottom by Albireo (translation = The Hen's Beak). On a clear night it appears that the Swan is flying along the Milky Way.

Deneb is one of the stars of the Summer Triangle [see Lyra]. It is over 1600 light years away yet it is the seventeenth brightest star in our sky. It is a supergiant, 60,000 times as bright as the Sun and 25 times more massive.

Albireo is considered one of the most beautiful double stars in the sky. It consists of a topaz and sapphire pair. A small telescope or strong pair of binoculars are needed to view them.

Legend

The Arabs saw the grouping at one time as a Roc (a bird from the legend of Sinbad the Sailor) and at another time as a game bird. The early Christians saw the pattern as the Cross of Calvary. The Chinese saw it as one of the herd in the tale of the "Weaving Girl and the Herd Boy" [see Lyra]. One of the Greek myths associated with this constellation is as follows: Patheon, a mortal, discovered that his father was Helios, the sun god. Patheon begged his father to let him drive the chariot of the sun across the sky. His father allowed him to do so. Patheon lost control of the chariot and was about to destroy the earth with the sun's heat. Zeus prevented this by striking Patheon with lightning. Patheon fell from the sky into the Erindanus River. Patheon's friend Cygnus, son of Mars, dived into the river to find his friend's body. Apollo took pity on Cygnus, and changed him into a celestial Swan.

Viewing

The best evening viewing for this constellation is June through November. In June you will see it low to the northeast with the cross on its side. In early winter you will see it setting in the west with the cross upright. To locate Cygnus, picture a line through the two stars in the Big Dipper's bowl near the handle. Follow this line across the sky to Deneb.

Lyra (The Harp)

Description

Lyra, the Harp, is a small, beautiful constellation distinguished by Vega (translation = The Harp Star), the fifth brightest star in the sky. Vega appears bright because it is only 23 light years away.

The star Epsilon (ϵ) near Vega is a famous Double star. On a clear night you can detect with the naked eye that Epsilon is a double star. When you view the pair through a small telescope or strong pair of binoculars, you will be able to see that each star itself is binary star system.

Another interesting star is Sheliak. It is an eclipsing variable (binary star system where one star blocks the light of the other) changing its brightness by a factor of 2 1/2 times in 13 days. Sulafat, another star of Lyra, can be used to estimate the brightness of Sheliak since it is just a bit brighter than Sheliak at its brightest.

Legend

In Bohemia this pattern was identified with a fiddle. The early Britons recognized the grouping as a harp. In India it was called the eagle. The Greek legend is as follows: The Harp was invented by Mercury, who gave it to his half-brother Apollo, who in turn gave it to Orpheus to play while on the Argonaut expedition. When Orpheus' wife died, he played the harp to charm Pluto, god of the underworld, to win her back from Hades. He was told he could bring her back on the condition that he not look back at her until she was in the Sun's light. Orpheus guided her out, but when he reached sunlight he looked back. Because his wife was not yet in sunlight, she returned to Hades, and was lost forever. Orpheus was later slain by the cruel priestesses of Bacchus for ignoring their attentions. After Orpheus died, Apollo placed him and the Harp among the stars.

The ancient Chinese identified Vega as the Weaving Girl and Altair, in Aquila, as the herd Boy in their tale "The Weaving Girl and the Herd Boy". The two young people fell in love. While wrapped up in their amorous delights they failed to pay attention to their duties in heaven. As a punishment they were banished to the sky and separated forever by the Celestial River (the Milky Way).

Viewing

The best evening viewing for this constellation is May through November. The Harp is almost directly overhead in the mid-summer evening sky.

Vega marks the apex of the Summer Triangle, a group of the 3 brightest summer stars that gleams overhead on a summer night. The other 2 stars of the group are Altair, in Aquila, and Deneb, in Cygnus.

Cassiopeia (The Queen's Chair)

Description

Cassiopeia, a mythological Ethiopian queen, is outlined in the sky by five bright stars. The pattern is often called Cassiopeia's chair. The constellation appears as a W in the summer sky and a M in the winter sky. On a dark, clear night you will notice that the Milky Way appears in the sky region of Cassiopeia.

Legend

The Egyptians saw this grouping as a deer. The Chinese saw a charioteer. The Arabs saw two dogs. Seventeenth Century Christians identified these stars, at different times with the Biblical figures Mary Magdalene, Deborah, or Bathsheba. The Greek myth for this grouping is as follows: Cassiopeia and Cephus had a beautiful daughter, Andromeda. Cassiopeia boasted that the beauty of Andromeda exceeded that of the sea nymphs. The nymphs were so upset by this that they asked Neptune, god of the sea, to punish Cassiopeia. Neptune dispatched Cetus The Whale to ravage the kingdom of Cepheus and Cassiopeia. Cassiopeia asked Zeus for help and was told that only the sacrifice of Andromeda to Cetus would appease Neptune.

So, Andromeda was chained to a rock by the sea to be devoured by Cetus. Before Cetus could strike, Perseus flew in on the winged horse Pegasus. Perseus killed Cetus by flashing the face of Medusa at it.

When Cassiopeia objected to the wedding of Perseus and Andromeda, Perseus flashed the face of Medusa and turned Cassiopeia to stone. Neptune then took her and bound her to her chair in the heavens. The sea nymphs, in order to teach the queen humility, had Neptune place her around the pole so that at certain times of the year she would be hanging upside down.

Viewing

Cassiopeia is a circumpolar constellation at northern latitudes, and therefore it can be seen year round. As it rotates around the pole, it flips from a W to a M (pick up a star wheel and try it....notice how the position changes in the evening sky from season to season). The best evening viewing for this constellation is August through January. This constellation can be found by sighting from Mizar (in the Big Dipper) through Polaris. This line will lead you to Cassiopeia.

Ursa Minor (The Little Bear)

Description

Ursa Minor, The Little Bear, is best recognized as the Little Dipper. The Little Dipper is not very conspicuous; in bright moonlight the outline of the dipper is difficult to find. The most prominent star of the Little Dipper is Polaris (the North Star), which is almost on the north celestial pole. As you watch the sky movement of this constellation, it appears as if the Little Dipper is swinging around in a circle with its handle fixed on Polaris.

Polaris has been called the most important star in the sky. In actuality Polaris is slightly over one full moon diameter away from the north celestial pole, yet it serves quite well as a guide to wayward travelers.

The two stars at the end of the bowl of the Little Dipper are fairly bright. They are called "The Guardians of the Pole", since they appear to march around Polaris like guards around a castle.

Legend

This grouping of stars has been associated, by the Greeks, with sister nymphs who took care of the infant Zeus. In Egypt it was called the Jackal of Set. The Danes called the group a chariot or, at other times, throne of Thor. It has also been called a little wagon by Germanic people, and at other times a little plough. The Greek Myth that follows explains how the Little Bear and the Big Bear both arrived in the sky: Zeus fell in love with Callisto of Acardia, daughter of King Lycaon. Together they had a son, Arcas. Zeus's jealous and wrathful wife, Juno, was quite upset. To protect Callisto Zeus disguised her as a Big Bear. Arcas grew up to be a hunter. While out hunting one time he was about to shoot a Big Bear, not realizing it was his mother Callisto. To protect Callisto, Zeus changed Arcas into a Little Bear. He then grabbed both of them by their tails and threw them into the heavens, where they reside to this day. Juno was annoyed by this honor. She took revenge by telling Neptune not to allow the Bears to take their rest below the rim of the earth like the other constellations. Because of this, according to Greek legend, the Big Bear and the Little Bear are circumpolar, never going below the horizon.

Polaris itself has been the source of many legends. Some of the names assigned to it are: The Lodestar, Steering Star, and Pivot Star. In China it was considered to be the axis of the universe.

Viewing

The Little Bear is a circumpolar constellation at northern latitude, therefore it is visible year round. Polaris can be located by following pointer stars on the tip of the bowl of the Big Dipper (see Ursa Major).

Ursa Major (The Big Bear)

Description

Ursa Major, The Big Bear, is best known as the Big Dipper. The seven stars of the Big Dipper make up one of the most impressive star figures in the sky.

The two stars at the tip of the bowl Dubne (translation = The Back of the Great Bear) and Merak (translation = Loin of the Great Bear) are called the pointer stars. By picturing an arrow up the cup through the pointer stars, Polaris, the North Star, can be found (see Ursa Minor).

Close to Mizar, the middle star of the Big Dipper, sits the star Alcor. The Arabs identified the pair as the "horse and rider". The American Indians saw them as a squaw and her papoose. The Indians used the pair to test vision. If one could see Alcor, he/she was considered to have normal vision.

Legend

In many cultures throughout the world this group of stars is associated with a bear. The pattern has also been identified as a plough, chariot, and wagon.

The Iroquois Indian legend for the Big Bear is as follows: The Iroquois identify the bowl of the Big Dipper as the Bear, and the three stars that comprise the handle as the remnants of a hunting party that was attacked by stone giants. The bear and the three surviving Indians were placed in the sky, following the attack, by a pair of invisible hands. The first Indian nearest the Bear carries a spear, the second carries a pot (Mizar being the Indian, Alcor the pot) for cooking the bear, and the third carries sticks to make a cooking fire. During the fall, when the Bear dips low on the horizon, the Indian carrying the spear is able to strike. The blood which drips from the wounds of the Bear falls onto the leaves of the forest and gives us our fall colors every year.

Viewing

The Big Bear is a circumpolar constellation at northern latitudes therefore it is visible year round. The Big Dipper rotates completely around Polaris each day, and it can be used to estimate time (try this out on a star wheel). Because it does rotate around Polaris, its position in the evening sky is different for each of the seasons. The drawing below illustrates the counterclockwise apparent annual motion of the Big Dipper about the celestial north pole.

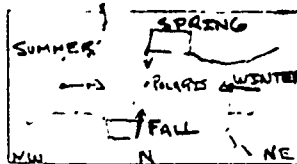

References

The constellation information sheets were adapted from the following references:

1. Stars in Your Eyes, U.S. Army Corps of Engineers (Portland District), U.S. Government Printing Office (1981 - 796 - 712160).
A good booklet for helping find the major summer constellations. Also contains star lore from Greek and American Indian legend.
2. Guidepost to the Stars, Leslie C. Peltier, Macmillian Publishing Co., Inc. (New York: 1972).
A concise book that leads you through the year by identifying the fifteen brightest stars through the season. Also points out nebulae, binary stars, clusters and other sky phenomena that can be observed with the naked eye or binoculars.
3. The Star, A New Way To See Them, H.A. Rey, Houghton Mifflin Co. (Boston: 1976).
Excellent Book. Rey redraws the patterns of the constellations to actually look like what they are named. The book also gives a very clear explanation of sky motions.
4. A Field Guide to the Stars and Planets, 2nd Ed., Revised (Peterson Field Guide Series), Donald H. Menzel & Jay M. Pasachoff, Houghton Mifflin Co. (Boston: 1983).
An excellent source book that is useful for the beginning observer and the experienced amateur. Has the what, when, and how to observe all sky phenomena. If you want to become more than just a casual observer, this book is for you.
5. Star Names, Their Lore and Meaning, R.H. Allen, Dover Publications, Inc. (New York: 1963).
The Classic in the field of star lore. The Dover printing is a reprint of the turn of the century original. The book is thorough, however it is at times difficult to follow.
6. Burnham's Celestial Handbook, An Observer's Guide to the Universe Beyond the Solar System, Vol. I, II, III, Robert Burnham, Jr., Dover Publications, Inc. (New York: 1978).
Beautiful, thorough work on the stars and deep sky objects. Much of the material covered in this set is for the serious observer. The star lore sections are elegant (they condense R.H. Allen's work) and well worth reading.
7. Astronomy Merit Badge Book, Boy Scouts of America (Irving, Texas: 1983).
A good primer on astronomy. Has several activities that could be used in the classroom.
8. Mythology, Edith Hamilton.
A classic. This is the source for Greek and Norse myths.
9. Giants, Dragons, and Gods: Constellations and Their Folklore, Dirk Gringhuis, Meredith Press (New York: 1968).
A book written for the juvenile age level. The constellation folklore is written in a story format.

CONSTELLATION CHART

NORTH CIRCUMPOLAR REGION

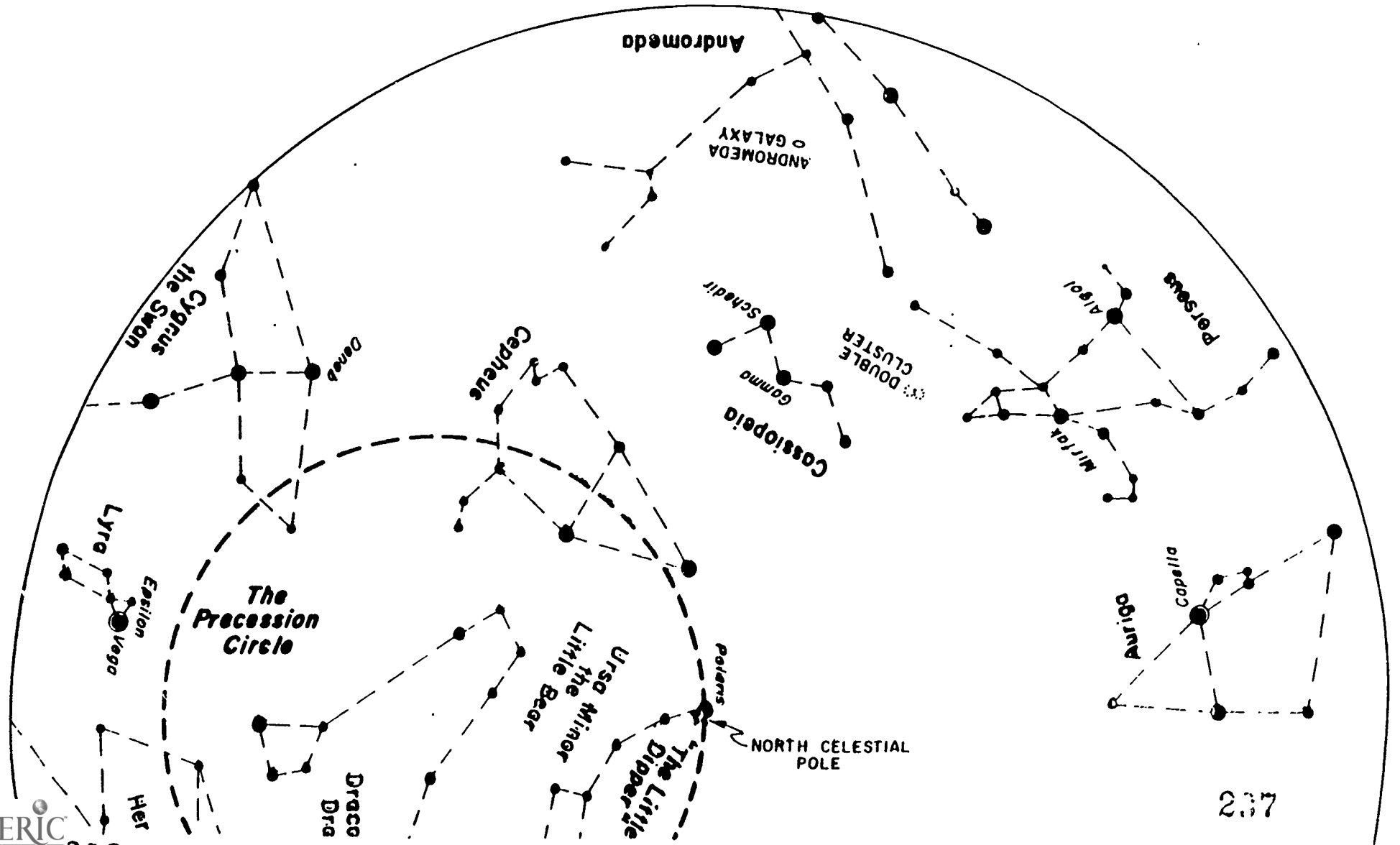

Cut on dotted line, then overlap this side

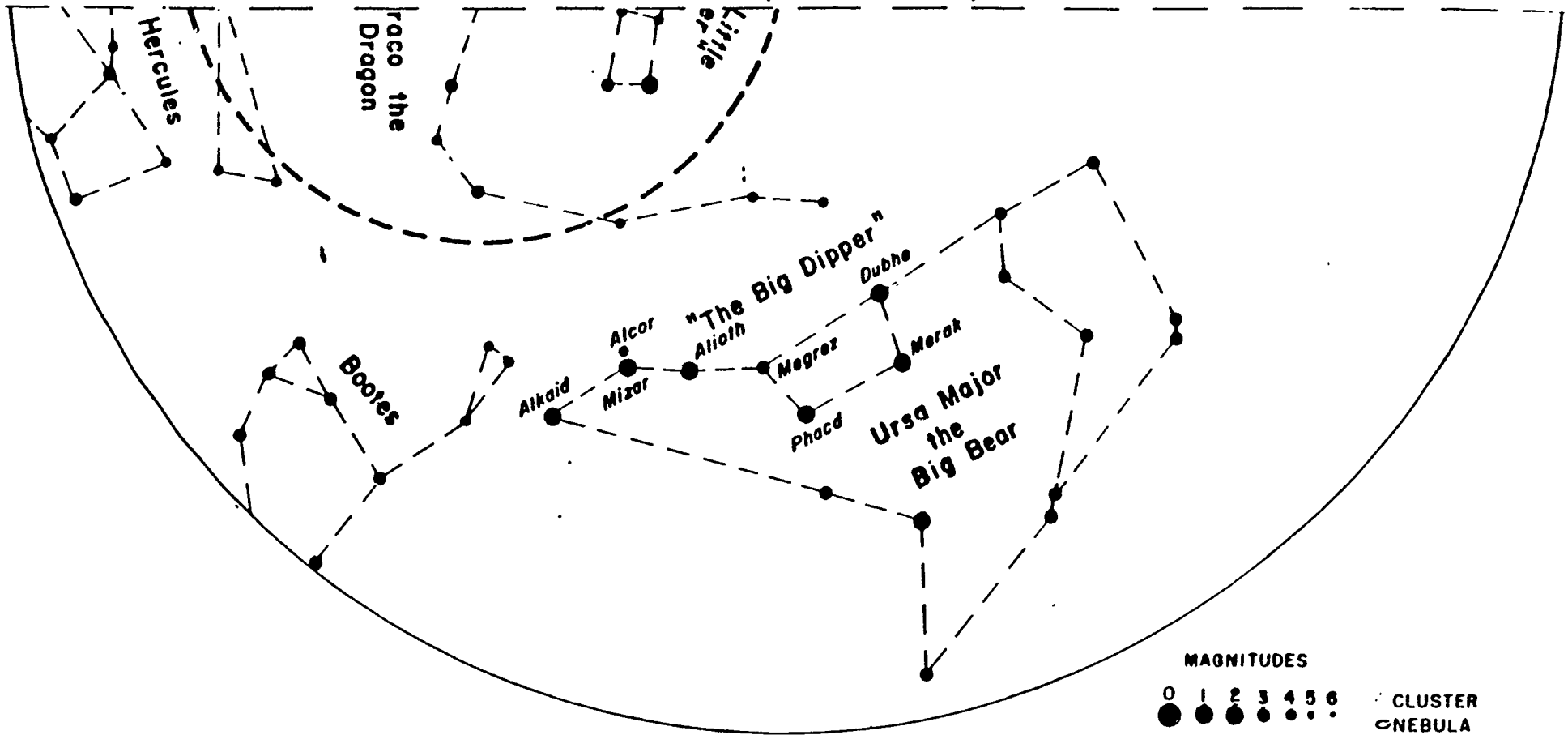

NORTH

Ursa Major
the Big Bear

Gemini
the Twins

Cancer
the Crab

Leo
the Lion

Castor
Pollux

M35

Denebola

Regulus

M44

Canis Minor

Orion

Betelgeuse

Procyon

EAST

ECLIPTIC

CELESTIAL EQUATOR

Hydra
the Water Snake

The Great
Hercules

Saiph

Sirius

Canis Major
the Big Dog

M41

Antares

The
Sailing Ship

Canopus

SOUTH

240

NORTH

Cassiopeia

DOUBLE CLUSTER

Mirfak

Capella

Auriga the Charioteer

Perseus

Algol

M31 ANDROMEDA GALAXY

Andromeda

Taurus the Bull

Aries the Ram

Alpheratz

The Great Square

M45

Pleiades

ECLIPTIC

Hyades

Aldebaran

Pisces the Fishes

Orion

Bellatrix

CELESTIAL EQUATOR

Cetus the Whale

OM42

Rigel

Eridanus River

Lepus the Hare

Cut on dotted line, then overlap this side

pus

SOUTH

241

NORTH

Cut 0.1 dotted line, then overlap this side

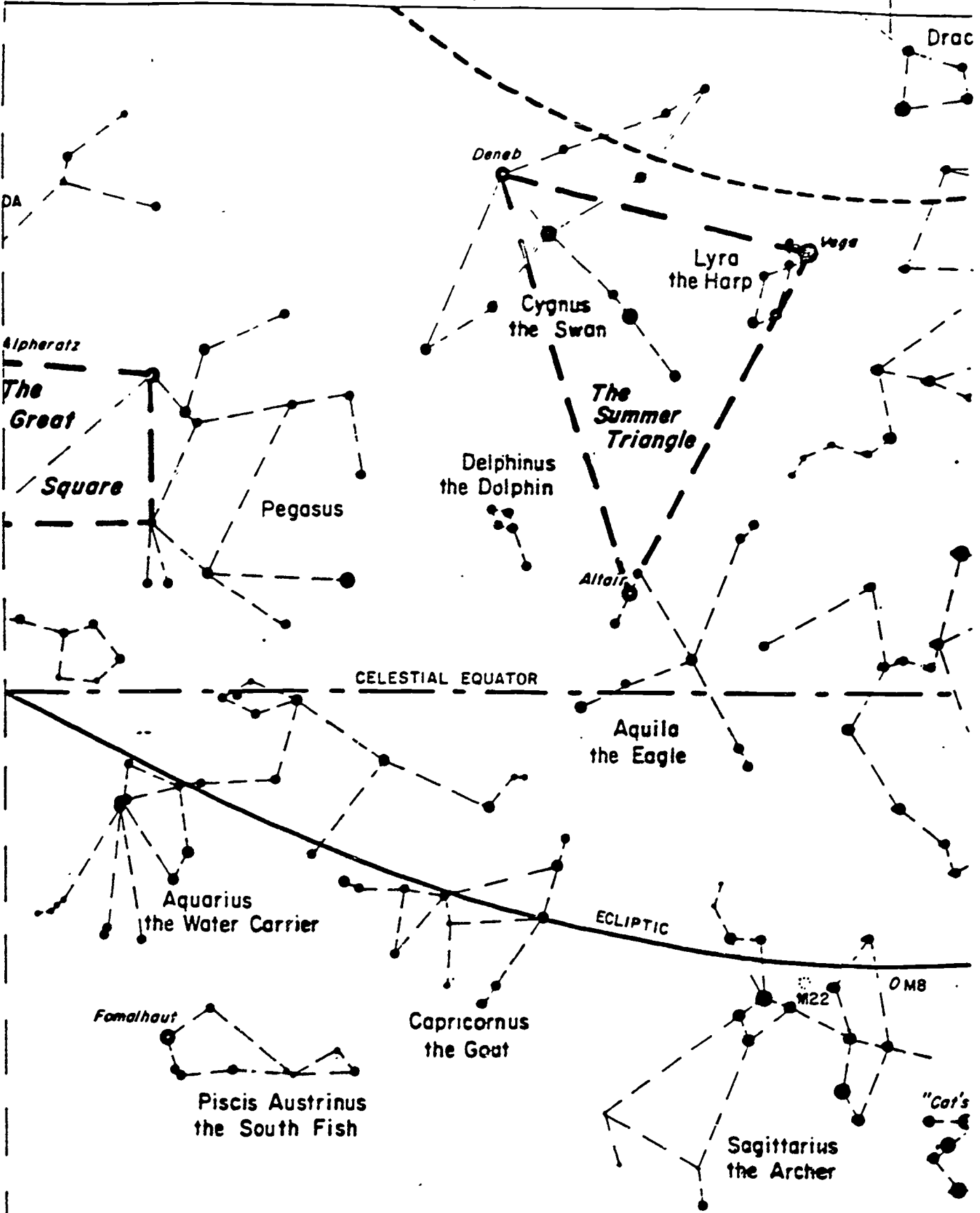

CONSTELLATION CHART

MAGNITUDES

-2 -1 0 1 2 3 4 5 6

○ CLUSTER
○ NEBULA

SOUTH

NORTH

Dra

DA

Deneb

Lyra
the Harp

Vega

Cygnus
the Swan

The
Summer
Triangle

Delphinus
the Dolphin

Altair

Alpheratz

The
Great
Square

Pegasus

CELESTIAL EQUATOR

Aquila
the Eagle

Aquarius
the Water Carrier

ECLIPTIC

Fomalhaut

Capricornus
the Goat

M22

OM8

Piscis Austrinus
the South Fish

Sagittarius
the Archer

"Cat"

Cut on dotted line, then overlap this side

CONSTELLATION CHART

MAGNITUDES									
-2	-1	0	1	2	3	4	5	6	○ CLUSTER
●	●	●	●	●	●	●	●	●	○ NEBULA

SOUTH



NORTH

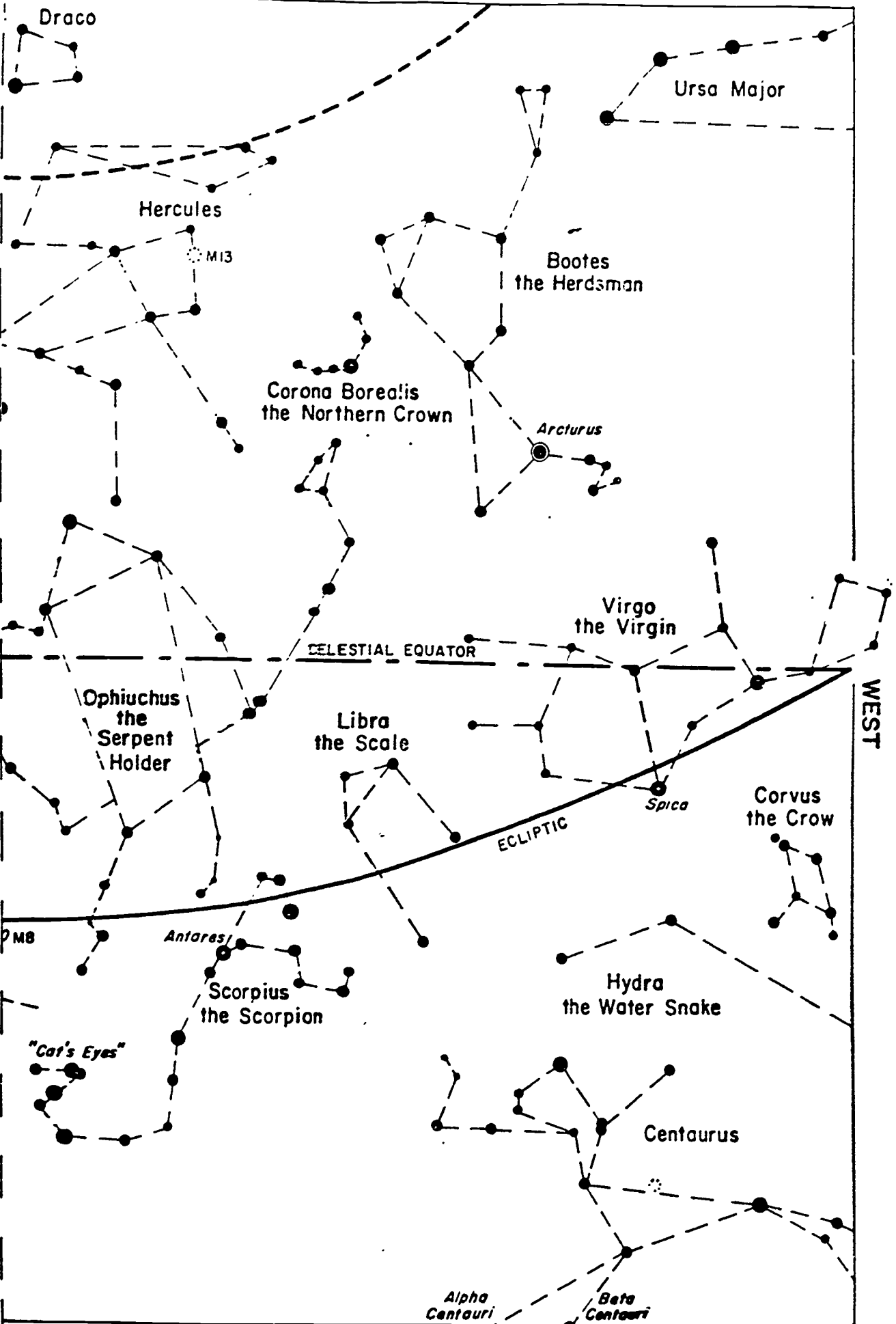

WEST

SOUTH

PHYSICAL SCIENCE 250, SPRING 1988
First Hour Exam
February 10, 1988

1. (5) At what phase of the moon do solar eclipses occur? Make a sketch of the earth, moon, sun and the moon's shadow at the time of a solar eclipse.

2. (5) What did Galileo do?

3. (5) State one of Newton's laws of motion and give an example.

4. (5) Explain why there are seasons on the earth.

5. (5) At what time of day does the full moon cross the meridian?

6. (5) Make a sketch of the celestial sphere. Label the celestial equator, the north celestial pole, the ecliptic, the vernal equinox and the winter solstice.

7. (5) Explain why there is a difference between "star time" and "sun time".

8. (5) Why was the leap year introduced into the calendar?

9. (5) Sketch the orbit of a planet going around the sun. Label the point in the orbit where the planet is moving fastest.

10. (5) Explain briefly the method that Erastosthenes used to calculate the circumference of the earth.

11. (5) Does the moon rotate? Justify your answer.

12. (5) What are the two major areas on the moon and what is one difference between them?

13. (5) What is one important difference between a reflecting telescope and a refracting telescope?

14. (3) List any three types of electromagnetic radiation in order from shortest to largest wavelengths.

15. (3) Name one date on which the sun rises due east.

16. (3) Who developed the laws of planetary motion?

17. (3) What is escape velocity?

18. (3) What type of spectrum is emitted by a hot gas under low pressure?

9. (4 pts.) Name and describe any two of the four major satellites of Jupiter.
10. (4 pts.) What is a supernova?
11. (6 pts.) Is there life on Mars? Justify your answer.
12. (4 pts.) What is an asteroid?
13. (4 pts.) How does the sun produce energy?

14. (4 pts.) What is the cause of meteor showers?

15. (4 pts.) Where is the youngest material in the Milky Way Galaxy found?

16. (2 pts. each)

Which satellite has an atmosphere? _____

Who discovered Uranus? _____

Which planet has a rotation period longer than its period of revolution? _____

What is the age (approximately) of the solar system? _____

"Elliptical" is a type of _____.

Olympus Mons is on _____.