

DOCUMENT RESUME

ED 296 864

SE 047 840

AUTHOR Modell, Harold, Ed.
TITLE Computers in Life Science Education. Volumes 1 through 4, 1984-1987.
INSTITUTION National Resource for Computers in Life Science Education, Seattle, WA.
PUB DATE 87
NOTE 340p.
AVAILABLE FROM National Resource for Computers in Life Science Education, Mail Stop RC-70, University of Washington, Seattle, WA 98195 (Subscription \$30.00 U.S., Canada; \$50.00 Mexico, Europe).
PUB TYPE Collected Works - Serials (022)
JOURNAL CIT Computers in Life Science Education; v1-4 1984-87

EDRS PRICE MF01 Plus Postage. PC Not Available from EDRS.
DESCRIPTORS *Biological Sciences; *College Science; Computer Assisted Instruction; *Computer Uses in Education; Courseware; Higher Education; Instructional Improvement; Microcomputers; *Newsletters; Science Education; *Science Instruction; Secondary Education; *Secondary School Science; Teaching Methods

ABSTRACT

Designed to serve as a means of communication among life science educators who anticipate or are currently using microcomputers as an educational tool, these four volumes of newsletters provide background information and practical suggestions on computer use in over 80 articles. Topic areas include: (1) teaching physiology and other life sciences by microcomputer; (2) enhancing lectures with a microcomputer; (3) simulation of biological systems; (4) projecting microcomputer images; (5) optical videodiscs; (6) computers in the student laboratory; (7) tutorials in anatomy and physiology community college classes; (8) computer-based exam construction in microbiology and immunology; (9) interactive video; (10) programing languages; (11) input/output design; and (12) computer-assisted instruction for health care professionals. Also provided are guidelines for the preparation and submission of articles to the newsletter, subscription information, indexes for each volume, and lists meetings and synopses. "Where's the Software?" and "Keeping Abreast of the Literature" are periodic feature articles. (ML)

 * Reproductions supplied by EDRS are the best that can be made *
 * from the original document. *

COMPUTERS IN LIFE SCIENCE EDUCATION

SAM

U.S. DEPARTMENT OF EDUCATION
Office of Educational Research and Improvement
EDUCATIONAL RESOURCES INFORMATION
CENTER (ERIC)

- This document has been reproduced as received from the person or organization originating it.
- Minor changes have been made to improve reproduction quality.
- Points of view or opinions stated in this document do not necessarily represent official OERI position or policy.

"PERMISSION TO REPRODUCE THIS MATERIAL IN MICROFICHE ONLY HAS BEEN GRANTED BY

Harold Modell

TO THE EDUCATIONAL RESOURCES INFORMATION CENTER (ERIC) "

ED 296864

HAROLD I. MODEL

Virginia Mason Research Center
Seattle, Washington

MARCEL BLANCHAER

Professor of Biochemistry
Faculty of Medicine
University of Manitoba
Winnipeg, Manitoba
Canada

THEODORE J. CROVELLO

Department of Biology
University of Notre Dame
Notre Dame, Indiana

JAMES W. ECKBLAD

Department of Biology
Luther College
Decorah, Iowa

TSEGAY HABTEMARIAM

School of Veterinary Medicine
Tuskegee Institute
Tuskegee, Alabama

DONNA LARSON

School of Nursing
Grand Valley State College
Allendale, Michigan

TERRY M. MIKITTEN

Graduate School of Biomedical Sciences
University of Texas Health Sciences Center
San Antonio, Texas

JAMES E. RANDALL

Department of Physiology
Indiana University
Bloomington, Indiana

PATRICIA SCHWIRIAN

College of Nursing
Ohio State University
Columbus, Ohio

RICHARD STULL

College of Pharmacy
University of Arkansas
Little Rock, Arkansas

JAMES W. WOODS

Lister Hill National Center
for Biomedical Communications
National Library of Medicine
Bethesda, Maryland

DOROTHY WOOLEY-McKAY

Department of Biology
Glendale Community College
Glendale, Arizona

GLENN YOSHIDA

Department of Life Sciences
Los Angeles Southwest College
Los Angeles, California

ELSEVIER

CONTENTS

USING THE COMPUTER IN THE CLASSROOM—FIRST STEPS	1
Harold I. Modell	
TEACHING PHYSIOLOGY BY MICROCOMPUTER IN SMALL GROUP CONFERENCES	4
Byron A. Schottelius	
THE COMPUTER LESSON	6
Allen A. Rovick and Joel A. Michael	

USING THE COMPUTER IN THE CLASSROOM—FIRST STEPS

Harold I. Modell
Virginia Mason Research Center, Seattle, Washington

Computer-based education, computer-assisted instruction, and computer-assisted evaluation are not new terms, and the notion of using computers in the classroom is not new. However, until relatively recently, interest in using computers in life science teaching was limited. The deluge of video games and low cost microcomputers that we have witnessed within the past 2 to 3 years has rekindled interest in using computers as a teaching aid in life science settings.

Unfortunately, the novice ready to embark on the adventure of bringing the computer into the classroom is immediately thrust into a seemingly alien world in which bits, bytes, and nibbles abound, and where the inhabitants speak in strange languages con-

sisting of 3-, 4-, and 5-letter words. To become involved, the newcomer feels as if he must first make key decisions regarding his specific computer needs. Hence, he tries to consider the merits of various computer systems, assess memory requirements, choose language options, and deal with other computer-related variables. In short order, he becomes overwhelmed by the task of choosing a specific system from seemingly endless possibilities, becomes discouraged, and postpones using the computer as an instructional aid.

The problem with the approach just outlined is that the starting point is the computer store rather than the desired educational outcome. The first step in preparing a computer-based exercise must be to answer a number of education-

SE 047 840

related questions and make key decisions that will establish guidelines for the design of the teaching aid. Anyone who has prepared lecture slides, demonstration materials, or a host of other teaching aids is acquainted with this process. However, when designing these materials, guidelines are established almost as a matter of habit. The flexibility that exists when these aids are used allows modification of guidelines during the actual presentation. For example, when designing slides, it is not difficult to arrive at a product that can be put into a variety of contexts. In the case of computer-based materials, however, numerous paths are available for program development, but once the program is completed, design flexibility is essentially lost. Hence, to insure that the program has the best chance of fulfilling the need for which it was intended, a conscious effort must be made to address a number of issues.

While the specific areas of concern may vary from application to application, several general questions are common to nearly all teaching aids. The first of these is, "What is the goal of the exercise?" Although this question may seem obvious, it is important to realize that the same program skeleton used with different input/output schemes may produce drastically different results depending on the educational setting. Consider, for example, a simple simulation of a physiological system with three different goals in mind. In all three situations, the model equations and solution are identical. In the first case, the program will be used in the lecture hall. The goal is to provide a momentary diversion to regain the attention of students whose thoughts have drifted away from the material at hand. In this case, bells, whistles, and any available flashing lights would probably be helpful. Any substantive message that the program has to offer may be over-

shadowed by the novelty, but the goal may be reached.

In the second case, the setting is again the lecture hall, only this time, the goal is to provide a means of demonstrating the influence of one variable on the physiology of the system. In this case, a simulated strip-chart recorder with an on-line trace of one or more parameters may be in order.

In the third case, the program is to be used in an independent study setting. In this case, no one is available to answer questions at the time the student interacts with the program. Thus a more well-defined output, such as a labeled picture showing one aspect of the system may best serve to reinforce the student's conceptualization of the physiology involved. In each of these examples, the goal of the exercise must be recognized and kept in mind during program development if the program is to provide a successful educational experience.

The next important consideration is whether or not the computer is really the best vehicle to use in reaching the desired goal. The educational specialist at the computer store (salesman) contends that "anything that can be done well without a computer can be done even better with a computer!" This, of course, is nonsense, and, in fact, very often the computer is not the vehicle of choice.

The computer does two jobs very well. It swallows and regurgitates information very easily, and it performs calculations at break-neck speed. Two areas in which the former capability is especially helpful are in the presentation of programmed learning material and in presenting various types of problem sets. The latter capability is essential to mathematical simulations. Consider the following applications:

1. Programmed learning material.
A programmed textbook may do

a much better job than the computer. Books are easier to carry and use on the bus, they cost considerably less than computers, and the student can easily review isolated portions of a book.

2. Problem sets. Depending on the goals of the exercise, alternatives are available for presenting problem sets. Latent image materials produced with a simple ditto machine, for example, can offer a number of advantages over the same exercise on a computer.¹
3. Simulations. Alternative options also must be explored when dealing with simulations. A physical model, for instance, may make the point of the exercise more vivid than a computer model.

There are instances in all three of these areas, however, in which the goals of the exercise can best be achieved by using a computer, and the computer should be the vehicle of choice. The point is that alternatives do exist, and they should be explored before deciding to use the computer.

The next task, and the one most crucial to program development is to determine the guidelines that will govern development of the teaching aid. Final decisions in this area depend heavily on the goals of the exercise, the setting in which it will be used, the background of the students using the exercise, and a variety of other factors. To illustrate how one group approached this task, the issues considered by Modell et al² while developing a set of computer simulations in respiratory physiology³ will be reviewed.

The set of programs was intended originally to be used in medical school and postgraduate education settings. The overall goal of the series was to provide an active learning experience in which students could review respiratory

physiology and learn to reason from basic facts to general concepts. The first questions asked dealt with developing the strategy to be used in communicating with the student. Examples include: Should it be assumed that the user will be familiar with computers? How much prompting should the program provide? In what form should variables be requested? Should the amount of oxygen in inspired gas, for instance, be requested in terms of partial pressure, percent, or gas fraction?

Guidelines governing the number and complexity of the simulations used were next addressed. Should the series reflect simple models at the outset and increase in complexity as the series continued, or should more complete models be developed initially, resulting in fewer components to the series?

Having dealt with the number and complexity of models in the series, the next issues focused on the latitude allowed by the exercises and the form and format of error messages. Should the programs be fairly limited in scope, or should they be able to accommodate the student who wishes to extend his study beyond the scope of the suggested procedure? How should input values outside physiological limits or physiologically inconsistent be handled? Should error messages serve as a basis for an additional learning experience?

The specific output format was also addressed with respect to the overall goals. What form should the

output take? Is a table of numbers the best format, or is some other format preferable? What should the output include? Should the experimental conditions defined by the student be repeated as part of the output? How should units be handled?

The final issues addressed dealt with the documentation provided with the computer programs. What form should the documentation take? Should the procedures be presented by the computer, or should they be provided in a separate document? What information should be included? How much direction should the document provide for the student?

The process just outlined may seem like a time-consuming effort, and one might ask whether the return is worth the effort. The series of programs developed by Modell et al was first distributed in 1975 and was provided primarily to the medical school population. The programs are still in use in a variety of institutions serving student populations ranging from pulmonary function laboratory technicians and undergraduate physiology students to fellows and residents in pulmonary medicine and anesthesiology.

It is evident that by answering education-related questions such as those enumerated above, specific hardware requirements are often defined. In the microcomputer world, similar questions might also include use of graphics,⁴ and the answers to these questions would

further define hardware limitations. Hence, by focusing first on the educational experience, the novice can avoid the task of becoming involved with a plethora of computer issues that are extraneous to his educational goals.

An outline of the initial steps that one must take when incorporating computers in life science education has been presented. When preparing teaching aids that involve computers, it is extremely important to keep in mind the educational goals, the setting in which the program will be used, and the level of sophistication of the audience using the program. If this is not done, the exercise will most likely lead to confusion, and the message that one conveys to the student may be very different from that which was intended.

REFERENCES

1. Modell HI: An approach to a physiology course for independent study. *Physiologist* 24:28-31, 1981.
2. Modell HI, Farhi LE, Olszowka AJ: Physiology teaching through computer simulations—problems and promise. *Physiol Teacher* 3:14-16, 1974.
3. Modell HI, Olszowka AJ, Klocke RA, Farhi LE: Normal and abnormal lung function, a program for independent study. New York: The American Thoracic Society, 1975.
4. Modell HI, Olszowka AJ, Plewes JL, Farhi LE: Role of computer graphics in simulations for teaching physiology. *Physiologist* 26:93-95, 1983.

TEACHING PHYSIOLOGY BY MICROCOMPUTER IN SMALL GROUP CONFERENCES

Byron A. Schottelius

*Department of Physiology and Biophysics, University of Iowa
Iowa City, Iowa*

Inflation, curricular changes, and greater student enrollments increasingly influence the adoption of cost-effective and time-efficient methods of presenting physiological concepts to health science students. Cost containment is essential, because teaching budgets generally have not maintained parity with expenses. Often there has been a concomitant reduction in the number of scheduled laboratory exercises. This has limited the opportunity for students to examine a gamut of physiological phenomena directly. Furthermore, this pedagogical dilemma, in instances, has been compounded by curricular crowding that has preempted some of the time previously assigned to laboratory courses. Enrollment increases tend to encourage the enlargement of laboratory course sections beyond optimal limits.

Computer simulations of physiological phenomena can supplement or replace some laboratory learning experiences for health science students. A good computer simulation, being dynamic, shows how bodily systems react and interrelate with better learner-media interaction than that provided by movies and much better than that afforded by books, with their built-in constraint of static illustrations. Moreover, computer simulations can even enhance the learning experience because they permit the introduction of new and complex experiments that exceed the student's manual dexterity or technical expertise (or where the subjects are available only in a clinical environment, ie, patients); they require the student to understand the as-

sumptions used in the simulation and thereby help develop critical reasoning; they are completed in a reasonable time span, which improves student attentiveness; they offer the opportunity to see phenomena, which might occur in real time very slowly or extremely rapidly, within a reasonable time span; and they are infinitely repeatable, which increases the student's satisfaction (nothing succeeds like success, and hands-on experiments do fail for lack of experience). Finally, the repetition tolerated by the computer can offer the instructor greater assurance that the student has had sufficient exposure to comprehend the basic mechanisms inherent in the phenomenon being simulated.

Recognizing the problem and its potential solution, as described above, our department introduced computer simulations into two major service courses—an aggregate enrollment of nearly 300—on a limited basis during the spring semester of 1981. Because of the immediate availability of software and because of its graphics resolution, the Apple II+ microcomputer was selected for use. Acquisition of hardware in quantities sufficient for direct use by all students was not feasible. Therefore, a conference-demonstration instructional format was adopted. For this, a microcomputer flanked by two 30-inch color monitors is mounted on a cart that can be moved easily to the site of the scheduled conference. Customarily these sessions are conducted for groups of 15–28 students. With groups of this size, all individuals have acceptable visual

access to the monitor displays and there is opportunity for adequate instructor-student interaction.

Some excellent computer simulations of physiological phenomena are available, principally by exchange between institutions, departments, and individuals. Many of these have appeared in various issues of *The Physiology Teacher*, a publication of the American Physiological Society. Our departmental learning resources facility now includes over 30 tested, quality simulation programs either obtained from other institutions or developed locally. The goal in each simulation is to emphasize that physiology is a quantitative science and that physiological functions are to be comprehended as a series of interacting, time-dependent processes. In most cases, the programs obtained elsewhere have been revised to incorporate more animation and graphics and especially to exploit the advantages of color presentations—color seems to be important to a generation of students maturing in an era of color television.

Our simulations benefit a large student population, ie, medical, dental, pharmacy, physician's assistant, nursing, physical therapy, and graduate students. Whereas the core of physiological knowledge is an essential element in the training of all of these student groups, we tailor our simulations for essentially three levels of student attainment. For the lower level, fewer options in parameter selection (eg, a fixed rather than variable total lung volumes) are offered in a given simulation. Where feasible, lower level programs incorporate more animated graphics to depict a concept more readily described to upper level students by a mathematical model.

When computer simulations are used in teaching, our students have in their possession a handout that states the objectives of the simulation, the minimum protocols (stu-

dents are encouraged to suggest others in class), a format for data collection, and a number of questions for study. Usually, baseline graphs of normal data also are provided. These are in a format large enough to enable the student to add experimental data as it is accumulated. Two conference exercises will be described in more detail in order to clarify the relationship of the handout to the simulation.

From a menu of neurophysiology programs, the Hodgkin-Huxley squid axon simulation, adapted from the original program written by Randall,¹ is most often chosen for class presentation. The "title page" of this simulation includes an animation that attempts to depict in three dimensional perspective the propagation of an action potential along an axon. It serves its purpose if it helps the student appreciate the three-dimensional nature of the nerve impulse. The handout offers as student objectives the need to be able to accomplish the following:

1. to define the concepts of conductance, depolarization, repolarization, accommodation, threshold, summation, refractoriness, and voltage clamping;
2. to distinguish activation of gNa^+ from inactivation of gNa^+ ;
3. to understand the interplay of sodium conductance and potassium conductance in the generation of an action potential;
4. to construct a strength-duration curve;
5. to explain the role of gNa^+ and gK^+ in refractoriness;
6. to recognize the effects of blocking Na^+ or K^+ channels, as well as the effect of changing $(Na^+)_o$.

A short introduction in the handout describes the studies of Hodgkin and Huxley and includes illustrations of a voltage clamp system, a typical ionic current record, and a hypothetical Na^+ channel with as-

sociated "gates". The computer simulation permits "experiments" to be performed by altering the resting potential and the amplitude and duration of applied stimuli. The computer generates membrane potential and conductance data in tabular and graphic formats. The first experiment demonstrates voltage clamping. In this, either the holding (resting) potential or the test potential is held constant while the other is changed in a step-wise fashion. Graphs of sodium and potassium conductance are followed on the monitor screen for a 10-msec time span that occupies 30 sec in real time. Subsequent experiments on threshold, strength-duration relationship, accommodation, summation, and refractoriness are all briefly described in the handout, and appropriate blank data tables are provided. When required, these experiments are illustrated by printer-generated copies of the high resolution graphics appearing on the monitor screen. A modification of the original Randall program permits the instructor to simulate the application of tetrodotoxin or tetraethylammonium to the axon in order to block Na^+ or K^+ channels, respectively.

Simulations of cardiovascular phenomena that are frequently used in teaching include a pulse pressure model and a baroreceptor reflex model, both dealing with blood pressure changes. These programs are also revisions of programs originally created by Randall.¹ The student objectives are to gain an appreciation of the manner in which arterial pressure and pulsations are influenced by mechanical factors (such as heart rate, duration of systole, and vascular compliance and resistance), and to understand how stability of this pressure is maintained by the baroreceptor reflex when such mechanical factors as gravity and blood volume are altered.

Mechanical analogs of the pulse pressure and baroreceptor models

constitute illustrations in the introductory material of the handout. These analogs are repeated on the "title pages" of the simulations in the form of animations. The animated pulse pressure analog shows a moving piston, changing volumes of an outlet vessel, valvular actions, and the effects of alterations in compliance and resistance upon volume rate of flow. In the baroreceptor reflex model, the animation includes a centrifugal pump, variable volume arteries and veins, syringe input to the system for producing volume changes, as well as manometer measurements of filling and carotid pressures. The pulse pressure simulation requires student input of values for heart rate, duration of systole, stroke volume, aortic compliance, peripheral resistance, and initial diastolic pressure. From this data, the computer generates a graphic display of blood pressure and ventricular ejection volume at 0.02-sec intervals for a period of 5 sec. Tabular data of cardiac output and the systolic and diastolic pressures are also available on the monitor screen. With this model, the instructor demonstrates the effects of exercise, hypertension, arterial hardening, hypovolemic shock (plus compensation), and anaphylactic shock (plus compensation) by appropriate manipulation of the variable parameters. A table for data collection appears in the handout. The baroreceptor reflex simulation requires input of values for total blood volume and arterial-carotid pressure drop. Computer output is a table displaying values for arterial pressure, carotid pressure, cardiac output, relative sympathetic activity (\times normal) and cardiac filling pressure under normal, open loop (no baroreceptor reflex) and closed loop (compensated) conditions. These data are entered into a table in the handout for experiments involving the erect position, assumption of the sitting and reclining positions, a 3-G pull-out from a dive,

and the head down (inverted standing) position. Each of these conditions is studied with and without a superimposed hangover and in open and closed loop modes. Whereas the inclusion of a 3-G pull-out and hangovers is somewhat theatrical, the results are impressive, readily comprehended, and well-retained by the student.

In addition to the examples of simulations described above, respiratory, renal, fluid balance, acid-base balance, endocrine, bile regulation, muscle, and synapse simulations are available to instructors for conference-demonstrations. Other simulations are being developed by interested and qualified departmental faculty as time allows. Initial student evaluations of this pedagogical approach, although subjective, have been favorable. Even though logistics at this time require that the simulations be performed as demonstrations, we make a sincere effort to accommodate in nonclass hours any student requesting hands-on experience with any, or all, of these simulations. Intensely motivated students have been gaining such experience. Our goal is to outfit a microcomputer laboratory where all students would be rotated through selected simulations on an individual basis. Meanwhile, a more immediate goal is to make the evaluation of microcomputer teaching more objective. To do so, we will shortly introduce criterion referencing evaluation, ie, students will be pretested and posttested over specific objectives that they have been previously provided.

The foregoing paragraphs indicate the expanding interest in the use of microcomputer simulations for teaching among faculty in this department. At this time it is attractive to use microcomputers to alleviate cost and time constraints. As computer literacy among students increases and medical technology advances, such use may become mandatory.²

REFERENCES

1. Randall JE: Microcomputers and physiological simulations. Reading, MA: Addison-Wesley, 1980.

2. Tidball CS, Shelesnyak MC (eds): Frontiers in the teaching of physiology: computer literacy and simulation. Bethesda, MD: American Physiological Society, 1981.

THE COMPUTER LESSON

Allen A. Rovick and Joel A. Michael

Department of Physiology, Rush Medical College, Chicago, Illinois

A computer lesson deals with a well-defined circumscribed topic. It is a series of questions, each with a set of conditional responses. It is interactive; each answer provided by the student elicits the response that will most appropriately assist him in mastering the material under consideration. By being interactive, the computer lesson should, and generally does, involve the student more actively than does note-taking in a lecture hall or page-turning while reading a text. In our view, computer lessons should not be used as the vehicle for initial learning of material, but rather, should be used as a means for self-assessment, remediation, or reinforcement.

Given the special capabilities and limitations of computers, we think that computer lessons are not the most effective or efficient way of initially presenting course content. Textbooks are far better for that. The printed page and text figures have higher resolution than the output of a CRT or a plasma screen. Many people can read a text faster than a screen, and in reading a text, students may take as little or as much time to digest the content as they need or want. Furthermore, the number of computers or terminals is usually limited, as is the time available for their use. One may read a text in a dormitory room, at the dining room table, or out under the old apple tree, but computer lessons must be done sitting at a terminal. Most often today, the computers or terminals are owned by the educational institution and are housed in a "sheltered" environment. This may

provide a benefit in that, with few distractions, the student's attention may be more completely captured, and this may result in more effective learning. Although some of the availability limitations of computers may disappear with increasing personal ownership of such equipment, computers (and, therefore, computer lessons) will never be able to compete with textbooks in portability, resistance to injury through physical misuse, and ease of accessibility on a bookshelf.

Computer lessons consist of a limited amount of text and a series of questions that are put to the students. Lessons also include a set of responses that are designed to reinforce and correct the students' knowledge and performance base. Some of the questions may simply challenge the students' memory. However, this should be a small part of a lesson. A good lesson will determine what facts a student knows by posing problems that may be solved only if the student user has an adequate command of the facts.

Problems may be quantitative. To solve them, the student must know the mathematical relationship(s) between variables and possibly the normal values of some of them. He must then be able to correctly calculate the value of the desired parameter, given some defined conditions. Students should also be able to solve qualitative problems. In this case, either an exact mathematical relationship is not known or does not exist. Instead, an understanding of the causal relationship between parameters is required along with

an ability to reason. Instead of generating numerical answers, students are asked to predict the direction in which parameters change, stemming from the conditions of the problem.

A computer lesson may direct students through a complex question or a series of questions providing immediate feedback appropriate to the entries as they are made, or the program may allow a number of entries to be made before responding. However, all lessons should be interactive in some manner and should respond to most, if not all of the student's input. In any case, the feedback is selected from the available responses in the program on the basis of a student's answer to the question. Hence, all interactions are specifically tailored to each student user.

When a student responds correctly, the program may reinforce this by noting that the answer is correct and explaining why. In this way, if the student answered correctly but for the wrong reason, that hidden error may be corrected and the student steered to the right path.

When a student responds incorrectly, he must be informed of his error and led to or given the correct answer. The response to an initial error may be to provide a hint or to define the problem or situation in different terms. If this does not help, the second response to an incorrect answer should be more specific, giving more direct information like the method for calculating the value requested or a statement of the relationship between the elements being reviewed. However, at this point the correct answer may be provided if the teacher-author desires. In most cases, students should not be allowed to give a wrong answer more than three times without receiving a complete explanation of the problem. Carrying the interaction beyond that point is likely to discourage further interest, generate frustration and compound the student's confusion.

After following the steps described above, the lesson should provide another opportunity for the student to demonstrate that he now understands the relationships that were reviewed in the previous interaction. If the student still cannot do so, a text or other reference source should be recommended, and the student should be advised to review this area. The student might be requested to terminate the lesson at this time in order to do the review. However, the student might be allowed to complete the lesson, do the review later, and then retry this lesson or a similar one. This decision should be based upon the likelihood that the student can adequately complete the lesson with the knowledge deficit that has been uncovered.

Students' cooperation and interest in using computer lessons depends in considerable measure on factors that are extraneous to the inherent accuracy and potential usefulness of the lesson. Like a boring lecturer with a well-written lecture, the best-written lesson loses its effectiveness if it does not hold the students' interest. One needs to put variety into the user-program interaction. For example, all of the questions or answers should not be in the same format. Because exchange is limited to multiple-choice questioning (in all of its manifestations), numbers, single-word, or at best short-answers entries (one can go beyond this only in the most sophisticated systems), the lesson designer should try to mix these up as much as possible. Often, something as small as changing the method of entering an answer provides enough variety to help keep students' interest.

Another way to animate lessons is to exploit the almost limitless graphic capabilities of the computer. Even simple graphic displays add a great deal of variety to a lesson and spark much student interest. More extensive (but still easily managed) graphics may also greatly ease

the task of making difficult material intelligible.

A final suggestion about lesson design is to include an exercise at the end of each unit that ties together as many of the lesson's facts and concepts as possible. A large-scale problem or situation that requires such application will permit the student to determine whether the content has been learned. Any errors made at this point may be designed to trigger specific recommendations for review and study. A good performance should evoke congratulatory messages for a job well done.

When a student completes a lesson, the program may suggest other instructional material that seems appropriate depending upon that student's performance on all or part of the lesson. In order to make study recommendations that are tailored to the student's performance, it is necessary to monitor the student's progress through the lesson. This, of course, may be done solely to make such study suggestions, or it may be done as all or part of evaluating the student's competence in an entire course or curriculum. Furthermore, this could be an informal evaluation or could be part of the official grading procedure.

In summary, a well-written computer lesson challenges students to apply previously learned facts and concepts to the solution of problems, thus showing students what they know and what they need to learn. The lesson captures the student's interest by being interactive, by using a wide variety of questioning and answering modes, and by exploiting the graphics capacity of the computer. It is tailored to each student by individually responding to specific entries and by using an entry-directed branching design. Computer lessons also provide potential assessment of each student's progress and of the course's success at meeting its objective.

AIMS AND SCOPE

The goal of *Computers in Life Science Education* is to provide a means of communication among life science educators who anticipate or are currently employing the computer as an educational tool. The range of content includes, but is not limited to, articles focusing on computer applications and their underlying philosophy, reports on faculty/student experiences with computers in teaching environments, and software/hardware reviews in both basic science and clinical education settings.

INVITATION TO CONTRIBUTORS

Articles consistent with the goals of *Computers in Life Science Education* are invited for possible publication in the newsletter.

PREPARATION AND SUBMISSION OF MATERIAL

Articles submitted for publication should not exceed 2000 words and should be typewritten, double spaced, with wide margins. The original and two copies including two sets of figures and tables should be sent to the Editor: Dr. Harold Modell Virginia Mason Research Center, 1000 Seneca Street, Seattle, WA 98101.

Title page should include full title, list of authors, academic or professional affiliations, and complete address and phone number of the corresponding author.

Illustrations should be submitted as original drawings in India ink or sharp, unmounted photographs on glossy paper. The lettering should be such that it can be legible after reduction (width of one column = 5.7 cm).

Reference style and form should follow the "number system" described in the Council of Biology Editors Style Manual. References should be listed in order of their first mention in the text, numbered consecutively, and cited in the text by these numbers as superscripts.

RESPONSIBILITY AND COPYRIGHT

Authors are responsible for accuracy of statements and opinions expressed in articles. All authors submitting manuscripts will be sent a copyright transfer form to complete. The completed form must be returned before the work will be published.

SUBSCRIPTION INFORMATION

Computers in Life Science Education is published monthly by Elsevier Science Publishing Co., Inc., 52 Vanderbilt Avenue, New York, NY 10017. Subscription rate is \$54.00 for 12 issues, including postage and handling in the United States and Canada. Add \$14.00 for postage (airmail) in Mexico and Europe and \$16.00 for the rest of the world.

This newsletter has been registered with the Copyright Clearance Center, Inc. Consent is given for copying of articles for personal or internal use, or for the personal or internal use of specific clients. This consent is given on the condition that the copier pay through the Center the per-copy fee stated in the code on the first page for copying beyond that permitted by the US Copyright Law. If no code appears on an article, the author has not given broad consent to copy and permission to copy must be obtained directly from the author. This consent does not extend to other kinds of copying, such as for general distribution, resale, advertising and promotional purposes, or for creating new collective works.

Address orders, changes of address, and claims for missing issues to Journals Fulfillment Department, Elsevier Science Publishing Co., Inc., 52 Vanderbilt Avenue, New York, NY 10017. Claims for missing issues can be honored only up to three months for domestic addresses and six months for foreign addresses. Duplicate copies will not be sent to replace ones undelivered due to failure to notify Elsevier of change of address.

Address editorial correspondence to Harold I. Modell, PhD, Virginia Mason Research Center, 1000 Seneca Street, Seattle, WA 98101.

POSTMASTER: Send address changes to *Computers in Life Science Education*, Elsevier Science Publishing Co., Inc., 52 Vanderbilt Avenue, New York, NY 10017.

COMPUTERS IN LIFE SCIENCE EDUCATION

HAROLD I. MODELL

Virginia Mason Research Center
Seattle, Washington

MARCEL BLANCHAER

Professor of Biochemistry
Faculty of Medicine
University of Manitoba
Winnipeg, Manitoba
Canada

THEODORE J. CROVELLO

Department of Biology
University of Notre Dame
Notre Dame, Indiana

JAMES W. ECKBLAD

Department of Biology
Luther College
Decorah, Iowa

TSEGAY HABTEMARIAM

School of Veterinary Medicine
Tuskegee Institute
Tuskegee, Alabama

DONNA LARSON

School of Nursing
Grand Valley State College
Allendale, Michigan

TERRY M. MIKITTEN

Graduate School of Biomedical Sciences
University of Texas Health Sciences Center
San Antonio, Texas

JAMES E. RANDALL

Department of Physiology
Indiana University
Bloomington, Indiana

PATRICIA SCHWIRIAN

College of Nursing
Ohio State University
Columbus, Ohio

RICHARD STULL

College of Pharmacy
University of Arkansas
Little Rock, Arkansas

JAMES W. WOODS

Lister Hill National Center
for Biomedical Communications
National Library of Medicine
Bethesda, Maryland

DOROTHY WOOLEY-McKAY

Department of Biology
Glendale Community College
Glendale, Arizona

GLENN YOSHIDA

Department of Life Sciences
Los Angeles Southwest College
Los Angeles, California

ELSEVIER**CONTENTS**

ENHANCING LECTURES WITH A MICROCOMPUTER Terry M. Mikitten	9
SIMULATION OF BIOLOGICAL SYSTEMS—WHAT SHOULD WE EXPECT FROM SUCH ACTIVITY? Thomas G. Coleman	11
STIMULATING BASIC HEALTH SCIENCE LEARNING WITH CLINICAL SIMULATIONS ON A MICROCOMPUTER Marcel C. Blanchaer	14

ENHANCING LECTURES WITH A MICROCOMPUTER

Terry M. Mikitten

Graduate School of Biomedical Sciences, University of Texas Health Sciences Center, San Antonio, Texas

Teachers are always on the lookout for innovative ways to present complex ideas in a lucid way. The microcomputer has been seen as a possible tool for classroom use. The general availability of microcomputers, their moderate cost, ease of control, and graphics capability suggest that the microcomputer can be an effective and dynamic tool in teaching.

What follows is a description of a test of this idea. It is a distillation of my experiences using microcomputers in teaching cellular neurophysiology and neuroscience, two fields in which complex ideas and graphics are encountered frequently. This two-year project has shown that a microcomputer in the

classroom can be a very effective tool and can, for the most part, live up to one's expectations about its potential. This discussion will also show some of the thinking that went behind a more ambitious endeavor: The Neuroscience Software Project (NSP), an experiment on the delivery of educational materials for medical students and graduate students in the biomedical sciences.

PROJECT DESCRIPTION

The aim of the project was to provide effective educational software to both students and teachers. Materials created for teaching were designed for use in the lecture setting. Other software was created for use

by the student without the participation of a teacher. This was in the form of tutorials, reviews, and even subject-oriented games. Whenever software was used in the classroom, the programs were made available to students after class. In all cases, the programs were accompanied by written materials that provided additional information about the subject matter. Microcomputers were made available in the Medical School Library's Teaching/Learning Center. Some of the software created in the project was used with an interactive video system (RAVE). The Apple II microcomputer, because of its moderate cost and graphics capability, was used throughout.

An important aspect of the Neuroscience Software Project was a system for recording use of software by students and others. Some of the results of a year-long study have been published.¹

Software written for use by the teacher in the classroom was one important focus of the project. In general, programs were created to allow the teacher to use an Apple computer as a display device during a lecture. In a typical session, a teacher might take the Apple into the classroom, connect it to a cluster of television sets, and then begin to lecture in a conventional manner. Blackboard, chalk, overheads, and any other devices necessary to conduct a lecture would be used in the usual way. However, at one or more points in the lecture, the microcomputer display would be activated, and the teacher would use it to convey information.

Using the microcomputer in this way caused interesting reactions from the students. Some were expected, and some were not. Some of these were problematic at the outset but were resolved as additional experience was gained with different student groups. What follows is a description of these problems, along with the solutions that have

been found effective. They are offered with the hope that the teacher who contemplates this approach for the first time will find some of these observations useful. Of course, the reactions we encountered were a function of the teacher and the student group. For this reason, teaching experiences in another educational environment could be significantly different.

PROBLEMS AND SOLUTIONS

It was clear in the earliest test lectures that it was important to be sensitive to the physical presence of the microcomputer at the front of the lecture hall. This was especially true with student groups that had not been exposed to this teaching technique before. Use of the computer was a departure from routine teaching methods and so was a source of anxiety for a surprising number of students.

Several rules quickly emerged from these initial experiences. First it was important to describe the equipment for those who had never seen it before. When teaching large classes, it was best to repeat this description at several lectures. Once the class became accustomed to the equipment, it ceased to be a novelty and a source of distracting conversations. Second, at the outset of a lecture it was helpful to explain what role the microcomputer would have. This helped the serious students and compulsive notetakers who were skilled in documenting the words of a teacher but were anxious about taking notes from a computer display. This problem also was minimized by the general NSP policy: any program shown during a lecture would be available for use in the library after the lecture.

Finally it was important to prepare the students for what they were about to see on the video display. Here it was useful to sketch the upcoming computer picture on the blackboard. An equally effective

technique was to use an overhead transparency that showed a hard copy of the actual display to be seen. A description of each component in the picture and an explanation of its relevance to the subject matter made it easier for students to interpret the computer image. When hard copy versions of the displays were available, they made useful handouts.

The duration of a computer demonstration was not an important determinant of its effectiveness as a teaching tool. Brief demonstrations lasting a minute or two were easiest to program and integrate into a lecture. The computer was used as a teaching tool in an intermittent way, much as the use of projected slides is interspersed with verbal lecturing. Used correctly, the slide projector is an almost invisible agent. All that is seen is the concept it conveys onto the screen. So it was with the proper use of a microcomputer. When the students' attention was diverted away from the subject matter of the lecture and the technology became visible, communication suffered. Just as the flow of a lecture is impeded when a slide projector malfunctions, the learning experience suffered when it was necessary for the lecturer to display a diskette catalog or directory listing in order to run a program. The process was confusing to students who were not familiar with computer operation, and it certainly damaged the illusion of control that the lecturer strives to maintain. All possible steps must be taken to avoid the intrusion of technology into the lecture. Computer technical information should never appear on the teaching screen.

One solution to the problem of control during a lecture was to create a program that operated during the course of a lecture, ready to respond to the teacher's needs as the lecture progressed. This system worked well provided there was a way to minimize the possibility of a wrong command being sent to the

waiting program. In one program, the instructor would press only one key to cause the desired display to be shown. Several displays were held in the computer's memory and the appropriate one called forth, depending on the needs of the lecturer. To ensure that the correct display was shown, a nearby sheet of paper listed the available options. The prospect of typing errors was minimized by providing big targets on the keyboard—the space bar, for example, rather than a specific letter key. This idea of target size was particularly important after doing many large-scale chalk drawings on the board. Moving to keyboard-sized hand motions is a change of scale fraught with possibilities for error, particularly if the transition is a quick one.

FOCUSING LECTURES ON SIMULATIONS

Apart from using the microcomputer as a device for augmenting a lecture presentation, it is also possible to create a lecture around a microcomputer display. Computer simulations of physiological processes, for example, might fill an entire lecture hour.

Some of the longer sessions using the microcomputer involved extended discussions of nerve mem-

brane models. One particularly useful simulation was published by Randall² on the Hodgkin-Huxley nerve membrane model. The screen display portion of the program was simplified for ease of viewing at long distances and was used as the focus for several large discussion groups. At the beginning of the session, the students were told they would be dealing with an experiment involving a squid axon. They were asked to choose the experiment to be performed as well as the numerical values of stimulating parameters, such as duration and intensity.

Some of the students' positive reactions to this activity undoubtedly can be attributed to the novelty of the situation. To test this idea, several sessions were conducted as open-ended reviews. After the third or fourth hour in such an extended demonstration, it became clear that more than novelty was involved; rather, the students were engrossed in the subject matter. These extended sessions served as excellent reviews and provided a vehicle for discussing new phenomena that surfaced during the operation of the simulation.

These extended sessions also revealed an interesting and surprising classroom phenomenon. It was the

appearance of a rare sense of comradeship between the lecturer and the students. When we had a microcomputer as an intermediary, the feeling developed that this was a natural way for students and teacher to work together. The goal was to solve the problems presented by the computer simulation. In a sense, the common adversary became the computer. Students reported that the experience was useful because it afforded them the opportunity to witness first-hand the problem-solving approaches used by the instructor. The establishment of an intimate contact between our collective minds in the classroom was one of the most satisfying teaching experiences I have had.

In summary, the microcomputer can be an effective teaching tool in the classroom. With care taken in the preparation and presentation of the displays, the experience can be rewarding to students and teachers alike.

REFERENCES

1. Mikiten TM, Pyka R: The Neurosoci-ence Software Project. Proceedings of NECC/5 National Educational Computer Conference. New York: IEEE Computer Society, 85-89, 1982.
2. Randall JE: Microcomputers and physiological simulation. Reading, MA: Addison-Wesley, 1980.

SIMULATION OF BIOLOGICAL SYSTEMS—WHAT SHOULD WE EXPECT FROM SUCH ACTIVITY?

Thomas G. Coleman

Department of Physiology and Biophysics, University of Mississippi Medical Center, Jackson, Mississippi

Biological simulation in this article will be constrained to mean taking the mathematical equations that describe some biological process and repeatedly solving them with the aid of a digital computer. The so-

lutions are predictions of how the biological process will respond to various perturbations or stimuli. For instance, we might use a mathematical model of the control of renin secretion by the kidney to

simulate the influences of arterial pressure, renal blood flow, and sympathetic nervous activity on renin levels in the circulation.

The question is: what should we expect from such activity? This might be a very appropriate time to expect a lot—a time to foster high expectations and a time to offer severe criticisms if there are apparent shortcomings.

Certainly, the availability of computer hardware is changing. More and more small digital computers (microcomputers) are becoming available to the academic commu-

nity. This is partly due to attractively low prices and partly due to the fact that many research and teaching activities other than simulation justify the acquisition of such hardware. Academic computing has traditionally used large digital computers and centralized resources; small computers offer some sharp contrasts to traditional activity—in both the type of application and the style of use. Small computers have transformed digital computing into a very personal activity: one person, one operating system, one program, one computer. The manufacture of thousands and thousands of identical computers has encouraged programmers to agonize over even the most minor software shortcomings, anticipating that the software will be duplicated in quantity. As one person running one program on one computer, the user has come to expect friendly, pleasant screen formatting and responsive, error-tolerant input and output; this is particularly true in word processing, spreadsheet programs, and other popular general-purpose software for home and business. The user has come to expect imaginative use of graphics where appropriate. The user has come to expect rapid responses—and this means that the underlying algorithms are often getting the maximum response from a relatively small, relatively slow computer. A generally high level of software quality continues to set the standard for further software development. Software for simulation will be judged accordingly, even though such software may not be distributed in large quantities and even though small computers may not be wholly appropriate for the computationally intense algorithms usually needed in simulation.

SIMULATION TOOLS

The scope of simulation has always been constrained by the tools

at hand and the skills of the craftsmen wielding these tools. Before the advent of the computer, equations were repeatedly simplified by applying one approximation after another until a general solution could be obtained—such models, of course, were always in danger of being too elementary to be relevant. Skills in classical calculus were required as well as skills in evaluating the impact of simplifying assumptions. The advent of the electronic analog computer allowed us to obtain specific solutions to more complex sets of equations. A significant time investment was required to translate mathematical relationships into electrical wiring diagrams; equations had to be scaled in terms of time and amplitude to match the electrical characteristics of the analog computer. Any mistakes at all in translation would generally invalidate the solution.

The invention of the digital computer was prompted in part by the need to solve nonlinear differential equations as quickly and accurately as possible. Numerical integration algorithms replaced electronic integration. The digital computer allowed us to obtain specific solutions to mathematical models that were possibly one or two orders of magnitude more complex than preceding models. However, large amounts of computer memory and large blocks of computer time were often required. This was an expensive proposition and it mainly attracted commercial or government applications. Academic environments often had neither the required hardware nor the required funds. Simulation using large, mainframe computers used high-level programming languages and special software packages. Such simulation also made full use of large computers' ability to do floating point arithmetic at high speed, i.e., rapidly multiplying and dividing decimal numbers. Simulation

was a tool of only the elite before the advent of the small computer.

Microcomputers have been in existence for about a decade and are continuing to evolve. The trend continues to even cheaper machines, even larger memories, and even greater intrinsic speed. Any evaluation of these machines as potential simulation tools remains tentative because offering critical comments is like shooting at a moving target. Nevertheless, there are inexpensive microcomputers in existence today that appear to have the computational power of many mainframe computers of two decades ago. This may be more than adequate for many applications—particularly in teaching. Further advances in the performance-price ratio will make small machines even more attractive.

Simulation's requisite tools may become available to virtually all of the research and teaching community over the next few years. One might conclude that simulation will no longer be restricted to the elite but will instead become a commonplace activity in both laboratories and classrooms. One might also note, however, that there are many problems often associated with simulation that could be magnified by the proliferation of potentially useful computers. Who will build these various biological models—especially models to be disseminated and used in teaching? Will there be a large enough number of identical or compatible computers in service to attract the best professional programmers? What will these programmers offer? Will they build new models or design support software? Will this support software cope with the intricacies of numerical methods in such a way that a biologist—in contrast to an applied mathematician—can produce useful mathematical models? Will rules emerge for validating models intended for wide dissemination? Will one class of models emerge to

be used solely for research purposes while a totally different class of models will come into being for teaching and demonstration? Are there inherent differences between such classes of models? There are no sure answers to these questions, of course, but some insight might be gained from further analyzing exactly what a model is.

A MODEL IS A HYPOTHESIS

Let's assume that the future will bring us user-friendly, professional software that makes very efficient use of high performance/price hardware. Simulation should increase in popularity, and there are many benefits to be gained in both research and teaching from the proper, imaginative use of mathematical models. What are the most important considerations? Ease of use, speed, and economy are important, of course, but there is one consideration that is even more important. If didactic simulation is to flourish, we must be given complete information on the internal structure of every model. The rationale is as follows: a mathematical model is only a hypothesis, and, as such, it is open to evaluation and criticism. Hypotheses are usually formulated and communicated verbally, but this is not absolutely necessary. In many instances the verbal description is less than ideal: additional precision might be needed, the hypothesis may be rather complex, or, possibly, the hypothesis has some aspects that just aren't suitable for verbal presentation such as a description of simultaneous events. In these cases, a mathematical description is used, and the exploration of the consequences of such a description is, in fact, simulation.

Some hypotheses have a very simple structure—possibly a single sentence. But complex phenomena often require complex hypotheses. As complexity increases—ie, as

models become larger—the hypothesis can become a rich mixture of generally accepted fact and unestablished speculation. The latter is the personal viewpoint of the model builder. We would like to know—right up front—which aspects of the model are well established and which are speculative. If one applies Newtonian mechanics to predict planetary orbital motion, one is restating a hypothesis with relatively strong validation; the faster planetary orbits have provided us with the opportunity for repeated observations. This is a model with strong general acceptance and minimal speculation. If we look at a model of national or international economics, there is going to be a much higher speculative content due to continual difficulties with validation, which are due in turn to the non-repetitive, uncontrolled nature of the economic system. Biological models generally have some mix of well-understood components and speculation. Content can vary greatly, of course. A model of pulmonary gas exchange may have a rich content of accepted, well-established physical principles. A model of the control of respiration during exercise, on the other hand, may be highly speculative.

When one is provided with the full details of the assumptions embedded in a mathematical model, this is comparable to understanding the underlying assumptions implicit in a verbal hypothesis. These assumptions help to define the implications of any hypothesis and, comparably, the suitability of any simulations that may be undertaken. A hypothesis might be directed to an endocrine process that is present only in a single species and, therefore, is not general to other species. Or a hypothesis might focus on only the short-term secretion of a hormone and not the long-term components of stimulation and response. Or, a hypothesis

might focus on general rather than detailed phenomena—such as a description of average blood flow through an organ versus a description of instantaneous and possibly non-Newtonian blood flow. We must know what all of the assumptions are because they define and constrain the appropriateness and interpretation of possible simulations. Without knowing these constraints early on, one will be encouraged to undertake unsuitable—ie, meaningless or erroneous—simulations.

One might accept the fact that mathematical models are only hypotheses but then go on to argue that highly speculative models should be used in research and not in the classroom. This is not necessarily a sound idea. The decline of the Roman Empire, the essence of the atom, and the etiology of atherosclerosis are all speculative topics that are regular components of formal coursework. We probably shouldn't avoid the use of speculative mathematical models in teaching, but we should be able to readily identify them.

When a single person both builds a model and solves it, this person is aware of the underlying assumptions and tempers interpretation accordingly. When one person builds a model and another uses the model in simulation, then assumptions have a tendency to become more inherent than explicit. It's likely that simulation will become increasingly popular in teaching in the near future, and model builders and model users will become more and more separated; special strategies must be devised to communicate assumptions.

In sum, small computers are now inexpensive and powerful, and are rapidly becoming even more so. It's already clear that these technological advances will have a broad and significant impact on society. As part of this advance, biological simulation should attain a more

prominent didactic role. What can we expect from such activity? We can expect confusion and disillusionment unless special care is taken to communicate what a model is as well as to demonstrate what it

does. It must be emphasized that simulation is nothing more than a tool to be used on the theoretical side of science; the fine balance between the theoretical and experimental aspects of science must

be maintained and taught without ambiguity.

Supported in part by NIH grant HL11678.

STIMULATING BASIC HEALTH SCIENCE LEARNING WITH CLINICAL SIMULATIONS ON A MICROCOMPUTER

Marcel C. Blanchaer

Department of Biochemistry, Faculty of Medicine, University of Manitoba, Winnipeg, Manitoba, Canada

Although many educators are concerned with the effects of the exponential growth of new knowledge on the quality of education in the health sciences, we continue to cram more and more facts and concepts into the curriculum. As a result, there has been a gradual erosion of the time formerly devoted to the learning of problem-solving skills. This phenomenon has been especially striking in basic science courses presented during the earlier years of professional education.

About 9 years ago, we attempted to address this problem by introducing into a first year medical biochemistry course patient-management exercises that require students to commit themselves to a series of decisions, each based on the evidence available at the time.¹ The instructor's response to each decision is hidden in a latent image on paper until the student's choice is made. Although these materials remain popular with students and do improve retention of both factual material and problem-solving skills, they are cumbersome to produce. A more serious defect is that they offer cues as to the possibly correct answer(s) because the choices must be offered in multiple choice format. Because health professionals rarely encounter clinical situations in which decisions to be

made present themselves in that format, it would seem more realistic to expect the users of case studies to generate and "write in" the most appropriate response.

This led to the conversion of some of the latent image case simulations to run on the Apple II microcomputer, using the readily learned PILOT/SuperPilot language that features graphics which are easily generated and can be made to respond dynamically to student input. Eight such computer-based simulations have been incorporated into our biochemistry course over the last 3 years.² They have proven popular and also effective in terms of examination performance. While designed primarily for our students, these programs are being used in some of the 12 health science faculties in North America, Europe, Africa, and Australia that have acquired them.

CASE STUDY OBJECTIVES

The aim of these case studies is to give students an opportunity to apply their recently acquired knowledge of the basic sciences to the identification of the physiologic, metabolic, or anatomical abnormality underlying a specific patient's clinical signs and symptoms. The principal objective in designing the exercises has been

to engage the user's commitment to solving a diagnostic problem and to deciding upon the appropriate treatment. This is done through a series of challenging interactions with the program in a clinical setting consistent with the student's anticipated future professional role.³

Real-life problems the health professional is called upon to solve are invariably multifactorial. Therefore in these simulations the expression of underlying organic disturbance in signs and symptoms is shown to be affected by psychosocial factors. Thus in one case study, the student is, as subtly as possible, guided to request and interpret the parents' story of the downward turn in their child's initially minor illness. Sooner or later, depending on her/his acuity, the student discovers that "It took quite a bit of aspirin to bring down Sydney's temperature." This, in turn, leads to laboratory confirmation of aspirin poisoning as the problem. In other simulations, information is available, if requested by the (student) "practitioner", from "colleagues" who may provide important diagnostic clues.

By these and other devices, problem solving has been broadened to include problem detection, identification, evaluation, and, finally, management. As a result, such simulations seem realistic to beginning students with no clinical experience. However, they are at best quasi-clinical, because the sensorial cues and interpersonal exchanges that play important roles in diagnosis and management are absent. Nevertheless, these exercises elicit a desire to learn basic science mate-

rial that otherwise often seems dry and abstract. Apart from the obvious "relevance" of the material, the students' personal success in using such facts and concepts in a professional situation with which they can identify is also strongly motivating.

PROGRAM STRUCTURE

The programs are structured so as to encourage users to follow the diagnostic approach actually practiced by competent health professionals.⁴ Rather than requiring an exhaustive gathering of information initially, students are encouraged by the program structure to think of various causal hypotheses quite early. These can then be explored in a series of information-gathering steps that stimulate continual revision of an internalized hypothesis list as the users progress through the simulation. Eventually each "practitioner" is required to show commitment to his/her diagnosis by using it as the basis of "treatment" of the patient's problem. Therapeutic mistakes are shown to aggravate the "illness" and in two simulations, threaten the patient's life.

Considerable simplification of complex situations often is necessary, resulting in an exercise that may resemble a game more than a true life experience. However, care is taken to ensure semifictional elements do not interfere with the overall validity of the information provided and that only legitimate problem-solving methods are illustrated.

This type of experience has been shown by others to lead to a greater facility in problem solving in similar situations encountered at a later time.⁴ Also, relatively abstract basic science concepts appear to be retained better when encountered in these settings, especially if they have been used successfully in decision making. To facilitate learning, users are allowed control over the speed and sequence in which the specific diagnostic approaches are

chosen. Such devices tend to give a (partially illusory) feeling of freedom and make the novice more comfortable in difficult and sometimes threatening situations.

It may seem strange that a computer-based simulation could be threatening to students some years before they actually encounter clinical responsibilities. However, efforts are made throughout the exercises to have the student self-identify as the health professional who must solve and manage a specific patient's problem. To maintain interest and commitment, the programs express approval of correct choices and yet provide progressively more explicit and helpful information after incorrect responses, especially at diagnostically important points. It also has proved important to include questions at intervals during the simulation to test the student's understanding of what has gone before. This is necessary because the linear nature of the computer medium makes it difficult for some students, unless stimulated to do so, to integrate new information as it is encountered with previously learned knowledge and especially, with information discovered earlier in the exercise. The process of integration also can be helped by asking the student to recall and use earlier findings, the implications of which may not have been fully appreciated at the time.

Although, as explained above, multiple choice questions are not totally suited for the present learning materials, they are employed in the early stages of the simulations because this is the questioning format with which the users are most comfortable and thus does not distract them from the substantive content of the inquiry. However, once most of the basic facts and concepts needed to begin understanding the patient's condition have been encountered, the type of questioning changes. The user is now expected to type in a word or

phrase, without the help of the cues inherent in the multiple choice format. Somewhat disconcerting initially, the "type in your answer" now being requested requires students to recall appropriate information from their long-term memory into the working memory. There it can be integrated with the incoming information to solve the immediate problem raised by the program's question. Research in medical problem solving indicates this is the way skilled physicians operate in real-life problem-solving situations.⁴

Although primarily meant for student self-instruction, preparing these case simulations has proved to be a stimulating learning experience for instructors, especially when students participate in refining the design of the case study and in the programming. The resulting interaction between the students and instructors knowledgeable in the various subject fields involved in designing a simulation has been mutually beneficial, resulting in a product better attuned to the students' needs and interests, and to the instructors' educational objectives. Such adventures in mutual education are reminiscent of one on-one tutorials on those rare occasions when student and instructor share a common interest in productive learning.

REFERENCES

1. Blanchaer MC. Simulated clinical problems in a medical biochemistry course. *Biochemical Education* 3:71, 1975.
2. Blanchaer MC: Microcomputer-based learning in a medical biochemistry course. *Biochemical Education* 10:107, 1982.
3. Blanchaer MC, Stevens FC: Programming a clinical case simulation on a microcomputer. *Biochemical Education* 12:29, 1984.
4. Elstein AS, Schulman LS, Sprafka SA: *Medical problem-solving: an analysis of clinical reasoning*. Cambridge, MA: Harvard University Press, 1978.

COMPUTERS IN LIFE SCIENCE EDUCATION

HAROLD I. MODELL

Virginia Mason Research Center
Seattle, Washington

MARCEL BLANCHAER

Professor of Biochemistry
Faculty of Medicine
University of Manitoba
Winnipeg, Manitoba
Canada

THEODORE J. CROVELLO

Department of Biology
University of Notre Dame
Notre Dame, Indiana

JAMES W. ECKBLAD

Department of Biology
Luther College
Decorah, Iowa

TSEGAYE HABTEMARIAM

School of Veterinary Medicine
Tuskegee Institute
Tuskegee, Alabama

DONNA LARSON

School of Nursing
Grand Valley State College
Allendale, Michigan

TERRY M. MIKITIEN

Graduate School of Biomedical Sciences
University of Texas Health Sciences Center
San Antonio, Texas

JAMES E. RANDALL

Department of Physiology
Indiana University
Bloomington, Indiana

PATRICIA SCHWIRIAN

College of Nursing
Ohio State University
Columbus, Ohio

RICHARD STULL

College of Pharmacy
University of Arkansas
Little Rock, Arkansas

JAMES W. WOODS

Eyster Hill National Center
for Biomedical Communications
National Library of Medicine
Bethesda, Maryland

DOROTHY WOOLLEY-MCKAY

Department of Biology
Glendale Community College
Glendale, Arizona

GLENN YOSHIDA

Department of Life Sciences
Los Angeles Southwest College
Los Angeles, California

ELSEVIER

CONTENTS

PROJECTING MICROCOMPUTER IMAGES IN THE CLASSROOM: A COMMENT ON TWO PROJECTION MONITORS	17
Frank F. Vincenzi	
COMPUTER-AIDED DATA ACQUISITION IN AN UNDERGRADUATE PHYSIOLOGY LABORATORY	19
Lloyd Barr and Randall Stein	
KEEPING AHEAD OF THE LITERATURE	23

PROJECTING MICROCOMPUTER IMAGES IN THE CLASSROOM: A COMMENT ON TWO PROJECTION MONITORS

Frank F. Vincenzi

*Department of Pharmacology, School of Medicine, University of Washington,
Seattle, Washington*

The widespread use of microcomputers is now a fact of life in research and education. Although fanciful scenarios imagine each student with his or her own computer, practical constraints dictate that for some time, most of us will be sharing micros. How best to share?

An extremely effective form of sharing can occur in a classroom with teacher and students going together through certain programs, simulations, etc. The average monitor, however, is really too small for all but very small groups. Television sets, even multiple TV sets, are not the answer. Our university, for example, built lecture halls with TV monitors, but, as most users here have found, the average TV set is marginal for data in 40 column

mode, barely adequate or inadequate for graphics, and totally unacceptable for information in 80 column mode. Nevertheless, this limitation need not preclude the use of microcomputers as demonstration devices in a classroom.

Recently, I had the opportunity to examine two hardware devices that project microcomputer video images on a regular screen. The images were sufficiently large that they could be useful in classrooms for up to perhaps 100-200 students, or more in one case. In this note, I will discuss the obvious advantages and disadvantages that I observed with each of the two devices.

First, some caveats. I am an Apple user, not a programmer, and I am certainly not a hardware person.

Thus, I don't really appreciate the niceties of "band pass" and all that. I do have some vague notion that TV sets don't do well in projecting 80 column data, for example, but frankly, I don't care very much about the details of why. As a user, and I suspect like many classroom instructors, I would like to find a projection device that I could plug in, connect to my micro rather simply, set at most any distance from a screen, and go. It would also be nice if the projection device gave an image of unlimited clarity, brightness, and resolution.

ELECTROHOME MODEL EDP-57

The first machine I used was the Electrohome Large Screen Monochrome Projection Monitor, model EDP-57. It was a very easy machine to use. It provided a virtually identical image as one would see on a green screen monitor—only much larger. The device was easy to hook up. After attaching the machine to 110 volts AC, a single coaxial cable was attached from the video output of the Apple to a video input (BNC connector) on the Electrohome machine. A single lens, approximately 5½ inches in diameter, on the front of the machine easily focused from a distance of about 15 feet a modestly bright image measuring approximately 5 × 8 feet on a standard projection screen. The distance from the screen was easily varied as the machine that we tested was on an optional pedestal base. This made it very easy to move the projection monitor around from class to class, and, of course, within the classroom. The beauty of it was that the machine was easily focused at almost any distance we tried. The image was an exact replica of what would have appeared on the monitor—except that now it was large enough to be seen by a class of about 90 students. Not bad!

It was necessary to have the room darkened to the level of note lights. This is one drawback of the ma-

chine. That is, the image, although very clear, was not very bright. This is probably because the projection monitor was designed to be used with a curved screen. If you will, we were misusing it, but it performed adequately. In fact, I was very pleased with its performance in displaying downloading of tabular database information in 80 columns and hi-res graphics from a pharmacokinetics simulation program. A distinct advantage of the Electrohome projection monitor was that it would focus at about any distance from the screen. As a test, we focused it on a wall some 40 feet away. The image was still sharp and readable—and huge! In other words, it could have been used effectively in our auditorium setting with the proviso that the level of lighting be at that of typical note lights.

The list price of the Electrohome projection monitor was about \$5000. You can check on specifications and prices by contacting Electrohome (USA) Ltd, 182 Wales Avenue, Tonawanda, NY 14150. A local distributor has told me that Electrohome will have available a similar device designed for flat screen applications.

SONY MODEL 10200

The second machine I saw was the Sony Model 10200. I did not use it personally but participated in a classroom test of it with a bevy of faculty, each with their own favorite microcomputer. The Sony projection monitor was a fussier machine. It used three separate color guns and had a fixed focal length. It is available in several models or settings with various preset focal lengths. The fixed length to the screen is necessitated by the use of more than one projecting lens. Of course, the three lenses allow one to produce excellent color images.

With an appropriate adapter box, the video output of our Apple IIe

was connected to the Sony projection monitor (which is designed for RGB input). A monochrome projection image was obtained, but there was some apparent color aberration or fuzziness, which was reduced by covering 2 of the 3 lenses. In 40 columns, the picture was adequate. In high resolution graphics, the data were still readable, but less sharp than I would have desired. In 80 column mode, it was hopeless! Most of the difficulty appeared to arise from the fact that the Sony instrument was set up as an RGB monitor, and we were giving it a composite video signal. It was suggested that an appropriate RGB board in the Apple would have given us a much better image. Since our university appears headed toward buying the Sony machine, I am looking into RGB boards. Since I have no experience with these boards, I cannot comment on whether they would really help the clarity of the data projection.

A colleague recently had occasion to view another Sony projector system in use with an Apple computer and reported that the image was very clear in 40 column mode and with the Apple hi-res screen. He did not, however, notice the model number of the projector, so my impression may have been influenced by the particular machine that was being demonstrated.

In the same test session, an IBM PC and an IBM clone were hooked up to the Sony projection monitor. This resulted in sharp, extremely color-dense pictures. I personally did not care for these images, but it was clearly a matter of taste because many of my colleagues who attended the same session were quite impressed with the Sony.

The price of this unit is also in the \$5000 range, and specific information may be obtained from Sony Video Communications, Sony Drive, Park Ridge, NJ 07656.

Other video projectors are available that might also be suitable for

microcomputer applications. Brand names includes Panasonic, VStar 4-C, and BarcoData. The price range of these projectors extends from \$5000 to \$15,000. Incidentally, Electrohome has a model ECP1000 which is a color projection monitor. I have not actually seen the ECP1000, but the advertising blurb for it emphasizes one possible advantage over the triple gun approach. That is, it uses internal alignment of three color guns, and projection out the front is through a

single lens. I don't know the price, but I suspect it is comparable to the more expensive machines.

In summary, there are several machines available for projection of our microcomputer monitor images. Look carefully into your needs and the needs of those you may represent. Buy wisely and then have a good time with the kind of on-line dynamic interaction possible with a microcomputer, your favorite program, and a group of interested minds.

traditional mode, less laboratory work was done than the faculty intended, and that the work completed was performed and understood by only a small number of the students who operated as group leaders. This concern was alleviated in the self-paced format because each student's performance is grade-reward driven. However, we clearly had to design lab exercises that could be done by single students. Even when considering the extra work this has demanded, we have felt it justified because of the laboratory's unique value. Others don't always feel that way. No doubt at various times we have all heard the arguments that reading a textbook, etc. will teach a person more science more effectively than working in the lab. Students say labs are nonproductive and boring. However, we feel that the first criticism is based on a misunderstanding of what labs should be teaching, and the second results from lack of involvement of all the students in what was going on. More importantly we feel that laboratory exercises should not be justified in terms of teaching the same kind of principles as do the textbook or lecture. Instead the laboratory should be teaching students the difference between textbook dogma and sensory reality. The former is only a predictive description of the latter. To the extent we can teach that distinction, of course, we have taught what science is. Considering the high priority that that goal must have, we decided to have a lab.

To some extent we feel that we are being successful and that students do learn not only what some or most physiologists say is true, but also what physiologists must do in order to make their arguments be persuasive. The involvement of each student is assured by the nature of the course. If we intend to reward precisely one certain performance in the lab, then we ought to take the responsibility for communicating

COMPUTER-AIDED DATA ACQUISITION IN AN UNDERGRADUATE PHYSIOLOGY LABORATORY

Lloyd Barr and Randall Stein

Department of Physiology and Biophysics, University of Illinois, Urbana, Illinois

Some ten years ago we converted the traditional (lecture-laboratory-discussion) undergraduate human physiology course at the University of Illinois into a Keller-PSI^{5, 6} type course, including the laboratory.^{1, 3} The design of the course was derived from reinforcement-learning theory,⁴ and within the constraints of a university setting, it is a self-paced, mastery learning and largely self-scheduled operation. Although it appears to the student to be flexible, it is highly structured from the staff's point of view. We have found over the years that this kind of course has several unanticipated advantages including: ease of modification, increased student affective learning, and increased personal contact. The central strategy of the course is to reward students with credit toward their grades only and always for accomplishing what we have asked them to do. A distinguishing characteristic of the Keller approach is the attentive conformity of the teaching tactics to that course strat-

egy. In our course, students can earn up to 41% of the total possible earnable credit by demonstrating that they have learned what we told them to learn from the textbook. They do this by passing written quizzes. They can earn 24% more by demonstrating that they have performed and understand nine laboratory exercises. They can do this by having their data approved by a lab teaching assistant and passing an oral quiz given by another teaching assistant. If students fail to pass a reading or lab unit, they may repeat it. It should be noted that we have a 15-week semester, so time is scheduled to be available for students to repeat lab exercises. The remaining 35% of the total earnable credit is assigned on the basis of their score on the final exam. Although this teaching mode has been extensively used for lecture courses, it has not been so widely tried in laboratories. Earlier, one aspect of the lab experience concerning us was that, according to our observation, as small groups of students worked in the

exactly what we will reward. In practical terms this means a kind of cookbook; one with an explanation for the procedures used to be sure, but definitely a "how, when, and why to do what." Not too long ago a cookbook was considered an inferior kind of teaching instrument because people said "cookbooks prevent students from thinking"; fortunately things have changed. One reason things have changed is that psychologists have learned the importance of communication in the learning process. Certainly in our case, we can't reasonably promise students to give grades for doing a lab exercise without providing instructions, i.e., the tools, for accomplishing it. As we will try to show below, the computer helps here a great deal. When we redesigned the lab to be an individualized, self-paced, "mastery-learning" experience, we were still using kymographs. Since then, we have worn out a complement of strip chart recorders and oscilloscopes. The point here is that when the time came for replacement of equipment, it was obvious that the cost and effort to replace the system with the same kind of old components amortized over a couple of years was greater than the cost and effort of converting to a computer data acquisition system. It is certain that students have more prior experience with a computer terminal than with a traditional oscilloscope. In fact, our students and many of our teaching assistants never become the least bit comfortable with any analog electronic gear. From an educational standpoint, it is also certain that the computer is also much more interactive. This feature is very important in terms of implementing "cookbook labs" because it allows the teacher to check whether students understand what they are being asked to do immediately before they are to do something, and also it can provide some

controllable limits as to what the student can do with the equipment.

Overall, what we hope to achieve in the laboratory is an experience that provides students with insight into the processes by which scientists obtain facts and concepts. Obviously, students in the lab differ from working scientists in that the students recognize that the observations they are trying to make have already been made before by someone else. Nonetheless, there are three important parallels that we are trying to maintain: first, we ask the students to have a clear idea of what they are going to do in the lab and why they are going to do it before they are allowed to start the exercise. Scientists, as a general rule, don't do experiments ad lib. The computer simplifies enforcing this prerequisite. Second, we ask the students to prepare the experimental setup including all of the dissection and to obtain interpretable data. In research experimentation there are tests of validity that data must pass in order to be acceptable. In the student lab we ask only that the student obtain data that are reasonably close to previously validated data. Third, we ask the students to be able to discuss the rationale of the specific measurements and of the overall experiment.

Coming post facto, our computer equipment (hardware) and computer programs (software) were designed with the nature of our course in mind. In this we were fortunate and wish to emphasize two points that tend to be forgotten when computers and education are combined:

1. Computers and computer programs should be selected after designing a course. It is important to consider the educational goals first and not to bow to the temptation to choose a computer system and work from there. The introduction of a computer into

an otherwise unsatisfactory course may hinder rather than aid the educational process.

2. Teachers can utilize the educationally powerful, interactive nature of computers much more effectively by deciding what kinds of teaching methods they want to become involved in before they choose the machines. The objectives of a course tend to narrow the choices of computer systems considerably, sometimes even pointing to distinct choices in both hardware and software.

HARDWARE

Although the choice of small, personal computers is often appropriate, we feel that the utility of the somewhat larger minicomputer has occasionally been overlooked to the detriment of some educational opportunities. Reasons commonly given for the choice of personal computers are their low purchase price, ready availability, and a plethora of inexpensive software. In the absence of sufficient initial capital, the technique of adding one microcomputer after another to a classroom is often effective. However, by the time 5-10 of these small computers have been placed in a laboratory, their price often equals that of a more powerful centralized (multiuser) system. More important than price alone, we feel that the multiuser operating systems confer distinct advantages to a centralized computer system. Furthermore, by our limited experience, the cost of the hardware is actually less expensive on a per-terminal basis and better in quality. Among the advantages of a centralized multiuser computer system in an educational setting are the following:

- I. Improved ability to gather statistics on laboratory usage and scheduling. We may:
 - A. Determine the hours when

the laboratory is most heavily used. This aids in the scheduling of laboratory assistants and tells students when the laboratories are less crowded.

- B. Determine how long an experiment usually takes. This is of use both to the student for scheduling his or her time and to the instructors in spotting problems with the laboratory exercise.
 - C. Identify students having to repeat a laboratory an inordinate number of times. Course policy requires students to repeat the laboratories until they are performed successfully in order to receive credit, so they should not be more difficult than students can manage.
- II. Ease of providing statistics on timing within each experiment. Monitoring the timing of various portions of the experiments indicates the clarity of the experimental protocol by drawing attention to parts of the laboratory that are troublesome.
 - III. Provide an important degree of security for the computer hardware. The multiuser system helps us to protect the computer and storage machine from vandalism, spilled solutions, frogs, and rats. The computer can be placed in an isolated room with only the relatively inexpensive terminals and wire links to the analog interfaces in the laboratory. We feel that this is especially important in the self-paced laboratory where students are often supervised in a less structured way.
 - IV. Provide preliminary proof of a student's attendance or performance. Our course does not use attendance as a grade criterion (other than performing the required laboratory tasks), but this helps us to identify stu-

dents who have not been able to adapt to self-directed study before they are too hopelessly far behind in their coursework.

- V. Our ability to monitor all the above provides a good environment for educational research since accurate, unbiased information may be acquired.

To repeat the earlier warning, we found that the design of our course directed us very strongly towards certain types of hardware and software. For example, our desire to allow a student to review his work through the semester and to be able to continue, without penalty, an experiment begun a different day dictated our requirement for high-capacity storage devices (hard-disks and magtape). Likewise, our decision to use a centralized multiuser operating system made us lean more heavily toward data acquisition hardware with direct memory access (DMA) capability, which allows one person to be computing while another is acquiring data. Our desire to be able to expand from our current 8 laboratory stations led us to consider only hardware (including data acquisition devices) and software with clear cut paths of expansion.

SOFTWARE

As with our choice of hardware, goals for our programs were developed before our software was designed. Two sets of guidelines were developed to guide implementation of these goals: a) a set of standards for the interaction between the student and the computer and b) a set of programming standards. The development of these standards necessarily preceded even the first line of program code actually written. Despite being tailored to a particular type of laboratory course, we feel that these criteria are of sufficient general interest to enumerate them here in condensed form.

Student and Teacher Interaction Guidelines

1. *Avoid teaching any computer science to the students.* Although computers occupy a distinct and growing position in the life sciences, we felt that the beginning physiology laboratory was not the place for this sort of instruction. Therefore, we have tried to make our software be extremely simple and as intuitive as possible. It should be possible for commands to the computer to be learned in a few minutes.

2. *Create a familiar environment for the student.* To accomplish this, we decided upon a simple terminal screen appearance that would always greet the student. This consists of a line of dashes a few lines above the bottom of the terminal screen. The educational text always appears above the line of dashes, whereas messages from the program are printed below the dashed line. Units, then, consist of screenfuls of text, which we refer to as frames. As one would expect from the self-paced nature of our course, students may move back and forth through the unit at will, with no penalty for repeating parts of the unit. Consistent spatial separation of instructions from textual material helps focus attention and makes important messages harder to miss.⁷ Interspersed within the frames of text are data acquisition, data manipulation, and data display functions. For example, a student may be instructed to "Press the 1-key to measure an action potential", or "Push '1' to record the muscle twitch response."

3. *It must be possible for our teachers to design and modify the course rapidly and without programming.* We accomplished this by providing teachers with commands not available to the student. In addition to being able to move back and forth through a unit, a teacher is also able to insert a new

frame anywhere in the unit, modify or delete existing frames, and cut-and-paste from one location in a unit to another. Creation of text frames is entirely interactive—teachers simply move a cursor around the frame and type wherever they desire. Teachers can also associate an “external process” such as data acquisition, manipulation, or display with any frame.

Programming Guidelines

Our programming guidelines deal with issues relating to the actual coding of data. Although our emphasis on some of these concepts reflects our special application, most of these concepts arise from common and long-held philosophies within the computer science community. They have no less importance here:

1. *System independence.* Because of the rapid advancements in computer hardware and the increasing power of computer operating systems, we decided to make a concerted effort to keep our programs as independent of any part of the computer or computer operating system as possible.⁸ All features that are dependent upon a particular computer, operating system, programming language, or even terminal are clearly marked and isolated (abstracted) from other parts of the program. The programs are largely written as though they are to be run on a single-user system, with distinct modules to enable use on a centralized system.

2. *Consistency.* Any familiarity a student perceives with a computer-driven unit system will be quickly destroyed if a very strong consistency is not maintained from unit to unit. To insure consistency, we have designed a very simple “interface” between the student and program which takes the form of a set of subroutines. By performing all interactions with the student via this set of subroutines, we ensure that all application programs are

consistent and familiar to the student.

3. *Immediate terminal response.* We believe that a part of the tension people feel when dealing with computers arises from their uncertainty as to whether they have pressed the correct keys or selected the correct commands. We attempt to relieve this tension in two ways. First, we provide as small a set of choices to the student as possible. Secondly, we immediately provide a message which either states that the requested command will be executed or that the command is illegal and a new command should be entered. This responsiveness is an intrinsic part of the interface. It counts as a reward in learning theory.

4. *Security.* Since our laboratory handles about 1200 students per year, concern with security needs to be mentioned. We achieve security primarily by designing all necessary functions into the unit programs and instructing the operating system never to let the student exit the application program (a capability of many multiuser operating systems). This means that the student never actually has access to the operating system functions such as file manipulations, data acquisition, and data storage are all handled under program control. Secondly, our use of a centralized computer allows us to physically isolate the computer, providing another layer of insurance against accident or vandalism.

5. *Rapid development.* We decided that we wanted to complete program development and get to the (more difficult) unit-designing stage as quickly as possible, proceeding from beginning installation to unit design within a semester. In order to develop our programs as rapidly as possible, we used the computer science concepts of modularity and abstraction.²

6. *Maintenance by minimal programming staff.* Since unit design can be accomplished without pro-

gramming, reprogramming should ideally only be required when new laboratory experiments require major changes in data acquisition or data display techniques, when the computer hardware is updated, or when operating system or compiler releases offer significant performance enhancements. Thus, we foresee occasional program maintenance rather than a permanent programming staff. To this end, we have created standards for both internal (within the programs) and external (manuals) documentation which are strongly enforced in the attempt to provide a degree of documentation that would allow a completely new programmer to quickly begin working on the application programs.

REFERENCES

1. Caveny C, Jakobsson E, Barr L: Managing a big PSI course. In Personalized instruction in higher education: proceedings of the second national conference. RS Ruskin, ed. Washington, DC: Center for Personalized Instruction. pp. 76–78, 1975.
2. Clark, DN: Overcoming computer shock. In Proc Digital Equipment Corporation Computer User's Society. Fall 1983 Symposium, Las Vegas. 416, 1984
3. Jakobsson E, Barr L: An experiment in applying PSI to a large introductory physiology course. In Personalized instruction in higher education: proceedings of the first national conference. RS Ruskin and SF Bono (eds.) Washington, DC: Center for Personalized Instruction. pp. 146–152, 1974.
4. Kalik JA, Kulik CL, Carmichael K: The Keller Plan in science teaching. Science 183:379–382, 1974.
5. Keller FS: Goodbye teacher. J Applied Behavior Analysis 1:19, 1968.
6. Keller FS: Learning: reinforcement theory. 2nd Ed. New York: Random House, 1969.
7. Robertson G, McCracken D, Newall A: The ZOG approach to man-machine communication. Int J Man-Mach Stud 14:461–488, 1981.
8. Tanenbaum AS, Klint P, Bohm W: Guidelines for software portability Software Pract Exper 8:681–698, 1978.

KEEPING ABREAST OF THE LITERATURE

The problem of keeping abreast of the literature for the person using computers in life science education is somewhat more complicated than keeping up to date in a specific scientific topic area. The number of papers that might be of interest is not overwhelming. However, finding those pertinent reports may not be an easy task. The interdisciplinary nature of the topic and the range of environments in which projects may be pursued are two key complicating factors. Because of these factors, pertinent reports are published in a wide variety of journals whose usual focus is neither education nor computer applications.

Because the primary aim of this newsletter is to promote communication among users of computers in life science education, one of the goals should also be to help readers become aware of what is in the literature and where to find it. Therefore, from time to time, we will publish selected bibliographies drawing attention to pertinent reports in the current and past literature. This month's entries span the past 5-6 years and were chosen to illustrate the scope of journals publishing reports in this topic area.

- Abdulla AM et al: Microcomputer-based medical education. *South Med J* 74:1251-1254, 1981.
- Abdulla AM et al: Classroom use of personal computers in medical education: a practical approach. *Med Educ* 17:229-232, 1983.
- Beck JR: Microcomputer aids to medical deciding making. Educational and clinical applications. *Med Decis Making* 3:3-7, 1983.
- Boettcher E et al: A comparison of the effects of computer-assisted instruction versus printed instruction on student learning in the cognitive categories of knowledge and application. *J Computer-Based Inst* 8:13-17, 1981.
- Bone KE et al: An interactive computer program to teach and investigate diagnostic processing. *Med Inf (Lond)* 4:89-91, 1979.
- Burson J: A ten point--seven criteria CAI materials appraisal process. pp. 131-136. In: J Eisele (ed). *Proc Ann Conf Assn Devel Comp Inst Syst*, 1981.
- Cavin CS et al: The use of computer-assisted instruction to provide optional assistance to students. *Educ Tech* 19:42-45, 1979.
- Davis PD et al: Micro computer control of a video cassette lecture. *Med Educ* 14:196-198, 1980.
- Dengler PE: Computer-assisted instruction and its use in occupational therapy education. *Am J Occup Ther* 37:255-259, 1983.
- Dow RM: Simulations teach management and nutrition counseling skills. *J Am Diet Assoc* 79:453-455, 1981.
- Essex DL et al: Effectiveness of instructional computers in teaching basic medical sciences. *Med Educ* 13:189-193, 1979.
- Gibbs JM et al: The computer as a teaching aid: with particular reference to anaesthesia. *Anaesth Intensive Care* 10:212-216, 1982.
- Gold RS et al: Computers and health education. *J Sch Health* 50:503-505, 1980.
- Grimm FM: Computer simulations as a teaching tool in community colleges. *Amer Biol Teach* 40:362-364, 1978.
- Grobe S: NEMAS: nursing education module authoring system—CAI software on nursing process. *Proc Ann Symp Comp Appl Med Care* 6:650, 1982.
- Hutton CW et al: Self-instructional learning packages as a teaching/learning tool in dietetic education. *J Am Diet Assoc* 75:678-681, 1979.
- Kenny GN et al: The use of a microcomputer in anaesthetic teaching. *Anaesthesia* 34:583-585, 1979.
- Kulik J et al: Effectiveness of computer-based college teaching: a meta-analysis of findings. *Rev Educ Res* 50:525-544, 1980.
- Larson D: Microcomputer tutorial-simulations to teach basic nursing skills. *Proc Ann Symp Comp Appl Med Care* 6:663-667, 1982.
- Marion R et al: Computer-based instruction in basic medical science education. *J Med Educ* 57:521-526, 1982.
- Modeil HI et al: Role of computer graphics in simulations for teaching physiology. *Physiologist* 26:93-95, 1983.
- Mullen EM et al: An evaluation of the use of mini-computers for computer assisted instruction in allied health curricula. *J Allied Health* 9:33-40, 1980.
- Pagliario L: CAI and instructional interactions. pp 151-160. In: *Proc Ann Conf Assn Devel Comp Inst Syst*, 1982.
- Pazdernik TL et al: A computer-assisted teaching system in pharmacology for health professionals. *J Med Educ* 58:341-348, 1983.
- Porter SF: Applications of computer-assisted instruction to continuing education in nursing: review of the literature. *J Cont Educ Nurs* 9:5-9, 1978.
- Pryor HG et al: Minicomputer simulation of medical emergencies and advanced life support. *J Dent Educ* 46:657-660, 1982.
- Raj PP et al: Microcomputer simulations as aids in medical education: application in clinical chemistry. *Med Educ* 16:332-342, 1982.
- Russi GD et al: Computer-assisted learning activities in a pharmacy practice laboratory. *Amer J Pharm Educ* 42:56-58, 1978.
- Schwartz MW et al: Microcomputers and computer-based instruction. *J Med Educ* 57:303-307, 1982.
- Skinner JB et al: The use of computerized learning in intensive care: an evaluation of a new teaching program. *Med Educ* 17:49-53, 1983.
- Steele AA et al: A computer-assisted examination resource. *Comput Programs Biomed* 11:238-248, 1980.
- Stolurow KA: A perspective on instructional uses of computing in medicine. *J Med Syst* 6:165-170, 1982.
- Stolurow KA et al: Instructional uses of computing in the health sciences: an annotated bibliography. *J Med Syst* 7:61-84, 1983.
- Tira DE: A computer-based dental diagnostic case simulation (DDS) system. *Comput Biol Med* 10:23-29, 1980.
- Ubaldi S et al: The use of microcomputers in radiologic technology training programs. *Radiol Technol* 53:271-273, 1981.

Continued

Votaw RG et al: Current trends in computer-based education in medicine. *Educ Tech* 18:54-56, 1978.
 Watson A: Computer-aided learning in a school of radiography. *Radiography* 49:103-105, 1983.

Wheeler LA: Medical student instruction in hematology via computer video material. *J Med Educ*. 58:667-668, 1983.

Williams RL et al: Introduction of computer-assisted instruction at

St. John's University College of Pharmacy and Allied Health Professions. *Amer J Pharm Educ* 42:58-59, 1978

Compiled by H. Modell

INVITATION TO CONTRIBUTORS

Articles consistent with the goals of *Computers in Life Science Education* are invited for possible publication in the newsletter

PREPARATION AND SUBMISSION OF MATERIAL

Articles submitted for publication should not exceed 2000 words and should be typewritten, double spaced, with wide margins. The original and two copies including two sets of figures and tables should be sent to the Editor: Dr. Harold Modell, Virginia Mason Research Center, 1000 Seneca Street, Seattle, WA 98101.

Title page should include full title, list of authors, academic or professional affiliations, and complete address and phone number of the corresponding author.

Illustrations should be submitted as original drawings in India ink or sharp, unmounted photographs on glossy paper. The lettering should be such that it can be legible after reduction (width of one column = 5.7 cm).

Reference style and form should follow the "number system with references alphabetized" described in the Council of Biology Editors Style Manual. References should be listed in alphabetical order by the first author's last name, numbered consecutively, and cited in the text by these numbers.

RESPONSIBILITY AND COPYRIGHT

Authors are responsible for accuracy of statements and opinions expressed in articles. All authors submitting manuscripts will be sent a copyright transfer form to complete. The completed form must be returned before the work will be published.

SUBSCRIPTION INFORMATION

Computers in Life Science Education is published monthly by Elsevier Science Publishing Co., Inc., 52 Vanderbilt Avenue, New York, NY 10017. Subscription rate is \$54.00 for 12 issues, including postage and handling in the United States and Canada. Add \$14.00 for postage (airmail) in Mexico and Europe and \$16.00 for the rest of the world.

This newsletter has been registered with the Copyright Clearance Center, Inc. Consent is given for copying of articles for personal or internal use, or for the personal or internal use of specific clients. This consent is given on the condition that the copier pay through the Center the per-copy fee stated in the code on the first page for copying beyond that permitted by the US Copyright Law. If no code appears on an article, the author has not given broad consent to copy and permission to copy must be obtained directly from the author. This consent does not extend to other kinds of copying, such as for general distribution, resale, advertising and promotional purposes, or for creating new collective works.

Address orders, changes of address, and claims for missing issues to Journals Fulfillment Department, Elsevier Science Publishing Co., Inc., 52 Vanderbilt Avenue, New York, NY 10017. Claims for missing issues can be honored only up to three months for domestic addresses and six months for foreign addresses. Duplicate copies will not be sent to replace ones undelivered due to failure to notify Elsevier of change of address.

Address editorial correspondence to Harold I. Modell, PhD, Virginia Mason Research Center, 1000 Seneca Street, Seattle, WA 98101.

POSTMASTER: Send address changes to *Computers in Life Science Education*, Elsevier Science Publishing Co., Inc., 52 Vanderbilt Avenue, New York, NY 10017.

COMPUTERS IN LIFE SCIENCE EDUCATION

CONTENTS

OPTICAL VIDEODISCS AND COMPUTERS IN LIFE SCIENCE EDUCATION James W. Woods	25
TEACHING RADIOLOGIC PRINCIPLES BY MICROCOMPUTER IN SMALL GROUP CONFERENCES John C. Lasher, Ralph Blumhardt, and Jack L. Lancaster	29

OPTICAL VIDEODISCS AND COMPUTERS IN LIFE SCIENCE EDUCATION*

James W. Woods

Health Professions Applications Branch, Lister Hill National Center for Biomedical Communications, National Library of Medicine, Bethesda, Maryland

In the first issue of this publication, Modell,⁴ Schouttelius,⁶ and Rovick and Michael⁵ presented the essential facts regarding the use of digital computers in the teaching and learning of the life sciences. This article attempts to build upon their excellent introductions by describing roles in this arena for optical discs under computer control.

* The term Computer Based Education (CBE) will be used throughout to describe activities variously called Computer Assisted Instruction (CAI), Computer Managed Instruction (CMI), Computer Based Evaluation (CBE), etc. Optical videodiscs are also commonly referred to as laser discs. Both terms are correct.

Woods et al⁸⁻¹⁰ have demonstrated the use of optical videodiscs in pathology and radiology CBE, Wheeler⁷ has produced a videodisc for diabetes education, and Clark¹ has produced an excellent videodisc for use in biology education. Videodiscs for the health sciences have also been produced at Florida State University, University of Iowa, University of Washington, and Rush-Presbyterian-St. Luke's Medical Center.

Modell correctly pointed out that CBE has not played a major role in learning of the life sciences during the first two decades in which com-

HAROLD I. MODELL
Virginia Mason Research Center
Seattle, Washington

MARCEL BLANCHAER
Professor of Biochemistry
Faculty of Medicine
University of Manitoba
Winnipeg, Manitoba
Canada

THEODORE J. CROVELLO
Department of Biology
University of Notre Dame
Notre Dame, Indiana

JAMES W. ECKBLAD
Department of Biology
Luther College
Decorah, Iowa

TSEGAYE HABTEMARIAM
School of Veterinary Medicine
Tuskegee Institute
Tuskegee, Alabama

DONNA LARSON
School of Nursing
Grand Valley State College
Allendale, Michigan

TERRY M. MIKITTEN
Graduate School of Biomedical Sciences
University of Texas Health Sciences Center
San Antonio, Texas

JAMES E. RANDALL
Department of Physiology
Indiana University
Bloomington, Indiana

PATRICIA SCHWIRIAN
College of Nursing
Ohio State University
Columbus, Ohio

RICHARD STULL
College of Pharmacy
University of Arkansas
Little Rock, Arkansas

JAMES W. WOODS
Lister Hill National Center
for Biomedical Communications
National Library of Medicine
Bethesda, Maryland

DOROTHY WOOLEY-McKAY
Department of Biology
Glendale Community College
Glendale, Arizona

GLENN YOSHIDA
Department of Life Sciences
Los Angeles Southwest College
Los Angeles, California

ELSEVIER

puters have been available for instructional purposes. One reason for that fact is that teaching and learning of the life sciences is a highly visually oriented activity, and the CBE systems of the past had scant capacity for using pictures. I often say to educators that any of us can teach all of the mathematics we know (which, for the writer, is not all that much) using only a chalkboard or flipchart. Not so with most of life science education. If I wish to discuss a blood smear with students, in the modern world a high quality color visual is a prerequisite.

Although CBE systems of the 1970s attempted to use visual databases in various forms (microfiche projection under program control, 35 mm slide projection with or without program control, and hardcopy pictures and graphics), none was highly successful.

The use of optical videodiscs to store the picture databases required by visually oriented curricula (biology, geography, art, medicine, etc.) affords an unusual opportunity for those interested in life sciences CBE. Up to 54,000 individual pictures (as video frames) may be stored on one side of an analog videodisc, and any one of them can be retrieved in less than 4 seconds. (Average search time is ordinarily less than one second.) Very high quality color pictures are obtainable.

Depending upon instructional strategy, the videodisc may contain: (1) individual frames intended for still-picture playback, (2) sequences intended for playback with sound and motion, and/or (3) a control program recorded on one of the two audio tracks. Sound may also be recorded on either or both audio tracks and, thus, a second language or a second script intended for a different audience may be supported. The present generation of videodiscs and videodisc players

requires playback at normal speed to support audio. Therefore, a two-minute discussion of a still picture on a videodisc requires that the picture be recorded on 3600 successive frames, which amounts to .4% of the frames available. To put it another way, a two minute discussion of each of fifteen slides would fill an entire side of a videodisc. However, one manufacturer has recently developed a process, using digital audio, which permits up to 20 seconds of audio on a single frame. Using that technology, a one minute discussion of a picture would require recording the picture on three frames instead of 1800. Another manufacturer plans to produce a device that plays back both videodiscs and digital audiodiscs with a capacity of one hour, but the system may prove too expensive for the educational market in the near-term. Extending single-frame audio capacity on videodiscs by either technique would be a mixed blessing: the "talking faces" of educational television in the 60s and 70s could become the "talking pictures" of the eighties. Talking pictures, in the writer's judgment, would not constitute the best use of the technology. Rather, it should be used to support interactive learning experiences.

Videodisc technology is not only available, it has become affordable by educational programs during the very recent past. The cost trend in this area is very similar to that observed in computer technology in general. In 1978, an optical videodisc player cost about \$20,000; the cost was down to 10% of that figure by 1981 and in 1984, a state-of-the-art player can be purchased for about half the 1981 figure.

VIDEODISC PLAYERS

Two types of players are currently available: consumer models that sell for as little as \$200 and indus-

trial models with a price range of \$800 to \$3000. Only the latter are useful for CBE, since the consumer models have no provision for a computer interface, but both types have remote hand controls available. Hand controls for the industrial model players can be used to affect user control of Level I and Level II discs (see Appendix). The same internal software that supports control of Level II discs also permits external computer control. Earlier industrial models had input jacks to accommodate adapters that provide the computer interface (serial interface adapters that accept standard ASCII code). Later models have either a serial (RS232) port or a parallel port built into the players.

VIDEODISC PRODUCTION

In the near term, most life science educators are likely to use visual databases produced by others, rather than becoming involved in videodisc production. Therefore, this section will be brief, and those interested in the technical aspects of production are referred to articles by Goldstein² and Levedrige.³

Almost any type of visual material (slides, motion pictures, microfiche, videotape, hardcopy pictures/graphics, x-ray film) can be reformatted on videodisc. CAUTION! Although it is possible to reformat existing visuals on videodisc, the aspect ratio of most such materials differs from that required for television. No matter what the source of the visual material, it must eventually be transferred to a videotape of a format required by the mastering and replication services. Those services require either a C-format one-inch or a time-encoded three-quarter-inch videotape.

The mastering and replication services produce a master videodisc and replicate it by injection processes. The 1984 cost for mastering is approximately \$2000 per side.

Copies cost around \$20 each for small numbers of copies. The cost/copy is reduced as the number of copies increases.

TYPES AND USAGE

There are two basic types of optical videodiscs: constant angular velocity (CAV) and constant linear velocity (CLV). CLV discs can store considerably more information than CAV discs, but they are essentially useless for CBE since they cannot be searched for specific frames or segments and cannot be used for slow motion, etc. On the other hand, each of the 54,000 tracks on a CAV disc represents a single frame (two fields) of video so that a CAV videodisc can be stopped at any track to produce a still-frame image. CAV discs can also be played forward and backward in variable slow motion (a feature that can be useful in the teaching and learning of psychomotor skills); they can be stepped (forward and backward) through individual frames; and they can be searched for any given frame since each frame has a unique five-digit "address."

There are three classes of CAV videodiscs: Level I, Level II, and Level III (see Appendix).

Level I videodiscs are of limited value for life science education, except when they contain frames that can also be used in the Level III mode (*vide infra*). When placed in PLAY mode, a CAV disc has only twenty-seven minutes of audio and video available. (If you do the arithmetic of dividing the 54,000 frames on a single side by 1300 frames/min., the answer is 30 minutes. However, the mastering process requires one minute of black signal and one minute of color bars at the beginning of the tape and one minute of black at the end.)

Level II discs are, in the writer's judgment, also of limited value in life science education, although they can be very useful in patient and public education and in various

cataloging and archiving applications. Since the control program is permanently embedded on the disc itself, and since life science education is a dynamic endeavor, it seems reasonable not to have the control program written on a tablet of stone. To do that requires remastering and replication of videodiscs every time something changes. The same end (control of rate, sequence, and branching of the presentation) can be achieved with a computer program written on read/write memory that can be changed at will.

Level III, or Level I with proper production technique, discs are the method of choice for those curricular areas in which change is predictable. The author has produced a two-sided disc in Basic Medical Pathology that is an example of the Level I/Level III method. Each side of the disc contains a single-concept presentation, but video and audio were recorded in a manner to enable use under computer control for interactive education. For instance, each micrograph used in the presentation was labeled by a video character generator, but the insertion of the label was withheld for a second or two after recording of the picture began. Thus, every videomicrograph presented makes a labeled and an unlabeled appearance. The unlabeled frames are used under computer control for student interaction in a CBE lesson.

CBE PRESENTATION FORMATS

There are basically three presentation formats for CBE lessons that reference visual databases resident on optical videodiscs. Each has its role, depending upon the nature of the content material and the instructional strategy. They are

- use of two display devices (either two video monitors or a video monitor and a CRT), displaying computer output on one and videodisc output on the other;

- use of a single display device (a video monitor) and a device (usually a ROM card for the computer) that switches between video sources and controls the player;
- use of a single display device (a video monitor) and a ROM card that supports overlaying of one video signal on another or switching of video signals.

An example of the use of the two-display device format is a drill and practice lesson in which pictures are displayed on one screen and multiple choice or open-ended questions are presented on the other. The author has used this format for Basic Medical Pathology lessons that utilize National Board type multiple choice questions and are now being used successfully in a number of US and Canadian medical schools. Optimum use of this format requires that a videopointer be used when recording the video so that interaction (questions/discussion) can later be referenced to the position of the pointer. Disadvantages of this format are that it divides attention of the user between two devices, salient features must be marked with a pointer at the time of recording, and the cost of the second display device.

Use of the second type of format (computer card for player control and switching between video sources) essentially serves the same purpose as the first format but uses only one display device. It has the disadvantage of not permitting interaction with the picture while the picture is actually displayed.

The most elegant and, naturally, the most expensive format is the last one. It permits display of a picture, overlaying the picture with computer generated text or graphics, and user interaction with the picture using keyboard, touch panel, or light pen. The writer is currently using this format in lessons designed to present fundamentals of radiographic (x-ray) image in-

terpretation. It has the disadvantage of expense. The video overlay boards are almost as expensive as the microcomputers, but prices for these devices will come down in the near future.

Although the number of videodiscs available to support life science education is limited, there are some that can be used effectively now, and there will be others. For those interested in getting started, the following videodiscs may be of interest:

1. Bio Sci Video Disc. Videodiscovery, Inc., Seattle, WA.
2. Medical Applications. University of Washington, Seattle, WA.
3. Human Genetics for Nurses, Part I. Florida State University, Tallahassee, FL.
4. Urology. University of Iowa, Iowa City, IA.

REFERENCES

1. Clark J: Exploring videodisc's potential. *J Biomedical Communications*, 1984
2. Goldstein CM: Optical disk technology and information. *Science* 215:862-868, 1982.
3. Leveridge L. The interactive videodisc. *Mobius* 3:68-72, 1983.
4. Modell HI: Using the computer in the classroom—first steps. *Computers in Life Science Education* 1:1-3, 1984.
5. Rovick AA, Michael JA: The computer lesson. *Computers in Life Science Education* 1:6-7, 1984.
6. Schottelius BA: Teaching physiology by microcomputer in small group conferences. *Computers in Life Science Education* 1:4-5, 1984.
7. Wheeler LA: Medical student instruction in hematology via computer-video material. *J Med Educ* 58:667-68, 1983.
8. Woods JW, Allman RM, Kaplan A, McClean PM, Brown RF: Reformatting of the ACR learning file. *Proc AAMSI Congress 83*, 1:370-373, 1983.
9. Woods JW, Allman RM, Kaplan A, McClean PM, Brown RF: On the possibility of a new radiology learning file in a more cost effective format. *Proc Assoc Univ Radiologists, Mobile*, March 20-25, 1983.
10. Woods JW, Jones RR: Preliminary results from field testing of the pathology videodisc. *GRIPE, Winter Bulletin*, Jan., 1984.

APPENDIX

Definitions

- **Optical Videodisc.** A read-only, approximately twelve-inch disc consisting of a "sandwich," an inner layer, which can have information recorded on both sides, covered by a layer of transparent protective plastic on both sides. It is an analog device that utilizes standard US (NTSC) television signal technology. It is mastered from videotape, using a frequency modulated laser to burn pits in the surface of the master disc, and replicated by injection molding.
- **OMDR Videodisc.** An optical videodisc, also analog, that is directly recorded on a blank disc using standard NTSC video signals. The cost of the OMDR recorder/player (\$18,000 and up) and of blank discs (\$500-800) places it outside the education market in the near-term and its applications are not discussed.
- **CLV Videodisc.** An optical videodisc that, on playback, is rotated at variable speed to achieve constant linear velocity with relation to the laser beam in the read head. Each complete track on the disc contains a variable number of video frames and 1/30th second of audio per frame.
- **CAV Videodisc.** An optical videodisc that, on playback, is rotated at a constant speed to achieve constant angular velocity relative to the read head. Each track on the disc contains a single video frame and 1/30th second of audio.
- **Industrial Videodisc Player.** A playback device that contains a programmable microprocessor, has a frame search capability, forward and reverse motion capability, and variable speed in both directions. It also has provision for connection to an external computer.
- **Consumer (Home) Videodisc Player.** A playback device without programmable internal memory.
- **Level I Videodisc.** A CAV videodisc that is meant to play from beginning to end (much the same as a videotape). When played on an industrial player, it can be manually searched for any frame, played in reverse, slow motion, etc. The industrial player can be programmed, using the hand controller, to present the material in an interactive manner, subject to a limitation of 1024 bytes of player memory.
- **Level II Videodisc.** A CAV videodisc that contains a digital program on audio track 2. The program is "dumped" to the player's microprocessor, and playback is then governed by choices made using the hand controller.
- **Level III Videodisc.** A CAV videodisc designed for control by an external computer.

TEACHING RADIOLOGIC PRINCIPLES BY MICROCOMPUTER IN SMALL GROUP CONFERENCES

John C. Lasher, Ralph Blumhardt, and Jack L. Lancaster
Department of Radiology, The University of Texas Health Science Center,
San Antonio, Texas

A literal or verbal description of a concept is a consecutive process. Envision an attempt to describe the phenomena that are observed when magnetic and radiofrequency (RF) fields are applied to a substance containing hydrogen atoms (Fig. 1). The collective effect on the hydrogen atoms can be represented by a net magnetization vector whose spatial orientation and magnitude is dependent on the field strength of the main magnet (B_0), local chemical and magnetic influences, and the frequency, phase, and magnetic field strength of the RF pulse (B_1).

As might be expected, numerous consecutive descriptions are required before the student can build mental images of the process. Also, the description of the temporal relationships of this phenomenon necessitates constant dialog. Not all students are able to understand these literal or verbal concepts; however, many students are good at extracting information from figures or images. Unlike the consecutive literal or verbal descriptions, the use of figures or images is a concurrent process where information can be presented simultaneously.

FIGURE 1. This is an example of a computer display of four time varying vectors from two different viewpoints: (1) Left viewpoint—above and perpendicular to the X-Y plane. (2) Right viewpoint—rotated and slightly above the X-Y plane. Points are used to represent values of the net magnetization vector at different times, thereby indicating the vector's path. The curve at the bottom is used to indicate the time varying amplitude of the net magnetization vector along the Y axis.

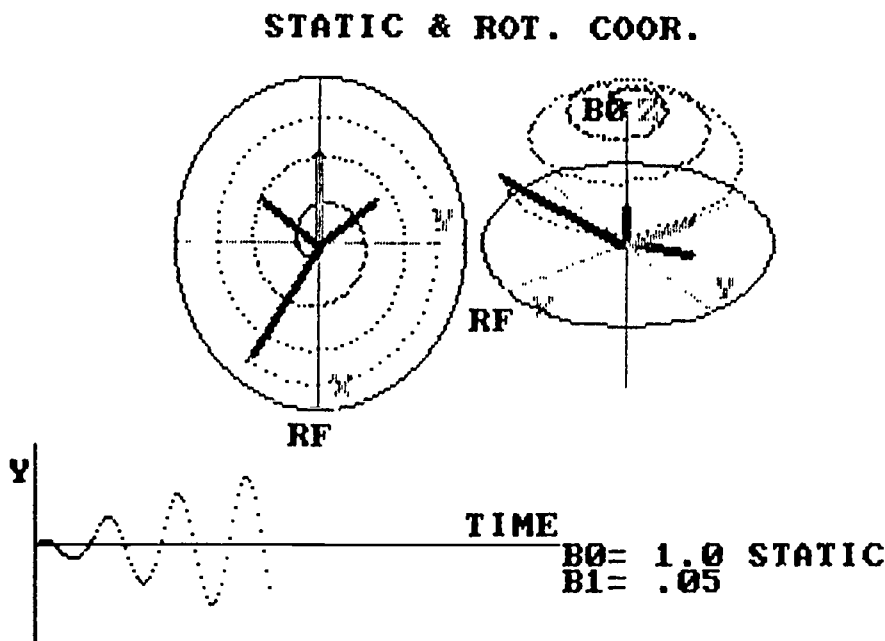

"A picture is worth a thousand words." That was true before the "information revolution" and is even more true today as computers increase the rapidity and quantity of information transmission. We are all familiar with high quality videotapes being used as an excellent means of explaining difficult physical concepts. Videotapes allow the presentation of images in rapid sequence permitting one to appreciate the temporal relationships of physical phenomena. However, they lack the interactive qualities that can be programmed into computer generated videographics.

Our radiology department will be acquiring a magnetic resonance imaging (MRI) scanner in early 1985. This revolutionary form of imaging has far-reaching possibilities since it is noninvasive, non-ionizing, and yields functional information based on the molecular-chemical characteristics of certain magnetic nuclei. Along with this new technique comes the task of education. This is especially demanding because of the complex multidimensional physical concepts that underlie MRI.

In an attempt to deepen our grasp of fundamental MRI principles, we conducted a course on "Fundamentals of MRI" in February 1984. The advertised purpose of this course was to familiarize members of the medical profession with physical principles, terminology, instrumentation, and the diagnostic potential of MRI. In an attempt to introduce the physical concepts, we decided to make extensive use of computer animated videographics.

Our goal was to develop an interactive computer based instructional environment that was capable of demonstrating some of the physical concepts through the use of animated videographics. The computer system had to be capable of displaying and erasing multiple vectors within a three-dimensional scene along with plotting curves,

updating variables, and tracking vector paths. The animation or movement of the vectors within the three-dimensional scene needed to be rapid enough to give the observer a feeling of continuous motion. The system also needed to be interactive so that the operator could select the desired program, momentarily stop program execution, and change program variables.

We felt that computer graphics would be most appropriate for our specific educational needs. We wanted it to be capable of generating scenes over which vector animation could be overlaid in accordance with Bloch's equations. These equations describe the interactions of magnetic and RF fields on certain nuclei (especially protons) found within the human body. In addition, we wanted to be able to change the variables of Bloch's equations in order to observe their effects and interactions (Fig. 2). Also, we

wanted the ability to vary the color of different parts of the animated scene and have a spatial and temporal resolution that was visually acceptable. For the initial version, we wanted the interaction to be controllable by a knowledgeable user who would direct the execution of the programs with one or more observers. We also wanted the system to be easily transportable for use in small meeting areas. With these guidelines in mind, we began to formulate a system.

Even though our department had multiple computer systems, the IBM-PC was chosen because of its portability and high-level graphics software routines. This system consists of an IBM-PC with two floppy disk drives, IBM color graphics adapter board, IBM color monitor, a QUADRAM memory expansion with RAM disk software, and the IBM BASIC compiler. It is capable of generating four color images in 320

x 200 pixel mode. The RAM disk allows for rapid access of data and programs.

The standard IBM software provided many essential graphics subroutines. However, we found that our requirements for rapid display and erasure of vectors and curves was not adequately supported. Therefore, a vector and curve generation subroutine was written in assembly language and used in conjunction with the standard IBM software. Herein lies one of the problems with institutional software development. Most educational institutions will not have programmers knowledgeable in lower-level software, so they will make use of existing software and possibly compromise their original guidelines. Also, in many cases, the individual most familiar with the educational concepts and the way they should be graphically presented, will not always be the same individual programming the computer. Interactive animated graphics is not a simple task. It is probably most easily developed by those few individuals familiar with all aspects of the application, hardware, and software.

The MRI computer aided educational system has been used on several occasions with groups ranging from one to thirty. The audience invariably felt that their rate of learning and degree of understanding was greatly enhanced. The computer graphics allowed difficult concepts to be presented in a concurrent fashion. The animation greatly aided the understanding of complex time-dependent processes. Also, the interaction allowed the instructor to direct the instruction at the level and depth determined by the audience and available time.

OTHER APPLICATIONS

We have also developed an interactive computer program that we use to teach the discrete Fourier transform (DFT). The DFT is a

FIGURE 2. This is a depiction of vectors from a partial saturation pulse sequence used in magnetic resonance devices. The X' , Y' , Z' coordinate system is different from Figure 1 in that it is rotating in a manner that stops the rotation of the net magnetization vector about the Z axis. This rotating coordinate system simplifies the visual presentation of complex time varying vector rotations. Variables $T1$, $T2$, $T1'$, and TR from Bloch's equation can be interactively modified. The curve at the bottom is used to indicate the time varying envelope of an RF signal resulting from the rotating net magnetization vector.

**PARTIAL SATURATION (PS)
90, [FID]: REPEAT EVERY TR**

**T1 = 600
T2 = 100
T1' = 0
TR = 600**

TIME = 1800

**NET MAGNETIZATION
X', Y', Z' COMPONENTS**

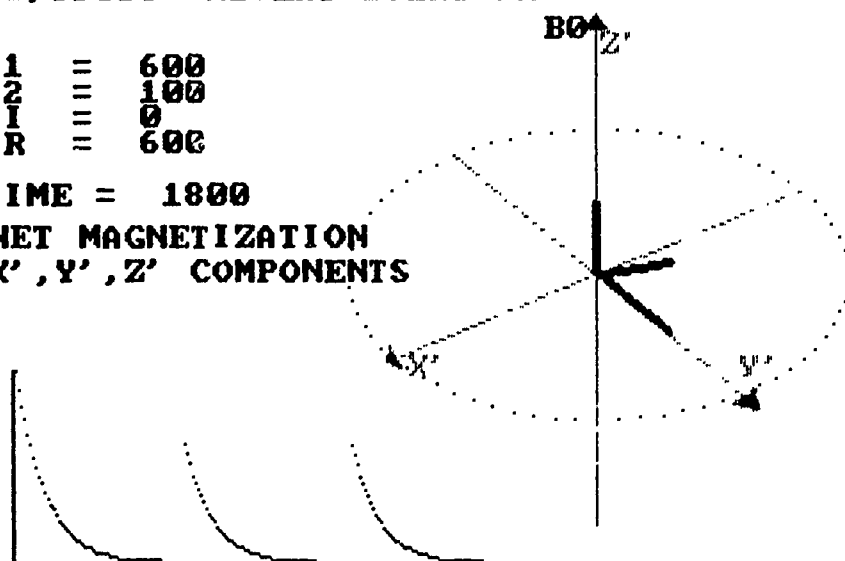

mathematical tool whose use is ubiquitous in radiology as well as other life science areas. It is used extensively in MRI, emission as well as transmission tomography, and image processing. The DFT computer program is capable of displaying sinusoidal curves with different amplitudes and frequencies. By summing these sinusoids, complex periodic functions with known frequency content can be created (Fig. 3). The program can then use the DFT to analyze the complex curve, yielding the frequency and amplitude of the various sinusoids that were used to create the curve. This is an extremely helpful program in explaining the mathematical relationships between spatial and frequency domains. The students were very positive about its use and felt that it could be extended to other complex mathematical concepts.

The IBM computer system has also been useful in developing educational slides. For this task we increased our resolution to 640×400 pixels and the number of colors to sixteen. This required the purchase of a Conographics Corporation color adapter board and a Mitsubishi 3419 analog RGB color monitor. Slide development software is commercially available, however, it wasn't available when we purchased the equipment so we developed our own. The software we use has a "mouse" as the main method of interaction with the program. It allows precise positioning of graphics and text and selection of the desired task from mouse generated menus. There are numerous graphics functions such as circle, ellipse, box, bar, line, paint, dither, window, text, color, draw, flood, hatch, pie, and print. The slides can be photographed directly off the screen using a 35-mm camera and a zoom lens (approximately 200 mm). The slides we have constructed have a professional appearance (Fig. 4). If 35-mm Polaroid

SOLVE FOR FOURIER COEFFICIENTS
 $A(H) = \text{SUM}(F(\text{ANGLE}) * \text{COS}(H * \text{ANGLE})) * (2/N)$
 $B(H) = \text{SUM}(F(\text{ANGLE}) * \text{SIN}(H * \text{ANGLE})) * (2/N)$

H	A	B	AMP	PHA
0	-26	+0	26	180
1	-22	+13	26	149
2	+9	-11	14	309
3	-6	+3	7	153
4	+7	-1	7	352
5	-5	+0	5	180
6	+4	+2	4	27

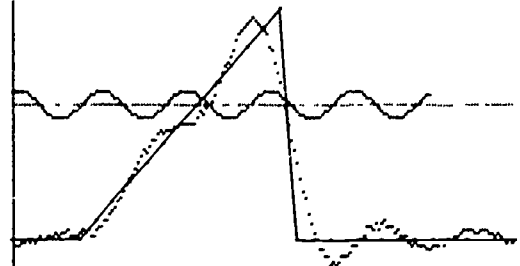
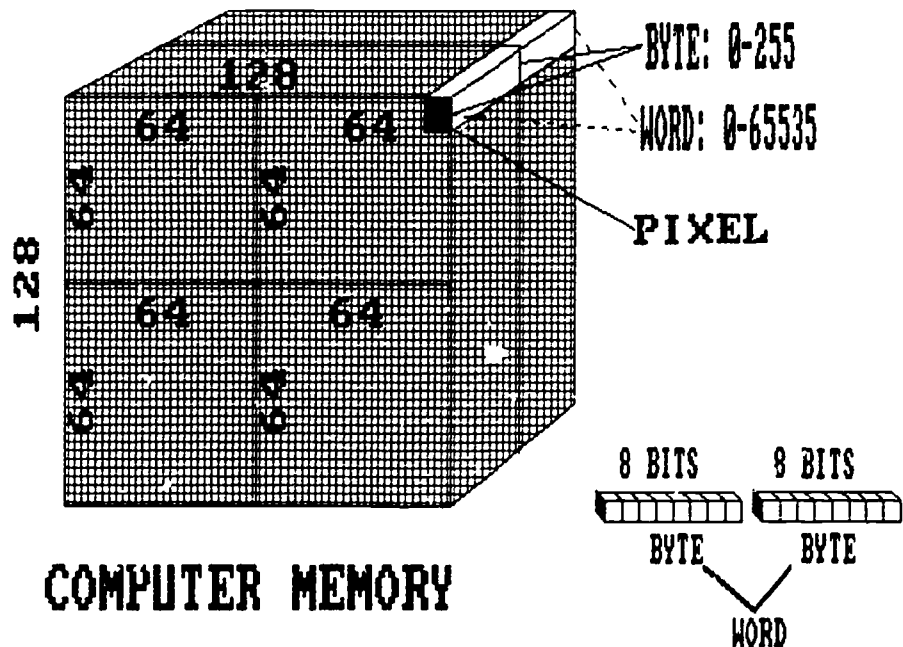

FIGURE 3. This display was taken from the discrete Fourier transform program. In this case a triangular reference curve (solid line) is overlaid by the summation of the first five harmonics (H). The sinusoidal appearing curve is the sum of the sine and cosine components for the sixth harmonic. This curve, after being completely drawn, will be added to the curve representing the previous five harmonics. The student can interactively generate different reference curves. The student can gain an understanding of the harmonic content of different shaped reference curves by watching the summation process. The following abbreviations are utilized. H, harmonic number (frequency), A, amplitude of the cosine component as a function of H, B, amplitude of the sine component as a function of H; AMP, amplitude derived from the vector sum of A and B; PHA, phase angle derived from the vector sum of A and B.

FIGURE 4. This is an example of a teaching slide produced with the 640×400 pixel 16-color slide development software.

FRAME MODE



film is used, the slides can be developed within minutes.

We feel that the computer has already proven to be invaluable in our teaching efforts, and we plan to greatly expand its educational use.

We also use many of the commercially available programs, especially word processors. We are presently in the process of purchasing an analog to digital conversion board for another IBM so we can

digitally acquire physiologic data from patients during cardiac catheterization. This is part of a five year NIH grant in which numerous programs will also be developed to massage the physiologic data.

INVITATION TO CONTRIBUTORS

Articles consistent with the goals of *Computers in Life Science Education* are invited for possible publication in the newsletter

PREPARATION AND SUBMISSION OF MATERIAL

Articles submitted for publication should not exceed 2000 words and should be typewritten, double spaced, with wide margins. The original and two copies including two sets of figures and tables should be sent to the Editor, Dr. Harold Modell, Virginia Mason Research Center, 1000 Seneca Street, Seattle, WA 98101.

Title page should include full title, list of authors, academic or professional affiliations, and complete address and phone number of the corresponding author

Illustrations should be submitted as original drawings in India ink or sharp, unmounted photographs on glossy paper. The lettering should be such that it can be legible after reduction (width of one column = 5.7 cm).

Reference style and form should follow the "number system with references alphabetized" described in the Council of Biology Editors Style Manual. References should be listed in alphabetical order by the first author's last name, numbered consecutively, and cited in the text by these numbers.

RESPONSIBILITY AND COPYRIGHT

Authors are responsible for accuracy of statements and opinions expressed in articles. All authors submitting manuscripts will be sent a copyright transfer form to complete. The completed form must be returned before the work will be published

SUBSCRIPTION INFORMATION

Computers in Life Science Education is published monthly by Elsevier Science Publishing Co., Inc., 52 Vanderbilt Avenue, New York, NY 10017. Subscription rate is \$54.00 for 12 issues, including postage and handling in the United States and Canada. Add \$14.00 for postage (airmail) in Mexico and Europe and \$16.00 for the rest of the world.

This newsletter has been registered with the Copyright Clearance Center, Inc. Consent is given for copying of articles for personal or internal use, or for the personal or internal use of specific clients. This consent is given on the condition that the copier pay through the Center the per-copy fee stated in the code on the first page for copying beyond that permitted by the US Copyright Law. If no code appears on an article, the author has not given broad consent to copy and permission to copy must be obtained directly from the author. This consent does not extend to other kinds of copying, such as for general distribution, resale, advertising and promotional purposes, or for creating new collective works.

Address orders, changes of address, and claims for missing issues to Journals Fulfillment Department, Elsevier Science Publishing Co., Inc., 52 Vanderbilt Avenue, New York, NY 10017. Claims for missing issues can be honored only up to three months for domestic addresses and six months for foreign addresses. Duplicate copies will not be sent to replace ones undelivered due to failure to notify Elsevier of change of address.

Address editorial correspondence to Harold F. Modell, PhD, Virginia Mason Research Center, 1000 Seneca Street, Seattle, WA 98101.

POSTMASTER: Send address changes to *Computers in Life Science Education*, Elsevier Science Publishing Co., Inc., 52 Vanderbilt Avenue, New York, NY 10017.

COMPUTERS IN LIFE SCIENCE EDUCATION

HAROLD I. MODELL

Virginia Mason Research Center
Seattle, Washington

MARCEL BLANCHAER

Professor of Biochemistry
Faculty of Medicine
University of Manitoba
Winnipeg, Manitoba
Canada

THEODORE J. CROVELLO

Department of Biology
University of Notre Dame
Notre Dame, Indiana

JAMES W. ECKBLAD

Department of Biology
Luther College
Decorah, Iowa

TSEGAYE HABTEMARIAM

School of Veterinary Medicine
Tuskegee Institute
Tuskegee, Alabama

DONNA LARSON

School of Nursing
Grand Valley State College
Allendale, Michigan

TERRY M. MIKITEN

Graduate School of Biomedical Sciences
University of Texas Health Sciences Center
San Antonio, Texas

JAMES E. RANDALL

Department of Physiology
Indiana University
Bloomington, Indiana

PATRICIA SCHWIRIAN

College of Nursing
Ohio State University
Columbus, Ohio

RICHARD STULL

College of Pharmacy
University of Arkansas
Little Rock, Arkansas

JAMES W. WOODS

Ester Hill National Center
for Biomedical Communications
National Library of Medicine
Bethesda, Maryland

DOROTHY WOOLEY-McKAY

Department of Biology
Glendale Community College
Glendale, Arizona

GLENN YOSHIDA

Department of Life Sciences
Los Angeles Southwest College
Los Angeles, California

ELSEVIER

CONTENTS

MICROCOMPUTER GRAPHICS AS A SUBSTITUTE FOR LECTURE SLIDES Sherman D. Levine	33
USE OF COMPUTER TUTORIALS IN COMMUNITY COLLEGE HUMAN ANATOMY AND PHYSIOLOGY CLASSES Dorothy Wooley-McKay	36
PROFESSIONALS IN COMPUTER-BASED EDUCATION AND TRAINING Ronald C. Comer	37
COMPUTER-BASED EXAM CONSTRUCTION IN MICROBIOLOGY AND IMMUNOLOGY: THE MITI BANK W.J. Meinke	39

MICROCOMPUTER GRAPHICS AS A SUBSTITUTE FOR LECTURE SLIDES

Sherman D. Levine

*Department of Medicine and Department of Physiology & Biophysics,
Albert Einstein College of Medicine, Bronx, New York*

While individualized student-computer interaction has made substantial inroads into education, the bulk of student teaching in most educational institutions remains limited to the lecture format. Here too, however, the computer can serve a useful purpose. Computer-generated lecture aids offer several advantages over conventional lecture tools such as blackboard and slides.

ADVANTAGES OF COMPUTER GENERATED VIDEO OVER BLACKBOARD AND SLIDES

Demonstration of Movement Over Time

In contrast to slides and the blackboard, the computer is ideally equipped to demonstrate changing phenomena and interactions. Figure 1 (A-E), for example, is a printout of stages in an experiment

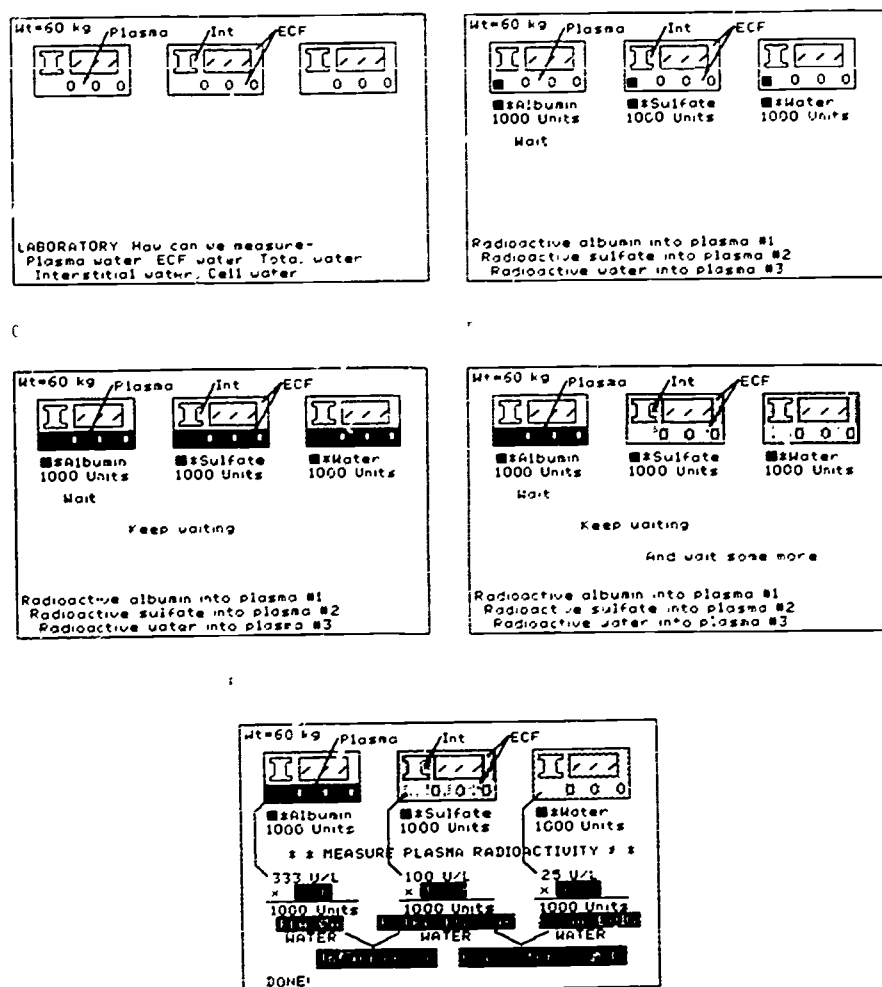

FIGURE 1. Stages in an experiment to measure body fluid spaces (see text)

to measure body fluid spaces. The student is able to view on the screen the movement of labeled test substances from space to space, decreasing its concentration as it increases its volume of distribution. Finally, the lecturer can proceed step by step through the calculations for the individual spaces measured.

Similarly, Figure 2(A-C) demonstrates an osmotic pressure experiment. Figure 2A is the starting point, in which either a hydrostatic pressure (the black triangle) or any of three solutes drives water (W) across a membrane permeable to water, impermeable to sucrose or

NaCl, and moderately permeable to urea. The student can observe the changes in the fluid column height over time, the relative effects on flow of changes in permeability and dissociation (Fig. 2B), and the eventual effects of dissipation of the urea gradient (Fig. 2C). The movement over time of the solutes and water in these two demonstrations would be difficult to duplicate with either slides or a blackboard. Furthermore, a single slide such as Figure 1E would be considered complex and confusing, while its appearance as the end of a synthetic process is readily accepted by the student.

Demonstration of Changing Experimental Parameters

One powerful use of computer-generated graphics is the simulation of important physiologic phenomena. Figure 3 shows one frame of a program demonstrating the physiology of the renal glomerular circulation. At this point in the lecture, the instructor demonstrates the effects of varying the resistance of the afferent arteriole (R_{aa}) or the efferent arteriole (R_{ee}) on the glomerular plasma flow (RPF) and the hydrostatic pressure gradient across the glomerular capillary membrane (ΔP_{ca}).

Using either a plug-in joystick or the keyboard (the A-S-D-F keys), the instructor can vary the resistance of the vessels (shown by movement of the graph arrows and the vessel-occluding squares to the right or left) while the effects of these resistance changes on the pressures and flows are shown by movement of the appropriate graph arrows as well. In this particular frame, R_{aa} is depicted in inverse video to indicate that its value is the one presently being modified by the instructor.

Student Access to Programs and Computers

We have several Apple computers in our library, and copies of the lecture diskettes are available at the circulation desk for student use. Having been introduced to the programs once during lecture, the students have had little difficulty working through them on their own later. Locally generated programs are not copy-protected, so that students may work at home if they have appropriate equipment available.

Modification of programs

One of the most useful aspects of computer-based teaching materials has been the ease of modification by the programmer in response to student feedback.

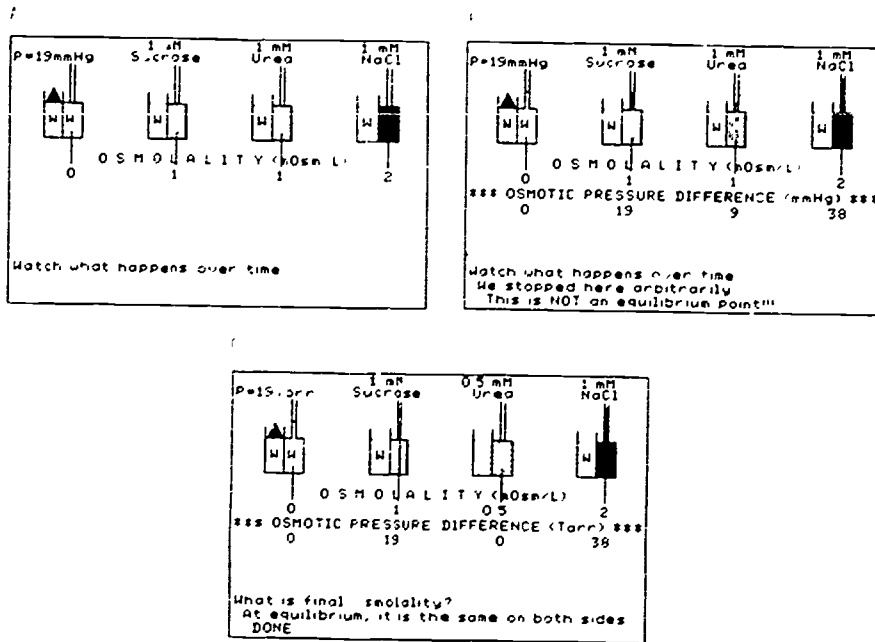

FIGURE 2. Demonstration of an osmotic pressure experiment (see text).

Focusing Student Attention

In contrast to the use of static slides, in which student attention often does not follow the lecturer's intent, frames generated by computer need not display information until the previously displayed concept is discussed and the instructor is prepared to proceed and display new material. Furthermore, the pace of movement through the program can be controlled by the instructor using the keyboard or a joystick.

Quality of Text and Graphics

Handwritten blackboard commentary is often difficult to read, and,

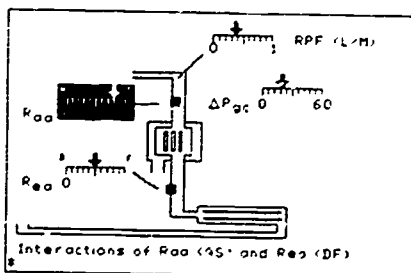

FIGURE 3. One frame of a series demonstrating the physiology of the renal glomerular circulation (see text).

once erased, is unavailable for subsequent student use. In contrast, computer-generated text, when displayed on a suitable monitor, is clear and permanently available to the student.

LIMITATIONS OF COMPUTER-GENERATED LECTURE AIDS

Cost of Equipment

The decreasing cost of microcomputers makes computer hardware a relatively minor portion of the total equipment cost. More critical is the quality (and thus the expense) of the video projector. The purchase of equipment capable of high-resolution projection of computer-generated images would seem to be a worthwhile investment, even at a cost several times that of the computer.

Program Preparation Time

This is probably the most critical limitation in lecture aid development. Writing a 10 minute lecture segment presented to students once per year may take many hours

of programming time, including development of program concept, creation of text and graphics, and final debugging. Consequently, one must often be satisfied either with producing a limited quantity of software or with adapting one's teaching style to software produced by others.

Limitations in Applicability

Computer-generated graphics as lecture aids seem most clearly applicable to quantified parameters such as pressures, forces, voltages, flow rates, currents, concentrations, and volumes. Thus classical physiology, pharmacology and biochemistry, statistics, and decision analysis are more readily assisted by computer graphics than are subjects such as pathology, anatomy, and microbiology.

TECHNICAL ASPECTS

How Can the Computer Generate Lecture Aids?

The computer video output is sent through a shielded cable to the input of a large-screen projection television mounted in the front of the lecture hall in view of both the lecturer and the class.

The video output of computers such as the Apple or Franklin is directly compatible with a standard "monitor" input of most video units. Computers with RGB (red-green-blue, corresponding to the three color guns) output may permit better resolution; however, the user must ensure that his monitor accepts RGB input. Other computers, for example the TRS-80 series, do not have external video output, and are thus less useful for this application.

Monochrome or Color

While color video is esthetically more pleasing than monochrome (white, yellow, or green on black) and offers advantages of "color-

coding" graphs and labels, many color monitors (particularly the older ones) have much less resolution than monochrome monitors. In addition, single-width "white" vertical lines generated by computers such as the Apple and Franklin are in fact drawn in any of several colors, depending upon their location on the screen, while horizontal lines appear their intended white color. This variegation makes text considerably less readable on a color monitor than the same output displayed on a monochrome unit. Finally, while there are 280 "white" vertical locations on the above mentioned computers, only 140 of these are a single color, so that colored structures can not have the same fine structure as white ones.

Because of these limitations on both monitor and computer resolution, my own preference has been to work with a monochrome video

signal, even when only color monitors are available, in order to eliminate the color variegation noted above. On the Apple II/II+ and Franklin 1000 computers, suppression of the color signal (that is, output of a high-resolution monochrome signal) can be achieved with a simple hardware modification. I do not know whether the Apple IIe can be modified in a similar way.

SUMMARY

Computer-generated graphics and text lecture aids can improve student education by focusing student attention, demonstrating processes that change with time, and simulating experimentally important phenomena. While their role may be limited to subjects that can be readily quantified, and software is limited in availability, the use of such aids can improve the clarity of lecture presentations in a meaningful way.

graphics in a slide show format. Graphics were drawn with the AppleMouse II and Mousepaint. The original graphics were drawn using the Koala Pad and the Microillustrator software. We found the Mousepaint graphics to be of higher resolution than those of the Koala Pad. However the Mousepaint graphics are better when used with a monochrome monitor. Koala pad/Microillustrator graphics are better with a color monitor. Figure 1 is a printout of one of the Mousepaint illustrations. Text was written within the Frameup program. Each screen page of text corresponds to one frame of the slide show.

Students can move from one frame to another by hitting the right and left arrow keys. The right arrow key moves forward a frame, and the left arrow key moves backward a frame. Students can therefore go back to a previous frame. Directions to do this were placed at the bottom of each text frame.

Knowing how to insert a disk into the disk drive, turn on the computer, and touch the arrow keys is all the computer knowledge students need! Students learned this very quickly. Just to make sure they remembered, we put directions for inserting disks and turning on the computer on the blackboard in the mini-microcomputer laboratory that students used.

We have three tutorials at present. One is on excitation-contraction coupling for skeletal muscle, one on several aspects of nervous system physiology (resting membrane potentials, action potentials, and synaptic transmission), and one on the protein phosphorylation theory of hormone and neurotransmitter action. We are writing more tutorials on other physiological concepts since we have had very positive results from the three we have.

The students have open access to the computer laboratory. When the above subjects are being discussed

USE OF COMPUTER TUTORIALS IN COMMUNITY COLLEGE HUMAN ANATOMY AND PHYSIOLOGY CLASSES

Dorothy Wooley-McKay

Department of Biology, Glendale Community College, Glendale, Arizona

Community college students sometimes have problems understanding difficult concepts in physiology. By using tutorials on the computer, students can supplement the lecture and textbook. They can go back and review the computer material as many times as they wish and as slowly as they wish.

Tutorials using graphics are particularly effective. Seeing material presented by the computer has an attraction that reading the textbook does not. We really have no explanation for this effect. It is possible that these individuals, having been

brought up on television, can relate to learning material from a TV screen. Also, interaction with the computer is nonthreatening.

However, most students at the present time have no knowledge of how to use a computer and indeed are a little afraid of them. We have found a tutorial slide show to be effective and suitable for students who have had very little computer experience.

We used a utility by Beagle Bros. for the Apple II series of computers. This utility is called Frameup. Frameup allows mixing of text and

Excitatory Synapse — Transmitter combines with receptor, opening chemical gates to Na^+ . Na^+ moves into cell, resulting in an EPSP.

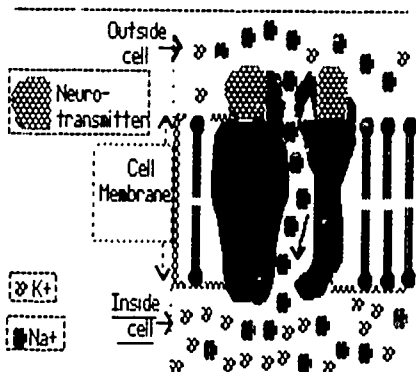

Diagram of tubular system. The T-tubules are extensions of the sarcolemma. Notice the I band, the A band and the H-zone where there are only thick filaments.

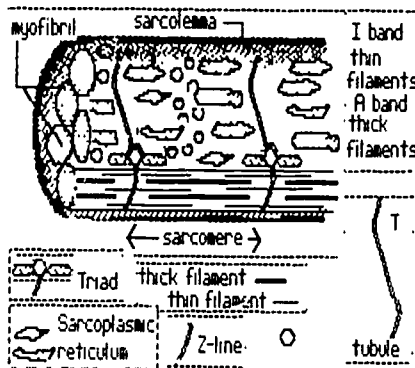

FIGURE 1. Examples of two frames of the "slide show" created with Mousepaint and Frameup software on an Apple II computer.

in lecture, we see students in the computer laboratory all of the time. Unfortunately, we do not have a statistical analysis of changes in student understanding (as reflected in test scores). This type of analysis is difficult because we do not feel that students should be asked to state on their test whether or not

they used the computer. We do not wish to put pressure on students at this time to use the computer.

However, from a qualitative standpoint, we have seen changes in test scores of struggling students. These changes were observed from tests over material that did not utilize the computer to the material

that did. In some instances, there were dramatic increases in test scores. Since our classes are relatively small, we get to know our students personally, so we can observe these changes.

Student interest in computer use is reflected in the question: "Where is the computer program on the next topic?" Disappointment is obvious when the students are informed that, unfortunately, there are no more right now.

In conclusion, we have found that slide show tutorials presenting difficult physiological concepts are received well by students. The tutorials seem to increase understanding of these concepts. They are fairly easy to write and can be done by someone with no programming experience. The documentation for Frameup and Mousepaint is excellent. We would recommend this type of computer use for life science classes at the community college level and freshman, sophomore, and perhaps junior levels in a four-year institution.

PROFESSIONALS IN COMPUTER-BASED EDUCATION AND TRAINING

Ronald C. Comer

Division of Computing Services for Medical Education and Research, The Ohio State University College of Medicine, Columbus, Ohio

The Association for the Development of Computer-based Instructional Systems (ADCIS) is a professional association of educators and trainers who have developed a substantial interest and expertise in the use of computer technology in education. ADCIS provides a professional focal point for all educators, from elementary/secondary schoolteachers to university professors, from profes-

sional trainers in business and industry to computer-based military and naval training, and from the computer expert to the content specialist interested in using this amazing new tool in a classroom environment. ADCIS provides a forum for communications, for sharing knowledge and experience, and for learning how to implement computer-based educational materials in a wide variety of curricula

and classrooms. ADCIS is a professional network linking theorists, practitioners, technicians, and administrators.

The purposes of the association are as follows.

- 1) to advance the investigation and utilization of computer-based instruction and computer-managed instruction.
- 2) to promote and facilitate the interchange of information, programs, and materials in the best professional and scientific tradition.
- 3) to reduce redundant effort among developers, and
- 4) to specify requirements and priorities for hardware and software development and en-

courage and facilitate their realization.

ADCIS history parallels the history of computer-based education. Formed in the latter part of the 1960s, ADCIS initially grew rapidly, stabilized during the middle part of the 1970s and has matured into a professional community of scholars devoted to this emerging discipline. With the advent of microcomputers and the current explosion of interest in computer-based education and training, ADCIS membership is increasing dramatically. Innovative programs, publications, and other benefits reflect the changing nature of our educational systems.

People with many different perspectives, backgrounds, and expertise come together to form an ADCIS membership that is willing to share in the common goal of excellence in instruction through effective use of computer technology. An international not-for-profit association with a worldwide membership, ADCIS provides an ideal mechanism for advancing the field of computer-based instruction.

The association is characterized by the interactions of both generalists and specialists. Special interest groups provide the opportunity for ADCIS members to interact with other professionals who wish to specialize or focus on particular

areas. Areas of special interest currently include the following:

- 1) computer-based training.
- 2) elementary/secondary/junior college educators.
- 3) educators of the handicapped.
- 4) health education.
- 5) home economics.
- 6) implementation.
- 7) IIS.
- 8) mini-microcomputer users.
- 9) music educators.
- 10) PLATO users.
- 11) theory and research in computer-based instruction, and
- 12) interactive video/audio.

ADCIS publications and annual meetings provide the opportunity to share information of a general nature for all computer-based education professionals, as well as an opportunity for those with special interests to interact in smaller discussion groups. ADCIS chapters are a regional outreach mechanism for members to periodically get together to share their ideas and experiences. In the very near future, these regional chapters will be supported by, and will be supporting, the implementation of a variety of workshops for educators will all levels of experience in using computers in instruction.

The association provides its membership with a bimonthly

newsletter, a quarterly refereed journal of research studies, interest group newsletters, chapter meetings, workshops across the United States and Canada, and an annual meeting for the entire membership to participate in a program of presentations, exhibits, and demonstrations related to the use of computers in instruction.

ADCIS is one of the few professional organizations at this time to furnish an opportunity for electronic communications among its membership. ADCIS-Net is a major new service providing the facilities for members to carry out electronic communications throughout the year on a variety of topics and issues associated with this field. In addition, electronic data bases will soon become available to assist members in their research efforts as well as support their need to identify other professionals working in similar areas throughout the United States, Canada, and many other countries around the world.

ADCIS is an active, dynamic professional association dedicated to adapting its publications, its program, and its communications vehicles to the needs of its membership. Membership information can be obtained from Mr. Gordon Hayes, ADCIS International Headquarters, 409 Miller Hall, Western Washington University, Bellingham, WA 98225.

COMPUTER-BASED EXAM CONSTRUCTION IN MICROBIOLOGY AND IMMUNOLOGY: THE MITI BANK

W.J. Meinke

Department of Microbiology and Immunology, College of Medicine, University of Arizona, Tucson, Arizona

Teachers of basic science medical education, like other teachers, often are faced with the yearly task of creating new exams consisting entirely of new test items. After a few years the task becomes increasingly difficult for the educator to compose yet another new exam. In microbiology and immunology, the problem of writing new exams containing new test items has largely been resolved by establishing a centralized Microbiology-Immunology Test Item bank, MITI Bank.

MITI Bank was established through the auspices of the Association of Medical School Microbiology Chairmen (AMSMC). The AMSMC solicits questions for the MITI Bank, which are reviewed by an editorial board to insure that test items are accurate. To date the number of test items in the MITI Bank exceeds 2900. These test items fall into six major subject designations: bacteriology, immunology, infectious disease, mycology, parasitology, virology. Each of the six major subject designations is

further subdivided into appropriate divisions. For example, virology is subdivided into the families of viruses known to infect man. These subdivisions allow for easy retrieval of pertinent test items when an exam is to be created from the test items in the MITI Bank.

Each test item has a code number that is used for its retrieval from the MITI Bank computer. In addition to the actual test item, each may be accompanied by its entry date into the computer, its last update, the major subject code, a short key description, and the institution and person who submitted the question. Finally, the correct answer for each test item is given.

To construct a test using the MITI Bank computer is relatively easy. After reviewing the retrieved test items, the computer is instructed to construct a test using the code number of each test item. The computer, in turn, randomly lists the test items and subsequently constructs the test. Only a few minutes are required to print out the test using a variety of software compati-

ble to the central MITI Bank computer.

Presently, about one-half of the medical schools in the United States and Canada subscribe to the MITI Bank. About one-half of these universities have submitted test items to the MITI Bank. Additional test items are being added routinely, and it is quite conceivable that the bank of test items will surpass the 5000 mark in the near future. When one considers that the average microbiology exam at the University of Arizona consists of 50-60 test items, it can readily be seen that a central pool of 3000-5000 test items allows for the creation of numerous exams.

It is obvious that the MITI Bank computer allows the teacher considerable flexibility in creating new exams. However, there is another valuable benefit. By reviewing the test items in the MITI Bank, a teacher can learn what his peers believe to be important course material. The number of test items on a subject should give an indication as to the importance of the material. Thus a teacher can gain considerable insight into what his colleagues across the nation believe to be important and necessary course material. This, in turn, allows a teacher to review his own course material and, if necessary, make appropriate changes. The outcome is a better course with the students the ultimate benefactors!

COMPUTERS IN LIFE SCIENCE EDUCATION

HAROLD I. MODELL

Virginia Mason Research Center
Seattle, Washington

MARCEL BLANCHAER

Professor of Biochemistry
Faculty of Medicine
University of Manitoba
Winnipeg, Manitoba
Canada

THEODORE J. CROVELLO

Department of Biology
University of Notre Dame
Notre Dame, Indiana

JAMES W. ECKBLAD

Department of Biology
Luther College
Decorah, Iowa

TSEGAYE HABTEMARIAM

School of Veterinary Medicine
Tuskegee Institute
Tuskegee, Alabama

DONNA LARSON

School of Nursing
Grand Valley State College
Allendale, Michigan

TERRY M. MIKITTEN

Graduate School of Biomedical Sciences
University of Texas Health Sciences Center
San Antonio, Texas

JAMES E. RANDALL

Department of Physiology
Indiana University
Bloomington, Indiana

PATRICIA SCHWIRIAN

College of Nursing
Ohio State University
Columbus, Ohio

RICHARD STULL

College of Pharmacy
University of Arkansas
Little Rock, Arkansas

JAMES W. WOODS

Lister Hill National Center
for Biomedical Communications
National Library of Medicine
Bethesda, Maryland

DOROTHY WOOLEY-McKAY

Department of Biology
Glendale Community College
Glendale, Arizona

GLENN YOSHIDA

Department of Life Sciences
Los Angeles Southwest College
Los Angeles, California

ELSEVIER

CONTENTS

NETWORKING CBE IN HEALTH SCIENCES J. Dale Brubeck	41
COMPUTERS IN BIOLOGY EDUCATION: FORMAL COURSEWORK AT NOTRE DAME Theodore J. Crovello	44
KEEPING ABREAST OF THE LITERATURE	47

NETWORKING CBE IN HEALTH SCIENCES

J. Dale Brubeck

*Division of Computing Services, The Ohio State University College of Medicine,
Columbus, Ohio*

National networking of computer-based educational materials (CBE) has been possible for many years, but it was not until the micro-computer explosion that widespread interest in this communication mechanism appeared. With microcomputers and modems, thousands of individuals have become potential end users of CBE materials. In the health sciences, CBE materials have been networked for over ten years, but new possibilities for continued growth and usefulness are emerging.

Recently *PC World* contained an article on "The Electronic University," whereby "education by modem becomes a reality."⁷ In many professions networks of computer-based resources have

been developed for training or information resources. The American Bar Association (ABA) has developed ABA/Net, an electronic mail and conferencing service. Legal data-bases such as WESTLAW, LEXIS, and INFOLAW provide texts of court decisions, case-law libraries, directories of law journals, and other resources for the legal profession.¹ The American Medical Association has organized a database service for physicians that includes educational programs and information databases for diagnostic and treatment purposes. CompuServe, an "information utility," has 130,000 subscribers who access a variety of database services and have formed numerous special interest groups (SIGs) for the ex-

change of information on an informal basis. Two of the most active SIGs are the aviation and the medical interest groups, and continued growth is projected as more professional groups recognize the value of communicating through electronic bulletin boards and accessing electronic information of professional interest.

The development of asynchronous technology and the ASCII protocol encouraged the growth of networking. Remote users with relatively low cost terminals can access computer systems over conventional telephone lines, either through dedicated local cables, leased telephone circuits, or dial-up connections. "The asynchronous serial line offers the ordinary user a high degree of convenience and control in establishing inter-system connections—at low cost."³

The history of national networking begins with ARPANET (Advanced Research Projects Agency) which was developed in the late 1960s by the federal government for research purposes and interinstitutional sharing.⁴ From this early experimentation in remote computing came the development of "Value added networks" (VANs). Two of the earliest and best known VANs are TYMNET and TELENET. These networks allow public access to a variety of database services usually through a local network telephone linkage to a network node (minicomputer). VANs have alleviated the need for database services to maintain their own private networks. With the widespread availability of microcomputers, information utilities oriented to the individual user began to develop, linking the user to a variety of information databases. These utilities, most notably The Source and CompuServe, used existing telecommunication networks until CompuServe developed its own telecommunications data network.

In the health sciences, a unique

national networking experiment was conducted in 1972. This experimental network was conducted by the Lister Hill Center for Biomedical Communications (National Library of Medicine). Computer assisted instructional materials at the Ohio State University College of Medicine, the Massachusetts General Hospital, and the University of Illinois Medical Center in Chicago were made available to medical institutions throughout the nation. Users of the Lister Hill Experimental CAI Network were required to provide an ASCII-compatible terminal and a modem that would allow access to a local node of TYMNET. The end user was then able to interact with the health sciences educational programs at any of the host databases.

In May 1975, the Lister Hill Center discontinued subsidy of the network. Network users, convinced of the usefulness of the sharing endeavor, elected to initiate a special interest group, the "Health Education Network Users Group," within the Association for the Development of Computer-Based Instructional Systems (ADCIS). Through this organization the early users of the network fulfilled the immediate goal of preserving and enhancing inter-institutional sharing of CAI resources and technology as initiated in the Lister Hill Experimental Network. From that time to the present, health related computer-based educational materials from both OSU and MGH continue to be provided for use as primary and continuing health education for a variety of users including medical, nursing, dental and allied health schools, university affiliated and community hospitals, technical schools, research projects, national medical organizations, and individual professionals.⁵

The use of remotely accessed computer assisted instruction varies from institution to institution, ranging from a required part of a

curriculum to an adjunct learning resource available in the health sciences library learning center. Many institutions make the materials available for remediation or advanced work, taking advantage of such special characteristics of CAI as individualized instruction, self-pacing, flexibility of access, and immediate feedback.

In two recent research studies, the University of Michigan and the University of Oregon used patient simulation programs from OSU to help medical students develop skills in history taking and diagnosis. These materials, CASE (Computer Aided Simulation of the Clinical Encounter) and TAKEHX (History Taking) are part of a library of over 500 hours of computer assisted instruction available to national network users from the Ohio State University College of Medicine.

Networking educational materials from a central database offers the remote user many advantages. The network user is spared the cost of maintaining a computer system as well as the costs of developing and maintaining CAI programs. Also, the central database is responsible for updating the programs, although users frequently influence the revision of programs through their comments. Network users can share or have access to CBE materials not available at their local site, the user can sample the material without committing large financial resources for up-front purchase. The central database host normally provides troubleshooting support, but the relative ease of network access makes networking a user-friendly experience.

One of the greatest obstacles to the growth of networking has been the relatively high costs of telecommunications. When several hundred students access many hours of programming, the cost per institution for student access can reach into thousands of dollars.

Administrators have questioned the cost-effectiveness of such access, especially when compared to traditional learning resources or maintaining a system at their own site. There may also be academic resistance to the introduction of materials that do not quite fit into the curriculum and that end users have little control over.

Another initial obstacle to the acceptance of networking from a host mainframe was the unexpected down periods either at the host site or in the national network. Most systems today, however, have resolved technical problems of access and run very reliable and stable systems.

An additional problem for some users is the rate of transmission in a networked environment. Twelve-hundred baud or 120 characters per second is the maximum available via a dial-up network. In fact, 300 baud is a more common transmission speed and can be distracting to someone who is accustomed to instant screen displays.

Other barriers to growth have been a lack of appropriate courseware in many academic areas and a lack of incentives for courseware development. In addition, it has taken time for instructional design techniques for CAI to develop to the point where the power of the computer is used in a sophisticated fashion.

Microcomputers are changing how computer-based education is perceived by educators. Recently there has been a burst of activity in courseware development, and institutions are beginning to address some of the issues involved in faculty development of courseware, such as royalties, copyrights, and credit as a scholarly effort.

In the June 1984 issue of *BYTE*, several articles point to the growing utilization of microcomputers on college and university campuses. Networking is perceived as a delivery mechanism for "electronic mail,

student bulletin board and information services, and electronic library catalogs as well as communication among faculty, students, and staff."⁶ Although national networking of educational materials is not described as part of the environment, the microcomputer can function as a terminal and, with proper communications equipment, can access national databases. Of course, payment for this access is the critical question, as well as system security when microcomputers with RS232 ports proliferate to every classroom and dormitory.

Microcomputers as stand-alone devices offer some of the advantages not currently available through networking: no down periods except for equipment failure; no telecommunication costs; availability of graphics; faster transmission speed; and possession of the CAI material. However, microcomputers continue to present problems as educational tools. Complex tutorial programs require several floppy disks for adequate storage. Screen size puts certain limits on design and graphics, and program exchange will require use of a mail service with the associated time delays and hazards. Student management reporting is logistically more cumbersome. Program exchange is further hampered by incompatibilities among microcomputer systems.

The future of sharing computer-based educational materials probably will rely on a combination of technologies that will include local and national networking. A possible scenario could include remote distributed processing whereby an end user thousands of miles away may dial up a host database via the network and request that a program or programs be downloaded to a hard disk for utilization on a local micro-computer. The telecommunications cost for downloading would be minimal when compared to on-line interaction time for stu-

dents. Student responses could be uploaded to the host database and processed for management or revision purposes and then the resulting information could be downloaded to the remote user upon request. This combination of microcomputer and networking technology should create the broadest and richest learning experience, assuming that appropriate materials exist for sharing and incompatibilities between systems can be overcome.

The history of networking computer assisted instruction, especially in the health sciences, has been a continuous one since the early 1970s, and the value to end users has been established. However, the cost of developing computer assisted instruction and then maintaining a network are not trivial; the fact that relatively few networks were developed or remain operational is an indication of the difficulties involved.

National networks offer many advantages to the user, and the exchange of educational materials will continue to be valuable in the future. The challenges for educators wishing to share materials are to reduce the cost of telecommunications, develop materials appropriate to audiences in remote locations, to update those materials on a regular basis, and to overcome technical barriers presented by the incompatibility problem.

One educator has noted that "an environment that is densely populated with computers represents a new type of world."² The challenge is to mold that new world in a positive way to achieve appropriate educational objectives.

REFERENCES

1. Berghem K: Taking the toil out of the law. *Infoworld* 6(23):34-35, 1984.
2. Chronor SL: Cautions on computers in education. *BYTE* 9(6):223-226, 1984.

3. da Cruz F, Catchings B: Kermit: a file transfer protocol for universities. *BYTE* 9(6):255-278, 1984.
4. Hammer C: Telecommunications and network trends. *The Journal* 11(8):100-104, 1984.
5. Health Education Network Information Brochure, Bellingham, WA. ADCIS, 1977.
6. Osgood D: A computer on every desk. *BYTE* 9(6):162-184, 1984.
7. Stahr LB: The electronic university. *PC World* 2(1):246-249, 1984.

produced two extreme types of biologists interested in CIBE: those who already are familiar with computer systems and programming; and those who have no background in programming or even in computer use, but have a strong desire to investigate this device that promises to enhance education (and also is popular and prestigious!). In addition some bioeducators have available only one type of computer while others have a variety. Some may have access only to a campus mainframe computer, or to a stand-alone minicomputer, or perhaps only to microcomputers. But other biologists have all three types available. The CIBE course at Notre Dame must accommodate participants with different combinations of these traits.

COMPUTERS IN BIOLOGY EDUCATION: FORMAL COURSEWORK AT NOTRE DAME

Theodore J. Crovello

Department of Biology, The University of Notre Dame, Notre Dame, Indiana

Faculty members have been using computers in bioeducation at Notre Dame for over 15 years. This results from our long-term philosophy that the wise use of computers can enhance all levels of education in the life sciences. Whenever possible we hire faculty who actively use computers in education or at least are receptive to considering their use.

The Biology Department has provided both computer hardware and software assistance to any faculty member who indicates a desire to explore how computers might enhance his or hers course. Sometimes this requires only the assignment of hardware. At other times the professor has no computing experience but does see how computers may help in part of a course. In such cases a graduate or undergraduate biology student with computing experience is assigned to work with the professor to produce a useful and reliable bioeducation computer module. Over the years the above philosophy and its resultant activity has raised the consciousness of the department toward educational computing. This in turn helped to create a need for a formal course in Computers In Biological Education (CIBE: pronounced as *cyber!*).

The purpose of this paper is to describe the course, its activities, what

worked and what did not, and other related issues. Of special interest is the fact that the course has been taught in two modes and to a different clientele in each. I have taught it as a regular semester course to Notre Dame biology students and as a special, summer, one-week, intensive short-course to biology faculty from colleges and universities throughout the United States. I emphasize that this is not a course in Computers In Biology that centers on research. It does not consider biological research uses of computers at all. My Notre Dame colleagues offer three other courses on that topic.

COMPUTERS IN BIOEDUCATION TODAY

To appreciate more completely certain aspects of Notre Dame's CIBE course, we must consider the status of CIBE at both Notre Dame and the national level.²⁻⁵ Biology is like other fields in many ways. Some older faculty are intimidated by a device that they feel may replace them as a teacher instead of assisting them. There is a scarcity of pedagogically sound, biologically meaningful software. CIBE interest has greatly accelerated since the availability of microcomputers.

These and other factors have

COURSE CONTENT

The CIBE course covers the following topics.

1) A CIBE Overview. It presents basic concepts of computers, of bioeducation, and of both combined. The goals and history of CIBE are discussed as are an overview of when, where, and how to use CIBE.

2) Computer Systems. Computer systems are presented as consisting of three parts, all essential: hardware, software, and people. Participants use some of the more than 50 CIBE programs available on various mainframe, mini-, and microcomputers at Notre Dame to become familiar with the pros and cons of the different systems and of the CIBE modules.

3) Bioeducation. Since biology teachers at the college and university level are not required to have taken even one education course, many are unfamiliar with even basic education concepts (eg, Bloom's taxonomy). These are discussed with readings from books like Hoover's.⁶ Additional topics include bioeducation as a multistage decision process, educational strategies, evaluation of

bioeducation modules, and the possible use (and misuse) of computers.

4) CIBE Module Case Studies.

Participants become familiar with CIBE programs and projects available at Notre Dame to see in more detail how computers can be used in bioeducation. Different programs demonstrate combinations of information retrieval, data analysis, simulation, decision making, experimental control, course review, etc.

5) Creation of a CIBE Module.

Each person in the course is asked to create one or more CIBE modules that are sophisticated both in their biological content and computer technology. The CONDUIT Author's Guide⁷ is used extensively to convey the rules and strategies of the design, development, style, packaging, and review of a CIBE module. Course participants choose a particular target course (eg, Genetics, Parasitology) and consult with teachers about what part of the course might benefit from computer use. This has had the valuable by-product of subtly introducing many hesitant professors to CIBE, in both a meaningful and friendly way. CIBE creation is presented as a multistage decision process.⁴ That is, CIBE creation involves many stages and sub-stages, and decisions must be made at each of them (eg, the interactive strategy, choice of models to use in a simulation). The important point is realized that such decisions made in the creation of a CIBE module determine whether it will be an educational success or failure.

6) Evaluation of a CIBE Module. We discuss criteria for the evaluation of a CIBE module. These cover biological, computer, and other aspects. Problems and disadvantages are considered, as are the difficulties of carrying out formal, meaningful, statistical analyses.

7) CIBE Day. The final meeting of the course is a day of celebration and demonstrations of student-produced CIBE modules. A schedule

is widely distributed around the campus. Everyone is invited to attend the first public demonstration of the newly created CIBE

modules. CIBE day has proven to be valuable to the participants because during the course it gives them an event and date on which to focus, and also lets them share their creations with others.

The diversity of CIBE modules created by course participants has been large. Examples include modules dealing with osmotic and ionic regulation, acid and base balance in animals, nerve function, the respiratory physiology of animals, a simulation of a ginseng population pest control by pathogens and pesticides, and tree identification using a microcomputer that also controls a videotape.

THE CIBE COURSE IN THE REGULAR SEMESTER

Notre Dame students taking the course in the regular semester include biology or premedical undergraduates and biology graduate students. Some have a programming background, and some do not. They are told at the outset that the course will be demanding of their time, both for creativity and routine programming. To provide further motivation, students were asked to carry out a joint role. They (and I too) were to assume we were a team from BIO&UND, a consulting firm for educational computing. Furthermore, we assumed that our team had been hired by Notre Dame's Biology Chairman to study and propose how computers could enhance bioeducation in specific courses in the department at Notre Dame and to create actual computer modules. This role playing proved very beneficial for several reasons. It motivated the students towards the goals of the course, but it also demanded that they take the initiative in many ways, eg, in seeking out the profes-

sor in the course they chose, in offering suggestions to the professor on aspects like the best interactive strategy to use in the computer module. Furthermore, by giving each student the freedom to choose their own biology area, they would be working in an area they liked and in which they already had a background. This latter point is important for two reasons: time during the CIBE course to learn the biological subject matter was minimized; and the CIBE course provided a meaningful opportunity for each student to efficiently reinforce his grasp of the subject.

Additional motivation for students in the CIBE course was effected by their knowing on the first day of classes that almost all of their grade would be based on the value of the CIBE modules they created and demonstrated to their peers and professors. Like most of us, students are most concerned about peer evaluation. They also were told that their classmates as well as the professor would be formally evaluating their modules. All of the above resulted in a solid team approach because they knew they were not competing against each other. For example, at several critical stages in the creation of a course module, a student was required to present a module flowchart (not a program code flowchart) in class. Other students in the class frequently offered excellent suggestions to improve the module's interactive strategy. As another example, in the minutes before classes started, it was a common occurrence to see one student helping another with a programming problem.

Another positive motivating factor for students was the realization that creation of CIBE modules was a rare opportunity to contribute something to the educational system instead of being only a student recipient. The knowledge that future students in other courses at Notre Dame and elsewhere would be using

their CIBE modules was important to them.

The format of this three-credit course began as three lecture periods per week. Lectures covered two topics. The first presented the state of the art of CIBE at the national level, of computer systems, of concepts of bioeducation, etc. The second set of alternating lecture periods were devoted to the mechanics of actually creating a good CIBE module. They included presentations and discussions of flowcharting, computer graphics, and critiques of primitive CIBE modules which they had run.

By midsemester, attention focused completely on their own modules. Each student was required to create 4 or 5 "civilized" programs (including Help menu, user protection, user friendliness, and of course biologically valuable content). Formal lectures were replaced by individual weekly meetings between the professor and a student. The entire class met together about once per week or two to discuss common problems and suggestions. To help students budget their time, each had to create a schedule indicating on which date each task of the CIBE module creation process would be completed. The one invariant date was CIBE Day, the last day of classes on which the oral presentations of their CIBE modules would occur. Each student was urged to finish one CIBE module completely as early as possible to obtain a realistic idea of the total time required for one module and thus for four or five.

CIBE Day, in which each student demonstrates his completed modules to his peers and professors, is always a day of amazement and pride. Everyone is amazed at the sophisticated and biologically meaningful modules, and each student is proud of his accomplishments, which now become part of his curriculum vitae and may provide that competitive edge in securing a good job.

THE CIBE COURSE IN ONE INTENSIVE WEEK

I have also offered the CIBE course as an intensive, week long, summer workshop for faculty from other colleges and universities. Such participants come highly motivated but with a diversity of computer backgrounds. Some have no experience at all. The week is intensive, but it is still only a week. Thus we ask participants to arrive at Notre Dame with ideas about how computers can be used in specific parts of the courses they teach. If they have had no programming experience, we send them a primer on the BASIC language and ask that they study it thoroughly.

The first morning is devoted to an overview of computers, computers in biology (including research), and more specific aspects of computers in bioeducation. The afternoon and evening involves their actual use and evaluation of several primitive and civilized CIBE programs. Those without programming experience are instructed in BASIC. Their assignments for the next day are to create a program flowchart of one of the available primitive programs, to suggest improvements to it, and to create a conceptual flowchart of their proposed CIBE module (each participant is urged to create and complete one CIBE module during the week). The second day and subsequent days (and nights!) involves their work at computer terminals, discussion of primitive versus civilized programs, oral presentations of their proposed CIBE modules, the CONDUIT Author's Guide, documentation, and fine tuning.

A general discussion of bioeducation and the role of CIBE in it is held whenever time allows, usually toward the end of the week. Some participants find these discussions to be valuable enough to justify the entire course. Why? Because as mentioned earlier, college and university professors are not required to take

even one education course, and thus many have never stepped back to evaluate their teaching effectiveness in an organized way. In other words, before responsible teachers can truly decide to use computers in their courses, they must know what their goals are. Computers also seem to have played an analogous role in some areas of biological research. For example, before the use of computers in plant and animal taxonomy, a researcher often would propose a phylogenetic tree based on some unexplainable procedure. Use of computers does not guarantee production of true phylogenetic trees, but it does demand that researchers adopt logical procedures and produce testable hypotheses.

While the CIBE course is constantly evolving, both students and faculty seem to come away highly motivated and pleased with their accomplishments. Several faculty participants expressed not only a more positive attitude towards CIBE but also towards biology teaching itself.

REFERENCES

1. Crovello TJ: Analysis of character variation in ecology and systematics *Ann Rev Eco Syst* 1:55-98, 1970.
2. Crovello TJ: Computers in biological teaching. *Bioscience* 24:20-23, 1974.
3. Crovello TJ: Computers in bioeducation: 1979 state of the art report. Iowa City, IA: CONDUIT, 1980.
4. Crovello TJ: Computers in the life sciences, V: Computers in the life sciences, V: Computers in bioeducation. *Bioscience* 31:859-860, 1981.
5. Crovello TJ, Smith WN: Plants and human affairs: educational enhancement via the computer: proceedings of the eighth conference on computers in the undergraduate curricula. 1-6, 1977.
6. Hoover KH: College teaching today: a handbook for post-secondary instruction. Boston: Allyn and Bacon, Inc. 1980.
7. Peters HJ, Johnson JW: Author's guide: design, development, style, packaging, review. Iowa City, IA. CONDUIT, 1978.

KEEPING ABREAST OF THE LITERATURE

This month's list of references pertinent to use of computers in life science education is the second in a series that will become a quarterly feature in CLSE. The first list, which appeared in the June issue, covered a six-year period and was designed to illustrate the scope of journals publishing reports in this topic area. This month's feature focuses on reports that appeared in 1983.

Asbury AJ: ABC of computing. Computers in medical education. *Br Med J [Clin Res]* 287:887-890, 1983.

Barker PG et al: A practical introduction to authoring for computer-assisted instruction. Part I-IPS. *Br J Educ Tech* 14:26-45, 1983.

Bright GW: Explaining the efficiency of computer-assisted instruction. *AEDS Journal* 16:144-152, 1983.

Butcher PG et al: Tutorial CAL and biology education. *J Biol Educ* 17:43-50, 1983.

Crovello TJ: Computer center: a diversity of publications on educational computing. *Amer Biol Teach* 45:167-169, 1983.

Day Mj et al: Computer simulation of a microbial genetics experiment as a learning aid for undergraduate teaching. *J Biol Educ* 17:40-42, 1983.

Geyer TA: An introduction to writing computer programs in ecology. its educational value. *J Biol Educ* 17:237-242, 1983.

Goodridge F: The teaching of protein synthesis — a microcomputer based method. *J Biol Educ* 17:222-224, 1983.

Harris AL: Microcomputers in the college environment. *CAUSE/EFFECT* 5:6-11, 1983.

Lehman JD: Microcomputer simulations for the biology classroom. *J Comput Math Sci Teach* 2:10-13, 1983.

Leveridge LL: The interactive videodisc. *MOBIUS* 3:68-72, 1983.

Levin W: Interactive video: the state-of-the-art teaching machine. *Comput Teacher* 11:11-17, 1983.

McDonald CJ: Computer technology and continuing medical education: a scenario for the future. *MOBIUS* 3:7-12, 1983.

McMarr S: Computer applications in education and training: taking that first byte. An overview of the field. *Comput Programs Biomed* 17:181-189, 1983.

McMarr S: Computer applications in education and training: taking that first byte. The process. *Comput Programs Biomed* 17:175-179, 1983.

Montagu WE et al: Quality CBI depends on quality instructional design and quality implementation. *J Computer-Based Inst* 10:90-93, 1983.

Pagliaro LA: CAI in pharmacology: student academic performance and instructional interactions. *J Computer-Based Inst* 9:131-144, 1983.

Painter JH: Approaching computer-based education. how will the university respond? *National Forum: Phi Kappa Phi J* 63:20-22, 1983.

Park D: Taxis through computer simulation programs. *J Biol Educ* 17:225-230, 1983.

Pearson RE et al: Experience with computer-assisted instruction in drug literature analysis. *Am J Pharm Educ* 47:108-112, 1983.

Pickering PW: A microcomputer program to show the effects of selection on gene frequencies. *Sch Sci Rev* 64:789-791, 1983.

Rothe CF: Trends in physiology teaching laboratories for medical students—1982. *Physiologist* 26:148-149, 1983.

Shortliffe EH: Problems in implementing the computer for continuing education. *MOBIUS* 3:52-55, 1983.

Simon FA: Computer analysis of residency training. *J Med Educ* 58:585-586, 1983.

Smith SR: An evaluation of a computerized exercise in teaching cost consciousness. *J Med Educ* 58:146-148, 1983.

Utsch Mj et al: Generator program for computer-assisted instruction: MACGEN. A software tool for generating computer-assisted instructional texts. *Comput Programs Biomed* 17:167-174, 1983.

Waller W: Development of a computer-assisted behavioral skill training system. *J Dent Educ* 47:107-109, 1983.

Watson JE: The impact of technology on the future of health/illness education. *Health Educ Q* 10:95-105, 1983.

Compiled by H. Modell

COMPUTERS IN LIFE SCIENCE EDUCATION

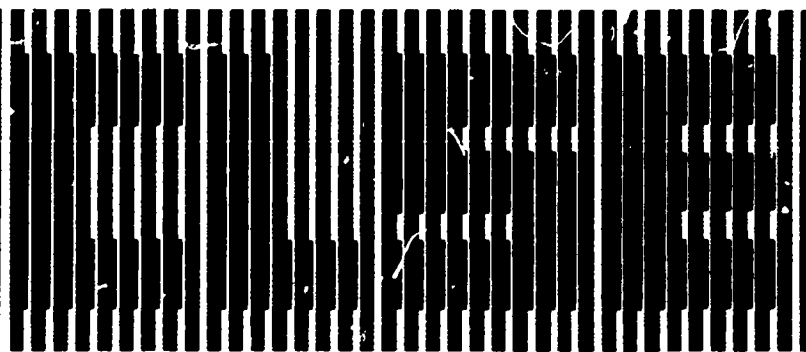

HAROLD I. MODELL

Virginia Mason Research Center
Seattle, Washington

MARCEL BLANCHAER

Professor of Biochemistry
Faculty of Medicine
University of Manitoba
Winnipeg, Manitoba
Canada

THEODORE J. CROVELLO

Department of Biology
University of Notre Dame
Notre Dame, Indiana

JAMES W. ECKBLAD

Department of Biology
Luther College
Decorah, Iowa

TSEGAYE HABTEMARIAM

School of Veterinary Medicine
Tuskegee Institute
Tuskegee, Alabama

DONNA LARSON

School of Nursing
Grand Valley State College
Allendale, Michigan

TERRY M. MIKITTEN

Graduate School of Biomedical Sciences
University of Texas Health Sciences Center
San Antonio, Texas

JAMES E. RANDALL

Department of Physiology
Indiana University
Bloomington, Indiana

PATRICIA SCHWIRIAN

College of Nursing
Ohio State University
Columbus, Ohio

RICHARD STULL

College of Pharmacy
University of Arkansas
Little Rock, Arkansas

JAMES W. WOODS

Luster Hill National Center
for Biomedical Communications
National Library of Medicine
Bethesda, Maryland

DOROTHY WOOLEY-McKAY

Department of Biology
Glendale Community College
Glendale, Arizona

GLENN YOSHIDA

Department of Life Sciences
Los Angeles Southwest College
Los Angeles, California

ELSEVIER

CONTENTS

SOLVING AN INSTRUCTIONAL PROBLEM WITH INTERACTIVE VIDEO	49
Mary Lou Mosley, Naomi O. Story, and Jim Walters	
HOW CAN YOU DETERMINE WHICH EDUCATIONAL SOFTWARE IS BEST FOR YOUR APPLICATION?	51
Clyde Tucker	
COMPUTERS AND UNDERGRADUATE COMPARATIVE PHYSIOLOGY	54
William H. Heidcamp	

SOLVING AN INSTRUCTIONAL PROBLEM WITH INTERACTIVE VIDEO

Mary Lou Mosley, Naomi O. Story, and Jim Walters
*Maricopa Community College District and Maricopa Technical Community College,
Phoenix, Arizona*

How can you teach respiratory therapy students to differentiate lung sounds when they auscultate the chest? They easily can learn to define the sounds and describe their characteristics. However, insuring that the students and the instructor hear the same sound is difficult when using traditional teaching methods. Providing enough review of the sounds and practice to meet varying individual needs also is hard and time-consuming. Some students can

differentiate the sounds quickly, while others need a lot of review and practice

An interactive videotape system appears to be the instructional method that best solves our problem. An interactive video system is a combination of videotape or disc, which provides much of the instruction, and a microcomputer, which accepts student input and controls the video. We are using an APPLE //e with a BCD Associates interac-

tive interface board and a Panasonic video cassette recorder and monitor. The interactiveness of the computer is enhanced by the advantages of video such as motion, sound, close-up shots, and color.

Sound was the key factor that indicated to us that interactive video was better than just computer-assisted instruction. We had examples of lung sounds that we could record onto the audio track of the videotape. We could then add visuals to reinforce the sounds and enhance learning. For example, the length of inhalation and exhalation is one way to identify lung sounds. While a lung sound is being played, lines representing inhalation and exhalation could be drawn.

An interactive video system also provides for highly individualized instruction keyed to specific objectives. We broke the lung sounds unit into four parts: characteristics (pitch, intensity, duration, continuity, and inhalation/exhalation), bronchial lung sounds, bronchovesicular lung sounds, and summary practice. The computer is programmed so that students have to master each part before moving on to the next. In addition, within each part, the computer will evaluate student input to determine if the student should have remediation or practice. The student also may select a review option. Thus, fast learners can proceed through the unit quickly, while slow ones are provided with remediation and additional practice based on skill deficiencies.

DESIGN CONSIDERATIONS

Designing an interactive video unit requires time, teamwork, and a combination of content, instructional design, computer, and video skills. Not only must the traditional con-

tent and instructional design decisions such as objectives, sequence, and instructional strategy be made, but also decisions unique to computers and video must be considered. These decisions include how much and what should be on the computer and on video as well as comparing the learning benefits versus time and programming costs.

Since we are producing the videotape for the lung sounds unit, we decide what content goes on the videotape and the most efficient sequence to limit access time. Access time is the time the computer searches for the beginning frame of a videotape segment. It is the primary limitation of an interactive videotape system, especially if commercially produced videotapes are used. The content for a skill may be scattered throughout a 30 minute tape. Not only would access time be long, but the video segments would be short and choppy. Previously faced with that situation, we put some of the content on the computer.

We have had to make several other decisions about the program design. We used an authoring language, SuperPILOT, rather than a programming language such as BASIC, or an authoring system such as Instructor (BCD Associates). SuperPILOT gave us more flexibility in designing the program than either BASIC or Instructor. We also had more options with SuperPILOT than with an authoring system, yet SuperPILOT was easier to use than BASIC.

Our other decisions concerned the degree of program sophistication. We wanted to use the interactive system as much as possible to individualize the unit for fast and slow students. But, we also weighed the learning benefits versus time and

programming costs. For example, we had to decide how much branching and how many difficulty levels to include. We programmed the computer to send students who missed two items on one sound through a remediation loop. Remediation included a review of the content and additional examples on the videotape. Yet, we also gave students the option of reviewing a specific sound or a part of the lesson. They can return to the menu and type the letter by the sound they wish to review (eg, type A for ronchi or B for rales).

We also wanted to generate problems randomly with some safeguards against repeating sounds in a row. However, we discovered that programming was too difficult, and access time too long to justify the safeguards. Thus, students will identify two practice items for each sound, but the items for the same sound may follow each other if randomly generated in that order. We can still use random generation which means students will learn the sounds rather than learn a pattern from the way practice items were presented.

Although the time and effort to design and produce this interactive video unit have been great, differentiating lung sounds is an important skill. By using the interactive video method, students are practicing the skill they need—differentiating lung sounds—and we have provided for individualization, review, and monitored practice with corrective feedback. We hope to have this unit ready for students in late fall. The students will work on the unit until they master the skills. We will collect data on how much time they take, how well they do, where they make mistakes, and what kind they make. Then, we will revise the unit.

HOW CAN YOU DETERMINE WHICH EDUCATIONAL SOFTWARE IS BEST FOR YOUR APPLICATION?

Clyde Tucker

Office of Educational Services and Department of Physiology, University of Colorado Health Sciences Center, Denver, Colorado.

From month to month you can sense the increased enthusiasm for the use of microcomputers in many different phases of our lives. Fueled by the steady improvement in performance, improving prices, and extensive advertising from the vendors, the pressure is constant. Every week we see announcements of "new and improved" educational software that is claimed to have value in our area. Brochures arrive in the mail, ads appear in magazines, and our colleagues always return from meetings or visits to other institutions with descriptions of new software that is claimed to have great potential in our program.

The educator is always searching for better educational methodology, and it is obvious that the microcomputer has the potential for many valuable applications in various educational settings. However, the value of the microcomputer as an educational tool will be no better than the quality of the educational software that is used.

We could each develop our own educational software, but, because of the impressive number of hours required to develop one hour of well designed instructional material, that is probably not the best choice for many educators. It may be relatively simple to design an instructional module that presents some new material, but, as Arons pointed out so well,¹ it requires considerably more investment of time to develop a module that is well designed to identify and deal with the more common stumbling blocks that students are likely to encounter with

certain material. That type of instructional design is essential if we are to take full advantage of computer technology in education, but it does require a substantial time investment. Determining whether software in the marketplace has been designed to meet our needs and finding out how well it is working in other institutions would ease this burden and be more efficient.

EVALUATION MECHANISMS

So how do you tell which software is most appropriate for your application? Thorough evaluation of a large program is likely to require many hours of effort on the part of several faculty members. It is often difficult to get that extensive faculty commitment, and budget limitations may not permit the acquisition of all software that should be evaluated.

Some vendors will provide demonstration packages. Some of these are adequate for an evaluation if you have suitable resources (faculty time). Other vendors provide a "mini sample" that gives you a brief look at the program but not a chance to conduct a thorough evaluation. Other vendors will provide a "purchase on approval," which requires that you purchase the package but have the opportunity to return it for full refund within 30 or 60 days if it is not satisfactory. That obviously requires careful scheduling to be certain that the appropriate faculty members are available to conduct the evaluation during the limited time that the program is available.

Under ideal conditions these techniques may give you a reasonable opportunity to determine if any given software module is acceptable, but is it the best that is available? It is usually not possible to know this because of the extremely rapid changes in the market. Often you are forced to make a decision with doubt as to whether or not you have thoroughly evaluated what is available on the market. It is apparent that this is more challenging than selecting textbooks (as if that was always easy!). And to make the whole situation more complex, the content of the marketplace is changing daily.

The challenge of making the best selection from available software is being faced by an increasing number of educators in all fields. It is impractical and wasteful for each educator to evaluate each new piece of software. What we urgently need is a method to provide timely sharing of the results that we gain from our evaluation and utilization of software. Even when a serious attempt is made to evaluate an instructional package adequately, there will still be some residual uncertainty until the program has been used by students and other faculty. It would be very helpful if we could learn easily about the experience that other educators have had with that package.

SHARING MECHANISMS

The results of our experience in reviewing, testing, and finally using any software should be shared with our colleagues. Newsletters such as

this one can provide a valuable vehicle for sharing information, but there is, or soon will be, more experience than any print format publication can handle. And a publisher would not care to publish the third, fourth, fifth, or hundredth report of experience with a particular set of software. Yet the experiences of our colleagues throughout the country and the world should be available for convenient and timely access and review by all educators.

Electronic networking should provide us with a solution to this dilemma. A large database including a description of all available educational software should be developed and maintained. That network should simultaneously provide a mechanism to summarize the experience that many educators have had with that particular package. The database should include the response to questions such as the following:

- How many schools are currently using the package?
- What type of students are using the package?
- How well is it meeting their needs?
- How many educators have discontinued use of the package?
- Why was use discontinued?

Current electronic technology can easily support this badly needed information exchange, but the technology will not do the job without appropriate organizational support. That support is essential to developing a suitable format and providing

the close attention that will be required in order to keep the database well organized and current, which includes reminding all of us to provide our input at the proper time.

There are several organizations or institutions that have the potential to support this activity. One is The Association for the Development of Computer-based Instructional Systems (ADCIS),² which has worked for years to facilitate the development and use of computer-based educational activities. With the emergence of the microcomputer as a major educational resource, ADCIS has focused increasing attention on this area.

ADCIS-NET

Recently ADCIS arranged for the development of a database on CompuServe. The database will be included in the ADCIS-Net, which is now accessible on CompuServe. The format of the network and its database are currently under development. This network should become a major asset to all who are searching for computer-based educational material. The network should reach full operation in the next few months and will hopefully include a provision to share user experience with software.

In addition to the development of the database regarding instructional software, ADCIS has negotiated a special CompuServe rate that its members can receive if they apply by December 31, 1984. For more information regarding ADCIS-Net

and the special rates, contact Ron Comer, president of ADCIS. His address is 076 Health Sciences Library, 376 W. 10th Ave., Columbus, OH 43210-1240.

When a network such as ADCIS-Net is in full operation, it will still be no better than the information that we enter. The network will be of some value if even a small number of educators make an ongoing commitment to provide input regarding their experience with educational software. The network will be of great value if a large number of educators are willing to provide periodic input of their experience.

Undoubtedly a few educators will provide periodic input, but the real potential of the system will be achieved only when the vast majority of educators who are using microcomputer-based educational software are willing to routinely update the network regarding their experience. If that does occur, we will all be able to examine the database and obtain valuable information that will enable us to make the best investment of time for our students and ourselves as well as gaining the best utilization of our fiscal resources.

REFERENCES

1. Arons AB: Computer based instructional dialogs in science courses. *Science* 224:1051-1056, 1984.
2. Comer RC: Professionals in computer-based education and training. *Computers in Life Science Education* 1(5):37-38, 1984.

WANTED

-Feedback-

- * Is CLSE meeting your needs?
- * Have important topic areas been overlooked?
- * Should more regular features (e.g., Keeping Abreast of the Literature) be added?

**CLSE IS NOW 6 MONTHS OLD. YOU CAN HELP
SHAPE ITS DEVELOPMENT. PLEASE SEND
COMMENTS AND CRITICISM TO:**

DR. HAROLD MODELL
VIRGINIA MASON RESEARCH CENTER
1000 SENECA STREET
SEATTLE, WASHINGTON 98101

COMPUTERS AND UNDERGRADUATE COMPARATIVE PHYSIOLOGY

William H. Heidcamp

Department of Biology, Gustavus Adolphus College, St. Peter, Minnesota

Beginning in 1976, Gustavus Adolphus College increased the academic use of computers in its curriculum. Assisted by an NSF grant, a Harris minicomputer was installed. The system has grown to include more than three dozen terminals and has become an integral part of our pedagogy. So successful is the college involvement that the machine became overworked, and pandemonium ensued when the system was "down." This was particularly true for the biology program and its computer-assisted laboratories.

More recently the college invested in microcomputers, principally IBM PCs, and an occasional Apple, TRS-80, Commodore, or Compaq. A typical system has one or two double-sided disk drives, a Quadram Board with RAM Disk, color graphics card, and dot-matrix printer. Several are equipped with RGB monitors and Hayes Smartmodems. The latter allow terminal emulation for interaction with our Harris System and thus use of previously developed software.

The typical system (as described) can be installed for about \$3000 using IBM PCs and depending on options. Less expensive configurations are available. The microcomputer can be placed on a mobile cart and made available during laboratory sessions. The modem brings the power of the minicomputer into the laboratory for the cost of a telephone outlet.

This article describes the use of microcomputers in an upper level undergraduate course in compara-

tive physiology, required of all biology majors. Since the computers are mobile, they are used extensively for other purposes, but those applications would be the subject of another report. This report is for those contemplating incorporation of computers into their teaching of physiology.

COMPUTER USE

Computer-assisted education can usually be divided into drills and simulations. Drills make excellent use of student and faculty time by handling the redundant and laborious repetitive aspects of any course that requires continued practice, which may be enriched by the ability of the computer program to interact with the student. The drills are as good as the thought and preparation that goes into the design of the program, and several books are now available on this subject.^{3,5,7}

Simulations are becoming increasingly popular but are fraught with their own problems. The main objection is that one begins to substitute the machine for analysis and study of the actual living organism.^{1,2} The advantage is eventual time saving for repetitive functions—the eventual is not insignificant, since initial use will most likely require more time than what you will end up saving.

Our own use of computers involves drill and simulation plus data analysis, interactive programs, and test generation. A key element in our approach is the joining of lab-

oratory experience with the abilities of the computer. We are sensitive to the need for avoiding substitution of the computer for reality, but are excited about the use of the computer as an educational tool when coupled with the other tools available.

A CASE IN POINT

General Physiology at Gustavus Adolphus College involves an average of 70 students per semester divided into four laboratory sections. During a three-hour lab session, approximately 18 students are divided into teams of six each, and three separate exercises are undertaken simultaneously in the laboratory. For example, in the first week of lab, an exercise on osmotic regulation of mussels, thyroxin action on cellular respiration, and surgical removal of adrenal glands from rats are all performed. This places pressure on the instructor and assistants since there are three preparations during each session. Its advantage is that it allows maximum use of expensive equipment since one need not have all students working on one type of instrument (thus utilizing one physiograph instead of three).

A major difficulty with this approach has been the lack of time for interaction with each group when it comes to analyzing the data collected during lab. Here the microcomputer finds its niche.

As an example, we can refer to a "typical" experiment performed in physiology laboratories, the use of the Gilson Respirometer (or Warburg Apparatus). Anyone who has used this piece of equipment knows that it requires a significant amount of data manipulation in order to have a "take-home" lesson from the laboratory. In the past, this required many hours with paper, pencil, and slide rule—made somewhat easier

with the introduction of programmable calculators. But, even then the laboratory write-up is usually done some days later, with little or no direct interaction with the instructor. When the results are submitted, there is frequently no opportunity to review the data acquisition process, and results are most often evaluated in terms of their general fit to some ideal criteria. This assumes the students performed the dozens of procedures flawlessly, a rather unusual event at best.

With a microcomputer (or nearby mini/mainframe terminal), things are different. Digital data is collected at ten-minute intervals from fourteen flasks, and it represents six duplicated experimental conditions plus a control. Each reading calls for individual corrections for background (thermobarometer) and subsequent analysis of trends for approximately 60–90 minutes (10 value sets). Of course, the computer can handle the data corrections in microseconds, but it can do so much more.

With the computer in the laboratory, data is entered as it is collected. Immediately, all corrections are applied, the data is presented graphically to the student (with linear regression), and, where appropriate, warnings can be flashed to pay attention to a given aspect of the data—a leak in the system, for example, would give a rapid increase in readings. The computer can be programmed to investigate “normal” errors and make immediate suggestions for assistance when they are detected.

More importantly, the data can be compiled and processed at once, while the exercise is still under way and while the students are together. Assistance from the instructor is

then called for when it is needed. We now spend the major portion of lab time in performing an exercise and discussing the significance of the results—a tremendous improvement over previous years in which many students never understood what they had done during these lab sessions.

In other exercises, the students can be comforted (or alerted) by comparison of their data with that of other groups or to published data. On line reference searches are a snap with a computer base, and comparison data is no further away than a few key strokes on the terminal. Glossaries and drills seeking to determine student understanding are also readily available, and the drills can be made interactive with little programming knowledge. With a little imagination, student results can be tabulated with class statistics for comparison.

We also make use of commercially available software. Enzyme kinetics is among the more popular (ENZKIN).⁷ CELLM⁸ is a fun package where the student becomes a cell membrane and must balance sugars and ions—if successful, you divide, if not, you die. Test item management programs make generation of exams and quizzes easier. We use microTIM⁶ and highly recommend it.

Additional use of the computer for feedback is made through interactive grading programs. Each student is given a personalized summary of all grades as they are earned, along with class statistics. The student can then ask the computer questions of “what if” or “what are my chances for.” It doesn’t eliminate the need for personal discussions with the instructor, but it helps.

Finally, we have written our own programs (mainly in BASIC for ease

of modification). These programs involve manipulation of data for glucose transport in intestine, poikilothermy, Q10 measurements, and photosynthesis, to name a few. Not all of our lab exercises make use of the computer, but it is becoming a small minority that do not. If one adds the use of the computer as a word processor (available to students), then most likely the computer is significant in all exercises from the student perspective. We have found it to be an excellent means of generating time for student/faculty interaction at a level not previously possible. The students are at ease with the computer and have come to expect the same treatment in other courses within the department. In the near future, it will be a rare course in biology at Gustavus Adolphus College that will not make extensive use of portable computers in the labs.

REFERENCES

1. Bradshaw GF, Langley PW, Simon HA: Studying scientific discovery by computer simulation. *Science* 222(4627):971–975, 1983.
2. Crovello TJ: Computer simulation in bioeducation. *The American Biology Teacher* 46(1):58–59, 1984.
3. Heines JM: Screen design strategies for computer-assisted instruction. Bedford, MA: Digital Press, 1984.
4. Heydeman MT: ENZKIN unit on enzyme kinetics. London: Edward Arnold Publishers, 1977.
5. Landa RK: Creating courseware: a beginner's guide. New York: Harper Row, 1984.
6. microTIM: Dallas: JL Educational and Computer Services, 1983.
7. Spain JD: Basic microcomputer models in biology. Reading, MA: Addison-Wesley, 1982.
8. Witt K: CELLM: A BASIC program (modified for the Harris System by K. Anderson), Gustavus Adolphus College, June 13, 1979.

COMPUTERS IN LIFE SCIENCE EDUCATION

HAROLD I. MODELL
Virginia Mason Research Center
Seattle, Washington

MARCEL BLANCHAER
Professor of Biochemistry
Faculty of Medicine
University of Manitoba
Winnipeg, Manitoba
Canada

THEODORE J. CROVELLO
Department of Biology
University of Notre Dame
Notre Dame, Indiana

JAMES W. ECKBLAD
Department of Biology
Luther College
Decorah, Iowa

TSEGAYE HABTEMARIAM
School of Veterinary Medicine
Tuskegee Institute
Tuskegee, Alabama

DONNA LARSON
School of Nursing
Grand Valley State College
Allendale, Michigan

TERRY M. MIKITTEN
Graduate School of Biomedical Sciences
University of Texas Health Sciences Center
San Antonio, Texas

JAMES E. RANDALL
Department of Physiology
Indiana University
Bloomington, Indiana

PATRICIA SCHWIRIAN
College of Nursing
Ohio State University
Columbus, Ohio

RICHARD STULL
College of Pharmacy
University of Arkansas
Little Rock, Arkansas

JAMES W. WOODS
Lister Hill National Center
for Biomedical Communications
National Library of Medicine
Bethesda, Maryland

DOROTHY WOOLEY-McKAY
Department of Biology
Glendale Community College
Glendale, Arizona

GLENN YOSHIDA
Department of Life Sciences
Los Angeles Southwest College
Los Angeles, California

ELSEVIER

CONTENTS

INPUT/OUTPUT DESIGN FOR DIFFERENT EDUCATIONAL SETTINGS Harold I. Modell	57
WHERE'S THE SOFTWARE?	62

INPUT/OUTPUT DESIGN FOR DIFFERENT EDUCATIONAL SETTINGS

Harold I. Modell
Virginia Mason Research Center, Seattle, Washington

Historically, use of the computer as a teaching tool has evoked a picture of an independent study setting. One visualizes a student or group of students gathered around a terminal located in a learning resource center or computer laboratory working with a program designed to be a tutorial (eg, a computer lesson) or a "laboratory" exercise (eg, a simulation).

The portability and graphics capabilities of the microcomputer along with advances in video technology (eg, the video projector) have made it feasible to consider the computer as an addition to the arsenal of visual aids used in the large lecture and the small group conference settings.^{2,6} In considering such a move, one's inclination is to

transport software that has worked well in the independent study setting directly to the lecture hall or conference room. For example, a simulation used as a "laboratory" exercise for 1-3 students can now form the basis of a "laboratory demonstration" for a group of 15-25 students. In some cases, such a move can lead to disaster, not because use of the simulation in this manner is a bad practice, but because the input/output schemes designed for the independent study setting may not be ideal for the lecture or conference settings.

The purpose of this communication is to illustrate how criteria for input/output design may differ depending upon the setting in which the software will be used. A simula-

tion of oxygen and carbon dioxide transport in blood will serve as the focus for this discussion.

BACKGROUND

Mechanisms of oxygen and carbon dioxide transport in blood are reflected in the oxyhemoglobin and carbon dioxide dissociation curves. It is important for students to understand the following key points concerning these curves.

- The quantity of oxygen and carbon dioxide carried in the blood as dissolved gas is very small, and this small amount of dissolved gas along with the solubility characteristics of the gas give rise to the partial pressures of oxygen and carbon dioxide in the blood.
- The amount of oxygen carried as oxyhemoglobin reflects an equilibrium with the oxygen partial pressure. Similarly, the amount of carbon dioxide carried in the form of bicarbonate ions and carbamino compounds reflects an equilibrium with the carbon dioxide partial pressure.

- The shapes of the dissociation curves are different, and the shape of each curve has significant physiological implications.
- A number of factors influence each of the dissociation curves, and one of these factors is the amount of the other gas present in the blood.

For the past 9 years, we have made a simulation of the oxyhemoglobin and carbon dioxide dissociation curves available to allow students to study these relationships in an independent study setting.⁴ The model assumes that hemoglobin concentration is fixed and that the blood being studied is at a constant temperature. The inputs to the model are arterial oxygen and carbon dioxide partial pressures. The original version of the program was designed for 80-column, hard-copy terminals and provided a tabular output. The output consisted of a table with the student's input values, oxygen and carbon dioxide contents consistent with those values, percent oxyhemoglobin saturation, and pH of the blood (Fig. 1).

MICROCOMPUTER OUTPUT IN AN INDEPENDENT STUDY SETTING

When microcomputers offering inexpensive graphics capabilities became available, the program was revised to take advantage of these capabilities. An example of the graphic portion of the revised output is shown in Figure 2.

The rationale behind our choice of a picture rather than a plot of the dissociation curves was based on the premise that a simulated laboratory exercise should provide "processed" data only when such processing is available on-line in the real laboratory setting.⁵ The experiment simulated by this program would generally require the investigator to equilibrate blood with different oxygen and carbon dioxide mixtures and then determine the resulting composition and pH. Hence, discrete data points would be obtained, and plotting the points would constitute an additional step. Should the student wish to take this additional step, appropriate axes are provided in the "laboratory" manual that accompanies the exercise.

Considerably more conceptual information relative to the points listed above is available to the student on the graphic output (Fig. 2) than on the original tabular output (Fig. 1). For example, the left panel makes the following points clear:

- 1) oxygen is carried as dissolved gas as well as being bound to hemoglobin;
- 2) the amount of dissolved gas is small, but it is this gas that gives rise to the partial pressure of oxygen;
- 3) the hemoglobin sites are "filled up" with oxygen until an equilibrium is reached between the partial pressure of oxygen and oxyhemoglobin binding sites;
- 4) the hemoglobin sites can be completely "filled", that is, oxyhemoglobin can be 100% saturated.

```

NORMAL AND ABNORMAL LUNG FUNCTION
PROGRAM 7 BLOOD
COPYRIGHT, AMERICAN THORACIC SOCIETY 1975

PO2 (TORR) ?80
PCO2 (TORR) ?40

BLOOD COMPOSITION AT PO2= 80 TORR   PCO2= 40 TORR
O2 CONT= 19.5 ML/100 ML             CO2 CONT= 47.8 ML/100ML
PCT O2 SAT= 95.9                    PH= 7.4

CHANGE ?

```

FIGURE 1. Input/output scheme from the original version of an oxygen and carbon dioxide dissociation curve simulation. This version was intended for use in an independent study setting using a hard-copy terminal. In answer to the prompt "CHANGE?", the student can change the value for one or both input variables.

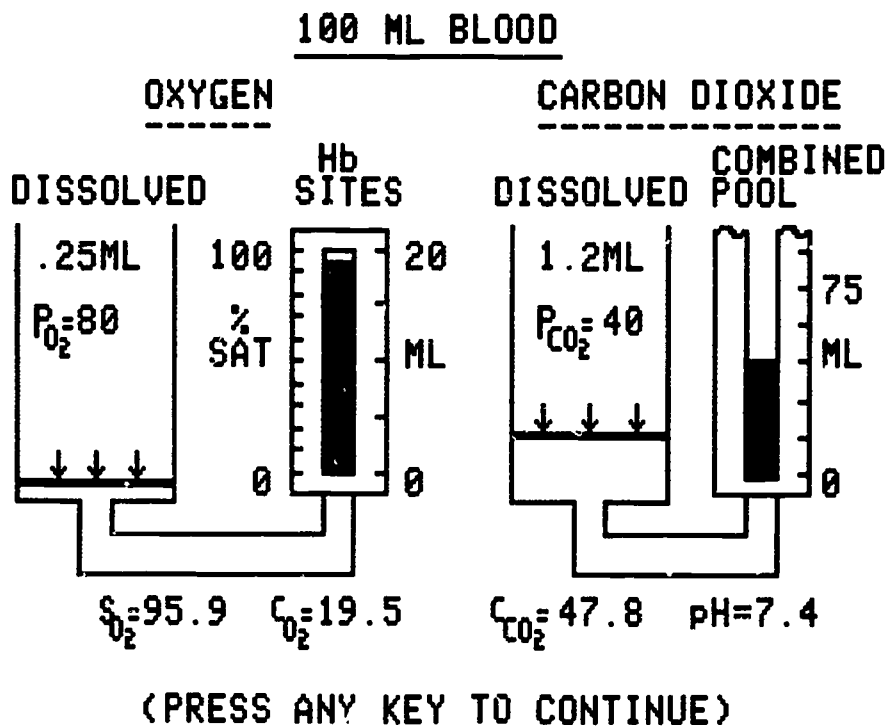

FIGURE 2. Graphic output of the oxygen and carbon dioxide dissociation curve simulation revised for use with a microcomputer. This output was also designed for use in an independent study setting. Input variables are the same as the version depicted in Figure 1.

The right panel of Figure 2 provides a similar picture depicting the relationships for carbon dioxide. However, in this panel, it is clear that, unlike the relationship between oxygen and the hemoglobin sites, the combined carbon dioxide pool does not become "filled up" in the physiologic range.

Although the graphic output provides a more complete conceptual picture than the original tabular output, the tabular output provided an opportunity for the student to compare the composition of a number of blood samples equilibrated with different gas mixtures. All that was necessary was to review what had already appeared on the paper. Of course, the student could always copy what appeared on the graphics screen onto a piece of paper, but it would be far more convenient if a data comparison capability was incorporated into the program. Thus a second output mode is provided in the microcomputer revision.

After the graphic output is completed, the student has the option of saving the data (up to four experiments) and comparing data from previous experiments to the current values. An example of this portion of the output is shown in Figure 3.

The independent study setting raises another issue with respect to the input/output scheme chosen. Input values must be checked to ensure that they are reasonable, both mathematically and physiologically. The form and format of error messages must be considered. Ideally, error messages should be of a form and format that will provide an additional learning experience for the student.³

USE IN THE LECTURE HALL

Using this simulation as part of a lecture on oxygen and carbon dioxide transport may prove very useful. However, use of the program in this setting may require a different

set of criteria for input and output. If the lecture is presented to a large group (75 or more students), it is unlikely that the students will participate in choosing input values. Hence, there should be no need for the input checking/error message routines that were essential in the independent study setting. The process of choosing variables or entering values should be streamlined, however, to minimize typing errors that result in messages that focus attention on the technology (eg, RE-ENTER, SYNTAX ERROR) and distract students from the message of the lecture.²

What about the output? The graphic shown in Figure 2 may be very helpful as a lecture aid. However, it is not necessary to have the computer in the lecture hall to show this static picture! It would be considerably easier logistically to dump the output to a printer and make one or more slides for the presentation. On the other hand, if the input/output scheme was modified so that a succession of frames showing the transition from one gas mixture to another was used, an additional dimension would be added to the teaching aid.

Another possible modification that might prove useful in the lecture hall is to have the program plot the oxyhemoglobin or carbon dioxide dissociation curves. Before using this scheme, however, it is necessary to ask whether, in the context of the specific presentation, the in-class computer display will serve as a better teaching aid than a slide of the dissociation curves. If the presentation focuses only on the entire curves, the slide would most likely be the visual aid of choice. If, on the other hand, the narrative approaches the curves by focusing on blood as it equilibrates with various gas mixtures, the computer program offers an advantage.

Figure 4 shows the output from a modification of the program designed with a lecture setting in mind. In

EXPT :	CURRENT	1	2	3	4
P_{O_2}	60	80	60	80	
C_{O_2}	18.9	19.5	18.5	19.7	
S_{O_2}	93.1	95.9	91.1	96.7	
P_{CO_2}	30	40	40	30	
C_{CO_2}	42.6	47.8	48.1	42.4	
P_{H}	7.48	7.4	7.41	7.48	

(PRESS ANY KEY TO CONTINUE)_

FIGURE 3. Tabular output for microcomputer revision that allows the student to compare data from up to four experiments. Units for each value are presented in the graphic portion of the output and are therefore not repeated in the table.

SMALL GROUP CONFERENCES

The small group conference (5–30 students) offers considerably more latitude than the large lecture setting. The instructor can approach this experience in a variety of ways ranging from a demonstration with no student interaction to a workshop that can involve the students almost as much as the independent study setting. The criteria chosen for input/output design for this setting may differ depending on how much student interaction is anticipated.

If the session is to be a pure demonstration with no student interaction, the input/output scheme must be essentially the same as that chosen for the large lecture setting. If, on the other hand, the workshop approach is taken, the instructor and students are working as a team, and a variety of possibilities exist.

The program designed for the independent study setting may work very well in this environment. As the workshop leader, the instructor plays the role of a knowledgeable peer providing some direction for the experimental procedure to be followed. In this role, he or she may ask students for input values and rely on the program to display error messages for physiologically unsound values. Maintaining the error messages in the program provides the student with a more dramatic feedback mechanism than the instructor's rejecting the input value, and it enhances the instructor's role as a peer.

Although the output from the independent study version may be adequate for the workshop environment, an expanded output scheme may prove more useful. The philosophy governing design of the independent study output was based on the premise that the program simulate a laboratory setting. It assumed that sufficient time would be available to gather, process, and interpret data. The class time allotted to the conference session may not provide

this version, hemoglobin concentration and the partial pressure of carbon dioxide in the blood are entered, and the program plots an oxygen dissociation curve. Students see the curve as it develops, and the plotting process can be stopped at any time to focus attention on specific aspects of the oxygen-hemoglobin relationship.

This particular output scheme also allows plotting multiple curves on the same axes. Thus the effects of changing carbon dioxide tension and hemoglobin concentration can be developed step by step on the same visual aid.

Another display mode that can be effective in a lecture setting involves using two graphics screens. Different conditions are plotted on the same axes on the two screens, and the lecturer can switch rapidly between the two screens to point out similarities and differences. This technique

may be more effective than plotting two curves on the same screen (Fig. 4C, D). In this program, for example, input values for each curve are retained with the curve, and the notion of the curve "shifting" (eg, with changing carbon dioxide tension) may be presented more dramatically.

Tabular output, an essential component in the independent study setting, would not be necessary in the lecture setting because, in this case, the data plots can be used for comparing two conditions. In some cases, presentation of data in a tabular format may be unacceptable in the lecture hall. Tabular data on multiple TV monitors is often too small to read from all locations within the room, and many video projectors do not have the resolution necessary to provide clear images of densely packed letters or numbers on the screen.

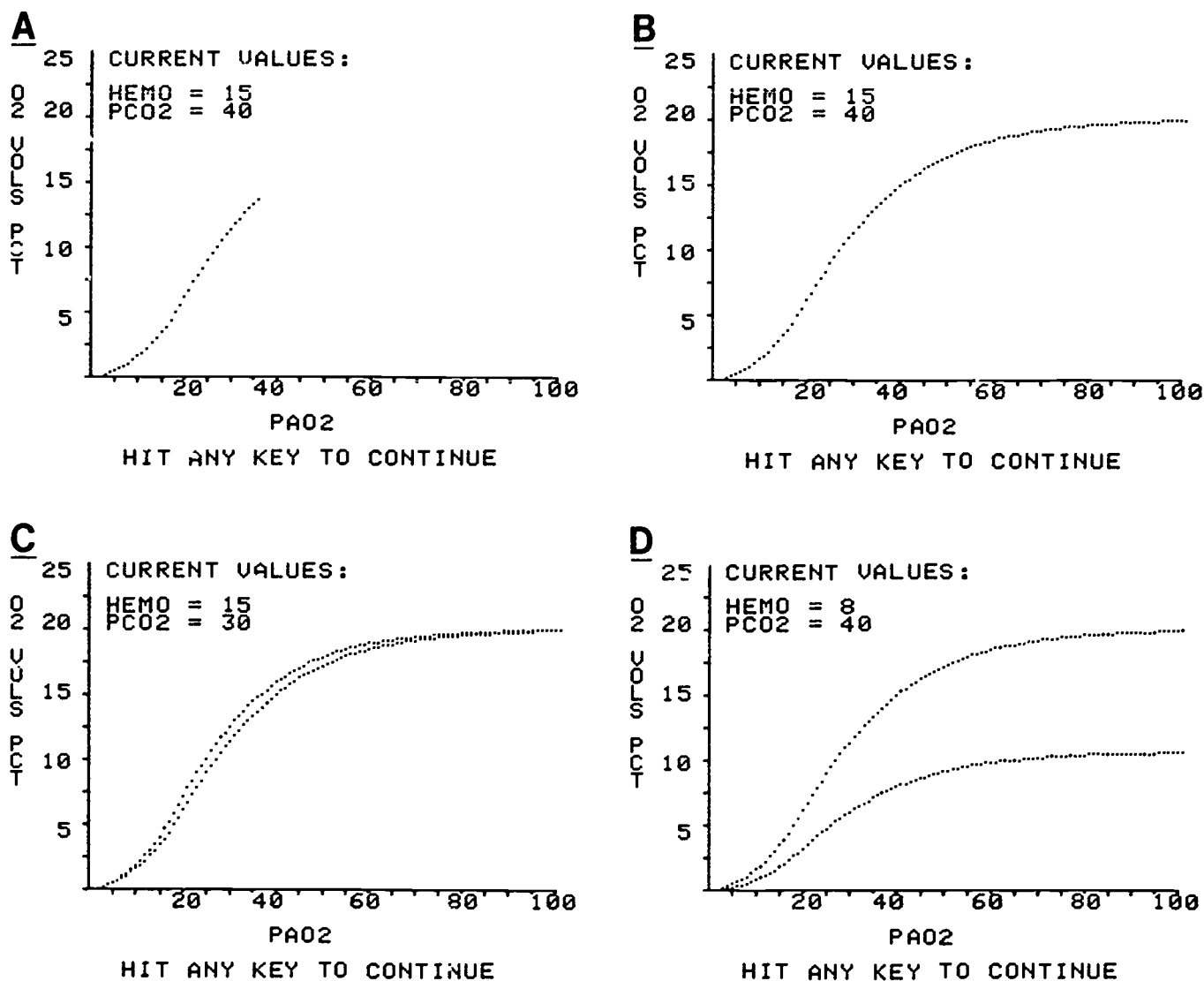

FIGURE 4. Graphic output of the oxygen dissociation curve from the same simulation used to generate the outputs shown in Figures 1-3. This output was designed for use in a lecture setting. In this version, the input variables are hemoglobin concentration (assumed constant in the other versions) and the partial pressure of carbon dioxide. (*Panel A*) Curve plotting was interrupted to focus attention on the steep portion of the curve. (*Panel B*) Curve plotting was allowed to continue so that the entire curve is presented. (*Panel C*) Two curves are presented on the same axis to illustrate the influence of carbon dioxide on the position of the dissociation curve. (*Panel D*) Two curves are presented on the same axis to illustrate the effects of changing hemoglobin concentration.

this time. Hence, the design criteria must be reevaluated with this in mind.

If the "experiment" is to be completed within time allotted to the workshop, it may be helpful to incorporate the possibility of plotting the dissociation curves (eg, as in Fig. 4) as a second output option. The purpose of this portion of the output would be different than that in the lecture hall. In the lecture, plotting

the curve served as the primary conceptual aid. In this setting, its purpose may be more of a review/integration aid. For example, one way to approach the session may be to examine a number of blood samples equilibrated with different gas mixtures. The output for this step would be the pictorial format (Fig. 2). Discussion of the results of each equilibration and comparison of each equilibration with prior sam-

ples using the tabular output (Fig. 3) would accompany this phase. The plotting output option could then be used to "put it all together" in one or two pictures, reinforcing those points discussed during data acquisition.

The possibility of providing hard copy output of some of the results obtained during the workshop might also be considered for such a session. This output could be produced be-

fore or during class, and it would give the student review material that he could relate to an active learning experience.

FINAL COMMENT

In this article I have tried to draw attention to some of the factors that should be considered when establishing input/output criteria for various educational settings. In doing so, I have used one example, that of a physiological simulation, with different possibilities for input and output formats. Many other types of programs may prove useful in each of the settings discussed. Levine's use of the computer as a sophisticated slide projector in the lecture hall¹ is but one example. However, regardless of the specific program

used, common questions must be considered. For example:

- Is the technology available to me that will allow the computer output to be seen clearly by all students in the lecture hall/conference room?
- Will using the computer make my message clearer than a series of slides, a videotape or some other type of presentation that requires less technology in the classroom?

Considering these and similar questions will result in input/output design that will not only enhance the presentation, but will also make the computer accepted by students in the classroom as an asset to learning rather than another gimmick to amuse the instructor.

REFERENCES

1. Levine SD: Microcomputer graphics as a substitute for lecture slides. *Computers in Life Science Education* 1:33-36, 1984.
2. Mikiten TM: Enhancing lectures with microcomputers. *Computers in Life Science Education* 1:9-11, 1984.
3. Modell HI, Farhi LE, Olszowka AJ: Physiology teaching through computer simulations—problems and promise. *Physiol Teacher* 3:14-16, 1974.
4. Modell HI, Olszowka AJ, Klocke RA, Farhi LE: Normal and abnormal lung function, a program for independent study. New York: The American Thoracic Society, 1975.
5. Modell HI, Olszowka AJ, Plewes JL, Farhi LE: Role of computer graphics in simulations for teaching physiology. *Physiologist* 26:93-95, 1983.
6. Schottelius BA: Teaching physiology by microcomputer in small group conferences. *Computers in Life Science Education* 1:4-6, 1984.

WHERE'S THE SOFTWARE?

The degree of success achieved when computers are used in any teaching effort depends heavily on the quality of the software chosen. With respect to software availability, two options are open to the educator: either write programs to fill specific needs or find high-quality programs written by others. Writing one's own software is a time-consuming process and one that may not reap the academic recognition that could be attained by using the same time for other endeavors. Hence, in many instances, it is preferable to use software written by other educators. However, it is most difficult to identify sources of quality software focused in a specific area. To aid in this quest, we have compiled the following list of life science software sources and programs or program areas available.

In the future, we would like to publish updates to this list, but to

accomplish this we need your help. If you have found specific software helpful in your teaching efforts, and it does not appear on our list, please let us know about the program(s) and the supplier. Send pertinent information to Dr. Harold Modell, Virginia Mason Research Center, 1000 Seneca Street, Seattle, WA 98101.

BIOBUND

Professor Theodore J. Crovello
Department of Biology
The University of Notre Dame
Notre Dame, IN 46556
(219) 239-7031

ABBAL, BIOHISTORY, BIO-
QUEST, CELLVOL CONTROL,
DIAPYCNOSIS, ESSIM, FIND,
IDMOPLE, MOM, PHYSLAB,
RAJIS, SQUID AXON

Biolearning Systems Inc.

Suite 2735
420 Lexington Avenue
New York, NY
(212) 687-8061

CARBOHYDRATES, LIFE
FUNCTIONS, LIPIDS,
NUCLEIC ACIDS, PROTEINS,
TEST DISKS

Cambridge Development Lab

100 Fifth Avenue
Waltham, MA 02154
(617) 890-8076

GENETICS, CELLULAR RE-
PRO, MICROBE (demo disk),
TEMP, DAISY

Classroom Consortia Media

28 Bay Street
Staten Island, NY 10301
In New York: (800) 522-2210
Outside New York: (800) 237-1113
LEAF, PHOTOSYNTHESIS
AND LIGHT ENERGY, CELL
GROWTH AND MITOSIS

CONDUIT

M310 Oakdale Hall
The University of Iowa
PO Box C
Oakdale, IA 52319
(319) 353-5789

BAFFLES, CATGENE,
CATLAB, COEXIST, COMPE-
TITION, COMPUTERS IN
BIOLOGY CURRICULUM,
DISCOVERY LEARNING IN
TRIGONOMETRY, ECOLOGI-
CAL MODELING, EVOLVE,
FAMID, LIFE TABLES, LINK-
OVER, MOLECULAR MOTION
AND DIFFUSION, OSMOTIC
PRESSURE, PREDATION,
PREDATOR FUNCTIONAL
RESPONSE, SURFACES FOR
MULTIVARIABLE CALCULUS,
TRIBBLES (Plus ad-
ditional programs in chemistry,
math, humanities, etc.)

Clyde Dawson

Department of Biology
The University of Notre Dame
Notre Dame, IN 46556
SIMPLE MEIOSIS

DEE, Diversified Education Enterprises, Inc.

725 Main Street
Lafayette, IN 47901
(317) 742-2690

BALANCE, PLANT, MOTHS,
OSMO, ENZYME, MONOCROS,
DICROSS, POLLUTE, DILUTE,
CLASSIFY, NICHE, POPGRO,
MANRGY, DNAGEN, FLYGON,
POPGEN

Edu Tech

634 Commonwealth Avenue
Newton Centre, MA 02159
BIRDBREED

Professor H. Herbert Edwards

Department of Biology
Western Illinois University
Macomb, IL 61455
PHOTOSYNTHESIS

E.M.E. Corporation

PO Box 17
Pelham, NY 10803
(914) 576-1121

AIR POLLUTION, INTRODUC-
TORY GENETICS, MEIOSIS,
MICROBIOLOGY TECH-
NIQUES, NATURAL SELEC-
TION, OSMOSIS AND DIFFU-
SION, POPULATION
FLUCTUATIONS

Encyclopedia Britannica Educational Corp.

425 North Michigan Avenue
Chicago, IL 60611

BIOLOGY: THE CELL, BI-
OLOGY: ENERGY AND LIFE

Hayden Software Company

600 Suffolk Street
Lowell, MA 01853
MICROSCOPIC JOURNEY

Heinemann Computers In Education Ltd.

England
PHYSIOLOGICAL SIMULA-
TION

HRM Software

Human Relations Media
175 Tompkins Avenue
Pleasantville, NY 10570
(914) 769-6900

EXPERIMENTS IN HUMAN
PHYSIOLOGY (DEMO DISK)
(by Robert Tinker, TERC, \$199)

J & S Software

140 Reid Avenue
Port Washington, NY 11050
(516) 944-9304

HEARTBEAT/HEART-
WORK/HEARTFLOW, \$39.95

Professor John Jungck

Department of Biology
Beloit College
Beloit, WI 53511
PROTEIN MASTERMIND

Microcomputer Workshops

225 Westchester Avenue
Port Chester, NY 10573
(914) 937-5440

GENETICS (Highschool, \$24.95),
ENGLISH and FRENCH
ACHIEVEMENTS, SOLVING
QUADRATIC EQUATIONS

Dr. Harold Modell

Virginia Masor Research Center
1000 Seneca Street
Seattle, WA 98101

RESPIRATORY PHYSIOLOGY
PROGRAMS

Oakleaf Systems

PO Box 472
Decorah, IA 52101
ALGAL GROWTH, AQUATIC
ECOLOGY, ECOLOGICAL
ANALYSIS, EVOLUTION,
KEY-STAT

Professor James E. Randall

609 South Jordan Avenue
Bloomington, IN 47401
PHYSIOLOGICAL SIMULA-
TIONS

SUMIT Courseware Project

Professor James Spain
Department of Biology
Michigan Technological University
Houghton, MI 49931

ENZYME, FOREST SUCCE-
SSION, ISLAND BIOGEOGRA-
PHY, PHOTOSYNTHESIS

Compiled by T. J. Crovello

COMPUTERS IN LIFE SCIENCE EDUCATION

HAROLD I. MODELL
Virginia Mason Research Center
Seattle, Washington

MARCEL BLANCHAER
Professor of Biochemistry
Faculty of Medicine
University of Manitoba
Winnipeg, Manitoba
Canada

THEODORE J. CROVELLO
Department of Biology
University of Notre Dame
Notre Dame, Indiana

JAMES W. ECKBLAD
Department of Biology
Luther College
Decorah, Iowa

TSEGAYE HABTEMARIAM
School of Veterinary Medicine
Tuskegee Institute
Tuskegee, Alabama

DONNA LARSON
School of Nursing
Grand Valley State College
Allendale, Michigan

TERRY M. MIKITTEN
Graduate School of Biomedical Sciences
University of Texas Health Sciences Center
San Antonio, Texas

JAMES E. RANDALL
Department of Physiology
Indiana University
Bloomington, Indiana

PATRICIA SCHWIRIAN
College of Nursing
Ohio State University
Columbus, Ohio

RICHARD STULL
College of Pharmacy
University of Arkansas
Little Rock, Arkansas

JAMES W. WOODS
Lister Hill National Center
for Biomedical Communications
National Library of Medicine
Bethesda, Maryland

DOROTHY WOOLEY-McKAY
Department of Biology
Glendale Community College
Glendale, Arizona

GLENN YOSHIDA
Department of Life Sciences
Los Angeles Southwest College
Los Angeles, California

ELSEVIER

CONTENTS

USING COMPUTER-ASSISTED INSTRUCTION IN THE EDUCATION OF HEALTH CARE PROFESSIONALS: WHAT THE DEAN NEEDS TO KNOW Donna E. Larson	65
COMPUTER PROLIFERATION: AN EXPERIENCE TO SHARE Patricia Tymchyshyn	67
KEEPING ABREAST OF THE LITERATURE	69
THE BULLETIN BOARD	70
INDEX FOR VOLUME 1	71

USING COMPUTER-ASSISTED INSTRUCTION IN THE EDUCATION OF HEALTH CARE PROFESSIONALS: WHAT THE DEAN NEEDS TO KNOW

Donna E. Larson

School of Nursing, Grand Valley State College, Allendale, Michigan

When the educator of health care professionals attempts to encourage the purchase, development, and use of computer-assisted instruction (CAI) in the curriculum, the dean of that program may voice some very real concerns about the credibility and advisability of the newly proposed instructional strategy. It is well for the proposing educator to be

prepared to put the best case forward in support of using computer-assisted instruction to improve the education of his/her students. This article summarizes the advantages of using computer-assisted instruction for selected aspects of the education of health care professionals.

Computer-assisted instruction is particularly well suited to the edu-

cation of health care professionals for several reasons:

1) *Effective, efficient instructional methodology.* Research on computer-assisted instruction in higher education in general and specifically in health professional education has demonstrated repeatedly that, when compared to the more traditional teaching strategies (eg, classroom lecture, discussion, role-playing, lab), students learn just as well with computer-assisted instruction, but in one-third to one-half the amount of time.^{1-6,8-10} This is certainly a finding with major implications, especially when one considers the rate at which the knowledge base of the health professions is growing.

2) *Equalizes learning opportunities.* Because of such variables as the changing nature of patient populations, the sometimes transient educational contracts with clinical agencies, and student clinical rotation scheduling problems, many clinical experiences are not consistently available to all students. Computer simulations are one way in which variable clinical learning opportunities can be better equalized among students. For example, even if real life maternity clinical experiences are in short supply, at least all students could be provided the opportunity to practice planning and managing the care for computer-simulated maternity patients. Additionally, computer simulations can provide students with rare learning opportunities. For example, even though a particular geographic location may have a very small black population, students could still be provided with the opportunity, through the use of computer simulations, to plan and manage various aspects of the care of patients experiencing sickle cell crisis.

3) *Provides repeated practice opportunities.* Computer-assisted instruction allows students to have repeated trials prior to implementa-

tion of care for actual patients. Students can learn using computer simulations and then apply what they have learned while caring for actual patients.

4) *Safe.* One of the primary advantages for computer-assisted instruction in clinical health care professional education is that it allows students to make their errors in a safe environment. A computer will not become gravely ill because of an erroneous medication dosage calculation or poor clinical decision making. Obviously, this is not the case with actual patients.

5) *Promotes creative problem-solving and manipulation of variables.* The computer can open up the world of "what if's" to student learning. Because no harm will come to actual patients, the student is free to explore many alternatives in solving patient care problems. The student is able to experiment actively with many different hypotheses. The student can also purposely make errors in order to validate his/her own abilities to problem-solve and remedy a rapidly deteriorating patient situation. Due to faculty concerns for patient safety, students are not usually allowed to engage in this active experimentation in clinical settings. Because of the faculty's own setting of limits, our students' creative problem-solving may be thwarted. Through the use of computer simulations, students could be encouraged to practice creative thinking and problem-solving.

6) *Provides a private learning environment.* Computers can provide a nonthreatening environment for student learning. Computer-assisted instruction allows students to make their learning errors in private, without fear of ridicule from peers or of making a bad impression on faculty. The provision of this kind of private learning environment is especially important for the student who may be a slower learner or speak English as a second language.

7) *Freedom from repetitive teaching.* Computer-assisted instruction can free the instructor from the lower level, repetitive aspects of teaching, so that more time can be devoted to higher level teaching activities, such as assisting students to apply theoretical knowledge to actual patient care situations. The education of health care professionals is costly, to a great degree because the education is labor intensive—small groups of students clinically taught by highly specialized health care professional faculty (physicians, nurses, dentists, pharmacists, respiratory therapists, physical therapists, dieticians, medical technologists, etc.). CAI can assist in making better use of scarce and expensive faculty by augmenting small group instruction, taking care of the more mundane and repetitive aspects of teaching, and generally allowing faculty to be more available for teaching, evaluating, and role-modeling for higher level clinical practice (such as application of clinical decision-making skills, research, administration, and so on).

8) *Cost-effective.* There have been few attempts to determine the actual cost of computer-assisted instruction in the education of health care professionals. However, this author's own research on the effectiveness, efficiency, and cost of computer-assisted instruction in psychomotor skill development for nursing students demonstrated that CAI was, indeed, cost-effective.⁷ Specifically, when CAI was compared to conventional skills laboratory instruction for teaching a basic nursing psychomotor skill (calculating and regulating intravenous flow rates), the cost per computer learner was \$.94 compared to \$2.17 per skills laboratory learner. The difference in cost was due mainly to the decreased amount of faculty time and expendable materials required when computer-assisted instruction was used. Interestingly, there were no

significant differences in the effectiveness, transfer, or retention of learning with either of the methodologies. The \$.94 versus \$2.17 comparative costs might be deceptive, however, because the setting already had the requisite microcomputer hardware and software. If it were necessary to purchase the hardware and software, if the costs were amortized over three years, and if the special costs incurred due to research conditions were removed, then it was projected that the cost per computer learner would be \$1.44, compared to \$2.01 per laboratory learner.

9) *Accessibility of instruction.*

Computer-assisted instruction can be accessible to the student virtually 24 hours a day, seven days a week—at least as long as the computer or microcomputer laboratory is open on campus. Moreover, because many health care professional students already have their own personal microcomputers, students can easily access CAI whenever their schedules and energies permit by simply having their computers at home communicate, via modem, with computers on campus.

10) *Provides students with immediate feedback.* If student answers or decisions are erroneous, most computer-assisted instruction programs will provide the student with specific, shaped, and immediate feedback, help, and remediation.

Therefore, students don't waste their time learning behaviors that must later be unlearned and corrected.

In summary, when one looks at both the previous research on the effectiveness, efficiency, and cost as well as the other advantages of using computer-assisted instruction in the education of student health care professionals, one can build a strong case for the adoption of this methodology for selected applications. In these days of limited and shrinking financial and faculty resources, coupled with the ever-expanding knowledge base required for all health care professionals, it seems sensible to use an instructional methodology that has been proven effective, efficient, and less costly—computer-assisted instruction.

REFERENCES

1. Bitzer M, Bitzer D: Teaching nursing by computer: an evaluative study. *Computers in Biology and Medicine* 3:187-204, 1973.
2. Boettcher E, Alderson S, Saccucci M: A comparison of the effects of computer-assisted instruction versus printed instruction on student learning in the cognitive categories of knowledge and application. *Journal of Computer-Based Instruction* 8:13-17, 1981.
3. Droste-Bielak E: The use of computer simulation in teaching interviewing techniques to beginning nursing students in a baccalaureate program. (Unpublished doctoral dissertation.) Ann Arbor: University of Michigan, 1980.
4. Huckabay L, Anderson N, Holm D, Lee J: Cognitive, affective, and transfer of learning consequences of computer-assisted instruction. *Nursing Research* 28:228-233, 1979.
5. Kulik J, Kulik C, Cohen P: Effectiveness of computer-based college teaching: a meta-analysis of findings. *Review of Educational Research* 50(Winter):525-544, 1980.
6. Larson D: Computer-assisted instruction in nursing. In: Specter A, ed. *Computer technology in nursing education*. Atlanta: Southern Council on Collegiate Education for Nursing, 37-46, 1984.
7. Larson D: The use of computer-assisted instruction to teach calculation and regulation of intravenous flow rates to baccalaureate nursing students. (Unpublished doctoral dissertation.) East Lansing: Michigan State University, 1981.
8. Maatsch JL, Hobar JD, Sprafka SA, Hendershot NA, Messick JR: A study of simulation technology in medical education. East Lansing: Michigan State University Office of Medical Education Research and Development, 1977.
9. Pagliaro L: CAI and instructional interactions. In: *Proceedings of the Annual Conference of the Association for the Development of Computer-Based Instructional Systems*, 151-160, 1982.
10. Rubinson LG, Robinson JA: Computer-assisted instruction in health education: a pilot study. *International Journal of Instructional Media*, 1977-78.

COMPUTER PROLIFERATION: AN EXPERIENCE TO SHARE

Patricia Tymchyshyn

Statewide Nursing Program, The Consortium of the California State University, Long Beach, California

Nurses around the world are sharing ways in which computers and information science can help their profes-

sion adapt to a technocratic society. Two significant undertakings directed at formal support of these

efforts are a working group established under the International Medical Informatics Association (IMIA), and an international nursing symposium planned for 1985 in Canada. Their ultimate goal is establishment of an International Nursing Informatics Association. There is also a strong commitment toward encouraging IMIA countries just beginning their computer explorations, and promoting publication of develop-

ment efforts and network building. Nursing informatics is broad in scope, encompassing the use of computers and information science to provide and improve patient care, develop educational courseware, assist with administrative tasks, and support research.

As an individual, my contributions are in the exchange of information and ideas about the use of computers in a nursing education setting. I am keenly interested in feedback about how our experiences and products may be of use to others.

NURSING PROGRAM OVERVIEW

Before proceeding with a description of computer applications, a brief overview of our instructional program in California may be of assistance to the audience. The Statewide Nursing Program (SNP) has offered a BS degree in Nursing since the spring of 1981. It is one of ten academic degree programs presented by the Consortium of the California State University to meet the needs of students who, because of employment, family, or geographic constraints, cannot enroll in traditional campus baccalaureate programs. Instruction is offered in the afternoon and evening, as well as on the weekend, in classrooms in or close to clinical facilities. Lectures, discussions, and seminars have been the main modes of teaching.

With a major grant from the Kellogg Foundation, however the entire degree program is being converted to a learner-centered format that uses print, video, and computer media, ie, workbooks, videotapes, computer-assisted instruction (CAI), and interactive videodisc lessons. There are 19 courses with 53 workbooks and approximately 24 videotapes and computer lessons under development. This is a team effort; instructional designers, content specialists, graphic artists, computer specialists, media specialists, actors, script writers, directors, producers,

word processors, and editors work together in developing instructional materials.

COMPUTER APPLICATIONS

Computer technology is integrated into each facet of the SNP program, administrative, and delivery, as well as instructional development. From micros to mainframe, IBM to Cyber, along with Xerox 820 IIs, a varityper and Z6000 thrown in for spice, the hardware is a glittering array of silicone marvels.

Instructional Development

Instructional designers and subject matter experts work together in developing content and learning activities for workbooks. Xerox 820 II and Osborne microcomputers utilize the Wordstar software program to replace pencil and typewriter in the process of text production. A modem and "move-it" software make the two micros compatible for word processing of text. Thus a designer or word processor can work away from the central office on a portable Osborne. The disc can be mailed in or transferred over phone lines.

Telecommunication also enables sophisticated print fonts to be added to workbook text. The text, contained on a Xerox 820 floppy disc is transferred through a 1200-baud modem to another floppy disc contained in a varityper computerized printer. The varityper inserts titles and headings according to coded instructions, resulting in camera-ready copy for printing.

Computers aid in producing titles and headings for videotapes, also. A character generator computer inserts titles, credits, and text at any point within the tape. Still another computer, the Z6000, assists the videotape editor in making cuts and dissolves. Thus hours of videotaped sequences are smoothly and accurately edited into a final product, which may be no longer than 15 minutes in length.

CAI is, of course, the largest computer application area. The basic components consist of four IBM PCs and an IBM XT, each with Mitsubishi RGB monitors; Okidata dot matrix printers (300 cps), graphic digitizer pads, and software; an Apple IIe; one Micro PLATO terminal; and a Hayes modem with subscriptions to CompuServe and Dialog databases and bulletin boards. NCI Pascal was the programming system selected because of its transportability, storage capacity, and quick response time. There are three programmers, two computer specialists, a graphic artist, a content specialist, and an instructional designer who heads the group. Some had had previous experience with PLATO and Apple projects, but none had worked with NCI Pascal or IBM PCs. For a few months everyone was learning on the job. Now the team is well organized and has produced a test authoring system, computer literacy lessons, a clinical simulation on the stress response for pathophysiology, a diagnostic chemistry test, and a remediation package. The pervasive instructional designs are simulation and problem solving inquiry modes. Because gaming is popular with learners, self-assessment quizzes have been adapted to run on a crossword puzzle format. The team is committed to incorporate as much as the computer's capabilities as possible into lesson designs. This includes complex branching and judging routines, computations, data storage and retrieval functions, as well as experimentation with color and music for feedback.

Administration and Delivery Computerization

Evaluation and record keeping tasks are computerized through an electronic mail service linking the 1000 miles that span the 19 California State campuses. dBASE II and ABstat software assist in processing class enrollment and questionnaire

analysis. In addition, an IBM XT, containing a 10-megabyte hard disc, has proved invaluable for processing budget information and developing job rate cards for each of our product areas, ie, workbook, videotapes, and computer lessons.

On the program delivery side, learning centers situated in clinical facilities within the 19 California State regional campus areas are equipped with IBM PCs, videotape players, video cameras, and monitors. A liaison from the development team visits each center and orients instructors to the hardware.

KEEPING ABREAST OF THE LITERATURE

The list of references below is presented as part of a quarterly feature in CLSE designed to help readers become aware of current literature pertinent to computer applications in life science education.

Alessi SM: Designing effective computer assisted instruction. *Amer Biol Teach* 46:146-151, 1984.

Amada G: Why educators should take the interactive media plunge. *Educational-Industrial Television* 15:45-46, 56, 1983.

Argo JK et al: A computer-managed clinical evaluation system: implications for competency-based dietetic education programs. *J Am Diet Assoc* 84:36-41, 1984.

Argo JK et al: A computer managed instruction system applied to dietetic education. *J Am Diet Assoc* 79:450-452, 1981.

Arons AB: Computer-based instructional dialogs in science courses. *Science* 224:1051-1056, 1984.

Baston E: Apple IIe and IBM PC. Comparison of America's most popular personal computers. *Postgrad Med* 75:279-282, 1984.

Billings DM: Evaluating computer assisted instruction. *Nurs Outlook* 32:50-53, 1984.

Brawley RJ et al: Interactive videodisc: an innovative instructional system. *Am Ann Deaf* 128:685-700, 1983.

CLOSING REMARKS

The rapid evolution of computers is both exciting and frustrating. On the one hand, it's exciting to be on the cutting edge of development, experimenting with telecommunication and CAI designs. On the other hand, as soon as a new piece of software or hardware is purchased, it's either obsolete or in need of immediate upgrading. By the end of 1985 we will have completed development of all products; just in time to begin again with revisions. Technology is not for the faint of heart.

Conklin DN: A study of computer-based instruction in nursing education. *J Computer-Based Inst* 9:98-107, 1983.

Crovello TJ: Evolution of educational software. *Am Biol Teach* 46:140-145, 1984.

Crovello TJ: Evaluation of educational software. *Am Biol Teach* 46:173-175, 1984.

Curry I. et al: Computerization of undergraduate medical curriculum content. *Med Educ* 18:71-74, 1984.

Ellis LBM et al: Health education using microcomputers: initial acceptability. *Prev Med* 10:77-84, 1981.

Eversole LR: Programmed instruction in general pathology: evaluation of performance in comparison to conventional instruction and scholastic achievement. *J Dent Educ* 43:214-216, 1979.

Galloway E et al: Information providers and videodisc/optical disk technology. *J Am Soc Informat Sci* 34:414-416, 1983.

Hassett MR: Computers and nursing education in the 1980's. *Nurs Outlook* 32:34-36, 1984.

Hicks D: Administrative dilemma: how to stop worrying and start loving the computer. *Am Ann Deaf* 128:557-563, 1983.

Hoekema J: Interactive videodisc: a new architecture. *Performance and Instruction* 22:6-9, 1983.

Holmes ZA et al: Computer simulated laboratory experiments in food science. *J Am Diet Assoc* 76:474-476, 1980.

Hord EV: Guidelines for designing computer-assisted instruction. *Instructional Innovator* 29:19-23, 1984.

Howe S: Interactive video. *Instructor* 93:108-110, 1984.

Jason H: Will computers dehumanize medical care and education? *J Fam Pract* 18:525-527, 1984.

Jones GL et al: Computer clinical simulations in health sciences. *J Computer-Based Inst* 9:108-114, 1983.

Kearsley G: Instructional videodisc. *J Am Soc Informat Sci* 34:417-423, 1983.

Kosinski RJ: Producing computer assisted instruction for biology laboratories. *Am Biol Teach* 46:162-167, 1984.

Lee EC et al: A model for competency-based, computer-managed instruction in allied health. *J Allied Health* 11:106-114, 1982.

Lee J: Individualized instruction and continuing education by computer. *J Am Optom Assoc* 50:441-442, 1982.

Lunin LF: Videodisc and optical disk: technology, research, and applications. *J Am Soc Informat Sci* 34:406-407, 439-440, 1983.

Manning DT et al: Student acceptance of videodisk-based programs for paramedical training. *Technological Horizons in Education* 11:105-108, 1983.

McIntyre JWR: Computer-aided instruction as a part of an undergraduate programme in anaesthesia. *Can Anaesth Soc J* 27:68-73, 1980.

McMillen JD et al: Microcomputers for laboratory data collection. *Am Biol Teach* 46:157-161, 1984.

Moore ML: The expansion of analytical thinking of the science student through interaction with the TRS-80. *Am Ann Deaf* 128:714-716, 1983.

Munro JGC: Computer analysis of the student log diary: an aid in the teaching of general practice and family medicine. *Med Educ* 18:75-79, 1984.

Pagliari LA: Analysis of computer-assisted instruction in pharmacology. *Proc West Pharmacol Soc* 24:113-115, 1981.

Paris J: Basics of videodisc and optical disk technology. *J Am Soc Informat Sci* 34:408-413, 1983.

Peterson JA et al: Managing a test item bank on a microcomputer: can it help you and your students? *Technological Horizons in Education* 11:120-122, 1983.

Rose DA: Optical disk for digital storage and retrieval systems. *J Am Soc Informat Sci* 34:434-438, 1983.

Rosenblatt RA et al: The microcomputer as a vehicle for continuing medical education. *J Fam Pract* 18:629-632, 1984.

Schleutermann JA et al: An evaluation of paper-and-pencil and computer-assisted simulations. *J Nurs Educ* 22:315-323, 1983.

Self CC et al: Computers in audio-tutorial biology. *Am Biol Teach* 46:168-172, 1984.

Sladen JG: The personal computer as a clinical research and teaching tool. *Am J Surg* 147:654-659, 1984.

Sustik JM et al: Retrieving information with interactive videodiscs. *J Am Soc Informat Sci* 34:424-432, 1983.

Talley RC et al: Computerized program for internal medicine junior clerkship cognitive knowledge. *J Computer-Based Inst* 9:115-119, 1983.

Tallon B et al: Microcomputers and biology teaching—an overview and some ideas for future development. *Sch Sci Rev* 65:255-263, 1983.

Timpke J et al: Teaching drug dosages by computer. *Nurs Outlook* 29:376-377, 1981.

Ward JS: Microcomputers in the teaching laboratory: a hematology case study. *Am J Med Technol* 45:248-249, 1979.

Wartak J et al: Computerized textbook of clinical pharmacology. *Drug Intell Clin Pharm* 18:419, 1984.

Wolf MB: Regulation of cell volume and electrolytes. a computer-assisted instruction program. *Physiologist* 26:394-396, 1983.

Yucha C et al: The use of computers in nursing education, practice and administration. *Computers and Education* 7:223-226, 1983.

Compiled by H. Modell

THE BULLETIN BOARD

The Bulletin Board will be published periodically to inform readers of upcoming meetings of interest. If you know of meetings, symposia, continuing education courses, etc. of interest to life science educators that do not appear in The Bulletin Board, please let us know. Send pertinent information to: Dr. Harold Modell, Virginia Mason Research Center, 1000 Seneca Street, Seattle, WA 98101.

January 9-11, 1985. Third Annual Scientific Meeting of the Society for Research in Nursing Education. San Francisco, California.

Contact:

Dr. Nancy Diekelmann
Graduate Program
Center for Health Sciences
University of Wisconsin-Madison
School of Nursing
600 Highland Avenue
Madison, WI 53792
(608) 263-5200

February 4-6, 1985. 1985 Office Automation Conference. Theme: "Today's Partnership: People and Technology." Atlanta, Georgia.

Contact:

OAC 85
American Federation of Information Processing Societies, Inc.
1899 Preston White Drive
Reston, VA 22091
(703) 620-8952

February 27-March 1, 1985. First Annual Nursing Interactive Video Conference. Target population: nurse educators, nurses in practice, media health professionals, and interactive video producers and users. Sacramento, California.

Contact:

Dr. Pat Tymchyshyn
The Consortium of the California State University
Statewide Nursing Program
6300 State University Drive
Long Beach, CA
(213) 498-4951

March 7-8, 1985. "On-line, Off-line: Computer use in nursing." Atlanta, Georgia.

Contact:

Dr. Ethel Tatro
Georgia State University
School of Nursing
University Plaza
Atlanta, GA 30303
(404) 658-3048

March 25-29, 1985. 26th International Conference on Computer-based Instruction. Philadelphia, Pennsylvania.

Contact:

Gordon Hayes
Executive Director
ADCIS International
409 Mills Hall
Western Washington University
Bellingham, WA 98225
(206) 676-2860

April 1-2, 1985. National Symposium in Using Microcomputers in Health Care Education. Omaha, Nebraska.

Contact:

James E. Van Arsdall, EdD
Center for Continuing Education
University of Nebraska Medical School
42nd St and Dewey Ave
Omaha, NE 68105
(402) 559-4152

or:

Robert S. Wigton, MD
Graduate Medical Education
(402) 559-7426

April 10-12, 1985. "Computers in nursing: a dynamic interface." Columbus, Ohio.

Contact:

Dr. Mary Beth Strauss
Director
Continuing Education
The Ohio State University
College of Nursing
1585 Neil Avenue
Columbus, OH 43210
(614) 422-5371

April 19-21, 1985. 2nd Annual Symposium of Computer Applications in Patient Care. Las Vegas, Nevada.

Contact:

Sheila Byrne
Director
Institute of Continuing Education for Nurses
University of Southern California
School of Medicine—Post-graduate Division
Department of Nursing
Los Angeles County-USC Medical Center
2025 Zonal Avenue
Los Angeles, CA 90033
(213) 224-7467

May 1-3, 1985. International Symposium on Nursing Use of Computers and Information Science. Theme: "Building Bridges to the Future." Calgary, Alberta, Canada.

Contact:

Lois Kokcski
Conference Coordinator
International Symposium on Nursing Use of Computers and Information Science
Conference Office, ED-102
The University of Calgary
Calgary, Alberta
Canada T2N 1N4
(403) 284-5051

Compiled by D. Larson

COMPUTERS IN LIFE SCIENCE EDUCATION, VOLUME 1 INDEX

anatomy, 5:36
auscultation, 7:49
axon, simulation of, 1:5

Barr L, 3:19-22

basic science, computer simulations and,
2:14

biological systems, simulation of,
2:11-14

biology, 6:44

Blanchaer MC, 2:14

Blumhardt R, 4:29-32

Brubeck JD, 6:41-43

carbon dioxide transport, 8:58

cardiovascular simulations, 1:5

classroom use of computers, 1:1-3

clinical simulations, 2:14

Coleman TC, 2:11-14

Comer RC, 5:37

computer lesson, structure of, 1:6

conferences, teaching in, 1:4, 8:60

cost-effectiveness of CAI, 9:66

Crovello TJ, 6:44-46

data acquisition, 3:19, 7:54
database services, 6:42
diagnosis, simulated, 2:15
discrete Fourier transform, 4:30
drills, 7:54

Electrohome projection monitor, 3:18
exams, 5:39

graphics

dissociation curves and, 8:58

in radiology, 4:30

slides and, 5:33

hardware, for physiology lab, 3:20

health care, 9:65

Heidcrmp WH, 7:54

Hodgkin-Huxley squid axon simulation,
1:5

immunology, 5:39

input-output design, 8:57

interactive video system, 7:49

laboratory, data acquisition in, 3:19

Lancaster JL, 4:29-32

Larson DE, 9:65

laser discs. *see* optical videodiscs

Lasher JC, 4:29-32

lectures, computer use in, 2:9, 8:59

Levine SD, 5:33-36

lung sounds, 7:49

magnetic resonance imaging, 4:29

mathematical models, 2:13

Meinke WJ, 5:39

Michael JA, 1:6

Micobiology-Immunology Test Item
bank, 5:39

Mikiten TM, 2:9-11

model. *see also* simulations

structure of, 2:13

Modell HI, 1:1-3, 8:57-62

Mosley ML, 7:49

multiple choice questions, 2:15

multiuser system, 3:20

networking, national, 6:41

Neuroscience Software Project, 2:9

nursing, 9:67

optical videodiscs, 4:25

osmotic pressure, 5:34

oxygen transport, 8:58

physiology, 1:4, 5:36

comparative, 7:54

laboratory data acquisition and, 3:19

- pictures, storage of, 4:26
 problems, 1:2
 programmed learning material, 1:2
 programs. *see also* software
 guidelines for, 3:22
 preparation time for, 5:35
 projection monitors, 3:17
- radiology, 4:29
 renal glomerular circulation, 5:34
 Rovick AA, 1:6
- Schottelius BA, 1:4-6
 simulations, 1:2
 biological systems, 2:11-14
 clinical, 2:14
 slides, graphics in lieu of, 5:33
 software, 8:62
 evaluation of, 7:51
 graphics, 4:30
 for physiology lab, 3:21
 Sony projection monitor, 3:18
 sound in instruction, 7:50
 Stein R, 3:19-22
 Story NO, 7:49
- tabular data, 8:60
 telecommunications, 6:42
 Tucker C, 7:51
 Tymchychyn P, 9:67
- videodiscs, 4:25
 Vincenzi FF, 3:17
 voltage clamping, 1:5
- Walters J, 7:49
 Wooley-McKay D, 5:36

INVITATION TO CONTRIBUTORS

Articles consistent with the goals of *Computers in Life Science Education* are invited for possible publication in the newsletter.

PREPARATION AND SUBMISSION OF MATERIAL

Articles submitted for publication should not exceed 2000 words and should be typewritten, double spaced, with wide margins. The original and two copies including two sets of figures and tables should be sent to the Editor Dr. Harold Modell, Virginia Mason Research Center, 1000 Seneca Street, Seattle, WA 98101.

Title page should include full title, list of authors, academic or professional affiliations, and complete address and phone number of the corresponding author.

Illustrations should be submitted as original drawings in India ink or sharp, unmounted photographs on glossy paper. The lettering should be such that it can be legible after reduction (width of one column = 5.7 cm).

Reference style and form should follow the "number system with references alphabetized" described in the Council of Biology Editors Style Manual. References should be listed in alphabetical order by the first author's last name, numbered consecutively, and cited in the text by these numbers.

RESPONSIBILITY AND COPYRIGHT

Authors are responsible for accuracy of statements and opinions expressed in articles. All authors submitting manuscripts will be sent a copyright transfer form to complete. The completed form must be returned before the work will be published.

SUBSCRIPTION INFORMATION

Computers in Life Science Education is published monthly by Elsevier Science Publishing Co., Inc., 52 Vanderbilt Avenue, New York, NY 10017. Subscription rate is \$54.00 for 12 issues, including postage and handling in the United States and Canada. Add \$14.00 for postage (airmail) in Mexico and Europe and \$16.00 for the rest of the world.

This newsletter has been registered with the Copyright Clearance Center, Inc. Consent is given for copying of articles for personal or internal use, or for the personal or internal use of specific clients. This consent is given on the condition that the copier pay through the Center the per-copy fee stated in the code on the first page for copying beyond that permitted by the US Copyright Law. If no code appears on an article, the author has not given broad consent to copy and permission to copy must be obtained directly from the author. This consent does not extend to other kinds of copying, such as for general distribution, resale, advertising and promotional purposes, or for creating new collective works.

Address orders, changes of address, and claims for missing issues to Journals Fulfillment Department, Elsevier Science Publishing Co., Inc., 52 Vanderbilt Avenue, New York, NY 10017. Claims for missing issues can be honored only up to three months for domestic addresses and six months for foreign addresses. Duplicate copies will not be sent to replace ones undelivered due to failure to notify Elsevier of change of address.

Address editorial correspondence to Harold I. Modell, PhD, Virginia Mason Research Center, 1000 Seneca Street, Seattle, WA 98101.

POSTMASTER: Send address changes to *Computers in Life Science Education*, Elsevier Science Publishing Co., Inc., 52 Vanderbilt Avenue, New York, NY 10017.

COMPUTERS IN LIFE SCIENCE EDUCATION

HAROLD I. MODELL
Virginia Mason Research Center
Seattle, Washington

MARCEL BLANCHAER
Professor of Biochemistry
Faculty of Medicine
University of Manitoba
Winnipeg, Manitoba
Canada

THEODORE J. CROVELLO
Department of Biology
University of Notre Dame
Notre Dame, Indiana

JAMES W. ECKBLAD
Department of Biology
Luther College
Decorah, Iowa

TSEGAYE HABTEMARIAM
School of Veterinary Medicine
Tuskegee Institute
Tuskegee, Alabama

DONNA LARSON
School of Nursing
Grand Valley State College
Allendale, Michigan

TERRY M. MIKITTEN
Graduate School of Biomedical Sciences
University of Texas Health Sciences Center
San Antonio, Texas

JAMES E. RANDALL
Department of Physiology
Indiana University
Bloomington, Indiana

RICIA SCHWIRIAN
College of Nursing
Ohio State University
Columbus, Ohio

RICHARD STULL
College of Pharmacy
University of Arkansas
Little Rock, Arkansas

JAMES W. WOODS
Lister Hill National Center
for Biomedical Communications
National Library of Medicine
Bethesda, Maryland

DOROTHY WOOLEY-McKAY
Department of Biology
Glendale Community College
Glendale, Arizona

GLENN YOSHIDA
Department of Life Sciences
Los Angeles Southwest College
Los Angeles, California

ELSEVIER

CONTENTS

- TOOLS FOR CREATING LESSONS ON A COMPUTER** 1
Stephen N. Graham
- FACTORS TO CONSIDER WHEN CHOOSING AN AUTHORING SYSTEM** 5
Craig Locatis and Victor Carr

TOOLS FOR CREATING LESSONS ON A COMPUTER

Stephen N. Graham

Office of Instructional Computing, University of Washington, Seattle, Washington

The computer can be used in a variety of ways to support life science education. One of the most promising lines is the creation of "courseware," software that teaches the student directly about some aspect of the curriculum. Courseware takes a variety of forms, from graphical simulation of biological phenomena to tutorial instruction on nomenclature or patient simulations.

Courseware can either be purchased from outside vendors or written to your direct specifications. When we first encounter computer courseware, we are often not very impressed by its quality. There is a great temptation to say, "I could write something better than that!" With the variety of authoring methods that are available today, it prob-

ably is true that you can write good courseware, no matter what your level of programming experience. Lack of programming background can often be compensated for by the purchase of software that supports the user and takes care of many of the details that otherwise would be time-consuming and frustrating.

The key to creating good courseware is developing a clear idea of what you want to do and then acquiring the correct tools and resources to accomplish what you need. This article will not address the conceptual problems, but will be concerned with the kinds of tools that are available today. We will identify three different types of tools and contrast their capabilities.

The discussion will be fairly abstract, and we will not evaluate par-

ticular software packages, but rather identify the kinds of capabilities that have been important to courseware developers in the past. Specific software products in the marketplace change so rapidly that product evaluations are almost always obsolete before they are printed. Nevertheless, we have cited several such evaluations,^{1-5,7} and the user can certainly find more. The high rate of change should encourage each of you to evaluate your own situation and the resources available to you before making a decision.

AUTHORING SOFTWARE FUNCTIONS

There are several different software functions that have been important in the creation of courseware, but the relative importance of each one will vary from application to application. Authoring methods support these functions to various degrees, so the selection of an authoring method depends largely on which functions are important to you and which functions the various methods available to you support.

One of the most important functions is graphics. Some courses really require a lot of graphical or pictorial output, while for others this output is unimportant or trivial. Some authoring methods, such as PILOT or LOGO, are highly oriented toward graphics and have a lot of functions in their language that create or modify graphical output. Others, such as IIS or Coursewriter from IBM, have less graphical capability, providing block or character graphics only.

Another important function is questioning the student. Some methods only support certain kinds of questions. Some will only allow true/false or multiple choice questions, while others will permit virtually any kind of question structure. Some will generate different questions for each student with some

kind of random number generating procedure. Others require a fixed set of questions for each student.

Related to this function is the analysis of answers. Authoring methods vary in their ability to analyze the answers that the student supplies. Some can accept only simple numerical or alphabetical answers, while others will perform complex analytical operations, allowing several different aspects of the answer to be analyzed separately. Some will allow alternate spellings of answers or permit text to be searched for specific key words or phrases.

Authoring methods also differ in their ability to vary the lesson by taking different paths in response to the student's answer. Some languages supply elaborate branching capabilities, while others force each student to follow the same path through the lesson, more or less regardless of their capability. Branching capabilities allow the author to create more complex lessons with more options for the student.

Another important function is student record-keeping. Methods vary in their ability to keep records of a student's performance. Some methods do almost no record-keeping, limiting themselves to informing the student about right or wrong answers. Some provide elaborate scoring systems that will keep track of all right and wrong answers and present an overall score at the end of the lesson. Others make a record of each student's response to each question and permit elaborate analysis of wrong answers after the lessons have been completed. This aids instructors in identifying typical error patterns and providing remedial instruction to correct them.

Finally, there is the matter of special input/output (I/O) devices. Some lessons require particular video or audio input that is not available from standard computer I/O devices. For example, some authoring

methods will drive video disk or tape players, while others will not. Some will permit the user to attach audio devices, high resolution graphics screens, color monitors, touch screens, etc, while others have a strictly limited range as to the devices they will drive.

All of the above considerations are important in the selection of an authoring language. The most important thing is to be clear in your own mind about what sort of lesson you are actually planning to write. This will help you to define the kinds of functions that will be important to you, and this in turn will lead to a good set of criteria for the selection of an authoring method.

Choices about authoring methods depend partly on your own programming ability and partly on your need for the particular functions described above. There are three major categories of authoring methods that you may use to construct courseware. You may use 1) an authoring system,²⁻⁴ 2) an authoring language,^{4,7} or 3) a general-purpose programming language.^{1,7}

Authoring systems are the simplest to use and require the least programming background of any of the above approaches. They also produce courseware more quickly. Authoring languages require somewhat more programming skill, and programming languages require even more background. These last two methods require more programming time per lesson and are also more difficult to learn.

On the other hand, authoring systems typically allow the author less flexibility in the creation of courseware. The product is more structured in advance, and the author cannot be as creative in the programming of the computer. The authoring languages and programming languages are more flexible and are usually required if the author wants to do something that is technically or structurally innovative.

AUTHORING SYSTEMS

An authoring system consists of a set of menus that direct you through each step of setting up a lesson. Authoring systems may run on either mainframe computers or micros, but they are usually easy to use and provide a lot of coaching in preparing lesson plans, outlining a course, setting up screens, preparing graphics, etc.

Authoring systems are usually set up as a series of menus that are presented to the user in a regular sequence. The menus allow the author to make a series of simplified choices that guide him/her through the process of lesson construction. The authoring system does much of the work of programming the computer, so the author can concentrate on problems of designing the lesson.

A sample menu is shown in Figure 1. This menu is taken from the CAI Toolkit software produced by Softcat Inc. This is a registration menu used to add, change, or remove students from the class list and to change lesson assignments. You can see that the options are simple, and the selection of them is straightforward.

Authoring systems also can provide a variety of features that are not offered by authoring languages. These features make the preparation of lessons easier, and make the administration of a lesson system possible without additional coding by the author.

One such feature allows the author to interact with lesson material as it is being prepared. Some systems allow the author to run lesson materials in a "testing mode." This permits the author to take the course as if he/she were a student but with the additional ability to jump in and out of the lesson to make changes as the lesson is presented. This feature can be very useful in updating lessons and can save a lot of compilation time and cost while the lesson is being prepared.

Another feature that many authoring systems offer is a course administration facility. This allows the author not only to create the lesson but also to set up a file that records which students are taking the lesson, keeps track of each student who has completed the lesson, and keeps track of the scores that each student has achieved. In addition, many authoring systems allow grading of each student and will record information on multiple classes having multiple lessons.

Examples of authoring systems are the Interactive Instructional System (IIS) from the IBM Corporation, the Scholar/Teach 3 system from IBM, and the Phoenix software from Goal Systems. Each of these has both a mainframe and a microcomputer version, with different capabilities. These are only examples. There are many other authoring systems on the market. You should consult journals in the area for reviews of individual products.

Authoring systems provide a lot of support for the author and can save time and improve productivity, particularly for inexperienced authors, by providing a lot of structure for the author. Each step of lesson preparation is predetermined, and the author is taken through each option every time a lesson is prepared.

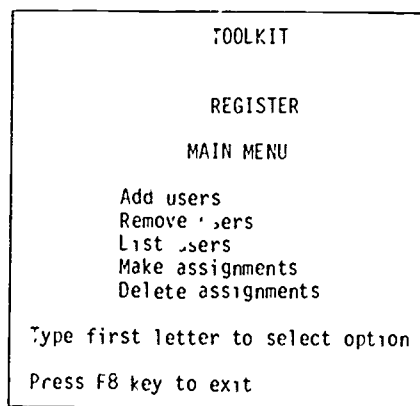

FIGURE 1. Sample menu

The structure that is so supportive, however, can also be a handicap. In many cases, authoring systems are quite restrictive in the kind of lessons that they will prepare.

Courseware must follow a fairly rigid format with little deviation permitted. There may be restrictions on the kind of screens permitted, the structure of lessons, the types of questioning that the system allows, and the graphics capabilities.

Authors should review the specifications carefully before purchasing such systems and, if possible, spend some time trying to use them to get an impression of how well the system is suited to their instructional goals.

Another problem with authoring systems is their cost. They tend to be quite a bit more expensive than authoring languages. In most cases, this cost is justified by the larger number of features and improved support for the author. You should bear in mind that software costs are generally quite low in comparison with costs of personnel time. If an authoring system saves you significant amounts of time, it will probably earn its cost back quickly.

However, that cost can run into thousands of dollars, so purchasing decisions must be carefully weighed.

AUTHORING LANGUAGES

An alternative to authoring systems is to use an authoring language directly. Authoring languages are computer languages that are specifically designed for creating computer-assisted instruction lessons.

Authoring languages are more flexible and may provide the author with more programming capability than an authoring system. They are also usually much cheaper. They lack, however, the support features of the more general authoring systems. Features such as lesson design aids and student accounting support are usually missing from authoring

languages. However, the author may program such features directly using the capabilities of the language.

An authoring language allows the user to create an actual computer program that delivers a lesson to the student. Programs are created one line at a time using a syntax that is somewhat similar to that used for general programming languages such as FORTRAN or PASCAL. The difference is that the syntax is specifically designed for lesson preparation. The basic instruction set includes commands for such functions as setting up a screen, presenting a question, and accepting an answer.

Most authoring systems have an authoring language associated with them. The authoring system may do the work of programming the computer in the authoring language. Some authoring systems provide the author with the capability of accessing the authoring language directly, and programming part of the lesson in line-by-line code.

Rules of syntax for authoring languages vary along with the capabilities of the languages. These differences can be important to the author, and you should examine the capabilities of each language before making a purchasing decision. Each authoring language has particular features that make it more effective for some applications than for others. It is wise to look at the kinds of lessons that have been written in a language when you are considering it for purchase. These will indicate how the language has been used successfully in the past and will point to the features that are most useful to the author.

Examples of authoring languages are PILOT and TUTOR. Each of these supplies the author with an instruction set that can be used to create lessons directly, one instruction at a time. The author controls the actions of the machine directly through language instead of indirectly as with an authoring system.

Courses written in an authoring language are compiled or interpreted by the computer and are executed by students in just the same way as those from authoring systems. They can be modified in response to student feedback and author evaluations, recompiled, and tested again. Courses written in authoring languages are often portable, that is, they can be run on different machines that have a compiler for that authoring language.

The advantages of an authoring language are the direct control that it gives over the coding process. The author can be more flexible in the design of the lesson and is not restricted by the structure of an authoring system. Authoring languages are usually much easier to learn than general purpose programming languages. The command set is well suited to the preparation of lessons and corresponds well with an intuitive view of what goes on during a lesson. The languages are simple enough that they can be learned quickly, even by a novice programmer, and they can be highly productive for experienced users.

On the other hand, authoring languages rarely provide the kind of user support that authoring systems provide, and they do not provide as much flexibility as a general-purpose programming language. There is rarely support for grading, student registration, class record-keeping, or lesson design as with an authoring system. Construction of lessons may be very tedious since each line of the screen must be entered and specified separately. At the same time, the syntax of most authoring languages is very simplified and does not provide the capabilities of the more sophisticated languages. Complex record structures are not permitted, and the author's creativity may be inhibited by the lack of options provided.

In some cases, you may not be able to find an authoring language

that supplies the kind of support that you need, or you may need to drive certain input or output devices that no authoring language will address. In that case, you may have to resort to writing the course in a general-purpose programming language.

GENERAL-PURPOSE PROGRAMMING LANGUAGES

General-purpose languages, such as FORTRAN, PASCAL, BASIC, and assembler languages, allow much more direct control of the functions of the machine and may well allow you to do things that are not possible in an authoring language. Complex record structures are supported, and virtually any kind of capability can be programmed into your courseware if you are willing to spend the time and resources to create it.

Unfortunately, you pay a penalty for this capability. Usually, courses written in a general-purpose language are much more time-consuming and tedious to write than those written in an authoring language. They are also more expensive to maintain and update than the simpler authoring language programs. A higher level of training is required for both the designer of the courseware and its programmer.

However, there are some cases in which it is much more appropriate to use general-purpose languages. If, for example, you need special graphics effects such as animation, or you want to execute some routines at very high speed, or you need to provide complex record structures to keep track of user activities, you may have to use the more general languages.^{6,9}

Many of the more innovative instructional developers will use general-purpose languages. This is because they are creating materials that use state-of-the-art effects not

available through standard authoring languages or authoring systems. The creation of these effects is relatively expensive and time-consuming, but it can result in greater instructional effectiveness.

One interesting application that requires the use of general-purpose languages is the use of artificial intelligence techniques in courseware. These programs usually build an internal model of the learning state of the student as he/she progresses through the lesson. This model is updated as the student responds to questions from the program, and the lesson is modified or adapted to the student's progress on the basis of the model.

This type of application is experimental and relatively time-consuming and complex to develop. It requires the full capability of the computer to create and can only be developed in a general-purpose language. It may turn out to be an important feature of successful courseware, however, and future authoring systems and languages may be adapted to provide such features as a standard.

SUMMARY

We have identified several software functions that are important in the creation of computer "courseware." We have developed a typology of authoring methods and discussed the relative merits and problems of each approach. Authoring systems were identified as the most "user-friendly" and simplest, but with the most restrictive structure and highest purchase cost. Authoring languages are an intermediate approach, offering moderate difficulty but with increased coding flexibility at reduced cost. General-purpose programming languages require the most training to use and the most programming time, but they provide the user with the maximum in design flexibility.

REFERENCES

1. Burke RL: If you're thinking about developing your own software, consider this. *Electronic Educ* 2:1 14, 37, 1982.
2. Hall-Sheey J: Promises, promises: what to believe about authoring systems. *Data Training* 3:17, 45, 1984.
3. Kearsley G: Authoring systems in computer based education. *ACM Communications* 25:429-437, 1982.
4. Kemske F: Guide to authoring systems. In: *Data training 1984. Computer-based training guide*. Boston, MA: Warren-Weingarten Inc, pp 1-21, 1984.
5. Rowell, NA, Barden M: An analysis of computer languages available for computer assisted instruction on the California State University system. In: *Western Educational Computing Conference, San Diego, 1982*. North Hollywood, CA: Western Periodicals Inc, pp 87-93, 1982.
6. Salisbury DS: Strategies for designing drill and practice programs for computers. *Proceedings of the 25th ADCIS Conference*, pp 201-207, May, 1984.
7. Schwartz J: Languages and systems for computer-aided instruction. *Machine Mediated Learning* 1:5-39, 1983.
8. Simonsen RH: Coaching/prompting: the answer for CAI? *Infosystems* 24(1):64-66, 1977.
9. Stoddard ML: Modelling the behavior of the computer-assisted instruction user. *Proceedings of the 24th ADCIS Conference*, pp 211-216, May, 1983.

FACTORS TO CONSIDER WHEN CHOOSING AN AUTHORIZING SYSTEM

Craig Locatis and Victor Carr

Training and Consultation Branch, Lister Hill National Center for Biomedical Communications, National Library of Medicine, Washington, DC

Faculty members who produce lesson-oriented⁵ computer-based education (CBE) materials have three options when it comes to formatting curriculum content for computer-controlled presentation. They can employ the services of an expert computer programmer and of an instructional design specialist, learn computer programming and CBE design (eg, "bootstrap" it), or use an authoring system.

For the novice faculty member, the first two options are seldom viable since the first demands additional fiscal resources and the second additional time. The third is a viable option, and the purpose of this article is to acquaint faculty members with some of the variables associated with authoring systems.

Authoring systems are software tools designed to ease the task of creating computer-based instructional materials (courseware). They

lead courseware developers through a process of writing instructional programs, and they generate the underlying computer code. This is usually accomplished by presenting menus of authoring options and prompts for input. If codes and commands must be used, they typically are displayed with a request for a choice by the author. Authoring systems can be contrasted with programming languages, such as BASIC, and authoring languages, such as COURSEWRITER, that require knowledge of programming logic, code, and syntax. It is not, however, correct to assume that these categories (programming languages, authoring languages, authoring systems) are absolutely clear cut. Some authoring systems require the use of a few commands from the underlying programming language, and some authoring languages (eg, PILOT) can also be viewed and used as high-level

programming languages. Finally, some high-level languages make calls to assembly language routines. Since authoring systems are themselves programmed user friendly interfaces, they are derivatives of underlying levels of computer code. Consequently, they are not as rich and versatile as the programming language and can impose certain instructional constraints, such as branching and answer-judging capacities. Some authoring systems, however, allow authors to incorporate programming routines into lessons to achieve any desired effect.

Great interest in authoring systems has been engendered because they can potentially enhance productivity and increase computer use by novices. There has been a rush by computer manufacturers, software firms, and publishers to develop and market systems. When we started researching authoring system technology about a year ago, we were aware of six commercial products. We have now identified over 60, and the two dozen systems we have reviewed are changing constantly. Evaluating authoring systems is especially difficult because of the rapidly changing technology and because both the quality of systems and the instruction they produce must be considered. Although systems vary, they have a number of common general attributes that can be described. The appropriateness of a system, however, should be determined within the context of local needs. Potential purchasers should see system demonstrations and get actual hands-on experience with those systems they find most relevant before making a final decision.

SOURCE

Once courseware development needs are determined, one of the first considerations is the reputation of the system producer or vendor. Their track records in software develop-

ment and customer service should be determined. Sometimes geographical proximity affects service, and the availability of a local customer service representative is important. A list of previous system purchasers, if available, is helpful in getting opinions about vendor service as well as the product.

HARDWARE REQUIREMENTS

Different systems are geared to producing learning materials on different brands of microcomputers that may have to be configured in special ways (videotape or videodisc interface, extra memory, and so on). Some systems have multiple versions for different brands or create transportable courseware. A system should be compatible with hardware either on hand or to be acquired. If courseware is to be shared, systems with multiple brand versions and transportable products might be favored.

COSTS AND TERMS

Authoring system prices and contracts vary considerably compared to other educational products. Some systems might be owned, others licensed or leased. Moreover, there might be certain restrictions on ownership distribution, sale, and use of the courseware produced, and there often are initial and residual costs. For example, some vendors may want royalties on courseware sales, and many require use of special lesson presentation diskettes. After authoring is complete, lessons usually are transferred to these diskettes, and the number of presentation diskettes required is generally equivalent to the numbers of students expected to take a course concurrently. Often presentation diskettes must be purchased, and the vendor is the sole source. Given the changing nature of systems, most contracts have provisions for up-

grades, and most vendors are willing to customize their products for a charge. Terms should not conflict with organizational policies, and anticipated use and costs, both upfront and ongoing, should be reasonable, including costs for special hardware that might be required.

SYSTEM OUTPUT

Some systems are intended to author specific kinds of lessons (or only tests) while others are more versatile. The more capabilities systems have, the more complicated and expensive they tend to be. An initial needs assessment will inhibit tendencies to become overinfatuated with "bells and whistles" that might create unique and unusual effects that have dubious influence on learning or not be relevant to the kind of courseware to be developed. Efforts should be made to match system output to local needs, and there may be situations where it may be desirable to acquire both a general purpose system and one that produces specific material. For example, if many multiple choice tests are to be generated, it may be useful to buy an inexpensive system that does nothing else and can be easily used by clerical staff. A more general system might be acquired for more sophisticated courseware.

AUTHORING FACILITIES

Systems have provisions for one or more of the following: text creation and editing, graphics, answer judging, branching, and interface to other input or output devices. Text may vary in terms of font, color, columns used, and prespecification of display format. Some systems have word processing capabilities and allow instant preview and modification of displays. Others allow use of external word processing software. Similarly, some systems have built-in graphics facilities, while others rely

on external software. Sometimes prompts for input are generated automatically, and there may be more or less flexible means of judging selected or completion responses.

Most systems have provisions for branching, but there may be restrictions on the number of branches from a given display and/or the total number of branches per lesson. Branching and lesson size will also be constrained by the amount of computer memory available. Sophisticated systems provide for videotape or videodisc interface and may have touch screen, light pen, or mouse input, or may allow the use of graphics tablets and overlay of graphics on video. Some new systems have voice input and speech output. Authoring facilities should accommodate the type of instruction required. Both the authoring system and the courseware created should be easy to use.

MANAGEMENT COMPONENTS

Some systems make no provision for record keeping and those that do vary considerably. When provided, record keeping capabilities range from rostering and registering students to recording lesson completion, paths through lessons, responses to specific questions, student comments, and overall test and individual test item performance. There may be provisions for test analysis and record security. The

question is whether management capabilities are needed and whether those provided are appropriate.

DOCUMENTATION / TRAINING

Finally, evaluation efforts should include system documentation and related training. Some systems are learned more rapidly because they are less complex and easier to use. However, some documentation usually must be consulted and formal or informal training may be necessary. Documentation can take the form of manuals, help facilities, and even comment or remark statements embedded in the underlying program that drives the system. The latter, however, are normally not accessible to typical users. Training usually is in the form of formal courses, one-on-one instruction with an expert system user, or self-instructional materials. Documentation and training should be accurate, clear, concise, and current with system updates.

CONCLUSION

Authoring systems are appearing that make courseware development easier. However, they do not necessarily ensure that better instruction will be produced. A thorough knowledge of learning theory and instructional design is still required. Moreover, authoring systems may not result in more courseware develop-

ment by faculty who are not otherwise inclined to do so or who may be adverse to new technology. The brief guidelines presented here may be helpful in focusing assessments of commercial systems currently available. We are preparing a more detailed resource and the references below might be consulted for further information.¹⁻⁴ New systems are being developed that use artificial intelligence techniques, and they will undoubtedly add capabilities that should be taken into account. However, the attributes described will remain important, and system selection will still be dependent upon local needs and preferably based on systematic review, demonstration, and actual use.

REFERENCES

1. Kearsley G: Authoring systems in computer-based education. *Communications of the Association for Computing Machinery* 25:429-437, 1982.
2. Locatis C, Carr V: Selecting authoring systems. *Journal of Computer-Based Instruction* (In press).
3. Merrill D, Wood L: Computer guided instructional design. *Journal of Computer-Based Instruction* 11:60-63, 1984.
4. Pogue R: The authoring system: interface between author and computer. *Journal of Research and Development in Education* 14:57-68, 1980.
5. Rovick AA, Michael JA: The computer lesson. *Computers in Life Science Education* 1:6-7, 1984.

COMPUTERS IN LIFE SCIENCE EDUCATION

HAROLD I. MODELL
Virginia Mason Research Center
Seattle, Washington

MARCEL BLANCHAER
Professor of Biochemistry
Faculty of Medicine
University of Manitoba
Winnipeg, Manitoba
Canada

THEODORE J. CROVELLO
Department of Biology
University of Notre Dame
Notre Dame, Indiana

JAMES W. ECKBLAD
Department of Biology
Luther College
Decorah, Iowa

TSEGAYE HABTEMARIAM
School of Veterinary Medicine
Tuskegee Institute
Tuskegee, Alabama

DONNA LARSON
School of Nursing
Grand Valley State College
Allendale, Michigan

TERRY M. MIKITEN
Graduate School of Biomedical Sciences
University of Texas Health Sciences Center
San Antonio, Texas

JAMES E. RANDALL
Department of Physiology
Indiana University
Bloomington, Indiana

PATRICIA SCHWIRIAN
College of Nursing
Ohio State University
Columbus, Ohio

RICHARD STULL
College of Pharmacy
University of Arkansas
Little Rock, Arkansas

JAMES W. WOODS
Lister Hill National Center
for Biomedical Communications
National Library of Medicine
Bethesda, Maryland

DOROTHY WOOLLEY-McKAY
Department of Biology
Glendale Community College
Glendale, Arizona

GLENN YOSHIDA
Department of Life Sciences
Los Angeles Southwest College
Los Angeles, California

ELSEVIER

CONTENTS

COMPUTER CULTURE SHOCK: A CASE FOR AFFECTIVE EDUCATION Judy A. Malone	9
EVALUATION OF COMPUTER-ASSISTED INSTRUCTION COURSEWARE Diane J. Skiba	11
COMPUTER RECONSTRUCTION OF A HUMAN ARM FROM SERIAL SECTIONS J. Michael Kabo and Roy A. Meals	14

COMPUTER CULTURE SHOCK: A CASE FOR AFFECTIVE EDUCATION

Judy A. Malone

The Ohio State University, College of Nursing, Columbus, Ohio

Computers have invaded our homes, the workplace, and our institutions of higher learning. Like storm troopers, computers are foreigners, speak an incomprehensible language, and are understood only by their creators and advocates. Many converts to this wave of technology have embraced this new computer culture. Others hope, and have said so publicly, to retire before being forced to accommodate the computer into their lives. Thus, it is of greatest importance that we, as educators and carriers of the computer culture, carefully attend to the affective domain of education.

Affective education addresses the values and beliefs of the learner. We

cannot afford to alienate our students or ignore the computer casualties. This paper addresses the culture shock that many students experience within the educational setting and many clinical practitioners experience when coerced into using the computer as part of their work. Unfortunately, computer literacy courses have devoted little attention to the values of computer technology, the learning environment, the attitudes of the students, and life experiences of the adult learner. Thus the diagnosis—culture shock.

Before launching into a discussion about this culture shock, it is necessary to talk about the stereotypes of

the opposing cultures. Ordinarily, I refrain from such references, as I like to consider the individuality of each learner, but stereotypes serve as illustrations of two extremes. The computer convert is enamored with the technology and converses easily in the jargon of bits and bytes. Typically, the computer convert or computer whiz knows the inner workings of the computer intimately. Many helping professionals, such as social workers, nurses, doctors, and physical therapists, tend to be more "people oriented." Their culture is far removed from the circuits of computers. In fact, many charge that computers are responsible for mechanized teaching and care without the qualities of human respect for individuality and, as a result, our society is doomed. These prophets of doom and the indoctrinated students are the targets of this discussion.

Culture shock is the feeling of helplessness, fear, and anxiety when one is exposed to a different set of beliefs and values. Victims of culture shock are often disoriented as they attempt to adapt to the new situation. In the educational setting, fear and anxiety undermine the best teaching strategies.

The culture gap can be seen in many ways, but for our purposes, only one illustration will be used. Consider the differences in language. Computer people use terms such as dump, crash, kill, delete, and down time. There is a certain finality conveyed by these words. Helping professionals use words like assist, facilitate, explore, intervene, and passed away. This list is much softer, more tentative than the words of the computer culture. Say these words out loud. Computerease is much more guttural, forceful, and dominant. The other list is more nurturing and caressing. I propose that the computer terminology is offensive and makes many people avoid computers.

DEFINITION OF THE PROBLEM

The reality is that the information age and computer technology are upon us and will not go away. When we teach computer literacy, we must be aware that (1) there may be a values conflict between the teacher and the learner, (2) the learner may feel coerced into learning about computers, and (3) the ordinary teaching techniques may not produce affective, or emotional, changes.

What we value is demonstrated in our behavior.¹ The criteria for valuing includes the following: choosing freely, choosing from alternatives, choosing after consideration of the consequences, prizing and cherishing, affirming in public, acting upon choices, and repetition.

Think about the plight of staff nurses who have just been given the dubious honor of using a hospital information system. Do they have a choice? What were their alternatives? Do they cherish the opportunity, and what do they say in public about the new computer system? Is there any reason for cooperation and acceptance? For another example, think about the student who has to use the computer for statistical analysis the first time. Is it by choice? What are the options? And if it is only for one assignment, are we engaging in an act of psychological abuse?

These examples highlight the very essence of the problem. We, the advocates of the computer culture, have not contemplated our actions. We assumed they were correct and morally justified. We have failed to consider the affective domain of education.

STUDENTS ARE ADULT LEARNERS

Students of science in institutions of higher education are adults. Another approach to the problem of affective education is within the principles of "andragogy," or adult learning. Adult learners are usually self-

directed, have many practical experiences in the real world, are ready to learn when the need is recognized, are oriented to solving problems, and are intrinsically motivated.² The computer is a tool and complements the activities of the student. Knowledge about computers and their workings is not an end-product of the educational process. Instead, it is a means. Computers are tools much as the stethoscope is a tool for the nurse or physician. The difference is that the attitude or affective behavior toward the type of tool is crucial.

Teaching the use of computers, or using the computer to supplement course material, requires that we acknowledge that attitudes shape behavior. Conversely, to alter attitudes, one may change the behavior. Festinger's theory of cognitive dissonance states that people are psychologically uncomfortable when behavior does not correspond to their attitude.⁴ Requiring a change in behavior through course requirements and assignments forces students to perform a task they would normally avoid. To resolve the conflict between the behavior and the attitude, the student will eventually alter the attitude. The task then is to create the atmosphere of an amiable environment that makes the change in attitude acceptable and transferable to other settings.

King¹ states that affective teaching is most effective using the strategies of group discussion, role playing, case studies, leaderless groups, and sensitivity training. But Knowles² supplies a broader perspective beyond teaching techniques. Knowles considers the process of learning as most important and the content of the subject to be secondary. To facilitate the process, seven factors must be considered. The first is the climate. The physical environment dictates how people sit and how they relate to the teacher. Lecture rooms are not conducive

to adult learning. But the psychological climate is more important. There must be a climate of respect and collaboration. The student and the teacher must be supportive of each other. The student and the teacher must be open and honest with each other and enjoy the process of learning. Above all there must be a quality of humanness about the entire climate.

The second factor is to involve learners in mutual planning of the learning process. Students also participate in diagnosing their own needs, designing the learning objectives, and planning for meeting the objectives (factors 3, 4, and 5). The sixth factor is that the teacher facilitates carrying out the plans for the learner. The teacher must be open to discussion of problems and available to the student. The seventh factor to consider when teaching adults is to help the learner evaluate the learning experience. The evaluation does not stop with the determination that the objectives were or were not met.

PROVIDING A ROLE MODEL

While it is true that not all learners are willing to change their attitudes and behaviors overnight, there is much to be said for the power of a role model, desensitization, and nurturing individuals as they progress. When dealing with the attitudes of others, it is difficult to isolate one's own feelings. Indeed, if you teach in the affective domain, your success will depend upon your own honesty and willingness for students to see such openness. I have jokingly dealt with computer fear,³ but I was a former victim of the computer culture and was dragged kicking and screaming to my first computer terminal. To this day I possess no infatuation with the circuits, K's, and number of drives. But I do like what they can do. I was fortunate that I had a teacher who was patient and kind, yet firm, and my

attitude became more positive. It is time, with the growing emphasis of computers in every field of education, that the affective components of the instructional process be deliberately planned, implemented, and evaluated. We cannot afford to lose the human element of the technological revolution. The participation of people and the "humanness" of the systems produced can come to fruition only if the users of the technology are captains of their own ships. It is time to be proactive and not reactive.

I have attempted to alert educators in the sciences that affective education is a component of the curriculum when teaching computer literacy or using the computer as a teaching aid. We need to actively teach the values and beliefs that we wish our students to learn, and we cannot leave that to chance. King's work on affective education in nursing and the strategies outlined are practical. Malcolm Knowles' theoretical constructs about the adult learner have been substantiated through research and serve to re-

mind us that most of the educators in the sciences are not educators by training. Rather we have specialized in a content area and are not, as a rule, well-versed in learning theories. In relation to the teaching of computer literacy or in using the computer as a tool for classroom instruction, we need to critically examine the type of learner and the environment, and recognize that culture shock between the helping professions and the computer age is a reality.

REFERENCES

1. King EC: Affective education in nursing: a guide to teaching and assessment. Rockville, MD: Aspen Publ, 1984.
2. Knowles MS, et al: Andragogy in action: applying modern principles of adult learning. San Francisco: Jossey-Bass, 1984.
3. Malone J: A brief note on computer fear. *Computers in Nursing* 1:1, 1982.
4. Raven BH, Rubin JL: Social psychology: people in groups. New York: John Wiley & Sons, 1976.

EVALUATION OF COMPUTER-ASSISTED INSTRUCTION COURSEWARE

Diane J. Skiba

Computer Resource Lab, Boston University School of Nursing, Boston, Massachusetts

Since the 1960s, the use of computers as educational tools has been implemented by a limited number of post-secondary schools. Costs, limited availability of courseware, and faculty resistance were cited as reasons for the limited use of computer-assisted instruction

(CAI).^{8,10,11} With the advent of microcomputers, the use of computers has grown in terms of numbers of users and types of applications.⁴ With the renewed interest in the computer as an educational tool and the increased development and purchasing of courseware, it becomes

imperative for faculty to understand the process of evaluating CAI courseware. The proliferation of CAI courseware has precipitated the analysis of evaluation criteria. Such an analysis has been presented in a previous paper.⁸ The purpose of this paper is to present an evaluation framework that can facilitate the decision-making process surrounding the purchase of CAI courseware. The framework includes several underlying principles and proposes a two-phase evaluation process.

EVALUATION FRAMEWORK

The proposed framework is based upon the results of a literature review,⁹ additional resources,⁷ and the author's background as an educational evaluator. The goal is to assist faculty in selecting and assessing CAI courseware. Several assumptions underlie the framework. First, courseware evaluation must be considered a constructive activity that involves the collection of data to facilitate decision-making about the selection of courseware and an assessment of its quality.

Second, courseware evaluation must be considered within the context of the overall evaluation for the planning and implementation of CAI in a curriculum. Accordingly, courseware evaluation occurs between the feasibility and effectiveness stages. The feasibility or preliminary stage begins with examination of several administrative, faculty, student, and curricular considerations.^{1,5} The second stage involves selection and assessment of both computer hardware and courseware. In terms of the courseware, there are two distinct phases that occur at this stage: selection and assessment. The final stage involves measurement of CAI effectiveness and efficiency. Third, the evaluation of courseware assumes that the evaluator has not only an understanding of the subject matter but also the basic principles of computer-assisted instructional

techniques. In addition, the evaluator must have an understanding of the power of the computer.³ Understanding conceptual design and instructional strategies² as well as technical aspects of CAI such as screen design⁶ are also considered requisite skills of an evaluator. Thus, given the assumptions about the various levels of knowledge needed for evaluation, it is advisable to have more than one evaluator for each assessment. An ideal evaluation team would be the following combination: content specialist, instructional design specialist, and students from the target audience. Since most schools may not have access to an instructional design specialist, it is advisable to seek a faculty member who has a working knowledge of both computer technology and CAI.

SELECTION PHASE

The framework proposes two phases of courseware evaluation. The first phase involves soliciting general descriptive information about the product so one can decide whether or not to purchase the courseware. During this phase, the evaluator, most likely a faculty member, would solicit information about the particular courseware from such sources as the company, brochures, advertisements, and product reviews in journals. Collecting these data does not require purchase of the courseware. Information should be collected according to the following six categories: company, author, hardware and software requirements, lesson content, courseware structure, and documentation/support. Under company information, one should know about the company's product line (Do they sell other CAI courseware?), demographics (How long has the company been in business?), marketing (Do they have vertical or horizontal markets?), and administrative issues such as pricing/costs, backup copies, and multiple copies. You will also want to collect infor-

mation about the author(s) such as their educational background and their previous experience in both teaching and CAI. Hardware and software requirements include such areas as computer brand/version, main memory, mass storage devices, output devices, other peripherals, operating systems, programming languages, utility programs, and program alterations. CAI type, instructional prerequisites, subject area, objectives, and the target student population are all factors to be considered under the lesson content category. Courseware structure requires collecting information about student's role, time estimates, activity flow/sequence, scoring, and reporting functions. The last area, documentation/support, includes field test results, supplemental materials required, ordering information, support policies, and descriptions of the types of manuals available for both students and faculty. Upon conclusion of this phase, a decision to purchase a copy (or review copy) can be made.

ASSESSMENT PHASE

The second phase involves the assessment of the courseware's quality. This phase requires the actual courseware (or a review copy, if possible) and appropriate documentation. Multiple evaluators should ask questions in the following domains to assess the quality of the courseware: instructional, student interactions, and technical. The domains represent a compilation of the various evaluation guides and allow input from multiple evaluators, including students.

Instructional Domain

The instructional domain covers the following areas: content, objectives, learning framework, and professionalism. The content specialist would be best suited to assess this domain. When examining the content of a CAI courseware, one should

ask questions related to the following:

- Accuracy (Is it free from factual errors, outdated information, or inaccurate graphs or displays?)
- Educational value (Does the content fit your intended purpose?)
- Organization (Is the content consistent and does it fit within the curriculum?)
- Completeness (Is the content complete and central to the subject area?)

In terms of objectives, one should ask whether the educational objectives of the courseware are clearly stated for both the instructor and student, achieved by the courseware, and fit your intended objectives.

The learning framework area covers items such as the following:

- Learning assumptions (Are there any prerequisites?)
- Learning theory (Is a particular theory used in the design?)
- Environment (Can it be used by an individual or a team? In what settings is it appropriate?)
- Transition (Is there a smooth transition between concepts and units?)
- Internal consistency (Is there consistency in terms of level of difficulty and presentation of content?)
- Computer capability (Does the courseware make use of the computer's capacity?)

In terms of professionalism, one should make sure the courseware is free from typographic errors and stereotypes.

Student Interactions

The student interaction domain investigates the nature of the student's interaction with the CAI courseware. Both students and other members of the evaluation team can provide an accurate assessment of

such categories as creativity, control, feedback, motivational devices, and independence from technology. Creativity issues are related to the student's role (What is the amount of interaction of the student in the learning process?) and the uniqueness of the learning situation (Does the courseware present information not easily duplicated by other media?).

Student control includes such areas as the following:

- Sequence of presentation (Does the student have control?)
- Level of difficulty (Does it make use of branching?)
- Speed of presentation (Can the student control the pace?)
- Number of items (Can the student control the number of items?)

Feedback to the student involves analysis of feedback given for both correct and incorrect responses. In addition, one should investigate how often feedback is given as well as whether or not the dialogue is personalized and if prompts are used effectively.

Factors related to motivational devices include the following:

- Graphics/color/sound (Are they used? How are these devices used?)
- Timing (Are these devices used periodically?)
- Scoring (When is scoring done—periodically or at the end?)
- Personalization (Does it approach the student in a personalized manner?)
- Independence from technology (Can the student operate courseware without any programming knowledge?)

Technical Design

The last domain concentrates on the technical aspects of the courseware and includes criteria such as screen design, error trapping, ease of oper-

ation, and speed of execution. All these criteria assume a working knowledge of computers and CAI and are therefore oriented toward an instructional design specialist. This does not preclude the fact that other evaluators could provide input for this domain.

Screen design includes such areas as the following:

- Organization (Is screen neat and uncluttered?)
- Spacing (Is there adequate spacing?)
- Transition (Can the student move freely back and forth between screens?)
- Amount of information (Is it too much or too little per screen?)

Ease of operation criteria include the following:

- Instructions (Are instructions clear and consistent?)
- External documentation (Is this necessary for operation?)
- Exit/movement (Is it easy to move or exit the courseware?)
- Reliability (Is it reliable in normal use?)
- Free of bugs (Is it free from programming bugs?)
- Data entry (Can student easily enter data and edit data?)

Error trapping relates to how the courseware handles and includes the following:

- Error messages (Are messages understandable?)
- Stops/breaks (Are there any dead-ends?)
- Escape (Is the escape key used?)
- Unanticipated responses (Does it cause the courseware to stop?)

The last area, speed of execution, concentrates on the amount of time for loading and screen to screen

movement as well as the use of distractors and cues.

SUMMARY

Upon completion of the criteria for the three domains, a summary of results should be compiled and reviewed by the evaluation team. The summary will provide sufficient data to decide whether or not to purchase copies of the courseware for use in the curriculum. A final word of caution, however, is that courseware will never satisfy all the various criteria proposed in this framework, but it is important to collect objective data to facilitate decision-making about the purchase of courseware. Therefore, one should not expect courseware to be perfect. Individual schools should use these criteria and determine standards for their own institutions. As courseware begins to proliferate at a fast pace, it is important for individual schools to establish policies that use objective data to facilitate the purchase of appropriate and quality courseware.

REFERENCES

1. Billings D: Evaluating computer assisted instruction. *Nursing Outlook* 32(1): 50-53, 1984.
2. Chambers J, Sprecher J: CAI: its

use in the classroom. Englewood Cliffs, NJ: Prentice Hall, 1983.

3. Coburn P, Kelman P, Roberts N, Synder T, Watt D, Weiner C: Practical guide to computers in education. Reading, MA: Addison-Wesley, 1982.
4. de Sola Pool I: Academic practices, freedom, and the new technologies. As cited in: Current issues in higher education: colleges enter the information society, AAHE, 1983-84.
5. Grobe S: Developing CAI for your school: a preliminary checklist. *Computers in Nursing*, 1(1):4, 1983.
6. Heines J: Screen design strategies for computer assisted instruction. Bedford, MA: Digital Press, 1984.
7. Jones N, Vaughan L: Evaluation of educational software: a guide to guides. Chelmsford, MA: Northeast Regional Exchange, Inc., 1983.
8. McCulloch D: The uses of computer-assisted learning system, in principle and practice. *Educational Technology* 20:12-15, 1980.
9. Skiba D: Evaluation criteria for computer assisted instruction courseware in nursing. Proceedings of the eighth annual symposium of computer applications in medical care, Washington, DC. New York: IEEE, 929-932, 1984.
10. Sprecher J, Chambers J: CAI: factors affecting courseware development. *Journal of Computer Based Instruction*, 7(2):47-57, 1980.
11. Wolitzer P: Faculty perspectives on computer based instruction. *Journal of Computer Based Instruction*, 4(1):76-83, 1977.

among the elements is lost and cannot be accurately reconstructed. In addition, the relative scarcity of specimens does not afford individual students their own specimen to dissect completely. This lack of continuity combined with the task of breaking down a complex entity into its basic elements understandably contributes to student confusion. In other disciplines one learns first by grasping a few basic concepts and gradually adding to this foundation to arrive eventually at the complex entirety. Color computer graphics provides a vehicle by which this building block approach can be applied for the first time to the teaching of anatomy.

With computer graphics, shaded-surface, lifelike representations of anatomical structures can be displayed. The student is able to view these displays at numerous orientations in various sequences, and with different elements in combination and thus learn anatomy in a manner that is conceptually logical. Dissection and reconstruction of a limb can be performed repeatedly without loss of detail of precise relationships. The student may study at times and locations independent of access to a cadaver laboratory.

With an educational computer graphic display of human hand and forearm anatomy as our ultimate goal, and Livingston's classic film "The Human Brain"² as our inspiration, we embarked on the ambitious task of developing a contour data base representing all identifiable structures in a human hand and forearm. Several techniques were explored initially to determine which would satisfy our requirements for multiple high-resolution images. Artistic drawings on a computer easel would easily meet the demands of sufficient resolution, but they are susceptible to artistic impression of the illustrator and would, at best, result in only a relative few static images because of the costs involved. Computer axial to-

COMPUTER RECONSTRUCTION OF A HUMAN ARM FROM SERIAL SECTIONS

J. Michael Kabo and Roy A. Meals

Division of Orthopaedics, UCLA School of Medicine, Los Angeles, California

Current methods of teaching anatomy have remained virtually unchanged for over 2000 years. Crucial to the education of the anatomist is the limited time spent in the actual

dissection of cadaveric specimens. These specimens, however, have only a fleeting usefulness since once the specimen has been dissected, the precise anatomical relationships

mography (CAT) scans and nuclear magnetic resonance (NMR) imaging are plagued with the lack of resolution (512×512) and the inability to clearly distinguish boundaries between adjacent muscles, nerves, arteries, and other small structures. Each of these noninvasive techniques would have led to less than optimal data acquisition. The remaining alternative that we chose to utilize was to obtain photographs of the specimen in cross section and manually digitize the individual contours.

SPECIMEN PREPARATION

A fresh limb specimen was obtained and carefully positioned in a bed of sand to minimize pressure artifacts. The limb was x-rayed to verify skeletal anatomy and was subsequently frozen in a block of ice. The entire block was then sectioned on a band saw that was specially adapted to make parallel, transverse cuts at precise 3-mm intervals. The frozen surface of the limb was photographed in the block to fix its orientation in an X-Y coordinate plane. The sections, which measured 2-mm thick (1-mm kerf loss), were then laid on a sheet of black Lucite cut to the same dimensions as the ice block for dimensional reference. The individual specimen sections were allowed to thaw, excess fluid was removed, and each section was uniformly photographed on a copy stand under polarized light. The photographs provided intricate detail and color separation of the individual anatomical structures. During the sectioning and photographing sequence, the specimens on the Lucite backing were tilted at a 5° angle to facilitate drainage of the thawed ice. Although drainage was adequate, some translation and rotation of the specimens was evident at the time. Additional translation was introduced by the film processing laboratory, which could not identify the individual frame boundaries in view of the black background. The final

problem that was identified with this technique was that the focal planes of the two camera systems were not identical, resulting in a magnification of 1.11 of the thawed specimens with respect to their frozen counterparts.

Recognizing these immediate problems, an attempt was made to use digital image processing techniques to realign the two sets of frames. Using a DANZA image processing system with a resolution of $512 \times 512 \times 8$ bit intensities, the slide of the frozen specimen was digitally photographed with three exposures using a black-and-white Eyecom camera with the appropriate red, green, and blue filters. The orientation and magnification of the thawed specimen were then adjusted to match that of the stored frozen image and then photographed. This technique, however, was abandoned as well since the resolution was deemed inadequate. Automatic contour-finding algorithms could not uniformly identify selected structures without extensive intervention, and for those frames with multiple elements per section (ie, sections through the fingers) where each element may have had a different amount of translation and/or rotation, multiple manipulations would have been required. The single benefit obtained from this method was that the true colors of each of the individual elements could be encoded as separate red, green, and blue digital intensities directly.

HARDWARE USED

The hardware utilized for the manual digitization consisted of a Tektronix 4956 digitizing board controlled by a Tektronix 4051 microcomputer. The resolution of this device is 0.005 inch in both coordinate directions with an active digitizing area of 48×36 inches. The slide of the frozen section was first projected as large as feasible on the platen, and reference points of the fixed coordinate frame and the

frozen outline of the skin were digitized. The slide of the thawed specimen was then projected, and selected objects were identified, digitized individually in counterclockwise fashion, and stored on cartridge tape. The data was eventually transferred to a DEC 11/44 minicomputer with a GENISCO color graphics system for further processing. Correction for translation errors was accomplished by first computing the centroid of the frozen skin contour with respect to the reference frame. The centroid of the thawed skin contour was then computed, and the difference of the two offsets was applied to the data representing each of the contours in the section to determine the new coordinates. In an attempt to correct for rotation anomalies, an areal moment of inertia was computed about the horizontal axis passing through the centroid for each of the frozen and thawed skin contours. The thawed skin contour was then rotated through a small angle about the centroid, and the moment of inertia was recalculated. This new value was compared to the previous, and the procedure continued in iterative fashion until the difference was minimized. Unfortunately, this technique proved inadequate since, as many of the skin contours were nearly circular in shape, the moment of inertia as a function of angular rotation was not unique. As a final attempt to salvage this first set of data, the rotation offset was determined by simultaneously viewing a combination of frozen and thawed skin contours that were adjacent to each other.

TECHNIQUE REFINEMENTS

Preliminary displays of this data consisted of wire frame contours without any attempt at hidden line removal. The digitized elements included the bones, skin, median nerve, and the flexor carpi ulnaris and pronator quadratus muscles. Viewing orientation was specified as a function of three Euler angles with the

specified frames centered at mid-screener in the size selected. The contours were displayed on a GENISCO GCT 3000 color graphics system with a visible resolution of 512×480 pixels and 8 memory planes. Although each of the individual contours was of the appropriate high resolution, the simultaneous display of the structure in its entirety clearly reflected the lack of adequate translation and rotation transformations. Rather than continue with the procedure outlined above for the remainder of the elements, 24×36 -inch posters were made of each of the slides, and the individual contours were outlined in pen prior to digitizing. This format allowed transfer of the reference marks directly to this hard copy medium and has proved satisfactory in eliminating the need for subsequent transformation of the data. The data base has subsequently been completed by redigitizing all of the specified contours directly from the posters for the 160 individual sections. The information thus obtained is represented by over 7000 contours, each with as many as 400 coordinate points per outline. Al-

gorithms to effect shaded surface display of the data with one level of transparency were developed along with the redigitization process. The method employed was similar to that used by Cook et al.,¹ which incorporated a disk resident Z-buffer for the determination of the depth of the display and the hidden surfaces. Although extremely slow, several frames were generated, which, for the first time, revealed the quality of the data base that we were so desperately striving for.³

Because the current capacity of the present hardware has been saturated, the data is currently being transferred to an IBM 4341 with 5058 display stations in the hopes of generating images at a much faster pace. These workstations are capable of real-time manipulation of the shaded surface images, which would expedite the process of creating the thousands of frames necessary for storage on a video disk as an anatomy teaching tool.

In summary, the first step leading to easy access of pictures of anatomical specimens and physiological and anatomical information is well underway. The initial growing pains

have been mastered, and preparations are in progress to achieve true lifelike representations using solid modeling techniques. Within a short time, we hope to have a sufficient number of frames for storage on a random access video disk and to develop the microcomputer software for controlling access to the display and disk resident physiological information. The initial goal of providing an anatomy teaching tool that will assist in a more logical comprehension of the subject appears finally attainable.

REFERENCES

1. Cook LT, Dwyer SJ, Batnitzky S, Lee KR: A three-dimensional display system for diagnostic imaging applications. *IEEE Computer Graphics and Applications* 3(5):13-19, 1983.
2. Livingston R: *The human brain. An educational movie*, University of California, San Diego, 1976.
3. Meals RA, Kabo JM: Computer graphic displays of musculoskeletal anatomy. *Proceedings of the eighth annual symposium on computer applications in medical care*, Nov. 4-7, 1984, Washington, DC. *New York: IEEE*, 861-3, 1984.

SUBSCRIPTION INFORMATION

Computers in Life Science Education is published monthly by Elsevier Science Publishing Co., Inc., 52 Vanderbilt Avenue, New York, NY 10017. Subscription rate is \$58.00 for 12 issues, including postage and handling in the United States and Canada. Add \$20.00 for postage (airmail) in Mexico and Europe and \$23.00 for the rest of the world.

This newsletter has been registered with the Copyright Clearance Center, Inc. Consent is given for copying of articles for personal or internal use, or for the personal or internal use of specific clients. This consent is given on the condition that the copier pay through the Center the per-copy fee stated in the code on the first page for copying beyond that permitted by the US Copyright Law. If no code appears on an article, the author has not given broad consent to copy and permission to copy must be obtained directly from the author. This consent does not extend to other kinds of copying, such as for general distribution, resale, advertising and promotional purposes, or for creating new collective works.

Address orders, changes of address, and claims for missing issues to Journals Fulfillment Department, Elsevier Science Publishing Co., Inc., 52 Vanderbilt Avenue, New York, NY 10017. Claims for missing issues can be honored only up to three months for domestic addresses and six months for foreign addresses. Duplicate copies will not be sent to the ones undelivered due to failure to notify Elsevier of change of address.

Address editorial correspondence to Harold I. Model, PhD, Virginia Mason Research Center, 1000 Seneca Street, Seattle, WA 98101.

POSTMASTER: Send address changes to *Computers in Life Science Education*, Elsevier Science Publishing Co., Inc., 52 Vanderbilt Avenue, New York, NY 10017.

COMPUTERS IN LIFE SCIENCE EDUCATION

HAROLD I. MODELL
Virginia Mason Research Center
Seattle, Washington

MARCEL BLANCHARD
Professor of Biochemistry
Faculty of Medicine
University of Manitoba
Winnipeg, Manitoba
Canada

THEODORE J. CROVELLO
Department of Biology
University of Notre Dame
Notre Dame, Indiana

JAMES W. ECKBLAD
Department of Biology
Luther College
Decorah, Iowa

TSEGAYE HABTEMARIAM
School of Veterinary Medicine
Tuskegee Institute
Tuskegee, Alabama

CONNIE LARSON
School of Nursing
Grand Valley State College
Allendale, Michigan

TERRY M. MIKITTEN
Graduate School of Biomedical Sciences
University of Texas Health Sciences Center
San Antonio, Texas

JAMES E. RANDALL
Department of Physiology
Indiana University
Bloomington, Indiana

PATRICIA SCHWIRIAN
College of Nursing
Ohio State University
Columbus, Ohio

RICHARD STULL
College of Pharmacy
University of Arkansas
Little Rock, Arkansas

JAMES W. WOODS
Lister Hill National Center
for Biomedical Communications
National Library of Medicine
Bethesda, Maryland

DOROTHY WOOLEY-McKAY
Department of Biology
Glendale Community College
Glendale, Arizona

GLENN YOSHIDA
Department of Life Sciences
Los Angeles Southwest College
Los Angeles, California

ELSEVIER

CONTENTS

**DESIGNING COMPUTER ASSISTED INSTRUCTION
MATERIALS FOR REMEDIAL FRESHMAN BIOLOGY
CURRICULUM** 17
Dany J. Washington

KEEPING ABREAST OF THE LITERATURE 22

WHERE'S THE SOFTWARE? 23

DESIGNING COMPUTER ASSISTED INSTRUCTION MATERIALS FOR REMEDIAL FRESHMAN BIOLOGY CURRICULUM

Dany J. Washington
Passaic County Community College, Patterson, New Jersey

Computer Assisted Instruction (CAI) is a method of instruction by which the computer teaches or reinforces teaching.

Good educational CAI courseware for remediation requires a major production effort of a team of professionals. This team might include programmers, graphic designers, technical writers, teachers, and learning specialists. With budget cuts threatening innovative programs in education, however, the dedicated instructor has to find a more pragmatic, cost-effective way

of developing courseware. This pragmatism usually results in the instructor acting as sole programmer, graphic designer, technical writer, and learning specialist. It is for this unique voyager that this article will attempt to chart a path through the maze of courseware development.

Although the production of any courseware may be extensive, the programs should be as simple as possible so that remedial students do not lose sight of the concepts to be learned. For once—with the com-

puter—we may be able to address the needs of the D and F students instead of lecturing only to the mythical C students. Better still, we can deal more effectively with those who have received inadequate academic preparation and who have learning disabilities.⁵

The result of a recent NSF Project (1982) for remedial science students at Passaic County Community College showed CAI to have a significant impact on the progress of academically weak students. With a regimen of 1 hour/day of remedial CAI, students gained an average of 2 years of science knowledge within 6 months.⁴

A *curriculum* is usually defined as a study plan that primarily concentrates on a particular subject. Specifically, curricula generally cover courses such as chemistry, biology, or other subject areas.

Developing CAI is an art, not a science. There are no rules or regulations that will work for all situations, courses, or students. However, there are some principles that are common to all CAI courseware if it is to be an effective tool in remedial classes. Computer assisted instruction should be explicit, consistent, interesting, informative, flexible, and interactive. Although memorizing facts is important if students are to know the body of information that surrounds each topic, it is also important that students be able to apply principles, be creative, organize material, and evaluate data.

HELLO, WHAT IS YOUR NAME? CHRIS
CHRIS, TODAY WE ARE GOING TO EXPLORE ENZYMES.
(PRESS THE [ENTER] KEY AFTER YOU TYPE YOUR NAME)

FIGURE 1.

One way of presenting curricula is by a discrete group of lessons called a *module*. Each lesson in the module presents instructional material that concentrates on a different area or aspect of the module topic (Diagram 1).

A remedial course that successfully uses computer assisted instruction consists of complete learning packages (modules) that include topics (lessons) on all areas of the curriculum (Diagram 2).

Homogeneity is seldom achieved even when a class has been classified as being remedial. There still exists a wide range of abilities and differences. Therefore, the curriculum should be designed to allow for differing degrees of knowledge, interest, and ability.

MODULE DESIGN

Ideally, modules should include objectives, instructions, the material to be learned, an examination, and suggested related study materials. Remedial students, more than others, need structure and continuity. The more concrete the lessons are made, the easier it will be for remedial

students to see the purpose and expected outcomes of the lessons (Figure 1).

Objectives help academically weak students to better understand the purpose of the lesson and the information they are expected to know once the tasks have been completed. The lesson might continue with the objectives (Figure 2), followed by text, graphs, or simulations.

Lessons should be sequential, reducing the ability to jump ahead, thereby guaranteeing that all material is covered. However, a mechanism should be built into the program to permit students to page backward through a lesson to review material.

Many independent companies and some computer manufacturers have Authoring Systems designed for non-programmers; the more famous of these systems include PLATO, CAIWARE, and COURSEWARE. As an adjunct to these systems, many companies have designed Tutorial Lesson Models that are fully prompted and menu driven. They allow for computer-based lessons with text, detailed graphics, and answer-judging.⁵

Diagram 1.

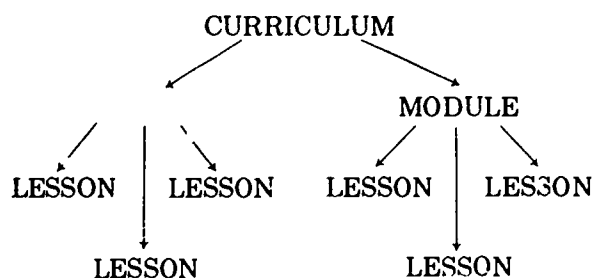
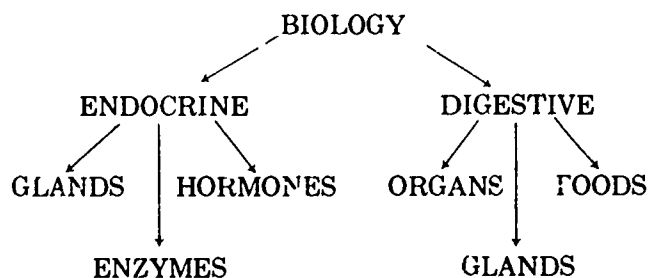

Diagram 2.



R. LESSON #1	ENZYMES
OBJECTIVES	
THIS LESSON DEFINES ENZYMES, EXAMINES THEIR CHARACTERISTICS, AND EMPHASIZES THE NUMEROUS BIOLOGICAL PROCESSES IN THE HUMAN BODY THAT DEPEND ON ENZYMATIC ACTION, REACTION AND INTERACTION.	

FIGURE 2. Objectives help students gain an understanding of the expected outcome of the lesson.

Simulations

In education, simulations are used to allow students to vicariously interact with a scientific phenomena by being electronically placed in a pedagogical situation. These situations require students to develop a methodology to solve the proposed problem.³

Although there are admitted advantages to simulations, instructors must be careful that the disadvantages do not outweigh the advantages. Many remedial students operate on an intellectual level that developmental psychologists call "concrete operational." Simulations, compared to real situations, require students to concentrate on an abstract intellectual (formal operational) level. Therefore, simulations for remedial students are most successful when they are closed simulations (guided discoveries); that is, they should be concrete and require limited convergent thinking.

Drill and Practice

Randomly generated drills minimize students' ability to memorize the order of the questions. Programs should recycle missed items into a pool of items to be learned. Most sophisticated programs can establish the number of times to wait before each missed item is repeated. All drills should have a completion criteria by which students are graded to insure mastery of the material. A good program keeps records of student performance for diagnostic use by the instructor and the student.

Tutorials

Programs should not have numerous lines or frames of text with little or no interaction with the students. Because of the reading problem associated with academically weak students, remedial students should be able to turn pages electronically backwards and forwards when going through a lesson. Frequent student interaction—and appropriate graphics—reduces boredom and increases the attention span.

Screen Format

The overall design of screen display is critical to remedial students. Concreteness and continuity are important to the understanding of difficult scientific concepts. Screen displays should be consistently presented so that students develop a legitimate set of expectations and procedures for lesson performance.

For example, the top one to four lines of the screen might be reserved for instruction, while the bottom one to four may be used for documentation of function keys. The middle of the screen might be reserved for the presentation of the lesson (text, drills, or graphics) and for student-computer interaction (Figures 3 and 4).

STRATEGIES

The best CAI strategies for remedial students involve lessons that utilize a combination of strategies such as drill and practice, dialogue, text, simulation, discovery learning, testing, and/or problem solving. While the presentation of some concepts are more conducive to one particular strategy, elements of each can be embedded in and around most lessons. With some of the more sophisticated computer-management packages, such as those inherent in PLATO or in the Digital Courseware Authoring System, many strategies can be constructed and controlled to facilitate learning.

The basic structure of each module should consist of some basic—but comprehensive—questions, including some supplementary questions of related topics. A few carefully thought-out questions ap-

DIRECTIONS: READ THE INFORMATION BELOW AT YOUR OWN SPEED.
A CATALYST IS A SUBSTANCE THAT REDUCES THE AMOUNT OF ENERGY TO START A REACTION AND THAT KEEPS THE REACTION AT A SPECIFIC RATE. IT COMBINES WITH THE REACTING SUBSTANCES (SUBSTRATES) BUT IS FREED AND UNCHANGED AT THE END OF THE REACTION, SO IT CAN BE USED AGAIN. ENZYMES ARE PROTEINS THAT ACT AS CATALYSTS FOR REACTIONS OCCURRING IN LIVING ORGANISMS.
(PAGE 2. PRESS [C] TO CONTINUE...OR PRESS [B] TO GO BACK)

FIGURE 3. Example of text screen. Directions appear on the first line. Presentation of lesson material appears in the middle of the screen. The last line is used for documentation of function keys.

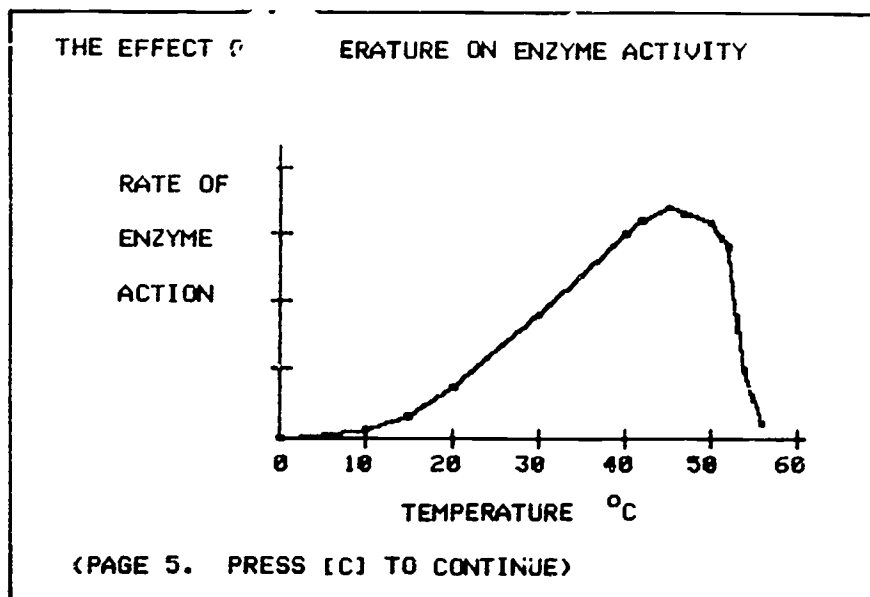

FIGURE 4. Example of a graphics screen. "The picture is worth a thousand words" is not a mere cliché. With weaknesses in cognitive development and reading ability, remedial students can benefit immensely from computer graphics.

appropriately placed in the development of a lesson may do more to encourage thinking than a continual bombardment of questions.¹

Sample Question

The "lock and key hypothesis" attempts to explain the mechanism of enzyme:

- 1) formation,
- 2) specificity,
- 3) . . .
- 4) decomposition,
- 5) concentration.

Supplementary questions, for example, might deal with the effect of a fever on the rate and ability of enzymes to digest food. Should the student answer the basic questions incorrectly, a series of two or three remedial questions—designed to reinforce the topic—should be presented.

Another possible approach to incorrect responses to basic questions would be to present tutorial text or graphics to reinforce the idea. Students could be given helpful hints when they respond with incorrect answers. The hints could be in the

form of data, graphs, diagrams, or examples.

Although there is some positive reinforcement to supplying the correct answers to incorrect student responses, every attempt should be made to have students discover the right answer (Figure 5). Such an approach facilitates long-term learning.

If the purpose of most questions is to motivate students to think, the program should pace questions and answers. Computers should be programmed with 3–10 second delays—even for multiple choice questions—so that students are forced to

think before seeing the responses. The length of the pause should be based on whether students are expected to analyze, synthesize, or recall facts in their response.

THE EXAMINATION LOOP

Here is a truism: The more students are involved, the more they will learn. The longer they will remember.

Once the lesson has been presented the student should be tested on the concepts.

The testing loop, when initiated, should first ask the following question: DO YOU WANT INSTRUCTION? Y/N.

Completion Questions

These kinds of questions usually require complete student involvement without hints or choices. Completion questions usually measure factual recall without the necessity for interpreting, analyzing, or evaluating. For the remedial biology student, this type of question can be used most effectively in testing vocabulary, formulas, definitions, and simple relationships.

True-False

There is a wide criticism (controversy) on the use of true-false questions. Educational specialists say that this is because many true-false questions are poorly constructed.

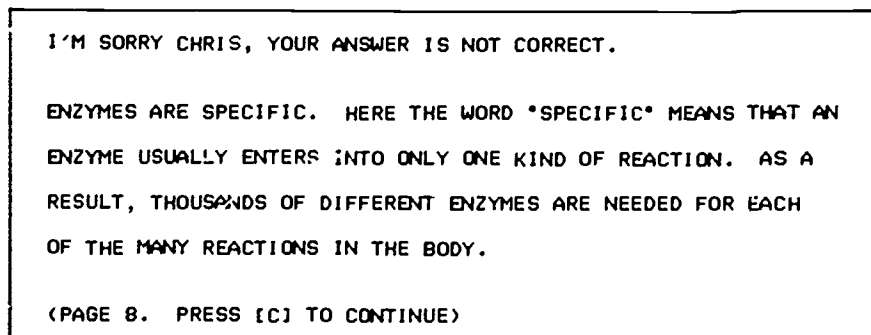

FIGURE 5.

Some argue that these questions encourage guessing, as well as giving the student a 50% chance of answering the questions correctly.

Although there are no agreed-upon rules for constructing true-false questions, the following guidelines seem to be most appropriate when dealing with academically weak students:

- 1) Have only one idea in a question.
- 2) Use simple, clear and direct questions.
- 3) Do not use questions that have exceptions.
- 4) Do not pick out isolated facts from text for students to recall.
- 5) Never state questions negatively.

The single, most important characteristic of a true-false question is that it is completely true or completely false (Figures 6 and 7). Remedial students do not need to spend unnecessary time attempting to determine the relative truth (or falsity) of the question. Students will often take an ambiguous question and try to infer (usually incorrectly)

TRUE OR FALSE

IF THE PANCREAS, SALIVARY AND INTESTINAL GLANDS ARE DAMAGED, YOU MIGHT EXPECT URINE TO CONTAIN LITTLE OR NO GLUCOSE? T/F

TYPE [T] OR [F] AND PRESS THE [ENTER] KEY TO GO TO THE NEXT QUESTION.

FIGURE 8. Example of a true-false question designed to test the student's convergent thinking ability.

the instructor's purpose for asking the question.

When properly written, true-false questions can force students to make inferences from data or observations. Consequently, the true-false question—when properly written—can be used to test the students' convergent thinking ability (Figure 8).

Points Indicators

Remedial students need positive reinforcement from every component of a lesson. To have a program calculate a score is not enough. Stu-

dents also need to know how their scores measure against the instructor's criteria. For example:

- | | |
|-------|---|
| 100 | Come on, now. No one is perfect. |
| 95-99 | Hold a conference, so that others can learn from you. |
| 90-94 | Fine! You have learned a lot. |

and so on.

SUMMARY

The best CAI development must conclude with two important steps that are too often ignored: field testing and modification. With all of the problems associated with remediation, good CAI material for students weak in biology should go through several rounds of testing and modification. These rounds should serve to sharpen the focus and correct any unanticipated problems.²

One highly acknowledged method for enabling remedial students to learn basic biology facts is the use of overlearning. Drill and practice programs lend themselves to this type of learning by repeatedly presenting the material. Many learning theorists would not call this rote method a type of learning but mere memorization; I am inclined to agree with them. However, there is a basic body of factual information that must be acquired before a student can use

TRUE OR FALSE

CATALYSTS SEEM TO WORK BY LOWERING THE ACTIVATION ENERGY? T/F

TYPE [T] OR [F] AND PRESS THE [ENTER] KEY TO GO TO THE NEXT QUESTION.

FIGURE 6.

TRUE OR FALSE

ENZYMES ARE PROTEINS THAT SERVE AS CATALYSTS FOR METABOLIC PROCESSES IN LIVING CELLS? T/F

TYPE [T] OR [F] AND PRESS THE [ENTER] KEY TO GO TO THE NEXT QUESTION.

FIGURE 7.

the higher cognitive processes of learning, such as synthesis, analysis, and evaluation. These kinds of convergent thinking processes can be facilitated by the appropriate kind of learning experiences.

Simulations are the best tool to use to allow remedial students to practice or demonstrate high-level cognitive skills. Teachers can use simulations to help assess the level of competence of remedial students as well as to encourage discovery learning.

Although drills, tutorials, and simulations all have merit, no approach represents a panacea for assisting remedial students. The greatest challenge lies with developing courseware that is educationally relevant and tailored to the specific

needs of a small group of special students.

REFERENCES

1. Blosser P: Handbook of effective questioning techniques. Worthington OH: Education Associates, 1973.
 2. Doerr C: Microcomputers and the 3 P's. A guide for teachers. Hayden Book Company, 1979.
 3. Hebenstreit J: Micro-computers in secondary education. E.D. Tagg (ed). New York: North-Holland Publishing Company, IFIP: 5, 1980.
 4. Washington D: National Science Foundation Grant; MISIP/Special Project/Basic Science Skills Improvement Through Computer-Assisted Instruction. SER-8020031, 1980-82.
 5. Weinstock H: So you've a microcomputer! Technol Horizons Educ, Nov:109-110, 1984.
- Fetter WR: Guidelines for evaluation of computer software (with an evaluation form). Educ Tech 24(3):19-21, 1984.
- Ford JD: Four educational concerns in using microcomputers. Teacher Educator 19(3):16-20, 1983-1984.
- Gale RJ et al: Data acquisition for undergraduate experiments using the IEEE-488 bus. J Comp Math Sci Teach 3(2):27-29, 1983-1984.
- Gill RA: Microcomputer simulation of enzyme kinetic behaviour. Sch Sci Rev 65:670-678, 1984.
- Grabowski B et al: Computers for interactive learning. Instructional Innovator 29:27-30, 1984.
- Hall-Sheey J: Promises, promises: what to believe about authoring systems. Data Training 3:17, 45, 1984.
- Harper D et al: Computer-assisted instruction and diagnosis of radiographic findings. J Med Syst 8:115-120, 1984.
- Hathaway MD: Variables of computer screen display and how they affect learning. Educ Tech 24(1):7-11, 1984.
- Holley HS et al: Microcomputers for computer-assisted instruction in anesthesiology. J Med Educ 59:521-522, 1984.
- Hunter TB: Experience with computer instruction for radiology trainees. Amer J Roentgenol 143:921-922, 1984.
- Jacoby CG et al: An evaluation of computer-assisted instruction in radiology. Amer J Roentgenol 143:675-677, 1984.
- Jim LK et al: A computer-assisted instructional approach to teaching applied therapeutics. Am J Pharm Educ 48:20-25, 1984.
- Jonassen DH: The generic disc: realizing the potential of adaptive, interactive video-discs. Educ Tech 24(1):21-24, 1984.
- Kernske F: Guide to authoring systems. In: Data training 1984. Computer-based training guide. Boston, MA: Warren-Weingarten Inc. 1984, pp. 1-21.
- Lane NR et al: Teaching programmes and computer assisted learning. Comp Educ 47:18-19, 1984.
- Lloyd WC et al: Rapid preparation of lecture slides using the computer. Ophthalmic Surg 15:678-679, 1984.
- McKay AB et al: The provision of management CAI through commercially available pharmacy computer systems. Am J Pharm Educ 48:11-19, 1984.
- McLellan AR et al: An interactive computer program modelling the colony dynamics of a social insect, the honeybee. J Biol Educ 17:311-314, 1983.
- McMullen BE et al: The top six compatibles: a closer look at the machines that are most compatible with the IBM PC. Popular Computing 3(6):132-134, 136, 1984.
- McMurray P et al: The educational uses of computers: hardware, software, and strategies. J Nutr Educ 16(2):39-43, 1984.
- Abdulla AM et al: Usefulness of computer-assisted instruction for medical education. Am J Cardiol 54:905-907, 1984.
- Baker PG: MUMEDALA—an approach to multi-media authoring. Br J Educ Tech 15:4-13, 1984.
- Blanchaer MC: Clinical simulations on a microcomputer. Comput Educ 8:397-399, 1984.
- Blanchaer MC et al: Clinical simulations on a microcomputer, in Wood EJ, (ed) Micro-computers in biomedical education. London: Taylor and Francis, 1984.
- Breazeale V et al: Selected bibliography on computers in education. J Nutr Educ 16(2):76C, 1984.
- Carew LB et al: A college-level, computer-assisted course in nutrition. J Nutr Educ 16(2):46-50, 1984.
- Cicciarella CF: Getting into the computer game: guidelines and pitfalls. J Physical Educ, Recreation Dance 55:46-47, 1984.
- Coggan PG et al: Educational applications of computers in medical education. J Fam Pract 19:66-71, 1984.
- Conen VB: Interactive features in the design of videodisc materials. Educ Tech 24(1):16-20, 1984.
- Cook RA: Two computer learning experiences for non-nutrition majors. J Nutr Educ 16(2):66, 1984.
- Crovello TJ: Computer center: computer world turns upside down again. Am Biol Teach 46:236-238, 1984.
- Davidson WD et al: Teaching dialysis kinetics with a minicomputer. Am J Nephrol 4:19-26, 1984.
- Davison FC: Computing at the University of Georgia: critical success factors. EDUCOM 19:5-10, 1984.
- Dreyfus HL et al: Putting computers in their proper place: analysis versus intuition in the classroom. Teachers College Record 85:578-601, 1984.
- Evans S: Implementation of a computer-based test generator to evaluate health professions continuing education. J Med Syst 8:121-126, 1984.
- Farrell P: Computer literacy: what does it mean? J Physical Ed Recreation Dance 55:54-55, 1984.

KEEPING ABREAST OF THE LITERATURE

The following citations are presented as part of a quarterly feature in CLSE designed to help readers become aware of current literature pertinent to computer applications in life science education.

- Merrill D et al: Computer guided instructional design. *J Computer-Based Instr* 11:60-63, 1984.
- Miller MJ et al: New trends in compatibility. *Popular Computing* 3(6):112-113, 115-118, 1984.
- Murphy PJ: An exercise in biometrical genetics based on a computer simulation. *J Biol Educ* 17:343-348, 1983.
- Pao YC, et al: Computer-graphics aided instruction of three-dimensional dental anatomy. *J Dent Educ* 48:315-317, 1984.
- Peterson NS et al: Simulated laboratory for teaching cardiac mechanics. *Physiologist* 27:165-169, 1984.
- Ploch M: Micros flood campuses. *High Technology* 4(3):47-49, 1984.
- Polack AF et al: Computer education for clinical pharmacy students—a program for use in teaching. *J Clin Hosp Pharm* 9:345-349, 1984.
- Powell L: Monitors. *Popular Computing* 3(4):129-135, 1984.
- Pressman I et al: CAI system costs: present and future. *Technol Horizons Educ* 11(6):94-98, 1984.
- Pressman I et al: CAL: its cost and its role. *J Educ Technol Syst* 12:183-208, 1983-1984.
- Raimondi SL: Electronic communication networks. *Educ Tech* 24(2):39-41, 1984.
- Richardson WK: IBM PILOT authoring language and the CAI course. *Sci Software Q* 1(3):7-15, 1984.
- Ries CP et al: Authoring a CAI lesson in nutrition education. *J Nutr Educ* 16(2):51-52, 1984.
- Rosenthal D: Software list. *Computers in Chemical Education Newsletter* 6/7(4/1):17-27, 1984.
- Salisbury DF: How to decide when and where to use microcomputers for instruction. *Educ Tech* 24(3):22-24, 1984.
- Salisbury DS: Strategies for designing drill and practice programs for computers. *Proceedings of the 8th ADCIS Conference* 1984, pp 201-207.
- Schrock JR: Computers in science education: can they go far enough? Have we gone too far? *Am Biol Teach* 46:252-256, 1984.
- Shahein HI: Computers in health-sciences education. An application to electrocardiography. *Comput Program Biomed* 17:213-223, 1983.
- Spokony-Smith M, et al: Getting the best software support. *Electronic Education* 3(6):23, 50, 1984.
- St Lawrence J: The interactive videodisc: here at last. *Electronic Learning* 3:49-52, 1984.
- Stanford JR: Use of a personal computer in continuing medical education. *Am J Sur* 148:249-251, 1984.
- Summers G: Tester. *J Coll Sci Teach* 13:356-358, 1984.
- Van Dongen CJ et al: Using microcomputers to teach psychopharmacology. *J Nurs Ed* 23:259-260, 1984.
- Watt D et al: Mass storage: special report. *Popular Computing* 3(7):113-134, 1984.
- Wiener RB: Evaluating courseware: you don't have to be computer literate to effectively select CAI materials. *Lifelong Learning* 7:14, 16-17, 28, 1984.
- Zemke R: Evaluating computer-assisted instruction: the good, the bad and the why. *Training* 21(5):22-47, 1984.
- Zollman D: Videodisc-computer interfaces. *Educ Tech* 24(1):25-27, 1984.
- Zucker A: Computers in education: national policy in the USA. *Eur J Educ* 17:395-410, 1982.

Compiled by H. Modell

WHERE'S THE SOFTWARE?

The quest for software continues. In November, we published our first list of life science software sources and programs or program areas available through them. The list below represents the first update to that list. Our intent is to make readers aware of resources. No attempt has been made by CLSE to review the materials. Note that a new address appears for Biolearning Systems, Inc.

If you have found specific software helpful in your teaching efforts, and we have not listed it, please let us know about the program(s) and the supplier. Send pertinent information to Dr. Harold Modell, Virginia Mason Research Center, 1000 Seneca Street, Seattle, WA 98101.

Biolearning Systems, Inc.
Route 106
Jericho, NY 11753
(516) 433-2992

PHOTOSYNTHESIS—Basic Unit

Tutorial for first year college level. Discusses chloroplast structure and function, ATP-ADP conversion, and the role of photosynthesis in the light-trapping process.

PHOTOSYNTHESIS—Advanced Unit

Tutorial for first year college level. Focuses on the chemical pathways involved in photosynthesis.

CELL RESPIRATION—Basic Unit

Tutorial for first year college level. Features a comprehensive discussion of ATP-ADP, oxidation/reduction and carrier molecules.

CELL RESPIRATION—Advanced Unit

Tutorial for first year college level. Presents an integrated lesson on the chemical pathways for

aerobic and anaerobic respiration.

Elsevier-BIOSOFT
68 Hills Road
Cambridge, CB2 1LA
United Kingdom

The Blanchaer CLINICAL CASE STUDIES

Simulations of clinical cases of biochemical defects in metabolism

Assumes student has some knowledge of biochemistry, physiology, and anatomy and that case notes and textbooks can be referred to while working through the cases.

MATHEMATICS, BIOLOGY AND MICROCOMPUTERS

Aimed at practitioners and students with an interest in methods for analysis of biological data, modelling of biological

processes and the determination of molecular properties.

KINCALC

Simulation of first order chemical kinetics.

CATLAB

Simulation of cat breeding experi-

ments focusing on principles of genetics.

OSMOTIC PRESSURE

Provides several simulated experiments involving osmotic pressure. Program 1 includes several experiments using a thistle tube.

Program 2 is an animation of a molecular model for osmosis.

TRIBBLES

Introductory unit on scientific method consisting of a written tutorial and computer simulation.

INVITATION TO CONTRIBUTORS

Articles consistent with the goals of *Computers in Life Science Education* are invited for possible publication in the newsletter.

PREPARATION AND SUBMISSION OF MATERIAL

Articles submitted for publication should not exceed 2000 words and should be typewritten, double spaced, with wide margins. The original and two copies including two sets of figures and tables should be sent to the Editor: Dr. Harold Modell, Virginia Mason Research Center, 1000 Seneca Street, Seattle, WA 98101.

Title page should include full title, list of authors, academic or professional affiliations, and complete address and phone number of the corresponding author.

Illustrations should be submitted as original drawings in India ink or sharp, unmounted photographs on glossy paper. The lettering should be such that it can be legible after reduction (width of one column = 5.7 cm).

Reference style and form should follow the "number system with references alphabetized" described in the Council of Biology Editors Style Manual. References should be listed in alphabetical order by the first author's last name, numbered consecutively, and cited in the text by these numbers.

RESPONSIBILITY AND COPYRIGHT

Authors are responsible for accuracy of statements and opinions expressed in articles. All authors submitting manuscripts will be sent a copyright transfer form to complete. The completed form must be returned before the work will be published.

SUBSCRIPTION INFORMATION

Computers in Life Science Education is published monthly by Elsevier Science Publishing Co., Inc., 52 Vanderbilt Avenue, New York, NY 10017. Subscription rate is \$58.00 for 12 issues, including postage and handling in the United States and Canada. Add \$20.00 for postage (airmail) in Mexico and Europe and \$23.00 for the rest of the world.

This newsletter has been registered with the Copyright Clearance Center, Inc. Consent is given for copying of articles for personal or internal use, or for the personal or internal use of specific clients. This consent is given on the condition that the copier pay through the Center the per-copy fee stated in the code on the first page for copying beyond that permitted by the US Copyright Law. If no code appears on an article, the author has not given broad consent to copy and permission to copy must be obtained directly from the author. This consent does not extend to other kinds of copying, such as for general distribution, resale, advertising and promotional purposes, or for creating new collective works.

Address orders, changes of address, and claims for missing issues to Journals Fulfillment Department, Elsevier Science Publishing Co., Inc., 52 Vanderbilt Avenue, New York, NY 10017. Claims for missing issues can be honored only up to three months for domestic addresses and six months for foreign addresses. Duplicate copies will not be sent to replace ones undelivered due to failure to notify Elsevier of change of address.

Address editorial correspondence to Harold I. Modell, Ph.D., Virginia Mason Research Center, 1000 Seneca Street, Seattle, WA 98101.

POSTMASTER: Send address changes to *Computers in Life Science Education*, Elsevier Science Publishing Co., Inc., 52 Vanderbilt Avenue, New York, NY 10017.

COMPUTERS IN LIFE SCIENCE EDUCATION

HAROLD I. MODEL
Virginia Mason Research Center
Seattle, Washington

MARCEL BLANCHER
Professor of Biochemistry
Faculty of Medicine
University of Manitoba
Winnipeg, Manitoba
Canada

THEODORE J. CROVELLO
Department of Biology
University of Notre Dame
Notre Dame, Indiana

JAMES W. ECKBLAD
Department of Biology
Luther College
Decorah, Iowa

TSEGAYE HABTEMARIAM
School of Veterinary Medicine
Tuskegee Institute
Tuskegee, Alabama

DONNA LARSON
School of Nursing
Grand Valley State College
Allendale, Michigan

TERRY M. MIKITTEN
Graduate School of Biomedical Sciences
University of Texas Health Sciences Center
San Antonio, Texas

JAMES E. RANDALL
Department of Physiology
Indiana University
Bloomington, Indiana

PATRICIA SCHWIRIAN
College of Nursing
Ohio State University
Columbus, Ohio

RICHARD STULL
College of Pharmacy
University of Arkansas
Little Rock, Arkansas

JAMES W. WOODS
Lister Hill National Center
for Biomedical Communications
National Library of Medicine
Bethesda, Maryland

DOROTHY WOOLEY-McKAY
Department of Biology
Glendale Community College
Glendale, Arizona

GLENN YOSHIDA
Department of Life Sciences
Los Angeles Southwest College
Los Angeles, California

ELSEVIER

CONTENTS

CREATIVE EDUCATIONAL USE OF SOFTWARE

WRITTEN BY OTHERS

Roy S. Meyers and Robert Parsons

25

CREATIVE EDUCATIONAL USE OF SOFTWARE WRITTEN BY OTHERS

Roy S. Meyers

*Department of Biology, Skidmore College
Saratoga Springs, New York*

Robert Parsons

*Department of Biology, Rensselaer Polytechnic
Institute, Troy, New York*

Science educators who wish to employ computer models in their teaching are often faced with using models written by others, usually for purposes somewhat different than they have in mind. While one might ideally like to sit down and program an original model from scratch designed to meet the specific needs and educational philosophy of the particular situation, this tack is often not practical for a variety of reasons, including the limits of time and programming background. Even though relatively few science educators are experienced in programming their own complete stand-alone models, many have sufficient programming background to either alter pre-existing models or utilize the output of those models in novel ways. The purpose of this article is to provide such individuals with

some ideas of how to go about the process of adapting software authored by others to meet their own particular educational needs.

We do this by discussing in some depth the use of two sample physiological models—the nerve action potential model and the HUMAN physiological simulation—by the authors at their respective institutions. For each of these two models the reader is given an idea of how alterations were made in either the original model itself or its output so that the model could be successfully employed in the variety of teaching situations particular to that institution, course, or instructor's educational philosophy. While the article is aimed principally at those individuals who are comfortable doing some actual reprogramming, we also wrote with the intention that two other

groups could profit from the article. Those users who do not do any programming should find the information here on what models are available and what strategies were employed in their use thought-provoking. Those who do write their own full stand-alone models should find interesting material on the needs and possible teaching approaches of others who may later become an audience for their models.

USE OF THE HODGKIN-HUXLEY MODEL

This section describes the use of one particular program, a nerve action potential simulation based on the Hodgkin-Huxley equations, to illustrate in depth how such a program may be adapted for use at different levels of college science education. While many computer implementations of this model exist (including Hodgkin-Huxley's original), the version discussed below was adapted from a program by Dr. James Randall.³ First, the program itself is described for those readers who have never seen it before. The uses of the program at different

levels of the education process at Skidmore are then detailed. Finally, one particular use in an advanced level course is dissected in detail to illustrate how alteration of a program by students and faculty can greatly expand its range of possible use.

The Randall Hodgkin-Huxley Model

Nerve axons exhibit a typical stereotyped electrical firing (the action potential) that underlies their behavior. In 1952, Hodgkin and Huxley² showed that underlying this repetitive discharging (depolarization) and recharging (repolarization) of the nerve axon membrane is a cyclical influx and efflux of ions down their physical-chemical gradients. The membrane depolarizes because Na^+ ions flow inward, and then it repolarizes because another positively charged ion, K^+ , flows outward. The cause of these cyclical ionic fluxes is a change in the conductance ("ease of flow") of the nerve membrane, first to Na^+ , then to K^+ , that alternately allows each of the charge carrying ions to flow

passively down their gradients. These changes in conductance, their resultant ionic current flows, and the subsequent membrane voltage changes they induce (ie, the action potentials) were expressed by the authors in a set of equations (the Hodgkin-Huxley model) that allowed them to input their experimental data and solve for the resultant action potentials.

The reader can get some idea of this process by looking at Figure 1, which shows the output of (what is essentially) Dr. Randall's original axon action potential program (based on the Hodgkin-Huxley model). On the left is shown the input module, in which the students are allowed to choose the size and duration of up to two stimuli with which they will "stimulate" the model nerve. In addition, the initial resting potential and delay time between the first and second stimuli may be controlled. The size of these stimulus parameters is also visible at the bottom of the output plot (right panel). This figure shows a typical program graphic output, which includes the voltage behavior of the

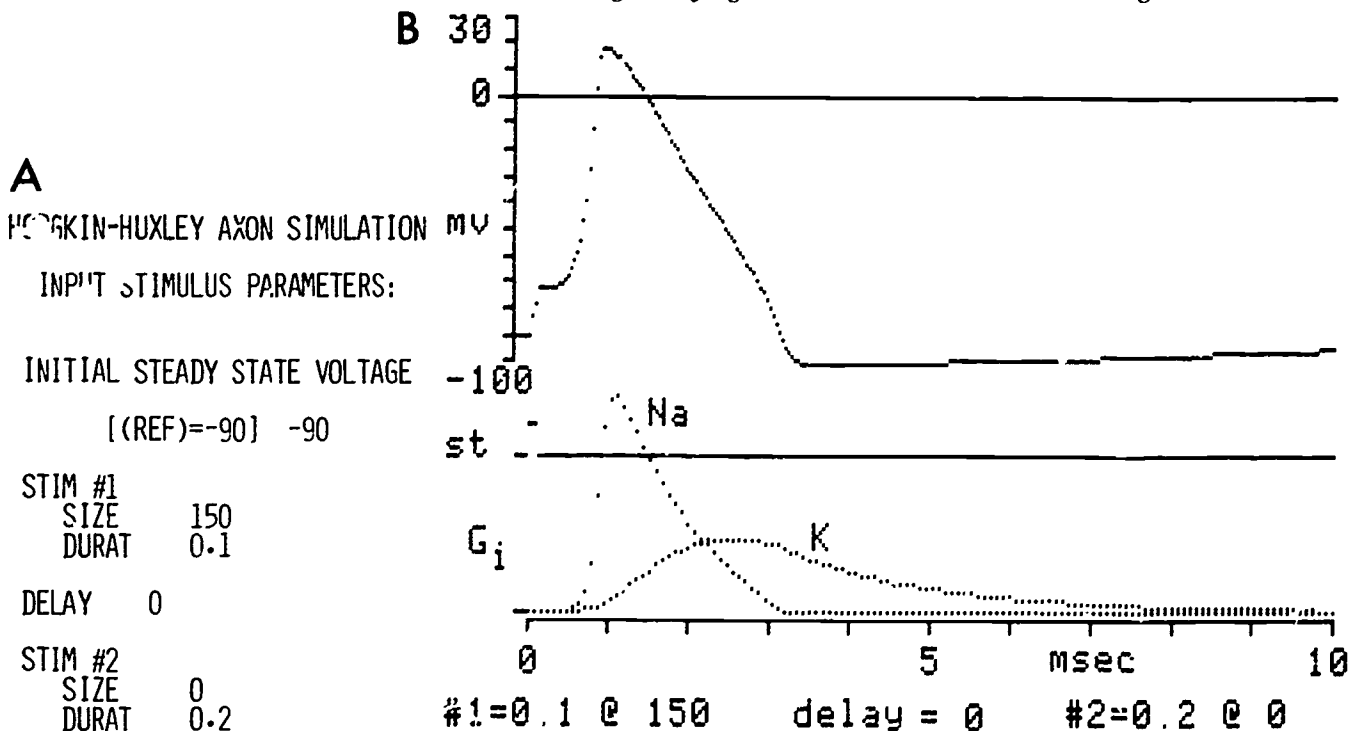

FIGURE 1. Sample program run for the unaltered Hodgkin-Huxley nerve axon simulation. (Left panel, 1(A)) Sample reconstructed input screen. (Right panel 1(B)) Sample graphic output for the values input on the left. The top shows a plot of transmembrane voltage while the bottom displays the underlying membrane conductances (G) to sodium (Na) and potassium (K).

membrane (ie, action potential, top) and the underlying ionic conductance changes for Na (G_{Na}) and K (G_K) on the bottom. The program essentially proceeds by first allowing the user to input experimental parameters and then generating output by solving the Hodgkin-Huxley equations while displaying that solution on an ongoing basis on a CRT graphics screen.

Use of the Model at Different Course Levels

Use in lower level and non-major courses. In lower level courses such as the physiology section of the freshman biology course or the non-majors January term course on the brain, it is inappropriate for students to concern themselves with the details of the ionic currents and their generation. On the other hand, it is crucial that they grasp that ion movements do indeed underlie nerve axon behavior and develop some visual concept of what an actual action potential is. The model provides an alternative to the sometimes cumbersome and poorly portable frog sciatic nerve demonstration. By altering the program output slightly so that it shows the ionic currents (flows) of Na and K instead of the conductances, the students get to see both the action potential itself (top) and the occurrence and time relationships of the underlying currents. In smaller classes, it is also possible to generate a Socratic interaction among the student, the instructor, and the model by urging the students to suggest further sets of experimental parameters.

Use in middle level (majors) biology courses. Students at the intermediate level (such as in comparative vertebrate physiology) are more prepared to begin to delve into an in-depth understanding of the ionic hypothesis and its implications for how electrically excitable tissues work. In addition to a discussion in lecture of nerve action potentials and some lab work with the sciatic nerve or a comparable preparation,

a session with the model in either class lecture form (with the instructor soliciting suggestions for inputs to the model) or in a small group microcomputer lab session (two students/micro) has proven effective. The microcomputer "lab" format most often starts with a handout that gives students specific procedures to carry out and ends by asking them to devise their own experimental design through which to test some additional hypothesis of their choice. The range of the suggested procedures is wide and includes many suggested by Dr. Randall himself such as investigation and characterization of the refractory period, local responses, the basis of the after-hyperpolarization, and latent responses. Because the program was originally written in a highly modular form, it is easy for an individual with a modicum of BASIC programming background to reprogram the output so that it can display whatever is desired and most appropriate for each particular use (tabular outputs, conductances, currents, the underlying variables M, N & H that control the conductances, etc).

Use in advanced level courses. In an advanced level course (electrophysiology) the model has proven to be the most useful. Since its inception, electrophysiology has included a considerable section on the behavior of nerve axons. At least part of a lecture devoted to the Hodgkin-Huxley equations themselves has always been included. While that lecture originally proved to be rather trying for some of the students, the use of the model has turned it into a highly effective teaching experience. The instruction sequence followed for the last two years has consisted of a reading of one of the original Hodgkin-Huxley papers (after suitable preparatory lecture work) followed by a lecture on the equations themselves. The students then work through some of the types of nerve axon modeling exercises described above. Having reached this

point, they are instructed to individually develop a design for an experiment involving the model that requires some alteration in the program itself. The implementation of their chosen design is then firmed up in one-on-one tutorial conferences with the instructor. To my great initial surprise and pleasure, each student in the last two years has proven able to reprogram (with my help as appropriate) the model to ask of it an interesting and valid question. In order to facilitate this independent work, the model has also been rewritten to run on the college's VAX 11-750s so that the student is not limited to working solely during the hours that the microcomputer lab is open. Again, it is the highly modular nature of the original program that allows individuals with limited (usually one course) programming experience to actually alter the program itself. An interesting aside is that while I make versions available for student use both in the original BASIC and PASCAL, all uniformly prefer the BASIC version. Indeed, despite its touted faults, the English language nature of BASIC statements appears to offer a very decided advantage to the inexperienced student. Those with a sound knowledge of the Hodgkin-Huxley equations but no programming experience have proven perfectly capable of working out simple alterations in the program in concert with me. The key is not the nature of the language, but that the program must be highly structured and modular.

The results of two such student projects may be seen in Figure 2. The experiment on the top was designed to generate data to simulate a tetrodotoxin (TTX) block of the nerve. TTX is a toxin produced by the puffer fish that blocks the membrane channels through which sodium enters, thereby effectively eliminating action potentials. This student decided to simulate the TTX block by reducing the sodium current proportionately to the level of block (ie, concentration of TTX)

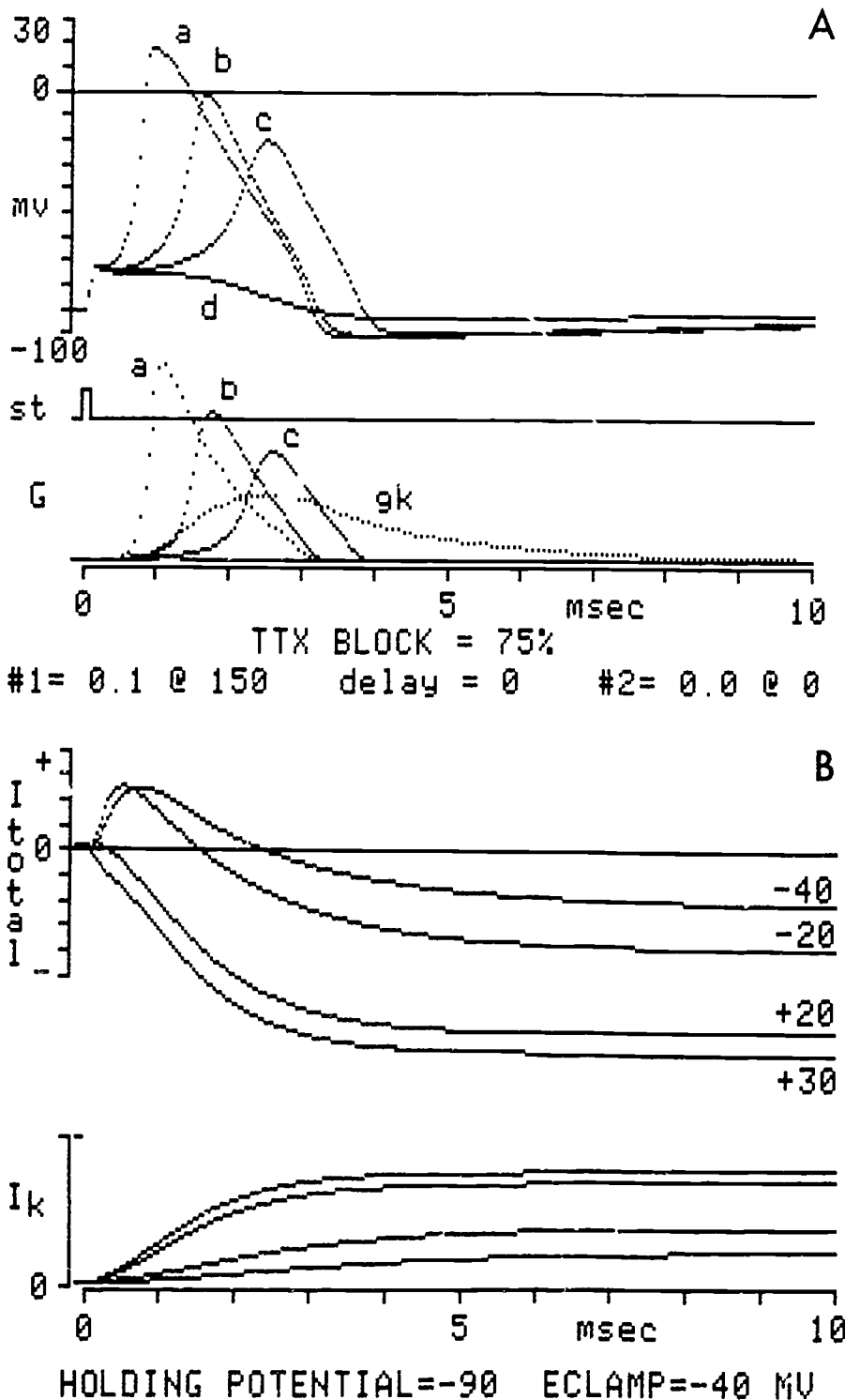

FIGURE 2. Sample student programmed modifications of the axon action potential model. (Top panel, 2(A)) Simulated block of the sodium channels by tetrodotoxin (TTX) at four differing levels were superimposed. The four levels (a-d) correspond to blockage of 0, 60, 70 and 75% of the maximum available number of channels. Transmembrane voltage (top), sodium ion conductance (bottom, a-c) and potassium ion conductance (bottom, g_K) are shown plotted. (Bottom panel, 2(B)) Simulated voltage clamp experiments. Four superimposed runs are shown with total ionic current (I_{total}, top) and potassium current (I_K, bottom) plotted. The clamp voltage level for each run is indicated at the right hand side of its corresponding current record. Potassium current decreases from top to bottom as clamp voltage becomes more negative.

selected at the beginning by the user. Early versions reduced I_{Na} linearly as a function of TTX concentration while later versions, after some library research, utilized a typical log dose-response relationship to reduce the current. The results of four superimposed experimental runs (a-d) at concentrations of TTX sufficient to reduce the sodium current by 0%, 60%, 70%, and 75% (of its maximum under these conditions) are shown. The top trace shows the membrane voltage response. Note particularly complete blockage of the action potential at the 75% concentration. That this is due to a lack of sufficient membrane voltage change to activate the Na channels is suggested by the matching progressive reduction in the corresponding four Na conductance curves on the bottom. In this process, the student greatly deepened her understanding of the factors involved in triggering the action potential. She also learned both how to model typical drug-receptor interactions and how to consult the literature to find the data necessary to extend a model.

The second set of traces (Fig. 2(B)) show the results of the experiment of a student who was interested in simulating voltage clamping of the nerve (ie, allowing the currents to flow but removing their voltage, changing results by holding the membrane potential constant at any desired level). The student wished to observe the effects of these different voltage levels on the resulting membrane currents. This is exactly the method employed by Hodgkin and Huxley in their original experiments to enable them to measure the actual ionic conductance changes. This student repro programmed the model by simply altering the program line that normally calculates the new voltage on each iteration to a new form in which the voltage is always restored to a level preselected by the user. The results of four such experimental runs are shown superimposed in Figure 2(B). On the top are

total membrane currents (sum of Na and K) at four levels of clamped voltage (-40, -20, +20, and +30). On the bottom are the corresponding potassium currents. The difference between the total current and potassium current gives the sodium current. Note in particular that the early inward (upwards) total current (top record) becomes smaller as the clamped voltages approach +20 to +25. This is the value at which Na is in equilibrium (has no net driving force on it). Consequently, all tendency for Na to move inward is removed.

Some other student-designed projects for this year included manipulation of the Na or K equilibrium potentials; studies of the effects on the underlying channel-gating variables of different initial resting (holding) potentials; and investigations of the effects on the cardiac action potential (Beeler-Reuter model) of a variety of experimental maneuvers. Through these projects, the students' understanding of the basic Hodgkin-Huxley hypothesis has been greatly enhanced because they had to grapple directly with the guts of the hypothesis itself, its assumptions, and how those assumptions are linked together. In the author's (RSM) 18 years of teaching experience at a variety of institutions and levels, he has never personally seen as large a group of students achieve as great a depth of penetration before.

USE OF THE HUMAN PHYSIOLOGICAL MODEL

A second example of the use (and alteration) of a program to fit the individual educational philosophy and situation of the instructor utilizes the HUMAN-80 model of the physiology of the body.¹ Again, the discussion will first focus on the model itself (in order to familiarize the reader with it). It will then proceed to illustrate uses of the model in various courses with the discussion focusing on ways to alter the original model itself (or in this

case its output) to allow users to do with it things beyond the original intent of the programmer.

The HUMAN-80 Model

HUMAN is a "comprehensive mathematical model of the physiology of the human body in health, disease and during treatment." The original mainframe and minicomputer version was written in FORTRAN by Dr. Tom Coleman at the University of Mississippi Medical Center. Microcomputer versions for the IBM and Apple II series, written by Dr. James Randall (Indiana University Medical School), are also now available. Skidmore has a minicomputer version running on its VAX 11-750s, and both Skidmore and RPI have the microcomputer versions available. In all frankness, one can only say that HUMAN is a stunning educational programming achievement. The model provides an integrated approach to many of the major physiological systems of the body including the cardiovascular, respiratory, renal, and thermoregulatory systems, and it also includes selected major components of many of the other body systems. It allows the user to change up to 60 physiological parameters and on each iteration computes (and therefore allows the user access to the values of) over 150 variables. The educational strength of the model is that it allows the student to work with the *integrated* physiology of these systems. Thus after perturbing one or several variables (eg, O_2 in inspired air, level of exercise), the user can observe the wide ranging, complex series of homeostatic adjustments that are made in the various body systems as they unfold sequentially. The range of educationally useful exercises seems virtually limitless, and student-designed experiments have included simulating high altitude and deep sea conditions, "blood doping" an exercising model, and many others.

A sample reconstructed output from a HUMAN experiment might

be instructive for those unfamiliar with the model. The results of one such sequence suggested in Dr. Randall's manual for the microcomputer version are shown in Figure 3. The first group of data shows the normal status of the subject. In this output the user has selected to display arterial pressure, cardiac output, muscle blood flow, lung ventilation, arterial O_2 content, blood lactic acid, O_2 debt, and the level of exercise (in L/min above resting O_2 consumption level). In the next block of lines, an exercise session begins at a level of 2 L/min above resting O_2 consumption level. We notice changes in cardiovascular parameters, including an increase in both cardiac output and the percentage of it that is sent to the exercising muscles. Because the subject progressively builds up an O_2 debt, the model ceases to exercise at around 25 min (this cutoff at 10-L O_2 debt is built into the model). The student then tries to slow the buildup of the O_2 debt by having the subject breathe 100% O_2 (data in block 5). While this succeeds in lengthening the time until the exercise cutoff to some 40 min, the 10-L O_2 debt level is eventually reached, and the subject again ceases exercising. At this point the student must conclude that the O_2 delivery problem does not lie in the respiratory system (which clearly can deliver no more O_2) and is directed to try to simulate cardiac exercise conditioning by increasing the basic strength of the right and left heart (ventricular contractility). The next series of data (fourth block) shows that this maneuver is indeed successful for the entire duration of the 80-min period shown, leading the student forcefully to the realization that it is the circulatory rather than the respiratory system that is the limiting factor in this type of endurance exercise. As an assignment for advanced students, we have had them work further through the limitations on endurance exercise by asking them to get the model to "run"

Baseline values								
DAY = 1 --- TIME = 12:00 AM								
TIME	SP	CO	MUSFLO	VENT	O2A	BLAC	O2DEBT	EXER
12:00	99.8	5451.	1099.	5.710	.194	1.000	0.0	0.0
12:05	99.7	5446.	1100.	5.710	.194	1.000	0.0	0.0
12:10	99.7	5449.	1100.	5.711	.194	1.000	0.0	0.0
12:15	99.6	5443.	1101.	5.710	.194	1.000	0.0	0.0
Exercise - 2.0 Liter/min								
DAY = 1 --- TIME = 12:15 AM								
TIME	AP	CO	MUSFLO	VENT	O2A	BLAC	O2DEBT	EXER
12:15	99.6	5443.	1101.	5.710	.194	1.000	0.0	2.000
12:20	109.	17477.	13865.	38.9	.197	1.422	.607	2.000
12:25	108.	16446.	12805.	44.3	.205	2.452	2.303	2.000
12:30	106.	15954.	12126.	46.8	.208	3.431	4.395	2.000
12:35	104.	15759.	11660.	47.1	.210	4.281	6.785	2.000
12:40	104.	15657.	11447.	46.1	.211	4.947	9.323	2.000
12:45	79.2	11927.	8580.	32.0	.211	4.517	8.498	0.0
Exercise - 100% O ₂ Breathing								
DAY = 1 --- TIME = 12:00 AM								
TIME	AP	CO	MUSFLO	VENT	O2A	BLAC	O2DEBT	EXER
12:00	99.8	5451.	1099.	5.710	.194	1.000	0.0	2.000
12:10	108.	16484.	12837.	47.8	.224	1.332	.582	2.000
12:20	104.	15775.	11656.	49.0	.229	2.481	2.796	2.000
12:30	104.	15573.	11381.	47.0	.231	3.386	5.758	2.000
12:40	105.	15516.	11322.	47.6	.232	3.798	8.813	2.000
12:50	76.4	11087.	8078.	28.0	.228	2.812	4.304	2.000
Exercise - Increased Contractility								
DAY = 1 --- TIME = 12:00 AM								
TIME	AP	CO	MUSFLO	VENT	O2A	BLAC	O2DEBT	EXER
12:00	99.8	5451.	1099.	5.710	.194	1.000	0.0	2.000
12:20	114.	19739.	14708.	45.6	.207	1.435	.821	2.000
12:40	115.	19418.	14341.	45.9	.210	1.953	2.879	2.000
1:00	115.	19259.	14212.	45.4	.211	2.122	5.157	2.000
1:20	115.	19117.	14100.	46.6	.212	2.203	7.573	2.000

FIGURE 3. Sample reconstructed tabular output from the HUMAN simulation. Four blocks of data are shown, each illustrating one phase of a student experiment exploring factors limiting endurance exercise. See the text for further details.

for 24 hours continuously at the 2.0 L/min O₂ level. In addition to the above factors, other problems they have to work through are salt depletion, water depletion, temperature control, and nutrient depletion.

Clearly, the possibilities for the creative generation of various physiological investigations are numerous, and we will not describe further the various ways in which we have employed the standard model. Rather, the remainder of the discussion will focus on ways to use the model that were not originally provided for directly in the program itself. Two such interlinked problems are the

lack of graphic output and the difficulties involved in employing the model to generate data for further student analysis. Graphic output is highly useful in allowing the student to detect overall trends. Difficulties in using the model as a data generator for further analysis of trends and relationships among variables come about because of the very strength of the model itself and the large number of variables it uses. This paradoxically results in printouts of reams of paper containing massive amounts of data that cause students inexperienced in experimental design to become lost. Both of these aspects

could be dealt with by rewriting the original FORTRAN source code to allow for outputs in the desired form. However, given the size of the program and the general lack of FORTRAN programming background among current educators, that option is not always a practical one. Rather, the tack taken is the simpler one of intercepting the output as it is generated (this can be done on the IBM or the VAX by specifying a file as the output from the command level). Then, once the data is captured in a file, it may be manipulated further by passing it into a graphing routine or into a package capable of allowing the student to manipulate the data. The use of each of these possibilities as tools in teaching experimental design and data handling at RPI is discussed below.

Teaching Experimental Design

Students are presented with a physiological principle such as that circulation is a major limiting factor during exercise (see discussion above). They are then asked to design an experiment or set of experiments that will support or refute the principle. This means deciding which eight parameters they are going to monitor, how they are going to perturb the system, how long they are going to run the experiment, how often they are going to take samples, etc. This requires running many experiments and results in many pages of solid numbers. As any experimenter knows, a very powerful way of seeing the general trends and important inflection points is to graph the data.

Our objective is to have the students spend the maximum amount of time thinking about designing the experiments rather than graphing poor results. Thus we have written a GRAPHICS program to plot the output from HUMAN. The GRAPHICS program is written in BASIC, while the simulation is a FORTRAN program. We use a small batch file to divert the output from

HUMAN to a file that later serves as input for the GRAPHICS program. The GRAPHICS program reads the output from HUMAN and removes all information except the parameter titles and the data values. The resulting data in the file can then be saved for use as input to other programs, such as LOTUS 1-2-3, or graphed for immediate viewing.

The GRAPHICS program initially provides a rough view of the eight variables that were sampled during the experiment. Figure 4(A) is how the data from an experiment similar to that in Figure 3 looks after it was run through the graphing program. The student can then choose to view any three variables simultaneously in more detail. Figure 4(B) shows cardiac output (CO), arterial oxygen content (O₂A), and exercise level (represented as total oxygen usage above normal). These variables are displayed in three colors on the CRT screen, which distinguishes them more clearly than does this black and white reproduction. Note the series of points just below the plotted lines. On the same line, also note the two solid (darker)

bars, the "A" bar, on the extreme left and the second "B" bar, above the "2" (in 12 min). Moving these bars (with the keyboard arrow keys) allows the user to obtain the X and Y values of any point on the plot. The X-axis values (time) at each bar location are given at the bottom of the screen and the Y-axis values (one for each of the three variables) are displayed in the table at the right of the screen. This arrangement eliminates the screen cluttering problem of putting three Y-axis scales on the graph and yet allows easy access to Y and X axis values.

The graph in Figure 4(A) has bar A at day 1 hour 12 min 0. This is during the control period before exercise began. Bar B is at day 1 hour 12 min 50, just before exercise stopped. The percent changes (values on the right, Fig. 4(B)) clearly show that cardiac output responded with a 188% change, but even with the increased ventilation, the oxygen content only increased by 8.7%. The student may then go on to examine other parameters such as the oxygen debt. By using this program the students can get a quick graphic interpretation of the particular

experiment they have just run and then decide if they should redesign the experiment. Once they have a satisfactory set of data, they can permanently save that information to a file that can be reloaded into the GRAPHICS program or can be used by other programs.

Teaching Data Handling

At this point the student has a set of data that he/she feels supports or refutes a particular physiological hypothesis. The next objective is to determine how the data should be presented to illustrate the conclusion most convincingly. Using our GRAPHICS program the student has saved each experiment in a file that can be read into a program such as LOTUS 1-2-3. Here the data can be easily manipulated and graphed in different ways. The example in Figure 5 is what I use to introduce the students to LOTUS. Using the same exercise example, the figure shows the rate of increase of oxygen debt of a normal subject, one who is breathing 100% O₂, and one who has a heart 30% stronger than normal (a conditioned heart). I then point out that while this graph

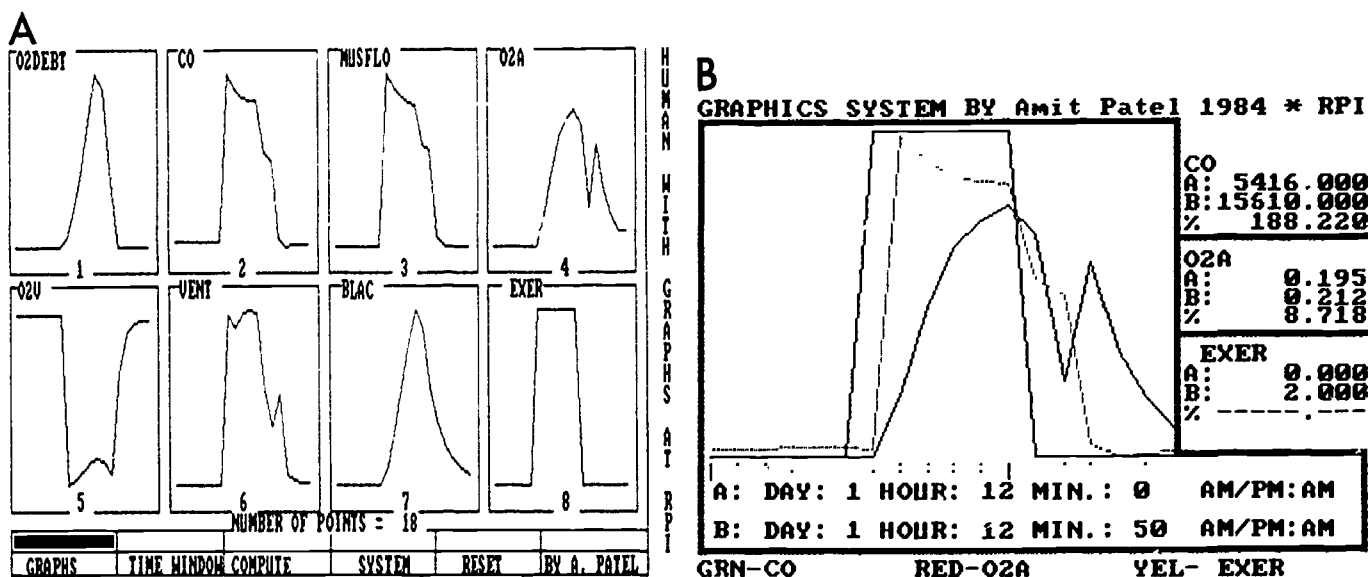

FIGURE 4. (Left, 4(A)) Graph of HUMAN data produced by GRAPHICS program. All eight variables are graphed using the IBM high resolution screen. The menu at the bottom of the figures allows the student selection of the other functions. The Graph option will produce a graph of three variables simultaneously (See Fig. 4(B)). Time Window allows selection of the time range to be plotted in Graphs. Compute will rerun HUMAN. System will allow the user to save a data set or reload an old data set. Reset will restart the program. This is done when a new experiment will be run. (Right, 4(B)) Simultaneous view of any three variables produced by HUMAN. Individual X and Y values for the data can also be obtained (see text for explanation). Three such sets of values are shown on the right.

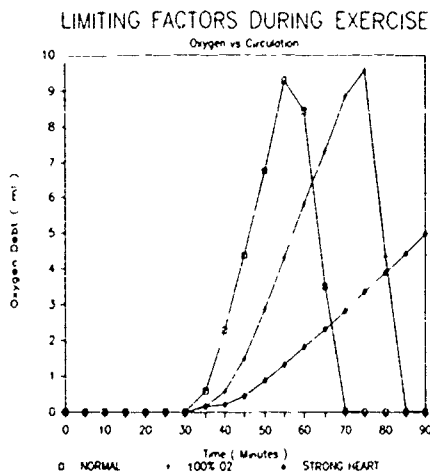

FIGURE 5. An example of data generated using HUMAN, saved using GRAPHICS, and plotted using LOTUS 1-2-3.

makes a point (that circulation is the main limiting factor in short term endurance exercise), the plot's effectiveness certainly could be improved upon. For example, the long control period could be left off the graph, although it was certainly necessary for a good experimental design. Indeed, a statement that a 20-min control period was measured

before each experiment could be better placed in the text or legend of the graph. Further, if one were only interested in the rate of increase in oxygen debt, a graph ending at 25 min would perhaps make that point more clearly. Or, perhaps a bar graph would be more effective. Once the data is in a graphing package such as LOTUS, these changes take only minutes. The student can then concentrate on how to best present the data without spending hours plotting a graph only to later regretfully decide that a different axis would have been better. I doubt that students ever make more than one graph of experimental data obtained in a laboratory experiment. Here the purpose of the laboratory exercise is to experiment with different graphic representations of the same data. In addition the students are encouraged to consider what parameters will best present their points. For instance, in our examples, the rate of O₂ delivery might be a better parameter to have measured and plotted. Using the computer, students can redesign and rerun an entire experiment in minutes.

CONCLUSION

Our goal in this article has been to illustrate how computer models designed for use under one educational philosophy can, with slight modifications, be used to accomplish different educational goals. The ease with which this can be done depends heavily on the quality of the original author's documentation and his/her willingness to share the source code of the program. When designing software, it is important to recognize that, by allowing colleagues access to this information, the utility and the educational impact of the program is greatly enhanced.

REFERENCES

1. Coleman TG, Randall JE: HUMAN—a comprehensive physiological model. *The Physiologist* 26:15-21, 1983.
2. Hodgkin AL, Huxley AF: A quantitative description of membrane current and its application to conduction and excitation in nerves. *J Physiol* 117:500-544, 1952.
3. Randall J: *Microcomputers and physiological simulation*. Addison-Wesley, 1980.

SUBSCRIPTION INFORMATION

Computers in Life Science Education is published monthly by Elsevier Science Publishing Co., Inc., 52 Vanderbilt Avenue, New York, NY 10017. Subscription rate is \$58.00 for 12 issues, including postage and handling in the United States and Canada. Add \$20.00 for postage (airmail) in Mexico and Europe and \$23.00 for the rest of the world.

This newsletter has been registered with the Copyright Clearance Center, Inc. Consent is given for copying of articles for personal or internal use, or for the personal or internal use of specific clients. This consent is given on the condition that the copier pay through the Center the per-copy fee stated in the code on the first page for copying beyond that permitted by the US Copyright Law. If no code appears on an article, the author has not given broad consent to copy and permission to copy must be obtained directly from the author. This consent does not extend to other kinds of copying, such as for general distribution, resale, advertising and promotional purposes, or for creating new collective works.

Address orders, changes of address, and claims for missing issues to Journals Fulfillment Department, Elsevier Science Publishing Co., Inc., 52 Vanderbilt Avenue, New York, NY 10017. Claims for missing issues can be honored only up to three months for domestic addresses and six months for foreign addresses. Duplicate copies will not be sent to replace ones undelivered due to failure to notify Elsevier of change of address.

Address editorial correspondence to Harold I. Modell, PhD, Virginia Mason Research Center, 1000 Seneca Street, Seattle, WA 98101.

POSTMASTER: Send address changes to *Computers in Life Science Education*, Elsevier Science Publishing Co., Inc., 52 Vanderbilt Avenue, New York, NY 10017.

COMPUTERS IN LIFE SCIENCE EDUCATION

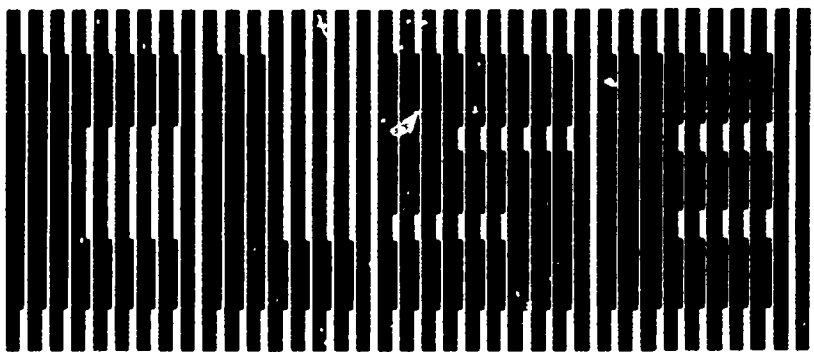

HAROLD I. MODELL
Virginia Mason Research Center
Seattle, Washington

MARCEL BLANCHAER
Professor of Biochemistry,
Faculty of Medicine
University of Manitoba
Winnipeg, Manitoba
Canada

THEODORE J. CROVELLO
Department of Biology
University of Notre Dame
Notre Dame, Indiana

JAMES W. ECKELAD
Department of Biology
Luther College
Decorah, Iowa

TSEGAYE HABTEMARIAM
School of Veterinary Medicine
Tuskegee Institute
Tuskegee, Alabama

DONNA LARSON
School of Nursing
Grand Valley State College
Allendale, Michigan

TERRY M. MIKITTEN
Graduate School of Biomedical Sciences
University of Texas Health Sciences Center
San Antonio, Texas

JAMES E. RANDALL
Department of Physiology
Indiana University
Bloomington, Indiana

PATRICIA SCHWIRIAN
College of Nursing
Ohio State University
Columbus, Ohio

RICHARD STULL
College of Pharmacy
University of Arkansas
Little Rock, Arkansas

JAMES W. WOODS
Lister Hill National Center
for Biomedical Communications
National Library of Medicine
Bethesda, Maryland

DOROTHY WOOLEY-Mc KAY
Department of Biology
Glendale Community College
Glendale, Arizona

GLENN YOSHIDA
Department of Life Sciences
Los Angeles Southwest College
Los Angeles, California

ELSEVIER

CONTENTS

CREATIVE EQUIPMENT ACQUISITION FOR DEVELOPMENT OF COMPUTER SOFTWARE Richard Stull and Richard Knoll	33
TECHNICAL ASPECTS OF USING MICROCOMPUTERS IN A GROUP SETTING Harold I. Modell	35
ERRATUM	38
THE BULLETIN BOARD	39

CREATIVE EQUIPMENT ACQUISITION FOR DEVELOPMENT OF COMPUTER SOFTWARE

Richard Stull and Richard Knoll
*College of Pharmacy
University of Arkansas for Medical Sciences
Little Rock, Arkansas*

One of the primary problems in producing educational software in the life sciences is placing hardware where it is easily accessible to faculty members. Ready access in most cases means within the individual faculty member's office or laboratory space. Usually even the most ardent backer of computer-based in-

structional programs is hard-pressed to be an active generator of programs if the equipment for creating those programs is located at a site that is not easily accessed. It is even proposed by some that equipment should be taken home by interested faculty not only to promote literacy and generate new educational uses,

but to make it easy for the faculty to sit at the machine and create programs. Obviously, other types of encouragement are necessary, but that of machine access is one that can be easily addressed.

During times when administrators are practicing budgetary restraint, it is difficult to place computer hardware so that faculty may have easy access. Alternative ways of acquiring equipment may be available. For example, several computer companies have made large contributions of equipment to universities either in the form of loans or as grant programs.

Equipment loan programs may aid in exposing faculty/students to varieties of equipment either to enhance literacy, in making decisions regarding acquisition, or to improve access for software generation. These programs that involve the lending of equipment to institutions are as varied in procedures as the number of companies involved. For example, IBM has a highly organized national program to foster the use of IBM PC Jrs by university faculty. Others, such as Digital, manage a somewhat less structured program on a regional basis, and Radio Shack has no organized loan program, but will lend equipment through their local outlets, depending on relationships built by the institution. Like most major personal computer equipment manufacturers, Tandy also has an educational grants program for computer equipment.

Loan programs are not always without hazard, oftentimes lending companies require maintenance that may cost as much as the equipment itself and some expressed intent on the part of the university to purchase the equipment at the conclusion of the loan period.

With regard to microcomputers, IBM appears to have one of the few national programs to lend equipment. The IBM loaner programs are designed around two different possi-

bilities. The first and probably the most desirable is where the company lends systems to college faculty. These systems, which are new IBM PC or XT computers, are eligible for sale to the school or professor at a discounted price at the end of the loan period.

Another is the loaner program mentioned earlier known as the "IBM Faculty Seminar Program." This program provides new or used IBM PC Jrs for faculty to use for an extended period of time (eg, 3-6 months). The individual faculty members involved have free access to the equipment for educational or personal use. At the end of the loan period the machines are not available for sale. Additional information on the program is available from an IBM sales representative or directly from IBM (Table 1).

Since April 1983, Radio Shack has sponsored a quarterly grant program to promote computers in education. The Tandy TRS-80 Educational Grants Program has awarded over \$850,000 worth of hardware and software to 79 individuals and institutions to date. Tandy presents the awards to individuals or schools that submit the best research proposals on a topic Tandy chooses. For example, the 10th quarterly cycle of the program, which ended December 31, 1984, accepted outlines on the topic "Managing Instruction with Microcomputers." The 11th cycle of the Tandy program will award prizes on the best proposals for "Applications of Microcomputers in Special Education." Proposals were due March 31, 1985. You can get a grant application, including format and content procedures, by writing to

Table 1.

Company	Program	Address
Apple	Faculty purchase	An Apple for the Teacher c/o B & M Publications PO Box 306 Half Moon Bay, CA 94019
Apple	Program development	The Foundation for the Advancement of Computer- aided Education 20863 Stevens Creek Blvd. Building B-2, Suite A-1 Cupertino, CA 95014
Digital	Educational grants	Digital Equipment Corp. Educational Services Dept. 12 Crosby Drive Bedford, MA 01730
		or
		Educational Services Dept. Santa Clara, CA 95051
IBM	PC Jr loan or PC & PC/XT loan	IBM Information Systems Group 900 King Street Rye Brook, NY 10573
Tandy	Educational grants	Radio Shack Education Div. 1400 One Tandy Center Fort Worth, TX 76102

Tandy c/o The TRS-80 Educational Grants Program (Table 1).

Apple supports a variety of programs for equipment acquisition, but currently has no organized national loan program. Individuals or institutions may borrow one or two pieces of equipment through regional Apple support centers, but for only short periods of time. Apple also currently has a "Test Drive a Mac" program, which allows local outlets to place Macintosh computers into the hands of prospective buyers for a day.

The "An Apple for the Teacher" program allows educators to buy selected Apple products at special

prices. The program is open to full-time instructional and administrative employees of accredited schools, colleges, and universities.

We have made an attempt to discuss typical programs of just a few of the major computer manufacturers; other manufacturers are likely to have comparable programs. Local outlets seem to be a prime place to start when you are unsure about a particular manufacturer or program. When having your hands on the machine is the rate-limiting step in generating computer-based materials in your setting, perhaps creative equipment acquisition may be helpful.

same individual in his conference sessions.

USE IN THE LECTURE HALL

The simulation was used for the first time in the lecture hall approximately 4 years ago. The computer, an Apple II+, was in full view of the students, and the output was fed to six 23-inch color video monitors suspended at various locations around the room. An additional monitor was placed in the front of the room.

The output scheme was similar to that shown in Figure 1. The output was in the form of tabular data on a 40-column, monochrome screen. A movable arrow could also be displayed to focus attention on the data that the lecturer was discussing. The lecture was designed to run several "experiments" using the simulation and then discuss the principles underlying the observed results.

On polling a selected number of students concerning the worth of the computer display in the lecture hall, three general responses were encountered. Those students who were computer oriented thought the experience was helpful. Those students who viewed the computer as merely another "gimmick" thought the simulation did not enhance the lecture. The third group was non-committal as to the effectiveness of the simulation. All three groups criticized the output as being difficult to read unless the monitor being viewed was directly overhead and in good adjustment.

From the lecturer's standpoint, several problems were noted. Because the monitors are suspended from the ceiling and seldom used, preventive maintenance and periodic adjustments are not performed on a regular basis. Hence, it was difficult for the lecturer to be sure

TECHNICAL ASPECTS OF USING MICROCOMPUTERS IN A GROUP SETTING

Harold I. Modell

Virginia Mason Research Center, Seattle, Washington

Schottelius,⁶ Mikiten,³ and others,² have reported on the utility of microcomputer simulations as teaching tools in group settings ranging from small group conferences to large group lectures. We have used simulations in both of these settings over the past four years with varying degrees of success. Although many factors may play a significant role in determining the level of success of a specific presentation, it is our experience that the technical aspects of the presentation represent a key element. The purpose of this article is to review our use of simulations in a medical school setting, focusing on the technical aspects of the presentation. The simulations used were mathematical models of various aspects of pulmonary function.⁴

The physiology curriculum at the University of Washington School of Medicine is based on an organ system approach with the majority of the coursework being presented in the second year. Approximately 175 students are enrolled in the cardiovascular/respiratory course presented each fall quarter. The respiratory section of the course consists of a series of 2-hour blocks of lectures to the entire class followed by 3-4 hours of small group conferences (22 students/group). In the lecture portion of the course, one simulation dealing with the alveolar gas equations has been used by one lecturer. This simulation along with others dealing with pulmonary mechanics, gas exchange, and acid-base balance has been used by the

	UD=150 ML	VT= 575 ML	FREQ= 12/MIN
	VO2= 300 ML/MIN	UCO2= 240 ML/MIN	
	VENT (L/MIN)	PO2 (TORR)	PCO2 (TORR)
EXPIRED	6.9	114.1	→ 30
ALVEOLAR	5.1	101.4	40.6

FIGURE 1. Output scheme for alveolar gas equation simulation first used in the lecture hall. Inputs to the model were tidal volume (VT), anatomical dead space volume (VD), respiratory frequency (FREQ), and oxygen consumption (VO2). The arrow could be moved to focus attention on any of the output values.

that the color monitors were providing a good black and white image. With students viewing monitors in different areas of the room, it was also difficult to ascertain whether the class was focusing on the message being conveyed. This was true in spite of the fact that an arrow on the screen could be pointed at the data being discussed. As a result of these perceptions, the simulation was not included in the lecture during the next two years.

In the fall of 1984, simulations were once again used in conjunction with the alveolar gas exchange lecture, this time with considerable success. Although the output scheme of the earlier model still provided numerical data, a graphical component had been added to clarify where the values of being "measured" (Fig. 2). The presentation mode was also changed. As suggested by Mikiten,¹ every attempt was made to make the technology transparent to the

class. An Apple //c computer was used instead of the II+. This machine was small enough to fit on the lectern, effectively hidden from the students' line of sight.

To minimize the chance of typing errors when accessing the models to be used, a controller program was written to load the appropriate simulation. This program set up the proper graphics conditions and accepted only three single characters as legal inputs. If the character typed was not a "1" (load the first program), "2" (load the second program), or "ESC" (quit), the input was ignored. The prompt for the input was hidden from the viewing screen by displaying the graphics screen, placing the cursor at the first line of the screen, and printing the prompt on the text screen. Each of the simulations used during the lecture terminated by calling the controller program.

The computer output was fed to a Sony Model VPH-1020QM video-projector for projection on the same screen used for presenting slides during the lecture. The Sony projector has a three gun projection system, and, as a result, has a fixed focal length that limits the image size. Unfortunately, this image size was not large enough to allow the abbreviations and numbers to be read from all parts of the lecture hall. To overcome this limitation, the red and blue guns were turned off (a feature of the projector), and only the green gun was used. By using a single gun, the image could be enlarged and focused sufficiently so that the image could be read by all students.

Using the same screen for slides and the computer output necessitated a mechanism of masking one output (ie, slide or computer) while projecting the other. This was easily accomplished by placing blank slides in the appropriate positions in the slide projector and by incorporating a toggle switch in the cord connecting the computer output to the projector.

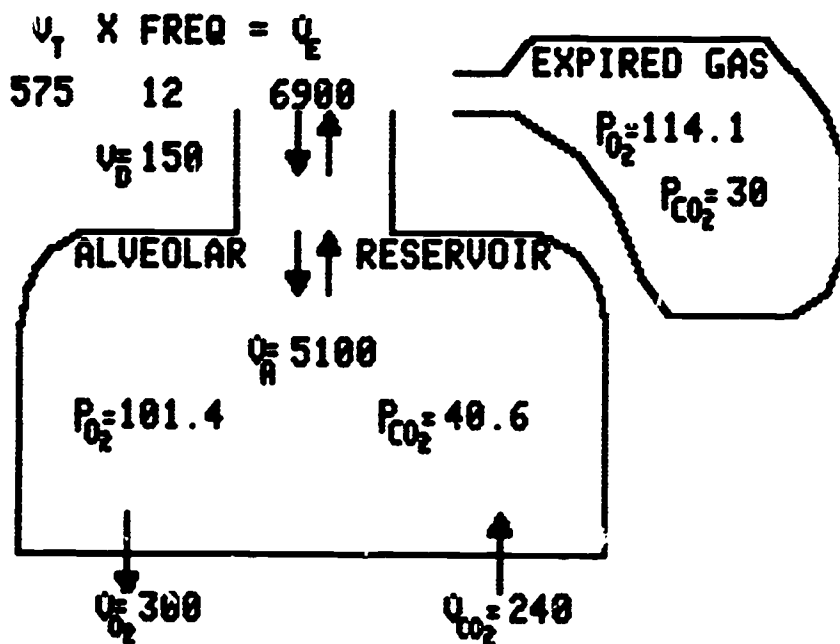

FIGURE 2. Revised output for alveolar gas equation simulation. The graphics are designed to indicate where values are being "measured."

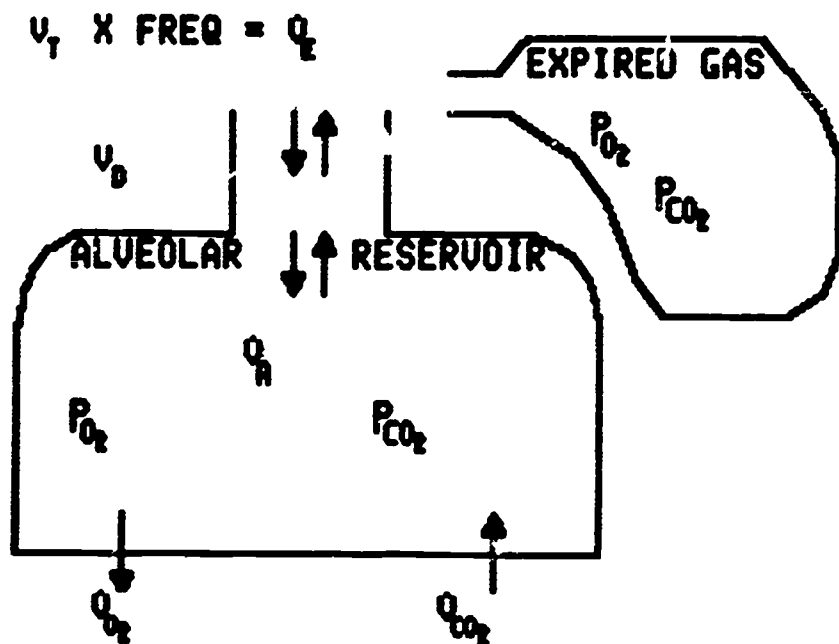

FIGURE 3. Preview of the output scheme depicted in Figure 2 shown to students as a slide.

To further limit the possibility of generating errors that would result in the computer technology intruding on the message of the lecture, it was decided that the computer output be used only for those aspects of the presentation that could not be presented with slides. Hence, when introducing the model, the assumptions and a preview of the output scheme (Fig. 3) were presented as slides, even though they could have been presented with the computer.

Another example of this practice is a second model shown during the lecture. This model presented carbon

dioxide exchange as a reservoir system (Fig. 4). The pictorial was presented first as a slide. The model was then used to provide an animation of moving from one steady state to another. Slides were once again used to build on this image while discussing oxygen exchange (Fig. 5).

Although the lecture material in the more recent presentation did not differ significantly from that in earlier years, the use of the simulation provided a more interactive session with a greater impact on the students than did the earlier attempt. This could certainly be attributed in part to differences in class personality and willingness to accept the computer as something other than a "gimmick." However, the technical refinements made in the mode of presentation and judicious use of the computer eliminated key problems identified by the lecturer in the earlier presentation.

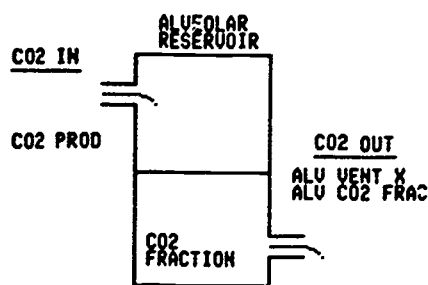

FIGURE 4. Model of carbon dioxide exchange shown first as a slide. The model was then run on the computer showing an animated transition from one steady state to another.

USE IN THE CONFERENCE ROOM

We have used a series of simulations covering various aspects of respiratory physiology^{4,5} in the conference sessions of the medical course for

the past three years. As in the lecture hall, the technical aspects of presentation have had a significant impact on the effectiveness of the presentation. In the conference room setting, the models were used to reinforce material presented in lecture and to provide additional data during discussion of various problem sets.

The conference group setting, by virtue of its more intimate nature, is more forgiving of the computer technology intruding on the discussion at hand. Thus, "hiding" the computer from view has not proved to be as important in this setting as it is in the lecture hall. We have used both the Apple II+ and //c in the conference room with equal success.

The rooms used for the small group sessions in this course were originally designed as student laboratories. Thus, each room has several laboratory tables at which 4-5 students sit. Because of this design, we initially chose to use daisy-chained 9-inch monitors to present the computer output. One monitor was placed on each table. An additional monitor (25 inch) was placed at the front of the room. The instructor used the large monitor for discussion, and the students could see the details of the output on the small monitors.

Although this arrangement was satisfactory, it was far from optimal. At times the 9-inch monitors proved to be too small for easy viewing by 5

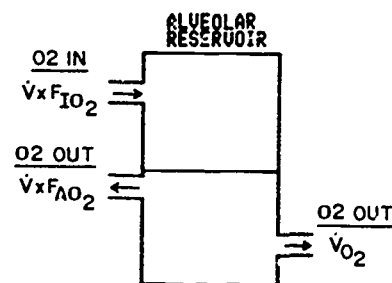

FIGURE 5. Extension of the model shown in Figure 4 to apply to oxygen exchange. This picture was shown only as a slide.

students; some students felt obligated to make frequent adjustments to the picture; and alternating attention between the small and large monitor led to confusion at times. Thus, while more latitude in the choice of video monitor is available in the conference room, the lessons learned in the lecture hall are also applicable here.

During the past two years, the small monitors have been replaced by a single 40-inch projection television system. The curved screen on this type of system limits side viewing at times, and, occasionally students must move toward the center of the room to view the image. Nevertheless, having the class focus on one output facilitates the discussion.

We have used two different projection television units. One unit did not provide a good white on black image when used with the computer. To overcome this, the red and blue guns were covered with cardboard (allowing ventilation for the guns), effectively converting the unit into a "green screen" monitor. Neither projection television provided as good an image as the video projector used in the lecture hall, but both proved very effective in the small group setting.

OTHER CONSIDERATIONS

Our experience with simulations in the classroom has been restricted to mathematical models of physiological systems. Another class of simulations, however, offers considerable potential for the lecture and small group settings. With the development of interactive video and natural language authoring systems,¹ clinical simulations previously designed for independent study settings have the potential for returning the clinical correlation in a "grand rounds" format back to the classroom.

The degree of success achieved by using clinical simulations will depend heavily on the technical aspects

of presentation. For example, use of multiple choice interaction with such simulations in a group setting will dampen rather than stimulate group problem solving. Natural language input, on the other hand, will serve to make the simulations even more realistic.

Input schemes in mathematical simulations generally involve a minimal amount of keyboard input, thereby minimizing the chances of typing errors that result in the technology intruding upon the discussion at hand. Use of natural language input with clinical simulations, while desirable from an interactive standpoint, may increase the potential for keyboard errors because of the amount of typing necessary for communication with the program. At least one group is experimenting with voice input for interaction with clinical simulations. This mode offers an attractive alternative for group settings.

Our goal in this article has been to share some of the experience that we have gained using the microcomputer as a lecture/discussion aid over the past four years. It has become clear to us that attention to the technical aspects of the presen-

tation can mean the difference between the simulation being viewed by students as another "toy" of the lecturer or as a useful adjunct to learning.

REFERENCES

1. Abdulla AM, Henke JS: The use of natural language and a laser video-disk player in high-fidelity microcomputer-based clinical simulations. Proceedings of the eighth annual symposium on computer applications in medical care, Washington, DC. New York: IEEE, p. 936, 1984.
2. Meyers RS, Parsons R: Creative educational use of software written by others. *Computers in Life Science Education* 2:25-32, 1985.
3. Mikiten TM: Enhancing lectures with a microcomputer. *Computers in Life Science Education* 1:9-11, 1984.
4. Modell HI, Olszowka AJ, Klocke RA, Farhi LE: Normal and abnormal lung function, a program for independent study. New York: The American Thoracic Society, 1975.
5. Modell HI, Olszowka AJ, Plaves JL, Farhi LE: Role of computer graphics in simulations for teaching physiology. *The Physiologist* 26:93-95, 1983.
6. Schottelius BA: Teaching physiology by microcomputer in small group conferences. *Computers in Life Science Education* 1:4-6, 1984.

ERRATUM

Washington DJ: Designing computer assisted instruction materials for remedial freshman biology curriculum. *Computers in Life Science Education* 2(3):17-22, 1985.

Diagram 1 should read:

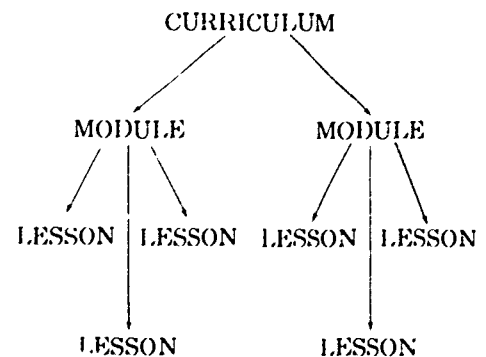

THE BULLETIN BOARD

The Bulletin Board is published periodically to inform readers of upcoming meetings of interest. If you know of meetings, symposia, continuing education courses, etc, of interest to life science educators that do not appear in THE BULLETIN BOARD, please let us know. Send pertinent information to Dr. Harold Modell, Virginia Mason Research Center, 1000 Seneca Street, Seattle, WA 98101.

May 20-22, 1985. Computer applications in medicine. AAMSI Congress 1985. San Francisco, California.

Contact:

Ben T. Williams, MD
AAMSI Congress General Chair
Director of Laboratories
Mercy Hospital
1400 West Park Avenue
Urbana, IL 61801
(217) 337-2175

June 20-21, 1985. Computers and nursing education: what and how-to. Traverse City, Michigan.

Contact:

Jack Payne
Continuing Education and Conference Coordinator
Grand Valley State College
66 North Division Avenue
Grand Rapids, MI 49503
(616) 242-6603

July 29-August 2, 1985. World Conference on Computers in Education. Norfolk, Virginia.

Contact:

WCCE/85
c/o AFIPS
1899 Preston White Drive
Reston, VA 22091

August 11, 1985. Workshop on computers in bioeducation. 36th Annual AIBS Meeting. Gainesville, Florida.

Contact:

Dr. Theodore J. Crovello
Department of Biology
University of Notre Dame
Notre Dame, IN 46556-0369
(219) 239-7031

November 10-13, 1985. 9th Annual Symposium on Computer Applications in Medical Care. Baltimore, Maryland.

Contact:

Michael J. Ackerman, PhD
SCAMC—Office of CME
George Washington University
Medical Center
2300 K Street NW
Washington, DC 20037
(202) 676-8928

February 3-6, 1986. 27th International Conference of the Association for the Development of Computer-based Instructional Systems. New Orleans, Louisiana

Submission deadline for presentations: July 1, 1985.

Contact:

Gordon Hayes
Executive Director
ADCIS International
409 Miller Hall
Western Washington University
Bellingham, WA 98225
(206) 676-2860/(206) 734-6574

WANTED

-Feedback-

- * Is CLSE meeting your needs?
- * Have important topic areas been overlooked?
- * Should more regular features (e.g., Keeping Abreast of the Literature) be added?

Please send comments and criticism to:

DR. HAROLD MODELL
VIRGINIA MASON RESEARCH CENTER
1000 SENECA STREET
SEATTLE, WASHINGTON 98101

COMPUTERS IN LIFE SCIENCE EDUCATION

HAROLD I. MODELL

Virginia Mason Research Center
Seattle, Washington

MARCEL BLANCHAER

Professor of Biochemistry
Faculty of Medicine
University of Manitoba
Winnipeg, Manitoba
Canada

THEODORE J. CROVELLO

Department of Biology
University of Notre Dame
Notre Dame, Indiana

JAMES W. ECKBLAD

Department of Biology
Luther College
Decorah, Iowa

TSEGAYE HABTEMARIAM

School of Veterinary Medicine
Tuskegee Institute
Tuskegee, Alabama

DONNA L. ARSON

School of Nursing
Grand Valley State College
Allendale, Michigan

TERRY M. MIKITTEN

Graduate School of Biomedical Sciences
University of Texas Health Sciences Center
San Antonio, Texas

JAMES E. RANDALL

Department of Physiology
Indiana University
Bloomington, Indiana

PATRICIA SCHWIRIAN

College of Nursing
Ohio State University
Columbus, Ohio

RICHARD STULL

College of Pharmacy
University of Arkansas
Little Rock, Arkansas

JAMES W. WOODS

Lister Hill National Center
for Biomedical Communications
National Library of Medicine
Bethesda, Maryland

DOROTHY WOOLEY-McKAY

Department of Biology
Glendale Community College
Glendale, Arizona

GLENN YOSHIDA

Department of Life Sciences
Los Angeles Southwest College
Los Angeles, California

ELSEVIER

CONTENTS

USING "HUMAN," A COMPREHENSIVE PHYSIOLOGICAL MODEL, IN TEACHING UNDERGRADUATE PHYSIOLOGY COURSES Charles W. Holliday	41
VIDEO - BASED INSTRUCTION AS AN ENHANCEMENT TO COMPUTER LEARNING John Heard, JR, and Barbara K. Heard	43
INSTRUCTIONAL DESIGN ISSUES AND THE EFFECTIVE USE OF GRAPHICS IN COMPUTER - ASSISTED INSTRUCTION Lynn D. Churchill	45
KEEPING ABREAST OF THE LITERATURE	48

USING "HUMAN," A COMPREHENSIVE PHYSIOLOGICAL MODEL, IN TEACHING UNDERGRADUATE PHYSIOLOGY COURSES

Charles W. Holliday

Department of Biology, Lafayette College, Easton, Pennsylvania

In a recent article in *The Physiologist*, Coleman and Randall have described the operation of their excellent physiological simulation of human systems physiology, HUMAN.¹ Although this simulation is intended for use in teaching human physiology and diagnosis to

medical students, I have had excellent results in using it as an adjunct in teaching an undergraduate, non-laboratory course in human physiology at Lafayette College. Further, I believe that it could be used effectively as an adjunct in advanced high school biology courses.

There are many pedagogic problems in teaching nonlaboratory courses in the sciences, and physiology is no exception to this rule. Students concentrate on learning the physiological concepts presented and develop little appreciation for the methods used to gather the data presented in graphic form during lectures and in the text. Further, they have little appreciation for the difficulties of formulating an hypothesis, experimental design, and the production of an "elegant record" that clearly demonstrates the effect of a given stimulus on a physiological variable. Even in courses with laboratory sections, it is difficult to measure more than two or three variables during any one experiment. Finally, a certain percentage of students in any class does not deal well with graphic presentation of data (eg, carbon dioxide partial pressure plotted as a function of alveolar ventilation) because they have had little previous experience in gathering and plotting data.

I have used HUMAN in several ways to enrich my students' experiences and to at least reduce some of the pedagogic problems noted above. The simulation iteratively computes values for over 200 physiological variables and allows the user to change more than 70 parameters (eg, fraction of oxygen in inspired air). Output from the simulation is a tabular listing of up to eight variables at user-selected time intervals. Thus, users of the simulation must design an experiment each time they use it and plot the output data as a function of time, if only in the mind.

I began by using HUMAN in my nonlaboratory human physiology course simply as an adjunct for interested students. Several of the experiments, included with the program disk by its authors, were recommended to the students, and an Apple II+ microcomputer with a CP/M card was made available at the College computer center. It quickly became clear that only a few

students voluntarily put enough time into the simulation to benefit from it.

At present I require that the students write a term paper based on experiments of their choice and design performed on HUMAN. First, the students run five of the "canned" experiments for familiarization. The students then submit a preliminary, two-page proposal for the project, which I return to them with suggestions for improvements. They then perform their experiments and submit a 10-page term paper in the form of a standard scientific paper with introduction, methods, results (including graphed data), and discussion sections and annotated output from the simulation as an appendix. Table 1 shows the output from an experiment to show the effect of reduced sympathetic output on heart rate, cardiac output, stroke volume, and blood pressure. Interpretation of these results by the student involves integration of knowledge of factors such as sympathetic control of heart rate, stroke volume, and arteriolar and venous tone.

Student response to the model has been uniformly favorable. The quality of the term papers has been

better than I expected, and many of the students have been motivated to consult Guyton's physiology text and papers in the literature to explain their results. Clearly, the simulation helps to provide at least some of the benefits of a laboratory section in the course.

I have also used HUMAN as an adjunct in my laboratory course in comparative animal physiology. Several of the laboratory exercises have long time intervals between data collections, and I have the students run simulations on HUMAN during these intervals. For example, during a respirometry exercise using roaches and Barcroft respirometers, the students investigate the effects of altitude on human respiratory rate and blood pH using HUMAN (barometric pressure is set to the equivalent of 32,500 feet). The simulation clearly shows the interaction of oxygen of pH (P_{CO_2}) chemoreceptors in controlling respiration rate (Table 2).

HUMAN has occasional malfunctions associated with huge or miniscule values for computed variables and will sometimes display values of variables that are not compatible with life (eg, blood pH values of 8.3). I like this feature of the model

TABLE 1. The Effect of Reduced Sympathetic Output on Pulse, Cardiac Output, Stroke Volume and Arterial Pressure in HUMAN^a

TIME	PULSE	CO	SVOL	AP
12:10	72.2	5445.	75.4	99.7
12:11	85.6	5295.	61.8	72.4
12:12	81.7	5306.	65.0	72.3
12:13	81.7	5273.	64.6	72.3
12:14	81.8	5254.	64.3	72.2
12:15	81.8	5236.	64.0	72.2
12:16	81.8	5214.	63.7	72.1
12:17	81.8	5194.	63.5	72.2
12:18	81.8	5174.	63.3	72.2
12:19	81.8	5166.	63.1	72.2
12:20	81.8	5153.	63.0	72.2

^aSYMCL is the value (X normal) at which sympathetic output is clamped, SYMSW is a switch that is set at "1" to actuate clamped output. The values at 12:10 AM are normal ones.

TABLE 2. The Effect of Altitude on Arterial Pressure, Cardiac Output, Respiration Rate, Blood pH, Arterial Oxygen Content, and Venous Oxygen Content^a

Value of BAROP is 760.0
New value of BAROP is 200.0
DAY = 1 TIME = 12:00 AM

TIME	AP	CO	RESPT	pH	O ₂ A	O ₂ V
12:00	99.8	5451.	11.531	7.409	.194	.148
12:02	99.7	54.	11.532	7.409	.140	.148
12:04	118	6038.	21.2	7.427	.133	.128
12:06	115.	6488.	23.2	7.479	.131	.116
12:08	113.	7051.	23.5	7.540	.130	.109
12:10	111.	7364.	22.8	7.600	.130	.107
12:12	111.	7526.	21.6	7.658	.128	.106
12:14	125.	8770.	21.0	7.716	.127	.106
12:16	124.	8557.	20.8	7.764	.127	.107
12:18	124.	8441.	20.6	7.811	.127	.107
12:20	124.	8380.	20.6	7.856	.128	.107
12:22	124.	8344.	20.6	7.900	.128	.107
12:24	123.	8298.	20.6	7.941	.128	.107

^aBAROP (barometric pressure) was changed to 200 mm Hg, a pressure roughly equivalent to 32,500 feet. Note that respiratory rate initially increases, probably due to the low arterial PO₂, which is sensed by carotid chemoreceptors. However, the rapidly increasing blood pH soon slows respiratory rate, this effect is probably mediated by medullary pH chemoreceptors which control respiratory rate. The drop in blood pH is due to respiratory alkalosis associated with high respiratory rates. Values at 12:00 AM are normal ones.

because it forcibly reminds the students that the simulation is only an approximation of real life phenomena in an extremely complex system. Students frequently "kill" HUMAN by not taking into account the effects

of changed parameters on physiological variables other than the ones they are studying. HUMAN does, however, demonstrate very well the interaction between physiological systems. Because the output from

the simulation is constantly changing, the students are challenged to explain the basis for the changes. I am pleased with the added depth the simulation gives to my courses, and I strongly recommend it to other instructors.

HUMAN is available in micro-computer versions for Apple II computers with CP/M and IBM PC. I use the PC version unmodified on the Tandy 2000 microcomputers in the College computer center. These "micro" versions of HUMAN are available from Dr. James E. Randall, Department of Physiology and Biophysics, Myers Hall, Indiana University, Bloomington, IN 47405. A mainframe version on computer tape for VAX computers is available from Dr. Thomas G. Coleman, Department of Physiology and Biophysics, University of Mississippi Medical Center, Jackson, MS 39216.

REFERENCE

1. Coleman TG, Randall JE: HUMAN, a comprehensive physiological model. *The Physiologist* 26:15-21, 1983.

VIDEO-BASED INSTRUCTION AS AN ENHANCEMENT TO COMPUTER LEARNING

John Heard, JR, and Barbara K. Heard

Department of Microbiology and Immunology, Kirksville College of Osteopathic Medicine, and Division of Education, Northeast Missouri State University, Kirksville, Missouri

We live in a world that continually impinges upon us with all sorts of varied sensations. From the familiar sound of a locomotive to the faint wisp of a haunting fragrance, we are constantly bombarded by our surroundings. In all phases of our endeavors we strive to replicate and present the most realistic models of our surroundings. In the area of

music, for instance, we have developed sophisticated audio reproduction components to give us the most faithful sounds available. One area where we seem to be failing to strive for excellence is in computer-aided instruction (CAI), especially in our pictorial representations. Not only do we not strive for faithful visual presentations, we accept crude im-

itations. While we cannot expect every picture to convey a thousand, or even a hundred words, we should expect them to convey a true representation. One method of accomplishing this, which has been around for several years, is the use of video-generated materials. These presentations have been made possible, and for the most part accessible to all, by the popularization of videotape and videodisc players. The combination of videodisc-generated pictures and interactive computer programs offers unlimited possibilities in the presentation of CAI.

At the simplest level, one can record a lesson on the disc, using the computer as the testing mode or for problems and drills. This method has several advantages. While not

coming close to utilizing the possible powers of the combination of these two technologies, the standard lecture-drill combination does allow an easy means of conveying information. By first videotaping the lesson and later editing it, a near-perfect presentation can be achieved. Facts that otherwise might not be available to a learner can be presented via experiments. This use also gives us the advantage of performing the experiment carefully to obtain the desired results and avoids the possible errors present in live demonstrations. Obviously, the use of the computer in this case is fairly limited and, in fact, serves more as a review and test instrument than as a truly educational medium.

The next level of integration involves the user and computer slightly more. This involves a standard video presentation of compact unit ideas, either single or a few concepts. At the end of each unit, the student would be assessed for comprehension with further advancement contingent upon successful attainment of a predetermined level of proficiency or number of correct responses. While this does not demand a high degree of interaction, it would involve the user in program control.

The third level of integration involves a greater degree of interaction. This mode would be essentially the same as the second level but with one very important difference. When the student found himself having difficulties, he would be able to request alternate presentations of the information. This method, like the previous ones, suffers from the disadvantage of having a sequential flow of information, i.e., concepts covered previously are no longer available for random perusal at the convenience of the student.

A fourth level of integration uses the capabilities of both the computer and videodisc to their fullest, i.e., while the flow of information is linear, any information, past, pres-

ent, or future, is available to the user. This mode utilizes the random search capabilities of the videodisc player. At the same time, the inclusion of the computer can be made more important, i.e., not only can it simply test for knowledge acquisition, it also can control program flow. In this combination, program control has been transferred to the computer. The user can choose to follow the preprogrammed flow or, by direct intervention, can choose where to go and what to do. This mode involves the greatest interaction between computer and videodisc player.

The final level of integration is simply a modification of the last mode. In this combination not only is the degree of interaction between the computer and videodisc great, but it also involves the greatest degree of user interaction. Unlike the previous methods, which were intended mainly to convey basic principles, this method assesses the comprehension integration and ability to utilize the principles presented. In essence, this becomes a sophisticated interaction with the real world. Here the user is not presented with a series of facts to be learned. Rather, a situation is presented that embodies, to various degrees of difficulty, principles previously learned. Through the interaction of the user with the videodisc and computer, further information may be requested as needed for the solution of the specific problem presented. A simple example should suffice to point out the difference among the methods of integration.

Suppose we wish to cover the disease of measles. The first method would simply present the characteristics of the disease, its diagnosis, prevention, and treatment. Actual cases could be presented to demonstrate the rash in its various stages. Following the presentation, the computer could be used to present a series of questions to assess the level of knowledge obtained. Repeated

viewing of the lesson could be recommended if necessary.

The second method first might present the clinical manifestations of the disease, allow assessment, then recommend reviewing the section or continue on to diagnosis. Again the program could assess the knowledge obtained and proceed through treatment and prevention, ending up with a final assessment.

In the third mode, if a student was unclear as to the exact clinical picture associated with the disease, following presentation of diagnosis, for example, he could request alternate presentations such as smaller units of diagnosis or more case presentations. These could be delivered as follow-ups to the regular presentation.

The fourth level of integration would be similar to the third except for the addition of random sequence capabilities. While the third alternative required any follow-up to be after a presentation, the fourth level allows any sequence to be requested and obtained randomly. This offers the obvious advantage of flexibility in learning.

The final mode might involve initial presentation of a patient with minimal clinical symptoms. Additional information could then be requested in order to select the most likely diagnosis. This obviously would have its application in the presentation not of a single disease state, but rather in the practice of differential diagnoses. Following final diagnosis (or as an adjunct to it), the symptomatology used to diagnose the original case could be presented. This method of presentation allows each user to have complete access to his own personal instructor.

While these examples might seem to indicate that the obvious advantages lie with the last two methods, this is not necessarily the case. It is true that these two do allow the maximum interaction of user, computer, and videodisc. On the

other hand, the first three methods could be adapted to the inexpensive videodisc players or even videotape recorders. Because their applications allow only sequential retrieval of information, they could also be used as developmental protocols for the more expensive videodisc players.

When should video-based instruction be used? Potentially almost any topic could lend itself to video enhancement. In particular, however, those areas are best suited that contain a strong visual image to the subject being presented. This is especially true in light of the process involved in production of a video-enhanced module. If one simply uses a video tape recorder, problems are minimized in that recordings can be redone until acceptable. All of the problems associated with making any video-based product are present. For example, if one is filming a chemical reaction in which temperature is critical, the heat generated from lighting necessary for filming

may accelerate the reaction to dangerous levels. In this case, cooling may be needed, whereas under normal laboratory conditions this would not be required. Filming of live objects may require many retakes in order to obtain the correct sequence of events.

When working with videodisc, the problems can be even more difficult. This arises from the fact that once the final tape is submitted for mastering, any mistakes discovered later are extremely costly. For example, if one has placed a sequence of frames at a particular location to be accessed for remedial action and inadvertently included material at a higher level, then the desired remediation would be lost.

One final problem that must be mentioned is the necessary interfacing between the computer, video player, and monitor. In most instances one requires two monitors: one for the video-generated signals and another for the computer-generated

information. Systems that allow one to overlay text- and video-generated images are now appearing on the market, but these usually cost more.

A great advantage to using video-generated images is the familiarity with, and almost magical acceptance of, television by the young. The transition from requisite TV watching to viewing a TV monitor for information is one made easily by most people.

In summary, while computer graphics may be increasing in resolution and sophistication, nothing can replace the actual thing as well as a video-generated picture. Inclusion of video-generated material in CAI modules can lead to a more effective and impressive presentation of information. Caution must be exercised, however, in the preparation of these modules to guarantee the proper sequencing of frames and inclusion of appropriate material.

INSTRUCTIONAL DESIGN ISSUES AND THE EFFECTIVE USE OF GRAPHICS IN COMPUTER-ASSISTED INSTRUCTION

Lynn D. Churchill

The Center for Instructional Development and Research, University of Washington, Seattle, Washington

The topic of using graphics in computer-assisted instruction (CAI) has received attention since the initial CAI projects of the 1960s and early 1970s. However, with the tremendous advancements in microcomputer technology and video technology over the last decade, effective use of graphics in CAI has become an increasingly important issue for educators to address. The critical questions concern the purpose and presentation of the graphics rather than whether or not one can create

related graphics. Questions of when graphics should be included and how graphics should be presented are best answered by considering aspects of general curriculum design and instructional design.

The purpose of this paper will be to discuss briefly some of the important design issues related to the effective use of graphics in CAI. These issues will be addressed from both curriculum design and instructional design perspectives. Curriculum design impacts the use of

graphics by designating the scope and sequence of the content in a specific CAI program. If that content is highly visual in nature, it is imperative that the students be involved with activities involving visual representations of the concept. On the other hand, graphics may be used from an instructional design perspective, because they assist in understanding the concept and not because they are necessary. For example, an advanced organizer for a particular lesson may include a simple flowchart of what was going to happen during various parts of a lesson. In this case, a simple graphic image will suffice. In many instances it is more important to have a simple diagram to illustrate a concept than a vivid real-life image from a videodisc player.

CURRICULUM DESIGN CONSIDERATIONS

From a curriculum standpoint, development of any CAI program is

related to the learning objectives the intended audience is to master and the prerequisite skills and knowledge the intended audience is expected to have prior to using the CAI. The latter is a critical component, as it provides a starting point. Designers should delineate the most important prerequisite skills. The end objective should be task-analyzed to determine the possible sequences of content that might lead to the final objective. This task analysis is usually done by working backwards from the intended goal to the place of entry level skills and knowledge. If recognition of various visual content is an objective, then it would be appropriate to look at the sequences of related graphics-based content that will lead the learner to mastery of that objective.

Curriculum design will impact the selection of the graphic images to be used in the CAI. For example, a CAI program on diagnoses that are heavily dependent on visual recognition of patient symptoms will require some sequence of graphic images that assist the learner in identifying and categorizing the symptoms appropriately. An obvious rule of thumb is that all graphics included in any lesson should be directly related to the content of the lesson at that moment. The purpose of the lesson should select the potential graphics that may be included; not the other way around.

The graphics identified as being related to the scope and sequence of the content will also have implications for the type of media needed to portray the selected graphics effectively. For instance, a delicate medical procedure may require a high-quality video reproduction of the actual procedure, whereas computer-generated graphics may suffice for the production of a flowchart. The use of interactive videodisc images and video sequences may be the only means to provide instruction in certain subjects efficiently and effectively via CAI. Hence, the

nature of the graphic image and the related media necessary to present it will depend on the particular objective being addressed in that lesson and on the appropriateness of including graphics to enhance the presentation of an idea or concept.

INSTRUCTIONAL DESIGN CONSIDERATIONS

Instructional design considerations also may influence the way that graphics are incorporated into CAI packages. In this case it isn't so much *what* is being taught as it is *how* it is being taught. There is no substitute for good instructional pedagogy, and the design of CAI demands that aspects of instructional design be considered. From an instructional design standpoint, the characteristics of most learners that have implications for how the content is presented are of principal concern. Many of these implications are related to the presentation of graphics and what they may do to contribute to learning. Other issues such as the type of questioning, the frequency of interaction, kinds of structured feedback, and branching also are instructional design issues that are not necessarily related to effective presentation of graphics in CAI. Some issues that are important and graphics related include the interplay of graphics and text; the effective placement of the graphics on the display; the selection of the appropriate graphics image; the use of color; and the use of motion or animation.

Although there are other issues we might address, these issues arise frequently in discussions regarding effective use of graphics in CAI.

THE INTERPLAY OF GRAPHICS AND TEXT

The combined use of graphics and text usually will be such that the graphics image is an enhancement of the text explanation. This implies that the graphics should not compete with the text for the student's attention. The addition of graphics

in this instance is an enhancement to the textual information. This usually implies the use of simple graphics that only illuminate the essential aspects of the concept being dealt with in the text. In this case, presentation of the graphics may actually be delayed to ensure that the student has read the related text first. It may be, however, that the text is a further explanation of a particular graphics image and that an explanation follows pointing to a particular part of a graphics image. In this case, the text enhances understanding the graphics image and should pertain only to that portion of the graphics image selected by the student. Regardless of the major emphasis of text or graphics, it is imperative that there be a consistent and narrowly defined relationship between the content of the text and the content of the graphics. The level of distraction from the primary objective by combined use of text and graphics should be kept to an absolute minimum.

EFFECTIVE PLACEMENT OF GRAPHICS

Effective placement of graphics on the screen depends on whether the emphasis is on the graphics image or on the text. In any case, it is important to realize that most students in Western civilization will track with their eyes from the top left side of the screen to the lower right side of the screen. Ideally, functional areas of the screen display will be established such that students are comfortable with finding frame headings, prompts, and instructions in the same areas of the display at all times. If the primary emphasis is on the graphics, then they should appear towards the top or to the left side of the display. The text will then appear to the right or at the bottom of the display. In this case, the text is enhancing understanding of the graphics image and not competing with it. On the other hand, if the graphics are being used

to enhance the understanding of the text, the text should appear on the left side of the display and the graphics on the right. These are not hard and fast rules, but they do reinforce the idea that placement of graphics should be considered in CAI design. Most modern authoring languages and authoring systems now include "windowing" capabilities to make it easy for a developer to experiment with placement of graphics and text.

SELECTION OF APPROPRIATE GRAPHICS

Selection of the appropriate graphics image is important, too. Again, depending on the purpose of the lesson and the role the graphic is playing, the type selected will follow. For example, a computer-generated diagram may be preferred in some situations because the amount of information displayed can be controlled to limit the amount of competing information to the learner. That is, it may be more important to have a clear graphics image of the essence of the structure of the spleen than to have a real video image from an operation where there may be considerable information that could distract the student from the main purpose of the lesson. On the other hand, there may be situations where real-life video images from interactive videodisc are the best option. This may happen in simulations requiring students to make decisions about patients based on information they have gathered through testing and observation. In any case, the selection of graphics is based on whether or not any particular graphics image will enhance the learning experience of the student and is appropriate for the situation. It is not a question of whether to use videodisc images or computer-generated graphics images but rather a question of the most appropriate use of graphics to enhance learning.

THE USE OF COLOR

Probably one of the most misused

properties of graphics is that of color. The use of color should enhance the information transferred by the graphics. It should not compete with the intended message to the learner. Color should be used to assist in discriminating between contents in the graphics image. Too much color, intended to make something pretty, may actually distract the student. One should try to limit the use of color to no more than four or five colors at any one time. One should also be aware of those color combinations that are difficult for a learner to watch for any extended period of time. These include green and red, red and black, green and magenta, and brown and any other color.

Certain colors, such as red, are such powerful "flags" for students that they should be used sparingly. Bright colors can be used to draw attention to specific parts of graphics or text, but they should be used on a limited basis to ensure maximum impact within any given lesson. Flashing or altering a display color back and forth should be avoided, except in very important and limited circumstances. Flashing may be considered an intrusion into most learning environments, as it will divert virtually any student's attention.

The requirement for clear and accurate display of color may also dictate the kind of graphics image and media selected. For instance, the study of hematology may be greatly influenced by the need for such images, thereby influencing the designer to use interactive videodisc.

USE OF MOTION AND ANIMATION

Any aspect of motion or animation on the screen is a powerful flag to the learner and should be used sparingly. It has the same effect as flashing, in that the majority of the student's attention will be directed to the movement on the screen. The design of the CAI lesson should be

considered whenever animation is being used. All situations involving motion or animation should be selected purposefully to enhance a particular segment of the lesson. This enhancement can be used to assist the student in drawing attention to a specific aspect of the screen display, understanding the essence of a concept through observation of specific motion (such as blood flow through an organ), or understanding a process over an extended or shortened time period (as in simulations of processes that happen either too slowly or too quickly to observe).

CONCLUSION

In conclusion, it is imperative that we not take a bandwagon approach to using various forms of graphics in instruction. The issue is not simply that one graphics approach is better or on a higher level than another. What is important is that we consider using a specific form of graphics only when it enhances our students' understanding. We need to constantly remind ourselves where instructional design fits into development of computer-assisted instruction.

Additional information on instructional design and the use of graphics can be found in the following references:

- Alesandrini K: Business graphics for information management. Englewood Cliffs, NJ: Prentice-Hall, in press.
- Burke RL: The CAI sourcebook. Englewood Cliffs, NJ: Prentice-Hall, 1982.
- Heines JM: Screen design strategies for computer-assisted instruction. Bedford, MA: Digital Press, 1984.
- Hudson K: Introducing CAI: a practical guide to writing computer-assisted learning programs. New York, NY: Chapman and Hill, 1984.
- Walker DF, Hess RD: Instructional software: principles and perspectives for design and use. Belmont, CA: Wadsworth Publishing Co, 1984.

KEEPING ABREAST OF THE LITERATURE

The following citations are presented as part of a quarterly feature in CLSE designed to help readers become aware of current literature pertinent to computer applications in life science education.

- Abdulla AM et al: The use of natural language entry and laser videodisk technology in CAI. *J Med Educ* 59:739-745, 1984.
- Aronberg DJ et al: Computer-assisted instruction in radiology. *Radiology* 154:345-348, 1985.
- Balson PM et al: Instructor-controlled versus student-controlled training in a videodisc-based paramedical program. *J Educ Technol Syst* 13:123-130, 1984-1985.
- Beam KB et al: Presenting case studies on a microcomputer. *Med Lab Observer* 16(5):83-86, 88, 90, 1984.
- Beam KB et al: The electronic canvas: teaching with computer graphics. *Med Lab Observer* 16(8):90-93, 1984.
- Bove R: Visual magic. *Training and Development Journal* 38(7):42-47, 1984.
- Boyer AL et al: Computer assisted instruction for radiotherapy residents. *Int J Radiat Oncol Biol Phys* 10:2345-2350, 1984.
- Brenner LP et al: Computers in health science education: communication and management. *J Educ Technol Syst* 13:97-106, 1984-1985.
- Burkhalter A: Teaching toxicology. use of computerized case histories. *Proc West Pharmacol Soc* 27:277-279, 1984.
- Fishman DJ: Development and evaluation of a computer assisted video module for teaching cancer chemotherapy to nurses. *Comput Nurs* 2(2):16-23, 1984.
- Friedman RB: The impact of technology on medical education. *J Educ Technol Syst* 13:137-141, 1984-1985.
- Fukushima M et al: Computer-assisted education system for arrhythmia (CAESAR). *Comput Biomed Res* 17:376-388, 1984.
- Gayeski DM: Interactive video: integrating design "levels" and hardware "levels". *J Educ Technol Syst* 13:145-152, 1984-1985.
- Greer M: A trainer's guide to software documentation. *Performance and Instruction* 23(3):6-7, 1984.
- Grobe SJ: Computer assisted instruction: an alternative. *Comput Nurs* 2:92-97, 1984.
- Grobe SJ: Nursing education module authoring system—NFEMAS. *J Educ Technol Syst* 13:83-89, 1984-1985.
- Holzemer WL et al: Development of a computer resources facility. *Nurs Health Care* 5:545-547, 1984.
- Horton JA: Press the space bar to learn about nematodes... learning by microcomputer. *Med Lab Observer* 16(10):93-4, 96, 98, 1984.
- Hudgings C et al: Software evaluation for nursing educators: a proposed tool. *Comput Nurs* 2(2):35-37, 1984.
- Kadner KD: Change: introducing computer-assisted instruction (CAI) to a college of nursing faculty. *J Nurs Educ* 23:349-350, 1984.
- Manning T: Computer assisted instruction: the right stuff, but does it work and should you buy it? *Comput Nurs* 2:214, 223, 1984.
- McColgan JJ Jr: A computer program to test drug dosage calculation abilities. *Nurs Health Care* 5:551-558, 1984.
- Mikau KJ: Computer integration: a challenge for nursing education. *Nurs Outlook* 32: 6, 1984.
- Molek R et al: How to evaluate computer software. *Instructional Innovator* 29(4):51-53, 1984.
- Murphy MA: Computer based education in nursing: factors influencing its utilization. *Comput Nurs* 2:218-223, 1984.
- Murphy PJ: A CAI-based distance education project in evolution: 1. Description of the project. *J Biol Educ* 18:37-44, 1984.
- Norman SE: Computers in nurse education— a personal perspective. *Nurse Educ Today* 3:108-110, 1984.
- Pomeroy EM: Videodiscs and medical education. *J Educ Technol Syst* 13:115-122, 1984-1985.
- Schwartz MD: An introduction to interactive video systems. *Comput Nurs* 2(2):8-15, 1984.
- Shaw-Nickerson E et al: Computer based simulations in evaluating registered nurse students in a baccalaureate program. *J Educ Technol Syst* 13:107-113, 1984-1985.
- Smith PL et al: Instructional design considerations in the development of computer-assisted instruction. *Educ Tech* 24(7):5-11, 1984.
- Spain JD: Computer center: it's time to take inventory. *Am Biol Teach* 46:347-349, 1984.
- Spain JD: Computer center: BASIC string models of genetic information transfer. *Am Biol Teach* 46:411-414, 1984.

Compiled by H. Modell

SUBSCRIPTION INFORMATION

Computers in Life Science Education is published monthly by Elsevier Science Publishing Co., Inc., 52 Vanderbilt Avenue, New York, NY 10017. Subscription rate is \$58.00 for 12 issues, including postage and handling in the United States and Canada. Add \$20.00 for postage (airmail) in Mexico and Europe and \$23.00 for the rest of the world.

This newsletter has been registered with the Copyright Clearance Center, Inc. Consent is given for copying of articles for personal or internal use, or for the personal or internal use of specific clients. This consent is given on the condition that the copier pay through the Center the per-copy fee stated in the code on the first page for copying beyond that permitted by the US Copyright Law. If no code appears on an article, the author has not given broad consent to copy and permission to copy must be obtained directly from the author. This consent does not extend to other kinds of copying such as for general distribution, resale, advertising and promotional purposes, or for creating new collective works.

Address orders, changes of address, and claims for missing issues to Journals Fulfillment Department, Elsevier Science Publishing Co., Inc., 52 Vanderbilt Avenue, New York, NY 10017. Claims for missing issues can be honored only up to three months for domestic addresses and six months for foreign addresses. Duplicate copies will not be sent to replace ones undelivered due to failure to notify Elsevier of change of address.

Address editorial correspondence to Harold I. Modell, PhD, Virginia Mason Research Center, 1000 Seneca Street, Seattle, WA 98101.

POSTMASTER: Send address changes to *Computers in Life Science Education*, Elsevier Science Publishing Co., Inc., 52 Vanderbilt Avenue, New York, NY 10017.

COMPUTERS IN LIFE SCIENCE EDUCATION

HAROLD I. MODELL
Virginia Mason Research Center
Seattle, Washington

MARCEL BLANCHER
Professor of Biochemistry
Faculty of Medicine
University of Manitoba
Winnipeg, Manitoba
Canada

THEODORE J. CROVELLO
Department of Biology
University of Notre Dame
Notre Dame, Indiana

JAMES W. ECKBLAD
Department of Biology
Luther College
Decorah, Iowa

TSEGAYE HABTEMARIAM
School of Veterinary Medicine
Tuakogee Institute
Tuakogee, Alabama

DONNA LARSON
School of Nursing
Grand Valley State College
Allendale, Michigan

TERRY M. MIKITTEN
Graduate School of Biomedical Sciences
University of Texas Health Sciences Center
San Antonio, Texas

JAMES E. RANDALL
Department of Physiology
Indiana University
Bloomington, Indiana

PATRICIA SCHWIRIAN
College of Nursing
Ohio State University
Columbus, Ohio

RICHARD STULL
College of Pharmacy
University of Arkansas
Little Rock, Arkansas

JAMES W. WOODS
Lister Hill National Center
for Biomedical Communications
National Library of Medicine
Bethesda, Maryland

DOROTHY WOOLEY-McKAY
Department of Biology
Glendale Community College
Glendale, Arizona

GLENN YOSHIDA
Department of Life Sciences
Los Angeles Southwest College
Los Angeles, California

ELSEVIER

A SURVEY OF MEDICAL / HEALTH SCIENCE INTERACTIVE INSTRUCTIONAL MATERIALS

Beth A. Johnson

The Center for Health Studies, Hospital Corporation of America, Nashville, Tennessee

Locating existing instructional materials that address specific learning objectives is never an easy task. Additional complications arise when these materials are presented via "new" technologies such as computers or videodisc players. Some of the difficulties are as follows:

- few vendors of interactive materials ("courseware") have taken a curriculum approach to instructional development or product packaging;
- there are no standardized hardware configurations for delivery of instruction;
- courseware marketing channels are not yet well-established, making it difficult to locate products available for purchase;
- many products are the result of research grants or have been developed for proprietary use (developers of these products may not have fully examined possibilities for outside marketing).

LOCATING COURSEWARE

A beginning step in addressing these issues was taken by the Medical/Health Sciences Committee of the Division of Instructional Design, Association for Educational Communications and Technology (AECT).

Members of this committee conducted a survey of vendors of medical and health science courseware. This article describes the survey results and future steps to be taken. It is followed by a list of vendors who responded as well as product information.

The survey was intended to

- 1) identify vendors currently distributing these materials; and
- 2) gather information about products available from each vendor.

Detailed hardware configuration information was not included in the survey. Given the current diversity of hardware, hardware selection is best driven by courseware availability. When courseware acquisition is limited to off-the-shelf products, it is necessary to first identify appropriate courseware, then determine the hardware required. We asked vendors to indicate whether their products required mainframe computers, micros, videodisc or tape players, or combinations of these.

RESULTS

Of the 98 organizations tentatively identified as medical courseware vendors, 43 responded. Of these, all but seven are currently involved in marketing medical courseware. Two

of the seven exceptions indicated that they may be marketing materials in the near future.

A total of 675 programs was identified. Approximately 450 of these are part of the PLATO Health Science Network at the University of Illinois College of Medicine; a catalog of these PLATO lessons is available from the College at a cost of \$10. The University of Illinois lessons are not detailed in the list of materials that follows.

The hardware configuration indicated by most vendors was micro-computer only. However, the large number of programs in the University of Illinois' PLATO library made the mainframe-only configuration the most common. Configuration figures *excluding* the PLATO programs are listed below:

Configuration	Total
Mainframe	1
Micro	177
Videodisc	22
Mainframe & Videotape/disc	1
Micro & Videotape/disc	29
Other	0

Vendors were asked to indicate all applicable target audiences for their products. A summary of this information follows:

mation follows:

Audience	Total
Physicians	106
Nurses	183
Hospital Employees	39
Dentists	15
Allied Health	99
Public Health	30
Patients	22
Preventive Medicine	31
Other	52

Specific target audience classifications were not provided by the College of American Pathologists or by the University of Illinois College of Medicine; the above totals do not include programs available from these organizations. "Other" target audiences listed by vendors include paramedics, EMTs, instructors, veterinarians, lab personnel, physiology students, social workers, and psychologists.

NEXT STEPS

In recent months, several professional organizations have established member services on existing telecommunications networks such as GTE Telenet and Compuserve. Two such organizations are AECT and Association for the Development of Computer-Assisted Instructional Systems (ADCIS).

These networks appear to be an excellent means of both maintaining the survey information as a database and making it available to interested parties. Discussions are under way to establish the medical courseware database as a subset of a larger courseware database on ADCIS-Net, in addition to making it available on AECT's system.

This information would be available to anyone subscribing to these telecommunication systems. The database will be vendor-updated, with mechanisms for adding more vendors as they are identified and reminding vendors to update their materials regularly.

This project is driven by the enthusiasm and support of those who might benefit from it. Comments, suggestions, and offers of assistance are welcome. If you would like to be included on a mailing list for information about further developments, please send a written request to Beth Johnson (The Center for Health Studies, Hospital Corporation of America, One Park Plaza, PO Box 550, Nashville, TN 37202).

The author wishes to thank Dr. Craig Locatis, Training Branch, NMAC/National Institutes of Health for his assistance in this project.

Vendor	Software	Equipment				Audience				
		Mainframe	Micro	Video	Other	Medical	Nursing	Allied health	Public health	Other
ACADEMIC HALLMARKS, INC. Box 998 Durango, CO 81301 303-247-8738 Contact: R. W. Sauer	Biology #1 Psychology Health		•			•	•		•	•
ACTRONICS, INC. 810 River Ave. Pittsburgh, PA 15212 412-231-6200 Contact: Lisa Cooper Jensen	Full BLS (Basic Life Support) Dysrhythmia Recognition				•	•	•	•	•	•
ADDISON-WESLEY PUBLISHING COMPANY, INC. Medical/Nursing Division 2725 Sand Hill Road Menlo Park, CA 94025 415-854-0300 Contact: Elaine Henderson	Gas man		•			•	•			

Vendor	Software	Equipment				Audience				
		Mainframe	Micro	Video	Other	Medical	Nursing	Allied health	Public health	Other
ALBERTA EDUCATIONAL COMMUNICATIONS CORP. Instructional Technology Unit 16930 114 Ave. Edmonton, Alberta T5M 3S2 403-452-7272 Contact: Linda Harmon	Urinary Catheterization			●		●	●	●		
ANDENT, INC. 1000 N. Ave. Waukegan, IL 60085 312-223-5077 Contact: S. Nye	Education Disk Encephalon Professional Disk Fit and Trim Re:ponse Time		● ● ● ● ●			● ● ● ● ●	● ● ● ● ●	● ● ● ● ●		● ● ● ● ●
C.M.E., INC. P.O. Box 85655 Seattle, WA 98145 206-524-0298 Contact: Steve Gould	Lower Abdominal Pain in a Young Girl Fatigue and Fever in a 38 Year Old Man Dysuria in a Young Woman A Case of Acute Bloody Diarrhea Respiratory Infection/ 62 Year Old Woman High Fever in a 7 Month Old Child Abdominal Cramping at 29 Weeks Gestation A Cardio-Pulmonary Life Support Simulation Recurrent Otitis Media in 17 Month Old Child A Painful Foot in a 42 Year Old Male Diarrhea and Vomiting in an Infant Chest Pain in a 30 Year Old Man		● ● ● ● ● ● ● ● ● ● ● ● ● ● ●			● ● ● ● ● ● ● ● ● ● ● ● ● ● ●	● ● ● ● ● ● ● ● ● ● ● ● ● ● ●			
COLLEGE OF AMERICAN PATHOLOGISTS Software Exchange Library 7400 Skokie Blvd. Skokie, IL 60077 312-677-3500	Microcomputer Software Exchange Program Computer Assisted Workload Recording Program SNOMED Software TDM (Therapeutic Drug Monitoring) GAS Today		● ● ● ● ● ●							
COMPRESS, DIVISION OF WADSWORTH, INC. P.O. Box 102 Wentworth, NH 03282 603-764-5831 Contact: Thomas L. Sears	Organic Chemistry 1-8 Introduction to General Chemistry 1-9 Molecule Animator CODON Organic Qualitative Analysis Nucleic Acid Connection		● ● ● ● ● ●			● ● ● ● ● ●				● ● ● ● ● ●
COMMAND APPLIED TECHNOLOGY, INC. P.O. Box 511 West 400 Main St. Pullman, WA 99163 509-334-6145 Contact: Dr. Dave Barbee	Isolated Heart Laboratory		●			●	●	●		●

Vendor	Software	Equipment				Audience				
		Mainframe	Micro	Video	Other	Medical	Nursing	Allied health	Public health	Other
CONCEPTS UNLIMITED 692 S. 450 E. Orem, UT 84058 801-225-6126 Contact: Sandra Magnum	Post-op Care Simulation Mr. Jay (Exercise in Charting) Mr. Foley (Exercise in Charting)		• • •				• • •			
DACIS SOFTWARE 250 S. 3rd St. Philadelphia, PA 19106 215-596-9444 Contact: William Schwartz	CAMPS Interactive Lessons PIIOT CASI Treatment Simulations		• • •			• • •	• • •			•
DU PONT HEALTHCARE LEARNING SYSTEMS Biomedical Products/P24-1234 Wilmington, DE 19898 302-992-4166 Contact: Thomas M. Jenkins	Cardiac Dysrhythmias Arterial Blood Gases Simulation of CO2 Respiration Drug Administration Ready Reference Cardiac Tamponade Case Study				• • • • • •	• • • • • •				
EDUCATIONAL SOFTWARE, INC. 9071 Metcalf #302 Overland Park, KS 66212 913-888-7030 Contact: Edith M. Hamilton	Care of Pediatric Client with Head Injury Care of the Patient with Diabetes Mellitus Medical Terminology Competency Tests Dosage Calculation Proficiency Test		• • • •				• • • •	• •	• •	
HESHI COMPUTING P.O. Drawer M Hitchcock, TX 77563 409-986-5775 Contact: Helen Ptak	Infection Control Healthy Living Health-Illness Continuum Food & Nutrition Test Construction		• • • • •				• • • • •	• • • • •	• • • • •	• • • • •
HEALTH EDUTECH, INC. One Paramount Plaza 7801 Bush Lake Rd., Suite 135 Minneapolis, MN 55435 612-831-0445 Contact: Rosemary Murphy-Nelson	Minnesota Right to Know for Health Care Hospital Orientation				• •		• •	• •		• •
HEALTH SCIENCES CONSORTIUM 103 Laurel Ave. Carrboro, NC 27510 919-942-8731 Contact: Chris Herndl	Pediatric Pulmonary Problems Pediatric Cardiac Problems Adult Problems in Dyspnea Common Family Practice Problems		• • • •							• • • •
J.B. LIPPINCOTT CO. E. Washington Square Philadelphia, PA 19105 215-238-4440 Contact: Jeanne A. Hallahan	Nursing Skills Simulations Calculate with Care Introduction to Nursing Diagnosis NEMAS (Nursing Ed Module Authoring System)		• • • •				• • • •			

Vendor	Software	Equipment				Audience				
		Mainframe	Micro	Video	Other	Medical	Nursing	Allied health	Public health	Other
MEDICAL SOFTWARE CONSORTIUM 401 Oakwood Enterprise, AL 36330 205-347-2525 Contact: Braxton H. DeGarmo	Blood Gas Consultant		•			•	•			•
	Radiography Consultant		•			•	•	•		•
	Drug Master		•			•	•	•		•
	"Consumer" Drug Watcher		•			•	•	•		•
	Procedure Registry		•			•	•	•		•
MEDICUS INTERCON INTERNATIONAL 909 3rd Ave. New York, NY 10022 212-826-0760 Contact: Kathy Emmans	Urinary Tract Infections: Prev & Control			•	•	•	•			•
	Methods to Investigate Hosp. Epidemics			•		•	•	•		•
	Potential Uses of Calcium Channel Blockers			•	•	•	•			
	The Hidden Language of Arthritis			•		•	•			
MEDI-SIM P.O. Box 13267 660 S. 4th St. Edwardsville, KS 66113 913-441-2881 Contact: Susan Matney	Shock		•				•	•		
	The Nursing Process		•				•	•		
	Pediatric C-V Surgical Patient		•				•	•		
	Patient with Myocardial Infarction		•				•	•		
	Developmental Concepts		•				•	•		
	Nutrition Assessment of Pregnant Woman		•				•	•		
	Asepsis		•				•	•		
	Computer Literacy for Nurses		•				•	•		
	Neurological Nursing: The Assessment		•				•	•		
	Admission of Full Term Infant to Nursery		•				•	•		
	Client with Cirrhosis of the Liver		•				•	•		
	Drug Dosage Calculations & Administration		•				•	•		
	Communicable Diseases in Children		•				•	•		
	Dietary Intervention/ Control of Hypertension		•				•	•		
	Ventilator Weaning		•				•	•		
	Pediatric Asthmatic COPD		•				•	•		
	CPR		•				•	•		
	Burn Patient		•				•	•		
	Myasthenia Gravis		•				•	•		
	Drug Overdose		•				•	•		
	Premature Neonate		•				•	•		
	Chest Trauma		•				•	•		
	Post-operative Pneumonia		•				•	•		
	Status Asthmaticus		•				•	•		
Croup		•				•	•			
Cystic Fibrosis		•				•	•			
Automobile Accident		•				•	•			
Near Drowning		•				•	•			
Aspiration Pneumonitis		•				•	•			

Vendor	Software	Equipment				Audience				
		Mainframe	Micro	Video	Other	Medical	Nursing	Allied health	Public health	Other
	Pulmonary Embolism Pulmonary Function Testing Pulmonary Edema ARDS Head Trauma Acute Epiglottitis Flail Chest Ventilator Management Ventilator Commitment Meconium Aspiration Oxygen Therapy Blood Gas Interpretations Aerosol Therapy Humidity Respiratory Anatomy Chest Physiotherapy Pharmacology Pulmonary Function Assessment of the Thorax I Chest Trauma Assessment		●				●	●		
MEPC SOFTWARE Medical Exam. Publishing Co. 3003 New Hyde Park Rd. New Hyde Park, NY 10042 516-328-6200 Contact: Maizie Jaffe	Medical-Surgical Nursing Simulations Maternity Nursing Simulations Psychiatric Nursing Simulations Pediatric Nursing Simulations		●				●			
MILES PHARMACEUTICALS 400 Morgan Ln. West Haven, CT 06516 203-934-9221 Contact: William Isbell	Intro. to The Miles Learning Ctr Ileocolic Resection for Recurrent Chron's Emergency Appendectomy/ Acute Appendicitis Trauma Training Materials -I Trauma Training Materials -II Profile of MEZLIN Medical Applications Videodisc: Hematology Bacteremia: Diagnosis & Prevention Preventing & Managing Infection Surgical Infections: Assessment of Risk Surgical Wound Infections: Data Collection, Feedback			●		●	●			
HAROLD MODEL Virginia Mason Research Center 1000 Seneca St. Seattle, WA 98101 206-223-6388	Simulations in Respiratory Physiology	●	●			●	●	●		

Vendor	Software	Equipment				Audience				
		Mainframe	Micro	Video	Other	Medical	Nursing	Allied health	Public health	Other
N-SQUARED COMPUTING 5318 Forest Ridge Road Silverton, OR 97381 503-873-5906 Contact: Laurie North	Internist		•			•	•	•	•	•
	Nutritionist Nutritionist II Physician's Data Base Manager		• • • •			• • • •	• • • •	• • • •	• • • •	• • • •
PROGRAMMING TECHNOLOGY CORP. 7 San Marcos Place San Rafael, CA 94901 415-485-5601 Contact: Craig Pagelow	Healthaide		•			•	•	•	•	•
	Healthaide Analysis		•			•	•	•	•	•
PSYCHOLOGICAL PSOFTWARE CORPORATION 4757 Sun Valley Road Del Mar, CA 92014 619-481-4182 Contact: Dr. Patrick Nidorf	Personalty Profile		•			•				•
	Stress Management		•			•				•
	Assertiveness Training		•			•				•
	Never Fat Again		•			•				•
	The Dream Machine		•			•				•
	Intimacy, the Art of Communication		•			•				•
	The Puppet		•							•
	On Becoming a Hero		•							•
	Will Somebody Please Love This Cat		•							•
JAMES RANDALL 609 South Jordan Ave. Bloomington, IN 47401 812-335-1574	Human—A Comprehensive Physiological Model		•			•	•	•		•
	Basic Electrophysiology		•			•	•	•		•
	Basic Cardiovascular		•			•	•	•		•
	Pharmacokinetics		•			•	•	•		•
T.J. DESIGNS 5905 Ironwood Rancho Palos Verdes, CA 90274 213-598-1423 Contact: Jane Timpke	Calculation of Drug Dosages		•				•	•		•
	CPR Certification Test		•			•	•	•	•	•
	CPR Recertification Test		•			•	•	•	•	•
UNIVERSITY OF ILLINOIS College of Medicine, Urbana-Champaign Medical Computing Lab 1408 West University Avenue Urbana, IL 61801 217-333-2284 Contact: Sherry Walker-Linares	Catalog of approximately 450 medical lessons in PLATO Health Sciences Network is available for \$10									
UNIVERSITY OF MINNESOTA MEDIA Box 742 Mayo Building 420 Delaware St. S.E. Minneapolis, MN 55455 612-376-8340 Contact: Susan Newman	Health Risk Appraisal		•			•	•		•	•
	Ketosa (Diabetic Ketoacidosis)		•				•			
	Sugar (Hyperglycemia and Hypoglycemia)		•				•			
	Chest Suction		•				•			
	Nasogastric Suction		•				•			
	I.V.-I		•				•			
	I.V.-II		•				•			

Vendor	Software	Equipment				Audience				
		Mainframe	Micro	Video	Other	Medical	Nursing	Allied health	Public health	Other
UNIVERSITY OF MISSOURI/ KC SCHOOL OF MEDICINE UMKC Software 2411 Holmes Kansas City, MO 64108 816-474-4100 Contact: Lee Willoughby	Basic Sciences Clinical Sciences Alcohol Abuse & Alcoholism Biostatistics & Epidemiology Family Medicine Study Practices Inventory Hypertension Diabetes Mellitus Cardiovascular Disease		• • • • • • • • •			• • • • • • • • •	•	•		• • • • • • • • •
UNIVERSITY OF WEST FLORIDA Office for Interactive Technology & Training Pensacola, FL 32514 904-474-2377 Contact: Patricia Lynett	Court Testimony & Documentation of Child Abuse & Neglect				•	•	•			•
UNIVERSITY PARK PRESS 300 N. Charles St. Baltimore, MD 21201 301-547-0700 Contact: Vince Spittal	Trauma Care Evaluation Emergency Dept. Trauma Care Evaluation: Intensive Care Unit Trauma Patient Assessment					•	•	•		• • •
WILLIAMS AND WILKINS/ WAVERLY PRESS 428 E. Preston St. Baltimore, MD 21202 301-528-4096 Contact: L. Ellison	Assessment: Neuromotor Dysfunction in Infants CPR by Computer		•		•	•	•	•		• •
WINTHROP-BREON LABORATORIES 90 Park Ave. New York, NY 10016 212-907-2720 Contact: Paul J. Drake	Critical Care Management of the Failing Heart Understanding Contrast Media: Nonionic Agents Endometriosis & Fibrocystic Breast				• • • •	• • • •	• • • •			

SUBSCRIPTION INFORMATION

Computers in Life Science Education is published monthly by Elsevier Science Publishing Co., Inc., 52 Vanderbilt Avenue, New York, NY 10017. Subscription rate is \$58.00 for 12 issues, including postage and handling in the United States and Canada. Add \$20.00 for postage (airmail) in Mexico and Europe and \$23.00 for the rest of the world.

This newsletter has been registered with the Copyright Clearance Center, Inc. Consent is given for copying of articles for personal or internal use, or for the personal or internal use of specific clients. This consent is given on the condition that the copier pay through the Center the per-copy fee stated in the code on the first page for copying beyond that permitted by the US Copyright Law. If no code appears on an article, the author has not given broad consent to copy and permission to copy must be obtained directly from the author. This consent does not extend to other kinds of copying, such as for general distribution, resale, advertising and promotional purposes, or for creating new collective works.

Address orders, changes of address, and claims for missing issues to Journals Fulfillment Department, Elsevier Science Publishing Co., Inc., 52 Vanderbilt Avenue, New York, NY 10017. Claims for missing issues can be honored only up to three months for domestic addresses and six months for foreign addresses. Duplicate copies will not be sent to replace ones undelivered due to failure to notify Elsevier of change of address.

Address editorial correspondence to Harold I. Modell, PhD, Virginia Mason Research Center, 1000 Seneca Street, Seattle, WA 98101.

POSTMASTER: Send address changes to Computers in Life Science Education, Elsevier Science Publishing Co., Inc., 52 Vanderbilt Avenue, New York, NY 10017.

COMPUTERS IN LIFE SCIENCE EDUCATION

HAROLD I. MODELL
Virginia Mason Research Center
Seattle, Washington

MARCEL BLANCHAER
Professor of Biochemistry
Faculty of Medicine
University of Manitoba
Winnipeg, Manitoba
Canada

THEODORE J. CROVELLO
Department of Biology
University of Notre Dame
Notre Dame, Indiana

JAMES W. ECKBLAD
Department of Biology
Luther College
Decorah, Iowa

TSEGAYE HABTEMARIAM
School of Veterinary Medicine
Tuskegee Institute
Tuskegee, Alabama

DONNA LARSON
School of Nursing
Grand Valley State College
Allendale, Michigan

TERRY M. MIKITEN
Graduate School of Biomedical Sciences
University of Texas Health Sciences Center
San Antonio, Texas

JAMES F. ANDALL
Department of Physiology
Indiana University
Bloomington, Indiana

PATRICIA SCHWIRIAN
College of Nursing
Ohio State University
Columbus, Ohio

RICHARD STULL
College of Pharmacy
University of Arkansas
Little Rock, Arkansas

JAMES W. WOODS
Lister Hill National Center
for Biomedical Communications
National Library of Medicine
Bethesda, Maryland

DOROTHY WOOLEY-McKAY
Department of Biology
Glendale Community College
Glendale, Arizona

GLENN YOSHIDA
Department of Life Sciences
Los Angeles Southwest College
Los Angeles, California

ELSEVIER

CONTENTS

- WHICH ASPECTS OF SOFTWARE ARE COPYRIGHTABLE?** 57
Patrick C. Boyden
- COMPUTER INTERFACING FOR SCIENCE EXPERIMENTS** 59
Carl O. Clark
- FACTORS INFLUENCING THE SUCCESS OF CAI PROGRAMS** 61
M.E. Jones, J.W. Mann, and M. Aucone

WHICH ASPECTS OF SOFTWARE ARE COPYRIGHTABLE?

Patrick C. Boyden
Kent State University, Kent, Ohio

The copyright law of 1976⁶ is the first full revision of the law since 1909, and several changes affect computer software directly. First of all, computer programs, which are considered to be "literary works" (Sec. 101), are now covered by copyright. Secondly, it is no longer necessary to register a work in order to hold copyright in it. Copyright exists from the moment a work of original authorship is fixed in some tangible form of expression (Sec. 102[a]). And lastly, the traditional concept of "fair use" was written into the law (Sec. 107).

The law is divided into eight chapters, but chapter one, regarding the subject matter and scope of copyright, is the most likely bat-

tleground for basic legal conflicts. All references to "Section" or "Sec." in this article refer to the copyright law of 1976.

Chapter one contains the following information: a) definitions, b) what is copyrightable and what is not, c) what the copyright holder's exclusive rights are, and d) what the user's rights are, ie, the limitations on the exclusive rights.

The definitions are most important to an understanding of the law. Simple terms can be far more inclusive or less inclusive than one would suppose. For example, the term "perform" includes showing a movie or a set of overhead transparencies and can include the running of a computer program. A copy

of a computer program is a "copy," but a copy of a sound recording is a "phonorecord."

Section 102(a) of the law tells us which categories of works are copyrightable. First among the categories is "literary works" which includes computer software. Part (b) of this section adds the following: "In no case does copyright protection for an original work of authorship extend to any idea, procedure, process, system, method of operation, concept, principle, or discovery, regardless of the form in which it is described, explained, illustrated or embodied in such a work."

The items enumerated in part (b) above are not meant to be left without some form of protection however, since other means, such as patent or trade secret, would be a possibility in many cases. Rather, the purpose here is to make a clear distinction between "expression," which is copyrightable, and the items in part (b) which are not. This is stated again in Circular R61,⁷ Copyright Registration for Computer Programs, from the Copyright Office: "Copyright protection extends to the literary or textual expression contained in the computer program. Copyright protection is not available for ideas, program logic, algorithms, systems, methods, concepts, or layouts."

RIGHTS OF AUTHORS

All parts of the law must operate around Section 106. This section states succinctly the five rights enjoyed by the copyright holder. These are exclusive rights according to Section 106 and therefore reserve all uses except those expressly allowed elsewhere in the law. These rights are the following: to copy, to make derivative works, to distribute copies, to perform the work publicly, and to display the work publicly.

This section of the law must always be read in the context of the definitions of Section 101 on the one

hand and the sections limiting the exclusive rights on the other. One very important point in regard to the copyright holder's rights is that these five rights can be sold, leased, etc, separately.

RIGHTS OF USERS

Section 107 begins the series of sections enumerating user rights. Only two of these sections warrant mention here. Section 107, Fair Use, lists four criteria that must be among those criteria considered when deciding what is fair. This section gives little aid in interpreting the criteria, however.

Section 117 is also brief but fairly clear. It says that the owner of a copy of a computer program may make another copy (load the program into the computer) as a necessary step in using the program. This copying is not illegal, nor is it illegal to make an adaptation of a program you own in order to make the program run on your machine. In addition, an archival copy may be made, as in the case of a program on disk that could be easily damaged.

Section 117 notes that if you transfer ownership of your copy of the program, any legitimate copies you made must be transferred also or destroyed. An adaptation must also be destroyed unless you received authorization from the copyright holder to transfer ownership of the adaptation also.

COMPUTER SOFTWARE COPYRIGHTABILITY

After the user rights of Section 117 were secured by the revision of that section in 1980,⁶ there were still problems with owner's rights.

Lawsuits^{1-5,12,16} were brought against companies that were copying certain programs and ROMs (Read Only Memory). The defense offered by those doing the copying was based on several arguments intended to show that the following items are not copyrightable: a) applications programs, b) object code,

c) operating systems, and d) the program in ROM.

All the arguments were rejected. Definitions of "literary work," "copies," "systems," and "computer programs" clearly allow for copyright of all the different kinds of programs and data banks, whether in source code, object code, or even in ROM.

COPYRIGHT REGISTRATION AND ADVANTAGES

Although copyright of original works is now automatic, registration is not. Form TX,¹⁰ which is used by the Copyright Office for all "literary works," is short and straightforward. Registration requires only that one fill out the form and send it in along with \$10 and a copy of the software. The form itself is printed on special paper, and a photocopy will not be acceptable. The copy of the software may be on any paper, including a dot matrix printout on fanfold paper straight from the printer. According to Circular R61, the Copyright Office prefers a source code listing as the deposit copy (for long programs or data banks, the first and last 25 pages may be enough), but other formats can be acceptable.

The registration and deposit of a copy need not be done at the same time. However, if copies of the software are distributed with a copyright notice, a copy of the software must be sent to the Copyright Office within three months (Sec. 407). In this case, if the registration application is sent along, the one copy will serve both as registration copy and as deposit copy.

COPYRIGHT OF MATERIALS CREATED BY THE SOFTWARE

Although materials appearing on the display screen oftentimes exist in the same form in the program's "print" statements, a great deal of the visual materials could also be assembled by the program from data

input by the user or from data stored within a program or file. In the latter cases, the "expression" appearing on the screen would be different from the "expression" appearing in the program listing and would presumably not be covered by the copyright of the program itself. However, according to Williams Electronics v. Artic,¹⁶ if the screen display appears essentially the same each time it is re-created by the program, this expression would be sufficiently "fixed" for it to enjoy copyright in itself and could therefore be registered separately from the program that creates it. Any text created in this manner would be submitted in hardcopy with registration form TX as with the program itself. Graphics would use Form VA, and graphics simulating motion would use form PA. The deposit copy could be on videotape.

REGISTRATION ADVANTAGES

Copyright registration is optional, but it does provide advantages in case of infringement. First of all, an infringement suit can not be brought against someone until the copyright is registered. Secondly, registration before the infringement takes place allows you to sue for attorney's fees and statutory damages even if you can not prove actual losses due to the infringement. A third advantage is that the certificate of registration is considered prima facie proof of the validity of the copyright. Not only does the certificate constitute the proof needed to get an injunction against the infringer, but it also puts the burden of proof on the infringer to show that the copyright is not valid.¹⁶

SUMMARY

Court cases have established the copyrightability of computer programs in all their forms, and at present there appears to be no easier or less expensive means of protecting software than by registering the copyright.

The particular problem of revealing programming secrets by registering the copyright will continue to be a problem as long as the copyright records are public. Other forms of protection such as leasing would be required where the software's value depends on any of the aspects that are not covered by copyright (concepts, etc) as mentioned above.

Lastly, there are lawyers who specialize in copyright matters. For an individual to be sure that he or she is protecting his or her software adequately, legal advice is recommended.

The full text of the copyright law, all the guidelines, and replicas of copyright registration forms can be found in Johnston's *Copyright Handbook*.¹¹

Free registration forms and information circulars can be obtained from the Copyright Office, Information and Publications Section, LM-455, Library of Congress, Washington, DC 20559.

REFERENCES

1. Apple Computer, Inc. v. Formula International, Inc. 562 F. Supp. 775, 1983.
2. Apple Computer, Inc. v. Franklin Computer Corp. 545 F. Supp. 812, 1982.
3. Apple Computer, Inc. v. Franklin Computer Corp. 714 F. 2nd 1240, 1983.
4. Apple loses fight over copyright (UPI). Record-Courier, December 8, 1983, p. 2.
5. Apple wins copyright appeal. Infoworld, June 25, 1984, p. 12.
6. Copyright law amended regarding computer programs. (Announcement from the Copyright Office, Library of Congress). Washington, DC: Copyright Office, 1981.
7. Copyright registration for computer programs. (Circular R61, Copyright Office, Library of Congress). Washington, DC: US Government Printing Office, 1983.
8. Copyrights. US Code, 1976 ed., supp II. vol. 1, 1979.
9. Final regulations, Part 202—Registration of claims to copyright; deposit requirements. (Announcement from the Copyright Office). Washington, DC: Copyright Office, 1978.
10. Form TX (United States Copyright Office). Washington, DC: US Government Printing Office, 1983.
11. Johnston, D.F. Copyright handbook, 2nd ed. New York: R.R. Bowker, 1982.
12. Micro corner. Small Systems World. February, 1984, p. 18.
13. National Commission on New Technological Uses of Copyrighted Works Final Report, July 31, 1978. Springfield, VA: US Department of Commerce, 1978. (NTIS No. PB 284 141).
14. Reproduction of copyrighted works by educators and librarians. (Circular R21, Copyright Office, Library of Congress). Washington, DC: US Government Printing Office, 1978.
15. US Congress House. Copyright Law Revision. Report No. 94-1476, 94th Cong., 2nd sess., 1976.
16. Williams Electronics, Inc. v. Artic International, Inc. 685 F.2nd 870, 1982.

COMPUTER INTERFACING FOR SCIENCE EXPERIMENTS

Carl O. Clark

South Carolina State College, Orangeburg, South Carolina

Many teachers and small research laboratories now have access to microcomputers such as the Commodore PET with its IEEE 488 bus, Apple II, Commodore 64, Atari 800,

or even the Sinclair ZX81. We have, in our laboratory, interfaced a number of experiments in physics, chemistry, and biology to microcomputers. Interfacing allows one to

connect a computer directly to an experiment and log data directly. The ability of a computer to graph the data versus time as the experiment is happening allows students to make the link between a physical phenomenon, the underlying theory, and its graphical representation. An additional advantage is that data in this mode from student experiments are more accurate than data taken manually. While we may want our students to have the experience of taking data and graphing it manually, we find that freeing them from the mechanics of this process allows them to focus on the science involved and perform more experiments in the time available.

Contrary to popular opinion, many of our research instruments are fundamentally similar in that they detect events with some device that produces an analog voltage which can be converted to a digital signal and interfaced with a microcomputer. Two very different approaches can be taken to the computerization of laboratory instruments: a microprocessor can be added to the instrument by the manufacturer and preprogrammed to perform a particular task; or a general purpose microcomputer system with an analog to digital (A/D) interface can be connected to a variety of different instruments. The software packages with such systems must either be very general in order to be adaptable to the multi-use function or be programmed by the user.

Any of the above five microcomputers can be used to command most instruments. Such a microcomputer system consists of a personal computer with its optional equipment as shown in Figure 1 and the hardware interface. For the Commodore PET, many instruments such as the Keithley model 177 digital multimeter have built-in IEEE 488 bus interfaces and can be connected directly to the microcomputer. We have acquired several interfacing devices that allow one to

perform this task for three of the other microcomputers. These include the game port interface (Apple //e and Atari 800) for measuring temperatures and pH and software for performing the following experiments: cooling curve, specific heat of metals, molecular mass of a solid, heat of neutralization, meaning and measurement of pH, standardization of a strong base, standardization of HCl, equivalent and pKa of a solid acid, titrimetric analysis of commercial antacids, acetic content of vinegar, titration analysis of a carbonate, the voltaic cell and standard reduction, titration of halides with silver nitrate, standard potential of the Ag/Ag electrode, potentiometric redox titrations. Data can be analyzed and graphed in a variety of ways and stored on disk.

Some experiments yet to be evaluated include the following in chemistry, physics, and biology: cooling curves, heat of solution and heat of reaction, reaction kinetics, light intensity, kinematics, light-energy equivalence, heart rate, reaction times, flicker fusion, evaporation, and humidity. Also included are eight great experiments in physiology and biofeedback including response time investigations, skin temperature measurements, respiration rate, heart rate, thermoregulation,

lie detector, exercise experiments, and biofeedback.

Using a heart rate sensor that attaches to the earlobe, a variety of experiments designed to explore the effects of variables such as exercise, smoking, coffee, and other stimulants on pulse rate can be performed. A heart rate zone for training purposes can be selected, and the computer will trigger an audio and/or visual alarm if the user is exercising too strenuously or not strenuously enough. A beep with each pulse and a tone proportional to heart rate can also be selected.

If you have the time and skill, you can build your own interface and write your own software. This is not the case for most teachers or small research laboratories. Many manufacturers now supply general purpose hardware and software to solve the interface problem. The following are examples of such interfaces:

- ISAAC data acquisition and control system, Cyborg Corporation; Apple II
- ADALAB data acquisition system, Interactive Microwave Inc.; Apple II
- EXPERIMENT INTERFACE, Cambridge Development Laboratories, Inc.; Apple II, Atari 800, TRS-80

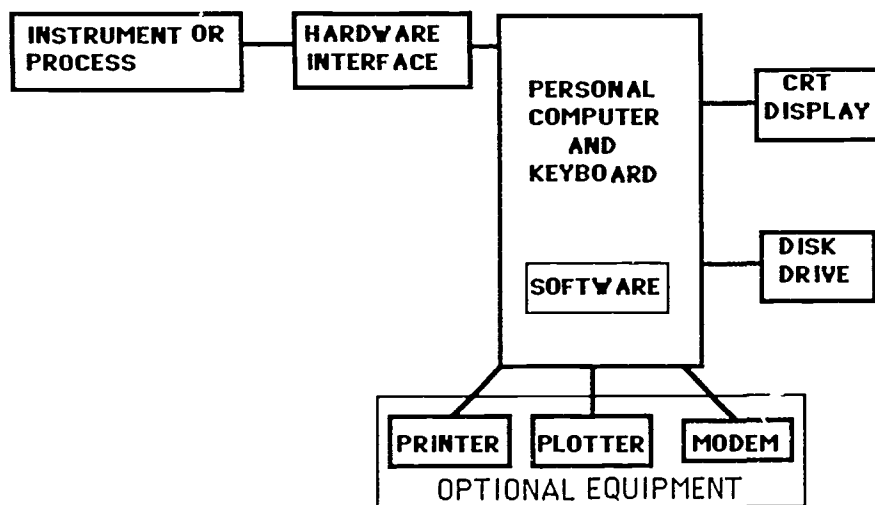

FIGURE 1. Typical interface system.

- **EXPERIMENTS IN CHEMISTRY**, Cambridge Development Laboratories, Inc.; Apple II
- **ACCELERATION**, Cambridge Development Laboratories, Inc.; Apple II
- **SOUND EXPERIMENTS**, Cambridge Development Laboratories, Inc.; Apple II
- **TEMPERATURE LAB**, Cambridge Development Laboratories, Inc.; Apple II, Commodore 64
- **EXPERIMENTS IN SCIENCE**, Cambridge Development Laboratories, Inc.; Apple II
- **EXPERIMENTS IN HUMAN PHYSIOLOGY**, Cambridge Development Laboratories, Inc.; Apple II
- **CARDIOVASCULAR LAB**, Cambridge Development Laboratories, Inc.; Apple II
- **NALANDATA A2 data converter**, Nalan Computer Specialties; Commodore 64
- **ATARILAB STARTER SET**, Cambridge Development Laboratories, Inc.; Atari 800
- **ATARILAB LIGHT MODULE**, Cambridge Development Laboratories, Inc.; Atari 800.

Interfacing the computer to the "real world" can open vast new horizons for computer applications in teaching. The addresses of the hardware vendors listed above and some references dealing with interfacing the computer for laboratory applications are presented below.

Hardware Vendors

CAMBRIDGE DEVELOPMENT LABORATORIES INC.

1696 Massachusetts Avenue
Cambridge, MA 02138

CYBORG CORPORATION

2 North Riverside Plaza
Chicago, IL 60606

INTERACTIVE MICROWARE INC.

P.O. Box 139, Dept. 10
State College, PA 16804-0139

NALAN COMPUTER SPECIALTIES
106 Highland Park Lane
Boone, NC 28607

BIBLIOGRAPHY

- Avery JP. Using microcomputers in the laboratory. *J Chem Inf Comput Sci* 23:1-2, 1983.
- Braithwaite A, Smith B. An analog to digital converter and control interface for microcomputers. *Computer Applications in the Laboratory* 2:190-194, 1984.
- Cobbs AI, Nonidez WK. General purpose program for analog to digital

signal conversion in the chemical laboratory. *Computer Applications in the Laboratory* 2:174-179, 1984.

Kramer R. Diverse applications of general-purpose laboratory workstations. *American Laboratory* 15(9):46-55, 1983.

Liscouski J. Interfacing—connecting experiments and computers: operating systems for data acquisition. *Computer Applications in the Laboratory* 2:80-84, 1984.

Liscouski J. Connecting computer and experiments: getting the signal to the computer. *Computer Applications in the Laboratory* 2:156-160, 1984.

FACTORS INFLUENCING THE SUCCESS OF CAI PROGRAMS

M.E. Jones, J.W. Mann, and M. Aucone

C.A.I. Laboratory, The School of Medicine, The Flinders University of South Australia, Bedford Park, South Australia

There are many ways in which computers are used in the education process. We will not include within the term computer-assisted instruction (CAI) circumstances in which the computer itself is the topic of study (ie, computer science and some aspects of digital electronics), or in which the topic is logically consequent upon the use of computers (ie, much of numerical analysis). The use of computers in life science education is conceptually quite different from these applications in that there is no logical connection between the computer and the life science subject being taught. Whereas the student studying digital electronics or the fast Fourier transform may have no option but to use a computer, the life-science student studying enzyme kinetics will use CAI only if it is a cost-effective way of studying. Good CAI will only be available for students in the life sciences if producing these lessons is an effective way for teaching staff to spend time.

Questions relating to whether CAI "works" in the life sciences or how

best to install and expand it obviously depend on the educational aims that CAI is required to meet. The specification of these aims is not as daunting as might first appear, however; it is, for instance, not necessary to document the overall aims of a four-year nursing course before designing a CAI lesson on identifying cocci and bacilli. It is only necessary to define the objectives of the particular lesson. By way of example, the objectives might be purely factual: to have the student master colony characteristics, morphology, staining, and biochemical tests. Alternatively, the aim might be to give the student an exercise in problem solving: to give the student free access to the criteria for identification and then to have the student identify an "unknown." In the second context memorization of facts might be considered irrelevant. Two CAI lessons might both address the identification of bacteria, but use quite different strategies to achieve their own aims. Each would be a failure when

judged against the aims of the other.

In defining CAI strategies most likely to succeed, it helps to consider five separate variables. Some combinations of these represent strategies that are bound, almost by definition, to fail. Others are clearly likely to succeed. The variables are the type of program, the type of presentation, the subject, the educational aims, and the student population. There is a tendency, when thinking about CAI, to have in mind one particular combination of factors representing the way it is used for some single subject in one's own institution. Even a limited tour of CAI facilities reveals a broad range of contexts in which CAI is used. This confusing array of possibilities often becomes more manageable when viewed as a combination of these five variables.

THE TYPE OF LESSON

CAI lessons are commonly, and conveniently, divided into three broad categories: tutorial, simulation, and multiple-choice question (MCQ). There is no fundamental reason why a lesson could not combine all three of the above, but for historical, philosophical, and programming reasons combinations are uncommon.

Banks of MCQ questions predate the widespread use of CAI. Computers were then seen as a convenient means of giving students practice at MCQs, and the computer's ability to do this without the student receiving a printed copy was seen as an advantage. Experience has shown, however, that any attempt to limit access to MCQs is only partly successful. The end result of any such attempt is usually to divide the student body into two populations, only one of which has managed to obtain a hard copy of the "secret" MCQs.

MCQs are here to stay and are easy to transport on floppy disc and to present on a computer. Optimal strategy for those involved in CAI is

probably to accept the inevitability of MCQs and then to work towards presenting them in a way that makes them more educationally sound. This involves giving the student suitable feedback on each answer; making it clear to the student if he is right, why he is right and if he is wrong, why he is wrong and where he can go to review the material. It may also involve telling the student why the question was sufficiently relevant to warrant asking it. Any MCQ for which these questions cannot be answered should probably be deleted from the lesson.

Once MCQs are provided with adequate feedback they begin to resemble the second type of lesson, the tutorial. MCQs and tutorials are alike in that they deal almost exclusively with alphanumeric text and rarely use significant graphics. The tutorial is less constrained than a sequence of MCQs, but the underlying structure is the same. The computer asks questions of the student. The student answers. The answer determines what the computer will tell or ask the student next. In the tutorial and MCQ formats, it is the computer that asks the questions and the student who gives the answers.

The role is reversed in simulations. There, the student asks the question, and the computer gives the answer. Obviously, in any given lesson there are rigid constraints on the questions that the student may ask. An example is a simulation of enzyme kinetics in which the computer will simulate any incubation the student specifies, within reasonable values. Thus the student specifies pH (2.0-12.0), temperature (15-60°C), initial substrate and enzyme concentration, the concentrations of two inhibitors, and the duration of the incubation. The computer responds by giving the concentration of product at the end of the incubation. Alternatively, the computer might draw a plot of product concentration as a function of

time during the incubation. Because simulations often rely heavily upon graphics, and because graphics routines vary enormously between machines (and even between peripherals attached to the same machine), simulations have been difficult to transport between machines.

Simulations are easy to use in the sense that the student can easily ask a question that the computer can answer. But the student can spend hours looking at a simulation and still come away with no idea of the precise quantitative science upon which the simulation was based.

THE TYPE OF PRESENTATION

The computer screen presents material either as text or as graphics, but the presentation of material during a lesson is not logically constrained to these. Microscope slides, X-rays and clinical photographs are essential adjuncts to some types of lessons. It is best to avoid the temptation to put complex diagrams on the screen. Even worse is the temptation to have the computer control a multiplicity of peripherals (35-mm slides, tape recorders, multicolor monitor). This sort of "bells and whistles" approach to CAI might be appropriate for the young in order to maintain their interest. In tertiary education it adds to time, expense, and maintenance costs while detracting from reliability and is often of little educational value.

The context in which the lesson is used is another significant aspect of presentation. We tend to think of CAI as a facility that students use independently, rather like a library, remote from the academic staff responsible for the overall course. Our experience recently has been that students often respond best when a group of them tackle a problem in the presence of a tutor.

THE TYPE OF SUBJECT

Academics involved in the teaching of a single subject may occasionally lose sight of the enormous difference

in the demands that various subjects make on students. Gross anatomy requires factual recall and three-dimensional visualization; histology is largely pattern recognition; membrane electrophysiology requires a conceptual grasp of the physics underlying the Goldman equation. Clearly the best type of program depends on the type of subject being taught, and some subjects do not currently lend themselves to CAI at all. Much of gross anatomy is best left to the dissection room, but the root values of the nerves of the lumbar plexus can be reviewed as well on MCQs as any other way. On the other hand, the thermal agitation of ions in an electrostatic field can be modeled on a simulation and the student asked to make precise calculations in a 'tutorial' program. MCQs are adequate to assess factual recall; tutorials and simulations are better suited to conceptually difficult material. The precise choice of presentation is often one of the educational philosophy.

EDUCATIONAL AIMS AND PHILOSOPHY

Education means different things to different people. It is sufficient for the present to mention three phrases that call to mind three different educational strategies: rote learning, discovery learning, and problem solving. It is not the purpose here to applaud or condemn these, but it is necessary to have a superficial acquaintance with the concepts if there is to be any meaningful discussion about the relative merits of different CAI strategies.

If you lecture on Ohm's law and present to the class the equation $I = E/R$, requiring them to mem-

orize it, then that is rote learning.

If you give them current sources, voltage sources, and resistors and a multimeter (suitably protected!) and ask for the relationship relating the current through a resistor to the voltage developed across it, that is discovery learning. In both cases the aim is that the student learn Ohm's law. The first method is quicker, but discovery learning may lead to a better understanding or leave them less likely to forget.

Problem solving is like discovery learning, but the emphasis is not so much on the problem to be solved, or on remembering the solution once arrived at, but on developing within the student the undifferentiated ability to solve problems in general. It is generally a very slow process.

Using CAI, simulations can be very useful if the educational aims center on problem solving or discovery learning, but they are less useful for rote learning. For the learning and understanding of concepts where the student is not required to "discover" them himself, tutorial lessons are effective and are easier to write than are simulations.

THE INTENDED AUDIENCE

The final variable is the intended audience. It is an unfortunate fact of life that the multicolored extravaganza that catches the eye and enthusiasm of itinerant deans and finance committees seldom teaches effectively. One almost needs a library of lessons to impress visitors and another to do useful teaching. Clearly the content and presentation must be matched to the knowledge, understanding, and attention span of the audience. Less obvious is the fact that the scope of the lesson

can be adjusted to allow for wide variations in ability within the audience. It is difficult to write tutorial lessons that teach junior classes effectively and still extend to the postgraduate students, unless one writes particular segments with different groups in mind. Simulations, on the other hand can be sufficiently realistic that they can be useful from introductory to postgraduate courses, allowing the poorer students to learn the basics, yet giving the cream of the class something difficult to tackle. By making a simulation sufficiently realistic, we can help all members of a heterogeneous class.

Although CAI has been used successfully in many areas of the life sciences, most CAI facilities contain lessons that are seldom used. The failure of these lessons is often due to the wrong combination of the above factors. A problem posed by an educator wedded to the philosophy of "discovery learning," but teaching a subject composed almost entirely of unrelated facts, will not be met enthusiastically by a student who knows that his final examination will be capable of measuring only the extent of his rote learning. On the other hand, a simulated practical in which the student devises and conducts the experiment may be regarded as successful by the educator who regards education as problem solving and by a student who regards the efficient conduct of the experiment to have been the educational aim. On the other hand, if mastery of the concepts rather than their discovery is the aim, a lecture followed by a CAI tutorial is much quicker and gives rise to a more uniform mastery of the subject.

COMPUTERS IN LIFE SCIENCE EDUCATION

HAROLD I. MODELL
Virginia Mason Research Center
Seattle, Washington

MARCEL BLANCHAER
Professor of Biochemistry
Faculty of Medicine
University of Manitoba
Winnipeg, Manitoba
Canada

THEODORE J. CROVELLO
Department of Biology
University of Notre Dame
Notre Dame, Indiana

JAMES W. ECKBLAD
Department of Biology
Luther College
Decorah, Iowa

TSECCAYE HABTEMARIAM
School of Veterinary Medicine
Tuskegee Institute
Tuskegee, Alabama

DONNA LARSON
School of Nursing
Grand Valley State College
Allendale, Michigan

TERRY M. MIKITTEN
Graduate School of Biomedical Sciences
University of Texas Health Sciences Center
San Antonio, Texas

JAMES E. RANDALL
Department of Physiology
Indiana University
Bloomington, Indiana

PATRICIA SCHWIRIAN
College of Nursing
Ohio State University
Columbus, Ohio

RICHARD STULL
College of Pharmacy
University of Arkansas
Little Rock, Arkansas

JAMES W. WOODS
Lister Hill National Center
for Biomedical Communications
National Library of Medicine
Bethesda, Maryland

DOROTHY WOOLEY-McKAY
Department of Biology
Glendale Community College
Glendale, Arizona

GLENN YOSHIDA
Department of Life Sciences
Los Angeles Southwest College
Los Angeles, California

ELSEVIER

CONTENTS

FAILED CAI: WHERE DID ALL THE EFFORT GO? M. E. Jones, J. W. Mann, and M. Aucone	65
NURSING EDUCATION AND MICROCOMPUTERS: FACTORS TO CONSIDER Linda Craig Jelemensky	67
KEEPING ABREAST OF THE LITERATURE	71

FAILED CAI: WHERE DID ALL THE EFFORT GO?

M. E. Jones, J. W. Mann, and M. Aucone

C.A.I. Laboratory, The School of Medicine, The Flinders University of South Australia, Bedford Park, South Australia

Computer assisted instruction (CAI) material takes a long time to prepare. Often that time is wasted because it does not end in a program that students use. Some programs are brought to completion but are unsuccessful. Others are never completed. Although the literature is replete with reports of successful programs, we all know that these are a minority. It is probably just as important to share our failures as it is to share our successes; only by analyzing and sharing the causes of wasted effort can we save others from committing the same mistakes.

While some CAI programs are undoubtedly bad per se, the failure of others is often extrinsic to the lesson as it exists on the floppy disk. If three of these extrinsic factors are recognized in advance, common mistakes can be avoided. They are the academic staff who will produce and maintain the CAI lessons, and who must provide money, space, and technical staff to support it; the existing curriculum into which CAI must be inserted, producing the inevitable timetable problems; and the student body whose learning techniques have evolved around lectures

and books and whose study habits may not be optimally suited to the CAI environment.

While CAI was in its infancy, most facilities were provided by a single department such as physiology or pharmacology specifically for its component of the overall curriculum. With the general acceptance of CAI, more units will evolve either autonomously or under the aegis of libraries and audiovisual units. Such units will be particularly prone to failure through poor interaction with academic staff or the existing curriculum.

THE ACADEMIC STAFF

For CAI to be cost-effective, it is only necessary for a minority of staff to organize some of their teaching around CAI. It is easy to engender staff enthusiasm, but it is difficult to maintain it. Because of this, it is probably a mistake to try to whip up universal enthusiasm for CAI from the start. If successful, such an attempt results in multiple CAI projects beginning simultaneously involving many staff. The facilities to organize, program, and check the material become swamped, and all projects advance very slowly. Enthusiasm wanes before the majority of projects are brought to completion, and the CAI facility becomes a depressing depository for half-completed ideas. It is far more productive to create enthusiasm with one or two staff at a time, and to devote all the resources to bringing their projects to completion quickly.

Although "few is better" seems to be the best rule with regard to the staff involved at any one time producing new material, the opposite holds with regard to physical facilities. There is a "threshold of commitment" in terms of facilities below which CAI cannot become cost-effective. CAI will be judged successful if a majority of students complete the CAI associated with a course, if they perform well in that component, and if the course coordi-

nator feels that CAI removed a significant teaching load. This will happen only if CAI is an integral part of the curriculum, not an optional add-on. If a CAI lesson logically belongs at a certain point in a course, the whole class must complete it within a day or two. If an average student occupies the terminal for an hour, and there are ten "free" hours over the two-day period, one needs at least a terminal for every ten students. One also needs a demonstrator available to help students with the mechanics of using the terminal. It is easy to see why the tentative introduction of CAI using one or two microcomputers borrowed from a research laboratory is almost doomed to failure; the students are unfamiliar with the machine, the CAI material is a "post hoc" addition not essential to the course, and there is not sufficient time for most students to use the lesson.

Because a major problem with CAI is still the time required to write new material, the various options need to be examined carefully. One option is to use material from another institution. This saves time but introduces difficulties arising from differing curricula, educational philosophies, and hardware. Even if the lesson runs on the recipient institution's hardware, most life sciences are changing so rapidly that modifications to the lesson will be necessary in a few years. Ultimately it is necessary to alter and update any CAI library. Early lessons written "in house" are often in poorly structured and undocumented BASIC and are so difficult to maintain that they are discarded when out of date; it is usually quicker to rewrite than to alter such a lesson. Authoring systems^{1,2} and drivers facilitate the writing of new material and should be widely used.

THE EXISTING CURRICULUM

Life sciences curricula are overcrowded and are under continual pressure to admit new material. CAI

requires a commitment of time from the students; unless it is formally scheduled in the curriculum, few students will have the time or incentive to use it. It is usually appropriate for CAI to substitute for, not add to, components of the existing curriculum. Curricular changes often need to be made well in advance. Once documented and approved they act as a useful incentive for the course coordinator to carry the CAI project through to completion. Experience has shown that it is very much easier to introduce CAI to a part of the curriculum that is currently being revamped than to a stable component that already runs smoothly and successfully.

THE STUDENT BODY

The students bring skills to the CAI laboratory that they have learned in classrooms, lecture-halls, tutorials, and libraries, where they make notes, flip back and forth through the pages of a book, and develop strategies for extracting the most useful information from a situation. The exercise of these skills in the CAI laboratory often results in behavior that the tutor sees as unexpected and counterproductive.

Although students are known to spend hours taking notes in the most unlikely situations, we are often surprised to find them transcribing text from the screen. It is wise to anticipate this and to allow students to copy from screen to printer at will.

The ability of computers to "branch" the lesson according to student response is the basis on which CAI is held to be useful. There is a tendency in writing lessons to assume that the student giving the correct answer needs no help and to put all the educational effort into parts of the program that will only be seen when a wrong answer is given. Student response to this is to run the program twice; once correctly to satisfy the ego, and again incorrectly to extract the pearls of wisdom attendant upon

the wrong answers. Feedback to the student is just as important when the answers are correct; particularly lucid expositions should be placed in the lesson such that all students see and benefit from them.

We often fall into the trap of regarding a book as a "sequential" lesson and a CAI program as being better because it is "branched." But students never read a book sequentially from cover to cover; they go back and forth, checking this and rereading that so that the progress of a student through a book is every bit as branched as a CAI lesson. The essential difference is that the student controls the branching while reading a book; the author controls it on a CAI lesson. Not surprisingly, students sometimes resent the control being taken out of their hands. Optimally, CAI should direct the student according to the author's wishes while always allowing the student to override that direction and control his own fate if he so desires. Not all commercially available software will accommodate that.

Students perhaps rightly bring a little paranoia with them to the CAI lesson. Here is a machine, programmed by their tutors and examiners, on which they will make repeated mistakes. They prefer anonymity. But significant problems may take some hours to work through, and the student may wish to leave the computer occasionally, reentering the lesson where it was

left. That requires the student to identify himself to be repositioned appropriately in the exercise on his return. The dilemma is resolved by having, in addition to the unique log-in code by which each student identifies himself, one or two common codes that anyone can use. When used, this does not guarantee correct positioning on reentering a lesson but it is an option that the paranoid minority appreciate. Indeed, the mere gesture of presenting the option of anonymity is usually sufficient to convince the class that we have no wish to "spy" on them.

If teaching staff were always approached well in advance of curricular and time-tabling deadlines, and a modest commitment made for the use of CAI in the "core" studies; if we could mount a new lesson in the short time that enthusiasm lasts; if there were an adequately supervised "common service" CAI lab with enough terminals to allow students to complete the material within a few days; and if we were more cognizant of students' preexisting study habits, then there would be far less effort wasted on unsuccessful CAI.

REFERENCES

1. Graham SN: Tools for creating lessons on a computer. *Computers in Life Science Education* 2:1-5, 1985.
2. Locatis C, Carr V: Factors to consider when choosing an authoring system. *Computers in Life Science Education* 2:5-7, 1985.

that the microcomputer can be a valuable educational resource. However, the literature focusing on the use of the microcomputers in nursing education is limited.

The purpose of this paper is twofold. First, a presentation of the applications and the advantages of using microcomputers in nursing education will be discussed. Next, the process of developing computer assisted instructional (CAI) programs for microcomputers will be described.

APPLICATIONS OF MICROCOMPUTERS TO NURSING EDUCATION

The trend toward a high-tech society has contributed to the use of microcomputers. Although this trend is only beginning to influence education, it is anticipated that the microcomputer will become indispensable to nursing and nursing education. For example, it is predicted that by 1987, nurses will have pocket-sized microcomputers to record client information, access nursing interventions, and enter individual nursing care plans. Furthermore, by 1990, nursing students will be using notebook-sized microcomputers with entire courses available twenty-four hours a day.⁵

Although these predictions may appear ridiculous, in special care areas this technology is being realized. For example, in some neonatal intensive care units, microcomputers are being used to record and access patient data. Additionally, in several agencies nurses are using microcomputers at the bedside to access and record essential patient information. In educational settings, the capabilities of computer assisted instruction allow faculty to teach complete courses via the microcomputer. The evolution of the microcomputer as a teaching strategy presents several implications for nursing education.

First, microcomputers can be used to facilitate computer literacy among faculty and students. Because of the

NURSING EDUCATION AND MICROCOMPUTERS: FACTORS TO CONSIDER

Linda Craig Jelemensky

School of Nursing, Texas Tech University Health Sciences Center, Permian Basin, Odessa, Texas

Although it may not be apparent, the microcomputer is a fundamental part of everyday life. This innova-

tive technology is significantly impacting education. More specifically, nursing educators are discovering

societal push toward computerization, children are becoming computer literate in elementary school. However, many students and nursing educators did not have this opportunity. The microcomputer allows the faculty to become computer literate without leaving their offices. Thus this technology can expedite computer literacy among faculty.

Another application of microcomputers to nursing education is computer assisted instruction. Although nursing software for the microcomputer is limited, some excellent CAI packages are available. Computer assisted instructional programs can be used to teach the simple intellectual skills, such as knowledge recall, application, and comprehension.

Using the microcomputer to teach the simple intellectual behaviors allows the faculty more time to teach the more complex behaviors, such as analysis, synthesis, and evaluation.

The third application of the microcomputer to nursing education is in relation to fiscal restraints. A universal concern of administrators is financial curtailment. This concern has contributed to the need to maximize faculty and financial resources.⁴ The microcomputer can assist in accomplishing this goal. For example, the tasks of record keeping, test construction, and grading can be facilitated by the computer, thus allowing the faculty more time to provide individualized instruction.

Before microcomputers, CAI programs were designed to be utilized for university mainframe systems. Using the large systems was expensive and inconvenient. Currently in nursing education, the microcomputer's primary function is to run CAI programs. The microcomputer can be more cost effective than the mainframe,⁸ thereby contributing to the maximization of financial resources.

The microcomputer can also assist in maximizing faculty resources be-

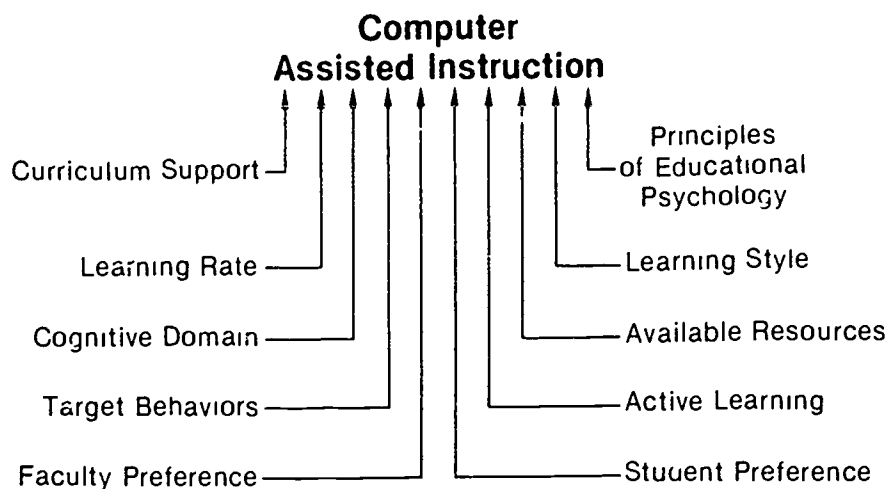

FIGURE 1. Factors to consider.

cause extensive computer expertise is not necessary. To become microcomputer literate requires little time and energy.

If used effectively, the microcomputer can assist in maximizing resources. In nursing education, microcomputers are frequently used to run CAI programs. However, to use this teaching strategy effectively, it must be determined if CAI is the appropriate educational resource.

IS COMPUTER ASSISTED INSTRUCTION THE BEST SOLUTION?

Computer assisted instruction may be viewed as a solution to a specific problem. However, to determine if CAI is the best solution, several factors should be considered. The first factor to consider is the curriculum and conceptual framework. Operant conditioning is the basis for computer assisted instruction. Therefore support for a teaching strategy based on operant conditioning is essential. Generally, curricula that emphasize self-paced, individualized learning support computer assisted instruction.⁷

Another factor to consider is the presentation of the content. The rate of content presentation should

correlate with the students' learning rate. For example, a CAI unit that is used to transfer information can present the content faster than a program that focuses on critical thinking skills.

Other significant factors include the target behaviors and the principles of educational psychology. It should be ascertained if the specific program will promote the desired behavior change. In making this decision, it is important to decide if CAI will convey the necessary content. The CAI program should also reflect the principles of educational psychology. The program should include factors such as motivation, transfer, extension, and reinforcement of knowledge.

Next, the students' learning style should be examined. Some students benefit from visual approaches. However, others benefit from verbal teaching strategies. Therefore the program should provide for both verbal and visual presentations.

The fifth factor to be examined is the type of learning provided by the program. According to Bevis² two types of teaching operations exist. They include passive and active learning. Passive learning occurs when the learner uses his senses to

absorb and retain information. Active learning involves the student in operations and behaviors that require participation. Because nursing is a process oriented profession, CAI programs should focus on active learning.

Finally, student and faculty preferences should be considered. Although the research regarding attitudes toward CAI is limited, it is an important factor to consider. Aiken and Braun¹ suggest that teacher acceptance toward CAI is probably the biggest challenge. Figure 1 illustrates these factors. Following careful consideration of these factors and the decision to use computer assisted instruction, program development can begin.

DEVELOPING COMPUTER ASSISTED INSTRUCTIONAL PROGRAMS: ANALYSIS OF THE COMPONENTS

Currently in education there is an increasing interest in developing CAI programs. However, the process of development frequently lacks planning or direction. When faculty are given the task of deciding which curriculum content should be included in the program, usually two discriminating methods are used. Either the content that is the most tedious and time consuming to teach is selected, or the individual's favorite content is chosen. Although these methods are producing CAI programs, a developmental strategy which incorporates the instructional design process can contribute to a higher quality program. Therefore, the first step in developing CAI programs is analysis of the instructional design process.

According to Kemp⁶ instructional design consists of eight components: a) the goals, b) the learner characteristics, c) the learning objectives, d) the subject content, e) the pre-assessment, f) the resources, g) the support services, and h) evaluation.

The first component of the instructional design process is describing the general purpose of the program. In doing so the desired goals of the program should be delineated. For example, a general purpose of the CAI program used to teach the process of calculating medication dosages to nursing students was to understand the reasons for giving the correct dosage.

The next component of the instructional design is to define the student characteristics. In this component, specific information that will affect the students' learning should be described.⁶ For example, in developing the dosage calculation program, it was important to know the students' previous clinical experience, reading level, math ability, motivation, and expectations of the course. This information was then used to build a tutorial or an exit into the program.

The third and one of the most difficult components of the instructional design is delineation of the learning objectives. The target behaviors should be incorporated into the learning objectives. These behaviors include expectations of the students following the program. For the dosage calculation program, a learning objective was the following: given the amount of medication ordered and the amount of medication available, the student will calculate the dosage correctly 80% of the time.

The next component is deciding on the subject content to be taught. This component also includes the procedures required to meet the objective. For example, in the dosage calculation program, it was necessary to teach the ratio of the amount of medication ordered to the amount of medication available. Therefore, basic algebra was included in the subject content.

The fifth component is pre-assessment of the students. For a successful program, it must be determined if each student has the same back-

ground knowledge. This component includes deciding if the student is already proficient in the skills or content being taught. Although this component is interrelated to the learner characteristics, it is important to determine specifically what prerequisites each student has acquired.

The next component is determining the teaching/learning activities and resources. Although CAI is considered a teaching strategy, other teaching/learning activities that will interface with the program should be evaluated. Successful completion of this component includes consideration of the instructional methods and resources that will accomplish each objective. The instructional methods that will be the most time efficient and cost effective should be evaluated. In making this decision, the strengths and weaknesses of alternative methods and various materials should be considered.

All instructional methods are related to either presentation to a group, teacher-student interaction, or individualized learning. However, CAI is most closely related to individualized learning. If you decide that the most appropriate instructional method for accomplishing the objectives is individualized instruction, then computer assisted instruction may be the solution.

The seventh component is the available support services. The support services include budget, facilities, equipment, time, schedules, and personnel. In looking at CAI programs you need to consider equipment, release time for faculty, facilities, and personnel needed to run the program. Furthermore, a program must coordinate with other activities.

Finally, the last component included in the instructional design process is evaluation. Measuring the students' learning outcomes is essential to this component. If well written, the objectives will indicate the learning outcomes. Measuring these

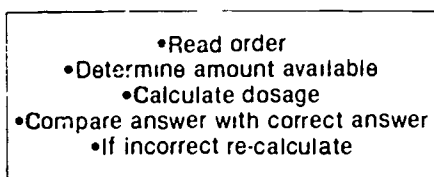

FIGURE 2. Algorithm example.

learning outcomes is usually accomplished by a final exam. However, a pretest-posttest design may be used. Prior to developing a successful lecture, one would consider the instructional design. Similarly, writing a successful CAI program requires evaluation of the instruction design process.

Following evaluation of the instructional design, the decision to implement computer assisted instruction can be made. If CAI is the

best solution to a teaching problem, then software development may begin. Because software development requires a set of accurate directions, two techniques may be used to develop the program.

One technique is the algorithm. This is a set of logical steps that carry out specific tasks, operations, or transformations of data. Figure 2 displays a simple algorithm that could be used for the dosage calculation exercise.

Another technique that may be used to develop software is the flowchart. A flowchart is a graphic representation of the logical sequence of the execution of a program. Figure 3 exemplifies the flowchart for the dosage calculation exercise. The final step in software development is the evaluation and revision process.

EVALUATION OF NURSING SOFTWARE

According to Scriven,⁹ evaluation can be either formative or summative. Formative evaluation is a review of materials used during the process of development. Formative evaluation provides feedback during the developmental process. This feedback may be used to change the product during the developmental period. In contrast, summative evaluation is the collection of data about the completed product, or its outcomes. Summative evaluation provides information concerning the effectiveness of the product but does not change the course of development. Generally, members want to know if the program teaches what it is supposed to teach. Therefore, the summative approach is frequently used.

Two manuals for evaluating software in general are available.³ Although these guides are excellent, they refer to general evaluation of software and do not specifically refer to nursing. Therefore other factors specific to nursing should be considered.

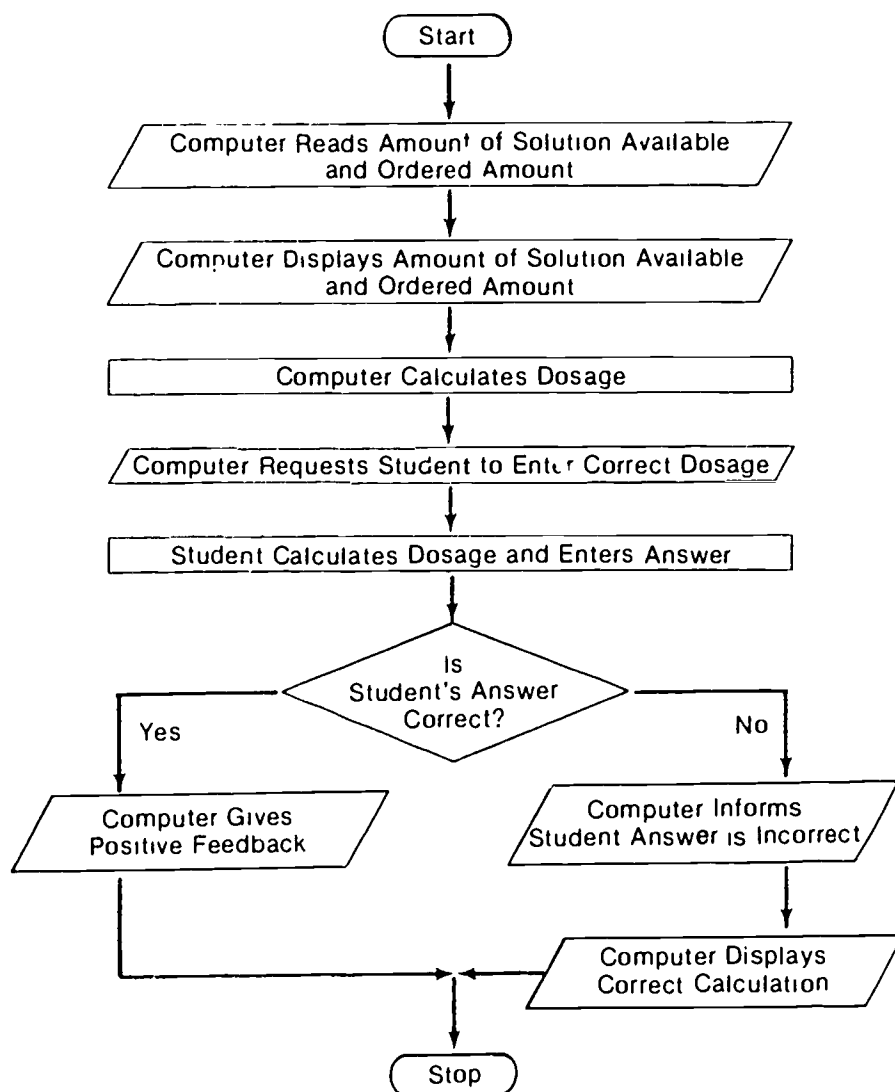

FIGURE 3. Flowchart example.

The first factor is the educational strategy. The teaching method used must be appropriate for the content and promote the target behaviors. The educational strategy must also be used appropriately. For example, if you wanted to teach assessment, diagnosis, and treatment of lung cancer, a simulation instead of a page turner program might be more appropriate.

The second factor specific to nursing is the content. It is important to identify the nursing theories that are being utilized. The theories should be appropriate to the content. Following identification of the theories it is essential to determine if the principles are congruent with the content. More importantly, the content should be applicable in clinical situations.

Equally important are the values concerning CAI. The CAI program must meet the teaching objectives; however, it should also satisfy the expectations about faculty. For example, the program should relate to individual and organizational effort. The effects on the philosophy, curriculum, and organizational setting should be considered.¹⁰ Furthermore, the continued use of the microcomputer and the accompanying software should be carefully evaluated.

In conclusion, this paper sought to present an overview of the applications and advantages of microcomputers and computer assisted instruction in nursing education. Although there is an increasing trend toward using the microcomputer in nursing education, the decision to incorporate this innovation into the curriculum should not be made hastily. Instead, the microcomputer should be viewed as an important educational tool. With further development and research the microcomputer enhanced by computer assisted instruction may significantly contribute to the education of efficient, well prepared nurses.

REFERENCES

1. Aiken R, Braun L: Into the '80s with microcomputer based learning. *Computer* 13:11-16, 1980.
2. Bevis EO: Curriculum building in nursing: a process (2nd ed). St. Louis, MO: C.V. Mosby, 1978.
3. Grobe SJ: Protocols for software selection, development and evaluation for nursing education. In Scholes M, Bryant Y, Barber B (eds), *The impact of computers on nursing: an international review*. Amsterdam: Elsevier Science, 300-307, 1983.
4. Hannah KJ: Computer assisted learning in nursing education—A macroscopic analysis. In Scholes M, Bryant Y, Barber B (eds), *The impact of computers on nursing: an international review*. Amsterdam: Elsevier Science, 280-288, 1983.
5. Hassett MR: Computers and nursing education in the 1980's. *Nurs Outlook* 32:34-36, 1984.
6. Kemp J: Instructional design: a plan for unit and course development (2nd ed). Belmont, CA: Fearon-Pitman, 1977.
7. Mirin S: The computer's place in nursing education. *Nurs and Health Care* 11:500-506, 1981.
8. Mirin S: Making the most of the microcomputer in nursing education. In Scholes M, Bryant Y, Barber B (eds), *The impact of computers on nursing: an international review*. Amsterdam: Elsevier Science, 291-300, 1983.
9. Scriven M: The methodology of evaluation. In Strake RE (ed), *AERA Monograph Series on Curriculum Evaluation No. 1*. Chicago, IL: Rand-McNally, 1967.
10. Townsend I: The second coming—Resurrection or reservation? In Scholes M, Bryant Y, Barber B (eds), *The impact of computers on nursing: an international review*. Amsterdam: Elsevier Science, 334-347, 1983.

KEEPING ABREAST OF THE LITERATURE

The following citations are presented as part of a quarterly feature in CLSE designed to help readers become aware of current literature pertinent to computer applications in life science education.

Atkinson ML: Computer-assisted instruction: current state of the art. *Computers in the Schools* 1(1):91-99, 1984.

Avner A: Special issue on authoring tools. *J Computer-Based Instr* 11:67-102, 1984.

Bidwell CM et al: Multidisciplinary team production of computer-based simulations to teach pediatrics. *J Med Educ* 60:397-403, 1985.

Campbell DF et al: The future of microcomputers in community colleges. *New Directions for Community Colleges* 12(3):101-108, 1984.

Clark DJ: How do interactive videodiscs rate against other media? *Instructional Innovator* 29(6):12-16, 1984.

Clogston CP et al: Trauma 1—a computer-based system for learning... antishock trousers. *Critical Care Quarterly* 7:66-71, 1984.

Day R et al: Comparison of lecture presentation versus computer managed instruction. *Comput Nurs* 2:236-240, 1984.

Dellow DA et al: The microcomputer revolution and its impact on community colleges. *New Directions for Community Colleges* 12(3):5-11, 1984.

DeMeersman RE et al: Computer applications in thermoregulatory research. *Sci Software Q* 1(3):20-22, 1984.

DeVries RA: Computer applications in education and training in the health professions. *World Hosp* 19(4):26-28, 1983.

Donahue TJ et al: Understanding interactive video. *Training and Development Journal* 37(12):26-31, 1983.

Ebner DG: Current issues in interactive videodisc and computer-based instruction. *Instructional Innovator* 29(3):24-29, 1984.

Ebner DG et al: Videodiscs can improve instructional efficiency. *Instructional Innovator* 29(6):26-28, 1984.

England E: Colour and layout considerations in CAI materials. *Comput Educ* 8:317-321, 1984.

Farrell RJ: Example of educational software adapted for radiography schools. *Radiography* 50:271-273, 1984.

Gayeski D et al: Authoring interactive media.

- Training 21(12):61-65, 69, 73-74, 79, 1984
- Granger CR: Computer-assisted presentations. *J Coll Sci Teach* 14:190-192, 1984-1985.
- Grishman R: Natural language processing. *J Am Soc Informat Sci* 35:291-296, 1984
- Howe SF: Interactive video. *Media and Methods* 20(3):9-11, 1983
- Hunter CB et al: Basic guide to the complex educational computer. *Media and Methods* 21(3):13-23, 1984.
- Jungck JR: Computer center: genetic engineering software: sequencing and cloning. *Am Biol Teach* 46:464-467, 1984.
- Kashka MS et al: A design for the development of a computer assisted instruction tutorial module. *Comput Nurs* 2:136-142, 1984.
- Kingman JC: Designing good educational software. *J Comp Math Sci Teach* 3(4):19-22, 1984.
- Koncher R: Microcomputers play bigger role in RT education. *AARTimes* 7(9):18-22, 1983.
- Kontos G: Cost-effective, teacher-made quality CAI—a fallacy. *Electronic Education* 3(8):23, 35, 1984.
- Kontos G: Instructional computing: in search of better methods for the production of CAI lessons. *J Educ Technol Syst* 13:3-14, 1984-1985.
- Larson DE: Effective screen designs for nursing CAI. *Comput Nurs* 2:224-228, 1984.
- Laurillard DM: Interactive video and the control of learning. *Educ Tech* 24(6):7-15, 1984.
- Mahoney FX et al: Design is what counts in computer-based training. *Training and Development Journal* 38(7):40-41, 1984.
- Mahr DR et al: Computer-aided instruction: overview and relevance to nursing education. *J Nurs Educ* 23:366-368, 1984.
- McLeod J: Special reports: optical disks: mass storage of information. *Systems and Software* 3(12):102-106, 108, 110, 112-115, 1984.
- Michael JA: Computer-simulated physiology experiments: where are we coming from and where might we go? *Physiologist* 27:431-436, 1984.
- Mizokawa DT et al: Guidelines for computer-managed testing. *Educ Tech* 24(12):12-17, 1984.
- Neale M et al: A computer-naive biology teacher's first use of a computer in teaching. *J Comp Math Sci Teach* 4(1):22-23, 1984.
- Neil VM: Effects of computer-assisted instruction on nursing student learning and attitude. *J Nurs Educ* 24:72, 74-75, 1985.
- Porter GJ: Considerations in choosing a microcomputer for graphics. *Collegiate Microcomputer* 2:113-120, 1984.
- Pugh WJ et al: Decisions, decisions, decisions: help in choosing microcomputer software and hardware. *Online* 9(1):18-30, 1985.
- Reigeluth CM et al: Using videodiscs in instruction: realizing their potential through instructional design. *Videodisc and Optical Disc* 4:199-215, 1984.
- Reinecker L: Computerized clinical simulations. *Computers and Education* 9:57-66, 1985.
- Reiss R et al: Teaching molecular biology with microcomputers. *Collegiate Microcomputer* 2:1-8, 1984.
- Reynolds A: An introduction to computer-based learning. *Training and Development Journal* 37(5):34-38, 1983.
- Saltinski R: Some software naturals: sometimes you are better off buying a book. *Natural History* 93(12):78-83, 1984.
- Spencer KA: Software for schools of radiography. *Radiography* 51:27, 1985
- Spraggs LD: Microcomputers in science education. *New Directions for Community Colleges* 12(3):13-21, 1984.
- Tait K et al: Some experiences in using a computer-based learning system as an aid to self-teaching and self-assessment. *Comput Educ* 8:271-278, 1984.
- Texley J: Some software naturals: masking education in a video game. *Natural History* 93(12):74-75, 77-78, 1984.
- Tzuket A et al: A computerized decision support system for patient selection in dental education. *Comput Biol Med* 14:277-284, 1984.
- Van Dongen CJ: Creating relevant computer-assisted instruction. *Nurse Educator* 10(1):21-25, 1985.
- Vismesky C et al: Choosing a microcomputer for use as a teaching aid. *New Directions for Community Colleges* 12(3):95-99, 1984.
- Wallace J et al: A hard look at software: what to examine and evaluate (with an evaluation form). *Educ Tech* 24(10):35-39, 1984
- Warrick TS: Legal aspects of purchasing microcomputer software. *Bulletin Am Soc Informat Sci* 10(6):9-12, 1984.
- Wedman JF et al: Guidelines for computer-based testing of student learning of concepts, principles, and procedures. *Educ Tech* 24(6):23-28, 1984.
- Woolery PA: Computer assisted evaluation of problem solving skills of primary health care providers. *J Contin Educ Nurs* 15:174-177, 1984.
- Wyer J: New bird on the branch: artificial intelligence and computer-assisted instruction. *Programmed Learning and Educational Technology* 21:185-191, 1984.
- Yaghmai NS et al: Expert systems: a tutorial. *J Am Soc Informat Sci* 35:297-305, 1984.
- Yarusso L: The decision to use a computer. *Performance and Instruction* 23(5):24-25, 1984.
- Ziemer MM: Issues of computer literacy in nursing education. *Nurs Health Care* 5:537-542, 1984.

Compiled by H Modell

SUBSCRIPTION INFORMATION

Computers in Life Science Education is published monthly by Elsevier Science Publishing Co., Inc., 52 Vanderbilt Avenue, New York, NY 10017. Subscription rate is \$58.00 for 12 issues, including postage and handling in the United States and Canada. Add \$20.00 for postage (airmail) in Mexico and Europe and \$23.00 for the rest of the world.

This newsletter has been registered with the Copyright Clearance Center, Inc. Consent is given for copying of articles for personal or internal use, or for the personal or internal use of specific clients. This consent is given on the condition that the copier pay through the Center the per-copy fee stated in the code on the first page for copying beyond that permitted by the US Copyright Law. If no code appears on an article, the author has not given broad consent to copy and permission to copy must be obtained directly from the author. This consent does not extend to other kinds of copying, such as for general distribution, resale, advertising and promotional purposes, or for creating new collective works.

Address orders, changes of address, and claims for missing issues to Journals Fulfillment Department, Elsevier Science Publishing Co., Inc., 52 Vanderbilt Avenue, New York, NY 10017. Claims for missing issues can be honored only up to three months for domestic addresses and six months for foreign addresses. Duplicate copies will not be sent to replace ones undelivered due to failure to notify Elsevier of change of address.

Address editorial correspondence to Harold I. Modell, PhD, Virginia Mason Research Center, 1000 Seneca Street, Seattle, WA 98101.

POSTMASTER: Send address changes to *Computers in Life Science Education*, Elsevier Science Publishing Co., Inc., 52 Vanderbilt Avenue, New York, NY 10017.

COMPUTERS IN LIFE SCIENCE EDUCATION

HAROLD I. MODELL
Virginia Mason Research Center
Seattle, Washington

MARCEL BLANCHAER
Professor of Biochemistry
Faculty of Medicine
University of Manitoba
Winnipeg, Manitoba
Canada

THEODORE J. CROVELLO
Department of Biology
University of Notre Dame
Notre Dame, Indiana

JAMES W. ECKBLAD
Department of Biology
Luther College
Decorah, Iowa

TSEGAYE HABTEMARIAM
School of Veterinary Medicine
Tuskegee Institute
Tuskegee, Alabama

DONNA LARSON
School of Nursing
Grand Valley State College
Allendale, Michigan

TERRY M. MIKITTEN
Graduate School of Biomedical Sciences
University of Texas Health Sciences Center
San Antonio, Texas

JAMES E. RANDALL
Department of Physiology
Indiana University
Bloomington, Indiana

PATRICIA SCHWIRIAN
College of Nursing
Ohio State University
Columbus, Ohio

RICHARD STULL
College of Pharmacy
University of Arkansas
Little Rock, Arkansas

JAMES W. WOODS
Lester Hill National Center
for Biomedical Communications
National Library of Medicine
Bethesda, Maryland

DOROTHY WOOLEY-McCARTHY
Department of Biology
Glendale Community College
Glendale, Arizona

GLENN YOSHIDA
Department of Life Sciences
Los Angeles Southwest College
Los Angeles, California

ELSEVIER

CONTENTS

- GENERIC VIDEODISCS: AN EDUCATIONAL RESOURCE** 73
John R. Bolles
- SIMULATED LABORATORY EXPERIMENTS** 76
M. E. Jones, J. W. Mann, and M. Aucone
- THE TRANSFER OF VIDEO IMAGES
TO MICROCOMPUTERS** 77
James W. Eckblad

GENERIC VIDEODISCS: AN EDUCATIONAL RESOURCE

John R. Bolles

*Health Sciences Center for Educational Resources, University of Washington,
Seattle, Washington*

During the late 1970s and early 1980s, the videodisc emerged from the laboratories. This new medium combined a storage capacity for 54,000 frames or 30 minutes of motion, a search time of 1-3 seconds, durability that far exceeded film or videotape, low cost of reproduction, and a high degree of computer compatibility. With these characteristics, the videodisc was touted as the ultimate in cost-effective, interactive educational technology. Since that time, however, economic factors and failures coupled with a profound absence of educational software and a singular and perhaps excessively rigid approach to the production and application of the medium have

led many educators to regard the videodisc as an expensive toy instead of a viable educational medium.

Both industry and the military have recognized, explored, and exploited the videodisc's potential. In these environments training is the most common and successful application. The stable funding and centralized decision-making processes found in these institutions allow long-term commitments of resources to the exploration of technologies that promise to enhance the marketing of and support for a set of products or the completion of a specific set of missions. The videodisc has shown great strength in

these relatively homogeneous environments. Companies like DEC and Ford Motor Company that have a need to train thousands of employees in the maintenance of a particular piece of hardware can direct a portion of their training budget to a medium that promises (and delivers) highly successful, interactive, cost-effective training.

Individually, educational institutions are small and decentralized when compared to giant industrial corporations or the military. There are many separate fields of study in any given educational institution, each with a faculty that chooses its own instructional goals and techniques. This disperses both the funding and authority that are necessary to implement new technologies on a meaningful scale. Furthermore, the goals of an educational institution are far more diverse than those of either an industry or the military. As a result, there has been little broad-scale use of the videodisc at the university level. What use has been made of videodisc technology has been primarily exploratory and research oriented. Actual large-scale implementation of this technology in the curriculum is extremely rare.

Because the videodisc has been predominantly a tool of industry and the military, the field of videodisc production and applications has been dominated by an approach that meets the needs of those institutions. As a result, it is often assumed (or taught) that the videodisc must be an integral part of a well-planned and financed endeavor. This endeavor adheres to a classic instructional design process and includes a well-defined and specific set of educational goals and objectives; precise knowledge of the learner audience; a well-selected delivery system (often expensive and sophisticated); flowchart-based scripting; a complicated production effort; and evaluation, revision, and implementation phases. The products of such rigor are generally attractive and effective. However they are also single-purposed and expensive.

It is extremely difficult for an educational institution to justify the commitment of finances and personnel implied by such a program, especially when the final product is so specifically directed to a limited set of instructional goals.

GENERIC VIDEODISCS

There is an alternative to the one-videodisc-per-program design that disperses the costs of production and allows users to develop programs that are tailored to their unique needs. Given the enormous variations in instructional goals and styles among institutions and instructors, this approach may be more acceptable to educators. The approach depends upon the creation and distribution of multi-use or "generic" videodiscs. Generic videodiscs are those that contain a sufficient quantity of visual and/or audio information to provide complete or near-complete coverage of a defined field of study. If high-quality collections can be made readily available, the decisions on the choice of playback equipment and the design and production of programs that utilize the resources of the videodiscs and the capabilities of the chosen delivery system to meet the unique needs of the institution may be deferred to the end-user.^{3,6}

Examples of such videodiscs that are now available in the life sciences include two videodiscs by Videodiscovery Inc., that together contain over 10,000 slides and numerous short film clips and sequences to support general biology education; and four videodiscs by the University of Washington—two of which contain a variety of materials (over 6000 slides, one film, and a total of over 45 min of high-quality videotaped microscopy) to allow instruction in hematology with particular emphasis on the acute leukemias—two others provide a base for the development of instruction in neurology with emphasis on motor disorders and mentation deficits. There is also a videodisc that was produced by Rush-

Presbyterian Medical Center. Although this disc contains approximately 10,000 pathology slides and is used for the development of computer-based education at that center, the disc has not been released for use at other sites. Generic discs that are currently being produced for widespread dissemination include a disc in veterinary pathology from the University of Georgia, a videodisc in basic hematology from the University of Washington, and an atlas of infectious disease from Miles Laboratories.

The videodiscs mentioned above are used in a variety of ways at a number of different institutions. They are used in a stand-alone mode to support lectures and discussions, with syllabi or catalogs as self-study or reference materials, and with a variety of computers and microcomputers as the visual elements in didactic presentations, simulations, or tests.

CHARACTERISTICS

Ideally a generic disc should contain the following: material of the best available quality; multiple examples of each major classification; the common and normal as well as the rare and exotic (In the biomedical sciences, demonstrations of the most common presentations of a disease are often far more valuable than a rare but spectacular presentation. Similarly, it is extremely important to be able to recognize variations of normal.); short motion sequences when the event or process to be demonstrated is dynamic (eg, a reflex or tremor); a complete, understandable, cross-referenced catalog of all entries. This catalog provides a reference both for those who are browsing through the subject matter and for those who want to create instructional programs. When possible, sample programs, syllabi, and other materials should be provided with the discs as models or stimuli for instructors who wish to develop programs using the videodiscs.

A generic videodisc should also be designed to be as machine-independ-

dent as possible. It should play on any brand of player, and the end-user should be free to make all microcomputer, interface, and special peripheral choices.

APPLICATIONS IN THE BIOSCIENCES

In training applications the analysis of the problem can often be readily broken down into a simple algorithmic format. Once the analysis is complete, the solutions to the problem are often quite straightforward. For example, there is only a limited number of paths involved in the analysis of a printer breakdown, and once a given path has proven merit, there is only a single fixed repair process that must be taught.

However, as problem-solving becomes more complex, as is usually the case in the life sciences, decisions are often based on the relative values of bits of data. Experience with a data base that far exceeds that provided in any one training program becomes the basis of judgments regarding the value of various data. For example in the biomedical sciences, the development of clinical judgment requires the ability to recognize various audio and visual cues and to interpret their relative meaning in light of the entire patient milieu.

The generic videodisc, through its ability to present multiple examples of the same phenomenon (therefore showing a number of different ways that a phenomenon may appear) as well as examples of related or contrasting phenomena, can offer a portion of the experience necessary for the development of clinical judgment.

The videodisc may be used in conjunction with a computer (or microcomputer) to create patient simulations that challenge students' problem solving abilities. If the instructor determines that a straightforward didactic approach is necessary, the videodisc is flexible and diverse enough to provide the basis for many didactic sessions. The multiplicity of examples also allows test-

ing based on frames that were not used during the didactic sessions. This helps ensure that the student is not merely remembering given images but that concepts are being understood.

A number of sites have produced a variety of materials using videodiscs. At these sites people who have had no formal training or previous experience with the medium have reviewed the information available on the videodiscs, selected appropriate segments, and integrated these segments into instructional programs that meet the educational goals of their particular institution.^{1,5,8,9} Some sites have encouraged students to develop programs that take advantage of the resources available to them on generic videodiscs. University of Washington undergraduates have produced a number of programs in pathology, hematology, and medical technology while learning the basics of computer programming and educational design.⁴

PRODUCTION

The basics of videodisc production and equipment and format capabilities were reviewed in an earlier issue of this publication.¹⁰ There are, however, particular points that should be emphasized regarding the process of identifying, collecting, and cataloging appropriate materials for generic videodiscs. This is by far the most costly and time-consuming phase of generic videodisc production. Consider, for example, the effort and cost to collect 10,000 high-quality still visuals and 24 min of short motion segments and to catalog and cross reference all of the above.

Producers often plan videodiscs to utilize both existing collections (films, slides, videotapes, and original art) and material produced exclusively for the videodisc. Using existing collections has certain obvious advantages, yet there are also several potential problems that must be considered.

• Copyright. Often collections are

bound by copyright restrictions or, particularly in the case of private instructional collections, include materials that have been duplicated from copyrighted sources within the "fair use" allowances. Obviously, all copyright restrictions must be cleared up before materials can be used on videodisc.

- Quality. Even the best of collections may contain a large percentage of materials that, due to poor storage or aging technology, are of inferior quality. Furthermore, images of marginal quality may degrade to unacceptable levels during transfer to the videotape master unless expensive electronic enhancement techniques are used.
- Scope. Many collections are extremely specific. Thus they may have more examples than necessary in one content area yet be deficient in many other desired areas. It is particularly common in the biomedical sciences to find that there are few or no examples of common disease states or findings.
- Format. The videodisc is limited to the format and resolution offered by television. Thus slides shot in a vertical format or illustrations that are particularly long will not fit conveniently on a video screen. Fine print or extreme detail is lost when subjected to the resolution of television.

Successful videodiscs that have been produced using existing collections include the Bio Sci Videodiscs produced by Videodiscovery, Inc., and the Medical Applications Videodisc and the Disorders of the Nervous System series produced by the University of Washington.

CONCLUSION

The videodisc medium is presently the most cost-effective and interactive means of storing large collections of visual material. Educators who want to use this powerful interactive educational tool may explore the medium through the use of generic videodiscs. These versatile

videodiscs may be adapted to many educational purposes (testing, reference, didactic instruction, or simulations); a variety of educational environments (classroom, library, or self-learning laboratory); and may be used with numerous different equipment configurations (ranging from player and monitor only to computer-controlled systems with graphic overlay and voice recognition).

Several existing videodiscs provide high-quality collections or atlases in given areas of bioscience. More are being produced as universities, professional associations, and private businesses recognize the educational potential of these large, easily-stored, readily accessible collections. As such collections become more readily available, inexpensive generic videodiscs should enhance instruction worldwide at sites that do not have the resources to collect,

catalog, and disseminate collections of their own.⁷

REFERENCES

1. Adams JS, Ashwood ER, Fine J, McArthur J: Medical education and a computer-video laser disc system. Proceedings; Symposium on Computer Applications in Medical Care 6:1034, 1982.
2. Ashwood ER, Fine JS, Behrens JA, Adams JS: Designing computer lessons in medical technology using an intelligent videodisc. *J Med Technol*, in press.
3. Clark J: Exploring videodisc's potential. *J Biomedical Communications* 12(2):34-36, 1984.
4. Crowell WA, Tyler DE, Trice RW, Mahaffey EA: Establishment of a 35mm transparency slide bank and videodisc in veterinary pathology. Unpublished, University of Georgia.
5. Fine J, Ashwood ER, Adams JS: Computer-video laser disc systems: applications in medicine. Proceedings; 1st Annual AMIA Congress on Medical Informatics, 188-191, 1982.
6. Gaponoff MA, McArthur JR, Bolles JR, Draye MA, Konikow NS, Pliske CB: Medical simulation: tutorials, videodiscs, and microcomputers. In: Leventhal LA (ed), *Modeling and simulation on microcomputers*. La Jolla, CA: Simulation Councils, Inc., 85-88, 1981.
7. McArthur JR: Conventional and high technology teaching methods for educating health professionals in developing nations. *Journal of Audiovisual Media in Medicine* 5:21-25, 1982.
8. Mitchell J, McNeely MDD, Chang EJH: A computer controlled video disc system for teaching white cell morphology and differential counting to medical technology students. *J Med Technol*, in press.
9. Skinner CR, Bormanis J: A system for tutorial and testing in neurology using microcomputer and laser videodisc. Unpublished, University of Ottawa.
10. Woods J: Optical videodiscs and computers in life science education. *Computers in Life Science Education* 1:25-28, 1984.

SIMULATED LABORATORY EXPERIMENTS

M. E. Jones, J. W. Mann, and M. Aucone

CAI Laboratory, The School of Medicine, The Flinders University of South Australia, Bedford Park, South Australia

The idea of the simulated practical (laboratory experiment) is not new. Real practicals are often messy, tedious, dangerous, expensive in terms of time and space, and frequently of little educational value. The alternative of having a computer simulate the essentials of the practical can be very appealing, but it too has its drawbacks. One option is to precede the real practical by a computer simulation. To see the advantages of this, consider first a comparison of the ideal practical with the way it usually runs in practice.

Ideally, the student would research the subject in advance, formulate precisely the question to be

asked, and design his experiment accordingly. Data would be gathered in full knowledge of how it would be analyzed. Reality, however, is quite different. Students rarely read the topic in advance of the practical and are in no position to propose either the aim or method of a relevant experiment. Constraints of time, space, and staffing in undergraduate laboratories often dictate that experiments be run on a tight schedule, and the only way to reconcile these conflicting factors is to present the student with a recipe for conducting the experiment. Even this usually requires the students to work in small groups, within which a bright extrovert often runs the ex-

periment while the remainder look on in passive confusion. Only later, during the write-up phase of the practical as the data are analyzed and discussed, does the full significance of the experiment reveal itself to the average student. By then it is too late to remedy the occasional pipetting error or recheck the obviously wild result. Rarely are there facilities to repeat or add to the observations. Widespread disenchantment with this system and well-founded doubts as to its educational value have contributed to a significant move away from laboratory practicals. This is unfortunate because experimental validation is the cornerstone of life sciences. The

difficulty that students have with real practicals is often related to the amount of conceptual material that must be understood before the practical aspects make sense.

Consider, for instance, the experimental determination of K_m and V_{max} for an enzyme. Our real practical uses β -galactosidase with the artificial substrate *o*-nitrophenyl- β -galactoside, the concentration of the product *o*-nitrophenol being determined spectrophotometrically by measuring absorbance at 420 nm. Although this seems trivially simple to anyone familiar with the assay, the conceptual pathway for an undergraduate confronting it for the first time is actually quite convoluted. It involves absorption (Lambert's law), logarithms and optical density, the molar absorption coefficient for *o*-nitrophenol, and the determination of initial reaction rate, in addition to an understanding of Michaelis-Menten kinetics and perhaps also of reciprocal transforms to estimate K_m and V_{max} . That is quite a lot of new conceptual material for a student to master at the same time as using pipettes, water baths, and spectrophotometers. The idea of the simulated prepractical is to let the student become thoroughly familiar with the conceptual, particularly the numerical, aspects of a practical well in advance of the scheduled real practical.

The simulation allows the student to choose temperature, pH, enzyme concentration, substrate concentration, the concentration of two inhibitors (competitive and noncompetitive), and the incubation time. The program responds by giving the change in optical density for that incubation. Students have access to the simulation for some weeks before the real practical, to which they are expected to bring their proposal for several incubations to determine V_{max} and K_m for β -galactosidase.

Although the original impetus for such a simulation was to act as a lead-up to an existing real practical, simulations are not constrained to

such a role. They can, of course, be used in any situation where the real thing is too difficult, time-consuming, expensive, small, or rapid (there are some nice simulations of enzymes undergoing conformational change, something that we can scarcely see in real life). Even in the context of a simulated introduction to a real practical, the computer can add a degree of complexity that in a real-life practical would be too time-consuming to encompass. This gives scope for the more motivated students to go beyond the minimal requirements of the curriculum. In a heterogeneous class, the better students can achieve their potential while using the same simulation that the class as a whole uses in performing the required exercise.

Using the enzyme simulation as an example, we have the facility to introduce competitive and non-competitive inhibitors. Students can determine which is which and the binding constant determining the interaction of each with the enzyme. Variation of V_{max} with temperature follows the Arrhenius equation, so the activation energy can be estimated from experimental series run at different temperatures. The non-competitive inhibitor increases this energy barrier. Above 45°C, the enzyme denatures at a rate depending on $(T - 45^\circ\text{C})$. Such a simulation not only allows for heterogeneous classes, in which both motivation and ability will vary from student to student, but it also allows for the inevitable change in curriculum content and educational philosophy that turn last year's successful tutorial style CAI lesson into this year's anachronism.

Simulations, provided they are suitably realistic, are relatively robust when faced with curricular changes and iterations in educational philosophy. For instance, in the enzyme practical, once inhibitors and temperature-dependent behavior have been programmed into the simulation, they can remain, regardless of the requirements of a chang-

ing curriculum. Equally, the simulation can be used with copious notes as to how to proceed, or alternatively, as a problem-solving exercise in which the students are told to go to the library and research the literature and then to investigate the simulated experiment.

Such simulations have come resplendent with graphics, and for some few applications this might be almost essential. For enzymes, a plot of V_{max} against substrate concentration, together with one or more reciprocal transforms might be offered. Such graphics, appealing as they may be superficially, often limit the usefulness of a simulation. They tie the simulation to a single type of monitor and present the results in a way quite different from the raw data of a real practical.

Even when the educational philosophy is such that the graphic presentation of results seems appropriate, the generation of such graphs is usually trivial if there is an adequate simulation algorithm to compute the numbers from the experimental conditions. It therefore follows that the crux of such a simulation is the few lines of computer code that do the numerical computation. Such algorithms can be used across a wide spectrum of educational levels independently of whether the underlying educational philosophy tends towards didactic teaching, problem solving, or discovery learning. The exchange of simulations between institutions is usually prevented only by the associated graphics routines (which are often heavily hardware dependent) and by the algorithm's being embedded in a lesson that reflects the curriculum and educational style of the originating institution. Yet these impediments to exchange are only the frills that a recipient institution can easily tailor to its own needs.

The skill and expertise behind writing a good simulation lies in the writing of the algorithm. These should be catalogued, documented, and exchanged freely.

THE TRANSFER OF VIDEO IMAGES TO MICROCOMPUTERS

James W. Eckblad
Luther College, Decorah, Iowa

In this brief report, I want to consider some of the options currently available to let users transfer video images to their microcomputers. I will focus on our experience with an inexpensive slow-scan device but also will suggest some other options that are commonly known as digital image processors. In general these devices take any standard video signal, such as that from a video tape recorder and convert the picture to a black and white digitized display on the hi-res graphics screen of a microcomputer. This technique, until recently available only with very sophisticated large computers, lets the microcomputer take snapshots of whatever appears on the video tape or video camera. A paper copy of the image can be obtained using a standard dot matrix printer.

Our department has been using the ComputerEyes system from Digital Vision, Inc., and an Apple II+. A similar version is available for the Commodore 64, and versions are under development for the IBM-PC and Atari 800. ComputerEyes is a small (4" x 4" x 1.75") black box that connects to the Apple 16-pin game I/O socket.

After ComputerEyes is connected to the Apple I/O socket, the RCA-type jack on the back of the box connects to the output from a video source. We had ours connected to a Panasonic video camera and began capturing images about 20 minutes after opening the package.

The software disk included with ComputerEyes is not copy-protected, and a menu program, written in BASIC, gives users access to a variety of features. These include options to acquire high-contrast and grey-scale images; view the last acquired image; save images and retrieve them from disk in both packed and unpacked formats; cata-

log the disk; and run a demo program. There is on-line help available so that one doesn't have to keep referencing the 27-page owner's manual.

The first menu option selected would normally be ADJUST SYNC, which lets you use the "Sync" knob on the ComputerEyes box to make adjustments according to the signal being received from your video source. After that you can CAPTURE an image as the ComputerEyes system performs a scan of the video signal. The machine language software records 192 samples during every vertical scan, storing one column of pixels in about 16.6 msec. (The smallest element of a display that can be controlled individually is called a picture element, or pixel.) The point in time during each horizontal scan period at which samples are taken is delayed from the horizontal sync by an amount that is very slowly increased as the ComputerEyes scan progresses across the screen from left to right. The result is that successive columns of pixels are acquired, with 280 columns being acquired in 280 x 16.6 msec, or a little under five sec. The user controls the background brightness with the second knob on the ComputerEyes box.

One of the nice features of this system is that images can be saved to a disk in a packed format, thereby saving space on the disk. When images have large areas of either all white or all black, the packed format can save them on the disk in as few as four sectors each. We've used this feature to make up a slide-show of over 40 images on a single disk for the Apple II. This greatly facilitates the addition of high-quality graphics to any computer-assisted instruction software you may develop.

A biologist who likes to get out of the lab and away from his computer every once in a while.

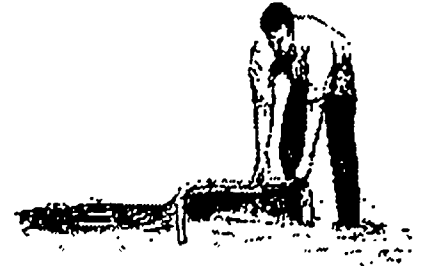

FIGURE 1.

The biologist seining image (Fig. 1) was created with ComputerEyes and printed on an Epson dot matrix printer. It used the normal 34 sectors when saved to a disk without being packed, six sectors when packed, and eight sectors when packed after lettering was added. It usually works best to add lettering after an image has been captured; in Figure 1 the Beagle Bros. program *Apple Mechanic* was used to add lettering to the hi-res screen.

The resolution of our Apple II+ version of ComputerEyes is limited to the standard 280 x 192 pixel hi-res screen. If you have an APPLE IIe with an extended 80-column board installed (128K), an additional ComputerEyes disk can be purchased (for \$15) to take advantage of double hi-res. This gives a display with twice as many pixels per area, or a 560 x 192 pixel screen.

ComputerEyes images can also be made compatible with Broderbund's *Print Shop* program by using a special disk (available for another \$15). You can personalize posters, etc. by using your custom images. This disk also has a more generally useful program that takes any previously saved hi-res image and lets you make it compatible with *Print Shop*.

Thus far we've used ComputerEyes primarily to generate some

TABLE 1. Some digital image processors for microcomputers

Product	Manufacturer	System
ComputerEyes (\$ 130)	Digital Vision, Inc. 14 Oak St., Suite 2 Needham, MA 02192	Apple II Commodore 64
Diplomat (\$ 295)	Computech Systems 168 Finchley Rd. London, NW3 6HP, ENGLAND	Apple II
DS-88 Digisector (\$ 350)	The Micro Works PO Box 1110 Del Mar, CA 92014	Apple II IBM Tandy Color
FAX640 (\$ 1595)	Scion Corp. 12310 Pinecrest Rd. Reston, VA 22091	IBM
Graphicom (\$ 200)	Computize PO Box 207 Langhorne, PA 19047	Tandy Color
Image Capture (\$ 1295)	AT & T Consumer Products 2002 Wellesley Blvd. Indianapolis, IN 46219	IBM
MacVision (\$ 399)	Koala Technologies 3100 Patrick Henry Dr. Santa Clara, CA 95052	Macintosh
Magic (\$ 350)	New Image Technology 10300 Greenbelt Rd. Seabrook, MD 20706	Macintosh
MicronEye Bullet (\$ 295)	Micron Technology 2805 E. Columbia Rd. Boise, ID 83706	Macintosh, IBM Apple II Commodore 64 Tandy Color
Micro-Imager (\$ 350)	Servidyne Systems 1735 Defoor Pl. Atlanta, GA 30377	Macintosh
PC-Eye (\$ 1495)	Chorus Data Systems PO Box 370 Merrimack, NH 03054	IBM
PCvision Frame Grabber (\$ 2995)	Imaging Technology 600 W. Cummings Park Woburn, MA 02801	IBM
PI-101 PhotoImager (\$ 995)	Commsoft 665 Maybell Ave. Palo Alto, CA 94306	Apple II
Private Eye (\$ 595)	I/O Video 222 Third St. Cambridge, MA 02142	Macintosh
ThunderScan (\$ 229)	Thunderware Inc. 19G Orinda Way Orinda, CA 94563	Macintosh

computer-assisted instruction in biology, obtained paper copy of video images seen through microscopes, and used it with the *Print Shop* program. We anticipate its use will expand to include a wider variety of applications in the near future.

There are some other options available for obtaining video images, and 15 different systems were recently reviewed by Linzmayer.¹ These range in price from \$130 for ComputerEyes to \$2995 for the PCvision Frame Grabber from Imaging Technology (Table 1). The mean price for the 15 systems was \$777. Five systems have versions that run on the Apple II, six on the IBM-PC, six on the Macintosh, four on the Tandy color computer, and two on the Commodore 64. If you've been convinced of the value of graphics, I suggest you consider a digital image processor.

REFERENCE

1. Linzmayer O: Choosing an image processor. *Creative Computing* 11(7):70-73, 1985.

COMPUTERS IN LIFE SCIENCE EDUCATION

HAROLD I. MODELL

Virginia Mason Research Center
Seattle, Washington

MARCEL BLANCHAER

Professor of Biochemistry
Faculty of Medicine
University of Manitoba
Winnipeg, Manitoba
Canada

THEODORE J. CROVELLO

Department of Biology
University of Notre Dame
Notre Dame, Indiana

JAMES W. ECKBLAD

Department of Biology
Luther College
Decorah, Iowa

TSEGAYE HABTEMARIAM

School of Veterinary Medicine
Tuskegee Institute
Tuskegee, Alabama

DONNA LARSON

School of Nursing
Grand Valley State College
Allendale, Michigan

TERRY M. MIKITTEN

Graduate School of Biomedical Sciences
University of Texas Health Sciences Center
San Antonio, Texas

JAMES E. RANDALL

Department of Physiology
Indiana University
Bloomington, Indiana

PATRICIA SCHWIRIAN

College of Nursing
Ohio State University
Columbus, Ohio

RICHARD STULL

College of Pharmacy
University of Arkansas
Little Rock, Arkansas

JAMES W. WOOLS

Lister Hill National Center
for Biomedical Communications
National Library of Medicine
Bethesda, Maryland

DOROTHY WOOLEY-McKAY

Department of Biology
Glendale Community College
Glendale, Arizona

GLENN YOSHIDA

Department of Life Sciences
Los Angeles Southwest College
Los Angeles, California

ELSEVIER

CONTENTS

SUBSTITUTION OF APPLE COMPUTERS FOR STORAGE OSCILLOSCOPES AND POLYGRAPHS Mary D. Coyne	81
THE USE OF DRIVERS IN COMPUTER-ASSISTED INSTRUCTION M.E. Jones, J.W. Mann, and M. Aucone	86

SUBSTITUTION OF APPLE COMPUTERS FOR STORAGE OSCILLOSCOPES AND POLYGRAPHS

Mary D. Coyne

Department of Biological Sciences, Wellesley College, Wellesley, Massachusetts

Three years ago we were faced with the necessity of updating our physiology equipment and needed new polygraphs as well as at least one storage oscilloscope. Several advertisements led us to consider Apple computers as substitutes, and we eventually purchased eight Apple //e systems plus associated hardware and software to give us the capabilities of both storage oscilloscopes and polygraph recorders.

We were interested in a storage oscilloscope in order to demonstrate human reflex responses as well as the nerve action potential. Two channels were necessary—one to show the stimulus, the other, the

response. The storage capacity was needed so that students could calculate time intervals from the oscilloscope screen. We became intrigued with an ad for COMPUTERSCOPE by RC Electronics (Santa Barbara, CA 93111) and decided to try it with the one Apple computer already in the department. The package included an A/D board that fit into two of the Apple's slots, as well as software to allow collection of data. We were impressed with the program and subsequently purchased four Apple //e computers and three more COMPUTERSCOPE packages to provide four workstations per lab. The sec-

Table 1. Equipment for a Workstation

Apple //e computer
One disc drive
COMPUTERSCOPE A/D board plus software
Grass stimulator
Nerve chamber
Two Grass amplifiers (connected to common power supply)
Imagewriter printer plus switch box to allow sharing with 1 other station

cond year we planned for and purchased four more Apples with COMPUTERSCOPE plus four Imagewriter printers. The components of each workstation are listed in Table 1. Three or four students work together at each station depending on the level of the course. Although four is not an ideal number of students, it has worked out satisfactorily so far. In the remainder of this report, I am going to describe the components of a single setup, the capabilities of the system, and some of the experiments in which the system is used.

MEASURING NERVE CONDUCTION VELOCITY

We particularly wanted to have the students in introductory biology classes perform a comparison of nerve conduction velocities in human and frog nerves. The Apple computer with the COMPUTERSCOPE board and program acted as the storage oscilloscope, but we needed to amplify the signal from the nerves. To do this we used two power supplies (Grass RPS107) and eight AC amplifiers (Grass P511). For the frog nerve experiment, we used available nerve chambers (home made) and Grass stimulators (Grass SD9).

The stimulator was connected to channel A (upper channel) of the A/D board as well as to the nerve chamber (see Fig. 1). Channel A records the electrical pulse. The output from the nerve chamber (recording electrodes) was connected to the second input on the A/D board (channel B—lower channel). There-

fore, the response of the nerve to the stimulus would be recorded on the lower channel (see Fig. 2(A)). The time between the beginning of the stimulus (channel A) and the nerve response (channel B) is the length of time it takes the action potential to travel from the site of stimulation on the nerve to the recording electrodes. The time interval can be read easily from the screen. By looking at TIME on the third line of text under the graphics in Figure 2, you can see that each horizontal division on the screen equals 0.001 seconds or 1 millisecond. Therefore the approximate time interval between the initiation of the stimulus shown in channel A and the peak of the action potential passing over the first recording electrode is about 0.8 msec. One of the advantages of this program is that two movable vertical lines can be called up, which will allow the user to accurately determine either time intervals (along the horizontal) or voltage differences (along the vertical).

Figure 2(B) shows a similar recording of a frog nerve action poten-

tial with the two vertical cursors positioned on the beginning of the stimulus (one on the left) and the peak of the action potential. The second line of text below the graph displays the voltage on channel A (+ 0.923) and the time (0.0 μ sec) at the leftmost vertical line. The third line of text displays the voltage on channel A (-0.021) and the time (821.4 μ sec) at the vertical line on the right. On the fourth line of text the numbers reflect the differences in voltage and time between the points where the two vertical lines are located. Therefore, in this recording the response time between stimulation and nerve response is 821.4 microseconds (0.8214 msec). This is much more accurate than the visual estimate that we took from Figure 2(A).

By taking several measurements and using this means of measurement, the students can see that the velocity of conduction remains fairly constant. After the students have measured the length of nerve between the stimulating electrode and the first recording electrode the speed of conduction in meters/second can be easily calculated. Any image on the screen can be immediately saved and/or dumped to the printer. The first year, when we only had one printer, the students saved the experimental data on the program disk and printed the graphics at the end of the lab period. We presently have one printer per two

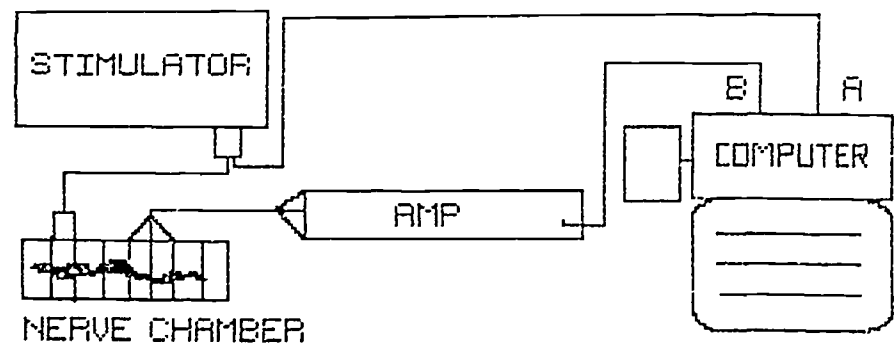

FIGURE 1. Diagram of equipment for measuring the biphasic action potential produced by electrical stimulation of the frog sciatic nerve preparation.

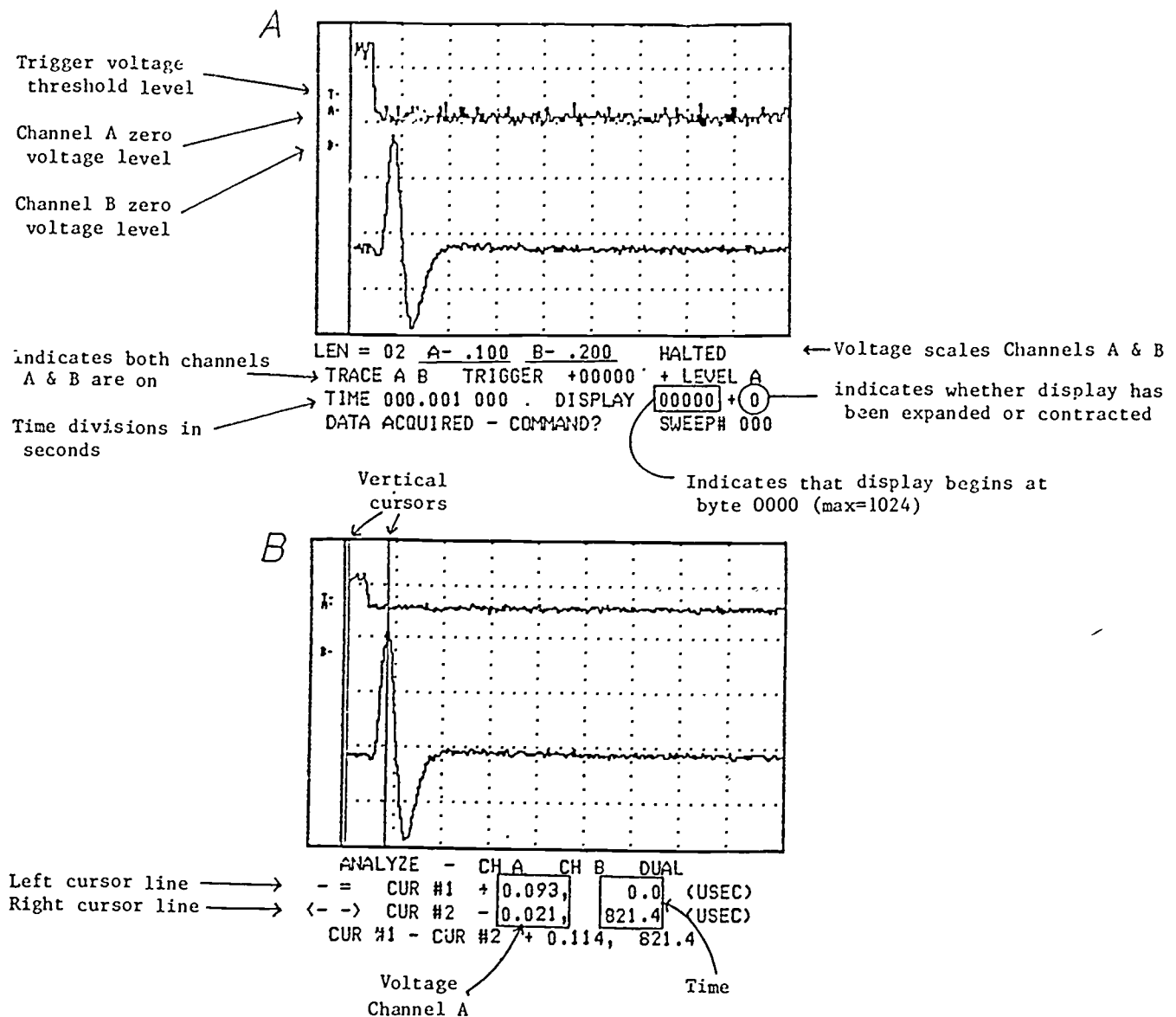

FIGURE 2. Printout of the screen display showing the stimulus (top channel A) and biphasic action potential (bottom channel B) in a frog sciatic nerve. A, standard screen, B, screen with vertical cursors for quantitation of voltage and time.

computers with a switch box; this has worked very well.

OTHER PROGRAM FEATURES

Another feature of the software has been very useful in demonstrating the refractory period of the frog sciatic nerve. Figure 3 is a printout of an experiment in which twin stimulatory pulses were delivered with varying time intervals. Figure 3(A) shows the two stimulatory pulses in channel A. They are 4 msec apart. Channel B is the response of the nerve. (Note that there is a

sizable stimulus artifact in this particular recording.) Some diminution in the biphasic action potential can be seen with the second pulse.

Figure 3(B) demonstrates two other features in the standard COMPUTERSCOPE program, that is, an expansion of the screen and the accumulation and display of repetitive experiments. The number "1" at the end of the third line of text indicates that the display has been expanded once. Therefore, two horizontal divisions are equal to 1 msec. Channel A shows the twin

pulses for four experiments overlaid on each other. The longest delay between the twin pulses is about 3.5 msec, while the shortest is about 1 msec. Channel B displays the results of the four experiments, showing the results stacked on top of each other with the first one at the bottom. The refractory period is quite obvious in the third experiment where the delay interval has been decreased to 1.5 msec. Only the stimulus artifact is seen in the last experiment where the delay between pulses has been shortened to 1 msec. Being

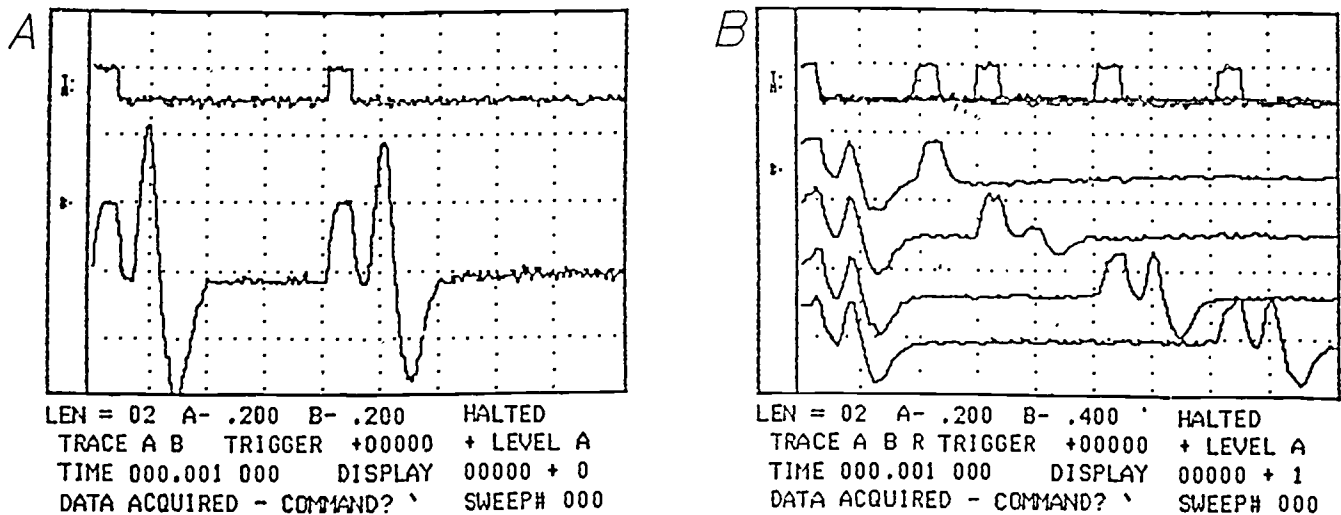

FIGURE 3. Printout of screen display showing multiple twin pulses (top channel A) and biphasic action potentials (bottom channel B) from frog sciatic nerve. A, standard screen. B, expanded screen with four experiments displayed, delay between pulses ranges from 1 to 3.5 msec.

able to print out the results of these four experiments simultaneously allows the student to understand the concept of relative and absolute refractory periods readily. Unlike a storage oscilloscope, the computer provides an immediate hardcopy of the data which can be labeled, annotated, and incorporated into laboratory reports.

The conduction velocity of human nerves is performed by the students on themselves using the Achilles tendon reflex and recording electrical activity in the gastrocnemius muscle. The equipment setup is shown in Figure 4. The construction of the reflex hammer and the experimental procedure are described in Oakley and Schafer's *Experimental Neurobiology* laboratory manual.¹ This experiment used an additional feature of the hardware, i.e., an external trigger. In this case the computer waits for an external signal before it begins to collect data. When the reflex hammer strikes the Achilles tendon, the hammer circuit diagramed in Figure 4 is closed, the computer begins collecting data, and the event is recorded in channel A. Two recording electrodes on the skin surface above the gastrocnemius muscle pick up the reflex muscle

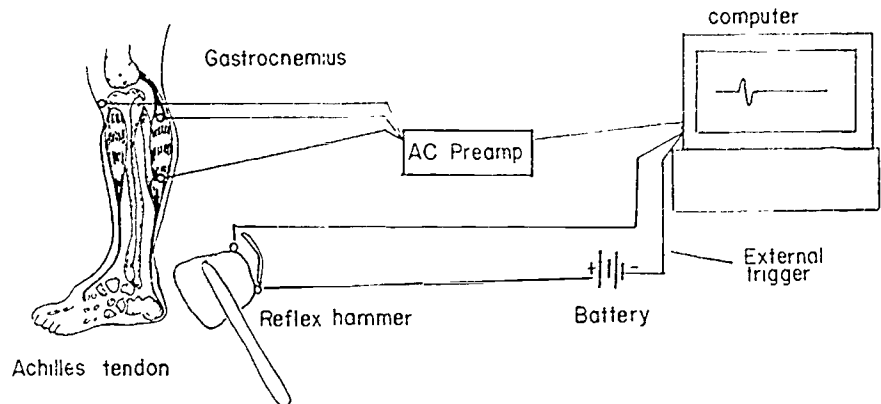

FIGURE 4. Diagram of equipment for measuring response time in the human Achilles tendon reflex.

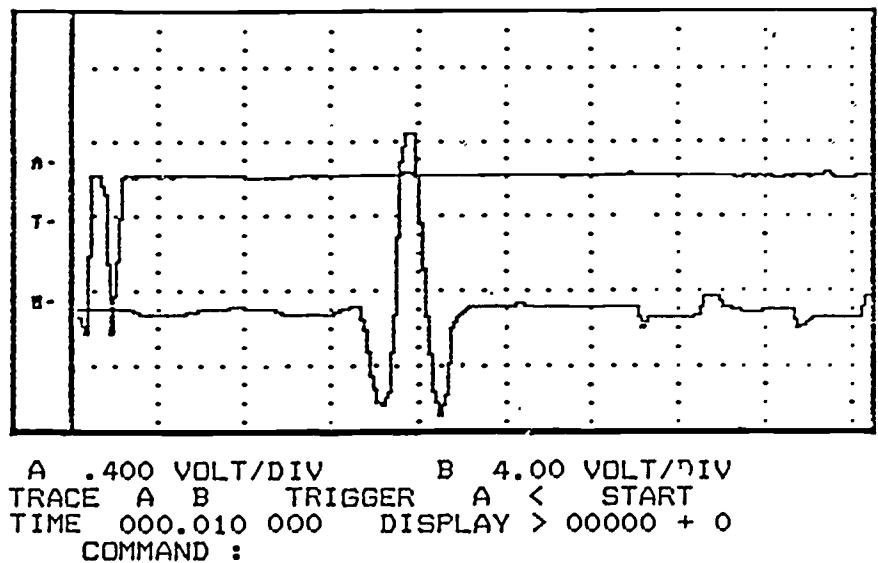

FIGURE 5. Printout of screen display of stimulus trigger (channel A) and electromyograph (channel B) produced during Achilles tendon reflex experiment.

activity, and it appears on channel B. Figure 5 shows both responses. The time between stretching the Achilles tendon by a hammer blow and the reflex muscle contraction is about 33 msec. By measuring the distance from the tendon to the spinal cord and back to the gastrocnemius muscle on the experimental subject, the student can calculate the conduction velocity in meters/sec. This value is then evaluated and compared with that of the frog sciatic nerve.

OTHER APPLICATIONS

In another experiment, students measure respiration rate and cardiac electrical activity using a setup shown in Figure 6. In this case the students can obtain a "chart" recording of the data as shown in Figure 7. This type of printout provides a hardcopy of the 1024 bytes of data collected in the computer memory just before collection time is halted, even though only 256 bytes are displayed on the screen. At this slow rate of collection, the computer collects and displays the data continuously. (In the experiments described above, the computer is set to make a single collection that begins at time 0 and continues until the memory buffer [1024 bytes] is full.) The "chart" printout is very similar to the type of data obtained with a two channel polygraph. However, in this case any portion of this collec-

tion of data can be displayed on the computer screen, enlarged and expanded, and accurately measured with the vertical cursors. For example, the students can move, enlarge, and examine three ECG recordings, noting time intervals, identifying P, QRS and T waves, and determining voltages. They can then make a printout of their enlargement.

The experiments described above and the computers with accompanying electrical equipment have been used successfully in the introductory freshman biology laboratories for the past two years. Because many students still had little exposure to computers and electronic equipment, I wrote a computer-assisted program using Superpilot language for the Apple computer. This program described the equipment and tested the students on their understanding. This probably could have been done with printed material, but it forced the students to learn how to boot a disk and overcome their resistance to computers before entering the lab. In addition, we required that they also use the COMPUTER-SCOPE program before coming to lab. They were given instructions on how to load a stored set of data and how to manipulate it on the screen so that they were familiar with the commands and potential of the program before using it to collect data. As expected, some jumped right in and loved it, others were not too

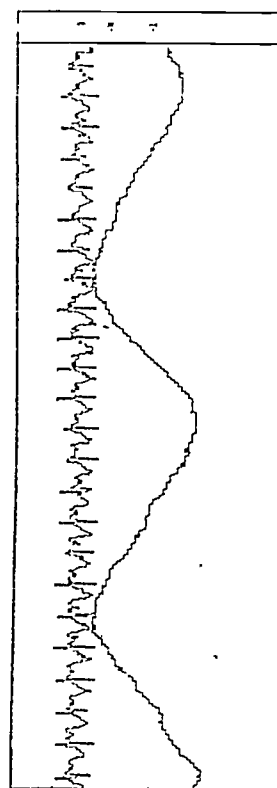

```
LEN = 02 A- 1.00 B- 1.00 HALTED
TRACE A B TRIGGER +0002S + SLOPE A
TIME 000.500 000 DISPLAY 00000 + 0
DATA ACQUIRED - COMMAND? SHEEP# 009
```

FIGURE 7. Printout of "chart" recording of respiration (channel A) and electrocardiogram (channel B), from a human subject. This type of printout displays all the data collected in memory (1024 bytes) whereas the previous printouts only show the first 256 bytes. However, any portion of the data in memory can be moved into the screen area for standard display and/or printing.

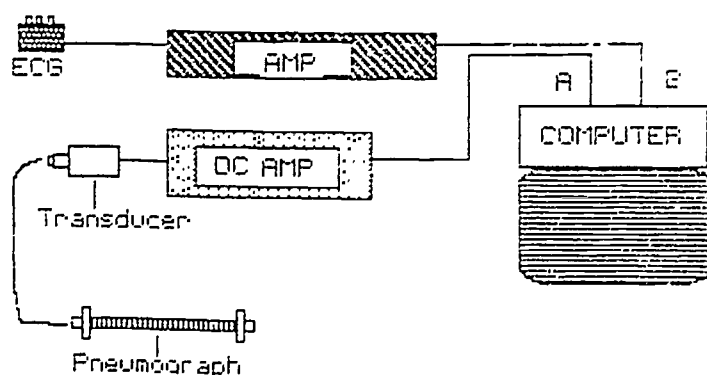

FIGURE 6. Diagram of equipment for measuring ECG and respiration rate in human subjects.

excited. The required preparatory session made the labs run smoothly, and the students were able to help themselves out of most problems. We have found that investment in the computers and printers has given us the ability to perform many more sophisticated experiments than would have been possible with standard physiology equipment. In addition, the students, rather than the instructor, are doing the experiments.

There is an additional sophisticated software package that comes with the COMPUTERSCOPE that

we have used in the more advanced courses. This package allows waveform integration, signal averaging, waveform comparison, and a histogram of interspike time intervals.

I would like to acknowledge the superb help of two colleagues, Howard Eichenbaum and Carol Anne Paul,

who worked together with me to set up the electrical equipment, design the experiments, and write the laboratory protocols

REFERENCE

1. Oakley B, Schafer R. *Experimental neurobiology: a laboratory manual*. Ann Arbor, MI: Univ of Michigan Press, 1978.

THE USE OF DRIVERS IN COMPUTER-ASSISTED INSTRUCTION

M.E. Jones, J.W. Mann, and M. Aucone

C.A.I. Laboratory, The School of Medicine, The Flinders University of South Australia, Bedford Park, South Australia

Most computer lessons are either simulations or tutorials. In a simulation, the student asks the questions of the computer, which answers by displaying, either graphically or numerically, the result of the conditions set by the student. Conversely, in the tutorial it is the computer which asks the question and the student who gives the answer. There is no compelling educational reason why a given computer-assisted instruction (CAI) presentation should not be a mixture of these two, but for practical reasons, most presentations are either one or the other; they generally involve quite different programming requirements.

Tutorial material, which includes multiple choice questions and true/false drill, is usually predominantly textual. The options that can be followed in mounting such material include authoring systems, authoring languages, and universal high level languages such as PASCAL, FORTRAN, and BASIC.^{1,2}

Despite the obvious benefits to be had from the use of authoring facilities, a large amount of CAI is written in universal languages. Disad-

vantages of authoring facilities may include limitation to particular hardware and a constraint on question format and lesson structure. In the tertiary environment, many people using CAI have two motives. One is to use the currently available facilities to the best advantage of their students. The second is a genuine interest in improving those facilities. By the very nature of tertiary institutions, such interest is almost inevitable. It follows that very few academics will follow a course of action that constrains the question format, the program sequencing, or indeed any significant variable. For those with an experimental approach to CAI, universal programming languages are usually the medium of choice.

The choice, however, is fraught with danger. On average it takes 200 hr to produce an hour of CAI. To produce good CAI, this option requires not only a grasp of the subject being taught and of some educational basics, but also of computer programming. Few are expert in all three fields, so lesson production becomes a joint effort of a pro-

grammer with the computing knowledge and an academic who understands the subject being taught. Educational expertise resides with either or neither. Programming is so slow that it requires only a few simultaneous projects to produce a bottleneck with unacceptable delays between conception and execution of the lesson. Academic enthusiasm dies in the interim, and many projects never come to completion.

Those projects that are completed are "hard-coded"; each lesson is a separate computer program and must usually be rewritten if it is to run on another machine. Update and modification requires the computer code to be modified, frequently a difficult task where program structure and documentation are inadequate.

By using a "driver" program, we can enjoy the best of both worlds. The concept is not new, and several drivers are currently in use. They facilitate lesson production and exchange, but are "open-ended" in the sense that any new format or facility can be incorporated into a driver. Perhaps because they facilitate the exchange of lessons between institutions with dissimilar hardware, they have not been widely promoted commercially.

A driver is something that a moderately proficient programmer can write for his institution's hardware. It is a single program, written once for any computer, which then accepts all lessons in a common format. Consider the simplest of tasks, the presentation of a lesson comprised of multiple choice questions. Instead of using a driver, one could write a computer program in which each line of each question was a "write" statement followed by "read" statements for student answers and then by code for marking and deciding which multiple choice question to ask next. That would be "hard-coded."

Alternatively one could put all the multiple choice questions in a

text file, following each by the correct answers, and then write a separate "driver" program that puts the first question on the screen, accepts the student's answer, compares it to the correct answer, adds a score, and decides which question to ask next. A new lesson would then require only a file of questions and answers; the lesson and the computer program have been separated, and a new lesson requires no new programming. If a second, different, computer is bought, the driver needs to be rewritten only once to be able to run all currently available lessons. To introduce some new facility (a new scoring system, diagnostics if a meaningless answer is given, statistics recording student use) there is only one program, the driver, to change. The driver then applies the changes to every file of questions that it runs.

The driver as described would have only one mode of action, multiple choice questions. To extend this it is necessary only to precede each question by some code, indicating whether it is multiple choice, true/false, etc. The driver then calls up the procedure appropriate to that mode of question. We found that all the tutorial and patient management material accumulated in "hard-coded" BASIC at Flinders, encompassing some hundred lessons written over five years, could be coded as sequences of six formats. Our driver has six "modes" corresponding to these, but it could be extended indefinitely by adding procedures for other modes. Two of the six modes allow for writing text on the screen, followed by the prompt "Press RETURN to continue." One writes in the top two thirds of the screen, the other in the bottom third. This allows us to erase and use the bottom while leaving text above and is useful when responding to a student's incorrect answer. Often the student has simply misread the question and if this has been erased, the ensuing explanation makes no

sense. When the student suspects he has misread the question, it is best that it still be available for re-reading.

Questions often invite an answer that can be right or wrong. Such questions will be followed by a binary branch in the lesson, coded for in one mode of the driver. Because there is no logical reason why the two options should be right and wrong, we use the term "target." In this mode, the target can be defined as letters, numbers (plus or minus a percentage), or as a set of words. The prompt will be "answer with a single letter," "answer with a single digit," "give your answer as a decimal to 3 sig. fig.," or "give a single word answer," as appropriate. Answers are classified as being either off or on target, and the program branches accordingly.

With numerical problems requiring calculation, students often "help" each other by swapping the answer without swapping the mechanism by which the answer is derived. To overcome this, we introduced a mode which we call "dynamic target." This involves choosing some parameters randomly from a range and adjusting the answer accordingly. Students get structurally identical problems with different answers. Thus, they can swap methods of solution but not "right answers."

Some questions permit a variety of answers and demand branching to more than two locations. We limit this to single digit or single character answers (within a predefined range). The lesson branches multiply according to the answer.

We have found it useful to have the driver keep two independent scores as the student progresses. For example, these might represent "knowledge" and "judgement" or "time in hospital" and "expense" depending on the whim of the author.

There are several benefits to be had from the use of such a driver. It

maintains virtually all the freedom of hard-coding in a universal language; new question formats and new facilities can be added to the driver at any time. The writing of new lessons using the driver is a "same day" task; typing in all the text, and even right and left margin justification can be carried out by a typist using the computer's editing or word processing facilities. Typographical errors and ambiguities can be eliminated at this stage, before any computing staff are involved. Once the author of the lesson has checked the text file, it remains only to add the "control" information specifying question formats, answers, scores, and branching. This may be specified on a separate file or incorporated in the text file. We follow the former strategy, but the practice is not universal. The lesson will then run on any machine which has the driver.

The use of drivers will facilitate lesson exchange if there are a few widely distributed drivers. Obviously a multiplicity of drivers would create a situation worse than no drivers at all, in which CAI libraries contained nearly as many drivers as lessons. Ideally, institutions contemplating writing their own material would use one of the current drivers, adding one or more new question formats as demanded by their own educational philosophy.

REFERENCES

1. Graham S. Tools for creating lessons on a computer. *Computers in Life Science Education* 2: 1-5, 1985.
2. Locatis C, Carr V. Factors to consider when choosing an authoring system. *Computers in Life Science Education* 2: 5-7, 1985.

COMPUTERS IN LIFE SCIENCE EDUCATION

HAROLD I. MODELL
Virginia Mason Research Center
Seattle, Washington

MARCEL BLANCHAER
Professor of Biochemistry
Faculty of Medicine
University of Manitoba
Winnipeg, Manitoba
Canada

THEODORE J. CROVELLO
Department of Biology
University of Notre Dame
Notre Dame, Indiana

JAMES W. ECKBLAD
Department of Biology
Luther College
Decorah, Iowa

TSEGAY, HABTEMARIAM
School of Veterinary Medicine
Tuskegee Institute
Tuskegee, Alabama

DONNA LARSON
School of Nursing
Grand Valley State College
Allendale, Michigan

TERRY M. MIKITTEN
Graduate School of Biomedical Sciences
University of Texas Health Sciences Center
San Antonio, Texas

JAMES E. RANDALL
Department of Physiology
Indiana University
Bloomington, Indiana

PATRICIA SCHWIRIAN
College of Nursing
Ohio State University
Columbus, Ohio

RICHARD STULL
College of Pharmacy
University of Arkansas
Little Rock, Arkansas

JAMES W. WOODS
Lister Hill National Center
for Biomedical Communications
National Library of Medicine
Bethesda, Maryland

DOROTHY WOOLEY-McKAY
Department of Biology
Glendale Community College
Glendale, Arizona

GLENN YOSHIDA
Department of Life Sciences
Los Angeles Southwest College
Los Angeles, California

ELSEVIER

CONTENTS

EDITORIAL COMMENT: REFLECTIONS AND FUTURE DIRECTIONS Harold I. Modell	89
TECHNOLOGY IN MEDICAL EDUCATION—A CASE STUDY APPROACH William G. Harless	92
KEEPING ABREAST OF THE LITERATURE	94

EDITORIAL COMMENT: REFLECTIONS AND FUTURE DIRECTIONS

Harold I. Modell
Virginia Mason Research Center, Seattle, Washington

This issue of CLSE marks the completion of two years of effort. It seems an appropriate time to evaluate the progress of the newsletter and think about its continued development. To do this, it is best to first review the goals of the project at its inception and then to address how well the articles met those goals.

HISTORICAL PERSPECTIVE

The project began as a means of addressing several concerns associated with the microcomputer explosion and the promotion of computers in education by the computer industry. An atmosphere reminiscent of the late 1960s was developing. It was during the late 1960s and early 1970s when interactive com-

puting was in its infancy that claims were being made that the computer was going to make instruction more efficient, free up instructors' time, promote independent study, and provide a multitude of educational benefits not yet realized by man.

Unfortunately, events did not support the claims. Most software took a "programmed learning" approach and presented material in a question and answer format. Much of the software was not well-designed, and life science educators dismissed the computer as an expensive, time-consuming fad rather than considering it a valuable teaching tool. It was clear several years ago that the same fate was in store for the microcomputer unless the novice was able to benefit from the experi-

ence of educators who found the computer an asset. The first goal of CLSE, then, was to provide a communication vehicle through which the novice could benefit from colleagues who had found the computer a useful educational tool.

The second goal was to promote communication among life science educators living in different academic environments. The rationale behind this goal stems from the belief that faculty living and working in a predominantly research-oriented environment (eg, medical school) can benefit substantially from the experience of faculty primarily engaged in teaching (eg, a four-year undergraduate college) and that materials designed with a specific student population in mind can often serve several diverse student populations.

The newsletter format was chosen over a journal format because, in a peer-reviewed medium, it allows sharing of anecdotal "tidbits" that often make the difference between success and failure when applying new technology.

MEETING GOALS IN VOLUME 1

The primary goal of volume 1 was to provide an overview of the diversity of computer applications in life science curricula. The inaugural issue set the tone for ensuing issues. In that issue, the diversity of applications was introduced with a caution that when using the computer as an educational tool, it is extremely important to keep in mind the educational goals of the application, the setting in which the computer is to be used, and the level of sophistication of the intended audience.²¹ Schottelius explored the use of mathematical simulations in a small group conference setting,²⁸ and Kovick and Michael discussed using the computer in a tutorial setting through computer lessons.²⁷ Subsequent issues provided additional insight into using computers for tu-

torials³² and in small group conferences.¹⁸

Computer use in the lecture hall was addressed from a number of standpoints. Mikiten²³ expanded on Schottelius' theme of using mathematical simulations in a group setting by discussing his experience in the lecture hall. His article provided insight into the importance of making the technology transparent to the student, and it noted the positive impact of this experience on student and instructor attitudes. Levine¹⁹ took a different approach to using the computer in the lecture hall. By using graphics to generate "slides" during the lecture, he was able to build complex slides one step at a time and incorporate animation into the process. Both authors make the software used in class available to students for review and further study. An important issue related to using computers in a group setting is the type and quality of video monitor used. Vincenzi³¹ addressed this issue when he reviewed two video projectors and their applicability to the lecture hall.

Another area in which the computer has proved beneficial is in the student laboratory. Barr and Stein¹ used a minicomputer system to replace physiological recorders in student laboratories in a medical school environment. Heidcamp,¹¹ on the other hand, incorporated microcomputers into undergraduate comparative physiology laboratories. Both authors indicated that use of the computer in these settings helped students gain a better understanding of the experiments being run, in part because of the ability to analyze data easily. Students can focus on the science involved rather than on details of the analysis.

The breadth of articles in volume 1 supported the hypothesis that communication among colleagues with students at differing educational levels is important because similar approaches are applicable in

multiple educational environments. Articles from the community college and four-year undergraduate levels^{9, 11, 26, 32} described similar approaches to problems as those from medical, graduate, and postgraduate settings.^{1, 2, 18, 27, 28}

MEETING GOALS IN VOLUME 2

Having sampled the spectrum of applications of computers in life science education currently used, the next step was to begin to provide more information of a "how-to" nature. Hence the primary goal of volume 2 was to delve into some applications in more depth and provide some of the "pearls of knowledge" harvested by colleagues experienced in using computers in the curriculum.

This process actually began in volume 1 with an article intended to provide ammunition for the battle with the dean's office for hardware support and space acquisition⁷ and with a discussion of factors to consider when designing input/output schemes for different educational settings.²⁵

The process continued with discussions of authoring systems,^{10, 20} software evaluation,²⁹ the "culture shock" experienced by health science students when dealing with computers,²¹ instructional design issues to consider when using graphics,⁵ interfacing the computer to analog devices for student labs,^{6, 8} and the practical details of using the computer in the lecture hall.

Articles by Holliday¹² and Meyers and Parsons²² provided an interesting contrast in applying the same software in an undergraduate setting. Holliday discussed his use of HUMAN,¹² a physiological simulation, as it is supplied by the authors. Meyers and Parsons, on the other hand, modified the same software to fit their curricular needs. The key elements in this process, of course, are having access to the software's source code, and having software

that is designed in a modular format, or at least with provision for understanding the logic behind the programming.

Other articles provided insight into the copyright laws that pertain to software,⁴ hardware acquisition for educational development,³⁰ a number of issues related to traditional computer-assisted instruction,^{14,15,16} and use of generic videodiscs.³

In another area of concern, Johnson¹³ provided valuable information for software seekers in a survey that resulted in a listing of computer-based instructional materials from over 40 vendors.

Although this brief review of material in volumes 1 and 2 of CLSE has not included all articles and features, it suggests that we have made progress in achieving our initial overall goals.

WHAT DOES THE FUTURE HOLD?

Perhaps the single most significant event to impact CLSE will occur next month as the newsletter becomes the communication arm of the National Resource for Computers in Life Science Education. In making the transition, publication responsibility will be taken over by the National Resource, and Elsevier will no longer be involved with CLSE publication. The editorial board will remain essentially intact, and the aims and scope of the newsletter as stated on the back page will not change. The subscription rate will change, however, to better match the funding status of the readership.

The National Resource for Computers in Life Science Education is a newly formed nonprofit organization aimed at cultivating collaborative efforts among faculty with expertise in using computers in life science education. The broad goal of this effort is fourfold: 1) to educate faculty in effective uses of computers in the curriculum; 2) to initiate research aimed at evaluating new ap-

plications of the computer to life science education; 3) to develop a critical mass of high-quality, versatile software; and 4) to serve in a consultant capacity for life science faculty currently active or interested in becoming active in this area.

Volume 3 of CLSE will begin with a full description of the National Resource and a discussion of philosophy behind the overall goal of the organization. Because the purpose of the Resource is service to the life science education community, your input will help shape the growth of the organization. If you have ideas, comments, or suggestions regarding development of the Resource, please send them to Harold Modell, PhD, Division of Nuclear Medicine, Mail Stop RC-70, University of Washington, Seattle, WA 98195.

REFERENCES

1. Barr L, Stein R: Computer-aided data acquisition in an undergraduate physiology laboratory. *Computers in Life Science Education* 1:19-22, 1984.
2. Blanchaer MC: Stimulating basic health science learning with clinical simulations on a microcomputer. *Computers in Life Science Education* 1:14-15, 1984.
3. Bolles JR: Generic videodiscs: an educational resource. *Computers in Life Science Education* 2:73-76, 1985.
4. Boyden PC: Which aspects of software are copyrightable? *Computers in Life Science Education* 2:57-59, 1985.
5. Churchill LD: Instructional design issues and the effective use of graphics in computer-assisted instruction. *Computers in Life Science Education* 2:45-47, 1985.
6. Clark CO: Computer interfacing for science experiments. *Computers in Life Science Education* 2:59-61, 1985.
7. Coleman TG, Randall JE: HUMAN, a comprehensive physiological model. *The Physiologist* 26:15-21, 1983.
8. Coyne MD: Substitution of apple computers for storage oscilloscopes and polygraphs. *Computers in Life Science Education* 2:81-86, 1985.
9. Crovello TJ: Computers in biology education: formal coursework at Notre Dame. *Computers in Life Science Education* 1:44-46, 1984.
10. Graham SN: Tools for creating lessons on a computer. *Computers in Life Science Education* 2:1-5, 1985.
11. Heidcamp WH: Computers and undergraduate comparative physiology. *Computers in Life Science Education* 1:54-55, 1984.
12. Holliday CW: Using "HUMAN," a comprehensive physiological model, in teaching undergraduate physiology courses. *Computers in Life Science Education* 2:41-43, 1985.
13. Johnson BA: A survey of medical/health science interactive instructional materials. *Computers in Life Science Education* 2:49-56, 1985.
14. Jones ME, Mann JW, Aucone M: Factors influencing the success of CAI programs. *Computers in Life Science Education* 2:61-63, 1985.
15. Jones ME, Mann JW, Aucone M: Failed CAI: where did all the effort go? *Computers in Life Science Education* 2:65-67, 1985.
16. Jones ME, Mann JW, Aucone M: The use of drivers in computer-assisted instruction. *Computers in Life Science Education* 2:86-87, 1985.
17. Larson DE: Using computer-assisted instruction in the education of health care professionals: what the dean needs to know. *Computers in Life Science Education* 1:65-67, 1984.
18. Lasher JC, Blumhardt R, Lancaster JL: Teaching radiologic principles by microcomputer in small group conferences. *Computers in Life Science Education* 1:29-32, 1984.
19. Levine SD: Microcomputer graphics as a substitute for lecture slides. *Computers in Life Science Education* 1:33-36, 1984.
20. Lichten C, Carr V: Factors to consider when choosing an authoring system. *Computers in Life Science Education* 2:5-7, 1985.
21. Malone JA: Computer culture shock: a case for affective education. *Computers in Life Science Education* 2:9-11, 1985.
22. Meyers RS, Parsons R: Creative educational use of software written by others. *Computers in Life Science*

- Education 2:25-32, 1985.
23. Mikiten TM: Enhancing lectures with a microcomputer. *Computers in Life Science Education* 1:9-11, 1984.
 24. Modell HI: Using the computer in the classroom—first steps. *Computers in Life Science Education* 1:1-3, 1984.
 25. Modell HI: Input/output design for different educational settings. *Computers in Life Science Education* 1:57-62, 1984.
 26. Mosley ML, Story NO, Walters J: Solving an instructional problem with interactive video. *Computers in Life Science Education* 1:49-50, 1984.
 27. Rovick AA, Michael JA: The computer lesson. *Computers in Life Science Education* 1:6-7, 1984.
 28. Schottelius BA: Teaching physiology by microcomputer in small group conferences. *Computers in Life Science Education* 1:4-6, 1984.
 29. Skiba DJ: Evaluation of computer-assisted instruction courseware. *Computers in Life Science Education* 2:11-14, 1985.
 30. Stull, R, Knoll R: Creative equipment acquisition for development of computer software. *Computers in Life Science Education* 2:33-35, 1985.
 31. Vincenzi FF: Projecting microcomputer images in the classroom: a comment on two projection monitors. *Computers in Life Science Education* 1:17-19, 1984.
 32. Wooley-McKay D: Use of computer tutorials in community college human anatomy and physiology classes. *Computers in Life Science Education* 1:36-37, 1984.

method. These combined technologies provide the educator with unprecedented capabilities for interactive and visual presentations, which point the way toward new educational designs and suggest new theoretical approaches to the process of medical education. In short, the new technology involving voice recognition, interactive videodiscs, and microprocessors seems to finally offer the fulfillment of the elusive promises of computer-aided instruction.

THE TIME PROJECT

This opportunity is the basis for the TIME (Technological Innovations in Medical Education) project at LHCNBC. The project involves the development of a series of interactive case studies, which utilize voice recognition technology, microprocessors, and interactive laser discs to facilitate the process of learning in medicine.

The first of these is a developmental model to define the characteristics of the interactive simulation; to develop techniques for dramatic presentation and effective interactivity; and to establish a multiple-disc player, voice-driven, microprocessor-controlled TIME delivery system.

The developmental model portrays a simulated patient named Frank Hall, who is played by a professional actor. Frank Hall is a 46-yr-old man who comes to the emergency room complaining of weakness and abdominal pain after an episode of vomiting blood two days earlier. The Frank Hall case requires two videodiscs. Each disc contains a variety of scenes depicting the patient's current experience in the hospital and, through flashbacks, significant past experiences which are related to his present illness. Other scenes depict elements of the physical examination and relevant diagnostic tests and procedures. All scenes are available to the student in any order, on command.

TECHNOLOGY IN MEDICAL EDUCATION—A CASE STUDY APPROACH

William G. Harless

*Lister Hill National Center for Biomedical Communications,
National Library of Medicine, Bethesda, Maryland*

Throughout its history the Lister Hill National Center for Biomedical Communications (LHCNBC) has supported the development of computer-aided learning in health professions education. As early as 1970, contracts were negotiated with the University of Illinois, Ohio State University, and the Massachusetts General Hospital to distribute their computer-aided learning materials over a telephone line network on a national basis. This early networking activity initiated by LHCNBC was the catalyst for the Health Education Network (HEN), which is self-supporting and continues to serve the medical community. Subsequent in-house research and development, coupled with a variety of presentations and associations with professional organizations in the field, are further evidence of

LHCNBC's commitment to computer-based education in the health sciences.

Although computer-aided learning has survived and even grown to some extent over the years, it has not emerged as the change force in education that the staunch advocates predicted. In fact, the difficulty of creating courseware, the limitations of visual presentations, and the restricted forms of interaction with the computer has caused a large proportion of the CAI materials to be educationally inadequate, and often boring.

However, recent technological developments, which include interactive laser discs, microprocessors, and voice recognition units, have transformed the concept of computer-aided learning and reignited a general enthusiasm of educators for this

In effect, the student may do any of the following. 1) conduct an interview with the simulated patient, taking a complete medical history and gathering relevant sociological and psychological information in the process; 2) request diagnostic procedures and perform a simulated physical examination; 3) admit the patient to the hospital and, after ordering diagnostic procedures and specifying a hospital management plan, observe the various hospital experiences the patient has; 4) be faced with a crisis (ie, rebleed, MI, DTs) determined by the system; 5) discharge the patient and observe the outcome.

Six characteristics are an integral part in the design of the Frank Hall interactive case study and distinguish the TIME model as a unique resource in medical education.

1. *Uncued interaction* allows the learner to use his or her natural spoken language while dealing with the patient.
2. Multiple health problems require *multiple diagnoses* for appropriate management.
3. A *full range of medical, social, and clinical information* available to the learner in dynamic visual and audio form portrays the drama of the patient's condition and life situation.
4. *Probability-based occurrences and outcomes* reflect the real clinical environment.
5. A *dynamic, time-related management* process responds to the learner's independent, uncued interventions.
6. Algorithms provide the learner with *formative feedback* by immediately portraying the impact of his or her clinical interventions and *summative feedback* which conveys his or her overall performance as a physician with the situation at hand.

The second and third TIME case studies will be created using the

knowledge and experience gained from the developmental model. Both will be placed in an academic setting with an experimental design and appropriate evaluation instruments to determine the effectiveness of this educational approach. It is hoped by the TIME staff that these prototypical interactive case studies will demonstrate to the medical academic community that new, highly desirable approaches to the education of medical students is possible through the effective use of these technologies

EDUCATIONAL CONSIDERATIONS

The Frank Hall case demonstrates the possibility for implementing effective, patient centered, problem oriented learning strategies by providing the student with a believable, engaging clinical scenario which encourages participation and requires that the student make independent decisions about the patient's situation. Several attempts have been made to implement similar experiential learning strategies over the past few years. Role playing, simulations by actors, and a variety of computer-aided simulations¹⁻³ are among the noble efforts which have only partially succeeded in their attempts to provide patient centered, cost effective learning in the medical school setting. The new technology, if properly designed, can succeed where others have failed in the effort to ground medical education in clinical experiences.

In addition, instruction can be offered concerning relevant medical and scientific concepts, physical examination techniques, and diagnostic procedures within the context of that medical problem. For example, an adequate program design within the Frank Hall case will permit the student to receive instruction in performing a neurological exam, examining the abdomen, taking vital signs, or starting an intravenous infusion. These tutorials are initiated

by the student using the control word "instruction." Such contextual instruction can also be offered by the professor controlling the interactive case study in the classroom. He or she may determine a "teachable moment" in the course of the case, freeze the action with the command "stop," and then lecture or answer questions. This efficient, effective process of "contextual instruction" can resolve many of the contemporary problems of information overload and student time constraints discussed in the recent GPEP report of the AAMC.⁴

Finally, in professional education it is essential that those being trained are helped to grow in their understanding of situations and their sensitivities to the human condition from the perspective of the profession they represent.⁵ Such consciousness raising is a specific goal of the TIME model. Implementation is accomplished through effective drama of the patient's experience designed to promote incidental insights about the patient's illness and revelations concerning the human condition. Also, the command word "thoughts" is available at any time to the student, which will cause the unspoken thoughts of the patient to be heard. The student may, in this way, stay aware of the psychological complexities of the patient's situation while he or she deals with the medical condition of the patient.

TECHNOLOGICAL CONSIDERATIONS

The TIME delivery system consists of an IBM PC/XT, Votan voice system (VPC-2000), Red Max videodisc interface, three LDV-6000 Pioneer videodisc players, and a Sony color monitor. The capabilities of the new technology for random access of high quality video and multiple audio tracks, coupled with the intelligence capacity of the computer, make possible the creation of an effective interactive case study which encompasses sophisticated

educational strategies while supporting engaging dramatic situations. Specifically, the purposes of the three component parts of the TIME delivery system are as follows:

- Voice Recognition
 - To make the technology invisible to the user.
 - To allow uncued, natural language interaction.
- Microprocessor
 - To control the voice driven, multiple videodisc system.
 - To support an intelligent interface between the user and the system.
 - To support a dynamic, time-related simulation.
 - To accomplish the tracking necessary to evaluate performance.
- Videodisc
 - To allow believable dramatization of the medical situation being simulated.
 - To allow immediate access to a variety of dynamic video and audio material depicting clinical information about the patient (eg, endoscopic views, physiological sounds, radiographs).

SUMMARY

The TIME staff has been successful in producing a working prototype of a simulation which embodies the following characteristics: 1) uncued interaction with the system through voice recognition; 2) a patient with multiple diagnoses; 3) a full range of medical, social, and clinical data concerning that patient's condition and situation; 4) a dynamic time-related management intervention capability; 5) a model that provides summative, individual evaluation for any learner who interacts with the simulated patient.

The prototype in its current stage of development has been presented to a variety of medical educators, professional groups, and organizations; and immediate plans call for its use in the introduction to clinical medicine classroom of several medical schools for field testing and evaluation.

Currently the TIME staff is working to complete the creation of two additional TIME interactive case studies which will also be field tested. Efforts are underway to track precisely the costs of development and to develop more effective procedures for producing high quality, low cost interactive case studies.

REFERENCES

1. Abrahamson S, Denson F, Wolf R: Effectiveness of a simulator in training anesthesiology residents. *J Med Educ* 44:515-519, 1969.
2. Friedman RB: A computer program for simulating the patient-physician

encounter. *J Med Educ* 48:92-97, 1973.

3. Harless WG, et al: CASE: a computer-aided simulation of the clinical encounter. *J Med Educ* 46:443-448, 1971.
4. Physicians for the Twenty-First Century: report of the panel on the general professional education of the physician and college preparation for medicine. Association of American Medical Colleges, Washington, D.C., 1984.
5. American Board of Internal Medicine: report of subcommittee on evaluation of humanistic qualities in the internist. American Board of Internal Medicine, Portland, Oregon, July, 1983.

KEEPING ABREAST OF THE LITERATURE

The following citations are presented as part of a quarterly feature in *CLSE* designed to help readers become aware of current literature pertinent to computer applications in life science education.

- Akers TK et al: Microcomputer physiological model simulation used in physiology class. *Biomed Sci Instrum* 21:103-107, 1985.
- Bell ME: The role of instructional theories in the evaluation of microcomputer courseware. *Educ Tech* 25(3):36-40, 1985.
- Blackman JA et al: Use of a computer-videodisc system to train medical students in developmental disabilities. *Medical Teacher* 7:89-98, 1985.
- Brown RF et al: American College of Radiology network and workstation. *Amer J Roentgenol* 144:665-666, 1985.
- Clarke RA: Computers in toxicological education: an overview. *Med Inf* 10:161-168, 1985.
- Day KH: CAI integration: it's time for a new approach... nurse consultants play an important role. *Nurs Success Today* 2(5):21-24, 1985.
- Felton G et al: Application of computer technology in two colleges of nursing. *J Nurs Ed* 24:5-9, 1985.
- First MB et al: QUICK (QUick Index to Caduceus Knowledge): using the INTER-NIST-1/CADUCEUS knowledge base as an electronic textbook of medicine. *Comput Biomed Res* 18:137-165, 1985.
- Gotlib D et al: A computerized database-management system for curriculum analysis. *Can Med Assoc J* 131:861-863, 1984.

Heller BR et al: Computer applications in nursing: implications for the curriculum. *Comput Nurs* 3:14-22, 1985.

Hofstetter FT: Eighth annual Peter Dean lecture: perspectives on a decade of computer-based instruction, 1974-84. *J Computer-Based Instr* 12:1-7, 1985.

Huntington JF: Computer comments: common standards; video and micro courseware. *Educ Tech* 25:33-34, 1985.

Joshi BD: Exploring reaction thermodynamics using a personal computer. *J Comp Math Sci Teach* 4(2):24-28, 1984-85.

Kearsley GP et al: Design factors for successful videodisc-based instruction. *Educ Tech* 25(3):7-13, 1985.

Kellogg B et al: Introducing nursing students to computers. *Comput Nurs* 3:128-132, 1985.

Lehman JD et al: Biology education with interactive videodiscs. *Am Biol Teach* 47:34-40, 1985.

Lunetta VN et al: Simulations in education: sharpening an old tool. *Curriculum Review* 24(4):30-32, 34, 1985.

Maude DL: Acid-base disorders—a computer simulation. *The Physiologist* 28:118-121, 1985.

McSherry D et al: Knowledge acquisition in the development of an introductory guide to diagnosis in rheumatology. *Med Inf* 10:43-49, 1985.

Mitchell MC Jr: Navigating the software maze. *VocEd* 59(3):25-26, 1984.

Olson S et al: Designing computer screen displays. *Performance and Instruction* 24:16-17, 1985.

Pattison L: Software writing made easy. *Electronic Learning* 4:30-36, 1985.

Reynolds JA: Using microcomputers in situa-

- tional testing... reducing test phobia
Nurse Educ 9(2):39-42, 1984.
- Risl V JS: Courseware review. Physics
Teacher 23:240, 1985.
- Smith JM: Courseware evaluation, a guide
for nursing educators. Comput Nurs
3:117-121, 1985.
- Sturm R: High tech breakthrough: interac-
tive videodisc. Wilson Library Bulletin
59:450-452, 1985.
- Suppes P et al: Computer-assisted instruc-
tion: possibilities and problems. NASSP
Bulletin 69(480):30-34, 1985.
- Thiele JE et al: A simulated practice environ-
ment. Computerville Regional Hospital.
Comput Nurs 3:113-116, 1985.
- van Dyk TAM et al: Motives for CAI in
post-secondary education. J Computer-
Based Instr 12:8-11, 1985.
- Whitney RV: Interactive computer systems
for health care educators. Hosp Forum
27(6):19-20, 1984

Compiled by H. Modell

EDITOR'S NOTE

Beginning with the January 1986 Issue, CLSE will be published by the National Resource for Computers in Life Science Education. Subscription Information may be obtained by writing to:

Harold Modell, Ph.D.
Division of Nuclear Medicine
Mail Stop RC-70
Univ. of Washington
Seattle, WA 98195

COMPUTERS IN LIFE SCIENCE EDUCATION, VOLUME 2 INDEX

- affective education, 2:9-11
- anatomy, of arm, 2:14-16
- animation, 6:47
- arm, anatomy of, 2:14-16
- Aucone M, 8:61-63, 9:65-67, 10:76-77,
11:86-87
- authoring
languages for, 1:3-4
systems for, 1:3-4, 5-7, 11:86
- axon action potential model, 4:26-29
- biology
remedial education in, 3:17-22
workstations in, 11:81-82
- Bolles JR, 10:73-76
- Boyden PC, 8:57-59
- Carr V, 1:5-7
- case studies, 12:92-94
- Churchill LD, 6:45-47
- Clark CO, 8:59-61
- color, 6:47
- computer-assisted instruction
drivers in, 11:86-87
graphics in, 6:45-47
in nursing, 9:67-71
in remedial biology, 3:17-22
success of, 8:61-63, 9:65-67
- videodisces in, 6:43-45, 10:73-76,
12:92-94
- computer literacy, effective teaching of,
2:9-11
- COMPUTERSCOPE, 11:81-86
- copyright, 8:57-59
- courseware
available, 3:23-24, 7:49-56
copyright of, 8:57-59
creation of, 1:1-7
evaluation of, 2:11-14
remedial, 3:17-22
Coyne MD, 11:81-86
- digital image processors, 10:77-79
- drivers, 11:86-87
- Eckblad JW, 10:77-79
- examinations
drivers and, 11:86-87
in remedial biology, 3:20-21
- experiments
interfacing with, 8:59-61
simulations of, 10:76-77
- Graham SN, 1:1-5
- graphics, 1:2, 6:45-47
from HUMAN model, 4:30-32
- hardware
access to, 5:33-35
for arm anatomy, 2:14-16
authoring systems and, 1:6
for interfacing, 8:61
for oscilloscope substitution, 11:81-82
- Harless WG, 12:92-94
- Health Education Network, 12:89
- Heard BK, 6:43-45
- Heard J Jr, 6:43-45
- Hodgkin-Huxley model, 4:26-29
- Holliday CW, 6:41-43
- HUMAN model, 4:29-32, 6:41-43
- interfacing, 8:59-61
- Jelemensky LC, 9:67-71
- Johnson BA, 7:49-56
- Jones ME, 8:61-63, 9:65-67, 10:76-77,
11:86-87
- Kabo JM, 2:14-16
- Knoll R, 5:33-35
- languages, authoring, 1:3-4
- literature, current, 3:22-23, 6:48,
9:71-72, 12:94-95
- Locatis C, 1:5-7
- Malone JA, 2:9-11
- Mann JW, 8:61-63, 9:65-67, 10:76-77,
11:86-87
- Meals RA, 2:14-16
- Meyers RS, 4:25-32
- microcomputers
interfacing to, 8:59-61

- microcomputers (continued)
 in nursing, 9:67-71
 simulations on, 5:35-38
 video images on, 10:77-79
 Modell HI, 3:22-23, 5:35-38, 6:48,
 12:89-92
 models
 HUMAN, 4:29-32, 6:41-43
 nerve, 4:26-29, 11:82-85
 TIME, 12:92-94
 multiple-choice questions, 8:62, 11:86-87
 National Resource for Computers in Life
 Science Education, 12:91
 nerve conduction velocity, 11:82-85
 nursing, 9:67-71
 oscilloscopes, 11:81-82
 patient simulation, 12:92-94
 physiology, HUMAN model of, 4:29-32,
 6:41-43
 polygraphs, 11:81-86
 Randall model, 4:26-29
 remedial education, in biology, 3:17-22
 simulations, 8:62
 of experiments, 10:76-77
 as lecture aids, 5:35-38
 patient, 12:92-94
 Skiba DJ, 2:11-14
 software
 available, 3:23-24, 7:49-56
 copyright of, 8:57-59
 creation of, 1:1-7
 evaluation of, 2:11-14, 8:70-71
 interfacing and, 8:60-61
 sources of, 3:23-24
 students, 9:66-67
 affective teaching of, 2:9-11
 interactions with, 2:13
 Stull R, 5:33-35
 TIME project, 12:92-94
 videodiscs, 6:43-45, 12:92
 generic, 10:73-76
 Washington DJ, 3:17-22

AIMS AND SCOPE

The goal of *Computers in Life Science Education* is to provide a means of communication among life science educators who anticipate or are currently employing the computer as an educational tool. The range of content includes, but is not limited to, articles focusing on computer applications and their underlying philosophy, reports on faculty student experiences with computers in teaching environments, and software hardware reviews in both basic science and clinical education settings.

INVITATION TO CONTRIBUTORS

Articles consistent with the goals of *Computers in Life Science Education* are invited for possible publication in the newsletter. For information on preparation and submission of material, write to Dr. Harold Modell, Virginia Mason Research Center, 1000 Seneca Street, Seattle, WA 98101.

SUBSCRIPTION INFORMATION

Computers in Life Science Education is published monthly by Elsevier Science Publishing Co., Inc., 52 Vanderbilt Avenue, New York, NY 10017. Subscription rate is \$58.00 for 12 issues, including postage and handling in the United States and Canada. Add \$20.00 for postage (airmail) in Mexico and Europe and \$23.00 for the rest of the world. See Editor's Note (p 95) for 1986 subscription information.

This newsletter has been registered with the Copyright Clearance Center, Inc. Consent is given for copying of articles for personal or internal use, or for the personal or internal use of specific clients. This consent is given on the condition that the copier pay through the Center the per-copy fee stated in the code on the first page for copying beyond that permitted by the US Copyright Law. If no code appears on an article, the author has not given broad consent to copy and permission to copy must be obtained directly from the author. This consent does not extend to other kinds of copying, such as for general distribution, resale, advertising and promotional purposes, or for creating new collective works.

Address orders, changes of address, and claims for missing issues to Journals Fulfillment Department, Elsevier Science Publishing Co., Inc., 52 Vanderbilt Avenue, New York, NY 10017. Claims for missing issues can be honored only up to three months for domestic addresses and six months for foreign addresses. Duplicate copies will not be sent to replace ones undelivered due to failure to notify Elsevier of change of address.

Address editorial correspondence to Harold I. Modell, PhD, Virginia Mason Research Center, 1000 Seneca Street, Seattle, WA 98101.

POSTMASTER: Send address changes to *Computers in Life Science Education*, Elsevier Science Publishing Co., Inc., 52 Vanderbilt Avenue, New York, NY 10017.

COMPUTERS IN LIFE SCIENCE EDUCATION

HAROLD I. MODELL

Department of Radiology
University of Washington
Seattle, Washington

MARCEL BLANCHAER

Department of Biochemistry
Faculty of Medicine
University of Manitoba
Winnipeg, Manitoba
Canada

THEODORE J. CROVELLO

Department of Biology
University of Notre Dame
Notre Dame, Indiana

JAMES W. ECKBLAD

Department of Biology
Luther College
Decorah, Iowa

TSEGAYE HABTEMARIAM

School of Veterinary Medicine
Tuskegee University
Tuskegee, Alabama

DONNA LARSON

School of Nursing
Grand Valley State College
Allendale, Michigan

TERRY M. MIKITEN

Graduate School of Biomedical Sciences
University of Texas Health Science Center
San Antonio, Texas

JAMES E. RANDALL

Department of Physiology
Indiana University
Bloomington, Indiana

PATRICIA SCHWIRIAN

College of Nursing
Ohio State University
Columbus, Ohio

RICHARD STULL

College of Pharmacy
University of Arkansas
Little Rock, Arkansas

JAMES W. WOODS

Lister Hill National Center
for Biomedical Communications
National Library of Medicine
Bethesda, Maryland

DOROTHY WOOLEY-McKAY

Department of Biology
Glendale Community College
Glendale, Arizona

GLEN YOSHIDA

Department of Life Sciences
Los Angeles Southwest College
Los Angeles, California

NRCLSE

CONTENTS

ESTABLISHMENT OF THE NATIONAL RESOURCE FOR COMPUTERS IN LIFE SCIENCE EDUCATION Harold I. Modell	1
THE BULLETIN BOARD	6
NRCLSE QUESTIONNAIRE	7

ESTABLISHMENT OF THE NATIONAL RESOURCE FOR COMPUTERS IN LIFE SCIENCE EDUCATION

Harold I. Modell

Department of Radiology, University of Washington, Seattle, Washington

The development of the microcomputer has focused new attention on the computer as an educational tool. Low cost, relatively portable computers offering high resolution graphics coupled with technological advances in video projection and recording devices have created new opportunities for advancement in life science education. In addition to the role that the computer has played in independent study settings through traditional computer-assisted-instruction, this new technology offers the promise of revolutionizing classroom instruc-

tion, transforming the traditional passive learning milieu into an environment in which active learning predominates. Consider, for example, a physiology class 'performing' experiments using mathematical simulations, a biochemistry class studying structure by 'manipulating' portions of molecules using three dimensional computer graphics techniques, or an introduction to clinical medicine class 'interviewing' a patient through a videodisc based, unqued inquiry, clinical simulation.

When compared to the activity that

would result in the life science community from a scientific development offering the same magnitude of potential impact, advancement in this area has been minimal. The reward system in the life science community and availability of funding are two factors which have contributed to this slow rate of progress.

The reward system in the life science community is, for the most part, directed toward scientific research productivity. The recent GPEP report of the Association of American Medical Colleges summarized the problem with respect to the medical school subgroup of this community, "Despite frequent assertions that the general professional education of medical students is the basic mission of medical schools, it often occupies last place in the competition for faculty time and attention. Graduate students, residents, research, and patient care are accorded higher priorities."¹

Because external funding, one measure of productivity, supporting personnel involved in educational research and development efforts in the life sciences is difficult, at best, to identify, and because educational research and development efforts in this area are labor intensive, few faculty are willing to make the time commitment necessary to pursue these activities at the expense of their scientific research efforts. Yet it is precisely these faculty whose content expertise is essential to development of high quality materials for use in the educational arena.

Although a nationally coordinated program does not exist currently, progress is being made in this area by a relatively small group of individuals in a variety of disciplines and institutions. Interest in symposia and workshops focused on computer based education held at national meetings of societies representing the life science community (eg, AIBS, FASEB), however, demonstrates a growing interest by other faculty to use this technology. Attendees have repeatedly voiced the need for direction in effective use of computers in teaching as well as a critical mass of quality

software versatile enough to allow tailoring to a variety of curricula. A collaborative effort among faculty with expertise in this area would represent a major step toward fulfilling these needs.

THE NATIONAL RESOURCE

The recently established National Resource for Computers in Life Science Education (NRCLSE) is a non-profit organization aimed at cultivating collaborative efforts among faculty with expertise in using computers in life science education. The broad goal of the Resource is fourfold:

- 1) to educate faculty in effective uses of computers in the curriculum;
- 2) to initiate research aimed at evaluating new applications of the computer to life science education;
- 3) to develop a critical mass of high quality, versatile software;
- 4) to serve in a consultant capacity for life science faculty currently active or interested in becoming active in this area.

Educating Faculty

Educating faculty will be accomplished through several mechanisms. The first will be through *Computers in Life Science Education*. The goal of the newsletter will continue to be to provide a means of communication among life science educators interested in using computers in their teaching efforts. Through publication of tutorial and review articles, faculty will have access to a regular source of information related to a variety of applications of computers in teaching.

A series of workshops and symposia to be conducted in conjunction with national meetings of the life sciences community and at other times on a regional basis will provide a second vehicle for faculty education. The focus of these workshops will, in some cases, be broad based and, in other instances, be directed toward applications in specific curriculum areas represented by Resource affiliates. For example, the first workshop in this effort will be

broad based and deal with using the computer and video projector in the lecture hall. It will be presented in February at the annual meeting of the Association for the Development of Computer-based Instructional Systems (ADCIS) and repeated in the fall at the annual meeting of the American Institute of Biological Sciences (AIBS).

In addition to the workshop format, the Resource will sponsor in-depth short courses (1-2 weeks) at affiliated sites in which 'student' faculty can gain experience in applying computers to teaching their area of expertise.

It is anticipated that the Resource will also establish a visiting faculty program in which faculty interested in learning specific techniques associated with software development or presentation can work intimately with investigators active in the area.

Research and Development

Traditionally, the most extensive use of computers in education has been in the area of independent study. Applications have, for the most part, been limited to presentation of material through text and simple graphics (and, more recently, pictorials using videodisc). Advancements in technology and computer techniques within the industrial complex (eg, computer-aided design, graphics simulations of terrain for flight simulators) offer considerable potential for application in the educational realm. The research and development effort of the Resource will be to instigate and coordinate a program-project approach to investigating innovative, cost-effective applications of this emerging technology to teaching in the life sciences. Emphasis on evaluating the impact of these applications on student understanding will be stressed.

Software Development

Because software development is a time-intensive effort and one that is not viewed consistently as 'scholarly' by promotion criteria, limited high quality software is available, and most available software was developed with one

application in mind. As a result, software potentially applicable to a given topic, regardless of the curricular approach, is limited to curricula sharing the presentation philosophy of the author. An early task of the Resource in this area is to establish a set of guidelines for software development aimed at making software versatile enough to fit into a variety of curricular applications. Because Resource collaborators will represent many life science disciplines, the software development effort will result in a critical mass of materials adhering to a common set of conventions.

Software developed will be viewed in the same light as scientific data and, hence, will be disseminated on a non-profit basis with both executable and source code available. The dissemination scheme will also give permission for purchasers to make copies of the software so that it can be utilized within the curriculum at a reasonable cost.

Consultation Services

NRCLSE will provide consultation services in several ways. In addition to the usual mode of personal contact (eg, telephone or correspondence), the Resource will staff exhibits at national meetings attended by life science educators. The purpose of the exhibits will be to make faculty aware of the Resource and to provide consultation services. Also included in this goal is development of a mechanism whereby life science educators engaged in independent software development projects can have their work critiqued by peers.

Impact

The potential impact of the Resource on life science education is substantial. NRCLSE represents a coordinated, interdisciplinary effort involving life science faculty distributed across the country. With establishment of this active communication vehicle, applications found to be effective in one discipline will be available for trial in other disciplines in a timely manner. In addition, by promoting development of versatile software adhering to a common set of de-

sign and implementation conventions, a broad spectrum of student populations can be served, perhaps as broad as high school to post graduate medical training.

FIRST PROJECTS

Having reviewed the overall goals and potential impact of NRCLSE, it is appropriate to address the issue of how these goals will be met. The key factor in achieving the goals of the Resource is establishment of a network of collaborators within the life sciences. The first priority of the Resource will be indentifying colleagues who have a common interest in using the computer in their educational efforts. The first step in this process will be a mailing to chairmen of the nearly 2700 academic departments making up the life science community in the United States. The mailing will consist of this issue of CLSE to provide a description of the Resource, and a letter encouraging all faculty with interests in this area to complete and return the questionnaire that appears on page 7 of this issue. The response will form the basis of several activities.

Through responses to the questionnaire and a polling of professional organizations (eg, American Association of Medical Colleges, American Institute of Biological Sciences, National Association of Biology Teachers, Society for College Science Teachers), common interest areas will be identified, and those people falling into each interest area will be made aware of colleagues in other institutions with similar interests. In this way, a person-to-person communication network will be initiated.

The questionnaire will also provide a base from which to identify expertise in various applications of computers in the curriculum. From this information, potential faculty for Resource sponsored workshops will be recruited, and a group willing to act as informal consultants for peers will be established.

A peer critique mechanism for re-

viewing software will also be initiated. The review process for software requires consideration of a number of factors including instructional design and relevance to curriculum philosophy in addition to content. For this reason, the concept of peer review as it normally applies to scientific journal articles, implying acceptance or rejection, is not directly applicable to all software review. The purpose of this review mechanism will be to provide constructive critique for colleagues developing educational software. However, it is also important that faculty be made aware of existing software and be given some information so that they can judge whether it will be helpful in their environment. Hence, in addition to the periodic "Where's the Software" feature that has appeared in Volumes 1 and 2, reviews of selected software will be published in CLSE.

Software Identification and Dissemination

One serious problem facing faculty wishing to use the computer as a teaching tool is identification and procurement of quality software at a reasonable price. Many individuals have developed software specific to their content area but not broad enough to warrant attention by commercial vendors. Because many authors view their software in the same light as their scientific data, that is, a scholarly effort to be shared with peers rather than commercialized, they do not wish to deal with publishers that establish high prices and impose severe restrictions on copying.

NRCLSE will attempt to identify this group of individuals and offer to provide a means of disseminating their software. The dissemination scheme will include a pricing schedule designed to recover duplicating costs and, in some cases, developmental costs for the author. Because the intent is to disseminate rather than distribute software, all software distributed by the Resource will not be copy protected and will include permission for purchasers to make enough copies to provide the soft-

ware to appropriate students. Authors will be responsible for supporting their software.

The first package to be made available through this mechanism is a series of simulations in respiratory physiology.^{2,5} An earlier version of these programs was distributed by the American Thoracic Society from 1975-1981. This revision, currently only available for the Apple II family of computers, includes one or more pictorial representations as part of the output of each program. These are designed to provide a conceptual aid to understanding the physiology involved, an indication of where values are measured, or a description of the model and how it is solved.⁵ The simulations were designed originally to be used as laboratory exercises,³ but this revision has also been used in group settings.² A student laboratory manual accompanies the series. The material covered by the series of 12 programs is summarized in Table 1. The materials are priced as follows.

- The executable (compiled) version of the programs (3 disks), documentation, and one copy of the student laboratory manual is \$100.
- The source code (1 disk), documentation, and one copy of the student laboratory manual is \$100.
- Student laboratory manuals are available in quantities of 1-25 for \$10.00 each and \$8.50 each for quantities above 25.

FUNDING

Funding for NRCLSE will be sought in three phases. Phase 1 funding will be sought for the starting projects outlined above. Phase 2 will represent initiation of research and development projects. Phase 3 will build on phase 2 funding to provide continued viability for the Resource. It is assumed that subscriptions to *Computers in Life Science Education* will fund production of the newsletter.

Table 1. Overview of *Simulations in Physiology - The Respiratory System*

PROGRAM TITLE	MATERIAL COVERED
Static Relationships	Elastic properties of the lung, chest wall, and total respiratory system
Dynamic Relationships I	Effects of lung compliance and airway resistance on development of a tidal volume
Work of Breathing	Oxygen cost of elastic, resistive, and total work during inspiration
Dynamic Relationships II	Respiratory dynamics in terms of the total respiratory system (lung and chest wall)
Alveolar Gas Exchange	Gas exchange between the atmosphere and the alveolar compartment
Chemoregulation of Respiration	Oxygen and carbon dioxide response curves
O ₂ and CO ₂ Dissociation Curves	Interrelationships between the O ₂ and CO ₂ dissociation curves
Exchange from Atmosphere to Tissues	Influence of alveolar ventilation, cardiac output, and anatomic shunt flow on arterial blood composition and gas exchange at the tissues
Gas Exchange in a Single Alveolus	Influence of ventilation-perfusion ratio and inspired gas on gas exchange in a single gas exchange unit
The Non-Uniform Lung	Gas exchange from atmosphere to tissues with a lung having high and low ventilation-perfusion ratio areas
Overall Gas Exchange	Gas exchange from atmosphere to tissues with a lung having high and low ventilation-perfusion ratio areas and an anatomic shunt
Acid Base Balance: Fundamental Relationships	Acid-base balance from a Base Excess point of view

Phase 1
Funding for identifying the critical mass of interested faculty, establishing the communication network, setting up the peer critique mechanism, and other initial efforts will be sought as donations or grants from foundations and

corporations with an interest in the use of computers in education.

Phase 2
This phase of funding will represent the beginning of research and development efforts. After the communication net-

work is established, colleagues will be solicited for preproposals for research and development projects that they would like to undertake. The Resource will then serve in a coordination and facilitation capacity to organize a series of program-project type grant proposals. The preproposals will be grouped into theme areas, and investigators with similar interests will be encouraged to develop joint projects. Formal program-project proposals will then be developed for submission to government agencies and private foundations. Each of the component projects in the program-project will be subcontracted to the institutions housing each of the respective investigators. The role of the Resource in this effort is two-fold: First, to promote research and development activity in this area, and second, to provide a national focus to such efforts in an attempt to educate funding agencies with regard to the importance of this activity.

By the end of this funding phase, the communication network will be well established, a group of active colleagues with sufficient expertise to provide meaningful consultation will have been organized, and a critical mass of versatile, transportable, computer-based edu-

cational materials should be available in several curriculum areas to serve as a basis for developing Phase 3 funding.

Phase 3

Continued funding for the Resource will be based on a continuation of Phase 2 efforts and on institutions subscribing to NRCLSE. Each subscriber would contribute a fixed amount (eg, 1/2 FTE) to the Resource. In return, each member institution would gain access to services and software outlined above. In addition, contributions for a critical mass of member institutions would allow the Resource to serve as a funding source for a limited number of peer reviewed proposals for research and development projects from member institutions.

CONCLUSION

The Resource can only function if it provides valuable support for that segment of the life science community interested in using the computer as a tool in educational programs. It is crucial, therefore, that the Resource has input from that segment of the community (you). Please take time to complete the questionnaire on page 7 and return it along with any suggestions,

comments, criticism, etc. concerning NRCLSE to Harold Modell, NRCLSE, Mail Stop RC-70, University of Washington, Seattle, WA 98195.

REFERENCES

1. Physicians for the 21st Century – The GPEP Report. Washington, D.C.: American Association of Medical Colleges, 1984.
2. Modell HI: Use of computer simulations to promote active learning in multiple teaching settings. *The Physiologist* 28:445-446, 1985.
3. Modell HI, Farhi LE, Olszowka AJ: Physiology teaching through computer simulations – problems and promise. *The Physiology Teacher* 3:14-16, 1974.
4. Modell HI, Olszowka AJ, Klocke RA, Farhi LE: Normal and abnormal lung function, a program for independent study. New York: The American Thoracic Society, 1975.
5. Modell HI, Olszowka AJ, Plewes JL, Farhi LE: Role of computer graphics in simulations for teaching physiology. *The Physiologist* 26:93-95, 1983.

THE BULLETIN BOARD

The Bulletin Board is published periodically to inform readers of upcoming meetings of interest. If you know of meetings, symposia, continuing education courses, etc, of interest to life science educators that do not appear in THE BULLETIN BOARD, please let us know. Send pertinent information to Dr. Harold Modell, NRCLSE, RC-70, University of Washington, Seattle, WA 98195.

March 31-April 1, 1986 Third National Symposium on Microcomputers in Medical Education. Omaha, Nebraska.

Contact:

Robert S. Wigton, MD
Department of Internal Medicine
University of Nebraska Medical Center
42nd and Dewey Avenue
Omaha, NE 68105

April 16-18, 1986. Computers and Nursing: A Dynamic Interface IV. Columbus, Ohio.

Contact:

Mary Beth Strauss, PhD, RN
Director
Continuing Education
The Ohio State University
College of Nursing
1585 Neil Avenue
Columbus, OH 43210
(614) 422-5371

May 2-5, 1986. Health Sciences Communications Association (HeSCA) 1986 Annual Meeting. Denver, Colorado.

Contact:

Jim Barrett
Center for Educational Resources,
SB-56
University of Washington
Seattle, WA 98195
(206) 545-1156

or:

Lionelle Elsesser
Executive Director, HeSCA
6105 Lindell Blvd
St. Louis, MO 63112

May 8-10, 1986. Computer applications in medicine and health care. AAMSI Congress 1986. Anaheim, California.

Contact:

Ben T. Williams, MD
Director of Laboratories
Mercy Hospital
1400 West Park Avenue
Urbana, IL 61801
(217) 337-2175

May 20-23, 1986. EURIT, the European Conference on Information Technology in Education, 1986. Enschede, The Netherlands.

Contact:

Peter Sinninghe Damste
c/o Twente University of Technology
C.O.I.
PO Box 217
NL-7500 AE Enschede
The Netherlands

July 13-18, 1986. XXX International Congress of Physiological Sciences. Vancouver, Canada.

A symposium and workshop on computer-based education in physiology are scheduled for July 16.

Contact:

Dr. K.E. Cooper
Department of Medical Physiology
University of Calgary
Calgary, Alberta
Canada T2N 4N1

October 26-30, 1986. 5th World Congress on Medical Informatics. Washington, D.C.

Contact:

MEDINFO 86 Organizing Committee
Secretariat:
c/o George Washington University
Medical Center
Office of Continuing Medical Education
2300 K Street NW
Washington, D.C. 20037
(202) 676-8929

NATIONAL RESOURCE FOR COMPUTERS IN LIFE SCIENCE EDUCATION QUESTIONNAIRE

To be effective in the effort to establish a communication network among life science educators interested in using computers in their educational efforts, *we need your help*. Please take a few moments to complete the questionnaire below and return it to:

Harold Modell, PhD
NRCLSE
Mail Stop RC-70
University of Washington
Seattle, WA 98195

Name: _____

Address: _____

_____ State _____ Zip _____

Phone: _____

What content areas do you teach? _____

What student population(s) do you serve? (Please check the appropriate categories)

Undergraduate Graduate Nursing Medical

Allied Health Dental Veterinary

Other (please specify) _____

Are you currently using this as an educational tool? Yes No

If yes:

How many years have you used the computer in this way? _____

What kind of equipment are you using (please check appropriate categories)

Apple II family IBM or IBM compatible

Macintosh Minicomputer (please specify) _____

Mainframe (please specify) _____

Have you written any software for use in your teaching efforts? Yes No

Would you be willing to help critique software for peers? Yes No

Suggested workshop topics, Additional comments or suggestions concerning NRCLSE:

COMPUTERS IN LIFE SCIENCE EDUCATION

HAROLD I. MODELL

Department of Radiology
University of Washington
Seattle, Washington

MARCEL BLANCHAEER

Department of Biochemistry
Faculty of Medicine
University of Manitoba
Winnipeg, Manitoba
Canada

THEODORE J. CROVELLO

Department of Biology
University of Notre Dame
Notre Dame, Indiana

JAMES W. ECKBLAD

Department of Biology
Luther College
Decorah, Iowa

TSEGAYE HABTEMARIA

School of Veterinary Medicine
Tuskegee University
Tuskegee, Alabama

DONNA LARSON

School of Nursing
Grand Valley State College
Allendale, Michigan

TERRY M. MIKITEN

Graduate School of Biomedical Sciences
University of Texas Health Science Center
San Antonio, Texas

JAMES E. RANDALL

Department of Physiology
Indiana University
Bloomington, Indiana

PATRICIA SCHWIRIAN

College of Nursing
Ohio State University
Columbus, Ohio

RICHARD STULL

College of Pharmacy
University of Arkansas
Little Rock, Arkansas

JAMES W. WOODS

Lister Hill National Center
for Biomedical Communications
National Library of Medicine
Bethesda, Maryland

DOROTHY WOOLEY-McKAY

Department of Biology
Glendale Community College
Glendale, Arizona

GLENN YOSHIDA

Department of Life Sciences
Los Angeles Southwest College
Los Angeles, California

NRCLSE

CONTENTS

- | | |
|---|----|
| AN ENTRY-LEVEL APPROACH TO INTERACTIVE VIDEO PROGRAM DEVELOPMENT
John F. Moore | 9 |
| VIDEO SIGNALS AND DEVICES IN INTERACTIVE VIDEO SYSTEMS
Eric Halsey | 12 |

AN ENTRY-LEVEL APPROACH TO INTERACTIVE VIDEO PROGRAM DEVELOPMENT

John F. Moore

Learning Resource Center, Virginia Polytechnic Institute and State University, Blacksburg, Virginia

An upsurge in interest in interactive video (IV) technology is occurring. In many institutions, though, some hesitation exists about experimenting with interactive video because it is thought to be too expensive, and not much software is available. Yet the desire to experiment with this new medium continues and, indeed, grows as one reads about more and more projects getting underway. I think we can agree that in many instances it would be desirable to demonstrate the *concept* of interactive video in some practical way. Because of the lack of videodiscs in many subject areas, interactive videotape (IVT) has proven to be a successful strategy.

Applying the medium to a real problem (not just creating a demonstration program) is part of this strategy.

PROJECT PLANNING

The first step in planning an IV project is to acknowledge why you want to use IV. Determine what problems you are trying to solve. Set some project goals, and try to reach agreement on the purpose of the project. Be sure to agree on the criteria for success. As is most often true in microcomputers, good software and appropriate applications should drive the selection of hardware. Choose your application wisely. Ensure that the problem you are trying to solve

is appropriate for this medium. Interactive video has many exciting uses, but most may be categorized as tutorial, simulation, or as an information access tool. Often, applications will involve some combination of the three general program types.

Try to bill your first IV project as a "learning experience" for the development staff. Go into the experience expecting to make a few mistakes and to learn from them. It would be a good idea to plan for a virtual revision of the pilot program after it is evaluated. Starting the project with evaluation and revision in mind will let your program-development group capitalize quickly on what was learned from working through the process and testing the results.

There are basically two approaches to developing interactive video. You can either create an original program or else adapt ("repurpose") an existing videotape. Taking the first approach may result in a program that is better matched to your specific needs. Some unique design and production problems will be encountered, though. Even if you have access to a video production, there are substantive differences between producing traditional linear and interactive video programs.

It may be easier and quicker to adapt an existing "linear" program. Doing this will let you explore the design and learning features of interactive video without getting involved in creating original video programming. For many beginners, this method is preferable. It lets the novice designer concentrate on those issues which differentiate IV from traditional programming (ie, the design and use issues) rather than video production. After learning the basics of interactive program design, perhaps, for a second project, an original production can be undertaken. This approach will probably produce a testable first program in the shortest time while also teaching the design and production staff progression on the learning curve.

HARDWARE

It's important to look carefully at your

existing resources. Does your institution have video production capabilities? Is there a programmer available who can lend assistance when needed? Are there any personal computers that can be assigned to your interactive video project? If so, will there be enough other uses of the computers so that users of your interactive video program will have to compete for time on the equipment? Depending on your project goals, this may or may not be acceptable. Is there going to be a problem if you introduce a "new" brand of computer into your organization? Similarly, are there relatively new industrial-grade videocassette players already available that can be allocated to your project? Although most interactive video computer interface cards work with three videotape formats (3/4 inch, VHS, and Beta), only certain players are acceptable. The VCRs need to be industrial grade and have a connector which communicates control track pulse information and directional control to the interfaced computer. Most industrial Sony Beta-I VCRs and most Panasonic industrial VHS VCRs will work. Check with the interface manufacturers for compatibility. Although it is possible to use a 3/4 inch U-matic player, such as a Sony VP-5000, keep in mind that the advantages of the smaller Beta and VHS formats are faster search times and lower tape costs.

It is wise to select an interface that can write an "address code" on the videotape. This will insure frame accurate search and retrieval of video segments. The control pulse-counting method is less accurate. This lack of accuracy gets worse during successive tape searches and can become a serious problem if your program gets heavy use. The frame address code is well worth any extra cost.

PROGRAM DESIGN

Remember that interactive video is an "omnibus" medium which can provide targeted media treatments for specific needs. This profusion of information organization and delivery options is fundamental to the medium's power.

Yet juggling these options can make designing an interactive program frustrating. There are almost too many options. Television is especially good for showing processes and dramatizing interpersonal relationships. Program ideas which are difficult to visualize may not be best suited for your first interactive video project. A reasonable approach is to use video footage when there is a definite need, not when there would be only a cosmetic enhancement to the program's goals. Flash and glitter probably will not wear well in repeated viewings of the program.

Suppose either a series of text frames or a short video segment might suffice in one portion of a program. Which option would be a better design choice? I do not believe that the content itself should be the sole basis for this type of decision. Other factors, including the following, should be weighed.

- 1) audience characteristics such as attention span;
- 2) the lesson duration;
- 3) the relative location of this segment within the overall lesson;
- 4) the number of interactions which have already occurred; and
- 5) the overall style of the presentation.

It's important to consider the program in a global fashion and put yourself in the student's place. For example, if five or six contiguous frames of text are needed, you should ask whether a short video segment might convey the same information in a more appealing manner. In such cases the design decisions are made according to the situation, considering the learner and what has likely already occurred while studying the program. There are no easy answers except to urge consideration of the user as you seek to meet the program's goals. Vary the presentation modes to build visual power and learner interest.

DEVELOPMENT PROCESS

Most instructional development literature refers to the benefits of using a team approach. These teams consist of subject matter expert(s), instructional

designer(s), and specialists in the production of software and video. Especially in a pilot project, try to familiarize the group's members with a basic understanding of the IV information delivery process. Show them samples of other programs.

The instructional designer may function as project leader. As soon as possible, the leader should work to help the group achieve a fairly cohesive and solid grasp of the project's purposes and goals. With these goals in mind, devote group time to brainstorming. Don't reject ideas as infeasible or impossible to achieve on your budget or with your equipment. Get each person on the team to describe how they envision the program's style and structure. Make it safe for different approaches to be explored by the group. Perhaps an exciting program structure or stylistic device will develop from this process, and the group can become more cohesive and willing to commit even more creative energy.

A next step would be to match these brainstorming ideas with information that is routinely generated in the instructional design process. This might include audience characteristics, learning goals, and utilization constraints. Be careful that these factors are kept in perspective and not allowed to overwhelm the ideas generated earlier.

The group also needs to understand and agree on quality standards, budget, and target dates. It is helpful if the project team can meet frequently during the planning and design stage so that creative momentum can be maintained.

PLANNING TREATMENTS

During the development of each unit, it is helpful first to outline in narrative form what a student will see and do during each section or module of the program. As this outline is created, an overall program flowchart should be sketched. Flowcharts can quickly illustrate a program's structure as well as indicate where gaps exist in treatment or logic. Since flowcharts are tedious to create and will frequently change during the project, using some way to

streamline the process is advisable. You might consider using a "flowchart generator" such as "Interactive Easyflow" from HavenTree Software Limited (RR 1, Seeley's Bay, Ontario, Canada, [613] 542-7270). Look for elements that can be given common screen and/or graphic treatments, such as menu layouts, to help streamline production. Individual program frames are then developed, using planning cards or storyboards. A more detailed flowchart can also be developed virtually simultaneously. Together, these planning tools carry information about each frame's screen layout ideas, branch destinations, scene lengths, and other variables and factors that affect the dynamics of the presentation. This information becomes the basis for the production stage of the project.

As new ideas are added and earlier treatments modified, note the changes on the storyboards and flowcharts. Documenting the program structure in this way is essential to insure efficient use of time during the initial tryout and debugging of the software. Try to keep the flowchart up to date; otherwise it will have little value during debugging when you are likely to need it most.

SOFTWARE PRODUCTION

The computer software can be created using several different approaches. Examples include a general purpose language like BASIC or PASCAL, a CAI language like SuperPILOT or PC-PILOT, or an authoring system like "The Instructor" or QUEST. There are many tradeoffs involved in this decision. Due consideration should be given factors such as the availability and amount of programming expertise, projected ease of software maintenance, and the application's need for the power and speed of each authoring alternative.

The scope and relative level of sophistication of the program(s) you are developing should, in large measure, point to the level of sophistication in the programming power you will need. Relatively simple tutorials and information-access programs can be produced adequately with either an authoring system

or language. If you are creating a simulation or a program which interacts in real-time with other software (such as a database), a traditional computer language may be the least restrictive.

If limited programming skills are available, an authoring system may be the best alternative. In the past, many authoring systems have forced compromises in the design of the program. Many such systems continue to be template-oriented which tends to force information and delivery styles into a prescribed pattern. Newer authoring systems show improvements in this regard, as they take a less prescribed, more "blank screen" approach. For example, a popular, but relatively older authoring system, requires questions to consist only of text; no graphics can be shown during a question. Similarly, questions cannot be posed during a video segment, for the keyboard is essentially locked to student input except for a program interrupt command. If using this authoring system, the design team must deal with these limitations and develop alternatives, such as putting illustrations in a workbook for reference when answering questions. A newer authoring system does not have these limitations.

The development team should be well aware of these kinds of limitations in whatever software is used. However, it is better to start designing the program as if there were no such limitations and then alter the design to fit the authoring software. This approach will help by not limiting the initial creative thinking, and it will often produce innovative ways to circumvent such software limitations.

In choosing an authoring system, careful attention should be given to several factors. For example, does the publisher require a run-time license for each machine on which your programs are run? If you decide to market your programs, is a license fee required? What is the publisher's record for supporting customers after the sale? Are software updates issued regularly, and is there a charge for them? Can you get knowledgeable help by telephone? Try

to get a list of current users from the publisher so that you can determine their level of satisfaction with the product. Compare systems carefully, and insist on an adequate evaluation period before making a commitment.

PROGRAM MANAGEMENT

Using a team approach will pay dividends in project management. Each team member is assured a better, deeper understanding of the purpose of each lesson component, frame, and scene. Doing this also helps generate a better range of ideas in designing the program.

The project manager should develop a

critical events timeline to help manage deadlines. Meeting this schedule can be partially assured by arranging for simultaneous activities during the production phase. Events need not be sequential during production; it is more efficient if a variety of related activities can be underway at the same time.

A point critical to a successful project is to insist on time for adequate try-out and revision of the materials. This is doubly important with a new technology such as interactive video since the design and production of the programs involves more than the usual number of unknowns. Project schedules should

allow for several rounds of formative evaluation and subsequent revision.

CONCLUSION

Exploring how to produce and use interactive video programs can be a challenging yet rewarding experience. Educators need to seek practical applications that will bear on significant problems to help justify the time and expense of production. While we all have a great deal to learn about the usefulness of interactive video in various settings, we must be careful to plan well and try to implement projects that can make a difference in our institutions.

VIDEO SIGNALS AND DEVICES IN INTERACTIVE VIDEO SYSTEMS

Eric Halsey

Center for Instructional Development and Research, University of Washington, Seattle, Washington

In this decade, microcomputers have put large-scale computing power into the hands of the individual, while at the same time, advancements in video technology have made it possible to generate, store, and instantly retrieve large amounts of high quality visual information. The marriage of these two technologies into interactive video presentation and teaching systems is ripe with promise for the future.

Microcomputer technology springs from a tradition of intense specialization and individualism where manufacturers have encourage closed, small-scale systems and where the barriers of noncompatibility have been conscious policies as often as not. Computer users have expected good resolution but not very quick response times from their presentation systems, and they have not been concerned with the long-distance transmission of images. All this is now changing.

Video technology, on the other hand, comes from a tradition of public broadcast, where the need for compatibility with older technologies and with the

emission and reception equipment of a whole nation have been a principal driving force. Producers and consumers have been concerned with the transmission of good quality motion images over noisy channels and have not been overly concerned with high resolution. This, too, is changing.

This article will discuss video presentation technologies from each of these converging traditions. The purpose is not to turn the reader into a television engineer, but to provide basic qualitative information about devices and specifications needed when building systems for interactive video presentations. Incompatibilities must be overcome, but this can be done, and it has been done with gratifying results.

TYPES OF VIDEO SIGNAL

Color video production is based on the generation of varying combinations of red, green, and blue light on the surface of a television tube. The signals controlling the three colors can be kept separate (RGB), combined into a single signal (composite), or further modulated

onto a radio frequency carrier wave (VHF wave).

In a typical conversion chain for a video signal, a television camera or signal generating device such as a computer graphics board, generates separate red, green, and blue signals. An encoder combines these three signals together with a fourth synchronization (synch) signal that matches the variations in color to the sweep of an electron beam reading or writing the video image. This is the "composite" signal. For long-distance transmission, the composite signal is combined with an audio signal and then modulated onto a radio frequency (Very High Frequency) carrier wave that can then be broadcast or carried through cable.

At the receiving end, a tuner (demodulator) selects the VHF signal from a spectrum of similar signals and converts it back into separate composite and audio signals. Any display device (such as a television set) that contains a tuner is called a *receiver*.

A decoder can further separate the composite signal into its separate red,

green, blue, and synch signals. Display devices that accept composite or RGB inputs directly are generally called monitors. Monitors usually have RCA (stereo cable) connectors on the back for composite input or multi-pin connectors for RGB input. Not all monitors have speakers. Those that do have connectors for one or two channels of audio input as well. Another type of video display device, the color video projector, is available in composite and RGB versions. Some video projectors, however, include the provision of accepting either type of input signal.

Devices such as videodisc players usually provide VHF output (VHF out) or composite output (video out), and they can be used with either receivers or monitors. Note that in the VHF signal, the audio and video signals are combined, but in the composite signal, there is no audio. If a videodisc or videotape player is connected to a composite monitor with a built-in speaker, separate audio connections to the monitor must be made. The particular application will determine whether two audio leads (stereo) or only one (with a Y-connector at the player) are sent to the monitor.

Many computer graphics boards provide both RGB (multi-pin) and composite (RCA plug) output and thus, can be used with either RGB or composite monitors. There are, however, significant deficiencies in most computer-generated composite outputs, and these will be discussed below.

SIGNAL PROCESSING AND RESOLUTION

The conversion path from the original RGB source to the final display can avoid the VHF stage, the composite stage, or both. To gain the highest display resolution, it is always desirable to take the shortest path from source to display since both encoding RGB-to-composite and modulating composite-to-VHF are band-limiting processes, and signal information is lost at each conversion.

In order to avoid bandwidth limitations, computer color displays should have the RGB output of the computer

connected directly to the input of an RGB monitor or projector. This arrangement produces good quality 80-column text in color. If, however, the computer graphics board is connected to a composite monitor or projector, 80-column text is no longer readable in color. The qualification "in color" is necessary because the color portion of the composite signal is the most degraded. Composite devices will, however, display readable 80-column text in monochrome.

At a lower level of demand for resolution, composite monitors or projectors display good quality 40-column text in color. At the lowest level, television receivers will display (via VHF) readable 40-column text in black-and-white but not in color.

HOW AN IMAGE IS DISPLAYED

Once the RGB signal has been received and decoded, the image being carried must be displayed on the face of a picture tube. In the case of a video projector, the image on the face of the tube is further projected onto a viewing surface such as a wall screen.

The image is painted by glowing phosphors that coat the inside of the

viewing surface of the tube. In a monochrome display, there is only one color of phosphor activated by a beam of electrons from a single electron gun. In a color display, there are three guns whose beams pass through a mask to strike red, green, and blue phosphors arranged in tiny triads on the face of the tube.

In either case, an electron beam scans the surface of the tube in a *raster*, a sequence of horizontal sweeps covering the viewing surface of the tube just as lines of printed text cover a page. In American (NTSC) television, there are 525 horizontal lines in a raster, scanned from left to right and from top to bottom once every one thirtieth of a second, creating one video frame.

A picture that is refreshed only every thirtieth of a second, however, has a visible flickering appearance, so the video image is actually refreshed twice as frequently by means of *interlacing*. The "odd" lines of the raster are scanned first to create a complete image (field 1) in one sixtieth of a second. The "even" lines (field 2) are scanned a sixtieth of a second later (see Figure 1). In order to complete all 525 lines in one thirtieth of a second, the electron beam must

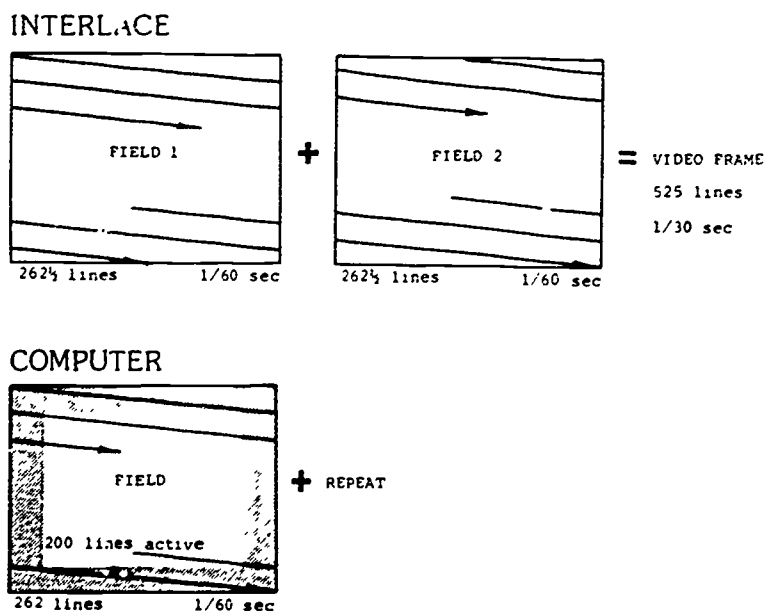

FIGURE 1. Schematic representation of how the raster is scanned with interlacing to form a broadcast video frame (top) and without interlacing forming a computer video frame (bottom).

scan at the rate of 15750 Hz.

Computer displays use a similar scanning technique, but with some differences. In the IBM color display, for example, a 262-line field is scanned once every sixtieth of a second. There is no interlacing in the computer image. The single field is repeated over and over each sixtieth of a second.

Because some of the scan lines in the computer display lie in the "border" area, and some are used up as the electron beam jumps back to the top of the screen, only 200 lines are left for an active computer display area. These generate 25 lines of characters with 8 scan lines per line of characters.

The 525 scan lines in the raster should not be confused with the *nominal resolution* of the picture tube, which is also measured in horizontal lines. The nominal resolution is an empirical measurement of how well the picture tube reproduces a test pattern composed of alternating horizontal black and white stripes, and, in theory, it can range up to about 480 lines (340 lines is a more realistic maximum for typical video images).

THE COMPOSITE (NTSC) SIGNAL

Composite video is a combination of red, green, blue, and synch signals into a single signal. In the United States and Japan, this is accomplished according to the National Television Standards Committee (NTSC) standard. Europe uses a different standard, called the PAL standard, while Mexico and Russia use the SECAM standard. As far as American and Japanese equipment are concerned, NTSC can be considered a synonym for composite.

In a typical NTSC waveform (Figure 2), each cluster of pulses corresponds to one sweep of the electron beam in the raster that paints a video picture on the face of the picture tube. The video portion of the signal has an amplitude of +.7 volts, and the horizontal synchronization pulses have an amplitude of -.3 volts and a frequency of 15750 Hz. This frequency corresponds to the horizontal sweep rate of the beam. Each pulse

tells the beam to jump back to the left side of the raster.

A vertical synchronization pulse occurs every sixtieth of a second (after 262.5 lines have been scanned), and it tells the beam when to begin its downward sweep. If the vertical synch pulse is a half-line late, the vertical sweep is a half line late, and the horizontal lines will be in the offset (interlaced) position required by field 2 of each video frame.

The amplitude (luminance) of the video signal controls the intensity of the electron beam as it sweeps across the surface of the picture tube, a high intensity producing bright colors and a low intensity producing dark during the sweep. The luminance information must be sent to the right color guns, and this distribution is controlled by the phase (chrominance) of each video pulse. The luminance and chrominance of the signal are sometimes called lum and chroma. They are measured relative to the average voltage level and phase of a color burst reference signal placed within the waveform (Figure 3).

USING NTSC DEVICES

The NTSC standard is just that. Any two "NTSC/composite" devices should, in theory, be able to communicate with each other. In practice, however, several difficulties arise. First, NTSC calls

for a certain phase relationship between the color and synch signals. Most microcomputer graphics boards do not respect this part of the standard, while some video devices (such as 1-inch broadcast-type videotape recorders) require it.

The NTSC synch signal itself is somewhat complex. It consists of vertical and horizontal synch pulses along with equalizing pulses to align them. Although computer graphics boards produce the vertical and horizontal synch pulses, they may or may not produce an "industrial quality" signal, or they may not mix it in a standard way with the video signal. On the other hand, all videotape recorders rely on the synch pulses and correct mixing for head control. Thus, computer graphics or text can seldom be connected directly to any kind of tape recorder.

The NTSC standard establishes a specific mixing technique for the color burst reference signal. Some computer graphics boards (including all IBM boards) ignore this part of the standard and simply superimpose the color burst on top of another portion of the video waveform (Figure 3). This results in a color signal with an elevated black-level which can only be captured by composite monitors with an exceptionally wide tuning range. The IBM color graphics boards, when used with most composite

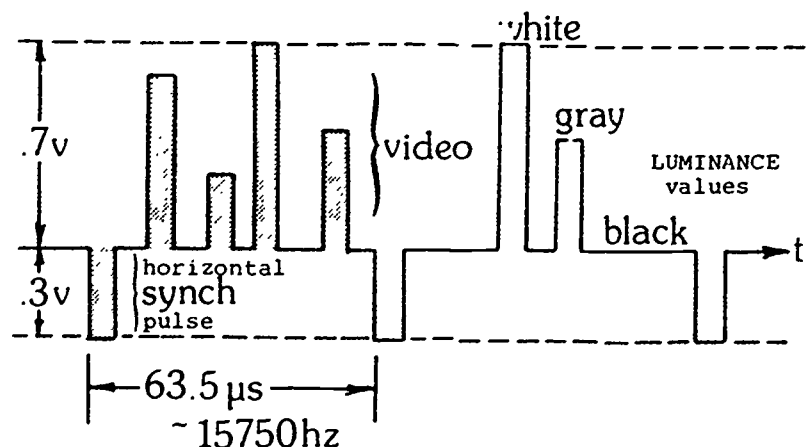

FIGURE 2. Schematic representation of a typical NTSC waveform.

video monitors, will only produce a black-and-white display or a display in which only one color has been captured.

Videodisc and videotape players are electromechanical devices, and as such, they lack the 3-nanosecond accuracy required by the NTSC standard for a stable video image. An electronic box that mediates such an "imperfect" mechanical device and a "perfect" external NTSC signal is called a *time-base corrector* (TBC). Most TBCs, like the videotape recorders themselves, will not respond to any composite video signal whose synch portion has been oversimplified. Specifically, TBCs expect alternate vertical synch pulses to be delayed in a manner consistent with interlacing.

Many computer/video overlay boards use a "genlock" circuit that solves this problem by keeping the composite output signal of the computer locked-in with the variations of the attached videotape or videodisc player. Genlock circuits only work, however, when they are receiving an active signal from the player. After a pause or search, they must relock, which may cause a momentary disturbance in the video display.

An informal distinction is often made between "computer" and "broadcast" composite monitors. However, NTSC is NTSC. Such monitors are, theoretically, indistinguishable, and in practice, they differ only in superficial details. "Computer" composite monitors are set to underscan (the video image does not fill up the whole face of the tube); they have built-in RCA connectors for input; and they have relatively wide tuning ranges. On the other hand, "broadcast" composite monitors are set to overscan; they are provided with BNC (push-twist) or UHF coaxial (screw-on) connectors, and they have relatively narrow tuning ranges.

RGB SIGNALS

Although the various forms of composite signal are all more or less accurate approximations of the NTSC standard, there are two fundamentally different types of RGB signal, analog RGB and digital RGB. Both types of RGB keep

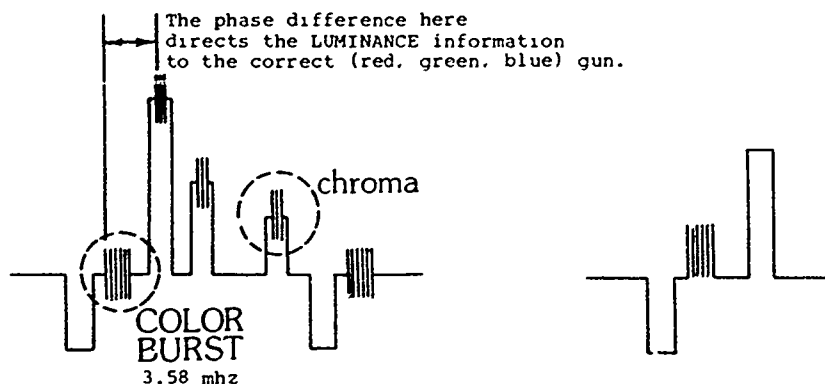

FIGURE 3. Video signal showing the location of the color burst and chroma signals (left panel). The average voltage of the color burst sets the black level. The right panel shows the location of the color burst from the IBM Color/Graphics Adaptor. Because the average voltage of this signal is higher than the NTSC standard, the black level is higher.

the red, green, blue, and synch signals separate, and they require multi-pin connectors. There is one exception. A digital RGB signal can have a signal that combines the synch with the green color signal (synch-in-green).

As the names suggest, analog RGB allows a continuous variation in the intensity of the color signals, while digital RGB allows only certain discrete levels. Analog RGB is the more expensive of the two technologies and, in some sense, is the "best." It produces an infinite variety of colors at high resolution. It is produced by some graphics boards (which therefore require "analog RGB" monitors), and it is used in some closed-circuit TV applications.

Digital RGB is usually called *TTL RGB* (TTL is an acronym for the phrase, Transistor-Transistor-Logic, but it has come to refer more broadly to any video signal with an amplitude of roughly 5 volts). The simplest form of TTL RGB allows each of the three primary colors to be "on" or "off," and thus, it can carry eight colors altogether. A variation on TTL RGB has three levels of luminance information coded into the color pulses. For example, the IBM color graphics board allows off, low, or high intensity, so that it provides 16 colors. Ladders with 16 levels of intensity (4096 colors) are widely available. Multilevel TTL signals provide so many colors that they are distinguish-

able from analog RGB primarily by their voltage levels.

Analog and TTL RGB monitors are not compatible, but there are monitors which switch between the two modes. Most RGB monitors will accept synch-in-green RGR. Special synch-in-green monitors can be used as green monochrome monitors for high-resolution applications. Finally, there are monitors that are switchable between the composite and RGB modes. The switching may be accomplished by a hardware switch on the monitor itself or by software drivers from a computer.

CONCLUSION

It is obvious from the foregoing discussion that many computer manufacturers have created their own "standards" with respect to the way in which their equipment deals with video signals. As a result, they have been able to provide a number of features (eg, higher resolution) not commonly available in the broadcast medium. However, because of the variety of ways in which these signals are handled, one cannot assume that the images that one sees with a given computer and monitor (or projector) will appear the same when used with a different monitor (or projector). Hence, before using such devices for teaching purposes, it is always advisable to test outputs on the specific computer-monitor combination to be used.

COMPUTERS IN LIFE SCIENCE EDUCATION

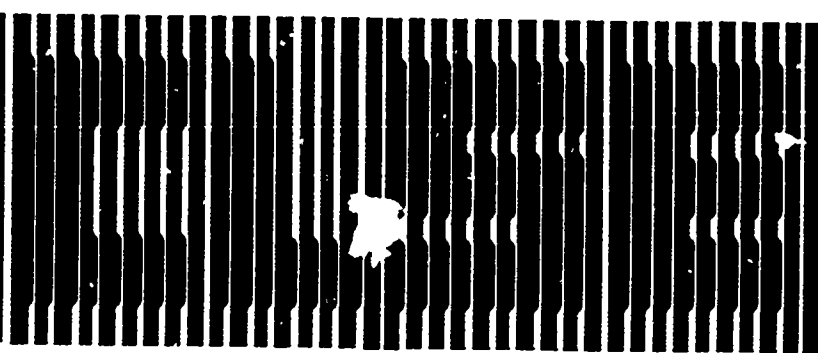

HAROLD I. MODELL

Department of Radiology
University of Washington
Seattle, Washington

MARCEL BLANCHAER

Department of Biochemistry
Faculty of Medicine
University of Manitoba
Winnipeg, Manitoba
Canada

THEODORE J. CROVELLO

Department of Biology
University of Notre Dame
Notre Dame, Indiana

JAMES W. ECKBLAD

Department of Biology
Luther College
Decorah, Iowa

TSEGAYE HABTEMARIAM

School of Veterinary Medicine
Tuskegee University
Tuskegee, Alabama

DONNA LARSON

School of Nursing
Grand Valley State College
Allendale, Michigan

TERRY M. MIKITTEN

Graduate School of Biomedical Sciences
University of Texas Health Science Center
San Antonio, Texas

JAMES E. RANDALL

Department of Physiology
Indiana University
Bloomington, Indiana

PATRICIA SCHWIRIAN

College of Nursing
Ohio State University
Columbus, Ohio

RICHARD STULL

College of Pharmacy
University of Arkansas
Little Rock, Arkansas

JAMES W. WOODS

Lister Hill National Center
for Biomedical Communications
National Library of Medicine
Bethesda, Maryland

DOROTHY WOOLEY-McKAY

Department of Biology
Glendale Community College
Glendale, Arizona

GLEN YOSHIDA

Department of Life Sciences
Los Angeles Southwest College
Los Angeles, California

NRCLSE

CONTENTS

COMPUTER-ASSISTED INSTRUCTION IN A FAMILY PRACTICE CURRICULUM: TWO YEARS LATER	17
Joseph A. Troncale	
MAKING CBE PROGRAMS "SMART": ONE GOAL OF ARTIFICIAL INTELLIGENCE RESEARCH	19
Joel A. Michael	
KEEPING ABREAST OF THE LITERATURE	22

COMPUTER-ASSISTED INSTRUCTION IN A FAMILY PRACTICE CURRICULUM: TWO YEARS LATER

Joseph A. Troncale

Department of Family Practice, University of South Alabama, Mobile, Alabama

The American Association of Medical Colleges (AAMC) has identified several problem areas in medical education that are amenable to correction by the use of computer-assisted instruction (CAI)¹. These include the following:

- Students are required to memorize a vast amount of factual detail without learning concepts necessary to organize them.
- There is a need for faculty to identify

concepts and principles rather than present only data.

- There is a need to help students become independent learners and problem solvers.
- There is a need to promote independent study and reduce formal lecture time.
- There is a need to increase small group interaction.

Based on these concerns, we obtained a grant to begin implementing a CAI program in the 6 week family practice preceptorship of the 3rd year medical school curriculum. The details of this program have been described elsewhere.³ Ten Apple IIe computers were purchased for use by students. Software covering case studies of the most frequent diagnoses seen in a family practice setting was developed by this department or purchased from outside sources. Topics included otitis media, diabetes, acute pyelonephritis, vaginitis, and upper respiratory tract infections.

IMPLEMENTATION

Based on the intended role of the exercise, a distinction has been made between two major types of CAI. The first, Adjunct CAI, merely supplements the learning situation and is meant to facilitate learning with the traditional methods of teaching. By contrast, Primary CAI is CAI that presumes to be a stand-alone instructional tool in which, for instance, a whole course is "taught" by the computer.² Adjunct CAI is the type of instruction used in the Family Practice Project and will be the focus of this discussion.

The first stage in the development of this project was acquisition of appropriate software. This was done in two phases. One phase was the development of cases by faculty here at the University of South Alabama using MED-CAPS, a computer-assisted instructional system that simulated a diagnostic patient work-up. This system was licensed by the Health Sciences Consortium in Carrboro, North Carolina. It required that various cases be authored at the University of South Alabama and sent back to the Health Sciences Consortium for configuration onto computer disks. This created certain formidable problems. Corrections of errors and text changes could not be made directly but rather had to be made through long distance correspondence. It required several months of writing, rewriting, and field testing to develop the Family Practice Problem Set which is now published

by the Health Sciences Consortium. Also, despite corrections and field testing, there remain a few minor but noticeable errors in some of the programs which hopefully will be corrected in the near future.

In a parallel phase, a search was begun for vendors of other software that would be valuable in doing the same sorts of clinical problem solving using computer-assisted instruction. Other computer-assisted instruction software that were subsequently purchased came from CME, Inc.; Cyberlog, published by Cardinal Health Systems, Inc.; and programs on alcoholism made available through Downstate Medical Center at Cornell University.

A number of problems emerged as soon as the computers were purchased and the software was acquired.

First, we had no experience with students carrying hardware into rural locations, transporting the machines in their cars, and leaving them in motel rooms and hospital call rooms. Also funds were not available to put the machines under any sort of extended warranty. An initial concern was how long the machines would hold up given this type of wear and tear. A similar concern existed for the software, in that the software would be transported from place to place with no control over the environment in which it would be used.

The second problem was the logistics of having 10 computers with all their attendant cords, power supplies and software, as well as the security for this equipment, when it was not in use by students.

The third concern was teaching the students how to be comfortable with the machines for those who had never used a personal computer.

The fourth and perhaps the most important concern was exactly how to incorporate computer-assisted instruction into the curriculum to maximize the learning experience for the students while getting the student's preceptors to accept the computers and the concept of CAI.

With these concerns in mind implementation was begun. This included

educating the preceptors, who would have students at their locations, on the value of CAI. An evening dinner meeting was called with the various preceptors, and a presentation was made concerning the computer-assisted instruction project. After the presentation, the preceptors had the opportunity to have hands-on experience with the computers and to examine a few of the cases for themselves. Local television coverage was arranged for this meeting, and the response was basically favorable.

With the stage now set, the computers were sent out with the students to their rural locations. At the beginning of the student's rotation, a one hour lecture and demonstration was inserted into the curriculum. During this hour, students were given a very brief overview of the concepts CAI, and a small amount of computer theory was presented. This session included topics such as basic instructions in computer operation, problems that might be encountered with the computer, basic troubleshooting, and how to handle the software. The end of this hour session was again a hands-on experience, so that the students themselves could use the computer before actually taking it out. One of the off-shoots of this tutorial experience was an observation that small group interaction could be facilitated using the computer. Having two or three students around a computer working the same problem rather than one student per computer could be a valuable learning experience.

The students were then assigned their own computer and software to be taken to their rural family practice preceptorship sites. They were asked as part of the course curriculum to go through each of the ten MED-CAPS cases as well as the various other CAI exercises.

PROBLEM AREAS

A basic problem became apparent with this mode of computer use. From feedback given by some of the students, it was apparent that the CAI as a stand-alone tool became another tool very similar to the textbook. The same material could be gleaned by reading

rather than by going through a case and having the computer interaction. Also, the material contained in the CAI programs were ubiquitous to medicine in general, and it was difficult to test whether specific knowledge had resulted from a computer-assisted instruction case *per se*, from a student's previous exposure to the problem or from merely reading about a particular topic.

Over time, it became obvious that group interaction would be helpful if the computer-assisted instruction programs were going to gain wide acceptance from the students. So, in response to this perception, a schedule was given to the students in which they were expected to go over a certain CAI case (eg acute pyelonephritis) by a certain date in the rotation. On that date the students, having done the case on their own, met with one of the faculty members in a small group setting to go over the particular case. At that time the case was discussed, didactic material was presented, and group interaction ensued. Since beginning the group instruction, the response to the computer-assisted instruction has become overwhelmingly favorable.

I believe that the favorable response is a function of two things. First, a definite structure is given to the use of the computer rather than merely assigning the students a number of cases without personal feedback. Second, the group interaction is stimulated and structured by a faculty facilitator.

FUTURE DIRECTIONS

Current plans call for a continuation of the computer-assisted instruction in the curriculum. It is hoped that new CAI cases will be generated so that the software library will continue to expand.

Some students have been interested in using other available software including logic games or word processing. Printers have been made available to the students, and some students with previous computer training have written programs of their own.

The department has been able to purchase some reconditioned videodisc players recently, and interactive video is beginning to be used as another learning modality within the department. Interactive video programs on primary care Radiology and Dermatology have been acquired from the National Library

of Medicine with the help of Dr. Jim Woods. Several authoring systems for interactive video have been acquired and should allow the faculty and students to use existing videodisc technology to author our own educational materials. It is also hoped that the advanced cardiac life support and chest pain cases course developed by Dr. Abdullah M. Abdullah from the Medical College of Georgia will be acquired sometime in the near future.

REFERENCES

1. Physicians for the 21st Century - The GPEP Report. Washington, D.C.: Association of American Medical Colleges, 1984.
2. Chambers JA, Sprecher JW: Computer-assisted instruction: current trends and critical issues. *Comm ACM* 23:332-342, 1980.
3. Troncale JA, Hallet J: Teaching a core curriculum in rural family practice preceptorships using microcomputers. *J Fam Prac* 21:407-408, 1985.

MAKING CBE PROGRAMS "SMART": ONE GOAL OF ARTIFICIAL INTELLIGENCE RESEARCH

Joel A. Michael

Department of Physiology, Rush Medical College, Chicago, Illinois

Currently available Computer-Based Education (CBE) programs, even the best of them, are "dumb". Your favorite piece of teaching software - however interactive it may seem to the student user and however much it appears to offer each user an individualized experience - suffers from two significant limitations that must reduce its effectiveness as a learning resource.

Today's CBE programs are interactive only in a restricted sense. They can ask a question of the user and branch to

different responses determined, possibly in complex ways, by the answers provided. The user, however, cannot ask a question of the program if he or she does not understand a concept being developed or the explanation just presented; the dialogue is essentially unidirectional. A human tutor behaving in such a fashion would not receive very high marks as a teacher!

As a consequence, at least in part because of this very limited form of interaction, current CBE software actually

does a very poor job of individualizing the teaching experience obtained by different students. Regardless of the nature of the error in a student's problem solving processes or in his or her knowledge base, each wrong answer elicits exactly the same feedback!

Artificial intelligence researchers are attempting to remedy these limitations through the creation of "intelligent" CAI (ICAI) programs, often called smart tutors. This work is exciting for a number of reasons. It promises more

effective teaching programs in the future; it is generating "tools" of great usefulness in current "conventional" CBE programs; and it is beginning to provide us with important insights about the teaching/learning process.

A program that can tutor a student successfully in some subject matter domain must have the ability to do the following:

- 1) "converse" in natural language, understanding the text entered at the keyboard by the user and, in turn, generating appropriate replies;
- 2) solve problems in the domain that it is designed to teach so that it, too, knows the "right" answer and how to arrive at it;
- 3) be able to create a "model" of the student learning that is underway;
- 4) be able to generate a tutoring strategy likely to correct the "bugs" that it detects in the student's thinking.

This is no small order! Frankly, progress towards the development of smart tutors has been slow.

One of the chief difficulties has been the implementation of an interface for user-computer communications. The usual multiple choice format employed in most CBE programs is severely limited as a response mode, and it is of no use as a means of querying the tutor. Newer software tools such as multiple windowed menus may offer a different approach to a form of two-way communications between the program and the user that is sufficiently flexible for use in ICAI programs. In spite of the great difficulty involved, however, most workers in this field have attempted to create a natural language environment in which the user can "talk to" the computer, and the computer can generate (not store) appropriate responses to us inputs. Even if such capabilities exist only in narrowly defined subject matter domains and usually employ an artificially limited language (minimal vocabulary, stereotyped syntax, etc), natural language is seen as essential for a smart tutor by most workers.

CHARACTERISTICS OF A SMART TUTOR

A truly smart tutor will also have to be an "expert system" in the domain in which it is tutoring. This means that it must possess the ability to solve the problems that the student is attempting to solve. This expertise can then serve as the basis for examining the students' attempt at a solution, the comparison revealing errors in process or knowledge. The development of expert systems is proceeding at a rapid rate, with each issue of any computer magazine containing ads for new, commercially available programs. While most of these have limited applicability to the kinds of problems in the life sciences that we want our students to solve, there are several programs whose performance rivals that of human "experts" on quite sophisticated problems.

For an ICAI program to "understand" the inputs provided by a student, it will be necessary for the program to be able to model the learning that is occurring. Such a model of student learning will be based in part on external knowledge gained from studies and experiments in cognitive psychology and in part from an internal analysis of the inputs provided by the user. This program module will then compare the pattern of student responses to either some "idealized" model of student learning or to the problem-solving process generated by the internal expert system. In either case, the differences will point to "bugs" in those aspects of the student's performance that need correction. Successful student models have been generated only for simple, stereotyped processes, such as subtracting two- or three-digit numbers, or for problem-solving in circumscribed problem domains such as fault-finding in electronic power supplies.

Once detected, student bugs must be remedied by computer-directed intervention carefully designed to ensure continued active learning and maintained interest. Tutoring strategies vary with the nature of the domain, the type of process being learned, the age of the stu-

dents, and their degree of prior sophistication in problem solving. Here too, successful tutoring has been limited to carefully constrained situations.

EXISTING SMART TUTORS

A modest number of smart tutors have been developed, fully or in part, dealing with such topics (domains) as: subtraction (Debuggy), geometry proofs, algebra, addition of fractions, symbolic integration, solution of quadratic equations, logic and set theory (Excheck), Lisp and FORTRAN programming, a maze exploration game (Wumpus), an arithmetic game (How the West Was Won), physical geography (the causes of rainfall - Why), equipment servicing, the interpretation of NMR spectra, medical diagnosis (infectious disease - Guidon), and circuit testing of power supplies (Sophie).

While the above list is not exhaustive, it is evident that nearly half of these smart tutors deal with arithmetic or mathematics, domains in which the procedures are fully describable, even if the problem-solving process itself remains much less obvious. All of the remaining domains are ones in which the procedures are also moderately small in number and are more or less completely describable.

To fully appreciate the complexity of the task facing the developer of a smart tutor, let us examine in some detail two of the smart tutors listed above.¹ We will first look at Debuggy, a program that deals with a seemingly simple process, subtraction of two numbers. We will then examine Sophie, a smart tutor that deals with diagnosis, a class of problems common to many biomedical science disciplines.

Debuggy

Subtracting two numbers is a seemingly simple task, although mastery of it takes much practice by learners. The developers of Debuggy point out that "subtraction is simple enough that it is possible to diagnose real students [more than a thousand students over several years] in a natural setting [real class-

rooms] and complex enough to provide an interesting case study of the subtleties involved." One of the obvious "simplicities" is the fact that no language processing is required to deal with this problem. Further, the developers have focused *only* on the problem of determining the nature of the errors that are present in the students' procedures (developing a model for the learner and the bugs, errors in a procedural skill, that explain the past errors that were made *and* predicts those that will occur on subsequent problems).

Nevertheless, the problem is a formidable one. As simple as the procedure for subtracting two numbers may seem to the expert, a set of 58 subskills have been identified. And the total number of bugs that was identified was 120! The task, then, was to identify (diagnose) which bug(s) from this long list best explained the students' test results (off-line) or on-going performance (answers to future problems to be delivered to the student).

In order to utilize Debuggy as an on-line coach it was necessary to develop a way of generating problems for delivery to the students that would most efficiently (least number of problems required) allow the confirmation of any error hypotheses (what bugs are present) being considered by the program. This could not be done with a library of stored problems since the large number of possible bugs would have required an impossibly large library of problems. Again, the limited domain in which this coach has to operate made it possible to successfully develop a problem generator.

The success of Debuggy at identifying the procedural errors that need correction is certainly encouraging, even if the nature of the problems to be solved, however long the list of subskills, seems grossly simpler than the kinds of problems most of us are attempting to teach our students.

Sophie

Sophie is a much more complex program. First, the cognitive problem that

it deals with is a more complex one, diagnosing faults in an electronic power supply. The development of an expert system needed to solve these problems was itself a major challenge, unlike the previous case in which the problem-solver is just a "calculator". Student interaction with the tutor required a modest natural language capability with which the user instructs the system to carry out certain diagnostic tests it wishes performed. The relatively narrow domain being dealt with here made this feasible: the number of components, parameter values, kinds of measurements, and the relationships between the numbers being measured was limited, thus permitting a relatively simple approach to language handling. Finally, the model of student behavior is complex, as it must evolve over time as the novice first becomes "competent" and then "expert."

Let's look first at some of the problems associated with allowing the users of Sophie to communicate with the program through natural language text entered at the keyboard. In the absence of a general-purpose language processor (certainly not available when Sophie was developed, and not yet available at the beginning of 1986), the developers of Sophie were successful with a modest effort because of two characteristics of the problem they confronted "... (a) [a] limited domain and (b) limited activity within that domain." That is, they could predict with a high degree of accuracy what the users were likely to say and what that verbal output "meant" (what action the user wanted taken, what data was being requested, etc). Nevertheless, the language interface had to be able to deal with such traits of human communicators as the use of pronominal reference ("...what's its value..."), anaphorae (use of the same repeated word, usually a pronoun, in a sequence of communications), and ellipsis (the omission of words needed for correct syntax but not needed for meaning). Here too, the limits to the domain being referred to made it possible to deal with these problems.

The expert problem-solver built into Sophie is based on a simulation of the particular power supply whose faults are to be diagnosed. To this was added a "trouble-shooter" capable of utilizing a knowledge of the circuit and its operation to deduce its faults from the "symptoms" that are present. This, then, is essentially a model of a problem-solver, one that is capable of both strategic thinking (how to approach the solution to the problem at hand) as well as planning the tactics to be employed (what specific measurements to request and in which sequence). This is clearly a more complex simulation than is required for the circuit itself.

The "coach", the program module responsible for assisting the student to master the trouble-shooting process, is the least developed component of Sophie, reflecting the inherent difficulty of this process in the absence of a good model for the cognitive processes used by the learner and the particular priorities of the developers.

Sophie is one of the most sophisticated smart tutors to have been developed. The general domain in which it works, diagnosis of system faults, is a broad one, and every life science discipline contains similar kinds of problems to be solved. To that extent, Sophie represents a useful model for thinking about the creation of other smart tutors.

CONCLUSION

Before those of us involved in life science education can hope to contribute to the development of ICAI programs, we must confront the difficult task of determining what it is we want our students to be able to do, deciding what problems we want them to be able to solve. We then need to confront the equally difficult task of determining what constitutes a solution to such problems (certainly not as trivial an issue as it is in the case of subtraction, or even electronic fault finding) and how acceptable solutions are determined. Only then can we turn to our artificial intelligence (AI) colleagues and begin

the collaborative work that will be needed to actually implement our ideas in a piece of software. Even if we do not succeed in writing a smart tutor, however, we will still have learned a good deal about the process of life science education.

Additional information on topics relevant to smart tutors can be found in the following references:

General topics in artificial intelligence that are germane to the ICAI effort and that are presented at a more or less "lay" level:

Amsterdam J: Expert systems. Popular Computing 4(7):70-75, 1985.

Anderson JR, Reiser BJ: The LISP tutor. Byte 10(4):159-175, 1985.

Lenat DB: Computer software for intelligent systems. Scientific American 251(3): 204-213, 1984.

Michaelson RH, Michie D, Boulanger A: The technology of expert systems. Byte 10(4):303-312, 1985.

Thompson BA, Thompson WA: Inside an expert system. Byte 9(4):315-330, 1984.

Winograd T: Computer software for working with language. Scientific American 251(3):131-145, 1984.

An introduction to general AI applications in teaching:

Richer MH: Applications of artificial intelligence in education--a personal view. The Physiologist 28:428-431, 1985.

Technical discussions of ICAI programs requiring some prior background or considerable study:

Anderson JR, Boyle CF, Reiser BJ: Intelligent tutoring systems. Science 228:456-462, 1985.

Technical discussions of expert systems:

Duda RO, Shortliffe EH: Expert system research. Science 220:261-268, 1983.

Hayes-Roth F: The knowledge-based expert system: a tutorial. Comput 17:11-28, 1984.

Michie D (ed): Introductory Readings in Expert Systems. New York: Gordon and Breach Science Publishers, 1982.

Technical discussions of natural language processing:

Burton RR, Brown JS: Towards a natural-language capability for computer-assisted instruction. In O'Neil HF, Jr (ed), Procedures for Instructional Systems Development. New York: Academic Press, 273-313, 1979.

Rich E: Natural-language interfaces. Computer 17:39-47, 1984.

REFERENCES

1. Sleeman D, Brown JS (eds). Intelligent Tutoring Systems. London: Academic Press, 1982.

KEEPING ABREAST OF THE LITERATURE

The following citations are presented as part of a quarterly feature in CLSE designed to help readers become aware of current literature pertinent to computer applications in life science education.

Adiga S: Expert systems: an overview. Science Software Quarterly 1(4):7-11, 1984.

Armstrong ML et al: Choosing software: the importance of instructional design. Nurse Educ 10(4):13-17, 1985.

Beatty J: Interfacing with a DMM. Computers in Chemical Education Newsletter 8(1):16, 1985.

Bigum CJ et al: A video monitoring technique for investigating computer-based learning programs. Computers and Education 9(2):95-99, 1985.

Bray DW: Personal computers at Clarkston University. Technological Horizons in Education 12(8):81-85, 1985.

Bunson S: CAI frame by frame. TechTrends 30(4):24-25, 1985.

Clark RE: Confounding in educational computing research. Journal of Educational Computing Research 1(2):137-148, 1985.

Clark RE: Research on student thought processes during computer based instruction. Journal of Instructional Development 7(3):2-5, 1984.

Coad P et al: The computer as a log of wood. Journal of College Science Teaching 14(6):509, 1985.

Crookall D et al: Participant and computer

roles in simulations. Simulation/Games for Learning 15(2):55-72, 1985.

Day MJ et al: GENMAP -- a microbial genetics computer simulation. Journal of Biological Education 19(1):67-70, 1985.

England E: Interactional analysis: the missing factor in computer-aided learning design and evaluation. Educ Tech 25(9):24-28, 1985.

Fedale SV: A videotape template for pretesting the design of an interactive video program. Educ Tech 25(8):30-31, 1985.

Graham I: ENZVU -- an enzyme kinetics computer simulation based upon a conceptual model of enzyme action. Journal of Biological Education 19(2): 147-151, 1985.

Grogono AW: Computer educational and training aids for anesthesia. Med Instrum 19(3):130-131, 1985.

Haigh RW: Evaluating computer resources. North Central Association Quarterly 60(1):7-13, 1985.

Hale ME et al: Using computer animation in science testing. Computers in the Schools 2(1):83-90, 1985.

Hammack GG et al: The computer controlled videodisk: a new technology in optometric education. Journal of Optometric Education 10(4):8-11, 1985.

Hannafin MJ: Guidelines for using locus of instructional control in the design of computer-assisted instruction. Journal of Instructional Development 7(3):6-10, 1984.

Hartley JR: Some psychological aspects of computer-assisted learning and teaching. Programmed Learning and Educational

- Technology 22(2):140-149, 1985.
- Haugness CA: Copyright and computer software. *AEDS Monitor* 24(1-2):13-14, 1985.
- Herron JD: Computer series, 59: how learning theory can help produce better software. *Journal of Chemical Education* 62(4):309-310, 1985.
- Hodson KE et al: Experiences in publishing nursing computer software. *Comput Nurs* 3(3):122-127, 1985.
- Jain DC et al: Computer software designs for college science courses. *Journal of College Science Teaching* 14(6):480-483, 1985.
- Jobe H: Are you breaking software laws? *American School and University* 57(10):13, 16, 1985.
- Jonassen DH: Interactive lesson designs: a taxonomy. *Educ Tech* 25(6):7-17, 1985.
- Kearsley G: Microcomputer software: design and development principles. *Journal of Educational Computing Research* 1(2):209-220, 1985.
- Kearsley G: Instructional design and authoring software. *Journal of Instructional Development* 7(3):11-16, 1984.
- Kemppainen TK: An apple a day: Rx for computer anxiety in nurse educators. *Comput Nurs* 3(4):148, 172, 1985.
- King FJ et al: Alternative designs for evaluating computer-based instruction. *J Instruct Develop* 7(3):23-29, 1984.
- Larsen MD: Faculty attitudes toward computer-based education. *Journal of Chemical Education* 62(5):415-417, 1985.
- Locatis C et al: Selecting authoring systems. *Journal of Computer-Based Instruction* 12(2):28-33, 1985.
- Mackintosh DR et al: The exploding field of software for health education. *SOFTWARE HEALTHCARE* 3(5):40, 42, 45-46, 1985.
- Magrus MM: Issues and concerns in computer technology in nursing education. *J NY State Nurses Assoc* 16(3):56-60, 1985.
- McDermott J: Experience of an interactive program in undergraduate investigative practicals. *Journal of Biological Education* 19(2):157-162, 1985.
- Moore JW: Computer series, 61: bits & pieces, 24. *Journal of Chemical Education* 62(6):495-500, 1985.
- Narducci WA: Development, implementation, and cost-assessment of an integrated computer-assisted instruction course on drug interactions. *American Journal of Pharmaceutical Education* 49(2):145-149, 1985.
- Norman S et al: About computers: a literature review. *Nurse Educ Today* 5(3):116-118, 1985.
- O'Brien V: Computers in nursing education: as important as the 3Rs. *RNABC News* 17(1):24-26, 1985.
- Peterson NS et al: Teaching cardiovascular integrations with computer laboratories. *The Physiologist* 28(3):159-169, 1985.
- Pritchard G et al: Test run...computer program to prepare multiple choice questions. *Nurs Mirror* 161(5):29-31, 1985.
- Roberts FC: An overview of intelligent CAI systems. *Peabody Journal of Education* 62(1):40-51, 1984.
- Rovick AA: Writing computer lessons. *The Physiologist* 28(3):173-176, 1985.
- Sacks J: To copy-protect or not to copy-protect? *Popular Computing* 4(12):73-75, 125, 1985.
- Sales GC: Design considerations for planning a computer classroom. *Educ Tech* 25(5):7-13, 1985.
- Smith TM et al: Computer-assisted video instruction: promises and pitfalls. *Computers in the Schools* 2(1):65-74, 1985.
- Stewart D: Putting natural language to work. *Popular Computing* 4(11):64-68, 123-124, 1985.
- Stubbs M et al: Artificial intelligence in teaching and learning: an introduction. *Programmed Learning and Educational Technology* 22(2):150-157, 1985.
- Thomas BS: A survey study of computers in nursing education. *Comput Nurs* 3(4):173-179, 1985.
- Trachtenberg SJ: Even if they survive demographics can universities survive computer? *College Board Review* 134 2-3, 33, 1984-1985.
- Vermeersch PE et al: Database management for nursing education. One school's experience with System 1022. *J Med Syst* 9(1-2):69-77, 1985.
- Waldrop MM: Personal computers on campus. *Science* 228(4698):438-444, 1985.
- Wehrenberg SB: Is the computer the ultimate training tool? *Personnel Journal* 64(4):95-96, 98, 1985.
- Whiting J: The use of a computer tutorial as a replacement for human tuition in a mastery learning strategy. *Computers and Education* 9(2):101-109, 1985.
- Wood P: Use of computer simulations in microbial and molecular genetics. *Journal of Biological Education* 18(4):309-312, 1984.

Compiled by H. Modell

COMPUTERS IN LIFE SCIENCE EDUCATION

HAROLD I. MODELL

Department of Radiology
University of Washington
Seattle, Washington

MARCEL BLANCHAEER

Department of Biochemistry
Faculty of Medicine
University of Manitoba
Winnipeg, Manitoba
Canada

THEODORE J. CROVELLO

Department of Biology
University of Notre Dame
Notre Dame, Indiana

JAMES W. ECKBLAD

Department of Biology
Luther College
Decorah, Iowa

TSEGAYE HABTEMARIAM

School of Veterinary Medicine
Tuskegee University
Tuskegee, Alabama

DONNA LARSON

School of Nursing
Grand Valley State College
Allendale, Michigan

TERRY M. MIKITTEN

Graduate School of Biomedical Sciences
University of Texas Health Science Center
San Antonio, Texas

JAMES E. RANDALL

Department of Physiology
Indiana University
Bloomington, Indiana

PATRICIA SCHWIRIAN

College of Nursing
Ohio State University
Columbus, Ohio

RICHARD STULL

College of Pharmacy
University of Arkansas
Little Rock, Arkansas

JAMES W. WOODS

Lister Hill National Center
for Biomedical Communications
National Library of Medicine
Bethesda, Maryland

DOROTHY WOOLEY-McKAY

Department of Biology
Glendale Community College
Glendale, Arizona

GLENN YOSHIDA

Department of Life Sciences
Los Angeles Southwest College
Los Angeles, California

NRCLSE

CONTENTS

MICROCOMPUTER-LED CLINICAL CASE TUTORIALS IN BASIC SCIENCE EDUCATION M.C. Blanchaer and F.C. Stevens	25
CONVERSION OF INSTRUCTIONAL VIDEOTAPES TO COMPUTER CONTROLLED FORMATS FOR CONTINUING MEDICAL EDUCATION Janet W. Azbell	27
THE BULLETIN BOARD	30

MICROCOMPUTER-LED CLINICAL CASE TUTORIALS IN BASIC SCIENCE EDUCATION

M.C. Blanchaer and F.C. Stevens

Department of Biochemistry, University of Manitoba, Winnipeg, Manitoba, Canada

For the past four years this faculty has included microcomputer-based clinical case studies in the first year medical curriculum. These were designed to help individual students evaluate their mastery of some major biochemical and physiological concepts and to test their problem solving skills in clinical situations they perceive as relevant to their future professional roles.¹ Although students are expected, as part of the Human Biochemistry course, to com-

plete only three of the five case studies available in the medical library, some work voluntarily through the remainder during free time.

The 98 class members used the programs 434 times in the 1984 session. However, during the first two years the case simulations were available, they were not used as actively as they are currently. Consequently, it was possible at that time to compare the performance of non-users with the remainder of

the class. In multiple choice examinations two to six months after the biochemistry course ended, recall of certain items of course content by simulation users was significantly better. In questions requiring written answers, these students were able to deal with an unfamiliar case by selectively applying information and concepts encountered some months earlier in a simulation.

While comments have been mainly supportive of this style of learning, some students indicate a degree of disorientation when they first attempt this new mode of learning. In part it seems to stem from not having mastered the appropriate course material before working on the simulation. However, others clearly are unaccustomed and/or unskilled in the hypothetico-deductive approach to problem solving featured in the simulated cases. If permitted, they bring along an experienced classmate to help, thus negating the educational objectives of the exercise. To address this problem it was decided that, before the simulations were made available for individual use, all students should have an opportunity to participate in a student-centered, small-group tutorial which was "led" by one of the case simulations rather than by a tutor. Since this was well received, a second tutorial of this type was introduced in 1984, and a third is being added this year.

TUTORIALS

Twelve students seated in a semicircle face the tutor who is at the keyboard of a microcomputer connected to two suitably placed 20" video monitors. The tutor informs the group they are about to encounter a clinical case on the computer. The students are then told that it will give them an opportunity to work together as a team to identify the disturbance underlying the illness of a "patient" they are about to meet. The nature of the problem is not revealed by the tutor. It must be discovered by the group.

The students are asked to choose a spokesperson who will convey to the tutor the group's response to the

various questions posed by the case program. The tutor's role is then explained to be that of a typist, communicating the students' decisions to the computer but offering no comment or advice while the group is working on the case. However, it may be desirable for the tutor to ask the occasional question to help hypothesis formulation. At the end of the session, the group is reminded that the simulation is available in the medical library for those who wish to repeat it individually to clarify residual uncertainties and to consolidate their understanding of how such a problem is best approached. The structure and educational design of the simulations are similar to others in a set of seven.² Two of these have been described previously.^{3,4}

At the beginning of the session, the student "doctors" are requested by the program to respond to multiple choice questions, a format with which our students are familiar and comfortable. However, because of the cues inherent in this type of interaction, it is gradually replaced as the case unfolds with enquiries that require a word or phrase to be typed in. Choosing these words for transmission to the tutor usually elicits a vigorous discussion as group members pool their knowledge and problem solving skills and thus share responsibility for the success or failure of the enterprise. Some students refrain from participating and elect to work through the simulation themselves at a later time. The number electing this route is usually small, and those students' reticence does not seem to interfere with the commitment of the others to the task. At the end of the session, the tutor may review with the group the adequacy of the knowledge exhibited and the strengths and weaknesses of its problem solving style. Remedial steps may be suggested for deficiencies.

TUTOR RESPONSE

To date, six instructors have presided over 32 such tutorial classes. Tutors are comfortable with the format since

the simulation can be worked through beforehand as many times as necessary to master the subject matter and become familiar with the events that occur when the various branches available in the simulation are chosen. The clinical knowledge necessary to deal with the topic of the simulation is minimal and can be acquired from a textbook. Also, it will be noted that the tutor is not expected to act as the problem solver since that responsibility is assigned at the beginning of the session to the students. Furthermore, it soon becomes clear that, in spite of its clinical setting, the simulation is primarily an exercise in problem solving with basic science information. In other types of tutorials, an instructor, often encouraged by subtle student prompting, may be tempted to deliver a mini-lecture, thus negating the purpose of the session which is student-centered problem solving. Such intervention is largely precluded here as students are aware that they, rather than the tutor, are responsible for completion of the case simulation in the hour scheduled for the task.

Some members of the student group may feel frustrated by what they see as an inappropriate group consensus being relayed to the tutor-typist. These concerns are usually mollified when they note the program responding appropriately to almost any typed input and, through hints and good-humored persistence, guiding the group to the correct decisions. Nevertheless, some would prefer alternate routes at a number of branch points. They can satisfy their curiosity and also consolidate their knowledge and understanding by repeating the simulation privately during free time scheduled for this purpose.

SUMMARY

Computer-based clinical case studies are useful for reinforcing basic science concepts, allowing medical students to test and consolidate their newly acquired knowledge while engaged in problem solving situations they perceive as being relevant to their future role.

Such simulations are effective when

students work through them individually. However, they are particularly useful in a tutorial setting designed to introduce students to this learning medium in a non-threatening, cooperative atmosphere in which they can pool their knowledge and skills to solve the problem(s) of a "patient".

REFERENCES

1. Blanchaer, MC: Clinical simulations on a microcomputer. *Comput Ed* 8:397-399, 1984.
2. Blanchaer MC (ed): *Clinical Case Studies*. Cambridge, England: Elsevier-Biosoft, 1984.
3. Blanchaer MC, Kerr AM, Stevens FC: Clinical case simulations on a microcomputer. In: Wood EJ (ed), *Microcomputers in Biochemical Education*. London: Taylor & Francis, 1984.
4. Blanchaer MC, Stevens FC: Programming a clinical case simulation on a microcomputer. *Biochem Ed* 12:29-33, 1984.

CONVERSION OF INSTRUCTIONAL VIDEOTAPES TO COMPUTER CONTROLLED FORMATS FOR CONTINUING MEDICAL EDUCATION

Janet W. Azbell

Department of Curriculum and Instruction, Illinois State University, Normal, Illinois

Instructional videotapes have been produced for several decades; produced and then stored in libraries across the country and around the world. Common complaints related to the use of conventional videotape include the length of time needed to view an entire tape, the non-relevance of many sections to particular viewers, and the incorporation of content not well suited to the medium. The problem concerning resolution becomes that of converting a stored videotape into a useable and instructionally useful media design.

Two relatively new instructional technologies, computers and video, have been combined to form an even newer instructional medium that can resolve some major problems associated with video or computer technology alone. Computer aided interactive video (CAIV) instruction combines the sound and action of video with the precise control, branching, and feedback capabilities of the microcomputer. In CAIV a computer program is used to determine the sequence in which video segments are selected and shown. Either videotape or videodisc (or in some cases both

tape and disc) may be used in developing CAIV courseware materials.

Computer aided video instructional materials using videotape can be prepared by using existing tapes, producing new tapes, or integrating existing tapes with new ones. Because making videotapes is a time-consuming process, one of the most efficient ways to develop CAIV courseware is to modify or combine existing tapes and add "personalized" introductions, comments, and conclusions made especially for the materials being developed. By converting existing videotapes to CAIV formats using a computer/video recorder interface, an unused instructional resource may gain new value as a learning tool.

BACKGROUND

Effective CAIV is not simply video with a computer program built around it as is often assumed. Because there are differences between CAIV instruction and instruction provided by conventional videotape, it is necessary as part of the conversion process to analyze the instructional format of the linear tape

before a CAIV design can be formulated. CAIV design procedures can then be used to modify and adapt the instructional format to the needs of specific users.

The process of converting conventional videotapes to an interactive video format can be illustrated by the initial development phase of a cooperative effort between the Methodist Medical Center of Illinois in Peoria, Illinois and faculty members of Illinois State University. Although content experts may have favorite video materials they wish to adapt to CAIV, they may not have a good grasp of the many ways in which the adaptations can be made. For this reason, instructional design specialists from the University work with content experts from the Medical Center to achieve effective CAIV designs.

The conversion process for videotapes of continuing medical education (CME) presentations has been implemented in two steps:

- 1) formalizing a tape format analysis that identifies tape segments to be used and defines the roles to be

played by the instructional designer and content specialist;³

- 2) creating an instructional design specific to the learning approach familiar to physicians in CME applications.

The continuing professional development of practicing physicians in this era of rapid technological change and medical advancement is a difficult task but one of great importance. Continuing professional education programs are expected to have some impact on the professional by producing a variety of new knowledge, skills, values, and attitudes. Those responsible for continuing medical education at Methodist Medical Center have found that most of the taped lectures of visiting specialists and expensive, commercially produced videotapes stored in the medical center library are not used frequently.

Physicians are acutely aware of the time pressures under which they work. They do not like to spend their time unprofitably regardless of whether their goal is more time for patient care, consultation, or staying current with the latest research. The current situation is neither time nor cost efficient from anyone's perspective. One form of computer aided video instruction that we have implemented directly addresses the problem of time efficiency.

THE COMPUTER AS AN INDEXING DEVICE

This form of CAIV uses the microcomputer simply as a device to allow users quick access to relevant portions of an existing videotape. It serves much the same function as an automated table of contents or index to a book. The instructional designer and physician content expert identify relevant segments of the tape. An electronic signal is then dubbed on the second audio track of the tape. This signal permits the computer program to determine precisely the video segment to be displayed on the screen. The entire computer program

consists of a series of menus listing video segments that can be displayed on the monitor. The physician-user may then control the sequence and content of the instructional presentation through the selection of various menu choices.

An existing videotape on the clinical diagnosis of dysplastic nevi was converted to this format. The converted tape will be used in several different settings. In one setting, a Methodist Medical Center pathologist will use the courseware during formal lecture presentations to residents. Another planned use of the tape is in local presentations to the general public for the American Cancer Society. The presenter will no longer find it necessary to search through the entire tape to locate relevant sections for display. The computer will automatically search for and display selected segments in the order determined by the presenter. The user will determine the segments appropriate to the learning need of the audience, select those segments, and sequence them accordingly.

OTHER APPLICATIONS

We are also concerned with developing a learning system for practicing physicians as part of the medical center's program in continuing medical education. Education is a formal structure within which learning is supposed to occur. Learning, however, is a process resulting in some modification of the behavior, way of thinking, feeling, or doing of the individual learner.¹ The aim of professional development for physicians should be continuing medical learning rather than continuing medical education. While significant learning may occur within education, much of the control over the experience resides outside of the individual. In most traditional and hospital-based CME activity, the teaching/learning process is one of instruction that is directed primarily externally. Because learning is an internal, largely self-directed process, the tapes we converted contain many design

features that allow the physician-users to direct and control their own learning.

This type of computer aided video instruction makes full use of the microcomputer's ability to perform complex branching operations to control the display of video segments and provide feedback to the user. Unlike conventional video, user-directed programs allow users to stop and start the program whenever and wherever they wish. Time for notetaking, glossaries of unfamiliar terms, and the give-and-take of questions and answers can also be easily provided.⁴

Four existing videotapes were converted to CAIV formats. A variety of design features were implemented in eleven courseware programs based on these four tapes. Various combinations of these design features are presently being evaluated within the CME program. The features being tested include using on-line instructional resources to enhance learning capabilities, using a video camera to aid physicians in self-assessment of skill mastery, and using influential colleagues to introduce content and establish its relevance to the learning needs of physician peers.

Providing access to on-line databases

The three most significant aids to physicians' learning and practice changes are reading, formal and informal interaction with colleagues, and attendance at organized CME activities. Of these three, reading is the most important. With this in mind, several features were incorporated into CAIV learning systems to capitalize on this well-established learning pattern.

CAIV courseware was developed using a videotape of a standard slide lecture presentation on toxic shock syndrome. At various points during the computer aided video instruction, menus are presented that allow the physician to use a modem to do on-line data searches using a medical database. Literature

abstracts on user-determined areas of inquiry are immediately available. After consulting relevant data sources, the physician is free to return to the CAIV courseware and continue with the presentation. Using this approach in other settings, provision could be made for the user to obtain information from any one of the user specialized medical databases now becoming available. With the additional CD-ROM databases now available, this option becomes much more cost effective for librarians concerned about inefficient searching of on-line databases by untrained users.³ This same design can also be used to enable physicians to access a word processor so that notes about possible follow-up can be recorded during the presentation. All can be controlled from the computer keyboard.

Use with a physical model and videocamera

A CAIV program was also developed from an existing tape on the use of the fiberoptic sigmoidoscope. It has been estimated that a physician requires forty attempts at passing the instrument using an anatomically correct model before a level of competence is reached that would allow practice in an actual clinical situation. In previous training situations, a twenty minute linear videotape was presented to illustrate the proper procedure. A trainer would then coach physicians in the actual use of the instrument in a simulated clinical situation. This was a time consuming process for the physicians involved as well as the trainer.

One of the reasons often mentioned by physicians, as well as other adult learners, for self-directed learning is that arranging time for group meetings is inconvenient to their already very busy schedules.² By using the CAIV learning system, the physician can, in effect, train himself in the use of the fiberoptic sigmoidoscope, thus eliminating the need for a group training exercise. The CAIV program developed makes use of

segments of the training video but allows the physician to review relevant sections on the use and manipulation of the instrument at will. This was impossible in the group viewing situation. After viewing animated and live-action video segments on the clinical procedure, the physician is instructed to practice the procedure with the instrument and model provided. This practice is automatically recorded by a video camera controlled by the computer interface. This videotaped practice session is then available for immediate self-assessment by the physician. The tape may be viewed and reviewed to assess areas of weakness. Using the program, the physician may then review segments of the instructional tape before attempting the procedure again. The physician continues this process of trial, tape, assessment, and review until he is confident of his skill in maneuvering the instrument. The final videotaped practice may then be evaluated by the trainer before the physician participates in actual clinical practice.

Making use of local colleagues

Influential colleagues are important agents in the acquisition of new information and in the adoption of possible changes in actual physician practice. A CAIV design which capitalizes on the recommendations and knowledge of peers was developed using the same videotape on dysplastic nevi mentioned previously. A medical center pathologist who was also a professor at the University of Illinois School of Medicine at Peoria videotaped a brief introduction and conclusion to the tape along with a short segment on the objectives of the courseware. This visual and vocal identification with a locally accepted expert in the field appears to have made a favorable impression on the physicians using the courseware.

An exciting design feature combining several of the options mentioned previously uses slides from a commer-

cially available videodisc. The hematology disc prepared by the University of Washington contains some excellent photomicrographs of dysplastic nevi in various stages of development. The existing videotape that we used for the conversion process did not include the same high quality video images. In order to take advantage of the videodisc images, it was necessary to combine the still-frames of the videodisc with the action of the actual clinical exam on the videotape. The computer program was designed to allow the interface to control either machine on command. A further refinement of this procedure was developed by Dent Rhodes of Illinois State. The audio track of the videotape (no video is shown) is played to narrate the slide from the videodisc as it is displayed on the computer monitor. Both the videodisc player and the videotape player are controlled by the computer to play at the same time. This process allows efficient still-frame audio which can be easily changed and updated. It also allowed us to use the voice of our local expert to narrate the important features of the videodisc slide. This opens up many possibilities for the conversion of generic videodisc image repositories to true interactive programs combining the longer action segments available on videotape.

CONCLUSION

Each of these courseware designs is in the process of being evaluated in the medical center setting. The feedback received thus far has been very favorable, with requests for future development in a variety of content areas. The design is by far the most difficult and time-consuming aspect of CAIV courseware development. Using an authoring system, effective courseware can be developed easily from existing videotapes within a two week period, excluding instructional design time. The development of CAIV materials has become so simple technologically that the real task

now becomes designing courseware that takes full advantage of the sophisticated options available.

REFERENCES

1. Houle CO: Continuing Learning in the Professions. San Francisco: Jossey-Bass, 1980.

2. Penland P: Individual Self-Planned Learning in America. Washington, DC: Office of Education, US Department of Health, Education, and Welfare, 1977.
3. Rhodes DM, Azbell JW: Demystifying Computer Aided Video Instruction. CCAIT Journal, Spring, 1986 (in press).

PO Box 217
NL-7500 AE Enschede
The Netherlands

June 9-13, 1986. 15th Annual Meeting of the MUMPS Users' Group. San Diego, California.

Contact:

MUMPS Users' Group Meeting
4321 Hartwick Road
Suite 510
College Park, MD 20740

June 23-27, 1986. The Micro-computer Institute for Nurses. Washington, D.C.

Contact:

Georgetown University
School of Nursing
CE Division
3700 Reservoir Road NW
Washington, D.C. 20057
(202) 625-2168

July 13-18, 1986. XXX International Congress of Physiological Sciences. Vancouver, Canada.

A symposium and workshop on computer-based education in physiology are scheduled for July 16.

Contact:

Dr. K.E. Cooper
Department of Medical Physiology
University of Calgary
Calgary, Alberta
Canada T2N 4N1

August 4-8, 1986. The Microcomputer Institute for Nurses. Lafayette, Louisiana.

Contact:

University of Southwestern Louisiana

THE BULLETIN BOARD

The Bulletin Board is published periodically to inform readers of upcoming meetings of interest. If you know of meetings, symposia, continuing education courses, etc, of interest to life science educators that do not appear in THE BULLETIN BOARD, please let us know. Send pertinent information to Dr. Harold Modell, NRCLSE, RC-70, University of Washington, Seattle, WA 98195.

May 2-5, 1986. Health Sciences Communications Association (HeSCA) 1986 Annual Meeting. Denver, Colorado.

Contact:

Jim Barrett
Center for Educational Resources,
SB-56
University of Washington
Seattle, WA 98195
(206) 545-1156

or:

Lionelle Elsesser
Executive Director, HeSCA
6105 Lindell Blvd
St. Louis, MO 63112

May 8-10, 1986. Computer applications in medicine and health

care. AAMSI Congress 1986. Anaheim, California.

Contact:

Ben T. Williams, MD
Director of Laboratories
Mercy Hospital
1400 West Park Avenue
Urbana, IL 61801
(217) 337-2175

Integrating Computing Into the Higher Education Curriculum (2 symposia):
May 12-13, 1986. Northwestern University. Evanston, Illinois.
May 27-28, 1986. Duke University. Durham, North Carolina.

Contact:

EDUCOM
P.O. Box 364
Princeton, NJ 08540
(609) 734-1886

May 20-23, 1986. EURIT, the European Conference on Information Technology in Education, 1986. Enschede, The Netherlands.

Contact:

F. van Sinninghe Damste
c/o Twente University of Technology
C.O.I.

College of Nursing - CE
P.O. Box 42490
Lafayette, LA 70506
(318) 231-6682
(318) 231-6782

August 10-14, 1986. 37th Annual Meeting of the American Institute of Biological Sciences (AIBS). Amherst, Massachusetts.

A workshop on computers in bioeducation will be held Sunday, 10 August 1986, from 9:00 a.m. to 5:00 p.m.

Contact:

AIBS Annual Meeting
730 11th Street NW
Washington, D.C. 20001-4784

August 17-22, 1986. Computers in Biology. Sixth Annual Notre Dame Short Course Series. Notre Dame, Indiana.

Contact:

Ronald A Hellenthal
Biocomputing Short Courses
Coordinator
Department of Biologicall Sciences

University of Notre Dame
Notre Dame, IN 46556
(219) 239-7255

September 17-19, 1986. The Second Annual Conference on Interactive Video in Nursing and Allied Health. Galveston, Texas.

Contact:

Gary D Hales, PhD
School of Allied Health Sciences
8th and Market Streets
The University of Texas Medical
Branch at Galveston
Galveston, TX 77550
(409) 761-3040
(713) 784-8326

October 25-26, 1986. Tenth Annual Symposium on Computer Applications in Medical Care (SCAMC). Washington, D.C.

Contact:

SCAMC
Secretariat: The George Washington
University Medical Center
Office of Continuing Medical

Education
2300 K Street, NW
Washington, D.C. 20037

October 26-30, 1986. 5th World Congress on Medical Informatics. Washington, D.C.

Contact:

MEDINFO 86 Organizing Committee
Secretariat:
c/o George Washington University
Medical Center
Office of Continuing Medical
Education
2300 K Street NW
Washington, D.C. 20037
(202) 676-8929

November 10-13, 1986. Association for the Development of Computer-based Instructional Systems 28th International Conference. Washington, D.C.

Contact:

ADCIS, 409 Miller Hall
Western Washington University
Bellingham, W.A. 98225
(206) 676-2860

EDITOR'S NOTE

The National Resource for Computers in Life Science Education is now accessible through the BITnet international computer network. To contact NRCLSE through BITnet, address mail to:

MODELL@UWALOCKE

COMPUTERS IN LIFE SCIENCE EDUCATION

HAROLD I. MODELL

Department of Radiology
University of Washington
Seattle, Washington

MARCEL BLANCHAER

Department of Biochemistry
Faculty of Medicine
University of Manitoba
Winnipeg, Manitoba
Canada

THEODORE J. CROVELLO

Department of Biology
University of Notre Dame
Notre Dame, Indiana

JAMES W. ECKBLAD

Department of Biology
Luther College
Decorah, Iowa

TSEGAYE HABTEMARIAM

School of Veterinary Medicine
Tuskegee University
Tuskegee, Alabama

DONNA LARSON

School of Nursing
Grand Valley State College
Allendale, Michigan

TERRY M. MIKITTEN

Graduate School of Biomedical Sciences
University of Texas Health Science Center
San Antonio, Texas

JAMES E. RANDALL

Department of Physiology
Indiana University
Bloomington, Indiana

PATRICIA SCHWIRIAN

College of Nursing
Ohio State University
Columbus, Ohio

RICHARD STULL

College of Pharmacy
University of Arkansas
Little Rock, Arkansas

JAMES W. WOODS

Lister Hill National Center
for Biomedical Communications
National Library of Medicine
Bethesda, Maryland

DOROTHY WOOLEY-McKAY

Department of Biology
Glendale Community College
Glendale, Arizona

GLEN YOSHIDA

Department of Life Sciences
Los Angeles Southwest College
Los Angeles, California

NRCLSE

CONTENTS

- | | |
|--|----|
| COMPUTERIZED VETERINARY MEDICAL INFORMATION SYSTEMS: IMPACT ON VETERINARY MEDICAL EDUCATION | 33 |
| Philip A. Bushby | |
| PILOT: THE LANGUAGE OF CHOICE FOR COMPUTER-ASSISTED LEARNING ON MICROCOMPUTERS | 37 |
| Marcel C. Blanchaer | |

COMPUTERIZED VETERINARY MEDICAL INFORMATION SYSTEMS: IMPACT ON VETERINARY MEDICAL EDUCATION

Philip A. Bushby

College of Veterinary Medicine, Mississippi State University, Starkville, Mississippi

Educational theorists have attempted to describe the relationship between formal schooling and learning. Webster's dictionary defines education as the process of training and developing the knowledge, skill, mind and character, especially by formal schooling. The strictest interpretations of this definition limit the educational experience to the classrooms of our schools and universities. Education is, however, not confined by

dictionary definitions nor to formal institutions. Education is a continuum; it begins at birth and for most of us does not end until death.

In 1956, B.S. Bloom defined a taxonomy of the cognitive domain.² He described learning as an hierarchical process with acquisition of knowledge as prerequisite to comprehension, application, analysis, synthesis, and evaluation. The acquisition of knowledge,

memory of information, was considered essential for the higher levels of thinking/learning to occur. Bloom's paper was simply an enunciation of the basic premise which had served as the foundation for higher education for decades. Information was essential; it had become the valued entity, "a core of knowledge must be taught".⁹ Possession of information is not, however, the sole goal of education. Scientific education consists of at least four basic components: acquisition of knowledge, use of knowledge, development of psychomotor skills, and the reinforcement of desirable behavioral characteristics. In veterinary medical education, students are expected to obtain a foundation knowledge base in several disciplines for several species. Students are expected to become astute problem solvers, integrating their knowledge base with the unique nature of patient problems, analyzing each problem to generate corrective and preventive plans in an economically efficient manner. Society expects graduate veterinarians to be thorough, reliable, and efficient in their evaluation of problem situations and to be critical thinkers. The ability of veterinarians to remember information and the amount of information to be recalled is of little importance to the consumer of our services provided we provide a competent service.

IMPACT OF THE KNOWLEDGE EXPLOSION

We are currently experiencing a knowledge explosion of geometric proportions. While the increase in medical/veterinary medical information is difficult to quantitate accurately, numerous examples which document the existence of the knowledge explosion can be cited. One representation of this knowledge explosion is the number of journals published in various fields. At present there are 4800 journals published relating to the medical sciences alone. Two hundred and six of these relate specifically to veterinary medicine.⁷ The sources of information are so numerous that each member of a

profession is engaged in a battle to stay abreast of current information and technology.

Another indicator of the current knowledge explosion is the proliferation of specialties. As information increases, each profession is forced into a series of progressive categorizations of knowledge into disciplines, specialties, and subspecialties. Just as it had been logical to categorize laborers by skills, it became not only logical, but essential, to categorize professions by their knowledge base. With the rapid expansion of information, specialization became necessary. Since no one could command mastery of all of the knowledge in a given field, that field was divided and subdivided until the amount of knowledge within any compartment could be mastered. The proliferation of specialties and subspecialties attests to the futility of attempting to master the information in a profession as complex and diverse as veterinary medicine. The American Veterinary Medical Association currently recognizes fourteen specialty boards.¹ Each of these boards has explicit requirements for eligibility including from 3 to 6 years of advanced training or experience. Many of these specialties recognize subspecialties in either a formal or informal manner.

In the book *Megatrends*, John Naisbitt discusses the impact of the knowledge expansion and describes the transition from an industrial society to an informational society. He documents that between 6,000 and 7,000 scientific articles are written each day. Scientific and technical information, which has been doubling at the rate of once every 5.5 years is now approaching a doubling rate of once every 20 months. Naisbitt claims that "this level of information is clearly impossible to handle by present means. Uncontrolled and unorganized information is no longer a resource in an information society. ... it becomes the enemy of the information worker. Scientists who are overwhelmed with technical data complain of information pollution and charge that it takes less time to do an

experiment than to find out whether or not it has already been done."³

The information relevant to veterinary medicine is documented by the totally explicit curriculum at the College of Veterinary Medicine at Mississippi State University. Over a period of eight years, the faculty at the college have published explicit course syllabi containing each behavioral objective the students were expected to learn or master. These syllabi represent the best estimate of the faculty at defining the knowledge base and skills required of a veterinarian. The syllabi have undergone extensive evaluation. Each year, faculty with the appropriate species, discipline, and/or system expertise review and modify the syllabi. In addition, the syllabi are reviewed by external examiners whose primary goal has been to certify the quality of the Mississippi State program. In 1983, a complete audit of this curriculum was conducted. Each objective was analyzed qualitatively and quantitatively. The qualitative analysis consisted of determining the type of learning (acquisition of knowledge, use of knowledge, psychomotor skills, or behavioral characteristics) and the level of learning required (memory, comprehension, application, analysis, synthesis or evaluation). The quantitative analysis consisted of counting the number of items and the number of actions within each objective. The syllabi representing the courses in the first three years of the DVM curriculum contain 215,492 requirements of the students. This equates to a requirement for the student to master one new thing every 6 minutes, 2 1/2 hours a day, 7 days a week for each of the 30 months of the first three years of the curriculum; a virtually impossible task for even the most talented student.

With the rapid expansion of knowledge over the past few decades, the nature of veterinary medical education has changed. Training in psychomotor skills, opportunities for development of problem solving capabilities, and the reinforcement of desirable behavioral characteristics have diminished in

veterinary medical curricula to accommodate the study of the prerequisite knowledge base. An overwhelming majority of examination questions used in veterinary medical education are Bloom Level one; testing memorization of factual information. Analysis of the National Board and other veterinary examinations reveal that few required higher levels of learning, the use of psychomotor skills, or encouraged the refinement of the desirable behaviors. Knowledge acquisition is disproportionately emphasized at the expense of the other components of education.⁴

Educators have been struggling with the knowledge explosion dilemma for the past two decades. Various approaches at solving this problem have failed to improve the quality of education or the quality of veterinary medicine practice significantly. The emphasis on educational innovation has, until recently, focused on improving the efficiency of instruction. The autotutorial emphasis of the 1970s, the introduction of learning by the use of specific behavioral objectives encompassed in the mastery concept, the increased use of audiovisuals in the classroom, and certain concepts in computer-aided instruction have all failed to deal effectively with the problem currently confronting education. The approaches of the past have failed to take into account the fact that cerebral capabilities are not expanding along with the expansion in information. The assumption that one can learn, in a four year veterinary curriculum, all information necessary to successfully practice veterinary medicine for a full career is erroneous. Educators will admit that their intent is not to teach all relevant veterinary information to their students. Many perceive that their role is to distill the vast quantities of veterinary literature to provide the student with only the most essential information. This approach, while in part diminishing the effect of the knowledge explosion, leads to superficiality and is contrary to the promotion of life long learning. Students need to develop the skills of analyzing the literature and

the skills of processing information. The content of the curriculum and the approach to teaching often prove contradictory to the long range goals of education. The classrooms, laboratories, clinics, and examinations emphasize what the student knows or does not know rather than expanding the students' abilities to use various information resources. Certification and licensure in most states are based upon evaluations of knowledge. Yet the practitioner who hires a new graduate rarely complains that the new graduate doesn't know enough information. Dissatisfaction focuses upon the lack of problem solving skills, inefficiency of psychomotor skills, inability to deal with clients, lack of "business sense," and less than desirable behaviors. Veterinary training needs to be refocused. The emphasis on knowledge acquisition, knowledge utilization, psychomotor skills, and behavioral characteristics must be balanced within veterinary curricula.

ROLE OF COMPUTERS

We have seen tremendous advances in computer technology within the last two decades. Computers, once considered to be nothing more than powerful calculators, are now used as information managers. The functions of the computer to store, retrieve, and manipulate information can be used to facilitate the practice of veterinary medicine if the profession will allow the use of the computer as a tool to expand the power of the human mind. The computer is beginning to assume importance in the information management systems of veterinary practice. To date, most of the emphasis has been on financial management and medical records, but systems dealing with reminder systems, inventory control, and other information management tools are being promoted. There is, however, a reluctance to venture into the broader field of computerized information management in terms of veterinary medical information.

Database management systems with

the capability of providing the veterinarian with rapid and accurate scientific information are currently available. The Problem Knowledge Coupler System was formally introduced to the veterinary community in October, 1982 at the First Symposium on Computer Applications in Veterinary Medicine⁸ and received significant attention at the Second Symposium on Computer Applications in Veterinary Medicine.⁵ This system provides information in a problem oriented fashion, expanding the ability of the veterinarian to diagnose and manage medical problems. The power of programs such as the Problem Knowledge Coupler far exceed the power of the human mind in recalling information accurately, integrating information, and dealing with multiple variables simultaneously. Programs such as this will free the student or graduate from the burden of attempting to become an encyclopedia of veterinary medical information, and they will open opportunities for expansion of training in the utilization of information, enhancement of psychomotor skills, and reinforcement of desirable behavioral characteristics.

Educators should begin to acquaint themselves with the information management capabilities of the computer. Naisbitt describes the various stages of the development and use of technology. The first stage is the development itself. The second is the application of the technology to improve previous systems. The last is the innovative use of new technology to move in new directions. The use of computerized veterinary information systems to assist in the solutions of health related problems fits into this third stage. The systems are available; they are merely waiting for additional development and for acceptance. "The problem is that our thinking, our attitudes, and consequently our decision making have not caught up with ...reality..."⁶ Veterinary education is facing a major challenge. We can use the computer for drill and practice, for simulations of patients and laboratory situations, or we can go

much further. We can choose to ignore the information explosion and choose to ignore the potential of the computer for information management or choose to use the computer as a tool to expand the power of the human mind.

In 1984, the College of Veterinary Medicine at Mississippi State University began a project unique in veterinary medical education. All incoming veterinary students were required to purchase a Macintosh microcomputer. The goals of the project were to graduate "computer literate" graduates in 1987 and to begin to develop veterinary medical information systems that would begin to supplant veterinary medical "knowledge acquisition" components of the curriculum. The project, now in its second year, will unquestionably meet the first goal of producing computer literate graduates. The development of veterinary medical information systems is occurring, and the Mississippi State student is receiving exposure to and developing expertise in using information systems. Serious consideration is being given to significant curricular modifications which would reduce the

classroom/laboratory component of the curriculum by one year and increase the "practical work related" aspects of the curriculum by one year.

Rapid progression towards the second goal is hindered by the natural resistance to change which occurs within a faculty and a profession. For the computer to assume its full potential within the veterinary medical curriculum and veterinary medical practice, many of the current knowledge-based systems will require serious review and modification. The nature of student evaluation, examination procedures for veterinary medical licensure, and the criteria for accreditation of veterinary medical programs will have to be altered if we are to use the full potential of computerized information systems.

Problem Knowledge Coupler is a trademark of the PKC Corporation, Cambridge VT

REFERENCES

1. AVMA Directory, American Veterinary Medical Association, Schaumburg, Illinois, 1984.
2. Bloom BS (Ed): Taxonomy of Education Objectives: The Cognitive Domain. McCay, New York, 1956.
3. Naisbitt J: Megatrends, Ten New Directions Transforming Our Lives. Warner Brothers, Inc., New York, 1982.
4. Pollock RVH: You Cannot Improve Teaching if You Don't Change the Exams; Three Practical Suggestions, *J Vet Med Educ* 10(1), 1983.
5. Proceedings of the Second Symposium on Computer Applications in Veterinary Medicine, College of Veterinary Medicine, Mississippi State University, 1984.
6. Program of the 121st Annual Meeting, American Veterinary Medical Association, Schaumburg, Illinois, 1984.
7. Urlick's International Periodicals Directory. 21st Edition, P.R. Bowker Company, New York, 1982.
8. Weed LL: Keynote Address First Symposium on Computer Application in Veterinary Medicine, College of Veterinary Medicine, Mississippi State University, 1982.
9. Weed LL: Your Health Care and How to Manage It. Essex Publishing Company, Inc., Essex Junction, VT, 1978.

PILOT: THE LANGUAGE OF CHOICE FOR COMPUTER-ASSISTED LEARNING ON MICROCOMPUTERS

Marcel C. Blanchaer

Department of Biochemistry, University of Manitoba, Winnipeg, Manitoba, Canada

As its name indicates, PILOT (Programmed Instruction Learning Or Teaching) is a computer language developed specifically for programming interactive computer-assisted learning lessons. It is especially useful when students are expected to respond to questions by typing words or phrases that must be recognized (matched), evaluated, and acted upon by the program. Standard computer languages such as BASIC, Pascal and C can, of course, be pro-

grammed to do the same tasks, but PILOT comes with the necessary built-in sophisticated machine language routines.

The different versions of PILOT currently available for the Apple II family, IBM PC and compatibles, Macintosh, and other microcomputers were all developed from the original PILOT language devised by J. Starkweather in the late 1960s. To a limited extent, lessons programmed with one version of

PILOT can be moved to computers that normally use another version. If the lesson consists only of text-based interactions between the user and program, it can be transported to another computer relatively easily. However, it is usually more difficult to move a lesson that utilizes version-specific commands for features such as graphics, sound, and viewports. Considerable rewriting may be necessary before the lesson will run in the new environment.

Because of space limitations, this article will present only a superficial overview of the features of PILOT which, in its more recent versions, approaches the versatility of high level languages such as BASIC and Pascal. The reader should consult the additional information references at the end of the article for further, more detailed information.

FEATURES OF PILOT

Only 20-25 commands are used in PILOT. These are easily remembered as they consist of one or two letter mnemonics. Thus, to program a paragraph of text, the first line is begun with the type command, T:, and each following line is started with a colon. Commands are available to produce multiple text and graphic screens which can be addressed independently and, if desired, can be made to respond to student input.

Perhaps the most sophisticated and useful features of PILOT are the two commands, Accept (A:) and Match (M:). The A: command accepts the answer typed by the student and, if desired, edits it in various ways to facilitate the function of the M: command that follows. M: is used to match text in the input with expected student responses previously stored in the lesson by the author. In these accept-match sequences, the user's input may be a number or letter expected in response to multiple choice questions. However, this command sequence is most useful for recognizing specific words, phrases, and word fragments present in whatever the student has entered. Thus, the statement, MS:heart!myocard!pump, recognizes each of these words or word fragments as equivalent; the modifier, S, in the command permits spelling errors. The @ in the statement, M:liver@heart@kidney, designates that all three words must be present in the user's entry, but they may occur in any order. In contrast, the & in M:heart&liver, requires that both words be present and in the order shown. The matching procedure ignores anything irrelevant in the student's response provided it is not

imbedded in one of the words to be matched.

A successful match can be followed by commands to produce an appropriate action such as displaying a textual or graphics response on the screen or branching the student to another section containing a remedial tutorial. These along with other commands that alter line spacing, call various fonts and character sizes, create new sets of characters, or call bold or plain text, facilitate the design and programming of effective interactive lessons.

In addition to being faced with new commands, the beginning PILOT programmer finds that the line numbers of BASIC and its most often used statements are missing. Instead of GOTO a line number, PILOT jumps (J:) to a specified label that begins with an asterisk. Instead of a GOSUB, PILOT uses (U:) a subroutine. Thus, the statement, J:review, will produce a jump to label *review. U:cont will call the subroutine *cont and then return to the program line after U:cont. An unusual feature of PILOT is that execution of most commands can be made conditional upon the contents of a variable or expression imbedded in the command. For example, the most recent user input accepted by an A: is always stored in the system variable, %b. Therefore, if the author wishes a line of text to appear on the screen only after the student has entered a number between 20 and 40, the desired text would begin with T(%b>=20&%b<=40): as a command. Most commands also can be controlled by evaluating an imbedded expression. Thus if a numeric variable, C, has been used to count the number of times a student has attempted a question, the command, J(C>=4):help, can be used to jump the student to a remedial section (*help) after four attempts.

File protection is available but differs in its effectiveness among versions of the language. Unauthorized access to the source code of Apple and SuperPILOT lessons and to student activity records is moderately difficult since the files can be read only with the Super-

PILOT or Apple Pascal Editor utilities. PC/PILOT and MacPILOT lessons are protected by having only binary encrypted files available to users. Although its use is not yet extensive, most current versions of PILOT allow control of a videodisc or videocassette player.

DISADVANTAGES OF PILOT

Lessons in PILOT may run relatively slowly, as do those of other authoring languages that use a runtime interpreter. However, interaction is usually not perceived as slow by the user when the response to the computer's question requires some time for thought before entering the answer. Mathematical calculations can be handled, but responses may be unacceptably slow with complex or repetitive operations. The response of Apple PILOT and SuperPILOT lessons is particularly sluggish because the lesson file is first interpreted to Pascal p-code and then converted into machine language before action is seen on the screen.

It is ironic that the most serious disadvantage of PILOT as an educational tool is its ease of use. The effortless way in which endless pages of text can be programmed, interspersed with multiple choice questions trivialized by the micro-step, snail's pace advised by the behaviorist school, can produce lessons that seem deadly to all except their author. Such bad examples denigrate PILOT's true educational potential. The problem, however, is not with the language but with poor educational design.

VERSIONS OF PILOT

Two important considerations in comparing the merits of different versions of PILOT are the ease and speed of using the authoring utilities and the "transparency" of the interface that deals with the student. Presumably, the student is concerned with the substantive content of the lesson and wishes to access it with as little interaction with the computer's operating system as possible. The mechanics of interaction

are best reduced to a minimum. A student should be able to start working on a lesson by simply inserting a diskette and pressing a switch. Apple PILOT, SuperPILOT, and PC/PILOT allow such direct access, but MacPILOT currently does not.

Apple and Super PILOT

SuperPILOT was released in 1982 and is a superset of Apple PILOT, first released in 1980. User support has slowed almost to the vanishing point but is compensated by excellent extensive manuals providing numerous examples that are readily adaptable to most instructors' needs. The text editor, based on the Pascal p-System editor, is versatile and responsive. The graphics, sound, and character set editors are pleasant and easy to use. Elaborate graphics resembling those produced by MacPaint on the Macintosh computer can be created with MousePaint on Apple II computers. However, to make these graphics usable by SuperPILOT lessons, they must be converted first from the ProDos to DOS 3.3 format and then, with the public domain utility, PUFFIN, to Apple Pascal files.

A serious defect of Apple and SuperPILOT is the slowness of the programming cycle. The source code is easily typed into a text file with the editor of the Author diskette, but it must then be saved on a lesson diskette before it can be tested. The lesson file and interpreter must be loaded into memory from separate diskettes to run the lesson. To make a correction, the editor must again be called from the Author diskette. The process is not at all interactive and is inefficient because of almost constant diskette activity. Masochists may argue that this enforces a more disciplined approach to programming. However, for all but the most patient and skilled, authoring soon becomes a tedious experience.

PC/PILOT

This version for the IBM PC and compatibles is a refinement of Common PILOT developed by G. Gerhold and L. Kheriaty from the original PILOT of J. Starkweather. After evolving over some years, it appears to be approaching its final form in version 2.1. The facilities available are more advanced than those of SuperPILOT. Programming with PC/PILOT is noticeably faster, and lessons run more quickly and respond more rapidly to student input. In contrast to the Apple products, the authoring utilities of PC/PILOT are not protected, so programming and testing can be speeded further by installing the necessary files on a hard disk. As mentioned earlier, lessons in their final form can be protected from unauthorized tampering by encryption.

The graphics editor of PC/PILOT is useful for creating simple shapes and pictures. For more elaborate pictures, other graphic creation products must be used. Files that use the BSAVE/BLOAD format can be compressed to conserve diskette and memory space and can be called directly from lessons. Other formats, such as that produced by PC Paint, must be converted with a utility obtained on a separate diskette from Washington Computer Services, the distributors of PC/PILOT.

Good example lessons are provided on the PC/PILOT diskette. However, the manual contains only a few illustrations of program fragments and is about one-fifth as large as the two manuals supplied with Apple and SuperPILOT. Indeed, an instructor unfamiliar with PILOT may have some difficulty learning the language using only PC/PILOT examples on the diskette and the manual. The problem is not so much with the commands and syntax of PILOT as with learning how to take full advantage of the language to generate educationally meaningful lessons.

In this regard, the tutorial section of the PC/PILOT manual and the examples supplied are of some, but limited, help to the beginner. A better approach is to start by studying examples (in any PILOT dialect) of educationally effective lessons, preferably in the beginner's own discipline.

As with other versions of the language, new lessons and revisions are made with a text editor. Unfortunately, the "EZ" text editor provided with PC/PILOT lacks a replace command, and the default setting for text entry is `.o` overwrite. Except when producing material for screen projection with 40 characters per line, I use PC Write to author and edit lessons. Despite these limitations, PC/PILOT version 2.1 is currently the version of the language that I prefer.

MacPILOT

MacPILOT, the version of the language for the Apple Macintosh computer, is a close relative of PC/PILOT and shares most of its strengths.

All the standard PILOT commands including those for generating sounds are available. Graphics are created with MacPaint. Also, photographs digitized with Thunder Scan can be transferred to MacPaint documents and called by MacPILOT, allowing lessons to be illustrated with half-tone images of biological specimens, radiologic films, or other visual aids. The standard Macintosh commands of Cut, Copy, and Paste are available for editing text, but a Find/Replace utility is not provided. It may therefore be necessary to transfer large lesson files to a text editor such as MacWrite for extensive changes and then back to MacPILOT for testing. The process is as tedious as working with Apple or SuperPILOT. However, the initial authoring and interactive response of the lessons are quite fast because of the speed of the Macintosh's

68000 processor.

Version 1.01 of MacPILOT permits programming of a few screen-oriented devices such as dialog boxes with buttons that can be clicked and windows. Most of these function like, but do not look like, the corresponding Macintosh features. This is no problem for students who are more concerned with the substantive content of a lesson rather than with using the machine in its standard "intuitive" mode.

MacPILOT communicates with the programmer through the standard Macintosh user interface. However, as noted above, the full interface is not yet available for the programmer to include in lessons. Consequently, the resulting product may seem primitive visually and operationally to those familiar with other applications on the Macintosh. This may not be a serious defect for the nonprofessional programmer who does not wish to learn the rather complex

concepts involved in using advanced features such as the Macintosh window manager and the event manager.

Hopefully, in future revisions of MacPILOT, the programmer will be given control over the presence or absence of the mouse pointer on the screen. It would be desirable to allow the student user to start a lesson directly without first learning how to deal with the mouse, the desk-top, and other peculiarities of the Macintosh interface. Perhaps later versions will also permit the programmer to end the learning session with a command to eject the diskette and reset the machine.

Additional information about PILOT and its various versions can be found in the following references:

PILOT:

Collins M: PILOT - a biologist's view of an authoring language. *Am Biol*

Teacher 47:493-495, 1985.

Merrill PF: The case against PILOT, the pros and cons of computer-assisted languages and authoring systems. *Creative Computing* 8:70-77, 1982.

SIG PILOT Newsletter: Association for the Development of Computer-based Instructional Systems, Vol 1, No 1, August, 1985.

Starkweather J: A user's guide to PILOT. Englewood Cliffs, NJ: Spectrum/Prentice Hall, 1985.

Apple PILOT and SuperPILOT:

Hazen M: Computer-assisted instruction with PILOT on the Apple computer. *Educ Tech* 22:20-22, 1982.

Weisman, SM: SuperPILOT. *InCider* 1:54-64, 1983.

IBM PC/PILOT:

Diamondstone J, Brodie J: Flying high with PILOT. *PC Magazine* 3:212-221, 1984.

EDITOR'S NOTE

The National Resource for Computers in Life Science Education is now accessible through the BITnet international computer network. Check with your campus computer center to learn more about BITnet and how to access the network at your location. To contact NRCLSE through BITnet, address mail to:

MODELL@UWALOCKE

COMPUTERS IN LIFE SCIENCE EDUCATION

HAROLD I. MODELL

Department of Radiology
University of Washington
Seattle, Washington

MARCEL BLANCHAER

Department of Biochemistry
Faculty of Medicine
University of Manitoba
Winnipeg, Manitoba
Canada

THEODORE J. CROVELLO

Department of Biology
University of Notre Dame
Notre Dame, Indiana

JAMES W. ECKBLAD

Department of Biology
Luther College
Decorah, Iowa

TSEGAYE HABTEMARIAM

School of Veterinary Medicine
Tuskegee University
Tuskegee, Alabama

DONNA LARSON

School of Nursing
Grand Valley State College
Allendale, Michigan

TERRY M. MIKITEN

Graduate School of Biomedical Sciences
University of Texas Health Science Center
San Antonio, Texas

JAMES E. RANDALL

Department of Physiology
Indiana University
Bloomington, Indiana

PATRICIA SCHWIRIAN

College of Nursing
Ohio State University
Columbus, Ohio

RICHARD STULL

College of Pharmacy
University of Arkansas
Little Rock, Arkansas

JAMES W. WOODS

Lister Hill National Center
for Biomedical Communications
National Library of Medicine
Bethesda, Maryland

DOROTHY WOOLEY-McKAY

Department of Biology
Glendale Community College
Glendale, Arizona

GLEN YOSHIDA

Department of Life Sciences
Los Angeles Southwest College
Los Angeles, California

NRCLSE

CONTENTS

APPROACHES TO SIMULATIONS FOR TEACHING Harold I. Modell	41
KEEPING ABEAST OF THE LITERATURE	46

APPROACHES TO SIMULATIONS FOR TEACHING

Harold I. Modell

Department of Radiology, University of Washington, Seattle, Washington

The range of applications of the computer in life science curricula is broad, extending from drill and practice multiple choice exercises to data base management of student records and use of word processors for syllabus preparation. Within this spectrum lies a variety of uses for simulations to promote problem-solving and conceptualization of principles and interactions exhibited in living systems.^{3,6,8} Computer models have provided students with a greater opportunity to work with elements of a controlled system or systems. Unfortunately, however, a critical mass of simulations covering most biological systems does not exist currently. Thus, one is faced with three options; 1) do not include simulations in the curriculum, 2) use computer models in those portions of the curric-

ulum for which software currently exists, or 3) develop a series of models covering all appropriate aspects of the systems being taught. The intent of this article is to provide some insight into issues to be considered and possible strategies for approaching simulations to be used in classroom settings. Specific examples will be drawn from the respiratory mechanics models in the series *Simulations in Physiology - The Respiratory System*.⁵

SHOULD MODELS BE SIMPLE OR COMPLEX?

Establishing an overall philosophy governing the complexity of the models to be developed is an important first step. In the research realm, there is no question that the simulation should include as much of the system as is pos-

sible to account for all factors contributing to observed phenomena. When approaching simulations for teaching, the tendency is to take the same attitude. Although such models may provide an excellent tool for demonstrating the operation of the entire system, they may mask the contribution of individual components. Unlike the real world, the computer offers the opportunity to dissect the system into its various conceptual components, examine each component, and reassemble the system to gain a better understanding of how components contribute to the workings of the whole. Hence, to help students build a conceptual framework, models based on a limited number of principles should precede larger complex models.

The step-wise set of models may be approached from several avenues. The most obvious is to create a family of simulations of varying complexities. A second approach is to build a complex model initially and instruct the student to set a group of variables to constant values representing the simpli-

fying assumptions. This avenue, however, does not allow the input/output scheme to be tailored to providing maximum insight into that portion of the system under investigation.⁴ A third avenue is to build a complex model initially, but make several versions of this model representing different levels of complexity available to the students. In this way, the input/output schemes, error messages, and procedures can be focused on relevant portions of the system.

The two programs dealing with respiratory dynamics in Simulations in Physiology provide a good example of this approach. Both programs are based on the same mathematical model, but different assumptions and choice of input/output values are used when the model is presented to the student.

A schematic representation of the general model is shown in Figure 1. Volume of the respiratory system, expressed as separate inspiration and expiration cosine functions, drives the simulation with inspiration representing 0.4

of the respiratory cycle.

Lung and chest wall compliances are assumed to contribute equally to the total respiratory compliance, and only the linear portions of the pressure-volume curves are considered. Functional Residual Capacity (FRC), the resting volume of the respiratory system, is determined from the pressure-volume curves of the lung and chest wall using the compliances provided by the student and fixed resting volumes of the lung and chest wall.

The tidal volume (V_t) and frequency define the characteristics of the cosine driving functions which determine volume changes (ΔV) within each time increment. The FRC locates the position of the volume changes within the volume range of the respiratory system. This volume (V), in conjunction with the pressure-volume characteristics of the lung and chest wall, determine the pressure difference across each of these structures opposing elastic forces within the structure (Pe_l and Pe_{lcw}). Flow (\dot{V}) during each increment, determined

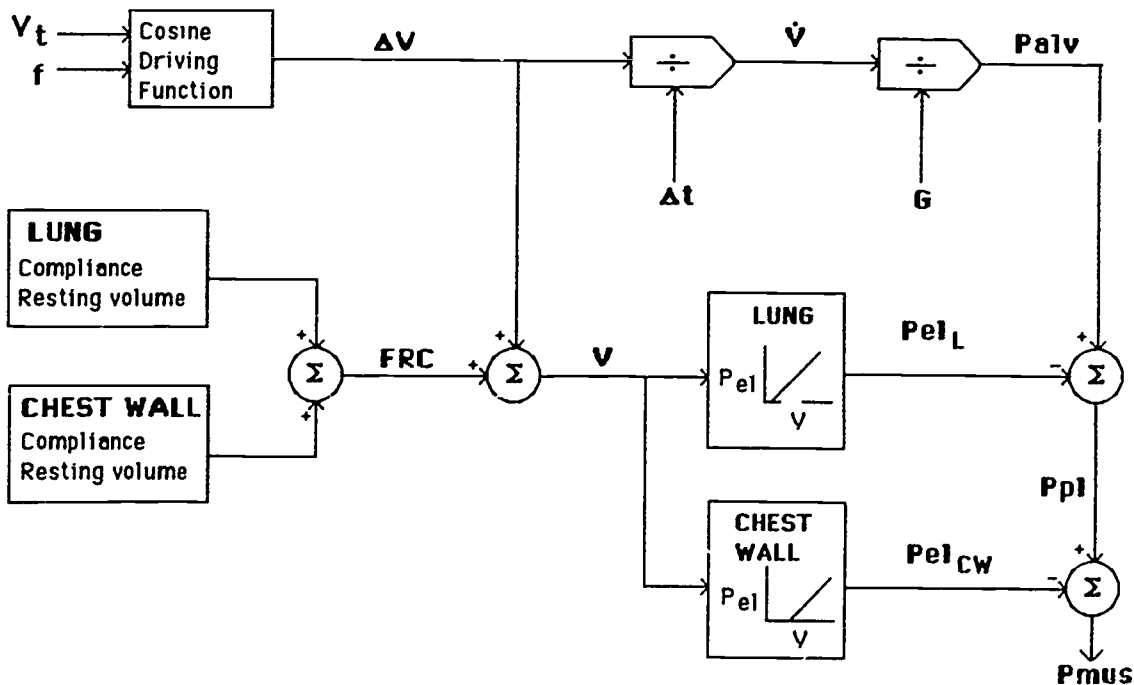

FIGURE 1. Schematic representation of respiratory dynamics model. See text for description.

by dividing the volume change by the time increment, is divided by the specific airway conductance (G) to yield the pressure difference across the airways responsible for the flow. Since pressure at the airway opening is assumed to be zero, this pressure represents alveolar pressure (Palv). P_{el} is subtracted from Palv to yield intrapleural pressure (Ppl), and subtracting $P_{el_{cw}}$ from Ppl provides a value for the effective pressure generated by the respiratory muscles (Pmus).

Specific airway conductance (conductance per unit lung volume) in the model depends upon airway resistance characteristics defined by the student through the input scheme.

When the student encounters the model as the first dynamics program, respiratory frequency is fixed, and chest wall characteristics are defined within the program. Input values pertain only to defining lung characteristics (compliance, airway resistance, and tidal volume), and the output includes values pertaining to the lung only (see Figure 2).

When encountered later in the series, the model appears quite differently to the student. Input values refer to the total respiratory system and provide a wider range of investigations. For example, respiratory frequency is now an input variable, and the ratio of airway resistance during expiration to that during inspiration can also be varied. The output scheme (see Figure 3) now provides information concerning the whole respiratory apparatus.

DEVELOPING SIMULATIONS

Having considered the complexity issue, the task of developing the actual simulations remains. For the novice, the key question becomes, "What is the best way to go about building a model?" Again, several avenues exist.

The respiratory dynamics model described above illustrates one approach. Based on a knowledge of the physiology of the system, mathematical equations were developed describing the various interactions. The equations in this model are primarily simple algebraic

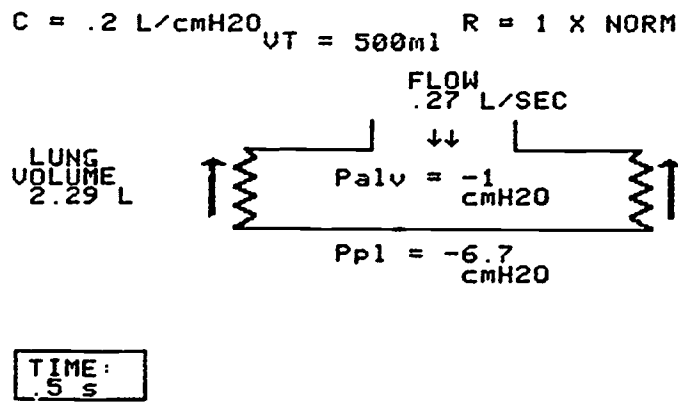

FIGURE 2. Output of first student program based on the model shown in Figure 1. The student enters values for lung compliance (C), airway resistance (R), and tidal volume (VT). The output displays data related only to the lung.

expressions that are not difficult to evaluate. Other simulations, however, may require solution of systems of differential equations, an apparently formidable task for one unfamiliar with numerical analysis techniques. The easiest way to approach such simulations is to determine reasonable initial values, integrate the appropriate equations using an Euler integration technique, and solve the system of equations through an iterative

process. The Euler integration technique is an incremental summation process described in most mathematics books that include a section on numerical analysis. It does not provide the fastest solution, but it is easy to understand and implement and will suffice for many applications.

Using established models
The literature offers another source of

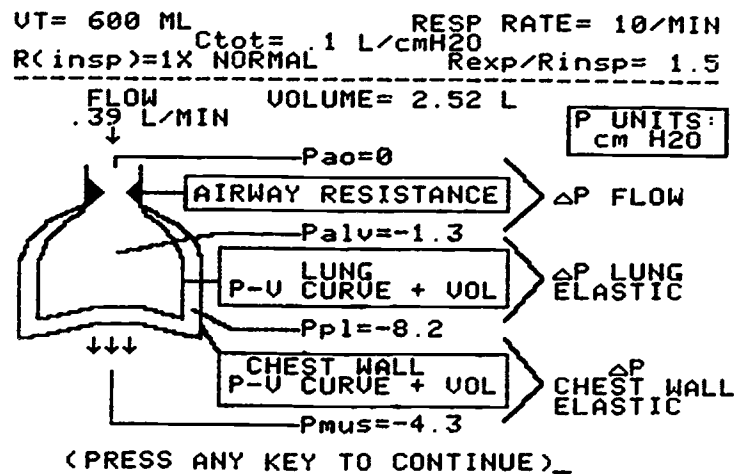

FIGURE 3. Output of second student program based on the model shown in Figure 1. The student provides values for tidal volume (VT), respiratory rate, compliance of the total system (Ctot), airway resistance during inspiration (Rinsp), and the ratio of airway resistance during expiration to that during inspiration (Rexp/Rinsp). This output provides data for the whole respiratory apparatus.

simulations. Numerous mathematical descriptions of life science phenomena exist in the literature, and the task then becomes solving these established models with the computer. The work of breathing program in Simulations in Physiology provides an example of this approach.

The model deals with the work of breathing in terms of its oxygen cost and is based on an equation developed by Otis⁷ describing the rate of work of breathing during inspiration:

$$W = \frac{1}{2C} fVt^2 + \frac{K_1}{4} \pi^2 f^2 Vt^2 + \frac{2K_2}{3} \pi^2 f^3 Vt^3$$

where C is the compliance of the respiratory system, f is the respiratory frequency, Vt is the tidal volume, and K_1 and K_2 are constants related to airway resistance. The first term in the above equation represents the rate of work done against elastic forces, while the remaining terms represent the rate of work done against resistive forces.

The relationship between constants K_1 and K_2 was derived from pressure-flow data fitted by Mead and Agostoni.² K_1 is taken as the airway resistance value provided by the student, and K_2 is 1.32 times this value.

Using physiological units in the work equation yields data expressed as $\text{kg}\cdot\text{m} \times 100$. To convert these values to oxygen consumption, it was assumed that 1 ml O_2 is equivalent to 2 $\text{kg}\cdot\text{m}^2$ and that the respiratory muscles are 10% efficient. Experimental data have yielded mechanical efficiencies of the respiratory system ranging from 2 to over 20%.⁷

The model calculates the oxygen cost of elastic, resistive, and total work of breathing during inspiration for a constant alveolar ventilation over a range of respiratory frequencies. The student defines the experimental conditions by providing values for the alveolar ventilation, airway resistance, and respiratory compliance.

Note that this model deals only with the inspiratory phase of breathing in a physiological system where the expiratory phase can make a significant contri-

bution to the total work of breathing. In choosing to use a simulation with this limitation for educational purposes, one must ask whether the model can enhance the student's understanding of factors contributing to the work of breathing. We decided that it did if the student was made aware of the limitation.

Using function generators

A third approach to the problem of generating simulations is to employ graphical analyses. The literature is replete with graphical data describing relationships between variables. Models can be generated by associating these relationships in an appropriate manner. The problem then becomes one of translating the graphical data into a form suitable for computer analysis. This can be achieved through potentially complicated curve-fitting and regression analyses, or more simply, through the use of function generators.

To use a function generator, the data plot is approximated by a series of straight line segments. The coordinates of the segments are recorded in a data array accessed by the function generator routine. When a value for the independent variable is entered, the routine searches for the two coordinates that bound the input value. The dependent variable value is then calculated by a linear extrapolation between these two coordinates. An example of a function generator written in BASIC is shown in Figure 4.

Extensive use of a function generator is used in the first program in the Simulation in Physiology series. This model allows examination of the elastic characteristics of the lung and chest wall and how these interact to determine the static characteristics of the respiratory system. The model is based on pressure-volume curves of the lung and chest wall presented by Knowles, Hong and Rahn.¹ Total lung capacity is assumed to be 6 liters. The lung pressure-volume curve is defined in the program as a series of nine straight line segments, and the chest wall curve is repre-

sented by seven straight line segments (Figure 5).

In this program, the student furnishes data for the resting volumes of the lung and chest wall expressed as per cent of total lung capacity, the lung and chest wall compliance expressed as per cent normal, and the pressure to be applied across the respiratory system after the resting volume of the system has been determined. The resting volume of each structure is defined as the volume at which the pressure difference across the structure (Pin-Pout) is zero.

Based on the data provided by the student, the "standard" curves are scaled to match the conditions described. The pressure axis is compressed or expanded for each curve to match the desired compliance, and each curve is positioned on the volume axis such that the point at which the curve crosses this axis coincides with the desired resting volume.

An iterative process is used to deter-

```

100 I=1 (counter)
105 Y=1 (dummy variable)
110 IF P>L(9,1) THEN 170
    (check to see if value
    exceeds data)
115 IF P<0 THEN 170
    (check to see if value
    is less than smallest
    data point)
120 IF L(I,1) < P THEN 145
125 IF L(I,1) = P THEN 135
130 IF L(I,1) > P THEN 155
135 Y=L(I,2) (value sought
    equals data point)
140 GOTO 175 (return value)
145 I=I+1 (increment counter)
150 GOTO 120 (check next
    point)
155 LO=I-1 (last point)
160 Y=L(LO,2)+((P-L(LO,1))/
    (L(I,1)-L(LO,1))) *
    (L(I,2)-L(LO,2))
    (extrapolate between
    points to get value)
165 GOTO 175
170 Y=1 (flags that value is
    not in the range of
    data)
175 V=Y (return value sought)

```

FIGURE 4. Listing of a simple function generator. Nine data pairs are assumed to be stored in a two-dimensional array, L .

mine the resting volume of the respiratory system. An arbitrary pressure is chosen for the pressure difference across the lung. The lung volume corresponding to this distending pressure is obtained from the scaled lung pressure-volume curve and is used in conjunction with the chest wall pressure-volume curve to determine the corresponding pressure applied to the chest wall. The error between the absolute values of the pressures applied to the lung and chest wall is then used to determine a new pressure difference across the lung. This process continues until the magnitudes of the two applied pressures are within 0.01 cm H₂O of each other. The corresponding volume is reported as the resting volume of the total system. A similar technique is used to determine the volume achieved when a specified pressure is applied to the respiratory system. In this case, the sum of pressures across the lung and chest wall must be within 0.03 cm H₂O of the specified applied pressure.

Compliance of the lung is calculated by choosing an arbitrary transpulmonary pressure greater than the transpulmonary pressure at the resting volume of the system. The volume attained at this pressure is determined from the function generator. Changes in volume and the corresponding changes in pressure are thus determined from which compliance is calculated. Compliance of the chest wall is calculated using the same volume change as for the lung and determining the corresponding pressure change from the chest wall pressure-volume curve. Total system compliance is then calculated from the lung and chest wall compliances.

CONCLUSION

Simulations provide an excellent aid to understanding and organizing concepts in both research and educational settings. The literature contains many examples of models that can be used for educational purposes, and actual model building need not be a difficult task.

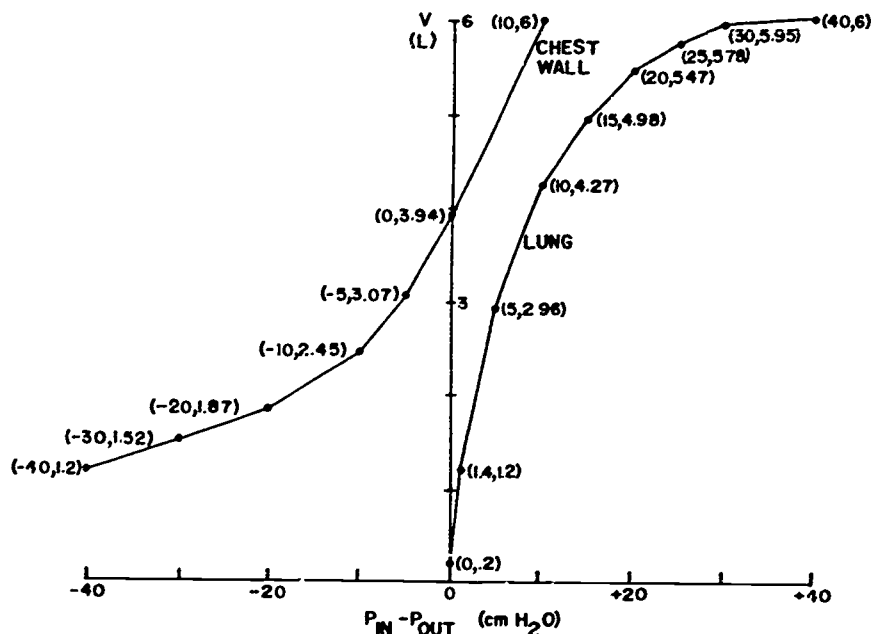

FIGURE 5. Straight line approximation of lung and chest wall pressure-volume curves presented by Knowles et al.¹ The data are used with a function generator of the type illustrated in Figure 4.

However, a simulation that may be ideal in one setting may be far from ideal in the other.

In addition to the complexity issue, other criteria related to input/output design, handling of error messages, and the form and degree of direction provided to students must be addressed before successful use of simulations in an educational setting can be achieved.

REFERENCES

1. Knowles JH, Hong SK, Rahn H: Possible errors using esophageal balloon in determination of pressure-volume characteristics of the lung and thoracic cage. *J Appl Physiol* 14:525-530, 1959.
2. Mead J and Agostoni E: Dynamics of breathing. p 411-427 *In* Fenn WO, Rahn H (eds), *Handbook of Physiology, Sec 3, Respiration, Vol I*, Washington DC, American Physiological Society, 1964.
3. Mikit: TM: Enhancing lectures with a microcomputer. *Computers in Life Science Education* 1:9-11, 1984.
4. Modell HI: Input/output design for different educational settings. *Computers in Life Science Education* 1:57-62, 1984.
5. Modell HI: *Simulations in Physiology - The Respiratory System*. Seattle, WA: National Resource for Computers in Life Science Education, 1986.
6. Modell HI, Farhi LE, Olszowka AJ: *Physiology teaching through computer simulations - problems and promise*. *Physiol Teacher* 3:14-16, 1974.
7. Otis AB: The work of breathing. p 463-476 *In* Fenn WO, Rahn H (eds) *Handbook of Physiology, Sec 3, Respiration, Vol I*, Washington DC, American Physiological Society, 1964.
8. Schottelius BA: Teaching physiology by microcomputer in small group conferences. *Computers in Life Science Education* 1:4-6, 1984.

KEEPING ABREAST OF THE LITERATURE

The following citations are presented as part of a quarterly feature in CLSE designed to help readers become aware of current literature pertinent to computer applications in life science education.

- Abdulla AM et al: Computer-aided learning using a laser videodisk player. *Physicians Comput* 2(10):38-39, 42-44, 1985.
- Ahijevych K et al: Microcomputers enhance student health fairs. *J Nurs Educ* 24(1):16-20, 1985.
- Arenson RL: Teaching with computers. *The Radiologic Clinics of North America* 24(1):97-104, 1986.
- Baird WE: Microcomputers in education. *J Comput Math Sci Teach* 4(3):51-52, 1985.
- Belland JC et al: Is the self-paced instructional program, via micro-computer-based instruction, the most effective method of assessing individual learning differences? *Educational Communication and Technology* 33(3):185-198, 1985.
- Bender HJ et al: Usage of computer technology in the training of assistants in anaesthesiology. *Der Anaesthetist* 34(10):516-521, 1985.
- Billings DM: An instructional design approach to developing CAI courseware. *Comput Nurs* 3(5):217-223, 1985.
- Bishop B: Computerization of the student neurophysiology laboratory. *The Physiologist* 28(5):443-444, 1985.
- Bishop CW: Teaching diagnosis by computer. *The Physiologist* 28(5):451, 1985.
- Blanchaer MC: A role for clinical case simulations in basic medical science education. *The Physiologist* 28(5):422-424, 1985.
- Bland JM: Computer simulation of a clinical trial as an aid to teaching the concept of statistical significance. *Statistics in Medicine* 5(2):193-197, 1986.
- Bolwell C: Computer-assisted instruction: state of the art. *Deans Notes* 7(1):1-3, 1985.
- Boyle J 3d: RESPSYST: an interactive microcomputer program for education. *The Physiologist* 28(5):452-453, 1985.
- Brodeur DR: Interactive video: fifty-one places to start - an annotated bibliography. *Educ Technol* 25(5):42-47, 1985.
- Brooks DT: Copyright and the educational uses of computer software. *EDUCOM Bulletin* 20(2):6-13, 1985.
- Buisson CJ: Computer applications in nursing continuing education. *Nurs Clin North Am* 20(3):505-515, 1985.
- Carew LB et al: Using computer-assisted instruction to teach nutrition. *The Physiologist* 28(5):425-427, 1985.
- Collins MM et al: Computer assisted test bank. *J Nurs Educ* 24(8):349-350, 1985.
- Crass JR: Computer-generated examinations for residents in radiology. *Amer J Roentgen* 146(2):413-415, 1986.
- Demas S: Microcomputer software collections. *Spec Libr* 76(1):17-23, 1985.
- Dolan DR: Downloading and integrated software. *Database* 8(2):86-89, 1985.
- Donovan DJ et al: Computers in respiratory therapy...a blood gas lab. *AARTimes* 8(9):24, 124, 1984.
- Felton BB: Planning and implementing computer learning in a department of nursing. *Nurs Health Care* 5(10):549-553, 1984.
- Francis K: Model of skeletal muscle length/tension relationship... interactive computer model. *Phys Ther* 65(2):238, 240, 242, 1985.
- Gothler AM: Nursing education update: computer technology. *Nurs Health Care* 6(9):508-510, 1985.
- Grabinger RS: From the conference. Criteria and checklist for CAI authoring tools. *Performance and Instruction* 24(8):14-15, 1985.
- Hales GD: State-of-the-art technology: computers and curriculum. *NLN Publ* 15-1974:101-115, 1985.
- Harper RM Jr: Software licensing for installations with multiple microcomputers. *Comput Educ* 9(3):165-170, 1985.
- Hazen M: Instructional software design principles. *Educ Tech* 25(11):18-23, 1985.
- Hermann F et al: Computer-assisted instruction provides dispensing experience. *Am J Pharm Educ* 49(3):242-246, 1985.
- Hersey K: A university dilemma: the use of third party-owned software. *EDUCOM Bulletin* 20(2):14-17, 22, 1985.
- Hodson KE et al: Design and development of cognitive mastery testing using an authoring system. *Comput Nurs* 3(4):166-172, 1985.
- Holzemer WL et al: Development of a computer resources facility. *Nurs Health Care* 5(10):545-547, 1984.
- Jensh RP et al: Program for increasing use of computers in medical education. *J Med Educ* 61(2):137-139, 1986.
- Johnson AT: User friendliness in micro-computer programs. *Computer Programs in Biomedicine* 19(2):127-132, 1985.
- Johnson JF et al: Storyboarding for interactive videodisc courseware. *Educ Tech* 25(12):20-35, 1985.
- Jones ME et al: The use of a common driver format for CAI. *The Physiologist* 28(5):456-457, 1985.
- Joseph LS et al: Developing educational software for publisher vendors. *Nurs Clin North Am* 20(3):529-547, 1985.
- Kearsley G: Embedded training: the new look of computer-based instruction. *Machine-Mediated Learning* 1(3):279-296, 1985.
- Kock B et al: Educational computing. *Nurs Times* 81(44): Quest 5(5):45-47, 1985.
- Lowe S: Computer and audio-visual technology applied to continuing education. *Amer J Hosp Pharm* 43(3):716-729, 1986.
- McAlister NH: The need for an undergraduate program in medical comput-

- ing. *J Med Educ* 60(10):803-804, 1985.
- McEwing RA et al: Individualizing learning with computer-based instruction. *Educ Tech* 25(5):30-32, 1985.
- McGilliard KL: Computer simulation of quantal dose-response relationships. *The Physiologist* 28(5):449-450, 1985.
- Meisenheimer JL: A microcomputer exercise on genetic transcription and translation. *J Coll Sci Teach* 15(1):36-37, 1985.
- Merrill MD: Where is the authoring in authoring systems? Peter Dean Lecture. *J Computer-Based Instr* 12(4):90-96, 1985.
- Mitchell J et al: A computer-controlled video disc system for teaching white cell morphology and differential counting to medical technology students. *J Med Technol* 2(10):655-658, 1985.
- Modell HI: Use of computer simulations to promote active learning in multiple teaching settings. *The Physiologist* 28(5):445-446, 1985.
- Newbern VB: Computer literacy in nursing education: an overview. *Nurs Clin North Am* 20(3):549-556, 1985.
- Nicklin RC: The computer as lab partner. *J Coll Sci Teach* 15(1):31-35, 1985.
- Norman GR et al: Simulation in health sciences education. *J Instructional Development* 8(1):11-17, 1985.
- O'Brien TC: Computers and education. *Am Biol Teach* 47:315-316, 1985.
- Peterson NS et al: An integrated cardiovascular teaching laboratory. *The Physiologist* 28(5):447-448, 1985.
- Peterson S: Using STELLA in environmental education. *Environmental Education Report and Newsletter* 14(2):13-18, 1985.
- Petosa R et al: Microcomputers in health education: characteristics of quality instructional software. *J Sch Health* 54(10):394-396, 1984.
- Pogrow S: Instructional uses of computers: stress problem-solving skills to capitalize on potential. *NASSP Bulletin* 69(484):1-54, 1985.
- Prentice JW et al: Medical student attitudes to computer-assisted learning in anaesthesia. *Med Educ* 20(1):57-59, 1986.
- Rhodes DM et al: Designing interactive video instruction professionally. *Training and Development Journal* 39(12):31-33, 1985.
- Richer MH: Applications of artificial intelligence in education—a personal view. *The Physiologist* 28(5):428-431, 1985.
- Robson EH: The role of computer simulation. *Int J Math Educ Sci Technol* 16:255-258, 1985.
- Rovick AA et al: Teaching problem solving in physiology with CBE. *The Physiologist* 28(5):435-438, 1985.
- Saltz CC et al: Perceptions and knowledge of medical students regarding computer applications in medicine. *J Med Educ* 60(9):726-728, 1985.
- Schloss CN et al: Placement of questions and highlights as a variable influencing the effectiveness of computer assisted instruction. *J Computer-Based Instr* 12(4):97-100, 1985.
- Schmidt TG et al: Dr. Sanger's apprentice. A computer-aided instruction to protein sequencing. *The Physiologist* 28(5):458-459, 1985.
- Sinclair VG: The computer as partner in health care instruction. *Comput Nurs* 3(5):212-216, 1985.
- Skiba DJ: Interactive computer experience. The missing ingredient. *Nurs Clin North Amer* 20(3):577-584, 1985.
- Soddell JA et al: CLASSIFY: a group teaching exercise in microbial identification and numerical taxonomy using a Commodore 64 microcomputer. *J Biol Educ* 19(3):232-236, 1985.
- Tamashiro RT: Build your own computer simulations. *Comput Teach* 13(3):36-42, 1985.
- Templeton AC: Videodisc-computer technology in the teaching of pathology. *The Physiologist* 28(5):432-434, 1985.
- Thursh DR et al: Computers and videodiscs in pathology education: ECLIPS as an example of one approach. *Human Pathology* 17(3):216-218, 1986.
- Troncale JA et al: Teaching a core curriculum in rural family practice preceptorships using microcomputers. *J Fam Pract* 21(5):407-408, 1985.
- Turgeon ML: Computer-assisted instruction: is it appropriate for medical technology education? *J Med Technol* 2(10):663-665, 1985.
- Vockell EL et al: Computerized review of factual information in nursing education...an easy-to-create computer program. *Comput Nurs* 3(4):159-165, 1985.
- Walaszek EJ et al: Use of computers in the teaching of pharmacology, toxicology and therapeutics. *The Physiologist* 28(5):419-421, 1985.
- Walker JR et al: A computer simulation of the interaction of drugs with cardiovascular reflexes. *The Physiologist* 28(5):454-455, 1985.
- Watson A: Computers in schools of radiography and radiotherapy: present problems and future possibilities. *Radiography* 51(598):223-224, 1985.
- Winkler JD et al: Pedagogically sound use of microcomputers in classroom instruction. *J Educational Computing Research* 1(3):285-293, 1985.
- Worrell PJ et al: Computer software directory for nurse educators... software preview guide. *Nurse Educ* 9(2):32-38, 1984.
- Worrell PJ et al: Software directory update...software programs from a variety of major nursing subject areas. *Nurse Educ* 10(2):37-38, 1985.
- Worthley LIG: A computer program to prepare and answer multiple choice questions. *Anaesth and Intensive Care* 13(4):417-419, 1985.
- Yoder M: CAI design considerations. *Comput Nurs* 3(6):245, 265, 1985.
- Yoder ME et al: The use of computer assisted instruction to teach nursing diagnosis. *Comput Nurs* 3(6):262-265, 1985.
- Yonuschot G et al: The medical computing curriculum at the University of New England College of Osteopathic Medicine. *J Am Osteopath Assoc* 85(4):264-267, 1985.

Compiled by H. Modell

COMPUTERS IN LIFE SCIENCE EDUCATION

HAROLD I. MODELL

Department of Radiology
University of Washington
Seattle, Washington

MARCEL BLANCHAER

Department of Biochemistry
Faculty of Medicine
University of Manitoba
Winnipeg, Manitoba
Canada

THEODORE J. CROVELLO

Department of Biology
University of Notre Dame
Notre Dame, Indiana

JAMES W. ECKBLAD

Department of Biology
Luther College
Decorah, Iowa

TSEGAYE HABTEMARIAM

School of Veterinary Medicine
Tuskegee University
Tuskegee, Alabama

DONNA LARSON

School of Nursing
Grand Valley State College
Allendale, Michigan

TERRY M. MIKITTEN

Graduate School of Biomedical Sciences
University of Texas Health Science Center
San Antonio, Texas

JAMES E. RANDALL

Department of Physiology
Indiana University
Bloomington, Indiana

PATRICIA SCHWIRIAN

College of Nursing
Ohio State University
Columbus, Ohio

RICHARD STULL

College of Pharmacy
University of Arkansas
Little Rock, Arkansas

JAMES W. WOODS

Lyster Hill National Center
for Biomedical Communications
National Library of Medicine
Bethesda, Maryland

DOROTHY WOOLEY-McKAY

Department of Biology
Glendale Community College
Glendale, Arizona

GLEN YOSHIDA

Department of Life Sciences
Los Angeles Southwest College
Los Angeles, California

NRCLSE

CONTENTS

TRANSFERRING BASIC PROGRAMS FROM THE APPLE II TO THE IBM-PC James W. Eckblad	49
MENTOR: A COMPUTER PROGRAM TO TEACH THE DIFFERENTIAL DIAGNOSIS PROCESS John D. Macias and Roy H. Maffly	52
LETTER TO THE EDITOR: COMMENT ON PILOT	55

TRANSFERRING BASIC PROGRAMS FROM THE APPLE II TO THE IBM-PC

James W. Eckblad

Department of Biology, Luther College, Decorah, Iowa

This article is written for the instructor who has access to software written in Applesoft BASIC but would like to run the programs on an IBM-PC or compatible computer. It is assumed that the reader has some knowledge of the BASIC language and is familiar with either the Apple II or IBM-PC.

The Advanced BASIC (BASICA) on the IBM-PC has many more commands than those found in Applesoft BASIC. For example, it would usually take at least a dozen Applesoft lines to draw a

circle of radius r with its center at screen coordinates x, y . The single BASICA command, $CIRCLE(x, y), r$, will accomplish the same thing on the IBM-PC. In this article, it is assumed that the conversion is from Applesoft BASIC to IBM-PC BASICA. The additional commands available in BASICA may make your program more efficient, but they are probably not essential to the conversion process. It is advisable to have a good reference work on IBM BASICA handy. My personal

favorite is the comprehensive work by Schneider.³

DIRECT FILE TRANSFER FROM APPLE TO IBM-PC

Because both computers use ASCII code, it is possible to transfer files between the Apple and IBM-PC. This is especially helpful with longer programs that would otherwise require typing the program lines on the IBM-PC. Apple files must first be converted to ASCII (text) files. There are several ways to accomplish this, but probably the simplest is to use the LIST command. When the LIST command is used with an Applesoft program in RAM, the program will normally be displayed on the monitor (slot 0). If, however, the output is redirected to slot 6 (the disk controller slot), the listing can be captured in an Apple TEXT file. The following 3 steps can be used to accomplish this:

- 1) Load the program into the Apple's RAM (suppose the program's name is MITOSIS).
- 2) Add the following line to the top of this program as line 0:

```
0 PRINT CHR$(4);"OPEN
MITOSIS TEXT":PRINT
CHR$(4);"WRITE MITOSIS
TEXT":LIS.' 1-:PRINT CHR$(4);
"CLOSE MITOSIS TEXT":END
```
- 3) After adding line 0 as shown above, RUN the program in memory.

After the program has run, you will see the newly created MITOSIS TEXT file when you CATALOG the disk. This newly created file is now suitable for transfer to the IBM-PC.

Some fairly common communications capabilities (ie, a MODEM and appropriate software) with an Apple and an IBM-PC can be used to transfer an ASCII file. Place one system (the Apple) into the ORIGINATE mode and the other (IBM-PC) into the ANSWER mode. Use the Apple communications

software to dial the IBM-PC (just as you would one of the bulletin boards like SOURCE or COMPUSERVE). Put the Apple software in a file-send mode and the IBM-PC software in a file-receive mode. Transmit the Apple file to the IBM-PC, and close the IBM PC file. Another way to do this for subscribers to services like COMPUSERVE or SOURCE is to upload your text file into the service using your Apple, call the service using an IBM-PC, and download the file. Both procedures require the same communications hardware and software, but in the latter procedure, you don't need simultaneous access to both an Apple and an IBM-PC.

Assume we decide to name our transferred file MITOSIS.BAS. The file extension, .BAS, designates a BASIC program on the IBM-PC. We can use the DOS TYPE command to see the program scroll on the screen. To obtain a print out of the listing rather than reading it from the screen, type COPY MITOSIS.BAS LPT1:<enter>. If file transfer was successful, it should look like the original file on the Apple.

Because the built-in editing features of the IBM-PC are much better than those of the Apple, it is most convenient to make changes in BASIC dialects after the file has been transferred.

TRANSFER TROUBLESHOOTING

The first time you try to transfer files, you may find that things are not perfect. Refer to your communications software documentation for assistance. You can repeat the transfer process again, or you might check for conformity of transmission speed (usually 300 or 1200 baud) and ASCII character structure (eg, both seven data bits, even parity). Parameters in the communications program should be set so that a carriage return and line feed are present at the end of each transmitted line. If there are some strange characters in the captured file, you may have had a noisy phone line.

RUNNING A BASIC PROGRAM ON THE IBM-PC

When you boot software on the Apple II, the Applesoft BASIC interpreter is present in ROM, and a program can be run as soon as DOS has been loaded from the disk. With the IBM-PC, it is necessary to first load the BASIC interpreter (usually BASICA), then load and run a program. This additional step can be made invisible to the user by using a batch file. For example, a batch file with the statement, BASICA A: MITOSIS.BAS,R, would first load BASICA from the floppy disk, then load and run the basic program, MITOSIS.BAS, from the disk in drive A. The BASICA that comes with an IBM-PC uses portions of the code stored in ROM that are not present in the ROM of compatibles. Hence, if you want your program to run on one of the IBM-PC clones, you will need to have all of BASICA on the disk so it can be loaded into RAM. Version 2.0 of GW-BASIC (from Microsoft Corporation) is like BASICA, and it will run programs on both the IBM-PC and compatibles. Of course, without proper licensing, it is illegal to sell or distribute disks with a copyrighted version of BASIC on the disk.

There is a special batch file on the IBM-PC and compatible computers using MS-DOS called AUTOEXEC .BAT that will run automatically when a disk is booted. The following steps would create this file and cause the program MITOSIS.BAS to be run:

```
COPY CON AUTOEXEC.BAT<enter>
BASICA A:MITOSIS.BAS,P <enter>
<ctrl-z><enter>
```

ADAPTING THE BASIC PROGRAM

If your Applesoft program is relatively short and limited to standard BASIC statements, a line-for-line translation can be attempted. However, if you note the presence of PEEKs, POKEs or CALLs, or if there is a major emphasis

on graphics in the Applesoft program, you will probably need to rewrite at least some portions of the code. In either case, you will need to modify your Applesoft dialect of BASIC to conform to the BASICA dialect. Some of these dialect differences are listed in Table 1. For example, the Applesoft statements, VTAB 5:HTAB 10, position the cursor on the screen at row 5, column 10. The BASICA statement to accomplish this is LOCATE 5,10.

Before you begin to rewrite portions of the Applesoft program, it will be helpful if you prepare a table of its variables. For each variable, describe what you think the variable does, and list the line numbers where it is found. There are several cross-reference utility programs that list line numbers where each variable is used. Make a similar list for your new BASICA version of the program. It is often helpful to append this list to your program with REM statements (this will assist someone who may want to modify the program in the future).

In Applesoft BASIC, only the first two letters of a variable are significant in distinguishing between variable names. However, in BASICA, variable names are significant to the first 40 letters. Thus, more descriptive variable names can be used. Another advantage of BASICA is the ability to designate double precision variables (16 significant figures compared to 6 significant figures in Applesoft). The variable, AA#, is designated as having double precision in BASICA by the inclusion of the # to the right of the name.

PEEKs, POKEs, AND CALLs

One of the major problems in converting an Applesoft program is handling PEEKs, POKEs and CALLs. The Applesoft BASIC programmer's manual lists dozens of PEEKs, POKEs, and CALLs that control the Apple text screen, graphics, cursor movement, input and output, game port, and error handling. Additional useful ones are

TABLE 1. Some language differences between Applesoft BASIC and BASICA on the IBM-PC.

Applesoft commands	BASICA commands
CATALOG	FILE (DIR in DOS only)
CHRS(7)	BEEP
CLEAR	ERASE
DEL 10,20	DELETE 10-20
EXEC	Use a batch file
FLASH	COLOR 16,7
GET AS (keyboard)	AS=INKEYS
GET AS (random file access)	GET #
GK	SCREEN1
HCOLOR	COLOR
HGR	SCREEN2
HIMEM	CLEAR
HOME	CLS
HTAB n	LOCATE,n
INVERSE	COLOR 0,7
NORMAL	COLOR 7,0
NOTRACE	TROFF
ONERR GOTO n	ON ERROR GOTO n
PEEK(37)	CSRLIN (row number)
PEEK(218)+PEEK(219)*256	ERL (error line number)
PEEK(222)	ERR (error number)
PDL(n)	STICK(n)
PLOT x,y	PSET(x,y)
PR#1:LIST:PR#0	LLIST (lst to printer)
VTAB n	LOCATE n,
SCRN(h,v)	POINT(h,v)
SPC(n)	SPACES(n)
TEXT	SCREEN 0,0
TRACE	TRON
T=S1:S1=S2:S2=T	SWAP S1,S2

presented in many references on the Apple. Unfortunately, when you attempt to convert programs to IBM-PC BASICA, the PEEKs, POKEs, and CALLs will not have the same meanings. You will have to identify what each of these does and convert them to their equivalents in BASICA. Their equivalents are probably not IBM-PC

POKEs, PEEKs, and CALLs, but most likely, part of the BASICA language. For example, from Table 1 we see that PEEK(222) in Applesoft BASIC can be replaced by the ERR statement in BASICA.

The greater control provided by BASICA on the IBM-PC has usually resulted in less dependence on PEEKs,

POKES, and CALLS. On the other hand, certain features of the hardware can be accessed only through PEEK and POKE statements or an assembly language program. For example, the statement POKE 1050,PEEK(1052) clears the keyboard buffer on the IBM-PC, and the size of RAM in kilobytes can be obtained with PEEK(1043)+256*PEEK(1044). These and other uses of PEEKs and POKES on the IBM-PC are described in the two-part article by Schneider.^{4,5}

GRAPHICS CONVERSION

There are enough hardware and software differences between the Apple and the IBM-PC that a one-for-one conversion of graphics portions of Applesoft BASIC programs is not practical. BASICA has much more powerful graphics features than Applesoft BASIC, but it will require some extra effort to become familiar with these features. If the program you are converting makes heavy use of graphics, it

will be helpful to consult one of the many books that explains graphics programming on the IBM-PC. In general, the code for the redesigned graphics portion of the program will be more concise than that needed in the Applesoft version.

OTHER CONSIDERATIONS

There are a number of additional differences you will discover when you attempt to convert programs from the Apple to the IBM-PC. Disks for the IBM-PC must be "formatted" rather than "initialized"; sequential files are handled in a very similar fashion, but random access files are handled differently; and the DOS on the IBM-PC is more advanced, especially compared to DOS 3.3 on the Apple. Before you get involved in program conversion, you may find it helpful to have easy access to the references by Crider,¹ Helms,² and especially the guide by Steck.⁶ After converting programs to BASICA, you may also wish to con-

sider compiling your programs with the IBM-PC BASIC Compiler. Your programs will run faster (usually from two to five times), and you won't have to load BASICA before programs can be run.

REFERENCES

1. Crider B (ed): BASIC program conversion. Tucson, AZ: HPBooks, Inc, 1984.
2. Helms H: The BASIC book, a cross-reference guide to the BASIC language. New York, NY: McGraw-Hill Co, 1983.
3. Schneider DI: Handbook of BASIC for the IBM PC, revised and expanded. Bowie, MD: Brady Communications Co, 1983.
4. Schneider DI: PEEKing at your PC's memory. PC Magazine 4(23): 201-218, 1985.
5. Schneider DI: PEEKing at your PC's memory, Part 2. PC Magazine 4(24):187-208, 1985.
6. Steck R: Apple to IBM PC conversion guide. Glenview, IL: Scott, Foresman and Company, 1985.

MENTOR: A COMPUTER PROGRAM TO TEACH THE DIFFERENTIAL DIAGNOSIS PROCESS

John D. Macias and Roy H. Maffly

Department of Medicine, Stanford University School of Medicine, Stanford, California

Traditionally, medical students are taught to evaluate patients by taking long, exhaustive histories and performing extensive physical examinations leading to a large body of information that is then sifted through to develop a list of possible diagnoses. This often results in a large list of hypotheses with the student requesting expensive diagnostic tests to either rule in or rule out the diagnoses. Experienced clinicians, on the other hand, have been

shown to use a more efficient approach to diagnosis.¹ After obtaining a few pieces of critical information, the clinician formulates a short list of hypotheses, then pursues each hypothesis by asking good, discriminating questions, revising his hypothesis list as he questions and examines the patient.

"Mentor" is a computer program designed to give medical students the opportunity to practice this differential diagnosis approach on simulated pa-

tients while being offered guidance by a computerized tutor. Our aim is to teach medical students to refine their diagnoses in the history and physical examination by asking those questions that can best discriminate between the diagnoses under consideration. This is a more efficient and cost-effective approach and is intended to supplement, rather than replace, the traditional comprehensive approach that medical students are taught.

PILOT PROGRAM

In our pilot program, students are presented with any one of 13 patients taken from the records of the Stanford University and Palo Alto Veterans Administration hospitals. Each patient presents with the same cardinal finding, bilateral ankle edema, but may have any one of 11 possible disease entities (Table 1). Given only the patient's age, gender, and the duration of the edema, we ask the student for at least 3 possible causes of the edema (Figure 1). Mentor can offer assistance should the student need help.

Once the student has developed a short hypotheses list, each hypothesis is pursued individually in the history and physical examination. Student performance is rated according to the student's ability to select the best questions to rule in and rule out a specific diagnosis.

The student can question the patient in natural, conversational language (Figure 2). The physical examination is also done in free text, with students asking Mentor about specific findings. Because we are trying to get the student to use hypothesis driven questioning instead of a shotgun approach, we require the student to be specific in asking about the presence of abnormal findings rather than asking more general

TABLE 1. Possible diagnoses for bilateral ankle edema.

1. Congestive Heart Failure
2. Constrictive Pericarditis
3. Cirrhosis of the Liver
4. Malnutrition
5. Acute Glomerulonephritis
6. Nephrotic Syndrome
7. Acute Thrombophlebitis
8. Inferior Vena Cava Obstruction
9. Lymphatic Obstruction
10. Idiopathic Cyclic Edema
11. Chronic Venous Insufficiency

Your patient is Maxine Brown, a 54 year old woman who has come to you because of swelling of both her ankles on and off for the past year.

To begin with our approach, when challenged by a patient with bilateral ankle swelling, what disease entities do you wish to consider in your differential diagnosis? That is, what are the hypotheses you would consider in any such patient?

FIGURE 1. Example of a patient introduction.

questions. For example, we want the student to ask whether a heart murmur is present rather than asking about abnormalities during auscultation of the heart. This also allows Mentor to evaluate the student's knowledge of what he or she expects to be present in a given disease state.

Mentor is capable of providing the student with many different types of

advice and feedback on the selection of questions and the evaluation of diagnoses. The program may point out that a question is not relevant to the hypothesis under investigation (Figure 3) or that some critical information supporting a particular diagnosis has yet to be uncovered. At various points in the program, the student is required to rate the likelihood of his diagnoses, and Mentor

??? How severe is the swelling?

Sometimes the swelling is so marked that I can't get my shoes on.

??? Does anything make the swelling better or worse?

Being on my feet makes the swelling worse. So does hot weather. Lying down with my feet up usually causes the swelling to go down some.

??? Have you recently felt short of breath?

Yes, I have had a lot of trouble getting my breath. It began about 5 years ago, and it's been getting steadily worse. Now I can barely walk up 3 or 4 steps without stopping to catch my breath.

FIGURE 2. Example of a student pursuing the diagnosis of congestive heart failure in Maxine Brown. The prompt, ???, indicates that Mentor is waiting for the student's question.

```

??? Are the patient's palms red?

PE: Palms are not reddened.

***   ***   ***   ***   ***   ***   ***   ***   ***   ***
The presence or absence of palmar erythema on physical
examination neither helps to rule-in nor rule-out the
diagnosis of Congestive Heart Failure.
***   ***   ***   ***   ***   ***   ***   ***   ***   ***

```

FIGURE 3. Example of student questioning in the Physical Exam mode with tutorial feedback between the rows of asterisks.

may agree or disagree, citing reasons for disagreement if appropriate (Figure 4).

UNDERLYING ALGORITHM

The tutorial system's capabilities rely on the concept of pattern matching. Using this method of reasoning, the patient's findings are best explained by the diagnosis that is most likely to present with those same findings. Our knowledge base consists of 141 symptoms and signs, each associated with 11 sensitivity values that relate the likelihood of that finding being present given the presence of each of the 11 disease states. These values are "best guess" estimates provided by Stanford faculty specialists and are employed in the absence of true probabilities. To this point, they have proven to be quite useful for our purposes. For example, we estimate that dyspnea on exertion is approximately three times more likely to be found in congestive heart failure than in cirrhosis of the liver (Figure 5). Our diagnostic algorithm uses this information in a number of ways to determine when a question is appropriate to evaluate a diagnosis and which diagnosis best explains the patient's findings.

Mentor also generates a theoretical ideal patient for each of the disease states to compare the real patient to an ideal patient who only has those findings that are likely to be seen in each

disease. The degree of overlap between the real patient and the ideal patient is both a measure of pattern fit and of con-

fidence in the diagnosis. The strength of this diagnostic algorithm is the ease with which evaluations can be explained to the student and in the flexibility it affords in offering the student different types of guidance given variable amounts of information.

OTHER APPLICATIONS

Although we have chosen bilateral ankle edema for our pilot program, Mentor's diagnostic algorithm and tutorial system are independent of the knowledge base and associated patients. We will, therefore, be able to substitute other cardinal findings, with their appropriate data files, and add new patients into the system without changes in Mentor's program code. The program

```

Before changing the diagnosis you are pursuing, please
rate the current diagnosis according to a scale of:

    1 for Excellent Likelihood,
    2 for Very Likely,
    3 for Likely,
    4 for Possible,
    5 for Unlikely,
    6 for Very Unlikely,
    7 for Not Enough Information.

Please type the NUMBER, then RETURN.

??? 5

***   ***   ***   ***   ***   ***   ***   ***   ***   ***
I disagree. I think the diagnosis is much more likely
than that. Your findings fit well given the disease.
Your findings strongly suggesting CHF are:
    History of Exertional Dyspnea
    History of Orthopnea
    History of Heart Murmur
PE: JVP Increased
PE: Grade 3 or More Murmur
***   ***   ***   ***   ***   ***   ***   ***   ***   ***

```

FIGURE 4. Student evaluation of the diagnosis of congestive heart failure with tutorial feedback between the rows of asterisks.

is being developed on the StanMed computer facility of the Stanford University Medical School and is designed to run on Apple microcomputers for ease of transportability to other institutions.

REFERENCES

1. Elstein AS, Shulman LS, Sprafka SA: Medical Problem Solving. Cambridge, MA: Harvard University Press, 1978.

History of Exertional Dyspnea											
Dx:	CHF	CP	Cirrh	Maln	AGN	NS	ATP	IVCC	LO	ICE	CVI
S+/D+:	0.95	0.85	0.33	0.10	0.33	0.33	0.10	0.10	0.10	0.02	0.02

(S+/D+ = Sensitivity value, Dx = Diagnosis)

FIGURE 5. Example of bilateral ankle edema knowledge base finding.

LETTER TO THE EDITOR: COMMENT ON PILOT

To the Editor: Referring to Computers in Life Science Education, Volume 3, Number 5 (May, 1986), the discussion of PILOT by Blanchaer focuses only on some versions of PILOT currently available. When considering PILOT in more general terms, the following omissions and inaccuracies should be corrected:

1. In addition to the PILOT versions mentioned, also available are NEVADA PILOT and Lister Hill PILOT for CP/M machines, UTAH PILOT for MS-DOS machines, PILOT PLUS for Apple and MS-DOS machines, and C-PILOT for UNIX machines. PILOT PLUS, in particular, has a rich graphics syntax.
2. In addition to the text editors mentioned by the author, there is NEVADA EDIT, which, in my experience, is excellent for beginners. Further, it should have been called to the reader's attention that, since PILOT source code amounts to an ASCII text file, any good text editor can be used to produce PILOT source code, no matter the screen width.
3. In discussing *Features of PILOT*, the article mentions the following commands or statements as if they were common to more than one dialect of PILOT: "MS:str1!str2!str3!str", "S", "@". They are not.
4. In the same section, the author states that "...the most recent user input is accepted by an A: is [always] stored in the system variable, %b. That is not always so.
5. Finally, to suggest that PILOT promotes, more than other languages, poor instructional strategy and design is specious. Over the years, I have seen more poorly designed lessons programmed in BASIC than any other language. I have also seen atrocious ones programmed in TUTOR, PASCAL, FORTRAN, and, yes, even in C.

James W. Woods
National Library of Medicine
Bethesda, MD

COMPUTERS IN LIFE SCIENCE EDUCATION

HAROLD I. MODELL

Department of Radiology
University of Washington
Seattle, Washington

MARCEL BLANCHAER

Department of Biochemistry
Faculty of Medicine
University of Manitoba
Winnipeg, Manitoba
Canada

THEODORE J. CROVELLO

Department of Biology
University of Notre Dame
Notre Dame, Indiana

JAMES W. ECKBLAD

Department of Biology
Luther College
Decorah, Iowa

TSEGAYE HABTEMARIAM

School of Veterinary Medicine
Tuskegee University
Tuskegee, Alabama

DONNA LARSON

School of Nursing
Grand Valley State College
Allendale, Michigan

TERRY M. MIKITEN

Graduate School of Biomedical Sciences
University of Texas Health Science Center
San Antonio, Texas

JAMES E. RANDALL

Department of Physiology
Indiana University
Bloomington, Indiana

PATRICIA SCHWIRIAN

College of Nursing
Ohio State University
Columbus, Ohio

RICHARD STULL

College of Pharmacy
University of Arkansas
Little Rock, Arkansas

JAMES W. WOODS

Lister Hill National Center
for Biomedical Communications
National Library of Medicine
Bethesda, Maryland

DOROTHY WOOLEY-McKAY

Department of Biology
Glendale Community College
Glendale, Arizona

GLEN YOSHIDA

Department of Life Sciences
Los Angeles Southwest College
Los Angeles, California

NRCLSE

CONTENTS

SIMULATED EXPERIMENTS IN BIOLOGY CLASSES Elizabeth H. Cooper	57
TEACHING CLINICAL MEDICINE USING COMPUTER AIDED INSTRUCTION Michael E. Jones, John E. Mann, and Michael Aucone	59
WHERE'S THE SOFTWARE?	62

SIMULATED EXPERIMENTS IN BIOLOGY CLASSES

Elizabeth H. Cooper

Biology Department, Glendale Community College, Glendale, Arizona

Members of the Biology Department at Glendale Community College are integrating computers into their teaching programs in a variety of ways including tutorial reviews, word-processing for lab reports, and simulations. I have developed several simulations for use in microbiology and genetics teaching.

In most introductory microbiology courses, students are asked to identify an unknown bacterium in a laboratory project that runs for several weeks. Because beginning students generally do not possess the skills necessary to handle pathogens safely, the bacteria used in the laboratory project are non-

pathogenic. However, most, if not all, of the students in these courses are pre-nursing or pre-med students who have great interest in pathogenic bacteria. They would enjoy and benefit from a project that would enable them to identify pathogens. This prompted development of a simulation that allows beginning students to conduct experiments with pathogenic bacteria.

The pathogens program package was developed in BASIC for use on the Apple //e computer. The package consists of 2 graphics files and 7 text files including 2 random access files storing information for 17 species of

bacteria and 14 tests. Unfortunately, the graphics are not in color.

The goals in designing this software were to simulate normal laboratory procedures as much as possible, to encourage students to follow a logical and systematic thought process, and to provide the user with as much flexibility and freedom as possible. I wanted the student to make choices and decisions and have as many choices to make as possible. As a result, the students decide which tests to run (Figure 1), observe test tubes as they appear before and after each test (Figure 2), and decide if the results are positive or negative. They determine whether identification of the bacterium is possible after each test and, if not, which bacteria can be eliminated from further consideration.

In a sense, the simulation provides more freedom than an actual laboratory project. In the lab, students run all the assigned tests in order to learn them. Some of those tests prove to be of value in identifying their specific unknown, while others prove to be of no value. On the computer, the students choose which tests to use and run only those necessary to make the identification. The number of tests run vary depending on the species being identified and the particular selections made by the student.

In the process of identifying their unknown, students observe the taxonomic process in action. Unfortunately, this observation is probably not made consciously or actively in most cases. Data collected during the experiment are recorded on data sheets to be handed in to the instructor. Beginning this fall semester, students will be asked to research their pathogen and write a brief summary of the infections and diseases that it causes. This will help to further integrate the computer experience with other course material.

GENETICS SIMULATION

The other simulations are intended for biology majors. Some biology majors wish to transfer to honors programs at the university level, but to graduate with honors, they must take several honors courses while attending community college. The number of honors students majoring in biology at Glendale is too small to justify separate honors sections. This means that the needs of honors biology majors must be met within the framework of the existing course. Honors work in biology should logically include additional experimentation. However, this could require considerable funds and space, both of which are limited.

Experimentation through computer

simulations can circumvent these difficulties. I am in the process of designing a series of simulations packages to supplement the lab program and serve as the basis for additional reading and lab reports. These programs, too, are written in BASIC, but most are written for an IBM-PC compatible computer (AT&T) and employ color graphics.

One of these packages deals with genetics. The programs explore inheritance of traits, singly and in combination and, ultimately, will culminate in studies of crossing over and gene mapping. The programs utilize 14 different mutants of *Drosophila* selected randomly. Again, the experiments are designed to follow procedures that would be carried out in a real laboratory setting. Students must first learn to distinguish between male and female flies, then to recognize several mutants including their own. Two generations of crosses are made. The students identify phenotypes of the offspring and record the number of each type. Once initial data are obtained, as many as 50 additional crosses may be carried out. Ultimately, conclusions are drawn about the manner by which the alleles are inherited. Rather than simply being told whether or not they are correct, a test cross is run so students can discover the answer for themselves. On the basis of their conclusions, students predict the offspring from a cross and compare those predictions with observed experimental results generated by the computer.

STUDENT RESPONSE

The simulations have been enthusiastically received by the great majority of students. There are a few each semester who are very uncomfortable with computers. Most of these are older students who have had little or no prior exposure to computers and approach them with great apprehension. An increasing number of the younger students have used computers at home or work and in other classes at school, and they are comfortable using them.

From student responses, it is clear

```

*****
          URE  GLU  LAC  MAN  IND  H2S  MR
          (gas)
CITROBACTER   +   +   +   +   U   -   +
EDWARDSIELLA -   +   -   +   +   +   +
ENTEROBACTER  U   +   +   -   -   -   -
ESCHERICHIA   -   +   +   +   +   -   +
PROTEUS       +   U   -   U   U   U   +
SALMONELLA    -   U   -   +   -   +   +
SERRATIA      -   U   -   +   -   -   U
VIBRIO        -   -   +   +   +   -   U
YERSINIA      +   -   -   +   U   -   +
*****
select a test which will
narrow down the possibilities-
type the 2 OR 3 LETTER ABBREVIATION
of your choice
and press RETURN>

HFE=HYDROLYSE GLU=GLUCOSE  NRE=NEUTRAL  RED
IND=INDOLE     LAC=LACTOSE   MAN=MANNITOL

```

Figure 1. Computer screen from which students choose tests they wish to run.



AT THE END OF THE TEST, THE BROTH
APPEARED YELLOW WITH OR WITHOUT A BUBBLE

(to continue, press <return>)

FIGURE 2. Example of computer screen showing the results of a test chosen by a student identifying a pathogen

that the microbiology students enjoy the pathogens program. They appreciate the questions incorporated into the program as an informal study aid for the lab quiz covering unknowns. They have also expressed pleasure with the identification process. Each student is required to identify one species on the computer. Twenty to thirty percent of the students go on to identify additional unknowns on their own "for the fun of it."

The genetics programs have not been used yet by honors students, but the first package has been tested by three biology classes. The majors who have

used the program have responded with requests for more. Again, each student is asked to run one experiment, but most of the majors have run several out of curiosity. Certainly the stimulation of student curiosity is one of the most positive educational effects we can hope to achieve.

Even though there has been a very positive response by students to the simulations, it is difficult to judge how much they actually learn from the experience. I am currently attempting an analysis of quiz scores in microbiology to see if the computer experience raises scores. I doubt that statistics will re-

veal any significant difference in scores with and without benefit of the computer exercises.

SIMULATIONS AS A SUBSTITUTE FOR LABS

One serious limitation of computer simulations is that they do not give students the opportunity to develop manipulative skills necessary to conduct experiments in a real laboratory setting, and certainly, one of the major functions of a biology lab program is to train students in laboratory technique. This is one reason, among others, that computer experimentation is no substitute for laboratory experimentation. However, computer simulations can be very effective as an adjunct to lecture and laboratory programs, greatly enriching students' educational experience. Simulations permit students to carry out experiments that would be too risky, too expensive, or too time consuming to perform in the laboratory. They provide another learning device, one clearly enjoyed and actively sought by many students. Simulations provide an opportunity to review information learned in class, and even more important, they provide students with an opportunity to integrate ideas they have learned and to apply their knowledge creatively in new situations to solve new problems.

TEACHING CLINICAL MEDICINE USING COMPUTER ASSISTED INSTRUCTION

Michael E. Jones, John W. Mann, and Michael Aucone
*C.A.I. Laboratory, The School of Medicine, The Flinders University of South Australia,
Bedford Park, South Australia*

Use of computers in teaching basic science subjects in medical schools is increasing. Those who teach subjects such as anatomy and physiology often spend most of their time in research, and the use of small computers in laboratory based research may well have

eased the transition towards computer assisted instruction (CAI) in these disciplines. By comparison, those who teach more clinically oriented subjects frequently spend most of their non-teaching time in clinically oriented rather than laboratory oriented pursuits.

Accordingly, these teachers have often had less exposure to the microcomputer than have their pre-clinical colleagues and are less inclined to see the microcomputer as a useful teaching aid.

There are administrative reasons why the application of CAI to clinical teach-

ing should not be overlooked. The experienced clinician teaching the well prepared student at the bedside of a diagnostically interesting patient probably represents the most important part of a good medical education. Good clinicians who teach effectively are a scarce commodity, as are good teaching cases willing to tolerate students. If there are rate limiting processes in medical education, a major one is the confluence of the good clinical teacher, the appropriate patient, and the receptive student. Too often these potentially valuable sessions are less useful than they might be because the student fails to master elementary clinical skills. Many of these skills can be practiced in computer simulations. The role of CAI here is not to replace good bedside instruction, but to enable the student to benefit maximally from this scarce and valuable commodity.

It is important that CAI be seen in this light by clinicians because money is always short, and an important source of discretionary funds is the practice of clinical medicine. A medical school contemplating the purchase of microcomputers for teaching may well be financing them from funds generated by clinical departments. Not surprisingly, this can lead to some searching questions, raised by those who generated the funds, as to the usefulness of microcomputers in teaching clinical medicine.

POTENTIAL APPLICATIONS

Different branches of medicine require very different skills of their practitioners, but at the intern level, a common denominator is the early diagnosis and treatment of common diseases. This involves taking a history, performing a clinical examination, determining a differential diagnosis, and performing a series of supplementary tests to distinguish between plausible diagnoses. These, and the subsequent treatment, often require basic procedural skills such as the ability to perform a spinal tap. Superficially, there appears to be very little of this that can be simulated

usefully on a microcomputer. Let us consider the process step by step.

The Clinical History

The clinical history is a basic series of questions asked of all (or most) patients, supplemented by further questions as the particular case requires. Difficulties that students have with history-taking fall into one of the following four categories.

- 1) The student forgets to ask a routine question.
- 2) The patient does not understand the questions but may randomly say 'yes' or 'no' anyway.
- 3) The student may not understand the patient's answer.
- 4) A patient's answer fails to prompt the student to ask supplementary questions because the student is concentrating so much on the act of questioning that he or she fails to appreciate the logical consequences of the answer.

Of these four common difficulties with the history, the computer can probably assist only with the last. The first problem may be difficult to tackle on some computers because 'free format' input is technically hard to interpret, so we have to prompt the student with a list of possible questions. Students do not forget to ask routine questions when prompted, so the simulation is unrealistic. The second and third problems are peculiar to human communication. Man-machine communication is, of course, often imperfect, but these difficulties are not a useful simulation of person-to-person communication difficulties. The first three problems are, in any case, best resolved by having the student practice taking a history from real patients.

The fourth problem with history-taking is by far the most difficult for students to overcome because it requires the student to sit down and think about the logical implications of an answer before phrasing the next question. It is much easier to ask a question than to

analyse the possible implications of an answer. For the student, the problem is not simply one of logic, but one of social interaction. The student in the ward is usually ill-at-ease with the patient, and a major concern is the maintenance of a professional image with all that it implies. To the student, it implies an easy flow of questions, smiles and reassurance, and above all, no embarrassing silences. Many students find it almost impossible to think analytically during the patient interview and are not prepared to interrupt the conversation to think in silence. Here, the simulated interview with the computer can be more useful than the real-life situation. There are no social disincentives to letting the microcomputer sit quietly while the student marshalls his thoughts.

The Physical Examination

The second stage is the process of physically examining the patient. Here, the contribution of a computer simulation is very limited. The extent of chest movement, the presence of bowel sounds, the enlargement of liver or spleen, and the assessment of anal sphincter tone are representative of things that must be mastered at the bedside. The microcomputer is not an efficient tool leading to the mastery of these skills. Neither is the 'bells and whistles' approach of appending a plethora of peripheral devices to the computer such as tape recorders to present heart sounds and automated slide projectors to present visual information. These appendages may be mechanically unreliable and rarely present more than a small fraction of the necessary clinical information. A tape recording of heart sounds, for instance, give an imperfect idea of the extent to which a murmur radiates to the axilla and neck and trains the student to concentrate only on the sounds and not their relationship to the palpated carotid pulse or the visual clues in the neck veins. Many of these objections may carry less weight when microcomputers are reliably connected to a random-access video disc, but the

principle will still be the same. Even in a predominantly visual field such as the differential diagnosis of rashes and skin lesions, the assessment of induration or skin temperature requires tactile information that audio-visual facilities cannot supply. It is a mistake to use computers in an increasingly expensive attempt to simulate patients unless the computer is intrinsically capable of being of more use as a teaching aid than a real patient. In general, the patient is far better at teaching physical examination than is a computer.

There is, however, one aspect of the physical examination in which the computer is better. It is analogous to the problem discussed earlier in history taking. When students perform a physical examination, the process often degenerates into something very similar to a dance routine in which ritual movements are performed with a minimum of cerebral input. Not only is the physical examination performed quite independently of the information obtained from the history, but pathological findings at one stage of the examination fail to alert the student to the possibility of abnormal findings elsewhere. A common example involves patients claiming to take beta-blockers as medication and the student failing to examine the fundi for hypertensive changes. Students often comment of the presence of ankle edema but fail to comment on the presence or absence of varicose veins.

The underlying problem, again, is that the student fails to recognize the significance of a physical finding and consequently fails to direct the physical examination accordingly. The reason for this, I believe, is not that students are universally stupid or lazy (as generations of attending physicians have unkindly assumed), but that they are too self-conscious to take time out to think while inconveniencing a patient with their presence. This is a major problem in teaching clinical skills, and it is one that persists well into postgraduate medical education. It is a problem that can be tackled effectively with CAI. The

computerized patient management problem allows the student to digest the significance of one physical sign before seeking another. For example, if a simulated patient is hypertensive, the student needs to know the position of the apex beat and, if this is displaced, tracheal deviation and scoliosis should be sought. The value of the computer is not in teaching students how to take a blood pressure, palpate the precordium, or recognize a scoliosis, but to train them in the branching logical process that leads them to seek these physical signs. Commonly, when students demonstrate poor clinical skills, it is not because they are incapable of eliciting physical signs, but because they fail to seek them. That is the major unresolved problem in the teaching of clinical skills, and it is an area in which the computer simulation has much to contribute.

Differential Diagnosis

After taking an adequate history and performing the physical examination, the next step is the diagnosis, or, failing that, listing a differential diagnosis. The extent to which the computer is seen to be useful here depends very much on how one believes a diagnosis is reached. As students, we often failed to progress from the data base of history and examination to the correct diagnosis until prompted by the attending or consultant physician. The consultant, impatient with our fumbling powers of deduction, would proceed to demonstrate how the application of elementary logic, together with a rudimentary grasp of anatomy and physiology, should lead even the feeblest mind to the correct diagnosis. Generations of medical students have come away from their ward exposure convinced of their total incapacity to think logically.

We all know that medical students are really quite bright and that doctors are past their intellectual peak by the time they reach consultant status. In fact, the arrival at a diagnosis is not so much an intellectual task as one of pattern recognition, rather akin to the process

by which a three-year-old learns to distinguish between a cow and a horse. Humans are very good at pattern recognition. The clinician diagnoses heart failure not by a supreme intellectual effort but because one case looks very much like another. In a teaching hospital, one has no choice but to intellectualize this and explain to students the difference between right ventricular failure, left ventricular failure, asthma, and terminal emphysema. In much the same way, to continue the analogy above, one could devise a set of rules whereby someone unfamiliar with the countryside could distinguish between a cow and a horse (presence or absence of udder and horns, auditory data such as 'moo' or 'neigh'), but no one seriously imagines such a cowboy consciously applies such a set of rules when deciding which animal to saddle up in the morning. The experienced clinician makes common diagnoses by pattern recognition and intellectualizes this retrospectively for the benefit of students. It is a process of retrospective induction rather than one of deduction.

The implication of this for CAI is that the computer is unlikely to be able to simulate the diagnostic process because it cannot provide the spectrum of clues that contribute to the pattern, clues such as the cool, clammy palms and anxious look of the patient. These are things that the experienced clinician will note subconsciously.

Having said that, it is clear that neither the medical student nor the raw intern can hope to reach a diagnosis that way. Diagnosis by pattern recognition is only possible after a disease has been seen many times. Interns often have to diagnose correctly the first time they see some diseases, so they must be taught a method of diagnosis that is quite different from that which they will use later in their careers. Once it is accepted that the initial diagnostic process for students and interns is often qualitatively very different from that used by their seniors, the artificial scenarios created in computerized patient management problems begin to

look more attractive as a teaching aid. They encourage the student to maintain a differential diagnosis of plausible diseases and gather additional data in a manner that will maximize diagnostic information at minimal patient risk. The computerized patient management problem can quite realistically simulate, and teach, the optimal use of laboratory

and other ancillary investigations to confirm or rule out diagnoses. Similarly, it can comment on response to treatment and the altered diagnostic probabilities that this implies. This is useful training, both for the initial diagnosis of uncommon diseases and for confirmation of diagnoses in common diseases. It is a mistake to assume that this sim-

ulates the process by which most common diseases are initially diagnosed in practice by senior clinicians. It is also a mistake, however, to imply that this seriously limits the usefulness of the computer in simulating the diagnostic process for trainees whose diagnostic processes are necessarily quite different from those of their senior colleagues.

WHERE'S THE SOFTWARE?

In the past, we have published several lists of life science software sources and programs or program areas available through them. The most notable, the result of a survey of 98 vendors by Beth Johnson, appeared in the July, 1985 issue. The following list is presented as the latest in a continuing effort to make colleagues aware of potential resources. As in the past, no attempt has been made by NRCLSE to review these materials. In future lists, after our planned peer critique mechanism is in place, indication of reviews will also be presented.

This month's software entries were presented at the 1986 meeting of the Federation of American Societies for Experimental Biology (April, 1986) or at the recent Congress of the International Union of Physiological Sciences (July, 1986). The content area is primarily physiology.

If you have found specific software helpful in your teaching efforts, please let us know about the program(s) and supplier(s) so that we can make this information available through future Where's the Software lists. Send pertinent information to Dr. Harold Modell, NRCLSE, Mail Stop RC-70, University of Washington, Seattle, WA 98195.

Drs. Joel Michael and Alan Rovick
Department of Physiology
Rush Medical College
1750 West Harrison Street
Chicago, IL 60612

CIRCSIM

Cardiovascular Physiology simulation

CIRCSYS

Cardiovascular Physiology lesson

REFLEX

Cardiovascular Physiology lesson

FLUID COMPARTMENTS

Physiology lesson

LENGTH-TENSION

Simulated Physiology laboratory

FORCE-VELOCITY

Simulated Physiology laboratory

Dr. Joseph Boyle

Department of Physiology
New Jersey Medical School
100 Bergen Street
Newark, NJ 07103
(201) 456-4464

PUFT

Calculates predicted values for common pulmonary function test after patient data are input.

CIRCSYST

Simulation based on ventricular force:impedance and the Guyton right atrial pressure:cardiac output relationship

CAPEXCH

Covers factors involved in the Starling Hypothesis determining filtration and reabsorption of water through the capillary endothelium.

RESPSYST

Respiratory Physiology simulation

GASEXCH

Simulation dealing with gas exchange

at the lungs and at the tissues

EKGTUTOR

Developed in association with K.J. Friedman, J. Black and G. Robinson. Utilizes graphics and simulation to teach basic EKG theory.

ABGAME

Acid-base tutorial in a game format

Dr. P. C. Specht

Department of Pharmacology
Puerto Rico Medical School
GPO Box 5067
San Juan, PR 00936
(809) 753-4731

CVMODL

Cardiovascular simulation

Dr. James Randall

Department of Physiology
Myers Hall
Indiana University
Bloomington, IN 47405

Basic Electrophysiology simulations

Basic Cardiovascular simulations
Human-80

Integrated systems physiology model

Dr. David Bashor

Department of Biology
University of North Carolina at
Charlotte

Charlotte, NC 28223

INSULIN

Physiology simulation

HH, HH2PULSE

Hodgkin-Huxley simulations

MCNEURON

Neuron model

LOOP

Counter-current multiplier simulation

Dr. Harold Modell

NRCLSE

Mail Stop RC-70

University of Washington

Seattle, WA 98195

Simulations in Physiology - The
Respiratory System

A series of 12 simulations covering
respiratory mechanics, gas exchange,
chemoregulation of respiration, and
acid-base balance

Dr. Harold Hempling

Department of Physiology

Medical University of South Carolina

Charleston, SC 29425

Exam generator

Dr. C.J. Dickinson

Department of Medicine

St. Bartholomew's Hospital Medical
College

West Smithfield, London EC1A 7BE

United Kingdom

MacPUFF

Simulation of the respiratory system

MacMAN

Cardiovascular Physiology simulation

MacPEE

Renal Physiology simulation

MacDOPE

Pharmacology simulation

Dr. R.L.B. Neame

Faculty of Medicine

University of Newcastle

New South Wales 2308

Australia

Pediatric patient simulation

Dr. Charles Bishop

508 Getzville Road

Buffalo, NY 14226

FRAMED - Framework of
Medicine

Relational data base

DISEL - Disease Elements

Information management tool

Dr. H. Glenn Bohlen

Department of Physiology and
Biophysics

Indiana University School of Medicine

635 Barnhill Drive

Indianapolis, IN 46223

Acid-Base Physiology

Simulation

Gas Diffusion in the Lung

Model of oxygen and CO₂ transfer
between alveolar air and blood

Dr. Richard Meiss

Department of Physiology and
Biophysics

Indiana University School of Medicine

635 Barnhill Drive

Indianapolis, IN 46223

Skeletal muscle mechanics

6 program set of simulations

Dr. Carl F. Rothe

Department of Physiology and
Biophysics

Indiana University School of Medicine

635 Barnhill Drive

Indianapolis, IN 46223

Cardiovascular interactions

Cardiovascular Physiology simulation

GRADEBK

Program for the analysis of a large set
of grades

Instructional Simulations

Nils Peterson

Computing Service Center

Washington State University

Pullman, WA 99164-1220

(509) 335-0411

CVSAD

Cardiovascular Physiology simulation

PML

Pulmonary mechanics lab

COMPUTERS IN LIFE SCIENCE EDUCATION

HAROLD I. MODELL

Department of Radiology
University of Washington
Seattle, Washington

MARCEL BLANCHAER

Department of Biochemistry
Faculty of Medicine
University of Manitoba
Winnipeg, Manitoba
Canada

THEODORE J. CROVELLO

Department of Biology
University of Notre Dame
Notre Dame, Indiana

JAMES W. ECKBLAD

Department of Biology
Luther College
Decorah, Iowa

TSEGAYE HABTEMARIAM

School of Veterinary Medicine
Tuskegee University
Tuskegee, Alabama

DONNA LARSON

School of Nursing
Grand Valley State College
Allendale, Michigan

TERRY M. MIKITTEN

Graduate School of Biomedical Sciences
University of Texas Health Science Center
San Antonio, Texas

JAMES E. RANDALL

Department of Physiology
Indiana University
Bloomington, Indiana

PATRICIA SCHWIRIAN

College of Nursing
Ohio State University
Columbus, Ohio

RICHARD STULL

College of Pharmacy
University of Arkansas
Little Rock, Arkansas

JAMES W. WOODS

Lister Hill National Center
for Biomedical Communications
National Library of Medicine
Bethesda, Maryland

DOROTHY WOOLEY-McKAY

Department of Biology
Glendale Community College
Glendale, Arizona

GLEN YOSHIDA

Department of Life Sciences
Los Angeles Southwest College
Los Angeles, California

NRCLSE

CONTENTS

DEVELOPING COMPUTER ASSISTED INSTRUCTION FOR ANATOMICAL SCIENCE EDUCATION Bruce J. Murphy	65
PLANNING AND DEVELOPING A MICROCOMPUTER LABORATORY FOR USE IN A COMMUNITY COLLEGE BIOLOGY CURRICULUM Dorothy Wooley-McKay	67
JANUS - A COMPUTER INTERFACE BETWEEN LABORATORY AND LECTURE Ruth M. Sprague	69
KEEPING ABREAST OF THE LITERATURE	70

DEVELOPING COMPUTER ASSISTED INSTRUCTION FOR ANATOMICAL SCIENCE EDUCATION

Bruce J. Murphy

*Discipline of Anatomy, University of Osteopathic Medicine and
Health Sciences, Des Moines, Iowa*

The most common mode of anatomical science instruction in medical school is the lecture and laboratory format. While this format has been generally adequate for mass education, increased student enrollments, decreased curriculum time, availability of anatomical materials, and faculty constraints have made it progres-

sively more difficult for students needing remedial help to obtain it. The Discipline of Anatomy at the University of Osteopathic Medicine and Health Sciences had a requirement for a mechanism to provide efficient remedial instruction. This mechanism needed to promote problem-solving and provide

visual re-enforcement to text but in an individualized and private learning environment. Consequently, the possibility of utilizing computer assisted instruction (CAI)³ to enhance and supplement first year medical anatomical science courses was explored by the Discipline. This paper details the development of our anatomy software.

Although the University maintained a data processing center containing a mainframe computer, the center was not used because of its inaccessibility to both faculty and students. After considerable evaluation, the hardware selected for CAI was the Apple II family of microcomputers with supporting peripheral devices. This choice was due to the wide selection of existing software. However, it was soon learned that, although there were considerable clinical and physiological simulation programs available, there was a lack of adequate microcomputer software in the anatomical sciences. This meant that we had to contract with a third party to develop materials, utilize authoring software, or have faculty invest their time in acquiring programming skills.

Interested faculty decided to learn to program their own software. This decision was based on the high cost of consultants and the need for considerable pictorial input. It was felt that most commercial programmers were unfamiliar with designing complex computer graphics, especially those relating to the human form. Other factors to be considered were the selection of a programming language, the number of disk drives to be used, and memory requirements. Of the various programming languages or authoring systems designed for the Apple, experimentation showed that, initially, BASIC would be the optimal language using DOS 3.3 and 5 1/4" floppy disks. Only a single drive would be used. Each program on a disk would require no more than 64K of memory.

SOFTWARE DEVELOPMENT

To develop CAI program content, the teaching faculty initially reviewed their

instructional materials, defined the specific subject matter, and then established definitive objectives for the material.¹ Based on student needs, programs were developed first in Gross Anatomy, then in Neurosciences, and finally in Histology. Of the three primary forms of CAI, Drill and Practice, Simulation, and Tutorial, only the first and last forms were considered appropriate for our first year students. Thus, faculty efforts were focused on developing tutorial software followed by drill and practice programs in the tutorial content areas.

As software development proceeded, faculty constructed their programs using a modified Mastery Oriented Teaching Unit (MOTU).⁴ Each disk covered a single broad topic and contained several MOTUs pertaining to that topic. Technically, structuring text was fairly easy, but producing quality illustrations consumed more faculty time than anticipated. Text was designed first, and the illustrations were added later. In the interim, students were provided with a printed set of pictures keyed to the text. The original graphics were drawn with an Apple Graphics Tablet using "The Complete Graphics System" by Penguin Software. Although several illustration programs were evaluated, this software system was found to be easier to use, giving superior control over the drawing procedure. The pictures were stored on the disk in an 8K format, but this drastically reduced the number of MOTUs that could be housed on a single disk. Updated editions of "The Complete Graphics System" allowed storage of images in either the 8K format or in a packed format. The packed format reduced the storage space to nearly 4K, thereby freeing up considerable space on each disk. The limitation of BASIC graphics commands also became a problem. As programs became more sophisticated, it became necessary to use pokes and short machine language routines to set text and graphic switches and to make more efficient use of memory. Descriptions by Heiserman² and Stanton⁵ provided the best

resource material. These routines allowed freer control of graphics displays on multiple screens and better interaction with text material.

Feedback is an important part of self-instructional media. To provide students with an indication of their level of performance, review questions were added to the end of each text sequence. Questions were either simple True/False or Multiple Choice. The open-ended type of question was avoided due to the high probability of spelling errors. If the student did not answer a question correctly, the program presented clues that provided guidance to the correct response. To provide positive re-enforcement, a screen indicating "You're Correct!" or "That's Right!" was presented after each correct response. If too many questions were missed, the student was sent back to the beginning of the MOTU.

The acceptable level of student performance on each program was determined by the authoring faculty member. Each student was required to enter his or her name which was recorded on the disk. Evaluation consisted of students taking a pre-test before presentation of the material and a post-test at the conclusion of the program. Students' pre- and post-test scores were also recorded onto the disk. This allowed faculty to track the progress of individual students.

PROBLEMS ENCOUNTERED

There were few problems implementing this type of software among students. However, many students were unfamiliar with computers. To orient students initially, directions were printed on the disk sleeve. Later, students were oriented to computer use during the first week of classes. Other problems arose because some students, trying to break into the programs, caused disk crashes or erasures. The Apple Security Program was later used to prevent tampering, but after the graphics were added to a disk, this program no longer functioned properly. As a low level program protection mechanism, the disk operating system was altered by delet-

ing direct commands. The "reset" key was programmed to re-boot the disk at any attempted interrupt. These changes were accomplished by finding the right combination of pokes by trial and error. A more common problem was the use of fictitious names on the pre- and post-tests.

Some students felt that the review questions in the MOTUs reflected the questions on regular course exams. Enterprising students copied the MOTU questions and answers, then distributed them to their classmates.

SYSTEM EVALUATION

This system has now been in use for nearly three years. It has been evaluated via two routes. First, students were asked to complete an evaluation of each program disk as it was used. They were asked to identify problems, rate effectiveness, ease of use, and provide comments on MOTU content. In general, programs were highly rated. Students frequently requested shorter program loading times, a means to return to previously displayed text, and animated graphics. Based on these recommendations, programs now use the left and right arrow keys to either advance or

backup the text. The illustrations are loaded behind the appropriate text screen. By pressing the "P" key, the student can switch between graphics and text. Loading time has been decreased by using the Diversi-DOS program.

The second evaluation method used was a comparison of pre- and post-test scores with course examination grades. It was found that students using the programs scored at a level on course exams consistent with their performance on the programs. During one summer, fourteen remedial students were strongly encouraged to use the software. Those not utilizing the software continued to attain unsatisfactory examination scores.

RESPONSE TO THE OVERALL PROGRAM

The student response to these programs has been enthusiastic and overwhelmingly in favor of continued efforts. Not only are medical students using the programs, but the University's allied health science and podiatric medical students are now also studying the programs. Students seem to enjoy the self-paced nature of the software, the immediate feedback, and especially the graph-

ic capabilities. For better student accessibility, more computers were put in the University's library, and a CAI media center was established. The student honor society has now purchased an additional computer for the media center.

The effect on faculty has also been positive. The University has now recognized program development as equivalent to research publications, thereby encouraging and rewarding faculty efforts.

REFERENCES

1. Alessi SM: Designing effective computer assisted instruction. *Amer Biol Teach* 46: 146-192, 1984.
2. Heiserman DL: Intermediate-level Apple II handbook. Indianapolis: Sams & Company, Inc., 141-193, 1983.
3. Larson DE: Using computer-assisted instruction in the education of health care professionals: what the dean needs to know. *Computers in Life Science Education* 1: 65-67, 1984.
4. Mavor SJ: Construction of a mastery-oriented teaching unit using a mini-computer. *Ohio State Med J* 71: 297-299, 1975.
5. Stanton J: Apple graphics and arcade game design. Los Angeles: The Book Company, 9-34, 1982.

PLANNING AND DEVELOPING A MICROCOMPUTER LABORATORY FOR USE IN A COMMUNITY COLLEGE BIOLOGY CURRICULUM

Dorothy Wooley-McKay

Department of Biology, Glendale Community College, Glendale, Arizona

During the last four or five years, the use of computers for simulations, tutorials, self tests, etc. has become more and more important in the Life Science curriculum. Students seem to like tutorials, and simulations can be used to mimic laboratory situations that cannot be performed in a community college biology laboratory.

At Glendale Community College, we are fortunate to have a microcomputer

laboratory dedicated for use by the biology and psychology departments. Implementation and construction of this microcomputer laboratory has been a long and expensive process. This article is an attempt to trace the history of the development and implementation of our microcomputer laboratory.

Use of computers in Human Anatomy and Physiology laboratories was begun spring semester, 1982 with pro-

grams on the oxyhemoglobin dissociation curve and acid-base balance. These programs became part of the Simulations in Physiology - The Respiratory System package.² Use of the programs met with some difficulty because there were no microcomputers on the Glendale Community College campus, and I had to bring my own Apple II+ from home to the laboratory. Use of the programs was very worthwhile. I felt that

the instructional value of the programs was worth the hassle of bringing my computer from home to school and back. In addition to increased student understanding of the oxyhemoglobin dissociation curve, and, later in the course, the various variables involved with acid-base balance, the programs served as an excellent starting point for classroom discussions.

IMPLEMENTING COMPUTERS IN THE CURRICULUM

Two key factors aided the implementation of computer use in the Biology Department and Glendale Community College. In the fall of 1982, the College Computer Committee was formed. It consists of faculty members representing clusters of various departments. The committee is very active, and committee members were instrumental in helping the Biology Department set up a mini-microcomputer laboratory. The second factor was an influential member of the Glendale Community College Biology Department who originally could see no use for computers. After attending a workshop on Apple II computers, he was "turned on" and became an important voice for the adoption of microcomputers in the Biology curriculum.

During the 1982-83 academic year, planning for future use of both microcomputers and the mainframe computer was the main thrust of the Computer Committee. Our planning was hampered by the fact that very little money was available for purchase of equipment. However, enough money was allocated to purchase three Apple //e computers for use by the Biology Department beginning fall, 1983. Initially these were placed in the offices of three faculty members. Because we had no space dedicated to a microcomputer laboratory, the computers were put on carts and moved to the laboratories if needed for instructional purposes. There was still very little interest in using computers on the part of most of the faculty. The understanding between the Biology faculty and the Chairman of the computer committee was that the

three Apples would be placed in a Biology-Psychology-Nursing computer laboratory beginning in the fall semester, 1984. We made plans to do this by converting a room used for special projects into a multipurpose room.

In the fall of 1984, a total of seven Apple //e computers and one or two IBM PCs were placed in the room designated as the multi-purpose room. Projectors for use with slide-tape modules written by members of the Biology Department were also placed in this room.

SOFTWARE DEVELOPMENT

Once the microcomputer hardware was in place, the search for software started. At that time there was little or no software that we considered suitable. Therefore, we were forced to write our own. Some software was developed by individuals on their own time, and some development was supported financially or with release time by Glendale Community College or the Maricopa County Community College District. Software developed includes:

- A slide-show format tutorial on excitation-contraction coupling²;
- A slide-show format tutorial on various aspects of nervous system physiology³;
- A simulation of contraction of rabbit *psoas* muscle;
- A program on anatomical terminology;
- Two programs on identification of microorganisms⁴;
- A program dealing with *Drosophila* genetics¹;
- Several statistical programs.

CONTINUING EFFORTS

We continue to progress with the expansion of our computer laboratory. For fall, 1986, we should have a total of 10-12 Apple //e computers, 6-12 Apple Macintosh computers, and 6-12 MS-

DOS machines (IBM clones). The IBM clones and the Macintoshes will be connected to an Apple LaserWriter. The Apple //es will share dot-matrix printers. The room will also be used for the slide-tape modules, and microscopes will be available for extra histology study for Anatomy and Physiology students. The room is being completely redesigned to accommodate its present use as a multi-use and microcomputer laboratory for the Biology and Psychology Departments. It will be open for student use 8-12 hours/weekday and 4 hours on Saturday. We continue to write our own software.

All of the Biology Department faculty will have a microcomputer of their choosing in their offices by fall semester, 1986. These will be used for a variety of purposes, including writing or rewriting lecture notes, making handouts, writing tests, and grade-keeping.

Obviously, we believe that all of these programs add a great deal to our instructional program. It is possible to implement certain laboratory activities on microcomputers that are impossible to do in a regular laboratory situation.

Students like to use computers. I have wondered about the immense interest shown by students in the tutorials. They will sit down and read text on the computer, but they do not read in their textbooks. I have a theory that, since present-day students have been "brought up" learning from TV, the computer monitor seems comfortable and natural. Perhaps this is a sad commentary on education, but if the use of computers is effective in the learning process, then by all means, we should pursue this use.

REFERENCES

1. Cooper EH: Simulated experiments in biology classes. *Computers in Life Science Education* 3:57-59, 1986.
2. Modell HI: *Simulations in Physiology - The Respiratory System*. Seattle, WA: NRCLSE, 1986.
3. Wooley-McKay D: Use of computer tutorials in community college human anatomy and physiology classes. *Computers in Life Science Education* 1:36-37, 1984.

JANUS - A COMPUTER INTERFACE BETWEEN LABORATORY AND LECTURE

Ruth M. Sprague

Department of Anatomy and Neurobiology, The University of Vermont College of Medicine, Burlington, Vermont

Throughout many years of teaching, I have noted that many students tend to compartmentalize information obtained in lecture and laboratory. They have difficulty putting together the separated lecture material on physiology and anatomy with the structural material presented in the anatomy laboratory because the two, lecture and corresponding laboratory, are separated from each other by days or even weeks.

The Human Anatomy and Physiology undergraduate course at this university consists of three hours of lecture per week and one three hour laboratory that alternates between anatomy and physiology. The anatomy laboratories, which include both microscopic and gross anatomy, are planned and taught by me. The enrollment for this course is approximately three hundred students, and it covers two semesters from September to May.

Working one-on-one or with small groups, I could help some students bring lab and lecture information together into a cohesive whole, but I could not reach all of the students to impart interconnecting concepts.⁴ The vision of the god, Janus, with one face toward the lecture and one toward the laboratory, suggested the adaptability and practicality of a computer programed with a review of lecture material that would be accessed in the laboratory. The computer would direct students toward the best of all graphics, the cadaver, histological slides, models, and demonstrations that related to the lecture material.

MATERIALS AND METHODS

The vision became a reality when a computer grant from the Tandy Co. was awarded.^{5,6} It consisted of two TRS Model 4 computers and Author I soft-

ware, a course authoring system that quickly enabled me to put most of the substance of the lectures on disks in a form that directed students toward the laboratory material at appropriate times. Author I's limited graphic capabilities were no drawback because the structural material was right there in the laboratory. The page-by-page material offered by the computer, to be taken at the student's own pace, interfaced with the lecture and laboratory information, and questions included in the program reinforced the student/computer interaction.

The computers were available to the students from 8 AM to 5 PM each weekday and until 8 PM on Wednesday. Weekend hours were added at the students request. Students using the computers had to identify themselves by signing in. They were told that their names would not be used but that they would be included in the computer-user group for statistical evaluation of the Janus program.

To assess the effect of computers in the anatomy laboratory, two populations of students were identified. One group, COMPUPRO, used the computers, and the other group, COMPUCON, did not use the computers.

Four numerical grades for each group were analyzed statistically. These data included the final grade for the semester (100%), the final exam grade (50%), the anatomy laboratory quiz grade (20%), and the physiology quiz grade (20%).

In addition, grades received on an exam given just prior to using the computers in the lab were analyzed for these same groups. Finally, to determine if a greater number of the computer user group were already performing at the top grade levels, a t-test was performed on the pre-computer exam grades of those students in each group

who earned at least 40 points out of a possible 50 (grades of 80 to 100%).

The final grade for the semester was calculated on the basis of performance on three examinations, the anatomy laboratory, and the physiology laboratory.

Student's paired two-tailed t-test was used to determine if the difference between the two groups was statistically significant.

Log books were placed with each computer in the laboratory so that students could make comments or corrections on the lessons.

RESULTS

Results of the comparisons are shown in Table 1. Students consistently performed better in all assessment categories after using the computers. However, when compared to the remainder of the whole class, this group also scored higher in the semester exam given before computers were used. Further comparison to determine if the COMPUPRO group was made up mostly of students who were already performing well indicated that this was not the case.

Computer log books contained many positive comments from student users, no negative comments, and some very helpful suggestions or corrections.

DISCUSSION

The objectives of the Janus interface project were met, and some additional benefits and insufficiencies that had not been anticipated were identified. Although only 37% of the class used the computers, the response of those who used them was excellent.

Some of the reasons given by the non-users were lack of time needed to come into the lab, fear of using a com-

TABLE 1. Results of paired t-test (n=80) comparing mean scores of computer users (COMPUPRO) and non-users (COMPUCON).

	Final Semester Grade	Final Exam Grade	Anatomy Grade	Physiology Grade	Prior Semester Grade
COMPUPRO	82.5	40.1	17.8	18.2	34.7
COMPUCON	76.4	35.3	16.9	17.6	32.5
Standard Error of Mean Difference	1.19	0.94	0.30	0.20	0.96
Probability	<.001	<.001	<.01	<.01	<.05

puter, didn't need extra help, and put it off until it was too late. The reason given most often by students not using the computer was that they could never find a free computer to use. Two computers just were not enough for this sized class.

The competition for the computers did, however, bring students into the lab to wait for a computer to become available, an unanticipated bonus. While they were in the lab, they studied the demonstrations and found others with whom to study. This extra lab time is reflected in the statistics.

The results of the test scores shown indicates that a significant difference exists between the grades of the computer users (COMPUPRO) and non-users (COMPUCON). As a control, exam grades by the two groups prior to the arrival of the computers were compared. The results show that the computer users scored higher than the non-user group ($P<.05$). This may indicate that the user group would have a slightly higher average than the non-user group even without computers.

Therefore, another comparison was made in order to see if the user group was made up mostly of students who were already performing well. The difference in performance between the two student populations in this comparison indicated that the computer user group was not over-populated by normally high scorers.

A study group, formed to tutor several

students who were failing, used the computers. All of these people improved sufficiently to pass the course. Although all the credit cannot be given to the use of the computers in this instance (the tutor utilized other learning aids besides the computers), the students in the study group continued to use the computers on their own after being introduced to them by the tutor.³ Students who need the most help are generally the ones who do not seek out their instructor and ask for this help. They are reluctant to demonstrate their ignorance to another person. They had no such reluctance to interact with a computer.⁷

KEEPING ABREAST OF THE LITERATURE

The following citations are presented as part of a quarterly feature in CLSE designed to help readers become aware of current literature pertinent to computer applications in life science education.

- Acker SR: Redesigning the human-machine interface for computer-mediated visual technologies. *J Educ Technol Systems* 14(1):23-33, 1985-1986.
- Armstrong, ML et al: Whither CAI? *Am J Nurs* 86(4):459, 1986.
- Barker PG et al: A practical introduction to authoring for computer-assisted instruction. Part 4: STAF. *Br J Educ Tech*

Does this mean that machines are superior to or should replace teachers? Of course not. The Janus interface shows how a teacher's ability and experience can be extended to "change, acquire, improve or alter performance".² "...and lest we forget, we are teaching machines as well - human teaching machines."¹

REFERENCES

1. Cole RW: Deus ex machina? (editorial). *Phi Delta Kappan*, (January):298, 1982.
2. Eisele JE: Instructional computing. *Instructional Computing* 26(6):25-26, 1986.
3. Eisenberg Y: The effects of computer based instruction on college students interest and achievement. *Instructional Computing* 24(4):40-42, 1986.
4. Judd W: A teacher's place in the computer curriculum. *Phi Delta Kappan*, (October):120-122, 1983.
5. Schiffman SS: Softwar infusion: using computers to enhance instruction. *Instructional Computing* 26(1):7-11, 1986.
6. Stull R, Knoll R: Creative equipment acquisition for development of computer software. *Computers in Life Science Education* 2:33-35, 1985.
7. Willis J: An overview of educational computing. *Education Digest*, (December):29-31, 1984.

16(2):115-135, 1985.

- Bellinger K et al: Nurse use of general-purpose microcomputer software. *Nurs Outlook* 33(1):22-25, 1985.
- Bialo ER et al: Microcomputer courseware: characteristics and design trends. *J Comp Math Sci Teach* 4(4):27-32, 1985.
- Bork A: Computers and information technology as a learning aid. *Education and Computing* 1(1):25-35, 1985.
- Bowker LS et al: Using computers to increase course efficiency: an example in a general ecology laboratory. *Collegiate Microcomputer* 4(1):1-6, 1986.

- Chasing BL: Computer-aided instruction in nursing education...research reported from 1966 through 1983. *Annu Rev Nurs Res* 4:217-233, 1986.
- Chiavaroli JJ et al: Graphics software packages as instructional tools. *Am Ann Deaf* 130(5):374-376, 1985.
- Cohen VB: A reexamination of feedback in computer-based instruction: implications for instructional design. *Educ Tech* 25(1):33-37, 1985.
- Collet LS et al: A computer simulation approach to teaching research and evaluation skills. *J Educational Computing Research* 1(3):339-354, 1985.
- Collins MAJ et al: Using computer tests to identify areas for remedial teaching of biology. *J Comp Math Sci Teach* 4(4):36-37, 1985.
- David CW: A proposal for assisted multiple choice testing. *College Board Review* 136:26-30, Sum 1985.
- Deardorff WW: Computerized health education: a comparison with traditional formats. *Health Educ Q* 13(1):61-72, 1986.
- Downes K: Videodisc development. *Systems International* 93-94, Oct 1985.
- Ellis LBM et al: Computers as learning resources in the health sciences: impact and issues. *Bull Med Libr Assoc* 74(2):95-99, 1986.
- Evans P et al: Computer-assisted learning. A software approach. *Nurs Times* 81(44):43-45, 1985.
- Gaar KA Jr: Oxygen transport: a simple model for study and examination. *The Physiologist* 28(5):412-415, 1985.
- Ganiel U et al: Student misconceptions in science -- how can computers help? *J Comp Math Sci Teach* 4(3):14-19, 1985.
- Garvey M: Authoring computer lessons -- it's easy! *Am Ann Deaf* 130(5):354-356, 1985.
- Gold RS: Computing health: sources of information for educators...microcomputers in instructional settings. *Health Educ* 15(2):39-40, 1984.
- Greenberg EA et al: A botanical garden data base implemented in SAS software. *Sci Software Q* 2(1):23-29, 1985.
- Hamby CS: A study of the effects of computer assisted instruction on the attitude and achievement of vocational nursing students...pharmacology math course. *Comput Nurs* 4(3):109-113, 1986.
- Hanton SD et al: A pilot study of a computer-based PMP (Patient Management Problem). *J Optim Educ* 11(3):20-25, 1986.
- Harkin PJR et al: Computer assisted learning systems in pathology teaching. *MedTeach* 8(1):27-34, 1986.
- Heaford J: Authoring tools: help or hindrance. *Interactive Learning International* 2(2):4-6, 1985.
- Herther NK: CD ROM technology: a new era for information storage and retrieval? *Online* 9(6):17-28, 1985.
- Hliwa WR Jr: The SPED system: self-programming education drills. *J Med Technol* 3(3):169-176, 1986.
- Hopper K: Computers in respiratory therapy education. *Respir Ther* 16(2):27-30, 1986.
- Huntley JS et al: Evaluation of 'Introduction to Computer Literacy' and 'Discwriter' authoring systems. *Videodisc and Optical Disk* 5(5):356-371, 1985.
- Jorgensen H et al: Dos and don'ts in buying microcomputers. *CAUSE/EFFECT* 9(1):18-19, 1986.
- Larsen RE: What communication theories can teach the designer of computer-based training. *Educ Tech* 25(7):16-19, 1985.
- Luffingham JK: An assessment of computer-assisted learning in orthodontics. *Br J Orthod* 11(4):205-208, 1984.
- Manion MH: CAI modes of delivery and interaction: new perspectives for expanding applications. *Educ Tech* 25(1):25-28, 1985.
- McCombs BL: Instructor and group process roles in computer-based training. *Educational Communication and Technology* 33(3):159-167, 1985.
- Meals RA et al: Computerized anatomy instruction. *Clinics in Plastic Surgery* 13(3):379-388, 1986.
- Merrill MD: Where is the authoring in authoring systems? *J Computer-Based Inst* 12(4):90-96, 1985.
- Michael JA et al: Problem-solving in the pre-clinical curriculum: the uses of computer simulations. *Med Teach* 8(1):19-26, 1986.
- Perkins B et al: Tutoring with microcomputers: the Micro-Mate project. *Educ Tech* 25(4):42-43, 1985.
- Pickell GC et al: Computerizing clinical patient problems: an evolving tool for medical education. *Med Educ* 20(3):201-203, 1986.
- Pollard G: The nuts and bolts of interactive video: how it works and how to get started. *Am Ann Deaf* 130(5):386-390, 1985.
- Prentice JW et al: Microcomputers in medical education. *Med Teach* 8(1):9-18, 1986.
- Reilly SS et al: Designing human/computer interfaces: a comparison of human factors and graphic arts principles. *Educ Tech* 26(1):36-40, 1986.
- Schloss CN et al: Placement of questions and highlights as a variable influencing the effectiveness of computer assisted instruction. *J Computer-Based Inst* 12(4):97-100, 1985.
- Soddell JA et al: CLASSIFY: a group teaching exercise in microbial identification and numerical taxonomy using a Commodore 64 microcomputer. *J Biol Educ* 19(3):232-236, 1985.
- Starkschall G et al: A computer-aided instructional module for radiological physics. *Int J Radiat Oncol Biol Phys* 12(3):421-426, 1986.
- Stringer C: Computer-aided learning. *Institute of Medical Laboratory Sciences Gazette* 30(2):73-74, 1986.
- Tate J: Helping nursing faculty overcome resistance to computer use in the curriculum. *Comput Nurs* 4(1):5, 48, 1986.
- Thiele J: The development of computer assisted instruction for drug dosage calculations: a group endeavor. *Comput Nurs* 4(3):114-118, 1986.
- Thomson AC: Software development procedures. *Educational Media International* 3:24, 1985.
- Tilden V: Development and use of computer managed instruction. *Comput Nurs* 3(5):207-211, 1985.
- Tritz GJ: Computer modelling of microbiological experiments in the teaching laboratory: the IMViC reactions as a prototype. *J Comp Math Sci Teach* 4(4):41-46, 1985.
- Tuscher LJ et al: Developing authoring tools and demonstration courseware for intelligent interactive videodisc systems. *Technol Horizons Educ* 13(3):85-88, 1985.
- Walton KD: Computers in the curriculum: science. *Electronic Learning* 4(5):44-48, 1985.

Compiled by H. Modell

COMPUTERS IN LIFE SCIENCE EDUCATION

HAROLD I. MODELL

Department of Radiology
University of Washington
Seattle, Washington

MARCEL BLANCHAEER

Department of Biochemistry
Faculty of Medicine
University of Manitoba
Winnipeg, Manitoba
Canada

THEODORE J. CROVELLO

Department of Biology
University of Notre Dame
Notre Dame, Indiana

JAMES W. ECKBLAD

Department of Biology
Luther College
Decorah, Iowa

TSEGAYE HABTEMARIAM

School of Veterinary Medicine
Tuskegee University
Tuskegee, Alabama

DONNA LARSON

School of Nursing
Grand Valley State College
Allendale, Michigan

TERRY M. MIKITEN

Graduate School of Biomedical Sciences
University of Texas Health Science Center
San Antonio, Texas

JAMES E. RANDALL

Department of Physiology
Indiana University
Bloomington, Indiana

PATRICIA SCHWIRIAN

College of Nursing
Ohio State University
Columbus, Ohio

RICHARD STULL

College of Pharmacy
University of Arkansas
Little Rock, Arkansas

JAMES W. WOODS

Lister Hill National Center
for Biomedical Communications
National Library of Medicine
Bethesda, Maryland

DOROTHY WOOLEY-McKAY

Department of Biology
Glendale Community College
Glendale, Arizona

GLEN YOSHIDA

Department of Life Sciences
Los Angeles Southwest College
Los Angeles, California

NRCLSE

CONTENTS

COMPUTER SIMULATIONS IN LIFE SCIENCE EDUCATION: SOME DESIGN ISSUES	73
Joel A. Michael and Harold I. Modell	
THE EVOLUTION OF A MICROCOMPUTER CENTER	76
Michael A.J. Collins	
THE BULLETIN BOARD	79

COMPUTER SIMULATIONS IN LIFE SCIENCE EDUCATION: SOME DESIGN ISSUES

Joel A. Michael and Harold I. Modell

*Department of Physiology, Rush Medical College, Chicago, Illinois and
Department of Radiology, University of Washington, Seattle, Washington*

The use of computer simulations in life science teaching has been a frequent topic in the pages of this newsletter. A number of simulations dealing with different biological systems have been described, usually with a focus on the approaches taken by the author in the design or use of a specific simulation. In this article, we will present some general ideas about the design of biological simulations by comparing three quite different simulations recently described at an international meeting.

On July 16, 1986, a symposium entitled "Computer-Assisted Learning in

Physiology" was held as part of the XXX International Congress of Physiological Sciences. The goal of the symposium was to present innovative uses of the computer in teaching physiology at the undergraduate and professional levels. Three of the speakers discussed quite different approaches to the design and use of simulations for teaching physiology. A consideration of the similarities and differences between these approaches will illustrate several important features that contribute to the successful use of simulations in teaching the integrated function of complex sys-

tems such as those encountered in all of the life sciences.

The three papers focused on using large-scale simulations to understand the dynamics and interactions characterizing physiological systems;⁴ explicit teaching and problem solving for learning integrative physiology;¹ and emphasizing the relevance of the basic sciences through a computer assisted patient simulation.¹³

THREE APPROACHES TO PHYSIOLOGICAL SIMULATIONS

In the first presentation, Dr. C.J. Dickinson discussed a series of simulations originated at MacMaster University.⁴ These models, most notably MacMan,⁵ dealing with the baroreceptor reflex controlling blood pressure, and MacPuf,³ a cardiopulmonary simulation, consist of fairly "naked" simulations. A simple interface allows users to vary parameter values and even alter the structure of the system. Outputs are displayed as data plotted on various axes and as tables of data. In MacPuf, an inspect option is available that allows examination of more than 100 parameter values in a tabular format.

In both of these programs, the user has complete freedom to design and perform any protocol within the input/output capabilities of the model. Obviously, even with only five controllable inputs in MacMan, the number of possible experiments that can be performed is very large, and only a small subset of them will be of any teaching value in a particular setting. Therefore, the "Mac" series of simulations are most often used in conjunction with some kind of laboratory manual that describes or suggests particular experiments to be attempted.

These simulations have no educational objectives built into them, and there is no didactic interaction between the user and the program about the significance of the physiology that is revealed. As in the more traditional wet lab situation, laboratory instructors are needed to guide students by asking and answering questions so that a positive learning

environment is ensured.

Dr. Kenneth Campbell also described models of the cardiovascular system.¹ In these programs, the focus is on the mechanical interaction between the heart as a pump and the circulation rather than on regulation of the system.^{2,14,15} The user interface has been specifically designed for computer-naïve students, and it makes use of icons to represent functions. The outputs of the model are displayed pictorially and graphically, with particular attention given to presenting these displays in ways that convey meaningful information about system function to learners.

The model employed has been built in a modular fashion so that the full complexity of the intact system is approached one step at a time. Thus, users are more or less constrained to begin with the elementary pieces of the system and proceed in a specified order until the complete system is being examined.

The very construction of the model, then, follows from a careful analysis of how students can best learn the complexities of the system. In this sense, there is considerable teaching built into the system. However, the actual protocols followed by the user at each step are not specified, and the user must make the necessary choices.

As in the MacMaster series, there is no didactic interaction between user and program about the physiology being revealed. Thus, a laboratory manual is also required to direct student use of this program.

Dr. Ron Neame presented a simulation that differs from those just described in two fundamental ways.¹³ Most obvious is the fact that a patient with a medical problem rather than an experimental setup is simulated. Not as obvious, but just as significant, is the fact that this model is constructed on a data base that contains the information describing the patient's state. The previous simulations are based on mathematical equations describing the operation of the biological system of interest.

Thus, the goal for the user is to determine the nature and underlying cause(s) of the patient's problem rather than to perform an experiment. This "diagnostic" process is accomplished by somewhat free exploration of the available data base. A menu-like series of lists is presented to the student, and after choices are made at several levels, the user is presented with the information being requested. The structure of the data base corresponds to the various ways medical information is acquired and structured by physicians, but the user is not constrained to follow any particular approach to solving the problem.

At any time during the exploration of the problem, the user may choose to exit the program. The program then, in effect, debriefs and critiques the student about his or her approach to the problem. At this stage, the program strongly reinforces the goal of understanding basic mechanisms, rather than assigning labels to conditions, and provides specific directions for future learning.

Thus, unlike the previous simulations, this program has specific didactic feedback built into it that is intended to ensure a worthwhile learning experience for the user. Like the other simulations, it, too, calls upon the student to integrate large bodies of information and use this information for solving problems.

ISSUES IN DESIGNING A SIMULATION

A comparison of the three models described here suggests that simulations can vary along several dimensions. These include the level of complexity of the system being modeled, the nature of the modeling process employed, and the degree to which learning objectives are explicitly built into the program.

Decisions related to model development require certain questions to be asked about the intended educational uses of the simulation.^{10,11} What lesson is to be taught with this exercise? What is the general background and/or educational level of the intended audience? What do the students already

know about the system to be modeled and its functions? How sophisticated are the users about modeling and computers? In what educational setting will the simulation be used?

The three programs described here clearly illustrate two different design philosophies reflecting different educational objectives. The MacMaster simulations and the patient simulations of Neame represent large-scale models that require the student to deal with the full complexity of the system being studied. Campbell's program, on the other hand, specifically forces the student to build up to the full, complex system from a simpler beginning point, one step at a time. Neither approach right or wrong, but each is probably most appropriate for only some audiences or for use with some educational objectives. Thus, the first questions that must be asked deal with educational issues, not modeling *per se*.

A word of caution is in order. Mathematical models developed for use in research environments have certain requirements for accuracy and comprehensiveness (complexity) that do not necessarily apply to the models used in teaching.⁸ In an educational environment, the relevant criterion is whether the models correctly simulate those phenomena that are to be taught to the student users. Do not be persuaded to build a complex model just for the sake of completeness, and do not hesitate to develop a model just because it would be impossible to include all aspects of the system.

How the simulation is approached depends on several factors including the designer's skills as a modeler and the availability of useful models in the literature. It also depends on how the simulation is intended to be used. If the intent is to use the simulation with a set of predetermined protocols, as is effectively the case with Neame's patient simulations, it may be adequate to use a data base from which the desired outputs can be drawn. Certainly, in the absence of analytical (mathematical) descriptions of the system, this may rep-

resent the only workable approach. On the other hand, if the protocol is to be defined by the user, as is the case in the MacMaster simulations, some kind of mathematical description of the system is needed to allow users freedom to define the experimental conditions. Even here, however, a variety of approaches to generating models can be adopted.⁸ Frankly, whatever approach will provide the outputs needed to realize the educational objectives of the exercise ought to be adopted. Again, the important issues are educational, not technical, in nature.

The issue of how much of one's educational objectives ought to be built into the program is as much a matter of individual style as it is of educational substance. If one of the design goals takes advantage of one of the strengths of CBE – ad lib, repeated access to a learning experience by providing a stand-alone program that can be used by a student without any faculty intervention,⁹ it is essential that some teaching be a part of the experience. Otherwise, the user is likely to have very busy fingers but a very inactive head.⁷ On the other hand, if the program is intended to be used in a faculty directed setting, little or no teaching needs to be built in,¹¹ although it may still be profitable to do so. But here too, the exact educational setting in which the programs are to be used is important. A program meant to be used as a lecture aid⁶ or in a discussion setting¹² needs less didactic output than might a program to be used in a laboratory setting.¹¹ After all, unless the student/faculty ratio in the laboratory is one, students will spend most of their time working on their own.

The question of how much didactic interaction or commentary to include should also be influenced by the complexity of the model. A simulated experiment involving a complex biological system may require more didactic feedback than does a simpler model, even if it will be used in a faculty directed setting. The very complexity of a model with a multiplicity of inputs and outputs can make *using* the pro-

gram difficult for the novice and certainly makes even elementary interpretation of system function difficult.

SUMMARY

Three categories of *educational* questions outlined below must be addressed by an author of a teaching simulation.

- 1) **Intended audience.** What is the intended audience and what are its characteristics? How experienced are the students with mathematical models and/or computer simulations? What is their level of knowledge about the biological system to be studied? Is the program aimed at several different audiences?
- 2) **Intended objectives.** What are the educational objectives of the exercises? What is to be taught, or what are the students expected to learn?
- 3) **Intended setting.** Will the program be used in an individual or group setting? Will the program be used in multiple settings?

Only after explicit answers to these questions are available does an author need to consider what aspects or components of the biological system ought to be modeled, whether to utilize a mathematical model or a data base approach to the simulation, and how much or little explicit teaching to build into the program.

REFERENCES

1. Campbell K, Hopkins R, Peterson N: Explicit teaching and problem solving for learning integrative physiology. *Proceedings of the International Union of Physiological Sciences* 16:317, 1986.
2. Campbell K, Zeglen M, Kagehiro T, Rigas H: A pulsatile cardiovascular computer model for teaching heart-blood vessel interaction. *The Physiologist* 25:155-162, 1982.
3. Dickinson CJ: *A Computer Model of Human Respiration*. Baltimore, MD, University Park Press, 1977.
4. Dickinson CJ: The use of large-scale

- simulations to understand the dynamics and interactions which characterise physiological systems. *Proceedings of the International Union of Physiological Sciences* 16:316, 1986.
5. Dickinson C, Goldsmith CH, Sackett DL: MACMAN: a digital computer model for teaching some principles of hemodynamics. *J Clin Computing* 2:42-50, 1973.
 6. Hogan P: Computer generated figures in physiology teaching: the 'smart video slide'. *The Physiologist* 25:343, 1982.
 7. Michael JA, Rovick AA: Computer simulated experiments in the teaching of physiology. *Proceedings of the 6th Annual National Educational Computing Conference*, Dayton, OH, July 13-15, 1984. p 20-24.
 8. Michael JA, Rovick AA: Simulations used in teaching: ways to generate them. *Collegiate Microcomputer* 4:201-207, 1986.
 9. Michael JA, Rovick AA: Problem-solving in the pre-clinical curriculum: the uses of computer simulations. *Medical Teacher* 8:19-25, 1986.
 10. Modell HI, Farhi LE, Olszowka AJ: Physiology teaching through computer simulations - problems and promise. *Physiol Teacher* 3:14-16, 1974.
 11. Modell HI: Input/output design for different educational settings. *Computers in Life Science Education* 1:57-62, 1984.
 12. Modell HI: Use of computer simulations to promote active learning in multiple teaching settings. *The Physiologist* 28:445-446, 1985.
 13. Neame RLB: Emphasizing the relevance of the basic sciences through a computer assisted patient simulation. *Proceedings of the International Union of Physiological Sciences* 16:317, 1986.
 14. Peterson N: Designing a simulated laboratory. *Byte* 9(June):287-296, 1984.
 15. Peterson NS, Campbell KB: Simulated laboratory for teaching cardiac mechanics. *The Physiologist* 27:165-169, 1984.

THE EVOLUTION OF A MICROCOMPUTER CENTER

Michael A.J. Collins

Department of Biology, Memorial University of Newfoundland, St. John's, Newfoundland, Canada

I first became interested in the use of computers in teaching while attending the American Biology Teachers' Annual Convention in 1981 where I listened to several talks on computer-based education (CBE). One of these talks, given by Ted Crovello, especially helped to convince me of the usefulness of the computer as a teaching tool, and I returned home from the convention with the intention of using computers in my teaching.

On my return, I convinced my department head of the usefulness of computers as teaching tools and, with his permission, ordered a number of biological software packages. Since the department did not own an Apple II+ microcomputer, the machine on which most commercial biology software ran at that time, I had to make arrangements to borrow a machine and come face-to-face with my first microcomputer. After having had to get a friendly computer user to show me where the power switch was located and how to insert a disk properly into a disk drive, I was off on my microcomputing way! Very quickly, the major barrier to using com-

puters in teaching became evident. The commercial software was either dreadful or not on a level appropriate for the students I was teaching. As a result, I reluctantly abandoned the idea of using commercial software in my teaching.

I still had not entirely given up the idea of using computers, but what was the next step? I had absolutely no knowledge of computing languages and didn't have the time to learn any. Perhaps, however, I could learn enough about BASIC to program some simple multiple-choice tests. I tried but quickly realized that there was more to programming than just composing test questions. For example, how did one store tests on a disk or store and retrieve student marks? It was at this point that fate luckily dealt a helping hand, for on scanning a new copy of a scientific supply house catalog, my eyes espied a commercial test production package that seemed to contain just about all the features I would ever need!

THE FIRST EXPERIMENT

The next step was to get the test package, but more importantly, something

to run it on, since I could hardly expect to keep borrowing a computer from another department. I, therefore, submitted a proposal to the Office of Junior Studies, which administered first year courses, to run an experimental section of one biology course in the fall semester. This experimental section would take weekly computer tests before taking the written tests common to all classes. The experiment would be proclaimed successful if this class achieved higher mean test scores than the other classes. My proposal was accepted, and I was given a grant of \$5500, sufficient to purchase an Apple II+, two disk drives, a monochrome monitor, and a printer. The seeds for the beginning of our present Biology Microcomputer Resource Center were sown, even if I didn't realize it at the time!

When the equipment arrived, the next problem surfaced! I realized that I would have to become an expert at assembling computer equipment that was often supplied with less than ideal instructions. Finally, in late August, equipment and software were ready and working and waiting to be used, all as-

sembled on a table in my office, which, for the time being, was to be the site of the experiment.

This first experiment was tried with one of six classes, the others being used as controls. Fortunately, the experiment was very successful, and a report on the project, together with analyzed data and conclusions, was forwarded to the Office of Junior Studies. A request for funding for a second computer and an office-size room to house the computers was also submitted.

It was at this time (December, 1982), that I decided to produce some of my own computer-assisted learning materials, but I was at a loss as to which computer language to use. A colleague suggested that I look at Pascal and PILOT. A visit to the local Apple dealer showed that PILOT was cheaper and had less documentation to go with it, so, as luck would have it, I bought ApplePILOT. A quick reading of the documentation convinced me that PILOT was just what I was looking for, and I spent most of the Christmas vacation reading the approximately 400 pages of accompanying documentation.

During the winter of 1983, several of these PILOT units were ready to be used. Consequently, the students in one of my classes not only had weekly tests but also had the opportunity of using these learning units instead of attending lectures. An analysis of student performance on the weekly tests clearly demonstrated that students who used the learning units did as well or better on relevant tests than students not using the units. These results were then used in support of a request for a third computer.

THE SEEDS GROW

Up until this point in time, I had been basically all on my own, doing the programming, maintaining the machines, changing disks for students, and administering tests. However, at the beginning of the fall semester, 1983, the situation changed drastically. A second faculty member decided to use the weekly tests and to cooperate in an experi-

ment involving two classes. In addition, a technician within the department was given the added responsibility of maintaining machines, processing orders, and completing similar tasks. Further, I was allowed to hire a person specifically to manage the room containing the computers. This semester was also a landmark in that I presented a paper on my computer-related work at an international conference.

With more students using our 3 machines, and more and more faculty expressing an interest in computers, and with several conference/seminar presentations to my credit, I was encouraged to apply for a major grant to obtain enough equipment to run a completely equipped resource center containing microcomputers and audiovisual aids. The main argument of the application was that such a help center would enable more of our academically weaker students to enter the regular courses without having to first take a remedial course. This would reduce the number of instructors required for teaching the course. The money saved in hiring instructors for this course would be more than enough to pay for the center. The application was sent to the Academic Vice-President, and the grant was approved with an accompanying request that funds be made available to convert a little-used set of rooms within the department into a microcomputer resource center.

The next six months was a time of hectic activity with the technician and myself searching through catalogs, telephoning suppliers, obtaining quotes, placing orders, and checking incoming purchases, all in addition to our regular work. During the summer, I drew up plans for a permanent home for the computers, and after many discussions with University design staff and after numerous revisions to the plans, the space for the center was renovated.

I then had to search for furniture for the center. Being limited to used furniture stored on campus, I chose individual student study carrels previously used in the library to serve as computer

work stations.

By the end of August, the center was completed and ready for use. In the meantime, I requested a full-time manager for the center, and this request was also granted.

THE BIOLOGY MICROCOMPUTER RESOURCE CENTER

The Biology Microcomputer Resource Center opened its doors to students in September, 1984, and in that first semester, it served up to 200 students each week. Most of these students used the weekly tests in the center, and a smaller proportion used the specially developed learning units. Very little use was made of the small amount of commercial software we had bought, and there was only minimal use of the audiovisual resources, mostly slide-tape programs, that we had bought for the center.

Since that time, the center has gone from strength to strength. Last semester, we had almost 700 registered users of the center, and we employed two students to help the manager on a part-time basis.

We have publicized the Resource Center through articles in internal campus publications and even on a local radio program to give it a higher profile within the University. The center has been visited by instructors from a number of other University departments and also by instructors from other local post-secondary educational establishments. We have also received a number of requests to give talks, demonstrations and the like from local computer clubs, educational organizations, and school boards, all of whom we try to accommodate. Our guiding principle is that the more visible the center is, the more likely it is to attract funds, and the less likely it is to succumb to budget cuts!

LESSONS LEARNED

What lessons have we learned from the evolution of this center that might be of help to others who are about to start on the same lengthy path? Conditions vary greatly from institution to institu-

tion, but it is likely that many, if not all, of the points presented below will apply equally to all institutions.

- The most important prerequisite to getting CBE off the ground is a supportive administration, preferably financially supportive! Good wishes don't buy computers. You may be able to financially bypass administrations if you have access to private funding from alumni associations, government agencies, or computer firms, but usually, such agencies only provide equipment, not funding for the hiring of personnel.
- Be prepared to start up CBE on your own and to continue for some time before others join in. This means that you will probably have to be your own expert programmer, instructional designer, keyboard typist, technician, etc.
- Don't browbeat others to join you. Publicize your work and results, and eventually, others will decide to adopt CBE as well.
- Bear in mind that personnel costs (programmers, managers, demonstrators) will, in all probability, be higher than the initial hardware and software costs.
- Obtain subscriptions to relevant periodicals (computer, educational computing, and subject) to get valuable advice. I have found the American Biology Teacher, even though a subject journal, to be valuable with frequent articles on computing, useful advertisements, and reviews in addition to a monthly computing column. I have also found the Journal of Computers in Mathematics and Science Teaching to be very useful. A subscription to a popular magazine dealing with your type of microcomputer is useful for hints and for keep-

ing abreast of developments involving your computer, new software, and peripherals.

- *Always* keep copies of your software. Single copy software appears to be far more mobile than multiple copies. Preferably, have backup equipment if possible. Even the more reliable machines can go out of service when you most need them!
- Using commercial software to develop tests is the easiest way to get your feet wet and can produce achievement gains as impressive as many learning programs. Testing seems to be an ugly word in CBE, and many people perhaps wouldn't even include it in CBE, but I am a great advocate of computer testing.
- Don't listen too attentively to those 'experts' who offer advice and dire warnings! I was given all sorts of advice from 'experts' when I started that I fortunately stored in short term memory. Otherwise, I would never have started. A number had grandiose ideas of their own that made my own plans look embarrassingly minuscule! They still have ideas, as yet unimplemented, while I am well underway. Perhaps we should listen to such advice with deaf ears! I am more inclined to listen to somebody who has *demonstrated* success rather than to somebody with high but unfulfilled expectations!
- Don't start CBE with the idea of making money. The chances of commercial success are extremely limited. Have as your objective better quality teaching and learning for your students.
- Where possible, contract out your programming (for example, to students who are good at it) and typing in of programs. These exercises are

time consuming, and you would be better advised to spend your time in planning and development.

- Don't expect rewards such as advancement or promotion from CBE activities. At the university level, the development of CBE is not usually considered a substitute for research. In fact, this is probably one of the biggest barriers to CBE in universities.
- P.I.L.O.T is probably one of the best all around authoring languages for computer assisted learning, but I still prefer BASIC for producing test packages.
- It is often easier to sell 'cost effectiveness of CBE' to administrators rather than 'enrichment' when looking for funding!
- Where possible, try out projects as controlled experiments. This makes it easier to demonstrate their success. Publish your results internally so that others see how successful the projects were. Your opinions are subjective, data are objective.
- Collect all your data, and publish the results for other teachers to see through journal articles and conference presentations. Such publications can then be regarded as legitimate published research. Publications also help to enhance your reputation as a CBE user.
- Don't forget to collect student opinions! It is the student population for whom you are designing CBE materials! Their feedback can help to improve your programs, and you can use good feedback as a lever to persuade administrations to continue the funding of CBE.
- When you are firmly established in

CBE, promote CBE yourself through local media, talks to groups, and opening your facilities to the public. The more prominent you are, the easier it is to ask for things!

As you become more successful in CBE, expect to spend more time talking to prospective CBE users and others interested in CBE and computers who seek your advice.

- Finally, always remember that any task you undertake will always be more difficult and time consuming than you think! Starting up CBE on your own sounds easier than it is.

THE BULLETIN BOARD

The Bulletin Board is published periodically to inform readers of upcoming meetings of interest. If you know of meetings, symposia, continuing education courses, etc, of interest to life science educators that do not appear in The Bulletin Board, please let us know. Send pertinent information to: Dr. Harold Modell, NRCLSE, RC-70, University of Washington, Seattle, WA 98195, or let us know via BITnet. NRCLSE's BITnet address is: MODELL@UWALOCKE

November 10-13, 1986. Association for the Development of Computer-based Instructional Systems (ADCIS) 28th International Conference. Washington, D.C.

Contact:

*ADCIS, 409 Miller Hall
Western Washington University
Bellingham, WA 98225
(206) 676-2860*

November 21-22, 1986. Computers and Nursing Education. A continuing education course sponsored by the Kirkhof School of Nursing, Grand

Valley State College, Grand Rapids, MI.

Contact:

*Colleen Curtin
Kent Health & Nursing Education Inc.
1459 Michigan N.E.
Grand Rapids, MI 49503
(616) 451-2217*

February 11-13, 1987. The Second Annual Conference on Interactive Video in Nursing and Allied Health. Galveston, TX.

Contact:

*Gary D. Hales, Ph.D.
School of Allied Health Sciences
8th and Market Streets
The University of Texas Medical
Branch at Galveston
Galveston, TX 77550
(409) 761-3040*

February 18-20, 1987. Second Annual Conference on Learning Technology in the Health Care Sciences. Orlando, FL.

Contact:

*Society for Applied Learning
Technology
50 Culpeper St.
Warrenton, VA 22186
(703) 347-0055*

February 26-28, 1987. Health Sciences Communications Association (HeSCA) conference, "Telelearning in the Health Sciences" in conjunction with COMMTEX '87. Atlanta, GA.

Contact:

*HeSCA
6105 Lindell Blvd.
St. Louis, MO 63112
(314) 725-4722*

May 13-16, 1987. Computer Applications in Medicine and Health Care. AAMSI Congress 1987. San Francisco, CA.

Contact:

*Ben T. Williams, MD
Director of Laboratories
Mercy Hospital
1400 West Park Avenue
Urbana, IL 61801
(217) 337-2175*

COMPUTERS IN LIFE SCIENCE EDUCATION

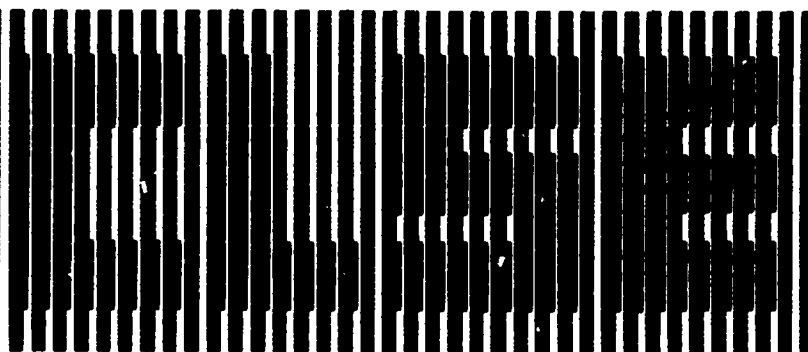

HAROLD I. MODELL

Department of Radiology
University of Washington
Seattle, Washington

MARCEL BLANCHAER

Department of Biochemistry
Faculty of Medicine
University of Manitoba
Winnipeg, Manitoba
Canada

THEODORE J. CROVELLO

Department of Biology
University of Notre Dame
Notre Dame, Indiana

JAMES W. ECKBLAD

Department of Biology
Luther College
Decorah, Iowa

TSEGAYE HABTEMARIAM

School of Veterinary Medicine
Tuskegee University
Tuskegee, Alabama

DONNA LARSON

School of Nursing
Grand Valley State College
Allendale, Michigan

TERRY M. MIKITEN

Graduate School of Biomedical Sciences
University of Texas Health Science Center
San Antonio, Texas

JAMES E. RANDALL

Department of Physiology
Indiana University
Bloomington, Indiana

PATRICIA SCHWIRIAN

College of Nursing
Ohio State University
Columbus, Ohio

RICHARD STULL

College of Pharmacy
University of Arkansas
Little Rock, Arkansas

JAMES W. WOODS

Lister Hill National Center
for Biomedical Communications
National Library of Medicine
Bethesda, Maryland

DOROTHY WOOLEY-McKAY

Department of Biology
Glendale Community College
Glendale, Arizona

GLEN YOSHIDA

Department of Life Sciences
Los Angeles Southwest College
Los Angeles, California

NRCLSE

CONTENTS

CLSE COLLEAGUE DIRECTORY - PART I

81

CLSE COLLEAGUE DIRECTORY - PART I

The primary goal of the National Resource for Computers in Life Science Education (NRCLSE) is to cultivate collaborative efforts among life science faculty interested in using the computer as a teaching tool. One of the first steps toward achieving this goal was publication of a questionnaire in the January, 1986 issue of CLSE. This issue was distributed by mail to nearly 2700 academic departments making up the life science community in the U.S. and Canada, and it was also made available at several national meetings of groups within the life science community.

NRCLSE received over 350 completed questionnaires. Approximately 160 respondents indicated that they have been using computers in their teaching

efforts for over 3 years. Approximately 130 have had between 1 and 3 years experience. The directory that follows was drawn from respondents to the questionnaire and is intended to help CLSE readers identify colleagues with common interest areas. It is arranged by the content areas identified in response to the question, "What content areas do you teach?" As a result, entries may appear under more than one heading. Although every attempt has been made to ensure that the information is current and correct, it is likely that some errors appear in this list. NRCLSE apologizes in advance for any inconveniences that may arise due to such oversights. Part II of the directory will appear in the January, 1987 issue of CLSE.

REMINDER - TIME TO RENEW

SUBSCRIPTION INFORMATION

MAY BE FOUND ON PAGE 88

AGRONOMY

ARNESON, PHIL A
DEPT OF PLANT PATHOLOGY
CORNELL UNIV
ITHACA, NY 14853
(607) 255-7871

DAVIS, THOMAS M
DEPTS OF PLANT SCIENCE
AND GENETICS
UNIV OF NEW HAMPSHIRE
DURHAM, NH 03824-3597
(603) 862-3217

ESTES, DR GEORGE O
DEPT OF PLANT SCIENCE
UNIV OF NEW HAMPSHIRE
DURHAM, NH 03824
(603) 862-3220

HELSEL, ZANE R
DEPT OF AGRONOMY
UNIV OF MISSOURI
COLUMBIA, MO 65211
(314) 882-2001

ANATOMY

BASHOR, DAVID P
DEPT OF BIOLOGY
UNIV N CAROLINA AT
CHARLOTTE
CHARLOTTE, NC 28223
(704) 597-4047

BAUR, JOHN M
DEPT OF BIOLOGY
BRESCIA COLLEGE
120 WEST SEVENTH ST
OWENSBORO, KY 42301
(502) 685-3131 EXT 276

BELLMER, SISTER ELIZABETH H
TRINITY COLLEGE
WASHINGTON, DC 20017
(202) 939-5190

BERGQUIST, BART
DEPT OF BIOLOGY
UNIV NORTHERN IOWA
CEDAR FALLS, IA 50614
(319) 273-2723

BUSHBY, PHILIP A
COLLEGE OF VET MED
DRAWER V
MISS STATE UNIV, MS 39762
(601) 325-1127

DICKINSON, WINIFRED
DEPT OF BIOLOGY
UNIV OF STEUBENVILLE
STEUBENVILLE, OH 43952
(614) 283-3771

DUGGAN, ELEANOR L
BIOLOGY DEPT
UNIV N CAROLINA AT
GREENSBORO
GREENSBORO, NC 27412-5001
(919) 379-5830

ELDER, DR BETTY
DEPT OF BIOLOGY
GEORGIA SOUTHWESTERN
COLLEGE
AMERICUS, GA 31709
(912) 928-1250

FERNER, JOHN W
DEPT OF BIOLOGY
THOMAS MORE COLLEGE
CRESTVIEW HILLS, KY 41017
(606) 344-3374

FINKELSTEIN, MICHAEL
DEPT OF ORAL PATHOLOGY
COLLEGE OF DENTISTRY
UNIV OF IOWA
IOWA CITY, IA 52242
(319) 353-7370

FREED, DR JAMES M
DEPT OF ZOOLOGY
OHIO WESLEYAN UNIV
DELAWARE, OH 43015
(614) 369-4431 EXT 400

GOOCH, VAN D
DEPT OF SCI & MATH
UNIV OF MINNESOTA
MORRIS, MN 56267
(612) 589-2211

GWINN, DR JOHN F
DEPT OF BIOLOGY
UNIV OF AKRON
AKRON, OH 44325
(216) 375-7160

GWYN, DR D G
DEPT OF ANATOMY
DALHOUSIE UNIV
HALIFAX, NOVA SCOTIA
B3H 4H7 CANADA
(902) 424-2051

HERRON, MARY A
BIOMED LEARNING RES CTR
COLLEGE OF VET MED
TEXAS A&M UNIV
COLLEGE STATION, TX 77843
(409) 845-1780

HILLIARD, STEPHEN
DEPT OF BIOLOGY
BALDWIN-WALLACE COLLEGE
BEREA, OH 44017
(216) 826-2265

HOUSE, EDWIN W
DEPT OF BIOLOGY
IDAHO STATE UNIV
PO BOX 8007
POCATELLO, ID 83209
(208) 236-3765

HOUSE, DR HERBERT W
ELON COLLEGE
BOX 2270
ELON COLLEGE, NC 27244-2010
(919) 584-5359

JONES, MICHAEL E
DEPTS OF ANAT & HIST
FLINDERS UNIV OF SOUTH
AUSTRALIA
SCHOOL OF MEDICINE
BEDFORD PARK, 5042
AUSTRALIA

KEETE, J RICHARD
DEPT OF ANATOMY
CASE WESTERN RESERVE
UNIV
CLEVELAND, OH 44106
(216) 368-2656

MIYERS, PAUL E
DEPT OF BIOL. CHEM &
STRUCT
THE CHICAGO MED SCHOOL
3333 GREEN BAY RD
NORTH CHICAGO, IL 60064
(312) 578-3000 EXT 458

MICKUS, JOHN
DEPT OF BIOLOGY
ILLINOIS BENEDICTINE COLL.
5700 COLLEGE ROAD
LISLE, IL 60532-0900
(312) 960-1500 EXT 509

RALSTON, H J
DEPT OF ANATOMY S-1334
UNIV CALIF, SAN FRANCISCO
3RD & PARNASSUS AVES
SAN FRANCISCO, CA 94143
(415) 476-1861

ROBBINS, DR HERBERT C
DALLAS BAPTIST UNIV
7777 WEST KIEST BLVD
DALLAS, TX 75211-9800
(214) 333-5302

SINNAMON, WALT
CENTRAL WESLEYAN
COLLEGE, BOX 443
CENTRAL, SC 29630
(803) 639-2453 EXT 356

SMALL, JAMES W
DEPT OF BIOLOGY
ROLLINS COLLEGE
BOX 2643
WINTER PARK, FL 32789
(305) 646-2433

SPRAGUE, RUTH M
DEPTS OF ANATOMY &
NEUROBIOLOGY
UNIV OF VERMONT COLLEGE
OF MEDICINE
BURLINGTON, VT 05405
(802) 656-0416

WILHELM, DALLAS
DEPT OF BIOLOGY
HASTINGS COLLEGE
HASTINGS, NE 68901
(402) 463-2402 EXT 264

WILLIAMS, STANLEY C
DEPT OF BIOL SCIENCES
SAN FRANCISCO STATE UNIV
1600 HOLLOWAY AVE
SAN FRANCISCO, CA 94132

WILSON, DR MARLENE
UNIV OF PORTLAND
5000 N WILLAMETTE BLVD
PORTLAND, OR 97203
(503) 283-7123

ZEITZER, SHIRLEY
DAVENPORT COLLEGE
415 EAST FULTON
GRAND RAPIDS, MI 49503
(616) 451-3511

ANIMAL BEHAVIOR
AMLANER, CHARLES J JR
DEPT OF ZOOLOGY
UNIV OF ARKANSAS
FAYETTEVILLE, AR 72701

ASHTON, GEOFFREY C
DEPT OF GENETICS
UNIV OF HAWAII
1960 EAST-WEST ROAD
HONOLULU, HI 96822
(808) 948-8552

ROGER GAMBS,
DEPT OF BIOL. SCIENCE
CAL POLYTECH STATE UNIV
SAN LUIS OBISPO, CA 93407
(805) 546-2551

HECKENLIVELY, DONALD B
DEPT OF BIOLOGY
HILLSDALE COLLEGE
HILLSDALE, MI 49242
(517) 437-7341

KESLER, DAVID H
DEPT OF BIOLOGY
RHODES COLLEGE
2000 NORTH PARKWAY
MEMPHIS, TN 38112
(901) 726-3557

LA BAR, MARTIN
CENTRAL WESLEYAN
COLLEGE
CENTRAL, SC 29630
(803) 639-2453

ODE, PHILIP
DEPT OF BIOLOGY
TRIEB COLLEGE
GREENVILLE, PA 16125
(412) 588-7700

STOUT, JOHN
DEPT OF BIOLOGY
ANDREWS UNIV
BERRIEN SPRINGS, MI 49104
(616) 471-3243

ANIMAL SCIENCE
KENNELLY, DR JOHN J
DEPT OF ANIMAL SCIENCE
UNIV OF ALBERTA
EDMONTON, ALBERTA
CANADA T6G 2P5
(403) 432-2133

BIOCHEMISTRY
BATES, WILLIAM K
DEPT OF BIOLOGY
UNIV NORTH CAROLINA
GREENSBORO, NC 27412
(919) 379-5391

BLANCHIER, MARCEL
DEPT OF BIOCHEMISTRY
FACULTY OF MEDICINE
UNIV OF MANTOBA
WINNIPEG, MANTOBA
CANADA R3E 0W3
(204) 788-6570

COOK, DAVID E
DIV SCI & MATHEMATICS
DAKOTA STATE COLLEGE
MADISON, SD 57042-1799
(605) 252-5194

CREUTZ, CHARLES
DEPT OF BIOLOGY
UNIV TOLEDO
TOLEDO, OH 43606
(419) 537-4159

- DICKINSON, WINIFRED
DEPT OF BIOLOGY
UNIV OF STEUBENVILLE
5111 BLVD N VILLE, OH 43952
(614) 283-3771
- ITERNER, JOHN W
DEPT OF BIOLOGY
THOMAS MORE COLLEGE
CHRISTVIEW HILLS, KY 41017
(606) 344-3374
- TORRESTER, JOE
DEPT OF BIOCHEMISTRY
UNIV OF MISSOURI
M121 MLD SCI BLDG
COLUMBIA, MO 65212
(314) 882-8795
- HOUSE, DR HERBERT W
ELON COLLEGE
BOX 2270
ELON COLLEGE, NC 27244-2010
(919) 584-5359
- JOHNSON, WALTER
NW COLLEGE OF
CHIROPRACTIC
2501 W 84TH ST
BLOOMINGTON, MN 55431
(612) 888-4777 EXT 290
- KIRBY, DR EDWARD
DEPT OF BIOCHEMISTRY
TEMPLE UNIV HEALTH SCI CTR
3420 N BROAD ST
PHILADELPHIA, PA 19140
(215) 221-4180
- KRUSE, ANNA C
CABRINI COLLEGE
RADNOR, PA 19087
(215) 687-2100
- NORRIS, THOMAS E
SENIOR ASSOC DEAN
MORTHOUSE SCH OF MED
720 WESTVIEW DR SW
ATLANTA, GA 30310-1495
- PETERSON, JULIAN A
DEPT OF BIOCHEMISTRY
UNIV TEXAS HEALTH SCI CTR
5323 HARRY HINES BLVD
DALLAS, TX 75235-9038
(214) 688-2361
- RAWITCH, ALLEN B
DEPT OF BIOCHEMISTRY
UNIV KANSAS MED CTR
RAINBOW BLVD AT 3911H
KANSAS CITY, KS 66103
(913) 588-6957
- SOLL, DIETER
DEPT OF MOLECULAR
BIOPHYS AND BIOCHEM
YALE UNIV
260 WHITNEY AVE
NEW HAVEN, CT 06511
(203) 436-3611
- SPENCER, TREVOR
DEPT OF BIOCHEMISTRY
QUEEN'S UNIVERSITY
KINGSTON ONTARIO
CANADA K7L 3N6
(613) 545-2997
- STRAFTON, LEWIS P
DEPT OF BIOLOGY
FURMAN UNIV
GREENVILLE, SC 29613
(803) 294-3249
- SUELLER, CLARENCE H
DEPT OF BIOCHEMISTRY
MICHIGAN STATE UNIV
EAST LANSING, MI 48824
(517) 355-1708
- TESKEY, SISTER NANCY
HOLY NAMES COLLEGE
3500 MOUNTAIN BLVD
OAKLAND, CA 94619
(415) 436-0111
- TREBLE, DONALD H
DEPT OF BIOCHEMISTRY
ALBANY MEDICAL COLLEGE
ALBANY, NY 12208
(518) 445-5364
- WAGNER, MARTIN J
DEPT OF BIOCHEMISTRY
BAYLOR COLLEGE OF
DENTISTRY
3302 GASTON AVE
DALLAS, TX 75246
(214) 828-8261
- WINTER, CHARLES G
DEPT OF BIOCHEMISTRY
UNIV OF ARKANSAS COLLEGE
OF MEDICINE
4301 W MARKHAM ST
LITTLE ROCK, AR 72205-7199
(501) 661-5190
- BIOLOGY
BASIOR, DAVID P
DEPT OF BIOLOGY
UNIV N CAROLINA AT
CHARLOTTE
CHARLOTTE, NC 28223
(704) 597-4047
- BAUR, JOHN M
DEPT OF BIOLOGY
BRESCIA COLLEGE
120 WEST SEVENTH ST
OWENSBORO, KY 42301
(502) 685-3131 EXT 276
- BERG, VIRGINIA
DEPT OF BIOLOGY
UNIV OF NORTHERN IOWA
CEDAR FALLS, IA 50614
(319) 273-2770
- BOWKER, LESLIE S
DEPT OF BIOL SCIENCE
CAL POLYTECH STATE UNIV
SAN LUIS OBISPO, CA 93407
(805) 546-2788
- BROADWAY, RUBY L
DEPT OF NATURAL SCIENCE
DILLARD UNIVERSITY
NEW ORLEANS, LA 70122
(504) 283-8822 EXT 246
- CARICO, JAMES E
DEPT OF BIOLOGY
LYNCHBURG COLLEGE
LYNCHBURG, VA 24501
(804) 522-8366
- CHUW, FS
DEPT OF BIOLOGY
TUFTS UNIV
MEDFORD, MA 02155
(617) 381-3189 EXT 3195
- CHIEN, PAUL K
DEPT OF BIOLOGY
UNIV OF SAN FRANCISCO
SAN FRANCISCO, CA 94117
(415) 666-6345
- COCKERHAM, BILL
FRESNO PACIFIC COLLEGE
1717 S CHESTNUT
FRESNO, CA 93702
(209) 453-2045
- COLLINS, DR MICHAEL A J
DEPT OF BIOLOGY
MEMORIAL UNIV OF
NEWFOUNDLAND
ST JOHN'S, NEWFOUNDLAND
CANADA A1B 3X9
(709) 737-8031
- DILLEHAY, DR JANE
DEPT OF BIOLOGY
GALLAUDET COLLEGE
800 FLORIDA AVE NE
WASHINGTON, DC 20002
(202) 651-5531
- DOVE, LEWIS
DEPT OF BIOL SCIENCES
WESTERN ILLINOIS UNIV
MACOMB, IL 61455
(309) 298-1166
- DUGGAN, ELEANOR L
BIOLOGY DEPT
UNIV OF N CAROLINA AT
GREENSBORO
ROOM 309, EBERHART BLDG
GREENSBORO, NC 27412-5001
(919) 379-5839
- EILEUS, LAWRENCE J
DEPT OF BIOLOGY
UNIV OF NORTHERN IOWA
CEDAR FALLS, IA 50614
(319) 273-2218
- FANNING, MARSHA E
DEPT OF BIOLOGY
LENOIR-RHYNE COLLEGE
HICKORY, NC 28603
(704) 328-7270
- FERNER, JOHN W
DEPT OF BIOLOGY
THOMAS MORE COLLEGE
CHRISTVIEW HILLS, KY 41017
(606) 344-3374
- FONTANE, DR AR
DEPT OF BIOLOGY
UNIV OF VICTORIA
PO BOX 1700
VICTORIA, BC V8W 2Y2
CANADA
(604) 721-7131
- FREY, DENNIS
DEPT OF BIOL SCIENCE
CAL POLYTECH STATE UNIV
SAN LUIS OBISPO, CA 93407
(805) 546-2802
- GBSON, LINDA
DEPT OF BIOLOGY
EASTERN WASH UNIV
CHENEY, WA 99004
(509) 359-2845
- GORMAN, MARK
BALDWIN-WALLACE COLLEGE
BEREA, OH 44017
(216) 826-2217
- HAMAN, AC
DEPT OF BIOLOGY
UNIV NORTHERN IOWA
CEDAR FALLS, IA 50614
(319) 273-2726
- HACKENLIVELY, DONALD B
DEPT OF BIOLOGY
HILLSDALE COLLEGE
HILLSDALE, MI 49242
(517) 437-7341
- HEDMAN, STEPHEN C
DEPT OF BIOLOGY
UNIV OF MINN AT DULUTH
2400 OAKLAND AVE
DULUTH, MN 55812
(218) 726-8122
- HEIMBROOK, MARGARET E
DEPT OF BIOL SCIENCES
UNIV OF NORTHERN
COLORADO
GREELEY, CO 80639
(303) 351-2644
- HODGSON, DR LYNN M
NORTHERN STATE COLLEGE
BOX 673
ABERDEEN, SD 57401
(605) 222-2432
- HOUSE, EDWIN W
DEPT OF BIOLOGY
IDAHO STATE UNIV
PO BOX 8007
POCATELLO, ID 83209
(208) 236-3765
- HOUSE, DR HERBERT W
ELON COLLEGE
BOX 2270
ELON COLLEGE, NC 27244-2010
(919) 584-5359
- HUMORA, PAUL
DEPT OF BIOLOGY
NORTH ADAMS ST COLLEGE
NORTH ADAMS, MA 01267
(413) 664-4511 EXT 343
- JANKAY, PIETER
DEPT OF BIOL SCIENCE
CAL POLYTECH STATE UNIV
SAN LUIS OBISPO, CA 93407
(805) 546-2860
- JOHNSON, J RONALD
DEPT OF BIOLOGY
MIDLAND COLLEGE
FREMONT, NE 68025
- KESSLER, SISTER IRMA
DEPT OF BIOLOGY
COLLEGE OF ST ELIZABETH
CONVENT STATION, NJ 07961
(201) 539-1600

- KLEINSMITH, LEWIS J
DEPT OF BIOLOGY
UNIV OF MICHIGAN
ANN ARBOR, MI 48109 1048
(313) 763-3290
- KRUSE, ANNA C
CABRINI COLLEGE
RADNOR, PA 19087
(215) 687-2100
- LEISMAN, DR GILBERT A
DEPT OF BIOLOGY
EMPORIA STATE UNIV
EMPORIA, KS 66801
(316) 543-1200 EXT 5617
- McCALLEY, DAVID V
DEPT OF BIOLOGY
UNIV NORTHERN IOWA
CEDAR FALLS, IA 50614
(319) 273-2581
- MELE, FRANK M
DEPT OF BIOLOGY
JERSEY CITY STATE COLLEGE
JERSEY CITY, NJ 07305-1597
(201) 547-3054
- ODE, PHILIP
DEPT OF BIOLOGY
THIEL COLLEGE
GREENVILLE, PA 16125
(412) 588-7700
- ORR, ALAN
DEPT OF BIOLOGY
UNIV NORTHERN IOWA
CEDAR FALLS, IA 50614
(319) 273-2150
- OWEN, LAWTON
KANSAS WESTERN
100 E CLAFLIN
SALINA, KS 67401
(913) 827-5741
- PIPERBERG, JOEL B
DEPT OF BIOLOGY
SIMMONS COLLEGE
300 THE FENWAY
BOSTON, MA 02115
(617) 728-2196
- POLLOCK, I.W.
DEPT OF BIOLOGY
DREW UNIVERSITY
MADISON, NJ 07940
(201) 377-3000 EXT 358
- QUINN, DAVID I.
DEPT OF BIOLOGY
MUSKINGUM COLLEGE
NEW CONCORD, OH 43762-1199
(614) 826-8225
- RALPH, CHARLES L.
DEPT OF ZOOLOGY
COLORADO STATE UNIV
FT COLLINS, CO 80523
(303) 491-6105
- RALSTON, HU
DEPT OF ANATOMY S-1334
UNIV CALIFORNIA AT SAN
FRANCISCO
SAN FRANCISCO, CA 94143
(415) 476-1861
- RENISH, ALMA JEAN
UNIV OF WISCONSIN -
PARKSIDE
BOX 2000
KENOSHA, WI 53141-2000
(414) 553 2213
- ROBBINS, DR HERBERT C
UNIV LAS BAPTIST UNIV
7777 WEST KREST BLVD
DALLAS, TX 75211-9800
(214) 333-5302
- RUNYAN, MICHAEL E
DEPT OF BIOLOGY
LANDER COLLEGE
GREENWOOD, SC 29646
(803) 229-8385
- SAVAGE, WAYNE
DEPT OF BIOLOGY
SAN JOSE STATE UNIV
SAN JOSE, CA 95192
(408) 277-2355
- SCHNEIWEISS, JEANNETTE W
DEPT OF BIOLOGY
HOVSTRA UNIV
HEMPSTEAD, NY 11550
(516) 560-5521
- SCHWARTZ, ORLANDO A
DEPT OF BIOLOGY
UNIV NORTHERN IOWA
CEDAR FALLS, IA 50614
(319) 273-2106
- SHOLES, OWEN DV
DEPT OF NATURAL SCIENCES
ASSUMPTION COLLEGE
500 SALISBURY ST
WORCESTER, MA 01609
(617) 752-5615 EXT 257
- SINGLETARY, ROBERT L.
DEPT OF BIOLOGY
UNIV OF BRIDGEPORT
BRIDGEPORT, CT 06601
(203) 576-4265
- SINNAMON, WALT
CENTRAL WESTERN
COLLEGE
BOX 443
CENTRAL, SC 29630
(803) 639-2453 EXT 356
- SKAVARIL, DR RUSSELL V
DEPT OF GENETICS
OHIO STATE UNIV
961 BIOL SCI BLDG
484 WEST TWILFTH AVE
COLUMBUS, OH 43210
(614) 422-1310
- SMALL, JAMES W
DEPT OF BIOLOGY
ROLLINS COLLEGE
BOX 2643
WINTER PARK, FL 32789
(305) 646-2433
- SOBIESKI, ROD
DEPT OF BIOLOGY
EMPORIA STATE UNIV
EMPORIA, KS 66801
(316) 343-1200 EXT 5620
- STANSFIELD, WILLIAM
DEPT OF BIOL. SCIENCE
CAL. POLYTECH STATE UNIV
SAN LUIS OBISPO, CA 93407
(805) 546-2875
- STANTON, GEORGE E
DEPT OF BIOLOGY
COLUMBUS COLLEGE
COLUMBUS, GA 31993
(404) 568-2065
- STEIN, PAUL
DEPT OF BIOLOGY
WASHINGTON UNIV
ST LOUIS, MO 63130
(314) 889-6824
- STEUCEK, DR GUY L.
DEPT OF BIOLOGY
MILLERSVILLE UNIV
MILLERSVILLE, PA 17551
(717) 872-3339
- STONE, LARRIE E
DANA COLLEGE
BLAIR, NE 68008
(402) 426-4101 EXT 229
- STRATTON, LEWIS P
DEPT OF BIOLOGY
FURMAN UNIV
GREENVILLE, SC 29613
(803) 294-3249
- SWEET, HAVEN
DEPT OF BIOLOGY
UNIV OF CENTRAL FLORIDA
ORLANDO, FL 32816
(305) 275-2922
- TAUB, STEPHAN R
DEPT OF BIOLOGY
GEORGE MASON UNIV
FAIRFAX, VA 22030
(703) 323-2181
- TESKEY, SISTER NANCY
HOLY NAMES COLLEGE
OAKLAND, CA 94619
(415) 436-0111
- TURNELL, MJ
DEPT OF ZOOLOGY
UNIVERSITY OF ALBERTA
EDMONTON, ALBERTA
CANADA T6G 2E9
(403) 432-0665
- VERCH, RICHARD
DEPT OF BIOLOGY
NORTHLAND COLLEGE
ASHLAND, WI 54806
(715) 682-4531 EXT 335
- VOORHEES, FRANK RAY
DEPT OF BIOLOGY
CENTRAL MISSOURI STATE
UNIV
WARRENSBURG, MO 64093
(816) 429-4933
- WALLACE, ROBERT L.
DEPT OF BIOLOGY
RIPON COLLEGE
RIPON, WI 54971
(414) 748-8122
- WALTERS, DIRK R
DEPT OF BIOLOGY
CAL. POLYTECH STATE UNIV
SAN LUIS OBISPO, CA 93407
(805) 546-2721
- WEISS, DR EDWARD
CHRISTOPHER NEWPORT
COLLEGE
50 SHOE LANE
NEWPORT NEWS VA 23606
(804) 599-7044
- WILLIAMS, MARVIN J
DEPT OF BIOL. SCIENCE
CAL. POLYTECH STATE UNIV
SAN LUIS OBISPO, CA 93407
(805) 546-1357
- WILHELM, DALLAS
DEPT OF BIOLOGY
HASTINGS COLLEGE
HASTINGS, NE 68901
(402) 463-2402 EXT 264
- BIOMETRICS**
BEAVER, JAMES S
DEPT OF AGRONOMY AND
SOILS
COLLEGE OF AGRICULTURAL
SCIENCE
UNIV OF PUERTO RICO
MAYAGUEZ, P R 00708
(809) 834-4040 EXT 2380
- BOYNTON, DR JOHN E
ST JOSEPHS COLLEGE
155 ROE BLVD
PATCHOGUE, NY 11772
(516) 654-3200
- STEUCEK, DR GUY L.
DEPT OF BIOLOGY
MILLERSVILLE UNIV
MILLERSVILLE, PA 17551
(717) 872-3339
- WATROUS, JAMES
DEPT OF BIOLOGY
ST JOSEPHS UNIV
PHILADELPHIA, PA 19131
(215) 879-7342
- WESSEL-BEAVER, LINDA
DEPT OF AGRONOMY AND
SOILS
COLLEGE OF AGRICULTURAL
SCIENCE
UNIV OF PUERTO RICO
MAYAGUEZ, P R 00708
(809) 834-4040 EXT 2566
- WILLIAMS, STANLEY C
DEPT OF BIOL. SCIENCES
SAN FRANCISCO STATE UNIV
SAN FRANCISCO, CA 94132
- BIOPHYSICS**
AMLANER, CHARLES J, JR
DEPT OF ZOOLOGY
UNIV OF ARKANSAS
FAYETTEVILLE, AR 72701
- RAM, JEFFREY L.
DEPT OF PHYSIOLOGY
WAYNE STATE UNIV SCH. MED.
DETROIT, MI 48201
(313) 577-1558

- SACHS, DR FREDERICK
DEPT OF BIOPHYSICAL SCI
SUNY AT BUFFALO
BUFFALO, NY 14214
(716) 831-3289
- SLAYMAN, C L
DEPT OF PHYSIOLOGY
YALE SCHOOL OF MEDICINE
NEW HAVEN, CT 06510-8026
(203) 788-4478
- WUNDER, CHARLES C
DEPT OF PHYSIOLOGY
UNIV OF IOWA
OAKDALE CAMPUS
OAKDALE IA 52319
(319) 353-4704
- BIOSTATISTICS**
- HECKENLIVELY, DONALD B
DEPT OF BIOLOGY
HILLSDALE COLLEGE
HILLSDALE, MI 49242
(517) 437-7341
- PETERSON, MARGARET GE
BIOSTATISTICS RES CTR
UNIV OF CONNECTICUT
HEALTH CTR AM034
FARMINGTON, CT 06062
(203) 674-3834
- SAKTI, JANA
DEPT OF CROP SCIENCE
UNIV OF SASKATCHEWAN
SASKATOON, SK S7N 0W0
CANADA
(306) 966-4952
- BOTANY**
- BLACK, JOE B
DEPT OF BIOLOGY
LOUISIANA COLLEGE
PINEVILLE, LA 71359
(318) 487-7611
- CASTNER, DAVID
DEPT OF BIOLOGY
CENTRAL MISSOURI STATE
UNIV
WARRENSBURG, MO
64093-5053
(816) 429-4933
- DICKINSON, WINIFRED
DEPT OF BIOLOGY
UNIV OF STEUBENVILLE
STEUBENVILLE, OH 43952
(614) 283-3771
- DOYLE, JAMES
DEPT OF BIOLOGY
AQUINAS COLLEGE
GRAND RAPIDS, MI 49506
(616) 459-8281 EXT 387
- GIBSON, LINDA
DEPT OF BIOLOGY
EASTERN WASHINGTON UNIV
CHENEY, WA 99004
(509) 359-2845
- HODGSON, DR LYNN M
NORTHERN STATE COLLEGE
ABERDEEN, SD 57401
(605) 222-2432
- HOLLAND, V L
DEPT OF BIOL SCIENCE
CAL POLYTECH STATE UNIV
SAN LUIS OBISPO, CA 93407
(805) 546-2789
- HOLM, F A
DEPT OF CROP SCI & PLANT
ECOLOGY
UNIV OF SASKATCHEWAN
SASKATOON, SK S7N 0W0
CANADA
(306) 966-5006
- JANKAY, PETER
DEPT OF BIOL SCIENCE
CAL POLYTECH STATE UNIV
SAN LUIS OBISPO, CA 93407
(805) 546-2860
- KEIL, DAVID J
DEPT OF BIOL SCIENCES
CAL POLYTECH STATE UNIV
SAN LUIS OBISPO, CA 93407
(805) 546-2043
- LA BAR, MARTIN
CENTRAL WESLEYAN COLL
CENTRAL, SC 29630
(803) 639-2453
- ROBBINS, DR HERBERT C
DALLAS BAPTIST UNIV
DALLAS, TX 75211-9800
(214) 333-5302
- RUNYAN, MICHAEL E
DEPT OF BIOLOGY
LANDER COLLEGE
GREENWOOD, SC 29646
(803) 229-8385
- SAVAGE, WAYNE
DEPT OF BIOLOGY
SAN JOSE STATE UNIV
SAN JOSE, CA 95192
(408) 277-2755
- SHAFF, M I
DEPT OF SCIENCE & MATH
RUST COLLEGE
HOLLY SPRINGS, MS 38655
(601) 252-4661
- SNOW, MICHAEL D
DEPT OF PHYS & LIFE SCI
UNIVERSITY OF PORTLAND
500 N VILLAMETTE BLVD
PORTLAND, OR 97203
(503) 283-7175
- VERCH, RICHARD
DEPT OF BIOLOGY
NORTHLAND COLLEGE
ASHLAND, WI 54806
(715) 682-4531 EXT 335
- WULF, BARRY
DEPT OF BIOLOGY
EASTERN CONNSTATE UNIV
WILLIMANTIC, CT 06226
(203) 456-2231
- YOSHIMURA, MICHAEL A
DEPT OF BIOL SCIENCE
CAL POLYTECH STATE UNIV
SAN LUIS OBISPO, CA 93407
(805) 546-2466
- CELL BIOLOGY**
- BATES, WILLIAM K
DEPT OF BIOLOGY
UNIV OF NORTH CAROLINA
GREENSBORO, NC 27412
(919) 379-5391
- BERNSTEIN, MAURICE H
DEPT OF ANAT & CELL BIOL.
WAYNE STATE UNIV SCH MED
540 E CANFIELD
DETROIT, MI 48201
(313) 577-1029
- CREUTZ, CHARLES
DEPT OF BIOLOGY
UNIV OF TOLEDO
TOLEDO, OH 43606
(419) 537-4159
- GRAY, F HARRIET
HOLLINS COLLEGE
BOX 9616
HOLLINS COLLEGE, VA 24020
(703) 362-6543
- PRESMOTT, LANSING M
DEPT OF BIOLOGY
AUGUSTANA COLLEGE
SIOUX FALLS, SD 57197
(605) 336-4719
- RALSTON, H J
DEPT OF ANATOMY S-1334
UNIV OF CALIFORNIA, SAN
FRANCISCO
3RD & PARNASSUS AVES
SAN FRANCISCO, CA 94143
(415) 476-1861
- SAVAGE, WAYNE
DEPT OF BIOLOGY
SAN JOSE STATE UNIV
SAN JOSE, CA 95192
(408) 277-2355
- STONE, LARRIE E
DANA COLLEGE
BLAIR, NE 68008
(402) 426-4101 EXT 229
- WILLIAMS, W E
DEPT OF BIOLOGY
TRINITY COLLEGE
HARTFORD, CT 06106
(203) 527-3151 EXT 570
- CHEMISTRY**
- HIRSTON, W M
CTR FOR NATURAL SCIENCES
NEW YORK INST TECH
OLD WESTBURY, NY 11568
(516) 686-7665
- COMPUTERS/COMP LITERACY**
- CHARDINE, DR JOHN W
DEPT OF BIOL SCIENCES
BROCK UNIVERSITY
ST CATHARINES, ONTARIO
CANADA L2S 3A1
(416) 688-5550
- CODY, RONALD
DEPT OF ENVIRON &
COMMUNITY MED
RUTGERS MED SCHOL L
PISCATAWAY, NJ 08854
(201) 463-4490
- CORBEIL, ROBERT R
DEPTS OF MATHEMATICS &
COMPUT SCI
UNIV OF SAN DIEGO
SAN DIEGO, CA 92110
(619) 260-4600 EXT 4459
- DUGGAN, ELEANOR ..
BIOLOGY DEPT
UNIV OF N CAROLINA AT
GREENSBORO
ROOM 309, EBERHART BLDG
GREENSBORO, NC 27412-5001
(919) 379-5839
- DURY, CARL G
OFFICE OF COMP & INFO
SERVICES
TEMPLE UNIV HLTH SCI CTR
3333 NO BROAD ST, RM 327
PHILADELPHIA, PA 19140
(215) 221-5479
- HOFMANN, WALLACE C
DEPT OF PLANT SCIENCE
UNIV OF ARIZONA
BUILDING #36
TUCSON, AZ 85721
(602) 621-1257
- KREIDER, DR DAVID L
DEPT OF ANIMAL SCIENCES
UNIV OF ARKANSAS
FAYETTEVILLE, AR 72701
(501) 575-4870
- KRULL, DR SARA
SCHOOL OF NURSING
ST LOUIS UNIV MED CTR
ST LOUIS, MO 63104
(314) 577-8903
- LEONG, KINGSTON
DEPT OF BIOL SCIENCE
CAL POLYTECH STATE UNIV
SAN LUIS OBISPO, CA 93407
(805) 546-2788
- LIBEY, TERRY
DEPT OF HEALTH CAREERS
LANSING COMMUNITY
COLLEGE
419 N CAPITOL AVE
LANSING, MI 48901-7211
- OLTJEN, JW
DEPT OF ANIMAL SCIENCE
OKLAHOMA STATE UNIV
STILLWATER, OK 74078
(405) 624-6670
- OWEN, WILLIS L
3224 N ROIF
OKLAHOMA CITY, OK 73112
(405) 271-2229
- PARISI, ANTHONY J
WRIGHT STATE UNIV SCHOOL
OF MEDICINE
DAYTON, OH 45401-0927
(513) 376-6711
- POTTINGER, JAN
RM2050 MSC
UNIV OF WISCONSIN AT
MADISON
MADISON, WI 53706
(608) 263-1595

- SCHAAD, DOUGLAS C
DIV RES IN MED EDUC
UNIV OF WASHINGTON SC-45
SEATTLE WA 98195
(206) 543 9320
- SESSLER, AMY
CURRICULAR SOFTWARE
STUDIO
TUFTS UNIVERSITY
MEDFORD, MA 02155
(617) 628-5000 EXT 2009
- SKAVARIL, DR RUSSELL V
DEPT OF GENETICS
OHIO STATE UNIV
COLUMBUS, OH 43210
(614) 422-1310
- STRINGFELLOW, HART R
DEPT OF DENTAL EDUCATION
UNIV OF FLORIDA COLLEGE
OF DENTISTRY
BOX J-406 JHMHC
GAINESVILLE, FL 32610
(904) 392-2674
- WETSTONE, SCOTT
UNIV OF CONNECTICUT
HEALTH CTR AM033
FARMINGTON, CT 06032
(203) 674-3836
- CYTOGENETICS
GRANT, WILLIAM F
GENETICS LABORATORY
PO BOX 4000
MACDONALD CAMPUS OF
McGILL UNIV
SIE ANNE DE BELLEVUE
QUEBEC, CANADA H9X 1C0
- CYTOLOGY
GRANT, WILLIAM F
GENETICS LABORATORY
PO BOX 4000
MACDONALD CAMPUS OF
McGILL UNIV
SIE ANNE DE BELLEVUE
QUEBEC, CANADA H9X 1C0
- KEETE, J RICHARD
DEPT OF ANATOMY
CASE WESTERN RESERVE
UNIV
CLEVELAND, OH 44106
(216) 368-2656
- DEVELOPMENTAL BIOLOGY
RALSTON, HJ
DEPT OF ANATOMY S-1334
UNIV CALIFORNIA AT SAN
FRANCISCO
3RD & PARNASSUS AVES
SAN FRANCISCO, CA 94143
(415) 476-1861
- STONE, LARRIE E
DANA COLLEGE
BLAIR, NE 68008
(402) 426-4101 EXT 229
- VOORHIES, FR
DEPT OF BIOLOGY
CENTRAL MISSOURI STATE
UNIV
WARRENSBURG, MO 64093
(816) 429-4933
- ECOLOGY
BEAVER, JAMES S
DEPT OF AGRONOMY AND
SOILS
COLLEGE OF AGRICULTURAL
SCIENCE
UNIV OF PUERTO RICO
MAYAGUEZ, P R 00708
(809) 834-4040 EXT 2380
- BELLMER, SISTER ELIZA-
BETH H
TRINITY COLLEGE
WASHINGTON, DC 20017
(202) 939-5190
- BOWKER, LESLIE S
DEPT OF BIOL SCIENCE
CAL POLYTECH STATE UNIV
SAN LUIS OBISPO, CA 93407
(805) 546-2788
- BOYNTON, DR JOHN E
ST JOSEPH'S COLLEGE
155 ROE BLVD
PATCHOGUE, NY 11772
(516) 654-3200
- CACCAMISE, DONALD F
DEPT OF ENTOMOLOGY
RUTGERS UNIV
NEW BRUNSWICK, NJ 08903
(201) 932-9459
- CALDWELL, DOUG
DEPT OF APPLIED MICRO &
FOOD SCI
UNIV OF SASKATCHEWAN
SASKATOON, SK S7N 0W0
CANADA
(306) 966-5026
- CAMERON, DAVID G
DEPT OF BIOLOGY
MONTANA STATE UNIV
BOZEMAN, MT 59717
(406) 994-2670
- CHARDINE, DR JOHN W
DEPT OF BIOL. SCIENCES
BROCK UNIVERSITY
ST CATHARINES, ONTARIO
CANADA L2S 3A1
(416) 688-5550
- CHEW, FS
DEPT OF BIOLOGY
TUFTS UNIV
MEDFORD, MA 02155
(617) 381-3189 EXT 3195
- CLOUTIER, CONRAD
DEPT OF BIOLOGY
UNIVERSITY LAVAL
QUEBEC 10, QUEBEC
CANADA G1K 7P4
(418) 656-3183
- COCKERHAM, BILL
FRESNO PACIFIC COLLEGE
FRESNO, CA 93702
(209) 453-2045
- CYR, ANDRE
DEPT OF BIOLOGY
UNIV OF SHERBROOKE
SHERBROOKE, QUEBEC
CANADA J1K 2R1
(819) 821-7074
- DOYLE, JAMES
DEPT OF BIOLOGY
AQUINAS COLLEGE
GRAND RAPIDS, MI 49506
(616) 459-8281 EXT 387
- DUDLEY, PATRICIA L
DEPT OF BIOL. SCIENCES
BARNARD COLLEGE
COLUMBIA UNIV
3009 BROADWAY
NEW YORK, NY 10027
(212) 280-2437
- FANNING, MARSHA E
DEPT OF BIOLOGY
LENOIR-RHYNE COLLEGE
HICKORY, NC 28603
(704) 328-7270
- GAMBS, ROGER
DEPT OF BIOL. SCIENCE
CAL. POLYTECH STATE UNIV
SAN LUIS OBISPO, CA 93407
(805) 546-2551
- GILES, ROBERT H Jr
DEPT OF FISHERIES &
WILDLIFE SCIENCE
VIRGINIA POLYTECH INST &
STATE UNIV
BLACKSBURG, VA 24061
(703) 961-5910
- HOLLAND, V L
DEPT OF BIOL. SCIENCE
CAL. POLYTECH STATE UNIV
SAN LUIS OBISPO, CA 93407
(805) 546-2789
- JOHNSON, DAVID W
DEPT OF BIOLOGY
CONCORDIA COLLEGE
MOORHEAD, MN 56560
(218) 299-3085
- JOHNSON, IVAN M
DEPT OF BIOLOGY
CONCORDIA COLLEGE
MOORHEAD, MN 56560
(218) 299-3085
- KESLER, DAVID H
DEPT OF BIOLOGY
RHODES COLLEGE
MEMPHIS, TN 38112
(901) 726-3557
- NOVEMSKY, LISA
NEW JERSEY INST TECH
NEWARK, NJ 07102
(201) 596-3253
- ROBBINS, DR HERBERT C
DALLAS BAPTIST UNIV
DALLAS, TX 75211-9800
(214) 333-5302
- SCHWARTZ, ORLANDO A
DEPT OF BIOLOGY
UNIV OF NORTHWEST IOWA
CEDAR FALLS, IA 50614
(319) 273 2106
- SHAFF, M I
DEPT OF SCIENCE & MATH
RUST COLLEGE
HOLLY SPRINGS, MS 38635
(601) 252-4661
- SINGLETARY, ROBERT I
DEPT OF BIOLOGY
UNIV OF BRIDGEPORT
BRIDGEPORT, CT 06601
(203) 576-4265
- STOEY, WILLIAM E
DEPT OF BIOL/MICROBIOL
UNIV OF WISC AT OSHKOSH
OSHKOSH, WI 54901
(414) 424-3068
- SNGW, MICHAEL D
DEPT OF PHYSICAL & LIFE
SCIENCES
UNIVERSITY OF PORTLAND
500 N WILLAMETTE BLVD
PORTLAND, OR 97203
(503) 283-7175
- STANTON, GEORGE E
DEPT OF BIOLOGY
COLUMBUS COLLEGE
COLUMBUS, GA 31993
(404) 568-2065
- UNGAR, IRWIN A
DEPT OF BIOLOGY
OHIO UNIV
ATHENS, OH 45701
- VAN AMBURG, GERALD I
DEPT OF BIOLOGY
CONCORDIA COLLEGE
MOORHEAD, MN 56560
(218) 299-3085
- WALTERS, BIRK R
DEPT OF BIOLOGY
CAL. POLYTECH STATE UNIV
SAN LUIS OBISPO, CA 93407
(805) 546-2721
- WELISS, DR EDWARD
CHRISTOPHER NEWPORT
COLLEGE
50 SHOE LANE
NEWPORT NEWS, VA 23606
(804) 599-7044
- WERNER, J KIRWIN
DEPT OF BIOLOGY
NORTHEAST MICHIGAN UNIV
MARQUETTE, MI 49855
(906) 227-2310
- WOLF, THOMAS M
DEPT OF BIOLOGY
WASHBURN UNIV OF TOPEKA
TOPEKA, KS 66621
(913) 295-6768
- WULF, BARRY
DEPT OF BIOLOGY
EASTERN CONNECTICUT UNIV
WILLMANTIC, CT 06226
(203) 456-2231
- EDUCATION
GROBMAN, HILDA
ST LOUIS UNIV SCIENCE
ST LOUIS, MO 63104
(314) 577-8645
- KARBESHIAN, I YNN
UNIV OF NODAK SCIENCE
OMIE MLD SCIENCE NO
GRAND FORKS, ND 58201
(701) 777-3833

- KROGULL, SHIVEN
DEPT OF EDUC SERVICES
MEDICAL COLLEGE OF WISCONSIN
MILWAUKEE, WI 53226
(414) 257-8546
- McCRADY, WILLIAM
SCIENTIFIC TRAINING CENTER
UNIV OF TEXAS AT ARLINGTON
ARLINGTON
BOX 19389
ARLINGTON, TX 76019
(817) 273-2129
- ELECTRON MICROSCOPY**
SAVAGE, WAYNE
DEPT OF BIOLOGY
SAN JOSE STATE UNIV
SAN JOSE, CA 95192
(408) 277-2355
- EMBRYOLOGY**
BILLMER, SISTER LILJA-BETH
TRINITY COLLEGE
WASHINGTON, DC 20017
(202) 939-5190
- BLURNSIEIN, MAURICE H
DEPT OF ANAT & CELL BIOL
WAYNE STATE UNIV SCH MED
540 E CANFIELD
DETROIT, MI 48201
(313) 577-1029
- FELBACK, DANIEL
DEPT OF ANATOMICAL SCI
UNIV OF OKLA HEALTH SCI CENTER
PO BOX 26901 BMSB540
OKLAHOMA CITY, OK 73190
(405) 271-2377
- HARRIS, THOMAS M
DEPT OF ANATOMY
MID COLLEGE OF VIRGINIA
RICHMOND, VA 23298-0001
(804) 789-9534
- HILLIARD, STEPHEN
DEPT OF BIOLOGY
BALDWIN-WALLACE COLLEGE
BIREA, OH 44017
(216) 826-7765
- KESSELER, SISTER IRMA
DEPT OF BIOLOGY
COLLEGE OF ST ELIZABETH
CONVENT STATION, NJ 07961
(201) 539-1600
- MILYEPS, PAUL I.
DEPT OF BIOL CHEM & STRUCT
THE CHICAGO MED SCHOOL
3333 GREEN BAY RD
NORTH CHICAGO, IL 60064
(312) 578-3000 EXT 458
- ROBBINS, DR HERBERT C
DALLAS BAPTIST UNIV
DALLAS, TX 75211-9800
(214) 333-5302
- ENDOCRINOLOGY**
CHAVTZ, R SCOTT
P A PROGRAM
UNIV OF NEBRASKA MED CTR
OMAHA, NE 68105
(402) 559-5266
- JEGLA, THOMAS C
DEPT OF BIOLOGY
KELBYN COLLEGE
GAMBIER, OH 43022
(614) 427-2244
- GRAY, F HARRIET
HOLLINS COLLEGE
HOLLINS COLLEGE, VA 24020
(703) 362-6543
- RAWTICHI, ALLEN B
DEPT OF BIOCHEMISTRY
UNIV KANSAS MED CTR
KANSAS CITY, KS 66103
(913) 588-6957
- SAGE, MARTIN
DEPT OF BIOLOGY
UNIV OF MISSOURI AT ST LOUIS
ST LOUIS, MO 63121
(314) 553-6218
- SCHMIDT, THOMAS J
DEPT OF PHYSIOL & BIOPHYS
UNIV OF IOWA
5-432 BOWEN SCIENCE BLDG
IOWA CITY, IA 52242
(319) 353-4018
- WOLF, RICHARD C
DEPT OF PHYSIOLOGY
UNIV OF WISCONSIN
MADISON, WI 53706
(608) 262-2939
- ZIMMERMAN, JAY
DEPT OF BIOL SCIENCES
ST JOHN'S UNIV
GRAND CENTRAL & UTOPIA
PKWS
NEW YORK, NY 11439
(718) 990-6161 EXT 5233
- ENTOMOLOGY**
CLOUTHER, CONRAD
DEPT OF BIOLOGY
UNIVERSITY LAVAL
QUEBEC 10, QUEBEC
CANADA G1K 7P4
(418) 656-3183
- FARRIER, M H
DEPT OF ENTOMOLOGY
NORTH CAROLINA STATE UNIV
RALEIGH, NC 27695-7613
(919) 737-2833
- HAMAN, A C
DEPT OF BIOLOGY
UNIV OF NORTHERN IOWA
CEDAR FALLS, IA 50614
(319) 273-2726
- HILTON, DONALD FJ
DEPT OF BIOL SCIENCES
BISHOP'S UNIVERSITY
LENNOXVILLE, QUEBEC
CANADA J1M 1Z7
(819) 569-9551
- JOHNSON, DONN T
DEPT OF ENTOMOLOGY
UNIV OF ARKANSAS
FAYETTEVILLE, AR 72701
(501) 575-2451
- LAMP, WILLIAM
DEPT OF ENTOMOLOGY
UNIV OF MARYLAND
COLLEGE PARK, MD 20742
(301) 454-5875
- LEONG, KINGSTON
DEPT OF BIOL SCIENCE
CAL POLYTECH STATE UNIV
SAN LUIS OBISPO, CA 93407
(805) 546-2788
- MUSICK, G J
DEPT OF ENTOMOLOGY
UNIV OF ARKANSAS
FAYETTEVILLE, AR 72701
(501) 575-2451
- ODE, PHILIP
DEPT OF BIOLOGY
THEIHL COLLEGE
GREENVILLE, PA 16125
(412) 588-7700
- PICKERING, JOHN
DEPT OF ENTOMOLOGY
UNIV OF GEORGIA
ATHENS, GA
(404) 542-2816
- WILLIAMS, STANLEY C
DEPT OF BIOL SCIENCES
SAN FRANCISCO STATE UNIV
SAN FRANCISCO, CA 94132
- ENVIRONMENTAL SCIENCE**
FORTNER, ROSANNE
OHIO STATE UNIV
SCHOOL OF NAT RESOURCES
COLUMBUS, OH 43210
(614) 422-2265
- SABOSKI, ELEANOR M
NEW ENGLAND COLLEGE
HENNIKER, NH 03242
(603) 428-2374
- SNOW, MICHAEL D
DEPT OF PHYS & LIFE SCI
UNIV OF PORTLAND
500 N WILLAMETTE BLVD
PORTLAND, OR 97203
(503) 283-7175
- EPIDEMIOLOGY**
KLAAS, JUDY C
DEPT OF BIOLOGY
FRAMINGHAM STATE COLLEGE
FRAMINGHAM, MA 01701
(617) 620-1220 EXT 459
- EVOLUTION**
CARICO, JAMES E
DEPT OF BIOLOGY
LYNCHBURG COLLEGE
LYNCHBURG, VA 24501
(804) 522-8366
- CHEW, FS
DEPT OF BIOLOGY
TUFTS UNIV
MEDFORD, MA 02155
(617) 381-3189 EXT 3195
- FANNING, MARSHIA L.
DEPT OF BIOLOGY
LENOIR-RHYNE COLLEGE
HICKORY, NC 28603
(704) 328-7270
- FERNER, JOHN W
DEPT OF BIOLOGY
THOMAS MORE COLLEGE
CRESTVIEW HILLS, KY 41017
(606) 344-3374
- GORMAN, MARK
BALDWIN-WALLACE COLLEGE
BIREA, OH 44017
(216) 826-2217
- ODE, PHILIP
DEPT OF BIOLOGY
THEIHL COLLEGE
GREENVILLE, PA 16125
(412) 588-7700
- SEAGER, BOB
DEPT OF BIOLOGY
UNIV OF NORTHERN IOWA
CEDAR FALLS, IA 50614
(319) 273-2670
- STANSFIELD, WILLIAM
DEPT OF BIOL SCIENCE
CAL POLYTECH STATE UNIV
SAN LUIS OBISPO, CA 93407
(805) 546-2875
- STANTON, GEORGE E
DEPT OF BIOLOGY
COLUMBUS COLLEGE
COLUMBUS, GA 31993
(404) 568-2065
- WILLIAMS, W F
DEPT OF BIOLOGY
TRINITY COLLEGE
HARTFORD, CT 06106
(203) 527-3151 EXT 570
- FAMILY PRACTICE**
PARISI, ANTHONY J
WRIGHT STATE UNIV SCH
MED
DAYTON, OH 45401-0927
(513) 376-6711
- FISHERIES**
WIALLS, MARVIN J
DEPT OF BIOL SCIENCE
CAL POLYTECH STATE UNIV
SAN LUIS OBISPO, CA 93407
(805) 546-1357

COMPUTERS IN LIFE SCIENCE EDUCATION

HAROLD I. MODELL

Department of Radiology
University of Washington
Seattle, Washington

MARCEL BLANCHAER

Department of Biochemistry
Faculty of Medicine
University of Manitoba
Winnipeg, Manitoba
Canada

THEODORE J. CROVELLO

Department of Biology
University of Notre Dame
Notre Dame, Indiana

JAMES W. ECKBLAD

Department of Biology
Luther College
Decorah, Iowa

TSEGAYE HABTEMARIAM

School of Veterinary Medicine
Tuskegee University
Tuskegee, Alabama

DONNA LARSON

School of Nursing
Grand Valley State College
Allendale, Michigan

TERRY M. MIKITEN

Graduate School of Biomedical Sciences
University of Texas Health Science Center
San Antonio, Texas

JAMES E. RANDALL

Department of Physiology
Indiana University
Bloomington, Indiana

PATRICIA SCHWIRIAN

College of Nursing
Ohio State University
Columbus, Ohio

RICHARD STULL

College of Pharmacy
University of Arkansas
Little Rock, Arkansas

JAMES W. WOODS

Lister Hill National Center
for Biomedical Communications
National Library of Medicine
Bethesda, Maryland

DOROTHY WOOLEY-McKAY

Department of Biology
Glendale Community College
Glendale, Arizona

GLEN YOSHIDA

Department of Life Sciences
Los Angeles Southwest College
Los Angeles, California

NRCLSE

CONTENTS

SELECTING AN ANALOG-DIGITAL INTERFACE: A TUTORIAL	89
Richard F. Olivo	
KEEPING ABREAST OF THE LITERATURE	93
INDEX FOR VOLUME 3	94

SELECTING AN ANALOG-DIGITAL INTERFACE: A TUTORIAL

Richard F. Olivo

Department of Biological Sciences, Smith College, Northampton, Massachusetts

For a computer to serve as a laboratory instrument, it must have an analog-digital interface added to it. A surprisingly large number of analog interface devices are available, differentiated not only by the computer for which they are made, but also by their capability and price. This tutorial is intended to help readers choose an appropriate analog system. It reviews the basics of

analog-to-digital conversion, discusses desirable features in commercially available products, and suggests sources of product review and other information. The tutorial is based on my own experience in designing, building, and programming a data-acquisition system for teaching⁶ and on my reading of manufacturers' catalogs as I prepare to devise a new system. Its orientation is largely

**REMINDER -- TIME TO RENEW
RENEWAL FORM MAY BE
FOUND ON PAGE 95**

towards the teaching laboratory, but most comments would apply equally well to choosing a system for use in the research laboratory.

THE RANGE OF CHOICES

Two extreme cases illustrate the choices that must be made in selecting an analog-digital interface. In the first, the computer automatically takes a series of measurements that might once have been written down by hand. More than one variable such as pH, temperature, gas volume, or time, might be tracked simultaneously. The task does not require high speed in taking samples, but it does require high precision. The data will be subject to further calculations, possibly using a spreadsheet or statistics package, before information derived from the data is printed or plotted.

At the opposite extreme, the second case simulates a digital storage oscilloscope on a computer's graphics screen. Acquisition speed is now important because tens of thousands of samples must be taken per second. Precision, however, is much less important. It need be no better than a typical oscilloscope, and it will, in any case, be limited by the resolution of the computer's graphics display. The computer in this example stores and displays the data but does little or no calculating.

The first example requires high data resolution but low speed, while the second example requires low data resolution but high speed. Analog interfaces are available that have both high resolution and high speed, but they are much less expensive if one can be less demanding about one feature or the other. In teaching, where multiple set-ups are needed, low cost can be very important. Readers whose budgets and style allow the use of high-priced equipment for low-cost tasks may skip the rest of this article.

BASIC HARDWARE COMPONENTS

The essential component of every analog interface is an analog-to-digital converter (ADC), a specialized integrated

circuit that, on command from the computer, changes the magnitude of an incoming analog voltage into a number that it sends to the computer. An interface may also have a multiplexer to allow several analog input channels to share one ADC, amplifiers to boost the analog input signal, sample-and-hold devices to freeze rapidly changing signals at a particular instant, and, sometimes, one or more digital-to-analog converters (DACs) to change digital values from the computer back into analog voltages to be sent to chart recorders or other display devices. We will consider these components in the order in which an input signal usually encounters them.

Signals, transducers, and amplifiers

Before any analog conversions can occur, the parameter to be measured must first be put into electrical form. Some signals, such as nerve or muscle potentials, start out in electrical form and need only be amplified. Other measurements, such as of temperature, light, or movement, require transducers to convert a physical quantity to an electrical signal. Examples of common laboratory transducers are strain gauges, thermistors, thermocouples, phototransistors, and pH meters. Often these are already on hand if laboratory data are recorded on strip charts, but they will have to be introduced if exercises presently involve reading meters or dials. Transducers are never part of an interface board itself, but some transducers require power sources, and some commercial interface boards provide the power for specific transducers, vastly simplifying the interfacing task.

Whatever its origin, an electrical signal usually requires amplification before it is sent to an ADC. Any ADC will have a fixed span of input voltages corresponding to a span of digital numbers. In one typical ADC, for example, an input of -5 volts emerges as the number 0, while +5 volts becomes the number 255. Intermediate voltages have intermediate numbers. For this ADC,

an input signal will be represented with the most precision if its values span the full range of -5 to +5 volts, in which case it can be represented at any one moment by one of 256 possible numbers from 0 to 255. If, on the other hand, the input signal spans only -0.5 to +0.5 volts, one tenth of the ADC's range, it will be represented by only 25 different values, a tenth of the numerical range. To maximize the resolution of the digital conversion process, the analog signal should almost fill, but not overflow, the ADC's input range. This usually requires adjustable amplification.

Some commercial interface boards have adjustable on-board amplifiers and accept a wide range of possible input signals. In some cases, the level of amplification (gain) is set by an on-board switch or jumper. In other cases, the amplification is set by a command from the computer. In my view, amplification on interface boards is often not well designed, especially if several analog input signals with substantially different ranges are to be measured. If the interface board has only a single amplifier that must be placed after the analog multiplexer so it can serve all the input channels, its gain can not be suitable for all channels simultaneously. If the gain is programmable, it will have to reset before sampling each channel, which means that the amplifier will need time to settle after each change in gain. This slows the sampling rate. If the amplifier is not programmable but has its gain set by jumpers, external amplification or attenuation will be essential to bring all the signals into the same range. A better design would provide independent, adjustable amplifiers for each channel and a separate ADC for each channel. It is also helpful if the amplifiers and their input connectors are in a separate box that can be placed near the experiment. The good news for life scientists is that if external amplification must be added, it is cheap and easy to build DC amplifiers that are adequate for most biological signals because

they seldom have components above 10 or 20 kHz. One example of a circuit using the common 741 operational amplifier is found in my interface design.⁶

Analog-to-digital converters

After amplification, the signal is routed to an analog-to-digital converter that changes the voltage into its digital equivalent, usually through an internal process resembling "twenty questions." Following a command to begin, the input voltage is compared to a shrewdly chosen series of test voltages until a match is found. The converter then signals that it has finished the conversion. Since it takes time to carry out this successive approximation process, the frequency with which samples can be taken will be limited. Conversion times for typical, moderate-cost ADCs range from 5 to 100 microseconds per sample.

The resolution with which the approximation is made also varies for different ADCs and is specified by the number of bits. Typical resolutions are one part in 256 (8 bits), a resolution adequate for a digital oscilloscope, one part in 1024 (10 bits), and one part in 4096 (12 bits). Higher speeds and higher resolutions are available but are much more expensive and require more precise amplifiers on the board if the resolution and speed are to have real value. In many cases, 8 bits are enough and offer the additional advantage of having one sample fit in one byte of memory. Anything greater than 8 bits requires two bytes per sample, halving the number of samples that can be stored in memory. However, a higher resolution ADC has the advantage that a signal filling only a fraction of the input range may still yield an adequate level of precision. This is important if the signal's amplitude is unknown or changes suddenly.

Digital-to-analog converters

In addition to the input circuitry, some analog interfaces have digital-to-analog converters (DACs), special integrated

circuits that convert numbers from the computer back into analog voltages or currents. DACs provide signals for controlling equipment or for display on oscilloscopes, chart recorders, and X-Y plotters. For example, a simulated digital oscilloscope with two channels might have two DACs, one for each channel, to permit dumping the two stored traces to a chart recorder for permanent copies. Although DACs are inexpensive and are intrinsically speedy, few general purpose interfaces include more than two DACs, and some have none, even if they have 8 or 16 multiplexed input channels. The DAC channels seldom are a major factor in choosing an interface as long as an adequate number is provided. Also, the resolution of the output DACs can safely be less than the input ADC because the program can scale the data before they are sent out.

Another form of output provided on some interface boards is a group of 8 or 16 digital output lines that the computer can toggle between 0 and +5 volts. Digital lines may be used to control warning lights, simple devices, and relays that switch on external equipment. Output-only interface boards with multiple DACs, digital lines, and, sometimes, on-board relays are available from some manufacturers.

INTERACTIONS WITH THE COMPUTER

Two more topics that must be considered are how the analog interface transfers numbers to the computer and the software that controls the interface.

There are several strategies for transferring data to the computer. One is to make the analog interface a small, independent, dedicated computer of its own that receives commands from the main computer and returns data in response. The interface may have a considerable amount of memory of its own, so it can "gulp" big blocks of data that it later sends more slowly to its host. Typically, the transfer is through a standard RS-232 serial port, an interface

that most computers have, but one that is relatively slow. Thus, RS-232 linked interfaces have the advantage of being usable with almost any computer but the disadvantage of not being able to send more than a few hundred samples per second. They also duplicate some of the hardware of the host computer, driving up the total cost, but this can be an advantage if the host computer has other tasks to do and is aided by this parallel processing. The Macintosh, which has had a closed architecture, requires an RS-232 linked interface, a limitation in using the Mac in the laboratory. Even if the Mac acquires slots, its processor is so busy running the system that a separate processor on the interface might be desirable.

In contrast to a serial link, higher performance can be obtained if the interface sits in the computer's address space, accessible directly by the processor. The majority of analog interfaces fall into this category and have been designed for one of the three standard families of computers that permit add-on cards: the IBM PC/XT/AT, the Apple IIe, and the Commodore 64. The fastest of these interfaces can acquire more than 100,000 samples per second. The next section deals with several additional aspects of these plug-in cards.

Timing, Interrupts, and memory transfers

Because samples must be taken at regular intervals, there has to be a source of timing information. The crudest approach is to employ a software loop in which samples are taken repeatedly at an interval determined by the number of instructions in the loop. This is an awkward approach and is seldom used.

For hardware approaches, which are always better, a programmable counter is provided on the interface board or sometimes on a separate board. The program loads the counter with the number of machine cycles that are to elapse between samples, and each time the counter times out, an action is initiated to acquire a new sample. This is slow

sampling rates, the system clock can also be used as a timer. The system clock drives the computer's built-in routine for maintaining the time of day and activating other housekeeping functions, and it can have data collection piggy-backed on it. On the IBM PC, the system clock ticks 18.2 times per second, which is too infrequent for many sampling tasks.

Whichever hardware clock is used, there are several approaches for finding out whether it is time to take the next sample. One is to poll the clock, repeatedly reading the appropriate memory locations to see if the clock has reached zero. For fast applications where the computer will not, in any case, have time for other tasks between samples, polling is very efficient.

An alternative to polling is to create an interrupt-driven routine. At each time-out, the processor is allowed to complete the current instruction and then forced to jump to a section of the program that collects and stores a sample. A special instruction at the end of the sampling routine returns the processor to the place at which it was interrupted. To avoid chaos, each interrupt has to save and then restore the processor's registers. Because of this overhead, interrupts are slower than polling, but they do permit more than one task to take place simultaneously.

The fastest way of collecting data uses direct memory access (DMA) which is available on the IBM PC but not on older personal computers. DMA is carried out by a special processor-like chip in the computer that takes over the computer's bus briefly to move data to or from memory. It automatically updates the address where the next sample will be stored. The main processor is bypassed completely making it free to carry out other tasks. This approach is much faster than polling or interrupts, permitting rates above 100,000 samples per second. A number of interface boards for the IBM PC offer DMA capability.

SOFTWARE

For most users, the software problem will be a matter of selecting a suitable package rather than writing their own programs. Many hardware manufacturers offer software packages for their interfaces, and some independent packages are available that can be used with several different interfaces. Most of these packages put the incoming data into a form that can be incorporated into standard spreadsheets; a few others simulate oscilloscopes. If a hardware/software package is available that accomplishes one's data collection task, this is by far the easiest route to take.

Some of us, however, will need to write our own software. If low speed sampling is all that is required, a data acquisition program may be relatively simple and can even be written in BASIC, which can handle tens of samples per second. The program's task will be essentially to send the interface a channel number and a start signal, to poll the converter to detect when the data are ready, and then to place the data into an array. If hundreds or thousands of samples are needed per second, it may be necessary to work in assembly language or in a language that easily incorporates assembly language routines such as FORTH. This approach requires attention to data structures — how the numbers will be arranged in memory — and to the hardware issues of interrupts and timing that were mentioned above. Those readers who are prepared to write such programs probably already know who they are, but it is not as forbidding a task as it may first appear, particularly if the manufacturer provides a set of subroutines.

SOURCES OF ADDITIONAL INFORMATION

Because a large number of companies manufacture data acquisition products, a list of products would be beyond the scope of this article. However, several manufacturers publish catalogs that provide substantial background on how

their products work. These include the following:

Burr-Brown Corporation
P.O. Box 11400
Tucson, AZ 85734

Cyber Research, Inc.
P.O. Box 9565
New Haven, CT 06536

Data Translation, Inc.
100 Locke Drive
Marlboro, MA 01752

Metabyte Corporation
440 Myles Standish Blvd.
Taunton, MA 02780

Two relatively general discussions of laboratory interfacing by Ford³ and Clune⁴ also provide useful background information.

For information on specific products for the IBM PC, a listing of data on 46 hardware products from 21 manufacturers is given by Conner,² who also provides information about nine software support packages. Unfortunately, her article appears in EDN, a magazine that may be hard to find in libraries. More easily found and deeper in its evaluations is a review by Miller⁵ that discusses 14 analog boards from seven manufacturers. Five software packages for the PC, all of which control either the Tectmar or Data Translation analog boards, are reviewed by Wirth and Ford.⁷ All of these articles also discuss some basic aspects of acquiring analog data.

For the Macintosh, where product choices are more limited, a brief review by McNeill and Freiburger⁶ discusses four hardware products and describes several Mac programs for laboratory simulation, statistics, and plotting.

Although the Apple //e and Commodore 64 computers have limited memory and speed, they can be useful and very cost-effective in teaching. Products for them are widely available, in-

cluding some from major manufacturers. I know of no collective source of information about these products other than catalogs and advertisements.

REFERENCES

1. Clune TR: Interfacing for data acquisition. *Byte* 10(2):269-282, 1985.
 2. Conner MS: Analog-I/O boards and software for IBM PCs. *EDN* 31(12):116-137, 1986.
 3. Ford LE: Laboratory interfacing. *Byte* 10(2):263-266, 1985.
 4. McNeill D, Freiburger P: The laptop Macintosh. *Macworld* 3(10):136-141, 1986.
 5. Miller EM: Digitizing analog data. *PC Tech Journal* 4(5):52-71, 1986.
 6. Olivo, RF: Microcomputer-based data acquisition for neurobiology. *Proc Nat Educ Comput Conf* 5:174-179, 1983.
 7. Wirth P, Ford LE: Five laboratory interfacing packages. *Byte* 11(7):303-312, 1986.
- The following citations are presented as part of a quarterly feature in CLSE designed to help readers become aware of current literature pertinent to computer applications in life science education.
- Barker P et al: A practical introduction to authoring for computer-assisted instruction. Part I: PHILVAS. *Br J Educ Tech* 16(3):218-236, 1985.
- Bender DA: Combining a laboratory practical class with a computer simulation: studies on the synthesis of urea in isolated hepatocytes. *Biochemical Education* 14(1):17-22, 1986.
- Blandford AE et al: The evolution of computer based learning software design: computer assisted teaching unit experience. *Computers and Education* 10(2):251-257, 1986.
- Bratt E et al: Using computers to teach basic facts in the nursing curriculum. *J Nurs Educ* 25(6):247-251, 1986.
- Brittain T: Chymotrypsin—a combined experiment and computer simulation of pre-steady state and steady-state enzyme kinetics. *Biochemical Education* 14(1):33-34, 1986.
- Brown JW: Some motivational issues in computer-based instruction. *Educ Tech* 26(4):27-29, 1986.
- Caffee HH: Computer applications in plastic surgery training programs. *Clin Plast Surg* 13(3):375-378, 1986.
- Cobb H: Computer applications in veterinary medical education. *Vet Clin North Am [Small Anim Pract]* 16(4):703-708, 1986.
- Dale RA et al: A comparison of simulation programs for endodontic review. *J Biocommun* 13(2):17-23, 1986.
- Danciger M: Bytes and bugs: integrating computer programming with bacteria identification. *J College Science Teaching* 15(5):454-456, 1986.
- Droar T: Managing a courseware development project. *Interactive Learning International* 2(4):4-9, 1986.
- Droste-Bielak EM: Two techniques for teaching interviewing: a comparative study...role-playing and computer simulation. *Comput Nurs* 4(4):152-157, 1986.
- Edwards MG et al: Compulab—computing for the physical sciences teaching laboratory. *Computers and Education* 10(2):307-313, 1986.
- Evans RD et al: Computer-based interactive instruction in trauma. *Am J Emerg Med* 4(4):384-386, 1986.
- Fasel J et al: Laservision-disk and computer-assisted medical learning. *J Audiovis Media Med* 9(1):15-16, 1986.
- Gall SA, Jr et al: Education in electronic fetal heart rate monitoring using the IBM Personal Microcomputer. *Am J Perinatol* 2(2):154-155, 1985.
- Gredler MB: A taxonomy of computer simulations. *Educ Tech* 26(4):7-12, 1986.
- Gwinnett A et al: Integrating computers into the curriculum: a development project...Computer Assisted Case Studies, or CACS. *Nurse Educ Today* 6(3):129-132, 1986.
- Harris SL: Development of computer assisted instruction lessons for teaching nursing research. *Comput Nurs* 4(4):140, 182, 1986.
- Hayes JR et al: A microcomputer-based tutorial program for computer-based training and patient care. *Am J Perinatol* 2(2):163-165, 1985.
- Holley HS et al: Microcomputers for computer-assisted instruction in anesthesia. *Int J Clin Monit Comput* 1(2):97-105, 1984.
- Irvine NR et al: Computer-assisted instruction in mixed dentition analysis. *J Dent Educ* 50(6):312-315, 1986.
- Jeffcoat MK et al: Computer education for dental students. *J Dent Educ* 50(5):260-263, 1986.
- Kemp GD: The display of protein conformation on a microcomputer. *Biochemical Education* 14(1):22-24, 1986.
- Lanier R: The interactive videodisc is in motion. *E-ITV* 18(4):36-37, 39-40, 42-43, 1986.
- Lewington J et al: BACLAB: a computer simulation of a medical bacteriology laboratory — an aid for teaching tertiary level microbiology. *J Biol Educ* 19(4):278-280, 1985.
- Locatis C et al: Authoring systems and assumptions about them. *J Biocommun* 13(2):4-9, 1986.
- McEnery KW: Interactive instruction in the radiographic anatomy of the chest. *Comput Methods Programs Biomed* 22(1):81-86, 1986.
- Nichols RC et al: Computer-assisted instruction for identifying enterobacteriaceae and other gram-negative rods. *Laboratory Medicine* 17(10):613-615, 1986.
- Parish RA: The efficacy of computer-assisted instruction (CAI) in an out-patient pediatrics clinic. *Clin Pediatr (Phila)* 25(5):255-256, 1986.
- Parks PL et al: Faculty and students perceptions of computer applications in nursing. *J Professional Nursing* 2(2):104-113, 1986.

KEEPING ABREAST OF THE LITERATURE

- Phelps JL et al: Microcomputer applications in allied health education: some new alternatives. *J Allied Health* 15(2):163-170, 1986.
- Reynolds A et al: CAI enhances the medication dosage calculation competency of nursing students. *Comput Nurs* 4(4):158-165, 1986.
- Scanlan CL: Developing computer-assisted learning materials for continuing education in the health professions. *New Directions for Continuing Education* 29:37-46, 1986.
- Schneider SM: Computer-aided instruction in the emergency department. *Am J Emerg Med* 4(4):337-340, 1986.
- Siliauskas G: Effective use of computer graphics in CAI: a review of the literature. *Canadian Journal of Educational Communication* 15(2):75-84, 1986.
- Smith LS: The computer: making it work through competency based education and evaluation. *AD Nurse* 1(3):16-18, 1986.
- Starkschall G et al: Computer-aided instruction in ethics for radiation therapy technology. *Radiol Technol* 57(5):450-453, 1986.
- Thomas RA et al: Development of electrocardiographic teaching materials using an MC68000-based interactive graphics microcomputer. *Comput Methods Programs Biomed* 22(1):87-91, 1986.
- Tinsley L et al: Pulmonary diseases in the neonate: a computer-assisted instruction. *Comput Methods Programs Biomed* 22(1):93-101, 1986.
- Walton S et al: Using computers in the marine science classroom. *J Comp Math Sci Teach* 5(1):38-41, 1985.
- Watkins D et al: Scientific software for the Macintosh. *Sci Software Q* 2(2):9-25, 1985.
- Wenzel A et al: Computer-assisted instruction for intraoral radiography. Part I. Description of program. *Dentomaxillofac Radiol* 14(2):123-128, 1985.
- Wenzel A et al: Computer-assisted instruction for intraoral radiography. Part II. Evaluation of program effectiveness. *Dentomaxillofac Radiol* 14(2):129-132, 1985.
- Whiting J: Student opinion of tutorial CAL. *Computers and Education* 10(2):281-292, 1986.
- Zettersten A: Authoring systems - the key to future expansion in CAI. *System* 13(2):133-136, 1985.

COMPUTERS IN LIFE SCIENCE EDUCATION, VOLUME 3 INDEX

- analog-to-digital conversion, 12:89-93
- anatomical science, 9:65-67
- Apple PILOT, 5:38
- Apple II, IBM-PC program conversion, 7:49-52
- AppleSoft BASIC, 7:50-51
- artificial intelligence, 3:19-22
- information sources, 3:22
- Aucone M, 8:59-62
- Azbell JW, 3:27-30
- BASIC, transferring programs, 7:49-52
- BASICA, 7:50-51
- biology,
microcomputer laboratory for, 9:67-68
simulated experiments in, 8:57-59
- Blanchaer MC, 4:25-27, 5:36-39
- Bulletin Board, 1:6, 4:30-31, 10:79
- Bushby PA, 5:33-36
- clinical case tutorials, microcomputer led, 4:25-27
- clinical medicine, using computer aided instruction for, 8:59-62
- Collins MAJ, 10:76-79
- computer-assisted instruction,
for anatomical science education, 9:65-67
in clinical medicine teaching, 8:59-62
- in family practice curriculum, 3:17-19
- computer-assisted learning languages, 5:36-39
- Cooper EH, 8:57-59
- Debuggy, smart tutor program, 3:20-21
- differential diagnosis process, computer program for teaching, 7:52-55
- digital-to-analog conversion, 12:91
- Directory, CLSE Part 1, 11:81-87
- direct memory access, 12:92
- Eckblad JW, 7:49-52
- education,
anatomical science, 9:65-67
basic science, 4:25-27
continuing medical, 4:27-30
grade analysis software, 8:63
test generator software, 8:63
veterinary medical, 5:33-36
- family practice, 3:17-19
- function generators, use in simulations, 6:44-45
- genetics, simulation, 8:58-59
- Halsey E, 3:12-15
- IBM-PC, Apple II program conversion, 7:49-52
- information systems, 5:33-36
- interactive video,
approach to program development, 2:9-12
conversion of videotape, 4:27-30
signal processing, 2:12-15
- JANUS, interface between laboratory and lecture, 9:67-68
- Jones ME, 8:59-62
- Keeping Abreast of the Literature, 3:22-23, 6:46-47, 9:70-71, 12:93-94
- laboratory/lecture interface, 9:67-68
- Macias JD, 7:52-55
- MacPILOT, 5:38-39
- Maffly RH, 7:52-55
- Mann JW, 8:59-62
- Mastery oriented teaching unit, 9:66-67
- MENTOR, program to teach differential diagnosis process, 7:52-55
- Michael JA, 3:19-22, 10:73-76
- microbiology, simulated laboratory in, 8:57-59
- microcomputer center, 10:76-79

microcomputer laboratory, 9:67-68
 Modell HI, 1:1-5, 6:41-45, 10:73-76
 Moore JF, 2:9-12
 Murphy BJ, 9:65-67

NRCLSE, 1:1-5
 NRCLSE Questionnaire, 1:7

Olivo RF, 12:89-93

PC/PILOT, 5:38
 PILOT, 5:36-39, 7:55
 sources of information, 5:39

simulations,

approaches for teaching, 6:41-45
 approaches in designing, 10:74
 as a substitute for labs, 8:59
 biology experiments, 8:57-59
 cardiovascular system, 8:62-63
 design issues, 10:73-76
 pediatric patient, 8:63
 physiology, 8:62-63
 respiratory system, 1:4
 smart tutors, 3:19-22
 software, sources of, 8:62-63
 Sophie, smart tutor, 3:21
 Sprague RM, 9:69-70
 Stevens FC, 4:25-27
 Super PILOT, 5:38

Troncale JA, 3:17-19
 tutorials, in basic science education, 4:25-27

video signals & devices, 2:12-15
 composite signals, 2:14-15
 RGB signals, 2:15
 videocamera, with interactive videotape,
 4:29
 videotape,
 conversion, 4:27-30
 use with interactive video, 2:9-12

Woods JW, 7:55
 Wooley-McKay D, 9:67-68

CLSE SUBSCRIPTION RENEWAL FORM

Subscription rates for Volume 4, 1987 (includes postage and handling):

U.S. and Canada - \$30.00
 Mexico and Europe - \$50.00
 Rest of the world - \$53.00

Please enter my subscription for Volume 4 (12 issues) of CLSE.

Payment enclosed in US funds

Please bill me

Send issues to:

Name: _____

Address: _____

State: _____ Zip: _____

Send invoice to:

Name: _____

Address: _____

State: _____ Zip: _____

Mail this form to: NRCLSE
 Mail Stop RC-70
 University of Washington
 Seattle, WA 98195

AIMS AND SCOPE

The goal of *Computers in Life Science Education* is to provide a means of communication among life science educators who anticipate or are currently employing the computer as an educational tool. The range of content includes, but is not limited to, articles focusing on computer applications and their underlying philosophy, reports on faculty/student experiences with computers in teaching environments, and software/hardware reviews in both basic science and clinical education settings.

INVITATION TO CONTRIBUTORS

Articles consistent with the goals of *Computers in Life Science Education* are invited for possible publication in the newsletter.

PREPARATION AND SUBMISSION OF MATERIAL

Articles submitted for publication should not exceed 2000 words and should be typewritten, double spaced, with wide margins. The original and two copies including two sets of figures and tables should be sent to the Editor: Dr. Harold Modell, NRCLSE, Mail Stop RC-70, University of Washington, Seattle, WA 98195.

Title page should include full title, list of authors, academic or professional affiliations, and complete address and phone number of the corresponding author.

Illustrations should be submitted as original drawings in India ink or sharp, high contrast reproductions. The lettering should be such that it can be legible after reduction (width of one column = 5.7 cm). High contrast computer outputs are acceptable.

Reference style and form should follow the "number system with references alphabetized" described in the Council of Biology Editors Style Manual. References should be listed in alphabetical order by the first author's last name, numbered consecutively, and cited in the text by these numbers.

RESPONSIBILITY AND COPYRIGHT

Authors are responsible for accuracy of statements and opinions expressed in articles. All authors submitting manuscripts will be sent a copyright transfer form to complete. The completed form must be returned before the work will be published.

SUBSCRIPTION INFORMATION

Computers in Life Science Education is published monthly by National Resource for Computers in Life Science Education, Mail Stop RC-70, University of Washington, Seattle, WA 98195. Subscription rate is \$30.00 for 12 issues, including postage and handling in the United States and Canada. Add \$20.00 for postage (airmail) in Mexico and Europe and \$23.00 for the rest of the world.

This newsletter has been registered with the Copyright Clearance Center, Inc. Consent is given for copying of articles for personal or internal use, or for the personal or internal use of specific clients. This consent is given on the condition that the copier pay through the Center the per-copy fee stated in the code on the first page for copying beyond that permitted by the US Copyright Law. If no code appears on an article, the author has not given broad consent to copy and permission to copy must be obtained directly from the author. This consent does not extend to other kinds of copying, such as for general distribution, resale, advertising and promotional purposes, or for creating new collective works.

Address orders, changes of address, and claims for missing issues to NRCLSE, Mail Stop RC-70, University of Washington, Seattle, WA 98195. Claims for missing issues can be honored only up to three months for domestic addresses and six months for foreign addresses. Duplicate copies will not be sent to replace ones undelivered due to failure to notify NRCLSE of change of address.

Address editorial correspondence to Harold I. Modell, PhD, NRCLSE, Mail Stop RC-70, University of Washington, Seattle, WA 98195. (BITNET MODELL@UWALOCKE)

POSTMASTER: Send address changes to *Computers in Life Science Education*, NRCLSE, Mail Stop RC-70, University of Washington, Seattle, WA 98195.

COMPUTERS IN LIFE SCIENCE EDUCATION

HAROLD I. MOELL

Department of Radiology
University of Washington
Seattle, Washington

MARCEL BLANCHAER

Department of Biochemistry
Faculty of Medicine
University of Manitoba
Winnipeg, Manitoba
Canada

THEODORE J. CROVELLO

Department of Biology
University of Notre Dame
Notre Dame, Indiana

JAMES W. ECKBLAD

Department of Biology
Luther College
Decorah, Iowa

TSEGAYE HABTEMARIAM

School of Veterinary Medicine
Tuskegee University
Tuskegee, Alabama

DONNA LARSON

School of Nursing
Grand Valley State College
Allendale, Michigan

TERRY M. MIKITEN

Graduate School of Biomedical Sciences
University of Texas Health Science Center
San Antonio, Texas

JAMES E. RANDALL

Department of Physiology
Indiana University
Bloomington, Indiana

PATRICIA SCHWIRIAN

College of Nursing
Ohio State University
Columbus, Ohio

RICHARD STULL

College of Pharmacy
University of Arkansas
Little Rock, Arkansas

JAMES W. WOODS

Lister Hill National Center
for Biomedical Communications
National Library of Medicine
Bethesda, Maryland

DOROTHY WOOLEY-McKAY

Department of Biology
Glendale Community College
Glendale, Arizona

GLEN YOSHIDA

Department of Life Sciences
Los Angeles Southwest College
Los Angeles, California

NRCLSE

CONTENTS

CLSE COLLEAGUE DIRECTORY - PART II

1

CLSE COLLEAGUE DIRECTORY - PART II

The primary goal of the National Resource for Computers in Life Science Education (NRCLSE) is to cultivate collaborative efforts among life science faculty interested in using the computer as a teaching tool. One of the first steps toward achieving this goal was publication of a questionnaire in the January, 1986 issue of CLSE. This issue was distributed by mail to nearly 2700 academic departments making up the life science community in the U.S. and Canada, and it was distributed at several national meetings of groups within the life science community.

NRCLSE received over 350 completed questionnaires. Approximately 160 respondents indicated that they have been using computers in their teaching efforts for over 3 years. Approximately

130 have had between 1 and 3 years experience. The listings below represent Part II of a directory that was drawn from respondents to the questionnaire. It is intended to help CLSE readers identify colleagues with common interest areas. It is arranged by the content areas identified in response to the question, "What content areas do you teach?" As a result, entries may appear under more than one heading. Although every attempt has been made to ensure that the information is current and correct, it is likely that some errors appear in this list. NRCLSE apologizes in advance for any inconveniences that may arise due to such oversights. Part I of the directory was printed in the November, 1986 issue of CLSE. The final listings will appear next month.

REMINDER - TIME TO RENEW

VOLUME 4 SUBSCRIPTION INFORMATION

MAY BE FOUND ON PAGE 8

- GASTROENTEROLOGY**
 BARDE, CHRISTOPHER J
 GI UNIT, VA MED CTR
 4100 W THIRD ST
 LAYTON, OH 45428
 (513) 268-6511
- GENETICS**
 ASHTON, GEOFFREY C
 DEPT OF GENETICS
 UNIV OF HAWAII
 1960 EAST-WEST ROAD
 HONOLULU, HI 96822
 (808) 948-8552
- BELLMER, SISTER ELIZABETH H
 TRINITY COLLEGE
 WASHINGTON, DC 20017
 (202) 939-5190
- BERNSTEIN, MAURICE H
 DEPT OF ANAT & CELL BIOL
 WAYNE STATE UNIV SCHOOL
 OF MEDICINE
 DETROIT, MI 48201
 (313) 577-1029
- BLACK, JOE B
 DEPT OF BIOLOGY
 LOUISIANA COLLEGE
 LOUISIANA COLLEGE
 STATION
 PINEVILLE, LA 71359
 (318) 487-7611
- BOYNTON, DR JOHN E
 ST JOSEPH'S COLLEGE
 155 ROE BLVD
 PATCHOGUE, NY 11772
 (516) 654-3200
- CAMERON, DAVID G
 DEPT OF BIOLOGY
 MONTANA STATE UNIV
 BOZEMAN, MT 59717
 (406) 994-2670
- CARICO, JAMES E
 DEPT OF BIOLOGY
 LYNCHBURG COLLEGE
 LYNCHBURG, VA 24501
 (804) 522-8366
- CORBEIL, ROBERT R
 DEPT OF MATHEMATICS &
 COMPUT SCI
 UNIV OF SAN DIEGO
 SAN DIEGO, CA 92110
 (619) 260-4600 EXT 4459
- DAVIS, THOMAS M
 DEPT OF PLANT SCIENCE/
 GENETICS
 UNIV OF NEW HAMPSHIRE
 DURHAM, NH 03824-3597
 (603) 862-3217
- DICKINSON, WINIFRED
 DEPT OF BIOLOGY
 UNIV OF STEUBENVILLE
 STEUBENVILLE, OH 43952
 (614) 283-3771
- DOYLE, JAMES
 DEPT OF BIOLOGY
 AQUINAS COLLEGE
 GRAND RAPIDS, MI 49506
 (616) 459-8281 EXT 387
- FREED, DR JAMES M
 DEPT OF ZOOLOGY
 OHIO WESLEYAN UNIV
 DELAWARE, OH 43015
 (614) 369-4431 EXT 400
- GORMAN, MARK
 BALDWIN-WALLACE
 COLLEGE
 LIFE SCIENCE BLDG
 BEREA, OH 44017
 (216) 826-2217
- GRANT, WILLIAM F
 GENETICS LABORATORY
 P.O. BOX 4000
 MACDONALD CAMPUS
 MCGILL UNIV
 STE ANNE DE BELLEVUE
 QUEBEC H9X 1C0
 CANADA
- HEDMAN, STEPHEN C
 DEPT OF BIOLOGY
 221 LIFE SCI BLDG
 UNIV OF MINNESOTA
 2400 OAKLAND AVE
 DULUTH, MN 55812
 (218) 726-8122
- JOHNSON, DAVID W
 DEPT OF BIOLOGY
 CONCORDIA COLLEGE
 MOORHEAD, MN 56560
 (218) 299-3085
- JOHNSON, IVAN M
 DEPT OF BIOLOGY
 CONCORDIA COLLEGE
 MOORHEAD, MN 56560
 (218) 299-3085
- KRAUSE, DR ELIOT
 DEPT OF BIOLOGY
 SETON HALL UNIV
 SOUTH ORANGE, NJ 07079
 (201) 761-9532
- LA BAR, MARTIN
 CENTRAL WESLEYAN
 COLLEGE
 CENTRAL, SC 29630
 (803) 639-2453
- NICKLA, HARRY
 DEPT OF BIOLOGY
 CREIGHTON UNIV
 OMAHA, NE 68178
 (402) 280-2811
- PIPERBERG, JOEL B
 DEPT OF BIOLOGY
 SIMMONS COLLEGE
 300 THE FENWAY
 BOSTON, MA 02115
 (617) 738-2196
- SEAGER, BOB
 DEPT OF BIOLOGY
 UNIV OF NORTHERN IOWA
 CEDAR FALLS, IA 50614
 (319) 273-2670
- SHAFI, M I
 DEPT OF SCIENCE &
 MATHEMATICS
 RUST COLLEGE
 HOLLY SPRINGS, MS 38635
 (601) 252-4661
- SKAVARIL, DR RUSSELL V
 DEPT OF GENETICS
 OHIO STATE UNIV
 COLUMBUS, OH 43210
 (614) 422-1310
- STANSFIELD, WILLIAM
 DEPT OF BIOL SCIENCE
 CAL POLYTECH STATE UNIV
 SAN LUIS OBISPO, CA 93407
 (805) 546-2875
- STONE, LARRIE E
 DANA COLLEGE
 BLAIR, NE 68008
 (402) 426-4101 EXT 229
- TAUB, STEPHAN R
 DEPT OF BIOLOGY
 GEORGE MASON UNIV
 FAIRFAX, VA 22030
 (703) 323-2181
- VAN AMBURG, GERALD L
 DEPT OF BIOLOGY
 CONCORDIA COLLEGE
 MOORHEAD, MN 56560
 (218) 299-3085
- VERCH, RICHARD
 DEPT OF BIOLOGY
 NORTHLAND COLLEGE
 ASHLAND, WI 54806
 (715) 682-4531 EXT 335
- WALKER, RICHARD
 STERLING COLLEGE
 STERLING, KS 67579
 (316) 278-2173
- WILHELM, DALLAS
 DEPT OF BIOLOGY
 HASTINGS COLLEGE
 HASTINGS, NE 68901
 (402) 463-2402 EXT 264
- WOLF, THOMAS M
 DEPT OF BIOLOGY
 WASHBURN UNIV OF TOPEKA
 1700 COLLEGE AVE
 TOPEKA, KS 66621
 (913) 295-6768
- HEMATOLOGY**
 GRACY, DAVID V
 DEPT OF BIOL SCIENCES
 CAL POLYTECH STATE UNIV
 SAN LUIS OBISPO, CA 93407
 (805) 546-2883
- KEETE, J RICHARD
 DEPT OF ANATOMY
 CASE WESTERN RESERVE U
 CLEVELAND, OH 44106
 (216) 368-2656
- HISTOLOGY**
 ADAMS, DON
 DEPT OF VETERINARY ANAT
 IOWA STATE UNIV
 AMES, IA 50011
 (515) 294-7710
- BERNSTEIN, MAURICE H
 DEPT OF ANAT & CELL BIOL
 WAYNE STATE UNIV SCHOOL
 OF MEDICINE
 DETROIT, MI 48201
 (313) 577-1029
- BLACK, JOE B
 DEPT OF BIOLOGY
 LOUISIANA COLLEGE
 LOUISIANA COLLEGE
 STATION
 PINEVILLE, LA 71359
 (318) 487-7611
- HAKIM, RAZIEL S
 DEPT OF ANATOMY
 COLLEGE OF MEDICINE
 HOWARD UNIV
 WASHINGTON, DC 20059
 (202) 636-6555
- HARRIS, THOMAS M
 DEPT OF ANATOMY
 MEDICAL COLLEGE OF
 VIRGINIA, BOX 709
 RICHMOND, VA 23298-0001
 (804) 789-9534
- HERRON, MARY A
 BIOMED LEARNING RES CTR
 COLLEGE VET MED
 TEXAS A&M UNIV
 COLLEGE STATION, TX 77843
 (409) 845-1780
- KEETE, J RICHARD
 DEPT OF ANATOMY
 CASE WESTERN RESERVE U
 CLEVELAND, OH 44106
 (216) 368-2656
- KISSLER, SISTER IRMA
 DEPT OF BIOLOGY
 COLLEGE OF ST ELIZABETH
 CONVENT STATION, NJ 07961
 (201) 539-1600
- MEYERS, PAUL E
 DEPT OF BIOL CHEM &
 STRUCT
 THE CHICAGO MEDICAL
 SCHOOL
 3333 GREEN BAY RD NORTH
 CHICAGO IL 60664
 (312) 578-3000 EXT 458
- MICKUS, JOHN
 DEPT OF BIOLOGY
 ILLINOIS BENEDICTINE
 COLLEGE
 LISLE, IL 60532-0900
 (312) 960-1500 EXT 509
- PADAWER, JACQUES
 DEPT OF ANAT & STRUCT
 BIOLOGY
 ALBERT EINSTEIN COLLEGE
 OF MEDICINE
 BRONX, NY 10461
 (212) 430-3057
- PAULSEN, DOUGLAS F
 DEPT OF ANATOMY
 MOREHOUSE SCHOOL OF
 MEDICINE
 720 WESTVIEW DR SW
 ATLANTA, GA 30310
 (404) 752-1559
- VOORHEES, FRANK RAY
 DEPT OF BIOLOGY
 CENTRAL MISSOURI STATE
 UNIV, WCM 306
 WARRENSBURG, MO 64093
 (816) 429-4933

- WILLISTON, JOHN S**
DEPT OF BIOLOGY
SAN FRANCISCO STATE UNIV
1600 HOLLOWAY AVE
SAN FRANCISCO, CA 94132
(415) 584-5319
- IMMUNOLOGY**
ALBRITTON, WILLIAM L
DEPT OF MICROBIOLOGY
UNIV OF SASKATCHEWAN
SASKATOON, SK S7N 0W0
CANADA
(306) 766-4306
- BAUR, JOHN M**
DEPT OF BIOLOGY
BRESCIA COLLEGE
120 WEST SEVENTH ST
OWENSBORO, KY 42301
(502) 685-3131 EXT 276
- CREUTZ, CHARLES**
DEPT OF BIOLOGY
UNIV OF TOLEDO
2801 W BANCROFT ST
TOLEDO, OH 43606
(419) 537-4159
- HALL, LEO**
PHILLIPS UNIV
BOX 2000 UNIV STATION
ENID, OK 73702
(405) 237-4433 EXT 398
- LA BAR, MARTIN**
CENTRAL WESLEYAN
COLLEGE
CENTRAL, SC 29630
(803) 639-2453
- SPITZNAGEL, DR JOHN K**
DEPT OF MICROBIOLOGY &
IMMUNOLOGY
EMORY UNIV SCHOOL OF
MEDICINE
502 WOODRUFF MEM BLDG
ATLANTA, GA 30322
(404) 727-5947
- STANSFIELD, WILLIAM**
DEPT OF BIOLOGICAL
SCIENCE
CAL POLYTECH STATE UNIV
SAN LUIS OBISPO, CA 93407
(805) 546-2875
- VOORHEES, FRANK RAY**
DEPT OF BIOLOGY
CENTRAL MISSOURI STATE
UNIV
WCM 306
WARRENSBURG, MO 64093
(816) 429-4933
- WOLF, THOMAS M**
DEPT OF BIOLOGY
WASHBURN UNIV OF TOPEKA
1700 COLLEGE AVE
TOPEKA, KS 66621
(913) 295-6768
- INSTRUCTIONAL DESIGN**
HEESTANT, DIANE
LEARNING RESOURCES
MERCER SCHOOL OF
MEDICINE
MACON, GA 31267
(912) 744-4026
- INTERNAL MEDICINE**
BETESH, DR JOEL
LAWRENCE PARK MEDICAL
OFFICE
2000 SPROUL ROAD
BROOMALL, PA 19308
(215) 359-1355
- TALLEY, ROBERT C**
UNIV OF SOUTH DAKOTA
2501 W 22ND ST
SIOUX FALLS, SD 57101
(605) 339-6790
- WAIVERS, LEO E**
UNIVERSITY HOSPITAL
NEW JERSEY MEDICAL
SCHOOL
100 BERGEN ST
ROOM 1-247
NEWARK, NJ 07103
(201) 456-6057
- LIMNOLOGY**
WHALLS, MARVIN J
DEPT OF BIOL SCIENCE
CAL POLYTECH STATE UNIV
SAN LUIS OBISPO, CA 93407
(805) 546-1357
- LIVESTOCK PRODUCTION**
OLTJEN, J W
DEPT OF ANIMAL SCIENCE
OKLAHOMA STATE UNIV
STILLWATER, OK 74078
(405) 624-6070
- MARINE SCIENCE**
BOYNTON, DR JOHN E
ST JOSEPH'S COLLEGE
155 ROE BLVD
PATCHOGUE, NY 11772
(516) 654-3200
- FORTNER, ROSANNE**
OHIO STATE UNIV
SCHOOL OF NATURAL
RESOURCES
2021 COFFEY ROAD
COLUMBUS, OH 43210
(614) 422-2265
- SINGLETARY, ROBERT L**
DEPT OF BIOLOGY
UNIV OF BRIDGEPORT
BRIDGEPORT, CT 06601
(203) 576-4265
- MEDICAL TECHNOLOGY/ ASS'T**
GRADY, DAVID V
DEPT OF BIOLOGICAL
SCIENCES
CAL POLYTECH STATE UNIV
SAN LUIS OBISPO, CA 93407
(805) 546-2883
- KLAAS, JUDY C**
DEPT OF BIOLOGY
FRAMINGHAM STATE
COLLEGE
BOX 2000
FRAMINGHAM, MA 01701
(617) 620-1220 EXT 459
- ZEITZER, SHIRLEY**
DAVENPORT COLLEGE
415 EAST FULTON
GRAND RAPIDS, MI 49503
(616) 451-3511
- MICROANATOMY**
FEEDBACK, DANIEL
DEPT OF ANATOMICAL SCI
UNIV OKLA HEALTH SCI CTR
PO BOX 26901 BMSB540
OKLAHOMA CITY, OK 73190
(405) 271-2377
- MICROBIOLOGY**
ALBRITTON, WILLIAM L
DEPT OF MICROBIOLOGY
UNIV OF SASKATCHEWAN
SASKATOON, SK S7N 0W0
CANADA
(306) 966-4306
- BAUR, JOHN M**
DEPT OF BIOLOGY
BRESCIA COLLEGE
OWENSBORO, KY 42301
(502) 685-3131 EXT 276
- CALDWELL, DOUG**
DEPTS OF APPLIED MICRO-
BIOLOGY & FOOD SCIENCE
UNIV OF SASKATCHEWAN
SASKATOON, SK S7N 0W0
CANADA
(306) 966-5026
- DILLEHAY, DR JANE**
DEPT OF BIOLOGY
GALLAUDET COLLEGE
WASHINGTON DC 20002
(202) 651-5531
- DOYLE, JAMES**
DEPT OF BIOLOGY
AQUIN COLLEGE
GRAND RAPIDS, MI 49506
(616) 456-8281 EXT 387
- EISENSTARK, A**
DEPT OF BIOL SCIENCE
UNIV OF MISSOURI AT
COLUMBIA
COLUMBIA, MO 65211
(314) 882-7098
- ELDER, DR BETTY**
DEPT OF BIOLOGY
GEORGIA SOUTHWESTERN
COLLEGE
AMERICUS, GA 31709
(912) 928-1210
- GIBSON, LINDA**
DEPT OF BIOLOGY
EASTERN WASH UNIV
CHENEY, WA 99004
(509) 359-2845
- GRADY, DAVID V**
DEPT OF BIOL SCIENCES
CAL POLYTECH STATE UNIV
SAN LUIS OBISPO, CA 93407
(805) 546-2883
- HALL, LEO**
PHILLIPS UNIV
BOX 2000 UNIV STATION
ENID, OK 73702
(405) 237-4433 EXT 398
- HEIMBROOK, MARGARET E**
DEPT OF BIOL SCIENCES
UNIV OF NORTHERN COLO
GREELEY, CO 80639
(303) 351-2644
- HODGSON, DR LYNN M**
NORTHERN STATE COLLEGE
BOX 673
ABERDEEN, SD 57401
(605) 222-2432
- KLAAS, JUDY C**
DEPT OF BIOLOGY
FRAMINGHAM STATE
COLLEGE
BOX 2000
FRAMINGHAM, MA 01701
(617) 620-1220 EXT 459
- KRUSE, ANNA C**
CABRINI COLLEGE
RADNOR, PA 19087
(215) 687-2100
- NIERLICH, DONALD P**
DEPT OF MICROBIOLOGY
UCLA
LIFE SCIENCES 5304
LOS ANGELES, CA 90024
(213) 825-6720
- PARKER, CHARLOTTE D**
DEPT OF MICROBIOLOGY
SCHOOL OF MEDICINE
UNIV OF MISSOURI M264
COLUMBIA, MO 65212
(314) 882-8152
- PRESCOTT, LANSING M**
DEPT OF BIOLOGY
AUGUSTANA COLLEGE
29TH AND S SUMMIT
SIOUX FALLS, SD 57197
(605) 336-4719
- REDD, MRS THOMASINA**
DEPT OF NATURAL SCIENCE
ALDERSON-BROADBUSH
COLLEGE
BOX 517
PHILIPPI, WV 26416
(304) 457-1700 EXT 243
- SABOSKI, ELEANOR M**
NEW ENG AND COLLEGE
HENNIKER, NH 03242
(603) 428-2374
- SINNAMON, WALT**
CENTRAL WESLEYAN
COLLEGE
BOX 443
CENTRAL, SC 29630
(803) 639-2453 EXT 356
- SOBIESKI, ROD**
DEPT OF BIOLOGY
EMPORIA STATE UNIV
1200 COMMERCIAL
EMPORIA, KS 66801
(316) 343-1200 EXT 5620
- SOTTNEK, HENRY M**
DEPT OF MEDICAL
TECHNOLOGY
GEORGIA STATE UNIV
ATLANTA, GA 30303
(404) 658-3034
- SPENCE, LESLIE**
18 INEZ COURT
WILLOWDALE, ONT M2M 1C2
CANADA
(416) 595-3079

- SPITZNAGEL, DR JOHN K
DEPT OF MICROBIOLOGY &
IMMUNOLOGY
EMORY UNIV SCHOOL OF
MEDICINE
502 WOODRUFF MEM BLDG
ATLANTA, GA 30322
(404) 727-5947
- STONE, LARRIE E
DANA COLLEGE
BLAIR, NE 68008
(402) 426-4101 EXT 229
- STRATTON, LEWIS P
DEPT OF BIOLOGY
FURMAN UNIV
GREENVILLE, SC 29613
(803) 294-3249
- WALKER, RICHARD
STERLING COLLEGE
STERLING, KS 67579
(316) 278-2173
- WILHELM, DALLAS
DEPT OF BIOLOGY
HASTINGS COLLEGE
HASTINGS, NE 68901
(40) 463-2402 EXT 264
- MODELING**
WATROUS, JAMES
DEPT OF BIOLOGY
ST JOSEPH'S UNIV
PHILADELPHIA, PA 19131
(215) 879-7342
- MOLECULAR BIOLOGY**
BERGQUIST, BART
DEPT OF BIOLOGY
UNIV OF NORTHERN IOWA
CEDAR FALLS, IA 50614
(319) 273-2723
- BOND, CLIFFORD
DEPT OF MICROBIOLOGY
MONTANA STATE UNIV
BOZEMAN, MT 59717
(406) 994-4130
- DILLEHAY, DR JANE
DEPT OF BIOLOGY
GALLAUDET COLLEGE
800 FLORIDA AVE NE
WASHINGTON, DC 20002
(202) 651-5531
- GORMAN, MARK
BALDWIN-WALLACE COLLEGE
LIFE SCIENCE BLDG
BEREA, OH 44017
(216) 826-2217
- KLEINSMITH, LEWIS J
DEPT OF BIOLOGY
UNIV OF MICHIGAN
2056 NATURAL SCIENCE
ANN ARBOR, MI 48109-1948
(313) 763-3290
- PRESCOTT, LANSING M
DEPT OF BIOLOGY
AUGUSTANA COLLEGE
29TH AND S SUMMIT
SIOUX FALLS, SD 57117
(605) 336-4719
- REDD, MRS THOMASINA
DEPT OF NATURAL SCIENCE
ALDERSON-BROADBUSH
COLLEGE
BOX 517
PHILIPPI, WV 26416
(304) 457-1700 EXT 243
- WOLF, THOMAS M
DEPT OF BIOLOGY
WASHBURN UNIV OF TOPEKA
1700 COLLEGE AV
TOPEKA, KS 66621
(913) 295-6768
- MOLECULAR GENETICS**
HALL, LEO
PHILLIPS UNIV
BOX 2000 UNIV STATION
ENID, OK 73702
(405) 237-4433 EXT 398
- NIERLICH, DONALD P
DEPT OF MICROBIOLOGY
UCLA
LIFE SCIENCES 5304
LOS ANGELES, CA 90024
(213) 825-6720
- NATURAL HISTORY**
GAMBS, ROGER
DEPT OF BIOL SCIENCE
CAL POLYTECH STATE UNIV
SAN LUIS OBISPO, CA 93407
(805) 546-2551
- NEUROANATOMY**
MEYERS, PAUL E
DEPT OF BIOL CHEM &
STRUCTURE
THE CHICAGO MEDICAL
SCHOOL
3333 GREEN BAY RD NORTH
CHICAGO, IL 60664
(312) 578-3000 EXT 458
- NEUROBIOLOGY/NEUROSCIENCE**
BUCHHOLZ, ROBERT H
DEPT OF BIOLOGY
MONTMOUTH COLLEGE
MONTMOUTH, IL 61462
(309) 457-2350
- NEAFSEY, E J
DEPT OF ANATOMY
LOYOLA UNIV MED CTR
MAYWOOD, IL 60153
(312) 531-3355
- RALSTON, H J
DEPT OF ANATOMY S-1334
UNIV CA SAN FRANCISCO
SAN FRANCISCO, CA 94143
(415) 476-1861
- STOUT, JOHN
DEPT OF BIOLOGY
ANDREWS UNIV
BERRIEN SPRINGS, MI 49104
(616) 471-3243
- YORK, DR DONALD H
DEPT OF PHYSIOLOGY
UNIV OF MISSOURI
MA415 MEDICAL SCI BLDG
COLUMBIA, MO 65212
(514) 882-7168
- NURSING**
ABBATE, JUDITH
COLLEGE OF NURSING
UNIV OF RHODE ISLAND
KINGSTON, RI 02881
(401) 772-2766
- BENEDICT, SUSAN
209 MOUNTAIN RIDGE DRIVE
HUNTSVILLE, AL 35801
(205) 536-7101
- BUDEY, WENDY
COLLEGE NURSING
SETON HALL UNIV
SOUTH ORANGE, NJ 07079
(201) 761-9299
- CLAUS, SACHIKO K
DEPT OF NURSING
SAGINAW VALLEY STATE
COLLEGE
UNIVERSITY CTR, MI 48710
(517) 790-4129
- DREHER, MARY ANN
25034 SHEFFIELD ROAD
GLEN ELLYN, IL 60137
- GARDINER, MARY
RED DEER COLLEGE
RED DEER, ALBERTA T5N 5H5
CANADA
(403) 342-3362
- GROBE, S J
SCHOOL OF NURSING
UNIV OF TEXAS
AUSTIN, TX 78701
(512) 471-7311
- HASKIN, DOUGLAS E
SCHOOL OF NURSING
UNIV TEXAS MEDICAL
BRANCH R-49
GALVESTON, TX 77550
(409) 761-1577
- HODSON, KAY E
SCHOOL OF NURSING CN355
BALL STATE UNIV
MUNCIE, IN 47306
(317) 285-5583
- KRISTENSEN, KAREN
TRI-COLLEGE UNIV OF NURS
NORTH DAKOTA STATE UNIV
FARGO, ND 58105
(701) 237-8170
- KUREN, KATHERINE
COLLEGE OF NURSING
SETON HALL UNIV
SOUTH ORANGE, NJ 07079
(201) 761-9303
- LIBEY, TERRY
DEPT OF HEALTH CAREERS
LANSING COMMUNITY
COLLEGE
419 N CAPITOL AVE
LANSING, MI 48901-7211
- LOUIS, MARGARET
DEPT OF NURSING
UNIV OF NEVADA, LAS VEGAS
LAS VEGAS, NV 89154
- MIKAN, KATHLEEN
SCHOOL OF NURSING
UNIV ALABAMA AT
BIRMINGHAM
BIRMINGHAM, AL 35294
(205) 924-4837
- MURRAY, LAURIE R
COLLEGE OF NURSING
UNIV OF RHODE ISLAND
KINGSTON, RI 02881-0814
(401) 792-2766
- RONALD, DR JUDITH
SCHOOL OF NURSING
SUNY AT BUFFALO
BUFFALO, NY 14214
(716) 831-3645
- SCHARF, MARY ANN
COLLEGE OF NURSING
SETON HALL UNIV
SOUTH ORANGE, NJ 07079
(201) 761-9293
- SINCLAIR, VAUGHN G
VANDERBILT UNIV SCHOOL
OF NURSING
NASHVILLE, TN 37235
(615) 322-2813
- SKIBA, DIANE
23 HOLMES ST
DEDHAM, MA 02026
(617) 461-0276
- TIEDE, LINDA Q
36203 DERBY DOWNS
SOLON, OH 44139
(216) 248-3537
- WHITE, JOYCE E
UNIV OF PITTSBURGH
426 VICTORIA BLDG
PITTSBURGH, PA 15261
(412) 624-3835
- NUTRITION**
DICKINSON, WINIFRED
DEPT OF BIOLOGY
UNIV OF STEUBENVILLE
STEUBENVILLE, OH 43952
(614) 283-3771
- HARROLD, ROBERT
DEPT OF ANIM & RANGE SCI
NORTH DAKOTA STATE UNIV
FARGO, ND 58105
(701) 237-7659
- HESTON, W M
CTR FOR NATURAL SCIENCES
NEW YORK INST TECH
OLD WESTBURY, NY 11568
(516) 686-7665
- HU, CHING YUAN
DEPT OF ANIMAL SCIENCE
OREGON STATE UNIV
CORVALLIS, OR 97331
(503) 754-4761
- OLTJEN, J W
DEPT OF ANIMAL SCIENCE
OKLAHOMA STATE UNIV
STILLWATER, OK 74078
(405) 624-6670

- SCHNEIWEISS, JEANNETTE W
DEPT OF BIOLOGY
HOFSTRA UNIV
HEMPSTEAD, NY 11550
(516) 560-5521
- SHORT, SARAH H
SYRACUSE UNIV
112 SLOCUM HALL
SYRACUSE, NY 13244-1250
(315) 423-2386
- WAGNER, MARTIN J
DEPT OF BIOCHEMISTRY
BAYLOR COLLEGE OF
DENTISTRY
DALLAS, TX 75246
(214) 828-8261
- ORAL HISTOLOGY**
FEEBACK, DANIEL
DEPT OF ANAT SCIENCE
UNIV OF OKLAHOMA HEALTH
SCIENCE CENTER
PO BOX 26901 BMSB540
OKLAHOMA CITY, OK 73190
(405) 271-2377
- ORAL PATHOLOGY**
ABBEY, LOUIS M
DEPT OF ORAL PATHOLOGY
VIRGINIA COMMUNWEALTH
UNIV
BOX 566 MCV STATION
RICHMOND, VA 23298
(804) 786-0547
- FINKELSTEIN, MICHAEL
DEPT OF ORAL PATHOLOGY
COLLEGE OF DENTISTRY
UNIV OF IOWA
IOWA CITY, IA 52242
(319) 353-7370
- ORNITHOLOGY**
CYR, ANDRE
DEPT OF BIOLOGY
UNIV OF SHERBROOKE
SHERBROOKE, QUEBEC
CANADA J1K 2R1
(819) 821-7074
- PARRISH, DR JOHN
DEPT OF BIOLOGY
EMPORIA STATE UNIV
EMPORIA, KS 66801
(316) 343-1200
- VERCH, RICHARD
DEPT OF BIOLOGY
NORTHLAND COLLEGE
ASHLAND, WI 54806
(715) 682-4531 EXT 335
- PARASITOLOGY**
BAUR, JOHN M
DEPT OF BIOLOGY
BRESCIA COLLEGE
OWENSBORO, KY 42301
(502) 685-3131 EXT 276
- PATHOLOGY**
FEEBACK, DANIEL
DEPT OF ANAT SCIENCE
UNIV OF OKLAHOMA HEALTH
SCIENCE CENTER
PO BOX 26901 BMSB540
OKLAHOMA CITY, OK 73190
(405) 271-2377
- GANDER, G WM
DEPT OF PATHOLOGY
MEDICAL COLLEGE OF
VIRGINIA
BOX 662
RICHMOND, VA 23298
(804) 786-7719
- JOHNY, DR SERGE
DEPT OF PATHOLOGY
McGILL UNIV
3775 UNIVERSITY ST
MONTREAL, QUEBEC H3A 2B4
CANADA
(514) 842-1231
- KLAAS, JUDY C
DEPT OF BIOLOGY
FRAMINGHAM STATE
COLLEGE
BOX 2000
FRAMINGHAM, MA 01701
(617) 620-1220 EXT 459
- LEIGHTON, FREDERICK A
DEPT OF VETERINARY
PATHOLOGY
UNIV OF SASKATCHEWAN
SASKATOON, SK S7N 0W0
CANADA
(306) 966-7293
- McMANNO, BRUCE
DEPT OF PATHOLOGY
UNIV NEBRASKA MED CTR
42ND & DEWEY AVE
OMAHA, NE 68105
(402) 559-5192
- PALMER, KENNETH C
DEPT OF PATHOLOGY
WAYNE STATE UNIV SCHOOL
OF MEDICINE
540 E CANFIELD
DETROIT, MI 48201
(313) 577-5152
- YOSHIMURA, MICHAEL A
DEPT OF BIOL SCIENCE
CAL POLYTECH STATE UNIV
SAN LUIS OBISPO, CA 93407
(805) 546-2466
- PEDIATRICS**
WINTER, ROBERT J
CHILDREN'S MEMORIAL HOSP
2300 CHILDREN'S PLAZA
CHICAGO, IL 60614
(312) 380-4196
- PHARMACOLOGY**
BEHEL, MARGARET A
ROUTE 3 BOX 77
PHIL CAMPBELL, AL 35585
(205) 993-5331
- CONAHAN, SHAWN T
DEPT OF PHYSIOLOGY
LOUISIANA STATE UNIV MED
CTR
1901 PERDIDO ST
NEW ORLEANS, LA 70112
(504) 582-5783
- GWINN, DR JOHN F
DEPT OF BIOLOGY
UNIV OF AKRON
AKRON, OH 44325
(216) 375-7160
- HAGEN, STANLEY VON
DEPT OF PHARMACOLOGY
NEW JERSEY MEDICAL
SCHOOL
NEWARK, NJ 07103
(201) 456-4385
- SPYKER, D A
UNIV OF VIRGINIA SCHOOL
OF MEDICINE
BOX 484 MEDICAL CENTER
CHARLOTTESVILLE, VA 22908
- PHYSIOLOGY**
ABRAHAMS, V C
DEPT OF PHYSIOLOGY
QUEEN'S UNIVERSITY
KINGSTON, ONTARIO K7L 3N6
CANADA
(613) 547-3022
- AMLANER, CHARLES J Jr
DEPT OF ZOOLOGY
UNIV OF ARKANSAS
FAYETTEVILLE, AR 72701
- BASHOR, DAVID P
DEPT OF BIOLOGY
UNIV N CAROLINA AT
CHARLOTTE
CHARLOTTE, NC 28223
(704) 597-4047
- BAUR, JOHN M
DEPT OF BIOLOGY
BRESCIA COLLEGE
120 WEST SEVENTH ST
OWENSBORO, KY 42301
(502) 685-3131 EXT 276
- BERG, VIRGINIA
DEPT OF BIOLOGY
UNIV OF NORTHERN IOWA
CEDAR FALLS, IA 50614
(319) 273-2770
- BERGQUIST, BART
DEPT OF BIOLOGY
UNIV OF NORTHERN IOWA
CEDAR FALLS, IA 50614
(319) 273-2723
- BORQUEZ, DR RICARDO LEON
UNIV AUTO GUADALAJARA
LOMAS DEL VALLE 1ERA
SECC
GUADALAJARA
MEXICO JAL 1-440
- BROOKE, DR JOHN D
NEUROPHYSIOLOGY LAB
UNIVERSITY OF GUELPH
SCHOOL OF HUMAN BIOLOGY
GUELPH, ONTARIO N1G 2W1
CANADA
(519) 824-4120 EXT 3416
- BROWN, DAVID E
DEPT OF ANIMAL SCIENCE
UNIV OF NEVADA AT RENO
RENO, NV 89557-0004
(702) 784-1629
- BRUMLEVE, STANLEY J
DEPT OF PHYSIOLOGY
SCHOOL OF MEDICINE
UNIV OF NORTH DAKOTA
GRAND FORKS, ND 58202
(701) 777-3974
- BUCHHOIZ, ROBERT H
DEPT OF BIOLOGY
MONMOUTH COLLEGE
MONMOUTH, IL 61462
(309) 457-2350
- BURNS, DR THOMAS A
DEPT OF BIOLOGY &
MICROBIOLOGY
NORTHWESTERN STATE UNIV
NATCHITOCHEES, LA 71497
(318) 357-5323
- CAMERON, DAVID G
DEPT OF BIOLOGY
MONTANA STATE UNIV
BOZEMAN, MT 59717
(406) 994-2670
- CAMPBELL, KENNETH
VCAPP
WASHINGTON STATE UNIV
PULLMAN, WA 99164-6520
(509) 335-6621
- CAMPBELL, KEVIN P
DEPT OF PHYSIOL & BIOPHYS
UNIV OF IOWA
IOWA CITY, IA 52240
(319) 351-5833
- CHEW, CATHERINE S
DEPT OF PHYSIOLOGY
MOREHOUSE SCHOOL OF
MEDICINE
ATLANTA, GA 30310-1495
(404) 752-1692
- CHIEN, DR SHU
DEPT OF PHYSIOL & BIOPHYS
COLUMBIA UNIV
620 WEST 168TH ST
NEW YORK, NY 10032
(212) 305-3686
- CHRISTOFFERSON, JAY P
DEPT OF BIOLOGY
CALIFORNIA STATE UNIV AT
STANISLAUS
TURLOCK, CA 95380
(209) 667-3476
- CLARK, FRANCIS J
DEPT OF PHYSIOLOGY
UNIV OF NEBRASKA MED CTR
42ND & DEWEY AVE
OMAHA, NE 68105
(402) 559-6478
- CLARK, JAMES R
DEPT OF ANIMAL SCIENCE
TEXAS TECH UNIV
PO BOX 4169
LUBBOCK, TX 79409-4169
(806) 742-2469
- COCKERHAM, BILL
FRESNO PACIFIC COLLEGE
1717 S CHESTNUT
FRESNO, CA 93702
(209) 453-2045
- CONAHAN, SHAWN T
DEPT OF PHYSIOLOGY
LOUISIANA STATE UNIV MED
CENTER
1901 PERDIDO ST
NEW ORLEANS, LA 70112
(504) 582-5783

- CONSIGNY, P MACK
DEPT OF PHYSIOLOGY
MEDICAL COLLEGE OF
PENNSYLVANIA
3300 HENRY AVE
PHILADELPHIA, PA 19129
(215) 842-7059
- CUBINA, JOSEFA M
DEPT OF LIFE SCIENCES
NEW YORK INST OF TECH
OLD WESTBURY, NY 11568
(516) 686-7622
- DE JONG, ALVIN A
DEPT OF BIOL SCIENCE
CAL POLYTECH STATE UNIV
SAN LUIS OBISPO, CA 93407
(805) 546-2209
- DICKINSON, PROF C JOHN
DEPT OF MEDICINE
ST BARTHOLOMEW'S HOSP
MEDICAL COLLEGE
WEST SMITHFIELD LONDON,
ENGLAND EC1A7BE
- DICKINSON, WINIFRED
DEPT OF BIOLOGY
UNIV OF STEUBENVILLE
STEUBENVILLE, OH 43952
(614) 283-3771
- HIGGINS, MAUREEN
DEPT OF BIOLOGY
AUGUSTANA COLLEGE
29TH ST AND S SUMMIT
SIOUX FALLS, SD 57197
(605) 336-4809
- DOBSON, ALAN
DEPT OF PHYSIOLOGY
NYS COLLEGE OF VET MED
CORNELL UNIV
ITHACA, NY 14853
(607) 253-3847
- DOVE, LEWIS
DEPT OF BIOL SCIENCES
WESTERN ILLINOIS UNIV
MACOMB, IL 61455
(309) 298-1166
- DUGGAN, ELEANOR L
BIOLOGY DEPT
UNIV OF N CAROLINA AT
GREENSBORO
ROOM 309, EBERHART BLDG
GREENSBORO, NC 27412-5001
(919) 379-5839
- ELDER, DR BETTY
DEPT OF BIOLOGY
GEORGIA SOUTHWESTERN
COLLEGE
AMERICUS, GA 31705
(912) 928-1250
- FANNING, MARSHA E
DEPT OF BIOLOGY
LENOIR-RHYNE COLLEGE
HICKORY, NC 28603
(704) 328-7270
- FERNER, JOHN W
DEPT OF BIOLOGY
THOMAS MORE COLLEGE
CRESTVIEW HILLS, KY 41017
(606) 344-3374
- FREED, DR JAMES M
DEPT OF ZOOLOGY
OHIO WESLEYAN UNIV
DELAWARE, OH 43015
(614) 369-4431 EXT 400
- GRAY, F HARRIET
HOLLINS COLLEGE
BOX 9616
HOLLINS COLLEGE, VA 24020
(703) 362-6543
- GREEN, JONATHAN
DEPT OF BIOLOGY
ROOSEVELT UNIV
CHICAGO, IL 60605
(312) 341-3676
- GOOCH, VAN D
DEPT OF SCIENCE &
MATHEMATICS
UNIV OF MINNESOTA
MORRIS, MN 56267
(612) 589-2211
- GRUENER, RAPHAEL
DEPT OF PHYSIOLOGY
UNIV OF MARYLAND AT
BALTIMORE
BALTIMORE, MD 21201
(301) 528-2678
- GWINN, DR JOHN F
DEPT OF BIOLOGY
UNIVERSITY OF AKRON
AKRON, OH 44325
(216) 375-7160
- HAMPTON, JOHN K
DEPT OF BIOL SCIENCES
CAL POLYTECH STATE UNIV
SAN LUIS OBISPO, CA 93407
(805) 546-2819
- HECKENLIVELY, DONALD B
DEPT OF BIOLOGY
HILLSDALE COLLEGE
HILLSDALE, MI 49242
(517) 437-7341
- HEMPLING, HAROLD G
DEPT OF PHYSIOLOGY
MEDICAL UNIV S CAROLINA
CHARLESTON, SC 29425-2653
(803) 792-3646
- HULLIARD, STEPHEN
DEPT OF BIOLOGY
BALDWIN-WALLACE COLLEGE
BEREA, OH 44017
(216) 826-2265
- HOUSE, EDWIN W
DEPT OF BIOLOGY
IDAHO STATE UNIV
POCATELLO, ID 83209
(208) 236-3765
- HOUSE, DR HERBERT W
ELON COLLEGE
BOX 2270
ELON COLLEGE, NC 27244-2010
(919) 584-5359
- JEGLA, THOMAS C
DEPT OF BIOLOGY
KENYON COLLEGE
GAMBIER, OH 43022
(614) 427-2244
- JENNINGS, MICHAEL L
DEPT OF PHYSIOL & BIOPHYS
UNIV OF IOWA
IOWA CITY, IA 52242
(319) 353-4035
- JOHNSON, CLYDE E
DEPT OF BIOL SCIENCES
SOUTHERN UNIVERSITY
BATON ROUGE, LA 70813
(504) 771-5210
- JOHNSON, DAVID W
DEPT OF BIOLOGY
CONCORDIA COLLEGE
MOORHEAD, MN 56560
(218) 299-3085
- JOHNSON, IVAN M
DEPT OF BIOLOGY
CONCORDIA COLLEGE
MOORHEAD, MN 56560
(218) 299-3085
- JOHNSON, WALTER
NORTHWEST COLLEGE OF
CHIROPRACTIC
2501 W 84TH ST
BLOOMINGTON, MN 55431
(612) 888-4777 EXT 290
- JONES, MICHAEL E
DEPT OF ANATOMY &
HISTOLOGY
FLINDERS UNIV OF SO
AUSTRALIA
SCHOOL OF MEDICINE
BEDFORD PARK,
SOUTH AUSTRALIA 5042
(618) 275-9911 EXT 4281
- JOYNER, RONALD W
DEPT OF PHYSIOLOGY
UNIV OF IOWA
IOWA CITY, IA 52242
(319) 353-7024
- KALICHSTEIN, DENNIS
DEPT OF SCIENCE
OCEAN COUNTY COLLEGE
TOMS RIVER, NJ 08753
(201) 255-4000
- KENDRICK, J E
DEPT OF PHYSIOLOGY
UNIV OF WISCONSIN
134 SMI
MADISON, WI 53706
(608) 262 1465
- KESSELEP, SISTER IRMA
DEPT OF BIOLOGY
COLLEGE OF ST ELIZABETH
CONVENT STATION, NJ 07961
(211) 539-1600
- LAGLER, REGIS
CRITICAL CARE DEPT
METHODIST HOSPITAL
1701 N SENATE BLVD
INDIANAPOLIS, IN 46202
(317) 929-5293
- LAROCHELLE, JACQUES
DEPT OF BIOLOGY
LAVAL UNIV
QUEBEC, PQ
CANADA G1K 7P4
(418) 656-3187
- MCDONALD, DR GORDON
DEPT OF BIOLOGY
McMASTER UNIV
1280 MAIN ST WEST
HAMILTON, ONTARIO L8S 4K1
CANADA
(416) 525-9140 EXT 4266
- McHALE, PHILIP A
DEPT OF PHYSIOL & BIOPHYS
COLLEGE OF MEDICINE
UNIV OF OKLAHOMA HEALTH
SCIENCE CENTER
PO BOX 26901
OKLAHOMA CITY, OK 73190
(405) 271-2226
- MELNYCHUK, MARK S
DEPT OF BIOL & ALLIED
HEALTH SCIENCE
HART BLOOMSBURG UNIV
SCIENCE CENTER
BLOOMSBURG, PA 17815
(717) 389-4219
- MICKUS, JOHN
DEPT OF BIOLOGY
ILLINOIS BENEDICTINE
COLLEGE
LISLE, IL 60532-0900
(312) 960-1500 EXT 509
- MILLS, STEVEN H
DEPT OF BIOLOGY
CENTRAL MISSOURI STATE
UNIV
WARRENSBURG, MO 64093
(816) 429-4933
- MODELL, HAROLD
DEPT OF RADIOLOGY RC-70
UNIV OF WASHINGTON
SEATTLE, WA 98195
- MORIARTY, C MICHAEL
DEPT OF PHYSIOL & BIOPHYS
UNIV OF NEBRASKA MEDICAL
OMAHA, NE 68105
(402) 559-7282
- OWEN, LAWTON
KANSAS WESTERN
SALINA, KS 67401
(913) 827-5541
- NOCENTI, DR MR
DEPT OF PHYSIOL & BIOPHYS
COLUMBIA UNIV
NEW YORK, NY 10032
(212) 305-3636
- ORTIZ, C LEO
DEPT OF BIOLOGY
UNIV OF CALIFORNIA
SANTA CRUZ, CA 95064
(408) 429-2247
- PALMER, KENNETH C
DEPT OF PATHOLOGY
WAYNE STATE UNIV SCHOOL
OF MEDICINE
DETROIT, MI 48201
(313) 577-5152
- PARRISH, DR JOHN
DEPT OF BIOLOGY
EMPORIA STATE UNIV
EMPORIA, KS 66801
(316) 343-1200

- PETERSON, NILS
WASHINGTON STATE UNIV
COMPUTER SERVICE CENTER
PULLMAN, WA 99164-1220
(509) 335-0411
- QUINN, DAVID L
DEPT OF BIOLOGY
MUSKINGUM COLLEGE
NEW CONCORD, OH 43762-1199
(614) 826-8225
- RAM, JEFFREY L
DEPT OF PHYSIOLOGY
WAYNE STATE UNIV SCHOOL
OF MEDICINE
DETROIT, MI 48201
(313) 577-1558
- REINKING, LARRY N
DEPT OF BIOLOGY
MILLERSVILLE UNIV
MILLERSVILLE, PA 17551
(717) 872-3792
- RIESEN, JOHN
DEPT OF ANIMAL SCIENCE
UNIV OF CONNECTICUT U-40
STORRS, CT 06268
(203) 486-2541
- ROBBINS, DR HERBERT C
DALLAS BAPTIST UNIV
7777 WEST KIEST BLVD
DALLAS, TX 75211-9800
(214) 333-5302
- ROE, WALTER E
DEPT OF VET PHYSIOL SCI
UNIV OF SASKATCHEWAN
SASKATOON, SK S7N 0W0
CANADA
(306) 966-7371
- ROSELLI, ROBERT J
DEPT OF CHEM ENGINEERING
VANDERBILT UNIV
BOX 36 STATION B
NASHVILLE, TN 37235
(615) 322-2602
- ROTHE, DR CARL F
DEPT OF PHYSIOL & BIOPHYS
INDIANA UNIV SCHOOL OF
MEDICINE
635 BARNHILL DRIVE
INDIANAPOLIS, IN 46223
(317) 264-8250
- ROVICK, ALLEN A
DEPT OF PHYSIOLOGY
RUSH MEDICAL COLLEGE
CHICAGO, IL 60612
(312) 942-6567
- RUF, DR KURT B
DEPT OF PHYSIOL & BIOPHYS
DALHOUSIE UNIV
HALIFAX, NOVA SCOTIA
CANADA, B3H 4H7
(902) 424-3517
- SAGE, MARTIN
DEPT OF BIOLOGY
UNIV OF MISSOURI AT
ST LOUIS
8001 NATURAL BRIDGE RD
ST LOUIS, MO 63121
(314) 553-6218
- SCHMIDT, THOMAS J
DEPT OF PHYSIOL & BIOPHYS
UNIV OF IOWA
IOWA CITY, IA 52242
(319) 353-4018
- SCHNEIWEISS, JEANNETTE W
DEPT OF BIOLOGY
HOFSTRA UNIV
HEMPSTEAD, NY 11550
(516) 560-5521
- SIMPSON, R J
DEPT OF BIOLOGY
UNIV OF NORTHERN IOWA
CEDAR FALLS, IA 50614
(319) 273-2645
- SINNAMON, WALT
CENTRAL WESLEYAN
COLLEGE
CENTRAL, SC 29630
(803) 639-2453 EXT 356
- SLAYMAN, C L
DEPT OF PHYSIOLOGY
YALE SCHOOL OF MEDICINE
NEW HAVEN, CT 06510-8026
(203) 788-4478
- SMALL, JAMES W
DEPT OF BIOLOGY
ROLLINS COLLEGE
WINTER PARK, FL 32789
(305) 646-2433
- STEIN, PAUL
DEPT OF BIOLOGY
WASHINGTON UNIV
ST LOUIS, MO 63130
(314) 889-6824
- STOUT, JOHN
DEPT OF BIOLOGY
ANDREWS UNIV
BERRIEN SPRINGS, MI 49104
(616) 471-3243
- SULAKHE, DR P V
DEPT OF PHYSIOLOGY
COLLEGE OF MEDICINE
UNIV OF SASKATCHEWAN
SASKATOON, SK S7N 0W0
CANADA
(306) 966-6534
- SWEET, HAVEN
DEPT OF BIOLOGY
UNIV OF CENTRAL FLORIDA
ORLANDO, FL 32816
(305) 275-2922
- TAYLOR, JAMES WM
KALAMAZOO VALLEY
COMMUNITY COLLEGE
KALAMAZOO, MI 49009
(616) 372-5356
- TESKEY, SISTER NANCY
HOLY NAMES COLLEGE
OAKLAND, CA 94619
(415) 436-0111
- TURNELL, M J
DEPT OF ZOOLOGY
UNIVERSITY OF ALBERTA
CW 312 BIOL SCI BLDG
EDMONTON, ALBERTA
CANADA T6G 2E9
(403) 432-0665
- VAN AMBURG, GERALD L
DEPT OF BIOLOGY
CONCORDIA COLLEGE
MOORHEAD, MN 56560
(218) 299-3085
- WALKER, RICHARD
STERLING COLLEGE
STERLING, KS 67579
(316) 278-2173
- WATROUS, JAMES
DEPT OF BIOLOGY
ST JOSEPH'S UNIV
PHILADELPHIA, PA 19131
(215) 879-7342
- WEISBART, DR MELVIN
DEPT OF BIOLOGY
ST FRANCIS XAVIER UNIV
ANTIGONISH, NOVA SCOTIA
CANADA B2G 1C0
(902) 867-2294
- WILHELM, DALLAS
DEPT OF BIOLOGY
HASTINGS COLLEGE
HASTINGS, NE 68901
(402) 463-2402 EXT 264
- WILLIAMS, W E
DEPT OF BIOLOGY
TRINITY COLLEGE
HARTFORD, CT 06106
(203) 527-3151 EXT 570
- WILLISTON, JOHN S
DEPT OF BIOLOGY
SAN FRANCISCO STATE UNIV
SAN FRANCISCO, CA 94132
(415) 584-5319
- WILSON, DR MARLENE M
UNIV OF PORTLAND
PORTLAND, OR 97203
(503) 283-7123
- WOLF, MATTHEW B
DEPT OF PHYSIOLOGY
SCHOOL OF MEDICINE
UNIV S CAROLINA
COLUMBIA, SC 29208
(803) 733-3241
- WOLLIN, A
DEPT OF PHYSIOLOGY
COLLEGE OF MEDICINE
UNIV OF SASKATCHEWAN
SASKATOON, SK S7N 0W0
CANADA
- WUNDER, CHARLES C
PHYSIOLOGY RESEARCH LAB
UNIV OF IOWA
OAKDALE, IA 52319
(319) 353-4704
- YORK, DR DONALD H
DEPT OF PHYSIOLOGY
UNIV OF MISSOURI AT
COLUMBIA
COLUMBIA, MO 65212
(314) 882-7168
- YOUNG, BRUCE A
DEPT OF ANIMAL SCIENCE
UNIVERSITY OF ALBERTA
EDMONTON, ALBERTA
CANADA T6G 2P5
(403) 432-3233
- ZEITZER, SHIRLEY
DAVENPORT COLLEGE
415 EAST FULTON
GRAND RAPIDS, MI 49503
(616) 451-3511
- ZIMMERMAN, JAY
DEPT OF BIOL SCIENCES
ST JOHN'S UNIV
GRAND CENTRAL &
UTOPIA PKWS
NEW YORK, NY 11439
(718) 990-6161 EXT 5233
- PLANT PHYSIOLOGY
STEUCEK, DR GUY L
DEPT OF BIOLOGY
MILLERSVILLE UNIV
MILLERSVILLE, PA 17551
(717) 872-3339
- PSYCHIATRY
PARISI, ANTHONY J
WRIGHT STATE UNIV SCHOOL
OF MEDICINE
DAYTON, OH 45401-0927
(513) 376-6711
- SEROLOGY
STANSFIELD, WILLIAM
DEPT OF BIOL SCIENCE
CAL POLYTECH STATE UNIV
SAN LUIS OBISPO, CA 93407
(805) 546-2875
- STATISTICS
BENEDICT, DR SUSAN
209 MOUNTAIN RIDGE DRIV
HUNTSVILLE, AL 35801
(205) 536-7101
- BROOKE, DR JOHN D
NEUROPHYSIOLOGY LAB
UNIVERSITY OF GUELPH
SCHOOL OF HUMAN BIOLOGY
GUELPH, ONTARIO N1G 2W1
CANADA
(519) 824-4120 EXT 3416
- CHEW, F S
DEPT OF BIOLOGY
TUFTS UNIV
MEDFORD, MA 02155
(617) 381-3189 EXT 3195
- CLARK, JAMES R
DEPT OF ANIMAL SCIENCE
TEXAS TECH UNIV
LUBBOCK, TX 79409-4169
(806) 742-2469
- CODY, RONALD
DEPT OF ENVIRON &
COMMUNITY MEDICINE
RUTGERS MEDICAL SCHOOL
PISCATAWAY, NJ 08854
(201) 463-4490
- FASHING, NORMAN J
DEPT OF BIOLOGY
COLLEGE OF WILLIAM
AND MARY
WILLIAMSBURG, VA 23185
- HAGEN, STANLEY VON
DEPT OF PHARMACOLOGY
NEW JERSEY MEDICAL
SCHOOL
NEWARK, NEW JERSEY 07103
(201) 456-4385

RIPPEY, ROBERT
RHE AMO34
UNIV CONN HEALTH CTR
FARMINGTON, CT 06073
(203) 674-2353

SCHWARTZ, ORLANDO A
DEPT OF BIOLOGY
UNIV OF NORTHERN IOWA
CEDAR FALLS, IA 50614
(319) 273-2106

TAUB, STEPHAN R
DEPT OF BIOLOGY
GEORGE MASON UNIV
FAIRFAX, VA 22030
(703) 323-2181

WERNER, J KIRWIN
DEPT OF BIOLOGY
NORTHERN MICHIGAN UNIV
MARQUETTE, MI 49855
(906) 227-2310

INVITATION TO CONTRIBUTORS

Articles consistent with the goals of *Computers in Life Science Education* are invited for possible publication in the newsletter.

PREPARATION AND SUBMISSION OF MATERIAL

Articles submitted for publication should not exceed 2000 words and should be typewritten, double spaced, with wide margins. The original and two copies including two sets of figures and tables should be sent to the Editor: Dr. Harold Modell, NRCLSE, Mail Stop RC-70, University of Washington, Seattle, WA 98195.

Title page should include full title, list of authors, academic or professional affiliations, and complete address and phone number of the corresponding author.

Illustrations should be submitted as original drawings in India ink or sharp, high contrast reproductions. The lettering should be such that it can be legible after reduction (width of one column = 5.7 cm). High contrast computer outputs are acceptable.

Reference style and form should follow the "number system with references alphabetized" described in the Council of Biology Editors Style Manual. References should be listed in alphabetical order by the first author's last name, numbered consecutively, and cited in the text by these numbers.

RESPONSIBILITY AND COPYRIGHT

Authors are responsible for accuracy of statements and opinions expressed in articles. All authors submitting manuscripts will be sent a copyright transfer form to complete. The completed form must be returned before the work will be published.

SUBSCRIPTION INFORMATION

Computers in Life Science Education is published monthly by National Resource for Computers in Life Science Education, Mail Stop RC-70, University of Washington, Seattle, WA 98195. Subscription rate is \$30.00 for 12 issues, including postage and handling in the United States and Canada. Add \$20.00 for postage (airmail) in Mexico and Europe and \$23.00 for the rest of the world.

This newsletter has been registered with the Copyright Clearance Center, Inc. Consent is given for copying of articles for personal or internal use, or for the personal or internal use of specific clients. This consent is given on the condition that the copier pay through the Center the per-copy fee stated in the code on the first page for copying beyond that permitted by the US Copyright Law. If no code appears on an article, the author has not given broad consent to copy and permission to copy must be obtained directly from the author. This consent does not extend to other kinds of copying, such as for general distribution, resale, advertising and promotional purposes, or for creating new collective works.

Address orders, changes of address, and claims for missing issues to NRCLSE, Mail Stop RC-70, University of Washington, Seattle, WA 98195. Claims for missing issues can be honored only up to three months for domestic addresses and six months for foreign addresses. Duplicate copies will not be sent to replace ones undelivered due to failure to notify NRCLSE of change of address.

Address editorial correspondence to Harold I. Modell, PhD, NRCLSE, Mail Stop RC-70, University of Washington, Seattle, WA 98195. (BITNET MODEL@UWALOCKE)

POSTMASTER: Send address changes to *Computers in Life Science Education*, NRCLSE, Mail Stop RC-70, University of Washington, Seattle, WA 98195.

COMPUTERS IN LIFE SCIENCE EDUCATION

HAROLD L. MODELL

Department of Radiology
University of Washington
Seattle, Washington

MARCEL BLANCHAER

Department of Biochemistry
Faculty of Medicine
University of Manitoba
Winnipeg, Manitoba
Canada

THEODORE J. CROVELLO

Department of Biology
University of Notre Dame
Notre Dame, Indiana

JAMES W. ECKBLAD

Department of Biology
Luther College
Decorah, Iowa

TSEGAYE HABTEMARIAM

School of Veterinary Medicine
Tuskegee University
Tuskegee, Alabama

DONNA LARSON

School of Nursing
Grand Valley State College
Allendale, Michigan

TERRY M. MIKITTEN

Graduate School of Biomedical Sciences
University of Texas Health Science Center
San Antonio, Texas

JAMES E. RANDALL

Department of Physiology
Indiana University
Bloomington, Indiana

PATRICIA SCHWIRIAN

College of Nursing
Ohio State University
Columbus, Ohio

RICHARD STULL

College of Pharmacy
University of Arkansas
Little Rock, Arkansas

JAMES W. WOODS

Lister Hill National Center
for Biomedical Communications
National Library of Medicine
Bethesda, Maryland

DOROTHY WOOLEY-McKAY

Department of Biology
Glendale Community College
Glendale, Arizona

GLEN YOSHIDA

Department of Life Sciences
Los Angeles Southwest College
Los Angeles, California

NRCLSE

CONTENTS

USES OF MICROCOMPUTERS IN SYSTEMS ECOLOGY AND WILDLIFE MANAGEMENT INSTRUCTION	9
Robert H. Giles, Jr.	
ADAPTATION OF INTERACTIVE VIDEODISC IN MEDICAL EDUCATION	12
James S. Fine	
CLSE COLLEAGUE DIRECTORY - PART III	15

USES OF MICROCOMPUTERS IN SYSTEMS ECOLOGY AND WILDLIFE MANAGEMENT INSTRUCTION

Robert H. Giles, Jr.

Department of Fisheries and Wildlife Sciences, Virginia Polytechnic Institute and State University, Blacksburg, Virginia

Practicing what you preach is difficult in any field, but it is particularly so when a teacher is enamored with general system theory and a systems approach and teaches systems ecology to undergraduates who have practical leanings.

The field of systems ecology is so broad that there is no agreed upon definition. At least participants tend to analyze individuals and populations as systems, usually engage in modeling, lean toward simulation for description and analysis, and lean toward optimization (eg, linear programming) either to

test an hypothesis that nature optimizes, or to select a strategy for dealing with a system that has a large natural dimension like a forest, watershed, or animal population.

Typical topics are, simultaneously, basic ecology, general systems theory, statistics, economics, computer usage, and a variety of specialized fields such as hydrology, forestry, wildlife management, agronomy, and pest control. The enormous scope is believed to be the scope of most modern problems, and so the emphasis is on the commonalities

found in general systems theory. The topics are those of the system components; the resource dimensions of time, space, energy, and matter; isomorphism; flows and cycles; analysis and design; multi-dimensionality and interactions.

Teaching about systems ecology without having access to or using a computer would be like teaching bacteriology without a microscope. This has been the case for many years, largely because access to the computer and competence with it were considerably less and costs considerably more than dealing with a microscope. Now these relationships are changing because of microcomputers. It is now possible to teach about system inputs, demonstrate them being made at a machine keyboard, and show their meaning in a simulation (eg, of solar radiation to a plant). Process can be demonstrated simply as arithmetic operations or by building progressively up a scale of complexity to animal and plant processes (eg, density-dependent birth rates) to various optimization algorithms for selecting forest cutting practices. Feedback can be taught by simple system error messages, program checking and error statements, and a variety of IF-based branching operations. Nowhere is the need for clear, precise objectives more clear than in computer programming. Objectives, quickly changed, allow students to see the need for different inputs, different processes, and occasionally different feedback operations.

I have used computer programs in instruction since 1964. These have been operated on a mainframe, and objectives have been (1) to aid in bringing computer use into natural resource management, (2) to improve understanding of topics in conventionally-taught wildlife management and ecology courses, and (3) to encourage use of techniques only practical with computers.

Based on student responses, I considered this use of the computer to be very successful. However, I judge these past efforts somewhat less successful than current uses of microcomputers (IBM-

PC with color terminals).

In this article I wish to present some thoughts about my current use of microcomputers.

In all classes, I start with how to turn on the computer. This indicates the knowledge level of some people in the junior- or senior-level classes, but it seems to be changing. Claims about advances in computer use in high schools, however, seem over-inflated, or few of those students are entering my classes. I use a test generator and a grade-keeping program, but I have not, as yet, automated this classroom management system.

The work to date has been to create BASICA programs that (1) teach and (2) are likely to be useful after graduation either for use directly or after slight modification. There have been only minor difficulties with these aims. In two cases, aids to memorizing long definitions have required considerable programming and, hopefully, are not likely to be used after class. Most other programs are likely to be of direct use after class.

PROGRAM OVERVIEW

I use a computer menu with the following major groups of topics on two diskettes called Wildlife01 and Wildlife02:

- 1) Animal Populations
- 2) Abiotic Factors
- 3) Time
- 4) Space and Habitat
- 5) Math and Statistics
- 6) Cybernetics (Management)
- 7) Variety
- 8) Ponus and Stream
- 9) Overview and Utilities
- 10) Social Engineering

Tables 1 and 2 show the menu for the programs in Group 3 and 4 on Time and on Space and Habitat.

After selecting a topic group, students are presented with several screens of information about programs (files) within each numbered topic. They enter a number, and a file is loaded. Currently there are 70 programs on the 2 disks. Others

are being developed to support a wildlife management textbook by Shaw¹ as well as two texts currently in preparation. The diskettes are self-instructive, and no manuals or written documents are prepared. An AUTOEXEC.BAT file starts the instructions as soon as the system is booted up.

Each program is a subsystem and a building unit of a larger system. For example, one program estimates a sex ratio of a population from observed animals. Another program then computes hunting permits using a sex ratio estimate similar to that derived from the first program. After deciding on hunting permits to issue, another relatively simple program is available for producing the list of random numbers needed to make the selection of permittees among hunters in a permit applicant pool.

Other programs are largely computational and include calculations such as times and dates, sunrise to sunset, distance seen from a height, area and edge calculations, and volume of a pond or lake computations.

Some programs are statistical. Short data sets may be entered quickly, and conventional statistics can be examined. These are very useful in reviewing instruction from other classes and in learning how to apply, for example, a regression equation relating crop yield to fertilizer and moisture.

Such equations, either from the literature or just developed, may be examined in 2 or 3 dimensions in the plotting program. This program has been extremely useful in a variety of ways including a review of analytical geometry, explaining sensitivity of a model, explaining equifinality (asking a class for an equation that produces a particular shape usually produces many different equations meeting the requirement), and explaining differences between curve-fitting and modeling.

STUDENT USE OF PROGRAMS

The students use the programs under my loose supervision in a computer lab containing 30 IBM-PCs. The emphasis

Table 1. Menu of options for Time topic on Wildlife disks

Time

3.01 Days Between Two Dates

Historical or forward, the exact number of days are calculated. The program is useful in feedforward operations and in biological data manipulation.

3.02 Professional Timeline

Shows time as linear. The program takes important dates of the professional and shows them in relation to each other and a planning horizon.

3.03 Sunrise to Sunset

Based on entries of a Julianized date and latitude, this program gives sunrise, sunset, and daylength.

3.04 Time Between Two Times

Based on entries of two specific times, down to the second, this program calculates the total time between the entries. The program may allow new control over experiments and observations.

3.05 Julian-Classical Dates Converted to Julianized Dates

Entering a classical date will result in presentation of an equivalent Julianized date.

is on process. I encourage them to "make up" populations or situations. While other classes within the curriculum spend considerable time on data collection and detail, my emphasis is on a general understanding of the process of the program, developing a mind-set for general "what if...?" simulations, beginning to think about subsystems and search for useful unions of subsystems, and to develop an attitude of managerial control over the real or computer simulated ecosystem. The latter is as simple as: "If I add X or subtract Y to the ecosystem, what will happen to my resource (some performance measure of it)? Feedback is discussed, and it is functional in most programs in error-checking and branching to promote correct responses.

Several large programs now require student involvement for over an hour. One is Safe Haven, a wildlife management area game or educational unit. The computer supplies the student with a budget for a typical year, and the student's task is to spend it to the penny. Thirty sets of choices (as if one every 3-4 days in the year) must be made. Wildlife resource benefits or points for the manager are produced after each expenditure. The objective is to maximize the score while minimizing the squared de-

viation from the total budget expenditure. Several plays of the game are encouraged before students are asked to use the random mode. This mode gives a realistic sense of managerial performance and requirements over time because under these conditions, prices, food production, and harvest rates vary. All decisions are taken from actual experience. It takes many plays ("years" of experience) for students to master the game.

Student frustrations created by randomness within the program or game, for example, of budget cuts or even additions of money near the end of the game, create learning opportunities. The final "win" criterion is always questioned by them. Frustration is expressed about the requirement that their total budget be expended in view of their desire to make minimum expenditures. This invariably leads to a variety of useful, practical discussions about effectiveness, efficiency, and fiscal policy in private and public groups.

OTHER UNITS

Another unit requires a student to make entries about the estimated costs of operating a large, complex, for-profit wildlife enterprise in the U.S. The objective of this unit is to raise issues about

the economies of scale, monetary and ecological interactions, shared resources, and the advantages of diversity both within ecosystems and enterprises. The diversity topic, much discussed in ecology, is one that is treated in a separate program. In one class, I use the diversity program before the enterprise unit; in another, after it. This is one example of personal experiments in educational methodology. Do you explain and then use a program to enhance understanding or do you create a demand for a topic (eg, how to express diversity), then make a program available to meet the demand?

One unit on deer population dynamics takes many inputs (class time) and requires 5-10 minutes of computer time – a temporal wasteland, since all students are not on the same schedule. It is a problem best used in long periods (eg, a 3-hour laboratory period) or assigned as a project.

STUDENT FEEDBACK

Some students have asked, "Is that all there is?" when using a program that was very difficult to program. The simple inputs and the brief answers that are quickly returned are deceptive. Such comments are discouraging, but no more so than the slept-through superior lecture. Another student reaction has been, "After 5 ecology courses, this is the first time I've really understood interaction!" Such comments are healing.

I have prepared diskettes organized to correspond with sections of a textbook used in class. These provide a functional aid to the text, sound, color, dynamics, heuristic opportunity, and enhancement. The reaction has been very positive. Quizzes on simple topics treated in such programs tell me that learning (mastery/time and effort) has occurred better than in any other way in my 22 years of teaching.

I still do not know how to grade the results of using computer simulations. On one hand, I want students to explore their use widely; on the other, I need one good (best) answer to allow a judgment on some types of performance.

Table 2. Menu of options for Space and Habitat topics on Wildlife disks

Space

4.01 Area of a Polygon

Enter the vertices for any area from the size of a leaf to that of a wildlife refuge and get the area and edge length.

4.02 Zone of Influence of a Road

Given a large area, the program calculates the zone of influence of a proposed or actual road or trail and the percentage of the total area influenced.

4.03 Crowding Index

How crowded are plants in a plot, animals in a quadrant, barnacles on a ship? This program calculates Deeve's crowding index.

4.04 Land Area blocks

Based on a data string that characterizes cells within a large area, this program maps the colors at a scale specified by the user.

4.05 Plot Frequency and Density

By entering the number of plants (or other items) observed within many plots, density estimates may be made.

4.06 Tree Bole Surface Area

Surface area of a tree bole can be estimated for insects, beaver feeding, rainfall interception, and other purposes.

4.07 Planning an Experimental Bog

An experimental peat bog is proposed for an area in the Appalachian Mountains at 2900 feet elevation. The program begins to probe questions about the costs and then about the experimental process.

4.08 The Broad View

The distance to the horizon is calculated along with the area viewed and the effects of modifying one of the axes of an ellipse.

4.09 Slopes

The difference between degrees and percent of slope can be quite profound. Managers need to be very familiar with the differences and their implications. This unit can help.

4.10 Organisms in Space

The spatial patterns resulting from an initial location of individuals in a population and changes based on various rules of reproduction, death, and dispersal can be observed using this unit.

4.11 Habitat Patterns

A small simulation of a map with areas burned progressively over time. The unit may be of value in comprehending random patterns and succession over large management areas.

FUTURE PLANS

My plans are to convert all old hand-outs to diskettes, to continue developing units, to implement a class management system, and to use animation in more of my units. I then plan to unify these with interactive videodiscs that include pictures of a local research area and data, sounds, and appropriate programs. These will build up from small units and also down from large ones, creating demands for understanding the parts. This reflects a personal evolution from a linear or sequential instruction mind set to one that is simultaneous, non-linear, heuristic, and student-specific.

In the past I have preached; "adopt a systems approach to resource management." Now I say it, try to demonstrate it in classes, and try to provide students with new tools (the computer programs) in addition to the words on their "brain disk" that the evidence suggests receives the equivalent of a FORMAT command when they hit the real world.

The diskettes Wildlife01 and Wildlife02 are available at no cost by sending formatted disks in a self-addressed, stamped mailer to Robert H. Giles, Jr., Department of Fisheries and Wildlife Sciences, VPI & SU, Blacksburg, VA 24061.

REFERENCES

- Shaw JH: Introduction to Wildlife Management. New York, NY, McGraw-Hill, 1985.

ADAPTATION OF INTERACTIVE VIDEO DISC IN MEDICAL EDUCATION

James S. Fine

Department of Laboratory Medicine, University of Washington, Seattle, Washington

Computers in the idealized medical curriculum are seen as devices for information retrieval, self-instruction, and self-examination.⁵ Computer-aided instruction (CAI) is often predominantly text

based. Text, however, is a unidimensional, sequential media. One must plod word by word, paragraph by paragraph, sometimes scanning for key words or other clues. However, the hu-

man mind is strongly visually oriented. People acquire information significantly faster by discovering relationships in pictorial representations. Properties such as color, shape, size, contour, dis-

tance, and texture can be dissected readily. While the student maintains an appreciation for the whole, any part of the picture can be addressed in a rather random fashion. CAI programs are often supplemented with computer generated graphics, not without a heavy burden on the computer resources and the author's creativity.

A new technology, the laser optical videodisc, is now available for storage and management of visual information.⁷ A standard 12 inch videodisc can store 54,000 images on one side. Each individual picture can be retrieved within 2 seconds or less and displayed on a television monitor for as long as desired. The videodisc can therefore be used in a manner similar to traditional atlases while providing a quantum increase in capacity. Unlike textbooks, it can be played as a sequential device at 30 frames/sec, providing a sense of motion, depth and time. The disc is also very durable and can be reproduced inexpensively.

The ultimate benefit of this technology to computer-aided instruction is that the videodisc player can be interfaced to and controlled by a computer. This permits the integration of a potentially phenomenal visual database into instructional programs. The computer can provide the index and the organization for the visual material.

A few years ago, we recognized the potential of the laser optical videodisc to computerized instruction in laboratory medicine. However, the practical implementation of this technology has not been trivial. The major problems revolved around videodisc source material. Additional considerations have included hardware configurations and program development.

VIDEODISC SOURCE

The first hurdle in incorporating this technology into instructional programs was finding a videodisc which contained applicable material. We began by using a disc that contained copies of a couple thousand 35mm photographic slides of various hematologic diseases,

pictures of other disease states, and some supplementary motion pictures.³ Employing this disc revealed three major shortcomings. Since the photographic slide collections used in this disc were compiled from a number of different sources, the quality of the pictures, including color and contrast, varied widely. This was compounded by the degradation inherent in the transfer process from a celluloid media to an electronic one. In addition, horizontal and vertical slides had to be accommodated to a format which conformed to television standards. This resulted in loss of image area from the vertical slides.

Another problem arose because the visual database was built primarily around existing slide collections made up of interesting pathologic material. Unfortunately, when this material was incorporated into instructional programs, significant holes in the visual database became apparent. For example, a specific malignant cell could be demonstrated, but contrasting normal cells or negative stains were nowhere to be found. Additional examples of the same disease state were often lacking. This is an inherent problem in trying to utilize an existing slide bank that is not necessarily designed with instruction in mind.

Finally, the index to the entire disc was available only in printed form. This made review and selection of existing images a tedious process.

VIDEODISC DEVELOPMENT

It was felt that, although the technology appeared to have great potential, a more encompassing disc had to be provided for our teaching needs. Because there were none available that met our needs, it was decided that a new disc would have to be developed.

The first question was where to get the material. It was decided that in order to avoid the limited scope and variable quality of existing slide collections and the problems associated with the transfer process, an attempt would be made to produce a disc from videomicroscopy in our laboratory using orig-

inal case material in our department.

Experimentation with videomicroscopy proved successful, and a prototype videodisc made with stills integrated with scans and focusing sequences of selected cells or areas was produced. The task of selecting lighting conditions was standardized with the use of a waveform monitor. Because videotape was used, there was virtually no degradation of image quality in the editing and mastering processes.

With the success of this prototype videodisc, work proceeded in the development of a videodisc that could be used in computer-aided instruction in our discipline. Defining the scope of the project was the first production step. The objective was a disc that could serve as a generic² visual resource encompassing the discipline of hematology.⁶ Planned uses included teaching and testing medical students, medical technology students, and residents. As a multipurpose, generic, resource, no specific lesson plan was used to dictate content.

An extensive outline was made to cover the visual aspects of hematology, with care given to including comparative images. The outline included 12 major subheadings ranging from non-diseased, or normal, bone marrow and peripheral blood to marrow involvement by non-hematologic processes. It was further subdivided, designating which material should be in the form of still pictures such as scans of bone marrow biopsies and smears, and which material could benefit from motion, (eg, focusing through a parasitic infestation). Given the massive storage capacity, up to 54,000 images/side, the outline included numerous normal examples for contrast with positive pathologic findings. The outline was developed on the computer. This allowed for updating as videotaping progressed. It also served as a guide for collecting material to be videotaped.

The laboratory was equipped with a videomicroscope so that all recording was performed locally at the convenience of the staff. Recording was done

exclusively with 60 minute, 1 inch, C format videotapes. When taping a single image, a three to five second recording was obtained. During this relatively short period, the focus was usually varied. At the time of editing, this segment was then reduced to the two frames in optimum focus. Longer sequences were recorded where motion was the desired objective. These were edited down to 10 seconds (300 frames) or less. Over the recording period, 39 one hour tapes were used. This represents approximately 20 hours of gathering and screening slides at the microscope for each hour of recording.

An additional computerized database, or sequential master file, containing descriptive information on all video sequences was constructed. Each image or scan sequence was identified with regard to all pertinent information including source of material, recording parameters and description of the tissue, and disease process. Selected information in this file would eventually be used to form the computerized index of the disc.

All recorded videotapes were copied to another 1 inch videotape, an edit source tape, onto which a continuous SMPTE timing code had been added so that each frame could be identified. The selection of individual frames and sequences required a minimum of 12 hours for each hour of edit source videotape. This was mandated by the quantity of recorded material. Each one hour tape contained over 100,000 frames. Therefore, selection of the frames, or sequence, with the best focus, lighting, and color required much cross-comparison and exhaustive decision making.

The specified video frames from the source tapes were then transferred to a single sequential 1 inch videotape containing 30 minutes real time of video recording. The transfer process alone required two weeks editing time on the videotape editor with one person constantly monitoring the editing machine. This tape, containing 54,000 frames divided amongst stationary images and short motion sequences, was then submitted to 3M (Minnesota Mining and

Manufacturing Co., St. Paul, Minn) for production of a disc master, produced in 12 inch NTSC continuous angular velocity (CAV) format, and the desired number of copies.

As described above, two files, the outline and the sequential master file, had been created to track the information on the videodisc. To organize the descriptive material, all pertinent and useful terms were classified under an existing medical encoding scheme, SNOMED.⁴ After the disc was manufactured, the videodisc frame numbers were added to the computerized files. This allowed the production of a computerized index, in frame order, which subsequently could be used in computer searches by SNOMED code. The final outline, which originally served to direct the collection of slide material for the disc, could serve subsequently as a table of contents for the disc.

HARDWARE SELECTION

The decision concerning the hardware configuration to use was relatively simpler. Characteristic of computer implementations, hardware development is usually far ahead of the software development. While the work continued in the development of videodisc material, a series of microcomputer-videodisc configurations were employed.

A two screen system was employed with the original disc. The computer information appeared on the computer monitor and the video information on the videomonitor. The computer controlled all access to the videodisc and enabled formulation of branching instructional programs that incorporated the visual information. However, switching attention between screens was somewhat distracting. An additional disadvantage was the inability to point directly to important findings in the picture.

The system was then upgraded to a one monitor configuration. Here, both video and computer images could be displayed simultaneously on the same screen. Now text and graphics could be superimposed on the video image. Im-

portant details in the picture could be highlighted with arrows, circles or whatever graphic seemed appropriate. The limitation now was in the capacity of the microcomputer.

The hardware has since been upgraded again, this time to a DEC Professional IVIS system (Digital Equipment Corp., Maynard, Mass). In addition to the high resolution graphics and touch screen, the quantum increase in computer memory allows for storage and use of the entire computerized outline and description files, vastly increasing the generic utility of the resource.

SOFTWARE DEVELOPMENT

The language selection has also followed an evolutionary course. Originally PASCAL and BASIC were employed. These were adequate in the initial experimentation. They resulted in a different approach to authoring with each program. After introduction of the first one monitor system, an authoring language, Apple SuperPILOT, was employed. This provided a more structured framework for lesson development. It also allowed graphics and crude animation, two features that readily enhanced the overlay capabilities.

Most recently we have been using the authoring language PRODUCER (Digital Equipment Corporation). This language takes advantage of the enhanced capabilities of the IVIS system, providing text, high resolution graphics, and touch screen interaction. It is designed for programming on a centralized mini-computer with downloading of software to individual IVIS systems. As lessons are developed, they can then be transmitted and stored at teaching stations in the affiliated hospitals.

The hematology disc was designed to be a generic visual resource without a specific lesson plan. This has allowed the creation of programs to serve a variety of users. The outline and description files provide computerized reference, allowing easy lookup of any topic and supplemental description. Teaching programs have been written for medical students and medical technology stu-

dents.¹ Students, residents, and faculty have authored lessons, individually tailoring the lessons to the topic and their particular style.

CONCLUSION

The laser optical videodisc represents a new technology that can provide a vast quantity of quality images. It is ideally suited for computer integration, which enhances its ability to serve as a visual archive and complement CAI. The availability of videodiscs will remain the limiting factor in utilizing this technology. The development of generic

medical videodiscs, although an extensive and exhausting process, will provide the greatest resource to the broadest audience.

REFERENCES

1. Ashwood ER, Fine JS, Behrens J, Adams JS: Designing computer lessons in medical technology using an intelligent videodisc. *J Med Tech* 3:457-461, 1986.
2. Bolles JR: Generic videodisc. An educational resource. *Computers in Life Science Education* 2:73-76, 1985.
3. Bolles JR, McArthur JR, Gapanoff M: *Medical Applications Videodisc, 1st*

edition. Seattle, WA, American Society of Hematology, 1981.

4. Cote RA, Robboy S: Progress in medical information management: Systemized nomenclature of medicine (SNOMED). *JAMA* 243:756-762, 1980.
5. Eichna LW: A medical-school curriculum for the 1980s. *N Engl J Med* 308:18-21, 1983.
6. Fine JS, Ashwood ER, Kidd P, McArthur JR: *Laboratory Medicine Video Library: Atlas of Hematology*. Seattle, WA, University of Washington, 1985.
7. Goldstein CM: Optical disk technology and information. *Science* 215:862-868, 1982.

CLSE COLLEAGUE DIRECTORY - PART III

The listings below represent Part III of a directory drawn from respondents to a questionnaire distributed by NRCLSE in 1986. It is intended to help CLSE readers identify colleagues with common interest areas. Although every attempt has been made to ensure that the

information is current and correct, it is likely that some errors appear in this list. NRCLSE apologizes in advance for any inconveniences that may arise due to such oversights. Part I of the directory was printed in the November, 1986 issue of CLSE, and Part II was

published in the January, 1987 issue. If you are aware of other colleagues that should be listed in future directories, please send their names, addresses, phone numbers, and teaching content areas to NRCLSE, Mail Stop RC-70, Univ of Wash, Seattle, WA 98195.

TAXONOMY

WALTERS, DIRK R
DEPT OF BIOLOGY
CAL POLYTECH STATE UNIV
SAN LUIS OBISPO, CA 93406
(805) 546-2721

VIROLOGY

BOND, CLIFFORD
DEPT OF MICROBIOLOGY
MONTANA STATE UNIV
BOZEMAN, MT 59717
(406) 994-4130

HALL, LEO
PHILLIPS UNIV
BOX 2000 UNIV STATION
ENID, OK 73702
(405) 237-4433 EXT 398

WILDLIFE MANAGEMENT

GILES, ROBERT H JR
DEPT OF FISHERIES & WILDLIFE SCIENCE
VIRGINIA POLYTECH INST & STATE UNIV
BLACKSBURG, VA 24061
(703) 961-5910

ZOOLOGY

BLACK, JOE B
DEPT OF BIOLOGY
LOUISIANA COLLEGE
LOUISIANA COLLEGE STA
PINEVILLE, LA 71359
(318) 487-7611

BUCHHOLZ, ROBERT H
DEPT OF BIOLOGY
MONMOUTH COLLEGE
MONMOUTH, IL 61462
(309) 457-2350

CARICO, JAMES E
DEPT OF BIOLOGY
LYNCHBURG COLLEGE
LYNCHBURG, VA 24501
(804) 522-8366

COCKERHAM, BILL
FRESNO PACIFIC COLLEGE
1717 S CHESTNUT
FRESNO, CA 93702
(209) 453-2045

DE JONG, ALVIN A
DEPT OF BIOL SCIENCE
CAL POLYTECH STATE UNIV
SAN LUIS OBISPO, CA 93407
(805) 546-2209

DICKINSON, WINIFRED
DEPT OF BIOLOGY
UNIV OF STEUBENVILLE
STEUBENVILLE, OH 43952
(614) 283-3771

DIGGINS, MAUREEN
DEPT OF BIOLOGY
AUGUSTANA COLLEGE
29TH ST AND S SUMMIT
SIOUX FALLS, SD 57197
(605) 336-4809

GAMBS, ROGER
DEPT OF BIOL SCIENCE
CAL POLYTECH STATE UNIV
SAN LUIS OBISPO, CA 93407
(805) 546-2551

GIBSON, LINDA
DEPT OF BIOLOGY
EASTERN WASHINGTON UNIV
CHENEY, WA 99004
(509) 359-2845

GRAY, F HARRIET
HOLLINS COLLEGE, BOX 9616
HOLLINS COLLEGE, VA 24020
(703) 362-6543

HILTON, DONALD FJ
DEPT OF BIOL SCIENCES
BISHOP'S UNIVERSITY
LENNOXVILLE, QUEBEC
CANADA J1M 1Z7
(819) 569-9551

LEONG, KINGSTON
DEPT OF BIOL SCIENCE
CAL POLYTECH STATE UNIV
SAN LUIS OBISPO, CA 93407
(805) 546-2788

MACHIN, DR JOHN
DEPT OF ZOOLOGY
UNIV OF TORONTO
TORONTO, ONTARIO
CANADA M5S 1A1
(416) 978-3506

MURPHY, GEORGE
MIDDLE TENNESSEE STATE
UNIV, BOX 60
MURFREESBORO, TN 37132
(615) 898-2847

OWEN, LAWTON
KANSAS WESLEYAN
100 E CLAFLIN
SALINA, KS 67401
(913) 827-5541

SINGLETERY, ROBERT L
DEPT OF BIOLOGY
UNIV OF BRIDGEPORT
BRIDGEPORT, CT 06601
(203) 576-4265

SINNAMON, WALT
CENTRAL WESLEYAN COLL
BOX 443
CENTRAL, SC 29630
(803) 639-2453 EXT 356

STANTON, GEORGE E
DEPT OF BIOLOGY
COLUMBUS COLLEGE
COLUMBUS, GA 31993
(404) 568-2065

STEVENS, E D
DEPT OF ZOOLOGY
UNIV OF GUELPH
GUELPH, ONTARIO
CANADA N1G 2W1
(519) 824-4120 EXT 2137

AIMS AND SCOPE

The goal of *Computers in Life Science Education* is to provide a means of communication among life science educators who anticipate or are currently employing the computer as an educational tool. The range of content includes, but is not limited to, articles focusing on computer applications and their underlying philosophy, reports on faculty/student experiences with computers in teaching environments, and software/hardware reviews in both basic science and clinical education settings.

INVITATION TO CONTRIBUTORS

Articles consistent with the goals of *Computers in Life Science Education* are invited for possible publication in the newsletter.

PREPARATION AND SUBMISSION OF MATERIAL

Articles submitted for publication should not exceed 2000 words and should be typewritten, double spaced, with wide margins. The original and two copies including two sets of figures and tables should be sent to the Editor: Dr. Harold Modell, NRCLSE, Mail Stop RC-70, University of Washington, Seattle, WA 98195.

Title page should include full title, list of authors, academic or professional affiliations, and complete address and phone number of the corresponding author.

Illustrations should be submitted as original drawings in India ink or sharp, unmounted photographs on glossy paper. The lettering should be such that it can be legible after reduction (width of one column = 5.7 cm).

Reference style and form should follow the "number system with references alphabetized" described in the Council of Biology Editors Style Manual. References should be listed in alphabetical order by the first author's last name, numbered consecutively, and cited in the text by these numbers.

RESPONSIBILITY AND COPYRIGHT

Authors are responsible for accuracy of statements and opinions expressed in articles. All authors submitting manuscripts will be sent a copyright transfer form to complete. The completed form must be returned before the work will be published.

SUBSCRIPTION INFORMATION

Computers in Life Science Education is published monthly by National Resource for Computers in Life Science Education, Mail Stop RC-70, University of Washington, Seattle, WA 98195. Subscription rate is \$30.00 for 12 issues, including postage and handling in the United States and Canada. Add \$20.00 for postage (airmail) in Mexico and Europe and \$23.00 for the rest of the world.

This newsletter has been registered with the Copyright Clearance Center, Inc. Consent is given for copying of articles for personal or internal use, or for the personal or internal use of specific clients. This consent is given on the condition that the copier pay through the Center the per-copy fee stated in the code on the first page for copying beyond that permitted by the US Copyright Law. If no code appears on an article, the author has not given broad consent to copy and permission to copy must be obtained directly from the author. This consent does not extend to other kinds of copying, such as for general distribution, resale, advertising and promotional purposes, or for creating new collective works.

Address orders, changes of address, and claims for missing issues to NRCLSE, Mail Stop RC-70, University of Washington, Seattle, WA 98195. Claims for missing issues can be honored only up to three months for domestic addresses and six months for foreign addresses. Duplicate copies will not be sent to replace ones undelivered due to failure to notify NRCLSE of change of address.

Address editorial correspondence to Harold I. Modell, PhD, NRCLSE, Mail Stop RC-70, University of Washington, Seattle, WA 98195.

POSTMASTER: Send address changes to *Computers in Life Science Education*, NRCLSE, Mail Stop RC-70, University of Washington, Seattle, WA 98195.

COMPUTERS IN LIFE SCIENCE EDUCATION

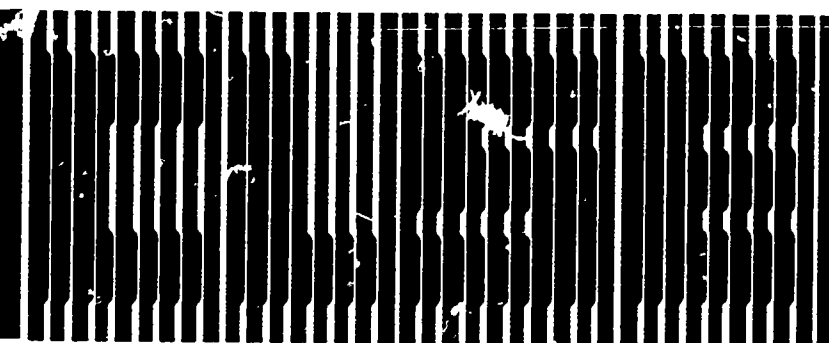

HAROLD I. MODELL

Department of Radiology
University of Washington
Seattle, Washington

MARCEL BLANCHAER

Department of Biochemistry
Faculty of Medicine
University of Manitoba
Winnipeg, Manitoba
Canada

THEODORE J. CROVELLO

Department of Biology
University of Notre Dame
Notre Dame, Indiana

JAMES W. ECKBLAD

Department of Biology
Luther College
Decorah, Iowa

TSEGAYE HABTEMARIAM

School of Veterinary Medicine
Tuskegee University
Tuskegee, Alabama

DONNA LARSON

School of Nursing
Grand Valley State College
Allendale, Michigan

TERRY M. MIKITTEN

Graduate School of Biomedical Sciences
University of Texas Health Science Center
San Antonio, Texas

JAMES E. PANDALL

Department of Physiology
Indiana University
Bloomington, Indiana

PATRICIA SCHWIRIAN

College of Nursing
Ohio State University
Columbus, Ohio

RICHARD STULL

College of Pharmacy
University of Arkansas
Little Rock, Arkansas

JAMES W. WOODS

Lister Hill National Center
for Biomedical Communications
National Library of Medicine
Bethesda, Maryland

DOROTHY WOOLEY-McKAY

Department of Biology
Glendale Community College
Glendale, Arizona

GLEN YOSHIDA

Department of Life Sciences
Los Angeles Southwest College
Los Angeles, California

NRCLSE

CONTENTS

DISCOURSE - A TECHNOLOGY BASED ALTERNATIVE FOR GROUP INSTRUCTION	17
Steven L. Robinson	
SYNTAX DIFFERENCES BETWEEN SUPERPILOT AND PC PILOT	20
Marianne E. Yoder	
KEEPING ABREAST OF THE LITERATURE	23

DISCOURSE - A TECHNOLOGY BASED ALTERNATIVE FOR GROUP INSTRUCTION

Steven L. Robinson
Amherst H. Wilder Foundation, St. Paul, Minnesota

This article introduces an alternative concept for technology based instruction, a concept that calls for the application of technology to problems of individual teachers who must cope with the demands and limitations of group instruction.

Teacher coordinated group instruction is an inescapable reality of educational enterprise. In almost every school, the total group is the vehicle for teaching, and the teacher is the pivotal figure in the group. This is not to say that the group context is optimal for learning. Classrooms are complex, multidimen-

sional, layered environments. Group instruction in these environments, which requires teachers to organize 20-30 students into working units that change over time, to select and arrange activities, to present material, provide opportunities to respond, monitor and pace instruction that accommodate individual needs, is, in the best of circumstances, less effective than other methods such as one-to-one tutoring.¹

Tutoring is most likely effective because this context permits maximum opportunity to respond with constant feedback and correction, all under the

direct supervision and guidance of a teacher. Tutoring, however, and other methods such as computer-assisted instruction (CAI), a form of tutoring without temporally present teachers, cannot replace group instruction for practical and cultural reasons. Due to limited resources, neither is practical on a large scale, and the social nature of human enterprise makes teacher-directed group instruction desirable even in the face of potentially more effective methods.

"Teachers play a vital role in the educational process, in large measure because an important part of becoming educated has to do with interpersonal relations – with learning to communicate and join in problem solving with others."²

Therefore, although groups distance the teacher from the student in terms of the teacher's ability to provide necessary amounts of critical instructional variables such as opportunities to respond, teacher monitoring, and feedback/correction, groups are an important context for instruction. For these reasons, Bloom suggested that the activities of researchers and teachers should focus on devising "... teaching-learning conditions that will enable the majority of students under group instruction to attain levels of achievement that can at present be reached only under good learning conditions."¹

TECHNOLOGY BASED GROUP INSTRUCTION ALTERNATIVE

The Discourse Educational Communication System (Discourse) represents an application of technology to the task set by Bloom. Discourse combines the power of the computer as an information processor that can calculate and store with the power of a teacher as a knowledge processor who can reason and inform.⁴ The system facilitates and processes student responses and makes this information available to the instructor. This provides the substance for teacher diagnosis, prescription, presentation, monitoring, and feedback, the critical teaching functions influencing student learning.⁵ In this manner, Discourse keeps the teacher at the center of instruction and employs a computer to

overcome the limitations to effective teaching imposed by a classroom of 20-30 students.

Discourse keeps the teacher at the center of instruction by electronically channeling student responses to a computer monitor viewed by the teacher. The system fundamentally operates as a communication tool. Each student in the class is supplied with a response device (Studycom) consisting of a standard QWERTY keyboard and a LED display line. These Studycoms are connected to one computer with a color monitor, printer, and keyboard used by the instructor. Operating software permits the teacher to control and coordinate instruction. Students are first prompted to "sign-on." As they type their names on the Studycoms, the names appear on the monitor in a column by the students' seat locations. The teacher may then prompt students to respond to spontaneous or prepared questions presented orally, by audio-visual media, or by workbooks or worksheets. Students type their answers on the Studycoms, and the answers are displayed simultaneously next to the students' names on the monitor. The teacher uses this information to provide corrective feedback, explain, reteach, or whatever is appropriate for the situation.

Discourse helps teachers accommodate instruction to individual needs in several ways. The system 1) provides facilities to prepare and conduct teacher-paced or student-paced lessons, 2) increases students' opportunities to respond under the teacher's direct supervision, 3) increases opportunities for immediate corrective feedback, 4) provides comprehensive, efficient, and timely record keeping facilities, and 5) permits the control and integration of a variety of audio-visual media for presentation purposes.

LESSON PREPARATION

The teacher, not the computer, delivers instruction with the Discourse system. The system collects, organizes, processes, and records student responses. There is no pre-packaged instructional software. Content comes from regular curriculum materials or materials pro-

vided by the teacher. The instructor, by use of a simple authoring system incorporated into the operating software, prepares lessons for storage on a floppy disk. With this facility, lessons can be prepared that may include 1) answers that the system will use to score student responses, 2) instructor notes (eg, "Show the overhead on cell division."), 3) instructions for automatic operation of audio-visual media, or 4) questions to be asked. Each lesson consists of a set of numbered frames that is named and stored on a disk.

The system, however, may be used simply as a communication tool without a preprogrammed lesson in memory. Teachers may prompt students to respond to questions provided by any means, and the system displays the students' answers on the teacher monitor.

Discourse lessons may be paced by the teacher or by the students. For the former, the teacher controls the sequence and timing of student responses. For the latter, students are provided with numbered worksheets. Answers to the items are entered on the Studycoms. The students control the sequence of items attempted and the time spent on each item.

The system also provides the capability of organizing multiple group student-paced instruction. Discourse will process the work of up to seven groups working on seven different lessons simultaneously.

OPPORTUNITY TO RESPOND AND TEACHER MONITORING

Opportunity to respond under a teacher's supervision is a critical component of achievement.³ The Discourse system provides a response device to every student. When the teacher asks a question, all students have an equal opportunity to respond. The responses are organized and displayed on the teacher's monitor for efficient processing, thus creating the potential for an environment with high levels of guided practice and enhanced accountability. Guided practice and accountability promote student engagement, another consistent correlate with achievement.⁷

Figure 1 shows an example of what the teacher sees when students type answers on the Studycoms. With more than 20 students, the teacher may page to another screen of names. This figure shows that students are not restricted to single letter or number responses. Students may construct responses with up to 186 characters, and they may edit their responses. Whatever the nature or length of the response and regardless of whether the lesson is teacher-paced or student-paced, the response is displayed for viewing by the teacher. This permits the teacher to direct immediate feedback and correction to individual students most in need of help.

Corrective Feedback

Immediate and direct verbal feedback is only one form of feedback facilitated by the Discourse system. When used with preprogrammed lessons that contain answers (eg, tests or worksheets), the system will scan each student's response and automatically provide instant response contingent feedback to individual students in the form of two flashing Studycom lights. An optional beep tone may also be paired with the lights. When the lesson is created, the teacher specifies which answers will be paired with feedback. These selections may be overridden at any time during the lesson.

Another form of feedback capability is the "public" display. The teacher may, even while students are typing, enter a student's seat location to display his/her individual response. This response appears for the entire class on a large video monitor (not the teacher's monitor) used also to display other media. Any number of responses may be displayed, one at a time.

Record Keeping

The Discourse system includes a wide range of record keeping facilities. These provide an additional form of performance monitoring to aid the diagnostic and prescriptive functions of teaching.

Three report types (detail, question, and student) are available instantly

```

01 @_0\;What are your current vocational interests?

A1 MEG R.           -VETERINARIAN

A2 MOLLY S.         -I'M NOT REALLY SURE AT THIS TIME.
LAW IS INTERESTING BUT I REALLY DON'T KNOW WHAT LAWYERS
DO WHEN THEY ARE NOT IN THE COURTROOM.

B6 JOSEPH B.        -I WANT TO BE A PROFESSIONAL
BASEBALL PLAYER.

B8 MARIA F.         -WELL, IT SEEMS THERE ARE SO MANY
JOBS YOU COULD DO. I WANT TO GO TO COLLEGE AND DECIDE
AFTER I HAVE TAKEN A FEW CLASSES.

C0 PATRICK F.       -MY PARENTS EXPECT ME TO GO TO
VOCATIONAL SCHOOL TO LEARN A TRADE BUT I WANT TO
ORGANIZE MY OWN BUSINESS MAKING HOCKEY EQUIPMENT. IT
SEEMS IN MINNESOTA A PERSON COULD DO WELL AT THAT.

C1 ANNE Z.          -ASTROPHYSICIST

D4 TOM Q.           -I DON'T KNOW YET.

```

FIGURE 1. Discourse teacher monitor screen display showing item number, question to be asked, students' seat locations, names and responses to an open-ended question.

during or after a lesson or test. The teacher may access these reports without disturbing students as they respond. Detail reports list the performance of each student on each question, scoring the items as correct, incorrect, or not attempted. Question reports list, in percentage form, the performance of the class as a whole on each item. Student reports describe, by percentage, the performance of individuals on the lesson as a whole. Each report may be displayed dynamically on the teacher monitor or may be printed. One option prints individual reports for each student. The teacher may therefore administer a test and distribute individual, hard-copy results before the end of the period. This saves valuable time normally spent correcting papers and gives students more timely information about their performance.

The teacher using Discourse may elect to record student responses and scoring data on a floppy disk. This information may be recalled at the end of the day, during a preparation period, or even

with a computer at home. The teacher may reevaluate responses, enter critical comments, and generate individual reports that include these comments. Other software automatically accumulates scores on lessons, tests, or individual objectives so that student performance may be tracked over time.

AUDIO-VISUAL MEDIA

Audio-visual media has excellent potential to complement group instruction but is not utilized fully in classrooms. Media devices typically must be obtained from a media center and require some technical knowledge for operating each device.

Discourse helps overcome these limitations by permitting the teacher to control a random access slide projector, a video cassette recorder, and a videodisc player from the computer keyboard. Any off-the-shelf slides, video cassettes, or videodiscs may be used. Digital "slides" generated with a graphics tablet and stored on floppy disks may also be accessed by the system.

The control of each media device is accomplished by pressing a function key (e.g., F7 for the VCR). This produces a menu explaining the control options such as "Press enter for play" or "Press F10 for stop."

These devices may also be automatically controlled by instructions within disk-stored lessons. For example, the item "01;P25PV15000,16500V" will display slide number 25 and will play from frame 15000 to frame 16500 on a videodisc. This capability creates the potential for high quality, interactive, media-based presentations that may be used repeatedly in group settings. The teacher is freed from concerns about how to present material and may consequently devote energy to teacher-student interaction and the adjustment of instruction to meet individual needs.

RESEARCH WITH DISCOURSE

For the past two years, with financial support from the 3M Foundation and the cooperation of Dr. Jack Zawels, the system's inventor, and the St. Paul School District, the Amherst H. Wilder Foundation has investigated the instructional effects of the Discourse system in classroom settings.

This research indicated the system may be a potent instructional tool. In one study, after 45 minutes of training on how to use the system, a teacher was able to produce over a 100 percent increase in the percentage of academic

responses students made during regular instruction.⁶ In another study with severely learning disabled elementary school students working on long division worksheets, accuracy increased from 70 to above 90 percent when the immediate feedback facility (flashing lights and beeps contingent on a correct response) was incorporated as part of the lesson. This and other research indicates that the Discourse system may be a useful tool for teachers to accommodate instruction to the needs of individual students in group settings. The critical mechanism appears to be that all students within a class have more opportunities to make academic responses under a teacher's direct supervision. A program of expanded research over the next three years will continue to explore the system's effects.

SUMMARY

This article describes an innovative application of technology to the problems of group instruction, the dominant environment for educational enterprise. This technology, called the Discourse Educational Communication System, places the teacher at the center of teaching in a manner that enhances control over important components of effective instruction such as opportunities to respond, student-teacher interaction, performance monitoring and feedback/correction. The focus of this technology on these components results in the

implication that the system may be applied beneficially to any training or educational setting where the group is the context for instruction.

REFERENCES

1. Bloom BS: The 2 sigma problem: the search for methods of group instruction as effective as one-to-one tutoring. *Educational Researcher* 13(6):4-16, 1984.
2. Calfee R: Computer literacy and book literacy: parallels and contrasts. *Educational Researcher* 14(5):8-13, 1985.
3. Delaquadri J, Greenwood CR, Whorton D, Carta JJ, Hall RV: Classwide peer tutoring. *Exceptional Children* 52(6):535-542, 1986.
4. Feigenbaum EA, McCorduck P: *The Fifth Generation*. Reading, MA: Addison-Wesley, 1983.
5. Fisher CW, Berliner DC, Filby NN, Marliave R, Cahen LS, Dishaw MM: Teaching behaviors, academic learning time, and student achievement: an overview. In Denham C, Leiberman A (eds) *Time to Learn*. Washington, DC: National Institute of Education, 1980.
6. Robinson SL, DePascale C: Effects of a technology-based communication system on student responding and teacher questioning. Research Report No 9, St. Paul, MN: Amherst H. Wilder Foundation, 1985.
7. Stallings J, Krasavage EM: Program implementation and student achievement in a four-year Madeline Hunter follow-through project. *The Elementary School Journal* 7(2):117-138, 1986.

SYNTAX DIFFERENCES BETWEEN SUPERPILOT AND PC PILOT

Marianne E. Yoder

College of Nursing, University of Arizona, Tucson, Arizona

PILOT has grown in popularity among computer-assisted instruction (CAI) authors. Developers ready to break out of the constraints of authoring systems are discovering the flexibility that PILOT provides. PILOT usually is learned

first on whatever microcomputer is available to the author/programmer. Often the developer then is asked by colleagues from other institutions to share the CAI program. A problem arises, though, when these colleagues

have different microcomputers. Software developers wishing to transport programs between the Apple II family and IBM/MS-DOS microcomputers are confronted with the reality of minor differences in the versions of PILOT

that prevent 100 percent compatibility. Although the PILOT language versions for both families of microcomputers contain basically the same syntax, the minor differences that exist can cause hidden bugs. This article will describe subtle and not so subtle differences between some of the most frequently used language statements that may be overlooked when reading the manuals.

PILOT is available for many different microcomputers. This article will concentrate on the PILOT versions available for two types of microcomputers: the Apple][and IBM/MS-DOS families.

The only PILOT version of note for the Apple][family is SuperPILOT. Previous editions of PILOT for the older Apple computers are not powerful enough to be considered for serious CAI development. Unfortunately, it has now been over five years since Apple Computer, Inc., distributor of SuperPILOT, has updated the language. As of last year, Apple has stopped providing technical support for SuperPILOT, although they still require an annual license fee of \$50 for each program developed with SuperPILOT, even those used within the author's educational institution.

There are multiple PILOT versions in use for the IBM/MS-DOS machines. The PILOT versions that seem to be most popular with CAI developers can be grouped into the following three types.

1. PC PILOT V1.6 and IBM PILOT
2. PC PILOT V2.x, Sperry PC/PILOT, and NCR PILOT
3. PC PILOT V3.0.

These three types will be referred to in this article as PC Version 1, PC Version 2, and PC Version 3.

DIFFERENCES IN LANGUAGE STATEMENTS

Compute - Assignment Statement* c: SuperPilot allows multiple Con, etc (c:) statements per line. PC Versions 1 and 2 allow only one c: statement per

line. In fact, only the first statement is read, and the rest of the line is simply ignored without triggering an error message. This can lead to some hard to track down bugs in your program, especially if a variable is often intended to be reinitialized to zero. PC Version 3 allows multiple c: statements, each separated by a semicolon.

Example Set 1 - c: SuperPILOT

```

c:x=0; r=0; fS="Correct"
PC Versions 1 and 2
c:x=0
c:r=0
c:fS="Correct"
PC Version 3
c:x=0; r=0; fS="Correct"

```

Dimension Statement, d:

In SuperPILOT, the variables dimensioned are separated by a semicolon. The same variable may be redimensioned for a different value in a later module.

In all PC Versions, the variables dimensioned are separated by a comma. In PC Versions 1 and 2, all the variables used throughout the modules can be dimensioned only once per program. You cannot redimension the same variable with a different value later in the program. In PC Version 3, you may redimension the same variable.

Example Set 2 - d: SuperPILOT

```

d:xS(5);fS(15)
...[later in another
module]
d:fS(25)
PC Versions 1 and 2
d:xS(5),fS(25)
[no further dimensioning
of xS or fS]
PC Version 3
d:xS(5),fS(25)
...[later in another
module]
d:fS(25)

```

Problem Statement, pr:
Most of the differences between the

SuperPILOT and PC Versions consist of the different options that can be set using the pr: command. In all PC Versions, pr: may be replaced by p:

In SuperPILOT, pr:p sends output to the printer, and pr:q shuts off the printer, much like the PR#1 and PR#0 commands of Applesoft BASIC.

The PC Versions are more involved, using fx:prn: and fo: and defining each space and each line to be printed.

Example Set 3 - pr: SuperPILOT

```

pr:p [all further output
to printer]
t: Go Cats!
PC Versions
fx:prn: [open printer as a
PILOT file]
fo:0," Go Cats!"!!
chr(13)!chr(10) [prints
phrase, advances to
beginning of next line]

```

All PC Versions include an option (an) that specifies the maximum length of an accept statement. The maximum length of the accept statement is set to the number assigned to n. For example, pr:a15 sets the maximum answer length that a student can type to 15 spaces.

PC Versions 2 and 3 include the following additional options.

- f - traps the function keys as "hot" keys; executed through *sysx
- i - error messages are not displayed, but an error flag is still set
- kname - assign a name to file written by a keep statement

PC Version 3 also contains an option (r) that draws a single or double lined rectangle.

PC Version 1 does not have the t (timed accept response limit) that SuperPILOT and PC Versions 2 and 3 have.

Type Screen Statement, ts:
The text screen statement differs consid-

crably between SuperPILOT and PC Versions. This is by far the statement that must be reworked the most when transporting programs.

SuperPILOT has a number of features that are not present on any of the PC Versions. Screen options such as `s2`, setting all characters to two lines high, and `t2`, setting all characters to double thickness, have no corresponding option in the PC Versions.

All PC Versions require that you select a mode, which will determine the number of columns the screen will have, whether you can use graphics or a newly defined character set, and even what color combinations are possible. Whereas the PC Versions allow 80 column screens, the SuperPILOT version will only support 40 column screens. The text screen is also one line longer on the PC Versions. The screen layout must be reworked when moving from the 80 column, 25 line environment of the PC Versions to the 40 column, 24 line environment of SuperPILOT.

In SuperPILOT, changing the line spacing through the `l` modifier begins after the statement is issued, so in effect, it does not show up until the second line of text following the change in spacing. In all PC Versions, the change in line spacing is immediate, so the change occurs with the first line of text following the statement.

Example Set 4 – `ts:l`

SuperPILOT:

Code	What appears on screen
<code>t:Hello,</code>	Hello,
<code>ts:l2 [double space]</code>	how is
<code>t:how is</code>	
<code>t:your mother?</code>	your mother?

All PC Versions:

Code	What appears on screen
<code>t:Hello,</code>	Hello,
<code>ts:l2 [double space]</code>	how is
<code>t:how is</code>	how is
<code>t:your mother?</code>	your mother?

SuperPILOT and PC Versions 2 and 3 allow the use of the `animate` modifier (`ts:an`) with a variable. PC Version 1

does not; the statement must be placed after the `a`.

Example Set 5 – `ts:a`
 SuperPILOT
 PC Versions 2 and 3
 `c:f$="Hello"`
 `ts:af$`
 PC Version 1
 `ts:aHello`

There is an interesting bug in PC PILOT version 1.6. When using a repeat factor on the `ts:` statement, it is actually repeated one more time than the repeat factor given. For example, `ts:*6(...)` causes the statement to be repeated 7 times, not 6. In transporting to other versions, be sure to add 1 to the new version (eg, `ts:*7(...)`).

Erasing viewports is done differently. In SuperPILOT, the viewport is erased using `ts:es`. In all PC Versions, the viewport is erased using `e` followed by the color wanted, `ts:e0` [erase viewport with color black].

Wait Statement – `w:`

In SuperPILOT, the number assigned to the wait statement indicates the length of time in seconds that the program is to wait for a key to be pressed. In all PC Versions, the number assigned indicates the length of time in *tenths* of seconds. Failing to modify the number when transporting programs can lead to unexpected results in the pacing of a program.

Example Set 6 – `w:`

SuperPILOT
 `w:10 [wait up to 10 seconds]`
 PC Versions
 `w:100 [wait up to 10 seconds]`

Execute Indirect Statement – `xi:`

When using the execute indirect statement in SuperPILOT, the expression must first be assigned to a dimensioned variable that is made the object of the `xi:`. In all PC Versions, the `xi:` may be replaced with `x:`, and the expression may be the object of the `xi:`.

Example Set 7 – `xi:`

SuperPILOT
 `c: a$="u:q"!!str(q)`
 `xi:a$`
 PC Versions
 `xi:"u:q"!!q$(k)`

ODDS AND ENDS

Saving student responses is a lot easier in all PC PILOT Versions. The `k:` statement is used to write directly to a disk file called `k.rec`. Each new response is automatically added to the end. Space is limited only by the number of spaces on the disk, not a predefined amount as in SuperPILOT. To add the response, plus a label, use the statement, `k:"Label:"!!%B%`.

There are other differences that are quite striking. Character `scr's` are handled differently in SuperPILOT and all PC Versions. Graphics must be completely reworked when transporting. Also, PC Versions 2 and 3 have a `gsx:` statement that allows the present screen to be saved temporarily and then instantaneously recalled using `gx:`. This is great for creating "pop-up" boxes. PC Versions 2 and 3 also have a function called `sfl` [shuffle] that is quicker and more efficient than using the random function. Finally, PC Versions 2 and 3 contain "Sprites" that provide the programmer with an easy to use graphics animation tool.

CONCLUSION

Two years ago, what could be done with SuperPILOT and PC Version 1 was, for the most part, equivalent. However, while SuperPILOT has remained stagnant, the PC versions have been evolving, meeting the needs of CAI designers as they produce programs of increasing sophistication. Unless SuperPILOT begins to keep pace with this increasing demand, it will be more and more difficult for the CAI developer to transport PILOT programs. This will occur not because of a lack of common syntax, but because SuperPILOT will no longer permit the designer to create a similar looking presentation.

KEEPING ABREAST OF THE LITERATURE

The following citations are presented as part of a quarterly feature in CLSE designed to help readers become aware of current literature pertinent to computer applications in life science education.

- Allan DME: The rationale for the interactive videodisc in continuing education. *MOBIUS* 6(3):37-42, 1986.
- Anderson K: Computer-assisted instruction. An overview. *J Med Syst* 10(2):163-171, 1986.
- Ashwood ER et al: Designing computer lessons in medical technology using an intelligent videodisc. *J Med Technol* 3(8):457-461, 1986.
- Balson PM et al: Videodisc instructional strategies: simple may be superior to complex. *J Educ Technol Syst* 14(4):273-281, 1985-1986.
- Barker P: A practical introduction to authoring for computer-assisted instruction: Part 6: interactive video. *Br J Educ Tech* 17(2):110-128, 1986.
- Bross TR: The microcomputer-based science laboratory. *J Comp Math Sci Teach* 5(3):16-18, 1986.
- Calhoun JH et al: Computer-assisted instruction in orthopedic biomechanics. *Orthop Clin North Am* 17(4):599-604, 1986.
- Chial MR: Student computer facilities. A guide to strategic planning. *ASHA* 28(8):37-40, 1986.
- Collier PA: Computers and education. *Minn Nurs Accent* 58(6):245-246, 1986.
- Collins MAJ: Using microcomputer administered tests. *Collegiate Microcomputer* 4(2):135-139, 1986.
- Craig JF: Potential for computer and optical videodisk technology in dental education. *Dental Clinics of North America* 30(4):713-720, 1986.
- Dear BL: Artificial intelligence techniques: application for courseware development. *Educ Tech* 26(7):7-15, 1986.
- Desch LW: Use of commercial 'authoring systems' for medical education. *Med Educ* 20(5):417-423, 1986.
- Diserens D et al: Measuring the problem-solving ability of students and residents by microcomputer. *J Med Educ* 61(6):461-466, 1986.
- Dooling SL: Developing computer simulations for staff nurse education. *J Med Syst* 10(2):139-149, 1986.
- Falk LL et al: Simulation exercises in population dynamics. *Collegiate Microcomputer* 4(3):235-241, 1986.
- Ferralli A et al: Interactive video: a tool for changing times. *Media and Methods* 22(3):10-12, 1986.
- French D: Using learning theory to design and evaluate computer-assisted instruction software. *Nurse Educ* 11(5):33-37, 1986.
- Ganiats TG et al: Interactive computer-assisted instruction on cancer screening guidelines. *J Fam Pract* 23(3):281-283, 1986.
- Garrett TJ et al: Computer-assisted instruction in patient management for internal medicine residents. *J Med Educ* 61(12):987-989, 1986.
- Harandi MT: Applying knowledge-based techniques to software development. *Perspectives in Computing: Applications in the Academic and Scientific Community* 6(1):14-21, 1986.
- Hativa N: The microcomputer as a classroom audio visual device: the concept and prospects for adoption. *Comput and Educ* 10(3):359-367, 1986.
- Heckenlively DB: Descriptive analysis of simulated bird songs. *Collegiate Microcomputer* 4(3):193-199, 1986.
- Helgeson LW: What to focus on when selecting a videodisc system. *Performance and Instruction* 25(7):6-10, 1986.
- Hertsgaard DM et al: An approach to faculty microcomputer literacy. *J Comp Math Sci Teach* 5(2):29-31, 1985-1986.
- Ignatz ME: Suggestions for selecting science education software. *J Comp Math Sci Teach* 5(1):27-29, 1985.
- Jones RR et al: Use of the interactive videodisc to teach pathology: a preliminary report. *J Biocommun* 13(3):22-27, 1986.
- Kannan N: The true power of interactive video: the role of the authoring language. *Videodisc Monitor* 4(7):18-19, 1986.
- Klopfer LE: The coming generation of tutoring software. *Science Teacher* 53(8):34-37, 1986.
- Lehman JD: Interactive video - a powerful new tool for science teaching. *J Comp Math Sci Teach* 5(3):24-29, 1986.
- Lele AD: Computer-assisted instruction in medicine. *J Assoc Physicians India* 34(7):509-513, 1986.
- Mirr MP et al: Using interactive video to supplement student experience in critical care nursing. *Focus Crit Care* 13(4):28-35, 1986.
- Murphy MA: Preparing faculty to use and develop computer-based instructional materials in nursing. *J Med Syst* 10(2):109-120, 1986.
- Nahata MC: Experience with an independent study program in pathophysiology for Doctor of Pharmacy students. *Am J Pharm Educ* 50(3):278-280, 1986.
- Nelson RB et al: Examining the organizational characteristics of CAI projects in institutions of higher education. *J Educ Technol Syst* 14(4):297-305, 1985-1986.
- Nicolson RI et al: Computers and education: the software production problem. *Br J Educ Tech* 17(1):26-35, 1986.
- Oberst DJ et al: BITNET: past, present, and future. *EDUCOM Bulletin* 21(2):10-17, 1986.
- Paulanka BJ: A regression model to identify successful learner traits with CAI. *J Med Syst* 10(2):121-138, 1986.
- Pryor HG: A computer system for making quick and economical color slides. *J Dent Educ* 50(6):319-321, 1986.
- Redland AR et al: Interactive video: rationale and practicalities of one experience. *Comput Nurs* 4(2):68-72, 1986.
- Rhodes SB: A microcomputer kymograph. *J Coll Sci Teach* 15(6):523-527, 1986.
- Schloss PJ et al: Attributional consistency in CAI tutorials. *J Educ Technol Syst* 14(4):317-325, 1985-1986.
- Tamir P: Current and potential uses of microcomputers in science education. *J Comp Math Sci Teach* 5(2):18-28, 1985-1986.
- Thomas BS: Instructional computing in American nursing programs. *Int J Nurs Stud* 23(3):221-229, 1986.
- Tira DE et al: Computers in dental education - promise of the past versus reality of the present. *Dental Clinics of North America* 30(4):681-694, 1986.
- Tritz GJ: An antibiotic resource program for students of the health professions. *J Comp Math Sci Teach* 5(3):51-55, 1986.

AIMS AND SCOPE

The goal of *Computers in Life Science Education* is to provide a means of communication among life science educators who anticipate or are currently employing the computer as an educational tool. The range of content includes, but is not limited to, articles focusing on computer applications and their underlying philosophy, reports on faculty/student experiences with computers in teaching environments, and software/hardware reviews in both basic science and clinical education settings.

INVITATION TO CONTRIBUTORS

Articles consistent with the goals of *Computers in Life Science Education* are invited for possible publication in the newsletter.

PREPARATION AND SUBMISSION OF MATERIAL

Articles submitted for publication should not exceed 2000 words and should be typewritten, double spaced, with wide margins. The original and two copies including two sets of figures and tables should be sent to the Editor: Dr. Harold Modell, NRCLSE, Mail Stop RC-70, University of Washington, Seattle, WA 98195.

Title page should include full title, list of authors, academic or professional affiliations, and complete address and phone number of the corresponding author.

Illustrations should be submitted as original drawings in India ink or sharp, unmounted photographs on glossy paper. The lettering should be such that it can be legible after reduction (width of one column = 5.7 cm).

Reference style and form should follow the "number system with references alphabetized" described in the Council of Biology Editors Style Manual. References should be listed in alphabetical order by the first author's last name, numbered consecutively, and cited in the text by these numbers.

RESPONSIBILITY AND COPYRIGHT

Authors are responsible for accuracy of statements and opinions expressed in articles. All authors submitting manuscripts will be sent a copyright transfer form to complete. The completed form must be returned before the work will be published.

SUBSCRIPTION INFORMATION

Computers in Life Science Education is published monthly by National Resource for Computers in Life Science Education, Mail Stop RC-70, University of Washington, Seattle, WA 98195. Subscription rate is \$30.00 for 12 issues, including postage and handling in the United States and Canada. Add \$20.00 for postage (airmail) in Mexico and Europe and \$23.00 for the rest of the world.

This newsletter has been registered with the Copyright Clearance Center, Inc. Consent is given for copying of articles for personal or internal use, or for the personal or internal use of specific clients. This consent is given on the condition that the copier pay through the Center the per-copy fee stated in the code on the first page for copying beyond that permitted by the US Copyright Law. If no code appears on an article, the author has not given broad consent to copy and permission to copy must be obtained directly from the author. This consent does not extend to other kinds of copying, such as for general distribution, resale, advertising and promotional purposes, or for creating new collective works.

Address orders, changes of address, and claims for missing issues to NRCLSE, Mail Stop RC-70, University of Washington, Seattle, WA 98195. Claims for missing issues can be honored only up to three months for domestic addresses and six months for foreign addresses. Duplicate copies will not be sent to replace ones undelivered due to failure to notify NRCLSE of change of address.

Address editorial correspondence to Harold I. Modell, PhD, NRCLSE, Mail Stop RC-70, University of Washington, Seattle, WA 98195.

POSTMASTER: Send address changes to *Computers in Life Science Education*, NRCLSE, Mail Stop RC-70, University of Washington, Seattle, WA 98195.

COMPUTERS IN LIFE SCIENCE EDUCATION

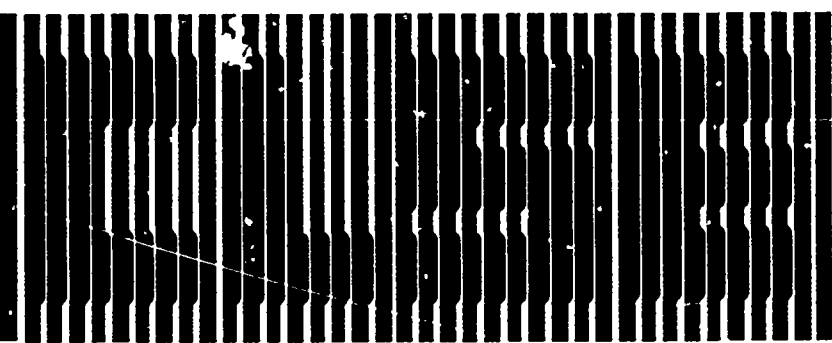

HAROLD I. MODELL

Department of Radiology
University of Washington
Seattle, Washington

MARCEL BLANCHAER

Department of Biochemistry
Faculty of Medicine
University of Manitoba
Winnipeg, Manitoba
Canada

THEODORE J. CROVELLO

Department of Biology
University of Notre Dame
Notre Dame, Indiana

JAMES W. ECKBLAD

Department of Biology
Luther College
Decorah, Iowa

TSEGAYE HABTEMARIAM

School of Veterinary Medicine
Tuskegee University
Tuskegee, Alabama

DONNA LARSON

School of Nursing
Grand Valley State College
Allendale, Michigan

TERRY M. MIKITEN

Graduate School of Biomedical Sciences
University of Texas Health Science Center
San Antonio, Texas

JAMES E. RANDALL

Department of Physiology
Indiana University
Bloomington, Indiana

PATRICIA SCHWIRIAN

College of Nursing
Ohio State University
Columbus, Ohio

RICHARD STULL

College of Pharmacy
University of Arkansas
Little Rock, Arkansas

JAMES W. WOODS

Lister Hill National Center
for Biomedical Communications
National Library of Medicine
Bethesda, Maryland

DOROTHY WOOLEY-McKAY

Department of Biology
Glendale Community College
Glendale, Arizona

GLEN YOSHIDA

Department of Life Sciences
Los Angeles Southwest College
Los Angeles, California

NRCLSE

CONTENTS

EDITORIAL COMMENT: THE ROLE OF COMPUTERS IN THE STUDENT LABORATORY	25
Harold I. Modell	
CAN YOU HELP?	32

EDITORIAL COMMENT: THE ROLE OF COMPUTERS IN THE STUDENT LABORATORY

Harold I. Modell

Department of Radiology, University of Washington, Seattle, Washington

Attempts to incorporate computers into student laboratories seems to be occurring with increasing frequency as life science departments become more aware of the capabilities of the computer and as more software becomes available. Defining the role of the computer in this educational setting, however, is not as clear cut as it may seem. In some cases, the computer promises to be an ideal solution to some very perplexing problems. In other cases, the computer may actually be detrimental to the educational goals of the laboratory. The intent of this commentary is to help focus on some of the educational goals of student laboratories and ask whether the computer provides a vehicle for

meeting those goals. Perhaps the end-product will be a definition of multiple roles rather than a singular role for the computer in the student laboratory.

WHY HAVE STUDENT LABS?

Before we can deal with the issue of computers in labs, we must define the role of the student lab within the curriculum. The most obvious answer to the question, "Why have student labs?" and one that most faculty use to justify their inclusion in the curriculum, is that labs provide a means of incorporating an active learning experience into the curriculum. They afford students the opportunity to have a "hands on" experience with material covered in

their reading and lectures.

Unfortunately, many faculty do not take the next step and define the *educational goals* of specific laboratory exercises. In deciding whether the computer is appropriate in a given laboratory, it is essential that these goals be defined explicitly. This may not be an easy task. Laboratory exercises are often designed to demonstrate a biological phenomenon and incorporated into a curriculum with little attention to specific educational goals. Current laboratory exercises seem to span a range of possible goals, however, that may be summarized under the following four general headings.

- 1) To familiarize students with technical issues;
- 2) To familiarize students with experimental and analysis issues;
- 3) To enlighten students in a problem-solving experience;
- 4) To provide students with a first-hand experience with a living system.

The response of many colleagues to this list is that student labs share all of these goals, and they cannot be separated. While it may be true that many labs have components that could fit within the scope of each of these headings, the primary reason for having students go through the exercise usually falls only under one category. Let us consider each of these and see whether the computer can help to achieve each type of goal.

FAMILIARIZING STUDENTS WITH TECHNICAL ISSUES

Some exercises are designed to familiarize students with various types of instrumentation. These sessions allow students to become familiar with the controls of the instrument, calibration procedures, and the limitations of the equipment. Other exercises may be aimed at enhancing psychomotor skills for specific tasks. In both areas, computer simulations offer a viable means

of meeting the educational goals at a savings in terms of necessary equipment, set-up time, and perhaps faculty time. Two examples serve to illustrate applications in this area.

Well counter simulation

The training program for residents in Nuclear Medicine at the University of Washington includes a laboratory designed to familiarize residents with the function and limitations of a Na-I well counter for counting gamma-emitting isotopes. In the laboratory procedure, the student obtains an energy spectrum for a given isotope by counting a standard. He then sets a window covering the portion of the spectrum in which counts are to be accumulated. Samples representing a range of concentrations (activities) are prepared and counted. During the course of the exercise, a variety of factors that affect counting statistics are examined.

We have recently completed a computer simulation of this exercise that could provide the same experience without imposing the space and time limitations associated with setting up the physical equipment in an area large enough to be accessed by the whole group. The program begins with a

menu listing standards that are available for the session. The student chooses a standard and the energy scale in which the spectrum will be displayed. The next step is to choose a counting window (Figure 1). Following these steps, the student prepares a test solution to be counted, defines a sample size for the counter, sets a time for counting the sample, and finally "counts" the sample. Displayed data (Figure 2) include the counts detected by the counter, the actual efficiency of the counter with this sample, and the apparent efficiency of the count. The efficiency values are not available from the real counter because they depend on the design characteristics of the instrument. However, this information helps the student gain an appreciation for the inherent inefficiencies of the equipment. The various steps in the procedure can be repeated at will (Figure 2) so that each factor affecting counting statistics can be examined. In many ways, a more thorough study can be conducted with the simulation than with the wet lab.

Nursing skills simulation

Larson has developed a series of simulations designed to help nursing stu-

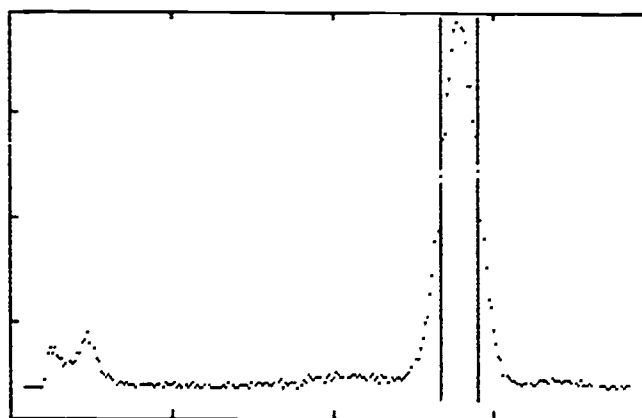

SET WINDOW UPPER LIMIT
 USE (- -) KEYS TO ADJUST HAIRLINE
 PRESS 'A' TO ACCEPT POSITION
 HAIRLINE POSITION: 203

FIGURE 1. Screen from well counter simulation showing energy spectrum of Technetium-99m. Student has set the window for counting between the vertical lines.

ISOTOPE: TC99M	OPTIONS:
COUNTER SETTINGS:	1) CHANGE ISOTOPE
WINDOW = 134 TO 147 KEV	2) RESET WINDOW
COUNTING TIME = 10 SEC	3) CHANGE AMOUNT OF INDICATOR
SAMPLE PREPARATION:	4) CHANGE VOLUME FOR DILUTION
10 MCI IN 1 L	5) CHANGE SAMPLE VOLUME
SAMPLE = 1 ML	6) DILUTE SAMPLE VOLUME
TOTAL COUNTS DETECTED = 76839	7) CHANGE COUNTING TIME
APPARENT COUNTING EFFICIENCY = 3 %	8) COUNT SAMPLE
ACTUAL OVERALL EFFICIENCY = 2 %	9) QUIT
(PRESS ANY KEY TO CONTINUE)	CHOICE?

FIGURE 2. Screens from well counter simulation. Left panel: Data presented to student after "counting" the sample. Right panel: Options available to the student after counting the first sample. The program allows the student to examine the influence of each parameter on counting statistics.

dents develop psychomotor skills such as calculating and dispensing drug dosages and calculating and regulating flow rates from intravenous drip chambers.⁹ These programs were designed so that they could replace conventional skills laboratories in which students worked with actual syringes and IV drip chambers. Larson reported that there were no significant differences between the traditional labs and computer-based exercises in terms of the effectiveness, transfer, or retention of learning achieved. However, the cost of instruction per student was 45-70% less with the computer exercises than with conventional laboratories.¹⁰ In this environment, the computer has again proven to be a viable alternative to the wet lab.

FAMILIARIZING STUDENTS WITH EXPERIMENTAL DESIGN AND ANALYSIS ISSUES

In some curricula, laboratories are intended to provide the student with a "preview" of the research laboratory. In this context, the laboratory exercises

deal with experimental design issues including the need to have a sound statistical basis for the design chosen, the importance of appropriate control groups, and issues related to gathering appropriate data (eg, measurement error, signal-to-noise ratio). Exposure to appropriate data analysis (including statistical tests) is also an integral part of these laboratories.

In this context, Heidcamp has provided one example of computer use as an adjunct to the wet lab.⁷ In his example, students run cellular respiration experiments using a Warburg apparatus. Data are collected once every ten minutes from fourteen flasks representing six duplicated experimental groups and a control. The data are entered into a microcomputer as the experiment is run. The computer program calculates appropriate corrections (eg, for background temperature and pressure) and displays the data in graphical form. By examining the data as the experiment is being conducted, and by comparing one group's data to data gathered by col-

leagues in other groups, students are better able to gain an appreciation for potential errors (eg, leaks in the system) as well as other factors related to experimental design and data gathering.

Kramm and Spain's Mark and Recapture simulation⁸ allows ecology students to examine issues related to experimental design and data analysis in a content area where actual student laboratory exercises may be difficult, if not impossible, to conduct. In this simulation, students define a population size of wildlife to "capture" and mark. This population is then released, and, at a later time, the student defines a sample size to "recapture" from the general population. The process may be repeated to examine the influence of a number of design parameters related to this class of experiments.

These examples illustrate that the computer can certainly play a role in laboratories focused on experimental design and analysis issues. In some cases, the computer can serve as a valuable adjunct to wet lab, providing an ability

to reduce large amounts of data in a timely manner so that class time can be devoted to discussion of the implications of the design characteristics of the experiment and the significance of the results. In other cases, the computer can provide a means of conducting "experiments" aimed specifically at the de-

sign and analysis issues that might not otherwise be included as part of the curriculum.

ENGAGING STUDENTS IN A PROBLEM-SOLVING EXPERIENCE

Although problem-solving represents a critical component of life science disci-

plines, few instances of wet labs having problem-solving as an educational goal can currently be found in life science curricula. With the time and financial constraints on today's curricula, it is doubtful that many wet labs intended to serve large classes can provide sufficient resources to allow students the latitude necessary to engage in an in-depth problem-solving experience. Perhaps use of the computer in an effort to attain this goal represents the application with the highest potential for impacting life science education. Computer simulations offer a latitude not available with living systems. A system may be examined as simplified components or groups of components and built up to a complex system. For example, in cardiovascular physiology, simulations are currently available that allow examination of the aspects of the system ranging from an isolated left heart preparation (Figure 3)¹³ to a complex system that includes interactions with other systems.³

In respiratory physiology, one can begin by examining exchange between the atmosphere and alveoli (Figure 4), build upon this to a system that takes ventilation-perfusion relationships, right-to-left shunt, and a tissue bed into account (Figure 5)¹¹ and ultimately examine a model of cardiopulmonary physiology that allows the user to examine more than 100 parameter values.⁶

Computer simulations also provide a mechanism of extending the scope of wet labs that do offer a problem-solving experience. Cooper uses a simulation to allow students in introductory microbiology to extend their wet lab experience of identifying unknown bacteria to include pathogens.⁴

PROVIDING STUDENTS FIRST-HAND EXPERIENCE WITH A LIVING SYSTEM

Traditionally, this has been the primary educational goal of student laboratories. In recent years, the rising costs of equipment and supplies, increased class sizes, and increased activity of animal rights

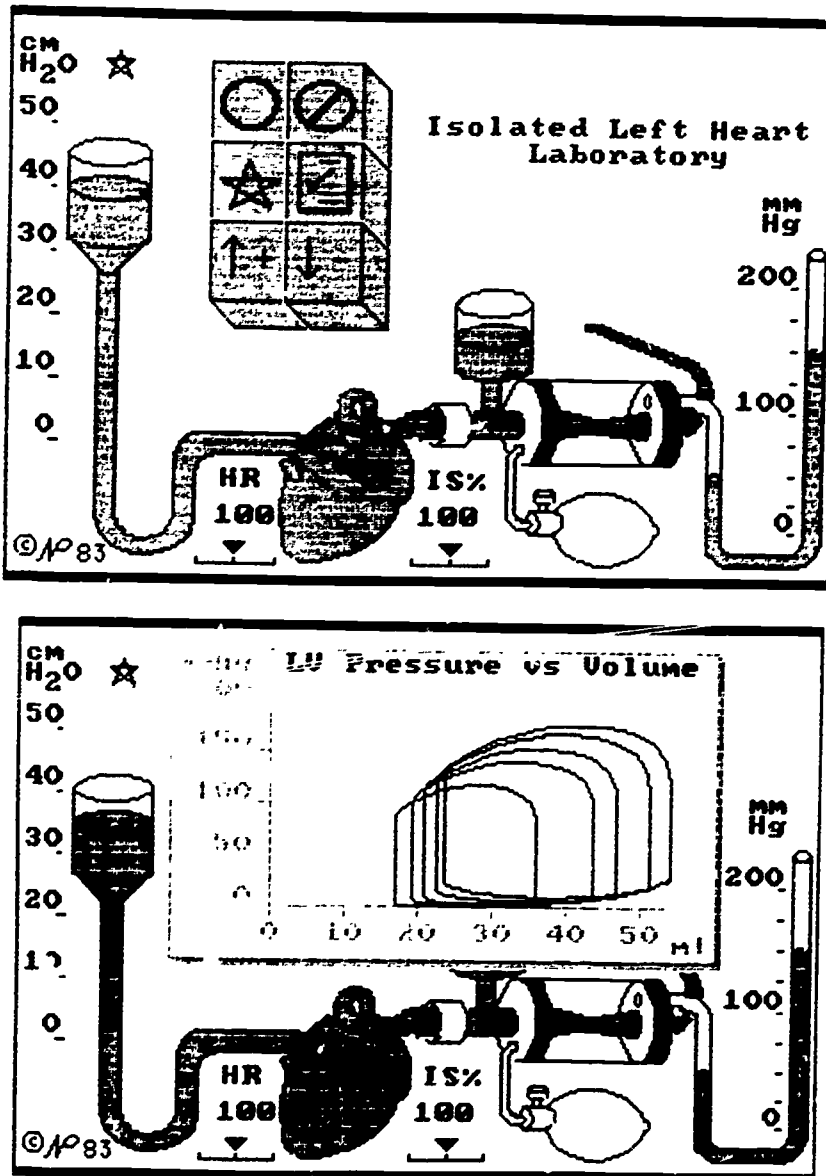

FIGURE 3. Output screens from isolated left heart laboratory simulation of Peterson and Campbell.¹³ Upper panel: Schematic representation of the experimental set-up. Lower panel: Data from a series of runs examining pressure-volume relationships of the left heart.

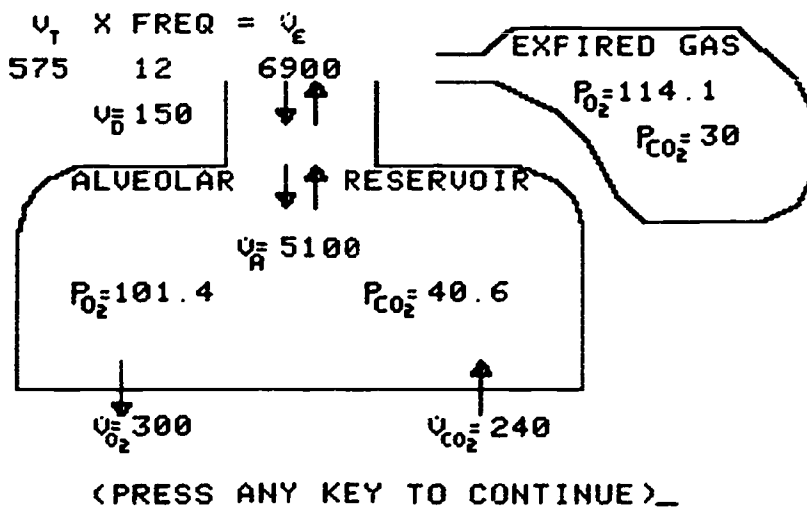

FIGURE 4. Output screen from the first program in a series of models of pulmonary gas exchange.¹¹ The student begins the series by examining exchange between the atmosphere and alveoli.

groups have led many life science departments to seek "alternatives" or "substitutes" for these laboratories. The words "alternative" and "substitute" are unfortunate choices for they imply that both the old and new activities accomplish the same goals. From a scheduling standpoint, other types of activities can certainly serve as alternatives or substitutes for wet labs. However, from the standpoint of attaining the educational goal of providing students with a first-hand experience with a living system, nothing is farther from the truth. If the goal of the laboratory is to have the student gain an appreciation for the feel of living tissue, the viability of a nerve or muscle preparation, or the difference between a beating and fibrillating heart, *there is no substitute for the living system.* The experience *cannot* be duplicated through simulations or by watching images stored on film, videotape or videodisc.

Does this mean that the computer has a role in this type of laboratory? On the contrary, it can play a very important role. It can, in fact, help the student gain more from the experience than is possible with more traditional equip-

ment. The key element in this application is the analog-to-digital (A-D) converter. By equipping the computer with an A-D converter and appropriate software, the computer can be converted into a strip-chart recorder with capabilities for repeating and manipulating data ac-

quired during an experiment.^{1,2,5,12}

Computer-based data acquisition can enhance wet labs in a number of ways. First, the cost of such equipment relative to traditional signal recording equipment is low. Thus, departments contemplating elimination of wet labs because the cost of replacing old equipment is prohibitive may have a viable alternative that will allow retaining or perhaps even expanding the wet lab experience.

The time that it takes for students to become familiar with the recording equipment is probably less because most have had some computer or keyboard experience. This means that in a given laboratory period, more time is available for focusing on the biological system being studied.

Because acquired data can be stored, manipulated, and redisplayed, data gathered at the beginning of the experiment before significant deterioration of the preparation takes place can be used in a variety of analysis schemes. In this way, the student may be able to broaden the scope of a study beyond that possible with more conventional

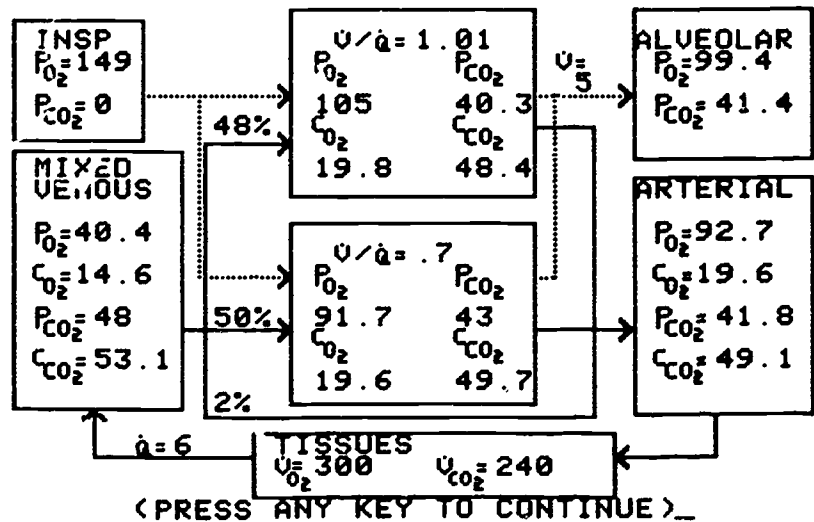

FIGURE 5. Output screen from the last program in a series of models of pulmonary gas exchange.¹¹ Components have been progressively added so that the student can now view the system as a whole.

recording equipment.

CONCLUSION

We have seen a trend in recent years towards reduction or elimination of student laboratories in many life science settings. The reasons given for reducing or eliminating these sessions include the increased volume of information that must be covered within a given time period, rising costs of laboratory equipment and supplies, and student opposition to using mammals in student laboratories. In succumbing to these pressures, it seems as if few departments seriously examined the educational goals of their student laboratories in an attempt to retain these potentially valuable educational experiences.

Perhaps it is time to reevaluate the overall goals of life science curricula and consider focusing on process rather than factual information. Student laboratories with explicit educational goals could contribute significantly to the emergence of a student body that is able to think about integrated biological systems rather than merely access

biological facts.

The computer is a versatile tool that can contribute in a variety of ways to achieving the educational goals of student laboratories. The key to success, however, is to define these goals for specific laboratory exercises and incorporate the computer in ways that are consistent with the established goals.

REFERENCES

1. Barr L, Stein R: Computer-aided data acquisition in an undergraduate physiology laboratory. *Computers in Life Science Education* 1:19-22, 1984.
2. Clark CO: Computer interfacing for science experiments. *Computers in Life Science Education* 2:59-61, 1985.
3. Coleman TG, Randall JE: HUMAN, a comprehensive physiological model. *The Physiologist* 26:15-21, 1983.
4. Cooper, EH: Simulated experiments in biology classes. *Computers in Life Science Education* 3:57-59, 1986.
5. Coyne, MD: Substitution of apple computers for storage oscilloscopes and polygraphs. *Computers in Life Science Education* 2:81-86, 1985.
6. Dickinson CJ: *A Computer Model of Human Respiration*. Baltimore, MD: University Park Press, 1977.
7. Heidcamp WH: *Computers and undergraduate comparative physiology*. *Computers in Life Science Education* 1:54-55, 1984.
8. Kramm K, Spain JD: *Mark and Recapture*. Iowa City, IA: Conduit, 1983.
9. Larson DE: *Computerized Nursing Skills Simulation*. Philadelphia, PA: J B Lippincott, 1984.
10. Larson DE: Using computer-assisted instruction in the education of health care professionals: what the dean needs to know. *Computers in Life Science Education* 1:65-67, 1984.
11. Modell HI: *Simulations in Physiology - The Respiratory System*. Seattle, WA: National Resource for Computers in Life Science Education, 1986.
12. Olivo RF: Microcomputer-based data acquisition for neurobiology. *Proc Nat Educ Comput Conf* 5:174-179, 1983.
13. Peterson NS, Campbell KB: Teaching cardiovascular integrations with computer laboratories. *The Physiologist* 28:159-169, 1985.

— NOTICE —

A limited number of back issues of CLSE have become available for purchase. Volumes 1, 2, and 3 are available at a cost of \$30.00 per volume (includes binder) plus shipping. Address orders to: NRCLSE, Mail Stop RC-70, University of Washington, Seattle, WA 98195.

— NOTICE —

CAN YOU HELP?

One of the goals of NRCLSE is to serve as a mechanism for life science faculty interested in using the computer as a teaching tool to become aware of colleagues with similar interests. From time to time, NRCLSE receives letters from life scientists requesting information in areas in which we lack expertise. It seems appropriate to initiate a new feature in which these questions are passed along to colleagues who can help. Therefore, from time to time we will seek the help of the CLSE readership in responding to these inquiries. If you can help, please respond directly to the person seeking information.

NRCLSE:

I am interested in obtaining an MS-DOS 3.2 compatible computer program that I

can use as a framework for the systematic and comprehensive documentation of selected life forms in the U.S. Virgin Islands, and I wondered if you could help me. I want a program that can place organisms within a classification system, as well as allow for documenting the relationships that organisms have with others. I would like to be able to access this data by any classification category name, as well as allow for documenting the relationships that organisms have with others. I would like to be able to access this data by any classification category name, specific relationships between organisms, and an artificial classification designation such as forage, fruit, ornamental, and vegetable crops.

My present thoughts are to use a commercial relational database management program. In one table, give each phylogenetic classification category name an identifying number. In another table, group the classification category names by their identifying numbers. In another table, describe each organism, give

it an identification number and link it to the phylogenetic classification system by its corresponding classification group identification number. The organism identification number could also identify the organism within an artificial classification group. Has this already been done?

I recognize that determining which phylogenetic classification system to use is of critical importance. The technical difficulty of designing the classification tree in the database without excessive duplication is also a concern.

I would appreciate any assistance that you could provide in directing this effort.

Houston Holder
Extension Specialist in Plant Protection
Virgin Islands Cooperative Extension Service
College of the Virgin Islands
P.O. Box "L", Kingshill, St. Croix
U.S. Virgin Islands 00850-000L

REMINDER

The National Resource for Computers in Life Science Education is accessible through the BITnet international computer network. Check with your campus computer center to learn more about BITnet and how to access the network at your location. BITnet is a *free* network. To contact NRCLSE through BITnet, address mail to:

MODFLL@UWALOCKE

AIMS AND SCOPE

The goal of *Computers in Life Science Education* is to provide a means of communication among life science educators who anticipate or are currently employing the computer as an educational tool. The range of content includes, but is not limited to, articles focusing on computer applications and their underlying philosophy, reports on faculty/student experiences with computers in teaching environments, and software/hardware reviews in both basic science and clinical education settings.

INVITATION TO CONTRIBUTORS

Articles consistent with the goals of *Computers in Life Science Education* are invited for possible publication in the newsletter.

PREPARATION AND SUBMISSION OF MATERIAL

Articles submitted for publication should not exceed 2000 words and should be typewritten, double spaced, with wide margins. The original and two copies including two sets of figures and tables should be sent to the Editor: Dr. Harold Modell, NRCLSE, Mail Stop RC-70, University of Washington, Seattle, WA 98195.

Title page should include full title, list of authors, academic or professional affiliations, and complete address and phone number of the corresponding author.

Illustrations should be submitted as original drawings in India ink or sharp, unmounted photographs on glossy paper. The lettering should be such that it can be legible after reduction (width of one column = 5.7 cm).

Reference style and form should follow the "number system with references alphabetized" described in the Council of Biology Editors Style Manual. References should be listed in alphabetical order by the first author's last name, numbered consecutively, and cited in the text by these numbers.

RESPONSIBILITY AND COPYRIGHT

Authors are responsible for accuracy of statements and opinions expressed in articles. All authors submitting manuscripts will be sent a copyright transfer form to complete. The completed form must be returned before the work will be published.

SUBSCRIPTION INFORMATION

Computers in Life Science Education is published monthly by National Resource for Computers in Life Science Education, Mail Stop RC-70, University of Washington, Seattle, WA 98195. Subscription rate is \$30.00 for 12 issues, including postage and handling in the United States and Canada. Add \$20.00 for postage (airmail) in Mexico and Europe and \$23.00 for the rest of the world.

This newsletter has been registered with the Copyright Clearance Center, Inc. Consent is given for copying of articles for personal or internal use, or for the personal or internal use of specific clients. This consent is given on the condition that the copier pay through the Center the per-copy fee stated in the code on the first page for copying beyond that permitted by the US Copyright Law. If no code appears on an article, the author has not given broad consent to copy and permission to copy must be obtained directly from the author. This consent does not extend to other kinds of copying, such as for general distribution, resale, advertising and promotional purposes, or for creating new collective works.

Address orders, changes of address, and claims for missing issues to NRCLSE, Mail Stop RC-70, University of Washington, Seattle, WA 98195. Claims for missing issues can be honored only up to three months for domestic addresses and six months for foreign addresses. Duplicate copies will not be sent to replace ones undelivered due to failure to notify NRCLSE of change of address.

Address editorial correspondence to Harold I. Modell, PhD, NRCLSE, Mail Stop RC-70, University of Washington, Seattle, WA 98195. (BITNET MODELL@UWALOCKE)

POSTMASTER. Send address changes to *Computers in Life Science Education*, NRCLSE, Mail Stop RC-70, University of Washington, Seattle, WA 98195.

COMPUTERS IN LIFE SCIENCE EDUCATION

CONTENTS

USE OF ELECTRONIC BLACKBOARD TELECONFERENCE TEACHING AT A REMOTE SITE Ken Kastella and Albert Gordon	33
WHERE'S THE SOFTWARE?	36

USE OF ELECTRONIC BLACKBOARD TELECONFERENCE TEACHING AT A REMOTE SITE

Ken Kastella and Albert Gordon

*WAMI Program, University of Alaska, Fairbanks, Alaska and
Department of Physiology and Biophysics, University of Washington, Seattle, Washington*

In addition to the main campus in Seattle, first year medical students at the University of Washington receive instruction at the remote sites participating in the WAMI Medical Education Program: Washington State University, Pullman (WSU); University of Alaska, Fairbanks (UAF); Montana State University, Bozeman (MSU); University of Idaho, Moscow (UI) (it should be noted that because of their geographic proximity, WSU and UI students are taught together as a single group). Equivalent courses are taught at the peripheral universities primarily by resident faculty. However, since no site has the full range of resource fac-

ulty available in Seattle, University of Washington faculty are required to participate in the courses at the remote universities. Because of the relative expense of such travel, both in actual monetary cost and faculty time, we decided to experiment with electronic media for long-distance teaching. Over the last three years, we have experimented with the use of the "electronic blackboard" to teach part of a course entitled "Mechanisms of Cellular Physiology" to students in Fairbanks, Alaska. This is a report on the success of the project.

From 1973 to 1979, we had experience with an experimental project using

HAROLD I. MODELL

Department of Radiology
University of Washington
Seattle, Washington

MARCEL BLANCHAER

Department of Biochemistry
Faculty of Medicine
University of Manitoba
Winnipeg, Manitoba
Canada

THEODORE J. CROVELLO

Department of Biology
University of Notre Dame
Notre Dame, Indiana

JAMES W. ECKBLAD

Department of Biology
Luther College
Decorah, Iowa

TSEGAYE HABTEMARIAM

School of Veterinary Medicine
Tuskegee University
Tuskegee, Alabama

DONNA LARSON

School of Nursing
Grand Valley State College
Allendale, Michigan

TERRY M. MIKITTEN

Graduate School of Biomedical Sciences
University of Texas Health Science Center
San Antonio, Texas

JAMES E. RANDALL

Department of Physiology
Indiana University
Bloomington, Indiana

PATRICIA SCHWIRIAN

College of Nursing
Ohio State University
Columbus, Ohio

RICHARD STULL

College of Pharmacy
University of Arkansas
Little Rock, Arkansas

JAMES W. WOODS

Lister Hill National Center
for Biomedical Communications
National Library of Medicine
Bethesda, Maryland

DOROTHY WOOLEY-McKAY

Department of Biology
Glendale Community College
Glendale, Arizona

GLEN YOSHIDA

Department of Life Sciences
Los Angeles Southwest College
Los Angeles, California

NRCLSE

full duplex audio and video satellite transmission between Seattle and Fairbanks to teach the same physiology course. The lectures were presented to medical student conference groups and turned out to be a highly successful, but extremely expensive didactic method. Our goal was to find a less expensive way to duplicate the interactive teaching that the satellite experiment provided. We have explored several other ways of doing this. Commercial telephone is far less expensive and the obvious initial choice. By themselves, telephones provide voice-only transmission, a major drawback for scientific subjects. Because of the need to transmit drawn or written information in teaching, we explored three methods for doing this using regular telephone lines. The choices were dictated mainly by the available technology in any given year. Although it never made it to the classroom, we first tried slow-scan TV but found that the images were too low in resolution with barely tolerable transmission speeds. In addition, slow-scan TV is relatively expensive.

THE ELECTRONIC BLACKBOARD

In 1984, we went to the use of an "electronic blackboard" as a means of transmitting pictorial information. During the first year's operation, we leased an AT&T electronic blackboarding system on an experimental basis. The system involved writing on a pressure sensitive blackboard with chalk (or, when the configuration is upgraded, on a white board with a pen). Visual information was digitized, transmitted over phone lines, and appeared almost instantaneously on a TV monitor at the remote site. A separate phone line was used for voice transmission. Technically, this proved to be a reasonable method for presentation and mimicked blackboard presentations to students in a normal classroom very closely. A major drawback to this system was the inability to pre-draw complex images for transmission or for later annotation. Another major drawback at the time was the purchase price

of the system, approximately \$12,000 for a single blackboard and electronics.

In the last two years (1985 and 1986), we have used the Telewriter II PC system from Optel Communications, Inc. (322 Eighth Ave, New York, NY 10001). In its present configuration, it uses a Pconcept digitizing pad interfaced to an IBM i-PC. Images, drawn on-line or pre-drawn and stored, can be transmitted via a modem to a microcomputer at the peripheral site and displayed or stored there for later retrieval. Display at the other end is on a computer monitor or various enlarged displays. Microphones and/or speaker phones at either end enable a two-way dialog between students and the instructor.

The system operates in one of two resolution modes: a CGA compatible, low resolution mode of 320 x 200 pixels with 4 colors or a higher resolution mode of 640 x 200 pixels with only black and white. In addition to the ability to draw on-line, the Optel software permits the instructor to pre-draw or pre-type a series of screens which could be stored, transmitted to the peripheral sites off-line, and called up one page at a time from the remote microcomputer for annotation or illustration. Because the Telewriter PC software can also operate in the background and capture 320 x 200 pixel graphic images generated by the Penware software as well as other graphics programs, such as PC Paint and Lotus 1-2-3, these pre-drawn images can be very complex. The Pconcept digitizing pad is also a "smart" tablet. It can recognize letters drawn on the tablet and record them as printed letters. The present modem multiplexes voice and data for transmission over a single telephone line, but only at 300 baud. On-line drawing or annotation is done virtually in real time with no noticeable delay in transmission. Depending on the resolution, transmission of whole frames takes a few minutes at the slow 300 baud rate, but this can be done off-line before the teaching sessions. The system is designed to permit two-way visual com-

munication by installing a Pconcept tablet at the remote end, but that option was not available to us. However, it does seem desirable and beneficial for students to be able to illustrate their questions and have it appear on the instructor's computer monitor. The price of the system as configured was about \$6000 excluding the price of the PC's and monitors.

APPLICATION OF THE SYSTEM

We used the electronic blackboard system for conference style teaching rather than in the lecture mode. The physiology course we were teaching has a common content at all of the peripheral sites, and a detailed syllabus has been developed for the course. For independent study, students were assigned course material from the detailed presentation in the syllabus. Teleconferences with the electronic blackboard were then used to review material, clarify difficult concepts, and answer students' questions. Pre-stored images permitted greater ease of review while the ability to draw and write on-line allowed clearer and more graphic answers to questions than the alternative, the telephone alone. The electronic blackboard was also used to expand on the basic material by presenting examples of the latest research developments. The goal was to show students future directions in the field, but it was not material for which they would be held responsible and tested on.

EVALUATION

Evaluation of the effectiveness of this mode of teaching took two forms, comparison of test performance and attitude surveys. Examinations at each of the five WAMI sites have a common content which, for this course, is 50 questions. Of those questions, approximately 10 examine the material covered using the electronic blackboard system. The success of the teaching experience using this media was evaluated primarily by comparing the common exam performance of the Alaska WAMI stu-

der s with the other sites. No peripheral site had a recognized expert in the subjects we covered with the electronic blackboard, but each used a different teaching method. Consequently, at various times, we had students who had learned the material through lectures and the syllabus (MSU), those who learned through independent study using the syllabus and in-person conference sessions (UW), those using only independent study (WSU-UI), and our students using independent study and electronic blackboard conference sessions. The Alaska students using the electronic blackboard teleconferencing system always tested at or above the level of the students at the other sites. However, differences in performance were not significant because of the small number of questions. In any case, in terms of real performance, students using the electronic blackboard teleconferencing system did not do any worse and may, in fact, have done better than students at the other sites.

The performance of Alaska students relative to the other sites has not been rigorously analyzed, but some relevant comments may be in order. All students go through the same selection process by the University of Washington, although Alaska students tend to have slightly lower MCAT scores and GPAs. Each WAMI course has common exam questions, and in a given course in a given year, a particular site may have an exam average that is better or worse than the other sites. When looked at over the years, however, there has been no consistent statistical difference between sites, and that was also true for the entire 50 common questions in the "Mechanisms of Cellular Physiology" course. The fact that the Alaska students were responsible for independent study could have been a factor in the first two years of the study, but the results were the same in the third year when both WSU-UI and UW also were involved in independent study. Perhaps the novelty of the presentation at Alas-

ka could have been a factor. Another factor that may be important is the size of the group. One hundred students are in Seattle; WSU-UI has 40 students; MSU has 20; and Alaska varied from 13 to 16.

Subjective feelings regarding the effectiveness of the electronic blackboard were obtained from a questionnaire prepared for the students. From the faculty viewpoint it was comforting to note that in spite of their performance, the subjective evaluation by Alaska students indicated that they preferred a real live instructor rather than the electronic media. Although they thought that the conferences were useful and the media good, the lack of more personal interaction with students was identified as a concern.

LESSONS LEARNED

A major problem with this method of instruction is the lack of visual communication between the instructor and student. Head nods and puzzled looks apparent in the classroom, especially with small groups, are not transmitted, and it can be difficult to get the students to be more vocally assertive about clarifying unclear points or concepts. Other problems, mostly technical in nature and which will most certainly be minimized in the future, include the following.

Transmission Speed

The speed of data transmission is currently limited to 300 baud. This rate is very restrictive, particularly if higher resolution screens are to be transmitted.

Screen Resolution

The screen resolution is IBM CGA compatible 320 x 200 pixels in four colors or 640 x 200 in black and white. With this resolution, all drawings and lettering have to be fairly large, and the content on the screen must be kept low.

Hard-copy Output

It would have been useful to have had a

means of turning the graphic images into printed images for the students. Of course, if materials were generated early enough, they could be duplicated and sent to the peripheral site prior to the session. However, for those instances where the instructor digresses from the script, it would be convenient to have been able to make a quick copy of this material for the students. Hardware is probably available for making this conversion.

Computer Display Size

We had problems with the size of the standard computer display. For a group of 10 or less, it is marginally large enough, but a larger monitor or some sort of projection system is required for larger groups.

Audio Exchange

We used a single speaker-phone for the audio. This is usable for a small number of students, however, the ideal would have been a good teleconferencing system with speaker and microphones so that students can both hear and be heard when asking questions.

CONCLUSION

This system, as set up, could be accessed quickly so that we could be on-line to answer students' questions within a few seconds of receiving a telephone call. This means that a firm schedule is not necessary, but the system could be used on a more casual basis to respond directly to students' questions, greatly expanding the flexibility and usefulness of the system. There are certainly many other uses for the electronic blackboard teleconferencing system in a university setting. For example, administrative conferences, one-on-one consultations, testing, demonstrations, simulation, and modeling are all possible uses that we did not explore. Overall, we feel that the experiment was successful and the media useful in this teaching setting.

WHERE'S THE SOFTWARE?

In the past, we have published several lists of life science software sources and programs or program areas available through them. The following list is presented as the latest in a continuing effort to make colleagues aware of potential resources. As in the past, no attempt has been made by NRCLSE to review these materials. In lists presented after our planned peer critique mechanism is in place, hopefully later this year, indication of reviews will also be presented.

This month's listing includes information drawn from 1986-87 edition of The Educational Software Selector, a data base created by the Educational Products Information Exchange (EPIE) Institute. For additional information about EPIE, write or phone EPIE Institute, P.O. Box 839, Water Mill, NY 11976, telephone (516) 283-4922.

If you have found specific software helpful in your teaching efforts, please share your good fortune by letting us know about the program(s) and supplier(s) so that we can make this information available through future "Where's the Software?" lists. Send pertinent information to Dr. Harold Modell, NRCLSE, Mail Stop RC-70, University of Washington, Seattle, WA 98195 or send us a note on BITnet. Our BITnet address is MODEL@UWALOCKE.

Academic Hallmarks
P.O. Box 998
Durango, CO 81301
(303) 247-8738

KNOWLEDGE MASTER - BIOLOGY 2

Test-item database for test generation. Content covers coelenterates, arthropods, insects, fish, amphibians, and reptiles. Part of a 5-program Biology series for Apple II equipment.

KNOWLEDGE MASTER - BIOLOGY 3

Test-item database for test generation. Content covers birds, mammals, pr-

mates, protists, bacteria and taxonomic zoology. Part of a 5-program Biology series for Apple II equipment.

Biosource Software

2105 S. Franklin, Suite B
Kirksville, MO 63501
(816) 665-3678

CONCEPTS IN THERMOGRAPHY

Tutorial covering basic DC concepts, peripheral vascular physiology, detecting skin temperature, amplifiers, and processing DC signals. Program for Apple II equipment.

NEUROMUSCULAR CONCEPTS

Tutorial covering muscle action potentials, use of electromyograph, contraction, muscle action and movement disorders. Program for Apple II equipment.

PRINCIPLES OF PHARMACOLOGY

Tutorial covering history, drug absorption and distribution, biotransformation and elimination, mechanisms of action, and drug safety and efficacy.

Program for Apple II equipment. SKELETAL MUSCLE ANATOMY/ PHYSIOLOGY

Tutorial covering three muscle categories, skeletal muscle microstructure, sliding filament theory, motor units, and lever systems. Program for Apple II equipment.

SKILLS IN ELECTROMYOGRAPHY

Tutorial covering skin preparation, reducing EMG artifact, testing a myograph's operation, electrode location, and preventing shock hazards. Program for Apple II equipment.

Classroom Consortia Media, Inc.

57 Bay Street
Staten Island, NY 10301
(800) 237-1113
(800) 522-2210

CELL GROWTH AND MITOSIS

Interactive simulation covering surface area-volume ratio, chromosome number, chromosome replication, and cytoplasmic division. Program for

IBM-PC (PC-DOS) equipment. LEAF: STRUCTURE AND FUNCTION

Tutorial-simulation covering the anatomy and physiology of the leaf with respect to its role as the "chemical factory" of the plant. Program for IBM-PC (PC-DOS) equipment.

PASSIVE TRANSPORT

Tutorial-simulation covering diffusion and osmosis. Program for MS-DOS compatible equipment.

PHOTOSYNTHESIS AND LIGHT ENERGY

Simulation focuses on characteristics of light and its role as an energy source. Program for IBM-PC (PC-DOS) equipment.

PLANT GROWTH

Tutorial-simulation covering physiology of growth beginning with the seed. Covers hormone control, feedback mechanisms, transport, and differentiation. Program for IBM-PC (PC-DOS) equipment.

COMpress

P.O. Box 102
Wentworth, NH 03282
(603) 764-5831

GENTIC DRIFT

Tutorial-simulation focusing on random changes with time in the distribution of individuals in small populations. Program for Apple II equipment.

LIFE

Educational game dealing with changing distributions of individuals. Program for Apple II equipment.

MONDELIAN GENETICS

Simulation covering dominance, partial dominance, lethality, linkage, and sex linkage. Program for Apple II equipment.

POPULATION GROWTH

Simulation dealing with exponential and density-dependent growth.

Program for Apple II equipment.

POPULATION SIZES

Simulation dealing with a dynamic

- population. Program for Apple II equipment.
- SIMULATION OF HEMOGLOBIN FUNCTION**
Simulations of hemoglobin and myoglobin functions. Program for Apple II equipment.
- Computer**
15 Centa. Road
Randolph, NJ 07869
(201) 366-8540
- LIMITS**
Simulation of the effects of growth on world population, pollution, food supply, industrial output, and natural resources. Program available for Apple II, PET/CBM and TRS-80 Model III equipment.
- MALARIA**
Simulation of the effects of various types of malaria epidemic controls. Program available for Apple II, PET/CBM, and TRS-80 Model III equipment.
- POLLUTE**
Simulation of factors affecting water quality. Includes temperature, amount and type of pollutant, and water treatment. Program available for Apple II, PET/CBM, and TRS-80 Model III equipment.
- POP**
Simulation of three growth models (exponential, logistical, and logistical with low density). Program available for Apple II, PET/CBM, and TRS-80 Model III equipment.
- RATS**
Simulation of rat control in city or apartment by sanitation and various poisons. Program for Apple II, PET/CBM, and TRS-80 Model III equipment.
- STERL**
Simulation exploring effectiveness of pest control methods. Program available for Apple II, PET/CBM, and TRS-80 Model III equipment.
- CONDUIT**
The University of Iowa
Oakdale Campus
Iowa City, IA 52242
- (319) 335-4100
- BAFFLES, BAFFLES II**
Game to help students develop deductive reasoning and problem solving skills. Program available for Apple II (BAFFLES) and IBM-PC compatible (BAFFLES II) equipment.
- CATGEN**
Simulation allowing students to mate domestic cats of known genotypes. Program available for Apple II and IBM-PC compatible equipment.
- CATLAB (Second Edition)**
Simulation in introductory genetics. Program available for Apple II and IBM-PC compatible equipment.
- COEXIST: Population Dynamics**
Simulation of the growth of two populations either independently or in competition for the same limited resources. Program available for Apple II equipment.
- COMPETE: Plant competition**
Simulation of experiments involving interaction between flowering plants. Program available for Apple II equipment.
- ECOLOGICAL MODELING**
Series of 7 programs dealing with a variety of techniques for modeling ecological systems and processes. Program available for Apple II and IBM-PC compatible equipment.
- ENZKIN: Enzyme Kinetics**
Simulation of enzyme-catalyzed reactions. Program available for Apple II equipment.
- EVOLUT: Evolution and Natural Selection**
Simulation of fluctuations in gene frequencies of wild populations. Program available for Apple II equipment.
- FAMILY IDENTIFICATION**
Data retrieval program to review the characteristics of 74 North American flowering plant families. Program available for Apple II equipment.
- ISLAND BIOGEOGRAPHY**
Three simulations of island communities dealing with the relationship between island area and number of species, colonization of a new island, and island immigration and extinction.
- Program available for Apple II equipment.
- LIFE TABLES AND THE LESLIE MATRIX**
Tutorial-simulation dealing with the basic life table and Leslie Matrix. Program available for Apple II equipment.
- LINKOVER: Genetic Mapping**
Simulation of genetic mapping experiments. Program available for Apple II equipment.
- MARK & RECAPTURE**
Simulation of mark and recapture experiments to explore three models for estimating population sizes. Program available for Apple II equipment.
- OSMOTIC PRESSURE**
Simulation of thistle tube experiments and animation of a molecular model for osmosis. Program available for Apple II equipment.
- POPULATION GROWTH**
Simulation of population growth. The package compares and contrasts the geometric or exponential growth model with the logistic or Verhulst-Pearl growth model. Program available for Apple II equipment.
- PREDATION**
Simulation of predator-prey interactions. Program available for Apple II equipment.
- PREDATION EQUILIBRIA**
Simulations of equilibrium models of predator-prey interaction. Program available for Apple II equipment.
- TRIBBLES: TRIBBLES Revisited**
Simulation to introduce students to the scientific method. Programs available for Apple II (Tribbles) and IBM-PC compatible (Tribbles revisited) equipment.
- Datatech Software Systems**
19312 East Eldorado Drive
Aurora, CO 90013
- CELLS AND GENETICS PICTURE FILE**
Hi-Res diagrams of animal cell, plant cell, mitosis, meiosis, Punnett Square, sex linked traits, DNA replication, protozoa, energy reac-

tions, and pedigree. Program available for Apple II equipment.

HUMAN ANATOMY PICTURE FILE

Hi-Res diagrams of heart, brain, eye, ear, respiratory system, kidney, endocrine system, neurons, circulatory system schematic, and digestive system. Program available for Apple II equipment.

PLANT ANATOMY PICTURE FILE

Hi-Res diagrams of roots, stem cross-section, leaf cross-section, photosynthesis, flowers, seeds, and germination. Program available for Apple II equipment.

Diversified Education Enterprises
725 Main Street
Lafayette, IN 47901
(317) 742-2690

BALANCE-PREDATOR-PREY SIMULATION

Simulation of the effects of food supply, carrying capacity, environmental conditions, and external pressures or predator/prey relationships. Program available for Apple II, TRS-80 Models I and III, IBM-PC, and Commodore 64/128 equipment.

CLASSIFY-CLASSIFICATION KEY PROGRAM

Presents an unclassified set of characteristics and labels for classification at various levels. Program available for Apple II, TRS-80 Model III, IBM-PC, and Commodore 64/128 equipment.

DICROSS-DIHYBRID CROSSES

Simulation of various types of dihybrid crosses. Program available for Apple II, TRS-80 Models I and III, IBM-PC, and Commodore 64/128 equipment.

DILUTE-MICROBIAL DILUTION SERIES

Simulation covering design and testing of microbial dilution series to determine concentration of a bacterial solution. Program available for Apple II, TRS-80 Model III, IBM-PC, Commodore 64/128 equipment.

DNAGEN-DNA/GENETIC CODE SIMULATION

Simulation of genetic code to produce protein sequences. Program available

for Apple II, TRS-80 Models I and III, IBM-PC, and Commodore 64/128 equipment.

ENZYME-SIMULATION, ENZYME ACTION

Simulation of enzyme action and the effects of inhibitors using acetylcholinesterase. Program available for Apple II, TRS-80 Models I and III, IBM-PC, and Commodore 64/128 equipment.

FLYGEN

Simulation of monohybrid or dihybrid crosses with 25 varieties of *Drosophila*. Program available for Apple II, TRS-80 Models I and III, IBM-PC, and Commodore 64/128 equipment.

MONOCROS-MONOHYBRID

CROSSES

Simulation of various monohybrid genetic crosses. Program available for Apple II, TRS-80 models I and III, IBM-PC, and Commodore 64/128 equipment.

NICHE-ECOLOGICAL GAME/SIMULATION

Game in which students attempt to place an organism in its proper ecological niche correctly by specifying environment, range, and competitor. Program available for Apple II, TRS-80 Models I and III, IBM-PC, and Commodore 64/128 equipment.

OSMO- OSMOSIS IN RED BLOOD CELLS

Simulation of red blood cells in hypertonic, hypotonic, and isotonic solutions. Program available for Apple II, TRS-80 Model III, IBM-PC, and Commodore 64/128 equipment.

PLANT-PLANT GROWTH SIMULATION

Simulation of the effects of light intensity and duration on growth and development of green plants. Program available for Apple II, TRS-80 Models I and III, IBM-PC, and Commodore 64/128 equipment.

POLLUTE:IMPACT/WATER POLLUTANTS

Simulation of the impact of various pollutants on typical bodies of water. Program available for Apple II, TRS-80 Models I and III, IBM-PC, and Commodore 64/128 equipment.

POPGEN-POPULATION GENETICS

Simulation of the effects of Hardy-Weinberg Law conditions on gene, genotype, and phenotype frequencies of a population over time. Program available for Apple II, TRS-80 Models I and III, IBM-PC, and Commodore 64/128 equipment.

POPGRO-POPULATION GROWTH SIMULATION

Simulation of unlimited growth (J-curve), limited growth (S-curve) and limited growth with response lag time (S-curve with oscillations) models of population growth. Program available for Apple II, TRS-80 Models I and III, IBM-PC, and Commodore 64/128 equipment.

DYNACOMP, Inc.
1064 Gravel Road
Webster, NY 14580
(716) 671-6160
(800) 828-6772

BIOLOGY FRUIT KEY

Identifies 125 trees and shrubs. Program available for Atari 400/800 equipment.

Educational Activities, Inc.
P.O. Box 392
Freeport, NY 11520
(800) 645-3739
(516) 223-4666

HEART LAB

Animated graphics simulation of human heart. Program available for Apple II, TRS-80 Models I and III, PET, and Atari 800/800XL equipment.

Educational Materials and Equipment Company.
P.O. Box 17
Pelham, NY 10803
(914) 576-1121

ADVANCED GENETICS

Tutorial-simulation presented as a nine-part program covering dominance and recessiveness, partial dominance, lethality, mechanism of inheritance, multiple alleles, sex linkage, multi-

- trait inheritance, crossing over, and gene mapping. Program available for Apple II equipment.
- AIR POLLUTION**
Simulation of carbon monoxide pollution in an urban environment. Program available for Apple II and TRS-80 Model I and III equipment.
- DNA-THE MASTER MOLECULE**
Simulation dealing with DNA structure. Programs available for Apple II equipment.
- INTRODUCTORY GENETICS**
Three part tutorial covering a variety of topics. Program available for Apple II, TRS-80 Models I and III equipment.
- MEIOSIS**
Tutorial-simulation providing an interactive portrayal of gamete formation. Program available for Apple II and IBM-PC equipment.
- MICROBIOLOGY TECHNIQUES**
Tutorial-simulation covering various laboratory procedures. Program available for Apple II equipment.
- NATURAL SELECTION**
Tutorial-simulation dealing with genetics and evolution to populations. Program available for Apple II equipment.
- OSMOSIS AND DIFFUSION**
Tutorial-simulation covering effects of temperature, concentration, solubility, molecule size and charge, and membrane pore size on flow of matter across semi-permeable membrane. Program available for Apple II, TRS-80 Models I and III equipment.
- POPULATION FLUCTUATIONS**
Tutorial covering factors influencing population growth. Program available for Apple II, TRS-80 Models I and III equipment.
- THE NUCLEIC ACIDS**
Tutorial-simulation dealing with principal nucleotides and synthesis of RNA. Program available for Apple II equipment.
- WATER POLLUTION**
Simulation of the effects of temperature, type of waste, dumping rate, and method of treatment on the impact of pollution on aquatic life. Program available for Apple II, TRS-80 Models I and III equipment.
- EduTech, Inc.**
303 Lamatine Street
Jamaica Plain, MA 02130
(617) 524-1774
- ANIMATIONS**
Contains animations for demonstrating DNA structure and synthesis, RNA structure and synthesis, and protein synthesis. Program available for Apple II equipment.
- DNA STRUCTURE AND SYNTHESIS**
Tutorial dealing with nucleotide structure and linkage between nucleotide, base complementarity, and hydrogen bonding. Program available for Apple II equipment.
- PROTEIN SYNTHESIS**
Tutorial dealing with the general structure of the amino acids and formation of peptide bonds. Program available for Apple II equipment.
- RNA STRUCTURE AND SYNTHESIS**
Tutorial extending the concept of hydrogen bonding between complementary bases to show the synthesis of RNA on the DNA template and the analogies in structure between DNA and RNA. Program available for Apple II equipment.
- Elsevier-BIOSOFT**
68 Hills Road
Cambridge CB2 1LA, United Kingdom
- 52 Vanderbilt Avenue
New York, NY 10017
- BLANCHAER CLINICAL CASE STUDIES**
Eight simulations of clinical syndromes. Program available for Apple II equipment.
- ENZLAB**
Simulations for designing and carrying out enzyme kinetics experiments. Program available for Apple II and IBM-PC compatible equipment.
- ENZPACK**
An enzyme kinetics teaching and calculation program. Program available for Apple II and IBM-PC compatible equipment.
- ENZYMЕ ACTION**
Tutorial on the basic nature and function of enzymes. Program available for Apple II equipment.
- GENESIM**
Simulations of experiments in bacterial and molecular genetics. Program available for Apple II and IBM-PC compatible equipment.
- ILEUM**
Simulates laboratory experiments investigating effects of drugs on the *in vitro* guinea pig ileum. Program available for Apple II and IBM-PC compatible equipment.
- LABPLOT**
Allows the Apple II with any A/D converter card to be used as a multi-pen chart recorder or as an X/Y plotter.
- MOLECULAR BIOLOGY SERIES**
Programs demonstrating central processes of RNA and protein synthesis and DNA synthesis and repair. Program available for Apple II and IBM-PC compatible equipment.
- MOLGRAF**
Molecular graphics package. Program available for Apple II and IBM-PC compatible equipment.
- MULTI-Q**
A general purpose question creation and presentation system. Program available for Apple II and IBM-PC compatible equipment.
- "Q" EDUCATIONAL AUTHORIZING SYSTEM**
Authoring system for tutorial and assessment material. Allows incorporation of graphics and videodisc material. Program available for IBM-PC compatible equipment.

AIMS AND SCOPE

The goal of *Computers in Life Science Education* is to provide a means of communication among life science educators who anticipate or are currently employing the computer as an educational tool. The range of content includes, but is not limited to, articles focusing on computer applications and their underlying philosophy, reports on faculty/student experiences with computers in teaching environments, and software/hardware reviews in both basic science and clinical education settings.

INVITATION TO CONTRIBUTORS

Articles consistent with the goals of *Computers in Life Science Education* are invited for possible publication in the newsletter.

PREPARATION AND SUBMISSION OF MATERIAL

Articles submitted for publication should not exceed 2000 words and should be typewritten, double spaced, with wide margins. The original and two copies including two sets of figures and tables should be sent to the Editor: Dr. Harold Modell, NRCLSE, Mail Stop RC-70, University of Washington, Seattle, WA 98195.

Title page should include full title, list of authors, academic or professional affiliations, and complete address and phone number of the corresponding author.

Illustrations should be submitted as original drawings in India ink or sharp, unmounted photographs on glossy paper. The lettering should be such that it can be legible after reduction (width of one column = 5.7 cm).

Reference style and form should follow the "number system with references alphabetized" described in the Council of Biology Editors Style Manual. References should be listed in alphabetical order by the first author's last name, numbered consecutively, and cited in the text by these numbers.

RESPONSIBILITY AND COPYRIGHT

Authors are responsible for accuracy of statements and opinions expressed in articles. All authors submitting manuscripts will be sent a copyright transfer form to complete. The completed form must be returned before the work will be published.

SUBSCRIPTION INFORMATION

Computers in Life Science Education is published monthly by National Resource for Computers in Life Science Education, Mail Stop RC-70, University of Washington, Seattle, WA 98195. Subscription rate is \$30.00 for 12 issues, including postage and handling in the United States and Canada. Add \$20.00 for postage (airmail) in Mexico and Europe and \$23.00 for the rest of the world.

This newsletter has been registered with the Copyright Clearance Center, Inc. Consent is given for copying of articles for personal or internal use, or for the personal or internal use of specific clients. This consent is given on the condition that the copier pay through the Center the per-copy fee stated in the code on the first page for copying beyond that permitted by the US Copyright Law. If no code appears on an article, the author has not given broad consent to copy and permission to copy must be obtained directly from the author. This consent does not extend to other kinds of copying, such as for general distribution, resale, advertising and promotional purposes, or for creating new collective works.

Address orders, changes of address, and claims for missing issues to NRCLSE, Mail Stop RC-70, University of Washington, Seattle, WA 98195. Claims for missing issues can be honored only up to three months for domestic addresses and six months for foreign addresses. Duplicate copies will not be sent to replace ones undelivered due to failure to notify NRCLSE of change of address.

Address editorial correspondence to Harold I. Modell, PhD, NRCLSE, Mail Stop RC-70, University of Washington, Seattle, WA 98195. (BITNET MODELL@UWALOCKE)

POSTMASTER: Send address changes to *Computers in Life Science Education*, NRCLSE, Mail Stop RC-70, University of Washington, Seattle, WA 98195.

COMPUTERS IN LIFE SCIENCE EDUCATION

HAROLD I. MODELL

Department of Radiology
University of Washington
Seattle, Washington

MARCEL BLANCHAER

Department of Biochemistry
Faculty of Medicine
University of Manitoba
Winnipeg, Manitoba
Canada

THEODORE J. CROVELLO

Department of Biology
University of Notre Dame
Notre Dame, Indiana

JAMES W. ECKBLAD

Department of Biology
Luther College
Decorah, Iowa

TSEGAYE HABTEMARIAM

School of Veterinary Medicine
Tuskegee University
Tuskegee, Alabama

DONNA LARSON

School of Nursing
Grand Valley State College
Allendale, Michigan

TERRY M. MIKITTEN

Graduate School of Biomedical Sciences
University of Texas Health Science Center
San Antonio, Texas

JAMES E. RANDALL

Department of Physiology
Indiana University
Bloomington, Indiana

PATRICIA SCHWIRIAN

College of Nursing
Ohio State University
Columbus, Ohio

RICHARD STULL

College of Pharmacy
University of Arkansas
Little Rock, Arkansas

JAMES W. WOODS

Lister Hill National Center
for Biomedical Communications
National Library of Medicine
Bethesda, Maryland

DOROTHY WOOLEY-McKAY

Department of Biology
Glendale Community College
Glendale, Arizona

GLEN YOSHIDA

Department of Life Sciences
Los Angeles Southwest College
Los Angeles, California

NRCLSE

CONTENTS

WHERE'S THE SOFTWARE?	41
KEEPING AHEAD OF THE LITERATURE	47

WHERE'S THE SOFTWARE?

In the past, we have published several lists of life science software sources and programs or program areas available through them. The following list is presented as the latest in our continuing effort to make colleagues aware of potential resources. As in the past, no attempt has been made by NRCLSE to review these materials. In future lists, presented after our planned peer critique mechanism is in place, indication of reviews will also be presented.

This month's listing continues last month's entries and includes information drawn from the 1986-87 edition of The Educational Software Selector, a data base created by the Educational Products Information Exchange (EPIE) Institute. For additional information about EPIE, write or phone EPIE Institute, P.O. Box 839, Water Mill, NY 11976, telephone (516) 283-4922. Another recent sourcebook for life science software is the 1987 Directory of Educational Software for Nursing published by the National League for Nursing, 10

Columbus Circle, New York, NY 10019.

If you have found specific software helpful in your teaching efforts, please share your good fortune by letting us know about the program(s) and supplier(s) so that we can make this information available through future Where's the Software lists. Send pertinent information to Dr. Harold Modell, NRCLSE, Mail Stop RC-70, University of Washington, Seattle, WA 98195 or send us a note on BITnet. Our BITnet address is MODELL@UWALOCKE.

HRM Software

175 Tompkins Avenue
Pleasantville, NY 10570
(914) 769-7496
(800) 431-2050

BIOFEEDBACK

Part of IO program package Experiments in Human Physiology. Experiments include biofeedback, condi-

tioning, and perception measurements. Program available for Apple II equipment.

BIOFEEDBACK MICROLAB

Package includes a pulse rate sensor that measures EMG, a thermistor probe to measure skin temperature, and an interface circuit that enables students to connect the sensors to the computer. Program available for Apple II and Commodore 64/128 equipment.

CALIBRATION

Part of 10 program package Experiments in Human Physiology. Temperature and timing functions are calibrated against standards. Program available for Apple II equipment.

CARDIOVASCULAR FITNESS LAB

Provides students with everything they need in order to use the micro-computer to monitor cardiovascular activity. Program available for Apple II and Commodore 64/128 equipment.

EXERCISE EXPERIMENTS

Part of 10 program package Experiments in Human Physiology. The effect of exercise and physical condition on heart rate, breathing rate, and skin temperature is investigated. Program available for Apple II equipment.

GENE MACHINE

Tutorial/Simulation dealing with DNA replication and protein synthesis. Program available for Apple II equipment.

HEART RATE

Part of 10 program package Experiments in Human Physiology. Light and light sensor for measuring and recording heart rate. Program available for Apple II equipment.

HEREDITY DOG

Tutorial covering various topics in genetics. Program available for Apple II and Commodore 64/128 equipment.

HOMEOSTASIS-

THERMOREGULATION

Part of 10 program package Experiments in Human Physiology. Students investigate the body's ability to maintain a constant internal tempera-

ture by subjecting a volunteer to mild temperature excursion while recording and displaying skin and body temperature. Program available for Apple II equipment.

HUMAN GENETIC DISORDERS

Simulation investigating inherited disorders. Program available for Apple II equipment.

PSYCHOLOGICAL STRESS-LIE DETECTOR

Part of 10 program package Experiments in Human Physiology. The physiological response to the stress of a frustrating and abusive quiz is measured. Program available for Apple II equipment.

RESPIRATION RATE

Part of 10 program package Experiments in Human Physiology. A napping subject is monitored for heart and breathing rate. Results are compared to the data acquired when the subject is awake. Program available for Apple II equipment.

RESPONSE-TIME

Part of 10 program package Experiments in Human Physiology. Users measure finger reaction times with a bright light stimulus (sensor included). Program available for Apple II equipment.

RESPONSE-TIME INVESTIGATIONS

Part of a 10 program package Experiments in Human Physiology. The effects on reaction times of stimulus type and response location are studied. Program available for Apple II equipment.

SKIN TEMPERATURE

Part of a 10 program package Experiments in Human Physiology. Temperature probe (included) senses body and skin temperatures. Program available for Apple II equipment.

SOLAR FOOD

Tutorial/Simulation dealing with photosynthesis. Program available for Apple II equipment.

Indiana University School of Medicine
Department of Physiology

635 Barnhill Drive
Indianapolis, IN 46223

ACID-BASE PHYSIOLOGY SIMULATION

Simulation of acid-base disturbances based on Davenport Diagram approach. Program available for IBM-PC compatible equipment.

GAS DIFFUSION IN THE LUNG

Simulation of oxygen and CO₂ transfer between alveolar air and blood. Program available for IBM-PC compatible equipment.

SKELETAL MUSCLE MECHANICS

Set of six simulations dealing with muscle physiology. Program available for IBM-PC compatible equipment.

CARDIOVASCULAR INTERACTIONS

Cardiovascular Physiology simulation. Program available for IBM-PC compatible equipment.

GRADEBK

Program for the analysis of a large set of grades. Program available for IBM-PC compatible equipment.

J & S Software

14 Vanderventer Avenue
Port Washington, NY 11050
(516) 944-9304

ANIMAL REPRODUCTION

Tutorial reviewing sperm development, egg, and fertilized egg. Program available for Apple II and TRS-80 Model III equipment.

ASEXUAL REPRODUCTION

Tutorial reviewing cell division. Program available for Apple II and TRS-80 Model III equipment.

BIOCHEMISTRY

Tutorial covering basic atomic structure, balancing equations, and properties of proteins and carbohydrates. Program available for Apple II and TRS-80 Model III equipment.

DIGESTION

Tutorial covering digestion in simple organisms and humans. Program available for Apple II and TRS-80

Model III equipment.

GENETICS

Tutorial covering various crosses in plants and fruit fly populations. Program available for Apple II and TRS-80 Model III and IV equipment.

ENDOCRINE SYSTEM

Tutorial covering hormones, effects and problems. Program available for Apple II and TRS-80 Model III equipment.

EXCRETION

Tutorial reviewing metabolic wastes, waste removal, and kidney function. Program available for Apple II and TRS-80 Model III equipment.

LOCOMOTION

Tutorial reviewing types and functions of bones and muscles. Program available for Apple II and TRS-80 Model III equipment.

NERVOUS SYSTEM

Tutorial covering nerves, reflexes, and chemical transfer of impulses. Program available for Apple II and TRS-80 Model III equipment.

PHOTOSYNTHESIS & TRANSPORT

Tutorial dealing with photosynthesis and transport in plants. Program available for Apple II and TRS-80 Model III equipment.

REPRODUCTION IN PLANTS

Tutorial reviewing asexual and sexual reproduction in plants. Program available for Apple II and TRS-80 Model III equipment.

Kinko's Service Corporation

4141 State Street
Santa Barbara, CA 93110
(800) 235-6919
in CA (800) 292-6640
outside USA (800) 967-0192

DRINKING AND NOT DRINKING

Tutorial designed to augment strategies for the prevention of substance abuse. Includes facts about drinking and the effects of alcohol. Program available for Apple II equipment.

ENERGETICS AND METABOLISM,

GARDEN OF BIOLOGY: VOLUME I

Data base illustrating reactions of

metabolism and interactions between the several metabolic compartments of a cell. Program available for Macintosh equipment.

EVOLUTION, GARDEN OF BIOLOGY: VOLUME 2

Data base illustrating relations among organisms of many kinds, emphasizing the history and mechanics of their evolutionary change. Program available for Macintosh equipment.

INTRODUCTION TO PSYCHOACTIVE DRUGS

Tutorial designed to augment strategies for the prevention of psychoactive drug abuse. Program available for Apple II equipment.

KEEP OFF THE GRASS

Tutorial designed to augment strategies for the prevention of marijuana abuse. Program available for Apple II equipment.

MODEL NEURON

Simulation of the behavior of an isolated neuron. Program available for Macintosh equipment.

SIX CLASSES OF PSYCHOACTIVE DRUGS

Tutorial designed to augment strategies for the prevention of psychoactive drug abuse. Program available for Apple II equipment.

SUBSTANCE ABUSE DATA BASE

Database containing contact information on substance abuse organizations. Program available for Apple II equipment.

Life Science Associates

1 Fennimore Road
Bayport, NY 11705
(516) 472-2111

BIOLOGY COMPUTER STIMULATIONS

Tutorial covering various biological concepts and experimental areas including enzymes, photosynthesis, respiration, diffusion, meiosis, muscles, nerves, and genetics. Program available for Apple II and TRS-80 Models I and III equipment.

GROSS ANATOMY TUTORIAL

Tutorial for gross anatomy review by region and for self-test in National Board format. Program available for Apple II equipment.

Neosoft, Inc.

CBS Interactive Learning
One Fawcett Place
Greenwich, CT 06836
(800) 227-2574

THE BODY IN FOCUS

Tutorial for investigating body systems including skeletal, muscular, respiratory, cardiovascular, gastrointestinal, endocrine, and integumentary. Available for Apple II and IBM-PC compatible equipment.

Oakleaf Systems

P.O. Box 472
Decorah, IA 52101
(319) 382-4320

ALGAL GROWTH

Simulation of the effects of eight variables on growth of algae. Program available for Apple II and IBM-PC compatible equipment.

AQUATIC ECOLOGY

Utilities to perform many of the calculations common to aquatic ecology. Program available for Apple II and IBM-PC equipment.

AQUATIC ECOLOGY DATA SIMULATION

25 simulations covering aquatic systems. Program available for Apple II and IBM-PC equipment.

ECOLOGICAL DATA SIMULATION

25 simulations covering ecological systems. Program available for Apple II and IBM-PC equipment.

ECOLOGICAL ANALYSIS PROGRAMS PLUS

Utilities that perform life table analysis, community similarity indices, diversity indices, predator-prey modeling, descriptive statistics, mark-recapture analysis, plus regression and correlation analysis. Program available for Apple II equipment.

ECOLOGICAL ANALYSIS - PC

Utilities that perform life table analysis, interspecific association indices, community similarity, diversity indices, descriptive statistics, mark-release recapture analysis, plus regression and correlation analysis. Program available for IBM-PC compatible equipment.

ECOLOGICAL ANALYSIS VOL. 2 - PC

Utilities that perform community similarity analysis, indices of dispersion, species-area curve, and step-wise multiple regression. Program available for IBM-PC compatible equipment.

EVOLUTION

Simulations covering mutation, gene flow, natural selection, and genetic drift on populations. Program available for Apple II and IBM-PC compatible equipment.

GRADE KEEPER - PC

Grade book manager that handles classes up to 300 students, up to 25 grades per student. Program available for IBM-PC compatible equipment.

PHYSIOLOGICAL DATA SIMULATION

25 simulations covering aspects of physiology. Program available for Apple II and IBM-PC compatible equipment.

Randall, Dr. James
Department of Physiology
Myers Hall
Indiana University
Bloomington, IN 47405
(812) 335-1574

BASIC HUMAN

Integrated systems model of human physiology. Program available for IBM-PC compatible equipment.

Rush Medical College
Drs. Joel Michael and Alan Rovick
Department of Physiology
1750 West Harrison Street
Chicago, IL 60612
(312) 942-6426
(312) 942-6567

CARDIOVASCULAR PHYSIOLOGY PART I: PRESSURE/FLOW RELATIONS

Tutorial dealing with a variety of calculations in the area of hemostatics/hemodynamics. Program available for IBM-PC compatible equipment.

CARDIOVASCULAR PHYSIOLOGY PART II: REFLEX

Tutorial dealing with carotid sinus regulation of blood pressure and reflex responses in hemorrhage and exercise. Program available for IBM-PC compatible equipment.

CIRCISM: A TEACHING EXERCISE ON BLOOD PRESSURE REGULATION

Simulated experiment based on a model of the baroreceptor reflex loop. Program available for IBM-PC compatible equipment.

MUSCLE MECHANICS: A COMPUTER-SIMULATED EXPERIMENT

Simulated experiment that permits the user to determine either the length-tension or the force-velocity relationship of a skeletal muscle. Program available for IBM-PC compatible equipment.

PROBLEMS IN FLUID COMPARTMENT RE-DISTRIBUTION

Tutorial covering solution of simple problems of fluid compartment changes in the face of perturbations. Program available for IBM-PC compatible equipment.

Scott, Foresman and Company
1900 East Lake Ave.
Glenview, IL 60025
(312) 729-3000

ADAPTATION AND IDENTIFICATION

Tutorial covering animal adaptation to different environments and animal identification. Program available for Apple II equipment.

CELLS: STRUCTURE AND FUNCTION

Simulation to reinforce basic concepts of cell structure, cell functions, water movement and concentration

gradients, and diffusion and active transport. Program available for Apple II equipment.

ECOLOGY

Simulation dealing with plant population sizes and growth pattern. Available for Apple II equipment.

GENETICS

Tutorial that allows students to explore Mendel's experiments, Punnett Squares, sex linkage in fruit flies, and multiple alleles. Program available for Apple II equipment.

HUMAN BODY-STRUCTURE AND FUNCTION

Simulation covering joint movement, movement of food through the digestive system, and enzyme activity. Program available for Apple II equipment.

MEIOSIS, MITOSIS, PROTEIN SYNTHESIS

Simulation demonstrating mitosis, meiosis, DNA replication, and protein synthesis. Program available for Apple II equipment.

PHOTOSYNTHESIS AND RESPIRATION

Demonstration and simulations dealing with light and dark reactions of photosynthesis, respiration, and ATP cycle. Program available for Apple II equipment.

Simpac Educational Systems
1105 North Main St.
Suite 11C
Gainesville, FL 32601
(904) 376-2049

DIFFUSION AND ACTIVE TRANSPORT

Tutorial covering diffusion, osmosis, and active transport in biological systems. Program available for Apple II equipment.

Sliwa Enterprises, Inc.
2360-J George Washington Hwy
Yorktown, VA 23666
(804) 898-8386

CELL CHEMISTRY I

Tutorial covering various chemical structures. Program available for Apple II and IBM-PC compatible equipment.

CELL CHEMISTRY II

Tutorial covering the chemical and physical processes that occur within cells. Program available for Apple II and IBM-PC compatible equipment.

ECOLOGY

Rote drill reviews and reinforces concepts of general terrestrial, and aquatic ecology. Available for Apple II and IBM-PC compatible equipment.

GENETICS

Tutorial examines DNA molecule and progresses to applied genetics. Program available for Apple II and IBM-PC compatible equipment.

ZOOLOGY I

Tutorial covering the general characteristics, structures, and functions that define the major invertebrate phyla. Program available for Apple II and IBM-PC compatible equipment.

ZOOLOGY II

Tutorial covering physiology in the

Phylum Chordata. Program available for Apple II and IBM-PC compatible equipment.

University of Texas System Cancer Center

MDAH
Box 6
6723 Bertner
Houston, TX 77030
(713) 792-2581

CELLGROW

Simulation of cell kinetics. Program available for Apple II equipment.

KILLER T-CELL

Maze game based on the evidence that T-lymphocytes can recognize cancer cells as harmful invaders, track them down, and destroy them. Available for Apple II and IBM-PC compatible equipment.

Williams & Wilkins
428 East Preston Street
Baltimore, MD 21202
(800) 638-0672

ARRHYTHMIAS: CASE STUDIES IN MANAGEMENT

Tutorial covering four case studies involving decision making related to diagnosis and treatment of arrhythmias. Available for Apple II and IBM-PC compatible equipment.

ARRHYTHMIAS TUTORIAL I: PATHOPHYSIOLOGY AND SUPRA-VENTRICULAR ARRHYTHMIAS

Tutorial dealing with nine different aspects of pathophysiology and supra-ventricular arrhythmias. Available for Apple II and IBM-PC compatible equipment.

ARRHYTHMIAS TUTORIAL II: VENTRICULAR ARRHYTHMIAS AND HEART BLOCK

Tutorial dealing with nine different aspects of ventricular arrhythmias and heart blocks. Available for Apple II and IBM-PC compatible equipment.

ARTERIAL BLOOD GASES

Tutorial presenting a method for interpreting arterial blood gases. Available for Apple II and IBM-PC compatible equipment.

NOTICE

A limited number of back issues of CLSE have become available for purchase. Volumes 1, 2, and 3 are available at a cost of \$30.00 per volume (includes binder) plus shipping. Address orders to: NRCLSE, Mail Stop RC-70, University of Washington, Seattle, WA 98195.

NOTICE

IBM-PC VERSION NOW AVAILABLE. . .

SIMULATIONS IN PHYSIOLOGY

– The Respiratory System –

Harold I. Modell, Ph.D.

School of Medicine, University of Washington, Seattle, Washington 98195

- Series of 12 Simulations in Respiratory Physiology
- 117 Page Laboratory Manual
- Designed for use in student laboratory and group discussion environments
- *Pictorial* outputs designed to provide conceptual aid, show where variables values are measured, or illustrate the model and how it is solved
- *Tabular* outputs allow comparison of data from up to 7 'experiments'
- Available for Apple II and IBM-PC compatible computers
- Purchase includes permission to make enough copies to supply appropriate student populations

ORDERING INFORMATION

Option A – Apple II version

Disks (Compiled code and source code)
Documentation
One copy of student laboratory manual
..... \$100

Option B - IBM-PC version (uses CGA graphics)

Disks (Executable source code)
Documentation
One copy of student laboratory manual
..... \$100

Option C - Student Laboratory Manuals

Quantities of 1-25 \$10 each
Quantities over 25 \$8.50 each

Address orders to: NRCLSE
Mail Stop RC-70
University of Washington
Seattle, WA 98195

PROGRAM OVERVIEW

Title	Material covered
MECHANICS	
<i>Static Relationships</i>	Elastic properties of the lung, chest wall, and total respiratory system
<i>Dynamic Relationships I</i>	Effects of lung compliance and airway resistance on tidal volume development
<i>Work of Breathing</i>	Oxygen cost of elastic, resistive, and total work during inspiration
<i>Dynamic Relationships II</i>	Respiratory dynamics of the total respiratory system
GENERAL GAS EXCHANGE	
<i>Alveolar Gas Exchange</i>	Gas exchange between atmosphere and alveolar reservoir
<i>O₂ and CO₂ Dissociation Curves</i>	Interrelationships between the O ₂ and CO ₂ dissociation curves
<i>Exchange from Atmosphere to Tissues</i>	Influence of alveolar ventilation, cardiac output, and anatomic shunt flow on arterial blood composition and gas exchange at the tissues
<i>Chemoregulation of Respiration</i>	O ₂ and CO ₂ response curves
V_A/Q RELATIONSHIPS	
<i>Gas Exchange in a Single Alveolus</i>	Effects of ventilation-perfusion ratio and inspired gas on exchange in a single exchange unit
<i>The Non-Uniform Lung</i>	Gas exchange from atmosphere to tissues with V _A /Q mismatching in the lung
<i>Overall Gas Exchange</i>	Gas exchange from atmosphere to tissues with V _A /Q mismatching and a true shunt
ACID-BASE BALANCE	
<i>Acid-Base Balance: Fundamental Relationships</i>	Acid-base balance from a Base Excess viewpoint

KEEPING ABREAST OF THE LITERATURE

The following citations are presented as part of a quarterly feature in CLSE designed to help readers become aware of current literature pertinent to computer applications in life science education.

- Abdulla AM et al: Computer-aided learning -- experiences, perspectives and promises. *J Amer Coll Cardiol* 9(3):678, 1987.
- Anderson MC et al: Use of microcomputer to help teach pathology. *J Clin Pathol* 39(10):1140-1142, 1986.
- Anderson NC: Future implications of videodiscs for the health care and medical sciences. *Optical Information Systems* 6(4):332-333, 1986.
- Baker JE et al: Simulating laboratory procedures. *Medical Teacher* 8(1):35-40, 1986.
- Baker Videoactive: The Baker Videoactive interactive guide to physical examination: a level III videodisc library. *Optical Information Systems* 6(4):310-312, 1986.
- Barker P et al: A practical introduction to authoring for computer-assisted instruction. Part 7: graphic support. *Br J Educ Tech* 17(3):194-212, 1986.
- Battista-Claderone A et al: Drugs and computers -- they are compatible!... computer assisted instruction. *AD Nurse* 2(1):28-30, 1987.
- Betlach JA: Framework for computer assisted instruction courseware: a case study. *Journal of Educational Technology Systems* 15(1):35-52, 1986-1987.
- Billings DM: Advantages and disadvantages of computer-assisted instruction. *Dimensions of Crit Care Nursing* 5(6):356-362, 1986.
- Bowen BE et al: Effects of classroom testing by microcomputer. *Journal of American Association of Teacher Educators in Agriculture* 27(4):2-7, 1986.
- Breckon DJ et al: Interactive videodiscs: a new generation of computer assisted instruction. *Health Values* 10(6):52-55, 1986.
- Constantian MB et al: The expert teaching system: a new method for learning rhinoplasty using interactive computer graphics. *Plast Reconstr Surg* 79(2):278-283, 1987.
- Fielding A et al: A program shell for the construction of computer-aided learning programs on the BBC microcomputer. *J Biol Educ* 20(2):117-120, 1986.
- Fincher RM et al: A prospective educational trial comparing efficacy of computer-assisted learning and weekly seminars in teaching EKG interpretation. *Proc Annu Conf Res Med Educ* 25:3-7, 1986.
- Fishman DJ: CAI: let the buyer beware! *Nurs Outlook* 35(1):48, 1987.
- Foucault A: Demystifying CAI: a team approach to authoring systems. *Technological Horizons in Education* 14(3):80-83, 1986.
- Hagen MD: Cardiac arrest: a simulation program. *MD Computing* 4(1):46-48, 1987.
- Harding RD: Computer illustrated texts. *Physics Education* 21(5):288-292, 1986.
- Harless WG et al: A voice-activated, interactive videodisc case study for use in the medical school classroom. *J Med Educ* 61(11):913-915, 1986.
- Krahn CG et al: Using an advance organizer to improve knowledge application by medical students in computer-based clinical simulations. *J Comp-Based Instruct* 13(3):71-74, 1986.
- Lippert HT et al: Computer-managed administration of examinations during clinical laboratory training. *J Med Technol* 3(11):582-585, 1986.
- Manning PR: The computer and the future of continuing medical education. *West J Med* 145(6):872-873, 1986.
- Nardone DA et al: Use of computer simulations to teach history-taking to first-year medical students. *J Med Educ* 62(3):191-193, 1987.
- Nordberg SC: Authoring tools: a perspective on the future of computer based education author systems. *Interactive Learning International* 3(1):20-28, 1986.
- Norman S: The student's flexible friend... computer-assisted learning. *Nurs Times* 82(47):40-41, 1986.
- Paulanka BJ: The learning characteristics of nursing students and computer assisted instruction. An exploratory study. *Comput Nurs* 4(6):246-254, 1986.
- Petrini MF: Distribution of ventilation and perfusion: a teaching model. *Comput Biol Meth* 16(6):431-444, 1986.
- Philip JH: Gas Man -- an example of goal oriented computer-assisted teaching which results in learning. *Int J Clin Monit Comput* 3(3):165-173, 1986.
- Quirm CA: Computer-assisted instruction: is it really your best choice? *Nurse Educ* 11(6):34-38, 1986.
- Ransberger PF: Producing a library of videodiscs for continuing medical education. *Optical Information Systems* 6(4):334-335, 1986.
- Rhodes D et al: Ready set...authoring systems to get you started on interactive video design. *TechTrends* 31(5-6):25-29, 1986.
- Schwid HA: A flight simulator for general anesthesia training. *Comp Biomed Res* 20(1):64-75, 1987.
- Scott PR: pH calculations with a micro. *Education in Chemistry* 22(2):40-42, 1985.
- Siegelman DL: Computer education in the hospital library. *Med Ref Serv Q* 5(4):65-68, 1986.
- Starkweather JA: The computer as a tool for learning. *West J Med* 145(6):864-868, 1986.
- Stewart S: The use of optical storage technology in health care and medical science. *Optical Information Systems* 6(4):298-302, 1986.
- Verbeek HA: Self-instruction through patient simulation by computer. *Med Educ* 21(1):10-14, 1987.
- Wedman JF: Making software more useful. *Computing Teacher* 14(3):11-14, 1986.
- Westerhof HP et al: Computerized history taking for training medical students. *Comput Biomed Res* 19(6):596-605, 1986.
- Wise PH et al: Effect of computer-based learning on diabetes knowledge and control. *Diabetes Care* 9(5):504-508, 1986.

AIMS AND SCOPE

The goal of *Computers in Life Science Education* is to provide a means of communication among life science educators who anticipate or are currently employing the computer as an educational tool. The range of content includes, but is not limited to, articles focusing on computer applications and their underlying philosophy, reports on faculty/student experiences with computers in teaching environments, and software/hardware reviews in both basic science and clinical education settings.

INVITATION TO CONTRIBUTORS

Articles consistent with the goals of *Computers in Life Science Education* are invited for possible publication in the newsletter.

PREPARATION AND SUBMISSION OF MATERIAL

Articles submitted for publication should not exceed 2000 words and should be typewritten, double spaced, with wide margins. The original and two copies including two sets of figures and tables should be sent to the Editor: Dr. Harold Modell, NRCLSE, Mail Stop RC-70, University of Washington, Seattle, WA 98195.

Title page should include full title, list of authors, academic or professional affiliations, and complete address and phone number of the corresponding author.

Illustrations should be submitted as original drawings in India ink or sharp, unmounted photographs on glossy paper. The lettering should be such that it can be legible after reduction (width of one column = 5.7 cm).

Reference style and form should follow the "number system with references alphabetized" described in the Council of Biology Editors Style Manual. References should be listed in alphabetical order by the first author's last name, numbered consecutively, and cited in the text by these numbers.

RESPONSIBILITY AND COPYRIGHT

Authors are responsible for accuracy of statements and opinions expressed in articles. All authors submitting manuscripts will be sent a copyright transfer form to complete. The completed form must be returned before the work will be published.

SUBSCRIPTION INFORMATION

Computers in Life Science Education is published monthly by National Resource for Computers in Life Science Education, Mail Stop RC-70, University of Washington, Seattle, WA 98195. Subscription rate is \$30.00 for 12 issues, including postage and handling in the United States and Canada. Add \$20.00 for postage (airmail) in Mexico and Europe and \$23.00 for the rest of the world.

This newsletter has been registered with the Copyright Clearance Center, Inc. Consent is given for copying of articles for personal or internal use, or for the personal or internal use of specific clients. This consent is given on the condition that the copier pay through the Center the per-copy fee stated in the code on the first page for copying beyond that permitted by the US Copyright Law. If no code appears on an article, the author has not given broad consent to copy and permission to copy must be obtained directly from the author. This consent does not extend to other kinds of copying, such as for general distribution, resale, advertising and promotional purposes, or for creating new collective works.

Address orders, changes of address, and claims for missing issues to NRCLSE, Mail Stop RC-70, University of Washington, Seattle, WA 98195. Claims for missing issues can be honored only up to three months for domestic addresses and six months for foreign addresses. Duplicate copies will not be sent to replace ones undelivered due to failure to notify NRCLSE of change of address.

Address editorial correspondence to Harold I. Modell, PhD, NRCLSE, Mail Stop RC-70, University of Washington, Seattle, WA 98195. (BITNET MODELL@UWALOCKE)

POSTMASTER: Send address changes to *Computers in Life Science Education*, NRCLSE, Mail Stop RC-70, University of Washington, Seattle, WA 98195.

COMPUTERS IN LIFE SCIENCE EDUCATION

HAROLD I. MODELL

Department of Radiology
University of Washington
Seattle, Washington

MARCEL BLANCHARD

Department of Biochemistry
Faculty of Medicine
University of Manitoba
Winnipeg, Manitoba

THEODORE J. CROVELLO

Graduate Studies and Research
California State University, Los Angeles
Los Angeles, California

JAMES W. ECKBLAD

Department of Biology
Luther College
Decorah, Iowa

TSEGAYE HABTEMARIAM

School of Veterinary Medicine
Tuskegee University
Tuskegee, Alabama

DONNA LARSON

School of Nursing
Grand Valley State College
Allendale, Michigan

TERRY M. MIKITTEN

Graduate School of Biomedical Sciences
University of Texas Health Science Center
San Antonio, Texas

JAMES E. RANDALL

Department of Physiology
Indiana University
Bloomington, Indiana

PATRICIA SCHWIRIAN

College of Nursing
Ohio State University
Columbus, Ohio

RICHARD STULL

College of Pharmacy
University of Arkansas
Little Rock, Arkansas

JAMES W. WOODS

Lister Hill National Center
for Biomedical Communications
National Library of Medicine
Bethesda, Maryland

DOROTHY WOOLEY-McKAY

Department of Biology
Glendale Community College
Glendale, Arizona

GLEN YOSHIDA

Department of Life Sciences
Los Angeles South West College
Los Angeles, California

NRCLSE

CONTENTS

CARDIOVASCULAR INTERACTIONS – A SIMULATION PACKAGE TO HELP LEARNING	49
Carl F. Rothe	
A GRAPHICS ORIENTED DATABASE FOR ANATOMY AND PHYSIOLOGY	54
Nelson Westmoreland	

CARDIOVASCULAR INTERACTIONS – A SIMULATION PACKAGE TO HELP LEARNING

Carl F. Rothe

*Department of Physiology and Biophysics, Indiana University School of Medicine,
Indianapolis, Indiana*

Cardiovascular system function evades easy explanations. It is complex in that the peripheral vasculature influences cardiac function, while a change in cardiac function influences the vasculature. The system is closed, but compliant. There are two pumps that fill passively. Cardiac output, the crucial variable for each ventricle, depends upon venous filling pressure (preload) and arterial pressure (afterload) as well as on the heart's contractility and beating rate. Memorizing the responses to various permutations of parameters is grossly inefficient, if not virtually impossible. There is hope, however, because computer simulation provides a

tool to guide understanding and promote learning. Our simulation, CVHUM, has been used for 3 years with our medical and graduate students.

To develop simulation packages, I suggest that the following five major facets must be considered.

- 1) Specify the *OBJECTIVES* in terms of concepts and relationships to be learned.
- 2) Develop the *MODEL* by choosing or developing the needed equations and parameter values, and show that it is reasonable.
- 3) Develop the *SIMULATION PROGRAM* for the teaching environment

by making information input easy and output readily understood.

- 4) Develop a *STUDY MANUAL* to guide the student along efficient learning pathways.
- 5) *EVALUATE* the students' responses to the program to discover items of confusion, misinformation, or loss of interest.

OBJECTIVES

In two sessions totaling about 4 hours, our students are asked to use the cardiovascular model to meet the following objectives.

- Explain changes in cardiac output, mean systemic arterial pressure, arterial pulse pressure, and blood volume distribution that are induced by changes in vascular resistance, arterial compliance, heart rate (plot cardiac output and stroke volume as a function of heart rate), and ventricular contractility.
- Obtain data for, plot, and explain the venous-return cardiac-output relationship.
- Describe the consequences of left or right heart failure; propose and test effective reflex compensatory changes.
- Discuss the effects of both systemic and pulmonary hypertension.
- Mimic the cardiovascular effects of vigorous skeletal muscle exercise, and explain effective reflex compensatory changes that act to maintain or restore arterial blood pressure while providing a cardiac output of five times normal.
- Describe the effects of blood volume changes on cardiac output and vascular pressures, and suggest effective compensatory changes to mimic reflex control of the cardiovascular system following hemorrhage.
- Describe and explain the effects on cardiac output and blood pressure of increased intrathoracic pressure (by either positive-pressure artificial respiration or opening the chest) or a decreased intrathoracic pressure.
- Predict changes in arterial blood pressure (systolic/diastolic) from changes in various parameters.

THE MODEL

To help the student understand cardiovascular function, an effective approach is to define the various modules making up the system. Equations are almost essential. Cardiac function can be described with a ventricular pressure-volume diagram with the heart alternating between the curve for diastole and that for systole. Integrating these modules into a coherent whole is daunting. We therefore developed a simulation package on a digital computer that provides realistic data in response to changes in various parameters. The challenge for this package was to keep the model as simple as possible while providing enough detail to be realistic. An earlier model¹ was ultrasimple, showing peripheral and cardiac interactions, but it did not have two ventricles or include heart rate and stroke volumes computed from end-diastolic and end-systolic volumes.

The model, implementing the circuit shown in Figure 1, has a left ventricle, arterial bed, venous bed, right ventricle and pulmonary bed. Thirteen parameters, represented by letters in parentheses in the figure, can be manipulated. The interactions shown in Figure 2 are

implemented. Flow through a vascular segment is computed as the pressure gradient divided by resistance. Pressure in a segment is computed as the distending volume divided by the compliance. The distending (stressed) volume of a segment is computed as the integral of inflow minus outflow. By solving these differential equations that define changing segment volumes, the computer provides physically realistic patterns of the dynamic changes in mean flow and pressure. Euler integration in steps of 0.06 or 0.3 second is adequate. The unusual feature of this quasi-dynamic model is the computation of cardiac output from stroke volume without having to compute the flow pulses at millisecond intervals. Ventricular outputs are computed as heart rate times stroke volume, and the stroke volume is the difference between end-diastolic and systolic ventricular volumes. Cardiac contractility, incorporated via the concept of ventricular end-systolic elastance (E_{max}), defines end-systolic volume (ESV) as

$$ESV = P_{arterial} / E_{max} + V_0$$

where, V_0 is the end-systolic volume

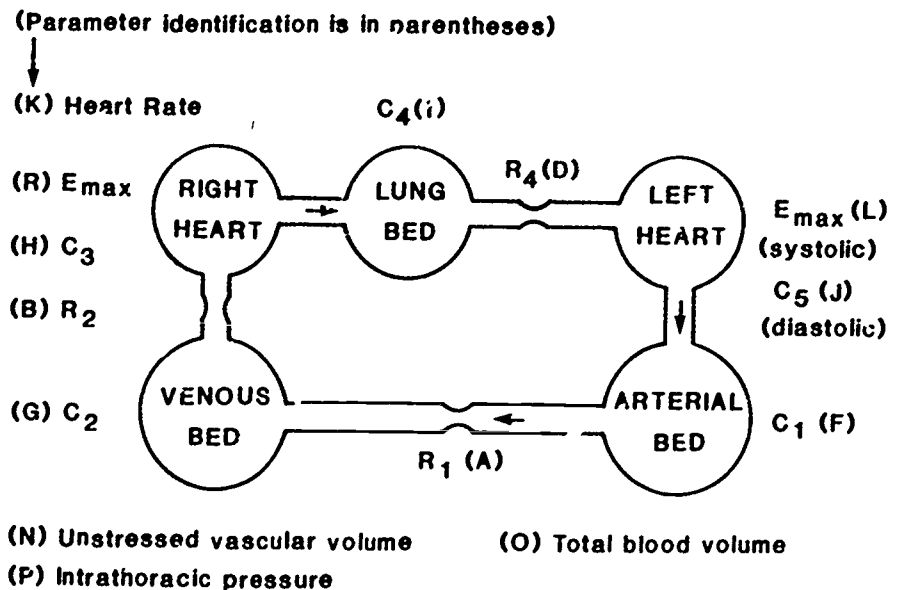

FIGURE 1. Cardiovascular circuit. The parameters that may be changed are identified by letters and are displayed on the computer monitor (see Figure 3).

with a zero afterload. This equation provides for changes in contractility as well as for the influence of afterload.

The end-diastolic volume (EDV) is computed as the integral of inflow minus outflow. Here, outflow is the product of stroke volume and heart rate. Inflow is computed from the filling pressure gradient, venous-to-right heart resistance, and a constant related to the duration of diastole and a filling time-constant. The effect of increased heart rate reducing filling because of lack of filling time, is simulated by computing the duration of the entire cycle at a given heart rate and subtracting the duration of systole to give the duration of diastole. A filling time-constant (75 msec) is used in conjunction with duration of diastole to attenuate the effective rate of inflow to the ventricle. The filling pressure gradient is from the small peripheral veins (mean systolic filling pressure) to the ventricular end-diastolic pressure. This end-diastolic pressure, in turn, is determined by the ventricular volume and compliance. (The response to decreased ventricular compliance, such as with ventricular hypoxia, can thus be simulated.)

In looking at the above relationships, it appears that the computer is programmed to compute a new value based on values not yet determined (it is attempting to hoist itself by its own bootstrap). By using iteration and small step sizes, the equations can be solved sequentially, the results are reasonable, and the system is stable.

A pericardium is included to reduce the ventricular compliance by 6 times, if the computed end-diastolic volume of either ventricle is greater than 175 ml. (At this level of sophistication, interaction between the two ventricles within a single pericardium is not incorporated.) Intrathoracic pressure (normally -4 mmHg) causes the computed distending or transmural pressure of the right heart, lung bed, and left heart to be correspondingly greater than the pressures displayed. The displayed pressures are relative to atmospheric pressures.

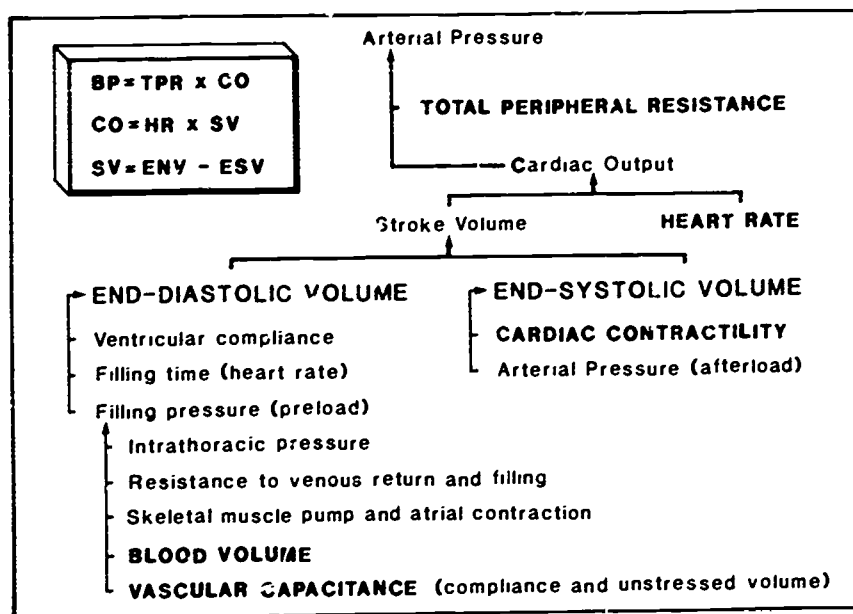

FIGURE 2. The CVHUM simulation implements the above relationships for each ventricle except for atrial contraction and the skeletal muscle pump.

In this simplified model, the right heart pressure displayed represents the end-diastolic pressure (preload) and equals the central venous pressure. The venous pressure represents the pressure in the small veins and venules and equals the mean systemic filling pressure. All of the lung blood volume is assumed to be in the pulmonary arterial bed. A more realistic *research* model incorporates a pulmonary vein segment and several parallel peripheral vascular segments, but for first year medical and graduate students, this seems to be excessively complex. Arterial systolic and diastolic pressures are computed based on mean arterial pressure, stroke volume, arterial compliance, and heart rate.

Parameter values of the model were chosen to simulate the cardiovascular system of a 70 kg person. The model has *no* transcapillary fluid shift compensatory mechanisms and has *no* reflexes. The student is expected to provide these responses by changing the appropriate parameters of the model. Although reflex compensation is blocked, the normal basal tone of pa-

rameters such as heart rate and peripheral resistance are chosen to be at normal resting levels. The "closeness of fit" of the model with biological data under various experimental or pathological conditions should be documented in detail, but this is difficult and time consuming.

THE SIMULATION PROGRAM

The model was programmed in BASIC and compiled so that it runs a bit faster than real time. Figure 3 shows the output screen for control values. Variables are displayed at 0.1 min intervals in tabular form. As should be expected, changing parameters such as total blood volume requires about 0.5 min to reach equilibrium. If the outflows of the 5 segments are not nearly equal, the user is asked to continue computing (Option 1).

Using a color monitor with several colors readily focuses attention on critical parts of the display. Parameter values in physiological units are displayed during the process of changing parameters (Option 2), but they are usually entered as percent of control

and displayed as percent of control. (Heart rate changes are handled in units of beats/min and blood volume changes as ml.)

At this stage, graphics are not used, in part because of difficulty in deciding which variables are critical for learning, and because it would extend the computing time. By choosing Option 3 at a steady state, all values are displayed as percent of control. This seems to be nearly as effective as graphics. Messages in contrasting color warning of "life threatening" situations add some realism (Figure 4).

Making the package easy to use and "faculty and student proof" required many trials, much effort, and neophyte, if not naive, users for testing. More than half my effort was expended on this facet of the project.

STUDY MANUAL

A *crucial key* to the effective use of computer simulations in teaching is a well-planned laboratory manual. (This is no different from student guides for animal laboratories.) The biology professor, not the computer scientist, creates this tool. After the students are familiar with the fundamentals and the model, they can be encouraged to explore on their own. We have found that asking the students to predict the direction of change of various critical variables *before* running the model with a parameter change induces them to think. After making the run, they can then check to see if they were correct. With students working in groups of 2 to 4, discussions are spirited and highly fruitful. Even for the experienced instructor, model response to parameter changes may not be obvious, especially if the instructor is not familiar with the effect of volume shifts throughout the system in response to changes in flow. For example, if the systemic arterial pressure is increased, the volume of the arterial bed must increase, and this volume must come from somewhere. Computer simulation, by giving reasonable answers to complex problems, provides a valuable tool for teaching problem-solving tech-

```

Time = 0.000          Current Values of VARIABLES and PARAMETERS
  SEGMENT  PRESSURE  OUTFLOW  VOLUME  COMPL (%)  RESIST (%)
1 Arterial    93.0     5800     747    F 100     A 100
2 Venous      7.5      5800    3528    G 100     B 100
3 Right Hrt   1.5      5800     118    H 100     --
4 Lung Bed   11.1     5800     484    I 100     D 100
5 Left Hrt    6.2      5800     123    J 100     --
  Art. Bld. Press. 120/80
Heart      HR   SV   ESV   EDV   SV/EDV   Emax
RIGHT K   72.0  81   38   118   0.68     R 100
LEFT K    72.0  81   42   123   0.66     L 100
Unstressed Bld Vol (ml) = N 3500  Stressed Bld Vol = 1500  Tot Vol = 0 5000
Intrathoracic P (mmHg) = P -4.0

Continue = 1  Chng parameters = 2  % Control = 3  Detailed = 4
Restart = 5  Dsply = 6  Help = 7  Dsply Int = 8  Quit = 9  (Press #) ?

```

FIGURE 3. Computer display under control conditions. Letters (A to P) are parameters that may be changed.

```

Time = 0.500          Current Values of VARIABLES and PARAMETERS
  SEGMENT  PRESSURE  OUTFLOW  VOLUME  COMPL (%)  RESIST (%)
1 Arterial    87.1     2802     735    F 100     A 200
2 Venous      4.5      2838    3189    G 100     B 100
3 Right Hrt   1.5      2837     120    H 100     --
4 Lung Bed   28.6     2810     749    I 100     D 100
5 Left Hrt    26.3     2806     207    J 100     --
  Art. Bld. Press. 100/81
Heart      HR   SV   ESV   EDV   SV/EDV   Emax
RIGHT K   72.0  39   80   120   0.33     R 100
LEFT K    72.0  39  168  207   0.19     L 20
Unstressed Bld Vol (ml) = N 3500  Stressed Bld Vol = 1500  Tot Vol = 0 5000
Intrathoracic P (mmHg) = P -4.0

WARNING ** LEFT HRT DISTENDED
HURRY ** PATIENT IN SHOCK ** Cardiac Output < 3000 ml/min
Please PRESS 1 to continue computing to reach a steady state
Continue = 1  Chng parameters = 2  % Control = 3  Detailed = 4
Restart = 5  Dsply = 6  Help = 7  Dsply Int = 8  Quit = 9  (Press #) ?

```

FIGURE 4. Computer display during left heart failure. (Left heart E_{max} at 20% of control and a reflex increase of peripheral resistance to 200% of control. Because the outflows from the 5 segments are not equal, the user is asked to PRESS <Option>1 to continue computing.)

niques of the form: "Given this situation, what will happen if I have this pathology or use this therapy?"

EVALUATION

The opinions of the students were polled after the 1985 course (Table 1) with over 90% agreeing that the materials were worth the time and effort required. In that some found it difficult to understand and interpret the manual, the printed material was revised and improved for both 1986 and 1987. The program was also improved in 1986.

Nearly 90% of these freshmen students agreed that "the simulation was sufficient for an adequate understanding of the physiological process, and the animal laboratory was unnecessary." Because most of the students had had no laboratory experience with mammals, these opinions do not allay the concern of some instructors that students need experience with the process of experimentation and the scientific method, and that there is more to learning physiology than that found in textbooks, lectures, and computer simulation.

The simulation program and the study manual should be in a form that each professor using it can modify, improve, and mold to their own needs and style. Unlike a book, these teaching tools can be easily and effectively changed once the major framework is provided.

The Cardiovascular Interaction simulation package is but one of six used in our Medical Physiology course since 1985. Others, developed by Indiana University faculty, include simulation packages on Nerve Action Potential, Skeletal Muscle Mechanism, Gas Diffusion in the Lung, Renal Glomerular Dynamics Function, and Acid-Base Physiology. Student learning has been directed via a conventional laboratory manual which offers suggestions for experimental approaches and poses questions which can be answered "experimentally" by using the simulation. To encourage discussions, students

Table 1. Student evaluation of laboratory simulation, *Cardiovascular Interactions*. Survey results (in percent) from 98 of 142 medical and graduate students after completion of the 1985 course. Opinions are scaled from strongly agree (5) to strongly disagree (1).

	Agree		Disagree		
	5	4	3	2	1
The cardiovascular simulation:					
... led to greater understanding	28	54	16	2	0
... reinforced lecture material	35	45	18	1	1
... knowledge was worth the time spent	27	39	27	6	3
... was easy to understand and interpret	20	44	25	10	1
... animal lab was not necessary	37	37	15	9	2
... was easy to operate	24	51	17	5	2
... complexity was appropriate	24	47	18	8	2
... printed instructional materials were					
... adequate in detail	17	47	26	10	1
... adequate in complexity	17	48	25	6	3
... adequate in clarity	12	41	25	21	1

work in groups of 2 to 4 at an IBM-PC with color display. To foster analytical thinking and problem-solving approaches, the students are asked, in many of the sessions, to predict the direction of response to a parameter change before making the run. Unguided experimentation with the model by the students, though encouraged, has been little used.

Instead of using the simulation packages as optional supplementary material for lectures, we expect all of the students to use them. In addition, we have a 1-2 hour discussion period with the students to review the results. Animal experiments have been eliminated, except for several in which the students are the subject, such as ECG, pulmonary function, and exercise. With the high predictability of results and simulation laboratory manuals that elicit thought and discussion while using the models, laboratory discussion periods are not as fruitful for the simulation laboratories as those conducted after animal experiments.

The project, initiated by the Department Chairman, Dr. Rodney Rhoades,

was supported in part by a joint venture with the IBM Corporation and involved several members of the Department. Because developing a complete simulation package can easily consume 200 hours of effort, even for an experienced author, appreciable administrative encouragement is needed for most faculty members to embark on such a project.

The program and manual for the cardiovascular interactions simulation (CVHUM) are available for evaluation from the author. Please include a \$10 check made out to the Indiana University Foundation to cover the cost of a diskette and the manual.

The author gratefully acknowledges the support of the Academic Information Systems Division of the IBM Corporation, the help and suggestions of colleagues and students, the assistance of Helen Glancy, and the support of NIH grant HL07723. (The model has been expanded for research purposes.)

REFERENCE

1. Rothe CF: A computer model of the cardiovascular system for effective learning. *The Physiologist* 23:49-53, 1980.

A GRAPHICS ORIENTED DATABASE FOR ANATOMY AND PHYSIOLOGY

Nelson Westmorland

College of Veterinary Medicine, Mississippi State University, Mississippi State, Mississippi

For the past three years, students entering the College of Veterinary Medicine at Mississippi State University have been required to purchase microcomputers.¹ Our long range goal is to make the computer an extension of memory so that our veterinary training can present fewer facts for memorization. We would like to spend more time training the student in problem solving and to be accurate, reliable and thorough.

The amount of information that a medically trained person needs to know keeps expanding, yet the training period does not. If the computer can be used primarily as a memory extension and secondarily as a training tool, we can change the focus of our instruction rather than the method.

This goal makes database management our first priority. If the use of this database also teaches the students some facts, we certainly will be pleased that secondary computer aided instruction has occurred.

The Macintosh microcomputer was chosen because it can be used for multiple applications with less initial training. It has also been a good choice because of the way it handles graphics. I teach anatomy and physiology, and there is a great deal of information in these disciplines which cannot be stored efficiently without diagrams.

Telos Software Products (3420 Ocean Park Blvd, Santa Monica, CA 90405-3395) markets two programs, Filevision and Business Filevision, that manage files, each record of which can be selected as a cursor points to an object entered on the monitor screen. The objects on the screen can be text, graphics or mixtures. In fact, a single object can be a labeled diagram. In Business Filevision, the newer program, the fields of the record can contain diagrams or text.

The objects on the monitor screen are organized by "type" so that each type

The Mean Electrical Axis of the Heart

A Measure of Size, Shape and Position

Definition - The electrical activity of the heart produces many potentials in many directions in a three dimensional field. The mean axis is the average direction during the cardiac cycle. In a frontal plane it can be estimated from ECG data.

Normal Axis = 70° - Range 40° to 100°

Left Axis Deviation - Clinical Significance?

Right Axis Deviation - Clinical Significance?

Leads

Lead I
Lead II
Lead III } Bipolar Standard Leads
Lead aVR
Lead aVL
Lead aVF } Augmented Unipolar
Limb Leads

Measurement Methods

Isoelectric lead
Lead with largest net QRS deflection
Two lead method

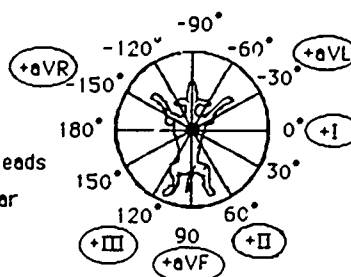

FIGURE 1. This file shows several methods to measure the Mean Electrical Axis of the heart. It also shows the standard ECG limb leads.

The Mean Electrical Axis of the Heart

A Measure of Size, Shape and Position

Definition - The electrical activity of the heart produces many potentials in many directions in a three dimensional field. The mean axis is the average direction during the cardiac cycle. In a frontal plane it can be estimated from ECG data.

Normal Axis = 70°

Left Axis Deviation -

Right Axis Deviation -

Leads

Lead I
Lead II
Lead III } Bipolar Standard Leads
Lead aVR
Lead aVL
Lead aVF } Augmented Unipolar
Limb Leads

Measurement Methods

Isoelectric lead
Lead with largest net QRS deflection
Two lead method

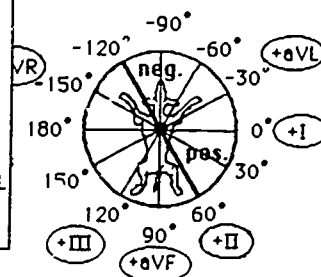

FIGURE 2. Lead II has been selected from the screen in Figure 1. This causes a "pop up" showing the connections for this lead. The selection is also highlighted on the original screen.

could be considered a "database" file. A number of types can be included in each screen, and each screen becomes a Macintosh file. The purpose of this article is to illustrate some of the capabilities of this software.

The diagram shown in Figure 1 is the Macintosh file organized to show several methods that can be used to calculate the mean electrical axis of the heart of a dog. Figure 2 shows the screen after the student selects Lead II (one of

Two lead method

3 The net deflection in Lead I w... in the diagram below and the net deflection in Lead aVF would be y. Thus the angle which had a tangent = $y/x = aVF/I$ would be the mean

description

3 Trig method If we use the ECG tracings shown in the "largest net deflection" example Lead aVF has a net deflection of 22-5:17 and Lead I has a net deflection of 23-5:18 so the mean electrical axis = $\arctan(17/18) = +43^\circ$. This is very near the $+40^\circ$ which we estimated by the other method

definition

$\theta = 43^\circ$

Table

2 Many ECG books have tables which have net deflections of Leads I and III cross referenced so all you need do is look for the mean electrical axis which corresponds to the two net values in the table

FIGURE 3. Record accessed by selecting "Two lead method" in Figure 1 screen followed by selecting the "Info" box. The field labeled "definition" is a diagram.

the standard electrocardiographic leads) from the screen in Figure 1. In this display, created with Business Filevision, a "popup" diagram has appeared showing how the leads are connected.

Figure 3 shows the record displayed when the student selects "Two lead method" from the Figure 1 screen. In this case, one of the fields (labeled definition) of this record is a diagram.

ELECTRONIC DISSECTION

The software allows fields in a record to be highlighted or hidden. In Figure 4, the student has chosen all the mus-

File Edit Types Tinker Text Symbols Lines Shades

SHOULDER AND BRACHIUM

Bones

Muscles

Intrinsic

Intrinsic

coracobrachialis

shoulder elbow

biceps

elbow

brachialis

Prev Next muscle: (3 highlighted) Info Link

FIGURE 4. Example of highlighted display. This screen is the result of a search of the innervation field for all muscles innervated by the musculocutaneous nerve.

cles innervated by a specific nerve. The location of the muscles are highlighted in the diagram portion of the screen. Since all objects of a specific type can be "hidden," electronic dissection is possible. This is illustrated in Figure 5.

HIERARCHAL STRUCTURES

An object can have a separate Macintosh file linked to it so that a hierarchal structure is created. By selecting the

object named *radial nerve* in the left panel of Figure 6 and then selecting the LINK box, the information shown in the right panel of Figure 6 can be accessed. In this way it is possible to cover a subject broadly in early files and then branch to more detail in the later files.

I have approximately 50 anatomy and physiology files in the musculoskeletal and alimentary systems that I am wil-

File Edit Types Tinker Text Symbols Lines Shades

To electronically strip away the muscles in layers, pull down the types window, choose the sup mus, then go to Tinker and choose Hide These. Repeat for each layer stripped away.

Muscles of the Canine Thoracic Limb and Shoulder

Prev Next middle mm. (total) Info Link

File Edit Types Tinker Text Symbols Lines Shades

To electronically strip away the muscles in layers, pull down the types window, choose the sup mus, then go to Tinker and choose Hide These. Repeat for each layer stripped away.

Muscles of the Canine Thoracic Limb and Shoulder

Prev Next superfic m (15 hidden) Info Link

FIGURE 5. Screens demonstrating electronic dissection capability. In this file, the muscles were entered as separate types from the deepest layer to the most superficial. *Left Panel:* This screen shows all types in the file. *Right Panel:* Screen resulting by selecting Superficial Muscles from the TYPE menu and Hide These from the TINKER menu. The dissection can continue by selecting successively deeper layers to "hide." The original screen is restored by choosing Show All Types from the TINKER menu.

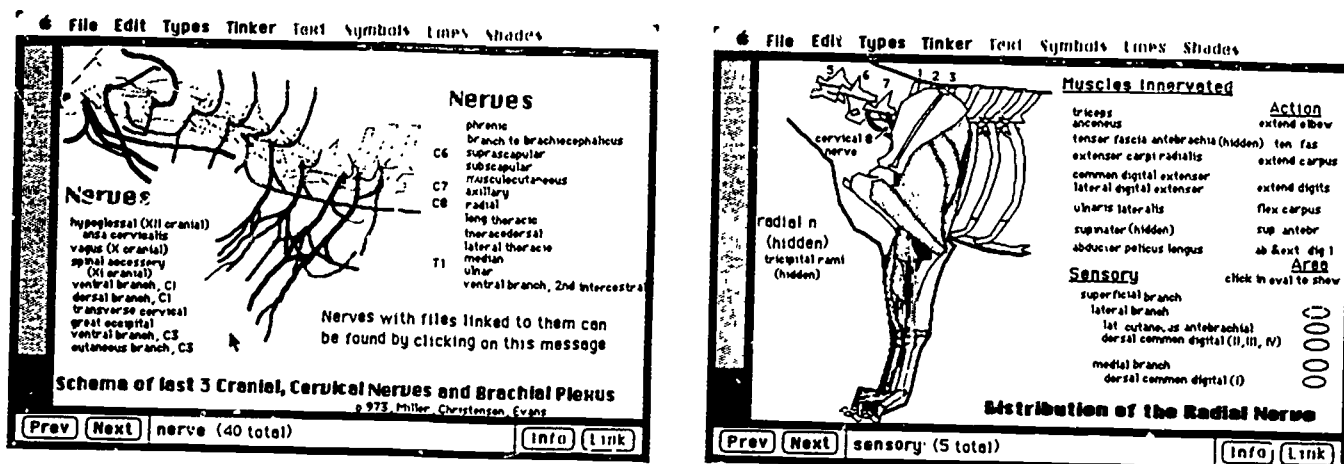

FIGURE 6. Example of hierarchal structure capability. *Left panel:* This screen shows the sources of the brachial plexus. If the radial nerve is selected, the LINK box (lower right) darkens. If LINK is then selected, the "Distribution of the Radial Nerve" file is opened and appears on the screen. *Right panel:* File showing the muscles innervated by the radial nerve and their actions. Sensory areas innervated by branches of the radial nerve are also shown.

ling to share if you send me blank disks. You will need the Business File-vision program to access the files.

REFERENCE

1. Bushby PA: Computerized veterinary medical information systems: impact

on veterinary medical education. *Computers in Life Science Education* 3:33-36, 1986.

SUBSCRIPTION INFORMATION

Computers in Life Science Education is published monthly by National Resource for Computers in Life Science Education, Mail Stop RC-70, University of Washington, Seattle, WA 98195. Subscription rate is \$30.00 for 12 issues, including postage and handling in the United States and Canada. Add \$20.00 for postage (airmail) in Mexico and Europe and \$23.00 for the rest of the world.

This newsletter has been registered with the Copyright Clearance Center, Inc. Consent is given for copying of articles for personal or internal use, or for the personal or internal use of specific clients. This consent is given on the condition that the copier pay through the Center the per-copy fee stated in the code on the first page for copying beyond that permitted by the US Copyright Law. If no code appears on an article, the author has not given broad consent to copy and permission to copy must be obtained directly from the author. This consent does not extend to other kinds of copying, such as for general distribution, resale, advertising and promotional purposes, or for creating new collective works.

Address orders, changes of address, and claims for missing issues to NRCLSE, Mail Stop RC-70, University of Washington, Seattle, WA 98195. Claims for missing issues can be honored only up to three months for domestic addresses and six months for foreign addresses. Duplicate copies will not be sent to replace ones undelivered due to failure to notify NRCLSE of change of address.

Address editorial correspondence to Harold I. Modell, PhD, NRCLSE, Mail Stop RC-70, University of Washington, Seattle, WA 98195. (BITNET MODELL@UWALOCKE)

POSTMASTER: Send address changes to *Computers in Life Science Education*, NRCLSE, Mail Stop RC-70, University of Washington, Seattle, WA 98195.

COMPUTERS IN LIFE SCIENCE EDUCATION

HAROLD I. MODELL

Department of Radiology
University of Washington
Seattle, Washington

MARCEL BLANCHAER

Department of Biochemistry
Faculty of Medicine
University of Manitoba
Winnipeg, Manitoba

THEODORE J. CROVELLO

Graduate Studies and Research
California State University, Los Angeles
Los Angeles, California

JAMES W. ECKBLAD

Department of Biology
Luther College
Decorah, Iowa

TSEGAYE HABTEMARIAM

School of Veterinary Medicine
Tuskegee University
Tuskegee, Alabama

DONNA LARSON

School of Nursing
Grand Valley State College
Allendale, Michigan

TERRY M. MIKITTEN

Graduate School of Biomedical Sciences
University of Texas Health Science Center
San Antonio, Texas

JAMES E. RANDALL

Department of Physiology
Indiana University
Bloomington, Indiana

PATRICIA SCHWIRIAN

College of Nursing
Ohio State University
Columbus, Ohio

RICHARD STULL

College of Pharmacy
University of Arkansas
Fayetteville, Arkansas

JAMES W. WOODS

Lister Hill National Center
for Biomedical Communications
National Library of Medicine
Bethesda, Maryland

DOROTHY WOOLEY-McKAY

Department of Biology
Glendale Community College
Glendale, Arizona

GLEN YOSHIDA

Department of Life Sciences
Los Angeles Southwest College
Los Angeles, California

NRCLSE

CONTENTS

COMPUTER-BASED LABORATORY EXERCISES	57
Michael Wang and James Heckman	
EXPERIMENTAL DATA SIMULATIONS IN BIOLOGY	60
James W. Eckblad	

COMPUTER-BASED LABORATORY EXERCISES

Michael Wang and James Heckman

Department of Physiology, Temple University Medical School, Philadelphia, Pennsylvania

There has been a dramatic decrease in the number of live animal laboratories presented in Medical School Physiology courses during the last ten years.¹ A number of factors have contributed to this decline. Costs have become unacceptably high, teaching faculty have been reluctant to spend the time necessary to prepare and present high quality laboratory exercises, students and society in general have objected to the use of live animals in teaching laboratories, and perhaps most importantly from an educational point of view, many of the physiological phenomena that need to be illustrated in a modern laboratory exercise are beyond the technical capability of medical students to perform during a single laboratory period.

At Temple Medical School, we have adapted to the loss of animal experiments in three ways. First, we have

maintained and placed increased emphasis on experiments involving human subjects. During these laboratory sessions, students learn tasks such as how to record EKGs, take blood pressures, listen to heart sounds, and perform pulmonary function tests while paying particular attention to the procedures by which accurate data collection is accomplished. Second, we have introduced workshop sessions in which students discuss the reduction and analysis of data. In these sessions and in the human subject laboratories, small group discussions are used to increase the student's ability to draw inferences from their observations and defend their opinions.

Finally, we have begun to introduce computer-based laboratories. One of these, *The Muscle Lab*, is described in this article.

DESIGN CONCEPT

There are at least two ways to present laboratory exercises by computer. In one, the physiological phenomena are simulated via an algorithm created by the programmer. Students are then able to manipulate various parameters and observe the effects these alterations have on measured variables. Since the equations are written to simulate the state of the organism, students are often free to choose any values within the boundaries of the formulae. A detailed description of this type of program has been reported recently by Carl Rothe.⁴ The cardiovascular system laboratory created by Nils Peterson and his colleagues³ is another fine example of this type of laboratory simulation.

An alternative method is for the programmer to preselect the range of values available for manipulation by the student. Although this produces a less flexible program, it is far easier to create. We have chosen this latter alternative for the muscle lab and for the other programs now under development by our department. This method has been chosen not only because it can be produced quickly, but also because of the heavy use of animations in our programs. Animations require large amounts of memory, and it is simply not possible to store enough images to produce all the animations a student may wish to observe.

Fortunately, the instructional objectives of computer-based laboratory exercises can be met quite nicely without having to produce an accurate simulation of the experimental system under study.

METHODS

The Muscle Lab demonstrates the effect of preload on the force of an isometric contraction and the effect of afterload on the velocity and extent of shortening in an isotonic contraction. The student selects a preload from 1.5 to 3.5 microns (in 0.1 micron steps) by striking the arrow keys. The animations show the muscle stretching (the sarcomeres lengthening) while an oscillographic recording on the left of the screen shows the passive tension in-

creasing. When the desired preload is reached, the student 'stimulates' the muscle and observes both the increase in tension on the oscillograph record and the animation of the actual muscle contraction. The animation shows the internal shortening of the sarcomeres and the lengthening of the series elastic component (SEC) of the muscle. The greater the force of contraction, the greater the internal shortening and the greater the lengthening of the SEC.

After the contraction is produced, the arrow keys are used to place the cursor at the peak of contraction. At this point, the student presses the 'record' key, and the passive and total tensions are recorded on a graph of tension versus preload. When the student indicates that enough values are collected, the passive tension is automatically subtracted from the total tension to yield active tension, and a line is drawn through the data points. The student then has the opportunity to collect more points or correct any errors in the data.

In the isotonic experiment, the preload is set at 2.2 microns, and the afterload is varied (Figure 1). When the student 'stimulates' the muscle, the animation of the isotonic contraction is

observed along with the oscillographic record of the change in length and force that occur during the contraction. The animation illustrates the increase in internal shortening (and the increase in SEC lengthening) that accompanies an increase in afterload (Figure 2). When the contraction is complete (Figure 3), the student measures the velocity of shortening (by entering the change in length occurring in a given time into the computer) and records the result on a graph of load versus velocity. The maximum velocity is determined by extrapolation to zero load.

The images for the animation of the muscle are drawn using PC Paintbrush and then automatically converted to a digital array using a program created by one of us (J.H.). The images are stored in a RAM disk as individual files. During the execution of the animation, the array is transferred from the RAM disk to a buffer and then to the video memory area of the PC. This can be done with sufficient speed to create true animations with very few images. The oscillographic records are produced on the computer screen in the interval between the retrieval of individual images so it appears that the two are occurring simultaneously.

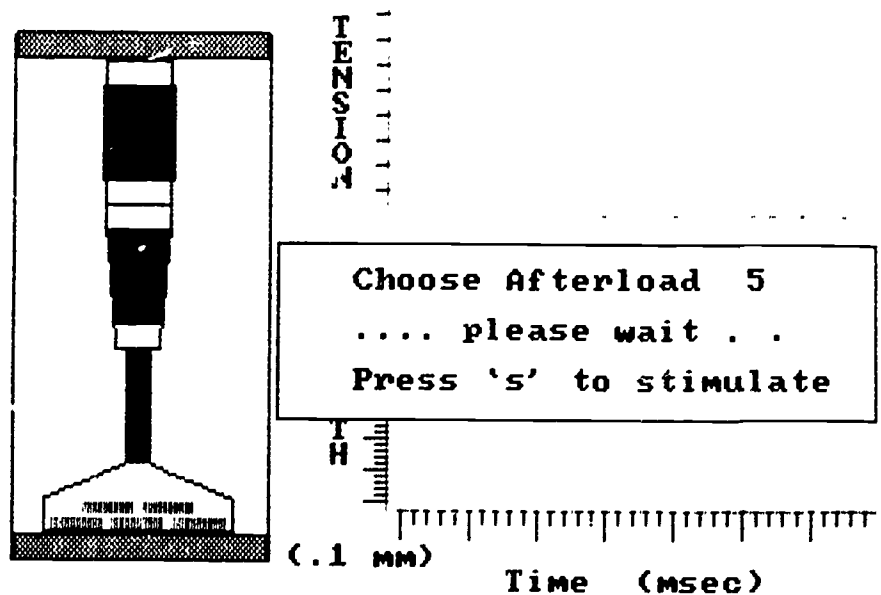

FIGURE 1. In the isotonic portion of the experiment, students are asked to select an afterload and stimulate the muscle.

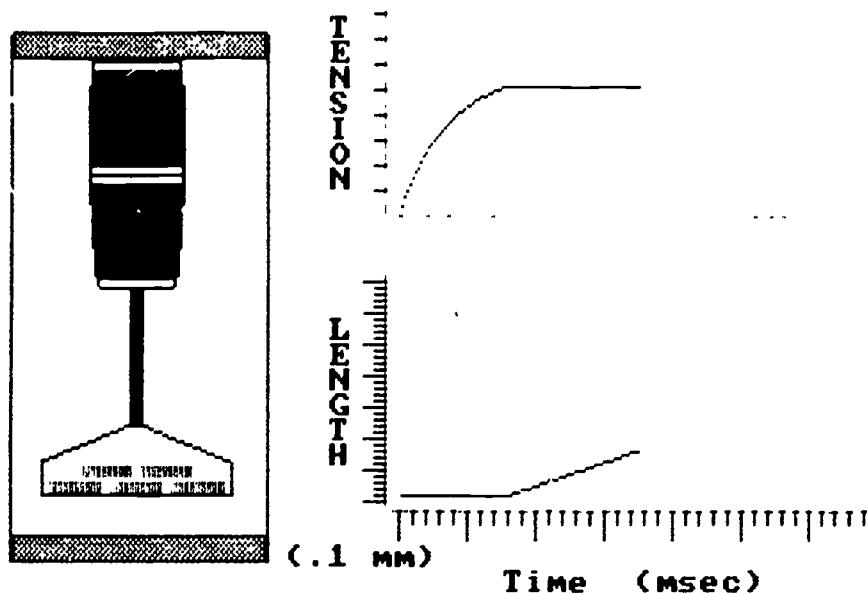

FIGURE 2. During stimulation, the SEC stretches and sarcomeres shorten until the force on the muscle begins to shorten. The oscilloscopic tracings show the change in force and length that occur during the stimulation.

DISCUSSION

The Muscle Lab is conducted in the same manner as an animal laboratory would be carried out. Students are given a laboratory manual describing the experiments to be carried out and the data to be collected. The class is divided into groups of 16 with four students assigned to each computer. There is ample time during the laboratory period for students to discuss the results among themselves and with their instructors.

Students laboratory exercises may serve multiple purposes². They can provide students with the opportunity to plan and carry out experimental procedures, to manipulate and observe the behavior of living tissue, to become familiar with the technical aspects of recording data, and to engage in problem solving exercises. Although computer-based experiments may provide a means of achieving some of these goals, it is fair to ask whether they are a legitimate substitute for live animal experiments.

The answer depends on the ultimate aim of Physiology education. If laboratory exercises are designed to expose

students to living organisms or tissues, then computer-based experiments are not an acceptable substitute. However, if laboratory exercises include among

their purposes the opportunity for students to observe the results of physiological experiments (as opposed to reading about them), to draw conclusions about the data, and discuss their observations, then computer-based experiments become a viable vehicle to achieve these goals.

We found that students approached *The Muscle Lab* animations as they would an actual experiment. The questions raised about the experiments were similar to those asked when students used frog muscles as an experimental model, there were no artifacts to 'explain away', and the discussions were just as thorough. Moreover, the students could observe events such as the internal shortening of the sarcomeres and the lengthening of the SEC that could only be talked about when a 'real' experiment was performed.

Our experience with *The Muscle Lab* was very positive, and we are currently in the process of animating several other laboratory exercises. We expect that the combination of problem solving workshop sessions, human laboratory exercises, and computer-based experiments will accomplish all the

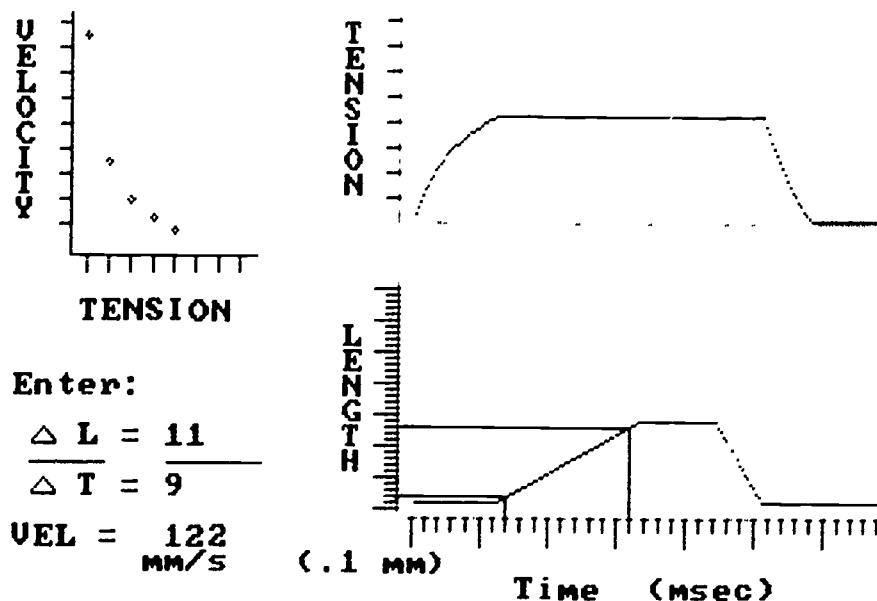

FIGURE 3. After the muscle relaxes, students use the oscilloscopic records to calculate the velocity of shortening. The data are recorded on the load-velocity axes. In this case, the afterload chosen was 4. Several data points have already been determined and appear on the graph.

goals set for student laboratories in Physiology.

REFERENCES

1. Greenwald GS: Survey on use of animals in teaching for association of chairmen of departments of physiology (ADCP), 1984.
2. Modell H: Editorial comment: the role of computers in the student laboratory. *Computers in Life Science Education* 4: 25-30, 1987.
3. Peterson NS, Campbell KB, Hopkins RH, Feiner SA: An integrated cardiovascular teaching laboratory. *The Physiologist* 28(5):447-448, 1985.
4. Rothe CF: Cardiovascular interactions - a simulation package to help learning. *Computers in Life Science Education* 4:49-53, 1987.

EXPERIMENTAL DATA SIMULATIONS IN BIOLOGY

James W. Eckblad

Department of Biology, Luther College, Decorah, Iowa

In recent years, a number of computer programs have been developed that attempt to simulate natural systems. These have often been designed to help students learn about the behavior of systems by modifying the values of variables or coefficients that are built into mathematical equations. Graphic displays, animation, and student tutorials have often been included. Although many of these programs are based upon sound pedagogy, their structure too often fails to 1) let students participate in planning experiments, 2) provide students with the sense of discovery so important in developing an appreciation for actually doing science, and 3) include the variety of experiments appearing in the recent biological literature.

The possibility that students could use the computer to design experiments testing current concepts in the life sciences was the motivation for developing a series of data simulation programs. Furthermore, it was felt that experimental situations could be considered on the computer that would otherwise be impossible given the constraints of an undergraduate curriculum. For example, the computer could be used to study the mid-summer oxygen profile in Lake Mendota, the recolonization of Krakatau, or the oxygen consumption in mountain climbers.

The goals in developing these data

simulations were to:

- Provide undergraduates with a chance to participate in the design of an experimental situation including the formulation of hypotheses;
- Simulate selected classical experimental studies as well as experiments that appear in the recent biological literature;
- Provide each student with data comparable to that obtained by investigators who have published about that system;
- Encourage student analysis of experimental data, but make provisions to supply instructors with a complete analysis (analysis of variance & regression analysis);
- Encourage students to compare their interpretations with those of the original investigators.

RATIONALE FOR SIMULATIONS

A major philosophical perspective behind the development of these simulations was that the computer should not shield students from the trouble of thinking. Also, the programs were not designed to provide the conceptual framework for the experiments being simulated. This was to be left to the instructor or to the student through his or her own reading. It was felt that this would increase the variety of ways programs could be used with students

of different scientific backgrounds and would help balance the unfortunate view that one turns to the computer for the interpretation of data. The analysis of data, or in this case, the generation of data, was felt to be a more appropriate role for a machine controlled by silicon chips.

Another important consideration in designing these simulations was the recognition that when experiments in the life sciences are repeated, they do not produce exactly the same results. This feature was incorporated into the design so that simulated experiments by different students, or the same student at different times, would result in unique sets of data. In addition, the variability between separate replicates within the same experiment was designed to correspond to what would usually be observed for that living system.

The mathematical equations needed to simulate empirical relationships taken from the scientific literature can be rather complex. However, that complexity is not apparent to the user of these data simulations. Students can use the simulated data with established mathematical models of the systems being studied. However, in many cases, there are no accepted mathematical models which describe these experimental systems. The principal focus of these simulations was to use experi-

mental data to discover relationships between variables rather than to be concerned about the mathematical manipulations used to generate these data.

ROLE OF THE INSTRUCTOR

These simulations of experimental data were designed to be used under the tutelage of an instructor. It was recognized that instructors might want to use these simulations in a variety of ways. To help accommodate these differences, several instructor options were incorporated into each program. First, an instructor can select the type of data summary display seen by students. The programs provide the following three display types.

- 1) No data summary is presented.
- 2) A brief summary including a mean and standard deviation is presented.
- 3) No data summary is presented after each simulation, but a more complete summary (including analysis of variance and regression analysis) is provided after all simulated data have been displayed.

Second, an instructor can adjust how much variation occurs between replicate simulated values by changing the size of the sample standard deviation. These instructor controlled options are specified before students begin using a simulation.

Data upon which each simulation is based is taken from the scientific literature, and citations are included in the program manual. A number of the experiments are also discussed in various textbooks. Instructors will usually want to provide some appropriate background information concerning the systems being examined. A few experimental questions about each system are suggested in the program manuals. These should assist in the formulation of testable hypotheses.

There are at least three different ways these simulations can be used with students. First, an instructor can have the program generate hard copies of individualized data sets and then distribute these to students for analysis and inter-

pretation. Usually, data summary type 3 would be specified in this mode, and the instructor would retain the analysis summary for comparison with the analysis completed by each student. When used in this fashion, the instructor specifies the particular independent variable, the number of replicates, and, probably, the hypothesis to be tested. This simple use of a data simulation helps determine if students are able to do an appropriate statistical analysis of experimental data.

In a second use of data simulations, the instructor suggests an hypothesis to be tested, but students obtain their own data sets from the computer. Students are required to make more decisions in this case. They need to specify which independent variable is considered, what levels are to be studied, and the number of experimental replicates at each level. In this case, the instructor would not have a paper copy of the data analysis summary, and the student data summary display could be either type 1 or type 2.

An even more open-ended use of these simulations occurs when students formulate their own hypotheses, specify the experimental conditions, and use the computer to obtain the simulated experimental data. These data are then analyzed, decisions are made about the validity of hypotheses, and additional data may be needed for a more in depth study of the characteristics of this system. Instructors might continue to guide this inquiry process by providing appropriate biological information about the system, and they may refer students to the cited scientific literature for comparison with the conclusions reached by the original investigators.

SIMULATIONS CURRENTLY AVAILABLE

There are five separate disks in a series of experimental data simulations in biology, each with 25 distinct experiments per disk. The following disks are available in versions that run on the IBM-PC and compatibles, the Apple II series, or the Macintosh series of computers.

- Ecological Data Simulation

- Aquatic Ecology Data Simulation
- Physiological Data Simulation
- Animal Behavior Data Simulation
- General Biology Data Simulation

Each disk is available from Oakleaf Systems, PO Box 472, Decorah, Iowa 52101 and includes a program manual and backup disk at a cost of \$59.95.

EXAMPLES

Lake Mendota oxygen values

One of the systems often considered in ecology or limnology classes is the concentration of dissolved oxygen at different depths within a lake. Students can obtain these measurements directly, but it is usually not practical to have them obtain data during different months of the year. Data originally obtained for Lake Mendota in Madison, Wisconsin, during the months of May, June, July, and August were used in developing the simulation of this system. Students using this simulation (included on the Aquatic Ecology Data Simulation disk) must specify the sampling month, sampling depth, and how many replicate samples are to be taken at that depth. During a single experiment, samples can be taken from up to 15 different depths. If a student selected the month of July, with samples at five depths (1, 5, 10, 15, and 20 meters), and three separate samples from each depth, the program would produce 15 simulated values of dissolved oxygen. These data could be displayed on the screen, sent to a printer, or represented as a scatter plot like the one shown in Figure 1.

Students could use these data, and similar data from other months, to address the following types of questions.

- At what depth does a metalimnion develop?
- At what depth does the greatest difference in oxygen levels occur between May and June?
- What type of oxygen profile is present in May and in July?
- Is there a significant difference in oxygen levels in the upper 5 meters during the month of June?

With some questions raised, students may find they require additional data;

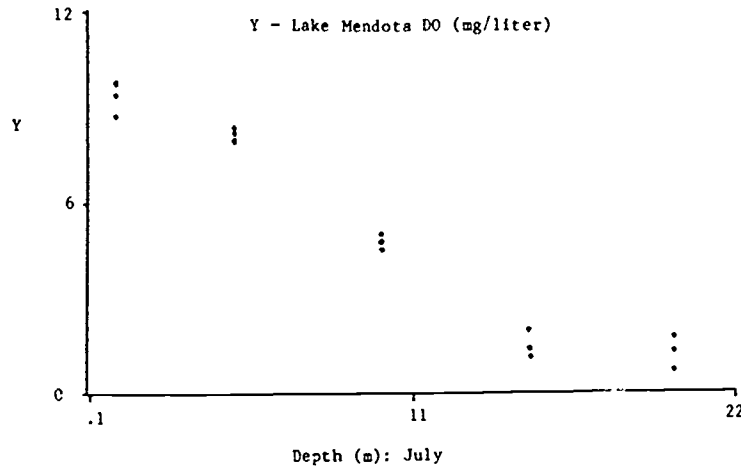

FIGURE 1. Scatter plot of data for dissolved oxygen values from five depths during July in Lake Mendota. Depth-oxygen profiles of this type are often rotated 90 degrees and displayed with depth along a vertical axis and oxygen as an upper horizontal axis.

what biologist hasn't experienced this situation. Taking more samples with this simulation program won't yield exactly the same values, but the same patterns will persist.

Old-field succession and plant cover
The secondary succession in vegetation that occurs in abandoned fields is usually considered in ecology classes. This can be difficult to observe over just a few years, let alone during a one-semester course. This simulation is based upon relationships taken from an analysis of 22 fields ranging in age from 1 to 56 years since abandonment as reported by Inouye et al.² It is one of the programs included on the Ecological Data Simulation disk.

Students select from one of four cover types (Nonvascular plants, Vascular plants, Bare ground, or Litter), enter different field ages in years (from 1 to 60), and specify the number of different fields of the same age sampled. The percent cover for each field is then simulated with data displayed on the screen, sent to a printer, or represented as a scatter plot. Various questions to be addressed might deal with which cover types increase their percent cover as succession continues or whether the percent cover by litter changes as succession continues.

Adrenalectomy and salt-gland function in ducks

The avian salt glands are commonly considered when topics on osmoregulation are covered in an animal physiology class. Osmotically sensitive neurons in the hypothalamus, plus input from peripheral osmoreceptors, activate parasympathetic pathways to

the salt gland directly and to the vessels supplying blood to the salt gland. Pituitary secretion of ACTH, which stimulates release of corticosterone from the adrenal medulla, is also activated. This interesting system is usually beyond the scope of direct laboratory activity in an undergraduate physiology class, but is easily investigated as a data simulation. A simulation based upon relationships presented by Thomas and Phillips,³ who considered the effect of adrenalectomy on salt-gland secretion in the duck, is one of the programs on the Physiological Data Simulation disk. Students can obtain simulated data on the rate of salt-gland secretion during an infusion of 10% NaCl into the blood under conditions of no removal of the adrenal gland, adrenalectomy, and adrenalectomy followed by corticosterone replacement therapy. After students obtain the data under the three different experimental conditions, they should be asked to describe the physiological functions that help explain any differences observed.

Starling flock size and vigilant time
The tendency for social behaviors and

TABLE 1. Simulated data as it would appear when sent to a printer. This illustrates data display type 3, where no data summary is displayed for the student.

Simulation of Time vigilant (sec per min)	(4 replicates)		
when Starling flock size: at midway = 10	26	31	16
.....			
Simulation of Time vigilant (sec per min)	(4 replicates)		
when Starling flock size: at midway = 30	18	16	9
.....			
Simulation of Time vigilant (sec per min)	(4 replicates)		
when Starling flock size: at midway = 100	19	13	13
.....			
Simulation of Time vigilant (sec per min)	(4 replicates)		
when Starling flock size: at midway = 150	12	10	7
.....			
Simulation of Time vigilant (sec per min)	(4 replicates)		
when Starling flock size: at midway = 200	15	6	9
.....			
.....			8
.....			0

TABLE 2. Data summary for the data given in Table 1. This summary would usually be retained by the instructor.

Data summary for Time vigilant (sec per min)				
		Mean	Stand. Dev.	
When Starling flock size: at midway = 10		24.0	6.3	
When Starling flock size: at midway = 50		15.5	4.5	
When Starling flock size: at midway = 100		14.5	3.0	
When Starling flock size: at midway = 150		9.3	2.2	
When Starling flock size: at midway = 200		7.5	6.2	
Testing for equality of the 5 means using One-way Analysis Of Variance				
SOURCE	Df	SS	MS	F
Between	4	668.8	167.2	7.4256105
Within	15	337.75	22.516667	
Total	19	1006.55		
F-value indicates that means are significantly different (p(0.01))				
Comparing data to least-squares linear equation				
$Y = 22.387782 - .080762565 (X)$				
Testing if the slope = 0 using One-way Analysis of Variance				
SOURCE	Df	SS	MS	F
Regression Y on X	1	602.16568	602.16568	26.803665
Unexplained	18	404.38432	22.465795	
Total	19	1006.55		
F-value indicates slope is significantly different (p(0.001)) from zero				
Coefficient of Determination (r ²) = .59824716				
Correlation Coefficient (r) = -.77346439				

their adaptive advantage are topics discussed in a course in animal behavior. The studies reported by Jennings and Evans¹ dealing with flock size and position within the flock versus time starlings had their heads up

and were watching for potential danger (time vigilant) were used to develop a simulation of this system. This is included on the Animal Behavior Data Simulation disk. To illustrate how an instructor might supply students with

data for analysis, simulated data for time vigilant for birds midway in the flock with 5 different flock sizes, is shown in Table 1. Data display type 3 was specified, and there is no data summary provided to the students. The complete data summary (Table 2) is retained by the instructor. It shows that overall mean times watching for potential danger were significantly different ($P < 0.001$) for different flock sizes, and these differences can be expressed by the linear regression of time vigilant on starling flock size. Each student would have a unique data set and should arrive at slightly different regression equations, but general trends would be similar.

REFERENCES

- Jennings T, Evans SM: Influence of position in the flock and flock size on vigilance in the starling, *Sturnus vulgaris*. *Anim Behav* 28:634-635, 1980.
- Inouye RS, Huntly NJ, Tilman D, Tester JR, Stillwell M, Zinnel KC: Old-field succession on a Minnesota sand plain. *Ecology* 68:12-26, 1987.
- Thomas DH, Phillips JG: Studies in avian adrenal steroid function IV: adrenalectomy and the response of domestic ducks (*Anas platyrhynchos* L.) to hypertonic NaCl loading. *Gen Comp Endocr* 26:427-450, 1975.

AIMS AND SCOPE

The goal of *Computers in Life Science Education* is to provide a means of communication among life science educators who anticipate or are currently employing the computer as an educational tool. The range of content includes, but is not limited to, articles focusing on computer applications and their underlying philosophy, reports on faculty/student experiences with computers in teaching environments, and software/hardware reviews in both basic science and clinical education settings

INVITATION TO CONTRIBUTORS

Articles consistent with the goals of *Computers in Life Science Education* are invited for possible publication in the newsletter.

PREPARATION AND SUBMISSION OF MATERIAL

Articles submitted for publication should not exceed 2000 words and should be typewritten, double spaced, with wide margins. The original and two copies including two sets of figures and tables should be sent to the Editor: Dr. Harold Modell, NRCLSE, Mail Stop RC-70, University of Washington, Seattle, WA 98195.

Title page should include full title, list of authors, academic or professional affiliations, and complete address and phone number of the corresponding author.

Illustrations should be submitted as original drawings in India ink or sharp, unmounted photographs on glossy paper. The lettering should be such that it can be legible after reduction (width of one column = 5.7 cm).

Reference style and form should follow the "number system with references alphabetized" described in the Council of Biology Editors Style Manual. References should be listed in alphabetical order by the first author's last name, numbered consecutively, and cited in the text by these numbers.

RESPONSIBILITY AND COPYRIGHT

Authors are responsible for accuracy of statements and opinions expressed in articles. All authors submitting manuscripts will be sent a copyright transfer form to complete. The completed form must be returned before the work will be published.

SUBSCRIPTION INFORMATION

Computers in Life Science Education is published monthly by National Resource for Computers in Life Science Education, Mail Stop RC-70, University of Washington, Seattle, WA 98195. Subscription rate is \$30.00 for 12 issues, including postage and handling in the United States and Canada. Add \$20.00 for postage (airmail) in Mexico and Europe and \$25.00 for the rest of the world.

This newsletter has been registered with the Copyright Clearance Center, Inc. Consent is given for copying of articles for personal or internal use, or for the personal or internal use of specific clients. This consent is given on the condition that the copier pay through the Center the per-copy fee stated in the code on the first page for copying beyond that permitted by the US Copyright Law. If no code appears on an article, the author has not given broad consent to copy and permission to copy must be obtained directly from the author. This consent does not extend to other kinds of copying, such as for general distribution, resale, advertising and promotional purposes, or for creating new collective works.

Address orders, changes of address, and claims for missing issues to NRCLSE, Mail Stop RC-70, University of Washington, Seattle, WA 98195. Claims for missing issues can be honored only up to three months for domestic addresses and six months for foreign addresses. Duplicate copies will not be sent to replace ones undelivered due to failure to notify NRCLSE of change of address.

Address editorial correspondence to Harold I. Modell, PhD, NRCLSE, Mail Stop RC-70, University of Washington, Seattle, WA 98195. (BITNET MODEL@UWALOCKE)

POSTMASTER: Send address changes to *Computers in Life Science Education*, NRCLSE, Mail Stop RC-70, University of Washington, Seattle, WA 98195.

COMPUTERS IN LIFE SCIENCE EDUCATION

HAROLD I. MODELL

Department of Radiology
University of Washington
Seattle, Washington

MARCEL BLANCHAER

Department of Biochemistry
Faculty of Medicine
University of Manitoba
Winnipeg, Manitoba

THEODORE J. CROVELLO

Graduate Studies and Research
California State University, Los Angeles
Los Angeles, California

JAMES W. ECKBLAD

Department of Biology
Luther College
Decorah, Iowa

TSEGAYE HABTEMARIAM

School of Veterinary Medicine
Tuskegee University
Tuskegee, Alabama

DONNA LARSON

School of Nursing
Grand Valley State College
Allendale, Michigan

TERRY M. MIKITTEN

Graduate School of Biomedical Sciences
University of Texas Health Science Center
San Antonio, Texas

JAMES E. RANDALL

Department of Physiology
Indiana University
Bloomington, Indiana

PATRICIA SCHWIRIAN

College of Nursing
Ohio State University
Columbus, Ohio

RICHARD STULL

College of Pharmacy
University of Arkansas
Little Rock, Arkansas

JAMES W. WOODS

Lister Hill National Center
for Biomedical Communications
National Library of Medicine
Bethesda, Maryland

DOLORETHA WOOLEY-McKAY

Department of Biology
Glendale Community College
Glendale, Arizona

GLEN YOSHIDA

Department of Life Sciences
Los Angeles Southwest College
Los Angeles, California

NRCLSE

CONTENTS

USE OF COMPUTER ASSISTED INSTRUCTION- INTERACTIVE VIDEO IN BASIC MEDICAL EDUCATION	65
Ronald P. Jensch	
HOW SHALL WE EVALUATE SOFTWARE - PEER REVIEW OR PEER CRITIQUE?	68
Harold I. Modell	
KEEPING ABREAST OF THE LITERATURE	69

USE OF COMPUTER ASSISTED INSTRUCTION - INTERACTIVE VIDEO IN BASIC MEDICAL EDUCATION

Ronald P. Jensch

Departments of Anatomy and Radiology, Jefferson Medical College, Thomas Jefferson University, Philadelphia, Pennsylvania

Computer assisted instructional materials have been available for a number of years at various educational levels. Only recently have such materials become available to medical educators,

particularly in the basic sciences. There is still a paucity of educational programs for medical students, and medical schools are only now beginning to realize the potential that com-

**REMINDER - TIME TO RENEW
SUBSCRIPTION RENEWAL FORM MAY
BE FOUND ON PAGE 71**

puters offer for enhancing the educational experience of the student. Although a medical student's knowledge of typing skills is a preselected concern, an increasing amount of computer instruction and daily use of computers in the early years and in undergraduate courses should lessen this problem with each succeeding freshman class.¹ In 1980 there were less than 100,000 computers in U.S. schools. Today it is estimated that more than half a million computers are in use. For many college students, computers are as commonplace as textbooks.⁴ However, there are still a considerable number of college graduates with only minimal computer experience. Using computers as an educational tool not only facilitates student education, but also introduces the students to computer related tasks that will be part of their daily professional life after graduation.

Until very recently, the use of computer technology in morphologic sciences such as anatomy and pathology has been limited because computer generated graphic representation could not address the objectives of these disciplines adequately. Development of the videodisc and the capability to interface the disc player with the computer has resulted in the ability of educators to manipulate photographic material freely and preprogram tutorials, reviews, self assessments, and tests. Each side of a videodisc is capable of storing 54,000 photographic images, and access to any one frame is immediate. The purpose of this study was to create self-paced tutorials on selected topics in histology using computer-assisted-instruction interactive video (CAI-IV) techniques, and to determine student reaction to this type of educational experience.

THE WORKSTATION

The video workstation consisted of an Apple IIe computer (64K memory) with two 5.25" disk drives, a Zenith Data Systems 12" monochrome monitor (Model ZVM-121), a Sony Trinitron 13" color monitor (Model KV-

1311CR), a Pioneer LD-V1000 Video Disc Player, and a Video Microcomputer Interface card (Allen Communications, Inc.). Since the first three items were readily available, the additional cost to set up the workstation was under \$1200. The workstation was on a mobile cart that could be taken to the student laboratory when appropriate. The first year class of 223 medical students at Jefferson Medical College of Thomas Jefferson University was given the opportunity to use CAI-IV tutorial programs as part of the first semester course in histology.

A videodisc had been produced as a generic library containing several hundred photomicrographs of histologic sections from the author's collection. A simple, but effective, English language authoring system was created to allow faculty members to quickly and efficiently design an interactive video tutorial with a minimum of computer related experience. Using the authoring system, two self-paced CAI-IV tutorials were created; Histology of the Respiratory System and Histology of the Integumentary System. A catalog program was also created, and an associated cross-referenced index of the videodisc was printed using the PFS File system (Software Publishing Co., Mountain View, CA). Using the catalog, students would find an item of interest in the index book, type in the frame number, and see a photograph of that item immediately.

STUDENT EVALUATION

Student evaluation forms were placed with the program disks. The form was short in order to elicit maximum response. The following items were included.

- 1) Check the programs that you have used;
- 2) These learning aids were helpful to me (5 point scale from Strongly Agree to Strongly Disagree);
- 3) The programs that were most helpful were;
- 4) The programs that were not helpful

were;

- 5) I believe more programs using the videodisc format should be created (5 point scale);
- 6) Comments (to be written in).

An oral evaluation was conducted during the final week of the course. One hundred and ninety of the 223 students enrolled in the course were polled to answer the following questions.

- 1) How many students used the computer programs?
- 2) Of those who used the programs, how many students found them to be helpful?
- 3) Do students believe that use of actual photographs is better than graphics?
- 4) Do students believe more resources should be committed to CAI-IV?

An evaluation of changes in student grades due to exposure to these programs was not done because only two subject areas were covered; the medical student population was academically too homogeneous to expect a major shift in test results; and isolating those students in academic difficulty and testing half of them after exposure versus half without exposure to the programs would create too small of a sample size. We felt that the student evaluations were a more efficient means of determining whether students gained better understanding of the subject matter and gaining an indication of their perception of learning efficiency (time expenditure).

The results of the written and oral surveys indicated that students were strongly in favor of the use of this type of educational tool. They considered such a methodology to be an efficient and effective method of learning. Thirty-eight written evaluations were completed at the time when students used the programs, and 90 of the 190 students polled in class indicated in the oral evaluation that they used the programs. Ninety-five percent of those students who completed the written

evaluation agreed that these educational aids were helpful. Ninety-seven percent believed that more CAI-IV programs should be created. Seventy-four percent of the respondents offered comments such as very helpful; tremendous; great; best type of review in the absence of a professor; enjoyed as a different learning tool - self paced; want more; I really liked it; The programs really helped me understand the material; and We really could use more programs like these. All of the users who responded to either survey believed that more resources should be committed to the production of CAI-IV materials. A number of students offered both written and oral comments on how to improve the programs and what changes might be made, indicating that these programs were stimulating not only in terms of content, but also in the design of the program relative to its educational objectives.

It was of interest to note that students used these programs not only as individuals interacting with the computer, but also as a focus of group activity for stimulating discussions. In many instances, the catalog program was used as a method for students to quiz each other and to stimulate further discussion.

DISCUSSION

CAI-IV is a powerful tool for the education process. The key to producing an effective computer program, of course, lies in the proper design of the content as well as the nature of the format itself. The quality of the product depends upon the expertise and commitment of the author and on a clear understanding of the objective and nature of the intended use of the program.

The present system was designed so that faculty with limited or no computer experience could easily and quickly create tutorials with only rudimentary typing ability. Once a script is written, and associated photographic frames are assigned, a non-computer related task, material can be typed into

the computer with ease. Average computer time for entering and recording each of the two programs used in the present study, which comprise more than 30 text frames, was less than three hours. In the present study, the computer programs were designed for use following a lecture-laboratory experience. However, similar programs could be designed to replace certain structured activities. As a result, faculty contact time could be reduced or used for more interactive purposes such as recitations and group discussions.

It is difficult to assess the full impact of CAI-IV among the medical student population because their academic abilities are very homogeneous. In addition, one would not expect to observe any meaningful grade changes for those students who easily attain passing grades, regardless of the methodologies used in their studies. However, students exposed to CAI-IV could learn the material more efficiently, could attain a greater understanding of the material, a factor seldom tested, and might increase their test scores. Students in academic difficulty could be used to objectively evaluate the effect of CAI-IV exposure. In addition, the present study used only two programs in one course. Since the relative number of test questions addressing the two areas presented was small, no extensive analyses could be completed. Therefore, it was appropriate to use subjective evaluations to determine how students felt about such programs compared to presentation modes used for other areas of histology that did not include any CAI-IV programs. The students participating in the two evaluation modes were unanimous in their favorable response.

Use of the computer in the medical education milieu provides an additional benefit. Since many students have limited computer experience when they enter medical school, providing access to the computer keyboard as part of the biomedical process will acclimate them to an increasingly important area in their future professional activities.

Computers are becoming widely used in all areas of medicine, medical education, and related fields. They are used for financial transactions, scheduling and appointment recording, and some cognitive processes such as continuing medical education, accessing medical literature, collecting patient histories, monitoring patient vital signs, storing patient clinical data, assisting in establishing diagnoses and helping to plan therapy, and record keeping.² Since the educational experience of medical students must encourage lifelong study in the medical profession,³ and since computers and their use in effectively and efficiently aiding in patient care will continue to play an increasingly important role in medicine, it is essential that students become familiar with computer use in medicine during their medical college experience.⁵

Veloski and Blacklow⁶ have stated that "the influence of the computer on medical care, education, and research is pervasive. In order to ensure that future professionals embrace this technology, it is necessary for medical educators to introduce students and faculty to the opportunities offered by computers." The use of CAI-IV programs as part of the educational experience not only augments the educational process, but it also prepares the student for professional life.

This study was supported by the Mr. and Mrs. Gabriel Lavine Clinical Scholarship Program of Jefferson Medical College of Thomas Jefferson University, Philadelphia, PA.

The author wishes to express his thanks to F. Scott Beadenkopf, Robert S. Blacklow, and J. Jon Veloski for reviewing the manuscript, Ruth-Eleanor Jensch for typing the manuscript, and Robert C. Weber II for his contribution in developing the computer program.

REFERENCES

1. Bresnitz EA, Stettin GD, Gabrielson IW: A survey of computer literacy among medical students. *J Med Educ* 61:410-412, 1986.
2. Chalmers TA: A computer-driven shift in the practice of medicine. p 7-11 *In* Javitt

- J (ed), *Computers in Medicine: Applications and Possibilities*, Philadelphia, PA, WB Saunders, 1986.
3. *Future Directions for Medical Education. A Report of the Council on Medical Education*. Chicago, IL, American Medical Association, 1982.
4. *Medical Education in the Information Age: Proceedings of the Symposium on Medical Informatics*. Washington, DC, Association of American Medical Colleges, 1986.
5. *Physicians for the Twenty-First Century: The GPEP Report*. Washington, DC, Association of American Medical Colleges, 1984.
6. Veloski JJ, Blacklow RS: The integration of the computer into medical education. p 134-155 *In* Javitt J (ed), *Computers in Medicine: Applications and Possibilities*, Philadelphia, PA, WB Saunders, 1986.

HOW SHALL WE EVALUATE SOFTWARE -- PEER REVIEW OR PEER CRITIQUE?

Harold I. Modell

Department of Radiology, University of Washington, Seattle, Washington

A mechanism is needed by which authors of educational software can receive the benefit of peer evaluation of their efforts. Such a mechanism must reflect standards for quality control and, in doing so, serve two populations. For users of the software, the process must provide a means of identifying high quality software appropriate for specific educational settings. For the life science community at large, the evaluation must establish criteria by which the community can determine if a specific author's activities represent scholarly effort in the context of faculty code guidelines for appointment and promotion.

PEER REVIEW

The first reaction to this definition of need is to extend the traditional peer review concept for research efforts to educational software. However, the peer review mechanism as it exists for research efforts may not be appropriate. Consider the questions a reviewer asks when evaluating a manuscript for publication. Aside from the presentation issues (Does the author communicate well with the reader?; Are the number of figures and tables appropriate?), the referee asks if the experimental design addresses the hypotheses to be tested, if the data are subject to errors that the author did not consider, if there are alternative explanations for

the data that the author did not consider, and if the findings represent new information for the scientific community. Although considerable debate can be generated regarding how referees go about answering these questions, the fact remains that the evaluation criteria are relatively few, and they are consistent among scientific disciplines and levels of sophistication because the basic product being evaluated is the same. This is not necessarily the case for educational software.

SOFTWARE EVALUATION ISSUES

Several years ago, the Education Committee of the American Physiological Society considered establishing an evaluation mechanism for educational software for physiology teaching. With the traditional peer review concept as a model, the intent was to recognize high quality software with some sort of APS or Committee endorsement. However, after considerable discussion, the idea was abandoned because committee members felt that they would not have the expertise necessary to make judgments on all areas that would have to be evaluated. For example, if a given piece of software was to be designated "acceptable", all aspects of the materials should be high quality. Hence, computer science issues would have to be addressed (is the program written in an efficient way) as

would educational design and educational research issues (does this program offer a better way to present material than other presentation modes?).

Modell has discussed input/output design for different educational settings.¹ Consider software written by an author whose focus is on the group setting being reviewed by a colleague whose focus is on the independent study setting. What impact does the lack of versatility have on the referee's rating of the software?

The traditional peer review process results in an "acceptance or rejection" type of judgment which, in the case of software review, would necessitate critical review of all aspects of the software. In this respect, the APS Education Committee was probably correct in its assessment. However, perhaps the traditional peer review mechanism is not the best model for software evaluation.

PEER CRITIQUE

An alternative mechanism, peer critique, would provide authors with valuable feedback from colleagues, provide a means of evaluating software development efforts in terms of their contribution to the life science community (ie, "scholarly effort"), and provide the life science community with information concerning high quality, versatile software.

In this model, authors would submit their software and documentation along with a description of the philosophy governing its development (eg, educational goals, educational setting, and student population) and any additional pertinent information (eg, student evaluation). The software would then be critiqued with the following questions in mind.

- How consistent is the software with the governing philosophy?
- Is the content appropriate for the intended student population?
- How versatile is the software in terms of use in other educational settings and with different student populations?
- How transportable is the software in terms of hardware and operating system requirements?
- Is a published review of the software appropriate?
- Is a published description of the software by the author appropriate?

Because this mechanism does not op-

erate on a "accept or reject" basis, authors could submit materials at various stages of development. In this way, they could gain a broader perspective, yielding a product that would be of use to a greater portion of the life science community.

Quality control would be assured by the last two questions. Published reviews of software may be appropriate for alerting the community to the shortcomings of readily available materials or for informing the community of high quality, versatile materials. The feedback mechanism to appointment and promotion committees represented by traditional peer review would also be available by the last question. If the software represents a significant contribution to education within the life science community, the author would be encouraged to submit a manuscript for publication. A review of the software would then be published with this manuscript. A number of journals could provide the vehicle for publication of manuscripts and reviews.

ESTABLISHMENT OF THE PEER CRITIQUE MECHANISM

NRCLSE is currently developing a proposal for the peer critique mechanism and seeking potential funding sources to initiate such a mechanism. Because this effort is intended to serve the life science community, it is essential that the community have input to developing the concept. The peer critique model outlined above represents the first stages of development. We encourage you to share your thoughts on the issue with us by mailing comments and suggestions to:

Harold Modell, Ph.D.,
NRCLSE, Mail Stop RC-70,
University of Washington,
Seattle, WA 98195

or contacting us through BITNET at
MODELL@UWALOCKE.

REFERENCE

1. Modell H: Input/output design for different educational settings. *Computers in Life Science Education*. 1:57-62, 1984.

KEEPING ABREAST OF THE LITERATURE

The following citations are presented as part of a quarterly feature in CLSE designed to help readers become aware of current literature pertinent to computer applications in life science education.

- Armstrong ML: Wrapping software inside learning packages. *Am J Nurs* 87(4):527, 1987.
- Bolwell C: 1987 directory of educational software for nursing. *NLN Publ* #41-2167:1-330, 1987.
- Branck CE et al: The validation of an interactive videodisc as an alternative to traditional teaching techniques: auscultation of the heart. *Educ Tech* 27(3):16-22, 1987.
- Bruce AW: A text-computer assisted

- instruction program as a viable alternative for continuing education in laboratory medicine: *Collegiate Microcomputer* 4(4):301-305, 1986.
- Canham GUR et al: The development of a computer-assisted drill program. *J Comp Math Sci Teach* 5(3):46-47, 1986.
- Cartwright M: Designing computer programs: two student projects. *Aust Nurses J* 16(7):43-45, 1987.
- Catanzarite VA et al: Computer applications in obstetrics. *Am J Obstet Gynecol* 156(5):1049-1053, 1987.
- Catanzarite VA: FMTUTOR: a computer-aided instructional system for teaching fetal monitor interpretation. *Am J Obstet Gynecol* 156(5):1045-1048, 1987.

- Cook V et al: Computer-assisted instruction for medicine and nursing: sources and programs. *Bull Med Libr Assoc* 75(2):101-108, 1987.
- Costanza R: Simulation modeling on the Macintosh using STELLA: *BioScience* 37(2):129-132, 1987.
- Dambolena IG: Using simulation in statistics courses. *Collegiate Microcomputer* 4(4):339-344, 1986.
- Day R et al: Computer-managed instruction: an alternative teaching strategy. *J Nurs Educ* 26(1):30-36, 1987.
- Dean JM: Gas Man. *MD Comput* 3(3):53-57, 1986.
- Dede C: A review and synthesis of recent research in intelligent computer-assisted instruction.

- International Journal of Man-Machine Studies 24(4):329-353, 1986.
- Eberts RE: Computer-aided education. MD Comput 3(3):20-28, 1986.
- Golding J: Cardiac rhythms and arrhythmias: a teaching program. Comput Methods Programs Biomed 23(3):331-336, 1986.
- Gordon S et al: Computer-based instruction in clinical medical education — a pulmonary medicine self-assessment. Int J Clinical Monitoring and Computing 4(2):111-114, 1987.
- Green KC et al: Software piracy: its cost and the consequences. Change 19(1):46-49, 1987.
- Greipp ME: Grant application strategies for computers in nursing education. Comput Nurs 5(1):20-23, 1987.
- Hammond N: Getting started with interactive video. Audiovis Libr 13(1):38-45, 1987.
- Herald J: Authoring languages and systems: an interview with Peter Crowell. Memoires Optiques 34:21-24, 1986.
- Hoffer EP et al: Computers in medical education: observations from 15 years experience. MD Comput 3(3):6-7, 1986.
- Jenkins E: Programming self-awareness...computers can act as a catalyst for discussion. Nurs Times 83(8):55-56, 1987.
- Jolicoeur K et al: Do we really know what makes educational software effective? A call for empirical research on effectiveness. Educ Tech 26(12):7-11, 1986.
- Jones L et al: Data capture and analysis using the BBC micro-computer — an interfacing project applied to enzyme kinetics. J Biol Educ 20(3):207-211, 1986.
- Klopfer LE: Intelligent tutoring systems in science education: the coming generation of computer-based instructional programs. J Comp Math Sci Teach 5(4):16-32, 1986.
- Konikow NS: Computer-assisted instruction: design and content in neuroscience nursing. J Neurosci Nurs 19(2):100-105, 1987.
- Kulik CC et al: Effectiveness of computer-based education in colleges. AEDS Journal 19(2-3):81-108, 1986.
- Larson DE: A day in the life of a computer-using nursing instructor. Comput Nurs 5(2):78-80, 1987.
- MacLachlan J: Psychologically based techniques for improving learning within computerized tutorials. J Comp-Based Instruc 13(3):65-70, 1986.
- Mandell A: A simulation of AI programming techniques in BASIC. J Comp Math Sci Teach 6(1):56-57, 94, 1986.
- McDonald CJ: The future of medical education: beyond CAI. MD Comput 3(3):15-18, 1986.
- McNairn JA et al: The perfect match! A computer and a tutor. Nurs RSA Verpleging 2(1):24-25, 33, 35, 1987.
- Meals RA et al: Computerized anatomy instruction. MD Comput 3(1):30-34, 1986.
- Miller C et al: Microcomputer use in vocational agriculture programs in the United States. Journal of the American Association of Teacher Educators in Agriculture 28(1):34-40, 49, 1987.
- Moore GAB: How costly are computer-based instructional systems? Canadian Journal of Educational Communication 16(1):33-43, 1987.
- Moran T: The ideal computer lab from floor to ceiling. TechTrends 32(2):18-20, 1987.
- Morrison DF: Computer simulation as a teaching aid in pharmacy management - part 1. Principles of accounting. J Clin Pharmacy and Therapeutics 12(3):187-192, 1987.
- Murphy PJ: Computer simulations in biological education: analogues or models? J Biol Educ 20(3):201-205, 1986.
- Niemiec R et al: Comparative effects of computer-assisted instruction: a synthesis of reviews. Journal of Educational Computing Research 3(1): 19-37, 1987.
- Putnam RW: CPR training by computer. MD Comput 3(3):39-42, 1986.
- Richards BF et al: The screen display syntax for CAI. Performance and Instruction 25(10):10-13, 1986-1987.
- Ronald JS et al: Guidelines for basic computer education in nursing. NLN Publ #41-2177:1-63, 1987.
- Rushinek SF et al: Computer assisted instruction performance standards for the design of interactive feedback and control software. AEDS Journal 19(2-3): 137-142, 1986.
- Shelley DC: Computer-assisted instruction (CAI) in arterial blood gas interpretation: the effect of CAI on students' ability to interpret blood gas values. Respir Care 32(2):95-98, 1987.
- Shelley DC: Computer-assisted instruction (CAI) in arterial blood gas interpretation: a comparison of the effects of CAI and classroom instruction. Respir Care 32(2):99-102, 1987.
- Spector AF: Using high tech tools to create microcomputer software. J Contin Educ Nurs 18(3):101-102, 1987.
- Tanner GE et al: ANSIM: an anesthesia simulator for the IBM PC. Comput Methods Programs Biomed 23(3):237-242, 1986.
- Touvelle M et al: Using micro-computers in the physical chemistry laboratory: activation energy experiment. J Comp Math Sci Teach 6(1):50-51, 93-94, 1986.
- Vertucci PJ et al: The active knee: a standard in Level III interactive videodisc medical education. Interactive Learning International 3(2):44-46, 1986.
- Wedman JF et al: Instructional design for developing computer-based learning materials. AEDS Journal 19(2-3):124-136, 1986.
- Whitney MA et al: The development

and use of interactive videodisc instruction for Navy medical ccrrpsmen. *Optical Information Systems* 6(4):335-337, 1986.
 Yang J: Individualizing instruction through intelligent computer-

assisted instruction: a perspective. *Educ Tech* 27(3):7-15, 1987.
 Zidon MG et al: Assessment of the use of microcomputers in North Dakota secondary vocational agriculture departments. *Journal*

of the American Association of Teacher Educators in Agriculture 28(1):9-16, 1987.
 Zucconi G: An introduction to PILOT. *MD Comput* 3(3):31-34, 1986.

CLSE SUBSCRIPTION RENEWAL FORM

Subscription rates for Volume 5, 1988 (includes postage and handling):

U.S. and Canada – \$30.00
 Mexico and Europe – \$50.00
 Rest of the world – \$53.00

Please enter my subscription for Volume 5 (12 issues) of CLSE.

Payment enclosed in US funds

Please bill me

A subscription agency will enter a renewal

Send issues to:

Name: _____

Address: _____

State: _____ Zip: _____

Send invoice to:

Name: _____

Address: _____

State: _____ Zip: _____

Mail this form to: NRCLSE
 Mail Stop RC-70
 University of Washington
 Seattle, WA 98195

AIMS AND SCOPE

The goal of *Computers in Life Science Education* is to provide a means of communication among life science educators who anticipate or are currently employing the computer as an educational tool. The range of content includes, but is not limited to, articles focusing on computer applications and their underlying philosophy, reports on faculty/student experiences with computers in teaching environments, and software/hardware reviews in both basic science and clinical education settings

INVITATION TO CONTRIBUTORS

Articles consistent with the goals of *Computers in Life Science Education* are invited for possible publication in the newsletter.

PREPARATION AND SUBMISSION OF MATERIAL

Articles submitted for publication should not exceed 2000 words and should be typewritten, double spaced, with wide margins. The original and two copies including two sets of figures and tables should be sent to the Editor: Dr. Harold Modell, NRCLSE, Mail Stop RC-70, University of Washington, Seattle, WA 98195.

Title page should include full title, list of authors, academic or professional affiliations, and complete address and phone number of the corresponding author.

Illustrations should be submitted as original drawings in India ink or sharp, unmounted photographs on glossy paper. The lettering should be such that it can be legible after reduction (width of one column = 5.7 cm).

Reference style and form should follow the "number system with references alphabetized" described in the Council of Biology Editors Style Manual. References should be listed in alphabetical order by the first author's last name, numbered consecutively, and cited in the text by these numbers.

RESPONSIBILITY AND COPYRIGHT

Authors are responsible for accuracy of statements and opinions expressed in articles. All authors submitting manuscripts will be sent a copyright transfer form to complete. The completed form must be returned before the work will be published.

SUBSCRIPTION INFORMATION

Computers in Life Science Education is published monthly by National Resource for Computers in Life Science Education, Mail Stop RC-70, University of Washington, Seattle, WA 98195. Subscription rate is \$30.00 for 12 issues, including postage and handling in the United States and Canada. Add \$20.00 for postage (airmail) in Mexico and Europe and \$23.00 for the rest of the world.

This newsletter has been registered with the Copyright Clearance Center, Inc. Consent is given for copying of articles for personal or internal use, or for the personal or internal use of specific clients. This consent is given on the condition that the copier pay through the Center the per-copy fee stated in the code on the first page for copying beyond that permitted by the US Copyright Law. If no code appears on an article, the author has not given broad consent to copy and permission to copy must be obtained directly from the author. This consent does not extend to other kinds of copying, such as for general distribution, resale, advertising and promotional purposes, or for creating new collective works.

Address orders, changes of address, and claims for missing issues to NRCLSE, Mail Stop RC-70, University of Washington, Seattle, WA 98195. Claims for missing issues can be honored only up to three months for domestic addresses and six months for foreign addresses. Duplicate copies will not be sent to replace ones undelivered due to failure to notify NRCLSE of change of address.

Address editorial correspondence to Harold I. Modell, PhD, NRCLSE, Mail Stop RC-70, University of Washington, Seattle, WA 98195. (BITNET MODELL@UWALOCKE)

POSTMASTER: Send address changes to *Computers in Life Science Education*, NRCLSE, Mail Stop RC-70, University of Washington, Seattle, WA 98195.

COMPUTERS IN LIFE SCIENCE EDUCATION

HAROLD I. MODELL

Department of Radiology
University of Washington
Seattle, Washington

MARCEL BLANCHAER

Department of Biochemistry
Faculty of Medicine
University of Manitoba
Winnipeg, Manitoba

THEODORE J. CROVELLO

Graduate Studies and Research
California State University, Los Angeles
Los Angeles, California

JAMES W. ECKBLAD

Department of Biology
Luther College
Decorah, Iowa

TSEGAYE HABTEMARIAM

School of Veterinary Medicine
Tuskegee University
Tuskegee, Alabama

DONNA LARSON

School of Nursing
Grand Valley State College
Allendale, Michigan

TERRY M. MIKITTEN

Graduate School of Biomedical Sciences
University of Texas Health Science Center
San Antonio, Texas

JAMES E. RANDALL

Department of Physiology
Indiana University
Bloomington, Indiana

PATRICIA SCHWIRIAN

College of Nursing
Ohio State University
Columbus, Ohio

RICHARD STULL

College of Pharmacy
University of Arkansas
Little Rock, Arkansas

JAMES W. WOODS

Lister Hill National Center
for Biomedical Communications
National Library of Medicine
Bethesda, Maryland

DOROTHY WOOLEY-McKAY

Department of Biology
Glendale Community College
Glendale, Arizona

GLEN YOSHIDA

Department of Life Sciences
Los Angeles Southwest College
Los Angeles, California

NRCLSE

CONTENTS

THE USE OF COMPUTER ANIMATIONS DURING LECTURES IN PHYSIOLOGY	73
James Heckman, Michael B. Wang, Michael Harris, Michael Gordon and Anthony Cardell	
PROJECTING COMPUTER DISPLAYS	76
Richard E. Stull and K. Richard Knoll	
THE BULLETIN BOARD	78

THE USE OF COMPUTER ANIMATIONS DURING LECTURES IN PHYSIOLOGY

James Heckman, Michael B. Wang, Michael Harris,
Michael Gordon and Anthony Cardell

*Department of Physiology, Temple University School of Medicine,
Philadelphia, Pennsylvania*

It is challenging for lecturers to describe events that have multiple steps, are cyclical in nature, and involve complex interactions among multiple structures. Examples of such topics in

physiology are excitation-contraction coupling and the cardiac cycle. Another difficult category includes topics that necessitate the use of mathematics, such as establishment of the resting

TIME TO RENEW
SUBSCRIPTION RENEWAL FORM MAY
BE FOUND ON PAGE 79

membrane potential and the physiological basis of the electrocardiogram. In part, the challenge lies in painting a mental picture for the students. Chalk and blackboard, overhead projectors, slides, and videotapes are frequently used by lecturers to amplify their oral presentations. Recently the computer and video projector have been used to display the results of simulations.^{1,2} During the last several years, we have investigated the use of computer animations to assist the lecturer. This paper describes the methods used to create and display the animations and discusses the advantages and disadvantages of this new technique.

CREATION OF ANIMATIONS

The animations consist of separate images, usually from 5 to 30, that are displayed in sequence at a rate that can, if necessary, give the illusion of motion. The process is similar to that used in cartoons. The images are created with an IBM PC XT or AT&T 6300 (an IBM PC compatible) computer by using a drawing or 'paint' program. (Microsoft Paintbrush, Microsoft Corporation).

Microsoft Paintbrush is a powerful tool that makes it possible for someone with no artistic talent to create useful images. It allows the operator to use a mouse to input drawings and provides functions to construct straight and curved lines, duplicate and move portions of images, alter colors, and save or retrieve images.

It is not always necessary to create images de novo. If suitable images are available from textbooks and other sources, a video camera is used to view the desired image. The output of the camera is digitized, and the digitized information is passed to Microsoft Paintbrush for modification and for creation of other images needed for the animation. This process works well if the original images are line drawings and less well if there are multiple tones or gray levels. The images that we use in the animations are, for the most part, schematic in nature. For

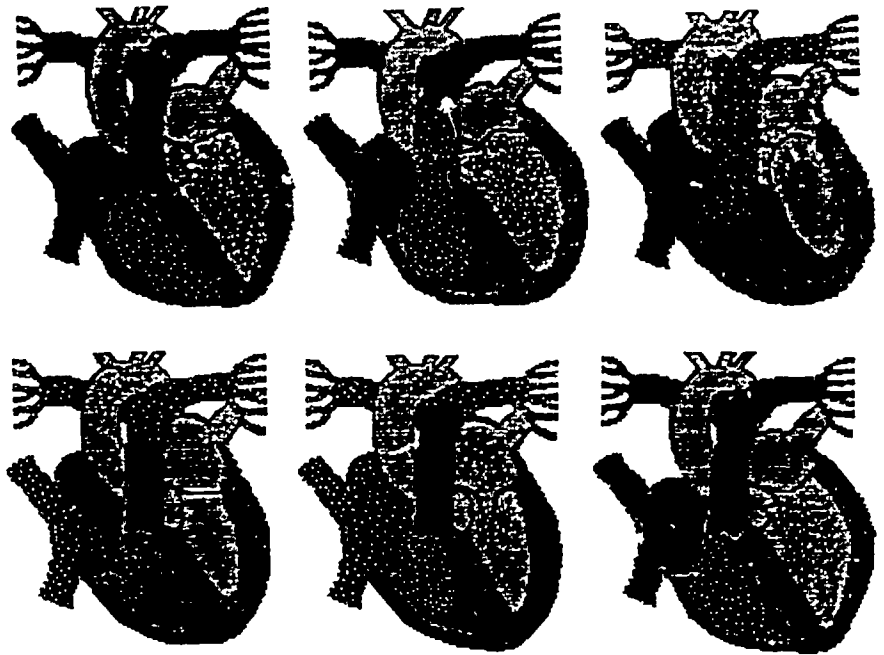

FIGURE 1. Six images taken from an animation of a beating heart. The complete series contained 30 images. The white dots indicate the direction of blood flow.

example, in an animation of a beating heart (Figure 1), the heart is represented schematically in order to enhance the presentation of information relevant to function. As mentioned below, limitations in screen resolution prevent detailed anatomical drawings from being created.

USE OF ANIMATIONS

The animations have been used during lectures to a class of approximately 200 first year medical students. The auditorium is equipped with a ceiling mounted, Sony color video projector. The video projector accepts either composite video or RGB (signals that carry red, green, and blue information) as input. While composite video from VCR tape is acceptable, we have found that the composite video from the IBM PC is not suitable for projection. We therefore use the RGB output. We have found that the outputs from the video cards of a number of makes and models of computers require RGB transformation before they can serve as input to a video projector. Great care

must be taken when selecting the computer-projector pair.

The images produced by the projector are projected onto a conventional 8 by 8 foot screen. All of the students sitting in all portions of the auditorium can see the images; there are no dead spots. Most images can be viewed with the ambient light level used to view slides.

Care must be used in color selection because the colors produced by the video projector are not identical to those viewed on the PC monitor. We have found that it is good practice to project the animations before class to ensure that the colors have been selected properly.

During the lecture, the computer is placed adjacent to the lectern. It is an IBM PC with two 5 1/4 inch floppy disk drives, 640 kilobytes of memory, and a color graphics card and monitor that can display 4 colors with a resolution of 320 by 200 picture elements. By using simple, single key commands, the lecturer can start and stop the animations, increase or decrease their

speed (the number of images per second), and either advance the next animation or regress a prior animation. It is also possible to jump in random fashion to any animation in the program.

We have experimented extensively with computer languages in order to find one that is optimal for displaying animations. An important feature in a language, particularly when creating graphics intensive programs, is the ability to view the effect of program changes immediately after they are made. We initially used an interpreter language (BASIC) that allowed changes to be viewed immediately and assembler language modules that gave the ability to move images rapidly to the monitor. Although this worked well, programming in BASIC with its line numbers and inability to name subroutines was tedious. Presently, we are investigating the use of QuickBASIC (Microsoft Corporation). Although this is a compiled BASIC, it compiles so rapidly that changes can be viewed seconds after they are made. In addition, among other advantages, line numbers are not necessary, and subroutines can be called by name.

We normally include computer generated static images, similar to traditional slides, among the animations. We have found that it is advisable not to have extensive labeling on the animation images. For this reason we display a computer generated slide containing the necessary labels before each animation.

Several constraints are encountered when using a standard IBM PC for animation. First, the color graphics (CGA) adapter allows only 4 colors and a resolution of 320 by 200 picture elements. While it is possible to acquire an enhanced graphics (EGA) or a professional graphics card to improve the display resolution, we have elected not to do so for several reasons. When image resolution is increased, the size of the image, in bytes, is increased which, in turn, slows the animation rate by increasing the time needed to write

the images onto the monitor. In addition, students have requested that they be able to run the animations in our microcomputer laboratory that contains IBM and AT&T computers with CGA cards.

Another limitation is that the video projector we use is an earlier model that cannot show the high resolution images available with newer models. However, despite the limited resolution of the CGA card, we have found the schematic images, additional examples of which are shown in Figure 2, are suitable for our purposes.

DISCUSSION

It has been said that a picture is worth a thousand words. Certainly an animation containing 30 pictures is worth more than thirty thousand words because it imparts a sense of the passage of time to the viewer. Animations allow the viewer to form mental images

rapidly of time dependent events or processes that can then be amplified by the oral presentation of the lecturer.

Computer animation has an advantage over videotape in that it can be repeated as many times as desired, without rewinding, at any desired speed, including stop frame. Animation in some instances has the advantage over mathematical simulation because it allows complex events to be depicted for which mathematical equations cannot be derived.

The animations have been well received by the medical students. By evaluating their questions during and immediately following lecture, it appears that they have been able to grasp difficult concepts more quickly than the students who have not been exposed to the animations. Admittedly this is a subjective evaluation, but since we must lecture to the entire class at one time, we cannot set up a suitable

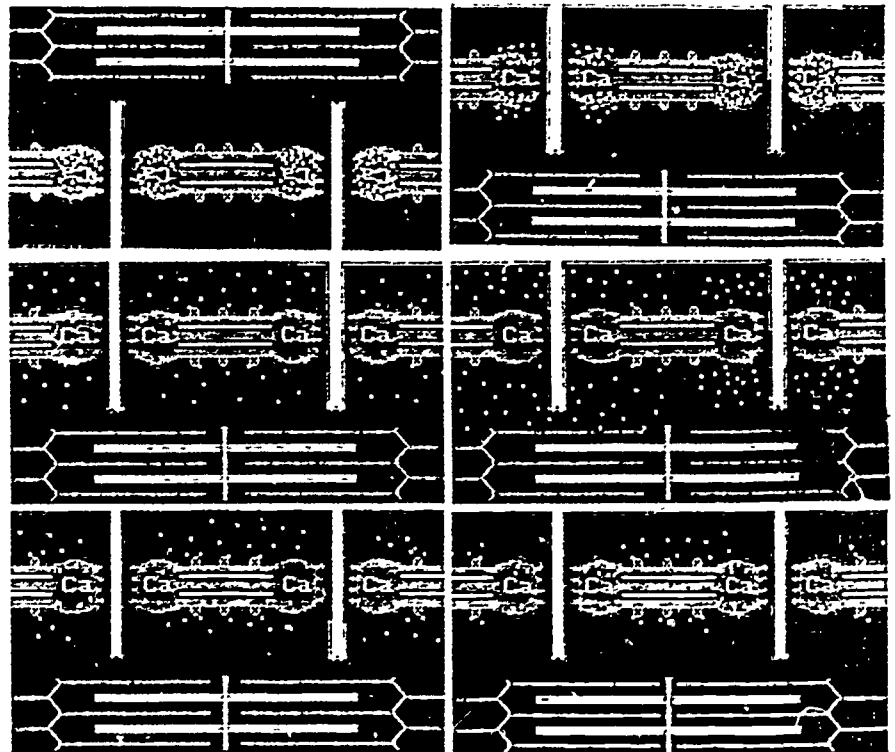

FIGURE 2. Six images from an animation of excitation contraction coupling. The complete series contained 40 images. The series depicts electrochemical events in the upper portion of each frame and mechanical events in the lower portion.

control group.

The major disadvantage of using animations is the time required to create them. We have attempted to reduce this time by using Microsoft Paintbrush and the video digitizing system. We also have enlisted the aid of medical students who have had physiology. After approximately a week of instruction and practice, they can create useful animations.

We have also found that the number of images needed to convey the desired information is much less than we first

believed. Generally, no more than 30 to 50 images are required, and only three or four animations in a one hour lecture are effective.

Of course once created, the animations can be used year after year. As opposed to videotape, it is a simple matter to make changes to update them as desired. Because the images are stored in digital form, it is also possible to alter the storage method to accommodate advances in display technology. There will be no need, therefore, to redraw the animations as new com-

puters become available.

In summary, we have found computer animation to be a helpful tool for use in lecture; one that is well received by the students.

REFERENCES

1. Modell HI: Technical aspects of using microcomputers in a group setting. *Computers in Life Science Education* 2:35-38, 1985.
2. Randall JE: Carrying technology to the lecture hall. *Fed Proc* 46:1519, 1987.

PROJECTING COMPUTER DISPLAYS

Richard E. Stull and K. Richard Knoll

College of Pharmacy, University of Arkansas for Medical Sciences, Little Rock, Arkansas

Projection of a computer's images in monochrome on a large screen allows an easier migration of the computer into the large classroom, workshop, conference, or seminar.

Lightweight, compact liquid crystal display (LCD) units that rest atop the stage of an overhead projector are currently available to display in black and white (monochrome) whatever is on the screen of a connected computer.

Despite certain differences, available units project an almost identical image quality of 640 by 200 pixel resolution in an 80-character by 25-line screen size. All units include a panel which sits on the overhead projector, an AC/DC converter, and necessary interfaces. Some units include a remote control unit with a variety of switchable functions. The remote unit may include computer controls (such as page-up and page-down) and the display controls on, off, contrast, on-screen pointer, and reverse colors. Reverse colors means that a white on black image can be converted to a black on white image — useful when contrast change alone won't make the image dark enough.

The panel is a translucent sheet of glass set in a metal or plastic frame

about 2 1/2 in. deep that houses the electronic components. Panels are about 12 by 15 inches. Weights vary depending on material, but generally are under six lbs, making them easily portable. This is lighter than most laptop portable computers.

Currently available units support only CGA-level graphics, not EGA. They require a host overhead projector with a low 250 or 300 watt light in the base. Hotter lights tend to heat up the unit and cause a contrast change in the image; that's why fans have been added to current models. Certain "slimline" overhead projectors may present heat problems because they have a light in the head that projects down and back up from the panel, rather than through it from the bottom.

Projection distance and brightness depends on the overhead projector, not on the display system. Most of the units come with cables and plug into RGB output, composite video, or serial (RS232) ports on your computer. The only major model that differs in this regard is the Magnabyte from Telex. Magnabyte comes with an interface card for installation into one of your computer's slots.

Software, though not required for projection, comes with several of the units to allow the user a straight-forward, menu driven approach to creating and sequencing of screens. Software products such as IBM's Storyboard may be useful in producing comparable programs for projection.

The first projector marketed was the Kodak Dataslow System, introduced about 18 months ago with a \$1,270 list price. It supports IBM-PCs and compatibles and, with an optional adapter, the Apple II computer family. It does not support the Macintosh.

Kodak did not provide a cooling fan when the unit was first introduced. Without a fan, contrast blur from heat build-up in the projector may affect the panel about 15 minutes into a lecture — and get progressively worse. The operator must adjust the contrast button during the presentation. This may not present a problem in a 45 to 60 minute lecture, and turning the overhead projector off for about 10 to 15 minutes during a break will return the panel's contrast to normal. Kodak now offers an optional cooling fan attachment, retailing for about \$100.

TABLE 1. Key features of available LCD displays for use with overhead projectors.

MODEL	VENDOR	COMPATIBILITY	CONNECTION	COOLING	REMOTE	SOFTWARE
Data Show	Kodak	IBM/Apple	RS232/RGB	Fan option	Infrared (IR)	"Showmaker"
Magniview	Dukane	IBM/Apple	RGB/Composite Video	Fan	No	"Presentation Partner"
MagnaByte	Telex	IBM/Apple	Adapter card	Fan	Wire remote	provided
QA 25	Sharp	IBM/Apple	RGB	Fan	No	None
Data Display	CA, Inc.	IBM/Apple	RGB/Composite Video	Fan	No	"Presentation Partner"

It took more than a year before major Kodak competitors appeared. Telex Communications, Inc. (Minneapolis) introduced the MagnaByte Electronic Imaging System with metal frame compared to the Datashow's plastic frame, and with a cooling fan to prevent contrast blur. It also is compatible with the IBM PC and Apple II families, excluding the Macintosh. Price for the complete system is about \$1,200. A distinguishing feature of this unit is that it requires the installation of a full slot adapter board and provides shades of gray when projecting color images from the computer. The adapter card makes the projector dependent on a specific computer which may lead to problems with portability.

Sharp Electronics Corp. (Mahwah, NJ) introduced the "Sharp Computer Projection Panel QA 25" at \$895. The QA 25 has a built in fan, weighs six lbs, with a 12 by 14-in. plastic housing. In terms of display, it is essentially the same as the Kodak. Computer Accessories markets the Data Display which is comparable to the Kodak or Sharp unit. Controls such as reverse video, contrast, and vertical and horizontal position are on the front-top of the unit.

CAUTIONS

With any monochrome system that projects images created in color, one must

be careful about the conversion of certain colors to a gray scale. If you're using a color program, you've got to think black and white. Green, brown and white will project as white. Black, red and magenta will project as black or gray. If you use green lettering on a white background, it will show as all white.

CONCLUSION

These additions to the peripheral options of the PC user who presents material to conference or larger groups have definite benefits. To make your selection from the available units, you may want to consider portability, if needed, and the price, since display quality is comparable for all units.

Although greater portability is provided by the non-board dependent units, if shades of gray are required to display color graphic imaging, the board dependent models are recommended.

Telex Communications Inc. has recently announced a color data display unit priced at \$1580.

Price will vary by vendor and availability. When the units are readily available, the price may be discounted as much as 30 to 33 percent off list price.

Table 1 highlights features that you may wish to consider in making your selection of a PC data display. Addi-

tional information may be found in the August 1987 issue of Computer Graphics Today, in an article by DZ Meilach entitled "Projecting graphics overhead."

Editor's note:

We have recently had occasion to compare the Kodak and Sharp displays. Several differences not outlined in the preceding article warrant mention.

- Display size. The Sharp unit is a rectangular display that covers about one half of the standard overhead projector display area. The Kodak unit has more of a square display that covers a significantly greater portion of the available projection area.
- Location of controls and connections. All of the controls as well as the RGB and power connections on the Sharp unit are on the left of the unit (as you face the projector). The connections, therefore do not interfere with display placement on the projector. Connection to the Kodak is through a fairly stiff cable that exits the unit on the right side near the projection head arm on a standard overhead projector. This may present some problems with display alignment.
- Available controls. The Kodak remote control unit allows adjustment of the image location on the display. Similar adjustments on the Sharp are not as easily accessible and are not intended to be adjusted on a routine basis.

THE BULLETIN BOARD

The Bulletin Board is published periodically to inform readers of upcoming meetings of interest. If you know of meetings, symposia, continuing education courses, etc. of interest to life science educators, and they do not appear in The Bulletin Board, please let us know. Send pertinent information to: Dr. Harold Modell, NRCLSE, RC-70, University of Washington, Seattle, WA 98195, or let us know via BITnet. NRCLSE's BITnet address is: **MODELL@UWALOCKE**

NOVEMBER 1-4, 1987. The 11th Annual Symposium on Computer Applications in Medical Care (SCAMC). Washington, D.C.

Contact:

William W. Stead, M.D.
SCAMC - Office of CME
George Washington University
Medical Center
2300 K Street, NW
Washington, DC 20037
(202) 994-8928

NOVEMBER 9-12, 1987. Association for the Development of Computer-based Instructional Systems (ADCIS) 28th International Conference. Oakland, California.

Contact:

ADCIS, 409 Miller Hall
Western Washington University

Bellingham, WA 98225
(206) 676-2860

NOVEMBER 19-20, 1987. 11th Annual Western Educational Computing Conference. San Francisco, California.

Contact:

Alexia Devlin, Treasurer
California Educational Computing Consortium
San Francisco State University
Accounting Data, NADM-358
1600 Halloway Ave.
San Francisco, CA 94132

DECEMBER 2-4, 1987. The 3rd Vermont Conference on Nursing and Computers. Topnotch at Stowe, Vermont.

Contact:

Sally Parrish, RN
Nursing Inservice
Medical Center Hospital of Vermont
Burlington, VT 05401
(802) 656-3766

JANUARY 13-15, 1988. The 6th Annual Conference on Research in Nursing Education. San Francisco, California.

Contact:

Elaine Zimble, MA, RN
Interim Director
Society for Research in Nursing
Education Forum
National League for Nursing

Ten Columbus Circle
New York, NY 10019-1350
(212) 582-1022

JANUARY 15-19, 1988. Association for Educational Communications and Technology (AECT) Convention and COMMTEX International, New Orleans, Louisiana.

Contact:

Association for Educational Communications and Technology (AECT)
1126 16th Street, NW
Washington, DC 20036
(202) 466-4780

JANUARY 25-28, 1988. Florida Instructional Computing Conference VIII. Kissimmee, Florida.

Contact:

Educational Technology Section
Florida Department of Education
Knott Building
Tallahassee, FL 32399
(904) 488 0980

JUNE 8-10, 1988. WorldMed, International Health Care Congress. Minneapolis, Minnesota.

Contact:

Continuing Medical Education
Box 202 UMHC
420 Delaware Street SE
Minneapolis, MN 55455
(612) 626-5525

CLSE SUBSCRIPTION RENEWAL FORM

Subscription rates for Volume 5, 1988 (includes postage and handling):

U.S. and Canada – \$30.00
Mexico and Europe – \$50.00
Rest of the world – \$53.00

Please enter my subscription for Volume 5 (12 issues) of CLSE.

Payment enclosed in US funds

Please bill me

A subscription agency will enter a renewal

Send issues to:

Send invoice to:

Name: _____

Name: _____

Address: _____

Address: _____

State: _____ Zip: _____

State: _____ Zip: _____

Mail this form to: NRCLSE
Mail Stop RC-70
University of Washington
Seattle, WA 98195

AIMS AND SCOPE

The goal of *Computers in Life Science Education* is to provide a means of communication among life science educators who anticipate or are currently employing the computer as an educational tool. The range of content includes, but is not limited to, articles focusing on computer applications and their underlying philosophy, reports on faculty/student experiences with computers in teaching environments, and software/hardware reviews in both basic science and clinical education settings.

INVITATION TO CONTRIBUTORS

Articles consistent with the goals of *Computers in Life Science Education* are invited for possible publication in the newsletter.

PREPARATION AND SUBMISSION OF MATERIAL

Articles submitted for publication should not exceed 2000 words and should be typewritten, double spaced, with wide margins. The original and two copies including two sets of figures and tables should be sent to the Editor: Dr. Harold Modell, NRCLSE, Mail Stop RC-70, University of Washington, Seattle, WA 98195.

Title page should include full title, list of authors, academic or professional affiliations, and complete address and phone number of the corresponding author.

Illustrations should be submitted as original drawings in India ink or sharp, unmounted photographs on glossy paper. The lettering should be such that it can be legible after reduction (width of one column = 5.7 cm).

Reference style and form should follow the "number system with references alphabetized" described in the Council of Biology Editors Style Manual. References should be listed in alphabetical order by the first author's last name, numbered consecutively, and cited in the text by these numbers.

RESPONSIBILITY AND COPYRIGHT

Authors are responsible for accuracy of statements and opinions expressed in articles. All authors submitting manuscripts will be sent a copyright transfer form to complete. The completed form must be returned before the work will be published.

SUBSCRIPTION INFORMATION

Computers in Life Science Education is published monthly by National Resource for Computers in Life Science Education, Mail Stop RC-70, University of Washington, Seattle, WA 98195. Subscription rate is \$30.00 for 12 issues, including postage and handling in the United States and Canada. Add \$20.00 for postage (airmail) in Mexico and Europe and \$23.00 for the rest of the world.

This newsletter has been registered with the Copyright Clearance Center, Inc. Consent is given for copying of articles for personal or internal use, or for the personal or internal use of specific clients. This consent is given on the condition that the copier pay through the Center the per-copy fee stated in the code on the first page for copying beyond that permitted by the US Copyright Law. If no code appears on an article, the author has not given broad consent to copy and permission to copy must be obtained directly from the author. This consent does not extend to other kinds of copying, such as for general distribution, resale, advertising and promotional purposes, or for creating new collective works.

Address orders, changes of address, and claims for missing issues to NRCLSE, Mail Stop RC-70, University of Washington, Seattle, WA 98195. Claims for missing issues can be honored only up to three months for domestic addresses and six months for foreign addresses. Duplicate copies will not be sent to replace ones undelivered due to failure to notify NRCLSE of change of address.

Address editorial correspondence to Harold I. Modell, PhD, NRCLSE, Mail Stop RC-70, University of Washington, Seattle, WA 98195. (BITNET MODELL@UWALOCKE)

POSTMASTER: Send address changes to *Computer: in Life Science Education*, NRCLSE, Mail Stop RC-70, University of Washington, Seattle, WA 98195.

COMPUTERS IN LIFE SCIENCE EDUCATION

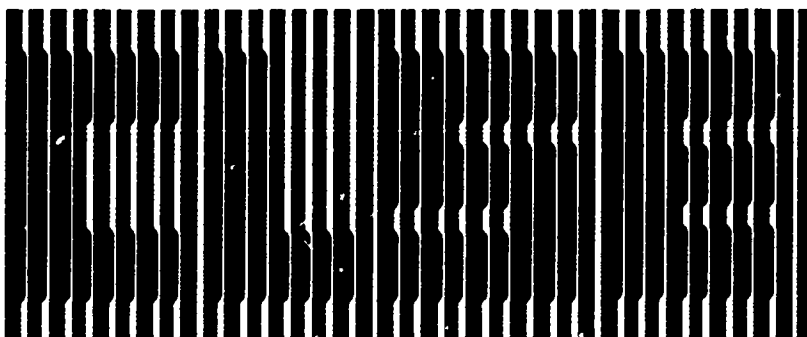

HAROLD I. MODELL

Department of Radiology
University of Washington
Seattle, Washington

MARCEL BLANCHAER

Department of Biochemistry
Faculty of Medicine
University of Manitoba
Winnipeg, Manitoba

THEODORE J. CROVELLO

Graduate Studies and Research
California State University, Los Angeles
Los Angeles, California

JAMES W. ECKBLAD

Department of Biology
Luther College
Decorah, Iowa

TSEGAYE HABTEMARIAM

School of Veterinary Medicine
Tuskegee University
Tuskegee, Alabama

DONNA LARSON

School of Nursing
Grand Valley State College
Allendale, Michigan

TERRY M. MIKITEN

Graduate School of Biomedical Sciences
University of Texas Health Science Center
San Antonio, Texas

JAMES E. RANDALL

Department of Physiology
Indiana University
Bloomington, Indiana

PATRICIA SCHWIRIAN

College of Nursing
Ohio State University
Columbus, Ohio

RICHARD STULL

College of Pharmacy
University of Arkansas
Little Rock, Arkansas

JAMES W. WOODS

Lister Hill National Center
for Biomedical Communications
National Library of Medicine
Bethesda, Maryland

DOROTHY WOOLEY-McKAY

Department of Biology
Glendale Community College
Glendale, Arizona

GLEN YOSHIDA

Department of Life Sciences
Los Angeles Southwest College
Los Angeles, California

NRCLSE

CONTENTS

COMPUTER ASSISTED INSTRUCTION FOR TEACHING DENTAL TREATMENT PLANNING Richard T. Ford and DeWayne Townsend	81
ERRATUM	85
NRCLSE QUESTIONNAIRE	87

COMPUTER ASSISTED INSTRUCTION FOR TEACHING DENTAL TREATMENT PLANNING

Richard T. Ford and DeWayne Townsend

*Departments of Operative Dentistry and Oral Pathology, University of Minnesota,
Minneapolis, Minnesota*

In 1982, the University of Minnesota School of Dentistry reorganized its adult clinics around a patient centered model. Important support for this reorganization was provided by a curriculum teaching comprehensive treatment planning and case presentation. Prior to the reorganization, treatment planning was taught as a component of each of the dental specialties. The new program was designed to teach comprehensive treatment planning while continuing to serve each area's specific speciality.

During this time, the School of Den-

tistry was also experiencing a reduction in class size and legislative funding retrenchment. It was imperative that any new treatment-planning curriculum not be labor intensive because there would be no additional faculty available.

Coincidentally, the School's learning resources center was being equipped with microcomputers, and small development grants were available to faculty to develop learning packages. The availability of this new resource suggested the application of Computer-Assisted Instruction (CAI) to treatment

planning and prompted the authors to review the literature on treatment planning and CAI in dental education.

LITERATURE REVIEW

The Dental Curriculum

The literature strongly suggests treatment planning in the dental curriculum is weak and greatly in need of change.^{5,10,12,13} Kress specifically stated that, "Dental educators agree that treatment planning education is one of the weakest areas of the curriculum."⁸ He noted that if treatment planning education were more effective, it would help ensure better patient treatment. He reported that a number of schools devote less than 10 hours to treatment planning instruction.

Many critics of dental education argue that students are inadequately taught to integrate their clinical knowledge with comprehensive planning. This might be a reflection of a fundamental weakness in the way clinical dentistry has evolved as a collection of specialities. Experts certainly exist within the clinical specialities, but few claim to be experts at integrating the various areas into a comprehensive patient care plan.⁸

Dentists' inability to integrate knowledge into planning might also be a symptom of the difficulty of the treatment planning task. Proshok et al¹¹ suggested that the dentist's planning process involves little difficulty in disease identification, but presents a considerable challenge in the proper sequencing of treatment, that is, the treatment plan. His study suggested that dentists were often ineffective at hypothesis generation and interpretation of diagnostic cues and that it might be necessary to modify their training to produce more effective decision making. This again suggests the need for a new approach in dental education.

As recently as 1985, Kennon et al, in a survey of dental educational institutions, reported that schools still seemed uncertain as to who had the responsibility of teaching treatment planning.⁶ She states that, upon careful analysis, "No discrete unit (of the institution)

will accept responsibility for either teaching or coordinating treatment planning."

Ward suggested that experience is essential to the successful coordination of treatment.¹⁶ She noted that, "even though the formulation of a usable treatment plan is carefully covered in the classroom, students are somewhat unclear in proposing a precise blueprint of treatment in the clinical area."¹⁶

Kersten et al⁷ affirmed the value of developing decision making skills when treatment planning. He studied the responses of inexperienced students and experienced dentists solving problems during treatment and made the following observations.

- Third year students cannot solve problems pertaining to the design of a treatment plan for decayed teeth, in spite of their knowledge of the different standard preparations and the principles of cavity preparation and restoration.
- Knowledge does not guarantee its practical application.
- Students come closer to the solution of a problem when they use a systematic scheme providing a problem-solving route.
- Experienced dentists quickly find a correct solution.

Kersten et al concluded that feedback is a vital factor in teaching student dentists to make better treatment planning decisions.

Computer-Assisted-Instruction
CAI programs have been used in health sciences and in dentistry in particular since 1967 and have been used primarily for teaching clinical dentistry.^{1,2,9,15} The value of self instruction was described by Williams who notes, "self instruction is capable of significantly increasing cognitive knowledge in a shorter period of time with increased student satisfaction, compared to conventional instructional methods."¹⁷ The "CAIDENT" program at the University of Michigan established that CAI in dentistry is most effective when

- 1) students require substantially different amounts of time to learn;
- 2) different responses are made by students to the same question;
- 3) students need to explore the effects of various decision strategies;
- 4) actions taken on the basis of student response can be identified;
- 5) each student is required to actively participate in the specification of or commitment to a particular decision;
- 6) it is cumbersome, difficult, or unnecessary to present all cues that comprise a particular problem situation; and
- 7) material is substantially repetitive.^{3,4}

CAI provides a non-threatening, non-evaluative environment in which students can explore alternatives without concern for criticism or "image." Sokolow¹⁴ addressed the issue of shortage of qualified faculty as another rationale for developing CAI in dental education.

THE CAI INSTRUCTIONAL PROGRAM FOR DENTAL TREATMENT PLANNING

Based on this information, we decided to supplement the treatment planning teaching with a program of computer-assisted patient simulations.

In 1984, the first of three intra-university development grants was awarded for the proposed program. A team was assembled that included 1) the author, a dental practitioner with 25 years of general practice experience and an advanced degree in education, who designed the simulations and was responsible for the didactic and treatment planning program, 2) a member of the Oral Pathology faculty with computer programming experience who designed and wrote the authoring software, and 3) a senior dental student who coordinated the pilot simulation with the software development. The following goals were established for the program.

- to provide the student dentist with a systematic approach to hypothesis generation and integration of data into

- a comprehensive treatment plan;
- to provide a library of simulations that would provide treatment planning experiences for student dentists prior to their first clinical patient care;
- to provide a broad base of experiences;
- to provide a self-instructional program that was not faculty labor intensive;
- to provide a program that met the school's budgetary constraints while taking advantage of the grants and microcomputers that were readily available; and
- to provide a resource that would also be available for all residents, graduate students, faculty, practicing dentists, and continuing dental education programs.

Creating the pilot simulation

A case study was selected and documented, and the simulation was laid out as a story board. The software was written to accommodate the story board.

To enhance the effectiveness of the educational instrument, each simulation was based on the same behavioral objectives and treatment planning philosophy as the school's clinic practice. This provided a consistent approach to hypothesis generation. The behavioral objectives of each simulation were to collect the data base, determine the treatment track, and develop the periodontal and preventive plan, the restorative rehabilitative plan, the maintenance plan, the final treatment plan, and the long-range treatment plan. Each simulation consisted of only two kinds of screens that the student would view on the monitor. Information screens were used to present information such as the objectives, philosophies, and instructions. Choice screens were used to identify a problem and present treatment choices for solving the problem. Fees could be designated for each choice to provide an accumulated total treatment fee.

The choice screens directed the student to make the "best" treatment choice, based on the treatment planning

philosophies and data previously presented on information screens. We limited the decision making to treatment choices and not the planning process or diagnostic decisions. Each choice screen was designed to offer from 3 to 5 treatment choices, and each choice selected was followed by a response. The responses, listed below, were standardized to provide similarity from one simulation to the next.

- A) Great Choice! Virtually all of the dentists who reviewed and treatment planned this patient selected this choice as the most optimal treatment.
- B) Good Choice. Most of the dentists who reviewed and treatment planned this patient selected this choice as the most optimal treatment.
- C) An "OK" choice but not the best. About half or less of the dentists who reviewed and treatment planned this patient selected this choice as the most optimal treatment. If you choose to remain with this choice press [option] to continue. If you choose to make another choice press [option] and make another choice.
- D) Poor Choice. Few of the dentists who reviewed and treatment planned this patient made this choice. Press [option] and review [topic] and then make another choice.
- E) Unacceptable Choice. Virtually none of the dentists who reviewed and treatment planned this patient made this choice. Press [option] and review [topic] and then make another choice.

An unacceptable choice was followed by an authored comment or a referral back to an information screen with the data base or a consultation. Another opportunity was then presented by repeating the same choice screen.

During the actual operation of the simulation, the patient's radiographs,

diagnostic models, 15 3X5 inch intra-oral color photos mounted on a stiff mounting board, written operational instructions, and a treatment planning worksheet were available to the student. The photos, models, and radiographs could be arranged easily so that they could be viewed while observing the monitor. The worksheet was completed in pencil as decisions were made, providing ready review and reinforcement as the plan evolved.

An effort was made to make each experience as realistic as possible. Each simulation was modeled after actual patient experiences. The treatment decisions, therefore, are not only technical choices based on clinical data, but often reflect the patient's profile, responses, needs, and personal situation.

A "post treatment" response that reflects the patient's reactions to the dental experience is presented at the end of the simulation. This provides positive reinforcement for a patient centered planning approach.

An evaluation component of the software allowed faculty to identify both the students who worked the simulation and the choices they made. This capability provided evaluation of the students' efforts and facilitates evaluation of the simulations.

After the pilot simulation was complete, a demonstration disk was created to present the objectives, treatment planning philosophy, and samples of each type of decision making. This has been a valuable tool when demonstrating the program to other interested faculty and schools.

SIMULATION AUTHORING

To encourage development of a library of simulations reflecting a broad base of experiences, we created an authoring manual to be used with the authoring software that we had developed. We assumed that new authors would not know how the computer program operated. Therefore, on each choice or information screen, the author is simply asked the question, "which screen is to follow?" This approach makes the authoring "friendly" for potential au-

thors who were not versed in computer applications.

The manual is in the form of a large looseleaf notebook and presents all 96 possible screens of the pilot simulation. When open, the manual has an example on the left and a corresponding page of the new simulation on the right. Where a new screen is to be created, appropriate blanks are provided. Where no change is indicated, the screen is presented as complete or mirrors the page on the left. After the faculty member has completed all entries in the workbook, it is converted to an operating simulation by the original faculty team or their staff. In this way, controls are exercised to preserve the prescribed format.

DISCUSSION

The library of simulations will be placed in the School of Dentistry and general Health Sciences learning resources libraries. All second year dental students will use the simulations as part of their treatment planning course prior to treating their first clinical patient. The simulations will also be made available to other undergraduate students, graduate dental students, and for continuing dental education as an instruction and remediation tool.

After a number of simulations have been completed, and the pilot has been tested with students, an evaluation method will be designed to identify those students who do not have acceptable treatment planning skills. A means of support and remediation will be developed and implemented, most likely by expanding the simulation program.

The CAI program has been demonstrated to students, residents, faculty, and graduate dentists. Levels of familiarity with computers accounted for varied responses from those who used the simulation, the age of the participants often reflecting the friendliness toward the program. When we demonstrated the program, virtually all students were familiar with computers and worked the program with ease, while

some of the faculty were quite unfamiliar with basic computer operation. Students tended to respond with great interest and asked for more programs. Faculty or dentists often responded with either fascination or discomfort.

Despite their lack of computer literacy, faculty has strong interest in the program. Many have asked for authoring manuals or have moved to secure a small grant for developing simulations.

CONCLUSIONS

The authors are pleased with the progress of the program and are committed to its development. We anticipate that future evaluation of this program will prove its appropriateness to dental education and will influence curriculum planners to consider CAI. This process will be facilitated by the familiarity with computers demonstrated by dental students and the interest shown by faculty in further developing this valuable educational resource.

REFERENCES

1. Brigham CR, Kamp M: The current status of computer assisted instruction in the health sciences. *J Med Ed* 49:278-279, 1974.
2. Brigham CR, Kamp M, Cross R: A guide to computer-assisted instruction in the health sciences. Springfield, VA: National Technical Information Services, 1972.
3. Fitzgerald WF: The cadent center - a pilot program in the teaching of dentistry. *Alumni Bul Univ Mich Sch Dent*, 1973, pp 51-58.
4. Fitzgerald WF: The instructional use of computers in dental education. *Comput Biol Med* 3:307-318, 1973.
5. Goldhaber P: Curriculum considerations. *In Meskin LH, Loupe MJ, Micik R (eds) Workshop proceedings on current and future dental roles in primary care.* Minneapolis, MN, Division of Health Ecology, School of Dentistry, University of Minnesota, 1976, pp 79-83.
6. Kennon S, Sleamaker TF, Forman AG: Treatment planning instruction in North American dental schools, 1984-1985. *J Dent Ed* 49:702-706, 1985.
7. Kersten HW, Steures RWR, Tromp TJM: Making of a Dental Treatment Plan. *Neth Dent J* 88:18-33, 1981.
8. Kress GC: Toward a definition of the appropriateness of dental treatment. *Public Health Reports* 95:564-571, 1980.
9. Linaburg RG, Marshall FJ, Gaston GW, Snodgrass M: Effectiveness of computer-assisted instruction in planning the treatment of regional pain. *J Dent Educ* 38:99-105, 1974.
10. Oliver RC: Curriculum considerations. *In Meskin LH, Loupe MJ, Micik R (eds) Workshop proceedings on current and future dental roles in primary care.* Minneapolis, MN, Division of Health Ecology, School of Dentistry, University of Minnesota, 1976, pp 75-79.
11. Proshok J, Loupe M, Serunian J: The process of dental diagnosis: an initial analysis. *Proceedings, annual meeting of the American Educational Research Association, New York, NY, April, 1977.*
12. Rovin S: Curriculum considerations. *In Meskin LH, Loupe MJ, Micik R (eds) Workshop proceedings on current and future dental roles in primary care.* Minneapolis, MN, Division of Health Ecology, School of Dentistry, University of Minnesota, 1976, pp 59-75.
13. Schoen MH: Manpower distribution and costs (a review). *In Meskin LH, Loupe MJ, Micik R (eds) Workshop proceedings on current and future dental roles in primary care.* Minneapolis, MN, Division of Health Ecology, School of Dentistry, University of Minnesota, 1976, pp 141-145.
14. Sokolow MA, Solberg W: Computer-assisted instruction in dental diagnosis: a product development. *J Dent Educ* 35:349-355, 1971.
15. Tira DE: A computer based dental diagnostic case simulation (DDS) system. *Comput Biol Med* 10:23-29, 1980.
16. Ward EA: Phased treatment planning: toward total patient care. *New Dentist* 10(3):31-32, 1979.
17. Williams RE: Self instruction in dental education; 1960-1980. *J Dent Ed* 45:290-299, 1981.

ERRATUM

Heckman J, Wang MB, Harris M, Gordon M, Cardell A: The use of computer animations during lectures in physiology. *Computers in Life Science Education* 4(10):73-76, 1987.

Figure 2 should appear as shown.

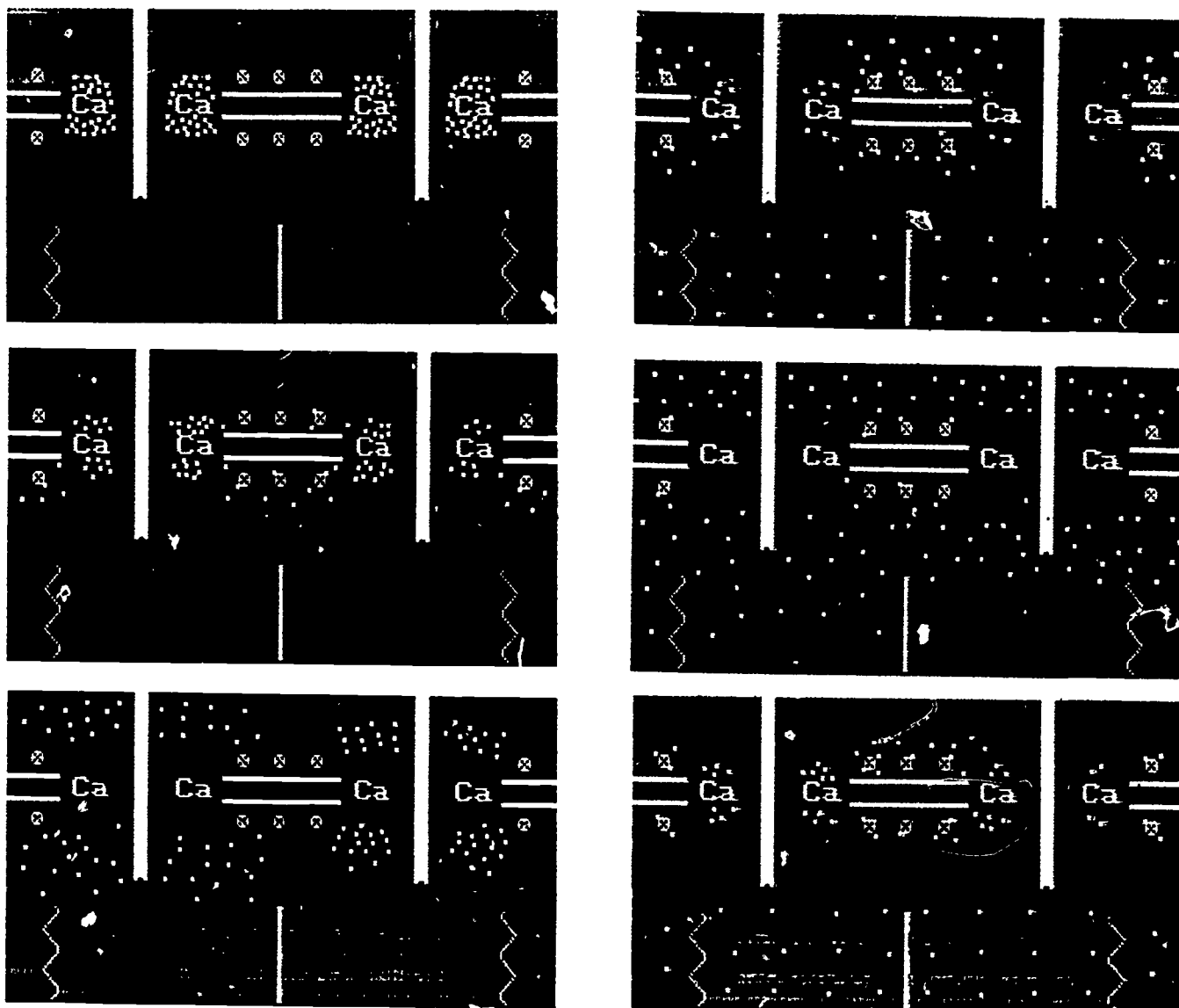

FIGURE 2. Six images from an animation of excitation contraction coupling. The complete series contained 40 images. The series depicts electrochemical events in the upper portion of each frame and mechanical events in the lower portion.

MACINTOSH VERSION NOW AVAILABLE. . .

SIMULATIONS IN PHYSIOLOGY

– The Respiratory System –

Harold I. Modell, Ph.D.

School of Medicine, University of Washington, Seattle,

- Series of 12 Simulations in Respiratory Physiology
- 117 Page Laboratory Manual
- Designed for use in student laboratory and group discussion environments
- Pictorial outputs designed to provide conceptual aid, show where variable values are measured, or illustrate the model and how it is solved
- Tabular outputs allow comparison of data from up to 7 'experiments'
- Available for Apple II, IBM-PC (MS-DOS) compatible, and Macintosh (requires Microsoft BASIC) computers
- Purchase includes permission to make enough copies to supply appropriate student populations

ORDERING INFORMATION

Computer Programs*

12 Simulations written in BASIC

Documentation

One copy of student laboratory manual

. . . . \$100

*IBM-PC version uses CGA graphics

Macintosh version requires Microsoft BASIC

Student Laboratory Manuals

Quantities of 1-25 \$10 each

Additional copies \$8.50 each

Address orders to:

NRCLSE
Mail Stop RC-70
University of Washington
Seattle, WA 98195

Be sure to indicate which version you need!

PROGRAM OVERVIEW

Title

Material covered

MECHANICS

<i>Static Relationships</i>	Elastic properties of the lung, chest wall, and total respiratory system
<i>Dynamic Relationships I</i>	Effects of lung compliance and airway resistance on tidal volume development
<i>Work of Breathing</i>	Oxygen cost of elastic, resistive, and total work during inspiration
<i>Dynamic Relationships II</i>	Respiratory dynamics of the total respiratory system

GENERAL GAS EXCHANGE

<i>Alveolar Gas Exchange</i>	Gas exchange between the atmosphere and alveolar reservoir
<i>O₂ and CO₂ Dissociation Curves</i>	Interrelationships between the O ₂ and CO ₂ dissociation curves
<i>Exchange from Atmosphere to Tissues</i>	Influence of alveolar ventilation, cardiac output, and anatomic shunt flow on arterial blood composition and gas exchange at the tissues
<i>Chemoregulation of Respiration</i>	Influence of chemoreceptor sensitivity and respiratory mechanics on O ₂ and CO ₂ response curves

V_A/Q RELATIONSHIPS

<i>Gas Exchange in a Single Alveolus</i>	Effects of ventilation-perfusion ratio and inspired gas composition on exchange in a single exchange unit
<i>The Non-Uniform Lung</i>	Gas exchange from atmosphere to tissues with V _A /Q mismatching in the lung
<i>Overall Gas Exchange</i>	Gas exchange from atmosphere to tissues with V _A /Q mismatching and a true shunt

ACID-BASE BALANCE

<i>Acid-Base Balance: Fundamental Relationships</i>	Acid-Base balance from a Base Excess viewpoint
---	--

NATIONAL RESOURCE FOR COMPUTERS IN LIFE SCIENCE EDUCATION QUESTIONNAIRE

As we begin to prepare to establish a peer critique mechanism for software evaluation (see CLSE September, 1987), it is imperative that we have a critical mass of colleagues willing to participate in this process. It is also time to update our CLSE colleague directory (see CLSE, November, 1986 and CLSE January, 1987). Please help us in these efforts. If you have not completed our first questionnaire (January, 1986), please take a few moments to complete the questionnaire below.

Return questionnaire to:

Harold Modell, PhD
NRCLSE
Mail Stop RC-70
University of Washington
Seattle, WA 98195

Name: _____

Address: _____

_____ State _____ Zip _____

Phone: _____

What content areas do you teach? _____

What student population(s) do you serve? (Please check the appropriate categories)

Undergraduate Graduate Nursing Medical
 Allied Health Dental Veterinary
 Other (please specify) _____

Are you currently using the computer as an educational tool? Yes No

If yes:

How many years have you used the computer in this way? _____

What kind of equipment are you using (please check appropriate categories)

Apple II family IBM or IBM compatible
 MacIntosh Minicomputer (please specify) _____
 Mainframe (please specify) _____

Have you written any software for use in your teaching efforts? Yes No

Would you be willing to help critique software for peers? Yes No

Suggested workshop topics, Additional comments or suggestions concerning NRCLSE:

AIMS AND SCOPE

The goal of *Computers in Life Science Education* is to provide a means of communication among life science educators who anticipate or are currently employing the computer as an educational tool. The range of content includes, but is not limited to, articles focusing on computer applications and their underlying philosophy, reports on faculty/student experiences with computers in teaching environments, and software/hardware reviews in both basic science and clinical education settings.

INVITATION TO CONTRIBUTORS

Articles consistent with the goals of *Computers in Life Science Education* are invited for possible publication in the newsletter.

PREPARATION AND SUBMISSION OF MATERIAL

Articles submitted for publication should not exceed 2000 words and should be typewritten, double spaced, with wide margins. The original and two copies including two sets of figures and tables should be sent to the Editor: Dr. Harold Modell, NRCLSE, Mail Stop RC-70, University of Washington, Seattle, WA 98195.

Title page should include full title, list of authors, academic or professional affiliations, and complete address and phone number of the corresponding author.

Illustrations should be submitted as original drawings in India ink or sharp, unmounted photographs on glossy paper. The lettering should be such that it can be legible after reduction (width of one column = 5.7 cm).

Reference style and form should follow the "number system with references alphabetized" described in the Council of Biology Editors Style Manual. References should be listed in alphabetical order by the first author's last name, numbered consecutively, and cited in the text by these numbers.

RESPONSIBILITY AND COPYRIGHT

Authors are responsible for accuracy of statements and opinions expressed in articles. All authors submitting manuscripts will be sent a copyright transfer form to complete. The completed form must be returned before the article will be published.

SUBSCRIPTION INFORMATION

Computers in Life Science Education is published monthly by National Resource for Computers in Life Science Education, Mail Stop RC-70, University of Washington, Seattle, WA 98195. Subscription rate is \$30.00 for 12 issues, including postage and handling in the United States and Canada. Add \$20.00 for postage (airmail) in Mexico and Europe and \$23.00 for the rest of the world.

This newsletter has been registered with the Copyright Clearance Center, Inc. Consent is given for copying of articles for personal or internal use, or for the personal or internal use of specific clients. This consent is given on the condition that the copier pay through the Center the per-copy fee stated in the code on the first page for copying beyond that permitted by the US Copyright Law. If no code appears on an article, the author has not given broad consent to copy and permission to copy must be obtained directly from the author. This consent does not extend to other kinds of copying, such as for general distribution, resale, advertising and promotional purposes, or for creating new collective works.

Address orders, changes of address, and claims for missing issues to NRCLSE, Mail Stop RC-70, University of Washington, Seattle, WA 98195. Claims for missing issues can be honored only up to three months for domestic addresses and six months for foreign addresses. Duplicate copies will not be sent to replace ones undelivered due to failure to notify NRCLSE of change of address.

Address editorial correspondence to Harold I. Modell, PhD, NRCLSE, Mail Stop RC-70, University of Washington, Seattle, WA 98195. (BITNET MODELL@UWALOCKE)

POSTMASTER: Send address changes to *Computers in Life Science Education*, NRCLSE, Mail Stop RC-70, University of Washington, Seattle, WA 98195.

COMPUTERS IN LIFE SCIENCE EDUCATION

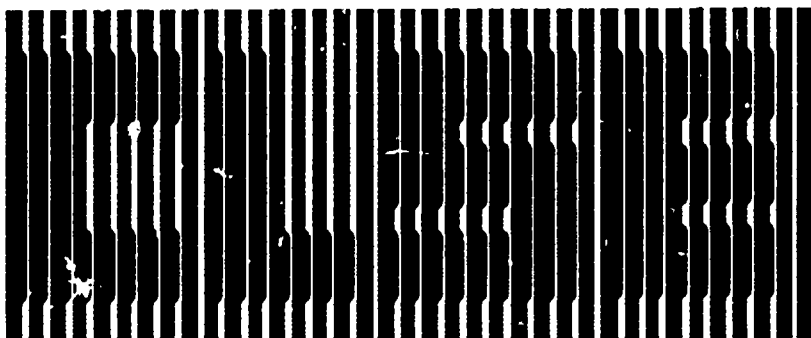

- HAROLD I. MODELL**
Department of Radiology
University of Washington
Seattle, Washington
- MARCEL BLANCHAER**
Department of Biochemistry
Faculty of Medicine
University of Manitoba
Winnipeg, Manitoba
- THEODORE J. CROVELLO**
Graduate Studies and Research
California State University, Los Angeles
Los Angeles, California
- JAMES W. ECKBLAD**
Department of Biology
Luther College
Decorah, Iowa
- TSEGAYE HABTEMARIAM**
School of Veterinary Medicine
Tuskegee University
Tuskegee, Alabama
- DONNA LARSON**
School of Nursing
Grand Valley State College
Allendale, Michigan
- TERRY M. MIKITTEN**
Graduate School of Biomedical Sciences
University of Texas Health Science Center
San Antonio, Texas
- JAMES E. RANDALL**
Department of Physiology
Indiana University
Bloomington, Indiana
- PATRICIA SCHWIRIAN**
College of Nursing
Ohio State University
Columbus, Ohio
- RICHARD STULL**
College of Pharmacy
University of Arkansas
Little Rock, Arkansas
- JAMES W. WOODS**
Lister Hill National Center
for Biomedical-Communications
National Library of Medicine
Bethesda, Maryland
- DOROTHY WOOLEY-McKAY**
Department of Biology
Glendale Community College
Glendale, Arizona
- GLEN YOSHIDA**
Department of Life Sciences
Los Angeles Southwest College
Los Angeles, California
- NRCLSE**

CONTENTS

FROM COMPUTERLESS TO COMPUTER LITERATE THROUGH RESOURCE SHARING	89
James F. Craig and Richard Manski	
LETTER TO THE EDITOR: COMMENT ON PEER REVIEW OR PEER CRITIQUE OF SOFTWARE	91
KEEPING ABREAST OF THE LITERATURE	93
INDEX FOR VOLUME 4	94

FROM COMPUTERLESS TO COMPUTER LITERATE THROUGH RESOURCE SHARING

James F. Craig and Richard Manski

Department of Educational and Instructional Resources and Department of Oral Health Care Delivery, University of Maryland Dental School, Baltimore, Maryland

While many elementary and secondary schools were quick to acquire micro-computers for use in their academic programs, dental educational institutions appear to be lagging behind in this regard. In a recent article entitled "Computers in Dental Education: Promise of the Past Versus Reality of the Present," the authors, who are re-

spected dental educators, indicated that "unlike the advances that have been made in the commercial sector, those in education, and more so in dental education, have been considerably short of anticipation as enumerated years ago."⁴ Evidence supporting these educators' comments regarding the use of computers, at least in the Baltimore area,

may be found in a recent guide to area private schools published in *Baltimore Magazine* in which computers have been added to the list of criteria used in assessing an institution's academic program.² For example, the computer to student ratio for Calvert School (pre-kindergarten through grade 6) and Gilman School (grades 1-12) is 1:9 and 1:25 respectively. The same ratio in 1985 for the University of Maryland Dental School (specializing in educating individuals interested in operating and managing a dental practice) was 1:140. While the computer to student ratio in other dental schools may vary significantly, there is clear evidence that the elementary and secondary schools recognize the importance of using this technology to prepare their students for the future.

Considering the rising costs of health care delivery, a declining patient population, and intense competition for patients among practitioners, integrating information and technological developments designed to improve the cost-efficiency of operating an office practice is essential in the preparation of "budding" health professionals. In fact, a recent study by Solomon and Whiton,³ using the results from 2448 senior dental students from 48 dental schools, indicated more than 70 percent of the students felt that the use of computers in the academic program should be increased. It appears that these senior dental students were quite aware of the importance of integrating computer technology into their office environments. While many dental institutions provide didactic instruction to assist students in selecting a computerized office practice system, students may not have the opportunity for gaining "hands-on" experience in actually utilizing this technology for a variety of business applications related to a dental practice. This article discusses an approach used by the University of Maryland for integrating computer literacy skills into the curriculum.

FACILITIES

One of the important inhibitors to the dental school's computer literacy efforts at the University of Maryland was the lack of microcomputer technology for academic purposes. This dental school, noted as being the "first" established solely for the purpose of dental education in 1840, is located on a campus steeped with tradition where the territorial lines (budgetary and otherwise) are well established. Therefore, finding funds for acquisition of a sizable number of microcomputers strictly for use by dental students represented a formidable problem. An innovative approach to this dilemma was presented by the Associate Vice-Chancellor for Information Resources Management, Dr. Marion J. Ball. She offered to create a Technology Assisted Learning (TAL) Center equipped with state-of-the-art technology as long as the Dental School provided space for the facility, made it available for scheduled classes at least 55 percent of the time, and allowed students, faculty, and staff from other schools on campus to use the equipment when it was not scheduled. The time allocated for scheduling was for computer literacy courses or special discipline specific applications in support of the academic and research programs for the schools on campus.

The Dean of the Dental School readily agreed, and the TAL Center was created. It was located in the same area as the school's learning resource center and included 21 microcomputers equipped with dual disk drives, 20Mb hard disk drives, color monitors, and dot-matrix printers. Special provisions made for teaching included a color, large-screen RGB/television projection system, dimmer controlled lights, and an audio system featuring a wireless microphone to enable the instructor to move freely around the room in order to observe student performance, offer assistance, or continue presenting information and still be heard.

INTEGRATING COMPUTER USE INTO THE CURRICULUM

The Dental School's Department of Oral Health Care Delivery (OHCD) is responsible for providing students with the business and management aspects of planning, organizing, staffing, and operating a dental practice. The installation of the TAL Center in the school was a welcome addition in general, and, in particular, for the department responsible for introducing students to the realities of operating a business. OHCD was quick to integrate the use of microcomputers into the curriculum beginning with 103 third year dental students. The following general objectives were to be achieved.

1. Introducing students to micro-computer technology;
2. Integrating management concepts using a microcomputer; and
3. Developing computer literacy skills in order to facilitate a student's ability to review and assess computerized dental office practice systems and software.

Although the focus of the instruction was on the preparation of a business plan, students were expected to complete the assignments using a micro-computer. To prepare for the assignment, students received instruction in basic computer application, economics, marketing, accounting, and finance. A total of four hours of classroom instruction were provided using the TAL Center. The first two hours concentrated on computer hardware and software, and the last two focused on voluntary small group seminars with hands-on experience. During the seminars, instruction focused on how to use spreadsheets to develop a financial projection, how to use wordprocessing to prepare a resumé, and ultimately how to prepare a business plan. To simplify the instruction, an integrated software package, ENABLE,¹ was used. In preparing a resumé, students were asked to

set margins, format text, insert, copy and delete text, and save files. In using a spreadsheet, students were asked to establish financial relationships by setting columns and rows using mathematical operators and functions. Both tasks required that students have a fundamental understanding of MS-DOS including, but not limited to, many of the operating system capabilities to create, save, copy, and retrieve files.

RESULTS AND DISCUSSION

Upon completion of the course, students were asked to fill out a questionnaire to provide feedback on their experience and to assist the department in planning this portion of the curriculum for the next group of students. Eighty-one percent of the students responded

to the request and indicated that the assignment was effective, appropriate, and useful. The results showed that over 74 percent of the students gained knowledge through working with the computer. This experience would not have been possible without the cooperation and resource sharing between the Information Resources Management Division and the Dental School. Since the installation of this facility, other schools on campus who were faced with a lack of resources have scheduled the TAL Center to meet their student and faculty computer literacy needs. For institutions faced with a similar set of circumstances, the results achieved at Maryland may be worth pursuing as a viable alternative for bringing computer literacy into a computerless

academic environment.

REFERENCES

1. ENABLE: Wordprocessing, Spreadsheet, Data Base, Telecommunications, and Graphics; software in an integrated format. New York, NY, The Software Group, 1986.
2. Keely K, Swingle AB: A guide to area private schools. Baltimore Magazine December:161-170, 1985.
3. Solomon ES, Whiton JC: Student evaluation of audio-visual teaching equipment. J Dent Educ 51:559-560, 1987.
4. Tira DE, Tharp LBK, Lipson LF: Computers in dental education: Promise of the past versus reality of the present. Dental Clinics of North America 30:681-694, 1986.

LETTER TO THE EDITOR: COMMENT ON PEER REVIEW OR PEER CRITIQUE OF SOFTWARE

As an author and a user of educational software, I have long felt frustrated by two characteristics of the computer-based education (CBE) field. It has been difficult to get and to disseminate information about teaching programs, and it has been difficult to get the personal contributions of individuals evaluated by their peers. Harold Modell's recent call for the establishment of a "peer critique" mechanism to operate through NRCLSE¹ would thus seem to address issues that have had a widespread impact in the CBE community. However, a clearer understanding of these issues is required if we, as a community, are to successfully resolve them.

As an author of CBE software, I have worked in relative isolation from even my colleagues in physiology. While I have had some opportunity to discuss and demonstrate my software in public forums, I have not had the

kind of vigorous (and rigorous) feedback from my peers that is characteristic in the research sphere.

As a user of CBE programs, I find that I know about only a small fraction of the potentially useful programs (and educational approaches that they embody) that others have written. Furthermore, my experience, and that of others, suggests that there is no comprehensive source of such information.

Finally, as an *academician* whose professional activity lies in the realm of CBE, I have a need for professional recognition and advancement (promotion) that is difficult to get because too few people know of my work, and no one has ever evaluated it.

Evaluation, however, is a complex issue, at least in part, because we are really talking about evaluating two quite different things: (1) single pieces of teaching software, and (2) an individual's contribution to the field.

As Dr. Modell has pointed out, evaluation of software is an extremely difficult task for both theoretical and practical reasons. The use of computers in teaching continues to generate controversy about the appropriateness and effectiveness of this approach. Even if we accept its validity, we still must grapple with significant, as yet unsettled, questions about the best form of CBE to most effectively attain particular educational objectives. Until we know more about how to use the computer as a teaching/learning tool, it will be hard to answer the question "is it any good" in evaluating software.

Pragmatically it is also difficult to evaluate programs. Reviewers must be qualified to comment on the scientific content, educational objectives and approach, most appropriate audience, and the effectiveness of the use of the computer medium. Finding two or three such individuals for each program

will be a daunting job, one made even more difficult by problems of program portability (for example, I may be qualified to review a program but may not have access to the necessary computer to do so).

The following two key needs face the CBE community.

1. a need for wider dissemination of more comprehensive information about teaching software, and
2. a need for some form of evaluation of our work, if not of our individual pieces of software.

Dr. Modell's proposal, it seems to me, does not adequately come to grips with either of these needs. On the one hand, the difficulties of the process of "peer critiquing" software will limit the number of programs that will be evaluated. Thus, the comprehensiveness of the NRCLSE Newsletter as a source of information will be compromised. On the other hand, the validity of such "peer critiques" will continue to be questioned until we know more about the appropriate criteria to apply. This will make "peer critiques" a poor vehicle for professional evaluation of an individual.

Let me propose two alternative approaches that I believe *will* meet the needs of the CBE community, approaches that ought to be pursued simultaneously.

NRCLSE, through Computers in Life Science Education, could perform a most valuable service as a central catalog of available CBE software. What would be required is the regular publishing of listings of programs available for distribution along with adequate descriptive information to allow potential users to determine whether the program is of any interest to them. Wide dissemination of such information in a central forum would certainly facilitate the eventual feedback from one's peers that we are all seeking.

Peer evaluation of our contribution to the CBE area could best be served by making available opportunities to publish in the professional, peer-reviewed literature. This is, after all, the basic mechanism by which professional evaluation takes place in the research sphere. Currently, few if any of the physiology journals will accept papers dealing with educational issues of any kind, considering them not appropriate for publication in a *research* journal. Efforts to persuade such journals, or

the societies that sponsor them, that education ought to be a topic worthy of the kind of intellectual creativity expected of research could make a significant difference. As an example, I would refer readers to the American Journal of Physics (published by the American Association of Physics Teachers) which each month contains scholarly peer-reviewed articles on a wide variety of topics relating to teaching. Citations to papers in such refereed journals would be of greater benefit to a CBE author in the life science area seeking promotion than software reviews, however well meaning they might be.

The issues that Dr. Modell and I have raised need to be more widely debated if workable solutions to our problems are to be devised.

REFERENCE

1. Modell, HI: How shall we evaluate software-peer review or peer critique? Computers in Life Science Education. 4:68-69, 1987.

Joel A. Michael
Department of Physiology
Rush Medical College
Chicago, IL

EDITOR'S NOTE

Dr. Michael has suggested an additional role for our *Where's the Software?* feature that we would like to pursue. To date, *Where's the Software?* has listed programs from vendor supplied information. We would like to expand this feature to include software and comments supplied by users. To do this, we **need your help!** If you have found software that has been helpful in your teaching efforts, please share the information with us. Send us the name of the program/package, the source of the program/package, content area, the student population using the software, and a few comments indicating *how* you use the software and *why* you like the software. Mail this information to NRCLSE, Mail Stop RC-70, University of Washington, Seattle, WA 98195 or use our BITNET address (MODELL@UWALOCKE) to send the information.

KEEPING ABREAST OF THE LITERATURE

The following citations are presented as part of a quarterly feature in CLSE designed to help readers become aware of current literature pertinent to computer applications in life science education.

- Bellinger A: Interactive video instruction - media or technique. *Training and Development* 5(7):v, 1986.
- Boyer PS: Constructing true stereograms on the Macintosh. *J Comp Math Sci Teach* 6(2):15-22, 1986-1987.
- Boyle J et al: Biologist's toolbox. Acid-base balance: an educational computer game. *BioScience* 37(7):511-513, 1987.
- Brannan P: Designing a computer-assisted orientation program for the operating room. *Periop Nurs Q* 2(3):43-47, 1986.
- Carlson KW: Experiment with Apples. *InCider* 5(8):56-61, 1987.
- Cecchini A et al: Gaming simulation: a general classification. *Simulation/Games for Learning* 17(2):60-73, 1987.
- Crawford W: Common sense clones: price and performance in PC-compatible computers. *Library F: Tech* 5(2):41-53, 1987.
- Cryer P: Designing an educational game, simulation or workshop: a 'course and curriculum' design perspective. *Simulation/Games for Learning* 17(2):51-59, 1987.
- Dauvin F: Read the instructions! ...microcomputers in nurse education. *Nurs Times* 83(7):34-35, 1987.
- Dean JM: HeartLab. *MD Comput* 4(2):46-49, 1987.
- DeMuynck A et al: A computer aided teaching program in epidemiology and biostatistics. *Ann Soc Belg Med Trop* 67(1):79-81, 1987.
- diSessa AA: The third revolution in computers and education. *J Research in Science Teaching* 24(4):343-367, 1987.
- Dobberstein K: Computer-assisted patient ed. *Am J Nurs* 87(5):697, 1987.
- Fincher RE: Comparison of computer-assisted and seminar learning of electrocardiogram interpretation by third-year students. *J Med Educ* 62(8):693-694, 1987.
- Fletcher P et al: Computer administered versus written tests - advantages and disadvantages. *J Comp Math Sci Teach* 6(2):38-43, 1986-1987.
- Freeman AW: Computer use in allied health programs. *J Allied Health* 16(2):177-183, 1987.
- Graham I: The application of spreadsheets to data analysis in biology. *J Biol Educ* 21(1):51-56, 1987.
- Gwinnett A et al: Integrating computers into the curriculum. (2). Transforming a concept into a working tool. *Nurse Educ Today* 7(3):116-119, 1987.
- Helgeson LW: Optical discs: new storage media for education. *Technol Horizons Educ* 14(7):50-52, 1987.
- Houston MS: Researcher makes recommendations for use of computer-aided instruction. *Pa Nurse* 42(5):8, 1987.
- Jameson D et al: Interactive video a new approach to training. *Occup Health* 39(3):88-90, 1987.
- Knapp RG et al: Experience with and attitudes toward computers in medicine of students and clinical faculty members at one school. *J Med Educ* 62(4):344-346, 1987.
- Levine RS et al: Comparison of computer-assisted learning with tutorial teaching in a group of first-year dental students. *Med Educ* 21(4):305-309, 1987.
- Lindell AR: Piracy: pirate or privateer. *J Prof Nurs* 3(2):78, 1987.
- Magill MK: Interactive video in family medicine. *Fam Med* 18(4):226-229, 1986.
- Merrill MD: The new component design theory: instructional design for courseware authoring. *Instructional Science* 16(1):19-34, 1987.
- Morrisor DF: Computer simulation as a teaching aid in pharmacy management - Part 2. *Stock control. J Clin Pharm Ther* 12(4):261, 1987.
- Nachmias R et al: Evaluation of science laboratory data: the role of computer-presented information. *J Research in Science Teaching* 24(5):491-506, 1987.
- Putnam W: Discotest. *MD Comput* 3(2):21-23, 1987.
- Rankin JA et al: Information system linking a medical school with practitioners and hospitals. *J Med Educ* 62(4):336-343, 1987.
- Renshaw S et al: CAI has greatest potential for clinical simulations. *Pa Nurse* 42(5):8, 1987.
- Rivers RH et al: Computer simulations to stimulate scientific problem solving. *J Research in Science Teaching* 24(5):403-415, 1987.
- Sizemore MH et al: CAI promotes nursing student mastery of health history taking. *J Comput Based Instr* 14(2):62-67, 1987.
- Stevens AL: The next generation of AI-based teaching systems. *Machine-Mediated Learning* 1(4):313-326, 1986.
- Streibel M et al: MENDEL: an intelligent computer tutoring system for genetics problem-solving, conjecturing, and understanding. *Machine-Mediated Learning* 2(1-2):129-159, 1987.
- Sybouts W: Optical disc technology. Videodisc technology: a national plan for its use in education. *Technol Horizons Educ* 14(8):47-48, 1987.
- Taylor M: The implementation and evaluation of a computer simulation

- game in a university course. *J Exptl Educ* 55(2):108-115, 1987.
- Thompson EC: Computer-assisted instruction in curricula of physical therapist assistants. *Physical Therapy* 67(8):1237-1239, 1987.
- Tritz GJ: Computer modeling of microbiological experiments in the teaching laboratory: animation techniques. *J Comp Math Sci Teach* 6(2):44-48, 1986-1987.
- Wenzel A et al: Computer-assisted instruction for intraoral radiography. Part III. Evaluation of time-consumption. *Dentomaxillofac Radiol* 15(2):73-77, 1985.
- Wenzel A et al: Retention after computer-assisted instruction in intraoral radiography. *J Dent Educ* 51(5):244-245, 1987.
- Wheeler DL: Artificial-intelligence researchers develop electronic 'tutors' to aid learning process. *Chronicle of Higher Education* 33(36):6-8, 1987.
- Winn W: Instructional design and intelligent systems: shifts in the designer's decision-making role. *Instructional Science* 16(1):59-77, 1987.

COMPUTERS IN LIFE SCIENCE EDUCATION, VOLUME 4 INDEX

- analog-digital conversion, 4:28-30
anatomy, 7:54-56, 9:65-68
animal behavior data simulation, 8:61
animations, 10:73-76
- biology, 8:60-63
Bulletin Board, 10:78
- Can You Help? 4:31
Cardell A, 10:73-76, 11:85
cardiovascular physiology, 4:28, 7:49-53, 7:54-55, 10:73-76
colleague directory, 1:1-8, 2:15
communication system, 3:17-20
computer animations, 10:73-76
computer-assisted instruction, 9:65-68, 11:81-84
computer literacy 12:89-91
Craig JF, 12:89-91
- database, 7:54-56
data simulations, 8:60-63
dental education, 11:81-84, 12:89-91
dental treatment planning, 11:81-84
Discourse, 3:17-20
- electronic blackboard, 5:33-35
ecology, systems, 2:9-12, 8:61
Eckblad JW, 8:60-63
erratum, 11:85
- Filevision, 7:54-56
Fine JS, 2:12-15
Ford RT, 11:81-84
- Giles RH, Jr 2:9-12
Gordon A, 5:33-35
Gordon M, 10:73-76, 11:85
graphics oriented database, 7:54-56
- group instruction, 3:17-20, 5:33-35, 10:73-76
- Harris M, 10:73-76, 11:85
Heckman J, 8:57-60, 10:73-76, 11:85
hematology videodisc, 2:12-15
- interactive videodisc, 2:12-15, 9:65-68
- Jensh RP, 9:65-68
- Kastella K, 5:33-35
Keeping Abreast of the Literature, 3:23, 6:47, 9:69-71, 12:93-94
Knoll KR, 10:76-77
- laboratory exercises, 4:25-30, 7:49-53, 8:57-60, 8:60-63
languages, 2:14 3:20-22
laser optical videodisc, 2:12-14
learning center 12:89-91
lecture setting, 10:73-78
liquid crystal display projectors, 10:76-77
- Macintosh, 7:54-56
Manski R, 12:89-91
medical education, 2:12-15, 9:65-68
Michael, JA, 12:91-92
microbiology, 4:28
Modell HI, 4:25-30, 9:68-69
muscle physiology, 8:57-60, 10:73-76, 11:85
- NRCLSE questionnaire, 11:87
nuclear medicine, 4:26-27
nursing skills simulation 4:26-27
- pathology, 2:12-15, 9:65-68
- peer critique, 9:68-69, 12:91-92
peer review, 9:68-69, 12:91-92
physiology, 4:27-30, 7:49-53, 7:54-56, 8:57-60, 8:61, 10:73-76
PILOT, 3:20-22
PRODUCER, 2:14
projecting computer images, 10:76-77
- respiratory physiology, 4:28
Robinson SL, 3:17-20
Rothe C, 7:49-53
- simulations, 4:25-30, 7:49-53, 8:57-60, 8:60-63
software evaluation, 9:68-69, 12:91-92
student laboratories, 4:25-30, 7:49-53, 8:57-60, 8:60-63
Stull RE, 10:76-77
SuperPILOT, 2:14 3:20-22
systems ecology, 2:9-12
- teaching at a remote site, 5:33-35
teleconferencing, 5:33-35
Townsend D, 11:81-84
- video workstation, 9:65-68
videodisc
development 2:13-14
hardware selection 2:14, 9:65-68
language selection 2:14
- Wang M, 8:57-60, 10:73-76, 11:85
Westmorland N, 7:54-56
Where's the Software? 5:36-39, 6:41-45
wildlife management, 2:9-12
- Yoder ME, 3:20-22

MACINTOSH VERSION NOW AVAILABLE. . .

SIMULATIONS IN PHYSIOLOGY

– *The Respiratory System* –

Harold I. Modell, Ph.D.

School of Medicine, University of Washington, Seattle.

- Series of 12 Simulations in Respiratory Physiology
- 117 Page Laboratory Manual
- Designed for use in student laboratory and group discussion environments
- *Pictorial* outputs designed to provide conceptual aid, show where variable values are measured, or illustrate the model and how it is solved
- *Tabular* outputs allow comparison of data from up to 7 'experiments'
- Available for Apple II, IBM-PC (MS-DOS) compatible, and Macintosh (requires Microsoft BASIC) computers
- Purchase includes permission to make enough copies to supply appropriate student populations

ORDERING INFORMATION

Computer Programs*

12 Simulations written in BASIC
Documentation
One copy of student laboratory manual
. . . . \$100

*IBM-PC version uses CGA graphics
Macintosh version requires Microsoft BASIC

Student Laboratory Manuals

Quantities of 1-25 \$10 each
Additional copies \$8.50 each

Address orders to:

NRCLSE
Mail Stop RC-70
University of Washington
Seattle, WA 98195

Be sure to indicate which version you need!

PROGRAM OVERVIEW

Title	Material covered
MECHANICS	
<i>Static Relationships</i>	Elastic properties of the lung, chest wall, and total respiratory system
<i>Dynamic Relationships I</i>	Effects of lung compliance and airway resistance on tidal volume development
<i>Work of Breathing</i>	Oxygen cost of elastic, resistive, and total work during inspiration
<i>Dynamic Relationships II</i>	Respiratory dynamics of the total respiratory system
GENERAL GAS EXCHANGE	
<i>Alveolar Gas Exchange</i>	Gas exchange between the atmosphere and alveolar reservoir
<i>O₂ and CO₂ Dissociation Curves</i>	Interrelationships between the O ₂ and CO ₂ dissociation curves
<i>Exchange from Atmosphere to Tissues</i>	Influence of alveolar ventilation, cardiac output, and anatomic shunt flow on arterial blood composition and gas exchange at the tissues.
<i>Chemoregulation of Respiration</i>	Influence of chemoreceptor sensitivity and respiratory mechanics on O ₂ and CO ₂ response curves
V_A/Q RELATIONSHIPS	
<i>Gas Exchange in a Single Alveolus</i>	Effects of ventilation-perfusion ratio and inspired gas composition on exchange in a single exchange unit
<i>The Non-Uniform Lung</i>	Gas exchange from atmosphere to tissues with V _A /Q mismatching in the lung
<i>Overall Gas Exchange</i>	Gas exchange from atmosphere to tissues with V _A /Q mismatching and a true shunt
ACID-BASE BALANCE	
<i>Acid-Base Balance: Fundamental Relationships</i>	Acid-Base balance from a Base Excess viewpoint

AIMS AND SCOPE

The goal of *Computers in Life Science Education* is to provide a means of communication among life science educators who anticipate or are currently employing the computer as an educational tool. The range of content includes, but is not limited to, articles focusing on computer applications and their underlying philosophy, reports on faculty/student experiences with computers in teaching environments, and software/hardware reviews in both basic science and clinical education settings.

INVITATION TO CONTRIBUTORS

Articles consistent with the goals of *Computers in Life Science Education* are invited for possible publication in the newsletter.

PREPARATION AND SUBMISSION OF MATERIAL

Articles submitted for publication should not exceed 2000 words and should be typewritten, double spaced, with wide margins. The original and two copies including two sets of figures and tables should be sent to the Editor: Dr. Harold Modell, NRCLSE, Mail Stop RC-70, University of Washington, Seattle, WA 98195.

Title page should include full title, list of authors, academic or professional affiliations, and complete address and phone number of the corresponding author.

Illustrations should be submitted as original drawings in India ink or sharp, unmounted photographs on glossy paper. The lettering should be such that it can be legible after reduction (width of one column = 5.7 cm).

Reference style and form should follow the "number system with references alphabetized" described in the Council of Biology Editors Style Manual. References should be listed in alphabetical order by the first author's last name, numbered consecutively, and cited in the text by these numbers.

RESPONSIBILITY AND COPYRIGHT

Authors are responsible for accuracy of statements and opinions expressed in articles. All authors submitting manuscripts will be sent a copyright transfer form to complete. The completed form must be returned before the work will be published.

SUBSCRIPTION INFORMATION

Computers in Life Science Education is published monthly by National Resource for Computers in Life Science Education, Mail Stop RC-70, University of Washington, Seattle, WA 98195. Subscription rate is \$30.00 for 12 issues, including postage and handling in the United States and Canada. Add \$20.00 for postage (airmail) in Mexico and Europe and \$23.00 for the rest of the world.

This newsletter has been registered with the Copyright Clearance Center, Inc. Consent is given for copying of articles for personal or internal use, or for the personal or internal use of specific clients. This consent is given on the condition that the copier pay through the Center the per-copy fee stated in the code on the first page for copying beyond that permitted by the US Copyright Law. If no code appears on an article, the author has not given broad consent to copy and permission to copy must be obtained directly from the author. This consent does not extend to other kinds of copying, such as for general distribution, resale, advertising and promotional purposes, or for creating new collective works.

Address orders, changes of address, and claims for missing issues to NRCLSE, Mail Stop RC-70, University of Washington, Seattle, WA 98195. Claims for missing issues can be honored only up to three months for domestic addresses and six months for foreign addresses. Duplicate copies will not be sent to replace ones undelivered due to failure to notify NRCLSE of change of address.

Address editorial correspondence to Harold I. Modell, PhD, NRCLSE, Mail Stop RC-70, University of Washington, Seattle, WA 98195. (BITNET MODEL@UWALOCKE)

POSTMASTER: Send address changes to *Computers in Life Science Education*, NRCLSE, Mail Stop RC-70, University of Washington, Seattle, WA 98195.