

DOCUMENT RESUME

ED 295 781

SE 048 887

**AUTHOR** Malone, Mark R., Comp.  
**TITLE** Physical Science Activities for Elementary and Middle School. CESI Sourcebook V. An Occasional Sourcebook of the Council for Elementary Science International.

**INSTITUTION** Council for Elementary Science International.; ERIC Clearinghouse for Science, Mathematics, and Environmental Education, Columbus, Ohio.

**SPONS AGENCY** Office of Educational Research and Improvement (ED), Washington, DC.

**PUB DATE** Dec 87  
**CONTRACT** 400-86-0016  
**NOTE** 263p.  
**AVAILABLE FROM** SMEAC Information Reference Center, The Ohio State University, 1200 Chambers Road, 3rd Floor, Columbus, OH 43212 (\$12.50).

**PUB TYPE** Guides - Classroom Use - Guides (For Teachers) (052) -- Collected Works - General (020) -- Information Analyses - ERIC Information Analysis Products (071)

**EDRS PRICE** MF01/PC11 Plus Postage.  
**DESCRIPTORS** Creative Activities; Creativity; Divergent Thinking; \*Elementary School Science; Elementary Secondary Education; Experiential Learning; Junior High Schools; \*Laboratory Procedures; \*Middle Schools; \*Problem Solving; \*Science Activities; Science Education; \*Secondary School Science

**ABSTRACT**

Mounting research evidence has shown that an activity centered approach to elementary and middle school science education can be quite effective. This sourcebook, developed for teachers by teachers, presents many activity oriented science lessons that could be done in any elementary or middle school classroom with minimal additional experience. Nearly all lessons use materials that could easily be found around most schools or homes or that could be purchased inexpensively from local sources. Each activity contains the focus of the activity, a challenge posed to the students, materials, procedures, further challenges and references. Topics include: teaching physical science activities; sound; light and color; electricity from static to circuits; electricity from magnetism to generators; forces and motion; simple machines; heat; forces in liquids and gases; matter; chemistry; and space. Numerous line drawings illustrate the activities. (CW)

\*\*\*\*\*  
 \* Reproductions supplied by EDRS are the best that can be made \*  
 \* from the original document. \*  
 \*\*\*\*\*

ED 295781

PHYSICAL SCIENCE ACTIVITIES FOR ELEMENTARY AND MIDDLE SCHOOL

CESI SOURCEBOOK V

Compiled and Edited by

MARK R. MALONE

School of Education  
P.O. Box 7150  
University of Colorado  
Colorado Springs, CO 80933

U S DEPARTMENT OF EDUCATION  
Office of Educational Research and Improvement  
EDUCATIONAL RESOURCES INFORMATION  
CENTER (ERIC)

This document has been reproduced as  
received from the person or organization  
originating it  
 Minor changes have been made to improve  
reproduction quality

• Points of view or opinions stated in this docu-  
ment do not necessarily represent official  
OERI position or policy

Illustrations by

Claude DeGrush

An Occasional Sourcebook of  
The Council for Elementary Science International

Published by

 Clearinghouse for Science  
Mathematics, and Environmental Education  
The Ohio State University  
1200 Chambers Road, Third Floor  
Columbus, OH 43212

December, 1987

SE 048 887

*Office of Educational  
Research and Improvement  
U.S. Department of Education*

This publication was prepared pursuant to a contract with the Office of Educational Research and Improvement, U.S. Department of Education. Contractors undertaking such projects under government sponsorship are encouraged to express freely their judgment in professional and technical matters. Points of view or opinions, however, do not necessarily represent the official views or opinions of the Office of Educational Research and Improvement.

Publisher's Page

The ERIC Clearinghouse for Science, Mathematics, and Environmental Education is pleased to cooperate with the Council for Elementary Science International in producing this fifth sourcebook. This sourcebook presents many ideas for improving the teaching of physical science in elementary and middle schools.

We invite your comments on this publication and your suggestions for future publications. For information on previous sourcebooks write to ERIC/SMEAC or phone (614) 292-6717.

Stanley L. Helgeson

Patricia E. Blosser

The purposes of the Council for Elementary Science International, according to the CESI Constitution, are ".to stimulate, improve, and coordinate science teaching at preschool and elementary school levels and to engage in any and all activities in furtherance thereof; to promote the improvement of science progress which begins in preschool or first grade and develops in a continuous and integrated fashion through grade 12 and beyond."

CESI provides a variety of resources in an effort to promote quality preschool-elementary science education. The intended audiences are classroom teachers, resource staff, supervisors, administrators, research personnel, and methods instructors. These resources include:

>Sessions at international, national, state and local science teacher conferences and meetings. Presenters include nationally recognized experts in the field of elementary science education and classroom practitioners who share hands on materials, research data, classroom activities, and inservice suggestions.

>Quarterly newsletter offering teaching suggestions and updates on current issues in preschool-elementary science education.

>Sourcebooks written on specific science topics of interest to preschool-elementary practitioners.

>Awards programs to recognize exemplary elementary science teachers, teachers new to our profession, and principals who are supportive of elementary science instruction.

>International projects to provide global perspectives and methods for the sharing of mutual interests/concerns.

>Directory of members, those people who have been identified as having an interest and voice in preschool-elementary science.

>Monographs and occasional papers on issues of specific interest to elementary science educators and those interested in promoting quality elementary science education.

>Positions on issues, spokesman for preschool-elementary science education.

>A forum of educators to voice their opinions, share their ideas, and develop a professional comradery with those having similar interests and needs.

>A professional link for preservice, inservice, and postservice science educators.

## Preface

The Council for Elementary Science International is the only organization committed to the sole purpose of improving the quality of preschool through elementary science at a national and international level. It is with this thrust in mind that the association participates in activities designed to stimulate, improve, and coordinate science teaching at all levels. The CESI Board of Directors has found the sourcebook concept to be an ideal mode in reaching classroom teachers with ideas to utilize in their everyday interactions with children.

The fifth sourcebook continues the tradition of quality science material, presented in a quick reference format, for use by classroom teachers. It contains materials developed for teachers by teachers who have tested them with children. You will find that the ideas are always uppermost in CESI Sourcebooks. An attempt is made to keep the cost within reach of all classroom teachers by keeping production costs at a minimum and offering them through ERIC and direct sales rather than through a for-profit publisher.

In an effort to reach our broad audience, the title of this sourcebook, Physical Science Activities for Elementary and Middle School Science: CESI Sourcebook V, represents the second in a series of specific content area related topics. The first was Understanding the Healthy Body: CESI Sourcebook III dealing with anatomy and health. Sourcebook VII will deal with Earth Science topics.

The quality of a sourcebook is determined by the project editor. Mark Malone has selected the topic, contacted authors, edited, formatted, and worked with ERIC/SMEAC to produce this final product. This process has taken more than two years of continual work. CESI Board of Directors would like to thank him for his dedication to this project and improving science education through his many educational activities.

This edition is produced through the efforts of many people. CESI would like to thank the many authors for sharing their ideas, and ERIC/SMEAC for their support and cooperation.

CESI Sourcebook VI is already underway. It will deal with the issue of Science/Technology/Society. The editor, Audrey Brainard would appreciate any input you might have.

Linda Froschauer  
President 1987-88

## Acknowledgements

Many individuals have contributed in various ways to the completion of this sourcebook. Thanks go to Sue and Emmett Malone who ungrudgingly postponed a summer vacation to allow me time to finish this work; Kris Fisher who worked evenings, weekends, and a holiday typing and proofreading; Claude DeGrush for spending long hours creating the majority of illustrations for the book; and all the contributing authors of activities who have freely shared their best ideas with other teachers. A special thanks is extended to Pauline Malone-Fledderman who supported and encouraged her son as he spent years in the basement of her home exploring physical science activities.

CESI (The Council for Elementary Science, International), an affiliate of the National Science Teachers Association, is an organization interested in improving the science education of children. It is an organization OF teachers, presenting conventions and publications BY and FOR teachers.

CESI OFFICERS AND DIRECTORS

1987-88

President

Linda Froschauer  
Weston Middle School  
Weston, CT 06883

Directors

Charles Barman  
Indiana University  
902 W. New York Street  
Indianapolis, IN 46223

President Elect

Walter Smith  
Baily Hall  
Kansas University  
Lawrence, KS 66045

Carolyn Blanding  
Detroit Public Schools  
4300 Marseilles  
Detroit, MI 48224

Retiring-President

Leon Ukens  
Physics Department  
Towson State University  
Towson, MD 21204

Timothy Cooney  
Malcom Price Lab School  
University of Northern Iowa  
Cedar Falls, IA 50613

Secretary-Treasurer

Robert Burtch  
J.B. Nelson School  
Batavia, IL 60510

Betty Graham  
E.J. Martinez Elementary School  
San Mateo Drive  
Santa Fe, NM 87501

Recording Secretary

Miram Buckland  
K.T. Murphy School  
Stamford, CT 06902

Donna Oliver  
Pierce Science Center  
Clarion University  
Clarion, PA 16214

Membership Chairperson

Betty Burchett  
212 Townsend Hall  
University of Missouri  
Columbia, MO 65211

Philip C. Parfitt  
Museum of Science and Industry  
57th and Lake Shore Drive  
Chicago, IL 60637



## CONTRIBUTING AUTHORS

Sandra K. Abell  
The University of Iowa  
Science Education Center  
459 Van Allen Hall  
Iowa City, IA 52242

Bonnie Barr  
State University College at Cortland  
Education Department 500028  
P.O. Box 2000  
Cortland, NY 13045

Stephen C. Blume  
Slidell Curriculum Center  
2552 Sgt. Alfred Drive  
Slidell, LA 70458

Richard Bollinger  
Public School 85  
2400 Marion Avenue  
Bronx, NY 10458

Robert Burtch  
J.B. Nelson School  
Batavia, IL 60510

Lawrence D. Calhoun  
Slippery Rock University  
117 McKay Bldg.  
Slippery Rock, PA 16057-1326

Michael J. Demchik  
Jefferson High School  
Shenandoah Junction, WV 25442

Marilyn Donalson  
Brigham Elementary School  
R.R. 13  
Box 594  
Bloomington, IL 61701

Gerald Wm. Foster  
542 Schmitt Academic Center  
DePaul University  
2323 Seminary Avenue  
Chicago, IL 60614

Janet Frekko  
Hands on Science Outreach Inc.  
4910 Macon Road  
Rockville, MD 20852

Linda K. Froschauer  
K-6 Science Coordinator  
Weston Middle School  
Weston, CT 06883

Patsy A. Giese  
Slippery Rock University  
Curriculum and Instruction Dept.  
Slippery Rock, PA 16057-1326

Tom Graika  
Park Junior High School  
325 N. Park  
LaGrange, IL 60525

Nadine L. N. Halligan  
Maryland Academy of Sciences  
Maryland Science Center  
601 Light Street  
Baltimore, MD 21230

Yvonne A. Johnson  
West School  
Sycamore, IL 60178

Carole Kuchinsky  
Museum-To-Go Resource Center  
The Franklin Ins. Science Museum  
20th and The Parkway  
Philadelphia, PA 19103-1194

Gwyneth E. Loud  
64 Conant Road  
Lincoln, MA 01773

Mark R. Malone  
School of Education  
University of Colorado  
P.O. Box 7150  
Colorado Springs, CO 80933-7150

Judith A. McKee  
Wilmette Public Schools  
6151 Locust Street  
Wilmette, IL 60093

Mildren Moseman  
123 Fairview Drive  
S. Sioux City, NE 68776

Charles Nease  
Preston Hollow Elementary School  
Dallas Independent School District  
Dallas, TX 75230

Ginny Petrie  
9970 Wisner Road  
Kirtland, OH 44094

Ruth M. Ruud  
Chestnut Hill School  
1001 W. 54th Street  
Erie, PA 16509

Donna Gail Shaw  
University of Alaska - Anchorage  
School of Education  
3211 Providence Drive  
Anchorage, AK 99508

Edward L. Shaw, Jr.  
College of Education  
Elem. and Early Childhood Education  
Instructional Lab. Bldg., Rm. 325  
Mobile, AL 36688

David R. Stronck  
Department of Teacher Education  
California State University - Hayward  
Hayward, CA 94542

Terri G. Switzer  
American Chemical Society  
Pre-High School Science Program  
1155 16th Street NW  
Washington, D.C. 20036

Joan B. Tephly  
The University of Iowa  
Science Education  
Iowa City, IA 52242

Thomas E. Thompson  
Dept. of Curriculum and Instruction  
Northern Illinois University  
DeKalb, IL 60115

Sue Dale Tunnicliffe  
Curriculum and Teacher's Centre  
London Borough of Richmond upon  
Thames  
Clifden Road  
Twickenham  
Middlesgy  
TW1 4Li  
United Kingdom

Mark Twiest  
2255C Winterville Road  
Athens, GA 30605

Meghan M. Twiest  
University of Georgia  
Science Education Department  
212 Aderhold Hall  
Athens, GA 30602

Linda Vance  
Memorial Junior High School  
2721 Ridge Road  
Lansing, IL 60438

Carole Van De Walle  
Illinois State University  
Dept. of Curriculum and Instruction  
Normal, IL 61761-6901

Rose West  
Huth Upper Grade Center  
3718 W. 213th Place  
Matteson, IL 60443

## WHAT IS THIS SOURCEBOOK ABOUT?

by Mark R. Malone

In the Spring 1986 meeting of the CESI Board of Directors, it was agreed that CESI should produce a fifth in a series of practical sourcebooks for teachers. The board decided that elementary science could presently benefit most from a sourcebook focused on physical science activities. This sourcebook was developed mainly for use with elementary and middle school students, although many activities could be easily adapted for use with older students.

Like the previous sourcebooks, Physical Science Activities for Elementary and Middle School emphasizes teaching science through activities. Mounting research evidence shows that an activity centered approach to elementary and middle school science education is quite effective. A synthesis study (Shymansky, Kyle, and Alport, 1983) involving over 45,000 students showed that students involved in activity oriented science programs performed better than 62 percent of students in non-activity science programs in general achievement, analytic skills, process skills, and related skills (reading, mathematics, social studies and communication). A related study (Bredderman, 1983) showed similar results with the activity approach in 1000 elementary classrooms on measures of science processes, creativity, attitudes, perceptions, and logical development. In addition, Bredderman found, through an analysis of classroom observation, that activity oriented classes resulted in decreased teacher talk and lecturing, increased use of higher level questioning, and more active engagement of students.

Currently, over ten available elementary science textbook series offer "integrated" equipment and material kits. In every case the manipulative materials are available as an option. Because of limited budgets, many schools now purchase the textbooks but cannot afford to buy the supplementary kits. As a result many elementary and middle school students still grow up thinking science is merely something else to read (Thier, 1986).

Sourcebook V, like its predecessors, presents many activity oriented science lessons that can be done in any elementary or middle school classroom with minimal additional expense. Nearly all lessons utilize materials that can be easily found around the school and home or that can be purchased inexpensively from local sources (grocery stores, hardware stores, department stores, etc.). Like previous sourcebooks, it should be a valuable resource for many classroom teachers.

Physical Science Activities for Elementary and Middle School is the fifth sourcebook of the Council for Elementary Science International. The other four are Outdoor Areas as Learning Laboratories, compiled and edited by Alan J. McCormack; Expanding Childrens' Thinking Through Science, compiled and edited by Michael R. Cohen and Larry Flick; Understanding the Healthy Body, compiled and edited by David R. Stronk; and Science Experiences for Preschoolers, compiled and edited by Leon Ukens. All of these sourcebooks have a similar format for the activities and emphasize inexpensive, easily obtained materials and equipment.

The format for the activities is as follows:

Title of Activity: We have tried to invent titles that reflect both the fun of the activity and its learning focus. In many instances, our hope is that the title itself will pique young students' natural curiosity.

Focus: This is a short description of the concepts and/or skills developed by the activity. It also provides a quick capsulation of the activity to assist readers in rapidly understanding what the activity is all about.

Challenge: Using a challenge or problem-oriented approach to activities is one good way to stimulate student interest.

Materials and Equipment: A list of everything needed is provided with each activity. Feel free to vary the amounts of the materials to meet the needs of any class size. Construction suggestions are often provided for homemade apparatus. Hopefully, you will be able to find all materials at little or no cost.

How-To-Do-It: These are suggestions for planning, organizing, and actually implementing the activities with students. These are teacher-tested methods that have worked well for the contributing authors. But, feel free to invent your own variations.

Further Challenges: One solved challenge always leads to new challenges and those, in turn, lead to new learning opportunities. This section includes a few ideas for related, but different, learning activities. These challenges are entirely open-ended, and solutions are left to the students and teachers.

References: Articles and books are identified to give both teachers and students useful information related to this activity.

#### REFERENCES

- Bredderman, T. "Effects of Activity-Based Elementary Science on Student Outcomes: A Quantitative Synthesis", Review of Educational Research, 53: 499-518, 1983.
- Shymansky, J., W. Kyle, Jr. and J. Alport. "The Effects of New Science Curricula on Student Performance", Journal of Research in Science Teaching, 20: 387-404, 1983.
- Thier, H. D. "Hands on Elementary Science" - The Challenge for the Nineties, Monograph and Occasional Paper Series, Washington, D.C.: Council for Elementary Science International, 1986.

## TABLE OF CONTENTS

### CHAPTER I - INTRODUCTION TO TEACHING PHYSICAL SCIENCE ACTIVITIES

An Ounce of Prevention Mark H. Malone . . . . .	3
Learning Cycle for Physical Science Mark R. Malone . . . . .	4
Selecting Science Process Activities Gerald Wm. Foster. . . . .	8
Making Good Science Programs Even Better! Joan Tephly. . . . .	11
You Can Teach Science All Day Long Joan Tephly. . . . .	13
Group Inquiry Gerald Wm. Foster. . . . .	15

### CHAPTER II - ACTIVITIES FOR TEACHING SOUND

Tuning-In to Sounds Gwyneth E. Loud. . . . .	19
Toys that Teach Sound - The Paper Whistle Linda Froschauer . . . . .	21
Toys that Teach Sound - The Soda Straw Whistle Linda Froschauer . . . . .	23
Toys that Teach Sound - The Cardboard Tube Kazoo Linda Froschauer . . . . .	25
Toys that Teach Sound - The Paper Cup Noise Maker Linda Froschauer . . . . .	27
Visible Vibrations Gwyneth E. Loud. . . . .	29
The Pitch and the Pendulum Marilyn Donalson . . . . .	31
Pitch Paradox Donna Gail Shaw. . . . .	33
Sound with a Pipe Xylophone Rose West. . . . .	35

Sound Track: A Race Between Sound and Light Gwyneth E. Loud . . . . .	38
CHAPTER III - ACTIVITIES FOR TEACHING LIGHT AND COLOR	
Retinal Fatigue and Color Michael J. Demchik . . . . .	41
Toys that Teach Light and Sight - The Thaumatrope Linda Froschauer . . . . .	42
Toys that Teach Light and Sight - The Chromatrope Linda Froschauer . . . . .	44
Toys that Teach Light and Sight - The Pinwheel Linda Froschauer . . . . .	46
Toys that Teach Light and Sight - The Phantascope Linda Froschauer . . . . .	48
Toys that Teach Light and Sight - The Taleidoscope Linda Froschauer . . . . .	50
Toys that Teach Light and Sight - The Kaleidoscope Linda Froschauer . . . . .	52
Bouncing Light Patsy Ann Giese . . . . .	54
Reflections and More Reflections Michael J. Demchik . . . . .	56
Straight, Curved, or Crooked? Patsy Ann Giese . . . . .	57
Do You Look Strange at Lunchtime? Patsy Ann Giese . . . . .	59
Simply Scientific Symmetry Patsy Ann Giese . . . . .	60
Can You Catch Fish? Patsy Ann Giese . . . . .	63
Look Who's Got Four Eyes Patsy Ann Giese . . . . .	65
Liquid Lenses Meghan Mahoney Twiest . . . . .	67
Demagnification Michael J. Demchik . . . . .	69

How Lenses Turn Us Upside Down David R. Stronck . . . . .	70
Where Do Flowers Get Their Colors? Mildred Moseman . . . . .	72
Rainbow Physics Judith McKee . . . . .	74
Diffraction Slits Gerald Wm. Foster . . . . .	76
Polarized Light Gerald Wm. Foster . . . . .	77
 CHAPTER IV - ACTIVITIES FOR TEACHING ELECTRICITY FROM STATIC TO CIRCUITS	
Dancing Dolls Meghan Mahoney Twiest and Mark Twiest . . . . .	81
Charge Your Classroom Yvonne A. Johnson . . . . .	83
Let The Sparks Fly Richard Bollinger . . . . .	85
Electric Circles Stephen C. Blume . . . . .	88
Build a Heavy-Duty Circuit Board Charles Nease . . . . .	90
Electric Sparklers Stephen C. Blume . . . . .	93
Breaking the Electric Connection Carole Kuchinsky . . . . .	96
The Electrical Penny Pitcher Ginny Petrie . . . . .	98
Circuit Puzzles Rose West . . . . .	100
 CHAPTER V - ACTIVITIES FOR TEACHING ELECTRICITY FROM MAGNETISM TO GENERATORS	
Household Attractions Sandra K. Abell . . . . .	105

Magnet Magic	
Sandra K. Abell . . . . .	106
The Strength Detector and Other Magnet Inventions	
Sandra K. Abell . . . . .	107
Making a Paper Clip Float	
Meghan Mahoney Twiest . . . . .	108
Magnetic Patterns	
Judith McKee . . . . .	110
Magnetic Sunprints	
Rose West . . . . .	112
Generating Homemade Electricity	
Mark R. Malone . . . . .	113
Powering The Motor/Generator System	
Mark R. Malone . . . . .	115
I Didn't Know The Generator Was Loaded	
Mark R. Malone . . . . .	117

CHAPTER VI - ACTIVITIES FOR TEACHING FORCES AND MOTION

Don't Tag Along	
Patsy Ann Giese . . . . .	121
Inertia	
Nadine L. N. Halligan . . . . .	123
Finding the Velocity	
Michael J. Demchik . . . . .	126
Meter Beater	
Sue Dale Tunncliffe . . . . .	127
Out of Gas	
Sue Dale Tunncliffe . . . . .	128
Marble Momentum	
Mark R. Malone . . . . .	129
Soup Can Races	
Gerald Wm. Foster . . . . .	132
The Amount of Matter Doesn't Matter	
Patsy Ann Giese . . . . .	13
Sticking Power	
Michael J. Demchik . . . . .	135



Center of Gravity	
Michael J. Demchik . . . . .	136

CHAPTER VII - ACTIVITIES FOR TEACHING SIMPLE MACHINES

I'm Inclined	
Sue Dale Tunncliffe . . . . .	139
Move It!	
Sue Dale Tunncliffe . . . . .	142
When Is Slowest the Best?	
Thomas E. Thompson . . . . .	144
All Geared Up	
Janet Frekko . . . . .	146
Problem Solving Using Simple Machines	
Thomas E. Thompson . . . . .	149

CHAPTER VIII - ACTIVITIES FOR TEACHING HEAT

Taking the Heat	
David R. Stronck . . . . .	153
Investigating Color and Heat	
Tom Graika . . . . .	155
How Much Time?	
Patsy Ann Giese. . . . .	156
Supercooling	
Michael J. Demchik . . . . .	158
Soda Cans that Blow Bubbles	
Lawrence D. Calhour. . . . .	159
Hot and Cold and Up and Down	
Patsy Ann Giese. . . . .	163
Fizz - Bubble - Pop (Fast Get-Aways)	
Terri G. Switzer . . . . .	165

CHAPTER IX - ACTIVITIES FOR TEACHING FORCES IN LIQUIDS AND GASES

Medicine Dropper Submarine	
Donna Gail Shaw. . . . .	169
Closed Systems	
Gerald Wm. Foster. . . . .	171

Heard It through the Grapevine Edward L. Shaw, Jr. . . . .	173
Heaping High Water! Donna Gail Shaw. . . . .	174
Vanishing Ice Cube Trick Mildred Moseman. . . . .	176
Soda Pop Sink or Float? Gerald Wm. Foster. . . . .	178
The Mystery of the Rising Water Donna Gail Shaw. . . . .	180
Don't Suffocate that Mouse! Donna Gail Shaw. . . . .	183
Making Your Own Bernoulli Blower Meghan Mahoney Twiest and Mark Twiest. . . . .	185
Jet Engines David R. Stronck . . . . .	187

CHAPTER X - ACTIVITIES FOR TEACHING MATTER

Particle Free for All Edward L. Shaw, Jr. . . . .	193
From Here to There Patsy Ann Giese. . . . .	195
Chemical Detectives Terri G. Switzer . . . . .	197
The Whole Is Less than the Sum of the Parts Patsy Ann Giese. . . . .	200
Fifty Plus Fifty Doesn't Always Equal One Hundred Donna Gail Shaw. . . . .	203
Solutions to Crystals (Rock Candy) Linda Vance and Rose West. . . . .	205
Growing Perfect Crystals in Minutes Michael J. Demchik . . . . .	207
Separating Mixtures Linda Vance and Rose West. . . . .	208



The Power of Salt Mildred Moseman . . . . .	210
--	-----

Water Magic Sue Dale Tunncliffe . . . . .	211
--	-----

CHAPTER XI - ACTIVITIES FOR TEACHING CHEMISTRY

Somewhere over the Rainbow Thomas E. Thompson . . . . .	215
--	-----

Examining Ink Michael J. Demchik . . . . .	217
---	-----

Secret Handwriting Edward L. Shaw, Jr. . . . .	219
---	-----

PCJ or Purple Cabbage Juice Yvonne A. Johnson . . . . .	220
--	-----

Color Magic with Fruits and Vegetables Stephen C. Blume . . . . .	222
--	-----

Alike or Not - A Search for Hidden Properties Bonnie Barr. . . . .	225
---	-----

Fire Egg-stinguisher Carol Van De Walle . . . . .	228
--	-----

A Gas Problem David R. Stronck . . . . .	230
---	-----

Plastic Bag Chemistry Bonnie Barr. . . . .	233
---	-----

Slime Bob Burtch . . . . .	236
-------------------------------	-----

CHAPTER XII - ACTIVITIES FOR TEACHING SPACE

Human Sun Dials Judith McKee . . . . .	241
---	-----

Rotate-Revolve Game Judith McKee . . . . .	242
---	-----

Sizing Up the Sun, Earth and Moon Judith McKee . . . . .	243
---	-----

Simple Solar System Model Judith McKee . . . . .	244
---	-----

Moon Mobile	
Ruth M. Rund . . . . .	246
A Cupful of Stars	
Ruth M. Rund . . . . .	247
How Big is That Sun?	
Tom Graika . . . . .	248
Finding Constellations	
Tom Graika . . . . .	250
CHAPTER XIII - ACTIVITIES FOR TEACHING MORE PHYSICAL SCIENCE	
Teach Physics through Sports and Games	
Charles Nease. . . . .	253
Use Cartoons to Reinforce Physical Science Concepts	
Charles Nease. . . . .	255
How Many Milliliters in a Gallon	
Michael J. Demchik . . . . .	257
Measuring Wide Things	
Michael J. Demchik . . . . .	258
Measuring Tall Things	
Michael J. Demchik . . . . .	259

CHAPTER I

INTRODUCTION TO TEACHING PHYSICAL SCIENCE ACTIVITIES

What will  
happen to  
the mouse  
when the  
candle stops  
burning...  
why ?

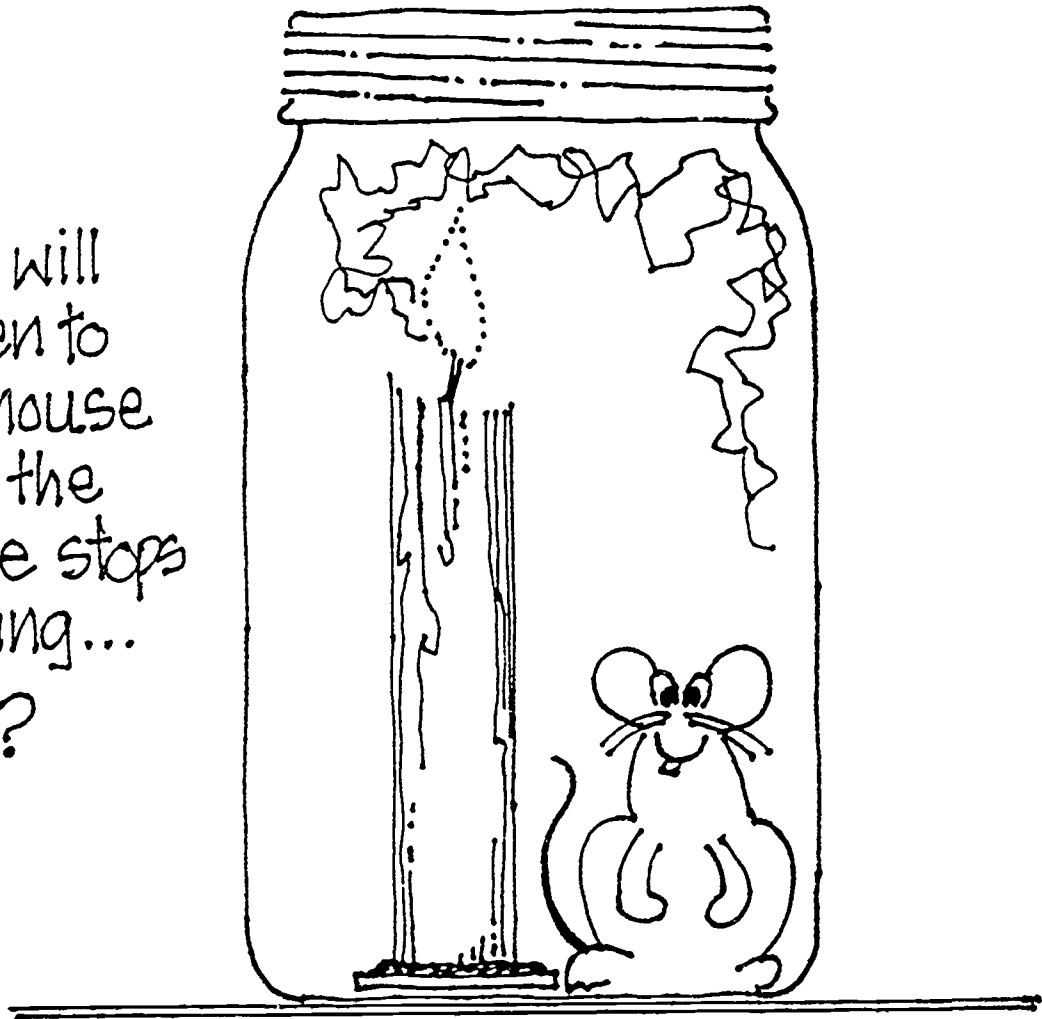

"Science is a way of thinking much more than it is a body of knowledge. Its goal is to find out how the world works, to seek regularities there may be, to penetrate to the connections of things..."

-Carl Sagan

## AN OUNCE OF PREVENTION

by Mark R. Malone

Every effort has been made in compiling this sourcebook to assure that all activities are academically sound, motivating and interesting for students, and reasonably safe for supervised student use. The ultimate responsibility for assuring that all of these goals are successfully met is the responsibility of the classroom teacher. As this book was compiled, close attention was paid to the safety aspects of the activities. Some activities were rejected due to safety concerns. Safety tips were added to others. In the end, however, it is the teacher's responsibility to assure that students are kept safe in conducting these activities and investigations.

Please pay careful attention to any safety tips included in activities. Unfortunately, it is not possible to predict all of the ways that these materials might be misused or malfunction in the hands of students. Just the fact that your students are doing some type of manipulative activity rather than sitting and reading a science text puts them at somewhat greater risk of injury.

All of these activities are designed to be done under adult supervision. Students should be reminded of this if they intend to repeat or extend any of these activities at home.

Precautions should be taken any time sharp objects, glassware, flame, chemicals, or other potentially hazardous materials are in use. When using chemicals (household or commercial), label directions should be read and carefully followed regarding safe use and poisoning. These label directions for safe use take precedence over any instructions stated or implied by this sourcebook. Properly store chemicals only in their original containers so that these directions are available in the event of an accident. It is hoped that these words of caution will help in preventing any unnecessary accidents.

## LEARNING CYCLE FOR PHYSICAL SCIENCE

by Mark R. Malone

With any science activity, the materials used are not as critical as the methods used in communicating ideas to students. Physical science activities included in this sourcebook lend themselves quite well to inquiry oriented strategies. One of the advantages of physical science activities is that they generally can be conducted in a short time frame. This characteristic of physical science activities allows students to see many phenomena associated with an apparatus or event in a short period of time. This is in contrast to other areas of science study, such as biological phenomena, that take several days, weeks, or months to observe and are often difficult to repeat if something goes wrong. The immediacy of results allows students to gather data under controlled circumstances, repeat observations, and correct immediately for procedural problems resulting in faulty data.

Learning cycle is a method of daily classroom instruction that allows students to explore in an inquiry fashion yet retains enough structure in a lesson so that a teacher can still feel in control of the teaching situation. It represents a significant compromise between the "free-form," "self-directed" inquiry methods promoted by some in the 1960's and "direct instruction" methods which are being promoted in the name of a "back-to-basics" movement by some in the 1980's. The learning cycle can allow you to take full advantage of the nature of physical science activities presented in this sourcebook.

Learning cycle, as presented here, incorporates and builds upon a general scheme of instruction developed by Karplus and Thier (1967). It is also sometimes identified as the SCIS Learning Cycle because its initial and most well known use was with the Science Curriculum Improvement Study (SCIS) developed by Karplus, Thier and others working at the Lawrence Hall of Science under a federal grant. The wide acceptance of this learning cycle is attested to by the fact that it is cited and described in nearly all college science methods textbooks for elementary teachers and in many contemporary books dealing with general elementary school curriculum. The learning cycle's purpose is to develop learning situations through which students can gain science concepts in such a way that they can interpret information as if they had obtained it themselves. Though this is a laboratory approach to learning, students are not expected to discover all concepts for themselves. The general scheme of instruction includes a three-phase sequence of exploration, invention, and expansion (originally referred to as discovery).

During the initial exploration phase, students are presented with materials or arrangements of materials which are unfamiliar to them. They must sort, identify, and label properties and characteristics of these materials. Aspects of the materials that are already familiar to them serve as a catalyst for organizing the learners' ideas about the materials. This phase is a period of free exploration or play with the materials. It gives

the children in a classroom setting an opportunity to be "children." They can explore freely and discover what they can on their own. It is a process that is very respectful of children "as children" rather than as "miniature adults." During this phase of inquiry the teacher must refrain from telling students why something has happened. They should concentrate on questions that focus students on what is happening or how a phenomenon occurs. This phase serves several purposes. It gives children an opportunity to do what they would do with the same materials in a non-school setting. They will choose to learn about what is most interesting and appropriate for them at the time. This exploration period provides common experiences from which all students can draw during the more directed phases that follow. This phase of the learning cycle also tends to diminish discipline problems for the teacher. Because playing, within guidelines of safety, is allowed and encouraged, students are more likely to be attentive and cooperative in the more structured tasks that follow.

This is in contrast to what might occur in a very directive laboratory approach. For example, picture an eight-year-old child, given a magnifying glass and a twig, being told to look at the buds on the twig and identify the parts. In this situation the magnifying glass itself is likely far more interesting than the twig. The student is expected to ignore all of the interesting characteristics of the glass, such as its ability to turn the whole world upside-down, to enlarge another student's eye, or to focus a concentrated circle of light on the twig to sear its bark. In a very directed lab situation the student is likely to get in trouble for any one of the above other than looking at the bud on the twig. The learning cycle assumes that the twig and the magnifying glass may be equally interesting and educational depending on the student's past experience. After the child has had an opportunity to explore the magnifying glass, he/she is much more likely to be able to focus later on a more structured look at the twig.

Exploration has set the stage for the next phase of inquiry, Invention. This phase helps students to organize experiences from their exploration. With the teacher's guidance, students group their experiences into descriptions, explanations, classifications, or hypotheses. This phase is the most teacher-directed of the three phases. It usually takes place in the context of a full group discussion. The teacher and students cooperatively "invent" names for concepts or phenomena described by students, based on their observations. The teacher also prompts students to plan to conduct more systematic investigation of the materials being explored. The teacher and students cooperatively devise a plan for further, usually systematic, study of the materials for the phase that follows, Expansion. During this phase procedures such as drill, reading, and passive listening to teacher lecture are inappropriate. Appropriate activities include further display or manipulation of the materials, discussion, directive questioning techniques, and organization of a plan for further study. Potential future learning lies within the inventions themselves as a basis for the Expansion phase which follows.



Expansion I, the testing of an invention's adequacy. Does the invention account for various arrangements, actions, or events with the materials, or for new objects under similar conditions? This phase is generally characterized by students conducting some type of controlled investigation. This process serves to strengthen, establish, modify, or destroy inventions. The teacher's role during this phase is to guide students to investigate the strengths, logic, and integrity of inventions through manipulative experiences. By this phase of expansion with manipulative experiences, the student has developed a cognitive structure for understanding the concept.

Further expansion of the concept can take place in Expansion II, using more formal information-presenting techniques such as assigned readings, writing, discussion, and lecture. These activities are appropriate at this time because students have developed a meaningful cognitive structure for dealing with material in a more abstract manner. This sub-phase of expansion will be referred to as Expansion II. This phase was alluded to, though not labeled as "Expansion II," in the early writings of Karplus and Thier. It was not, however, included as a dominant part of the SCIS program's applications of learning cycle procedures. If one of your goals of instruction is to enable students to read written material related to physical science concepts taught, Expansion II is the most appropriate placement for this type of instruction. Any type of age-appropriate reading related to the concepts developed in the lessons will aid students in fully understanding these concepts. You are encouraged to locate appropriate readings from current journals, magazines, or textbooks that enhance students' understanding of these physical science concepts. To be true to the learning cycle, these readings must be placed in the sequence of the lesson after, not before, the manipulative experience portion of a lesson.

The Expansion II phase of the learning cycle allows you to expand childrens' understanding of science concepts through inclusion of other contemporary goals of science instruction. Through formal teaching strategies such as reading, discussion, or brief lectures, students can learn how the science concepts or skills from earlier phases of the learning cycle fit into a larger scheme of understanding. Potential careers in science related to a topic studied can be explored. Real world examples of applications of a concept become more meaningful. Students can engage in meaningful discussions pertaining to how information learned can assist them in becoming responsible citizens. Personal utility of information or skills studied can be explored. This new phase of the learning cycle can also aid students in seeing how academic information or skills learned in the current lesson may apply to future study. It also provides teachers with a mechanism for bringing closure to a lesson.

Many activities presented in this sourcebook can be greatly enriched when implemented with learning cycle strategies. It should be kept in mind, however, that many other teaching strategies can also be used effectively for presenting these activities to children. Learning cycle should be viewed as one of many tools appropriate for designing good instruction for elementary and middle school. Varying your approach to instruction from

time to time will help to motivate and hold the interest of your students.

Reference:

Karplus, R. & H.D. Thier. A New Look at Elementary School Science - Science Curriculum Improvement Study, Chicago, IL: Rand McNally & Company, 1967.

## SELECTING SCIENCE PROCESS ACTIVITIES

by G. Wm. Foster

Process science requires a variety of teaching skills and behaviors ranging from keeping track of materials to asking appropriate questions. Not only does a teacher have to contend with children using the materials correctly but also with the fear that the activity may not go as planned. That is, how will children react to the activity? Will they be bored or interested? Will they hurry through it or will they take their time? Developing a systematic analysis of science activities can allay fears of the unknown. It also helps to have a clear understanding of why process science needs to be a part of the elementary curriculum. With this understanding, many of the common problems associated with hands-on activities will no longer be considered problems but situations with positive outcomes.

First of all, the reader must keep in mind that the primary reason for hands-on science activities in the classroom, rather than the traditional textbook centered approach, is that science itself is an activity. The second reason is that most science investigations require students to use mental operations that are important to intellectual development. Data are collected by observing, classifying, analyzing, predicting, hypothesizing, etc. How data are collected and conclusions reached varies greatly from one individual to another. Thus, science calls upon each individual to use a variety of critical thinking skills. Elementary and middle school children are at an age when critical thinking skills are developing. It is important that they can have the opportunity to abstract basic science concepts from concrete hands-on experience.

Science activities that nurture critical thinking skills and reflect the processes of science can be identified. The characteristics of science activities that help develop critical thinking skills are outlined below:

1. These activities include objects that have inherent observable relationships. The child can explore these relationships by his/her physical actions upon the objects. That is, a child can find these relationships without the aid of another person or a list of procedures. For example, in "Pitch Paradox" a student can observe a direct relationship between the change of pitch and changes made on the pop bottles.
2. These activities include an assortment of objects to explore natural phenomena with a variety of observable relationships. For example, in "Electric Circles" students can explore circuits using a variety of types of batteries, bulbs, and wires that will give them a variety of relationships between variables such as bulb intensity, short circuits, parallel and series circuits.
3. Children can enter these activities at their own level of understanding. For example, "Closed Systems" allows a child who has never had experience with density of liquids to make a

"diver" while on the other hand a child who has had experience with a "diver" can explore the effects of different liquids upon the "diver."

4. These activities have a variety of extensions to compensate for different levels of critical thinking skills and creativity. As you will notice, all of the activities in this book have extensions (usually labeled "Further Challenges"), which allow for different ability levels and act as motivators to keep the child interested in the activity.
5. These activities deal with scientific phenomena that appeal to a child's curiosity. For example, magnetism is a scientific phenomenon that children can easily explore and find fascinating at the same time.
6. These activities have relevancy to the child. Again taking magnetism as an example, magnets are found in toys, appliances, tools, etc. This scientific phenomenon is an excellent example of illustrating the relationship of science, technology, and their effects upon society.

Analyzing elementary science activities according to these criteria would give evidence that more physical science activities fit the criteria than do the biological science activities. In most biological science activities, a child cannot act directly upon the living objects without doing some harm to them. To properly explore living systems, most experiments call upon the investigator to change the environment of the living organisms. The effects of the changes may be slow and hardly observable. Finally, the complexity of the variables associated with living things often makes it frustrating for children to sort out the changes that occur or don't occur to the living organisms. Thus, a student may lose interest before the changes occur or may lose interest because the science concepts are too abstract. By emphasizing physical science activities, many of the natural scientific phenomena found in living organisms can be better understood by children. For example, observing capillary action in straws, paper towels, and capillary tubes can pave the way to understanding the flow of sap in trees.

However, no matter whether the activity involves a biological or a physical concept, a teacher can ask several questions to determine whether the activity is appropriate to the student:

1. Does the activity allow for different levels of critical thinking skills?
2. Does the activity include objects so that relationships are clearly observable to the student?
3. How is the activity presented? Does it allow freedom of exploration, within the given classroom rules, or does it contain numerous directions that stifle children's natural curiosity?

4. As a teacher, do I spend my time giving and explaining directions or am I a facilitator of learning?

Most science activities can be adapted so that students find them rewarding and teachers find themselves facilitators of learning rather than directors of procedures and disciplinarians. In addition to adapting or finding activities that nurture critical thinking skills, a teacher can also do the following to help facilitate learning:

1. There is no such thing as a fool-proof science activity. Crickets will die, bulbs burn out, chemicals will not react, etc. When things do not go according to plan, use the experience to find out what happened. It could lead to new and exciting understandings and discoveries for both student and teacher. Most breakthrough discoveries in science were made when things didn't proceed as expected.
2. Accept the variety of answers and questions you may receive from children. Each child may have a different understanding of the same scientific concept. Processing information is more important than memorizing information.
3. Explore with the children. This helps model the type of learning that is expected in hands-on science classrooms.
4. Accept inquiry as part of teaching. Ask questions to find out what the child is thinking rather than "fishing" for particular answers. Use questions as an assessment tool. What does Johnny know about calories? Why are the children restless? How can I adapt the activity to their level of understanding? Why didn't the activity work?

To make science teaching successful in your classroom, you must become a facilitator through questioning, a motivator through ideas, and an advocate through listening to children. Science can be exciting and fun if both teacher and students explore together an important frontier: the mind.

## MAKING GOOD SCIENCE PROGRAMS EVEN BETTER

by Joan Tephly

If you are reading this book, you are interested in extending your science curriculum. While this sourcebook is filled with many excellent ideas you may want to incorporate, there are also some broader guidelines to apply to science programs.

Since 1982, the National Science Teachers Association has yearly drawn up criteria for excellence in different areas of science education. National searches have been conducted to find programs best matching the criteria (The Search for Excellence in Science Education). In these few years, elementary science education has twice been surveyed, middle school/junior high has been examined once, and physical science, once.

The criteria used in the NSTA search are worth considering as yardsticks for your science program. They have been carefully developed by committees of experts in the varied aspects of science education. The following is a condensation of the primary criteria.

- The criteria always stress the need for students to be actively involved in their learning. This ranges from identification of science problems or questions to solution-seeking techniques, formulation of conclusions and interpretation of information. Programs should include concrete, hands-on experiences, exposure to inquiry and problem-solving skills, and the opportunity to actually do some research.
- The science program should integrate with other areas of the school curriculum and other science disciplines, thereby aiding students in understanding and appreciating the technological and everyday applications of science. In striving to do this, the larger community must be part of the science program as curriculum resources, as representations of applied science, as sites for field trips, and as individuals who can serve as role models of science and science related careers. These role models provide early exploration of possible career choices and as such they should represent a range of sex, socio-economic and ethnic exposures.
- Exemplary programs strive to move beyond the textbook and identify and study real-world problems. In so doing, students are exposed to topics of immediate and future concern in the larger environment. Students will learn to apply science knowledge as effective consumers, as individuals striving for effective personal health practices, as citizens making thoughtful decisions concerning their country and their planet.
- Students, even young students, should begin to develop an understanding of the means by which scientific knowledge is generated and scientific models and theories developed. What science is and what it is not, what it can do and what it cannot do are critical understandings about the nature of science.

- The backgrounds, abilities and interests of students must be considered in planning a science program. A variety of instructional content, strategies, and resources creates an interesting and individualized program.
- To teach science and do a good job, adequate time and materials are a necessity. They are not always present in an educational system's basic structure. They are goals worth struggling for.

In case these condensed criteria for really good programs sound overwhelming, a look at some of the characteristics of teachers who have created programs recognized as exemplary may stimulate you further.

Programs always reflect their creators. Exemplary programs were almost always developed because the teachers perceived a need among their students which was not being met by the curriculum in use. Usually a team of two or more teachers were the innovators, although exceptional single teachers have been found. A leader existed within the team and most often the efforts were with administrative support. The new programs evolved with carefully designed goals and were implemented over a sustained time period. Linkages were established with higher education through continued coursework on the part of the innovators, and consultation and assessment support from college/university personnel. These new programs are never "in place." Even programs receiving national recognition as exemplary are constantly striving for improvement.

Any teacher striving to make curriculum changes can learn some pointers from these teachers:

- There is greater strength and wisdom in numbers (teams of two or more). Try to find others to build with.
- Administrative support, even involvement, is so important -- a teaming, trusting, respectful relationship. Strive to nurture it. Don't give up easily. Teachers dedicated to improvement do generate support.
- Consider networking with institutions of higher learning for support and expanded expertise. Personnel at such institutions can also provide the rationale you need to justify your desired changes.
- Value sustained inservice opportunities (release time, visiting, courses, workshops, professional meetings). Avoid burnout through the stimulation of new ideas. Appreciate that growth and change are slow and sustained.
- Think creatively, both to address your program needs and to expand into your community. Community support impresses administrators.
- Don't try to change your program too fast. You'll risk burnout.
- Never think your program has arrived. You'll risk stagnation.

## YOU CAN TEACH SCIENCE ALL DAY LONG

by Joan Tephly

Ask any elementary teacher what curriculum area receives the greatest time emphasis during the school day and you will be told "Reading." Ask next what curriculum area most likely receives the least time in the daily schedule and you will be told "Science." And with rare exception, the imbalance is greatest in the lower elementary grades. As an educator, you probably know this. But have you struggled with ways to do something about it?

Science lends itself well to instruction all day long. It is easily integrated with other curriculum areas. Start with reading. Of course, in too many classrooms a lot of reading goes on in the brief amount of time allotted to science. But what about the large block of reading time? Can you teach science there? And can you justify teaching science during reading?

Reading and science build upon many of the same basic skills. This alone establishes a strong case for science during reading. Many of the skills used in the scientific method of investigation are also necessary in reading, such as observing, identifying and labeling, classifying and sequencing, describing, asking questions, seeking and recognizing relationships, gathering information, drawing conclusions, and communicating or reporting. There is a lot in common.

Topics and concepts under study in the regular science curriculum can be incorporated into reading time as learning center activities to be explored by children who are finished with meaningful reading assignments and are not working directly with the teacher. The vocabulary or reading content associated with the science activity can also have some reading skill assignments attached to it; for example, find all the science vocabulary words with long vowels, or find the compound sentences in the reading materials. Vocabulary from the regular science curriculum can also be used as reading vocabulary from which language experience-type activities can be built. If appropriate, this same vocabulary can become meaningful spelling words. Teachers will need to do this particular match of reading skills and science content for their particular classroom of children.

Mathematics receives the second largest block of time in the school day. How easy it is to integrate the science and math time. Mathematical calculations need application to real problems. Scientific exploration demands record-keeping, calculation, and problem solving.

Other language arts areas (listening, writing, oral communication, literature) all effectively build on science content. Oral speaking and expression as well as creative writing can be based on a topic of choice, and why not a science related topic? A science topic can be dealt with in an expository manner or as a basis for creative diversion (create a new insect, plan a landing on Mars, write a poem from the perspective of a bird, etc.). Children's books are full of fact as well as fantasy. Listening skills are always focused on sounds in the physical world.



Social studies is such a natural for integration with science that it's hard to believe that integration doesn't always occur. Whether you are studying your students' families or neighborhood or more global studies, there are always elements of the studied topic which deal with science. These relationships can readily be seen when studying: technology; people; science related careers; industries; geography; or concerns, problems, and questions rooted in scientific understandings and applications.

The very production of musical sound is science. How sounds are produced; how varied instruments, bands, and orchestras create their ranges of sound; and why a given sound (or note) is the same yet different on different instruments, even the human voice, are all science related topics. Many colleges now have courses on the physics of sound. The technological applications which have brought about the fantastic music recording and reproduction industries are ripe areas for study. Listening skills and musical sounds are a natural match.

Literally any object a child chooses to draw, sculpt, or create in any other art dimension is an object which can be studied for its scientific value. The very act of reproducing an object in an art form requires detailed reproducing observation and examination of its various parts and their relationships. Close attention to colors and to one's own ability as an artist to create, combine, and reproduce those colors is science and can be extended to many understandings about light and color. Three-dimensional art forms demand experimentation with gravity, balance, and sometimes motion.

A lot happens in physical education which can motivate children to learn more about what they are experiencing in a particular activity. Students can begin with their own personal bodies and ask how they manage to move them around for the necessary range of motion for a particular physical activity. The various apparatus used in the many games that young people play lend themselves to learning more about force, motion, and gravity.

What's really happening when teachers start overlying curriculum areas as discussed above? They are putting the parts back into the whole. Teachers can become so immersed in their teaching that they fail to notice the compartmentalized climate which may result. In the world outside the classroom, life does not split itself into separate curriculum areas. Yet what goes on in the classroom is primarily about the outside world. Educators sometimes forget what it's all about.

It is not only science that suffers from this myopic vision. Likewise, reading and mathematics need to be viewed as a means to an end. They represent skills which are meant to be applied to some exciting content. And science can be pretty exciting.

Teachers who integrate curriculum areas are building very important skills in young people which go far beyond content knowledge. Asking questions, seeking information and answers, critically evaluating, and making choices and decisions, are all skills for life!

## GROUP INQUIRY

by Gerald Wm. Foster

"HANDS-ON, MINDS-ON" is often used to characterize a frame of reference for teaching science in the elementary classroom. The meaning refers to elementary students experiencing science through action on concrete objects for understanding basic scientific phenomena. But I would like to attach a slightly different meaning. Not only do children need the concrete hands-on experience, but they also need a "minds-on" experience through verbal interactions with other students. In other words, children also learn science by interacting with the ideas of others. Piaget states,

As far as intelligence is concerned, cooperation is thus an objectively conducted discussion (out of which arises internalized discussion, i.e., deliberation or reflection), collaboration in work, exchange of ideas, mutual control (the origin of the need for verification and demonstration), etc. It is therefore clear that cooperation is the first of a series of forms of behavior which are important for the constitution and development of logic.  
(Piaget, 1966)

What Piaget is saying is especially true for upper elementary grades and middle school students. Their maturity, experience, and logical development allow them to consider other possibilities and/or points of view that are different from their own internal sets of knowledge. This makes them capable of coordinating different viewpoints with their own viewpoints. In contrast, younger children are usually only capable of relating to their own set of knowledge and not to that of others.

Before students can coordinate differing points of view of other students, they must have some understanding of the concept(s) that are under consideration. To gain this basic understanding, they need to process the concept through concrete experience prior to interacting with other students on the same concept. Otherwise, students may feel lost and incapable of participating in the group work. Possibly, this is the reason why many teachers observe some students in groups sitting back and letting other students do all of the work. For example, a student needs to have a personal cognitive structure for working with a group of students who are working with complex electrical circuits. If a student does not have a basic understanding of how to light a bulb, that particular student will not understand what the other students are doing or saying in relation to the circuits they are building. Activities on building electrical circuits appearing in this sourcebook are excellent examples of science activities that allow students the opportunity to develop and coordinate different points of view. There are enough materials and ways to devise circuits that each student can contribute to the development of circuits.

In most cases, a well functioning group will take on the characteristics of a unit or act as one individual. To achieve this, ground rules such as respecting the opinions of others and assigning each student a responsibility must be a priority in the formation of student groups. Thus, to some extent, individualized classroom teaching strategies can apply to individual groups. For example, groups work at different paces

and extensions are needed for those who are getting bored or who have completed the initial stages of the activity before any of the other groups. Groups may have to be motivated in different ways to keep them on task. For example, one group may need clarification of the goals of the activity while another group needs to be reminded of the classroom rules for working in groups.

Another consideration in the formation of groups is their size and student mix. Groups of four to five students appear to be the optimum size. If the group consists of three people, often one feels left out of the group activities, or, if the group consists of two people, then the diversity of ideas is extremely limited. If the group is larger than five, it is possible that the group will break down into sub-groups or that students can sit back and remain anonymous. Also, as the group gets larger, it becomes increasingly difficult to assign different responsibilities to each group member.

Groups should be heterogeneous rather than consisting of students of the same I.Q., sex, or socio-economic background. In other words, certain student characteristics should not determine the make-up of the group. Group work ought to be fluid and dynamic, based upon cognitive needs of students rather than just an alternative to individualized work or whole group instruction. Working groups can be formed spontaneously as those needs arise. They can be readily dissolved when another form of instructional setting is appropriate. For example, students can develop classification schemes on their own. Those who finish early can share their schemes. They can discuss the differences and similarities of their schemes, modify their own, or work together to develop one main scheme from the individual work.

In summary, group inquiry in the science classroom can be very rewarding not only for the students but also for the teacher. It can be rewarding to the teacher in terms of seeing the diversity of opinions and creativity that can arise from a group. It can also be rewarding to see students who do not participate in large group activities share their ideas with others. In other words, a whole new viewpoint of individual students and their potential may emerge from observing student in group activities. For students, this may mean a stronger and more positive self-image than that they had before, because they can share their ideas and opinions to a small group of students and not feel intimidated by the whole class.

Thus, not only does group work help in the development of children both socially and intellectually, but it also puts them in situations similar to the everyday work of the scientist. Ideas in science are rarely shaped by one person's research but are shaped by the acceptance and rejection of other scientists. The more students understand how science works, the less alienation they will feel toward science.

#### Reference:

Piaget, Jean. The Psychology of Intelligence, Totowa, NJ: Littlefield, Adams, & Co., 1966.

CHAPTER 2

ACTIVITIES FOR TEACHING SOUND

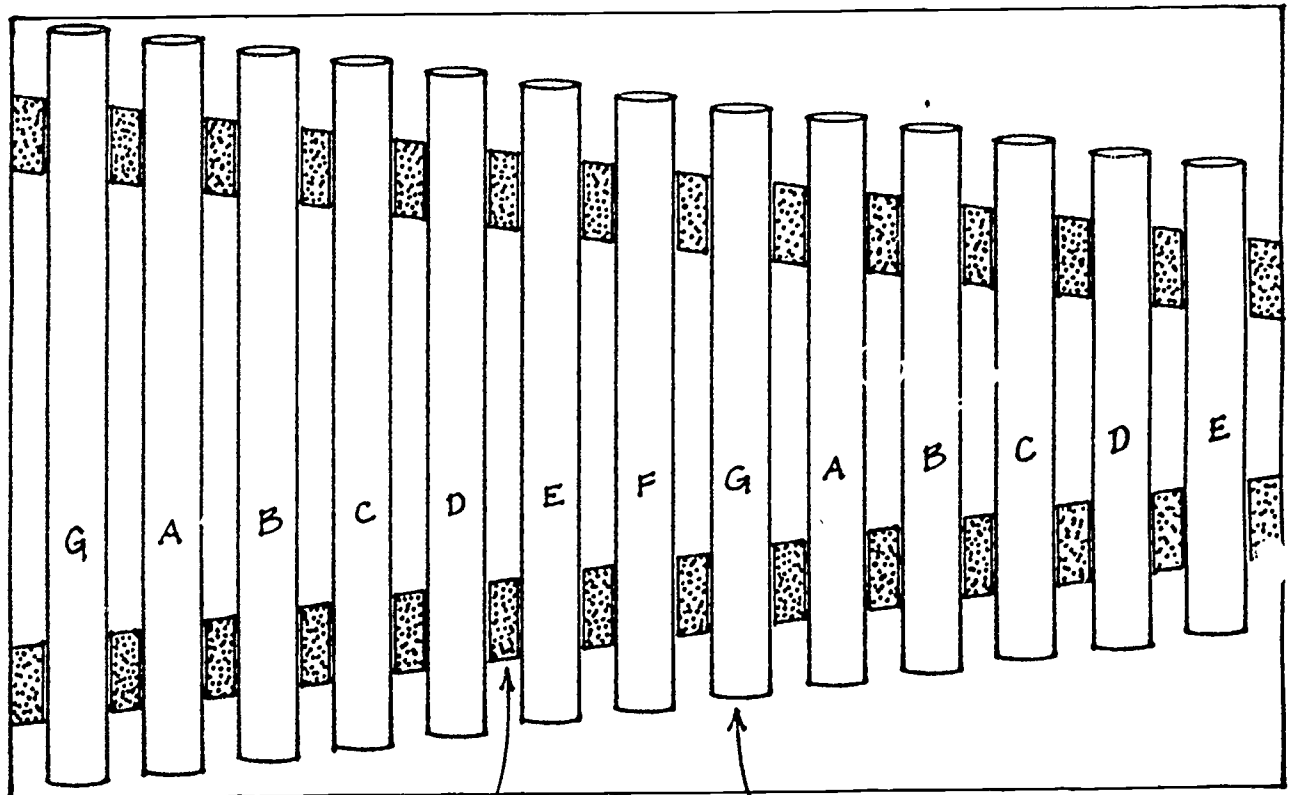

foam spacers  
-glue to foam strip

conduit-  
metal pipes

## TUNING-IN TO SOUNDS

by Gwyneth E. Loud

Focus: Most of the time we live in a noise-filled world. We get so used to the sounds and noises around us that we do not even notice most of them and they blur into general background noise. This is a sensory activity which heightens awareness of the sounds around us.

Challenge: When we close our eyes and focus attention on the sounds around us, what do we hear?

### Materials and Equipment:

Pencil  
Paper

How-To-Do-It: This activity can be done with any size group, indoors or outdoors. (If the group is outdoors and lying on grass, leaves, pine needles, etc., this is a sensory experience in itself and usually requires several minutes for the group to feel comfortable, settle down, and stop talking.)

Sit or lie quietly with eyes closed for a given length of time (3-10 minutes, depending on the age and interests of the children).

Older children make their own lists of all the sounds they hear, man-made as well as sounds of nature.

After the time is up, gather together and share lists or make a large group list of all the sounds heard.

Further Challenges: Think of ways to classify the sounds heard, e.g., high/low pitch, duration, made by living or non-living objects, natural or man-made, etc.

Discuss or do research about how well animals other than humans hear. Dogs, bats, and insects, for example, can hear pitches out of the human range. Some children will know about echolocation used by such animals as dolphins.

Discuss health and social effects of noise pollution and high decibels.

Have students use tape recorders to record sounds in the environment.

Play identifying "mystery sounds" games. Most libraries have records of various animal and environmental sounds which can be used for these games. Common household and school sounds could also be tape recorded if commercially produced materials are not available.

References:

Allison, Linda. Blood and Guts. Boston: Little, Brown and Co., 1976.

Russell, Helen Ross. Ten-Minute Field Trips. Chicago: J. G. Ferguson, 1973.

## TOYS THAT TEACH SOUND - THE PAPER WHISTLE

by Linda Froschauer

Focus: This and related lessons teach children that sound is caused by vibrations. Energy is necessary for sound to occur. The source of energy varies. In the case of the activities that follow, the energy source is the person conducting the activity. (If an object vibrates 16 times per second or faster, the sound can be heard by humans. If the object vibrates faster than approximately 20,000 times per second, humans cannot hear the sound.) Sound must have a conductor. That conductor may be air, a solid, or a liquid. There is no sound in space because there is no atmosphere to serve as a conductor.

Challenge: After constructing this instrument, students will look for evidence of what causes sound.

### Materials and Equipment:

Paper template  
Scissors

How-To-Do-It: Have students cut out the paper whistle found on the next page. The solid lines should be cut out, making sure to cut out the diamond shape in the center. Next they should fold along the dotted lines.

They should hold the whistle to their lips, separate the pieces of paper slightly, and blow sharply. Ask them to try to explain how the sound is formed, based on their observations. It may be helpful for them to place their thumb and index fingers around a partner's whistle as it is being blown.

Further Challenges: What can you do to change your whistle so that it makes a different sound?

What is the smallest or largest whistle you can make that will still create sound? How does the sound of a larger or smaller whistle differ from the sound of the original one you made?

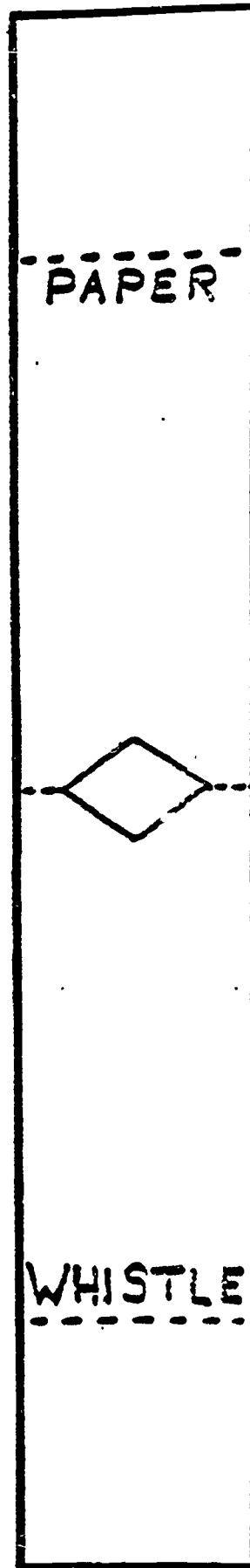
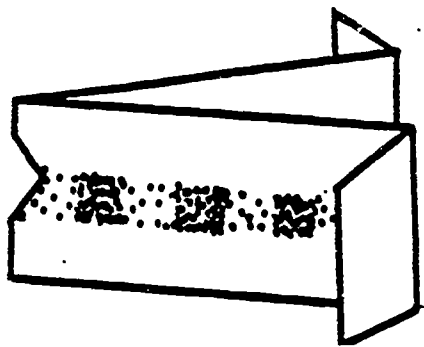



## TOYS THAT TEACH SOUND - THE SODA STRAW WHISTLE

by Linda Froschauer

Focus: Reinforce concepts introduced in "Toys That Teach Sound - The Paper Whistle."

Challenge: With this new instrument it is not possible to see evidence of what makes the sound. But, is it possible to feel evidence of what makes sound?

### Materials and Equipment:

2 soda straws  
Scissors

How-To-Do-It: Flatten about 2 cm (3/4 in) of one end of a soda straw. Placing the straw between your teeth and chomping down hard while pulling it out of your mouth works quite well. Cut away a small triangle on each side of the flattened end of the straw to form a point as shown on the next page.

Put the flattened end in your mouth and blow hard. It is necessary to put the straw deep enough into your mouth so that the tip is not touching the lips or tongue. The teeth should be held slightly apart so they do not interfere with the straw's vibration or air flow. If you do not hear a sound, you may need to flatten the end of the straw a bit more.

Ask students to describe what they feel when they blow into the straw.

Further Challenges: Try to make a soda straw whistle that is shorter than the one just made. Compare the sounds it makes with the other one.

Make a whistle that is higher in pitch than either of the straw whistles you have made thus far.

Get a group of friends together and create a band. Each player should have a whistle with a different pitch. Can you play a simple song?

Make a straw whistle that is narrower than the one first made. How is the sound different?

Place a straw that is narrower into the bottom of the first straw whistle. Slide it up and down as you are blowing. What musical instrument works on a similar principle?

Join several straws together to make a very long whistle. Try blowing into it. What did you find out? Why does this happen?



## TOYS THAT TEACH SOUND - THE CARDBOARD TUBE KAZOO

by Linda Froschauer

Focus: Reinforce concepts introduced in "Toys That Teach Sound - The Paper Whistle."

Challenge: Don't be fooled. There are several things that vibrate when using this instrument. Think about all of them as you work on this project.

### Materials and Equipment:

Toilet paper roll  
Wax paper  
Rubber band  
Sharp pencil

How-To-Do-It: Wrap a 10 cm by 10 cm square of wax paper around the end of a cardboard tube. (Empty toilet paper roll tubes are a particularly good size.) Secure the wax paper in place (as shown on the next page) with a rubber band. About 2 cm from the covered end, make a small hole with a sharp pencil.

Instruct students to hold the open end of the instrument to their mouths. They should open their mouths slightly and hum a tune. Ask them to identify everything that vibrates to make sound.

Further Challenges: What causes the sound?

What changes the pitch?

What changes the sound?

Would a longer tube sound different? Try using a tube from a paper towel or gift wrapping.

How would the sound be affected if something other than wax paper were used to cover the end? They might wish to try newspaper, aluminum foil, tissue paper, etc.

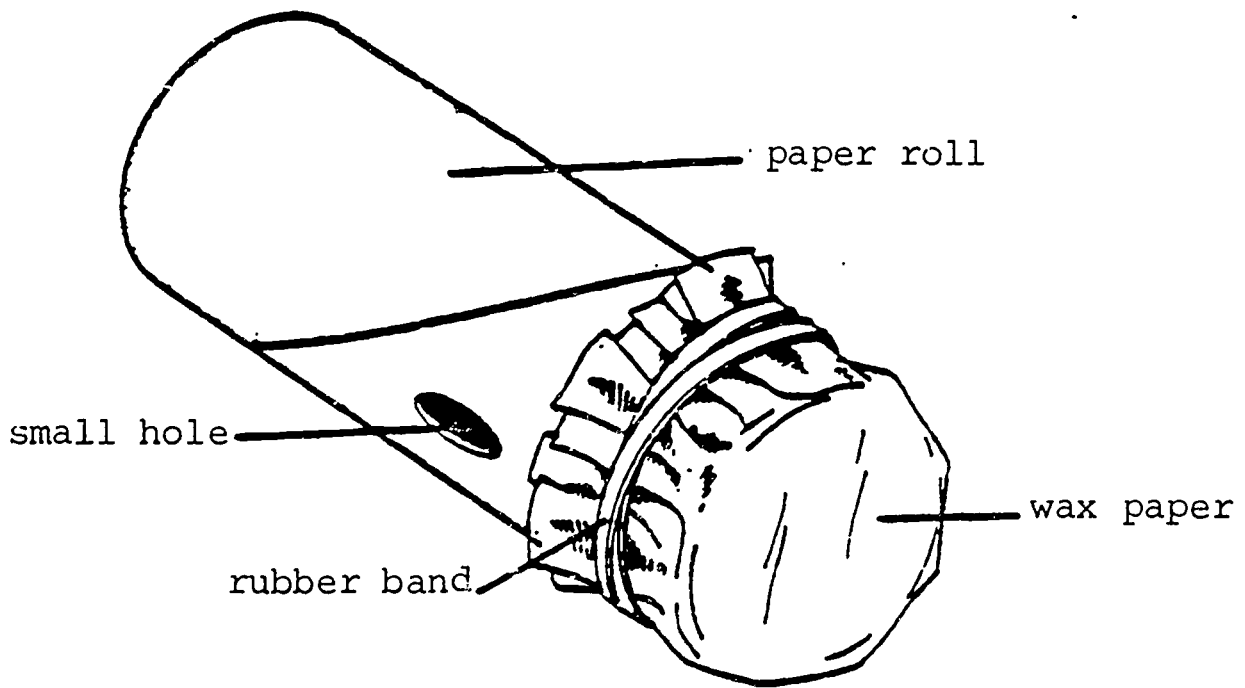

## TOYS THAT TEACH SOUND - THE PAPER CUP NOISE MAKER

by Linda Froschauer

Focus: Reinforce concepts introduced in "Toys That Teach Sound - The Paper Whistle."

Challenge: Vibrations in this instrument are not as obvious as with previous instruments. Students should be instructed to think about what must be vibrating (even though no vibrations can be seen) as they are constructing this device.

### Materials and Equipment:

Paper cup  
String  
Toothpick  
Fabric  
Paper towel  
Water

How-To-Do-It: Use a toothpick to punch a hole in the center of the bottom of a paper cup. See the diagram on the next page. Thread a piece of string approximately 60 cm (24 in) long through the hole. Tie the toothpick to the string so that the toothpick will be on the inside of the cup. Pull on the string so that the toothpick lies flat on the bottom of the cup. It may be necessary to break off one end of the toothpick if it is too long.

Hold the cup in one hand and the end of the string in the other. Have a partner hold a piece of fabric between their thumb and index finger and rub it along the string. Have them try to explain what produces the sound.

Further Challenges: Try several different materials on the string. Does the sound change with different materials?

Dampen the piece of fabric. Rub it along the string. What is the type of sound made when the wet fabric is rubbed along the string?

Substitute a rubber band for the string. Pluck the rubber band with your finger. Note the sound produced. How does the sound change as the rubber band is stretched more tightly?

What is the source of the energy for sound in this activity?

What is the sound conductor? amplifier? receiver?

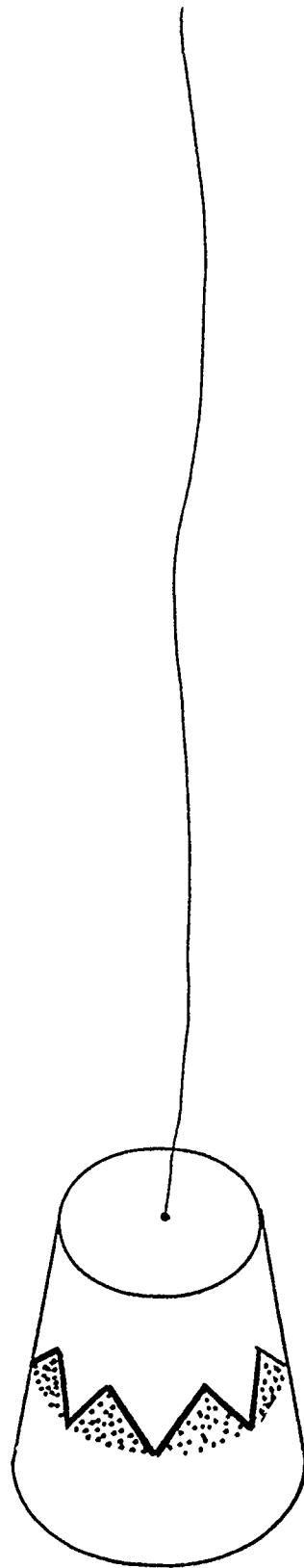

46

## VISIBLE VIBRATIONS

by Gwyneth E. Loud

Focus: The concept of sound waves, or vibrating air molecules, is hard for some children to grasp because it is so abstract and invisible. If "seeing is believing" these activities should help children realize that when a sound is made, vibrations are created.

Challenge: What happens when a tuning fork is struck and then touched to a movable object such as a ping pong ball or water?

### Materials and Equipment:

Ping pong ball  
Thread  
Tape  
Tuning fork  
Shallow pan of water  
Overhead projector  
Shallow clear plastic container of water

How-To-Do-It: The first two activities are best done in groups of eight to ten to avoid a lot of waiting for each child to take a turn.

1. Ping pong ball vibrations: Hang a ping pong ball with tape and thread from the edge of a desk or table. Make sure the ball is hanging still. Strike the tuning fork and quickly touch a tine lightly to the ping pong ball. The ball should start "dancing" back and forth, showing that the tines of the tuning fork are vibrating as it is creating sounds.
2. Vibrations in water: set a pan of water on the floor or table where a group can gather around it. Strike the tuning fork and quickly touch the tines to the surface of the water. The vibrations should create little splashes, and delight the children.
3. Vibrations in water using the overhead projector: this activity can be used with larger groups because it is a demonstration by the teacher, visible on a screen. Set a shallow clear plastic container of water on the overhead projector. Strike a tuning fork and quickly touch the tines lightly to the water surface. The vibrations should be clearly projected on the screen.

Further Challenges: Do these experiments mean that every time a tuning fork is struck vibrations are caused? If so, why don't we see the table or floor vibrating?

Think of other ways to show that sound creates vibrations (including the classic twanging of a rubber band).

Every time we see something vibrating, does that mean there is sound also? If so, why is no sound heard when a hand is waved back and forth? This leads to another subject: the ability of the human ear to hear sounds only within certain frequencies.

References:

Schmidt, Victor E. and Verne N. Rockcastle. Teaching Science with Everyday Things. New York: McGraw-Hill, 1968, Chapter 8.

Stein, Sara. The Science Book. New York: Workman Publishing, 1979.



## THE PITCH AND THE PENDULUM

by Marilyn Donalson

Focus: After completing other activities in this sound chapter, the children will come to understand that pitch is determined by how fast or slow an object vibrates. This pendulum activity graphically demonstrates that long things usually vibrate slower than do short things and thus have a lower pitch.

### Materials and Equipment:

String (varying lengths from 10 cm to a meter)  
Masking tape  
Timer or clock with second hand  
Washer

How-To-Do-It: Refer to the drawings on the next page. Give each child a piece of string, varying in length from 10 cm to a meter. Have them tie their washer to one end of the string. Be sure that everyone is spaced far enough apart to keep their strings from getting tangled. Have them practice swinging the pendulum while holding their arm still. Then have them take the end of the string in one hand (the arm should be extended slightly), and hold the washer out level with the other hand. When the teacher says "Go," they let the washer go, and count one number for every forward and backward motion. They must count silently as they will not all be counting at the same speed. Practice doing this a few times, and then time them for one minute. On the blackboard, record (in ascending order by 5's) the number of swings for each pendulum. Give each child a piece of tape and have them place their pendulum below the correct number. They should notice that the shorter pendulums have a higher number of swings, and vice versa. You might also have them make a graph by measuring the length of the string plotted against the number of vibrations. It won't be a perfect ascension, but it should show a basic pattern. This would be a good time to talk about variables, and why everything didn't come out perfectly.

Further Challenges: From the data table compiled in class, can students predict the number of swings per minute of a longer pendulum? A shorter pendulum? The swing in the schoolyard?

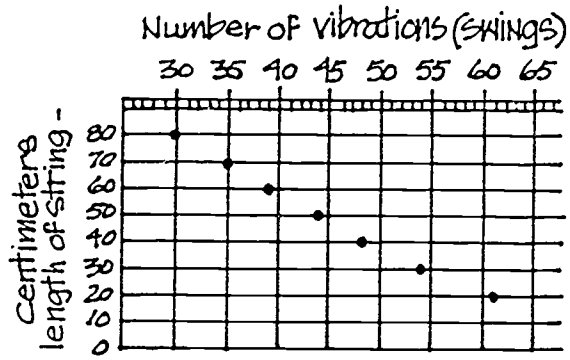
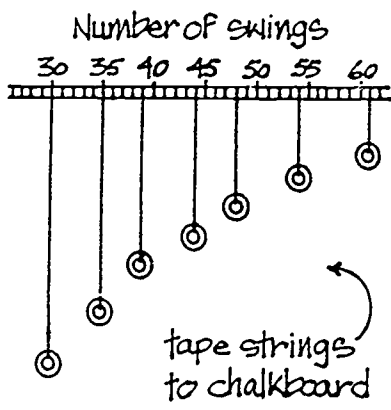

50

## PITCH PARADOX

by Donna Gail Shaw

Focus: The more there is of something vibrating, the lower the sound. The less there is of something vibrating, the higher the sound. The following activity presents an event that appears to be discrepant until you think about what is doing the vibrating to make the sound.

Challenge: Observe what happens when you blow across the tops of several soda bottles with varying water levels. Next, observe what happens when you tap these same bottles with a pencil. Make inferences about the difference in pitch.

### Materials and Equipment:

8 or more soda bottles  
Water  
Pencil

### How-To-Do-It:

1. Many students have blown across the tops of soda bottles and noticed the sound they make with varying levels of liquid. Many have even tapped bottles to make musical sounding tones. However, few have compared the sound made when blowing and the sound made when tapping.
2. Fill 8 soda bottles with varying levels of water so that a "musical" scale may be played when tapped. (See the diagram on the next page for a suggestion of how to arrange the soda bottles.)
3. Have a student come to the front of the class and tap the bottles using a pencil. You might even want to have the student play a very simple song on the bottles.
4. Next, have another student come to the front of the room to play the same scale or song. However, this time have the student blow on the bottles.
5. The class will soon notice that the scales or song don't sound the same. The tones are reversed!
6. Lead the class in a discussion about how this might be explained. What causes sound? Have the students use their observing skills to notice the relationship between the amount of water and the sound. Have them use their inferring skills to determine why the sounds reverse when you tap or blow.

Explanation of Results: When blowing, the air is vibrating; a larger column of air (empty bottle) produces a lower sound. When tapping the bottle, the bottle and its contents are vibrating; a full bottle produces the lower sound. In each case the larger mass produces the lowest sound.

Further Challenge: Blow over a straw and notice the sound. Place one end of the straw in a glass of water and blow. Raise and lower the straw in the water and blow. You will notice as you lower the straw into the water, the air column becomes shorter and the pitch becomes higher.

Reference:

Friedl, Alfred E. Teaching Science to Children. New York: Random House, Inc., 1986.

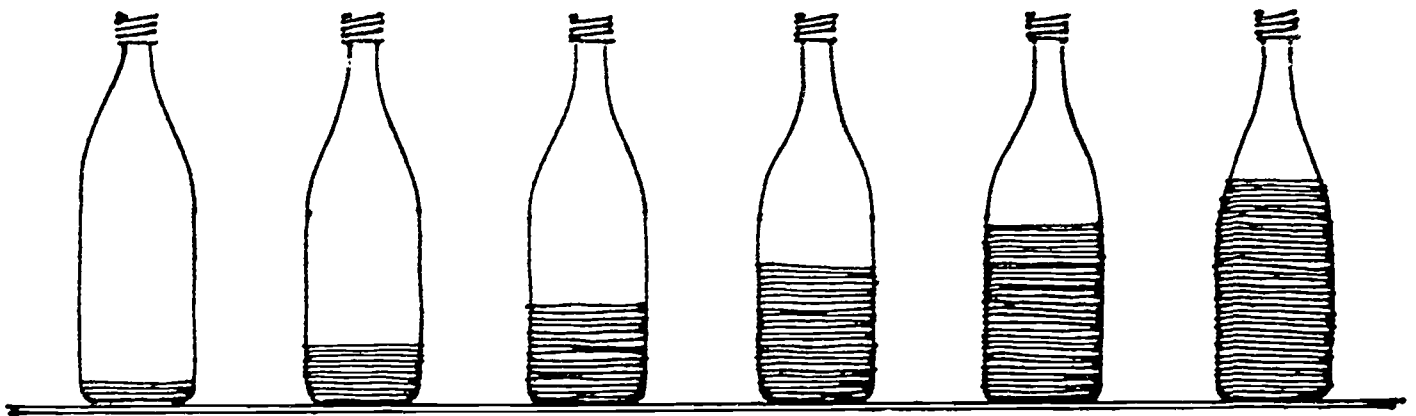

## SOUND WITH A PIPE XYLOPHONE

by Rose West

Focus: Children of all ages enjoy making sound. This activity will focus on producing a pipe xylophone. The student will develop an understanding that different length pipes create different tones. The shorter pipe compresses the sound waves closer together thus producing a high pitch. The longer pipe allows the sound waves to spread apart, thus producing a lower pitch.

Challenge: What can you discover about sound from a pipe xylophone?

### Materials and Equipment:

13 mm (1/2 inch) electrical metallic tubing (conduit), approx. 3 meters (10 feet) long

Foam padding (approx. 2 cm thick)

One board (approx. 30 x 60 x 2 cm thick)

Two dowel rods

Two wooden drawer knobs or tinker toy wheels

Hack saw or pipe cutter

Scissors

Glue

Ruler

File

How-To-Do-It: Refer to the diagram at the end of this activity. Cut the conduit with a hack saw or pipe cutter into the following lengths:

29.3 cm (11 1/2 inches)	sol	G
27.7 cm (11 3/32 inches)	la	A
26.0 cm (10 7/16 inches)	ti	B
23.3 cm (10 1/8 inches)	do	C
23.9 cm (9 9/16 inches)	re	D
22.6 cm (9 1/16 inches)	mi	E
21.8 cm (8 3/4 inches)	fa	F
20.5 cm (8 7/32 inches)	sol	G
19.5 cm (7 13/16 inches)	la	A
18.1 cm (7 1/4 inches)	ti	B
17.6 cm (7 1/16 inches)	do	C
16.5 cm (6 5/8 inches)	re	D
15.5 cm (6 7/32 inches)	mi	E

Smooth the edges with a file. It is better to cut the pipe too long and sand off the extra length rather than cut the pipe too short!!

Cut the foam to make two long strips about 4 cm wide and 60 cm long. You will also need 28 small foam pieces for spacing between the pipes. These should be cut approximately 1.5 x 3 cm long. These can be cut in a parallelogram shape so they will align with the slanted supports.

Lay the strips of long foam on the board to form a V shape. The wide point should be about 20 cm apart and the small end about 1 cm apart. The pipes will then be supported at the points that create the least interference with the music.

Attach the pieces of foam to the wood with plenty of white glue. The spongy material tends to absorb the adhesive quickly.

Glue the first pair of small foam strips flush with the ends of the strips just to the left of the point where the longest pipe will be located. Lay the longest pipe in place barely touching the spacers. Glue on the next pair of small foam strips and continue until all pipes and foam strip spacers are in place. The pipes can then be removed while the glue dries.

On the board below each pipe, label the note value. The longest pipe is G and the notes continue as listed above.

Mallets can be made from a dowel rod and wood drawer knob or tinker toy wheel. Place the drawer knob or tinker toy wheel on the end of the dowel rod. (You could also purchase mallets.)

Your pipe xylophone is now complete and ready to use.

#### Discussion Questions:

What causes sound? Vibrations produce sound waves -- these waves are a series of compressions and refractions. A compression squeezes air together. Refractions spread the waves of air apart.

How does sound travel? Sound goes through air in all directions. Sound must have matter to conduct it.

What is pitch? Pitch is the range a note can produce -- high or low. The pitch is controlled by how slowly or rapidly the sounds or sound waves vibrate. In high pitch the sound waves are compressed closer together. In low pitch the sound waves are further apart.

What happens to sound as it travels? Some objects absorb sound (take it in), i.e., furniture, carpets, curtains. Some objects reflect sound (turn it away), i.e., bare floors, empty rooms.

Further Challenges: Can you produce a different sound by changing the mallets?

Try to make a stringed instrument by using various types of strings cut to different lengths.

Try to produce a wind instrument.

Try to produce some percussion instruments.

Do research on early instruments.

References:

"Mother Earth News," July, 1984, Simple Instruments to Make and Play,  
Box 70, Hendersonville, NC, 28719.

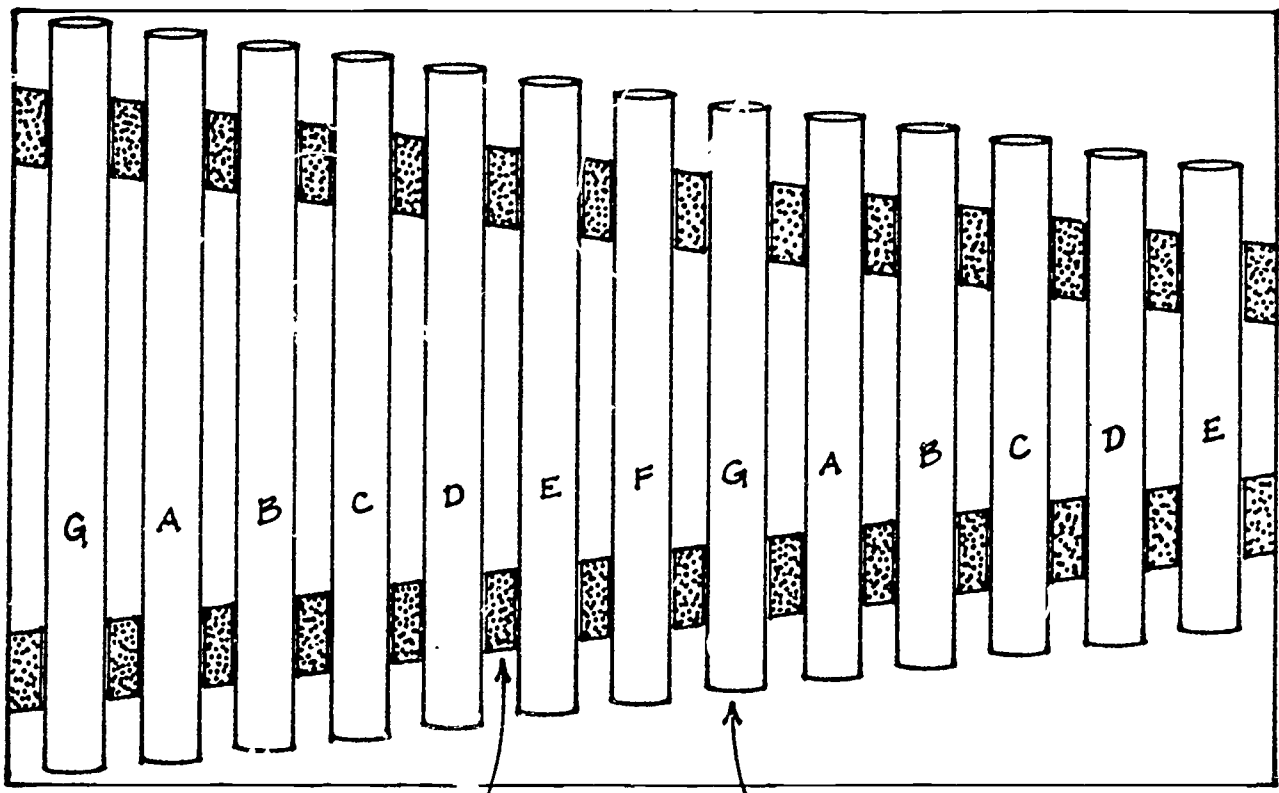

foam spacers  
-glue to foam strip

conduit-  
metal pipes

## SOUND TRACK: A RACE BETWEEN SOUND AND LIGHT

by Gwyneth E. Loud

Focus: To show that there is a difference between the speeds at which sound and light travel (sound travels at 1/5 mile per second and light travels at 186,000 miles per second).

Challenge: Find out which travels faster: sound or light?

### Materials and Equipment:

Flag, or easily visible piece of cloth or paper.  
A loud instrument or noisemaker such as a drum, horn, cymbals, or pot lids.

How-To-Do-It: This activity can be done with a group of any size. It must be done in a large flat open area such as a playing field or park. There must be good visibility from one end of the space to the other.

Two students go to one end of the field with the instrument and the flag. The rest of the class lines up at the other end of the field, watching the first two, in silence.

At exactly the same moment, one student makes a loud noise with the instrument and the other raises the flag overhead.

The rest of the class should see the flag go up before the sound arrives, illustrating that light travels faster than sound.

Further Challenges: Do the same activity several times, but move the two students closer to the group each time to discover at what distance the group sees the flag and hears the sound at the same time.

Using the instrument and the same open space, experiment to see at what volume the noise must be made for the group to hear it at various distances. These activities provide opportunities for students to practice measuring distances and making charts and graphs.

Observe and listen to jet planes as an example of the differing travel speeds of sound and light. The sound always seems to travel behind the plane.

### References:

Schmidt, Victor E. and Verne N. Rockcastle. Teaching Science, with Everyday Things, New York: McGraw-Hill, 1968, Chapter 8.

Stein, Sara. The Science Book. New York: Workman Publishing, 1979.



# Conflicting interests struggle

AMER

By Jon Anderson  
Chicago

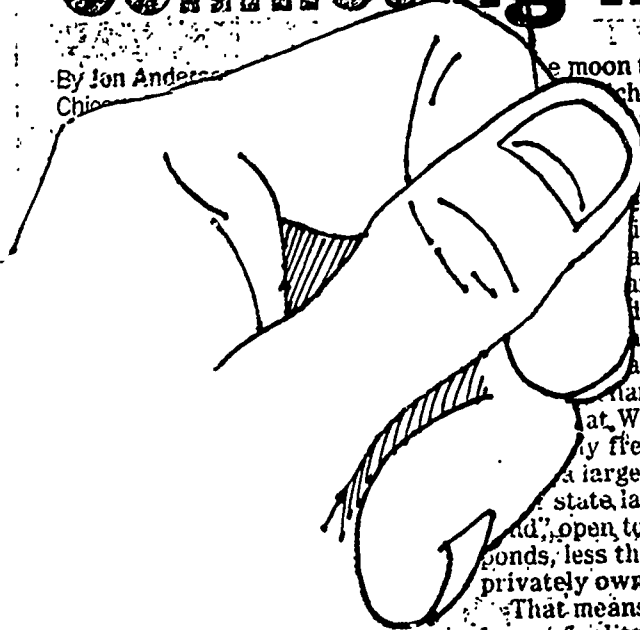

the moon travelling  
 which is strewn with  
 the forest, and  
 but the wildest  
 can conceive of the  
 we are living.  
 lizard."  
 as "a homely  
 and hairy, with  
 long arms, a great  
 and wide gray  
 au loved the spot.  
 change. The problem  
 at Walden, at 61 acres,  
 ly freshwater pond in  
 large enough to qualify  
 state law as a "great  
 and open to all. Smaller  
 ponds, less than 10 acres, can be  
 privately owned.  
 That means, says one local  
 lover of solitude, that "the  
 pressure is on Walden because  
 there isn't really any other place  
 to develop. You can't make a  
 pond."

According to historical records, Walden Pond became an international attraction in 1957, when, without warning, it was knocked down 100 feet. A section of shoreline formerly used for bathing beach and walking was

county to restock the woods. In 1974, the state gained control, taking measures to ban rubber boats, motorcycles racing through the woods and other nuisances. In a \$650,000 restoration, workers razed two bathhouses and a pier, carted out debris and built a parking lot. Beach access was limited to

## RETINAL FATIGUE AND COLOR

by Michael J. Demchik

Focus: The retina of the eye becomes tired of continuously attending to one specific color. As a result, the eye sees the complement of that color. This condition is called retinal fatigue.

Challenge: What is the complement of each primary color? How does the eye perceive a color after attending to it continuously for several minutes?

### Materials and Equipment:

American flag  
Several white poster boards  
Colored construction paper  
Magic marker

How-To-Do-It: Outline several pieces of colored construction paper with a black magic marker. Use yellow, cyan (blue-green), and white construction paper. Attach each to separate pieces of white poster board. Ask the students to stare at one of these colors for about one minute without blinking. Then have them move their eyes slightly to focus on the white poster area and observe the results. The result is the complement of the observed color.

Place an American flag across the front of the blackboard and a piece of white poster board next to it. Stare at the star in the inside corner of the flag for about one minute. Shift the eyes slightly to the white poster board. Results? How do you account for what you see?

Further Challenge: Use a different color poster board with the same colors as used with the white poster board. See if you can account for the results.

## TOYS THAT TEACH LIGHT AND SIGHT - THE THAUMATROPE

by Linda Froschauer

Focus: "Persistence of vision" is the ability of the eye to retain an image for at least 1/15 of a second. Therefore, if we see more than 15 images in a second, our brains perceive motion or a blend of images and color. This phenomenon is the basis for the production of movies, television, and cartoon animation. Motion pictures at your hometown theater project 16 frames per second. Your television set flashes approximately 60 images per second on its screen. Without the "persistence of vision" these flashes would be just a series of pictures and would not be perceived as movement.

Challenge: After trying your thaumatrope several times, explain what you think "Persistence of vision" means.

### Materials and Equipment:

White oak tag  
String  
Marking pens  
Scissors

How-To-Do-It: Cut out a 75 mm (3 inch) circle of oak tag. Create a design on each side of the oak tag circle. A different color should be used for each side. Each side should be part of a total drawing. For example a large fish bowl could be drawn on one side of the circle and a small fish drawn on the other. When the drawing is spun as explained below, the fish will appear to be inside the fish bowl. Other possibilities include: a cat and a basket, a spider and a web, a frog and a lilly pad, flowers and a vase.

Use a sharp pencil to make two holes on opposite sides near the edge of the disk. Thread a string (approx. 24 cm or 8 inches in length) through the two holes. A knot should be tied at each end. (See drawing on the following page.)

Hold the end of each string loop and wind it up by swinging it over. It should be consistently wound in one direction. When it is wound tightly the ends of the string should be pulled gently. This should cause the disk to rotate. Students should observe carefully and describe their findings.

Further Challenges: Can this be done using oak tag cut into shapes other than a circle?

Can this be done using a larger or smaller disk? Try making a large thaumatrope. What is the biggest problem with getting a very large thaumatrope to work?

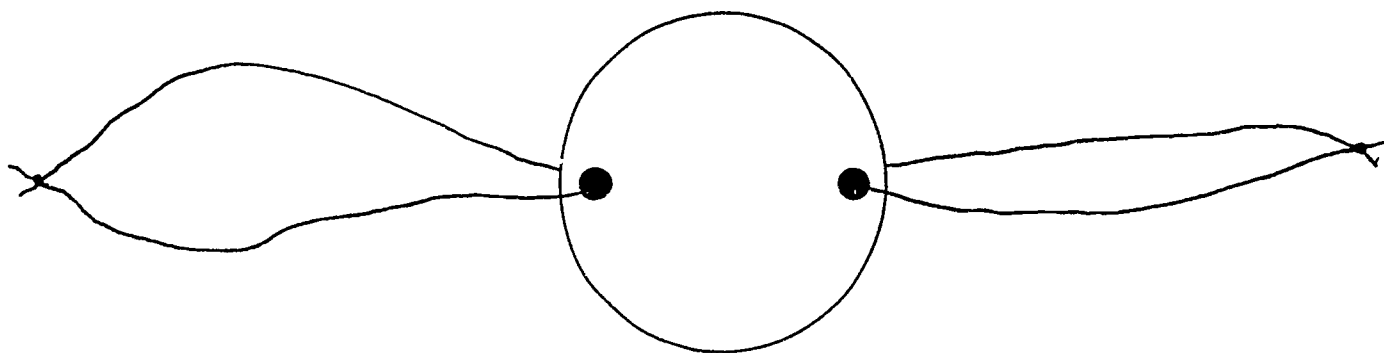

## TOYS THAT TEACH LIGHT AND SIGHT - THE CHROMOTROPE

by Linda Froschauer

Focus: This activity reinforces the concept of "persistence of vision." It also demonstrates the additive effect of mixing colors of reflected light. As two or more colors are spun on the chromotrope at the same time, reflected light from the multiple colors reaches the eye at nearly the same instant. This has the effect of mixing the colors of light.

Challenge: What effects do different color combinations have on what you see? Can you determine which colors combine to produce new apparent colors on a chromotrope?

### Materials and Equipment:

White oak tag  
String  
Marking pens  
Scissors

How-To-Do-It: See the sketches on the following page. Using a 75 mm (3 inch) circle of oak tag, create a colorful geometric design on each side. Use at least two different colors. Make the design on each side different from the other by using different color combinations.

Use a sharp pencil to make holes 20 mm (3/4 inch) apart near the center of the disk. Thread a 100 cm (40 inches) piece of string through the two holes as shown. Tie the ends of the string in a knot.

Hold each end of the string loop and wind it up by swinging it over in a consistent direction. When it is wound tight, gently pull the ends of the string apart with your hands and then relax your grip. With a little practice of repeatedly pulling and relaxing your grip, the disk can be kept spinning indefinitely.

Further Challenges: Try new color combinations and patterns to create new effects.

What is the longest period of time you can keep your chromotrope spinning?  
What variables effect how long it will spin?

Make a chromotrope that resembles the pattern of a barber pole when you spin it.

Stare at something really hard for several seconds. Close your eyes and describe what you see. How is this an example of "persistence of vision."

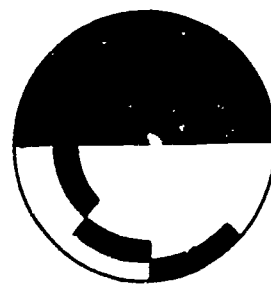
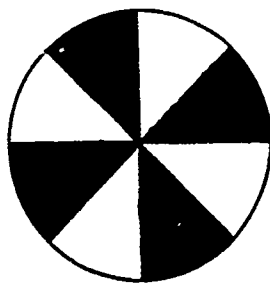
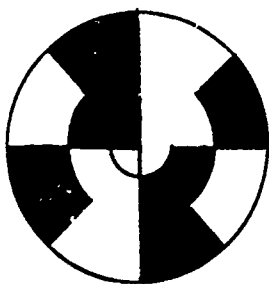
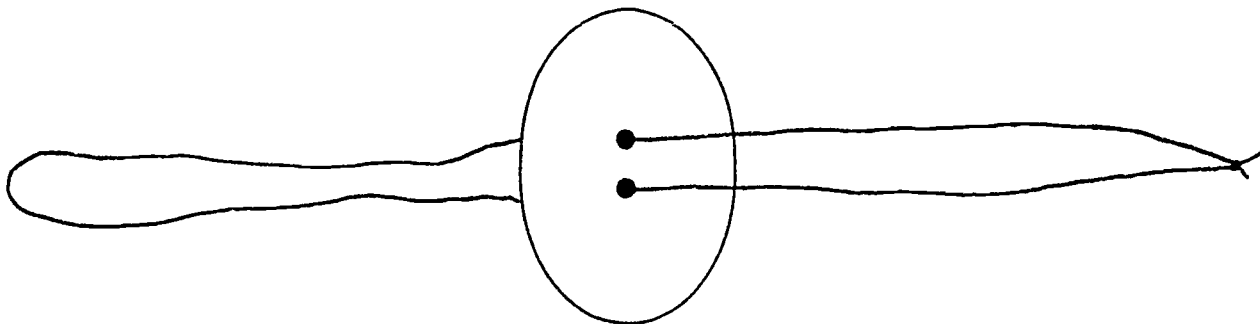

## TOYS THAT TEACH LIGHT AND SIGHT - THE PINWHEEL

by Linda Froschauer

Focus: This is a toy most children have played with at one time. This activity will take a closer look at it to reinforce the concept of "persistence of vision." It also demonstrates the additive effect of mixing colors of reflected light. As two or more colors are spun on the chromotrope at the same time, reflected light from the multiple colors reaches the eye at nearly the same instant. This has the effect of mixing the colors of light.

Challenge: Place two primary colors on your pinwheel (such as yellow and blue). What happens to the colors when you get the pinwheel spinning very fast?

### Materials and Equipment:

White paper  
Pencil  
Thumbtack  
Marking pens  
Scissors

How-To-Do-It: See the sketches on the following page. Cut out a 25 x 25 cm (10 x 10 inch) square of white paper. Using a ruler, draw two diagonal lines connecting opposite corners of the square. The two lines should cross at the exact center of the paper. Make patterns on each section drawn and color them. Use at least two colors.

Draw a circle of about 35 cm (1/2 inch) diameter in the exact center of the paper. Cut along the lines drawn from the corners up to the circle. Do not cut all the way to the center!

Bend one corner of each of the triangular areas toward the center of the paper and secure them by pushing a thumbtack through each corner and the center of the paper. Push the thumbtacks into the eraser of the pencil.

If there is sufficient breeze, the pinwheel should spin freely on its own. If there is no breeze, it will be necessary to blow on it. Students should observe colors and patterns created as the pinwheel spins.

Further Challenges: Make a variety of pinwheels using colors or different patterns in the designs. Which ones do your eyes tend to blend together? Which designs can be clearly seen no matter how fast the pinwheel spins?

Which way does the pinwheel spin? How could it be made to spin in the opposite direction?

Can a pinwheel be made in shapes other than a square? What about a triangle? a circle? a hexagon?

Experiment with other materials to try and make the pinwheel spin faster. (Hint: Cut down on the friction created by the paper touching the eraser.)

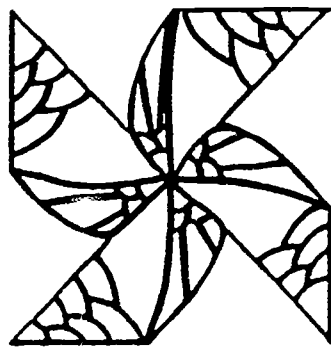
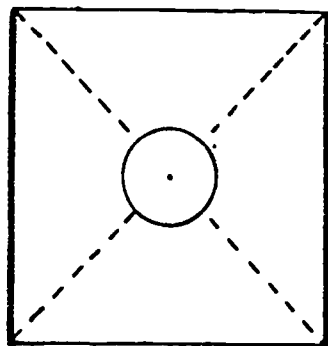
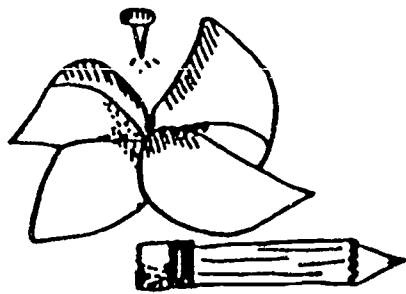

C4



## TOYS THAT TEACH LIGHT AND SIGHT - THE PHANTASCOPE

by Linda Froschauer

Focus: This activity explores a device once known as the "magic disk." This was a childrens' toy capable of showing moving pictures created before the invention of the motion picture projector.

Challenge: Make a series of drawings on a phantascope that depict some type of motion.

### Materials and Equipment:

Marking pens  
Pencil  
Phantascope template on white paper  
Thumbtack  
Scissors

How-To-Do-It: See the sketches on the following page. Cut out the phantascope disk and the viewing slits. Draw an action picture on each line above the viewing slits. These eight pictures will need to be drawn in sequence. Students may wish to make practice drawings on scrap paper before beginning. The drawings may be colored if desired.

Push a thumbtack or straight pin in through the center of the disk and into the eraser of a pencil. The pencil should be on the blank side of the disk.

Stand in front of a mirror and hold the phantascope at eye level such that you can see through the viewing slits. Spin the disk and watch through the slits. Students should describe what they see occurring.

Further Challenges: Try making another phantascope showing a series of pictures that are continuous and non-stop motion. The pattern of motion should repeat over and over again. Some possible topics include: a person peeking out of a doorway, pulling back, and peeking again; someone in a rocking chair moving back and forth; a worm moving into and out of an apple.

Instead of drawing a series of pictures on the phantascope, try making designs using different colors.

Make a flip book. Staple together several small pieces of paper or index cards. Draw a figure on each piece of paper. Each drawing should represent one phase of the moving figure. Flip the pages with your thumb and watch the figure move.

The phantascope works on the principle of optical illusion. Find other examples of optical illusions and share them with the class.

### Reference:

Caney, Steve. Toy Book. New York: Workman Publishing, 1972.

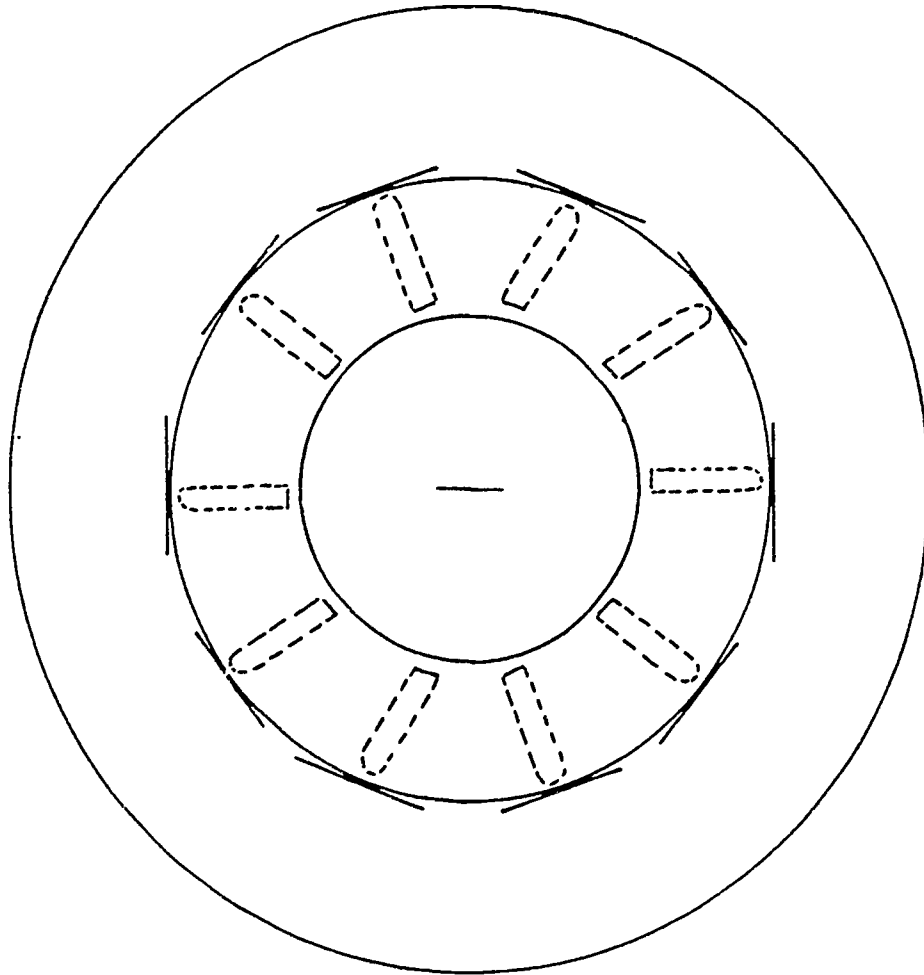
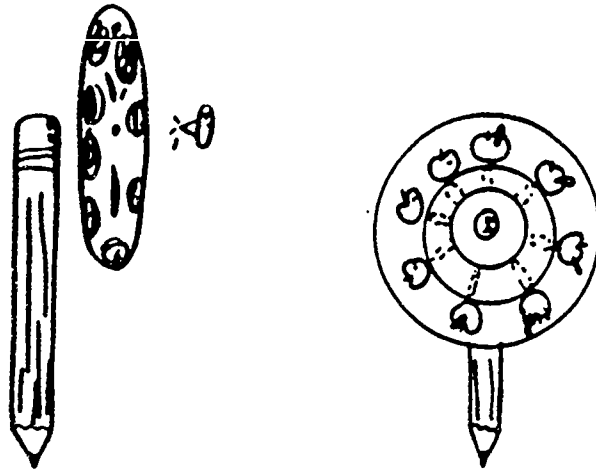

## TOYS THAT TEACH LIGHT AND SIGHT - THE TALEIDOSCOPE

by Linda Froschauer

Focus: This instrument is actually more familiar to children when its mechanism is covered. It is the inside workings of a better known instrument called the kaleidoscope. Students are able to use this device to explore the effects of multiple reflections in plane mirrors.

Challenge: Describe in your own words how a taleidoscope works.

Materials and Equipment (for each child or small group):

Black tape  
3 microscope slides

How-To-Do-It: See the sketches on the following page. Place three microscope slides next to one another on a flat surface with their long edges almost touching. Connect the slides to one another using black tape. Turn the slides over so that the taped side is touching the table. Fold two of the slides up so that they touch one another. You should have formed a triangle. Connect these two slides to one another. Take a look at the triangle formed. If any of the glass is still bare (not covered with black tape) cover it with small strips. Look at any objects around you through the taleidoscope. It works best when there is a lot of light on the object. Investigate various objects and patterns with the device.

Further Challenges: Try making a four sided taleidoscope. How is the view different from the three sided version?

Make a large taleidoscope. Use acetate sheets such as overhead projector sheets or report covers instead of the slides. Strips approximately 5 x 20 cm work quite well. The acetate strip may be painted or covered with black tape on one side. They should be connected like the taleidoscope above.

Hold a magnifying glass in front of the opening of the taleidoscope. Have students describe the results of this variation.

Try writing your name while looking though the taleidoscope.

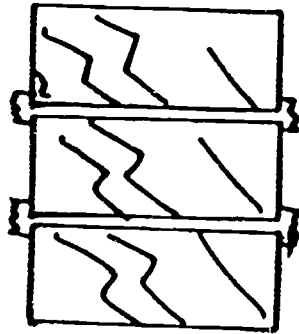
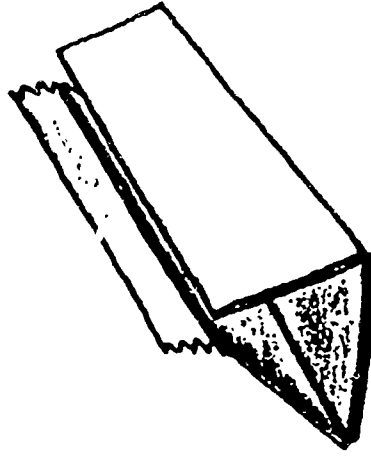

## TOYS THAT TEACH LIGHT AND SIGHT - THE KALEIDOSCOPE

by Linda Froschauer

Focus: Exploration of multiple reflections in a plane mirror.

Challenge: Describe in your own words how a kaleidoscope works.

### Materials and Equipment:

Black tape  
3 microscope slides  
Clear acetate sheet  
Straight pin  
Marking pens  
2 film canisters  
Scissors  
Glue  
Beads  
Ribbon  
Colored cellophane  
Tape

How-To-Do-It: Construct the kaleidoscope from the previous activity.

See the sketches on the following page. Cut the end off the end of one film canister. Put a hole approximately 1 cm in diameter in the end of another film canister. Attach the two canisters with tape. The open ends should be touching. Insert the kaleidoscope into the tube you have made.

Cut an 8 cm disk out of the acetate sheet. Glue beads, scraps of paper, ribbon, cellophane, etc. onto the disk. Push a pin through the center of the disk and the lip of the canister.

Point the kaleidoscope tube toward a light and look through the small hole. Have students spin the disk and describe what they see. Ask them to describe why the various patterns are formed.

Further Challenges: Make a larger kaleidoscope using a tennis ball can instead of film canisters and acetate sheets instead of microscope slides.

Make a variety of disks for the kaleidoscope. Try using permanent markers on the acetate. Use two pieces of acetate with bits of confetti sandwiched between them.

Kaleidoscopes are made of many types of materials. Design your own kaleidoscope. Determine what it would be made of and how it would be constructed. Make drawings of this instrument, label its parts, and tell how it works. If possible, construct the instrument as an independent project.

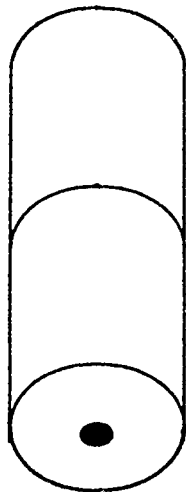
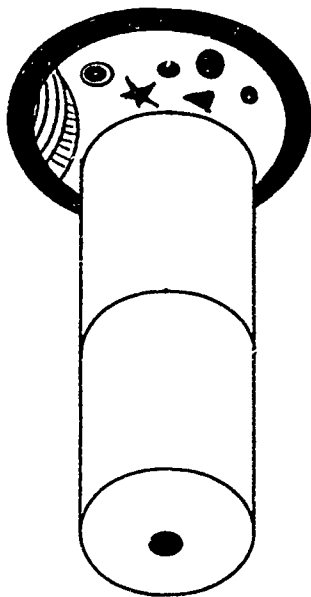

## BOUNCING LIGHT

by Patsy Ann Giese

Focus: Light is reflected from plane shiny surfaces. Light can be reflected by several surfaces before reaching a person's eyes.

Challenge: Observe images formed by multiple reflections. Count how many images can be seen in a pair of mirrors.

### Materials and Equipment:

Mirror squares  
Washers, coins, and/or other small objects  
Cardboard  
Ball  
Plywood or quart milk cartons  
Pocket mirrors  
Packaging tape and/or glue  
Kaleidoscope  
Paper

How-To-Do-It: Have each student count how many images of him/herself can be seen in two mirror squares taped together along one edge. Images of other objects can be counted, too. If coins are used, have students add up the total value of the coins they see. The number of images seen can be increased by decreasing the size of the angle between the mirror surfaces.

Have each student hold a mirror square on his/her chest and then look into a larger mirror. Again have each student count how many images of him/herself can be seen. Explain that vision does not leave their eyes and vision does not bounce off the mirrors, but instead light bounces off the mirrors and then enters their eyes.

Ask students if they have seen the backs of their heads. For each student who has not, use two mirrors -- one in front and one behind -- to enable him/her to see the back of his/her head.

A durable easy-to-use periscope can be made from plywood pieces about 1 meter long and 15 cm wide. Instead, students can make their own periscopes from quart milk cartons. Into diagonal slots at 45 degrees with the top and bottom of the periscope, place the two mirrors parallel to each other, reflecting sides inward. Tape or glue the mirrors firmly in place. A viewing hole needs to be cut in front of each mirror. After predicting what they will see in a periscope as it is placed in various horizontal and vertical positions, have students check the accuracy of their predictions by looking into the periscope. For example, set the periscope horizontally with one end on a desk top so one looks down at the desk to see the floor beyond the desk. Explain to students that they see the various objects, not because their vision goes through the periscope, but because light travels through the periscope to their eyes.

Repeat this activity except use a periscope in which the mirrors are not parallel to each other, but are still at 45 degrees with the top and bottom of the periscope. With this periscope, one could look down at the desk and see the ceiling.

Have students look through a commercially made kaleidoscope. Make a kaleidoscope by taping three pocket mirrors together, facing inward. Set the mirrors on a piece of white paper. Drop bits of colored paper into the triangle formed by the mirrors.

Further Challenges: Have two students play catch by throwing a ball against a wall or bouncing a ball on a floor. The students should stand in one position to play, not run after the ball. Then they must throw or bounce the ball so it hits the wall or floor midway between the two students. Have a third student mark where the ball hits. Compare two angles -- the angle between the wall or floor and the path of the ball from the first student with the angle between the wall or floor and the path of the ball to the second student. The two angles should be approximately equal.

Have students, using the law that the angle of incidence equals the angle of reflection, predict if the reflected image of an object will be seen by another student in a particular position, with the position of the mirror and object fixed. Repeat, changing the positions of the mirror, object, and observing student.

Have students draw pictures of the object, mirror, and observer with the rays of light included, showing both the paths of the incoming light and the reflected light.

Discuss how long a mirror a person needs to see his/her entire self. Obtain a mirror and check the answer. Cardboard can be taped over some of the mirror to get a reflecting surface the exact length of one's prediction.

Safety: Warn students to not drop or knock over the mirrors. If a mirror is broken, do not let the students pick up the broken glass in their hands.



## REFLECTIONS AND MORE REFLECTIONS

by Michael J. Demchik

Focus: Reflections in a plane mirror are virtual images that are laterally reversed. When two plane mirrors are placed together at an angle, multiple images are formed. The number of images formed depends on the angle between the mirrors.

Challenge: How many images are formed when two plane mirrors are placed at 90, 60 and 45 degrees?

### Materials and Equipment:

Index card  
Marker  
Clay  
Two plane mirrors  
Protractor  
Tape

How-To-Do-It: Tape together two plane mirrors to create a moveable hinge as shown. The mirrors should be able to stand freely on a flat surface. Place a dark circle on a piece of index card. Support the index card with clay in front of the mirror. Observe the results. Place the same card in front of two mirrors placed at an angle of 90 degrees. How many images are formed? Try 60 and 45 degrees. Results? Count the images formed in each case.

Further Challenge: Repeat the above procedures with the mirrors arranged at various angles. Have students graph the relationship between the number of reflections and the angle of the mirror.

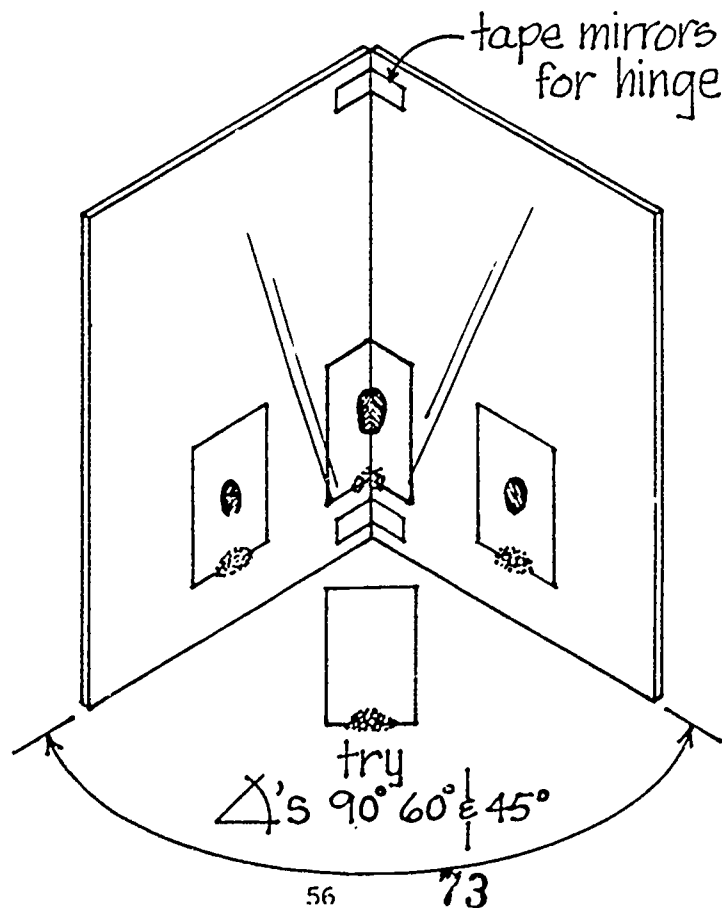

## STRAIGHT, CURVED, OR CROOKED?

by Patsy Ann Giese

Focus: In any one substance, such as air, light always travels in a straight line.

Challenge: Observe evidence and infer that light does not curve as it travels through air.

### Materials and Equipment:

Cardboard  
String  
Blocks of wood  
Thumbtacks or glue  
Candle, camping light, or flashlight  
Candle holder and matches if using a candle  
Pieces of rubber or plastic garden hose  
Pencil, washer, empty food can, and/or ball  
Heavy wire  
High intensity lamp or other light source  
Posterboard

How-To-Do-It: Cut a hole in the center of five squares of cardboard. Attach each cardboard square with thumbtacks or glue to a block of wood large enough that the cardboard, when attached to the wooden base, will stand upright. Darken the room. Have students stand the cards in front of a candle, camping light, or flashlight, checking which positions allow the light to shine through all the holes. A taut string through the holes can aid in aligning the holes and the light source.

Have students look through straight sections of garden hose. Then have them bend their sections of hose as they continue to look into the hose. Discuss the differences between the two sets of observations.

Further Challenges: Suspend objects, for example, a pencil, a washer, an empty food can, or a ball, from a piece of heavy wire. Wire clipped from a clothes hanger works well. Set up a piece of white posterboard vertically by wedging or tacking it up against a wall, bookcase, or other surface. Show students how you will hold the objects in various orientations between a light source and the posterboard. Have students draw pictures of the objects with straight rays of light included. Based on their pictures, have students predict what shape shadow will be made on the posterboard. Check their predictions by darkening the room, turning on the light source, and observing the shape of the shadows.

Repeat the above activity, except change the distances between the light source, the objects, and the posterboard.

Repeat the above activity, except place the posterboard horizontally on the floor, a table, or a desk. Hold the objects below the light source and above the posterboard.

Have a student whisper into a straight section of garden hose with another student listening at the other end of the hose. Repeat the activity with the hose curved. Discuss how sound is different from light.

## DO YOU LOOK STRANGE AT LUNCHTIME?

by Patsy Ann Giese

Focus: Reflecting plane and convex surfaces make all things look right-side-up. Reflecting concave surfaces make close things look right-side-up, but distant things upside-down. A person cannot get close enough to see a right-side-up image of him/herself in very curved concave surfaces such as spoons. A person can see a right-side-up image of him/herself in less curved concave surfaces such as shaving mirrors.

Challenge: Find which orientations of a knife and of a spoon give an upright image of a person looking at his/her reflection. Find at what distance from a person his/her image in a shaving mirror changes from right-side-up to up-side-down.

### Materials and Equipment:

Knives  
Spoons  
Shaving mirrors

How-To-Do-It: Each student should look at the image of him/herself in the blade of a shiny knife. Repeat the activity, but with each student looking into the bowl of a shiny spoon with the handle vertically down from the bowl. Then pose the challenge to move the spoon in such a way that each sees him/herself right-side-up. Most students will continue to look into the bowl, rotating the spoon so the handle is horizontally to the side of the bowl or vertically up from the bowl. They need to look into the convex back of the spoon to meet the challenge. Looking at the back of the spoon, again have each student notice the changes in the shape of his/her image as they rotate the spoon handle up, down, and sideways.

Have one student hold a concave shaving mirror so a second student can see his/her image. Have the first student back away slowly, holding the mirror level. The second student should give directions to the first in order that the mirror is oriented so the second student can continue to see his/her image. The second student should notice how far away the first student is when the image from the mirror inverts.

Further Challenges: Have students think of other shiny curved surfaces in which they can see an image of themselves. Possible answers are convex rear-view mirrors, car bumpers, silver goblets, steel thermos bottles, and reflections from flashlights or headlights.

Have students draw pictures of the shiny objects with the rays of light included, showing both the paths of the incoming light and the reflected light.

## SIMPLY SCIENTIFIC SYMMETRY

by Patsy Ann Giese

Focus: Symmetry is an important property in scientific research about things as diverse as nuclear particles and human organs. Objects symmetrical about the horizontal axis are unchanged by refraction through a test tube. Objects symmetrical about the vertical axis are unchanged by reflection from a plane mirror. Multiple reflections can make the image appear the same as the object.

Challenge: See symmetry in physical objects. Identify images reflected from a plane mirror as reversed left to right, and identify images refracted from a horizontal cylindrical surface as up-side-down.

### Materials and Equipment:

Mirror squares  
Thin typing paper  
Cardboard  
Paper plate  
Hair clips, ribbons and/or asymmetric hats  
Clear spice jars, olive jars, or large test tubes  
Stoppers or lids  
Water  
Index cards  
Posterboard  
Paper  
Magazine or other large pictures

How-To-Do-It: Fill large test tubes with clear tap water. Insert cork or rubber stoppers into the ends of the test tubes. As an alternative to the test tubes, use small clear jars, for example, ones in which green olives or spices are sold. Jars with larger diameters will not work well.

Write on index cards so that most of the letters symmetrical about the horizontal axis are one color and all other letters are another color. You could write "CHOICE MYSTERY BOOK" with the words "CHOICE" and "BOOK" in red and the word "MYSTERY" in blue. You could write "CHECK OUT THAT CODE" with the words "CHECK" and "CODE" in black and the words "OUT" and "THAT" in green. Have each student place a test tube directly over the message on a card. Then each student should raise the test tube, watching the letters become out of focus. Each student should stop raising the test tube when the letters are again in focus. At this point, each student should hypothesize whether color, symmetry, or other properties determine which letters look usual. Each student should test his/her hypothesis by making new cards to read.

Have students predict how they will look winking their right eye or waving their right hand in front of one mirror. Have them check which hand or eye appears to be moving in the image formed by light reflected off a

mirror. Put a clip or a ribbon or an asymmetric hat on a student's head. Have him/her check if the image of the front of his/her head is reversed left to right. Using two mirrors, have him/her check if the image of the back of his/her head is reversed left to right.

Make a clock face on a paper plate. Have students look at the image of the clock face reflected from one mirror. Ask in what ways the image is different from the actual clock face. Repeat this activity, except reflect from a second mirror the image from the first mirror.

Write a message on a piece of cardboard. Have students try to read the image of the message reflected from one mirror. Ask which letters are readable and which are not. Ask what property is common to all the readable letters.

Have students compare the symmetry of letters about the horizontal axis that were unchanged by refraction through a test tube with the symmetry of letters about the vertical axis that were unchanged by reflection from a plane mirror.

Using the message and mirror from the previous activity, reflect from a second mirror the image from the first mirror. Students should observe that all the letters are readable this time.

Further Challenges: Write a message on thin typing paper. Turn the paper over and trace over the letters to darken them as viewed from that side of the paper. (An alternative is to write on paper over carbon paper, carbon side up.) Place the front side of the paper against a piece of cardboard, and tape the two together. Have students try to read the message viewing the backside of the paper. Then have the students try to read the image of the backside of the paper reflected from one mirror. As above, try reading the image from a double reflection of the message.

Put the two taped mirrors at right angles to each other. (An alternate approach is to cut away one corner and the top of a cardboard box, and then glue two mirrors in the opposite corner.) Center the clock face in front of the taped edge. Have students again look at the image of the clock face. Have students wink or wave into the mirrors. Have them look at themselves wearing a hair clip, a ribbon, or an asymmetric hat. Ask if the reflections are reversed left to right.

Have students look around the classroom and identify objects that are symmetrical about one or more axes.

Discuss in what ways people are symmetrical and in what ways asymmetrical.

Have students set a magazine or other large picture horizontally on a table or desk. Hold a mirror square vertically on the picture. Look at the edge where the reflecting surface touches the picture.

Have each student draw a picture. Keeping it horizontal, the student should place a vertical mirror on one border as in the previous activity. The student should repeat this procedure, except place the mirror on another border.

Make triangles or other shapes from several colors of posterboard or cardboard. Then have students create symmetrical designs from the pieces. Have each student challenge a second student to make the first student's design using half as many pieces on a horizontal surface next to a vertical mirror.

Safety: Warn students to not drop or knock over the mirrors. If a mirror is broken, do not let the students pick up the broken glass in their hands.

## CAN YOU CATCH FISH?

by Patsy Ann Giese

Focus: A ray of light bends as it travels from one substance to another because the speed of light is different in different substances. Because our eyes interpret any light received as though it did not bend, appearances can be deceiving from light that has passed through a refracting surface.

Challenge: Observe evidence and infer that the apparent position of objects is different in water than in air.

### Materials and Equipment:

Plastic container

Water

Aquarium

Corks

String

Washers

Narrow tube

Metal rod or wooden dowel that fits inside of tube

Coins or washers

Opaque bowls

How-To-Do-It: See the sketch on the next page. Cut a fish shape out of the bottom of a discarded plastic container, for example-a laundry soap bottle. Place the fish-shaped object on the bottom of an aquarium filled with water. As an alternative, glue a fish-shaped object to a cord, and then tie the cord to a washer leaving a little string between them. Repeating this procedure, but varying the length of strings, will make the fish-shaped objects seem to be swimming at various depths. Have a student sight down a narrow tube, for example, a piece of water pipe, locating the fish-shaped object. It is easier to hold the tube steady with one's arm resting against a table, wall, or other massive object. Then without moving the tube, have another student pass a metal rod or a wooden dowel through the tube. Have other students check if the rod touches the fish-shaped object. The rod will not touch, because the fish-shaped object, when sighted through the tube, appears to be in line with the ray of light that reaches the student's eyes. However, the ray of light bent as it passed from water to air.

Repeat this activity, except have no water in the aquarium. Finally students will be able to catch fish.

Further Challenges: Have each pair of students put a washer or coin in a small opaque bowl, the size of one serving of fruit. (A cup, a flat pan, or the bottom of a cut-off milk carton can be used instead of a bowl.) Have one student move away from the bowl until the side of the bowl blocks the washer or coin from sight. This student should remain there, being particularly careful to not move his/her head at all. Have the second



student pour water into the cup slowly enough that the washer or coin does not move. The first student should be able to see the washer or coin again.

Discuss why a pond may appear shallower than it really is to a person standing on its banks.

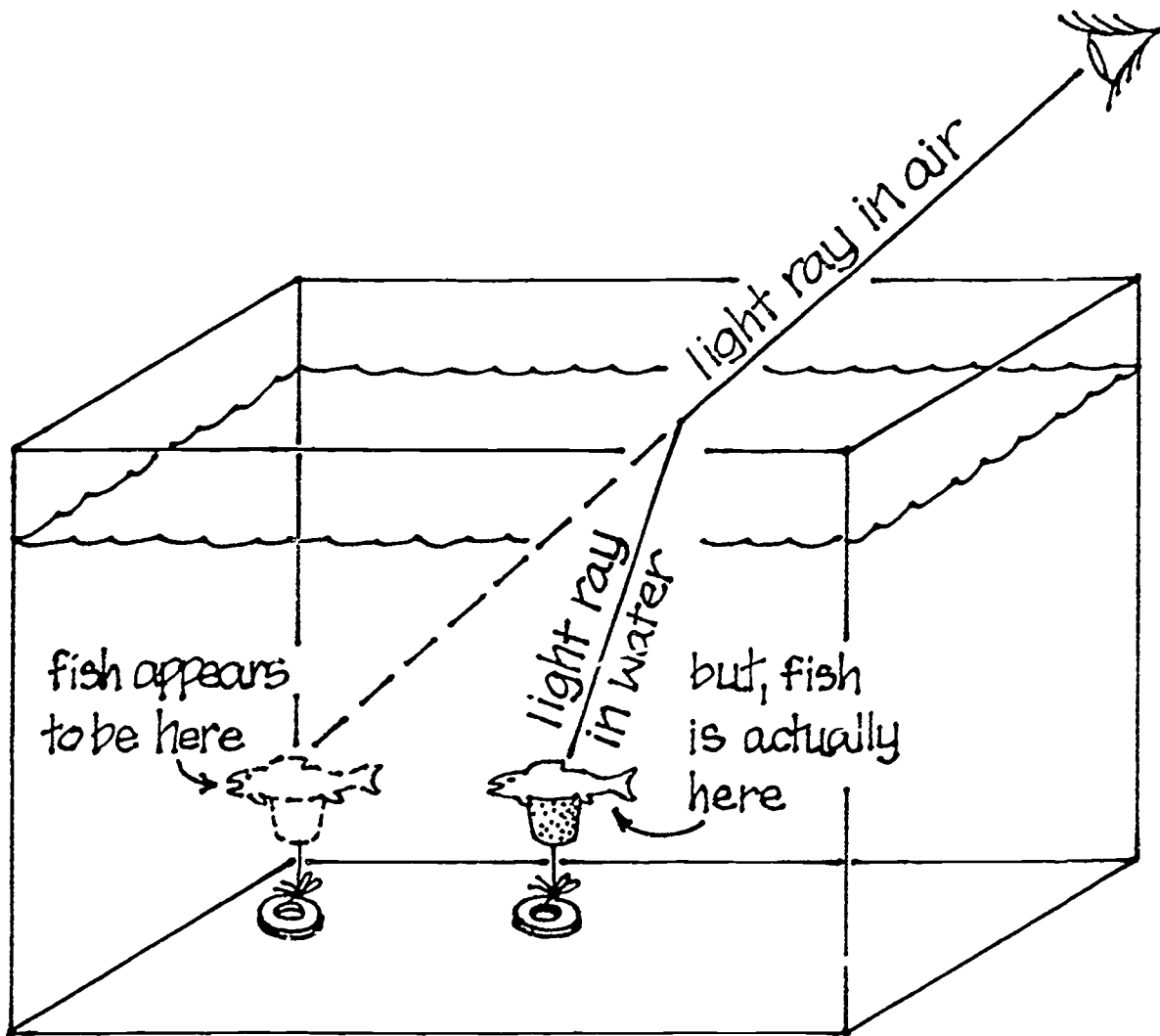

## LOOK WHO'S GOT FOUR EYES!

by Patsy Ann Giese

Focus: Light is bent as it passes through curved transparent surfaces, changing the appearances of objects viewed through the refracting surfaces.

Challenge: Observe images formed by refracted light.

### Materials and Equipment:

Clear beakers, jars, drinking glasses, and/or large test tubes with stoppers or lids

Aquariums or clear flat-sided pans

Water

Rulers

Glass marble, bowl and/or spherical flask

Magnifying glasses and/or other lenses

How-To-Do-It: Fill large test tubes with clear tap water. Insert cork or rubber stoppers into the ends of the test tubes. As an alternative, use small clear jars, for example, ones in which green olives or spices are sold. Have some students look at the room with a test tube in front of their eyes. They should also look at their classmates through the test tube. The test tube will make one's eyes appear elongated vertically or, at the proper distance from one's face, will make each eye appear as two eyes -- one above the other. Have students also describe what they saw as they looked at the room.

Have students look at rulers placed vertically in clear beakers, jars, or glasses of water. Ask if the width and/or the length of the rulers looks unusual. Ask if the rulers look straight. Then have students tilt the rulers and answer the above questions again. Have students move the rulers to containers with smaller diameters and then describe the change in the appearance of the rulers. Repeat this activity, except use containers with very large diameters. Containers with larger diameters do not magnify the width of a vertical ruler as much as do containers with smaller diameters. The length of a vertical ruler is not magnified.

Empty the water out of the containers used in the above activity, and put a small washer or other weight in each. Then stand these containers in one or more aquariums of water. Clear flat-sided pans, such as bread pans, can be substituted for the aquariums. The water in an aquarium should be about 2 cm lower than the top of the shortest container so that no water flows into those containers. Repeat the above activity with the rulers. Containers with larger diameters do not reduce the width of a vertical ruler as much as do containers with smaller diameters. The length of a vertical ruler is not reduced.

Further Challenges: Have students look through a clear glass marble, bowl, and/or spherical flask. Look through a water drop on a window screen, window glass, or a microscope slide.

Discuss why straight objects look wavy when seen through thick irregular glass as is found in some old windows. Discuss why the same type of objects look straight when seen through thin uniform window glass.

Have students form images with magnifying glasses and/or other lenses. Have students draw pictures of the lenses with the rays of light included, showing both the paths of the incoming light and the refracted light.

Have students think of man-made objects which require lenses. Possible answers are eyeglasses, binoculars, opera glasses, cameras, movie projectors, telescopes, and microscopes.

Discuss lenses in the eyes of living organisms.

## LIQUID LENSES

by Meghan Mahoney Twiest

Focus: The path of light waves can be controlled with two basic types of lenses -- concave and convex.

Background: A lens is a tool for bending light and can be made of many different materials such as plastic, glass, or living matter. A convex lens, which is thickest in the middle, makes the beams of light passing through it converge. A concave lens, which is thickest around the edges, spreads the beams of light that pass through it.

Challenge: Make a convex and a concave lens and see what happens to images when you look through them.

### Materials and Equipment:

For each student or pair of students:

Microscope slide  
Eyedropper  
Metal washer  
Petroleum jelly  
Newspaper

How-To-Do-It: This intriguing activity fits well into a variety of lessons such as anatomy of the eye, use of the senses, or refraction of light through a lens. See the sketch on the following page.

To assemble your own lenses, have the students spread a very thin layer of petroleum jelly onto the microscope slide. Next, place a washer (one that completely fits on the slide) on top of the layer of jelly. Now the washer won't slide around. After the washer is secure, have the student put 1-2 drops of water into the center of the washer and spread it around with the dropper until water is touching all the sides of the washer. A concave lens is formed when the layer of water is thickest around the edges and thinnest in the middle. When the lens is held over a newspaper, the print will appear much smaller than it really is. This is because the light rays are spread out as they pass through the water.

To make a convex lens, place 2-3 more drops of water inside the washer until the water "heaps" up in the center. The surface tension of the water forms this heap as the water molecules adhere to each other. When using this lens to look at the newspaper, the print will be magnified.

Further Challenges: Shine a flashlight through the lenses onto a piece of paper and see what differences you will discover.

Have an optometrist come into the classroom and explain types of lenses and how they are used to correct eye problems.

Reference:

Mallison, George G., Jacqueline B. Mallison, Douglas G. Brown, John W. Knapp and William L. Smallwood. Science: Understanding Your Environment. Morristown, N.J.: Silver Burdett Company, 1981.

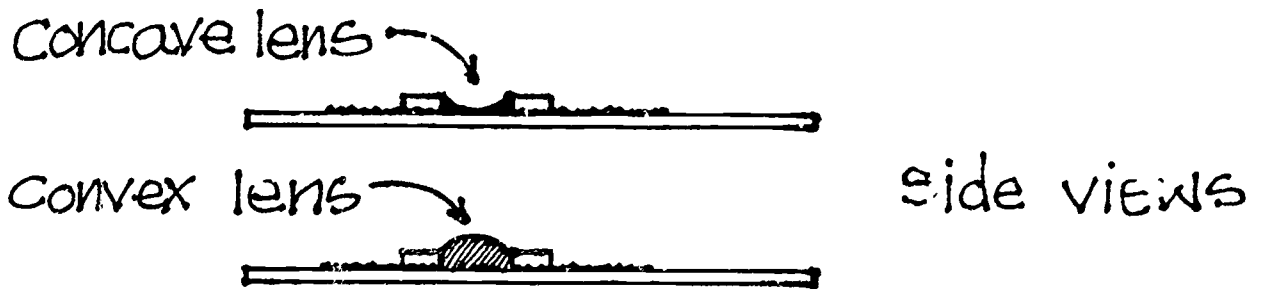
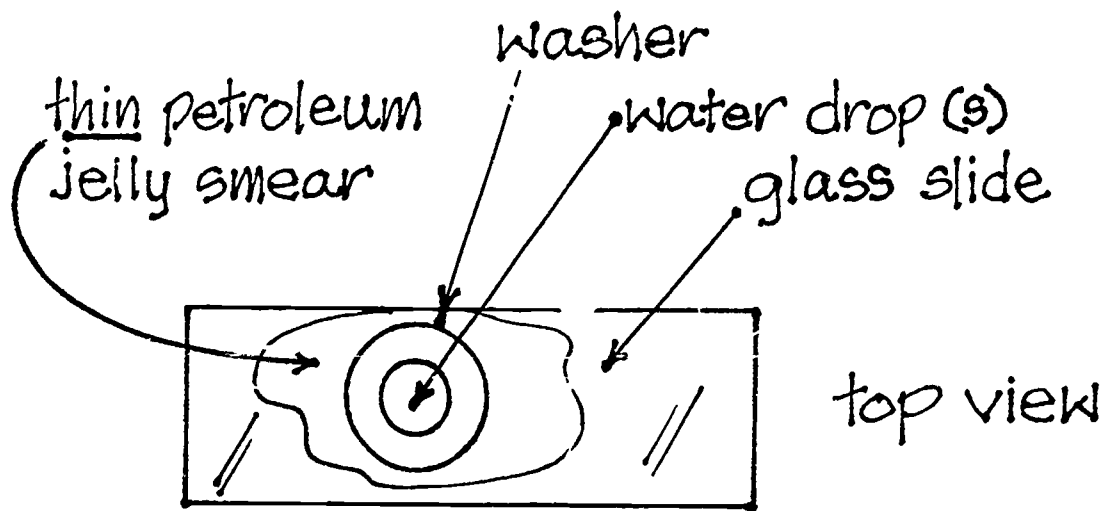

## DEMAGNIFICATION

by Michael J. Demchik

Focus: Demagnification is a topic often left out of the study of light.

Challenge: What kind of a lens produces demagnification? What relationship exists between distance and demagnification? Do compared distances provide measures of demagnification?

Materials and Equipment:

Depression slide or concavity slide (3" x 1")  
Newspaper print  
Ruler

How-To-Do-It: Select a newspaper that has a large headline. Find a letter "C" which just fits into the depression. Use the letter "C" for your investigation. Start with the concave surface toward you and place the letter under the slide. Move the concave surface away from the surface of the letter and observe that the letter gets smaller. Select several points to view the letter. At each of these points, measure the distance from the slide to the letter. Then estimate and record the apparent size of the letter as it appears in the circle as viewed through the slide. Measure and record the distance from the letter to the lens. Record the data in chart form. Plot the distance away against the demagnification (apparent size). Determine the relationship between the two variables.

Further Challenges: Put a penny into a graduated cylinder partially filled with water. Look down the tube and place your finger where you think that the penny is located. Vary the depth of the water and then compare the data. See if you can determine the relationship.

AMER

# Conflicting interests struggle

By Jon Anderson

...the moon travelling  
...ch is strewn wi  
...the forest, and  
...g but the wildest  
...conceive of the  
...we are living.  
...izard."  
...as "a homely  
...and hairy, with  
...long arms, a great  
...and wide gray  
...au loved the spot.  
...ange. The problem  
...Walden, at 61 acres,  
...-hwater pond in  
...-nough to qualify  
...as a "great."  
...all. Smaller  
...eds, less than 10 acres, can be  
...the best."  
...Four months, says one local  
...power of solitude, that "the  
...pressure is on Walden because  
...there isn't really any other place  
...to develop. You can't make a  
...pond."

According to historical records, Walden Pond became an international bathing beach and was knocked down 100 tons of shoreline for bathing beach and w

county to restock the woods. In 1974, the state gained control, taking measures to ban rubber boats, motorcycles racing through the woods and other nuisances. In a \$650,000 restoration, workers razed two bathhouses and a pier, carted out debris and built a parking lot. Beach access was limited to

## HOW LENSES TURN US UPSIDE DOWN

by David R. Stronck

Focus: Light rays are bent as they travel through lenses. When light travels through double convex lenses, the image created beyond the focal point is inverted.

Challenge: Discover what lenses do to light rays.

### Materials and Equipment:

A very dark room

Small candles, e.g. birthday-cake candles (that can stand upright by making a holder of aluminum foil)

Matches

Magnifying lenses

White cardboard cards

How-To-Do-It: Ask the children to predict what light rays do when they pass through a magnifying lens. Invite them to see what happens by doing the following (see the sketch on the following page):

1. Organize the youngsters into teams of three persons. The first student has responsibility for the candle. The second student takes the magnifying lens. The third student holds the white cardboard card.
2. Light the candle. Darken the room. Hold the magnifying lens between the candle and the white card. Move the magnifying lens slowly back and forth between the candle and the white card. Observe the image of the candle flame on the white card.
3. Answer the following questions about the image: Is the magnifying lens close to the flame when the image of the flame appears to be upside down? Where do you move the magnifying lens if you want a larger image of the flame. Can the magnifying lens be placed to present such a small image that there is no image at all? Can the magnifying lens be placed to produce an image that is not inverted?
4. Discuss with the students how the rays of light pass through the lens and sharply bend their direction when they leave the lens. The result is an image that is inverted. Students can draw a diagram showing a light ray from the top of the flame entering the top of the lens but leaving at such an angle that it is at the bottom of the image. Similarly a light ray from the bottom of the flame enters the bottom of the lens but leaves at such an angle that it is at the top of the image.

Further Challenges: Use flashlights in place of candles. To mark the top of the flashlight's ray of light, tape a small piece of cardboard over the part of the flashlight's glass window. Do similar activities as described above.

Use a ruler to measure distances between the magnifying lens and the image. Use these measurements to find the focal point where all of the light rays will converge at one spot. Measure the height of the image on the white cardboard card. Describe how the height of the image changes as the magnifying lens is moved. Have the students compare their measurements of similar observations.

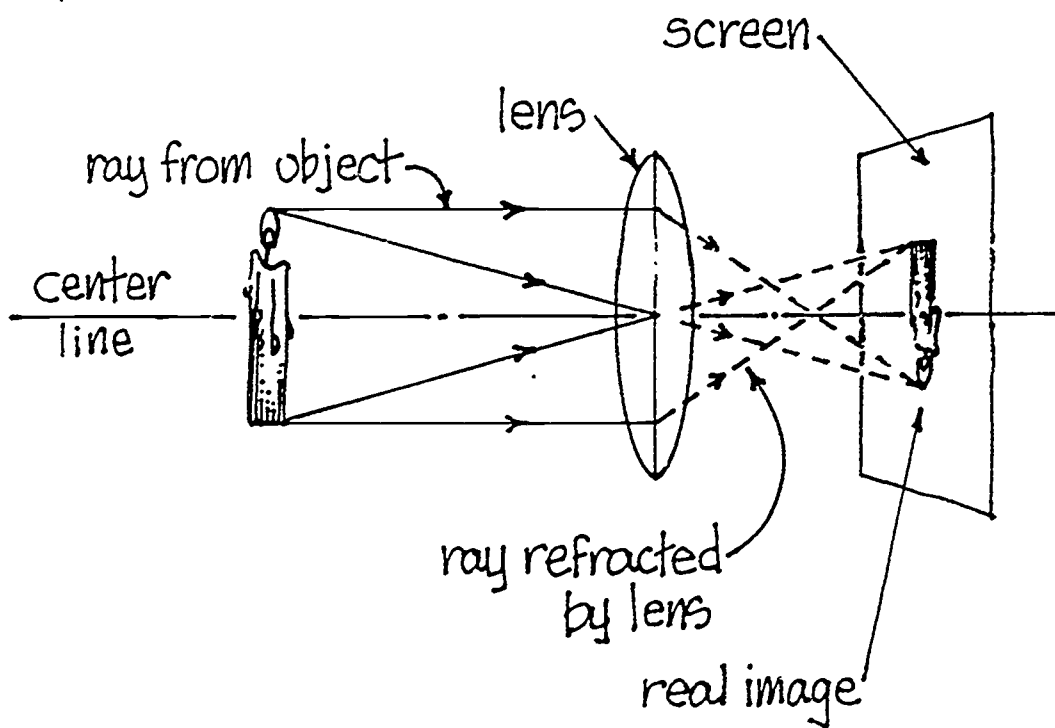



## WHERE DO FLOWERS GET THEIR COLORS?

by Mildred Roseman

Focus: Chromatography can be used to show the different components of pigments in plants.

Challenge: Hold up a purple blossom from a petunia. What gives it its color? How could we use chromatography to find out?

### Materials and Equipment:

Rubbing alcohol

Mortar and pestle (a spoon and jar lid may be substituted)

Red geranium, purple petunia blossoms

Chromatography paper (strips of white paper towel or coffee filter may be substituted)

Toothpicks

Test tubes and test tube racks (can be borrowed from junior high or high school labs. Glasses or jars may be substituted)

### How-To-Do-It:

1. See the sketch on the following page. Have children crush torn bits of the blossoms in a small amount of alcohol with a mortar and pestle. Do this with various blossoms in separate operations.
2. Cut several pieces of chromatography paper 15 cm. x 1 cm.
3. Draw a horizontal line across a piece of paper near the bottom of the paper with a pencil.
4. With a toothpick, place a dot of the plant pigment on the center of the line.
5. Place the end of the paper in a test tube in which 10 mm. of alcohol have been placed. The solvent must not touch the mark. Place test tubes in a test tube rack. (Other glassware such as jars or drinking glasses may be substituted for test tubes. The strips may be taped to the outside of the glass.)
6. Have children keep track of color sequence, band widths, travel time, and distance traveled of each blossom. Excitement mounts when colors begin to creep up the paper.) This can also be done with green leaves.

Further Challenges: What are some other possible uses for chromatography? How are plant pigments formed?

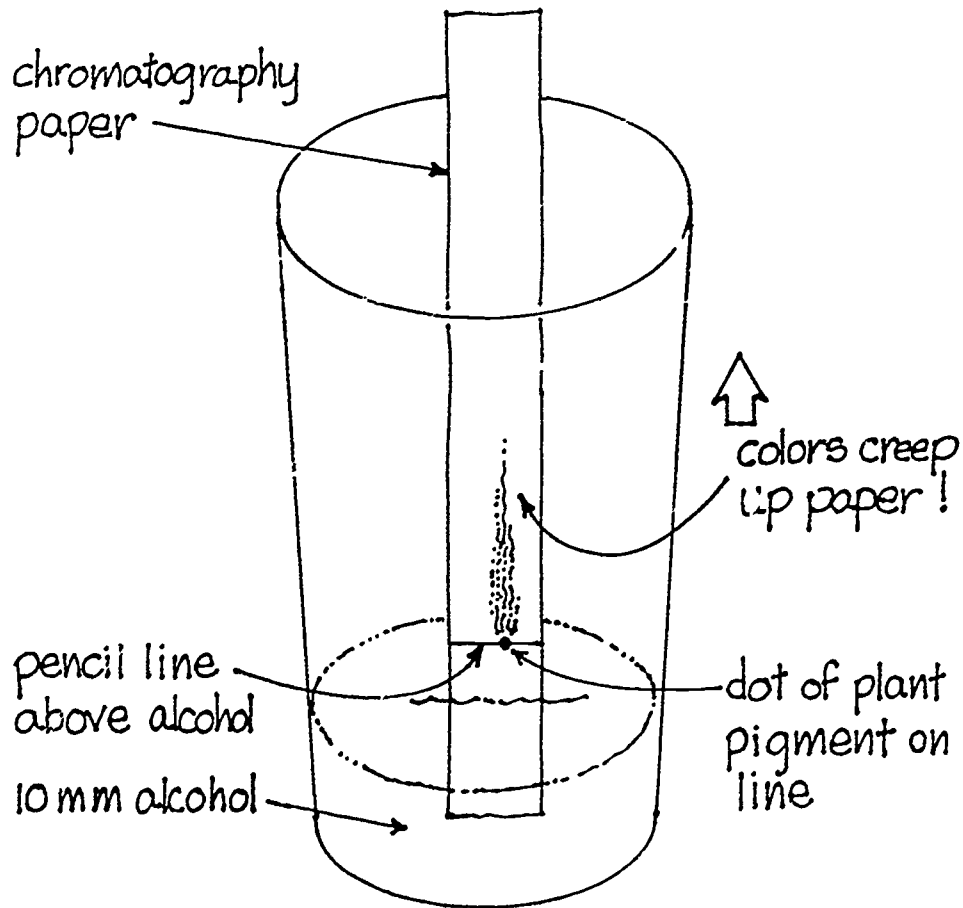

## RAINBOW PHYSICS

by Judith McKee

Focus: A rainbow is a portion of a complete circle which is not visible because of the horizon. Occasionally, a rainbow can be viewed in its entirety from an airplane.

Challenge: Demonstrate a complete rainbow using a horizon line which obscures the total configuration.

### Materials and Equipment:

Crayons or marking pens  
Circle template  
White construction paper

How-To-Do-It: Use a template outline of a single circle as a starting point for the rainbow. Then, with the acronym ROY G BIV (red, orange, yellow, blue, indigo and violet) as a guide for ordering colors, have the children make their own rainbows. Remember that violet is the shortest band of the light in the spectrum and red is the longest. Then make a horizon cover so that the rainbow is viewed as we usually see it. This is a good opportunity for creativity to flourish as each scene will, hopefully, be unique.

Further Challenges: By looking at the completed rainbow circle, the children can easily see that the violet band in the rainbow is shorter than the red one.

Experiment with light (sunlight or an artificial light source) and various prisms to make rainbows. Note the length of the band of color in the spectrum.

Discuss why the rainbow curves into a circle shape.

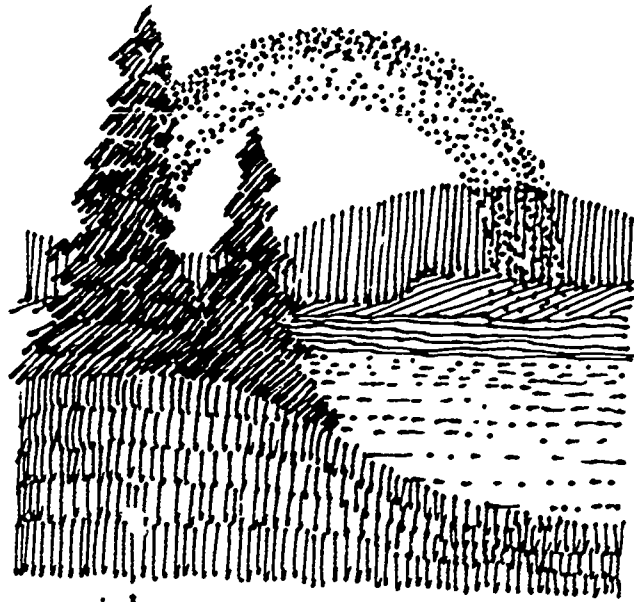

a rainbow as seen from Earth...  
appears half-hidden

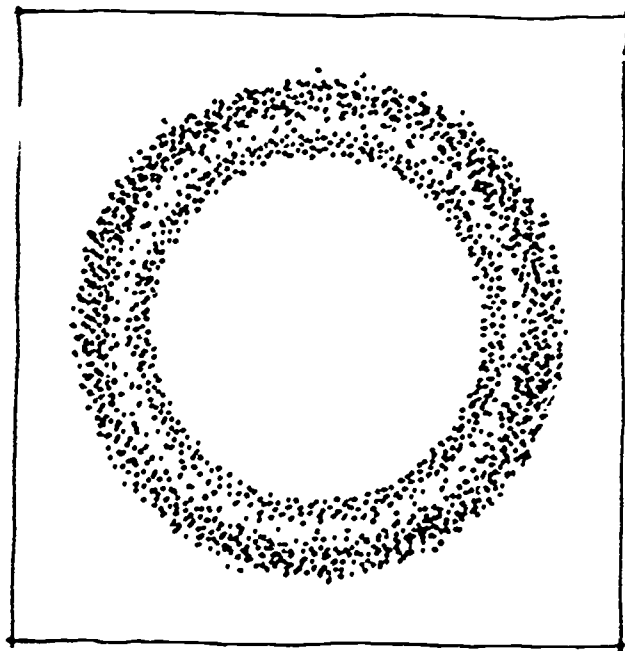

a rainbow as seen from an  
airplane... is a complete circle

## DIFFRACTION SLITS

by Gerald Wm. Foster

Focus: Producing a light spectrum by diffracting light.

Challenge: Finding various ways to diffract light.

### Materials and Equipment:

Microscope slides  
Spray paint (flat black)  
Single edged razor blade  
Newspaper

How-To-Do-It: Cover desk or table with newspaper. Spray one side of a microscope slide with black paint. Allow to dry which takes approximately five minutes.

Take a razor blade and make a fine line through the paint. Hold the slide with the line up to a light and look for bands of light and dark.

Further Challenges: Make several lines to see what happens. Try making the lines at different distances from each other to see what happens.

Try different kinds of light sources. For example: light from a window, fluorescent light, incandescent bulbs that have a vertical filament as well as those that have a horizontal filament.

Use colored cellophane to cover the slide to see if certain colors will block out certain parts of the spectrum.

Try other ways to diffract light: hold two fingers close together and look between them at a light source. Try nylon stockings or some other finely meshed materials that allow light through and look at a light source. Use finely meshed window screen to produce a spectrum.

## POLARIZED LIGHT

by Gerald Wm. Foster

Focus: Diffracting light using cellophane and polarized film.

Challenge: Students will create different colored designs by making slides using polarized film and cellophane.

### Materials and Equipment:

Cardboard slide covers purchased from a camera store

Polarized film

An assortment of cellophane tape

An assortment of cellophane packaging

Slide projector and screen

Scissors

How-To-Do-It: Cut a piece of polarized film to fit into a slide cover. Seal it shut with a piece of tape.

Cover one side of the prepared slide with strips of cellophane tape. Put the strips of cellophane at different angles and overlap them. The way the strips are placed will create the design. The type of cellophane will create the intensity of the different colors.

Put the slide into a slide projector. With the projector light on, rotate a larger piece of polarized film in front of the projector lens. The rotation creates different patterns and different colors of the spectrum.

Further Challenges: Use pieces of cellophane wrapping on top of an overhead projector and rotate a piece of polarized film above the cellophane as the image is projected on a screen.

Make a slide that contains a drop of water or oil in the center.

Try different kinds of sunglasses on the overhead projector. As the piece of polarized film is rotated, determine which sunglasses contain polarized lenses and to what degree they contain the polarizing element.

Play music in the background and let students create different moods with the colors projected on the screen as they rotate the polarized film in front of the projector lens with the beat of the music.

CHAPTER 4

ACTIVITIES FOR TEACHING ELECTRICITY  
FROM STATIC TO CIRCUITS

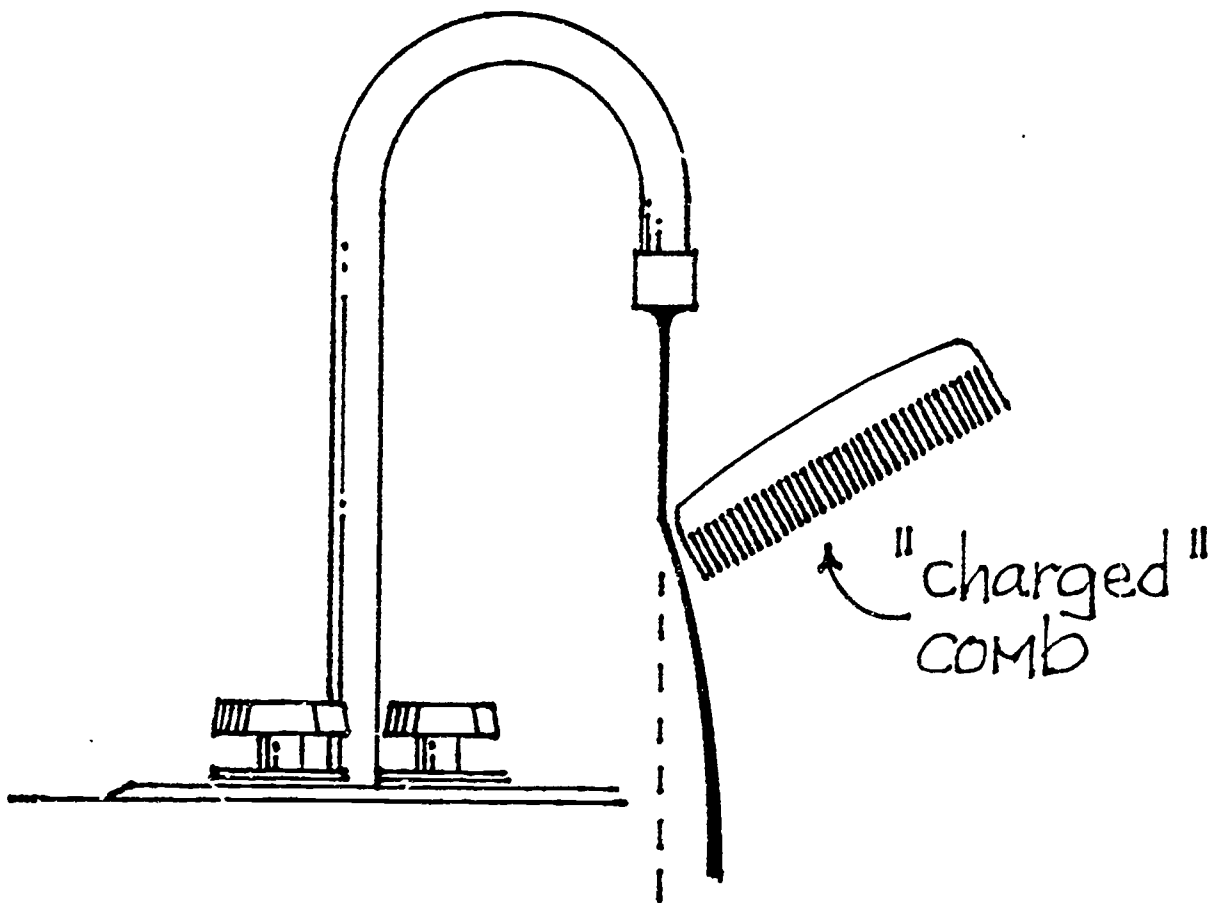

## DANCING DOLLS

by Meghan and Mark Twiest

Focus: This experiment demonstrates how oppositely charged particles attract each other.

Challenge: Make paper dolls dance through the use of static electricity.

### Materials and Equipment:

1 piece of glass, approximately 12 x 25 cm.  
2 thick books, such as dictionaries  
1 piece of silk cloth  
1 piece of tissue paper  
Scissors

How-To-Do-It: Abstract concepts such as electrical charges can be explained more easily through the use of concrete examples which the students can handle and explore.

See the sketch on the following page. First, on a high counter, visible to all students, place the two thick books about four inches apart. Have each of the students cut paper dolls out of the tissue paper. Allow them to put their names on their dolls so that they can easily be identified. Then place the dolls on the table between the books. Ask the children to think of ways to make the dolls move, without touching them. After the students shake the table and blow on the dolls, tell them you know of another way to make the dolls move. Place the glass over the dolls so that it is propped on top of the two books. Next, rub it vigorously with the piece of silk. The dolls will dance up and down between the glass and the table top.

When the glass is rubbed with the silk, the silk takes some of the electrons from the glass and becomes negatively charged. The glass having lost the negative charge subsequently becomes positively charged. The paper receives an induced negative charge from the glass and is attracted to it.

Further Challenges: A hair comb can pick up small pieces of paper after running the comb through your hair, using this same principle.

Does this activity work better on days with low or high humidity? Why?



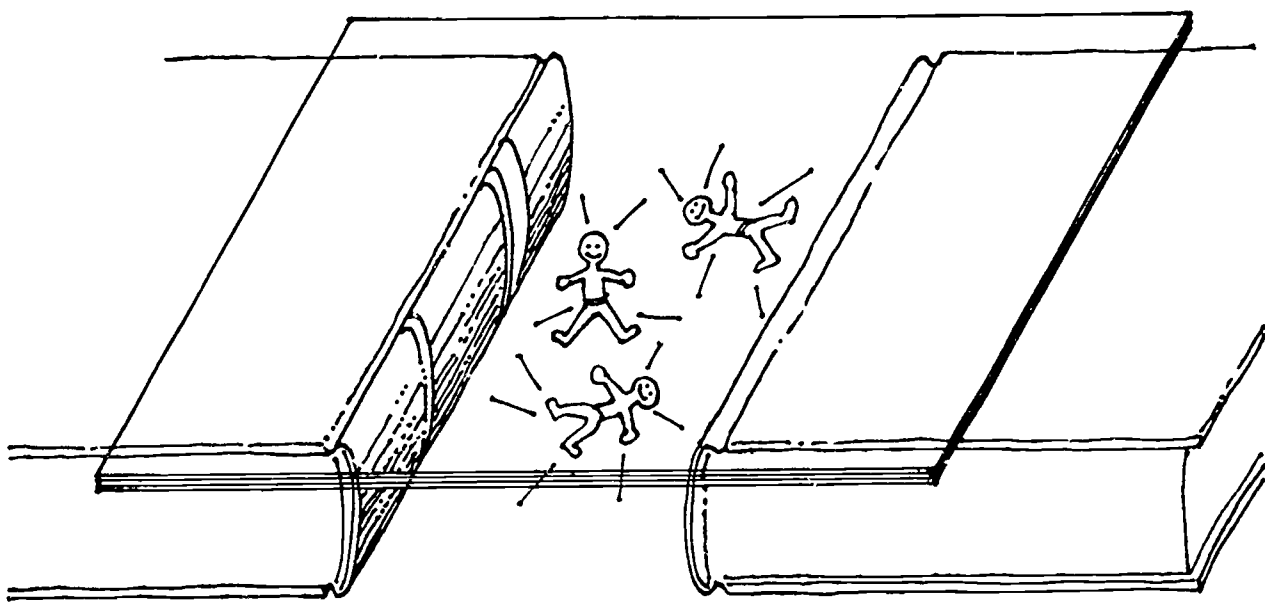

87

## CHARGE YOUR CLASSROOM

by Yvonne A. Johnson

Focus: Observation is the major emphasis in this series of activities for electrostatics. Children should be encouraged to experiment in finding other ways to produce electricity.

Challenge: Through a series of related experiments children will discover that static electricity is produced when you create friction.

### Materials and Equipment:

Comb  
Inflated balloon  
Stream of water  
Cereal  
Electrician's tape

How-To-Do-It: A word of caution before beginning work with electrostatics: these experiments work best in winter when it is cold and dry. If you comb your hair to charge the comb, the hair should be clean, dry, and free of creme rinse and hair spray.

Bring a comb near small bits of paper.

Run a comb through your hair several times and bring it near small bits of paper.

Run a comb longer and harder through your hair and bring it near small bits of paper.

Run a comb many times through your hair and bring it near a stream of water coming from a faucet. (See the sketch on the following page.)

Bring an inflated balloon that has been rubbed near small bits of paper.

Touch an inflated balloon that has been rubbed to a wall.

Bring an inflated balloon that has been rubbed near to someone's hair.

Rub a comb to charge it and bring it near cereal.

Flip/shake your blanket hard when you go to bed.

In a dark room, sharply pull electrician's tape away from the roll.

In all of the above cases, the child should make observations concerning what he/she has seen occur.

Further Challenges: Why was fabric softener developed to be used for doing laundry?

Why do gas trucks have a chain that touches the ground?

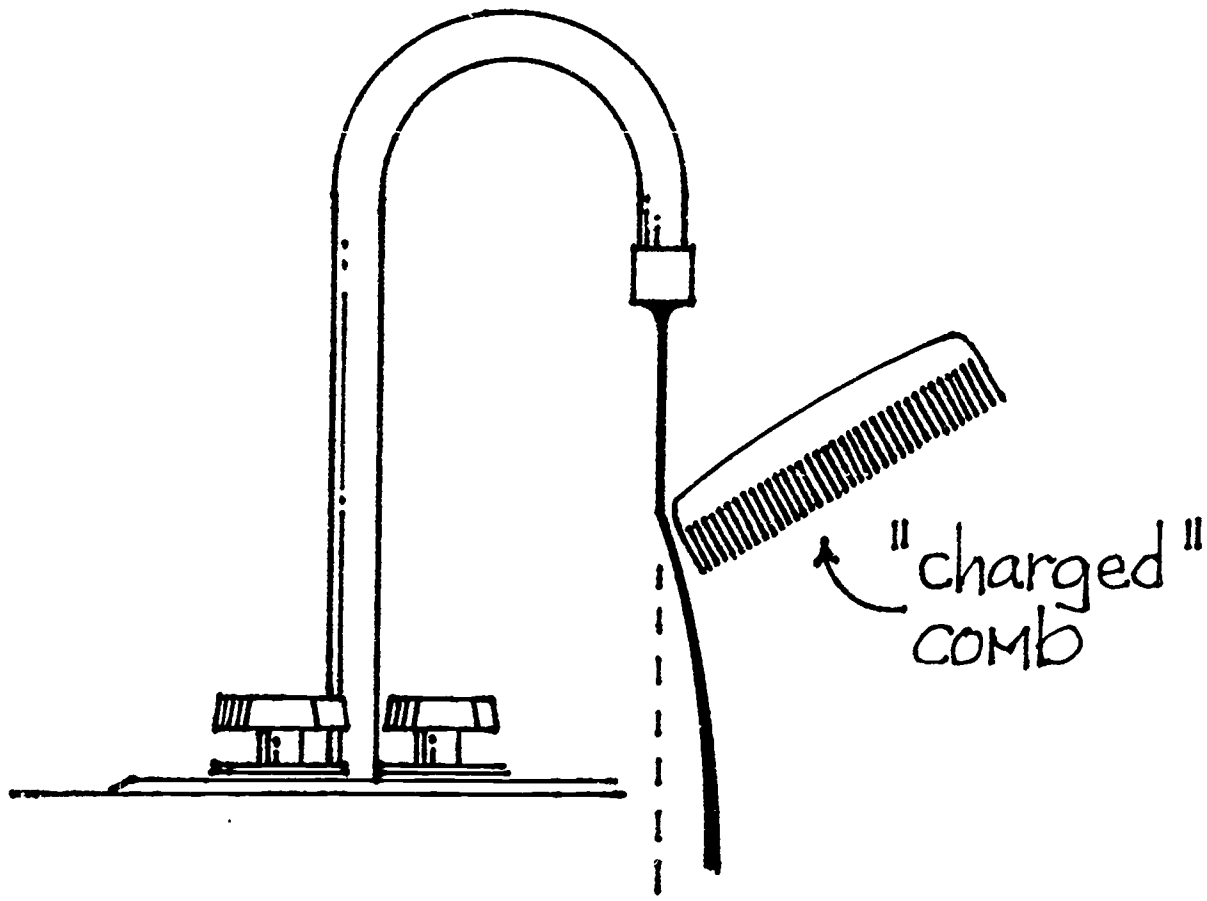

## LET THE SPARKS FLY

by Richard Bollinger

Focus: Static and current electric charges are essentially the same.

Electrical charges are found in everything.

Static electric charges can be easily generated by friction.

Challenge: How can you demonstrate the similarity between static and current electricity?

How can static electricity be produced?

How can an object be tested for the presence of electrical charges?

### Materials and Equipment

Balloon

Clay

Sharpened pencil

Index card

Aluminum pie pan

Two rubber bands

Fluorescent bulb (dead or working)

Assorted static electricity items (see Activity 3)

How-To-Do-It: Start the lesson by pointing out a balloon stuck to the wall. Ask students to explain the cause of the balloon sticking. You may remove the balloon at one point, rub it on your hair, and stick it back on the wall.

After a student states the cause as (static) electricity, ask students if they can see the electricity in the balloon. Many students have seen this demonstrated at parties and have already been told that the balloon is filled with electricity, but they have little or no understanding of static electricity. Ask the students if electricity is dangerous to touch? How can we discover if the balloon is filled with electricity?

Activity One: Construct a static electricity tester.

See Figure 1 at the end of the three activities. Place a sharpened pencil, eraser first, into a ball of clay so that the pencil is able to stand erect. Fold an index card in half the long way and balance it upon the pencil point so that it is able to pivot around.

Bring the charged balloon(s) near the index card and watch how it attracts the card causing it to spin around.

Activity Two: Testing to see if the balloon is really charged with electricity.

Construct an electrophorus by placing two rubber bands across an aluminum pie pan in an "X" shape. Holding onto the rubber bands as a handle, rub it across a sheet of plastic. (See Figure 2.) Experiment using several types of plastic until you find the kind that produces the strongest charge. Being careful not to touch the pie pan with your hand (the charge will enter your body) bring it near the metal ends of the fluorescent tube. The tube may even be dead! The fluorescent tube will briefly glow demonstrating that you are generating "real electricity." (See Figure 3.) Bring the charged pie pan near the electricity tester and see if the tester can indicate the presence of an electric charge. Movement of the card shows that the "index card electricity tester" is working.

Activity Three:

Being by asking students to describe the common factors when the balloon and pie pan were charged. (Both were rubbed.) Encourage students to experiment with a variety of materials by rubbing them against each other or a soft cloth. Such materials may include rubber or plastic combs, plastic pens, plastic rulers, wax candles, crayons, small glass drinking glasses, soda straws, pieces of rubber hose, small pieces of paper, plastic bags, scraps of wool, silk, fur, and cotton cloth.

Have students test which materials will produce static electricity, as indicated on the "index card static electricity tester," when rubbed together. Materials such as wood and metals, which do not produce electrical charges, should also be included.

Further Challenges: Does the direction in which you rub cause any change in the charge?

Why do many pieces of clothing stick to each other when they come out of the dryer?

What causes the spark to come out of your fingertip after you walk on carpeting?

What would we have to do to keep the fluorescent tube lit for a longer period of time? (Keep the charges coming.) This is an excellent lead-in for the topic of current electricity.

Investigate the causes of lightning.

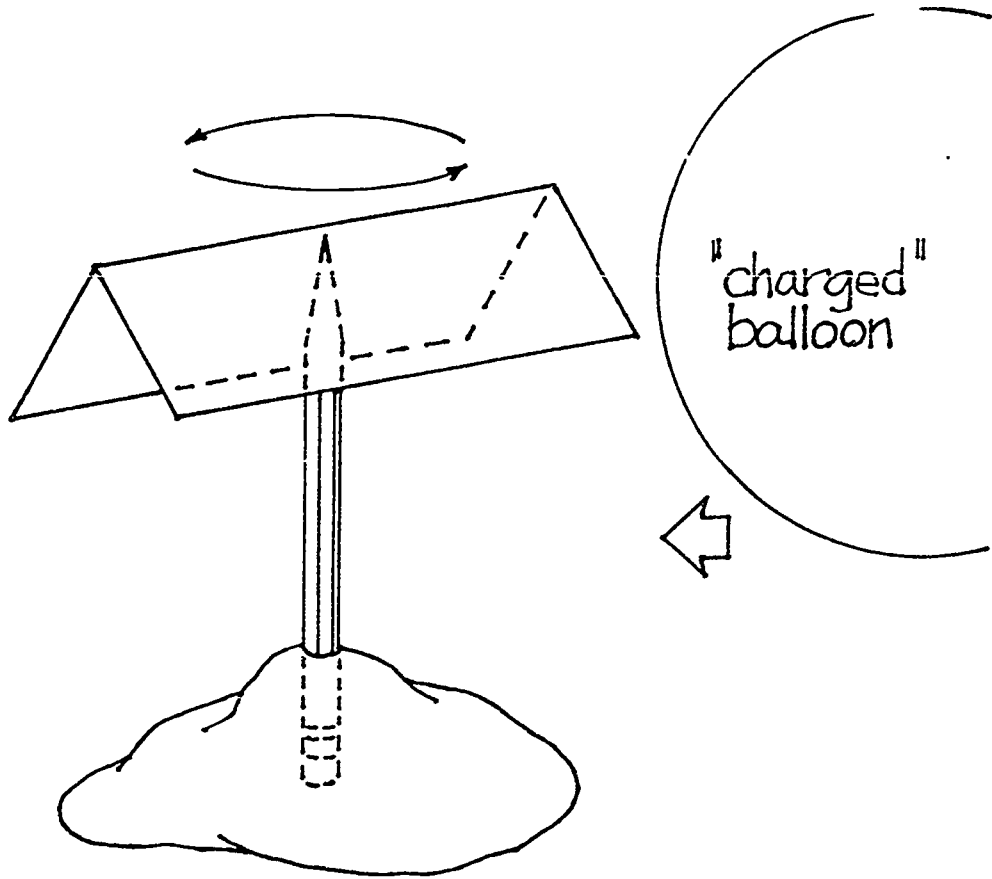

Figure 1

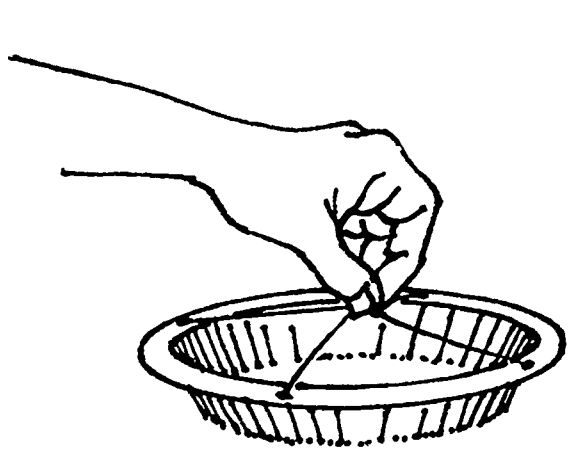

Figure 2

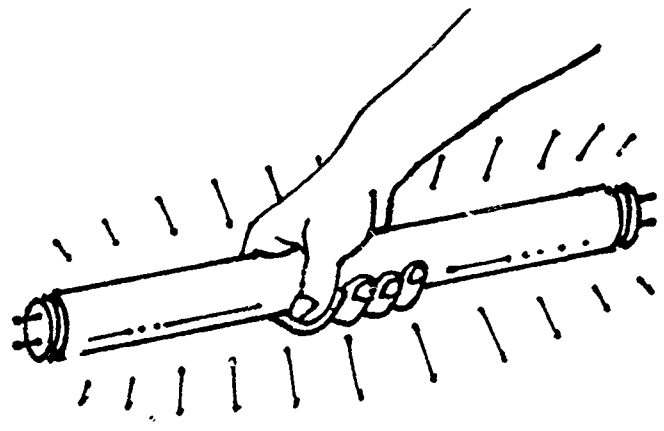
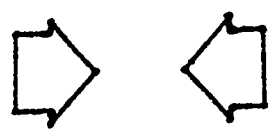

Figure 3



## ELECTRIC CIRCLES

by Stephen C. Blume

Focus: Although children can define a circuit after studying a textbook, they need concrete experiences with a battery, bulb, and wire to really understand the concept of circuit.

Challenge: How many ways can you get a bulb to light using a battery, a bulb, and one wire? Where does the electric current flow when the bulb lights? What are the special places on the battery that must be touched to get the bulb to light? What are the special places on the bulb that must be touched to get the bulb to light?

### Materials and Equipment:

D cell batteries  
Copper wire  
Flashlight bulbs

How-To-Do-It: Each child is given a battery, a bulb, and one wire. Tell the children to get the bulbs to light as many ways as they can. By manipulating the materials in different ways, the children will light the bulb. Eventually, one or two children will get the bulb to light. The other children will copy the arrangement to get their bulbs to light. Ask the children what special places on the battery have to be touched to get the bulb to light. Also, ask them what special places on the bulb must be touched to get the bulb to light.

Note that the dry cell battery has two special places. The top of the battery is the positive terminal, and the bottom of the battery is the negative terminal. Electrons flow from the negative pole to the positive pole of the battery when connected in a circuit. The bulb has two special places that must be connected to the dry cell to light the bulb. The silver tip or the bottom of the bulb and the gold threads on the side of the bulb are the two special places that must touch or be connected by a conductor to the two poles of the battery.

Tell the children to find other ways to light the bulb. If necessary give the children hints such as "I wonder if the bulb will light if the battery is upside down," "Try to light the bulb with the bulb lying down on the battery," or "Are you touching all the special places on the battery and bulb?"

Have the children describe how the electricity flows through their circuit. Then, have the children draw the arrangements that lit the bulb.

Next, give the children another wire so that they have a battery, two wires, and a bulb. Tell them to get the bulb to light with their materials, but the bulb cannot touch the battery this time. Again, give them hints as necessary, have them describe how electricity flows through their circuit, and have them draw the arrangement that lighted the bulb.

Further Challenges: How many bulbs can you light with one battery and one wire? What happens to the brightness of the bulbs when more than one bulb lights up? How can you explain what happens to the brightness?

How many bulbs can you light with one battery and two wires? Get a partner and try to light as many bulbs as you can without any of the bulbs touching the battery. What happens to the brightness of the bulbs when more than one bulb lights up? How can you explain what happens to the brightness?

What do you think will happen if you connect two batteries to one bulb? Try it with your partner. What happens to the brightness of the bulb? How can you explain what happens to the brightness of the bulb?

References:

Friedl, Alfred E. Teaching Science to Children: An Integrated Approach. New York: Random House, 1986.

Hone, Elizabeth B., Joseph, Alexander, and Edward, Victor. A Sourcebook for Elementary Science. New York: Harcourt Brace Jovanovich, Inc., 1971.

Liem, Tik L. Invitations to Science Inquiry. Lexington, MA: Ginn Press, 1981.

Lowery, Lawrence F. The Everyday Science Sourcebook. Palo Alto, CA: Dale Seymour Publications, 1985.

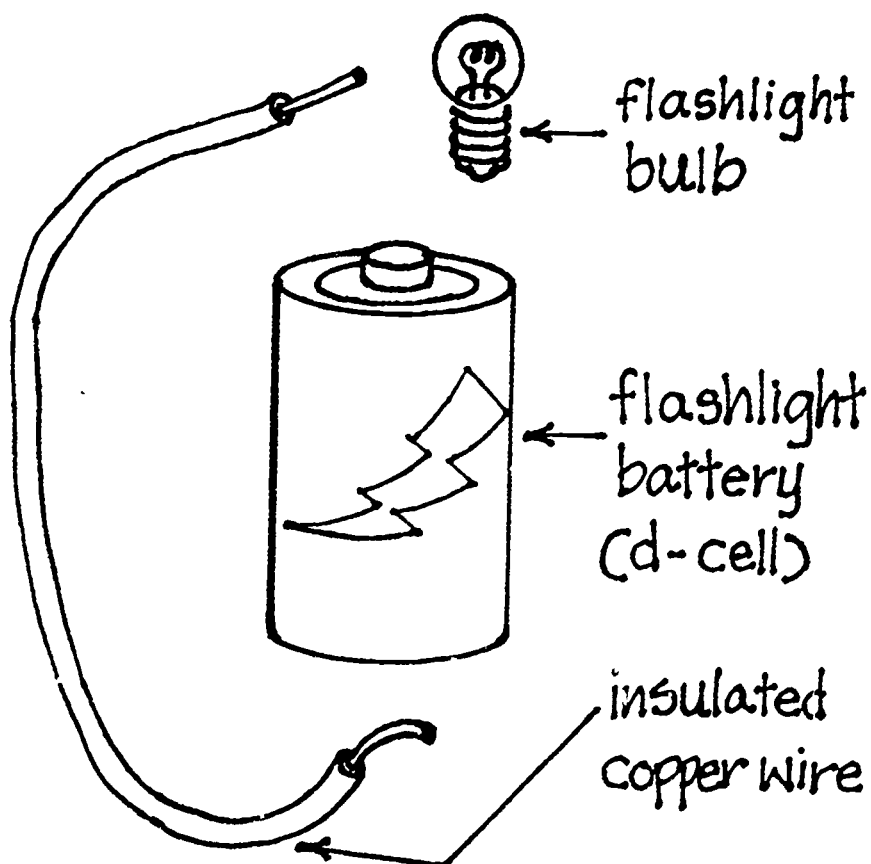



## BUILD A HEAVY-DUTY CIRCUIT BOARD

by Charles Nease

Focus: Students need hands-on experience in setting up and manipulating series and parallel circuits. They need materials which facilitate systematic comparisons and explorations. The common practice of using a loose assortment of sockets, bulbs, wires, and batteries, however, may promote confusion rather than understanding. Instead, use a circuit board that provides beginners with an unambiguous arrangement of these items.

Although commercial circuit boards are available, they tend to be both costly and fragile. Fortunately, teachers can make less expensive and far more durable ones with parts obtained from hardware stores or supply catalogs.

Challenge: Complete the series and parallel circuits by adding the missing wires. Then make as many comparisons as possible between the two types of circuits.

### Materials and Equipment:

- 1 masonite board, 1/4" thick, 12" x 12"
- 2 batteries (Radio Shack)
- 4 D cells
- 2 knife switches, single pole, single throw
- 6 lamp sockets, miniature, screw base
- 6 3-volt dry cell lamps, screw base
- 1 roll, 18 gauge bell wire (annunciator wire)
- 20 each: 6-32 x 3/4" machine screws, washers, lock washers, nuts
- 5 rubber bumpers
- 1 drill with bit
- 1 wire stripper
- 1 screwdriver
- 1 illustration of series and parallel circuits (optional)

How-To-Do-It: Build circuit boards as illustrated at the end of the activity for each group of students. All components (battery holders, sockets, switches) may be fastened to the masonite board with screws. Holes drilled slightly smaller than the diameter of the screws will make this part of the construction easier. To protect the working surface from the machine screws protruding from the bottom of the circuit board, mount five rubber bumpers underneath the board. Place one in each corner and one in the center.

Have students work in groups of two or three to add the wires as shown by dashed lines in the illustration. They will need instruction in using the wire stripper, and a clear illustration of the two types of circuits may be helpful. Since they may inadvertently set up short circuits, instruct them to turn off the switches and ask for help if any wires start to heat up.

When the circuits are complete, ask these questions. What differences do you see with the switches off? With them on? What do you think is causing this difference? (Have the students unscrew one bulb in each circuit.) Now what differences do you see? What is causing this? Show me the paths the current is taking now. Which circuit is like those in your house or apartment? How can you tell? How do you know that the batteries are not causing the differences in brightness? How can you prove whether they are or not?

Have the students draw and label the two circuits in their notebooks. After the hands-on experience, these drawings will be meaningful for review purposes.

Further Challenges: Have students use two U-shaped pieces of wire to bypass one bulb in each circuit, but this time do not have them fasten the wires down. Have them make comparisons and trace the paths of the current. (The short circuit on the parallel side will cause the wires to heat up, so remind them to remove the new wires when this occurs.)

Let them connect the batteries and bulbs in any configuration they wish. Again, have them trace the current paths to explain what is happening. (Repeat the warning about short circuits.)

After they have become proficient at tracing current paths, give them a socket with a bulb, two single pole, double throw switches, a battery box, and wire or alligator clips. Have them set up a circuit with two-way switches. (The clips will save time and wire. This activity may require dozens of trials.)

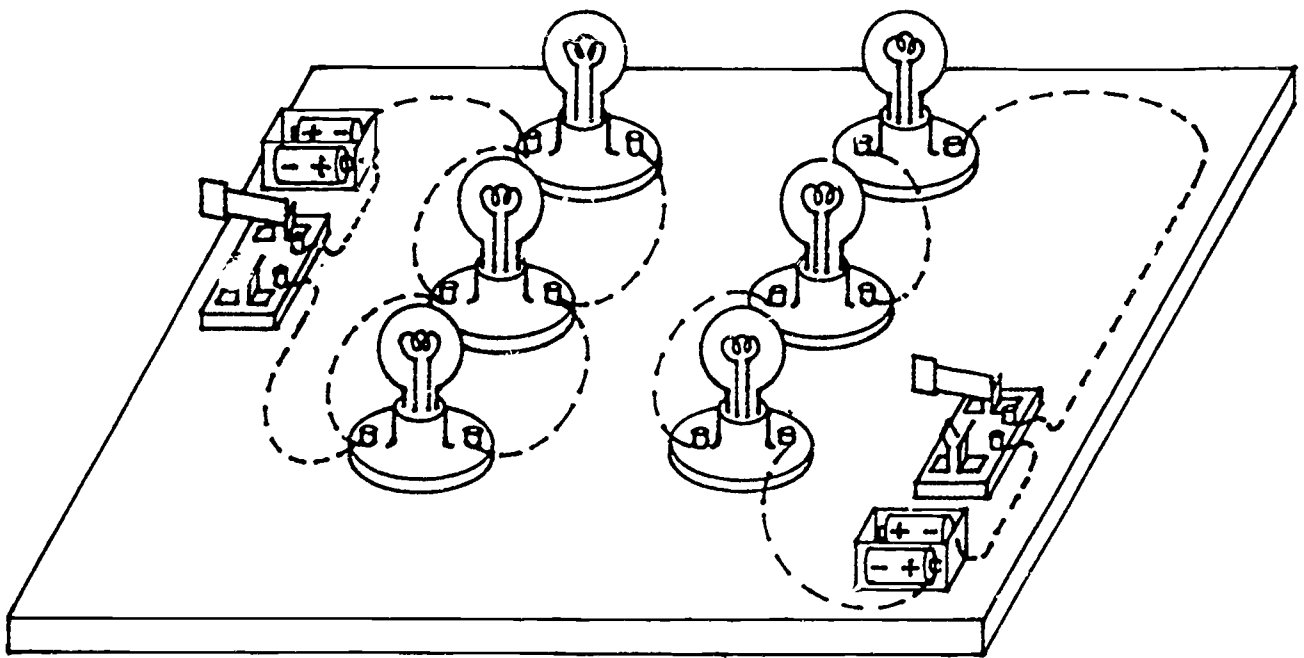

107

## ELECTRIC SPARKLERS

by Stephen C. Blume

Focus: Children can better understand how a light bulb works by being given the opportunity to create a working model of a light bulb. Then, by performing investigations with their light bulb, they can better understand electrical resistance.

Challenge: How can you make a model of a light bulb using batteries, two wires, a lump of clay, and your special wire? What do you observe happening to the filament of the model light bulb just before it glows? How can you explain why the wire glows? How many batteries does it take to get your "bulb" to light? What happens if you use too many batteries with your model light bulb? How do the number of batteries affect the brightness of the model light bulb? How does the length of the filament wire affect the brightness of the model light bulb? What do you observe when you use steel wool as the filament of your light bulb? How can you explain what happens to the steel wool?

### Materials and Equipment:

D cell batteries  
Copper wire  
Clay  
Stranded galvanized steel picture hanging wire (or #32 nicke chromium wire)  
Masking tape  
Metric ruler  
Steel wool

How-To-Do-It: The children are assigned to groups of 4 or 5 students. Each group is given 4 fresh D dry cell batteries, two 40 cm lengths of copper wire, a small lump of clay, masking tape (to hold batteries together), a metric ruler, and 10 cm of stranded picture hanging wire. If the children are using nichrome wire, give each group three batteries. Tell the children to make a model of a light bulb using the materials. Direct them to use only one strand of the galvanized wire. Also, tell them that the length of the filament between the copper wires should be 1 cm in length. If the children have trouble getting started, it may be helpful if you pass around an unfrosted bulb for them to look at and discuss how it is constructed. See the sketch at the end of the activity.

Eventually, a group will get the bulb to light. Other groups will observe the arrangement and also get their bulbs to light. Ask the children to describe what they observed when the circuit was completed. Also, ask the children how they can explain why the special wire glowed.

Next, tell the children that they are going to determine how the number of batteries affects the brightness of the filament. Have each group make certain that the length of their filament is 1 cm. Then, tell the children to try lighting the bulb with different numbers of batteries starting with

one battery and continuing until they use six batteries. When the activity is completed, ask the children how many batteries it took to get their "bulb" to light and what happened if too many batteries were used.

Now ask the children how they would determine the effects of the length of the filament wire on the brightness of the bulb. Ask questions until the children decide that they will need to use different lengths of filament wire and keep the number of batteries constant throughout the experiment. After completing the activity, ask the children questions such as "What happened to the brightness of the bulb as the length of the filament wire was increased?" "What was the longest length of filament used and the bulb still lit?" and "How can you explain how the length of filament affects the brightness of the bulb?"

To culminate this series of activities, have the children use a small ball of steel wool as the filament of their model light bulb. This activity is especially effective in a darkened room. The children will observe "sparklers" as the steel wool burns. Ask the children what they observe and how they can explain why the steel wool sparkles.

Further Challenges: What happens to one strand of steel wool if it is placed between the copper wires? What do you think will happen to two strands of steel wool twisted together? How many strands of steel wool will it take before you can make a model light bulb using steel wool as the filament? Try it with your group.

Can you think of any other kind of wire that might be used to make a model light bulb? Do you think that a very thin copper wire would make a good light bulb filament? Do you think that a thin piece of aluminum foil from a gum wrapper would work as a light bulb filament? Try them with your group. If these metals do not work as a light bulb filament, can you think of another electrical use for them?

Ask students "What is a fuse?" Using what you have learned, how would you make a fuse? What material could be used for a fuse? Try using a thin strip of aluminum foil from a gum wrapper as a fuse in a circuit with your group.

#### References:

Education Development Center, EDC. Batteries and Bulbs. St. Louis, MO: McGraw-Hill, 1966.

Liem, Tik L. Invitations to Science Inquiry. Lexington, MA: Ginn Press, 1981.

Lowery, Lawrence F. The Everyday Science Sourcebook. Palo Alto, CA: Dale Seymour Publications, 1985.

d-cell batteries  
(tape together)

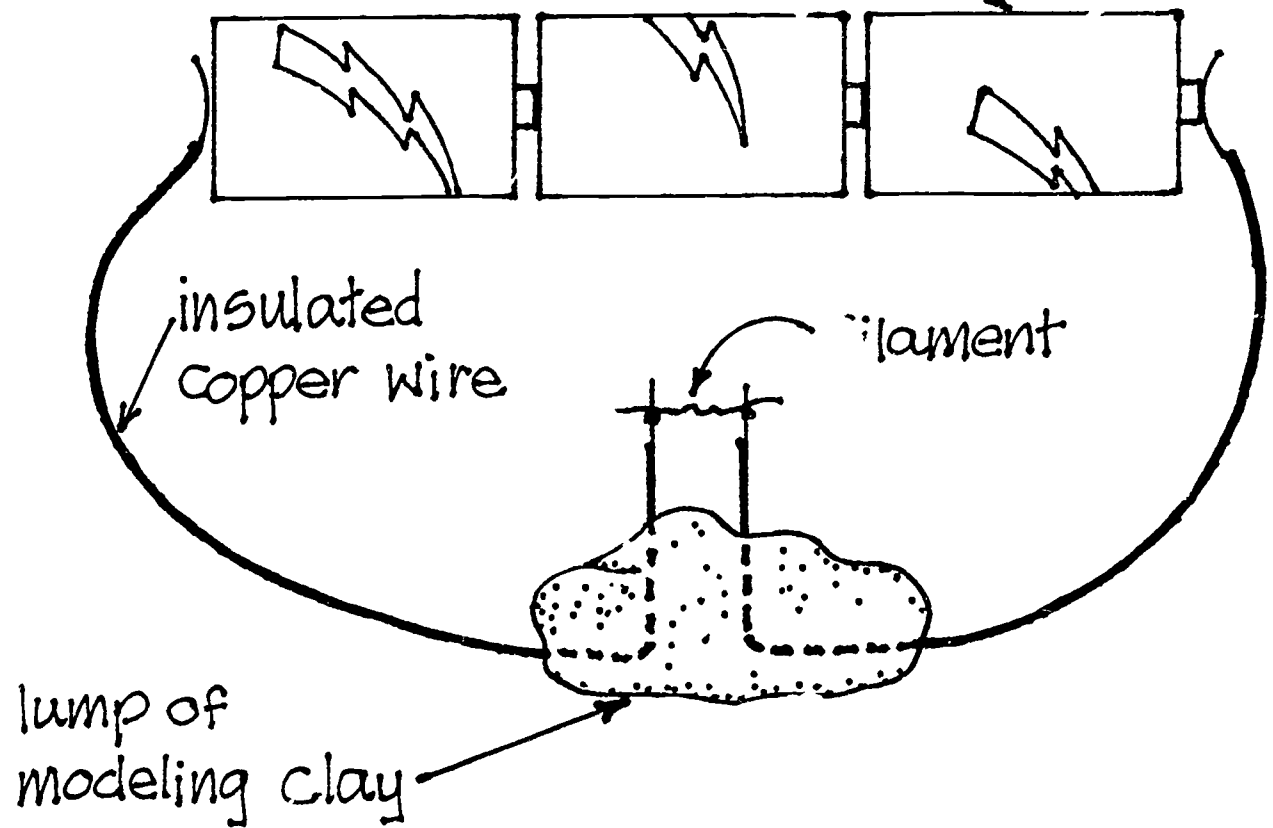

## BREAKING THE ELECTRIC CONNECTION

by Carole Kuchinsky

Focus: A fuse will cause a break in an electric circuit when the amount of current flowing through it exceeds a certain limit.

Challenge: What happens to the fuse when placed in the series circuit? How does steel wool act like a fuse? Is it possible to construct the series circuit so th "fuse" does not cause an open circuit?

### Materials and Equipment:

For 2 to 4 students

3 batteries and holders

6-15 cm wires, switch, light bulb and holder

Steel wool

Construct a circuit with a fuse!

How-To-Do-It: The electrical system in any building can cause a fire if not constructed properly or used safely. A fuse is a safety device used to protect an electric circuit against overloading. Wires within a circuit that become overheated can cause a fire. The fuse prevents this by melting and therefore breaking the circuit when an unsafe amount of current is flowing.

Safety: This device should be constructed on a noncombustible surface.

Set up a series circuit using three batteries, a switch and a bulb. Test the circuit.

Remove the end of one wire from the end of the battery holder. Attach another wire to the end of the battery holder.

Connect the two free ends of wire together with several strands of steel wool as shown in the diagram. The steel wool is the fuse. (Alligator clips fastened to the end of these wires will make fastening the steel wool easier.)

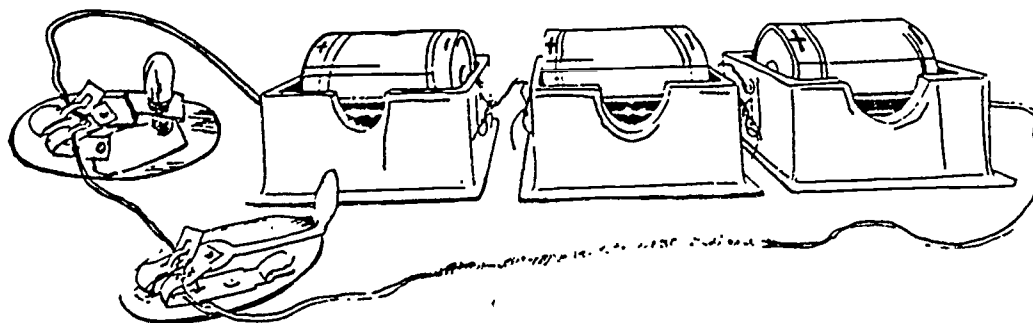

Close the switch. Observe the steel wool closely.

Describe what happened to the "fuse" when it was placed in the circuit.

Results: The electric current will be conducted by the steel wool. The heat energy generated will cause the steel wool to reach its "combustion" temperature: it will burn briefly, the circuit will be broken, the current will no longer have a continuous path to follow, and the bulb will no longer be lit.

In many houses today, fuses have been replaced by circuit breakers. A circuit breaker serves the same function as a fuse - it breaks an electric circuit. The difference is in the method. The circuit breaker contains a bimetallic strip which will bend when overheating occurs and, in bending, acts like a switch - it opens the circuit.

Further Challenges: How is a circuit breaker a safety device in an electric circuit? Repeat this experiment using a parallel circuit. Make a list of electrical hazards in your home and make some suggestions for eliminating them.

This activity is taken from The Franklin Institute's Museum-To-Go Electric Circuits activity kit.



## THE ELECTRICAL PENNY PITCHER

by Ginny Petrie

Focus: Certain materials will conduct electricity. However, no matter how well a material conducts electricity, a complete circuit must be in evidence to allow electrons to flow and produce an effect.

Challenge: Children will build a maze from aluminum foil that is connected on only one end of each parallel path to a dry cell (see diagram on the following page). When a penny is tossed in such a way as to complete the circuit on the maze, a bulb that is wired into the circuit will light. This "toy" demonstrates the principle of completed circuits to youngsters who have made the game for themselves.

### Materials and Equipment:

9" or large paper plate (or any stiff cardboard)  
2 brass brads (to connect wires to maze)  
Aluminum foil  
Rubber cement  
1 light bulb and bulb holder  
3 pieces of wire  
1 D battery and battery/wire hold (rubber band will do)  
Several pennies or steel washers

How-To-Do-It: Construct a penny pitch yourself to demonstrate to the class before challenging them to construct one.

Make a pattern out of paper first to try out. Strips should be about 1/4" wide. Once the pattern is okay, then transfer to foil.

- a. This can be done by putting the pattern on top of a large piece of foil and tracing it out.
- b. As an alternative, the pattern could be traced onto the cardboard with pieces of foil placed onto the pattern marked cardboard. (Younger children find this to be easier.)

However you transfer the pattern to the cardboard, you next glue the foil to the cardboard wiping away any excess glue.

At one end of the maze, where the parallel patterns come to the edge, stick in two brass brads.

Connect wires, battery and bulb as shown in the diagram.

Take a penny and move it along the maze until contact is made.

Further Challenges: Try making the maze with other materials. Does it work as reliably? Does it work better? Use other materials for pitching: other coins, paper clips, washers, etc.

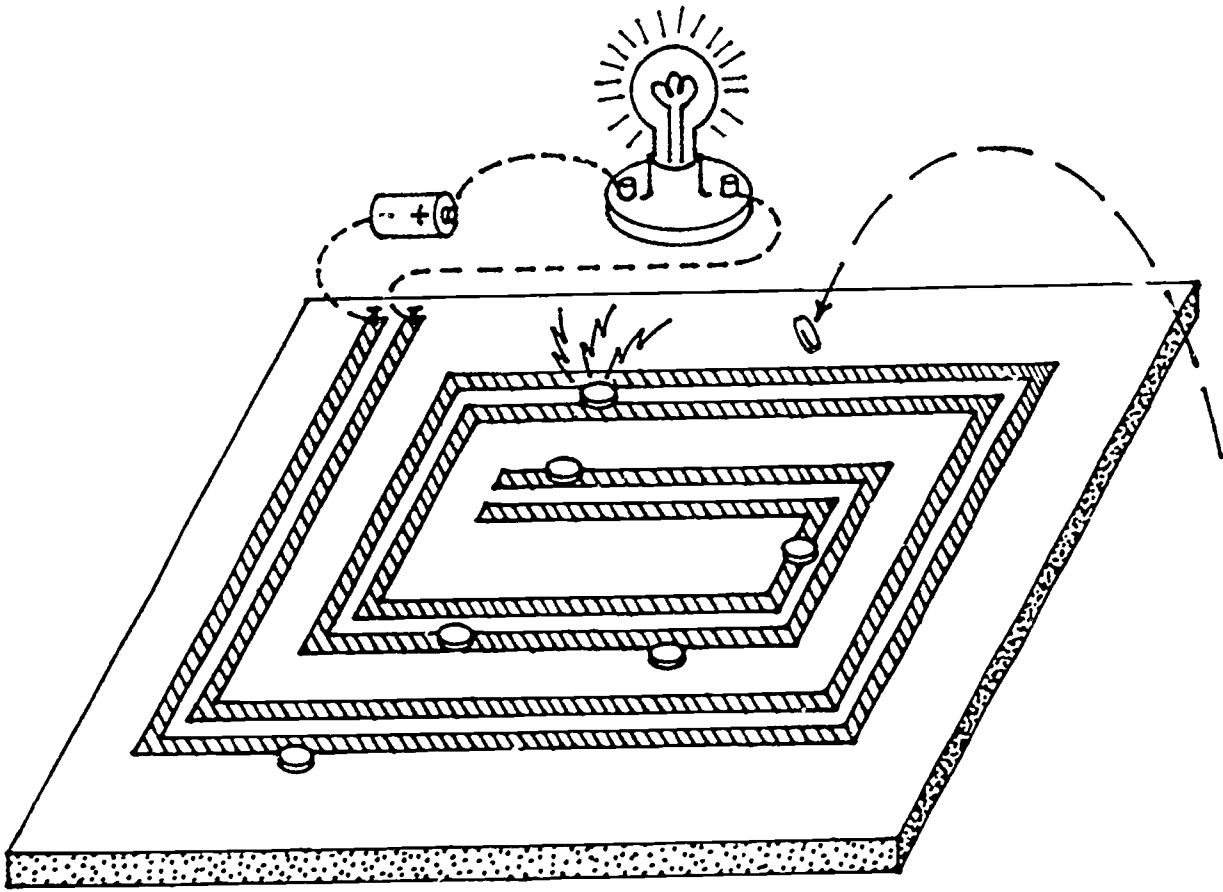

## CIRCUIT PUZZLES

by Rose West

Focus: Circuit puzzles will be used to tie in other subject areas. Circuit puzzles will be built with easily obtained materials.

Challenge: To build a circuit puzzle using information from various sources.

### Materials and Equipment:

File folders  
Brass fasteners  
Bell wire  
Circuit tester (battery, bell wire, bulbs)

How-To-Do-It: The students do research to select a topic for their circuit puzzle. They might select countries and their capitals, authors and their books, elements and their symbols, math problems and solutions, etc. Using the front of the file folder, the student will list, for example, the countries of Europe on the left side. On the right side they would list the capitals of the countries in jumbled order.

Beside each name the students insert a brass fastener. On the back of the cover a wire is attached to the brass fastener by a country. The other end is attached to the capital of that country.

A circuit tester can be made by attaching a wire to one end of a battery and the other end to the side of a bulb. Attach a second wire to the opposite end of the battery. A third wire is attached to the end of the bulb. When wires two and three touch the circuit is closed and the bulb will light. (See diagram on the following page.)

If the circuit puzzle is constructed correctly, the light bulb will light when wires two and three are touched to the brass fasteners of a country and its capital.

By using this method, students do research for social studies, language arts, math, science, or foreign language. In this way they are able to learn about circuits and increase their knowledge of other subject areas as well.

Further Challenge: Show the circuit puzzle to social studies or language arts classes and get input from them.

Do circuit puzzles for each class.

Help others do circuit puzzles.

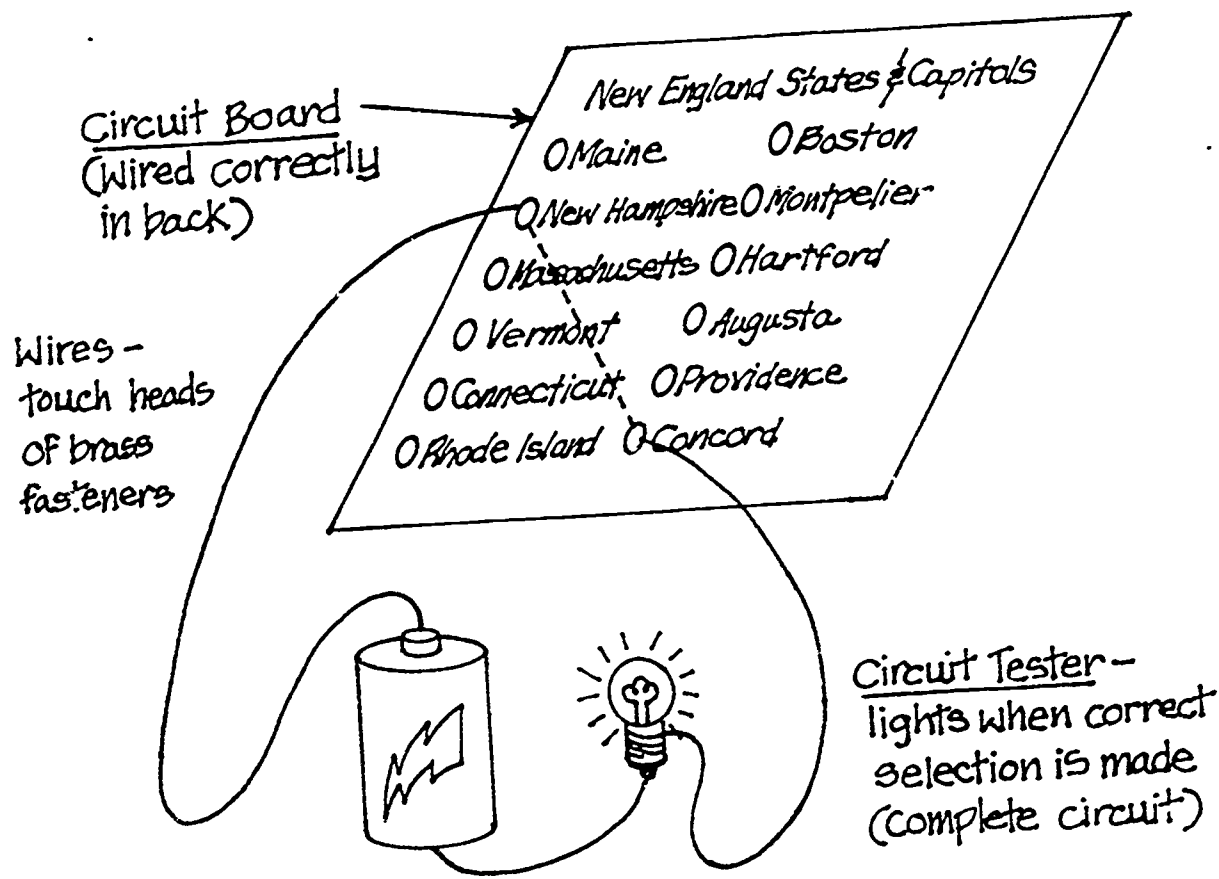

CHAPTER 5

ACTIVITIES FOR TEACHING ELECTRICITY  
FROM MAGNETISM TO GENERATORS

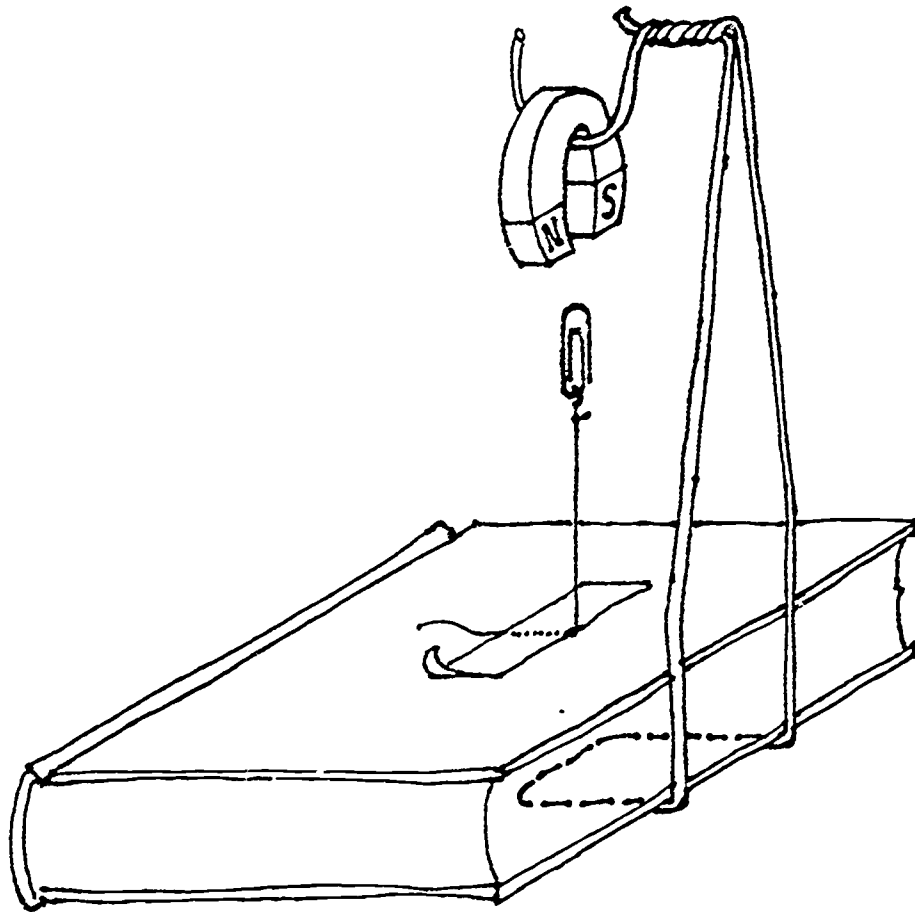

## HOUSEHOLD ATTRACTIONS

by Sandra K. Abell

Focus: Discovering real life applications of classroom concepts is an essential step in the learning process. In this activity students have an opportunity to connect school with home as they look for uses of magnets in their world.

Challenge: How many different ways can you find magnets being put to use at your home?

How-To-Do-It: Have your students guess the number of magnets they think they will find in use around their homes. They should also predict which room (e.g. kitchen, bedroom, garage) will be richest in magnets. After they collect their at-home data, summarize class findings on a chart:

<u>Room</u>	<u>Use</u>	<u>Number of Magnets</u>
Kitchen	Can opener	1
Kitchen	Cabinet latches	10
Family Room	Stereo speakers	2
Basement	Wall stud finder	1
etc.		

Be sure to compare the results to their predictions.

Further Challenges: The time will now be ripe to explore magnet applications in other settings. Field trips and phone calls to various work places (police station, TV studio, garage, power plant) combined with personal interviews and tours should give your students a better idea of the many practical uses of magnets.

## MAGNET MAGIC

by Sandra K. Abell

Focus: Children enjoy sharing their discoveries with others. A magic show is a delightful vehicle for applying and communicating findings from magnet investigations.

Challenge: Can you create a "magic" act that uses magnets to do the magic?

### Materials and Equipment:

Assorted magnets  
Cloth (to use as a magic scarf)  
Paper clips  
Classroom junk box from which children can choose items to use

How-To-Do-It: After your students have had plenty of time to discover which items are attracted by magnets, tell them they are going to use magnets to perform some "magic." Share with them your own magnet magic trick: start with a pile of paper clips on the table. Cover them with your magic scarf and say some magic words. Raise the scarf and--what do you know--the paper clips have disappeared! (Of course! You were palming a magnet that attracted the paper clips when you lifted the scarf.)

Challenge your students to figure out your "magic" and then allow them, individually or in pairs, to design original magnet magic acts. All of the tricks can be put together into a traveling magic show to be performed for other classes in your school.

### Further Challenges:

Try to figure out the "magic" involved in a particular magician's tricks. Then attempt to do the trick yourself.

How can you use magnets to create a treasure hunt in your classroom?

Design puppets that operate magnetically and use them to perform a puppet show for some friends.

### Reference:

Freeman, M. The Book of Magnets. New York: Four Winds Press, 1967.

## THE STRENGTH DETECTOR AND OTHER MAGNET INVENTIONS

by Sandra K. Abell

Focus: Inventive thinking is one way to encourage creativity in your classroom. In this activity and its extensions students will start to look at magnets in new ways and put them to new uses.

Challenge: Can you design an invention that will determine the relative strength of different magnets?

### Materials and Equipment:

Assorted magnets  
Classroom junk box

How-To-Do-It: Throughout earlier magnet investigations no doubt your students have noticed that not all of the magnets in the class collection are equal in strength. Take a class vote on which magnet they think is weakest/strongest. Then present the invention challenge to small groups (3-5 students) who will work cooperatively to solve it. (They will probably need several class periods to perfect their products.) The solutions can be named and then presented and tested during a class Invention Convention.

### Further Challenges:

Invent a game in which magnets are an essential part.

Invent a Rube Goldberg contraption to do a simple task (for example, stapling your papers) in which magnets are used for one or more steps. The invention can be drawn or actually built, depending on time and materials available.

### References:

Keller, C. The Best of Rube Goldberg. Englewood Cliffs, NJ: Prentice-Hall Inc., 1944.

McCormack, A. J. Inventors Workshop. Belmont, CA: David S. Lake Publishers, 1981.



## MAKING A PAPER CLIP FLOAT

by Meghan Mahoney Twiest

Focus: Forces of magnetism travel through the air and through other matter.

Challenge: Make a paper clip float in mid air with the magic of magnetism.

### Materials and Equipment:

1 paper clip  
1 horse shoe magnet  
1 wire coat hanger  
1 or 2 heavy books  
Thread  
Tape

How-To-Do-It: Either as an introduction or a follow up activity, this demonstration captures the students' attention. See the sketch on the following page. Begin by designing support apparatus. Bend the coat hanger on one end so that it can be tucked under a book and will stand upright. Bend the top of the coat hanger so that it has a small hook at the top from which the horse shoe magnet can be hung. With your support now ready to go, place it under the book and hang the magnet from the top. Next tie the thread to the paper clip and tape the other end of the thread to the top of the book so that there is at least a one inch space between the magnet and the paper clip. Presto! The magnet "floats" in mid air!

Ask the students to use what they have learned about magnetism to explain why the magnet appears to be floating in the air. They should be able to tell you that there is actually a force that is present between the magnet and the paper clip that is drawing them together. Ask the students what might happen if the string were cut? You may want to try it and find out.

How strong is the magnetic force that is drawing the paper clip toward the magnet? The force passes through the air without any problem. What other matter will the magnetic force pass through? Try other materials such as paper, foil, wax paper, wood (a pencil perhaps), cellophane, etc. Have students predict what materials will be able to break the force between the magnet and the paper clip. Then have them experiment and record the results.

### Further Challenges:

See if the force between several magnets is equal by measuring the maximum distance between the paper clip and each magnet.

How many magnets does it take to support a chain of paper clips?

Reviews on magnetism can be made even more fun by letting them "fish" for review questions. This can be done by putting paper clips on

review questions and using a pole with a magnet hung on it to fish for the questions. This can be a challenging way to reinforce the concept of magnetism!

Reference:

Baker, T. Baker Physical Science Packet for Elementary and Junior High School. Holland, Michigan: Baker Science Packets, 1961.

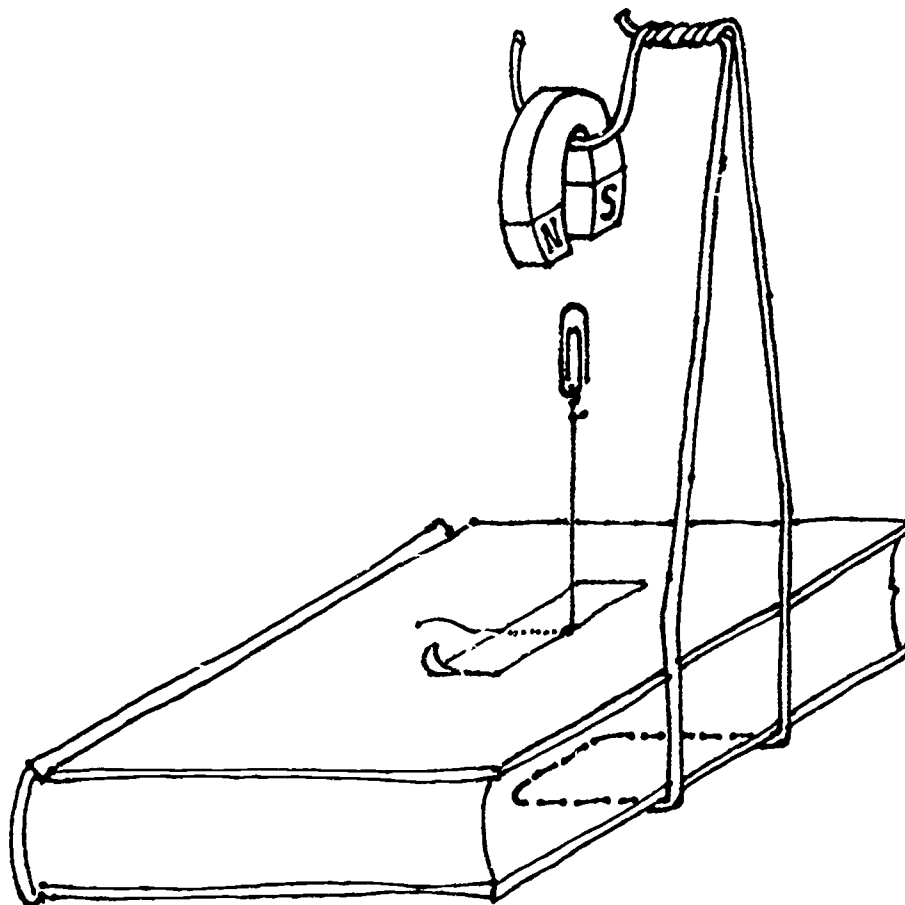

## MAGNETIC PATTERNS

by Judith McKee

Focus: Magnetic lines of force are lines in which the magnetic force reaches out from a magnet. A magnetic field is the space around the magnet in which its magnetic force will work. Though magnetic fields and lines of force are invisible, they can be felt. They can be seen as well when we utilize iron filings. Pictures of these patterns can be saved for display and study.

Challenge: Experiment with iron filings and magnets to find magnetic fields and lines of force. Compare and contrast examples from various magnets.

### Materials and Equipment:

Cardboard or paper plates  
Bar magnets  
U-shaped magnets  
Circle magnets  
Iron filings

How-To-Do-It: See the figures on the following page. Have the children place cardboard or paper plates over various shaped magnets. Sprinkle the iron filings over the cardboard and tap gently so that the filings are evenly distributed along the lines of force of each magnet. The magnetic field will also be shown. Preserve the patterns by spraying them with clear acrylic.

### Further Challenges:

Repeat the experiment to see if the patterns remain the same.

Try the experiments with weak magnets versus strong ones.

iron filings  
card or paper

any magnet

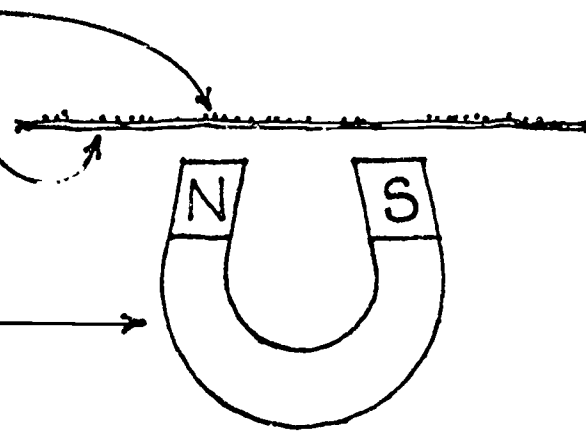

Side view



Figure 1

top edge of  
card - iron  
filings  
align with  
magnetic  
lines of  
force ↗

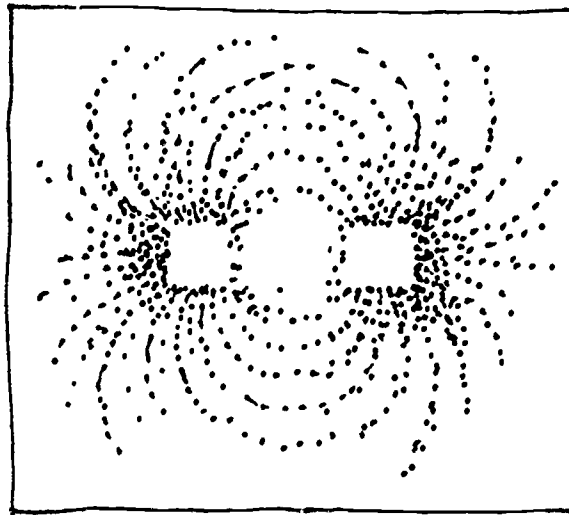

Top view



Figure 2

## MAGNETIC SUNPRINTS

by Rose West

Focus: Many students have seen the magnetic field made with iron filings. In this activity they will produce the magnetic field on a piece of sunprint paper and thus preserve the magnetic field for as long as they keep the paper.

Challenge: To preserve the magnetic field with sunprint paper.

### Materials and Equipment:

Per student: 2 magnets, iron filings, sunprint paper, tray

Per class: flat pan, water, paper towel, plastic wrap

How-To-Do-It: Before class, prepare the flat pan for the activity on a work table. Fill the pan with water. Place paper towels on the table for drying prints. Give each student a tray and two magnets. Wrap the magnets in clear plastic if desired, to avoid getting iron filings stuck to them. Put the two magnets under the tray. Pour iron filings on the tray and allow the students to experiment finding the magnetic field. Pour the filings back into their first container. Place a piece of sunprint paper on the tray. Pour the filings onto the sunprint paper. After the field is as the student desires, go outside and expose the sunprint paper to the sun. (Caution the students to not move the magnets.) The sunprint paper will turn from blue to white after about five minutes. Do not move the magnets--carefully walk back inside. Pour the iron filings into the jar. Place the sunprint paper in the water for about one minute. Remove the paper from the water, place on the towels to dry.

### Further Challenges:

Try to make fields which repel rather than attract.

Construct a poster of different prints.

### Reference:

"Nature Print Paper," P.O. Box 314, Moraga, CA 94556.

## GENERATING HOMEMADE ELECTRICITY

by Mark R. Malone

Focus: An electrical generator is a device that converts mechanical energy into electrical energy by moving a wire through the magnetic lines of force of a magnet. The amount of electrical current produced can be affected by using more or stronger magnets, by using more coils of wire, or by increasing the spinning speed of the generator.

### Materials and Equipment:

(for each small group)

10 strong rectangular magnets  
Enamel coated bell wire  
2 alligator clips  
Paper cup (approx. 6 oz.)  
A sharpened pencil  
A magnetic compass

To construct the system, wrap the magnetic compass with a length of enamel wire as shown on the following page. Bare the ends of this wire. Coil the enameled wire around a paper cup as shown in the diagram. It may be helpful to place tape over the coils of wire to hold them in place. There is no set number of turns although increasing the number of turns of wire will increase the effect. Attach alligator clips to the bare ends of the wire. Connect the alligator clips to the bare ends of the compass coil wire. Tape 10 small magnets to a pencil as shown in the drawing. Position them on the pencil such that they will be at the same height as the coil of wire when spun in the cup. The pencil holding the magnets can be spun more easily if a small hole is poked in the bottom center of the cup. This helps to hold it in place and to spin more freely.

How-To-Do-It: Spin the magnets inside the cup. The current generated is indicated by movement of the compass needle. Because the current generated by this system is alternating current, the needle indicating current moves back and forth in rhythm with the spinning of the magnets. The degree to which the needle moves back and forth from the neutral position is an indication of how much electrical current is being produced.

Once the students have seen that current can be generated in this manner, a more systematic investigation may be carried out. Students should be instructed to explore what factors affect how much current is generated. The most obvious factor is how rapidly the bar magnet is spun. If magnets of varying strength are available, they could be tested with the system. Another variable that can be systematically explored is the number of turns of wire around the glass. The number of turns of wire can be increased systematically and the amount of current produced can be read on the panel meter. Students could wrap 10, 20, 30, 40 and 50 turns of wire around the cup and compare readings on the meter and compare the results.

Unfortunately, the nature of the homemade meter does not lend itself very well to data which are readily recorded and analyzed. Because the system produces alternating current rather than direct current, the change in direction makes readings of strength difficult to measure. Students will have to judge visually, based on the movement of the compass needle, which system seems to produce the strongest effect.

Further Challenges: Can students design a system that would produce enough electricity to light a flashlight bulb?

Ask students to describe in their own words how a generator works.

Ask students to find out how alternating and direct current differ.

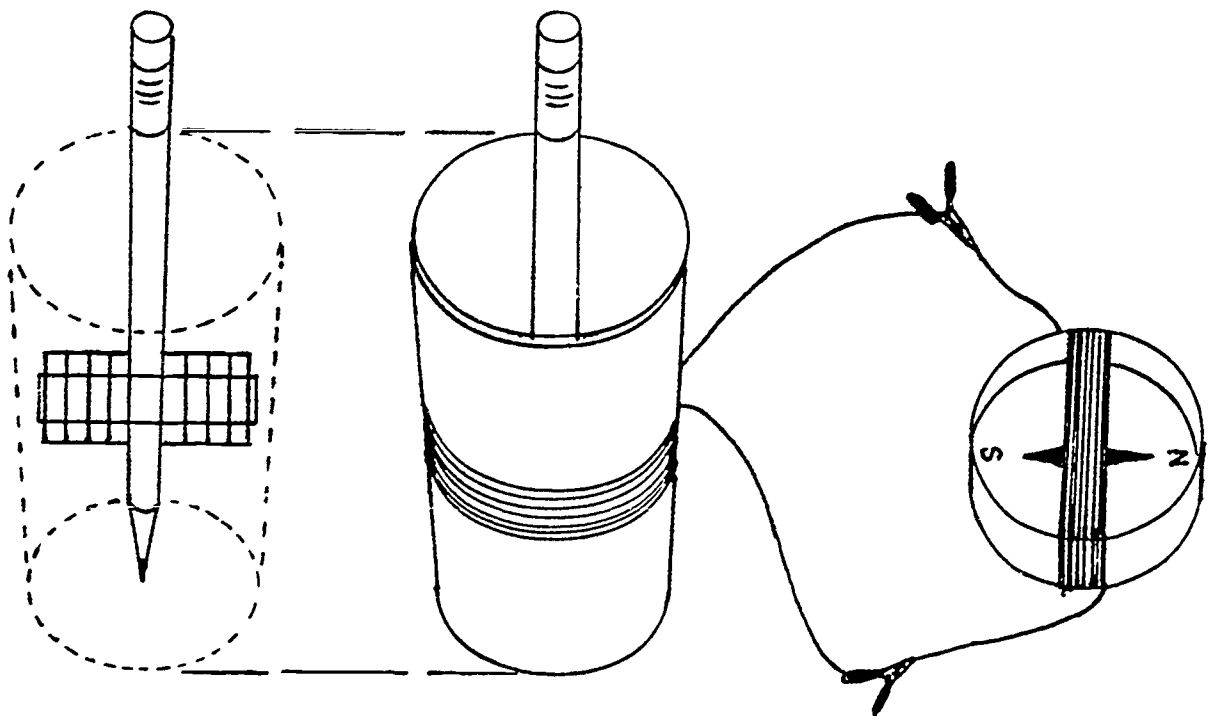

## POWERING THE MOTOR/GENERATOR SYSTEM

by Mark R. Malone

Focus: Most commercial generators are simply variations of materials used in the previous activity (Generating Homemade Electricity). The main difference between commercial generators and the one constructed for that activity is that the commercial generators use a spinning coil of wire inside a magnetic field rather than spinning magnets inside a coil. Most commercial motors and generators are constructed in this manner. A motor and a generator are nearly identical in terms of their internal components. Therefore, any motor that contains permanent magnets can also serve as a generator simply by spinning its shaft. The faster the shaft is spun, the greater the amount of electrical current generated.

Challenge: Ask students to determine various factors that might cause the simple generator to produce more electrical current.

Ask students why it is possible for a motor to be used as a generator.

Determine what happens when more drycells are added to the motor/generator system.

### Materials and Equipment:

(for each small group)

3 electric motors (1.5 - 3 volts DC)  
Light bulb (1.5 - 3 volt)  
Light bulb holder for above  
Plastic coated bell wire  
4 alligator clips  
1 to 4 (AA) drycells  
1 to 4 drycell holders  
Small wooden base (apprx. 1 x 4 inches)  
Clear carton tape

See the diagram at the end of this activity. When constructing the motor/generator system, two motors must be joined shaft to shaft. The two shafts can be easily joined by wrapping them with a piece of carton tape which has been cut to size. The motors could be fastened to a mounting board by a number of means, but using clear carton tape makes all of the parts of the system easily visible while being used. Connections of alligator clips to wires should be soldered as shown.

How-To-Do-It: Assemble the motor/generator system as shown in the diagram. Fasten the electrical leads from one motor to the bulb holder. Fasten the leads from the other motor to the battery holder. Note that although there is no direct electrical connection between the battery pack and the second motor, the light bulb attached to the second motor lights. This is caused because the second motor is serving as a generator. When the number of drycells is increased (2, 3, or 4 cells) the motor/generator



system speeds up and the light bulb burns brighter. Students should discuss why this is possible.

As a follow-up to this activity, have students disassemble the third motor to determine its internal components. Most small motors can be easily disassembled with a pocket knife by bending back small clips that hold it together. Those that are built a little better may require prying with a small screwdriver and pliers. Students should identify and label the internal parts and try to determine how they function as a generator and/or motor.

Small electric motors such as those found in most battery powered toys consist of several easily recognizable parts: two small magnets glued to the inside of its case, a shaft that holds small coils of wire, coils of wire are often wrapped around iron cores that increase the power of the motor, and brushes that conduct electricity to the coils of wire. If the shaft of the motor is spun rapidly, such as when connected to another motor, the system converts the spinning energy into electrical energy that can be seen when the light bulb glows.

Further Challenges: Will a bulb powered by the motor/generator system stay lit as long as one powered directly by the battery? Why or why not? Can you determine the efficiency of the motor generator system? (This can be done by timing how long a bulb lights when fastened to the motor generator system (Time 1) and timing how long a bulb lights when fastened directly to the battery (Time 2). Using this method, the system is generally determined to be approximately 60 percent efficient.)

$$\text{Percent Efficiency} = \frac{\text{Time 1}}{\text{Time 2}} \times 100$$

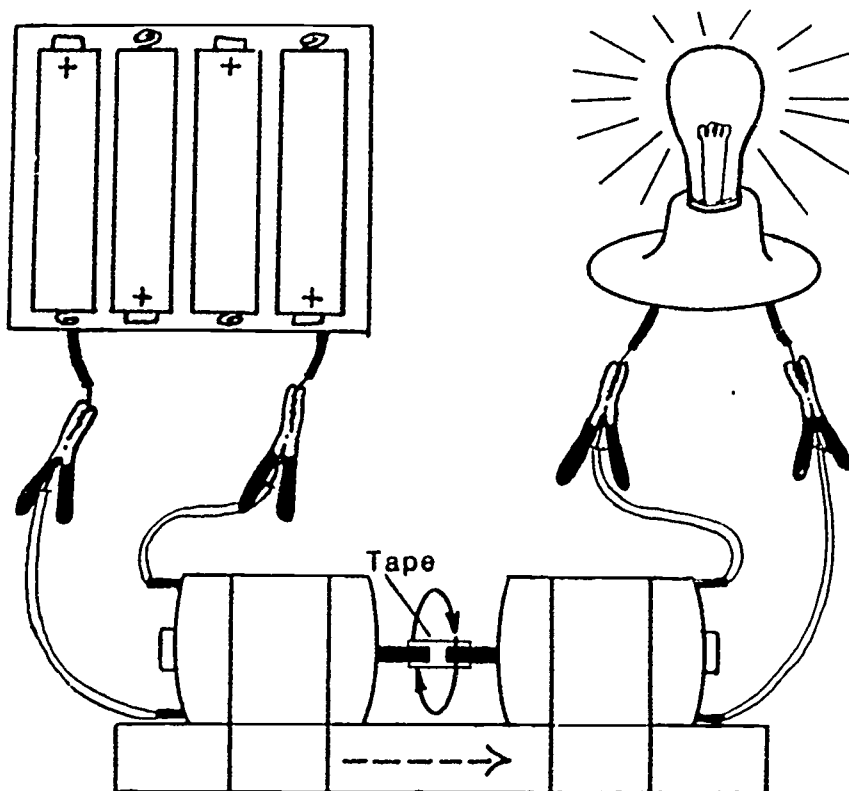

Motor powered by battery → Generator powered by motor

## I DIDN'T KNOW THE GENERATOR WAS LOADED

by Mark R. Malone

Focus: All electrical systems have a maximum amount of force that they can exert in a given period of time. If the amount of work required by an electrical system is increased, one of three things will likely happen: 1) the work will be done slower and require more total energy, 2) the work will be only partially done if no additional energy is available, 3) the system may be so overloaded that no work is done. If a system is overloaded to a point where it is undesirably slow or no work can be done, addition of more force by adding a new power subsystem may enable the system to continue to function or to function faster.

Challenge: Predict the likely effects of increasing the load on a system.

### Materials and Equipment:

(for each small group)

2 electric motors (1.5 - 3 volts DC)  
5 light bulbs (1.5 - 3 volt)  
5 light bulb holders for above  
Plastic coated bell wire  
14 alligator clips  
4 (AA) drycells  
Drycell holders for above  
Small wooden base (apprx. 1 x 4 inches)  
Clear carton tape

How-To-Do-It: See the diagram on the following page. Assemble a motor/generator system as described in the previous lesson (Powering the Motor/Generator System). Have students start the system running. One by one, connect light bulbs to the generator end of the system. Bulbs should be added to the system in parallel circuits. Students should observe changes in both the speed of the motor generator system and the brightness of the light bulbs as more bulbs are added. Students may also explore the effects of adding bulbs to the system in series versus parallel. A series arrangement draws less power but fewer bulbs can be lit.

Further Challenges: Describe how the concepts of load with the motor/generator system are related to load on a municipal electrical generating station. (A municipal power generating station must be prepared for the largest expected load of a community or area. When the base load generators are working at near full capacity and more power demands are expected, more expensive generators that often sit idle must be put into service. If a community as a whole could cut the amount of power required through conservation, the overall cost of power to the area would be reduced because no new power generators would have to be built and existing reserve generators could be used less often.)

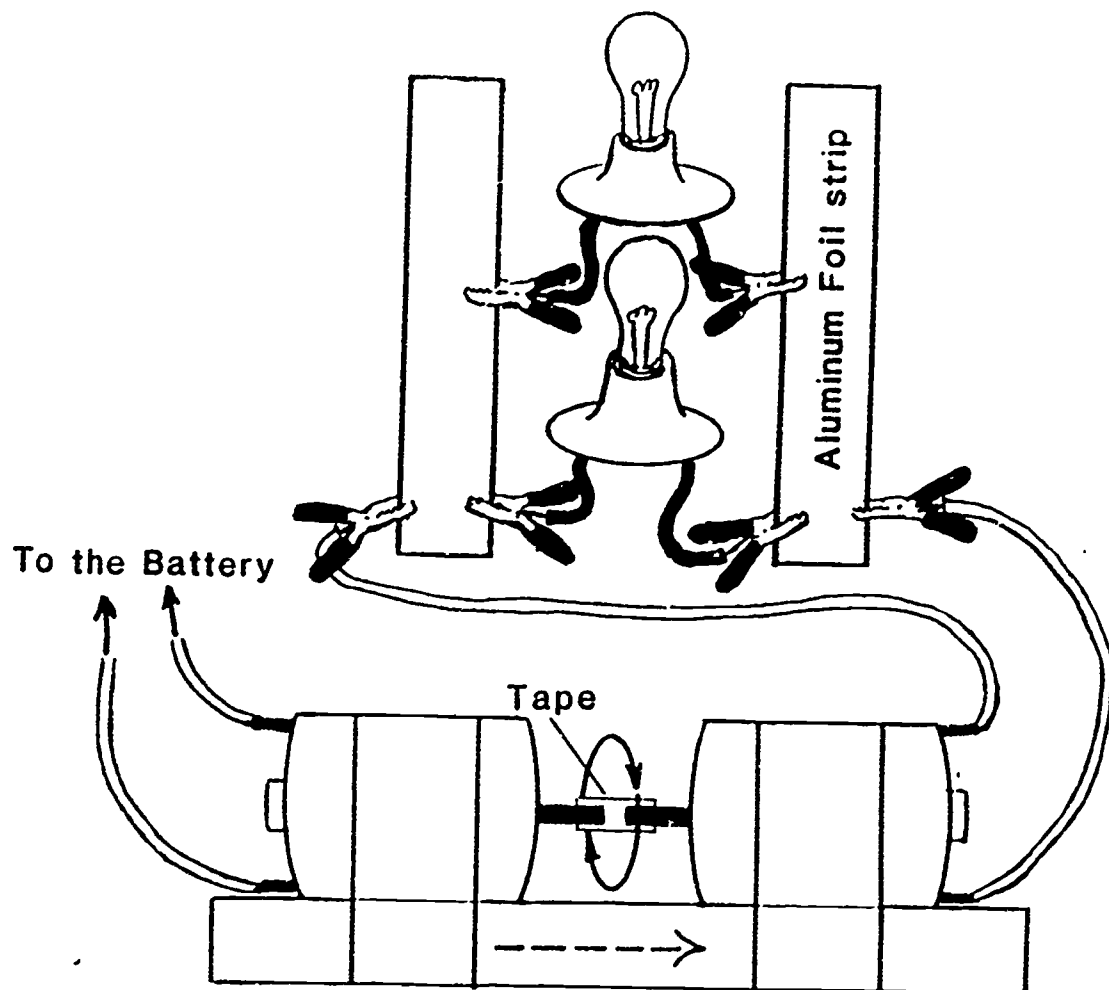

Motor powered by battery → Generator powered by motor

CHAPTER 6

ACTIVITIES FOR TEACHING FORCES AND MOTION

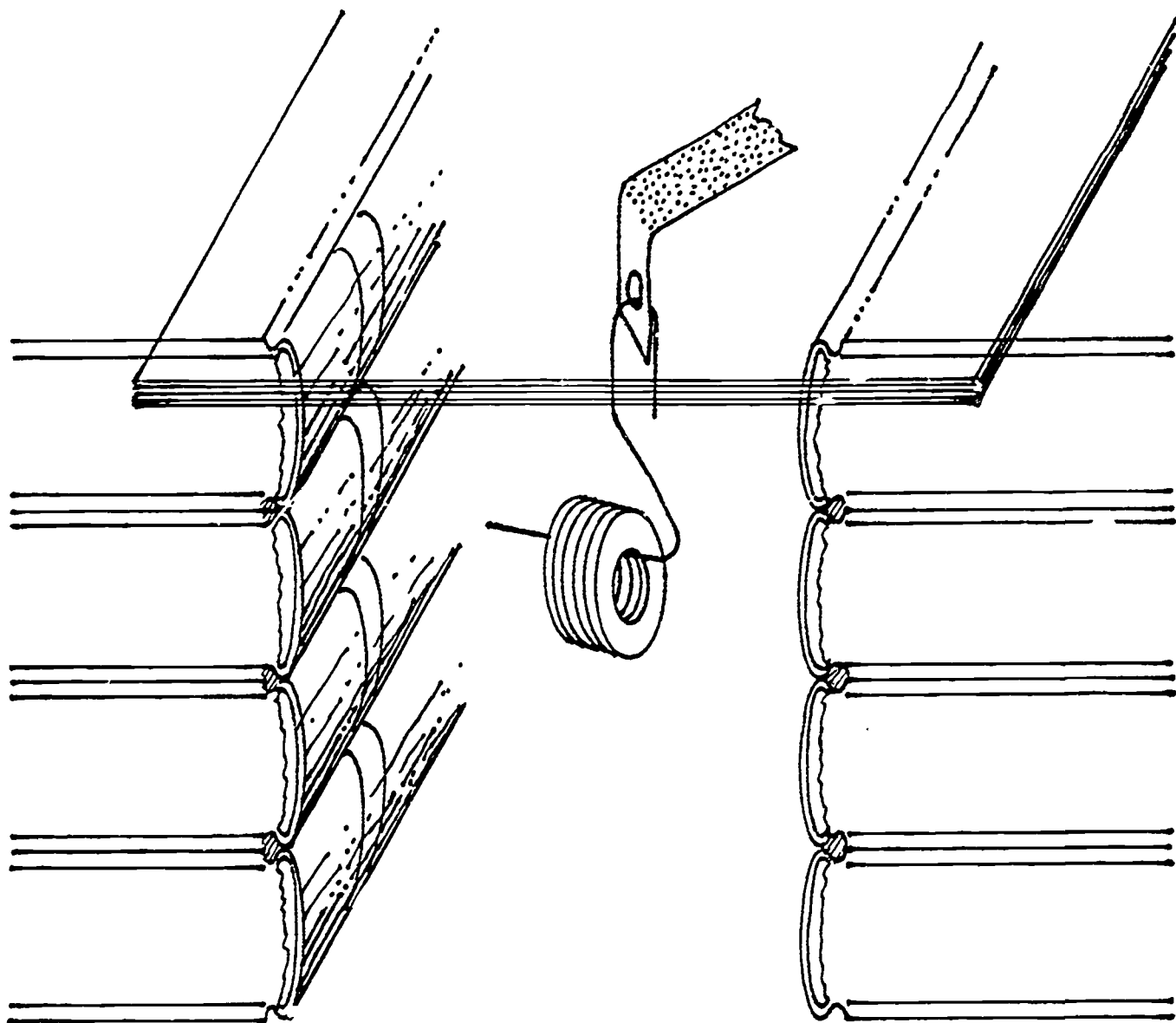

## DON'T TAG ALONG

by Patsy Ann Giese

Focus: Any stationary object tends to stay stationary unless acted on by an unbalanced force. Any moving object tends to stay moving, following a straight line path at constant speed unless acted on by an unbalanced force. This property of matter is called inertia. An unbalanced force changes an object's motion towards the direction of the force.

Challenge: Observe the effects of inertia.

### Materials and Equipment:

Playing cards or index cards  
Paper punch  
String  
Glasses or cups  
Washers or coins

How-To-Do-It: See the diagram on the following page. Have each student place a card with a string tied to it over an empty glass or cup. They should place a coin or washer on the card and jerk the string. If the jerk is hard enough, the washer or coin will fall into the container. (A steady gentle pull will not overcome friction between the washer or coin and the card.)

Have each student stack several wooden blocks on top of a block with an eyelet and string. Then he/she should jerk the string. If the jerk is hard enough, the lowest block will slide forward without the upper blocks.

Further Challenges: Put a ball in the back of a cart or wagon. Pull the cart or wagon for awhile, and then stop suddenly. Have students observe the motion of the ball rolling forward after the cart or wagon has stopped. Explain that the rolling forward is due to the ball's inertia.

Have each student place a washer or coin in a glass or cup held with the open end vertical. They should walk fast for a few seconds with the open end of the container forward, and then stop suddenly. The washer or coin will continue to move forward.

Outdoors have a student grasp a ball using only their fingertips and hold the ball with their arms and hand extended downward. Have another student standing about 25 meters away grasp another ball similarly. Have the first student run past the second. At the moment they are together, a third student should yell, "drop." Compare the paths of the two dropped balls.

Discuss why dirt can be thrown off of a shovel and not fall directly down. Discuss why a ball flies forward when a person pitching the ball lets go.

Discuss why a person falls forward in a car or an airplane that stops suddenly. Discuss why a person feels pushed against the back of his/her seat in a car or airplane that starts suddenly.

Ask students to imagine they are standing in front of someone on a bus. Ask if it is likely that the other person will fall against them when the bus starts suddenly or when the bus stops suddenly.

Discuss why a person can coast on a bike even if they are not going downhill.

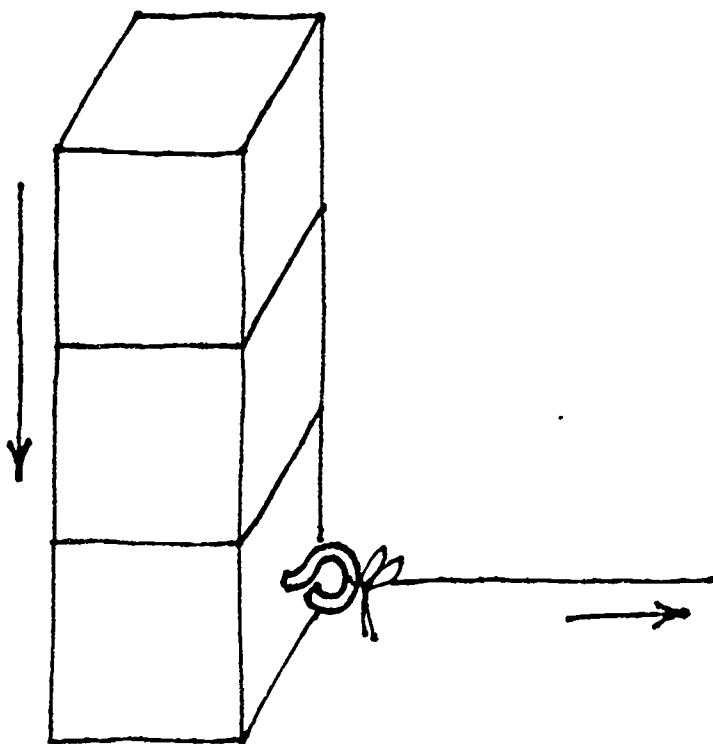
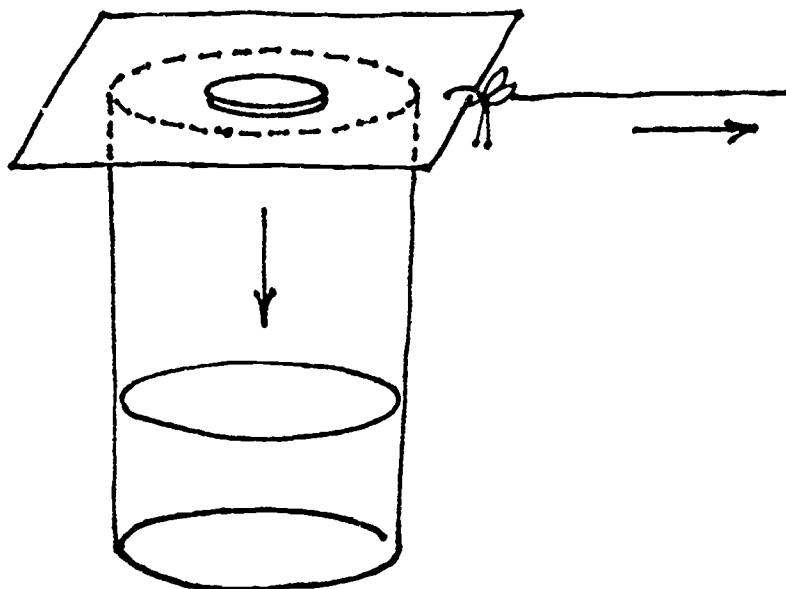

## INERTIA

by Nadine L. N. Halligan

Focus: Several states have recently enacted laws requiring the driver and passengers in a car to wear seatbelts. Investigate Newton's First Law of Motion (the Law of Inertia) and why this physical law has caused the enactment of seatbelt laws.

Challenge: Perform a series of activities, observe the set up at the beginning, during and after the activity is finished. What do they all have in common? Look especially at where force is being applied and what is moving in response to that force.

Background: Inertia was first described by Sir Isaac Newton as the tendency for an object at rest to remain at rest unless an outside unbalanced force acts upon the object. An unbalanced force is one which has no equal and opposite force counteracting it. Inertia for an object in motion is the tendency for that object to remain in motion unless an outside unbalanced force acts upon it.

### Materials and Equipment:

Backgammon pieces or smooth checkers  
Pennies  
Coffee cups (heavy restaurant quality)  
Plastic coated playing cards or similar size index cards  
Small toy cars  
Modeling clay (plasticine)  
Saucers (heavy restaurant quality)  
Plastic eggs which can be opened and tightly closed (e.g. L'eggs stocking eggs)  
100% nylon cloth (e.g. the material used to line sport jackets, approx. 1 meter square)  
Water  
Wood blocks (approx. 5 x 5 x 25 cm) with ends sanded smooth  
Liter plastic soda bottles filled with sand and sealed  
Paper (legal size)

How-To-Do-It: Set up lab stations so that a single activity can be done by several students at the same time. Instruction cards for a single activity are placed with its materials at a station. Students may do activities individually or in pairs. Students record their observations on paper which they carry from station to station.

### Activities:

Snap the checkers: Set up eight checkers in a straight stack. All checkers should be the same color except the one second from the bottom. A single checker is placed on end. (See Figure 1) It is shot toward the stack by placing an index finger on top of it and pressing down so that

the checker rolls forward as the finger moves backward. When aimed correctly, the second to the bottom checker in the tower shoots out from under the stack and the rest of the checkers remain standing in a stack. Be sure to erect barricades around the checkers so that they do not go flying all over the room if someone should miss.

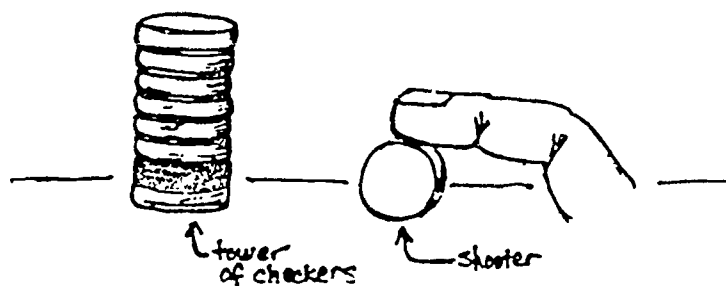

Penny drop: Place a penny on top of an index card on top of a coffee cup. (See Figure 2) By tapping the edge of the card only, the penny drops directly into the cup as the card flies out from under it. What would you expect would happen if this were done while in outer space? (Hint: there is no gravity.)

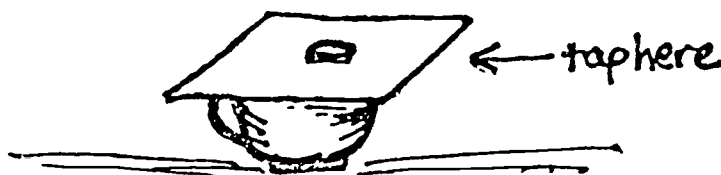

Snatch the paper: Place a piece of legal size paper on a desk, then place the wood block on end on it toward the edge of the paper. (See Figure 3) Remove the paper without lifting the block or knocking it over. If the edge of the paper farthest from the block is pulled smartly, the block should remain standing.

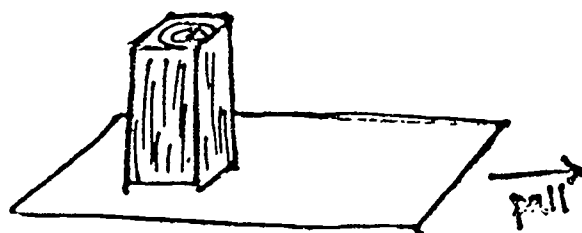

Spinning eggs: This activity can be done with real eggs, but that may cause a major mess. Place 50 grams of plasticine clay inside one L'eggs egg and 50 ml of water inside another. The eggs should have the same mass. Be sure that the egg containing the water does not leak. Place each egg on a saucer and have a pair of students spin them at exactly the same time. Which stops first? A liquid has more inertial drag than a solid, so the liquid filled egg will stop first. How can this be used to tell hard-boiled from raw eggs?

Man in the car: This activity is directly related to seatbelts. Form a standing clay figure big enough to fit in a small toy car (Mr. Bill) and start the car rolling with a push (Mr. Hands). Stop the car suddenly by sticking a finger in front of it or crashing it into a wall. What happens to the man? (Ohh nooo!)



### Further Challenges:

Ask students to explain how a table cloth can be snatched from beneath a set of cups and saucers containing water without spilling a drop. Do this demonstration by purchasing heavy, glazed cups and saucers from a restaurant supply house. Be sure that the bottom of the saucer is completely glazed. Place the unhemmed nylon cloth on a clean and smooth desk so that one edge is even with the desk edge. Show the students the cups and saucers as you alternately stack a cup on a saucer to prove there is nothing strange about the cups. With each cup, be sure to fill it half full with water. Do not spill any water on the cloth as you build the tower. (See Figure 4) Ask the students to predict whether the cups or saucers will fall and why. To successfully snatch the tablecloth, hold the end of the tablecloth which is opposite the cups and place your hands so that they are just on either side of the cups and saucers. When you feel confident, pull the cloth straight down toward the floor very quickly to counteract any friction which can knock the cups over. In this case, friction is the outside unbalanced force that can cause the saucers to fall.

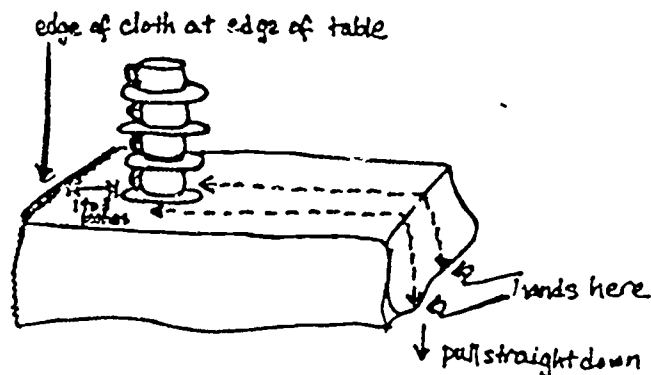

Discuss which brakes you should put on first when coming to a stop on a bike with hand brakes.

Discuss past experiences where students may have noticed inertia.

References: For more activities with inertia, please consult the following sources.

Brown, Robert J. 333 Science Tricks & Experiments. 333 More Science Tricks & Experiments. Blue Ridge Summit, PA: Tab Books, Inc., 1984.

Gardner, Martin. Entertaining Science Experiments with Everyday Objects. New York, NY: Dover Publications, Inc., 1981.

Mandell, Muriel. Physics Experiments for Children. New York, NY: Dover Publications Inc., 1968.

Ontario Science Center. Scienceworks. Reading, MA: Addison-Wesley Publishing Inc., 1986.

UNESCO. 700 Science Experiments for Everyone. Garden City, NY: Doubleday & Co. Inc., 1958.

Vivian, Charles. Science Experiments and Amusements for Children. New York, NY: Dover Publications, Inc., 1967.

## FINDING THE VELOCITY

by Michael J. Demchik

Focus: Uniform velocity of an object is defined as one which has the same displacement during each second of motion. Distance/time = velocity is the simple equation by which this uniform velocity is defined.

Challenge: Predict the velocity of the rolling ball by observing its motion along a rail.

### Materials and Equipment:

Half round molding strips (two 3 meter strips and two 50 cm strips)  
Several small scrap pieces of wood  
Small nails (brads)  
Small rubber ball  
Stop watch

How-To-Do-It: See Figure 1. Prepare a three meter track by putting together two three-meter sections of half round molding strips with small cross pieces nailed underneath. Prepare another 50 cm rail to act as a ramp for a ball. The width of the rail and ramp depends on the size of the ball. One width that could accommodate several sized balls would be appropriate. The ramp may be supported by a book(s) in order to get the desired velocity.

Allow the ball to roll down the ramp and start the timer as it strikes the rail, then stop the timer when the ball reaches the end of the rail. The velocity can be determined by dividing the distance (three meters) by the time in seconds. The ramp may be raised a number of times to get the velocity arrived at different ramp heights above the ground. The ramp height versus the velocity can be plotted on a graph.

Further Challenge: Convert each value arrived at for the velocity at various heights to values in kilometers per hour (kph). The following formula gives a good estimate of kph:

$$\frac{3.6}{\text{seconds}} \times \text{distance in meters} = \text{kph}$$

What is the optimum angle to get the fastest speed? Slowest speed?

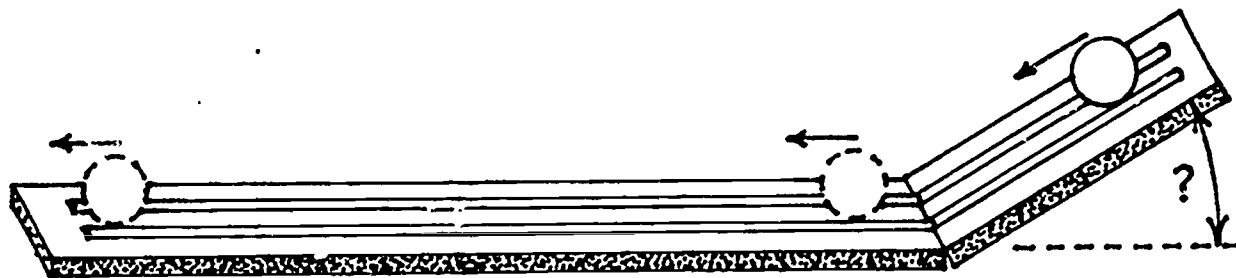

## METER BEATER

by Sue Dale Tunncliffe

Focus: This work focuses on the relationship between the speed of a vehicle, the distance it travels, and the time it takes. Through doing this activity students usually come to understand the formula in their math work:

$$S = \frac{d}{t}$$

Challenge: What is the fastest you can get a given toy car to travel?

How are you going to produce the speed of the test car? How can you increase this speed? How will you measure speed? Is there a relationship between speed, distance and time?

### Materials and Equipment:

A toy car that rolls freely  
A ruler to measure distance traveled  
A stop watch to time the car's travel (it must measure time in seconds)  
A smooth rolling surface  
Chalk to mark on floor the spot where the car stopped  
A ramp support and ramp surface  
Recording sheet

How-To-Do-It: (This activity is suitable for small groups of five students.)

Students need to have had previous experience of running toy cars down slopes of various heights to see that the higher the slope, the further the car will run. They also need to be able to use a stopwatch and use a ruler for measuring distance. Roles for the experiment need to be allocated by the group amongst themselves, e.g., a time keeper, a distance measurer, a data keeper, a starter, a retriever.

Encourage the group to discuss what they already know that is relevant to the challenge. What do they think will happen in light of their previous knowledge and experience? How will they record their results?

Suggest, if the group does not include provisions in their plans, that a table for the data keeper would make recording easier.

Test Run Number	Distance Traveled	Time Taken	Speed
-----------------	-------------------	------------	-------

Further Challenges: What is the effect of altering the height from which the run starts? What effect is produced by altering the surface on which the car runs? What happens if you change the car being tested?

## OUT OF GAS

by Sue Dale Tunnicliffe

Focus: This investigation focuses on the rate of movement of a toy car.

Challenge: Does the weight of a moving object such as a toy car have any effect on the distance it will travel before stopping? What do you already need to know? How can you ensure that it is a fair test? Should you use the same car for all the tests?

Materials and Equipment: (for each group)

Toy cars  
Modeling clay to use as added mass  
Balance  
Measure for distance  
Running track, e.g. floor  
Slope and support for starting off car's run each time

How-To-Do-It: This activity works best in small groups of three to four students. Get the group to organize their roles in the resource management and in the task allocation such as Director of Operations, Data Collector, Chief Measurer, Director of Communications.

Each group needs to discuss the task, brainstorm some solutions, and then choose one for experimentation. They should design their experiments and predict the outcome before collecting equipment and assembling it.

Encourage the students to draw up a table to fill in their experimental results. Each test should be repeated at least three times to obtain an average reading.

A line graph showing the distance traveled against weight of vehicle should be drawn.

Evaluation of the experimental method should occur and the results and evaluation presented to the class.

Further Challenges: If the same car and load traveled over different surfaces, what would you expect to happen?

## MARBLE MOMENTUM

by Mark R. Malone

Focus: Several concepts related to energy transfer can be demonstrated with this simple apparatus. Students can design and conduct investigations that show various aspects of energy transfer: (1) As the mass of an object is increased, more energy is required to move it. This activity demonstrates the effects of an increase in inertia as the number of washers on the slider is increased. (2) They can also determine that if the energy in a system is increased and a mass to be moved remains the same, the mass will move farther. In this demonstration, increasing the number of marbles increases the total energy available for transfer to the slider. This demonstrates a key attribute of momentum. (3) They can also study the optimum efficiency of a system when the angle of a ramp is changed. As the angle of the ruler is increased, the marble's position becomes higher. While more total energy is available, at very steep angles much of the energy is lost due to impact with the rolling surface. (4) Effects of friction on the system can be studied by placing the slider on various surfaces. In addition, students gain practice in conducting a controlled investigation, gathering data, and interpreting those data.

Challenge: In the ramp and slider picture shown below, how will the distance the slider slides be affected by the number of washers added to the slider?

Materials and Equipment: (for each small group)

- 1 plastic ruler (12 inch or 30.5 cm) grooved down the center
- 1 paper cup (approx. 250 ml)
- 1 metric ruler (any length or type)
- 5 small glass marbles
- 1 large glass marble
- 1 machine screw with nut (approx. 35 mm long)
- 10 flat washers (approx. 25 mm in diameter)
- Masking tape

To construct the slider (see Figure 1), cut a paper cup in half vertically. Punch a small hole approximately 2 cm from the bottom of the cup and midway between the edges. From the inside of the cup, insert a screw through the hole and attach it with a nut on the outside. The screw will hold the washers that will be used to increase the mass of the slider.

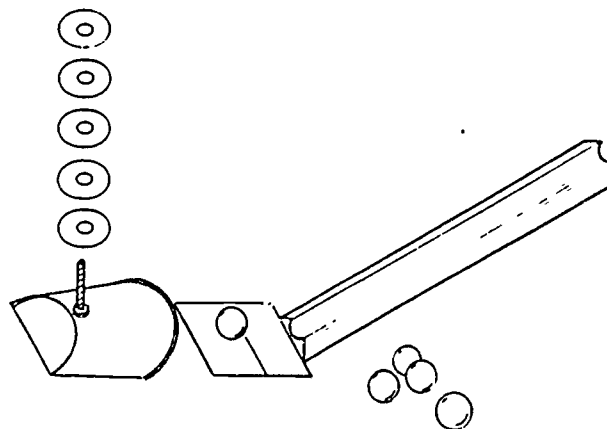

How-To-Do-It: See Figure 2. Students may begin this activity by rolling marbles down the ramp (ruler) and measuring how far the slider (cup) moves. You may wish to let them freely explore how various arrangements of the materials affect the distance the slider moves.

After a period of free exploration, students can proceed to systematically add one, two, three, four, or more washers at a time to the slider and compare how these additions affect the movement of the slider. Measurements of the slider's movement should be taken and recorded. You may also wish to have students graph the data for various trials. Students should see clearly that as the number of washers on the slider increases, the distance the slider moves decreases. You may wish to formally label this as a demonstration of inertia.

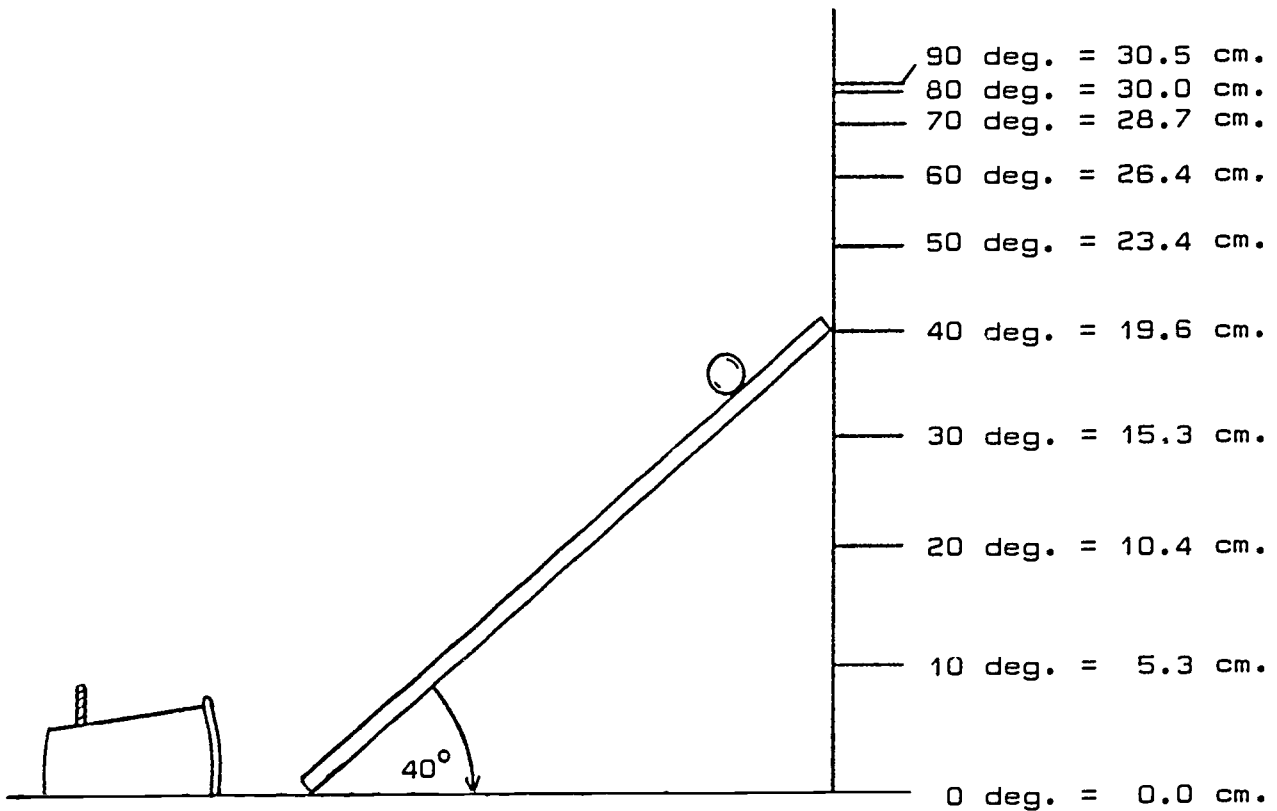

Ramp Angle at Various Heights

Further Challenges: Ask students to give examples of inertia from their personal experience.

Challenge students to determine the effect of increasing the number or size of marbles released from the ruler. This demonstrates a key momentum concept that as the mass of a moving body is increased, it can impart more energy to a stationary body. Ask students to give examples of momentum from their personal experience.

Challenge students to explore the effects of changing the angle of the ruler on the movement of the slider. (A means of setting various angles is shown in the drawing below.) Ask students to determine the optimum angle to impart the most energy into the slider. Can students explain why initially increasing the angle increases the energy imparted, while further increases in angle decreases the energy imparted? Can students give other examples of optimum operating range from their personal experience?

Challenge students to determine the effects of placing the slider on various surfaces (sandpaper, waxpaper, newspaper, wood, concrete, linoleum, etc.). Ask them to give other examples of friction from their personal experience.

Reference:

Malone, M. R. "Investigating Ramps and Sliders," Science and Children, February, pp. 11-14, 1986.

## SOUP CAN RACES

by Gerald W. Foster

Focus: To observe the influence of different densities of liquids upon rolling motion.

Challenge: Students will attempt to figure out why some soup cans roll farther and faster than others.

### Materials and Equipment:

1 board of plywood sheet (approx. 250 cm x 60 cm x 2 cm - 8' x 24" x 3/4")

Objects such as books, bricks, etc. to raise one end of the board approximately 15 cm off the floor

Narrow and thin board such as a yard stick or meter stick to release objects at the same time

Hollow and solid cylinders of same length and diameter (approx. 6 cm x 1.5 cm). Try to get a variety of cylinders representing materials such as wood, metal, glass, and plastic.

Several clear plastic bottles that hold approximately 500 ml of liquid. They should have lids and be free of ridges so that they can be rolled. Glass could be used, but plastic is preferred for safety reasons.

Liquids such as oil, water, soap, alcohol, etc., that can be put into clear containers. Try to use some liquids that are "thick" such as corn syrup, sweetened condensed milk, etc.

A variety of full soup cans that have the same weight and diameter. They should represent soup contents that range from almost solid to completely liquid.

Measuring devices such as meter sticks, stop watches, and metric measuring cups or cylinders

How-To-Do-It: Prior to rolling the soup cans, students may need help visualizing what is happening in the soup cans. This can be accomplished by using the cylinders to see the behavior of rolling solid and hollow objects. The liquids in the soup cans behave like hollow and solid rolling objects. The clear plastic containers of liquids allow students to see what is happening inside a soup can.

Students may start with the cylinders, then the clear plastic bottles, and, finally, the soup cans. In each case students can time how long it takes the objects to reach the bottom of the inclined plane and measure the distance they roll before stopping. When using the cylinders, students can compare hollow versus solid of the same material. They may also compare materials identical in size but made of different materials. Objects made of the same material but of different sizes can also be tried.

Finally, students can organize their data in charts for each of the three sets of materials.



Further Challenges: Change the height of the inclined plane.

Try other types of canned food such as spaghetti and tuna.

Try other types of canned food and liquids but in different sizes.

## THE AMOUNT OF MATTER DOESN'T MATTER

b. Patsy Ann Giese

Focus: If air caused no friction, light and heavy objects dropped from the same height would take the same amount of time to hit the ground.

Background: With little or no friction, all objects accelerate (gain speed) as they fall. The amount of this acceleration, called "g," is the same for all objects.

Air friction noticeably slows falling objects that are not streamlined. Air friction increases as an object gains speed. When friction gets large enough to balance an object's weight, the object stops accelerating and starts falling at a constant speed.

Challenge: Predict which objects will fall faster than others.

### Materials and Equipment:

Ball  
Feather  
Paper  
Metal dowel  
Wooden dowel

How-To-Do-It: From the same height and at the same time, drop a ball and a feather. Have students form hypotheses as to why the ball hit the floor before the feather. Ask students to design experiments to test their hypotheses about the ball and feather. Remind students not to throw objects downward because that would not be a fair test of which variables affect free fall.

Students could drop a metal and a wooden dowel of the same size and shape to test if mass affects the time of fall. Students could drop a crumpled and a flat piece of the same type of paper to test if shape affects the time of fall. Other objects can be substituted for these if pairs of objects can be found in which only one property is different. If variables are not controlled, as in dropping the ball and feather, hypotheses cannot be tested.

Further Challenges: Discuss what would happen if the ball and the feather were dropped on the moon.

Discuss why a parachute slows a person's fall. Discuss why a heavy person will fall faster than a light person when both have identical parachutes.

## STICKING POWER

by Michael J. Demchik

Focus: The adhesive force between various materials varies depending on the type of material and its composition. The force of attraction can be measured and compared for various materials.

Challenge: What are the criteria for good adhesive power? How can adhesive power be measured?

### Materials and Equipment:

Various flat surfaces (i.e., glass, wood, vinyl)  
Various types of tape (i.e., masking, cellophane adhesive)  
Books (or other materials to support flat surfaces)  
Many heavy masses (i.e., large steel washers)  
Large paperclip

How-To-Do-It: See the diagram below. Cut one piece of masking tape approximately 4 cm in length. Cut a small piece of paper to cover 2 cm of the length of the tape. Use a hole punch to make a small hole near the end of the piece of tape covered with paper. Stick the other end of the tape to a flat surface such as a sheet of glass. (For safety reasons the edges of the glass should be covered with tape.) Suspend the piece of glass (tape side down) over a support such as stacks of books. Bend a paperclip to form a hook on each end. Place one end of the paperclip through the hole punched in the tape. One by one, add washers or similar masses to the paperclip hook until the tape falls free of the glass. Follow the same procedure with various lengths of tape. Graph the length of tape versus the amount of mass required to remove it. Draw conclusions about the relationship of length of tape to the amount of mass required to pull it free of the glass.

Further Challenges: Have students repeat the investigation using various types or brands of tape. Have students explore how well tape adheres to various surfaces by replacing the glass with other materials.

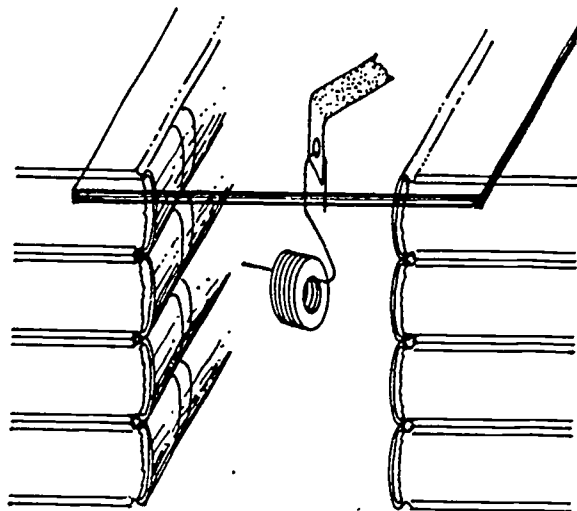

## CENTER OF GRAVITY

by Michael J. Demchik

Focus: The point at which an object balances is its center of gravity.

Challenge: Where is the center of gravity of an object? What factors, if any, affect the center of gravity?

### Materials and Equipment:

6 pencils  
String  
2 ring stands or other supports  
Tape  
Washers  
Stiff wire

How-To-Do-It: Line up the system as shown in Figure 1. In order to do this, line up six pencils that have been sharpened to various lengths. Cut a piece of wire somewhat longer than each pencil. Bend the ends of each wire and shape the remainder into a curve as shown. Insert one end into the eraser portion of the pencil. Tie a string between the two supports. Place the tip of one of the pencils on the string and balance the washers on the free end. Do the same with the remaining pencils. Line them up from largest to smallest. Have the students account for all the variables that are involved in this arrangement.

Further Challenges: Have students locate readings about "Center of Gravity." Have students experiment with methods of determining the center of gravity for various objects.

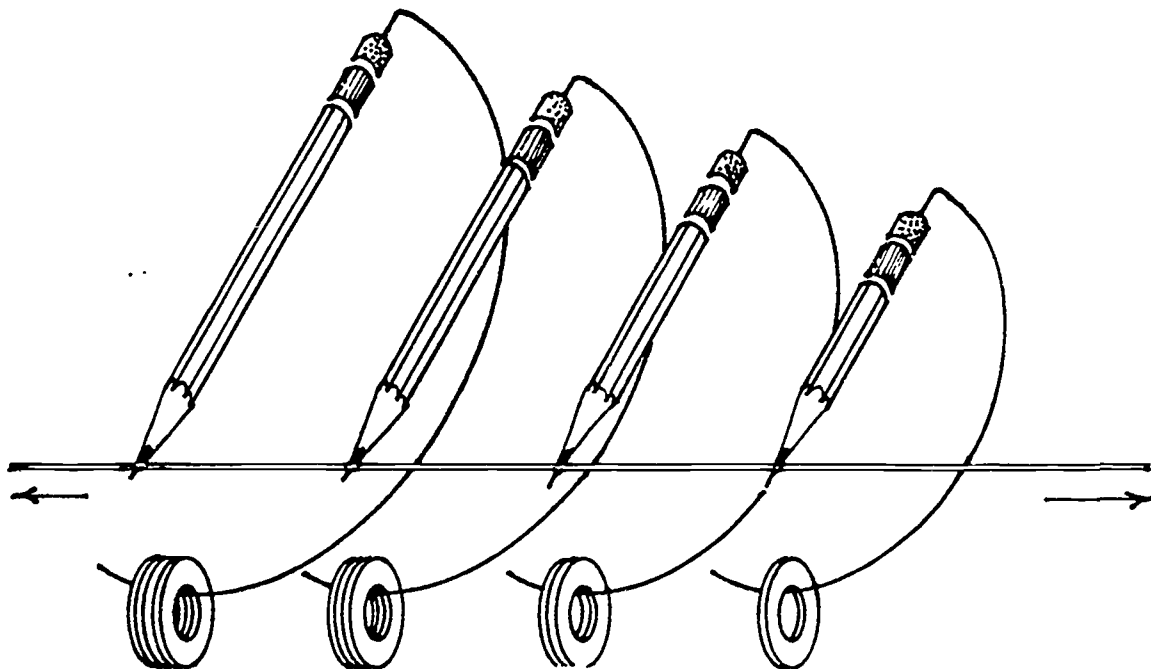

CHAPTER 7

ACTIVITIES FOR TEACHING SIMPLE MACHINES

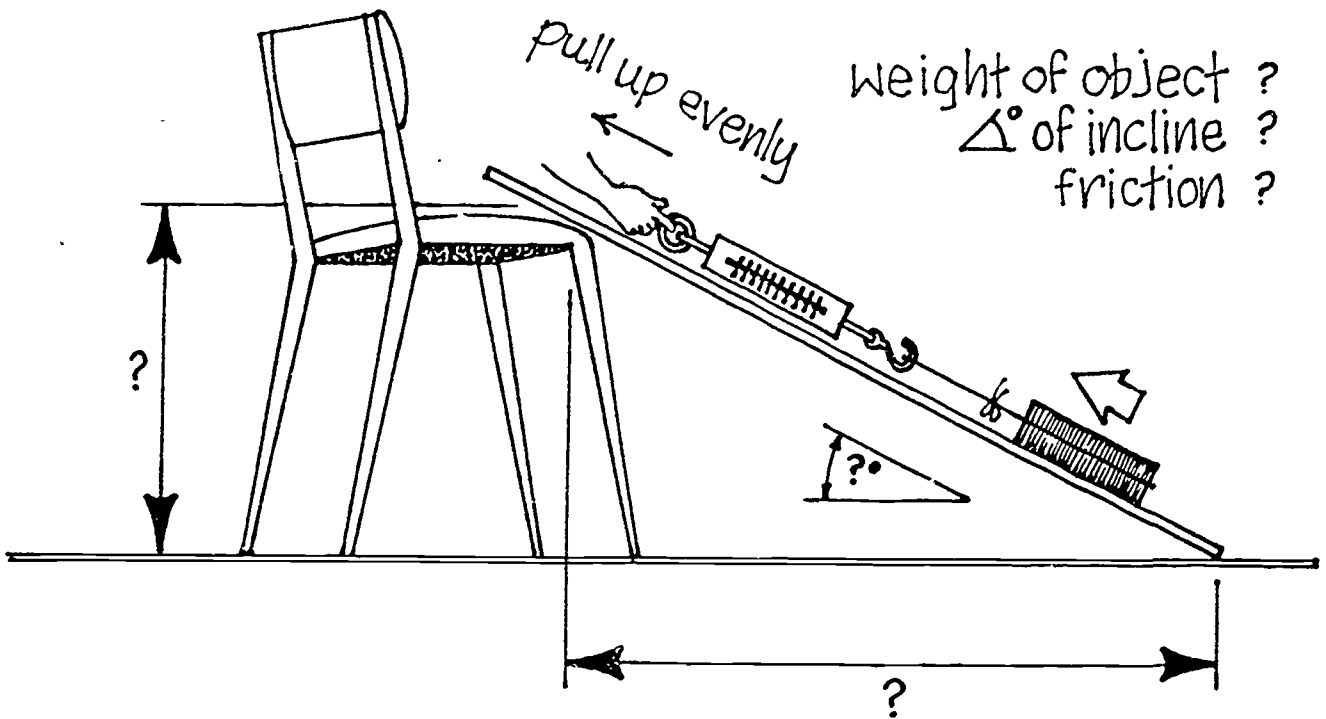

## I'M INCLINED

by Sue Dale Tunnicliffe

Focus: This activity is concerned with making work easier by using a ramp or incline as a simple machine.

Challenge: Can you move a mass through a given vertical height by means other than a straight vertical lift? The method employed must use less effort than the effort needed for a straight vertical lift. Effort is measured on a spring balance. How could you meet this challenge?

Materials and Equipment: (for each group)

1 spring balance

1 brick or wooden block (size should be determined by the capacity and range of the spring balance)

String

1 support (such as a chair or desk)

Several boards (wide enough to hold the load and ranging in length from the height of the lift to as long as possible)

How-To-Do-It: Ask students a few questions related to ramps and inclines such as: Which way would you choose to push a shopping cart full of groceries up a very tall hill? A very steep path going directly to the top or a gently sloping path that zigzags up the side? Why?

The task of this investigation is to lift a block from the floor to a given height (such as the seat of a chair or the top of a desk). Ask students how they could complete this task and what equipment they might choose to use. Also ask them to speculate how they could use a spring balance to calculate the effort involved.

In our experience with this activity, most children do not choose the incline as an obvious way to raise the blocks. Many of them attempt to use a lever. While this does solve the problem, the pivot must be very high and the lever must be very long. A few students have even attempted to make a screw out of paper wrapped around a pencil while toying with solutions. While a screw could also solve the problem, it would have to be very long to lift the load any substantial distance.

The method of choice for this investigation is the ramp (see the diagram at the end of the activity). Explain to students that lifting the block straight up might be the simplest method, but it can be done with less effort. Effort can be measured by tying one end of a string to the block and the other to the spring balance with a loop. The effort is read from the spring balance as grams (dynes). Students will have to practice pulling the spring balance with a smooth even motion to be able to take a reading on the scale when the block is moved. As longer ramps are used, the amount of force needed to move the block decreases. Be sure in taking measurements of ramp length that students measure from the end of the ramp touching the floor to the point

where the ramp makes contact with the chair or table. The length of the board is of no consequence unless it is at the height being measured. The table below could be used as a guide for collecting data. The measurements shown are based on ideal measurements for lifting a 500 gram block. Actual measurements of force and therefore total work will be somewhat higher due to friction.

Height of ramp (cm)	Length of ramp (cm)	Force required to move load dynes (grams)	Total work done length x force = work (ergs or dyne-cm)
100 cm	100 cm	500 dynes	50000 ergs
100 cm	150 cm	333* dynes	50000 ergs
100 cm	200 cm	250 dynes	50000 ergs
100 cm	250 cm	200 dynes	50000 ergs
100 cm	300 cm	166* dynes	50000 ergs

\*Numbers rounded

Students should discover that, as the slope of the ramp gets steeper, more effort is required to lift the load. As the slope of the ramp nears vertical, the amount of effort required to lift the load approaches the effort required to lift the load straight up. As the ramp becomes longer and less steep, less effort is required to raise the load to the same height. Students may notice, however, that the total work done is nearly the same for all arrangements. While effort decreases with a longer ramp, the total effort expended may actually seem to increase due to friction between the board and the load. In an ideal sense which disregards friction, the total work done is the same for all arrangements. In a practical sense, more effort is really expended. Students measurements reflect effort expended rather than an ideal measurement of work as defined in physics.

While measurements made with this system are interesting, be sure that children have a chance to experience the feel of pulling a weight up ramps of differing length. A real understanding of how force changes as the slope increases may be better understood by how it feels than by interpreting a chart. The experience may actually give more meaning to such a chart.

Further Challenges: While less force is required to lift a load with a long ramp, what is the expense of this gain? (The longer distance it must travel.) Could you design an arrangement for raising the load that would further decrease the force required? Could other simple machines be added to this system to make a compound machine? Is it possible to create a system that requires less total work than the vertical lift? (No - such a machine could produce perpetual motion.)

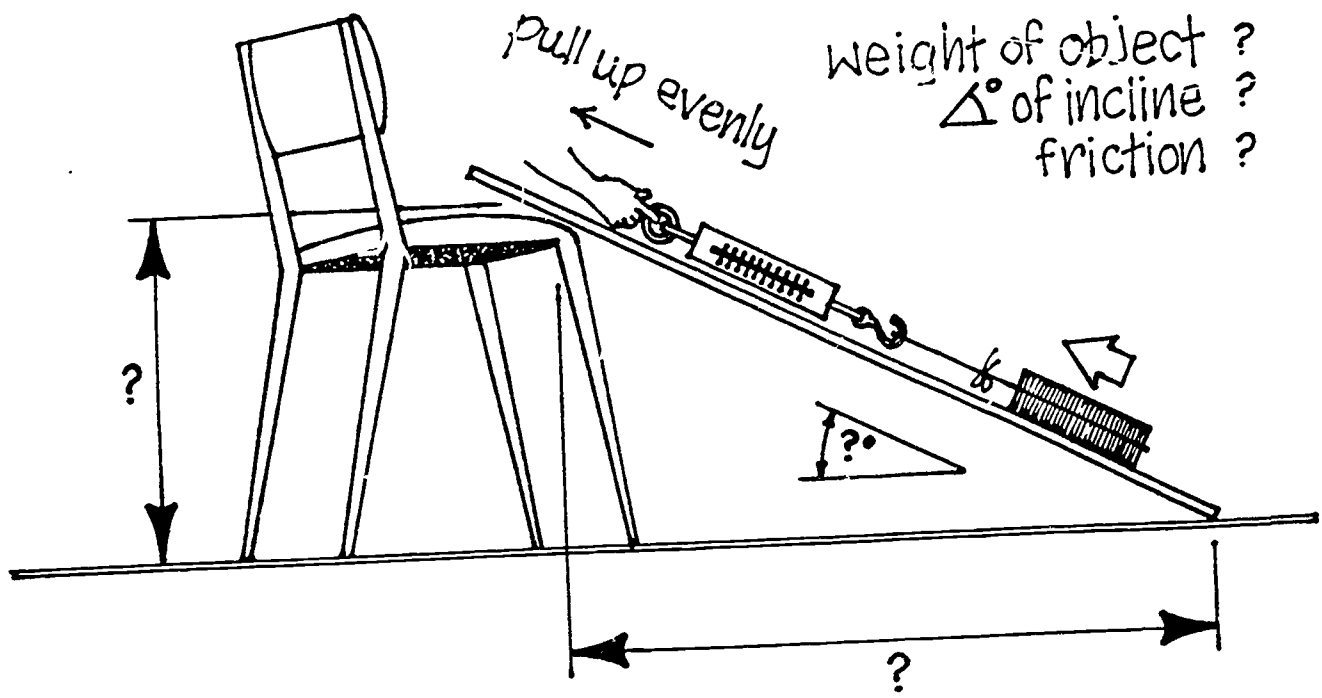



## MOVE IT!

by Sue Dale Tunnicliffe

Focus: The less friction there is, the easier it is (less effort required) to move a given load. This activity will help children experience this phenomenon.

Challenge: How can you move an object more easily across a level surface without tipping the surface? What do you already know that will make it easier to move an object across a level surface? Is there any way you could separate the surfaces which would make it easier to move an object without lifting the object out of contact with the surface?

### Materials and Equipment:

A load (such as books or a brick)  
Various work surfaces (such as sandpaper, cloth, polished wood, corrugated cardboard, pencils, or rods to use as rollers)  
1 spring balance  
String  
Masking tape

How-To-Do-It: See the diagram on the next page. Students will select a load to pull that measures within the range of calibration of the spring balance. They should determine this with a few test trials of the surface of a table or the floor. They will tie the string around the load and attach the other end of the string to the spring balance with a loop. They can now tape other materials (such as the sandpaper, cloth, polished wood, corrugated cardboard, pencils, or rods to use as rollers) to the working surface of the load to determine their effect on the force exerted by the spring balance. They may wish to record measurements and repeat the procedure several times for each surface tested. This will improve the accuracy of the results. The table below should aid in recording and interpreting data.

Students should discover that the smoother the sliding surface, the easier it is to move a load. This is due to the presence of less friction. If the load and the surface are separated by something such as a lubricant or rollers, the effort required to move the same load is less.

Surface Separator	Effort required [in dynes (grams)]	Comments
_____	- _____	- _____
_____	- _____	- _____
_____	- _____	- _____
_____	- _____	- _____
_____	- _____	- _____

Further Challenges: Are there some methods of moving the load with less effort other than altering the surface?

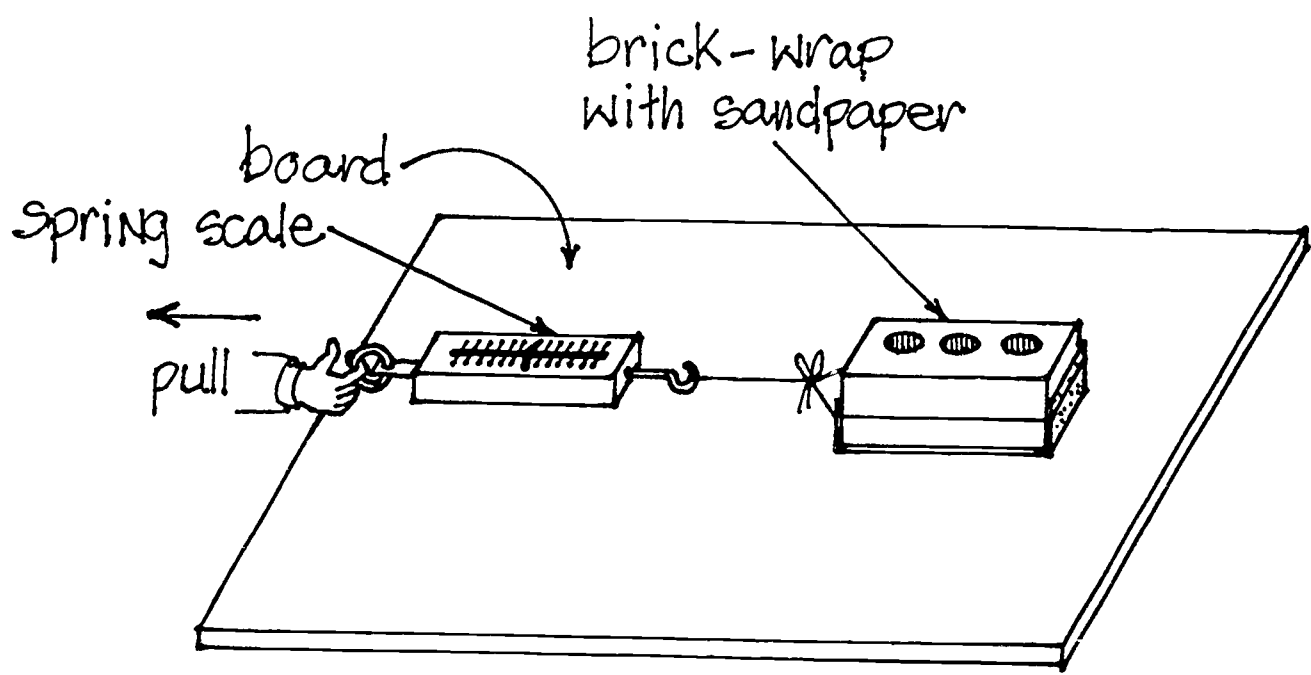

## WHEN IS SLOWEST THE BEST?

by Thomas E. Thompson

Focus: Two skills are stressed with this activity:

1. Using Space/Time Relations is the primary skill. Children are instructed to get a marble to roll from one end of a table to another in the longest period of time. Simple calculations are then performed in order to introduce the concept of rate of motion, i.e., centimeters/second.
2. Hypothesizing is another skill which receives considerable attention. Students hypothesize how selected variables affect the rate of motion of the marble.

Challenge: What is the maximum time it takes for a marble to roll from one end of a table to another?

### Materials and Equipment:

#### Marbles

Standard classroom tables (apprx. 180 x 75 cm)

Stopwatches or clocks with second hands

A variety of miscellaneous items from which students can select to slow the marble (i.e., paper, rulers, pieces of fabric, tape, etc.)

How-To-Do-It: This activity works best with groups of students around a table. Generally four or five in a group is ideal because one student can release the marble, one can be the timer, and the others can manipulate objects to slow the marble down.

Begin by explaining the task to be performed. Simply stated, a marble must roll from one end of a table to the other. A force may be imparted only once at the beginning when the marble is released. After the initial force is applied, the group must stand back away from the table and not interfere with the marble until it reaches the other end of the table. The length of time is measured for the marble to traverse the length of the table.

Some students may attempt to prop the table (that is considered an imparted force), some may place paper, cloth or water in the path of the marble, some may alter the marble itself, some may position barriers similar to those found in a pinball machine, and others may do the unexpected. The important condition which must be maintained is that once the marble is placed in motion, everyone must stand back and not intervene until the marble drops off the opposite end of the table.

Friendly competition is inevitable. However, the nice part of this activity is that the focus is on the slowest marble rather than the fastest. Potential discipline problems are held to a minimum.

Also be prepared for this activity to last for nearly an hour. When groups begin to test their hypotheses, modifications of their original ideas become frequent occurrences.

Further Challenges: A natural extension for this activity is to have the children compute the time it would take their marble rolling at "x" centimeters per minute or hour to roll different distances. For example, how long would it take to go from one end of the school to the other? How long would it take to traverse the length of the playground? How long would it take to travel from their home to the school building?

Comparisons could also be made between groups whose marbles rolled different speeds. Other comparisons could be made with various animals found in the classroom or outdoors, i.e., turtles, mealworms, goldfish, sowbugs, ants, etc.

## ALL GEARED UP

by Janet Frekko

Focus: Gears were probably used in Egypt and Babylonia in clocks and lifting equipment 3,000 years ago. The Chinese may have used gears even as long ago as 5,000 years. At any rate, this modification of the simple wheel has been around for a very long time. Gears are used in almost all of our machines transferring motion from one part to another. Gears can speed up or slow down a machine as well as change the direction of the motion. The following activities use simple, inexpensive materials for your students to manipulate to show how gears work.

Challenges: What happens to the direction of the rotation of each gear when two gears are meshed together? What happens when two gears are separated and turned as a unit by a chain (as in a bicycle) or a band? How does the size of each gear affect the number of rotations?

Materials and Equipment: (per student)

Whiteglue

Pencil

Scissors

Light weight corrugated paper (3 cm along the groove, 1.5 meters across)

2 rubber bands

1 styrofoam meat tray (approx. 12 x 18 cm)

1 paper clip

20 cm plastic straw

Tape

How-To-Do-It: The children will construct two gears each mounted on a straw shaft. One gear will be twice the diameter of the other. (The gears are made from light weight corrugated paper. It is available in 2 1/4" x 50 ft. rolls generally used for trimming bulletin boards as well as in 4 ft. x 5 ft. rolls.) The cuts must be made across the grooves as shown in the illustrations. Use the cutting guide on the back of the paper.

Give each child a 30 cm by 3 cm piece of corrugated paper cut across the grooves. (An older group can do their own cutting.) Cut a 20 cm straw in half. Make a mark on the straw one cm from the end. Tape the end of the corrugated paper (grooved side out) to the straw at the mark so that the end of the straw is sticking out 1 cm past the paper. Roll the 30 cm length of paper around the straw (jelly-roll fashion) to make a gear. Glue the last 2 cm. Secure the roll with a rubber band to hold in place until the glue dries.

Make a second gear as above using a 1.5 meter by 3 cm piece of corrugated paper and the other half of the plastic straw. See Figure 2.

Measure the diameter of each gear. The smaller gear should be approximately 3 cm in diameter and the larger gear should be approximately 6 cm in diameter. Adjust the tightness of the roll as necessary.

When the glue is dry, remove the rubber bands. Hold the gears next to each other on a table with the gears of one meshed to the other. Turn the straw shaft of the larger gear while in contact with the smaller gear. In which direction does each turn? (The opposite direction from each other.)

Give each child a meat tray. Place the meat tray upside down on the table (see Figure 3). Using a pencil, poke a hole 3 cm from each end of the meat tray (lengthwise). The hole needs to be large enough to fit a straw into snugly. Fit the gears onto the meat tray with the 1 cm piece of straw going through the meat tray toward the table. There will be 8-12 cm of space between the two gears. With another 3 cm wide strip of corrugated paper (again cut across the grooves) the children will simulate a bicycle chain. With the corrugated side next to the gears, place the paper around the two gears. Attach with a paper clip so that the chain may be adjusted. Turn the larger gear by rotating the straw shaft. (This would be the pedal end of a bike. Draw pedals here if you like.) What happens? The chain causes the other gear to turn. Notice that the gears are turning the same direction. The chain causes the direction of both gears to be the same.

With the chain still in place, make a mark on each of the gears and a corresponding spot on the tray. Rotate the larger gear  $1/2$  turn. Where did the second gear stop? Now try one full turn. (If our corrugated paper rolls were accurate one full turn of the large gear would equal two turns of the small gear.) Old fashioned bicycles (the ones with the giant wheel in front) got speed by using a big wheel. Peddles would go around once and the wheels would go around once. Modern bicycles get the same speed using smaller wheels by using a gear to make the wheels turn more often.

Further Challenges: Examine a bicycle. Compare a 3-speed to a 10-speed bike. What happens as you change gears?

Bring in several simple kitchen or shop tools or children's toys which use gears. Examine closely the ways in which gears are used.

Explore gear ratios and have the children do some calculations.

Take a look at various types of gears. When are spur gears, helical gears, bevel gears, worm gears, planetary gears and rack-and-pinion gears used?

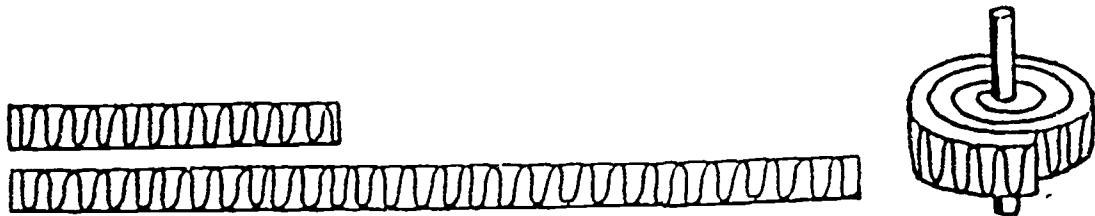

Figure 1

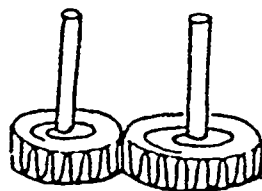

Figure 2

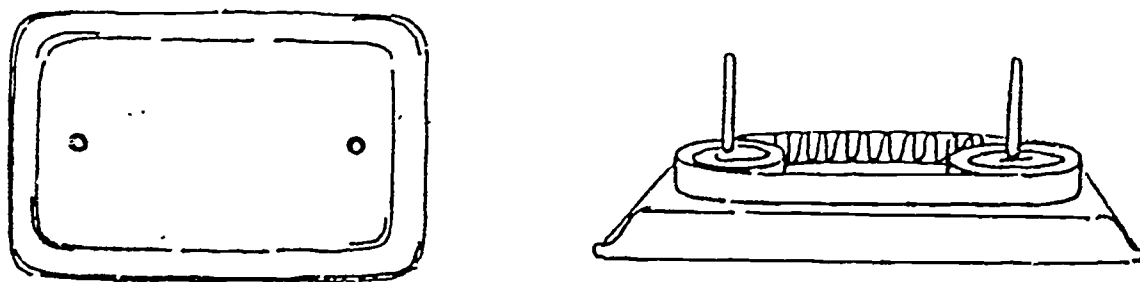

Figure 3

159

## PROBLEM SOLVING USING SIMPLE MACHINES

by Thomas E. Thompson

Focus: This activity serves a dual purpose in the area of simple machines. The primary focus is as a culminating activity which provides young children with the opportunity to apply previously learned concepts about selected types of simple machines. It also could be used as a mechanism for evaluating students understanding about simple machines and selected process skill acquisition.

Challenge: Select the "best" or most appropriate simple machine from a large group of simple machines in order to successfully complete a prescribed task in the shortest amount of time.

Materials and Equipment: A variety of simple machines available for student use:

Paper punch  
Tweezers  
Scissors  
Screwdriver  
Pliers  
Wire cutters  
Six foot wooden plank  
Other assorted items  
Wooden dowels (2 cm diameter) to be used as rollers  
Staple remover  
Tongs  
Hammer and nails  
Wooden dowels (5 mm diameter)  
Stapler  
Long nose pliers  
Pencil sharpener

How-To-Do-It: This activity works best if you divide the class into two large groups similar to that in a spelling contest. Each group will have a duplicate set of simple machines available from which to select.

Directions are relatively straight forward. The teacher identifies a specific task to be performed by one child from each group (i.e., remove four paperclips from a baby food jar with a simple machine). The two competing children then select a tool from identical piles of simple machines which they believe will be successful in enabling them to complete the prescribed task. Next, they compete against one another to see who can complete the task in the shortest possible time. Every child is given an opportunity to compete in a minimum of one task.

A point system can be used to keep a running total score. For example, a group may receive a point if the most appropriate simple machine is selected. A second point may be awarded for successfully completing the



task. A third point may be awarded to the group which completes the task in the shortest time period. At the end of the contest, the group with the highest accumulated point total is the winner.

The following is a list of some suggested tasks to be used during the competition: (a duplicate set of problems for each group must be prepared ahead of time.)

- a. Make an eight cm diameter hole in a piece of paper.
- b. Make a one cm diameter hole in a sheet of paper.
- c. Fasten four sheets of paper to form a square.
- d. Remove a staple from a set of stapled papers without tearing the papers.
- e. Make a triangle from three tongue depressors which will stay intact when picked up.
- f. Remove four paperclips from a baby food jar.
- g. Remove four marbles from a wide mouth canning jar.
- h. Separate a paperclip into three approximately equal sections.
- i. Lift a heavy box of books up to the seat of a chair.
- j. Move a heavy box of books from one side of a room to the other.
- k. Other tasks can be defined depending upon previous experiences and availability of simple machines.
- l. Sharpen a five mm wooden dowel.

Because children will tend to copy what another child tries, position an artificial barrier of desks to obstruct each group's view.

When the competition is completed, discussion should occur which focuses on which simple machine was best for a particular task.

This activity can also be used as one possible source of information the teacher can use to evaluate a child's ability to apply previously learned information about simple machines.

Further Challenges: Ask the children to design additional tasks to be completed. Also have them bring in an appropriate simple machine which can be used to successfully complete the task.

CHAPTER 8

ACTIVITIES FOR TEACHING HEAT

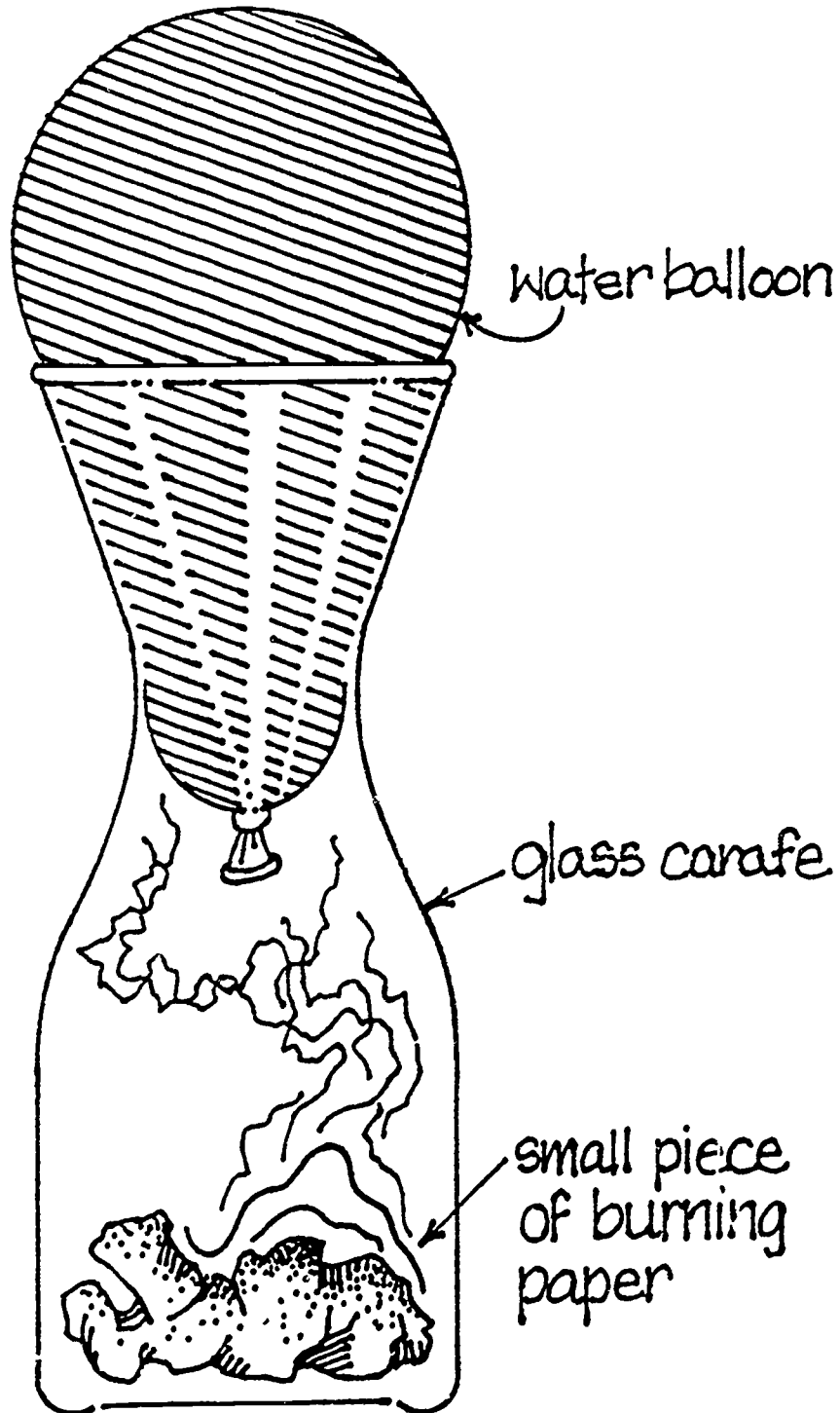

## TAKING THE HEAT

by David R. Stronck

Focus: A calorie is the amount of heat needed to raise the temperature of one gram of water by one degree Celsius. Foods give off calories when we digest them or when we burn them.

Challenge: Which kind of food is the richest source of calories?

### Materials and Equipment:

Wire coat hangers (with one pair pliers used by the teacher)  
Small "tin" cans  
Corks  
Needles  
Thermometers with Celsius scale of temperature  
Balances (that can weigh the tin can with 100 g of water, i.e. at least a total of about 200 g. This balance must also be sensitive enough to accurately weigh the food samples.)  
Matches  
Small marshmallows  
Peanuts  
Water

How-To-Do-It: See the diagram at the end of the activity. Before the lesson begins, prepare the coat hangers to serve as racks for holding the can with water. Use pliers to bend each coat hanger. The wire coat hanger has two parts: (1) the top hook that fits over a rod and (2) the bottom loop that fits into the shoulder area of clothes. Start by bending the far ends of the bottom loop toward each other to form a somewhat circular pattern. Now the bottom loop can be placed on a table top and will stand upright. The top hook area is then bent forward toward the center of this circle. Adjust the size of the hook until it will support a small can above the center of the circle.

Ask the students what they know about calories. If necessary, explain to them that a calorie is a measurement of the heat energy that is contained in foods, fuels, etc. We can measure the amount of calories available in a variety of foods and can test which foods give the richest source of calories. Follow these procedures:

Weigh an empty can. Record this weight. Add exactly 100 grams (100 ml) of water to the can.

Place the can with water on the hook platform of the bent coat hanger. Directly below the can place the upright cork with a needle stuck in it. Weigh each food item before using it and record this weight. At the top end of the needle stick the selected food, e.g., a small marshmallow.

Place the thermometer in the water in the can. Record the starting temperature. Strike a match and use the flame to begin burning the

food at the top of the needle. Allow the food to burn as completely as possible. Gently stir the water with the thermometer while the food is burning. Record the final temperature. Subtract the starting temperature from the final temperature to calculate the temperature change. The 100 grams of water has changed by this number of degrees. Since a calorie is the amount of heat that changes one gram of water by one degree Celsius, the number of degrees of temperature change is multiplied by 100 to give the number of calories that were generated.

$$\text{Change } ^\circ\text{C} \times 100 \text{ g of H}_2\text{O} \times \frac{\text{calorie}}{(1 ^\circ\text{C} \times 1 \text{ g of H}_2\text{O})} = \text{calories from the change}$$

The data recorded above allows us to calculate the calories from burning each piece of food. The samples of food probably have different weights. Now we need to divide the total number of calories given off by each food sample by the weight of the food sample. This calculation will give the calories per gram of the food. Finally, we can compare these calories per gram of each food to recognize which food is the richest source of calories.

Further Challenges: Invite the students to test many other foods for their caloric content.

Note that the "food calorie" described in books equals 1000 scientific calories (as we calculated in this activity.) Consult with various books on nutrition about the calories in various foods. Compare the answers in books with results done by the students' measurements. Why are there differences?

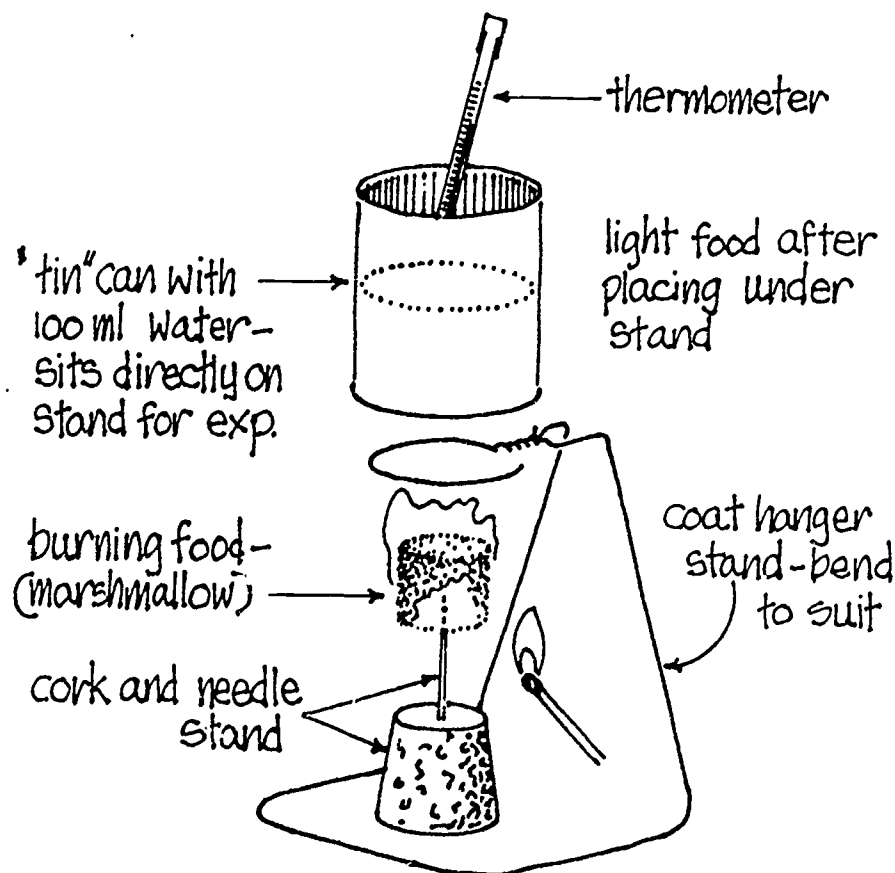

## INVESTIGATING COLOR AND HEAT

by Tom Graika

Focus: Stepping barefooted from a lawn in the summertime onto a blacktop road can be a painful experience. The road feels hotter than the lawn felt. The color of objects is one of the factors that seems to determine how much heat is absorbed. A black car in the sun seems hotter to the touch than a white car.

Challenge: How does the color of a liquid effect how much heat is absorbed?

### Materials and Equipment:

Several containers  
Food coloring  
Thermometers  
Heat lamp or sunny window ledge  
Water

How-To-Do-It: Place the same amount of water in several containers of the same size. Place 10 drops of food coloring in one of the containers and stir until the color is evenly distributed in the water. Prepare the other containers in the same manner using different colors of food dye.

Place the containers on a sunny window ledge or an equal distance from a heat lamp. Place a thermometer in each of the containers and record the temperature. Allow the containers to stand in the heat for 30 minutes. Record the temperature in each container at the end of the 30 minutes. Determine which color absorbed the most heat. Determine which color stayed the coolest. Try to determine a pattern, if any, between color and heat absorption.

Further Challenges: Find out how much heat plain water absorbs compared to colored water.

Find out how much heat is absorbed by different colored liquids such as grape juice, orange juice, cherry pop, or tomato juice.

Find out if keeping liquids in a heat source for twice as long will double the amount of heat that is absorbed.

Keep track of heating liquids by taking temperatures every five minutes and preparing graphs of the heating rates.

Use colored construction paper and thermometers to find out if colored solids absorb heat the same way colored liquids do.

## HOW MUCH TIME?

by Patsy Ann Giese

Focus: Particles of matter (atoms and molecules) move further apart when heated. Therefore, water becomes less dense when heated. More dense cold water, pulled down by gravity, pushes up the less dense hot water. This motion is called a convection current. When two sections of water are the same temperature, and therefore the same density, there are no convection currents. Mixing occurs only by diffusion, which is considerably slower than mixing by convection.

Challenge: Predict how long convection and diffusion take. Check predictions with observations.

### Materials and Equipment:

4 identical bottles with flat rims  
Water  
Food coloring  
Hot pads or gloves  
Plastic playing card or credit card  
Flask with one-hole stopper  
Glass tube about 5 cm long to fit stopper  
Rubbing alcohol  
Masking tape

How-To-Do-It: Fill completely one bottle with hot water and one bottle with cold water. So that the two bottles can be distinguished later label the bottles "hot" and "cold" or add two different colors of food coloring to the bottles. Cover the bottles with plastic wrap to prevent evaporation. Let the bottles cool to room temperature, perhaps overnight. Have students check the water levels and discuss the observed changes. As hot water cools, particles move closer together causing the water level to drop. As cold water warms, particles move farther apart causing the water level to rise. (See the exception discussed below in the seventh part of "Further Challenges.") Explain that the atoms and molecules do not change size as objects contract or expand due to temperature change. Discuss the phrases "cool down" and "warm-up."

Color a pot of hot water yellow and a pitcher of cold water blue then fill two bottles with hot and two bottles with cold water. Have students predict what will happen when you invert a hot bottle over a cold and a cold bottle over a hot. Have them include in their prediction an estimate of the time required for changes to occur. Perform the experiment, but before inverting a bottle cover it up with a card to prevent spilling water. After that bottle is in place on top of another bottle, gently pull the card out. Discuss any discrepancies between students' predictions and the experimental results.

In a few minutes, the water will be green in the bottles where cold water was placed over hot water. Many students will predict that the water in

the other pair of bottles will be green when the bottles reach room temperature. However, at room temperature, only diffusion is occurring; mixing completely by diffusion may take more than a month.

Further Challenges: Discuss which bottles have more water molecules in them when completely full -- the bottles with cold water or the bottles with hot water.

Pour hot colored water into a small bottle. Cover with aluminum foil, and prick one or two small holes in the foil. (An alternative is to use a small flask with a one- or two-hole stopper. Short pieces of glass tube can be inserted into the stopper.) Set the bottle under cold clear water in a larger container. Have students observe the movement of the hot colored water. Repeat this activity, except put cold colored water in the small bottle and put hot clear water in the larger container.

Float an ice cube of colored water in a larger container of hot, clear water. Have students observe the movement of the cold water formed from the melting ice.

Discuss why the liquid in a thermometer takes up more space on a hot day compared to a cold day. Make a thermometer by inserting a glass tube about 5 cm long into a one-hole rubber stopper. (An alternative is to use a straw in a ball of clay.) Fill a flask with colored water or rubbing alcohol, and seal the flask with the rubber stopper. Add enough liquid that part of the glass tube is filled. Stick to the tube a piece of tape with the top of the tape at the top of the liquid. Heat the liquid and observe the change in the height of the liquid.

Ask students if they have ever felt the water get colder as they dived deeper in water. Discuss the decrease of temperature with increasing depth in a lake or an ocean.

Discuss the movement of warm and cold ocean currents.

Explain that, although most substances contract when cooled, water expands when cooled from four degrees Celsius to its freezing point at zero degrees Celsius. Discuss how this fact is related to the formation of ice on the tops of lakes as very cold water rises instead of sinks. Discuss why life could not live in lakes if ice formed on the lake bottoms.

Safety: Before inserting the glass tube into the rubber stopper, wet the glass tube with water or lubricate it with petroleum jelly. Hold a paper towel around the glass tube to protect your hands in case the glass tube might break. Twist the glass tube as you insert it, not applying excessive force.

## SUPERCOOLING

by Michael J. Demchik

Focus: Supercooling or dropping the temperature to various positions below the normal freezing temperature of liquids or solutions can take place in special freezing mixtures.

Challenge: Can you explain why samples of liquids or solutions fall below their normal freezing temperature, yet don't freeze? How long can you get temperatures of liquids or solutions by conventional methods without having them freeze? What are some methods used to drop the temperature that do not involve the use of chemicals?

### Materials and Equipment:

Ice  
Water  
Salt  
Acetone  
Alcohol  
Various salt water solutions  
Thermometers  
Test tubes  
Beakers

How-To-Do-It: Prepare four test tubes of distilled water. Put a clean thermometer into each test tube. Place each in the following four beakers containing the listed mixtures.

Beaker 1 - ice  
Beaker 2 - ice and salt  
Beaker 3 - ice, salt and alcohol  
Beaker 4 - ice, salt, alcohol and acetone

Allow to stand for several minutes. Observe. Results? Continue to observe the temperature over time. Results? Remove the test tube and shake slightly. Results?

Challenge: Prepare various strength solutions of salt and ice in the test tubes. Repeat the same procedure. Collect temperature data every 30 seconds and plot the results. What effect does the presence of salt in the water have on the freezing temperature of the water? Try other materials such as calcium chloride.

Note: Whenever chemicals are being used, be sure to consult container labeling for safety precautions.



## SODA CANS THAT BLOW BUBBLES

by Lawrence D. Calhoun

Focus: When gases are heated they expand and become lighter in OPEN SYSTEMS. When gases are cooled, they contract and become heavier in OPEN SYSTEMS. When these same events occur in CLOSED SYSTEMS, heated gases result in increased pressures. The opposite is true for cooled gases.

Challenge: How can two identical empty paper bags have different weights? How can you make a soda can blow bubbles?

### Materials and Equipment:

Aluminum soda cans  
Soap bubble solution  
Aluminum pie pans  
Rubbing alcohol  
Cotton balls  
Paper lunch bags  
String  
Scissors  
Tape  
Meter stick  
Balance rod  
Clay or wax candle  
Matches  
Bucket of water or fire extinguisher (for safety)  
Plant mister

### How-To-Do-It:

#### Activity One

Balance two identical paper lunch sacks as shown in Figure 1. Since an open flame is used, teachers should demonstrate this to the class as a motivator. Stress safety by doing the following: 1. have a bucket of water or a fire extinguisher handy, 2. spray paper bags with a plant mister before balancing them. Some balancing tips include: letting some wax from a small birthday candle drip on the "lighter" bag after you've tried to rough balance the two bags, moving the string loops closer or farther from the center of the suspended meter stick (refer to Figure 1), and adding a pinch of modeling clay to the lighter side of the meter stick.

After the class decides the bags are perfectly balanced (the soda straw indicator should align with a perpendicular chalk mark on the board), ask what the class thinks: Do both bags contain the same amount of air? Could we call these OPEN SYSTEMS? Why? What do you predict will happen if we carefully hold a small burning candle under one of the bags? Why?

Next the candle is lit and placed under one of the bags. The class observes as the heated bag rises and the unheated bag drops. Students

should be asked to speculate as to why this occurred. Ask students to name other examples of this phenomenon. (e.g., hot air balloons, smoke rising, chimney drafts, etc.) Students should be led to a formal summary of related phenomena such as: when air is heated in an open system, the air expands and some escapes causing it to weight less. An identically sized container system which is not heated contains more air and is therefore heavier.

### Activity Two

Divide the class into groups of two. Give each group an empty soda can, container of soap solution, some cotton balls, and a paper cup filled with rubbing alcohol. Ask students to respond to the following questions and statements:

- Is the soda can an open or closed system?
- If we dip the open end of the can into the soap solution, a soap film will cover the soda can hole. Is it still an open system?
- What do you thing will happen now if we heat the air inside the closed system can?
- What would happen if we cooled the air instead?
- Using just your hands and the materials in front of you, how could you heat and cool the air inside the soda can? (Caution students not to crush or squeeze the can so that it's bent.)

Students should discover that rubbing their hands briskly together creates heat from friction. They should discover that a cotton ball dipped in alcohol and spread on their hands results in cooling. Blowing or fanning creates even more cooling as a result of the evaporation process. Now ask students to apply their heating and cooling techniques gently to the soda can. Students should observe results similar to those seen in Figure 2.

The concepts developed here apply to CLOSED SYSTEMS. When air is heated in a closed system, the air expands and an increase in air pressure results. When air is cooled in the closed system, the air contracts, takes up less space. As a result, the air pressure becomes less than that of the outside surrounding air. The bubble being blown larger by the can being warmed by the rubbed hands shows this well. The bubble being pressed in on the cooled can also shows clearly the contraction of a cooled gas.

Encourage students to study the effects of different degrees of heating (number of times the hands are rubbed together) and/or cooling (fanning and no fanning of alcohol). Everyday events to help support the concept include: bicycle tires or basketballs "swelling" on a hot day; a helium party balloon "shrinking" when taken outside on a winter day; and aerosol cans exploding in an incinerator, etc.

Further Challenges: The teacher could summarize by demonstrating the "egg-in-the-bottle" trick. How can this hard-boiled egg be put in an old-fashioned milk bottle without pushing it through and smashing the egg? Ask students to use their activity to brainstorm a solution. Teacher demonstrates by quickly dropping a burning paper strip or piece of wound up paper towel into the milk bottle and quickly setting a shelled, hard-boiled egg on the bottle opening. The effect is almost instantaneous and quite dramatic with a loud accompanying plunk. The greater outside air pressure pushes the egg into the bottle where the burning paper has rapidly expanded the air with some air escaping around the edge of the egg. This is followed by a quick drop in pressure as the air inside the bottle quickly cools and contracts as the flame is extinguished by the egg cover.

Teachers may prefer using a small water balloon in place of an egg. See Figure 3. Almost any size container will be usable then, since some may find glass milk bottles unavailable. An empty wine carafe is an excellent substitute.

Have students compare the egg-in-the-bottle to their soda can bubble blowers. What parts of the two systems are similar? How were the results of the soap bubble and egg/water balloon investigations similar?

References:

Brown, Robert J. 333 Science Tricks and Experiments and 333 MORE Science Tricks and Experiments. Blue Ridge Summit, PA: TAB Books, Inc.

Lanners, Edi. Secrets of 123 OLD-TIME Science Tricks and Experiments. Blue Ridge Summit, PA: TAB Books, Inc.

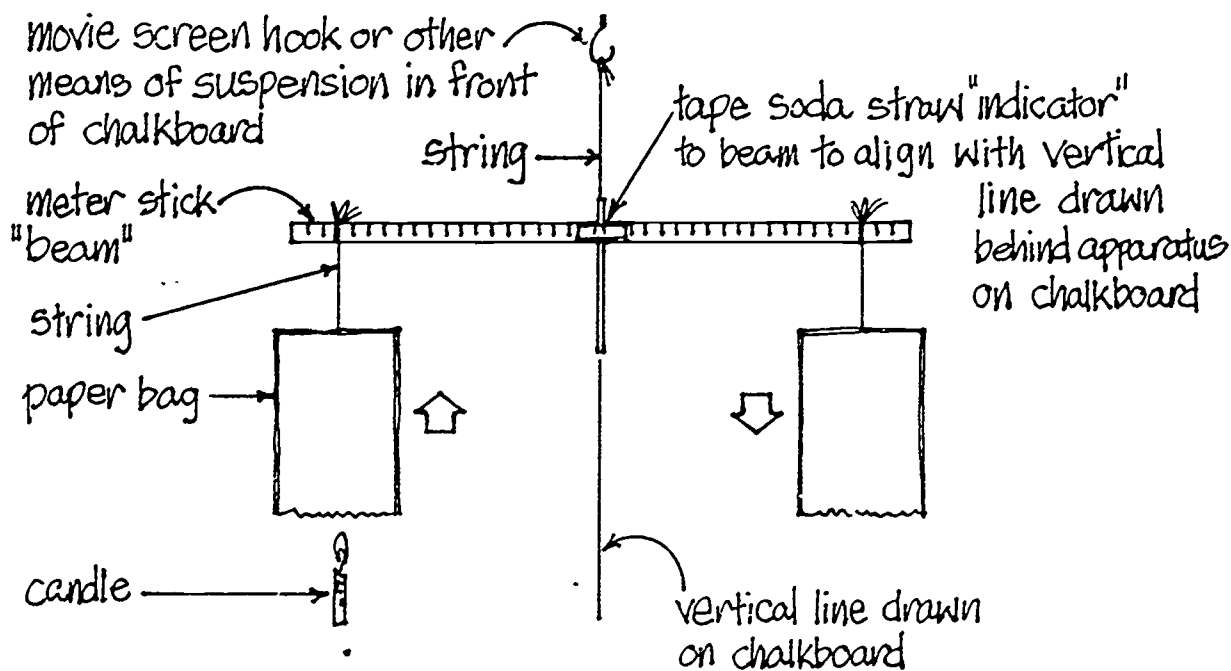

Figure 1

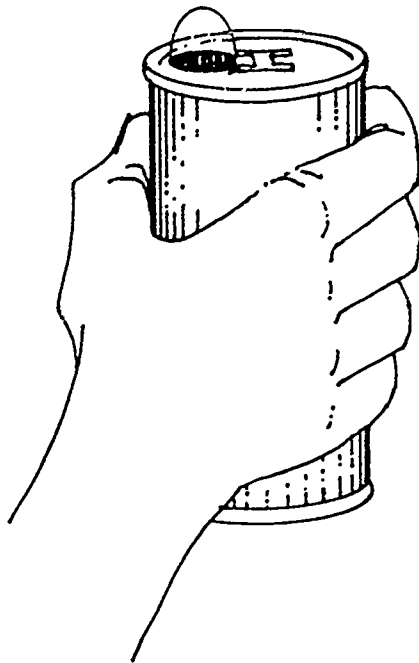
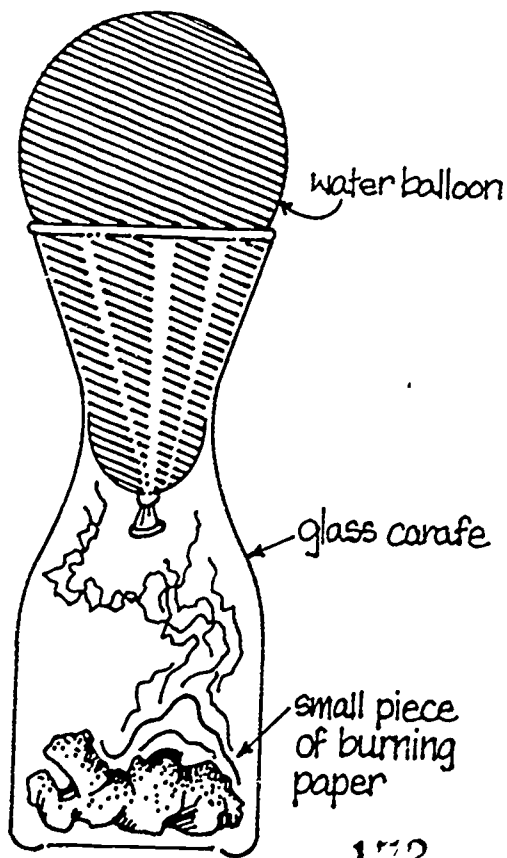

Figure 2



172

Figure 3

## HOT AND COLD AND UP AND DOWN

by Patsy Ann Giese

Focus: Particles of matter (atoms and molecules) move further apart when heated. Therefore, air becomes less dense when heated. More dense cold air, pulled down by gravity, pushes up the less dense hot air. This motion is called a convection current.

Challenge: Observe evidence and infer that hot air rises while cold air sinks.

### Materials and Equipment:

Cardboard or wooden carton  
Transparent glass or shrinkable plastic  
Packaging tape  
Two glass lamp chimneys  
Candle  
Matches  
Cotton rag or thick rope  
High intensity or other small lamp  
Black posterboard  
Ruler  
Cotton thread  
Hot plate  
Paper streamers  
Shallow pan  
Water

How-To-Do-It: Take off the top of the carton, and cover it with glass or plastic used over windows. Turn this box so the transparent material forms a vertical front. Then cut two holes in the top (one near each end of the carton, but centered front to back) the same diameter as the bottoms of two glass chimneys. Directly beneath one of the holes, cut a hole in the bottom of the box. Light a candle, and then gently put the box over it. Place two lamp chimneys in the top. To improve the visibility of smoke, lean a piece of black posterboard up against the wall behind the chimneys. Darken the room, and light the box with a lamp to one side of the box. Use a match to light a rolled-up cotton rag or a thick rope. After it has burned for a few seconds, blow out the flame. Hold the smoking rag or rope over first one, and then the other, chimney. Have the students observe motion of the smoke. Discuss why smoke moves up over the candle and down in the other chimney.

Repeat this activity immediately after extinguishing the candle. Repeat it again after all the air in the box has cooled.

Further Challenges: Separate a piece of cotton thread (seven or eight cm long) into the fine strands that make up the thread. Tape one end of these threads to the end of a ruler. Hold the threads over a hot plate, below

and above an open refrigerator door, below and above an oven door. Ask students where the coldest part of a refrigerator is. Ask students why cold air stays in open chest freezers at grocery stores. Ask students where the hottest part of an oven is. Ask students why candles are placed below, not above, food in chafing dishes and fondue pots.

Threads or thin paper streamers can be used to detect movement of air in and out of windows. When the temperature is hotter outdoors than in the room, check the direction of motion in front of the highest window opening in the room and in front of the lowest window opening. All other windows in the room should be closed. Repeat this activity when the temperature is colder outdoors than in the room.

Have each student hold one hand above a shallow pan of hot water and one hand below. The two hands should be equal distance from the water. Have students state which hands feels warmer.

Bring to class a decoration in which a pinwheel turns above lighted candles. Discuss how the decoration works. Have students make pinwheels and hold the pinwheels over hot radiators. (They can cut a square of aluminum foil 7.5 cm on a side and then cut along each diagonal to within 1 cm of the center. They should fold back every other point to the center and insert a straight pin through these corners, the center of the foil, and finally into a pencil eraser.)

Discuss the distribution of heat throughout a room by convection currents. At home, have students check the locations of radiators and the locations of gratings for hot air ducts and cold air returns. Discuss which rooms are usually hotter -- those on an upper story or those on a lower story. Have each student explain any other places consistently warmer or colder than the rest of his/her home. Possible reasons are distance from the furnace, number of radiators, number of windows, and amount of insulation.

Discuss the reason why operating ceiling fans can reduce heating costs in a home. The fans can make a room, particularly one with high ceilings, feel warmer to a person sitting in the room because the fans force warm air downward.

Discuss why smoke from a campfire rises instead of sinks. Discuss why firemen sometimes crawl out of rooms containing smoke.

Discuss weather phenomena, such as major air currents, cold/warm fronts, and sea/land breezes, in which cold air sinks beneath warm rising air.

Safety: Be sure the threads are well above the hot plate so they do not burn. Be sure no child is burned by a candle flame or by hot wax dripping from a candle.

## FIZZ-BUBBLE-POP (FAST GET-AWAYS)

by Terri G. Switzer

Focus: Soda pop gets its fizz from carbon dioxide gas. Carbon dioxide is added to the soda before the bottle is sealed. As soon as you open a carbonated soda, the gas starts to escape. Tiny bubbles filled with carbon dioxide gas pop and tickle your face when you drink the soda. But, carbon dioxide is odorless and colorless. Students must use other senses to detect evidence of this gas. They can feel and measure carbon dioxide when it is trapped in a container such as balloon.

Challenge: What do you think causes a soda to lose all its gas and go flat? Try this experiment to find out whether temperature affects the speed at which carbon dioxide gas escapes from soda pop.

### Materials and Equipment:

3 identical bottles of room-temperature soda  
3 balloons, same size and shape  
3 plastic bowls, fill one with ice-water, one with room-temperature water, and one with hot tap water  
Piece of string or ribbon  
Metric ruler

How-To-Do-It: This experiment is best done in large groups so you won't have to buy as many sodas! Students can also do this experiment quite easily at home. Let them share their results.

Have students predict whether warm soda will lose its carbon dioxide gas faster, slower, or at the same speed as cold soda.

Open the three bottles of soda. Quickly cover each bottle with a balloon.

Set the balloon covered bottles in the bowls of ice-water, and hot tap water.

Wait five minutes. Wrap a string around the widest part of each balloon. Measure the length of the string with a metric ruler. Record the measurements in a data table.

Bottle In:	Size of balloon after 5 mintues
Ice Water	cm.
Room Temp.	cm.
Hot Tap	cm.

Compare the size of each balloon. Which temperature caused the carbon dioxide gas to have the fastest get-away from the soda?

Which of these sodas would lose its gas (go flat) the quickest? Why?

- an open soda in the refrigerator
- a sealed soda on the counter
- an open soda left on a picnic table in the sun

Further Challenges: Compare different brands of sodas. Do they all have the same amount of carbonation?

If you left the soda bottles covered for a longer period of time, would you collect more gas?

Why is it not safe to put carbonated drinks inside a glass-lined thermos?

Reference:

Adapted from WonderScience, March, 1987 © American Chemical Society.  
Included in this Sourcebook by permission of the copyright holder.

For subscription information contact:

WonderScience  
American Chemical Society  
1155 Sixteenth Street, NW  
Washington, DC 20036  
(202) 452-2113

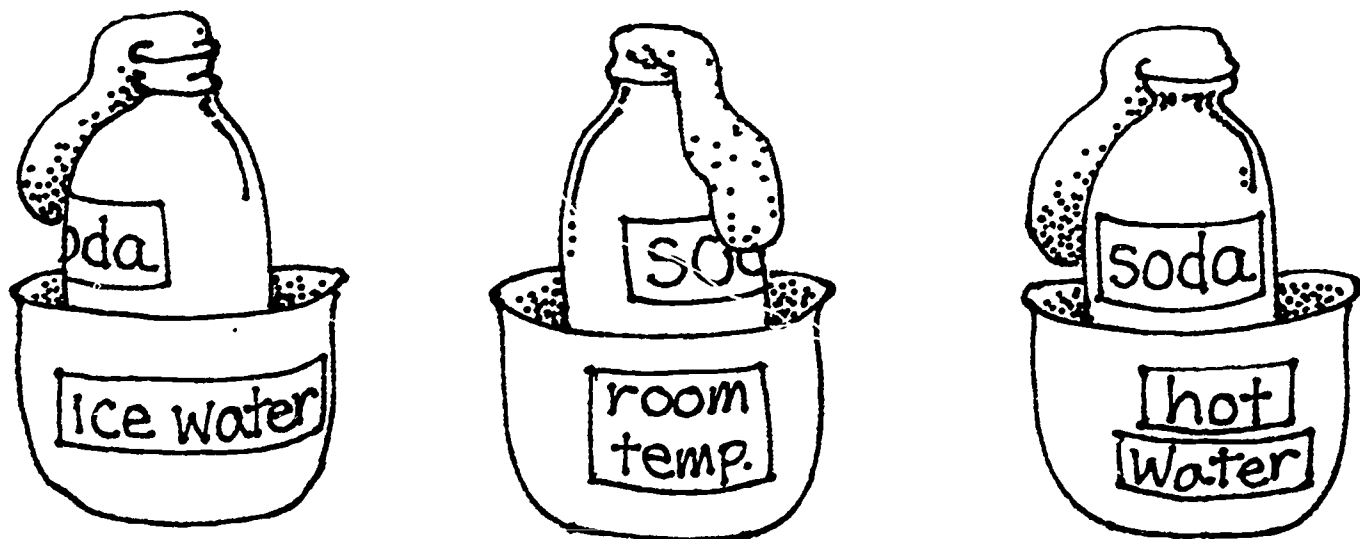



CHAPTER 9

ACTIVITIES FOR TEACHING FORCES IN LIQUIDS AND GASES

What will  
happen to  
the mouse  
when the  
candle stops  
burning...  
why?

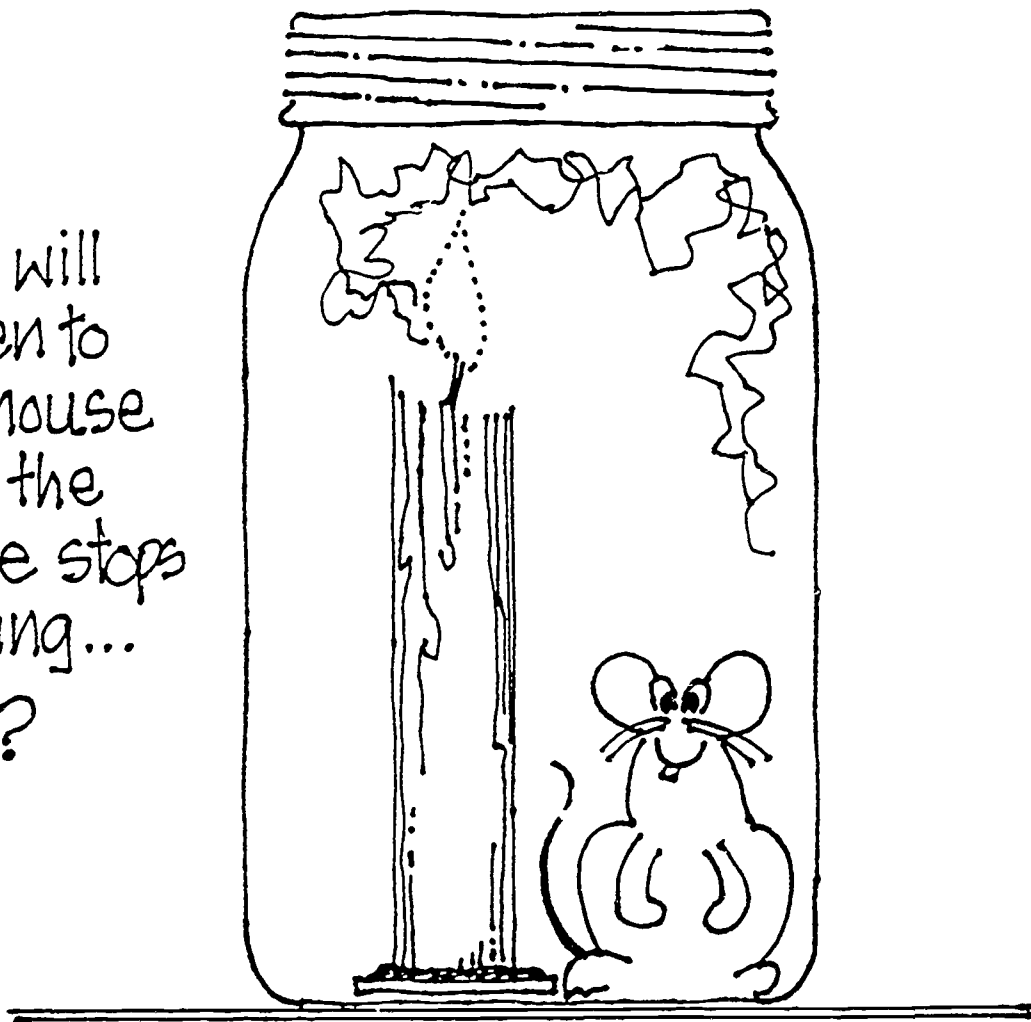

## MEDICINE DROPPER SUBMARINE

by Donna Gail Shaw

Focus: In preparation for submergence, the main ballast tanks of a submarine are filled with water to destroy nearly all the vessel's positive buoyancy. One way to make the submarine float again is by using compressed air to force the water out of the tanks. The following experiment can be used to help illustrate this process.

Challenge: How do submarines sink and then float again?

### Materials and Equipment:

Glass soda bottle  
Glass medicine dropper  
Water  
Paper towels (for spills and clean up)

How-To-Do-It: Gather enough materials prior to conducting the experiment. You should have one set of materials for demonstration purposes and one set of materials for every group. The ideal group size is two to three students.

Begin the activity with a teacher demonstration and explain to the students that they will discover how it is possible for a submarine to sink and float again.

Students should carefully observe the demonstration because they will perform the experiment in their groups. You may want the students to record the steps on paper.

Teacher Demonstration (Only perform the experiment at this point. Do not discuss results.)

- a. Fill a glass soda bottle full of water.
- b. Fill a medicine dropper with enough water so that it will barely float in the bottle of water.
- c. Place your thumb or palm over the opening of the bottle.
- d. Press down. The dropper should sink.
- e. Release pressure. The dropper should rise.

Make sure that all students know how to perform the experiment. Pass out sets of materials to each group and have them repeat the experiment, record the results and record why they think the dropper sinks and floats.

After the groups have had a chance to perform the experiment a few times (with teacher moving about from group to group providing assistance), discuss the students' explanations.

Relate the experiment's results to the real world application of how submarines operate. Submarines take on water in order to sink and compressed air is used to force out water to make them float again.

Explanation of Results: The medicine dropper submarine works because of the ability to expand and contract air. When you apply pressure to the top of the soda bottle with your thumb or palm, notice that water is pushed into the dropper. The air inside the dropper is forced upward into the dropper's rubber bulb. With this extra water, the dropper becomes heavier and sinks. When you release the pressure by removing your thumb or palm, the air that was forced into the rubber bulb of the medicine dropper forces water out of the dropper and it becomes light enough to float again.

Further Challenges: Instead of using your thumb or palm, use a piece of rubber from a balloon and attach it to the top of the soda bottle with a rubber band. Press and release the rubber.

Try to blow hard enough on the top of the glass or plastic bottle to make the dropper sink.

Use a large plastic soda bottle instead of a glass bottle. Put the lid on the plastic bottle and then squeeze the sides. Observe the medicine dropper as you squeeze and then release.

Try this experiment with a plastic medicine dropper. Is it possible to fill the plastic dropper with enough water to make it heavy enough to sink? (Hint - If the plastic dropper will not sink, wrap a little copper wire around its base.)

#### References:

Friedl, Alfred E. Teaching Science to Children. New York: Random House, Inc., 1986.

UNESCO. 700 Experiments for Everyone. New York: Doubleday & Company, Inc., 1962.

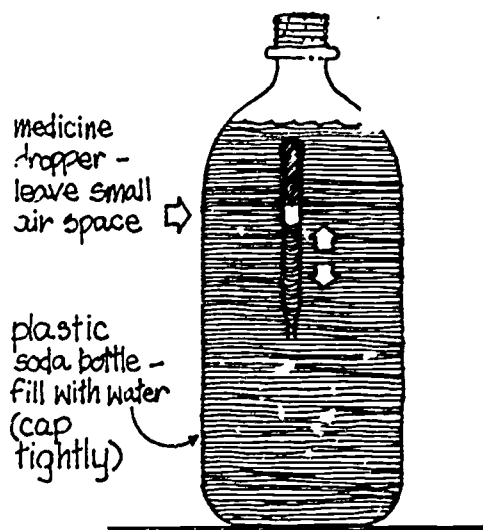

## CLOSED SYSTEMS

by Gerald Wm. Foster

Focus: To observe the effects of various variables upon the density of liquids.

Challenge: Students will attempt to make a floating test tube or some other objects sink.

### Materials and Equipment:

Large test tubes (20 cm x 2.5 cm)

Small test tubes (7.5 cm x .9 cm) or small glass or plastic vials  
4 cm x 1 cm with lids

Pieces of rubber balloon and rubber bands

Scissors

Various liquids such as: water, oil, vinegar, alcohol, salt water, glycerin, hydrogen peroxide, clear shampoo, etc.

Various clear plastic containers with lids such as: 1 liter soda pop bottles, shampoo bottles, dishwashing liquid bottles, etc.

Dishwashing tubs for water source

Newspapers and/or dropcloths

How-To-Do-It: Fill a large test tube with water and invert a small test tube into large test tube. The small test tube needs to have enough water in it to make the bottom of it float evenly with the water level of the large test tube. Stretch a piece of balloon over the opening of the large test tube and secure it with a rubber band (see diagram). Have one closed system made so that students can refer to it as they make their own.

When the stretched balloon is depressed, the small test tube should sink to the bottom of the large test tube and remain there until released. Have students depress the stretched balloon with their thumb.

Once they have successfully operated the closed system, have students write down an explanation of how it works. They also need to identify the variables that affect the closed system. After that, they can start changing the variables. For example, students can use different liquids in the large test tube as well as the small test tube. Each time they use a different liquid, they should compare the level of the liquid in the small test tube to the level of water in the original closed system.

Students can also try various plastic containers filled with various liquids using the small test tube as the diver. A lid is put on the container rather than a stretched balloon. The sides are squeezed to make the test tube sink.

Further Challenges: Rather than using a plastic bottle or large test tube, use a narrow glass bottle such as a salad dressing bottle for the closed system. Make sure the water level is completely to the top of the glass bottle and screw on the cap as tightly as possible. The small test tube

will sink when the glass bottle is squeezed if the amount of water in the small test tube is at the critical point of the small test tube sinking or floating.

Use a clear glass tube spacer tube as a closed system. You will need a large rubber stopper in one end of the tube. Several small test tubes can be put in the large tube or even larger test tubes. Students can have test tube races to see which ones will reach the bottom first.

Students can try the liquids at different temperatures to see the effect on the rate at which the small test tubes will sink.

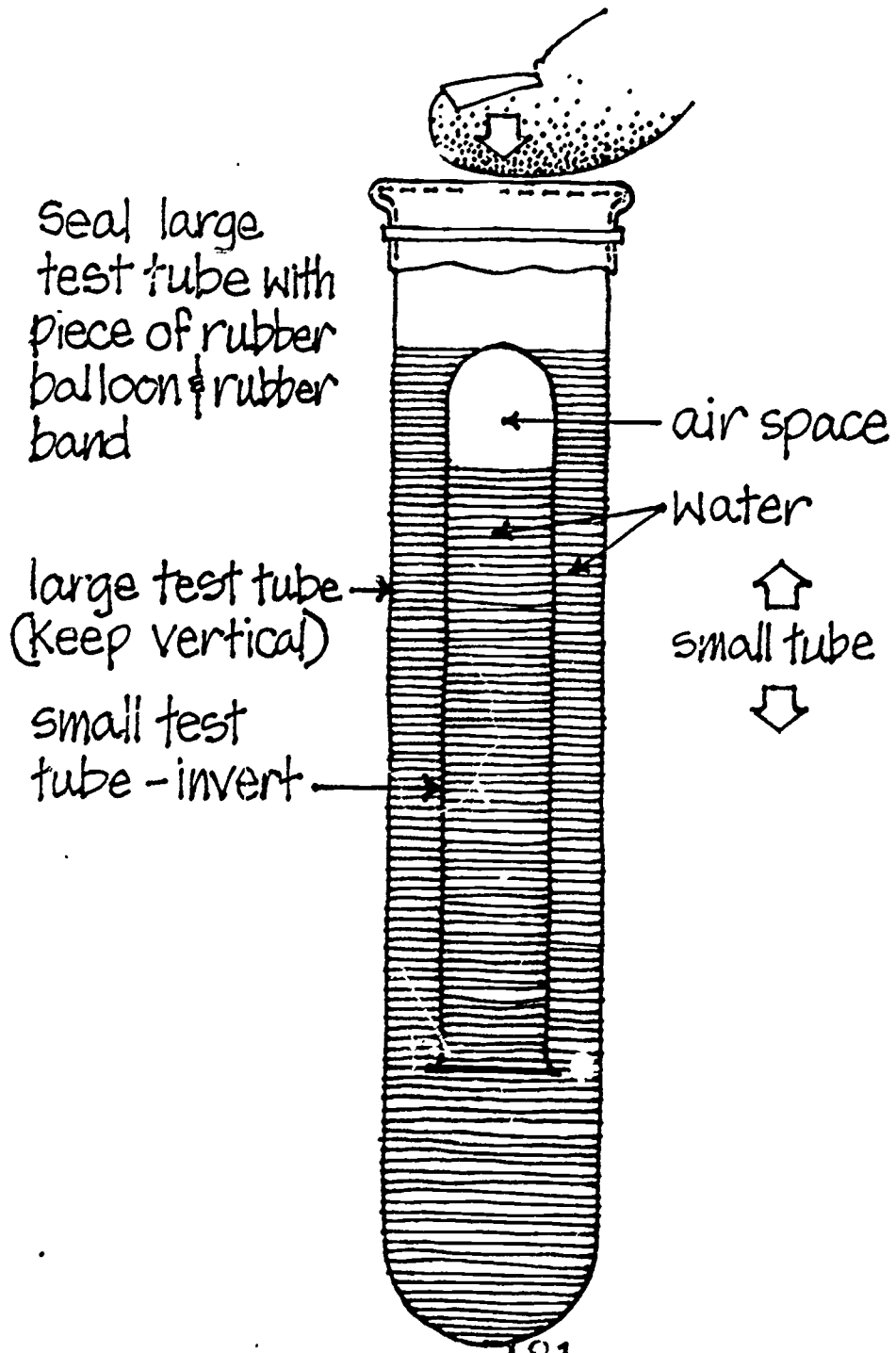

## HEARD IT THROUGH THE GRAPEVINE

by Edward L. Shaw, Jr.

Focus: Carbon dioxide is a gas made up of one atom of carbon and two of oxygen. It is a gas with a variety of uses ranging from the powering of fire extinguishers to providing the fizz and bubbles in non-alcoholic carbonated beverages.

An easy way to demonstrate CO<sub>2</sub> gas to students is to show how the bubbles rise to the top of the bottle when a carbonated beverage container is shaken and the top removed. Another method is to have students mix vinegar and baking soda in a container and show how the bubbles produced are carbon dioxide. An additional proof of the presence of CO<sub>2</sub> is that a lighted match will be extinguished if it is placed into the container.

Challenge: Observation of carbon dioxide gas within a liquid.

### Materials and Equipment:

Colorless carbonated beverage  
Raisins  
Colorless glass

How-To-Do-It: This activity can be used as an introduction to the vinegar and baking soda activity. It is easy, inexpensive, and fun to do.

Ask students if they know how to make a raisin go up and down in a liquid without touching either the raisin or the liquid? Solicit answers and place them on the board.

Distribute the raisins informing students not to disturb them because they have a lot of traveling ahead of them. Now distribute small glasses of the carbonated beverage, telling the students not to touch, smell, or taste it.

Tell them to carefully place the raisins in the liquid. Observe what happens. The CO<sub>2</sub> will accumulate on the raisins and they will rise to the top. Once the CO<sub>2</sub> bubbles pop, the raisins sink to the bottom only to repeat the process.

Now ask the students, what is the liquid? After they have guessed that it is a carbonated beverage, allow them to drink it and eat the raisins. At the same time, discuss what the bubbles are and the reason why they rise to the top of the liquid.

Further Challenges: Have students determine if there are other fruits, vegetables, or food that will duplicate the process.

Have students test to see if temperature of the beverage affects the movement of the raisins.

Have students determine the length of time the raisins will float. Have them graph the number of round trips per five minutes.

## HEAPING HIGH WATER!

by Donna Gail Shaw

Focus: Surface tension is caused by cohesion, a force that causes molecules of a substance to be attracted to one another. Surface tension causes a liquid to behave as if a thin, elastic film covers its surface. In actuality, no such film is present.

Challenge: How many drops of water will it take to overflow a medicine cup full of water?

### Materials and Equipment:

Medicine cups (two for each group)  
Medicine droppers (one for each group)  
Water  
Paper towels

How-To-Do-It: Teacher demonstration set-up: One medicine cup full of water, one medicine cup half full of water and one medicine dropper.

Ask the students how many drops of water they think it will take for the water to spill over the edges of the full cup. Demonstrate how to hold the medicine dropper an inch from the surface and explain that you will carefully drop one drop at a time. Have the students record their guesses on paper. Ask for volunteers to give you their guesses and record these on the board.

After you are sure the students know what to do, pass out the materials to each group. Each group should receive two medicine cups (one full of water; the other half full to be used as a source of water for the experiment), one medicine dropper and paper towels.

Students, using the medicine dropper, will take water from the half full medicine cup and carefully drop it into the full cup. One member of the group should be in charge of dropping the water into the cup, one should be in charge of counting the drops and one should watch for the point of overflow.

The teacher should circulate from group to group, encouraging the students to look at the water from the side as it heaps up. Students should record the actual number of drops it took to overflow their cups of water and record why they think it took so many drops.

When all groups are finished, record the actual results on the board by the guesses. Discuss the students' reasons why they think it took so many drops to overflow the cup. Why did it take one group more drops than another? Discuss variables such as drop size, original amount of water in cup, height from which water was dropped, table/desk movement, air movement, etc.

Explanation of Results: In the heaping activity there is a point at which one more drop will cause the liquid to spill over. This point depends on the liquid's density, viscosity, and surface tension. The extremely strong cohesive forces in plain water will cause the water in the cup to pile up or heap until the weight of the water becomes so great that it spills over.

Further Challenges: Will other liquids heap as high as water?

Will soapy water heap as high as plain water?

How many drops of water will a penny hold? Will the face or back of the penny hold more water?

Reference:

Kitchen Physics, (Elementary Science Study.)

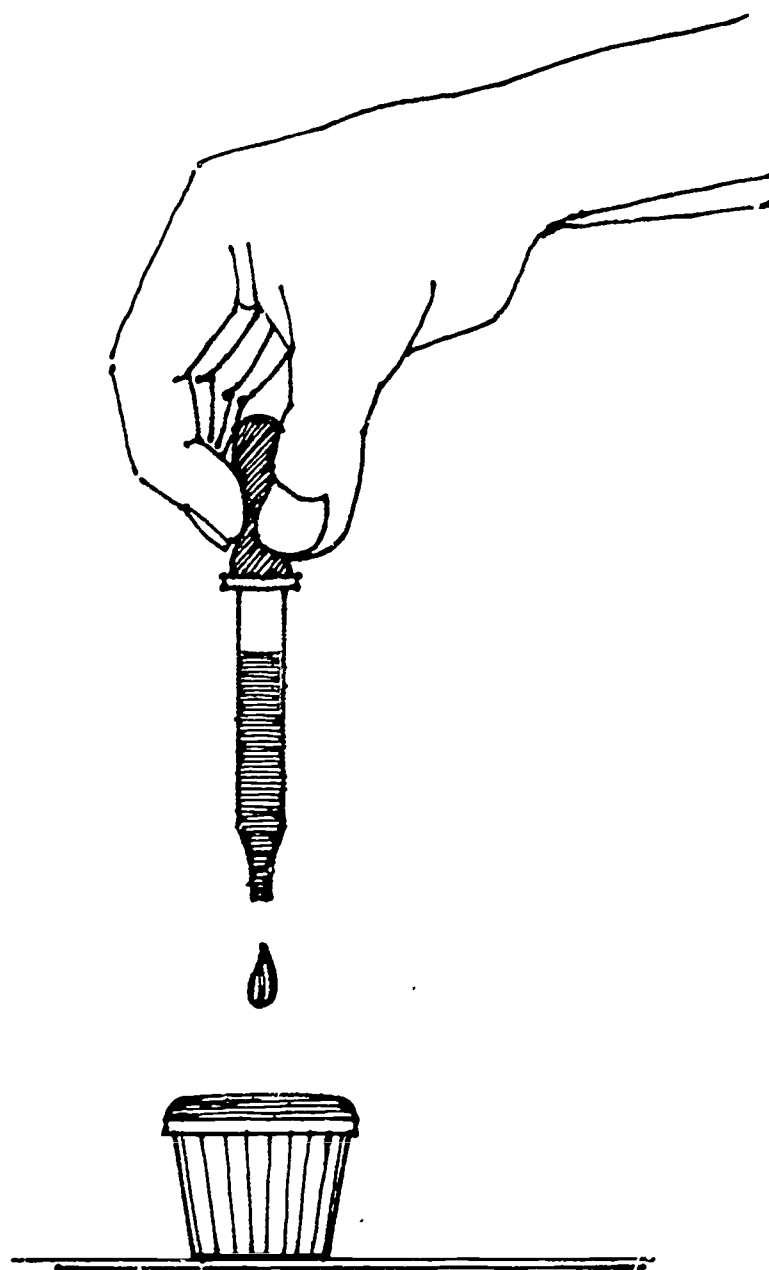



## VANISHING ICE CUBE TRICK

by Mildred Moseman

Focus: The fact that ice floats is very important to us. Most liquids become heavier (more dense) as they turn into a solid. Because ice is less dense than water, it floats.

Challenge: Floating ice traps the water of a pond underneath it, thus protecting the water from freezing. If ice sank, entire rivers and lakes could freeze solid from top to bottom. What would happen to fish in such a lake? How do bodies of water affect climate? How could the earth be affected if ice were heavier than water? Would climates change? How would people and wildlife be affected?

### Materials and Equipment:

Glass  
Water  
Ice cubes

How-To-Do-It: Fill a glass with water almost full.

Add one large ice cube that will float freely in the glass (see the figure on the following page).

Now very carefully add more water. If you do it slowly, you can add enough water so the level rises above the top of the glass without spilling over. (This is due to the surface tension of the water itself.) At this point, the ice cube will be floating above the top of the glass.

Further Challenges: What will happen to the water level when the ice cube melts? (As the ice cube melts, its volume decreases. Therefore the glass will not overflow.)

What happens to water frozen in a paper cup? How does it illustrate the principle of the floating ice cube?

surface tension  
of water allows  
glass to be  
"overfilled"

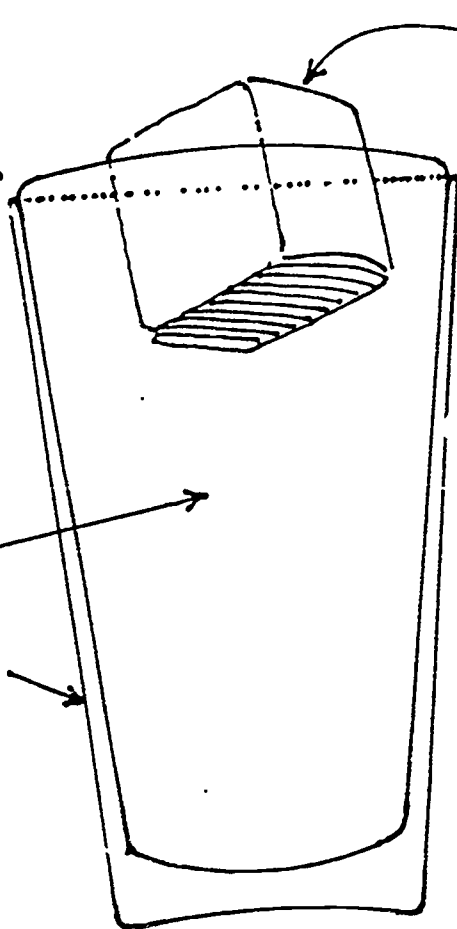

ice cube -  
floats on water

top of glass

water

drinking glass

What will happen  
to water level  
as ice cube  
melts?

## SODA POP SINK OR FLOAT?

by Gerald Wm. Foster

Focus: Exploring the concept of density through observing that some unopened soda pop cans float while others sink when completely submerged in water.

Challenge: Have students try to determine why some unopened soda pop cans will float in water while others will not.

### Materials and Equipment:

Tubs or other types of containers to hold water that are deep enough to allow the soda pop to float or sink.

An assortment of soda pop, possibly ten to twelve different kinds that represent colas, non-colas, diet and regular. Be sure to include Pepsi and Diet Pepsi as these demonstrate the phenomena very well. Plenty of newspaper, paper towels and/or drop cloths to catch water spillage.

Optional: scales, hot plates, yeast, plastic bags.

How-To-Do-It: Place soda pop cans in tub of water and record which ones sink and which ones float.

This activity allows students using a familiar material to do a fairly simplified scientific experiment of sorting and controlling variables. For example, they may want to try all of the colas first. They should also be aware of the volume and shape of each can and whether or not they are filled to the top. Students will have to check for air bubbles trapped underneath the cans to see if that might be the reason why they are floating.

Students need to record their data to keep track of emerging patterns of those that sink and those that float.

Further Challenges: Check the contents of the can to see if that is making the difference in whether a soda pop can sinks or floats. How much of the content is water, sugar, carbonation, and other types of ingredients?

Checking for sugar: put 50 ml of soda pop in a plastic lock top baggie with a package of dry Fleischman yeast. Allow the mixture to set for approximately 15 minutes in a warm (45°C) water bath. Students can approximate the amount of gas given off by how big the sealed bag becomes. The more gas given off the more sugar is in the mixture. Make one bag as a control by placing one level spoonful (5 ml) of sugar and 50 ml of water. It would also be a good idea to allow the soda pop to stand to allow the contents to go "flat" prior to producing gas with the yeast. Otherwise, the carbon dioxide gas in the soda will become a confounding variable.

Students may want to weigh each unopened can to see if there are differences in weight of the cans even though the volume may be the same.

They may also want to heat the contents of the can to evaporate the liquid to see what kind of residue is left. This may also be affecting the ability of the can to sink or float.

Students could also try floating the cans in other liquids such as salt water to see what happens.

Have students try soda pop bottles and repeat the steps given above.

## THE MYSTERY OF THE RISING WATER

by Donna Gail Shaw

Focus: The manipulation of the flow of air or the amount of air inside or outside a container can cause mysterious and interesting results.

Challenge: Make observations and inferences about what happens when you reduce the air inside a container that is placed in water.

### Materials and Equipment:

Widemouthed jar  
Glass dish, pan or pie tin  
Matches  
Candle  
Water  
Food coloring  
Coin (large enough to serve as candle support)

How-To-Do-It: Prior to conducting the activity, students should understand that air takes up space, air is everywhere, and air exerts pressure. An adult helper(s) would be a good safety precaution for this activity.

Gather enough materials prior to conducting the experiment. You should have one set of materials for demonstration purposes and one set of materials for every group. Ideal group size is three students.

Begin the activity with a teacher demonstration. Ask the students to watch each step carefully, because they will be asked to repeat the same steps in their groups. You may even want the students to record the steps on paper.

Teacher Demonstration (Only perform the experiment at this point. Do not discuss results. See the figure at the end of the activity.)

- a. Fill a pan about half full of water.
- b. Color the water with a few drops of food coloring. This is done to make the results easier to observe.
- c. Attach your candle to a coin by dripping hot wax from the candle on the surface of the coin. Insert the candle into the wax on the coin.
- d. Place the candle, with the coin attached, into the middle of the pan of water.
- e. Light the candle
- f. Place the jar over the candle. Do this quickly so that all reactions can be observed.
- g. Observe results.

Make sure that all students know how to perform the experiment. Pass out sets of materials to each group and have them repeat the experiment, record the results and record inferences about what they think happened.

After the groups have had a chance to perform the experiment a few times (with the teacher moving about from group to group providing assistance), record the students' observations on the board.

Some expected observations include:

- a. Bubbles appeared around the mouth of the jar when it was placed over the candle.
- b. Candle stops burning.
- c. Water rises in jar.
- d. Water rises about one-fifth of jar's height.

Next, write inferences about the results on the board. Some expected inferences include:

- a. The bubbles are caused by hot air rushing out of the jar.
- b. The candle went out because of lack of oxygen.
- c. Since air is about one-fifth oxygen and the water rises about one-fifth the height of the jar students might conclude that all the oxygen in the jar was burned up and the water replaced the space the oxygen was occupying. (Please note that this inference is incorrect - see "Don't Suffocate That Mouse Activity.")
- d. The water replaced the space the air was occupying before it rushed out of the jar.

Discuss observations and inferences as they are recorded on the board.

Explanation of Results: When the air inside the container is heated, the molecules of air speed up their movement and rush out of the container causing bubbles to form around the jar's mouth. The candle ceases to burn due to insufficient (not complete lack of) oxygen. As soon as the flame goes out, the air molecules in the container slow down their movement. This creates a low pressure area inside the jar. The relatively higher air pressure outside the container presses down on the surface of the water forcing it to go into the jar.

Further Challenges: Use clear plastic containers in place of jars. Put a hole in one or two of the groups' clear plastic containers. One of two things will happen; the water will not rise in the container or it will rise and then quickly fall again. This is because air is allowed back in the container.

Experiment with larger or smaller candles. Will this affect the results?

Experiment with different container sizes. Will this affect the results?

Reference:

Nelson, L. W. Science Activities for Elementary Children. Iowa: Wm. C. Brown Publishers, 1984.

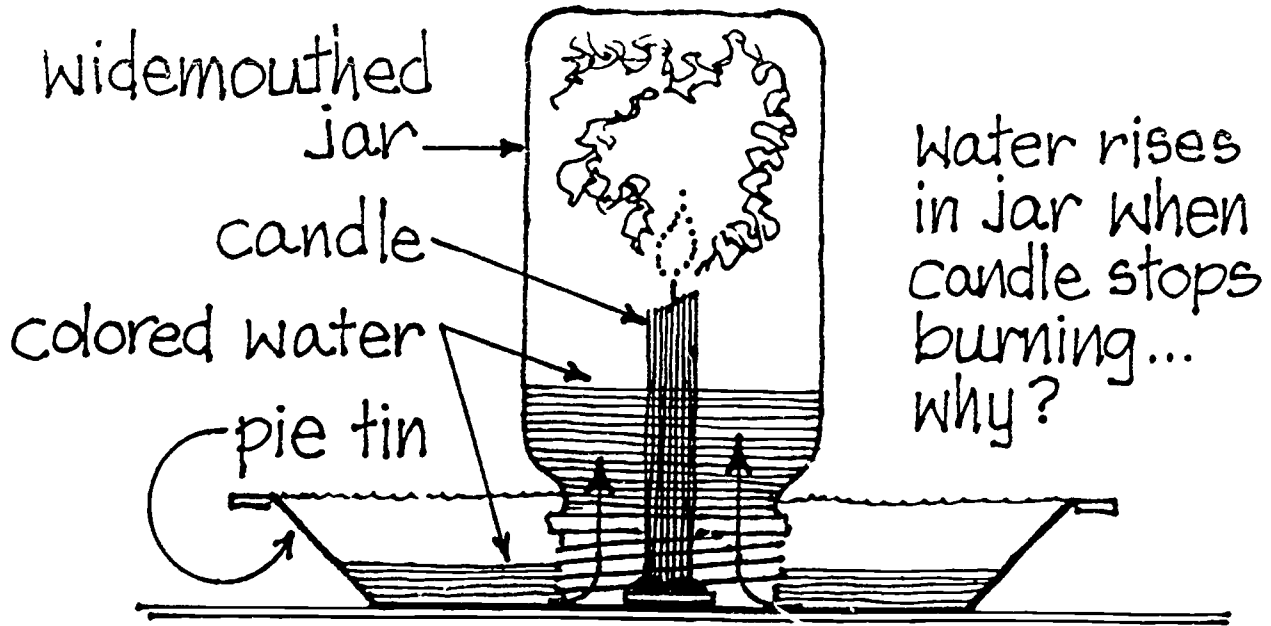

191

## DON'T SUFFOCATE THAT MOUSE!

by Donna Gail Shaw

Focus: The manipulation of the flow of air or the amount of air inside or outside a container can cause mysterious and interesting results as seen in "The Mystery of the Rising Water Activity." However, sometimes just doing one experiment can cause one to develop incorrect hypotheses. This could easily happen in the previously mentioned experiment.

Though a candle ceases to burn in an enclosed container, all of the oxygen is not burned up. Only enough oxygen is burned off to no longer support a flame.

Challenge: Will a mouse suffocate if placed inside an enclosed jar with a burning candle?

### Materials and Equipment:

White mouse (can be purchased from local pet store)  
Candle with candle holder (candle wick needs to be out of easy reach of mouse)  
Glass container with lid (large enough to accommodate mouse and candle)  
Matches

How-To-Do-It: This activity is a teacher demonstration. It is highly recommended that the activity entitled "The Mystery of the Rising Water" be conducted prior to this lesson. Refer back to the rising water activity. Review the observation and inferences. Particularly focus on the fact that the candle ceases to burn and why. If the students have concluded that all the oxygen is burned up, don't correct them. Tell them the purpose of this activity is to determine if the candle's flame did burn off all the oxygen in the container. You may want the students to record their observations and inferences as you demonstrate.

Put the mouse in the jar (see the figure on the next page).

Put the candle in the jar.

Light the candle.

Put the lid on the jar.

Observe results:

- a. Candle will go out.
- b. Mouse will remain alive and active.

After students are sure that the mouse is breathing normally, remove the mouse from the jar.

Discuss results with students.



Explanation of Results: The candle goes out because there is insufficient oxygen to support combustion. Because not all the oxygen is consumed, the mouse remains alive and active.

Further Challenge: How long will it take for the mouse to use up enough oxygen in the container to slow down his/her activity?

What will  
happen to  
the mouse  
when the  
candle stops  
burning...  
Why?

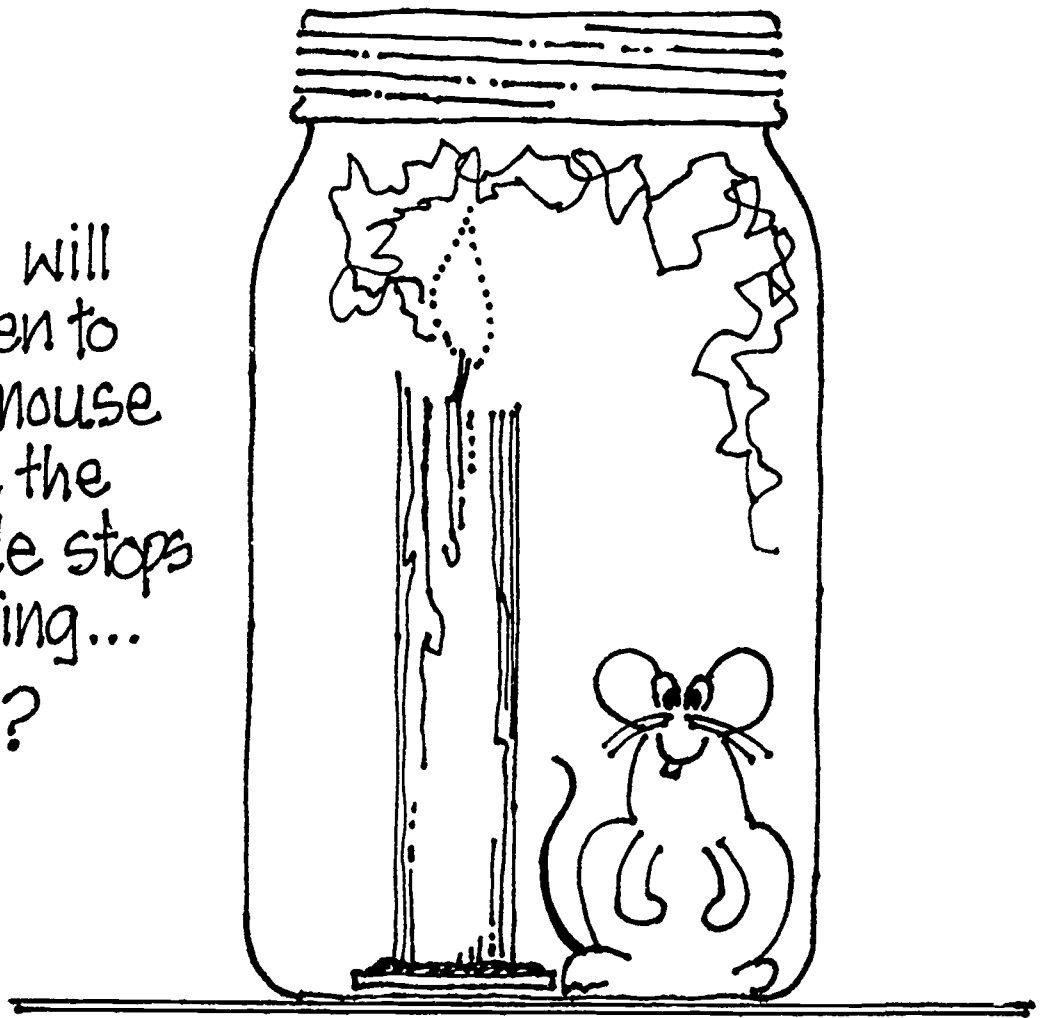

## MAKING YOUR OWN BERNOULLI BLOWER

by Mark and Meghan Twiest

Focus: Investigate the principle that gives airplanes their lift.

Challenge: Suspend a ball in the air through the application of Bernoulli's Law.

### Materials and Equipment:

Vacuum cleaner with a detachable hose  
Plastic ball, 3-6 inches in diameter

How-To-Do-It: This simple demonstration illustrates a very important concept. Bernoulli's Law states that fast moving air creates low pressure. You can verify this fact by conducting this simple and interesting experiment. (See the figure on the following page.)

To begin, attach the hose to the vacuum cleaner so that the air blows out of the hose rather than being sucked in as it usually does. When you first turn the vacuum on after doing this, be sure to point the nozzle of the hose towards the ground. This will prevent any objects in the hose from striking you or your students. Once the hose is free of any loose particles, point the nozzle straight up. You now have a column of air moving vertically at high speed. Take the plastic ball and place it in this column of air. You may find that if you place the ball too low in the column, it will shoot up and out of the column. Conversely, if you place the ball too high in the air stream, it will fall out of the stream's grip. In only a few tries, you and your students should be able to place the ball so that it will remain suspended in midair after you release it. Now that you have successfully floated the ball, ask one of your students to very gently pull the ball perpendicularly out of the air stream. You should be able to feel the ball resisting your efforts to move it. This is because when the ball is half in and half out of the column of air, the fast moving air on one side of the ball creates low pressure. The resulting higher pressure on the other side of the ball tends to force the ball back into the column of air.

This experiment can also be done on a larger scale using a floor fan turned sideways and a beach ball.

Further Challenges: Can you make the ball float when the column of air is not vertical?

Can you design another shape that will float in the air stream?

How does this principle relate to the shape of an air foil?

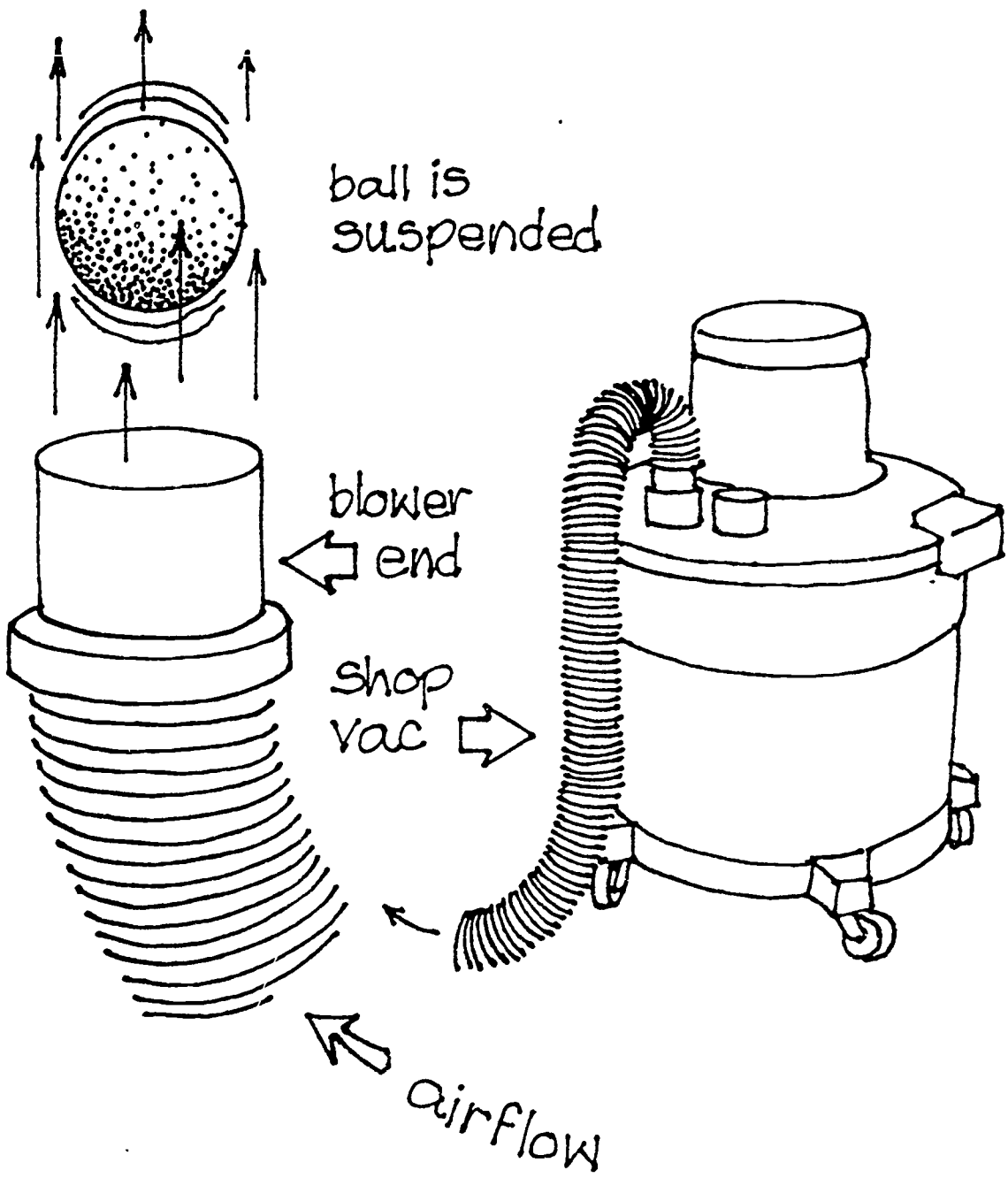

## JET ENGINES

by David R. Stronck

Focus: Children know that airplanes and space vehicles have jet engines. But they may not know why such engines can cause motion. This activity will help the children to understand the process that begins with a chemical reaction. This chemical reaction generates a gas that is released through a small opening. The action of the gas moving out through this opening generates an equal but opposite reaction. The airplane or other vehicle moves forward because of this reaction, i.e., the gas expulsion from the rear of the vehicle.

Challenge: Can you build your own jet engine and make it do work?

### Materials and Equipment:

Empty containers with small nozzles, i.e., containers commonly used for such products as liquid soap  
Vinegar (or other "safe" acids)  
Baking soda  
Paper cups  
Spoons, e.g., plastic spoons  
Water supply, ideally from a sink in the room or from a bucket outdoors  
Facial tissue  
Twist tie (for plastic bags)

How-To-Do-It: Ask the children to explain what they know about jet engines. Ask them if they know how they work. Invite the children to make and test their own jet engines. (See the two figures at the end of this activity.)

Provide each pair or team of students with an empty container having a small nozzle opening that can be opened and closed (e.g., the plastic bottle that was used for liquid soap). Have the children remove the cap of this bottle and add in a couple of tablespoons of vinegar and several tablespoons of water. Next, they will place a teaspoon of baking soda onto a facial tissue. They will then fold up the edges of the tissue and tie them together with a twist tie. This forms a small pouch. Excess tissue above the twist tie should be cut off and discarded.

The rest of the activity is best done outdoors or in a large open space\*. Tell the children to carefully place the tissue pouch into the container. Instruct them to be careful that the baking soda pouch does not come into contact with the vinegar solution. Make sure the nozzle on the cap is closed and place the cap tightly on the container. Now have them place their thumbs firmly over the nozzle (to assure that the pressure does not open the nozzle prematurely) and shake the container briefly to mix the vinegar with the baking soda in the pouch. Finally place the container on its side on the floor (or pavement) and open the nozzle. Record the behavior of the container.

Discuss with the children what happened. Help them to explain how the chemical reaction generated a gas. This gas is carbon dioxide. The same gas is generated in our stomach if we ate baking soda and drank vinegar. The same gas is in soda pop. The gas causes motion because it can escape through only one place. This gives the container motion in the opposite direction.

Further Challenges: Invite the children to make such improvements on the container that it will move in one consistent direction. For example, if the container had wheels it could move as if it were a jet propelled automobile. If the container was suspended by a couple of paper clips to a long wire strung tightly and horizontally, the container could seem to move through air like an airplane. The children may suggest wings, tails, etc.

Ask the children to improve the chemical reaction. Should they add more or less of the baking soda, water, and/or vinegar? What mixture gives the best results? (The children must record each combination that they choose.) How can they measure which mixture gives the best results? (For example, they can measure the distances that the jet engine car travels with different combinations of fuels.) Who will win the contest of making their vehicle go the farthest?

\*Note: Be sure that the surface where this investigation is conducted will not be damaged by the vinegar/baking soda solution. Safeguards should also be taken to assure that students are not accidentally sprayed with the jet of solution.

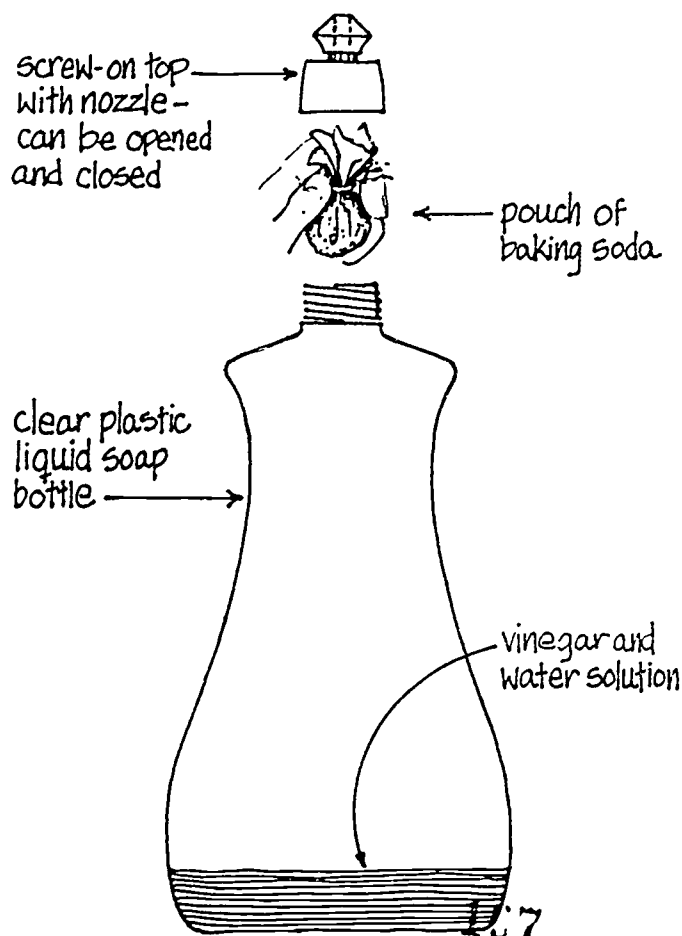

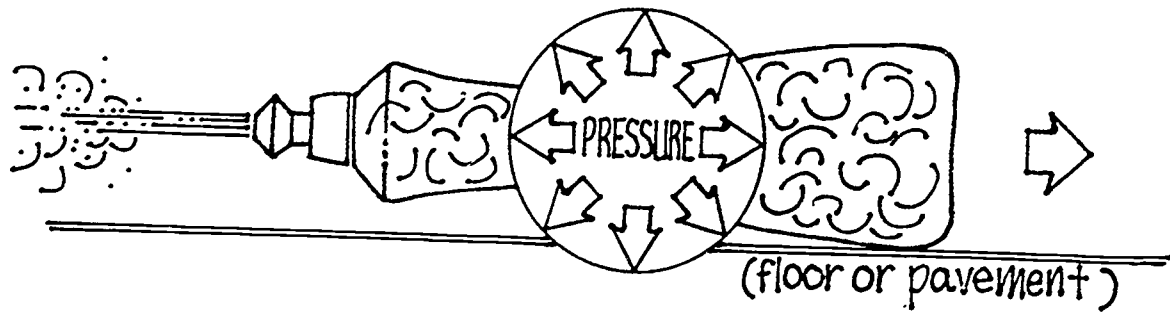

CHAPTER 10

ACTIVITIES FOR TEACHING MATTER

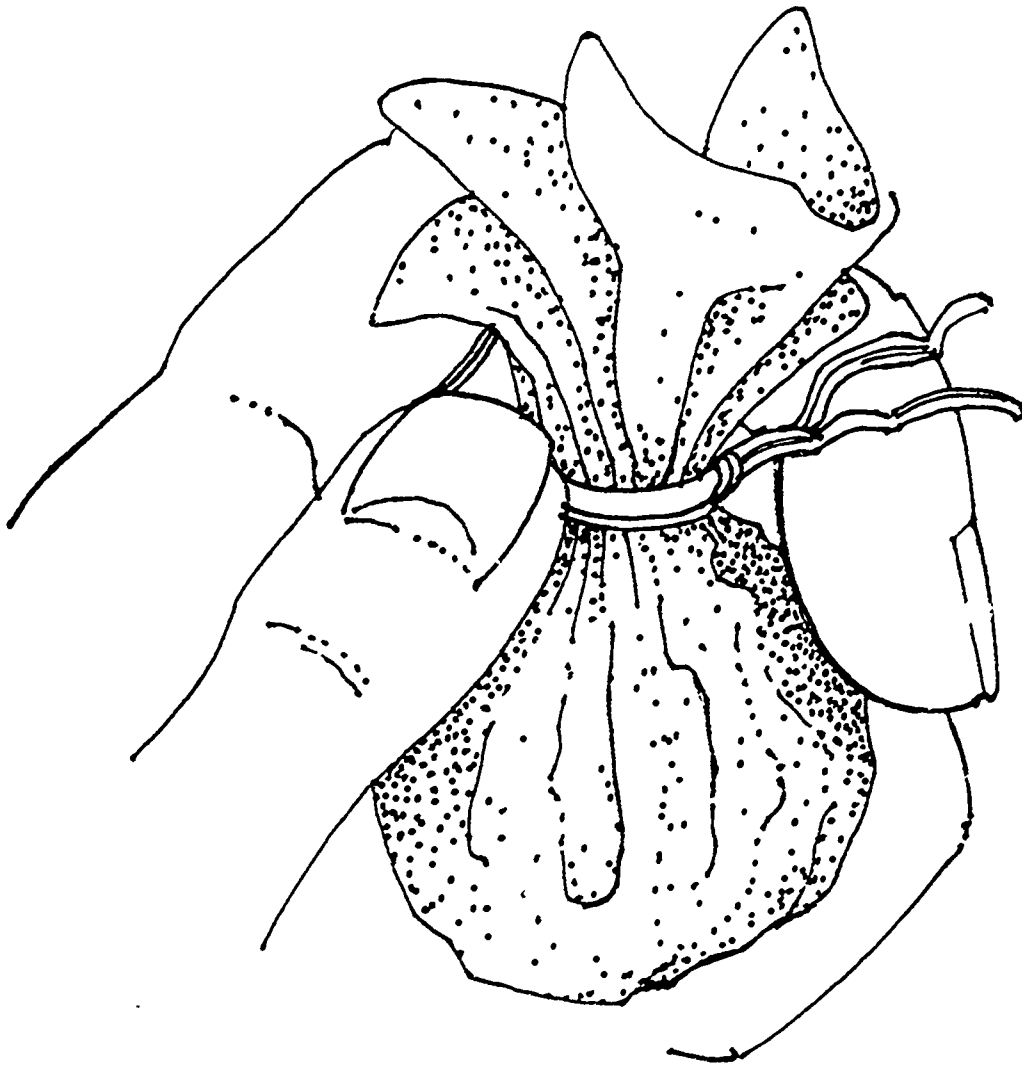

## PARTICLE FREE FOR ALL

by Edward L. Shaw, Jr.

Focus: The "Brownian Movement" is the irregular motion or movement of an organic or inorganic body, arising from the thermal motion of the molecules of the material in which the body is immersed. The body will have many collisions with the molecules, which results in the imparting of energy and momentum to it. Because there will be fluctuations in the magnitude and direction of the average momentum transferred, the motion of the body will appear irregular and erratic. (This concept was discovered by Robert Brown, a Scottish botanist, in 1858.)

Challenge: Observation of the "Brownian Movement."

### Materials and Equipment:

Dark classroom  
Filmstrip or slide projector  
Chalk erasers  
250 ml beaker  
100 ml of water  
15 g of non-fat dried milk (powdered milk)  
Stirring rod

How-To-Do-It: There are two ways to perform this experiment; both are easy and inexpensive. The first and simplest way begins with darkening the classroom. Have a filmstrip or slide projector directed toward the front of the room with the lamp switch on. Have students sit very quietly so that the movement of air is minimal. Clap the two erasers together to release the chalk particles. Ask students what they see. What are the chalk particles doing? Are there certain patterns formed by the chalk particles?

Now the second or follow-up activity should begin by having a beaker of water already prepared. Have students predict what will happen when the powdered milk is added to the water. Stir the solution enough so that it becomes opaque. Stop stirring and have students observe what happens. Are there any patterns? What are the particles doing?

After the two demonstrations have been completed, discuss with students their observations. Introduce the concept "Brownian Movement or Motion." The particles from the chalk and powdered milk represented bodies coming in contact with molecules (air and water.) The result of the collisions was an increase in the momentum and energy of the bodies. Since momentum and energy were not consistent, the motion of the bodies appeared irregular and erratic.

Further Challenges: Have students determine if there are other media which can be used to demonstrate this concept - such as a gas or a less viscous liquid (i.e., oil and vinegar dressing.)



Ask if students believe that a temperature increase or decrease will affect the motion of the bodies.

Ask students to make observations of food coloring dropped into water. This is particularly interesting when observing differences between hot and cold water.

201

## FROM HERE TO THERE

by Patsy Ann Giese

Focus: Particles of matter (atoms and molecules) are in constant motion. The temperature of a quantity of matter is a measure of the average rate of motion of the particles.

Background: The particles in a solid, usually bound into a crystalline structure, vibrate within a limited space. Distances traveled by particles in a liquid are greater, and in a gas are the greatest. Some gas molecules reach speeds of more than 1000 miles per hour.

Challenge: Observe evidence and infer that particles of matter are constantly moving.

### Materials and Equipment:

Overhead transparency projector  
2 petri dishes or other small clear flat-bottomed containers  
Potassium permanganate crystal or powder  
Small measuring spoon  
Water  
Cotton  
Wooden dowel  
Masking tape  
Phenolphthalein solution (0.5 grams of phenolphthalein crystals in 100 mm of rubbing alcohol)  
Household ammonia  
Onion  
Knife  
Cutting board  
Perfume  
Cellophane  
Food coloring or ink  
Large clear container  
A package of powdered dye or drink mix

How-To-Do-It: Place a petri dish or other clear flat-bottomed container on an overhead transparency projector. Add lukewarm water to the dish. When the water is still, add a crystal or a little powdered potassium permanganate ( $KMnO_4$ ) to the water. Have students draw pictures of what they see.

Repeat the above activity simultaneously using a petri dish of cold water and a petri dish of hot water. The demonstration is more graphic the greater the difference in temperature between the two dishes of water. Be sure the same amount of potassium permanganate is put into both petri dishes. Students should infer that particles move faster when heated.

Tape cotton to a dowel to form a large cotton swab. Soak the cotton in a solution of phenolphthalein, which should be clear. Then hold the cotton above an open bottle of household ammonia. The cotton will turn pink, showing particles of ammonia are escaping from the bottle.

Further Challenges: At the back of the room, slice an onion or pour perfume out of a bottle. Have students raise their hands (without looking behind them) when they can smell the onion or perfume. Have students in the back row describe the order in which students raised their hands.

Punch small circles out of heavy cellophane. Use blue dots to represent water molecules and red dots to represent potassium permanganate molecules. Place the red dots surrounded by the blue dots in a petri dish on an overhead transparency projector. Move the red dots out among the blue to have a model of dissolving a solid in a liquid.

Drop food coloring or ink into a large clear container of still water. Have students draw pictures of what they see.

Dump a package of powdered dye or drink mix into a large clear container of still water. Have students observe at regular intervals, and see how long it takes for the powder to dissolve without any stirring.

Discuss why brightly colored clothes should be washed in cold water. Discuss why strong coffee or tea must be made with hot water.

Discuss why cookie or bread dough has a stronger odor when cooking than when waiting to be cooked. Discuss why barnyards have a stronger odor during summer than during the other seasons.

Discuss whether clothes on a line would ever dry if particles of water did not constantly move. Discuss whether clouds would form in the sky under that same condition.

Discuss what happens to the molecules in a mothball as the mothball disappears.

Safety: Do not let any children sniff the ammonia close to the bottle. Ammonia fumes, if concentrated, can irritate one's eyes and nose.

## CHEMICAL DETECTIVES

by Terri G. Switzer

Focus: All chemicals are built from small particles. These particles, such as atoms, molecules, ions, and electrons, are too small for students to see or feel directly. But, by experimenting with common food chemicals from the kitchen, students can use indirect evidence to detect that substances contain smaller particles.

Challenge: If you add a teaspoon of Kool-aid, or sugar, or salt to a glass of water and stir with a spoon, the food chemical dissolves (mixes with the water.) But what would happen if you wrapped a teaspoon of the same food inside a paper towel sack before you put it in the water? Do you think the food will be able to get out of the bag and mix with the water?

### Materials and Equipment:

Teaspoons  
Sweetened Kool-aid or other dry soft-drink mix  
Sugar  
Salt  
Pencils  
Paper towels (cut each sheet into 4 squares -- or use coffee filters cut in half)  
Wire twist-ties  
Clear plastic glasses (half-filled with room-temperature water)  
Newspaper, towels, or styrofoam trays (to cover the work area)  
Magnifying glasses (hand lenses)

How-To-Do-It: Point out that while Kool-aid, sugar, and salt are food chemicals we commonly use at home, students should never test or taste any food chemicals unless a teacher or parent says it is safe to do so. There are many household materials that may seem safe, but aren't, especially when mixed together or used improperly.

Supervise this activity closely to ensure that students use only clean glasses and spoons, freshly opened Kool-aid, sugar, and salt, and that they wash their hands. If these precautions are taken, you can give students permission to take one small taste of these foods when directed. (They are NOT TO EAT THE FOODS -- only taste!) Your students can obtain valuable sensory information from tasting during this activity, but it is NOT MANDATORY to taste anything to be a chemical detective!

Conserve supplies by having students work in teams of three -- with each team member responsible for testing one of the foods.

Look closely at the dry Kool-aid, sugar, and salt with a hand lens. Have students compare the shapes, sizes, colors, and smells they observe.

Place a teaspoon of Kool-aid in the center of one of the paper towel squares. Tie the corners of the towel firmly together with a twist-tie

to make a sack (see the figure on the next page.) Hang this sack from a pencil by the twist-tie. Make another sack for sugar and one for salt.

Gently shake and squeeze each sack. Can the students get the food to come out of the sacks without breaking or tearing the bags? Students should notice that the food pieces are too big to pass through the tiny pores in the towel. If they don't see the pores, have them look closer with a hand lens, or hold the towel up to the light.

Have students predict what they think will happen if they soak the sacks in water. Have them think about how the different sizes and shapes of the food pieces may affect what happens.

Students can test their predictions by laying the pencil across a glass of water so the sack hangs down into the water. Watch closely, and have students describe what happens. They should see a "river" or "water fall" of the food leaking through the bag and into the water. Is this what they predicted? Watch for several minutes.

Lift each sack out of the water and lay it on a tray or newspaper. Open the bags and look closely at what is left inside. Compare the WET foods to the DRY foods they observed in step one. Students should notice that water leaked into the bag and the pieces have changed shape, size, and color. They may notice that there is LESS food in the bag now. Where did the food go and how did it get out of the bag?

Students can detect the salt, sugar, or Kool-aid in the glasses of water by dipping their clean finger into the glass and tasting a tiny amount. Ask them to explain why the dry food couldn't get out of the bag but the wet food could! They should discover that water leaked into the bag and helped tiny food particles leak out through the holes in the paper.

Further Challenges: Let students make more sacks and test other foods THAT YOU APPROVE. (i.e., brown sugar, flour, cornstarch, coffee, tea, baking soda) Which foods leak particles in the same way as Kool-aid, sugar, and salt? Let students try to figure out why some foods won't leak through in the same way. Maybe the particles are still too big to get through the towel!

After soaking the sacks, pour the water from the glasses into shiny metal pie pans or cookie trays. Label the pans so students remember what was in each one. Set the pans in a sunny place for a few days to let the water evaporate. Use a hand lens to see if the tiny particles left behind on the bottoms and sides of the pan are similar to the foods you started with. When the water evaporates, the tiny food particles that were mixed with the water are left behind.

What would happen if you let a pan of plain tap water evaporate? Would there be any particles left behind then? Try it!

Reference:

Adapted from WonderScience, November 1986, © American Chemical Society.  
Included in this sourcebook by permission of the copyright holder.

For subscription information contact:

WonderScience  
American Chemical Society  
1155 Sixteenth Street, N.W.  
Washington, D.C. 20036  
(202) 452-2113

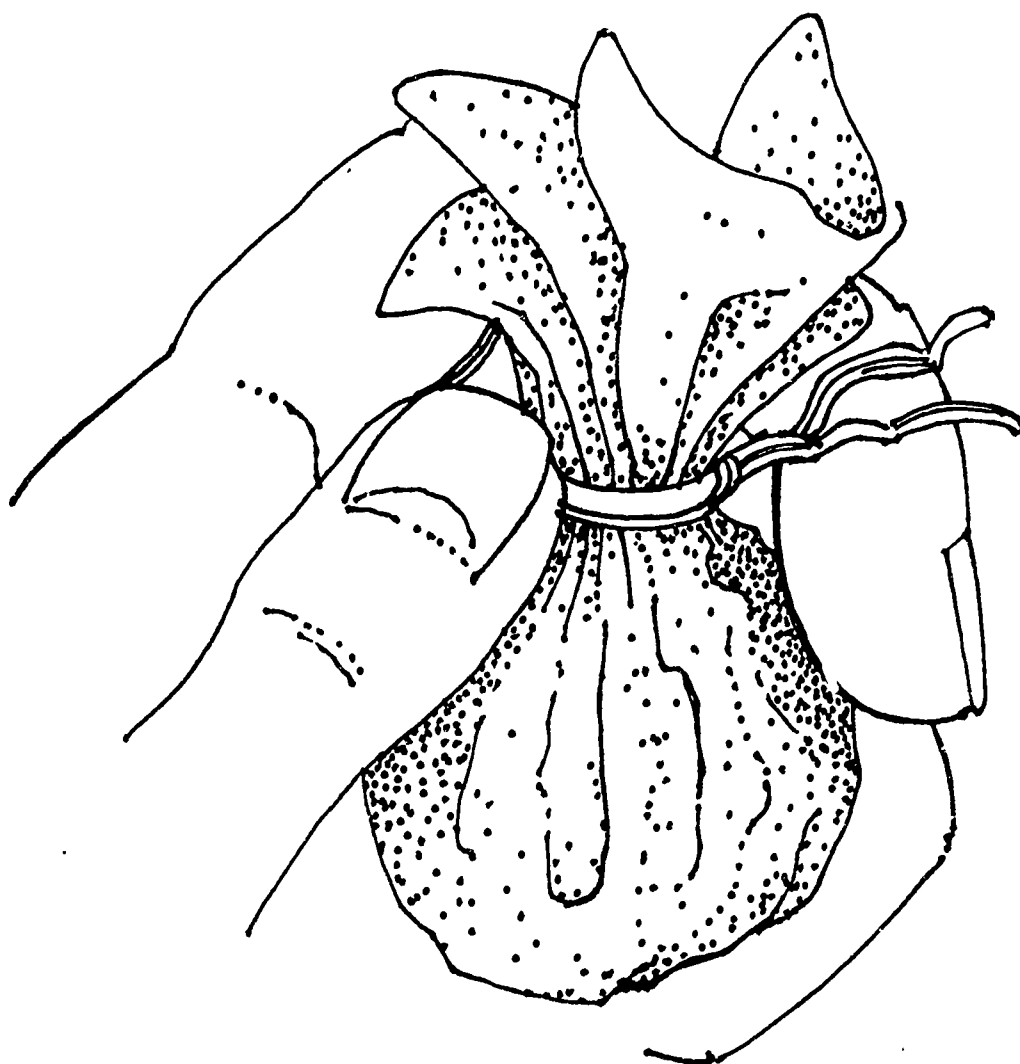

## THE WHOLE IS LESS THAN THE SUM OF THE PARTS

by Patsy Ann Giese

Focus: All matter is made of very small particles (atoms or molecules.) The space between the particles is greater than the space occupied by the particles themselves. A smaller particle can occupy the space between larger particles. Therefore, the sum of the volumes of two separate substances is greater than the volume formed when the two are mixed.

Background: The fraction of the total volume of a solid that is occupied by particles varies with the crystalline structure of the solid. In any liquid, about  $\frac{1}{3}$  of the total is space occupied by the particles. Changes in temperature or pressure do not change this fraction much. In any gas at normal temperature and pressure, about  $\frac{1}{2500}$  of the total is space occupied by particles. This fraction changes considerably with changes in temperature or pressure.

Challenge: Observe evidence and infer that particles of matter are separated by spaces.

### Materials and Equipment:

Clear jar or pitcher, at least as large as 2 liters  
Clear graduated cylinder or narrow jar, at least as large as 200 ml  
Water  
150 ml of sugar  
A package (about 0.2 ounces) of powdered drink mix without sweetening  
Spoon with a long handle  
Paper cups, one for each student  
Four 500 ml beakers  
400 ml small beads or BB shot  
400 ml large beads or marbles  
10 mm diameter glass tube about 1 meter long  
2 corks to fit ends of glass tube  
Rubbing alcohol  
Food coloring  
Masking tape

How-To-Do-It: Fill a jar or pitcher with about 1500 ml of water. Stick to the container a piece of masking tape with the bottom of the tape at the top of the water. Likewise mark the height of about 150 ml of sugar in a container. For best results, use a container with a small diameter, such as a graduated cylinder. Pour the sugar into the water, and mix with a spoon until the sugar is dissolved. Then pour enough sugar water back into the sugar container so that the level in the water container is the same as before adding sugar. Have students notice that the height of sugar water in the sugar container is less than the original height of sugar. Water molecules are smaller than sugar molecules so water molecules fit into the spaces between sugar molecules. Add a package of powdered drink mix so students can enjoy consuming the experimental evidence.

Put a cork into the bottom opening of a glass tube. Pour colored water into the tube until it is almost half full. Gently pour rubbing alcohol over the water, making sure the two liquids mix as little as possible. When the tube is nearly full, seal the top of the tube with a cork. Mark the height of the liquids with a piece of masking tape wrapped around the tube with the bottom of the tape at the top of the alcohol. Then alternate inverting the tubing and checking the height of the liquids. As the liquids mix, the height of the liquids will decrease. Ask students if you could get rid of all the liquid this way. Then show that the height stabilizes when the liquids are thoroughly mixed. (If you do not invert the tube, the liquids will not mix for months. Convection currents based on the different densities of water and alcohol do not develop because the tube is too narrow.)

Further Challenges: Have students check if they can taste the sugar in the water even though the sugar particles disappeared (got too small to see) as they dissolved. You can sample various parts of the container by putting a straw in the liquid, covering the top with your finger, and lifting the straw and a little liquid out of the container. Pour sugar water through a coffee filter, and then have students taste it. Have students infer that sugar passes through the filter because sugar molecules are smaller than the openings in a coffee filter. Boil or evaporate the water from the sugar water obtaining sugar as the residue.

Repeat the procedures described above, except pour clear water over colored water in a tube. Because the molecules of water are all the same size, mixing will not result in loss of volume. Repeat again, except pour clear alcohol over colored alcohol.

Repeat the procedures described above, except pour alcohol into a tube before colored water. The two liquids mix immediately because water molecules are more dense than alcohol molecules. The density of alcohol (about 0.8 grams per cubic cm) is less than the density of water (about 1.0 gram per cubic cm), so gravity is not causing the mixing.

Put 200 ml of small beads or BB shot in a 500 ml beaker and 200 ml of large beads or marbles in another 500 ml beaker. Pour the small objects over the larger ones. Have students notice that the total volume is less than 400 ml because the small objects fit into spaces between the large objects. Repeat, pouring the large objects over the small ones. Have students describe the difference in total volume compared to the previous demonstration. Then mix together the large and small objects, checking the total volume. These objects form a model for the particles that are too small to see in the sugar, water, and rubbing alcohol. (An alternate model is clean sand used with small beads or BB shot.)

Fill a narrow-necked flask about 1/3 full of water-softener salt pellets. Then add warm water till the water level is in the upper part of the



narrow neck, and mark the water level with tape as described above. Measure the water level every five minutes for an hour. Also, observe the size of the salt pellets.

Have students find the volume of a glass marble using the formula for a sphere ( $\frac{4}{3}$  times pi times the cube of the radius.) Then fill a graduated cylinder about half full of water. The inside diameter of the graduated cylinder must be larger than the diameter of the marble. Read the water level, add the marble to the water, and read the water level again. Repeat these procedures, except use a steel marble the same size as the glass marble. The sum of the volumes of a marble and water separately is the same as the volume formed when the marble is added to the water. Unlike two liquids, the marble and water cannot be mixed together with the water molecules fitting in between the marble molecules. Although the steel marble is heavier, it does not raise the level of the water any more than the glass marble does.

Safety: Remind students to never taste an unknown substance. They can taste the sugar water only because you have told them it is safe. If you place marbles in a glass graduated cylinder, tilt the cylinder as you roll the marbles in along the side of the cylinder. Otherwise, they will drop too fast and break the bottom of the cylinder.

## FIFTY PLUS FIFTY DOESN'T ALWAYS EQUAL ONE HUNDRED

by Donna Gail Shaw

Focus: Molecules are so small that they cannot be seen with a regular classroom microscope. It is difficult for children, and even adults, to conceptualize that there are spaces between molecules of a substance since the space is not visible to the naked eye. The following activity illustrates that liquids have space between their molecules.

Challenge: Fifty ml of duplicating fluid and 50 ml of plain water will not make 100 ml of liquid when mixed. Where does the missing liquid go?

### Materials and Equipment:

3 olive jars\* (mark off ml using masking tape)  
Duplicating fluid for ditto machines or alcohol\*\*  
Water

How-To-Do-It: This activity can be conducted as a teacher demonstration or in small groups. Safety precautions for using dangerous liquids apply.

Pour 50 ml of water into one olive jar or graduated cylinder.

Pour 50 ml of duplicating fluid or alcohol into another jar.

Next, combine the 50 ml of water with the 50 ml of duplicating fluid into another jar. Mix well.

Observe results. The level of liquid when the two liquids are mixed will not equal 100 ml. What happened to the missing liquid? Have the students infer what happened. Guide them toward a discussion of molecules.

Explanation of results: When mixed together, the combined molecules of water and duplicating fluid fit together better than when they are alone. As a result, they take up less space. It is similar to mixing together dirt and marbles. If you pour dirt into a container with marbles, some of the dirt will find room in the spaces between the marbles and the combined volume will not total the two separate volumes.

Further Challenges: What will happen if you combine 25 ml of water and 25 ml of duplicating fluid? Predict the results.

What will happen if you combine 100 ml of water and 100 ml of duplicating fluid? Predict the results.

Reference:

Friedl, Alfred E. Teaching Science to Children. New York: Random House, Inc., 1986.

- \* Graduated cylinders will work if you have them available.
- \*\* Both alcohol and duplicating fluid are flammable and poisonous. Close supervision is essential to avoid injury.

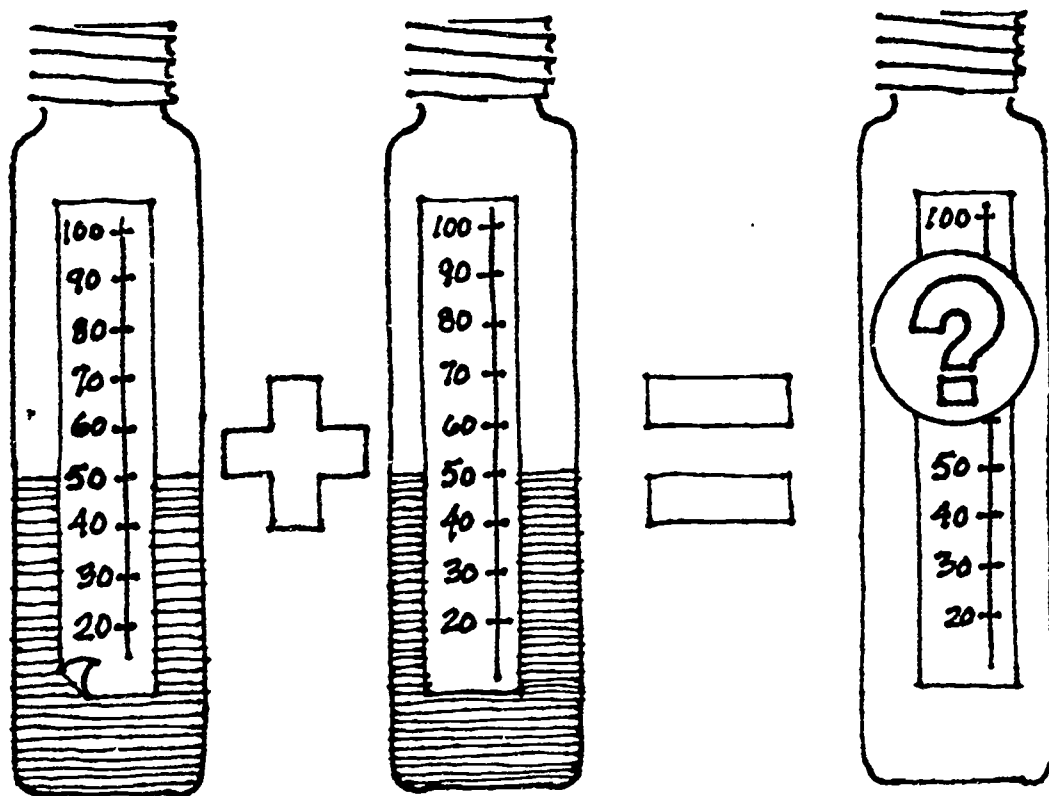

## SOLUTIONS TO CRYSTALS (ROCK CANDY)

by Linda Vance and Rose West

Focus: Growing rock candy crystals is a great activity for learning about solutions, saturated solutions, mixtures, expansion and contraction. All of these terms can be discussed while mixing the sugar crystal solution. Students become more involved when they volunteer to donate the sugar. Since the crystals belong to them they might decide to share the rock candy when it is ready. The most important thing to remember is to have PATIENCE.

Challenge: What can be discovered about dissolving, solutions, saturated solutions, and mixtures while observing a demonstration of how to make rock candy?

### Materials and Equipment:

1/2 cup water  
2/3 cups granulated sugar (sucrose)  
Pyrex beaker  
Stir rod  
Wooden stick (popsicle stick, pencil)  
Heat source  
Tripod stand for beaker  
Plastic tumbler for growing crystals  
Small bolt or other suitable weight  
Cheesecloth

How-To-Do-It: Pour 1/2 cup water into the glass beaker and place it on the tripod which is placed over the heat source (glass is best so that the students can observe the sugar dissolving). Bring the water to a boil. Gradually stir in sugar until no more will dissolve (about 2/3 cups). Cool slightly. Pour into a plastic tumbler. Tie a string slightly shorter than the depth of the tumbler onto the wooden stick. Tie a small bolt or some object which will not float onto the other end of the stick. Place the string in the sugar solution in a warm place where it will not be disturbed. To keep dirt out and to allow evaporation, a piece of cheesecloth can be placed on top. Wait patiently -- it may take several weeks to make crystals.

Discussion Questions: What is all matter made up of? SMALL PARTICLES

What happens to particles when they are heated? THEY MOVE FASTER

What happens to the spaces between the particles of water when heated?  
SPACES BECOME LARGER

Where does the sugar go? MOLECULES OF SUGAR SEPARATE AND GO BETWEEN THE SPACES OF WATER

Why does more sugar dissolve when water is heated? PARTICLES OF WATER MOVE FASTER, BUMP INTO EACH OTHER, CAUSE LARGER SPACES AND THUS MORE SUGAR DISSOLVES.

Do you think that the identifying properties of sugar or water change when they are mixed? NO, SUGAR IS STILL SWEET, WATER IS STILL WET. THEY CAN BE SEPARATED BY A PHYSICAL MEANS.

Explain why this is a mixture. IT CAN BE TAKEN APART

Does dissolving sugar cause a chemical change? NO, WHEN THERE IS A CHEMICAL CHANGE MATERIALS THAT COMBINE CANNOT BE SEPARATED BY PHYSICAL MEANS.

What happens to the mixture when it cools? PARTICLES SLOW DOWN AND THERE IS LESS SPACE BETWEEN THEM.

What happens to the sugar when the mixture cools? THE SPACES GET SMALLER, THERE IS LESS ROOM FOR THE SUGAR MOLECULES, THEY PACK TOGETHER INTO SPECIAL SHAPES CALLED CRYSTALS.

How can we get more crystals to form? LEAVE THE SOLUTION AND WHEN THE WATER EVAPORATES THERE WILL BE EVEN LESS SPACE FOR THE SUGAR MOLECULES.

Further Challenges: Try making rock candy at home under parent supervision.

Grow crystals using other substances: salt, epsom salts (magnesium sulfate), alum.

Observe different crystals using a hand lens. (Mica, granite, quartz, sugar, table salt. This could be done while visiting other places. Many vacation spots sell nice crystals for little money.)

Teachers can demonstrate other crystal formations using potassium ferricyanide, copper sulfate, potash alum.

References:

Freeman, Mae and Ira. Fun With Chemistry. New York, NY: Scholastic Book Service, 1973.

Holden, Alan and Phylis Morrison. Crystals and Crystal Growing. Cambridge, MA: MIT Press, 1982.

## GROWING PERFECT CRYSTALS IN MINUTES

by Michael J. Demchik

Focus: Seven classes of crystals can be prepared through the use of a microprojector.

Challenge: Can you identify the various shapes of the crystals formed from each of the saturated solutions given? What factors affect the rate of crystal formation? Why do the colors of some crystals change after the process of evaporation starts?

### Materials and Equipment:

Microprojector  
Glass slides  
Copper sulfate  
Nickel sulfate  
Sodium nitrate  
Potassium chlorate  
Eyedropper  
Beakers or jars  
Sodium chloride  
Sodium triphosphate  
Potassium nitrate

How-To-Do-It: Turn on the microprojector. Allow it to warm up for a few minutes. Set the objective in line with the stage and focus with a drop of water on the slide. With an eyedropper place one drop of saturated solution of copper sulfate on the slide and place the slide on the stage and focus. Observe while the water evaporates. Within a short time crystals begin to form along the periphery. The specific color of the compound gradually changes to black because of the quantity of solid precipitated. As the solution becomes reduced in amount, a noticeable formation of gradients will occur. It is at this point that the perfect crystals begin to precipitate. Search the slide for the presence of others or focus on the one found and the crystal will grow before your eyes. Try the other samples.

## SEPARATING MIXTURES

by Linda Vance and Rose West

Focus: Given a few simple materials students will use problem solving skills to separate a mixture. While introducing the concept of mixtures and compounds students will discover that mixtures can be separated by using various physical methods.

Challenge: To separate a mixture of four substances based on their known properties.

Materials and Equipment: (per group of 3 or 4 students)

1 small cup containing 1 teaspoon salt  
1 small cup containing 1 teaspoon sand  
1 small cup containing 1 teaspoon gravel  
1 small cup containing 1 teaspoon iron filings  
Magnets (plastic wrap around each will aid in clean up)  
Small piece of screening or tea strainer  
Funnel  
Ring stand with funnel support  
Filter paper  
Stirring stick  
2 empty beakers  
Beaker of water

How-To-Do-It: Have lab stations set up ahead of time with the materials as listed above. This is an inquiry lab, therefore the only instructions of help might be on how to fold filter paper to fit into the funnel. Instruct the students to combine all of the substances from the small cups into a beaker. After the substances are combined, tell them to now separate them with the materials provided. See Table 1 on the next page for a suggested way to record data.

Discussion Questions: What are some properties of iron filings? **THEY CAN BE DRAWN TO A MAGNET.**

What property does salt have that sand does not? **SALT DISSOLVES IN WATER.**

After trials have been made the students should realize that to separate these mixtures they will need to:

Pull out the iron filings by using the magnet (**IRON FILINGS**)

Sift the material through the screen to separate the large pieces of gravel (**GRAVEL**)

Add water and then put the water mixture through the filter paper (**SAND**)

Allow the water to evaporate (SALT). This is optional -- to speed the process the water can be heated.

Further Challenge: Investigate other ways of separating mixtures such as chromatography or distillation.

Do a lab involving chemical change to see that sometimes things are mixed and cannot be separated. (Chemical change as opposed to physical change)

Table 1

Data Table to use with this activity:

SUBSTANCE	METHOD
IRON FILINGS	
GRAVEL	
SAND	
SALT	



## THE POWER OF SALT

by Mildred Moseman

Focus: At least one percent of the people in this country are on severely restricted sodium diets. Snow removal practices throughout the snow belt areas of the country create a situation with the potential to increase this sodium danger.

Challenge: Salt, used to keep traffic going on glazed roads, mixes with snow and ice and enters the water table affecting drinking water. Is there a way to detect the amount of salt found in melted snow or ice? How far from the origin does salt affect snow?

### Materials and Equipment:

Small test tubes for each student  
Silver nitrate  
Distilled water  
Sample of snow from various locations

How-To-Do-It: Fill test tubes with snow or melted ice from various locations and label.

Fill one test tube with some distilled water. (This is the control.)

Into each test tube put 3 drops of silver nitrate. (Procure from a high school chemistry lab.) The cloudier the solution becomes, the more likely salt is present and in higher concentration.

Further Challenges: Why can salt be dangerous to health? What is the ecological danger due to salt? Why does salt break the bond between the road and the ice?

Note: As with all activities involving chemicals, refer to labeling for appropriate safety precautions and first aid information.

## WATER MAGIC

by Sue Dale Tunnicliffe

Focus: This investigation focuses on the concept of dilution.

Challenge: If you are given a drink made from a concentrated powder such as iced tea, orange drink, punch, or other soft drink, what do you do if its taste is too strong? What do you do if it tastes too watery? How do you dilute the drink to suit your taste? How could you make the color of a given solution seem to disappear?

If students have had experience in designing their own investigations, you may wish to have them develop their own method of determining the point at which the solution is so diluted that the color can no longer be seen. If they are unsuccessful in this attempt, the procedures below may serve as a guide.

Materials and Equipment: (for each group)

Powdered drink mix

Water

2 plastic buckets (one full of water and the other empty for waste)

2 measuring cups (small jars carefully marked off with masking tape to indicate 100 ml and 200 ml level may be substituted)

How-To-Do-It: This activity works best in small groups of three to five students. Assign roles for each of the participants such as: director of operations, data recorder, equipment manager, and director of communications.

The teacher will mix a large pitcher of powdered soft drink. Each group will fill one measuring cup (or marked jar) with 100 ml of the solution. They will then draw 100 ml of clear water from their bucket of water. The clear water will then be poured into the cup of soft drink. Students will then note on the chart below whether or not the color of the soft drink could still be seen at this one-half strength solution. Next, one-half (100 ml) of the new solution will be discarded. Repeat the procedure of adding and discarding water and solution until the color of the soft drink is no longer visible. Through this method, students should be able to determine the point where the solution is so diluted that the color can no longer be seen.

Each time half of the contents of the cup are withdrawn and the volume left is topped up with water, the color is diluted. Eventually the color can not be seen with the naked eye. Some children may like the idea of adding more and more water to the original volume. Allow them to try this method if a large enough container can be located.

### COLOR DILUTION CHART

(Indicate by circling whether color is visible for each trial.)

trial 1 - full strength	yes - no	trial 2 - 1/16 strength	yes - no
trial 2 - 1/2 strength	yes - no	trial 2 - 1/32 strength	yes - no
trial 2 - 1/4 strength	yes - no	trial 2 - 1/64 strength	yes - no
trial 2 - 1/8 strength	yes - no	trial 2 - 1/128 strength	yes - no

Further Challenges: How does the point of dilution where the color is no longer visible compare to the point of dilution where the soft drink can no longer be tasted? How does the concept of dilution relate to environmental pollution? How does the method of dilution used in this investigation relate to radioactive decay and half-life? Are there other ways of removing color? (Removing a stain from clothing, or bleaching color from hair? What household chemicals are used for this type of thing?) What other sort of things do we intentionally dilute?

CHAPTER 11

ACTIVITIES FOR TEACHING CHEMISTRY

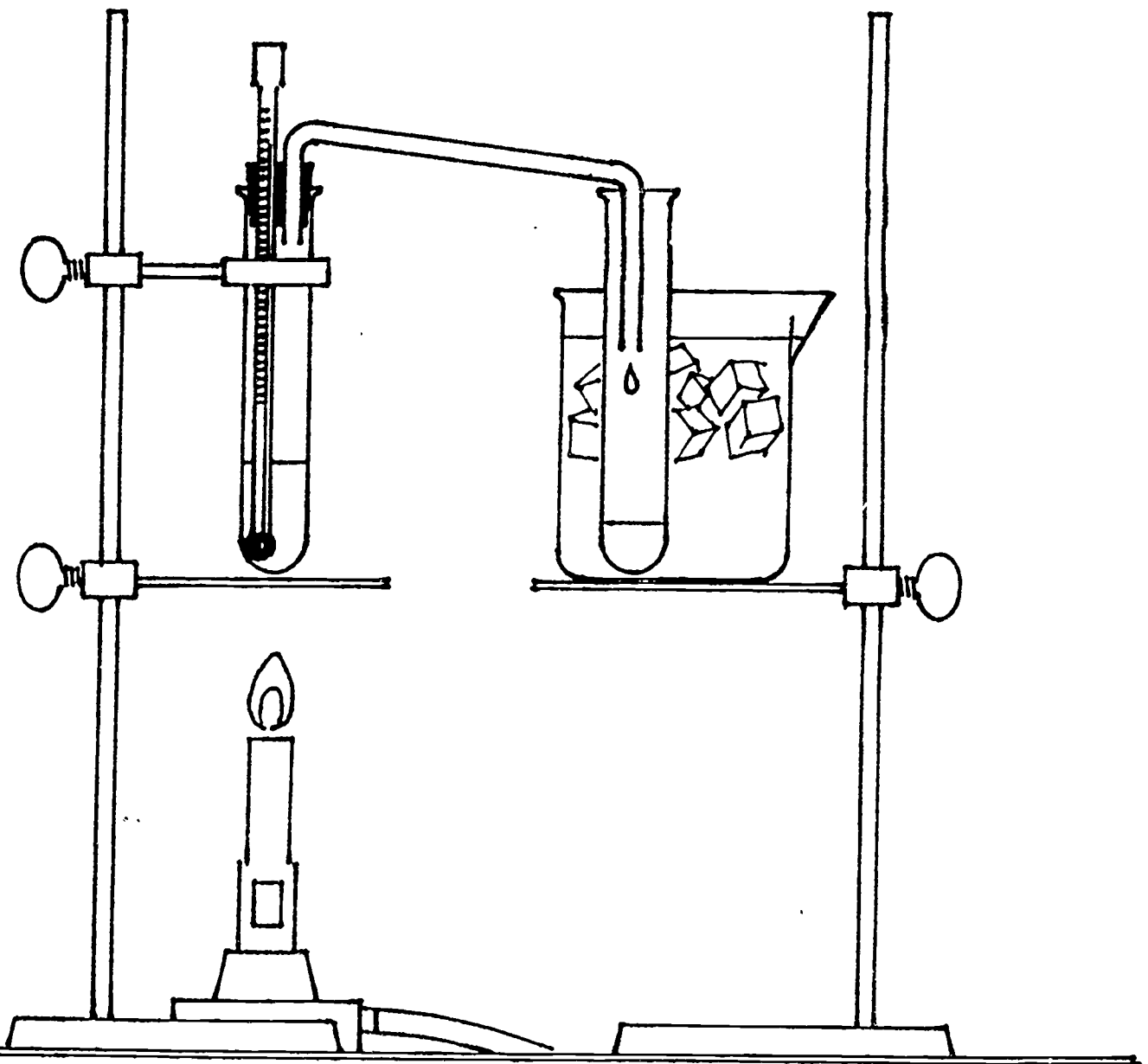

## SOMEWHERE OVER THE RAINBOW

by Thomas E. Thompson

Focus: This activity can be used at both the primary and intermediate grades. For younger children the emphasis can be on the concepts of primary and secondary colors; or on the skills of observing, predicting, or inferring.

For older children the emphasis can be on the concepts of absorption or chromatography and the skill of hypothesizing. The activity enables one to stress both concept and process simultaneously.

Challenge: Separate the individual pigment components found in the inks in felt-tip pens.

### Materials and Equipment:

Approximately 8-10 different colored, water soluble, felt-tip pens  
White filter paper (either circular pieces used for filtering solids from liquids, or rectangular strips approximately 3 x 10 cm)  
Clear containers (baby food jars work well)  
Water  
Ruler  
Timer

How-To-Do-It: Chromatography is a common laboratory procedure used to separate the different plant pigments contained in a leaf. This activity uses the same basic procedure, but uses water instead of alcohol for the solvent, and ink found in felt-tip pens instead of plant pigments for the absorbing agent. See the figure on the following page.

The basic procedure to follow is:

Fill a baby food jar with approximately 25 ml of water. Place a small dot of ink about 2 cm from one end of the rectangular piece of filter paper. Insert the paper into the water inside the jar as shown below. If a circular piece of filter paper is used, make two parallel cuts toward the center and place the small dot as shown on the suspended strip.

Fold the strip down so that it is perpendicular to the circular disc and insert into the water contained in the baby food jar. Note: It is imperative that the colored dot remain above the surface of the water.

As the water is absorbed up the filter paper, it will "carry" the ink pigment up the strip and deposit the ink pigment in a fan shaped pattern. Secondary colors will break up into a variety of other colors. Brown and black felt-tip pens give the most dramatic effects. However, one might be surprised when a color such as gray is used.

Once the basic procedure is mastered, be prepared for the children to begin to ask a number of "what if?" type questions. For example, a few possibilities are:

What if I used a different brand of felt-tip pen?  
What if I used a line instead of a dot?  
What if I used hot water?  
What if I positioned one color dot on top of another?  
What if I used a different liquid?  
What if I varied the type of paper used?

It is obvious that this activity integrates with the study of primary and secondary colors in the art curriculum. Also, the opportunity for reading children's books dealing with colors and rainbows is available. Just to name a few:

How the Birds Got Their Colors by Mary Albert  
Adventures of Three Colors by Annette Tison and Talus Tayler  
The River That Gave Gifts by Margo Humphrey.

Further Challenges: After the children have experienced the results of paper chromatography, the teacher could display strips of filter paper with the color separation patterns of two or more combined colored dots. The challenge can be given to determine which colors were used. This would necessitate returning to examine collected data and to make some inferences involving known patterns.

Children could also make up new patterns and have other children play detective.

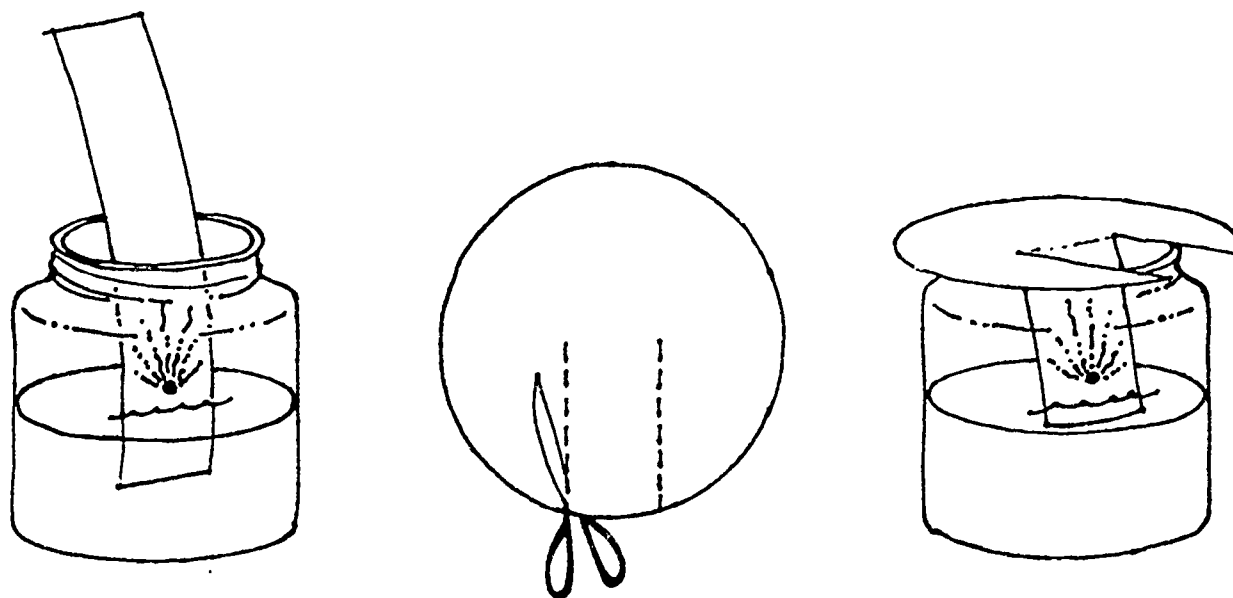

## EXAMINING INK

by Michael J. Demchik

Focus: Ink is either water or alcohol based and contains ingredients for color and binding.

Challenge: What is the composition of standard ink? Can it be separated? What base materials are present? What is India Ink? How do we use ink? Ballpoint pens?

### Materials and Equipment:

Ring stand and clamp  
Beakers  
Thermometers  
Test tubes  
Filter paper  
Ink  
Rubber hose  
Glass tubing  
Burner or heat source

How-To-Do-It:\* Set up the apparatus as shown in the figure. Fill the outside beaker with cold water. Heat the sample of ink placed into the test tube with an alcohol burner or bunsen burner.\*\* Record the temperature and observe the changes that take place. A liquid collects in the test tube. After heating the sample almost to dryness, remove from the flame and examine the residue. Results?

Challenge: Repeat the activity and take the temperature every 30 seconds. Plot a graph of the results. What does the plateau indicate? Try other approved liquids to see if they separate. Try this ink with the chromatography procedures in "Where do the Flowers Get Their Color?"

\*Note: Most inks also are hard to remove from anything if spilled. You may want to use washable ink for this activity.

\*\*Note: Eye protection should be worn any time liquids are heated in glass containers.

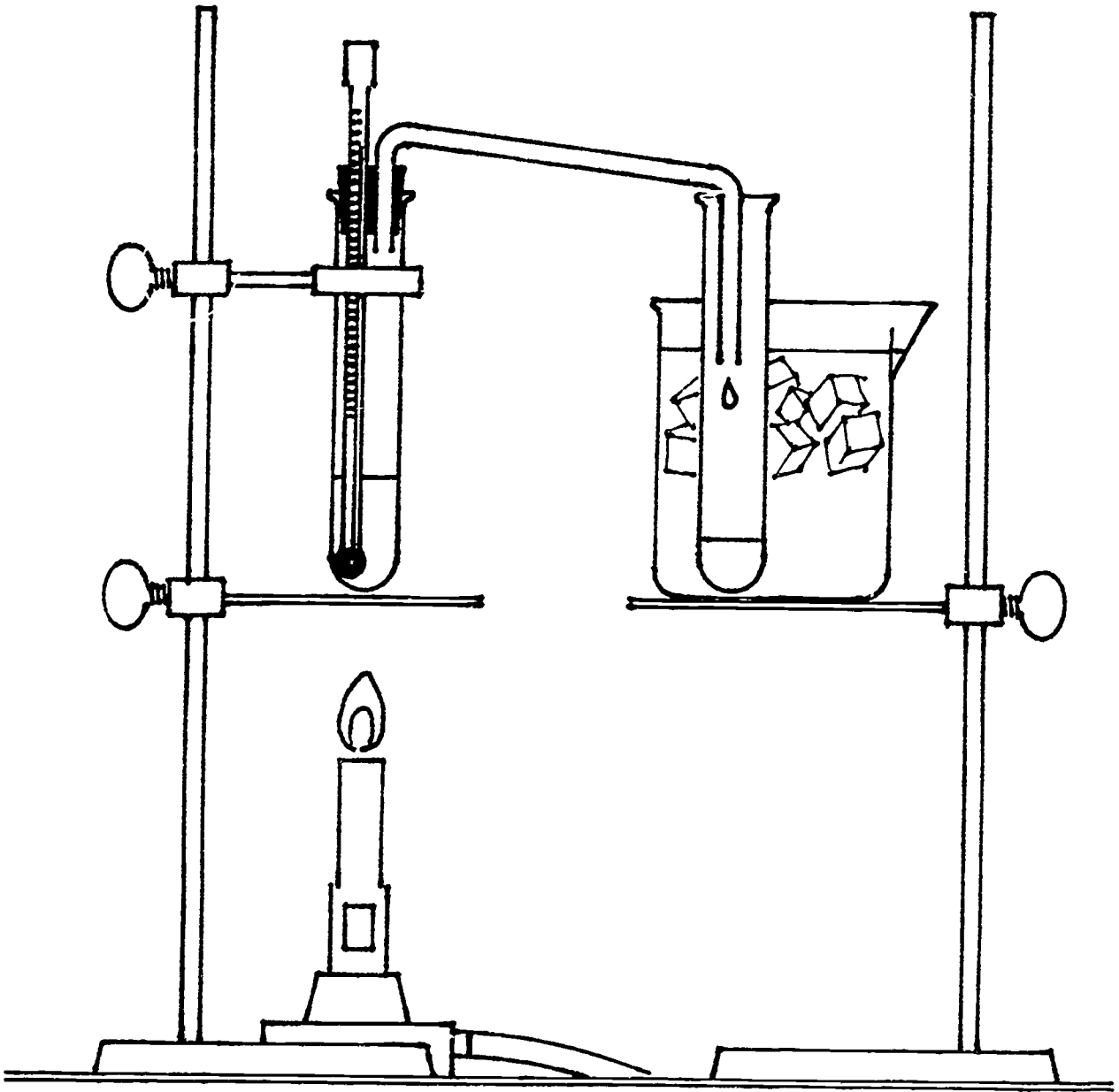

234



## SECRET HANDWRITING

by Edward L. Shaw, Jr.

Focus. Code writing using lemon juice on regular notebook paper is an interesting and inexpensive way for elementary school children to practice handwriting skills as well as participating in a science experiment. Paper is made from wood by-products; wood contains cellulose. The wood cellulose in the paper, when combined with an acidic solution such as lemon juice, will produce sugar. When heat is applied, the sugar caramelizes and turns brown.

### Materials and Equipment:

15 ml of lemon juice/student  
Cotton swabs (a fountain pen also works well if available)  
Notebook paper  
Baby food jars  
Graduated cylinder  
Paper towels  
Heat source - hot plate, or electric lamp with a bare bulb\*  
One tray for materials/student

\*Note: While other heat sources such as candles and alcohol burners will work, these should be avoided as they may readily cause the paper to burn.

How-To-Do-It: Before beginning the experiment, place on a tray: 15 ml of lemon juice in the number of baby food jars to allow one for each students, at least 2 cotton swabs per students, notebook paper, and paper towels.

Give students instructions before distributing materials. Allow the students to practice writing their brief secret messages with the cotton swabs without using the lemon juice. Distribute the materials and have students dip the swabs into the lemon juice and write their messages. Don't allow them to use an excess amount of the juice for each letter. The teacher, for safety reasons, should do the next part. Each paper is passed over the heat source until the message appears. As a safety precaution, a fire extinguisher or bucket of water should be kept nearby. Students should be warned to repeat the investigation only with adult supervision. The teacher can allow students to exchange messages and display the best around the room.

Further Challenges: Have students determine if more or less lemon juice will produce the same quality message.

Determine if there are other solutions, such as vinegar or pickle juice which will produce the same type of message.

Ask if there are other types of paper products that will produce the secret message.

## PCJ or PURPLE CABBAGE JUICE

by Yvonne A. Johnson

Focus: Using purple cabbage juice as an indicator, children will be able to tell if materials are acidic, basic, or neutral.

Challenge: Chemicals can be grouped together because they share common properties. Acids neutralize a base, and contain hydrogen. They have a sharp, sour taste. Bases neutralize acids and contain a hydroxide ion. They may feel slippery or soapy.

### Materials and Equipment:

Red cabbage  
Wooden or plastic spoon  
Glass dish -- heat proof  
Vinegar  
Ammonia  
Clear plastic cups -- 1 oz size  
Glass jar, quart or gallon

How-to-Do-It: To prepare the PCJ or purple cabbage juice:

Place the shredded cabbage in the glass bowl. Do not use any metal utensils in doing this so that there cannot be a metallic reaction with the PCJ.

Cover the shredded cabbage with cold water.

Place on the stove and heat. You may use the wooden or plastic spoon to press the cabbage down in the bowl.

When the water is blue, pour it off into a clean glass jar.

Repeat this process until you have enough PCJ to use for your class.

Store in the refrigerator. It will keep 2-3 weeks if refrigerated.

Give the students 3 - 1 oz clear plastic cups which will be placed in a row on their desk or lab table.

Pour the same amount of PCJ in each cup. Use the middle cup as the constant.

In the left hand cup, add vinegar (a weak acid) until there is a color change. The PCJ will turn pink.

In the right hand cup, add ammonia (a weak base) until there is a color change. The PCJ will turn green.

Using these three cups for comparison, the student can test a variety of other materials to determine if they are acidic or basic.

If there is not an apparent change, the material is neutral (neither acidic nor basic).

Further Challenges:

Collect a variety of materials to test.

apple juice	baking soda	baking powder	soda water
lemon juice	saliva		

Investigate to find other methods of determining if materials are acidic or basic.

## COLOR MAGIC WITH FRUITS AND VEGETABLES

by Stephen C. Blume

Focus: Children can make indicators of acids and bases from many fruits and vegetables. After observing the color changes of the indicators, they can use the indicators to determine acids and bases in their homes or the relative strength of different acids or bases.

Challenge: How can you make an indicator of acids and bases out of fruits and vegetables? What color does your indicator change to when an acid is added? What color does your indicator change to when a base is added? .

### Materials and Equipment:

Alcohol

Nonsudsy clear ammonia

Clear vinegar

Spoon

Fruits and vegetables such as blueberries, cherries, apples, beets, onions, and purple cabbage

Medicine droppers

Baby food jars or clear containers

Containers for rinsing

Containers for dumping

How-To-Do-It: Acid-base indicators can be made from many other substances. In this activity children will make indicators of acids and bases from fruits and vegetables such as blueberries, cherries, apple skins, beets, onions, and purple cabbage leaves and then test the indicators with an acid and a base.

This is a good activity to follow classroom experiences with acids and bases using litmus paper, phenolphthalein, or bromothymol blue. The activity can be performed individually as a whole class activity or in groups of three to five students. Also, the materials and directions can be set up as a learning center.

Select a fruit or vegetable for your acid-base indicator. Cut it into small pieces. Place the pieces into a baby food jar, and fill the jar 1/2 full with alcohol. Then, mash the indicator with a spoon.

Allow the fruit or vegetable to soak in the alcohol for 15 minutes or until the alcohol takes on the color of the fruit or vegetable. Then, drain off the liquid into two clean baby food jars. This liquid can now be used to check for acids and bases.

Test each liquid and observe and record any color changes by adding drops of vinegar (an acid) to one baby food jar and drops of ammonia to the other baby food jar. Record your observations of any color changes in a chart.

Name of indicator	Color	Color with acid	Color with base

Further Challenges: Once an indicator has been changed to a different color with an acid, do you think that it will change back to its original color or to the color of a base? Or, once an indicator has been changed to a different color with a base, do you think that it will change back to its original color or the color of an acid? Try it and see! How can you explain what happens?

What other fruits and vegetables might make indicators of acids or bases? Try them. (You might want to try purple grape juice or cherries.)

Do you think that flower parts might be indicators of acids or bases? Try some. (You might want to try daisy petals, rose petals, or red poinsettia leaves.)

What other household substances might be acids or bases? Add drops of various household liquids to an indicator, or add household powders to water and add drops to an indicator. (Liquids you might want to try might include shampoo, liquid detergent, fruit juices, soft drinks, pickle juice, milk, and window cleaner. Powders you might want to try might include baking soda, cream of tartar, cleanser, and soap powder.)

How many drops does it take to change the color of your indicator? Count and record the number of drops that it takes to change the color of your indicator using acids that you have discovered. For example, which takes more drops to change your indicator: apple juice, orange juice, or grapefruit juice? How can you explain why one juice takes more drops than another juice?

References:

Cobb, Vicki. More Science Experiments You Can Eat. New York: J. B. Lippincott, 1979.

Cobb, Vicki. Science Experiments You Can Eat. New York: J. B. Lippincott, 1972.

Liem, Tik L. Invitations to Science Inquiry. Lexington, MA: Ginn Press, 1981.

Melbane, Robert C. and Thomas R. Rybolt. Adventures with Atoms and Molecules. Hillside, NJ: Enslow Publishers, Inc., 1985.

230

ALIKE OR NOT  
A SEARCH FOR HIDDEN PROPERTIES

by Bonnie Barr

Focus: Solutions which look, smell and feel alike may have different hidden properties. Hidden properties are those which cannot be observed directly. A major responsibility of a chemist is to determine the hidden properties of matter. The hidden properties may affect how chemicals interact. Predicting interaction is an important job of a chemist. In this activity students as young as kindergarteners can get the feel for hidden properties of matter.

Challenge: What colorless solutions cause "the red cloth" to turn blue? Will all red cloth turn blue in that solution? What common foods turn purple cabbage juice red? What hidden properties are similar in the "fizz" of baking powder and water, soda pop and alka seltzer?

Materials and Equipment:

Baking soda/water solution (1 tablespoon baking soda to 1 quart of water)  
Citric acid (fruit - fresh)/water solution (1 tablespoon citric acid to 1 quart of water)  
2" x 2" squares of cotton cloth dyed with congo red stain (one square per group)  
2 small plastic cups per group (put an A on one cup and a B on the other)  
1 popsicle stick per group

How-To-Do-It: Have students work in pairs. Tell the students that one of the major jobs of a chemist is to determine properties of solutions. Tell the students that each group will receive two plastic cups, one marked A and the other B. Each cup will be filled with a liquid. Tell the students that they are to use their sense of sight, smell and touch to determine if the solutions in the cup are alike or not. (Although solutions are safe, do not have students taste the solutions.)

Half fill cups A with baking soda solution. Half fill cups B with citric acid solution. The two solutions will look, smell and feel the same. Give one of each cup to each group of students. After the students have had the opportunity to examine the solutions, ask them, based on what they have observed, if they think it is the same solution in both cups. (My experience indicates that students think the two solutions are the same.)

Tell the students that you are going to give each group a square of red cloth and a popsicle stick. Tell the students to put the square in the solution in either cup A or B. Stir the cloth in the solution. With the stick remove the cloth from the solution and put in into the second solution. Stir the cloth. They may transfer the cloth between the two cups as often as they like. Tell the students to record their observations.

Give a square of the congo-red dyed cloth and popsicle stick to each group. Have the groups proceed with the activity. The square will turn

blue in the citric acid solution and back to red in the baking soda solution. The reaction is reversible. Ask the students if, based on their new observations, they think the solutions are the same. The answer will be a resounding "No." When asked for their reasoning, students will say that the solutions cannot be the same because each causes the red cloth to change a different color.

Ask the students what variables need to be studied in order to better understand the hidden properties of the two solutions. A variety of variables are likely to be mentioned. Make sure the list includes the following: Will any red cloth change color when transferred from one solution to the other? Will other substances than the two solutions cause the cloth to change color? Set up investigations to answer the questions. Try dipping a variety of different pieces of red cloth into the two solutions. (Only the cloth dyed with congo-red changes color.)

Try dipping the congo-red dyed cloth into a variety of solutions such as vinegar, orange juice, scouring powder, diluted ammonia. The cloth will turn blue in vinegar or orange juice and back to red in scouring powder and diluted ammonia.

Ask the students to summarize what they have learned about the hidden properties of the materials involved in these investigations. Some conclusions are: a) Hidden properties of the red cloth (congo-red dyed) cause it to change color in solutions A and B. b) Solutions that look, feel, and smell the same may have different hidden properties. c) Solutions which cause the red cloth to change blue have a similar hidden property; solutions which change the cloth back to red have a similar hidden property. d) Solutions which look, smell and feel differently may have a hidden property that is the same.

Further Challenges: Obtain purple cabbage juice by boiling a quarter of a head of purple cabbage in a gallon of water. Try mixing the purple cabbage juice in common, safe to use household foods/chemicals. Which cause the juice to change red? Green? Is the strength of the hidden property the same in all substances that cause the purple cabbage juice to turn red? (No.) How can you tell? (With the same dilution some mixtures produce a darker hue of red than others.) Conclusion: Hidden properties of a substance can vary in both quality and quantity.

Using purple cabbage juice, determine if all brands of shampoo have a similar hidden property.

Obtain 1/2 cup, at a concentration suitable for drinking, of fresh, frozen, dehydrated, and canned orange juice. Add 1/2 cup of purple cabbage juice to each orange juice sample. Do all mixtures change to the same color hue? (No.) Which orange juice sample has the most of the hidden property? (The juice which produces the deepest red hue.)



Insert a 25 cm length of plastic tubing into a one hole stopper. Make sure the fit is tight. (If not, seal with plastiscine.) Unseal a bottle of soda-pop. Quickly seal the bottle with the stopper. Allow the gas from the soda-pop to bubble through the tubing into a small container filled with purple cabbage juice. How does the "fizz" change the cabbage juice? Set up similar investigations in which the fizz of a baking powder/water solution and an alka-seltzer solution are bubbled into purple cabbage juice. Describe how the fizz from each solution affects the purple cabbage juice. Conclusion: Gases produced in a variety of different ways may be the same gas if their hidden properties are the same.

## FIRE EGG-STINGUISHER

by Carol Van De Walle

Focus: This activity features a chemical change using materials the students are familiar with and which are easy to obtain. The students will become familiar with a chemical change and recognize some common characteristics of carbon dioxide. In addition, they will learn much about the egg.

Background: Egg shells are primarily calcium carbonate. Vinegar is an acid. Calcium carbonate reacts to vinegar in a chemical reaction which gives off carbon dioxide. Carbon dioxide has no taste, no odor, no color, is not combustible, and is more dense than air.

Challenges: Does the strength of the vinegar affect the chemical reactions? Does the quantity of vinegar or egg shell affect the speed of the chemical reaction? Does the height of the candle affect the speed of extinguishing the flame? If so, what could be the explanation?

Capture some of the gas given off in the chemical reaction and put it through limewater to further demonstrate that it is carbon dioxide.

Materials and Equipment: (each group will need)

1 birthday candle  
Crushed egg shells, about 100 - 150 ml  
Vinegar, about 100 - 150 ml  
Matches, wooden or fireplace  
2 beakers, 500 ml or larger (may use assorted jars)  
Clay, small pieces to anchor candle  
Stop watch or clock with second hand

How-To-Do-It: (each group should)

Place about 20 - 25 ml of egg shell into a container. Add an equal amount of vinegar. Record your observations; direct students to note a gas is given off. Can they determine what the gas is from this information?

Next, in a clean beaker, place a small piece of clay in the bottom; insert candle into clay holder. Add egg shells.

Light the candle carefully, then quickly but gently pour vinegar down the side of the beaker. Start timing as soon as bubbling begins. Stop when candle goes out. Record time.

Repeat experiment to verify.

Discuss observations about the gas that was formed.

Further Challenges: Repeat the experiment but change one variable, such as the amount of shell or the amount of vinegar. Continue to observe the egg shell in vinegar for several days, record your observations. Try assorted candle sizes, does the thickness or height of the candle affect the time to extinguish the flame?

Reference:

De Vito, Alfred. Teaching With Eggs. West Lafayette, IN: Creative Ventures, Inc., 1982.



## A GAS PROBLEM

by David R. Stronck

Focus: People can suffer distress from various pains in the stomach. They can have "gas pains" which sometimes are relieved by burping (i.e., emitting some gases.) Often they turn to the use of over-the-counter medicines that are designed to help an upset stomach. Youngsters can do a series of chemical reactions that will help them understand reactions that occur inside their bodies.

Challenge: Does the same gas (carbon dioxide) come from a variety of sources, e.g., from your stomach, your lungs, and some chemicals?

### Materials and Equipment:

Baby food jars and caps (use a hammer and nail to punch a small hole in each metal cap)  
At least 4 additional baby food jars (or paper cups or plastic cups) for each team of students  
Plastic (Tygon) tubing cut with scissors into lengths of about 18 inches (use the thin tubing commonly used in fish tanks)  
Alka-Seltzer tablets and Tums tablets  
Teaspoons (e.g. plastic spoons)  
Vinegar  
Baking soda  
Water  
Modeling clay

How-To-Do-It: Ask the students to explain what is going on when a person has gas pains in their stomach. Can any student explain what antacid tablets do to help? Invite the youngsters to observe the action of these tablets by doing the following:

Add enough water to fill most of a small jar or cup. Then drop in a Tums tablet. Use a clock or watch to observe how much time passes before the tablet is dissolved. Into a second jar or cup, add enough vinegar to more than cover the bottom surface. Add water to fill most of the jar. Add another Tums tablet to this second jar or cup. Record the amount of time before this second tablet is dissolved. Which reaction went faster?

Pour a third of the contents of the first jar (in which a Tums tablet has been dissolved) into two additional jars or cups. Each team of students will now have three jars with Tums solutions.

After constructing the gas generator as described below\*, add enough water to the baby food jar to fill it slightly more than half-way. Drop in an Alka-Seltzer tablet. Quickly cover the jar with its cap assembly. Carbon dioxide gas will come through the tubing from the dissolving Alka-Seltzer tablet. Place the other end of the tubing into the Tums solution of one

jar. What can be observed? (Calcium ions from the Tums tablet can react with carbon dioxide gas in water to form calcium carbonate, a white powdery substance that dissolves poorly in water.) If a white powder appears in the water, will the addition of some vinegar to the water make this white powder disappear? (Vinegar contains acetic acid that may allow the calcium ions to remain dissolved in the water as calcium acetate.) Discard the contents of this jar or cup.

\*Construction - Use a hammer and a nail to punch a small hole in the metal cap. Snugly fit one end of the plastic tubing through this hole in the center of the cap. The area between the tubing and the hole must be made air-tight. This may be accomplished by plugging any gaps with wads of modeling clay.

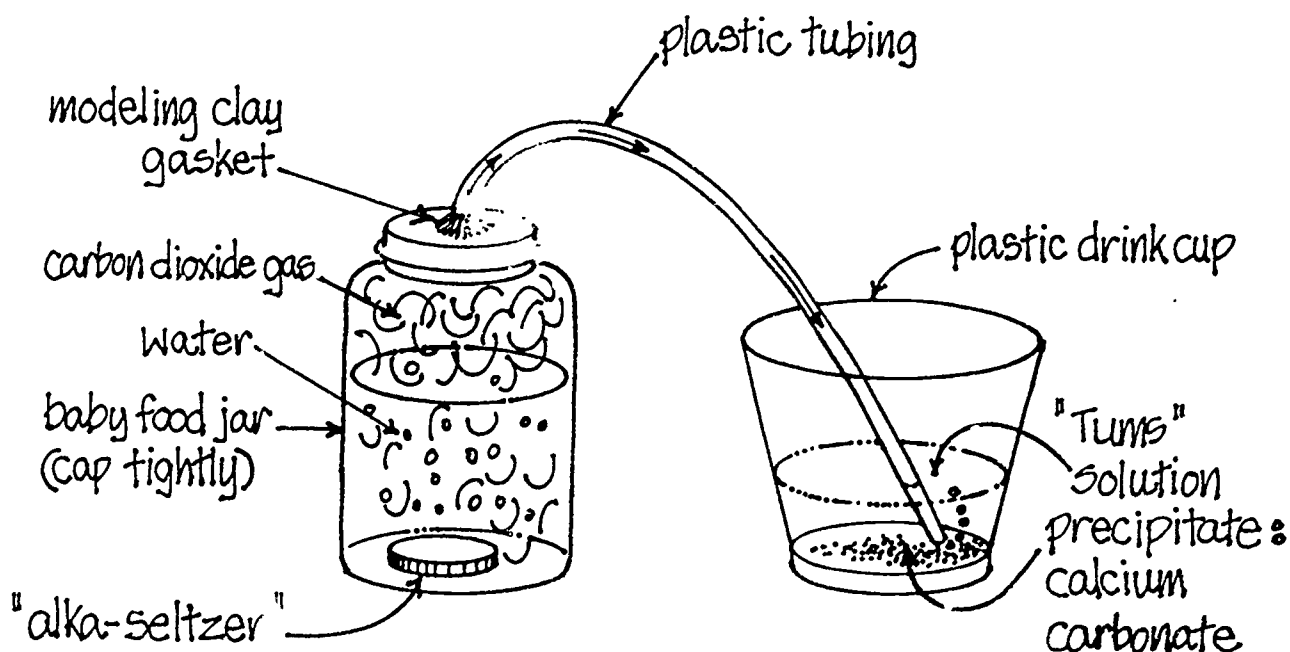

Discard from the baby-food-jar gas generator the contents with the used Alka-Seltzer tablet. Wash out the inside of the jar. Add enough water to fill more than half of the jar. Then add half a teaspoonful of baking soda to this water. Stir it until it dissolves. Finally add at least a teaspoonful of vinegar. Quickly put on the cap with the plastic tubing. Place the other end of the tubing into one of the jars with a dissolved Tums tablet. Does this gas give the same reaction that occurred with the gas from the Alka-Seltzer? Discard the contents of this jar or cup.

Remove the tubing from the baby-food-jar gas generator. Put one end of the tubing in your mouth and insert the other end of the tubing into one of the jars with a solution of a dissolved Tums tablet. Exhale air from your lungs into the jar. Does the gas from your lungs give the same reaction as the gas from the Alka-Seltzer and/or the gas from the vinegar and baking soda reaction?

Discuss with the students that the gas carbon dioxide reacts with calcium ions in water to precipitate the rock-like material calcium carbonate.

Further Challenges: Invite the students to change the quantities of any of the chemicals to observe possible differences. Note that vinegar has the opposite effect on reactions than has baking soda.

## PLASTIC BAG CHEMISTRY

by Bonnie Barr

**Focus:** In the following activity students will be able to observe three indicators of a chemical change: change in color, gas production, and change in temperature. Students will have the opportunity to explore exothermic (resulting in an increase in temperature) and endothermic (resulting in a decrease in temperature) changes. The activity attempts to use a problem solving approach to monitor factors affecting chemical changes.

**Challenge:** What indicators can be used to determine if the chemical change resulting from the mixture of materials that look the same is the same? How does a change in the amount of one component of a reaction affect the chemical change? Is it possible to predict the temperature of a specific endothermic or exothermic change?

### Materials and Equipment:

Baking powder (one teaspoon per group)  
Granular ammonium nitrate (one teaspoon each for half of the groups)  
Granular calcium chloride (one teaspoon each for half of the groups)  
1 plastic food storage bag with twist-tie for each group  
1 paper cranberry cup per group  
2 tablespoons of aqueous bromothymol blue solution per group  
Optional: thermometers

**How-To-Do-It:** Prior to class, put one teaspoon of baking powder into enough food bags for each group of students ... two students per group. To half of the bags add a teaspoon of ammonium nitrate. To the remaining bags add a teaspoon of calcium chloride. Tie off each bag with a twist-tie. (Self-sealing bags also work quite well.)

Tell the students that you are going to give each group a plastic bag with a white powder in it. Randomly distribute the prepared plastic food bags. Ask the students to observe the powder through the bag. Ask them to determine if there is one or more powders in the bag. Have the students describe the properties of the powder. (One is silky; the other granular.) Ask the students to compare the powders in their bag with the powders in the bags of their neighbors. Ask, "Are the powders in your neighbor's bag similar to yours?" (Yes.)

Have the students open their bags. Give each group a paper cranberry cup containing 2 tablespoons of bromothymol blue (BTB). Without spilling the contents, have the students place the cup into the bag. To seal the bag tie off its mouth with the twist-tie. When bags are sealed have the students pour the contents of the cup into the powder. Have the students record their observations.

**Observations:** The blue liquid turns yellow. Gas bubbles are given off. The bag inflates. Some students will say their bags are cold; others

respond that theirs is hot. Tell the students that they have just witnessed a chemical change. Evidence which they observed of a chemical change were: color change, gas production, and a change in temperature. Ask the students if they think the chemical change occurring in all bags is the same. The answer will be "no." When asked to explain their reasoning students will respond that the change cannot be the same if some bags turned cold and others hot. Ask the students what components of the mixture must differ. Since the BTB was the same in all bags, the students will conclude that even if the powders looked the same they must differ. The different powders would result in different reactions.

Explanation of Observations: BTB turns yellow in the presence of an acid. In the reaction of BTB and baking powder a gas ( $\text{CO}_2$ ) is produced. The reaction is acidic, causing a change in color of the BTB. The mixing in some bags of the BTB solution (water in the BTB solution is the active ingredient) and the ammonium nitrate results in an endothermic (cold) reaction. In other bags, the water in the BTB solution and the calcium chloride combine to produce an exothermic (hot) reaction.

Further Challenges: Have students investigate to see who can make the warmest heat pack, or a heat pack that stays warm the longest. Students may try varying the amounts of either the calcium chloride or water.

Have students investigate to see who can make the coldest ice pack. Or the ice pack that stays cold the longest. Students may try varying the amounts of ammonium nitrate or water.

The chemical ice packs which can be purchased in a drug store contain ammonium nitrate.

Have students construct a time released ice pack or heat pack. In response to this challenge one student with a bead of white school glue divided a self-sealing plastic food storage bag into three compartments. A teaspoon of ammonium nitrate was placed into each compartment. A cranberry cup filled with water was placed into the first compartment. The bag was sealed. The water was emptied into the ammonium nitrate resulting in an endothermic reaction. In the mean time, the water dissolved the bead of the glue separating compartments 1 and 2. The ammonium nitrate in the middle compartment was added to the reaction. The cold was prolonged as the ammonium nitrate in each of the three compartments became part of the reaction.



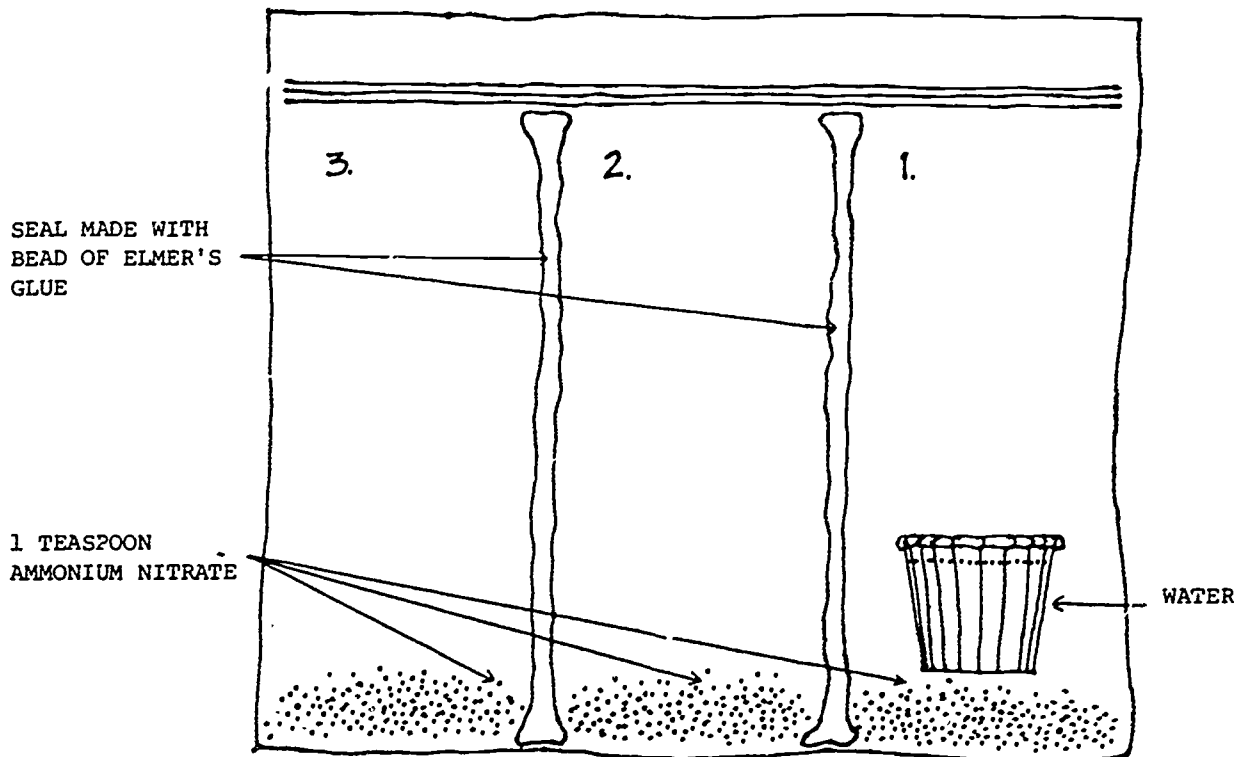

## SLIME

by Bob Burtch

Focus: This activity specifically introduces the idea of polymers. Introduce this activity by sharing excerpts from articles in the references "The Plastics Man" and "Slime, Glop, Putty, and Goo: Amazing Fluids That Defy Even Newton."

Challenge: Students will better understand via guided discovery and dramatization what constitutes bonding.

### Materials and Equipment:

Polyvinyl alcohol  
Sodium borate (see references on where to order these)  
Hot plate  
5 oz paper cups  
Beakers (500 or 1000 ml)  
Popsicle sticks  
Paper towels  
Pencil  
Ball point pen  
Water base markers  
Highlighter pens

How-To-Do-It: Order polyvinyl alcohol from Flinn (see references). (Tell them you are making slime. They know exactly what you need.) It comes in powdered form. When mixing use 600 ml water near boiling and slowly add 25 g of polyvinyl alcohol so it does not lump up. I also add fluorescent dye (about 1 ml) to the water. Any food coloring will work. The solution may be made the night before you plan to use it.

Put sodium borate solution in a wash bottle or beaker for easy dispensing. The amount used is 120 ml water to about 5 g of sodium borate. You may need to heat the water to get it to dissolve.

Now you're ready to start this activity. Pass out the polyvinyl alcohol solution. Pour to 1" depth in 5 oz cup. Pass out stirrer and paper towel to each student.

Have students describe liquid (don't tell what it is yet). Have them stir with stick and describe the liquid.  
green, clear, bubbles when stirred, etc. (observations)  
syrupey (introduce viscous)

Now tell students it is a solution of polyvinyl alcohol and water. (Write the words on the chalkboard.) Set solution back on desk.

## "Mer" Dramatization - Part II

Choose four or five volunteers.

Put them in a line and call them "mer" units.

Stand behind each students with hands on shoulder and say "You are a mer." "How many mers?"

You get a special chemical "polymer". Poly = many. Make chemical by joining hands of two "mers" together - say "How many hands are joined?" What would we call this joining? (dimer) Link another hand to the first two. (trimer) Four hands joined together = quadmer. The chain grows until a lot of mers together we call "polymer."

Lead the polymer chain around the room.

Say "Describe the chain." (flexible, mobility) Your chain is like the aqueous polyvinyl solution.

Call five more volunteers (mers) - form chain

Have volunteers join hands and go around room. (They are free.)

\*A polymer has many chains moving around with lots of water between them.

Have the two polymer chains back in front of the class.

Say, "We will add another chemical to your polymer called a "crosslinker." (It links chains together.)

Teacher stands in middle of the two chains and links hands with the two chains. Say, "How is the solution different now?"

Have the chains try to go and teacher holds in place.  
Original chain = wet piece of spaghetti

Is crosslink polymer as mobile as before?  
Is it flexible at all?  
What would happen if more crosslinker were added?

Now add sodium borate to the polyvinyl and stir vigorously (gel forms).

Remove the slime ffrom the cup and knead it.

Pulling the slime slowly creates thin strands.

High stress breaks it.

Rolled into a ball it bounces.

ES

When squeezed, it flattens

When thrown, it breaks into pieces.

Have students write their names on ordinary white paper. Use water soluble felt-tip marking pen. Have students place slime on their name, lift the slime up and describe the results. (Water soluble inks will be lifted by the slime and students will see the mirror image of what they wrote.)

Slime lasts between two days and two weeks depending on how much handling it gets and how clean the hands are. It usually molds and should be discarded at this point. There is no real danger in handling it but, as with all chemicals, students should wash hands after use.

References:

Casassa, E. Z., A. M. Sarquis, and C. H. Van Dyke. The Gelation of Polyvinyl Alcohol with Borax. Journal of Chemical Education. January, 1986.

Flinn Scientific, Inc. Box 231, 917 W. Wilson St., Batavia, IL 60510, (Request Flinn Chemical Catalog and their article about slime. telephone 312-879-6900.)

Friedal, Robert. "The Plastics Man." Science 84. November issue, p. 49-51.

Killgore, J. "Slime, Glop, Putty, and Goo: Amazing Fluids That Defy Even Newton." Scholastic Science World. P. 23-26, March 23, 1987.

Marek, L. "Slime." ISTA Spectrum. P. 21-24, Spring/Summer 1986.

244

CHAPTER 12

ACTIVITIES FOR TEACHING SPACE

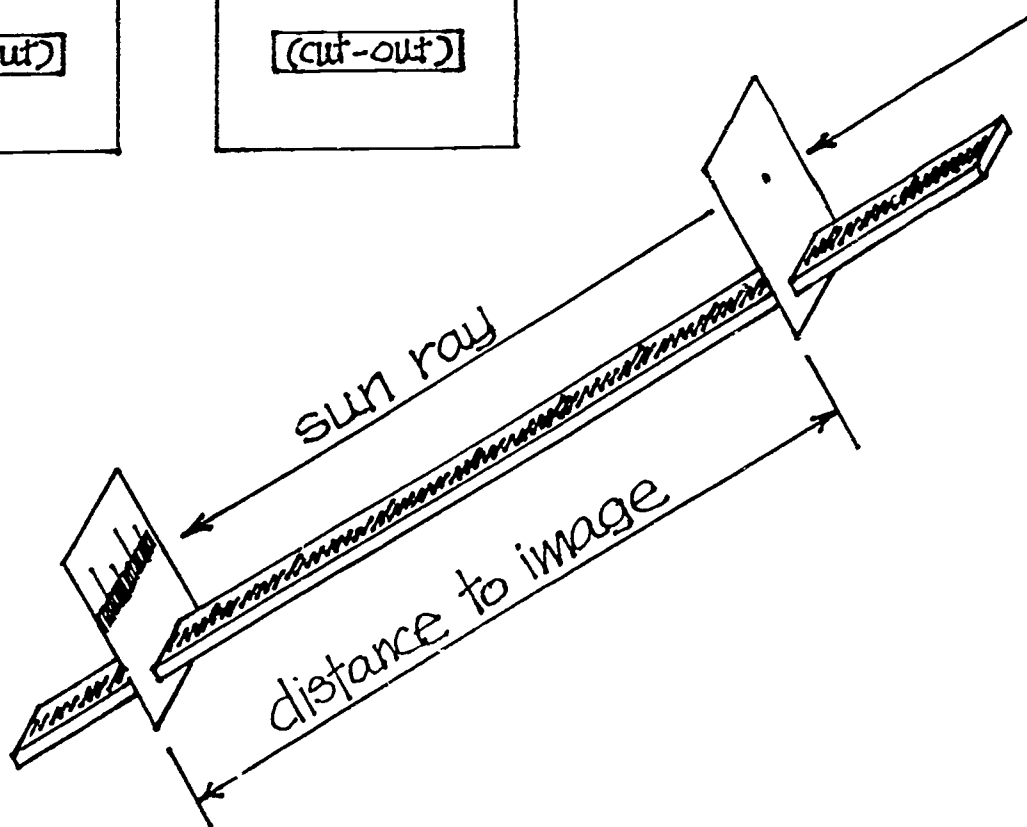
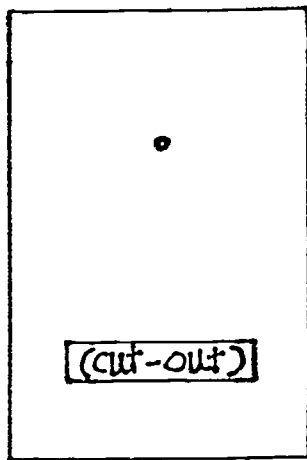
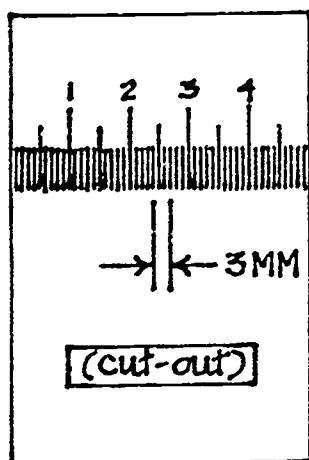

23

## HUMAN SUN DIALS

by Judith McKee

Focus: The oldest way of telling time was done by looking at the location of the sun in the sky. This method was followed by using shadows in various forms of the sundial.

Challenge: Use children's shadows to tell time.

### Materials and Equipment:

Chalk  
Paved outdoor area

How-To-Do-It: Each child will be working with a partner. The children will go to the playground and take turns drawing each other's shadows. The first child stands facing north while the partner traces around the child's shoes and labels this outline with the child's name. Then the shadow is drawn, preferably on the hour. It is best to start early in the day. The activity is repeated with the second child's shoe outline and shadow being drawn. The children will step into their shoes and repeat the shadow drawing procedure at various (on the hour) times during the day. They should mark the time on the changing shadows.

The activity can be repeated the next day to compare each day's shadows.

It is important to emphasize that the sun really isn't moving, though it gives the illusion that it is. Of course, it is the Earth that is moving.

Further Challenge: Ask students if they can devise other methods and materials to create a sun dial.

## ROTATE-REVOLVE GAME

by Judith McKee

Focus: Two important motions in the universe are rotation and revolution.

Rotate - to turn around an axis or a center.  
The earth rotates on its axis.

Revolution - to go around in an orbit.  
The earth revolves around the sun.

Challenge: Become familiar with the above terms and know what they mean.

### Materials and Equipment:

Large open area

How-To-Do-It: Play this game outside or in a gym. The children circle around one child (perhaps one who is wearing yellow or orange) who is to be the sun. They must respond when "the sun" calls "rotate" or "revolve." When the child in the center says, "rotate," the children turn "on their axis" in place. (Their axis is one foot which they leave in one position while twisting around.) The center child may call, "revolve," which means that the children orbit the sun. Encourage them to stay an even distance away from the sun so the planet won't get too hot or too cold. The object of the game is for the center child to "catch" one of the others "revolving" when they should "rotate" or vice versa. The order can be given quickly so as to trick children. Those who are "caught" are out. The last person or persons still "rotating and revolving" at the right time are the winners.

Further Challenges: A possible variation on this game is to have the student in the center (the sun) trade places with the first person caught making the wrong motion. This version of the game is less competitive and involves all students for a longer period of time. The game should be concluded when most students are clear about the distinction between revolution and rotation.

247

## SIZING UP THE SUN, EARTH AND MOON

by Judith McKee

Focus: It is difficult for children to understand the size relationships of the sun, earth, and moon. Discussions and demonstrations are needed to call attention to how things appear smaller the farther away we are from the objects.

Challenge: Experience the differences in the size of the sun, earth, and moon by making and using models.

### Materials and Equipment:

Beach ball or other ball approximately two feet in diameter  
A dried pea  
A pin  
A quarter  
Clay  
Marking pens and/or tempera paint  
Pictures of earth, sun and moon  
String

How-To-Do-It: Display the beach ball, the dried pea, and the head of the pin. Explain that if the sun were the beach ball, earth would be the size of the pea and the moon would be the size of the head of the pin. Explain that a million earths could fit inside the sun.

Hold up the quarter for all to see. Walk away continuing to hold up the quarter while the children watch the quarter appear to get smaller. Discuss their experiences with perspective.

Give each child a large fistful of clay. Have them make seven balls of clay of approximately equal size. When finished, put six of the balls together to form one big sphere. (This sphere represents the earth.) The remaining ball is a model of the moon as compared to the earth. Then continents, the equator, etc. can be etched into the earth while craters can be put on the moon. Photographs should be available for viewing. Later, after the clay dries, the spheres can be colored with marking pens and/or tempera paint to look like the photographs. Remind them to include the earth's polar caps and its swirls of atmosphere.

Further Challenges: Ask the children to guess how far the moon would be from earth using their clay models. They can put these on their desks. Then, using a piece of string, demonstrate how to measure the diameter of the earth. The moon is 30 of these diameters away from earth. The children can each do this using their own models and a length of string.



## SIMPLE SOLAR SYSTEM MODEL

by Judith McKee

Focus: It is easy for the children to remember the names of the planets and their order away from the sun by repeating this: My Very Educated Mother Just Served Us Pink Noodles. Mercury, Venus, Earth, Mars, Jupiter, Saturn, Uranus, Pluto and Neptune are the planets in their current order away from the sun. The traditional mnemonic device reads "Many Very Ernest Men Just Showed Us Nine Planets." However, because of Pluto's eccentric orbit, it is occasionally closer to the sun than Neptune. This is the case now, as this sourcebook is being published.

Challenge: The idea of "astronomical unit" will be introduced and a model of the members of the solar system with their relative distances away from the sun will be made.

### Materials and Equipment:

Rulers  
Adding machine tape  
Crayons or markers  
Pencils

How-To-Do-It: Introduce the term "astronomical unit" (the distance between Earth and the sun in any model). Give each child a length of adding machine tape at least 4 meters long. Tell children to use 10 cm as their astronomical unit, though any size will work if you have enough adding machine tape. Then they are to make their model of the solar system by marking off where the other planets are to be on the tape. All the planets should be spaced as shown below. Each length is measured from the sun.

Planet	Astronomical Units	Centimeters at 10 cm = 1 A.U.	Millions of Kilometers	Millions of Miles
Mercury	.4	4	58	36
Venus	.7	7	108	67
Earth	1.0	10	150	93
Mars	1.5	15	225	140
Asteroid Belt	2.3	23	350	217
Jupiter	5.1	51	770	480
Saturn	9.6	96	1430	890
Uranus	19.4	194	2900	1800
Neptune	30.1	301	4500	2800
Pluto*	39.8	398	6000	3700

\*Note: The average distance from Pluto to the sun is being used here.

Small drawings of the planets can be made. The planets are rarely aligned like this. Usually they are scattered in various places on their elliptical orbits which, from outside the solar system would look like disks. Pluto's orbit, however, is a peculiar one because it deviates greatly from the others.

Further Challenges: Repeat the activity but use one meter as the astronomical unit. String can be substituted for the adding machine paper. Names of the planets could be attached at the appropriate places. To give the children an idea of the size relationships of the planets, supply the following information:

The approximate size of the sun and planets in relation to the size of the Earth are as follows:

	Earth Diameters	Diameter in Kilometers	Diameter in Miles
Sun	109	1,400,000	864,000
Mercury	0.4	4,800	2,900
Venus	0.9	12,200	7,530
Earth	1	12,600	7,900
Mars	0.5	6,700	4,200
Jupiter	11.0	139,000	86,800
Saturn	9.0	115,000	71,500
Uranus	3.7	47,000	29,400
Neptune	3.5	45,000	28,000
Pluto	0.2	2,900	1,800

Challenge students to create a model of the solar system that is accurate in scale for both size and distance.

Hint: With a scale of 1 A.U. = 10 meters, the sun will be approximately 92 mm in diameter. This is quite small considering Pluto will be nearly 400 meters away. Even on this large scale, the planets will be very small. (i.e. Earth is less than 1 mm.) Students can calculate this size from the information given in the charts above. For your convenience, these related sizes have been calculated and are listed below. (Sun = 92 mm. Mercury = 0.3 mm. Venus = 0.8 mm. Earth = 0.8 mm. Mars = .4 mm. Jupiter = 9.3 mm. Saturn = 7.6 mm. Uranus = 3.1 mm. Neptune = 3.0 mm. Pluto = 0.3 mm.)

## MOON MOBILE

by Ruth M. Rund

Focus: The purpose of this lesson is to familiarize the students with the different phases of the moon, the sequence of the phases, and time of moonrise and moonset.

This lesson can be adapted for various ages.

### Materials and Equipment:

One wire hanger

4 to 8 pieces of string about 15 cm long

Patterns of the moon phases

Construction paper, yellow and black (for full and new moon)

Challenge: Demonstrate the reflected light of the moon and its phases by using a flashlight or light source, an orange, and a golf ball. Discuss the various phases that are formed.

How-To-Do-It: Have students trace the patterns of the phases of the moon onto the construction paper. Punch a hole at the top of each phase. Tie the string to the phase and then to the hanger. Students then can see the phases beginning with new moon, waxing crescent, first quarter, full moon, waning crescent, and last quarter.

Further Challenges: Add the gibbous phases.

Add the moonrise and moonset for each phase.

Have the students chart the moon phases for one month.

## A CUPFUL OF STARS

by Ruth M. Rund

Focus: Children can become aware of the constellation patterns in the night sky by recognizing them in different ways. The big and little dipper, Casseopeia, and Orion are the easiest constellations for children to find.

Challenge: Have a student recognize a constellation by its pattern. Have the student make the pattern and identify it.

### Materials and Equipment:

Styrofoam cups  
Pencils  
Flashlight  
Copy of the constellation patterns

How-To-Do-It: Give each student a styrofoam cup.

With a pencil have the student mark where the stars will go.

The students will then punch the holes through in the bottom of the cup.

Have the student shine the flashlight through the cup in a dark place.

Further Challenges: Set up a learning center with the flashlight, cups with familiar constellation patterns, and a box with a lid. Have the students identify the constellations.

## HOW BIG IS THAT SUN?

by Tom Graika

Focus: The sun is a long way from Earth. Yet when viewed from Earth it appears to be about the same size as the much closer moon. In fact, when a solar eclipse occurs, the moon just about blocks out the entire sun. Using very simple equipment, it is possible to make an estimation of the size of the sun. For this activity an average distance to the sun of 93 million miles will be used.

Challenge: How can the size of the sun be measured from Earth?

### Materials and Equipment:

2 index cards  
Meterstick  
Millimeter ruler  
Pin  
Paper

How-To-Do-It: Cut a hole near the base of each of the index cards so that the cards could be slipped onto the meterstick as shown on the diagram. On one of the cards punch a small hole with a pin. On the other card mark out a series of lines one millimeter apart.

Slip the cards onto the meterstick with the millimeter scale facing the card with the pinhole. Go outside on a sunny day and use this equipment to measure the size of the sun. Instruct students NOT TO LOOK DIRECTLY AT THE SUN. Working with partners will make the task easier. Work with your back to the sun. Point the end of the meterstick that has the card with the pinhole toward the sun. When the light passes through the pinhole it will form an image of the sun on the other card. This card will be in the shadow of the pinhole card for easy viewing of the image. Slide the cards back and forth until an image three millimeters in diameter is formed. Measure the distance in millimeters between the two cards.

To calculate the size of the sun a simple ratio will have to be used. The sun's size can be calculated in either miles or kilometers.

$$\frac{\text{diameter of the sun}}{\text{distance to sun}} = \frac{\text{diameter of image}}{\text{distance to image}}$$

$$\frac{\text{diameter of the sun (miles)}}{93,000 \text{ miles}} = \frac{3 \text{ millimeters}}{? \text{ millimeters (distance between cards)}}$$

or

$$\frac{\text{diameter of the sun (kilometers)}}{150,000,000 \text{ kilometers}} = \frac{3 \text{ millimeters}}{? \text{ millimeters}}$$

Cross multiplying and dividing by the distance between the cards will produce your estimate of the diameter of the sun.

Compare your answer with one given in a reference book. How close did you estimate the diameter?

Further Challenges: Try the experiment several times using different sized images.

Take an average of all your findings. Does this come closer to the actual diameter of the sun?

Find out how scientists measure the size of objects in space.

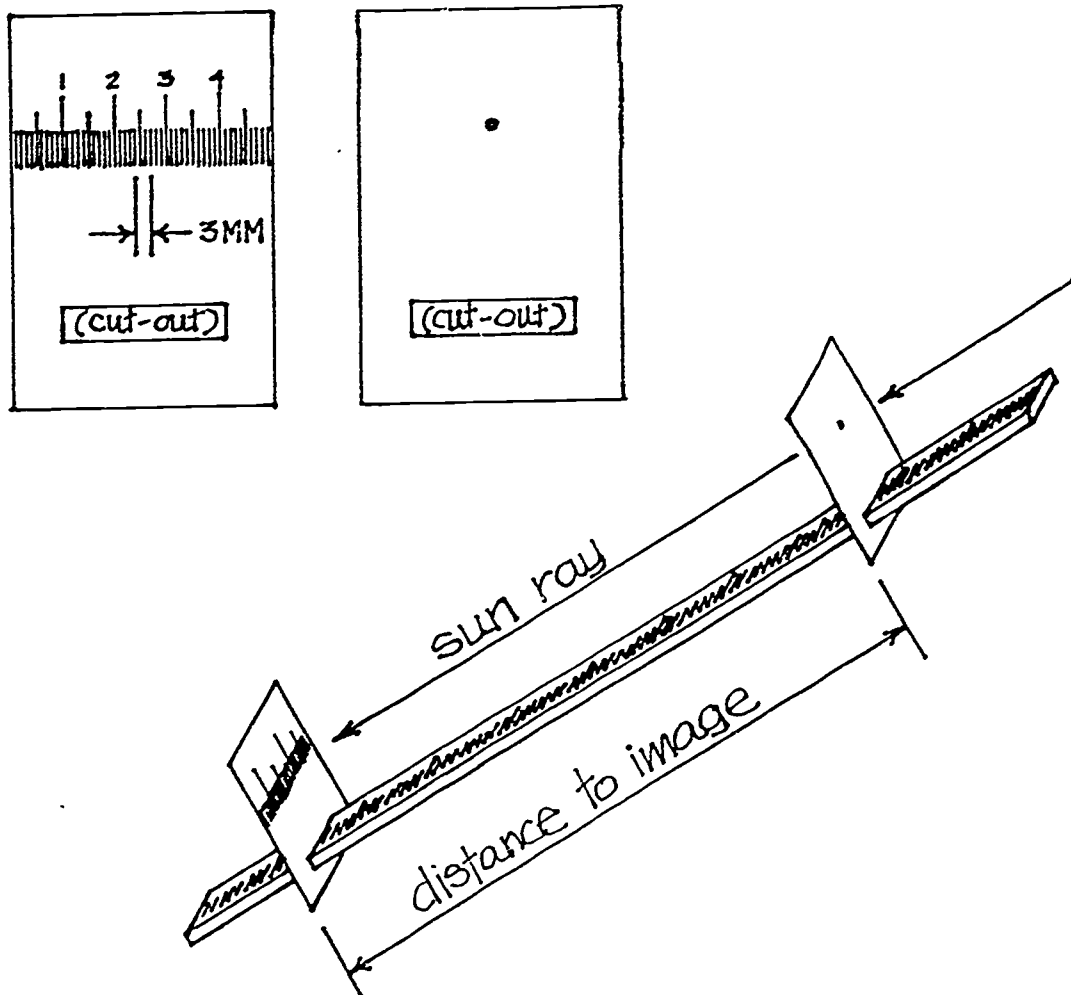

## FINDING CONSTELLATIONS

by Tom Graika

Focus: The stars in the sky seem to be scattered in an endless array. Sometimes by connecting the stars with imaginary lines we can see patterns or even the shapes of familiar objects. The big dipper is a good example. Ancient peoples used the patterns in the sky to tell stories. They imagined hunters, animals, and many other objects in the sky to illustrate their stories.

Challenge: How many different "constellations" can be found in the pattern of stars in the box below?

### Materials and Equipment:

A copy of illustration (or similar teacher-made scattergram)  
A pencil

How-To-Do-It: Give each student a copy of a scattergram of dots similar to the one illustrated. Ask the students to find different "constellations" on their scattergram of "stars".

Further Challenges: Have students make up a story using some of the "constellations" they found.

Have students find out about some of the myths and stories associated with constellations in the sky.

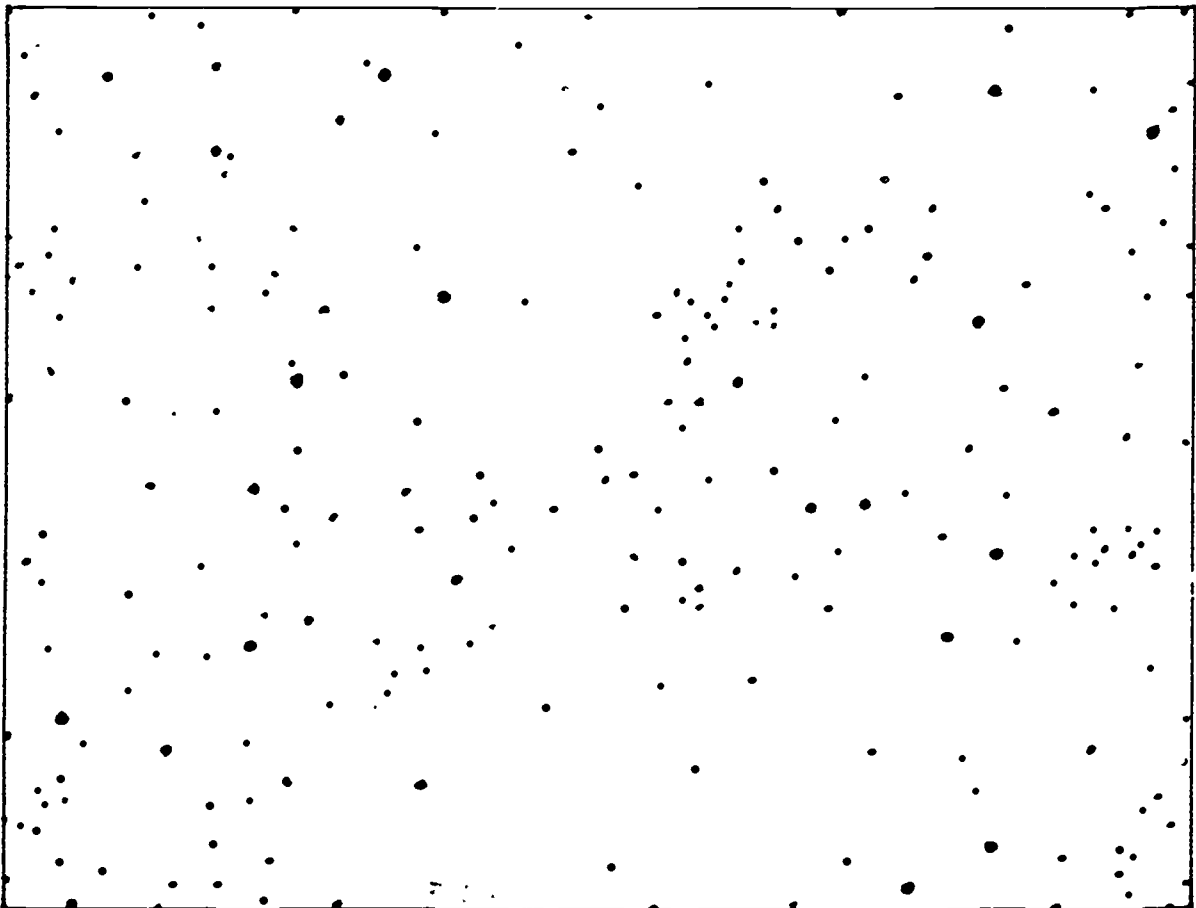

CHAPTER 13

ACTIVITIES FOR TEACHING MORE PHYSICAL SCIENCE



## TEACH PHYSICS THROUGH SPORTS AND GAMES

by Charles Nease

Focus: By relating science to sports and games, you will not only enrich your curriculum. You will also be doing your part to head off the fear of physics which afflicts many teenagers and adults.

Concepts such as force, power, and momentum make sense to elementary students when they see them operating in their favorite activities. For example, a discussion of different types of forces becomes meaningful when it is preceded or followed by a "laboratory" on the softball field.

Challenge: Identify and explain the forces at work during selected moments of a class softball game.

### Materials and Equipment:

Bat  
Softball  
Bases (carpet squares are good)  
Gloves (desirable but optional)

How-To-Do-It: Begin with a short discussion of types of forces, which can be organized into the categories below. (See Brancazio, Ch. 2.)

#### Contact Forces

Pushes  
Pulls  
Friction  
Elastic force

#### Action-at-a-Distance Forces

Gravity  
Magnetism  
Electrical force  
Nuclear force

Define force as "an action that can cause an object to change speeds" (accelerate or decelerate). Elicit as many examples of forces as your students can contribute and let them help you categorize and demonstrate them. Use these demonstrations to help them make connections between what they know and the terms they are learning.

Pushes and pulls can be exerted by our bodies or with instruments such as bats. Friction, the resistance between two objects moving against each other, makes pushing things more difficult, but it also allows us to walk, grip objects, and perform our everyday activities. Elastic force causes a distorted object, such as a hit ball, to return to its original shape.

Actually, the term "contact" is used to describe these forces only for practical reasons. You may wish to point out that "contact forces" are due to electrical forces between the atoms of objects. You may also want to explain that no one knows why the forces operate as they do, but that we are able to study them and understand their effects.

Follow or precede the discussion with a "lab" on the playing field. At appropriate times suspend play and ask questions like the following.

Why didn't the ball keep going into outer space? (I didn't hit it with enough force to overcome the force of gravity and friction against air particles.)

Why didn't you slide all the way across the playground and crash into the fence? (Friction between the ground and my body slowed me down.)

What happened when the ball hit your hand? (The force of the moving ball pushed my hand back, and the force of my hand made the ball slow down and stop.)

Why hasn't the ball become pancake-shaped from the pounding it has taken? (We haven't hit it with enough force to break down its structure, so the elastic force keeps returning it to its original shape.)

What made you slip and fall when you were rounding first base? (There wasn't enough friction between the wet grass and my shoe to resist the push I gave with my leg.)

Further Challenges: The activity described above is only a beginning; it is only one of many possibilities. Use the references below to develop additional lessons on power, momentum, trajectories, etc.

Have students apply what they have learned to demonstrate physics principles associated with rope jumping, Frisbee, soccer, and other games.

References:

Brancazio, Peter J. Sport Science: Physical Laws and Optimum Performance. New York: Simon and Schuster, 1984.

Epstein, Lewis C. and Paul G. Hewitt. Thinking Physics: Questions with Conceptual Explanations. San Francisco: Insight Press, 1981.

Schrier, Eric W. and William F. Allman. Newton at the Bat: The Science of Sports. New York: Charles Scribner's Sons, 1984.

## USE CARTOONS TO REINFORCE PHYSICAL SCIENCE CONCEPTS

by Charles Nease

Focus: In a hospital nursery a furtive figure rubs a bundled baby over his shirt. Two infants are already affixed to the ceiling. The caption reads, "Late at night, and without permission, Reuben would often enter the nursery and conduct experiments in static electricity." (See Larson, p. 60.)

Students in the upper elementary grades recognize that this scenario is impossible, but they find the idea hilarious. And the cartoon is perfect for reviewing the phenomena associated with static electricity.

Challenge: What scientific concepts can you discover in these cartoons?

### Materials and Equipment:

Cartoons from books, magazines, and other sources  
Slide film or transparencies  
Camera with copy stand or a suitable copy machine  
Slide projector or overhead projector

How-To-Do-It: Select 20 to 30 cartoons related to the concepts your class has studied. Newspapers, magazines like Omni and The New Yorker; and books such as those listed at the end of this article are good sources. You may wish to concentrate upon one or two areas from your curriculum, or you may prefer to choose a wide variety for a general review.

You could cut out the cartoons, mount or laminate them, and then use them in a center designed for individuals or small groups. However, whole-class viewing is much more enjoyable and allows students to share more ideas through teacher-directed discussions. The goal is to identify and explain as many science-related concepts as possible for each cartoon.

Slides are the most dramatic way to conduct this lesson, but overhead projectors can also be used effectively. A good copy center can enlarge any cartoon to fit a standard transparency. (Making a single copy of a cartoon for use in the classroom is legal under current copyright law.)

Further Challenges: Have students search for science-related cartoons and bring them to class to share.

Have students create their own cartoons to illustrate the content and processes they have studied.

### References:

Chast, Roz. Parallel Universes. New York: Harper & Row Publishers, 1984.

This book has some truly bizarre ideas which you can use to stimulate your students' imaginations. Try "Just Asking" (p. 81) or "Underutilized Ice Breakers" (p. 123).

Harris, Sidney. What's So Funny About Science? Los Altos, California: William Kaufmann, Inc., 1977.

Many of the cartoons in this volume deal with social issues. One caption (p. 113) reads, "You win a little and you lose a little. Yesterday the air didn't look as good, but it smelled better."

Larson, Gary. The Far Side Gallery. Kansas City: Andrews, McMeel & Parker, 1984.

This is a science cartoon treasure trove, as are most of Larson's earlier books.

Mueller, P. S. The Spread of Terror. Chicago: Bonus Books, 1986.

"Enter the Variable" (p. 3) and "Control Group -- Out of Control Group" (p. 28) are probably the best cartoons available for reviewing experimental design.

Note: Some works with usable cartoons also contain sexually oriented humor, ethnic humor, and other unsuitable material. It would be prudent to scrutinize books before bringing them to the classroom for students to explore.

## HOW MANY MILLILITERS IN A GALLON?

by Michael J. Demchik

Focus: Estimating the number of milliliters in a gallon or similar type of estimation activity takes skill and practice.

Challenge: How many milliliters are there in a gallon?

### Materials and Equipment:

Gallon jug  
Water  
600 ml and 1000 ml beakers

How-To-Do-It: Fill a gallon jug to the neck with water. This usually is the exact point where one gallon is found. Ask students to guess the number of milliliters in a gallon after having shown them what one ml looks like. Ask them to write down the number of ml. Then record all the student guesses. Remove 500 ml of water from the jug and stand the container next to the gallon jug. Ask the students to make a "guestimate" of the number of ml in the gallon after they have written down their value. List the value next to each of the previous guesses. Remove 1000 ml from the gallon jug and have the students estimate the number of ml in the gallon jug. Record as before. Have the students compare the results for each student and the class. Determine what factors affect the data listed.

Further Challenges: Ask students to estimate and/or measure the number of milliliters in various other containers such as: a bucket, a flower pot, a wastebasket, a bath tub, a sink, a coffee cup, etc.

## MEASURING WIDE THINGS

by Michael J. Demchik

Focus: This activity should be performed after the activity called "Measuring Tall Things." The width of a road, river or ball field can be determined with the hypsometer. The operation is the same as when measuring height. All that is needed is a reference point.

Challenge: How are the measurements of height and width related when the hypsometer is used?

### Materials and Equipment:

Cardboard hypsometer (see previous activity)

How-To-Do-It: Place the cardboard hypsometer parallel with the ground. Find a reference point such as a tree or a rock and sight along the diagonal until the line of sight is in line with the reference object. Mark this sighting point on the ground. Walk to a point perpendicular to the reference point and sight along the edge of the hypsometer from the new position. Mark it. Measure the distance between the two points. This should be the distance across the road or the river.

Further Challenge: Compare the results with different sized hypsometers.

## MEASURING TALL THINGS

by Michael J. Demchik

Focus: Indirect measurements of height can be accomplished with an instrument known as a hypsometer. The hypsometer employs the principle that when two angles formed are at 45 degrees and the other angle is at 90 degrees, it is possible to make an indirect measurement of height. The instrument works only in the manner to be described when the angles are 45-45-90.

Challenge: What is the height of the tree to be used in this activity? What methods can be used to determine the height of tall objects? How is a hypsometer used? Are there any instruments that are used to measure height in the same fashion as this homemade hypsometer?

### Materials and Equipment:

Scissors  
Cardboard  
Meter stick or measuring tape

How-To-Do-It: Construct a hypsometer by cutting a square piece of cardboard along the diagonal such that, when the cut is complete, the angles formed are 45-45-90. Sight a distant object by placing the hypsometer to one's eye and sighting along the diagonal to the top of that object. Have another student level the hypsometer until it is parallel with the ground. Move either backward or forward until the diagonal and the top of the object are in line. Measure the height from the ground to the eye and add this distance to the distance found when one measures from the sighting point to the object. This distance is the height of the object.

Further Challenges: Measure the actual distance of the object being measured and compare it to the distance found with the hypsometer. The percentage of error is found by using the following formula:

$$\frac{\text{Hypsometer height} - \text{Actual height}}{\text{Actual height}} \times 100 = \text{percent error}$$

Try various sized hypsometers and determine which has the smallest percentage error.