

DOCUMENT RESUME

ED 295 052

CE 050 315

TITLE Construction Trades Resources.
INSTITUTION Alaska State Dept. of Education, Juneau. Div. of Adult and Vocational Education.
PUB DATE 87
NOTE 121p.; For the Construction Trades Curriculum to which this is a supplement, see ED 275 903.
PUB TYPE Guides - Classroom Use - Guides (For Teachers) (052)
EDRS PRICE MF01/PC05 Plus Postage.
DESCRIPTORS Behavioral Objectives; *Building Trades; Competence; Competency Based Education; *Construction (Process); *Construction Materials; Course Content; Educational Resources; Energy Conservation; Learning Activities; Roofing; Secondary Education; Site Development; Soil Science; *Solar Energy; State Curriculum Guides; Vocational Education
IDENTIFIERS *Air Quality; *Alaska

ABSTRACT

This guide was developed as a supplement to the Alaska Department of Education's Construction Trades Curriculum. The special topics included in it focus on competencies from the curriculum for which materials were not readily available to Alaskan teachers and provide information that is either required by Alaska's environmental conditions or is not sufficiently covered by existing curricula. They are designed to be integrated into the regular curriculum at the appropriate times. The guide contains six sections covering the following topics: passive solar site selection, foundations, energy, indoor air quality, plywood beams, and metal roofs. Each section contains one or more units focusing on competencies within the topic. Each unit consists of an introduction, overview, resource list, tasks, and information sheets illustrated with line drawings. (KC)

 * Reproductions supplied by EDRS are the best that can be made *
 * from the original document. *

ED 295052

Construction Trades Resources

Steve Cowper, Governor

Developed by the...

ALASKA DEPARTMENT OF EDUCATION
Adult and Vocational Education

William Demmert, Commissioner

Karen Ryals, Administrator for Vocational Education

This publication was prepared with the support of U.S. Department of Education funds under the Vocational Education Act as amended 1976, PL 94-482. Copies are available from the Alaska Department of Education, Adult and Vocational Education, Alaska Vocational Materials Library, Box F, Juneau, Alaska 99811, (907) 465-2980. This publication may be duplicated.

U.S. DEPARTMENT OF EDUCATION
Office of Educational Research and Improvement
EDUCATIONAL RESOURCES INFORMATION CENTER (ERIC)

- This document has been reproduced as received from the person or organization originating it.
- Minor changes have been made to improve reproduction quality.

• Points of view or opinions stated in this document do not necessarily represent official OERI position or policy

"PERMISSION TO REPRODUCE THIS MATERIAL HAS BEEN GRANTED BY

KRCrane

TO THE EDUCATIONAL RESOURCES INFORMATION CENTER (ERIC)."

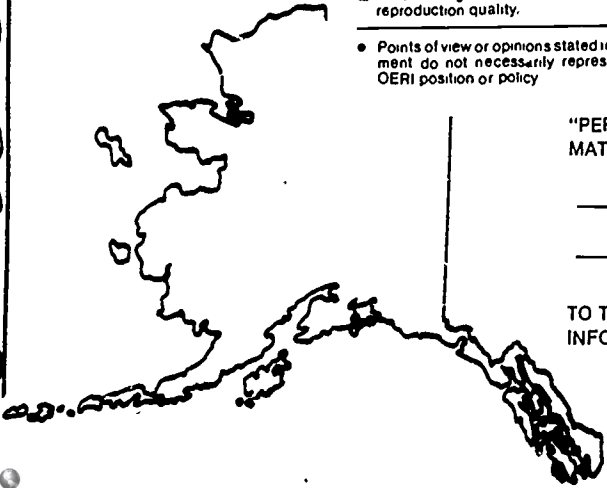
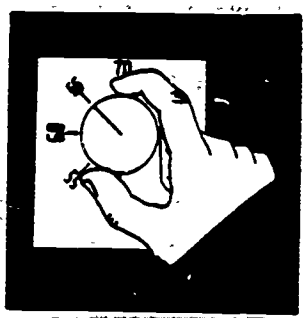
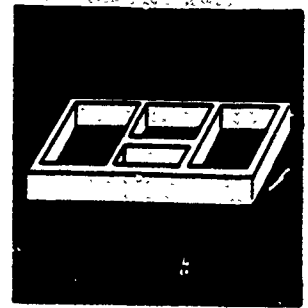
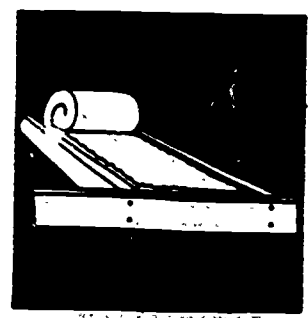

Alaska Department of Education 1987

CE 050315



The Alaska Department of Education is an equal opportunity employer and will not discriminate in Department employment, supervision, practices, services or educational programs on the basis of race, religion, color, national origin, age, sex, handicap, marital status, changes in marital status, pregnancy, parenthood, veteran's disability or political affiliation.

Construction Trades

Table of Contents

Introduction	i
Acknowledgements	ii
Instructional Materials	
Passive Solar Site Selection	1
Foundations	12
Soils	14
Slope and Flood Hazards	18
Foundation Principles	24
Foundation Types	28
Foundations for Good Soils	39
Foundations for Silts and Clays	42
Muskeg Foundations	43
Foundations for Permafrost	44
Foundation Thermal, Moisture and Pest Management	48
Energy	52
Energy Conservation	54
Introduction to Superinsulated Structures	58
Insulation	62
Air and Vapor Barriers	67
Insulation Materials	78
Superinsulated Floor Options	80
Indoor Air Quality	84
Indoor Air Quality Principles	87
Ventilation Systems	92
Alternative Heating Methods	94
Ventilation Requirements	98
Heating Requirements	103
Plywood Beams	107
Metal Roofs	111

Introduction

In 1986, the Alaska Department of Education developed the Construction Trades Curriculum. This volume, Construction Trades Materials, was developed as a supplement to the curriculum. The special topics included here focus on competencies from the curriculum for which materials were not readily available to Alaskan teachers, and provide information which is either required by Alaska's environmental conditions or is not sufficiently covered by existing curricula.

These topics are presented in the order in which they would logically be taught, if all were to be taught. However, they are also intended to stand alone. Normally, instructors would integrate them at the appropriate time with such topics as siting, framing, and roofing. The amount of time devoted to each topic and the depth of coverage is left to the instructor's discretion. Covering each competency is expected to require from one to three days, and considerable longer if the students actually perform the calculations, installation, construction, and related activities.

The very week that writing on this book began, the Alaska Craftsman Home Builders' Manual hit the street. Instructors not already familiar with that publication should review it at their earliest convenience. Ideally, instructors will integrate materials from that publication with this one. Although there is some duplication, a concerted effort was made to present materials in this publication which this new building professionals' manual had overlooked. In particular, this publication strives to present the underlying scientific principles and theories most important to siting, foundations, energy conservation, and indoor air quality. This approach is designed to give students the basic understanding which should make all subsequent construction-related experiences that much more meaningful.

Acknowledgements

Special appreciation is expressed to Mike Macy of Superscript Consultants for researching and writing the construction trades materials. Appreciation is also expressed to Susan Sloan Doherty of The Northern Institute who administered the curriculum development project, and to Danelle Corrick of The Northern Institute, who developed the final copy.

Special thanks are due to Carin Smolin, Resource Librarian at the Office of Adult and Vocational Education, for research assistance; to Linda Van Houten of the Alaska Department of Health and Social Services for editorial assistance; to Vivian Hegg, Computer Sciences Instructor at the University of Alaska-Juneau for electronic transfer of curriculum; to Susan Swiderski who provided illustrations for the publication; and to Dave Wood of the Southeast Regional Resource Center, who designed the cover.

Thanks are also expressed to Craig Aldworth of QUADRA Engineering in Juneau; Dick Hamilton of Alaska DOTPF in Juneau; Steve Shows, City and Borough of Juneau Building Inspector; Sidney Heidersdorf, State Radiological Physicist in Juneau; Axel R. Carlson, Northern Construction Expert, University of Alaska Cooperative Extension, Ret. in Fairbanks; and Jack Anderson, Construction Instructor, Juneau-Douglas Community College.

Appreciation is expressed to the Cooperative Extension Service and Alaska State Department of Community and Regional Affairs Office of Energy Programs for permission to use information and illustrations from the Alaska Craftsman Home Builders' Manual, February, 1987 edition. Appreciation is also expressed to the Institute of Northern Engineering, University of Alaska-Fairbanks for permission to reproduce materials from Building in the North, by Eb Rice, Revised 2nd Edition, 1985.

Finally, Verdell Jackson, Curriculum Specialist for the Office of Adult and Vocational Education, must be recognized for participating in every step of the development of this publication and ensuring that it provides Alaskan students and instructors with curriculum materials of the highest quality.

Karen Ryals
Administrator
Office of Adult and Vocational Education
Alaska Department of Education
June, 1987

Passive Solar Site Selection

Passive Solar Site Selection

Introduction

This unit presents material which describes the potential significance of solar radiation in residential heating. It also describes the ideal passive solar site, and the various calculations used to determine site selection.

Overview

While there are few jobs in passive solar site selection, passive solar design and construction will continue to be a small but growing segment of the construction industry. Knowledge of the subject and an ability to apply the principles will be of advantage to both amateur and professional builders--in fact to anyone living in the north.

Resources

Alaska Regional Profiles. Arctic Environmental Information & Data Center, University of Alaska, Fairbanks.

The Complete Passive Solar Home Book, Brad Schepp & Stephen M. Hastie, Tab Books, Blue Ridge Summit, PA.

Passive Solar Energy Book, Edward Mazria, Rodale Press, 1979, Emmaus, PA.

Site Selection

Competency: Understand Passive Solar Site Selection and Design

- Tasks:** Explain passive solar terms and principles
Explain site selection terms and principles
Explain location techniques
Calculate solar gain

How is a site chosen?

Because the sun is so low in the sky during the winter when the need to heat structures is highest, structures should be sited and designed to maximize the amount of solar energy striking the windows during the winter.

What is solar energy?

Solar energy is energy that comes from the sun, and it takes many forms: sunlight, falling water, wind. However, for present purposes, solar energy is sunlight.

What is the difference between passive and active solar energy?

The difference between passive and active has nothing to do with the source--solar energy is solar energy--but rather the degree of effort which must be made to capture and utilize the energy. Sunlight flowing through a window to warm the interior of a house is passive solar energy. On the other hand if it is pumped into a thermal mass or trapped in photovoltaic cells for conversion to electricity, it becomes active solar.

Most passive solar energy collection uses the direct gain method.

What is direct gain?

Direct gain occurs when sunlight shines on objects and transfers heat directly into those objects. For example, when sunlight shines through a window and strikes an interior wall, the wall experiences a direct gain of heat.

How is passive solar energy collected?

The simplest way to collect passive solar energy is to have south-facing windows. In a normal structure, much of this solar energy is soon lost to the outside environment. In the superinsulated structure, however, the building envelope retains the heat much longer.

Are there any problems with passive solar heating?

This method tends to result in large fluctuations between day and night temperatures. Storing the heat in a thermal mass, such as a masonry wall, concrete slab, or water barrels which then release it during the night, results in less indoor temperature fluctuation and more comfort.

What is passive solar site selection?

Passive solar site selection means choosing a building site with maximum solar heating potential. And it also means orienting and designing a structure to maximize its potential for utilizing solar heating.

How does one go about selecting a site with high passive solar heating potential?

Exposure is the primary consideration.

What is exposure?

Exposure means which way the site faces. Flat land faces all directions equally. Hillsides however, slope in one compass direction or another. If your building site sits on the north-side of a hill, it has a northern exposure, because when you stand on the hill and look out, you look north. Similarly, the opposite side of the hill has a southern exposure. In the Northern hemisphere, to take maximum advantage of sunlight for heating, locate your house on a south-facing slope.

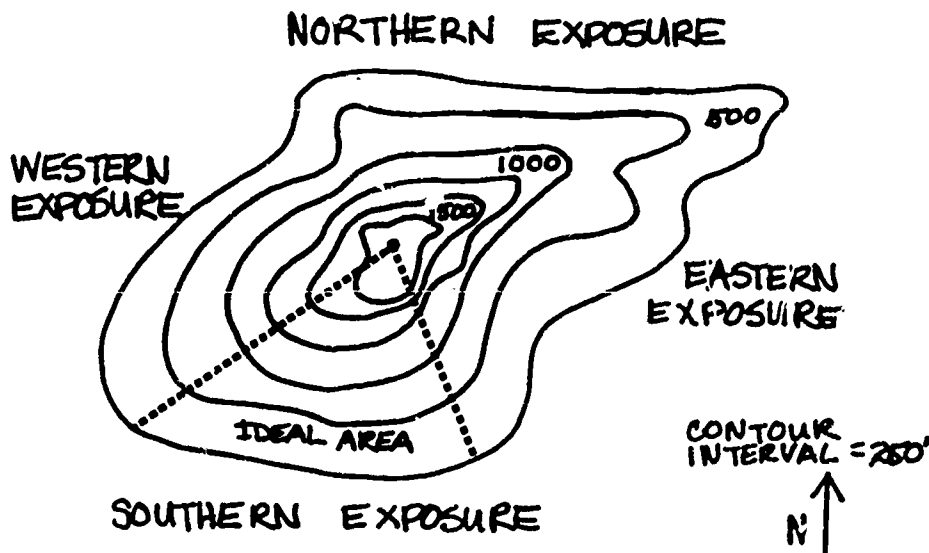

What's so hot about south-facing slopes?

When sun is directly overhead, sunlight is strongest because the rays hit the earth's surface at right angles. In the United States, Canada, Alaska and other parts of the northern hemisphere, the sun, even at midday in the summer, is never directly overhead. Instead, the rays come from south of directly overhead, and they strike flat ground at an angle--which means the light is spread out over a larger area. Sunlight strikes south facing slopes at more of a right angle, so that the solar energy is focused on a smaller area. What this means is that south-facing slopes receive more solar radiation per square foot than do north facing-slopes.

SUN ANGLE AT NOON ON JUNE 22

SOUTH

NORTH

SUN ANGLE AT NOON ON DECEMBER 22

SOUTH

NORTH

How much energy are we talking about?

In a normal house, passive solar heat isn't going to reduce energy bills very significantly. In a super-insulated house, on the other hand, sunlight shining in through windows can reduce fuel consumption by nearly 1/3--even in Alaska where the sun seems relatively weak in winter.

How does one capture this incoming radiation?

If you can build on a site with a southern-exposure, you already are taking advantage of this differential heating--because south-facing slopes tend to be the warmest places. As the sun's rays hit your slope, they warm it and the warm air rises.

On the other hand, the north-side of the ridge is either in shadow or relatively weakly sunlit. In either case, cool air is likely to be sinking because it is dense and heavy. The coldest building sites are in valleys, on flats, along river-bottoms and at the base of slopes--and particularly at the base of north-facing slopes.

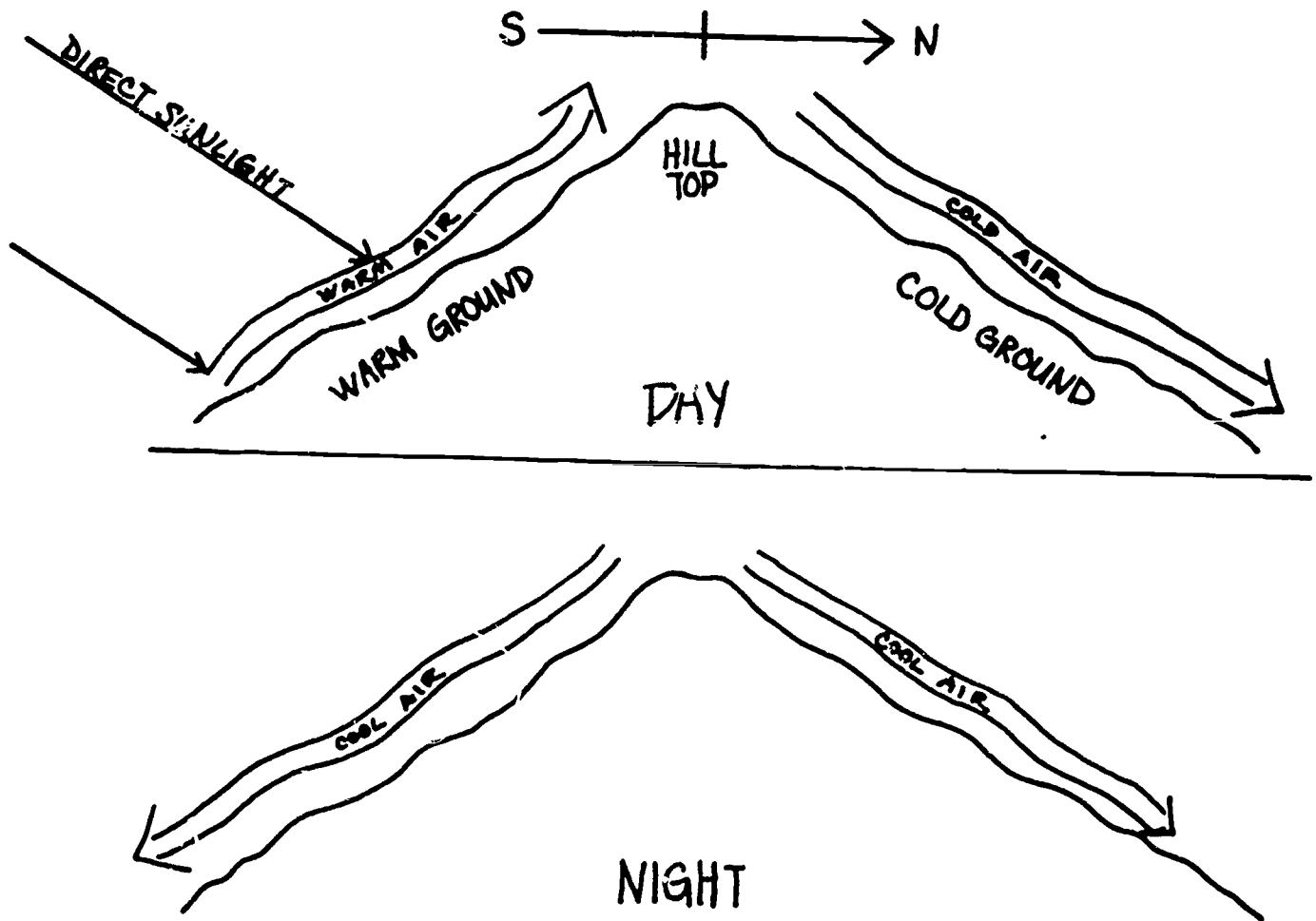

Surely there is more passive solar heating than building on a south-facing slope

There is. But the conditions are the same. Windows should be on the south side of structures. Windows on the north side should be kept to an absolute minimum. In fact, in the coldest parts of Alaska, about the only reason to have a window on the north side of a building would be to serve as a potential fire escape.

Is there a limit to how much south-facing glass a structure should have?

Yes; no more than 6-9% of the floor area should be south-facing windows, otherwise the structure will overheat during the day and cool excessively during the night.

South Glass Area

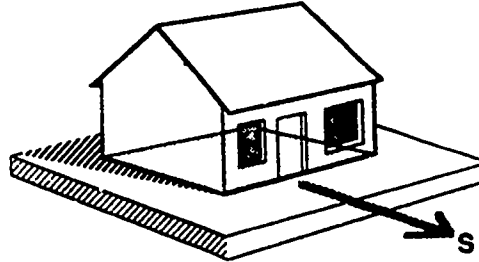

No more than 6-9% of liveable floor area can be south facing glass or overheating may result.

Illustration from Alaska Craftsman Home Building Manual

What is wrong with north-facing windows?

Even the most energy-efficient, triple-pane, glazed windows lose heat at night. In Alaska north-facing windows receive direct sunlight only during midsummer nights when it is least needed for heat and when people have a hard enough time sleeping without having the sun shining on them. The rest of the time, north-facing windows will be losing heat.

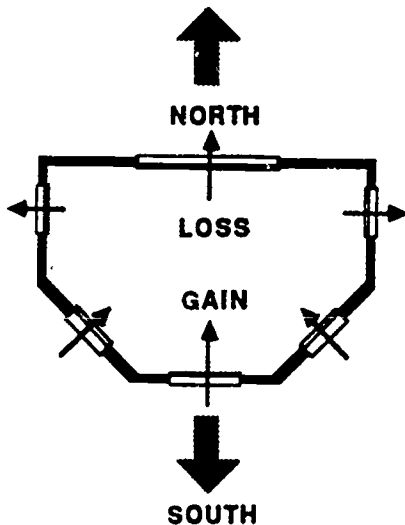

Energy Flow Through Double Glazed Windows

Illustration from Alaska Craftsman Home Building Manual

How do windows loose heat?

Windows loose heat by conduction and radiation. They conduct heat from the warm air on the inside to the cold air on the outside. Heat waves radiate directly through the glass. When the sun is shining, the net energy transfer through a thermally-efficient window will be positive, in passive, more heat will flow into the house than out. With sunset, the net energy flow will be from the inside out. The best way to capture the day's gains are to install some sort of thermal shutter system which allows you to "plug" the thermal hole each night.

There are now window glazings, or films, that reduce a window's "transparency" to certain wavelengths of light--notably infra-red. These glazings reduce the amount of heat that the window can radiate back outside and are therefore valuable for homes built in cold climates.

How do I figure out which way is exactly south?

A compass will tell you where magnetic south is. Correct for declination and local magnetic anomalies to determine geographic south. Otherwise, south is the direction to the sun when it is at its highest in the midday sky (solar noon). Be sure not to stare at the sun while making the determinations. Looking directly at the sun, even while wearing sunglasses, causes permanent blindness!

The sun isn't very high in the winter sky. How can I be sure it will clear trees and other obstacles and shine on my structure?

If you live north of the arctic circle, you'll be out of luck---and out of sunlight--for part of each winter. But even then, the principles for determining whether and/or how much your house will be shaded are the same.

First determine the altitude, or height above the horizon in degrees, of the sun for your latitude on the shortest day of the year, the winter solstice. December 21. This can be done with a clinometer or it can be looked up in navigational tables. Having done that, it is a simple matter of trigonometry to calculate whether or not a given object will shade your structure. Having done that, you can calculate the sun's altitude for the equinox and the summer solstice. In fact, can calculate whether or not sun will shine on your east and west walls, and at what time of

Should I cut everything down that shades my structure?

Although you'll want to maximize the solar exposure on your structure's south-face during winter, there are other considerations to make before cutting down obstacles. Trees, for example, also provide privacy, slope stability, and wind-protection.

Terrain, trees, fences, outbuildings, and other objects affect wind patterns. They can either shelter a structure from cold winds and cold air drainages, or they can focus those winds on a structure. Beware of building in the lee of a bluff where prevailing winter winds may leave enough snowdrift to bury your structure.

Building on a south-facing slope should reduce the amount of tree-removal necessary. If the slope is steep enough, you may just need to remove the tops of the trees.

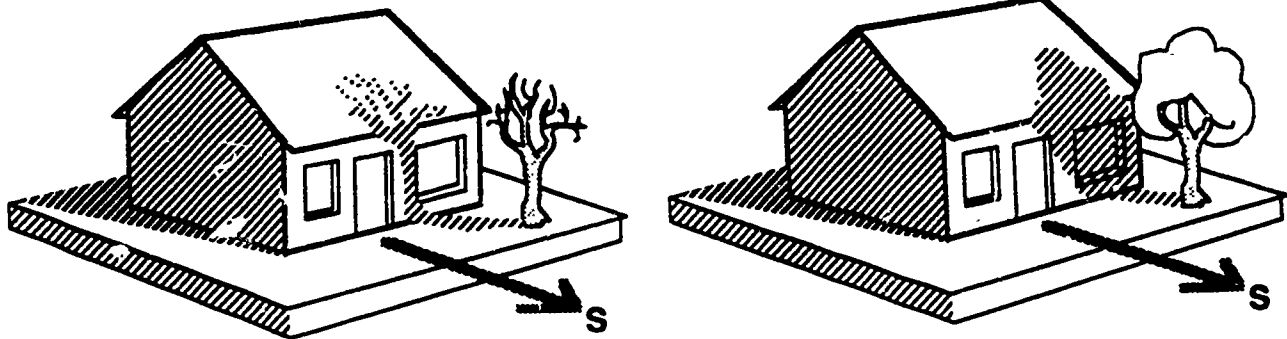
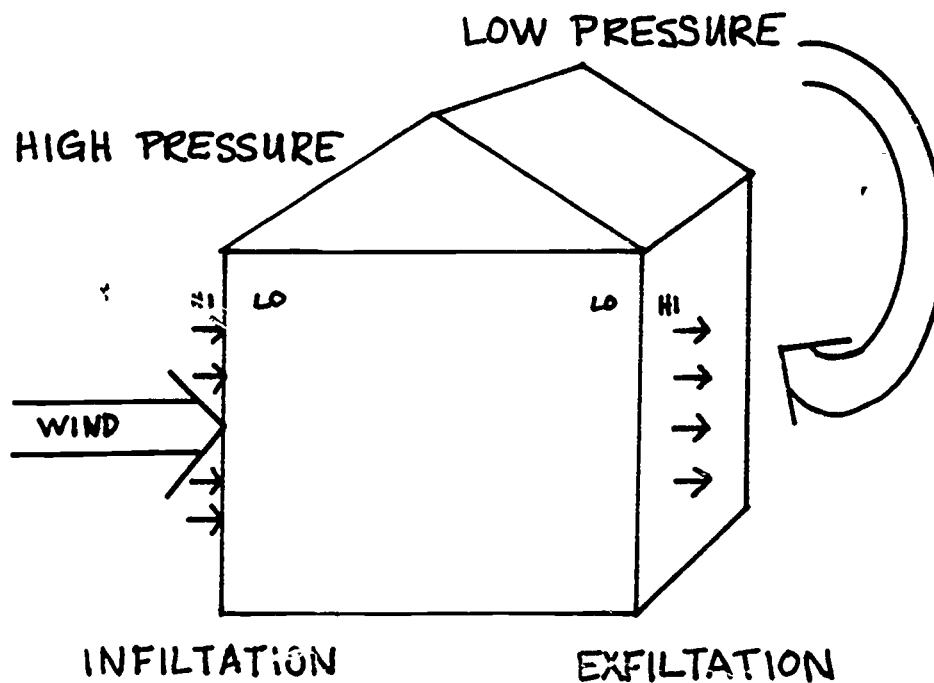

Illustration from Alaska Craftsman Home Building Manual

Generally, you should not disturb trees on the north side of the site. The fate of trees to the east, south, and west should be carefully weighed in light of their potential to provide privacy, wind-protection, and, during summer, shade.

Why should wind effect a super-insulated house?

The wind-chill factor applies to structures just as much as it applies to people. Wind blowing against a house continually delivers unwarmed air to the building surface and whisks away whatever heat has escaped. Wind also creates pressure differentials between a structure's interior and exterior, and these differences in pressure accelerate movement of air through gaps in the building envelope whether they be vapor barriers, downpipes, vents, or gaps in doors and windows.



Can wind effects be controlled?

To a certain extent, topography and trees can be used to minimize the wind effects on structures. In areas like Southeast Alaska where trees can be very tall, a builder always takes a risk by not removing trees which would strike the structure if toppled by high winds.

One also has to keep in mind that the sun rises in any given direction only twice a year. This direction is called azimuth, and it's the angle that would form between someone's arms when they faced south and pointed at true south with their right arm and at the spot the sun rises with their left. On the winter solstice, this direction is approximately southeast. By the spring equinox, sun rise has moved north towards due east. By the summer solstice, sunrise has moved to its northernmost location on the north east horizon.

The actual azimuth differs for each latitude, but the significance for the passive solar builder remains somewhat constant. Whenever possible, houses should be sited so that the mid-day winter sun (in Alaska from August 21 until April 21 and from 9 AM to 3 PM) has an unobstructed shot at east, south, and west walls.

On flat or gently sloping ground, it may not be energy-effective to remove trees which block the sun at noon on the winter solstice or early in the morning at other times of the year because when the solar altitudes are lowest, solar heating will be minimal. However, whenever possible the building site should be exposed to the mid-day sun.

Foundations

Foundations

Introduction

This chapter is broken into nine units, each of approximately one hour's length. The units proceed from the general to the particular. While not all of the soil types may be found in the immediate vicinity of the school, it is hoped that the instructor will at least mention the differences because students may end up working in other parts of the state which have vastly different soil conditions and foundation requirements.

Overview

The statement that a house is as good as its foundation is nowhere more true than in Alaska. Here, climates and natural processes create special soils demanding careful site investigation and foundation construction strategies. Because a good foundation is so important and because soils can be so tricky, there are many engineers and technicians who specialize in site and foundation design and soil analysis. Similarly, many contractors limit their practice to foundation construction. Individuals with a solid understanding of soils and foundation considerations will continue to be in demand in Alaskan construction.

Resources

Alaska Craftsmen Home Building Manual; Cooperative Extension Service, Suite 240, 221 E. Northern Lights Blvd., Anchorage, AK 99508-4143.

Alaska Science Nuggets; Neil Davis, Geophysical Institute University of Alaska, Fairbanks, AK 99775.

All-Weather Wood Foundation System Manual; National Forest Product Association, 1619 Massachusetts Ave. N.W., Washington, D.C., 20036.

Avalanche Handbook, (Agriculture Handbook 489) Ronald I. Perla & M. Martinelli, Jr. U.S.F.S., U.S.D.A., U.S. Government Printing Office, 1975.

Building In the North; Eb Rice, Institute of Water Resources/Engineering Experiment Station, University of Alaska, Fairbanks, AK, 99775-1760.

Construction of and on Compacted Fills, Edward J. Monahan, P.E., John Wiley & Sons, New York, 1981.

Earthquake Resistant Building Design & Construction, 2nd Ed., Norman B. Green, Van Nostrand Reinhold, New York, 1981.

Environmental Geology: Conservation, Planning, and Resource Management; Peter T. Flawn, Harper & Row, 1970.

Muskeg Engineering Handbook; National Research Council (of Canada), Ivan MacFarlane, Ed., University of Toronto, 1969.

THE NORTHERN ENGINEER: Applied Science in the North, a quarterly publication of the Geophysical Institute, University of Alaska, Fairbanks.

Soils

Competency: Understand soils

Tasks: Explain soil types and terms
Explain how soils are formed
Explain how soil characteristics relate to foundation construction

Where does soil come from?

Soil comes from two sources. Soil is derived from rock through physical or chemical weathering, or from plants by rotting.

What's the difference?

Plant-derived soils contain large amounts of carbon removed from the atmosphere through the process of photosynthesis.

From the atmosphere? You mean plant-derived soils are full of gas?

Sometimes. That's where the swamp-gas in muskegs comes from. And because they contain a great deal of gas, they tend to compact under pressure. That's one of the reasons they tend to make poor materials to build a house on--even when they aren't full of water.

Full of water?

Sure, muskegs and peats are like sponges when they aren't frozen. They shrink each time they dry out and swell each time they get soaked. If they're dry, they're always ready to soak up moisture. When they're dry they can catch fire and burn for months.

How about coal?

Coal is fossilized plant-derived soil. People do build on it, but then sometimes their houses collapse because fires have consumed the coal underground.

Can we build on rock-derived soils?

It's generally a better idea than building on plant-derived soils, but not all rock-derived soils are created equal. Their suitability for construction purposes depends on several factors including grain size, composition, climate, and how the soil was formed.

What does grain-size have to do with anything?

Rock-derived soil can be categorized by grain size: cobbles, gravel, sand, silt, etc. Partly because of grain-size, sand and gravel tend to make ideal materials upon which to place foundations. They can be packed closely enough to be somewhat solid, yet there is enough space between each grain to allow water to drain away. If this water did not drain away, but froze, the soil would heave and/or creep because water expands upon freezing.

What's the difference between heave and creep?

Heave is an upward motion caused by freezing. Creep is a downslope motion in response to gravity. Creep puts extra strains on foundations because it is most pronounced at the surface and decreases with soil depth.

What other factors influence soil strength?

Shape is another important consideration. Exceedingly smooth-grained or rounded particles tend to act like ball-bearings or marbles. Even though marbles are hard and resistant to weathering, we wouldn't want to build on them--even if we could afford to because the weight of the structure would tend to eject the marbles.

How does a soil's chemistry affect its suitability for construction?

If the soil grains absorbed water, they would expand, then contract again after the soil dried out. This cycle could eventually produce settling. If the water froze before it escaped, heaving and creeping in the spring settling would result. Because these forces tend to concentrate under only part of the foundation, they can quickly destroy it.

Chemical composition also makes certain material more vulnerable to chemical and physical weathering. Limestones for example are soluble; in other words, they dissolve when exposed to acidic water.

How does the manner of formation affect a soil's suitability for foundations?

Rock can be weathered into soil by chemical and/or physical attack. Freezing and thawing cycles, running water, grinding ice, and pounding surf are turning rock to soil somewhere in Alaska at this very moment. Each of those processes has distinctive effects on each type of rock --effects which can be recognized by trained observers.

Because the mechanisms of transportation and deposition also affect the soil and its properties, soils are often described in terms of their origin or source. Glaciers, for example, produce moraines or tills which include randomly mixed clay, silt, sand, gravel, and boulders. Depending on how far the material was carried and whether it was exposed to running water, it may be sharp and angular or relatively smooth and rounded.

They also produce eskers, long ridges of coarse gravel deposited in channels under the ice. Winds blowing off the ice sheets frequently pick up the finest clay and silt particles which have deposited in front of the ice and whisk them far away to areas with less wind where they settle out in deposits called loess.

So how are plant-derived soils formed?

In swamps, ponds, former lakes and other poorly drained areas, decaying plant matter may build up over decades and centuries to form muskeg or peats.

What is topsoil?

Topsoil results from the interaction of plant and mineral-derived soils over long periods of time. Chemicals released by the plants weather underlying mineral or organic soil, turning it into topsoils which are ideal for crop-growing.

How are soils classified?

The term soil means different things to different people. To most farmers, soil is material which will support crops--and agricultural soil scientists have developed complex classification systems which describe the various types of soils and the entire soil horizon from the surface of the ground down to bedrock. To engineers, the word soil means all weathered, unconsolidated material above bedrock. The engineer's concern focuses on how the soil will respond to different human activities in its vicinity. Geologists may be more interested in the history or origin of the soil, where it came from, how it was transported, how the transportation changed it, how and why it was deposited, and what has happened to it since.

These geological questions may be of interest to the builder, particularly because they all relate to how the soil will behave. However, builders tend to look at soil from the engineer's perspective.

How do engineers classify soil?

Usually sediments are classified on the basis of their grain-size and physical properties.

Cobbles are the largest, the size of pastries and larger. Gravels range in size downward to the size of peas. Sands range in size from 2 mm down to 1/16 mm.

Silts are angular, fine-grained (between 1/16 and 1/256 mm) unconsolidated rock-derived materials that have been transported and deposited by wind, water, or ice. Under pressure, silts tend to fracture.

Clays are also rock-derived and are approximately the same size as silts, but they differ in that clay particles are linked by chemical bonds. Clays tend to be highly plastic, which means that they readily deform and flow, without fracturing, in response to pressure.

How does the origin of soil influence foundation design?

Each soil has unique load-bearing characteristics which result from grain size, chemistry, permeability, water content, temperature, and slope. Certain types of clay are great for making ashtrays, but add too much water and they become a greasy mess. You wouldn't want to build a house on a greasy hillside, would you?

How are soil composition and characteristics determined?

In the cases of cobbles and gravels on the one hand and muskegs on the other, it is frequently possible to make a good guess as to its suitability or unsuitability for construction. In many cases, however, detailed investigations must be made. With large, heavy buildings, it's not enough to know what the soil is like at the surface. One must know what lies ten and twenty feet below.

Usually this involves boring test holes from all parts of the building site. It's important to make many borings because very different soils can lie in contact with one another. These borings are then sent to a soil lab. In the lab, the soil's water content, grain size, and chemistry, can be readily determined. In addition, it can be tested for its reaction to compression, tension, and shearing. Taken together, all of these can accurately predict a soil's suitability for supporting various types of structures.

Slope and Flood Hazards

Competency: Understand slope and flood hazards

Tasks: Explain slope hazards terms, principles and mitigation strategies
Explain flood hazard terms, principles, and mitigation, strategies.
Explain seismic hazard terms and principles

What is a slope hazard?

A slope hazard is any increased risk resulting from sloping ground. Landslides, mudflows, debris flows, solifluction, creep, avalanche, glaciers, rock glaciers, flood planes, are some of the better known results of slope hazards.

What causes slope hazards?

Although there may be a variety of factors leading to the failure of a given slope, gravity is always ultimately responsible. As everything on the earth is subject to the force of gravity, it shouldn't be surprising that soil, rock, and other materials tend to move downslope. Water and ice act as lubricants, increasing the tendency of materials to respond to the pull of gravity.

Are all materials equally prone to fail?

No. Anyone who has tried to build a sand castle or a mud pie knows, for example, that the builder is limited by how much water the sand or mud contains. If the sand is too wet, the castle walls and turrets flow downhill as fast as they are made. Similarly, once the walls dry, there is nothing to cement the grains together and the walls tend to collapse on their own or blow away in the wind. This demonstrates something called the angle-of-repose.

What is angle-of-repose?

The angle-of-repose is that angle at which a material such as sand can be stacked. Stack the material more steeply, and it soon slides. For each material, the angle-of-repose differs. For dry sand, it is approximately 34%.

What is the significance of the angle-of-repose?

If you build on level ground, you won't have to worry about angle-of-repose. However, if you build on a slope, you will. In the case of sand, for example, every time you remove a shovel full of material from the side of the pile, another shovelful slides down to take its place, and this continues until you have shoveled so much of the pile away that its top is the same height as your excavation.

Each soil responds differently, but all exert pressure on a foundation built into a slope. Eventually, the foundation may be destroyed.

Can I build on a hillside as long as the slope is less than the angle-of-repose for that soil?

Not necessarily. If you stack up dry sand at the angle-of-repose, your stack should retain its height and shape. But what happens if you load it? Say the town bully steps in the pile? His foot indents the pile; the surrounding grains are displaced or extruded. Well, your structure will be heavy, too. Rather than have it sink into the surrounding material, you'll need to ensure that the surface that you are building on can withstand the disturbance caused by excavation, construction, and the additional weight of the structure and its foundation.

When building on a slope, the preferable substrata for a foundation is bedrock--although even it can fail in certain circumstances.

What is bedrock?

Bedrock is consolidated rock--as opposed to boulders or cobbles which are also rocks, but ones that have been weathered or eroded from bedrock--that is part of a formation. Substrata is merely the material underfoot, or under the surface. The substrata can be either bedrock or sediments which are materials derived from bedrock.

The main danger is landslides, right?

Land and rock slides, mud and debris flows, and avalanches tend to be life and structure threatening. Because they happen so swiftly and change the scenery so dramatically, they tend to overshadow other slope hazards. But creep and solifluction, which are continuous, small-scale movements can render structures just as uninhabitable and eventually destroy them.

What is the difference between solifluction and creep?

Creep can occur in dry soils. Solifluction occurs when water percolating down through soils lubricates and rafts individual grain along with it.

Are there any signs which indicate these hazards are present?

Although sometimes there will be no indication that a slope is on the brink of failure, more often than not there is. There may be old rockslide scars, or angular boulders scattered on the flats below. The upper slopes may have scarps where landslides broke away, the slopes may be gullied, and slope toes may show fan-shaped deposits where former slides came to rest. It's a good bet that if a slope has failed before, it could again. The presence of creep may be impossible to detect. On timbered slopes, otherwise vertical tree trunks with downslope curves at the base are often a good sign of creep.

In the oversteepened fiord valleys of coastal Alaska, entire mountainsides--including bedrock--are prone to collapse. Sometimes, as has been the case at Lituya Bay, the rock has been weakened by repeated faulting and the collapse is triggered by an earthquake. In other cases, the weakness could result from the rock's structure, for example its bedding planes. In the Haines area, Tlingit villages on the Chilkat and Chilkoot rivers were overwhelmed by landslides.

Should buildings be sited on the flats whenever possible?

Not necessarily. In Alaska, where exposure to sunlight is an important concern, south-facing slopes are frequently the site of choice--assuming that soil conditions permit. In fact, in discontinuous permafrost areas of Interior and Western Alaska, south-facing slopes frequently offer the only ground that is not underlain by permafrost.

Before building on slopes, the soil should be analyzed to make sure it will remain stable after it has been disturbed by the construction, the additional weight of the structure, and changes in drainage patterns and moisture content.

Building on slopes and elevated ground has the advantage of avoiding floodplains.

What is a flood plain?

Flood plains are low-lying areas which are subject to periodic flooding. They are typically found along streams, rivers, lakes, and sea-coasts. In larger communities, the flood plains have often been mapped; flood plain maps are frequently available from local planning and other agencies.

What causes flooding?

When areas receive more precipitation than the soil and drainage systems are capable of managing, floods result. As in other parts of the world, excessive rainfall and intense storms cause most flooding. During such periods, rivers carry huge loads of sediment and are likely to change course from one side of their floodplane to the other, carrying away old banks, creating new islands, and destroying whatever lies in their path. In addition, parts of Alaska are subject to flooding as a result of ice-dammed rivers during breakup.

What's an ice-dam?

An ice-dam forms when ice-floes pile-up in a river channel, typically where the channel enters a canyon or rounds a sharp bend with high banks. These floods are doubly-destructive because of the presence of ice. First the country upstream from the dam floods. Then when the ice dam breaks, the country downstream is inundated while massive ice flows bulldoze forests, bridges, and communities. Dumping lakes are another variation on this theme.

What is a dumping lake?

Dumping lakes are associated with glaciers which terminate in lakes. Water rises until the icebergs are suddenly rafted downstream or the water finds and quickly scours itself a new outlet. Like the outbursts of ice-dammed rivers, dumps can be terribly destructive for tens of miles downstream.

What are the signs of prior flooding?

Any low-lying area is prone to flooding. Highwater often deposits twigs, leaves, and branches in the trees along stream banks. Logs and ice being swept downstream will collide into these same trees and scar their trunks. Make sure your building site is significantly above the highest scars.

How will I know if my site is safe from flooding?

Whenever possible, obtain flood hazard maps for your area. If at all possible, select a site that is above the 500 year or 1000 year flood zone. If you must build in a flood zone, consider a piling foundation.

Is overflow a flood hazard?

Overflow threatens roads and structures throughout Alaska. Whenever water courses freeze solid, overflows can occur. It is typically found on streams and on hillsides where springs are near the surface.

What causes flooding in coastal areas?

Coastal flooding generally results when high tides combine with intense storm systems. Low atmospheric pressure, winds, waves, tides, and the earth's rotation combine to pile up more of the ocean than is normal against part of the coast.

What are the signs of coastal flooding?

Waves usually strand debris and driftlogs at the highwater mark. Frequently they leave rafts of flotsam and jetsam in sloughs and lowspots which are normally not reached by the tides. Make sure your site is inland and upslope from the highest strand line. If your area is on an eroding coast (where there is no beach or waves sometimes reach the base of cliffs), make sure you build well back from wave-cut cliffs.

What are seismic hazards?

Seismic hazards are those hazards which are related to earthquakes. They fall into two broad categories: those which result directly from the destructive seismic waves themselves, and those resulting from forces or events unleashed by the seismic waves.

What do earthquake waves do?

Seismic waves from a strong earthquake can turn a formerly stable hillside--or even a seemingly solid rock mountainside--into a landslide. It can turn flat-lying sands and silts into quivering jelly-like masses. This is another reason why one wants to always have a good safety margin when one builds on slopes--and why one should build on good soil whenever possible.

Sometimes these landslides will travel considerable distances across flat ground. When they fall from the summits of the highest peaks as they have in South America, they may gain enough momentum to sweep over low hills and engulf structures and communities a dozen and more miles from their source.

During the Good Friday Earthquake in 1968, many houses built on the Bootlegger Cove formation, which is fine-grained silt, were destroyed when parts of the formation slid as much as a quarter mile into Cook Inlet. The next time you get to Anchorage, visit Earthquake Park near the end of Northern Lights Boulevard. Don't miss the exhibit in the parking lot.

What can builders do to increase the chances of their structure's surviving seismic waves?

Bedrock is the best setting for a foundation because the rock will tend to heave as a unit. Wood-frame structures are much more likely to survive than block, brick, or masonry walled buildings, because the wood and the nails are much less rigid than the concrete and mortar.

What's a tsunami?

When earthquakes occur near coasts or trigger submarine landslides, tsunamis can be produced. Tsunami is a Japanese word meaning wave in the harbor, but they can occur in any water body. When underwater topography focuses tsunami waves on harbors, damage can be particularly severe as it was in Seward, Valdez, Kodiak, and half a dozen other communities as a result of the Good Friday Earthquake of 1964.

Is seismic risk the same everywhere?

No. Nearly the entire Gulf and Pacific Coast of Alaska is in the zone of highest seismic risk. This includes communities like Sitka, Yakutat, Cordova, Valdez, Seward, Anchorage, Homer, Kodiak, Sand Point, Dutch Harbor, and Adak. Many of these places have special building requirements or codes, to help insure that buildings will survive intense earthquakes. Other communities such as Juneau, Glennallen, and Fairbanks, while in less active seismic zones, still face significant risks from earthquakes and the forces they unleash. Alaska's North Slope is the lowest risk or seismically quietest area in the state-but that doesn't mean that a major earthquake won't occur there.

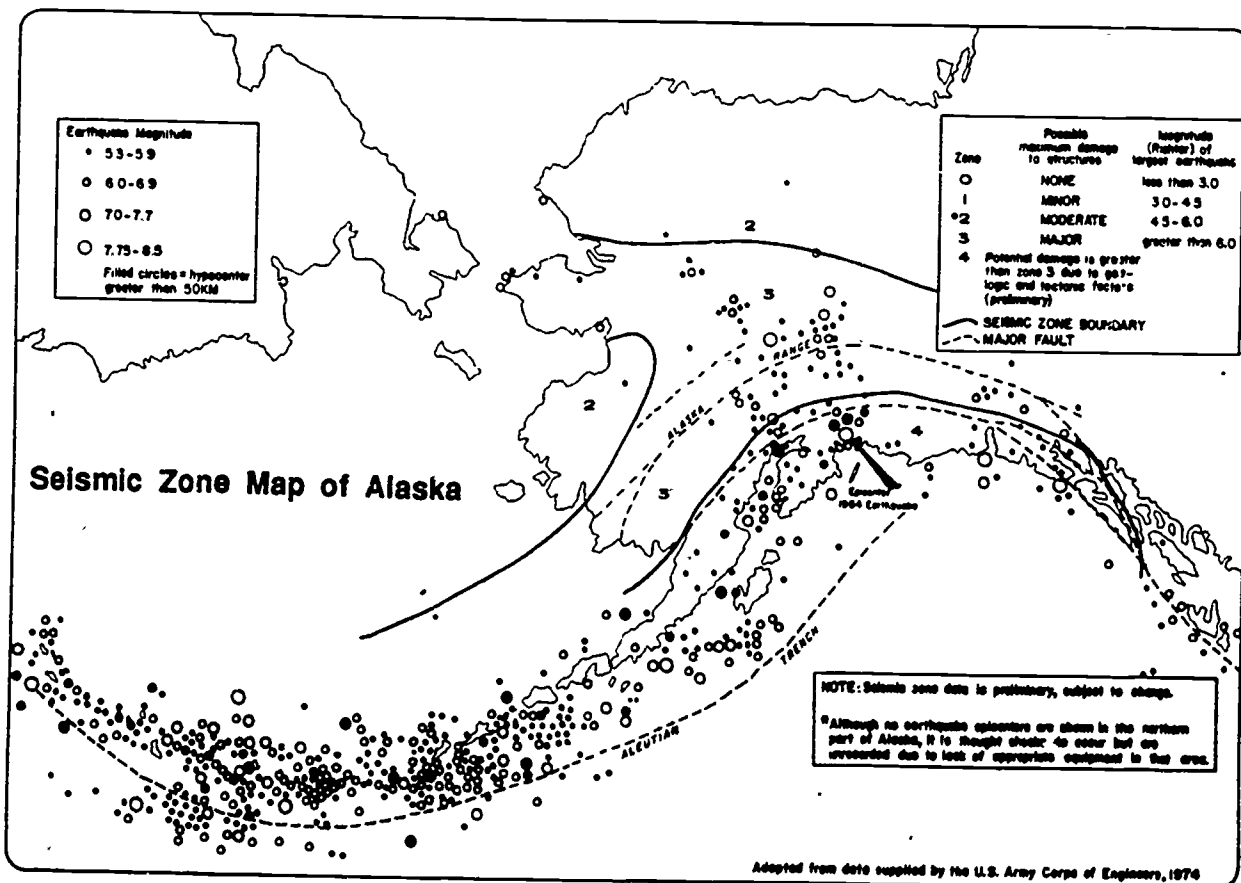

What are subsidence hazards?

Parts of Alaska, such as the east side of the Kenai Peninsula, are rapidly subsiding or sinking into the sea as a result of large scale movements of the earth's crustal plates. When building in such an area, one would do well to locate any structures 50 to 100 feet above present day sea level.

If you've ever driven past Portage on the Seward Highway, you've probably noticed the dead trees and abandoned structures in the swamps on either side of the road. These lands were flooded when the area subsided during the Good Friday Earthquake. The invasion of salt water killed the trees.

Are there other types of subsidence hazards?

Yes. Areas underlain by limestone such as Indiana, Kentucky, and parts of Texas are vulnerable to collapse because water can dissolve limestone. Areas where underground mining has removed significant amounts of material are prone to subsidence. Where large amount of groundwater are withdrawn for irrigation, land can subside very rapidly (from several inches to nearly a foot a year), as it has in parts of California's Sacramento River Delta.

All this sounds so technical. How can I know whether my site is suitable for construction?

In practically every area of the state, in the city or the bush, there are individuals who either through formal training or experience may be able to give you sound advice. Furthermore, these natural processes almost always leave telltale signs. Like the phone company sign says: ask before you dig!

Foundation Principles

Competency: Understand foundation principles

Tasks: Explain foundation terms and principles
Explain the purposes of foundations

What are foundations for?

Foundations provide solid and permanent bases for structures. The ideal foundation will not move in any direction--not horizontally or vertically, neither downslope nor upslope.

If part of the foundation were to move, or if all of it were to tilt, the structure above it would be distorted, and if the movement continued, the structure would eventually be destroyed.

How does one make an ideal foundation?

An ideal foundation begins with selecting a building site with soil suitable for the structure you intend to build on it. Then the foundation design must be suitable both for the soil and for the size and weight of the structure you intend to build. Finally, the foundation must be built properly. Problems encountered during its construction must be solved at that time--even if it means developing a new design or abandoning the site.

How does a foundation work?

There are two ways to make a stable base. The most obvious is to anchor your base to something stable, for example bedrock, or clean, well-drained, stable gravels. If the bedrock or sand and gravel is at or close to the surface, you may be able to place your foundation directly on it--and be reasonably certain that you have a permanently stable foundation.

What if there are no ideal surfaces to build my foundation on?

You still have some options. Your basic strategy becomes one of "floating" your structure. As long as your foundation is a good match between the sea of soil and the structure above, your house should not sink or capsize.

How does one "float" a structure?

If the soils at your site are less than ideal, you have several options. Sometimes, there is a shallow overburden of poor soil which can be removed and replaced by a gravel pad which you can then build upon. The structure's weight tends to be distributed throughout the pad, as if the pad was a raft. At the same time, underlying instabilities tend to be modulated by the pad, so that destructive forces are not concentrated on any one part of the foundation. It's the same principle that makes it possible to sleep on rough ground using an air mattress.

If good soil is only ten or twenty feet below the surface, you can drive piles into it and build on them.

What if there is no solid ground near the surface?

You may be able to sink pilings either until they reach a more solid material, or until the friction acting along their entire length exerts the same holding power as would a solid base. In the latter case, you are still floating your structure. Actual conditions will determine which option is best.

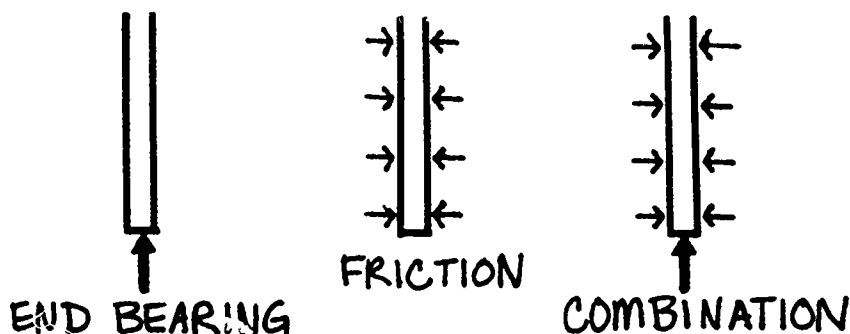

Does this mean that I can build on anything?

Of course not. Muskegs for example, should be avoided where ever possible. Although muskeg may cost less than other land, the cost of driving piling or some other foundation may more than make up the difference--and you still have poor land and a questionable foundation. In some cases, soils may be so deep and/or unstable that building on them is not worth the risk.

How does a foundation support a structure?

The foundation absorbs and redistributes the structure's weight. Force is dissipated down and outwards at 45 degree angles. If the soil is unable to resist these forces or if on the other hand the soil unequally exerts other forces on the foundation, the foundation will fail and your structure may be destroyed.

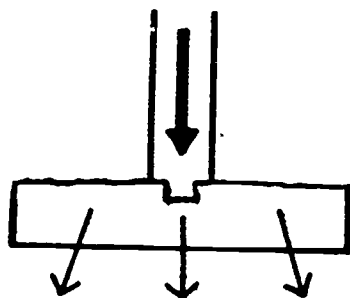

Why would a structure sink into the soil?

Any object whose mass exceeds the strength of the surface on which it sits will sink until equilibrium is established.

Some soils turn plastic or fluid when they are agitated or put under stress. These soils may be perfectly solid when frozen, and nearly as fluid when thawed. Perhaps you've discovered a silt like this along an Alaskan river. It looks solid. It may even seem solid when you stand on it. But if you move around or jump up and down, the whole mass starts quivering, water appears on its surface, and you may even find yourself sinking into something which seems to have a consistency somewhere between quicksand and pudding.

If the soil upon which you intend to build is such a soil, you'll either have to find another building site or employ special construction techniques. Strategies for building on fluid soils or those with low internal strength include distributing the weight over a larger area, improving drainage so soils are kept dry, and driving piles through the soil into more solid material below.

In such a situation, it takes soil tests and an engineer to design a dependable foundation, but the best strategy is to find a site with better soils.

Sometimes a foundation will straddle several different soil types. In such a case, obtaining a successful foundation may depend on engineering tests which show the load-bearing strength of each soil. Once each soil's load-bearing capacity is known, a foundation can be designed which supports the structure equally well at all points. This may require varying the size or area of the footings, pilings, piers, pads, etc. so that where soils are weak, the load-bearing member is relatively wide.

On some of the better silts, clays, or muskegs, you may be able to build on a gravel pad. But unless you place a barrier between the gravel and the substrate, the underlying soil, the two will tend to intermix. The weight of the building can punch the gravel into the underlying material, or capillary or frost action can squirt the underlying material up through the gravel, or both. The solution to this problem is geotextiles.

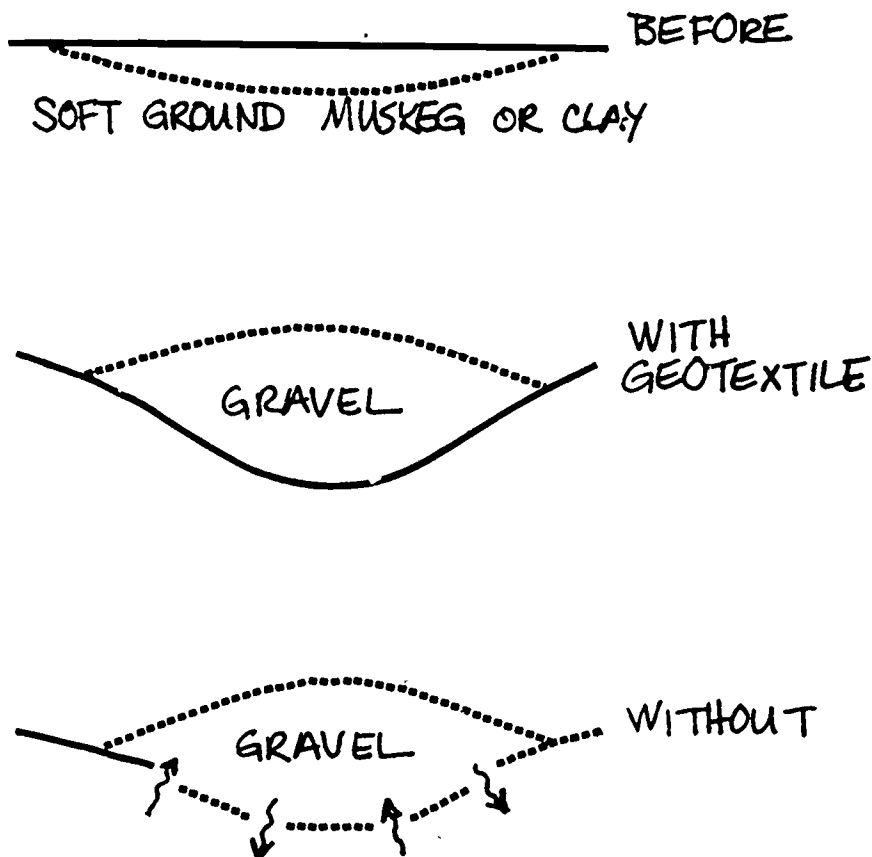

What are geotextiles?

Geotextiles are specially-designed plastic sheeting, which are laid down on top of muskeg and poor soils and on to which are placed fill materials for roadbeds and building foundations. Like other plastics, they decompose very slowly, unless exposed to UV (ultra-violet) radiation (sunlight).

Why can't I pour a concrete slab directly on marginal soils?

Concrete is strong, but not as strong as some of the force in the soil. Think of a small raft which is just able to support you when you stand exactly in the middle. As you walk towards the edge, the raft tilts increasingly, until the far edge rises in the air and the submerged edge begins to slide towards the bottom of the pond. This can happen to any foundation which is differentially jacked by frost and/or soil which varies in consistency from one side of the foundation to the other.

Frost can also punch a hole in slabs. Think of a concrete slab as a cracker. If you hold the corners of the cracker in four fingers and push on its center, it won't take long for the cracker to fail, or break. Concrete may be stronger than crackers, but forces in the earth are stronger than those in your fingers, too.

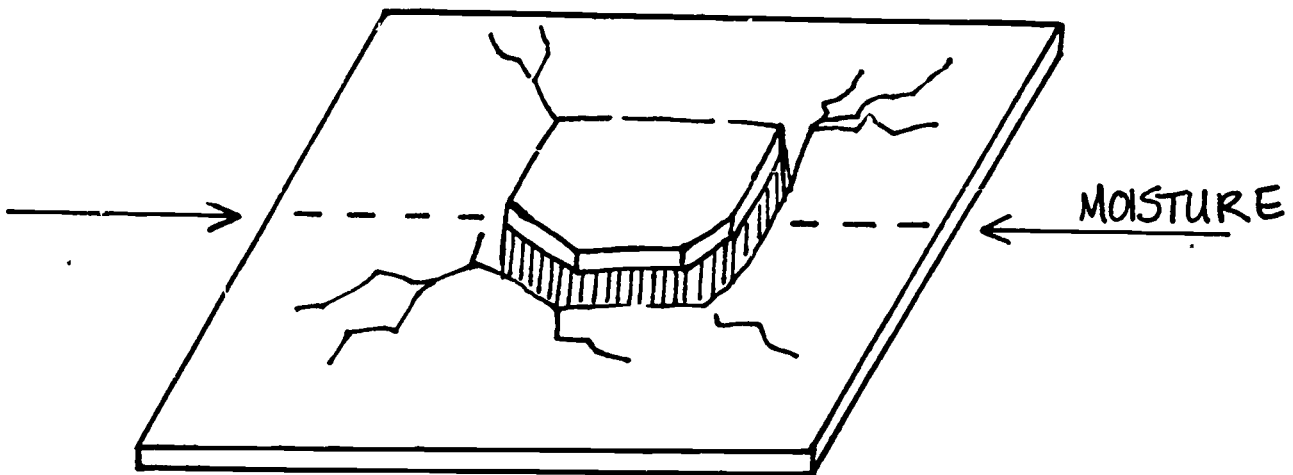

Slab failure when moisture migrates to the center and freezes.

Tilting can also threaten foundations which are too small for the structure's weight or windload.

What's windload?

That's the force exerted by the wind on an object. Think of your structure as a sail, and the foundation as a boathull. If your building site is exposed to high winds, the foundation may need to be enlarged or strengthened to prevent what sailors call a knockdown. The solutions are to incorporate a sufficient safety factor, by either avoiding marginal soils and/or building more of a foundation than would be absolutely necessary on the same soil at a sheltered site.

Foundation Types

Competency: Understand foundation types

Tasks: Explain the different types of foundations

What do foundations do?

Foundations do far more than just support structures. They are part of the structure's thermal, moisture, and pest management systems--and they should be thought of as systems, in their own right. There is a direct relationship between soil conditions, foundation-type selection, and selecting the building envelope design. In other words, foundation-type selection depends both on the soil and the intended use of the space within the foundation perimeter directly above. Moreover, whether or not the foundation is insulated depends again on similar considerations.

For example, one would not build a stem-wall foundation on permafrost. Having said that, foundation design should include insulation strategies and any openings for utilities and access.

What is a stem wall foundation?

The Stem wall-type foundation is perhaps the most common residential foundation in the United States. It consists of a poured concrete footing, or base, (usually reinforced), and a stem, or wall, of block or masonry. The top of the footing is generally at or below grade. The word stem probably refers to the fact that in profile the wall, or vertical section, looks like the stem of a wineglass.

In Alaska, the stem should be below the frost, or active, zone. In many communities, building codes specify the exact depth even though the depth may vary from site to site. In Juneau, code requires that the bottom of the footing be at least 32" inches below the surface. In Anchorage, the active zone may be ten or more feet deep, in Fairbanks, 15 feet.

How is a stem-wall foundation usually built?

Once investigations have determined that the soil is appropriate, the site is excavated to the appropriate depth. If drainage is likely to be a problem, a drainage system, usually consisting of gravel and drain pipes is installed.

Forms are then built for the footing, and for the wall, if it is to be poured. Steel reinforcement bar (re-bar) is installed, and then the concrete is poured, preferably when temperatures are well above freezing.

For the first few days, the concrete should be allowed to cure slowly. As curing can continue for weeks and months, with the release of substantial amounts of water, the longer one can delay installing insulation, sealants, and vapor barriers, the better.

If the wall is to be made of blocks, the first course should be laid within a day of pouring the footing to insure a good bond.

Systems for anchoring the structure to the foundation, termite barriers, moisture barriers, and insulation should be installed at the appropriate time.

What are the elements of stem-wall systems?

Although the relative position of certain components may vary somewhat, the elements generally consist of the following starting with the outside:

- Free-draining backfill
- Dampproofing or sealant to grade
- Concrete or blocks
- Dampproofing or sealant
- Insulation
- Air or Vapor Barrier
- Sheathing (if space is to be inhabited)

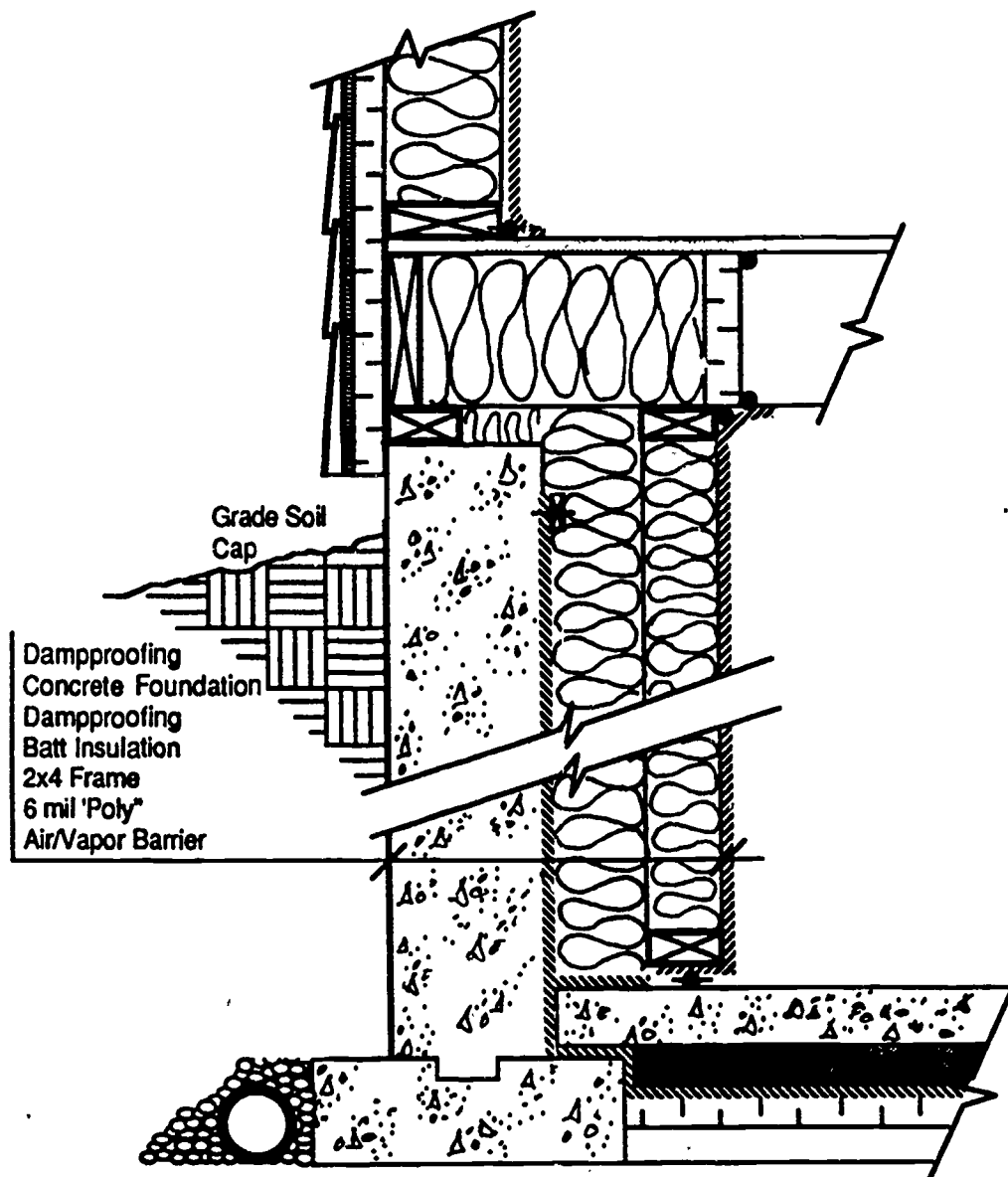

Some insulation strategies put the insulation between the wall and the backfill. This takes advantage of the wall's potential for thermal storage. However, its success depends on using an insulation which is not compromised by dampness or water--such as bluefoam.

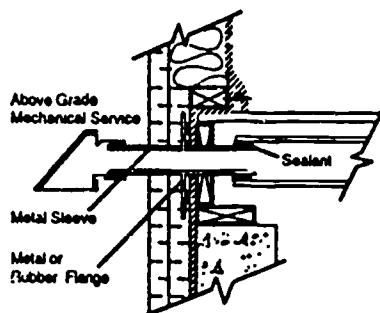

Service Penetration Through Joist Header

Illustration from Alaska Craftsman Home Building Manual

Other strategies leave the foundation uninsulated and insulate underneath the floor instead. This procedure is very-energy efficient. Plumbing should be suspended between the floor joists above the insulation. Plumbing insulation should be of a type which is not compromised by moisture, or the insulation should somehow be protected from potential pipe sweating and leakage.

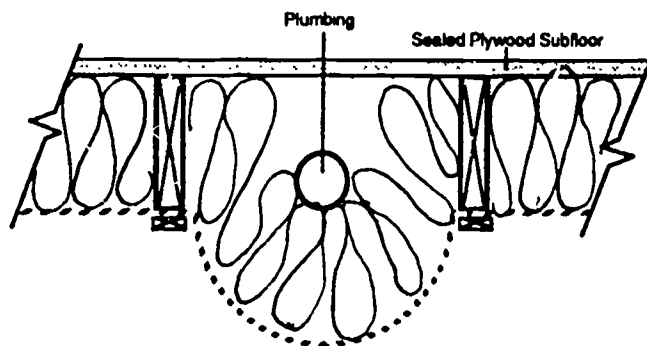

Illustration from Alaska Craftsman Home Building Manual

When the stemwall and crawspace are left uninsulated, the ground within the foundation should be covered with polyethylene to minimize the introduction of moisture. The foundation design should also include adequate ventilation to remove moisture.

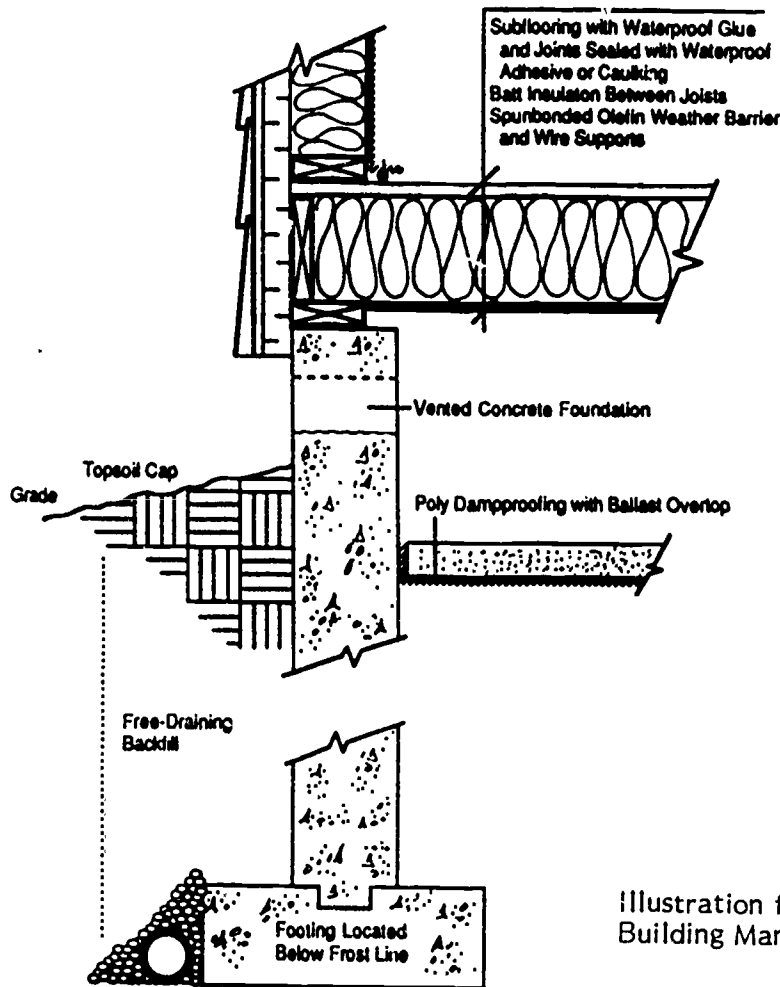

Illustration from Alaska Craftsman Home Building Manual

Are there situations which rule out stem wall foundations?

Yes. You would never use a stem wall foundation on permafrost.

What is a piling foundation?

Typically, piling refers to wooden posts--as opposed to piers which are often made of concrete cylinders or stacks of concrete blocks. Piling foundations consist of a geometrical array of wooden posts driven into the ground in positions such that each post bears approximately the same load. Piling must be made of pressure-treated wood if it is to last more than a few years.

What situations are appropriate for piling foundations?

Marginal soil, muskeg, permafrost, slopes, and flood plains may dictate piling foundations. Piling foundations have the benefit of minimizing disturbance to the ground and elevating structures six feet and more which can be critical considerations in marginal situations.

What is the difference between end-bearing and friction piling?

In end-bearing piling, the weight of the structure and the piling is borne by the material at the bottom end of the pile. In friction-piling, the material along the length of the piling supports the structure and piling weight by friction. Usually piling is a combination of the two. Piling which rests on bedrock would be mostly end-bearing, whereas piling driven in silts and sands would be mostly friction.

How are piling foundations installed?

The soil should be analyzed. If it proves suitable, the exact position for each piling is marked on the ground. The pilings are then either mechanically driven or vibrated into the ground, or holes are bored in the ground and then the pilings are set in the holes. In order for the pilings to do their job, they must be placed in the exact proper position.

How deep must the piling go?

Piling should be driven until either it reaches solid soil, bedrock, or its equivalent--and well below the active layer--or that part of the ground which alternately freezes and thaws with the seasons. If solid ground or its equivalent is not reached, the site is probably not suitable for a piling foundation. In marginal situations, only an expert familiar with local conditions is likely to know whether a piling foundation system will work. In permafrost, piling should be driven well into the permafrost layer, well below the area which might thaw in an unusually warm summer.

What are the weaknesses of piling foundations?

Installation methods sometimes weaken and/or thaw the ground into which they are driven. Pilings should be given adequate time to freeze back or settle in before building construction proceeds. Pilings can conduct heat into and thaw out permafrost layers. In permafrost situations, special techniques may have to be used to insulate the pilings and/or refrigerate the ground. Pilings are also vulnerable to frost jacking.

What is frost-jacking?

In areas where the active layer is thick, pile jacking is a serious problem. Pile jacking occurs when the ground begins to freeze and in so doing expands, forming a grip around the piling(s). The expanding ground heaves, or rises, taking the piling with it. In the spring, the ground thaws from the surface downward, slowly returning to its original position. But the piling is

held in the jacked position by the remaining ice until the last few inches of the active layer are melted, and will remain jacked--unless someone re-drives it. Furthermore, this jacking process can continue winter after winter so that each year the structure resting upon them becomes increasingly deformed. In some cases, the piles can be completely ejected from the ground.

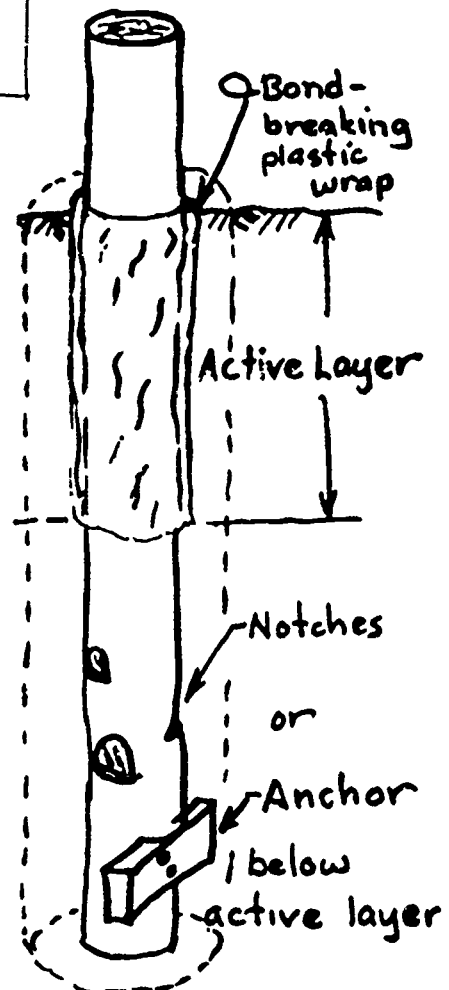
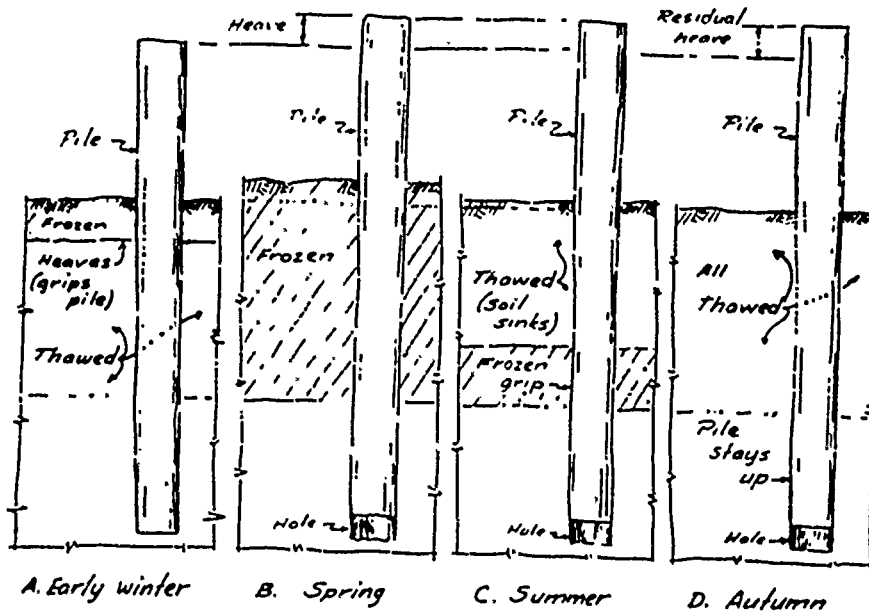

"Taken with permission from: Rice, E 1984. Building in the North."

So how does one prevent jacking?

The late Eb Rice, an engineer at the Geophysical Institute in Fairbanks, identified five ways to prevent frost jacking. For any given location, only some of the steps will prove practical. They include: 1) never let the surrounding ground freeze, or 2) never let the surrounding ground thaw, and 3) anchor the pile against uplift, and 4) break the bond between the piling and the active layer, or 5) place piling in non-frost susceptible soil. In the case of wood pilings, Mr. Rice recommended placing the big end down, as the piling's taper in this position resists jacking. Piling should be driven to twice the depth of the active layer.

39

"Taken with permission from: Rice, E 1984. Building in the North."

Is jacking predictable?

Yes. Frost jacking is rarely a problem in crushed rock or clean sand. However, soils with silt contents of 7% or more are likely to heave, especially if water gets into them. In many cases, it will be impossible to detect silt or determine its relative abundance without performing soil tests.

How does one drive piling in frozen ground?

There are a number of different approaches depending on the composition of the piling, soil type and temperature, and the availability of equipment. Pile driving generally doesn't work in frozen ground, except that steel piles can be driven into fine-grained or peaty permafrost. Ice-cemented gravels are extremely resistant to driven piles, and generally need to be thawed. The ground must be thawed before wood and concrete piles can be driven. Whenever pilings are placed in thawed ground, it must be allowed to completely freeze-back before a structure is built or foundation failure is a very real and inevitably disastrous possibility.

Aren't there alternatives to thawing the ground?

Drilling holes has become the most popular and economical method for placing pilings. As opposed to thawing a hole, drilling has the advantage of minimizing the amount of heat introduced to the ground--a significant consideration in most of Interior Alaska where the permafrost is dangerously close to thawing anyway. A hole slightly larger than the pile is drilled into the permafrost well below the expected maximum thaw depth. After placing the piles, the hole is backfilled, preferably with dry sand or gravel.

What are the advantages of piling foundations?

In many cases, pilings are the most economical foundations. They are lighter than cinder blocks and mortar and can be readily transported by aircraft. They can be installed without a great degree of technical expertise. Finally, their use minimizes the disturbance to ground cover and surface and subsurface drainage patterns--important considerations in areas underlain by permafrost or subject to slope hazards.

What is a pier foundation?

Piers are generally made of cement or masonry. Generally, they are made by drilling down to good foundation soil or bedrock and; installing sono tubes, which are cardboard forms and pouring concrete into the tubes. Many of the same principles apply with piers as apply with piling foundations. For example, the same problems with frost jacking are present. These can be reduced by backfilling with gravel, and adding sleeves which prevent the ground from gripping the pier.

What is a post-and-pad foundation?

Post-and-pad foundations usually consist of wooden posts and wooden pads, with the pads at or near grade.

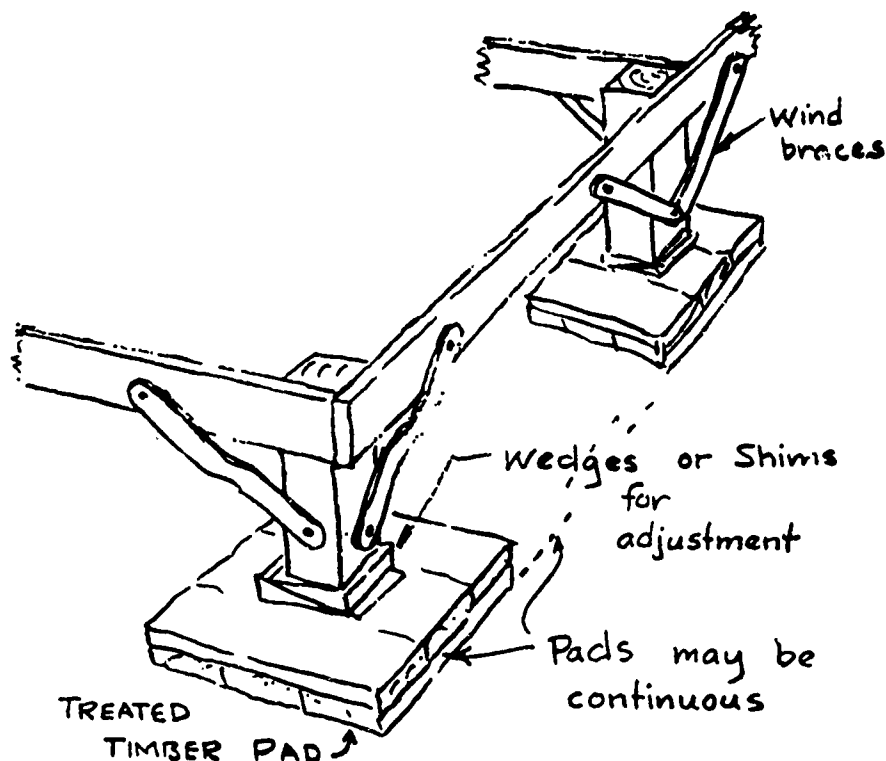

"Taken with permission from: Rice, E 1984. Building in the North."

Where are post-and-pad foundations used?

For light structures which will not be exposed to high winds where either soil conditions are too marginal or it is prohibitively expensive to drive pilings, post-and-pad foundations may be acceptable.

How are post and pad foundations built?

The post should be sufficiently (several feet) tall so that the underneath of the building is readily accessible, because differential heaving and settling makes frequent re-shimming and adjustment necessary to keep the structure level.

Because the pads are in contact with the ground, the wood must be specially treated to resist water and rot. Untreated wood, or wood that has merely been painted with wood preservative will only last a couple of years in such conditions. Only wood that has been pressure-treated will be satisfactory. Pressure-treatment drives in the preservative only about half-an-inch --which means that saw cuts and nail holes become avenues through which rot can enter.

Are there any problems working with treated-wood?

Yes, pressure treated wood is highly-toxic. A respirator or mask should be worn whenever you saw or apply new preservative. The skin should be protected with special gloves which are impervious to the chemicals. Any sawdust should be washed from the skin as soon as possible. If the wood is subsequently cut or cracked by weathering, it should be retreated with wood preservatives. These preservatives tend to be exceedingly toxic. In fact, in many cases, one now needs a license to purchase them.

Do you insulate post-and-pad foundations?

Usually, post-and-pad foundations are not insulated. Instead, insulation is suspended beneath the floor which keeps the living area warm but the crawlspace cold. If the crawlspace is skirted in, adequate ventilation should be provided to prevent the build-up of moisture on structural members and insulation.

Although there are situations and locations where post-and-pad foundations are the only practical foundation, they should only be used where someone will be available to re-shim several times a year.

What is a below-grade wood foundation?

A below-grade (or all-weather) wood foundation is similar to the post-and-pad type. However, as its name suggests, the timber footing rests on a gravel or concrete pad below grade. Generally, the gravel pad should be at least three feet below grade. This type of foundation should only be used where soil conditions are relatively good.

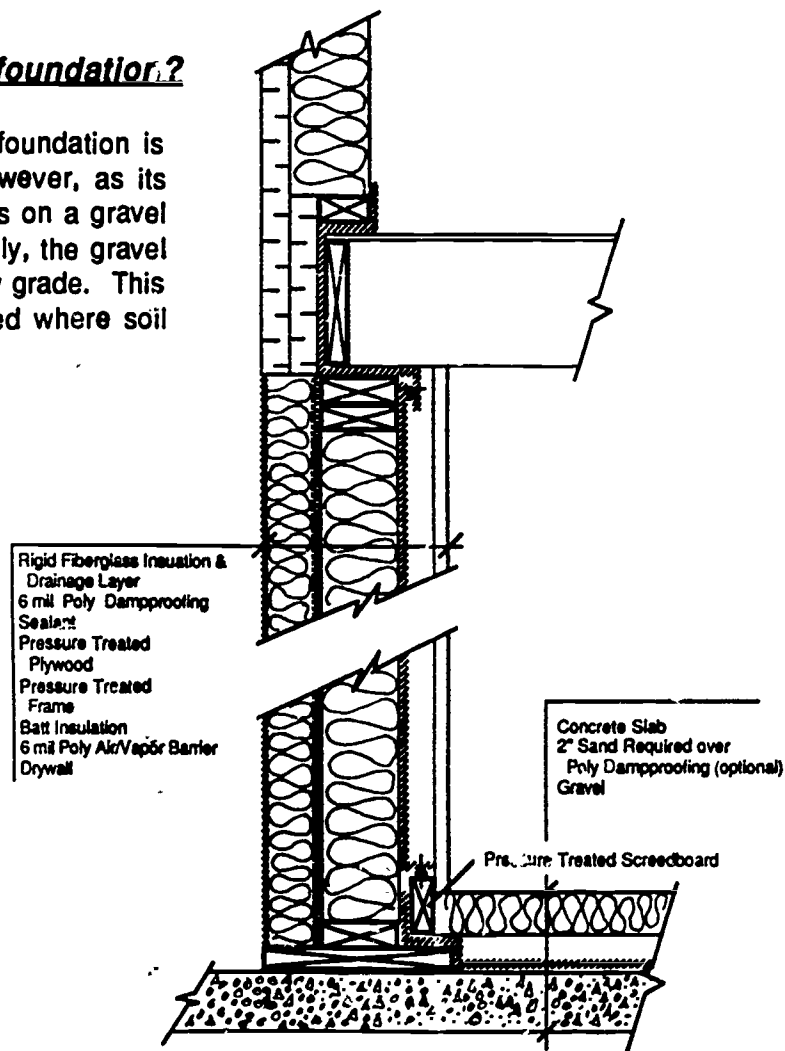

What special considerations are involved?

Most of the considerations which apply to post-and-pad foundations apply to below-grade-wood foundations. Again, pressure-treated wood is essential. And one must take the same safety precautions when handling and sawing the wood. Pads should be insulated from the ground with a rigid insulation. A crawspace between the ground and the bottom of the building sufficient to allow access for periodic inspection and building leveling is essential. Crawspaces, in general, should not be skirted in.

Just as a house is only as good as its foundation, foundations are only as good as the ground on which they are installed. If the ground is subject to heaving and settlement, then so, too, will be the foundation. Where ground heaving or settlement is likely, only pilings driven to bedrock or its equivalent, and protected from jacking, are likely to prove satisfactory.

What is a slab-on-grade foundation?

A slab-on-grade foundation consists of a concrete slab at or slightly above the surface of the ground. Usually, the slab is poured on a gravel pad.

What's the difference between load-bearing and floating slabs?

Load bearing slabs function as true foundations carrying all or a significant proportion of the building's weight. Floating slabs are not designed to support the structure overhead. In the case of a floating slab, structural support for the building would probably be provided by a stem-wall foundation. A true floating slab would not be anchored to the stem wall or its footing but would rest on a gravel pad.

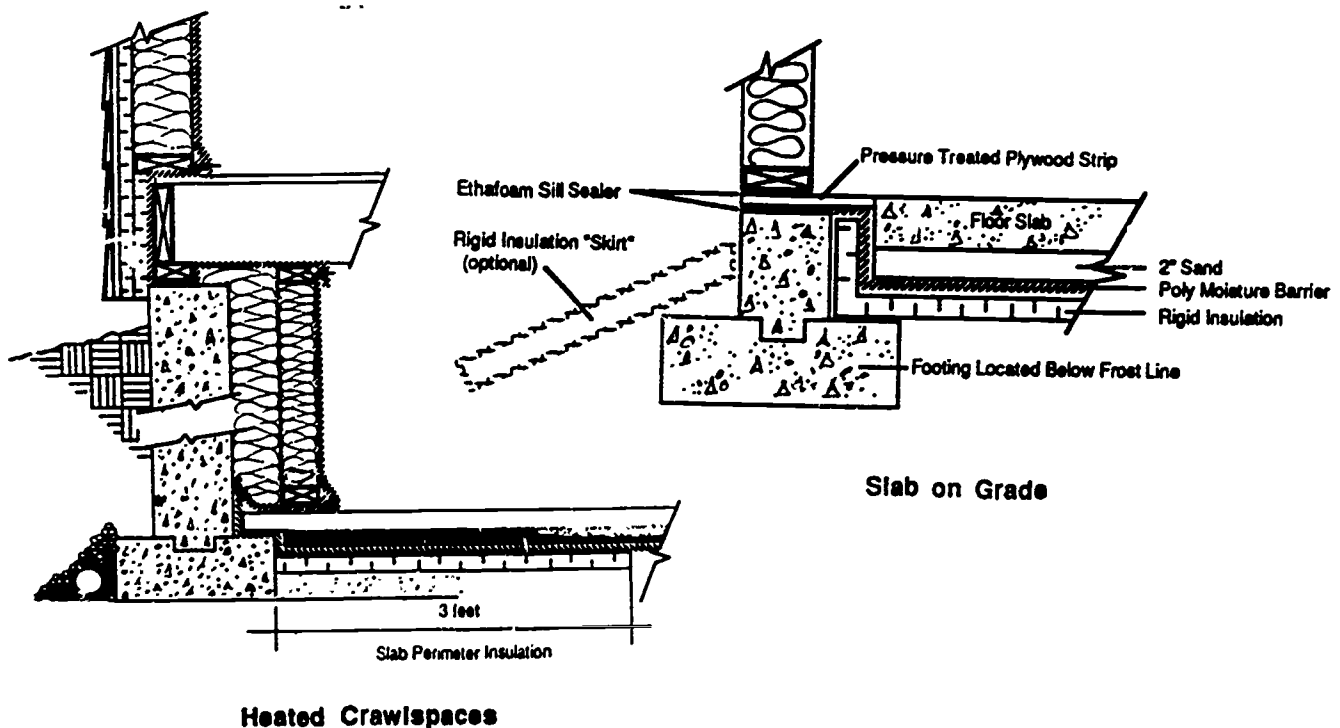

Where are slab-on-grade foundations used?

This foundation is very popular in parts of the United States--and less popular in Alaska because of the high cost of concrete.

Are slab-on-grade foundations practical in any soil conditions?

Only well-drained sands and gravels are suitable for slab-on-grade foundations. In other soils which will accept a gravel pad and functional drainage systems, slab-on-grade foundation systems may work.

However, if the building site contains permafrost, special measures must be taken to prevent building heat from passing through the slab into the substrata. Generally, these precautions include insulating the undersurface of the slab with expensive foam-type insulation, special pad ventilation systems to dissipate heat conducted through the insulation, and refrigeration systems to super-cool the underlying permafrost during the winter.

Foundations for Good Soils

Competency: Understand foundation strategies for sites with bedrock, sand, and gravel substrates

Tasks: Explain foundation options for bedrock, sand, and gravel substrates
Explain the difference between permanent and non-permanent foundations
Explain the relationship between foundation selection, building codes and bank loans

What are the best materials to build on?

With few exceptions, bedrock is the preferred material. The exceptions include areas underlain by limestone (which is subject to chemical weathering by rain and groundwater) coal (which can catch fire and burn-up), and weak, highly fractured and/or weathered rock. When rock structures such as bedding planes or cooling joints parallel the slope, slope failures are a real possibility. Well-drained sand and gravels also make excellent foundation substrates.

Is any particular type of foundation best?

Any and all of the foundation types previously mentioned are suitable for building sites on bedrock, sand, or gravel. The ultimate choice will be dictated by consumer preference, economic considerations, slope and flood hazards, and the nature of the structure to be built.

One should remember that sands and gravels can contain significant amounts of clay and/or silt. Whenever possible, soil tests should be conducted to determine whether enough clay and or silt is present for frost-jacking, drainage impairment, and other problems.

What makes a given foundation type the best for a given site?

Generally speaking, consumers want the most economical foundation capable of supporting their structure. Foundation costs are largely controlled by availability of materials and excavataion and construction equipment. In Alaska, these factors are heavily influenced by location. For example, in the largest communities, Juneau, Anchorage, and Fairbanks, many building sites can be accessed by backhoes and cement mixers. The cost of concrete, gravel, and other manufactured materials is reasonable.

Assuming that one is building a relatively large and expensive structure--as opposed to a shack or small cabin--one will probably want to invest in as good a foundation as possible. In the absence of permafrost, this will probably be a stem-wall foundation. When properly built on appropriate sites, stem-wall foundations are more permanent and dependable than other types.

However, at remote building sites where access is limited, heavy-equipment is not available, and most building materials must be barged, flown, or hauled long distances, high transportation costs will dictate the selection of some more economical foundation system. This may be piling, post-and-pad, or below-grade-wood. When properly built and maintained, these systems can provide decades of service.

What is a permanent foundation?

Permanent foundations are those which can be relied on indefinitely to support a structure with minimal repair and adjustment. They tend to be made out of rock, concrete, and other materials which either do not degrade over time, or degrade very slowly. Non-permanent foundations, by comparison, might need to be adjusted annually and repaired and/or replaced every few years. Permanent foundations sometimes prove less-permanent than was originally hoped, and non-permanent foundations sometimes last much longer than was anticipated. Nevertheless, when environmental conditions are favorable the so-called permanent foundations have so many advantages over non-permanent foundations that the former should be used whenever you can afford to.

What other factors influence foundation-type selection?

In some parts of Alaska, however, the cost of importing concrete and other permanent foundation materials will be prohibitive. In such an event, the builder will have to decide which less-than permanent foundation is the best option for the site and the structure.

How do building codes influence selecting a foundation-type?

Builders are frequently tempted to cut corners to save money. This isn't necessarily bad. One tries to build the best house for the least money. If cheaper materials or designs will do the job, builders and consumers will be inclined to substitute them. However, the money saved may not be worth the cost if the substitution makes it harder to finance or sell the structure. Banks tend to be reluctant to finance experimental designs and other departures from accepted building practices--regardless of the merits. Even if your design is used widely in other parts of the world, if it isn't allowed under the local building code, you'll have great difficulty talking an inspector into approving it or obtaining bank loans for its construction.

Is all construction in Alaska governed by building codes?

Although all major communities in the state have building codes, many unorganized communities and most of the bush do not. In areas without codes, builders are free to build any way they see fit. However, if bank-financing is required, the bank may demand the builder to follow some code.

Whether or not they are subject to codes, builders should be aware of standard codes because codes tend to be based on a great deal of trial-and-error experience. Understanding the principles behind the codes may enable a builder to anticipate and avoid problems which others have encountered.

Is the code always "right"?

Unfortunately, codes can be wrong. Sometimes following code won't make sense at a specific structure and site--although the idea behind the code might be sound in general. In order to be enforceable, codes have to be specific. Yet no matter how detailed they become, they cannot anticipate every problem. Furthermore, in trying to solve problems they can create others. Sometimes, these other problems are not recognized by those who write and approve building codes. In other cases, the authors assume that the solution is worth the problems which it creates.

Before you deviate from code, try to obtain approval. This can save lots of trouble later-- indeed, inspectors have the authority to require builders to tear out non-code designs. Maintain good working relations with inspectors; they can be valuable sources of information and advice --if you haven't forced them into an adversarial position.

Always calculate the long-term positive and negative aspects of any given design innovation or variation from the code. Be sure not to underestimate the cost, in terms of money, time, and frustration of having to retrofit or rebuild a foundation or other major building element at a later date.

Foundations for Silts and Clays

Competency: Understand Foundation Strategies for Silts and Clays

Tasks: Explain Foundations strategies for silts and clays

How can I select a foundation for silts and clays?

Selecting a foundation type for these fine-grained soils, should begin with a careful analysis of the soils at the site. Once soil properties are determined, a foundation design can be developed which matches soil conditions with structural and economic considerations.

Generally, foundation-type selection, design, and construction should minimize disturbance of these soils and minimize the potential for the soil-caused structural problems after construction. Design should include workable measures to improve drainage and segregate fill and foundation from substrata. Design should also have a safety margin to accommodate unforeseen circumstances, such as flooding, unusually deep frosts, and seismic disturbances.

What is blue clay?

Blue clay is a local Alaskan term for a variety of fine grained mineral-derived materials. In most cases, blue clay is actually a silt. Unlike a true clay, it lacks chemical bonds from grain to grain. It tends to fracture under pressure and can't be used to make pottery. Blue clay is often found under muskeg and topsoil. In many cases, especially where a glacier has previously ridden over and compacted it, blue clay is extremely hard and compacted. However, if disturbed or saturated it can turn to soup. Blue clays also change in volume with changes in water and/or ice content. Volume and phase changes are blue clay characteristics which threaten foundations and structures.

Can you build on blue clay?

With care. On the flat ground, one common practice is to remove the peats, muskegs, and topsoil, then importing clean gravel fill. On slopes, with shallow clays, pilings which extend into more solid material are the only option. When deep, sloping clays should be avoided.

Muskeg Foundations

Competency: Understand foundation strategies for muskeg

Tasks: Explain foundation strategies for muskeg

What is muskeg?

Muskeg is another soil which should be avoided whenever possible. Furthermore, there are certain type of muskegs which should never be built on. This category includes the wet and "bottomless" muskegs. Shallow muskegs, and particularly, those which are dry most of the year can be built upon.

What type of foundation should be used on muskeg?

Generally, piling-type foundations are the best solution for muskeg situations. Although roads and structures can be floated on muskeg using geotextiles, these tend to sink over time. In the case of a road, it is relatively easy to add more material to keep up with the rate of sinking. Continually adding material between a foundation and its substrata and/or building new foundations under existing structures is not so easy.

In addition to the potential for your structure to sink into the muskeg, extra care must be taken to keep pilings from being frost-jacked clear out of the ground--even when weighed down by structures. Either event can destroy the structure. Generally, if the muskeg is too deep for your pilings--if they cannot reach more solid soil, you shouldn't build on it.

Foundations for Permafrost

Competency: Understand foundation strategies for permafrost

Tasks: Explain permafrost terms and foundation strategies

What Is Permafrost?

As its name suggests permafrost is permanently frozen ground. It has been formed as the result of decades or centuries of climate during which the mean annual temperature is 27 degrees F or colder. Moisture in the soil has been trapped as ice. In the arctic, permafrost may extend nearly to the surface. In the sub-arctic, in areas like Interior Alaska, permafrost may be overlain by an active layer five or ten feet thick. The active layer is frozen during part of the year, but thaws out during the summer. The thicker the active layer, the more complicated the task of the builder.

Where is permafrost found in Alaska?

Although permafrost is rare in Southeast, Southcentral, and the Aleutians, it is common in the rest of the state. Most of Interior and Southwestern Alaska has what is known as discontinuous permafrost--often limited to north-facing slopes and flat ground covered by trees which prevent much of the summer sunlight from reaching the ground. Much of this permafrost is "warm", which means it is close to thawing. In Northernmost Alaska, permafrost is nearly continuous and tends to be colder and less prone to thawing.

How does one know if there is permafrost underneath a site?

In some areas, the only way to determine the presence of permafrost may be to take soil borings. And anyone contemplating building in an area potentially underlain by permafrost or discontinuous permafrost should not proceed until the presence or absence of permafrost has been confirmed. In the arctic, one can assume that the ground is underlain by permafrost.

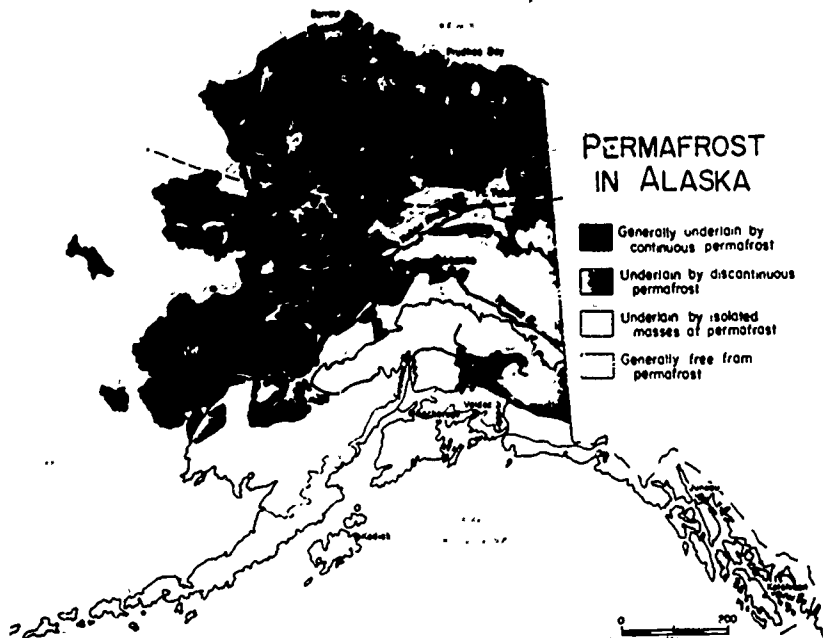

What are the signs of permafrost?

Permafrost often produces surficial evidence of its presence. Polygons similar to those formed from the repeated drying of mud frequently mark tundra underlain by permafrost. Pingos, large pressure mounds caused by the upward expansion of water constricted by the surrounding frozen ground, form over the site of former lakes. Smaller pingos are sometimes found in Interior Alaskan valleys. Ice wedges are another sign of permafrost.

What's an ice wedge?

Ice wedges grow in cracks formed by the contraction of fine-grained soil as a result of freezing. The wedges gain depth and size each year. They express themselves on the surface as cracks. Roads crossing ice wedges often have sudden dips and pavement breaks and frequently have to be repaired each year. The same fate awaits foundations built over ice wedges when adequate precautions are not taken to prevent the wedge from thawing.

Are there other signs of permafrost?

Trees, telephone poles, and pilings often tilt as a result of differential thawing of the ground beneath them, and subsequent jacking. In Interior Alaska, a south-facing, open slope is not likely to contain permafrost, but if heavily forested, the same slope may contain permafrost. North-facing slopes and tree-shaded or terrain-shaded flats are also likely to contain permafrost.

Does permafrost occur in all types of soil?

Yes, and bedrock too. If the soils are well drained sands and gravels, permafrost is less likely to occur, and even if it does occur, is less likely to cause problems to builders. Poorly-drained, fine-grained soils such as muskegs, clays, silts, and loess are much more likely to contain significant amounts of ice, and are more likely to present serious problems to builders.

So how does one build on permafrost?

People have been building on permafrost for decades--and with varying degrees of success. Frozen ground can make a solid footing. Indeed, ice is almost as solid as rock. The key to building on permafrost is the same as the key to building on ice. One must make sure that the permafrost does not melt. One must also make sure that the foundation extends well past the active layer to rest on that part of the permafrost which will not melt.

The need to keep the permafrost from thawing means that stem-wall foundations are unacceptable.

What happens if the permafrost melts?

If the previously frozen soil is fine-grained, say a silt, clay, or muskeg, it will liquify and your house will settle--probably differentially. If the house settles differentially, then all sorts of structural problems will result, and the house can even be broken apart. Even if all parts of the structure settle at exactly the same rate, settling can be a real problem. Indeed, if someone was foolish enough to build on deep muskeg, it's not inconceivable that the entire structure could eventually sink clear out of sight. A building which houses a Fairbanks radio station is doing just that. The first floor has sunk almost completely underground and has long since been abandoned in favor of the second floor.

How can you put a warm structure on top of frozen ground and not expect the ground to melt?

That's just it. You can't. You have to separate the structure from the ground, and insulation isn't enough. Insulation merely slows the rate of heat transfer--and the rate of thaw. Instead of insulation, the source of heat--your structure--must be completely isolated from the frozen ground. The most common way of segregating your structure from the ground is to build on piles, thoroughly insulating the structure's floor, and leaving an air space of at least three feet between the ground and the bottom of your structure.

What does the air space accomplish?

Assuming that someone doesn't make the mistake of skirting in the air space, it allows the winter cold to circulate beneath the structure and refrigerate the ground. But the air space has another important job, it prevents moisture from accumulating on the underside of the building and the structural support. Moist air would readily conduct heat from the structure to the ground. Without ventilation, rot can also set in very quickly.

Is an un-skirted airspace enough to prevent the permafrost from thawing?

In the far north, where the active layer is minimal, it probably will be. Sometimes, the foundation must also be shaded to reduce the warming effect of the summer sun. In areas where the active layer is very thick or where the permafrost is warm and extremely susceptible to thawing, special designs which remove heat from the ground are the only way to guarantee that your permafrost will not thaw.

The following illustration shows several designs which remove heat from piling foundations.

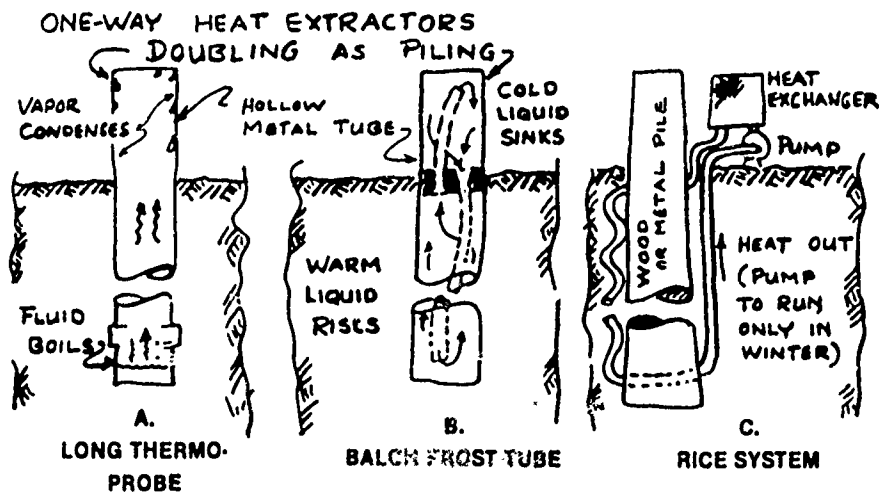

"Taken with permission from: Rice, E 1984. Building in the North."

How do these designs work?

They are all based on the principle that heat rises. They use ammonia because it stays fluid at the very low temperatures of -75 degrees C and boils at -33 degrees C.

What is permafrost made out of?

Although permafrost can occur in every type of soil from gravel to muskeg, and even bedrock can be permanently frozen, the process by which permafrost forms and grows over time can result in the exclusion of the original soil so that permafrost can approach 100% ice. In other words, permafrost can be almost pure water. No wonder it's important not to keep it from thawing.

What kind of foundation does permafrost blue clay require?

The foundation strategy is the same as for other types of permafrost. The first consideration is to prevent the ground from thawing. Usually this entails not disturbing the ground cover which can be accomplished by either using pilings or adding geotextiles and a gravel pad. Pilings and pads should be insulated to prevent their conducting heat from the structure into the ground. Shading and refrigerating may also be required.

What kind of foundation should be used for muskeg permafrost?

Although solid ground is preferable to muskeg when it comes to building sites, one can build on the drier, firmer muskegs--on others only a houseboat would work. Muskeg is a soil composed of organic material. Even the driest muskegs can be extremely boggy at certain times of year. Muskeg soils can range in consistency from soft ice cream through sponge to a mixture of moss and tree limbs. Generally, pilings driven well into underlying bedrock or more solid sediments are the best foundations for muskegs. As the depth of muskegs can easily exceed fifty feet, the cost of piling foundations can become excessive--especially for large structures.

Another option for permafrost muskeg is a below-grade wood foundation. Typically, such a foundation consists of heavy timbers, chemically treated to resist rot and pests.

Piling-type foundations are generally used for muskegs with permafrost. Pilings must be driven into the permafrost twice as far as the active layer is deep. They should also be insulated and include anti-jacking strategies, and if necessary refrigeration devices.

Foundation Thermal, Moisture, and Pest Management

Competency: Understand thermal, moisture, and pest control strategies for foundations

Tasks: Explain thermal control terms, principles, and strategies
Explain moisture control terms, principles, and strategies
Explain pest control terms principles and strategies

What is the purpose of energy management?

In areas without permafrost, the main thermal control goal is energy conservation. The idea is to prevent heat from being lost through the bottom of the structure. As much as 1/3 of a structure's heat can be lost through the floor and foundation.

How is heat lost through foundations?

Air may leak between the bottom plates and the foundation wall or through cracks and utility openings in the foundation. Foundation walls and floors can also conduct heat directly into the atmosphere, ground, or water table or through the ground into the atmosphere.

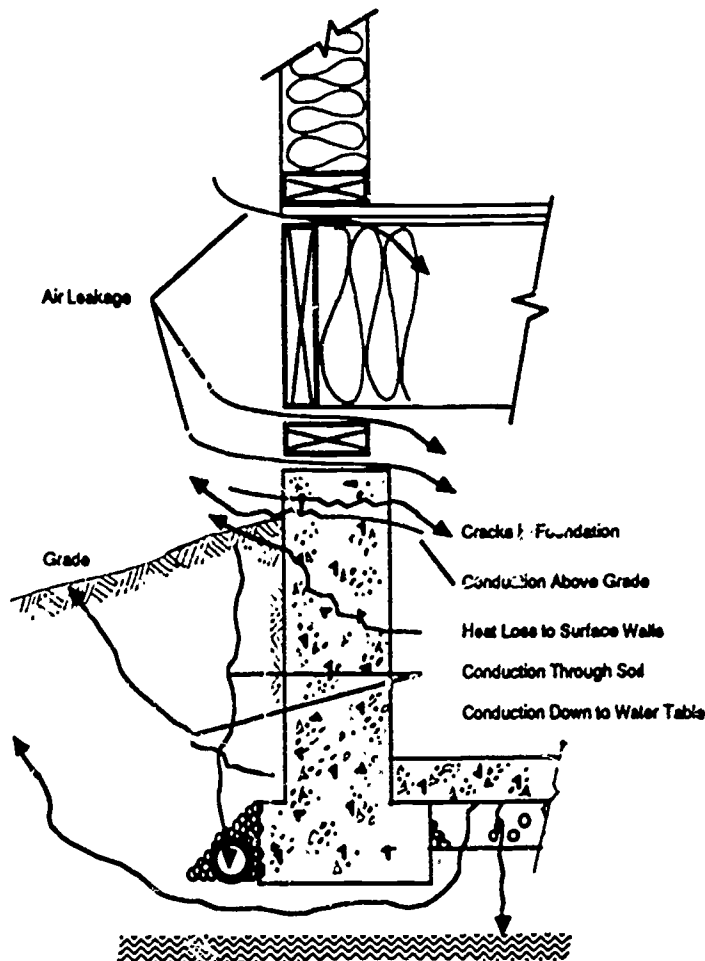

How is foundation heat loss minimized?

Foundation heat loss is minimized by understanding heatloss mechanisms, anticipating heat loss routes, and designing and carefully installing a comprehensive heat loss prevention system during construction. Depending on the foundation-type, this may mean insulating underneath the floor (piles, post-and-pad, piers, below-grade wood), or it may mean insulating the entire foundation (stem-wall, slab on grade).

Strategies for insulating specific foundation types have already been shown. The following diagrams show methods of insulating various types of foundation penetrations.

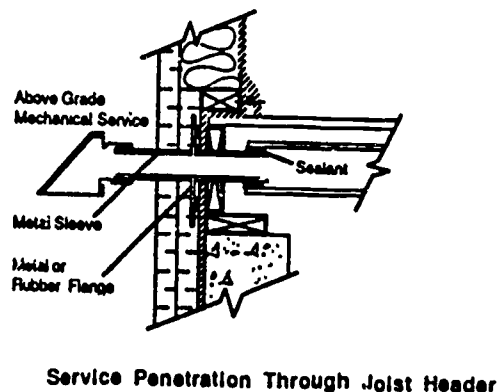
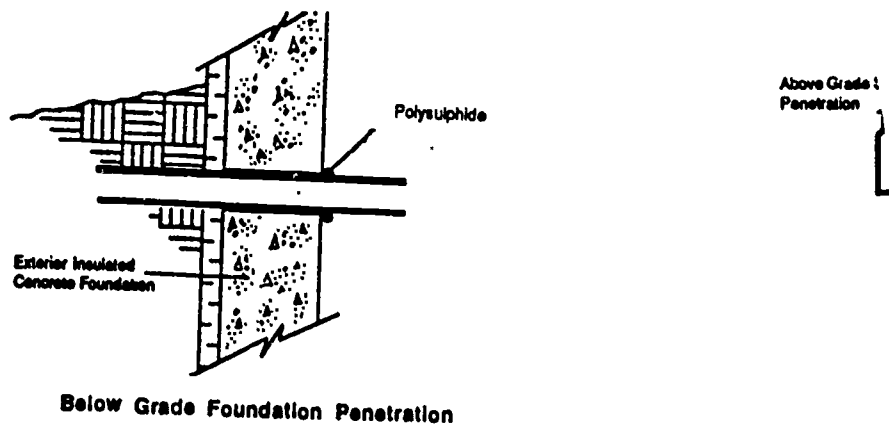

Illustration from Alaska Craftsman Home Building Manual

On sites with permafrost, the foundation must also be thermally isolated from the substrata to prevent thawing. Insulation alone is inadequate to prevent thawing because insulation merely slows the rate of heat transfer. Instead, the permafrost is protected by elevating the structure and leaving an unskirted crawlspace of several feet for the winds to blow through. In many cases, additional wintertime cooling is created by insulating the pilings, shading, removing insulating snow, and installing tubes which remove heat from the permafrost.

Will pilings be practical for all structures?

When the structure's purpose (heavy equipment repair-shop, warehouse, aircraft hangar, etc) requires a strong and warm concrete slab-type floor, the slab must be insulated from the underlying gravel pad. In addition, the pad may need to include piping capable of circulating large amounts of cold air during the winter. These may need to be augmented by other devices which remove heat directly from the permafrost.

Many of these techniques have been used successfully. However, they can rapidly drive up the cost of construction to the point where building becomes uneconomical.

Why manage moisture?

Because moisture, whether in the form of vapor or water, causes rot and structural problems, compromises and/or destroys insulation, and is so efficient at conducting heat, moisture management is an integral part of thermal management. Wet air, wet soil, wet wood, and wet concrete conduct heat much more rapidly than their dry counterparts. That's why most insulation materials are designed to trap dry air. Indeed, without a vapor barrier, most insulation can soon become worthless.

What are the standard moisture management techniques?

Moisture management strategies fall into two categories: prevention and removal.

Prevention means reducing the potential for the introduction of moisture into the foundation area. Improving drainage, by adding gravel and drain pipes, reduces soil moisture, thereby reducing the soil's ability to conduct heat away from the foundation and improving the soil's insulating quality. Concrete footings and pads should be allowed to thoroughly dry--even though this may take several months--before they are moisture-sealed. Once dry, it is important to keep them that way.

If local water tables are high and drainage is poor, one could insulate a stem wall foundation on the inside, instead of on the outside, although there are insulation materials (bluefoam) which are not compromised by moisture.

The moisture in relatively warm air condenses on surfaces which are at or below the dewpoint. If the area between the foundation and the living area is not going to be kept warm, it should be well-vented. Floors must be well-insulated so that the occupants are not tempted to close the vents or install skirts around the crawlspace. The floor insulation envelope should incorporate an effective vapor barrier so that warm moisture-laden air from the house does not escape into the the foundation cavity. In permafrost areas, there should be no skirting at all and buildings should be elevated at least three feet.

Cover the soil with plastic sheeting to minimize the introduction of moisture into the space beneath the structure.

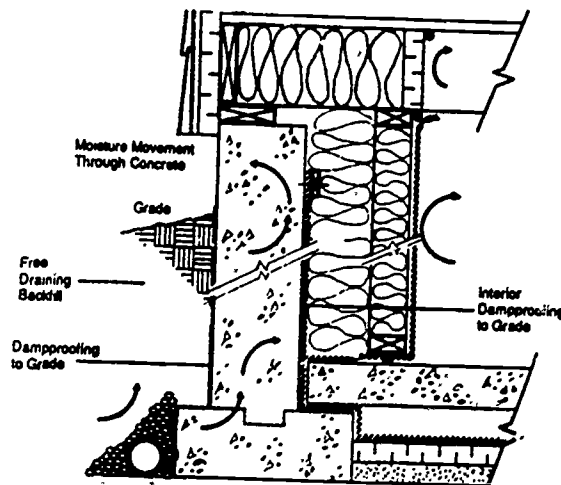

How do I control pests?

There are ways to keep pests from taking up residence in your foundation and in the insulation under your floor, or from tunneling into the living area through the floor. The methods depend on the nature of the pest and on the type of foundation.

A good, tight building envelope will keep out most flying insects--although in places with termites and carpenter ants, fumigation may be necessary.

In other parts of the world, termite barriers are installed between the foundation and the structure. Most pressure treated woods are toxic to most pests.

Mice, moles, voles, lemmings, shrews, squirrels, porcupines, and marmots can destroy the integrity of a building envelope. If it looks like they may be a problem, you should install the appropriate sizes of wire mesh to the underside of your floor insulation--before they perforate the moisture barriers, compress the insulation and fill the structure with grass, spruce cones, mushrooms, and the like.

With large animals like wolverines and bears the first line of defense is keeping a clean house. Odoriferous foods like tuna and bacon should not be left out on counters. Garbage should be thoroughly burnt or hauled away to a sanitary landfill before it begins to smell. Large animals can sometimes be kept out with heavy wire mesh, plexiglass, and shutters. Once animals become accustomed to human's foods, nail-studded window sills, and doors--though ugly--provide the only reliable defense.

Energy

Energy

Introduction

Advances in thermal and moisture management design have the potential to conserve significant amounts of energy with accompanying savings in costs. Some of these techniques have been used widely in the construction industry for more than a decade. However, many of the most promising have been employed in only a relatively small number of "custom" or "experimental" homes. Nevertheless, many of these systems will soon be required, either by code or consumers, and those entering the work force will be expected to know how to install them.

As important as many of these systems are, it is even more important that the individuals who build and install them thoroughly understand the principles upon which they are based. These systems may be rendered ineffective either by faulty installation techniques or sequence. Failure to treat a structure and its components as one interrelated system virtually guarantees that neither components nor system will perform up to potential.

Overview

The construction industry is cyclical, and construction workers frequently need to relocate to find work. If the underlying principles are understood, the student will be able to adapt them--and the systems upon which they are based--to local conditions throughout Alaska and the rest of the world. Even in periods of decline for the construction industry, the need for workers skilled in energy-efficient new construction, renovation, and retrofitting will continue.

Resources

Alaska Craftsman Home Building Manual, Alaska Department of Community & Regional Affairs.

Resources and Man, Preston Cloud, Ed., National Academy of Sciences, W. W. Freeman & Co., San Francisco, 1969.

The Superinsulated House, Ed McGrath, That New Publishing Company, Fairbanks, AK. 1981.

Energy Conservation

Competency: Understand Energy Conservation

Tasks: Explain energy conservation terms and principles

What is energy?

Energy is the ability to do work, and it comes in many forms. Gasoline, for example, releases a great deal of heat when burned, and if combined in an internal combustion engine, it can perform such work as powering automobiles, aircraft, and generators. Electricity is a form of energy which can be used to make heat, light, or power machinery. Many substances, such as petroleum, wood, food, and water store energy which in certain circumstances can be used to perform work. A mountain brook contains energy which can be harnessed by dams and made to power turbines to produce electricity. Similarly, an alpine lake is a reservoir of energy, as well as water, which can be used to generate hydropower.

But where does the energy really come from?

The sun put the water in the alpine lake by evaporating it from the ocean and land, by driving the winds which transported it to the mountains and caused it to rise and cool until it was precipitated either as rain or snow--and if as snow by melting it in the summer. In the case of food, wood, coal, and petroleum products, the sun also provided the energy which was captured by plants or microorganisms and concentrated and stored by biological, geological, and physical processes into forms which man and other organisms can use.

Energy formed from the decay of uranium and other radioactive elements probably came from the sun originally, too. Indeed, all of the earth's energy probably originated in the sun, the star at the center of our solar system.

What is energy conservation?

Energy conservation means different things to different people, but at the most basic level it means the wise use of energy resources. It includes turning lights off when they aren't being used. It includes not leaving the windows open during winter when the furnace is running. To modern-day house builders, it means building with materials and techniques which conserve, or save, energy.

Why do we need to conserve energy?

If the sun keeps sending the earth energy, why do we need to worry about wasting it? Sophisticated as it may be, our technology allows us to use only a small fraction of the energy coming in from the sun every day. A significant portion of the energy we do use arrived from the sun hundreds of millions of years ago, was captured by plants and microorganisms, and slowly converted by geological processes into fossil fuels like coal and oil. Civilization is using fossil fuels so much faster than they are being formed, that much of the world's recoverable oil will probably be gone by the middle of the next century, if not sooner. Conservation can help these reserves last longer.

Another reason to conserve energy is its cost. In Alaska energy costs more than in any other state. If Alaskans don't want to spend all their earnings on energy for heating, lighting, and transportation, they have to find energy efficient ways to live. But energy consumption has another cost. Even if energy were free, using it entails environmental and social costs.

Why should energy consumption have social and environmental costs?

The First Law of Thermodynamics states that heat is a form of energy. It is an application of the principal of the conservation of energy which holds that in a closed system energy is neither created nor lost; it is conserved--but its form may change. These changes and forms have environmental significance. Most structures are not closed systems; energy in various forms enters and leaves them. These transactions--the residential energy budget--have social costs.

What is a closed system?

A closed system is one in which there is no interchange between the system and other systems--no exchange of materials or energy. In nature, such systems are rare. The Earth, for example, is an open system, receiving energy and materials (in the form of meteorites) from elsewhere. Even a superinsulated house is an open system. Energy enters in the form of electricity, heating oil, firewood, sunlight, water, food, pets, people, and air. Energy leaves in the form of people, pets, garbage, ash, waste water, stale air. Much of the energy which leaves a house is in a less concentrated and/or less useful form than the form in which it arrived.

What about "free" energy?

When people talk about free energy, they usually mean you don't have to pay somebody else for it. Often they think that as long as they don't have to pay the local utility or fuel supplier for their energy, it is free. Most of the time when they talk about free energy, they are referring to firewood or wind, hydro, or solar power. But anyone who has gathered firewood knows that a lot of work is involved. Felling, bucking, splitting, hauling, and stacking wood takes a lot of energy; and the sources of that energy--groceries and chainsaw gas and oil--aren't free, either.

Wind isn't "free"?

Wind and hydropower aren't free either. Someone has to design, manufacture, and transport the machinery. Someone has to locate a good power site and purchase, install, connect, and maintain the equipment. Even then the power isn't free. The windmill removes more energy from the wind than it delivers to the user--the balance lost to friction and other inefficiencies. Just because an observer cannot see any difference in the wind after it's passed the windmill, doesn't mean that the wind hasn't changed.

The change is much more obvious in the case of hydropower, where a wild, tumbling river is turned into a lake. Like the windmill with the wind, the dam makes it possible to harness the water's energy, but the river is forever changed. Much of the water's power has been squeezed out by the turbines. The water at the base of the dam has very little usable energy. It's energy has been changed from largely potential to largely kinetic, from a higher more useful form to a lower, less useful form of energy.

Why is energy always seeming to run out of gas?

In each of the above examples, the process of using energy degrades it. The Second Law of Thermodynamics states that systems tend toward random disorder. The energy in systems tends to degenerate into less useful forms, unless something acts or performs work on those systems. The Second Law says that you don't get something for nothing, that there is no free lunch.

Another word for this phenomenon is entropy. Think how hard it is to keep a room clean, or to remember something you studied a year ago. Maintaining rooms, information, and temperature's requires energy. According to the Second Law, as soon as the energy source is interrupted, the system begins to decline. Think what happens to a house or a vehicle which isn't maintained.

Why does entropy always prevail?

Inefficiencies have something to do with it. The most efficient processes if allowed to continue endlessly would bury themselves with their own products. But most processes are inefficient and the machinery soon breaks down if it isn't continually maintained. Burning gasoline in an engine produces heat, water, carbon dioxide and other chemical compounds--some of which are harmful. The engine may perform some valuable work, like propelling a vehicle or a chain saw. However, no matter how efficient the engine, energy will be lost to friction--and most engines are only about ten percent efficient which means that most of the energy is unavailable for the original purpose for which the gasoline was burned. Most of the unused energy is in the form of waste heat. What is the useful life of the average passenger car: five or ten years? And that can only be attained by increasingly frequent and expensive maintenance which includes replacing lubricants and worn parts.

Taken together, the two laws of thermodynamics explain why it is hard to keep warm in the winter: It takes energy to make the heat in the first place; no sooner is it made than the heat tends to flow toward the lower temperature environment outside. We can also see why energy consumption has environmental and social costs: because of inefficiencies, because we don't get something for nothing, and because using energy fatigues equipment and creates waste products.

So what's the solution? What keeps engines from slowing down and stopping? What keeps structures warm?

The old way was to just keep adding more fuel, to pour on the coal, step on the gas. But fuel costs and pollution keep increasing. As soon as we stop adding energy, engines begin to stop, houses begin to chill. The solution then is to build a better heat-trap.

However, when energy is burned in a closed system the heat remains in the closed system. Energy-wise, a properly built superinsulated house approaches being a closed system. If the structure captures and uses the waste heat, less fuel will be needed.

Why is energy conservation such a big deal in Alaska?

In the first place, most forms of energy cost more in Alaska than anywhere else in the United States.

Because the climate is so cold, keeping warm in Alaska can require a lot of heat. Alaskan home builders have another good reason to conserve energy. Anyone who has been to Hawaii knows that the sun does not heat all parts of the globe equally. There, temperatures average in the 70's year round. In Alaska, on the other hand, temperatures average in the 20's and 30's.

Since the current fashion in Alaska is to live in houses where the temperature is between 60 and 70 degrees F, Alaskans have to figure out how to keep their houses an average of 40 to 50 degrees warmer than the outside environment. There are only two ways to do this: by adding heat or increasing insulation. Recent increases in energy costs suggest what many observers long suspected: the only sensible way to keep an Alaskan house warm is to insulate it properly.

Which way does heat flow?

The Second Law of Thermodynamics predicts that energy flows from systems of high energy to those of low. When you sit on something cold, you become chilled because your heat is flowing into it, not because the cold is flowing into you. If the opposite were true, you wouldn't be burned when you touched something hot.

How is thermal energy transferred?

Heat is transferred in three ways: radiation, conduction, and convection. All objects radiate heat in the form of light waves to all other objects. However, warm objects radiate more heat towards cold objects, than vice versa. So if you are in a building with cold walls, you will radiate more heat to those walls than they radiate to you and you will likely feel cold.

Heat is conducted whenever two objects of differing temperatures come into contact. If you sit on a cold object, your body's heat will be conducted into the object.

Heat is transferred within fluids and gases primarily by convection. Without the ocean currents and global weather systems which transfer heat from the equatorial region towards the poles, life would not be possible in the arctic and antarctic. In houses, heated air rises from lights, stoves, and radiators and moves toward cool surfaces such as windows and walls where it sinks toward the floor. The resultant currents are known as drafts, but their scientific name is convection currents.

To minimize the drafts in a structure, you design, build, and operate it so that the temperature differentials between the walls, ceiling, floors, and heat sources are minimal. The current term for such designs is superinsulation.

Introduction to Superinsulated Structures

Competency: Understand superinsulation terms and principles

Tasks: Explain the concept of superinsulation
Explain the components of a superinsulated structure

What is superinsulation?

Superinsulation is a fancy term for structures which have been insulated to the point where heat loss is minimized. Most superinsulated structures try to optimize the amount of insulation so that the cost of the insulating material is offset by energy savings. Most superinsulated structures have insulation values at least double those of conventional structures in the same area. In Alaska, superinsulated structures typically have R-values of R-30 to R-50, depending on the local climate.

What is a superinsulated house?

Any house built in such a manner that minimizes heat transfer from the the inside to the outside, or vice versa, is superinsulated. Superinsulation is realized by meticulous calculation, design, and construction.

What are the components of a superinsulated house?

Any superinsulated structure has one basic element, the building envelope. As the word envelope suggests, a superinsulated structure is a container, and its interior is relatively sealed off, or insulated, from the outside environment.

From what in the outside environment are we trying to insulate the interior of the structure?

Although structural insulation could be designed to eliminate noise, dust, or some other nuisance, in Alaska the overriding purpose of superinsulation is to provide thermal protection, to isolate the inside of the building envelope from the extreme low wintertime temperatures outside the walls.

Why superinsulate? What is the payoff?

Look at the following diagrams. The first holds true for any structure, non-insulated, insulated, or superinsulated.

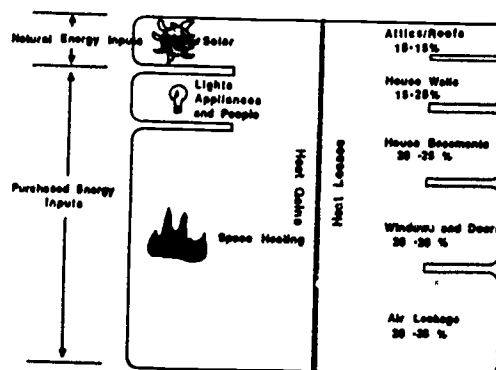

Illustration from Alaska Craftsman Home Building Manual

The next figure compares the energy requirements of typical and superinsulated houses. Note that superinsulation has the effect of eliminating over half of the space heating needs. In turn, reduced total energy needs have the effect of doubling the relative importance of the other two heat source categories in the total house heating budget. Payoffs are potentially huge. Energy sources whose contributions to the structural energy budget were previously overlooked suddenly cut space heating requirements in half.

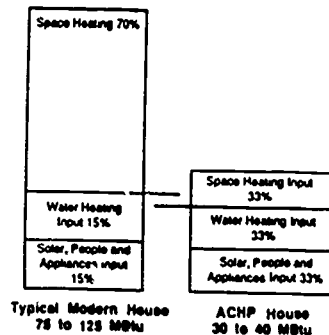

Illustration from Alaska Craftsman Home Building Manual

How is superinsulation accomplished?

Materials which are good insulators, or poor conductors of heat, are used. Generally, the building envelope consists of many layers of different materials, each of which has a different purpose--and each of which forms a vital component of the complete system. The superinsulated house is like a coat of armor--it can't fulfill its purpose if there are holes and thin spots. Therefore every attempt is made to maintain the same degree of insulation throughout the structure. This prevents the extreme (10-50 F) differences in temperature between floor and ceiling (caused by air stratification) found in poorly-insulated houses.

What exactly is the building envelope?

The envelope includes the ceiling, floors, walls and windows. But the top, bottom, and sides of the envelope are special. They are more than surfaces, they are systems. Working from the inside out, these systems typically consist of a sandwich of fire-resistant material, a radiant heat barrier, an air barrier, a moisture barrier, perhaps an airspace, structural members, insulation, structural sheathing, felt, and exterior sheathing.

Surely you don't cover up all the windows with all these layers?

No, a south-facing window which lets in winter sunlight is an essential component of a superinsulated structure's strategy. Even in northern Alaska, sunlight entering through south-facing windows can supply approximately 25% of a house's heating needs.

Superinsulated houses generally dispense with north-facing and some east and west-facing windows. Special steps are made to increase the window's resistance to heat loss. Rather than single pane, windows are double or triple pane, sometimes with dead air spaces to reduce conduction between each pane. The latest window systems include special glazings which allow the full spectrum of sunlight in, but reduce the amount of infra-red which can be radiated back out. The most energy-efficient window systems include thermal shutters which can be closed at

What about the doors?

Like any other structural envelope, the superinsulated one has holes in it, openings for doors, vents, and stovepipes. However, each of these is carefully designed and installed so as to minimize heat transfer. The doors, for example, are typically as well-insulated as the walls.

To further guard against an invasion of cold air each time the door is opened, superinsulated houses may include an arctic entryway. The most energy-efficient arctic entries rely on the same principles which Canadian Eskimoes used to keep their igloos warm without any door at all.

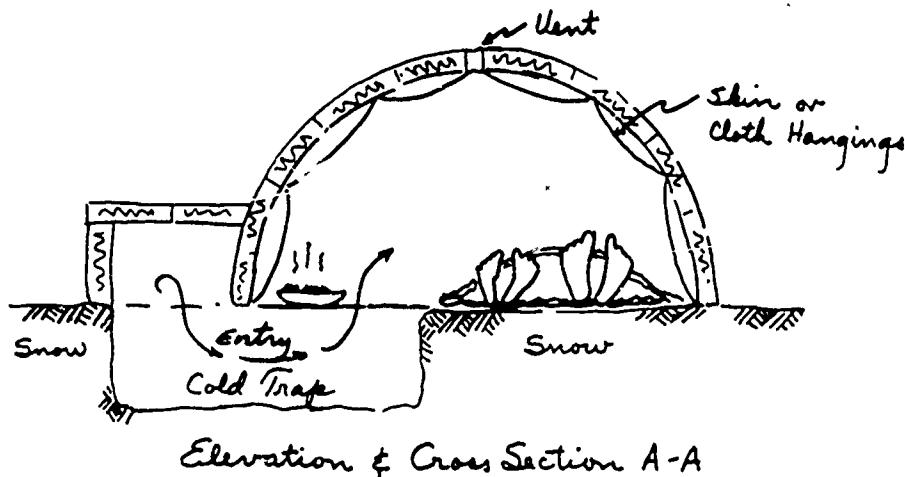

"Taken with permission from: Rice, E. 1984. Building in the North."

The igloo design is based on the fact that cold air tends to sink while warm tends to rise. The warm air is trapped in the igloo by the insulated roof and the pool of cold dense air in the entry.

If the superinsulated structure is airtight, how do you breath?

Good point. Most conventional buildings are so leaky that the air changes every 20 to 60 minutes which means that every 20 to 60 an entire building-full of cold air must be heated. This consumes a lot of energy.

Superinsulated structures require special equipment to maintain indoor air quality: air-to-air heat exchangers. These devices warm incoming fresh air with waste heat from the outgoing stale air--without burning a lot of fuel.

Superinsulated structures may also have special devices which import air for combustion appliances like furnaces from directly outside--thus reducing the tendency of these appliances to draw in and vent heated air from the structure's interior.

With structures becoming increasingly air-tight and with a proliferation of building products which emit toxic substances, indoor air quality has become a major health concern.

You still have to heat the structure. don't you?

Maybe. Humans and their pets radiate a great deal of heat, so do lights, ovens, refrigerators, and other appliances. Some homes are so well designed and built that they require almost no mechanical heating, no woodstoves, furnaces, or space heaters. They provide year-round comfort for a fraction of the heating costs incurred by traditional structures.

It sounds great in theory but how does it work?

When properly designed and carefully built, superinsulated structures work great. There are several keys to maximizing the value of the extra insulation. The first is a sound design which minimizes the number and size of openings, penetrations, and thin spots in the building envelope. The second is to build carefully, paying particular attention to maintaining the integrity of the vapor barrier and the insulation.

Can I superinsulate an existing structure?

It is possible to retrofit structures with insulation and vapor barriers to minimize heat loss--possible but not easy or cheap. The difficulty in superinsulating pre-existing conventionally designed structures stems from the fact that their entire designs are energy inefficient. In fact, experts argue that the conventional stud-wall is little more than a wooden radiator. If this is true--and these experts have calculations and figures to back up their opinions--then a retrofit must somehow overcome or thwart the heat conducting tendency of the pre-existing wall. Obstacles such as these are what makes superinsulating conventionally-designed structures so difficult--and why entire new framing systems have arisen since the early 1970's.

Once again, it's far easier to correctly design and carefully build a superinsulated structure than to retrofit a conventional structure.

Does this mean that a superinsulated structure won't look like an ordinary house?

Yes and no. Superinsulated homes don't need to be buried underground or look like spaceships. Any conventional-style design including southern-colonial mansions, New England saltbox, pueblo adobe, and California modern can be adapted and superinsulated. The superinsulated house won't look that different from conventional houses. In fact, the only real difference in appearance will be the thickness of the walls, special windows glazings, an absence of windows on the north side, an arctic entryway--and only architects, builders and smart consumers will recognize them. Superinsulated structures needn't be ugly; in fact, if properly designed they should be more aesthetically pleasing than their conventional predecessors--especially when their energy efficiency is considered.

Insulation

Competency: Understand Insulation terms and principles

Tasks : Explain insulation terms and principles
Explain the insulation values of various building materials
Calculate heating degree days for your area
Calculate local superinsulation requirements

What is insulation?

Insulation is the ability to resist or restrict the flow of energy. Some substances like rubber, glass, and porcelain are good insulators when it comes to electricity, but builders generally mean resistance to heat flow when they talk about insulation.

How is resistance to heat flow measured?

Perhaps you've heard about R-values. The R simply stands for resistance to heat flow. The higher the R-value the greater the resistance. Each material has its own R-value, and the R-value increases as the thickness of the material increases. If the R-value of one inch of a material is 4, the R-value of two inches of the material would be 8, three inches would be 12, and so on.

What does R stand for?

R is the amount of heat which would be lost through a square foot times the temperature difference between each side of the material divided by the BTU's (British Thermal Units: a measure of heat). In other words:

$$R = \frac{ft \times F}{BTU}$$

The bigger the R-value, the more resistance a material has to heat flow.

Is the goal stopping heat flow?

That's right. Completely stopping heat flow may be impossible, but reducing heat flow is relatively simple. The object is to prevent the transfer of heat from a structure's interior to its exterior. Heat transfer is a function of three factors, the area of the surface, the temperature difference, and the R-value:

$$\text{Heat transferred} = \frac{\text{area} \times \text{temperature difference}}{R\text{-value}}$$

This formula explains why buildings in cold climates need more insulation. In order to maintain a constant rate of heat transfer as the temperature outside the structure gets colder, the R-value must be increased correspondingly.

But you can't change the R-value of your building envelope every time the temperature changes. can you?

That's right. Instead, you design the structure so that the insulation will be adequate for those cold winter nights.

Do you insulate for the coldest night of the year. or what?

No, that would not be economical because for the other 364 nights of the year you would not be taking full advantage of all that insulation. You do, however, size the heating system so that it will be adequate for the coldest nights. This is called design temperature.

How do you determine the optimum amount of insulation for your locale?

That's a good question, and one that the experts have given a great deal of thought to. Their conclusion is that the maximum useful insulation for any and all exterior building sections can be roughly determined by the formula:

$$R = \text{Heating degree days} \times .004$$

What's a heating degree day?

A heating degree day is based on the assumption that most people prefer to live in 65 F homes. When the average daily temperature falls below 65 F, people will add heat to maintain the 65 F temperature inside their houses. Heating degree days are calculated on the basis of the average daily temperature.

For example, if the temperature (outside) averages 10 F on a given day, then it would take 55 degree days to restore it to the 65 F level (65 - 10 = 55).

Adding the number of heating degree days for each day of the year provides the annual heating degree day number. Obtain the heating degree days number for your locale from tables, or from weather bureau records. However, if your building site is significantly warmer or colder than the spot where the weather bureau makes its observations, adjust your total accordingly.

What does the .004 represent?

Some call it the Roggasch variable R value rule; you can call it the Roggasch constant. It's a number which superinsulation expert Bob Roggasch obtained after long hours of computer analysis, and it's based on his assumption that a properly insulated house would lose only 6,000 BTU's per-year per-square-foot of exterior building section. Therefore the house is designed to lose only this amount of heat regardless of where it is built. In other words, the walls thicknesses increase in areas with colder climates.

Mr. Roggasch, who lives in Anchorage, is the first to admit that these numbers are based on present building and energy costs and on educated guesses about future economic conditions, but most experts agree that they work.

Anchorage has approximately 11000 heating degree days a year. Plugging that number into our formula

$$R = 11,000 \times .004$$

or

$$R = 44$$

According to the formula then, a house in Anchorage with R 44 insulation in all sections of the building envelope should experience minimal heat loss and incur minimal heating expenses--perhaps as little as \$50 per year.

What are the components of such a structure?

Superinsulated structures consist of many components. However, for the purposes of energy management there are two principal categories: insulation and moisture management.

Most insulation works on the principle of trapping dry air. Fiberglass, polyurethane, wood, clothes trap varying amounts of air. Even dry snow makes a good insulator (because of the trapped air), which is why the eskimos of northeastern Canada were able to survive in igloos and why people shovel snow away from structures built on permafrost. The greater the thickness and air content and the less circulation and humidity within the material, the better the insulation.

The thickest insulation will be of little value if air and/or moisture can move freely through it. Moisture management, in the form of a vapor barrier greatly improves the performance of insulation by keeping humid warm air from the building's interior out of the insulation. Without a vapor barrier, insulation would never attain its potential, its rated R-value. Without a vapor barrier, insulation may quickly lose all its insulating potential as it becomes saturated with water or ice.

If it is impossible to completely stop the movement of heat, can you completely stop the movement of moisture?

No, unless the house is made of glass. But with the proper moisture barrier, properly installed, you can come very close to stopping the movement of all moisture. And even if some does get through, that doesn't mean that every precaution shouldn't be taken to install and maintain a perfect vapor barrier.

In addition to a vapor barrier, the building envelope must be ventilated to remove stray moisture introduced either from inside or outside the building.

The main difference between traditional designs and superinsulated designs is that the latter views building materials and structural components in terms of their role in the building envelope while traditional approaches frequently pay insufficient attention to how each component relates to each other component as well as the whole. Superinsulated designs sequence and organize the various envelope components so that no component detracts from the overall goal of building the most energy-efficient structure for the least possible cost.

For example, a structural member should not make a thermal bridge. (It should be designed and installed in a manner which minimizes heat loss.)

What's a thermal bridge?

A thermal bridge is something, say a 2" X 4", which conducts heat across an otherwise insulated space. In a normal wall with three inches of fiberglass insulation between each framing member, the 2" X 4"s connect the inside of the building, say the sheetrock, with the outside, say perhaps plywood sheathing.

Now, the fiberglass has an R-value of slightly over 3 per inch for a total of about 10. Dry wood, on the other hand, has an R-value of slightly over 1 per inch, for a total of about four. So the presence of the R-4 2" X 4"s reduces the R of the wall significantly from its potential of R-10.

Furthermore, half a dozen or more nails probably penetrate each 2" X 4", each acting as a further thermal bridge, reducing the R-potential of the 2" X 4".

Superinsulation requires building without nails and 2" X 4"s?

No. It's not practical to build without nails, and superinsulated houses can and sometimes do incorporate 2" X 4"s. What things like thermal gaps and their moisture equivalent, vapor gaps, mean, is that careful consideration must be given to the selection, positioning, and fastening of each part of the building envelope.

The following diagrams illustrate typical situations where the purpose of the building envelope has been defeated.

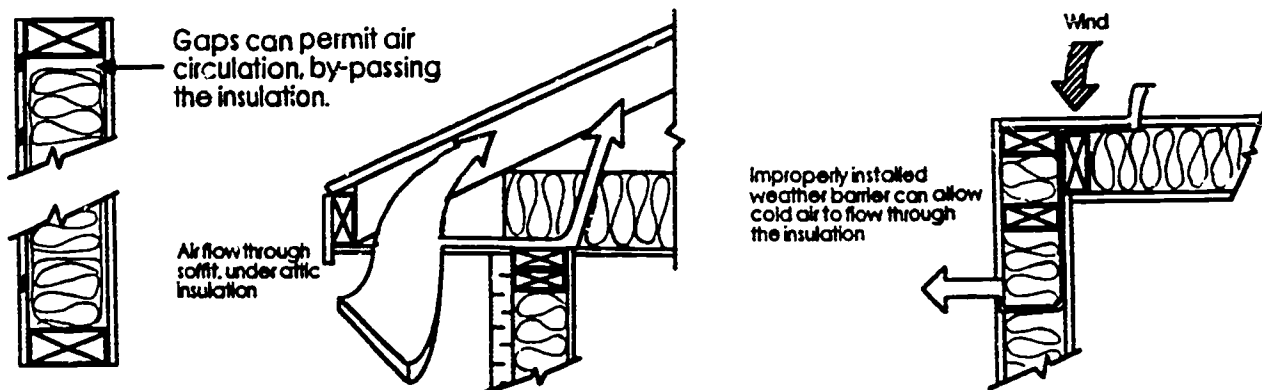

Illustration from Alaska Craftsman Home Building Manual

This sort of systematic thinking sounds pretty complex!

Well, it might be if you had to do it all at once or if you were the first person to design a superinsulated structure. Fortunately, you can benefit from the designs and experience of others who have preceded you. You can also simplify your task by separating the building envelope into its components--the top (ceiling or roof), sides (walls), and bottom (floor or foundation and slab).

Once you determine the best design for each of these components, you can check to make sure that where each section meets another section no thermal or moisture gaps occur. As long as you understand the principles and take your time, you can build a superinsulated structure.

The Alaska Craftsman Home Building Manual (p. 3-9) summarizes the major considerations for the superinsulator:

***In resisting the flow of heat the builder will want to:**

- **Install the maximum economic amount of insulation**
- **Reduce the use of excessive framing materials, and minimize thermal bridging**
- **Ensure that insulation is properly installed to resist compression and convections within the air cavities, and**
- **Restrict the flow of outside air into the insulated sections**

Air and Vapor Barriers

Competency: Understand air and vapor barrier terms and principles

Tasks: Explain air and vapor barrier terms and principles

What is a barrier?

A barrier is an obstacle that blocks the passage of some substance, in this case indoor air and its components.

Why does the air want to move across/through the building envelope?

The Second Law of Thermodynamics states that systems tend towards maximum disorder. If two adjacent systems differ in their amount of order or energy, the higher order/energy system will tend to transfer or export energy to reach a state of equality or equilibrium with the lower energy system. The term used to describe the movement of air through the building envelope is filtration.

What exactly is filtration?

Exfiltration is the process of inside air filtering out through the envelope. Infiltration is the reverse process. In conventional structures in cold climates these two processes can completely replace a structure's air as often as several times every hour. While this maintains the quality of the indoor air (assuming the outdoor air is good), filtration loses a great deal of heat.

What pre-conditions are required for filtration to occur?

All that filtration requires is a pressure difference between the interior and exterior of the building envelope and holes in the building envelope.

Buildings have holes?

About the only envelopes that don't have holes and gaps are plastic bags and toy balloons. Even the best sealed, superinsulated building envelope will have about .5 square feet of holes--when the areas of all the perforations made by nails, tacks, and staples are added together. Conventional, non-superinsulated structures frequently have several square feet of holes in their "skins."

What makes for pressure differentials?

Pressure differentials result from one or more of the following three factors. differences in inside and outside temperatures, winds, and mechanical air supply and exhaust systems.

How does a temperature differential create a pressure differential?

The relationship between temperature and pressure of a closed system are described by the formula:

$$PV = nRT$$

Where P stands for pressure, V for Volume, n is the number of molecules (moles actually), R is a gas constant, and T is temperature.

Another way of saying this is that temperature is proportional to pressure times the volume. For example, if the indoor temperature rises, the product of the indoor pressure and volume must rise proportionally. However, the building envelope is relatively inflexible which means the pressure is going to change more than the volume. As soon as inside pressures exceed outside, the two systems will attempt to reach a new equilibrium--by squeezing some of those molecules out through whatever openings exist.

Furthermore, the greater the temperature difference between indoors and out, the faster the rate of filtration. This is one reason why when temperatures get really cold, the furnaces of not superinsulated homes tend to run constantly. Heating indoor air also creates the stack effect.

How does wind cause pressure differentials?

Wind exerts pressure the same way your hand does when it presses against an object such as an inflated balloon or the lid of an overstuffed suitcase. At the same time on the opposite side of the house, turbulence and lower wind velocities result in a pressure lower than that inside. Hurricane-force winds and tornadoes can create such sudden and enormous pressure differentials that structures "explode."

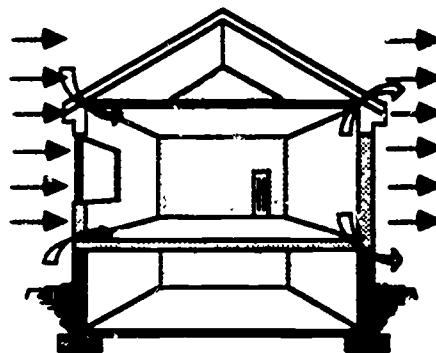

Wind Effect

Illustration from Alaska Craftsman Home
Building Manual

How do combustion and exhaust appliances create pressure differentials?

Appliances create pressure differentials by changing indoor temperatures and by exhausting indoor air to the outside of the building envelope. The first factor is one of the prices we pay for heat (there is no "free lunch," remember). Something can be done about the second factor, and that is to install a system which imports combustion air from outside the building envelope. Such a system minimizes the pressure differentials across the building envelope.

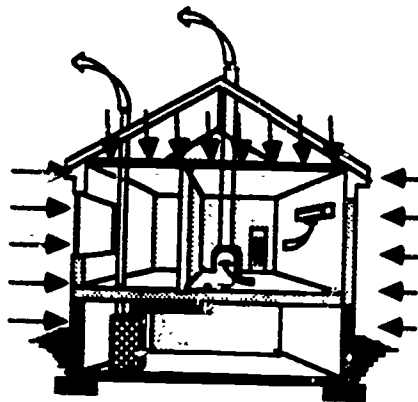

Illustration from Alaska Craftsman Home Building Manual

What is the difference between positive and negative pressure differentials?

When builders talk about differentials, their frame of reference is generally the inside of the structure--and this is the case with pressure differentials. To a builder then, when the pressure inside a building envelope is greater than that outside, this is a positive pressure situation. The reverse situation--outside pressure greater than inside-- would be a negative.

Is positive pressure better than negative?

Positive and negative do not necessarily have good or bad connotations. They do suggest the direction (from high to low, from positive to negative) which air will flow or filtrate in order to reach a pressure equilibrium.

Some builders argue that maintaining a slight positive pressure inside the envelope reduces air infiltration and therefore reduces heat losses. From a strictly theoretical point of view, this assertion may not make sense. For it should hardly matter whether cold air is drawn into a structure, or warm air is driven out, the heat loss should be the same for any given differential.

Maintaining slightly positive pressure inside the structure would have significance in terms of maintaining indoor air quality if combustion appliances did not have outdoor air supplies. However, no superinsulated structure should have any combustion appliance (except possibly a well-vented gas cook stove) without a sealed, independent air supply/exhaust system.

Some experts argue that maintaining a slight negative pressure is the way to go. They note that a positive pressure drives warm air and moisture into the building envelope and wall where it can compromise insulation and rot structural members. Negative pressure draws into the wall cooler, drier exterior air, air which is less likely to cause damage.

What is the stack effect?

The stack effect works on the same principle that makes smoke rise up through a stovepipe or chimney, the fact that warm air rises. Basically, all structures function like stacks with warm air rising. Warm air tends to escape through holes in the upper portion of the building envelope and cold air tends to enter through the lower holes in the building envelope.

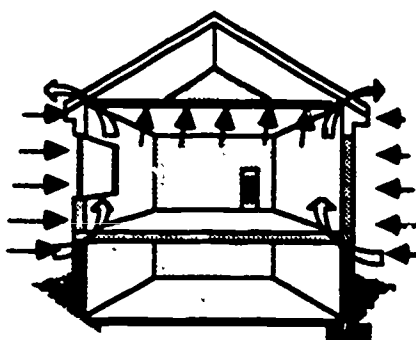

Illustration from Alaska Craftsman Home Building Manual **Stack Effect**

When there are no holes in the building envelope, convection currents are driven by the heat sources and cold sinks (the envelope's surfaces). An igloo's dome shape minimizes the possibility that these convection currents will become channeled or concentrated into drafts.

So air barriers prevent the movement of air through the building envelope, thereby saving energy costs?

Right.

What is the difference between an air barrier and a vapor barrier?

An air barrier stops the movement of air, however any moisture in the form of vapor or humidity will continue to move from the side of high vapor pressure to the side of low vapor pressure unless there is a vapor barrier.

What is vapor?

Vapor is any liquid in its gaseous form. Builders are almost exclusively concerned with water vapor.

Which way does vapor flow?

Vapor flows in the same direction that heat flows. Vapor flows from areas with high vapor to areas with low vapor. Since warm air can hold more vapor than cold air, vapor tends to flow from indoors to the out of doors during the winter. The greater the difference in relative humidity between the indoors and the out-of-doors, the faster the rate of vapor exchange.

What is a vapor barrier?

A vapor barrier is any material which is impervious to air and moisture, in both liquid and vapor forms. Many materials are vapor-resistant, but only the few which are impermeable make ideal vapor barriers.

What is permeability?

Permeability is a material's tendency to allow substances to flow or pass through it.

Are all vapor barriers created equal?

No. Most of the common vapor barriers allow at least some moisture to pass if the material isn't sufficiently thick. Even 10 mil polyethylene, the thickest used for vapor barriers is slightly permeable to vapor. Only glass and 1 mil and thicker aluminum foil provide complete vapor barriers.

Common building materials have been rated in terms of the permeability in the table below. The best vapor barriers--those which are most resistant to flow have the lowest numbers.

Material	Permeability
Vapor Barriers	
6 mil Polyethylene	.052
10 mil Polyethylene	.033
Asphalt Kraft Paper Facing	.075
1 mil Aluminum Foil	.018
Paints	
1 Coat Latex Vapor Barrier Paint	.592
3 Coats Oil-based paint on Wood	.975
2 Coats Oil-based paint on Plaster	1.932
Insulation	
1" Extruded Polystyrene	.063
1" Expanded polystyrene	4.351
1" Polyurethane Insulation	.975
4" Fiberglass, Cellulose, or Rock Wool	28.999
Other Building Materials	
8" Concrete Block	1.932
3/4" wood board	2.910
Gypsum drywall	58.016

Adapted from Alaska Craftsman Home Building Manual Appendix C.

Why have a vapor barrier?

Vapor barriers accomplish several important tasks. As you remember, moist air contains and conducts much more heat than dry air. Vapor barriers prevent interior air from losing its heat and moisture to exterior surfaces. They also keep the moisture out of the insulation. Vapor barriers also prevent exfiltration and infiltration.

What constitutes an ideal vapor barrier?

An ideal vapor barrier completely blocks the passage of all vapor and air. It also should span large areas without seams and be relatively inexpensive to purchase and install. The latter requirements mean that vapor barriers are most commonly made of polyethylene or aluminum foil.

Are polyethylene and aluminum foil otherwise equally good barriers?

Each material has its own attributes. Polyethylene is easier to work with and comes in larger sheets which means fewer seams and fewer gaps through which moisture can escape. However, its R-value is negligible. When placed on the outside of and adjacent to an airspace, aluminum foil reflects heat and can have an R-value of from 2 to 4, depending on whether it's in a wall, ceiling or floor.

How does a vapor barrier work?

When properly installed, a vapor barrier prevents the migration of warm air and moisture from the inside of a building into the outer layers of the building envelope.

Doesn't the heat migrate out no matter what?

That's correct (as long as outdoor temperatures are colder than indoor--in the summer and in tropical climates the direction reverses), insulation only slows the rate of thermal transfer. But if insulation becomes damp, it loses much of its insulating potential. Fiberglass for example, loses 90% of its insulating value when its moisture content rises to 3%.

What produces all this vapor in the first place?

Although indoor humidity seems less of a problem in Interior and Northern Alaska because the ambient (natural outdoor) humidity is so low, an Interior household can produce as much humidity as one in Southeast or the Aleutians. And the huge difference between indoor and outdoor humidity in Interior Alaska only increases the tendency of the inside humidity to migrate out through the building envelope. During winter, whatever moisture evades the vapor barrier inevitably freezes somewhere in the building envelope, thereby creating a thermal gap.

The following illustrates typical sources of residential vapor.

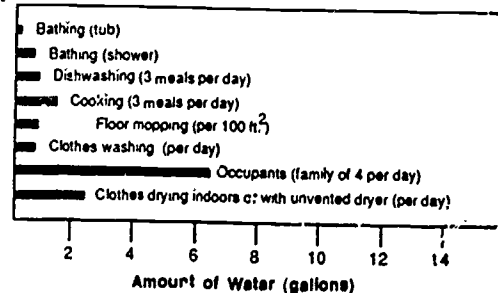

Why does escaping warm air leave its moisture in the insulation?

Warm air can hold more moisture than cool air. As air cools to the dewpoint, moisture condenses or is squeezed from it. A common example of this process can frequently be found on the windows around meal times during winter. Cooking increases the humidity in the air and when the air contacts the cold window, the moisture condenses. When outdoor temperatures are far below freezing, ice may form on the glass.

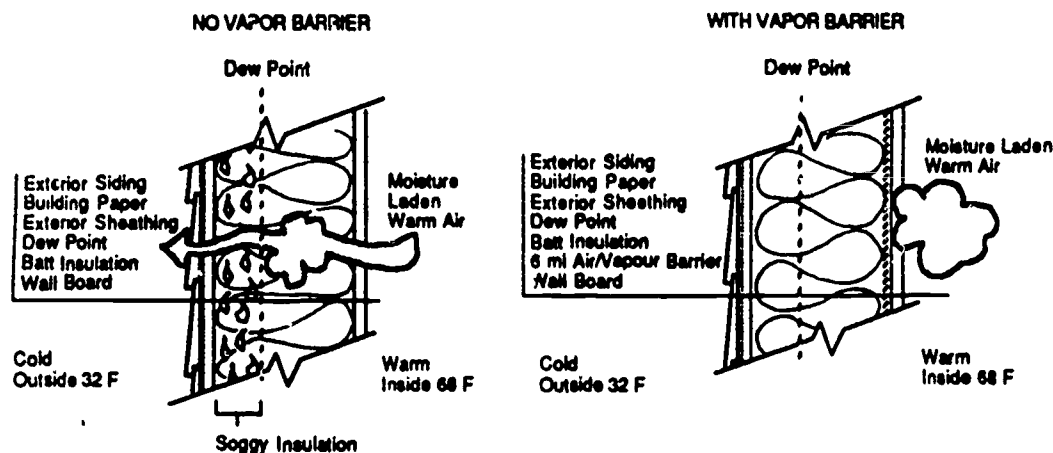

Movement of Water Vapor Through a Wall

Illustration from Alaska Craftsman Home Building Manual

What exactly is the dewpoint?

The dewpoint is simply that point at which moisture or dew forms. The dewpoint is a function of the temperature, pressure, and relative humidity. Generally speaking the lower the relative humidity the lower the dewpoint.

The most important thing to remember about the dewpoint is to make sure that your building envelope is constructed in such a way that the vapor barrier is always closer to the living area (warm side) than that part of the building envelope which is at the dewpoint.

How do I do that?

Assume that it is cold outside and warm inside. The outside of the building, its skin, is approximately the same temperature as the outside air. The temperature rises in successive layers of the building envelope. At the inside surface, it is approximately the same temperature as the air in the room.

How do I determine where the dewpoint will be at a given temperature and relative humidity?

You could calculate it if you knew the R-value of each component of your building envelope. But you don't need to. As long as the building envelope is designed for the temperature and humidity extremes in your area, and as long as indoor humidity doesn't become excessive, you can follow a simple rule of thumb. Vapor barriers placed on the warm side of $5/6$ of a superinsulated building envelope's total R-value are inside of the dewpoint.

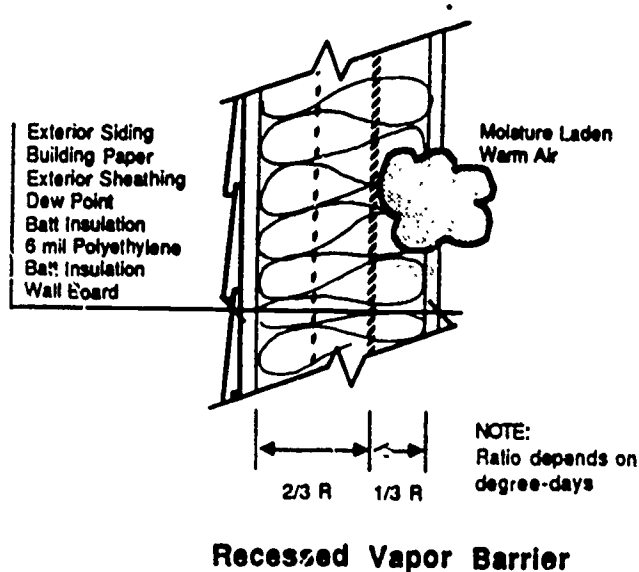
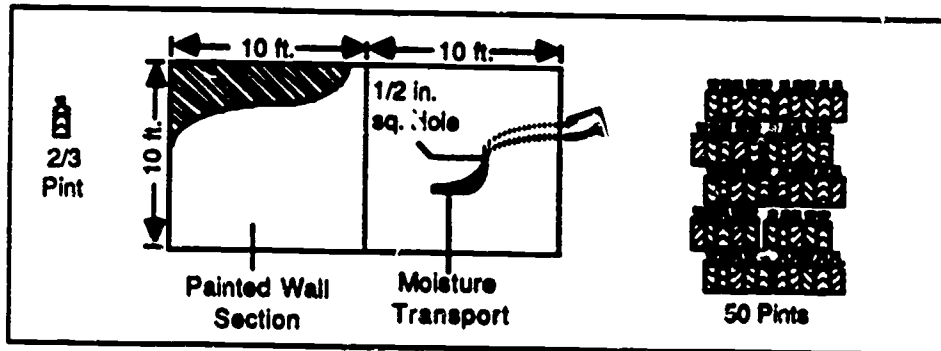

Illustration from Alaska Craftsman Home
Buildin. Manual

What other factors influence air and vapor filtration?

Diffusion is the process of moisture and air moving through relatively impermeable materials such as dry wall, paint, and plywood. Convection, on the other hand, requires gaps such as nail holes and tears in the air/vapor barrier (s). The following diagrams illustrate diffusion and convection in action.



Moisture Transport via Diffusion Vs Air Leakage

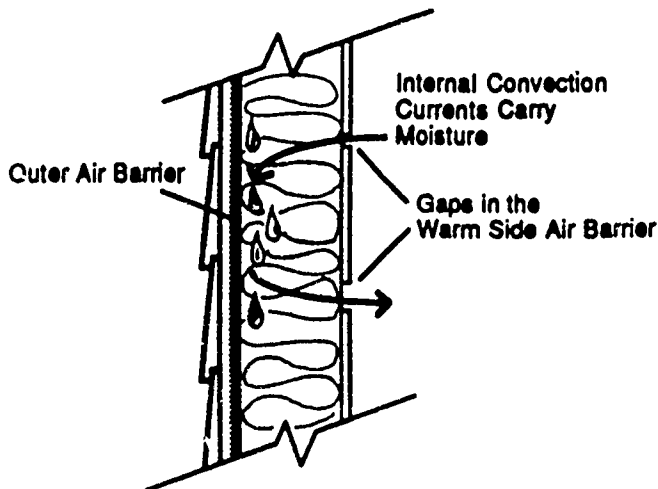

Internal Convection Currents

Illustration from Alaska Craftsman Home Building Manual

Do special climatic conditions require special placement of the vapor barrier?

Yes. In structures with very high relative humidities in very cold climates, the vapor barrier should be even closer to the living side of the envelope, and some sort of dehumidifier may be required to prevent moisture damage. In moderate climates, vapor barriers in superinsulated structures could be safely placed closer to R-value center of the building envelope--say 1/3 of the R-value out from the inside.

How many factors effect the location of the vapor barrier?

Five: Interior and exterior temperatures. Interior and exterior humidity. And the relationship between the lowest expected outdoor temperatures and the total R-value of the building envelope. For example, as the total insulation value in the building envelope increases, the vapor barrier can be moved further into the envelope.

Are there advantages to having the vapor barrier further from the inside surface of the building envelope?

The material on the living side of the vapor barrier constitutes part of the thermal mass, so the more materials on the inside of the vapor barrier the greater the thermal mass. However, no amount of gain in thermal mass is worth the risk of the dewpoint occurring close to or inside the vapor barrier.

Some experts argue that in climates where the average annual temperature is above 32 F, the air barrier is more important than the moisture barrier. Their reasoning is based on their experience that in wet climates like those of Southeast Alaska and the Aleutians, mold and moisture cause far more structural damage than the build up of ice in insulation and walls is ever likely to.

Given the importance of keeping insulation and other components of the building envelope dry, builders should pay careful consideration to all the likely outcomes of their air and vapor barrier design strategies.

What are the main considerations in installing vapor barriers?

The two main considerations are to install the vapor barrier at the proper position in the building envelope relative to the potential dewpoint during the coldest anticipated weather. The other concern is to install the tightest barrier possible. This means minimizing the number of seams and preventing the material from being punctured or otherwise damaged during and after construction. Special steps should be taken to make seams as airtight as possible.

How are airtight seems made?

Overlapping the adjoining sections of vapor barrier helps, but french seams are even better. Where attachment to structural surfaces requires puncturing the vapor barrier with staples. The staples and their accompanying holes can be taped over.

FRENCH SEAM

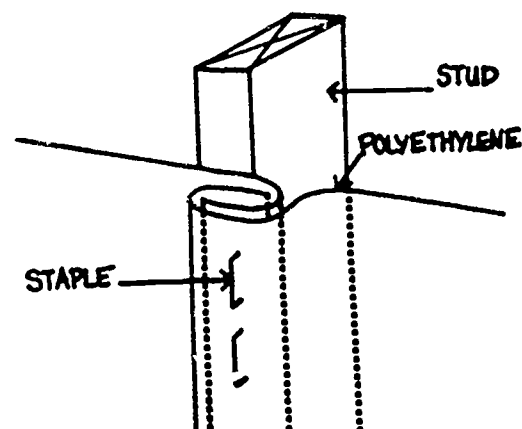

How does one determine if the superinsulated envelope is "tight"?

Currently, the best way to determine whether or not a building is airtight is to measure its filtration rate. This pressure test is done with a special fan which creates pressure differentials between the structure's interior and exterior. Pressure-test results tell exactly how tight the structure is--or exactly (within one/one-thousandth of a square foot) the total area of its leakages.

How about water from the outside?

Moisture must be kept out of the building envelope, no matter the direction from which it comes. Roofs should be designed to keep rain and snow away from building walls. However, even in areas where there is no wind, precipitation can still reach the exterior walls.

All building designs should include a weather barrier to make sure that moisture from the outside gets no further than the building's surface. Common weather barriers include metal flashing and siding; wood siding sealed by paints, stains, or varnish; and asphalt felt or tar paper.

In wet climates, the exterior layers of the envelope including the weather barrier are often isolated from the insulation by an airspace which fosters drainage and drying.

Insulation Materials

Competency: Understand the insulating qualities of various building materials

Tasks: Explain the Pros and Cons of various insulation materials

What questions should be asked and answered before determining the best insulation for a given application?

Cost per R.

Purchase cost

Installed cost (purchase cost plus labor)

Flammability: Will it burn? If so, how rapidly can flame retardants be added?

Health hazards: Does it emit toxic compounds during fabrication, installation and/or once in service?

R-value per inch: How much bulk will be required to do the job?

Response to UV radiation/sunlight: Will it degrade?

Response to moisture: Will it degrade and/or lose R-value when wet?

Response to compaction: Will it degrade and/or lose R-value when compacted?

Degradation rate: How long will insulating qualities persist? When will material need to be replaced? What will replacement entail?

Pest factor: Will pests eat or nest in the material?

Special logistical considerations: Will transportation, storage, or handling create any unique needs?

What are some insulation materials?

Cellulose is a loose fill made from shredded paper and fire retardant and provides R 3.8 to R 4.2 per inch. However, it settles over time leaving gaps.

Fiberglass rolls and batts are rated at R3.1 to R 3.7 per inch. Made of minerals, the fibers are fire-resistant but irritate skin and lungs. It can be compacted without significantly reducing its insulating capacity, but small amounts of moisture virtually eliminate its insulating qualities.

Moss when dry can have a R-value of up to 3.8 per inch. Though cheap, it burns and rots readily, attracts insects, and must be replaced almost annually.

A petroleum product rated at R4.5 per inch, polystyrene comes either rigid in boards or loose in beads. Moisture does not reduce its insulating value, so beadboard is suitable for sheathing below-grade walls. Loose beads are sometimes used to insulate special windows, but polystyrene is vulnerable to UV degradation and emits toxic fumes when burned.

At R2.6 per inch, dry sawdust has many of the same characteristics of moss.

Styrofoam is a rigid sheet insulation rated at R 5.7 per inch. A petrochemical, it degrades in UV but does not absorb moisture and resists compression making it good under slabs and footings.

Popular in retrofitting, urea-formaldehyde is mixed in-place and has a fairly high R-Value (4.4 to 4.8 per inch) but it is expensive, tends to shrink and emit toxic vapors on drying and should not be used.

Rated at R4 to R 7 per inch urethane foam is a petrochemical compound which insulates by entrapping freon gas. Though a better insulator than air, freon gas liquefies at -20 F at which point it loses much of its insulating qualities. Once popular, urethane is expensive, degraded by moisture and UV radiation, flammable, and can lose 40% of its insulating value within a few years of installation.

Wood is a poor insulator, R1-1.5 per inch. However, wood logs, because of their mass, are slow to warm but hold large quantities of heat once warmed.

Most of the above insulation materials are prone to degradation by animals and moisture. If these and other characteristics cannot be accommodated because of the building site, design, or application, some other material must be substituted.

What materials are most commonly used for insulation?

Houses often use several different kinds of insulation. Though it isn't much fun to work with because it irritates the skin, fiberglass batts continue to be one the most popular insulations. In applications where moisture is likely beadboard is common. Moisture and compression conditions demand styrofoam.

Superinsulated Floor Options

Competency: Understand Superinsulated Floor Options

Tasks: Explain Superinsulated floor systems

What is a superinsulated floor system?

A superinsulated floor system forms the bottom side of a superinsulated building envelope. Like any superinsulated envelope system it consists of structural elements (joists, stringers, floor and subfloor) as well as the all important insulation and vapor barrier.

Why does one superinsulate a floor? Doesn't heat rise?

While it's true that hot air rises, it's equally true that heat seeks cold--and moves any direction equally well. A superinsulated envelope without a superinsulated bottom is like a bucket without a bottom. The former won't hold heat any more than the latter will hold water.

What situations call for insulating the floor rather than the foundation?

Basically, there are two situations calling for insulated floors. In the case of permafrost, foundations systems are designed to prevent building heat from reaching the ground. Almost always, this requires elevating the bottom of the structure at least three feet above the ground and leaving the ground exposed to the cooling effects of the winter wind by not skirting in the area between the bottom of the building envelope and the ground.

In cases where there is no basement, or the basement is not heated, the floor must be insulated otherwise the building will be uncomfortable and heat and moisture escaping through the floor will create conditions ideal for rot and mold beneath the floor.

What about the plumbing? Won't it freeze?

Subfloor system water and wastewater pipes are vulnerable to freezing. However, designing superinsulated floor systems to accommodate these and other utilities presents no serious problems. Designs should minimize the potential for wetting the insulation. This can be accomplished by using insulation in the vicinity of the pipes which is not affected by moisture, by heating tapes, and/or vapor barriers.

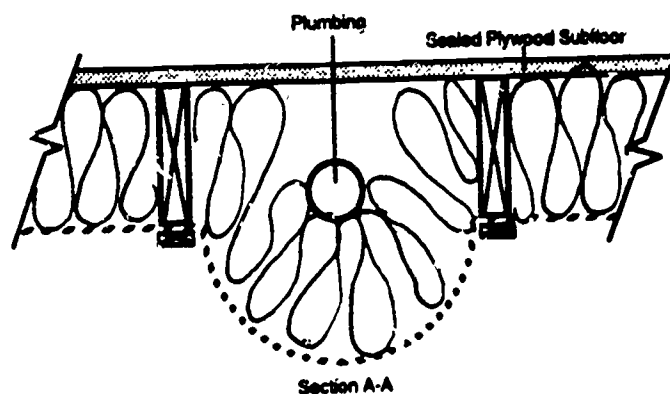

The most important consideration is to carefully design plumbing penetrations and details in the superinsulated floor envelope so that the plumbing and the floor are protected from the cold-- and the floor, insulation, and vapor barrier are protected from the plumbing and the potential need to repair it.

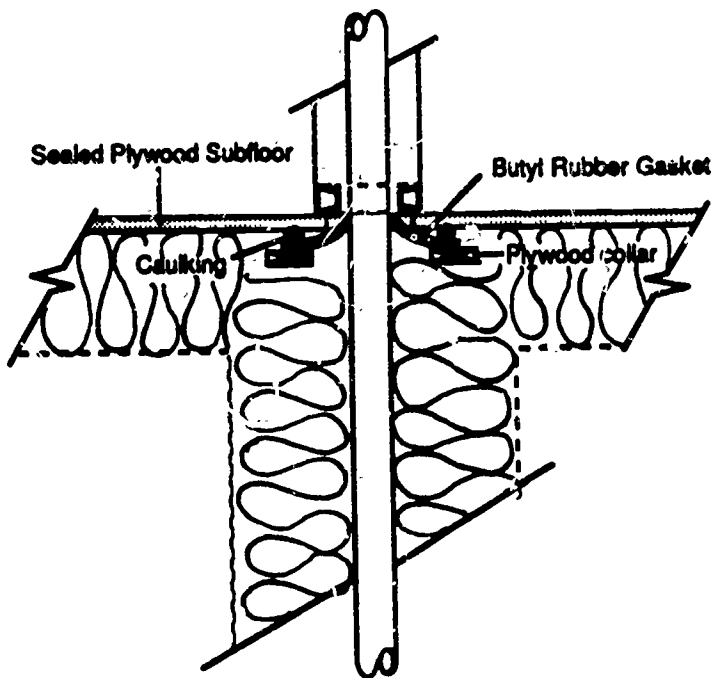
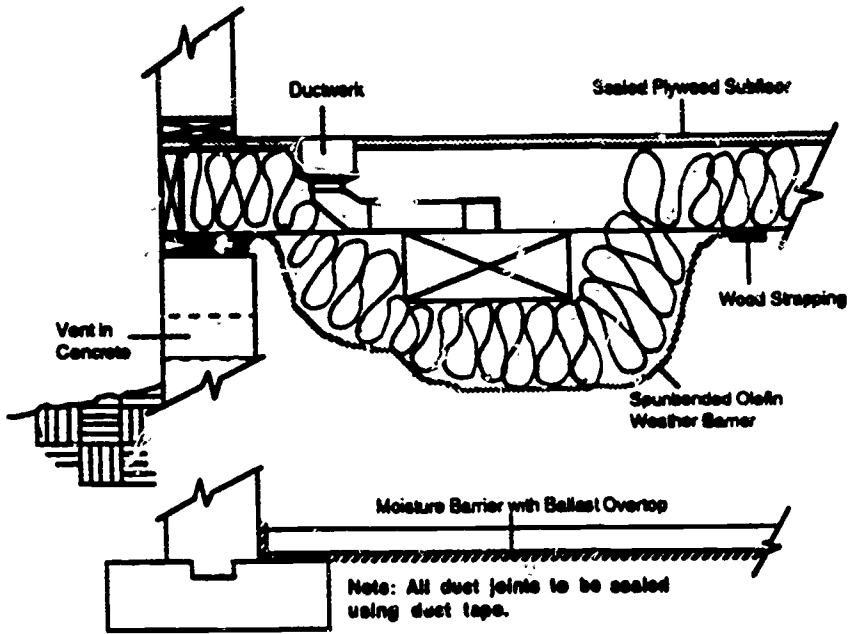

Superinsulated floor designs usually employ insulation batts between the floor joists. In the coldest climates special measures should be taken to minimize thermal bridging from the house interior to exterior by structural members. The following depicts a typical superinsulated floor.

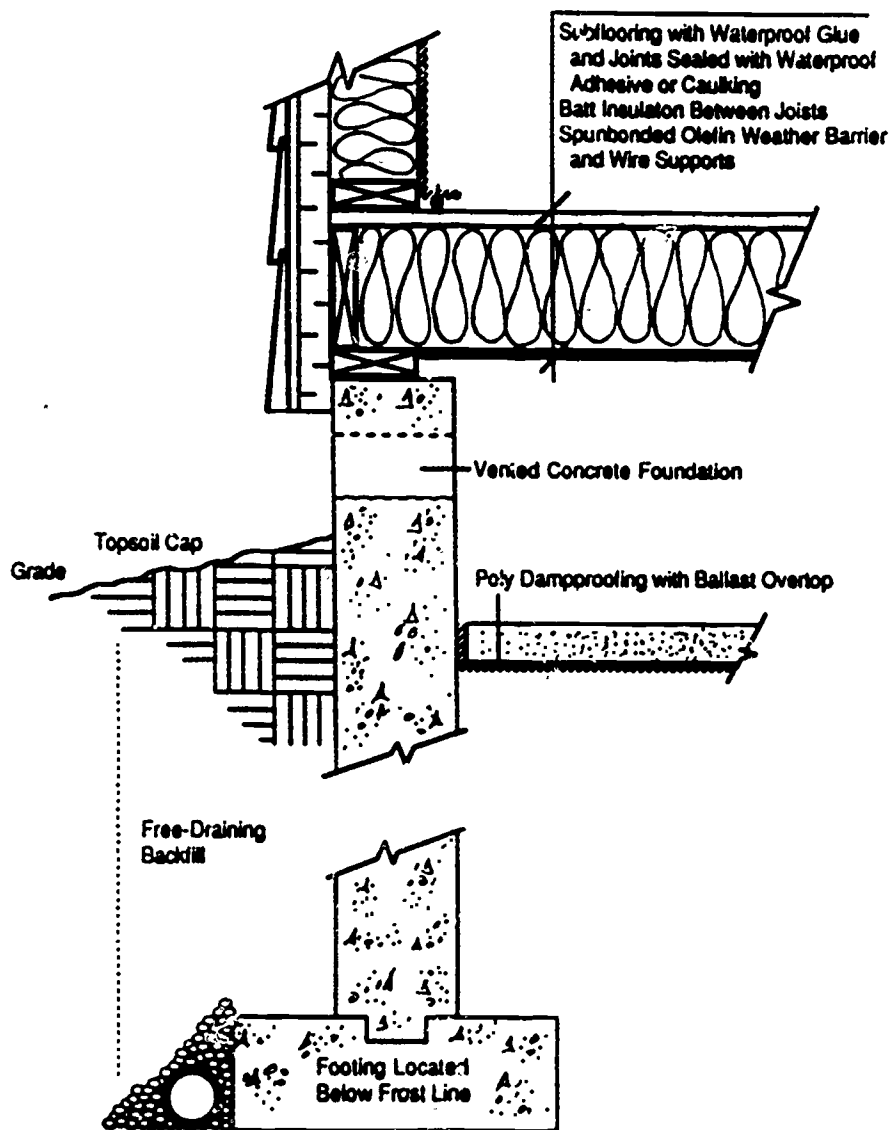

Illustration from Alaska Craftsman Home Building Manual

In addition, to the details shown, screen and/or wire mesh might be needed to prevent pests (insects, animals, and children) from invading the envelope from underneath.

In what order is the superinsulated floor assembled?

Superinsulated floor construction follows completion of the foundation. Sandwich lovers know that the relative position of ingredients makes a difference in how the final product tastes. Superinsulated builders know that the relative position of building materials and the order of construction make a vital difference in heat-loss tests. The following list comes directly from the Alaska Craftsman Home building manual:

Floor framing follows conventional procedures except that all joints on the floor sheathing must be caulked or glued with waterproof adhesive. If polyethylene is used for a vapor barrier, it should be installed prior to subfloor insulation (between the subfloor and the joists) and after the walls and roof have been made weathertight. This sequence reduces the potential for water damage from above during construction and for gaps in the vapor barrier at the wall-floor junction.

After the roof and walls are made weathertight, oversize holes are cut in locations where conduit or plumbing passes through the floor. Rubber gaskets are installed in each hole.

Duct boots passing through the floor must be sealed to the subflooring.

Seal all ductwork seams and joints with tape.

Complete installation of ductwork, plumbing, and wiring.

Place batt insulation between floor joists until total space is filled with insulation.

Support batts from below with wire mesh, spunbonded olefin, or rigid sheathing. Protect from pests.

Indoor Air Quality

Indoor Air Quality

Introduction

Although the material in this section is meant to stand alone, it will be much more meaningful to students already familiar with the earlier discussion on superinsulated structures in the energy section.

Furthermore, the Technological Impacts section of the Industrial Education curriculum presents related issues such as air pollution (outdoor) and conservation of natural resources.

Although there may be a temptation to skip the sizing/calculations competencies, this would be a mistake. In addition to allowing students to flex their math muscles, these units graphically illustrate the interrelationship between heating and ventilation systems and the building envelope.

Overview

Although at first thought, it may appear that most of the career potential in heating and air quality lies in the sales, installation, and maintenance of mechanical ventilation and heating systems by specialists, this needn't be the case. Many of the best systems are based on simple principles and can be installed by builders. Furthermore, heating and ventilation are such integral components of superinsulated structures that builders must fully understand their interrelationship.

Resources

AIR: An Atmosphere of Uncertainty, National Geographic Magazine, April, 1987, pp. 502-538.

Alaska Energy Education Series, Alaska Departments of Education and Community & Regional Affairs.

Energy Conservation Options for Alaskan Mobile HOMes, Division of Energy & Power Development, Department of Commerce & Economic Development, 338 Denali, Anchorage, AK 99501.

Energy Efficient Housing--A Prairie Approach, Energy Conservation Branch, Alberta Energy and Natural Resources, 2nd floor, Highfield Place, 10010 - 106 Street, Edmonton, Alberta, Canada T5J 3L8.

Homeowner's Manual, Residential Energy Conservation Program, Department of Commerce and Economic Development, Division of Energy and Power Development.

Indoor Air Quality: Is My Home Healthy for Me? Building In Alaska, Cooperative Extension Service/University of Alaska/Sea Grant, March 1985.

Moisture and Home Energy Conservation, U.S.D.O.E., U.S. Government Printing Office, Washington, D.C. 20402

National Appropriate Technology Assistance Service (NATAS) U.S. Department of Energy, P.O. Box 2525, Butte, MT 59702-2525, 1-800-428-2525.

The Nontoxic Home, Debra Lynn Dadd, Jeremy P. Tarcher, Inc., Los Angeles, 1986.

Radon Reduction Methods: A Homeowner's Guide, Environmental Protection Agency (EPA).

Recommended Housing Energy Design Criteria for Southeast Alaska, Juneau Energy Advisory Committee, Alaska Department of Community & Regional Affairs.

RurAL CAP (Rural Alaska Community Action Program), P.O. Box 3-3908, Anchorage, AK 99501 (907) 279-2441.

Wood Stove Features and Operation Guideline for Cleaner Air. Environmental Protection Agency.

Office of Energy Programs, Division of Community Development, Department of Community & Regional Affairs, 949 East 36th Ave., Suite 403, Anchorage, AK 99508 (907) 563-1955.

Energy Specialist, Room 207-D, Eielson Building, Cooperative Extension Service, University of Alaska, Fairbanks, AK 99775-5200 (907) 474-7201.

Energy Agent, Cooperative Extension Service, Suite 240, 2221 E. Northern Lights Blvd., Anchorage, AK 99508-4143.

Cooperative Extension Service, 709 W. 9th, Juneau, 586-7102.

Renewable Energy Information, Box 8900, Silver Springs, MD 20907.

Indoor Air Quality Principles

Competency: Understand Indoor Air Quality

- Tasks:** Explain indoor air quality terms and principles
Explain indoor air pollution sources
Explain indoor air quality strategies

What is indoor air?

"Indoor air" refers to the air inside a structure. The quality of that air directly affects the health of the structure's occupants and visitors.

Why is indoor air quality a concern?

Until recently, most people didn't think about the quality of indoor air. When builders started improving the energy-efficiency of structures, they purposely eliminated as much infiltration and exfiltration as possible. The resultant almost air-tight structures proved very energy efficient. However, unless equipped with equally efficient ventilation systems, something about the structures began making occupants ill. Investigators soon determined that indoor air pollution was the culprit.

What is indoor air pollution?

Indoor air pollution is anything which reduces the quality of the air inside a building. Indoor air pollution could take the form of suspended dust particles, microorganisms, or gases, such as carbon monoxide.

Where does the pollution come from in the first place?

The contaminants can come from inside or outside the building, from natural or industrial processes, from building materials, furniture, clothing, and appliances, from heating, cooking, and smoking. Indeed, it is the multiplicity of sources which makes indoor air pollution such a potential problem.

Just how bad a problem is indoor air pollution?

Chances are, the building that you are sitting in at this very moment--whether it is your home, school, doctor's office, or favorite restaurant--has indoor air pollution problems. Indoor air pollution is a BIG problem. Although studies have only recently begun, some researchers believe that indoor air pollution may be responsible for ten times more illness than outdoor air pollution, or one hundred billion dollars a year in medical costs in the United States alone.

What are some of the common forms and sources of indoor air pollution?

Carbon Monoxide & Nitrogen Dioxide

Carbon monoxide (CO) and nitrogen dioxide (NO₂) are two of the most common by-products of internal combustion. These gases are deadly because they are absorbed (by hemoglobin) into the blood stream through the lungs more readily than oxygen (in the case of CO, 250 times more readily than oxygen). Nearly every year, Alaskan are killed by carbon monoxide which has

seeped into their homes from vehicles idling in garages. When carbon monoxide levels are high, the onset of poisoning is so rapid that victims are oblivious to the symptoms (drowsiness and cherry-red skin color). Carbon monoxide frequently kills builders working in space-heated enclosures and plays a role in aviation accidents.

Prolonged exposures to quantities as low as 25 ppm (parts per million) impairs vision and brain functions. Exposures to 9 ppm for even a few hours may be hazardous to pregnant women and especially their fetuses. Research is underway to determine the effects of even smaller concentrations of these compounds.

Present EPA outdoor exposure standards of 35 ppm for a one-hour period and 9 ppm for an eight-hour exposure may have to be revised when more is learned.

Indoor concentrations of carbon monoxide typically average .5 to 5 ppm. However, gas stoves increase background levels by 5 to 10 ppm--and 30 times that rate if improperly adjusted (as indicated by presence of yellow flame).

Convective-type kerosene heaters produce an average concentration of 5 ppm, while radiant-types produce 13 ppm on the average.

Relatively inexpensive carbon monoxide detection devices are available which will alert builders and occupants to the presence of dangerously-high CO levels.

Aromatic Hydrocarbons (Benzenes)

Incomplete combustion from appliances, cigarette smoking, firewood, and automobiles also produce aromatic hydrocarbons, highly carcinogenic compounds. The process of breathing draws them far into the lungs where they become trapped and can, over periods of years, cause cancerous mutations in the lung tissue. Because of the small size of these particles, the body has almost no way to prevent them from entering the lung, and once in the lung, little chance of ejecting them.

Formaldehyde

Combustion-type appliances and smoking also produce formaldehyde, a colorless but pungent, water-soluble gas. However, especially in the first few years following construction, the most important source of formaldehyde is the glue used in building materials such as plywood, particle board, furniture, drapes, carpets and textiles. According to the American Lung Association, formaldehyde is known to cause cancer in animals and is found in as many as 3,000 different building products. Homes built in the 1970's may contain significant amounts of UF (urea-formaldehyde) foam insulation. Although rates may slacken after a few years, these products continue to emit formaldehyde throughout their existence.

Formaldehyde irritates the respiratory system. About 10 to 20 percent of the population is highly sensitized to formaldehyde, although most people soon recover once exposure is terminated. The American Society of Heating, Refrigeration, and Air-Conditioning Engineers (ASHRAE) has set acceptable standards at 0.1 ppm.

Radon

Radon is a naturally-occurring, colorless, odorless, and tasteless radioactive gas produced by the decomposition of uranium. Found world-wide, radon generally presents a health problem only in those areas with elevated uranium concentrations in the soil or underlying bedrock. Lighter than air, radon rises from the ground and becomes trapped in structures.

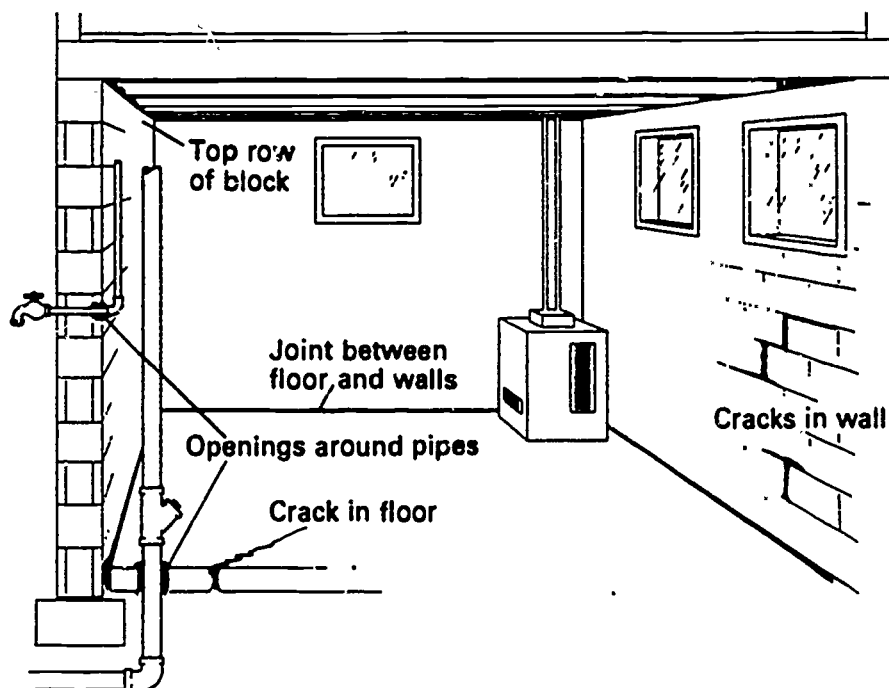

"Illustration courtesy from Radon Reduction Methods, A Homeowner's Guide."

Radon causes lung cancer when it becomes trapped in lungs and decays into other radioactive products releasing bursts of energy. Radon concentrations are measured in terms of picocuries per liter (pCi/l) (a Curie is a measure of radioactive energy). Experts become concerned when indoor air radon levels exceed 5 to 10 pCi/l.

Radon was first recognized as a health problem after houses and schools were built from and on uranium mine tailings in the Southwestern U.S. in the 1960s. Some houses in parts of the Eastern U.S. where soils have high concentrations of uranium (eastern Pennsylvania and New Jersey) have such high radon levels that their owners have abandoned them.

At the present time, radon levels are not known to be dangerously high in any part of Alaska; most structures which have been tested are under the 10 pCi/l level. However, even at that level lung cancer death rates would increase by approximately 13 people per hundred over a population which had no exposure to radon. Most structures can easily be defended against potential radon problems.

Radon should be less likely to enter superinsulated structures, and--assuming the structure has been equipped with an appropriate-sized air-to-air heat exchanger--that which does enter should be readily exhausted by the structure's ventilation system.

Structures suspected of harboring high levels of radon can be tested. For more information, contact the EPA or the State Radiologist at the Department of Health and Social Services.

Micro-organisms

Mold, fungi, and bacteria are found in every structure. In air-tight superinsulated buildings, they can become a real problem--especially if humidity and/or airborne dust are excessive. In large concentrations, micro-organisms have been known to cause headaches, dizziness, and allergic responses. Micro-organisms from air-conditioning systems have been blamed for epidemics (now called Legionnaire's Disease) which killed more than twenty people in the early 1980's.

Tobacco Smoke

According to the American Lung Association, several studies have shown that breathing second hand tobacco smoke more than doubles the non-smoker's risk of lung cancer. In sensitized individuals, second hand smoke also causes dizziness, headaches, sore throat, and other flu-like symptoms.

Volatile Organic Compounds

Furniture, paint, adhesives, solvents, upholstery, draperies, carpeting, spray cans, clothing, construction materials, cleaning compounds, dry-cleaning compounds and clothes which have been dry-cleaned, deodorizers, copy machine toners, felt-tip markers and pens, and correction fluids are some of the thousands of substances which emit volatile organic compounds. Over the short term, volatile organic compounds irritate the eyes, skin, and respiratory system; over the long term, they can damage the kidneys and liver and cause cancer and birth defects.

Asbestos

Asbestos is a highly carcinogenic fibrous material which is added to paints and finishes as a fire retardant and which is also installed in sheets as fire-proof insulation.

Asbestos is highly friable which means it tends to disintegrate into dust. The resultant particles are so small that upon inhalation, they are carried so far into the lung that the body cannot eject them. Once in the lung, they lodge and irritate the lung tissue and over a period of 5 to 20 years, cause asbestosis, a form of deadly lung cancer.

Asbestos is often encountered while re-modeling older structures. In most cases, only fully-trained and certified technicians wearing approved respirators and protective clothing should enter such structures or handle and/or remove the materials.

If you suspect the presence of asbestos in a building product, do not use that product until you are certain that it contains no asbestos.

Asbestos is also found in automotive brakes, power tools, and other electrical appliances. People who work with and service such mechanisms should take the appropriate precautions.

What are the strategies for minimizing indoor air pollution and its accompanying risks?

The basic strategy is to avoid wherever possible the use of toxic compounds in the building. The first step in this process is to become a diligent reader of labels--an amateur sleuth and an informed citizen. The second step is to learn which products are harmful and try to develop building designs which substitute less toxic materials. The third step is to install an adequate ventilation system.

Some problems like asbestos cannot be addressed by ventilation systems, but most of the above can.

As you know, the Second Law of Thermodynamics predicted that there would be no free lunch. The above survey of indoor air pollution sources suggests that high-tech compounds are not immune to the workings of this law. Some of these high-tech compounds may be cheaper to buy, transport, install, and maintain, but these considerations may become insignificant in comparison to their long-term health effects. Even from a strictly economic (dollars-and-cents) standpoint, these compounds may prove unworthy. The long term costs of addressing health effects may exceed by many times the short term savings. The case of asbestos has amply demonstrated that when a product is finally proven to be carcinogenic and is subsequently banned, the cost of removing or isolating it can be thousands of times more expensive than it would have been to use a more expensive substitute in the first place.

Ventilation Systems

Competency: Understand Ventilation Systems

Tasks: Explain ventilation system terms, principles, and methods

Aren't heating and ventilation related?

Ventilation and heating systems are so inter-related, that one should not be selected without giving careful thought to the other. Indeed, the engineering community lumps all these concerns into one field described by the acronym HVAC (Heating, Ventilation, Air Conditioning). Since covering all these topics at once is impossible, ventilation will be explained first, but heating could have just as easily been the first topic presented. Students, builders, and consumers should always remember that heating and ventilation systems are different sides of the same coin.

What is the purpose of ventilation?

The purpose of ventilation is to exhaust stale air from the structure and import fresh air.

Does every room in the building need to have fresh air import and stale air export ducts?

No. Rooms like bathrooms and kitchens which have exhaust systems may not need to have fresh air ducts because the exhaust system will draw fresh air into those rooms from elsewhere in the house.

How is supply air distributed?

The answer to this question depends on whether heating and ventilation systems are integrated. For example, in the case of forced air heating, fresh air can be distributed via the heating ducts. In houses without centralized heating, supply air must be distributed via the heating cuts. In houses without centralized heating, supply air must be distributed through an independent ventilation system.

When systems are separate, doesn't the introduction of cool fresh air create the potential for discomfort?

Yes, air-to-air heat exchangers may only warm incoming air to 50 F. This air must be mixed with existing room air, or drafts and cold air pockets may make the room unpleasant. (Because cool air sinks, cold air deposited on the floor could pool, causing cold feet.) The best way to avoid these problems is to place the ducts either high on the wall directing the air horizontally, or on the ceiling with the air directed horizontally. If ducts must be located on the floor, they should direct the air towards and up a wall.

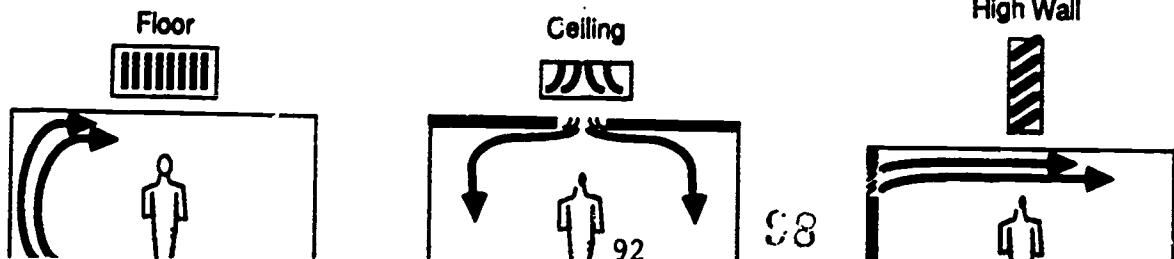

Does integrating heating and ventilation systems have advantages?

Yes. By integrating the heating and ventilation systems, builders can reduce the amount of ducts, wiring, and appliances. Whether an integrated system is the best solution to a given structure depends on the structure's design and intended use and on local fuel options and costs.

What else does a ventilation system do?

Properly designed, ventilation systems also help control humidity levels. This becomes critical in superinsulated structures in cold, damp climates and in dry, arctic climates.

What is humidity?

Humidity is a measure of the amount of moisture in the air. Some people prefer relative humidity as low as 20%; others find 50% more comfortable.

What is relative humidity?

Relative humidity is a measure of the percentage, or concentration, of humidity relative to how much humidity air at that particular temperature can hold--as opposed to the absolute amount of moisture in the air. The warmer the air, the more moisture it can hold; the cooler the air, the less humidity it can hold.

What is so bad about humidity?

Humidity is neither all good nor all bad. Too little humidity can make a person itch or feel all dried out. Too much can make a person arthritic, stiff. Too little humidity can make a structure difficult to heat. Too much humidity turns a warm structure into a steam bath and fosters the growth of mold, fungus, and dryrot, all of which cause health problems for both the structure and its occupants.

How does an adequate ventilation system control humidity?

First, it exhaust moisture from cooking, bathing, and clothes drying as well as other activities. Secondly, it often includes a dehumidifier, a machine which squeezes moisture out of the air by cooling it in an enclosed space.

When should dehumidifiers be installed?

Ventilation systems for tight, superinsulated structures in places with climates like Southeast Alaska should include dehumidifiers--preferably the automatic type which are activated whenever relative humidity exceeds a certain percentage. Similarly, in extreme cold, if inside relative humidity becomes excessive, dehumidifiers will be needed to lower the dew point to prevent condensation in, and damage to, the building envelope.

Alternative Heating Methods

Competency: Understand Alternative Heating Methods

Tasks: Explain Alternative Heating Methods

Do superinsulated homes have special heating requirements?

Yes. Each structure has unique heating requirements, and superinsulated homes are no different. Superinsulated homes need much smaller heating systems than conventionally-designed structures. And because of added indoor-air quality concerns, combustion-type appliances must have special air-supply/exhaust systems.

What are these special air supply and exhaust systems?

Generally, the entire supply-combustion-exhaust loop is independent or isolated from the indoor air. In other words, the combustion system is directly connected to the out of doors and is sealed to prevent any exchange of gases or combustion products with the indoor air. Sometimes, the combustion appliance is located outside the building envelope.

Do these special systems cost more?

Not usually. Rather than costing more than systems for comparably-sized conventional structures, most heating system for superinsulated structures should cost less to purchase, install and operate.

What factors influence the type of heating system?

Most consumers select heating systems on the basis of the present and anticipated costs and convenience of locally-available fuels. Other important considerations include purchase, installation, and maintenance costs of the heat supply and distribution system. In order to select the best heating system for a given structure and location, builders and consumers must know all about the options on the market and how each relates to the structure's design and ventilation system.

What are the components of typical heating systems?

All heating systems have an energy source or supply, a device (furnace, stove, boiler, heater) which converts the energy into heat, and a heat transfer method, which may or may not include heat distribution (ducts, pipes) and storage systems (thermal mass).

What are some of the limitations on the choice of systems created by superinsulated homes?

Air quality concerns have already been mentioned. They dictate that all combustion must have induced or forced venting systems or sealed combustion systems which draws combustion air directly from outside.

All combustion appliances must have special provisions for removal of their combustion products.

Wood stoves or fireplaces and gas-fired fireplaces must be sealed and provided with a separate outdoor air supply to the firebox.

Gas-fired domestic hot water (DHW) heating systems must have reduced standby losses.

Electric DHW heaters must have a factory installed insulation level of at least R-10.

Why all the concern about combustion-type heating appliances?

In addition to carcinogenic gases and particulates resulting from incomplete combustion, these appliances produce carbon monoxide. Buildings with very tight envelopes have greater potential for backdrafting from flues and chimneys than do structures with leaky envelopes. Importing combustion air reduces the likelihood of the heating appliance creating large negative pressure differentials indoors while operating. Such differentials should increase the leakage of combustion products into the living area. The likely presence of deadly carbon monoxide makes it essential to import combustion air directly from outside--where carbon monoxide levels should be lower. The importation of fresh air makes combustion more complete and reduces the amount of CO produced.

What about dual-fuel systems?

The same safety and health concerns apply to all heating systems regardless of the type.

What are dual-fuel systems?

As their name implies, dual-fuel systems have the ability to run on two different types of fuel. What most people mean when they talk about dual-fuel systems is two completely different systems. Typical dual-fuel combinations in Alaska include:

- Electric-wood
- Electric-oil
- Electric-natural gas
- Electric-coal
- Wood-oil
- Wood-natural gas
- Wood-coal
- Natural gas-coal
- Natural gas-oil

What are the advantages of dual-fuel systems?

Dual-fuel systems increase the consumer's flexibility, making it possible to burn the cheaper fuel at a given time.

Why wouldn't someone just build for the cheapest fuel source available, then add on additional capabilities later as necessary?

Although this is an option, heating systems, like superinsulated envelopes, work best when they are properly planned and designed before construction. Adding on one or more additional systems after construction can be very expensive, involving tearing out walls and structural members and the other problems accompanying any retrofit.

Dual-fuel systems installed during construction can often share combustion-air supply, thermal mass and distribution systems--at considerable savings.

On what basis are fuel system(s)/sources(s) selected?

The Alaska Craftsman Home Building Manual lists several factors upon which system selection hinge:

performance, especially with regard to comfort
cost, availability and desirability of different fuels
availability of system components and ongoing servicing
overall capital costs
customer preferences for the type of heat distribution system

Each fuel has attributes and drawbacks. How are these prioritized to obtain the best possible fuel and system?

Familiarity with local preferences and all the available options will help. The lifestyle of the future occupants is an important consideration. For example, will they have the time and strength to operate a system which requires their participation in hauling wood or shoveling coal? Will they have the money to buy the energy, whether it is oil or electricity? Is a system needed which will operate without interruption during prolonged absences of the occupants?

Doesn't the decision ultimately boil down to cost?

In a conventional home, cost-of-fuel is the overwhelming consideration. In superinsulated homes, because so much less fuel is needed, the monetary cost of fuel may be much less significant. Then other costs, such as convenience and indoor air quality, may be the over-riding concerns.

What types of heating systems are available?

Gas-fired Induced Draft Furnace
Condensing Gas Furnace
Gas pulse Combustion Furnace
Induced Draft Gas Boilers
Induced Draft Oil
Furnace
Oil-fired Boilers
Kerosene Heaters
Electric Furnaces
Electric Boilers
Electric Baseboards
Wood Space Heating Appliances
Wood Boilers

What are the Domestic Hot Water Heating (DWH) options?

Many of the above systems can be used to heat domestic hot water (domestic means drinking/cooking/bathing as opposed to heating). Common types include:

- Gas-fired Hot Water Tanks
- Electric Point-of-Use Hot Water
- Electric DHW Tanks
- Induced Draft Hot Water
- Sealed-Combustion
- Heat Pump Water Heater

Because superinsulated homes have such small heating requirements, heating devices can have capacities several times smaller than those required by conventional structures. For examples, this means that very small wood stoves, such as those used in Scandinavia, could provide all the heat needed. In the case of wood stoves, smaller units can be operated at much higher temperatures with less risk of making the structure uncomfortably warm. The advantage of this is that combustion is more complete and produces less pollution. (Large stoves generate so much heat that owners tend to dampen them way down to keep the fire small--thus resulting in incomplete combustion which increases creosote build-up, fire-hazards, and the emissions of pollutants.)

It also means that a monitor stove (a small kerosene/heating oil stove designed for mobile homes) may be adequate for larger, superinsulated structures. The best models currently available use little fuel and, when installed with outdoor combustion air supplies, lower the risk of indoor air pollution.

If a combustion type-heating device is used in a super-insulated structure, it would be wise to monitor the resultant indoor carbon monoxide levels under various operating conditions (such as when all combustion-type appliances are in operation, when the wind is blowing, etc.)

Ventilation Requirements

Competency: Size a ventilation system

Tasks: Calculate ventilation requirements for a given structure

Who usually sizes ventilation systems?

In many bush and owner-built homes, the builder sizes all the heating and ventilation systems. In contractor-built homes in urban settings, a ventilation subcontractor frequently performs the calculations and/or tests necessary to size the system. However, though they may seem complicated, these calculations are not beyond the ability of most builders.

Why build airtight envelopes in the first place?

Going to all the trouble to make an airtight envelope and then installing a device which changes the indoor air every hour or two may seem strange. However, infiltration and exfiltration result in the loss of tremendous amounts of heat (as you'll soon see). Having achieved an airtight envelope, the superinsulated builder must address the future occupants' need for fresh air.

Why not just leave a window or two cracked open?

Although open windows could produce the required amount of air exchange, that wastes huge amounts of heat. In some houses, the normal opening and closing of doors associated with the activities of children and pets might produce sufficient air exchange at certain times and in certain parts of the house, but what is needed is a system which continually replaces the air throughout the house, exporting the stale air but not the heat in that air. The most common type of system which can accomplish such a task is an air-to-air heat exchanger.

What exactly is an air-to-air heat exchanger?

Air-to-air heat exchangers are mechanical systems that bring the outgoing and incoming air into close proximity so that most of the outgoing heat transfers to the incoming cold air.

Isn't that similar to a car radiator?

Exactly! In the car, cool air passing through car radiator fins removes heat which the circulating radiator fluid has brought from the engine. Of course, car radiators are designed to get rid of, or radiate, heat--rather than retain it.

Do air-to-air heat exchangers use water?

No, but the principles are the same. The heat from the car engine is carried in a fluid; in the house, the heat-carrying fluid are gases (air). The main difference is that while the car radiator retains the fluid and radiates the heat, the air-to-air heat exchanger retains the heat but exhausts the fluid, the stale air. Like car radiators, the most efficient air-to-air heat exchangers use metals to conduct heat directly from one fluid mass to the other.

What drives the air through the systems?

Generally, one electric fan is all it takes. The fan can either pull air in or push it out; pressure differentials do the rest.

How can one small fan move a whole house full of air in two directions?

The earlier discussion of pressure differentials explained why, as soon as a pressure differential is created, nature will try to restore the balance. The fan creates the differential. If the fan blows air in to the structure, the pressure inside will be greater than that outdoors, and the indoor air will seek an escape valve which the air-to-air heat exchanger supplies. Conversely, if the fan pumps air out of the house, the pressure outdoors will be greater, and outdoor air will tend to flow into the house. Again, if the envelope is otherwise airtight, the air has little choice but enter through the heat exchanger.

If nature seeks to return to equilibrium, what keeps the system going?

The fan is the only thing which drives the system and keeps the air moving. As soon as the fan stops, the air exchange rate declines and indoor air quality rapidly deteriorates. A reliable, energy-efficient, and properly-sized fan is essential.

What insures that the air is distributed throughout the house?

In most cases, a centralized distribution system is needed to ensure that all rooms receive fresh air. Fresh air should be warmed by the heat-exchanger before distribution. To minimize stratification and discomfort caused by the introduction of relatively cool, fresh air, the air should either be further heated by a heating system before distribution, or delivery vents should be located high on the walls or on the ceiling.

What are the current fresh air standards?

The Alaska Craftsman Home Building Program has established a minimum exchange rate of 10 cubic feet per minute (cfm) for each habitable room, kitchen, and bathroom, and 20 cfm for basement and utility rooms.

The system must be able to provide additional outdoor air at the rate of 50 cfm and must also be able to exhaust air at the rate of 100 cfm from the kitchen and 50 cfm from each bathroom.

How does one calculate how much air needs to be exchanged, and at what rate?

The following instructions and example come almost verbatim from the Alaska Craftsman Home Building Manual. Make yourself a table with three columns across the top and a line down for every room in the house, except for closets:

Room	Min.	Continu. Vent. (cfm)	Req. Exhaust Cap. (cfm)
Bedroom		10	
Bedroom		10	
Bathroom		10	50
Kitchen		10	100
Living Room		10	
Dining Room		10	
Family		10	
Utility		20	
Bathroom		10	50
TOTAL CONTINUOUS VENTILATION		120	
REQUIRED ADDITIONAL CAPACITY		50	
TOTAL SYSTEM CAPACITY		170	200

The actual figures for your structure depend on the total number and type of rooms. Be sure to include additional rooms and their needs as necessary. Treat combined areas (rooms without barriers like living room/dining room) as individual rooms. (A single living room/kitchen/dining room would count as three separate rooms, etc.)

Calculate the TOTAL CONTINUOUS VENTILATION requirements first by adding the first column of figures. (in the sample, the sum is 120 cfm.)

Add the intermittent supply capability to the previous sum to obtain the continuous supply rate total system capacity of outdoor air for the the house. In the sample, the sum is 170 cfm. At the very minimum, the ventilation system designed for the house must be capable of providing air at this rate.

Calculate the Required Dedicated Exhaust capability from the third column. In the sample, the sum is 200 cfm. In many cases, the central ventilation systems will be designed to accommodate this demand. Otherwise, it can be met by the installation of exhaust fans located in the appropriate areas (over the kitchen stove, in the bathrooms, etc.)

Is the size of the fan important?

If the ventilation fan was too powerful, pressure differentials could become excessive, causing a filtration problem. The next step in sizing the ventilation system is to calculate the structure's make-up air requirements. The goal is to limit pressure differentials across the building envelope to 10 Pascals (Pa) during continuous operation and 20 Pa during peak operation of the system.

In order to make the calculation, you'll need to know:

- the unbalanced air flow of the ventilation equipment that will be providing the continuous ventilation load, or
- the capacity of the largest single exhaust appliance which might lead to depressurizing of the building
- the Equivalent Leakage Area (ELA) of the building envelope, either as estimated during the design, or as measured during a fan test.

The following graph and table will allow you to avoid most of the mathematics which would otherwise be required to size the system.

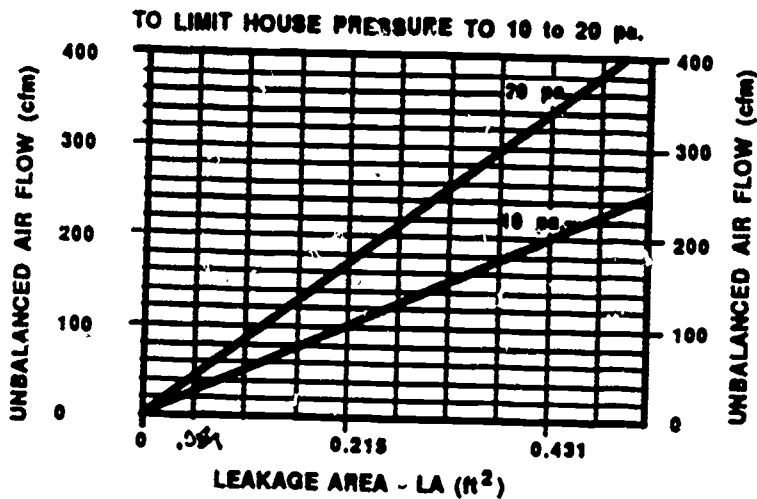

EQUIVALENT LEAKAGE AREA (ELA) PROVIDED BY INLET DUCTS of VARIOUS DIAMETERS	
DUCT DIAMETER (in.)	ELA PROVIDED (ft ²)
3	0.0266
4	0.0560
5	0.0860
6	0.1576
7	0.2663
8	0.3660

Maximum Unbalanced Airflow

Assume that during continuous operation, the system will remain in a balanced mode (no pressure differential). During peak operation, the unbalanced flow is 20 cfm. Pressure testing revealed an ELA of .16 square feet. The graph indicates that the required leakage at 20 Pa to meet an unbalanced air flow is 0.027 square feet (considerably less than the leakage--0.16 square feet) so no additional measures are needed.

If, however, some appliances were installed (a barbecue grill or vacuum-cleaning system exhausted to the outdoors) which created a maximum unbalanced air flow of 220 cfm, the graph indicates that to limit pressure to 20 Pa, the required leakage area is approximately 0.27 square feet, which exceeds the amount provided by leakage.

The graph gives the duct size required to make up the difference: First, subtract the leakage required from that provided by the structural envelope to obtain the remaining ELA needed (0.27 square feet - 0.16 square feet = 0.11 square feet). The chart indicates that a 6-inch duct has an area of 0.1679 square feet--more than adequate to provide the required additional ELA.

Heating Requirements

Competency: Calculate Heating Requirements

Tasks: Explain calculation methods

How is a residential heating system sized?

The size of the heating systems depends on the amount of heat needed to keep indoor temperatures comfortable on the coldest expected night of the year.

How does one determine how much heat will be required to keep the structure comfortable at a given temperature?

The amount of heat required depends on three factors:

- the energy efficiency of the building envelope
- the design temperature
- the exterior surface area of the building envelope.

How is energy-efficiency determined?

Energy-efficiency is expressed in terms of R-values (resistance to heat flow) or conductance (ease of heat flow). Conductance equals $1/R$ -value.

What is design temperature?

Design temperature is related to the coldest outdoor temperature the structure is designed for. The number which is used for the design temperature actually is the difference between the indoor temperature and the coldest expected outdoor temperatures. Although some other temperature--such as 65 F or 67 F--could just as easily be chosen, most builders usually assume that the indoor air temperature should be 70 F--regardless of where the structure is located. In parts of Juneau where the coldest expected temperature is -10 F, the design temperature would be 80 F ($70\text{ F} - -10\text{ F} = 80\text{ F}$). In parts of Fairbanks where the coldest expected temperature is -65 F, the design temperature would be 135 F ($70\text{ F} - -65\text{ F} = 135\text{ F}$).

Once the design temperature is determined, what is the next step?

Heat loss through the building envelope must be calculated. The envelope includes all exterior surfaces (ceiling, doors, windows, floor, and air infiltration).

How are heat losses expressed?

Heat losses should be expressed in total heat conductance (U) in terms of BTU's, per hour per square foot of exterior surface area, per degree F of difference between indoor and outdoor temperatures.

(Recall: $U = 1/R$ -value)

Divide the R-value of each envelope surface by the square footage of that surface:

NOTE: There are several sequences in which these calculations can be done. The following example first determines the conductivity of each envelope unit for a one-degree F temperature differential; totals all the results to arrive at a figure for the entire structure; then multiplies this figure by the design temperature to generate a figure expressing the heating requirements.

ASSUME:

- a one-story 40 X 30 structure (1200 sf) in Fairbanks
- the long (40-foot) dimensions face north and south
- the ceiling (rather than the roof) is insulated
- the exposed portions of the walls are 8 feet high
- east and west walls combined include 48 square feet of glass
- south wall has 108 sf of glass
- all the glass is quadruple-pane, R-3.5
- walls, doors, and ceiling are otherwise R-50
- the air changes hourly (once) through a 70% efficient heat exchanger
- filtration and accompanying heat loss negligible
- heat loss through service entrances (vents, electric panels, etc.) negligible
- assume entire internal volume is filled with air (ie. ignore presence of people, appliances, furniture, possessions, and internal walls and partitions)

(Obviously, some of these assumptions would not be valid in a real structure; they are only intended to simplify the calculations.)

Calculations for North Wall:

Conductance = $U = 1/R = 1/50 = .02$ BTU/hour/sf/ degree F

Area = $40 \times 4 = 320$ square feet (sf)

Total U for North Wall = 6.4 BTU/hr/degree F

Calculations for Ceiling:

$U = 1/R = 1/50 = .02$

Area = $40 \times 30 = 1200$ sf

Total U for Ceiling = $1200 \text{ sf} \times .02 = 24$ BTU/hr/ F

Calculations for Floor:

Total U should be same as for ceiling because R-value and area are identical.

Total U = 24 BTU/hr/ F

East & West Wall calculations:

$[2 \text{ (walls)} \times (30 \times 8)] - 48 \text{ sf (windows)} = 432 \text{ sf}$

Total U for E & W walls = $432 \text{ sf} \times .02 = 8.64$ BTU/hr/ F

Calculations for East, West, & South Wall Windows:

$$(48 + 108) = 156 \text{ sf}$$

$$\text{Conductance} = U = 1/3.5 = .286$$

$$\begin{aligned} \text{Total conductance for all windows} &= 156 \text{ sf} \times .286 \\ &= 44.6 \text{ BTU/hr/ degree F} \end{aligned}$$

Calculations for South Wall:

$$(40 \times 8) - 108 = 212 \text{ sf} \times .02 = 4.2 \text{ BTU/hr/degree F}$$

Calculations for Air-to-Air Heat Exchanger:

$$\text{Air volume} = 40 \times 30 \times 8 = 9600 \text{ cubic feet}$$

$$\text{Efficiency} = 70\%, 1 \text{ change per hour}$$

The formula for heat loss due to air exchange:

Volume X changes per hour X specific heat capacity of air (CP) X air density (Rho) X hours per day (hrs) X efficiency (1 - efficiency). Assume that CP = .24, and that Rho = .075. Then:

$$9600 \text{ cf} \times 1 \text{ change/hr} \times .24 \times .075 \times (1 - .70) = 51.8 \text{ BTU/hr}$$

If this seems large, think how much larger (more than three times!) it would be if there was no heat exchanger.

Summary of calculations for total envelope:

Surface	BTU/hour/degree F
North Wall	6.4
Ceiling	24.0
Floor	24.0
East & West Walls	8.6
All Windows	44.6
South Wall	4.2
Air-to-Air Heat Exchanger	51.8
Total:	163.70

Total Heating Requirement = Total envelope conductance X design temperature

Design Temperature = Desired Indoor temperature - coldest expected outdoor air temperature
(in this case 135 F)

$$\begin{aligned} \text{Total heating requirement} &= 163.7 \text{ BTU/hr/ F} \times 135 \text{ F} \\ &= 22,099.5 \text{ BTU/hour} \end{aligned}$$

In other words, the structure appears to need a heating source capable of putting out at least 22,100 BTU/hour. To be certain of adequate heat, you would probably have to settle for a system capable of 25,000 BTU's per hour, since manufacturers tend to sell units with capacity ratings in increments of 5,000 BTU's per hour.

However, faced with the above situation, some experts would opt for a 20,000 BTU system on the rationale that they would rarely (only on the very coldest nights) need those extra 2,000 BTU's and the difference could probably be supplied by some other heat source.

As previously mentioned, the above example is somewhat simplified and is meant only to convey the steps and calculations needed to size a heating system.

In addition to ignoring envelope openings, filtration, and other details which might increase total overall heat loss, the above example makes no allowance for other heat sources, such as solar, people and pets, cooking, and domestic hot water heating.

Research indicates that these sources might contribute two-thirds of the heating needs of a super-insulated, passive solar house, thereby reducing heating system capacity requirements by as much as two-thirds! In other words, a heating system with a capacity of 8,000 to 10,000 BTU's might be sufficient--especially if the structure includes thermal shutters and a large thermal mass for heat storage.

The above calculations illustrate the heat-loss significance of windows and air exchange. For example, thermal shutters which halved window heat loss and changed the air only once every two hours (half as frequently) would lower thermal loss on the -65 F night by 6,507 BTU's per hour.

In many cases--such as large urban houses--builders will engage a heating ventilation expert to size these systems. Even then, for their own peace of mind--to assure themselves that the "experts" know what they are doing--builders should have a general understanding of how heating and ventilation systems are sized. Once the system is sized, the builder will be able to select the best system(s) from the options available.

Plywood Beams

Plywood Beams

Competency: Understand the Uses of Plywood Constructed Beams

Tasks: Explain the terms and principles associated with plywood beams and their construction

What is a plywood constructed beam?

A plywood constructed beam is one in which the beam incorporates plywood--as opposed to metal or wood timbers--for most of its strength.

Why make beams out of plywood?

Plywood has many advantages over both wood and metal in certain superinsulated applications. These include superior insulating qualities, greater strength for the same weight, and certain logistical advantages.

How can plywood be a better insulator than wood?

Wood, as you remember is rated at $R-1$ per inch. Most wood beams incorporate 2" X 4"s, 2" X 6"s, or 2" X 8"s. Even the largest of these has a total R-value of less than 10--and can only accommodate 8 inches of insulation. A plywood beam, on the other hand, can be any thickness, although most will be some common division of 48" (such as 8", 12", 16", or 24"). A beam of these dimensions can accommodate more insulation and constitutes less of a thermal bridge.

Metals conduct heat so well that metal beams are essentially radiators.

Why would plywood have greater strength-per-weight than solid wood beams?

The strength of a beam is proportional to the cube of its depth. In other words, strength increases exponentially with depth. So a few 16" plywood-constructed beams can do the work of many 2" X 4"s.

Why do plywood constructed beams have logistical advantages?

Wood beams have to be at least as long as the distance they must span. These can be difficult and/or expensive to transport. Plywood constructed-beams, on the other hand, are made from relatively small components (4' X 8' plywood sheets and 2" X 3" or 2" X 4" nailers. These can be readily transported by small vehicles and aircraft. If necessary, the plywood sheets can be further ripped into their final dimension (depth-wise) so that instead of 4' X 8', the sheets are 12", 16", or 24" X 8'.

Metal beams are relatively heavy. Although they can be assembled from small sections (say 8'), this introduces weakness which must be compensated for by increasing their number or dimensions.

How are plywood beams made?

Most plywood-constructed beams consist of plywood sheets and two or more dimensional wood nailers. There are essentially four different types or styles, the simplest of which is the box beam.

BUILT-UP BEAMS

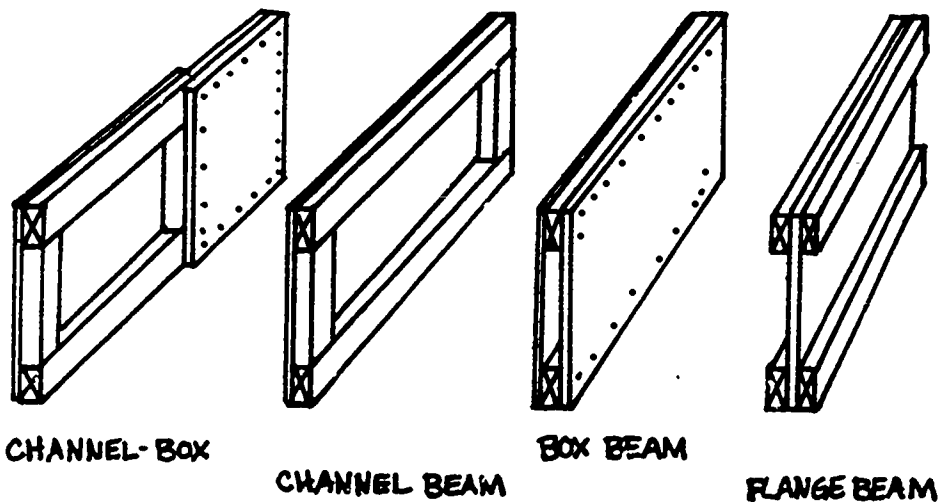

Are plywood-constructed beams commercially available?

Truss companies manufacture plywood-constructed beams, including the TJI which is a flange-type beam made completely of plywood (nailers are plywood). However any builder can manufacture his or her own.

How are plywood constructed beams manufactured?

Once the beam's insulation and strength requirements have been calculated, a jig can be established.

What is a jig?

A jig is a form which helps guarantee that mass-produced items have essentially equal dimensions. If the beams varied more than a fraction of an inch, they would bear structural loads unequally, increasing the potential for structural failure.

How are ligs made?

Typically, the beams' dimensions and eventual shape are laid out (with chalk lines) on the shop or structure floor. Wood blocks are temporarily nailed in place to ensure that none of the elements extends beyond or falls short of the design requirements. The beams are assembled one at a time, then stored out of the way. The same procedure can be used for other structural components such as walls.

How are plywood constructed beams attached to pilings?

PLYWOOD MFG BEAM PILING
VARIOUS ATTACHMENT STATAGIES

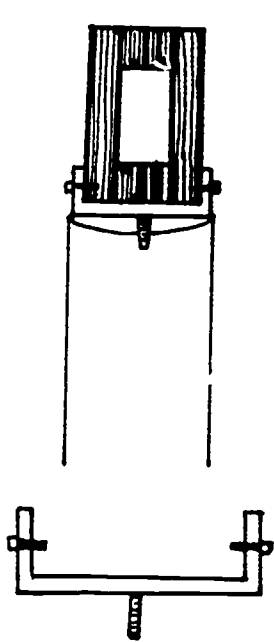

SADDLE STIRRUP WITH BOLTS

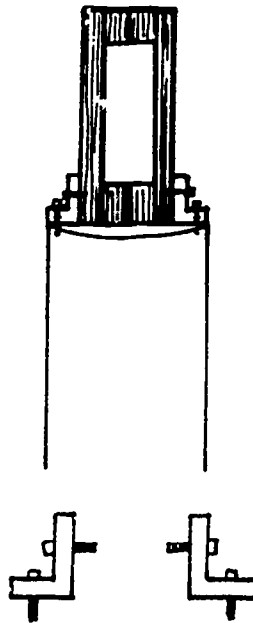

ANGLE IRON WITH LAG BOLTS

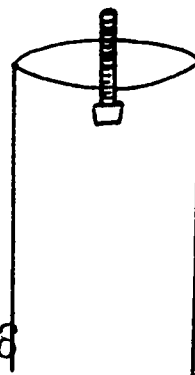
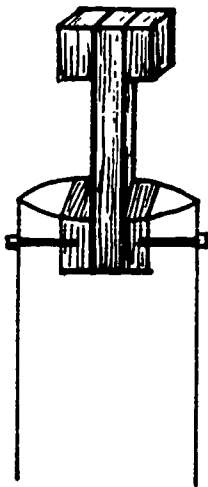

Metal Roofs

117

Metal Roof Installation

Competency: Understand Metal Roof Installation Strategies

Tasks: Explain metal roofing terms and principles

What are the advantages of metal roofs?

Metal roofs have several advantages over wood or asphalt roofs. Metal roofs tend to weigh less, install faster, offer more water and fire-protection, last longer, and cost less. In addition, they shed water and snow more rapidly and can double as domestic water collectors.

Why do metal roofs weigh less than wood and asphalt roofs?

Metal roofs tend to be made out of lightweight, rust-resistant alloys which weigh less per square foot than most other roof coverings. Because metal roofs come in large panels, overlapping is minimized.

Why are metal roofs faster to install?

Metal roofs require but a fraction of the number of fasteners as wood and asphalt shingles. That means less measuring, less chalk lining, and less fastening.

Why do metal roofs offer more water and fire-protection?

Metals can be manufactured with smoother surfaces than asphalt or wood shingles. That means they offer less resistance to running water. Asphalt and wood shingles burn at temperatures lower than 500 F. Metal roofs will not burn at temperatures twice as hot.

Why do metal roofs tend to have longer service-lives?

Rust-resistant metal alloys are less subject to rot, mildew, moss, and fungus than asphalt and wood shingles. In addition, manufacturing processes can be more closely controlled, so that quality varies less from sheet to sheet. Each wood shingle, on the other hand, is unique. Some are bound to have blemishes which will over time, become leaks. Fasteners can also damage wood shingles. Running water erodes asphalt shingles faster than it does metal. Asphalt is also more easily damaged during installation.

Why do metal roofs cost less?

Metal roofs generally cost less because their manufacture, shipping, and installation is less labor intensive.

Why do metal roofs shed water and snow better?

The smoother finish offers less resistance to water and less of a grip to snow. Except in cases of structures with flat roofs designed to take advantage of the insulating potential of the snow load, the sooner the roof sheds snow, the longer the structure will last--and the less it will be deformed by snow loads.

How do metal roofs double as water collectors?

Certain types of metal roofs equipped with gutters and attached to a cistern can make ideal domestic drinking water collectors. Although water can be collected from any type of roof; however, each type of roof presents potential health problems. Cedar shingles discolor and impart a creosote taste to water. Asphalt shingles contribute sediment to the water, and these asphalt sediments contain tars and aromatic hydrocarbons which are carcinogenic.

Is it safe to drink water from metal roofs?

The answer to that question depends on a number of factors, including: the type of alloy, the finish (paint), the acidity of local rainfall, and incoming pollutants (dust content and origin, wood ash, car exhausts, etc.)

Most manufacturers will say that their metal roofs make ideal water collectors. They base those statements on what is scientifically-proven about the health effects of chemical residues of the type and quantity likely to be leached from their roofs under certain conditions--conditions which may vary significantly from those on your roof.

The only way to be sure that drinking water is safe is to filter it highly and have it tested for heavy metals and other impurities by a qualified lab. Over time, acceptable limits for pollutants tend to become more stringent. In other words, medical science is able to detect the harmful affects of increasingly smaller concentrations of toxic substances--and so the allowable concentrations become ever smaller. If your water contains known toxins at levels close to recommended standards, it may prove unsafe at a later time.

How are metal roofs installed?

Each manufacturer tends to have a different fastening strategy. Before installing any metal roof, the builder should read and fully understand the manufacturer's installation recommendations. Failure to do so could result in a leaky roof.

As with any other roofing materials, metal roofs are generally installed from the bottom up (from the eaves to the crown) one course or row at a time.

What kind of fastening systems are used?

Most metal roofs are fastened to the underlying structure with special rubber gasket equipped nails or screws. The gaskets are designed to prevent leakage. These fasteners may, or may not be, exposed to the weather. In order to completely avoid roof penetrations, some manufacturers have developed fastening systems which rely on brackets which are fastened to the underlying structure (a beam, for example). The metal roof sheet is then snapped into place, held by gravity and friction.

Again, check the manufacturer's instructions to determine the fastening and installation strategies most appropriate for your roof. Make sure the manufacturer's fastening system is more than adequate for wind levels expected at the building site.

SEAM TYPES

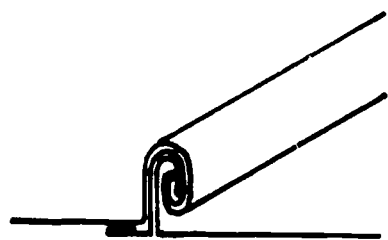

STANDING SEAM

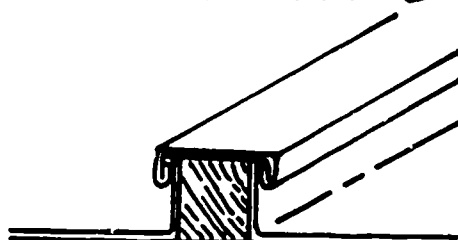

BATTEN SEAM

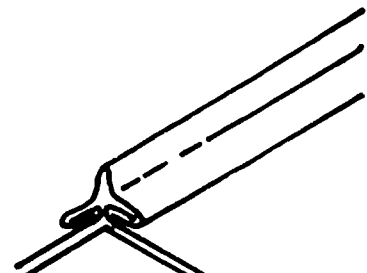

RIDGE SEAMS

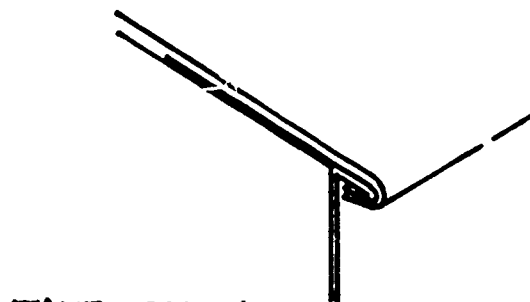
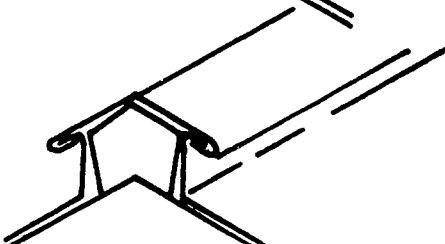
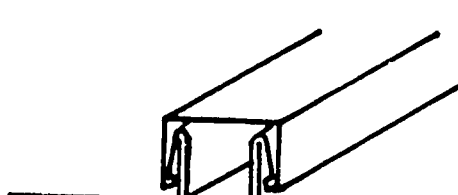
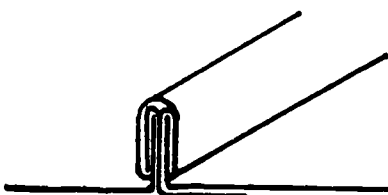

EAVE SEAM

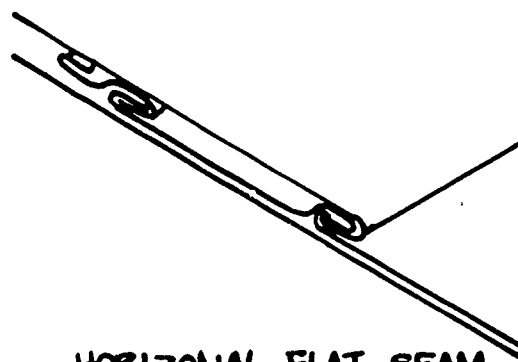

HORIZONTAL FLAT SEAM

How are metal roofs installed over valleys?

In most cases, installation techniques for metal roofs differ little from those for wood or asphalt shingle roofs. In other words, where two roofing planes meet, the resultant valley is covered with flashing. The actual metal roofing materials may either touch or terminate several inches from the valley bottom, depending on manufacturer's specifications.

How steep should a metal roof be?

Roof slopes depend on anticipated snow loads and the strength of the underlying structure. However, in general, metal roofs should always have a minimum slope of 3:12 or three feet of rise for every twelve feet of run. The steeper the slope, the faster the roof will shed snow. In locations prone to heavy snowfalls (Anchorage, Seward, Valdez, Cordova, Yakutat, Haines, etc.), a 6:12 (45 degree) or steeper roof may save a great deal of worry. Except for under the most unusual circumstances, it should not need to be shoveled (and that alone will prolong its service life). The roof's natural snow-shedding qualities will reduce snowloads and the resultant structural deformations and wear and tear. The additional investment required for a steep roof should pay for itself over the lifetime of a well-built structure.

What distances can metal roofing span?

The span varies from roof to roof and should be obtained from the manufacturer. If not available from the dealer, have them call the manufacturer for you. If at all possible, talk to the manufacturer yourself.

What underlayments are required?

Again, underlayment requirements and recommendations vary with the manufacturer. If the dealer does not have this information, call the manufacturer.

Are there any other special considerations?

Yes. One characteristic of metals is their tendency to expand and contract with temperature. The fastening system for your metal roof must allow for expansion and contraction--no matter where you live. This is critical in Alaska where temperature changes of 50 F and more in just a few hours are not uncommon.

What are some of the common types of metal roofs?

Most metal roofs fall into one of two categories, corrugated on the one hand and standing seam or batten on the other. Corrugated roofs have closely-spaced ripples, or corrugations, like the interior of cardboard, and are installed so that these are parallel to the fall line or slope. The standing seam or batten-type roofs are composed of basically flat sheets of metal with occasional ridges regularly spaced. As in the case of corrugated roofs, the standing seam and batten-type are installed so that the ridges are parallel to the slope.