

DOCUMENT RESUME

ED 293 290

EC 202 489

AUTHOR Campbell, Shirley
TITLE COME PLAY WITH ME! Handmade Toys for Infants. First Years Together. Project Enlightenment.
INSTITUTION Wake County Public School System, Raleigh, N.C.
SPONS AGENCY Special Education Programs (ED/OSERS), Washington, DC. Handicapped Children's Early Education Program.
PUB DATE 86
NOTE 106p.; For related documents, see EC 202 488-497.
AVAILABLE FROM Project Enlightenment, 501 S. Boylan Ave., Raleigh, NC 27603 (\$6.00).
PUB TYPE Guides - Non-Classroom Use (055)
EDRS PRICE MF01 Plus Postage. PC Not Available from EDRS.
DESCRIPTORS *Developmental Disabilities; *Infant Behavior; *Parent Participation; *Play; Premature Infants; Preschool Education; *Skill Development; *Toys

ABSTRACT

This book describes 21 toys that were designed to stimulate development in low birthweight babies, ages 0-3, and can be made from basic materials found in the home. Step-by-step instructions are given for each toy along with a list of necessary supplies. Illustrations and/or patterns are provided as needed. Each entry includes suggestions for using the toy and a list of the specific skills it is intended to enhance. An appropriate age span is also indicated for each toy, although the ages may need to be adjusted for premature infants. (VW)

 * Reproductions supplied by EDRS are the best that can be made *
 * from the original document. *

ED293290

U.S. DEPARTMENT OF EDUCATION
Office of Educational Research and Improvement
EDUCATIONAL RESOURCES INFORMATION
CENTER (ERIC)

- This document has been reproduced as received from the person or organization originating it.
- Minor changes have been made to improve reproduction quality.
- Points of view or opinions stated in this document do not necessarily represent official OERI position or policy.

COME
PLAY
WITH
ME!

Handmade Toys for Infants



First Years Together
Project Enlightenment
Wake County Public School System

PERMISSION TO REPRODUCE THIS
MATERIAL IN MICROFICHE ONLY
HAS BEEN GRANTED BY

Alice K. Burrows

TO THE EDUCATIONAL RESOURCES
INFORMATION CENTER (ERIC)."

68200200489

COME
PLAY
WITH
ME!
Handmade Toys
for Infants



by Shirley Campbell
Toy Developer

Mary de Wit
Design and Illustration

Val Wilson
Photography

This book was developed by First Years Together through a grant from Handicapped Children's Early Education Program, U. S. Office of Special Education to Project Enlightenment, Wake County Public School System, 501 S. Boylan Avenue, Raleigh, NC 27603. For additional information, write or call (919) 755-6935.



© 1986 Project Enlightenment

First Years Together
Project Enlightenment
Wake County Public School System

594 202 489

COME PLAY WITH ME!

Handmade Toys for Infants

The toys in this booklet were developed out of the experiences of First Years Together (FYT), a program of Project Enlightenment, Wake County Public School System. Funded by the U. S. Office of Education as a model demonstration project, FYT has developed resources to help families of low-birthweight infants get off to a good start in caring for and relating to their babies.

We believe that babies learn from their very earliest days and that they learn most from playing with the people who love them. Babies learn from play and parents learn about babies from playing with them. Play is also a wonderful way for babies and their parents to enjoy each other.

We have described some simple toys that can be made right at home, using materials that are easy to find or collect. The toys described were selected as the best from a large number of toys developed by FYT. All the toys are fairly easy to make, and some that are especially easy are marked with the symbol EZ. We invite you to make the toys as described or you may want to take the basic ideas and add your own variations to the toys.

The toys are designed to have sound, touch and sight appeal to engage your baby's senses. They invite your baby to move them, discovering that actions cause reactions and that he or she can cause things to happen. Some toys,

like the puppets, are designed to encourage the development of your baby's language.

For each toy we have suggested, under the heading "Come Play With Me," several of the different ways the toy can be used in play. Also, for those of you who might be interested, we have included a section called "Skills Enhanced" which lists the skills a child is developing through playing with the toy in different ways. Because each play activity involves so many skills, we have described only the major skills being developed with each toy. For instance, a simple red ball hung on the side of the crib will help a new baby learn to focus her eyes. The same simple toy, held by an adult who talks softly and lovingly as the ball is moved slowly from side to side, will enhance the baby's ability to follow moving objects with her eyes, encourage her to begin discriminating different speech sounds and patterns and increase her awareness of other people.

We also suggest an age span for each toy. For babies born early, like those in the FYT Program, these ages should be adjusted for prematurity.

You will need to think about the safety of the various throw-away objects that can be made into toys. For example, don't use containers that have held substances which are harmful if swallowed, or those that will break under the wear and tear an eager child will provide. Always be on the look-out to avoid objects with sharp edges. Never use a medicine or household cleaner container. A small child or baby may not discern the difference between the full and empty containers and an accident may result. Test food containers for strength to be sure they will not

crack if smashed. Cans and cardboard containers with metal rims are not safe. All fabrics and yarns should be washed and checked for colorfastness: do not use if any dye bleeds. Also check fabrics with nap to make sure the fibers will not come loose in the baby's mouth. Do not use items such as buttons or spools that are small enough to fit in the baby's mouth, or are made of styrofoam or other material which can be chewed apart. Never use glass containers. Check all toys, homemade or bought, regularly. If you find cracks, open seams or loose parts, discard the toy.

You may wish to read the "Crib Hugger" and "Loop and Hang" units first. These items were designed to be used with the toys in the manual to provide visual stimulation to the infant in the very early days. The purpose of the "Crib Hugger" and "Loop and Hang" is to hold the toys near the infant as objects the baby can focus on while alone, and for easy access when the parent plays with the baby.

As you use the materials, remember these most important guidelines about play:

- Play should be fun for the adult and the baby;
- Play should occur often;
- Play should be simple and safe.

We hope you will find the booklet useful. If you are interested in other materials developed by First Years Together, call or write:

Project Enlightenment
501 South Boylan Avenue
Raleigh, North Carolina 27603
(919) 755-6935

Many people helped to develop this book. The contributions of the following First Years Together and Project Enlightenment staff and consultants is gratefully acknowledged:

Mac Anderson

Sara Burroughs

Linda Carothers

Mary Snow Crawley

Jane Hewitt

Gerry Highsmith

Rosemary Hornak

Charles Kronberg

Lanelle Taylor

Sally Walton

Val Wilson

All of the toys described in this book have been designed to help you stimulate your baby's development, and all of them are made out of materials which you can recycle or buy inexpensively. Most of the toys are very easy to make; some of them are particularly simple, and these are marked EZ.

The following is a list of items you may wish to start saving or to buy in order to make the toys. They are listed here so that you can see at a glance what types of materials are used to make the toys in this book. You will not need all of them for each toy; you can check the supplies section for any toy you are particularly interested in making.

- Batting (cotton or fiber)
- Blanket binding
- Blocks, children's, 1" x 1" x 3 1/2"
- Cardboard: poster board; save cardboard from cereal boxes
- Cloth:
 - Brightly-colored cloth
 - Dotted Swiss
 - Fake fur
 - Flesh-colored cloth
 - Nylon net
 - Quilted Flannelette
 - Soft, stretchy cloth
 - Terrycloth
 - Velveteen
 - Vinyl (oilcloth)
- Save: torn or worn clothing, towels, crib sheets, curtains, etc. which may be cut up for cloth
- Contact paper
- Containers: save clear plastic 2-liter soda bottles, diaper wipe, salt, frosting containers
- Fabric roll: inner cardboard core for cloth or carpeting
- Foam rubber: 1/2" and 3/4" thick
- Equipment:
 - Scissors
 - Iron

- Pinking Shears (helpful, not necessary)
- Sewing Machine (helpful, not necessary)
- Laundry clips of plastic-covered metal
- Lids, plastic: save from baby foods, powdered drinks, shortening cans, coffee cans, etc.
- Mirror, camping type (must be unbreakable!)
- Paper, brightly-colored, heavy
- Pictures: from magazines, from family photographs
- Photo album pages (type with resealable adhesive)
- Puddle pad
- Rattles, old baby rattles
- Resealable plastic bags (such as Ziploc)
- Sewing Notions:
 - Interfacing (sew-on and iron-on)
 - Needles (small and large-eyed)
 - Ribbon, 1/4" and 1" wide
 - Tape, nylon fastener (such as Velcro)
 - Thread (or waxed dental floss), embroidery thread
- Shower rod cover, plastic
- Straws: drinking; save from treats at fast food restaurants, wash, dry, and store
- Stuffing: fiber filling or other type
- Tape: fiber packaging tape
- Yarn: Brightly colored
- Save: old knitted hats and sweaters which may be unraveled for their yarn. (Wind the yarn around some cardboard, wet it and let it dry on the board. It will dry straight.)

In addition to the above supplies, you will need a pair of scissors. For some of the toys you will need an iron, and for many it is helpful to have a sewing machine, iron, ironing board, a ruler, and pinking shears.

PATTERNS

At the end of the manual you will find several pages of patterns for the toys. Some of them are as simple as a rectangle; these are included for your convenience. Other patterns are full-sized pieces for making the various toys. You may wish to trace the patterns if you want to leave your book intact and for ease in cutting, as some of the patterns overlap in order to fit in the manual. All patterns are coded to the toys by a number and a letter. Directions for each toy mention which patterns you will use under the SUPPLIES section.

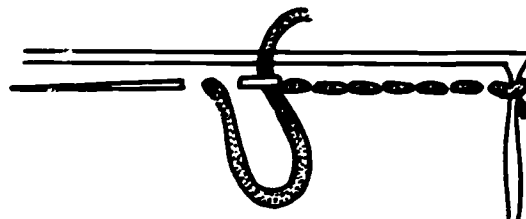
Please be sure to read the paragraph concerning safety in the introduction to the manual.

SEWING TERMS

Backstitch:

A strong handstitch which looks like machine stitching and is used to make a seam.

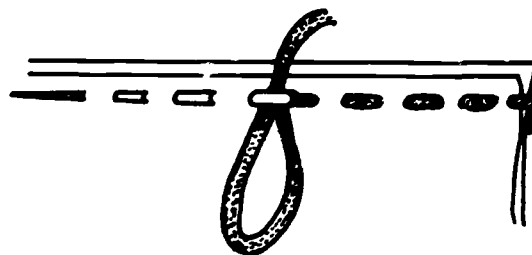
Bring needle and knotted thread from the underside of the fabric through all layers to the upper side. Bring needle to a point about 1/8" behind where the thread comes out, and then go to the underside and come up in front of that stitch by 1/8". Continue inserting and bringing up the needle 1/8" behind and in front of the thread from the stitch before.



Baste:

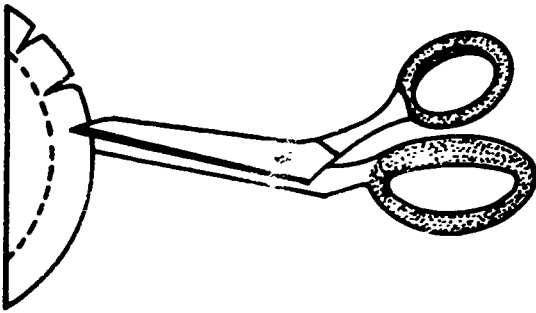
A temporary stitch which is used to hold two or more layers of fabric temporarily, holding the fabrics more securely than pinning.

Work from right to left and take several evenly spaced stitches onto the needle before pulling it through.



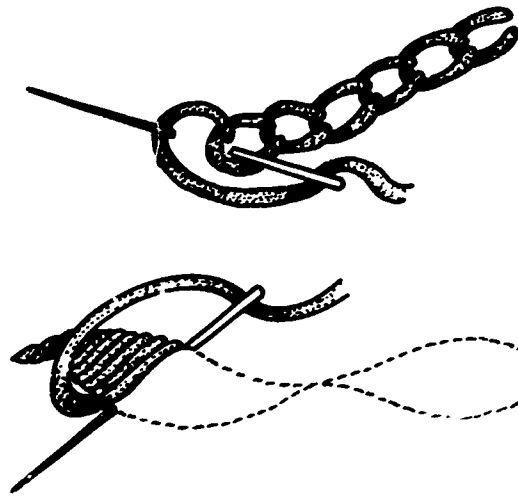
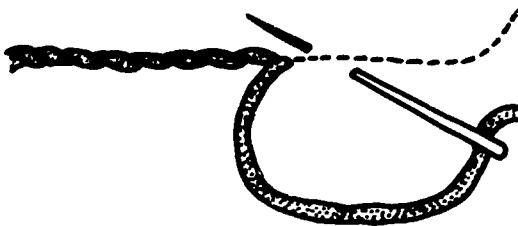
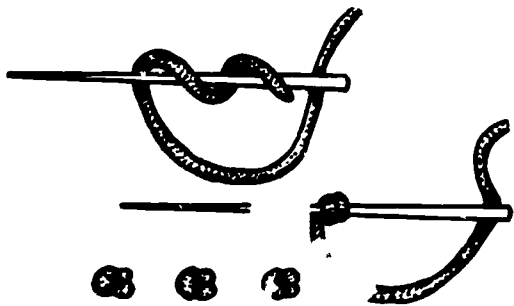
Clip Corners:

A technique used to make nicely pointed or rounded edges when turning a sewn piece right side out. Sew the article, right sides together. Before turning the article right side out, cut each corner diagonally, about 1/8" away from the stitching. To achieve nicely rounded edges, carefully clip towards the seam in a series of cuts, stopping the cut about 1/8" from the seam.



Embroider:

Decorative stitches applied to the top surface of a cloth article. Popular stitches, illustrated here, are the french knot, outline stitch, chain stitch and satin stitch.



Finger Press:

To flatten a stitched seam with your hands.

Spread open a stitched seam and press your finger or fingernail along the length of the seam to flatten it. You may also fold the seam over an edge (such as the edge of a table) and press your finger along the fold.

Fuse:

A method of attaching 2 fabrics to each other using a special material called fusible web (referred to in this manual as iron-on interfacing.) Place the fusible web, sticky side up, on the fabric, and apply heat with an iron according to the manufacturer's directions.

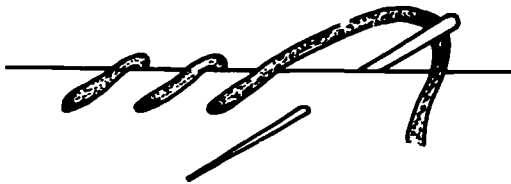
Gathering Stitch:

A long running stitch, which, when pulled tight, will gather the material. Form stitches in the same fashion as a running stitch, making the spaces between the stitches wider. When thread reaches the end of the fabric, pull gently on the thread to gather the material on the thread.

Overcast:

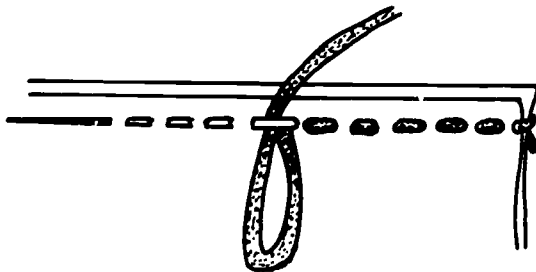
A hand stitch used to finish the raw edges of a fabric to keep them from ravelling.

Working from left or right, take diagonal stitches over the edge. Keep stitches an even distance apart and at an even depth.



Running Stitch:

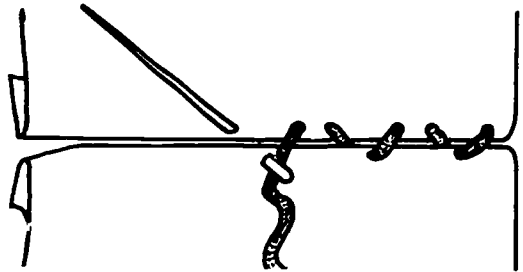
A very short, even stitch used to make fine seams, to mend and to gather. Work from right to left and weave the point of the needle in and out of the fabric several times before pulling the thread through. Keep stitches and the spaces between them small and even.



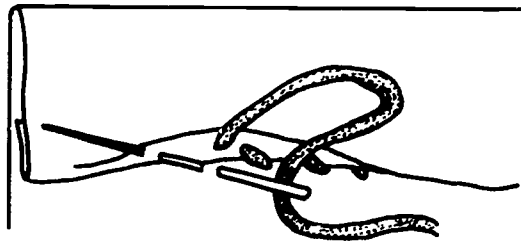
Slipstitch:

A nearly invisible stitch used to join two folded edges, or to join one folded edge to a flat surface.

To join two folded edges: Work from right to left. Fasten the thread and bring the needle and thread out through one folded edge. For the first stitch and alternating stitches, slip the needle through the fold of the opposite edge about 1/4", bring the needle out and pull the thread through. Continue to slip needle and thread through opposite folded edges.



To join a folded edge to a flat surface: Work from right to left. Fasten thread and bring needle and thread out through the folded edge. In the opposite piece (the flat fabric), take a tiny stitch and catch only a few yarns of the fabric. Next, put the needle through the folded edge of the fabric about 1/4", then pull out the needle and pull the thread through. Repeat.



BABY BOOKS



SKILLS ENHANCED

In presenting books to a baby, we seek to strengthen visual and language skills. The baby's abilities to focus her eyes, to refocus as the page is turned, to perceive, and later, to recognize different colors and shapes, are all used in looking at books. The number of words a baby understands increases as she looks at pictures and hears you name and describe them. As she listens to your words she learns the sounds and patterns of speech.

AGE SPAN

Newborn to
2 years

SUPPLIES

Baby's First Book:

- | 4 bright fabric pictures of equal size (from old crib sheets, curtains, or scrap fabrics, or new nursery fabric)
- | Iron-on cloth or interfacing (heavy), sufficient to back pictures
- | Waxed dental floss or thread
- | Needle
- | A sewing machine is helpful but not necessary
- | Iron

Optional:

- | brightly colored iron-on tape

Baby's Own Book:

- | 4 bright fabric pictures of equal size (from old crib sheets, curtains, or scrap fabrics, or new nursery fabric)
- | Needle
- | Thread
- | Embroidery thread or yarn
- | A sewing machine is helpful but not necessary
- | Pinking shears are helpful but not necessary

Zipper Bag Picture Book:

- | 3 1 quart size resealable plastic bags (such as Ziploc)
- | 3 pieces of posterboard, 7 3/4" x 6 15/16"
- | 6 colorful, clear pictures from cards or magazines
- | 2 yards of yarn
- | Clear tape
- | Pattern (1 A)

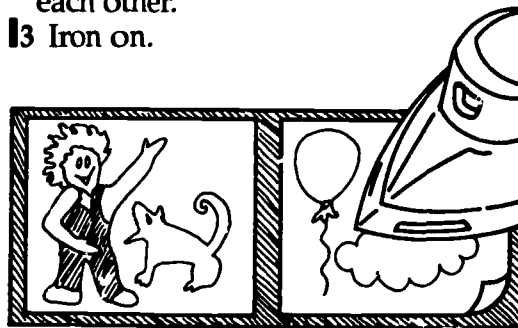
Photo Page Book:

- | 3 adhesive photo album pages
- | Vinyl, 11" x 4"
- | 2 yards brightly colored yarn
- | Bright, simple pictures

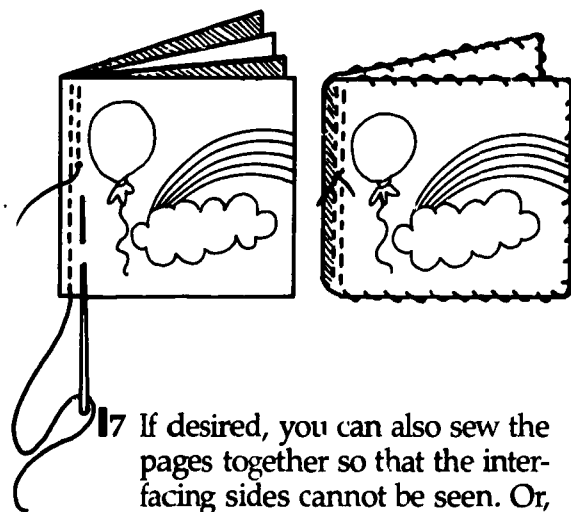
HOW TO MAKE

Baby's First Book:

- 11 Cut two strips of interfacing of the same measurement, top to bottom, as the pictures you are using, and twice as wide as the pictures.
- 12 Place two of the pictures side by side on the interfacing. Be sure that the wrong sides of pictures and sticky side of interfacing are next to each other.
- 13 Iron on.



- 14 Repeat the process above with the other two pictures.
- 15 Put the 2 strips together so that the interfacing sides face each other and the colorful pictures are on the outsides.
- 16 Fold in half, and with waxed dental floss or double thread, sew from the middle to the top, then back down to the bottom, and finally back up to the middle. Knot to secure.

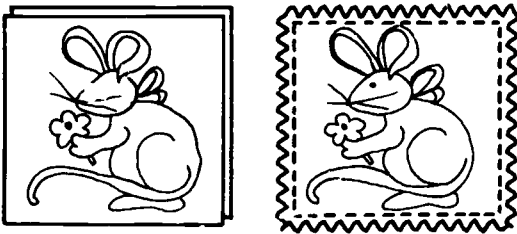


- 17 If desired, you can also sew the pages together so that the interfacing sides cannot be seen. Or,

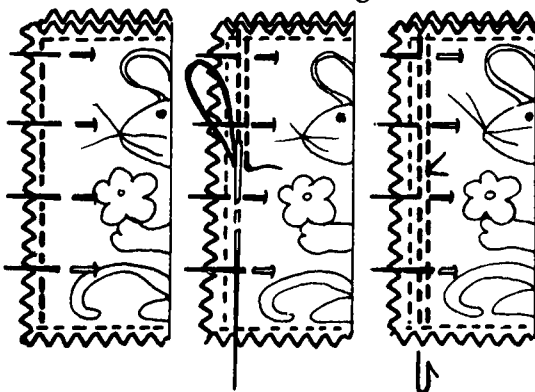
you can cut circles, triangles and squares from bright iron-on tape and press them onto the blank pages. For safety, stitch around the shape outlines and overcast in two or three places on each shape.

Baby's Own Book:

18 Place 2 pictures back to back. Sew together with a small running stitch or machine stitch about 1/4" from edges. Overcast edges if possible, or cut along edges with pinking shears.



- 19** Repeat the process above with the other two pictures.
- 110** Now place the 2 double sections together. Pin to secure.
- 111** Thread a large-eyed needle with 2 strands of embroidery thread or yarn.
- 112** Begin sewing at the middle of the left side of picture to make the spine of the book, about 1/2" from the edge. Leave a 3" tail of thread.
- 113** Sew a small running stitch to the top of the picture, then turn and sew back down, closing the spaces between existing stitches to the middle and continuing on down

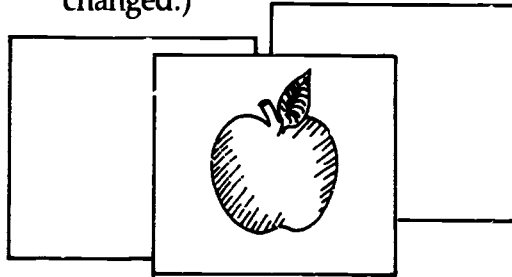
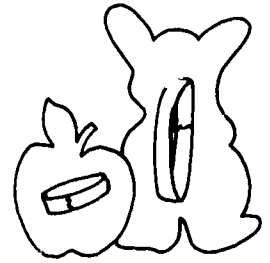


to the bottom of the picture.

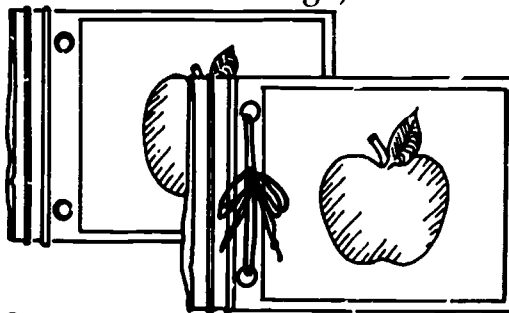
- 114** Turn once more and sew back to the middle, closing existing spaces.
- 115** Knot the two ends and cut thread.

Zipper Bag Picture Book:

- 116** Cut three pieces of posterboard, using pattern (1 A), into rectangles of 7 3/4" x 6 15/16".
- 117** Cut 6 clear, colorful pictures from cards or magazines.
- 118** Stick pictures on posterboard with a loop of clear tape. (The bag will hold pictures firmly, and if not glued on, pictures can be changed.)



- 119** Slide posterboard into bags and close tops.
- 120** With single hole punch or scissors, make a hole 3/4" from the top and a hole 3/4" from the bottom, at the point where the posterboard ends and the bag closure begins. (Do this on all three bags.)

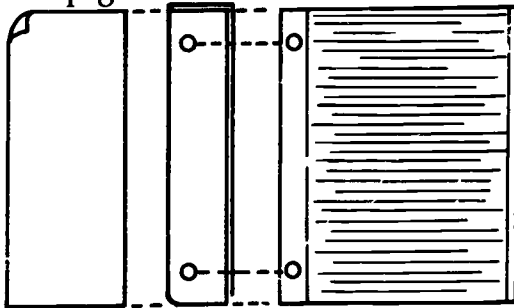


- 121** Fold the yarn in half and knot each end.
- 122** Thread yarn through all holes and tie in a floppy bow near the top hole in the front. Tie loop ends of bow in a knot.

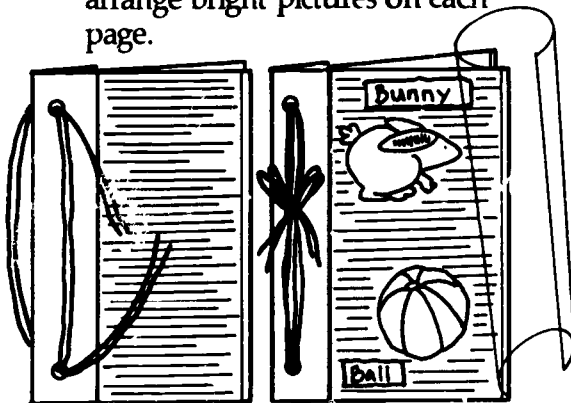


Photo Page Book:

- 123 Fold the vinyl strip in half. Lay it along the edges of the photo book pages, and make holes through both halves of the vinyl in the same position as the holes on the pages.



- 124 Double the yarn, and thread through the top hole of the upper half of vinyl, the top hole in each page, the top hole in the lower half of vinyl, then back up through the bottom holes of all layers.
- 125 Repeat above step, so that you have 4 thicknesses of yarn.
- 126 Knot and make a nice bow.
- 127 Folding back the plastic sheets, arrange bright pictures on each page.



- 128 Write simple, easy to say words on paper strips, then place them in the album close to the pictures they describe. The first picture and words should be things that begin with lip sounds (M, B, and P). These sounds will come most easily to baby.

COME PLAY WITH ME!

“There are several ways that you can make books for me, so you can choose whatever method you like. The cloth books I can play with on my own, because they are soft and safe. The plastic covered books are nice because you can change the pictures in them for variety, but you should not leave me alone with these books because I might tear the plastic and swallow bits of it. We can look at the pictures together. You can describe the colors, animals or shapes, what they are doing, or anything else you can think of, and I will listen to you. Later, I may even try to tell you about my books!”

CAUTION

Since the plastic page covers can be torn and placed in the mouth, do not allow the baby to play with these books alone. (The first two books made of cloth are safe for the baby to enjoy alone.)

2

CHANGEABLE MOBILE



SKILLS ENHANCED

In focusing his eyes, following the movement of the mobile with his eyes and looking at shapes and colors, the baby will exercise his visual skills. By changing the items on the mobile

regularly, you offer the baby new visual experiences. In time he will begin to recognize differences in shape and color. If you talk to him about items on the mobile, you will help him increase his thinking and language skills.

AGE SPAN

Newborn to
1 year

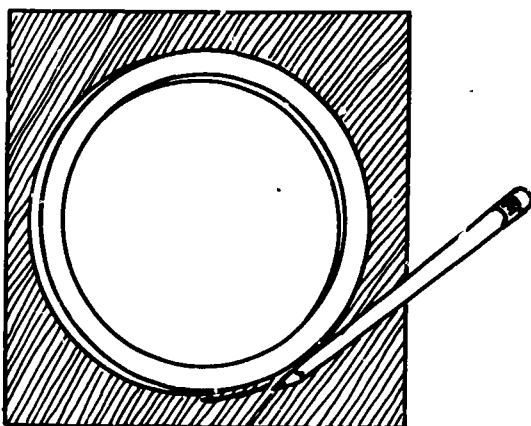
SUPPLIES

- 1 Small or large plastic lid cover
- 1 3 to 6 yards of yarn (to make "Loop and Hangs")
- 1 piece of brightly colored vinyl, about 6" square
- 1 3 pieces of bright yellow vinyl, each 3" x 3" (or 3 small, brightly colored objects)
- 1 Pattern (2 A) and (2 B)

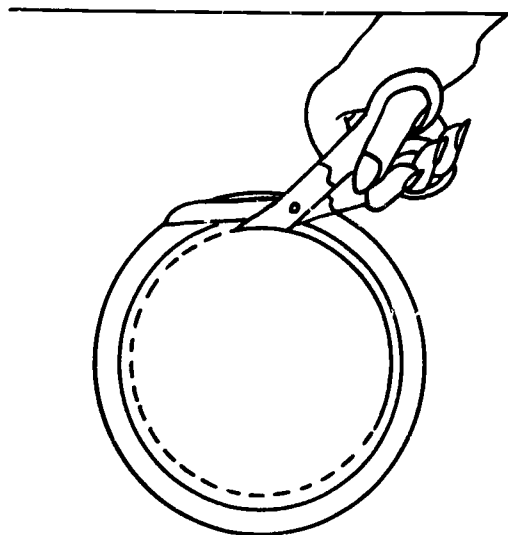
HOW TO MAKE

To make Mobile:

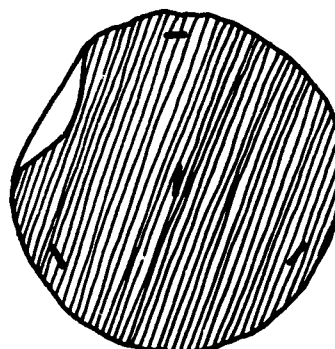
- 1 Take a round plastic lid of any diameter over 3 3/4" (suggest small for bassinet and large for crib).
- 2 Take a piece of paper and draw a circle around the outside of the lid.



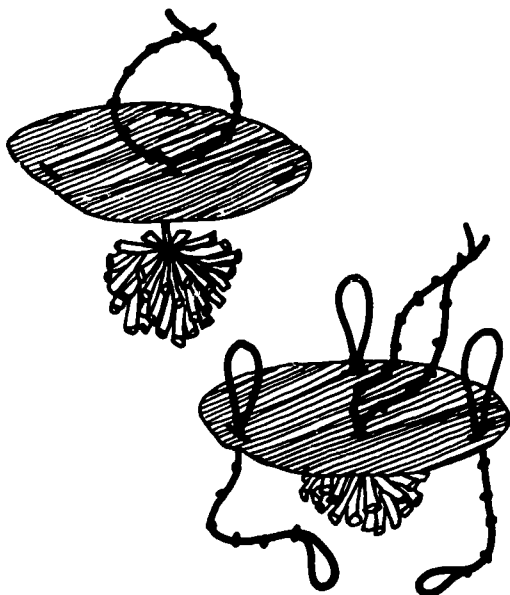
- 3 Keep the paper circle to use as your pattern for the vinyl circle which fits inside the lid ring.
- 4 Cut a circle 1/2" from the edge of the plastic lid, to form a ring.
- 5 Make 3 "Loop and Hangs" following directions in the "Loop and Hang" section #9 of this book.
- 6 Cut a vinyl circle using the pattern you have made.



- 7 Cut 3 slits in the vinyl circle about 1/3" from the edge and of equal distance from each other. Cut one slit in the center of the ring.



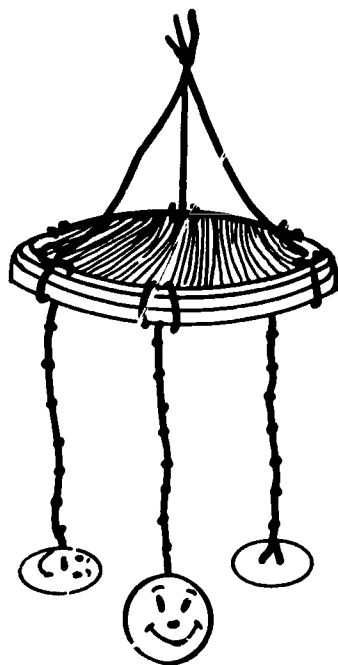
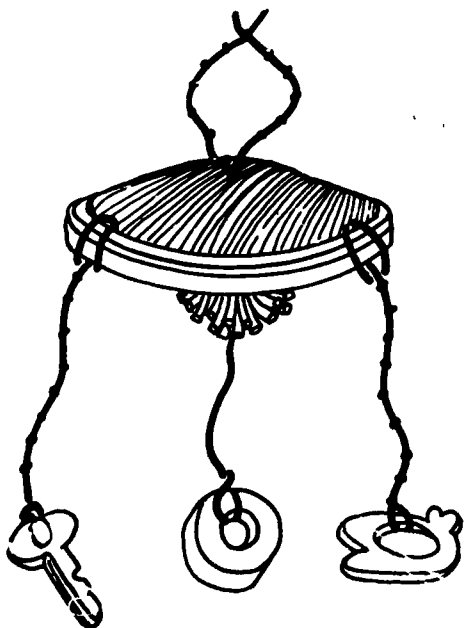
- 8 Take a small pompom from directions in the "Loop and Hang" section #9 of this book. Use about 24" of yarn in tying off the pompom. Keep equal lengths of yarn on each side of the tie-off knot and do not cut them off.
- 9 Slip the long ends of the pompom yarn through the slit in the vinyl circle. Tie a knot in the ends of the yarn. This will be your means of hanging the mobile.



- 10 Attach small toys, etc. to the 3 "Loop and Hangs" (see "Come Play With Me!" for suggestions). Take the other end of each "Loop and Hang," slip it through a side slit in the vinyl circle. Fit the vinyl circle inside the plastic ring.
- 11 Take the end of each "Loop and Hang," bring it over the ring from the center. Bring the toy to the outside of the ring and slip it through the end of the "Loop and Hang." Pull downward.

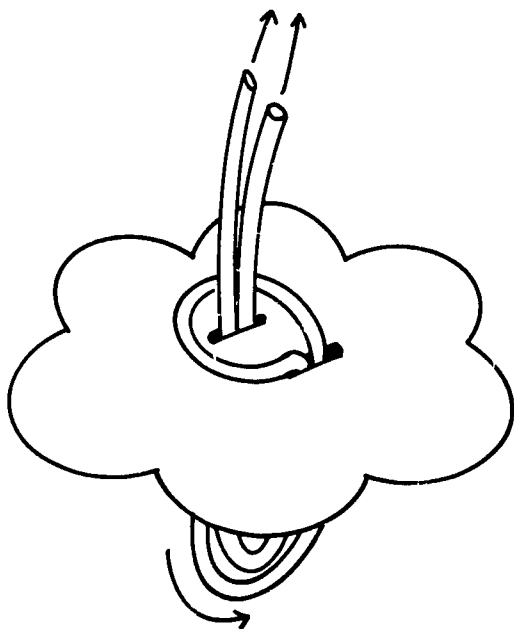
Variations for hanging Mobile from a central hook:

- 1 Use an uncut plastic lid for the center ring. Make a 1/2" slit in the middle of the lid.
- 2 Tie a toy or pom-pom to the middle of a 24" length of yarn.
- 3 Slip the two ends of the yarn through the underside of the slit.
- 4 Knot the two ends and use as a hanging loop.
- 5 With a one-hole punch or scissors, cut 3 equally spaced holes around the edge of the lid. Use 3 "Loop and Hangs" in the outside holes.
- 6 Or, make 3 more "Loop and Hangs" and attach them to a ring at equal distances from each other, before placing vinyl circle in the center.
- 7 Knot the ends together to make a hanging loop. This method is best for hanging heavier objects. (Mobile will have 6 "Loop and Hangs.")



To make Sunflowers:

- 1 Using pattern (2 A), cut 3 Sunflowers out of vinyl.
- 2 Make 2 slits in each Sunflower as indicated on the pattern.
- 3 Take the unknotted end of a "Loop and Hang" and slip it through the slits of a Sunflower, then through the loop of the hanger. Repeat this step for each flower.



To make Smiley Faces:

- 1 Using pattern (2 B), cut 3 Smiley Faces (circles) out of vinyl.
- 2 Draw a face onto each of the circles, following the guide on the pattern.
- 3 Make 2 small slits in each Smiley Face where the nose is, as indicated on the pattern.
- 4 Slip the unknotted end of a "Loop and Hang" through the slits, then loop. Repeat this step for each Smiley Face.

COME PLAY WITH ME!

“I will enjoy looking at my mobile when I am lying in my crib. If you make several different objects for my mobile, like the Sunflowers or Smiley Faces, I will have many different experiences. Since it is so easy for you to change what you hang on my mobile, I know you will want to give me a lot of variety. You could even hang other light, bright objects, such as pompoms, fake flowers, or bits of folded colored paper, from my mobile. Tell me the names of the things you hang for me to see. Tell me the colors of the animals or bows or pompoms. Blow softly on the objects as I watch the mobile; I will be excited by the movements.”

CAUTION

Be sure that you hang the mobile out of the baby's reach.

CHEWABLE CHARMER



SKILLS ENHANCED

Visual experience comes as the baby focuses her eyes or follows the movement of the colorful toy with her eyes. Tactile skills are enhanced as you touch the separate sections to the baby's body, and later, as the baby uses the toy in play. The dangling units promote motor development as the baby reaches for them and as she holds them.

AGE SPAN

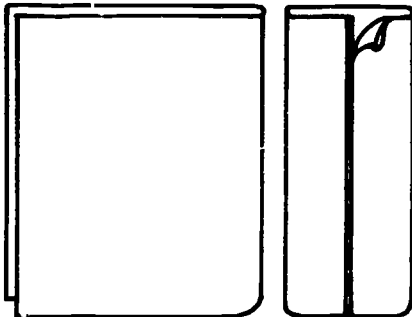
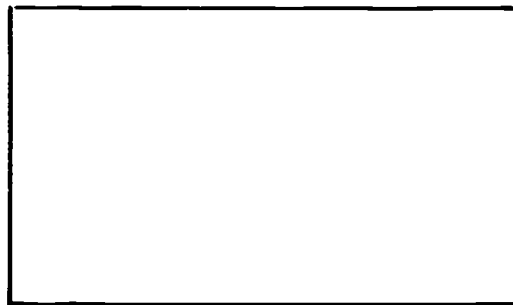
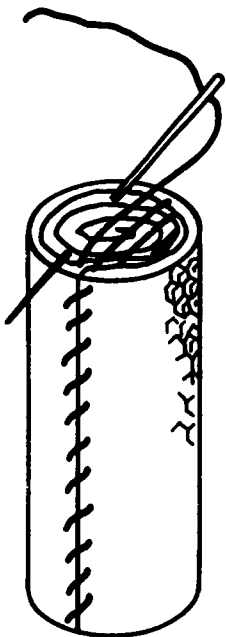
Newborn to
development of
first teeth



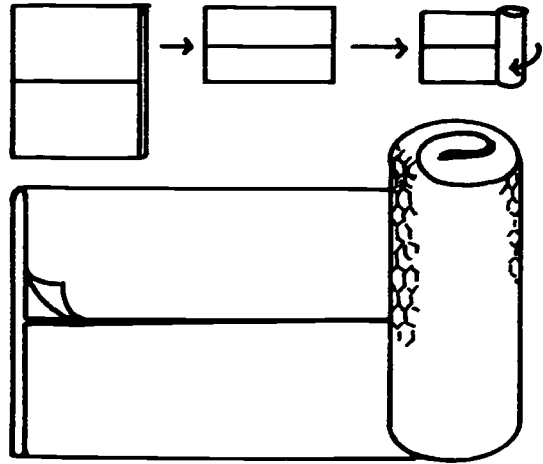
HOW TO MAKE

Net Charm:

- 1 Spreading the nylon net in front of you so that the top is the 18" side, fold the net in half from right to left; then fold the right and left sides to the middle. You will have a folded rectangle of 4 1/2" x 10".



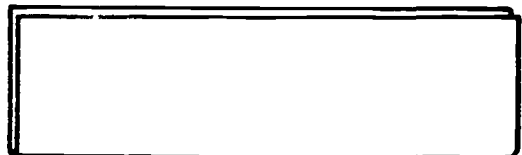
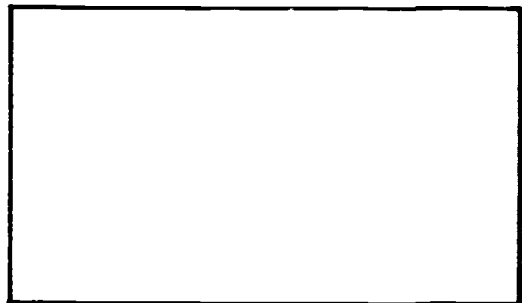
- 2 Now fold the top and bottom to the middle, for a rectangle of 4 1/2" x 5". Double again in the same manner, top to bottom. Your rectangle will now be 4 1/2" x 2 1/2".
- 3 Beginning with a 2 1/2" side, roll the cloth tightly.



- 4 Sew along the outer edge to make a side seam.
- 5 Sew back and forth at the top.

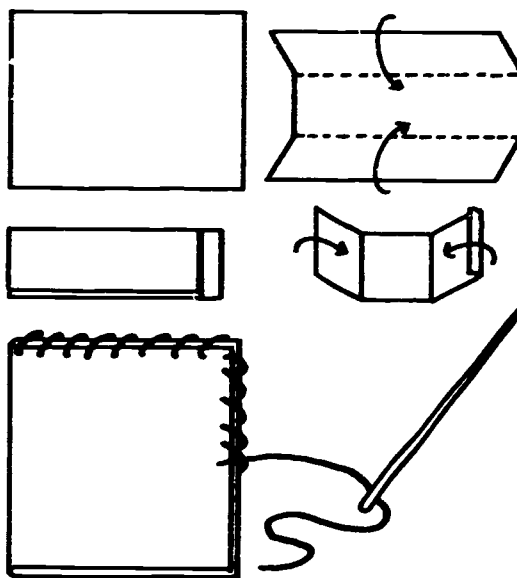
Cotton Charm:

- 6 Fold the rectangle in half lengthwise, for a rectangle of 9" x 2 1/2".



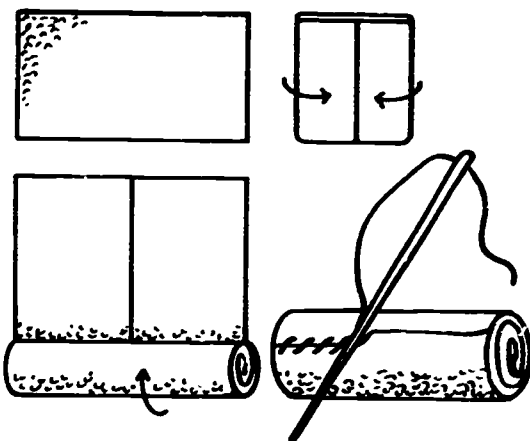


- 17 Now fold the sides in to the middle, for a rectangle of $4\frac{1}{2}'' \times 2\frac{1}{2}''$.
- 18 Beginning with a $2\frac{1}{2}''$ side, roll the cloth tightly.
- 19 Sew along the outer edge to make a side seam.
- 20 Sew back and forth at the top.



Terrycloth Charm:

- 11 Fold the $2\frac{1}{2}''$ edges in to the middle of the $5''$ length to make a rectangle of $2\frac{1}{2}'' \times 2\frac{1}{2}''$.
- 12 Beginning with one of the unfolded-edge sides, roll the cloth tightly.
- 13 Sew along the outer edge to make a side seam. Turn under as you sew.
- 14 Sew back and forth at the top.

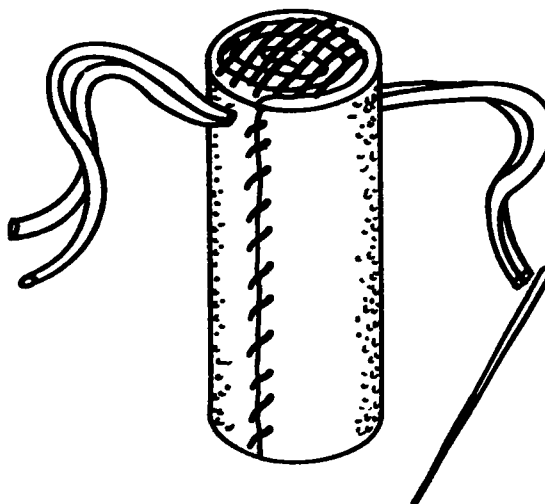


Vinyl Charm:

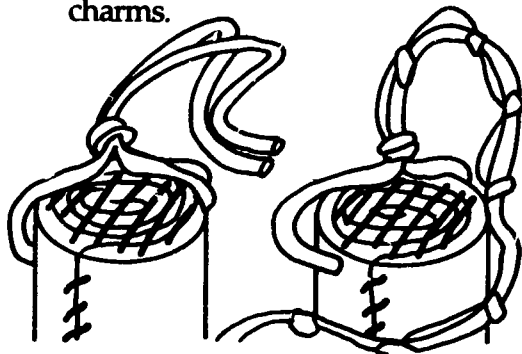
- 15 Fold the $5''$ length into 3 parts (two folds, as you would fold a letter).
- 16 On the $6''$ length, fold in $1''$, then fold into 3 parts as above, keeping the folded edge on the outside.
- 17 Sew $1\frac{1}{2}''$ of the three open edges. Leave needle and thread attached.

To complete:

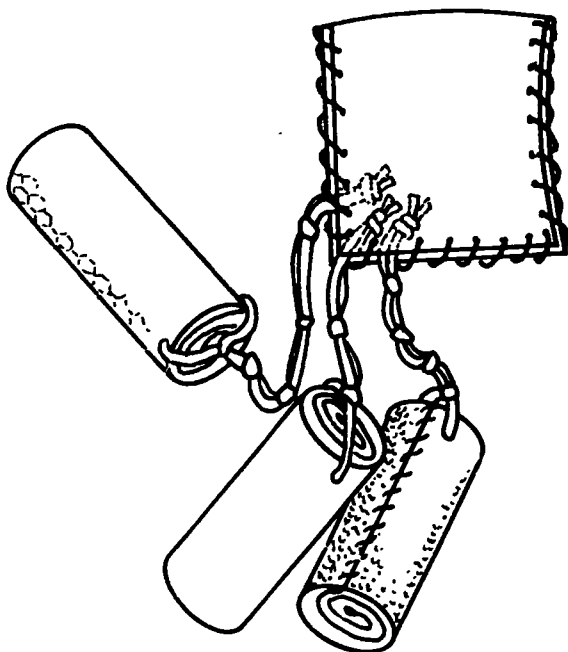
- 18 Cut 3 1-yard pieces of yarn. Thread one piece of yarn through a large-eyed needle and pull yarn double. Push needle through the top of the nylon net charm about $\frac{1}{4}''$ from top. Pull yarn through until there is an even amount of yarn on each side of the charm. Clip yarn close to eye of needle.



- 119 Tie the yarn in a tight knot at the top of the charm. With all four strands of yarn held together, tie a knot every 1/2" to make 5 knots.
- 120 Repeat for cotton and terrycloth charms.



- 121 Push the knotted yarn of each of the three charms into the open sides of the vinyl square. You will have 4 knots outside of the square, and 1 knot inside the square for each charm.
- 122 Sew the square closed, being careful to sew through the 3 inside knots to give extra strength.



- 123 If desired, make a "Loop and Hang Clip" following directions on the "Loop and Hang" section #9 of this book.

COME PLAY WITH ME!

“At first I will enjoy looking at my Chewable Charmer as it hangs from my crib. I can watch the colors move gently, and you can use it to get my attention when you hold it about a foot away from my face. Soon, I will want to hold it myself, and feel the different textures of the cloth and the knots. I will put it in my mouth and chew on it, and it will make my gums feel good. The charms are nice, small shapes that I will be able to hold onto easily.”

CAUTION

As the baby chews, watch out for frayed and raveled edges that can get caught in her throat. You should take it away from the baby as her first teeth appear.

NOTES

Knitting the "Loop and Hang" yarn makes it less likely that the baby's fingers or toes will get caught in the double yarn. It also adds strength, neatness and texture.

4

CLUTCH BALLS



SKILLS ENHANCED

Motor skills will become stronger and more varied as the baby exercises them in using the "Clutch Balls." The sections and texture of the balls allow the baby to grasp and hold them more easily than a regular ball. For this

reason, they're less likely to roll out of his reach. Success in holding the balls gives the sense of achievement that stimulates interest in more advanced motor activities. Balls made from different fabrics, such as terrycloth, give the baby experiences in touching a variety of textures.

AGE SPAN

4 months
to 3 years

SUPPLIES

For a Large Ball:

- 8 pieces fabric, each 8" x 8"
- 8 pieces thick batting, each 6 1/2" x 6 1/2" (or 4 squares foam, same size)
- Patterns (4 A) and (4 B)

For a Small Ball:

- 8 pieces fabric, each 4" x 4"
- 8 pieces thick batting, each 3" x 3" (or 4 squares foam, same size)
- Patterns (4 C) and (4 D)

Both:

- Needle and thread (waxed dental floss works best)
- A sewing machine is helpful, but not necessary
- A rubber band is helpful

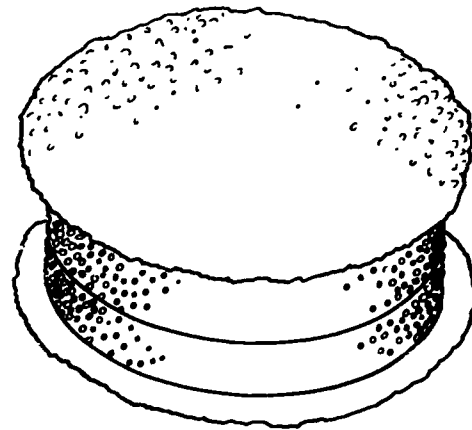
HOW TO MAKE

For either size Ball:

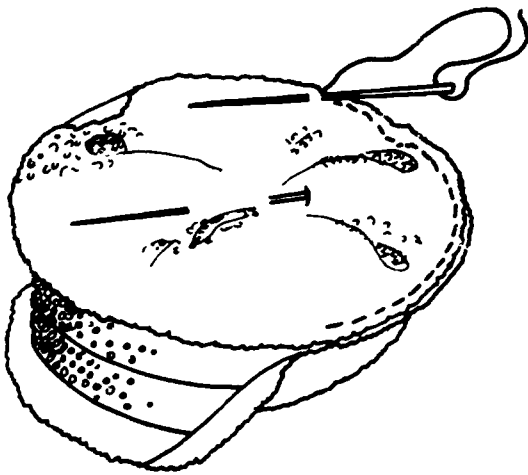
- 1 Cut 8 circles of cloth, using either pattern (4 A) or (4 C), depending on whether you want a large or a small Clutch Ball.
- 2 Cut 8 circles of batting, or 4 circles of 1" thick foam, using pattern (4 B) or (4 D) to fit your large or small ball.

Make 4 ball sections as follows:

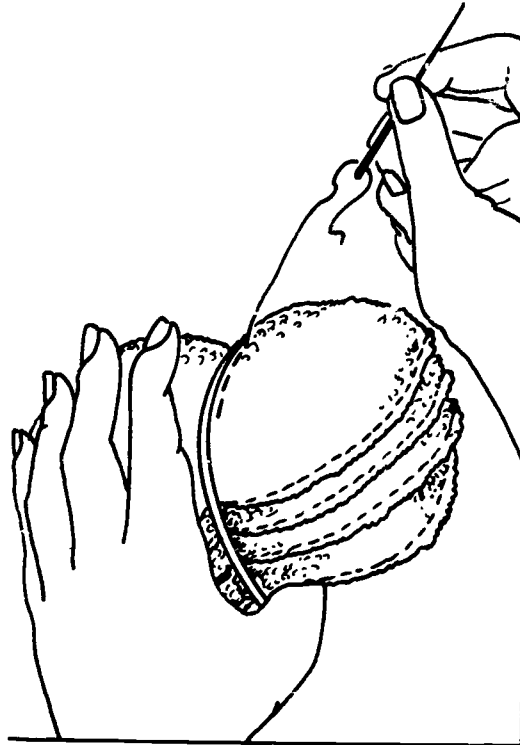
- 3 Between two layers of cloth, sandwich two layers of batting (or one layer of foam), with the cloth layers placed so that the back side of the cloth touches the batting or foam.



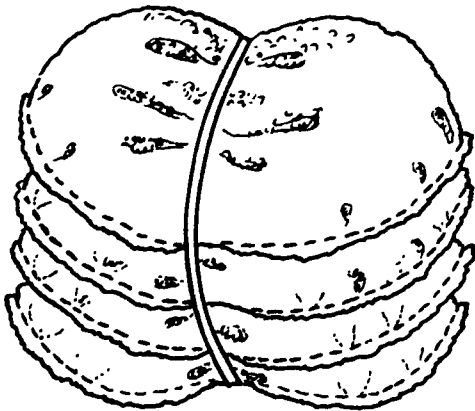
- 4 Pin together.
- 5 Sew 1/4" from the edge all the way around with sewing machine, or a running stitch by hand. If fabric frays, the edge should be overcast by hand or machine.



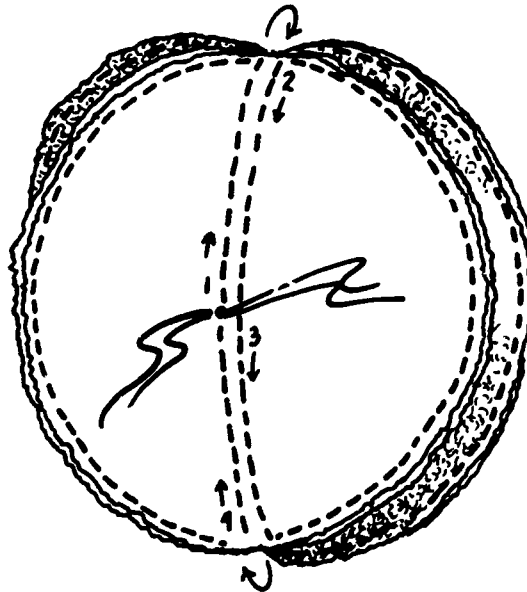
- 16 When pieces have been sewn into 4 thick circles, place them directly on top of one another like a stack of pancakes. (For ease in holding the circles together as you sew, and to clarify the sewing line, you can place a rubberband around the stack in the middle.)



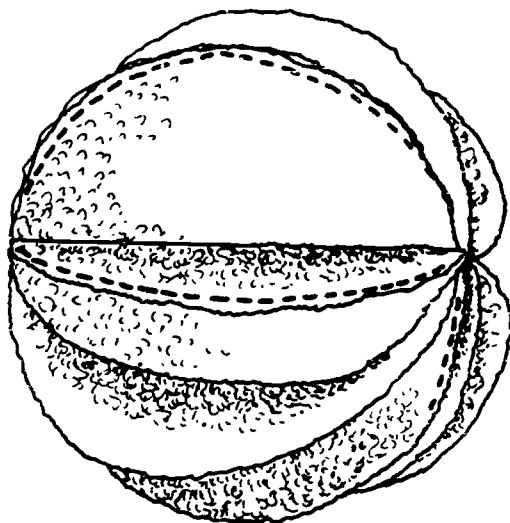
- 18 Sew back towards the bottom of the circle, filling the spaces between the first stitches. At the bottom of the circle, turn and sew toward the center, filling the spaces between the first stitches. Pull tight, overcast three times, then tie off.



- 17 Take the stack firmly in hand and, with waxed dental floss or double thread, sew a double line right across the middle with a running stitch. Begin this stitching in the center of the circle, overcasting twice and leaving a 3" tail of thread. Pull the thread very tightly as you sew to the top of the circle.



- 19 Clip any long threads and wash or brush off any loose pieces of cloth on the ball before giving it to baby.



CAUTION

Since this toy is bound to be "well-loved," keep a look out for possible holes; the batting could be dangerous if swallowed.

NOTES

The above directions instruct you to sew the ball from the outside for simplicity, but more experienced sewers may want to sew right sides together, clip curves, turn, and stuff. This would be better if using fragile fabrics such as satin or dotted swiss.

COME PLAY WITH ME!

“The sections in my Clutch Ball make it much easier for me to catch and hold than a regular ball, so it is my favorite first ball. You can show me how to throw the Ball up and watch it come down. I can throw and roll it to you, and you can throw it and roll it back to me. We can roll the Ball behind a chair, and watch it come out on the other side. We can put the Ball into a pot, and take it back out. We can share the Ball with each other, and take turns with it. You can give it to me while I am alone in my crib or in my seat, and I can hold it myself and feel the textures. I will like this ball for a long, long time. It’s a good thing you can wash it!”

CRIB HUGGER



SKILLS ENHANCED

This unit for hanging toys was designed to be used with several of the toys in the manual. The "Soft and Ready Ball," "Picture Frame," "Sunflower Mirror," "Rattle Roll," "Touching Hand Band," and "Finger Puppets" are

all good toys to hang on the "Crib Hugger." The baby will enjoy looking, touching, and listening while alone in her crib, and the toys are there handy and ready to use when you want to play with her. The skills enhanced by each toy are described in the separate toy units.

AGE SPAN

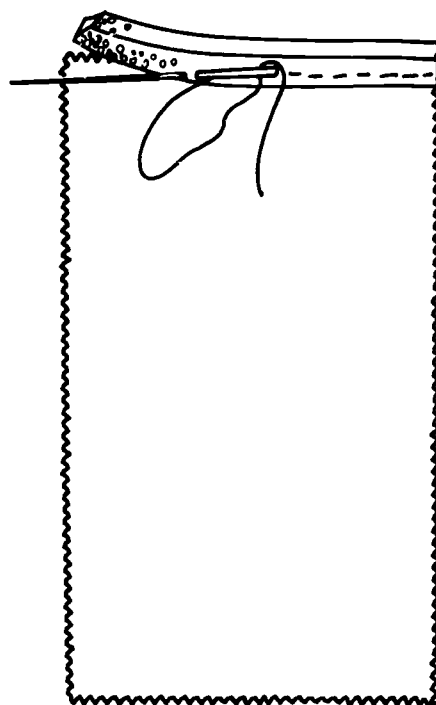
Newborn to 4
months

SUPPLIES

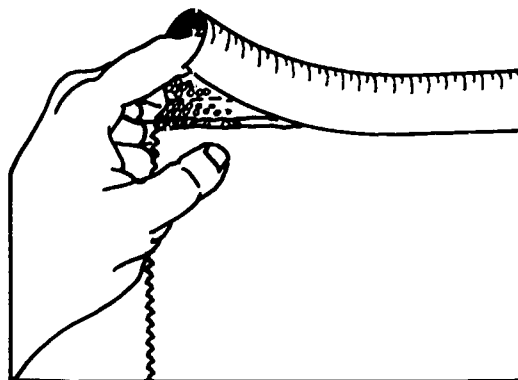
- 1 piece of fabric (non-ravelling, fire retardant) or vinyl, 21" x 13"
- 1 section of plastic shower rod cover, 12" long
- 1 piece of foam, 1" x 11" x 3/4" thick
- Sew-on nylon fastener tape (such as Velcro), 3/4" x 4 1/4"
- Needle and thread
- Pinking shears
- Pattern (5 A)

HOW TO MAKE

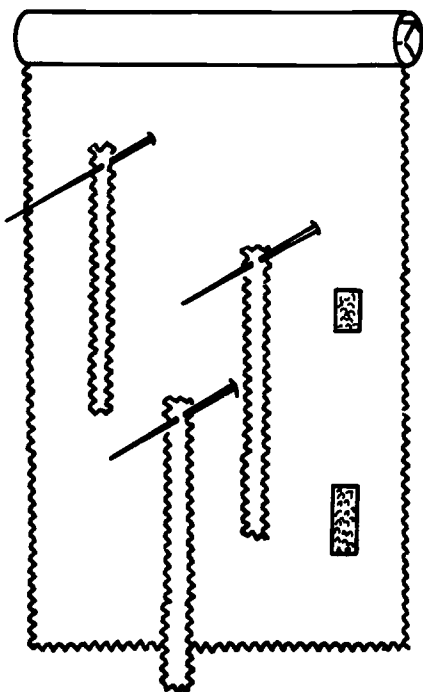
- 1 Using pinking shears, cut a rectangle 21" x 12" (Pattern A) from the fabric.
- 2 Baste the strip of foam across one of the short ends of the large rectangle, about 1/4" from the edge of the fabric.



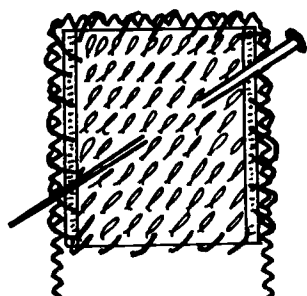
- 3 Slip the foam into the shower rod cover.



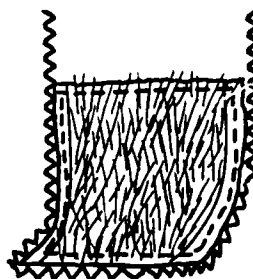
- 14 Cut a strip of the same cloth (or a contrasting color) 21" x 3/4", again using pinking shears.
- 15 Cut the strip into three pieces, each 7" long.
- 16 Pin the strips into place on the large rectangle, using the illustration as your guide.



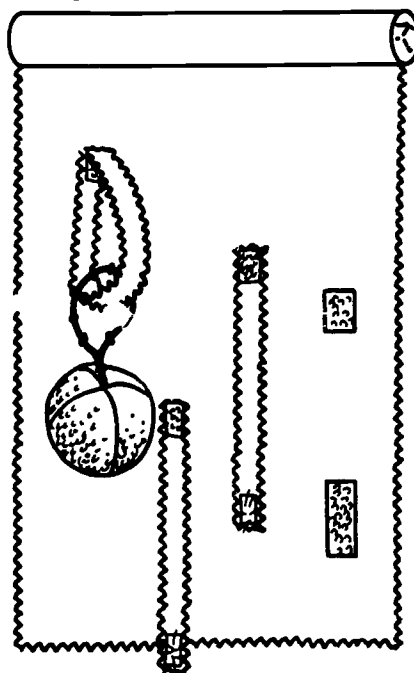
- 17 Cut three pieces of fastener tape, each 1/2" long.
- 18 Place the loopy texture of each piece of fastener tape face up at the pinned top of each of the three fabric strips.
- 19 Sew through the fastener tape, strip, and large rectangle, anchoring them securely, on each of the three strips.



- 10 Sew the fuzzy texture of each piece of fastener tape, face up, at the bottom of each of the three fabric strips so that the strips form a loop when the fastener tape pieces are pressed together.



- 11 Cut a 2" strip of the loopy texture of the remaining fastener tape and sew it, face up, to the lower right corner of the large rectangle, using the illustration as your guide.
- 12 Cut a 3/4" strip of the loopy texture of the remaining fastener tape and sew it to the top right side of the large rectangle, using the illustration as your guide.
- 13 Attach the "Crib Hugger" to the side of the crib by opening the rod and slipping it onto the crib railing.



COME PLAY WITH ME! CAUTION

“The best thing about my Crib Hugger is that I can look at all the toys while you are away, and they will keep me company and attract my attention with their bright colors. You could hang up my Duck, Butterfly, or Bear Finger Puppet, my Picture Frame, or my Sunflower Mirror. Or you could use the loops to hang up my rattles and other bright toys, like my Red Ball. The loops make it easy for you to change the toys you hang up by my side when you want to give me some variety, and easy for you to remove the toys when you are ready to play with my toys and me.”

Be sure to use sew-on fastener tape, as the stick-on type might be pulled off and swallowed by baby. The age span of the “Crib Hugger” is from newborn to about 3 months, but can be used longer if the baby is not grasping. If the baby is very active, you may need to remove the hugger from the crib earlier. This precaution is to prevent her from poking herself with the rod cover or getting the foam in her mouth. If there are other young children in the home, be sure to hang the “Crib Hugger” next to a wall so that they won’t grab it and flip the rod from the top.

NOTES

If the hugger is too long for your crib, the excess fabric can be gathered up inside the rod.

EXERCISE ROLL



SKILLS ENHANCED

The use of the exercise roll will encourage the baby to lift his head and to use his arms to push up. Playing on the roll will also encourage the use of his stomach muscles in a pre-crawling position. The strengthening of these motor abilities allows the baby to observe and investigate his world more fully, so other skills will also be enhanced.

AGE SPAN

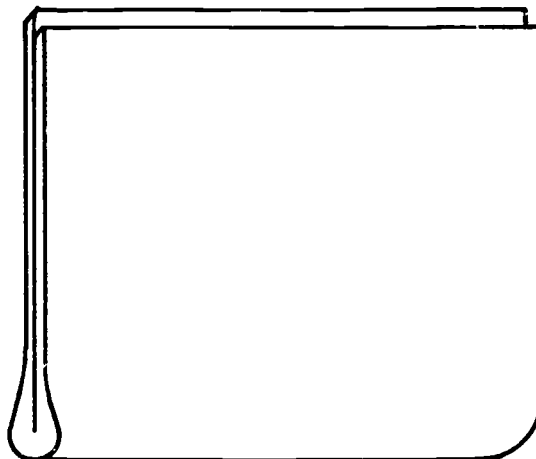
Pre-crawling

SUPPLIES

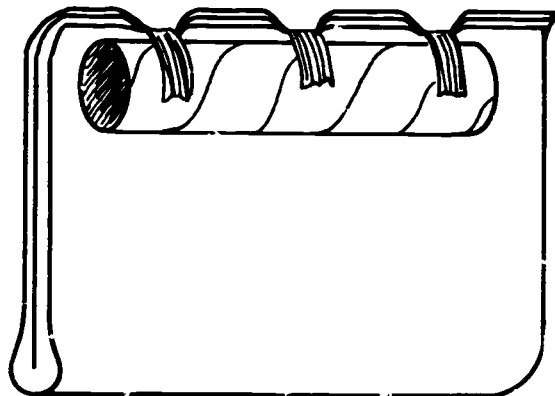
- ! Fabric core roll, 2" in diameter
(Larger sized exercise rolls can be made from larger fabric core rolls, computer print-out rolls, or rug rolls.)
- ! Batting or foam rubber, 30" x 18", about 1/2" thick
- ! Fiber-reinforced packaging tape
- ! Vinyl cloth, 17" x 12" (must be thick to provide the necessary firmness)
- ! Needle and thread

HOW TO MAKE

- !1 Using a knife or blade, cut a 13" length from the fabric core roll.
- !2 Fold the batting or foam in half to make it 15" x 18".

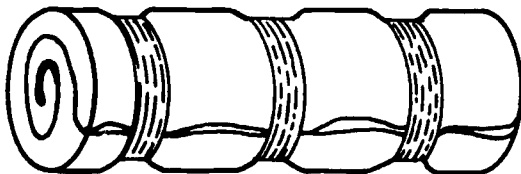


- !3 Anchor the batting to the roll with the tape so that the batting extends past the ends of the tube.

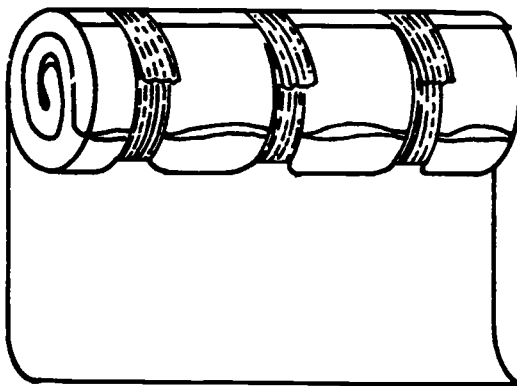


14 Wrap the batting tightly around the roll, and tape it all the way around in the middle of the roll.

15 Circle both ends of the roll with tape.

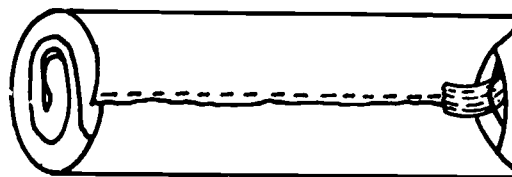
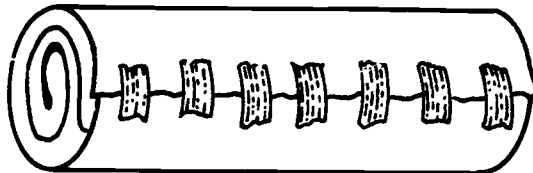


16 Tape the vinyl or plastic to the batting in three places to anchor it in position.

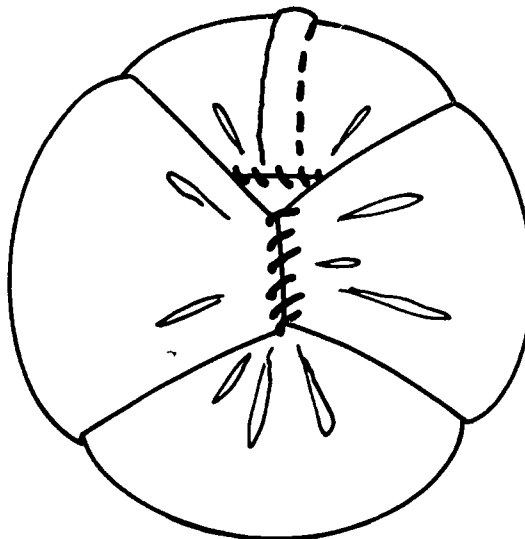


17 Wrap plastic tightly around the roll; secure it with several small pieces of tape.

18 Using needle and thread, sew across the taped seam of the vinyl with a backstitch or a small running stitch. Remove the tape. Fold in the ends as though you were wrapping a package. Tape to hold. (You can use the bits of tape removed from the sides.)



19 Stitch the folded ends closed, first the inside fold and then the points on the overlapping fold.



COME PLAY WITH ME!

“Please put me over this roll on my tummy. Help me to reach forward in front of the roll and put my hands down. Show me a toy or talk to me so that I look up. Try this three or four times. If I am really good at this, try to help me bring my knees up under me. I will look like I am trying to crawl. If I push forward, that is okay...it is good exercise for me. Just put me back on the roll and try again.”

CAUTION

Do not balance the baby over the roll unless he is supported carefully by you. It is best to hold him at his hips.

NOTE

The vinyl makes it easy to keep the roll clean. Or, if you wish, you can make a removable cotton cover, or cover the roll with an athletic tube sock.

The size described here is for the very small, probably premature, baby. Larger sizes can be made.

7
EZ

FINGER PUPPETS: BUTTERFLY, DUCK, AND BEAR



SKILLS ENHANCED

Puppets promote growth in language. The baby learns to listen for the puppet's sounds and words, and watches the puppet's movements. Touching and handling the puppet is fun, too. As she gets older, the baby may begin to play with the puppet on her own.

AGE SPAN

3 months to
2 years

SUPPLIES

For each puppet:

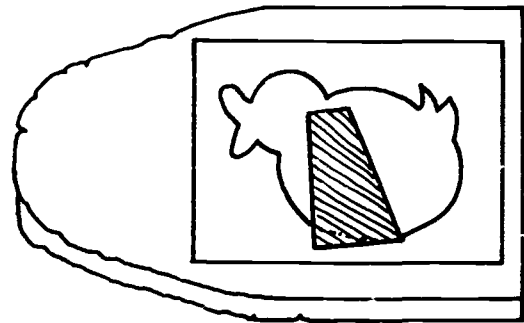
- 1 piece of bright fabric, 5 1/2" x 4 1/2"
- 1 piece of regular interfacing, 2" x 3"
- 1 piece of iron-on interfacing (Shirt Tailor, Heavy Weight), 5 1/2" x 4 1/2"
- Sew-on nylon fastener tape (such as Velcro), 3/4" x 3/4" (if puppet is to be used on "Crib Hugger")
- Needle and thread
- Iron
- Pattern (7 A), (7 B), or (7 C)
- Pattern (7 D)

Optional:

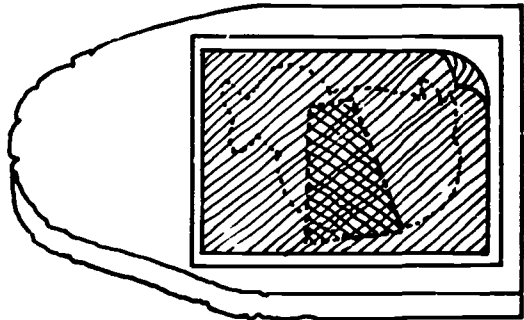
- Permanent markers
- Pieces of colored cloth

HOW TO MAKE

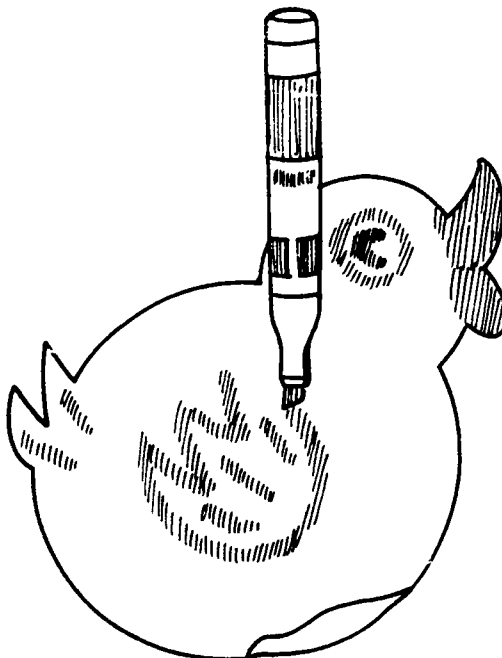
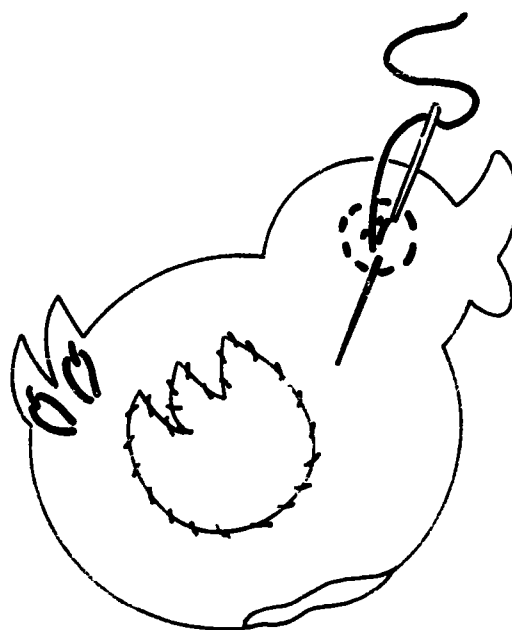
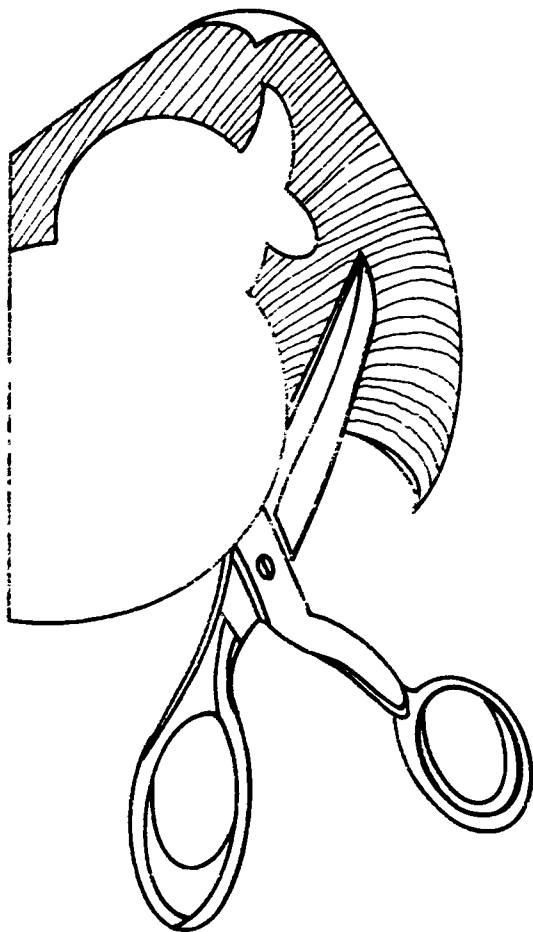
- 1 Place a sheet of white paper on your ironing board. (The paper will attach to any overlapping iron-on interfacing and can be trimmed away from the cloth later. This will protect your ironing board cover.)
- 2 Using pattern (7 A) for the butterfly, (7 B) for the duck, or (7 C) for the bear, cut 1 piece in the desired shape from the bright fabric.
- 3 Place the animal face down on the white paper on the ironing board.
- 4 Cut a finger section from pattern (7 D) out of regular interfacing, and place it on the wrong side of the animal, in the position indicated on the pattern.



- 5 Place the iron-on interfacing over the other sections, being sure that the sticky side of this interfacing is facing the wrong side of the animal and covers the regular interfacing section, too.



- 16 Iron, connecting the three fabrics.
 17 With scissors, trim all around the outline of the animal, including the interfacing section where your finger slips in.



- 18 If you like, you can make facial features and colorful patterns on the animals with permanent markers or with sewn-on pieces of cloth.

- 19 If you plan to use the puppet with the "Crib Hugger" (see the "Crib Hugger" section in this book), sew a piece of fastener tape to the back of the finger section, being careful not to sew through the layer of bright fabric. Be sure that you use the fuzzy texture of the fastener tape so it will be opposite to the loopy textures sewn on the "Crib Hugger."



COME PLAY WITH ME!

“It is so nice for me to be able to look at these bright animals while I am lying in my crib. Imagine how wonderful it will be for me when they come to life on your finger! You can move the animals slowly across my field of vision, and I will watch them move. I will be excited by the bright colors and the movements, and I will enjoy it even more when you talk to me about what the animal is doing, where it is going, what colors it is, and the sounds it might make. Tell me stories about each of the animals, and give them names. Then, when you have to leave me, put the animals back on my Crib Hugger and they will keep me company and attract my attention while you are gone.”

CAUTION

Stick-on fastener tape must not be used, because as the baby becomes more active she may pull it off and swallow it.

NOTES

You may be able to find cloth pre-printed with different animals. Look on nursery curtains, used crib sheets, or children's used clothing, or in cloth shops. Use the printed animals instead of the patterns in this book, and follow the same instructions for using the interfacing as backing and as the finger slot.

FRIENDLY FEET



SKILLS ENHANCED

Visual skills are enhanced by the "Friendly Feet" as the baby's eyes are attracted to the brightly colored faces on his feet. When he discovers that he can move his feet to make the faces move about, his motor coordination will develop and his sense of mastery and enjoyment at being able to do interesting things on his own will increase.

AGE SPAN

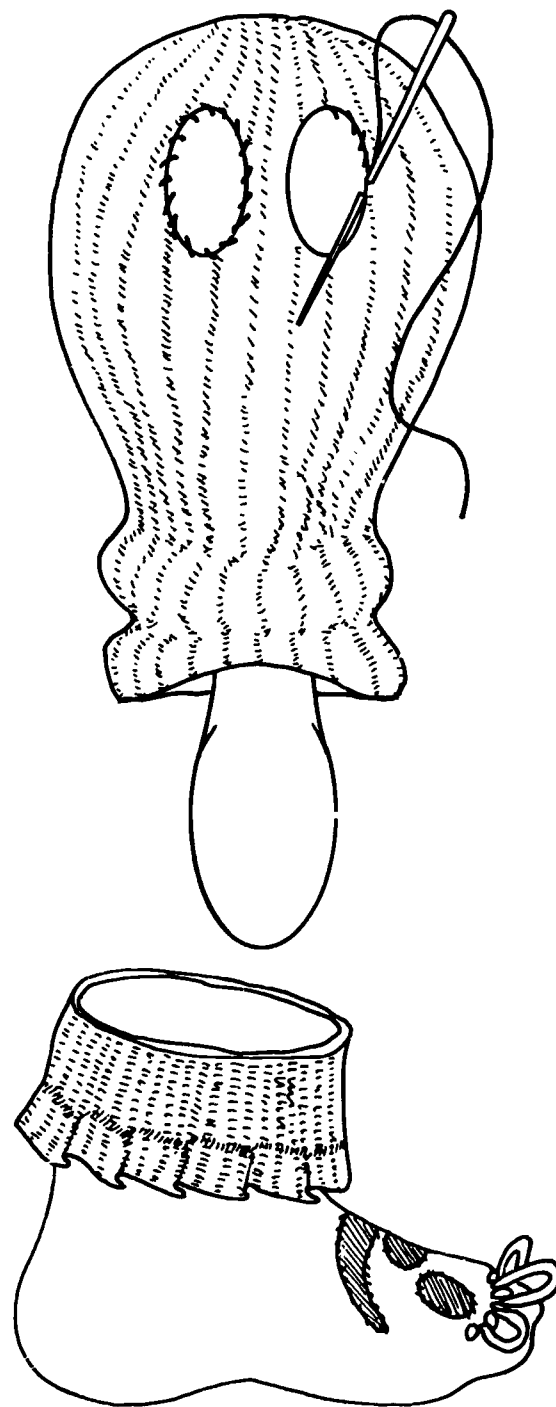
Newborn to
6 months

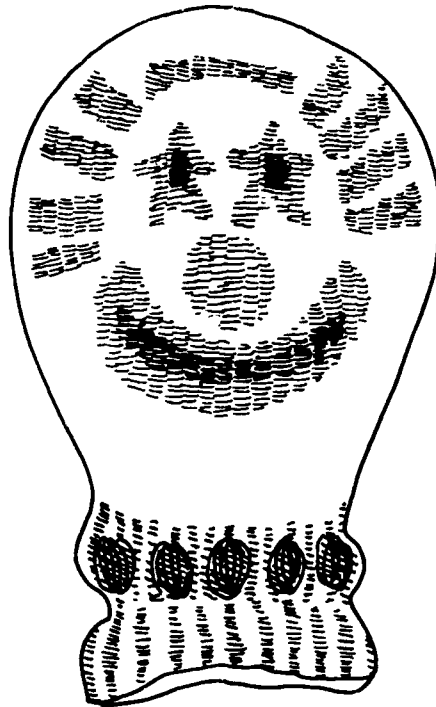
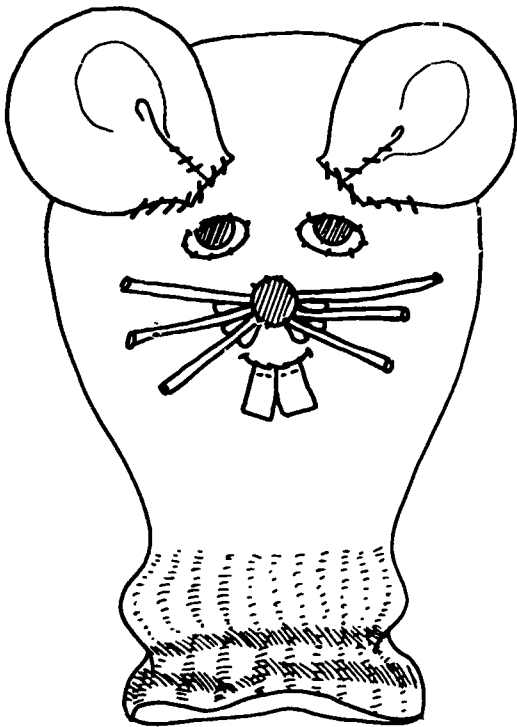
SUPPLIES

- 1 2 infant socks
- 1 Cloth scraps, different colors (or permanent markers)
- 1 Yarn scraps, different colors (if desired)
- 1 Needle and thread
- 1 A darning egg is helpful but not necessary

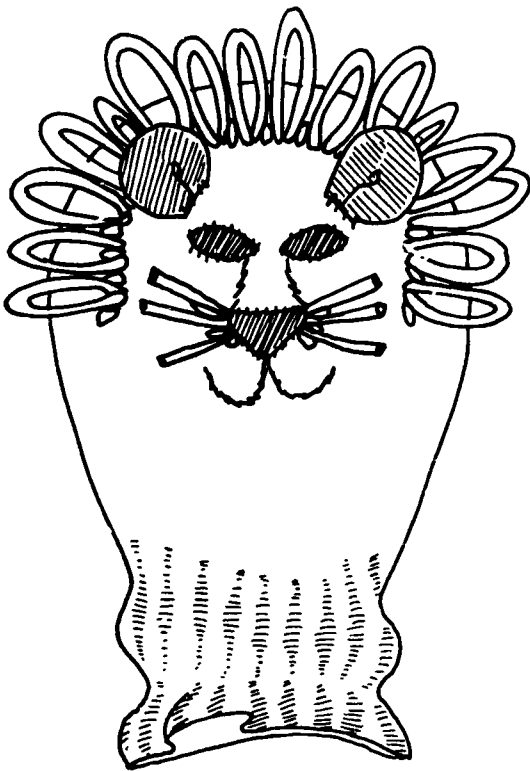
HOW TO MAKE

- 1 Cut facial features (eyes, nose, mouth, rabbit or cat ears) from brightly colored scraps of cloth.
- 2 Sew them on the top part of each sock.





13 (Facial features can also be drawn onto the socks with permanent markers instead of sewing them.)



COME PLAY WITH ME!

“This toy will let me have a good time while I am in my crib, or you can let me wear my Friendly Feet no matter where I am. I will have a good time looking at the faces you put on my feet! It will be funny when I discover that those faces are attached to me, and that I can make them move when I move my feet.”

NOTES

To sew the faces onto the socks with ease, you may wish to insert a darning egg or serving spoon into the sock. This will prevent your sewing through the sole of the sock.

LOOP AND HANG UNIT, CLIP, YARN DOLL and POMPOM



SKILLS ENHANCED

These early toys are primarily for the development of the visual skills. Hang them close to the infant and she will begin to focus on the bright colors. Move the doll or pompom and her eyes will follow their movements. Tactile skills will be enhanced if you

touch the soft toys to various parts of her body. As the baby's motor skills strengthen, the toys will have to be moved out of reach, but she will still stretch toward them. The "Loop and Hang" can be used to hold rattles and other safe toys close enough for her to tap and kick. (The "Loop and Hang" is not a toy itself, but is a tool to make other toys more accessible to the baby.)

AGE SPAN

Yarn Doll or Pompom:
Newborn to 3 months displayed on the "Loop and Hang"

Indefinitely as mobile or in parent/child play (see CAUTION)

Loop and Hang:
Through crib and high chair months with rattles and other safe toys.

SUPPLIES

For each Loop and Hang:

- 1 yard of yarn

For each Loop and Hang Clip:

- 1 yard of yarn
- 1 covered-metal clothespin

For 2" Pom-pom:

- 8 yards bright yarn
- 1 piece of cardboard, 1 1/2" x 2 1/2"
- Pattern (9 A)

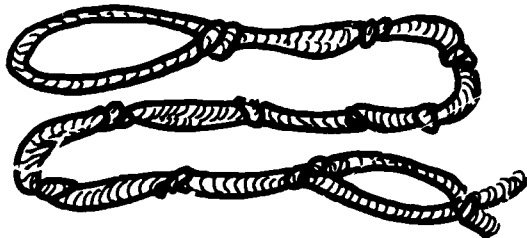
For Yarn Doll:

- 17 yards of heavy 4-ply yarn
- 1 piece of cardboard, 7" x 5 1/2"
- Pattern (9 B)

HOW TO MAKE

For Loop and Hang:

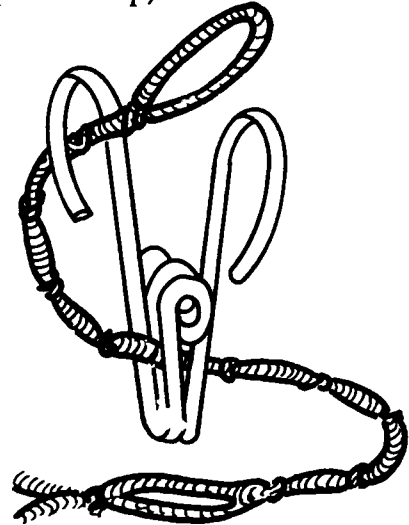
- 1 Fold the end of yarn in half and knot the ends together.
- 2 Make knots about 2 1/2" from the other end to make a loop.
- 3 Make 10 more knots, one every 1/2" along the length of the doubled yarn. There should be about 3" of unknotted yarn left which makes a second loop at the end which has the cut tips of the yarn.



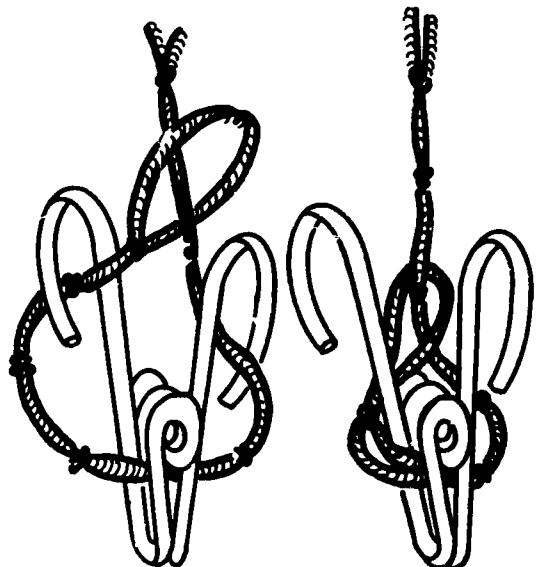
For Loop and Hang Clip:

- 4 Make a "Loop and Hang" as directed above.

- 5 Slip the "Loop and Hang" through the lower section of the clothespin (the part which holds onto clothes).
- 6 Bring one end of the "Loop and Hang" up through one side of the top section of the clothespin (the part you grasp with your fingers to open the clip).

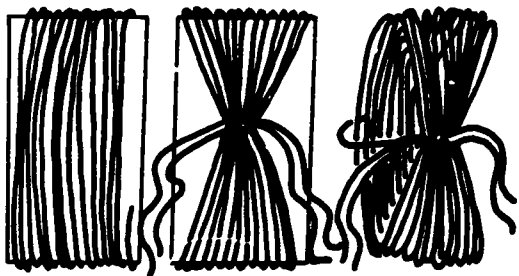


- 7 Bring the other end of the "Loop and Hang" up through the other side of the top section of the clothespin, and pull it through the first end of the "Loop and Hang."
- 8 Pull until "Loop and Hang" holds the clip snugly.

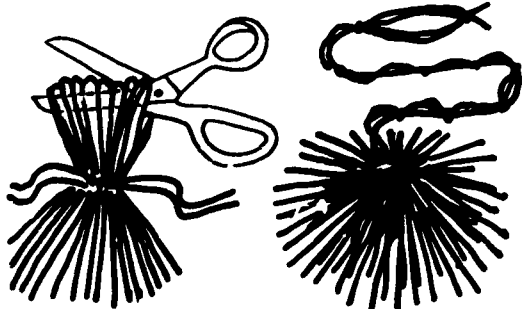


For Pompom:

- 19 Wind yarn around the length of the cardboard about 50 times. Cut 18" of extra yarn; tie this tightly around the middle of the yarn loops on one side of the cardboard. (Do not clip off the long ends of the yarn, but use them to hang the pompom later.)

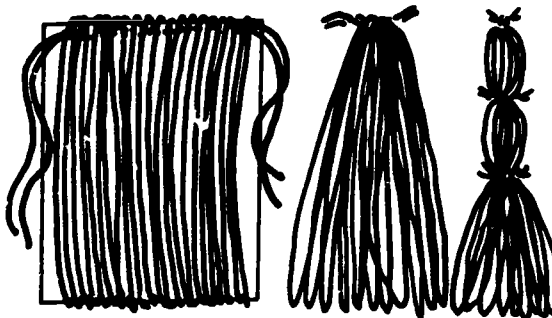


- 10 Slip yarn loops from cardboard. Tightly tie around the middle of all of the loops two or three times more with the long ends of yarn.
11 Cut through top and bottom loops.
12 Roll between palms of hands to fluff up. Trim short ends to make a round ball. Use the long ends to make a "Loop and Hang" (see instructions above for knotting).

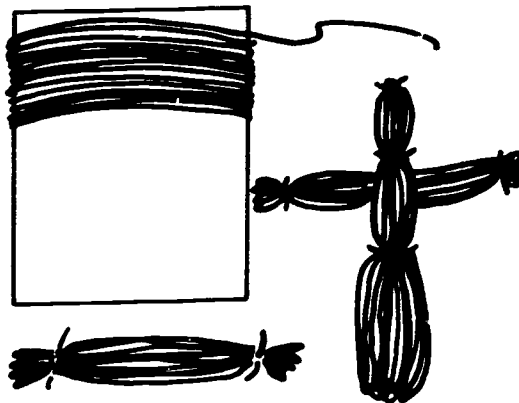
**For Yarn Doll:**

- 13 Wind yarn around 7" length of cardboard 30 times. Slip a 12" piece of extra yarn under the loops at the top of the cardboard.
14 Tie a tight knot. Cut off ends of extra yarn. Remove looped yarn from cardboard.

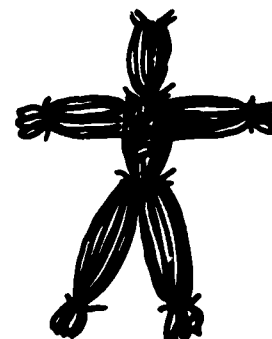
- 15 With extra yarn, tie around the loops 1 1/4" from the top and again at 2 1/2" from the top.



- 16 Wind yarn around the 5 1/2" length of cardboard 16 times. Cut yarn.
17 Cut 12" extra yarn. Remove looped yarn from cardboard. With extra yarn tie tightly around each end of looped yarn, about 3/4" from the end.
18 Slip the smaller bunch of yarn loops through the center of the larger bunch of looped yarn, between the two areas that were tied.



- 19 Separate the lower part of the large bunch into two equal parts. With extra yarn tie tightly around each part about 3/4" from the bottom.
20 To keep arm section from slipping out, make two "buttons" on doll's chest by sewing through body of doll several times in one place.



COME PLAY WITH ME!

“You will be able to do a lot of nice things for me with these Loop and Hangs and Loop and Hang Clip. You can use them to hold a toy close to me by hanging them on the crib rail, my infant seat, or from my Crib Hugger. There are a lot of toys that you can hang near me. I will enjoy watching the bright colors of the Yarn Doll or my Pompom as they dangle near my reach. You can hang my Doll on the rail of my crib with the Loop and Hang Clip, too. Talk to me about my Doll, give it a name, tell me about its adventures! When you hang my Pompom or anything else from my Loop and Hang, I can watch it. You can move the toy very slowly, and I will follow it with my eyes. Soon, I will begin to turn my head to watch it, until I can't see it anymore. When you move it back into my view, I will learn where to look for it

again. You can even touch me with the soft pompom, and I will enjoy the feeling. The Loop and Hangs make it easy for you to hang different toys in front of me.”

CAUTION

Do not use the “Loop and Hang Clip” around baby once he is old enough to reach it and clutch it. It may pinch his fingers or lips. Also, if you have other little children in your home, it may not be wise to use the clip. Because the Pompom and Doll are made of yarn pieces which could be pulled out (even if tied very tightly), do not ever give these toys to the baby.

NOTES

If you have no tape measure or ruler, use your arm to measure the yarn for the “Loop and Hangs:” with your arm outstretched, the length from your nose to your hand is approximately one yard.

Use “Loop and Hangs” whenever the toy you want to hang has a hole or a handle you can slide the yarn through. The “Loop and Hang Clips” will be easier to use with toys or objects that don't have holes or handles, such as the “Yarn Doll” or “Pompom.”

The length of the “Loop and Hangs” can be varied to fit your need, simply by using a longer or shorter length of yarn. The end loops can be made larger to accommodate bigger objects.

10
EZ

PEEK-A-ROUND



SKILLS ENHANCED

The baby's motor, visual and listening skills all benefit from the fun of knocking, kicking, shaking, rolling, chasing and dragging the "Peek- a-Round." Used in play on the floor, the toy will make one sound as the baby makes it

move and others as you shake it, gently or hard. Soon, the baby will grasp and shake it himself. Rolling away from him as he crawls, it will make yet another sound. The sounds are different again when the toy is used in the bathtub. Using the toy in water also adds new dimensions to the motor activities.

AGE SPAN

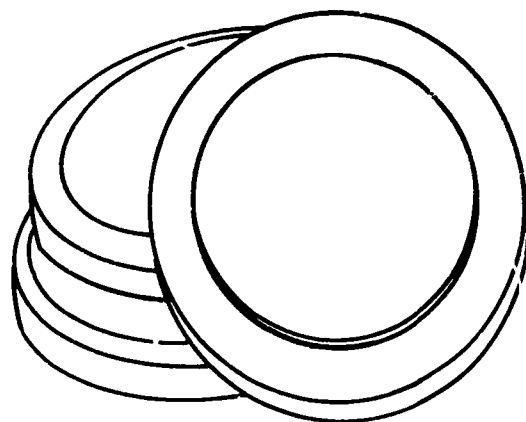
3 months to
18 months

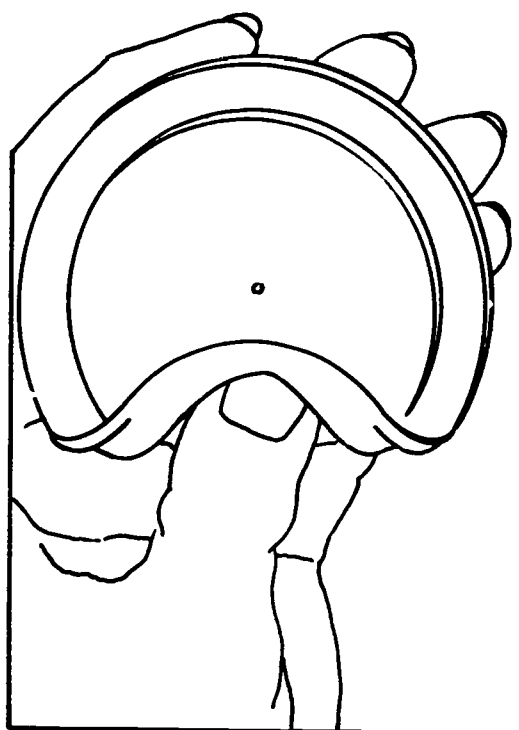
SUPPLIES

- 1 empty clear plastic 2-liter soda bottle
- 4 brightly colored plastic lids (from powdered drinks, baby foods, yogurt, etc.)

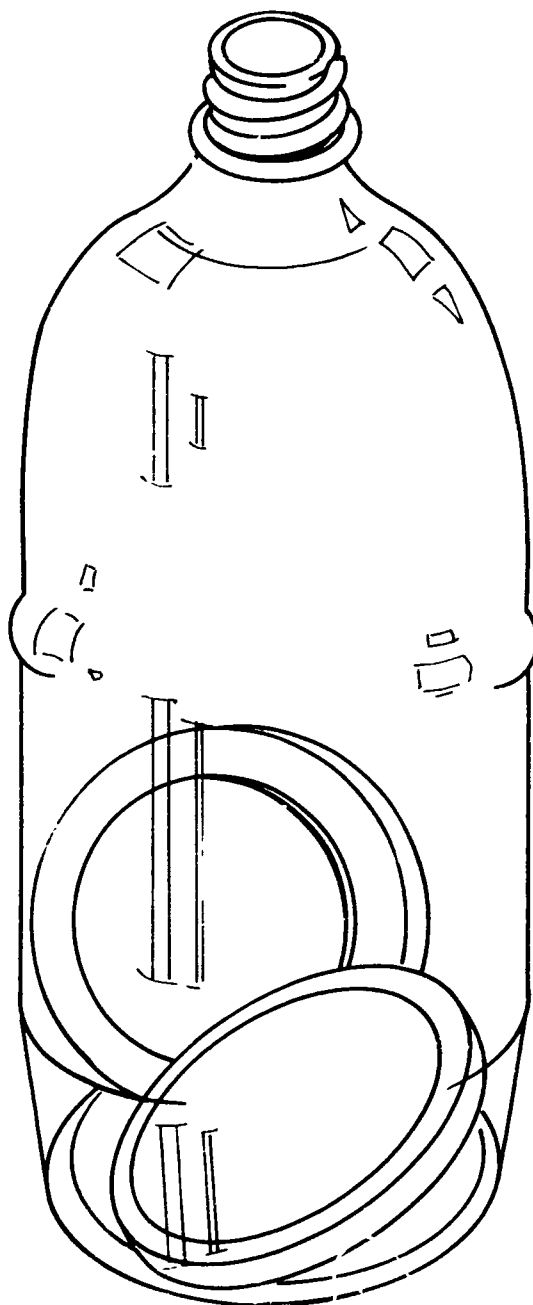
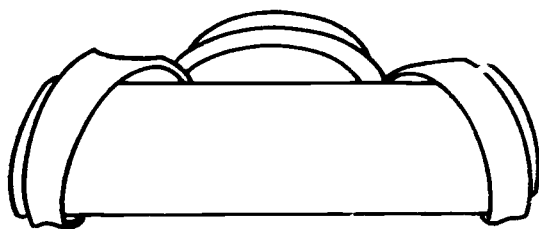
HOW TO MAKE

- 1 Remove lid and label from bottle. Scrape off any remaining glue and wash bottle.
- 2 Soak off paper labels (if necessary) of 4 brightly colored lids. If lids with lettering on them are used, remove lettering by soaking in soapy water and scrubbing with a pot scrubber or nylon net, or remove with nail polish remover.





13 Take each lid and roll it tightly from one edge. Pop each rolled lid through the bottle opening. (Once inside, the lid will unroll and return to its circular form.)



COME PLAY WITH ME!

“When you first give me this toy, I will enjoy looking at the brightly colored lids and may even reach for them. I will quickly discover the wonderful sound the lids make. I will shake the bottle, roll it, and even crawl after the bottle as it rolls across the floor. I will enjoy making the lids “rattle” over and over again. We can use this toy in the bathtub, too. It will be fun to watch the lids as the bottle bobs around on the water, and we can fill it with water and watch it pour out while the lids swirl and make sounds.”

CAUTION

Check the bottle for sharp edges which you may need to smooth with sandpaper or a nail file.

NOTES

Suggested lids:

Heinz Instant Baby Food
Light-and-Lively Yogurt
Sunkist Light drink crystals

PICTURE FRAMES: SEWN or IRON-ON



SKILLS ENHANCED

The colorful frames attract the baby's attention and stimulate use of her visual skills. At first she will just focus on the frame. Soon, she will begin to see a face within the frame. Thinking and language skills may be enhanced if you change the pictures regularly; choose bright, clear pictures and talk about them when you are beside the crib.

AGE SPAN

Newborn to
4 months

SUPPLIES

For Sewn Picture Frame:

- 2 pieces of vinyl or heavy colored paper, $4\frac{1}{2}'' \times 4\frac{1}{2}''$
- Needle and thread
- Pinking shears or regular scissors
- Pattern (II A)
- A sewing machine is helpful, but not necessary
- Sew-in nylon fastener tape (such as Velcro), $\frac{3}{4}'' \times \frac{3}{4}''$ (if picture frame is to be used as "Stick and Hold" unit with the "Crib Hugger")
- A magazine picture or family photograph

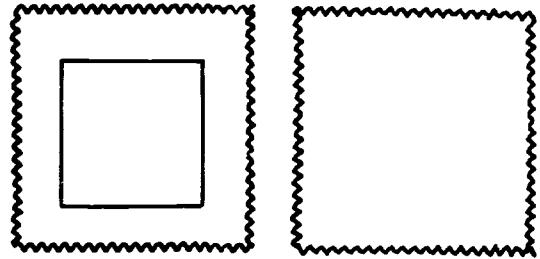
For Iron-On Picture Frame:

- 1 piece fabric, $4\frac{1}{2}'' \times 4\frac{1}{2}''$
- 1 piece iron-on interfacing, $5'' \times 5''$
- 1 piece regular interfacing, $4'' \times 4\frac{1}{2}''$
- Sew-in nylon fastener tape (such as Velcro), $\frac{3}{4}'' \times \frac{3}{4}''$ (if picture frame is to be used as a "Stick and Hold" unit with the "Crib Hugger")
- A magazine picture or family photograph
- Pattern (II B)

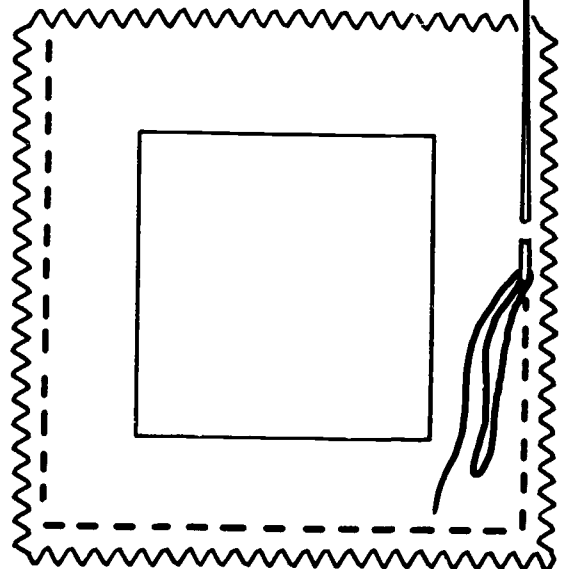
HOW TO MAKE

For Sewn Picture Frame:

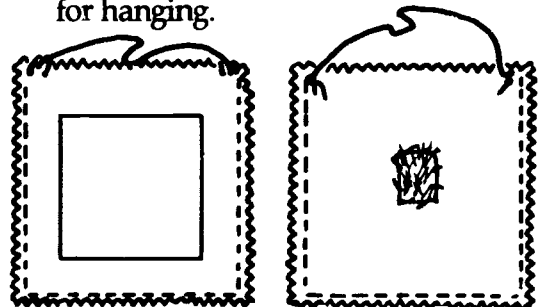
- 1 Using pattern (II A), cut front and back pieces from vinyl or heavy colored paper. (The front will have a square hole cut out, and the back will be a solid square.)



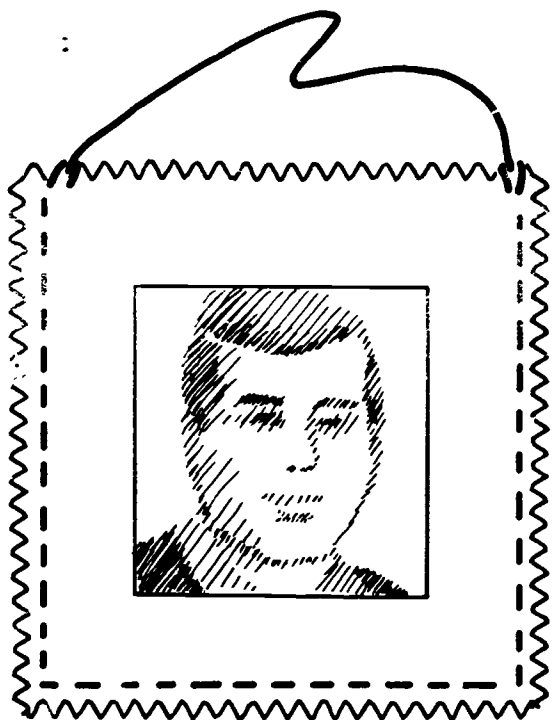
- 2 Place wrong sides together and sew on three sides, by hand or machine, about $\frac{1}{2}''$ from the edges.



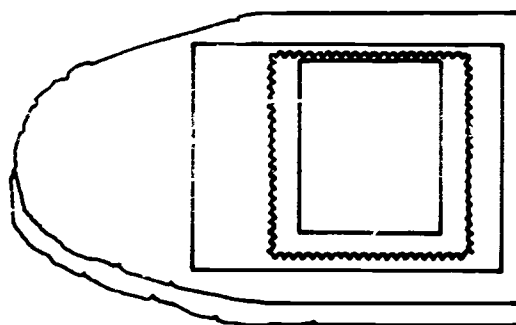
- 3 Attach thread or yarn to two adjacent corners (on the side which is not sewn closed) to make a loop for hanging.



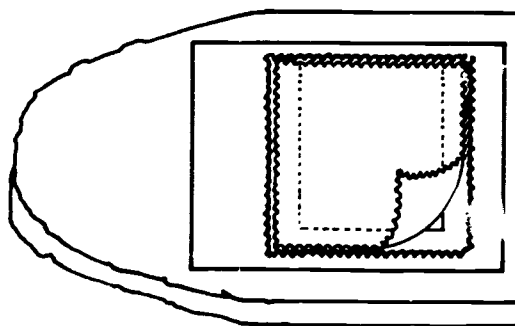
- 14 If desired, sew a square of fastener tape to the back of the frame for use with your "Crib Hugger." Be sure to use the fuzzy texture on the tape so it will be opposite to the loop texture you used on your "Crib Hugger."
- 15 Slip the picture into the frame.



- 17 Using pattern (11 A), cut the front of the picture frame from brightly colored fabric.
- 18 Using pattern (11 B), cut the back of the frame from iron-on interfacing.
- 19 Using pattern (11 C), cut the frame insert from regular interfacing.
- 110 Place the right side of fabric front down on the sheet of paper on the ironing board. Place the regular interfacing insert on the frame, centering it along the top edge.

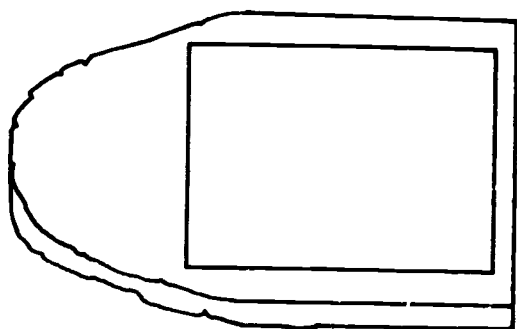


- 11 Place the sticky side of the iron-on interfacing frame back down against the frame insert, and align carefully with the fabric front.

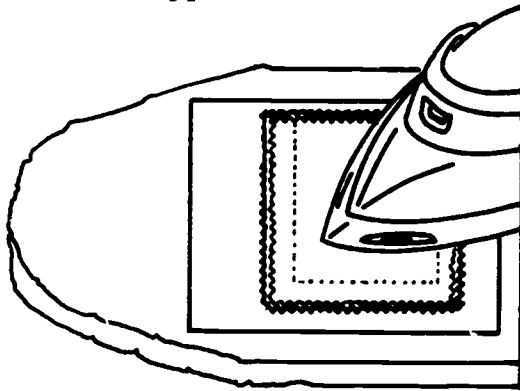


For Iron-on Picture Frame:

- 16 Place a sheet of white paper on the ironing board. The paper will attach to any overlapping iron-on interfacing and can be trimmed away from the cloth later. This will protect your ironing board cover.



- 12 Fuse the three sections together with a hot iron. The front and back sections will be fused together around three edges. The regular interfacing section will be fused to the top back section and will thus allow a photo or picture to be slipped into the frame.



- 13 If desired, sew a square of fastener tape to the back of the frame for use with your "Crib Hugger." Be sure to use the fuzzy texture on the tape so it will be opposite from the loopy texture you used on your "Crib Hugger."
- 14 Attach thread or yarn to the two top corners (on the side which is not fused closed) to make a loop for hanging.
- 15 Slip the picture into the frame.

COME PLAY WITH ME!

“I like to look at pictures, especially if they are bright, clear and simple. Close-ups are nicest, especially when I can see the eyes and smile of someone’s face. You could put any kind of picture in my Frame; it might even be nice if you put in a picture of someone in my own family. The colorful frame will keep attracting my eye, and this picture will give me some company when you are away from me. Please change the pictures in my Frame often so I have a variety of experiences.”

CAUTION

Use sew-in fastener tape rather than the iron-on type. Once the baby becomes active, she may pull iron-on fastener tape off and put it in her mouth. Also be careful that the baby does not pull the photograph or picture out and put it in her mouth.

NOTES

Try to find pictures of close-up faces, so that the baby can see eyes and smiles.

PLAY
PAD**SKILLS ENHANCED**

Tactile sensations are introduced to the infant as he lies on the "Play Pad." As his arms or legs move against a variety of textures, he learns to distinguish the different ways things feel. Motor skills are developed as he moves in response to the feelings.

AGE SPAN

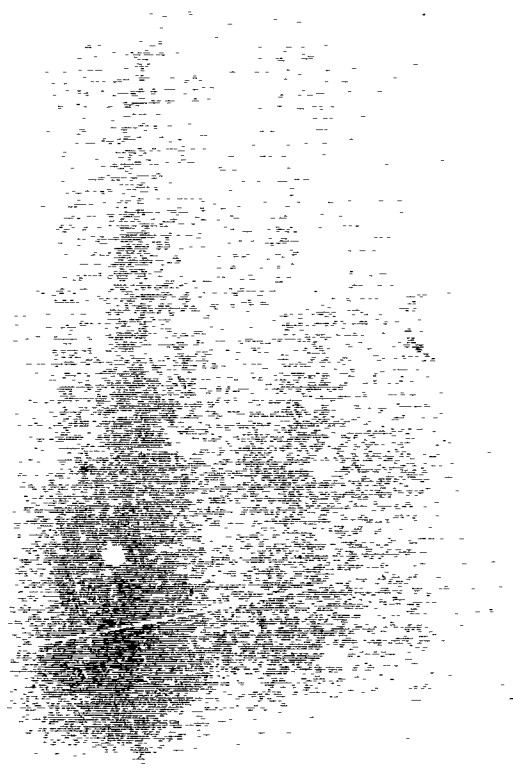
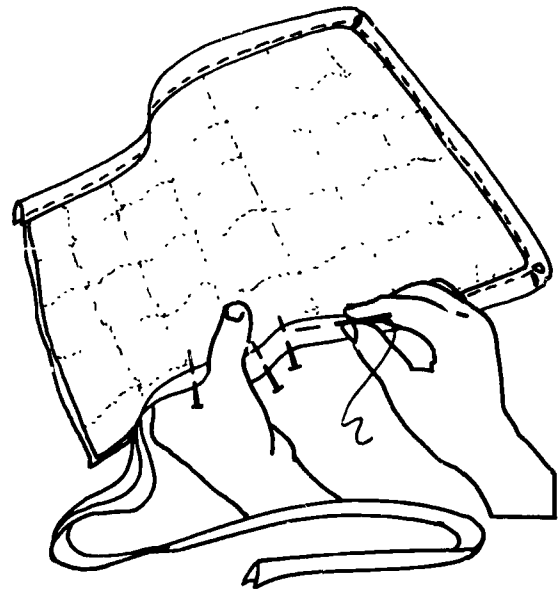
Newborn to
6 months

SUPPLIES

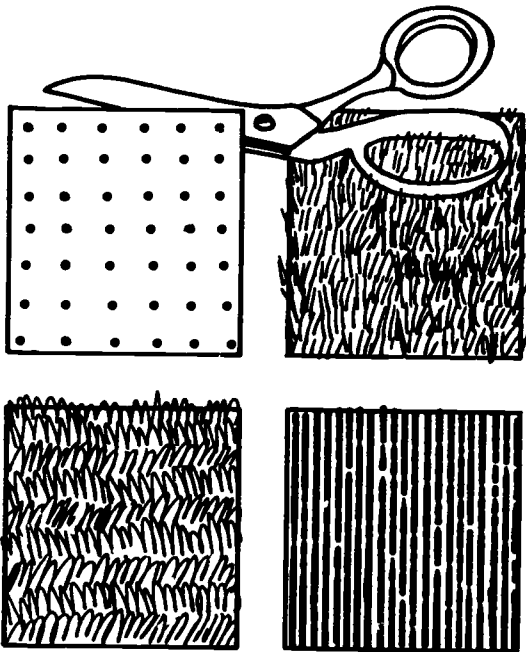
- 1 piece of quilted flannelette or a manufactured "puddle pad," about 12" x 14"
- 2-6 patches of differently textured materials of about 4" x 4" (try terry cloth, denim, fake fur, silky cloth, flannel, or dotted swiss)
- Blanket binding if needed to finish edges
- Needle and thread
- A sewing machine is helpful but not required
- An iron is helpful but not required

HOW TO MAKE

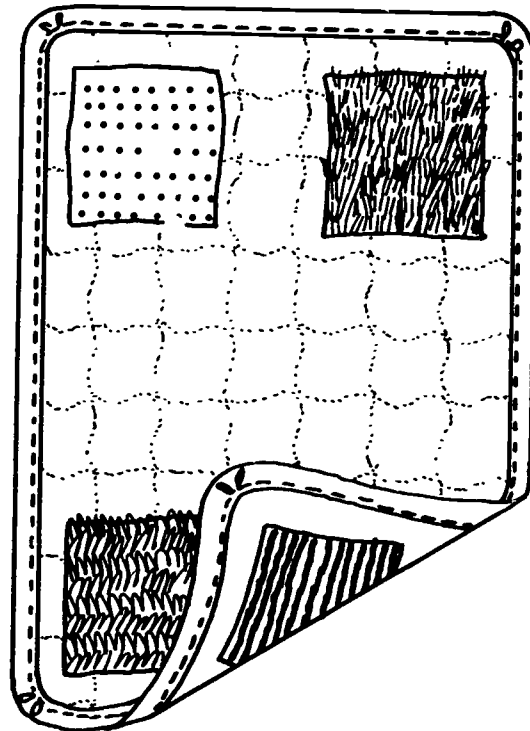
- 1 Finish edges of the pad or cloth with binding, if necessary.



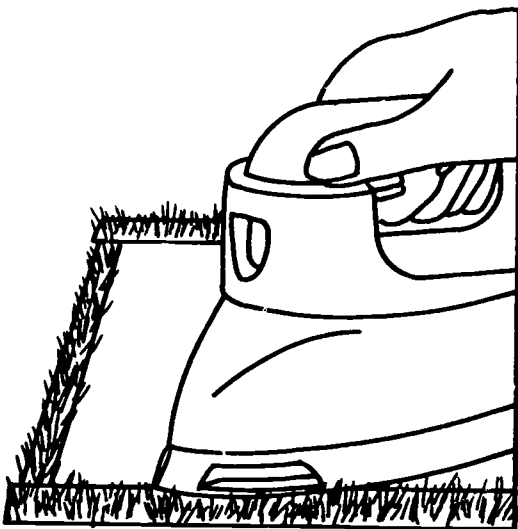
12 Cut 2-6 patches of textured materials, 4" x 4" each.



14 Sew patches along 2 opposite sides of the pad, as shown in the illustration.



13 Turn under 1/4" along all sides of patches, press with iron.



PLAY WITH ME!

“We can play with the pad on your lap, on the floor, or in my crib, even when you are changing my diaper. I like to kick when my legs are free, and to reach as far as my hands can go. When you lay me on my Play Pad, I can feel the different textures touching me. I can feel patches of smooth, rough, soft, slippery, bumpy and fuzzy. If you turn me around so that my legs touch what my arms already felt, and my arms touch what my legs already felt, I can identify something familiar which is felt in a different way. Talk to me as I move, and tell me the word for what I feel. I will learn to relate your words to what I am feeling.”

CAUTION

Do not use materials which can scratch the baby. Do not use materials which shed loose particles such as some types of fur which pull away easily from the backing material.

NOTES

You may want to make more than one Play Pad. If you do, try using just 2 patches on each pad so your baby can concentrate on the feelings more easily. You could also sew 2 patches on the front and 2 different patches on the back of your pad.

POKE-A-DOT

**SKILLS ENHANCED**

Tactile development is the focus of this toy. As the baby touches the different textures, she gathers new information about how things feel. If you name the

texture as rough, smooth, etc. you will help her add to the words she understands. As she deliberately pokes her finger in the holes and reacts to what she feels, she will exercise her motor abilities.

AGE SPAN

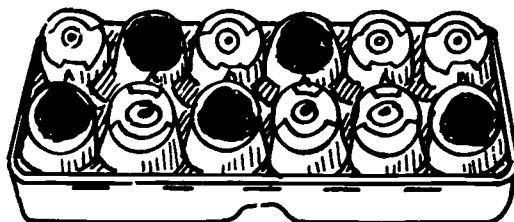
6 months to
1 year

SUPPLIES

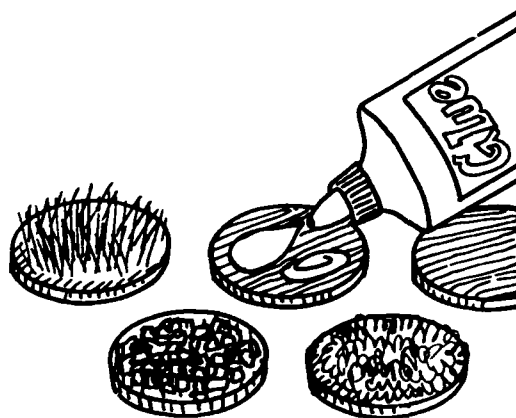
- 1 empty paper egg carton
- Pieces of heavy cardboard
- Bits of foil, smooth fabric, terry-cloth, fake fur, velvet, sandpaper, cotton, leather, Velcro, or other textured materials
- About 2 yards of brightly colored plastic tape, 1 1/2" wide
- Elmer's Glue-All
- Scissors

HOW TO MAKE

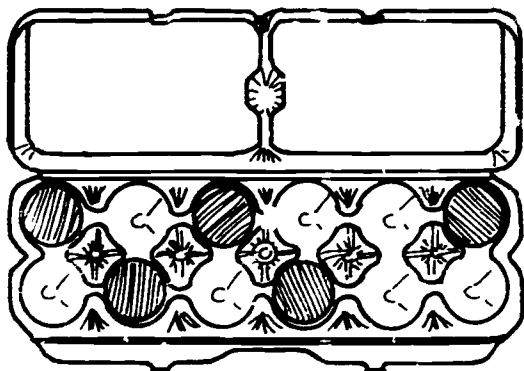
- 1 With scissors or a single edge razor blade, remove the bottoms of several of the egg-holding sections of the carton.



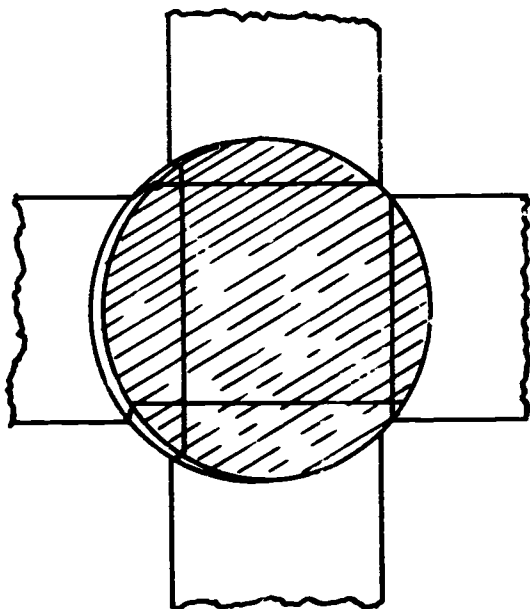
- 2 Using pattern (13 A) as a guide, cut as many cardboard circles as you need to have one for each bottom section you removed from the egg carton.
- 3 Glue a differently textured material to each of the cardboard circles, and allow to dry.



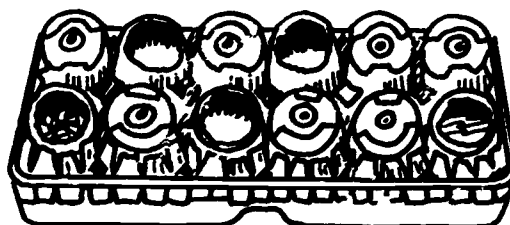
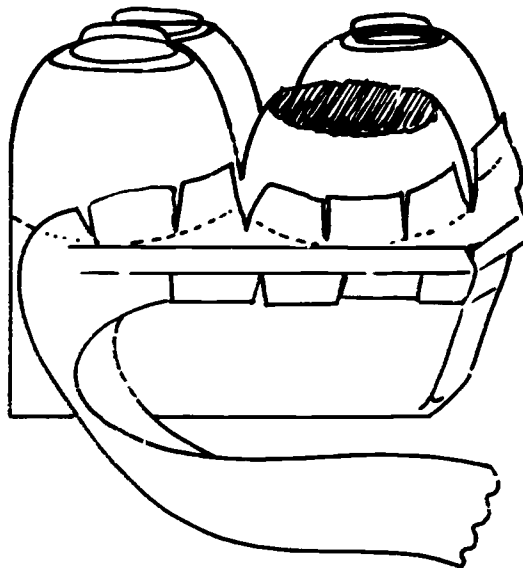
- 14 Open the egg carton, and press one of the covered cardboard circles into each of the cut egg-holding sections, so that the textured part is facing down.



- 15 Tape each circle to the carton securely, in a criss-cross for extra strength.



- 16 Close the egg carton, and seal it shut with the plastic tape around the entire circumference. You will need to clip the tape at 1/2" intervals to get a fairly smooth seal.



COME PLAY WITH ME!

“I enjoy poking my finger into each of the holes, because I never know which sensation I will feel next! If you want to play with me, you can tell me the name of each feeling, such as “rough,” “smooth,” “scratchy,” or “soft.” Then I will learn the names of the feelings myself. I might even try to poke some of my blocks into the holes.”

CAUTION

Be sure to glue the textures securely so the baby can't pull the pieces out of the holes and put them in her mouth.

14

PREMIE BEAR



SKILLS ENHANCED

Visual skills are strengthened as the baby looks at the features on the bear's face or the bow around its neck. Motor

abilities are enhanced as you move the bear, causing the baby to follow it with his eyes and head, and later, as the baby reaches to grasp the bear. Touching the bear adds to the baby's information about how things feel.

AGE SPAN

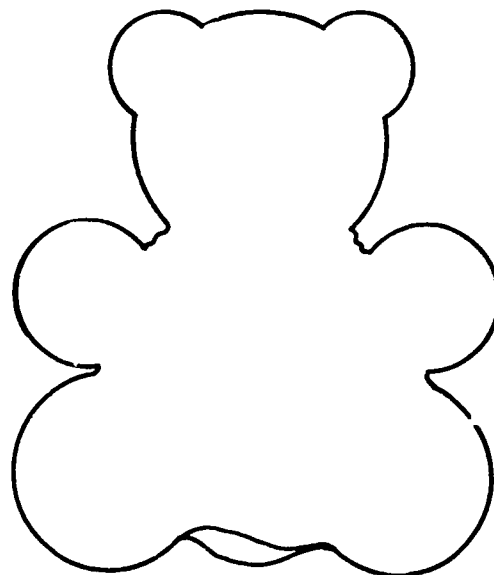
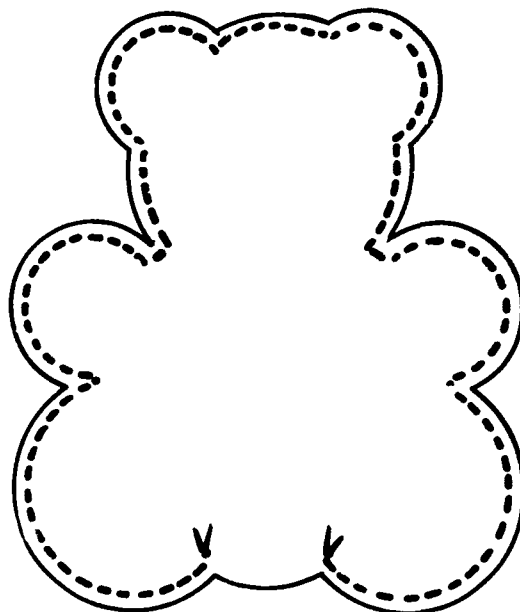
Newborn to
3 years

SUPPLIES

- 1 2 pieces of terrycloth, fleece, or fake fur fabric, 6" x 5"
- 1 12" red yarn or ribbon
- 1 Small amount of polyester fiber filling or other washable stuffing
- 1 Tiny pieces of white, black, red and contrasting fabrics for nose, eyes, and mouth (non-ravelling fabrics work best)
- 1 Needle and thread
- 1 A sewing machine is helpful but not necessary

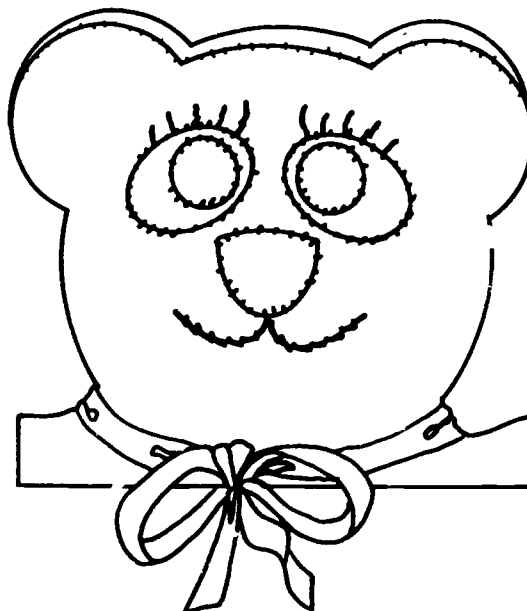
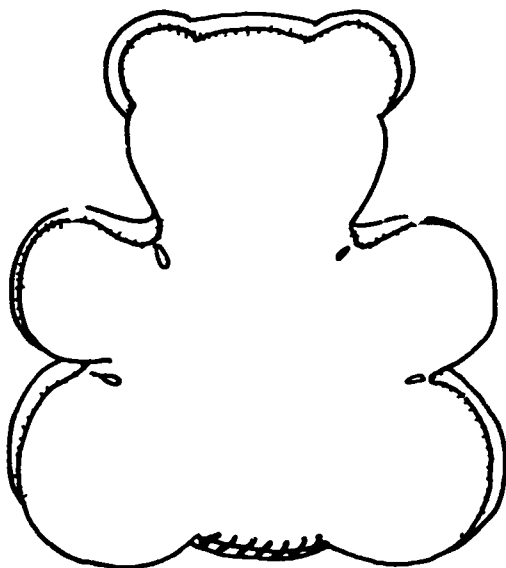
HOW TO MAKE

- 11 Cut 2 body sections using pattern (14 A) from cloth or fur.
- 12 With right sides together, sew around the outside edge in a $\frac{3}{8}$ " seam, leaving an opening of 1 $\frac{1}{2}$ " along the bottom. Clip corners, trim and clip curves. Turn right side out.

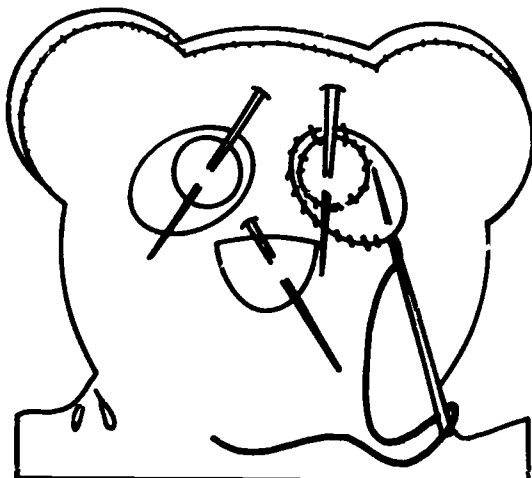
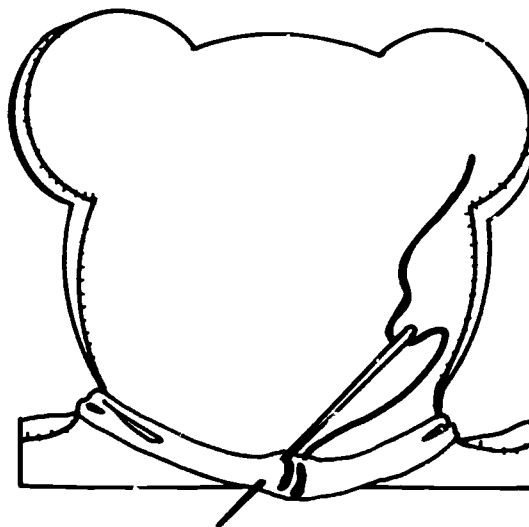


- 13 Stuff the Bear with fiber filling or other washable stuffing, beginning with the arms, ears, and legs before filling the rest of the body. As you stuff the head, push the nose area outwards with your finger and pack filling tightly.
- 14 Sew the bottom opening closed.

- 17 Tie the ribbon or yarn around the front of the Bear's neck in a pretty bow, then double tie the bow. Knot the ends of the yarn or ribbon to prevent ravelling. Sew in place at the back of the Bear's neck.



- 15 Using pattern (14 B), cut out eyes, pupils, nose, and mouth.
- 16 You must sew the features on for baby's safety. To hold the facial features in place while you sew them, you may dab a touch of glue to the backs.



COME PLAY WITH ME! CAUTION

“When you are with me, you can introduce me to my Bear by holding him about 10’ from my face. Tell me my Bear’s name. At first, I like to look at the Bear’s eyes and the bow around his neck, and can enjoy watching him if you place him at the side of my crib. When you want to play with me, you can move the bear very slowly in front of me, and I will focus on my Bear and watch him as he moves. Later, you can move him a little more quickly, and gradually move him farther away from me. You can also touch me with my Bear, very gently at first so I don’t get scared. Later, you can play ‘tickle tummy’ with me and my Bear, or even a little game of ‘hide and seek.’”

If fake fur is used, make sure that pieces can’t be pulled from the backing. Be sure to sew the facial features and bow onto the Bear so that the baby can’t remove them and stick them in his mouth. When the baby is very young, move the Bear slowly and touch the baby gently with the Bear. You can play more quickly and less gently as the baby grows.

NOTES

Baby may enjoy several bears of various fabrics. Different textures make play interesting

15
EZ

PUT AND KEEP



SKILLS ENHANCED

This simple toy can strengthen several motor skills. Kicking, knocking, holding and shaking the container are among the early skills. When the baby can sit, she will reach for and pick up blocks, too. Later, she'll remove the lid and dump the blocks; with help, she'll replace the lid. Reasoning, memory and language skills are also enhanced.

The baby will learn that the blocks disappear through the hole, but can be retrieved. That the container, with blocks, makes noise when shaken; empty, it does not. Simple explanatory terms, such as "in," "out," "off," "on," "shake," and "turn," spoken as you play, will begin to have meaning for the baby. Listening skills are stimulated by the sounds made as the blocks knock together and against the container.

AGE SPAN

6 months
to 2 years

SUPPLIES

- 1 small refrigerator bottle or 1 plastic frosting container
- 2 small wooden blocks (must be too large for baby to swallow)

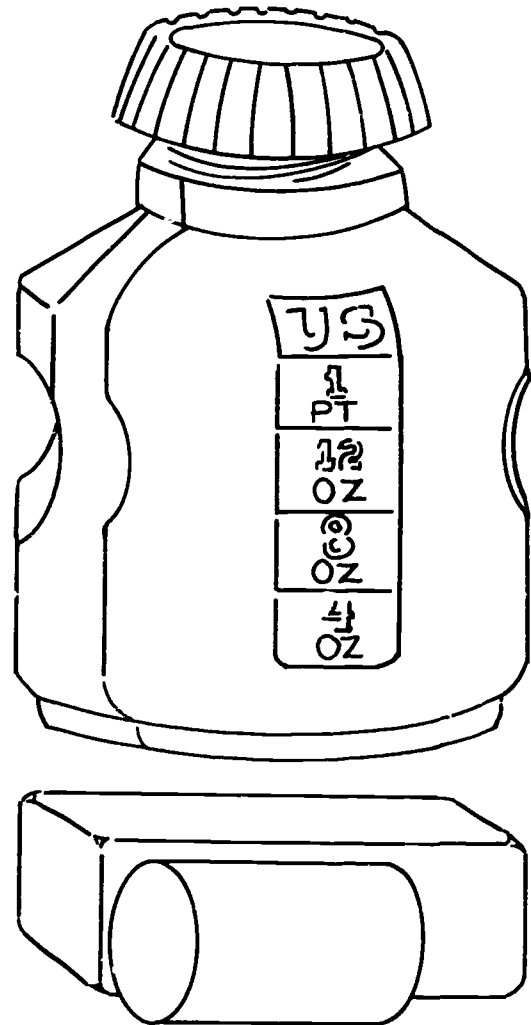
Optional:

- 1 piece of bright, textured cloth, 12" x 5 1/2"
- Waxed dental floss or heavy thread
- An iron is helpful but not necessary
- Fiber packaging tape
- Pattern (B A)

HOW TO MAKE

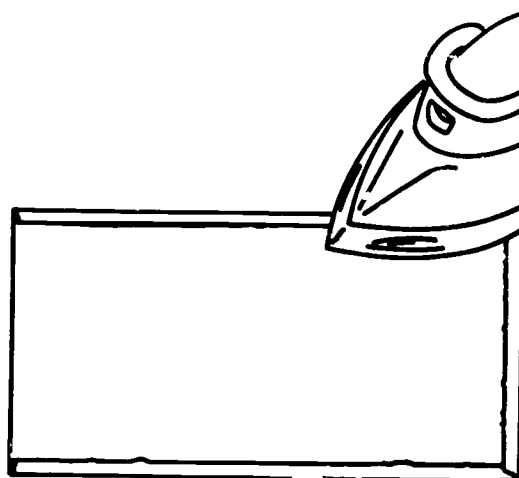
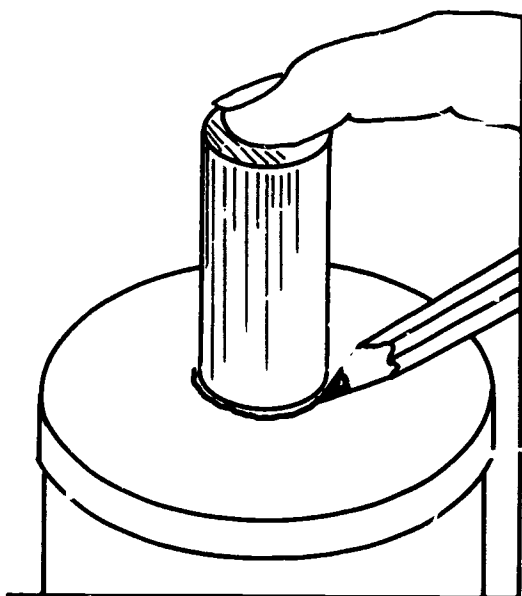
To make a very simple Put and Keep:

- 1 Place blocks into colorful refrigerator bottle and close the lid tightly.



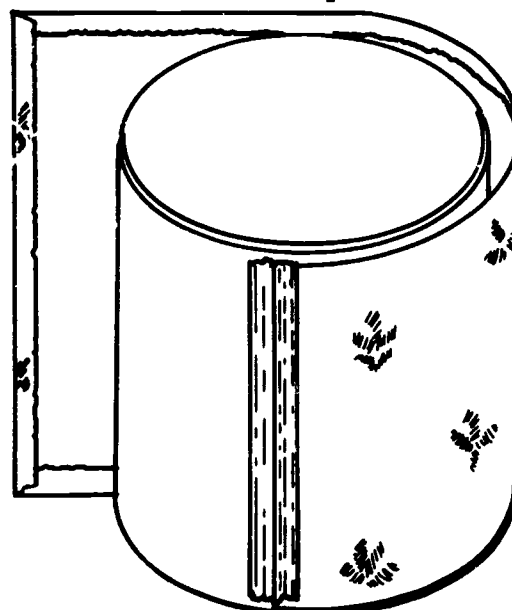
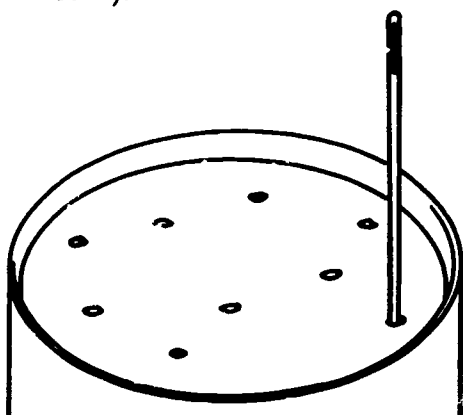
For a more advanced Put and Keep:

- 12 Place a block on top of the lid of the plastic frosting container. Draw around the block. Cut just outside of the outline, so that the hole will be a little larger than the block.



- 15 Tape the short edge, which was not turned under, to the plastic.

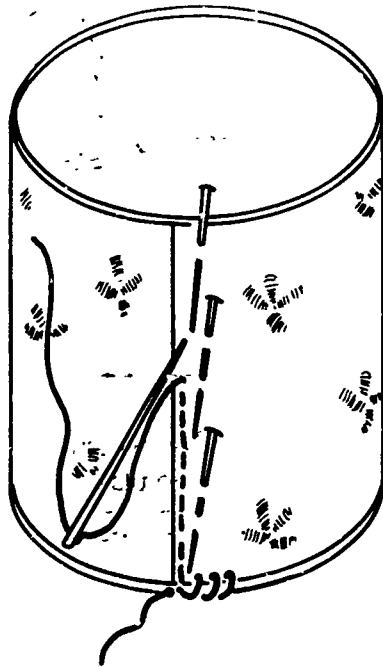
- 13 With a thick pin or needle, punch a circle of holes into the bottom of the container (to prevent baby from creating suction over nose and mouth).



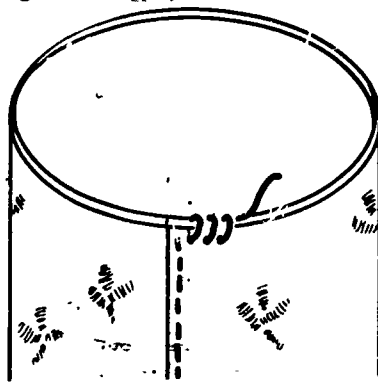
- 14 Cut a piece of cloth, using pattern (15). Fold under 1/2" on each of the long sides and on one of the short sides of the bright cloth (either by hand or with an iron.)

- 16 Wrap the fabric around the container with the raw edges against the plastic.
- 17 Wrap the short edge, which has been turned under, over the taped short edge to make an overlap; pin into place to make a side seam.
- 18 With floss or double thread, overcast through the bottom plastic edge 3 times. (If your container does not have a bottom edge, make a knot in the thread or floss and begin sewing through the container bottom.)

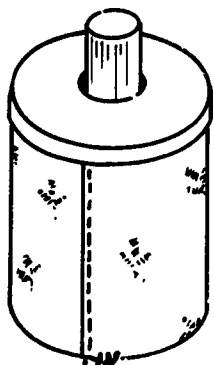
running stitch.



- 10 Overcast through the top plastic edge 3 times.



- 11 Place top on and push blocks through hole.



COME PLAY WITH ME!

“At first, I will enjoy knocking and kicking the Put and Keep so that I can listen to the sound. When I

am able to sit up and shake it with my hands.

When I am able to sit up alone, you can take the top off the bottle or container, and show me how to put the blocks in and how to dump the blocks out. With the container Put and Keep, you might want to make 2 lids with holes for the blocks; the first one could have a bigger hole so I can learn how to put the blocks in, and once I learn how to do it, you could put the second lid on with the smaller hole. This will make it a little harder for me!☺☺

CAUTION

Be sure to follow instructions for poking holes in the bottom of the container so that the baby cannot make a suction with the toys over her nose and mouth.

NOTES

Some large diaper wipe containers (such as “Wash A Bye Baby”) convert quickly and easily into “Put and Keep” form. Because of their size they are best for the older baby. Simply clean off the label, pop out the circular opening and cap, then add several round blocks.

RATTLE ROLL



SKILLS ENHANCED

The visual skills will be the first skills exercised by the "Rattle Roll". As the toy hangs beside him in the crib, the baby will focus on the bright colors; he will follow with his eyes when the toy is moved. Before long, the baby will use his motor skills as he tries to reach the colors. He'll discover that he can

make the toy move and rattle. When he kicks the toy the sound may be different from the sound that comes when he knocks the "Roll" with his hands. He'll begin to use his listening skills to discriminate sound differences. The baby will continue to develop both motor and listening skills as he crawls after the "Rattle Roll," or drags it behind him as he walks.

AGE SPAN

Newborn to
2 years

SUPPLIES

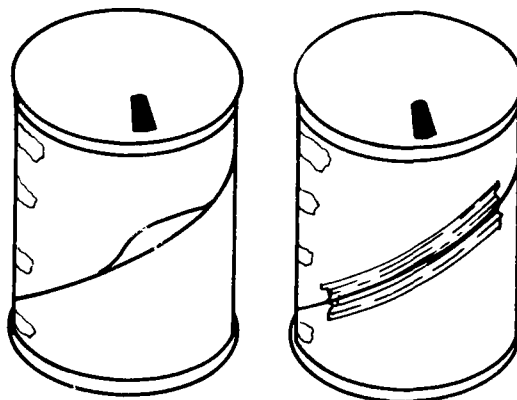
- Empty salt box
- 2 yards of colored yarn
- 1 small used rattle
- Fiber packaging tape
- Colorful fabric, 10" x 12" (or colorful contact paper, about 5 1/2" x 21")
- 1 large-eyed needle
- Pattern (16 A)

For cloth-covered Rattle Roll, you will also need:

- 1 regular sewing needle
- Waxed dental floss or heavy thread

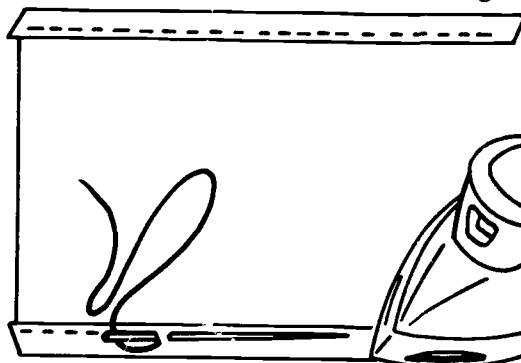
HOW TO MAKE

- 1 Remove metal spout and outer wrapping of salt box. Knock out any remaining grains of salt.
- 2 Gently separate at middle seam, making a slit just large enough to slip in one small, used rattle.
- 3 Tape the seam opening shut with fiber tape.

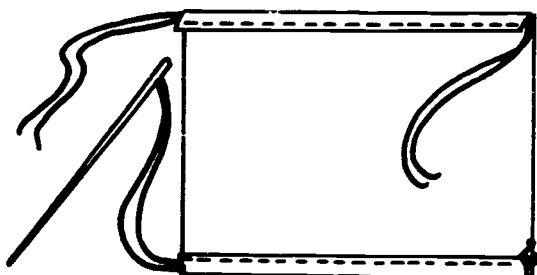


For Cloth-Covered Rattle Roll:

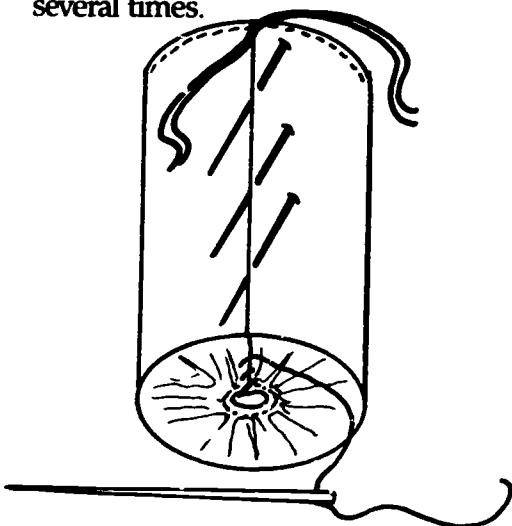
- 4 Turn under 5/8" along top and bottom of the 12" edge. Hand or machine sew about 1/2" from edge.



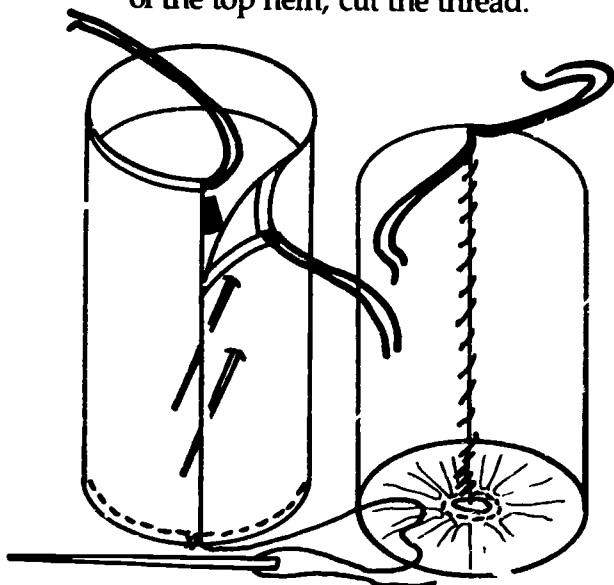
- 5 Thread the yarn through the large-eyed needle; pull yarn double. Pass needle through top hem until equal amounts of thread project from each side of the fabric. Cut yarn at base of needle. Remove needle, leaving yarn through fabric hem.
- 6 Thread small needle with floss or thread. Overcast 3 times at edge of bottom hem. Run thread through hem.



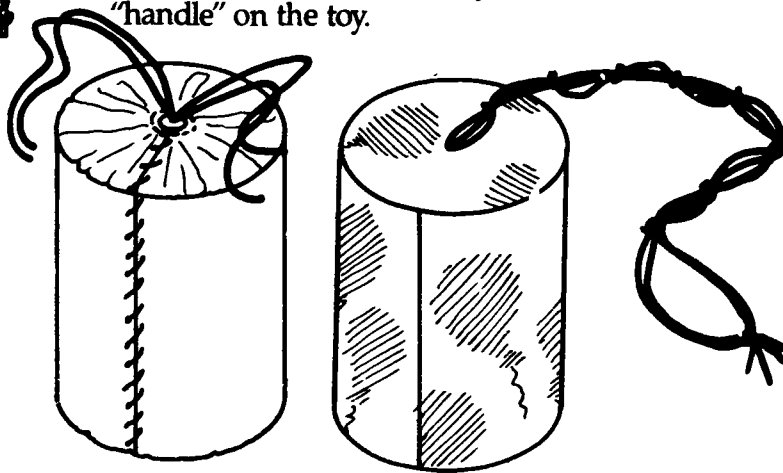
- 17 Keeping needle and thread attached, wrap fabric around salt box. Turn under 1/2" hem, overlap fabric, and pin.
- 18 Pull bottom thread tight. Overcast several times.



- 19 Slipstitch up the side seam.
- 20 Overcast several times at the base of the top hem; cut the thread.

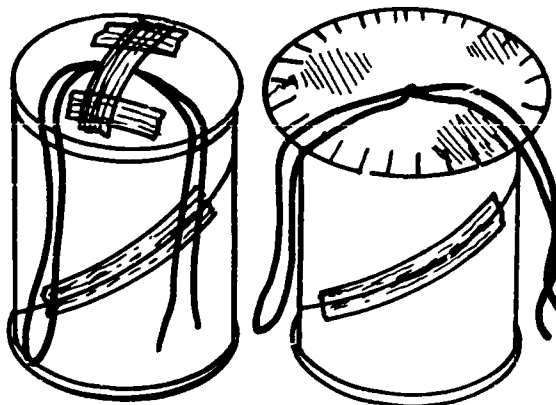


- 21 Pull the yarn tight. Knot securely.
- 22 Make 5 or 6 more knots, 1 every inch. Leave about 5 1/2" unknotted to use as a "Loop and Hang" (see the "Loop and Hang" section #9 in this book) or to give the baby a "handle" on the toy.

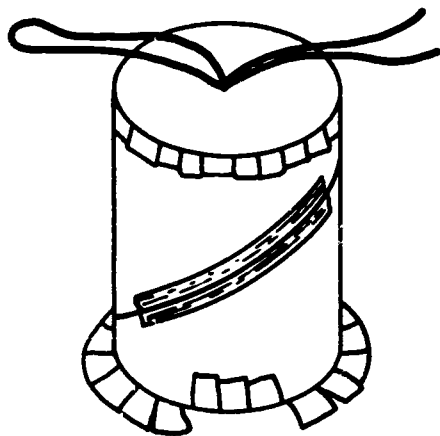


For Contact Paper-Covered Rattle Roll:

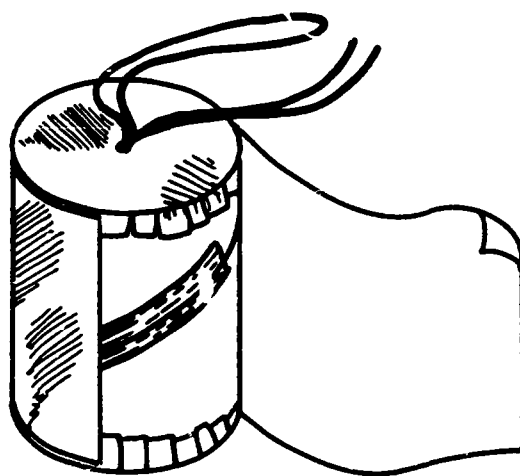
- 23 Cut 1 piece of contact paper 5 3/8" x 11 1/2".
- 24 Cut 2 circles of contact paper from pattern (16 A) (or cut a circle which is 4 3/8" in diameter).
- 25 Fold yarn in half. Attach center of doubled yarn to the center of the top of the salt box with fiber tape. Tie yarn in a knot close to container.
- 26 Cut a 1/2" slit in the center of 1 of the contact paper circles. With backing still attached to contact paper, push all 4 thicknesses of yarn through the slit.



- 17 Roll backing away for about $\frac{1}{3}$ of the circle. Stick exposed contact paper to container top. Then roll off the rest of the backing, tearing it off if necessary, and attach to top surface of salt box.
- 18 Make cuts all around the edge of the circle, about $\frac{3}{4}$ " apart. Smooth down around sides of container.
- 19 Remove backing from remaining circle. Place it face down on your work surface, with sticky side of circle up. Place the container bottom in the center of the contact paper circle.



- 20 Clip an 1 stick circle edges to container sides as above.
- 21 Remove about 2" of backing from the long side of the contact rectangle.
- 22 Smooth down onto side of container, being very careful to begin straight so that the edges don't hang over the top or bottom, and so you don't end up with an uncovered gap at the end. Continue to remove backing from underside and smooth onto container. Overlap at end.
- 23 Make 9 more knots in yarn which extends from top. Leave a 5 $\frac{1}{2}$ " loop at the end to use as a "Loop and Hang".



COME PLAY WITH ME!

“You can hang this Rattle Roll from the side of my crib. If you make it for me, I can look at the bright colors and hear it rattle. I can try to hit it with my own hands, or kick it with my feet to see if I can make the same sounds. Once I am able to sit up, I can roll it around by myself and hear it rattle. You can hang it from the side of my highchair as I can knock it off the tray, then pull it back to me. And when I can crawl or walk, I can pull it behind me by the handle.”

CAUTION

The roll covered with contact paper may lose adherence. Watch to see that it doesn't come loose or that baby isn't chewing on it.

SITTING PRETTY DOLL



SKILLS ENHANCED

Visual abilities are enhanced as the baby focuses on the doll's face or watches as you move it. Motor abilities are used as you play "Hide and Seek"

and as the baby reaches for the doll. The doll and she can "do" many things together. Your conversations as you play with the doll can help to build her language and her enjoyment of being with people.

AGE SPAN

6 months
to 3 years

SUPPLIES

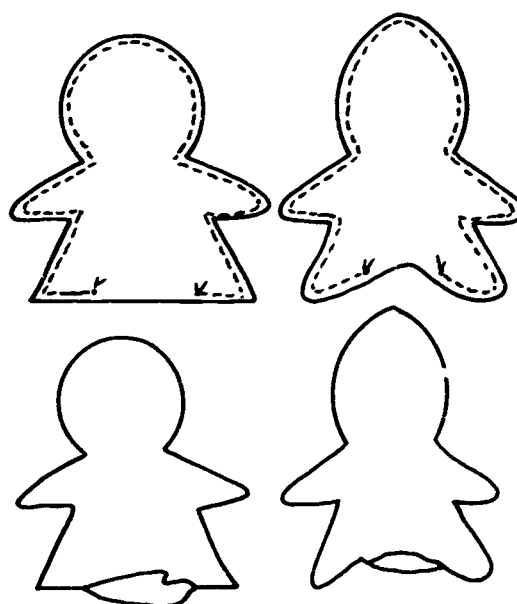
- 1 2 pieces of soft, stretchy material, 7" x 7"
- 1 1 piece of interfacing, 2 1/2" x 3"
- 1 1 piece of flesh colored material, 2 1/2" x 2 1/2"
- 1 1 yard of yar., black or yellow or red (match your baby's hair)
- 1 Thin ribbon, 12" x about 1/4"
- 1 Small amount of fiber filling or other stuffing
- 1 Needle and thread
- 1 Tiny piece of black fabric or black thread (for eyes)
- 1 A sewing machine is helpful but not required
- 1 Pattern (17 A) or (17 B)
- 1 Pattern (17 C)
- 1 Pattern (17 D) or (17 E)

Optional:

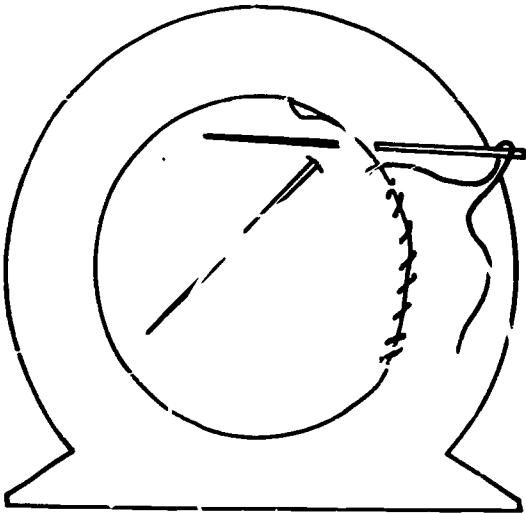
- 1 Elmer's Glue-All

HOW TO MAKE

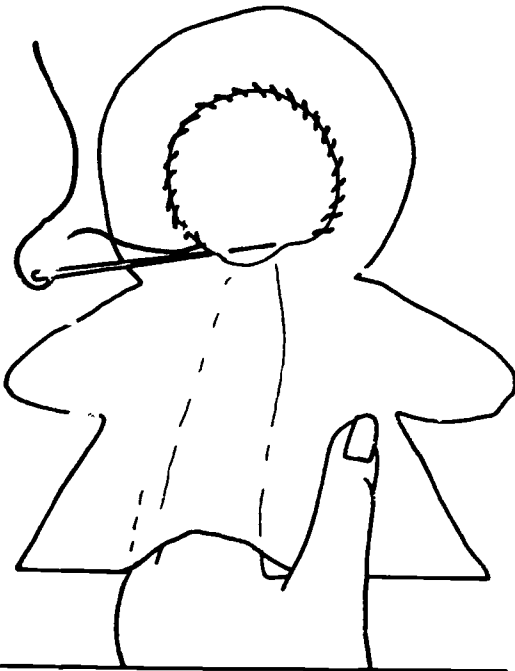
- 1 Using pattern (17 A) or (17 B), cut 2 shapes for the doll from the soft, stretchy material.
- 2 Put the 2 sections right sides together and sew around the edge, about 1/4" from the edge, beginning and ending at the bottom. Leave 1 1/2" open at the bottom edge. Clip corners and curves. Turn right side out.



- 3 Cut face section from flesh colored fabric, using pattern (17 C).
- 4 Cut hat insert from interfacing, using pattern (17 D).
- 5 Slip the hat insert up through the opening into the head section.
- 6 Put the face section in place on the doll, following pattern (17 A). Pin through all layers.
- 7 With needle and thread, slipstitch around the outer edge of the face, turning the edge under as you sew. You should begin sewing at the right side bottom tip of the bonnet, and sew through all layers as you go.

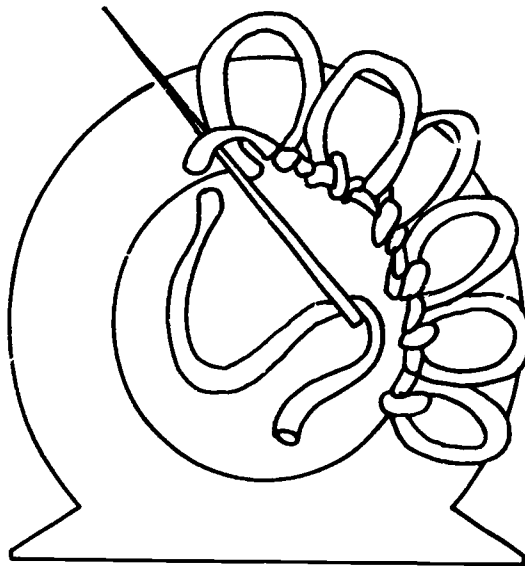


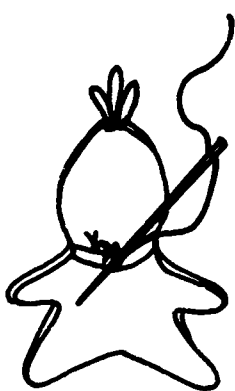
- 18 When you reach the left side bottom tip of the hat, remove the pin, and place a finger up through the bottom of the doll. Continue sewing around the face, but only through the face layer and the first layer of the doll's body fabric.



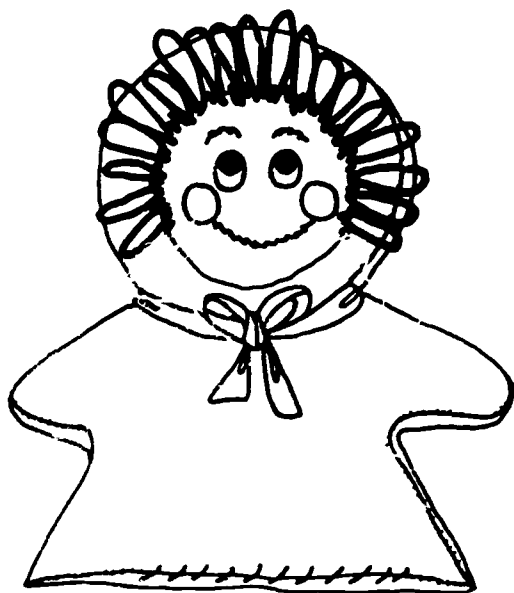
- 19 Stuff the doll, beginning with the face. When it is full and round, stuff the arms, and then stuff the rest of the body. Sew the bottom opening closed.

- 10 Thread the large-eyed needle with yarn. (For thick hair, pull the yarn through the needle and double, bringing the two ends together.) Knot the end(s) of the yarn.
- 11 Make hairline by putting the needle through the fabric at the edge of the face, making a small loop of yarn on the end of the needle, then putting the needle back through fabric.
- 12 Holding the loop with your finger, or slipping a pencil or straw through the loop to hold it, make another loop beside the first one. Bring the needle through this loop, and pull until the loop hugs the fabric tightly. This will make a knot next to your longer loop to keep the hair from coming loose.
- 13 Continue to do steps 11 and 12 all around the face.





- 14 Cut out eyes, and stick in place with a touch of glue, but then you must sew them on for baby's safety.
- 15 Embroider a nose and mouth with thread, or draw them on with a permanent marker.
- 16 Tie the ribbon around the doll's neck, make a pretty bow, and sew it in place in the back of the neck for baby's safety.



COME PLAY WITH ME!

“I will like it when you make my Sitting Pretty Doll look like me. My Doll can sit in the crib with me, and you can talk to me about my Doll and about me. When you are not with me, she will keep me company. I can touch her, look at her smiling face and talk to my Doll myself. She is soft and cuddly, and I can take her with me when you take me for a drive or a walk.”

CAUTION

Be sure to sew the eyes and ribbon and hair onto the doll carefully, so that they will not come off and go into baby's mouth.

18
EZ

SOFT 'N' READY
RED
BALL
and
FISH 'N' FUN
BATH TOY



SKILLS ENHANCED

The strengthening of visual and tactile skills are probably primary in the use of these bright toys. The outlines of the toys attract the baby's gaze and hold

his attention as they move. Touching them to different parts of his body helps him learn differences in the way things feel. Baby's motor skills are exercised as he reaches to touch, and later, to grasp and squeeze.

AGE SPAN

3 months
to 3 years

SUPPLIES

For Soft 'n' Ready Ball:

- ! 1 piece soft, bright cloth (terry cloth is a good choice)
- ! Fiber filling or other stuffing, small amount
- ! Needle and thread
- ! 1 yard bright yarn
- ! Pattern (18 A)

For Fish 'n' Fun Bath Toy

- ! 2 pieces vinyl, 4 1/2" x 5 1/2"
- ! 1 square of foam, 2" x 2" x 1/2" thick (or sponge, same size)
- ! Needle and thread
- ! Patterns (18 B) and (18 C)

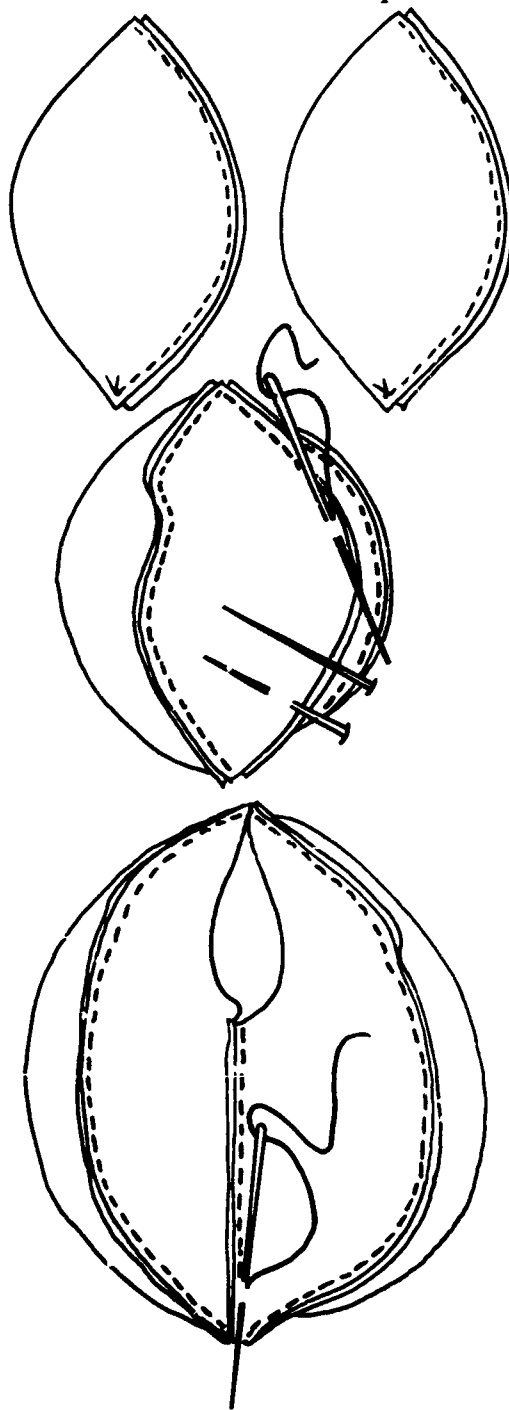
For both toys:

- ! A sewing machine is helpful but not necessary

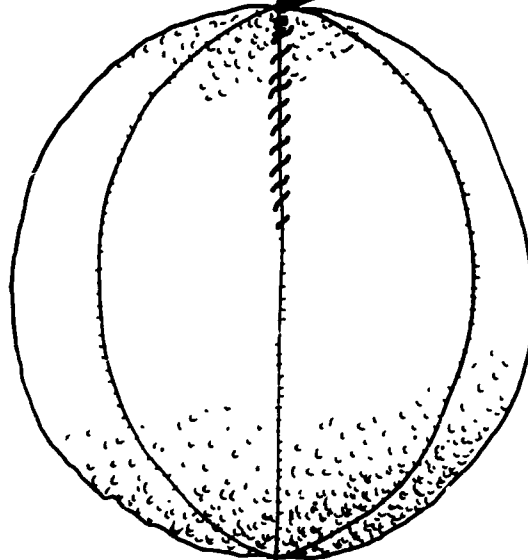
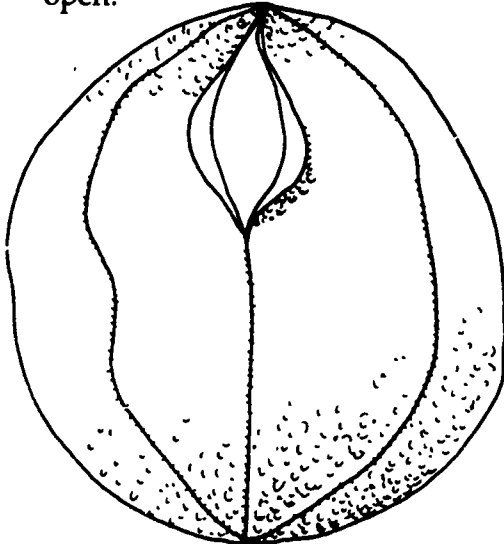
HOW TO MAKE

For Soft 'n' Ready Ball:

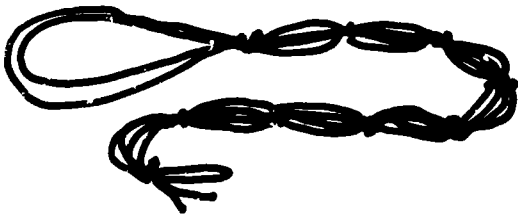
- !1 Using pattern (18 A), cut 4 pieces from soft fabric.
- !2 With right sides together, machine or hand sew sections together 3/8" from edge. Leave 1" open on final seam. Trim seams and clip curves.



- 13 Turn the ball right side out, and stuff the ball with a safe, washable batting or filling. Leave the seam open.



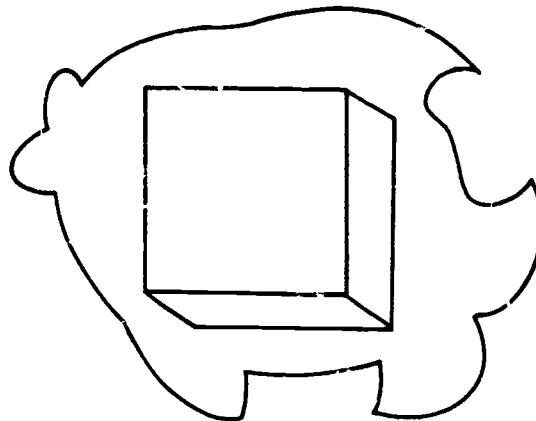
- 14 Fold yarn in half, then in half again. Make a knot 1 1/4" from the "double loop" end. Make 4 more knots, one every 1/2".

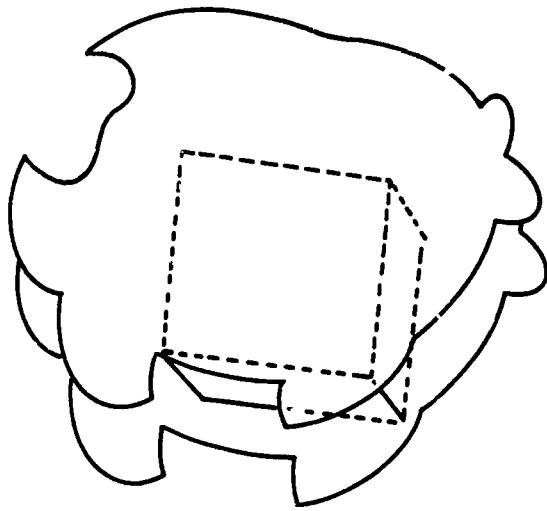


For Fish 'n' Fun Bath Toy:

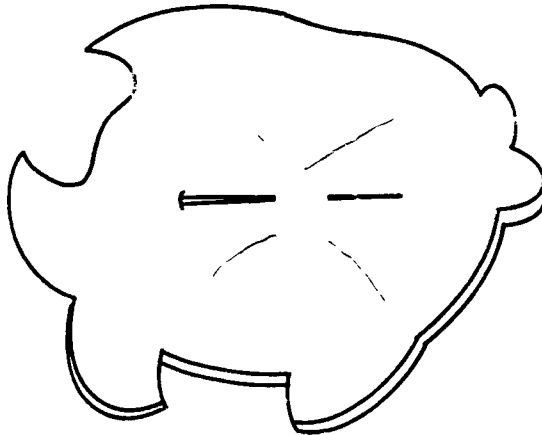
- 17 Using pattern (18 B), cut 2 fishes from vinyl, so that edges match when both right sides of the vinyl are on the outside.
- 18 Put the foam between matched vinyl cut-outs. You may have to place the foam on an angle or slant to make the fishes fit together.

- 15 Tuck the end of the small loop into the opening of the ball, so that the fifth knot is inside the ball and the other 4 knots are outside the ball.
- 16 Sew the seam shut. Sew through the inside knot several times to secure it.



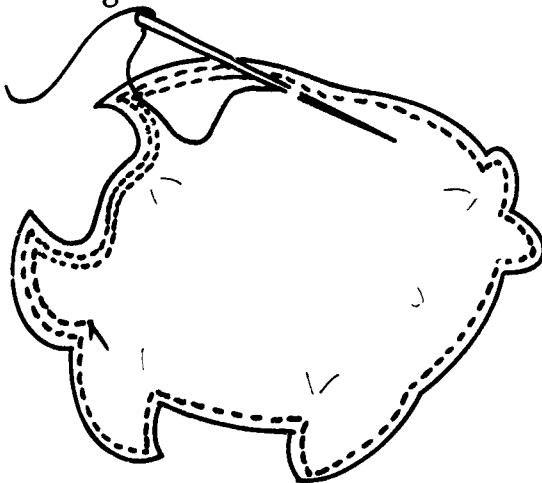


19 Pin through all layers to hold.



110 Sew around outline, about 1/4" from edge.

111 Sew once more, about 3/8" from edge.



COME PLAY WITH ME!

“Hang my Soft ‘n’ Ready Ball by my crib, so it will be ready for playtime together. You will see how wide my eyes get when you move my Ball in front of me! I may even like it if you gently stroke my cheek with my Ball. Or try touching my tummy, toes, or the palms of my hands with the ball and see my response. Later, I will try to hold my Ball myself. It is small and soft, and I can try to squeeze it. To play with my Fish ‘n’ Fun Bath Toy, move the fish slowly through the water and I will watch it. I will listen to you as you talk to me, and to the soft splashing sounds of the water as we play. I may try to grab for the fish myself—at first, I might use my whole body to reach, so be sure you support me in the water. Later I will be able to reach for the fish with one hand as it floats by, and I will squeeze it.”

SUNFLOWER MIRROR



SKILLS ENHANCED

The baby will enjoy watching his reflection and yours. Enhancement of visual skills occurs during the early months. Then motor coordination will be exercised increasingly as baby sees

his movements reflected in the mirror. Gradually, the baby's understanding of what he sees in the mirror grows. At first, he'll just understand that he can look into a mirror and make the "picture" move or come and go, but later, he'll recognize the connection between the "picture" and himself.

AGE SPAN

Newborn to
24 months

SUPPLIES

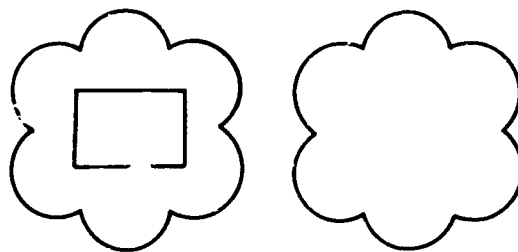
- 1 2 pieces of vinyl or non-raveling fabric, 7" x 7 1/2"
- 1 2 pieces of batting or foam, 7" x 7 1/2"
- 1 1 camping mirror (must be UNBREAKABLE), 2 3/4" x 4"
- 1 1/2 yard fiber packaging tape
- 1 Needle and thread
- 1 Sewing machine helpful, but not necessary
- 1 Patterns (19 A) and (19 B)

Optional:

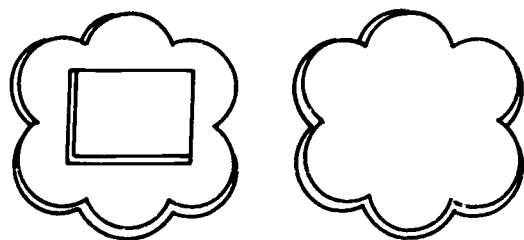
- 1 Sew-on nylon fastener tape (such as Velcro), if using with "Crib Hugger" 3/4" x 2"

HOW TO MAKE

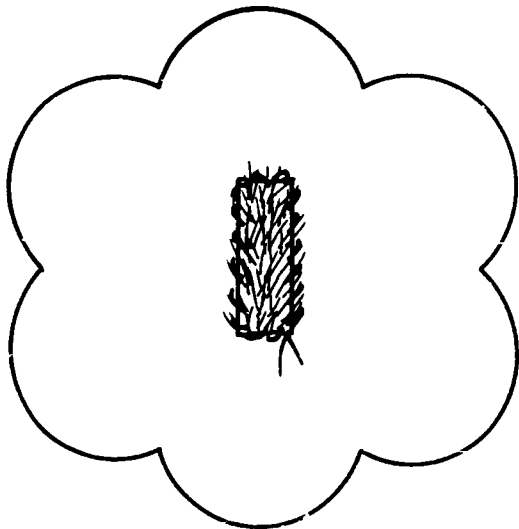
- 1 Using pattern (19 A), cut front and back sections of mirror covering from cloth. Notice that 1 piece should be cut as a whole sunflower (back), and 1 piece should be cut with a rectangle removed from the middle of the flower (front).



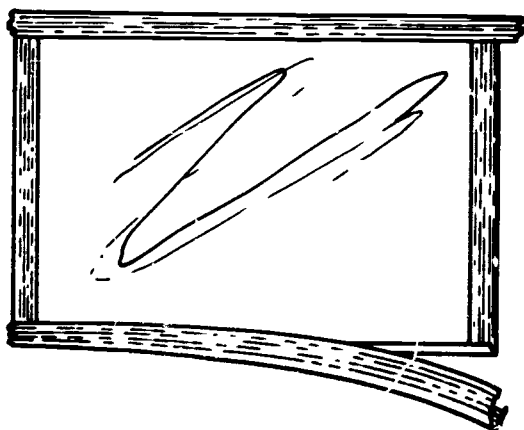
- 2 Using pattern (19 B), cut front and back sections from the foam or batting. Notice that 1 piece should be cut as a whole sunflower (back), and 1 piece should be cut with a rectangle removed from the middle of the flower (front).



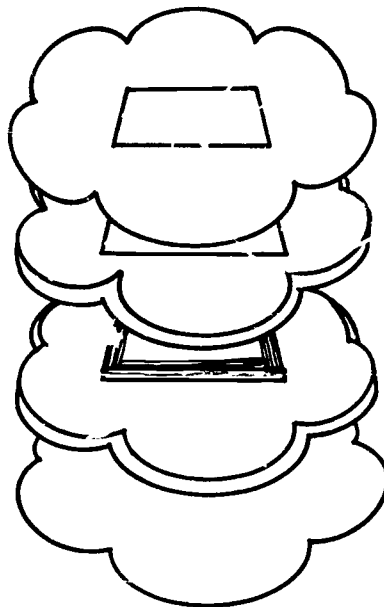
- 13 If you plan to use the mirror on a "Crib Hugger" (see "Crib Hugger" section in this book), sew the fastener tape strip in the center of the cloth back of the sunflower. Be sure to use the fuzzy texture of the tape, facing up, so that it will be opposite to the loopy texture you used on your "Crib Hugger."



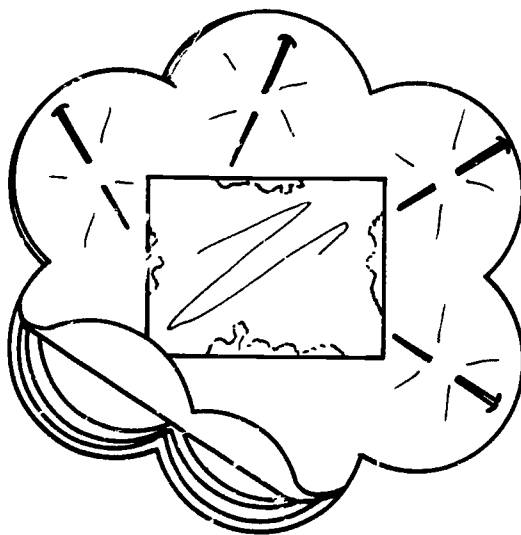
- 14 Cover all edges of the mirror with the fiber tape for safety.



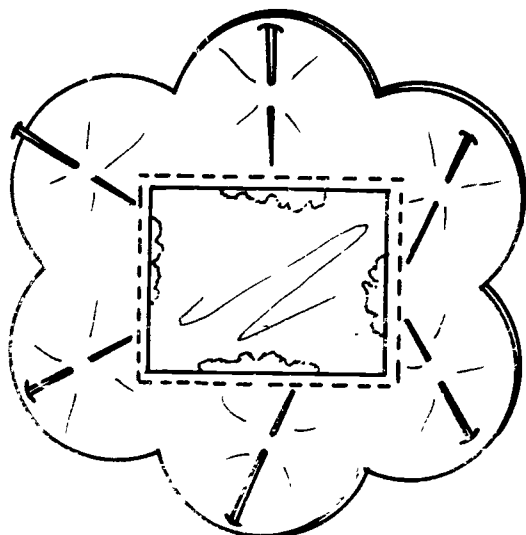
- 15 Place the mirror, backside down, in the center of the batting section which does not have the rectangle removed. Place the other batting section over the front of the mirror.



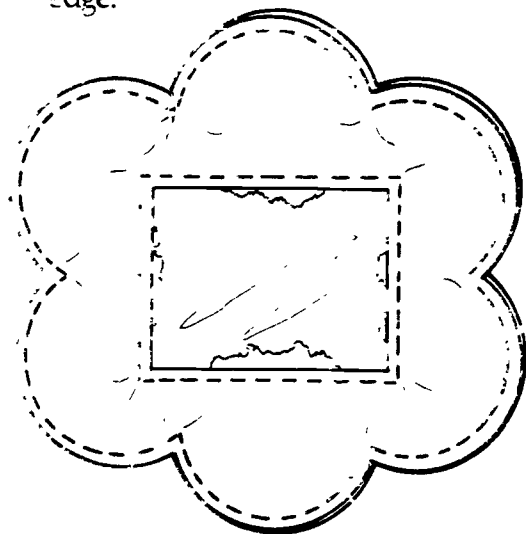
- 16 Place the front and back cloth sections outside the batting sections. Pin along each side of the mirror, through all layers.



- 17 Machine sew or hand sew with a small running stitch all around the outside edge of the mirror.



- 18 Now sew around the outside of the sunflower, about 1/4" from the edge.



- 19 Trim away any batting that protrudes around the mirror opening and push the rest back around the mirror edge, so that the baby can't pull the batting out and put it in her mouth

COME PLAY WITH ME!

“Hang my Sunflower Mirror on my Crib Hugger, or put it at the side of my crib. At first, it will just be something bright that I can focus on. Later, I will notice that I see something moving in the mirror.”

CAUTION

You must use an unbreakable mirror. You must use sew-on fastener tape, as the stick-on type could be peeled off by the baby and put into her mouth. For the same reason, be sure to remove any batting that protrudes around the mirror opening.

20

TAP AND TOUCH CRIB TOYS



SKILLS ENHANCED

Motor, visual touch and listening skills are all enhanced. As these bright toys hang just within the baby's reach, motor activities will be stimulated. The

baby, by chance or intent, will touch the various textures and watch the motion of the toys. As the blocks tap against one another or the crib rail, he will listen and learn that there are differences in the sounds.

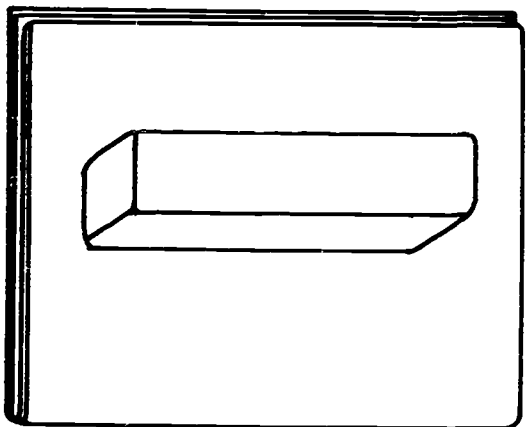
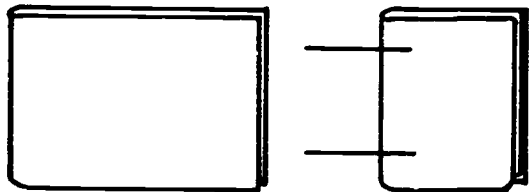
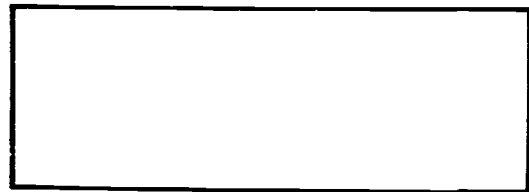
AGE SPAN

Newborn to
6 months



HOW TO MAKE

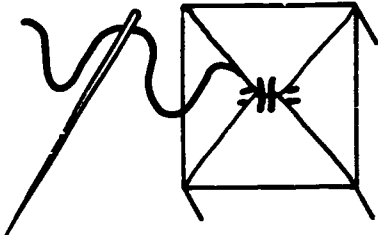
- 1 Fold the nylon net into four thicknesses so that the total measurement is $5\frac{1}{2}'' \times 4''$, the same size as the vinyl and terrycloth.
- 2 For each type of fabric, prepare a block as follows:
- 3 Wrap the fabric around the block, overlapping ends and having $\frac{3}{4}''$ of cloth extending at the bottom and $1\frac{1}{4}''$ extending at the top.



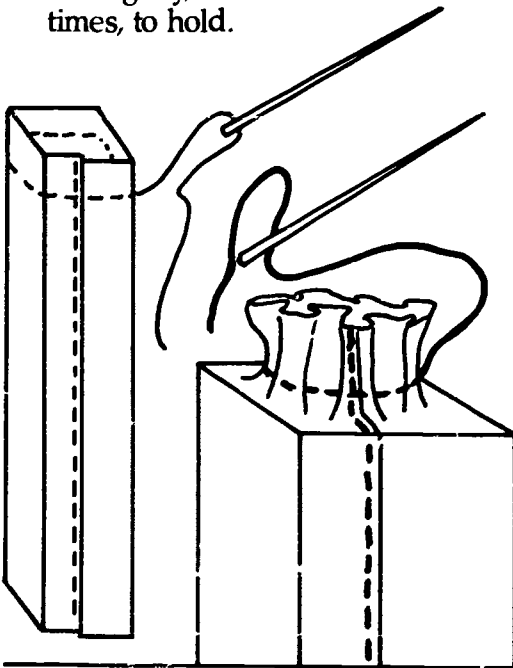
- 4 With needle and thread, sew along side seam with a running stitch.



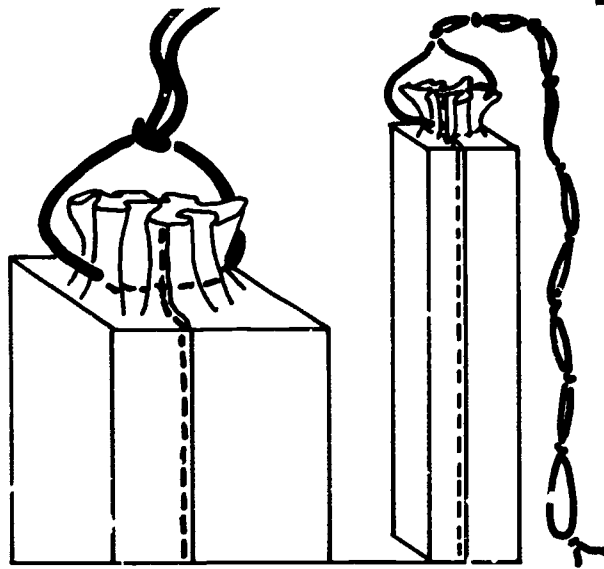
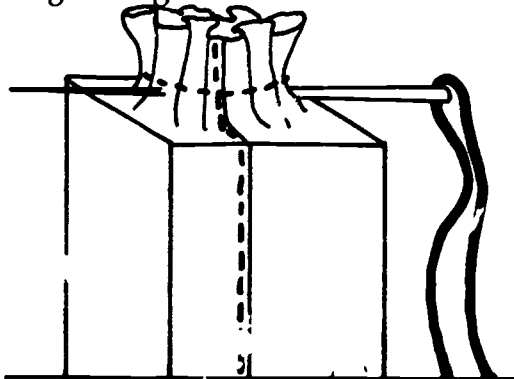
- 15 Fold in the fabric at the bottom as though you are wrapping the side of a package. Overcast the points.



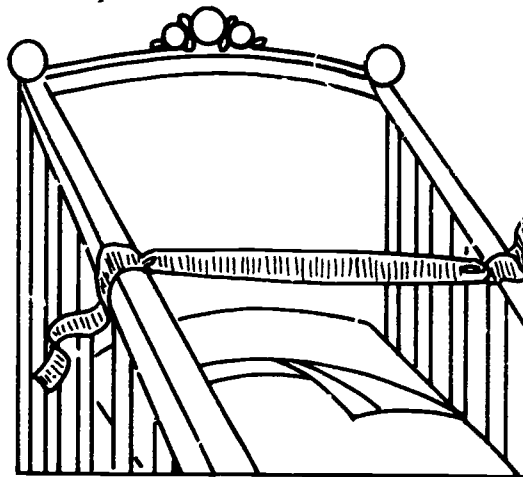
- 16 Sew a gathering stitch around the fabric 1/2" above the block.
17 Pull tightly, then overcast several times, to hold.

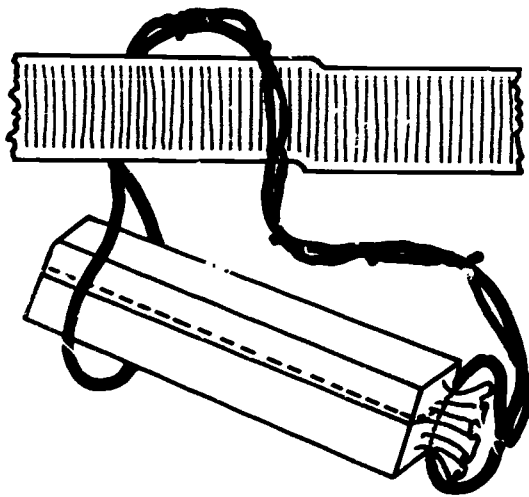


- 18 Thread the large-eyed needle with 1 yard of yarn. Push the needle through the fabric just below the gathering thread.

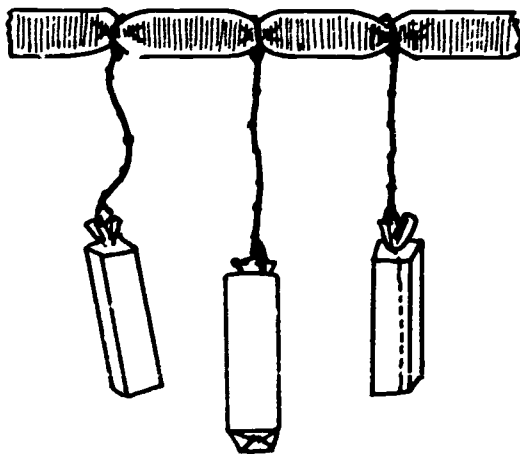


- 19 Pull the yarn through until there is an equal length of yarn on each side; remove needle.
20 Tie a knot at the middle with the two yarn ends.
21 Holding the two ends together, tie a knot every 1/2" along the yarn until you have a knotted rope about 8" in length. Tie one more knot at the very end of the yarn. You will have a loop at this end for hanging the toy above the crib.
22 Tie the ribbon tightly across the top of the crib.





- 13 Use the loop on each block to dangle the blocks from the ribbon by placing the loop across the top of the ribbon, then slipping the block through the loop. Pull tightly.



COME PLAY WITH ME!

“When you use a variety of textures and colors on my Tap and Touch Toys, I will have a good time watching the bright colors and the way the blocks move. You may even make them spin gently for me. After a time, I might accidentally touch them with my hand or foot, and discover that I can make them move, myself. I will try to touch them so that I can feel the smooth or rough ones, and so that I can hear them tap together to make nice sounds.”

CAUTION

As with any toy strung across the crib, once the baby begins to grasp and pull up, the toy should be taken down.

NOTES

It is easy to adapt these instructions to fit other sized blocks that you may have on hand. Hang several brightly covered blocks from the same ribbon, and slide some of them close together so they will knock together to produce sounds when you or the baby move them.

TOUCHING HAND BAND and TOUCH PLAY MITT



SKILLS ENHANCED

Your baby gathers information about the way things feel as you use the band or mitt in play. A wide variety of textures can be used; start with the smooth textures and introduce new textures gradually. The baby will learn that things feel different when touched to different parts of the body. You may

discover that she likes one type of touch more than another. Try gentle, soft strokes, and firm, gentle contact without movement and patting. Social/emotional skills will be enriched as you touch and talk to the baby. The band and mitt must be worn by someone else at first, which puts emphasis on interaction, but as she grows, the baby will enjoy wearing the band or mitt on her own arm.

AGE SPAN

Newborn to
6 months

SUPPLIES

For Hand Band:

- 4 pieces of fabric, 2 1/2" x 4", each a different texture and color

For the Body:

- 4 pieces of fabric, 7" x 7", each a different texture and color

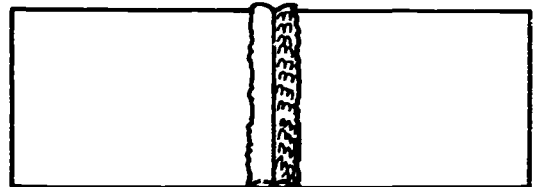
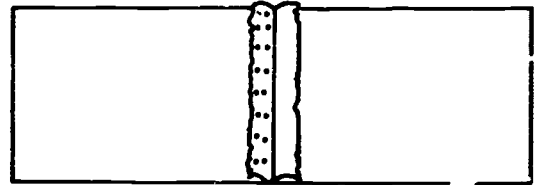
- 1 piece of fabric, 12" x 12", each a different texture and color

- 1 piece of fabric, 12" x 12", each a different texture and color

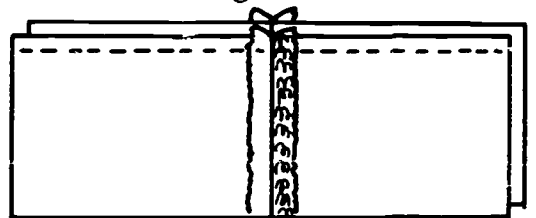
HOW TO MAKE

For Hand Band:

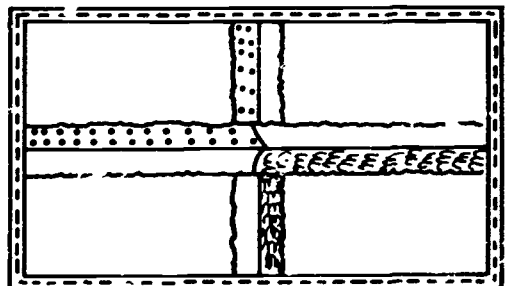
- 1 Sew two pieces of fabric together along one short side, right sides of the material facing each other.



- 2 Repeat for the other two pieces of fabric.
- 3 Press open the seams. Now pin the two joined pieces together, right sides of the material facing each other, and sew a 1/4" seam down one of the long sides.



- 4 Press open the seam, and press under 1/4" all around the outside edges of the 4 joined pieces of cloth. Stitch along the turned up edges.

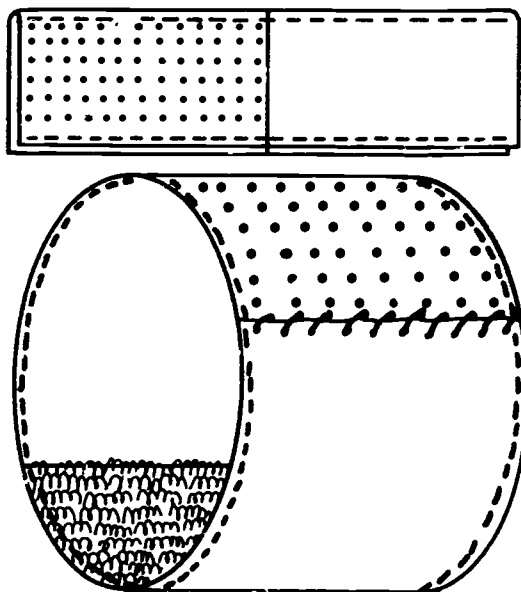


NOTES

Some suggested fabrics:

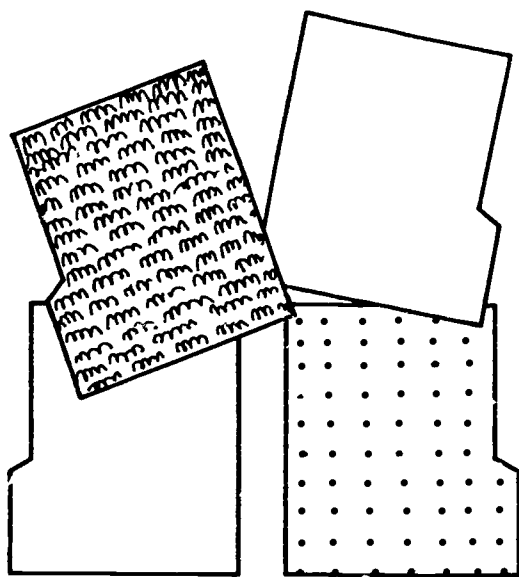
- Terry cloth
- Corduroy
- Dotted swiss
- Velveteen
- Flannel
- Velour
- Fleece
- Denim

- 15 Fold fabrics in half along the middle seam, wrong sides together.
 16 Topstitch the long edges together.
 17 Join the two short ends by carefully overcasting very close to the edge.

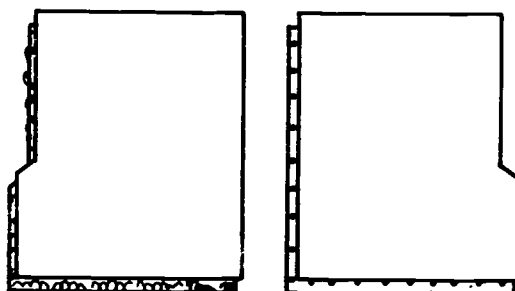


For Play Mitt:

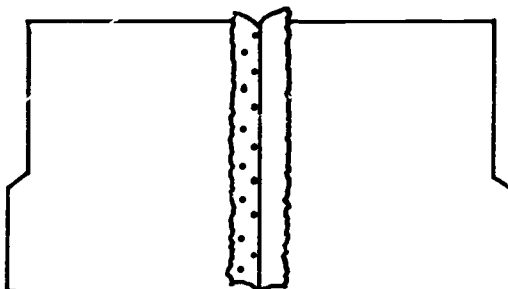
- 18 Using pattern (21 A), cut two shapes with the pattern right side up on correct side of the cloth, and two shapes with the pattern right side down on correct side of the cloth; you will have two sets of opposite shapes.



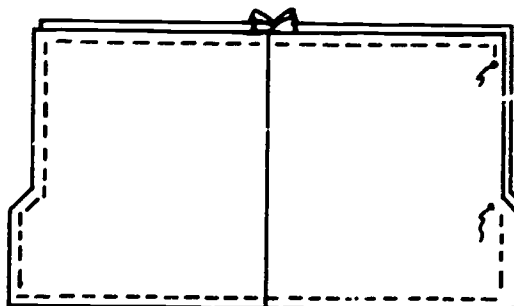
- 19 Lay the four sections of fabric out so there are two sections with the right sides facing up. Put these sides together, so that you now have two matching sandwiches, with the correct sides of the fabrics facing each other.



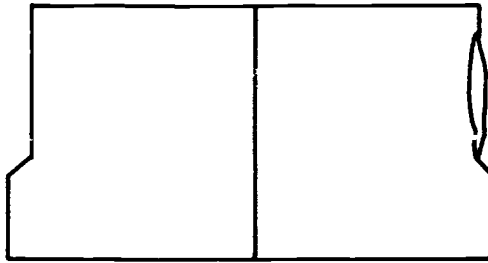
- 10 Sew a seam $\frac{3}{8}$ " from the edge of the long straight side of each fabric pair, then press the seams open.



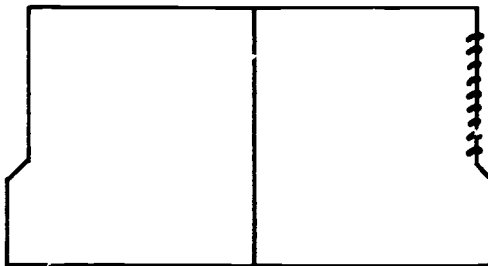
- 11 Put the right sides of the two opened pairs together. Sew a seam $\frac{3}{8}$ " from the edge around all the outside edges, beginning at the projection on the right and ending 1" from the top edge on the same side.



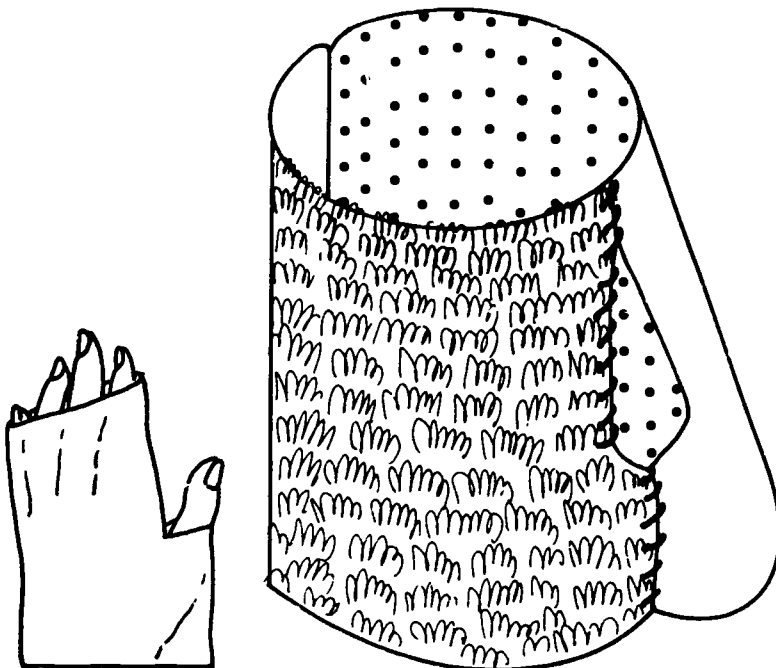
- 12 Clip corners and turn right side out through the side opening.
- 13 Press flat.



- 14 Use slipstitch to close opening.



- 15 Fold mitt in half. Sew side edges together below projection.
- 16 On same side, overcast 1 1/2" down from the top of the mitt. Leave middle section open for thumb.



PLAY WITH ME!

“Both of these toys will help you teach me to feel different textures. You can put my Hand Band over your fingers and gently rub it over my arms, legs, back or tummy. Softly touch my cheeks, my fingers, my toes. On another day, turn the band inside out and you will have two new textures to teach me. You can put my Play Mitt on one of your hands when you pick me up, and my own movements will create new sensations for me. Or you can use it like you do the Hand Band. The palms of my hands and the bottoms of my feet are very sensitive, so you might want to touch the other parts of my body first, until I am more familiar with the feelings.”

CAUTION

Care should be taken in using materials that aren't too scratchy or that have loose fibers that can be removed and swallowed.

Vinyl
(3 A)
Cut 1

Nylon Net
(3 A)
Cut 1

Cotton
(3 A)
Cut 1

Terrycloth
(3 A)
Cut 1

Place on fold

