

DOCUMENT RESUME

ED 289 685

SE 048 770

AUTHOR Sands, Florence
 TITLE Tools of Oceanography. Ocean Related Curriculum Activities.
 INSTITUTION Pacific Science Center, Seattle, Wash.; Washington Univ., Seattle. Washington Sea Grant Program.
 SPONS AGENCY National Oceanic and Atmospheric Administration (DOC), Rockville, Md. National Sea Grant Program.; Washington Office of the State Superintendent of Public Instruction, Olympia.
 PUB DATE 80
 NOTE 46p.; Drawings may not reproduce well.
 AVAILABLE FROM Pacific Science Center Giftshop, 200 2nd Ave. North, Seattle, WA 98109 (\$6.00).
 PUB TYPE Guides - Classroom Use - Guides (For Teachers) (052)
 EDRS PRICE MF01 Plus Postage. PC Not Available from EDRS.
 DESCRIPTORS Boat Operators; Environmental Education; Interdisciplinary Approach; Marine Biology; *Marine Education; *Measurement; *Navigation; Oceanography; *Science Activities; Science and Society; Science Curriculum; Science Education; *Science Instruction; Secondary Education; *Secondary School Science; Vectors (Mathematics); Water Resources
 IDENTIFIERS *Project ORCA; Washington

ABSTRACT

The ocean affects all of our lives. Therefore, awareness of and information about the interconnections between humans and oceans are prerequisites to making sound decisions for the future. Project ORCA (Ocean Related Curriculum Activities) has developed interdisciplinary curriculum materials designed to meet the needs of students and teachers living in Washington State. Each activity packet provides the teacher with a set of lessons dealing with a particular topic related to the oceans. Included are student worksheets, lesson plans, a vocabulary list, and a bibliography. This packet for grade levels 7, 8, and 9 is designed to familiarize the student with some of the tools that the oceanographer uses when he/she goes to sea. It begins with the early tools that sailors developed to help them navigate the seas. It describes the first major scientific expedition and compares the equipment oceanographers use with that used on the Challenger Expedition. (TW)

 * Reproductions supplied by EDRS are the best that can be made *
 * from the original document. *

ED289685

TOOLS OF OCEANOGRAPHY

U.S. DEPARTMENT OF EDUCATION
Office of Educational Research and Improvement
EDUCATIONAL RESOURCES INFORMATION
CENTER (ERIC)

This document has been reproduced as
received from the person or organization
originating it
 Minor changes have been made to improve
reproduction quality

• Points of view or opinions stated in this docu-
ment do not necessarily represent official
OER position or policy

"PERMISSION TO REPRODUCE THIS
MATERIAL IN MICROFICHE ONLY
HAS BEEN GRANTED BY

Andrea Marrett

TO THE EDUCATIONAL RESOURCES
INFORMATION CENTER (ERIC) "

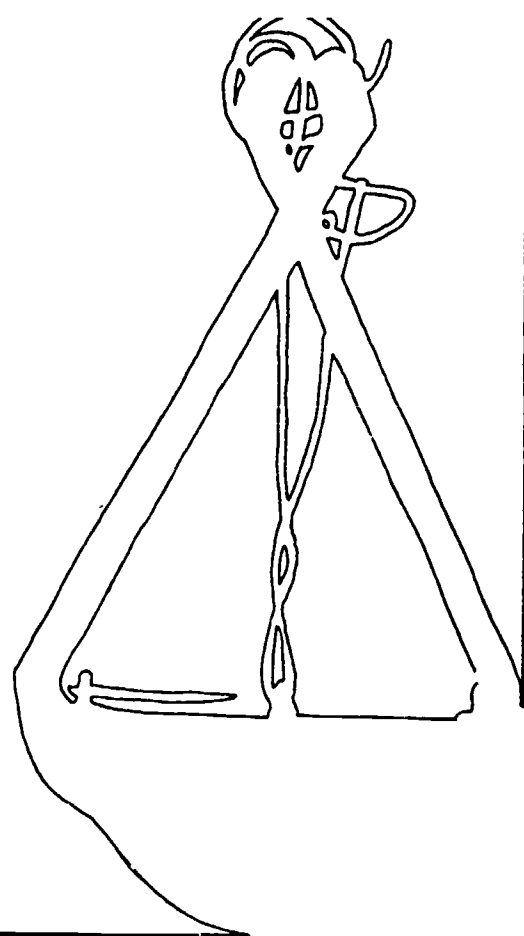

SE 04X 270



ORCA OCEAN RELATED CURRICULUM ACTIVITIES

PACIFIC SCIENCE CENTER / SEA GRANT
MARINE EDUCATION PROJECT

FLORENCE SANDS, AUTHOR
ANDREA MARRETT, MANAGER

ORCA PUBLICATIONS

ELEMENTARY

High Tide, Low Tide (4th Grade)
Life Cycle of the Salmon (3rd - 4th Grade)
Waterbirds (4th - 5th Grade)
Whales (4th - 6th Grade)

JUNIOR HIGH

Beaches
Beach Profiles and Transects
Early Fishing Peoples of Puget Sound
Energy from the Sea
Literature and the Sea
Tides
Tools of Oceanography

SENIOR HIGH

American Poetry and the Sea
Marine Biology Activities
Marine Biology Field Trip Sites
Marshes, Estuaries and Wetlands
Squalls on Nisqually: A Simulation Game

© Copyright by Pacific Science Center, 1980.

This activity packet was produced at the Pacific Science Center in cooperation with Washington Sea Grant and Office of the Superintendent of Public Instruction. Permission to reprint these materials is subject to approval by the Pacific Science Center. For permission or further information contact the Pacific Science Center, 200 Second Avenue North, Seattle, WA (206) 625-9333.

PROJECT ORCA

The ocean? It's 2 miles away; it's 200 miles away; it's 2000 miles away. What does it matter to me? For those students who live close to the ocean, a lake or a stream, the effect of water might be more obvious. For the student who lives on a wheat farm in the arid inlands, the word ocean is remote. It may conjure up images of surf, sand and sea gulls, experiences far removed from their daily lives; or it may have no meaning at all. Yet for that same youngster, the reality of the price of oversea wheat shipments or fuel costs for machinery are very real. The understanding of weather and its effects on the success or failure of crops is a basic fact of everyday life. The need for students to associate these daily problems with the influence of the marine environment exists. It requires exposure to ideas, concepts, skills and problem solving methods on the part of the youngsters. It also requires materials and resources on the part of our educators.

The goals of ORCA (Ocean Related Curriculum Activities) are: 1) to develop a basic awareness of ways in which water influences and determines the lives and environments of all living things; and 2) to develop an appreciation of the relationship of water to the study of the natural sciences, social sciences, humanities and the quality of life.

ORCA attempts to reach these goals by: 1) developing interdisciplinary curriculum materials designed to meet the needs of students and teachers living in Washington State, 2) developing a marine resource center, and 3) providing advisory services for marine educators. In conjunction with these efforts, ORCA is coordinating communication among educators throughout the state and the rest of the nation.

The curriculum materials are developed to be used in many areas including the traditional science fields. They consist of activity packets which fit existing curricula and state educational goals and are designed for use as either a unit or as individual activities.

The ocean affects all our lives and we need to be aware and informed of the interconnections if we are to make sound decisions for the future of the earth, the ocean and our own well being. We hope that through Project ORCA, teachers will be encouraged to work together to help students understand and appreciate the ocean and the world of water as a part of our daily existence.

ACKNOWLEDGEMENTS

The Ocean Related Curriculum Activities (ORCA) are a product of a cooperative effort. These materials were developed at the Pacific Science Center. Assistance was provided by the National Oceanic and Atmospheric Administration (NOAA) Sea Grant held by the University of Washington. The Office of the Washington State Superintendent of Public Instruction provided technical support and assistance.

TRIAL TEACHERS

Trial teachers test us and answer the most important question of all: "Does it work?" The teachers who gave their time, effort and advice were:

Lynda Hughes and Allen Husker, Edmonds School District
Lee Boulet; Highline School District
Barbara Deihl and Susan Swenson; Kent School District
Andrea Marrett; Lake Washington School District
Claire Jones and Jenifer Katahira; Pacific Science Center School for Science
Greg Aveleson, Joe Budde and Mary Ketcham; Renton School District
Margaret Bonhom, Ivan Ellis, Willim Lippit, Barb Norsen and Jay Sasnett;
Seattle School District

CONSULTANTS

Several marine consultants provided valuable assistance and expertise. Our grateful thanks to:

Wolf Bauer, Hydraulic Engineer, Seattle
Dave Borden, Director of the Marine Science Center, Poulsbo
Dennis Campbell, Teacher, Edmonds School District
Alyn Duxbury, Ph.D., Assistant Director for New Programs, Division
of Marine Resources, University of Washington
Charles J. Flora, Ph.D., Director of Aquatic Studies, Western
Washington University
Charles Hardy, Coordinator, Math and Science, Highline School District
Richard Sternberg, Ph.D., Department of Geology, University of Washington

The aid, advice and encouragement of the following educators were essential to the successful development of this project:

Ann Foley, Reading Specialist; Edmonds School District
Angela Hoffman, Teacher, Pacific Science Center
David Kennedy, Supervisor of Science and Environmental Education,
Office of the Superintendent of Public Instruction
Nan Munsell, Supervisor for the Archeology Project, Pacific Science Center
Pam Phillips, Program Assistant, Pacific Science Center
Ann Sankey, Manager of Elementary Programs, Pacific Science Center
Elizabeth Sears, Biology Teacher, Edmonds School District
Jan Turnbull, Environmental Education and Energy, Shoreline School District
Beverly Williams, Education Intern, Pacific Science Center

Other consultants who offered their time and special expertise were:

Sally Snyder, Ph.D., Anthropologist
Hilary Stewart, Author
Jerry Strain and Joel Rogers, Photographers
Terry Taffoya, United Indians of All Tribes

ADVISORY COMMITTEES

The Marine Education project was reviewed annually by the Sea Grant Site Evaluation committee. We thank them for their advice and support.

Continuing guidance for the program direction was provided by the Pacific Science Center Education Committee, the members of which are:

A.D. Ayrault, Jr., Headmaster, Lakeside School
Levon Balzer, Ph.D., Dean of Instruction, Seattle Pacific University
Charles Hardy, Coordinator, Math and Science, Highline School District
David Kennedy, Supervisor of Science and Environmental Education;
Office of Superintendent of Public Instruction
Roger Olstad, Ph.D., Associate Dean of Graduate Studies, University
of Washington, Committee Chairperson
Alice Romero, Teacher, West Seattle High School
Sally Stapp, Teacher, Frank Wagner Elementary
William Stevenson, Superintendent, Shoreline School District

STAFF

Finally, our heartfelt appreciation to the staff members who were instrumental in creating, developing and supporting this project. Thank you to the curriculum writers Jenifer Katahira, Claire Jones, Andrea Marrett, Florence Sands and Sally Snyder. We appreciate the efforts of the people responsible for graphics and paste up; Susan Lundstedt, graphics; Luann Bice, artwork; Valene Starrett, covers; and Andrea Marrett and Carolyn Hanson, paste up. We sincerely thank our project investigator, Bonnie DeTurck, Director of Education and Debbie Fowler, the Marine Education Intern at the Pacific Science Center. We wish also to express our gratitude to Patty Kelley, Jan McLachlin, Leslie Wozniak and Peggy Peterson, for their patience in typing, retyping and alas, typing it all over one more time.

A special thanks to my husband, John Pauls, for all the moral support he provided during the development of these materials and his idea-generating questions.

Shirley Pauls
Project Manager
September 1977 to February 1979

For current information of project activities and/or materials, contact:

Andrea Marrett
Manager, Marine Education Project
Pacific Science Center
200 2nd Avenue North
Seattle, WA 98109

TOOLS OF OCEANOGRAPHY (3-4 days)

ABSTRACT:

This packet is designed to familiarize the student with some of the tools that the oceanographer uses when he/she goes to sea. It begins with the early tools that sailors developed to help them navigate the seas. It describes the first major scientific expedition and compares the equipment oceanographers use with that used on the Challenger Expedition. Minimum time for the basic activities is four days. Optional activities can make it a longer project.

SUBJECT AREAS:

Biology, Marine Biology, General Science, Physical Science, Oceanography

GRADE LEVELS:

Junior High 7, 8, 9

WRITTEN BY:

Florence Sands

TOOLS OF OCEANOGRAPHY

OBJECTIVES:

The student will be able to:

1. Identify oceanographic tools from a picture or description.
2. Describe the uses of oceanographic tools.
3. Understand the need for collection of oceanographic data.
4. Identify the kinds of data that is collected.

TOOLS OF OCEANOGRAPHY

PLAN AHEAD LIST:

1. This unit has been designed so it may be used with the University of Washington box which may be rented from the Burke Museum
2. Check your district audio visual catalogue for films and other materials. A set of slides to accompany this lesson should be available from your district or from the Pacific Science Center.

TABLE OF CONTENTS AND OVERVIEW:	PAGE
ACTIVITY 1: EARLY NAVIGATION AND EXPLORATION (2 DAYS)	6
<p>Students examine the kinds of tools that early fishermen and mariners would need to build and sail their boats. Students experiment with a simple water compass. Students read an article on the Challenger Expedition and then invent and describe a tool that would have been useful on the expedition.</p>	
ACTIVITY 2: WHAT DO I MEASURE? (2 DAYS)	14
<p>Students look at pictures and slides of oceanographic tools and then examine the tools from the Burke Oceanographic Box.</p>	
ACTIVITY 3: BUILD YOUR OWN TOOLS (1-2 DAYS)	26
<p>An optional activity. Students will build simple equipment for field work.</p>	
ACTIVITY 4: A SAMPLING FIELD TRIP (1 DAY)	30
<p>Optional. Students take a field trip and use the oceanographic tools they have made, or others, to take measurements such as turbidity, oxygen content, bottom samples, cores, and plankton tows.</p>	
EVALUATION: VOCABULARY: BIBLIOGRAPHY:	36

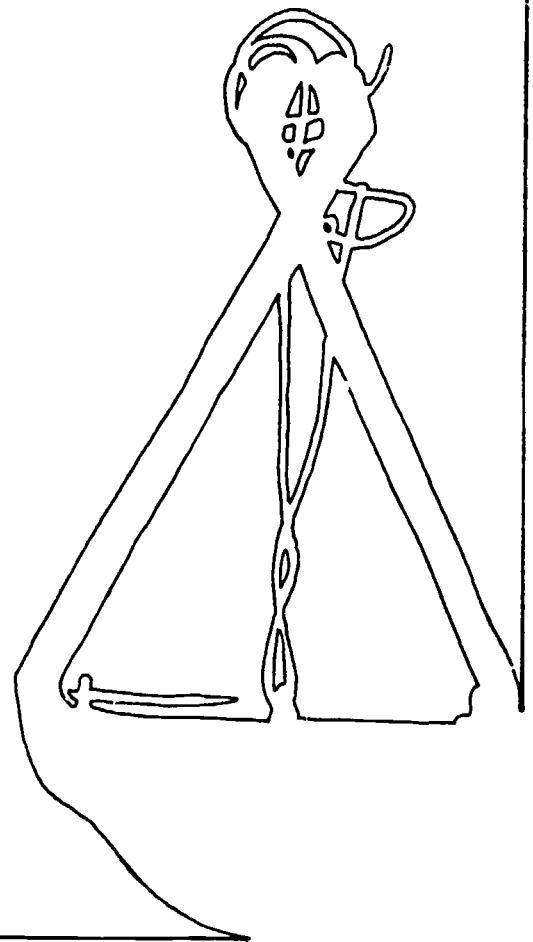

ACTIVITY 1:

● EARLY NAVIGATION AND EXPLORATION (2 class periods)

ACTIVITY 1: EARLY**AND EXPLORATION (2 class periods)****CONCEPTS:**

1. The early mariners had to know the positions of the stars to navigate.
2. They had developed tools and tables to help them do this.
3. Shipbuilding was an art and a science thousands of years ago.

The students will be able to:

1. list 3 pieces of equipment early mariners needed to go to sea.
2. identify the significance of the Voyage of the Challenger to the study of oceanography.

TEACHER**PREPARATION:**

1. Get the slide set - Tools of Oceanography - from the school library, district audio visual center, or Pacific Science Center.
2. Check the school library for books on the sea and the encyclopedias for any article on the sea.
3. Arrange to borrow films on oceanography if any are available in the district.
4. Arrange to borrow the Sea Grant Oceanographer Box from the University of Washington Burke Museum.

MATERIALS:

1. Make a class set of the Challenger Expedition story.
2. Make overhead transparencies of the Challenger and the map of the expedition route.
3. Put together a kit of pins, needles, small nails, magnets, small slivers of wood and some small dishes for floating the water compasses. A transparent dish may be used on the overhead projector to show the results to the class.

PROCEDURES:

Introduce the topic by showing the students a picture or slide of an Indian dugout or an old clinker built whaling boat. Ask the students what tools they would need to build the boat.

Bring the discussion around to the tools the original builders of these boats might have had and how they differ from the tools and machines of today.

What tools were necessary for the people since they used these boats for fishing and transportation? Answers might include paddles, oars, fishing hooks, harpoons, nets and anchors.

Waterways were the natural highways of ancient people. The seas, however, were dangerous and the sailors stayed close to shore; only the most daring ventured away from the sight of lands. Even so, ships went aground on reefs. What tools were developed to make sailing safer?

One of the most important instruments was the magical sliver of loadstone which pointed North when it was floated on water. With these crude compasses, men could sail the world.

Let the students try to make a water compass similar to the kind the ancient mariners used. Magnetize the pin or other object by stroking it on a magnet, attach it to the sliver of wood so that it will float on water. The results will vary.

Check the effect of a large piece of iron or of one of the magnets placed near the dish. Ask the students to judge the reliability of the early magnets.

The Astrolab, the cross-staff and the octant were all devices that measured the angle between the sun or the Pole star and the horizon. The modern sextant, still used for celestial navigation was developed from these tools.

Time was estimated by the position of the sun. An ordinary clock was not very useful - Why? Compare the time changes on the ocean with the time changes as a traveller crosses land.

The speed of a ship was difficult to measure. The sailor would drop a log weighted on one end so it was upright in the water. A line with measured marks was attached to the log and allowed to pay out. The speed was calculated or estimated by the amount of line between the ship and the log after a determined amount of time.

The depth was determined by dropping a lead weight on a line that had measured marks. The seaman counted out the units until the lead hit bottom.

With these tools, men sailed the seas for thousands of years. The first major scientific expedition was the Challenger Expedition starting from England in 1872.

Show the students the pictures of the Challenger and the map of Challenger's voyage. You may want to trace the voyage on a globe. If desired, assign the students to library research. Grolier's, Our Wonderful World, is a very good resource for material related to this unit. Give each student a copy of the Challenger voyage contained in this unit.

After the students have read the assigned materials, ask them to invent or improve some tools that could have been used on the early voyages.

You may want to have some discussion before the students work on their inventions. There was no electricity at that time and no diesel engines so a decision will have to be made about allowing any tools using these conveniences.

Save the inventions for Activity 3. The students may want to improve on them.

The scientists from the Challenger worked on the data for twenty years and published 50 volumes filled with information on weather and currents for the mariner. They classified thousands of species of animals for the biologists.

Since that time, most maritime nations have been adding to the information. The United States provides funds for studies by Sea Grant Colleges and the National Oceanic and Atmospheric Agency. Some of the equipment they use is similar to that used by the scientists on the Challenger. Those millions of square miles of water are being sampled and documented by thousands of oceanographers, from many countries.

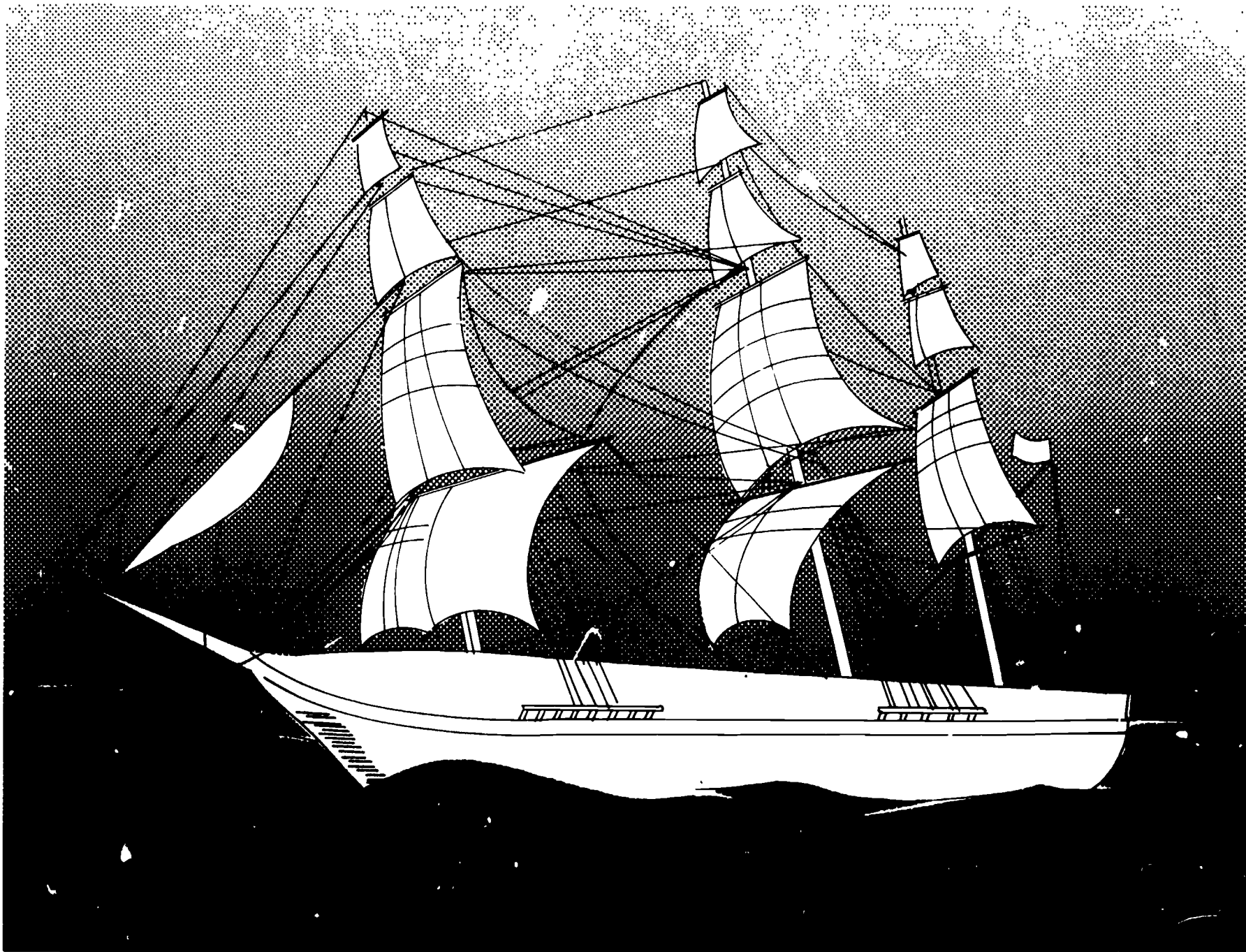

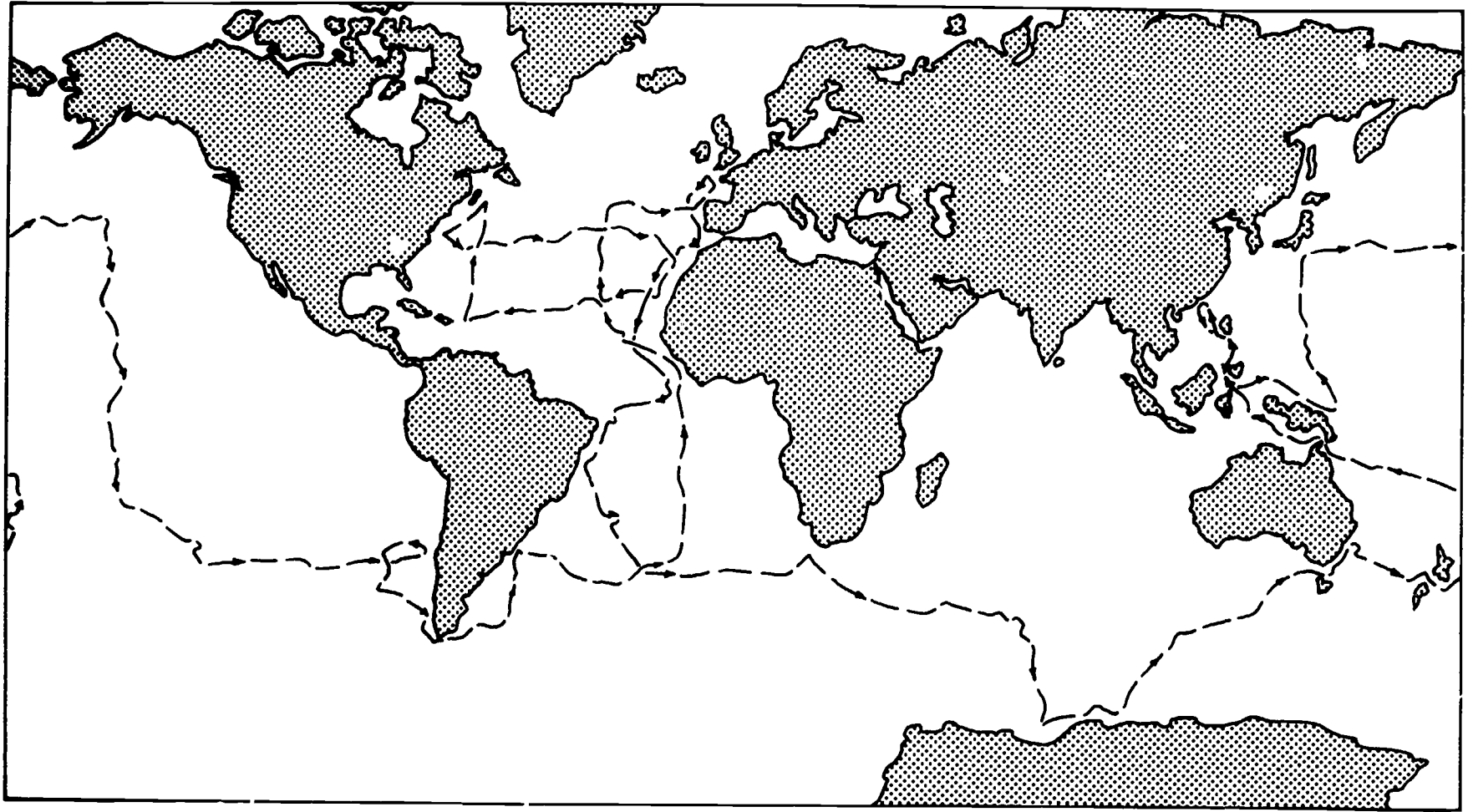

The Voyage of the Challenger

Just about 100 years ago the British ship Challenger returned to England. She was home after a voyage covering three and a half years and almost 70,000 miles. The six scientists and the Navy crew had collected enough information to keep many scientists busy for many years. They had found thousands of new species of plants and animals and had collected and preserved samples of most of them. They had found a trench where the water was over 5 miles deep. The log of the experiences, as written by crew members, thrilled the public.

For many years explorers and sailors had been returning with stories of strange adventures in distant seas; Atlantis - the land that had sunk beneath the sea, sea serpents so long that one could wrap itself around a ship and sink it. There was a living slime covering the bottom of the ocean. It was called Bathybus and was either the origin or end of all life. There were places where seaweed grew so thick it could trap a ship. Huge whirlpools could spin a ship around until it was swallowed up by the sea. Some myths are still told today.

By 1835, Darwin had come back from a trip around the world with detailed and accurate information about land animals and plants. He published a book on the theory of evolution that made it necessary for other naturalists to learn more about living things. One scientist of that time believed nothing could live under the great pressure of the deep water. The arguments could not be ended until more information was collected.

A group of scientists applied to the Royal Navy for a small ship so they could study the "Ocean Basins and the Deep Seas". The ship was to have a steam engine as well as sails. They outfitted the ship with miles of rope and cable and put a donkey engine (steam) and winches on the deck. They built all sorts of nets, trawls and dredges to collect samples of animals, mud and anything else they might find. Laboratories were built into the ship and equipped for the scientists.

They sailed from the British Isles in December 1872 and ran into a howling storm. It took ten to twelve hours to get a dredge sample in deep water. The ropes and cables snapped in the rough seas and they lost equipment. Some of their tools did not work well. Repair work kept everyone busy. They learned that a mop dragged on the sea bottom would pick up animals that got caught in the tangled string. If the dredge would not work a lead weight smeared with tallow or grease would pick up bits of sand and shell. They invented new tools and fixed old ones.

When the ship returned to England, they had taken water samples and temperatures at all depths. Dredgings were made in the deep waters. Nets had collected samples at all depths. When the final reports were published 20 years later, they formed the base of the science of oceanography.

NAME: _____

DATE: _____

PERIOD: _____

Additional Readings on the
Challenger Expedition

Guberlet, Muriel; Explorers of the Sea
(Famous Oceanographic Expeditions)

Foss and Bergouet, Oceanographers in Action

Link, Eric; Challenger Expedition

Grolier, The Voyage of the Challenger
Book 2, Our Wonderful World

Dougherty, Charles; Searchers of the Sea
Pioneers in Oceanography

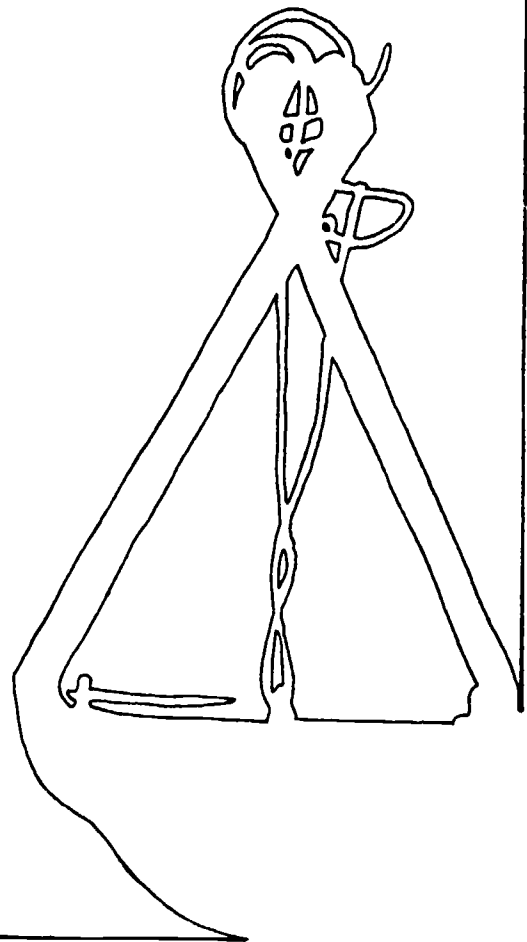

ACTIVITY 2:

● WHAT DO I MEASURE?

(2 class periods)

ACTIVITY 2:**(2 class periods)****CONCEPTS:**

Scientists need to know many things about the ocean. Special tools have been invented to take oceanographic measurements.

OBJECTIVES:

The students will:

1. Identify oceanographic tools from a picture.
2. Describe the use of oceanographic tools.
3. Be able to list 3 types of data oceanographers measure.

TEACHER**PREPARATION:**

See materials list below

MATERIALS:

slide projector

screen

overhead projector

overhead transparency of: Tools of Oceanography
Ships with tools outline

Burke Museum Oceanography Box

Class sets of:

Student worksheet "Name the Tools of Oceanography"

Student evaluation

PROCEDURES:

Show the slides to the students and encourage them to guess what each of the devices can do. Use the narration sheet to fill in and validate the information given by the students.

Display the Burke Box of tools. Use the Teacher Information Sheet "Tools of Oceanography" to arrange the display so that students may complete the "Name the Tools of Oceanography" worksheet.

Hand out the student worksheet "Name the Tools of Oceanography". Direct students to view the tools from the Burke Box and complete the worksheet. They might make their own sketches of the tools and write a short description of the function of each tool.

If the Burke Box is not used with the lesson, show the line drawings on the overhead projector to help them with sketches or give them copies of the drawings and have them write up the descriptions.

TITLE: TOOLS OF OCEANOGRAPHY		PAGE NO. <u>1</u>
PICTURE DESCRIPTION	NARRATION OR AUDIO DIRECTION	
PIC. NO. <u>1</u>	Oceanographers need a sturdy, stable ship with plenty of deck space when they work at sea. They need space for equipment, laboratories for working with samples and specimens, and quarters for living.	
PIC. NO. <u>2</u>	<u>Winches</u> hold the <u>cables</u> for lowering equipment into the sea.	
PIC. NO. <u>3</u>	We can learn something of the history of the ocean by looking at the sediments in the bottom of the sea. The sediment contains the skeletons of animals, volcanic dust and dirt from the land. The <u>corer</u> is a hollow tube that can be dropped to the bottom of the ocean to collect cylinders of this material for later study.	
PIC. NO. <u>4</u>	The first samples of sea water were probably taken with a bucket tied to a rope. A lot of improvements have been made. The <u>Nansen bottle</u> is a metal bottle used to collect samples at any depth. It carries thermometers to show the exact temperature at the depth the water sample is taken.	
PIC. NO. <u>4</u>	When several sampling bottles are put on a single cable, the bottle releases a <u>messenger</u> to trip the bottle below. In this way many samples may be taken at the same station. A messenger can be seen here hanging below the Nansen bottle.	
PIC. NO. <u>5</u>	The <u>Frautsche Bottle</u> is a plastic sampling bottle used to collect sea water. The samples are bottled on the ship and stored for analysis at a later time. Plastic bottles are used to collect water samples to be tested for iron and other metals.	

TITLE: TOOLS OF OCEANOGRAPHY		PAGE NO. <u>2</u>
PICTURE DESCRIPTION	NARRATION OR AUDIO DIRECTION	
PIC. NO. <u>6</u>	A <u>cable meter</u> shows how much cable has passed through the pulley. Why is it important to have this information?	
PIC. NO. <u>7</u>	Currents, wind, and waves, however, do not allow the cable to hang straight down. Therefore this <u>angle meter</u> is used to measure the angle at which the line hangs. With this information and the amount of line that passed through the pulley an approximate depth can be determined.	
PIC. NO. <u>8</u>	A <u>bathothermograph</u> is another oceanographic instrument. It is pulled alongside the oceanographic vessel while it is moving and records the temperature at a given depth. Reversing thermometers were also used on the water sample bottles.	
PIC. NO. <u>9</u>	Another device that brings up material from the ocean floor, besides the corer, is the <u>bottom grab</u> . This design clamps shut when it hits the bottom, grabbing a sample of the ocean floor. In shallow water it is used to collect animal specimens.	
PIC. NO. <u>10</u>	A <u>trawl</u> is used to bring up samples of marine life from the ocean. A large metal frame allows the trawl to be opened and closed from the surface.	
PIC. NO. <u>11</u>	A <u>plankton net</u> is used to obtain samples of microscopic plant and animal life from the sea. A collecting bottle at the end of the net will collect the plankton while the water passes through the mesh of the net. Plankton nets and other oceanographic equipment must be cleaned after use so that they will function properly.	

TITLE: TOOLS OF OCEANOGRAPHY		PAGE NO. <u>3</u>
PICTURE DESCRIPTION	NARRATION OR AUDIO DIRECTION	
PIC. NO. <u>12</u>	The <u>Clarke-Bumpus</u> sampler is a plankton net fitted with a valve that may be opened and closed to control sampling. It may also be fitted with a current meter so the amount of water flowing through the net is known.	
PIC. NO. <u>13</u>	Probably the simplest of all oceanographic tools is the <u>Secchi disc</u> . It is lowered over the side of the vessel and the length of line from the ship to the disc is measured when the disc can no longer be seen. This measurement indicates the distance into the water light can penetrate.	
PIC. NO. <u>14</u>	Devices such as <u>Sonar</u> are used to record depths. Sound waves are bounced off of the ocean floor and their echoes recorded. The depth measurements on charts are determined in this way. These are just a few of the tools an oceanographer uses to collect samples from the ocean.	
PIC. NO. <u>15</u>	The latest tool is <u>Sea Sat</u> which monitors the oceans as it circles the earth - or perhaps the tool is the radar that does the detecting.	
PIC. NO. _____		
PIC. NO. _____		

Teacher Information Sheet

Student Worksheet
"Tools of Oceanography"

After viewing the slide presentation "Tools of Oceanography", complete the following worksheet. Match the name of the tool with the drawing of the tool and write a description of how it is used and what information can be collected.

- | | |
|--------------|--------------------------|
| 1. <u>F</u> | A. Messenger |
| 2. <u>L</u> | B. Secchi disc |
| 3. <u>A</u> | C. grab |
| 4. <u>H</u> | D. Nansen bottle |
| 5. <u>I</u> | E. Corer |
| 6. <u>J</u> | F. Trawl |
| 7. <u>E</u> | G. Plankton net |
| 8. <u>C</u> | H. Bathythermograph |
| 9. <u>D</u> | I. Frautsche bottle |
| 10. <u>K</u> | J. Clarke-Bumpus Sampler |
| 11. <u>G</u> | K. Cable meter |
| 12. <u>F</u> | L. Angle meter |
| 13. <u>M</u> | M. Sonar |

Tools of Oceanography
Teacher Information Sheet
Transparency

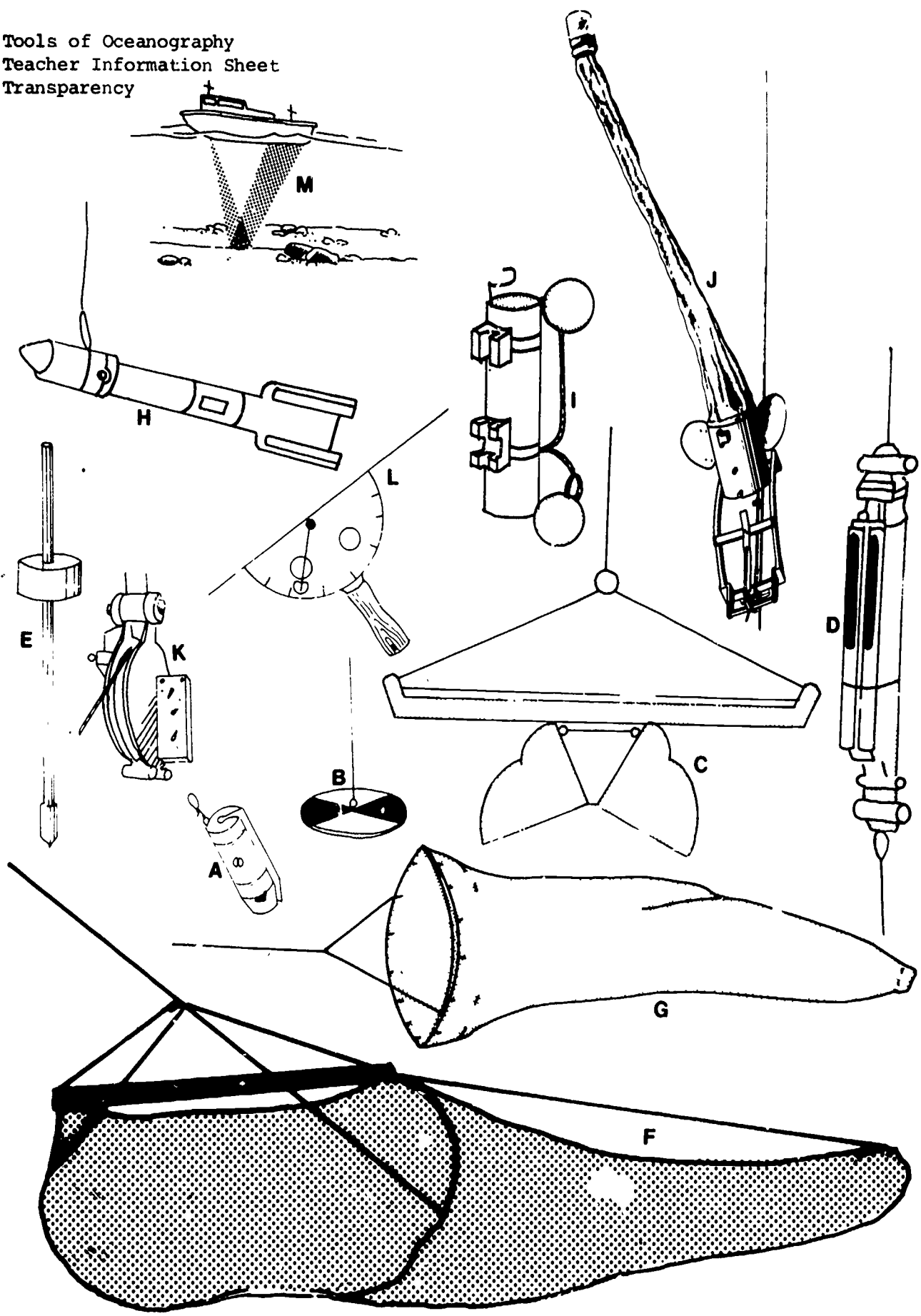

Tools of Oceanography
Overhead Transparency

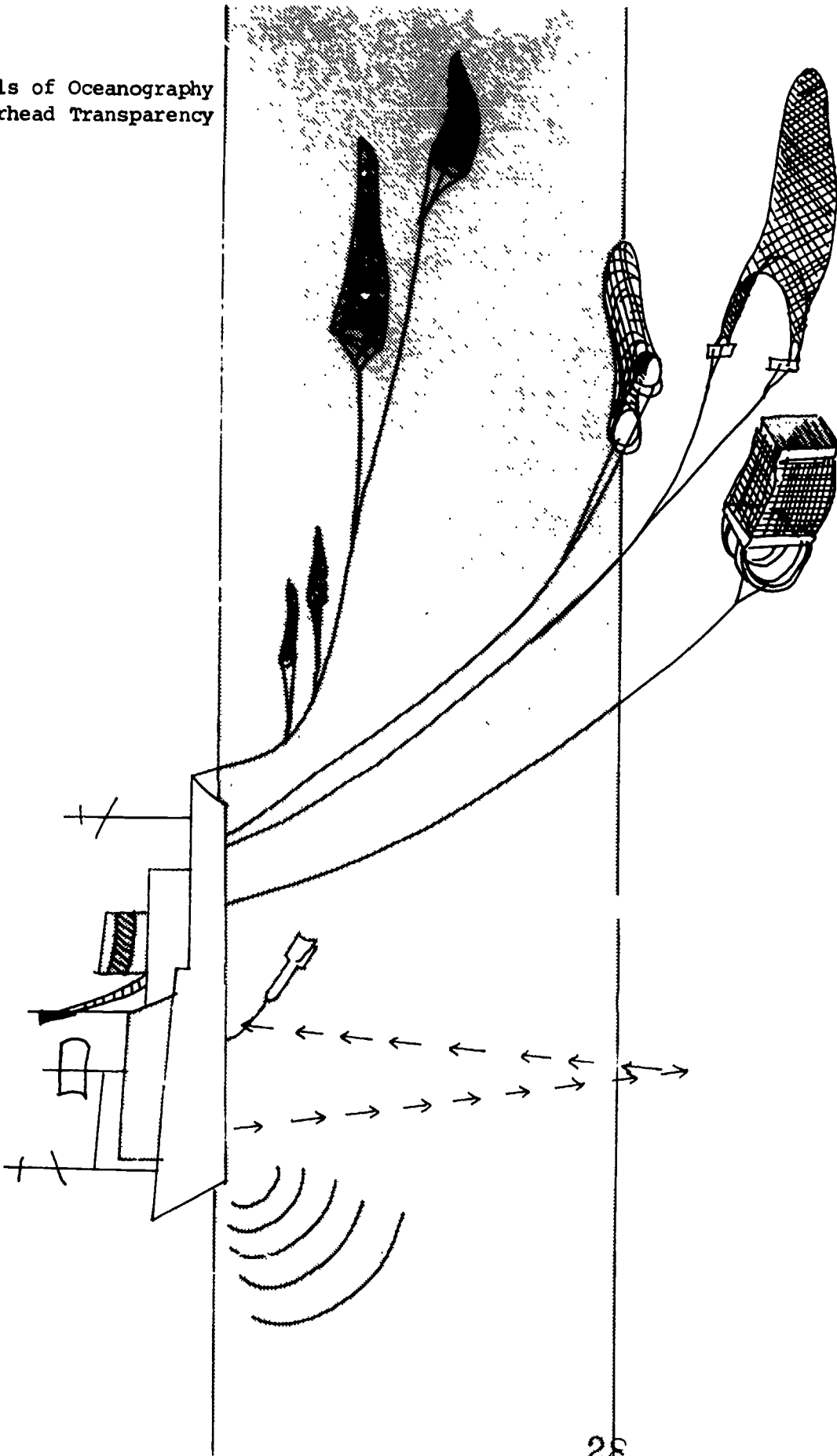

Student Worksheet
 "Name the Tools of Oceanography"

NAME _____

DATE _____

PERIOD _____

After viewing the slide presentation "Tools of Oceanography". complete the following worksheet. Match the name of the tool with the drawing of the tool and write a description of how it is used and what information can be collected.

- | | |
|-----------|--------------------------|
| 1. _____ | A. Messenger |
| 2. _____ | B. Secchi disc |
| 3. _____ | C. grab |
| 4. _____ | D. Nansen bottle |
| 5. _____ | E. Corer |
| 6. _____ | F. Trawl |
| 7. _____ | G. Plankton net |
| 8. _____ | H. Bathythermograph |
| 9. _____ | I. Frautsche bottle |
| 10. _____ | J. Clarke-Bumpus Sampler |
| 11. _____ | K. Cable meter |
| 12. _____ | L. Angle meter |
| 13. _____ | M. Sonar |

Teacher's Copy

NAME _____

Student Evaluation

DATE _____

PERIOD _____

Match the name to the description.

Name of Instrument

- | | |
|------------------------------------|--|
| <u>10</u> A. Trawl | 1. Plastic water sample. |
| <u>11</u> B. Bathythermograph | 2. Measure angle at which line is suspended. |
| <u>4</u> C. Corer | 3. Tripping mechanism for several tools, e.g., Nansen Bottle. |
| <u>2</u> D. Angle Meter | 4. Collects sediment samples in the order in which they were deposited. |
| <u>8</u> E. Nansen Bottle | 5. Determines depth of effective light penetration - turbidity. |
| <u>7</u> F. Grab | 6. Measures the amount of cable let out when an oceanographic tool is lowered overboard. |
| <u>1</u> G. Frautsche Bottle | 7. Collect samples from the bottom. |
| <u>12</u> H. Plankton Net | 8. Metal water sampler. |
| <u>3</u> I. Messenger | 9. Used to determine the depth of the ocean. |
| <u>5</u> J. Secchi Disc | 10. A net to collect fish and other specimens of similar size. |
| <u>9</u> K. Sonar | 11. Records temperatures at a particular depth. |
| <u>13</u> L. Clarke-Bumpus Sampler | 12. Used to collect microscopic plants and animals. |
| <u>6</u> M. Cable Meter | 13. A net that can be opened and closed by using a messenger. |

Student Evaluation

NAME _____

DATE _____

PERIOD _____

Match the name to the description.

Name of Instrument

- | | |
|--------------------------------|--|
| _____ A. Trawl | 1. Plastic water sample. |
| _____ B. Bathythermograph | 2. Measure angle at which line is suspended. |
| _____ C. Corer | 3. Tripping mechanism for several tools, e.g., Nansen Bottle. |
| _____ D. Angle Meter | 4. Collects sediment samples in the order in which they were deposited. |
| _____ E. Nansen Bottle | 5. Determines depth of effective light penetration - turbidity. |
| _____ F. Grab | 6. Measures the amount of cable let out when an oceanographic tool is lowered overboard. |
| _____ G. Frautsche Bottle | 7. Collect samples from the bottom. |
| _____ H. Plankton Net | 8. Metal water sampler. |
| _____ I. Messenger | 9. Used to determine the depth of the ocean. |
| _____ J. Secchi Disc | 10. A net to collect fish and other specimens of similar size. |
| _____ K. Sonar | 11. Records temperatures at a particular depth. |
| _____ L. Clarke-Bumpus Sampler | 12. Used to collect microscopic plants and animals. |
| _____ M. Cable Meter | 13. A net that can be opened and closed by using a messenger. |

Student Evaluation

NAME _____

DATE _____

PERIOD _____

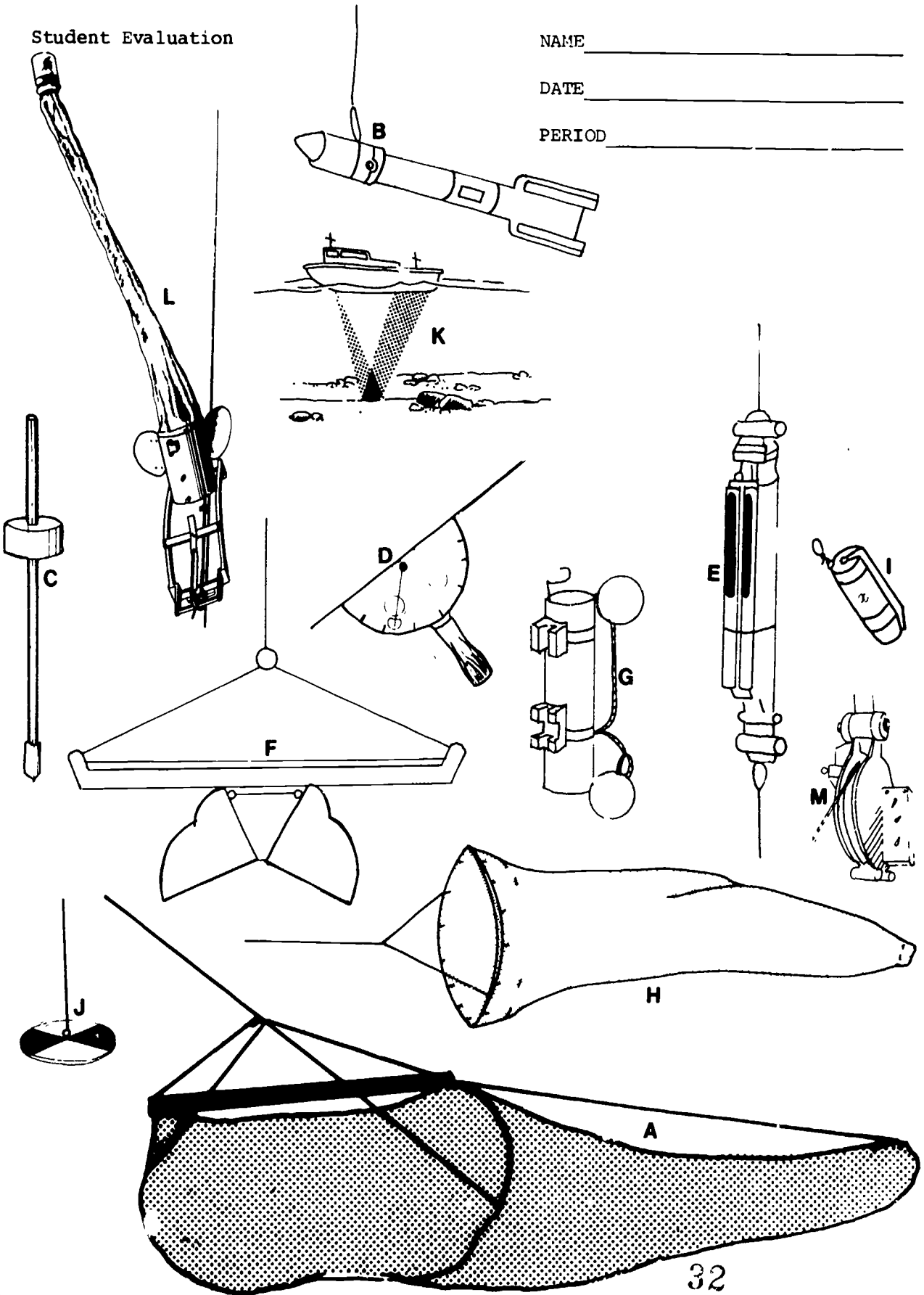

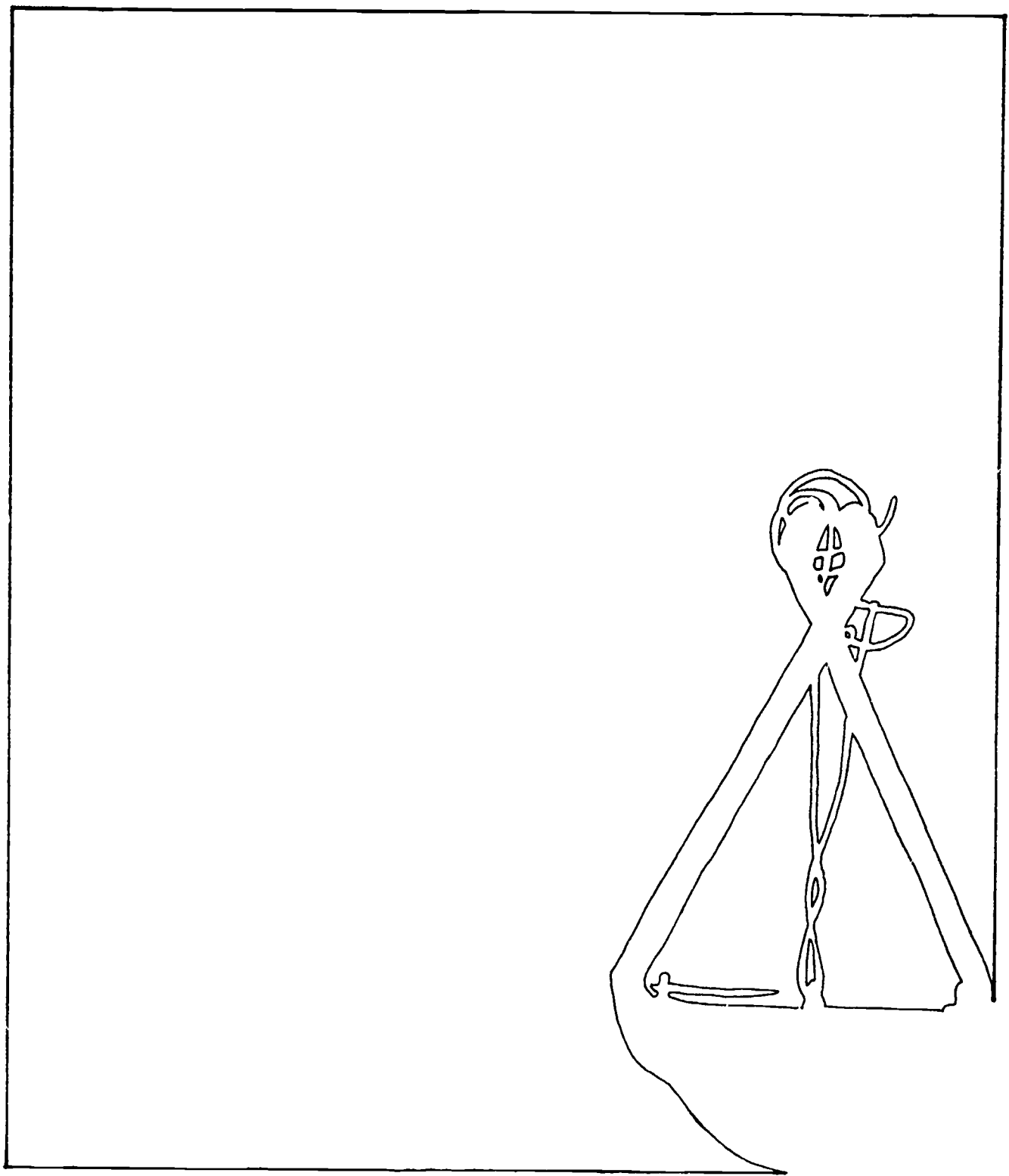

ACTIVITY 3:

● BUILD YOUR OWN TOOLS

(optional 2 days +)

ACTIVITY 3: BUILD YOUR OWN TOOLS (optional 2 days +)

CONCEPTS:

1. Many oceanographic tools are easily built.
2. Measurements with homemade tools are easily taken.

OBJECTIVES:

Students will be able to:

1. build their own oceanographic tool
2. take measurements with the oceanographic tool they have built.

TEACHER

PREPARATION: Copy instruction sheets for building equipment.

MATERIALS: Accumulate materials listed on instruction sheets you intend to use, or have students submit a list of needs if they are building their own design.

PROCEDURES: Allow students or a group of students to choose or assign them the building of simple oceanographic tools. You may copy the instruction sheets enclosed or allow students to design and build their own tools. This may be done during class time or on their own as a special project.

EXTENDED

ACTIVITIES:

1. Do a display or showcase in the classroom showing the tools built by your students.
2. Take measurements over a period of time (a few weeks to a year) using student tools and relate data to seasonal changes.
3. Have students check out the equipment and take measurements (core samples, bottom samples) on vacation and do a report or a display of the results.

Teacher Information Sheet

The Secchi Disc: Turbidity Measurements

One of the most common devices for determining water transparency is the Secchi disc. This is a white disc that is lowered into the water until it just disappears from view. The depth of disappearance is recorded as the secchi disc depth and is related to the water transparency. The simplicity of the measurement belies the complexity of the processes involved in seeing the disc and what the final measurement relates to. However, for simple analysis of water transparency the disc readily provides useful comparative information over a given period of time.

Construction of a Secchi Disc:

I. Materials

30 cm (about 12") diameter circular wooden disc, 3/4 inch thick (plywood can be used but glue used between veneer need be marine rated)

18 m of cord, 1/4" nylon is best

Colored yarn (red, orange, yellow)

Eye bolt, 1/4" diameter by 3" with two flat washers and one lock washer together with appropriate nut. Use galvanized materials if available.

Lead weight (other types of metal may be used however lead is ideal) lead has low melting point and weight can be made using bottom of juice can and kitchen stove. Scrounging suggestions--metal scrap yards (lead pipe), plumbers, tire stores.

1/2 pint white gloss polyurethane

II. Fabrication

Determine the smoother side of disc and finish same with fine grit sandpaper. This will be the reflecting surface. Apply 3 to 4 coats of gloss white polyurethane.

Drill 1/4" hole in center of weight and center of disc. Assemble as illustrated.

Attach cord to bolt and from reflecting surface of disc measure off increments of 1m each. Mark with short lengths of colored yarn.

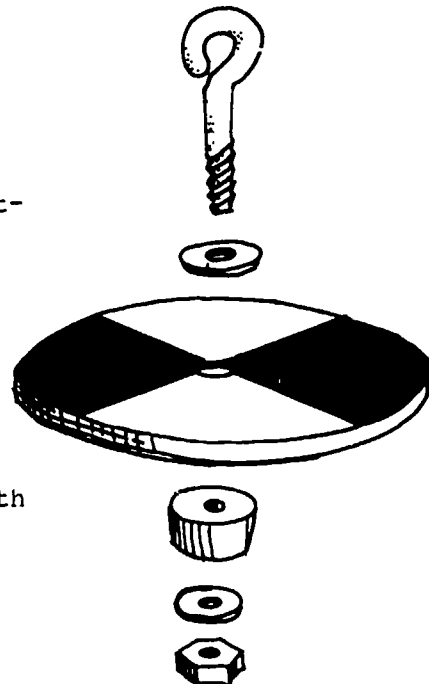
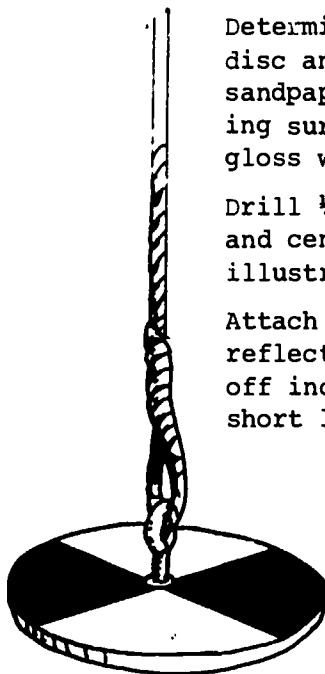

Construction of Plankton Net:

I. Materials

Nylon knee hose with elastic tops
 Baby food jar with lid
 Tuna fish can or plastic margarine dish
 2 meter long cord, 1 meter of heavy string

II. Fabrication

Cut the bottom out of the tuna can or margarine dish - punch three holes for the cord.

Drop the jar into the toe of the stocking and fasten in place with cord.

Slide the elastic over the tuna can. Tie a cord around it to make it secure.

The finished net should look like this:

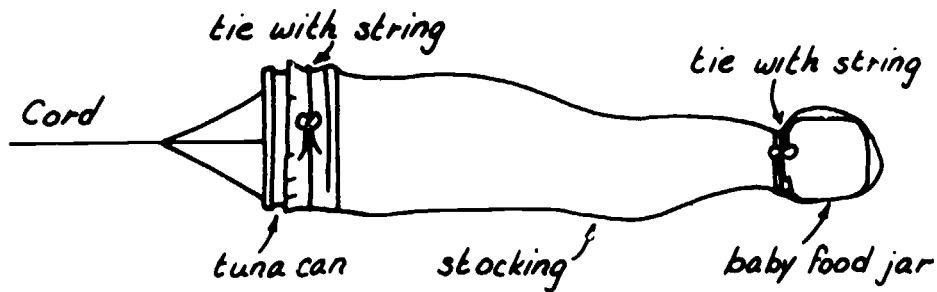

To make a larger net: use pantyhose slipped over a plastic bucket that has had the bottom cut out.

Source: Florence Sands

Make a drift bottle; put in your address and a note - stopper the bottle with a cork and seal it with paraffin. Throw it into the water and wait.

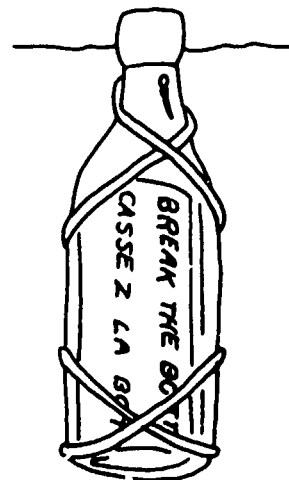

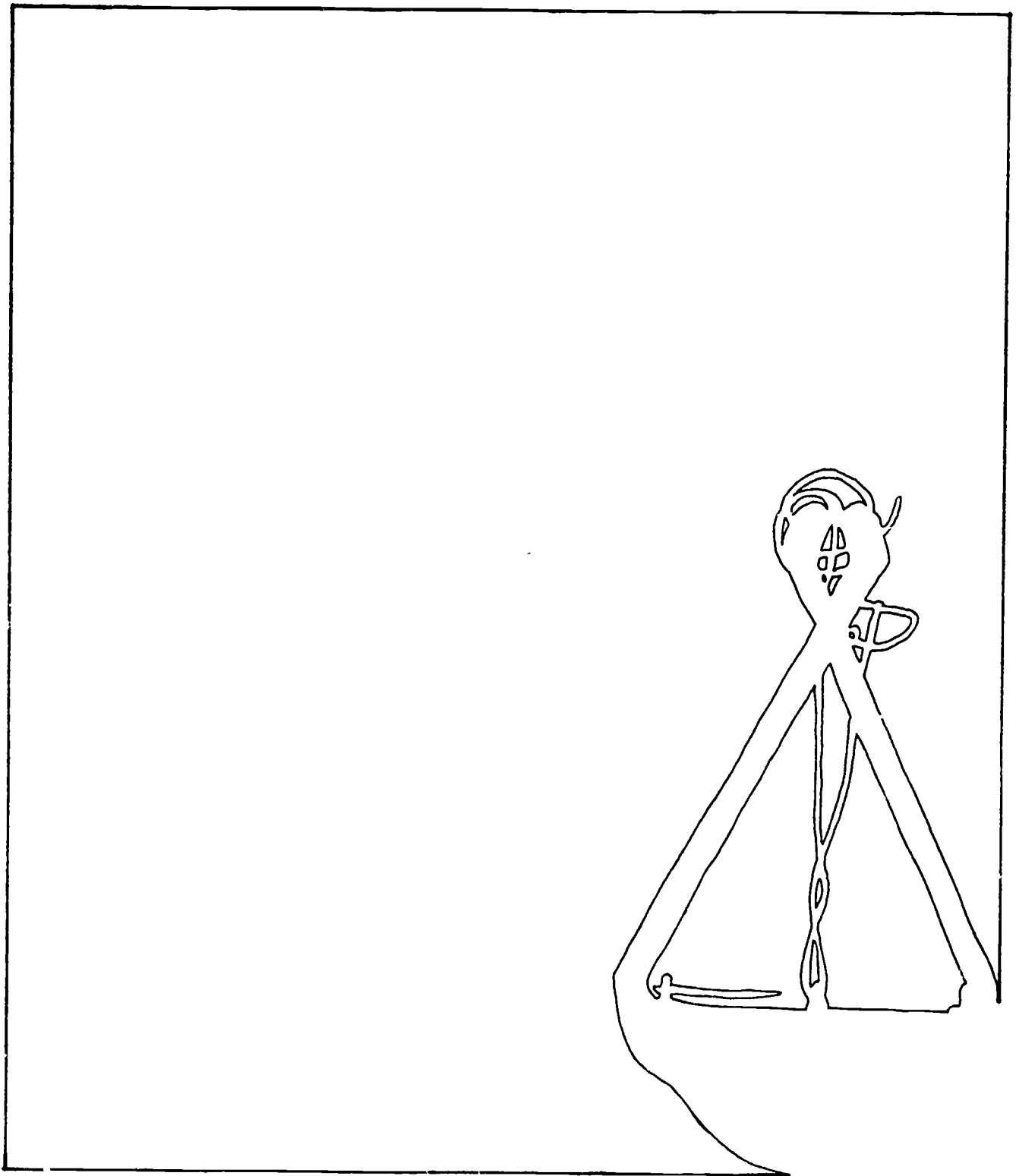

ACTIVITY 4:

● A SAMPLING FIELD TRIP

(1-2 days)

ACTIVITY 4: A SAMPLING FIELD TRIP (1-2 days)

CONCEPTS:

1. Beaches are fragile environments and should be treated with respect and care.
2. Sampling done by students in the field illustrates the use of equipment and the usefulness of information measured by it.

OBJECTIVES:

The student will:

1. be able to take measurements with tools built by him/her other class members.
2. take care to turn rocks back over and return living specimens to the habitat where they were found.

TEACHER

PREPARATION:

Read the teacher information sheet "Field Trip Guidelines" and "For Safety's Sake" included in Activity 4. For more information on how to set up a field trip, what to do and where to go, get a copy of Pacific Science Center's "A Field Trip Guide to Puget Sound Beaches".

MATERIALS:

Those listed in "A Beach Field Trip Guide"
clipboards
paper
pencils

PROCEDURES:

Cover how to use equipment and how to act on the beach (see two teacher information sheets included). Form work groups and assign duties before leaving the classroom. Spend time on safety procedures now and there will be less chance of problems on the field site.

EXTENDED

ACTIVITIES:

1. combine this field trip with one on intertidal life studies and have students rotate from group to group taking their samples, (see Pacific Science Center's "A Field Trip Guide to Puget Sound Beaches").
2. Cook lunch on the beach and play some games; frisbee, etc.
3. Have an overnight campout with a biology portion, oceanographic measurement portion, and geology portion.

FIELD TRIP GUIDELINES

EMPHASIZE CONSERVATION

A field trip to the seashore can be an exciting experience as well as a valuable educational tool. We in the Pacific Northwest are fortunate in the extent and variety of tidelands and marine life along our shores. This is an enviable natural resource and it is just as important to conserve seashore life as it is to conserve forests and other wild life. The attitudes and practices that you, the teacher, display are important, as much of what your students learn about conservation is better 'caught' than taught.

1. Take nothing from the beach unless there is a planned use for it. Squelch the "save it and take it home" impulse. Seashore life is best seen and studied in its natural habitat. Unless there is a good, valid use for a specimen to be brought back into the classroom, leave it undisturbed in its natural setting so it may be observed by other groups.
2. Replace turned-over rocks
Rocks protect many intertidal animals from shore birds and drying by sun and wind. If you turn over a rock and do not turn it back the way it was, you expose the creatures sheltering beneath it and at the same time destroy algae and animals that were living on top. Imagine what would happen to the marine life on a beach if everyone that visited turned over a rock and left it that way.
3. Help stamp out litter
Make it a habit to carry a strong bag or other container on all your beach trips. Litter is not only unsightly on the beach, but may play a part in changing the balance of life on the shore.
4. Watch your step
One person can do considerable damage to plants and animals by stepping on them, so think what a group of 30 could do. Avoid using rocks as stepping stones, as this concentrates your weight and may crush creatures living underneath.
5. Leave things as they are
If students pick up animals and examine them, they should return them to the spot where they found them. Some animals have specific feeding requirements, and they live at specific tidal heights. Moving them to another part of the beach will kill them just as surely as removing them from the beach. A good practice for groups is to take one or more large plastic tubs to be filled with sea water and placed in a central location. Interesting specimens can be placed there for observation and returned to their 'home' a half hour or so later.

FIELD TRIP GUIDELINES (continued)

6. Respect the life forms you find

Handle marine animals carefully if you move them. It is senseless to poke these creatures with a stick or otherwise thoughtlessly disturb and damage them. Some creatures cannot reattach themselves once they are pried off. Do not pry anything loose from a rock or shell if it seems firmly attached.

FOR SAFETY'S SAKE

1. Take only a group of manageable size to the beach. If your group is larger than 30 students, have an adequate number of adults along to help supervise. One adult for every 10 students is a good ratio.
2. Be sure students are dressed properly; long pants, rubber boots or tennis shoes, and a warm jacket are musts for the beach.
3. Have a first aid kit along. Algae on rocks can be slippery, and barnacles and mussels are razor sharp.
4. Check weather conditions before starting; a stormy winter beach is not a good place to take students. In the Seattle area, call 662-1111 for the daily weather report.
5. Climbing on rocks, playing on logs near the water and wading where currents exist are all potentially dangerous activities.
6. Caution students not to let the tide come in behind them, and to watch out for that extra large 'sneaker wave'.
7. Assign students to a buddy system while at the beach.

PLANNING HINTS

1. Always visit the site beforehand so that you are certain it is appropriate and can gear your activities and discussion to its unique qualities.
2. Plan to be at the beach an hour before low tide; it is safer to be on the beach with an outgoing tide. Tides of +1 or lower are good for tidepooling trips. These tides usually occur during the daylight hours of fall and spring months. Tidetables are available at sporting goods stores, the chamber of commerce, tourist information office or local newspaper.
3. Schedule a familiarization time when you first hit the beach. Discussion can include these points: what kinds of rocks are present? how steep is the beach? what is the surf condition?
4. Dividing the class into small groups, each with a specific task, can make the trip more worthwhile.
5. Be sure to bring all the materials you need. No matter what the activities, always bring: large litter bag, first aid kits, tub for observation of good specimens.
6. Prepare your class beforehand as to what they can expect to find and what they will be doing. A variety of literature and films is available to use in preparing for the trip.
7. After the trip, do some follow-up activities. You might want the students to share with each other, or with other classes. It's a good idea to keep a file on what you will change the next time you go to the intertidal.

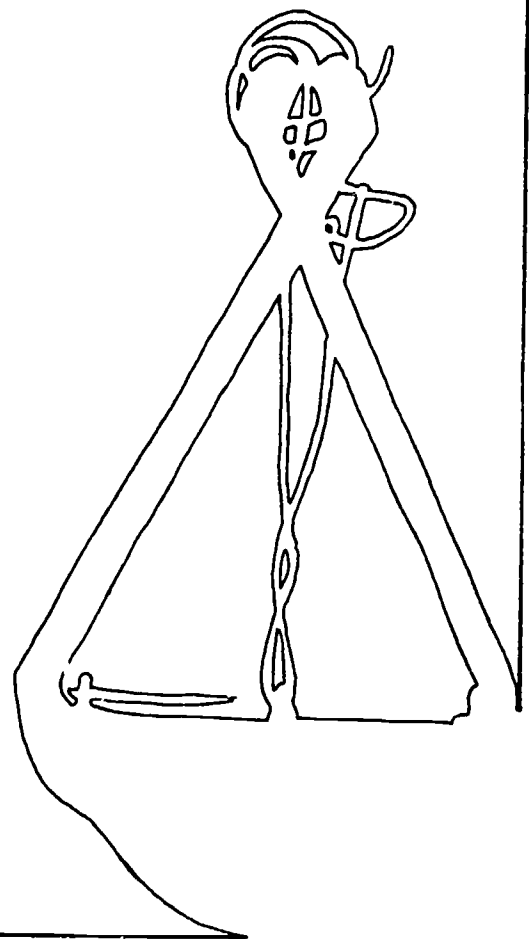

VOCABULARY BIBLIOGRAPHY

VOCABULARY:

- The Challenger** - the first major scientific exploration sailed on this ship from England in 1872. Information gathered from this trip forms the base of oceanography.
- Compass** - an instrument for showing direction.
- Sextant** - an instrument for measuring angular distance, usually between a star and the horizon, to determine position at sea.
- Winch** - a device for holding cables securely.
- Cable** - a sturdy line that lowers equipment into the sea.
- Corer** - a hollow tube that can be dropped to the ocean floor to collect cylinders of bottom material for later study.
- Nansen bottle** - a metal bottle used to collect samples of water at any depth.
- Messenger** - a metal weight sent down the cable to activate a sampling bottle or other sampling device.
- Thermometer** - an instrument for measuring temperature.
- Frautsche bottle** - a plastic water sampling bottle.
- Cable meter** - a device that shows how much cable has passed through the pulley when lowering equipment.
- Angle meter** - a device indicating the angle of which the cable hangs while lowering equipment into the ocean.
- Bathymograph** - a device pulled alongside a vessel while it travels, recording the temperature at a specified depth.
- Bottom grab** - a device used to bring up material from the ocean floor.
- Trawl** - a large metal frame with a net that is used to bring up samples of marine life from the bottom of the ocean.
- Plankton** - microscopic plants and animals floating in the sea.
- Plankton net** - a net used to strain plankton out of the water as it passes through the mesh of the net. A collecting bottle at the end of the net holds the collected plankton.
- Clarke-Bumpus sampler** - a plankton net fitted with a valve that may be opened and closed to control sampling.

Secchi disc - a device that is lowered into the ocean to indicate the distance into the water that light can penetrate.

Sonar - a device using sound waves bounced off the ocean floor to determine depth. Depth measurement charts are made from these measurements.

Sea Sat - a satellite that monitors the oceans as it circles the earth.

Turbidity - water transparency or how far light can travel in the water.

Drift bottle - a bottle in which one puts his name, address, and phone number and tosses it into the ocean. Whoever finds the bottle contacts the person who sent the bottle originally. Determination of currents are made this way.

Sediment - deposits that accumulate on the ocean floor.

STUDENT HANDOUT
VOCABULARY

NAME _____

DATE _____

PERIOD _____

The Challenger-

Compass-

Sextant-

Winch-

Cable-

Corer-

Nansen bottle-

Messenger-

Thermometer-

Frautsche bottle-

Cable meter-

Angle meter-

Bathymograph

Bottom grab-

Trawl-

Plankton-

Plankton net-

Clarke-Bumpus sample-

Secchi disc-

Sonar-

Sea Sat-

Turbidity-

Drift bottle-

Sediment-

BIBLIOGRAPHY:

- Browning, Robert. Fisheries of the North Pacific. Alaska Northwest Publishing, 1974.
- Cromis, William J. Exploring the Secrets of the Sea. Prentice Hall, 1966.
- Mo, Robert J. Readings From Scientific American Oceanography. W.H. Freeman and Company, 1971.
- Student Reading
- Bergust, Eric and Fass, William. Oceanographers in Action. Putnams Sons, 1968.
- Dougherty, Charles. Searchers of the Sea: Pioneers in Oceanography. Viking Press, 1961.
- Gubenlet, Muriel. Explorers of the Sea: Famous Oceanographic Expeditions. Ronald Press Company, 1964.
- Simon, Seymour. Projects in Oceanography. Franklin Watts, 1972.
- Waters, John. What Does An Oceanographer Do? Dodd, Mead, and Company, 1970.
- Shannon, Terry and Payzant, Charles. The Sea Searchers: Men and Machines at the Bottom of the Sea. Golden Gate Junior Books, 1966.
- Briggs, Peter. Science Ship: A Voyage Aboard the Discoverer. Simon and Schuster, 1969.
- Cambs, Charles. Deep Sea World, The Story of Oceanography. W.M. Morrow and Company, 1966.
- Cox, Donald. Explorers of the Deep. Hammond, 1968.