

DOCUMENT RESUME

ED 289 674

SE 048 759

AUTHOR Marrett, Andrea
 TITLE Beaches. Ocean Related Curriculum Activities.
 INSTITUTION Pacific Science Center, Seattle, Wash.; Washington Univ., Seattle. Washington Sea Grant Program.
 SPONS AGENCY National Oceanic and Atmospheric Administration (DOC), Rockville, Md. National Sea Grant Program.; Washington Office of the State Superintendent of Public Instruction, Olympia.
 PUB DATE 80
 NOTE 93p.; For a related document, see SE 048 758. Drawings may not reproduce well.
 AVAILABLE FROM Pacific Science Center Giftshop, 200 2nd Ave. North, Seattle, WA 98109 (\$6.00).
 PUB TYPE Guides - Classroom Use - Guides (For Teachers) (052)
 EDRS PRICE MF01 Plus Postage. PC Not Available from EDRS.
 DESCRIPTORS Elementary Education; *Elementary School Science; Environmental Education; Interdisciplinary Approach; Marine Biology; *Marine Education; *Oceanography; *Physical Environment; *Science Activities; Science and Society; Science Curriculum; Science Education; *Science Instruction; Water Resources
 IDENTIFIERS *Project ORCA; Washington

ABSTRACT

The ocean affects all of our lives. Therefore, awareness of and information about the interconnections between humans and oceans are prerequisites to making sound decisions for the future. Project ORCA (Ocean Related Curriculum Activities) has developed interdisciplinary curriculum materials designed to meet the needs of students and teachers living in Washington State. Each activity packet provides the teacher with a set of lessons dealing with a particular topic related to the oceans. Included are student worksheets, a vocabulary list and a bibliography. This activity packet, designed for the junior high school level, introduces students to the physical and biological processes of the beach zone. Activities deal with the beach as a habitat for plants and animals. Students are encouraged to examine the physical configuration of beaches and learn to identify and label the parts of a beach. The activities focus on an understanding of the processes that help form beaches. The final activity examines the impact of human use of the beach on the natural beach processes and habitats. (TW)

 * Reproductions supplied by EDRS are the best that can be made *
 * from the original document. *

BEACHES

U.S. DEPARTMENT OF EDUCATION
Office of Educational Research and Improvement
EDUCATIONAL RESOURCES INFORMATION
CENTER (ERIC)

X This document has been reproduced as received from the person or organization originating it.
 Minor changes have been made to improve reproduction quality.

• Points of view or opinions stated in this document do not necessarily represent official OERI position or policy.

"PERMISSION TO REPRODUCE THIS MATERIAL IN MICROFICHE ONLY HAS BEEN GRANTED BY

Andrea Marrett

TO THE EDUCATIONAL RESOURCES INFORMATION CENTER (ERIC)."

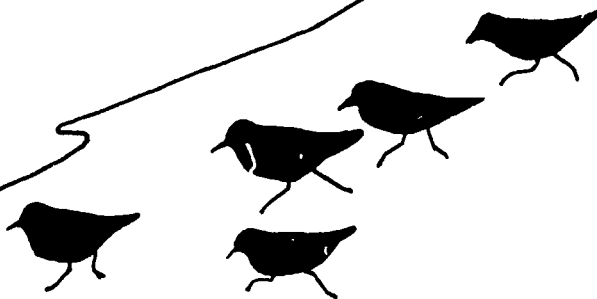

SE 04/87 759



OCEAN RELATED CURRICULUM ACTIVITIES

PACIFIC SCIENCE CENTER / SEA GRANT
MARINE EDUCATION PROJECT

ANDREA MARRETT, AUTHOR
ANDREA MARRETT, MANAGER

BEST COPY AVAILABLE

ED289674

ORCA PUBLICATIONS

ELEMENTARY

High Tide, Low Tide (4th Grade)
Life Cycle of the Salmon (3rd - 4th Grade)
Waterbirds (4th - 5th Grade)
Whales (4th - 6th Grade)

JUNIOR HIGH

Beaches
Beach Profiles and Transects
Early Fishing Peoples of Puget Sound
Energy from the Sea
Literature and the Sea
Tides
Tools of Oceanography

SENIOR HIGH

American Poetry and the Sea
Marine Biology Activities
Marine Biology Field Trip Sites
Marshes, Estuaries and Wetlands
Squalls on Nisqually: A Simulation Game

© Copyright by Pacific Science Center, 1980.

This activity packet was produced at the Pacific Science Center in cooperation with Washington Sea Grant and Office of the Superintendent of Public Instruction. Permission to reprint these materials is subject to approval by the Pacific Science Center. For permission or further information contact the Pacific Science Center, 200 Second Avenue North, Seattle, WA (206) 625-9333.

PROJECT ORCA

The ocean? It's 2 miles away; it's 200 miles away; it's 2000 miles away. What does it matter to me? For those students who live close to the ocean, a lake or a stream, the effect of water might be more obvious. For the student who lives on a wheat farm in the arid inlands, the word ocean is remote. It may conjure up images of surf, sand and sea gulls, experiences far removed from their daily lives; or it may have no meaning at all. Yet for that same youngster, the reality of the price of oversea wheat shipments or fuel costs for machinery are very real. The understanding of weather and its effects on the success or failure of crops is a basic fact of everyday life. The need for students to associate these daily problems with the influence of the marine environment exists. It requires exposure to ideas, concepts, skills and problem solving methods on the part of the youngsters. It also requires materials and resources on the part of our educators.

The goals of ORCA (Ocean Related Curriculum Activities) are: 1) to develop a basic awareness of ways in which water influences and determines the lives and environments of all living things; and 2) to develop an appreciation of the relationship of water to the study of the natural sciences, social sciences, humanities and the quality of life.

ORCA attempts to reach these goals by: 1) developing interdisciplinary curriculum materials designed to meet the needs of students and teachers living in Washington State, 2) developing a marine resource center, and 3) providing advisory services for marine educators. In conjunction with these efforts, ORCA is coordinating communication among educators throughout the state and the rest of the nation.

The curriculum materials are developed to be used in many areas including the traditional science fields. They consist of activity packets which fit existing curricula and state educational goals and are designed for use as either a unit or as individual activities.

The ocean affects all our lives and we need to be aware and informed of the interconnections if we are to make sound decisions for the future of the earth, the ocean and our own well being. We hope that through Project ORCA, teachers will be encouraged to work together to help students understand and appreciate the ocean and the world of water as a part of our daily existence.

ACKNOWLEDGEMENTS

The Ocean Related Curriculum Activities (ORCA) are a product of a cooperative effort. These materials were developed at the Pacific Science Center. Assistance was provided by the National Oceanic and Atmospheric Administration (NOAA) Sea Grant held by the University of Washington. The Office of the Washington State Superintendent of Public Instruction provided technical support and assistance.

TRIAL TEACHERS

Trial teachers test us and answer the most important question of all: "Does it work?" The teachers who gave their time, effort and advice were:

Lynda Hughes and Allen Husker, Edmonds School District
Lee Boulet; Highline School District
Barbara Deihl and Susan Swenson; Kent School District
Andrea Marrett; Lake Washington School District
Claire Jones and Jenifer Katahira; Pacific Science Center School for Science
Greg Aveleson, Joe Budde and Mary Ketcham; Renton School District
Margaret Bonham, Ivan Ellis, Willim Lippit, Barb Norsen and Jay Sasnett;
Seattle School District

CONSULTANTS

Several marine consultants provided valuable assistance and expertise. Our grateful thanks to:

Wolf Bauer, Hydraulic Engineer, Seattle
Dave Borden, Director of the Marine Science Center, Poulsbo
Dennis Campbell, Teacher, Edmonds School District
Alyn Duxbury, Ph.D., Assistant Director for New Programs, Division
of Marine Resources, University of Washington
Charles J. Flora, Ph.D., Director of Aquatic Studies, Western
Washington University
Charles Hardy, Coordinator, Math and Science, Highline School District
Richard Sternberg, Ph.D., Department of Geology, University of Washington

The aid, advice and encouragement of the following educators were essential to the successful development of this project:

Ann Foley, Reading Specialist; Edmonds School District
Angela Hoffman, Teacher, Pacific Science Center
David Kennedy, Supervisor of Science and Environmental Education,
Office of the Superintendent of Public Instruction
Nan Munsell, Supervisor for the Archeology Project, Pacific Science Center
Pam Phillips, Program Assistant, Pacific Science Center
Ann Sankey, Manager of Elementary Programs, Pacific Science Center
Elizabeth Sears, Biology Teacher, Edmonds School District
Jan Turnbull, Environmental Education and Energy, Shoreline School District
Beverly Williams, Education Intern, Pacific Science Center

Other consultants who offered their time and special expertise were:

Sally Snyder, Ph.D., Anthropologist
Hilary Stewart, Author
Jerry Strain and Joel Rogers, Photographers
Terry Taffoya, United Indians of All Tribes

ADVISORY COMMITTEES

The Marine Education project was reviewed annually by the Sea Grant Site Evaluation committee. We thank them for their advice and support.

Continuing guidance for the program direction was provided by the Pacific Science Center Education Committee, the members of which are:

A.D. Ayrault, Jr., Headmaster, Lakeside School
Levon Balzer, Ph.D., Dean of Instruction, Seattle Pacific University
Charles Hardy, Coordinator, Math and Science, Highline School District
David Kennedy, Supervisor of Science and Environmental Education;
Office of Superintendent of Public Instruction
Roger Olstad, Ph.D., Associate Dean of Graduate Studies, University
of Washington, Committee Chairperson
Alice Romero, Teacher, West Seattle High School
Sally Stapp, Teacher, Frank Wagner Elementary
William Stevenson, Superintendent, Shoreline School District

STAFF

Finally, our heartfelt appreciation to the staff members who were instrumental in creating, developing and supporting this project. Thank you to the curriculum writers Jenifer Katahira, Claire Jones, Andrea Marrett, Florence Sands and Sally Snyder. We appreciate the efforts of the people responsible for graphics and paste up; Susan Lundstedt, graphics; Luann Bice, artwork; Valene Starrett, covers; and Andrea Marrett and Carolyn Hanson, paste up. We sincerely thank our project investigator, Bonnie DeTurck, Director of Education and Debbie Fowler, the Marine Education Intern at the Pacific Science Center. We wish also to express our gratitude to Patty Kelley, Jan McLachlin, Leslie Wozniak and Peggy Peterson, for their patience in typing, retyping and alas, typing it all over one more time.

A special thanks to my husband, John Pauls, for all the moral support he provided during the development of these materials and his idea-generating questions.

Shirley Pauls
Project Manager
September 1977 to February 1979

For current information of project activities and/or materials, contact:

Andrea Marrett
Manager, Marine Education Project
Pacific Science Center
200 2nd Avenue North
Seattle, WA 98109

BEACHES (10 days)

ABSTRACT:

Beaches is an activity packet that introduces students to the physical and biological processes of the beach zone. Activities familiarize students with the beach as a habitat for plants and animals. Students will also examine the physical configuration of beaches and learn to identify and label the parts of a beach. They will work toward an understanding of the processes that help form beaches. The final activity examines the impact of human use of the beach on the natural beach processes and habitats.

SUBJECT AREAS:

Science; Biology; Geology; Oceanography; Social Studies; Environmental Studies

GRADE LEVELS:

Junior High

WRITTEN BY:

Andrea Marrett

BEACHES

OBJECTIVES:

- A. Beaches can be divided into parts that can be identified and labeled. By doing Activity #1, Parts of the Beach, students should be able to:
1. recognize the terms for beach parts
 2. define the beach terms used to describe a feature
 3. fill in the correct names of beach parts on a blank diagram of a beach
 4. make a diagram of the beach with the parts properly labeled
 5. correctly name the beach features pointed out to them in a photograph
 6. point out spots on a photograph or on the beach that most clearly represent a named feature
 7. explain why some of the parts seem to overlap
- B. Beaches are the result of natural processes acting upon rocks and other existing material. Following Activity #2, Beach Formation and Processes, students should be able to:
1. name 5 beach types
 2. describe the different rock types and particle sizes that make up the 5 beaches
 3. state which particle size moves most easily in water
 4. state which particle size requires the most energy to move it
 5. describe where the energy comes from to move the rock particles on the beach
 6. define what a beach is
 7. list the sources of beach material
 8. define longshore transport
 9. explain how beach material is moved along the beaches
 10. explain the beach process as it works in Puget Sound
 11. diagram the beach process as it works in Puget Sound
 12. explain why we find rocky, gravel, and sand beaches beside each other
- C. Plants and animals that live on the beach have special needs and can be found in specific locations (zones) on a particular beach. By doing Activity #3, Biological Zonation of a Beach, students should be able to:
1. list the 5 zones of the beach
 2. describe the general location of each zone on the beach face
 3. explain what influence the tides have on life zones
 4. list the needs organisms have to meet to survive on the beach
 5. state what mechanisms the snail has to survive on a beach

6. list at least one animal from each zone
7. state why that animal is found in that zone
8. describe how the biological zones overlap with the geological parts of the beach

D. The beaches of Puget Sound have had many uses. Some human activity has an impact on the beach. Following Activity #4, Human Use and Impact on Beaches, students should be able to:

1. list the uses of the beach
2. describe human activities that have had a positive impact on beaches
3. describe human activities that have had a negative impact on beaches

TABLE OF CONTENTS AND OVERVIEW:	PAGE
ACTIVITY 1: PARTS OF THE BEACH (2 DAYS)	6
<p>This activity is a simple examination of the geological names that have been applied to beach morphology. It includes definitions and identifications of beach features. Students participate in small group activity for identifying and labeling features.</p>	
ACTIVITY 2: BEACH FORMATION AND PROCESSES (4 DAYS)	14
<p>Develops the idea that beaches are part of a natural geological system and are constantly changing. It includes two slide presentations and a lab activity.</p>	
ACTIVITY 3: BIOLOGICAL ZONATION OF A BEACH (2 DAYS)	48
<p>Allows students, in a very simple way, to examine what animals and plants are found at a beach, where they are located and why. This activity develops the idea of biological zones. It includes one slide presentation and a lab activity.</p>	
ACTIVITY 4: HUMAN USE AND IMPACT ON BEACHES (2 DAYS)	72
<p>Shows how human beings use and modify the beaches. It is designed to show that human impact has had both positive and negative effects on intertidal organisms and beaches.</p>	
EVALUATION VOCABULARY BIBLIOGRAPHY	82

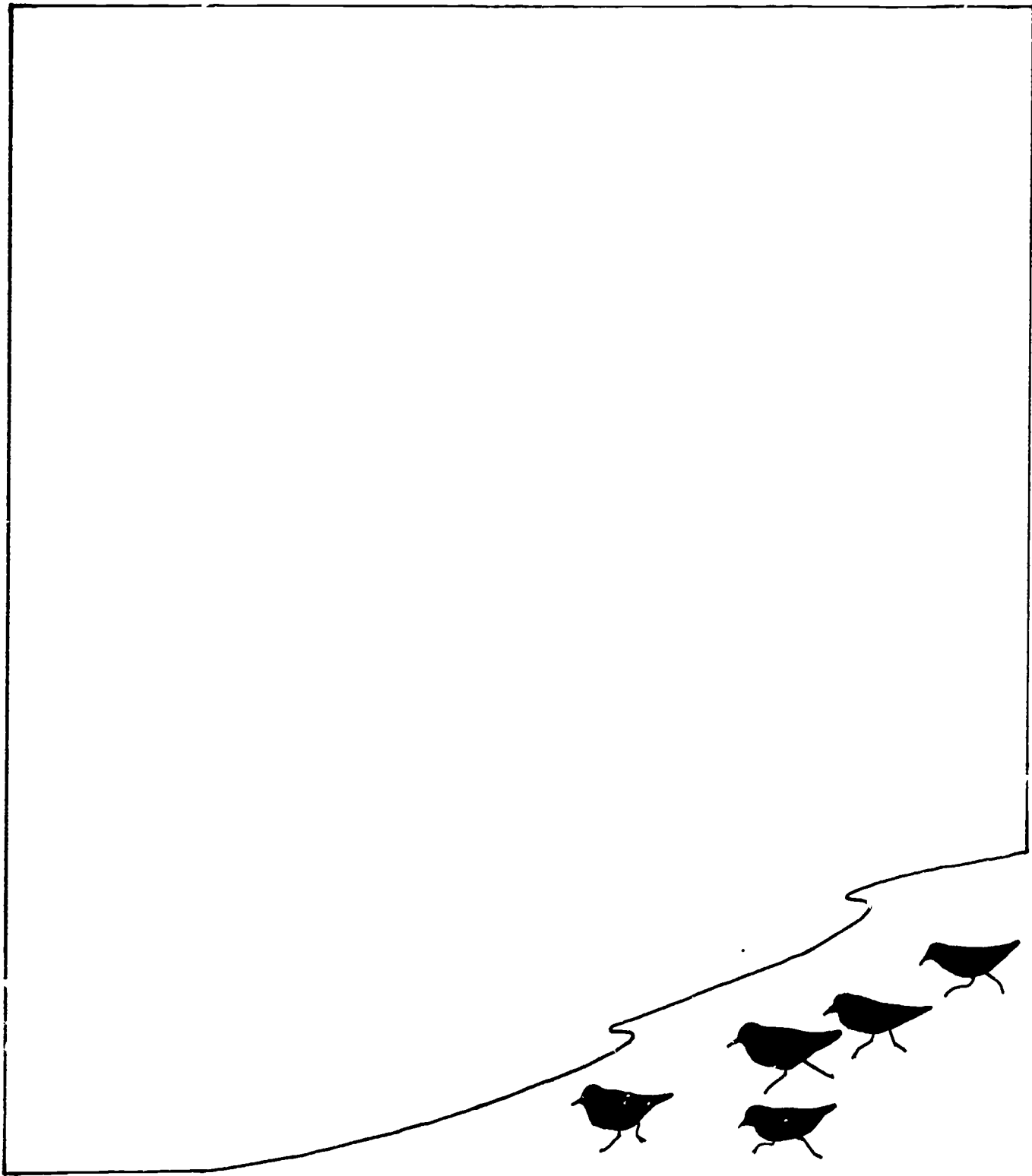

ACTIVITY 1:
PARTS OF THE BEACH
(2 days)

ACTIVITY 1: PARTS OF THE BEACH (2 days)

CONCEPTS: Beaches can be divided into many parts. These parts can be identified and labeled.

OBJECTIVES: Following the activity, the learner will demonstrate his/her ability to:

1. recognize the terms for beach parts
2. define the beach terms used to describe a feature
3. fill in the correct names of beach parts on a blank diagram of a beach
4. make a diagram of the beach with the parts properly labeled
5. correctly name the beach features pointed out in a photograph
6. point out spots on a photograph or on the beach that most clearly represent a named feature
7. explain why some of the parts seem to overlap

**TEACHER
PREPARATION:**

1. Before class the teacher should read Teacher Information Sheet, Scientific American reprint, "Beaches", by Willard Bascom.
2. Before class the teacher should read Teacher Information Sheet, "Beach Terms - Definitions".
3. For the optional field trip activity - "Field Trip Guidelines" (for the teacher) - from Sea Grant, University of Washington publications.

MATERIALS:

1. Butcher paper - 1 sheet per 4 students (optional)
2. Figure 1 - Beach Parts diagram (labeled)
3. For the optional field trip activity:
Per student: pen or pencil, small notebook with paper.
4. Figure 2 - Beach Parts diagram (unlabeled)
Student Evaluation

PROCEDURES:

1. Lead a discussion to introduce these ideas:
 - beaches are not just stretches of land leading from the water.
 - they have features that result from physical and biological action that takes place at the border of the sea.
 - the features are identifiable and have been given labels.
2. Display as a transparency and/or give as a handout to students the diagram of the physical features of the beach. Define the terms for the students. If possible, display photographs (from magazines

or the slide collection) for students to see these features.

3. Review of terms

ASSIGNMENT:

4. Have students (in small groups) draw their own diagram of a beach, similar to the handout given previously, on a large sheet of butcher paper. Working together, have them label the parts of the beach from recall.
5. Have groups exchange and correct each other's diagrams.
6. Distribute the unlabeled copy of the beach. Have the students label and describe each lettered feature.
7. Special Note: The terms used to identify beach features are a compilation of what is being currently used by marine geologists, oceanographers, and geohydraulic engineers. There is some disparity between these sources regarding common usage. Do not allow this to throw you.

**EXTENDED
ACTIVITIES:**

1. Instead of giving the student the labeled beach diagram, give them the blank student evaluation form. First, this can be used as a pre-test. Then proceed as described in the procedure outline, complete the activity by using the student evaluation as a post-test.
2. Give the students the blank student evaluation form and a set of beach term definitions. Have them work from the definitions to label the diagram. Then review terms and display or distribute the labeled diagram.
3. Since it is vastly different to "see" the parts of a beach on a diagram and to see those parts as they really exist, you might want to obtain several photographs or slides of beaches. Point to the various parts of the beaches and have students identify, by name, that part. This can work as an evaluation of the recall of names and also of how well the students have transferred learning from one type of circumstance to another.
4. Go on a field trip to the beach!!! Helpful for this activity is the Activity Packet titled "Field Trip Guidelines". This carefully explains how to prepare for and carry out a beach field trip activity. Once at the beach, gather students together. Explain that as

you walk along the beach you will stop and stand at a particular spot. You will tell students to identify by name, on paper, the part of the beach at which you are standing. Each time you stop be certain to say "This is location #1" (or 2 or whatever). Make certain students identify on their paper the location number and the name. As you go, be sure you also make the key--otherwise you will forget that location #1 was a berm, for instance.

BIBLIOGRAPHY:

Gross, M. Grant, Oceanography
Hoyt, John A. Field Guide to Beaches
Bascom, Willard, Beaches
C.O.A.S.T. Marine Environment Curriculum Study -
#240, Beaches: A Geological Study, 1974.

Beach Terms - Definitions

- A. Coast - The permanent land facing the open waters.
- Cliff - The high rising sections of land against which the high waves break.
- Dune - The collection of drifts of beach sand brought in by wave action and winds. Found mostly on the open coast, such as Long Beach Peninsula.
- Feeder Bluff - An eroding cliff that faces the breaking waves. The eroded sand and rocks provides some of the materials for beach formation.
- B. Beach - The loose material (sand, rocks, shell particles) that collect along the edge of an ocean, lake, river or sea. May be sorted and moved by waves and currents.
- Berm - This marks the highest limit of storm wave action at normal high tides. The berm is slightly elevated when approached from the backshore. It then falls away abruptly on the foreshore side. It is formed by wave action, which moves materials up and down on the beach.
- Backshore - The part of the beach that is rarely touched by waves. It generally extends from the highest point of the beach (the berm) to the cliff or dune base. Size may vary from quite wide to nearly non-existent. End can usually be identified by the storm tide-line. (A collection of large logs, etc. tossed shore during stormy weather.) Permanent vegetation begins here.
- Foreshore - This area extends from the point of the lowest low tide line to the berm. It is covered and uncovered by water during daily changes.
1. High tide line - This spot is the highest point the water reaches during the high phase of the tidal cycle. Two high tide lines can frequently be identified.
 - A. the highest of the high tides during the month--spring high tide line--often can be determined by the dried and decaying seaweed found close to the berm.
 - B. the recent high tide line (if not the spring tide) can be shown by the still damp seaweed.
 2. Shoreline - The point which the water reaches on the beach face at any given moment. Not readily identifiable because water moves up and down the beach with each wave. (Swash and Backwash)
 - A. Swash - the forward movement of the water on the beach, brought in by each wave crest.
 - B. Backwash - after the swash has moved forward to a certain point, the water begins to flow back down the beach face to the open water. This movement is called backwash.
 3. Low Tide Line - where the water recedes to at the lowest point during the daily lunar cycles.

Spring tides - The highest of the high tides during the month.
Occurs twice during the 28-day lunar cycle. It is a result of the combined gravitational pull of the sun and moon on the waters of earth (when the sun, moon, and earth centers are approximately lined up.)

Neap tides - Neap high tides are lower than spring high tides. Neap tides occur twice during the month and alternate with the spring tides. It occurs when the moon is in the first and last quarters.

C. Offshore - From the edge of the beach face to the edge of the continental margins.

Continental Margins - The place in the open water where the land (under the ocean) falls steeply to the ocean depths.

Submarine bar (also Longshore Bar) - a ridge of sand found offshore, parallel to the beach. It is separated from the beach by a trough.

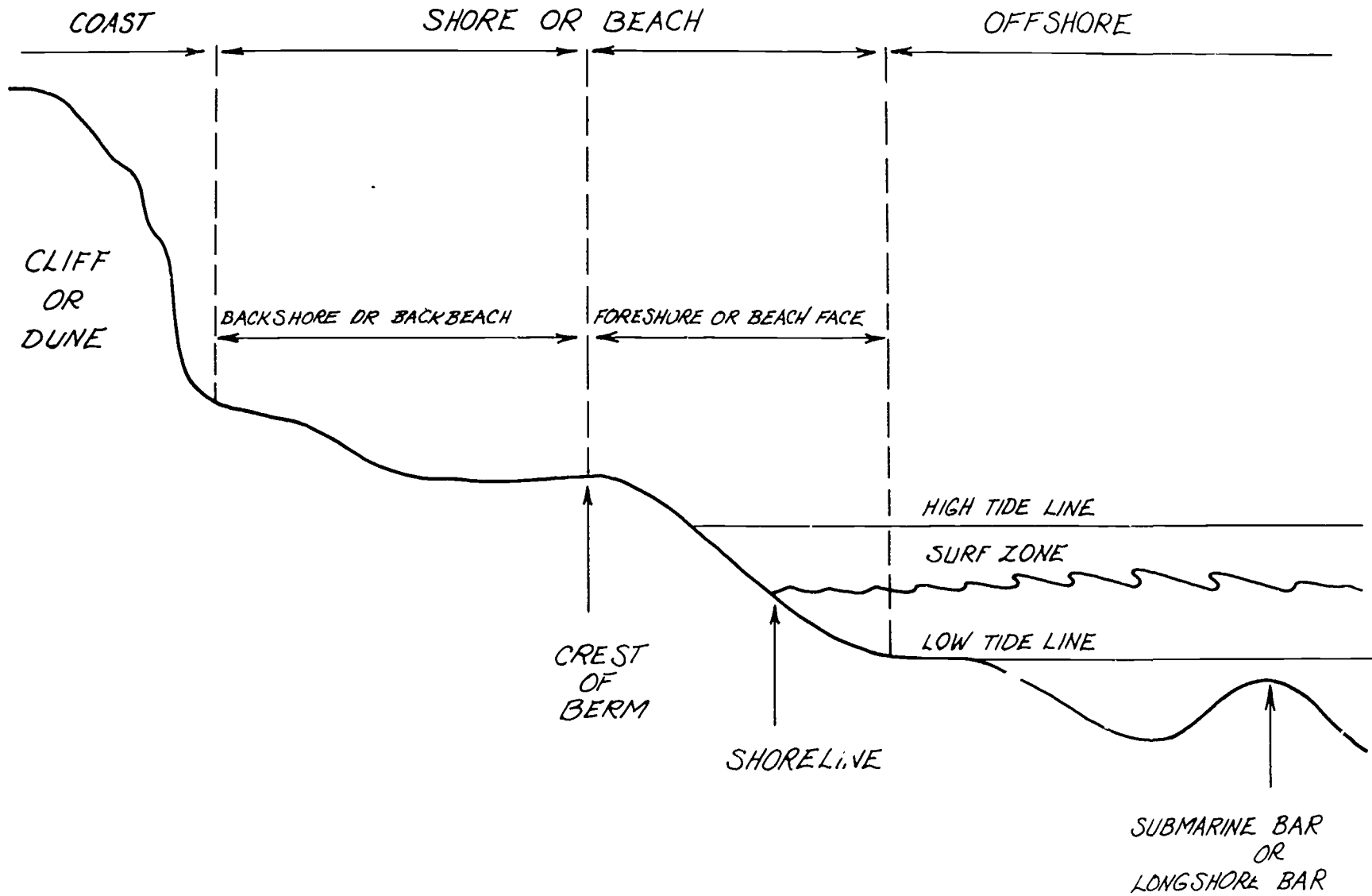
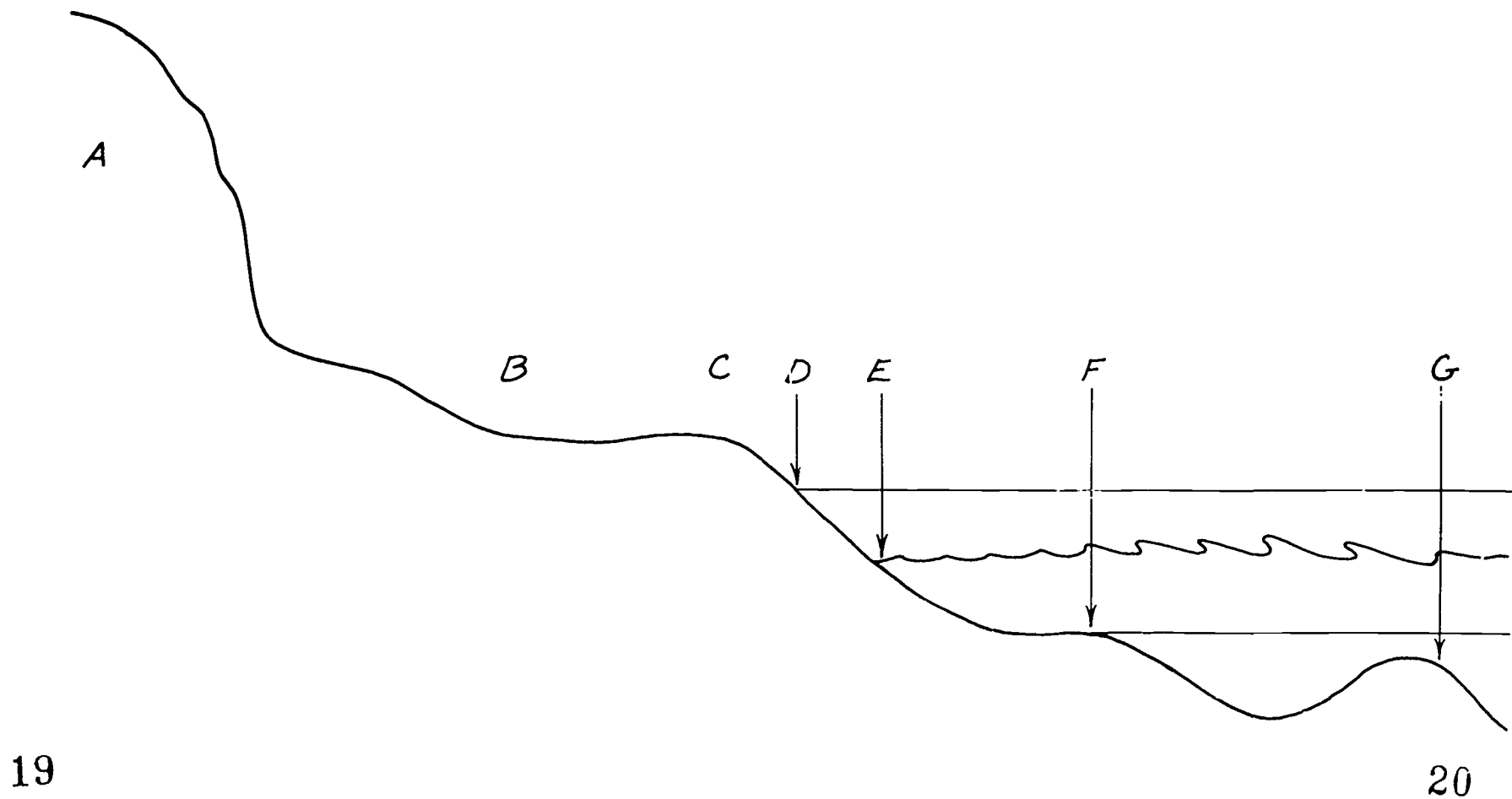

FIGURE 1 Typical Sandy Beach Profile Labeled



19

20

FIGURE 2

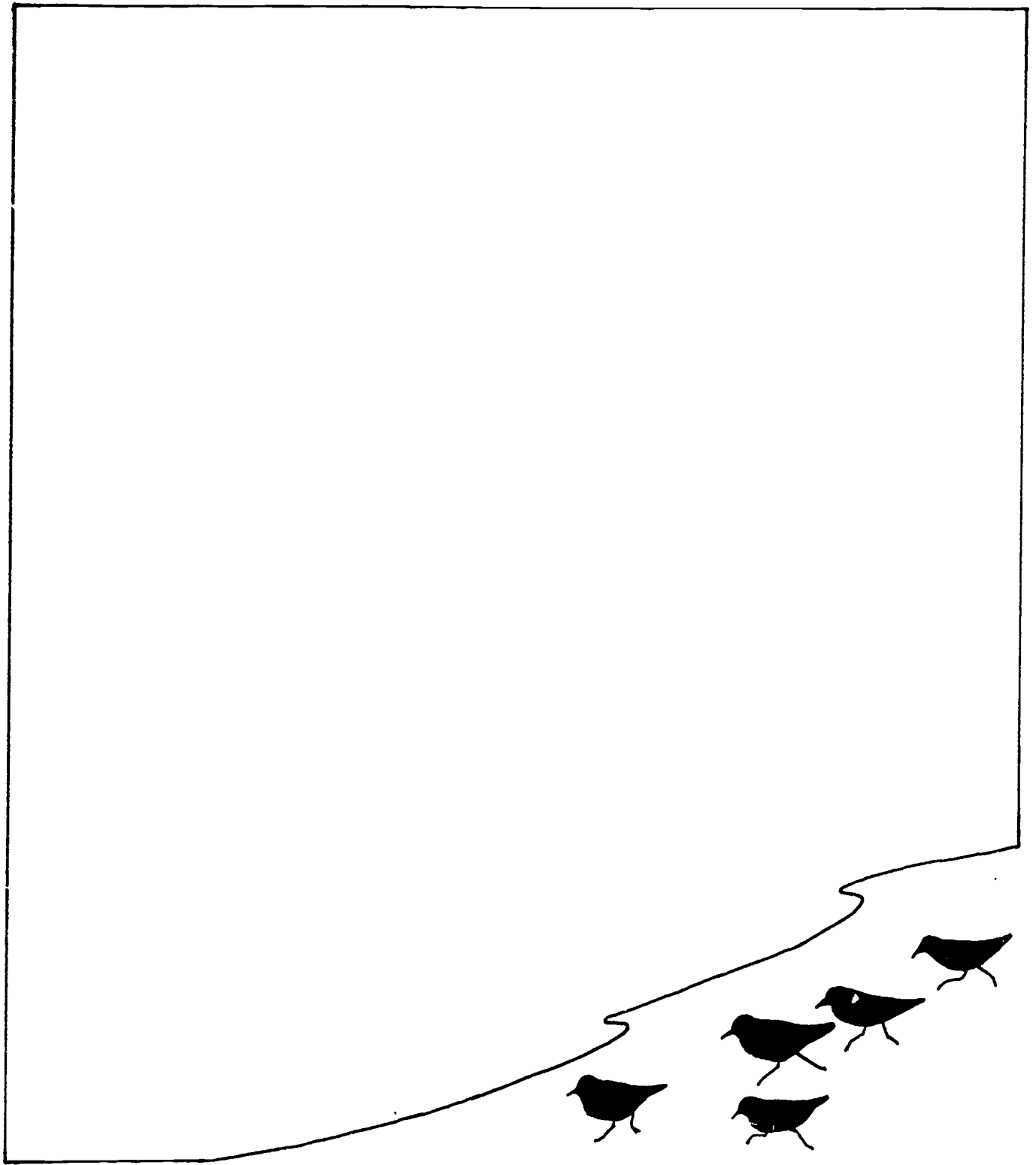

ACTIVITY 2:
BEACH FORMATION AND PROCESSES
(4 days)

ACTIVITY 2: BEACH FORMATION AND PROCESSES (4 days)

CONCEPTS: Beaches are the result of natural processes acting upon rocks and other existing material. Following Activity #2, Beach Formation and Processes, you should be able to describe what material makes up a beach, where the material comes from, how the beach material moves and what energy moves it.

OBJECTIVES: Following the activity, the learner will demonstrate his/her ability to:

1. name 5 beach types.
2. describe the different rock types and particle sizes that make up the 5 beaches.
3. state which particle size moves most early in water.
4. state which particle size requires the most energy to move it.
5. describe where the energy comes from to move the rock particles on the beach?
6. define what a beach is.
7. list the sources of beach material.
8. define longshore transport.
9. explain how beach material is moved along the beaches.
10. explain the beach process as it works in Puget Sound.
11. diagram the beach process as it works in Puget Sound.
12. explain why you find rocky, gravel, and sand beaches beside each other.

TEACHER

PREPARATION:

1. Teacher Information Sheet; Classification Table for Beach: rock size.
2. Teacher Information-Scientific American reprint, "Beaches", by Willard Bascom, from Activity #1.
3. (Student Reading) - Waves and Beaches

MATERIALS:

1. Slide presentation "Beach Types" Slides A1-A5
2. Script for slides A1-A5
3. Slides B1-B8 (Sources of Beach Material)
4. Script for slides B1-B8
5. Slide projector
6. Screen
7. Lab - "Sort It Out For Yourself"
 - a. Student Instruction

- b. Teacher's copy with suggested questions/answers, given orally or as a ditto for students.
- c. Lab Materials:
 - 1) Stream table or rectangular tray (at least 3-4 inches deep--like a rectangular dishpan.)
 - 2) Small bucket or similar container.
 - 3) Mixture of sand, mud, and gravel (perhaps obtained from the school grounds).
 - 4) Watering can with a single pour spout or small hose attached to a nearby faucet.
 - 5) Water supply.
 - 6) Brick or similar size text book.
- 8. 30 copies of Student Reading - Waves and Beaches
- 9. Film: Beach, A River of Sand, available from ESD #121, #109, and University of Washington. (20 minutes)
- 10. 16mm film projector and screen.
- 11. Film guide, Beach, A River of Sand, teacher's copy, 30 student copies.
- 12. Slide presentation, Beach Processes of Puget Sound, C1-C27.
- 13. Script.
- 14. Evaluation Handout.

PROCEDURES:

- 1. Lead a discussion:
Have students describe the kinds of beaches they know. Generally, they will describe the types rocky and sandy. If you push them, they may come up with the labels: boulder, cobble, gravel, sand and mud.
- 2. Beaches can be classified by the type of materials that are found there. Using the size chart given as teacher information, guide the students to the definition and use of those terms. If possible, obtain rocks, sand and gravel of the appropriate sizes to help students visualize the sizes of beach particles.
- 3. Show slides A1-A5 of "Beach Types". Ask why some beaches are nearly all sand and some beaches filled with gravel? Why are some beaches a mixture of sizes? Students at this point can only guess, but try to get them to suggest that something in nature is causing them to be that way. This will prepare students for finding out why.
- 4. Beaches are sorted because heavy particles require more energy to be moved. Heavy particles don't move as far as finer particles in a given current.
- 5. Lab - do the "Sort It Out For Yourself".*
Pass out Student Instructions for lab "Sort It Out

For Yourself". The procedure sheet and worksheet are designed to answer the problem of why some beaches are sand and some are gravel. The student should discover that waves (as energy) move the beach material according to size and amount of energy. The more energy, the larger the particles that can be moved. As the wave energy or turbulence is decreased, only the smaller particles can be moved.

*It is possible to alter this lab for more complexity and/or less classroom mess. Please note the alternative directions to the teacher on the Teacher Information Sheet for the "Sort It Out For Yourself" lab.

6. Student should note:
 - a. Gravel tended to remain stationary. Why?
(Because the water current or turbulence wasn't enough to move these larger rocks.)
 - b. Sand moved the farthest. Why?
(The sand particles are small and can be moved by this small amount of water current.)
 - c. At some point there was a mixture of sand and gravel. Why?
(At this point the amount of energy of motion was able to move a few rocks and some of the sand.)
 - d. What function did the water fulfill?
(It was the source of energy--like the waves on the beach.)
7. Lead a discussion that allows students to try to formulate a definition for beaches that includes the three elements: material, movement, and energy.
 - a. Definition of beaches. . .
"A beach is a deposit of material which is in transit either along shore or off and on shore"--Douglas W. Johnson,
Columbia University
 - b. Three elements are:
 1. There must be a quantity of (rocky) material.
 2. There must be a shore zone area in which it moves.
 3. There must be a supply of energy to move it.

8. Lead the student discussion to the following conclusion, "that if most Puget Sound beaches are sand and gravel, then beach material must come from deposits containing rocks."
9. Show the slides, "Sources of Beach Materials", B1-B8.
10. Continue the discussion to have students draw conclusions from their observations made in the experiment. These conclusions should consider the following:
 - a. Beaches are formed by natural forces (waves causing erosion and deposition) and are made from whatever material is available (including man-made litter).
 - b. The sources of material are:
 1. erosion--from mountains brought in by rivers, from cliffs fronting the water.
 2. deposition--of eroded materials, and from biological sources such as shells.
 - c. The source of energy for movement of rocky material is moving water. The energy from water movement moves the beach particles. As energy increases, the water can move more and larger rock particles, i.e., a faster current and greater turbulence.
 - d. Beaches are a result of natural processes acting upon existing materials.
 - e. Longshore transport is the mechanism by which the material is moved from river mouths and beach cliffs along the shore zone.

ASSIGNMENT

11. Hand out the Student Reading, Waves and Beaches. Assign this reading to be completed before the next day. Have them complete the waves and beaches worksheet.

PROCEDURES:

12. Show the film, Beach, A River of Sand. This film introduces the idea of longshore transport. Be sure students understand that energy for longshore transport comes from several sources such as :
 - river currents
 - tidal currents
 - wave and wind currents

This film is an integral part of this activity because it clarifies longshore transport. If it must be omitted for whatever reason, students must gain an understanding

of longshore transport from some other source. Some suggested resources are identified in the bibliography for this activity.

ASSIGNMENT:

13. Hand out the film guide before the film is shown. Explain that most of the questions will be answered by the narration, however questions 9 and 10 are thought questions, to be answered based on what they have learned about beach processes.

PROCEDURES:

14. Show the slide presentation "Beach Processes of Puget Sound." It shows the natural processes and how they are working along Puget Sound.

EVALUATION:

15. Give the student the evaluation diagram. Explain that this diagram gives them some more information about what currently exists on this beach. Their objective is to use the diagram and explain what is currently happening to the beach.

**EXTENDED
ACTIVITIES:**

1. Assign students to vary the experiment by changing the amount of water flow; or by changing the duration of water flow.
2. Change the "substrate" by covering a layer of sand with a layer of gravel. Have students predict what will happen.
3. If you have a patio or drive area available and a hose and water source, do the activity outside.
4. Build a small "mountain" or "cliff face" in the center of the pan. Direct the water from a hose/faucet to the base of the mountain. Note the erosion.
5. If you have a wave tank you can "build" a beach in one end. By generating waves of different sizes and different directions, you can see how the respective particles move.

(This experiment can also be done with the rectangular trays. Have a student generate waves by moving a board backwards and forward at one end of the tray. It has the potential for being quite a messy lab however.)

6. One way, of course, to cut down on the needed equipment is to do the lab as a demonstration.

7. Take a field trip to the beach. At the beach determine the type of substrate (boulders, cobble, gravel, sand or mud). Then determine the direction of the longshore transport by marking a starting point on the beach. At that point, toss an object that floats into the surf and watch which direction it moves. (A great way to do this is to take along some oranges or grapefruit; they float, will show visibly and get chilled in the process - for later lunching). Have the students attempt to evaluate what natural processes are doing to the beach. (Beach processes are very complex. Do not expect students to make an authoritative statement about what is happening. Hopefully the student will be able to make some observations about the substrate, the longshore transport, the source of beach material, and draw some kind of conclusions.)
8. Have students take sand samples from beaches they may visit.* Ask students who go on a vacation or weekend trip to the beach to collect sand, dry the sand and keep it in specimen jars labeled with the beach name. Given enough students, trips and time, the collection will clearly show that beaches are made from different materials. (Washington beaches tend to be from the mountainous granite and gneiss and appear gray. Hawaiian beaches are made of basalt or shell and appear either black or white.)
9. Make a large map of Puget Sound. As students visit various beaches in the area, have them note what type of beach material is found there. Have them try to evaluate the map to determine the source of each beach.

* Note: Consider conservation when the sand collecting activity is advised. In some locations the collecting of sand is inappropriate or prohibited.

**CLASSIFICATION TABLE FOR BEACH ROCK SIZE
(MODIFIED FROM WENTWORTH SCALE)**

<u>Name of Particles</u>	<u>Size Limits</u>	<u>Approximate Inch Equivalents</u>
Boulders	>265 mm	>10 in.
Cobbles	64-256 mm	2.5-10
Gravel	2-64 mm	0.08-2.5 in.
Sand	.0625-2 mm	0.002-0.08 in.
Silt	.0039-.0625 mm	0.00015-0.002 in.
Clay	<.0039 mm	<0.00015 in.

These terms describe the size of particles forming the beach and not the color or chemical composition of the materials.

ACTIVITY #2

TITLE: "BEACH TYPES"		PAGE NO. <u>1</u>
PICTURE DESCRIPTION	NARRATION OR AUDIO DIRECTION	
PIC. NO. <u>A-1</u>	BOULDER BEACH - This beach is made of rocks of a large size. While some rocks may be small, the majority of rocks here are larger than 10 inches.	
PIC. NO. <u>A-2</u>	COBBLE - The majority of rocks on this beach are between 2 and 10 inches. The average size is about that of a grapefruit. Note the several large boulders which help provide a size comparison.	
PIC. NO. <u>A-3</u>	GRAVEL - A gravel beach is made of stones ranging from tiny quarter-inch pebbles to rocks of about 2 inches.	
PIC. NO. <u>A-4</u>	SAND - The best beaches for sunbathing and for walking are sand beaches. Sand is made of tiny particles of rock. The size is smaller than $\frac{1}{4}$ inch.	
PIC. NO. <u>A-5</u>	MUD FLAT - This student is working in a mud flat. The rock particles here are fine. The spaces between particles hold a lot of water, making the sediments like an ooze.	
PIC. NO. _____		

Sort It Out For YourselfMaterials:

1. Stream table or rectangular tray (at least 3-4 inches deep, such as a rectangular dishpan).
2. Small bucket or similar container.
3. Mixture of sand, mud, and gravel (perhaps obtained from the school grounds).
4. Watering can with a single pour spout or small hose attached to a nearby faucet.
5. Water supply.
6. Brick or similar size textbook.

Procedure:

1. Fill a small bucket with sand, mud, and gravel mixed.
2. Dump the contents into one end of a large tray or stream table.
3. Elevate that end using the brick or book.
4. Using a stream of water from a hose connected to the faucet, or using a sprinkling can with a 1-hole pour spout, begin washing the sand and gravel (gently). Since the tray is elevated, avoid flooding the far end of the tray.

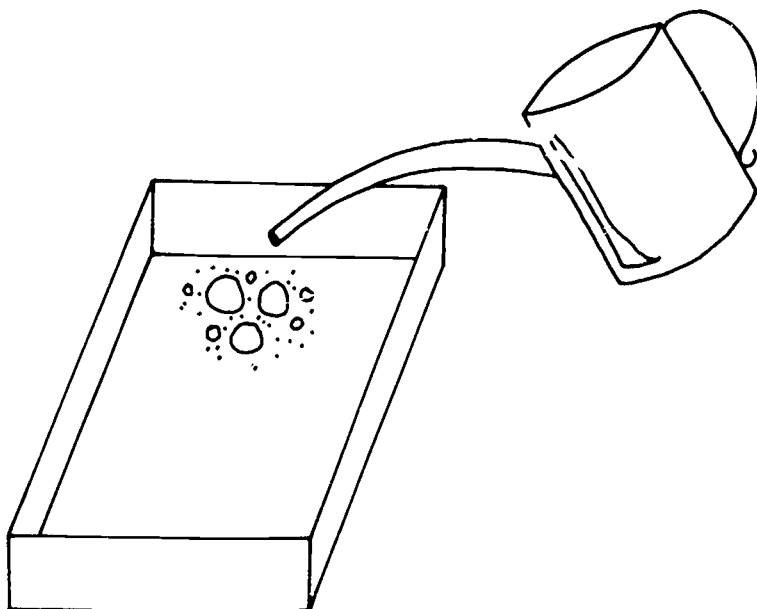

Results: Students should find the gravel, sand, and mud sorted out with the smaller particles traveling downslope the farthest. The larger sizes require more energy to travel the same distance as the smaller sizes.

Teacher Information Sheet
Sort It Out For Yourself
Page 2

Questions:

1. What happened to the sand, mud, and gravel mixture when the steady stream of water was added?

The sand, mud, and gravel sorted out.

2. Which rock size moved the least?

Gravel.

3. What difference would it make if more energy (stronger stream of water) was added to this system?

The gravel would be able to move farther than before.

4. Will bigger rocks need more or less energy to move the same distance as the sand?

More.

- 5a. On the diagram below, show where the gravel was after adding the water.

- 5b. On the diagram below show where you might find the gravel after adding more energy.

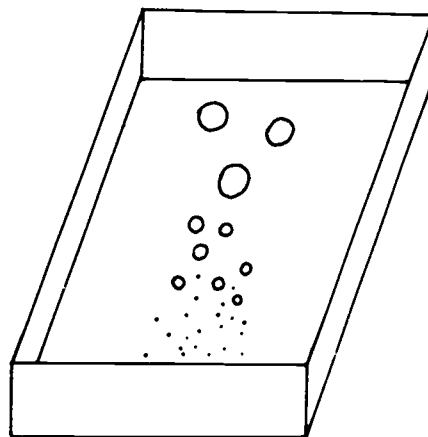
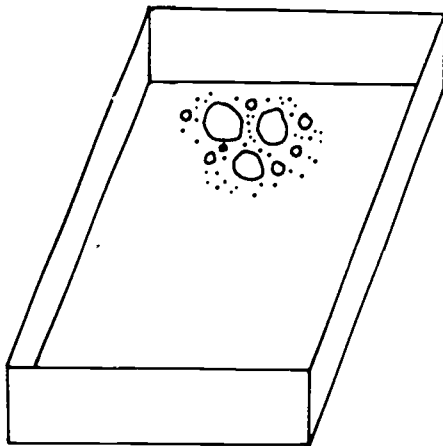

NAME _____

DATE _____

PERIOD _____

Sort It Out For Yourself

Students' Instructions

Materials:

1. Stream table or rectangular tray (at least 3-4 inches deep, such as a rectangular dish pan).
2. Small bucket or similar container.
3. Mixture of sand, mud, and gravel (perhaps obtained from the school grounds).
4. Watering can with a single pour spout or small hose attached to a nearby faucet.
5. Water supply.
6. Brick or similar size textbook.

Procedure:

1. Fill a small bucket with sand, mud, and gravel mixed.
2. Dump the contents into one end of a large tray or stream table.
3. Elevate that end using the brick or book.
4. Using a stream of water from a hose connected to the faucet, or a sprinkling can with a 1-hole pour spout, begin washing the sand and gravel (gently). Since the tray is elevated, avoid flooding the far end of the tray.

Questions:

1. What happened to the sand, mud, and gravel mixture when the steady stream of water was added?
2. Which rock size moved the least?
3. What difference would it make if more energy (stronger stream of water) was added to this system?
4. Will bigger rocks need more or less energy to move the same distance as sand?

Student Handout
Sort It Out For Yourself
Students' Instructions (continued)

NAME _____

DATE _____

PERIOD _____

Questions (cont'd)

- 5a. On the diagram below show where the gravel was after adding the water.
- 5b. On the diagram, show where you might find the gravel if the water flow were greater and more turbulent.

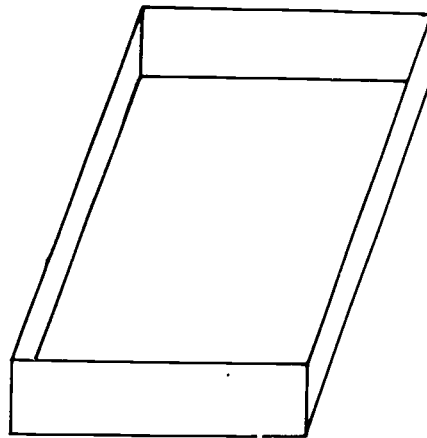
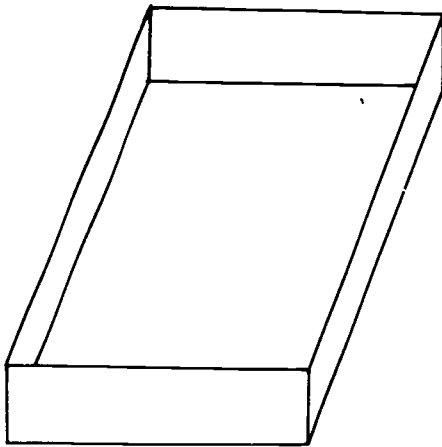

Beaches - Activity #2
Beach Formation and Processes

TITLE: "Sources of Beach Material"		PAGE NO. <u>1</u>
PICTURE DESCRIPTION	NARRATION OR AUDIO DIRECTION	
PIC. NO. <u>B-1</u>	ERODING CLIFFS/BLUFFS - In the Puget Sound region, much of the beach material is obtained from cliffs which face the water; waves come in and erode the base of a cliff. Soon the top part has no support, and it crashes to the beach below. Subsequent waves take this "new" material, sort it, and carry it along.	
PIC. NO. <u>B-2</u>	Cliffs that are eroding can be recognized by the lack of vegetation. Plants must anchor their roots in stable soil. If the soil is being eroded, plants won't have time to grow. Look for bare cliffs and you'll find erosion. They are called <u>feeder bluffs</u> .	
PIC. NO. <u>B-3</u>	RIVER OUTWASH - This slide shows the accumulation of sand carried to the shore zone by a river. Rain and weather break rocks high in the mountains. The rain washes the rock particles (both large and small) into the river.	
PIC. NO. <u>B-4</u>	The river carries the particles down the steep mountain sides to the beach. The beach slope is gentle and the sand is deposited, to be picked up and carried by incoming waves.	
PIC. NO. <u>B-5</u>	ERODING HEADLANDS - Like the cliffs the headlands are another source of beach material. Here, wave energy is directed onto a point of land sticking out into the water. Gradually the rock is eroded.	
PIC. NO. <u>B-6</u>	Sometimes, however, some of the rock is more resistant to the wave action than the surrounding rock. The result is that part of the headland remains while the water erodes around it. These features are called <u>sea stacks</u> .	

Beaches - Activity #2
 Beach Formation and Processes

TITLE: "Sources of Beach Material"		PAGE NO. <u>2</u>
PICTURE DESCRIPTION	NARRATION OR AUDIO DIRECTION	
PIC. NO. <u>B-7</u>	SHELL FRAGMENTS - Beaches are made from whatever materials are available; note this beach consists of tiny broken shell fragments.	
PIC. NO. <u>B-8</u>	ERODED ROCKS - It is quite easy to see the scouring power of the sea. These rocks have been carved by the waves. Some organisms, such as boring clams and urchins, which live in or on the rocks, weaken them. This makes the rocks more susceptible to wave action and erosion.	
PIC. NO. _____		
PIC. NO. _____		
PIC. NO. _____		
PIC. NO. _____		

Student Handout

NAME _____

Student Reading
Page 1

DATE _____

PERIOD _____

If you live inland, you probably think the ocean beach is a never-changing spread of sand. But this is far from what a beach is really like. The beach bordering an ocean is constantly changing. This is due to the force of the wind, waves, and currents. As we have already said, the energy of the wind is picked up by the waves far out at sea. When these waves travel to a beach all this energy is released on the beach. The larger the wave, the more energy it releases.

Although waves appear to hit the beach straight on, they seldom hit exactly parallel. Instead, they come from an angle. When a wave comes to a beach at an angle, the part closest to the beach touches bottom first. This part is then slowed down by friction with the bottom. This allows the rest of the wave to "catch up." From the air, the wave would appear to be bent so that it would be parallel to the beach. This bending is referred to as REFRACTION. Refraction tends to make the wave crests parallel with the beach, but there is usually a slight angle remaining.

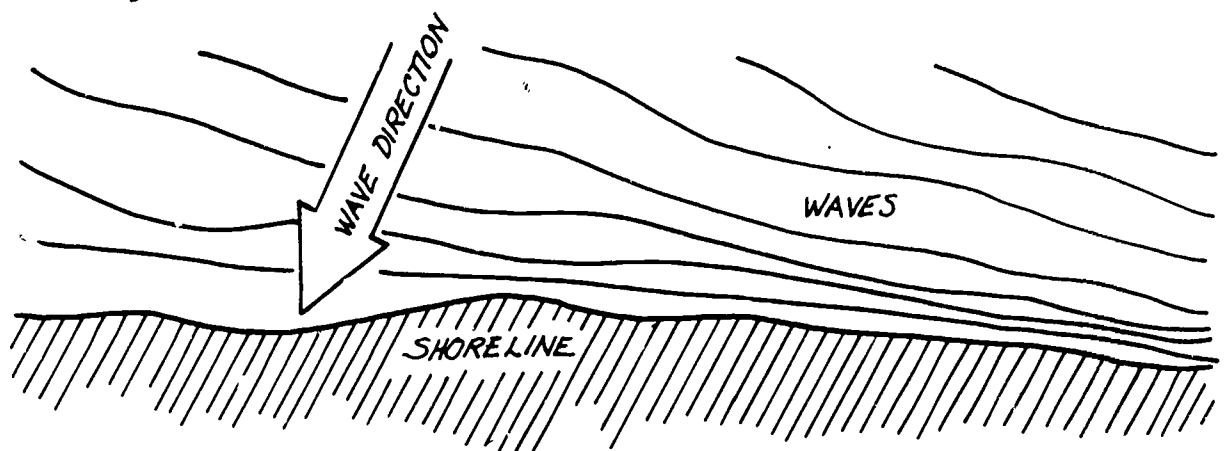

Waves approaching a beach at an angle will be refracted. As they approach the beach, the part of the wave near the shore will touch bottom and slow down. The other part will continue to move as fast as always and will seem to catch up with the other part.

Since breakers are translation waves that carry water, many breakers hitting the beach at the same angle can transport large amounts of water along the beach. This movement of water along the beach is called the LONGSHORE CURRENT. The longshore current is only found in the breaker zone.

Student Handout
 Student Reading (cont'd)
 Page 2

NAME _____

DATE _____

PERIOD _____

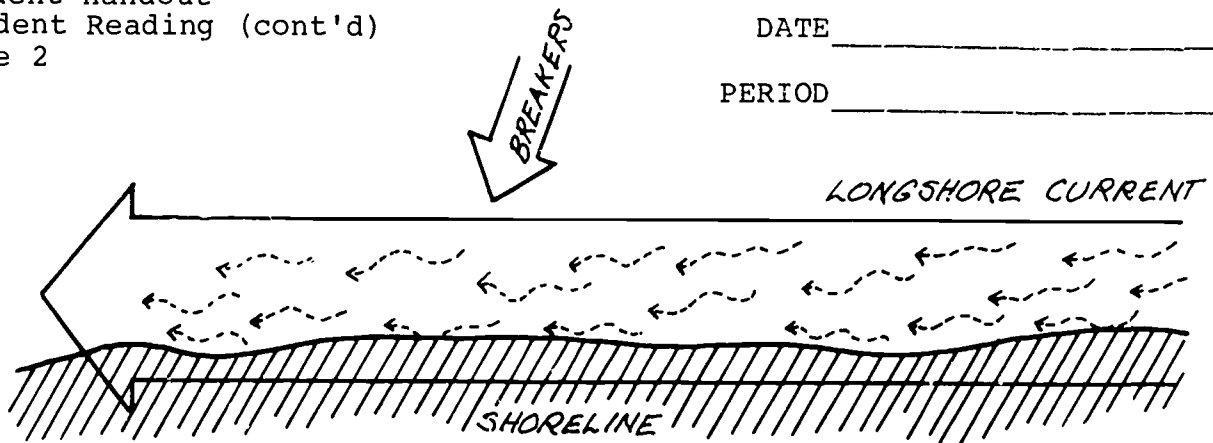

Waves hitting the shore at a slight angle cause a water current in the surf zone (wave zone) in the direction of the wave.

Longshore Currents

The longshore current is responsible for many of the natural alterations taking place on beaches. It can and does move tons of sand from one spot on the beach to another. For instance, next time you go to the beach notice the sand kicked up by incoming breakers. This sand kicked up from the bottom is moved along by the longshore current. The movement of sand along the beach is called the LITTORAL DRIFT or LONGSHORE TRANSPORT. The effects of the littoral drift can be seen on the ends of islands or peninsulas where the longshore current is operating. There, the waves no longer hit against the shoreline and the longshore current loses its energy. Sand is no longer carried along, but settles to the bottom. The results are long extensions of sand on the ends of these islands or peninsulas. We call these SPITS.

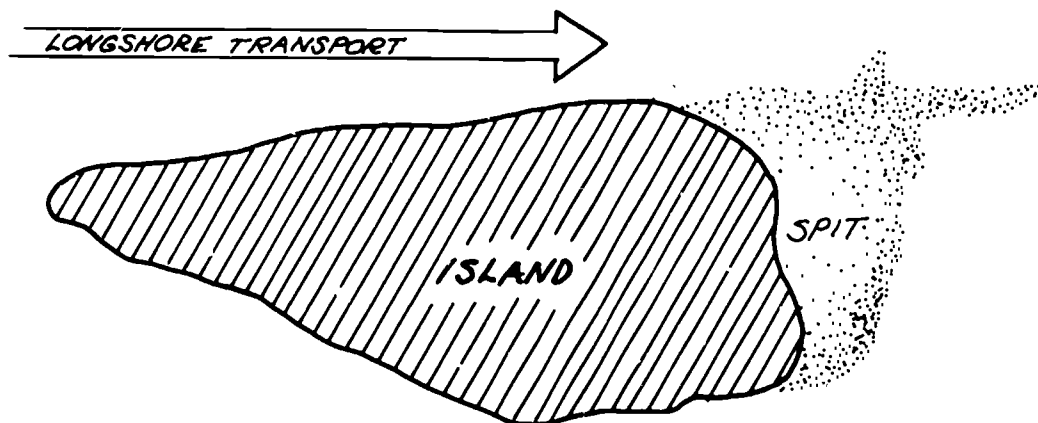

Island with a sand spit deposited on the end by the littoral drift.

Student Handout
 Student Reading (Cont'd)
 Page 3

Another common movement of sand at the beach is a movement offshore and onshore. One result of this movement is long mounds of sand parallel to the beach called SAND BARS. Sand bars are usually present offshore after a week or two of high breakers. When the waves are small for long periods, the sand bar is pushed toward shore and spread out by the waves.

Associated with sand bars are RIP CURRENTS. Breaking waves carry large amounts of water over the sand bar. The force of many waves breaking over the bar keeps water trapped between the bar and the beach. If the bar is broken anywhere along its length, water will go back to the ocean through the hole. This water comes from both directions inside the bar, and a current going straight away from the beach results in a break in the bar. This is the rip current.

Rip currents are responsible for carrying many bathers "over their head" at the beach. Rips are strong and should be avoided. However, when necessary, surfers and lifeguards can use rips to get through the surf rapidly. Coming back through a rip is very difficult and should be attempted only if you are an excellent swimmer. If you are ever caught in a rip, swim parallel to shore. When you get out of the current, swim to shore. With just a little practice you can learn to spot rip currents. They usually hold back waves and are sometimes discolored by sand and other debris picked up from the bottom.

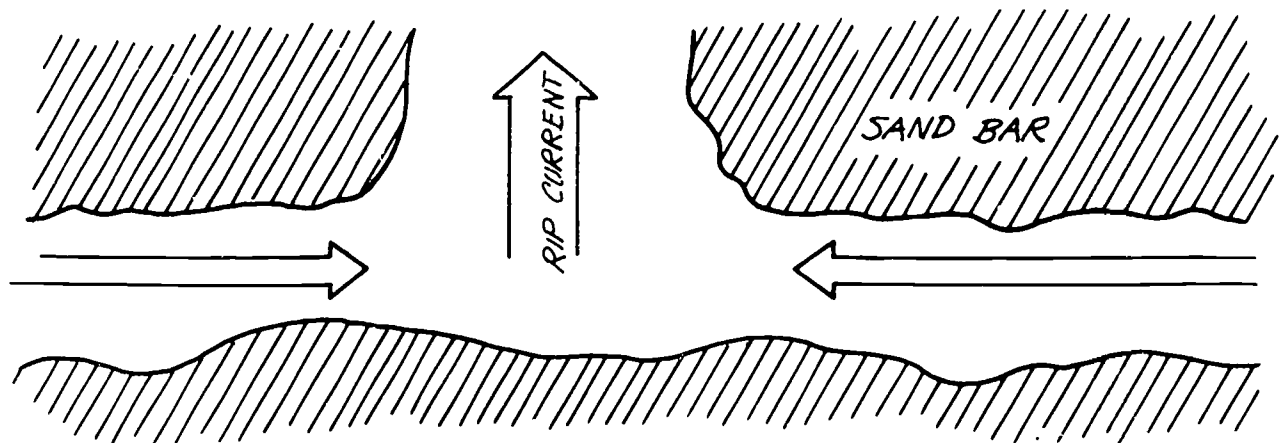

Water getting trapped between a sand bar and the beach can escape through a hole in the bar. This may produce a strong current running away from the beach. This current is called a rip current.

Man's Control of the Beach Environment

Years ago, ocean engineers thought barriers were the best way to keep a beach from washing away. Lately, they have found that stabilizing a beach in one spot can cause trouble somewhere else along the beach. For instance, if we stopped the littoral drift at the middle point on one of Puget Sound's beaches, the downcurrent section of the beach would

Student Handout
 Student Reading (Cont'd)
 Page 4

erode away; the upcurrent section of the beach would build up and become much wider because the barrier stops the sand here.

Many materials have been tried as barriers, but large rocks are the cheapest and easiest to obtain. These rocks are used to form JETTIES, GROINS, and BREAKWATERS. Jetties are structures that extend into the ocean at the entrance of rivers or bays. They restrict the flow of water out of the river to a narrow channel. This tends to prevent SHOALS (sand mounds in rivers or lagoons) from accumulating at the river mouth.

Groins are similar to jetties but are usually placed perpendicular to the shore. They are grouped at critical points in a series in order to catch and hold sand.

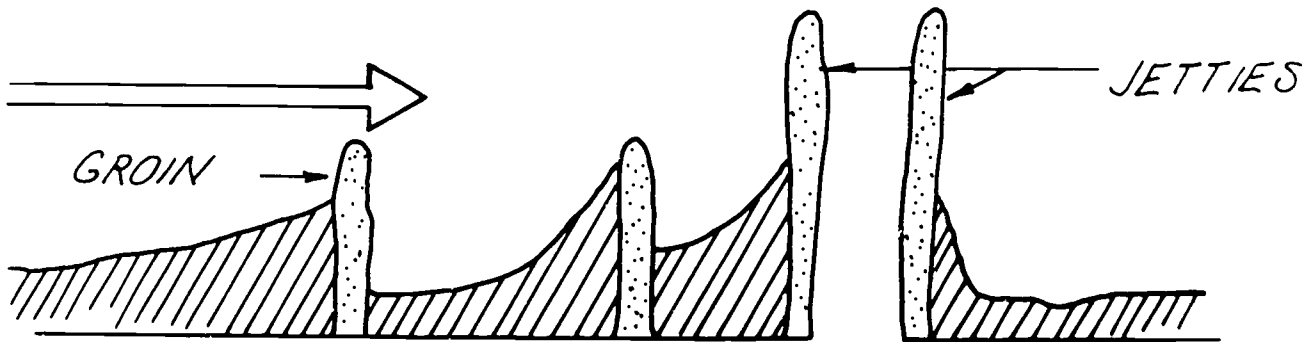

System of groins and jetties. The groins are perpendicular to the beach and are used for catching and holding sand from the littoral drift. The jetties are found on each side of the mouth of the inlet or river; their purpose is to keep sand from "shoaling up" in the entrance.

NAME _____

DATE _____

PERIOD _____

Waves and BeachesVocabulary:

Refraction - *The bending of waves as they approach the shore*

Longshore Current - *The net movement of water along the beach*

Littoral Drift - *The transport of sand along the beach. Carried by
by the longshore current*

Longshore Transport - *same as littoral drift*

Spit - *The extension of sand on the ends of islands or peninsulas*

Sand bars - *Long mounds of sand parallel to the beach. They are caused
by the offshore-onshore movement of water*

Rip Current - *A current going straight away from the beach which is
formed by a hole in the offshore sand bar that allows water,
trapped between the bar and shore, to rush back to the open
ocean.*

Jetties - *Man-made structures that extend beyond the mouths of rivers
or bays into the ocean area. They are used to prevent silting
up of the entrances.*

Groins - *Man-made structures placed perpendicular to the shore. They
are designed to catch and hold sand for a beach.*

Shoals - *Shallow areas in river mouths, lagoons, etc. caused by the
piling up of sand.*

Reading for Understanding:

1. In Hawaii there is a famous surfing contest where surfers "shoot the tube" or "ride the pipe". Actually the wave begins to break and curl over at one end of the beach and then continues the curl to the other end. Why doesn't the entire wave break all at the same time?

The entire wave doesn't break at any given moment in time because of the principle of refraction. The waves approach the island at an angle and "bend" to follow the shoreline.

2. One day two children were playing with a beach ball on the waterfront of Puget Sound. The ball was overthrown and landed in the surf area. It quickly was beyond their reach. As the children watched the ball, it traveled along the beach in a certain direction. Why didn't the ball simply stay in the area where the children had been playing?

The ball was carried by the longshore current. This process is called longshore transport.

Reading for Understanding (cont'd):

3. On Anderson Island in Puget Sound there is a sand spit which is quite large. It extends out from the island for over 100 feet. Children can play on it even at high tide. The spit ends abruptly. What caused this spit to form?

Wave action (energy) against the island picked up the sand. The longshore current transported the sand to where the waves no longer beat against the island. When this happens, the carrying energy of the wave is lost and the sand is deposited. Eventually, it builds up and forms a spit.

4. In Edmonds, a groin is located north of the ferry dock. The direction of longshore current is moving north. Draw a diagram showing the ferry dock, the groin and where the sand is accumulating. Be sure to show which direction is north.

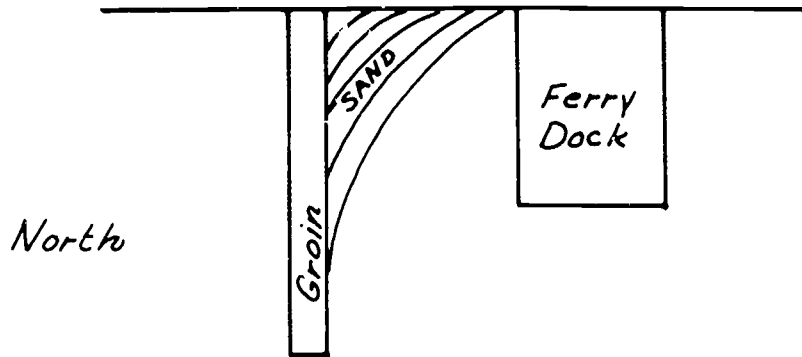

Student Worksheet

NAME _____

DATE _____

PERIOD _____

Waves and BeachesVocabulary:

Refraction:

Longshore Current:

Littoral Drift:

Longshore Transport:

Spit:

Sand bars:

Rip Current:

Jetties:

Groins:

Shoals:

Reading for Understanding:

1. In Hawaii there is a famous surfing contest where surfers "shoot the tube" or "ride the pipe". Actually the wave begins to break and curl over at one end of the beach and then continues the curl to the other end. Why doesn't the entire wave break all at the same time?
2. One day two children were playing with a beach ball on the waterfront of Puget Sound. The ball was overthrown and landed in the surf area. It quickly was beyond their reach. As the children watched the ball, it traveled along the beach in a certain direction. Why didn't the ball simply stay in the area where the children had been playing?
3. On Anderson Island in Puget Sound there is a sand spit which is quite large. It extends out from the island for over 100 feet. Children can play on it even at high tide. The spit ends abruptly. What caused this spit to form?
4. In Edmonds, a groin is located north of the ferry dock. The direction of longshore current is moving north. Draw a diagram showing the ferry dock, the groin and where the sand is accumulating. Be sure to show which direction is north.

Teacher Information Sheet
 Film Guide
 "Beach, A River of Sand"

NAME _____

DATE _____

PERIOD _____

1. What are beaches made of?

Students should be aware that beaches are made from whatever loose material is available. It could be quartz and feldspar grains (as in California), basalt (Hawaii), shell fragments (Florida).

2. Where do the rock particles come from?

From mountains - where rains and weathering wear down the rocks and the particles are washed into rivers which eventually wash out to the marine waters.

3. How are beaches formed?

Waves pick up the sand grains from the mouths of the rivers. The waves move the sand.

4. What happens to beaches during the summer? Winter?

During the summer, waves are gentle and have little energy. The sand grains can't be carried very far and are deposited on the beach. The winter waves are strong due to storms. The sand is eroded (picked up and carried away) by the waves.

5. Waves usually hit the beach at an angle. What effect does this have on the beach?

The sand grains being carried by the surf move along the shore zone - generally in a southerly direction.

6. Define: Longshore current - net water movement along the beach
 (found in the breaker zone)

Longshore transport - the movement of water and sand particles along the beach.

7. Why did a spit form in the Santa Barbara Bay?

The longshore transport carried the sand around the breakwater and into the bay where it settled due to little wave energy. Note: Dungeness Spit could be used as an example in Washington State.

8. Why did the bulge form behind the Santa Monica Breakwater?

The breakwater stopped the waves from hitting the shore. The energy is less, so the water deposits the sand.

Teacher Information Sheet
 Film Guide
 "Beach, A River of Sand"

9. What do you think would happen here:

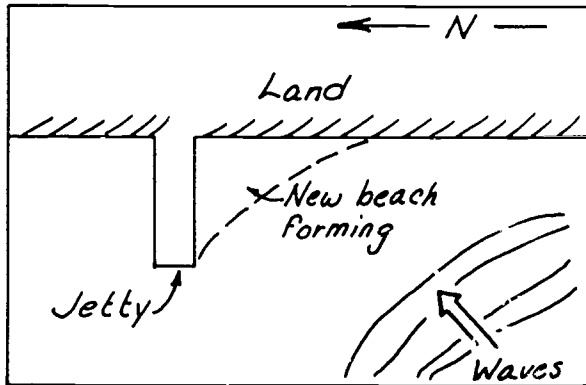

Students may diagram or explain that sand will accumulate on one side.

If students have fully learned that the material for beaches must come from somewhere, then probably the left side (northern) would begin to erode.

10. What do you think would happen to the beaches if all the rivers that empty into Puget Sound were dammed?

Students should suggest that much of the material that forms beaches would be "stored" behind the dams and beaches would be deprived of sand material.

Student Handout
Film Guide
"Beach, A River of Sand"

NAME _____

DATE _____

PERIOD _____

1. What are beaches made of?
2. Where do the rock particles come from?
3. How are beaches formed?
4. What happens to beaches during the summer? Winter?
5. Waves usually hit the beach at an angle. What effect does this have on the beach?
6. Define: Longshore current -
Longshore transport -
7. Why did a spit form in the Santa Barbara Bay?
8. Why did the bulge form behind the Santa Monica Breakwater?
9. What do you think would happen here?

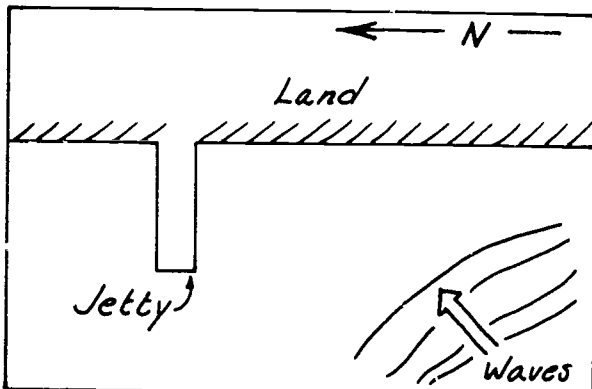

Student Handout
Film Guide
"Beach, A River of Sand"

NAME _____

DATE _____

PERIOD _____

10. What do you think would happen to the beaches if all the rivers that empty into Puget Sound were dammed?

Beaches - Activity #2
Beach Formation and Processes

TITLE: "Beach Processes of Puget Sound"		PAGE NO. <u>1</u>
PICTURE DESCRIPTION	NARRATION OR AUDIO DIRECTION	
PIC. NO. <u>C-1</u>	As one approaches an island in Puget Sound, the forces that alter the landscape and create the beaches become evident.	
PIC. NO. <u>C-2</u>	Wind, mainly from the southwest, blows over vast open areas of water.	
PIC. NO. <u>C-3</u>	Pushing the water into waves.	
PIC. NO. <u>C-4</u>	These waves reach the shoreline and crash into the land.	
PIC. NO. <u>C-5</u>	The energy of the waves carves the rocks and sea cliffs of the islands and the mainland.	
PIC. NO. <u>C-6</u>	No narration.	

Activity #2 (continued)

TITLE: "Beach Processes of Puget Sound"		PAGE NO. <u>2</u>
PICTURE DESCRIPTION	NARRATION OR AUDIO DIRECTION	
PIC. NO. <u>C-7</u>	At a place facing the wind and wave energy, one can see a "feeder bluff." The feeder bluff is a high cliff that faces the water. The bluffs may be composed of rocks or clay/sand/gravel in varying amounts.	
PIC. NO. <u>C-8</u>	As waves, wind, and weather work on the bluff, the material is eroded. The bluffs eventually crumble.	
PIC. NO. <u>C-9</u>	The softer material is washed away quickly by the energetic sea, leaving the more resistant and larger bits of rock.	
PIC. NO. <u>C-10</u>	When a resistant piece of land becomes separated from the mainland, sea stacks or small islands are left standing.	
PIC. NO. <u>C-11</u>	A wave is a form of energy. The more energy the larger the chunks of rock that can be transported.	
PIC. NO. <u>C-12</u>	A wave's energy is spread out as it reaches the beach. Less material is carried by the water, and more particles are left to form beaches.	

Activity #2 (continued)

TITLE: "Beach Processes of Puget Sound"		PAGE NO. <u>3</u>
PICTURE DESCRIPTION	NARRATION OR AUDIO DIRECTION	
PIC. NO. <u>C-13</u>	The energy from the waves that carries the beach material along the shoreline is called the <u>longshore current</u> . If we follow along the <u>shoreline</u> in the direction of the long-shore current we can see the changes in the beach material.	
PIC. NO. <u>C-14</u>	At the base of the cliff large boulders remain.	
PIC. NO. <u>C-15</u>	Beyond the boulders, in the direction of the longshore current, the beach is made of cobble size stones.	
PIC. NO. <u>C-16</u>	As the beach moves into the bay where the energy is less, the rocks become smaller in size.	
PIC. NO. <u>C-17</u>	Eventually, we step onto a sandy beach region. Here the waves lap more gently on the shore.	
PIC. NO. <u>C-18</u>	This diagram charts the direction of the wind and waves. It shows the feeder bluff and relative location of the beaches.	

Activity #2 (continued)

TITLE: "Beach Processes of PugetSound"		PAGE NO. <u>4</u>
PICTURE DESCRIPTION	NARRATION OR AUDIO DIRECTION	
PIC. NO. <u>C-19</u>	Another factor involved in forming Puget Sound beaches is the many rivers which drain into Puget Sound from the Olympic and Cascade mountains.	
PIC. NO. <u>C-20</u>	As these rivers erode the mountain faces, they carry rock and sand particles to the river mouths.	
PIC. NO. <u>C-21</u>	Here, at the river mouths, fine grains of sand are deposited, to be picked up and carried by the next incoming tide.	
PIC. NO. <u>C-22</u>	The sand from the rivers and the matter eroded from the shoreline are carried by the water along the shore zone. This process is called <u>longshore transport</u> . Note the light brown areas of sand in the water. They are evidence of longshore transport of sand.	
PIC. NO. <u>C-23</u>	Eventually, the longshore transport ends. This is usually at a jetty, spit or point of land. Note the build-up of sand on the one side of the jetty and the erosion on the other.	
PIC. NO. <u>C-24</u>	There are other factors which influence beach processes. One of these is tides. In this slide the tide is out. The height of the tide is shown by the growth of barnacles on the piling. The height of the material that can be eroded and/or deposited on a beach is determined by the highest tide.	

Activity #2 (continued)

TITLE: "Beach Processes of Puget Sound"		PAGE NO. <u>5</u>
PICTURE DESCRIPTION	NARRATION OR AUDIO DIRECTION	
PIC. NO. <u>C-25</u>	Animals which bore like this, as piddock clams and sea urchins, can break down the rocks. The weakened rocks eventually crumble and become beach material.	
PIC. NO. <u>C-26</u>	Finally, humans influence the beach process. In this slide you can see a railroad track near the shoreline at the base of the cliff. At one time this was a feeder bluff. The more recent vegetation indicates that the hillside has become more stable.	
PIC. NO. <u>C-27</u>	What do you think happens to longshore transport and beach processes when human beings add jetties, dikes, and bulkheads to water fronts?	
PIC. NO. _____		
PIC. NO. _____		
PIC. NO. _____		

NAME _____

DATE _____

PERIOD _____

Beach Formation and Processes

Evaluation

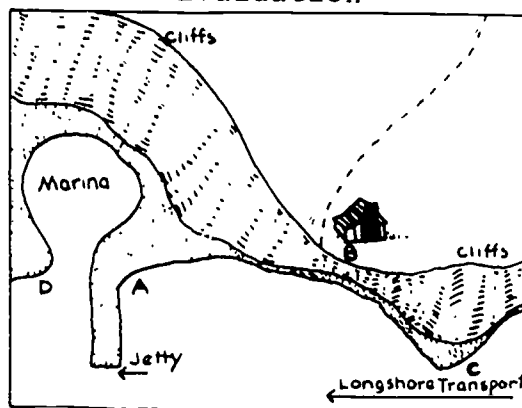

Given the information in the diagram above, answer these questions:

1. Where are you likely to find the beach area eroding?

Headland (point C) and possibly point D.

2. What is probably happening to the beach at point A. Why?

Sand is beginning to build up because of longshore transport and the jetty stopping the further transport of sand.

3. At point B the land lowers from high bluffs to a low beach front area, where someone has built a home. What beach material is likely (if any) to be in front of the home?

Gravel, boulders, or sand.

4. What beach material are you likely to find at point A?

Sand. At point C? Rocks.

5. Suppose a stream was located emptying into the bay at point B. What kind of beach might begin to appear and why?

Sand. A result of deposition of eroded mountain material.

Student Evaluation

NAME _____

DATE _____

PERIOD _____

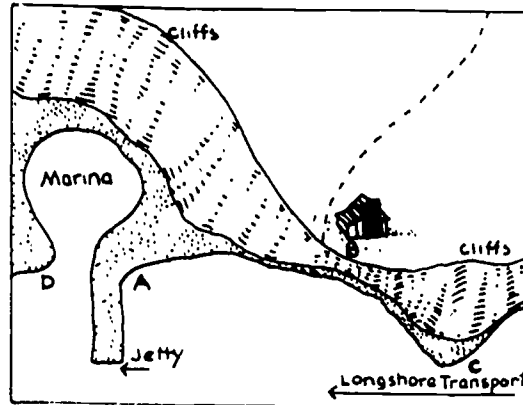

Given the information in the diagram above, answer these questions:

1. Where are you likely to find the beach area eroding?
2. What is probably happening to the beach at point A? Why?
3. At point B the land lower from high bluffs to a low beach front area, where someone has built a home. What beach material is likely (if any) to be in front of the home?
4. What beach material are you likely to find at point A?
At point C?
5. Suppose a stream was located emptying into the bay at point B. What kind of beach might begin to appear and why?

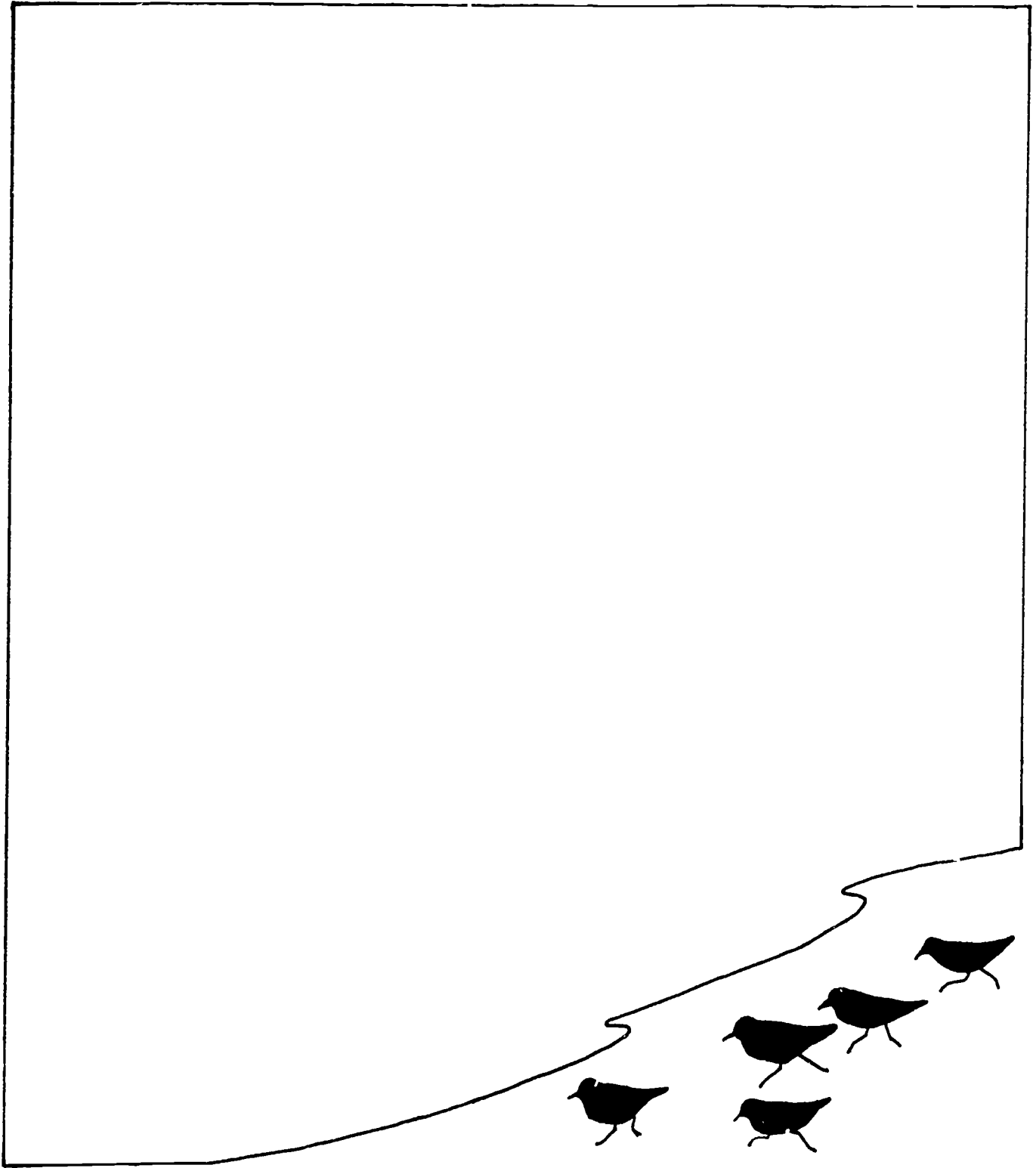

ACTIVITY 3:
BIOLOGICAL ZONATION OF A BEACH
(2-3 days)

ACTIVITY 3: BIOLOGICAL ZONATION OF A BEACH (2-3 days)

CONCEPTS:

Plants and animals that live on the beach have special needs and can be found in specific locations (zones) on a particular beach. By doing Activity #3, Biological Zonation of a Beach, you will learn a little bit about the organisms found on the beach, what each one needs to live, in which biological zones the organism can be found. Biological zones are different from the geological parts of the beach. However, they may overlap.

OBJECTIVES:

Following the classroom instruction and activities the learner will demonstrate his/her ability to:

1. list the 5 zones of the beach.
2. describe the general location of each zone on the beach face.
3. explain what influence the tides have on life zones.
4. list the needs organisms have to meet to survive on the beach.
5. state what mechanisms the snail has to survive on a beach.
6. list at least one animal from each zone.
7. state why that animal is found in that zone. (Here, think about the needs of the animal and what it has done to meet those needs.)
8. describe how the biological zones overlap with the geological parts of the beach.

TEACHER PREPARATION:

1. It is important that the teacher and the students have some awareness of marine organisms, the phylogenetic classifications and the survival needs and adaptations for individual species. If the student has not had background in this area, there are films, filmstrips, and easy readings available to aid in understanding. Please see the bibliography at the end of this activity for specific titles.
2. Optional -- The Sound and the Sea - J. Flora.

MATERIALS:

1. Make Figure 1 (from Activity #1) and Figure 3 into transparencies.
2. Overhead projector
3. Screen
4. Student Handout, "Beach Zone Definitions"
5. Overhead transparency of Figure 3 - "Biological Zones of a Beach"
6. Packet - "Tides" (optional)
7. Lab - "A Snail's Pace" - 30 copies; 2 per student.

- a. Littorina snails (See teacher note regarding the number and availability of littorina on the Teacher's Information Sheet for this lab.
- b. Beakers, 1 for every 4 students
- c. Sea water
- d. Centimeter ruler
- e. Petri dish/shallow dish
8. Slide presentation - "Habitat and Zonation"
9. Slide projector
10. Figure 4, "Biological Zones"
11. Student Handout, "Names of Animals and Descriptions of Habitats"
12. Worksheet, "Zonation"
13. Optional materials: "Puget Sound Habitat Charts"-- Shoreline Community College, Jack Serwold.

PROCEDURES:

1. Make classroom presentation or discussion-- Beaches can also be divided into biological zones. The zones are determined primarily by water level.
2. Prepare a ditto or transparency of Figure 3, "Biological Zones of a Beach." This should be accompanied by the handout of "Beach Zone Definitions". Discuss how students could identify the zones. Given also is the generally accepted name and the corresponding zone number (as established by J. Flora, Western Washington University.)
3. Habitats are determined by water level and the type of substrata (i.e. rocks, gravel, or sand). Make transparencies (or dittos) of Figure 1 (from Beach Parts) and Figure 3, "Biological Zonation." Since the outline is the same, overlaying one transparency on another allows students to see that the biological zones coincide with the geological place names (as established in the Beach Parts section).
4. Review with students about tides; what causes them and what happens to the water level on the beach. Remind the students that tides are the daily change of water level. Tidal movements are a result of the gravitational pulls of sun, moon, and earth. The combined tides are not equal at all times. Therefore all tides are not of equal height. The highest high tides of the month are called spring tides, and the lowest low tides of the month are called neap tides. Puget Sound also experiences a type of daily tide called a mixed tide. This means that it receives 2 high tides of unequal value and 2 low tides of unequal value about every 25 hours.
5. Introduce the idea that Life Zones are determined by tidal movements.

- a. Organisms in Puget Sound must adapt to this variable environment.
 - b. Organisms can be found in zones that best suit their needs.
 - c. The needs that must be met in some way are:
 - 1) how to avoid drowning and/or drying out
 - 2) how to survive heavy wave action
 - 3) how to obtain oxygen
 - 4) how to obtain food
 - 5) how to reproduce
6. Lab - Do the "Snail's Pace" lab:
 In this lab students will place several small littorina snails in a glass of water. Students should observe and time the movements of snails out of the water. Draw the students to the conclusion that while these snails can survive a short period of time under water, the snail moves to dry areas rather quickly. Point this out as students watch the snails climb out of the jar. They will see the muscular foot. When the animal is picked up and held, the muscular foot is hidden behind the operculum (a trap-door-like covering over the shell opening). This is to prevent desiccation (drying out).
7. Review the observations made from the "Snail's Pace" lab. Help students conclude that organisms can be found on a beach in the location that best suits their needs for survival.
8. Animals may be divided into groups by the zones along the beach in which they live:

Splash zone (Zone I)

Isopods
 Snails

High Beach Animals (Zone II)

Shore crabs
 Barnacles
 Mussels
 Snails
 Limpets

Middle Beach Animals (Zone III)

Worms
 Sea Urchins
 Snails
 Crabs
 Chitons
 Limpets
 Clams
 Anemones
 Sea Stars

Lower Beach Animals (Zone IV)

Anemones
 Sea stars
 Sea urchins
 Crabs
 Clams

Open Water Animals (Zone V)

Jellyfish
 Fish

9. Show slide presentation "Zonation". Have Students note the names of the zones and organisms found there.

ASSIGNMENT:

10. Give the students the worksheet "Zonation". Have them complete the worksheet of a beach drawing by placing the symbols for the organisms in the proper zones on Figure 4.
11. Note: Have students recognize that because tide pools have permanent water, animals may appear to be found in a different zone. The trapped water enables lower beach animals to live in a higher zone.

**EXTENDED
ACTIVITIES:**

1. Prior to or following the review of tides you might decide to insert the activity packet on "Tides".
This optional activity would take 3 to 5 days to complete. Its function would be to clarify tide types and definitions.
2. This activity introduces a new vocabulary. To call it to students' attention and to help retention, post a large butcher sheet of paper in the room. Whenever students locate new words, they can then list them. To make it fun, they can challenge another student to find the definition before the next day.
3. It might be beneficial to have students do an independent research project on a species found at the beach.
4. Make a large mural across a room wall which depicts a beach scene at "low tide". Have students draw or find photographs of various species and place them at the appropriate location.
5. Have students do research and phylogenetic classifications. Have them choose a representative

organism and either draw it or find a picture of it. Display the facsimile and identify those phylogenetic characteristics.

BIBLIOGRAPHY:

Benson, Shirley Ann, "An Ecological Unit Utilizing Invertebrate Phyla of the Mid-Puget Sound Region".

Flora, Charles J. & Eugene Fairbanks, M.D. The Sound and the Sea

Kozloff, Eugene, Plants and Animals of the Pacific Northwest. University of Washington Press, Seattle, 1976.

Metropolitan Park District, Tacoma, Washington, 1968.

Activities - Seattle Aquarium

The Tidal Zone
Distribution of Plants
and Animals

Films-

Life Between the Tides
Seashore Life, Community Life
Beach and Sea Animals
The Sea

Marine Animals of
the Open Coast

Visual Aids-

Puget Sound Habitat - Shoreline Community College,
Jack Serwold

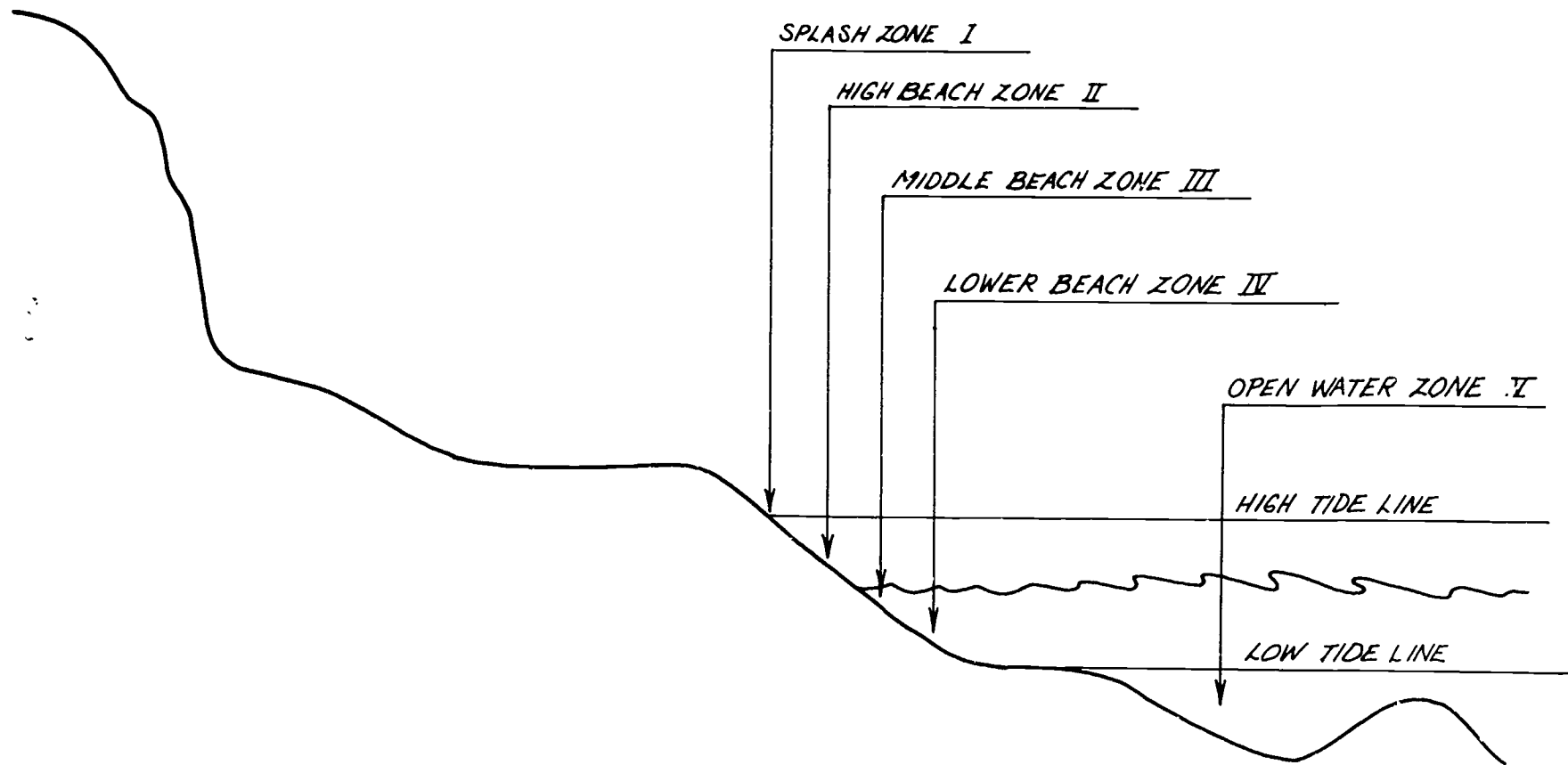

Figure 3 - Biological Zones of a Beach

NAME _____

DATE _____

PERIOD _____

Beach Zone Definitions

1. Splash zone (Zone I) - almost completely dry, receiving spray only from storm winds and very high tides. Extends down to about the average of all high tides.
2. High Beach (Zone II) - this zone is only covered with water at very high tide. This is the home of animals accustomed to tolerating more air than water.
3. Middle Beach (Zone III) - typically covered twice each day and uncovered twice each day. This is the true intertidal zone. Animals in this zone are accustomed to exposure to both air and water.
4. Lower Beach (Zone IV) - always covered by water except for a few hours each month. Animals here are accustomed to tolerating more water than air.
5. Open Water (Zone V) - the salt water mass itself.

Teacher Information Sheet

NAME _____

DATE _____

PERIOD _____

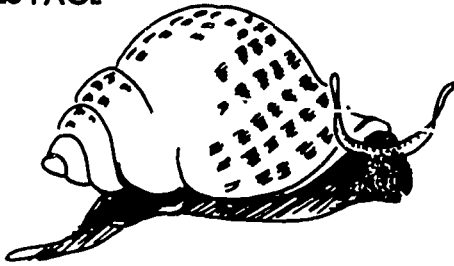
A SNAILS PACE

Littorina - a species of small snail found on Puget Sound beaches.

Concept:

Some salt water snails are adapted for intertidal life and select the water's edge.

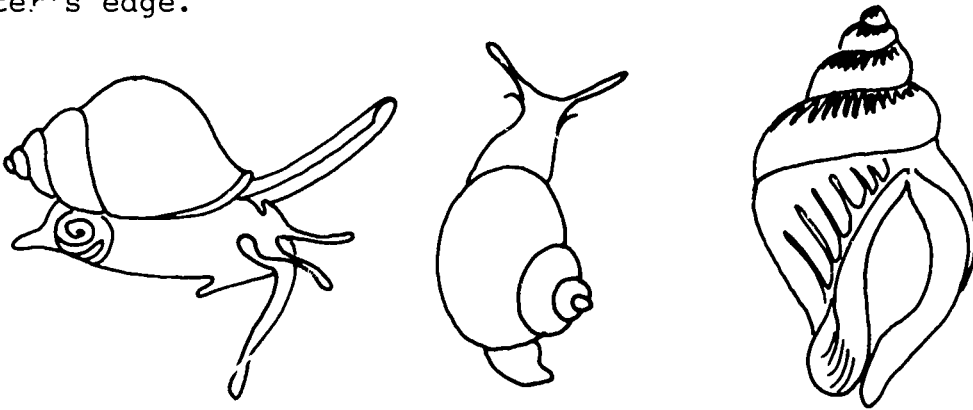

Fig. 1. Sea snails move over rocks along the edge of the sea and use a radula (a file-like tongue) to graze on algae. Other snails use the radula to wear holes in clams and oysters so they may be eaten. The circular plate just below the shell in the righthand snail, above, is the operculum. It closes the shell when the snail's body is withdrawn.

Materials:

1. 2 Littorina snails per student.
2. One beaker of salt water per 4 students.
3. Student Handout: "Snail's Pace"
4. Petri dish or shallow dish

Procedures:

1. Divide students into groups of 4.
2. Gently place four snails in one place on the bottom of a beaker of salt water.

Teacher Information Sheet

"Snail's Pace"

3. Observe and record the position of each snail at ten-minute intervals on the diagram below. Use these four symbols: ○ ✱ □ ×

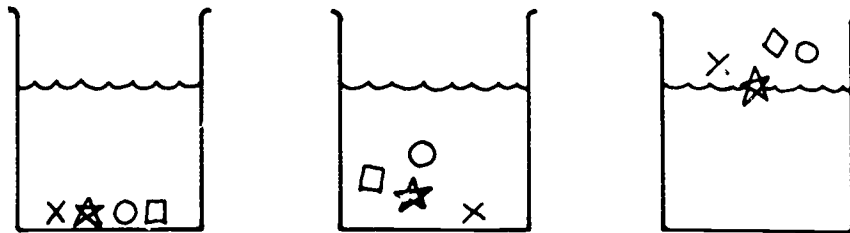

4. During the ten-minute waiting intervals, take your second snail, observe it, and answer the following questions.

Questions:

Gently remove your snail from the Petri dish and observe its head.

1. Does the head have any appendages (antennae)? *Yes*
2. Measure or estimate the length of the antennae. (varies) cm
3. What might the antennae be used for?
(Sensing the environment)
4. Measure the length of the snail's shell. (varies) cm
5. Measure the length of the snail's foot. (varies) cm
6. How many swirls does your snail's shell have? (varies)
7. Is the opening of the shell a left-handed or a right handed opening?

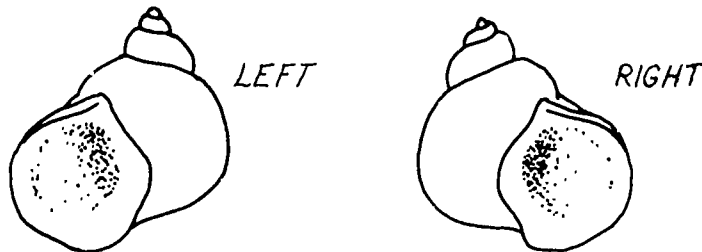

8. Why is it important for a snail to have a shell?
(To protect it from the smashing wave and from predators)
9. Find the operculum and touch it. How does the snail react?
(It closes the operculum)
10. Name two things the operculum might protect the snail against.
 - a. *(Desiccation - drying out)*
 - b. *(Predators)*
11. Measure the operculum. It is (varies) cm across.

Teacher Information Sheet
 "Snail's Pace"

After completing your laboratory observations, answer the following questions.

12. Recall the positions of the snails in the beakers after 30 minutes. What biological zone would snails tend to locate themselves in on the beach?

The upper zones; the splash zone or high tide zone (Zones I and II)

13. Why do you think the snails moved to that zone?

The upper reaches of the beach provides for the needs of the littorina.

Conclusions:

1. *Students should be led to discover snails will move out of water.*
2. *Students can see the muscular foot as the snail climbs out of the beaker.*
3. *The muscular foot is hidden when the snail is out of water - behind the operculum.*
4. *The operculum is a "door" the snail can shut to conserve water.*

Note: Littorina may be found on virtually any rocky beach. They are generally a numerous species. However, if all teachers took snails indiscriminately the beaches would soon be decimated. Therefore, consider how many snails you will need. Do not take more than necessary for one class at a time. These snails are hardy and can survive repeated experiments. Snails should be returned to the beach when the observations are complete.

You might even consider reducing the number of snails per group. The experiment can be easily modified.

NAME _____

DATE _____

PERIOD _____

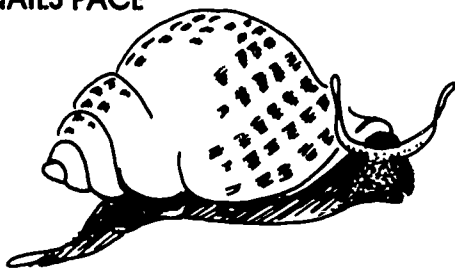
A SNAILS PACE

Littorina - a species of small snail found on Puget Sound beaches.

Concept:

Some salt water snails are adapted for intertidal life and select the water's edge.

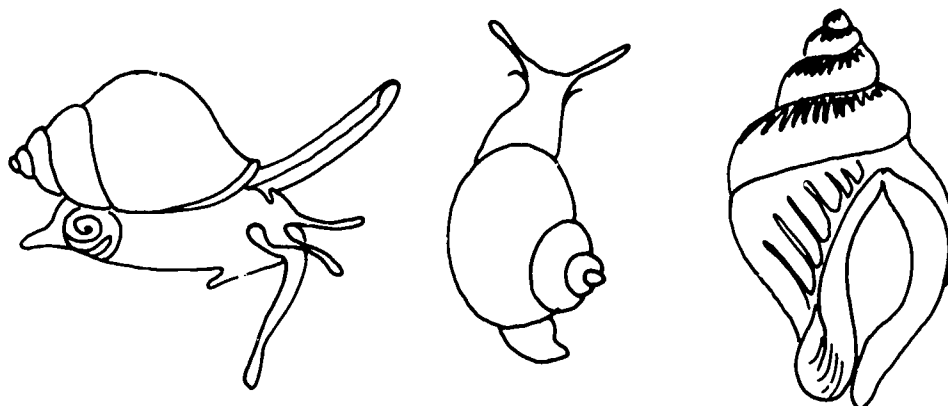

Fig. 1. Sea snails move over rocks along the edge of the sea and use a radula (a file-like tongue) to graze on algae. Other snails use the radula to wear holes in clams and oysters so they may be eaten. The circular plate just below the shell in the righthand snail, above, is the operculum. It closes the shell when the snail's body is withdrawn.

Materials:

1. 2 Littorina snails per student.
2. One beaker of salt water per 4 students.
3. Student Handout: "Snail's Pace"
4. Petri dish or shallow dish

Procedures:

1. Divide students into groups of 4.
2. Gently place four snails in one place on the bottom of a beaker of salt water.

"Snail's Pace" (continued)

3. Observe and record the position of each snail at ten-minute intervals on the diagram below. Use these four symbols: \times \square \star \circ

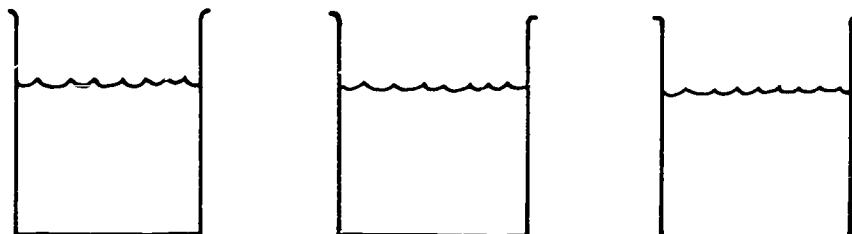

4. During the ten-minute waiting intervals, take your second snail, observe it, and answer the following questions.

Questions:

Gently remove your snail from the Petri dish and observe its head.

1. Does the head have any appendages (antennae)?
2. Measure or estimate the length of the antennae. _____ cm.
3. What might the antennae be used for?
4. Measure the length of the snail's shell. _____ cm.
5. Measure the length of the snail's foot. _____ cm.
6. How many swirls does your snail's shell have? _____
7. Is the opening of the shell a left-handed or a right-handed opening?



8. Why is it important for a snail to have a shell?
9. Find the operculum and touch it. How does the snail react?
10. Name two things the operculum might protect the snail against.
 - a.
 - b.
11. Measure the operculum. It is _____ cm. across.

Beaches - Activity #3

TITLE: "Habitat and Zonation"		PAGE NO. <u>1</u>
PICTURE DESCRIPTION	NARRATION OR AUDIO DIRECTION	
PIC. NO. <u>D-1</u>	"Habitat and Zonation"	
PIC. NO. <u>D-2</u>	All beaches have life zones along them, which are determined by tidal movements. Animals may be divided into groups by the vertical beach zones in which they live.	
PIC. NO. <u>D-3</u> Splash Zone	The highest zone on the beach is the splash zone. Animals here must be able to withstand extremely long periods of exposure to air. Only spray hits this zone at high tide. Some animals found here include:	
PIC. NO. <u>D-4</u> Isopods and snails	Isopods, shown here at the tip of the index finger and snails. at the tip of the little finger.	
PIC. NO. <u>D-5</u> High beach	Below the splash zone is found the high beach zone. Animals who live in this zone must be able to withstand more air than water. This zone is only covered with water at high tide. Animals here include:	
PIC. NO. <u>D-6</u> Shore crabs	Shore crabs	

Activity #3 (continued)

TITLE: "Habitat and Zonation"		PAGE NO. <u>2</u>
PICTURE DESCRIPTION	NARRATION OR AUDIO DIRECTION	
PIC. NO. <u>D-7</u>	Barracles, mussels, snails, and limpets.	
PIC. NO. <u>D-8</u> Middle beach	Below the high beach, covered and uncovered twice a day, is found the middle beach zone. Animals that live here must be able to withstand equal exposure to water and air. Some animals found in this zone include:	
PIC. NO. <u>D-9</u>	Worms	
PIC. NO. <u>D-10</u>	Sea urchins	
PIC. NO. <u>D-11</u>	Snails	
PIC. NO. <u>D-12</u>	Crabs	

Activity #3 (continued)

TITLE: "Habitat and Zonation"		PAGE NO. <u>3</u>
PICTURE DESCRIPTION	NARRATION OR AUDIO DIRECTION	
PIC. NO. <u>D-13</u>	Chitons	
PIC. NO. <u>D-14</u>	Limpets and sea stars	
PIC. NO. <u>D-15</u>	Clams	
PIC. NO. <u>D-16</u>	and Anemones.	
PIC. NO. <u>D-17</u> Lower beach	The lower beach is covered by water most of the time. It is exposed only during very low tides. Animals here must be able to withstand more water than air. Some residents of this area include:	
PIC. NO. <u>D-18</u>	Anemones	

Activity #3 (continued)

TITLE: "Habitat and Zonation"		PAGE NO. <u>4</u>
PICTURE DESCRIPTION	NARRATION OR AUDIO DIRECTION	
PIC. NO. <u>D-19</u>	Sea stars	
PIC. NO. <u>D-20</u>	Sea urchins	
PIC. NO. <u>D-21</u>	Crabs	
PIC. NO. <u>D-22</u>	and Clams.	
PIC. NO. <u>D-23</u>	Open water animals must be free-floaters or able to swim. some cor..on animals found here are:	
PIC. NO. <u>D-24</u>	Jellyfish and Fish.	

Activity #3 (continued)

TITLE: "Habitat and Zonation"		PAGE NO. <u>5</u>
PICTURE DESCRIPTION	NARRATION OR AUDIO DIRECTION	
PIC. NO. <u>D-25</u>	These five zones may be quite broad on a gently sloping beach or very narrow on a steep beach or piling. Using the information from this slide presentation and worksheet, "Zonation," place the symbols for the animals in the appropriate area on the beach drawing in the worksheet.	
PIC. NO. <u>D-26</u> Produced by Shirley Benson		
PIC. NO. _____		
PIC. NO. _____		
PIC. NO. _____		
PIC. NO. _____		

Student Handout

NAME _____

DATE _____

PERIOD _____

Worksheet: ZonationConcept:

Animals are associated in groups by the vertical zones of the beach where they live.

Materials:

1. Worksheet - "Zonation" (including drawing of a beach)
2. Notes from slide presentation, "Zonation"

Procedures:

1. Read the descriptions of tidal zones, animals, and habitats on pages 52, 53 and 66-68. Symbols are given for each animal.
2. Draw the symbols in the zone on the beach drawing where each organism might be found.
3. After completing the beach drawing, answer the following questions.

Questions:

1. Was there overlap (i.e., were some organisms found in more than one zone)? If so, list some.
2. How is this zonation shown on a piling? (Make a drawing and label it.)

Student Handout

NAME _____

DATE _____

PERIOD _____

Figure #4 - Biological Zones

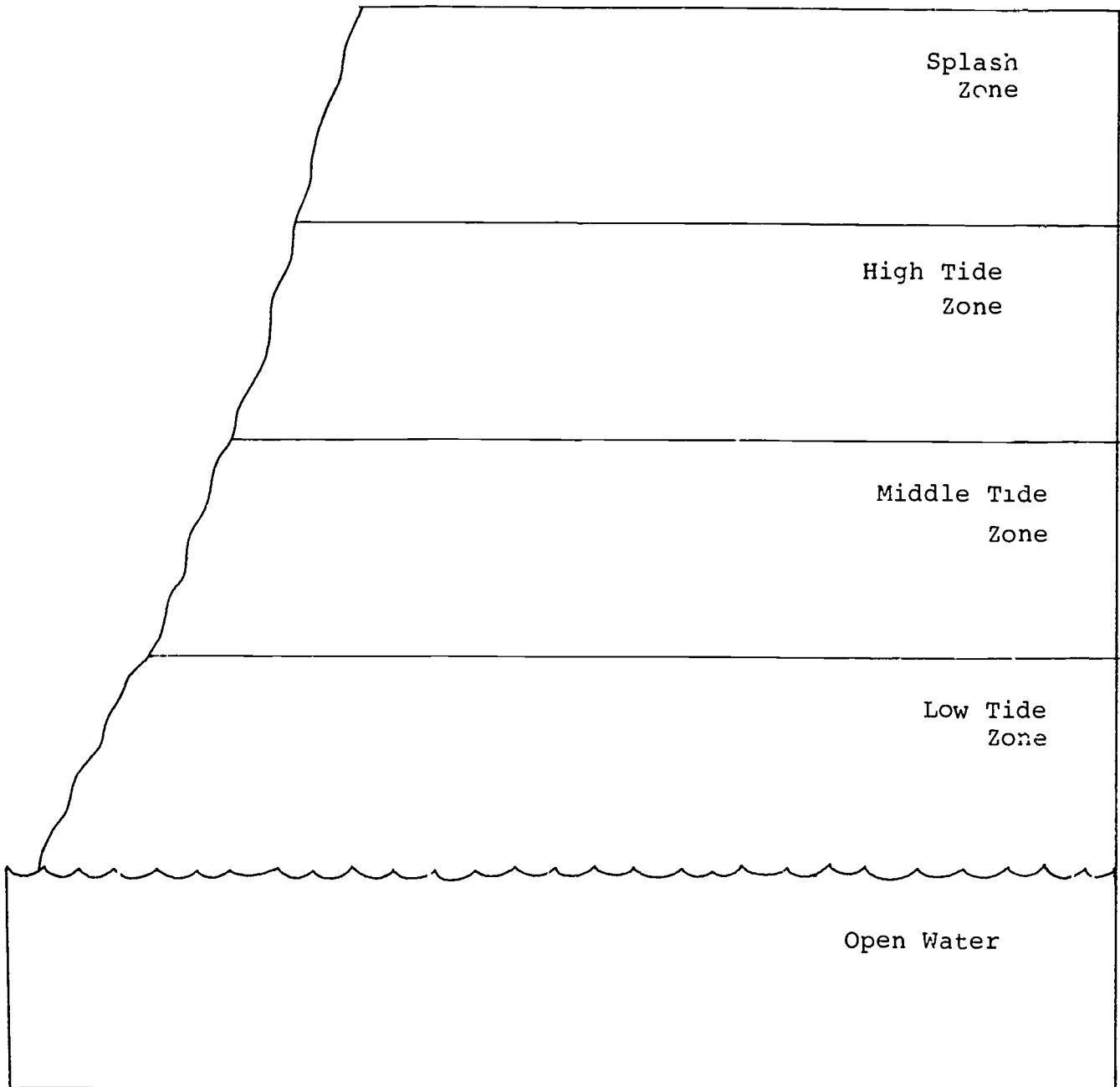











NAME _____

DATE _____

PERIOD _____

NAMES OF ANIMALS AND DESCRIPTIONS OF HABITAT

1. Isopods - under rocks, in sea weed mats, where they may remain moist during low tides. 
2. Shore crabs - tide pools and under rocks. They are able to survive tidal exposure if gills remain moist. 
3. Worms - they live in tubes and are grouped to survive wave shock. They feed only during times when covered with water. 
4. Anemones - they are found attached to rocks and in sand. They close during low tide to conserve water for survival. 
5. Jellyfish - free floating and swimming organisms. They are not accustomed to exposure to air. 
6. Fish - swimmers who need gills covered with water at all times. Found under rocks and sea weed. 
7. Sea stars - found on underside of rocks. They hold water in their water vascular systems to survive exposure to air. 
8. Sea urchins - often bore into soft rock to survive wave shock. May survive some exposure to air. 
9. Barnacles - attached to rocks and other objects by a strong glue-like substance. They live in groups to break wave shock. They can close their tough shells to survive long exposure to air. 
10. Snails - found in rocky and tide pool areas. They are able to withdraw into their shells for extended periods of time. 

NAME _____

DATE _____

PERIOD _____

Names of Animals and Descriptions of Habitat

11. Mussels - live in groups called "beds" attached by byssal threads, which hold them securely to rocks and other strata. Can close shells to conserve water during long exposure to air.



12. Chitons - mobile organisms with shell plates or tough water covering. Can adhere tightly to rocks with muscular feet for frequent, short exposure to air.



13. Clams - found in sandy or soft rocky areas. Each has a muscular foot for digging into beach to avoid desiccation during low tide.



14. Limpets - single shells which serve as protection during long exposure to air. Each has a muscular foot which helps it adhere tightly to rock surfaces so that it will not be swept away.



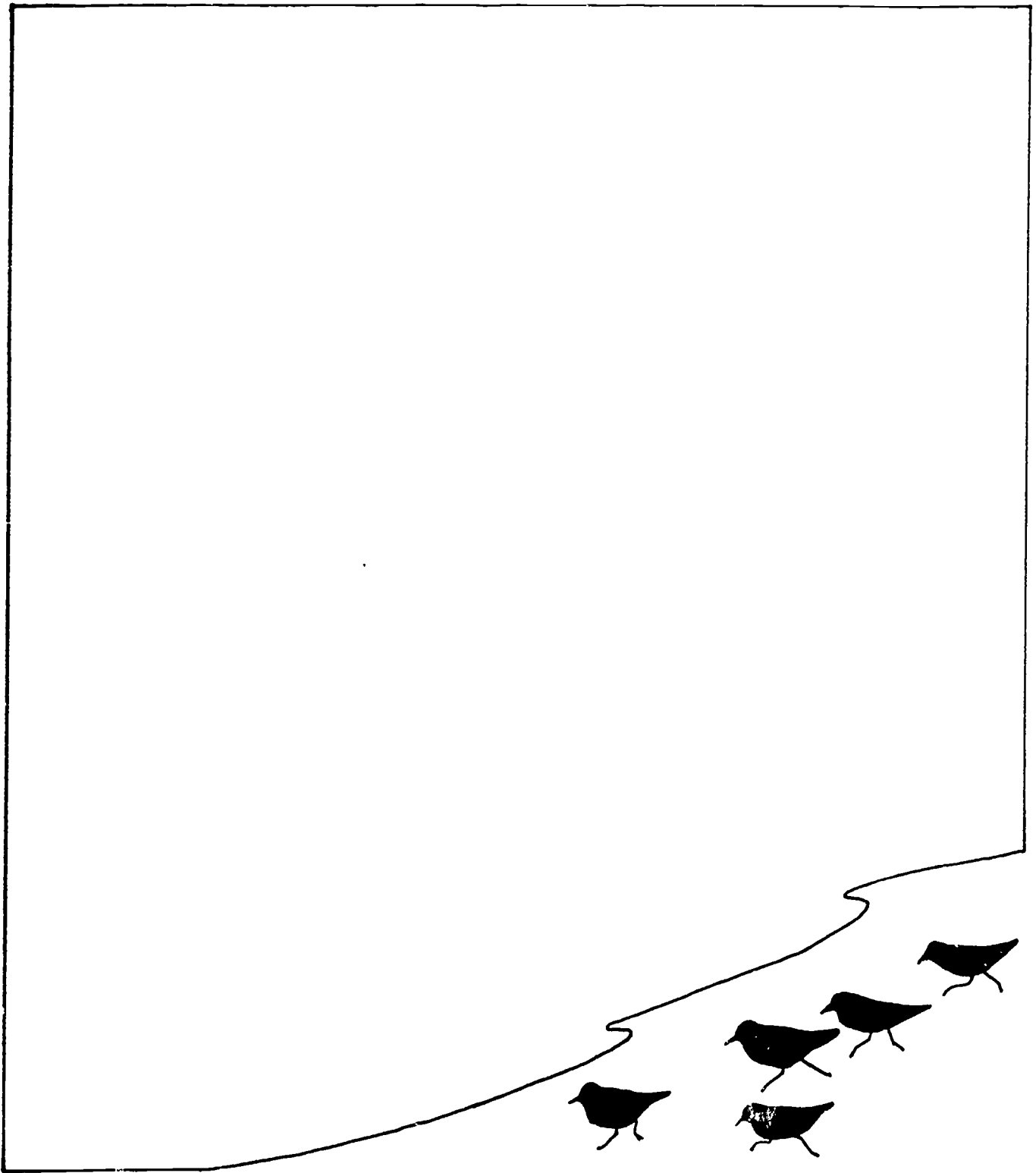

ACTIVITY 4:

HUMAN USE AND IMPACT ON BEACHES

(2 days)

ACTIVITY 4: HUMAN USE AND IMPACT ON BEACHES (2 days)

CONCEPTS:

1. The beaches of Puget Sound have had many uses. Some human activity has an impact on the beach.
2. The activity on and use of the beach can have both positive and negative effects on marine organisms.

OBJECTIVES:

Following this activity the learner will demonstrate his/her ability to:

1. list the uses of the beach.
2. describe human activities that have had a positive impact on beaches.
3. describe human activities that have had a negative impact on beaches.

TEACHER

PREPARATION:

See Materials list below.

MATERIALS:

1. Butcher paper sheets--2 ft x 2 ft; 1 per group; 4-5 groups.
2. Pens--1 per group
3. Slide presentation, "Environmental Modification" EL-E36
4. Script
5. Slide projector
6. Screen

PROCEDURES:

1. Divide students into several groups. Explain what brainstorming is. Brainstorming is an activity designed to generate ideas. Encourage students to say all they think about the given topic. Even "far out" ideas can help. They may cause someone else to think of a truly useful idea. No answers are right or wrong or absurd at a brainstorming session.

Have students brainstorm all the ideas they have about how human beings use the beach. Have them write ideas on butcher paper and then compare with other groups. Form one long composite list.

2. Some suggestions for the list might be as follows:

The beaches of Puget Sound have had many uses. For example:

swimming	oyster picking
boating	summer cabins
industry	homes
fishing	etc.
clam digging	

3. Divide the classroom into two groups. Have one group describe any negative impact each use (listed by the students) might have on any of the beach organisms. The other half will describe any positive impact each use might have. Urge students to really consider their positions as seriously as if they were going to court. It is very easy to say all human activity has only a negative impact. Some organisms thrive because of human intervention. (Compare results)
4. Human use of Puget Sound beaches has left its impact. Show the slide presentation, "Environmental Modifications." Following the presentation lead a discussion about human use and impact on the beaches of Puget Sound. Help students conclude that human activities can have a negative and/or positive effect on the beach. Litter and pollution may eliminate some species or provide homes for some species and nutrients for plant growth. These plants may then attract new species. Human beings are a part of the total marine eco-system.

EVALUATION:

5. Evaluation - this evaluation covers beach formation, processes and human use.
6. Optional film - film produced by Shell Oil Company called Undersea Oasis depicts the impact of man-made objects that have found their way to the bottom of the oceans. See bibliography.

BIBLIOGRAPHY:

Benson, Shirley Ann; An Ecological Unit Utilizing Invertebrate Phyla of the Mid-Puget Sound Area. Master's Thesis, University of Washington, Oct. 1975.

Film - Undersea Oasis, Shell Film Library
1433 Sadlier Cir. W. Drive
Indianapolis, Indiana
46239

Activity #4

TITLE: "Environmental Modifications"		PAGE NO. <u>1</u>
PICTURE DESCRIPTION	NARRATION OR AUDIO DIRECTION	
PIC. NO. <u>E-1</u>	Man modifies the marine environment in a variety of ways. These modifications may be from direct pressures or from indirect pressures. Direct pressures include:	
PIC. NO. <u>E-2</u> Broken bottle	Discarding litter on the beach,	
PIC. NO. <u>E-3</u> Dog and master	depositing human and animal wastes directly on the beach,	
PIC. NO. <u>E-4</u> Fisherman	removal of animal life such as this fisherman taking worms for bait,	
PIC. NO. <u>E-5</u> Clam diggers	this clam digger,	
PIC. NO. <u>E-6</u> Boys	or these boys.	

Activity #4 (continued)

TITLE: "Environmental Modifications"		Page NO. <u>2</u>
PICTURE DESCRIPTION	NARRATION OR AUDIO DIRECTION	
PIC. NO. <u>E-7</u> Marina	Indirect pressures include marinas,	
PIC. NO. <u>E-8</u> Wharves	wharves, such as this one used for public fishing at Edmonds,	
PIC. NO. <u>E-9</u> Storm drain	storm drains, sewage disposal,	
PIC. NO. <u>E-10</u> Oil dock	oil refineries and loading docks	
PIC. NO. <u>E-11</u> Tanker	which attract tankers	
PIC. NO. <u>E-12</u> Industrial plant	and industrial plants. These human pressures may	

Teacher Information Sheet

76

Activity #4 (continued)

TITLE: "Environmental Modifications"		PAGE NO. <u>3</u>
PICTURE DESCRIPTION	NARRATION OR AUDIO DIRECTION	
PIC. NO. <u>E-13</u> Barnacle marks	eliminate habitats,	
PIC. NO. <u>E-14</u>	or increase the possibility of direct human pressure by attracting more people to an area.	
PIC. NO. <u>E-15</u>	New surfaces on which animals may live are provided by pilings,	
PIC. NO. <u>E-16</u> Bulkhead	bulkheads,	
PIC. NO. <u>E-17</u> Jetty	jetties,	
PIC. NO. <u>E-18</u> Boat bottom	boat bottoms,	

Activity #4 (continued)

TITLE: "Environmental Modifications"		PAGE NO. <u>4</u>
PICTURE DESCRIPTION	NARRATION OR AUDIO DIRECTION	
PIC. NO. <u>E-19</u> Pipe	pipes,	
PIC. NO. <u>E-20</u> Wizard can	and litter.	
PIC. NO. <u>E-21</u> Broken bottle		
PIC. NO. <u>E-22</u> Oil spill	Habitats are changed or destroyed by: oil spillage,	
PIC. NO. <u>E-23</u> Effluent	excessive industrial effluent, containing toxins,	
PIC. NO. <u>E-24</u> Sewage	raw or improperly treated sewage,	

Activity #4 (continued)

TITLE: "Environmental Modifications"		PAGE NO. <u>5</u>
PICTURE DESCRIPTION	NARRATION OR AUDIO DIRECTION	
PIC. NO. <u>E-25</u> Dump	land fills, dumps,	
PIC. NO. <u>E-26</u> Hot effluent	and increases in temperature. These changes may include:	
PIC. NO. <u>E-27</u> Barnacle marks	generally reduced animal populations, or vacating of an area by an entire species,	
PIC. NO. <u>E-28</u> Pipe with growth	increases in populations of an indigenous species or introduction of a new species.	
PIC. NO. <u>E-29</u> Litter pick-up	It is man's duty to moderate his impact upon the environment. This may be done on an individual basis such as picking up litter or	
PIC. NO. <u>E-30</u> Oil demonstration	demonstrating your views on a subject.	

Activity #4 (continued)

TITLE: "Environmental Modifications"		PAGE NO. <u>6</u>
PICTURE DESCRIPTION	NARRATION OR AUDIO DIRECTION	
PIC. NO. <u>E-31</u>	becoming an active member of a concerned citizens committee such as PTSA, schools, city councils, science clubs, garden clubs, or voting for candidates who support sound environmental legislation.	
PIC. NO. <u>E-32</u>	State and national changes may be made by joining and participating in organizations such as Sierra Club, Isaak Walton League, Northwest Steel Headers, Nature Conservancy, or Friends of the Earth.	
PIC. NO. <u>E-33</u>	Supporting legislative action, such as those shown here will help moderate man's impact on a state and national level.	
PIC. NO. <u>E-34</u> Little girl	If we fail to take care of our precious salt water areas, we will find one of our most necessary food sources and enjoyable recreation areas.	
PIC. NO. <u>E-35</u> Dead fish	altered beyond repair.	
PIC. NO. <u>E-36</u>	Produced by Shirley Bensch.	

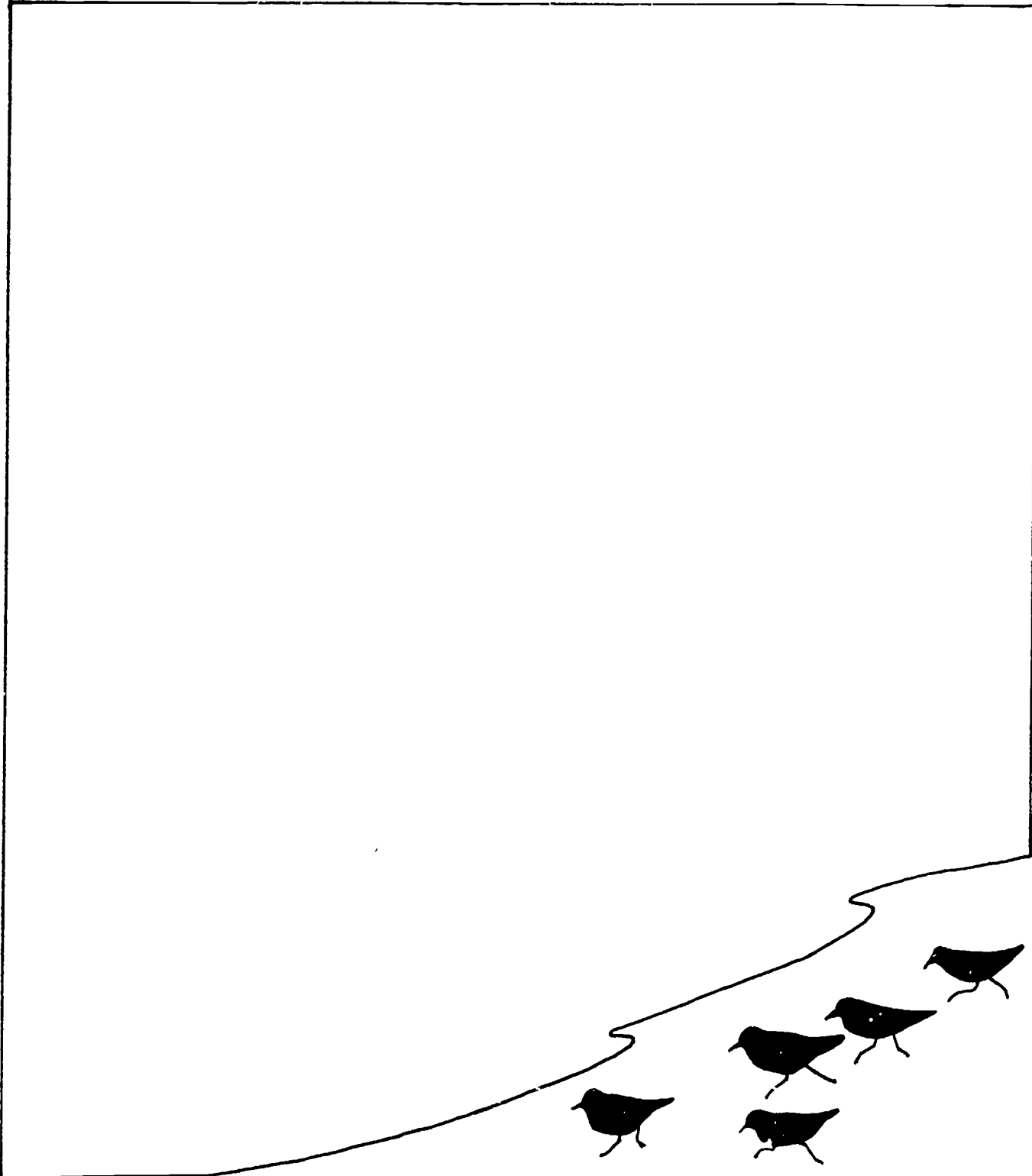

**EVALUATION
VOCABULARY
BIBLIOGRAPHY**

NAME _____

DATE _____

PERIOD _____

BEACH PROCESSES AND HUMAN IMPACT ON BEACHES

1. In Edmonds, a railroad company built the track bed at the base of an eroding hillside, just a few feet from the waterfront. To prevent erosion of the hillside they placed a bulkhead at the edge of the water. What impact will this have on the beach formation process? What impact will it have on different species of animals?

(The beach formation process will be interrupted by the bulkheads. The "material" for the beach will be cut-off and the longshore transport will eventually remove the existing beach. Animals that need a beach to survive, such as clams which bury into sand, will lose their habitats. However, bulkheads provide new homes for organisms like barnacles.)

2. Off the beach at Alki, scuba divers have placed old rubber tires. What impact might this have on the marine organisms? On the human use of the beach?

(The tires have provided new homes for organisms. The entire "reef" has become an underwater park for divers to explore.)

Student Evaluation Sheet

NAME _____

DATE _____

PERIOD _____

BEACH PROCESSES AND HUMAN IMPACT ON BEACHES

1. In Edmonds, a railroad company built the track bed at the base of an eroding hillside, just a few feet from the waterfront. To prevent erosion of the hillside they placed a bulkhead at the edge of the water. What impact will this have on the beach formation process? What impact will it have on different species of animals?
2. Off the beach at Alki, scuba divers have placed old rubber tires. What impact might this have on the marine organisms? On the human use of the beach?

BEACHES**VOCABULARY:**

coast
cliff
dune
beach
berm
backshore
foreshore
feeder bluff
swash
backwash
shoreline
spring tides
neap tides
offshore
continental margins
submarine bar
river outwash
eroding headlands
longshore current
longshore transport
refraction
littoral drift
spit
sand bars
rip current
jetties
groins
shoals
operculum
zonation
splash zone
high beach
lower beach
phylogenetic classification
desiccation

BEACHES

BIBLIOGRAPHY:

Books:

Modern Earth Science - Ramsey et. al., Holt, Rinehart and Winston.

Cross, M. Grant, Oceanography, Charles E. Meru Publishing Company, Columbus, Ohio, 1976.

Hoyt, John H., Field Guide to Beaches, Houghton Mifflin Company, Boston, Mass., 1971.

Flora, Charles J. and Eugene Fairbanks, M.D. The Sound and The Sea. The Washington State Department of Printing, Olympia, Washington, 1977.

Kozloff, Eugene, Plants and Animals of the Pacific, University of Washington Press, Seattle, WA., 1976.

Friese, U. Erich, Guide to the Point Defiance Aquarium. Metropolitan Park District, Tacoma, WA., 1968.

Periodicals:

Bascom, Willard. "Beaches", Scientific American reprint, August, 1960.

Curricula and Reports:

Benson, Shirley Ann, An Ecological Unit Utilizing Invertebrate Phyla of the Mid-Puget Area, Master's Thesis, Central Washington State University, Oct. 1975.

C.O.A.S.T. MARINE ENVIRONMENT CURRICULUM STUDY, Underkoffler and Hughes, Marine Advisory Service, University of Delaware and Population-Environment Curriculum Study, College of Education, University of Delaware.

#240, Beaches: A Geological Study, 1974.

#225, The Rocky Shore, 1974.

OCEANOGRAPHY SUMMER INSTITUTE. Hall, Stanley; McLeod, Roderick; and Scott, Sarah.

Puget Sound Marine Environments, 1961.

Resources:

Slides, courtesy of Jerry Strain, Shirley Pauls, Ray Taylor, Andrea Marrett, Dr. Richard Sternberg, Steve Kohn, and Father Christopher Abair.

Visual Aids:

Resource person - Wolf Bauer

Puget Sound Habitat Charts - Shoreline Community College, Jack Serwold.

Films and Filmstrips:

The Beach, A River of Sand. A study of the movement of a river of sand between the land and the water. EBEC 1965, 20 minutes. COLOR

The Restless Sea. Surveys the many aspects of oceanography, including what makes waves and tides, nature of marine life, erosion of land, nature of sea bottom, analysis of sea water and tracing of storms. Bell 1964. 60 minutes. COLOR

Seacoasts: A first film. Describes the various kinds of seacoasts and the variety of animals that live in the intertidal zone. BFA 1970. 10 minutes. COLOR

The Seashore: Pacific Coast. Explores beaches and coastlines of the Pacific shore. Examines plants, birds, shells and animals along beaches and in tide pools. BARR 1969. 10 minutes. COLOR

How level is Sea Level. Illustrates the constant changes created by waves and tides and provides data for the investigations of the question, how level is sea level. Points out that mean sea level is not the same for all oceans. EBEC 1970. 13 minutes. COLOR.

The Tidal Zone. Describes plant and animal life in the Tidal Zone where a river and an ocean meet, and shows the major problems of survival in an area where there is daily reversal in salinity. VEVA 1966. 14 minutes. COLOR.

Films and Filmstrips: (continued)

Distribution of Plants and Animals. A study in plant and animal ecology. Traces the various factors which influence the distribution and survival of animals in a given geographical area. EBEC 1963. 16 minutes. COLOR.

Life Story of the Oyster. How the oyster develops into an adult and how it feeds, grows, and reproduces; the place of this mollusk in the marine food cycle. EBEC 1963. 11 minutes. COLOR.

Life Story of the Sea Star. Depicts the life cycle of the starfish showing its adaptations to intertidal zone environment. Demonstrates characteristics which brittle stars, sand dollars and sea urchins have in common with starfish. EBEC 1963. 11 minutes. COLOR.

Seashore. A portrait of the marvels of the seashore with a low key message to preserve these wonders for future generations. Pyra 1972. 8 minutes. COLOR.

Sense of Wonder. Based on Rachel Carson's best-selling books "The Sense of Wonder" and "The Edge of the Sea". This film gives visual expression to what the author felt about the beauty and meaning of nature. MGHTOP 1970. 53 minutes. COLOR.