

DOCUMENT RESUME

ED 286 742

SE 048 581

TITLE Industrial Waste Treatment. A Field Study Training Program.

INSTITUTION California State Univ., Sacramento. Dept. of Civil Engineering.; California Water Pollution Control Association, Sacramento.

SPONS AGENCY Environmental Protection Agency, Washington, D.C. Office of Water Programs.

PUB DATE 87

GRANT T900690010

NOTE 645p.; For another manual in this series, see SE 048 582. For earlier manuals under the title "Operation of Wastewater Treatment Plants," see ED 196 689. Diagrams and other illustrations are included. Pages containing final examination and answers are printed on dark grey paper and may be illegible.

AVAILABLE FROM Office of Water Programs, California State University, Sacramento, 6000 J St., Sacramento, CA 95819-2694.

PUB TYPE Guides - Classroom Use - Materials (For Learner) (051) -- Tests/Evaluation Instruments (160)

EDRS PRICE MF03 Plus Postage. PC Not Available from EDRS.

DESCRIPTORS *College Science; *Environmental Education; Environmental Standards; *Environmental Technicians; Higher Education; Sanitation; Science Activities; Science Education; *Science Instruction; Science Tests; Sludge; Technological Advancement; Vocational Education; Waste Disposal; *Waste Water; *Water Treatment

ABSTRACT

This operations manual represents a continuation of operator training manuals developed for the United States Environmental Protection Agency (USEPA) in response to the technological advancements of wastewater treatment and the changing needs of the operations profession. It is intended to be used as a home-study course manual (using the concepts of self-paced instruction) or as a textbook for college and university courses. It contains chapters on: (1) the industrial plant operator; (2) activated sludge; (3) physical-chemical treatment; (4) instrumentation; (5) industrial waste monitoring; (6) industrial waste treatment processes; and (7) maintenance. Each chapter contains textual information, discussion and review questions, suggested answers, and an objective test. Included in the appendix are a final examination, tips on solving industrial waste arithmetic problems, a glossary of terms, and an index. (TW)

 * Reproductions supplied by EDRS are the best that can be made *
 * from the original document. *

U.S. DEPARTMENT OF EDUCATION
Office of Educational Research and Improvement
EDUCATIONAL RESOURCES INFORMATION
CENTER (ERIC)

This document has been reproduced as received from the person or organization originating it.

Minor changes have been made to improve reproduction quality.

• Points of view or opinions stated in this document do not necessarily represent official OERI position or policy.

"PERMISSION TO REPRODUCE THIS MATERIAL IN MICROFICHE ONLY HAS BEEN GRANTED BY

[Signature]
[Signature]

TO THE EDUCATIONAL RESOURCES INFORMATION CENTER (ERIC)."

ED286742

180 PRO SE

BEST COPY AVAILABLE

Environmental Protection Agency Review Notice

This training manual has been reviewed by the Office of Water Program Operations, U.S. Environmental Protection Agency, and approved for publication. Approval does not signify that the contents necessarily reflect the views and policies of the Environmental Protection Agency. Mention of trade names or commercial products does not constitute endorsement or recommendation for use by the Environmental Protection Agency, California State University, Sacramento, California Water Pollution Control Association, authors of the chapters or project reviewers and directors.

INDUSTRIAL WASTE TREATMENT

A Field Study Training Program

prepared by

**California State University, Sacramento
Department of Civil Engineering**

**in cooperation with the
California Water Pollution Control Association**

**Kenneth D. Kerri, Project Director
John Brady, Consultant and Co-Director**

for the

**Environmental Protection Agency
Office of Water Program Operations
Municipal Permits and Operations Division
First Edition, Technical Training Grant No. 5TT1-WP-16-03 (1970)
Second Edition, Grant No. T900690010**

1987

OPERATOR TRAINING MANUALS IN THIS SERIES available from Ken Kerri, California State University, Sacramento, 6000 J Street, Sacramento, CA 95819-2694, phone 916-278-6142

1. **Operation of Wastewater Treatment Plants, 2 Volumes,**
2. **Advanced Waste Treatment,**
3. **Treatment of Metal Wastestreams,**
4. **Pretreatment Facility Inspection,**
5. **Operation and Maintenance of Wastewater Collection Systems, 2 Volumes,**
6. **Water Treatment Plant Operation, 2 Volumes,**
7. **Small Water System Operation and Maintenance, and**
8. **Water Distribution System Operation and Maintenance.**

NOTICE

This manual is revised and updated before each printing based on comments from persons using the manual.

FIRST EDITION (Volumes I and II)

First printing, 1971	5,000
Second printing, 1972	7,000
Third printing, 1973	9,000
Fourth printing, 1974	6,000
Fifth printing, 1975	4,000
Sixth printing, 1977	11,000
Seventh printing, 1979	4,000

SECOND EDITION (Volume III)

First printing, 1980	7,000
Second printing, 1982	8,000

THIRD EDITION (Volume III)

First printing, 1985	8,000
----------------------	-------

FIRST EDITION (Industrial Waste Treatment)

First printing, 1987	5,000
----------------------	-------

Copyright 1987 by
Hornet Foundation, Inc.
California State University, Sacramento

PREFACE TO THE FIRST EDITION of INDUSTRIAL WASTE TREATMENT

This operations manual is a continuation of the evolution of operator training manuals developed for the US Environmental Protection Agency by California State University, Sacramento, and the California Water Pollution Control Association. As the technology of wastewater treatment advances and the training needs of the operations profession changes, we strive to keep our training programs current.

An analysis of the subject matter and the users of *OPERATION OF WASTEWATER TREATMENT PLANTS*, Volume III, revealed two distinct categories of operators using this manual to meet their training needs and to serve as an operations, maintenance and troubleshooting reference. Operators of industrial wastewater treatment plants need a training program that covers biological treatment processes as well as physical-chemical treatment processes. Operators of advanced wastewater treatment plants (tertiary plants) have similar needs, but with a different emphasis. One could argue that both groups could be served by a single manual or that two separate manuals could better serve the operations profession. If two separate manuals were to be prepared, how could the subject matter be appropriately divided and/or duplicated in each training program?

We have accepted this challenge and have prepared two new operator training programs using two new manuals, (1) *INDUSTRIAL WASTE TREATMENT*, and (2) *ADVANCED WASTE TREATMENT*. *INDUSTRIAL WASTE TREATMENT* covers the importance and responsibilities of an industrial wastewater treatment plant operator. Other topics include the activated sludge process, physical-chemical treatment, instrumentation, industrial waste monitoring, industrial waste treatment processes and maintenance. *ADVANCED WASTE TREATMENT* is a continuation of Volumes I and II of *OPERATION OF WASTEWATER TREATMENT PLANTS*. *ADVANCED WASTE TREATMENT* covers the topics of odor control, activated sludge, solids handling and disposal, solids removal from secondary effluents, phosphorus removal, nitrogen removal, wastewater reclamation and instrumentation. The decision to leave out the handling, treatment and disposal of industrial process solids from *INDUSTRIAL WASTE TREATMENT* was a difficult one. The industrial solids problem is serious and highly regulated. Since the processes used by many industries are highly specific and specialized, an attempt was not made to cover these processes. However, *ADVANCED WASTE TREATMENT* contains information on anaerobic and aerobic digestion, gravity thickening, centrifuges, chemical stabilization, thermal conditioning, wet oxidation, pressure filtration, belt filter presses, vacuum filtration, composting, incineration and land disposal.

Whenever California State University, Sacramento, reprints one of the operator training manuals, the material is updated in accordance with the comments and suggestions received from the operators enrolling in the courses which use the manual. While you are reading the material in this Manual, please make notes of questions and areas where you would improve the material. By sending your comments and suggestions to me, operators who use the manual in the future will benefit from your experience, knowledge and experience. Thanks.

Kenneth D. Kerri
Program Director
Office of Water Programs
CSU, Sacramento
6000 J Street
Sacramento, CA 95819-2694
Phone: (916) 278-6142

PREFACE TO THE FIRST EDITION OF OPERATION OF WASTEWATER TREATMENT PLANTS

The purposes of this home study program are:

- a. to develop qualified treatment plant operators;
- b. to expand the abilities of existing operators, permitting better service to both their employers and the public; and
- c. to prepare operators for *CERTIFICATION EXAMINATIONS*.¹

To provide you with information needed to operate wastewater treatment plants as efficiently as possible, experienced plant operators prepared the material on treatment plant processes. Each chapter begins with an introduction and then discusses start up, daily operation, interpretation of lab results and possible approaches to solving operational problems. This order of topics was determined during the testing program on the basis of operators' comments indicating the information they needed most urgently. Additional chapters discuss maintenance, safety, sampling, laboratory procedures, hydraulics, records, analysis and presentation of data, and report writing.

Plant influents (raw wastewater) and the efficiencies of treatment processes vary from plant to plant and from location to location. The material contained in this program is presented to provide you with an understanding of the basic operational aspects of your plant and with information to help you analyze and solve operational problems. This information will help you operate your plant as efficiently as possible.

Wastewater treatment is a rapidly advancing field. To keep pace with scientific advances, the material in this program must be periodically revised and updated. This means that you, the operator, must recognize the need to be aware of new advances and the need for continuous training beyond this program.

Originally the concepts for this manual evolved from Mr. Larry Trumbull, 1967 Chairman of the Operator Training Committee of the California Water Pollution Control Association. Messrs. Bill Dendy and Kenneth Kerri, Project Directors, investigated possible means of financial support to develop and test the manual and prepared a successful application to the Federal Water Pollution Control Administration (5TT1-WP-16-03). The chapters were written, tested by pilot groups of operators and potential operators, reviewed by consultants and the Federal Water Quality Administration, and rewritten in accordance with the suggestions from these sources.

The project directors are indebted to the many operators and other persons who contributed to the manual. Every effort was made to acknowledge material from the many excellent references in the wastewater treatment field. Special thanks are due Messrs. John Brady and William Crooks who both contributed immensely to the manual. Mr. F.J. Ludzack, Chemist, National Training Center, Environmental Protection Agency, Water Quality Office, offered many technical improvements. A note of thanks is also due our typists, Miss Linda Smith, Mrs. Gloria Uri, Mrs. Daryl Rasmussen, Mrs. Vicki Sadlem, Mrs. Peggy Courtney, and Mrs. Pris Jernigan. Illustrations were drawn by Mr. Martin Garrity.

Following the first year of use by over 6500 operators and persons interested in operation, minor editing changes were necessary to correct typing errors and omissions and also to rewrite and expand questions and sections that could be clarified. Improvements suggested by operators using the manual were summarized and forwarded to a special Technical Advisory Task Force composed of operators familiar with the manual. This Task Force was formed as a subcommittee of the Water Pollution Control Federation's Personnel Advancement Committee and was chaired by Mr. Sam Warrington. We gratefully thank John Brady, Carlos Doyle, Otto Havens, Wilbur Holst, William Johnson, F.J. Ludzack and David Vandersommen for their efforts to improve our original version.

Kenneth D. Kerri
Bill Dendy

1973

¹ *Certification examination. An examination administered by a state or professional association that operators take to indicate a level of professional competence. In most states the Chief Operator of a plant must be "certified" (successfully pass a certification examination), and in a few states certification is voluntary. Current trends indicate that certification of operators will be mandatory in all states in the near future.*

PREFACE TO THE SECOND EDITION OF OPERATION OF WASTEWATER TREATMENT PLANTS

During the 1970's many people decided that something must be done to control water pollution. The United States Congress passed the "Federal Water Pollution Control Act Amendments of 1972" (PL 92-500) and subsequent amendments. The objective of this Act is to restore and maintain the quality of the Nation's waters. In order to achieve this objective, the Act contains provisions for a financial grant program to assist municipalities with the planning, construction, start up and training of personnel in publicly-owned wastewater treatment plants. Grant funds have been used to build many new plants to date and many more plants will be built in the future. These plants are becoming more complex and are requiring operators with higher levels of knowledge and skills in order to insure that the plants produce a high quality effluent.

This manual, *OPERATION OF WASTEWATER TREATMENT PLANTS*, was used by over 40,000 persons interested in the operation of treatment plants during the 1970's. Every year when more manuals were printed, the manual was updated on the basis of comments and suggestions provided by persons using the manual. After six years of use by operators, the authors, the California Water Pollution Control Association, and the U.S. Environmental Protection Agency (EPA) decided that the contents of the manual should be reexamined, updated and revised. To accomplish this task, EPA provided the Foundation of California State University, Sacramento, with a grant to conduct the necessary studies, writing and field tests.

Recently the U.S. Environmental Protection Agency and the Association of Boards of Certification (ABC) have undertaken studies to document "need to know" tasks performed by wastewater treatment plant operators, skills required, alternative methods of training, training material needs and availability, and the development of instructional materials for certification examinations. Every effort has been made to incorporate the results of these studies in this Second Edition of *OPERATION OF WASTEWATER TREATMENT PLANTS*.

The project directors are indebted to the many operators and other persons who contributed to the Second Edition. Material from the many excellent references in the wastewater treatment field has been acknowledged wherever possible. Joe Bahnick, Ken Hay, Adelaide Litty, Frank Lapsensee, Jack Samson and Bob Rose, U.S. Environmental Protection Agency, served ably as resource persons, consultants and advisers. Special thanks are due our project consultants, Mike Mulbarger, Carl Nagel and Al Petrasek who provided technical advice. Our education reviewers were George Gardner and Larry Hannah. Christine Umeda and Marlene Itagaki administered the national field testing program. A note of thanks was well earned by our typists Charlene Arora, Elaine Saika and Gladys Kornweibel. Illustrations were drawn by Martin Garrity.

Kenneth D. Kerri
John Brady

1980

USES OF THIS MANUAL

Originally this manual was developed to serve as a home-study course for operators in remote areas or persons unable to attend formal classes either due to shift work, personal reasons or the unavailability of suitable classes. This home-study training program used the concepts of self-paced instruction where you are your own instructor and work at your own speed. In order to certify that a person had successfully completed this program, an objective test was included at the end of each chapter and the training course became a correspondence or self-study type of program.

Once operators started using this manual for home study, they realized that it could serve effectively as a textbook in the classroom. Many colleges and universities have used the manual as a text in formal classes often taught by operators. In areas where colleges were not available or were unable to offer classes in the operation of wastewater treatment plants, operators and utility agencies joined together to offer their own courses using the manual.

Occasionally a utility agency has enrolled from three to over 300 of its operators in this training program. A manual is purchased for each operator. A senior operator or a group of operators are designated as instructors. These operators help answer questions when the persons in the training program have questions or need assistance. The instructors grade the objective tests at the end of each chapter, record scores and notify California State University, Sacramento, of the scores when a person successfully completes this program. This approach avoids the long wait while papers are being graded and returned by CSUS.

This manual was prepared to help operators run their treatment plants. Please feel free to use it in the manner which best fits your training needs and the needs of other operators. We will be happy to work with you to assist you in developing your training program. Please feel free to contact

Ken Kerri, Project Director
Office of Water Programs
California State University, Sacramento
6000 Jay Street
Sacramento, California 95819-2694
Phone (916) 278-6142
or 278-6366

INSTRUCTIONS TO PARTICIPANTS IN HOME-STUDY COURSE

Procedures for reading the lessons and answering the questions are contained in this section.

To progress steadily through this program, you should establish a regular study schedule. For example, many operators in the past have set aside two hours during two evenings a week for study.

The study material is contained in seven chapters. Some chapters are longer and more difficult than others. For this reason, many of the chapters are divided into two or more lessons. The time required to



complete a lesson will depend on your background and experience. Some people might require an hour to complete a lesson and some might require three hours; but that is perfectly all right. **THE IMPORTANT THING IS THAT YOU UNDERSTAND THE MATERIAL IN THE LESSON!**

Each lesson is arranged for you to read a short section, write the answers to the questions at the end of the section, check your answers against suggested answers; and then *YOU* decide if you understand the material sufficiently to continue or whether you should read the section again. You will find that this procedure is slower than reading a normal textbook, but you will remember much more when you have finished the lesson.

At the end of each chapter, you will find an "objective test." Mark your answers on the special answer sheet provided for each chapter. Some discussion and review questions are provided following each lesson in the later chapters. These questions review the important points you have covered in the lesson.

The objective test at the end of each lesson contains true or false, multiple-choice, fill-in-the-blank, or match-the-answers types of questions. The purposes of this exam are to review the chapter and to give experience in taking different types of exams. **MAIL TO THE PROGRAM DIRECTOR ONLY YOUR ANSWERS TO OBJECTIVE TESTS ON THE PROVIDED ANSWER SHEETS.**

After you have completed the last objective test, you will find a final examination. This exam is provided for you to review how well you remembered the material. You may wish to review the entire manual before you take the final exam. Some of the questions are essay-type questions which are used by some states for higher-level certification examinations. After you have completed the final examination, grade your own paper and determine the areas in which you might need additional review before your next examination.

You are your own teacher in this program. You could merely look up the suggested answers from the answer sheet or copy them from someone else, but you would not understand the material. Consequently, you would not be able to apply the material to the operation of your plant nor recall it during an examination for certification or a civil service position.

YOU WILL GET OUT OF THIS PROGRAM WHAT YOU PUT INTO IT.

SUMMARY OF PROCEDURE

A. OPERATOR (YOU)

1. Read what you are expected to learn in each chapter (from Chapter 2 on, the major topics are listed at the beginning of the chapter).
2. Read sections in lesson.
3. Write answers to questions at end of sections in your notebook. You should write the answers to the questions just like you would if these were questions on a test.
4. Check your answers with suggested answers.

5. Decide whether to reread section or to continue with the next section.
6. Write answers to discussion and review questions at the end of lessons in your notebook.
7. Mark answers to objective test on answer sheet.
8. Mail material to project director.

Ken Kerri, Project Director
Office of Water Programs
California State University, Sacramento
6000 Jay Street
Sacramento, California 95819-2694



B. PROJECT DIRECTOR

1. Mails answer sheet for each chapter to operator.
2. Corrects tests, answers any questions, and returns results to operators.

C. ORDER OF WORKING LESSONS

To complete this program you will have to work all of the chapters. You may proceed in numerical order, or you may wish to work some lessons sooner.

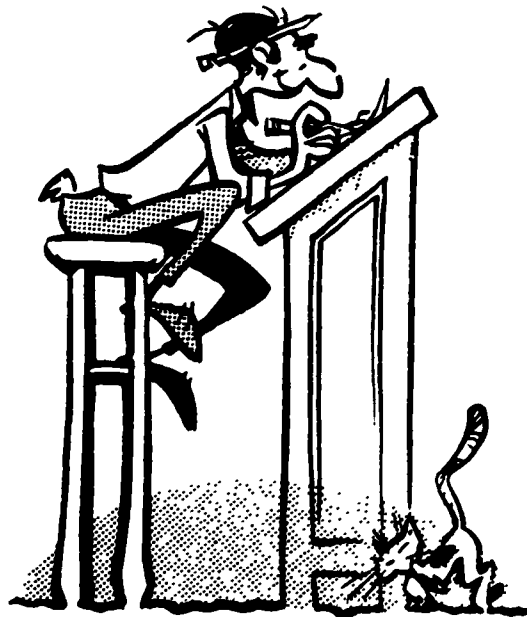

COURSE OUTLINE

Chapter	Topic	Page
1	The Industrial Plant Operator	1
2	Activated Sludge	11
3	Physical-Chemical Treatment	101
4	Instrumentation	173
5	Industrial Waste Monitoring	231
6	Industrial Waste Treatment Processes	283
7	Maintenance	457
Appendix	Final Examination	552
	How to Solve Industrial Waste Arithmetic Problems	565
	Glossary	588
	Index	617

TECHNICAL CONSULTANTS (previous editions and other volumes)

**William Garber
George Gardner
Larry Hannah
Mike Mulbarger
Carl Nagel
Joe Nagano**

**Frank Phillips
Al Petrusek
Warren Prentice
Ralph Stowell
Larry Trumbull**

**OPERATION OF WASTEWATER TREATMENT PLANTS
COURSE OUTLINE
VOLUME I, THIRD EDITION**

Chapter	Topic	Page
1	The Treatment Plant Operator	1
2	Why Treat Wastes?	11
3	Wastewater Treatment Facilities	25
4	Racks, Screens, Comminutors and Grit Removal	55
5	Sedimentation and Flotation	101
6	Trickling Filters	155
7	Rotating Biological Contactors	197
8	Activated Sludge (Package Plants and Oxidation Ditches)	227
9	Waste Treatment Ponds	275
10	Disinfection and Chlorination	319
Appendix	Final Examination	397
	How to Solve Wastewater Treatment Plant Arithmetic Problems	405
	Glossary	445
	Index	475

**COURSE OUTLINE
VOLUME II, THIRD EDITION**

Chapter	Topic	Page
11	Activated Sludge (Conventional Activated Sludge Plants)	1
12	Sludge Digestion and Solids Handling	107
13	Effluent Disposal	197
14	Plant Safety and Good Housekeeping	219
15	Maintenance	253
16	Laboratory Procedures and Chemistry	349
17	Applications of Computers for Plant O&M	489
18	Analysis and Presentation of Data	503
19	Records and Report Writing	535
Appendix	Final Examination and Answers	553
	How to Solve Wastewater Treatment Plant Arithmetic Problems	565
	Glossary	588
	Index	617

CHAPTER 1

THE INDUSTRIAL PLANT OPERATOR

by

Ken Kerri

TABLE OF CONTENTS

Chapter 1. The Industrial Plant Operator

	Page
1.0 What is an Industrial Plant Operator?	3
1.01 What does an Industrial Plant Operator do?	3
1.02 Who does the Industrial Plant Operator work for?	3
1.03 Where does the Industrial Plant Operator work?	3
1.04 What pay can an Industrial Plant Operator expect?	3
1.05 What does it take to be an Industrial Plant Operator?	3
1.1 Your Personal Training Course	4
1.2 What Do You Already Know?	4
1.3 The Water Quality Protector: <i>YOU</i>	4
1.4 Your Qualifications	5
1.41 Your Job	5
1.5 Manpower Needs and Future Job Opportunities	6
1.6 Training Yourself to Meet the Needs	7

CHAPTER 1. THE INDUSTRIAL PLANT OPERATOR

This portion of Chapter 1 was prepared especially for the new or the potential industrial *WASTEWATER*¹ treatment plant operator. If you are an experienced operator, you may find some new viewpoints.

1.0 WHAT IS AN INDUSTRIAL PLANT OPERATOR?

Before modern society entered the scene, water was purified in a natural cycle as shown below:

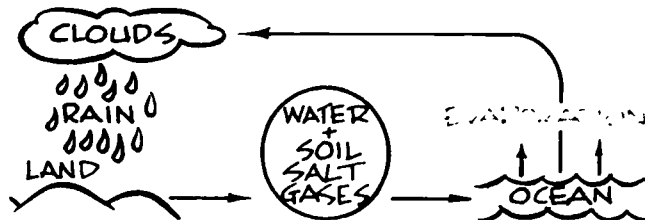

Simplified natural purification cycle

But modern society and the intensive use of the water resource and the resulting water pollution could not wait for sun, wind, and time to accomplish the purification of soiled water; consequently, municipal and industrial treatment plants were built. Thus, nature was given an assist by a team consisting of designers, builders, and treatment plant operators. Designers and builders occupy the scene only for an interval, but operators go on forever. They are the final and essential link in maintaining and protecting the aquatic environment upon which all life depends.

1.01 What does an Industrial Plant Operator do?

Simply described, the operator keeps an industrial wastewater treatment plant working. Physically the operator turns valves, pushes switches, collects samples, lubricates equipment, reads gauges and records data.

An operator may also maintain equipment and plant area by painting, weeding, gardening, repairing and replacing. Mentally an operator inspects records, observes conditions, makes calculations to determine that the plant is working effectively, and predicts necessary maintenance and facility needs to assure continued effective operation of the plant. The operator also has an obligation to explain to supervisors, management, civic bodies, and even the general public what the plant does, and most importantly, why the industry and its facilities are vital to the welfare of the community.

1.02 Who does the Industrial Plant Operator work for?

An operator's paycheck comes from the industry which employs the operator. As an operator you are responsible to

your employer for maintaining an economically and efficiently operating facility. An even greater obligation rests with the operator because the great numbers of people who rely upon downstream water supplies are totally dependent upon the operator's competence and trustworthiness for their welfare. In the final analysis, the operator is really working for these vitally affected downstream water users.

1.03 Where does the Industrial Plant Operator work?

Obviously the operator works in an industrial treatment plant. But the different types and locations of treatment plants offer a wide range of working conditions. From the mountains to the sea, wherever people congregate into communities, industrial treatment plants will be found. From a unit process operator at a complex industrial facility to a one-person manager of a small pretreatment facility, you can select your own special place in industrial plant operation.

1.04 What pay can an Industrial Plant Operator expect?

In dollars? Prestige? Job satisfaction? Community service? In opportunities for advancement? By whatever scale you use, returns are what you make them. If you choose a large industry, the pay is good and advancement prospects are tops. Choose a small facility and pay may not be as good; but job satisfaction, freedom from time-clock hours, service, and prestige may well add up to outstanding personal achievement. Total reward depends on you.



The operator's duties

1.05 What does it take to be an Industrial Plant Operator?

Desire. First you must choose to enter this profession. You can do it with a grammar school, a high school, or a college education. While some jobs will always exist for manual labor, the real and expanding need is for *TRAINED OPERATORS*. New techniques, advanced equipment, and increasing instrumentation require a new breed of operator,

¹ *Wastewater. The used water and solids from an industry or a community that flow to a treatment plant. Storm water, surface water, and groundwater infiltration also may be included in the wastewater that enters a plant. The term "sewage" usually refers to household wastes, but this word is being replaced by the term "wastewater."*

4 Treatment Plants

one who is willing to learn today, and gain tomorrow, for surely your industrial plant will move towards newer and more effective operating procedures and treatment processes. Indeed, the truly service-minded operator assists in adding to and improving the plant performance on a continuing basis.



Tomorrow's forgotten operator stopped learning yesterday

You can be an industrial operator tomorrow by beginning your learning today; or you can be a better operator, ready for advancement, by accelerating your learning today.

This training course, then, is your start towards a better tomorrow, both for you and for the industry and public who will receive better water from your efforts.

QUESTIONS

Place an "X" by the correct answer or answers. After you have answered all the questions, check your answers with those given at the end of the chapter on page 8. Reread any sections you did not understand and then proceed to the next section. You are your own teacher in this training program, and YOU should decide when you understand the material and are ready to continue with new material.

EXAMPLE

This is a training course on

- A. Accounting
- B. Engineering
- C. Industrial Treatment Plant Operation
- D. Salesmanship.

1.0A. Wastewater is the same thing as:

- A. Rain
- B. Soil
- C. Sewage
- D. Condensation.

1.0B. What does an industrial operator do?

- A. Collect samples.
- B. Lubricate equipment.
- C. Record data.

1.0C. Who employs Industrial Plant Operators?

- A. Cities.
- B. Sanitation districts.
- C. Industries.

Check your answers on page 8.

1.1 YOUR PERSONAL TRAINING COURSE

Beginning on this page, you are embarking on a training course which has been carefully prepared to allow you to improve your knowledge of and ability to operate an industrial wastewater treatment plant. You will be able to proceed at your own pace; you will have an opportunity to learn a little or a lot about each topic. The course has been prepared this way to fit the various needs of operators, depending on what kind of plant you have or how much you need to learn about it. To study for certification examinations, you will have to cover all the material. You will never know everything about your plant or about the wastewater which flows through it, but you can begin to answer some very important questions about how and when certain things happen in the plant. You can also learn to manipulate your plant so that it operates at maximum efficiency.

1.2 WHAT DO YOU ALREADY KNOW?

If you already have some experience operating an industrial wastewater treatment plant, you may use the first chapter for a review. If you are relatively new to the industrial wastewater treatment field, this chapter will provide you with important background information. The remainder of this introductory chapter describes your role as a *PROTECTOR OF WATER QUALITY*, your *QUALIFICATIONS* to do your job, a little about manpower needs in the industrial wastewater treatment field, and some information on other *TRAINING OPPORTUNITIES*.

1.3 THE WATER QUALITY PROTECTOR: YOU

Historically Americans have shown a great lack of interest in the protection of their water resources. We have been content to think that "the solution to pollution is dilution." For years we were able to dump our wastes with little or no treatment back into the nearest *RECEIVING WATERS*.² As long as there was enough dilution water to absorb the waste material, nature took care of our disposal problems for us. As more and more towns and industry sprang up, waste loads increased until the natural purification processes could no longer do the job. Many waterways were converted into open sewers. Unfortunately, for many areas this did not signal the beginning of a clean-up campaign. It merely increased the frequency of the cry: "We don't have the money for a treatment plant," or the ever-popular, "If we make industries treat their wastes they will move to another state." Thus, the pollution of our waters increased.



Water quality protector

Within the last few years, we have seen many changes in this depressing picture. We now realize that we must give nature a hand by treating wastes before they are discharged. Adequate treatment of wastes will not only protect our health and that of our downstream neighbors; it can also increase property values, allow game fishing and various recreational uses to be enjoyed, and attract water-using industries to the area. Today we are seeing massive efforts being undertaken to control water pollution and improve water quality throughout the nation. This includes the efforts not only of your own industry, community, county and state, but also the federal government.

² *Receiving Water.* A stream, river, lake, or ocean into which treated or untreated wastewater is discharged.

Great sums of public and private funds are now being invested in large, complex municipal and industrial wastewater treatment facilities to overcome this pollution; and you, the treatment plant operator, will play a key role in the battle. Without efficient operation of your plant, much of the research, planning, and building that has been done and will be done to accomplish the goals of water quality control in your area will be wasted. You are the difference between a facility and a performing unit. You are, in fact, a **WATER QUALITY PROTECTOR** on the front line of the water pollution battle.



Pollution

The receiving water quality standards and waste discharge requirements that your plant has been built to meet have been formulated to **PROTECT** the water users downstream from your plant. These uses may include domestic water supply, industrial water supply, agricultural water supply, stock and wildlife watering, propagation of fish and other aquatic and marine life, shellfish culture, swimming and other water contact sports, boating, esthetic enjoyment, hydroelectric power, navigation, and others.

Therefore, you have an obligation to the users of the water downstream, as well as to the people of your district or municipality and industry. You are the **KEY WATER QUALITY PROTECTOR** and must realize that you are in a responsible position.

QUESTIONS

Write your answers in a notebook and then compare your answers with those on page 8.



Visitors touring a treatment plant.

1.3A Why must municipal and industrial wastewaters receive adequate treatment?

1.3B How did many receiving waters become polluted?

1.4. YOUR QUALIFICATIONS

The skill and ability required for your job depend to a large degree on the size and type of treatment plant where you are employed. You may work at a large modern treatment plant treating several complex industrial wastestreams and employing ten or more operators. In this case you are probably a specialist in one or more phases of the treatment process.

On the other hand, you may operate a small plant or pretreatment facility. You may be the only operator at the plant or, at best, have only one or two additional employees. If this is the case, you must be a "jack-of-all trades" because of the diversity of your tasks.

1.41 Your Job

To describe the operator's duties, let us start at the beginning. Let us say that the need for a new or improved wastewater treatment plant has long been recognized by your industry. The industry has allocated the funds to finance the project, and the consulting engineers have submitted plans and specifications. It is to the best interests of the industry and the consulting engineer that you be in on the ground floor planning. If it is a new plant, you should be present or at least available during the construction period in order to become completely familiar with the entire plant, including the equipment and machinery and their operation. This will provide you with the opportunity to relate your plant drawings to actual facilities.

You and the engineer should discuss how the treatment plant should best be run and the means of operation the designer had in mind when the plant was designed. If it is an old plant being remodeled, you are in a position to offer excellent advice to the consulting engineer. Your experience provides valuable technical knowledge concerning the characteristics of wastewater, its sources, and the limitations of the present facilities. Together with the consultant, you are a member of an expert team able to advise the industry.

Once the plant is operating, you become an administrator. In a small plant your duties may not include supervision of personnel, but you are still in charge of records. You are responsible for operating the plant as efficiently as possible, keeping in



Visitors touring a treatment plant.

6 Treatment Plants

mind that the primary objective is to protect the receiving water quality by continuous and efficient plant performance. Without adequate, reliable records of every phase of operation, the effectiveness of your operation has not been documented (recorded).

You may also be the budget administrator. Most certainly you are in the best position to give advice on budget requirements, management problems, and future planning. You should be aware of the necessity for additional expenditures, including funds for plant enlargement, equipment replacement, and laboratory requirements. You should recognize and define such needs in sufficient time to inform the proper officials to enable them to accomplish early planning and budgeting.

You are in the field of public relations and must be able to explain the purpose and operation of your plant to visitors, civic organizations, school classes, representatives of news media, and even to city council or managers and directors of your industry. Public interest in water quality is increasing, and you should be prepared to conduct plant tours that will contribute to public acceptance and support. A well-guided tour for officials of regulatory agencies or other operators may provide these people with sufficient understanding of your plant to allow them to suggest helpful solutions to operational problems.



Special care and safety must be practiced when visitors are taken through your treatment plant. An accident could spoil all of your public relations efforts.

The appearance of your plant indicates to the visitor the type of operation you maintain. If the plant is dirty and rundown with tools and litter scattered about, you will be unable to convince your visitors that the plant is doing a good job. **YOUR RECORDS SHOWING A HIGH-QUALITY EFFLUENT³ WILL MEAN NOTHING TO THESE VISITING CITIZENS AND OFFICIALS UNLESS YOUR PLANT APPEARS CLEAN AND WELL-MAINTAINED AND THE EFFLUENT LOOKS GOOD.**

Another aspect of your public relations duties is your dealings with the downstream water user. Unfortunately, the operator is often considered by the downstream user as a polluter rather than a water quality protector. Through a good public information program, backed by facts supported by reliable data, you can correct the impression held by the downstream user and establish "good neighbor" relations. This is indeed a challenge. Again, you must understand that you hold a very responsible position and be aware that the sole purpose of the operation of your plant is to protect the downstream user, be that user a private property owner, another city or district, an industry, or a fisherman.

You are required to understand certain laboratory procedures in order to conduct various tests on samples of wastewater and receiving waters. On the basis of the data obtained from these tests, you may have to adjust the operation of the treatment plant to meet stream standards or discharge requirements.

As an operator you must have a knowledge of the complicated mechanical principles involved in many treatment mechanisms. In order to measure and control the wastewater



Clean Stream

flowing through the plant, you must have some understanding of hydraulics. Practical knowledge of electrical motors, circuitry, and controls is also essential.

Safety is a very important operator responsibility. Unfortunately too many operators take safety for granted. This is one reason why the wastewater treatment industry has one of the worst safety records of any industry. **YOU** have the responsibility to be sure that your treatment plant is a safe place to work and visit. Everyone must follow safe procedures and understand why safe procedures must be followed at all times. All operators must be aware of the safety hazards in and around treatment plants. You should plan or be a part of an active safety program. Chief operators frequently have the responsibility of training new operators and should encourage all operators to become certified.

Clearly then, the modern day industrial treatment plant operator must possess a broad range of qualifications.

QUESTIONS

Write your answers in a notebook and then compare your answers with those on page 8.

1.4A Why is it important that the operator be present during the construction of a new plant?

1.4B How does the operator become involved in public relations?



1.5 MANPOWER NEEDS AND FUTURE JOB OPPORTUNITIES

The industrial treatment field, like so many others, is changing rapidly. New plants are being constructed, and old plants are being modified and enlarged to handle the wastewater from our growing population and to treat the new chemicals being produced by our space age technology. Operators, maintenance personnel, foremen, managers, instrumentation experts, and laboratory technicians are sorely needed.

³ Effluent. Wastewater or other liquid - raw, partially or completely treated - flowing FROM a basin, treatment process, or treatment plant.

A look at past records and future predictions indicates that wastewater treatment is a rapidly growing field. Municipalities employed approximately 20,000 operators in 1967 and over 67,000 operators in 1974. Industry employed approximately 3,500 operators in 1967 and around 12,000 plant operators by 1972.⁴ In 1980 73,600 persons were employed in the wastewater treatment field and the need for new operators was estimated at 5,000 per year for every year up to the year 2000.⁵ A report to Congress⁶ in 1985 estimated that there were over 105,000 operators in the United States. The need for trained operators is increasing rapidly and is expected to continue in the future.

1.6 TRAINING YOURSELF TO MEET THE NEEDS

This training course is not the only one available to help you improve your abilities. The states have offered various types of both long- and short-term operator training through their health departments or water pollution control associations have provided training classes conducted by members of the associations, largely on a volunteer basis. State and local colleges have provided valuable training under their own sponsorship or in partnership with others. Many state, local and private agencies have conducted both long- and short-term training as well as interesting and informative seminars. The California Water Pollution Control Association as prepared two textbooks, one on laboratory procedures and one on mathematics.

Listed below are several very good references in the field of wastewater treatment plant operation that are frequently re-

ferred to throughout this course. The name in quotes represents the term usually used by operators when they mention the reference. Prices listed are those available when this manual was published and will probably increase in the future.

1. "MOP 11." OPERATION OF WASTEWATER TREATMENT PLANTS, WPCF Manual of Practice No. 11, Publications Order Department, Water Pollution Control Federation, Order No. M0012 0H0. Price \$29.00 to members; \$37.50 to others.
2. "NEW YORK MANUAL." MANUAL OF INSTRUCTION FOR WASTEWATER TREATMENT PLANT OPERATORS, distributed in New York by the New York State Department of Health, Office of Public Health Education, Water Pollution Control Board. Distributed outside of New York State by Health Education Service, P.O. Box 7126, Albany, New York 12224. Price \$6.60.
3. "TEXAS MANUAL." MANUAL OF WASTEWATER TREATMENT, prepared by Texas Water Utilities Association. Obtainable from Texas Water Utilities Association, 6521 Burnet Lane, Austin, Texas 78757. Price \$18.00, plus \$1.15 postage.

These publications cover the entire field of treatment plant operation. At the end of many of the chapters yet to come, lists of other references will be provided.



⁴ Data contained in this paragraph were obtained from "Manpower and Training Needs in Water Pollution Control," Report of the Department of the Interior, Federal Water Pollution Control Administration to the Congress of the United States, Senate Document No. 49, 90th Congress, First Session, Washington, D.C., 1967 and from "Study of Municipal Wastewater Treatment Plant Manpower and Training Needs and Resources," Municipal Permits and Operations Division, Office of Water Program Operations, U.S. Environmental Protection Agency, Washington, D.C., 1974.

⁵ Bryant, James O., "Manpower Needs in Wastewater Treatment and Collection Systems for the Years 1980-2000." Paper presented at the Third Annual NETA National Conference and Workshop, Seattle, Washington, August 11, 1981.

⁶ "Report to Congress on Training for Operators of Publicly Owned Wastewater Treatment Plants." Office of Municipal Pollution Control, U.S. Environmental Protection Agency, Washington, DC 20460, February 1985.

SUGGESTED ANSWERS

Chapter 1. THE INDUSTRIAL PLANT OPERATOR

You are not expected to have the exact answer suggested for questions requiring written answers, but you should have the correct idea. The numbering of the questions refers to the section in the manual where you can find the information to answer the questions. Answers to questions numbered 1.0 can be found in Section 1.0, What is an Industrial Plant Operator?

Answers to questions on page 4.

- 1.0A. C
- 1.0B. A, B, C
- 1.0C. C

Answers to questions on page 5.

- 1.3A. Municipal and industrial wastewaters must receive adequate treatment to protect receiving water users.
- 1.3B. Receiving waters became polluted by a lack of public concern for the impact of waste discharges and by discharging wastewater into a receiving water beyond its natural purification capacity.

Answers to questions on page 6.

- 1.4A. The operator should be present during the construction of a new plant in order to become familiar with the plant before the operator begins operating it.
- 1.4B. The operator becomes involved in public relations by explaining the purpose and operation of the plant to visitors, civic organizations, newspaper people, and supervisors.



DIRECTIONS FOR WORKING OBJECTIVE TEST

Chapter 1. THE INDUSTRIAL PLANT OPERATOR

1. You have been provided with a special answer sheet for each chapter. Be sure you follow the special directions provided with the answer sheets. If you lose an answer sheet or have any problems, please notify the Project Director.
2. Mark your answers on the answer sheet with a dark lead pencil. Do not use ink.
For example, Question 2 has three correct answers (1, 2 and 3). Therefore, you should place a mark under Columns 1, 2 and 3 on the answer sheet.
Questions 4 through 7 are true or false questions. If a ques-

tion is true, then mark Column 1, and if false mark Column 2. The correct answer to Question 4 is true; therefore, place a mark in Column 1.

Please mark your answers in your workbook for your record because answer sheets will not be returned to you.

3. Mail answer sheet to the Project Director immediately after you have completed the test.
4. Answer sheets may be folded (but not into more than 3 equal parts) and mailed in a 4 x 9½ standard white envelope.

**INDUSTRIAL WASTE TREATMENT
IMPORTANT**

OFFICE USE ONLY
DO NOT MARK

PLEASE READ INSTRUCTIONS ON REVERSE SIDE BEFORE COMPLETING THIS FORM.

Name: Operator Joe B
Last First MI

Address: 711 Main Street
Clearwater Ca 01234
City State Zip Code

Mail to: Professor Kenneth Kerri
California State University, Sacramento
6000 J Street
Sacramento, California 95819

SOCIAL SECURITY NUMBER										CHAPTER NUMBER
9	8	7	6	5	4	3	2	1		01
0	0	0	0	0	0	0	0	0	0	0
1	1	1	1	1	1	1	1	1	1	1
2	2	2	2	2	2	2	2	2	2	2
3	3	3	3	3	3	3	3	3	3	3
4	4	4	4	4	4	4	4	4	4	4
5	5	5	5	5	5	5	5	5	5	5
6	6	6	6	6	6	6	6	6	6	6
7	7	7	7	7	7	7	7	7	7	7
8	8	8	8	8	8	8	8	8	8	8
9	9	9	9	9	9	9	9	9	9	9

FOLD

IMPORTANT DIRECTIONS FOR MARKING ANSWERS

- Use black lead pencil only (# 2 or softer).
- Make heavy black marks that fill the circle completely.
- Erase clearly any answer you wish to change.
- Make no stray marks on this answer sheet.

EXAMPLE

1. MULTIPLE CHOICE QUESTIONS: Fill in the correct answers. If 2 and 3 are correct for question 1, mark:

1 2 3 4 5
1

2. TRUE-FALSE QUESTIONS: If true, fill in the circle in column 1; if false, fill in column 2. If question 3 is true, mark:

1 2 3 4 5
3

SAMPLE
Do Not Use

SOCIAL SECURITY NUMBER										CHAPTER NUMBER
1	2	3	4	5	6	7	8	9		01
0	0	0	0	0	0	0	0	0	0	0
1	1	1	1	1	1	1	1	1	1	1
2	2	2	2	2	2	2	2	2	2	2
3	3	3	3	3	3	3	3	3	3	3
4	4	4	4	4	4	4	4	4	4	4
5	5	5	5	5	5	5	5	5	5	5
6	6	6	6	6	6	6	6	6	6	6
7	7	7	7	7	7	7	7	7	7	7
8	8	8	8	8	8	8	8	8	8	8
9	9	9	9	9	9	9	9	9	9	9

ACS Trans-Optic Co. 1645 1-108766 AZ803

FOLD

1 <input type="radio"/> <input type="radio"/> <input type="radio"/> <input type="radio"/> <input type="radio"/>	11 <input type="radio"/> <input type="radio"/> <input type="radio"/> <input type="radio"/> <input type="radio"/>	21 <input type="radio"/> <input type="radio"/> <input type="radio"/> <input type="radio"/> <input type="radio"/>	31 <input type="radio"/> <input type="radio"/> <input type="radio"/> <input type="radio"/> <input type="radio"/>	41 <input type="radio"/> <input type="radio"/> <input type="radio"/> <input type="radio"/> <input type="radio"/>	51 <input type="radio"/> <input type="radio"/> <input type="radio"/> <input type="radio"/> <input type="radio"/>
2 <input type="radio"/> <input type="radio"/> <input type="radio"/> <input type="radio"/> <input type="radio"/>	12 <input type="radio"/> <input type="radio"/> <input type="radio"/> <input type="radio"/> <input type="radio"/>	22 <input type="radio"/> <input type="radio"/> <input type="radio"/> <input type="radio"/> <input type="radio"/>	32 <input type="radio"/> <input type="radio"/> <input type="radio"/> <input type="radio"/> <input type="radio"/>	42 <input type="radio"/> <input type="radio"/> <input type="radio"/> <input type="radio"/> <input type="radio"/>	52 <input type="radio"/> <input type="radio"/> <input type="radio"/> <input type="radio"/> <input type="radio"/>
3 <input type="radio"/> <input type="radio"/> <input type="radio"/> <input type="radio"/> <input type="radio"/>	13 <input type="radio"/> <input type="radio"/> <input type="radio"/> <input type="radio"/> <input type="radio"/>	23 <input type="radio"/> <input type="radio"/> <input type="radio"/> <input type="radio"/> <input type="radio"/>	33 <input type="radio"/> <input type="radio"/> <input type="radio"/> <input type="radio"/> <input type="radio"/>	43 <input type="radio"/> <input type="radio"/> <input type="radio"/> <input type="radio"/> <input type="radio"/>	53 <input type="radio"/> <input type="radio"/> <input type="radio"/> <input type="radio"/> <input type="radio"/>
4 <input type="radio"/> <input type="radio"/> <input type="radio"/> <input type="radio"/> <input type="radio"/>	14 <input type="radio"/> <input type="radio"/> <input type="radio"/> <input type="radio"/> <input type="radio"/>	24 <input type="radio"/> <input type="radio"/> <input type="radio"/> <input type="radio"/> <input type="radio"/>	34 <input type="radio"/> <input type="radio"/> <input type="radio"/> <input type="radio"/> <input type="radio"/>	44 <input type="radio"/> <input type="radio"/> <input type="radio"/> <input type="radio"/> <input type="radio"/>	54 <input type="radio"/> <input type="radio"/> <input type="radio"/> <input type="radio"/> <input type="radio"/>
5 <input type="radio"/> <input type="radio"/> <input type="radio"/> <input type="radio"/> <input type="radio"/>	15 <input type="radio"/> <input type="radio"/> <input type="radio"/> <input type="radio"/> <input type="radio"/>	25 <input type="radio"/> <input type="radio"/> <input type="radio"/> <input type="radio"/> <input type="radio"/>	35 <input type="radio"/> <input type="radio"/> <input type="radio"/> <input type="radio"/> <input type="radio"/>	45 <input type="radio"/> <input type="radio"/> <input type="radio"/> <input type="radio"/> <input type="radio"/>	55 <input type="radio"/> <input type="radio"/> <input type="radio"/> <input type="radio"/> <input type="radio"/>
6 <input type="radio"/> <input type="radio"/> <input type="radio"/> <input type="radio"/> <input type="radio"/>	16 <input type="radio"/> <input type="radio"/> <input type="radio"/> <input type="radio"/> <input type="radio"/>	26 <input type="radio"/> <input type="radio"/> <input type="radio"/> <input type="radio"/> <input type="radio"/>	36 <input type="radio"/> <input type="radio"/> <input type="radio"/> <input type="radio"/> <input type="radio"/>	46 <input type="radio"/> <input type="radio"/> <input type="radio"/> <input type="radio"/> <input type="radio"/>	56 <input type="radio"/> <input type="radio"/> <input type="radio"/> <input type="radio"/> <input type="radio"/>
7 <input type="radio"/> <input type="radio"/> <input type="radio"/> <input type="radio"/> <input type="radio"/>	17 <input type="radio"/> <input type="radio"/> <input type="radio"/> <input type="radio"/> <input type="radio"/>	27 <input type="radio"/> <input type="radio"/> <input type="radio"/> <input type="radio"/> <input type="radio"/>	37 <input type="radio"/> <input type="radio"/> <input type="radio"/> <input type="radio"/> <input type="radio"/>	47 <input type="radio"/> <input type="radio"/> <input type="radio"/> <input type="radio"/> <input type="radio"/>	57 <input type="radio"/> <input type="radio"/> <input type="radio"/> <input type="radio"/> <input type="radio"/>
8 <input type="radio"/> <input type="radio"/> <input type="radio"/> <input type="radio"/> <input type="radio"/>	18 <input type="radio"/> <input type="radio"/> <input type="radio"/> <input type="radio"/> <input type="radio"/>	28 <input type="radio"/> <input type="radio"/> <input type="radio"/> <input type="radio"/> <input type="radio"/>	38 <input type="radio"/> <input type="radio"/> <input type="radio"/> <input type="radio"/> <input type="radio"/>	48 <input type="radio"/> <input type="radio"/> <input type="radio"/> <input type="radio"/> <input type="radio"/>	58 <input type="radio"/> <input type="radio"/> <input type="radio"/> <input type="radio"/> <input type="radio"/>
9 <input type="radio"/> <input type="radio"/> <input type="radio"/> <input type="radio"/> <input type="radio"/>	19 <input type="radio"/> <input type="radio"/> <input type="radio"/> <input type="radio"/> <input type="radio"/>	29 <input type="radio"/> <input type="radio"/> <input type="radio"/> <input type="radio"/> <input type="radio"/>	39 <input type="radio"/> <input type="radio"/> <input type="radio"/> <input type="radio"/> <input type="radio"/>	49 <input type="radio"/> <input type="radio"/> <input type="radio"/> <input type="radio"/> <input type="radio"/>	59 <input type="radio"/> <input type="radio"/> <input type="radio"/> <input type="radio"/> <input type="radio"/>
10 <input type="radio"/> <input type="radio"/> <input type="radio"/> <input type="radio"/> <input type="radio"/>	20 <input type="radio"/> <input type="radio"/> <input type="radio"/> <input type="radio"/> <input type="radio"/>	30 <input type="radio"/> <input type="radio"/> <input type="radio"/> <input type="radio"/> <input type="radio"/>	40 <input type="radio"/> <input type="radio"/> <input type="radio"/> <input type="radio"/> <input type="radio"/>	50 <input type="radio"/> <input type="radio"/> <input type="radio"/> <input type="radio"/> <input type="radio"/>	60 <input type="radio"/> <input type="radio"/> <input type="radio"/> <input type="radio"/> <input type="radio"/>

OBJECTIVE TEST

Chapter 1. THE INDUSTRIAL PLANT OPERATOR

Please mark correct answers on the answer sheet. There may be more than one correct answer to each question.

1. The used water and solids from a community that flow to a treatment plant are called _____?
 1. Effluent
 2. Mixed Liquor
 3. Sludge
 4. Wastewater
2. Receiving water uses protected by an operator include
 1. Boating.
 2. Drinking water supply.
 3. Fishing.
 4. None of these
3. What kinds of jobs are available in the industrial treatment field in addition to those available for operators?
 1. Foremen
 2. Instrumentation experts
 3. Laboratory technicians
 4. Maintenance personnel
 5. Manager

TRUE OR FALSE:

4. In many treatment plants the operator must be a "jack-of-all-trades."
 1. True
 2. False
5. A treatment plant operator is a *WATER QUALITY* protector.
 1. True
 2. False
6. Plant visitors are impressed by records showing efficient plant operation, and their opinions are never influenced by the appearance of the plant and grounds.
 1. True
 2. False
7. After finishing this program, an operator will need to continue to study in order to keep pace with changes occurring in the field.
 1. True
 2. False

END OF OBJECTIVE TEST

CHAPTER 2

ACTIVATED SLUDGE

Pure Oxygen Plants and Operational Control Options

by

Ross Gudgel

and

Larry Peterson

OPERATION OF WASTEWATER TREATMENT PLANTS

**Volume I, Chapter 8
Package Plants and Oxidation Ditches**

OPERATION OF WASTEWATER TREATMENT PLANTS

**Volume II, Chapter 11
Operation of Conventional Activated Sludge Plants**

TABLE OF CONTENTS

Chapter 2. Activated Sludge

Pure Oxygen Plants and Operational Control Options

	Page
OBJECTIVES	22
GLOSSARY	23
 LESSON 1	
2.0 The Activated Sludge Process	29
2.1 Pure Oxygen	29
2.10 Description of Pure Oxygen Systems	29
2.11 PSA (Pressure Swing Absorption) Oxygen Generating System	33
2.12 Cryogenic Air Separation Method	33
2.13 Process and System Control	36
2.14 System Start-Up	36
2.15 Control Guidelines	36
2.16 Process Safety	37
2.17 Operator Safety	37
2.18 Pure Oxygen System Maintenance	38
2.19 Acknowledgment	38
 LESSON 2	
2.2 Return Activated Sludge	39
2.20 Purpose of Returning Activated Sludge	39
2.21 Return Activated Sludge Control	39
2.210 Constant RAS Flow Rate Control	39
2.211 Constant Percentage RAS Flow Rate Control	39
2.212 Comparison of Both RAS Control Approaches	39
2.22 Methods of RAS Flow Rate Control	41
2.220 Sludge Blanket Depth	41
2.221 Settleability Approach	41
2.222 SVI Approach	43
2.23 Return Rates with Separate Sludge Re-Aeration	43
2.24 Acknowledgment	44

LESSON 3

2.3	Waste Activated Sludge	45
2.30	Purpose of Wasting Activated Sludge	45
2.31	Methods of Wasting Activated Sludge	46
2.310	Sludge Age Control	46
2.311	F/M Control	47
2.312	MCRT Control	49
2.313	Volatile Solids Inventory	50
2.314	MLVSS Control	51
2.32	Microscopic Examination	51
2.33	The AI West Method	54
2.34	Summary of RAS and WAS Rates	54
2.35	Acknowledgment	54

LESSON 4

2.4	Treatment of Both Municipal and Industrial Wastes	55
2.40	Monitoring Industrial Waste Discharges	55
2.400	Establishing a Monitoring System	55
2.401	Automatic Monitoring Units	56
2.41	Common Industrial Wastes	56
2.42	Effects of Industrial Wastes on the Treatment Plant Unit Processes	56
2.43	Operational Strategy	57
2.430	Need for a Strategy	57
2.431	Recognition of a Toxic Waste Load	57
2.432	Operational Strategy for Toxic Wastes	57
2.433	Recognition of a High Organic Waste Load	57
2.434	Operational Strategy for High Organic Waste Loads	58
2.5	Industrial Waste Treatment	58
2.50	Need to Treat Industrial Wastes	58
2.51	Characterization of Influent Wastes	58
2.52	Common Industrial Wastewater Variables	58
2.520	Flow	58
2.521	pH	59
2.522	BOD and Suspended Solids	59
2.523	COD	59
2.524	Nutrients	59
2.525	Toxicity	59

2.53	Flow and Pre-Treatment Considerations	59
2.530	Flow Segregation	60
2.531	Flow Control	60
2.532	Screening	60
2.533	Grit, Soil, Grease and Oil Removal	60
2.534	Central Pre-Treatment Facilities	60
2.535	Start-Up or Restart of an Industrial Activated Sludge Process	62
2.54	Operational Considerations (Activated Sludge)	63
2.540	Neutralization	63
2.541	Nutrients	63
2.542	Daily System Observations	64
2.543	Return Activated Sludge	64
2.544	Waste Activated Sludge	64
2.545	Clarification	64
2.55	Pulp and Paper Mill Wastes	65
2.550	Need for Recordkeeping	65
2.551	Wastes Discharged to the Plant Collection System	65
2.552	Variables Associated with the Treatment of Paper Mill Wastes	66
2.553	Start-Up and Shutdown Procedures	67
2.554	Management of Shutdowns and Start-Ups	67
2.555	The Periodic-Feeding (Step-Feed) Technique for Process Start-Up of Activated Sludge Systems	69
2.556	Operation of a Municipal Plant Receiving Paper Mill Wastewater	71
2.557	Acknowledgments	71
2.56	Brewery Wastewaters	71
2.560	Operational Strategy	71
2.561	Sources and Characteristics of Brewery Wastewater	72
2.562	Brewery Wastewater Treatment Plant Tour	72
2.563	Nutrient Addition	74
2.564	Aeration Basin Flow Scheme	75
2.565	Activated Sludge System Operation	75
2.566	Sludge Wasting	78
2.567	Filamentous Organisms	79
2.568	Laboratory Testing	81
2.569	Recordkeeping	81

2.57	Food Processing Wastes	81
2.570	Treatment of Artichoke Wastewater	81
2.571	Pilot Project	81
2.572	Daily Operational Procedures	83
2.573	Treatment of Dairy Wastes	83
2.574	Operation	83
2.575	Plant Effluent	85
2.576	Operational Techniques for Upgrading Effluent	85
2.58	Petroleum Refinery Wastes	85
2.580	Refinery Wastewater Characteristics	85
2.581	Activated Sludge Process	85
2.582	Frequency of Sampling and Lab Tests	85
2.583	Operational Procedures	85
2.584	Response to Sulfide Shock Load	85
2.585	Correcting Excessive Phenols	87
2.586	Treating Ammonia	87
2.59	Summary and Acknowledgments	87
2.590	Summary	87
2.591	Acknowledgments	87
2.6	Effluent Nitrification	87
2.60	Need for Effluent Nitrification	87
2.61	Nitrogen Removal Methods	87
2.610	Ammonia-Stripping	87
2.611	Ion Exchange	87
2.612	Breakpoint Chlorination	88
2.62	Biological Nitrification	88
2.63	Factors Affecting Biological Nitrification	88
2.64	Rising Sludge and the Nitrification Process	91
2.65	Acknowledgments	91
2.7	Review of Plans and Specifications — Pure Oxygen Activated Sludge Systems	91
2.70	Need to be Familiar with System	91
2.71	Physical Layout	91
2.72	Oxygen Generation Equipment	92
2.73	Reactors (Aeration Tanks)	92
2.74	Safety and Instrumentation	92
2.75	Preventive Maintenance	92
	SUGGESTED ANSWERS	94
	OBJECTIVE TEST	98

NOTE: The following Tables of Contents for the Activated Sludge chapters in *OPERATION OF WASTEWATER TREATMENT PLANTS* are provided for your information in case you wish to learn more about the activated sludge process.

OPERATION OF WASTEWATER TREATMENT PLANTS

TABLE OF CONTENTS

Chapter 8. Activated Sludge

(Volume I. Package Plants and Oxidation Ditches)

	Page
OBJECTIVES	230
GLOSSARY	231
 LESSON 1	
8.0 The Activated Sludge Process	236
8.00 Wastewater Treatment by Activated Sludge	236
8.01 Definitions	236
8.02 Process Description	236
8.1 Requirements for Control	242
 LESSON 2	
8.2 Package Plants (Extended Aeration)	243
8.20 Purpose of Package Plants	243
8.200 Use of Package Plants	243
8.201 Types of Package Plant Treatment Processes	243
8.202 Aeration Methods	247
8.21 Pre-Start Check-Out	247
8.22 Starting the Plant	250
8.23 Operation of Aeration Equipment	250
8.24 Wasting Sludge	250
8.25 Operation	250
8.250 Normal Operation	250
8.251 Abnormal Operation	251
8.252 Troubleshooting	251
8.253 Shutdown	251
8.254 Operational Strategy	251
8.26 Laboratory Testing	252
8.27 Safety	252
8.28 Maintenance	253
8.29 Additional Reading	253

LESSON 3

8.3 Oxidation Ditches	254
8.30 Use of Oxidation Ditches	254
8.300 Flow Path for Oxidation Ditches	254
8.301 Description of Oxidation Ditches	254
8.31 Safety	257
8.32 Start-Up	257
8.320 Pre-Start Inspection	257
8.321 Plant Start-Up	258
8.33 Operation	259
8.330 Normal Operation	259
8.331 Abnormal Operation	262
8.332 Shutdown	262
8.333 Troubleshooting	262
8.334 Operational Strategy	264
8.34 Maintenance	264
8.340 Housekeeping	264
8.341 Equipment Maintenance	264
8.35 Operational Guidelines	265
8.350 English System	265
8.351 Metric System	266
8.4 Review of Plans and Specifications	267
8.40 Package Plants	267
8.41 Oxidation Ditches	267
8.5 Arithmetic Assignment	268
8.6 Metric Calculations	268

OPERATION OF WASTEWATER TREATMENT PLANTS

TABLE OF CONTENTS

Chapter 11. Activated Sludge

Volume II. Operation of Conventional Activated Sludge Plants

	Page
OBJECTIVES	6
GLOSSARY	7
 LESSON 1	
11.0 Basic Variables and Record Keeping	13
11.00 Need for Record Keeping	13
11.01 Variables in Collection System	13
11.010 Combined Sewer Systems	13
11.011 Waste Dischargers to the System	13
11.012 Maintenance of the Collection System	13
11.02 Operational Variables	13
11.03 Plant Records	15
11.04 Typical Lab Results for an Activated Sludge Plant	16
11.05 Design Variables	16
11.050 Aeration Methods	16
11.051 Variation of Activated Sludge Process	16
 LESSON 2	
11.1 Aeration Systems	20
11.10 Purpose of Aeration	20
11.11 Mechanical Aeration Systems	20
11.12 Diffused Aeration Systems	20
11.120 Air Filters	22
11.121 Blowers (Process Air Compressors)	22
11.122 Air Distribution System	28
11.123 Air Headers	28
11.124 Diffusers	28
11.2 Safety	28
11.20 Aeration Tanks and Clarifiers	28

11.21	Surface Aerators	35
11.22	Air Filters	35
11.23	Blowers	35
11.24	Air Distribution System	35
11.25	Air Headers and Diffusers	35

LESSON 3

11.3	Checking Out a New Plant	36
11.30	A New Activated Sludge Plant: Description	36
11.31	Aerator	36
11.310	Control Gates	36
11.311	Storm Flow Gates and Pedestal Lift Gates	38
11.312	Weirs	38
11.313	Movable Gates	38
11.314	Water Sprays for Froth Control	38
11.315	Air System	38
	A. Air Filters	38
	B. Blowers (Compressors)	39
	C. Air Headers	40
	D. Diffusers	40
	E. Blower Testing	41
11.32	Secondary Clarifiers	41
11.33	Return Sludge and Waste Sludge Pumps	41

LESSON 4

11.4	Process Start-Up Procedures	43
11.40	General	43
11.41	First Day	43
11.42	Second Day	44
11.43	Third through Fifth Days	44
11.44	Sixth Day	44

LESSON 5

11.5	Routine Operational Control	46
11.50	How to Control the Process	46
11.51	Determination of Sludge Age	46
11.52	Wasting Activated Sludge	47
11.53	Determination of Waste Sludge Pumping Rate	49
11.54	Operational Strategy	49

20 Treatment Plants

11.540	Influent Characteristics	49
11.541	Aeration Tank Environment	49
11.542	Secondary Clarifier	50
11.543	Plant Effluent	50
11.55	Actual Operation Under Normal Conditions	50
11.550	Initial Inspection	50
11.551	Process Adjustment	50
11.56	Actual Operation Under Abnormal Conditions	54
11.57	Summary	54

LESSON 6

11.6	Operational Problems (Abnormal Operation)	57
11.60	Typical Problems	57
11.61	Plant Changes	57
11.62	Sludge Bulking	59
11.63	Septic Sludge	60
11.64	Toxic Substances	60
11.65	Rising Sludge	60
11.66	Foaming/Frothing	60

LESSON 7

11.7	Aerator Loading Guidelines	62
11.70	Use of Loading Guidelines	62
11.71	Food/Microorganism Ratio	62
11.72	Calculation of Food/Microorganism Aerator Loading	62
11.73	Mean Cell Residence Time (MCRT)	63
11.74	Calculation of Mean Cell Residence Time	63
11.8	Activated Sludge Process Equipment	63
11.80	Need for Understanding Equipment	63
11.81	Shutdown	64
11.810	Surface Aerators	64
11.811	Positive Displacement Blowers	64
11.812	Centrifugal Blowers	64
11.813	Air Distribution System	64
11.814	Air Headers and Diffusers	64
11.82	Abnormal Conditions	64
11.820	Surface Aerators	64
11.821	Air Filters	64
11.822	Blowers	66

11.823	Air Distribution System	66
11.824	Air Headers	66
11.825	Air Diffusers	66
11.83	Maintenance	66
11.830	Surface Aerators	66
11.831	Air Filters	66
11.832	Blowers	70
11.833	Air Distribution System	71
11.834	Air Headers	71
11.835	Diffusers	71
11.84	Modifications of the Activated Sludge Process	71
11.840	Reasons for Other Modes of Operation	71
11.841	Contact Stabilization	71
11.842	Kraus Process	73
11.843	Step-Feed Aeration	73
11.844	Complete Mix	73
11.845	Modified Aeration	77

LESSON 8

11.9	Microbiology for Activated Sludge by Paul V. Bohler	78
11.90	Importance of Microbiology	78
11.900	Who Should Know Microbiology	78
11.901	Better Control of Process	78
11.91	Collection of Samples	78
11.910	Equipment Needed	78
11.911	Sampling Location	79
11.92	Sample Preparation	79
11.920	Laboratory Supplies Needed	81
11.921	Procedure for Preparing Sample	81
11.93	Microscopic Observation	81
11.930	The Microscope	81
11.931	Microorganisms of Importance	83
11.932	Recording Observations	88
11.94	Interpretation of Results	91
11.940	Desirable Microorganisms	91
11.941	Undesirable Microorganisms	91
11.942	Comparing Microscopic Results	91
11.943	Changes in Numbers or Types of Microorganisms	93
11.95	Response to Results	93
11.950	Decision: To Make or Not to Make a Process Change	93

22 Treatment Plants

11.951	Waiting to Analyze More Data	93
11.952	Making a Process Change	94
11.96	Monitoring	96
11.960	Frequency of Microscopic Organization	96
11.961	Watching for Changes or Trends	96
11.97	Acknowledgment	97
11.10	Arithmetic Assignment	97
11.11	Acknowledgment	97
11.12	Additional Reading	97

INDUSTRIAL WASTE TREATMENT OBJECTIVES

Chapter 2. ACTIVATED SLUDGE

Pure Oxygen Plants and Operational Control Options

Following completion of Chapter 2, you should be able to:

1. Safely operate and maintain a pure oxygen activated sludge plant,
2. Review the plans and specifications for a pure oxygen system,
3. Describe the various methods of determining return sludge and waste sludge rates and select the best method for your plant,
4. Operate an activated sludge process that must treat both municipal and industrial wastes,
5. Operate an activated sludge process that must treat strictly an industrial waste, and
6. Operate an activated sludge process to produce a nitrified effluent.



GLOSSARY

Chapter 2. ACTIVATED SLUDGE

ABSORPTION (ab-SORP-shun)

Taking in or soaking up of one substance into the body of another by molecular or chemical action (as tree roots absorb dissolved nutrients in the soil).

ABSORPTION**ACTIVATED SLUDGE (ACK-ta-VATE-ed sluj)**

Sludge particles produced in raw or settled wastewater (primary effluent) by the growth of organisms (including zoogical bacteria) in aeration tanks in the presence of dissolved oxygen. The term "activated" comes from the fact that the particles are teeming with bacteria, fungi, and protozoa. Activated sludge is different from primary sludge in that the sludge particles contain many living organisms which can feed on the incoming wastewater.

ACTIVATED SLUDGE**ACTIVATED SLUDGE PROCESS (ACK-ta-VATE-ed sluj)**

A biological wastewater treatment process which speeds up the decomposition of wastes in the wastewater being treated. Activated sludge is added to wastewater and the mixture (mixed liquor) is aerated and agitated. After some time in the aeration tank, the activated sludge is allowed to settle out by sedimentation and is disposed of (wasted) or reused (returned to the aeration tank) as needed. The remaining wastewater then undergoes more treatment.

ACTIVATED SLUDGE PROCESS**ADSORPTION (add-SORP-shun)**

The gathering of a gas, liquid, or dissolved substance on the surface or interface zone of another substance.

ADSORPTION**AERATION LIQUOR (air-A-shun)**

Mixed liquor. The contents of the aeration tank including living organisms and material carried into the tank by either untreated wastewater or primary effluent.

AERATION LIQUOR**AERATION TANK (air-A-shun)**

The tank where raw or settled wastewater is mixed with return sludge and aerated. The same as aeration bay, aerator, or reactor.

AERATION TANK**AEROBES**

Bacteria that must have molecular (dissolved) oxygen (DO) to survive.

AEROBES**AEROBIC DIGESTION (AIR-O-bick)**

The breakdown of wastes by microorganisms in the presence of dissolved oxygen. Waste sludge is placed in a large aerated tank where aerobic microorganisms decompose the organic matter in the sludge. This is an extension of the activated sludge process.

AEROBIC DIGESTION**AGGLOMERATION (a-GLOM-er-A-shun)**

The growing or coming together of small scattered particles into larger flocs or particles which settle rapidly. Also see FLOC.

AGGLOMERATION**AIR LIFT**

A special type of pump. This device consists of a vertical riser pipe submerged in the wastewater or sludge to be pumped. Compressed air is injected into a tail piece at the bottom of the pipe. Fine air bubbles mix with the wastewater or sludge to form a mixture lighter than the surrounding water which causes the mixture to rise in the discharge pipe to the outlet. An air-lift pump works similar to the center stand in a percolator coffee pot.

AIR LIFT**ALiquot (AL-li-kwot)**

Portion of a sample.

ALiquot**AMBIENT TEMPERATURE (AM-bee-ent)**

Temperature of the surroundings.

AMBIENT TEMPERATURE**ANAEROBES**

Bacteria that do not need molecular (dissolved) oxygen (DO) to survive.

ANAEROBES

24 Treatment Plants

BACTERIAL CULTURE (back-TEAR-e-al)

In the case of activated sludge, the bacterial culture refers to the group of bacteria classed as *AEROBES*, and facultative organisms, which covers a wide range of organisms. Most treatment processes in the United States grow facultative organisms which utilize the carbonaceous (carbon compounds) BOD. Facultative organisms can live when oxygen resources are low. When "nitrification" is required, the nitrifying organisms are *OBLIGATE AEROBES* (require oxygen) and must have at least 0.5 mg/L of dissolved oxygen throughout the whole system to function properly.

BACTERIAL CULTURE

BATCH PROCESS

A treatment process in which a tank or reactor is filled, the water is treated, and the tank is emptied. The tank may then be filled and the process repeated.

BATCH PROCESS

BENCH SCALE ANALYSIS

A method of studying different ways of treating wastewater and solids on a small scale in a laboratory.

BENCH SCALE ANALYSIS

BIOMASS (BUY-o-MASS)

A mass or clump of living organisms feeding on the wastes in wastewater, dead organisms and other debris. This mass may be formed for, or function as, the protection against predators and storage of food supplies. Also see *ZOOGLICAL MASS*.

BIOMASS

BULKING (BULK-ing)

Clouds of billowing sludge that occur throughout secondary clarifiers and sludge thickeners when the sludge becomes too light and will not settle properly.

BULKING

CATHODIC PROTECTION (ca-THOD-ick)

An electrical system for prevention of rust, corrosion, and pitting of steel and iron surfaces in contact with water, wastewater or soil.

CATHODIC PROTECTION

CILIATES (SILLY-ates)

A class of protozoans distinguished by short hairs on all or part of their bodies.

CILIATES

COAGULATION (ko-AGG-you-LAY-shun)

The use of chemicals that cause very fine particles to clump together into larger particles. This makes it easier to separate the solids from the liquids by settling, skimming, and draining or filtering.

COAGULATION

COMPOSITE (PROPORTIONAL) SAMPLE (corn-POZ-it)

A composite sample is a collection of individual samples obtained at regular intervals, usually every one or two hours during a 24-hour time span. Each individual sample is combined with the others in proportion to the flow when the sample was collected. The resulting mixture (composite sample) forms a representative sample and is analyzed to determine the average conditions during the sampling period.

COMPOSITE (PROPORTIONAL) SAMPLE

CONING (CONE-ing)

Development of a cone-shaped flow of liquid, like a whirlpool, through sludge. This can occur in a sludge hopper during sludge withdrawal when the sludge becomes too thick. Part of the sludge remains in place while liquid rather than sludge flows out of the hopper. Also called "coring."

CONING

CONTACT STABILIZATION

Contact stabilization is a modification of the conventional activated sludge process. In contact stabilization, two aeration tanks are used. One tank is for separate re-aeration of the return sludge for at least four hours before it is permitted to flow into the other aeration tank to be mixed with the primary effluent requiring treatment.

CONTACT STABILIZATION

CRYOGENIC (cry-o-JEN-nick)

Low temperature.

CRYOGENIC

DENITRIFICATION

A condition that occurs when nitrite or nitrate ions are reduced to nitrogen gas and bubbles are formed as a result of this process. The bubbles attach to the biological flocs and float the flocs to the surface of the secondary clarifiers. This condition is often the cause of rising sludge observed in secondary clarifiers.

DENITRIFICATION

DIFFUSED-AIR AERATION

A diffused air activated sludge plant takes air, compresses it, and then discharges the air below the water surface of the aerator through some type of air diffusion device.

DIFFUSED-AIR AERATION

DIFFUSER

A device (porous plate, tube, bag) used to break the air stream from the blower system into fine bubbles in an aeration tank or reactor.

DIFFUSER

DISSOLVED OXYGEN

Molecular oxygen dissolved in water or wastewater, usually abbreviated DO.

DISSOLVED OXYGEN**ENDOGENOUS (en-DODGE-en-us)**

A reduced level of respiration (breathing) in which organisms break down compounds within their own cells to produce the oxygen they need.

ENDOGENOUS**F/M RATIO**

Food to microorganism ratio. A measure of food provided to bacteria in an aeration tank.

F/M RATIO

$$\begin{aligned} \frac{\text{Food}}{\text{Microorganisms}} &= \frac{\text{BOD, lbs/day}}{\text{MLVSS, lbs}} \\ &= \frac{\text{Flow, MGD} \times \text{BOD, mg/L} \times 8.34 \text{ lbs/gal}}{\text{Volume, MG} \times \text{MLVSS, mg/L} \times 8.34 \text{ lbs/gal}} \\ \text{or} &= \frac{\text{BOD, kg/day}}{\text{MLVSS, kg}} \end{aligned}$$

FACULTATIVE (FACK-ul-TAY-tive)

Facultative bacteria can use either molecular (dissolved) oxygen or oxygen obtained from food materials such as sulfate or nitrate ions. In other words, facultative bacteria can live under aerobic or anaerobic conditions.

FACULTATIVE**FILAMENTOUS BACTERIA (FILL-a-MEN-tuss)**

Organisms that grow in a thread or filamentous form. Common types are thiothrix and actinomycetes.

FILAMENTOUS BACTERIA**FLIGHTS**

Scraper boards, made from redwood or other rot-resistant woods or plastic, used to collect and move settled sludge or floating scum.

FLIGHTS**FLOC**

Groups or clumps of bacteria that have come together and formed a cluster. Found in aeration tanks and secondary clarifiers.

FLOC**FLOCCULATION (FLOCK-you-LAY-shun)**

The gathering together of fine particles to form larger particles.

FLOCCULATION**FOOD/MICROORGANISM RATIO**

Food to microorganism ratio. A measure of food provided to bacteria in an aeration tank.

FOOD/MICROORGANISM RATIO

$$\begin{aligned} \frac{\text{Food}}{\text{Microorganisms}} &= \frac{\text{BOD, lbs/day}}{\text{MLVSS, lbs}} \\ &= \frac{\text{Flow, MGD} \times \text{BOD, mg/L} \times 8.34 \text{ lbs/gal}}{\text{Volume, MG} \times \text{MLVSS, mg/L} \times 8.34 \text{ lbs/gal}} \\ \text{or} &= \frac{\text{BOD, kg/day}}{\text{MLVSS, kg}} \end{aligned}$$

Commonly abbreviated F/M Ratio.

HEADER

A large pipe to which the ends of a series of smaller pipes are connected. Also called a "manifold."

HEADER**INTERFACE**

The common boundary layer between two fluids such as a gas (air) and a liquid (water) or a liquid (water) and another liquid (oil).

INTERFACE**MCRT**

Mean Cell Residence Time, days. An expression of the average time that a microorganism will spend in the activated sludge process.

MCRT

$$\text{MCRT, days} = \frac{\text{Solids in Activated Sludge Process, lbs}}{\text{Solids Removed from Process, lbs/day}}$$

MLSS

Mixed Liquor Suspended Solids, mg/L. Suspended solids in the mixed liquor of an aeration tank.

MLSS

26 Treatment Plants

MLVSS Mixed Liquor Volatile Suspended Solids, mg/L. The organic or volatile suspended solids in the mixed liquor of an aeration tank. This volatile portion is used as a measure or indication of the microorganisms present.	MLVSS
MANIFOLD A large pipe to which the ends of a series of smaller pipes are connected. Also called a "header."	MANIFOLD
MEAN CELL RESIDENCE TIME (MCRT) An expression of the average time that a microorganism will spend in the activated sludge process.	MEAN CELL RESIDENCE TIME (MCRT)
$\text{MCRT, days} = \frac{\text{Solids in Activated Sludge Process, lbs}}{\text{Solids Removed from Process, lbs/day}}$	
MECHANICAL AERATION The use of machinery to mix air and water so that oxygen can be absorbed into the water. Some examples are: paddle wheels, mixers, or rotating brushes to agitate the surface of an aeration tank; pumps to create fountains; and pumps to discharge water down a series of steps forming falls or cascades.	MECHANICAL AERATION
MICROORGANISMS (micro-ORGAN-is-ums) Very small organisms that can be seen only through a microscope. Some microorganisms use the wastes in wastewater for food and thus remove or alter much of the undesirable matter.	MICROORGANISMS
MIXED LIQUOR When the activated sludge in an aeration tank is mixed with primary effluent or the raw wastewater and return sludge, this mixture is then referred to as mixed liquor as long as it is in the aeration tank. Mixed liquor also may refer to the contents of mixed aerobic or anaerobic digesters.	MIXED LIQUOR
MIXED LIQUOR SUSPENDED SOLIDS (MLSS) Suspended solids in the mixed liquor of an aeration tank.	MIXED LIQUOR SUSPENDED SOLIDS (MLSS)
MIXED LIQUOR VOLATILE SUSPENDED SOLIDS (MLVSS) The organic or volatile suspended solids in the mixed liquor of an aeration tank. This volatile portion is used as a measure or indication of the microorganisms present.	MIXED LIQUOR VOLATILE SUSPENDED SOLIDS (MLVSS)
MOVING AVERAGE To calculate the moving average for the last 7 days, add up the values for the last 7 days and divide by 7. Each day add the most recent day to the sum of values and subtract the oldest value. By using the 7-day moving average, each day of the week is always represented in the calculations.	MOVING AVERAGE
NITRIFICATION (NYE-tri-fi-KAY-shun) A process in which bacteria change the ammonia and organic nitrogen in wastewater into oxidized nitrogen (usually nitrate). The second-stage BOD is sometimes referred to as the "nitrification stage" (first-stage BOD is called the "carbonaceous stage").	NITRIFICATION
OXIDATION (ox+DAY-shun) Oxidation is the addition of oxygen, removal of hydrogen, or the removal of electrons from an element or compound. In wastewater treatment, organic matter is oxidized to more stable substances. The opposite of REDUCTION.	OXIDATION
POLYELECTROLYTE (POLY-electro-light) A high-molecular-weight substance that is formed by either a natural or synthetic process. Natural polyelectrolytes may be of biological origin or derived from starch products, cellulose derivatives, and alginates. Synthetic polyelectrolytes consist of simple substances that have been made into complex, high-molecular-weight substances. Often called a "polymer."	POLYELECTROLYTE
POLYMER (POLY-mer) A high-molecular-weight substance that is formed by either a natural or synthetic process. Natural polymers may be of biological origin or derived from starch products, cellulose derivatives, and alginates. Synthetic polymers consist of simple substances that have been made into complex, high-molecular-weight substances. Often called a "polyelectrolyte."	POLYMER
PROTOZOA (pro-toe-ZOE-ah) A group of microscopic animals (usually single-celled) that sometimes cluster into colonies.	PROTOZOA
PURGE To remove a gas or vapor from a vessel, reactor, or confined space.	PURGE

RAS

Return Activated Sludge, mg/L. Settled activated sludge that is collected in the secondary clarifier and returned to the aeration basin to mix with incoming raw or primary settled wastewater.

RAS

REDUCTION (re-DUCK-shun)

Reduction is the addition of hydrogen, removal of oxygen, or the addition of electrons to an element or compound. Under anaerobic conditions in wastewater, sulfate compounds or elemental sulfur is reduced to odor-producing hydrogen sulfide (H_2S) or the sulfide ion (S^{-2}). The opposite of OXIDATION.

REDUCTION

RETURN ACTIVATED SLUDGE (RAS)

Settled activated sludge that is collected in the secondary clarifier and returned to the aeration basin to mix with incoming raw or primary settled wastewater.

RETURN ACTIVATED SLUDGE (RAS)

RISING SLUDGE

Rising sludge occurs in the secondary clarifiers of activated sludge plants when the sludge settles to the bottom of the clarifier, is compacted, and then starts to rise to the surface, usually as a result of denitrification.

RISING SLUDGE

ROTIFERS (ROE-ti-fers)

Microscopic animals characterized by short hairs on their front end.

ROTIFERS

SECCHI DISC (SECK-key)

A flat, white disc lowered into the water by a rope until it is just barely visible. At this point, the depth of the disc from the water surface is the recorded secchi disc reading.

SECCHI DISC

SEIZING

Seizing occurs when an engine overheats and a component expands to the point where the engine will not run. Also called "freezing."

SEIZING

SEPTIC (SEP-tick)

This condition is produced by anaerobic bacteria. If severe, the wastewater turns black, gives off foul odors, contains little or no dissolved oxygen and creates a heavy oxygen demand.

SEPTIC

SHOCK LOAD

The arrival at a plant of a waste which is toxic to organisms in sufficient quantity or strength to cause operating problems. Possible problems include odors and solids in the effluent. Organic or hydraulic overloads can cause a shock load.

SHOCK LOAD

SLUDGE AGE

A measure of the length of time a particle of suspended solids has been undergoing aeration in the activated sludge process.

SLUDGE AGE

Sludge Age, $\frac{\text{Suspended Solids Under Aeration, lbs or kg}}{\text{days}} = \frac{\text{Suspended Solids Added, lbs/day or kg/day}}{\text{days}}$

SLUDGE DENSITY INDEX (SDI)

This test is used in a way similar to the Sludge Volume Index (SVI) to indicate the settleability of a sludge in a secondary clarifier or effluent. $SDI = 100/SVI$. Also see SLUDGE VOLUME INDEX (SVI).

SLUDGE DENSITY INDEX (SDI)

SLUDGE VOLUME INDEX (SVI)

This is a test used to indicate the settling ability of activated sludge (aeration solids) in the secondary clarifier. The test is a measure of the volume of sludge compared to its weight. Allow the sludge sample from the aeration tank to settle for 30 minutes. Then calculate SVI by dividing the volume (ml) of wet settled sludge by the weight (mg) of the sludge after it has been dried. Sludge with an SVI of one hundred or greater will not settle as readily as desirable because it is as light as or lighter than water.

SLUDGE VOLUME INDEX (SVI)

$$SVI = \frac{\text{Wet Settled Sludge, ml}}{\text{Dried Sludge Solids, mg}} \times 1000$$

STABILIZED WASTE

A waste that has been treated or decomposed to the extent that, if discharged or released, its rate and state of decomposition would be such that the waste would not cause a nuisance or odors.

STABILIZED WASTE

STEP-FEED AERATION

Step-feed aeration is a modification of the conventional activated sludge process. In step aeration, primary effluent enters the aeration tank at several points along the length of the tank, rather than all of the primary effluent entering at the beginning or head of the tank and flowing through the entire tank.

STEP-FEED AERATION

28 Treatment Plants

STRIPPED GASES

Gases that are released from a liquid by bubbling air through the liquid or by allowing the liquid to be sprayed or tumbled over media.

STRIPPED GASES

SUPERNATANT (sue-per-NAY-tent)

Liquid removed from settled sludge. Supernatant commonly refers to the liquid between the sludge on the bottom and the scum on the surface of an anaerobic digester. This liquid is usually returned to the influent wet well or to the primary clarifier.

SUPERNATANT

TOC

Total Organic Carbon. TOC measures the amount of organic carbon in water.

TOC

TURBIDITY METER

An instrument for measuring the amount of particles suspended in water. Precise measurements are made by measuring how light is scattered by the suspended particles. The normal measuring range is 0 to 100 and is expressed as Nephelometric Turbidity Units (NTU's).

TURBIDITY METER

vOLUTE (vol-LOOT)

The spiral-shaped casing which surrounds a pump, blower, or turbine impeller and collects the liquid or gas discharged by the impeller.

VOLUTE

WAS

Waste Activated Sludge, mg/L. The excess growth of microorganisms which must be removed from the process to keep the biological system in balance.

WAS

WASTE ACTIVATED SLUDGE (WAS)

The excess growth of microorganisms which must be removed from the process to keep the biological system in balance.

WASTE ACTIVATED SLUDGE (WAS)

ZOOGLAAL MASS (ZOE-gee-al)

Jelly-like masses of bacteria found in both the trickling filter and activated sludge processes. These masses may be formed for or function as the protection against predators and for storage of food supplies. Also see BIOMASS.

ZOOGLAAL MASS

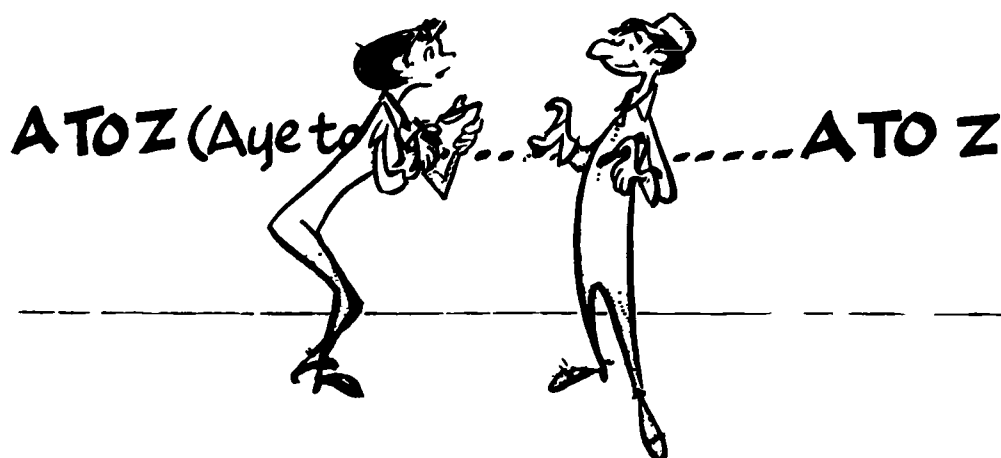

CHAPTER 2. ACTIVATED SLUDGE

Pure Oxygen Plants and Operational Control Options

(Lesson 1 of 4 Lessons)

NOTE: Review Volume I, Chapter 8, and Volume II, Chapter 11, of *OPERATION OF WASTEWATER TREATMENT PLANTS* for additional information.

2.0 THE ACTIVATED SLUDGE PROCESS

Research and operational experience are gradually revealing how the activated sludge process treats wastes and how to control the process. One objective of this chapter is to provide operators with a better understanding of the factors that can upset an activated sludge process and how to control the process to produce a high quality effluent. Pure oxygen systems dissolve oxygen into wastewater with a high efficiency for use by microorganisms treating the wastes. This allows the use of smaller aeration (reactor) tanks than air activated sludge systems. Operators need greater skill and knowledge to operate pure oxygen systems than conventional systems.

Operation of either pure oxygen or conventional aeration activated sludge processes is very complex. The quality of your plant's effluent depends on the characteristics of the plant's influent flows and wastes, as well as how the actual process is controlled. Two very important factors are:

1. RETURN ACTIVATED SLUDGE (RAS) RATE, and
2. WASTE ACTIVATED SLUDGE (WAS) RATE.

Several methods have been developed to help operators select the proper rates. This chapter reviews some of these methods and their advantages and limitations. You must remember that each of these factors affects the others and the impact on all process variables must be considered before changing one variable.

Some NPDES permits require the removal of ammonia from plant effluents. Biological nitrification (converting ammonium (NH_4^+) to nitrate (NO_3^-)) is the most effective way to remove ammonia unless total nitrogen removal is necessary. If total nitrogen removal is required, biological nitrification is the first step of the biological nitrification-denitrification approach to nitrogen removal. The biological nitrification process is an extension of the activated sludge process and is operated on the basis of the same concepts.

Industrial wastes are becoming more common in many municipal wastewaters. Whether you operate an activated sludge plant in a small town or a large city, you must know how to treat the industrial wastes that may be present with your municipal wastewaters. Many industries pretreat their own wastewaters before discharge to municipal collection systems while other industries treat all of their wastewaters rather than discharge into municipal collection systems. Whether you are treating strictly industrial wastewaters or a mixture of industrial and municipal wastewaters, this chapter will provide you with

the information you need to know to safely treat these different types of wastewaters using the activated sludge process.

QUESTIONS

Write your answers in a notebook and then compare your answers with those on page 94.

- 2.0A Why are pure oxygen systems used instead of conventional aeration methods?
- 2.0B What treatment process can be used to remove ammonium (NH_4^+) from wastewater, but not total nitrogen?

2.1 PURE OXYGEN

2.10 Description of Pure Oxygen Systems

The pure oxygen system (Fig. 2.1) is a modification of the activated sludge process (Fig. 2.2). The main difference is the method of supplying dissolved oxygen to the activated sludge process. In other activated sludge processes, air is compressed and released under water to produce an air-water *INTERFACE*¹ that transfers oxygen into the water (dissolved oxygen). If compressed air is not used, surface aerators agitate the water surface to drive air into the water (dissolved oxygen) to obtain the oxygen transfer. In the pure oxygen system, the only real differences are that pure oxygen rather than air is released below the surface or driven into the water by means of surface aerators and the aerators are covered.

In the pure oxygen system, oxygen is first separated from the air to produce relatively high-purity oxygen (90 to 98 percent oxygen). Pure oxygen is applied to the wastewater as a source of oxygen for the microorganisms treating the wastes. As with forced-air activated sludge systems, the pure oxygen must be driven into the water. This is accomplished by a diffuser mechanism or by mechanical agitation consisting of *TURBULENT MIXERS*² and surface aerators. The agitators also supply the energy to mix the reactor (aeration tank) contents to distribute the waste food (measured as BOD or COD) to the activated sludge microorganisms in the mixed liquor suspended solids (MLSS) and to prevent buildup of MLSS deposits in the reactor.

The pure oxygen reactors are staged (divided into two to five sections by baffles as shown in the three-stage system on Fig. 2.3) and are completely covered to provide a gas-tight enclosure. The wastewater, return sludge, and oxygen are fed into the first stage. The mixed liquor and atmosphere above it flow in the same direction from the first stage to the last.

¹ *Interface.* The common boundary layer between two fluids such as a gas (air) and a liquid (water) or a liquid (water) and another liquid (oil).

² *Turbulent Mixers.* Devices that mix air bubbles and water and cause turbulence to dissolve oxygen in water.

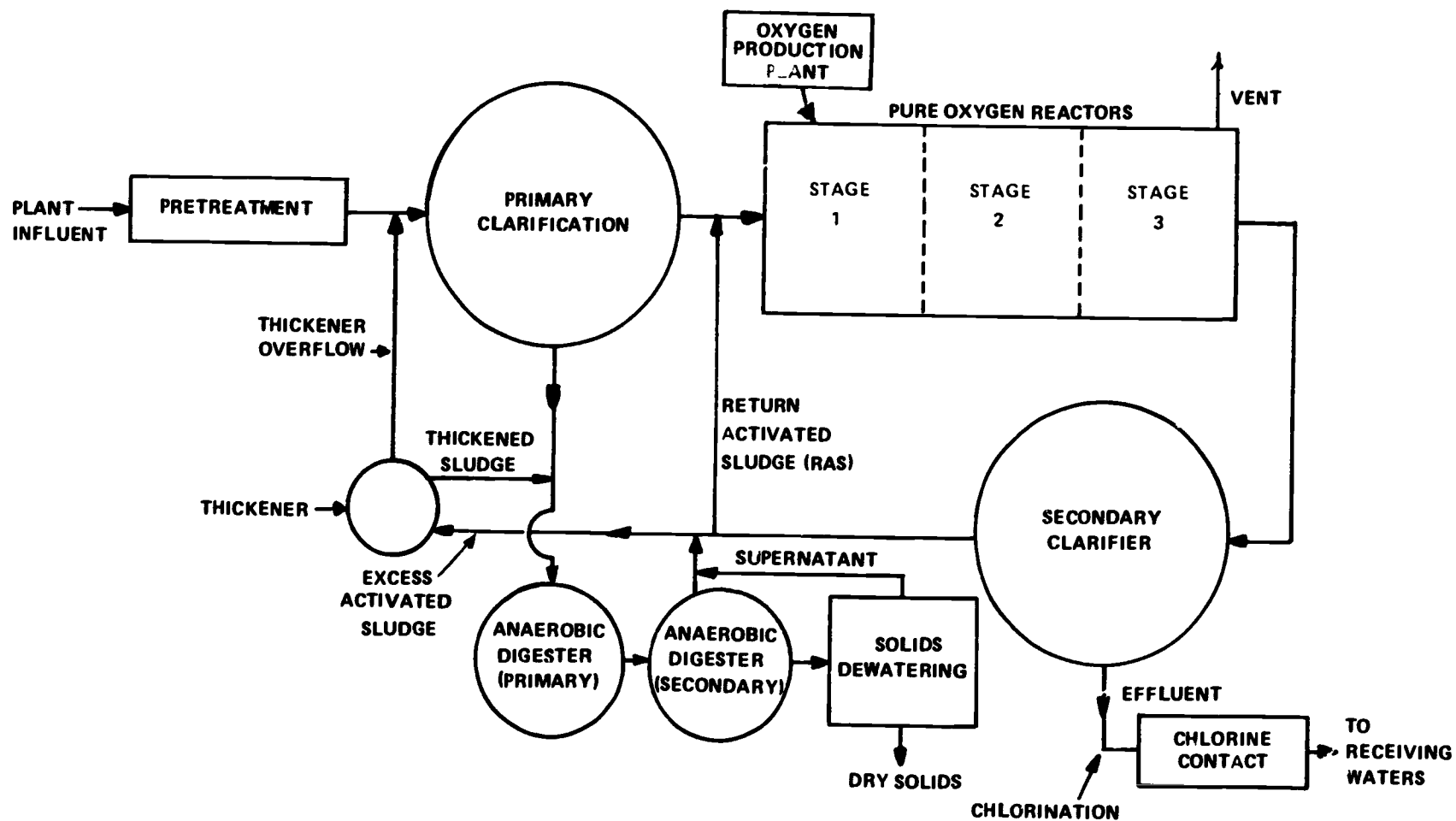

Fig. 2.1 Plan layout of a typical pure oxygen activated sludge plant

TREATMENT PROCESS

FUNCTION

PRETREATMENT

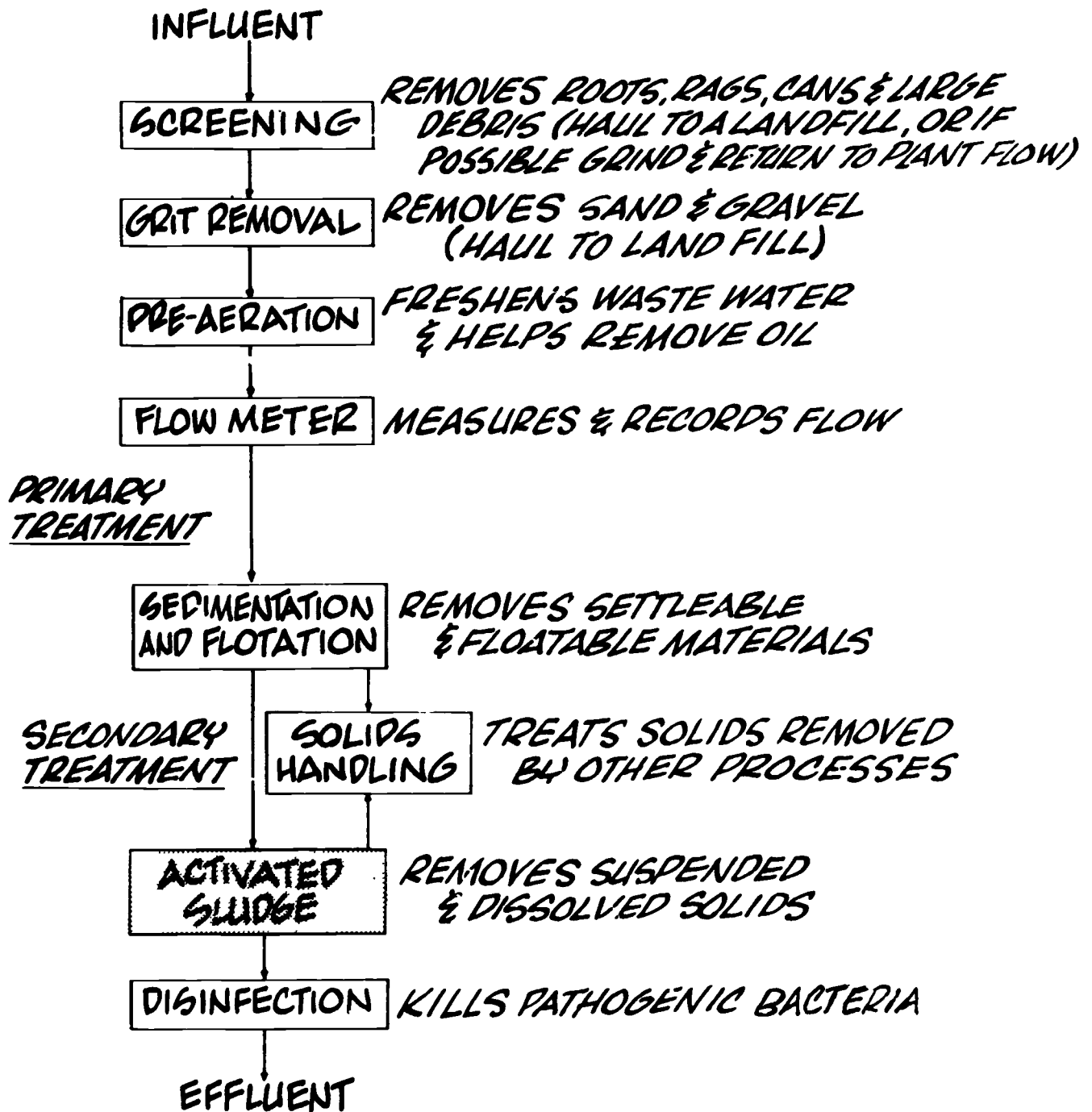

Fig. 2.2 Flow diagram of a typical plant

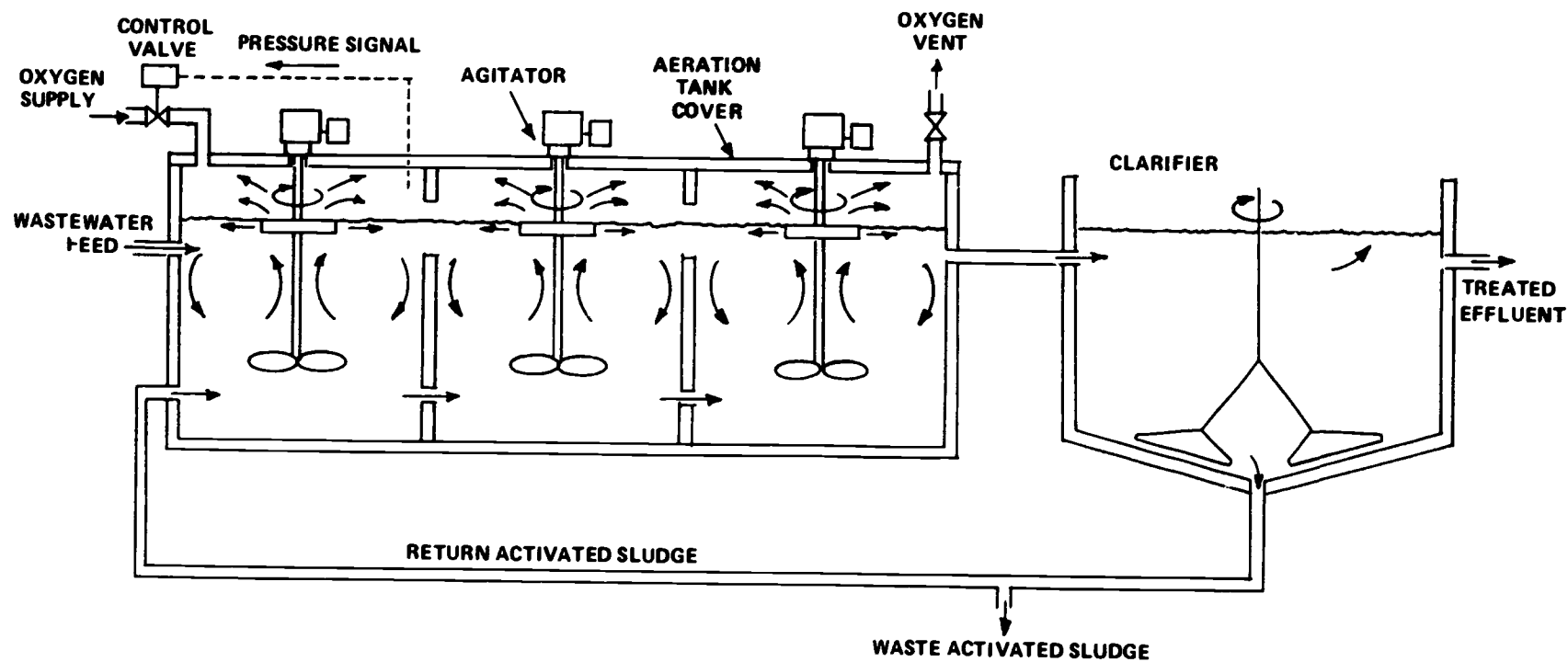

Fig. 2.3 Schematic diagram of pure oxygen system with surface aerators
(3 stages shown)

(Permission of Union Carbide Corporation)

When pure oxygen is driven into the water, it behaves similar to air and the bubbles rise to the water surface. During this rise to the surface, only a small portion of the oxygen is absorbed into the mixed liquor. Covering the reactor and sealing it from the outside atmosphere allows the oxygen that is not dissolved into the water (mixed liquor) to be used again. This contained gas over the water is still relatively high in oxygen concentration, the main contamination consisting of carbon dioxide gas given off by the respiration (breathing) of the activated sludge microorganisms and the nitrogen stripped from the incoming wastewater. The number of stages and the methods of containing the liquid and oxygen vary from one system to another. In one type of design, the oxygen-rich gas that accumulates in the space between the mixed liquor water surface and the roof of the reactor is removed, compressed, and recycled back to the diffuser of the reactor. In another type of design, surface aerators are used to drive the oxygen-rich gas into the water. In deep reactors (40 feet or 12 m), the surface aerator device may also be equipped with an extended shaft and submerged impeller to keep the tank contents well mixed. A third type of design incorporates both submerged diffusers and surface aeration. Some reactors vent the excess oxygen along with the carbon dioxide. Uncovered reactors skim the surface sludge for wasting.

In all types of design, a valve opens automatically and admits more pure oxygen to the first-stage reactor whenever sufficient oxygen is removed from the gas space of the first-stage reactor to drop the pressure below the required 1 to 4 inches (2 to 10 cm) of water column pressure. This constantly replenishes the oxygen supply and the pressure is sufficient to force gas movement through the succeeding stages. This pressure prevents air from leaking into the reactors, diluting the oxygen concentration and possibly creating an explosive mixture. Oxygen leaking from a reactor can create an explosive condition on the roof or around the reactor. Potentially explosive conditions inside the reactor from a mixture of hydrocarbons and oxygen are avoided by an automatically activated analysis and purge system.

In each of the succeeding stages, the gas above the mixed liquid in that stage is reinjected into the mixed liquor of the same stage (by compressor or surface aerator). As the oxygen-rich gas passes from one stage to the next, the oxygen is used by the activated sludge microorganisms and the atmosphere becomes more and more diluted by the carbon dioxide produced by the organisms and nitrogen *STRIPPED*³ from solution. The last stage in the reactor is equipped with a roof vent controlled by a valve mechanism that is called an oxygen vent valve. This valve vents gas from the last stage to the atmosphere and is normally set to vent gas when the oxygen concentration drops below 50 percent. As gas is vented from the last stage, more pure oxygen is released into the first stage to maintain the desired 1 to 4 inches (2 to 10 cm) of water column pressure.

Two methods are commonly used to produce pure oxygen. One is the Pressure Swing Absorption (PSA) Oxygen Generating System and the other is the *CRYOGENIC*⁴ Air Separation Method.

QUESTIONS

Write your answers in a notebook and then compare your answers with those on page 94.

- 2.1A Why are the pure oxygen reactors staged?
 2.1B How is the pure oxygen diluted as it passes from one stage to the next stage?
 2.11 PSA (Pressure Swing Absorption) Oxygen Generating System (Fig. 2.4)

The PSA Oxygen Generating Systems are usually installed in smaller plants. They take air from the atmosphere and compress it to 30 to 60 psi (2 to 4 kg/sq cm) and cool the compressed air in a water-cooled heat exchanger called an after cooler. The after cooler condenses and removes the moisture from the air stream. Next the air passes through an adsorbent vessel filled with a molecular sieve. Under pressure, this molecular sieve has the ability to adsorb nitrogen and other impurities from the atmospheric air, thus allowing the remaining pure oxygen to be used in the reactor. While one adsorber vessel is separating air into oxygen and nitrogen, the other two vessels are in various stages of desorption (or cleanup). The cleanup cycle consists of depressurizing and *PURGING*⁵ with some product oxygen. The last step involves pressurizing with compressed air before going back on stream. During this process, product oxygen is flowing continuously to the activated sludge plant.

The PSA unit can be turned down to 25 percent of its rated oxygen throughout without a significant loss of efficiency. Compressor and valve maintenance can be scheduled so as not to have more than one or two days of downtime per year by the use of multiple compressors. A backup tank of liquid provides oxygen after evaporation to handle peak loads or downtime oxygen demand. The switching valves are selected on the basis of their ability to withstand very severe conditions over long periods of time.

2.12 Cryogenic Air Separation Method (Fig. 2.5)

Oxygen produced by the cryogenic air separation method uses low temperature (cryogenic) or refrigeration principles to separate oxygen from air. Air is filtered, compressed, cooled to remove moisture, and then routed to the cold box or "cryo" plant tower. These towers are heavily insulated to conserve energy by minimizing heat leaks or losses. In Fig. 2.5 all the items contained in the dash-lined box are located in the "cryo" plant tower.

The reversing heat exchanger primarily removes carbon dioxide and water. This heat exchanger has two directional gas flows; one of air going into the tower and the other of nitrogen being exhausted to the atmosphere. As the flowing air removes carbon dioxide and water, ice will form in the heat exchanger and restrict the air flow through the heat exchanger. After several minutes of operation, a valve is activated that interchanges the gas stream flows by reversing the direction of flow. The nitrogen exhaust is routed through the inlet air pas-

³ Stripped Gases. Gases that are released from a liquid by bubbling air through the liquid or by allowing the liquid to be sprayed or tumbled over media.

⁴ Cryogenic (cry-o-JEN-nick). Low temperature.

⁵ Purge. To remove a gas or vapor from a vessel, reactor or confined space.

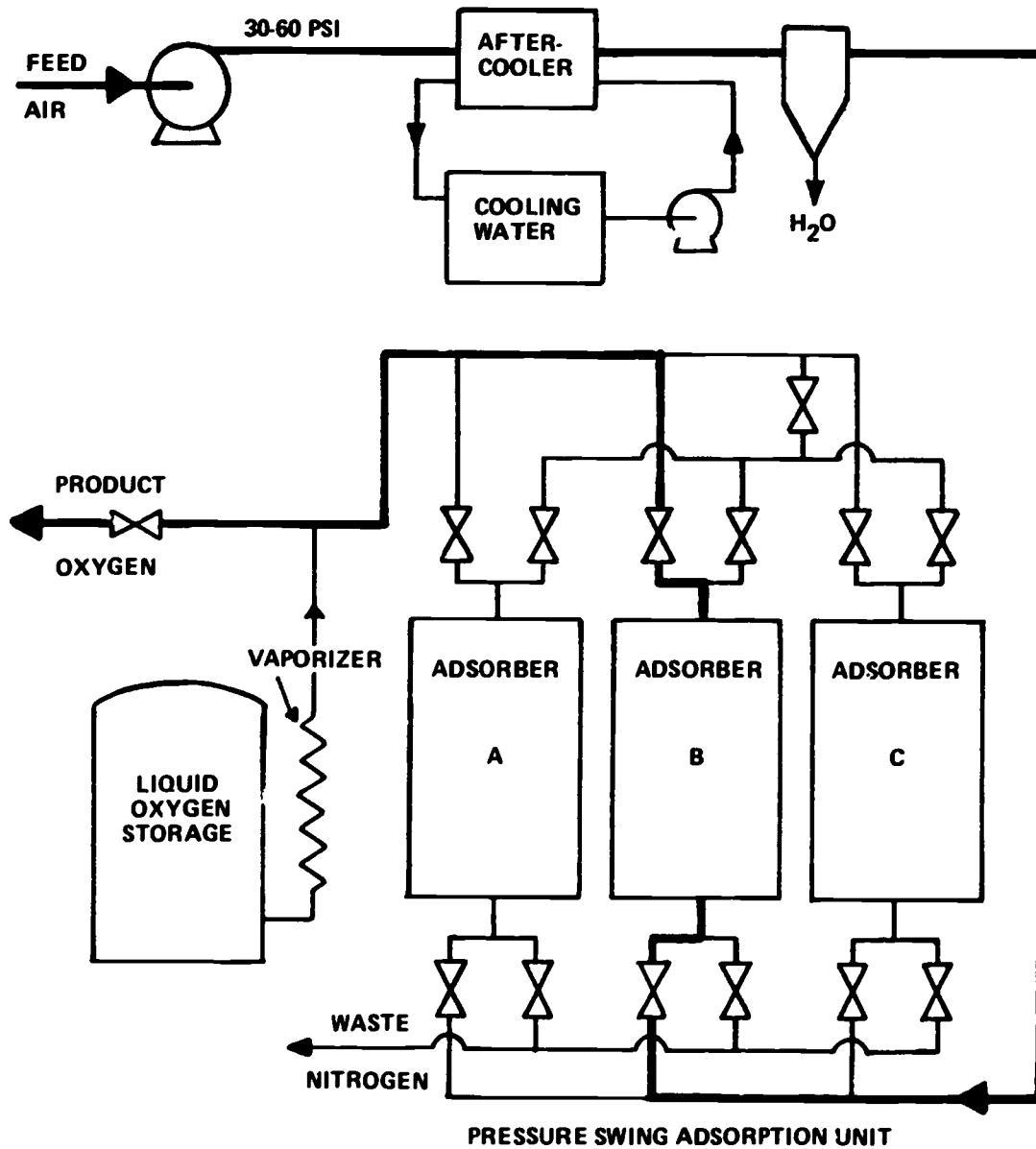
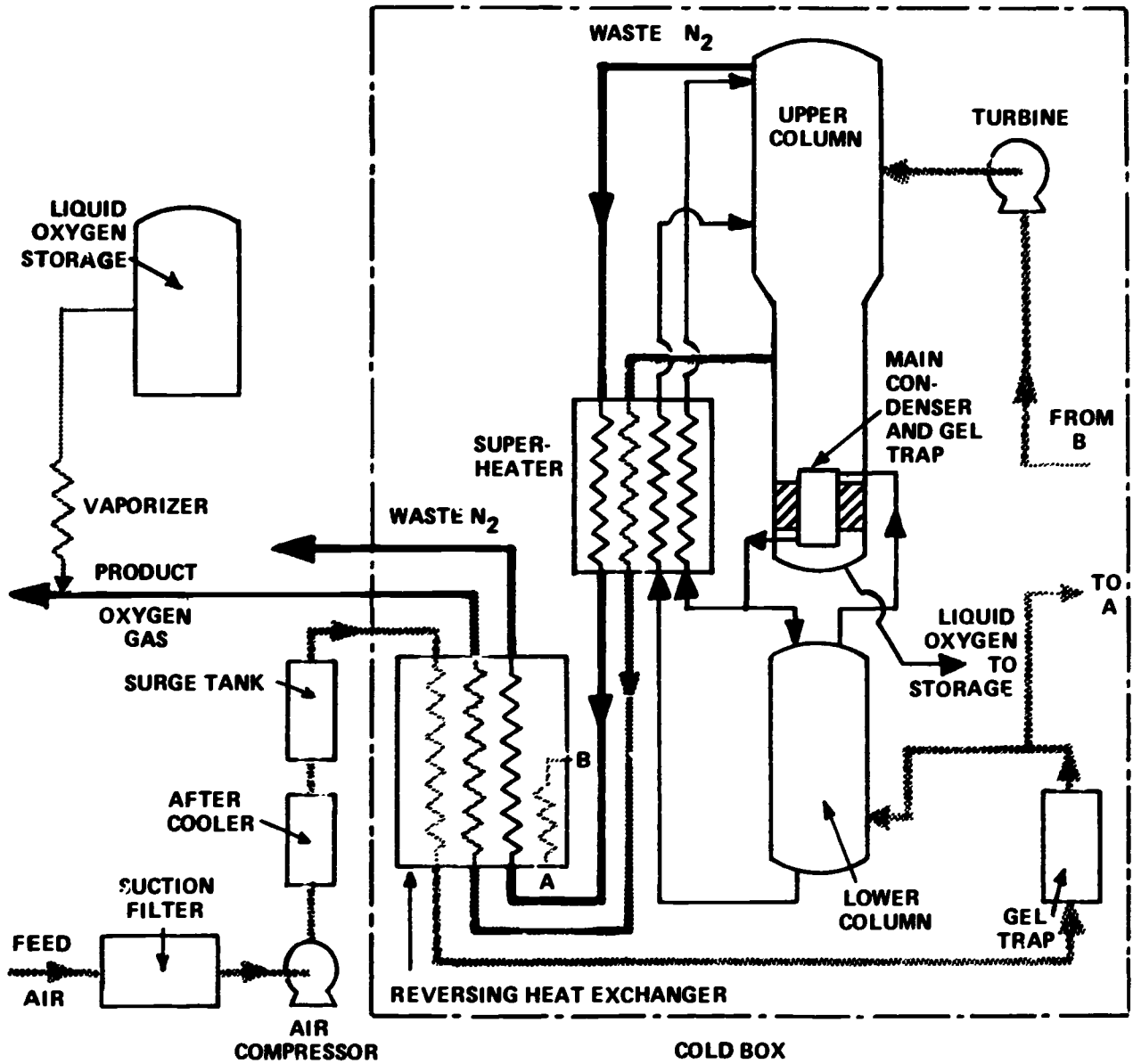

Fig. 2.4 Flow diagram of a three-bed PSA (Pressure Swing Adsorption) oxygen generating system
(Permission of Union Carbide Corporation)



1 J. 2.5 Flow diagram of a cryogenic oxygen generating system
(Permission of Union Carbide Corporation)

sage and thaws the partially blocked passages. A small portion of the water and carbon dioxide leave as tiny ice particles. The inlet air then travels through the previous nitrogen exhaust side until once again the ice builds up in the passage. Again the valve is activated and switches the routes of the two gas flows. This cycle usually varies from five to twenty minutes depending on the system. The exiting pure oxygen is also heat exchanged against the incoming air. In this case, however, the passages are never switched. This allows the oxygen to remain at high purity (about 98 percent pure oxygen).

A silica gel trap absorbs any remaining moisture that may have gotten past the reversing heat exchanger. Trace hydrocarbons are also picked up by the gel trap. The clean, cold air is liquified and separated into oxygen and nitrogen by fractional distillation in a two column arrangement. The lower high pressure column produces pure liquid nitrogen to use as reflux (flow back) in the low pressure upper column. Nitrogen, the most volatile component of air, is taken from the top of the upper column. Pure oxygen, the less volatile component, is taken from near the bottom of the upper column. A 98 percent purity oxygen stream is sent to the activated sludge process after heat exchange against the incoming air to recover its refrigeration (cool incoming air). Refrigeration to run the process comes from expanding a portion of the cooled and cleaned incoming air through an expansion turbine before it enters the upper column.

Approximately three percent of the capacity of the oxygen plant is available as liquid oxygen. This liquid can be used to keep the stored liquid oxygen backup tank full and ready to supply oxygen during peak loads or plant start-up.

To start an *AMBIENT TEMPERATURE*[®] cryogenic plant producing oxygen without liquid oxygen requires about three to five days. If liquid oxygen is available, a few hours is all that is required to place the plant in production. The oxygen production rate of a plant is determined by the oxygen demand in the activated sludge plant. As less production is required, the oxygen plant air compressors are partially unloaded.

Cryogenic plants are usually shut down once a year for approximately five to seven days for maintenance. During this period the gel traps are warmed to drive off moisture and hydrocarbons. By the use of multiple compressors and operational maintenance thaws, this downtime can be reduced to two or three days per year. During downtime, oxygen vaporized from the backup liquid oxygen storage tank is used. Sometimes in larger plants more than one oxygen producing facility is supplied to minimize the use of backup liquid oxygen.

QUESTIONS

Write your answers in a notebook and then compare your answers with those on page 94.

- 2.1C What two methods are commonly used to produce pure oxygen?
- 2.1D What does cryogenic mean?
- 2.1E How often and for how long are cryogenic plants shut down for maintenance?

2.13 Process and System Control

Pure oxygen systems may be used to supply oxygen to any of the activated sludge process modes — conventional, step-feed, complete mix or contact stabilization.

2.14 System Start-Up

Pure oxygen system start-up is basically much the same as starting conventional air systems. Individual components and starting procedures are usually outlined in the O&M manual or the manufacturer's literature. Take special care with the reactor because flow and organic loadings must be determined prior to start-up. Overloading or underloading may cause problems. Careful review of design data usually provides sufficient information to initially start the system. After start-up, the system is "fine tuned" to prevailing conditions in the wastewater.

2.15 Control Guidelines

- REACTOR VENT GAS** — A mixture of unused oxygen (about 5 to 10 percent of the oxygen supplied), inert gases and carbon dioxide is continually discharged from the last stage of the reactor. The vent purity, or percentage of oxygen contained in the mixture of gases, is an indicator of oxygen use efficiency. A low oxygen purity reading (25 percent or below) indicates that sufficient oxygen is not present and adequate BOD removal may not be accomplished. A high purity reading (50 percent or higher) indicates that too much oxygen is being wasted with the by-product gases. A manually controlled vent valve is adjusted to control vent purity. If purity is low, the valve could be opened further and closed down if purity is high. In normal operation (after start-up), "fine tuning" of this setting usually is not changed unless there is a drastic change in either the quantity or strength of the wastewater entering the plant.
- REACTOR GAS SPACE PRESSURE** — Gas space pressure is set by controlling the vent rate in the last stage. This will automatically establish the pressure level throughout the reactor. Gas pressure will vary to some extent within the reactor, dropping as more oxygen is vented and rising as venting is decreased or consumption is reduced. Pressure is usually preset at two inches (5 cm) water column in the first stage and the system will automatically feed oxygen at the required rates to maintain this condition. However, during high loading periods, the operator can increase oxygen transfer and production by increasing the pressure set point from 2 to 4 inches (5 to 10 cm) of water column, providing the vent valve setting is not changed. Relief valves on the first and last stage of each reactor prevent overpressurization. Similarly, during periods of unloading, a vacuum release provided by these same valves prevents a negative pressure.
- DISSOLVED OXYGEN** — A dissolved oxygen probe is sometimes located in the diversion box prior to the secondary clarifier or in the last stage of the reactor. It indicates the amount of DO in the mixed liquor. Typical oxygen systems usually operate with a DO range of 4 to 10 mg/L of dissolved oxygen. If the organic load increases over an extended period which would tend to drop the dissolved oxygen level below 4 mg/L, the operator should adjust the vent valve to a more open position which will increase oxygen production. Above a DO of 10 mg/L, the amount of oxygen being produced could be decreased if this is anticipated to be a long-term condition.

By measuring and monitoring these control guidelines, the operator can establish the most efficient treatment method on the basis of plant performance and experience. Operation of the secondary clarifiers, return rates, wasting rates and other control guidelines, are much the same for the pure oxygen system as they are for the conventional air activated sludge system.

[®] Ambient Temperature (Am-bee-ent). Temperature of the surroundings.

2.16 Process Safety

Potentially explosive or flammable conditions can be present when pure oxygen gas is mixed with any hydrocarbon such as gasoline, fuel oil and lubricating oils. In addition to normal safety devices found on motors, compressors, electrical components and control mechanisms, the pure oxygen system uses safety devices to ensure process safety when working with oxygen gas. These safety devices are:

1. **L.E.L. (LOWER EXPLOSIVE LIMIT COMBUSTIBLE GAS DETECTOR)** — Indicates potential explosive conditions within the reactor, and analyzes samples collected from the first and last stage of each train in the reactor. Readings are made based on all components being analyzed as propane. If a hydrocarbon spill gets through the primary treatment system without being diverted and causes a reading of more than 25 percent of the L.E.L., an alarm will sound. The product valve from the oxygen system will shut down and air will automatically be directed to the reactor gas space to *PURGE*⁷ the system. The purge will continue until normal readings are obtained. If the spill is so large that the L.E.L. continues to rise to the 50 percent level, in addition to an alarm sounding, an electrical restart of the purge blower will occur. The mixers will shut down to stop hydrocarbon stripping and they cannot be restarted until readings below the 10 percent L.E.L. are obtained.

No electrical work is ever installed below the roof nor are there any metal-to-metal contact potentials present. The mixers pass through the roof through a water seal. This eliminates the potential for sparks and a source of ignition. By eliminating sources of ignition and any chance of ignitable mixtures, the chances of an explosion become virtually zero. To date the safety record at activated sludge plants using pure oxygen has been excellent. Also, having a deck (roof) over the reactor provides a safe and easily accessible place for maintenance work and further minimizes the chances of having accidents.

One way to help prevent explosive conditions from developing is to install a Lower Explosive Limit (L.E.L.) Combustible Gas Detector in the plant headworks. This detector should trigger an alarm whenever hydrocarbons reach the headworks so action can be taken to prevent hydrocarbons from reaching reactors containing pure oxygen. Wastewater containing hydrocarbons can be diverted to emergency holding ponds if available.

2. **LIQUID OXYGEN (STORAGE TANK) LOW TEMPERATURE ALARM** — Provides an alarm and shutdown of the liquid storage system in the event heated water recirculation within the vaporizer reaches a low temperature level. A temperature monitor measures temperature levels of the oxygen gas and if the vapor falls below -10 degrees Fahrenheit (-23°C), an alarm will sound on the instrument panel. At an indication of -20 degrees Fahrenheit (-29°C), the liquid system will shut down until the temperature returns to normal conditions, but must be manually reset.
3. **EMERGENCY TRIP SWITCH** — In the event that any other unsafe condition should arise within the compressor system, liquid oxygen system or electrical panels, an emergency trip switch may be manually pulled. When pulled, the entire oxygen system shuts down and must be reset manually and each major piece of equipment restarted. This safety switch is not commonly used. It is only used as a last resort if safety systems fail or a major problem exists within the system which threatens the well

being and the safety of personnel. This switch is usually located away from a source of danger. As with any treatment plant, the operator must follow safety precautions established by the manufacturers and design engineers. Caution and warning signs should be posted in areas where danger is present.

2.17 Operator Safety

Special safety rules must be applied when operating and maintaining pure oxygen systems because of the unique properties of high purity oxygen. Cold liquid oxygen (LOX) can cause skin burns. Always wear rubber gloves and protective clothing when taking liquid oxygen samples from columns. This is the only time operators need to handle liquid oxygen.

Pure oxygen supports and accelerates combustion more readily than air. Therefore, all types of hydrocarbons and other flammable materials must be kept from mixing with the oxygen. The following precautions are intended to eliminate the possibility of combustion and explosions.

1. Special non-hydrocarbon lubricants as specified by the manufacturer should be used for equipment in contact with oxygen.
2. Tools and equipment must be specially designed to be compatible for use in oxygen service.
3. Flammable materials must be kept far away from oxygen systems and storage tanks.
4. Grease and oil must be removed from tools and equipment by the use of a solvent such as chloroethane.
5. Smoking and open flames are prohibited near oxygen systems and storage tanks.

Liquid oxygen is delivered by specially designed trucks and transferred by specially trained technicians. Therefore, the chances of liquid oxygen spills are remote. If a liquid oxygen spill occurs, the liquid could saturate a combustible material and this material could ignite or explode. Ignition can be caused by hot objects, open flames, glowing cigarettes, embers, sparks, or impact such as might be caused by striking with a hammer, dropping a tool or scuffing with your heel. Typical combustible materials that are dangerous when saturated with spilled liquid oxygen include asphalt in black top pavements, humus in soil, oil or grease on concrete floors or pavements, articles of clothing, or **ANY OTHER SUBSTANCE THAT WILL BURN IN AIR**. Any equipment involving liquid oxygen should be constructed on a concrete pad to avoid the potential of soaking a black top surface with liquid oxygen.

Every possible effort must be made to prevent the spillage of liquid oxygen. If a spill does occur, the following procedures must be followed:

1. No one may set foot in any area still showing frost marks from an oxygen spill.
2. The affected area must be roped off as soon as possible. When rope, barricades and signs are not immediately available, someone must stay at the area to warn other persons of the hazard.
3. No tank car or truck movements are allowed over an area still showing frost marks from an oxygen spill.

These procedures apply to any oxygen spillage on any surface, including cement, gravel, black top, or dirt either inside buildings or outdoors. **NO ONE IS ALLOWED TO STEP ON ANY AREAS WHERE FROST MARKS EXIST FROM A SPILL.**

⁷ Purge. Remove pure oxygen from the reactors and attempt to dilute hydrocarbon vapors to below the explosive limit.

2.18 Pure Oxygen System Maintenance

Maintenance of a pure oxygen production system is specialized for the specific equipment. However, this equipment is similar to the equipment found in other types of activated sludge plants, including air compressors, valves and instruments. Manufacturers commonly aid the operator during start-up with training sessions and field work. A maintenance contract with the supplier can be used to provide the technical services needed. As with any large scale production system, equipment preventive maintenance ensures proper operation and greater efficiency.

QUESTIONS

Write your answers in a notebook and then compare your answers with those on page 94.

- 2.1F What special measures are used to control pure oxygen systems?
- 2.1G How can hydrocarbons be detected before they reach the reactor?
- 2.19 Acknowledgment

This section was reviewed by Mr. R.W. Hirsch. The authors thank Mr. Hirsch for his many helpful comments and suggestions.

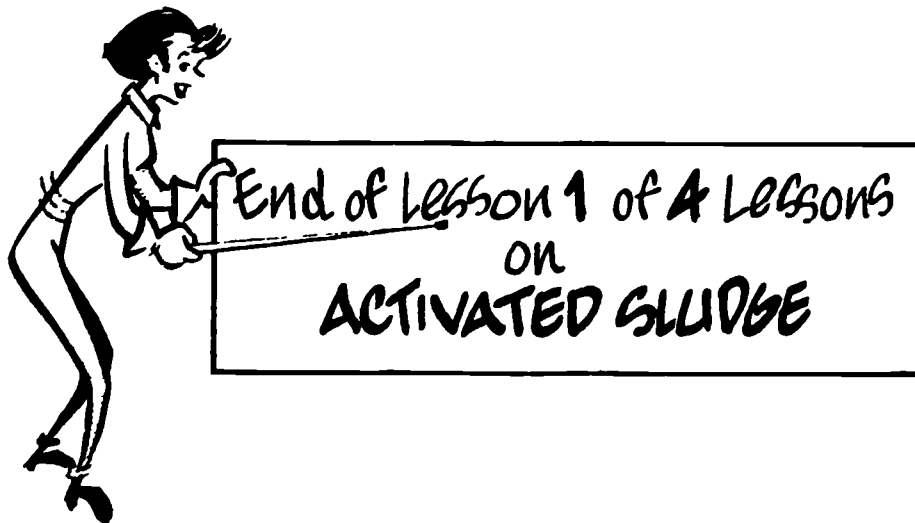

Please answer the discussion and review questions before continuing with Lesson 2.

DISCUSSION AND REVIEW QUESTIONS

(Lesson 1 of 4 Lessons)

Chapter 2. ACTIVATED SLUDGE

At the end of each lesson in this chapter you will find some discussion and review questions that you should answer before continuing. The purpose of these questions is to indicate to you how well you understand the material in this lesson. Write the answers to these questions in your notebook before continuing.

1. Why does the pure oxygen process normally use covered reactors?
2. How is pure oxygen separated from impurities and other gases in the PSA system?
3. What safety hazards might an operator encounter when working around a pure oxygen system?
4. What safety systems are found around pure oxygen systems to protect operators and equipment?

CHAPTER 2. ACTIVATED SLUDGE

(Lesson 2 of 4 Lessons)

NOTE: The next two lessons, Section 2.2, Return Activated Sludge, and Section 2.3, Waste Activated Sludge, are provided to familiarize you with different ways to control both the pure oxygen and air activated sludge processes. **YOU**, the operator, will have to determine which ways will work best for your plant. Once a particular procedure is selected, **EVERY OPERATOR ON EVERY SHIFT MUST FOLLOW THE SAME PROCEDURE.** If the procedure does not produce satisfactory results, then new procedures must be developed and tested for everyone to follow.

Abbreviations used in this section include:

1. MLSS, Mixed Liquor Suspended Solids, mg/L.
2. MLVSS, Mixed Liquor Volatile Suspended Solids, mg/L.
3. RAS, Return Activated Sludge, mg/L.
4. F/M, Food to Microorganism Ratio, lbs BOD or COD added per day per lb of MLVSS or kg/day per kg MLVSS.
5. Q, Flow, MGD or cu m/sec.

2.2 RETURN ACTIVATED SLUDGE

2.20 Purpose of Returning Activated Sludge

To operate the activated sludge process efficiently, a properly settling mixed liquor must be achieved and maintained. The mixed liquor suspended solids (MLSS) are settled in a clarifier and then returned to the aeration tank as the Return Activated Sludge (RAS) (Fig. 2.6). The RAS makes it possible for the microorganisms to be in the treatment system longer than the flowing wastewater. For conventional activated sludge operations, the RAS flow is generally about 20 to 40 percent of the incoming wastewater flow. **CHANGES IN THE ACTIVATED SLUDGE QUALITY WILL REQUIRE DIFFERENT RAS FLOW RATES DUE TO SETTLING CHARACTERISTICS OF THE SLUDGE.** Table 2.1 shows typical ranges of RAS flow rates for some activated sludge process variations.

2.21 Return Activated Sludge Control

Two basic approaches that can be used to control the RAS flow rate are based on the following:

1. Controlling the RAS flow rate independently from the influent flow; and
2. Controlling the RAS flow rate as a constant percentage of the influent flow.

2.210 Constant RAS Flow Rate Control

Setting the RAS at a constant flow rate that is independent of the aeration tank influent wastewater flow rate results in a continuously changing MLSS concentration. The MLSS will be at a minimum during peak influent flows and at a maximum during low influent flows. This occurs because the MLSS are flowing into the clarifier at a higher rate during peak flow when they are being removed at a constant rate. Similarly, at minimum influent flow rates, the MLSS are returned to the aeration tank at a higher rate than they are flowing into the clarifier. The aeration tank and the secondary clarifier must be

TABLE 2.1 A GUIDE TO TYPICAL RAS FLOW RATE PERCENTAGES*

Type of Activated Sludge Process	RAS Flow Rate as Percent of Incoming Wastewater Flow to Aeration Tank	
	Minimum	Maximum
Standard Rate	15	75
Carbonaceous Stage of Separate Stage Nitrification	15	75
Step-Feed Aeration	15	75
Contact Stabilization	50	150
Extended Aeration	50	150
Nitrification Stage of Separate Stage Nitrification	50	200

* **RECOMMENDED STANDARDS FOR SEWAGE WORKS (10 STATE STANDARDS)**, Great Lakes-Upper Mississippi River Board of State Sanitary Engineers, 1978 Edition, published by Health Education Service, Post Office Box 7126, Albany, New York 12224. Price, \$1.75 plus 48¢ for shipping and handling charges.

looked at as a system in which the MLSS are stored in the aeration tank during minimum wastewater flow and then transferred to the clarifier as the wastewater flows initially increase. In essence, the clarifier has a constantly changing depth of sludge blanket as the MLSS moves from the aeration tank to the clarifier and vice versa. The advantage of using this approach is simplicity, because it minimizes the amount of effort for control. This approach is especially effective for small plants with limited flexibility.

2.211 Constant Percentage RAS Flow Rate Control

The second approach to controlling RAS flow rates requires a programmed method for maintaining a constant percentage of RAS flow to the aeration tank influent wastewater flow rate. The program may consist of an automatic flow-measurement device, a programmer system, or frequent manual adjustments. The programmed method is theoretically designed to keep the MLSS more constant through high and low flow periods.

2.212 Comparison of Both RAS Control Approaches

The advantages of the constant RAS flow approach are the following:

1. Simplicity.
2. Maximum solids loading on the clarifier occurs at the start of peak flow periods.
3. Requires less operational time.

The advantages of the constant percentage RAS flow approach are the following:

1. Variations in the MLSS concentration are reduced and the F/M ratio varies less.
2. The MLSS will remain in the clarifier for shorter time periods which may reduce the possibility of denitrification in the clarifier.

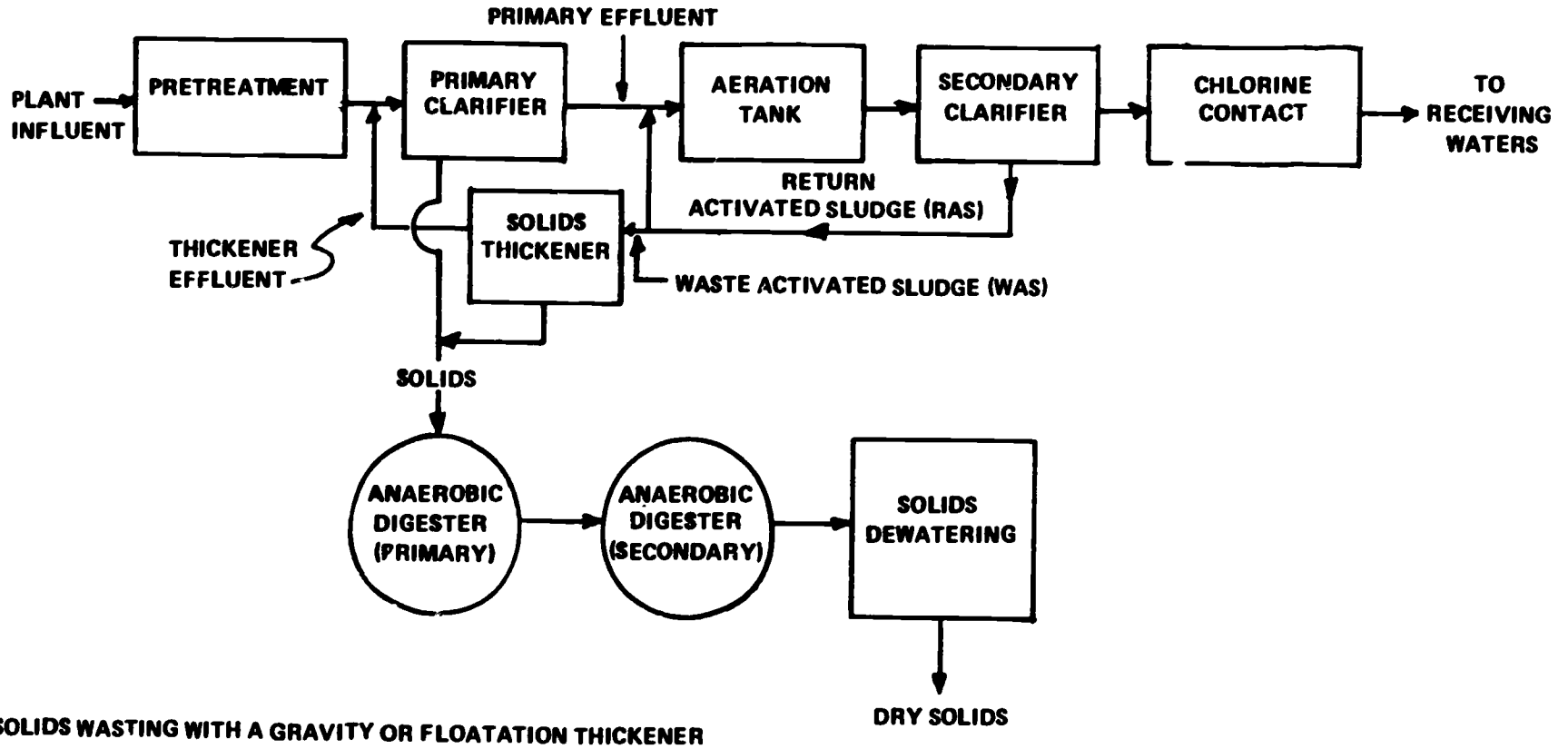

Fig. 2.5 Return and waste activated sludge flow diagram