

DOCUMENT RESUME

ED 285 258

EA 019 598

TITLE Planning a Fieldhouse.
 INSTITUTION North Carolina State Dept. of Public Instruction, Raleigh. Div. of School Planning.
 PUB DATE Jul 87
 NOTE 19p.
 PUB TYPE Guides - Non-Classroom Use (055)

EDRS PRICE MF01/PC01 Plus Postage.
 DESCRIPTORS Athletic Coaches; *Athletics; Construction (Process); Design Requirements; *Educational Facilities Design; *Educational Facilities Planning; Elementary Secondary Education; *Facility Guidelines; *Field Houses; Legal Responsibility; Maintenance; School Districts; *Space Utilization; Student Needs; Student School Relationship
 IDENTIFIERS *North Carolina

ABSTRACT

Area design, plan diagrams, and planning procedures for athletic fieldhouses adopted by North Carolina schools are recommended in this guide. The fieldhouse, generally a separate building accommodating the football team, is used by other teams of both sexes during their sports season. Location should be near play areas and planned for building protection. The locker room should accommodate the largest team; each player requires 20 square feet of floor space. Shower and toilet facilities should have direct access from the locker room. The coaches' office size depends on the number of occupants. In addition to 30 square feet for each desk and chair, storage, dressing, toilet, and shower space should be provided. Each sport's storage needs should be available in the equipment room. The training room's functions correspond with fieldhouse size and specialties. The weight room accommodates equipment for 15-25 people with 400 square feet and 30-40 people with 800 square feet. Rehabilitation implements require 80 additional square feet. Other facility considerations include interior surfaces, electricity, acoustics, and heating/cooling. The school board is responsible for fieldhouse construction and maintenance; the administration assumes design program responsibilities. The guide provides supplemental fieldhouse planning sources and concludes with five pages of plan diagrams. (CJH)

 * Reproductions supplied by EDRS are the best that can be made *
 * from the original document. *
 :*****

E 9285258

<p>U.S. DEPARTMENT OF EDUCATION Office of Educational Research and Improvement EDUCATIONAL RESOURCES INFORMATION CENTER (ERIC)</p> <p><input checked="" type="checkbox"/> This document has been reproduced as received from the person or organization originating it.</p> <p><input type="checkbox"/> Minor changes have been made to improve reproduction quality.</p> <p>• Points of view or opinions stated in this document do not necessarily represent official OERI position or policy.</p>	<p>"PERMISSION TO REPRODUCE THIS MATERIAL HAS BEEN GRANTED BY <i>E. Brunstach</i></p> <hr/> <p>TO THE EDUCATIONAL RESOURCES INFORMATION CENTER (ERIC)"</p>
--	--

PLANNING A FIELDHOUSE

DIVISION OF SCHOOL PLANNING

July 1987

NORTH CAROLINA DEPARTMENT OF PUBLIC INSTRUCTION

EH C19 598

BEST COPY AVAILABLE

**A. CRAIG PHILLIPS, STATE SUPERINTENDENT
NORTH CAROLINA DEPARTMENT OF PUBLIC INSTRUCTION**

**WILLIAM W. PEEK, SENIOR ASSOCIATE STATE SUPERINTENDENT
NORTH CAROLINA DEPARTMENT OF PUBLIC INSTRUCTION**

**DARRELL SPENCER, DIRECTOR
DIVISION OF SCHOOL PLANNING**

Publication Staff:

Rolf Seifert *Architect*

Chuck Reed *Architect*

Randy Craven *Artist*

Alice Phillips *Secretary*

Staff members from the Division of Health,
Physical Education, Safety, and Sports
provided invaluable assistance in the
preparation of this publication.

BEST COPY AVAILABLE

THE FIELDHOUSE

The Fieldhouse is generally a separate building planned to accommodate the football team, but is used by other athletic teams of both sexes during their sports season. It contains dressing areas, shower facilities, coaches' office, training room, equipment room and storage for the varsity, junior varsity and visitors' teams.

In addition, larger fieldhouses have a weight room, taping spaces, a laundry, a custodial room and special inside and outside storage rooms. The football stadium is frequently remote from the school; consequently, the fieldhouse is an ideal structure to house public toilets and a concession stand for those attending the athletic contest.

Location - Fieldhouses should be located close to play areas. Site planning is essential. To protect the building, exterior grades must drain storm water away from the structure. It is good practice to keep the finished floor elevation at least 8" higher than the final exterior grade as this will minimize humidity penetration through the floor.

Public areas require supplementary surface treatment as grass cannot take much abuse. Hard surface areas are more permanent and easier to maintain than natural surface materials like grass, bark or pine straw. In areas where it is difficult to grow turf or where there will be heavy traffic, define and develop pedestrian traffic paths. Where walkways change from hard to soft surfaces or vice versa, traffic should be dispersed over a wide area.

The Locker Room shou'd accommodate the largest team (generally 40 to 50 football players). Each player needs about 20 square feet of floor space. A plan carefully drawn to scale is needed with the placement of lockers, aisles, benches, access paths and visual barriers indicated. Such a plan will determine the actual size of the locker room.

There are several distribution systems for uniforms and equipment, and each system influences the locker room design. Educational specifications (user requirements) will determine which system is used, and the system in turn determines the ultimate design of the locker room.

Typical locker and dressing arrangements and their dimensions are as follows:

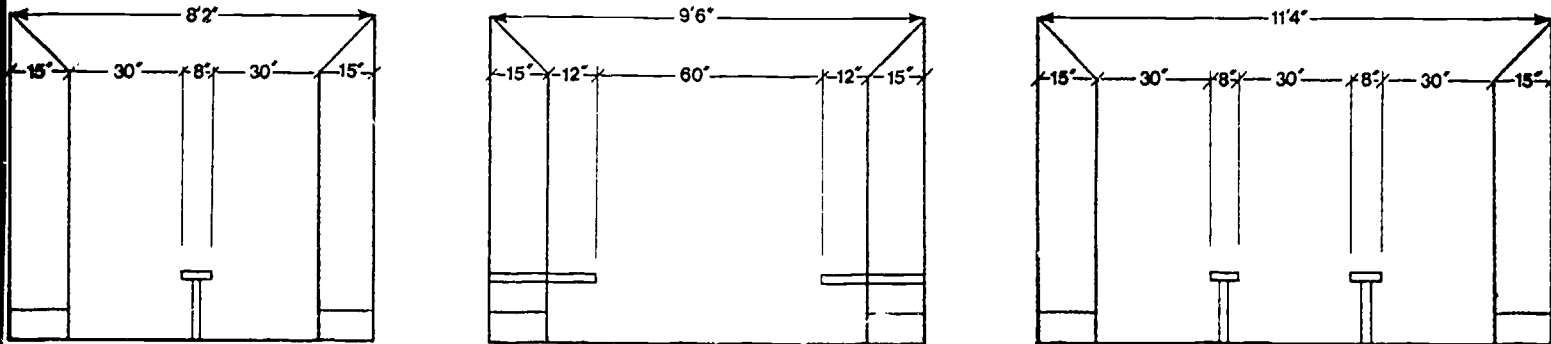

Toilet and Shower Facilities - The shower and toilet areas should have direct access from the locker room. For sanitary reasons the two areas should be separated. A drying area adjacent to the shower entrance is a good plan. Sometimes access to the toilets is through the drying area. This arrangement keeps all areas which need drainage together.

Provide one shower head for every four players; place shower heads 36" from center to center. Other recommended ratios and dimensions are as follows:

<u>Male</u>	<u>Female</u>
30 players per water closet	15 players per water closet
30 players per lavatory	30 players per lavatory
20 players per urinal, 28" from center to center	

The width of gang showers is 10-12 feet. For sanitary reasons, design a perimeter gutter under shower heads. The height of shower heads in the Junior High School is 60 inches; in the Senior High School, 66 inches. Locate full-length mirrors away from lavatories and provide outlets for hair dryers. The drying area needs benches and a place to hang towels.

The size of the Coaches' Office depends on the number of occupants. Approximately 30 square feet will be needed for each desk and chair; also, provide storage, dressing, toilet and shower space. Some fieldhouses provide a separate office for the visiting team coach. The location of the office varies depending on local program requirements.

The Equipment Room is one of several storage rooms. Each sport has its own needs. The bulkiest equipment is used by the football team. Provide approximately three square feet of hanging/drying space for each uniform. All other sports need less space for drying and storing uniforms. Only educational specifications and scaled drawings can address the various requirements.

Other storage requirements are for audio-visual equipment, out-of-season gear, uniforms, equipment repair, outside field storage and maintenance equipment.

The Training Room in small fieldhouses serves a variety of functions. Furnishings such as a whirlpool, a first aid station, taping tables and an athletic trainer's desk are placed in the training room. The training room should be accessible to junior varsity and varsity locker rooms. Sometimes laundry appliances, a custodian's sink and storage space are included in the training room; however, this should not be done. Training and cleaning functions should remain separated.

In larger fieldhouses, several training areas are developed. A first aid and taping area, a hydro and electro therapy area, an athletic trainer's office, a storage room and sometimes a special rehabilitation and examining room are provided. These specialty areas function as one cluster.

The whirlpool needs special considerations such as a sloped floor with drain and a ground-fault electrical interrupter. The whirlpool tub requires an area of approximately

7 X 7 feet. Six-foot long tables are useful for taping and for rehabilitation therapy.

The Weight Room has the least definable area. An area of 400 square feet can accommodate 1 10-Station Exercise Machine, 1 Vertical Chest, 1 Roman Chair and 1 Abdominal Board. This equipment accommodates 15 - 25 people during one session. The 400 square feet area does not include circulation space. Rehabilitation services would add exercise bikes, indoor jogger boards, a scale and a treadmill. All of the rehabilitation implements require an additional 80 square foot area.

A larger weight room equipment layout may include 1 15-Station machine, 1 Vertical Chest Bench, 1 Leg Squat Machine, 1 Roman Chair/Back hyperextension bench, 1 Quad-kick Pulley, 1 Abdominal Conditioning board, 1 Treadmill, 3 Exercise Bikes, 2 Indoor Joggers, 1 Incline Exercise Bench, 4 Dumbbell packs and a Flat Exercise Bench. The required space for this equipment without access or perimeter circulation is 800 square feet and can accommodate 30 - 40 people during one session.

The Laundry Room should be accessible to both team rooms but not invade the privacy of either team room as the facility may be used by both sexes. The area should have a floor drain. The laundry room access doorway width should allow for commercial washer and dryer installation and replacement.

Fieldhouse Construction - Any structure built on a school site is the legal responsibility of the local board. The board's agent is the local school superintendent. The local school administration is responsible for the design program of the fieldhouse while the architect is

responsible for plans, specifications and coordination of all plans with the consulting engineers.

The final plans are reviewed by the owner, School Planning, the N. C. Department of Insurance and local review officials. Construction is the responsibility of licensed contractors and the experienced craft trades. And last, but not least, the local school board is responsible for the maintenance of the building.

Lay people who assume the work of licensed professionals in the building process should be aware that they assume also their legal responsibilities and liabilities.

All floors with the exception of the shower, drying, toilet facilities and whirlpool need a hard surface which is easy to clean, can withstand cleacs (or spikes), and remains skid-free when wet. Shower, drying area and toilet floors must be impermeable; ceramic tile is still the best floor for these areas.

Walls need a finish which can be cleaned easily and is impermeable. They must be strong enough to resist impact; concrete block walls and partitions perform best.

Ceilings must be at least 10 - 12 feet high to be beyond the reach of players and to provide the necessary height for equipment and assure good ventilation. Ceilings must be able to weather high humidity and be strong enough to endure vandalism. It will be good practice to consult with the local sanitation officer to determine specific requirements for floors, walls and ceilings. Requirements differ from county to county.

The Electrical Needs should be determined in the planning stage. There are special electrical requirements for the laundry and the whirlpool areas and for water heaters, heating, ventilating and air conditioning, or other equipment which is electrically operated. Consider key-operated switches in all student areas to discourage horseplay. The number of outlets per area is determined by local and state codes, functional requirements and local preferences.

Maintenance - Thought must be given to maintenance of fieldhouses in off-season, summer and winter. The problem is how to protect:

- 1) the building itself;
- 2) fixtures: toilets, showers, heaters, laundry, whirlpool;
- 3) equipment: weight room equipment, TVs and office equipment; and
- 4) storage: uniforms, play utensils, grounds equipment.

The most destructive factor of structures and equipment is water or humidity. Control of storm water was discussed in site planning. Control of humidity is more complicated as warm and humid air condenses on cold surfaces. Good ventilation is essential. This is of prime importance for storage areas. The common practice is operable sash in windows, vents or mechanically forced air distribution. As in any school building, avoid louvers in doors as none are strong enough to take the abuse of players. The importance of good ventilation cannot be emphasized often enough.

Acoustics are often disregarded in school buildings though most communication is verbal. Each fieldhouse is an instructional station and as such needs good acoustics.

Acoustics is the science of sound waves and in construction deals with the reflection of sound from hard planes. The most effective surface to influence sound waves is the ceiling, the next best is the floor, and the least effective is the wall surface. Most insulating materials are good sound-absorbing elements, but they are easily damaged by impact and humidity. Good judgment of selecting the right material for the particular situation is better left to an experienced professional.

Heating/Cooling Systems pose a dilemma. The remote location requires a separate system if heating and/or cooling is required during winter and summer months. The mechanical room should have direct access from the outside as interior mechanical rooms can present serious code problems.

Additional Resources on Planning Fieldhouses - The following resources will be helpful:

"Planning Facilities for Athletics, Physical Education and Recreation"

American Alliance for Health, Physical Education, Recreation and Dance

1201 Sixteenth St., N.W., Washington, D.C. 20036

"Architectural Graphic Standards" by Ramsey/Sleeper

"N.C. State Building Code" published by the N.C. State Building Code Council and the N.C. Department of Insurance

The following pages are fieldhouse plan diagrams for particular requirements of several North Carolina High Schools:

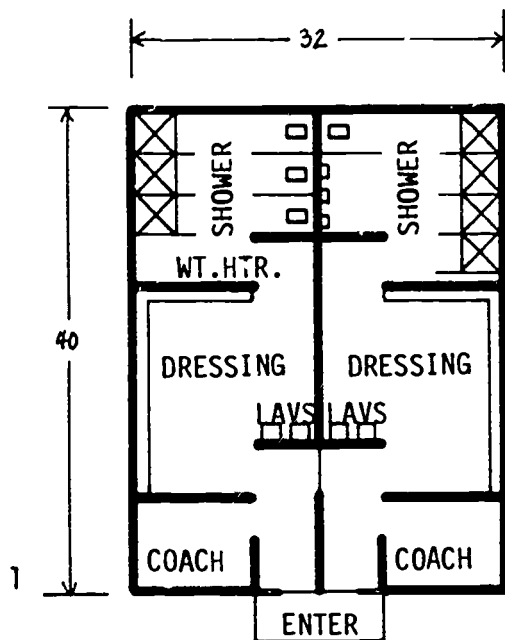

This 1,200 sq. ft. plan is intended to be constructed of 8" concrete block bearing walls and standard wood roof rafters.

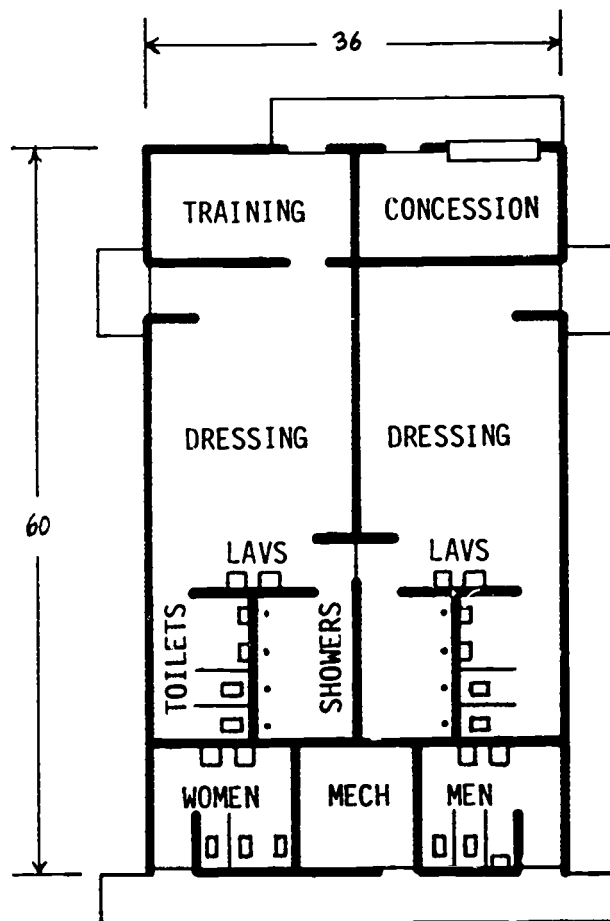

This 2,160 sq. ft. floor plan includes public toilets and a concession area for athletic events.

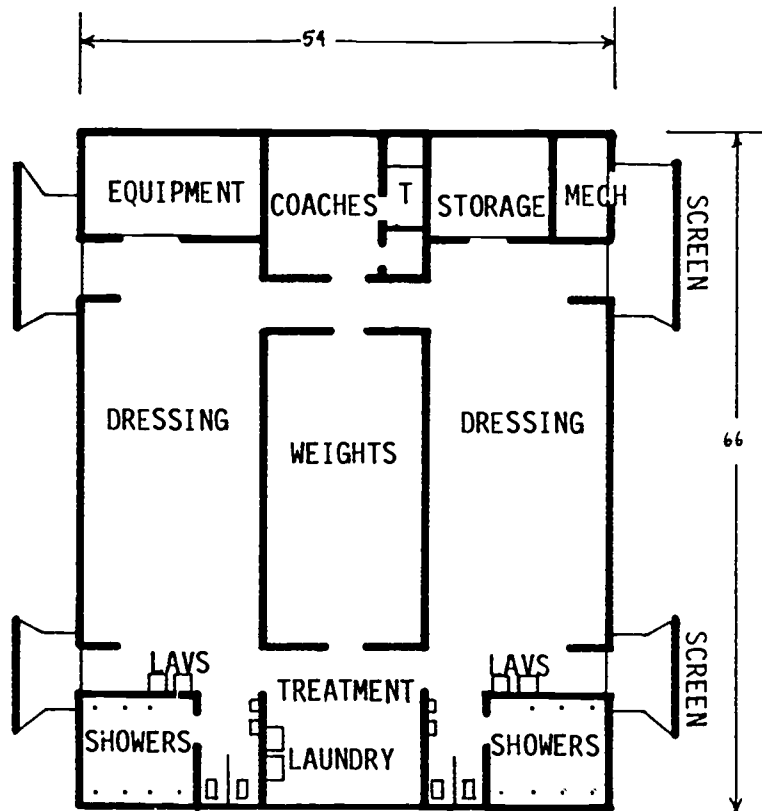

A 3,564 sq. ft. plan easily allows for separated shower and toilet facilities where there are girls and boys athletic programs.

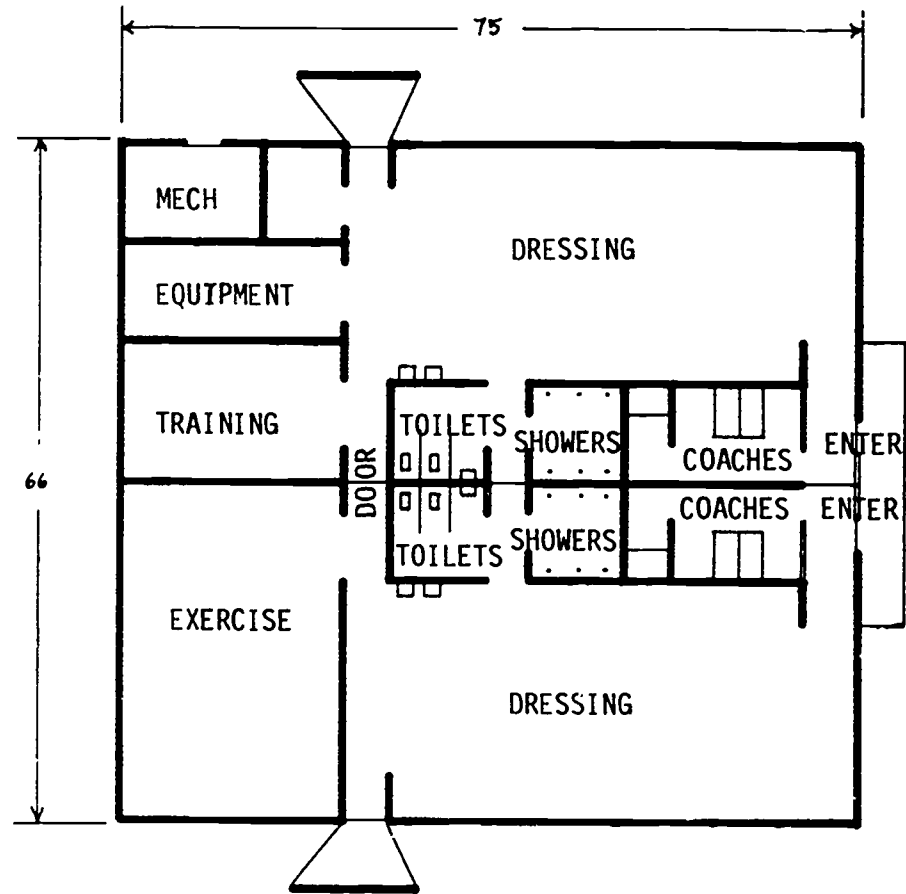

A project of this size, 4,950 sq. ft., allows plenty of area for auxiliary exercise rooms and a large coaching staff.

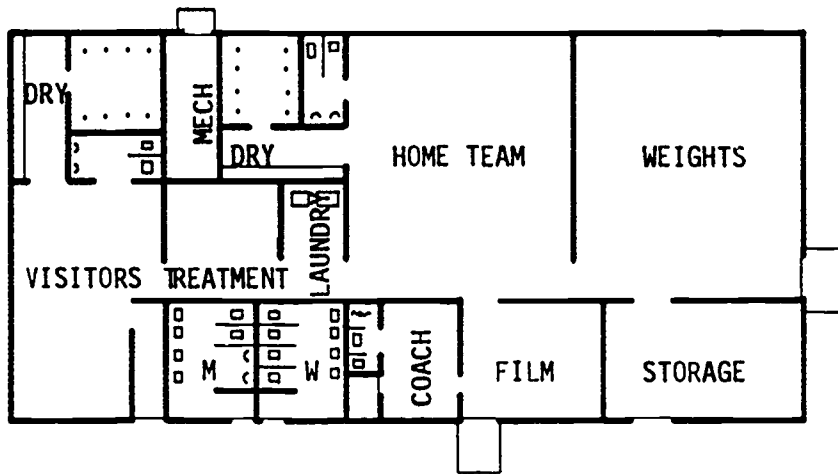

Visiting and home team rooms are connected by support areas making them useful to both teams. Public toilets are part of this scheme. All "wet" areas are grouped together.

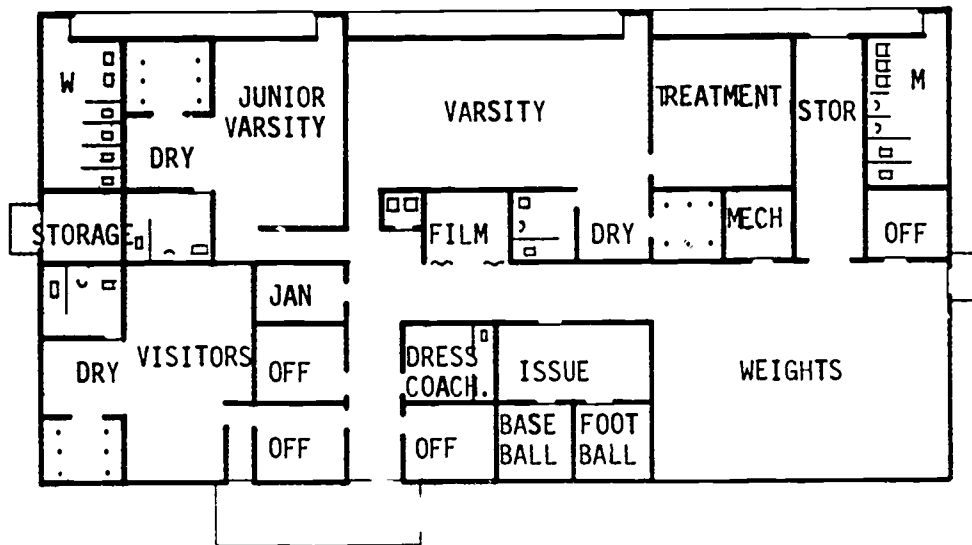

This large fieldhouse (7,440 sq. ft.) contains not only the customary requirements for home and visitors' teams, but also public toilets and an area for the junior varsity team. Home and visitors' lockers are separated by an office. The support areas are part of the home team only.

The cruciform plan diagrams suggest a building plan with a center core of showers and toilets. The center core is arranged so that half of the showers and toilets are directly accessible from one or the other dressing area or all of the showers and toilets are accessible from both sides. A connecting door can be open or closed in order to control accessibility. All other support areas are located along each side of the core.

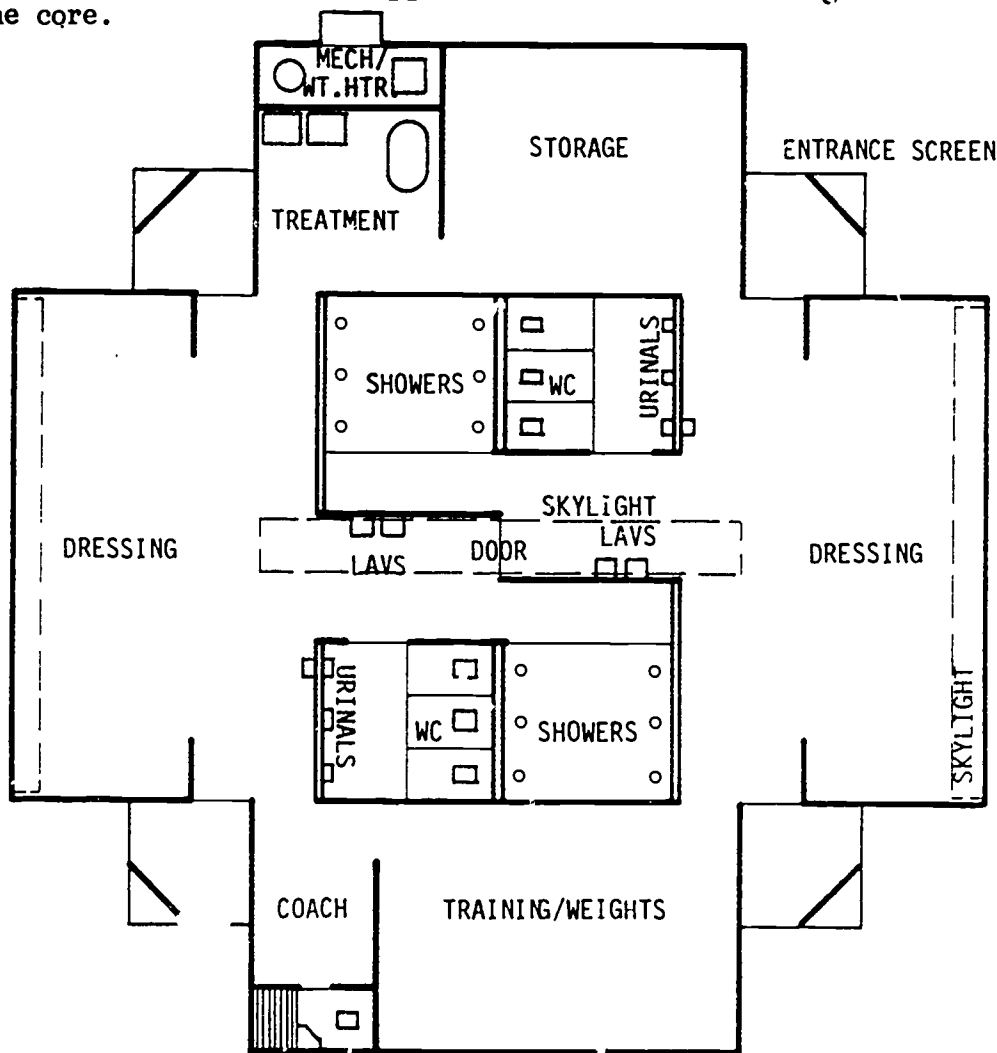

The concept is represented by two intersecting 2 X 4 rectangles. Any unit of measure can be assigned to the rectangles. The size of the rectangles is limited only by the required square footage. The plan diagram illustrates the 2 X 4 rectangles containing approximately 2,700 square feet if a value of 30' X 60' is assigned to each of the intersecting rectangles.

These diagrams illustrate how the cruciform plan can be modified to suit special conditions. Each of the four sides can vary in size, proportion, and share according to design program needs. In each one, the center core with its connecting doorway is unchanged. The center core can be larger where a large number of users are anticipated.

