

DOCUMENT RESUME

ED 275 874

CE 045 474

**AUTHOR** Harland, Cliff; And Others  
**TITLE** Toward Effective Training in Remote Areas. Report on the Review of Trade-Based Training in Aboriginal Communities.  
**INSTITUTION** TAFE National Centre for Research and Development, Payneham (Australia).  
**REPORT NO** ISBN-0-86397-169-5  
**PUB DATE** 86  
**NOTE** 184p.; The final appendix uses small print.  
**AVAILABLE FROM** Nelson Wadsworth, P.O. Box 4725, Melbourne, Victoria 3001, Australia.  
**PUB TYPE** Reports - Research/Technical (143)  
**EDRS PRICE** MF01/PC08 Plus Postage.  
**DESCRIPTORS** \*Apprenticeships; Curriculum Development; Foreign Countries; Learning Modules; \*Minority Groups; Pilot Projects; Postsecondary Education; \*Program Development; Rural Areas; \*Rural Education; Systems Approach; \*Trade and Industrial Education  
**IDENTIFIERS** \*Aboriginal People; \*Australia

**ABSTRACT**

Because none of the traditional programs that have been introduced to provide trade and skills training in remote Aboriginal communities has produced qualified tradespersons, a project was undertaken to develop and pilot test an apprenticeship training system called the Modular Integrated Training System (MITS). Visits to remote Aboriginal communities indicated that Aboriginal people generally shy away from traditional apprenticeship programs because of their reluctance to form close relationships with Europeans, difficulty in coming to terms with the Western work ethic, and difficulties in relating to technical instruction. Existing apprenticeship training programs were then examined to find ways of overcoming these difficulties. Pursuant to this examination, the MITS was designed to allow trainees to determine the rate at which their training progressed, obtain training in their own remote communities doing the work that is normally carried on in local workshops, and acquire any of several levels of training rather than being forced to choose between the all or nothing alternatives of traditional apprenticeship programs. MITS also works to demystify the trades by focusing on the knowledge and skills required for effective job performance. (Appendixes include the interview schedules for visits to Aboriginal communities and training institutions, notes on preparation of the pilot module and a sample of the modular materials, results of the pilot test, resources recommended for use in preparing modular training system programs, and criteria for the Rural Communities and Associations Northern Territory Award.) (MN)

\*\*\*\*\*  
 \* Reproductions supplied by EDRS are the best that can be made \*  
 \* from the original document. \*  
 \*\*\*\*\*

ED0275874



TAFE NATIONAL CENTRE FOR RESEARCH AND DEVELOPMENT

# Toward Effective Training in Remote Areas

## Report on the Review of Trade-based Training in Aboriginal Communities

The views expressed in this report are the authors and do not necessarily represent the position of the Northern Territory Department of Education

Researched and Developed by Cliff Harland and Gerald Sellinger

Edited by Tom Marling

CE 045474

U.S. DEPARTMENT OF EDUCATION  
Office of Educational Research and Improvement  
EDUCATIONAL RESOURCES INFORMATION CENTER (ERIC)

This document has been reproduced as received from the person or organization originating it.  
 Minor changes have been made to improve reproduction quality.

• Points of view or opinions stated in this document do not necessarily represent official OERI position or policy.

"PERMISSION TO REPRODUCE THIS MATERIAL HAS BEEN GRANTED BY

TO THE EDUCATIONAL RESOURCES INFORMATION CENTER (ERIC)."

© TAFE National Centre for Research  
and Development Ltd., 1986

ISBN 0 86397 169 5  
TD/TNC: 12.9

Published by:

TAFE National Centre for  
Research and Development  
296 Payneham Road  
Payneham SA 5070

(Incorporated in South Australia)

Distributed by Nelson Wadsworth, PO Box 4725, Melbourne VIC 3001,  
for TAFE National Centre for Research and Development Ltd.

Printed by D. J. WOOLMAN, Government Printer, South Australia

## FORWARD

There have been many attempts in the past four decades to give trade and skills training in remote Aboriginal communities. While limited skills have been imparted, none of these programs have produced qualified tradespersons. For the skills that have been gained by Aboriginal people, no accreditation or record has been kept to recognise or record any achievements. The review of Trade Based Training in remote communities which took over two years to complete, including pilot testing the recommendations of the review team, is the first step in establishing systematic trade training programs for Aboriginal people.

This document will provide the basis for further development of trade based training programs in remote Aboriginal communities. The pilot testing program results were most encouraging and indications are that, with some minor modifications, the recommended Modular Integrated Training System can provide programs leading to trade status where previous attempts have failed. There is much work to be done yet in formalising accreditation procedures, designing and producing curriculum materials, and implementing programs. The prospects for achieving an on-going successful program are very encouraging.

The TAFE Division of the Northern Territory Department of Education wishes to express thanks to the review team, the TAFE National Centre for Research and Development, the Northern Territory Department of Industry and Small Business, trades union, the Aboriginal Consultative Group (FEPPI), members of the automotive and construction industries, the Darwin Institute of Technology, and the many individuals who have assisted with this project.

The report provides a much needed contribution to the development of trade based training programs vitally needed in remote Aboriginal communities.

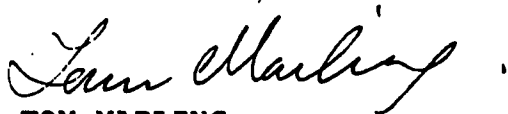

TOM MARLING

Senior Education Officer

Curriculum Research and Development TAFE



IVOR LOPES

Director

Adult Education and Training Branch TAFE

## A C K N O W L E D G E M E N T S

The authors would like to express their thanks to:

- All of the Aboriginal community leaders who spoke with us about training; the community tradesmen who shared their ideas with us and especially Bob Bilton and Peter Hickson, auto mechanics at Barunga and Beswick respectively, for providing the technical input for the Task Specification on Braking Systems; the community adult educators who assisted in the project.
- The TAFE National Centre for Research and Development for providing funds for the research involved in the project; Clare McBeath of the TAFE National Centre for her support and assistance.
- Dick Cohen and Alex Monaghan of the Darwin Institute of Technology for their ideas on Aboriginal training.
- The Hon B F Coulter MLA, Minister for Community Development, for his encouragement.
- John Milne and Frank Spry of the TAFE Adult Education and Training Branch of the Northern Territory Department of Education for their assistance in developing the learning elements needed to complete the pilot module.
- Bill Green of the TAFE Adult Education and Training Branch of the Northern Territory Department of Education for his support and help.

Jill Hopkins for typing and processing the report.

## TABLE OF CONTENTS

	Page
FOREWORD	ii
ACKNOWLEDGEMENTS	iii
CONTENTS	iv
TABLES	viii
GLOSSARY OF TERMS	ix
ABBREVIATIONS	x
RECOMMENDATIONS	xi
INTRODUCTION AND TERMS OF REFERENCE	xii

### CHAPTER 1

APPRENTICESHIP TRAINING IN THE NORTHERN TERRITORY	1
Duration of Apprenticeships	1
Educational Requirements for Entry into Apprenticeship	1
Age Limits on Entry into Apprenticeship	2
Compulsory Technical Training	2
Examinations	2
Issue of Trade Certificates	2
Participation in Apprenticeship Programs by Aborigines	3
Attendance and Technical Training Achievement	4
Need for an Alternative System of Training for Aboriginal People	6

### CHAPTER 2

LITERATURE REVIEW AND COLLECTION OF INFORMATION	7
Literature	7
Visits to Aboriginal Communities	10

	Page
<b>CHAPTER 3</b>	
<b>RESULTS AND DISCUSSION</b>	12
<b>Findings of Visits to Aboriginal Communities</b>	12
Interviews	12
Workshops	17
Trainees	18
Trades Needed	18
Levels of Trade Skills Presently Held by Aborigines	19
Levels of General Education of Trainees	19
<b>Reasons for Small Numbers of Aboriginal People in Remote Communities with Recognised Trade Skills</b>	21
<b>Aboriginal Cultural Factors</b>	21
Factors Relating to Aborigines' Experiences	21
Factors Relating to Systems of Interpersonal Relations Among Aborigines	22
Difficulty of Aborigines in Coming to Terms with the Western Concept of Work	23
Factors Relating to the Structure and Functions of Conventional Training Programs	24
Factors Relating to the Nature and Functions of Tradespersons in Remote Aboriginal Communities	25
 <b>CHAPTER 4</b>	
<b>SEARCH FOR A MORE EFFECTIVE TRAINING SYSTEM</b>	27
Visits to Training Institutions	27
Apprenticeship Training in Australia Outside the Northern Territory	30
Duration of Apprenticeships	30
Educational Requirements for Entry into Apprenticeship	30
Age Limits on Entry into Apprenticeship	31
Compulsory Technical Training	31
Examination and Issue of Trade Certificates	31
Apprenticeship Training Outside Australia	32
United Kingdom	32
School System Initiatives	32
Youth Training Scheme	33
Modernisation of Occupational Training	33



	Page
West Germany	33
Denmark	34
United States	35
Canada	35
The International Labour Organisation's Modular Training System	36
A Comparison of Conventional and MES Training Styles	37
Essential Nature of a Trade	38
Structure and Functions of Training Programs	38
Definition of a Tradesperson	40
 CHAPTER 5	
AN ALTERNATIVE TRAINING SYSTEM	41
The Modular Integrated Training System	41
Definitions	42
Task	42
Task Specification	42
Task Element	42
Learning Element	42
Progress Check	42
Module	43
Task Performance Test	43
Preparation of Learning Material	43
Instruction and Assessment	44
The Task Performance Test	47
Preparation of Task Performance Tests	47
Certification	48
Relevance of MITS to Specific Training Problems of Aboriginal People in Remote Communities	48
 CHAPTER 6	
NOTES ON IMPLEMENTATION	54
The Northern Territory Department of Industry and Small Business	54

	Page
Option 1: Training Without Employment	54
Option 2: Qualifications via Tradesmen's Rights	56
Option 3: Exemption from Legislation	57
Changes to Legislation Needed	57
Trade Unions	57
Financial Incentives for Trainees	59
Role of the Tradesperson	60
Briefing Instructors and Trainees	61
Concluding Remarks	62
References	64
Appendix A Interview Schedules for Visits to Aboriginal Communities	66
Appendix B Interview Schedules for Visits to Training Institutions	75
Appendix C Notes on the Preparation of the Pilot Module and Sample of Modular Materials	79
Appendix D Results of the Pilot Test	125
Appendix E Resources Recommended for the Preparation of MITS Programs	135
Appendix F "Rural Communities and Associations" Northern Territory Award 1985	139

## TABLES

Table		Page
1	Comparison of Formal Training Achievements Between Aborigines and the Total Population	4
2	Comparison of Attendance Rates in Block Release Courses Between Traditional Aboriginal Apprentices and Non-Traditional Aboriginal Apprentices	5
3	Aboriginal Communities Visited Grouped by Region with Residents Interviewed and Information on Trades Currently Practised and Needed	13
4	Estimates of Levels of Practical Skill and Theoretical Knowledge Held by Trainees Employed in Community Workshops as Provided by Tradespersons	19
5	Number of Years Since Each Trainee Attended School as a Regular Pupil	20

## GLOSSARY OF TERMS

Learning Element: A booklet of learning material usually covering between one and five units of knowledge relating to a task element.

Module: A collection of learning elements containing all units of knowledge essential to completing a task.

Performance-Based Evaluation: A method of assessing progress in learning in which learners show mastery of knowledge and skills by actual demonstration.

Progress Check: An objective test appearing at the end of each learning element designed precisely to measure whether the trainee has assimilated adequately the knowledge and skills specified in the learning element.

Task: A unit of work identified as a result of dividing a job into self-contained parts.

Task Element: Each step in a sequence of steps carried out by a workman in the course of performing a task.

Task Specification: An analysis comprising requirements, actions and knowledge observed or applied by a workman in completing a task to an acceptable standard together with a list of items for evaluating the performance of trainees.

Task Performance Test: A test administered at the end of each module designed precisely to measure whether a trainee has assimilated adequately the knowledge and skills of a module.

Trade Test: A practical test covering a representative sample of the skills needed for working effectively in a particular trade.

## GLOSSARY OF ABBREVIATIONS

<b>DISB</b>	<b>Department of Industry and Small Business</b>
<b>ILO</b>	<b>International Labour Organisation</b>
<b>MES</b>	<b>Modules of Employable Skill</b>
<b>MITS</b>	<b>Modular Integrated Training System</b>
<b>NTVTC</b>	<b>Northern Territory Vocational Training Commission</b>
<b>AGPS</b>	<b>Australian Government Printing Service</b>
<b>TAFE</b>	<b>Technical and Further Education</b>
<b>LE</b>	<b>Learning Element</b>

## RECOMMENDATIONS

1. That the Modular Integrated Training System be implemented in Aboriginal communities in the areas of automechanics, carpentry/joinery and welding.
2. That appropriate application be made for Aboriginal community councils and housing associations to be granted exemption from legislation governing apprenticeship training.
3. That programs offered using the Modular Integrated Training System be accredited by TAFE.
4. That Aboriginal trainees be employed for wages and under conditions of work specified in the proposed "Rural Communities and Association Northern Territory Award".
5. That a team of specialists be established within the TAFE Division to form a unit to research, develop and maintain a bank of modular learning material.
6. That TAFE research and develop methods of assisting tradespersons employed in Aboriginal communities in the performance of their work as trainers.
7. That test supervisors be assigned by TAFE to conduct task performance tests.
8. That Aboriginal communities adopt the financial plan outlined in the report for rewarding employees who can demonstrate competence in the performance of trade skills.
9. That the Modular Integrated Training System be evaluated at an appropriate future time.

## INTRODUCTION

In August 1984, the Northern Territory Vocational Training Commission (NTVTC) began a review of the system of trade training as it operates for Aborigines in remote communities. The project became the responsibility of the TAFE Division of the Department of Education when the NTVTC was disbanded in January 1985. The review team generally accept that traditional apprenticeship programs are inadequate to cope with Aborigines' special training needs. Following the review the TAFE Adult Education and Training Branch of the Department of Education was given responsibility for developing an alternative system of training more appropriate to the needs of Aboriginal people.

This report covers a description of the research carried out in connection with the review of the present system of training and also the design of the new system.

The guidelines established for the conduct of the review are as follows:

1. At four months from date of commencement

Report to include:

- (a) Report on orientation to the project through initial reading and visits to training institutions and Aboriginal communities;
- (b) Description of how the current apprenticeship and other approaches to trade training in and for Aboriginal communities operate;
- (c) Success of trade training in the communities under the present system during the past five years;
- (d) Alternative systems and methods of trade training outside the Northern Territory (literature search).

2. At seven months

Report to include:

- (a) Description of present level of trade skills in Aboriginal communities; and levels of general education of likely trainees;
- (b) Trade skills requirements;
- (c) Objectives of a new trade training system;
- (d) Training resources currently available in Aboriginal communities;
- (e) Report on reasons for lack of Aboriginal people with recognised trade skills in the community.

3. At ten months

Report to include:

- (a) Consideration of socio-economic factors relevant to the development of a new system of trade-based training;
- (b) Consideration of legislative and industrial difficulties and how they might be overcome;
- (c) Broad design for the new system and for two or three selected modules of skills.

4. After twelve months

Report to include:

- (a) Samples of proposed modular materials in two or three specific skills;
- (b) Detailed plans for piloting these modules in two or three selected communities.



## APPRENTICESHIP TRAINING IN THE NORTHERN TERRITORY

This chapter outlines apprenticeship training in the Northern Territory and describes participation rates by Aborigines. From the data presented, the need for a new training initiative is axiomatic.

Duration of Apprenticeships

At present, all persons undertaking apprenticeship training in the Northern Territory follow the same basic pattern of training. This involves a combination of theoretical and practical training. Apprenticeships in most trades take four years.

An apprentice is required to serve a probationary period of three months. During the probationary period it is the employer's duty to monitor the trainee's progress and interest in the trade. The probationary period is subsequently counted as part of the total apprenticeship term.

Educational Requirements for Entry into Apprenticeship

No particular educational qualifications are required for entry into apprenticeship training in the Northern Territory.

All applicants are required to sit an entrance examination. The examination consists of a 60-minute test in Mathematics, a 40-minute test in English and an essay to be completed in 30-minutes. Results are taken by the training authority as a guide to an applicant's ability to cope with the theoretical aspects of the training program. Applicants not achieving the desired results in the examination are advised to undertake additional study. Practical suitability for a trade is assessed by the employer during the period of probation.

### Age Limits on Entry into Apprenticeship

As 15 years is the minimum age for leaving school an apprenticeship normally begins at or after that age.

### Compulsory Technical Training

Apprentices are required to attend all approved courses of technical study. Technical courses usually take one of the following forms:

1. Block Release in which technical instruction is given in continuous periods over several weeks.
2. Day Release in which technical instruction is given one day per week for each year of the approved college course.
3. Correspondence in which technical instruction is carried out by mail.

In a small number of apprenticeship programs technical instruction is not available in the Territory. In the case of these programs trainees attend block release courses interstate.

Reports on the progress of trainees in the area of technical training are given periodically throughout the term of the apprenticeship.

Employers are required to release apprentices from employment as necessary to enable them to attend approved technical classes.

### Examinations

Annual examinations in theory and practical subjects are conducted by the approved training institutions. Success in examinations is one of the requirements which an individual must fulfil in order to be recognised as a fully qualified tradesman.

### Issue of Trade Certificates

In order to qualify for the trade certificate (Certificate of Trade Competency) an apprentice must: (1) show practical

competence on the job; (2) successfully pass all examinations in technical subjects; and (3) complete the full term of the apprenticeship.

Participation in Apprenticeship Programs  
by Aborigines

Table 1 shows a comparison between Aboriginal people and the total population of the Territory in terms of formal trade training achievements as defined by numbers of trade certificates held.

Among 16 794 Aboriginal individuals 15 years or older only 53 possess trade certificates. This translates into a percentage of 0.32. In contrast, among the population as a whole which numbers 84 891 individuals 15 years or older 6 380 possess trade certificates. This represents 7.52 per cent.

Table 1  
Comparison of Formal Trade Training Achievements  
Between Aborigines and the Total Population

<u>Number of individuals</u>	<u>Aborigines</u>	<u>Total Population</u>
Male	8 045	45 718
Female	8 749	39 173
Total	<u>16 794</u>	<u>84 891</u>

Number with Trade Certificates

Male	49	4 458
Female	4	1 922
Total	<u>53</u>	<u>6 380</u>

Percentage with Trade Certificates

Male	0.61	9.70
Female	0.05	4.90
Total of population	0.32	7.52

Source: Department of Industry and Small Business apprenticeship training records.

The description presented by these figures is of the situation with respect to formal training achievements for all Aboriginal people in the Northern Territory at present regardless of background.

Focusing on traditionally oriented Aboriginal people exclusively the picture is still more unfavourable. Among a sample of thirty-nine Aborigines from traditional communities who began apprenticeship training since 1978, twenty-four abandoned training prior to Stage 1 Block Release and as additional thirteen abandoned training after completing Stage 1. Stages 2 and 3 were attempted by only two of the original number. At present only one of the original trainees has completed Stage 3.

In April 1984, the total number of apprentices in training in the Northern Territory was 1 174. Although exact figures are not available, it is likely that only ten of these were Aboriginal apprentices with only five being from traditional communities.

#### Attendance and Technical Training Achievement

In addition to the extremely low rate of participation by traditionally oriented Aboriginal people in apprenticeship training programs, levels of attendance and achievement in programs are also poor. Table 2 shows a comparison between traditional Aboriginal apprentices and non-traditional Aboriginal apprentices in relation to 'possible' and 'actual' attendance in block release courses for 1978-1984. 'Possible' attendance figures were calculated by multiplying the length in days of a block release course by the number of apprentices attending.

Table 2

Comparison of Attendance Rates in Block Release Courses  
Between Traditional Aboriginal Apprentices and Non-Traditional  
Aboriginal Apprentices

---

<u>Stage 1</u>	<u>Aboriginal Apprentices</u>	
	<u>Traditional</u>	<u>Non-traditional</u>
Possible attendance (days)	378	422
Actual attendance (days)	301	433
Percentage	79.6	97.9
<u>Stage 2</u>		
Possible attendance (days)	56	195
Actual attendance (days)	35	183
Percentage	62.5	93.8
<u>Stage 3</u>		
Possible attendance (days)	-	83
Actual attendance (days)	-	83
Percentage	-	100

---

Source: Department of Industry and Small Business apprenticeship training records.

Non-traditional Aboriginal apprentices attended 433 of 442 possible days in Stage 1, 183 of 195 possible days in Stage 2 and 83 of 83 possible days in Stage 3. In terms of percentages, attendances for the three stages were 97.9, 93.8 and 100 respectively. Traditional Aboriginal apprentices attended 301 of 378 possible days in Stage 1 and 35 of 56 possible days in Stage 2. Expressed as percentages attendances for the two stages were 79.6 and 62.5. There are no figures available for attendance in Stage 3. However, as mentioned previously all but one of the apprentices from traditional communities abandoned training prior to Stage 3.

Among Aboriginal apprentices from traditional communities who attended Block Release for Stage 1 the average results attained were as follows: Theory 37 per cent, Mathematics 21 per cent and Practical 49 per cent.

Need for an Alternative System  
of Training for Aboriginal People

The conventional system of training tradespersons, while functioning effectively for Europeans, has failed to work for traditional Aborigines seriously interested in working in trade areas. The definitive indicator of failure is the inordinately small number of Aboriginal people with trade qualifications. Recognising the low levels of performance in apprenticeship programs the need for a major initiative in training for Aboriginal people is clear. In order to address seriously the problem of providing effective training to traditional Aborigines an entirely new approach to training is required.

## LITERATURE REVIEW AND COLLECTION OF INFORMATION

Research and development of an alternative system of training for Aboriginal people in remote communities began with project officers surveying the relevant literature. Following the literature survey, officers visited a number of remote Aboriginal communities in the Territory.

This chapter contains a summary of the literature directly relevant to the training of Aborigines and a brief outline of Aboriginal communities visited.

Literature

Although the literature relating to trade training for Aborigines is not extensive, some significant contributions have been made. The Joint Working Party under the Chairmanship of HM Ford (1981) examined important gaps in training systems for Aboriginal people in remote communities as well as training, employment and supervision of special advisors in Aboriginal communities. The Working Party also made recommendations for achieving progress in these areas which are summarised below:

1. Training among Aboriginal people would show most positive results if they understood clearly its reasons and purposes, their roles and responsibilities and the benefits for individuals and communities which accrue from training.

Therefore, each Aboriginal community should be fully consulted in relation to its goals in all areas of training and development.

2. Areas in which training is offered in Aboriginal communities should be determined through a consideration of future employment opportunities coupled with a knowledge of existing levels of skills of Aboriginal people. This formula for assessing training areas would result in due recognition of existing skills held by Aborigines and would lead to training programs tailored to meet real future employment opportunities.
3. There is a need for an effective system of counselling to assist trainees in identifying suitable training applications of training needed for the development of skills necessary to practice successfully in a chosen area of work.
4. Training should be carried out within Aboriginal communities. In relation to this point the Working Party (1981:90) makes the following statement:

A number of Aboriginal leaders, in voicing a need for community-based training, said that they did not want any increase in the number of non-Aboriginal people residing permanently in the community. There was much more support for the concept of trainees going away for training to other Aboriginal communities rather than to centres such as Darwin. These Regional Skills Centres located in larger Aboriginal communities and servicing a group of surrounding communities could provide an appropriate alternative to formal courses which cannot be successfully mounted in individual communities. Such centres could make this training of small groups more economical, avoid the use of non-Aboriginal centres of population for many courses, and provide a more satisfactory venue which could still attract good participation in courses.

5. Aboriginal people have difficulty relating to training in situations removed from the workplace. Training should therefore be practical and carried out on the job.



6. On accreditation of training, the Working Party offers the following remarks:

Many Aboriginal people commented .... that the scope of trade training courses frequently embraced matters which went beyond what was expected of the employee in his day-by-day operation. Many people seem to lack interest in the wider aspects of training unless they could directly apply those skills. On the other hand, many groups expressed a strong desire for courses which led (sic) to properly accredited certification.

The desire to possess qualifications no different from non-Aboriginals while at the same time reluctant (sic) to undertake more comprehensive training, would seem at first incompatible. (1981:94)

[However], if a trade course was broken into small training packages on aspects of motor mechanics for example, Aboriginals should be able to undertake and be accredited for each package. If the desire came to learn other aspects of the trade more packages are (sic) undertaken until eventual completion of all aspects of the course occurs and accreditation is given for full tradesman's rights.

Such a system is recommended, as little positive value can be gained by issue of certificates to Aboriginals, which are worthless when presented to a non-Aboriginal employer. (1981:95)

Accreditation of training courses should be by way of certificated which can be recognised by business and commerce in the general community. Training in specific aspects of trades should accrue towards full tradesman status. (1981:98)

According to Harris (1980), most learning in Aboriginal society occurs in one or more of the following ways: (1) by observation and imitation rather than through verbal instruction; (2) by personal trial and error rather than through a combination of instruction and controlled demonstration, e.g. as is the case in laboratory exercises in high school science classes; (3) by practising in real-life situations rather than through repetition in contrived settings; (4) by successive approximation of an end product rather than through the practice of incomplete portions of an activity. Therefore, success in the transfer of skills to Aboriginal trainees may be expected to hinge somewhat on instructors' abilities to present training within the framework of these learning styles.

Strike (1981) questions the validity of the goal of self-sufficiency for Aboriginal communities in the Northern Territory. He regards the concept of self-sufficiency as unrealistic at present because of the nature of the physical environment. No settled aggregate of persons anywhere in the Territory is self-sufficient. Thus, to press Aboriginal communities to strive for self-sufficiency is to impose inordinately high aims onto Aboriginal people.

On the basis of the available literature, certain guidelines for the development of a sound training system for Aborigines can be defined. They are: (1) the need for a modular approach to training emphasising skills needed to work successfully, with recognition given for segments for a full training program completed, (2) the need to deliver instruction to Aboriginal people with attention to their traditional methods of learning where possible and (3) the need to maintain a sensible perspective in relation to goals which Aboriginal communities can achieve as a result of training.

#### Visits to Aboriginal Communities

Researchers visited sixteen remote Aboriginal communities. The purpose of the visits was to orientate researchers to problems that Aboriginal people experience with respect to trade training and to gather information in the following areas: (1) training

resources available, (2) possible numbers of trainees, (3) trade skills needed in remote communities, (4) levels of trade skills presently held by traditionally oriented Aboriginal people and (5) levels of general education of prospective trainees.

Information was gathered by means of semi-structured interviews. Two separate interview schedules were used (Appendix A) . The first was used in the communities of: Nguju, Pularumpi, Milikapiti, Lake Nash, Milingimbi, Caliwinku, Barunga and Beswick. The second was used in the communities of: Angurungu, Yirrkala, Ali Curung, Ngukurr, Santa Teresa, Ntaria, Papunya and Yuendumu.

Researchers interviewed as many people, both Aboriginal and European, as it was possible to interview in the time available. The primary objective was to interview community council presidents. After that the priorities were to interview tradespersons operating in the communities, any Aborigines who wanted to speak on the subject of training and anyone else connected with the community who could be expected to offer insights into training problems of Aboriginal people.

RESULTS AND DISCUSSION

This chapter contains the results of the research and an analysis of the training problems experienced by Aboriginal people. First, the findings from the visits to remote Aboriginal communities are outlined. Then, on the basis of both the facts collected and impressions developed during the interviews conducted, an explanation is given as to why so few Aboriginal people in remote areas have recognised trade skills.

Findings of Visits to Aboriginal Communities

Table 3 shows communities visited as well as residents interviewed, training facilities available, trainees presently engaged and trade areas in which training was reported as needed.

Interviews

Community leaders when asked whether their people required training, invariably replied in the affirmative. Project Officers then attempted to identify through conversation the underlying cause of the perceived need.

The conclusion drawn was that Aboriginal leaders saw training as a means to gainful employment and personal stability for at least some of their young people within the community environment. A carefully prepared training program should exert a stabilising influence on young people as well as preparing them for useful work. Aboriginal people appear to have no strong desire to take full responsibility for the maintenance of their communities and have little intention of replacing European tradespersons with Aboriginal tradespersons.

Table 1  
Aboriginal Communities Visited Grouped by Region with Residents Interviewed  
and Information on Trades Currently Practised and Needed

Community by Region	Residents Interviewed (Aboriginal and European)	Community Work Areas Available for Training	Number of Trainees Involved	Trades where training Is Reported As Needed
<b>ARWINK NORTH</b>				
gulu	council president, administrative officer, CES representative, auto mechanic, housing supervisor, shop manager, school principal, Aboriginal school teacher	automotive house construction	2-4 2-10	auto mechanics house construction and maintenance
ularumpi <sup>1</sup>	council president, essential services manager, auto mechanic, housing manager, butcher, adult educator, two concerned Aboriginal men	automotive carpentry machine maintenance	- - -	-
ilikapiti	council president, adult educator, auto mechanic, two concerned Aboriginal men	automotive carpentry	2-3 'several'	auto mechanics house construction and maintenance
<b>EAST ARNHEM</b>				
ilingimbi	Aboriginal school teacher, adult educator, literature production supervisor, several concerned Aboriginal men	automotive workshop reported under construction plumbing house maintenance	- - 2-10	auto mechanics house maintenance plumbing and welding

Community by Region	Residents Interviewed (Aboriginal and European)	Community Work Areas Available for Training	Number of Trainees Involved	Trades where training Is Reported As Needed
liwinku	council representative, ADC, officer on a visit from Gove, carpenter, adult educator, coordinator of outstation resource centre	automotive house maintenance plumbing electrics essential services workshop	2 (unsupervised) <sup>2</sup> 'several' 3-4 3-4  'several'	auto mechanics house maintenance plumbing and welding electrics
gurugu	council president, mechanic, carpenter, printer, electrician, adult educator GEMCO training officer, shop manager, town clerk, several concerned Aboriginal men	automotive printing house maintenance electrics carpentry	2-3 1 2-4 2-3	auto mechanics house maintenance
rrkala	plumber, house builder (an exceptional Aboriginal person), adult educator, shop manager, carpenter, school principal, auto mechanic, two electricians, NABALCO training officer	automotive carpentry plumbing electrics	2 1-2 'several' 2	auto mechanics carpentry plumbing
<b>TIERINE</b>				
runga	entire community council, mechanic, plumber, council work supervisor	automotive carpentry plumbing	1-4 'several' 3	auto mechanic house maintenance
swick	council president, shop manager	council workshop	1-2	auto mechanics welding

Community by Region	Residents Interviewed (Aboriginal and European)	Community Work Areas Available for Training	Number of Trainees Involved	Trades where training Is Reported As Needed
---------------------	---	---	-----------------------------	---

BARKLY

Yukurr	council president, diesel mechanic, adult educator, office coordinator, assistant office coordinator, two leading council members, Aboriginal automotive workshop manager (non-tradesman), school principal, education adviser, carpenter (under contract to repair houses), several concerned Aboriginal men	diesel workshop	0	auto mechanics house maintenance
Mike Nash <sup>3</sup>	two school teachers	-	-	-
Li Curung	council president, several council members, community adviser, auto mechanic, electrician, school principal, superintendent of education for Barkly Region	auto mechanics electrics house maintenance plumbing	2 1 3 -	auto mechanics electrics house maintenance plumbing and welding

ICE SPRINGS

Anta Teresa	administrative officer, mechanic, welder, electrician, plumber, maintenance and renovation supervisor, adult educator, retired adult educator, Aboriginal assistant adult educator	automotive welding electrics plumbing and maintenance printing	2 0 1 1	auto mechanics
-------------	--	--	------------------	----------------

Community by Region	Residents Interviewed (Aboriginal and European)	Community Work Areas Available for Training	Number of Trainees Involved	Trades where training Is Reported As Needed
Permannsburg	council president, essential services supervisor, mechanic, housing manager, bricklayer, two school teachers	automotive essential services house maintenance plumbing electrics	2 2 2-4 1 1	house construction electrics plumbing and welding bricklaying
Yuendumu <sup>4</sup>	housing manager, mechanic, essential services supervisor, printer, bricklayer, teacher/linguist, adult educator, school principal, Aboriginal assistant adult educator, manager of Yuendumu Mining Co and store	automotive carpentry printing plumbing	3 'several' 0 1	bricklaying carpentry painting
Opunya	auto mechanic, housing manager, school principal, two school teachers, adult educator	automotive plumbing and house maintenance	2-3 2-3	auto mechanics house construction

Rain fell heavily during our second day in the community and, as is the custom in some remote Aboriginal communities, work slowed down significantly. We were unable to visit workshops.

The community was in the process of recruiting an auto mechanic at the time of the visit.

The community was in the early stages of development at the time of the visit. No training facilities were available and no tradesmen were employed.

The community was in the process of electing a president and other council officers at the time of the visit. None of the candidates were available for interview.



However, community leaders would like their people to take a greater interest in work in trade areas and a more active role in community maintenance.

Most communities visited, employ tradespersons. The tradespersons, by and large, seemed aware of their duty as trainers and most showed a willingness to work toward the development of trade skills in Aborigines. However, tradespersons working in remote Aboriginal communities are required to provide training for Aboriginal people as well as doing the job. Production demands on tradespersons often mean that training is given the lowest priority.

Interviews with tradespersons consisted of: (1) outlining the nature and purpose of the project, (2) discussion the applicability of the modular training concept and (3) obtaining considered responses to the question of whether it was possible for them, given supporting learning material, to impart the theoretical knowledge necessary for trainees to operate as tradespersons as the trades are practised in the communities. In response to this important question, all but two tradespersons replied that it was possible if trainees applied themselves diligently and for a prolonged period. Most tradespersons reported that the main barrier to acquiring trade skills is the difficulty Aboriginal people have in carrying on training regularly and for a sufficient time.

All but two of the tradespersons interviewed, stated that they would co-operate in implementing the proposed training program. A minority (approximately 20-25 per cent) although reporting that they would co-operate did not show sufficient enthusiasm to warrant confidence in them. The majority (approximately 75 per cent) agreed that the modular concept was appropriate. These seemed to have a genuine desire to see the program move forward.

### Workshops

Aboriginal community leaders stated that training would be most effective if it was community-based, practically oriented and carried out in the workplace. This would mean that training would have to take place in community workshops.

Most Aboriginal communities visited, have workshops covering a number of trade areas. These appear to be adequately equipped for work. None of the tradespersons interviewed complained about a lack of materials or equipment necessary for doing the job. If a tradesperson is operating effectively in a community, ie, to the satisfaction of his or her employers and the community at large, then it can be taken for granted that the materials and equipment necessary for doing the job - and for training - are available.

### Trainees

Aboriginal people are highly mobile. One manifestation of this mobility is a high turnover of trainees in the various community workshops. The number of trainees operating in any community workshop at a given time varies between nil and ten and sometimes more. Trainees regularly abandon the workplace for indefinite periods. Also, individuals are known to train in several trade areas. For example, a man may take training in auto mechanics, house maintenance and plumbing all within a few months. In short, the present training scene in Aboriginal communities is an exceedingly complex and continuously changing phenomenon.

This rules out the use of statistical methods to build a data base from which to move toward the design of a program. It would be an excessively difficult and costly task to prepare valid and reliable statistical descriptions of training potential. Profiles would be obsolete, in most cases, before they were completed. A modular system would be sufficiently flexible to deal with the high mobility characteristic of Aboriginal society. Trainees would acquire skills in trade areas exactly as dictated by their living schedules and their individual levels of motivation.

### Trades Needed

Most Aboriginal communities visited, indicated a need for training in automotive mechanics, carpentry and joinery, welding, plumbing and electrics.

Plumbing and electrical trades are licensed trades throughout Australia and the Northern Territory and, therefore, present special difficulties to Aboriginal trainers.

## Levels of Trade Skills

### Presently Held by Aborigines

Tradespersons working in the Aboriginal communities visited were asked to estimate levels of practical skills and theoretical knowledge held by trainees employed in their workshops. Table 4 shows the estimates.

Aboriginal trainees learn practical skills in trade areas more effectively than theoretical knowledge. Project officers were told that within Aboriginal communities at the present time there are individuals with notable levels of skill in a range of trade areas.

Table 4  
Estimates of Levels of Practical Skill and Theoretical  
Knowledge Held by Trainees Employed in Community Workshops  
as Provided by Tradespersons

	Pre- App	App Year 1	App Year 2	App Year 3	App Year 4	Number
Theoretical Knowledge	5	10	2	2	-	19
Practical Knowledge	3	5	3	5	3	19

## Levels of General Education of Trainees

For the purpose of gathering information on levels of schooling of likely trainees it was decided to focus on those individuals presently working as trainees in workshops in the communities. Table 5 shows schooling levels.

Table 5  
Number of Years Since Each Trainee Attended School  
as a Regular Pupil

<u>Trainee</u>	<u>Highest</u> <u>Grade</u>	<u>Mainstream</u> <u>Equivalent</u> <u>Grade</u>	<u>Years Away</u> <u>From School</u>
Number 1	7	4-5	10
Number 2	not known	not known	not known
Number 3	7	4-5	8
Number 4	7	4-5	8
Number 5	7	4-5	5
Number 6	7	4-5	5
Number 7	7	4-5	5
Number 8	not known	not known	not known
Number 9	7	4	15
Number 10	9	6	5
Number 11	not known	not known	not known
Number 12	not known	not known	not known
Number 13	7	4-5	7
Number 14	7	4-5	10
Number 15	7	4-5	7
Number 16	7	4-5	10
Number 17	7	4-5	10
Number 18	7	4-5	not known
Number 19	7	4-5	not known

Information regarding the schooling of trainees was obtained from tradespersons, school teachers and others in the communities. In regard to four trainees no information on schooling could be found. These individuals were middle-aged men who possibly had little schooling and who, in any case, had not attended school for at least twenty years.

Adult educators reported that Aborigines tend not to use whatever literacy and numeracy skills they attain, after leaving school. One would, therefore, expect declining levels of proficiency with increased time away from school. Discussions with tradesmen and others confirmed that traditionally oriented Aboriginal adults generally have very low levels of proficiency in literacy and numeracy.

## Reasons for Small Numbers of Aboriginal People in Remote Communities with Recognised Trade Skills

The factors influencing success in training among Aboriginal people are interrelated and they operate simultaneously. Taken together they have the effect of preventing most trainees from progressing beyond the first Block Release.

### Aboriginal Cultural Factors

Factors Relating to Aborigines' Experiences. Aboriginal young people by virtue of their range of experiences lack a fundamental awareness of the real nature and purpose of apprenticeship training. The isolation of a remote community functions as a barrier to appreciating the complexity of modern Western technology and to acquiring a sense of what must be learned in order to complete a program of training. Aboriginal apprentices are unaware of the intensity and duration of striving which an individual serving an apprenticeship in most trades at present must undergo. While training in aspects of traditional life requires some forms of striving these are significantly different from the type required to train successfully in a trade.

Aboriginal apprentices have difficulty in relating to Western methods of instruction. This is seen most readily in technical classes. Harris (1980) has shown that emphasis on verbal explanations and practising isolated portions of activities in contrived settings conflicts at a basic level with Aboriginal forms of instruction and learning. As such, compulsory technical classes represent a barrier to the acquisition of formal trade qualifications by Aboriginal people.

Aboriginal apprentices generally have little or no understanding of the intended outcomes of apprenticeship training. They lack the background necessary to form a realistic image of life as a tradesperson. They begin apprenticeship training without a clear picture of the effects of practising a trade in terms of changes to individual habits, attitudes, interpersonal relations and ways of living in general. Principal

role models for Aboriginal young people are adults of their own race. Contact with tradespersons is infrequent at best. This is significant in terms of shaping the aspirations of young people. Aboriginal young people aspire to approximately those forms of activity carried out by Aboriginal adults and more or less exclude the forms of activity carried out by European adults. As a result, young Aboriginal people have limited conceptions of life in the trades.

Aboriginal apprentices are generally not able to function effectively alone and without assistance for prolonged periods in an urban environment. Factors including the absence of family support and traditional fellowship, diversions of the city and others combine to cause an overpowering feeling of alienation in a young person and the desire to return to the home community. As such, technical classes in urban centres represent a barrier to the acquisition of trade qualifications by Aboriginal people.

#### Factors Relating to Systems of Interpersonal Relations Among Aborigines

Aboriginal individuals are often discouraged by their peers from forming close relationships with Europeans. Frequently when an individual is seen being friendly with a European, he is ridiculed in the hope that it will end the relationship. Harris (1980:64) comments on this behaviour:

Sometimes when Yolngu go to Darwin for training courses and come back to Milingimbi, if they are not very careful about using their new-gained knowledge discreetly, they will be mercilessly, though subtly, teased until they behave largely as they did before they were trained. And in another area, Yolngu who spend too much time with Balanda sometimes are 'cut down' and soon spend less time with them.

This has important implications for training. Trainees, in order to be successful, must develop and maintain close working relationships with tradespersons. Pressure directed at preventing such relationships can act as a barrier to the acquisition of skills.

The suggestion has been made that having skills in trade areas, functions to increase the status of individual Aborigines in their home communities. Whether this is so, is not clear. An adult of some status may find trade skills useful in this regard. However, it is questionable whether an adolescent with trade skills would find them equally useful in boosting his status.

Individuals who through persistence and determination are able to acquire high levels of skill in trade areas - irrespective of whether the skills are formally recognised - often find that they are too much in demand. This is particularly so when relatives make demands on them which are considered legitimate in the context of Aboriginal culture, but which can lead to overwork. The result, very often, is that these exceptional individuals withdraw from practising the skills they have learned.

#### Difficulty of Aborigines in Coming to Terms with the Western Concept of Work

European beliefs and ways of living differ at a basic level from those of traditional Aborigines. Work in the sense of a regular application of effort for financial reward, forms a basic building block in the structure of European culture. The significance of work can be seen from the fact that its declining availability is currently presenting a major difficulty for Western societies. Work, or the desire for it, represents a central point of reference in the lives of most European people. Among traditional Aborigines this is not the case. Aborigines hold characteristic conceptions of situations requiring effort but these are not congruent with the European concept of work.

At present, a large number of traditional Aboriginal people are not inclined toward full participation in the economy according to European standards. They are not interested in full-time long-term employment. Where work is available, such as in industries located near remote communities, turnover among Aboriginal staff is extremely high. In addition, tradespersons and others employed in Aboriginal communities report that workers

regularly abandon the workplace for such periods that they lose skills previously acquired. Young people are often directed into training by elders merely in order to occupy them so they avoid becoming involved in undesirable activities. Having little interest in work, most trainees abandon the workplace.

At present time, there is no compelling economic reason why Aboriginal people in remote communities should acquire and use skills in trade areas. The apprenticeship system is designed in part to give young people the skills they require to earn a living and satisfy their needs. Aborigines in remote communities are able to satisfy their needs without many of the skills considered by Europeans to be essential.

#### Factors Relating to the Structure and Functions of Conventional Training Programs

In addition to barriers to the acquisition of trade skills resulting from aspects of Aboriginal culture, there are also barriers associated with the structure and functions of the system of training itself. The conventional system of apprenticeship training prepares individuals for mobility in employment. Mobility here refers both to the location of employment and to movement between classifications of work within a trade. A person trained in a trade in a particular location should be able to practise that trade in any other location in Australia regardless of variations in climate, materials or techniques of work. Also, a person trained in a trade should in theory be able to practise in any form of work which occurs within the trade regardless of the variations in knowledge and skill required. For example, a plumber who has completed an apprenticeship with a firm specialising in plumbing family homes should be equally competent in plumbing multi-storey buildings.

It is desirable that training aims provide for mobility in employment so that the scope of technical knowledge and practical skills which apprentices must acquire is wider than would be necessary to train individuals for work in one location or trade classification.



As Harris (1980) points out, Aboriginal people are extremely pragmatic by nature and unlike Europeans are generally not preoccupied with learning. Where a form of knowledge has no application to their situation they tend to show little interest in it. Thus, the emphasis in training programs on knowledge and skills which have no application in Aboriginal communities acts as a barrier to the acquisition of trade skills by traditional Aboriginal people.

Similarly, the current system of training contains an incongruity between the knowledge which an apprentice must assimilate in order to satisfy the requirements of block release and the knowledge which he must have to operate effectively as a tradesperson. The two sets of knowledge are typically quite different. The problem originates in the differences which exist between the technical education in the classroom and the reality of the workplace. Curriculum advisory committees and instructors in technical colleges sometimes take the view that where theoretical knowledge is concerned more is better. The final effect can be a set of block release requirements which bear little relation to efficient practice on the job.

Aboriginal people have difficulty relating to technical instruction. Reasons for this are: (1) they tend to have a lower standard of literacy and numeracy than apprentices representing the mainstream; (2) they are handicapped by their relative inability to relate to the European instructional style; and (3) they are pragmatic and take little interest in assimilating knowledge which has no immediate application. Thus, the emphasis on technical knowledge, much of which is extraneous to the practice of a trade, represents a barrier to the acquisition of trade qualifications by Aboriginal people.

#### Factors Relating to the Nature and Functions of Tradespersons in Remote Aboriginal Communities

Most tradespersons working in remote Aboriginal communities are not able to fulfil their function as trainers of Aboriginal people. The training component in almost all cases represents a substantial portion of a tradesperson's set of duties. In most

cases, however, in order to meet the production requirements and expectations of the community, they are unable to find the time necessary to provide training.

Also, it appears that the negative view of Aborigines held by a small percentage of the tradespersons operating in remote Aboriginal communities makes them unsuitable to providing training.

## SEARCH FOR A MORE EFFECTIVE TRAINING SYSTEM

In this Chapter, the details of the search for an alternative training system are outlined.

After discovering why so few Aboriginal people in remote communities possess recognised trade skills, project officers began searching for a method of training which would address all - or most of - the problems. First, a number of training institutions both in the Territory and elsewhere were visited. Then the literature on apprenticeship training systems throughout Australia and in some other countries was examined.

One of the training systems studied was developed by the International Labour Organisation (ILO) for use in developing countries, and it was this method which was finally selected and adapted for use by Aboriginal people.

The ILO method is fundamentally different from the apprenticeship style of training of most industrialised countries. It may, at first, be difficult to grasp. With this in mind, some time has been devoted to comparing details of the ILO with conventional training methods.

#### Visits to Training Institutions

Training institutions visited by researchers included institutions in the Northern Territory and in other States. The purpose of the visits to institutions in the Territory was for general observation, while the purposes of the visits interstate were: (1) to develop a basic understanding of current trends, in training elsewhere in Australia, (2) to gather ideas which might be useful in designing an alternative system of training for

Aboriginal people in remote communities and (3) to avoid if possible the costly duplication of material and effort in relating to the new training system.

Institutions visited in the Northern Territory were the Territory Training Centre at Darwin, Batchelor College at Batchelor and the Arnhem Land Progress Association Training School at Galiwinku. The Territory Training Centre operates courses in pre-apprenticeship training as well as in practical work for apprentices in their first year of training. Batchelor College offers programs in teacher education for Aboriginal students and is also equipped with workshops suitable for training in several areas. The Arnhem Land Progress Association School offers short courses in retail work for Aboriginal people in remote communities throughout central and Northern Australia.

As part of the survey of training systems in other States, a communique was sent to offices of training authorities including industrial training commissions and TAFE centres. Information was requested in the areas of training programs designed especially for Aboriginal communities, modular training programs and mobile training workshops in operation. The request was made with a view to deriving benefit from the experiences of other States as well as to avoid the duplication of material and effort.

Interstate travel included visits to fifteen training institutions, government departments and other relevant organisations in Victoria, New South Wales, Queensland and the Australian Capital Territory.

An interview schedule was prepared prior to undertaking travel (Appendix B).

Innovative methods of training were observed in several institutions. However, all new developments in training were seen to involve work within institutions. No initiative has yet appeared in the way of basing training in remote areas.

None of the States visited, differentiate statistically between Aboriginal trainees and others. Therefore, they were unable to assess the effectiveness of training programs for Aboriginal people.

The state of the apprenticeship system gave rise to a range of reactions. At one extreme, respondents favoured the traditional system and wanted it to continue more or less in its present form indefinitely. At the other extreme, respondents saw the traditional system as an anachronism and recommended extensive revision of it.

Respondents from the majority of institutions tended toward the latter view. The general belief is that the conventional system of apprenticeship is gradually disappearing and should be replaced with a more flexible system of training. The indicator of decline was taken to be the decreasing number of apprenticeships available throughout Australia. The more flexible system of training would take the form of accelerated institution-based training with short courses in specialised areas.

Most respondents reported an expectation of gradual moves away from the traditional system of training in the direction of institution-based training. Virtually all respondents reported expecting opposition to this trend from various groups in the community.

Most responses were supportive of modular instruction. Some respondents stressed the need for a combination of modular instruction and performance-based assessment.

The question of the use of video also drew opposite responses. Respondents who felt that its usefulness was exaggerated preferred training which was entirely practical. The opposite view was that video, although costly, produced good results when used in combination with other instructional methods. Adherents to this view stressed that video should not be overused and should not replace an instructor.

A mobile training unit was visited and was observed to be operating with some success; however, the main problem was that no sponsors for trainees exist in many of the outlying areas visited by the unit. The result is that training is short-term and does not lead to extended practice in the trades.

Most respondents agreed that the concept of a national bank of training materials was a useful idea.

## Apprenticeship Training in Australia Outside the Northern Territory

This section describes apprenticeship training systems outside the Northern Territory. The main points of the systems are highlighted. The details of systems peculiar to individual States are not mentioned unless they seem particularly relevant to the project. Readers wishing to obtain a more detailed description of apprenticeship programs throughout Australia should consult Essential Features of Australian Apprenticeship Systems (1982).

### Durations of Apprenticeships

Most terms of apprenticeship are for four years. Apprenticeship begins with a probationary period of three months but may be extended up to a maximum of twelve months in some States. Systems in all States contain provisions for reducing apprenticeship terms. The two most common factors permitting a trainee to take part in a reduced term of indenture are:

1. Knowledge and Skill. If a trainee has gained knowledge and skill relevant to the apprenticeship the term of indenture may be reduced.
2. Age. If a person begins an apprenticeship at an age which the apprenticeship authority considers advanced for the commencement of an apprenticeship, the term of the apprenticeship may be reduced.

Authority to determine the length of an apprenticeship typically lies with a committee of representatives from government, industry and the trades.

### Educational Requirements for Entry into Apprenticeship

Educational qualifications for entry into apprenticeship vary among States. Some States require no formal qualifications

for entry into training. Others require qualifications at the level of min-secondary school for entry into some training programs and no qualifications for entry into other programs.

Still other States have grouped the trades into categories and require varying qualifications for entry - usually at the level of mid-secondary school - depending on the nature of the trade.

### Age Limits on Entry into Apprenticeship

Most States specify fifteen years as a minimum age for entry into apprenticeship training. Other States do not specify that an applicant must be a minimum of fifteen years of age in order to begin training although in these States the minimum age for leaving school is fifteen years.

None of the States specify a maximum age for entry into apprenticeship training.

### Compulsory Technical Training

Technical training for apprentices is compulsory in all States. In most States trainees are required to attend block release or day release classes where these are available. Where classes are not available trainees must undertake technical training by correspondence.

In some States failure to participate in technical instruction may lead to an apprentice being fined. In all States failure to participate in technical training may result in the suspension of training or the cancellation of indenture.

Employers are required to grant apprentices leave to attend approved courses of technical instruction.

### Examination and Issue of Trade Certificates

TAFE authorities in all States are responsible for conducting examinations in technical training courses.

In most States successful completion of technical training is not essential for the completion of an apprenticeship and the issue of a trade certificate. However, in order to be formally recognised as a fully qualified tradesperson (this occurs in the form of the issue of a higher form of trade certificate) a trainee must complete both the period of indenture and the prescribed technical courses.

Only Western Australia at present routinely requires apprentices to submit to an on-the-job trade examination, which is conducted by representatives of the apprenticeship training authority.

### Apprenticeship Training Outside Australia

Apprenticeship training systems in most countries are complex and dynamic. They vary extensively both among administrative divisions and between trades. A description of all pathways to tradesperson's status in countries selected is beyond the scope of this report. The purpose of this section is to give a general sense of the range of methods used to train tradespersons.

#### United Kingdom

According to Henneken (1984) apprenticeship training in the United Kingdom has changed dramatically in the past two decades. The situation since the early 1960s has moved from one in which there was minimal government involvement in training with apprenticeships being conducted by industry in line with agreements between employers and unions, to one in which government, through a series of Training Boards, regulated training initially to a fairly high degree and later to lesser degrees, to the present situation in which training in most trades is again being done under voluntary agreements between employers and unions. In addition, there have been major developments in several areas representing non-traditional training. We shall consider three such areas and outline briefly the nature of the initiatives.

School System Initiatives. At present there are a number of pilot projects in operation involving four-year programs in apprenticeship training for secondary students. The aim is to prepare a route leading to nationally recognised qualifications



within the secondary education system. In addition to this, a number of pre-vocational courses have been provided for young people remaining in school after the age of sixteen years (Henneken, 1984).

Youth Training Scheme. This initiative provides an integrated program of training and work experience. The program lasts one year and includes a minimum of thirteen weeks off-the-job training. The aim of the program is to give school leavers a range of skills and thus prepare them to compete more effectively in the job market (Henneken, 1984).

Modernisation of Occupational Training. This scheme represents an attempt to make apprenticeship more flexible and responsive to changing occupations while developing the skills needed to practise successfully in trade areas. Coherent sets of training standards and certificates of competence are currently being developed. These are intended to cover achievement in apprenticeship training and throughout working life. After completion of the development of these mechanisms there will appear a range of methods by which the standards could be achieved (Manpower Services Commission, 1984).

### West Germany

The apprenticeship system in Germany has two aspects. One involves training on the job. The other involves training at a part-time vocational school. The legal frameworks for practical and theoretical training are maintained by the Federal and State Governments respectively. Most young people who undertake apprenticeship do so according to this system.

The apprenticeship training contract which is established between an employer and an apprentice is basic to the structure of the training system. The contract contains agreement on the following points (Henneken, 1984:21).

- (a) The occupation for which training is to be given;

- (b) the time of commencement and the duration of apprenticeship [Apprenticeship periods are three years in most trades];
- (c) details of technical education to be undertaken;
- (d) normal hours of training;
- (e) duration of the probation period;
- (f) payment to the apprentice;
- (g) details of leave for the apprentice;
- (h) conditions leading to possible termination of the contract.

Apprenticeship finishes with a final examination. The examination indicates whether the apprentice has been successful and certifies the individual as a tradesperson.

### Denmark

Apprenticeship in Denmark, according to Henneken (1984), operates both in trade areas and in commercial and clerical work. This description concerns apprenticeship as given for positions in trade areas only.

Before beginning an apprenticeship, a contract is established between the employer and the apprentice. Terms of the contract are set out in accordance with guidelines provided by the Directorate of Labour.

The first months of an apprenticeship represent a probationary period during which the contract may be cancelled by either party without prejudice.

The term of an apprenticeship in most trades is four years. Shortly after beginning an apprenticeship an apprentice attends the first block at a technical college. The course operates for forty hours a week for twelve weeks. In both this first block and in the later blocks, instruction is both practical and theoretical. Toward the end of the first block the employer is given the opinion of the school as to the aptitude of the apprentice for training in the trade in question (Henneken, 1984).

A test is normally given during the fourth block. Details of the test are specified by a testing commission of the government (Menneken, 1984).

When the term of the apprenticeship has expired, an apprenticeship certificate is issued.

### United States

As in Australia, approaches to apprenticeship in the United States vary between States. In addition, the system is such that in most States apprenticeship is only one of several pathways leading to tradesperson's status. Besides the conventional four-year apprenticeship, training can be undertaken through private training institutions, through union sponsored programs or through federally run training agencies. In addition, in some States a route to tradesperson's status is experience on the job, i.e., a labourer works in a particular occupational area so long as his experience is regarded (by the union) as equivalent to the training needed to be classified as a tradesperson (Stevenson, 1980).

It should be noted here that the degree to which an individual is able to work in a particular trade is often determined by the extent of control which unions hold in that trade. Often unions act as arbiters with respect to determining the acceptability of alternative training methods.

In the State of California apprenticeship operates in ways which are quite different from the conventional method. The principal route to tradesperson status is experience on the job of a type and duration regarded by the union as adequate for classification as a tradesperson. Secondary routes include training with Federal agencies and training with union supported schemes (Stevenson, 1980).

Technical instruction is given in high schools and Regional Occupational Centres. In addition to apprentices taken technical instruction many university students take it for credit toward a degree. The content of technical courses in most cases is set by course instructors (Stevenson, 1980).

### Canada

In Canada, systems of apprenticeship vary between provinces. For the most part, however, apprenticeships are of four years'

duration and consist of technical instruction and practical experience. Regulation of training is carried out by trade advisory committees in the various provinces. The committees are made up of representatives of employers, employees and provincial governments.

Technical instruction is undertaken in blocks. Most block courses run for eight weeks per year (Stevenson, 1980).

In a few provinces training in certain selected trades is modular. Secondary schools suitably equipped are free to select modules from the trade program and teach them. Students who successfully complete modular components receive full credit for these in subsequent apprenticeship.

Some provinces provide pre-vocational courses in the form of full-time programs of one year for school leavers. Success in pre-vocational programs can result in credit for all technical training in an apprenticeship program and up to two years of credit for time served toward an apprenticeship (Stevenson, 1980).

An extensive search of the literature on apprenticeship in other countries yielded no indication of the existence of the kind of program envisaged for Aboriginal people in remote communities. Some interesting programs have been implemented in parts of the United States and Canada; however, these are relatively small-scale local initiatives as opposed to State-wide programs. In addition, invariably the programs involve training within institutions instead of on the job.

#### The International Labour Organisation's Modular Training System

The International Labour Organisation (ILO) has developed a system of training which is proving very effective in developing countries. The system is called Modules of Employable Skill (MES). It is founded on a philosophy of training which is different from that which underlies training systems in most industrialised countries.

The basic characteristics of the system are as follows:

- . instruction is systematic, modular and learner-centred;

- . skills learned by trainees are those needed for effective performance on the job;
- . knowledge acquired by trainees is that which is essential to safe and efficient work;
- . standards of training are the same standards of work displayed by successful workmen in the workplace;
- . success in training is indicated by trainees passing an accredited task performance test involving activities which they would be expected to carry out on the job and standards of work as required by the employer.

MES training programs have the advantage of flexibility both in terms of rates of progress of individual trainees and in relation to potential for updating in response to changes in technology.

With some adaptation the MES system should prove useful for Aboriginal people in remote communities.

At this point the discussion moves to a brief comparison of conventional and MES training systems. The purpose of the comparison is to provide some background in the theory of MES training. This should assist the reader in comprehending the system as outlined later.

#### A Comparison of Conventional and MES Training Styles

Conventional apprenticeship programs as they are organised in most industrialised countries are based on conventional training principles. The MES approach to training, a variation of which is recommended for Aboriginal people in remote communities, is founded on an alternative set of principles. The two sets of principles, if considered in their complete forms, are mutually exclusive. The purpose of this section is to compare the two sets of training principles. The principles and their respective systems are examined with respect to: (1) the essential nature of a trade, (2) the structure and functions of training programs, and (3) the definition of a tradesperson.

## Essential Nature of a Trade

A trade, in conventional terms, is a particular area of work defined as such by legislation, preparation for which involves a fixed term of apprenticeship and prescribed technical instruction and for which a certificate is given. Trades are broad areas of craft work involving both general and specific tasks and skills and requiring both generalised and specialised technical knowledge. Standards of work, while said to be important are not specified. There exists among tradespersons, employers and government training authorities an informal understanding of what constitutes acceptable standards. Ideal practice of a particular trade means performing, or being able to perform, all work normally undertaken by tradespersons trained in that trade (DISB, 1985).

In contrast, in the MES approach to training, a trade is defined as skilled work in a recognised trade area as carried out in a specified workplace at any given time and for which a tradesperson's wage is paid. Trades are areas of craft work involving specific tasks and skills and requiring specialised technical knowledge. Standards of work are agreed upon by industry, labour and government training authorities. Standards are clearly specified and are available to anyone involved in production or training.

Ideal practice of a trade within the framework of the MES model means performing the job of a tradesman in the workplace to the accepted standard (ILO, 1984).

## Structure and Functions of Training Programs

In the conventional system, training programs are time-based. In order to qualify as a tradesperson an individual must serve a formal apprenticeship as well as completing a program of technical study. The length of the apprenticeship in all trades is specified by legislation. In most trades the term is four years. Knowledge and skills essential to performing the job of a tradesperson in any particular trade are nowhere specified (DISB, 1985).

The emphasis in conventional training is on the structure of programs. The period of time served and the technical study are primary while the skills and standards of work required are secondary. This is not to suggest that knowledge and skills are viewed as unimportant. The point is that it is taken for granted that as long as the structure of a program is adhered to with sufficient rigour the knowledge and skills needed to work effectively as a tradesperson will be transferred to trainees more or less as a matter of course (DISB, 1985).

MES is performance-based. To qualify as tradespersons, trainees must demonstrate in a formal test that they can perform the job of tradespersons to the standard acceptable to industry, labour and government (ILO, 1984).

The MES model emphasises the content of programs. The knowledge and skills required for competence on the job are primary while the training process is secondary. This is not to say that the structure of training programs is unimportant. However, it is not taken for granted that a training program will necessarily prepare a person for competent practice in a trade. A valid trade test must be taken before a person can be certified as competent. On the structure of training programs, the MES approach is flexible. In general, designs are useful if they aim to bring trainees to accepted standards of practice without reference to a specified period of time. MES also recognises as valid skills acquired informally, i.e. outside systematic training programs, as long as the person holding the skills is able to meet the accepted standard of work as demonstrated by passing a valid trade or performance test (ILO, 1984).

In the conventional apprenticeship system the technical knowledge which apprentices must assimilate in order to qualify as tradespersons is determined through interactions between representatives of industry, labour, government training authorities and technical training institutions. The relationship between the technical knowledge which apprentices must learn and the practice of the trade in the workplace is not precisely stated. It is assumed that the technical knowledge learned in attendance in technical classes will have useful application in the workplace (DISB, 1985).

In the MES model decisions on technical knowledge which trainees must learn are made in the course of preparing the learning material. Technical knowledge is included only if it is regarded by practising tradespersons to be essential to performing the work of a tradesperson as it is done in the workplace to the accepted standard. Training programs are based on careful analyses of jobs and include only that technical knowledge which is necessary to the competent performance of jobs.

In the conventional system of apprenticeship (as practised in most States and the Northern Territory) schooling to the level of mid-secondary is required for entry into most apprenticeship programs. Literacy and numeracy skills and a general education to this level are seen as necessary to enable apprentices to cope effectively with the technical knowledge and instructional style in compulsory technical classes (DISB, 1985).

MES generally requires less than the conventional system in terms of qualifications for entry into training programs. Entrance requirements are specific to each task as determined by the requirements of various tasks. While this means that in theory the entrance requirements for a range of tasks could be quite diverse, in practice, most tasks require only basic familiarity with the workshops. The only entrance requirements which apply to all tasks as a rule are: (1) the physical fitness needed to work successfully in the job, and (2) a clear indication that the trainee can benefit from instruction (ILO, 1984).

#### Definition of a Tradesperson

In conventional practice a qualified tradesperson is an individual who has fulfilled the requirements of an apprenticeship program including indentures and technical instruction (DISB, 1985).

In terms of the MES model a qualified tradesperson is an individual who has taken and passed a valid trade or performance test based on standards of work agreed upon by industry, labour and government and is, therefore, able to perform the work of a tradesperson as it is done in the workplace.



## AN ALTERNATIVE TRAINING SYSTEM

This chapter contains an outline of the proposed alternative system of training. After identifying an alternative training system for adaptation, project officers prepared a learning module for pilot testing. The procedures described here were followed in developing and testing the pilot module. They involved identifying a task, establishing task specifications and performance standards, and assembling relevant learning material.

This chapter also contains a selection on the relevance of the system to specific training problems of Aboriginal people in remote communities.

The Modular Integrated Training System

The alternative training method is entitled the Modular Integrated Training System (MITS). MITS is a systems approach to training designed specially for Aboriginal people in remote communities. It aims to equip Aboriginal people with employable skills in trade areas. The design is based on the International Labour Organisation's approach to training entitled Modules of Employable Skills (MES).

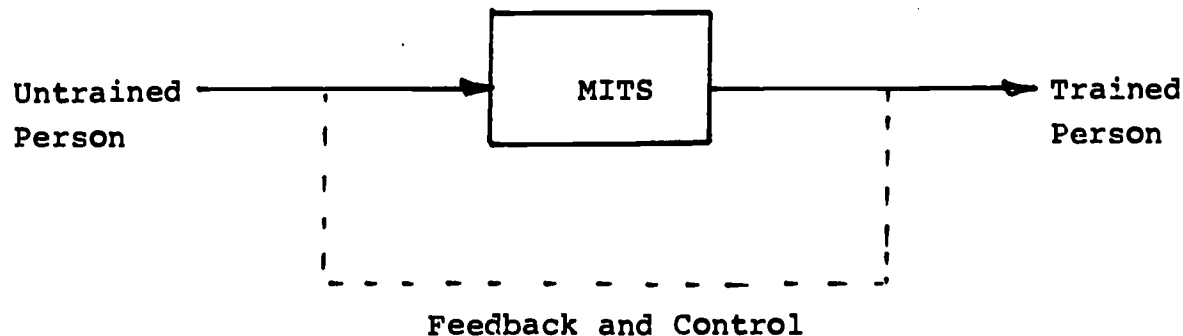

The characteristics of MITS are as follows:

1. Instruction is modular and learner-centred;
2. Knowledge and skills acquired by trainees are those needed to perform the job of a tradesperson as it is done in the workplace;
3. Standards of training are those which apply in the workplace;
4. Assessment is performance-based;
5. Recognition is given for previously acquired knowledge and skills where they meet the standard of work required.

At this point definitions of key terms relating to MITS are given. These are intended to aid the reader in interpreting the detailed outline of the system which follows.

#### Definitions

- Task. A unit of work identified as a result of dividing a job into self-contained parts.
- Task Specification. A detailed analysis of the requirements, actions and knowledge observed as applied by a tradesperson in completing a task to an acceptable standard together with a list of items for assessing the performance of trainees.
- Task Elements. Individual steps logically sequenced as carried out by a tradesperson in the course of performing a task.
- Learning Element. A booklet of learning material usually covering between one and five units of knowledge relating to a task element.

- . Progress Check. An objective test at the end of a learning element which precisely measures whether the trainee has assimilated the knowledge and skills specified in the learning element.
- . Module. Comprises the Task Specification and a set of learning elements containing all units of knowledge essential to completing a task.
- . Task Performance Test. A test administered at the end of each module designed to measure whether a trainee has assimilated adequately the knowledge and skills of a module.

### Preparation of Learning Material

This procedure should be followed in preparing all learning material for MITS programs.

- A particular area of work is identified as requiring MITS application.

Areas of work identified as requiring MITS application up to the present time are: automotive mechanics, carpentry and joinery, welding, plumbing and electricians.

- A list of tasks is assembled.

The task list should include all forms of skilled work which a tradesperson is required to perform in the course of carrying out the normal duties of his position. In order to assemble the list of tasks the National Core Curricula should be referred to. Also, advice should be requested from selected tradespersons employed in Aboriginal communities and where necessary to avoid confusion tradespersons in Aboriginal communities should be observed doing their work.

- Each individual task is analysed in terms of the method in which the work is done.

Specific steps carried out by tradespersons when performing the task should be outlined in detail.

- Each step is analysed in terms of the knowledge needed to carry it out. The units of knowledge are placed in the following categories as applicable: (1) technical knowledge, (2) safety and hygiene, (3) other information.
- The knowledge is divided into small measurable units. The measure of one unit of knowledge should be the application of a single precise behavioural objective.
- Booklets of learning material are prepared covering the units of knowledge needed to carry out all steps of all tasks on the list of tasks.  
Learning elements should generally contain between one and five units of knowledge and should be grouped with attention to both relatedness and convenience.
- Learning elements are prepared in a standard format each containing a precise statement of objectives, learning material and a progress check.

### Instruction and Assessment

Instruction in MITS programs should proceed as follows:

- Instruction takes place in community workshops under the supervision of tradespersons employed by Aboriginal communities.
- Training consists of trainees working through individual learning elements relating to specific modules.

Learning material should be prepared so as to permit trainees to proceed with a minimum of instruction by tradespersons. Where trainees are not able to interpret the learning material, step-by-step instruction should be given by tradespersons. In these instances the learning elements should function as precise guides to instruction for the tradespersons.

- A trainee should work through the learning material and acquire knowledge and skills at his own pace.
  
- Selection of particular modules for training should be made by trainees. Selection of modules is subject to approval by tradespersons and within the constraints imposed by the work in the workshops.

MITS: Preparation of Learning Material

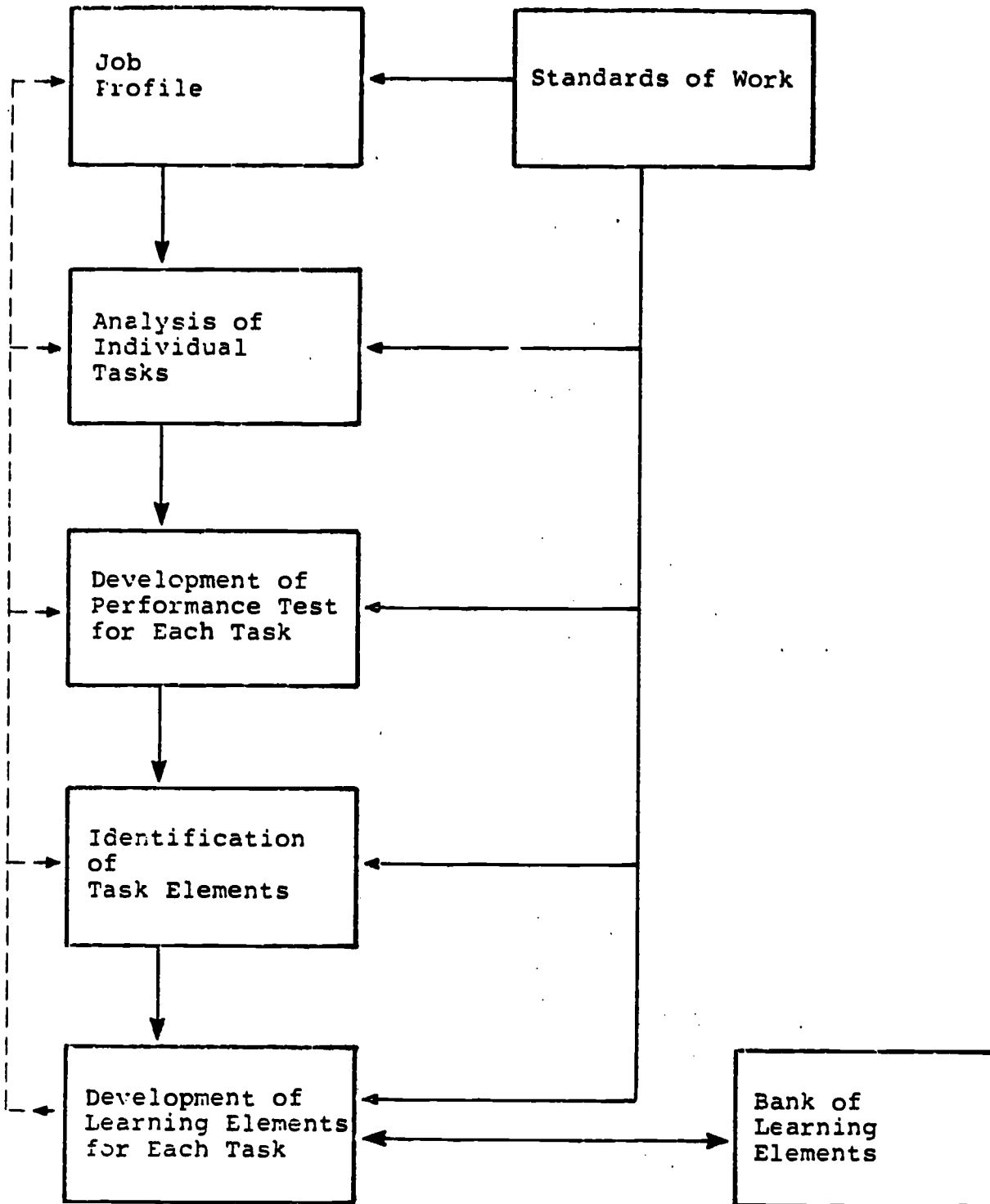

----- feedback and control

- A trainee successfully completes the progress check of a particular learning element before moving to the next learning element.
- Normally when a trainee has successfully passed the progress checks of all learning elements in a module he would be eligible to take the performance test for that module.

Trainees would not necessarily be required to complete all of the learning elements in a module before undertaking the modular performance test. The test can be taken by a trainee after the tradesperson reports that he has reached the required standard of work for that module.

- A trainee should normally complete one particular module including passing the performance test before undertaking work on another module.

The Task Performance Test. A test for each individual module should be undertaken by a trainee as soon as possible after the tradesperson reports that the trainee has reached the required standard of work for that task.

The testing procedure is as follows:

- Preparation requirements for the test are carried out by the tradesperson.
- The test is administered by test supervisors assigned by TAFE. Test supervisors should observe candidates performing specified tasks and should check their performance against the minimum performance standard.
- Results of a task performance test are interpreted as either 'pass' or 'fail'.

Preparation of Task Performance Tests. The design of the task performance test for each individual module is based on the following considerations:

1. Work related activities which a person will be expected to carry out after completion of the module,
2. Standards of work which the person will be required to achieve as outlined by employers and supervisors,
3. Conditions under which the person will be expected to work.

### Certification

Certification of trainees should take place as follows:

- A TAFE statement of achievement should be issued for each module which a trainee completes.  
Completion of a module can be taken to be the passing of the task performance test for that module.
- After trainees have passed the task performance test for all the modules in a particular trade area, they may have "tradesperson status" conferred via the NT TAFE accreditation process.

### Relevance of MITS to Specific Training Problems of Aboriginal People in Remote Communities

A central part of the research in this project was an analysis of the failure of the conventional apprenticeship system to transfer Aboriginal apprentices into tradespersons. The analysis was prepared after extensive discussion with Aboriginal people in remote communities, adult educators, tradespersons employed by community councils, representatives of the Darwin Institute of Technology and others. The various points outlined were given careful consideration by project officers in the course of developing the alternative system of training.

A point-by-point summary of the identified reasons for the small numbers of Aboriginal tradespersons as discussed in Chapter 3 and the corresponding advantages of the Modular Integrated Training System follows:



- Aboriginal young people by virtue of their range of experience lack a fundamental awareness of the nature and purpose of apprenticeship. They are unaware of the intensity and duration of striving necessary for success in apprenticeship.

In a conventional training program the apprentice is in an all-or-nothing situation. He either completes the requirements for full trade qualifications or he fails. He must strive sometimes intensely and for a prolonged period. For a traditionally oriented Aboriginal trainee this typically means anticipation, anxiety and tension, gradual recognition of an inability to cope, eventual failure and, finally, feelings of frustration.

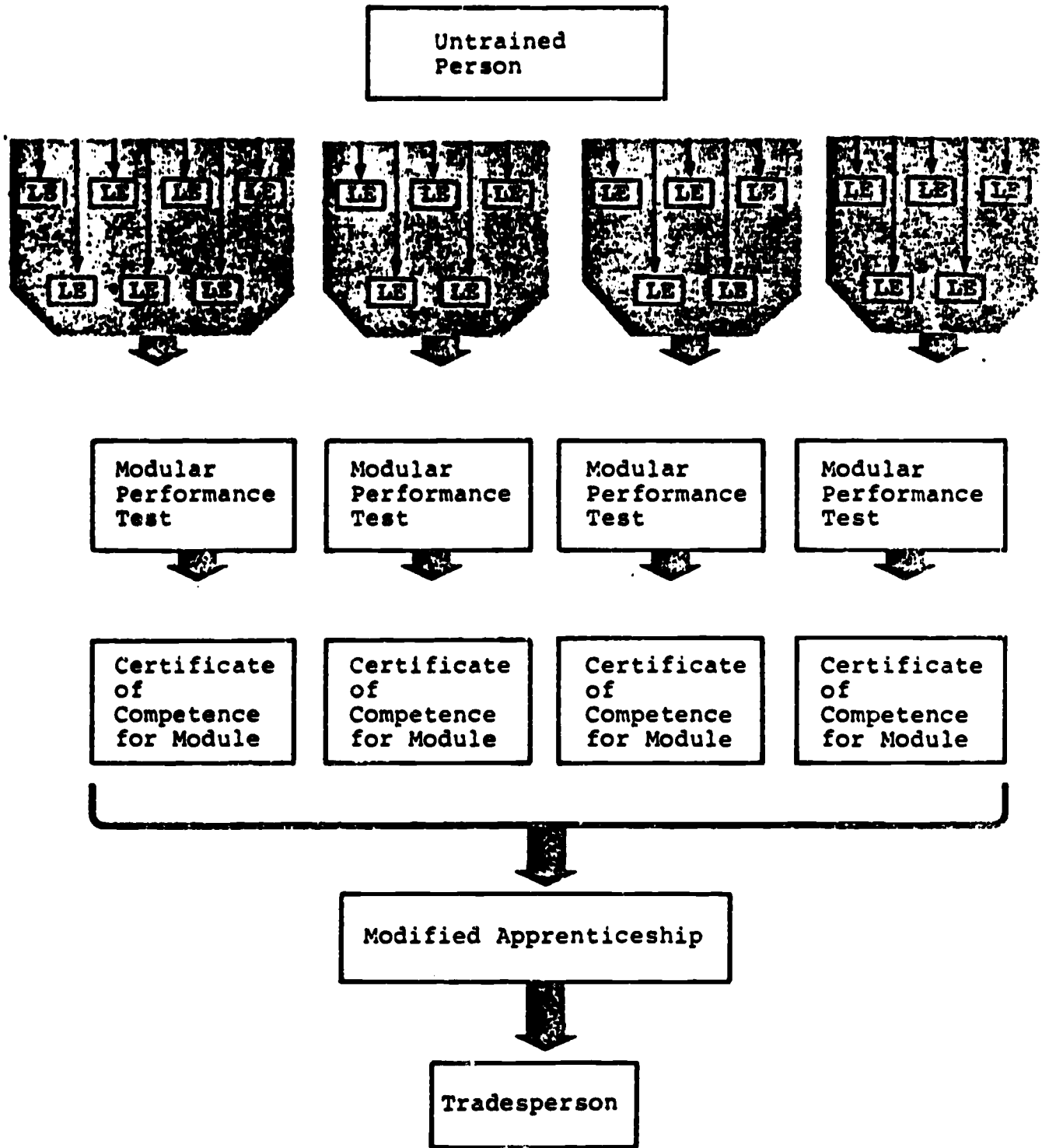

LE = Learning Element

In the MITS approach to training, trainees are able to progress at a rate which they define. As they are not bound to fixed times for training they are in a more favourable position to come to terms with technical knowledge and skills which are basically alien to Aboriginal culture.

- Aboriginal apprentices have difficulty in relating to Western methods of instruction. Emphasis on verbal explanations and practising isolated portions of activities in contrived settings conflict with Aboriginal forms of instruction and learning.

In conventional apprenticeship programs Aboriginal apprentices have difficulty with block release. In block release sections of programs they are required to move from their home communities to an urban environment and they are required to assimilate a relatively large amount of technical knowledge in a classroom setting.

MITS training is carried out in the workshops of remote Aboriginal communities and relative to the work normally carried on in the workshops. A MITS program requires that a tradesperson is present who is committed to Aboriginal training. Where this is the case the system can capitalise on the good relations between a tradespersons and their trainees. As the knowledge and skills involved are entirely Western, attempts to teach in the Aboriginal way may not be possible or, as far as some potentially dangerous tasks are concerned, not even desirable.

- Aboriginal apprentices have little or no understanding of the intended outcomes of apprenticeship training. They begin apprenticeship programs without a clear picture of the effects of practising a trade in terms of changes to individual habits and ways of living.

In conventional training programs it is desirable that apprentices change their habits and ways of living so as to meet the demands which apprenticeship places upon them. For Aboriginal apprentices this may require far greater adjustments than for Europeans. In any case, Aboriginal apprentices, in attempting the transition, are not able to carry it on for the time required to complete an apprenticeship. They typically withdraw from apprenticeship at some point and revert to the habits and schedules most familiar to them.

In the MITS approach the behaviour of trainees is constrained to the minimum by participation in training. Trainees are able to train according to their preferred schedules governed by their relationships with their instructors (the tradespersons).

- Aboriginal apprentices are not able to function effectively for prolonged periods in an urban environment.

The conventional apprenticeship requires that apprentices take some part of their training in an urban setting. MITS training, by contrast, is carried on in remote Aboriginal communities.

- Aboriginal individuals are often discouraged by their peers from forming close relationships with Europeans.

MITS contains nothing which addresses this point. In situations where Aboriginal people are effectively prevented from forming sound working relationships with tradespersons it is difficult to see how technical knowledge and skills could be transferred to them by any means.

- Aboriginal people are not inclined toward full participation in the economy according to European standards.

Unlike the conventional apprenticeship in which an apprentice is faced with only two outcomes: tradesperson and failure, the MITS alternative permits trainees to aspire to many outcomes. In the MITS approach each trainee acquires knowledge and skill as determined by his or her own personal level of motivation. A trainee can take training in whatever number of tasks he or she likes subject to the approval of the instructor including all tasks relevant to work in a trade.

- Aboriginal people take little interest in knowledge which has no application to their immediate situation.

In conventional apprenticeship programs apprentices are typically required to assimilate technical knowledge beyond that which is essential for the effective performance of the job as it is carried out in the workplace.

The MITS approach to training functions to de-mystify the knowledge of the trades by focusing on the knowledge and skills required for effective performance on the job. The trainee is able to see direct application of the knowledge presented to him or her. As a result, the trainee is less likely to become bewildered by the technical knowledge.

- In some cases tradespersons do not have sufficient time to provide training for Aborigines.

As with the conventional apprenticeship system MITS relies on qualified tradespersons to develop trade skills in trainees. In terms of training methodology, however, MITS represents an improvement on the conventional system. Where trainees have a reading comprehension level which is sufficiently high for them to read the learning material they may work somewhat independently with only occasional help from the tradesperson. If trainees are not able to read the learning material, considerable leading is required on the part of the tradesperson. Where this is the case the learning material represents a clear, precise and systematic guide to instruction for the tradesperson.

- The economic factor: At the present time there is no compelling economic reason why Aboriginal people in remote communities should acquire and use skills in trade areas.

This is another factor which the MITS alternative is not equipped to address.

## NOTES ON IMPLEMENTATION

Presenting a design for an alternative system of training is one step on the path toward the ultimate goal of having Aborigines acquire and use trade skills. Before the design can be put into use legislative restrictions on training must be removed, the concerns of DISB and the trades union regarding the new training system must be addressed, details of payment (economic incentives) for trainees must be negotiated with community councils and other government departments and the role of the tradesperson as instructor must be explored.

This chapter is concerned with some of the problems relating to the implementation of MITS.

The Northern Territory Department of Industry  
and Small Business

Three meetings were held with representatives of the Department of Industry and Small Business (DISB). The first meeting took place in September 1984 shortly after officers began the project. The second meeting was held in March 1985 and the third in July 1985. The purpose of the meetings was to identify options for an alternative system of training for Aboriginal people in remote communities which would be acceptable to DISB as the government training authority and which would operate within the framework of existing legislation. Three options emerged. Each option is outlined and evaluated in terms of its usefulness.

Option 1: Training Without Employment

In this option Aborigines would undertake modular training in community workshops without being employed by their

communities. At some point in the training program, TAFE would certify that a trainee had reached the equivalent of a DIT-trained tradesperson in terms of technical knowledge. DISB would then grant an exemption from technical classes for the trainee and would set a lesser term of apprenticeship. The envisaged length of time to be served by the trainee under this option was in the order of two years. At the end of the period specified DISB would give the trainee full trade qualifications.

This option takes account of Section 38(1) of the Northern Territory of Australia Vocational Training Commission Act which states that:

Subject to this section, a person shall not employ a person who has not attained the age of 21 years in an apprenticeship trade unless -

(a) The person so employed -

- (i) is a registered applicant for an apprenticeship;
  - (ii) is an apprentice; or
  - (iii) has completed an apprenticeship in that trade.
- or

(b) The employer ensures that the person so employed makes an application under section 46 for registration immediately upon his becoming so employed.

Where Aboriginal people under the age of 21 are employed in community workshops while not being formally registered as apprentices they are acting illegally. Application of the first option would provide a solution to the problem. However, it would also mean that trainees would be required to resign from their positions of employment with their communities. The suggestion from DISB was that income could be provided in the form of government training grants. In this time of increasing economic uncertainty one could question seriously the wisdom of the suggestion that people resign positions and become dependent on government grants.

Another difficulty with the option is that it carries a substantial time-based component. One of the main barriers to Aboriginal people gaining trade qualifications is the rigid time schedules of the conventional training system. One could therefore question whether this option would achieve the desired result.

A problem relating to this option is that the goal of trainees assimilating technical knowledge to the level of a DIT-trained tradesperson is not realistic. Much of the technical knowledge offered in such training programs would be extraneous to performing the job of a tradesperson as it is done in an Aboriginal community. The effect of insisting that Aboriginal trainees assimilate irrelevant technical knowledge would be that they would lose interest in trade work.

#### Option 2: Qualifications via Tradesmen's Rights

In the second option Aborigines would work in particular trades and, in addition, would be given systematic on-the-job training. They would continue in this way until they attained the level of competence needed to gain full trade qualifications through the process of Tradesmen's Rights.

The Tradesmen's Rights Regulation Act provides for the 'relaxation of certain customs...in the trades to which the Act applies...'. The purpose of Tradesmen's Rights is:

- (a) to make provision for dealing with [certain] abnormal industrial conditions...; and
- (b) to make provision for the training and employment of members of the Forces...as a measure of rehabilitation of those members.

Those trades covered by Tradesmen's Rights legislation are as follows: engineering trades, boilermaking trades, blacksmithing trades, electrical trades, sheet metal trades and bootmaking trades.

The option involving Tradesmen's Rights would offer nothing in the way of a solution to the problem of Aborigines under 21 working with the tools of the trades without being apprenticed. Also, Tradesmen's Rights do not cover certain trades essential to the pattern of work in Aboriginal communities. The building trades are not covered. Training in the building trades is essential if training is to be undertaken with a view to greater degrees of self-sufficiency for Aboriginal communities.



### Option 3: Exemption from Legislation

In this option Aboriginal community councils, together with community housing associations, would be granted exemption from regulations governing apprenticeship. This would mean that Aborigines could continue to work in community workshops and also participate in modular training. For each module successfully completed TAFE would grant a statement of achievement. At the completion of all modules required in a particular trade a trainee would approach DISB. DISB would recognise the collection of TAFE statements of achievement as equivalent to a portion of a time-based apprenticeship and would set a lesser apprenticeship term to be served. Time to be served in connection with this option is envisaged to be in the order of one month. At the end of the specified time the trainee would be given full trade qualifications.

Application of this option is subject to approval of MITS via the TAFE accreditation process in which TAFE institutions and industry will be represented.

Clearly, this is the option preferred.

### Changes to Legislation Needed

Most of the legislation needed to fulfil this option is already in place:

- Section 38(2) of the Northern Territory of Australia Vocational Training Commission Act states that:  
An employer who is specified or who is a member of a class of employers which is specified by the Commission for the purposes of this sub-section may employ a person in contravention of sub-section (1).
  
- Section 39(3) states that:  
A person may employ a person who is or who is a member of a class of persons which is specified by the Commission for the purposes of this sub-section in contravention of sub-section (1).

Thus, within the framework of existing legislation, exemption can be granted to Aboriginal community councils and community housing associations.

- Section 58(2) states:

The Commission may, if it is of the opinion that it is impractical for an apprentice or a probationer to attend a training course or part of a course determined under section 57 in respect of that trade, by notice in writing served on the apprentice or probationer, give directions as to the training to be obtained by the apprentice or probationer in that trade in substitution for that course or part of the course.

- Section 58(3) states:

The Commission may, if it is satisfied that the theoretical knowledge of the apprentice or probationer in relation to the apprenticeship trade to which his apprenticeship relates and the practical experience in that trade gained by him in that trade warrants it, exempt an apprentice or probationer from attendance at the training courses or parts of such courses determined by the Commission.

Aboriginal trainees can be granted exemption from regulations involving practical training as well as attendance in technical classes.

- Section 51(2) states that:

The Commission shall not approve a lesser term for indentures of apprenticeship under sub-section (1)(b)(ii) unless it is satisfied that the theoretical knowledge of the apprentice in relation to the apprenticeship trade to which the apprenticeship relates or the practical experience in that trade gained by him warrants the reduction in the term of the indentures of apprenticeship.

Aboriginal trainees can be assigned a lesser term of apprenticeship after they have successfully completed all of the training modules in a particular trade.

- Section 81 states:

The Commission may certify that a final certificate or other document held by an apprentice or tradesman which fulfils the requirements specified in the law of a State or another Territory is equivalent to such certificate or other document required or permitted to be given under this Act as is specified in the certificate so given by the Commission.

This Section has been suggested by representatives of DISB (subject to clarification) as appropriate for granting recognition of TAFE statements of achievement as equivalent to a portion of a time-served apprenticeship.

One change to existing legislation appears to be necessary in order to implement the third option. Legislation would need to be altered to take account of European apprentices working in Aboriginal communities. European contractors undertaking work in Aboriginal communities according to this plan would not be granted exemption from the regulations governing training. European apprentices employed by outside contractors also would not be granted exemption. However, Aboriginal trainees employed by outside contractors for community work would be exempt.

### Trades Union

Two meetings were held with representatives of the Northern Territory Trades and Labour Council. The first meeting was held in February 1985, the second in July 1985. The purposes of the meetings were to inform labour unions in the Territory of the details of the alternative training initiative and to take note of their concerns and suggestions with respect to the development of the new training system.

The union representatives stated that in principle they support programs aimed at assisting disadvantaged groups. However, they did outline three specific concerns with respect to the Review of Trade-based Training and the development of an alternative system of training for Aboriginal people in remote communities. The concerns are as follows:

1. That on-the-job training in remote Aboriginal communities may not result in trainees being exposed to the breadth of trade work necessary;
2. That tradespersons currently working in Aboriginal communities may not be competent to teach the theoretical aspects of trades; and
3. That the training program may result in the establishment of an inferior class of tradesperson.

At this point, it should be stated that planners share an understanding of the potential problems which have given rise to these concerns and are undertaking actions to ensure that these potential problems do not materialise.

A high standard of performance is being set for the alternative training programs. In no sense is a compromise in standards of work being sought. The standard required for each individual task will be fully documented in the task specification. Where in the view of unions, industry or government training authorities this standard requires modification, program developers will seek advice on changes required. Changes may take the form of essential knowledge relating to a task which has been omitted in the preparation of the learning material but which must be included, alterations to the description of work within a particular task or other specific changes to tasks.

#### Financial Incentives for Trainees

A corresponding wage and skill plan should be implemented in communities in conjunction with the training system. The structure should consist of skill levels and corresponding wage rates. Skill levels should equate to numbers of modules completed. The purposes of the wage and skill plan are to recognise formally degrees of skill in trainees and also to provide an incentive for trainees to succeed in training.

Trainees should undergo training for wages as specified in the 'Rural Communities and Associations Northern Territory Award'. A copy of the Award appears in Appendix G. Trainees who are successful in completing training modules, as well as receiving TAFE statements of achievement, should be eligible to receive a higher rate of pay for their work than others who are unskilled. Payment should be in the form of an incremental increase over the Award rate for each module successfully completed. A trainee who completes three modules would receive the Award rate plus three increments.

Modules vary considerably in degree of difficulty. This suggests that financial rewards be varied depending upon the difficulty of individual modules. However, assessing each task in terms of the level of financial reward appropriate would be a cumbersome exercise. Also, as greater numbers of modules are completed by trainees the problems of administering payment would multiply. In order to avoid these problems payment should be at a flat rate for all modules. The recommended amount is \$2.00 per training module per week.

Payment to trainees for modules completed would be under the control of community councils. TAFE has no authority over councils and can only suggest that they adopt the incentive plan. Discussions held with representatives of the Department of Community Development (1985) yielded encouraging results in relation to development of the plan. Their view is that something like what is being proposed is already happening in communities as more productive workers are given larger financial rewards. Their suggestion was that TAFE work with the town clerks in the communities where modular training programs are implemented. According to Community Development personnel, implementing the financial incentive plan would merely involve a slight alteration to each community's budget.

### Role of the Tradesperson

The only persons resident in remote Aboriginal communities and considered qualified to impart trade skills to Aboriginal people are tradespersons. All others regardless of their qualifications and interests should be regarded as unskilled.

In order for the MITS alternative to prove effective TAFE should develop and maintain sound working relationships with community tradespersons. Tradespersons should be viewed as an essential resource and given support and encouragement appropriate to their role as trainers.

### Briefing Instructors and Trainees

MITS differs substantially from the conventional apprenticeship system. Because of this difference, tradespersons and trainees will need pre-training briefing. This will take the form of instructions outlining the role of the instructor/tradespersons in supervising training as well as what is expected of trainees. The instructions should be studied carefully by tradespersons who should then explain to trainees their obligations in the program.

### Concluding Remarks

In developing the Modular Integrated Training System project officers have tried to recognise and take account of the cultural differences between Aborigines and Europeans. Special attention has been taken to plan programs so as to minimise disruptions to life in Aboriginal communities, many of which already show signs of acute cultural trauma. The aim has been to present the knowledge and skills of the trades in a way which permits Aboriginal people to develop at a pace which they themselves define.

Project officers have attempted to find a way of reconciling the wants, needs and deficiencies (in terms of Western learning) of Aborigines with the limited flexibility of European institutions and laws. Officers have tried to fashion a method of training Aborigines in knowledge and skills which are alien to Aboriginal society in a way which is acceptable both to Aborigines themselves and to a number of European institutions and authorities, some of which show diametrically opposing values and goals.

The potential of the new system in terms of the number of traditional Aboriginal tradespersons practicing in the next few years is not clear. What seems likely is that only a small percentage of trainees will move to full tradesperson's status while most will acquire lesser degrees of skill as prompted by individual levels of motivation.

The MITB design represents a serious attempt to reach out to Aboriginal people and to offer them a practical development experience which they can succeed in and grow with.

## REFERENCES

- Commonwealth-State Apprenticeship Committee. (1982). Essential Features of Australian Apprenticeship Systems. Canberra: AGPS.
- Discussions between project officers and representatives of the Northern Territory Department of Community Development. (1985).
- Discussions between project officers and representatives of the Northern Territory Department of Industry and Small Business. (1985).
- Ford, H.M. (Chair, Australian Aboriginal Affairs Council). (1981). Report of Joint Working Party on Job Training for Aborigines. Canberra: AGPS.
- Harris, S. (1980). Culture and Learning: Tradition and Education in Northeast Arnhem Land. Darwin: Northern Territory Department of Education.
- Henneken, P. (1984). 'Report on Visit to the United Kingdom, Denmark, The Federal Republic of Germany and The Netherlands to Examine Trends in Vocational Training for Industry and Commerce.' Unpublished report prepared for the Division of Employment, Planning and Training, Department of Employment and Industrial Affairs.
- International Labour Organisation. (1984). A Systematic Approach to Vocational Training. Geneva: ILO.
- Manpower Services Commission. (1984). A New Training Initiative: Modernisation of Occupational Training. (A Position Statement). Sheffield, UK: Manpower Services Commission.
- 'Rural Communities and Associations' Northern Territory Award, 1985.



Stevenson, J.C.      Designing Vocational Courses: Observations on  
Other Countries Practices.  
No Publisher given.

Strike, T.M. (1981). 'An Introduction to the Philosophy of  
Aboriginal Adult Education in the Northern  
Territory'.  
Unpublished research project submitted for  
the Bachelor of Education Degree, Adelaide  
College of Advanced Education, Adelaide,  
South Australia.

The Tradesmen's Rights Regulation Act, 1946.

Vocational Training Commission Act.

A P P E N D I X A

INTERVIEW SCHEDULE FOR VISITS  
TO ABORIGINAL COMMUNITIES

# Review of Trade-based Training- DATA

Name of community and region:

Aboriginal Council President:

Adult Educator or other contacts:

Telephone number:

Leave message with:

Date information was collected:

1 Details of trade-training programs and practices currently operating:

Effectiveness:

2 Reasons for low levels of success of trade-training programs:

Community's view:

Educator's view:

3 Trade skills needed at present and in the next 2 years.  
Give some indication of priority of skills needed.

Community's view:

Educator's view:

4 Personnel available to assist in training:

	<u>Tradesmen</u>		<u>Aboriginals</u>		<u>Others</u>
Broad-skilled	..	..	..		
Narrow-skilled	..	..	..		
Other	..	..	..	..	

5 Facilities available, e.g. workshops:

6 Levels of general education of likely trainees:

7 Recommendations for the nature and delivery of trade programs:

8 Aspects of this community which make it unique:

9 Other remarks:

# Review of Trade-based Training— DATA

## Stage 2 Questionnaire

Name of community and region:

Aboriginal Council President:

Adult Educator or other contacts:

Telephone number:

Leave message with:

Date information was collected:

1 Estimate of the level of each trainee in relation to practical skills and theoretical knowledge. (Include only those individuals who appear for work more or less regularly).

PRACTICAL SKILLS

<u>Trainee</u>	<u>Pre-App.</u>	<u>App. Year 1</u>	<u>App. Year 2</u>	<u>App. Year 3</u>	<u>App. Year 4</u>	<u>Other (specify)</u>
1.	┌──┐	┌──┐	┌──┐	┌──┐	┌──┐	┌──┐
2.	┌──┐	┌──┐	┌──┐	┌──┐	┌──┐	┌──┐
3.	┌──┐	┌──┐	┌──┐	┌──┐	┌──┐	┌──┐
4.	┌──┐	┌──┐	┌──┐	┌──┐	┌──┐	┌──┐
5.	┌──┐	┌──┐	┌──┐	┌──┐	┌──┐	┌──┐
6.	┌──┐	┌──┐	┌──┐	┌──┐	┌──┐	┌──┐
7.	┌──┐	┌──┐	┌──┐	┌──┐	┌──┐	┌──┐
8.	┌──┐	┌──┐	┌──┐	┌──┐	┌──┐	┌──┐
9.	┌──┐	┌──┐	┌──┐	┌──┐	┌──┐	┌──┐
10.	┌──┐	┌──┐	┌──┐	┌──┐	┌──┐	┌──┐

THEORETICAL KNOWLEDGE

<u>Trainee</u>	<u>Pre-App.</u>	<u>App. Year 1</u>	<u>App. Year 2</u>	<u>App. Year 3</u>	<u>App. Year 4</u>	<u>Other (specify)</u>
1.	┌──┐	┌──┐	┌──┐	┌──┐	┌──┐	┌──┐
2.	┌──┐	┌──┐	┌──┐	┌──┐	┌──┐	┌──┐
3.	┌──┐	┌──┐	┌──┐	┌──┐	┌──┐	┌──┐
4.	┌──┐	┌──┐	┌──┐	┌──┐	┌──┐	┌──┐
5.	┌──┐	┌──┐	┌──┐	┌──┐	┌──┐	┌──┐
6.	┌──┐	┌──┐	┌──┐	┌──┐	┌──┐	┌──┐
7.	┌──┐	┌──┐	┌──┐	┌──┐	┌──┐	┌──┐
8.	┌──┐	┌──┐	┌──┐	┌──┐	┌──┐	┌──┐
9.	┌──┐	┌──┐	┌──┐	┌──┐	┌──┐	┌──┐
10.	┌──┐	┌──┐	┌──┐	┌──┐	┌──┐	┌──┐



Record answers for questions 2, 3 and 4 on table following

2 Highest grade in school completed by each trainee.

3 Equivalent grade in the mainstream school system.

4 Number of years since each trainee attended school as a regular pupil.

<u>Individual Trainee</u>	<u>Highest Grade</u>	<u>Mainstream Equivalent Grade</u>	<u>Years Away</u>
1.	_____	_____	_____
2.	_____	_____	_____
3.	_____	_____	_____
4.	_____	_____	_____
5.	_____	_____	_____
6.	_____	_____	_____
7.	_____	_____	_____
8.	_____	_____	_____
9.	_____	_____	_____
10.	_____	_____	_____

5 Trade areas most important to the community

6 Personnel available to assist in training.

7 Facilities available, e.g. workshops

8 In your view, as a tradesman working in the community, is it possible (with supporting learning materials) for you to impart the theoretical knowledge necessary for a trainee to operate as a tradesman in the community?

9 Other remarks

A P P E N D I X    B

INTERVIEW SCHEDULE FOR VISITS  
TO TRAINING INSTITUTIONS

INTERSTATE VISIT REPORT

Organisation visited:

Date:

Contact name:

Position:

Address:

Telephone:

Details of trade-training:

Entrance requirements:

Term of apprenticeship:

Details of on-the-job training:

Details of technical education, i.e. block release, day release, correspondence, etc.

Details relating to any intermediate level certificates granted:

Ways of gaining full tradesman's qualifications other than by means of the traditional mainstream method (if any):

Aspects of trade-training programs which apply especially to Aborigines:

Any booklets available which outline trade-training programs:

Modular training systems -

Example of development:

Reaction to idea of interchangeable bank

Mobile training units -

Method of operation:

Advantages:

Subjects taught:

Use of video -

Is example available:

Effectiveness:

Cost:

View of potential of video:

Expertise and degree of finish:

Anticipated moves away from time-served system:

Reactions of trade unions/employers:

Legislative difficulties and how they can be overcome:

Reasons for low-level of success of existing Aboriginal programs:

Recommendations to rectify above:

Other comments:

A P P E N D I X C

NOTES ON THE PREPARATION OF THE PILOT MODULE  
AND SAMPLE OF MODULAR MATERIALS

## Preparation of the Pilot Module

Materials included here are examples of what was prepared in connection with developing a module of learning material for pilot testing. The procedure for developing the module used was as follows:

- A community-based mechanic interested in Aboriginal training was asked by project officers to suggest an appropriate module to be developed for pilot-testing. His suggestion was: Braking Systems in Cars and Light Commercial Vehicles.
- The mechanic was then asked to specify all actions he carried out in his workshop when completing the task of checking, servicing or repairing braking systems. Following that he was asked to state all technical knowledge, safety related information and other information which a workman would need to know in order to complete that task.
- After noting carefully all information supplied another mechanic in a nearby Aboriginal community was asked for the same information. The information supplied by the two was virtually identical.
- Project officers then compared the information needed to complete the task as given by the community-based mechanics with a list of prepared learning material available from the ILO. Of 25 learning elements needed for the module - based upon the technical information supplied by the mechanics - 21 were available. The remaining four were developed by project officers with technical assistance from mechanics employed by TAFE.

Principal reference materials used in preparing the pilot module were as follows:



- International Labour Organisation, (1980), Modules of Employable Skill (MES): Handbook on Practices. Geneva: ILO.
- , (1981), Application of Modules of Employable Skill to Vocational Training: Defining Key Concepts in a System. Geneva: ILO.
- , (1981), Application of Modules of Employable Skill to Vocational Training: Designing a Vocational Training System in Terms of Efficiency and Effectiveness. Geneva: ILO.
- , (1981), Application of Modules of Employable Skill to Vocational Training: Describing Component Characteristics Within a System. Geneva: ILO.
- , (1981), Application of Modules of Employable Skill to Vocational Training: Establishing Criteria for Key Components in the Modules of Employable Skill Approach. Geneva: ILO.
- , (1981), Application of Modules of Employable Skill to Vocational Training: Identifying the Steps of Work Performed within a Modular Unit. Geneva: ILO.
- , (1981), Application of Modules of Employable Skill to Vocational Training: Identifying Titles, Scope and Categories of Learning Elements. Geneva: ILO.
- , (1983), 'Curriculum Development for Vocational Training, Skill Standards, Trade Testing and Certification'. A paper presented by the ILO to the South Asia Regional Conference on Skilled Manpower Development.

Review of  
trade-based training  
in remote areas

---

# **task specification**

---

This specification is based on the task of  
CHECKING AND SERVICING THE BRAKING SYSTEM  
as performed in remote areas of the Northern Territory of Australia

Tasks, objectives and standards, where possible, have been related  
to the TAFE National Core Curriculum

# SPECIFICATION

Reference No. ASCO 6052-A

WORKING AND SERVICING THE BRAKING SYSTEM  
(Passenger Cars and Light Commercial Vehicles)

NCC Automotive Mechanics (1983)

Topic No.	Title
13	BRAKES

## Performance standard

- ) Brake fluid level will be correct
- ) All braking components will be safe and serviceable
- ) The brake lines will be free of leaks
- ) The brakes will be correctly adjusted
- ) The braking system will be free of air
- ) The braking system will be effective on road test

## Performance requirements

One used light vehicle	Wheel chocks	Access to spare parts, eg:
Supply of brake fluid	Safety stands	Replacement shoes and/or pads
Mechanic's tools	Wiping rag	Replacement wheel cylinder kits
Floor jack	Bleeding tube	Replacement master cylinder kit
Supply of rubber grease	Bleeding jar	Replacement caliper repair kit

## Requirements

Three months' experience in an Automotive Workshop

**Education:** Must have completed primary school

**Health:** Normal health without physical impairment

**Considerations:** Manual dexterity to manipulate tools and make fine adjustments

## Other notes

None

10A

## Task elements

1. Ensures level of brake fluid is correct
2. Determines amount of pedal travel
3. Checks master cylinder for fluid leaks, pedal creep and pedal-free play (repairs as necessary)
4. Loosens wheel nuts
5. Jacks up the vehicles and fits safety stands
6. Removes road wheels
7. Removes brake drum
8. Checks adjustment of wheel bearings
9. Cleans all wheel brake areas
10. Inspects linings and wheel cylinders (removes, repairs and replaces as necessary)
11. Replaces brake drum
12. Adjusts brake shoes
13. Checks all hydraulic lines for serviceability
14. Inspects disc brakes for serviceability
15. Removes disc pads (if necessary)
16. Levers pistons to starting position (if necessary)
17. Inserts new pads (if necessary)
18. Bleeds the braking system
19. Replaces the road wheels
20. Checks handbrake and adjusts
21. Tops up the master cylinder with brake fluid
22. Advises supervisor that the car is ready for road test

# TASK TRAINING DATA

Reference No. ASCO 6052-A

IF No	Technical knowledge	Safety and hygiene	Other information
1	Location of brake fluid reservoir.  Knowledge of brake fluid.  Technique of cleaning and filling reservoir (including air passage in cap).	Hazard of brake failure due to incorrect fluid.  Affect of brake fluid on paintwork.  Danger of spreading brake fluid onto paintwork through use of compressed air.	-  -  Necessity to avoid damaging cap diaphragm.
2	Knowledge of possible faults in system and how to recognise them.	Need for effective braking where public safety is concerned.	-
3	Knowledge of free travel of pedal and pedal-creep.  Knowledge of effect of fluid leaks,  Procedure for removing and replacing the master cylinder.	-  Necessity for free play in brake adjustment.  -	Difference between free play and normal pedal travel.  -
4	Use of spanners and wrenches.	Danger of using incorrect size spanner.	-
5	Methods of lifting vehicle and using safety stands.  Knowledge of lifting points.  Identification of mobile lifting devices and their uses.	Knowledge of possible damage to vehicle when using jacks.  Awareness of hazards when lifting or lowering vehicle, and safety rules to be followed.  -	-  -  -
6	Method of removing and replacing road wheels.	Necessity of final check on wheel nuts when vehicle is lowered.	-
7	Knowledge of drum brakes, and drum brake parts.  Technique of removing brake drums.	-  -	-  -

85

107

# TASK TRAINING DATA

Reference No. ASCO 6052-A

No	Technical knowledge	Safety and hygiene	Other information
8	Method of checking wheel bearing adjustment.	-	-
9	Method of cleaning brake assembly area.	Importance of using safe methods to remove asbestos dust.	-
10	<p>Knowledge of minimum lining thickness.</p> <p>Technique of measuring lining thickness.</p> <p>Procedure for removing brake shoe assembly.</p> <p>Procedure for removing and dismantling wheel cylinder.</p> <p>Knowledge of faults occurring in wheel cylinder parts.</p> <p>Method of repair and assembling of wheel cylinder. Knowledge of repair kit.</p> <p>Knowledge of importance of cleaning and inspecting brake drum for defects.</p>	<p>Necessity of checking manufacturer's manual for minimum permitted thickness of brake linings.</p> <p>Necessity of cleanliness when working with brake parts.</p> <p>Danger of using compressed air to remove parts.</p> <p>Knowledge of safety requirements when handling inflammable or dangerous liquids.</p> <p>Dangers involved when using power tools.</p> <p>Harmful effects of asbestos dust to health.</p>	-
11	Method of replacing brake drum.	-	-
12	Procedure for adjusting brake shoes.	-	-
13	<p>Method of removing and replacing hydraulic hose and piping.</p> <p>Technique of making flared ends.</p>	<p>-</p> <p>Ability to recognise unserviceable piping.</p>	<p>Importance of avoiding kinking and unnecessary bends in piping.</p> <p>-</p>

# TASK TRAINING DATA

Reference No. ASCO 6052-A

TE No	Technical knowledge	Safety and hygiene	Other information
14	Knowledge of function and types of disc brakes.	Hazards of malfunctioning braking system.	-
	Knowledge of disc run-out and parallelism.	-	-
	Knowledge of serviceability of disc.	-	-
15	Procedure for removing disc pads.	Knowledge of minimum permitted thickness of lining and necessity to check manufacturer's manual.	-
16	Technique of levering piston back into cylinder.	Methods of removing rust from caliper body.	-
	Knowledge of damping shims and need for replacement.	-	-
17	Method of inserting and securing new pads.	Necessity of replacing pads on both wheels to maintain braking consistency.	-
18	Knowledge of when bleeding is required and procedure for changing brake fluid in the system.	Affect of heat, moisture and ageing on brake fluid.	-
	Technique of bleeding brakes.	-	-
19	<u>see</u> Task Element No. 6.		
20	Knowledge of handbrake systems and how to adjust them.	-	-
21	Necessity to check level of fluid in master cylinder after bleeding system.	-	-
22	-	Importance of leaving work area tidy after completing task.	-

87

111

112

# LEARNING ELEMENTS

These Learning Elements are appropriate to the task of:

## CHECKING & SERVICING THE BRAKING SYSTEM (Light Vehicle Braking Systems)

The sequence of titles presented here is a guide for their use in instruction.

Specific suggestions for alterations to the above list should be directed to:

Principal Education Officer  
TAFE Curriculum Research & Development  
GPO Box 4821, Darwin NT 5794

Brake Fluid

Topping-up Brake Fluid

Spanners/Wrenches - Kinds and Sizes

Using Spanners and Wrenches

\*Identifying Major Faults in the Braking System

Identification of Mobile Lifting Devices and Support Stands and Their Uses

Lifting Up Cars Using Mobile Jacks

Adjusting Wheel Bearings

Removing and Fitting Wheels

Identifying Drum Brakes and Their Function

Removing/Installing Brake Drums

Inspecting/Cleaning Brake Shoes

Measuring Using Metric Rules

\*Overhauling Wheel Cylinders

\*Recognising Brake Drum Defects

Adjusting Drum Brakes

\*Removing, Repairing, and Replacing Hydraulic Tubing

Identifying Function of Disc Brakes

Identifying Disc Brakes of Fixed Caliper Type

Identifying Disc Brakes with Sliding Caliper Assembly

Disc Brakes: Replacing Brake Pads on Fixed Caliper Type

Disc Brakes: Replacing Brake Pads on Sliding Caliper of Single Type Piston

Bleeding Hydraulic Brake System

Changing Brake Fluid in the Hydraulic Brake System

Adjusting Parking Brakes

\*Indicates Learning Element titles not available from the LE bank and needing to be developed.



# INSTRUCTIONS FOR TEST SUPERVISOR

The main Test Items are taken directly from the Task Performance Standard. Read the test items very carefully, and make sure that you understand what the candidate has to do in order to meet each Test Performance Standard.

Remember, either the candidate can meet the Performance Standard or he cannot. There is no in between. If the candidate cannot, then you must indicate under 'further training required' exactly why he/she did not meet the required Performance Standard by referring to the Evaluation Guide which is part of each Test Item, or Test Performance Standard. In addition, based on your observation of the test results, add whatever comments you think will assist those conducting the training course to improve the quality of the training, or the selection of trainees.

Remember that the purpose of testing is to determine the level of skill and knowledge possessed by the candidate as objectively and as fairly as possible.

Careful preparation for the test is critical. You must ensure that all of the items listed under Test Requirements are available, and that the candidate fully understands what he/she has to do in order to meet the Test Performance Standards.

When a candidate successfully meets the Test Performance Standard complete the details in the box provided on this page, detach the whole page and return to:

TAFE Adult Education and Training

GPO Box 4821

Darwin NT 5794

## Test Supervisor's Report

Candidate name \_\_\_\_\_

Address \_\_\_\_\_  
\_\_\_\_\_  
\_\_\_\_\_

Identification \_\_\_\_\_  
\_\_\_\_\_

The above candidate successfully met the Task Performance Standard for:  
\_\_\_\_\_  
\_\_\_\_\_

at \_\_\_\_\_ on \_\_\_\_\_

Instructor's signature \_\_\_\_\_

Supervisor's signature \_\_\_\_\_

### FOR OFFICE USE ONLY

Registration no. \_\_\_\_\_

Certificate no. \_\_\_\_\_

Issued on \_\_\_\_\_

Authorised by \_\_\_\_\_

# TASK PERFORMANCE TEST

Task title	Registration No.	Candidate's name
CHECKING AND SERVICING THE BRAKING SYSTEM (Cars and Light Commercial Vehicles)	Course accreditation No.	

## Test performance requirements

One used light vehicle	Wheel chocks	Piece of steel brake pipe	Access to spare parts, ie: Replacement shoes and/or pads Replacement wheel cylinder kits Replacement master cylinder kit Replacement caliper repair kit
Supply of brake fluid	Safety stands	Two tube nuts	
Mechanic's tools	Wiping rag	Flaring tool capable of making ball flares	
Floor jack	Bleeding tube	Selection of pipes (two serviceable and at least four others illustrating differing pipe faults)	
Supply of rubber grease	bleeding jar		

## Test performance standard (minimum)

Test items	Evaluation guide	Pass	Further training required
<p><i>Did the candidate:</i></p> <p>(i) Correctly fill the master cylinder.</p> <p>(ii) Work safely.</p>	<p>'Correctly fill' means - clean around the filler cap, check hole in cap is clear, ensure rubber dust excluder under cap is in good condition, fill to the MAX level mark <math>\pm 2\text{mm}</math>, securely replace caps, wash off any spillage (the foregoing is to be applied to all sections of the master cylinder).</p> <p>'Work safely' means that the vehicle is chocked to prevent movement and lifted at a correct lifting point, safety stands are securely positioned before working on the vehicle, the jack and stands are to be placed on a level and solid surface, the vehicle is lifted without causing damage to bodywork or components.</p>		
117			118

Test items	Evaluation guide	Pass	Further training required
<i>Did the candidate:</i>			
(iii) Correctly clean the brake assembly.	'Correctly' means - using water or steam; 'clean' means - clear of all removeable dust, rust and dirt.		
(iv) Remove brake shoes and correctly replace.	'Remove brake shoes' means - brake shoes together with attached parts; 'correctly replace' means - using re-lined shoes (if required), reassemble in the same position from which they were removed, or if they are replaced differently a valid reason must be given supported by the manufacturer's manual.		
(v) Overhaul the wheel cylinder and correctly reassemble.	'Overhaul' means - dismantle wheel cylinder for inspection, change all parts for which a replacement is provided; 'correctly reassemble' means - lubricate all parts with rubber grease or brake fluid prior to assembly, assemble all parts in the correct order, and maintain high standards of cleanliness.		
(vi) Overhaul the caliper and correctly reassemble.	'Overhaul' means - dismantle caliper for inspection, change all parts for which a replacement is provided; 'correctly reassemble' means - lubricate all parts with rubber grease or brake fluid (with the exception of the caliper dust seal) prior to assembly, assemble all parts in the correct order, and maintain high standards of cleanliness.		

Test items	Evaluation guide	Pass	Further training required
<i>Did the candidate:</i>			
*(vii) Check and rectify the brake lines.	<p>'Check' means - all brake lines will be without pitted rust damage or damage that reduces wall thickness or bore size, be free of visible fluid leaks enabling the brake pedal to remain steady and in the same position for 30 seconds when pressed hard down.</p> <p>'Rectify' means - be able to demonstrate the ability to make a ball flare and double flare.</p>		
(viii) Correctly adjust the brakes.	<p>'Correctly adjust' means - handbrake and footbrake travel conforms to manufacturer's specification.</p>		
(ix) Ensure the brake system was correctly bled and free of air.	<p>'Correctly bled' means - the brake system is bled at all possible points commencing firstly at the master cylinder (if a bleed screw is fitted) then working from the longest line (using a bleeding tube and jar) finishing with the shortest line. 'Free of air' means - when the brake pedal is depressed there is no sponginess.</p>		

- \* To measure these critical items the candidate will:
- (a) identify serviceable piping from a selection of damaged pipes;
  - (b) demonstrate the ability to complete the Progress Check from the Learning Element 'Removing and Replacing Hydraulic Tubing'.

Test items	Evaluation guide	Pass	Further training required
<p><b>Did the candidate:</b></p>			
<p>(x) Apply good workshop practice.</p>	<p>'Good workshop practice' means - wipe clean any spillage, use the correct tool for the job, replace all caps and safely store containers, leave the work area clean and tidy.</p>		
<p>(xi) Complete the task within an acceptable time limit.</p>	<p>'Acceptable time limit' means - the task will be completed within 7 hours.</p>		



**Title:**

Repairing Wheel Cylinders

**Occupational Area:**

AUTOMOTIVE ENGINEERING

**Code:**

--	--	--	--	--	--	--	--	--	--



Objectives

When you have completed this learning element, you will be able to:

- take a wheel cylinder apart;
- clean and check wheel cylinder parts;
- name the internal parts;
- assemble the wheel cylinder.

Equipment, Materials and Aids you will need

Quantity	Item/Description
One	Used cylinder
One	Mechanic's tool set
One	Wheel cylinder repair kit (new parts)
Supply	Brake fluid or rubber grease
One	Soft bristle brush
Supply	Clean rags or cloth
Supply	Compressed air

Related Learning Elements

- 'Removing and Fitting Wheels'
- 'Removing/Installing Brake Drums'
- 'Spanners/Wrenches - Kinds and Sizes'
- 'Brake Fluid'



## Learning Element

Title: Repairing Wheel Cylinders

Occupational Area: AUTOMOTIVE ENGINEERING

Code:

Date of Issue:  
Darwin, July 85

Page:  
2

1. If a wheel cylinder is faulty there are two possible solutions:
  - replace it with a new wheel cylinder; or
  - repair the wheel cylinder using a repair kit.

This learning element tells you how to overhaul a wheel cylinder.

2. Below is a drawing of a wheel cylinder. Look at the drawing and try to remember each of the parts by its correct name.

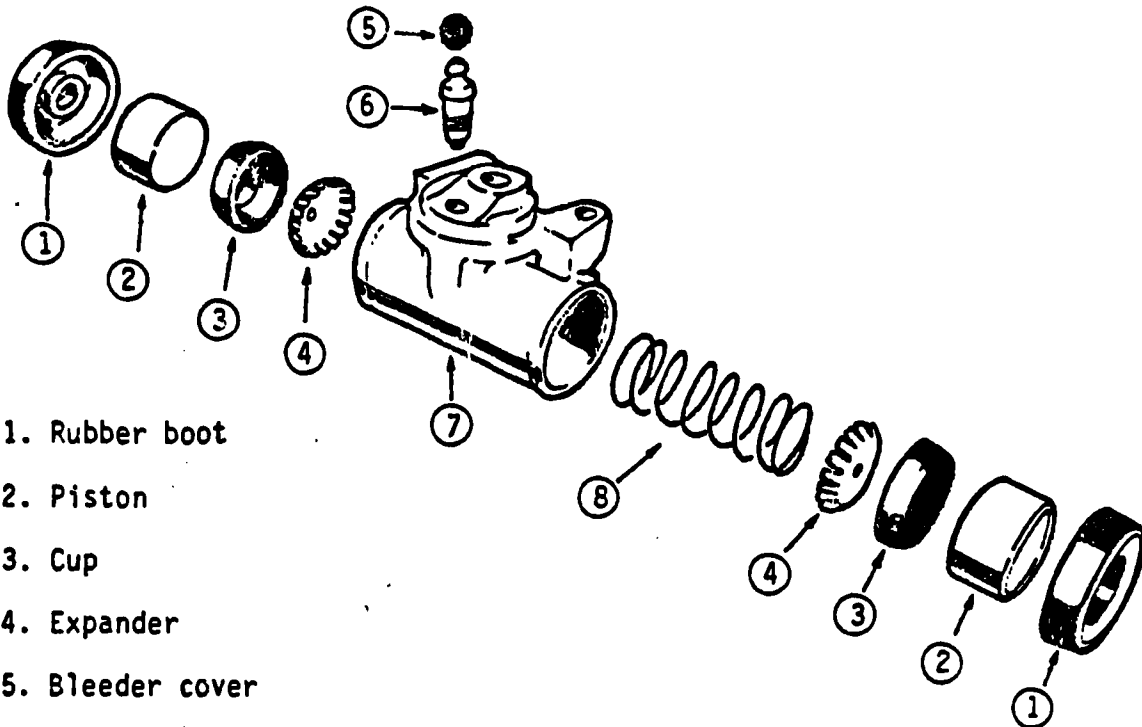

1. Rubber boot
2. Piston
3. Cup
4. Expander
5. Bleeder cover
6. Bleeder valve
7. Cylinder
8. Spring

3. Now you know the names of the parts and you are ready to begin to take apart the wheel cylinder. Using the wheel cylinder supplied follow the instructions on the next few pages.





## Learning Element

Title: Repairing Wheel Cylinders

Occupational Area: AUTOMOTIVE ENGINEERING

Code:

Date of Issue:

Darwin, July 85

Page:

3

### Dismantling the Wheel Cylinder

4. Remove the rubber boots, and remove the piston by tapping the edge of the wheel cylinder against a block of wood. Do not use pliers to remove the piston. The other internal parts will come out after the piston is removed.

**CAUTION:** Do not use compressed air to remove wheel cylinder parts. This may make parts fly-out and cause injury.

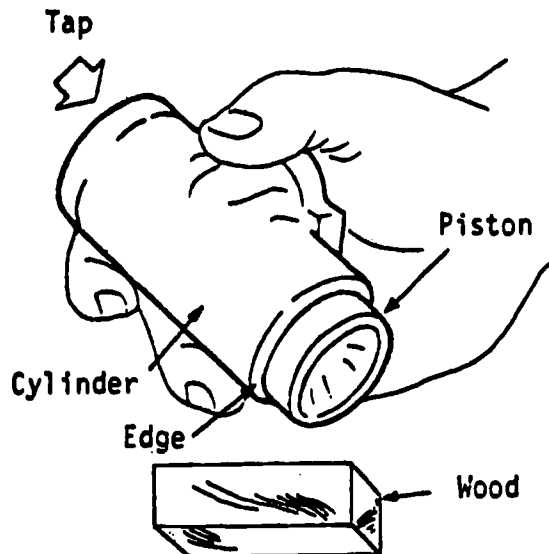

### Cleaning and Checking

5. Clean all of the parts in water or brake fluid. (Compressed air can be used to dry parts.)

Check:

- the inside of the cylinder bore for scratches, rust, and corrosion;
- the spring for damage;
- the bleeder valve by loosening it to make sure that it is not seized (stuck) in the cylinder bore. Then replace the bleeder valve and tighten firmly.

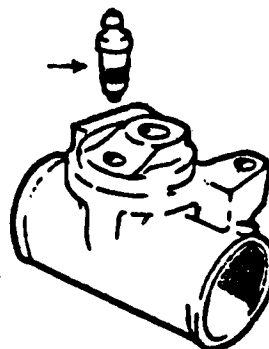
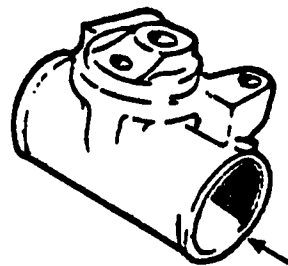

6. NOW CALL YOUR INSTRUCTOR who will demonstrate how a wheel cylinder is honed.



## Learning Element

Title: Repairing Wheel Cylinders

Occupational Area: AUTOMOTIVE ENGINEERING

Code:

Date of Issue:  
Darwin, July 85

Page:  
4

### Assembling the Wheel Cylinder

7. Cleanliness is important when assembling wheel cylinder parts. Prepare a clean surface on the workbench and use a clean cloth or paper to put your parts on.
  
8. Carefully empty the contents of the repair kit onto the workbench and check that all the worn rubber parts have a new replacement.
  
9. Using rubber grease or brake fluid, grease:
  - the cylinder bore;
  - the piston; and
  - the cups.

**WARNING: Do not use ordinary oils or greases.**

10. Following the drawing as a guide, place one of the cups into the bore. The lip must be facing into the bore.

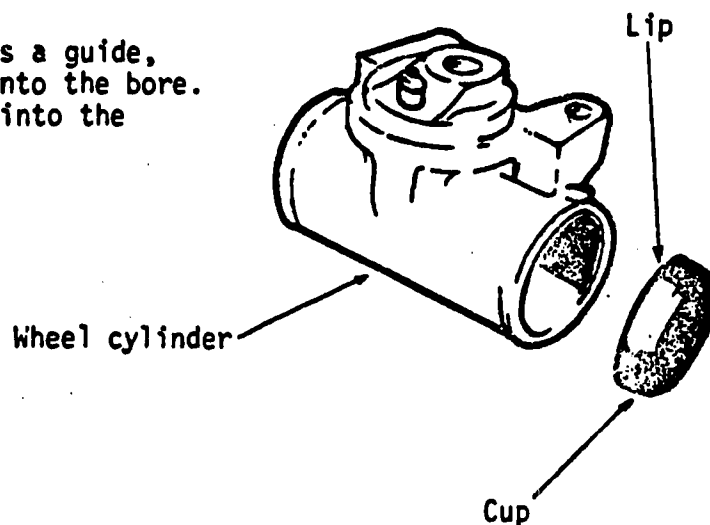



## Learning Element

Title: Repairing Wheel Cylinders

Occupational Area: AUTOMOTIVE ENGINEERING

Code:

Date of Issue:  
Darwin, July 85

Page:  
5

11. The piston goes in next. The flat surface must be against the flat part of the cup.

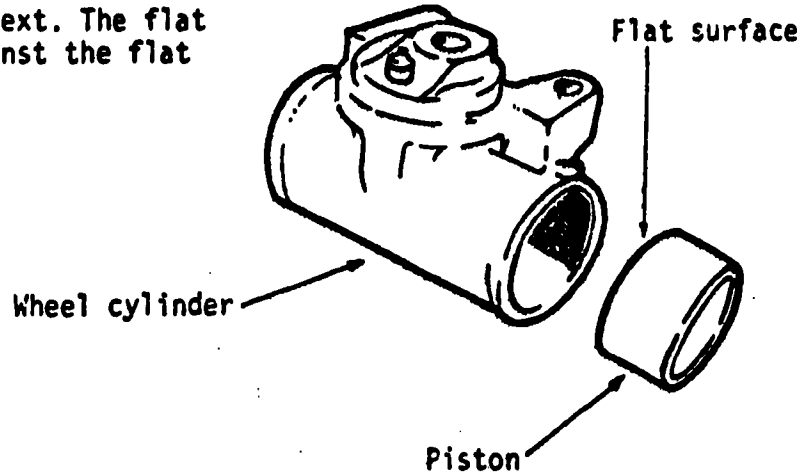

12. Now, place the rubber boot over the end of the wheel cylinder.

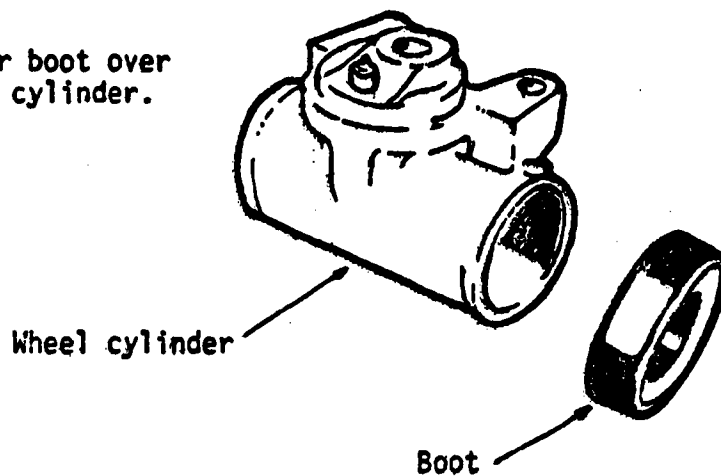

13. Place the wheel cylinder with the rubber boot facing down on the work bench. Make sure that the work area is kept clean.

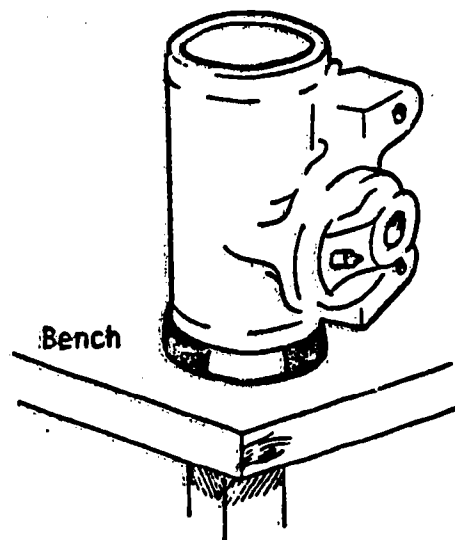



Title: Repairing Wheel Cylinders

Occupational Area: AUTOMOTIVE ENGINEERING

Date of Issue:  
Darwin, July 85

Page:  
6

14. Now, slide the cup expander, or filler, into the cylinder bore so that it sits inside the rubber cup.

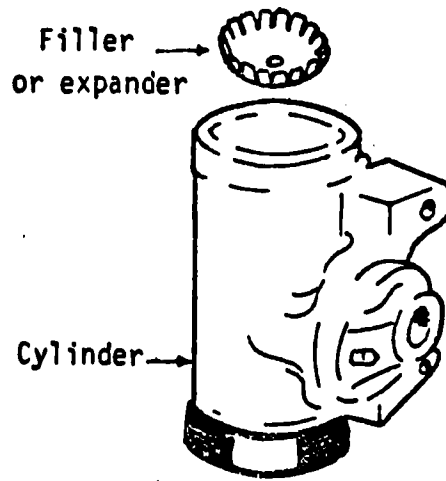

15. Next, slide the spring into the bore so that it fits into the expander groove.

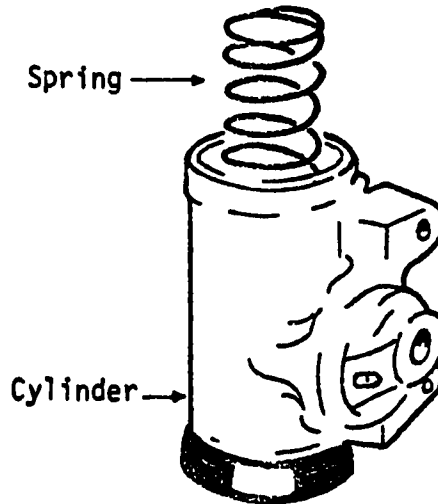

16. Place the second expander on top of the spring.

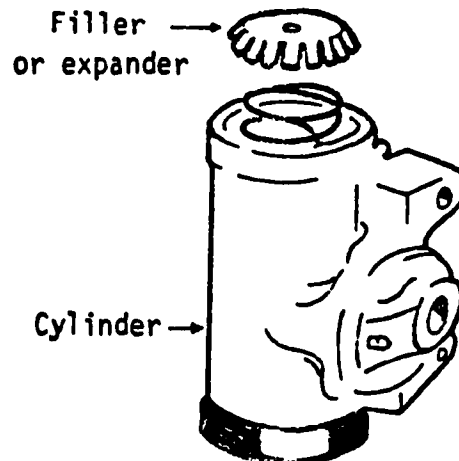



## Learning Element

Title: Repairing Wheel Cylinders

Occupational Area: AUTOMOTIVE ENGINEERING

Code:

Date of Issue:

Darwin, July 85

Page:

7

17. Next, put the cup, with its lip facing down into the bore, and over the expander. Now push the cup into the bore with your finger. Make sure that the cup doesn't twist in the bore.

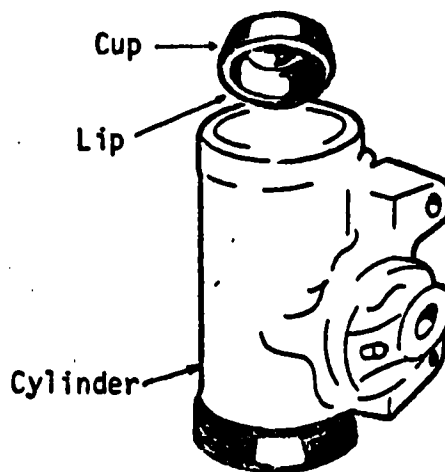

18. Next, put the piston into the bore. The flat surface must be against the flat part of the rubber cup.

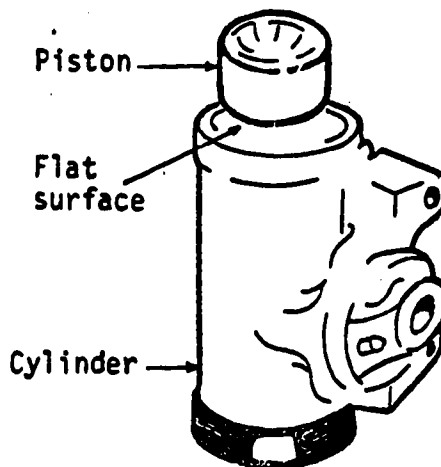

19. Finally, fit the rubber boot over the end of the wheel cylinder.

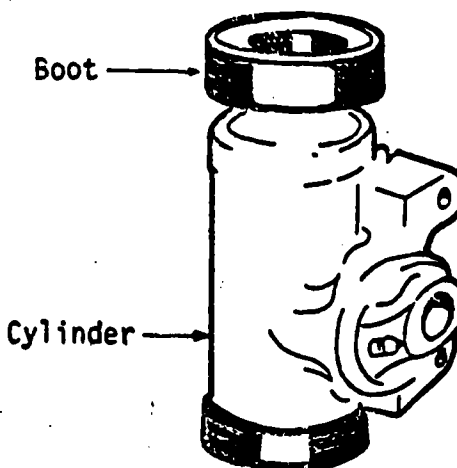



# Learning Element

Code:

Title: Repairing Wheel Cylinders

Occupational Area: AUTOMOTIVE ENGINEERING

Date of Issue:  
Darwin, July 85

Page:  
8

20. The wheel cylinder has now been repaired and, if you have followed this learning element correctly, will be as good as new.

## Assignment

When you feel confident that you can correctly assemble the wheel cylinder CALL THE INSTRUCTOR who will watch you repair the wheel cylinder.

Continue to next Page		Instructor
Repeat Assignment		.....



## Learning Element

Title: Repairing Wheel Cylinders

Occupational Area: AUTOMOTIVE ENGINEERING

Code:

Date of Issue:

Darwin, July 85

Page:

9

21. When repairing wheel cylinders always remember to:

- check with your Supervisor that the used wheel cylinder is suitable for repairing;
- use a clear bench covered with a cloth or paper to be certain that all parts are kept dust-free;
- only use rubber grease or brake fluid for lubrication;
- use all the parts in the repair kit.

22. Wheel cylinders should be repaired instead of replaced wherever possible as the cost of replacement is much more than the cost of repair.



# Learning Element

Title: Repairing Wheel Cylinders

Occupational Area: AUTOMOTIVE ENGINEERING

Code:

Date of Issue:  
Darwin, July 85

Page:  
10

## Progress Check page one of two

Below is a drawing of a wheel cylinder, all of the parts have a number with an arrow pointing to it.

Find the correct name that goes with the number on the drawing, from the list of names at the bottom of the drawing.

Place the number that you think is correct in the box provided.

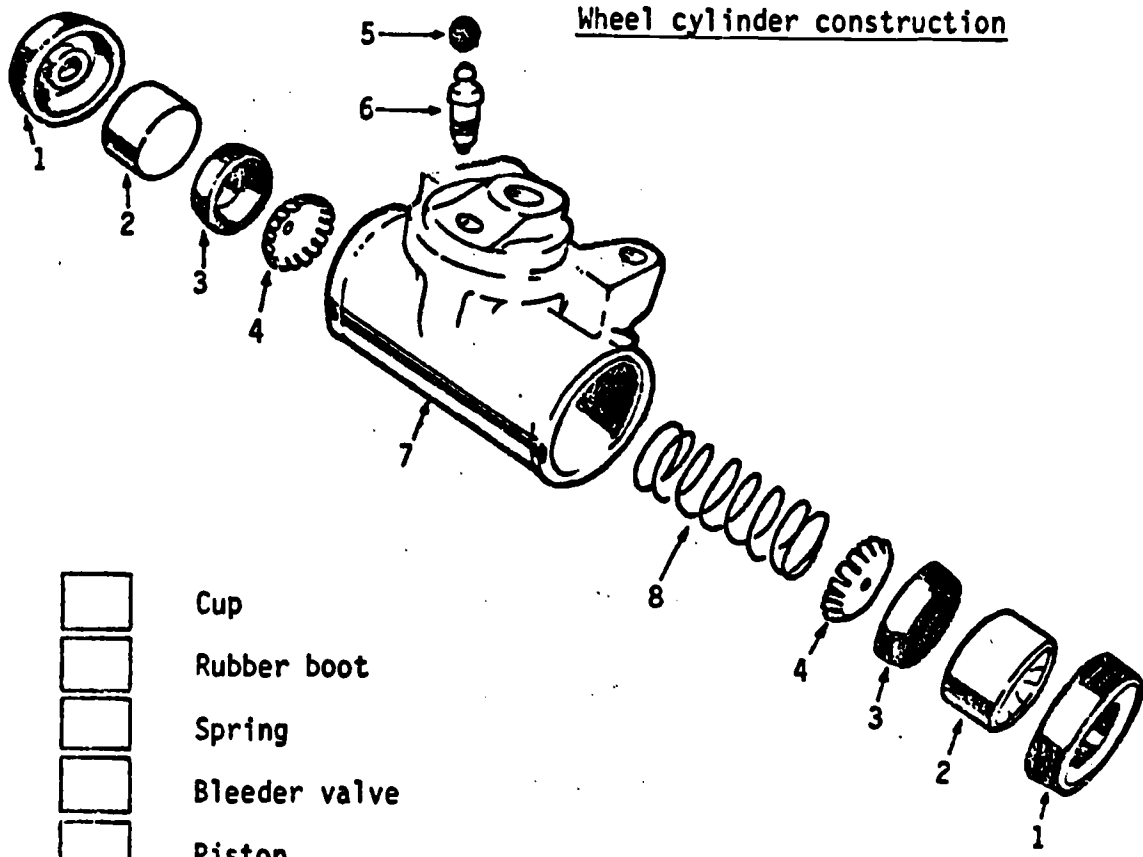

5

- Cup
- Rubber boot
- Spring
- Bleeder valve
- Piston
- Bleeder cover
- Expander
- Cylinder

Continue to next Page





# Learning Element

Title: Repairing Wheel Cylinders

Occupational Area: AUTOMOTIVE ENGINEERING

Code:

Date of Issue:  
Darwin, July 85

Page:  
11

## Progress Check page two of two

In the following questions mark your answer in one of the boxes provided.

- |  | <u>Acceptable</u> | <u>Not Acceptable</u> |
|--|-------------------|-----------------------|
| 1. The piston in a wheel cylinder should be taken out by:                                | .....             | .....                 |
| (a) Using compressed air .. .. . <input type="checkbox"/>                                | .....             | .....                 |
| (b) Tapping piston out with hammer and chisel.. .. . <input type="checkbox"/>            | .....             | .....                 |
| (c) Tapping the wheel cylinder on a block of wood .. .. . <input type="checkbox"/>       | .....             | .....                 |
| (d) Using a pair of pliers .. .. . <input type="checkbox"/>                              | .....             | .....                 |
| 2. Wheel cylinder parts should be cleaned with:  | .....             | .....                 |
| (a) Water .. .. . <input type="checkbox"/>   | .....             | .....                 |
| (b) Petrol .. .. . <input type="checkbox"/>  | .....             | .....                 |
| (c) Brake fluid .. .. . <input type="checkbox"/>   | .....             | .....                 |
| (d) Oil .. .. . <input type="checkbox"/>   | .....             | .....                 |
| 3. The rubber cup on a wheel cylinder should be fitted:                                  | .....             | .....                 |
| (a) With the <u>lip</u> facing towards the rubber boot .. .. . <input type="checkbox"/>  | .....             | .....                 |
| (b) With the <u>lip</u> facing into the cylinder bore .. .. . <input type="checkbox"/>   | .....             | .....                 |
| (c) With the <u>lip</u> facing out of the cylinder bore .. .. . <input type="checkbox"/> | .....             | .....                 |
| (d) With the <u>lip</u> facing towards the piston <input type="checkbox"/>               | .....             | .....                 |

### Evaluation Guide

The trainee's performance should be evaluated as 'Not Acceptable' if he or she fails to answer all questions correctly.

Continue to next Element	Instructor
Repeat Element and Check	.....

# EDUCATION LEARNING ELEMENT

**Title:**

Removing, Repairing, and Replacing Hydraulic Tubing

**Occupational Area:**

AUTOMOTIVE ENGINEERING

**Code:**

--	--	--	--	--	--	--	--	--	--



**Objectives**

When you have completed this learning element you will be able to:

- make an inverted flare;
- make a double flare;
- apply this knowledge to repairing steel brake tubes.

**Equipment, Materials and Aids you will need**

Quantity	Item/Description
One metre	Small bore steel tubing
Four	Inverted flare nuts (steel)
Four	S.A.E. flare nuts (steel)
Two	Inverted flare double unions (steel)
Two	S.A.E. flare double unions
One	Flaring tool
One	Tube cutter
One	Tube bender
One	Workbench fitted with a vice

Note: Tubing, nuts, and unions must all be of the same size.

**Related Learning Elements**

- 'Measuring Using Metric Rules'
- 'Spanners/Wrenches - Kinds and Sizes'
- 'Using Spanners and Wrenches'
- 'Bleeding the Hydraulic Braking System'

# Learning Element

Code:



Title: Removing, Repairing, and Replacing  
Hydraulic Tubing  
Occupational Area: AUTOMOTIVE ENGINEERING

Date of Issue:  
Darwin, July 85

Page:  
2

1. This learning element is designed to teach you to repair hydraulic brake tubes.

2. Similar tubing is used in many areas such as:

- refrigeration;
- air-conditioning;
- hydraulics;
- plumbing; and
- vehicle fuel systems.

3. The material used for tubing can be any of the following:

- steel;
- copper;
- Bundy;
- aluminium.



## Learning Element

Code:

Title: Removing, Repairing, and Replacing  
Hydraulic Tubing

Occupational Area: AUTOMOTIVE ENGINEERING

Date of Issue:  
Darwin, July 85

Page:  
3

4. The knowledge in this learning element can be applied to the above areas and materials.
5. There are many types of flares in use in industry today. This learning element deals with:
- the 'inverted flare'; and
  - the 'reverse flare'.
6. There are also two standards in common use, they are:
- S.A.E. (with a flare angle of 45 degrees);
  - J.I.C. (with a flare angle of 37 degrees).
7. It is important that the correct flare is used for the installation concerned. S.A.E. flares are normally used on braking systems and either S.A.E. or J.I.C. on hydraulic systems.

NOTE: For brake tubes only steel tubing may be used.



# Learning Element

Title: Removing, Repairing, and Replacing  
Hydraulic Tubing  
Occupational Area: AUTOMOTIVE ENGINEERING

Code:

Date of Issue:  
Darwin, July 85

Page:  
4

8. The following pictures show the two types of flare dealt with in this element. Remember what they look like. They are quite different in their shape and the seats they fit into are also different. They cannot be interchanged.

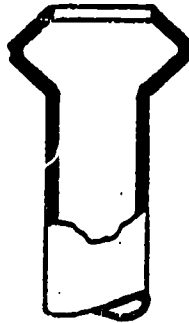

'Inverted flare', sometimes called a 'ball flare'

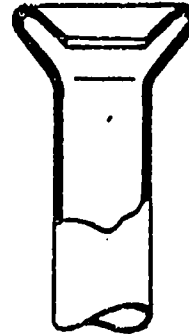
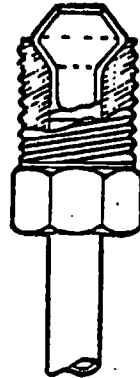

'Double flare', sometimes called a 'reverse flare'

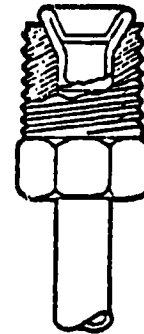

9. Take the piece of tube supplied and cut a piece 150 mm long using the tube cutters.

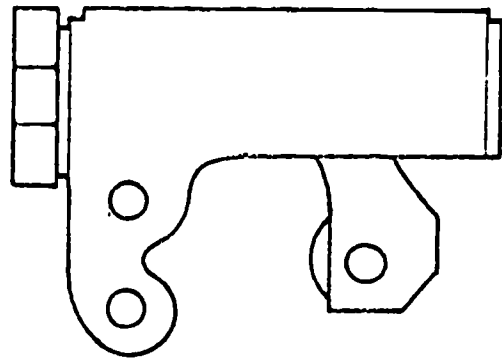

NOTE: Damaged tubes should be replaced with genuine replacement parts if possible.



# Learning Element

Title: Removing, Repairing, and Replacing Hydraulic Tubing  
Occupational Area: AUTOMOTIVE ENGINEERING

Code:

Date of Issue:  
Darwin, July 85

Page:  
5

10. Check that the end of the tube is square and free from burrs. Any error can be corrected with a fine file if necessary.



Square

Not square

11. Slide a tube nut onto the tube.

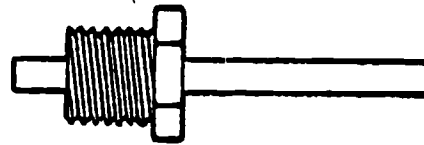

12. Select the dies of the correct size for the tube being flared.

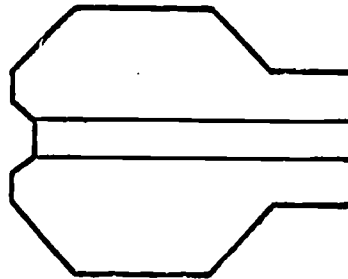

13. Clamp the flaring tool in a vice.

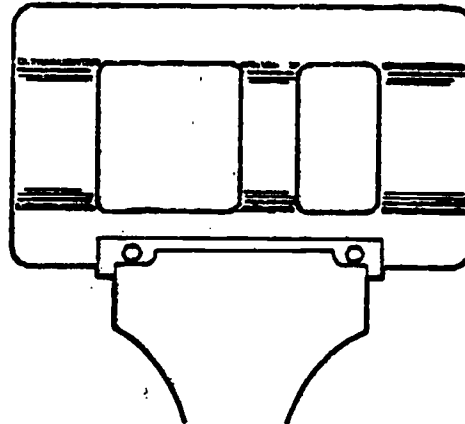



## Learning Element

Code:

Title: Removing, Repairing, and Replacing  
Hydraulic Tubing

Occupational Area: AUTOMOTIVE ENGINEERING

Date of Issue:  
Darwin, July 85

Page:  
6

14. Ensure the tube nut is on the tube, that it is in good condition, and the correct way round (thread to the end of the tube).

15. Place the locking nut from the flaring tool over the tube.

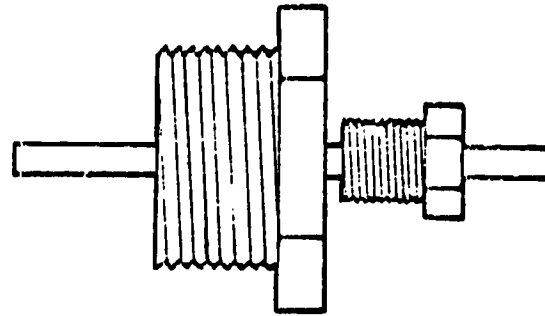

16. Place the dies on the tube making sure that the shaped part is at the correct end and that the tube sticks out at least one pipe diameter.

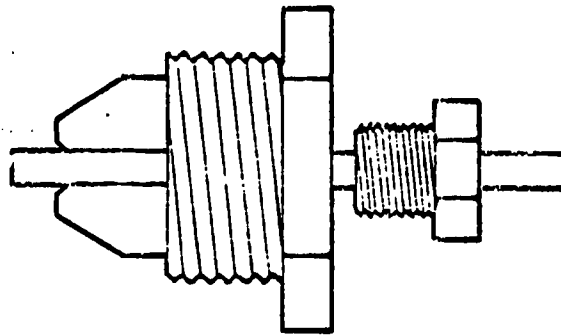

17. It is very important that the distance the tube extends varies with the diameter of the pipe. At this stage it is better to be out too far as this can easily be corrected later.

18. Put the whole assembly into the flaring tool and hand-tighten the locking nut.

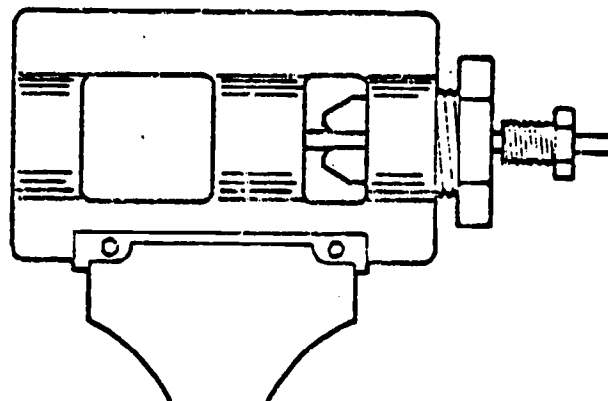





## Learning Element

Title: Removing, Repairing, and Replacing  
Hydraulic Tubing

Occupational Area: AUTOMOTIVE ENGINEERING

Code:

Date of Issue:  
Darwin, July 85

Page:  
7

19. Check that the tube extends exactly one pipe diameter past the end of the dies and adjust as necessary. You can use any of the mandrills from the flaring tool and the forcing screw to push the tube in the correct amount.

20. Tighten the flaring tool locking nut.

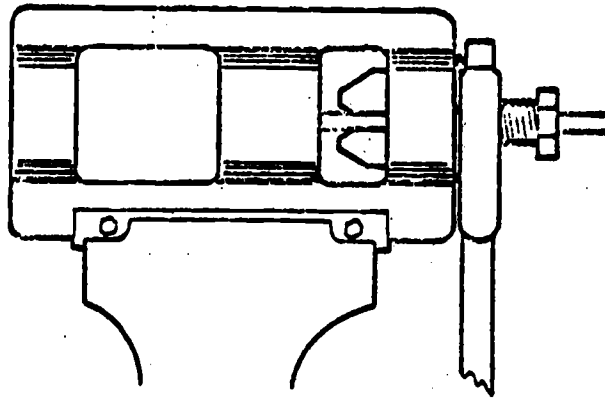

21. Place the mandrill with the spigot in the flaring tool (the spigot must be the same size as the inside diameter of the tube).

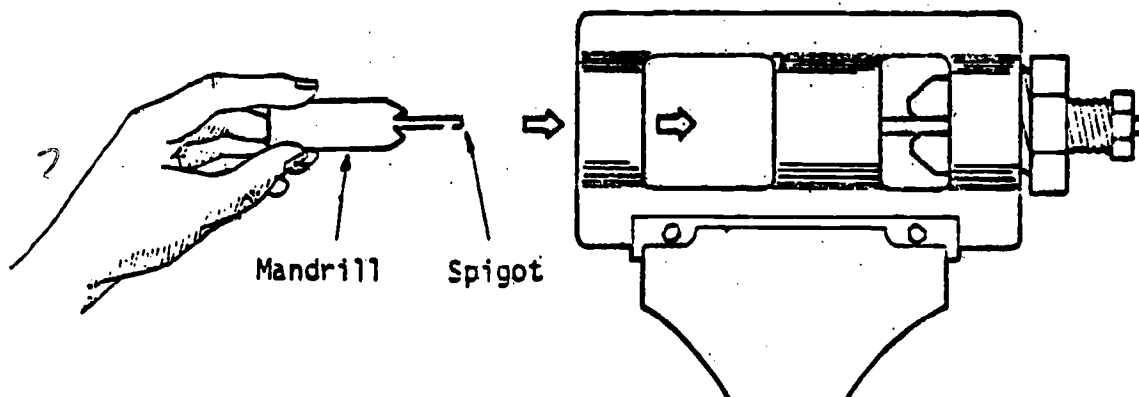



## Learning Element

Title: Removing, Repairing, and Replacing  
Hydraulic Tubing  
Occupational Area: AUTOMOTIVE ENGINEERING

Code:

Date of Issue:  
Darwin, July 85

Page:  
8

22. Put the forcing screw into the flaring tool and tighten with the tommy bar until the mandrill touches the end of the die.

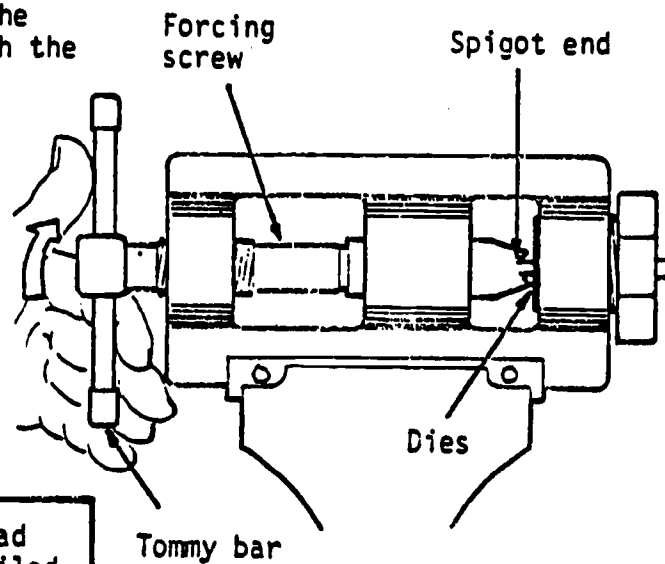

NOTE: The forcing screw thread should always be clean and oiled.

23. Unscrew the forcing screw a few turns and then undo the locking nut and remove the tube from the flaring tool.

24. Examine the tube end and check that the flare looks neat with no cracks or kinks in it, check with your Instructor.

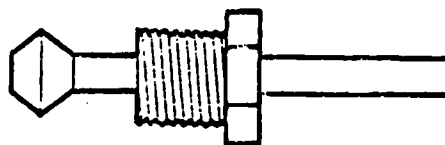



## Learning Element

Title: Removing, Repairing, and Replacing  
Hydraulic Tubing  
Occupational Area: AUTOMOTIVE ENGINEERING

Code:

Date of Issue:  
Darwin, July 85

Page:  
9

25. Now you must clean the tube using compressed air. Make sure the air hose is directed away from yourself before turning on the tap.

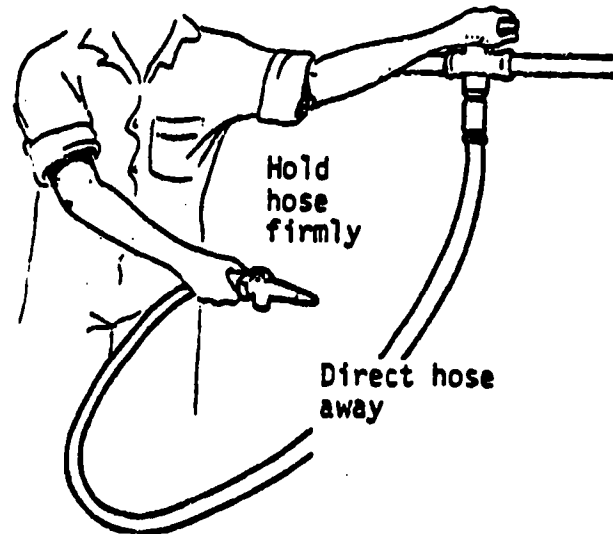

**WARNING:** Observe normal safety precautions when using compressed air. If in doubt, ask your Instructor.

26. Blow through the tube with compressed air to remove any dirt.

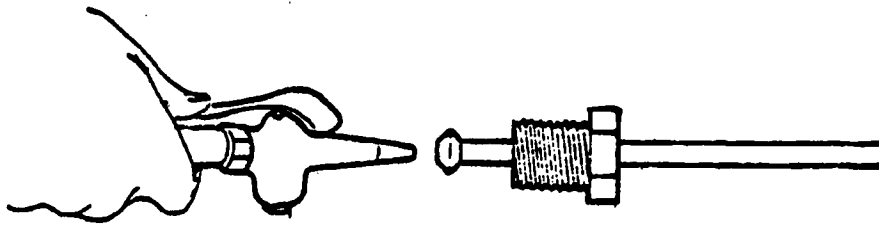

27. Now you know the procedure for making flares. Practice making flares on scrap pieces of tubing.
28. Before proceeding further you must demonstrate making a flare to your Instructor. When you feel confident at making flares CALL YOUR INSTRUCTOR and ask him for the materials to complete the assignment below.



## Learning Element

Title: Removing, Repairing, and Replacing  
Hydraulic Tubing  
Occupational Area: AUTOMOTIVE ENGINEERING

Code

Date of Issue:  
Darwin, July 85

Page:  
10

29. Your Instructor will evaluate you on the following points:

- cutting the ends of the tube square;
- removing any burrs before flaring the tube;
- fitting the tube nut before flaring the tube; and
- blowing the tube out with compressed air.

### Assignment

Using a piece of steel tube, make an inverted flare on both ends and assemble it to a suitable fitting.

Continue to next Page		Instructor .....
Repeat Assignment		



## Learning Element

Title: Removing, Repairing, and Replacing  
Hydraulic Tubing  
Occupational Area: AUTOMOTIVE ENGINEERING

Code:

Date of Issue: Darwin, July 85  
Page: 11

### Making a Double or Reverse Flare

30. Using the skill you have learned in the first part of this learning element make an inverted flare. Do not remove the tube from the flaring tool. Continue working through the following frames to make a reverse flare.

31. Unscrew the forcing screw and remove the mandrill with the spigot.

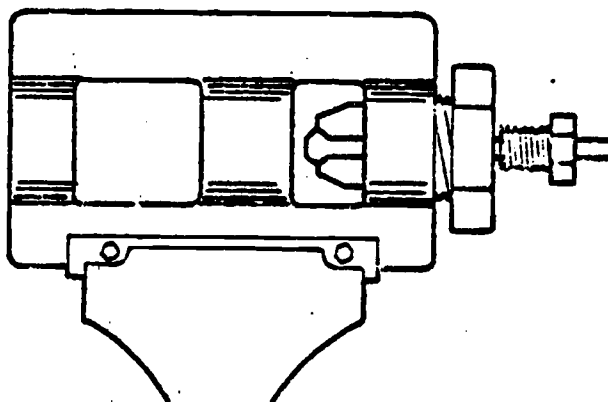
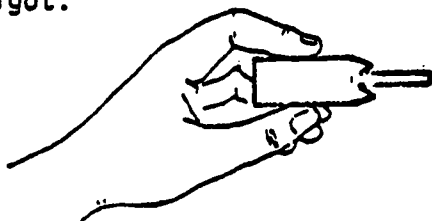

32. Some flaring tools have a flat-ended mandrill for flattening out the ball shape before using the cone-shaped mandrill. If this is supplied in your set use it before the cone-shaped mandrill.

33. Insert the cone-shaped mandrill.

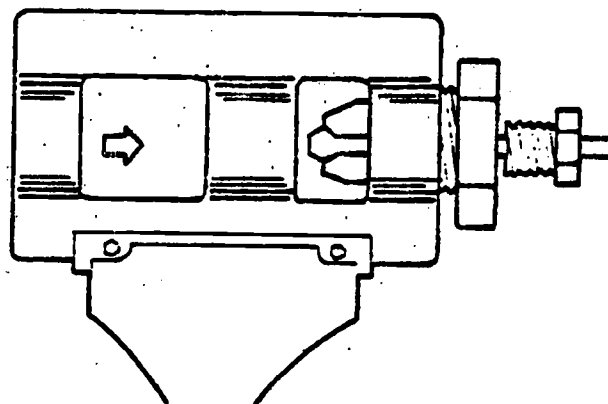
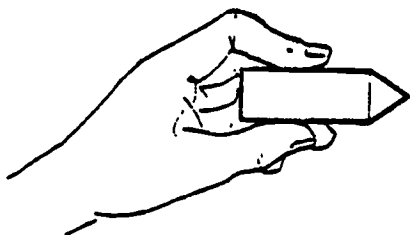



## Learning Element

Title: Removing, Repairing, and Replacing  
Hydraulic Tubing  
Occupational Area: AUTOMOTIVE ENGINEERING

Code:

Date of Issue:  
Darwin, July 85

Page  
12

34. Replace the forcing screw in the flaring tool and tighten the forcing screw to fold the balled end of the tube back into itself.

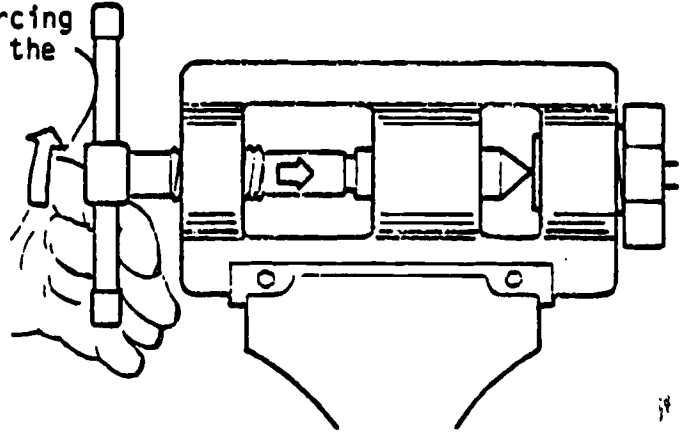

35. Unscrew the forcing screw a few turns and then undo the locking nut and remove the tube from the flaring tool.

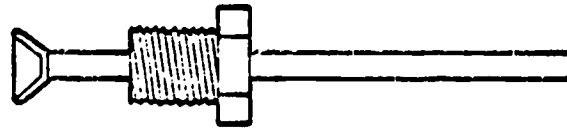

36. Examine the tube end and check that the flare looks neat with no cracks or kinks in it. Check with your Instructor.

37. Blow through the tube with compressed air to remove any dirt or other foreign matter.



# Learning-Element

Title: Removing, Repairing, and Replacing  
Hydraulic Tubing  
Occupational Area: AUTOMOTIVE ENGINEERING

Code:

Date of Issue:						Page:			
Darwin, July 85						13			

38. You now know how to make an inverted flare and a reverse flare. Remember it is important to know the difference and to use the correct flare for the replacement or repair of tubing.

39. CALL YOUR INSTRUCTOR and ask him for the materials to complete the assignment.

## Assignment

Using a piece of steel tube make an inverted flare on one end and a reverse flare on the other. Assemble it to a suitable fitting. You will be evaluated as in the previous assignment.

Continue to next Page		Instructor
Repeat Assignment		



## Learning Element

Title: Removing, Repairing, and Replacing  
Hydraulic Tubing  
Occupational Area: AUTOMOTIVE ENGINEERING

Code:

Date of Issue  
Darwin, July 85

Page  
14

### Reclaiming Damaged Hydraulic Tubing

40. When a replacement hydraulic tube is not available, a faulty tube can be reconditioned as follows.

41. Remove the damaged brake tube from the vehicle using the correct spanners for the job.

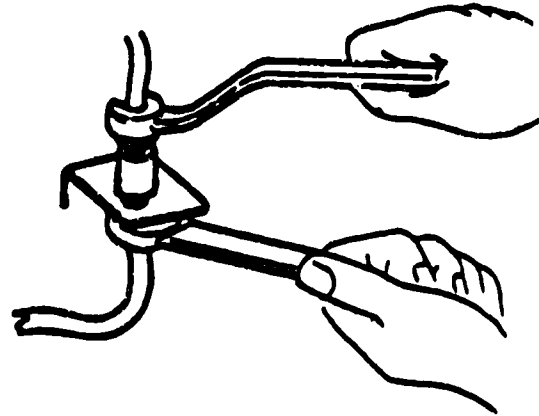

42. When only the flared end of the tube is damaged cut the damaged end off using a tube cutter or fine-toothed hacksaw.

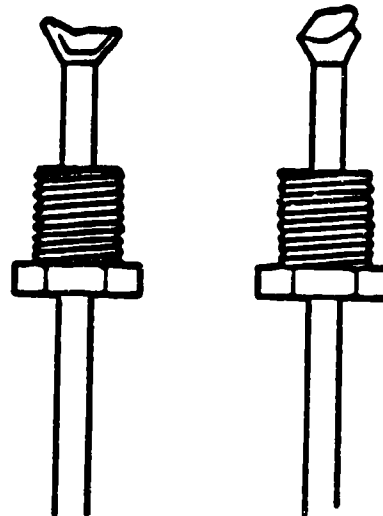





## Learning Element

Title: Removing, Repairing, and Replacing  
Hydraulic Tubing  
Occupational Area: AUTOMOTIVE ENGINEERING

Code:

Date of Issue:						Page:			
Darwin, July 85						15			

43. Check that the tube is still long enough.

44. If the tube is too short a new part should be used. If a new part is not available you may make one. If you make one you must use steel tube of the same size as the original. Carefully measure its length. When you have put the correct flares on the ends carefully shape it to the same shape as the old tube.

NOTE: If you put only a short section in a tube to repair it the Motor Vehicle Registry may require you to show that it is correctly double flared. Therefore it is best to replace the whole section and make it look original.

45. When repairing a brake tube the tube will probably have to be straightened so that it will fit into the die of the flaring tool. Take care not to bend the tube any more than is absolutely necessary.



# Learning Element

Title: Removing, Repairing, and Replacing  
Hydraulic Tubing  
Occupational Area: AUTOMOTIVE ENGINEERING

Code:

Date of Issue:  
Darwin, July 85

Page:  
16

46. To straighten the tube:

- Hold one end firmly on a flat surface;

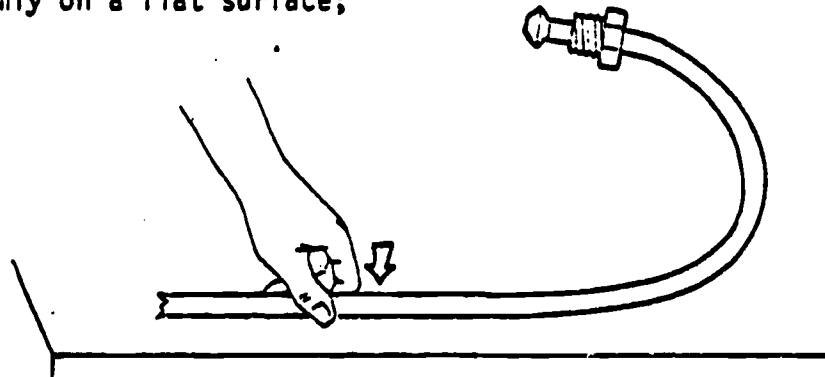

- Roll out the tube by hand;

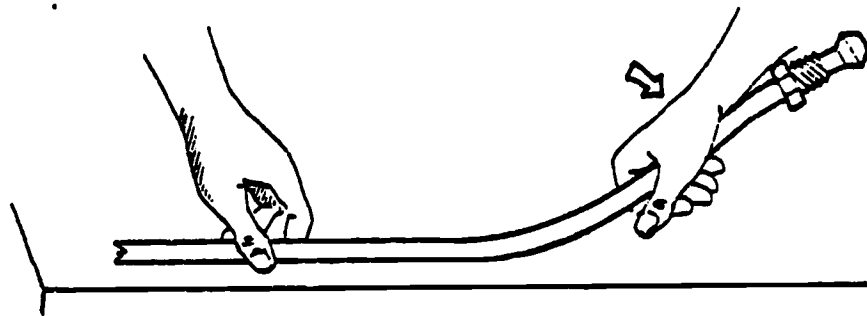

- Continue until the tube is straight.

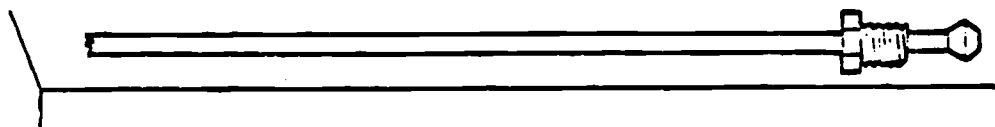

47. Use the knowledge you have gained in this learning element to make a new flare of the correct type on the tube.



## Learning Element

Title: Removing, Repairing, and Replacing  
Hydraulic Tubing

Occupational Area: AUTOMOTIVE ENGINEERING

Code:

Date of Issue:  
Darwin, July 85

Page:  
17

### Bending Steel Tubing

48. After you have repaired or made a new steel tube you will probably have to bend it into the correct shape.
  
49. NOW CALL YOUR INSTRUCTOR and ask him to demonstrate the use of the 'tube bender' and then practice on some pieces, of tube.
  
50. All bends should be made using a proper bending tool.
  
51. Some very complex shapes can be made using a tube bender. It is important to be able to use a tube bender as bending tube without it usually produces kinks and damages the tube.
  
52. When you feel confident with the contents of this learning element you can practically apply your knowledge by attempting the Progress Check on the next page.



# Learning Element

Title: Removing, Repairing, and Replacing  
Hydraulic Tubing  
Occupational Area: AUTOMOTIVE ENGINEERING

Code:

Date of Issue:  
Darwin, July 85

Page:  
18

## Progress Check

1. Name the two types of flares shown below -

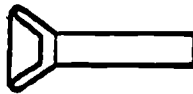
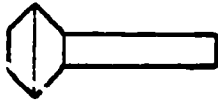

This is a  
.....flare

This is a  
.....flare

Acceptable

Not  
Acceptable

2. Remove a brake pipe from a vehicle. Ask your Instructor which one to use. Make a new brake pipe of the same length and with the same type of flares on each end. Install it in the vehicle, bleed the brake system, and check for leaks.

## Evaluation

Using the correct spanner to remove and replace the tube. ....

Correctly lifting the vehicle (if necessary). ....

Cleaning any spills that were made. ....

Cutting the tube square at the ends. ....

Correctly measuring the length of tube required. ....

Cleaning the tube before fitting to the vehicle. ....

Ensuring the tube did not leak when the brakes were applied. ....

(To satisfactorily complete the Progress Check ALL answers and procedures must be evaluated as 'Acceptable'.)

Continue to next Element		Instructor
Repeat Element and Check		.....

A P P E N D I X D

RESULTS OF THE PILOT TEST

## Pilot Test

After completing the Review of Trade-Based Training and the design of the Modular Integrated Training System, including the preparation of a module of learning material for pilot testing, project officers were directed to carry out the pilot test of the module.

### Method

Communities selected for pilot testing were Barunga, Beswick, Santa Teresa and Ntaria. These communities were chosen because: (1) they contain most of the kinds of problems common to both the northern and southern regions of the Territory and (2) as the two northern and two southern communities are fairly close together project officers had easy access to them for purposes of monitoring pilot testing.

The module tested was "Checking and Servicing Braking System" in cars and light commercial vehicles. The task specification for the module was prepared in consultation with the auto mechanics in Barunga and Beswick. The task performance test was prepared to the standards of work required as reported by these mechanics.

The module contains 25 learning elements. All but four of the learning elements were purchased from the International Labour Organisation. The four additional learning elements required to complete the module were prepared by project officers with technical input from TAFE automotive experts.

The following was the schedule for pilot testing the module:

- July 30. Began pilot testing in Barunga and Beswick.
- August 13. Began pilot testing in Santa Teresa and Hermmansburg.
- September 9-13. Visited Barunga and Beswick to monitor pilot testing.

- September 23-27. Visited Santa Teresa and Ntaria to monitor pilot testing.
- October 25. Presented final report on the results of pilot testing.

Pilot testing began with project officers travelling to the selected communities. Officers distributed packages of learning material to mechanics and trainees in each community. Each package of material contained a task specification including a task performance test and the learning elements of the module.

In addition to distributing the material project officers explained to the mechanics the procedures they and the trainees should follow in order to apply MITS correctly.

After a period of six weeks from the start of testing project officers visited each community to monitor progress. An interview guide for this purpose was prepared prior to undertaking the visits.

## Results

### Progress of Trainees

The progress chart shows the number of learning elements successfully completed by each trainee as at 23 October 1985. One of the five trainees completed 19 learning elements of the 25 contained in the module, two completed 17, one completed five and one completed none.

The three trainees who completed 19 and 17 learning elements respectively expect to take the task performance test for the module early in 1986.

The trainee who completed five learning elements is making no progress at present. His instructor, the community mechanic, resigned his position and left the community. Project officers were given no information on a replacement.

The trainee who completed no learning elements may be an exceptional person. European tradespersons in the community reported that although the trainee attends work only occasionally he is regularly engaged in repairing motor vehicles belonging to community residents. Tradespersons stated that the trainee is highly skilled mechanically and could easily pass the task performance test without working through the learning elements. (The community mechanic was not among the group of tradespersons interviewed by the project officer. He was away from the community at the time of the visit.) Tradespersons interviewed stated that, since MITS has the capability of assessing skills acquired by means other than progressing through the learning elements, project officers should arrange for the trainee to take the task performance test.

As at 23 October 1985 arrangements for the trainee to take the task performance test were in progress.

#### Responses to Items on the Interview Guide

The interview guide was filled in by project officers during discussions with auto mechanics in three of the communities involved in pilot testing. In the fourth community the interview guide was not filled in as the trainee had completed no learning elements at the time of monitoring and the auto mechanic was away from the community at the time of the visit.

The response to the question of whether individual trainees could perform the task of checking and servicing braking systems before undertaking training in all three cases was that they could not.

When asked if the training module covers all of the requirements essential to checking and servicing braking systems all three tradespersons replied that it does. In response to the question of whether the module is sufficient for a trainee to achieve competence in the task without having to leave the community for further training all three tradespersons stated that it is sufficient.

When asked if the training module could be improved two of the tradespersons replied that the language should be simplified further.



In reply to the questions of whether the trainees could cope effectively with the learning material the mechanics stated that none are able to proceed through the material with a minimum of assistance. A good deal of help is required from tradespersons. Help usually takes the form of interpreting the learning elements for trainees and occasionally preparing demonstrations in the workshops.

One mechanic reported that his trainee is gaining a good deal of personal satisfaction and enjoyment as well as skill from the training. Having become familiar with the system the trainee attacks new learning elements with enthusiasm and confidence. The mechanic also reported that the trainee's retention rate has improved significantly in the past few weeks.

A number of instructor-related difficulties were apparent in discussions with the mechanics. Generally, the mechanics themselves were not certain how the learning material should be used. One, for example, confused progress checks and task performance tests thinking that progress checks were practical tests which would be administered by TAFE itinerant instructors.

Although the confusion was minor when MITS was implemented it is recommended that participating tradespersons attend a two-day workshop in the theory and application of MITS before beginning training programs.

The only trainee-related difficulty reported was a literacy level which is too low to cope effectively with the learning material.

All three tradespersons reported that there appeared to be no conflict between MITS and Aboriginal culture.

The response by all three tradespersons to the question of whether MITS would be worthwhile implementing in remote Aboriginal communities was that it would be worthwhile. Two of the tradespersons stated that a modular system like MITS is the best possible method of training Aborigines in trade skills at the present time. They offered a number of suggestions for topics of modules which should be developed.

These suggestions were (1) Steering Systems, (2) Welding for Automotive Mechanics, and (3) Ignition Systems.

In reply to the question of how TAFE can best support community tradespersons as instructors two of the mechanics replied that regular visits by TAFE personnel, ie three of four times a year, would be helpful as an aid to motivation for both instructors and trainees. One mechanic replied that if adult educators wished to become involved in training they could assist trainees to understand the learning material. A newsletter giving brief details of progress was also identified as an appropriate motivational factor for all concerned with training on communities.

BEST COPY AVAILABLE

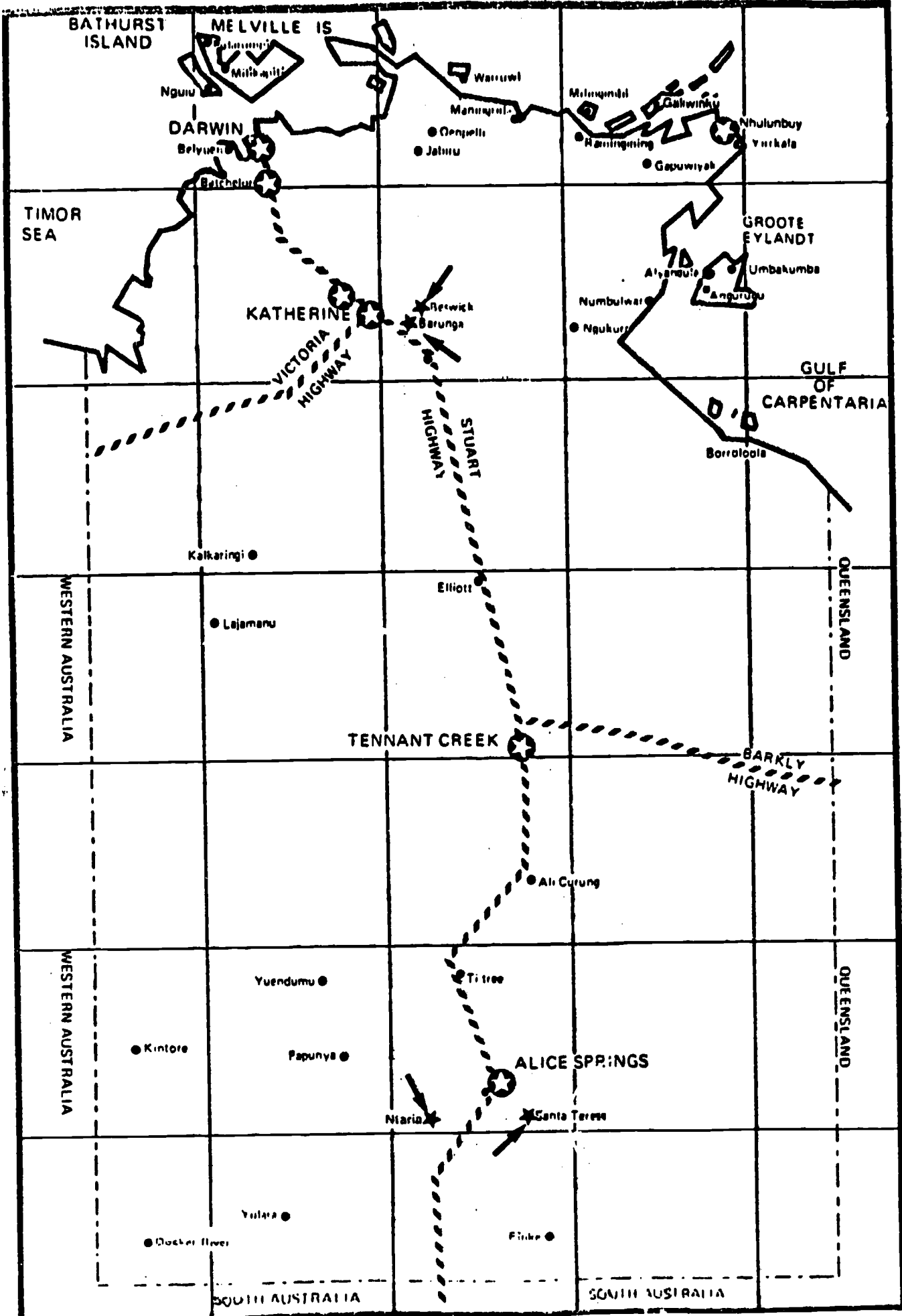

BEST COPY AVAILABLE

★ TAFE College or Centre

● Resident Adult Educator



**FROGRESS CHART**

**Trade-based Training Pilot Program**

**Module: CHECKING AND SERVICING THE BRAKING SYSTEM**

*R Koimala, Barunga*

*A Anderson, Beswick*

*R Kernam, Santa Teresa*

*D Palmer, Santa Teresa*

*M Tucker, Ntaria*

Adjusting Parking Brakes				
Changing Hydraulic Fluid in the Hydraulic Brake System				
Bleeding Hydraulic Brake System	★			
Disc Brakes: Replacing Brake Pads on Sliding Caliper of Single Piston				
Disc Brakes: Replacing Brake Pads on Fixed Caliper Type				
Identifying Disc Brakes with Sliding Caliper Assembly	★			
Identifying Disc Brakes of Fixed Caliper Type	★			
Identifying Function of Disc Brakes	★		★	★
Removing, Repairing, and Replacing Hydraulic Tubing			★	★
Adjusting Drum Brakes	★		★	★
Recognising Brake Drum Defects				
Overhauling Wheel Cylinder	★		★	★
Measuring Using Metric Rules	★		★	★
Inspecting/Cleaning Brake Shoes	★		★	★
Removing/Installing Brake Drums	★		★	★
Identifying Drum Brakes and Their Function	★		★	★
Removing and Fitting Wheels	★		★	★
Adjusting Wheel Bearings	★		★	★
Lifting Up Cars Using Mobile Jacks	★		★	★
Identification of Mobile Lifting Devices and Support Stands and Their Uses	★	★	★	★
Identifying Major Faults in the Braking System	★	★	★	★
Using Spanners and Wrenches	★		★	★
Spanners/Wrenches - Kinds and Sizes	★	★	★	★
Topping-up Brake Fluid	★	★	★	★
Brake Fluid	★	★	★	★

## Interview Guide for Pilot Testing

- 1      Would trainees have been able to check and service braking systems before undertaking training?
  
  
  
  
  
  
  
  
  
  
- 2      (i)     Do you think this type of training will enable trainees to achieve competence in checking and servicing braking systems without leaving the community for other training?
  
  
  
  
  
  
  
- (ii)    Does the material cover the essential requirements to check and service braking systems? If not, what specifically is needed?
  
  
  
  
  
  
  
- (iii)   Can the module be improved? If so, how?
  
  
  
  
  
  
  
  
  
  
- 3      (i)     Do trainees proceed through the learning elements with a minimum of instructor assistance?
  
  
  
  
  
  
  
  
  
  
- (ii)    Are the trainees able to read and understand the learning elements with a minimum of help?

- 4 Have you encountered any instructor-related difficulties?  
If so, how can they be overcome?
- 5 Have you encountered any trainee-related difficulties?  
If so, how can they be overcome?
- 6 Are any aspects of the training system in conflict with  
Aboriginal culture?
- 7 Is it worthwhile implementing this system of training in  
remote Aboriginal communities?
- 8 How can TAFE support the instructor most effectively?
- 9 Other comments:

---

Community:

Instructor:

Date:

Information collected by:

A P P E N D I X     E

**RESOURCES RECOMMENDED FOR THE  
PREPARATION OF MITS PROGRAMS**

Resources Recommended for the  
Preparation of MITS Programs

In order to implement the MITS alternative modular learning material would need to be prepared. Production of MITS material would consist of:

- Occupational analysis;
- Curriculum writing;
- Preparation of artwork;
- Editing for context and style;
- Typing and word processing;
- Photocopying/printing;
- Packaging of programs;
- Distribution and learning bank administration; and
- Program co-ordination

A module of learning material contains several learning elements. The number of learning elements in a module cannot be fixed as the knowledge content of tasks varies enormously with their complexity. The number of learning elements in a task ranges between 2 and 23. The ideal module contains 12 learning elements. Likewise, the number of pages in a learning element cannot be fixed. The length of a learning element varies with the number of units of knowledge to be covered. Generally, a learning element contains 12-16 pages.

Production time for one learning element in one trade area can be estimated at three weeks. Therefore, one module in one trade area utilising input from one technical expert would take approximately 36 weeks.

A good deal of prepared learning material is available from the International Labour Organisation. The purchase of prepared material would mean substantial cost and preparation time savings. However, purchased material may have to be revised and adapted to take account of problems and conditions in remote Aboriginal communities.

Two options for preparing and revising purchased modular learning material are outlined as follows:



### Option 1: Establishment of a Production Unit

A unit could be established within TAFE especially for the purposes of researching, writing and distributing MITS learning material.

Personnel needed for such a unit would be as follows:

- Program Co-ordinator;
- Editorial Supervisor with ESL skills;
- Secretary;
- Graphic artist;
- Qualified tradesperson in each of the trade areas for which material is prepared.

Equipment and other expenses involved would include:

- Word processor;
- Two single-reflex cameras with flash packs;
- Graphic arts supplies;
- Printing or photocopying facilities or support;
- Considerable travel to Aboriginal communities.

### Option 2: Learning Material Prepared Under Contract

Recognising the need for financial restraint at the present time, it may be feasible to engage, on contract, expertise in the areas of:

- Graphic arts production;
- Technical input.

Still needed would be personnel in the following areas:

- Program Co-ordinator;
- Editorial supervision;
- Typing and word processing.

The second option would carry a number of advantages besides cost effectiveness. These would be:

1. Greater flexibility of production: learning elements could be commissioned for training programs in any trade area or even in areas outside the traditional trades.
2. Accelerated development: several learning elements could be developed at any given time for any program by increasing the numbers of technical experts.
3. Increased quality control: experts able to develop effective learning elements could contribute more material to programs than those who were found to be less productive.

A P P E N D I X F

"RURAL COMMUNITIES AND ASSOCIATIONS NORTHERN TERRITORY AWARD  
1985"

1. TITLE

This award shall be known as the "Rural Communities and Associations" Northern Territory Award, 1985.

2. ARRANGEMENT

Aged, Infirm & Slow Workers	36
Annual Leave	19
Apprentices	8
Arrangement	2
Bereavement	21
Contract of Employment	12
Date of Operation	5
First Aid Qualifications	31
Hours of Work	13
Incidence and Parties Bound	3
Inclement Weather	37
Interpreters Allowance	38
Job Delegates	33
Junior Rates	7
Jury Service	24
Leading Hands	9
Maternity Leave	22
Meal Times and Tea Breaks	16
Mixed Functions	30
No Extra Claims	34
No Reduction In Wages and Conditions	35
Overtime	15
Payment of Wages	14
Protective Clothing	28
Public Holidays	18
Right of Entry of Union Officials	27
Scope	4
Sick Leave	20
Special Rates	10
Special Unpaid Leave	32
Sunday Duty	17
Time Lost Waiting for Tools or Equipment	29
Time Records	23
Title	1
Tool Allowance	11
Tools to be Supplied	26
Wage Rates	6

3. INCIDENCE AND PARTIES BOUND

This award shall apply to employees in the listed categories in Clause 6 employed by the Aboriginal Communities, Councils and Associations in the Northern Territory and shall be binding upon:

All Communities, Councils and Associations listed in Appendix A, The Federated Miscellaneous Workers Union of Australia, its officers and members.

4. SCOPE

This award shall govern the wages and conditions of employment of employees engaged in the performance of all work on or in connection with or incidental to Rural Communities and Associations but will not be binding on employees employed in the building industry by Housing Associations.

5. DATE OF OPERATION

This award shall operate as from the beginning of the first pay period commencing on or after.....1985. The award will remain in operation until.....1986.

6. WAGE RATES

The following will be the minimum rates payable to all adult employees herein.

Group 1

Labourers (Parks and Gardens, Garbage, Hygiene, Road Maintenance), Cleaners, Caretakers - \$248.30

Group 2

Trades Assistants (Tradesman, Essential Services), Bar Persons Waiters/Waitresses - \$267.20

BEST COPY AVAILABLE



Group 3

Swimming pool caretakers, Security Wardens,  
Health Workers - \$229.30

Group 4

Plant operator - \$309.00

Group 5

Tradesmen and essential service supervisor - \$330.40

7. JUNIOR RATES

The rate of pay for junior employees shall be calculated on the following age percentage scale on the adult rate for the appropriate classification.

At 16 years of age or under	60%
At 17 years of age	70%
At 18 years of age	80%
At 19 years of age	90%
At 20 years of age	100%

8. APPRENTICES

- (a) The contract of employment of apprentices under this award shall be by the week or as otherwise deemed by a competent authority established under Northern Territory legislation and they shall be entitled to the allowances and general conditions of this award.
- (b) The weekly wage rate for apprentices shall be the undermentioned percentage (or other percentages as may be determined from time to time under the Industrial Training Act 1979 or other competent legislation) of the ordinary weekly rate of pay payable, under clause 6 of this award, for the trade classification in which the apprentice is employed.

<u>YEAR</u>	<u>PERCENTAGE</u>
1st year of apprenticeship	40%
2nd year of apprenticeship	50%
3rd year of apprenticeship	70%
4th year of apprenticeship	85%

The foregoing rates shall be calculated to the nearest 10 cents.

- (c) An employe. may, by agreement in writing with the apprentice, elect to provide the apprentice with a kit of tools and subject to establishing the value of the tools at the time of so providing, deduct the tool allowance which an apprentice would otherwise be paid under clause 11 of this award until the cost of the kit of tools is reimbursed.  
  
In the event of the apprentice being dismissed or leaving his or her employment before the cost of the tool kit has been reimbursed, the employer shall be entitled to:
  - (i) deduct from any monies owing to the apprentice the amount then owing, or,
  - (ii) by agreement retain tools at the originally nominated value to the amount still owing.
- (d) When an apprentice reaches the age of 21 and the appropriate rate of wage is not at least equal to the wage applicable to Group 1 contained in Clause 5 of this award, he or she shall be paid at the rate applicable to this classification until his or her appropriate rate increases to above the rate aforementioned.

9. LEADING HANDS

Leading hands shall be paid the below listed rates of allowance for all purposes of the award.

If in charge of:

- (a) More than three and not more than 10 employees \$15.00
- (b) More than 10 and not more than 20 employees \$22.40
- (c) More than 20 employees \$28.50

10. SPECIAL RATES

(a) Lavatory Cleaning

An employee directed by the employer, to clean lavatories shall be paid an extra 10 cents per hour.

(b) Dead Animals

An employee directed by the employer to remove a dead animal shall be paid an extra 50 cents per day on each day engaged on this duty.

Toxic Substances



- (i) An employee required to use toxic substances shall be informed by the employer of the health hazards involved and instructed in the correct and necessary safeguards which must be observed in the use of such materials.
  - (ii) Employees using such materials will be provided with and shall use all safeguards as are required by legislation in the Northern Territory or in the absence of such requirements such safeguards as are defined by a competent authority or person chosen by the employer and the union.
  - (iii) An employee using toxic substances or required to work in a place where fumes of sulphur or acid or other offensive fumes or toxic substances are present shall be paid 35 cents per hour extra.
- (d) Height Allowance
- An employee directed by the employer to work at a height exceeding 15 metres shall be paid an extra 35 cents per hour whilst so engaged.
- (e) Sewerage Allowance
- An employee directed by the employer to work on any sewerage, drain or apparatus, where he is in contact with raw sewerage or effluent shall be paid an extra 35 cents per hour whilst so engaged.

#### 11. TOOL ALLOWANCE

In addition to any other amounts payable, employees required to use their own tools shall be paid for all purposes of the award \$7.62 per week.

#### 12. CONTRACT OF EMPLOYMENT

##### OPTION 1

- (a) All employment with the exception of that of apprentices and casuals, under this award shall be by the day. One day's notice of termination of the employment engagement shall be given on either side or one day's pay shall be paid or forfeited in lieu thereof. Notice given at or before the usual starting time of any ordinary working day shall be deemed to expire at the completion of that day's work.
- (b) An employee engaged under this award shall be paid an hourly rate (calculated to the nearest cent) equivalent to one thirtyeighth of the rate for his/her classification.
- (c) Nothing in this clause shall affect the right of the employer to dismiss an employee without notice for malingering, inefficiency, neglect of duty or misconduct.
- (d) Casual Employees

A casual employee is one engaged and paid as such and shall be subject to an hourly contract of hire. For work performed in ordinary time a casual employee shall be paid one thirtyeighth of the weekly rate prescribed by this award for the work which is performed plus a loading of twenty percentum thereof.

##### OPTION 2

- (a) the contract of hiring of every employee bound by this award shall, in the absence of express contract to the contrary, be deemed to be hiring by the week. Except in the case of casual employees employment shall be terminated by a weeks' notice on either side given at any time during the week or by payment or forfeiture of a weeks' wages as the case may be. This shall not affect the right of an employer to dismiss any employee without notice for malingering, inefficiency, neglect of duty, or misconduct and in such cases the wages shall be paid up to the time of dismissal only.
- (b) Where the employee has given or been given notice (in accordance with subclause (a) of this clause) he shall continue in his or her employment until the date of expiration of such notice.
- (c) Part Time Employee
  - (i) An employee may be engaged by the week to work on a part time basis for a constant number of hours less than thirtyeight each week. An employee so engaged shall be paid per hour one thirtyeighth of the weekly rate prescribed by this award for the work they perform.
  - (ii) An employee engaged on a part time basis shall be entitled to payments in respect of annual leave, public holidays and sick leave arising under this award on a proportionate basis.
- (d) Casual Employee

A casual employee is one engaged and paid as such and shall be subject to an hourly contract of hire. For work performed in ordinary time a casual employee shall be paid one thirtyeighth of the weekly rate prescribed in this award for the work which is performed plus a loading of twenty percentum thereof.

### 13. HOURS OF WORK

- (a) The hours of work shall be 40 per week and shall be worked between the hours of 7 am and 6 pm and shall not exceed 8 in any one day.
- (b) These hours may be altered to 6 am and 5 pm in the summer months by mutual agreement between employer and employee.

### 14. PAYMENT OF WAGES

- (a) Wages shall be paid weekly or fortnightly as mutually agreed between employer and employee.
- (b) Wages shall be paid on a set day of the week and this day shall not be deviated from.
- (c) Wages shall be paid in cash, cheque or bank deposit, as mutually agreed by employee and employer.

### 15. OVERTIME

- (a) All work done outside 8(7.6) hours in any one day or 40(38) in any one week shall be paid for at the rate of time and one half for the first three hours and double time thereafter.
- (b) Provided the employee shall be allowed off duty with pay for a period equal to the overtime worked. Such time off duty shall be given and taken within the succeeding eight weeks unless the employer and employee agree that it be taken together with annual leave.
- (c) No overtime shall be worked without permission of or under instructions of the employer or the employer's authorised representative.
- (d) In computing overtime, each days work shall stand alone.
- (e) When overtime work is necessary, it shall wherever reasonably practicable be so arranged that employees have at least 12 consecutive hours off duty between the work of successive days. If, on the insistence of his or her employer an employee resumes or continues work without having had ten consecutive hours off duty an employee shall be paid at the rate of double time until he or she is released from duty for such period and shall then be entitled to be absent until he or she has had ten consecutive hours off duty without loss of pay for the ordinary time occurring during such absence.
- (f) An employee working overtime shall be allowed a crib break of twenty minutes without deduction of pay after each four hours of overtime worked if the employee continues work after such crib time.
- (g) Where the period of overtime is more than two hours an employee before starting overtime after working ordinary hours shall be allowed a meal break of twenty minutes which shall not be counted as time worked.
- (h) The employer and employee may agree to any variation of this provision to meet the circumstances of work in hand.
- (i) (i) When an employee is called upon to work overtime for more than two hours after the usual ceasing time, the employer shall supply such employee with an adequate meal or pay an amount of \$4.00 to meet the cost of a meal.
- (ii) Where the amount of overtime to be worked necessitates the partaking of a second or subsequent meal (as the case may be) the employer shall supply such second and/or subsequent meal or make payments to the employee of \$4.00 for the second meal and \$4.00 for each subsequent meal.
- (iii) Providing that if the employee returns to his home for the meal subclause g(i) and (ii) shall not apply, but he will be allowed a half hour unpaid meal break.

### 16. MEAL TIMES AND TEA BREAKS

- (a) All employees shall be allowed a meal break of not less than thirty minutes, nor more than one hour, which time shall not be paid for. No employee shall work more than five hours without a break for a meal.
- (b) An employer and employee may agree to any variation of this clause to meet the circumstances of the work in hand provided that for any time worked during a meal break a penalty rate of overtime rates shall apply. This penalty rate shall continue to be paid for all time worked until the meal break is taken.
- (c) Arrangements for partaking of morning and afternoon tea shall be mutually agreed upon between employer and employee. Employees shall be allowed two breaks each day of fifteen minutes duration for morning and afternoon tea, for which time the employee shall be paid. These breaks shall be taken at such times as will not interfere with the continuity of work where continuity of work is necessary.

### 17. SUNDAY DUTY

For all time worked on a Sunday an employee shall be paid at the rate of double time.

## 18. PUBLIC HOLIDAYS

- (a) An employee other than one who is paid at casual rates, shall be entitled to the unmentioned public holidays without deduction of pay:

New years Day

Good Friday

Anzac Day

Picnic Day

Christmas Day

National Aboriginal Day

Show Day (on the day and in the locality for which it is gazetted.)

Australia Day

Easter Monday

Queen's Birthday

Labour Day

Boxing Day

Or any such other days as are generally observed in the locality in substitution for any of these days.

- (b) Should an employee be entitled to a holiday on a working day and such holiday occurs during the currency of the employee's annual leave, an additional day shall be added to the leave in lieu of such holidays.
- (c) Except as otherwise provided in this award, work done on a public holiday shall be paid at the rate of double time and a half but, at the employee's request they may, in lieu of additional pay be allowed to be credited with a day's leave to be included with annual leave, or otherwise may be agreed.
- (d) Where employees are absent from their employment on the working day before or the working day after a public holiday without reasonable cause, or without the consent of the employer, the employee shall not be entitled to payment for such holiday.
- (e) Where in the Northern Territory or in a locality within the Northern Territory an additional public holiday is proclaimed or gazetted by the authority of the Commonwealth Government or of the Northern Territory Government and such proclaimed or gazetted holiday is to be observed generally by persons throughout the Northern Territory or a locality thereof, other than by those covered by Federal Awards, or when such a proclaimed or gazetted day is, by any required judicial or administrative order, to be observed, then such day shall be deemed to be a holiday for the purposes of this award, for the employees covered by this award who are employed in the Northern Territory or locality in respect of which the holiday has been proclaimed or ordered as required.

## 19. ANNUAL LEAVE

- (a) A period of 28 consecutive days leave without loss of pay shall be allowed annually to an employee on daily hire as an employee in any one or more of the occupations to which this award applies after twelve months' continuous service (less the period of annual leave) with the employer.

### (b) Annual Leave Exclusive of Public Holidays

Subject to this subclause the annual leave prescribed by this clause shall be exclusive of any public holiday and, if any such holiday falls within an employee's period of annual leave and is observed on a day which in the case of that employee would have been an ordinary working day, there shall be added to that period one day for each holiday falling as aforesaid.

Where a holiday falls as aforesaid and the employee fails without reasonable cause, proof whereof shall be upon the employee, to attend for work at the employee's ordinary starting time on the working day immediately following the last day of the period of the employee's annual leave, the employee shall not be entitled to any such holiday.

### (c) Calculation of Continuous Service

For the purpose of this clause service shall be deemed to be continuous notwithstanding:

- (i) Any interruption or termination of the employment by the employer if such interruption or termination has been made merely with the intention of avoiding obligations hereunder in respect of leave of absence.
- (ii) Any absence from work on account of personal sickness or accident or on account of leave granted, imposed or agreed to by the employer excepting Special Unpaid Leave granted under Clause 32.
- (iii) Any absence with reasonable cause, proof whereof shall be upon the employee.

In cases of personal sickness or accident or absence with reasonable cause, the employee to become entitled to the benefit of this subclause shall notify the employer if practicable within 24 hours of the commencement of such absence of the employee's inability to attend for duty. If in calculating the period of twelve months continuous service, any such absence as aforesaid shall not, except to the extent of not more than fourteen days in a twelve monthly period in the case of sickness or accident, be taken into account in calculating the period of twelve months continuous service.

Any absence from work by reason of any cause not being a cause specified in this subclause shall not be deemed to break the continuity of service for the purposes of this clause unless the employer within fourteen days of the termination of the absence notifies the employee in writing that such absences will be regarded as having broken the continuity of service.

Absence from work granted by the employer under Clause 32 "Special Unpaid Leave" shall not be counted as accrued service. An employee shall be required to serve an equivalent period before



becoming entitled to annual leave entitlements.

(d) Calculation of Service

Service before the date of this award shall be taken into consideration for the purposes of calculating annual leave but an employee shall not be entitled to leave or payment in lieu thereof for any period in respect of which leave or payment in lieu thereof has been allowed or made. The period of annual leave to be allowed under this subclause shall be calculated to the nearest day, any broken part of a day in the result not exceeding half a day to be disregarded.

Where the employer is a successor or assignee or transferee of a business, if an employee was in the employment of the employer's predecessor at a time when that employer became such successor or assignee or transferee, the employee in respect of the period during which the employee was in the service of the predecessor shall for the purposes of this clause be deemed to be in the service of the employer.

(e) Calculation of Month

For the purposes of this clause, a month shall be reckoned as commencing with the beginning of the first day of the employment or the period of employment in question and as ending at the beginning of the day which in the latest month in question has the same date number as that which the commencing day had in its month, if there be no such day in such subsequent month shall be reckoned as ending at the end of such subsequent month.

(f) Leave to be Taken

The annual leave provided by this clause shall be allowed and shall be taken and except as provided by subclause (i) hereof, payment shall not be made or accepted in lieu of annual leave.

(g) Time of Taking Leave

Annual leave shall be given at a mutually agreed upon time and failing agreement at time fixed by the employer within a period not exceeding six months from the date of its becoming due, and after not less than one month's notice to the employee.

(h) Payment for Period of Leave

Each employee before going on leave shall be paid such wages which have accrued on account of annual leave at the rate applicable at the time when leave is taken.

Each employee before going on leave shall be paid the wages he or she would have earned in respect of the ordinary time he or she would have worked had he or she not been on leave during the relevant period.

(i) Proportionate Leave on Termination

If after one month's continuous service in any qualifying twelve monthly period an employee lawfully leaves his or her employment or his or her employment is terminated by the employer through no fault of the employee, the employee shall be paid at his or her ordinary rate of wage for 3.75 hours in respect of each completed week of continuous service being service in respect of which leave has not been granted hereunder.

(j) Loading on Annual Leave

(i) During a period of annual leave an employee shall receive a loading of 17 1/2 per cent calculated on the rate of wage prescribed by subclause (h) hereof.

(ii) The loading prescribed by this subclause shall not apply to proportionate leave on termination. Provided that an employee who has not taken all of the annual leave to which he or she is entitled shall on termination be entitled to payment of annual leave loading for leave already accrued on account of completed years of service.

(k) An employee who suffers a personal illness or injury while on annual leave shall be entitled to additional paid leave for a period not exceeding the period of illness or injury during annual leave, subject to the following conditions and limitations.

(i) Within twenty four hours of the employee's return to work the employee shall produce to his employer a certificate from a qualified medical practitioner to the effect that had the employee not been on annual leave the employee would have been unfit to perform his normal duties for a period of not less than five consecutive days.

(ii) The additional paid leave shall be subject to the existence of an entitlement to paid sick leave in accordance with clause 19 and shall be set off against accumulated sick leave credits.

(iii) Subject to the provisions of placitum (iv) hereof, the employee provided he is fit to perform his or her normal duties shall return to work at the time the employee would have returned had the employee not suffered personal illness or injury during annual leave.

(iv) Notwithstanding the provisions of subclause 19(g) the additional paid leave shall be given and taken at a mutually convenient time.

(v) An employee proceeding on leave pursuant to placitum (iv) hereof shall not be entitled to annual leave loading pursuant to subclause 19(j) for any period of leave for which the loading has been paid.

- (v) While an employee leaves the employment of the employer or his employment is terminated by the employer for any reason before the additional paid leave is taken such leave shall be treated as accrued annual leave.

Provided that nothing in this subclause shall be construed as increasing the quantum of annual leave prescribed in subclause 19(a) or of paid sick leave prescribed in Clause 20.

## 20. SICK LEAVE

- (a) An employee on weekly hiring who after one month's service with the employer, is absent from work on account of personal illness or incapacity due to any cause other than the employee's own misconduct, shall be entitled to leave of absence without deduction of pay subject to the following conditions and limitations:
- (i) The employee shall not be entitled to paid leave of absence for any period in respect of which the employee is entitled to workers' compensation.
  - (ii) The employee shall promptly inform the employer of his or her inability to attend for duty and state the nature of the injury or personal illness and the estimated duration of the absence.
  - (iii) The employee shall prove to the satisfaction of the employer (or in the event of a dispute to a Board of Reference) that he or she was unable on account of such illness or incapacity, to attend for duty on the day or days for which sick leave is claimed.
  - (iv) An employee shall not be entitled to (whether in the employ of one employer or several) leave in excess of 80 hours paid sick leave in each year of service, accruable at the commencement of each such year. Provided that during the first six months service with an employer the entitlement shall accrue at the rate of eight hours paid sick leave for each completed month of service, with the balance of the year's entitlement being accruable at the completion of six months service.
  - (v) Sick leave allowable under this clause which is not availed of during the year in which it was accrued shall, while an employee is employed by the same employer, be allowed to accumulate indefinitely.
- (b) An employer taking over a business shall be responsible for all sick leave accrued by an employee during the employee's period of employment with the employer from whom the business was taken over.

### (c) Single Day Absences

In the case of an employee who claims to be allowed paid sick leave in accordance with this clause for an absence of one day only, such employee shall be entitled to sick pay if they produce within 48 hours of the absence a signed Statutory Declaration stating that they were unable to attend for duty on account of personal illness or injury by accident. This procedure shall be deemed to be sufficient for up to two days in any one year. If in the year such employee has been allowed paid sick leave on two such occasions they shall not be entitled to payment for additional one day absences unless they produce to the employer a certificate of a the sister in charge or health worker stating that in his or her opinion, the employee was unable to attend for duty on account of personal illness or on account of injury by accident.

- (d) Absence from work granted by the employer under Clause 32 "Special Unpaid Leave" shall not be counted as accrued service. An employee shall be required to serve an equivalent period before becoming entitled to sick leave entitlements.

## 21. BEREAVEMENT LEAVE

- (a) The employer shall grant to an employee up to three days leave per year with pay, on the death of a spouse, de facto, parent, step-parent, brother, step-brother, sister, step-sister, child, step-child or grandparent of the employee or other relations at the discretion of the employer, where attendance of the employee is of some family consequence.
- (b) At the discretion of the employer, five days unpaid travelling time may also be allowed, for any death that requires excessive travelling.

## 22. MATERNITY LEAVE

### (a) Eligibility for Maternity Leave

An employee who becomes pregnant shall, upon production to her employer of a certificate from a duly qualified medical practitioner stating the presumed date of her confinement, be entitled to maternity leave provided that she has had not less than 12 months continuous service with that employer immediately preceding the date upon which she proceeds upon such leave.

For the purposes of this clause:

- (i) An employee shall include a part-time employee but shall not include an employee engaged upon casual or seasonal work.
  - (ii) Maternity leave shall mean unpaid maternity leave.
- (b) Period of Leave and Commencement of Leave

- (j) Subject to subclause (c) and (f) hereof, the period of maternity leave shall be for an unbroken period of from six to 52 weeks and shall include a period of six weeks compulsory leave to be taken immediately following confinement.
- (ii) An employee shall, not less than 18 weeks prior to the presumed date of confinement, give notice in writing to her employer stating the presumed date of confinement.
- (iii) An employee shall give not less than four weeks' notice in writing to her employer of the date upon which she proposes to commence maternity leave, stating the period of leave to be taken.
- (iv) An employer by not less than 14 days' notice in writing to the employee may require her to commence maternity leave at any time within the six weeks immediately prior to her presumed date of confinement.
- (v) An employee shall not be in breach of this clause as a consequence of failure to give the stipulated period of notice in accordance with paragraph (iii) hereof if such failure is occasioned by the confinement occurring earlier than the presumed date.

(c) Transfer to a Safe Job

Where in the opinion of a duly qualified medical practitioner, illness or risks arising out of the pregnancy or hazards connected with the work assigned to the employee make it inadvisable for the employee to continue at her present work, the employee shall, if the employer deems it practicable, be transferred to a safe job at the rate and on the conditions attaching to that job until the commencement of maternity leave.

If the transfer to a safe job is not practicable, the employee may, or the employer may require the employee to, take leave for such period as is certified necessary by a duly qualified medical practitioner. Such leave shall be treated as maternity leave for the purposes of subclauses (g), (h), (i) and (j) hereof.

(d) Variation of Period of Maternity Leave

- (i) Provided the addition does not extend the maternity leave beyond 52 weeks, the period may be lengthened once only, save with the agreement of the employer, by the employee giving not less than 14 days notice in writing stating the period by which the leave is to be lengthened.
- (ii) The period of leave may, with the consent of the employer, be shortened by the employee giving not less than 14 days notice in writing stating the period by which the leave is to be shortened.

(e) Cancellation of Maternity Leave

- (i) Maternity leave, applied for but not commenced, shall be cancelled when the pregnancy of an employee terminates other than by the birth of a living child.
- (ii) Where the pregnancy of an employee then on maternity leave terminates other than by the birth of a living child, it shall be the right of the employee to resume work at a job nominated by the employer which shall not exceed four weeks from the date of notice in writing by the employee to the employer that she desires to resume work.

(f) Special Maternity Leave and Sick Leave

- (i) Where the pregnancy of an employee not then on maternity leave terminates after 28 weeks other than by the birth of a living child then -
  - (1) She shall be entitled to such period of unpaid leave (to be known as special maternity leave) as a duly qualified medical practitioner certifies as necessary before her return to work, or
  - (2) for illness other than the normal consequences of confinement she shall be entitled, either in lieu of or in addition to special maternity leave, to such paid sick leave as to which she is then entitled and which a duly qualified medical practitioner certifies as necessary before her return to work.
- (ii) Where an employee not then on maternity leave suffers illness related to her pregnancy, she may take such paid sick leave as to which she is then entitled and such further unpaid leave (to be known as special maternity leave) as a duly qualified medical practitioner certifies as necessary before her return to work, provided that the aggregate of paid sick leave, special maternity leave and maternity leave shall not exceed 52 weeks.
- (iii) For the purposes of subclause (g), (h) and (i) hereof, maternity leave shall include special maternity leave.
- (iv) An employee returning to work after the completion of a period of leave taken pursuant to this subclause shall be entitled to the position which she held immediately before proceeding on such leave or, in the case of an employee who was transferred to a safe job pursuant to subclause (c), to the position she held immediately before such transfers.

Where such position no longer exists but there are other positions available, for which the employee is qualified and the duties of which she is capable of performing, she shall be entitled to a position as nearly comparable in status and salary or wage to that of her former position.

**10) Maternity Leave and Other Leave Entitlements**

Provided the aggregate of leave including leave taken pursuant to subclause (1) and (2) does not exceed 52 weeks:

- (1) An employee may, in lieu of or in conjunction with maternity leave, take any annual leave or long service leave or any part thereof to which she is then entitled.
- (2) Paid sick leave or other paid authorized award absence (including annual leave or long service leave), shall not be available to an employee during her absence on maternity leave.

**11) Effect of Maternity Leave on Employment**

Notwithstanding any award or provision to the contrary, absence on maternity leave shall not break the continuity of service of an employee but shall not be taken into account in calculating the period of service for any purpose of any relevant award or agreement.

**12) Termination of Employment**

- (1) An employee on maternity leave may terminate her employment at any time during the period of leave by notice given in accordance with this award.
- (2) An employer shall not terminate the employment of an employee on the ground of her pregnancy or of her absence on maternity leave, but otherwise the rights of an employer in relation to termination of employment are not hereby affected.

**13) Return to Work After Maternity Leave**

- (1) An employee shall confirm her intention of returning to her work by notice in writing to the employer given not less than four weeks prior to the expiration of her period of maternity leave.
- (2) An employee, upon the expiration of the notice required by paragraph (1) hereof, shall be entitled to the position which she held immediately before proceeding on maternity leave, or, in the case of an employee who was transferred to a safe job pursuant to subclause (1), to the position which she held immediately before such transfer, where such position no longer exists but there are other positions available for which the employee is qualified and the duties of which she is capable of performing, she shall be entitled to a position so nearly comparable in status and salary or wage to that of her former position.

**14) Replacement Employees**

- (1) A replacement employee is an employee specifically engaged as a result of an employee proceeding on maternity leave.
- (2) Before an employer engages a replacement employee under this subclause, the employer shall inform that person of the temporary nature of the employment and of the rights of the employee who is being replaced.
- (3) Before an employer engages a person to replace an employee temporarily promoted or transferred in order to replace an employee exercising her rights under this clause, the employer shall inform that person of the temporary nature of the promotion or transfer and of the rights of the employee who is being replaced.
- (4) Provided that nothing in this subclause shall be construed as requiring an employer to engage a replacement employee.
- (5) A replacement employee shall not be entitled to any of the rights conferred by this clause except where her employment continues beyond the twelve months qualifying period.

**15) Time Records**

- (1) The employer shall keep or cause to be kept a time book or time record. The employer shall enter or cause to be entered in such time book a correct record of hours worked, together with the time of commencing and finishing work.
- (2) The employer shall produce such records for inspection by the Branch Secretary or other authorized representative of the Union, each of whom shall have the right to inspect such book or record and also the right to visit the office in the Northern Territory of the employer during ordinary hours the purpose of investigating any breach or suspected breach of this Award.
- (3) The employer shall retain current employee wage records dating back six years. If an employee's employment is terminated the employer shall only be required to hold records for the twelve months prior to termination.

**16) Jury Service**

- (1) Employees required to attend for jury service during ordinary working hours shall be reimbursed by the employer (on amount equal to the difference between the amount paid in respect of their attendance for such jury service and the amount of wages they would have received in respect of the ordinary time they would have worked had they not been on jury service).

- (b) Employees shall notify their employer as soon as possible of the date upon which they are required to attend for jury service.
- (c) Employees shall give their employer proof of their attendance, the duration of such attendance and the amount received in respect of such jury service.

#### 25. ATTENDANCE AT BLOOD BANK

An employee shall not suffer any deduction in pay where during normal working hours he or she attends a local blood bank and donates blood.

The employer and employee shall agree to a mutually convenient time for the employee to attend the blood bank or the employer may arrange for the blood bank to visit his or her establishment.

#### 26. TOOLS TO BE SUPPLIED

- (a) The employer may supply and/or provide all necessary tools and equipment required for the carrying out of the job.
- (b) The tools and equipment shall remain the property of the employer. Providing that reasonable facilities are made available by the employer for the safe keeping of such equipment, the value of such tools and equipment proved to be wilfully or negligently lost or damaged may be deducted from the wages of the employee responsible for their loss or damage.

#### 27. RIGHT OF ENTRY OF UNION OFFICIALS

The Secretary or any duly authorised official of the Federated Miscellaneous Workers Union shall have the right to enter the premises of an employer bound by this award for the purposes of interviewing an employee during working hours or during lunch hour. Providing the official first obtains a permit (where required) to enter aboriginal land.

If an official so authorised makes himself objectionable during such visit, his right to enter may be determined by the employer affected. The official shall have the right to bring such refusal before the board of Reference.

#### 28. PROTECTIVE CLOTHING

- (a) An employer shall provide suitable protective clothing and personal safety equipment where necessary to protect the employee's person or clothing, such protective clothing and personal safety equipment to include:
  - (i) in the case of tarrers, basli aprons, basli gloves and suitable boots.
  - (ii) in the case of bitumen pourers, bitumen workers, tar or bitumen sprayer attendants, tar workers, spray operators and sprayer drivers of bitumen plant, gloves.
  - (iii) employees operating pneumatic tools canvas or leather, gloves
  - (iv) employees using emery wheels, goggles which shall contain material other than celluloid.
  - (v) employees using compressed air for blowing dust from electrical machinery or equipment, suitable masks.
- (b) An employee performing work necessitating handling of water pipes shall be provided with suitable gloves.
- (c) An employee working at the tar or bitumen kettle or handling drums of tar or bitumen shall be provided with the same clothing etc as provided for tarrers.
- (d) The employer shall provide a sufficient supply of the unde mentioned equipment to enable such welder and assistant engaged on work necessitating its use to be supplied with the same;
  - (i) suitable asbestos sheets
  - (ii) sand screens or helmets fitted with coloured glass (or in the case of oxy-acetylene operators, protective glasses with slide shields)
  - (iii) anti-flash goggles
  - (iv) aprons, leather sleeves and leggings (overall's of flame-proof material) and gauntlet gloves
  - (v) gum or other insulating boots where working in places so damp that danger from electric shock exists.

#### 29. TIME LOST WAITING FOR TOOLS OR EQUIPMENT

Payment at the ordinary rate shall be made to an employee whilst idle during ordinary working hours

waiting for material, tools or repair of equipment provided that the employer may place such employee on any work available.

### 30. MIXED FUNCTIONS

- (a) An employee required to perform on any one day two or more classes of work to which different rates are applicable, such employee if employed for more than two hours on the class or classes of work carrying a higher rate, shall be paid in respect of the whole time during which the employee works on that day at the highest rate fixed in respect of any such classes of work.

Provided that where an employee works for two hours or less on such higher duties, the employee shall be paid at the higher rate for the time so worked.

- (b) An employee who is temporarily employed on work for which a lower rate is applicable shall not have his or her rate of wage reduced.

### 31. FIRST AID QUALIFICATIONS

- (a) Whenever and wherever available, a qualified first aid attendant shall be provided for each gang consisting of more than 20 employees.
- (b) Employees holding first aid qualifications from St John Ambulance or similar body and appointed by the employer to perform first aid duties shall be paid an allowance of \$6.00 per week in addition to their ordinary wage. This payment shall be regarded as wages for all purposes of the award but the appointed first aid attendant shall not be entitled to any payment for aid rendered outside ordinary working hours unless he or she is actually on duty at the time, or has been granted permission to accompany a patient to receive treatment.
- (c) The employer will reimburse an employee for the actual cost of the course and text book expenses incurred when an employee carries out first aid training at the request of the employer.

### 32. SPECIAL UNPAID LEAVE

- (a) Special unpaid leave may be granted at the discretion of the employer for attendance at ceremonial activities or non-local council business.
- (b) In respect of absences of the kind mentioned above, an employee shall serve such additional period as part of his qualification for annual leave as will equal the period of such absence.

### 33. JOB DELEGATES

An employee who has been appointed union delegate at a place of work shall upon notification in writing to the employer, be recognised by the employer as the accredited representative of the union.

### 34. NO EXTRA CLAIMS

It is a term of this award (arising from the decision of the Australian Conciliation and Arbitration Commission in the National Wage Case 1983 print No F2900) that the union undertakes that for a period until 6 October 1985, it will not pursue any extra claims, award or over award, except where consistent with the principles.

### 35. NO REDUCTION IN WAGES AND CONDITIONS

No employee in the employment of an employer covered by this award shall have his or her wage, or conditions of employment reduced merely as a consequence of this award.

### 37. INCLEMENT WEATHER

If due to inclement weather employees cannot be employed outdoors, they can be required to carry out other productive work under cover. If they elect to cease work payment shall only be made up to the time of ceasing work.

### 38. INTERPRETERS RATE

An employee required to act as an interpreter, shall be paid an extra 25 cents per hour whilst acting in this capacity.



SCHEDULE OF RESPONDENTS

Yulngu Association Inc, PO Box 318, KATHERINE NT 5780  
Malano Community Association Inc, Malano Farm, PO Box 646, KATHERINE NT 5780  
Angurugu Community Government Council, Angurugu Community Bag Service 1, VIA DARWIN NT 5791  
Milyakburra Community Council Inc., Bickerton Island, C/- Angurugu Council, Angurugu, GROOTE EYLANDT NT 5791  
Galiwinku Community Inc., Elcho Island, VIA DARWIN NT 5791  
Gapuwiyak Community Inc., Gapuwiyak, Lake Evella, VIA NHULUNBUY NT 5797  
Milingimbi Community Inc., Milingimbi, VIA DARWIN NT 5797  
Milingimbi Resource Centre, Milingimbi, VIA DARWIN NT 5797  
Numbulwar Numburindi Council Inc., Numbulwar, VIA KATHERINE NT 5780  
Remingining Community Inc., PMB 10, DARWIN NT 5791  
Umbakumba Community Council Inc., GROOTE EYLANDT NT 5791  
Jurnkurakurr Resource Association, TENNANT CREEK NT 5760  
Brunette Downs Community, Brunette Downs Station, VIA TENNANT CREEK NT 5760  
Epanarra Community, Epanarra Station, VIA TENNANT CREEK NT 5760  
Murray Downs Community, Murray Downs Station, VIA TENNANT CREEK NT 5760  
Neral Junction Community, VIA TENNANT CREEK NT 5760  
Rockhampton Downs Community, Rockhampton Downs Station, VIA TENNANT CREEK NT 5760  
Miyikampi Community, VIA TENNANT CREEK NT 5760  
Nguranidgee Community, VIA TENNANT CREEK NT 5760  
Warrawulla Council, BORROLOOLA NT 5772  
Brinyung Community, C/- Yulngu, PO Box 318 KATHERINE NT 5780  
Bulla Community, C/- Yulngu, PO Box 318, KATHERINE NT 5780  
Eulman Community, C/- Yulngu, PO Box 318, KATHERINE NT 5780  
Jilminggan Community, c/- Yulngu, PO Box 318, KATHERINE NT 5780  
Dawhanga Association, Maningrida, VIA DARWIN NT 5791  
Mingilang Community Council Inc., Croker Island, VIA DARWIN NT 5791  
Warrubi Community Inc., Goulburn Island, VIA DARWIN NT 5791  
Warrubi Outstation Resource Centre, Goulburn Island, VIA DARWIN NT 5791  
Cualba Damara Association Inc., PO Box 40690, CASUARINA NT 5792  
Aboriginal Development Foundation, PO Box 2784, DARWIN NT 5794  
Amecuna Aboriginal Community Inc., PO Box 780 ALICE SPRINGS NT 5750  
Areyonga Community Inc., Areyonga, VIA ALICE SPRINGS NT 5750  
Kaltukatjara Community Council Inc., PMB Docker River, VIA ALICE SPRINGS NT 5750  
Kaltukatjara Nguratjaku Council Inc., PMB Docker River, VIA ALICE SPRINGS NT 5750  
Ikuntji Community Council Inc., Naasts Bluff, VIA ALICE SPRINGS NT 5750  
Papunya Community Council Inc., Papunya, VIA ALICE SPRINGS NT 5750  
Santa Teresa Progress Association Inc., Santa Teresa, VIA ALICE SPRINGS NT 5750  
Santa Teresa Mission, Santa Teresa, VIA ALICE SPRINGS NT 5750  
Willowra Community Inc., Willowra Station, VIA ALICE SPRINGS NT 5750  
Yuelamu Community Inc., PMB 67, Mt Allen Station, VIA ALICE SPRINGS NT 5750  
Yuendumu Community Council Inc., Yuendumu, VIA ALICE SPRINGS NT 5750  
Tangentyere Council Inc., PO Box 2363, ALICE SPRINGS NT 5750  
Urapuntja Council Aboriginal Corp., Utopia Station, VIA ALICE SPRINGS NT 5750

Ntaria Council (Hermannsburg) Inc., Hermannsburg, VIA ALICE SPRINGS NT 5750  
 Wallace Rockhole Community Inc., VIA ALICE SPRINGS NT 5750  
 Walangurra Council Inc., VIA ALICE SPRINGS NT 5750  
 (Barunga Town Council Inc., PMB No 25, VIA KATHERINE NT 5780  
 Barunga Progress Association, PMB 25, VIA KATHERINE NT 5780  
 Beswick Council Inc., PMB 26, VIA KATHERINE NT 5780  
 Beswick Progress Association, PMB 26, VIA KATHERINE NT 5780  
 Dagaragu Community Council Inc., Wave Hill Centre, VIA KATHERINE NT 5780  
 Wave Hill Social Club, Wave Hill Centre, VIA KATHERINE NT 5780  
 Lajamanu Community Government Council, Lajamanu (Hooker Creek), VIA KATHERINE NT 5780  
 Wulalgh Resource Centre, Lajamanu (Hooker Creek), VIA KATHERINE NT 5780  
 Ngukurr Township Association Inc., Roper River PMB, KATHERINE NT 5780  
 Yuqal Mangi Resource Centre, Roper River PMB, KATHERINE NT 5780  
 Tjuwarpa Outstation Resource Centre Inc., Hermannsburg, VIA ALICE SPRINGS NT 5750  
 Finke River Mission, Finke River, VIA ALICE SPRINGS NT 5750  
 Imanpa Community Inc., Imanpa, VIA ALICE SPRINGS NT 5750  
 Imanpa Co-operative, Imanpa, VIA ALICE SPRINGS NT 5750  
 Western Desert Outstations Council (Aboriginal Corporation) Inc., Kintore, VIA ALICE SPRINGS NT 5750  
 Nturiya Community Inc., Nturiya, VIA ALICE SPRINGS NT 5750  
 Nyirripi Community Inc., Nyirripi, VIA ALICE SPRINGS NT 5750  
 Laramba Community Inc., Napperby, VIA ALICE SPRINGS NT 5750  
 Atitjere Community Inc., Harts Range, VIA ALICE SPRINGS NT 5750  
 Wilora Community Inc., Wilora, VIA ALICE SPRINGS NT 5750  
 Jurnkurekurr Aboriginal Resource Centre, VIA TENNANT CREEK NT 5760  
 Hodgson Downs Community, Hodgson Downs Station, VIA KATHERINE NT 5780  
 Urapunga Community, C/- Yulngu, PO Box 318, KATHERINE NT 5780  
 Prara Jutunta Community, Ti-Tree, VIA ALICE SPRINGS NT 5750  
 Mount Barkly Community, Mount Barkly, VIA ALICE SPRINGS NT 5750  
 Ali Curung Council Inc., Community Mail Bag, Ali Curung, VIA ALICE SPRINGS NT 5750  
 Ali Curung Co-operative, Community Mail Bag, Ali Curung, VIA ALICE SPRINGS NT 5750  
 Elliott/Newcastle Waters Progress Association, Post Office, ELLIOTT NT 5760  
 Borroloola Council, BORROLOOLA NT 5772  
 Mobjunki Outstation Resource Association, BORROLOOLA NT 5772  
 Catholic Missions, PO Box 547, DARWIN NT 5794 np Belyuen Community Council, Belyuen, VIA DARWIN NT 5791  
 Gundalanya Council Inc, CSB 6, Oenpelli, VIA DARWIN NT 5791  
 Kandu Naminda Inc, C/- Wadeye Post Office, Port Keats NT 5791  
 Maningrida Council Inc, MANINGRIDA NT  
 Milikapiti Community Government Council, Snake Bay, MELVILLE ISLAND NT  
 Nauyu Nambiyu, Daly River Mission PMB 28, VIA DARWIN NT 5791  
 Ngulu Ullintjinni, PO Box 2478, DARWIN NT 5794  
 Ngulu Council, Bathurst Island, NT  
 Ntaria Council Inc, Hermannsburg, VIA ALICE SPRINGS NT 5750  
 Peppimenarti Association, Peppimenarti Community, VIA DARWIN NT 5791



Pulerumpi Community Council, Garden Point, Melville Island, VIA DARWIN NT 57  
The Bagot Road Community Inc, PO Box 38871, WINNELLIE NT 5789  
Urepuntia Council, Utopia Station PMB, VIA ALICE SPRINGS, NT 5751  
Yirrkale Dhanbul Association, PO Box 115, YIRRKALA NT 5797  
The Business Manager, Church Missionary Society, PO Box 39352, WINNELLIE NT 5789  
The President, Avon Downs, Epenarra, Orwaitilla Association, PO Box 321, TENNANT CREEK NT 5760  
The Secretary, Djembere Community, Elsey Station, VIA KATHERINE NT 5788  
The President, Larrakia Association Inc., GPO Box 254, DARWIN NT 5794  
The President, Robinson River Community, VIA TENNANT CREEK NT 5760  
The President, Alpururulam Community, Lake Nash, VIA TENNANT CREEK NT 5760