

DOCUMENT RESUME

ED 274 597

SO 017 580

TITLE Art. Elementary Teacher Resource, 1985.  
 INSTITUTION Alberta Dept. of Education, Edmonton.  
 PUB DATE 85  
 NOTE 226p.; For related document, see SO 017 581.  
 PUB TYPE Guides - Classroom Use - Guides (For Teachers) (052)

EDRS PRICE MF01/PC10 Plus Postage.  
 DESCRIPTORS \*Aesthetic Values; \*Art Activities; \*Art Education;  
 \*Art Expression; Creative Activities; Elementary  
 Education; \*Elementary School Curriculum; Foreign  
 Countries; Grade 1; Grade 2; Grade 3; Grade 4; Grade  
 5; Grade 6; Integrated Curriculum; Teaching Skills  
 IDENTIFIERS Alberta

ABSTRACT

Designed to accompany the "Elementary Art Curriculum Guide," this resource is divided into 3 levels: level 1 grades 1-2, level 2 grades 3-4, and level 3 grades 5-6. The material is presented in a standardized format which includes four major components: reflection, depiction, composition, and expression. Once a concept has been chosen, suggested methods or strategies are given as examples of how the concept might be taught. These approaches can be selected on the basis of the student's background and abilities. Once the concept has been taught using the activity, an integration section follows that relates it to other art content areas and other subject areas. Included are teaching components for levels 1, 2, and 3 and a chapter on areas of expression which include drawing techniques, painting techniques, printmaking techniques, sculpture techniques, fabric art, and photography techniques. A chapter on resources includes basic and recommended resources, teacher resources, print resources, visual resources, personnel, centers, organizations and institutions. (APG)

\*\*\*\*\*  
 \* Reproductions supplied by EDRS are the best that can be made \*  
 \* from the original document. \*  
 \*\*\*\*\*

# ART



# ELEMENTARY Teacher Resource 1985

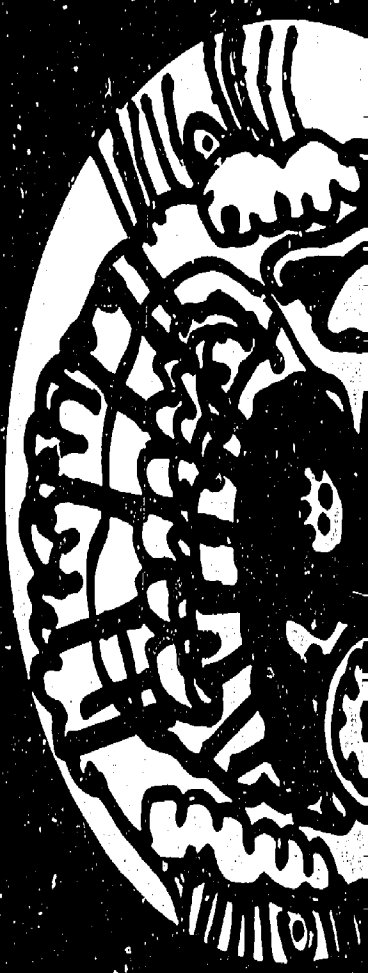
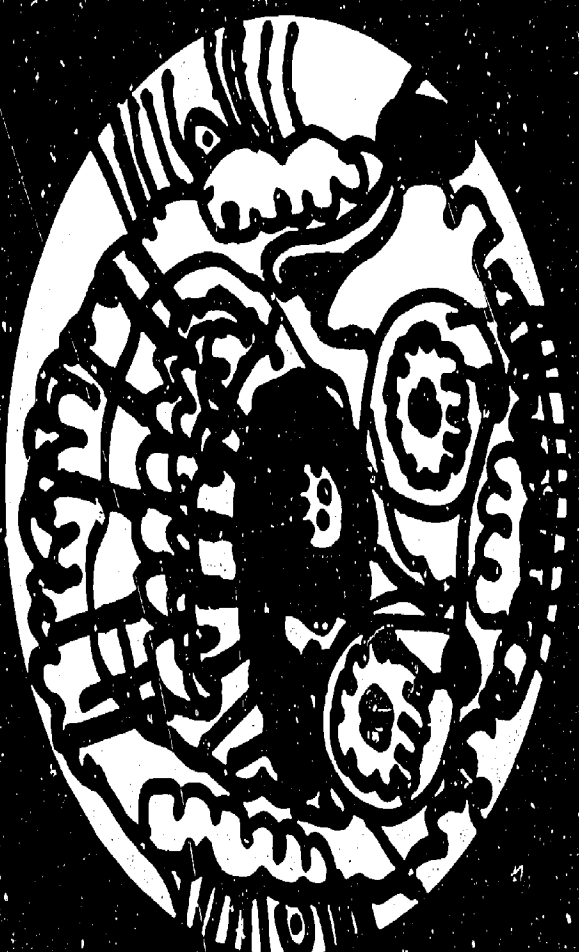
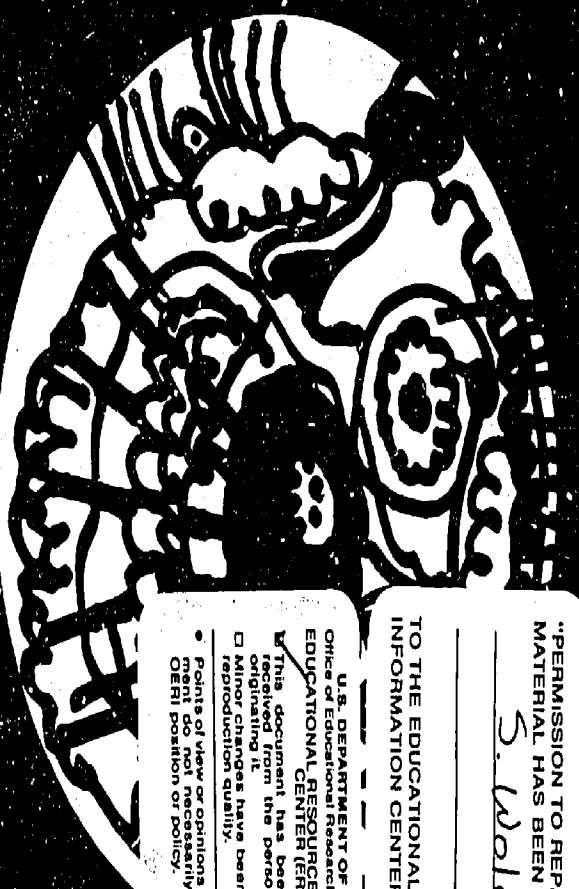

TO THE EDUCATIONAL RESOURCES  
INFORMATION CENTER (ERIC)."

S. Wolodka

U.S. DEPARTMENT OF EDUCATION  
Office of Educational Research and Improvement  
EDUCATIONAL RESOURCES INFORMATION  
CENTER (ERIC)

This document has been reproduced, as  
received from the person or organization  
originating it, and has been made to improve  
reproduction quality.

Points of view or opinions stated in this docu-  
ment do not necessarily represent official  
ERIC position or policy.



Teatr Daniel Gr. 2

# Teacher Resource 1985

This resource is designed to accompany your Elementary Art Curriculum Guide. The following items are designed to facilitate the teaching of art and the locating of resources and resource information. Included in this document are the following titles:

Scope and Sequence Chart of Elementary Art Objectives .....	1
Introduction to the Teaching Components .....	4
Teaching Components for Level One: Plans and Suggestions for Organization and Implementation .....	6
Teaching Components for Level Two: Plans and Suggestions for Organization and Implementation .....	60
Teaching Components for Level Three: Plans and Suggestions for Organization and Implementation .....	106
Areas of Expression:	
Drawing Techniques .....	168
Painting Techniques .....	170
Printmaking Techniques .....	172
Sculpture Techniques .....	176
Fabric Arts .....	180
Photography and Technographic Art .....	184
Resources:	
Basic and Recommended .....	190
Teacher Resources .....	191
Print Resources .....	192
Visual Resources .....	195
Personnel, Centres, Organizations and Institutions .....	202



# Objectives - Scope and Sequence

## reflection

REFLECTION IS BASED ON THREE VISUAL CATEGORIES: THE NATURAL WORLD, THE DESIGNED WORLD AND THE ART WORLD. THE STRUCTURE AND DESIGN OF THE NATURAL WORLD PROVIDES THEMATIC MATERIAL FOR THE STUDENT-ARTIST. THE DESIGNED WORLD HAS SIGNIFICANCE INsofar AS IT IS USEFUL AND STIMULATING FOR INDIVIDUALS AND GROUPS. ART WORKS ARE STUDIED SO THAT STUDENTS CAN APPRECIATE THEM AS EXPRESSIVE FORMS THAT CONVEY MEANING.

	Level One STUDENTS WILL	Level Two STUDENTS WILL	Level Three STUDENTS WILL
<b>COMPONENT 1</b>			
ANALYZING STRUCTURES IN NATURE	- notice commonalities within classes of natural objects or forms	- make distinctions within classes of natural objects or forms	- study and analyze the individual character of natural objects and forms
<b>COMPONENT 2</b>			
ASSESSING DESIGNED OBJECTS	- assess the use or function of objects	- assess the visual qualities of objects	- impose standards on designed objects and invent improved versions
<b>COMPONENT 3</b>			
APPRECIATING ART	- interpret art works literally	- interpret art works by examining their context and less visible characteristics	- interpret art works for their symbolic meaning

## depiction

DEPICTION IS A SYMBOL-MAKING SKILL INVOLVING OBSERVATION AND NOTATION. FUNDAMENTAL STRUCTURES AND SURFACE QUALITIES OF OBJECTS ARE STUDIED IN ORDER THAT STUDENTS BECOME MORE PERCEPTIVE. STUDENTS ARE ENCOURAGED TO PURSUE A VARIETY OF STYLES FROM DECORATION TO ABSTRACTION AND FROM REALISM TO DISTORTION. DEPICTION STRATEGIES ARE REHEARSED AND DEVELOPED IN THIS AREA.

<b>COMPONENT 4</b>			
CAPTURING MAIN FORMS AND PROPORTIONS	- learn the shapes of things as well as develop decorative styles	- perfect forms and develop more realistic treatments	- modify forms by abstraction, distortion and other transformation
<b>COMPONENT 5</b>			
STUDYING ACTIONS AND VIEWPOINTS	- increase the range of actions and viewpoints to be depicted	- select appropriate references for depicting	- refine methods and techniques for more effective image-making
<b>COMPONENT 6</b>			
ATTENDING TO QUALITIES AND DETAILS	- represent surface qualities of objects and forms	- create and refine surface qualities of objects and forms	- limit and employ surface qualities for specific effects

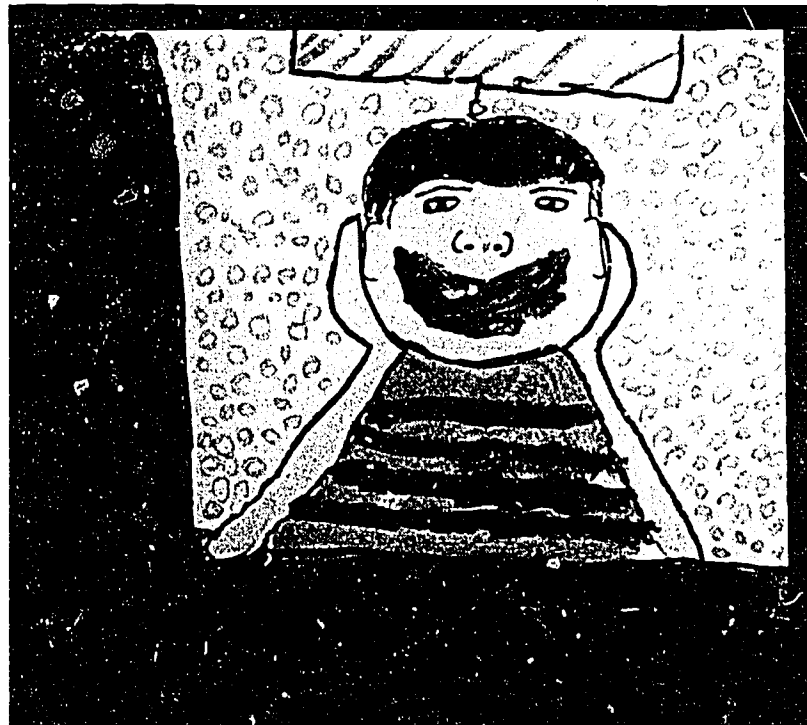

# composition

COMPOSITION IS THE SKILL OF ORGANIZING FORMS AND THEIR QUALITIES TO CREATE INTEGRATED AND UNIFIED VISUAL STATEMENTS OR ART WORKS. PRINCIPLES OF DESIGN ARE LEARNED AND PRACTISED IN THIS AREA.

## COMPONENT 7

EMPHASIS: MAKING A SELECTED IDEA PROMINENT AND INTERESTING

- create emphasis based on personal choices

- create emphasis by the treatment of forms and qualities

- create emphasis through the use of structural devices and strategies.

## COMPONENT 8

UNITY: RELATING THINGS COHERENTLY

- create unity through density and rhythm

- create unity by interrelating the parts of the composition

- create unity by integrating the parts of the composition to the whole

## COMPONENT 9

CRAFTSMANSHIP: COMPLETING WORKS WITH FINESSE

- add finishing touches (details, accents, contrasts, etc)

- improve compositions by refining, rehearsing and critiquing

- perfect images through economical use of material and efficiency of effort

# expression

EXPRESSION INVOLVES THE SKILL OF CREATING OR INVENTING FORMS WHICH REPRESENT THE IDEAS OR FEELINGS OF THE STUDENT-ARTIST AND THE ABILITY TO MAKE DECISIONS THAT AFFECT THE MAKING OF THOSE FORMS. IDEAS AND FEELINGS ARE INVESTED IN APPROPRIATE MEDIA THROUGH SELECTED TECHNIQUES FOR SPECIFIC PURPOSES.

## COMPONENT 10

(i) PURPOSE: HAVING A REASON FOR MAKING IMAGES

- record or document activities, people and discoveries

with an advancing degree of difficulty and sophistication:

with an advancing degree of difficulty and sophistication:

- illustrate or tell a story

- record or document activities, people and discoveries

- record or document activities, people and discoveries

- decorate items personally created

- illustrate or tell a story

- illustrate or tell a story

- create an original composition, object or space based on supplied motivation

- decorate items personally created

- decorate items personally created

- express a feeling or a message

- express a feeling or a message

- create an original composition, object or space based on supplied motivation

- create an original composition, object or space based on supplied motivation



---

(ii) SUBJECT MATTER: DEVELOPING THEMES AND CONTENT	develop themes with an <u>emphasis on personal concerns</u> , based on:	develop themes with an <u>emphasis on social concerns</u> , based on:	develop themes with an <u>emphasis on global awareness</u> , based on:
	<ul style="list-style-type: none"> <li>- plants and animals</li> <li>- environments and places</li> <li>- manufactured or man-made things</li> <li>- fantasy</li> <li>- people</li> </ul>	<ul style="list-style-type: none"> <li>- plants and animals</li> <li>- environments and places</li> <li>- manufactured or man-made things</li> <li>- fantasy</li> <li>- people</li> </ul>	<ul style="list-style-type: none"> <li>- plants and animals</li> <li>- environments and places</li> <li>- manufactured or man-made things</li> <li>- fantasy</li> <li>- people</li> </ul>

---

(iii) MEDIA AND TECHNIQUES: USING TOOLS, MATERIALS AND PROCEDURES	use media and techniques, with an <u>emphasis on exploration and direct methods</u> , in:	use media and techniques, with an <u>emphasis on mixing media and perfecting techniques</u> , in:	use media and techniques, with an <u>emphasis on more indirect, complex procedures and effects</u> , in:
	<ul style="list-style-type: none"> <li>- drawing</li> <li>- painting</li> <li>- printmaking</li> <li>- sculpture and assemblage (collage)</li> <li>- fabric arts</li> <li>- photography and technographic arts</li> </ul>	<ul style="list-style-type: none"> <li>- drawing</li> <li>- painting</li> <li>- printmaking</li> <li>- sculpture</li> <li>- fabric arts</li> <li>- photography and technographic arts</li> </ul>	<ul style="list-style-type: none"> <li>- drawing</li> <li>- painting</li> <li>- printmaking</li> <li>- sculpture</li> <li>- fabric arts</li> <li>- photography and technographic arts</li> </ul>

# Introduction to Teaching Components

## The Content:

The content of the art curriculum consists of four major components: REFLECTION, DEPICTION, COMPOSITION and EXPRESSION as defined in the OVERVIEW. Although DEPICTION is often based on REFLECTION, and skill in COMPOSITION is partially dependent on depicting skills, this order need not always be maintained in teaching the program. Hypothetically, any concept within a component could be chosen as a beginning.

Once a concept has been chosen, suggested methods or strategies are given as examples of how the concept might be taught. These approaches can be selected on the basis of the students' background and abilities. One or more activities could be chosen and tried. Once the concept has been taught by means of the activity or activities, an integration section follows that relate it to other art content areas and in some cases other subject areas.

An opportunity for EXPRESSION is given for almost all concepts, because as students gain skill in reflecting, depicting and composing, the more expressive their work will become. Some choices should be given to students with regard to PURPOSE, SUBJECT MATTER and MEDIA TECHNIQUES. Since the other three content areas are structured and teacher directed, the EXPRESSION component should be based on student choice and student decision making as much as possible. The activities given as opportunities for EXPRESSION should be treated as suggestions only. The interrelationships among concepts are drawn and given as teacher information and need not be pursued in that order. They should aid the teacher in providing a flexible, balance program that offers experiences in all four content areas.

Depicting and composing skills tend to be based, in the main, on drawing and painting skills. The other studio areas are built into the EXPRESSION component as well as drawing and painting. It might be necessary to spend time introducing students to a new method or technique in a studio area before using the suggested activity in EXPRESSION, Component 10. Information on the major studio areas is given in the resource book.

Students at every level need time to explore and practise with new tools and materials when they are introduced. It may also be necessary to refer back to concepts written for a lower level if students have not acquired the skills upon which their level is built.

Time:

A minimum of seventy-five minutes per week should be provided for art instruction. This time can be divided into two or more periods depending on grade and timetable flexibility. It is suggested that one of the periods be longer than the other to provide enough time to organize and clean up when studio activities are planned. For the teacher who plans an integrated curriculum, art time will also occur during other subject periods.

The program uses levels rather than grades to allow for greater flexibility. It allows the teacher to make decisions as to which activities should be used to teach the concepts within each component. All concepts should be taught at each level. Some concepts require more time than others to teach. Students should be made aware of the objective for each concept at the beginning of a lesson.

Charting the Course:

A scope and sequence chart has been provided at each level which can be used as a checklist for planning and teaching a balance of all four content areas. Although one or more concepts can be taught in sequence, it is suggested that no one content area be taught as a unit. The following examples show units that can be taught based on the inter-relationships shown as the program develops.

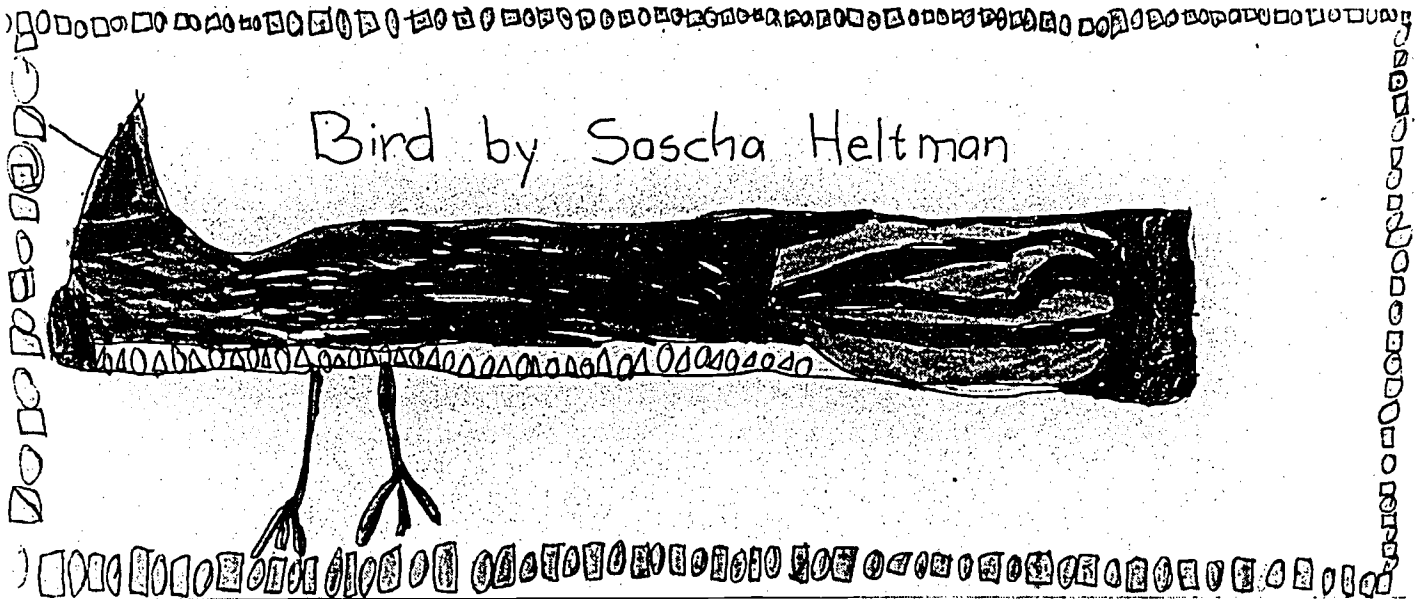

# Teaching Components Level One

# Level One Grade 1-2

## REFLECTION

### STUDENTS WILL

- Component ANALYSIS 1.** NOTICE COMMONALITIES WITHIN CLASSES OF NATURAL OBJECTS OR FORMS.

#### Concepts:

- Natural forms have common physical attributes according to the class in which they belong.
- Natural forms are related to the environment from which they originate.
- Natural forms have different surface qualities in colour, texture and tone.
- Natural forms display patterns and make patterns.

- Component ASSESSMENT 2.** ASSESS THE USE OR FUNCTION OF OBJECTS

#### Concepts:

- Designed objects serve specific purposes.
- Designed objects serve people.
- Designed objects are made by man or machine.
- Designed objects must function well to be valuable.

- Component APPRECIATION 3.** INTERPRET ART WORKS LITERALLY

#### Concepts:

- Art takes different forms depending on the materials and techniques used.
- An art form dictates the way it is experienced.
- An art work tells something about its subject matter and the artist who made it.
- Colour variation is built on three basic colours.
- Tints and shades of colours or hues affect the contrast of a composition.
- All aspects of an art work contribute to the story it tells.

## DEPICTION

- Component MAIN FORMS AND PROPORTIONS 4.** LEARN THE SHAPES OF THINGS AS WELL AS DEVELOP DECORATIVE STYLES

#### Concepts:

- All shapes can be reduced to basic shapes, i.e., circular, triangular, rectangular.
- Shapes can be depicted as organic or geometric.
- Shapes can be made using different procedures, i.e., cutting, drawing, tearing, stitching.
- Animals and plants can be represented in terms of their proportions.
- A horizon line can be used to divide the picture plane into interesting and varied proportions of the sky and ground.

- Component ACTIONS AND VIEWPOINTS 5.** INCREASE THE RANGE OF ACTIONS AND VIEWPOINTS DEPICTED

#### Concepts:

- Movement of figures and objects can be shown in different ways.
- An x-ray view shows the inside of something.
- Forms can be overlapping to show depth or distance.

- Component QUALITIES AND DETAILS 6.** REPRESENT SURFACE QUALITIES OF OBJECTS AND FORMS

#### Concepts:

- Texture is a surface quality that can be captured by rubbings or markings.
- Textures from patterns.
- Primary colours can be mixed to produce new hues.
- Colour can be lightened to make tints or darkened to make shades. These tints or shades are also referred to as tone or value.
- Images are stronger when contrasts of light and dark are used.
- Details enrich forms.

## COMPOSITION

- Component EMPHASIS 7.** CREATE EMPHASIS BASED ON PERSONAL CHOICES

#### Concepts:

- An active, interesting part of the theme can become the main part of the composition.
- The main part of the composition can be treated thoroughly before adding related parts.
- Contrast the subject matter with the ground for emphasis.
- Forms can run off the edges of the picture space in a composition.

- Component UNITY 8.** CREATE UNITY THROUGH DENSITY AND RHYTHM

#### Concepts:

- Families of shapes and shapes inside or beside shapes create harmony.
- Overlapping forms help to unify a composition.
- Repetition of qualities such as colour, texture and tone produce rhythm and balance.
- A composition should develop the setting or supporting forms as well as the subject matter.

- Component CRAFTSMANSHIP 9.** ADD FINISHING TOUCHES

#### Concepts:

- Finishing touches (accents, contrasts, outlines) can be added to make the work more powerful.
- Stepping back from a work helps in judging how it can be improved.

## EXPRESSION

- Component (i) PURPOSE 10.** RECORD OR DOCUMENT ACTIVITIES, PEOPLE AND DISCOVERIES

#### Concepts:

- Everyday activities can be documented visually.
- Special events such as field trips, visits and festive occasions can be recorded visually.
- Family groups, people relationships can be recorded visually.
- Knowledge gained from study or experimentation can be recorded visually.

- DEVELOP THEMES, WITH AN EMPHASIS ON PERSONAL CONCERNS, BASED ON:

- Plants and animals
- Environment and places
- Manufactured or man-made things
- Fantasy
- People

- ILLUSTRATE OR TELL A STORY

- A narrative can be retold or interpreted visually.
- An original story can be created visually.

- DECORATE ITEMS PERSONALLY CREATED

- Details, patterns, textures can be added to two-dimensional works.
- Details, patterns, textures can be added to the surface of three-dimensional works.

- EXPRESS A FEELING OR A MESSAGE

- Feelings and moods can be interpreted visually.
- Specific messages, beliefs and interests can be interpreted visually or symbolized.

- CREATE AN ORIGINAL COMPOSITION OBJECT OR SPACE BASED ON SUPPLIED MOTIVATION

- Outside stimulation from sources such as music, literature, photographs, film, creative movement, drama, television and computer can be interpreted visually.

(III) MEDIA AND  
TECHNIQUES

1. USE MEDIA AND TECHNIQUES, WITH AN EMPHASIS ON EXPLORATION  
AND DIRECT METHODS IN DRAWING, PAINTING, PRINTMAKING,  
SCULPTURE, FABRIC ARTS, PHOTOGRAPHY AND TECHNOGRAPHIC ARTS:

Concepts:

A. Drawing

- Use a variety of drawing media in an exploratory way to see how each one has its own characteristics.
- Use drawing tools to make a variety of types of lines -- curved, straight, thick, thin, broken, continuous
- Use drawing tools to make a variety of shapes -- open, closed forms, straight, curved forms, geometric (rectangles, squares, circles, and triangles) and free form.
- Make drawings from direct observation.
- Use drawing media in combination with other media such as painting, printmaking or fabric.
- Use drawing to add details, textures or to create pattern.

B. Painting

- Learn simple brush skills: holding and unloading the brush, applying paint, cleaning the brush.
- Experiment with the medium to explore its possibilities.
- Work primarily with tempera paint or tempera paint with additives using large brushes to paint.
- Mix primary colours and lighten and darken colours.
- Paint using experimental methods including without a brush.
- Paint directly without preliminary sketching.
- Use paint in combination with other media and techniques.
- Make small group and/or large group murals.

C. Printmaking

- Use frottage (texture rubbings).
- Make lifts or transfers using wax crayon or fabric crayon.
- Explore the use of printmaking materials and the application of paint using brushes and rollers (brayers).
- Use printmaking images in making pictures or compositions.

D. Sculpture

- Make two and three-dimensional assemblages from found materials.
- Learn the care and handling of clay and explore the modelling possibilities.
- Use simple clay modelling techniques of rolling, pinching, adding, pressing, making coils, texturing.
- Create three-dimensional forms using paper sculpture techniques of folding, scoring, cutting, curling, weaving, rolling, twisting, joining.
- Cast plaster of Paris relief sculptures in sand molds.

E. Fabric Arts

- Decorate fabric using printmaking techniques of relief printing, stamping, stencilling.
- Use collage techniques for picture-making with fabric.
- Learn the basics of thread and needle manipulation and use simple stitchery (running stitch and blanket stitch) for decoration and picture-making.
- Use a simple, hand-made loom to weave plain or tabby pattern.
- Braid wool or cloth strips to be used as enhancements.
- Tie-dye using one colour of dye.
- Use simple batik or resist dyeing using a safe resist such as flour and water paste or margarine.

F. Photography and Technographic Arts

- Take advantage of visual art implications of any available technological device and explore the potential of emerging technologies. Include at this level:
  - \*simple camera for documentation and sequencing of events
  - \*overhead projectors for experimenting with shapes, colours, compositions, and the relating of a story using cut-out shapes, real objects, or drawings on acetate rolls.
  - \*computer software packages and input devices such as the light pen, Koala pad, the mouse, and any other advancements in this area to explore design and compose.

\*copy devices or Xerox to record images and textures

\*slides handmade using ink, crayon, acrylic paint or felt pen for exploring line and shape.

\*emerging technologies as available and applicable

- Employ technological media techniques, practices and capabilities to promote art understandings and create designs and compositions.

Included at this level:

\*storyboards to show a sequence of events

\*roll movies to show sequence or tell a story

\*different kinds of viewfinders to select and frame shots

\*shadow puppets

\*moving, changing, experimenting to obtain different effects, designs, compositions

\*retaining copies of only that which is of particular interest

\*photograms with found objects

# COMPONENT 1: ANALYZING STRUCTURES IN NATURE

**Objective: STUDENTS WILL NOTICE COMMONALITIES WITHIN CLASSES OF NATURAL OBJECTS OR FORMS.**

Teaching/Learning Materials for the Component:

A collection of natural objects or pictures of natural objects representing a particular class, e.g., dogs, cats, trees, flowers, fish, seashells, etc.

Visuals showing classes of objects can be found in Townley's ANOTHER LOOK (Level A: Forests; Level B: How Else Can You See?, Weeds; Level C: Clouds, Hair) and in the Alberta Heritage Flora and Fauna Kits.  
**FABRIC IDEAS**

Magazines: Ranger Rick, Chickadee, Owl.

<b>Concepts:</b>	<b>A. Natural forms have common physical attributes according to the class in which they belong.</b>
------------------	--

Suggested Methods or Strategies:

- Through questioning, get the children to tell you how all the objects or forms are the same, e.g., all dogs, all cats, all shells. Then encourage a discussion about why they can be called by the same name even though there are differences.  
Make a list of common attributes arrived at through discussion.
- Show pictures from different classes of objects and have the students categorize them.
- Have the children do a magazine search to find many examples from a class of natural objects or forms based on their own choice.

Integrating with Art Content Areas:

This lesson can be used as a basis for lessons in

DEPICTION, Component 4: Capturing Main Forms and Proportions,

Concept A: All shapes can be reduced to basic shapes, i.e., circular, triangular, rectangular.

Concept B: Shapes can be depicted as organic or geometric.

Concept D: Animals and plants can be represented in terms of their proportions.

Integrating with Other Subjects:

Science - Division One (LIVING THINGS AND ENVIRONMENTS): Living things can be classified according to properties.

**B. Natural forms are related to the environment from which they originate.**

Suggested Methods or Strategies:

- Arrange a walk in a park or wooded area to observe the kind of natural forms native to the area.
- If there is a conservatory in your area, arrange a visit so that students can understand how different climates can produce different plant forms.
- Have students choose an environment: desert, tropical, arctic or temperate and then find out what kind of animals and plants live there and how they have adapted to the environment.
- Use pictures of animals to motivate discussions on adaptation and how the animal relates to its habitat, e.g., a polar bear relates to its arctic environment by its lack of colour, its heavy coat, its way of moving.

Integrating with Art Content Areas:

This lesson can be a motivation or lead up to lessons in

DEPICTION, Component 4: Capturing Main Forms and Proportions,  
Concept D: Animals and plants can be represented in terms of their proportions.

OR

COMPOSITION, Component 8: Unity,  
Concept D: A composition should develop the setting or supporting forms as well as the subject matter.

OR

EXPRESSION, Component 10:

- |                            |  |
|----------------------------|--|
| (i) Purpose                | )▶ Students may document a field trip or the knowledge acquired through study by |
| (ii) Subject Matter        | )▶ choosing a plant or animal to represent in its habitat                        |
| (iii) Media and Techniques | )▶ by means of drawing, painting or photography.                                 |

Integrating with Other Subjects:

Science - Division One (LIVING THINGS AND ENVIRONMENTS): Plants and animals live in many different habitats within an environment. "Population" describes a group of organisms of the same kind in a particular environment.



**C. Natural forms have different surface qualities in colour, texture and tone.**

Suggested Methods or Strategies:

- Through tactile examination have students determine differences in surface qualities of a class of natural objects or forms.
- Use rubbings to capture the different surface qualities of the objects studied.
- Introduce the term tone by showing students variations of one colour in the room that represent both dark and light values of that colour. Have them point out dark and light values of a colour. Then see if they can distinguish tones in natural objects.
- See **ANOTHER LOOK**, Level A, Smooth or Rough, Smooth and Rough.
- Have students classify natural objects according to colour, texture or tone.
- Develop vocabulary that relates to colour, texture and tone as it is needed in discussion.

Integrating with Art Content Areas:

This lesson can be used as a basis for lessons in

**DEPICTION, Component 6: Attending to Qualities and Details,**

**Concept A: Texture is a surface quality that can be captured by rubbings or markings.**

**Concept D: Colour can be lightened to make tints or darkened to make shades. These tints or shades are also referred to as tone or value.**

OR

**EXPRESSION, Component 10:**

- |   |  |
|---|--|
| <p>(i) Purpose</p> <p>(ii) Subject Matter</p> <p>(iii) Media and Techniques</p> | <p>▶ Let students create an original composition</p> <p>▶ showing the textural qualities of a natural object or form of their own choice</p> <p>▶ using rubbings to make a collage or other printmaking methods or by using stitchery. (See <b>FABRIC IDEAS</b> by Pluckrose.)</p> |
|---|--|

Integrating with Other Subjects:

Science - Division One (**LIVING THINGS AND ENVIRONMENTS**): Living things can be classified according to properties.

**D. Natural forms display patterns and make patterns.**

Suggested Methods or Strategies:

- See ANOTHER LOOK (Level A: Trees, Forests, Between the Trees; Level B: Spiral or Concentric, Parallel or Branching; Level C: Patterns).
- Direct students to look at trees without their foliage to see the linear patterns of branches against the sky.
- With the class, examine the radial patterns of flowers, the linear symmetry of leaves.
- Natural objects can be classified according to patterns. Encourage students to distinguish between regular and irregular patterns.
- Introduce objects or pictures of natural forms that show radial, symmetrical, asymmetrical, cellular, or random patterns.

Integrating with Art Content Areas:

Again, one or more of the preceding activities can be used as a motivation for lessons in

DEPICTION, Component 6: Attending to Qualities and Details,

Concept B: Textures form patterns.

Concept D: Colour can be lightened to make tints or darkened to make shades. These tints or shades are also referred to as tone or value.

OR

COMPOSITION, Component 8: Unity,

Concept C: Repetition of qualities such as colour, texture and tone produce rhythm and balance.

OR

EXPRESSION, Component 10:

- |   |  |
|---|--|
| <p>(i) Purpose</p> <p>(ii) Subject Matter</p> <p>(iii) Media and Techniques</p> | <p>► Students may decorate a two-dimensional work</p> <p>► using patterns found in natural forms</p> <p>► by means of drawing, print-making or cut paper. (These can be borders that frame a composition.)</p> |
|---|--|

Integrating with Other Subjects:

Mathematics - Grade Two (geometry): Symmetry demonstrated through folding and cutting.

Patterns developed and continued using 3-dimensional objects and 2-dimensional figures.

Science - Division One (LIVING THINGS AND ENVIRONMENTS): Living things can be classified according to properties, e.g., structure.

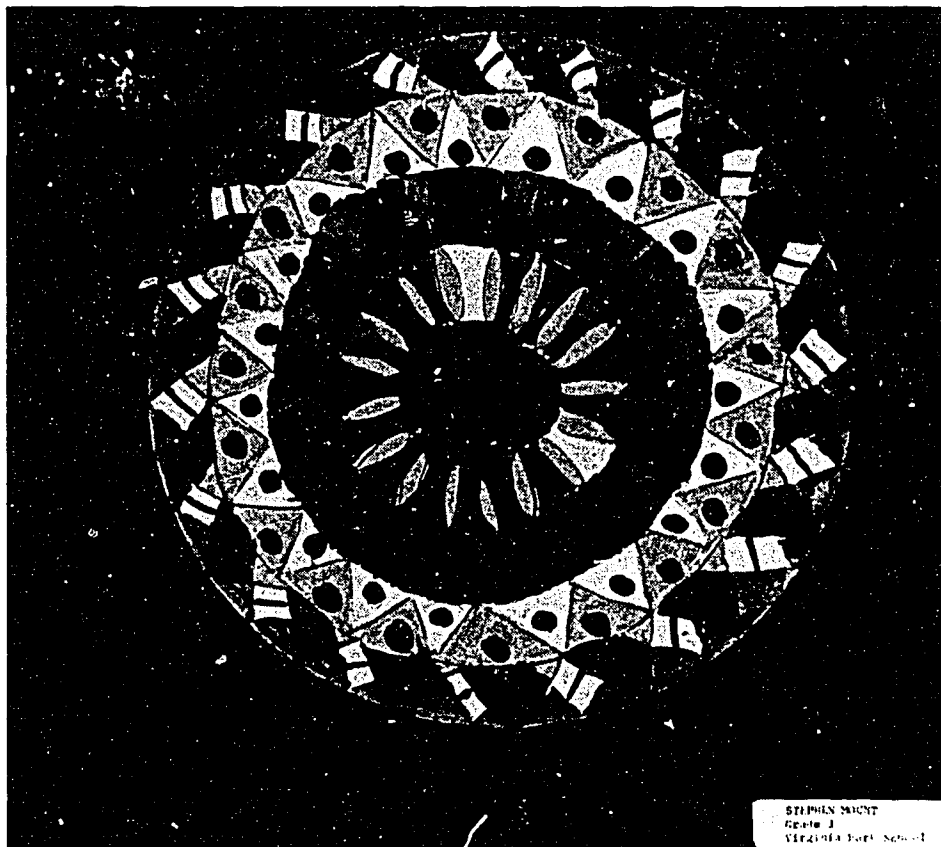

STEPHEN MOUNT  
Grade 1  
VIRGINIA EARLY SCHOOL

## COMPONENT 2: ASSESSING DESIGNED OBJECTS

**Objective: STUDENTS WILL ASSESS THE USE OR FUNCTION OF OBJECTS.**

Teaching/Learning Materials for the Component:

Designed objects collected at home and school  
ANOTHER LOOK, Levels B and C  
MODEL IDEAS and FABRIC IDEAS  
Materials for cardboard construction  
Drawing media  
Painting media  
Clay  
Fabrics

**Concepts: A. Designed objects serve specific purposes.**

Suggested Methods or Strategies:

- Have a brainstorming session in which students name as many designed objects as they can. Begin with those in the school environment and then consider those in the home. Once a list has been made, encourage students to classify them according to different uses.
- Use these headings to generate lists of designed objects:
  - Objects that do work for us
  - Objects that move us from place to place
  - Objects that you can play with
  - Objects that clothe us
  - Objects that cover us
  - Objects that help us communicate
- Make a collection of safe hand operated tools (e.g., egg beater, garlic press, pliers, scissors, etc.). Have students operate them and tell what each might be used for. (Encourage creativity of responses as well as the traditional use of the tool.) Some kitchen tools could have new uses in an art room.

- Make a collection (with students' help) of one kind of object in different forms e.g., can openers, pitchers, balls, chairs, spoons, pencils, papers, etc. This can be a sharing session in which students bring an item from home or find one at school. Once the objects have been pooled, students can discuss how each is different and how this affects their use. For example, because the balls are different sizes, weights and materials, they are used for different kinds of games.
- Encourage students to mime people using useful objects.

Integrating with Art Content Areas:

This lesson can provide themes for lessons in

**EXPRESSION, Component 10:**

- |                            |   |
|----------------------------|---|
| (i) Purpose                | )▶ Allow students to document               |
| (ii) Subject Matter        | )▶ people using useful objects              |
| (iii) Media and Techniques | )▶ by choosing a drawing or painting media. |

Integrating with Other Subjects:

Drama - Refer to the Drama Curriculum for experiences in mime. Students could mime the use of the objects and then add sound effects. A guessing game could be played to identify the object.

Science - In Division One, students compare, order and classify objects according to one or more properties.

<b>B. Designed objects serve people.</b>
--

Suggested Methods or Strategies:

- Encourage students to generate lists for these headings:
  - Designed objects that extend sound e.g., radio, telephone
  - Designed objects that extend sight e.g., binoculars, glasses
  - Designed objects that extend touch e.g., typewriter, pencil
  - Designed objects that extend thinking e.g., computers, books
- Introduce students to the concept of architecture. List the many kinds of buildings one finds in the community. Classify them according to purpose, e.g., houses, apartments are private residences; churches, schools, hospitals are public buildings.

- See ANOTHER LOOK, Level B: "Buildings", "Space-City" and Level C: "Shelters".
- Choose one item such as a chair. Ask students to name natural objects that man might have used before chairs were invented. Discuss how man has improved on these simple solutions with designs that will make sitting more comfortable or suit the chair to the purpose.
- Have students evaluate their school building for different kinds of designed spaces, i.e., play spaces, work spaces, private spaces, public spaces, auxiliary spaces, useable spaces, wasted spaces, traffic spaces, multi-purpose spaces.
- Use pictures that show different kinds of public spaces (malls, town squares, pedestrian streets, grain elevators, main streets, markets, arenas, etc.). Have students identify each one by name. Students could depict themselves in a public space setting.

Integrating with Art Content Areas:

Concept B provides some background for learning in Concept C that follows. (Designed objects are made by man or machine.)

It can also be used as a basis for an opportunity in

**EXPRESSION, Component 10:**

- |                            |  |
|----------------------------|--|
| (i) Purpose                | )▶ Students may create models of shelters  |
| (ii) Subject Matter        | )▶ for animals, pets or people   |
| (iii) Media and Techniques | )▶ with cardboard and boxes using construction techniques. See Model Ideas: "Houses and Buildings" and "Making a Model Village." |

Integrating with Other Subjects:

Social Studies: In Grade One, learning about the five senses can be integrated with the first activity on extending man's senses.  
In Grade Two, students look at the facilities that provide services for the neighborhood and community.

Language Arts: In *Cartwheels* by Gage, students can read about "Fingers Before Forks" and "Dogs Before Snowmobiles" to extend the learning in the fourth activity of Concept B. In *Somersaults* by Gage, students can view different homes in Canada.

**C. Designed objects are made by man or machine.**

Suggested Methods or Strategies:

- Invite students to a sharing session in which they bring an object and explain to other students how the object was made. This activity could also be restricted to one class of items such as toys. (At this level, students could be expected to explain that the toy was carved, sewn, molded, painted, cut, glued, riveted, stapled, laminated, etc., after observing a variety of construction methods.) Encourage students to seek evidence to determine whether it was handmade or machine made.
- Collect an assortment of handmade objects. Ask students to examine them to discover the clues that tell they were handmade.
- Collect a variety of one kind of an object to show handmade and machine made examples (such as dolls). Distinguish between handmade using machines and machine made during a manufacturing process using assembly line techniques. Have students compare those items which were manufactured with the handmade ones. Discuss whether good and poor craftsmanship are possible in both groups. Also discuss the attitudes and values people have with regard to each group.
- Have students make individual lists of useful items which they can make by hand. Ask them to consider whether they would prefer to fashion those items by hand rather than buy them as factory produced items. Discuss the benefits of making things by hand in terms of the creator and the usefulness of the object.

Integrating with Art Content Areas:

This concept can provide background for learning Concept D that follows. (Designed objects must function well to be valuable.) It can also be used as a basis for an opportunity in

**EXPRESSION, Component 10:**

- |   |  |
|---|--|
| <p>(i) Purpose</p> <p>(ii) Subject Matter</p> <p>(iii) Media and Techniques</p> | <p>▶ Students can design a three-dimensional object to be used (cup, bowl, jug, plate)</p> <p>▶ using pinchpot and/or slab techniques in clay.</p> |
|---|--|

Have students evaluate the object by using it to see how well it functions.

### Integrating with Other Subjects:

Language Arts - Students can read about how pencils are manufactured in Leapfrogs by Gage "Making a Pencil" and about hand-made carvings in "Wood Carvers" found in Somersaults by Gage.

Science - Division One - Students learn that objects exhibit a number of properties and properties can be determined through use of the senses.

**D. Designed objects must function well to be valuable.**

### Suggested Methods or Strategies:

- Provide building blocks of many different shapes and sizes. Primary children should have some time during the day to organize the blocks according to their own design. Once they have had some play, suggest activities in which function becomes very important. Some ideas are:
  - a building that has doorways and windows for miniature people to see from;
  - a town or village that has roadways for model cars;
  - a bridge under which a river may flow and over which a car may cross;
  - furniture that dolls could sit on;
  - a tall building with "look-out" towers;
  - an imaginary room with furniture made from blocks or small boxes;
  - fences to separate one yard from another.
- Pose the hypothetical dilemma that paint brushes are no longer available. Have students create one using a wide variety of materials that could be collected for the purpose: sticks, sponges, heavy cloth scraps, grasses, jute, string, etc. Students should help collect. Have students decide whether their "invented" brushes are worth keeping after using them. Also discuss the qualities these brushes achieved which their traditional counterparts do not.
- Direct the students' attention to flower pots in their different forms. Compare plastic ones to clay ones for usefulness. Discuss why holes are placed in the bottom of pots, and why clay pots are not usually glazed on the inside. Then have students build their own small flower pot from clay using a pinch pot technique. After firing and perhaps glazing the outside, let them be the judges of their usefulness.
- Invite students to select items that do or do not function well and tell why by demonstrating the use of the item in question.



Integrating with Art Content Areas:

An opportunity for

EXPRESSION, Component 10:

- (i) Purpose                                    )► Students can design a useful three-dimensional object
- (ii) Subject Matter                        )► of their choosing (kite, toy, mask, belt, purse, hat, jewelry)
- (iii) Media and Techniques            )► using media and techniques appropriate for the item.

See *Fabric Ideas* by Pluckrose for some ideas. *Emphasis Art* by Wachowiak has suggestions on mask making, pp. 210-214.



## COMPONENT 3: APPRECIATING ART

**Objective: STUDENTS WILL INTERPRET ART WORKS LITERALLY.**

Teaching/Learning Materials for the Component:

Art reproductions: paintings, drawings, prints, sculpture  
Art originals: paintings, drawings, prints, sculpture, photography  
Visits to art galleries and/or in-school tours of art displays  
ANOTHER LOOK, Levels A and C

**Concepts: A. Art takes different forms depending on the materials and techniques used.**

Suggested Methods or Strategies:

- Students will need to make distinctions between materials and tools. Materials refer to paper, paint, canvas, clay, ink and so forth. Encourage students to make a list of art tools and art materials. Once these have been compiled make two sets of cards for each classification. Students can match a card from each list and tell what kind of art form is produced when both are used together, e.g., paper and pencils can be used to produce a DRAWING.
- Refer to studio lessons in which students have learned specific techniques. For example, they may have used a resist technique in painting, a stamping technique in printmaking or a stitching technique in fabric arts. From the examples in which they experienced discuss what a technique is and how it relates to the art tools and materials. Identify different techniques in the work of other artists.
- As students create art forms, art vocabulary can be learned. For example, students will need to refer to brayer, inks, plate, print, etc., when doing printmaking. They should be encouraged to use the relevant art terms during the creative process and afterwards in discussing their work. Keep an ongoing vocabulary list of materials, tools, techniques and art forms as they are introduced to the class.

- Introduce good quality reproductions of art work to young students. Show them the difference between an original and a reproduction. Children's book illustrators provide a good source of high quality reproductions that are appealing to primary children.
- Once students have viewed different kinds of art forms in their school or during a gallery visit, encourage them to identify the paintings, prints or drawings from a group containing some of each. Have them explain why they have classified a certain group as painting, i.e., evidence of brushstrokes, the way the colour is applied, evidence that the artist drew first and then painted in his/her drawing.
- Organize a game using reproductions or originals in which students sort them and classify as to drawing, painting, prints, sculptures or photography.

Integrating with Art Content Areas:

This concept can be used as a basis for Concept B (an art form dictates the way it is experienced) and Concept F (all aspects of an art work contribute to the story it tells) which follow within this component.

It can also be used as a basis for a lesson in

**EXPRESSION, Component 10:**

- |  |   |
|--|---|
| <ul style="list-style-type: none"> <li>(i) Purpose</li> <li>(ii) Subject Matter</li> <li>(iii) Media and Techniques</li> </ul> | <ul style="list-style-type: none"> <li>)▶ Students can illustrate a story</li> <li>)▶ of their own choosing or creation</li> <li>)▶ using drawing, painting or printmaking techniques appropriate to the subject matter.</li> </ul> |
|--|---|

Integrating with Other Subjects:

Language Arts - The illustrations suggested as an activity in EXPRESSION can be for a story that the class composes together.

**B. An art form dictates the way it is experienced.**

Suggested Methods or Strategies:

- In these activities students will have an opportunity to see that because painting, sculpture, fabric arts, printmaking, drawing, sculpture and photography are unique in themselves, one approaches each form differently with different viewer expectations.

- During a gallery visit have each child stand beside his favourite work and describe what he likes best about the art work.
- Try lessons from **ANOTHER LOOK, Level A "The Sun in Art"**.
- Discuss the difference between a painting and a sculpture by introducing originals or replicas of each to students. Ask them to view each and talk about difference in viewing stance. (The sculpture could either be picked up and examined from all sides or one could walk around it to view it from all angles and viewpoints.)
- Give students an opportunity to view a wide variety of art forms: sculpture, fabric arts (stitchery, weaving, soft sculpture), painting, drawing, printmaking, photography, film. Discuss and classify into categories according to visual appeal, visual and tactile appeal, visual and aural appeal.
- Provide experiences for students to view still photography and moving pictures of the same subject matter if possible. Discuss the differences in the experience and how each form has its own value for us depending on the context in which each is used.
- Provide opportunities so that students can see that painting is used in different contexts, e.g., murals; formal paintings; decorative element on useful items such as dishes and furniture; frescos; enhancements for buildings, architectural features, vehicles; book illustrations. Ask students how viewing some of these provide different experiences because of the variety of uses to which painting can be put.
- Have students "describe" a narrative art work by assuming the roles of the characters in frozen tableau form. When they become proficient at duplicating the scenes or settings, have them add dialogue.

#### Integrating with Art Content Areas:

This concept provides background knowledge for Concept C (an art work tells something about its subject matter and the artist who made it) and Concept F (all aspects of an art work contribute to the story it tells) which follow. It can also be used as a basis for a lesson in

#### **EXPRESSION, Component 10:**

- |                            |   |
|----------------------------|---|
| (i) Purpose                | ▶ Students can create a 2-D and a 3-D art form    |
| (ii) Subject Matter        | ▶ based on the same subject matter                |
| (iii) Media and Techniques | ▶ using media and techniques appropriate to both. |

#### Integrating with Other Subjects:

Mathematics - In Grade Two, students will learn distinctions between 2-D and 3-D figures and objects.

**C. An art work tells something about its subject matter and the artist who made it.**

Suggested Methods or Strategies:

- Lesson in **ANOTHER LOOK, Level C: "Sky-Water-Boats"**.
- The subject matter of paintings, photographs, drawings or prints can be classified as to: landscape, seascape, portraits, abstracts, figurative works. Bring a variety of reproductions into the classroom that cover these broad categories. Students can be encouraged to classify them according to the categories given or sort them according to their own classification system.
- Choose three art works by different artists and present them to students by asking them to decide what each art work is about (theme) and what that tells us about the artist. In discussing the artist's intent, students need to make some inferences such as:
  - the artist is showing us what particular things look like
  - the artist has tried to convey a certain feeling (calmness, excitement, etc.)
  - the artist is displaying interest in people, landscapes, colour and shapes.
- Collect reproductions representing the same subject matter. Ask students to identify likenesses and differences. Once this has been established, discuss why the same subject matter is treated differently and what this has to do with the artist who created it. See **ANOTHER LOOK, Level A, "The Sun in Art"** and **"Forests"** for examples.
- With the class make a list of all the obvious information that can be identified about an artist by looking at his/her art works.  
Examples:
  - the physical viewpoint the artist assumed to create the art work (i.e., inside a house, outside in a field, from a top window, etc.)
  - the style the artist used (young students are not expected to identify specific styles in art history but could tell if the work was created with dots of colour or with geometric shapes, etc.)
  - the artist's preference for certain colours and certain subject matter if students are exposed to many examples of an artist's work
  - what the artist might have been like, given the above considerations.

### Integrating with Art Content Areas:

This lesson can be used as a basis for learning Concept F which follows this component (all aspects of an art work contribute to the story it tells).

#### **EXPRESSION, Component 10:**

- |                            |   |
|----------------------------|---|
| (i) Purpose                | )▶ Students can create an art work of their choice                |
| (ii) Subject Matter        | )▶ based on a theme agreed upon by the class                      |
| (iii) Media and Techniques | )▶ using media and techniques appropriate to the art form chosen. |

### Integrating with Other Subjects:

Language Arts - (Grades One and Two) Read a variety of illustrated materials.

<b>D. Colour variation is built on three basic colours.</b>
---

### Suggested Methods or Strategies:

- Identify the three primary hues: blue, red and yellow. Have students identify these colours in the classroom. Explain that all other colours are based on these. Then have them identify secondary colours. This can be a review exercise since it is suggested that children experience the mixing of colour in COMPONENT 6, Concept C, before this concept is taught.
- Students can identify the primary and secondary colours in illustrations found in the classroom.
- Ask students to group themselves together according to the colours they are wearing. Other students can identify the dominant colour in each grouping. Vary the game by asking for a group of light blue, dark blue, etc.
- List the secondary colours on the board. Ask students to identify these in the classroom. Once they do this easily have them consider if, for example, in a violet that is identified, it appears to have more red or more blue in it. Students should be able to see that there are red or blue violets, yellow or red oranges, blue or yellow greens.
- Introduce students to an art work or art reproduction that has a monochromatic colour scheme (lights and darks of one colour). Use book illustrations or pictures from Picasso's Blue or Rose Period as examples.

### Integrating with Art Content Areas:

This concept can be taught as an introduction to Concept E that follows. (Tints and shades of colours or hues affect the contrast of a composition.)

It could also be followed by a lesson in

#### EXPRESSION, Component 10:

- |                            |  |
|----------------------------|--|
| (i) Purpose                | ▶ Students can create an original composition using variations of one colour |
| (ii) Subject Matter        | ▶ based on a subject of their choice   |
| (iii) Media and Techniques | ▶ using crayons, pastels, paints or paper collage.                           |

**E. Tints and shades of colours or hues affect the contrast of a composition.**

### Suggested Methods or Strategies:

- Review what is meant by contrast in COMPONENT 6, Concept E.
- Use the black and white illustrations in **ANOTHER LOOK, Level A: Trees and Forests** to show examples of extreme contrast (black and white). Discuss how black against white helps define a shape and make it stand out. Then view the illustrations for Sunlit Forests (same level) which are in colour. Discuss the contrasts of light and dark which are more subtle than in the black and white photographs.
- Discuss art prints or illustrations in children's books to identify colour contrasts. Ask students to tell which subject matter the artist wanted to draw attention to by using high contrast.
- Collect colour chips from paint stores that show tints and shades of a particular colour. Introduce the terms tint (white added to a colour) and shade (black added to a colour). Ask students to identify tints and shades in their own clothing. Encourage use of terms light and dark to indicate tints or shades of a colour.
- By selecting a particular colour on the students' clothing, ask one student at a time to line everyone up who is wearing that colour, showing a tonal range from lightest to darkest.

Integrating with Art Content Areas:

In **EXPRESSION, Component 10:**

- |                            |   |
|----------------------------|---|
| (i) Purpose                | )▶ Have students create an original composition to show light and dark values |
| (ii) Subject Matter        | )▶ based on geometric shapes  |
| (iii) Media and Techniques | )▶ using black, white and varying degrees of grey tempera.                    |

**F. All aspects of an art work contribute to the story it tells.**

Suggested Methods or Strategies:

- Ask students to identify and list everything they can about an art work (colours, shapes, subject matter, style, artist, materials used to make it). Once they have done this, encourage them to consider each item and what it might contribute to understanding the composition and enjoying it more fully.
- Display a large art work or reproduction and give students three minutes to study it. Then put it away and ask students to tell you as much as they can remember about the work. Make a list to avoid repetition. When they have exhausted the list, show the work to them again, and get them to generalize about how the qualities named work together to make a composition that may tell a story or convey a message to the viewer.
- Display an art work or reproduction that has interesting details. Ask students to use the work as a basis for a story. Give each student a chance to add to the story.
- View some wordless books such as those by Mitsumasa Anno. (Anno's Journey, Anno's Italy, Anno's Flea Market, etc.) Ask students to supply a sentence for each page, thereby developing a story as the book progresses.

Integrating with Art Content Areas:

Students may do a lesson in

**EXPRESSION, Component 10:**

- |                            |   |
|----------------------------|---|
| (i) Purpose                | )▶ Students tell a story through illustration |
| (ii) Subject Matter        | )▶ based on their own choice of theme         |
| (iii) Media and Techniques | )▶ using drawing media of their choice.       |



Integrating with Other Subjects:

Language Arts - Students could write sentences to accompany the illustrations in the EXPRESSION activity above.

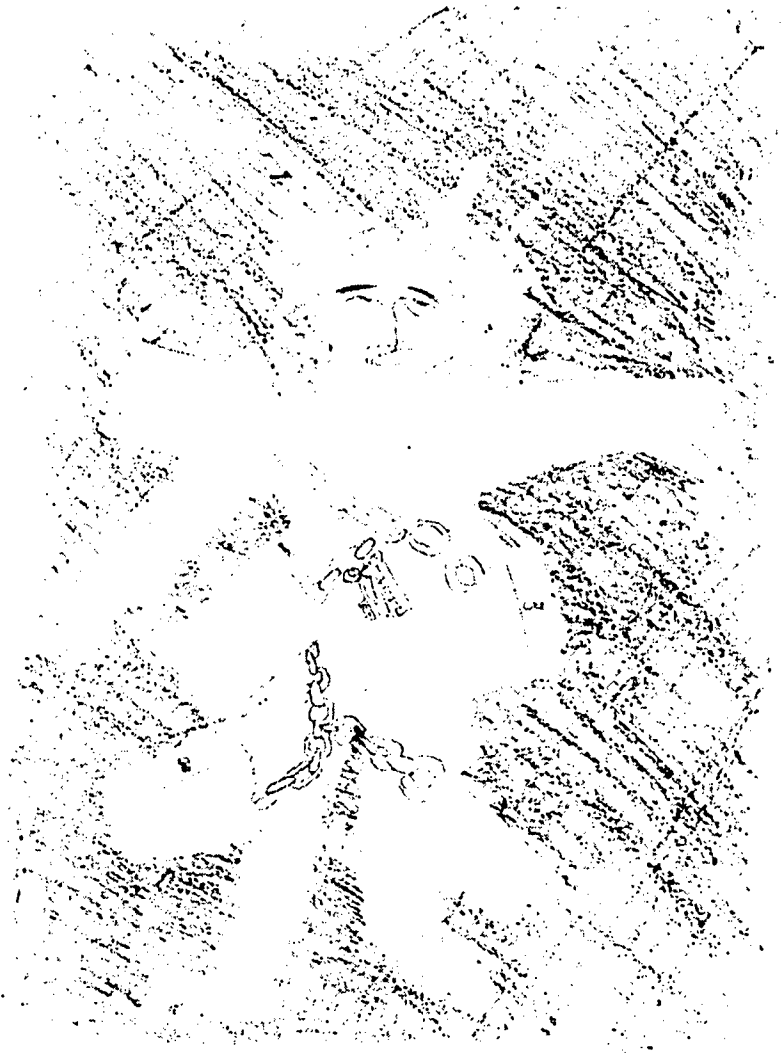

# **COMPONENT 4: CAPTURING MAIN FORM AND PROPORTION**

**Objective: STUDENTS WILL LEARN THE SHAPES OF THINGS  
 AS WELL AS DEVELOP DECORATIVE STYLES.**

Teaching/Learning Materials for the Component:

ANOTHER LOOK SERIES, Levels A, B and C as cited specifically with each concept.

Three-dimensional models of geometric shapes.

Natural forms: rocks, shells, wood, seed pods, fruits, vegetables, etc.

EMPHASIS ART.

**Concepts:      A. All shapes can be reduced to basic shapes, i.e., circular, triangular, rectangular.**

Suggested Methods or Strategies:

- Introduce basic shapes to students using 3-D models. Develop vocabulary related to these. Encourage students to describe shapes using the adjectives given in the concept and to draw them.
- Have a shape search in which students identify the basic shapes which reside in other objects (although the completed shape may have a modification).
- Students may use cut paper geometric shapes to use in combination to create new shapes.
- Natural forms can be examined to determine the shapes on which they are based.
- Use a lesson or lessons from ANOTHER LOOK, Level C: Angles or Curves; Level A: Building Shapes.

Integrating with Art Content Areas:

Learning the preceding concept can be a basis for a lesson in

**EXPRESSION, Component 10:**

- |                            |   |
|----------------------------|---|
| (i) Purpose                | )▶ Students can create an original object               |
| (ii) Subject Matter        | )▶ using geometric shapes                               |
| (iii) Media and Techniques | )▶ based on fantasy with clay, plasticene or cardboard. |

Integrating with Other Subjects:

Mathematics - Grade One (geometry): Circle, triangle, square and rectangle are recognized and named.

<p><b>B. Shapes can be depicted as organic or geometric.</b></p>
--

Suggested Methods or Strategies:

- Teach or review "Concept A" preceding this one to make sure students understand the idea of geometric shapes.
- Introduce organic shapes by having students examine natural or man-made forms that display curves. Have students identify forms from their environment that are organic (curved).
- Teach lessons from **ANOTHER LOOK, Level A: Straight or Curved or Straight and Curved.**

Integrating with Art Content Areas:

Have students use what has been learned about geometric and organic shapes for a lesson in

**EXPRESSION, Component 10:**

- |                            |   |
|----------------------------|---|
| (i) Purpose                | )▶ Students can decorate a 2-D or 3-D work                          |
| (ii) Subject Matter        | )▶ using geometric and/or organic shapes on a theme of their choice |
| (iii) Media and Techniques | )▶ using printmaking, drawing, painting or stitchery.               |

Integrating with Other Subjects:

Science - Division One (LIVING THINGS AND ENVIRONMENT): The environment can be classified as man-made or natural.

**C. Shapes can be made using different procedures, i.e., cutting, drawing, tearing, stitching.**

Suggested Methods or Strategies:

- Have students create a multitude of shapes using straight and/or curved lines by: cutting, drawing, tearing, stitchery and/or printing. Then discuss how each procedure alters the look of a particular shape using the examples created.
- Choose one or more lessons from **ANOTHER LOOK**, Level A: Open or Closed, Open and Closed and Separated or Touching; Level B: Spiral or Concentric and Separated and Touching.

Integrating with Art Content Areas:

This lesson can be an introduction to

**COMPOSITION, Component 8, Concept A: Families of shapes and shapes inside or beside shapes create harmony.**

Also try a lesson in

**EXPRESSION, Component 10:**

- |  |  |
|--|--|
| <ul style="list-style-type: none"><li>(i) Purpose</li><li>(ii) Subject Matter</li><li>(iii) Media and Techniques</li></ul> | <ul style="list-style-type: none"><li>► Students can depict shapes based</li><li>► on natural or man-made forms</li><li>► using a method of their choice: cutting, drawing, tearing, stitchery, or printmaking. See <b>EMPHASIS ART</b> on animals, pp. 95-99.</li></ul> |
|--|--|

**D. Animals and plants can be represented in terms of their proportions.**

Suggested Methods or Strategies:

- With students, select a human or animal model or a model from the plant world. Discuss its proportions as it is examined, i.e., the head is smaller than the body, the length of the arms extends to the knees, etc. Students may use crayon, pastel or soft pencil to capture the outside proportions of the figure used as a model.
- Have students relate the proportions of plant or animal forms to the proportions of the drawing or painting surface. Encourage them to use horizontal lines as guides to establish the proportions of a figure. (Check halfway down the page and halfway down the figure.)

Integrating with Art Content Areas:

Students can gain more skill in depicting proportions through practice.  
Organize lessons in

**EXPRESSION, Component 10:**

- |                            |   |
|----------------------------|---|
| (i) Purpose                | ) Provide opportunities for students to portray             |
| (ii) Subject Matter        | ) plant or animal forms with attention to proportions.      |
| (iii) Media and Techniques | ) Use drawing or painting techniques for these "portraits". |

**E. A horizon line can be used to divide the picture plane into interesting and varied proportions of sky and ground.**

Suggested Methods or Strategies:

- Display a number of landscapes which illustrate a variety of ways in which sky and ground are divided. Compare these ways through discussion.
- Encourage students to draw or paint two or more compositions varying the horizon line. Discuss how the horizon line changes with the point of view.
- Have students use two colours of 9" x 12" construction paper and cut each horizontally in different proportions. Then use each half as the foreground or background on another 9" x 12" paper. Use as the basis for a composition.

Integrating with Art Content Areas:

Have students apply their knowledge of foreground and background by doing a lesson or lessons in

**COMPOSITION, Component 7: Emphasis,**

Concept C: Contrast the subject matter with the ground for emphasis.

OR

**COMPOSITION, Component 8: Unity,**

Concept D: A composition should develop the setting or supporting forms as well as the subject matter.

OR

**EXPRESSION, Component 10:**

- |                            |  |
|----------------------------|--|
| (i) Purpose                | ) Students can document                      |
| (ii) Subject Matter        | ) a geographical environment of their choice |
| (iii) Media and Techniques | ) using drawing, painting or photography.    |

Integrating with Other Subjects:

Language Arts - (Grades One and Two) Viewing: Students will discriminate and remember spatial position, figure-ground.



## COMPONENT 5: ACTIONS AND VIEWPOINTS

**Objective: STUDENTS WILL INCREASE THE RANGE OF ACTIONS AND VIEWPOINTS DEPICTED.**

Teaching/Learning Materials for the Component:

ANOTHER LOOK, Levels B, C  
 printmaking mediums  
 drawing mediums  
 painting mediums  
 a variety of surfaces in different shapes and sizes  
 magazines for collages

**Concepts: A. Movement of figures and objects can be shown in different ways.**

Suggested Methods or Strategies:

- To show how certain shapes can be used to suggest movement use lessons from ANOTHER LOOK, Level C: "Arrow Shapes" and "Moving Matter".
- Flowing lines can be used to indicate movement. Students can practise lines while listening to music that is rhythmic and flowing. Shapes can be made from isolating some of these lines and adding details.
- To learn how the direction of a shape can be used to create an illusion of movement, use ANOTHER LOOK, Level B: "Diagonal".
- Movement can also be suggested by varying the angles of the picture plane. Ask students to suggest examples of inclines in their environment (stairs, ramps, escalators, hills, mountains, pitched roofs, etc.). Get them to depict one from the list and show an object or figure on the incline.
- Cartoonists often use a series of disconnected or parallel lines to indicate the movement of a vehicle or figure. Ask students to look for examples in comic books or the funnies. Provide long strips of paper so that students can design their own cartoons using such lines for movement.

- If possible, show students an example of time lapse photography in order to study the multi-images that represent one figure. Discuss how this creates an illusion of movement. Have students cut a figure from cardboard and ink it a number of times in the same colour, overlapping slightly each time to capture the feeling of movement through space.
- Use stamp or gadget printing to create patterns that suggest movement. Before beginning, brainstorm for words that describe rhythmic movement: swirling, rotating, revolving, circling, dancing, etc. Encourage students to draw in the air or move their bodies to show these movements. Some may find it easier to describe after "acting" it out. Each student can then choose a word to depict using printmaking.

Integrating with Art Content Areas:

This concept can be used as a basis for learning Concept C in this component. Forms can be overlapped to show depth or distance.

An opportunity can be provided in

**EXPRESSION, Component 10:**

- |                            |   |
|----------------------------|---|
| (i) Purpose                | )▶ Students can portray themselves moving                         |
| (ii) Subject Matter        | )▶ in a setting of their choice                                   |
| (iii) Media and Techniques | )▶ using drawing, painting or sculpture using clay or plasticene. |

Integrating with Other Subjects:

Drama - Students should develop the ability to use dramatic movement to enhance learning in other areas of the curriculum. In this case, drama activities in which students practise moving in different ways in response to a variety of stimuli and discover how to use the body as a vehicle for expressing ideas are appropriate to the art activities on depicting movement.

**B. An x-ray view shows the inside of something.**

Suggested Methods or Strategies:

- If possible, show students actual x-rays taken or pictures of x-rays. If these are not available, show students a fruit or vegetable and ask them what they think it looks like inside. Tell them that their image would be the x-ray view of the object. Cut it in two to show



them the actual view. Ask them to imagine other x-ray views, e.g., buildings: houses, churches, coliseums, department stores; vehicles; animal homes like beaver lodges, wasp's nests, beehives, anthills, burrows for rodents, caves for hibernating bears; machines. Make a list of possible x-ray views so children have lots to choose from. Have them depict one.

- Another approach to the x-ray view is to capture an event from a story to show the passage of time, e.g., showing all the things that a person has eaten, showing the movement from room to room in a house, Jonah inside the Whale, animals inside the ark. Have students depict an x-ray view that illustrates a part of a story.
- Allow students time to fantasize. Ask them to show an x-ray view of a foreign spaceship, another planet, an extra-terrestrial being, . plant or animal.
- Ask students to find story books in the library that show x-ray views, e.g., Brambly Hedge by Jill Barklem. Pop-up books often use this technique as well. This will help to identify other sources of inspiration.

#### Integrating with Art Content Areas:

This concept can be used as a basis for learning in **DEPICTION**, Component 6 (Qualities and Details); **Concept F: Details enrich forms.** Component 8 (Unity), **Concept A: Families of shapes and shapes inside or beside shapes create harmony.**

It can also provide an opportunity in

**EXPRESSION, Component 10:**

- |                            |   |
|----------------------------|---|
| (i) Purpose                | )▶ Students can use x-ray views to illustrate |
| (ii) Subject Matter        | )▶ their choice of subject matter             |
| (iii) Media and Techniques | )▶ using drawing, painting or fabric collage. |

#### Integrating with Other Subjects:

Language Arts - Students can tell, dictate or write stories (depending on their skills and abilities) that use their x-ray views as a setting for the plot.

**C. Forms can be overlapping to show depth or distance.**

Suggested Methods or Strategies:

- Use cutouts for flannel boards and get students to create their own arrangements which will illustrate events or tell a story. Encourage grouping and overlapping. Use events or stories from other school subjects.
- Have students create a composition by cutting apart separate drawings and regrouping them in overlapping arrangements. This method can be used to create a class mural based on a field trip experience.
- Use groups of students or items from the classroom to illustrate different arrangements of overlapping. Have students use paint or drawing materials to illustrate such topics as: a flock of birds, a fleet of boats, etc. Look for examples of grouping in the environment: a school of fish, a herd of sheep, a gaggle of geese, a cluster of buildings, a rack of bikes, a forest of trees, a bunch of flowers.
- Magazines provide a good source of thematic material for collages. Ask students to create a collage by overlapping figures that have been cut from magazines. Get them to consider the size relationships in order to decide which figures will be in the foreground. The class can decide on themes such as: a crowd, a sporting event, a queue, a group portrait, etc.
- Stencil printing or simple cardboard shapes that can be inked and printed could provide a means of creating a composition with overlapping. The colours can be varied to avoid monotony.
- Use ANOTHER LOOK, Level C: "Two Heads for One Giraffe" and "Crowds".

Integrating with Art Content Areas:

This concept provides a good foundation for learning in COMPOSITION, Component 8 (Unity), Concept B: Overlapping forms helps to unify a composition.

An opportunity can be provided in

**EXPRESSION, Component 10:**

- |                            |  |
|----------------------------|--|
| (i) Purpose                | )▶ Students can use overlapping in recording |
| (ii) Subject Matter        | )▶ family portraits                          |
| (iii) Media and Techniques | )▶ using drawing or painting medias.         |

# COMPONENT 6: QUALITIES AND DETAILS

**Objective: STUDENTS WILL REPRESENT SURFACE QUALITIES OF OBJECTS AND FORMS.**

Teaching/Learning Materials:

- drawing mediums
- ANOTHER LOOK, Levels A, C
- printing mediums
- PRINT IDEAS
- FABRIC IDEAS
- cloth, wool, thread, needles
- plastic lids to be used for colour mixing
- painting mediums
- magazines, scissors, glue
- cameras, film
- copying machine
- light sensitive paper for photograms
- Alberta Heritage Flora and Fauna Kits
- EMPHASIS ART

**Concepts: A. Texture is a surface quality that can be captured by rubbings or markings.**

Suggested Methods or Strategies:

- Discuss the meaning of texture. Ask students to feel a variety of surfaces in the classroom and to describe how each surface feels. Make a vocabulary list of all the adjectives that describe rough and smooth surfaces. Encourage students to collect objects that display different surfaces.
- Ask the class to make rubbings (frottage) by placing paper over textured surfaces and rubbing with crayon, pencil or charcoal. The rubbings can be cut out and used to make a texture collage. Students might like to make rubbings using fabric crayons and then iron them onto cotton cloth. The cloth patterns can then be cut out and used for applique.
- The teacher can prepare texture boards from which students can make rubbings. Different textured surfaces can be mounted on heavy card.

- Textures can be created in clay. Have students roll out a flat piece of clay (slab) and experiment with textures by using the hand and fingers in as many ways as possible. Then introduce simple tools like a ruler or piece of cardboard. The clay can be pressed into a cardboard box lid and plaster can be poured on it to make a plaster mould of the textured surface. A paper clip can be inserted in the wet plaster if a hanger is needed.
- Have students prepare a relief surface that can be printed using printing inks. A simple one can be made by squeezing white glue onto a piece of heavy cardboard (to make a pattern) and letting it dry before inking. Light weight paper will take the print especially well.
- Use **ANOTHER LOOK**, Level A: "Smooth or Rough" and "Smooth and Rough".

Integrating with Art Content Areas:

Learning about texture will provide a basis for using texture to form patterns in Concept B that follows.

An opportunity can also be provided in

**EXPRESSION, Component 10:**

- |                            |  |
|----------------------------|--|
| (i) Purpose                | ) Students can make textured containers                                  |
| (ii) Subject Matter        | ) to be used for flower pots, bowls, mugs or other uses                  |
| (iii) Media and Techniques | ) by means of decorating pinch pots. SEE EMPHASIS ART (section on clay). |

<b>B. Textures form patterns.</b>
-----------------------------------

Suggested Methods or Strategies:

- Use **ANOTHER LOOK**, Level C: "Patterns" to teach students the difference between a design and a pattern as well as concepts about pattern, i.e., patterns give the illusion of texture.
- Have students look for patterns in the natural world and represent some of them with drawing media. Do the same for the man-made world.
- Use gadgets and found objects to create patterns using printing inks or thickened tempera paint. Have students experiment with pattern first. Then suggest they create patterns based on a diagonal, a radial, a horizontal or vertical direction. See **PRINT IDEAS** for further suggestions.

- The study and creation of texture and pattern in the fabric arts can be a worthwhile endeavor at this level since students can make real textures rather than the illusion of texture as in drawing or painting. Have students make a stitchery sampler using loosely woven fabric. Encourage them to invent stitches as well as introducing some stitches to them. See **FABRIC IDEAS**.

Integrating with Art Content Areas:

This concept can provide background for Component 8, Concept C: Repetition of qualities such as texture produces rhythm and balance.

An opportunity can also be provided in

**EXPRESSION, Component 10:**

- |                            |  |
|----------------------------|--|
| (i) Purpose                | ▶ Students can create patterns to design                               |
| (ii) Subject Matter        | ▶ writing paper, wrapping paper, book covers, cushion covers, t-shirts |
| (iii) Media and Techniques | ▶ using printmaking mediums and techniques.                            |

Integrating with Other Subject Areas:

Language Arts - Introduce students to simple rhyming patterns in poetry. Show how the pattern can be represented graphically, e.g., abab.

**C. Primary colours can be mixed to produce new hues.**

Suggested Methods or Strategies:

- Introduce the three primary colours to your students: blue, yellow and red. Explain that these are basic to the mixing of all other colours. Have them fold a piece of paper into six rectangles. Ask them to paint three of the rectangles in the primary colours. Then instruct them to mix a different pair each time to produce the secondary colours. Ask them to keep the proportions as equal as possible. Let them discover the secondary colours and name them. Use plastic lids as palettes for colour mixing.
- Once the secondary colours have been mixed using paints, ask children to produce two of each colour: a red orange and a yellow orange; a blue violet and a red violet; a blue green and a yellow green. In this exercise students will learn that even though it takes two primaries to make a secondary colour, the proportions can be altered to produce what is called a tertiary colour that carries more of one primary colour than another. (The term tertiary need not be introduced at this time.)

- Provide coloured gels, cellophane or food colouring so that students can experiment with mixing colours.
- Have students blend crayons or pastels to make secondary colours.

Integrating with Art Content Areas:

This concept provides the necessary background for APPRECIATION, Component 3, Concept D (colour variation is built on three basic colours).

An opportunity can also be provided in

**EXPRESSION, Component 10:**

- |                            |   |
|----------------------------|---|
| (i) Purpose                | )▶ Students can use primary and mixed colours to depict |
| (ii) Subject Matter        | )▶ a scene from the natural or man-made environment     |
| (iii) Media and Techniques | )▶ using paint.   |

**D. Colour can be lightened to make tints or darkened to make shades. These tints or shades are also referred to as tone or value.**

Suggested Methods or Strategies:

- Introduce the term tint to students by having them mix white tempera paint with a selected colour. Also introduce the term shade by instructing students to mix black tempera paint with their selected colour. Once they have done this and can see the difference between tints and shades, allow them to experiment by mixing many tints and shades of a colour or hue. Conclude the lesson by explaining that their samples of tints and shades are known as colour values.
- Provide magazines, scissors and glue so that students can search for samples of tints and shades. These can be cut out and arranged in collages. Ask students to find only tints and shades of one colour. In this way, all colours can be represented by the class.
- Provide an opportunity for students to mix tints and shades using waterbased printing inks. These are best mixed on a cookie sheet, plexiglass sheet or linoleum tile. A brayer should be used for blending the inks together. Once the colour values have been mixed, have students use them with found objects to make patterns that show dark and light values.

Integrating with Art Content Areas:

This concept provides background information for learning in APPRECIATION, Component 3, Concept E (tints and shades of colours or hues affect the contrast of a composition) and in DEPICTION, Component 6, Concept E (images are stronger when contrasts of light and dark are used).

An opportunity can also be provided in

**EXPRESSION, Component 10:**

- |                            |  |
|----------------------------|--|
| (i) Purpose                | )▶ Students can mix and use tints and shades |
| (ii) Subject Matter        | )▶ to create a landscape                     |
| (iii) Media and Techniques | )▶ using painting media.                     |

**E. Images are stronger when contrasts of light and dark are used.**

Suggested Methods or Strategies:

- Explain to students that when dark values and light values are placed side by side, you get a strong contrast. White and black make the strongest contrast of all because they are exactly opposite. Have students make a cut paper design using only black and white paper. Begin to use the term contrast in other art lessons.
- Ask students to do printmaking using dark values for the paper and light values for the inks or vice versa. Get students to view their work from a distance to see if there is enough contrast to make the printing show up.
- Ask students to draw or paint the same subject matter using dark colours for the background and light ones in the foreground. Then reverse the darks and lights in the second composition. Discuss the different feeling each picture evokes when the contrast is inter-changed.
- Have students paint an entire composition using tints or shades of a colour or hue. Ask them to place dark tones beside light ones for contrast.

Integrating with Art Content Areas:

This concept provides background for learning in: **APPRECIATION, Component 3, Concept E** (tints and shades of colours or hues affect the contrast of a composition) and **COMPOSITION, Component 7, Concept C** (the front of the picture ground should contrast with the subject matter for emphasis).

An opportunity can also be provided in

**EXPRESSION, Component 10:**

- |                            |  |
|----------------------------|--|
| (i) Purpose                | )▶ Students can use dark and light contrasts in compositions |
| (ii) Subject Matter        | )▶ based on their choice of subject matter                   |
| (iii) Media and Techniques | )▶ using photography, photograms or a copying machine.       |

**F. Details enrich forms.**

Suggested Methods or Strategies:

- Have students trace each other's body outlines on large pieces of brown paper. Then ask them to show all the details of their body: facial features, patterns and surface qualities of clothing. These can be cut out when the details have been added with paint and/or felt pens. Be prepared to draw attention to details the students may have missed. Use a large mirror so students can keep checking for details.
- Select slides from the Alberta Heritage Flora and Fauna Kits to represent plant and animal life. Have students do some drawings while viewing the slides to encourage the inclusion of surface details rather than just outlining of forms.
- Encourage students to experiment with ways of decorating clay: coils, small balls of clay flattened to create patterns, shapes cut from cookie cutters, plastic caps or bottle caps added on, corrugated cardboard cut in strips, shapes cut from the surface, etc.
- Ask students to look at people to see the kinds of details that make people-watching interesting: patterned clothing, ornamental jewelry, unusual hair styles, tattooing, interesting footwear. Have students depict a person wearing detailed clothes and jewelry. Another way of motivating students is to read a poem such as "Pirate Don Durk of Dowdee" or an excerpt from a story describing a person in great detail (like the greengrocer in "Jacob Two Two and the Hooded Fang"). Students will enjoy illustrating such characters. Be prepared to read the descriptions more than once; as students won't be able to remember everything from a first reading.



Integrating with Art Content Areas:

This concept can be used to develop Concept B in COMPOSITION, Component 7. The main part of the composition can be treated thoroughly before adding related parts.

An opportunity can also be provided in

**EXPRESSION, Component 10:**

- |                            |  |
|----------------------------|--|
| (i) Purpose                | )▶ Students can use stitchery to add details |
| (ii) Subject Matter        | )▶ to a subject matter of their choice       |
| (iii) Media and Techniques | )▶ in fabric collage or applique.            |

Integrating with Other Subjects:

Language Arts - Compare details in art with details in literature where the images are mental rather than physical. Ask students to translate descriptive language into an art work using drawing, painting or fabric mediums.



## COMPONENT 7: EMPHASIS

**Objective: STUDENTS WILL CREATE EMPHASIS BASED ON PERSONAL CHOICES.**

Teaching/Learning Materials for the Component:

ANOTHER LOOK, Level A, viewfinders, collections of items that can be arranged in groups to make compositions (these can be classroom objects or natural or man-made objects that represent a particular topic of study).

**Concepts: A. An active, interesting part of the theme can become the main part of the composition.**

Suggested Methods or Strategies:

Theme refers to the overall subject matter of a composition.

- Children can draw or paint themselves participating in an event. Begin compositions with the main action and figures. Add supporting items and environments afterwards.
- Arrange collected items to find the best organization for a composition. (Use items that are found on the teacher's desk or work table, or other items from the classroom.) Encourage students to focus on a major attraction and to rearrange items until something stands out prominently. Animals, figures, buildings, etc., are suitable units.
- Have students make a composition of cut shapes (based on what they learned about geometric shapes in Component 4, Concept A). Ask them to emphasize one shape by means of colour or size. The compositions can be evaluated by asking the class to locate the shape that is most prominent.
- Viewfinders may be used to frame mini-compositions in the classroom or outdoors. Students can be directed to search for a composition that contains a prominent size, shape or colour.

### Integrating with Art Content Areas:

The lesson suggestions above can be used as a basis for lessons in

#### **EXPRESSION, Component 10:**

- |                            |   |
|----------------------------|---|
| (i) Purpose                | ▶ Students may create an original composition |
| (ii) Subject Matter        | ▶ based on a field trip experience            |
| (iii) Media and Techniques | ▶ using drawing or painting methods.          |

**B. The main part of the composition can be treated thoroughly before adding related parts.**

### Suggested Methods or Strategies:

- Decide what is to be the most interesting part of a picture. Make it first, largest and in most detail. Then fill out the rest of the picture space with supportive content - harmoniously related to the main idea. Let some items run off the page and others can be partially hidden or overlapped by the major forms.
- Have students create compositions that show cross sections of school desks, buildings, vehicles, underground, fruit, underwater, or x-ray pictures to show the interior of what things look like. Make the most prominent item the strongest to create a centre of interest.
- Students can draw or paint themselves in interesting activities. Add specific items, actions and details after brainstorming with the class. Strengthen lines and add details to the compositions so that they stand out from a distance and from all other parts of the picture.
- See ANOTHER LOOK, Level A: Between the Trees (Drawing to Emphasize Space).

Integrating with Art Content Areas:

This lesson can be used as a basis for lessons in

**DEPICTION, Component 6:**

Represent Surface Qualities  
and Details, Concept F: Details enrich forms.

**COMPOSITION, Component 8:**

Create Unity Through Density  
and Rhythm, Concept D: A composition should develop the setting  
or supporting forms as well as the subject  
matter.

**EXPRESSION, Component 10:**

- |                            |  |
|----------------------------|--|
| (i) Purpose                | )▶ Students could illustrate a story showing the main characters prominent before adding supporting details. |
| (ii) Subject Matter        | )▶ Base it on a fantasy from children's literature   |
| (iii) Media and Techniques | )▶ using drawing and painting media together or a collage technique with fabric or paper.                    |

**C. Contrast the subject matter with the ground for emphasis.**

Suggested Methods or Strategies:

- Discuss the difference between foreground and background. A simple composition may just include these two picture planes. Identify each on landscapes that have been photographed or painted. Cut paper can be used to create foreground and background. When one is cut out, it defines the other. A simple horizon line also establishes the two picture planes. The subject of the composition should stand out from the ground and be contrasted with it in order to be prominent.

Integrating with Art Content Areas:

Concept B can be used as a basis for a lesson in

**EXPRESSION, Component 10:**

- |                            |   |
|----------------------------|---|
| (i) Purpose                | )▶ Students may create a composition contrasting the subject matter with the ground                   |
| (ii) Subject Matter        | )▶ based on an environment of their choosing,   |
| (iii) Media and Techniques | )▶ using fabric and simple stitchery (or applying wool with glue to create contrast to fabric areas). |

or as a follow up to **DEPICTION, Component 4, Concept E.**

**D. Forms can run off the edges of the picture space in a composition.**

Suggested Methods or Strategies:

- Work with themes such as: My Neighbourhood, In the Forest, In a Jungle. Let the surrounding things run off the edges of the paper. View closely and frame (possibly with a viewfinder) the more central things. For example: look through or between big trees, between big buildings, etc. Refer to Townley's **ANOTHER LOOK, Level A: Between the Trees.**
- After one object with interesting detail has been chosen for the class (bicycle, automobile, a musical instrument, a machine like a projector that has a variety of shapes within it), have students draw it by choosing one part of it as their starting point. Encourage them to concentrate on the chosen part alone until all of its detail has been captured, and then to draw all other parts that relate to it until they run out of paper. If students start the drawing on a large scale, they will not be able to include the entire object but the class will yield a variety of viewpoints according to the central focus selected.
- Use viewfinders to frame smaller portions of a large object. Students can then draw only that which is enclosed in the viewfinder.

Integrating with Art Content Areas:

The previous suggestions can be used as a basis for a lesson in

**EXPRESSION, Component 10:**

- |                            |   |
|----------------------------|---|
| (i) Purpose                | )▶ Students can create an original composition                  |
| (ii) Subject Matter        | )▶ based on a manufactured or man-made object of their choosing |
| (iii) Media and Techniques | )▶ using drawing media that will show fineness of detail.       |

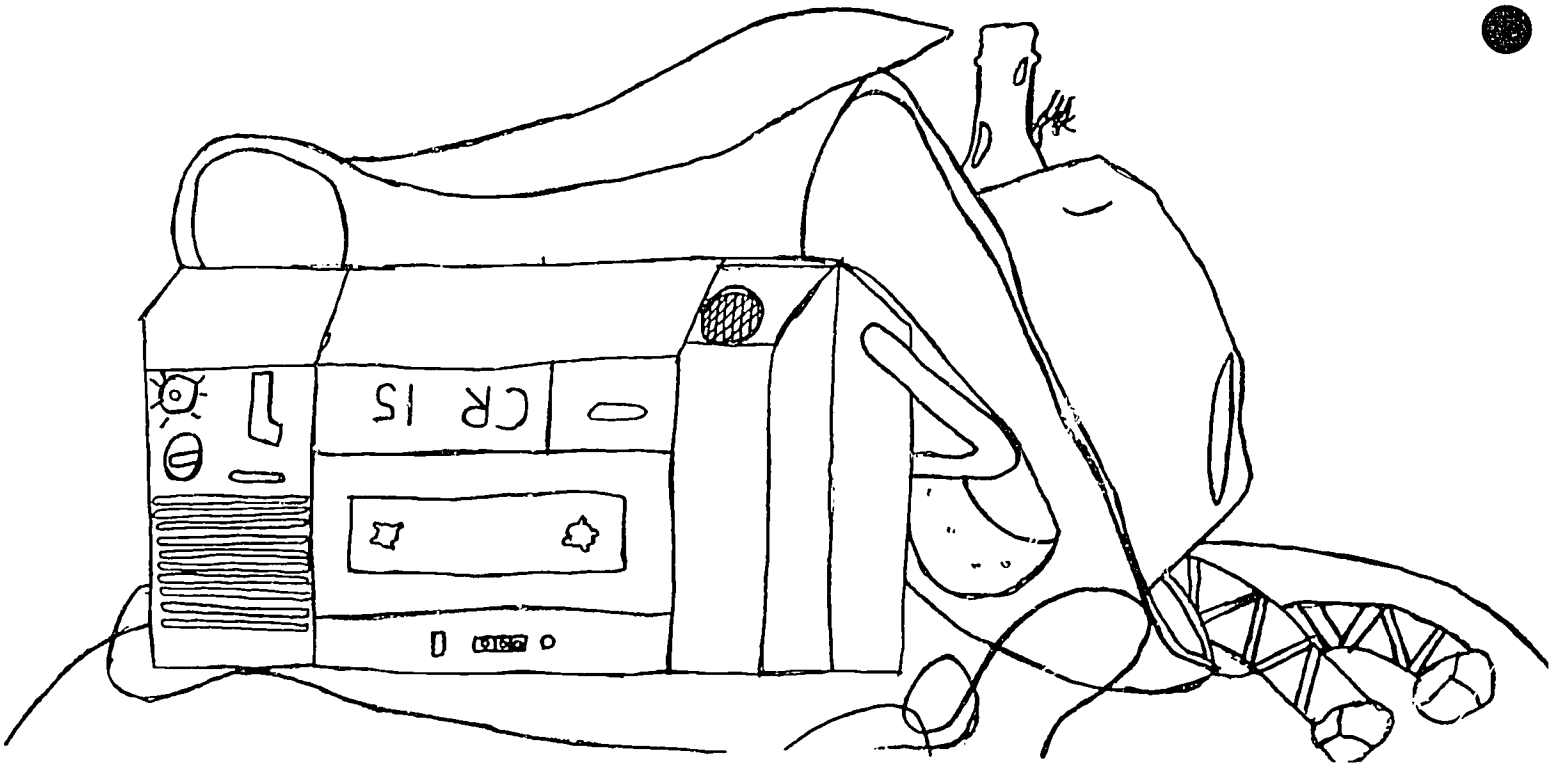

## COMPONENT 8: UNITY

**Objective: STUDENTS WILL CREATE UNITY THROUGH DENSITY AND RHYTHM.**

Teaching/Learning Materials:

flannel board  
overhead projector  
ANOTHER LOOK, Levels A, B and C  
neighborhood walks  
MODEL IDEAS  
COLLAGE IDEAS  
construction paper  
scissors  
glue  
PICTURE IDEAS  
printing media  
EMPHASIS ART

**Concepts: A. Families of shapes and shapes inside or beside shapes create harmony.**

Suggested Methods or Strategies:

- Discuss how people in families tend to resemble one another. Ask students to make shapes that resemble each other from coloured paper and show them on a flannel board or overhead projector. When students seem to understand what is meant by a family of shapes, ask them to make a composition of a family of shapes in which the size and colour varies, but the shape stays much the same. Suggest geometric shapes or simple curved shapes that will be easy to duplicate. When the compositions are completed, ask students to view them and talk about why the shapes in each composition seem to belong to the same family. Tell them that when shapes belong together in this way, we say the picture has unity or harmony.
- Read or play the musical version of "There Was an Old Lady Who Swallowed a Fly". Ask students to illustrate it using the x-ray technique learned in Component 5. Talk about which shapes will surround other shapes before illustrating. Use Acetate sheets to show additions.

- Show students a Matrioska doll (Russian doll containing one or more other dolls that fit inside each other). Line the dolls up in ascending order after showing how they fit together, and ask students to show an x-ray vision of all inside another.
- Collect many small boxes of different sizes. Ask students to paint each box in a decorative way and to find a series of three or more that will fit inside each other. Discuss why the boxes seem to belong together. Ask the class to bring other examples of shapes inside shapes to school (children's toys, nesting baskets, etc.).
- Use **ANOTHER LOOK, Level C, "Caves, Tunnels and Holes"** for a lesson on enclosed space.
- Encourage the class to search inside and outside the classroom for objects that enclose other shapes. Have students make sketches of some of these. Provide magazines to locate other objects that have shapes inside shapes. See **PICTURE IDEAS** pp. 16-19 for examples of growth patterns.
- Ask students to locate a repetition of shapes inside the classroom or out in the neighborhood. Tell them that when the same shape is repeated over and over, it makes a kind of rhythm. Ask students to draw a picture to show a rhythm created by buildings (repetition of doors, windows, shingles, etc.), or by objects in the classroom (blackboards, desks, windows, cupboards, etc.), or natural objects (honeycomb, pine cones, butterfly wings, rows of trees, flower gardens).
- Introduce one or two techniques in paper sculpture that make a rhythmic pattern: cat stairs, fringing, hole-punching, accordion pleating, etc. Then ask students to invent other ways that will create patterns through repetition. After some experimentation, ask students to create paper sculptures using two or more of the techniques learned. Some assistance or suggestions may be needed in fastening one surface to another. Use stapling, glue or tape. See **MODEL IDEAS**, pp. 57-63, for some examples.
- See **COLLAGE IDEAS**, pp. 56-71, for ideas on paper collage that show rhythm and repetition.

Integrating with Art Content Areas:

This concept can provide background for Concept B that follows (overlapping forms helps to unify a composition). Opportunities can also be provided in

**EXPRESSION, Component 10:**

- |  |  |
|--|--|
| <ul style="list-style-type: none"> <li>(i) Purpose</li> <li>(ii) Subject Matter</li> <li>(iii) Media and Techniques</li> </ul> | <ul style="list-style-type: none"> <li>▶ Students can create an object or composition to show shapes inside shapes</li> <li>▶ on a theme of their choice</li> <li>▶ using clay modelling or stamp printing or fabric collage.</li> </ul> |
|--|--|



Integrating with Other Subjects:

Mathematics - Grade One - Students compare two or more objects as shorter, longer, thinner, thicker, heavier, and lighter than.

Grade Two - Students develop and continue patterns using 3-dimensional figures.

**B. Overlapping forms help to unify a composition.**

Suggested Methods or Strategies:

- Ask a small group of students to stand so that overlapping occurs. Have students identify how many children are in the group, who can be seen entirely, and who is standing behind or in front of whom. After a brief discussion, ask the small group to stand separately. Discuss how this changes the way in which the group is viewed. Together, the group makes a unified whole; apart, each is a shape unto itself. Get students to make a continuous line drawing to show the group standing together.
- Use a number of geometric shapes on an overhead projector. Ask students to take turns "composing" by clustering the shapes together to show that they are related.
- Use ANOTHER LOOK, Level A: "Separate or Touching" or "Separated and Touching".
- Use ANOTHER LOOK, Level C: "Two Heads for One Giraffe" or "Crowds".
- Show your students some cityscapes and have them identify examples of overlapping buildings. Ask them to show a crowded city space using cut paper buildings and adding details with felt pen or crayons. Discuss why the buildings belong together. (They will most likely be a family of rectangular shapes.)

Integrating with Art Content Areas:

Opportunities can be provided in

**EXPRESSION, Component 10:**

- |                            |   |
|----------------------------|---|
| (i) Purpose                | ▶ Students can use overlapping techniques to indicate rhythms in nature |
| (ii) Subject Matter        | ▶ (field of flowers, forest, flight of birds, school of fish)           |
| (iii) Media and Techniques | ▶ using fabric collage or stencil printing in a variety of colours.     |

**C. Repetition of qualities such as colour, texture and tone produce rhythm and balance.**

Suggested Methods or Strategies:

- Collect objects which show a repetition of colour, texture and/or tone in their design. Talk about the rhythmic effect created by these repetitions. Compare rhythm in music with visual rhythms. Ask students to identify visual rhythm in the classroom showing repetitions of colour, texture or tone. Ask students to make a stamp print in which the colour texture or tone is repeated at regular intervals to create rhythm (which gives the feeling of movement). Discuss the uses for regular printed patterns on paper, e.g., wrapping paper, note paper, wall paper, rug designs, textile design.
- Ask students to create clay tiles that repeat various textures made using objects for imprinting or using the fingers to pinch and push the clay to make designs. If the clay tiles are to be used together, the clay should be rolled out in a large piece and measured as it is cut into tiles. The back of the tile can be scored before firing to prevent some warping. Ask students to find a use for their tiles. Can they be applied around a sink or water fountain, or is there a place in the hallways that needs a face lift?
- Use ANOTHER LOOK, Level C: "Patterns".
- Repetition of tone can be used to create rhythm and balance in a composition. Once this effect is achieved, the composition is unified. Ask students to paint a composition in which the tones are limited, thereby ensuring repetition of tone. Themes can be chosen which lend themselves to values of one colour or hue: forests, under-water scenes, cityscapes, a bunch of flowers.

Integrating with Art Content Areas:

An opportunity can be provided in

**EXPRESSION, Component 10:**

- |   |  |
|---|--|
| <p>(i) Purpose</p> <p>(ii) Subject Matter</p> <p>(iii) Media and Techniques</p> | <p>▶ Students can use colour, textural or tonal rhythms</p> <p>▶ choosing their own subject matter</p> <p>▶ using mixed media. (See EMPHASIS ART for mixed media techniques: tempera-India ink batik, crayon resist, crayon engraving, oil pastel resist.)</p> |
|---|--|

Integrating with Other Subjects:

Music - Grade 1 - Students learn that long sounds, short sounds and silences may be grouped to form rhythmic patterns.

- Grade 2 - Students learn that rhythmic patterns can accompany melody and may move in relation to the beat in music.

**D. A composition should develop the setting or supporting forms as well as the subject matter.**

Suggested Methods or Strategies:

- Have students create a unified background for an art work (with finger paint, or applying paint or printing ink with sponges, brayers, or other devices -- tissue paper, colour washes). Then encourage them to superimpose other patterns or prints on the figured surface.
- Ask students to draw or paint a picture of an undersea adventure, a herd of jungle animals, a flower garden. Suggest that they draw the things that are nearest to them large and then add the ones behind by tucking them in behind the ones in front. Things should be smaller and less detailed as they are farther away.  
Possible themes for this composition:

a flock of birds, a fleet of boats, a swarm of bees, a stand of trees, a gang of workers, a team of players, a rack of bikes, a bunch of flowers, a school of fish, a herd of cows, antelope, deer, etc.

- Use lessons from ANOTHER LOOK, Level B: "Space - Country" and "Space - City".
- Students should be encouraged to evaluate their own work when it is finished. If the art work deals with representative subject matter, ask students to look at their work to see if the space around the main subject is related to that subject. Sometimes children will not add supporting details to the main subject and through some interaction with the student, you can explore the possibilities from which a student can choose to make the composition more unified and interesting.
- A magazine collage can be created by asking students to choose a main figure (animate or inanimate) that they find interesting. Once this has been chosen and placed within a picture space (background), ask students to search for smaller figures that would relate to the main figure. Talk about how these could be added by means of overlapping and placing them at different levels within the picture plane.

Integrating with Art Content Areas:

This concept will help students assess their own work in Component 9 (Craftsmanship), Concept B: Stepping back from a work helps in judging how it can be improved.

An opportunity can also be provided in

**EXPRESSION, Component 10:**

- |                            |  |
|----------------------------|--|
| (i) Purpose                | )▶ Students can create a diorama                         |
| (ii) Subject Matter        | )▶ choosing geographic settings<br>or building interiors |
| (iii) Media and Techniques | )▶ using paper folding, paper<br>collage, paint, etc.    |

Integrating with Other Subjects:

Language Arts - The concept of supporting the main subject can also be developed in a reading lesson. Students can be asked to identify the main characters and the supporting characters in a story. These main and supporting characters can be the subject for a drawing or painting which can be enhanced by including details from the story setting.



# COMPONENT 9: CRAFTSMANSHIP

**Objective: STUDENTS WILL ADD FINISHING TOUCHES.**

Teaching/Learning Materials:

Both of the following concepts should be used by the student for self-evaluation each time a lesson is taught in COMPOSITION.

**Concepts:      A. Finishing touches (accents, contrasts, outlines) can be added to make the work more powerful.**

Suggested Methods or Strategies:

- This concept is learned by having students evaluate their work when it is finished. The class can make a checklist of finishing touches and the teachers and students can use them as reminders when work is completed. If the process is performed often enough students will begin to do it automatically. Some finishing touches are: accents (adding bright colour or bolder lines to make something stand out), contrasts (darks beside lights), outlines (to be added often with another media to make main forms more prominent), additional detail (to enrich the main forms or increase interest in the background and/or supporting forms).

**B. Stepping back from a work helps in judging how it can be improved.**

- This concept is also evaluative and should be encouraged by the teacher and practised by students. Often by the time the work is displayed, it is too late to alter a composition. Provide a tackboard space where students can tack their work in order to view it from a distance. Use the criteria developed in Concept A of this component to evaluate the work when seen from afar. Encourage students to do this each time a composition has been completed.

Integrating with Art Content Areas:

The activities suggested in this component can be used each time a composition has been completed.

# Teaching Components

## Level Two

# Level Two Grade 3-4

## REFLECTION

### STUDENTS WILL

#### Component ANALYSIS

### 1. MAKE DISTINCTIONS WITHIN CLASSES OF NATURAL OBJECTS OR FORMS.

#### Concepts:

- Each class of natural forms has distinguishing characteristics.
- Natural forms are related functionally to their environment.
- Earth and water forms reveal many variations.
- Environments are altered by natural forces.
- Change in natural forms occurs over time.

#### Component ASSESSMENT

### 2. ASSESS THE VISUAL QUALITIES OF OBJECTS.

#### Concepts:

- Form should follow function.
- Durability influences the function of an object.
- Materials should be used honestly.
- Materials influence the form and function of an object.
- Useful objects can be derived from designs in nature.
- Surface treatments should harmonize with and not distract from the main form.

#### Component APPRECIATION

### 3. INTERPRET ART WORKS BY EXAMINING THEIR CONTEXT AND LESS VISIBLE CHARACTERISTICS.

#### Concepts:

- Contextual information (geographical, historical, biographical, cultural) may be needed to understand works of art.
- Artistic style is largely the product of an age.
- Technological change affects the types of art.
- Our associations influence the way we experience a work of art.
- Art is valued for different reasons (aesthetic, economic, symbolic, associative, etc.).
- Art serves societal as well as personal needs.

## DEPICTION

#### Component MAIN FORMS AND PROPORTIONS

### 4. PERFECT FORMS AND DEVELOP MORE REALISTIC TREATMENTS.

#### Concepts:

- Shapes can suggest movement or stability.
- Many shapes are symmetrical.
- Images can be portrayed in varying degrees of realism.
- Internal as well as external proportions can be depicted.
- Landscapes can show middle ground, background and fore-ground.
- Size variations among objects give the illusion of depth.

#### Component ACTIONS AND VIEWPOINTS

### 5. SELECT APPROPRIATE REFERENCES FOR DEPICTING.

#### Concepts:

- Looking at negative shapes helps create a different view of something.
- Drawing strategies (such as gesture to capture action, contour to study important edges, and massing to show bulk or weight) are helpful in depicting animate forms.
- Actions among things in a setting create a dynamic interest.
- Objects can be depicted selectively from a broad range of viewpoints.

#### Component QUALITIES AND DETAILS

### 6. REFINE SURFACE QUALITIES OF OBJECTS AND FORMS.

#### Concepts:

- Texture can be represented from a range of different studio techniques.
- Colour can be made to appear dull or bright.
- Gradations of tone are useful to show depth or the effect of light on objects.
- By increasing details in the foreground the illusion of depth and reality can be enhanced.

## COMPOSITION

#### Component EMPHASIS

### 7. CREATE EMPHASIS BY THE TREATMENT OF FORMS AND QUALITIES.

#### Concepts:

- The centre of interest can be made prominent by contrasting its size, shape, colour, texture from the other parts of the composition.
- The format can be adjusted and the composition tightened by editing or cropping the unnecessary areas from the edges of a work after it is completed.
- Details, accents and outlines will enhance the dominant area or thing

#### Component UNITY

### 8. CREATE UNITY BY INTERRELATING THE PARTS OF THE COMPOSITION.

#### Concepts:

- The parts can be arranged so that movement in the picture space leads the eye around and not out of the picture area.
- Parallel edges induce harmony within the composition.
- Every major area of a composition should be interesting in itself.
- Limited colours and materials tighten a composition.

#### Component CRAFTSMANSHIP

### 9. IMPROVE COMPOSITIONS BY REFINING, REHEARSING AND CRITIQUING.

#### Concepts:

- Refinement of forms and surface qualities is necessary in giving a finished appearance to the composition.
- Rehearsals and ongoing critiques should be scheduled to improve composing skills.

## EXPRESSION

#### Component (1) PURPOSE

### 10. RECORD OR DOCUMENT ACTIVITIES, PEOPLE AND DISCOVERIES.

#### Concepts:

- Everyday activities can be documented visually.
  - Special events such as field trips, visits and festive occasions can be recorded visually.
  - Family groups, people relationships can be recorded visually.
  - Knowledge gained from study or experimentation can be recorded visually.
  - Local and provincial events can be recorded visually.
- ILLUSTRATE OR TELL A STORY.
    - A narrative can be retold or interpreted visually.
  - An original story can be created visually.
  - Material from any subject discipline can be illustrated visually.
    - Details, patterns, textures can be added to two-dimensional works.
  - Details, patterns, textures can be added to the surface of three-dimensional works.
    - EXPRESS A FEELING OR A MESSAGE.
      - Feelings and moods can be interpreted visually.
  - Specific messages, beliefs and interests can be interpreted visually or symbolized.
    - CREATE AN ORIGINAL COMPOSITION, OBJECT OR SPACE BASED ON SUPPLIED MOTIVATION.
      - Outside stimulation from sources such as music, drama, literary photographs, film, creative movement, television and computers can be interpreted visually.

**(II) SUBJECT MATTER**

1. DEVELOP THEMES, WITH AN EMPHASIS ON SOCIAL CONCERNS, BASED ON:

- A. Plants and animals
- B. Environments and places
- C. Manufactured or man-made things
- D. Fantasy
- E. People

**(III) MEDIA AND TECHNIQUES**

1. USE MEDIA AND TECHNIQUES, WITH AN EMPHASIS ON MIXING MEDIA AND PERFECTING TECHNIQUES IN DRAWING, PAINTING, PRINTMAKING, SCULPTURE, FABRIC ARTS, PHOTOGRAPHY AND TECHNOGRAPHIC ARTS:

**Concepts:**

A. Drawing

- Continue to explore ways of using drawing materials.
- Use drawing tools to make a variety of lines extending beyond Level One into character and direction -- passive, vertical, horizontal, diagonal, parallel.
- Use drawing tools to make a variety of shapes and structures beyond Level One into symmetrical and asymmetrical, skeletal, spiral, and into mass drawing (blocking in the main parts of a composition).
- Place more emphasis on direct observation as a basis for drawing.
- Use drawing to add details, texture or to create pattern including drawing for high detail.
- Make quick sketches.
- Make drawings from a wide range of viewpoints.
- Experiment with blind contour drawing and continuous line drawing.
- Use drawing media to achieve gradations of tone or value in drawings.
- Use simple methods to indicate depth or perspective (increase details in the foreground, use lighter tones or values in the background, large objects in foreground).

B. Painting

- Extend brush skills and further experimentation with the medium so as to achieve special effects such as textures.
- Continue to paint, using experimental methods including those without brushes.
- Continue working with tempera paint or tempera paint with additives and be introduced to watercolour.
- Mix paints to show intensity of colour.
- Continue to use paint in combination with other media and techniques.
- Apply washes using tempera or watercolour.
- Use preliminary sketches as the basis for a painting as well as painting directly.

C. Printmaking

- Further explore printmaking materials and their uses and effects.
- Make relief prints (printing from a built-up surface) using glue line, string, cardboard or collage materials.
- Make prints using stencils.
- Make smudge or blot prints by folding paper with ink between.
- Explore printing with more than one colour.
- Make monoprints working directly with the plate or a surface.
- Continue using printmaking techniques learned in other grades.
- Apply printmaking techniques to compositions.

D. Sculpture

- Continue to make two- and three-dimensional assemblages from found materials reaching for more sophistication leading to specifics such as puppets, mobiles, mosaics, papier mâché.
- Continue exploring modelling possibilities of clay beyond Level One -- techniques such as wedging, welding, making of slabs by rolling, throwing, paddling, impressing with objects, decorating with coils, pellets, extruded clay, firing, glazing.
- Continue exploring paper sculpture as a means of making three-dimensional forms.
- Explore wood relief using fastening techniques such as nailing and gluing, and finishing techniques such as sanding and staining.
- Continue casting of plaster, advancing to include both relief and intaglio with a greater emphasis on composition and finishing work.
- Explore the possibilities of simple wire sculpture including bending, twisting, cutting, looping.

E. Fabric Arts

- Decorate fabrics using simple stitching techniques such as running stitch, blanket stitch, cross-stitch, couching, French knot, satin stitch.
- Continue to advance weaving techniques beyond Level One to include such things as warping a simple loom; achieving interesting surface qualities with open weave, double weave; using looms that are not rectangular in shape; altering the weave of an existing loosely woven fabric.
- Use simple batik using melted wax and one colour of dye.
- Continue using collage, braiding and tie-dyeing techniques from previous grades, if possible.
- Decorate and/or design using applique.

F. Photography and Technographic Arts

- Take advantage of visual art implications of any available technological device and explore the potential of emerging technologies. Included at this level and advancing from previous grade:
  - \* simple camera for recording specific effects such as textures, rhythm, pattern
  - \* overhead projector for experimenting with shapes, colours, compositions, sequencing of events using felt pen on acetate
  - \* filmstrips handmade with felt pen for experimenting and sequencing
  - \* slides as a basis for study and motivation in reflection and depiction; handmade for experimenting with line, shape and pattern
  - \* computer and computer software packages and input devices such as the light pen, Koala pad, the mouse, and any other advancements in this area to explore design, compose, animate, and program to make simple geometric forms
  - \* copy devices or Xerox to make compositions and designs
  - \* laserdisc visuals as basis for study and motivation in reflection and depiction
  - \* 8mm movie camera for documentation, sequencing and animation
  - \* lighting sources such as spotlights, flashlights, overhead projector light, disco lights for experimenting with effects
  - \* emerging new technologies as available and applicable
- Employ technological media techniques, practices and capabilities to promote art understandings and create designs and compositions. Included at this level and advancing from previous grade:
  - \* adjustable framing devices to select and cut out scenes from a larger picture and to sequence
  - \* shadow puppets
  - \* photograms to make compositions or develop a story line
  - \* printers to record computer compositions or direct photography off the screen)
  - \* animation techniques available through computer software packages
  - \* stop film animation with jointed figures, moveable paper shapes or plasticine models
  - \* lighting techniques for highlighting and creating an effect or mood



# COMPONENT 1: ANALYZING NATURAL FORMS

**Objective: STUDENTS WILL MAKE DISTINCTIONS WITHIN CLASSES OF NATURAL OBJECTS OR FORMS**

Teaching/Learning Materials for the Component:

natural objects such as cones, shells, driftwood, plants, rocks,  
photographs of classes of animals and/or plants  
Alberta Heritage Flora and Fauna Kits  
visit to a greenhouse or conservatory  
magazines: Ranger Rick, Chickadee, Owl  
terrarium  
aquarium  
field trips to outdoor places  
trips to the playground or neighborhood for specific purposes  
ANOTHER LOOK, Levels A and B

**Concepts: A. Each class of natural forms has distinguishing characteristics.**

Suggested Methods or Strategies:

- Isolate a class of plant or animal forms. Using photographs or actual objects encourage students to examine them for characteristics which have caused them to be grouped together. Look at one of the slide sets of the Alberta Heritage Flora and Fauna Kits to see how biologists group plants or animals.
- Visit a local greenhouse or conservatory with your students to look at different classes of plant forms, e.g., succulents, ferns, ivies, palms, cacti, etc. Each student could choose a group that has similarities and sketch them to show this.
- Use ANOTHER LOOK, Level A: "Trees" and Level B: "Weeds".
- Students can choose a group of similar objects from the natural environment. Once the environment has been scanned, and a similar group of objects chosen, have students examine the group in detail focussing on similarities and differences in size, shape, colour, texture, tones, lines and patterns. Magnifying glasses or viewfinders can be used to make careful examinations of various parts. Encourage the students to view the objects within the group from different points of view (range, angle). Students should be

encouraged to group the objects having one or more similar characteristics. Follow this with recordings of the objects within the group to show similarities and differences. Focussing on similarities and differences helps to train the eye as well as provide compositional effects of contrast, harmony and variety. Pencil, felt pen, charcoal or pastel drawings/sketches can be made. Students could make pencil or crayon rubbings of similar parts of the group members. Plaster of Paris castings of some selected groups could be made.

- Ask each student in the class to bring to school a natural object or photograph of a natural form which can be classified as plant, animal or mineral. Give time for students to place their contribution within those three groups. Then consider each group individually as to the differences and similarities in shape, colour, texture, and size. Based on these, break each larger groups into smaller groups. Allow each child to identify their object within the group and tell what it has in common with the other objects in that group. This activity can be further extended by having students study their object for an allotted time (2 or 3 min.) after which it is removed from view and they must try to describe the object from memory.
- Ask students to bring a fruit or vegetable to school. After studying its shape, instruct them to dissect it to view its inside shapes and forms. Discuss the patterns within the dissected shapes and identify them (symmetrical, asymmetrical or radial). Encourage students to make quick sketches to capture these patterns. While cutting the fruit and vegetables into smaller pieces have students consider the shapes these cuts will create. Arrange the cut pieces to make a salad that repeats a shape or combines shapes in ways that create new shapes.

#### Integrating with Art Content Areas:

This concept can be used to help develop Concept B that follows as well as DEPICTION, Component 4 (Main Forms and Proportions) Concept B: Many shapes are symmetrical and Component 5 (Actions and Viewpoints) Concept D: Objects can be depicted selectively from a broad range of viewpoints.

In addition, students can apply their knowledge of natural forms in

#### **EXPRESSION, Component 10:**

- |  |   |
|--|---|
| <ul style="list-style-type: none"> <li>(i) Purpose</li> <li>(ii) Subject Matter</li> <li>(iii) Media and Techniques</li> </ul> | <ul style="list-style-type: none"> <li>▶ Students can record their knowledge</li> <li>▶ by choosing a plant or animal form</li> <li>▶ to sketch using a variety of drawing tools. A sketchbook can be used throughout the year to capture drawings of forms and figures that might be used later in a composition.</li> </ul> |
|--|---|

Integrating with Other Subjects:

Science - Students can examine the classification system used by scientists to group plants and animals.

**B. Natural forms are related functionally to their environment.**

Suggested Methods or Strategies:

- With the class identify different kinds of environments, e.g., forest, tropics, desert, arctic, marine. Choose one example and locate pictures of plant and animal forms that live in that environment. Use magazines, encyclopedia and picture files in the library. Encourage students to identify some of the environmental factors that suit the organism to its environment.
- Encourage the class to observe birds (at a sanctuary, feeding station, barnyard or natural setting) or fish (aquarium). After some viewing time is given brainstorm for words that describe the movements they have seen and the shapes of the organisms. Discuss how the shape helps the animal to function in its habitat.
- With the help of your students gather a collection of sea shells. Group them according to shape. Note the distinctions between univalves (one shelled mollusks) and bivalves (hinged mollusks like clams, scallops and oysters). Research the behaviors of these two kinds of mollusks and infer why the bivalves are shaped to open and close whereas the univalves have a different adaptation for feeding and locomotion.
- View slides from the Alberta Heritage Flora and Fauna Kits to compare birds, plants or animals that have adapted to different kinds of habitats. The script with each slide set speaks to the adaptive qualities in each species.
- Introduce the class to the different ways in which rocks form, and show examples of each. Discuss the qualities that each has in terms of its formation. View them under a microscope to make their differences even more noticeable. See if students can infer the origins of other rocks which can be collected and examined.

### Integrating with Art Content Areas:

The lesson that has been acquired in this concept about plant and/or animal forms can be used as theme material for the drawing strategies taught in DEPICTION, Component 5, Actions and Viewpoints, Concept B: Drawing strategies (such as gesture to capture action, contour to study important edges, and massing to show bulk or weight) are helpful in depicting animate forms.

It can also be used as theme material to teach  
DEPICTION, Component 4, Main forms and Proportions, Concept A:  
Shapes can suggest movement or stability.  
Some opportunities for expression can also take place in

#### EXPRESSION, Component 10:

- |                            |   |
|----------------------------|---|
| (i) Purpose                | )> Students can record knowledge gained from their study of |
| (ii) Subject Matter        | )> plants or animals in their habitat                       |
| (iii) Media and Techniques | )> using photography or painting a group mural.             |

### Integrating with Other Subjects:

Science - Division Two (LIVING THINGS AND ENVIRONMENTS): Adaptations allow plants and animals to survive in their environment.

<b>C. Earth and water forms reveal many variations.</b>
---

### Suggested Methods or Strategies:

- Use lessons in ANOTHER LOOK, Level C: "Clouds" and "Cloud Colours".
- Encourage students to list as many earth forms as possible: earthquakes, volcanoes, mud pots, mountains, hills, valleys, mesas, plateaus, gullies, caves, moraines, etc. Use encyclopedia and the library picture file to find as many illustrations of earth forms as possible. Encourage students to choose one form to draw.
- This activity requires a winter day when the temperature is not severe. Tell your students that the Inuit have at least a dozen words for snow. Have them conjecture as to why. Take a trip out to the playground to look for different kinds of snow and different snow formations. Discuss which kind of art tools and materials would best represent falling snow and snow formations. Try out some of these.
- With the help of students brainstorm for as many water forms as possible: hail, snow, sleet, rain, puddles, glaciers, lakes, rivers, streams, oceans, geysers. Discuss the characteristics which distinguish one form from another. Use line patterns to represent

the movement of one of these forms, e.g., rippling, gushing, flowing, churning, whirling, splashing, rising and falling, showering, sprinkling.

- During warm weather set aside time for water play at a local wading pool or by using large containers for water in the playground. Have each student try to control the way in which water can move by approaching it in different ways: squirting, dropping objects into water, creating waves, pouring, floating objects on its surface. Get students to record the different kinds of games that use water. Play some of them. Students could illustrate their water games.

#### Integrating with Art Content Areas:

This concept will provide an understanding of some of the natural forces involved in altering the environment as taught in the concept that follows.

The study of earth and water formations would also provide thematic material for DEPICTION, Component 6 (Qualities and Details) Concept C: Gradations of tone are useful to show depth or the effect of light on objects.

Opportunities for expression can also be given

#### EXPRESSION, Component 10:

- |                            |  |
|----------------------------|--|
| (i) Purpose                | )▶ Students can illustrate                                 |
| (ii) Subject Matter        | )▶ water and/or earth forms as<br>a background for a mural |
| (iii) Media and Techniques | )▶ using painting techniques.                              |

#### Integrating with Other Subjects:

Music - Have students listen to music that was inspired by water forms, e.g., The Moldau by Smetana, Water Music by Handel. Identify the rhythms that suggest water movement.

Poetry - Students could collect and share poems that are based on water themes.

Science - Division Two - Concepts about erosion, the water cycle and geological formations are taught.

### **D. Environments are altered by natural forces.**

#### Suggested Methods or Strategies:

- Brainstorm with the class to make a list of natural forces: wind, fog, rain, snow, hail, volcanic actions, glaciation, blizzards, earthquakes, etc. Then discuss how each of these alters the environment. Mime some of them, e.g., wind blowing trees and bending them.

- Visit a creek, stream or river to observe the direction and flow of the water and to note currents or whirlpools. Encourage students to notice whether the bank has been cut away by the water and the action it has had on other objects in its path. Quick sketches to catch the rhythm of the water or the path it makes can be made.
- On a windy day take a walk with your class to observe the effects of the wind on the environment. Observe trees, grass, people, animals and plants. Talk about how you would depict these things when the wind affects them.
- Look at photographs and/or art works in which fog, smog, mist or a dazzling rain is captured. Talk about how artists achieve this effect. (The teacher may refer to **Level Three, Composition: Component 8 [Unity] - Concept F** for ideas about depicting such effects.)

Integrating with Art Content Areas:

This concept provides a background of knowledge for understanding Concept E which follows. It can provide the stimulus for learning about movement and stability in **DEPICTION, Component 4 (Main Forms and Proportions) Concept A: Shapes can suggest movement or stability.**

It can also be used to gather information for a lesson in

**EXPRESSION, Component 10:**

- |  |  |
|--|--|
| <ul style="list-style-type: none"> <li>(i) Purpose</li> <li>(ii) Subject Matter</li> <li>(iii) Media and Techniques</li> </ul> | <ul style="list-style-type: none"> <li>▶ Students can record the influence of natural forces on the environment</li> <li>▶ choosing subject matter that is appropriate to Concept D</li> <li>▶ in drawing, painting or photography.</li> </ul> |
|--|--|

Integrating with Other Subject Areas:

Science - Division Two - Earth/Space/Time: Students observe, measure, record and predict weather conditions and changes.

**E. Change in natural forms occurs over time.**

Suggested Methods or Strategies:

- Arrange a neighborhood walk so that students can observe and discuss the gradual seasonal changes that are taking place. Identify the obvious and more subtle signs that mark a transition from one season to the next. A sketchbook could be used to record some of them.

- Start some plants from seedlings in the classroom. Ask students to keep a visual diary of their growth over a number of months. Early spring would be the best time for this activity.
- Students can observe and depict the stages of growth that occur in the animal kingdom, e.g., tadpole to frog, pupa to butterfly, egg to bird. These stages of growth can be depicted by means of serial drawings, on a scroll format or in a flip book.
- With your students identify a neighborhood tree that can be photographed each month over the course of the school year. Display the photographs as the gradual changes can be observed. Use the photographs as a basis for a drawing or painting.

Integrating with Art Content Areas:

The experiences students gain in this concept can provide thematic material for activities in DEPICTION, Component 5 (Actions and Viewpoints) Concept C: Actions among things in a setting create a dynamic interest.

Students can also use their knowledge in

**EXPRESSION, Component 10:**

- |  |   |
|--|---|
| <ul style="list-style-type: none"> <li>(i) Purpose</li> <li>(ii) Subject Matter</li> <li>(iii) Media and Techniques</li> </ul> | <ul style="list-style-type: none"> <li>▶ By illustrating a change in natural forms</li> <li>▶ Which they have selected</li> <li>▶ Using drawing or painting.</li> </ul> |
|--|---|

Integrating with Other Subject Areas:

Science - Division Two - Moving water erodes and changes the land over time.

Division One and Two - Organisms show behavioral adaptations to environmental changes.

# COMPONENT 2: ASSESSING DESIGNED OBJECTS

**Objective: STUDENTS WILL ASSESS THE VISUAL QUALITIES OF OBJECTS.**

Teaching/Learning Materials for the Component:

Manufactured and man-made objects, magazines that show a wide variety of designed objects.

ANOTHER LOOK, Level C.

**Concepts: A. Form should follow function.**

Suggested Methods or Strategies:

- Emphasize the idea that an object's use helps to determine what the object will look like. Consider useful objects like a broom, a flight of stairs, a chair, etc., and mime their use. Students should be able to observe how the physical movements correspond with the shape of the objects.
- Examine what is meant by "form should follow function", by means of the following: Choose one object such as an automobile and look at the different forms that it takes. Then decide which ones are designed for: racing or faster speeds, as a family vehicle, rough terrain, two passengers, many passengers, etc. Students can then relate the function of the vehicle to its form.
- Ask students to list items that may serve a similar function but are different in appearance and design. For example: Which items can protect one from rain? Which items can be used to beat a mixture in a mixing bowl? Which items can be used for drawing? Which items aid sight? Which items cut? Which items transport? Encourage students to examine the items from one of these classifications to identify differences in appearance and function and similarity in their use. Also, consider which function more effectively in the use to which they are put. Consider whether there is a relationship between design and function.



Integrating with Art Content Areas:

Concept A can be further developed by choosing a lesson from

**EXPRESSION, Component 4:**

Main Forms and Proportions,

Concept A: Shapes can suggest movement or stability.

- |                            |  |
|----------------------------|--|
| (i) Purpose                | )▶ Students can create an original object (e.g., a mask, simple toy) that will function well |
| (ii) Subject Matter        | )▶ based on manufactured or man-made designs   |
| (iii) Media and Techniques | )▶ using papier-mache, wood scraps or cardboard.   |

**B. Durability influences the function of an object.**

Suggested Methods or Strategies:

- Have students define durability. Then get them to identify objects that have been proven durable, as well as objects that were less durable. Conclusions can be drawn relating durability to function.
- Collections of one class of objects can be made so that students can see examples of those that are more durable and less durable. Encourage them to relate durability to function.
- Students can evaluate their own toys on the basis of durability. A list can be compiled of durable and less durable materials based on their own experiences with the toys.

Integrating with Art Content Areas:

Lessons from this concept can be used as a basis for teaching Concept E in this component (useful objects can be derived from designs in nature) as well as in

**EXPRESSION, Component 10:**

- |                            |   |
|----------------------------|---|
| (i) Purpose                | )▶ Students can design a toy that will be durable |
| (ii) Subject Matter        | )▶ on a theme of their choice                     |
| (iii) Media and Techniques | )▶ from a wide selection of materials.            |

**C. Materials should be used honestly.**

**D. Materials influence the form and function of an object.**

Suggested Methods or Strategies:

- Point out to students that each material has its own unique characteristic and disguising one material to appear like another is dishonest unless the designer does it with humorous or whimsical intent. For example: A soft sculpture hamburger has a different purpose than plastic materials that imitate wood grain patterns. The first is intended as a visual joke while the latter was probably manufactured to pass for wood. Since each material usually has some different advantages, it is not necessary to make it appear as something else. Students can identify examples of objects in which a material is used in a dishonest way (plastic that masquerades as leather, metal or ceramics).
- Collect a variety of items from one class of objects: e.g., footwear, tools, utensils, or any object that may have current appeal with students. Have them consider how all the items are similar and different. Encourage them to describe the items and relate their usefulness to their design and the materials used to make them.
- Collect a group of containers made of different materials (styrofoam, glass, metal, china, wood, plastic, fibre) with different purposes (bowl, cup, pitcher, basket, plate, insulator, goblet, etc.). In discussion, encourage children to verbalize how the different materials affect how the container will function and the form the container takes.
- Students can go on a materials search in the school to identify and list the variety of materials used in the interior and exterior of the building. Once the list has been compiled, discuss the possible reasons for using each material as it relates to function.
- Collect a group of different chairs. Let each student have a chance to sit in each chair and keep their own checklist to determine the situation in which each chair would function best. Have them consider how the materials relate to function.
- Or, children can respond to the following headings in evaluating the chairs:
  - The chair that is most comfortable. Tell why.
  - The chair that is for relaxing. Tell why.
  - The chair that is appropriate for desk work. Tell why.
  - The chair that is not functional. Tell why.
  - The chair that is most attractive. Tell why.
  - The chair that is appropriate for a kitchen, a classroom, a bedroom. Tell why.

- Look at a number of everyday objects and discuss each in terms of other materials that could have been used to make it, and how such a change would effect the way it functions.

Integrating with Art Content Areas:

This concept can be used as a basis for a lesson in

**EXPRESSION, Component 10:**

- |   |   |
|---|---|
| <ul style="list-style-type: none"> <li>(i) Purpose</li> <li>(ii) Subject Matter</li> <li>iii) Media and Techniques</li> </ul> | <ul style="list-style-type: none"> <li>)▶ Students may design a container that will function based on a theme of their choice</li> <li>)▶ using the materials needed to fulfill its intended function (clay, woven fibres, fabric, wood, cardboard).</li> </ul> |
|---|---|

Integrating with Other Subjects:

Social Studies - Grade 3 - Gather and organize data by surveying own home to find out where (in Canada) goods used by the family are made (from Topic A).

**E. Useful objects can be derived from designs in nature.**

Suggested Methods or Strategies:

- Students can consider how man's clothing has often been based on the kind of surface covering that animals have as a result of adaptation. They can list different types of clothing that may have been borrowed from animals and identify which animals may have been motivations for the design. Some examples: swimming fins, fake furs, slickers or raincoats, leather jackets, waterproof footwear, sequined dresses, hats like busbies, wet suits. Encourage students to extend the list.
- Students may compare architectural forms with structures built by animals and search for similarities. Consider what man has built based on honeycombs, beehives, bird's nests, beaver house or dam.
- Use lessons from **ANOTHER LOOK, Level C: Shelters.**
- The following list compares a designed object with a natural one that may serve the same function:

toadstool	- umbrella
puddle	- mirror
cave	- house
sunlight	- electric light
shell	- bowl
cupped hand	- drinking vessel
moss	- pillow
stump	- foot stool
log	- bench
stick	- fork

Discuss how each pair is the same and how each is different. Students can decide which of the pair would function most satisfactorily. Encourage students to extend the list.

Integrating with Art Content Areas:

Lesson in

EXPRESSION, Component 10:

- |                            |   |
|----------------------------|---|
| (i) Purpose                | › Students may design a useful object       |
| (ii) Subject Matter        | › based on a natural object of their choice |
| (iii) Media and Techniques | › using materials of their choice.          |

<p><b>F. Surface treatments should harmonize with and not distract from the main form.</b></p>
--

Suggested Methods or Strategies:

- Collect a variety of useful objects that have surface decoration. These can be examined to see if the surface treatment harmonizes with the shape of the object, e.g., a plate will have designs that are circular and enhance the roundness of the plate itself.
- Have students choose an object (articles of clothing, cars, furniture, etc.) and collect a number of illustrations of that article showing different surface treatments. They can assess each object as to whether its surface treatment enhances or detracts from its general shape.
- Drawings of different geometric shapes can be made and students can use lines, textures and shapes that will enhance each individual shape. Make a display to show the variety of ways that each shape can be enhanced yet still retain its identity.

- Paints can be used to decorate plain paper plates to enhance the feeling or roundness their shape conveys.

Integrating with Art Content Areas:

Concept F can be a basis for lessons in

UNITY, Component 8, Concept A: The parts can be arranged so that movement in the picture space leads the eye around and not out of the picture area.

CRAFTSMANSHIP, Component 9,

Concept A: Refinement of forms and surface qualities is necessary to a finished appearance to the composition.

AND

EXPRESSION, Component 10:

- |  |  |
|--|--|
| <ul style="list-style-type: none"> <li>(i) Purpose</li> <li>(ii) Subject Matter</li> <li>(iii) Media and Techniques</li> </ul> | <ul style="list-style-type: none"> <li>)&gt; Students can decorate a three-dimensional object (so the surface treatment harmonizes with its shape)</li> <li>)&gt; based on a theme of their choice</li> <li>)&gt; using tools and materials appropriate to the material of the object. Examples: Sgraffito, brush painting or glazes on a clay object, stitchery or applique on a fabric object. Printmaking techniques on cloth, paper or cardboard.</li> </ul> |
|--|--|



## COMPONENT 3: APPRECIATION

**Objective: STUDENTS WILL INTERPRET ART WORKS BY EXAMINING THEIR CONTEXT AND LESS VISIBLE CHARACTERISTICS.**

Teaching/Learning Materials for the Component:

visits to art galleries, museums or an artist's studio  
 art reproductions: sculpture, drawing, painting, printing  
 children's book illustrations  
 ANOTHER LOOK, Levels A, B and C (Use guide for older students with grade 4)  
 computer, overhead projector, copying machine  
 transparencies  
 tempera powder  
 clear acrylic medium  
 wallpaper paste

**Concepts:** A. Contextual information (geographical, historical, biographical, cultural) may be needed to understand works of art.

Suggested Methods or Strategies:

- Make arrangements for students to visit an artist in his/her studio or for the artist to visit the classroom with some of his/her work. Provide an opportunity for your students to ask the artist questions about his/her work. Interaction between the artist and the class will help to increase their understanding of art works and the life of an artist.
- After a visit with an artist ask students to write a short biography of the artist to be printed in the school newspaper or displayed with some of the artist's work.
- Ask children to write a report on their favorite artist. Provide art reproductions and material written at your student's level. Your library may have some of the Ernest Raboff series: Art for Children, published by Doubleday. These are short biographical sketches on individual artists with coloured illustrations of their work. Provide a sharing time when the reports are completed.
- Organize a visit to a local art gallery to view the works of a specific artist. After viewing the exhibit find out more about the artist from the gallery notes provided on exhibiting artists. Discuss which facts contribute to a further understanding of the artist's work.

- Do some research on a famous painting that interests you and organize a time when you can introduce the work to your students. There is often very interesting, anecdotal information on famous art works that students would find fascinating if the information were written at their level. By doing the research yourself and making the presentation rather dramatic, the interest of younger students can often be captured.

Integrating with Art Content Areas:

This concept can provide background for learning Concept B (artistic style) and Concept C (technological change) in Component 3.

Integrating with Other Subject Areas:

Language Arts - Biographical reports can be written on artists by making a simple outline that covers what the student would like to find out.

**B. Artistic style is largely the product of an age.**

Suggested Methods or Strategies:

- Discuss the meaning of style. Begin by discussing styles of clothing, cars or houses. Once students can identify with these they can also understand that there can be different styles in art. Tell students that each age may produce many styles. Visit a gallery to see some of the styles of today. For a general frame of reference, painting styles can be characterized by realism, abstraction or distortion (forms are distorted for humor, satire or emotional effect). Many specific styles of painting can be attributed to each category, but need not be identified at this level unless the situation calls for it.
- Collect a number of children's books from the library that represent different styles of illustration over a period of time. (This can be done just by choosing the Caldecott winners over a span of years.) Ask children to examine the illustrations to determine whether the style of the art is recent or from past decades. Compare with styles of clothing so that students see that painting styles or styles of illustration also experience fads or characteristics that mark their era.
- Research a particular art movement in order to study it with your students. Some examples: Pop Art, Op Art, Impressionism, Cubism, Primitivism, Expressionism. Provide a number of painting reproductions to represent the movement selected.

- Use **ANOTHER LOOK, A Guide for Using Level C with Older Students** "Sky-Water-Boats", and Level A "Open and Closed" and Level B "Horizontal or Vertical" to compare painting styles.
- Have students choose a favorite illustration. Give them time in the library to make choices. Introduce them to Maurice Sendak, Anno Mitsumuso, Tomi de Paolo, Marcia Brown, Fiona French and Brian Wildsmith (to name a few). Ask each student to select and share a book illustration and to use some descriptive words to capture the artist's style, i.e., bold, delicate, colourful, animated, decorative, orderly, amusing, realistic, fantasy-like, etc.
- Make a display of one artist's work. Choose an artist that has shown some variation in his/her artistic development. Use the display as a basis for discussing similarities and differences, as well as development of a style.

Integrating with Art Content Areas:

This concept can provide background for learning about technological change in art (Concept C which follows).

Integrating with Other Subjects:

Music - Grade Three - In listening skills, students compare styles of music. These can be compared with styles in art.

<p><b>C. Technological change affects the types of art.</b></p>
---

Suggested Methods or Strategies:

- Ask students if there are art forms in existence that were non-existent when their parents were growing up. Examples: music videos, xeroxed art, computerized graphics, synthesized music. Then encourage them to identify and/or research art forms that have been products of the 20th century: mobiles, abstract art; movies, (silent, moving and animated); Pop art; Op art; constructivism, assemblage and kinetics in sculpture, Inuit printmaking. Ask students how technology helped to produce each kind of art.
- With the class, research the history of Inuit printmaking which developed in the 1950's due to the influence of James Houston and his introduction of materials and tools that were not part of Inuit technology at that time in history.



- Explain to students that hundreds of years ago artists painted in tempera (which was a mixture of pigment and egg which served as a binder to help transfer the colour to a surface). Artists used tempera before the invention of oil paints in the 15th century. Acrylic paint is a product of the 20th century. Talk about the differences among all three. Students can make their own acrylic paint by adding a clear acrylic medium such as Rhoplex to tempera powder. Tell students that early artists had to make their own paints by grinding pigments from rocks and minerals or securing colourants from natural sources, most often plants. Give students time to experiment by mixing tempera with starch, wall paper paste, acrylic mediums, etc., to make it thicker or bind it better. Discuss and share their technological discoveries.
- Have students use the overhead projector, the copying machine or the computer as technological instruments to create an art form. Guidelines for use and careful supervision can be discussed before students prepare something. This may be good to try with small groups.
- Canada's Norman McLaren was a pioneer in the field of film animation. Have students find out more about McLaren and how technology led him into such an exciting field. If there is access to a film library (McLaren produced for National Film Board for decades), plan a McLaren retrospective film festival.

Integrating with Art Content Areas:

An opportunity can be provided in

**EXPRESSION, Component 10:**

- |  |   |
|--|---|
| <ul style="list-style-type: none"> <li>(i) Purpose</li> <li>(ii) Subject Matter</li> <li>(iii) Media and Techniques</li> </ul> | <ul style="list-style-type: none"> <li>)▶ Have students invent a new art form</li> <li>)▶ based on fantasy or science fiction</li> <li>)▶ from a wide selection of materials (encourage them to combine mediums and techniques).</li> </ul> |
|--|---|

**D. Our associations influence the way we experience a work of art.**

Suggested Methods or Strategies:

- Display an art reproduction and ask students to write several sentences reacting to it (how it makes them feel, what association it has for them). Then give students a chance to share their reactions. The difference in responses will reinforce the idea that an art work can have different meanings to people or that "beauty is in the eye of the beholder".

- Ask students to identify an object in their possession which has meaning because of its association (where or when it was found, who gave it to them, or what it represents). Talk about the associations that people attach to things. Have students choose a work of art that reminds them of an experience they have had. Share these experiences and the preferences they were based on.
- Change the conditions by which a work of art is viewed. View it: outside in bright sunlight; in a partially darkened room; in a small, cramped space; in a large spacious room, hanging low on the wall, hanging high on the wall. Have students react to the work in a variety of contexts. Talk about how physical conditions affect you as you view art works.

Integrating with Art Content Areas:

The associative aspect of experiencing art is also considered in Concept E that follows (art is valued for different reasons).

Integrating with Other Subjects:

Music - Students could discuss association made when listening to instrumental music. Ask students to choose music to accompany particular paintings or sculptures.

Language Arts- Students can read poetry that has emotional impact and discuss the association it recalls for them. Have them try writing a poem based on their association to go with a particular painting or sculpture.

**E. Art is valued for different reasons (aesthetic, economic, symbolic, associative, etc.).**

Suggested Methods or Strategies:

- Art is created and valued for a variety of different reasons. Have a brainstorming session in which students try to identify some of the reasons (religious or symbolic purposes, utilitarian purposes, economic purposes - artist must make a living, some people collect art as an instrument, decorative or aesthetic purposes - documentation such as commemorating historical events or documenting political life and communication or self expression of the artist). Divide the class into groups for each major purpose and have each group generate a list of examples for that purpose.

- Students should become aware that an artist often had a specific message or purpose or intention which is inherent in the art work, but that the viewer may also interpret the art work on his/her own terms. Arrange for students to look at a variety of paintings or sculptures to see if they can determine whether the artist's intention was:

- to communicate a specific message (social, personal, political, religious)
- to decorate
- to narrate a story.

Encourage them to explain why or point out the clues within the context of the art work which lead to such a conclusion.

- Encourage students to make judgments about the different purposes involved in creating sculpture for public buildings. Visit some of these sculptures to determine whether they are commemorative, narrative, decorative, attention-seeking, functional or a combination of these.

Organize a trip to the cinema to see a film that has visual richness. Set the objective with the class prior to the viewing experience. (Ask them to interpret the film in terms of the cinematography.) If the students have seen the film previously, so much the better. As a result they will be able to concentrate more on the film techniques rather than the story line in order to see how these techniques enhance, detract or endorse the story line or the film's message. If the school has a VCR, a movie could be rented.

#### Integrating with Art Content Areas:

This concept will provide background for Concept F that follows (art serves societal and personal needs).

<b>F. Art serves societal as well as personal needs.</b>
--

#### Suggested Methods or Strategies:

- Have students refer to the broad categories which identify the main purposes for art (Concept E, first activity in Component 3). Students can decide which purposes are personal, societal and which can be both.
- Ask students to make a list of ways that art can serve society. Encourage students to look at artists in a broad sense. Make a list of all the kinds of artists that serve society: architects, landscape artists, portrait painters, photographers, interior designers and decorators, city planners, graphic designers, weavers, stage designers, etc. Visit one of them or arrange for a classroom visit so students can find out more about the contributions they make to public life.

- Ask students to discuss their own personal satisfactions in creating something. Have them consider whether artists feel much the same in creating works of art. Identify some of the personal fulfillments an art work can provide for the artist: economic survival; emotional expression or release; a chance for visual problem-solving; attainment of a goal and the satisfaction it brings; further knowledge about a subject matter, medium and/or technique; increased skill.
- Ask students what their feelings might be if they owned a famous art work.
- Have students investigate the purposes of artifacts from primitive cultures (utilitarian purposes and/or religious purposes). Explain to students that the word "art" was not usually a part of their language. Many of these artifacts are now displayed in museums and prized solely for their aesthetic qualities. Ask students to consider which items in our society might be unearthed by anthropologists hundreds of years hence and regarded as "art".

Integrating with Other Subjects:

Social Studies - When students are engaged in cultural studies, try to provide art visuals in context. They can be examined as a basis for discussing the societal or personal needs they may fulfill. Students will be better able to discuss works in relation to what they are learning about a particular culture.



# COMPONENT 4: MAIN FORMS AND PROPORTIONS

**Objective: STUDENTS WILL PERFECT FORMS AND DEVELOP MORE REALISTIC TREATMENTS.**

Teaching/Learning Materials for the Component:

ANOTHER LOOK, Levels A, B and C (Use Guide for Older Students for Grade 4)

MODEL IDEAS

- variety of drawing tools
- variety of drawing papers and surfaces
- clay, plast\_cene
- construction paper
- pictures of landscapes
- materials for mobiles
- neighborhood walks to observe and sketch
- sketchbook
- overhead projector

**Concepts:      A. Shapes can suggest movement or stability.**

Suggested Methods or Strategies:

- Use lesson suggestions in ANOTHER LOOK: Level A: "Separate or Touching", "Straight or Curved", or Level C: "Moving Matter" or Level B: "Horizontal or Vertical" and "Diagonal".
- Show how a geodesic dome is based on a triangular space frame (the triangles fit together like a puzzle to make the dome). If pictures of Buckminster Fuller's invention of this dome are available, show them. Explain that triangular shapes not only strengthen a structure but give a feeling of solidity to a design, e.g., Egyptian pyramids. Have students create a design using only triangles to show stability.
- Discuss the differences between sculpture that is stationary and a mobile. Talk about the conditions needed to balance a mobile and make it move. Experiment with materials to create shapes that move and shapes that remain stationary. Consider whether a stationary shape could give a feeling of movement (implied movement). Identify sculptures and paintings in which this is so.

- Have students depict the same form twice, once to show stability, the second time to imply movement. Consider such things as a young tree on a calm day and a windy day, a person standing and running. Talk about the direction the shape takes to show movement (diagonal) as opposed to the direction indicating stability (vertical or horizontal).
- Take a neighborhood walk so students can identify forms that show stability or movement. Some of them can be sketched and used later in a composition.

Integrating with Art Content Areas:

This concept can provide information for the study of symmetry in Concept B that follows. Many shapes are symmetrical.

**EXPRESSION, Component 10:**

- |                            |  |
|----------------------------|--|
| (i) Purpose                | ▶ Students can express a feeling or mood                                 |
| (ii) Subject Matter        | ▶ using shapes to show stability and/or movement                         |
| (iii) Media and Techniques | ▶ using printmaking, drawing, painting, paper collage or wire sculpture. |

**B. Many shapes are symmetrical.**

Suggested Methods or Strategies:

- Introduce symmetry by displaying shapes that are symmetrical. Ask students to identify the way in which the shapes are alike. Then ask students to identify all those forms in the room which are symmetrical. Have them choose one and draw it. This will help the teacher to evaluate the student's understanding of symmetry. You might also have students create two-handed designs or figures. First, they can practise in the air, and then try some examples on the chalkboard. Finally, with two drawing tools (chalk, crayons, pencils, etc.), one in each hand, they can begin at the same position on each side of the vertical centre. (Make sure the paper is taped to the table top.) The drawing should be bold and symmetrical. Decorative details or decorative shapes can be added later. Colour can be applied to the forms. A title can be given to the composition.
- Use **ANOTHER LOOK, Level A: "Open and Closed" and "Building Shapes"** (use the Guide for Older Students with grade four) for lessons that relate to symmetry.

- Use **ANOTHER LOOK, Level B: "Exploring Your Face"** for an exploration of symmetry in the human face.
- Introduce bilateral symmetry and radial symmetry to students. (Bilateral symmetry exists in shapes that can be folded along a central axis to reveal two halves of the same shape. Radial symmetry is when all the parts of a shape are alike from the center to the rim.) Show students examples of each. Ask them how each is different. Get them to find examples in the classroom. Have them make sketches showing each kind of symmetry.

Integrating with Art Content Areas:

This concept can provide students with background for Concept C (images can be portrayed in varying degrees of realism) and Concept D (internal as well as external proportions can be depicted).

An opportunity can also be provided in

**EXPRESSION, Component 1:**

- |                            |   |
|----------------------------|---|
| (i) Purpose                | ▶ Students can illustrate symmetry  |
| (ii) Subject Matter        | ▶ by choosing forms from the natural or manmade environment   |
| (iii) Media and Techniques | ▶ to depict in stitchery and/or fabric collage.<br>(See <b>FABRIC IDEAS</b> , pp. 22-29, for more specific examples.) |

Integrating with Other Subject Areas:

Mathematics - Grade 3 - Student identifies symmetric figures and draws lines of symmetry on two-dimensional figures.

Grade 4 - Student determines whether or not a two-dimensional figure is symmetric and draws axes of symmetry.

**C. Images can be portrayed in varying degrees of realism.**

Suggested Methods or Strategies:

- Discuss the concept of realism with your class. Look at works of art that show varying degrees of realism. Identify those that are most realistic and least realistic, and discuss why they have been classified in that way. Ask students to choose an item and depict it as realistically as possible. Allow each student to evaluate his/her work and decide how it might be more realistic.

- Discuss the difference between two-dimensional and three-dimensional art work. If the same form were depicted in two-dimensions and three-dimensions, which would be more realistic? Have students choose a simple item to depict in clay, plasticene or papier-mache.
- Introduce the idea that depth illusion is one way of making objects appear real in a drawing or painting. Look at some examples. Art works with depth illusion show shapes as if they were three-dimensional and use value or tone to give the shape dimension. Choose some simple geometric forms at first and ask students to depict them as three-dimensional forms, varying the tone by showing the light and shade on the object. Discuss whether the background can be treated to increase the realism of the object.
- Use **ANOTHER LOOK: A Guide for Using Level C with Older Students: "What's Behind the Mask?"**

Integrating with Art Content Areas:

This introduction to realism can be useful for teaching Concept D (internal as well as external proportions can be depicted) and Concept E (landscapes can show middle ground, background and foreground) as well as in Component 6, Qualities and Details, Concept D (enhancing reality by means of details).

An opportunity can also be provided in

**EXPRESSION, Component 10:**

- |                            |   |
|----------------------------|---|
| (i) Purpose                | ▶ Students can record realistic               |
| (ii) Subject Matter        | ▶ portrayals of each other                    |
| (iii) Media and Techniques | ▶ using drawing techniques or clay modelling. |
|                            | See MODEL IDEAS, pp. 9-14.                    |

**D. Internal as well as external proportions can be depicted.**

Suggested Methods or Strategies:

- Using students as models, point out and have students identify various external proportions of the human figure, e.g., the head comprises about 1/8 of the entire body, the legs 1/2. Ask students to show how far the elbows extend, where the wrists end, where the shoulders begin in relation to the rest of the body. Paper can be folded horizontally to make eight divisions so that students can use them as guidelines when depicting the entire figure.
- After examining the external proportions of the human figure, draw your students' attention to the internal proportions in the human face. Square-shaped paper can be folded into quarters to depict the face. The eyes should be placed on the horizontal fold dividing the paper in halves and the vertical fold can be the imaginary line that



indicates the symmetry of the face. Again have students examine the length, width and placement of ears, nose, eyes and mouth in relationship to each other before students draw them.

- Use lessons from ANOTHER JOOK, Level B: "How Else Can You See?" and "Exploring Your Face". Use the Guide for Older Students with Grade 4.
- Take a neighborhood walk and choose buildings to draw. Before beginning have students establish the external proportions of the building by comparing it with other buildings near it. Discuss the approximate fraction of the building that is occupied by doors, windows and other features. Also discuss the lines that are parallel with one another (both vertical and horizontal). Drawings will improve as students become more aware of the proportions within and without the buildings.
- Let students choose and draw natural or manmade objects in which attention is given to external and internal proportions.

#### Integrating with Art Content Areas:

An understanding of proportions will be helpful in depicting landscapes in the concept that follows as well as in DEPICTION, Component 5 (Actions and Viewpoints); Concept B: Drawing strategies are helpful in depicting animate forms and Concept C: Actions among things in a setting create a dynamic interest.

An opportunity can be provided in

#### EXPRESSION, Component 10:

- |                            |  |
|----------------------------|--|
| (i) Purpose                | )▶ Students can record   |
| (ii) Subject Matter        | )▶ animal, plant or human figures  |
| (iii) Media and Techniques | )▶ using drawing or painting techniques to capture realistic proportions of those figures. |

#### Integrating with Other Subjects:

Mathematics - Grade 3 - Identifies, writes and compares proper fractions from concrete and pictorial representation (halves, thirds, quarters, fifths and tenths).

Grade 4 - Identifies, reads and writes a fraction to represent a part of a region.

**E. Landscapes can show middle ground, background and foreground.**

Suggested Methods or Strategies:

- Refer to **LEVEL ONE, DEPICTION, Component 4 (Main Forms and Proportions)**; Concept E: review the concept of foreground and background.
- Have students place three sheets of 9" x 12" construction paper in different colours on top of each other. Get them to make cuts horizontally through all three sheets to divide each sheet into three pieces. Encourage a curving line (point out the horizon line that can be seen when looking outside the school). Have students trace it in the air. Reassemble the pieces so there are three compositions, each with three colours and each will fit together like a puzzle. Ask students to glue them to a 9" x 12" backing (manila tag would work well). Treat the three levels as foreground, middle ground and background. Ask students to turn them around completely and decide which level to use as foreground and background (middle ground remains the same, either way). Composition can be made using cut paper figures. Again direct attention outdoors so that students can see that figures appear at many levels within the picture plane.

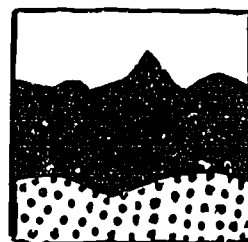
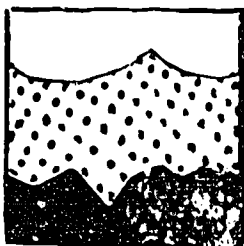
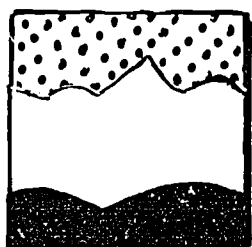

- Use viewfinders to frame a composition within a landscape that includes foreground, middle ground and background. Have students make a series of thumbnail sketches that show the proportions of sky and ground. One could be developed as a composition upon returning to the classroom or art room.
- Collect a variety of pictures of landscapes that show the different proportions that exist between sky and ground because of geographic location. Have students choose a geographic location other than their own to depict. Ask them to consider all three grounds: background, middle and foreground. Use coloured washes to represent the grounds and then the painting can be developed once these have been established.

### Integrating with Art Content Areas:

An understanding of the proportions of sky and ground are needed in showing depth illusion in Concept F that follows.

This learning will also assist students in COMPOSITION, Component 8 (Unity), Concept C: Every major area of a composition should be interesting in itself.

An opportunity can also be provided in

#### EXPRESSION, Component 10:

- |                            |   |
|----------------------------|---|
| (i) Purpose                | )▶ Students can record  |
| (ii) Subject Matter        | )▶ proportions of figure and ground   |
| (iii) Media and Techniques | )▶ in fabric collage and stitchery<br>or in a group mural using<br>painting techniques. |

### Integrating with Other Subjects:

Mathematics - An understanding of fractions and the use of fractions to represent the proportions of grounds in a landscape would be useful.

<b>F. Size variations among objects give the illusion of depth.</b>
---

### Suggested Methods or Strategies:

- In order to show depth, students must be able to see that objects do not all appear on the horizon (base line) in the landscape. Observations of the landscape are needed so that students become more aware of the relative size and placement of objects within the landscape.
- Groups of students can be organized to stand at different distances from the class. Identify those nearer and farther away. Discuss how such a group might be depicted in terms of size, before drawing.
- Use an overhead projector and cut out figures to show different ground levels and sizes for figures. Sketches can be made of one of these compositions.
- Have students cut a series of rectangular shapes in graduated sizes and ask them to arrange them on a background to show the largest is closest and the smallest is farthest away. Cardboard strips in different lengths could be inked and printed on their edges to give the illusion of depth.
- Use **ANOTHER LOOK, Level C: "Sizes" and Level B: "Space-Country"**. Use the Guide for Older Students with Grade 4.

- Have students view the landscape from the playground. Ask them how distant objects appear to them. Discuss the colour and lack of detail. Ask students to depict an object such as a building from close up and far away to record this difference in appearance.
- Discuss the need for a unit of measurement in determining the scale or proportion of an object. Have students use their pencils or fingers to measure objects in the distance. Use this means of measuring to compare objects before depicting them.

Integrating with Art Content Areas:

This concept will be useful in depicting in Component 5 (Actions and Viewpoints), Concept C: Actions among things in a setting create dynamic interest and Concept D: Objects can be depicted selectively from a broad range of viewpoints. It can also be applied in COMPOSITION, Component 7 (Emphasis), Concept A: The centre of interest can be made prominent by contrasting its size, shape, colour, texture from the other parts of the composition.

An opportunity can also be provided in

**EXPRESSION, Component 10:**

- |  |   |
|--|---|
| <ul style="list-style-type: none"> <li>(i) Purpose</li> <li>(ii) Subject Matter</li> <li>(iii) Media and Techniques</li> </ul> | <ul style="list-style-type: none"> <li>▶ Size variation can be recorded</li> <li>▶ in family groups or animal families</li> <li>▶ using drawing, painting, sculpture or cut paper collage.</li> </ul> |
|--|---|

Integrating with Other Subjects:

Mathematics - Standards of measurements learned can be used to compare sizes of objects that students depict.



## COMPONENT 5: ACTIONS AND VIEWPOINTS

**Objective: STUDENTS WILL SELECT APPROPRIATE REFERENCES FOR DEPICTING.**

Teaching/Learning Materials for the Component:

Photographs and their negatives, art reproductions, illustrations, a variety of drawing media and surfaces, figures and objects to serve as models.

ANOTHER LOOK (Levels A & C).

ART EMPHASIS.

**Concepts: A. Looking at negative shapes helps create a different view of something.**

Suggested Methods or Strategies:

- Have students glue a cut shape from dark construction paper onto a light coloured sheet of paper. Explain that the cut shape is the positive image and the space around is the negative image. Repeat the process reversing the two colours. Discuss how this reversal affects the total image.
- Photographs and their negatives can be examined together so students can see that the positive space in the photograph becomes the negative space in the negative.
- Do lessons from ANOTHER LOOK, Level A: *Between the Trees*.
- Collect examples of compositions that show varying degrees of negative space. Encourage students to discuss how the amount of negative space in the composition affects the meaning of a composition. Students can use cut or torn paper shapes to create compositions in which the negative shapes are deliberately controlled.
- City and country landscapes can be depicted to demonstrate that the negative shapes help to create a particular view of rural or urban life.

### Integrating with Art Content Areas:

The preceding concept can be taught as a basis for learning in

#### COMPOSITION, Component 7;

Concept A: The centre of interest can be made prominent by contrasting its size, shape, colour, texture from the other parts of the composition.

AND

#### EXPRESSION, Component 10:

- |                            |   |
|----------------------------|---|
| (i) Purpose                | )▶ Students can create a sculpture that shows negative shapes (enclosed shapes) |
| (ii) Subject Matter        | )▶ on an abstract theme   |
| (iii) Media and Techniques | )▶ using clay or plasticene.  |

### Integrating with Other Subjects:

Social Studies - Grade 3 - Topic A: Students will learn concepts relating to rural and urban life (this will relate to the last activity suggested in this concept).

**B. Drawing strategies (such as gesture to capture action, contour to study important edges, and massing to show bulk or weight) are helpful in depicting animate forms.**

### Suggested Methods or Strategies:

- Discuss the meaning of the word gesture with students. Ask several students to pose as athletes demonstrating the action of a particular sport as if "frozen in action". Compare poses to identify the one showing the most action. Ask students to make quick line drawings to capture the action (one or two minutes). The side of a crayon, a soft pencil, charcoal or pastels may be useful media. Tell students that gesture drawings are exercises that might be useful in making sketches for a painting or a more finished drawing.
- Use one of the students in the class as a model. Run bright tape down the limbs of the model as a quick guide to action. Do quick sketches of the model in various poses. Study directional changes on main edges of the model.
- Gesture drawings of action poses can be made using large sheets of paper and paint brushes or wide nibbed felt pens. In this way, students will not spend time erasing and can concentrate on the lines of the figure that indicate action. (Gesture drawings can be a series of thrust lines and are not concerned with capturing contours.)

- Contour drawings are done by concentrating on the inside and outside lines that describe an object. Students can trace the outside edge with fingers first to get a tactile feeling for the object. It is most helpful if the drawing is made with eyes on the object rather than the paper. Let students know that accuracy or realistic portrayal is not the object of the exercise; but capturing a sensitivity of edge is. Use felt pens, ballpoints, charcoal or crayons for an uninterrupted flow of line. Choose simple objects to start with and work up to more complex ones. You can also refer to **ART EMPHASIS** (pp. 54 and 55).
- In massing, the weight or bulk of an object is captured by using crayon, pastel, conte or charcoal on its side to make wide strokes that can quickly build up the surface of a building, figure or other object. Large paper should be provided and the total effect should be one of massiveness or weightiness.

Massing is done by pushing out a shape from the middle to its edges using the side of a crayon or piece of charcoal. Have students try this to depict animal forms. Once the basic shape is created, finer lines using felt or pencils can help to outline and refine the shape or to add detail where needed. This method of massing can also be done using a small sponge and paint.

Integrating with Art Content Areas:

The preceding concept can be taught as an introduction to

**DEPICTION, Component 5 (Actions and Viewpoints)**

Concept C: Actions among things in a setting create a dynamic interest.

**DEPICTION, Component 4 (Main Forms and Proportions)**

Concept A: Shapes can suggest movement or stability.

**COMPOSITION, Component 8 (Unity)**

Concept A: The parts can be arranged so that movement in the picture space leads the eye around and not out of the picture area.

or a lesson in

**EXPRESSION, Component 10:**

- |  |  |
|--|--|
| <ul style="list-style-type: none"> <li>(i) Purpose</li> <li>(ii) Subject Matter</li> <li>(iii) Media and Techniques</li> </ul> | <ul style="list-style-type: none"> <li>)▶ Students can make action drawings illustrating</li> <li>)▶ their favorite sports</li> <li>)▶ using their choice of drawing media.</li> </ul> |
|--|--|

**C. Actions among things in a setting create a dynamic interest.**

Suggested Methods or Strategies:

- Use **ANOTHER LOOK, Level A: "Separated or Touching"** for activities that deal with actions among things in a setting.
- Follow suggestions for gesture drawings covered in the last concept and then suggest that students use their gesture drawings as the focus of a composition. In adding the figures or objects, they should consider how they can be related to the central figure to provide a dynamic interest (feeling of movement). To do this, students must consider the activity engaged in by the figure and what props might be used by the figure, how the lesson figures in the composition relate to the main figure and the kind of setting that is appropriate to the activity.
- Take the students outside on a sunny day to observe cast shadows from objects that are airborne (bouncing ball, airplane, birds, clouds, telephone wires, etc.). Then have students depict such an object and its cast shadow. When the shadow is detached from an object, the object appears in suspension. This relationship creates dynamic interest.
- Students can be encouraged to depict an object (trees, telephone poles, buildings) that varies in size, diminishing as they move from foreground to background. The gradual changes in size will lend the eye from one shape to the next until they disappear from view.
- Have the students print a cardboard shape over and over (repeating patterns or echoing). The gradation in colour often adds charm to the print and gives a feeling of movement or the appearance of receding in space.
- Have the students create a "crowd" painting. Start with light or flesh colour. Paint several "heads" or oval shapes on the paper. Then add shoulders, arms, torso, and legs to each head. This can be done in a simple stroke, but should show maximum action. Decide where this crowd is located and what the people are doing. Finally, add colours and details to all of the figures and then add the setting for the event. Attempt to "feature" or "zero in" on a special, selected part of the whole scene.



### Integrating with Art Content Areas:

Concept C can be taught as a follow-up to Concept B (drawing strategies are helpful in depicting animate forms) in this component and in Component 4, Concept A (looking at negative shapes helps create a different view of something). It can also be used as a basis for a lesson in

#### EXPRESSION, Component 10:

- |                            |   |
|----------------------------|---|
| (i) Purpose                | )▶ Students can document a school activity or event |
| (ii) Subject Matter        | )▶ showing figures in action                        |
| (iii) Media and Techniques | )▶ using a choice of drawing or painting mediums.   |

### Integrating with Other Subjects:

Science - Concept Area: (A) Position and Direction.

**D. Objects can be depicted selectively from a broad range of viewpoints.**

### Suggested Methods or Strategies:

- Use lesson suggestions in **ANOTHER LOOK**, Level C: "Two Heads for One Giraffe" and "Crowds".
- Have students:
  - Draw or paint compositions from different points of view, e.g., the countryside or city streets from the above like a bird looking down. Draw an ant's view of grass and your house, the school, etc.
  - Draw a scene as if part of it were being viewed through a telescope.
  - Draw what you see through a microscope or another magnifying device.
  - Draw someone being reflected in a mirror.
  - Draw a street scene as if it were reflected on a rain-wet street, on a shiny car door, or from a pane of glass.
  - Draw what might be reflected in someone's eye-glasses or other shiny surfaces.
  - Draw a view of something through a window or through a doorway.

- The following kinds of viewfinders can be made and used to view objects before depicting them:
  - Look through a small, cut-out square and choose a selective view to enlarge and use as a composition.
  - Two L-shaped pieces of cardboard can be used to frame a view of something. The view can be enlarged or reduced by moving each L shape.
  - Use cardboard tubes as viewfinders.
  - Join the index fingers and thumbs together to make a finger frame.
- Students should recognize that objects appear different when seen in part or from a different angle. Have them choose an object (e.g., interesting shaped fruits, vegetables, flowers, kitchen utensils) and view it from different angles as well as selecting only portions of it (using viewfinders). Then have them make a number of drawings to illustrate the differences in viewpoint.

Integrating with Art Content Areas:

The depicting skills learned can be used as a basis for a lesson in

**DEPICTION, Component 4 (Main Forms and Proportions)**

**Concept C: Images can be portrayed in varying degrees of realism.**

**EXPRESSION, Component 10:**

- |                            |  |
|----------------------------|--|
| (i) Purpose                | )▶ Students can record objects from different viewpoints |
| (ii) Subject Matter        | )▶ based on a choice of subject matter                   |
| (iii) Media and Techniques | )▶ using drawing media of their choice.                  |

Integrating with Other Subjects:

Science - (Division One) from Concept Area: (A) Position and Direction (An object's position, size and direction can be described by the terms: up/down, forward/back, right/left, short/tall, in/out, near/far, and above/below.)

# COMPONENT 6: QUALITIES AND DETAILS

**Objective: STUDENTS WILL REFINE SURFACE QUALITIES OF OBJECTS AND FORMS.**

Teaching/Learning Materials:

- ANOTHER LOOK, Level A, B, C (use guide for older students with Grade 4)
- drawing mediums
- painting mediums
- printing mediums
- collection of objects in relief for printing

**Concepts: A. Texture can be represented from a range of different studio techniques.**

Suggested Methods or Strategies:

- In drawing, crosshatching can be used to give the illusion of texture. Have students try hatching (parallel lines drawn close together) and crosshatching (parallel lines drawn close together which are intersected by other parallel lines) in different ways. When they have experimented ask them to use crosshatching as a method of indicating rough textures on natural forms, e.g., tree bark, markings on a shell, parts of a leaf, parts of a flower.

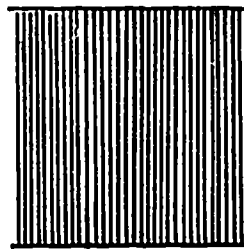
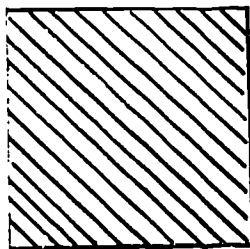

Hatching

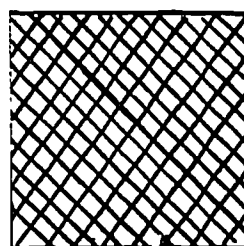
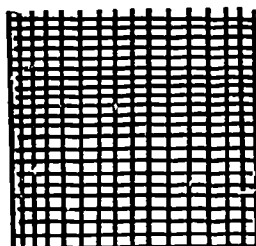

Crosshatching

- Make a texture bag by placing an object into a bag and passing it to students so they can feel it but not see it. Then ask students to draw the object, representing the texture as they can.
- Use lessons called "Hair" and "Patterns" in **ANOTHER LOOK, Level C**. Use the guide for older students with Grade Four.
- Make a collection of objects that will represent textures when printed with printing inks (sponges, corks, plastic or rubber objects, bottle caps, plastic caps, etc.). Enlist the help of your students. Give some time for them to experiment using those items. Then have them make an illustration in felt pen and use some of the objects to create textures with printing inks that will add to the visual interest of the illusion.
- Provide time for students to experiment using lines, dots and shapes to give the illusion of textures. With the class make a list of textures that could be represented using these drawing techniques. Some examples: hair, a sandy beach, foliage, wood grain, marble, grass, rippling water, feathers, bark.
- Introduce watercolour techniques (See Level 3, Component 6, Concept D or page 46 in **ANOTHER LOOK, Level A** - guide for older students) and have students use them to represent textures in the natural and manmade environment.

Integrating with Art Content Areas:

This concept will be useful in **COMPOSITION, Component 7, Concept C** (details, accents and outlines will enhance the dominant area or thing).

An opportunity can also be provided in

**EXPRESSION, Component 10:**

- |                            |   |
|----------------------------|---|
| (i) Purpose                | )▶ Students can give the illusion of texture    |
| (ii) Subject Matter        | )▶ in a landscape or seascape                   |
| (iii) Media and Techniques | )▶ using painting, printing or drawing mediums. |

Integrating with Other Subjects:

Language Arts - Ask students to find excerpts from prose or poetry that describe textures. Have them make a list of adjectives used. These words could be illustrated in a texture dictionary.

## **B. Colour can be made to appear dull or bright.**

### Suggested Methods or Strategies:

- Colours can be made to appear bright when two complementary colours are placed side by side. Introduce the term complementary colour to students and if it is possible to show them a colour wheel, point out that the complementaries are exactly opposite one another. If a colour wheel is not available see the information entitled **COLOUR WHEEL** in the Guidebook or **ANOTHER LOOK, Level A** (guide for older students) p. 15. Ask students to use felt pens or paint to make simple arrangements of geometric shapes in which only one pair of complementaries is used.
- To see how two complementaries placed side by side give the illusion of being brighter than they are, place two pieces of construction paper in complementary colours beside each other. Then place two more pieces together, one representing one of the complementary colours already used and one of a colour near it on the colour wheel. Compare the two pairs to see which complementary colour seems brighter. A similar activity can be done by placing a square of a particular colour on a larger background that is complementary and a larger background that is not complementary and compare results.
- Colours can be dulled by adding gray or by mixing two complementaries together. Provide time for experimentation so that students can make a sampler of dull colours using paint. When mixing two complementaries, the larger proportion of one colour will reduce the intensity of that colour. For example, mixing red and green together with a greater proportion of green, will produce a dull green. Likewise, mixing red and green together with a greater proportion of red, will produce a dull red. Discuss which parts of a landscape might use dulled colours. (Colours seem grayer as they appear farther away.)
- Have students cover a sheet of paper with dots of two complementary colours intermixed. Then ask them to stand back far enough so the eye mixes the colours together. Ask them if the colour is "grayed" or intense from a distance.

### Integrating with Art Content Areas:

This concept can be applied to **COMPOSITION, Component 7, EMPHASIS, Concept A** (centre of interest can be made prominent by contrasting colour) and **Component 8, Unity, Concept D** (limited colours tighten a composition).

An opportunity can also be provided in

**EXPRESSION, Component 10:**

- |                            |   |
|----------------------------|---|
| (i) Purpose                | )▶ Students can use bright or dull colours to express a feeling or mood |
| (ii) Subject Matter        | )▶ based on their choice of subject matter                              |
| (iii) Media and Techniques | )▶ using painting or drawing mediums.                                   |

Integrating with Other Subject Areas:

Language Arts: Students can make a list of opposites that relate to art vocabulary - black-white, bright-dull, red-green, etc.

**C. Gradations of tone are useful to show depth or the effect of light on objects.**

Suggested Methods or Strategies:

- Explain to students that gradations involve gradual changes in tone or value. Look for objects in the room that show this or set up a strong light source so that objects have a light side and a shadow side. Ask students to make a value chart using a soft lead pencil. A narrow strip of paper would be suitable and the chart could be divided into vertical sections so that gradations from white to black can be shown.
- Place geometric shapes on a table top near a strong light source (natural or artificial) and have students draw them using charcoal or soft lead pencils to capture the light on the object, the shadow, the gradations in-between.
- Ask students to draw or paint a scene that takes place outdoors in the bright sunshine. Using felt pens, direct them to texture areas that are in the shadows to show the contrast of light and dark.
- Direct a light from one side of a display so that strong shadows are cast. They should draw or paint the still life, accentuating the shadows. Students can use tints to highlight areas and shades to the shadowed areas.
- Have students look away in the distance to note how distant objects appear to be grayer or bluer. Get students to mix dull blues (by adding white and black, or by adding some orange to blue). These can be used to paint distant things in the landscape. Ask students to try painting the background before the foreground.

- Use **ANOTHER LOOK, A Guide for Using Level B with older students, "Parallel or Branching", and "How Else Can You See?"** for exercises on gradation.
- Have students experiment to determine whether a shape can appear lighter or darker by changing its background. Ask them to place white, black and white, black and grey shapes on gray backgrounds. Students can decide whether a shape advances in one setting and recedes in another.

Integrating with Art Content Areas:

An opportunity can be provided in

**EXPRESSION, Component 10:**

- |                            |  |
|----------------------------|--|
| (i) Purpose                | )▶ Students can use gradations of tone to illustrate |
| (ii) Subject Matter        | )▶ a landscape or a special event                    |
| (iii) Media and Techniques | )▶ using paint or drawing mediums.                   |

**D. By increasing details in the foreground the illusion of depth and reality can be enhanced.**

Suggested Methods or Strategies:

- Have students use viewfinders to frame a composition. Ask them to note all the details that are closest to them. Direct them to make quick sketches of their composition including all the detail that is closest to them. Evaluate the results to see if an illusion of depth was achieved. Point out the importance of size relationships in achieving this illusion.
- Large or heavy objects usually appear in the foreground which gives a sense of balance to the composition. Have students draw an arrangement (still life would be suitable) in which the larger, heavier objects are more dominant. Encourage the inclusion of as much detail as possible to add to the realism of the composition.
- Encourage students to draw the largest and most obvious part of a form before adding the details. Practise this by drawing objects that can be viewed by the student through a classroom window, from slides or pictures. Get them to see the basic shapes that make up the large shape to be drawn. This shape can be sketched lightly and then modified where needed. Details can be added once students have captured the modified basic shape.

107

Integrating with Art Content Areas:

An opportunity can be provided for

**EXPRESSION, Component 10:**

- (i) Purpose )▶ Students can use details in the foreground in documenting
- (ii) Subject Matter )▶ a special event
- (iii) Media and Techniques )▶ by means of painting or drawing mediums.

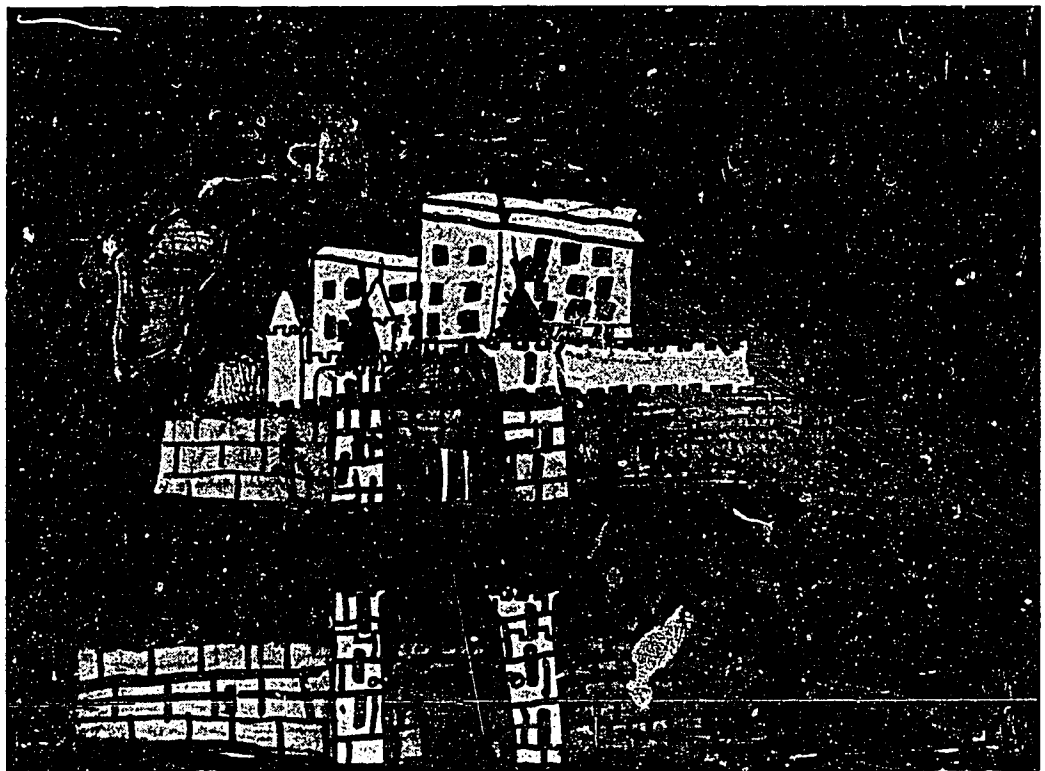



## COMPONENT 7: EMPHASIS

**Objective: STUDENTS WILL CREATE EMPHASIS BY THE TREATMENT OF FORMS AND QUALITIES.**

Teaching/Learning Materials:

- drawing media
- painting media
- printmaking media
- a variety of papers and surfaces
- paper cutter
- pictures of animals with high contrasts of colour
- FABRIC IDEAS**
- ANOTHER LOOK, Level A** (use Guide for Older Students with Grade 4)
- field trip to a photographer's studio

**Concepts: A. The centre of interest can be made prominent by contrasting its size, shape, colour, texture from the other parts of the composition.**

Suggested Methods or Strategies:

- Review with students what is meant by contrast. See **LEVEL ONE, COMPOSITION, Component 6 (Qualities and Details): Concept E.** Ask students why a zebra, giraffe or tiger would stand out among most other animals. Ask students what tones they would use for maximum contrast (black or white). Look at black and white combinations that are near other colours and notice how they reinforce and brighten the other colours. Have students study pictures of animals that show extreme contrasts: penguin, magpie, skunk, European badger, pandas, some snakes, Dalmatians, etc. Encourage them to choose one to depict, using painting and/or drawing media. Background treatments should be considered that will make the animal most prominent.
- Have students identify those things in the classroom that stand out because of their colour. Assign a composition in which colour is used to give emphasis to one object: a warm colour among cool colours, a cool colour among warm colours, a complementary contrast (red and green, blue and orange or yellow and violet), an intense colour among dull ones, a dull colour among intense ones. Use drawing, painting or printmaking mediums. The composition may be a pattern or a landscape which features one item (seascape, jungle, desert, etc.).
- Use **ANOTHER LOOK, Level A "Smooth and Rough"** on contrasting texture for emphasis.

- Have students make a composition in which the supporting things run off the edges of the paper and only the centre of interest is shown in its entirety.
- Another way of creating emphasis is through size contrast. Ask students to create a composition by tearing a family of shapes in different sizes from coloured paper. Have them arrange the shapes in a rhythmic way on a coloured background without overlapping. Identify the shapes that are most prominent.
- Contrasts of texture also create emphasis in a composition. Use printmaking materials to create patterns in which heavily textured areas are next to solid colours or densely textured areas are next to sparsely textured areas. Gadget printing and stamp printing would be appropriate techniques.

Integrating with Art Content Areas:

Once contrasts in the art elements are used consciously, students can be introduced to limitations in COMPOSITION, Component 8 (Unity), Concept D: Limited colours and materials tighten a composition.

An opportunity can be provided in

**EXPRESSION, Component 10:**

- |                            |   |
|----------------------------|---|
| (i) Purpose                | ▶ Students can make original compositions to show emphasis                  |
| (ii) Subject Matter        | ▶ based on their choice of subject matter                                   |
| (iii) Media and Techniques | ▶ using fabric collage and stitchery, weaving, photo collage, or sculpture. |

**B. The format can be adjusted and the composition tightened by editing or cropping the unnecessary areas from the edges of a work after it is completed.**

Suggested Methods or Strategies:

- Students can be introduced to this concept by having them choose an artwork that has already been completed. Suggest that a work can be cropped by removing some of the empty space (some students often draw or paint on a scale that is too small for the picture space available) or by removing areas from the composition that do not enhance the total work or detract from the areas of emphasis. Provide a paper cutter and show students how to use the grid for even cropping.
- Organize a visit to photographer's studio. Ask him/her to show your students how he crops a photograph to make a point of interest more significant.

- Students can also consider whether or not the format used for their artwork is the most appropriate in terms of its subject matter. A format can be circular, triangular, square or rectangular or even combinations of these. Encourage students to change formats whenever it seems necessary to their editing.

#### Integrating with Art Content Areas:

This concept should be an on-going activity that is done after each composition is completed for display purposes.

#### Integrating with Other Subjects:

Language Arts - Compare editing of written work with editing in art.

**C. Details, accents and outlines will enhance the dominant area or thing.**

#### Suggested Methods or Strategies:

- Have students create a composition in which the centre of interest is given more detail than the other figures. Explain that the center of interest is most often largest and relatively closer to the viewer in the picture plane. As a result, the central figure should have more detail than those figures farther away.
- Paintings at this level often have less detail than those of older children because of lack of control and experience when working in painting mediums. Have students take one of their paintings and add details, accents or outline figures with fine nibbed felt pens or pencil crayons.
- Have students make compositions using fabric collage or applique. (See Art Sources - Themes for ideas for subject matter.) Use stitchery and/or braid, wool and trims to outline and provide accents for the centre of interest. With younger children, cut fabric pieces can be applied to a fabric background by sandwiching a piece of thin plastic (such as dry cleaner's bags) between the background and the cut pieces. A piece of paper is then placed over the entire surface and ironed until all the plastic melts. The plastic under the cut pieces causes them to adhere to the background and the remaining plastic comes off on the paper. This works better than gluing or stitching with young children who may be using large needles and coarse fabric. Another way to simplify the process is to glue the fabric onto a paper surface first. This aids young children in handling the fabric and gluing fabric pieces to another surface. The accents and outlines can be stitched or glued.

111

Integrating with Art Content Areas:

This concept can be used to introduce Component 9 (Craftsmanship), Concept A: Refinement of forms and surface qualities is necessary to a finished appearance to the composition.

An opportunity can also be provided in

**EXPRESSION, Component 10:**

- |                            |   |
|----------------------------|---|
| (i) Purpose                | )▶ Students can create banners that show emphasis                                   |
| (ii) Subject Matter        | )▶ based on their choice of subject matter  |
| (iii) Media and Techniques | )▶ in fabric or fabric collage using stitchery, tie dye or batik. See FABRIC IDEAS. |

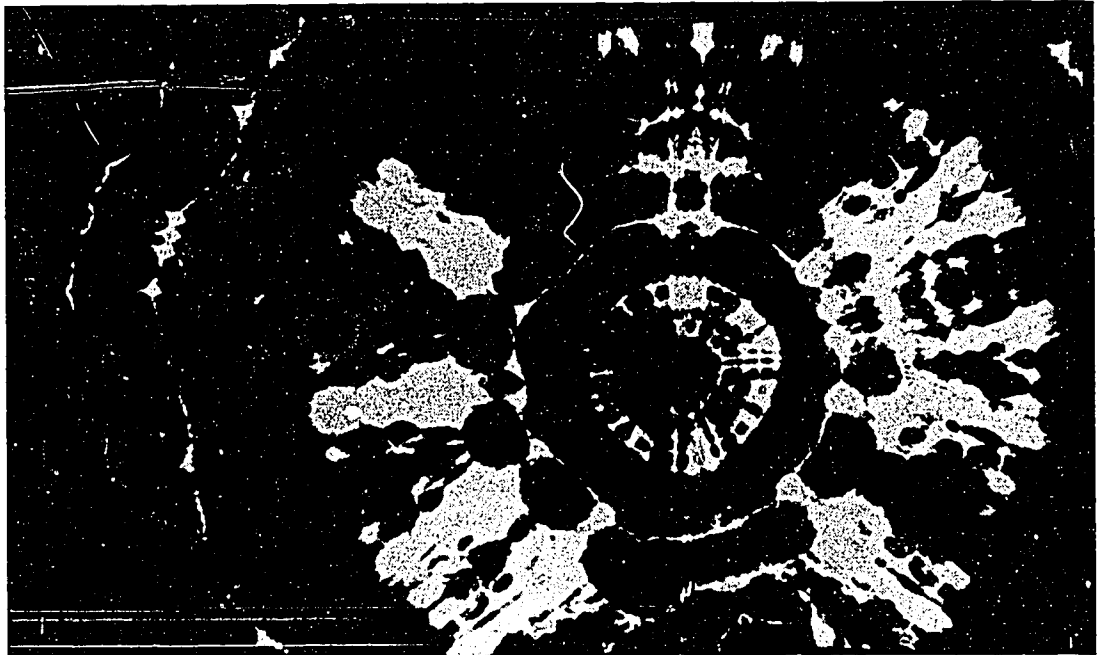

## COMPONENT 8: UNITY

**Objective: STUDENTS WILL CREATE UNITY BY INTERRELATING THE PARTS OF THE COMPOSITION.**

Teaching/Learning Materials for the Component:

drawing media  
 painting media  
 construction paper  
 scissors  
 glue

**ANOTHER LOOK; Levels B, C**

**EMPHASIS ART**

**MODEL IDEAS**

**FABRIC IDEAS**

wool, fabric

**Concepts:      A. The parts can be arranged so that movement in the picture space leads the eye around and not out of the picture area.**

Suggested Methods or Strategies:

- The illusion of movement can be created by repeating colours in a design. Ask your students to choose one bright colour and a number of more subdued tones. Instruct them to cut multiples of several simple geometric shapes from the colour palette chosen. Encourage them to create patterns by interspersing the dominant colour within the more subdued colours. When students are ready to glue their shapes to a background have them trace the imaginary line the eye follows as it moves from one dominant colour shape to the other. If the arrangement leads the eye around and not out of the picture area, they have achieved the objective.
- Lines can also be used to lead the eye around the picture space. Ask students to fold a piece of paper into six rectangles. In each rectangle ask students to show one of the following:
  - (1) repeated lines that start short and get gradually taller
  - (2) repeated lines that are faint and get gradually darker
  - (3) dots or short strokes that are far apart and become more dense
  - (4) lines that outline shapes that gradually get larger, e.g., concentric circles
  - (5) converging lines
  - (6) flowing lines

Once students have experimented and produced each kind of linear rhythm, ask them to choose one of the methods as a means of making a larger composition. Different drawing media can be explored as well.

- Linear qualities are also explored in **ANOTHER LOOK, Level B: "Spiral or Concentric"** or **Level C: "Hair"**.  
Use the guides for older students with grade 4.
- Gradual changes in value lead the eye from one shape to another. Brainstorm with the class for subject matter which could be depicted using a monochromatic colour scheme (tints or shades of one colour or hue) e.g., forests, field of flowers, city at dusk, inside a cave, mountains, etc. Ask students to make tints and shades of the colour they chose on a separate paper in order to see the colour range possible. When the subject matter has been decided and the tonal range explored, ask students to paint a composition that shows gradual changes from darks to lights. The same exercise could be done using magazine collage or fabric collage.

#### Integrating with Art Content Areas:

An opportunity can be provided in

##### **EXPRESSION, Component 10:**

- |                            |  |
|----------------------------|--|
| (i) Purpose                | )▶ Illustrations can be made using linear qualities  |
| (ii) Subject Matter        | )▶ based on animal or human figures  |
| (iii) Media and Techniques | )▶ using glue line relief prints or aluminium foil reliefs. See <b>EMPHASIS ART</b> for an explanation of both techniques. |

#### Integrating with Other Subjects:

Drama - In dramatic movement the student learns to move at high, medium and low levels in all directions of space (the area within which one works). Activities that involve this movement within a designated area can visually illustrate movement which leads the eye around.

### **B. Parallel edges induce harmony within the composition.**

#### Suggested Methods or Strategies:

- Ask students to look for shapes that have parallel edges. Then expand the search to include the classroom or outdoor environment. Use viewfinders to zero in on some of these shapes so that students can concentrate on them as mini-compositions. Look for examples in the

designed world that demonstrate this kind of repetition, e.g., striped fabrics, fence posts, support beams, stair railings, rungs of chairs, etc. Once students have identified visual examples ask them to sketch one. Discuss how each unifies the composition. (The repetition of an element such as line, shape, colour, texture or tone makes a composition unified or harmonious.)

- Ask students to draw a straight vertical line to divide their picture space in half. Then instruct them to add lines on either side which are parallel but gradually bulge out without touching the lines parallel to them.

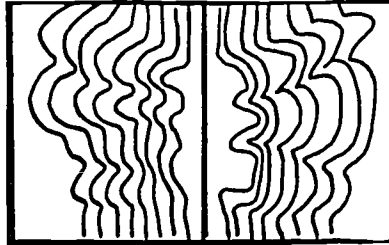

- Direct students to use close parallel lines on a picture space to surround and expand a field of objects, e.g., holes or obstacles. The objects should be drawn first.

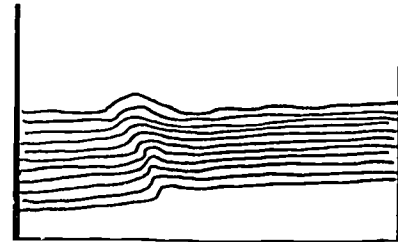
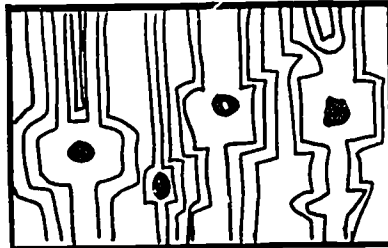

See below

- Students may also use continuous parallel lines across a drawing surface to give the illusion that the surface is warped or that the surface is being viewed from the top or bottom of a well or cave.
- Ask students to compose a "low relief assemblage" from multiple segments of toothpicks, drinking straws, or other multiple items that would produce parallel edges when placed side by side. Glue them to heavy cardboard or wooden backing and create a centre of interest by varying the direction of the pieces.
- Two-handed line drawings can be practised and refined as coordination improves. Ask students to draw using both hands simultaneously and keeping the lines in parallel motion. Encourage designs that are more complex as the students improve.

- Use **ANOTHER LOOK, Level B: "Parallel or Branching"** and/or "Parallel and Branching". Use Guide for Using Level B with older students for grade 4.

Integrating with Art Content Areas:

An opportunity can be provided in

**EXPRESSION, Component 10:**

- |  |  |
|--|--|
| <ul style="list-style-type: none"> <li>(i) Purpose</li> <li>(ii) Subject Matter</li> <li>(iii) Media and Techniques</li> </ul> | <ul style="list-style-type: none"> <li>▶ Students can document</li> <li>▶ natural forms that have parallel lines (ripples on water, grain in wood, cloud banks)</li> <li>▶ using photography or multi-media such as crayon engraving or oil pastel resist. See <b>EMPHASIS ART</b> for detailed instructions in these two techniques.</li> </ul> |
|--|--|

Integrating with Other Subjects:

Math - Grade 3: Students will identify symmetric figures and draw lines of symmetry on 2-dimensional figures. (A concept of symmetry is necessary for two-handed drawings.)

Grade 4: Students will determine whether or not a 2-dimensional figure is symmetric.

**C. Every major area of a composition should be interesting in itself.**

Suggested Methods or Strategies:

- Have small groups of 5 or 6 students create a mural for which each student has one colour of paint, and is given 3 or 4 minutes at each specific location on the mural. The student rotates from one place to another until all locations have some of his/her touches. The colour unifies the composition since each colour is applied throughout. Each student elaborates on the forms and patterns begun by other students preceding him/her. After the paint is dry, details can be "firmed up" with pencils, crayons or felts. Suggest themes in which families of shapes also help to unify the composition: underwater life, spring flowers, imaginary insects.



- In a landscape, the objects in the picture space relate the sky and the ground to each other. The overlapping of objects in figures also relates the parts to each other. Ask students to use diluted tempera to make a coloured wash for sky and ground. Objects can be added when the background wash dries. Those closest to the viewer should be brighter and larger than those objects farther away. Overlapping should be used to create an illusion of distance.
- Show students some examples of pictures that tell a story. (Wordless books in the library are a good source.) Discuss the pictures in terms of the story each tells and the kind of detail that contributes to the story. Choose a story that can be read and illustrated by the students. Compare student illustrations to see which story events and settings are used. Ask students to evaluate their own work on the basis of how well it tells the story.
- Ask students to look at three dimensional objects in the room as if they were sculptures. Direct them to view the object from all sides to assess whether or not each view relates to every other view to make a unified whole. Look at size relationships as well as colour, texture and structural qualities. Finally ask students to create a three dimensional object that is unified from every angle. See **MODEL IDEAS** for suggestions on different materials and techniques.
- Ask students to develop an animal or plant theme using tempera-India ink batiks. The ink helps to unify a composition and the development of a theme that includes families of shapes is also unifying. See **EMPHASIS ART** pp. 109-112.

Integrating with Art Content Areas:

These concepts can lead the student to evaluating his/her work as taught in Component 9 (Craftsmanship), Concept A: Refinement of forms and surface qualities is necessary to a finished appearance to the composition.

An opportunity can also be provided in

**EXPRESSION, Component 10:**

- |  |  |
|--|--|
| <ul style="list-style-type: none"> <li>(i) Purpose</li> <li>(ii) Subject Matter</li> <li>(iii) Media and Techniques</li> </ul> | <ul style="list-style-type: none"> <li>)▶ Students can illustrate</li> <li>)▶ their own story</li> <li>)▶ using cartooning (comic strips) or printmaking techniques such as styrofoam etching or collographs. (See <b>EMPHASIS ART</b> for details and examples showing collographs.)</li> </ul> |
|--|--|

### Integrating with Other Subjects:

Language Arts - Students can compose stories to be illustrated, with attention to the supporting details that make the story interesting.

<p><b>D. Limited colours and materials tighten a composition.</b></p>
---

### Suggested Methods or Strategies:

\* Each media in itself imposes limitations on a composition.

- Direct students attention to colour schemes in room interiors, in clothing and in works of art. Look at some colour schemes in which the palette is quite limited (very few colours are used). These limited colour palettes tend to harmonize or unify a composition or thing, because the colours are related or can be repeated throughout. Ask students to "borrow" a colour scheme from something they have observed and use it to paint a still life arrangement or an abstract composition.
- Ask students to use a monochromatic colour scheme in order to see how limited colour can harmonize a composition. An abstract composition could be made in which shapes are repeated, overlapped and made in various sizes. These qualities will also help to unify the composition.
- Direct your students' attention to colour schemes that are lacking in unity because of lack of repetition. Compare with limited colour schemes. Discuss the differences. Ask students to choose a colour palette in wool using only four colours. These can be used for a weaving or a stitchery project. (See FABRIC IDEAS for a variety of projects.)
- Ask students to consider the art projects they have done in the past, and the materials used. In most cases, the materials were limited to selected drawing, painting or printmaking media, etc. When the media are limited, they contribute to the harmony of a composition.

Integrating with Art Content Areas:

This concept can be used as a basis for evaluation in COMPOSITION, Component 9 (Craftsmanship), Concept B: Rehearsals and ongoing critiques should be scheduled to improve composing skills.

An opportunity can be provided in

EXPRESSION, Component 10:

- |                            |   |
|----------------------------|---|
| (i) Purpose                | )▶ Students can make murals using a limited colour scheme |
| (ii) Subject Matter        | )▶ based on their choice of subject matter                |
| (iii) Media and Techniques | )▶ using painting media.                                  |

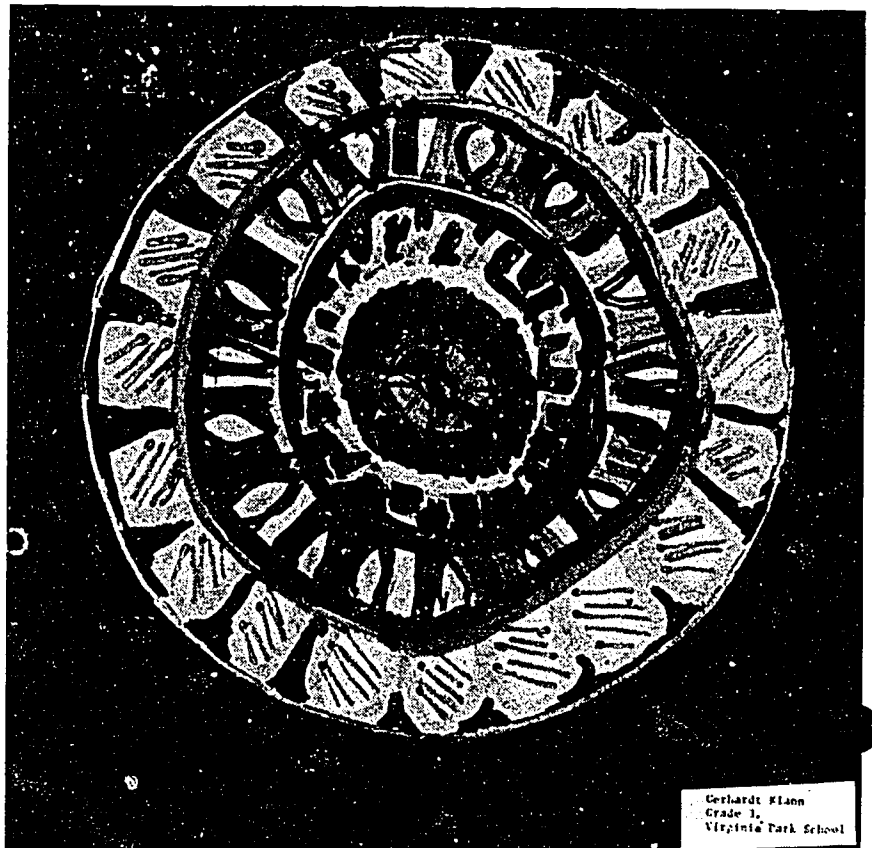

Gerhard Flann  
Grade 1,  
Virginia Park School

119

## COMPONENT 9: CRAFTSMANSHIP

**Objective: STUDENTS WILL IMPROVE COMPOSITIONS BY REFINING, REHEARSING AND CRITIQUING.**

Teaching/Learning Materials for the Component:

The students' art works are necessary for Concepts A and B.

Art gallery visits.

**A. Refinement of forms and surface qualities is necessary for a finished appearance in a composition.**

Suggested Methods or Strategies:

- Student art works produced by means of activities in DEPICTION, Component 6, are necessary for this component. Once students have completed a work, they should be asked to consider its quality of craftsmanship which refers to the care with which something is made. Discuss the meaning of craftsmanship with students. Ask them to look for examples of good and poor craftsmanship in their environment. Then get them to consider the craftsmanship of their own work. Students might develop a checklist of qualities that can often be improved through refinement: textures, colours, tones, increased detail. They should be encouraged to evaluate their own work and then make changes that will further refine forms and surface qualities. This kind of evaluation can be done occasionally in a more formal way until students begin to internalize some of the criteria. At this level, it should not be treated as an onerous task nor be applied after every art work. It can be very helpful to consider craftsmanship after a mural or large group project as well as to art works produced when working in different studio areas.

**B. Rehearsals and ongoing critiques should be scheduled to improve composing skills.**

Suggested Methods or Strategies:

- With students, discuss the meaning of the word "rehearsal". Compare rehearsals in music, dance theatre and art. Apply it to the graphic arts and explain to the students that many of the drawings they have done in DEPICTION have been rehearsals that have helped them when it came to COMPOSITION.
- Students can plan group murals by deciding what skills need rehearsing before the actual painting is begun, e.g., painting skills, figure drawings, spatial layouts, drawing or sketching skills (outlining, gesture drawings, use of thrust lines). Provide lots of newsprint so that students can rehearse before beginning the larger composition.
- Students can make drawings or sketches as rehearsals to a painting.
- When a new technique has been taught in a particular studio area, students should be provided with materials in order to experience and explore the technique before using it in a more complex way, i.e., stitchery sample before a composition using different stitches, watercolour, brayer printing before using the brayer with other tools in printmaking.
- Ongoing critiques can also be used to improve composing skills. These critiques can be handled in a variety of ways, but most of them should be oral:
  - Have students critique their own work in group sessions by discussing briefly how well they feel the lesson objective was achieved by means of their own work. (Students should critique their own work, or the work of professional artists on gallery visits.)
  - Provide time to meet with students individually for a two-way critiquing session.
  - Circulate during the studio lesson to encourage students to tell about their work during its creation and to give suggestions if the student needs assistance.
- After a succession of lessons in a studio area, ask students to critique their work as a part of unit evaluation. Encourage them to tell what they have learned by working in that area and what they feel their weaknesses are.

# Teaching Components

# Level Three

# Level Three Grade 5-6

## REFLECTION

### STUDENTS WILL

- Component ANALYSIS 1.** STUDY AND ANALYZE THE INDIVIDUAL CHARACTER OF NATURAL OBJECTS OR FORMS.
- Concepts:**
- Natural forms tell something about the way they were made.
  - Natural forms can be examined for less visible characteristics.
  - The conditions under which something is viewed affects what is seen, e.g., natural screens like snow and rain, or lenses such as telescopic, microscopic and coloured glass, etc.
  - A form can be examined analytically to see how the whole is composed of its parts.
  - A form can be examined synthetically to see how the parts make up the whole.
  - Natural forms reveal many different structures (skeletal, spiral, orbital, radial, floating, grid, fan, arch, concentric, faceted, etc.).
- Component ACTIONS AND VIEWPOINTS 5.** REFINE METHODS AND TECHNIQUES FOR MORE EFFORTLESS IMAGE-MAKING.
- Concepts:**
- Different drawing techniques (seeing basic shapes, noticing the direction of forms, plotting the position of extremities, etc.) are useful to depict actions.
  - Using a finder or viewing frame helps to see an action within a format.
  - Pushing out a shape from the inside to the edges allows a flexible way to catch the position.
  - Size interchange affects the apparent position of something.
  - Surface reflections, shading and shadows affect the viewpoints.
- Component QUALITIES AND DETAILS 6.** EMPLOY SURFACE QUALITIES FOR SPECIFIC EFFECTS.
- Concepts:**
- Colour harmonies affect the mood and feeling of the viewer.
  - Tonal interchanges enhance a work.
  - Distinguishing characteristics of things can be portrayed vividly or subtly.
  - The character of marks is influenced by drawing or painting tools and methods.
- Component ASSESSMENT 2.** IMPOSE STANDARDS ON DESIGNED OBJECTS AND INVENT IMPROVED VERSIONS.
- Concepts:**
- Shapes evolve and change over time.
  - Designed objects can be evaluated on the basis of function and attractiveness.
  - Criteria are necessary for the evaluation of designed objects.
  - Improved designs can be conceived for any object.
- Component APPRECIATION 3.** INTERPRET ART WORKS FOR THEIR SYMBOLIC MEANING.
- Concepts:**
- Artistic style affects the emotional impact of an art work.
  - An art work can be analyzed for the meaning of its visible components and their interrelationships.
  - Art works contain symbolic representations of a subject or theme.
  - Art works can be appreciated at many different levels (literal and symbolic).
  - An art critic helps us to understand works of art.

## DEPICTION

- Component MAIN FORMS AND PROPORTIONS 4.** MODIFY FORMS BY ABSTRACTION, DISTORTION AND OTHER TRANSFORMATIONS.
- Concepts:**
- The direction of shapes determines the static or dynamic quality of the work.
  - Shapes can be enhanced with complexities (embedded or extended forms).
  - The metamorphosis and transformation of shapes can be depicted (one shape becomes another, e.g., a cloud becomes an animal, or one shape changes within itself, e.g., pupa to butterfly).
  - Forms can reveal their functions.
  - Shapes can be abstracted or reduced to their essences.
  - Shapes can be distorted for special reasons.
  - Sighting techniques can be used to analyze the proportions of things.
  - Receding planes and foreshortened forms create depth in a picture plane.
  - Gridding can be used for systematically capturing or distorting the proportions of things.
- Component EMPHASIS 7.** CREATE EMPHASIS THROUGH THE USE OF STRUCTURAL DEVICES AND STRATEGIES.
- Concepts:**
- Viewfinders are useful devices to determine the best format for what will be portrayed and the centre of interest.
  - The important area in a composition can be enhanced by radial, conical and framing structures.
  - Rhythmic features can lead the eye to the dominant area in a composition.
  - Arrangements of forms into shapes and patterns can tighten a design, direct attention and hold interest in a composition.
  - Labelling (title and signature) demands artistic sensitivity as to placement, size, shape and medium.
- Component UNITY 8.** CREATE UNITY BY INTEGRATING THE PARTS OF THE COMPOSITION TO THE WHOLE.
- Concepts:**
- Implied line produces tensions and connections to achieve unity.
  - Foreground to background movement keeps the interest within the composition.
  - Transitions of colour, texture or tone relate the parts of a composition to a unified whole.
  - Attention should be given to well distributed negative space as well as to the balance of positive forms.
  - Interesting negative space complements and binds the positive areas into an harmonious whole.
  - Pervasive colour, texture or tone can unify a composition such as an overall wash of paint, a glaze, a textural additive, a surface treatment or the like.

- Component CRAFTSMANSHIP 9.** PERFECT IMAGES THROUGH ECONOMICAL USE OF MATERIAL AND EFFICIENCY OF EFFORT.

- Concepts:**
- Minimal actions and limited media result in stronger forms, as in Chinese painting, cartoons or Inuit sculptures.
  - Skill in getting the most from the least.

# EXPRESSION

## Component 10. (I) PURPOSE

- Concepts:**
1. RECORD OR DOCUMENT ACTIVITIES, PEOPLE AND DISCOVERIES.
    - A. Everyday activities can be documented visually.
    - B. Special events such as field trips, visits and festive occasions can be recorded visually.
    - C. Family groups, people relationships can be recorded visually.
    - D. Knowledge gained from study or experimentation can be recorded visually.
    - E. National and international events can be recorded visually.

### 2. ILLUSTRATE OR TELL A STORY.

- A. A narrative can be retold or interpreted visually.
- B. An original story can be created visually.
- C. Material from any subject discipline can be illustrated visually.
- D. Slogans, causes, promotions can be told visually.

### 3. DECORATE ITEMS PERSONALLY CREATED.

- A. Details, patterns, textures can be added to two-dimensional works.
- B. Details, patterns, textures can be added to the surface of three-dimensional works.

### 4. EXPRESS A FEELING OR A MESSAGE.

- A. Feelings and moods can be interpreted visually.
- B. Specific messages, beliefs and interests can be interpreted visually or symbolized.

### 5. CREATE AN ORIGINAL COMPOSITION, OBJECT OR SPACE BASED ON SUPPLIED MOTIVATION.

- A. Outside stimulation from sources such as music, literature, photographs, film, creative movement, drama, television and computers can be interpreted visually.

## (II) SUBJECT MATTER

- DEVELOP THEMES, WITH AN EMPHASIS ON GLOBAL AWARENESS, BASED ON:
- A. Plants and animals
  - B. Environments and places
  - C. Manufactured or man-made things
  - D. Fantasy
  - E. People

## (III) MEDIA AND TECHNIQUES

- Concepts:**
- USE MEDIA AND TECHNIQUES, WITH AN EMPHASIS ON MORE INDIRECT, COMPLEX PROCEDURES AND EFFECTS IN DRAWING, PAINTING, PRINTMAKING, SCULPTURE, FABRIC ARTS, PHOTOGRAPHY AND TECHNOGRAPHIC ARTS.
- A. Drawing
    - Continue to explore ways of using drawing materials.
    - Use drawing tools to make a variety of lines extending beyond previous levels into illusion.
    - Use drawing tools to make a variety of shapes and structures extending beyond previous levels to exploding and enclosing forms, active and passive forms, concave, convex forms, concentric and branching structures.
    - Use models to make drawings with increasing accuracy.
    - Use drawing to add details, textures, create pattern or suggest volume including hatching and cross-hatching, shading, dotting.
    - Make gesture drawings or scribble drawings to show action or movement.
    - Use distortion of line and shape in drawing for special design effects, cartoons or caricatures.
    - Make serial drawings to simulate movement.
    - Abstract or simplify a form.
    - Indicate perspective in drawings.

### B. Painting

- Continue to strive for more sophistication in brush skills by using techniques learned in earlier years.
- Continue to paint, using experimental methods including those without brushes.
- Continue working with tempera paint or tempera thickened with additives such as liquid laundry starch, fabric softener, or wallpaper paste and watercolour, and be introduced to acrylic.
- Mix and use colour tones to achieve perspective.

- Use analogous colours (colours close to each other on the colour wheel) to harmonize the colours of the composition.
- Continue to use paint in combination with other media and techniques.
- Use washes under and over painted images to indicate colour value from light to dark and simulate depth of field.
- Create impasto effects.

### C. Printmaking

- Further explore printmaking materials and their uses and effects.
- Continue to use printmaking techniques learned in lower grades.
- Make prints by using incised (carved or indented) surfaces -- wood, soap, wax, erasers, plaster of Paris, clay, styrofoam.
- Use prepared brayers or rollers to make pattern.
- Apply printing techniques to composition including block out techniques, combination of types of printing, and use of more than one colour.

### D. Sculpture

- Continue to make two- and three-dimensional assemblages from found materials reaching for more sophistication than previous levels.
- Continue clay modelling going beyond previous levels to include more advanced slab techniques (cutting, welding to make cylindrical shapes, draping over objects); use of armatures, coil pots; coloured slip; application of stains.
- Continue exploring paper sculpture techniques.
- Advance wood construction from previous grades to include such techniques as pegging, using screws, finer shaping by sanding, filing, drilling, chiselling, carving and experimenting with texture of wood.
- Continue casting of plaster and advance to casting blocks of plaster of Paris mixed with a material such as vermiculite, zonalite, coffee grounds for the purpose of carving (subtractive sculpture).
- Advance wire sculpture to include tying, coiling, wrapping, soldering and combination with other materials.

### E. Fabric Arts

- Decorate fabric with more complex stitching techniques than previous levels including variations of cross-stitch, feather stitch, chain stitch, daisy stitch.
- Continue to advance weaving techniques to include more sophisticated looms and weaving in combination with other techniques such as knotting.
- Continue to advance batik techniques to include two or more dyes.
- Continue to use collage, braiding and tie-dyeing techniques from previous grades, if applicable.
- Continue to use applique as a designing or decorating device and extend to quilting selected areas.
- Use stitchery methods of one's own invention.

### F. Photography and Technographic Arts

- Take advantage of visual art implications of any available technological device and explore the potential of emerging technologies. Included at this level and advancing from previous grade:
  - \* simple camera used for specific purposes such as close-ups, medium shots, long shots of same subject matter; various viewpoints, action, composition
  - \* overhead projector for experimenting and composing with shape, line, colour including using fluid media (water, oil, food colouring), coloured acetates.
  - \* computer and computer software package and input devices such as light pen, Koala pad, the mouse, tablets, H-Plot, and any other advancements in this area to explore design, compose, animate and program, to make geometric shapes and designs
  - \* copy devices or Xerox to make compositions that involve paste-ups, distortions, reductions, block-outs
  - \* laserdisc visuals interfaced with the computer for study and motivation purposes
  - \* 8mm movie camera for documentation, sequencing, capturing movement, animation
  - \* lighting sources such as spotlights, flashlights, overhead projector light, disco lights for experimenting with effects
  - \* video camera to compose



## COMPONENT 1: ANALYZING NATURAL FORMS

**Objective: STUDENTS WILL STUDY AND ANALYZE THE INDIVIDUAL CHARACTER OF NATURAL OBJECTS OR FORMS.**

Teaching/Learning Materials:

ANOTHER LOOK, Levels A, B and C (use Teacher's Guide for Older Students)

Alberta Heritage Flora and Fauna Kits

natural objects from the plant and animal kingdom as well as minerals and rocks

field trips to greenhouse, conservatory, playground, neighborhood  
microscope, telescope

simple lenses: coloured glass or gels, magnifying glasses

magazines: Ranger Rick, Chickadee, Owl, National Geographic

transparent and translucent materials

sketchbooks, simple cameras

PRINT IDEAS and FABRIC IDEAS

<p><b>Concepts:      A. Natural forms tell something about the way they were made.</b></p>
--

Suggested Methods or Strategies:

- Use lessons from ANOTHER LOOK, Level A: "The Sun" or Level C: "Clouds" and "Hair" (Use the Teacher's Guide for Older Students)
- Ask students to dissect a fruit or vegetable and examine its seeds and the way in which they appear inside the flesh. Compare one sample with another for similarities and differences. Discuss what this tells you about the way the plant matures and seeds itself. Simple sketches can capture some of its qualities.
- Compare a cone from a coniferous tree with the tree itself or a leaf from a deciduous tree with the tree itself. Have students decide whether the cone or the leaf contains within it the blueprint for the mature plant. Both can be sketched.
- Make a collection of smooth stones, shells and/or driftwood. With your students discuss how the action of water upon the objects has helped shape them. Display them in interesting combinations to be used for a still life drawing.

- Visit a greenhouse or conservatory to observe bud formations for leaves and/or flowers and the leaves and flowers when they have matured. Students can try to identify the plant in both stages. Capture the immature and mature plant using sketchbooks or photographs.

Integrating with Art Content Areas:

Once the student becomes more aware of the more visible qualities of a plant, the less visible characteristics can be studied (Concept B). The activities in Concept A can also provide thematic material for DEPICTION, Component 4 (Main Forms and Proportions), Concept C: The metamorphosis and transformation of shapes can be depicted, and Concept D: Forms can reveal their functions.

Also an opportunity can be provided in

**EXPRESSION, Component 10:**

- |                            |  |
|----------------------------|--|
| (i) Purpose                | ▶ Students can record their knowledge        |
| (ii) Subject Matter        | ▶ about natural forms they have selected     |
| (iii) Media and Techniques | ▶ using drawing, painting or fabric collage. |

Integrating with Other Subjects:

Science - Students will learn that organisms live where environmental factors are suited to their needs.

**B. Natural forms can be examined for less visible characteristics.**

Suggested Methods or Strategies:

- Pass around a natural object to groups of eight or ten students seated in a circle. Ask each person to say something different about the object (these observations can relate to taste, sound and tactile qualities as well as visual qualities). Also, encourage students to describe it from different angles. Students can "pass" if the pause is too long between responses. The same activity can be done with a recorder for each group so there can be group sharing and the written information can be used for poetry or prose descriptions.
- Show some slides from one set of the Alberta Heritage Flora and Fauna Kits without the accompanying script. Ask the class to tell what they have learned from their observations. Then use the script for the slide set for additional information, much of which is less visible and dependent on biological research. Identify that which has been learned which is not readily understood through observations.

- To examine natural forms for concave or convex qualities, use ANOTHER LOOK, Level B, "Open or Closed" (use the Teacher's Guide for Older Students).
- Give each student a paper bag containing a natural object. Allow them three minutes to examine the object by means of touching only! Provide clay or plasticene and ask them to model the object they have just explored using only the tactile sense. Students can compare and evaluate their own handiwork with the mystery object. Discuss how much can be learned about objects without using vision. Decide which qualities are impossible to render using only this approach (e.g., colour).

Integrating with Art Content Areas:

This concept provides some background for learning Concept C (the conditions under which something is viewed affects what is seen), Concept E (a form can be examined synthetically to see how the parts make up the whole), and Concept F (natural forms reveal many different structures) in this component. It can also be used to provide thematic sources for learning in DEPICTION, Component 4 (Main Forms and Proportions), Concept B: Shapes can be enhanced with complexities.

Students can demonstrate what has been learned in

**EXPRESSION, Component 10:**

- |                            |   |
|----------------------------|---|
| (i) Purpose                | )▶ Students can construct and decorate objects  |
| (ii) Subject Matter        | )▶ using textures and patterns borrowed from natural forms  |
| (iii) Media and Techniques | )▶ using clay sculpture, papier mache constructions or fabric arts. See FABRIC IDEAS and MODEL IDEAS. |

Integrating with Other Subjects:

Science - Students examine structural and behavioral adaptations of plants and animals.

Language Arts - Grade 5 and 6 students should demonstrate growth in thought processes by perceiving and comprehending increasingly complex written and illustrated descriptions.

**C. The conditions under which something is viewed affects what is seen, e.g., natural screens like snow and rain, or lenses such as telescope, microscopic and coloured glass. etc.**

Suggested Methods or Strategies:

- Use a microscope so students can view small samples of plants, animals or rocks. Encourage them to sketch what they see.
- Organize students into groups of 8-10. Select a large natural object, preferably in its own setting. Have students in different positions and at different angles in relation to the object (tree, large rock, decaying log, bush or shrub). Ask each student to describe the object from his/her viewpoint. Change vantage points after each has had a turn.
- Provide a transparent medium (e.g., cellophane, acetate, glass) and a translucent medium (e.g., tissue paper, some plastic) so that students can view objects and the landscape through both. Discuss how the two views differ. Identify situations in which an artist would want to use each view. Encourage students to experiment with coloured transparent and translucent mediums to note how each colour affects the view.
- Provide an opportunity for students to view the landscape through a natural screen (mist, fogs, rain, snow, branches, spider's web, frosted windows, vines, etc.). If this is not possible, provide photographs based on viewpoints through natural screens. Thumbnail sketches of these can be made in sketchbooks.

Integrating with Art Content Areas:

This concept provides background knowledge for Concept D (a form can be examined analytically to see how the whole is composed of its parts) and Concept F (natural forms reveal many different structures) that follow. It can also be used to provide thematic sources for DEPICTION, Component 4 (Main Forms and Proportions), Concept F: Shapes can be distorted for special reasons.

An opportunity can be provided in

**EXPRESSION, Component 10:**

- |                            |   |
|----------------------------|---|
| (i) Purpose                | )▶ Students can express a mood or feeling by means of viewpoint |
| (ii) Subject Matter        | )▶ about some part of the landscape (their choice)              |
| (iii) Media and Techniques | )▶ using drawing or painting techniques.                        |

Integrating with Other Subjects:

Language Arts - Descriptions from more than one viewpoint of the same object or landscape can be written and compared.

**D. A form can be examined analytically to see how the whole is composed of its parts.**

Suggested Methods or Strategies:

- Students can make a "square" frame by using the index finger and thumb of each hand. Direct them to view a form through their frame and then to "zero" in on each small part of the entire form. A sketchbook can be used to record partial views as well as the whole form.
- Students can dissect fruits and vegetables in different ways cross-wise, lengthwise, etc.) to see how the whole is composed of its parts. Sketches can be made of these cross-sections.
- Use **ANOTHER LOOK, Level A: "Trees"** (A Guide for Using Level A with Older Students).
- Provide a hand lens for each student. Have them look at a natural form through the lens to identify and explore the way in which the form is put together (pine cones, flowers, seed pods, shells, etc.). Have them make sketches that magnify the form several times to show its detail.

Integrating with Art Content Areas:

This concept can provide background for learning in Concept E that follows. It can also precede **DEPICTION, Component 4 (Main Forms and Proportions)**, Concept I: Gridding can be used for systematically capturing or distorting the proportions of things.

An opportunity to demonstrate what has been learned can be provided in

**EXPRESSION, Component 10:**

- |                            |   |
|----------------------------|---|
| (i) Purpose                | )▶ Students can decorate items  |
| (ii) Subject Matter        | )▶ based on cross-sections of fruits, vegetables or plants  |
| (iii) Media and Techniques | )▶ using printmaking techniques (relief plates can be made using cardboard shapes and/or string on a cardboard background). Have students consider the different forms that could be decorated: notepaper, wrapping paper, end papers for a book, book covers. See <b>PRINT IDEAS</b> and <b>FABRIC IDEAS</b> . |

Integrating with Other Subjects:

Science - Students examine the aspects that make up an ecosystem.

**E. A form can be examined synthetically to see how the parts make up the whole.**

Suggested Methods or Strategies:

- Use slides from the Alberta Heritage Flora and Fauna Kits that show close-ups of different aspects of plant or animal forms. Have students view the close-ups before they view the entire form.
- Cut a black and white photograph into equal-sized rectangles so that it resembles a puzzle. Distribute a portion to each student and ask them to draw it on a large scale. Students will have an opportunity to use various crosshatching techniques to approximate the textures and tones of the photograph. Assemble the large scale drawings and let students see the whole of which they have created a part.
- Use **ANOTHER LOOK**, Level B for older students: "How Else Can You See?", "Exploring Your Face", "Weeds".

Integrating with Art Content Areas:

This concept can be used as background for examining structures of forms in the next concept.

An opportunity can also be provided in

**EXPRESSION, Component 10:**

- |   |  |
|---|--|
| <p>(i) Purpose</p> <p>(ii) Subject Matter</p> <p>(iii) Media and Techniques</p> | <p>▶ Students can create a composition</p> <p>▶ based on natural forms</p> <p>▶ in paper mosaic (to determine how the parts make the whole).</p> |
|---|--|

Integrating with Other Subjects:

Science: Students can examine plants or animals synthetically to see how the parts make up the whole and to generalize about other plants or animals in the same class.

**F. Natural forms reveal many different structures (skeletal, spiral, orbital, radial, floating, grid, fan, arch, concentric, faceted, etc.).**

Suggested Methods or Strategies:

- Collect a variety of natural objects or pictures of the objects that reveal some of the variety in structure mentioned above. Ask students to describe the structure of the objects. Make a vocabulary list that accurately describes them. Ask students to search for other objects that fit within the same categories as resource material for drawing exercises and design motivations.
- Use lessons in **ANOTHER LOOK, Level A: "The Sun"** and **"Level B: "Spiral or Concentric", "Parallel or Branching", "Parallel and Branching" and "Weeds"**. Use the Guide for Older Students.
- Encourage students to identify architectural forms that are based on the natural structures that are found in nature, e.g., spiral staircases, domed buildings, parkades, etc. Compare the natural structure with its man-made counterpart.
- Use a microscope so that crystals and/or plants can be magnified in order to see their structural makeup. Encourage quick sketches to capture these structural differences.
- Ask students to compare circular structures for similarities and differences: spiral, orbital, radial, concentric. Encourage them to identify natural forms that represent each one. Drawings can be made to illustrate the differences.

Integrating with Art Content Areas:

This concept can provide a basis for enhancing shapes in **DEPICTION, Component 4 (Main Forms and Proportions), Concept B: Shapes** can be enhanced with complexities, and **COMPOSITION, Component 7 (Emphasis), Concept D: Arrangements of forms into shapes and patterns** can tighten a design, direct attention and hold interest in a composition.

It can also provide opportunities in

**EXPRESSION, Component 10:**

- |                            |   |
|----------------------------|---|
| (i) Purpose                | )▶ Students can decorate items  |
| (ii) Subject Matter        | )▶ using patterns selected from nature  |
| (iii) Media and Techniques | )▶ in stitchery or tie dyeing or by imprinting in clay. See <b>FABRIC IDEAS, p. 22, "Designs from Nature" and pp. 74-85, on tie dyeing.</b> |

Integrating with Other Subjects:

Science - Students can generalize about plants or animals based on their structure.

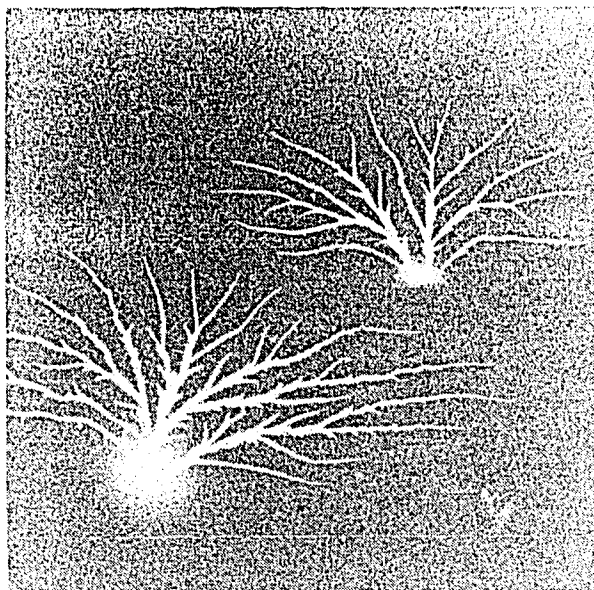

Student Photograph

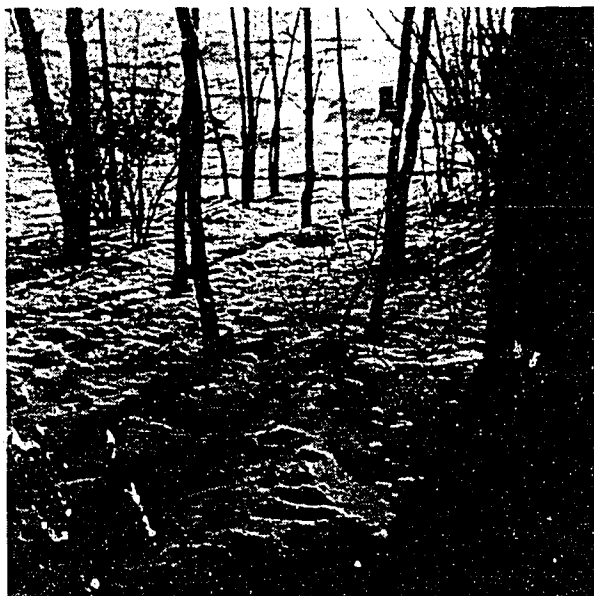

Student Photograph



# COMPONENT 2: ASSESSING DESIGNED OBJECTS

**Objective: STUDENTS WILL IMPOSE STANDARDS ON DESIGNED OBJECTS AND INVENT IMPROVED VERSIONS.**

Teaching/Learning Materials for the Component:

Many pictures of one kind of item

Field trips to view objects in their sittings or spaces

MODEL IDEAS

FABRIC IDEAS

ANOTHER LOOK, Level A and Teacher's Guide for Older Students

Functional objects found within home or school environments e.g., drinking fountain

**Concepts: A. Shapes evolve and change over time.**

Suggested Methods or Strategies:

- With the help of your students choose an interesting item that can be studied in terms of its shape through history. Some suggestions: footwear, costume, cars, airplanes, telephones. Collect pictures that show how the shape of the object evolved over time. Discuss the reason for these changes (invention of new materials, context within which the object functions often change, more efficient production methods are possible, technological changes).
- Discuss tableware (dishes and cutlery) and how many of these items evolved from natural forms: e.g., spoons from shells, bowls from gourds or pods, plates from trenchers of dry bread or large flat leaves, baskets from roots.
- Have students research the evolution of our alphabet from pictographs to the abstract symbols of today.

## Integrating with Art Content Areas:

The previous activities can be used as a basis for learning in

**DEPICTION, Component 4 (Main Forms and Proportions),**

**Concept C: The metamorphoses and transformation of shapes can be depicted.**

**EXPRESSION, Component 10:**

- |                            |  |
|----------------------------|--|
| (i) Purpose                | )▶ Students can design a useful object   |
| (ii) Subject Matter        | )▶ choosing their own subject matter e.g., cars, clothing, toys etc. (see Art Sources - Themes for list of functional objects) |
| (iii) Media and Techniques | )▶ using drawing media or creating a model using techniques appropriate to construction.                                       |

**B. Designed objects can be evaluated on the basis of function and attractiveness.**

### Suggested Methods or Strategies:

- Students may be interested in evaluating items of clothing that are of interest or in vogue: blue jeans, t-shirts, sports shoes, hats, ski jackets, etc. Get them to identify features that serve no other function than that of decoration or embellishment. Do these make the article more or less attractive? Which features relate to the function of the article? How can articles function differently?
- Encourage students to react to designed objects within a space in order that they see relationships between objects and settings. Have them choose settings in which the objects are appropriate or inappropriate. They should be able to react to situations such as these, and defend their judgments.
- Organize visits to public spaces where sculpture, fountains or other man-made designs have been used to enhance the space. Discuss the feeling or mood that is created by these additions to a setting. Encourage students to judge whether the sculpture is appropriate for the setting.
- Use objects to compare differences in function. Consider whether visual appeal is related to function. Relate the materials used for the object to function. Consider which functions better because of the materials used.  
Also consider the relationship between function and appearance. If necessary refer back to Level Two, ASSESSING DESIGNED OBJECTS:  
Concept A: Form should follow function.

### Integrating with Art Content Areas:

The learning that takes place in these activities will help students to establish criteria for assisting in Concept C, which follows. (Criteria are necessary for the evaluation of designed objects.)

An opportunity for visual expression can also be provided:

#### EXPRESSION, Component 10:

- |                            |  |
|----------------------------|--|
| (i) Purpose                | )▶ Students can design a useful and attractive item  |
| (ii) Subject Matter        | )▶ of their choice (hockey mask, school bag, pencil container, doll clothes, etc.)                                   |
| (iii) Media and Techniques | )▶ using media appropriate to the object.<br>Refer to MODEL IDEAS and FABRIC IDEAS for suggestions and instructions. |

### Integrating with Other Subjects:

Drama - By means of mime have students express their reactions to a crowded space, an open space, a space big enough for one person, a cluttered space, a labyrinth, a richly decorated room, a dilapidated space, a filthy space. They can compare their own reactions with those of others to see if all spaces affect people the same way.

<b>C. Criteria are necessary for the evaluation of designed objects.</b>
--

\* Previous concepts have developed some of the criteria for evaluation.

### Suggested Methods or Strategies:

- Encourage students to react to designed objects that have some significance in their lives. Allow them to choose items such as blue jeans, sports shoes, sportswear, sports equipment, toys, books, bikes, etc. Give them an opportunity to share their thoughts and feelings about specific items they have chosen and why these items are desirable or undesirable. Criteria should be established so that students begin to react on a level that is based on fact as well as feeling.

- Throughout the study of designed objects, students should be encouraged to give their reactions and give reasons for their choices. They should be able to establish a criteria as a basis for evaluation to include such aspects as: visual appearance, the degree to which it fulfills its purpose or function, how well the appearance of the object relates to its function, factors that affect personal preferences.
- Divide the class into small groups to encourage more active participation. Provide each group with an object to be assessed in terms of their own criteria. Have each group share their assessments and the criteria on which these are based.
- Students can list the criteria used in the above activities. Consider what these criteria have in common.

Integrating with Art Content Areas:

Once students can establish their own criteria for assessing objects they will have a framework for improving the design of an object which follows in Concept D (improved designs can be conceived for any object).

Integrating with Other Subjects:

Language Arts - Grades 5 & 6 - Students should demonstrate growth in thought processes by expressing orally increasingly complex feelings, preferences, opinions and judgments.

**D. Improved designs can be conceived for any object.**

Suggested Methods or Strategies:

- Encourage students to analyze their classroom in terms of the way space is used. Have them diagram the way space is being used at present and then make a second diagram showing how they would like space used. Decide on symbols to represent furniture in the diagrams. Consider the scale of the room and its contents in executing the diagram.
- Have students evaluate a space (e.g., classroom, bedroom, pedestrian space in a mall, playground) according to how well it serves its function. Students must ask themselves the purpose for which the space is designed. They must take time to observe the space in use, in order to evaluate it. Encourage them to suggest ways in which the space could be reorganized so it could be used more efficiently.

- Have students evaluate a display space in the school in terms of its possibilities for mounting art displays. Get them to decide what kinds of art works can be displayed and whether the space can be reorganized to accommodate two and three dimensional art works. Then have them mount a display to demonstrate its effectiveness in terms of their goal.
- Visit a commercial area to view window spaces of different businesses or the display spaces used in one department store. Following the visit students could apply their learning by designing a display for a showcase in the school. Consider the kinds of displays possible for each subject area.
- Encourage discussions in which specific functional objects are assessed and improvements for the object are suggested. Students may choose objects from the following classifications: toys, furniture, clothing, sporting goods, vehicles, tools.

Integrating with Art Content Areas:

The previous lessons can give students experience in expressing their suggestions for the improvement of functional objects and can be used as a basis for lessons in:

**EXPRESSION, Component 10:**

- |                            |  |
|----------------------------|--|
| (i) Purpose                | )▶ Students can make three-dimensional models of objects to show improvements in design  |
| (ii) Subject Matter        | )▶ which could be chosen from these classes: toys, playground equipment, buildings, vehicles, furniture or sports equipment (see Art Sources - Themes) |
| (iii) Media and Techniques | )▶ using materials appropriate to the object.  |

Integrating with Other Subjects:

The learning in Concept D can be applied to improving the design of displays representing each subject area.

## COMPONENT 3: APPRECIATING ART

**Objective: STUDENTS WILL INTERPRET ART WORKS FOR THEIR SYMBOLIC MEANING.**

Teaching/Learning Materials for the Component:

Painting reproductions or originals, magazine illustrations, illustrations in children's books, sculptures, comic books, student art work, ANOTHER LOOK, Level A.

**EMPHASIS ART.**

Possible field trips to art galleries and/or the cinema (Concept E).

**Concepts: A. Artistic style affects the emotional impact of an art work.**

Suggested Methods or Strategies:

- Have students look at paintings that employ different styles: Impressionistic, Expressionistic, Realism, Surrealism. See glossary for definitions. Encourage them to discuss how one style differs from another. Then try to relate the style with the effect it produces in the viewer.
- Have students search for illustrations in magazines or children's literature which provoke strong feelings for them personally. Encourage them to tell how the illustration affects them and why. Also look for examples of realistic, abstract, distorted and decorative styles in art.
- Visit an art gallery and encourage students to identify works that have strong emotional appeal. Discuss whether style, composition, subject matter or all contribute to this strong appeal.
- Make cards that identify a range of human emotions. Distribute a card to each child so a visual search can be conducted to find an art work that expresses that emotion. Use library picture files, children's books, magazines, postcard reproductions of art works. Start an art file in the classroom.

- Because art is a language of emotion, among other things, students should become familiar with the artistic styles that exemplify this content. Some of these are:
  - Romanticism (in which the artist is drawn to exotic or dangerous themes or romanticizes the ordinary, e.g., Gauguin, Delacroix, Gericault).
  - Distortion of imagery (in which objects and figures are distorted due to the artist's feeling toward the subject or theme, e.g., Lautrec, Munch, Giacometti, van Gogh, Michelangelo, Shahn, Chagall, Picasso).

Choose works from one or more of the artists whose work is characterized by romanticism or distortion of imagery. Identify the emotions or feelings that are aroused in the viewer by the art work.

Integrating with Art Content Areas:

The learning of Concept A in this component can be used as a basis for a lesson in

**DEPICTION, Component 4 (Main Forms and Proportions)**

Concept F: Shapes can be distorted for special reasons.

and for lessons in

**EXPRESSION, Component 10:**

- |                            |   |
|----------------------------|---|
| (i) Purpose                | ▶ Students can express their own strong feelings      |
| (ii) Subject Matter        | ▶ about a subject of their choice                     |
| (iii) Media and Techniques | ▶ in drawing or painting using distortion techniques. |

**B. An art work can be analyzed for the meaning of its visible components and their interrelationships.**

Suggested Methods or Strategies:

- Use lesson suggestions in Townley's **ANOTHER LOOK, Level A: Sunlit Forests, Sunlit Forests in Art, Straight or Curved.**
- In making their own art, students will be using colour, line, shape, and space to show relationships, e.g., space may be organized to create depth illusion; tints and shades may be used to vary the colour values of a composition; crosshatching lines may be used to provide contrast to the linear qualities of a drawing or to create some depth and tone to what is essentially a flat surface. When students are required to create specific effects or to show specific relationships

between art elements or among them, they may profit from viewing art works in which these kinds of relationships exist. Provide original art or reproductions of drawings, paintings, prints and photographs. Ask students to point out one of the following at any given time:

- contrasting colours
- complementary colours
- analagous colours
- changes in colour values
- colour emphasis in a composition
- regular linear patterns
- irregular linear patterns
- lines that create texture
- shapes that create irregular patterns
- distorted shapes
- clustered shapes
- overlapped shapes
- shapes emphasized in a composition
- figure-ground relationships
- depth illusion created by spatial arrangement
- colour and space working together to create depth illusion
- boundary bursting (images that appear to go beyond the edges of the picture space)

As students identify these characteristics, they should be considering the effect they have on the total composition and the effect that these relationships have on the viewer. For example:

"The elongated figures in this painting are graceful."

"The elongated figures in this painting are absurd."

"The elongated figures in this painting are dreamlike."

"The elongated figures in this painting make me feel weightless."

Students should learn that they are analyzing a work of art in order to enhance their own appreciation and expand its meaning for them. In order to make these lessons most meaningful, concentrate on one aspect at a time and focus on it in teaching **COMPOSITION**.

- Have students identify the visible components of an art work (colour, line, shape, texture). Once they have been identified they can begin to look at how these components relate to each other, i.e., how a colour and shape may work together to produce a particular visible effect such as making the shape appear to recede or advance.



### Integrating with Art Content Areas:

This concept is necessary to the understanding of Concept D in this component. It may also be used as a basis for a lesson in

#### EXPRESSION, Component 10:

- |                            |  |
|----------------------------|--|
| (i) Purpose                | )▶ Students may create an abstract composition   |
| (ii) Subject Matter        | )▶ to convey a feeling of boldness, delicacy, monotony, excitement, calmness (to name a few ideas) |
| (iii) Media and Techniques | )▶ using cut paper collage, drawing or painting techniques or combinations of these.               |

<b>C. Art works contain symbolic representations of a subject or theme.</b>
---

#### Suggested Methods or Strategies:

- Direct students to use a variety of body postures to represent different kinds of trees or trees in various stages of growth and decay. Then ask each child to represent a tree in a forest. Once this enactment has taken place explain that they were representing or symbolizing a tree. Discuss with students how artists might represent a tree (by using different media and techniques).
- Follow lesson suggestions in **ANOTHER LOOK, Level A: The Sun in Art.**
- Students can be encouraged to view sculptures within their community or city and to discuss their symbolic meanings. A representational sculpture of an historical figure not only represents the person depicted, but may also symbolize certain qualities or human values held by that person.
- Students may look at comic book art to find characters that symbolize good and evil. Discuss the visible qualities employed by the artist to convey character traits.
- Have students view Native art or pictographs to look for ways in which these people represented commonplace objects with stylized forms.
- Research the history of our alphabet to follow its evolution from picture writing to more abstract symbols.

### Integrating with Art Content Areas:

This concept provides background for the understanding of Concept D (art works can be appreciated at many different levels) in this component. It can also be used as a basis for learning in

#### **EXPRESSION, Component 10:**

- |                            |  |
|----------------------------|--|
| (i) Purpose                | )▶ Students may represent a person, place or thing                 |
| (ii) Subject Matter        | )▶ using three different media                                     |
| (iii) Media and Techniques | )▶ to show how the same subject matter can be treated differently. |

**D. Art works can be appreciated at many different levels (literal and symbolic).**

#### Suggested Methods or Strategies:

- Explain to students that art works can be appreciated at a literal level as well as a symbolic level. For example, an artist's depiction of an oak tree represents the tree itself (literal) and at a symbolic level, it may symbolize strength or greatness. Refer students to vivid characters from literature they have read, who have an identity as a certain person but also stand for certain human qualities. Look at book illustrations of these characters to see if the illustrator has captured both literal and symbolic qualities. (A good illustrator will capture both qualities.)
- Since colour is very often used symbolically by artists, encourage students to concentrate on that aspect when viewing art works. Begin by discussing the symbolic meanings of colour in our own culture, i.e., red for danger or anger, black for mourning, white for purity, etc. Identify art works in which colour seems to be used symbolically by the artist. Tell students that the artist does not always conform to the normal interpretations so may not use colour with the same meaning as those in his/her culture. Students might like to look at art works from Picasso's Blue Period and Rose Period to discuss why he might have stressed those particular colours.
- A collection of portraits can be made (photographs of famous persons from magazines are readily accessible). Ask students to identify the persons portrayed (literal interpretation). Then ask them to relate the person to a particular feeling or emotion (symbolic interpretation). Try to collect portraits that show a range of human emotions.

- Play a landscape game. After collecting pictures of landscapes and seascapes, distribute one to each student. Within a limited amount of time, have each student study his/her picture and prepare to describe it to others on a literal level without showing it to them. Class members might try to arrive at an adjective that would describe the effect of the total picture from its description, i.e., gloomy, peaceful, hysterical, exciting and so on. Students will begin to see that their verbal description is very important and it is not only the content or subject matter but the way in which it is presented that affects the viewer. (Once a descriptive word is offered by the class, the picture can be revealed and a decision made as to whether it accurately describes the work or whether another adjective would be more appropriate.)

#### Integrating with Art Content Areas:

Learning this concept will help students to understand Concept E in this component as well as in

##### DEPICTION, Component 4 (Main Forms and Proportions)

Concept E: Shapes can be abstracted or reduced to their essences.

Concept F: Shapes can be distorted for special reasons.

##### DEPICTION, Component 6 (Qualities and Details)

Concept A: Colour harmonies affect the mood and feeling of the viewer.

One or more lessons can also be taught in

##### EXPRESSION, Component 10:

- |                            |   |
|----------------------------|---|
| (i) Purpose                | )▶ Students may express a feeling or emotion through colour |
| (ii) Subject Matter        | )▶ using subject matter of their choice                     |
| (iii) Media and Techniques | )▶ in a studio area of their choice.                        |

#### Integrating with Other Subjects:

Language Arts - Grades 5 and 6 - Students continue to interpret visual materials.

**E. An art critic helps us to understand works of art.**

Suggested Methods or Strategies:

- An art critic bases his judgment on a critical process that involves:
  - a) a description of the art work
  - b) an analysis of the relationships that exist among the visual qualities of line, shape, colour, texture and tone.
  - c) an interpretation that is based on the description and analysis, but goes beyond the literal meaning to arrive at a symbolic meaning.

Ask students to choose an art work and prepare an oral presentation that describes, analyzes and interprets. Emphasize the fact that art works can be interpreted in many ways.

- Have students create an art work with a specific purpose in mind. Then they can give interpretations of each other's work before checking with the artist for his own interpretation.
- Select an artwork that has a narrative quality or a panoramic view. Encourage students to examine its various details, events or sequences in order to interpret the work in its entirety. Use art reprints by such artists as Pieter Brueghel, Grandma Moses, Marc Chagall, Jacques Seurat, Altdorfer, Alex Colville, Andrew Wyeth, Uccello.
- Art critics gain information from talking to artists. After an art project, pair students for a role playing situation in which one student plays the role of artist and the other, critic. The critic must interview the artist in order to find out about the art work (result of the art project). After the interview the critic can critique the work. Provide time for students to play both roles.
- Have students adopt the role of critic to interpret differences in mood in paintings, drawings or prints. Encourage them to interpret the mood on the basis of visual relationships.
- Organize a trip to the cinema to see a film that has visual richness. Set the objective with the class prior to the viewing experience. (Ask them to interpret the film in terms of the cinematography.) If the students have seen the film previously, so much the better. As a result they will be able to concentrate more on the film techniques rather than the story line in order to see how these techniques enhance, detract or endorse the story line or the film's message.

Integrating with Art Content Areas:

The knowledge gained in this component will assist students in **DEPICTION** and **COMPOSITION** since it will lead to artistic considerations beyond literal representation toward a more expressive, interpretive realm.

Some suggestions for

**EXPRESSION, Component 10:**

- |                            |   |
|----------------------------|---|
| (i) Purpose                | )▶ Students can use portraiture   |
| (ii) Subject Matter        | )▶ to express moods or feelings   |
| (iii) Media and Techniques | )▶ using clay slabs in relief or magazine collage portraits (combining parts of many faces) or fabric collage portraits using stitchery for features. |

Integrating with Other Subjects:

Language Arts - Students can also interpret their own work by giving a short oral report during a sharing session or writing a short paragraph to accompany a display of their work.



145

# COMPONENT 4: CAPTURING MAIN FORM AND PROPORTION

**Objective: STUDENTS WILL MODIFY FORMS BY ABSTRACTION,  
DISTORTION AND OTHER TRANSFORMATIONS.**

Teaching/Learning Materials:

drawing media  
painting media  
sketchbooks  
ANOTHER LOOK, Levels A, B and C  
MODEL IDEAS  
EMPHASIS ART  
neighborhood walks, field trips  
Alberta Heritage Flora and Fauna Kits  
picture files  
cartoons, caricatures  
COLLAGE IDEAS  
FABRIC IDEAS

<p><b>Concepts:      A. The direction of shapes determines the static or dynamic quality of the work.</b></p>
---

Suggested Methods or Strategies:

- Ask students to locate objects (inside and outside the classroom) that are horizontal, vertical or diagonal. Consider whether vertical or horizontal forms give a feeling of stability and diagonal forms suggest motion. Sketch forms from the environment that are vertical, diagonal and horizontal.
- Have students choose subject matter appropriate to horizontal, vertical or diagonal and draw or paint a composition based on one direction only. Compare them for the differences evoked in mood or feeling.
- Use lessons from ANOTHER LOOK, A Guide for Using Level B with Older Students: "Horizontal or Vertical" and/or "Diagonal".
- Ask students to sketch portraits of human figures to show horizontal, vertical and diagonal poses. The diagonal poses will create a feeling of movement or instability.

### Integrating with Art Content Areas:

The awareness of direction is needed in order to represent forms in **DEPICTION, Component 5 (Actions and Viewpoints), Concept A: Different drawing techniques are useful to depict actions.**

An opportunity can also be provided in

#### **EXPRESSION, Component 10:**

- |                            |  |
|----------------------------|--|
| (i) Purpose                | )▶ Students can express a mood or feeling by means of direction of forms   |
| (ii) Subject Matter        | )▶ based on their choice of subject matter   |
| (iii) Media and Techniques | )▶ using sculpture (see <b>MODEL IDEAS and EMPHASIS ART</b> (constructions in space) for some suggestions) or photography. |

### Integrated with Other Subjects:

Drama - Students discover how to use the body as a vehicle for expressing and interpreting feelings and ideas. (Activities could use horizontal, vertical and diagonal as directions for movement.)

**B. Shapes can be enhanced with complexities (embedded or extended forms).**

### Suggested Methods or Strategies:

- Ask students to identify shapes that are embedded within a form and shapes that extend a form from both the natural and the man-made world. Some forms will have both qualities, e.g., the human form has extensions (appendages) and embedded shapes. Have students create an abstract design based on natural forms using embedding and extending. See **EMPHASIS ART** (Tempera-India Ink Batik) for some good examples.
- Take a neighborhood walk to view architectural forms that have embedded and extended forms. Modern skyscrapers usually only have embedded forms such as doors and windows and often no extensions of any kind. This may make it less interesting visually. Ask students to choose a building to sketch that has both embedding and extending.
- For a lesson using the sun as an extended form use **ANOTHER LOOK, A Guide for Using Level A with Older Students: "The Sun"**.
- Lessons using the terminology enclosing (embedded) and exploding (extended) appear in **ANOTHER LOOK, A Guide for Using Level C with Older Students: "Enclosing - Exploding"**.

### Integrating with Art Content Areas:

This concept can provide background for COMPOSITION, Component 7 (Emphasis), Concept D: Arrangement of forms into shapes and patterns can heighten a design, direct attention and hold interest in a composition.

An opportunity can also be provided in

#### EXPRESSION, Component 10:

- |                            |   |
|----------------------------|---|
| (i) Purpose                | )▶ Students can show embedded and extended forms                                  |
| (ii) Subject Matter        | )▶ based on floral patterns   |
| (iii) Media and Techniques | )▶ using stitchery or fabric dyeing methods (See FABRIC IDEAS for these methods). |

### Integrating with Other Subjects:

Drama - Small groups of students can illustrate embedding and extending using a variety of poses.

**C. The metamorphoses and transformation of shapes can be depicted (one shape becomes another, e.g., a cloud becomes an animal, or one shape changes within itself, e.g., papa to butterfly).**

### Suggested Methods or Strategies:

- Provide visual material that illustrates the life cycle of plants and/or animals. The Alberta Heritage Flora and Fauna Kits contain slides that show some examples. Then ask students to choose a plant or animal to depict its life cycle. A round format would be suitable for this kind of assignment.
- Use ANOTHER LOOK, A Guide for Using Level B with Older Students: "Open and Closed".
- Many students are already cloud watchers. Give them some time to pursue this activity in earnest on a suitable day. Ask them to look for shapes that may represent other things. These could be sketched quickly with charcoal and used as a basis for a number of sketches in which the cloud gradually forms a shape and then disperses. A cartoon format or a flip book format would be appropriate.
- Have students choose a simple shape that can be recorded on blank 16mm film with felt pen. The shape must be repeated many times each time a change is recorded in order for it to register on the screen. Each child could be given a length of film which could be spliced to make one class film. Some trial and error is in order to see how many times an image needs repeating. (Ask students to look at the frames of an actual movie to determine an approximate length.) This activity



could also be done on acetate and shown on the overhead projector (a static rendition rather than a moving one). Encourage students to keep their shapes simple. Get them to try a transformation from one shape to another (triangle to sphere, rectangle to triangle, etc.).

- Ask students to choose an object or thing that has an approximate similarity in configuration to another object. The object or thing should be changed each time it is represented until gradually it is transformed and becomes the second object or thing, e.g., one leaf becomes a tree, one kind of bird becomes another bird, one person becomes another. Some research is encouraged before attempting this rather difficult assignment. Five or six drawings may be needed to make the transition. If possible have students view some of Escher's transformations from fish to fowl.

An opportunity can be provided in

**EXPRESSION, Component 10:**

- |                            |   |
|----------------------------|---|
| (i) Purpose                | )▶ Students can design an advertisement using transformations |
| (ii) Subject Matter        | )▶ based on their choice of subject matter                    |
| (iii) Media and Techniques | )▶ using drawing techniques.                                  |

Integrating with Other Subjects:

Science - Students learn that some organisms develop through stages of a life cycle with each stage exhibiting special adaptations. (The stages of the life cycle can be studied and depicted in Concept C.)

Mathematics - Students identify, translate, rotate, reflect and enlarge 2-dimensional figures. These skills can be used in the activity in Concept C that uses geometric shapes.

**D. Forms can reveal their functions.**

Suggested Methods or Strategies:

- Ask students to examine pictures of homes from many different geographic regions. Discuss the ways in which each structure is adapted to the environment for which it is built. (This is not necessarily true of architecture in countries that have central heating.) Then ask students to depict one of the following:

A building in a place where

- the snowfall is very heavy each year

- the climate is dry and hot
- the view is magnificent
- the land is constantly flooding
- the people and their animals live under one roof
- the rain falls are torrential
- the forests are dense
- the summers are hot and the winters cold.

Ask students to evaluate their drawings on the basis of whether other viewers can identify how the building should function in adapting to the climate it was designed for.

With the class discuss briefly, how the body is designed to perform specific functions. Ask students to design a creature from another planet after listing the various functions "it" can perform. Some things to consider:

- how it moves
- what senses it has
- how it sustains itself
- what vital organs keep it alive
- where it lives.

- Use lessons in ANOTHER LOOK, Level A: "Trees", Level B: "Open or Closed," and Level C: "Moving Matter". Refer to the guides for older students.

Integrating with Art Content Areas:

An understanding of forms that reveal their functions will be helpful in DEPICTION, Component 4 (Main Forms and Proportions) Concept C: The metamorphosis and transformation of shapes can be depicted.

An opportunity can also be provided in

EXPRESSION, Component 10:

- |  |   |
|--|---|
| <ul style="list-style-type: none"> <li>(i) Purpose</li> <li>(ii) Subject Matter</li> <li>(iii) Media and Techniques</li> </ul> | <ul style="list-style-type: none"> <li>)▶ Students can create a mural to show the relationship between form and function</li> <li>)▶ in plants or animals</li> <li>)▶ using mixed media techniques (see EMPHASIS ART: Murals).</li> </ul> |
|--|---|

Integrating with Other Subjects:

Science - Students study structural and behavioral adaptations of organisms.

**E. Shapes can be abstracted or reduced to their essences.**

\*Abstract shapes do not represent actual things in the environment. Shapes that are reduced to their essences (basic shapes) are known as stylized (simplified) shapes.

Suggested Methods or Strategies:

- Show students an unfocussed slide. Ask them to make a drawing of the slide. When they have finished show the slide to them in sharp focus. Explain that many artists are able to make something abstract by translating directly from realism to abstraction. Ask students if they could have done this by looking at the slide in focus. Give them an opportunity to try.
- Another way that artists reduce realistic forms to stylized forms is through transitions. Organize for a series of lessons that will allow students to try this approach. Begin by having students choose and study natural forms such as flowers, fruits, fish or birds. Ask them to study their choices (using pictures or actual items) and to make pencil drawings capturing as much detail and realism as possible. Drawings should be made with pictures or objects as models. To avoid tracing or attempts to copy the models exactly, ask students to draw them on a larger or smaller scale depending on the size of the model itself. Once the drawings have been completed, ask students to cut their object from coloured paper. This forces the students to ignore some of the finer details which cannot be captured in cut paper. They must consider the outline of the form and add details later with felt pens, etc. These could be used later for a paper collage. Then ask students to use the cut paper form as a template to cut the same form from fabric. Again some of the details will be lost and a variety of patterned fabrics will add further to its stylized quality. (The shape could also be cut from a clay slab and textured.) Have students use the fabric cut-outs for an applique project. Stitches can be used for enhancement. See **FABRIC IDEAS** for some basic stitches. A display could be mounted to show the drawings, cut paper collages and applique or flat clay objects. As students proceed from one technique to another encourage them to see the simple shapes that make up a more complex shape. This approach could be carried even further so that eventually students lose the representative quality of their shape and it becomes truly abstract.
- Direct students to make a paper collage by selecting only parts of things, as well as negative shapes, to make an abstract composition that is totally abstract. (Patterns, colours, shapes and textures should be represented rather than items that can be identifiable.)

- Ask students to bring an example of their favorite cartoons from the weekend funnies. Conduct a discussion about the ways the cartoonists have used to simplify (stylize) human forms. Give students an opportunity to make drawings of their friends in which they simplify their shapes. Use these as preliminary sketches for a class strip based on incidents that have happened at school. If the school "publishes" a newspaper their comics might be appropriate entries.
- Use **ANOTHER LOOK, A Guide for Using Level C with Older Students: "Patterns" and "Hair"**.

Integrating with Art Content Areas:

The ability to abstract and/or stylize is a skill that can be applied in **DEPICTION, Component 4 (Main Forms and Proportions) Concept C:** The metamorphosis and transformation of shapes can be depicted and in **Concept F:** Shapes can be distorted for special reasons.

An opportunity can also be provided in

**EXPRESSION, Component 10:**

- |                            |  |
|----------------------------|--|
| (i) Purpose                | ▶ Students can design crests or shields that symbolize their interests |
| (ii) Subject Matter        | ▶ based on subject matter of their choice                              |
| (iii) Media and Techniques | ▶ using cut paper collage, fabric applique or clay tiles.              |

**F. Shapes can be distorted for special reasons.**

Suggested Methods or Strategies:

- If possible, have students look through gels, distorted glass or any translucent medium that distorts the image. Discuss the meaning of distortion. Talk about fun mirrors at a carnival or fair. Identify different kinds of distortion (sight, sound, tactile). Collect some examples of caricatures as examples of visual distortion. Political cartoons are a good source. Talk about the distortion of facial features in the caricatures. Ask students how they think the artist decides which features to distort (usually ones that are already emphasized, such as a large nose, are made bigger). Pair students so they can study their partner and make a caricature by exaggerating their most prominent features.
- For a lesson on using cut paper rectangles and squares to make distorted shapes see **COLLAGE IDEAS** pp. 65-68.

- Have students choose a composition from a magazine and cut it out. Then have them cut it into pieces as if it were a puzzle. When the pieces are reassembled they should be placed leaving spaces between each other, but in the same order as in the picture. Encourage students to experiment with the kinds of patterns they use in cutting up the composition. Also they should try straight lines and curved lines to see which produce more distortion.
- Distortion can be achieved by creating objects from materials that are unrelated to the object, e.g., inflatable hamburgers, soft sculpture cakes, clay clothing. Artists often create these kinds of distortions to make a visual joke or pun. Have students choose an object that they value in some way, e.g., piece of sports equipment, ballet slippers, bicycle. Ask them to represent the object in three dimensions using unconventional materials. Provide clay, wire, wood, cardboard, plaster, and fabric to choose from.
- If possible show students art reproductions that use distortion techniques. Some examples: van Gogh, Munch, Picasso, Dali, Duchamp, Oldenburg, Chagall. Compare artists for the different ways in which things are distorted (altered from their natural or original shape). Discuss the emotional impact this work has. Have students choose subject matter that has strong emotional appeal and paint a composition that distorts some of the subject matter to convey a feeling or message. (A classic example is Picasso's "Guernica", an indictment on war and fascism.)

Integrating with Art Content Areas:

Distortion techniques may be useful in learning Concept C in DEPICTION, Component 4 (Main Forms and Proportions), (the metamorphosis and transformation of shapes can be depicted). They may also be used to create rhythmic features in COMPOSITION, Component 7 (Emphasis), Concept C: Rhythmic features can lead the eye to the dominant area in a composition or to distort surface reflections in DEPICTION, Component 5 (Actions and Viewpoints) Concept E.

An opportunity can also be provided in

**EXPRESSION, Component 10:**

- |  |  |
|--|--|
| <ul style="list-style-type: none"> <li>(i) Purpose</li> <li>(ii) Subject Matter</li> <li>(iii) Media and Techniques</li> </ul> | <ul style="list-style-type: none"> <li>▶ Students can use distortion to symbolize their beliefs</li> <li>▶ about a controversial topic</li> <li>▶ using painting, cut paper collage or three-dimensional materials.</li> </ul> |
|--|--|

### Integrating with Other Subject Areas:

- Music - Students can listen to music in which the composers or improvisors have distorted the sound of specific instruments for special effect.
- Language Arts - Students can identify examples of literacy forms in which distortions of the truth appear: fairy tales, legends, folk tales, epic poetry, myths. Ask students to write their own story in which an everyday event is so distorted or altered as to defy belief.

### **G. Sighting techniques can be used to analyze the proportions of things.**

### Suggested Methods or Strategies:

- Many students at this level desire to depict in a realistic way. The purpose of measuring and becoming more accurate in seeing size relationships is to capture the correct proportion of things as they are represented in drawing, painting or sculpture. A sighting technique involves holding a pencil or brush at arm's length and lining up the top of the object to be measured. The thumb is then placed on the pencil or brush where you see the base of the object being viewed. The arm must be kept straight to maintain accuracy. The method is really measuring size relationships, not actual sizes. Begin by choosing some simple items in the classroom and have students "sight" them and then depict them.
- Have students use the sighting technique before doing figure drawings of each other (to establish the proportions of head, torso, legs, abdomen).
- Organize a sketching trip out of doors so students can use sighting techniques in depicting a landscape.

### Integrating with Art Content Areas:

The sighting techniques can be applied whenever figure drawings or landscapes are made. It can also be useful when using the different drawing techniques taught in Concept A of DEPICTION, Component 5 (Actions and Viewpoints).

### Integrating with Other Subjects:

- Mathematics - Grade 5 - The student expresses and generates proportional ratios. Grade 6 - The student identifies and uses proportional ratios.

## **H. Receding planes and foreshortened forms create depth in a picture plane.**

### Suggested Methods or Strategies:

- Ask students to take one long strip of heavy paper or light cardboard (approximately 30 cm long by 5 cm wide). Tell students that their strip is a simple flat plane. Then ask them to make a number of vertical folds along the strip and stand it up on their desk as a three-dimensional form. Have them place it so that one end is closer to them and the other end farther away. Discuss the changes in appearance from the flat plane it once was. Ask students to draw their viewpoint of the strip now that it is three-dimensional. Get them to trace the lines that recede into the distance.
- Explain that artists working in drawing or painting mediums must use receding lines or planes to give the illusion of depth to a composition. Ask students to establish a horizon line on their picture plane. Tell them that the horizon line is always at the eye level of the viewer no matter where the viewer happens to be. Instruct students to draw two lines that converge at the horizon line (this gives the appearance of a road or a river that reaches the vanishing point at the horizon line). Give students a chance to experiment with receding parallel lines that converge. Some themes to try: roads, sides of buildings, streams, fences, telephone poles. Evaluate as to whether they achieve the illusion of depth.
- Ask students to sketch aerial views of empty boxes that show some of the inside and some of the outside of the box. Talk about the parallel lines used to create depth and how drawing the angles is important.
- Direct students to use their viewfinders to frame a composition that shows one of the four corners of the classroom. Ask them to draw what they see. Discuss whether drawing where the ceiling and the walls meet will help to further the illusion of depth.
- Foreshortening is an illusion in which things seem to be shorter than they really are. Pair students so that each student in the pair can view and model foreshortened positions. Ask those who are modelling first, to sit or lie in positions that make the arms and legs appear shorter than they really are. The viewers can respond when they notice that the arms or legs appear shorter. Provide time for the pairs to experience both tasks. Once students have experienced the illusion get them to make some quick sketches of an arm or a leg in a foreshortened position. (In foreshortening the distant parts of the figure appear to be smaller than they are and the nearby parts (knees, lower legs) to be longer.)

- Ask students to draw a model that is seated on a high stool from their own positions on the floor. This will produce a foreshortened view if they draw what they see rather than what they know.
- Place a number of objects at angles or heights that would give a foreshortened view. Ask students to draw what they see.
- Use **ANOTHER LOOK, A Guide for Using Level C with Older Students: "Two Heads for One Giraffe"** and **"Crowds"** or **Level B: "Space - Country"** for activities that relate to overlapping and converging parallel lines.

Integrating with Art Content Areas:

Skill in creating depth illusion will help to achieve Concept B (foreground to background movement keeps the interest within a composition) in **COMPOSITION, Component 8 (Unity)**.

An opportunity can be provided in

**EXPRESSION, Component 10:**

- |                            |  |
|----------------------------|--|
| (i) Purpose                | )▶ Students can use foreshortening, overlapping or converging parallel lines |
| (ii) Subject Matter        | )▶ to capture a special event or holiday celebration                         |
| (iii) Media and Techniques | )▶ using drawing or painting media.  |

**1. Gridding can be used for systematically capturing or distorting the proportions of things.**

\*Gridding is used to analyze spatial relationships.

Suggested Methods or Strategies:

- The famous German artist, Durer, looked through a wire grid as a means of sighting a composition and capturing the proportions of things within it. He superimposed a pencilled grid of the same size on his drawing paper to match the real object with his translation. Provide time for students to draw light intersecting lines that will divide a piece of tracing paper into equal squares. This can be taped to the window and the students can trace the outlines of all the objects that appear within the perimeters of their paper. Another paper of the same size can be lightly gridded afterward so the students can copy their compositions from the tracing paper to their drawing paper. (Acetate sheets and felt markers could be used instead of tracing paper.)



- Ask students to choose a composition from a magazine. Have them make a pencil grid over the composition. Their own composition can be enlarged by using larger paper than the magazine composition but making sure that the same number of squares are used both vertically and horizontally on their drawing paper. Ask them to make their pencil grid very lightly so it can be erased later. Students can then copy the magazine composition onto their drawing paper by concentrating on the lines within each square of the grid.
- Have a few students design a grid to use when viewing a subject to be drawn. A wooden frame with nails and string would make a satisfactory grid.
- Once students can use a grid to capture the correct proportions of things, ask them to use it for distorting things. In this instance the picture to be distorted should have a grid of equal spaces over it while the drawing paper has a grid in which some squares are larger than others in the grid. Encourage students to experiment. If they want something to look squashed or compressed the grid square will be smaller in the bottom half. To make objects look lengthened or stretched, the squares must be larger in the top rows than on the picture to be copied. Even though the squares on the grid are different sizes on the drawing paper they should be the same number vertically and horizontally as on the picture to be copied. The student will copy square for square even though they differ in size. Lightly numbering each square on the grid can be a useful way of not losing one's place.

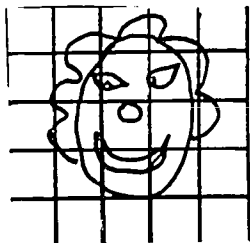

Picture to be distorted

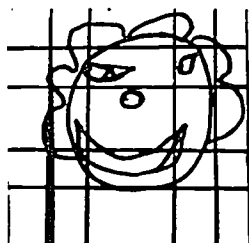

Distorted drawing

Integrating with Art Content Areas:

Gridding can be used to make caricatures or other distortions in Concept F of this component.

An opportunity can be provided in

**EXPRESSION, Component 10:**

- |                            |   |
|----------------------------|---|
| (i) Purpose                | )▶ Students can use graphing systems to transfer drawings |
| (ii) Subject Matter        | )▶ of their choice  |
| (iii) Media and Techniques | )▶ into computer drawings.                                |

Integrating with Other Subjects:

Social Studies - Maps can be drawn using a grid system.

# COMPONENT 5: STUDYING ACTIONS AND VIEWPOINTS

**Objective: STUDENTS WILL REFINE METHODS AND TECHNIQUES FOR MORE EFFECTIVE IMAGE-MAKING.**

Teaching/Learning Materials:

ANOTHER LOOK, Levels B, C (use the guides for using each level with EMPHASIS ART older students)  
 drawing media  
 construction paper  
 scissors  
 a variety of papers  
 painting media  
 pictures or photographs showing specific viewpoints

**Concepts: A. Different drawing techniques (seeing basic shapes, noticing the direction of forms, plotting the position of extremities, etc.) are useful to depict actions.**

Suggested Methods or Strategies:

- For activities that relate to the direction of forms use ANOTHER LOOK, Level B (a guide for using Level B with older students): "Diagonal" or Level C: "Arrow Shapes".
- One way that students can use to capture the illusion of movement in figures is to look for and identify the action lines a figure makes. Action lines are imaginary lines that show the position of the body and what it is doing. Collect pictures of figures in different poses from magazines. Ask students to use a felt pen on the pictures to show the action lines. Then have them repeat these lines in light pencil on a drawing surface. They will serve as guides for fleshing out entire figures. The main shapes can be drawn using ovals of different widths and lengths. From these, outlines can be drawn and details can be added. The photographs can be used as models throughout the entire exercise. This is an activity that merits repetition. Practice is needed to draw the human figure well.
- Sometimes students can capture a more spontaneous, flowing movement from tearing or cutting paper without preliminary drawing. Give students time to cut or tear figures in action. Pictures can serve as models to be studied while the figure is being cut.

- Using construction paper, have students tear a figure in pieces to represent the head, neck, torso, abdomen, forearms, upper arms, hands, feet, upper legs, lower legs. These pieces can be arranged in many different action poses using an overhead projector. Quick sketches can be made by students using action lines or by massing. (See Concept C for activities that teach the massing technique.) The torn figures can also be glued to another surface to represent various actions (students can mime these actions to provide models).
- Ask students to analyze a picture of a figure in action in terms of the basic shapes. Get them to draw the figure by using those basic shapes as a way of capturing the bulk of the figure. Outlines can refine the shapes and then details can be added.

Integrating with Art Content Areas:

For another technique used for capturing action, see Concept C in this component. (Pushing out a shape from the inside to the edges allows a flexible way to catch the position.) For more economical use of these techniques see COMPOSITION, Component 9 (Craftsmanship); Concept A. (Minimal actions and limited media result in stronger forms.)

An opportunity can also be provided in

**EXPRESSION, Component 10:**

- |                            |  |
|----------------------------|--|
| (i) Purpose                | )▶ Students can record action figures in                     |
| (ii) Subject Matter        | )▶ sporting events or special celebrations                   |
| (iii) Media and Techniques | )▶ using drawing media, painting media or cut paper collage. |

Integrating with Other Subject:

Drama - In grades 5 and 6, students will develop fluency of movement and gesture in mime. These techniques can be useful in demonstrating actions which the class would like to depict in art.

**B. Using a finder or viewing frame helps to see an action within a format.**

Suggested Methods or Strategies:

- A number of framing devices can be used to zero in on the action within a larger format:
  - a small square can be cut from the centre of a piece of cardboard
  - the index finger and thumb of each hand can make a finger frame

- a cardboard tube will give a round format to a viewpoint
  - two L-shaped pieces of card can be used together to make a rectangular frame that can be adjusted to enlarge or reduce the view.
- Sometimes students need to block out extraneous details when concentrating on one particular aspect of a scene such as the action of a particular figure or figures. Quick sketches can help to record the actions after viewing. Refer to Concept A that precedes this one for sketching techniques.

Integrating with Art Content Areas:

This activity can be used as a prelude to Concept C which follows. (Pushing out a shape from the inside to the edges allows a flexible way to catch the position.)

An opportunity can also be provided in

**EXPRESSION, Component 10:**

- |                            |  |
|----------------------------|--|
| (i) Purpose                | )▶ Students can interpret feelings or moods            |
| (ii) Subject Matter        | )▶ showing action figures in a setting of their choice |
| (iii) Media and Techniques | )▶ using drawing or painting media.                    |

**C. Pushing out a shape from the inside to the edges allows a flexible way to catch the position.**

Suggested Methods or Strategies:

- The technique described by this concept is called massing. It was introduced as one of the drawing strategies helpful in depicting animate forms in Level Two, Component 5. This method needs to be practised from time to time if students are to gain any proficiency at it. The side of a short piece of chalk, crayon, pastel, conte or charcoal should be used. Students need to study the action of the figure to be depicted and then using their drawing tool, push out from the inside of the figure to its extremities. Once the bulk of the figure has been captured, a fine nibbed tool can be used to outline and refine the shape. Allow for a series of sketches each time until students are pleased with the result, and feel that the finishing touches are worth doing. Have students model for each other during these sessions.
- Try the massing technique to portray animals, especially those with great mass or bulk: elephants, rhinoceros, bears, etc.

### Integrating with Art Content Areas:

This concept develops a technique that relates to **COMPOSITION**, Component 9 (Craftsmanship), Concept B: Skill is getting the most from the least.

### Integrating with Other Subjects:

**Drama** - In mime, the child should observe and study the animal kingdom, the size, shape and weight of animals and the ways they move and react to their environment. (These kinds of mime activities can be used to help children depict animals in action.)

### **D. Size interchange affects the apparent position of something.**

### Suggested Methods or Strategies:

- Size interchange refers to the principle that the size of a shape varies depending on its position in space. Have students cut a simple geometric shape in five sizes and five colours. Get them to arrange them in descending order on the picture plane. This is one of the simplest ways to show depth. Then have them arrange them so that they interrelate in a sequence that shows a larger one farther back in the picture plane and a smaller one closer to the front. Discuss how size is relative. Compositions can be made more permanent by gluing the shapes once they show a mix of shapes that give a feeling of depth.
- Have a small group of students who are approximately the same height stand in one line and get the other students to view them. Then have some students stand farther forward and others farther back. Discuss the change in viewpoints, considering the students are about the same height. Students can make thumbnail sketches recording the change in viewpoint as the sizes change due to position in the picture plane.
- For a lesson on size relationships use **ANOTHER LOOK, A Guide for Using Level C with Older Students: "Size"**.
- Have students cut 10-12 narrow rectangles from one sheet of coloured paper. The lengths should be varied and can be trimmed when the composition is arranged. The rectangles should be arranged horizontally on a larger background so that some disappear into the picture plane at each side and others appear at different levels within the picture plane. Discuss how depth is created by placing shapes higher and lower on a picture plane.
- Arrange a still-life composition by overlapping some objects with others. Discuss which objects are nearer and farther than others before the students begin to draw the arrangements. Faint pencil guidelines can be used to place the various objects on different levels of the picture plane. See **EMPHASIS ART**, pp. 89-93, for more information on drawing still life arrangements.

### Integrating with Art Content Areas:

Once students can use size to indicate depth in a picture space, they can learn other methods of affecting the viewpoint in Concept E that follows:

An opportunity can also be provided in

#### **EXPRESSION, Component 10:**

- |                            |  |
|----------------------------|--|
| (i) Purpose                | )▶ Students can make a mural that shows size interchange |
| (ii) Subject Matter        | )▶ based on their choice of animal theme                 |
| (iii) Media and Techniques | )▶ using painting media.                                 |

### **E. Surface reflections, shading and shadows affect the viewpoints.**

#### Suggested Methods or Strategies:

- Locate pictures (photographs, art reproductions) in which there are reflections, shadows or shading. Discuss how these qualities affect the viewpoint. Consider each picture without one of those qualities. If shadows are evident in the picture, discuss the approximate time of day the picture was taken by the length and shape of the shadows.
- Place an object outside on a bright sunny day and have students sketch it with its shadow in the morning, at noon and in the late afternoon. Compare the differences. Notice when the shadow is a distortion of the actual shape.
- Make a display of three-dimensional geometric shapes. Ask students to draw the still-life using lines only. Once this has been done, discuss how the shapes can be made to appear three dimensional (by shading and/or shadows). Then use the techniques discussed to add the illusion of depth to the shapes.
- Reflections help create a double image which can often be disconcerting. Brainstorm to make a list of all the surfaces that will reflect an image. Ask students to choose a surface that because of its contours distorts the image. Get them to make self-portraits from the reflections.
- Discuss the different kinds of reflections you can see in water due to varying weather conditions. Ask students to depict part of a landscape reflected in a still, glassy lake. Then have them depict the reflection on a rough day.
- For lessons in shading use **ANOTHER LOOK, A Guide for Using Level B with Older Students: "How Else Can You See?"** and **Level C: "Clouds."**

Integrating with Art Content Areas:

This concept can provide background in working with tones for COMPOSITION, Component 8 (Unity); Concept C (transition of tones to achieve unity).

An opportunity can also be provided in

EXPRESSION, Component 10:

- |                            |   |
|----------------------------|---|
| (i) Purpose                | )▶ Students can show reflection, shading or shadows |
| (ii) Subject Matter        | )▶ in a landscape of their choice                   |
| (iii) Media and Techniques | )▶ using painting or drawing media.                 |

Integrating with Other Subjects:

Science - Students learn that light is a form of energy that tends to travel in straight lines and can be reflected, refracted and absorbed.





## COMPONENT 6: QUALITIES AND DETAILS

**Objective: STUDENTS WILL EMPLOY SURFACE QUALITIES FOR SPECIFIC EFFECTS.**

Teaching/Learning Materials for the Component:

Tempera paint, watercolour paint, coloured construction paper, brushes, mixing dishes (plastic lids from ice cream pails), coloured tissue paper, oil pastels, variety of drawing tools, variety of painting and drawing surfaces.

ANOTHER LOOK, A Guide for Using Level A with Older Students.

**Concepts: A. Colour harmonies affect the mood and feeling of the viewer.**

\*See Colour Theory in the guide.

Suggested Methods or Strategies:

- Explain that colour harmonies refer to the relationship of colours. Because related or analogous colours are near to each other, they are said to be harmonious. Have students paint a still-life using three related colours. Compare the results. Students can be encouraged to explain how the different colour harmonies chosen affect the mood of the viewer.
- Sometimes colour harmonies are referred to in groups or families such as warm colours (reds, yellows and oranges) and cool colours (blues, greens and violets). These warm or cool properties are, of course, relative. When used in concert, cool colours tend to recede and warm colours to advance. Have half the students depict a landscape using a cool palette and the other half using a warm one. Check to see if "cool landscapes" are passive and receding.
- Students can also try a landscape picture in which colour is used opposite to the way it is seen in nature (warmer colours in the distance, cooler colours in the foreground). The mood or feeling will be affected because the perspective will be destroyed by the colour reversals.
- Contrasting colour schemes can also be used to harmonize a composition. Complementary colours can be used for contrasting intensities. Lights and darks can be used to contrast tone or value.

Students can choose one of these contrasts for depiction using an abstract composition.

- Another way of achieving colour harmony is to use a triad (three colours that are equidistant from each other on the colour wheel). See **ANOTHER LOOK, A Guide for Using Level A with Older Students** (p. 15) or **COLOUR THEORY** in the guide for a colour wheel. Instruct students to create a repeat pattern in which the three colours they choose (based on the triad) are used.
- Students can choose one colour and then using tempera paint, create a number of variations on that colour (by adding those close to it on the colour wheel, i.e., blue green, yellow green). Encourage them to experiment by varying the proportions of the two colours being mixed. Once a wide colour range has been created, have students make a painting using their "new" palette. Each student can describe the feeling of their completed work. This activity could also be done by means of a monochromatic colour scheme (tints and shades of one colour or hue).

Integrating with Art Content Areas:

Concept A can be the basis for learning in

**COMPOSITION, Component 8 (Unity)**

**Concept F: Pervasive colour, texture or tone can unify a composition.**

AND IN

**EXPRESSION, Component 10:**

- |                            |  |
|----------------------------|--|
| (i) Purpose                | )▶ Students can express mood or feeling through colour harmonies   |
| (ii) Subject Matter        | )▶ on a theme of their choice                                      |
| (iii) Media and Techniques | )▶ using printmaking, fabric or tissue paper collage, or painting. |

**B. Tonal interchanges enhance a work.**

Suggested Methods or Strategies:

- Tonal interchanges in a work occur when a variety of tones is presented throughout the work. (Tone is synonymous with value and refers to the lightness or darkness of a colour or surface.) With paint, have students mix three tints of a colour or hue and three shades. Once this palette is completed, they can paint an abstract composition using both tints and shades of the colour, juxtaposing the darker tones with the lighter tones.

- Use a checkerboard to show students that interchanges of black and white can be monotonous and predictable when used in alternation. Set an assignment in which students use the checkerboard format to display a range of tints and shades of one colour or hue. Mixed tempera or pastels could be used. Allow for some repetition of a tint or shade but emphasize the interchange of dark with light throughout.
- Have half the class paint a composition using strong contrasts of tone, while the others paint one with gradual changes of value in colour. Compare the results. The strong contrasts should attract immediate attention, while the gradual changes should lead the eye from one colour to the next.
- Use black and white photographs from magazines to create a photo-collage in which tonal interchanges are used. This will require cutting and combining of many shapes and tones.
- Have the students select two sheets of coloured paper, one light and the other dark. Save one sheet and cut the other in half horizontally through the centre. Using only one of the two cut papers, lightly sketch (with chalk) several items along "the edge" of the paper. Cut out all the objects carefully saving the cut-out shapes and the remaining piece of paper with the "holes" in it (positive and negative shapes). Then, paste the "cut out" half sheet over the bottom of the saved whole sheet. Finally, position the cut-out shapes above their corresponding negative "reflections" and glue them in place.

Integrating with Art Content Areas:

This concept can provide a basis for learning in

**COMPOSITION, Component 8 (Unity)**

**Concept C: Transitions of colour, texture or tone relate the parts of a composition to a unified whole.**

**EXPRESSION, Component 10:**

- |                            |   |
|----------------------------|---|
| (i) Purpose                | )▶ Students can record  |
| (ii) Subject Matter        | )▶ activities or objects of their choice  |
| (iii) Media and Techniques | )▶ using black and white photography to capture tonal interchanges in their compositions. |

**C. Distinguishing characteristics of things can be portrayed vividly or subtly.**

Suggested Methods or Strategies:

- Arrange a collection of drawing and/or painting reproductions that show objects depicted in a subtle way and a vivid way. Discuss the meaning of subtle and vivid with students. Identify subtle and vivid colours within the classroom.

- In **Level Two, Component 6: Concept B**, colour intensity is taught. Review the process by which colours can be made to appear dull or more intense. Have students paint an object using intense colours and the same object using dull or earthy colours. Discuss how each affects the viewer in a different way.
- The kinds of lines used in a drawing can denote subtlety. Contour drawing is a technique that produces subtlety (see **Level 2, DEPICTION, Component 5, Concept B** for activities on contour drawing.) Have students make a contour drawing of an object and then use a coloured wash as background (to show how lines and colour can work in concert to produce unity and subtlety). A coloured wash can be applied using: a wet-on-wet watercolour technique, a wash technique, torn coloured tissue applied to a wet surface which is then removed after it dyes the surface.
- In many cases, vivid colour is executed with bold lines to emphasize a particular shape or thing. Encourage students to use bold, strong lines in vivid colours using large paint brushes. Some topics that may lend themselves to this kind of rendering: action figures, plants, trees and flowers.
- Colours are often made to appear more vivid or intense by placing complementary colours side by side. Have students depict an object using drawing or painting media. They can make the object more vivid and emphatic by rendering the background in a colour that is complementary to the colour of the object. See **Level Two, Component 6, Concept B** for a lesson on complementary colours.

Integrating with Art Content Areas:

The lessons on using line to portray subtle or bold effects can be used as a basis for learning Concept D that follows. (The character of marks is influenced by drawing or painting tools and methods.) Also try a lesson in

**EXPRESSION, Component 10:**

- |                            |   |
|----------------------------|---|
| (i) Purpose                | )▶ Students can make a composition showing vividness and subtlety |
| (ii) Subject Matter        | )▶ based on a subject of their choice                             |
| (iii) Media and Techniques | )▶ in drawing, painting or print-making.                          |

**D. The character of marks is influenced by drawing or painting tools and methods.**

Suggested Methods or Strategies:

- Organize an exploratory session in which students use a variety of drawing tools to record marks or lines. Have them describe each line: soft, bold, delicate, strong, etc. Extend the lesson by having students choose a subject matter that would be appropriate to a particular kind of line and use a specific drawing tool to achieve that effect.
- Review drawing techniques learned in Level 2, Component 5, Concept B. Discuss the adjectives that could be applied to the kinds of line achieved by these techniques.
- Organize an exploratory session in which students use a number of paint brushes of varying widths to make marks. Encourage them to make strokes that are: short and quick, long and extended, wet and dry, and change direction. Invite students to invent different kinds of strokes. Also encourage them to write an adjective for each stroke. Discuss how a stroke can convey meaning depending on its character. Extend the lesson by:
  - looking at painting reproductions to see how artists employ brush strokes for specific effects or to convey a certain meaning;
  - creating an abstract painting using all of the brush strokes tried and invented;
  - making drawings that use ink and brush or paint and brush to delineate forms that display a particular character (bold, soft, subtle, calligraphic, etc.).
- Encourage students to use drawing and painting tools in the creation of a composition for a rich surface quality. Subject matter that lends itself to this treatment should be chosen (decorative style is appropriate). See Thematic Sources - Subject Matter for suggestions.
- Introduce brush techniques using watercolour paints. (Water can be added to tempera to make watercolour paint.) Have students try:

Dry brush - strokes are made when the loaded brush is almost dry, a streaky texture is created.

Wet-on-wet - wet paint applied to a wet surface, a radiating pattern is created.

Wash - a brush loaded with watery paint is applied using horizontal strokes, one under the other.

Once techniques are learned, encourage students to paint a landscape employing these techniques. Dry brush can be used to represent grass, bark, foliage. Wet-on-wet can be used to create a heavy, stormy sky or flowers. Washes can be used to create a great expanse of sky or ground. See **ANOTHER LOOK, A Guide for Using Level A with Older Students** p. 46 for illustrations of watercolour techniques.

Integrating with Art Content Areas:

The learning of this concept can be used as a basis for learning in

**REFLECTION, Component 3 (Appreciation)**

**Concept B: An art work can be analyzed for the meaning of its visible components and their interrelationships.**

**AND IN**

**EXPRESSION, Component 10:**

- |                            |   |
|----------------------------|---|
| (i) Purpose                | )▶ A feeling or message can be conveyed                       |
| (ii) Subject Matter        | )▶ about natural forms  |
| (iii) Media and Techniques | )▶ using drawing or painting techniques learned in Concept D. |

Integrating with Other Subjects:

Social Studies - Contour maps can be drawn after students are introduced to contour drawings.  
Watercolour washes and fine line drawing tools can be employed in drawing maps.

Science - Diagrams of cross-sections of natural forms and microscopic views of natural forms can be suitably rendered using watercolour washes and fine line drawing tools.

## COMPONENT 7: EMPHASIS

**Objective: STUDENTS WILL CREATE EMPHASIS THROUGH THE USE OF STRUCTURAL DEVICES AND STRATEGIES**

Teaching/Learning Materials:

viewfinders (a variety, if possible)  
construction paper, glue, scissors  
ANOTHER LOOK, (A Guide for Using Levels A and C with Older Students)  
drawing mediums  
painting mediums  
printing mediums  
overhead projector

**Concepts: A. Viewfinders are useful devices to determine the best format for what will be portrayed and the centre of interest.**

Suggested Methods or Strategies:

- Provide different kinds of viewfinders (L-shaped pieces of card, cardboard tubes) as well as encouraging students to use fingers (thumb and index fingers placed together) to frame subject matter as possible compositions. Give students guidelines which will help them frame an arrangement. Examples: Composition should have: foreground, middleground and background, larger items in the foreground, items in the foreground that partially frame the composition. Thumbnail sketches of different arrangements can be made and used as rehearsals for a finished composition. By experimenting with different views using the viewfinders students can place the main subject where they want it to be.
- Have students lie down on the ground and use viewfinders to frame a composition from looking up. Again, quick sketches can be made to outline the major parts or actions of the composition. Also try viewing from a height if it can be done safely.

Integrating with Art Content Areas:

Using viewfinders to find a composition is a useful device for approaching any composition, especially when isolating the main forms for emphasis.

**B. The important area in a composition can be enhanced by radial, conical and framing structure.**

Suggested Methods or Strategies:

- Framing structures are lines that frame the main part or parts of a composition. These are especially useful in abstract compositions. In representational compositions they tend to be used more subtly i.e., tree branches in the foreground may partially frame the composition. The shape of frame to be used will depend on the shape of the forms being emphasized. Have students make an abstract composition using geometric shapes from cut paper. Ask that some be larger to give the composition emphasis. Conical, radial or rectangular lines using crayon or felt pen can be used to frame the main forms. Get them to experiment with different kinds of lines (thick, thin, wavy, disconnected, etc.). The same kinds of framing could be used on prints that have been made using found objects.
- Use **ANOTHER LOOK, A Guide for Using Level C with Older Students, "Caves, Tunnels and Holes"**.
- Have students draw or paint a composition in which the framing device is part of the subject matter. Some suggestions:
  - A view through: a large hole in a fence
  - a cave door
  - a telescope
  - a window
  - swimming goggles
  - a tunnel
  - somebody's legs (a small child's view)
  - a cage at the zoo
  - an aquarium.

Integrating with Art Content Areas:

An opportunity can be provided in

**EXPRESSION, Component 10:**

- |                            |  |
|----------------------------|--|
| (i) Purpose                | )► Students can make compositions on different shapes of paper |
| (ii) Subject Matter        | )► based on their choice of subject matter                     |
| (iii) Media and Techniques | )► using drawing, painting or printmaking mediums.             |



**C. Rhythmic features can lead the eye to the dominant area in a composition.**

Suggested Methods or Strategies:

- Explain to students that one of the reasons for a composition in art is to control the eye movement of the viewer. Have students place an acetate sheet over a composition cut from a magazine and trace the lines that lead the eye to the emphasized form or forms in the composition. Ask students to make an abstract composition from the linear qualities outlined on acetate.
- Use **ANOTHER LOOK, A Guide for Using Level A with Older Students, "Straight or Curved"**.
- Rhythm can be a repetition of lines or textures. Look at handwriting as an example of rhythmic lines. Ask students to create a composition by using one continuous line. This can be done with drawing mediums or by using wire to make a wire sculpture.
- Have students paint or draw compositions in which trees, paths, streams, fences, telephone poles or other repetitions draw the eye to the most significant shapes or forms.
- Freeform clay sculptures can be made in which lines or textures are used to emphasize the rhythm of the form.

Integrating with Art Content Areas:

This concept can be used as background in **COMPOSITION, Component 8 (Unity), Concept A** (implied line produces tensions and connections).

An opportunity can be provided in

**EXPRESSION, Component 10:**

- |   |   |
|---|---|
| <p>(i) Purpose</p> <p>(ii) Subject Matter</p> <p>(iii) Media and Techniques</p> | <p>)▶ Students can create wall-hanging or other flat format using rhythmic qualities</p> <p>)▶ to emphasize their choice of subject matter</p> <p>)▶ using stitchery or printing on fabric.</p> |
|---|---|

Integrating with Other Subject Areas:

Music - Students learn about rhythmic patterns in musical compositions.

**D. Arrangements of forms into shapes and patterns can tighten a design, direct attention and hold interest in a composition.**

Suggested Methods or Strategies:

- One way of directing attention in a composition is to group shapes. Rather than to line shapes up side by side, they can be grouped so that they appear on different base lines and some overlap with others. Have students draw or paint a landscape in which trees or buildings are grouped in this way.
- Use **ANOTHER LOOK, A Guide for Using Level A with Older Students: "Separated and Touching"; Level C: "Two Heads for One Giraffe" and "Crowds"**.
- Have students use the overhead projector and multiples of one object such as a paper clip to make arrangements that can be projected onto a screen for the class to see the "finished" arrangement. It will be a challenge for students to organize them into the same types and sizes so the result is not monotonous and directs the eye along a pattern. Vary this activity by using many small items in which only some are to be emphasized.
- The previous activity is a good exercise to use before planning a pattern with cut paper. Have students explore vertical, horizontal and diagonal directions for patterns before glueing them down. The design can be given emphasis by changing direction; making some shapes larger, textured or more intense in colour.

Integrating with Art Content Areas:

This concept can be useful in learning Concept B in Component 8 (Unity): Foreground to background movement keeps the interest within the composition.

An opportunity can be provided in

**EXPRESSION, Component 10:**

- |  |   |
|--|---|
| <ul style="list-style-type: none"><li>(i) Purpose</li><li>(ii) Subject Matter</li><li>(iii) Media and Techniques</li></ul> | <ul style="list-style-type: none"><li>▶ Students can make compositions in which there are stylized fruit and/or vegetable forms</li><li>▶ using cut paper or drawing mediums.</li></ul> |
|--|---|

**E. Labelling (title and signature) demands artistic sensitivity as to placement, size, shape and medium.**

Suggested Methods or Strategies:

- The labelling (title and signature) of an art work can add to the art work or detract from it, depending on how it is done. Discuss the importance of size in signing or titling an art work. Ask students whether the signature should go in the right hand corner as is most traditional. Often the signature is illegible in student's work because a child uses the same large brush the picture was painted with. Discuss which kind of drawing tools would be appropriate for signatures. Also discuss titling the work in terms of spelling and use of upper and lower letters. Look at the way famous artists have signed their work. Encourage students to take care in labelling once these matters have been discussed.
- One way of signing clay pieces is to use a stamp of the artist's logo. It can be used to imprint the wet clay and can be decorative enough to be incorporated within the patterns on some pieces. Have students pour a mixture of plaster of Paris and water into a styrofoam cup. After the plaster sets but is not dry, the styrofoam can be peeled away and the bottom surface of the cup can be carved to create a logo or a symbol that will represent the student's trademark.
- Direct attention to the way printmakers label their work. Use an original print if possible. If not, follow this order: left hand corner: edition number, middle: title of composition, right hand corner: artist's signature and year. Pencil is most often used as it is unobtrusive. The labelling is done in the border space beneath the picture. Except for monoprints, have your students label their prints in this manner.

Integrating with Art Content Areas:

Labelling is a consideration each time a drawing, printing or print is made.

# COMPONENT 8: UNITY

**Objective: STUDENTS WILL CREATE UNITY BY INTEGRATING THE PARTS OF THE COMPOSITION TO THE WHOLE.**

Teaching/Learning Materials for the Component:

Drawing tools to include some that are fine nibbed; overhead projectors; variety of papers; glue; scissors; clay; fabric; a variety of yarns, cord and/or ribbons; needles, wire; water soluble printing inks, brayers, tempera paints, oil pastels, watercolour paint, cameras and film; brushes, sponges, **ANOTHER LOOK, Levels A, B and C; Model Ideas, Picture Ideas, Collage Ideas and Fabric Ideas.**

**Concepts:      A. Implied line produces tensions and connections to achieve unity.**

Suggested Methods or Strategies:

- Implied line is an imaginary line between two points or an imaginary connection or continuation of partial lines. Implied line is used to create cohesion, the illusion of form or dimension on a flat surface. Direct students' attention to a topographical map or a geological drawing of rock strata for examples of how implied lines produce a feeling of depth.
- Lines are implied by the edges of shapes. Direct students' attention to various shapes in the classroom. Point out that the outside edge of a shape creates an implied line (this is often referred to as an outline). Have students identify other implied lines that take the eye around the mass of the object. Look at sculpture in the same way. (See Townley's **ANOTHER LOOK, Level C: Curves, Tunnels and Holes.**) Students could then create clay sculptures in which open spaces (implied shapes) are enclosed within the solid mass of clay. They should be able to identify the implied lines made by their sculptures when they are completed.
- Line can be implied by a series of points as in a star constellation. Direct students to make a series of dots on paper. Ask if the eye seems to connect them into a line. Drawings of simple shapes can be made by first plotting with dots. Once some practice has taken place, students can create a composition in which a shape is repeated over and over using a dotted line or in which the shape is centred and dotted lines are used to repeat its shape right to the outer edges of

the paper. Discuss how using this approach gives unity to a composition.

- Encounter experimentation with other kinds of disconnected lines besides the dotted line explored in the previous exercise. Some suggestions: short parallel lines, zigzag lines, scalloped lines, etc. Transfer this learning by composing a fabric collage (using a variety of yarns, cord and/or ribbons) or a stitchery project in which running stitches, French knots or other stitches which give the illusion of being connected, are used. See p. 8 of *Fabric Ideas* by Pluckrose for some stitches.
- Discuss how implied line is also a quality in weaving (the line appears and reappears with regularity or irregularity depending on the weaving method chosen). Make a weaving on a cardboard loom. (See Pluckrose's *Fabric Ideas*.)
- Students can create a wire sculpture to show how the linear quality implies volume or shape. See *Model Ideas: Models Made with Wire, Wire Sculptures and String Shapes*.
- A paper punch can be used to create implied lines. Once students have had some practice at this, compositions can be made.
- A repetition of shapes can also create implied lines. The eye follows a "line" of telephone posts, fence posts or people. Encourage students to use one shape or figure in repetition, diminishing in size as they recede towards the horizon. Discuss the eye movement involved in following this "line" of shapes.

#### Integrating with Art Content Areas:

This concept will help students to learn Concept B which follows in this component. (Foreground to background movement keeps the interest within a composition.) This concept can also be used as a basis for a lesson in

#### EXPRESSION, Component 10:

- |                            |   |
|----------------------------|---|
| (i) Purpose                | » Students can create a composition to show implied lines |
| (ii) Subject Matter        | » by choosing their own subject matter                    |
| (iii) Media and Techniques | » using photographs or photography.                       |

#### Integrating with Other Subjects:

Health - Diagrams of the circulatory and skeletal systems use implied lines and can be used as examples if these are pertinent to the health topic studied. See *ANOTHER LOOK, Level A* by Townley p. 36, for an illustration of the skeletal system.

Math - In grade 5 students identify and name line segments, lines, rays and angles.

**B. Foreground to background movement keeps the interest within the composition.**

Suggested Methods or Strategies:

- Foreground to background movement can occur when gradual changes in colour or tone lead the eye from the most prominent shapes to those surrounding what is emphasized. Have students choose a black and white photograph in which value changes are gradual, to use as a basis for a painting, in which they use colours to show the gradual changes from foreground to background.
- Direct students to compose abstract compositions that are based on one shape used in repetition to achieve an effect of foreground to background movement. Discuss how size, colour and value are important in achieving this movement. Cut paper, printmaking (paper or light card shapes which can be inked and printed) or painting can be used.
- Rhythmic movement is another element in producing foreground to background movement in a composition. Use an overhead projector and multiples of one shape cut in many sizes to allow students some practice in organizing these shapes in patterns, to lead the eye from foreground to background. After the practice provide tissue paper or construction paper and glue so that students can create a more permanent example.
- Implied line made through repetition of shapes can be used to create foreground to background movement. Ask students to depict an object repeatedly, but decreasing in size as it recedes. Use plants, human figures or animals. Let them be the focal point for a setting which is built around them. Try drawing, painting or printing the composition.
- Use a cut paper figure or a found object that can be inked with water based printing inks. From one inking, stamp the figure or shape as many times as possible, moving toward the background. The gradations of colour from strong to weak will cause the eye to move from foreground to background.

Integrating with Art Content Areas:

These activities can be used as a basis for a lesson in

**EXPRESSION, Component 10:**

- |   |  |
|---|--|
| <p>(i) Purpose</p> <p>(ii) Subject Matter</p> <p>(iii) Media and Techniques</p> | <p>▶ Have students create a composition showing foreground to background movement</p> <p>▶ choosing their own subject matter</p> <p>▶ using photography.</p> |
|---|--|

**C. Transitions of colour, texture or tone relate the parts of a composition to a unified whole.**

Suggested Methods or Strategies

- Invite students to look at the room through coloured gels. Discuss how the colour unites the composition (portion of room selected by the viewer) in a way not possible when viewed without the gel. Students can then use viewfinders to frame a composition that could be painted using only reds, blues, greens, violets, yellows or oranges.
- Make a still life arrangement using a collection of baskets of different sizes. Ask students to indicate different ways of representing the texture of each basket. Explain that the arrangement is unified not only because of subject matter but because each basket is woven and therefore the transition from one kind of pattern or texture to the other is gradual. Encourage students to draw the entire arrangement to show the transitions in texture.
- Make a still life arrangement of two or more plants or use coloured photographs or slides of a forest. Discuss how the many different greens help to unify the composition. Have students mix tempera paints or blend oil pastels in representing a plant still life or a forest. See Townley's *ANOTHER LOOK, Level A* for photographs of forests.
- Students can use tissue paper shapes that are cut or torn to illustrate differences in colour value. Overlapping the shapes creates new values since the paper is translucent. Get them to create a composition based on overlapping floral, vegetable or fruit shapes.
- Crosshatching can be used to communicate the dark tones of an object. Ask students to make a composition using only black felt pen (fine nibbed) or pen and ink. As a beginning exercise, make only one object using crosshatching to show its dark tones and perhaps its shadow. Students can then use black and white photographs or parts of them to make a composition using the crosshatching technique. The darkest tones will be denser than the lighter ones.

### Integrating with Art Content Areas:

This concept can be used as a basis for learning Concept F in this component. It can also be used as a basis for an opportunity in

#### EXPRESSION, Component 10:

- |                            |  |
|----------------------------|--|
| (i) Purpose                | )▶ Students can make a composition using tonal transitions   |
| (ii) Subject Matter        | )▶ by choosing their own theme   |
| (iii) Media and Techniques | )▶ using printmaking (found object printing, cardboard or paper printing are appropriate for this activity). |

**D. Attention should be given to well distributed negative space as well as to the balance of positive forms.**

#### Suggested Methods or Strategies:

- To review concepts of positive and negative space refer to Level Two, Component 5, Concept A.
- See lesson "Black and White Designs" in *Collage Ideas* by Pluckrose.
- Have students take a piece of 9 x 12 dark construction paper and cut it in two, horizontally or vertically, making an irregular path as they cut. Then the two pieces can be taken and moved apart on a white sheet of paper to allow different amounts of space between them. Encourage students to try different amounts of space before gluing the two pieces down. Get them to evaluate the composition in terms of how well the positive (dark shapes are balanced by the negative white space left in between).
- Review the concept that, in a landscape, the foreground or subject is the positive space, and the background is negative space. Direct attention to landscape and have students trace around the positive space with their fingers. Discuss whether the distribution of negative space balances the composition. Then ask students to use construction paper to cut a city skyline that will divide sky and buildings in an interesting way. (There should be variation in heights and sizes.) When evaluating these compositions for well distributed positive and negative space, view them upside down, since even when subject matter is ignored, the balance between the spaces should be interesting rather than predictable and monotonous.



- Have students paint one large deciduous tree on white paper so that it disappears bottom and top into the picture plane. Encourage them to add branches without leaves and to paint the tree off center on the paper. Once this has been done, ask them to evaluate the balance between the tree and its background. Let them decide individually depending on the width of the trunk, the amount of branches shown, whether to add additional positive space to the amount of negative space left.
- See ANOTHER LOOK, Level A, "Trees".

Integrating with Art Content Areas:

This concept can be used as a basis for teaching Concept E that follows. (Interesting negative space complements and binds the positive areas into an harmonious whole.)  
An opportunity can also be provided in

**EXPRESSION, Component 10:**

- |                            |   |
|----------------------------|---|
| (i) Purpose                | )► Students can make a mock-up for a quilt, rug or floor tiles showing a balance of positive and negative space |
| (ii) Subject Matter        | )► using squares and triangles (cut from the same size squares)   |
| (iii) Media and Techniques | )► in cut paper.  |

**E. Interesting negative space complements and binds the positive areas into an harmonious whole.**

Suggested Methods or Strategies:

- Have students draw or paint a composition in which the positive space frames a composition within the negative space. Some examples: views through a hole in the fence, a cave opening, a look out in a fort or castle, the legs of a tall person, a scuba diving mask, a beaver house. Ask students to suggest others. Evaluate the results on the basis of how interesting the negative space is, and how will it complement the positive space frame.
- In a room arrangement, the furniture and accessories represent the positive space and the walls, ceiling and floor the negative space. Using shoe boxes for settings, have students create dioramas in which various rooms of a house are represented. Discuss with students ways in which the walls, ceiling and floor can complement the furniture, especially in colour. Scale should be an important consideration.
- Arrange a still life to be drawn or painted. Then ask students to add the background to it, using imagination and keeping in mind that the background should complement, not overpower, the still life arrangement.

- Try a lesson from ANOTHER LOOK, Level B: "Space - Country" or "Space - City".

Integrating with Art Content Areas:

Concept E can be followed with an opportunity for

**EXPRESSION, Component 10:**

- |                            |   |
|----------------------------|---|
| (i) Purpose                | ▶ Have students create a landscape in which the negative space complements the positive space |
| (ii) Subject Matter        | ▶ based on a theme of their choice  |
| (iii) Media and Techniques | ▶ in drawing, painting or cut paper.  |

**F. Pervasive colour, texture or tone can unify a composition as from an overall wash of paint, a glaze, a textural additive, a surface treatment or the like.**

Suggested Methods or Strategies:

- Pervasive qualities such as colour, texture or tone refer to qualities that are spread through the entire composition. One way of using colour pervasively in a composition is to start the composition with a watercolour wash as background. The paper should be taped to a surface and then dampened with a wet sponge. A wash is applied by loading the brush and starting at the top of the paper applying horizontal, slightly overlapping strokes from left to right, right to left until the paper is covered. This will provide a background for a composition that will help to unify it. A gradated wash can be made by diluting paint each time the brush is reloaded. Other suggestions for backgrounds:

- wet paper and apply torn pieces of tissue paper that overlap, remove after a few minutes (tissue provides a stain)
- use wet-on-wet watercolour technique
- use staining technique with watercolour.

This can be applied like a wash except that more than one colour is used. Application of second and third colours should be made once the initial colour is dry. Since watercolour is transparent one colour over another produces a stained effect. Tempera can be diluted to make watercolour paint.

- Pervasive textures can be applied to a composition using a wax resist method. White crayon or candle wax can be applied to represent fog, smoke, rain, or snow before paint is applied. Paint could also be applied using a sponge or a spatter method for an overall textural effect, before or after the composition is created. Small amounts of

salt or white sand can be added to watercolour paint before it dries for a grainy effect. (Have students consider an appropriate theme if trying for this effect.)

- Pervasive tones can also be applied in a number of ways. Cross-hatching can be used as background to a drawing and its darkness can be controlled by density. It will also provide a textural effect that is pervasive. The foreground rather than the background could be treated with cross-hatching techniques throughout. Charcoal can be used for tone as well. Smudging it will provide a soft overall tone for the background of a composition or to provide shadows on objects in the foreground. (Fingers, erasers, kleenex or paper towels can be used for smudging.)
- Have students texture a clay built form to unify it. Provide clay for experimentation in texture before the form is decorated. Use found objects, pinching, pulling, pushing the clay with fingers.
- See **Picture Ideas** by Pluckrose for other ways of providing pervasive qualities to a composition.
- See **Emphasis Art** for instructions on tempera-India ink batik, pp. 109-112, which will also provide pervasive qualities to a composition.

#### Integrating with Art Content Areas:

The lesson suggestions for pervasive qualities in a composition can provide a basis for an opportunity in:

#### EXPRESSION, Component 10:

- |                            |   |
|----------------------------|---|
| (i) Purpose                | ▶ Students may create a composition with pervasive color, texture or tone |
| (ii) Subject Matter        | ▶ based on a theme of their choice  |
| (iii) Media and Techniques | ▶ using drawing or painting techniques described in Concept F.            |

# COMPONENT 9: CRAFTSMANSHIP

**Objective: STUDENTS WILL PERFECT IMAGES THROUGH ECONOMICAL USE OF MATERIAL AND EFFICIENCY OF EFFORT.**

Teaching/Learning Materials:

- soft, pointed brushes
- India ink
- ANOTHER LOOK, A Guide for Using Level C with Older Students
- vermiculite, plaster of Paris
- waxed cardboard cartons
- drawing mediums
- pictures of Inuit a

**Concepts: A. Minimal actions and limited media result in stronger forms, as in Chinese painting, cartoons or Inuit sculptures.**

Suggested Methods or Strategies:

- Have students look at one or more of the forms such as those suggested in Concept A, in which materials are used economically and efficiently. Note that calligraphy, cartooning and Inuit sculpture all simplify or stylize a shape or form. Even though the forms appear very simple, a high degree of skill is needed to execute them.
- Provide soft, pointed brushes and India ink or black tempera paint and direct students to experiment with brush strokes. The brush should be held in a vertical position and the arm must move to make the strokes. This is an activity that requires much practice if students are to gain any skill at all. Once they can make strokes that are short, long, thick, thin, straight and curved, have them study some natural forms (weeds, branches, grasses) which could be represented in brush strokes. Students might also like to decorate some pottery pieces once they improve. Mix some colourants with water (this is called a stain) and brush them on clay that has been bisqued once. A clear glaze can be applied over the stain before the second firing.
- Gather some books that show Inuit sculptures if originals are not available. Inuit sculptors felt that they were releasing the spirit of an animal by carving it from soapstone. They examined the basic shape of the stone to decide which animal form was embedded in it. Have students try carving an animal form from artificial stone (vermiculite and plaster of Paris). See p. 46 of ANOTHER LOOK, A Guide for Using Level C with Older Students, for directions on mixing.

- Review the drawing strategies introduced at Level Two, **DEPICTION, Component 5, Concept B**. Contour drawings are an economical way of capturing surface detail. Have students practice blind contour and contour drawing to capture the essence of an object or thing.
- Refer back to cartooning and stylizing of forms done in **DEPICTION, Component 4, Concept E and F**. Ask students to evaluate the results on the basis of efficiency of effort and economy of materials. Would the elimination of some details help to simplify the forms?
- Have students make stencil prints. Because these are made by subtracting shapes from a piece of cardboard and inking or painting where the shapes have been removed, most detail must be eliminated. The outline of the shape defines it.

Integrating with Art Content Areas:

Whenever the desired result in a composition or sculpture is simplicity, ask students to evaluate their work and decide how it could be simplified (by means of materials and/or skill).

**B. Skill in getting the most from the least.**

Suggested Methods or Strategies:

- Explain to students that our own alphabet is a simplified version of forms that were once picture symbols. These symbols were gradually simplified over many centuries to make our present-day alphabet. Ask students to cut out 26 squares of coloured paper about 9 cm x 9 cm. Have them cut out each letter of the alphabet without drawing in pencil first. Direct them to cut away as little as possible from the square to represent each letter. Because the letter will have a thickness that it doesn't have when represented with lines, they can be made very simply. Round or angular letters can be made.

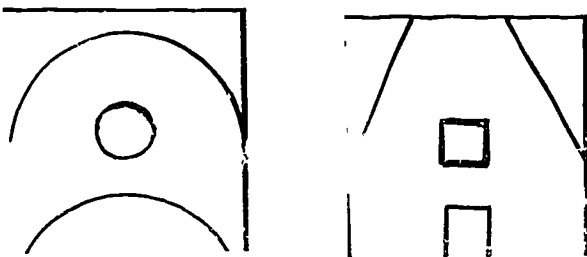

Their completed alphabet can be used as templates when making posters or art displays throughout the year.

- Compare tempera painting with watercolour painting. Because watercolour is transparent, each stroke must be deliberated. With tempera paint, the painter can paint over mistakes and make changes throughout the progress of the composition. Review the watercolour techniques learned in Component 6, Concept D and practice painting every day for a week. Ask students to assess their work to see if they can see improvement. All art skills take time and practice. Give students an opportunity to choose an art skill they would like to improve. They will learn many shortcuts and easier ways of doing techniques the more practice they have.
- Provide time for students to evaluate their compositions from time to time. Give them an opportunity to decide how they might improve their work and whether more practice and exploration with the art medium is necessary.

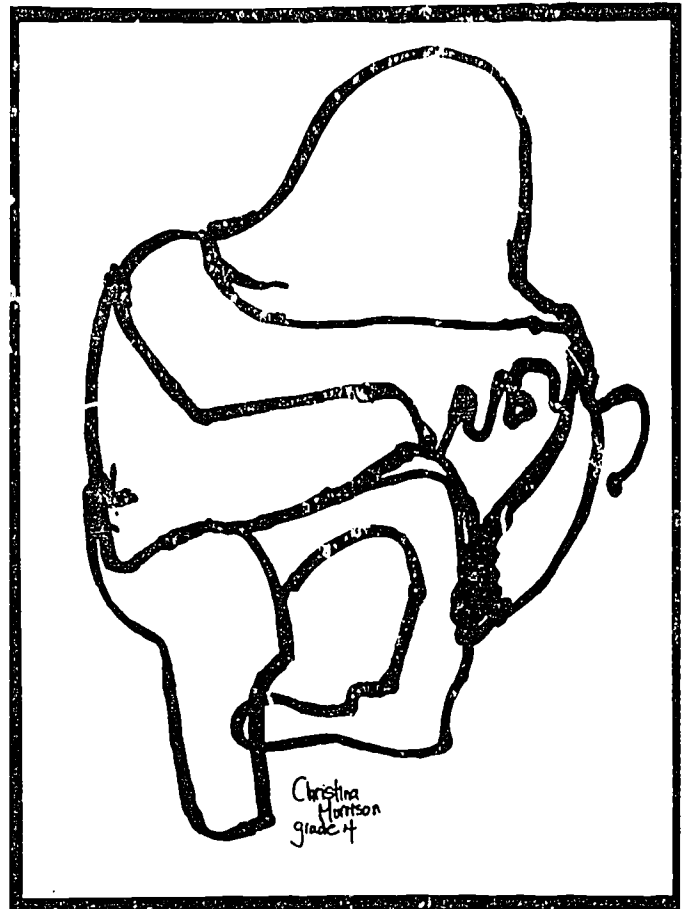
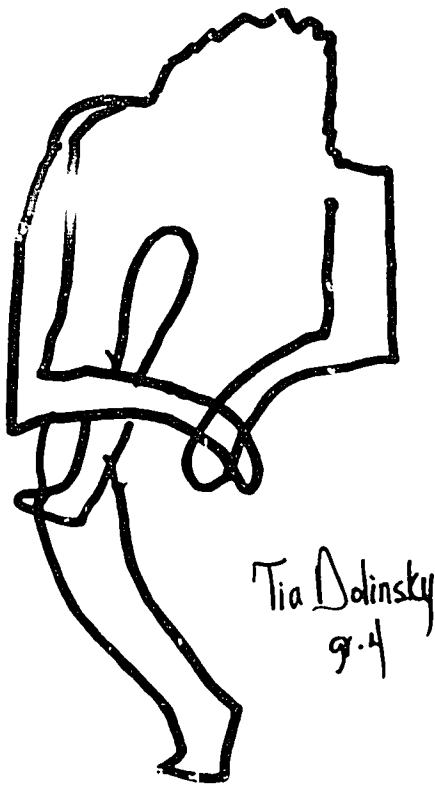

186

SAS HA

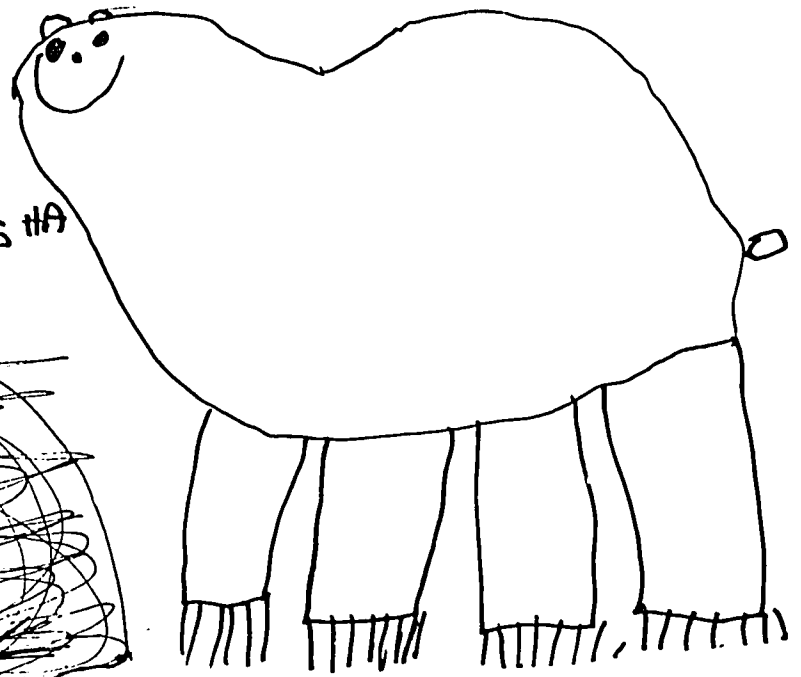
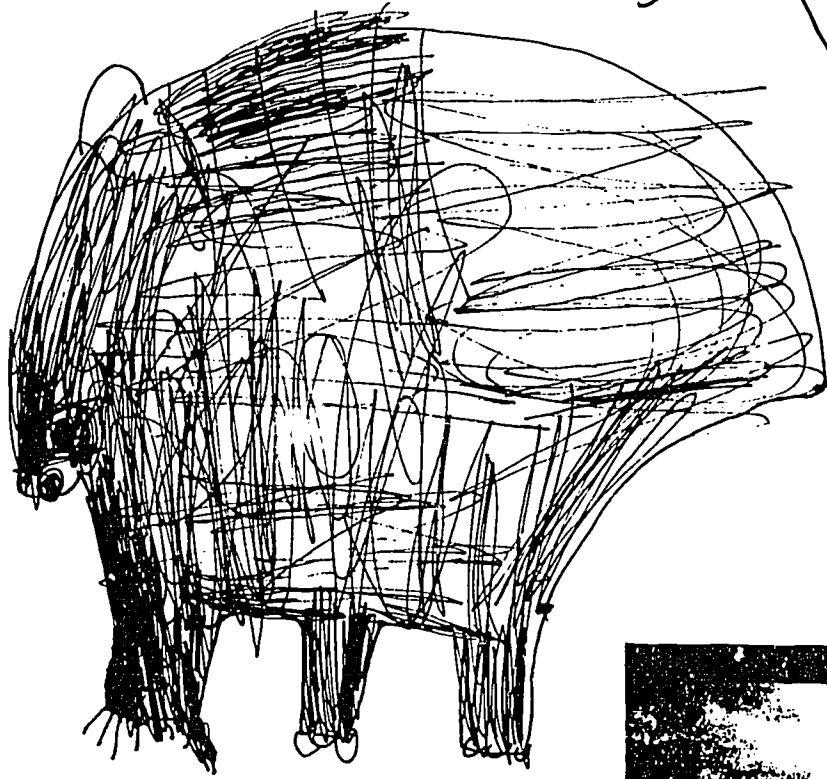

TYLER



187



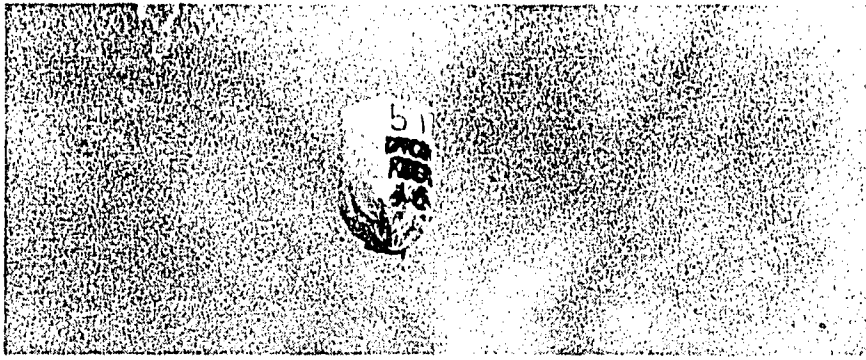

Miniature hot air balloons designed and constructed by Grande Prairie students.



# Drawing Techniques

The most interesting and natural (or "honest") drawings that children produce are often made when they set out to tell a story. Teachers might want to consider the findings of Kane in the September, 1980 issue of Language Arts (p. 642) which suggests the following implications for providing communication skills through art activities in the elementary grades:

1. Drawing activities generate more oral language than other, more structured types of pictorial stimuli...
2. When given the opportunity, children seem to work out their ideas through drawing before they verbalize those ideas. They frequently refer to their drawing when verbalizing.
3. Drawing seems to stimulate language for children... rather than language stimulating drawings, as is often suggested.
4. Drawing and other forms of graphic representation are methods of communication and should be integrated with the other communication skills.

As children grow and develop, they reach a point, individually, where they want to make their drawings look real. Teachers can help by teaching techniques, to the whole class or to individual children. Following are brief descriptions of the major techniques that lead to more convincing (realistic) drawings.

**Gesture Drawing** is often regarded as a loosening or warm-up activity. The artist employs a multitude of fairly fast and free-flowing arm movements to capture the structure and movement (gesture) of the model.

**Contour Drawing** occurs when the artist observes the model (figure, still life or landscape) very carefully to seek out the inner and outer significant edges of the shapes that form the model. The artist draws these edges in the form of sensitive lines. The result is linear. Contour drawing is a rehearsal that should begin when children indicate they want to draw more realistically. It is a technique that encourages students to observe the model very carefully and it gradually and eventually leads to realism.

Modelling is the technique where hatching, crosshatching and other forms of shading are used to depict the third dimension or depth.

High Detail Drawing is another method of lending verisimilitude to drawings. Try having the children draw every line of hair on the model's head separately. Draw every line or square or dot from the model's shirt. Draw every seam...every hole and thread in the buttons. High detail drawing encourages the artist to observe the figure, still life or landscape very carefully. It can lead to interesting patterns, decorations and embellishments.

**Materials and Equipment** required for a school drawing programme can be fairly rudimentary (HB pencils, newsprint, cream manilla and white cartridge paper) but as one discovers the interest and excitement that can be aroused by teaching children to draw, the teacher will want to begin a collection of more versatile drawing mediums. Softer lead pencils, coloured pencils, ball point pens, felt and fibre tipped pens (thick and thin), charcoal, chalks and pastels, pen and ink, watercolours, tempera and erasers can be gathered over the years. Children like to draw on all kinds and sizes of paper. Tiny note pads to large sheets of finger painting paper can be collected. Tiny cash register rolls and large rolls of newsprint can be used for continuing picture stories.

Any time the children can spend drawing outdoors should be considered well occupied. Drawings from May, June, and September should be saved in art folders or scrapbooks as a basis for more elaborate works (paintings, prints, batiks, etc.) in the winter. Sketchbooks or paper can be fastened to drawing boards for drawing both inside and outdoors. A collection of small folding campstools for field trips would be most useful and would lend importance to field trips.

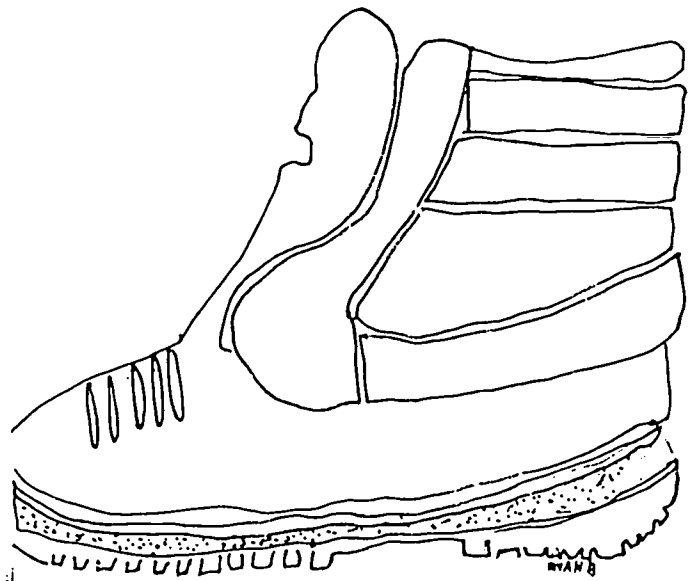
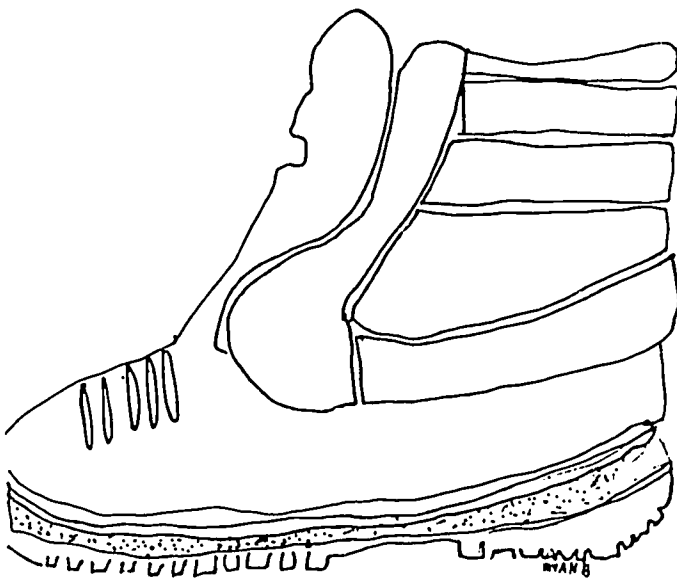

190

# Painting Techniques

Painting should not always be regarded as a technique that is totally different from that of drawing. Most works of art usually begin with plans and sketches made by drawing with pencils, pens, crayons or brushes. The mixing of media to produce a picture is a technique that children find helpful in making their images more realistic. For example, the artist may wish to "firm up" the details in a tempera painting by "overdrawing" with coloured pencil. Please refer to the chapter on Organizing the Classroom for Art for more information on painting.

## Strategies for Painting

Starting and completing a painting all in one session is called "alla prima" or "all-at-once". Though such a strategy may be successful for children, especially young ones, paintings may benefit from planned development and being executed in two or more sessions. Careful thought about the theme and subject matter as well as the purpose and the composition is encouraged. After a visually rich motivation about the content of paintings, decisions on where and how to begin and how best to proceed are real problems or challenges which should be discussed generally or individually. One cannot err by delving into the heart of the matter immediately, i.e., by pushing out the main forms first so that they become the centre of interest in the picture. Don't stop there, however. Often we see children's paintings with only one fully exposed item in them. That is not a composition! All of the pictorial space ought to be considered - for related and supporting images, other forms, settings, story elements, and the like. While completing a painting or developing on entire format, consider the following suggestions:

1. Repeat colours, tones, textures and forms for cohesion and rhythms. Expand on the main elements or fill in additional areas with echoes of the major colours and treatments.
2. Consider the grounds in a picture, foreground, middle ground and background, and expose them in varying degrees of brightness, detail and contrast. Allow them to overlap and let things run off the edges.
3. Sometimes we want a painting to appear flat, without depth. Then, too, a balanced distribution of colours, textures, tones and shapes are important to the integration of the work.

4. Step back frequently and judge the work in progress. Ask yourself what you can do to strengthen it and don't be afraid to repaint anything. Nothing is sacred until you have decided to keep it there. Sometimes accenting forms with outlines or strong contrasts of light and dark will improve their carrying power and "legibility". By the opposite token, parts can be blurred or melded together to tone down something or to blend things harmoniously. Everything in a painting affects everything else. One must experiment to find out what works best in a given environment of images, colours and tones. The finished work should appear unified and complete. If it has a spontaneous and fresh quality, that is a bonus! Facility may come from lots of practice or from unhesitating directness. Ideally, children ought to paint frequently and regularly so that familiarity with implements, media, procedures, etc., enables them to override concerns about equipment and to concentrate on what they are saying in their works, not on how to paint.



# Printmaking Techniques

Printmaking has earned its place as one of the major techniques in art because it makes multiples of original art which are then available to more people (patrons) than are drawings, paintings, sculptures and other "one-of-a-kind" original works of art. The prints that make up an edition are considered to be original works of art, not just copies. The art reproductions that we see of famous paintings (often misnamed "art prints") are not to be confused with original prints.

Children can be taught that a print is signed (traditionally in pencil) by the artist just below the plate mark (the edge of the printed area). Prints are matted (framed with cardboard) so that the plate mark is visible.

An edition is numbered and dated beside the signature. In an edition of ten prints, the first print is numbered 1/10, the second 2/10 and so on. The last print will be 10/10. The theory is that the quality of the printing plate deteriorates as the printing goes on, so that the lower numbered prints are more valuable than the higher numbered prints of an edition. The most effective way to teach these concepts is to have children pull and sign editions of their own prints.

## Relief Printmaking

Probably the most popular and practical method of making prints in the elementary school is that of relief printmaking. A relief print is made by rolling ink with a brayer onto a printing plate that has a raised (relief) surface. Porous paper is then laid onto the plate and pressure is applied to the back of the paper by rubbing with a baren or by rolling the plate and paper through a printmaking press.

The most recognized type of relief (or block) printmaking is that of linoleum block printmaking. However, the type of linoleum required is now hard to find and is, as a result, expensive. A more available, a safer, substitute is poplar plywood which can be readily ordered at the lumberyard.

A much easier method of printmaking is to make use of the styrofoam trays with which supermarkets package meat. Relief designs can be cut out of the trays with scissors and further design can be impressed onto the plate with simple tools such as a dinner fork or a pencil.

Another method of making relief plates is to use such collage methods as making raised lines on a cardboard printing plate with liquid Elmer's Glue, gluing down string to make raised lines, or gluing down shapes of cardboard and other "found" materials (like embossed wallpaper).

Children will discover that the raised surfaces will print and the recessed areas (the deeper area where the brayer couldn't deposit ink) will not print. They will also discover that the design they made on the printing plate will appear in reverse when the print is pulled.

#### Materials and Equipment for Relief Printmaking

1. **Printing Plate:** Can be cut from linoleum, poplar plywood, thin styrofoam sheets, or stiff cardboard.
2. **Cutting Tools:** Gouging tools can be obtained by art supply houses. However, wood turning tools are far superior, x-acto blades can be used when making woodcuts.
3. **Brayers (or ink rollers):** Should be the soft rubber brayers sold in photo supply stores.
4. **Inking Plate:** A plate of glass or any smooth, non-porous surface on which ink is placed to be picked up by the brayer. The best inking plate for elementary children is a cookie pan.
5. **Baren:** Can be a soup spoon or a small, smooth piece of wood. It is used to rub the backing of the printing paper so that the ink from the printing plate will be transferred to the paper. Clean brayer.
6. **Printmaking Press:** Can be a rolling pin or a wringer from an old washing machine. It would be extremely valuable to acquire a real printmaking press such as a proof press or an etching press. The press is a better method of transferring the ink from the plate to the paper.
7. **Bench Hook:** Required to hold a lino or wood block secure against the table edge while a design is being cut.

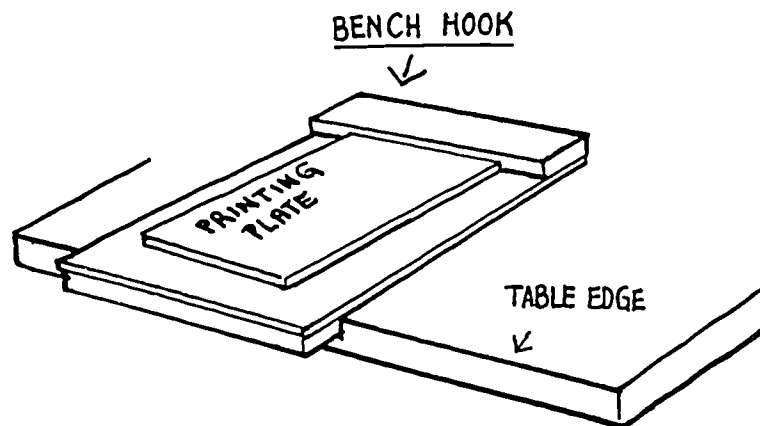

8. **Ink:** Lino ink comes in tubes and is available from school and art supply houses. Water soluble ink is much easier to handle than oil soluble ink. A cheaper but less suitable ink can be made by mixing powdered tempera with a liquid laundry starch or fabric softener.

9. Paper: Inexpensive cream manilla and other school papers can be used but superior results will come with the use of soft, porous printmaking papers.

### Other Printmaking Techniques

Monoprints (one of a kind printed images or designs) can be made in several ways. A cardboard mailing tube or a printmaking brayer can be wrapped with string or yarn, rolled on the inking plate and then rolled onto the surface that is to be printed (paper, or cloth for a wall hanging or even a box). Children can make prints by inking their hands and fingers to make impressions. Synthetic sponge can be cut to fit into a margarine container. The sponge is soaked with tempera to form a stamp pad to ink gadgets (found objects) that can be stamped onto the printing surface. Children can draw or paint on the inking plate (a cookie pan or a sheet of glass) and then press paper on the plate to pull a monoprint.

Another method of making prints is that of using stencils. The stencil printing process is one of applying paint or ink to a surface through an opening or around the outer edge of a cut-out shape. The shape may be cut from paper, cardboard, wood, etc., and this is known as the positive shape or positive stencil. The material from which the stencil is cut is called the negative shape. The paint or ink can be applied by spraying, spattering, brushing or sponging.

A more sophisticated and exciting form of stencil printmaking is that of screen printing. Onto a screen of nylon fabric stretched over a frame are placed stencils of various materials which will resist ink pulled by a squeegee across that surface. Where there is stencil, ink will resist and therefore appear blank on your printing paper, while clear areas of silk will allow ink to pass to form an image. The stencil or resist can be simply cut paper shapes, though more detailed work can be achieved with liquid tusche or cut film. Multi-colour prints are achieved by using one screen for each ink, and care must be taken in moving from light colours to dark.

### SCREEN PRINTING FRAME

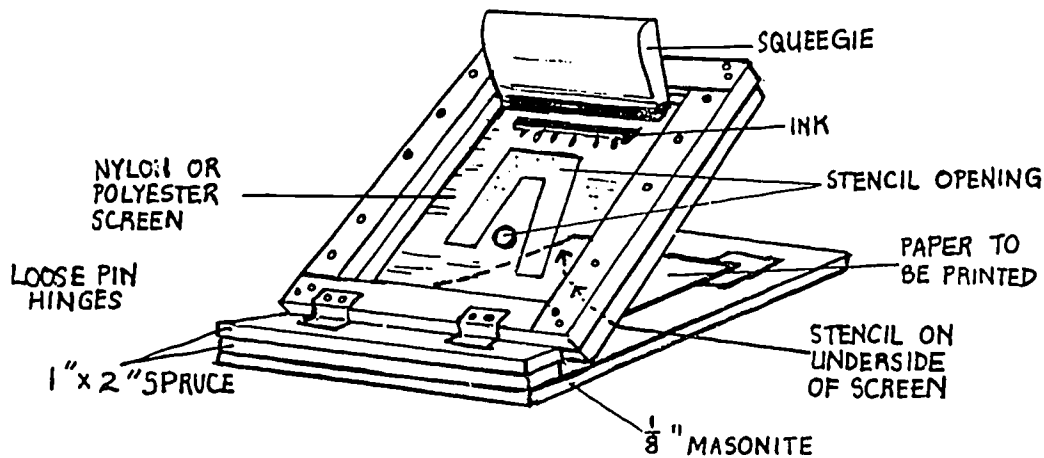





# Sculpture Techniques

Modelling, building, carving or casting forms in 3D media requires vision, skill and determination. Projecting a plan, making preparations and executing the work brings a final and lasting satisfaction which equals the coordinated effort involved. Even for a class, the preliminary organization of making sculptures is as important as the act itself. Readiness of materials, tools, concepts and strategies affect the success of the outcome. Initial experiences should be exploratory. Delving into clay, wood or plaster without a thought of direction or appropriate intention is risking disappointment, if not disaster. In the planning phase, materials required should match the purpose of the sculpture to insure adequate strength, safety and aesthetic or functional appeal. For example, if a class were undertaking soft sculptures for toys; the fabric, thread, needle, stitches and accessories must be suitable for successful handling without damage to the envisioned product. Sometimes preliminary practices, as in making stitches, are necessary for a satisfying execution of the project.

Children can model expressive forms in clay or pliable wire. They can build objects such as bridges, vehicles, architecture and animals from modular units or multiples such as toothpicks, drinking straws, cardboard pieces, wood scraps, spools, twigs, stones and the like. They can carve into material such as soap, plaster, wax, wood and styrofoam. Many forms of sculpture are available to young students but the basic skills can be developed with only a few of the most readily available materials such as firing clay or paper and paste.

## Ceramics

Unfired clay can be used over and over for rehearsals in modelling before finally preserving best results in the kiln. The clay is easily reconstituted by dropping thoroughly dried pieces into a container of water. The shapes will disintegrate and clay particles will settle to the bottom of the container. Water will clarify on top of the clay. It can be removed carefully. Allow the clay to dry in exposed air until large cracks form on the surface. Then cover it air-tight until ready to use again. No stirring is necessary in reclaiming used clay. Clay is the most flexible and expressive sculptural medium for children. It should be used frequently until students feel easy success in making active, interesting forms. Urge them to portray animate subjects in action. Avoid static, symmetrical poses. Pinch out the forms from the general, largest parts to the specific details. Avoid small, extended and unsupported appendages. Create families of creatures!

Many different kinds of pots such as wall pouches, boxes, candle lanterns and holders, piggybanks, cups, vases for flowers or dried weeds, and bowls of all kinds can be made from clay.

The simplest method of production is the pinch pot. Cut, with a strong, thin wire (equipped with handles), enough clay from the package it comes in so that the child can work it with two hands. Have the child roll the clay into a ball. One or two thumbs are pressed into the ball to start the centre of the inside of the pot. That opening is widened and smoothed with slightly moistened hands until the pot has its desired shape. The walls of a pinch pot should be consistently even in thickness and as thin as reasonable for its size and purpose.

The most versatile, hand building technique in clay is that of slab building. Slabs are joined by scoring (roughing up) the edges. They should be slightly moist before pressed together and sealed on the seam.

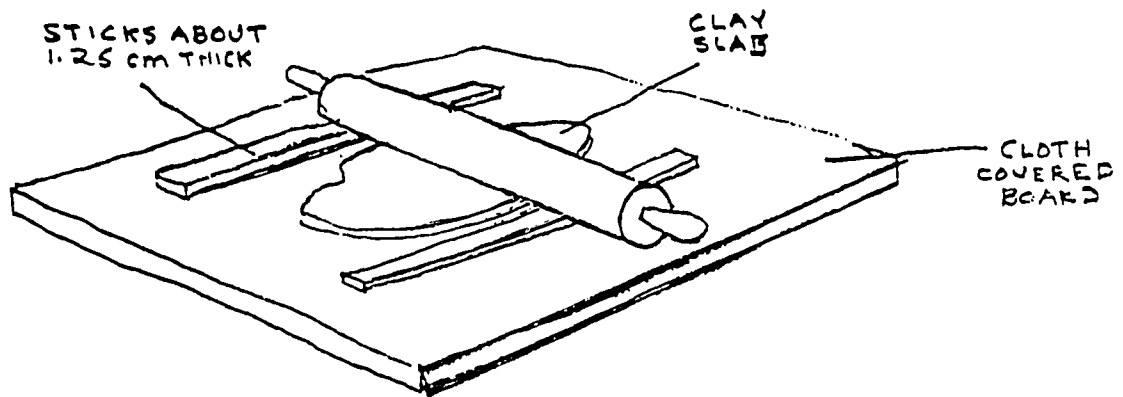

Slab Pot

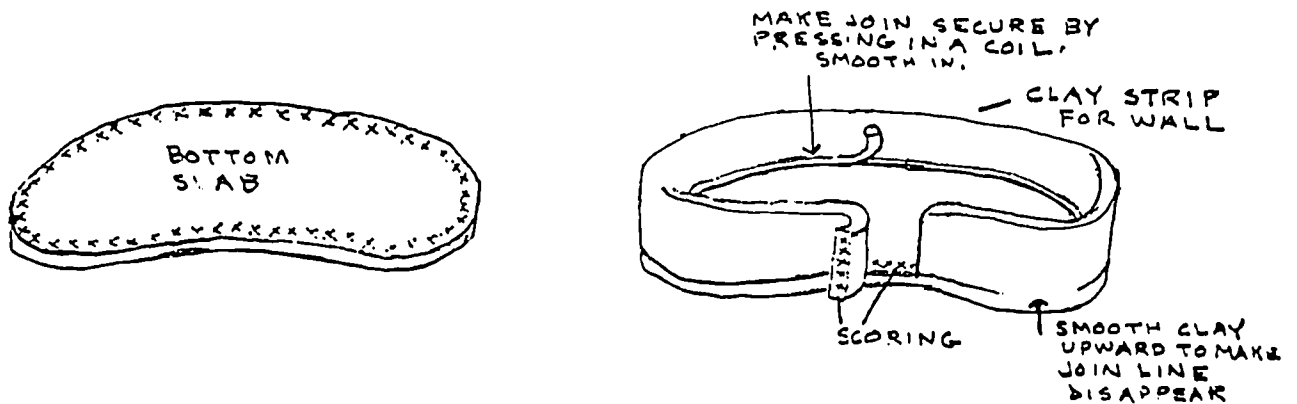

Coils allow the potter to build large or carefully shaped vessels. The bottom of a coiled pot can be a slab. Build up from the base by wrapping thick coils around and up until the desired height and shape is reached. Remember that in order for the clay to adhere properly, wet and roughen each coil that is joined to another. Cover with a damp cloth and a plastic bag to keep in the working state or dry in a controlled, slow way when completed and before firing.

Clay can be decorated by impressing found objects such as mesh fabrics, string, grass or hard materials into the still-wet clay. Relief decoration can be achieved by appliques of coils, pellets, or clay shapes onto the still-wet clay. Decoration can also be incised or engraved on the surface of the clay with a variety of tools.

### Paper Sculpture

In building sculptures with paper and paste, start with a strong armature made from tightly rolled tubes of newspaper wrapped with a long piece of iron wire. Three such tubes of equal length will form almost any kind of animal or figure, depending on what proportions and relationships one uses in binding the tubes together for the armature. (See examples.)

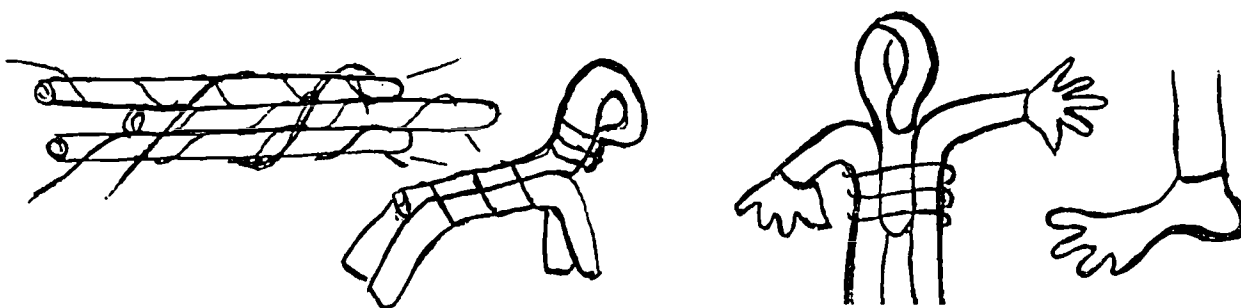

Thoughtfully select the best position for the sculpture, something really interesting or functional. Then fill out the form with dry, crushed paper held in place with paste-coated pieces of torn newspaper. Keep the inner bulk as dry as possible. Let the outer layer dry thoroughly before a second session for refining the form with additional crushed paper and pasted "skin". A final coat of paper towelling and paste makes an excellent surface for painting, decorating and varnishing. Clothing can be designed and cut out of paper, then added with coats of paste. Yarns make excellent hair, tails, fur, etc. Tie a knot in the centre of a few strands to make a tuft. Then dip the knot in paste before inserting it into holes drilled into the surface of the animal - using the pointed end of a pencil or tool. Hands and feet can be added with wire bent into fingers or foot shapes. They are easily bent into exaggerated

expressions and sizes and installed by inserting the ends into the arm and leg tubes. "Flesh out" hands or feet with crushed paper and pasted layers of towelling modelled around these appendages bent into interesting positions.

Paper and paste is a strong and flexible medium as well as inexpensive and readily available. Commercial paste for these school sculptures is non-abrasive on skin and non-deteriorating during the working process, but substitutes such as flour or wallpaper paste are equally effective. This medium is suitable also for crafted items such as buttons, buckles, hats, jewelry, for sets of drawers made from boxes, for toy vehicles such as ships, beds, cars, trucks, puppets, and almost anything that can be built - bookcovers, containers, picture frames, wall pieces and the like. Essentially, everything from jewelry to full sized furniture can be made functionally from paper and paste. Don't underrate this simple sculptural medium.

200

# Fabric Arts

Crafts involving fabric are often inexpensive, challenging and educational experiences in the classroom. They include the making of fabric (weaving, knotting, knitting, etc.), the decorating of fabric (dyeing, stitching, printing, etc.), and the uses of fabric (bookmaking, wall hangings, cases-covers-pouches, simple garments, quilt making, etc.). Whether practical or purely aesthetic in purpose, the planning and executing of fabric crafts provide students with an opportunity to manage the designing and handling of a project from beginning to end. Manipulations and adjustments from feedback characterize this management. Moreover, manual dexterities and visual taste are developing. Fabric arts adequately exemplify the craft areas. Other crafts in materials such as wood, glass, leather, metal, basket fibres and the like are also educational and personally satisfying but they may be less adaptable to classes of children. Paper and fabric crafts are most suitable in the classroom.

Weaving can be rehearsed in paper and applied to the making of bags, covers, cases, caps, etc., by warping a cardboard loom with strong cord. Heavy cardboard looms may be shaped for various products - even vests, skirts, gloves and the like - but the beginner will be delighted with a little purse, a marble bag, a pencil or glasses case or something quite simple in shape or concept. The flat, thick cardboard is equipped with a row of straight dressmaker's pins wherever an opening is required in the design. See the sketches for an example. Then the warping is done by looping each pin head from both sides of the loom - in the direction of the preceding warping from left to right or vice versa - until the end where the thread is knotted on an extra pin installed at the bottom of the cardboard. This extra warp thread allows an uneven number of them for the continuous tabby weaving at the top and bottom of each product.

Finally, the weaving of soft and coloured yarns proceeds by attaching a limited length of about 2 meters to a bodkin or its facsimile and pulling the entire length through the weaving pattern - in the center of a flat side of the loom. Flip the cardboard over and continue weaving on the other side, always pulling the complete length of woof or weft yarn through to the end - until all weft is woven. Do not knot this weaving yarn. Simply begin a new piece wherever the former length was depleted. Pack each length of woven yarn either down to the bottom or up to the top of the cardboard loom - with a comb or fingers.

A few rows of plain weave or tabby ought to be made for both top and bottom to ensure maximum strength in those critical places. The rest of the weaving can be done in other weaving patterns such as twill or basket. Complete the weaving with the possible exception of a narrow open channel near the top - for installing a drawstring which can be made simply from a combination of the weaving yarns in a twisted rope. Other mechanisms for closing a simple bag or case might be a zipper, a flap and button, velcro, etc. Linings can be made and added as well.

Patterns or designs can be created for these projects - such as a monogram of letters, a simple picture or logo, etc. When using a design, draw it in size on the cardboard loom or on a piece of paper slipped under the warp threads and taped in place. Then weave the design before proceeding to weave the background or remaining area, taking care to interlock the weft yarns wherever the two edges meet. This weaving experience gives students some insight into the nature and importance of weaving in our culture.

Weaving is the most fundamental of fabric making skills and it ought to be a part of every child's art experiences in the school curriculum. Other fabric making techniques such as macrame, crocheting, felting, etc. are more optional, depending upon teachers' capabilities and interests.

Fabric decorating can be considered twofold based on the type of media involved, 1) a design which is drawn, painted or printed on the surface of the fabric, and 2) a design which is stitched from threads or other materials and attached to the fabric. These two types of decorating fabric include the following specific techniques.

#### Enhancing the fabric decoratively

Press crayon designs into cloth with a hot iron or use fabric crayons.

Batik with melted wax and various applicators. Successive dyeing.

Stencil or spray with fabric dyes.

Print designs on fabric with acrylic paints.

Paint directly on the fabric.

#### Altering the fabric structurally

Decorate with stitchery after practising a repertoire of stitches.

Fringe edges or draw out threads from the fabric. Weave in colourful "borders".

Applique with or without stuffing.

"Reverse applique" as in Pan American Indian molas, which is cutting through multi-layered, various coloured fabrics and turning back edges while stitching them into place. This technique reveals the underlying colours and fabrics.

Sewing on buttons, yarns, tapes, etc., for decoration.

Fabric sculptures.

202

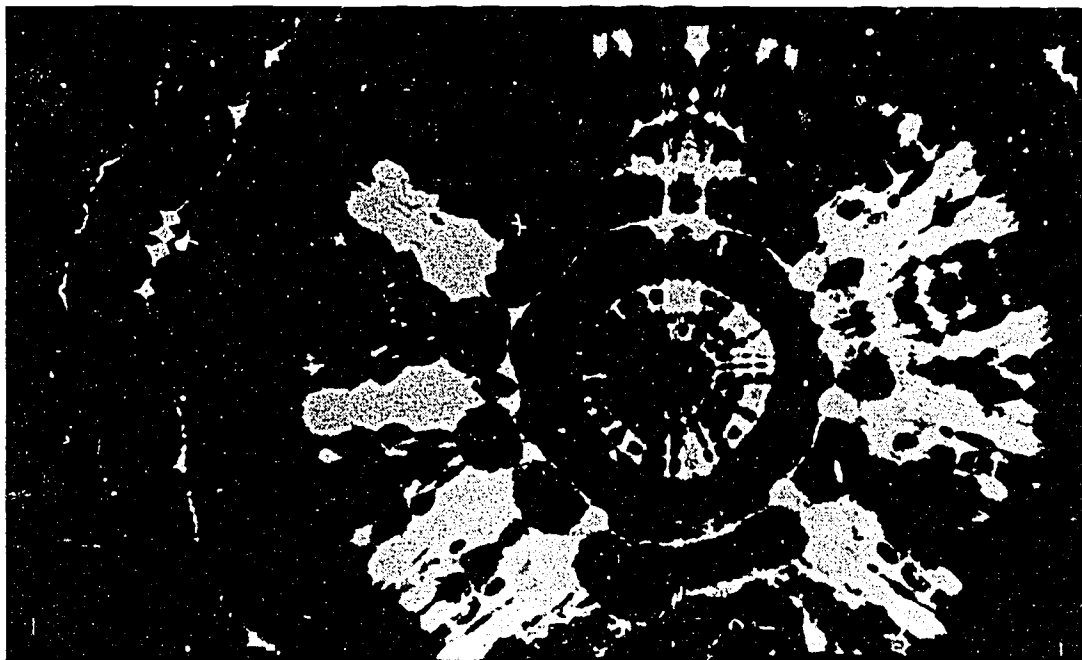

### Batik

Designs can be built up directly on the fabric without detailed pre-planning or they can be carefully planned in both structure and colour. In either case, the dyeing should proceed from the highest hue (yellow) to the darkest (black) -- with intermittent waxing for preserving the previous dyed areas. Dyeing should be limited to only one of the two colour families -- either the warm family of colours or the cool family. If one must use both families, then the opposite hues should be painted in directly -- before any dipping of fabric into dye vats -- and waxed over as soon as cloth is dry. Normally, however, restrict colour plans to one family only.

### Dyeing Procedure

#### Warm Colours

gold  
orange  
red  
wine

White  
Yellow

Black

#### Cool Colours

yellow-green  
green  
blue-green  
navy blue (green)

Batik is the best way of learning about colour theory because of its accumulative and interacting process. Colours or hues affect each other dramatically through the transparent dyes which are like ink.

Wax for batikting is best composed of 1/3 beeswax (to reduce the brittle effect) and 2/3 paraffin (to promote the characteristic cracking texture). When heated, it should be as hot as possible without smoking. An electric skillet is useful, but it should be set in the center of a working table where no one can upset it. Wax applicators can be made by wrapping a soft styrofoam square around a handle and securing it with masking tape.

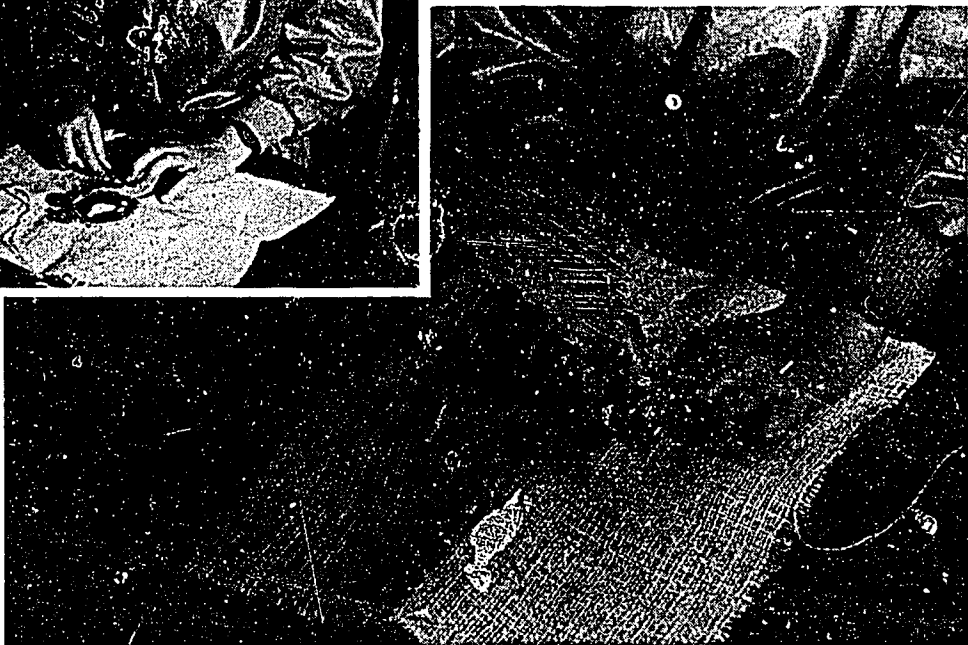
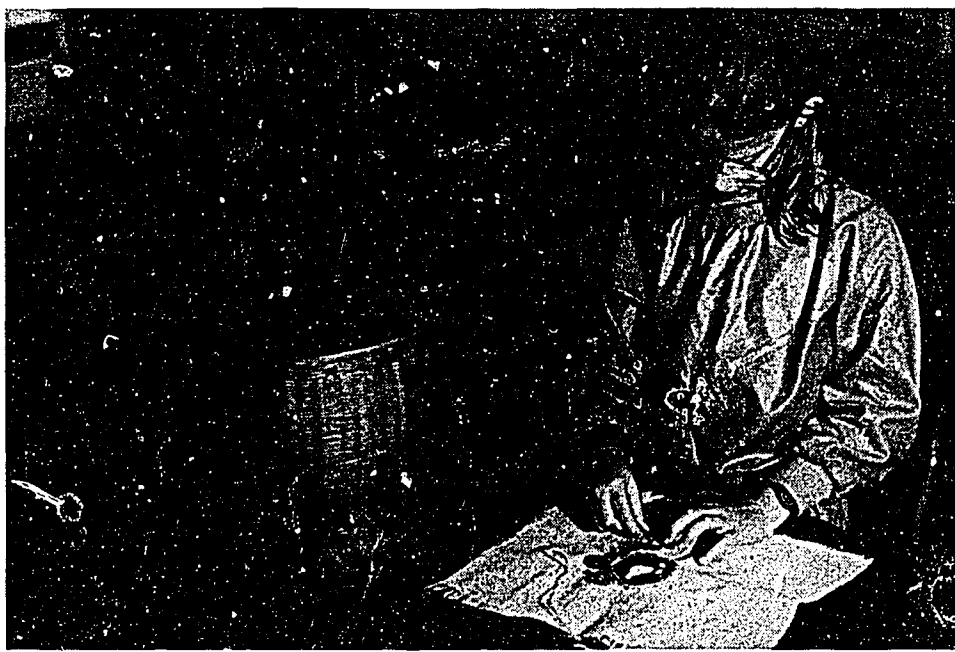



# Photography and Technographic Media Techniques

Technology brings to us new media for the creation of images that go beyond the scope of the hand of human technical skill. New possibilities are now a reality for today's artist, possibilities that permit features such as:

1. Easy and instant change; and easy and instant recording of that change.

Cameras can record instantly changes in a composition based on reality: movement of objects, changes in lighting, alteration of point of view (aerial, head-on, worm's eye), changes in distance of viewing (close-up, wide-angle, telescopic, zoom), and even collapse of time. Photographic techniques can modify images easily: enlarge, reduce, super-impose, crop, airbrush, touch-up, montage, manipulate. The results are easily recorded and viewed through prints, slides, transparencies, videotapes, films, laserdiscs.

Computers can be used to create instant images that can perpetually change if so desired and which can be saved immediately at any point the artist desires.

2. Creation of images beyond human capacities.

Technology permits the creation of images beyond human capacities. Holographs add a realistic three-dimension inviting viewing from various angles and permitting us to "see" around. Computers can simulate perspectives and detail works in ways the human hand cannot and with the programs now available it can almost become "child's play." Copying devices can reduce images, duplicate images, and respond to compilations and deletions instantly. Simple photography can be manipulated easily to produce a myriad of effects. Videos and films can multiply the effect of a visual by adding sound and juxtaposing it with still further images. Printing techniques can outreach the capability of any human hand.

3. Compounding of messages and communication.

Photography and technographic art surround the individual in today's world. We must constantly read visuals - for daily life functions, for employment, for recreation. Today's artist, as never before, must be a communicator; and today's child must be a visual reader and a communicator.

# Using Photography and Technographic Arts in the Classroom

## Project Ideas

The following list is meant to provide starting points for meaningful media experiences. It does not provide all the steps in carrying out the project. There still will be a need to check with your Learning Resource Centre or Audio Visual Supervisor for technical steps in some instances.

### Simple Camera

1. Use the camera for documentation or recording detailing which you wish to use later.
2. The camera can be an exploration device to study basic design principles and elements - types of shapes, open and closed curved, perspectives, texture, light and dark, rhythm, etc. Film and cameras can be shared; pictures mounted, discussed, shared. Picture set-ups can be manipulated to get certain effects or to alter effects (such as placing a white object against a white background and then placing the same object against a dark background, or putting a textured surface on an object and comparing the difference in a before and after picture).
3. Use the camera for sequencing events.
4. The camera can be used for studying viewpoints (close-up, long shots, overhead, worm's eye, etc.).
5. The camera can capture action for you. This can be incorporated into further projects or form the basis of discussion.
6. Use the camera for composition in creating still lifes and studying lighting.
7. Experiment with time-exposures to achieve special effects.
8. Take color landscape photographs to study perspective. Note the intensity of color in foreground, distinctness of objects, etc.
9. Experiment with manipulation of several photographs or pictures from magazines (such as take objects or parts of figures from one picture and insert in another, etc.), and then rephotograph.

### Overhead Projector

10. Use the overhead for experimenting with shapes, colors, compositions. Use real objects, cut-outs or drawings on acetate.
11. The overhead can be used for relating a story by creation of a series of images that can be shared by a large number of people.
12. Use the overhead for problem solving in compositions (balance, unity, directional lines, etc.).
13. The overhead can become a tool in evaluation. Use shapes, colours, etc., to set up questions for individual response or group discussions.
14. Use an acetate roll for your own little movie story.
15. Coloured liquids (water, oil, food colouring) can be mixed on glass surface to achieve visual effects.

### Computer Software Packages and Input Devices

16. Use devices and packages available for drawing, composing, exploring, colouring. Work with line, colour, shape, space.
17. Use devices and packages available for individual study and evaluation. (Vocabulary, concepts).
18. Program the computer to make geometric shapes, etc.
19. Use the computer for animation.
20. Use the computer to make multiple three-dimensional shapes moving through planes.
21. Use the printer to retain desired works in a hard format.

### Copy Devices or Xerox

22. Use these devices for recording and sharing visuals such as drawings and textures.
23. Compose a picture using cut-outs, pasted-up to form a composition. Compose an alternate composition using the same shapes. Compare.
24. Use white-out, picture manipulation, etc., to get original compositions. Include print manipulation for posters, etc.

25. Use the reducing capacity if available.
26. Distort images by bending paper, etc.
27. Try experiments with real objects and shapes to achieve unusual results.

#### Slides

28. Make use of slide collections available to you - your own, the school's, the Learning Resource Centre, Sightlines laserdisc.
29. Hand-make slides for original studies in line, colour, shape, texture, pattern.
30. Have students use cameras to make slides for the same reasons listed under simple cameras.

#### Filmstrips

31. Hand-make filmstrips for experimenting and sequencing.
32. Use hand-made filmstrips for storytelling and documentation.

#### 8mm Movie Camera and Video Camera

33. Use the 8mm movie camera or the video camera for documentation of art elements and principles of design found in the natural environment or compositions assembled by students.
34. The 8mm movie camera or video camera can also be used for sequencing a series of drawings or scenes.
35. Use the 8mm movie camera for simple animation using material such as cut-paper shapes, clay or plasticene figures, figures with moveable parts, puppets.
36. The 8mm movie camera or video camera can be used for the integration of sound and script with art visuals for composite projects.

### Laserdiscs

37. Make use of the thousands of visuals available on Sightlines, a visual encyclopedia for the arts, sciences and humanities available through the School Book Branch. Use the pictures for teaching.
38. Create your own computer programs to make use of laserdisc visuals or have your students work on this.

### Lighting Sources

39. Use lighting sources such as spotlights, flashlights, overhead projector light, disco lights for experimenting with effects (shadows, light and dark, contrast, mood, definition of shape, dramatic impact, message). Use the results in a composition such as a still life.
40. Create a light story or production.
41. Use rear-screen projection in combination with real life objects or people to create new compositions.
42. Shadow puppets can be created.
43. Make photograms using real objects or cut-outs to create original compositions, to study negative and positive space or to study the impact of high contrast.
44. Use a lighting source merely for highlighting objects for study and drawing.

### Advanced Projects

45. Make your own pin-hole cameras. Combine science and art through the formation of images.
46. Develop your own film.
47. Make an animated film by drawing directly or scratching on film.
48. Select and synchronize music and/or sound effects for a set of slides, short film or videotape.
49. Make or capture visuals that carry a story and/or accompany a script.
50. Create a computer program using material from video laserdisc, Sightlines.

## **Index to Resources**

- A. Basic and Recommended Resources
- B. Listing of Teacher Resource Books
- C. Print Resources: Names, Addresses, and Materials Description
- D. Visual Resources: Names, Addresses, and Materials Description
  - 1. Slide Resources
  - 2. Art Works and Art Reproductions
  - 3. Audio-visual Materials (loan, rental, purchase)
- E. Personnel, Centres, Organizations and Institutions: Names, Addresses and Brief Description

210

## **A. Basic and Recommended Resources**

### Basic Learning Resources (Students)

Townley, Mary Ross. Another Look Series. Don Mills: Addison-Wesley Publishing Company, 1978.

Level A: Grade 1

Level B: Grade 2

Level C: Grade 3

Level A with a guide for using Level A with older students:  
Grade 4.

Level B with a guide for using Level B with older students:  
Grade 5.

Level C with a guide for using Level C with older students:  
Grade 6.

Note: It is recommended that there need not be a full class set (15) and that the books not be used in a consumable manner. It is also recommended that the teacher should have a copy of each of the other levels for reference.

### Recommended Learning Resources (Teachers)

Wachowiak, Frank. Emphasis Art. 3rd ed. New York: Harper and Row Publishers, 1977.

Pluckrose, Henry (senior editor). The New Starting Points. London: Evans Brothers Limited, 1979. (Distributed by John Irwin.)

## B. Listing of Teacher Resource Books

1. Chapman, Laura                    Approaches to Art in Education,  
New York, N.Y.: Harcourt Brace  
Jovanovich, 1978.
2. Eisner, E.                         Educating Artistic Vision, New York:  
MacMillan Publishing Co. Inc., 1972.
3. Gaitskell, Charles D.  
et al.                                 Children and Their Art, Fourth Edition,  
New York: Harcourt Brace Jovanovich.
4. Hurwitz, Al,  
Stanley S. Madeja                 The Joyous Vision, A Source Book for  
Elementary Art Appreciation.  
Englewoods Cliffs, New Jersey:  
Prentice Hall Inc., 1977.
5. Linderman, Marlene M.         Art in the Elementary School, Second  
Edition, Dubuque, Iowa: Wm. C. Brown  
Company Publishers.
6. Lowenfeld, Victor                 Creative and Mental Growth, Sixth  
Edition, New York: MacMillan  
Publishing Co. Inc.
7. Pluckrose, Henry                 The New Starting Points, Series:  
Evans Brothers Limited, 1979.
8. Wachowiak, Frank                 Emphasis Art, Third Edition, New York:  
Thomas Y. Crowell, Harper & Row  
Publishers.



**C. Print Resources: NAMES, ADDRESSES, AND MATERIALS DESCRIPTION**

Alberta Education Regional Offices

Grande Prairie      5th Floor, Nordic Court  
10014 - 99 Street  
Grande Prairie, Alberta  
T8V 3N4

Edmonton            8th Floor, Harley Court  
10045 - 111 Street  
Edmonton, Alberta  
T5K 1K4

Red Deer             4th Floor  
Royal Trust Building  
4814 Ross Street  
Red Deer, Alberta  
T4N 1X4

Calgary              Room 1200  
Rocky Mountain Plaza  
615 MacLeod Trail, S.E.  
Calgary, Alberta  
T2G 4T8

Lethbridge          Provincial Building  
200 - 5 Avenue, South  
Bag Service 3014  
Lethbridge, Alberta  
T1J 4C7

- Consultants.
- Library availability.
- Booklet listing available.

- Alberta Culture  
Information Centre  
Visual Arts  
3rd Floor, 10158 - 103 Street  
Edmonton, Alberta  
T5J 0X6  
(403) 427-2031

All publications are available free of charge. Phone or write for Art Information Catalogue.

- Technical manuals, bibliographies and materials and supplies list for major art media.

- Information on Arts Administration, Art Marketing, Art Promotion, Exhibition and Display.
  - Descriptions of various components of Alberta Culture, as well as the programs offered.
  - Visual Arts Newsletter is published bimonthly.
- A.T.A. Fine Arts Council  
Barnett House  
11010 - 142 Street  
Edmonton, Alberta  
T5N 2R1
    - Provincial organization.
    - Membership and subscription information.
    - Visual and print bibliographies.
    - Publication: FINE.
    - In-services.
  - Canadian Society for Education Through Art (C.S.E.A.)  
National Office  
3186 Newbound Court  
Malton, Ontario  
L4T 1R9
    - National organization.
    - Membership and subscription information listings.
    - Pamphlets and article reprints.
    - Publications: Annual Journal; Canadian Review of Art Education Research.
  - Catalogues of Canadian Artists include information about: biographies, works of art, exhibitions, sales, reproduction availability. Information is available for historic and contemporary artists, and encompasses artists from all geographic regions in Canada.

Some catalogues listed in library holdings:

- A Directory of Eskimo Artists in Sculpture and Prints.
- Alberta Art Foundation - Inventory of Art Works Acquired to February, 1980.
- Catalogue of the Library of the National Gallery of Canada.
- Art Gallery of Ontario - the Canadian Collection.
- Canadian Art at Auction.

- National Art Education Association (N.A.E.A.)  
1916 Association Drive  
Reston, Virginia  
22091
  - International organization.
  - Membership and subscription information.
  - Pamphlets and research listings.
  - Publications: Art Education, Studies in Art Education,  
Visual Arts Newsletter.
  
- Provincial Museum of Alberta  
12845 - 102 Avenue  
Edmonton, Alberta  
T5N 0M6  
  
Attn.: Museum Bookshop.  
(403-427-1765)
  - Profiles is a binder style book containing histories and  
source list readings for 50 ethnic groups in Alberta;  
very reasonable cost.
  
- Material is available also through media centers or Teacher  
Resource Centers within each School Board.
  
- Over 200 art periodicals are listed in various library indexes.

215

## **D. Visual Resources : NAMES, ADDRESSES, AND MATERIALS DESCRIPTION**

### 1. Slide Resources

- . School Book Branch  
Alberta Education  
10410 - 121 Street  
Edmonton, Alberta  
T5N 1L2
  - Nature slides in Flora and Fauna of Alberta kits.
  - Art slides, nature slides and a vast number of theme slides available on laser videodisc called Sightlines.
  
- . Alberta Culture  
Information Centre  
Visual Arts  
3rd Floor, 10158 - 103 street  
Edmonton, Alberta  
T5J 0X6  
(403-427-2031)
  - An inventory of slides is available from the Child Art Education program.
  
- . American Slide Library  
Color Slide Co. Inc.  
P.O. Box 5810  
Grand Central Station  
New York, N.Y. 10017
  - Catalogues available.
  - Individual slides and sets.
  
- . Art Gallery of Ontario  
317 Dundas Street West  
Toronto, Ontario  
M5T 1G4
  - Individual slides of Canadian artists.

- Glenbow Museum  
130 - 9th Avenue S.E.  
Calgary, Alberta  
T2G 0P3
  - 'Photographic Price List: Curatorial' is available.
  - Individual slides.
  
- National Gallery of Canada Slide Sales  
Publications Dept.  
Ottawa, Ontario  
K1A 0M8
  - Catalogue available of Canadian Artists' works;  
individual slides and sets.
  
- National Gallery of Art  
Extension Service  
Washington, D.C. 20565
  - Catalogue of slide programs is available.
  
- Rosenthal Slide Library  
Rosenthal Art Slides  
5456 South Ridgewood Court  
Chicago, Illinois 60615
  - Catalogues available.
  - Individual slides and sets.
  - Includes all areas of the visual arts.
  
- Sandak, Inc.  
180 Harvard Avenue  
Stamford, Conn. 06902
  - Catalogues of major museum collections, modern and historic.
  - Individual slides and sets.

## 2. Art Works and Art Reproductions

- Alberta Art Foundation  
Information Centre  
Visual Arts  
3rd Floor, 10158 - 103 Street  
Edmonton, Alberta  
T5J 0X6  
(403-427-2031)
  - Brochures and catalogues of exhibitions held.
  
- Alberta Culture  
Information Centre  
Visual Arts  
3rd Floor, 10158 - 103 Street  
Edmonton, Alberta  
T5J 0X6  
(403-427-2031)
  - Catalogues of exhibitions held.
  - Posters of past exhibitions, as well as art education promotion.
  
- Glenbow Museum  
130 - 9th Avenue S.E.  
Calgary, Alberta  
T2G 0P3
  - 'Photographic Price List: Curatorial' is available.
  - Black and white, and colour photographs and enlargements.
  
- Metropolitan Museum of Art  
82 Street - 5th Avenue  
New York, New York 10028
  - Slides, sound/slide sets, prints, posters, publications, recordings, postcards, 3-D reproductions.
  - Catalogues available.
  
- Museum of Modern Art  
11 West 53 Street  
New York, New York 10019
  - Reproductions available.

- N.A.E.A.  
1916 Association Drive  
Reston, Virginia 22091
- Lists of visual material available.
- National Gallery of Art  
Washington, D.C. 20565
- Catalogues of reproductions available.
- Postcards are available from many art galleries and museums. Packets of postcards can be used as a teaching aid - one concept rendered by several artists or, the development of an artist's style - for individual student or small group study.
- Reinhold Visual Series  
Van Nostrand Reinhold Ltd.  
1410 Birchmount Road  
Scarborough, Ontario  
M1P 2E7
- Reproductions; black and white and colour.

3. Audio-visual Materials (loan, rental, purchase)

- ACCESS  
Media Resource Center  
16930 - 114 Avenue  
Edmonton, Alberta  
T5M 3S2  
(403-451-3160)
- Catalogue available in most schools.
- Videotape material.
- Alberta Agriculture  
Film Library  
7000 - 113 Street  
Edmonton, Alberta  
T6H 5T6
- Catalogue available.
- Loan.
- Films on quilting, fabric work batik, block printing.

- Alberta Culture  
(see address listed previously)
  - An inventory of films, slides and kits available from the Child Art Education program.
  
- Alberta Cultural Heritage Foundation  
202, 9924 - 106 Street  
Edmonton, Alberta  
T5K 1C4
  - Alberta People Kit - multimedia, cultural heritage awareness education kit for upper elementary classes.
  - Purchase.
  
- Canadian Film Institute  
Film Library  
#204 - 211 Watline Avenue  
Mississauga, Ontario  
L4Z 1P3
  - Catalogue, charge of \$15.00.
  - Rental, rates approx. \$2.00 a minute, decreasing with length of film.
  
- Films from Consulates and Embassies may be useful.
  
- Films on Art (book)  
Watson - Guptill Publications.
  - Composite listing of art films and sources.
  
- Institutional Media Centers - Universities, Technical Schools, Art Colleges.
  
- McIntyre Educational Media Ltd.  
86 St. Regis Crescent North  
Downsview, Ontario
  - Catalogues available.
  - Purchase filmstrips and cassettes.
  - Individual filmstrips, and series.



Media Centers or Teacher Resource Centers in School Boards may have film listings.

Regional Film Centers:

- Zone 1 Ms. Marg Simpson  
Film Supervisor  
Peace River School District #10  
P.O. Box 988  
Peace River, Alberta  
T0H 2X0  
(403) 624-3187
- Zone 2/3 Mr. Gerry Gibeault  
Film Supervisor  
CAMS (Central Alberta Media Services)  
Sherwood Park Catholic School District  
2017 Brentwood Boulevard  
Sherwood Park, Alberta  
T8A 0X2  
(403) 464-5540
- Zone 4 Mr. Doug Ayers  
Film Supervisor  
Alberta Central Regional Educational Services  
County of Lacombe #14  
Bag Service 108  
Lacombe, Alberta  
T0C 1S0  
(403) 782-6601
- Zone 5 Ms. Doreen Smith  
Film Supervisor  
South Central Alberta Film Federation  
County of Wheatland #16  
Box 90  
Strathmore, Alberta  
T0J 3H0  
(403) 934-5028
- Zone 6 Mrs. Myrna Girardi  
Film Supervisor  
South Central Alberta Regional Film Center  
McNally School  
P.O. Box 845  
Lethbridge, Alberta  
T1J 3Z8  
(403) 320-7807

- Films and other audio-visual materials.

- National Film Board  
Main Floor, 222-1 Street, S.E.  
Calgary, Alberta  
T2P 3C3

Centennial Building  
10031 - 103 Avenue  
Edmonton, Alberta  
T5J 0G9

  - Catalogue available.
  - 16mm films.
  - Loan.
  
- Sandak, Inc.  
180, Harvard Avenue  
Stamford, Connecticut 06902

  - Catalogues available.
  - Filmstrips and cassettes, available individually or in series.
  - Purchase.
  
- The Center for the Humanities, Inc.  
2 Holland Avenue  
White Plains,  
N.Y. 10603

  - Filmstrip and slide programs.
  - Purchase.
  
- Time-Life Video  
Time-Life Building  
Chicago, Illinois 60111

  - Catalogue available.
  - Rental.

**E. Personnel, Centres, Organizations and Institutions: NAMES, ADDRESSES  
AND BRIEF DESCRIPTION**

- . Alberta Association of Multicultural Education  
c/o Treasurer, AAME  
Edmonton Public School Board  
10010 - 107A Avenue  
Edmonton, Alberta  
T5H 0Z8
  - Organization to support multicultural and intercultural education in schools and communities.
  
- . Alberta College of Art  
1301 - 16 Avenue, N.W.  
Calgary, Alberta  
(403) 284-8651
  - Gallery.
  - Open house tours.
  
- . Alberta Culture  
(see address previously listed)  
  
Cultural Heritage: Programs and Services
  - Funding program, Multicultural Training program.
  - Information Program: a directory of ethno-cultural groups in Alberta; Heritage, a magazine; Update, a newsletter; Profiles, a book.
  - Alberta Culture Library is on the 11th floor, CN Tower, in Edmonton.
  
- . Alberta Culture  
(see address previously listed)
  - Workshops, programs, services are listed in the Art Information Catalogue,
  - Beaver House Gallery shows works of amateur, student and professional artists.
  
- . Art Consultants  
Alberta Education Regional Offices  
(see addresses in Print Resources section)

- ATA Fine Arts Council  
 Barnett House  
 11010 - 142 Street  
 Edmonton, Alberta  
 T5N 2R1
  - Membership and newsletter.
  - Regional conferences.
  
- Banff Center  
 School of Fine Arts  
 Visual Arts Department  
 P.O. Box 1020  
 Banff, Alberta  
 T0L 0C0
  - Gallery; winter/summer courses.
  - Coordinates 'Artists in the Schools' program.
  
- Canadian Society for Education Through Art  
 National Office  
 3186 Newbound Court  
 Malton, Ontario  
 L4T 1R9
  - Membership and newsletters.
  - National conferences.
  
- Cultural Centers  
 (provided by Glenbow)
  
- Continuing Education Departments of Community Colleges and  
 Universities offer a variety of art courses.
  
- Edmonton Art Gallery  
 Art Education Department  
 2 Sir Winston Churchill Square  
 Edmonton, Alberta  
 T5J 2C1  
 (403) 422-6223
  - Exhibitions, art classes, lectures, gallery magazine, research  
 library, slide library.

Glenbow Museum  
Education Department  
130 - 9 Avenue, S.E.  
Calgary, Alberta  
T2G 0P3

- Historical and contemporary exhibitions.
- Lectures, films, education and extension programs,  
Glenbow magazine, library, archives, artists' biographies.

Leighton Center for Arts and Crafts  
Box 38  
Midnapore, Alberta

- Courses in a variety of media.

Multicultural Heritage Centre  
5411 - 51 Street  
Box 908  
Stony Plain, Alberta  
T0E 2G0  
(403) 963-2777

- Gallery, heritage programs, art courses, craft courses,  
a museum, and, artists' biographies.

Muttart Gallery  
2nd Floor, 1221 - 2 Street, S.W.  
Calgary, Alberta  
T2R 0W5

- Galleries.
- Community exhibitions.

National Art Education Association  
1916 Association Drive  
Reston, Virginia 22091

- Membership and newsletters.
- Regional and international conferences.

- Nickle Art Gallery  
University of Calgary  
2500 University Drive, N.W.  
Calgary, Alberta  
T2N 1N4
  - Educational tours.
  - Permanent collection.
  
- Prairie Art Gallery  
9809 - 102 Street  
Grande Prairie, Alberta  
T8V 2V1
  - Galleries.
  - Workshops and classes.
  
- Provincial Museum of Alberta  
12845 - 102 Avenue  
Edmonton, Alberta  
T5N 0M6  
(403) 427-1730
  - Art exhibitions emphasize documentary or historical representational works.
  - Art education classes.
  
- Red Deer and District Museum  
Box 762  
Red Deer, Alberta  
T4N 5H2  
(403) 343-6844
  - Historical works in all media, lectures, films and other events in connection with its exhibitions.
  
- Southern Alberta Art Gallery  
601 - 3rd Avenue, S.  
Lethbridge, Alberta  
T1J 0H4
  - Galleries.
  - Classes and workshops.