

DOCUMENT RESUME

ED 274 531

SE 047 226

AUTHOR Brinkman, Dennis; Nerdahl, Rodney
TITLE Nighttime Astronomy for Middle School Children and Their Parents. A Course for Parents and Children.
INSTITUTION Minnesota Univ., Minneapolis.
SPONS AGENCY National Science Foundation, Washington, D.C.
PUB DATE 82
GRANT 07872
NOTE 199p.; For related documents, see SE 047 223-225 and SE 047 227-228. Drawings may not reproduce well.
PUB TYPE Guides - Non-Classroom Use (055) -- Guides - Classroom Use - Guides (For Teachers) (052)

EDRS PRICE MF01/PC08 Plus Postage.
DESCRIPTORS *Astronomy; Elementary Education; *Elementary School Science; Instructional Materials; Intermediate Grades; Observational Learning; *Parent Child Relationship; *Parent Materials; Parent Participation; Planetariums; *Science Activities; Science Education; Science Facilities; *Science Instruction; Space Sciences; Teaching Guides
IDENTIFIERS Informal Education; *Parent Child Program

ABSTRACT

The nighttime astronomy course described in this manual is designed to allow parents and middle school children to learn together. Using the resources of the planetarium and the real sky, the document provides a series of lessons that are intended to enable the participants to become more knowledgeable observers of the night sky. The course is divided into five two-hour sessions. Each session is composed of two segments. The first half of each session makes use of the planetarium, while the other uses either the classroom or the real sky. One of each of the five sessions deals with: (1) the constellations; (2) the celestial sphere; (3) the solar system; (4) a visit to an observatory; and (5) the location of the moon. The sections of the document which deal with the above topics include an overview of the topic and descriptions of all of the activities to be done at home. The appendices contain sky maps, diagrams and planetary settings for the solar system session. (TW)

 * Reproductions supplied by EDRS are the best that can be made *
 * from the original document. *

© 1982, University of Minnesota.

This materials is based upon work supported by the National Science Foundation under Grant No. 07872. Any opinions, findings, conclusions, or recommendations expressed in this publication are those of the author(s) and do not necessarily reflect the views of the Foundation.



NIGHT TIME ASTONOMY
FOR MIDDLE SCHOOL CHILDREN AND THEIR PARENTS

BY: DENNIS BRINKMAN
RODNEY NERDAHL

EDITED BY: EUGENE GENNARO
PATRICIA HELLER
STEVEN RAKOW

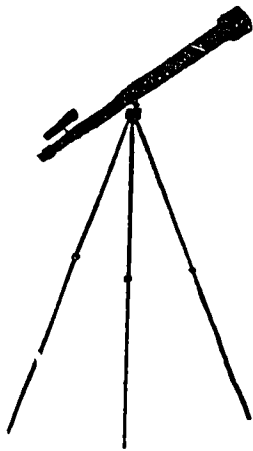

This project is supported by the Development
in Science Education (DISE) Program of the
National Science Foundation, Grant # 07872.

Eugene Gennaro, Project Director
Patricia Heller, Associate Director

ACKNOWLEDGEMENTS

The authors wish to acknowledge with gratitude the contributions of the following individuals and organizations in the development of the Nighttime Astronomy course.

Dr. Jan Van der Hulst, Astronomy Department, University of Minnesota
Science Museum of Minnesota, Children's Center and Planetarium
Como Planetarium, St. Paul Public Schools

Art Work - Sandy Peterson

Typing - Kristin Dahl
Jeanne Eich
Deda Jenkins

TABLE OF CONTENTS

ACKNOWLEDGEMENTS	ii
TABLE OF CONTENTS.....	iii
INTRODUCTION.....	vi
TEACHING PARENTS AND THEIR CHILDREN	vii
FACILITIES	viii
MATERIALS	viii
ORDERING	xi
ADVANCE PREPARATION	xi
SESSION 1: THE CONSTELLATIONS	
OVERVIEW	1
MATERIALS	1
ADVANCE PREPARATION	2
TEACHING SUGGESTIONS	4
Getting Started	4
Introducing Constellations	4
Identifying Circumpolar Constellations	7 6
Identifying Southern Constellations	10 0
Home Activities	11
Optional Activity	13
HANDOUTS.....	14

SESSION 2: THE CELESTIAL SPHERE

OVERVIEW	21
MATERIALS	21
ADVANCE PREPARATION	22
TEACHING SUGGESTIONS	28
Getting Started	28
Introducing Star Trails	29
Predicting and Observing Star Trails	30
Predicting and Observing Star Trails at the North Pole, Equator, and South Pole	31
Introducing Altitude and Azimuth	34
Building an Astrolabe	35
Home Activity	37
HANDOUTS.....	38

SESSION 3: THE SOLAR SYSTEM

OVERVIEW	47
MATERIALS	47
ADVANCE PREPARATION	48
TEACHING SUGGESTIONS	49
Getting Started	49
Introducing Planets	49
Tracking the Planets Mars, Jupiter and Saturn	51
Introducing the Zodiacal Constellations	53
Building a Model of the Solar System	55
Optional Activity: Tracking Mercury and Venus	60
Home Activity	60
HANDOUTS.....	61

7

SESSION 4: VISIT TO AN OBSERVATORY

OVERVIEW.....62
MATERIALS.....62
ADVANCE PREPARATION.....62
TEACHING SUGGESTIONS..... 64
 The Observatory..... 64
 Home Activity..... 64
HANDOUTS..... 68

SESSION 5: WHERE IS THE MOON?

OVERVIEW..... 69
MATERIALS..... 69
ADVANCE PREPARATION..... 69
TEACHING SUGGESTIONS..... 71
 Getting Started..... 71
 Tracking the Moon..... 71
 The Lunar Phases..... 74
 Optional Discussion..... 80
HANDOUTS..... 82

APPENDIX A: MONTHLY SKY MAPS..... 88

APPENDIX B: CONSTELLATION DIAGRAMS..... 115

APPENDIX C: PLANETARIUM SETTINGS FOR SESSION 3..... 137

INTRODUCTION

For centuries human beings have observed the star-filled skies and marvelled at the perpetual display of light and motion. From these "night lights" our ancestors learned to tell time and find their way. In the last 150 years, we humans have steadily lost touch with the stars. Buildings and city lights now shut the night out, and the stars often go unnoticed.



The sky, however, is still available to those who have the interest, the time, and the willingness to seek a clear spot to watch. Often people who have the interest and the time are not able to find a good spot for observing the sky. One way to get around this barrier is by means of a planetarium. In a planetarium, the entire sky is available for viewing, unhindered by light pollution, tall buildings or inclement weather. In addition, the planetarium

can show in a few seconds or minutes, events that take days or weeks in nature.

The night-time astronomy course described here is designed to allow parents and children together to learn the mysteries of the sky. Using the

resources of the planetarium and the real sky, participants are guided through a series of lessons that are designed to enable them to become more knowledgeable observers of the night sky and to learn to interpret what they see.

The course is divided into five two-hour sessions. Each session is composed of two segments: one half makes use of the planetarium, while the other requires either the classroom or real sky. It is a good idea to include a short break between these two segments, with some refreshments served. At the end of each session, families are given home activities to work on throughout the week that involve observing the night sky outdoors.

The first session introduces participants to the constellations visible in the current evening sky. The second session concerns the celestial sphere--its apparent motion and the way we locate objects found on it. In session three, participants discover the planets and their wanderings within the zodiac. The fourth session is devoted to a visit to a local observatory so that participants will be able to view the sky in greater detail and learn to distinguish a planetarium from an observatory. The last session deals with the moon's motion and phasing.

TEACHING PARENTS AND THEIR CHILDREN

The advent of the space shuttle, probes to the outer planets, science fiction films, and other space-related events have provided parents and children with the motivation to become better acquainted with the night sky. This course differs from most astronomy courses in that the activities are designed to encourage interaction between children and their parents. Each activity requires that family units work together to solve problems or learn new skills. By interacting in this manner, both groups have the opportunity to act as the teacher for the other. In some instances the children were the first to visualize a

concept, and in turn, helped their parents. In other situations, the opposite occurred, and in some circumstances, both parents and children acted as equals. The outline of the sessions presumes that for the most part, participants have only a limited familiarity with the material to be covered. This course is designed primarily as an introduction to observational astronomy.

FACILITIES

Planetariums, which are ideal locations to teach naked eye astronomy, come in all sizes and shapes. This course was designed to be taught in any planetarium. To insure this degree of flexibility, the course was piloted in two completely different planetariums. Any planetarium teacher should be able to use this course in his/her facility without a great deal of time spent in modification or preparation. In addition to the planetarium itself, it is advantageous to have available a nearby classroom. To relate the planetarium experiences to the real sky, it would also be helpful to have access to a large open field that is relatively unhampered by large amounts of artificial lighting nearby.

Although the observatory trip is an important part of this course, it is not essential that an observatory be available. There are options that can be used in place of the observatory trip. For example, a local astronomy club or avid amateur might be willing to host a star party, thus giving the class an opportunity to view the sky with a telescope, and become aware of amateur astronomy in the local setting.

MATERIALS

Although a list of materials is included for each session, the total list of materials is given below for convenience in preparing the materials.

This list has been divided into a section for those items which can be reused in subsequent classes ("reusables") and those which cannot ("expendables").

I. Reusables--

For each family:

- 1 red-filtered flashlight
- 1 lap board (necessary only if your planetarium seating lacks desk tops)
- 1 pencil for each family member
- 1 medium-sized standard blade screwdriver
- 1 ping-pong ball glued to a golf tee

For the instructor:

- 1 Kodalith slide of a square for each direction
- 1 slide projector for each direction
- 2 or more "classroom stars" (see Session Two)
- 1 prize for the constellation identification contest
- A system for projecting altitude and azimuth scales in the planetarium
- 1 set of slides showing the mythological figures associated with each zodiac constellation (optional)
- 1 set of slides showing the mythological figures associated with each circumpolar constellation (optional)
- 1 set of slides showing the mythological figures associated with each current season constellation (optional)
- 1 set of twelve cards, each containing the name of one of the zodiac constellations
- 10 cards with the words "Earth," "Sun," "East," "West," "Mars," "Jupiter," "Saturn," "Venus," and the names of two seasonal constellations

II. Expendables--

For each family (handouts):

- 1 unmarked northern sky map for the current season
- 1 marked northern sky map for the current season
- 1 set of circumpolar constellation diagrams
- 1 set of current season constellations diagrams
- 2 Home Activity 1: Observer's Log
- 1 Home Activity 2: Spanning the Night Sky (3 pages)
- 1 Home Activity 3: Photographing the Night Sky (3 pages)
- 2 "Star Trails" prediction sheets
- 1 "Building an Astrolabe" (3 pages)
- 2 Astrolabe Scales (azimuth and altitude)
- 1 Home activity 4: Finding Positions with your Astrolabe (2 pages)
- 1 unmarked southern sky map for the current season
- 1 marked southern sky map for the current season
- 1 set of Zodiac constellation diagrams
- 1 "Where is the Moon" worksheet
- 1 "Lunar Phases" worksheet (2 pages)

For each family (materials):

- 1 notebook to hold handouts (optional)
- 1 roll of 35mm color slide film
- 1 map of current night sky showing the location of a few deep sky objects (e.g., Abrams Planetarium's "Sky Calendar")
- 1 Edmund Scientific 8x refractor telescope kit (#71,473) or 10 kits (#P-71,474), which is less expensive
- 1 Astrolabe Kit, consisting of:
 - 1 8" x 8" x 1/2" piece of particle board

- 1 9" length of 1" x 4" pine board
- 1 6" plexiglass disk (1/8" thick)
- 1 4-1/2" x 6-1/2" piece of masonite
- 1 1-1/2" x #8 wood screw
- 1 1/2" #8 wood screw
- 1 5/8" #8 wood screw
- 1 small washer
- 1 5" length of string
- 1 small weight or nut

ORDERING

Well in advance of the course, order the Edmund Scientific 8x refractor telescope kits and arrange for transportation to and from the observatory. It is a good idea to confirm your transportation just before you actually plan to use it. Also, be sure to make arrangements for the use of the observatory and services of a staff member or an astronomy club and one or more of its members for the fourth session ("Visit to an Observatory").

ADVANCE PREPARATION

The home activity for the third and fourth session asks participants to observe and record the position and shape of the moon at sunset. This activity works best if the new moon falls very close to the date of the third session. Select your dates for teaching this course so that the new moon is near the date for this third session.

Read the chapters describing each session to get an idea of the time needed to prepare for each class session. Most of the worksheets, diagrams, and home activity sheets can be duplicated before the first class session. Secure enough red-filtered flashlights, lap boards (if needed), pencils, and screwdrivers before

the first class session. Obtain the ping-pong balls and golf tees and glue them together. All materials that need to be prepared as Kodalith slides for the sessions should be taken care of well in advance of the class. In addition, slides of star trails should be taken and developed before the second class session (see the "Advance Preparation" section of Session 2).

It is important that the astrolabe kits be made well in advance of the course. They are not difficult to make, but do require some time to get ready (see the "Advance Preparation" section of Session 2 for details).

SESSION 1

THE CONSTELLATIONS

OVERVIEW

In this session, participants are introduced to the night sky. Initially, most participants view the night sky as a disorganized collection of stars. They are given an unmarked star map that also, at first glance, appears disorganized. Through the use of the planetarium, printed constellation diagrams, projected constellation figures and a pointer, participants learn how to divide the sky into easily recognized constellations. Once they learn to read star maps, the participants are encouraged to apply their new-found skill to the real sky.

MATERIALS

For each family:

- 1 red-filtered flashlight
- 1 lap board (optional)
- 1 roll 35 mm color slide film
- pencils for each family member

For the class:

- 1 or 2 slide projectors
- 1 set of Kodalith slides of circumpolar and current season constellations
- 1 set of slides of mythological figures of constellations (optional)
- 1 set of handouts and home activity sheets
- 1 notebook for all handouts (optional)

ADVANCE PREPARATION

1. Unmarked and Marked Sky Maps

Select from Appendix A the unmarked (constellations not identified) and marked (constellations identified) northern and southern sky maps for the month you are teaching. Duplicate a copy of each map for each family. An unmarked and marked northern and southern sky map is available for each two-month period of the year (January–February, March–April, May–June, July–August, September–October, and November–December). Appendix A also contains a description of how the sky maps were generated.

2. Constellation diagrams

Select from Appendix B the appropriate southern and northern constellation diagrams, referring to the constellations identified on the marked sky maps for the month you are teaching. In trial classes we found that it was difficult to introduce more than eight or nine constellations in this first two-hour session. You may want to limit yourself to nine constellations in the entire sky. Once you have selected your constellations, duplicate a complete set of the constellation diagrams for each family. Below is a list of the constellation diagrams available in Appendix B.

Northern:

Cassiopeia	Ursa Major
Cepheus	Ursa Minor
Draco	

Southern:

Andromeda	Cancer
Aquarius	Capricornus
Aquila	Canis Major
Aries	Canis Minor
Auriga	Cetus
Bootes	Corona Borealis

Corvus	Orion
Cygnus	Pegasus
Gemini	Perseus
Leo	Pisces
Lepus	Sagittarius
Libra	Scorpius
Lyra	Taurus
Ophiuchus	Virgo

3. Constellation Slides

Photograph the selected constellation diagrams using kodalith film. After processing and mounting, these slides can be projected to aid the participants in (1) locating the stars of each constellation, and (2) grouping them together by means of hand-drawn lines.

4. Home Activities

Prepare an "Observer's Notes" sheet with a list of the circumpolar and current season constellations you have selected (see page 14 for an example). Duplicate this sheet and the remaining home activity sheets (northern and southern sky maps, "Spanning the Night Sky", and "Photographing the Night Sky") for each family. In trial classes we found it convenient to place these materials in notebooks. In the following weeks, families can keep all the class activity and home activity sheets and records in these notebooks. Purchase enough 35 mm color slide film so that each family has a roll to take home for the "Photographing the Night Sky" activity. (You may want to get several different film speeds, such as ASA 100, 160, 200 and 400, just to experiment with films and see which produce the most pleasing results.)

5. The Planetarium Activity

Prepare the red-filtered flashlights and lap boards. Before the session begins, set the planetarium sky to match the unmarked sky maps (see Appendix A) and install the slides showing the constellation diagrams (Kodalith slides) and the mythological figure slides (if you have them). Be sure that these slides are projected to one side of each constellation so the participants can use the slide illustration to locate each particular group of stars.

TEACHING SUGGESTIONS

Getting Started (10 minutes)

One way of starting the class is to have the children introduce their parents and the parents introduce their children. After introducing yourself, give a brief overview of the course, showing the participants the astrolabe and telescope they will build.

Introducing Constellations (10 minutes)

Objective: Participants will be able to define a constellation as an artificial pattern of stars.

Begin the planetarium session by asking the participants to list orally the objects they can identify in the night sky. Typical responses might include:

North star	Meteor	Planet
Big Dipper	U.F.O.	Airplane
Little Dipper	Moon	Satellite
Orion	Evening star	Milky Way

Lead the group to the realization that the sky is filled with many other things that they can find and identify. To most people, the sky is so full of stars that it becomes confusing. Distribute the unmarked northern and

southern sky maps and explain that they represent the current night's sky. The sky maps will probably also look confusing. Explain to the group that it is the intent of this session to organize the sky in a meaningful way.

Ask the participants, "How did our ancestors organize the sky long ago?". This question usually leads to the concept of a constellation, or artificial grouping of stars. If no one suggests this idea, explain to the group that early skywatchers grouped the stars into the recognizable patterns we now call constellations. Explain further that to aid them in remembering these star groupings, our ancestors often named these portions of sky after things they were interested in -- gods and goddesses, heroes and villains, hunters and their prey, and the like.

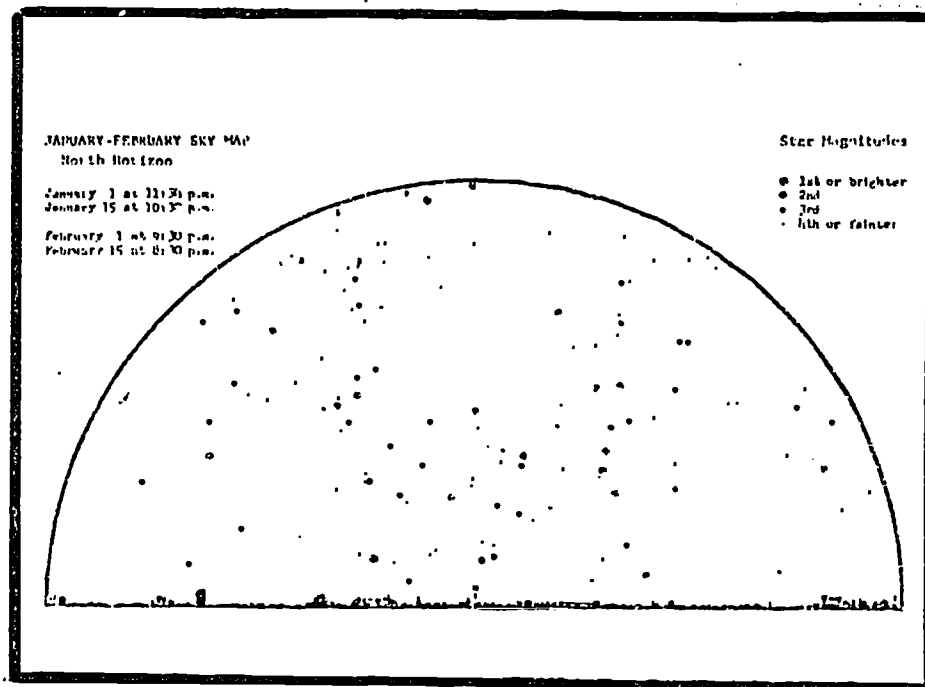

January-February Sky Map
North Horizon

Identifying Circumpolar Constellations (20 minutes)

Objective: Using the planetarium sky, red-filtered flashlights, pencils, and an unmarked sky map of the northern stars, participants will be able to:

- (1) find each circumpolar constellation in the planetarium sky, and
- (2) draw each constellation (connect the stars) on the unmarked sky map.

Hand out the constellation diagrams, pencils, flashlights and lap boards. Explain that the red-filtered flashlights will enable everyone to perform the activities without losing their night vision and that the constellation diagrams will help in identifying the constellation patterns. Further explain that you will introduce each constellation in the following manner: (1) by projecting a slide showing the stars of the constellation connected by lines to one side of the constellation as shown in the planetarium (this is the Kodalith slide of the constellation diagram), (2) by having the participants locate the same stars in the planetarium sky (3) by having each family locate the same stars on their unmarked sky maps, connect those stars in a dot-to-dot fashion to match the constellation diagram/constellation slide,

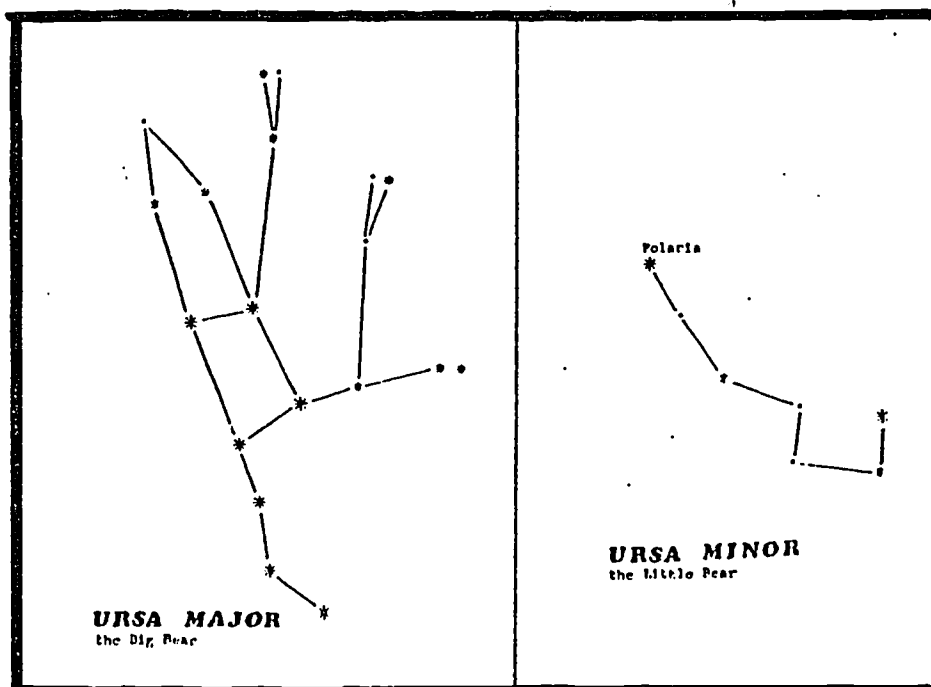

and place the name of the constellation beside the completed figure on their sky map and (4) by projecting an illustration of the mythological creature onto the sky (the latter slide may overlap the appropriate planetarium star field or the Kodalith constellation slide).



Bring the cove lights down slowly to reveal the evening sky. Begin with circumpolar constellations. It is best to begin with the Big Dipper, the star group that will be most familiar to the participants. Relate the notion that not everyone imagined a dipper in these stars. Some people saw a casserole dish. Others saw a plow, a wagon, and some even managed a coffin (complete with mourners). To the Greeks, however, it was a great bear. You might ask the group what they see. Of all these ideas, it was the Greek ones which astronomers selected for the official constellation patterns. The Greeks called their bear "Ursa Major", which means "greater bear". At this point, turn on the slide showing the Kodolith constellation diagram of Ursa Major. Have participants find the constellation diagram sheet for Ursa Major. They may use these aids to locate the stars of Ursa Major in the planetarium sky. Next, they are to find the same stars on their unmarked sky maps and connect the stars exactly as shown by the slide and constellation diagram. Once this has been completed, have the participants label the star group "Ursa Major". Finally, project the slide showing the figure of the great bear.

At this point, relate one of the mythological stories of Ursa Major. Remind the group that many of the constellation figures were derived from tales told long ago -- tales of heroes and villains, gods and goddesses, hunters and their prey -- all achieving immortality with places among the stars. In trial classes we used the Greek tale about Zeus flinging Callisto and Arcos into the sky after transforming them into bears. Their tails became stretched in the process, and so we see the big bear and the little bear in the sky. This story logically leads to locating the lesser bear, Ursa Minor.

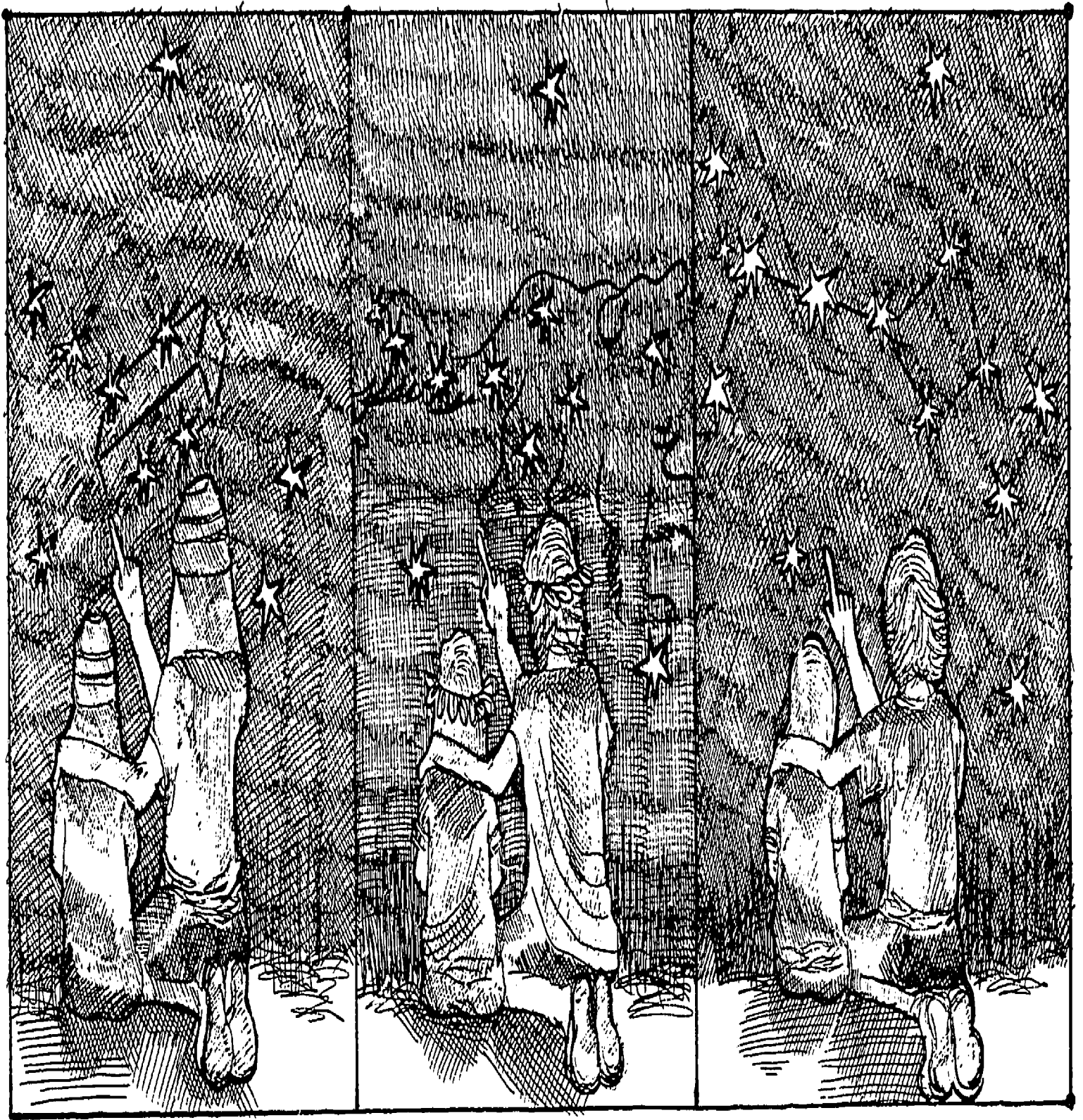

Not everyone imagined a dipper in these stars. Some people saw a coffin complete with mourners, while the Greeks saw a big bear.

Indicate that we locate the little bear by means of the Big Dipper's Pointer stars. Draw a line through the Pointer stars to the North Star, Polaris. This is an old technique for locating the North Star which the group will probably already know. Most groups will tell you the name of this star when asked. Emphasize the fact that the North Star is always seen in the north and that this fact enables us to find the directions at night. Also indicate that the North Star represents the tip of the little bear's tail. Project the Kodolith slide of Ursa Minor, and have them find the constellation in the planetarium sky. Once they have found it, ask someone to take a pointer and locate the stars in question. Participants should next connect the stars on their unmarked sky maps and label the constellation Ursa Minor. Finally, project the picture showing the mythological figure of the little bear.

Proceed in this same manner for the constellations Cassiopeia.

It is important that participants be able to find the stars of these three constellations and that they develop a sense of the spatial relationship of each one to the others.

Identifying Southern Constellations (40 minutes)

Objective: Using the planetarium sky, red-filtered flashlights, pencils, and an unmarked southern sky map, participants will be able to

- (1) find each southern constellation in the planetarium sky, and
- (2) draw each constellation (connecting the stars) on their sky map.

Having completed the circumpolar group of constellations, focus the group's attention on the southern sky and begin locating some of the seasonal constellations. Proceed as before, presenting the Kodolith slide showing the constellation

diagram, having the participants locate the stars in the planetarium, and then on the unmarked sky maps, and finally showing the mythological figure. To reinforce the spatial relationships of the constellations, begin each seasonal sky with a bright central constellation. In the spring sky, this would probably be Leo. The summer sky would logically focus on the summer triangle (Aquila, Lyra, and Cygnus) and Scorpio. Pegasus works best in the fall sky, and the winter triangle (Orion, Canis Major, and Canis Minor) work well during that season.

Home Activities (15 minutes)

- Objectives:
- (1) Participants will be able to identify (in the real sky) the constellations that were pointed out in the planetarium.
 - (2) After reading "Spanning the Night Sky", participants will be able to use their own hands to measure angular distances between the stars.
 - (3) After reading "Photographing the Night Sky", participants will be able to
 - a. take photographs of the night sky
 - b. observe the different colors of the stars, and
 - c. observe star trails.

Once the planetarium session has been completed, bring up the cover lights and distribute the notebooks containing the homework activities, marked sky maps and Observer's Notes sheets. The activities, it should be explained, focus upon (1) observing and identifying the constellations learned in the planetarium session, and (2) measuring angular distances using parts of the hands, and (3) photographing the sky using a 35 mm camera.

Explain that the Observer's Notes Sheets are to be completed during each home observation period. Participants are to record the date, time, and place of observation, and check off each constellation definitely identified. A small space is also provided to record any additional observations. The Observer's Notes sheets will be used to help select participants for the next session's "constellation finding contest". The most successful family or families will be awarded a prize. Emphasizing the contest increases participant motivation to locate the constellations in the real sky.

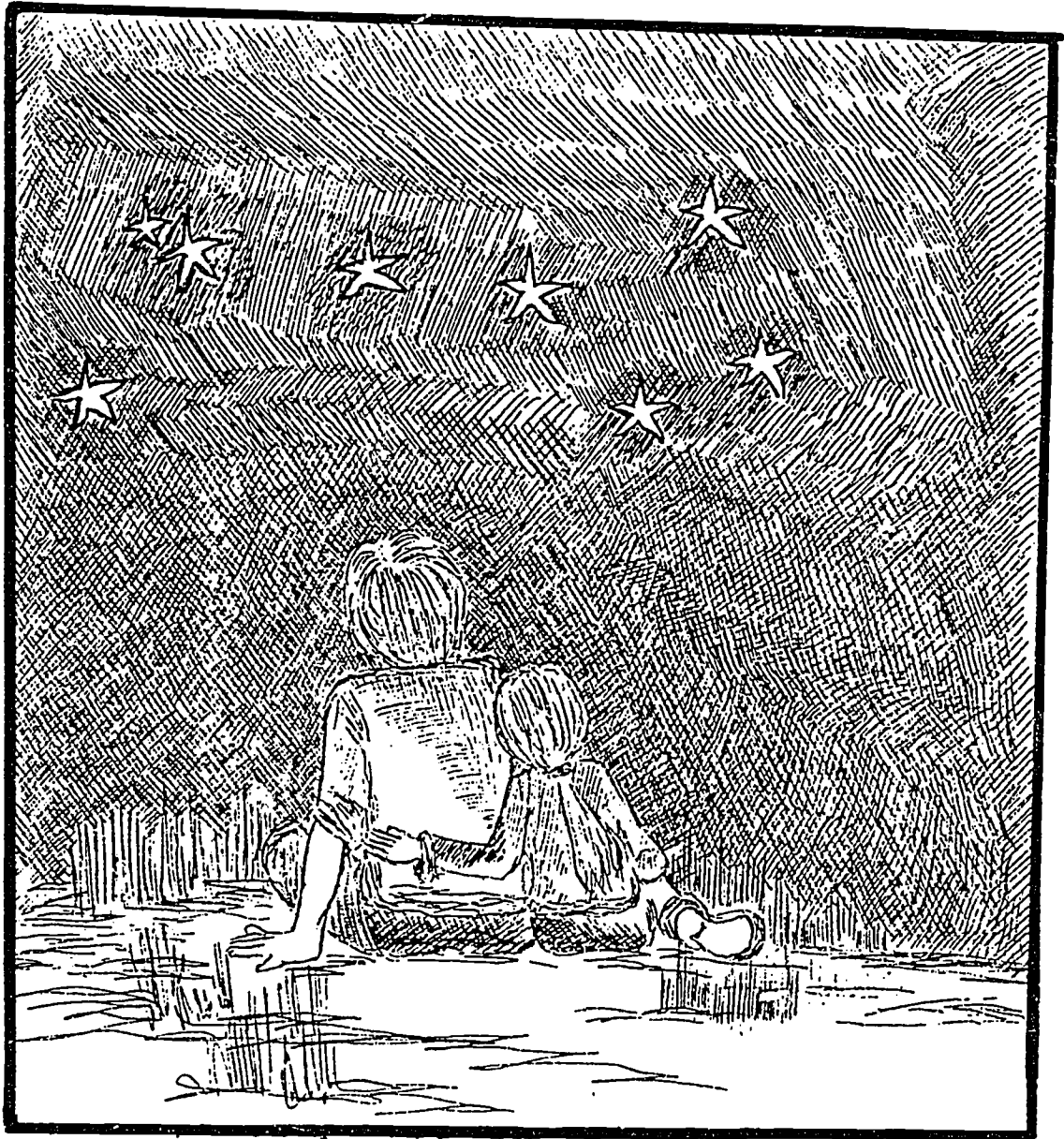

The activity concerning measuring angular distances is self-explanatory and should not require much in the way of additional comment. The astrophotography activity will be more successful, however, if given a simple demonstration before the group leaves. Explain that each family may take home a roll of 35 mm slide film, but must have access to a 35 mm camera to

complete the activity. Showing the participants how to take astrophotographs with a camera, tripod, and cable release will help generate enthusiasm to try the activity. In addition, you can demonstrate do-it-yourself alternatives to a tripod and cable release, such as a beanbag and plastic-bay-of-clay mounting technique, and the "rubber band and pebble" method of locking the shutter button down.

Optional Activity (15 minutes)

To help the participants find the constellations in the real sky, an optional observing session can be held for about fifteen minutes after the conclusion of the class session (weather permitting). This will help the participants to make the transition from the planetarium sky to the real one. Proceed through the constellations in the same order as in the planetarium session. Tell participants that they may use their sky maps to help. Remind the participants to use their sky maps during their own sky observing at home.

If there is a little haze in the air, an ordinary flashlight will make an easily seen pointer that can be used outdoors. As each constellation is named, the participants locate its stars and one person can pinpoint it for the other by means of the flashlight. On clear evenings, simply ask participants to point to the constellation with an outstretched arm once they have found it.



14
Home Activity I
Observer's Notes

Session 1

Date: _____ Time Observation began: _____

Location: _____ Observation lasted _____ minutes

Seeing conditions: The sky was (check one)

- | | |
|---|--------------------------------------|
| <input type="checkbox"/> Absolutely clear | <input type="checkbox"/> Raining |
| <input type="checkbox"/> Partly cloudy | <input type="checkbox"/> Snowing |
| <input type="checkbox"/> Foggy | <input type="checkbox"/> Other _____ |
| <input type="checkbox"/> Cloudy | _____ |

Check each constellation positively identified:

- | | | | |
|--------------------------------------|---------------------------------|--|-------------------------------------|
| <input type="checkbox"/> Orion | <input type="checkbox"/> Taurus | <input type="checkbox"/> Big Dipper | <input type="checkbox"/> Ursa Major |
| <input type="checkbox"/> Canis Major | <input type="checkbox"/> Auriga | <input type="checkbox"/> Little Dipper | <input type="checkbox"/> Ursa Minor |
| <input type="checkbox"/> Canis Minor | <input type="checkbox"/> Gemini | <input type="checkbox"/> Cassiopeia | <input type="checkbox"/> Draco |
| <input type="checkbox"/> Lepus | <input type="checkbox"/> Leo | <input type="checkbox"/> Cepheus | |

List others: _____

Date: _____ Time Observation began: _____

Location: _____ Observation lasted _____ minutes

Seeing conditions: The sky was (check one)

- | | |
|---|--------------------------------------|
| <input type="checkbox"/> Absolutely clear | <input type="checkbox"/> Raining |
| <input type="checkbox"/> Partly cloudy | <input type="checkbox"/> Snowing |
| <input type="checkbox"/> Foggy | <input type="checkbox"/> Other _____ |
| <input type="checkbox"/> Cloudy | _____ |

Check each constellation positively identified:

- | | | | |
|--------------------------------------|---------------------------------|--|-------------------------------------|
| <input type="checkbox"/> Orion | <input type="checkbox"/> Taurus | <input type="checkbox"/> Big Dipper | <input type="checkbox"/> Ursa Major |
| <input type="checkbox"/> Canis Major | <input type="checkbox"/> Auriga | <input type="checkbox"/> Little Dipper | <input type="checkbox"/> Ursa Minor |
| <input type="checkbox"/> Canis Minor | <input type="checkbox"/> Gemini | <input type="checkbox"/> Cassiopeia | <input type="checkbox"/> Draco |
| <input type="checkbox"/> Lepus | <input type="checkbox"/> Leo | <input type="checkbox"/> Cepheus | |

List others: _____



Home Activity II

SPANNING THE NIGHT SKIES:
Measuring Celestial Angles with Body Parts

I. Introduction:

Long ago people learned to use the sky to navigate and tell time. Early sailors and travelers could easily estimate their latitude or determine the number of hours until sunset. All it took was one simple tool. This tool never rusted and could not get misplaced. But best of all, everyone had a pair of them--and so do each one of us. They're called hands! With them we can also estimate the altitude of the sun, a star or any other celestial object. We can also use them to determine the angular separation between any pair of objects.

II. Measuring Angles with Your Hands:

A finger held at arm's length is about four times the apparent width of the moon or sun. Since both of these objects cover about half a degree of sky, one finger corresponds to an angle of about 2° . How large an angle will a fist (with the thumb held outside) cover? We'll call this angle a fist. A spread hand--from the tip of the thumb to the tip of the little finger, again at arm's length, covers about twice the angle of a "fist", or about 20° . Let's call this angle a span. With the help of fingers, fists and spans, it is relatively easy to estimate angular distances in the sky.

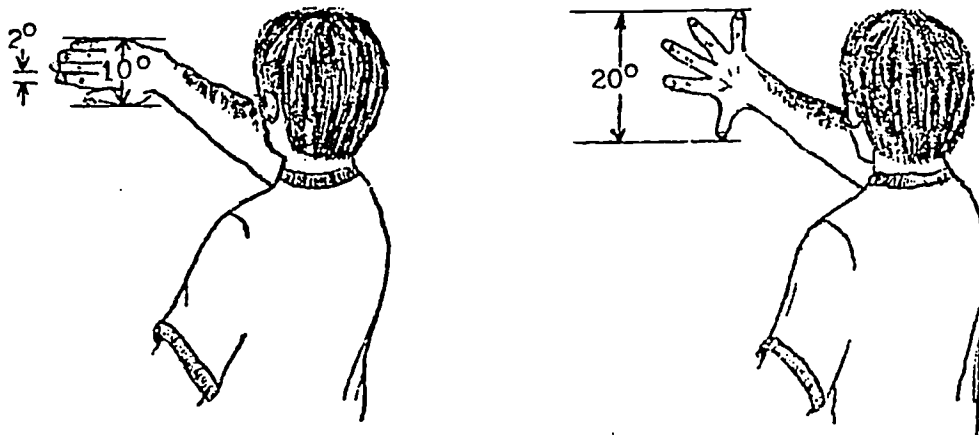

Perhaps you're wondering whether a child's hand, a woman's hand and a man's hand measure the same distance in the sky. They do for most people, since a child's hand is proportionately smaller than an adult's, and so too is the child's arm length compared to an adult's. Thus, the child's arm is just enough shorter to make the smaller hands cover about the same angle in the sky as an adult's.

Even so, not all hands are exactly the same size. With the help of the Big Dipper, you can check your "fingers",

Spanning the Night Skies (continued)

"fists" and "spans" to be sure that they measure 2° , 10° and 20° respectively. The two stars farthest from the handle--the rear top and bottom of the bowl--are about $5\frac{1}{2}^\circ$ apart. How many fingers would be needed to cover this distance? The width of the top of the bowl is about 10° --one fist. From the star at the front bottom of the bowl to the star at the end of the handle is a distance of nearly 20° --a span.

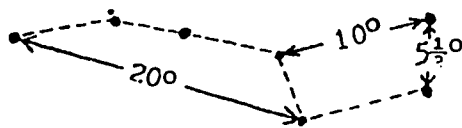

With these facts at hand, you are ready to make a few measurements. Determine each of the following angles. Be sure to fully extend your arm each time you take a measurement:

- 1) Determine the altitude of the North Star, Polaris. (By the way, finding this angle will provide you with a fairly accurate estimate of your latitude.)
- 2) Measure the angular distance between the top rear star in the bowl of the Big Dipper and Polaris.
- 3) Determine the altitude of at least one other bright star.
- 4) Locate as many of the following star groups as you can and determine the angles involved:
 - a) The Winter Triangle (the stars Betelgeuse, Procyon and Sirius). Measure the distance along each of the three sides.
 - b) The distance between the star at the end of the Big Dipper's handle and Regulus, Leo's brightest star.
 - c) The Summer Triangle (the stars Altair, Vega and Deneb). Determine the angular length of each of the three sides.
 - c) The distance between the star Fomalhaut and the southwestern-most star in the Great Square of Pegasus.

III. Telling Time with Your Hands:

Every 24 hours, the Earth completes one 360° turn or one rotation. How many degrees does the Earth turn in one hour?

Spanning the Night Skies (continued)

How many fingers would it take to cover this distance? How many fists? How many spans? Knowing these facts, you can usually estimate the time remaining until sunset or moonset to within a few minutes error. Try this activity some day late in the afternoon or some evening when the moon is a little ways above the western horizon.

IV. Conclusion:

With a minimum of equipment, determining latitude, time, and celestial angles is a fairly easy task. This trick can also be used to estimate the length of a meteor's tail or the length of a comet's tail. And it can be used in one more way--the next time you spot a "UFO", please don't report that it was "as big as a house" or "about 200 feet across." Use your hands to estimate the angular size of the object and the length of its path across the sky. Such a report is much more useful to a UFO investigator.



Home Activity III

PHOTOGRAPHING THE NIGHT SKY

I. Introduction:

Taking pictures of the night sky is a relatively simple and inexpensive activity that anyone can enjoy. All you need is a camera equipped to take time exposures, a stable platform on which to mount the camera, and fast film.

II. Equipment:

For most night sky photography, practically any camera will work provided that its shutter is adjustable to permit time exposures. Cameras so equipped will have an adjustable shutter speed dial that features either a "B" (bulb) or "T" (time) setting before taking any pictures. With these shutter settings you begin exposing the film as soon as the shutter is depressed and stop the exposure by releasing the shutter button.

It is also important to know that some cameras are equipped with adjustable lenses. These adjustments are of two kinds, and are not difficult to make. First, because stars are very distant objects, you'll need to set the focus for infinity (∞). This insures that your star images will be sharp and clear. Secondly, many camera lenses have adjustable lens openings or "apertures". Because of the low light levels involved in night sky photography, you should generally use the widest aperture possible. This insures getting enough light through the lens to properly expose the film.

In order to take night sky photographs, your camera must be mounted on a steady support. A lightweight tripod provides a very steady platform for your camera. There are, however, other alternatives to purchasing a tripod if you don't already own one. You might begin by securing your camera to the end of a long, narrow board with rubber bands. By propping up one end of this board with concrete blocks, for example, you can easily aim your camera in whatever direction you desire--and you'll have a fairly stable camera platform. This is just one possibility, of course. Many other household items can be combined to give you a steady camera platform. So, use your imagination and experiment a little. The goal, of course, is always the same, to provide a stable platform with which you can take time exposures.

PHOTOGRAPHING THE NIGHT SKY (continued)

Because night sky photography involves subjects that are very much fainter than any daytime subject, it makes good sense to use films that respond quickly to light. These so-called "fast films" have speeds of between ASA 100 and ASA 500. Slide films are preferred over color or black and white print films because they give more impressive results and are less costly per unit than prints. This is especially important for the beginning night sky photographer who will take many exposures in order to find out what lens settings and exposure times work best. It is also important to take a couple bright light photos at the beginning of each roll of slide film--since it is very hard for commercial processing labs to distinguish the dark margin between night sky exposures. Providing a couple bright subjects at the beginning of a roll of film will insure getting the processed slides properly cut and mounted by your photo processor.

III. What to Shoot:

Once you have set your lens aperture, focus and shutter speed, the actual procedure for photographing the night sky is quite simple. You might try photographing the portion of sky around the North Star, Polaris. Objects along the eastern, western or southern horizon also make interesting subjects. Including some of the foreground objects (trees, buildings, etc.) in such horizon shots can make for very pleasing pictures. You should also try varying the exposure times with a given subject. Try exposures of, say, 10 seconds, 30 seconds, 50 seconds, 2 minutes, 5 minutes and 10 minutes with each subject you choose. If possible, you might also try varying the aperture settings with a given subject as well (keeping the exposure time fixed). Be sure to record all the data for each photo--that is, 1) subject, 2) length of exposure, 3) aperture setting, and 4) sky conditions. In this way, you will soon learn how to take very satisfying photographs of the night sky.

IV. Additional Information

See one of the following --

A. Articles in Astronomy Magazine

- (1) "It's Simple to Photograph Constellations", November 1973, pages 35-46.
- (2) "Catch a Falling Star", August 1974, pages 31-37.
- (3) "Sky Photography Without a Telescope", November 1974, pages 35-41.
- (4) "Astrophotography - With Camera Only!", June 1978, pages 42-47.
- (5) "Film the Eclipse", November 1978, pages 44-46.

B. Pamphlets

- (1) "Astrophotography", Kodak Customer Service Publication AC-40. Free.
- (2) "More Here's How", Kodak Customer Service Publication AE-83. \$1.50.
(These publications are available at most photo dealers or can be obtained by writing: Eastman Kodak Company, Dept. 454, Rochester, N.Y., 14650).

C. Books

- (1) Outer Space Photography for the Amateur by Dr. Henry E. Paul. American Photographic Book Publishing Co., Inc., Garden City, N.J. Copyright 1976.
- (2) Skys shooting by Mayall and Mayall. Ronald Press.



SESSION 2

THE CELESTIAL SPHERE

OVERVIEW

In this session the participants develop a better understanding of the celestial sphere. To do this, the participants observe examples of astro-photography slides. These astro-slides lead to the discussion to the cause of star trails. The class participates in a lesson where they predict and observe how star trails would look when a camera is pointed in different directions. The participants also predict and observe what the star trails would look like from other locations on the earth (north pole and equator). The participants are then introduced to the concept of altitude and azimuth in the planetarium. Their knowledge of altitude and azimuth is further developed when they construct an astrolabe learn how to use it, and then practice using this device at home.

MATERIALS

For each family:

- 1 red-filtered flashlight
- 1 lap board
- 1 screw driver

Astrolabe Kit (for each family):

- 1 8" x 8" x 1/2" piece of particle board
- 1 9" length of 1" x 4" pine board
- 1 4-1/2" x 6-1/2" piece of masonite
- 1 6" plexiglass disk (1/8" thick)
- 1 1-1/2" #8 wood screw
- 1 5/8" #8 wood screw
- 1 1/2" #8 wood screw
- 1 small washer

- 1 weight or nut
- 1 5" length of string
- 1 copy of 360° azimuth scale
- 1 copy of 180° altitude scale

For the class:

- 1 Kodalith outline of a square for each direction
- 1 slide projector (for each direction)
- 2 or more "classroom stars"
- 1 prize for constellation identification contest
- 1 system for projecting altitude and azimuth scales in planetarium
- 1 can of spray glue
- 1 set of handouts and home activity sheets

ADVANCE PREPARATION

1. Kodalith Square Outline

This is simply a kodalith slide of a square that can be projected at the horizon in each direction. To make the kodalith slide, simply draw a square (outline) with black ink on white paper. Photograph the square with kodalith film.

You may want to make a number of different sized square slides and choose one that projects a square about 20° on the dome. If your planetarium does not have an azimuth change capability, you will need to project a square on each of the four directions. Therefore, you will need four slides and four projectors.

2. Astrophotography Slides

You cannot depend upon the participants to show up for this session with slides they took during the previous week. As a matter of fact, don't depend on anyone to bring in slides. It is recommended that you try some

astrophotography yourself. When you set your camera up, try to get examples of constellations the class can recognize without star trails. Then take three or four exposures of the same area of the sky, to get star trails of different lengths. It is also recommended that you take long exposures of an area near the horizon of each of the four cardinal directions. Be sure to include Polaris in the North-facing slide. When you arrange the slides in the projection tray, start with the slides without star trails. Next include the slides with different length star trails. Finally, include the slides of the four directions. Arrange these four slides with the East first, then South, then West and lastly North.

3. Altitude and Azimuth Projection

The capability to project altitude and azimuth lines on the dome varies with the planetarium. If your planetarium does not have instrument-mounted altitude and azimuth scales, you may have to improvise. One simple way to produce an azimuth scale without the use of projectors is to attach an azimuth scale to your cove line. Make scale markers out of white paper or light cardboard about $1\frac{1}{2}$ " by 6". You may want to make them easier to see in the dark by treating them with fluorescent paint or reflective tape. If you want to be fancy, try illuminating them with a black light. To help you fix the markers accurately around the cove, tip the planetarium instrument up so that the coordinate scale on the celestial equator is projected along the horizon (remember that one hour is equal to 15°). Most planetariums are equipped with a hand held meridian projector. This can be conveniently used for the altitude projector. If you do not have

one of these projectors, your class will have to be satisfied with estimating altitude values.

4. Classroom stars

You will need to make a couple of stars to hang in your classroom. These stars will be used by your class to practice using their astrolabes. There are two ways this can be done; one is quite simple, the other requires a small amount of preparation:

- a) Tape a few dots one inch in diameter around the room. One dot can be designated as Polaris. The other dots should be identified with alphabet letters.
- b) If you want to have more realistic "stars", tape a small flashlight bulb to a "d" cell battery. Arrange the wiring so that you can turn it on by twisting two wires together. You should have at least two of these assemblies. If you are ambitious, make more of them.

When the students practice with these, be sure to designate one of the lights as Polaris before you turn the lights off. The participants will be able to get a more realistic impression of how to work the astrolabe in the dark. You will also have to provide each group with a red-filtered flashlight.

5. Astrolabe Construction

There are many different astrolabe designs. You may choose any design with which you are comfortable. The model we developed is sturdy, relatively frustration-free, and economical to build. If you choose to use our model you will have to pre-cut and pre-drill all of the pieces before the class time; the participants will only have time to assemble and learn how to use it.

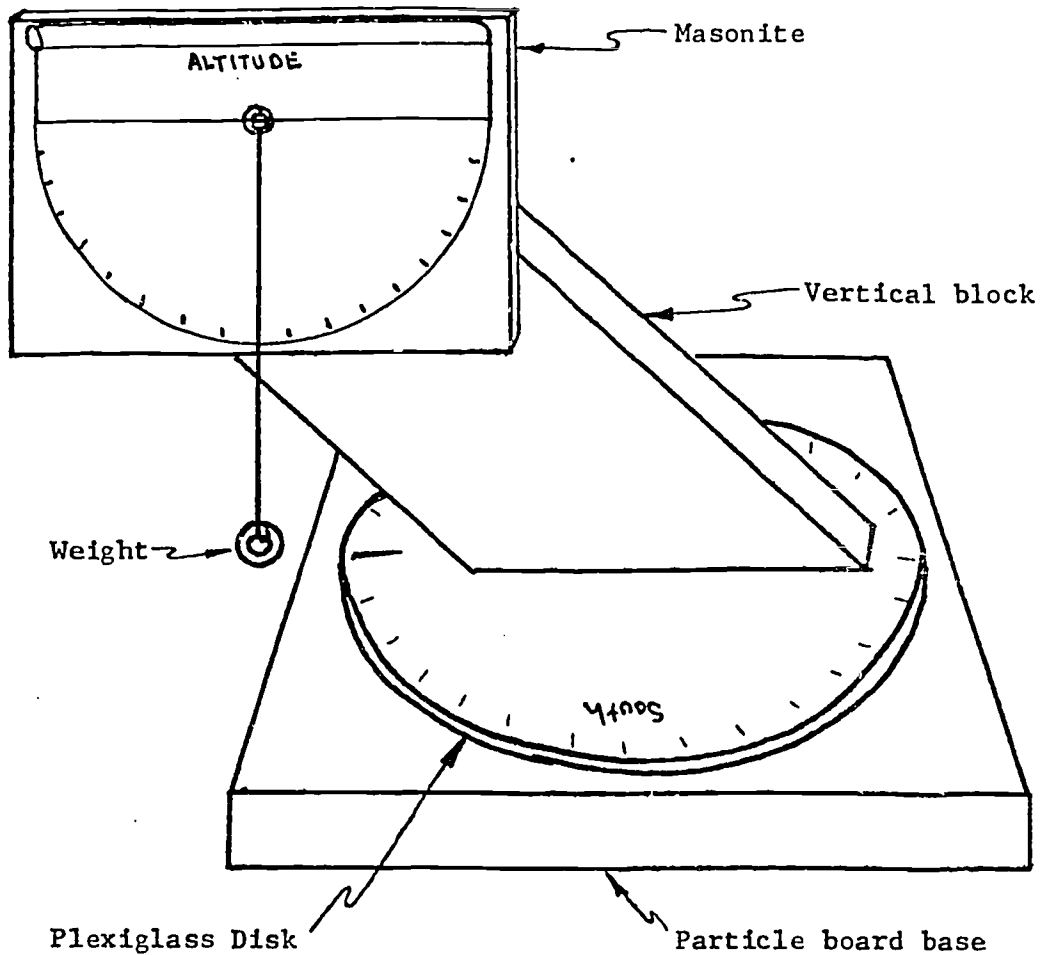

The plexiglass disk is designed to add stability and make the azimuth rotate smoothly. You should be able to have these made for you by any window and glass shop; you will, however, have to drill the holes. The two outside holes that fasten the vertical block should be countersunk so that the screw heads will not scratch the azimuth scale. Scratch a $\frac{1}{2}$ " line perpendicular to a tangent of the perimeter. This line made on the bottom of the disk can be stained with black ink to make it visible. The line is used to indicate the azimuth reading. For that reason, the indicator line should be aligned with the center line of the vertical block, as shown in the diagram on the next page.

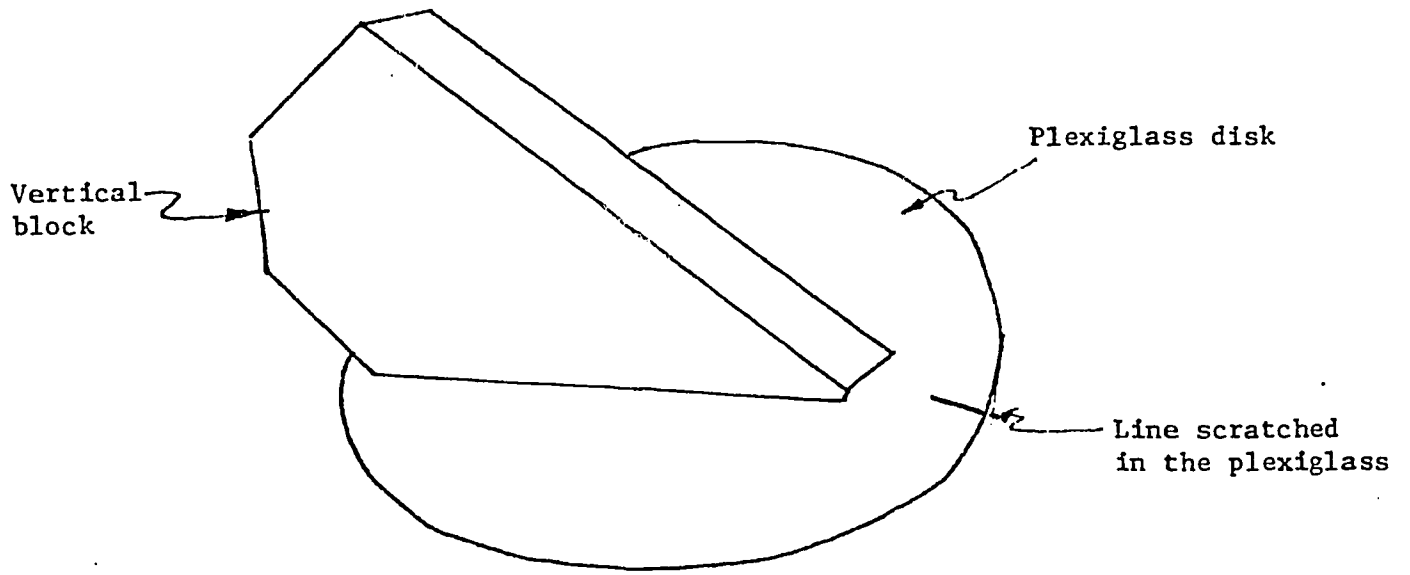

The vertical block can be cut out of a 1" x 4" pine board. The actual dimension of this material is, of course, $3/4"$ x $3\frac{1}{2}"$.

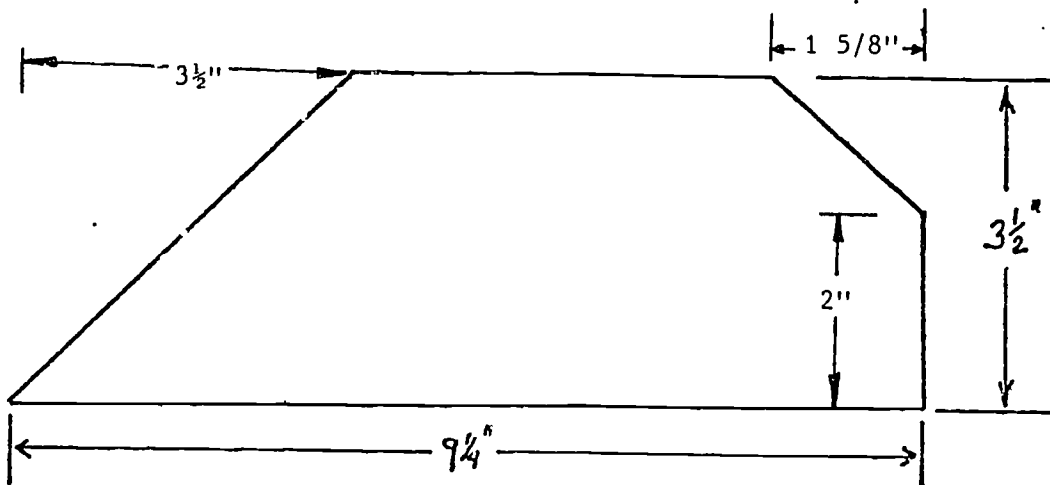

The altitude and azimuth scales are glued to the appropriate pieces by the participants. We suggest that you use an adhesive that comes in a spray can. The top of the altitude scale is rolled around a pencil and glued into place to form a sighting tube. The smaller washer should fit snugly around the 5/8" screw shank. This allows a small space around the screw head to hang the weighted string.

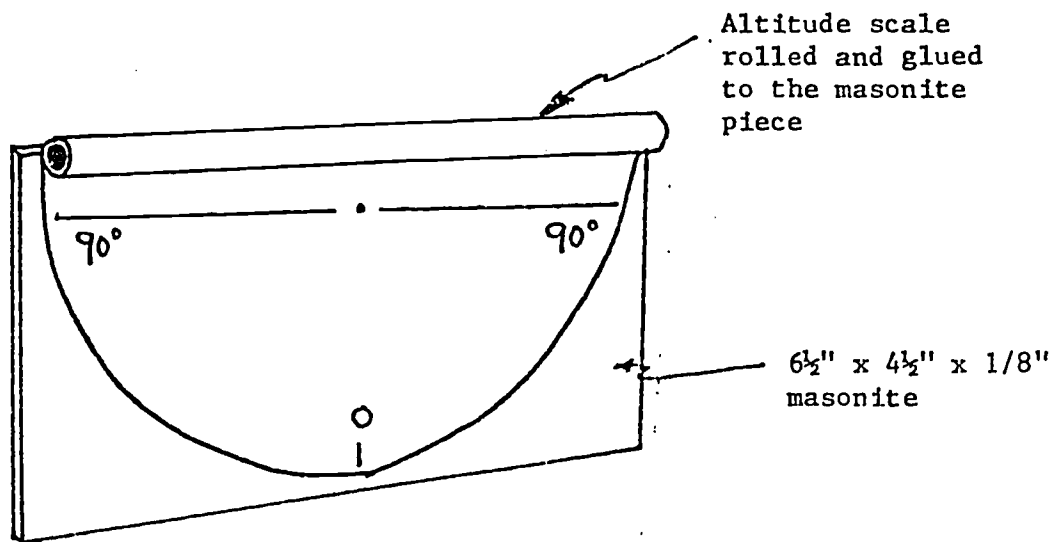

Use the exploded-view diagram of the astrolabe as a guide to assemble the instrument. This will enable you to anticipate problems participants might encounter. Duplicate a copy of the altitude and azimuth scales for each family.

6. Preparing the home activity, "Finding Positions with the Astrolabe"

For the home activity, participants are given a list of current season bright stars. They are asked to predict and then measure the altitude and azimuth angles of these stars. In addition, participants are given the altitude and azimuth angles of several other bright stars seen in the evening at about 8:00 PM. Participants are asked to identify these stars. Use the astrolabe that you built to (1) identify six or seven current season stars that participants can easily measure, and (2) measure the altitude and azimuth angles of five or six additional bright stars at 8:00 PM. Prepare a home activity sheet similar to the one on page 45 and 46.

Planetarium Setting

Before the participants arrive, set the planetarium instrument for the current date and one hour after sunset. You will need this setting to conduct the contest at the start of this session.

Contest Prizes

The selection of a prize or prizes for the constellation contest is up to you. Some suggestions are:

1. Commercially constructed starfinders,
2. Inexpensive book such as an Astronomy Field Guide, or
3. Simple sundial.

TEACHING SUGGESTIONS

Getting Started (10-15 minutes)

It is a good idea to chat individually with the participants as they arrive to become better acquainted. This will give you an opportunity to look

through their notebooks to see how successful they were at locating constellations. You may want to start this session by determining which family was the most successful at locating constellations. You can do this with a contest of your own design or you can follow these suggestions:

Determine how many constellations each family could confidently locate in the night sky and pick the best three or four families. Give each of these families a turn at pointing out selected constellations in the planetarium sky. You can keep score for each family. The family that correctly finds the most is the winner.

Introducing Star Trails (10 minutes)

Objective: The participants will recognize that the star trails on the long time exposure photographs of the night sky are caused by the rotation of the earth.

If time permits, you may want to introduce a few more constellations. Then move right into the astrophotography slides. As you view each slide, have the participants tell which constellation they are looking at, the names of bright stars, and the direction the camera was pointed. Point out the definite color differences of the stars, and other things of interest. Be sure to give the exposure settings and any other technical data. If the participants have tried to do any astrophotography, they will have many questions.

When you get to the slide with the star trails, either you or a participant may ask, "Did the camera move?." Some discussion of camera stability and cable release may result. The bottom line, of course, is the base upon which the tripod was standing did move. The earth rotated. Ask the participants, "What determines the length of the star trails?." This question can be explored by looking at slides taken of the same area of the sky but for different lengths of time.

Predicting and Observing Star Trails (10 minutes)

Objective: Given a planetarium sky, red-filtered flashlights, pencils, and a prediction sheet, participants will be able to predict and observe star trails in the four directions, north, south, east, and west.

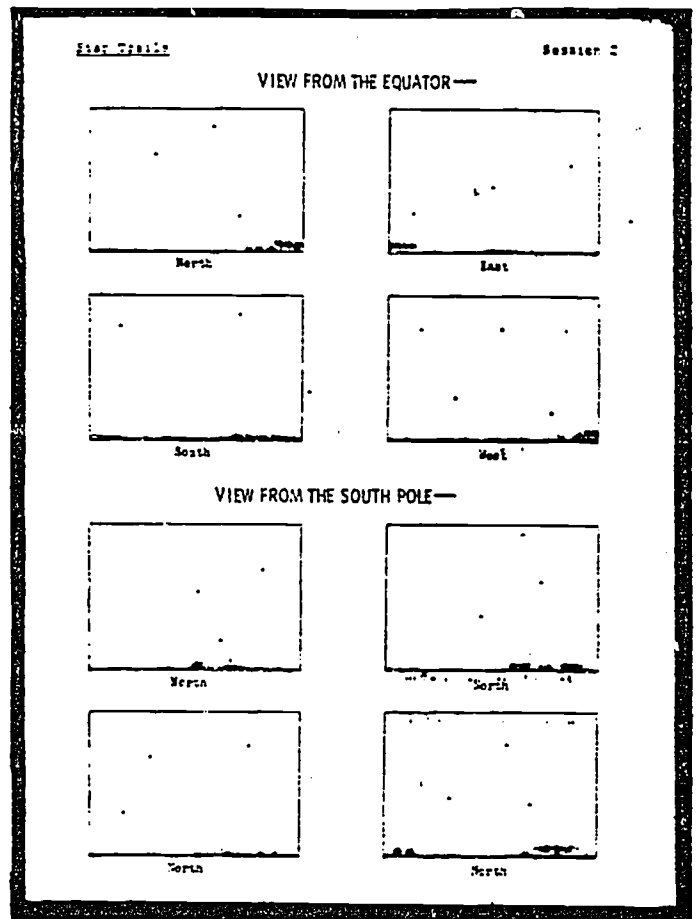
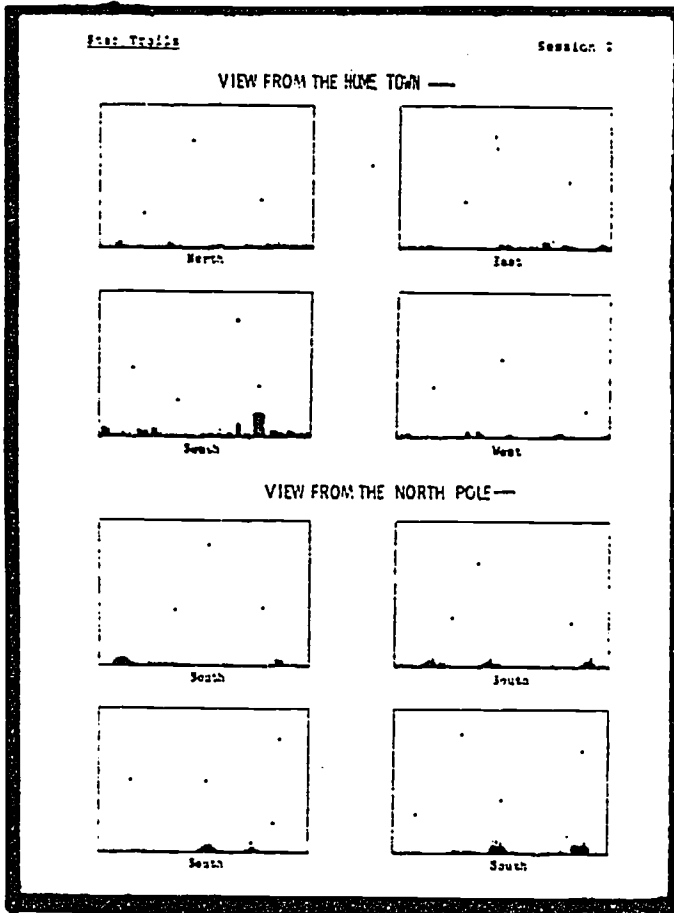

Ask the participants, "Would the direction the camera points affect the pattern of the star trails?". As the discussion is taking place, raise the lights a small amount.

Hand out pencils, lap boards, red-filtered flashlights and the star trail prediction sheets. Explain that each square on the sheets represents a picture taken through a camera in each one of the directions indicated. If the camera shutter were left open for at least 10 minutes, star trails would appear on the pictures. The participants predict how the star trails would appear. To make a prediction, the participants should draw a line from one of the dots given. This line will represent the path of the star.

Explain that you will work with one direction at a time, giving the participants time to make their predictions. Then you will run the planetarium's daily motion control to demonstrate the actual path of the stars.

Have students begin with the east view. To get them started, suggest that they consider the sun's path in this direction. After each family has drawn their star trails lower the lights and run daily motion at a moderate speed. Focus their attention to a small area of the sky by means of the projected kodalith square (see Advance Preparation). While the daily motion is running, have the participants draw lines from the remaining dots indicating their observations of the motion of the stars.

The actual path of the star trails can be demonstrated with a slide taken toward the eastern horizon. Ask the families to check their predicted star motions against those shown in the photograph. Have them correct their star trails if necessary. Repeat this procedure for the other three directions, ending with north. Participants will discover that the path of the stars appears to vary with the direction one is looking. You may want to point out that observing the motion of the stars is another way to determine direction without using the North Star.

Predicting and Observing Star Trails at the North Pole, Equator and South Pole (25 minutes)

Objective: Given a planetarium sky, red-filtered flashlights, pencils, and prediction sheets, participants will be able to predict and observe star trails at the North Pole, Equator, and South Pole.

Ask the participants whether one's location on the surface of the earth would affect the star trails. After the discussion, tell the participants that they will get an opportunity to see star trails from three other locations on earth -- the North Pole, the Equator, and the South Pole. Before you actually change latitude with the planetarium, ask the students to orally predict how the sky would appear at the North Pole. Following this discussion, ask the participants to get out the sheet for the North Pole. While you make the latitude change, instruct the group to observe the North Star. When you arrive at the North Pole, spend a few minutes looking for familiar constellations.

Before the participants make their predications of the star trails at this location, ask them to recall how the star trails appeared when looking North from their home latitude. They should remember that the stars appeared to describe circles centered around the North Star. Now, the North Star is directly overhead. Ask the group to fill in one of the "pictures" to show how they expect the star trails to appear. Turn on the kodolith square slide and run daily motion. Have the participants correct their pictures if necessary. Repeat this step until students realize that the star trails are the same no matter which South they pick.

At this point, the participants have become "seasoned travelers". Ask them to predict how the stars would appear from the equator. Pay particular attention to where the North Star would appear. Direct the group to watch the North Star and reset the planetarium for the equator. After you arrive, be sure that everyone has turned to the prediction sheet for this latitude. Repeat the same basic steps you used with the class at their home location.



Finally, ask the participants to predict how the sky would appear at the South Pole. Proceed in the same way as you did at the North Pole and Equator. You may want to take some time to identify some southern hemisphere constellations that cannot be seen from the United States.

Introducing Altitude and Azimuth (10 minutes)

Objective: (1) The participants will be able to define the terms "altitude" and "azimuth".
 (2) The participants will be able to estimate the altitudes and azimuths of at least three stars in the planetarium sky and explain how these values would change in an hour's time.

After viewing the effects of the earth's rotation, the students should have developed a feeling for the celestial sphere. This activity introduces the concept of altitude and azimuth as a means of pinpointing objects on the celestial sphere. Point to a bright star in the sky (it need not be one the participants can easily identify) and give the class a brief scenario, similar to the following:

"Suppose you noticed something peculiar about this object and you wanted to find out more about it. You have an astronomer friend who lives in a town a few miles away. Your friend has a telescope and you would like her/him to look at this object with her/his instrument. How can you tell your friend, over the phone, where to point her/his telescope in order to see the object?"

Allow the students time to formulate methods to accomplish this task. Hopefully someone will recall the homework hand out "Spanning the Skys". If the participants do not pick up on this you will have to use this as a starting point. The idea of altitude could be "so many" fists or spans above the horizon. Project an altitude scale on the dome and determine the unknown object's exact altitude (see Advance Preparation).

The idea of azimuth can be built up from the cardinal points of direction. For example, an object can be a little north or east or one third of the way from west to south. From ideas of this type, move to more precise methods. Introduce azimuth as the same scale that is on the compass face. Project an azimuth scale on the horizon and explain that north is 0° , east is 90° , south is 180° , etc. Determine the azimuth of the unknown object.

Determine the altitude and azimuth of a few other stars. Then give the students a chance to predict the altitude and azimuth of at least two more objects. Ask the participants to predict what the altitude and azimuth of these objects would be in an hour's time. Run daily motion for about an hour to check their predictions.

The discussion of altitude and azimuth should lead to a question asked either by a student or teacher: "How can you accurately determine the position of an object outside where no scales can be projected?". The answer is, of course, the astrolabe.

Building an Astrolabe (40 minutes)

Objective: Given appropriate materials, participants will be able to assemble an astrolabe and measure the altitude and azimuth of at least two classroom "stars".

Move the families to the classroom and start with a previously constructed astrolabe. Point out each scale and demonstrate very briefly how it is used. Hand out all of the materials each family will need to construct their astrolabes. The instruction sheet should be detailed enough so very few verbal directions need to be presented. This encourages families to work together to accomplish this construction project. Set the spray glue and some newspapers

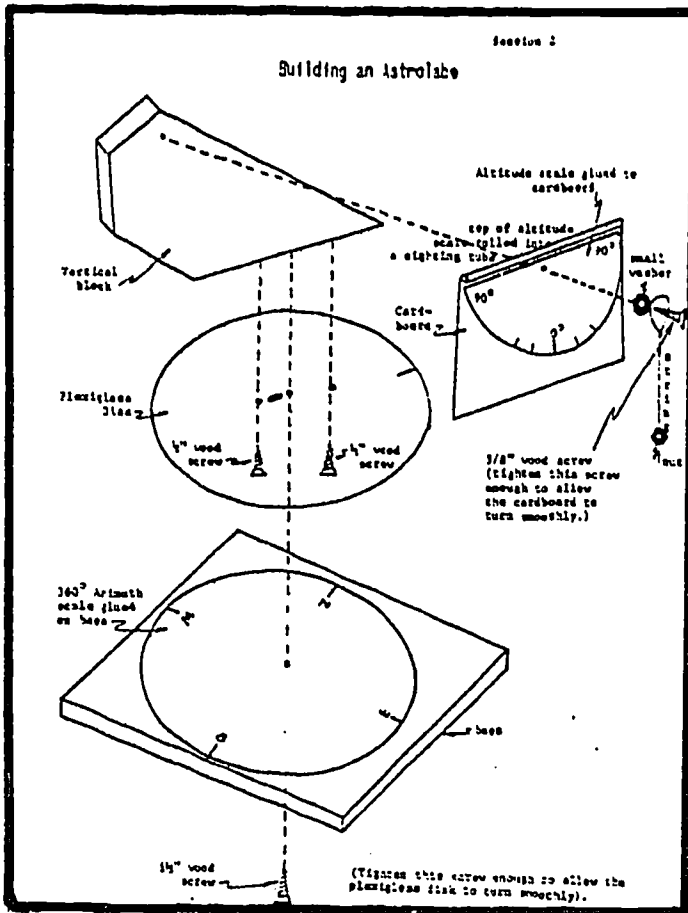

Section 2
How to Use Your Astrolabe

The astrolabe is the oldest scientific instrument known to man. It was invented long before the telescope, the microscope, or television. No one knows for sure what the first astrolabe was used, but it is at least a few hundred years older than the robot screw.

The model you are using was designed specifically for your class. It contains features never thought of by some of the astronomy geeks, such as Galileo, Copernicus, and Herdahl. Some astrolabes are frustrating and difficult to work with. They jiggle and move before you have a chance to read them. Your astrolabe was developed to eliminate some of that frustration and reduce the number of cuss words.

In order to be a good astrolabe operator you should first find a good location for which to practice operating your astrolabe. You must be able to see Polaris and most of the other stars.

Secondly, you need a place to put your astrolabe. A small table, the fender of the top of your car, are adequate places to rest your astrolabe. The absolutely, positively best thing on which to place your astrolabe is a backless, swivelless car stool! (The reason a bar stool of this type to rest will become obvious to you after you use your astrolabe for a while.)

After you are standing in a good location and have selected a suitable stand on which to rest your astrolabe, you must align the 0° mark on the azimuth scale with Polaris the North Star. To do this, align the black mark on the flexiglass disk with the 0° mark on the azimuth scale. Then move the base of the astrolabe and the altitude scale until you can sight on Polaris through the straw. (Remember now to find Polaris using the pointer stars of the Big Dipper. Once 0° azimuth is aligned to the north do not move the base. It might help to tape the base to your stand.)

To find the azimuth of any object just turn the vertical block and flexiglass disk. The altitude of the object, when sighted through the straw, can be read behind the weighted string.

If you are given an altitude and azimuth of an object and you want to sight the object, you must make sure the base is aligned with Polaris and secured. Then move the flexiglass disk so that the given azimuth reading is under the mark. Now adjust the altitude scale so that the given altitude reading is directly behind the weighted string. When you look through the straw, you should be looking at some fascinating astronomical object, such as a bright star or perhaps some unknown black hole.

How to Use Your Astrolabe (continued)

Once you master the intricate art of operating an astrolabe, you will enjoy many hours of fun and relaxation sighting objects and recording their positions with altitude and azimuth. If you don't believe that, then you might accept the idea that this astrolabe is a useful device for gaining a "feeling" for positions of objects on the Celestial Sphere.

out in a corner of the room, preferably near an open window. The participants can take turns using the spray glue to attach their altitude and azimuth scales to the wood.

As the students work on their astrolabe, hand out the sheet "How to Use Your Astrolabe". This will get them started using the astrolabe. When everyone has finished their assembly, demonstrate how to use the astrolabe. Give the families a chance to find the

altitude and azimuth of a couple of classroom stars (see Advance Preparation). You and the class will discover that it is nearly impossible to find a star in the sighting tube when it is dark. This problem can be eliminated by shining a flashlight (preferably red-filtered) on the far end of the sighting tube. Aim the flashlight so that it is pointing away from the person looking into the tube. If this is done properly, the sighting tube will appear as a glowing, out of focus, circle to the viewer. It is then an easy task to center a star in the sighting tube.

The families will not be able to share results; because they are too close to the stars, everyone will get different results. Walk around and check each family to make sure everyone is able to use the astrolabe properly.

Home Activity (5 minutes)

Objectives:(1) The participants will be able to use their astrolabe to measure the altitude and azimuth of at least three bright stars in the real sky.
 (2) Given a list of altitudes and azimuth angles for several stars participants will be able to locate and identify these stars.

About five minutes before the end of class, hand out the home activity sheet and explain briefly. Encourage the participants to try their astrolabes with the "real" sky. The astrolabe must be placed on a level surface. Discuss briefly some surfaces they might use at home (e.g., step ladder, plant stand, small table, etc.). You may want to demonstrate how participants can be prepared for their outside observations with (1) the astrolabe taped to a step ladder or other level surfaces, (2) record sheets taped to clipboard, (3) star maps taped to clipboard, and (4) red-filtered flashlights ready.

VIEW FROM THE HOME TOWN —



North

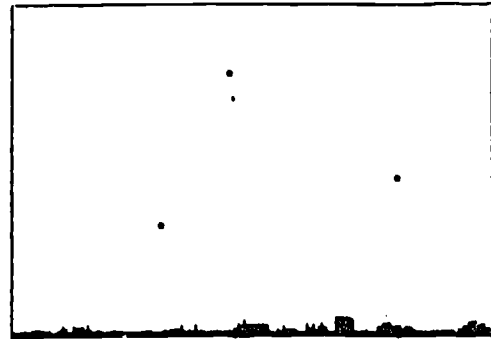

East

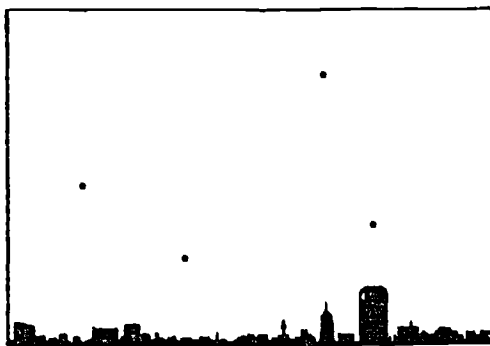

South

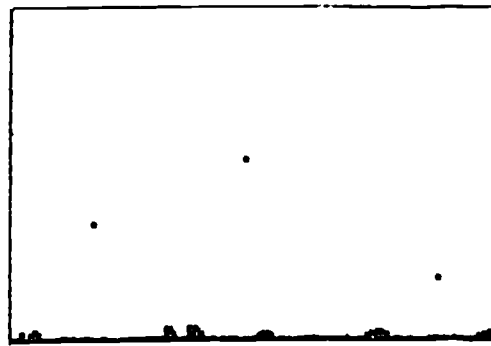

West

VIEW FROM THE NORTH POLE —

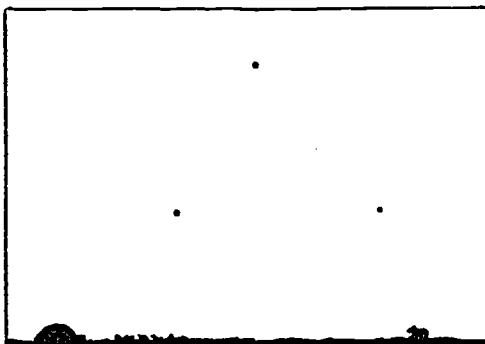

South

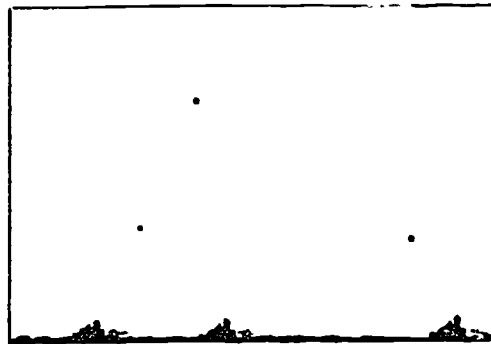

South

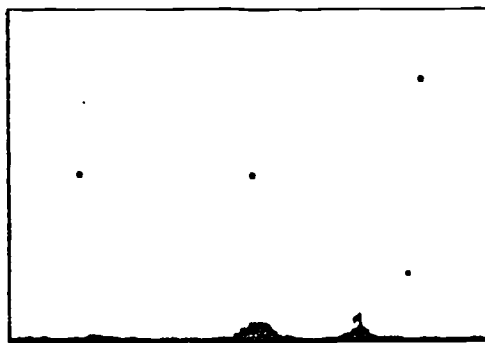

South

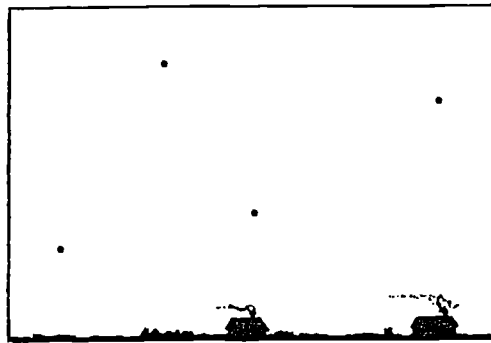

South

VIEW FROM THE EQUATOR—

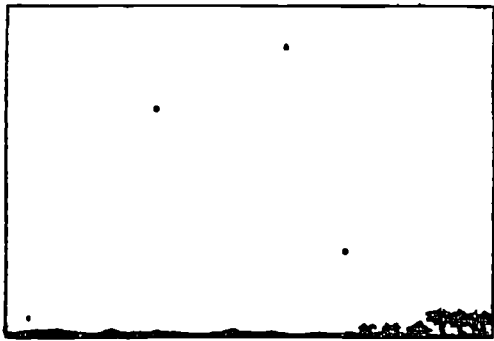

North

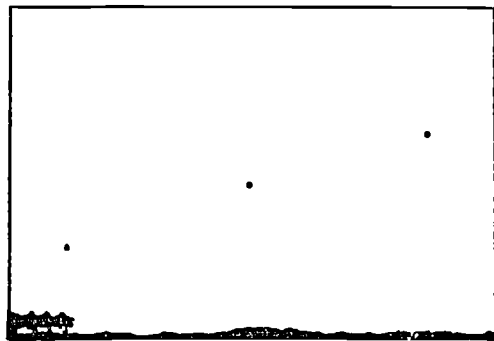

East

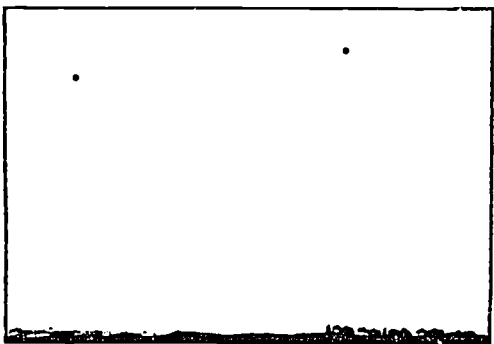

South

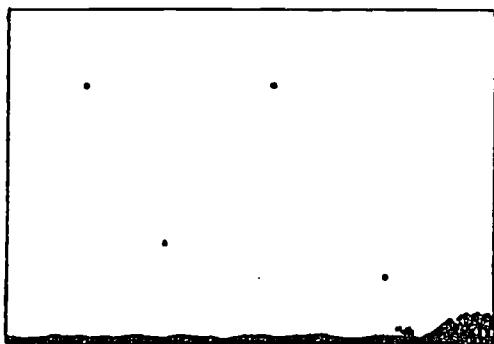

West

VIEW FROM THE SOUTH POLE—

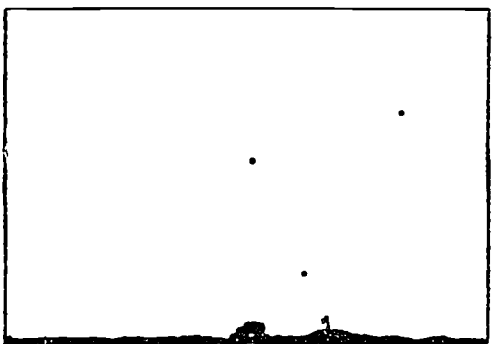

North

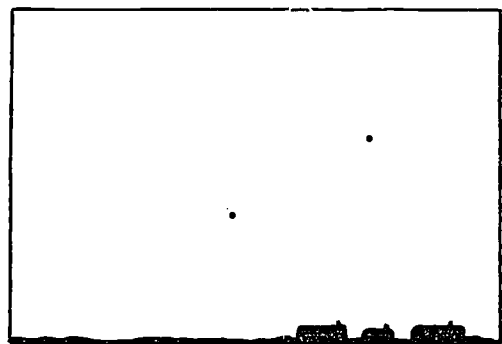

North

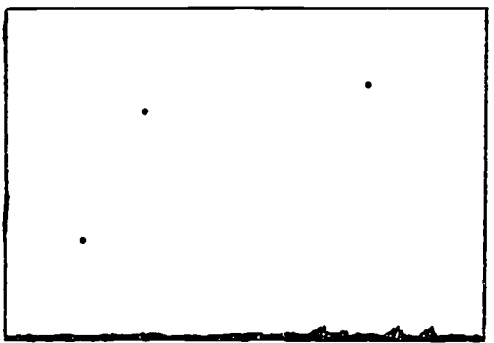

North

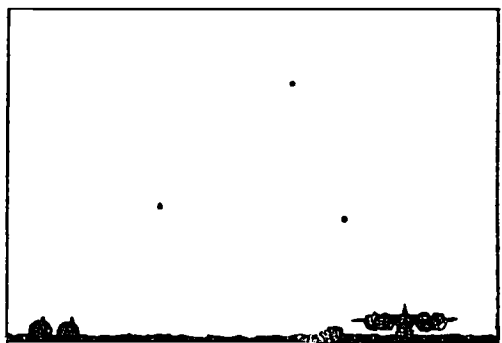

North

Building an Astrolabe

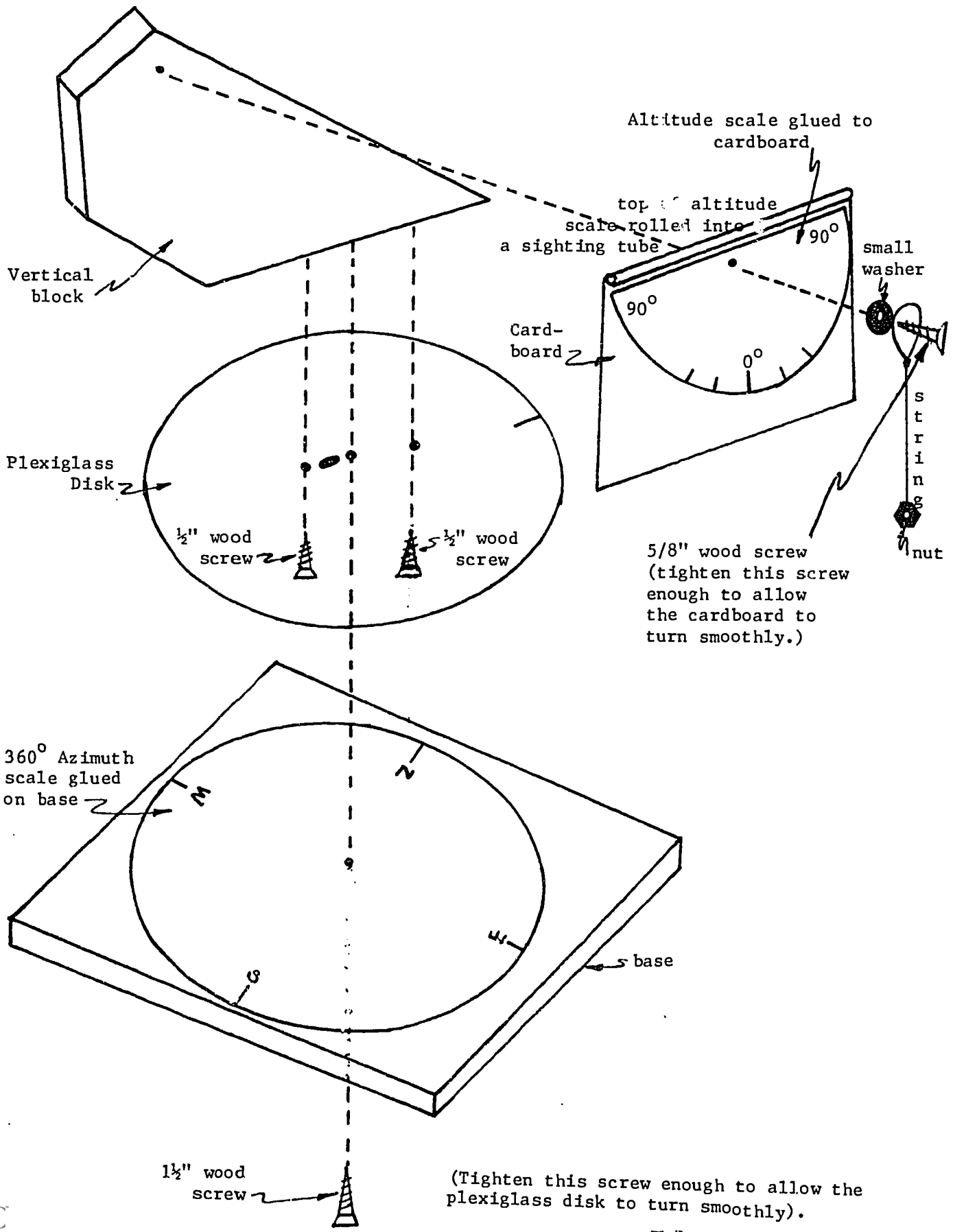

(Tighten this screw enough to allow the plexiglass disk to turn smoothly).

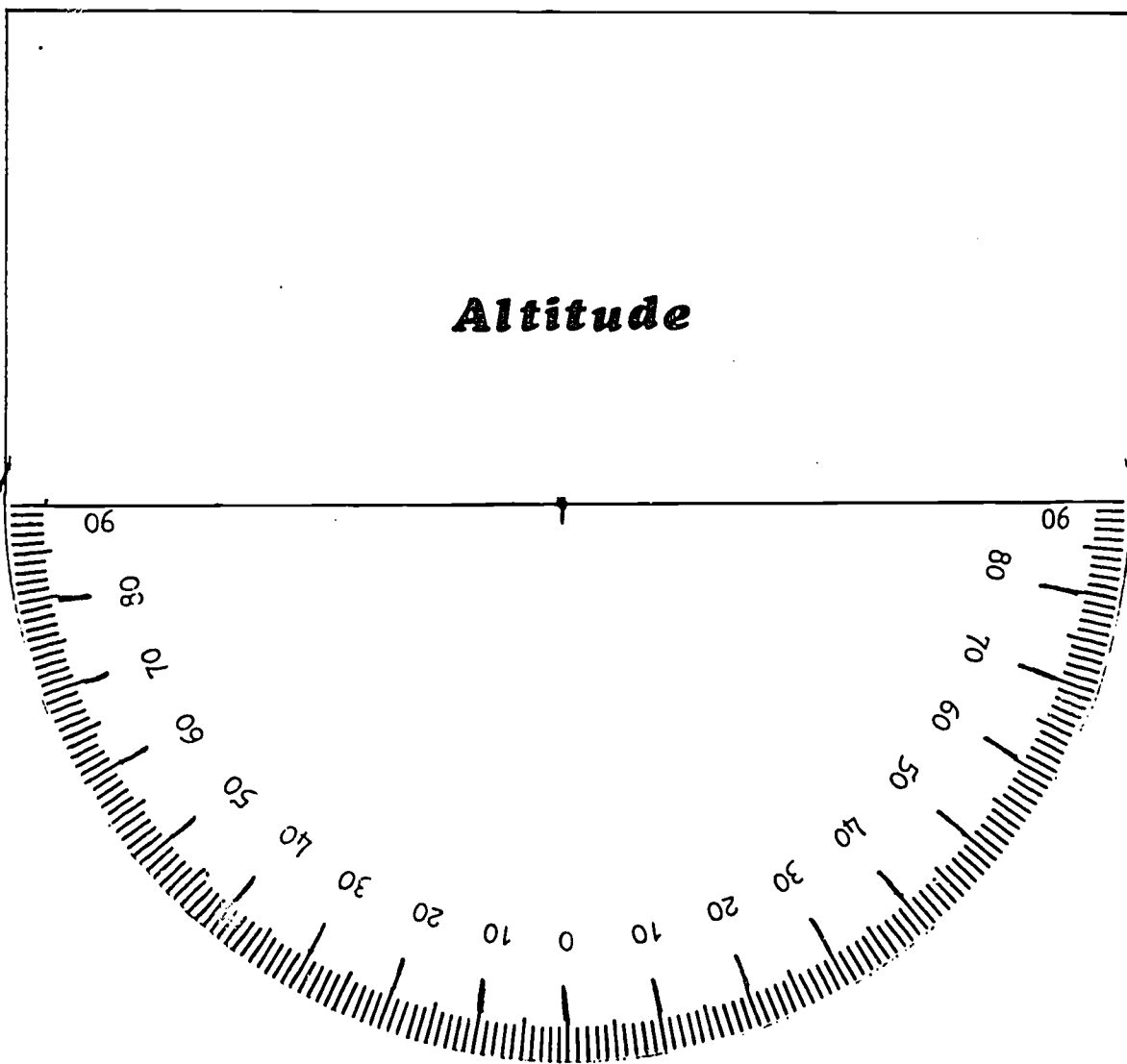

Altitude Scale

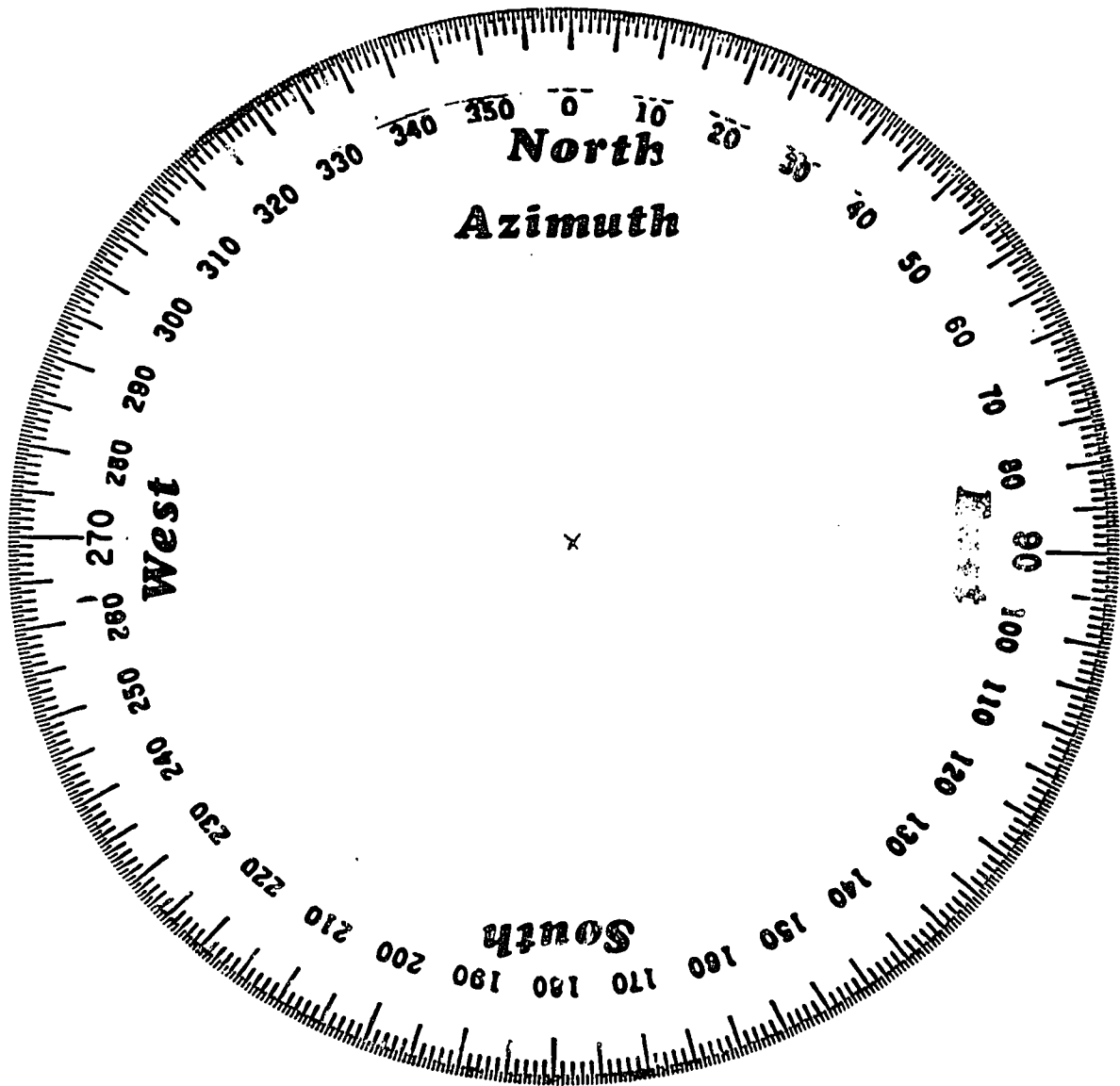

Azimuth Scale

How to Use Your Astrolabe

The astrolabe is the oldest scientific instrument known to man. It was invented long before the telescope, the microscope, or television. No one knows for sure when the first astrolabe was used, but it is at least a few hundred years older than the corkscrew.

The model you are using was designed specifically for your class. It contains features never thought of by some of the astronomy greats, such as Galileo, Copernicus, and Nerdahl. Some astrolabes are frustrating and difficult to work with. They jiggle and move before you have a chance to read them. Your astrolabe was developed to eliminate some of that frustration and reduce the number of cuss words.

In order to be a good astrolabe operator you should first find a good location from which to practice operating your astrolabe. You must be able to see Polaris and most of the other stars.

Secondly, you need a place to put your astrolabe. A small table, the fender of the top of your car, are adequate places to rest your astrolabe. The absolutely, positively best thing on which to place your astrolabe is a backless, swivelless bar stool! (The reason a bar stool of this type is best will become obvious to you after you use your astrolabe for a while.)

After you are standing in a good location and have selected a suitable stand on which to rest your astrolabe, you must align the 0° mark on the azimuth scale with Polaris the North Star. To do this, align the black mark on the plexiglass disk with the 0° mark on the azimuth scale. Then move the base of the astrolabe and the altitude scale until you can sight on Polaris through the straw. (Remember how to find Polaris using the pointer stars of the Big Dipper.) Once 0° azimuth is aligned to the north do not move the base. It might help to tape the base to your stand.

To find the azimuth of any object just turn the vertical block and plexiglass disk. The altitude of the object, when sighted through the straw, can be read behind the weighted string.

If you are given an altitude and azimuth of an object and you want to sight the object, you must make sure the base is aligned with Polaris and secured. Then move the plexiglass disk so that the given azimuth reading is under the mark. Now adjust the altitude scale so that the given altitude reading is directly behind the weighted string. When you look through the straw, you should be looking at some fascinating astronomical object, such as a bright star or perhaps some unknown black hole.

Once you master the intricate art of operating an astrolabe, you will enjoy many hours of fun and relaxation sighting objects and recording their positions with altitude and azimuth. If you don't believe that, then you might accept the idea that this astrolabe is a useful device for gaining a "feeling" for positions of objects on the Celestial Sphere.

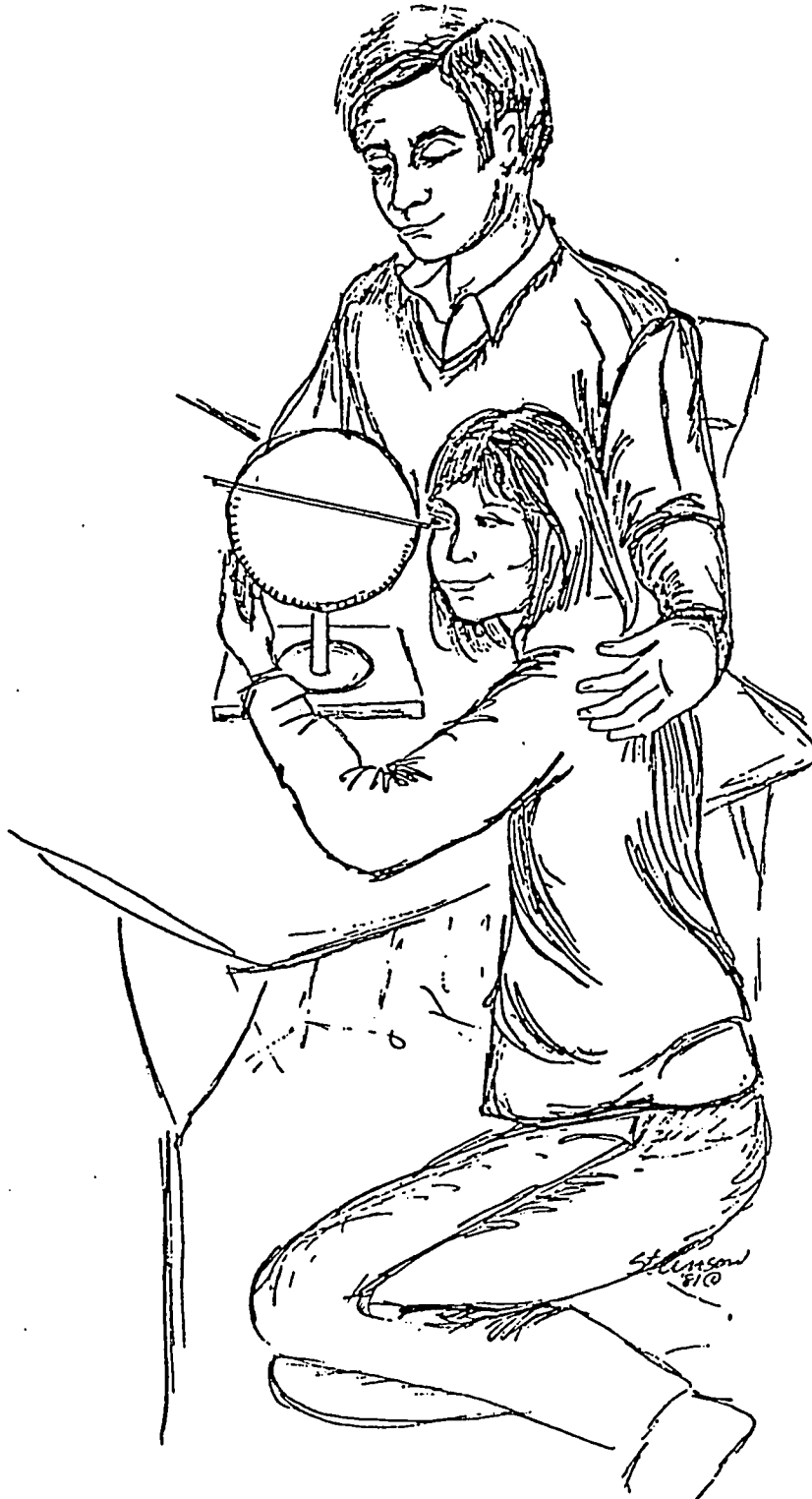



Home Activity IV

Finding Positions With the Astrolabe

1. Take your star maps, astrolabes, and this sheet out on a clear evening (about 8:00 p.m.). Find the bright stars listed below, then do the following:

- a) Without using your astrolabe, try to predict the altitude and azimuth of each star.
- b) After you predict the positions of all the stars, use your astrolabes to find the altitude and azimuth of each star.

 * Be sure you do not move the base after you align the *
 * astrolabe to Polaris. *

Predicted

Measured

STAR	Predicted		Measured	
	Alt.	Az.	Alt.	Az.
Sirius				
Rigel				
The bottom star of Cassiopeia				
Procyon				
The top star in the Big Dipper (Merak)				
Regulus				
Castor				

Finding Positions With the Astrobabe (continued)

2. The following altitude and azimuth settings are the positions of bright stars. Can you identify them?

 * Be sure you do not move the base after you align the *
 * astrolabe to Polaris. *

<u>Altitude</u>	<u>Azimuth</u>	<u>Name of Star</u>
60	255	_____
74	195	_____
34	52	_____
34	103	_____
11	74	_____
37	327	_____

SESSION 3

THE SOLAR SYSTEM

OVERVIEW

During this lesson, the participants pretend that they are ancient astronomers watching the heavens over a period of several nights. They discover that not all of the "stars" remain fixed with respect to one another. These "wanderers" are the planets. By recording the planet's changing positions on a star chart, participants also discover that the motion is confined to a part of the sky which we call the zodiac. A few zodiac constellations are introduced. Finally, the group will act out a model of the solar system in order to better understand the motion of the planets through the zodiac.

MATERIALS

For each family:

1 red-filtered flashlight

1 lap board (optional)

For the class:

1 set of slides of mythological figures for each zodiacal constellation (optional)

12 8" x 10" cards with the name of each zodiacal constellation

10 8" x 10" cards with the words "Sun", "Earth", "East", "West", "Mars", "Jupiter", "Saturn", "Venus", and two of the current season constellations.

1 set of handouts (2 unmarked southern sky maps and set of zodiacal constellation diagrams)

pencil for each family member

ADVANCE PREPARATION

1. Preparing the Planetarium

In the planetarium activity, participants plot the path of the superior planets through the sky. The basic concept to be taught is that the planets appear to move through a set of constellations called the zodiacal constellations. To demonstrate the motion of Mars (including a retrograde loop), set your planetarium for one of the dates indicated in Appendix C. In order to get Mars to traverse the sky, it is necessary to advance the planetarium through several months without turning on the sun or operating daily motion. You may want to practice one-month stops without using the sun and ecliptic, so that you don't have to stop the presentation to set the planet for the one month intervals. Although this situation is contrived, it reduces the number of variables participants have to keep track of during the activity, allowing them to focus their attention exclusively on the motion of the planets.

Install the slides of the appropriate zodiacal creatures so that they can be projected after participants have located each constellations' stars. (These pictures may overlay the actual stars, but it is not necessary that they do.)

2. Preparing the Handouts

For each family, duplicate a copy of the appropriate sky map listed for the date you have chosen (see Appendix C), as well as the appropriate zodiacal constellation diagrams are in Appendix B.

3. Model of the Solar System

Move all the chairs out of your classroom or place them against the walls. Obtain 22 8" x 10" index cards. Write the name of each zodiac constellation on twelve cards. The remaining ten cards are for the names "Earth", "Sun", "East", "West", "Mars", "Jupiter", "Saturn", "Venus", and two or three of the current season constellations.

TEACHING SUGGESTIONS

Getting Started (10 minutes)

Discuss the home activity with the participants. Ask them to identify the star for each altitude and azimuth pair on the home activity sheet.

Introducing Planets (10 minutes)

Objective: Participants will observe that certain objects called planets change position in the sky with respect to the fixed stars.

Before you bring the lights down, introduce this lesson with a short scenario such as, "I would like you to pretend you are astronomers of ancient times. Your job will be to observe the heavens on a number of evenings and see if you can note any changes in the stars." Bring the lights down slowly and the stars and planets up at the same time. Point out any constellations with which they might be familiar as a quick review. If a planet is in an area of the sky they know, don't point it out. Divide the class into four groups and assign each group a bright object to observe. Make sure one of the objects is the planet Mars, and one the planet Jupiter.



Ancient astronomer observing the sky.

After a quick tour of the sky, bring the house lights up and turn off the stars and planets. Advance the annual motion one month. As you do this, explain that they will next see the same sky as it would appear one month later. Also inform them that in order to keep this demonstration simple, they will be looking at the same area of the sky as before (don't advance the daily motion).

Bring down the lights and the stars/planets up. Briefly review the constellations again. Ask if any of the groups have noticed any changes. One group should notice a change in their "star's" position. The object, planet Mars, has moved. Bring the lights up and the stars/planets down. Advance the annual motion another month. Inform them that you are again advancing one month in time. Music can provide a nice interlude while you perform this task.

This time after the lights come down, all the participants should recognize that Mars has definitely changed positions; all of the other stars have remained in their fixed positions. Explain to the participants that the Greeks described these stars as "wanderers". The word the Greeks used, of course, is planet, which means "wanderer". At this time you should also point out Jupiter and Saturn.

Tracking the Planets Mars, Jupiter, and Saturn (20 minutes)

Objective: Given a planetarium sky, red-filtered flashlights, pencils, and a star map, participants will be able to

- (a) draw the path of Mars, Jupiter, and Saturn against the background of stars, and
- (b) conclude that the planets appear to move from west to east along nearly the same line, although at different speeds.

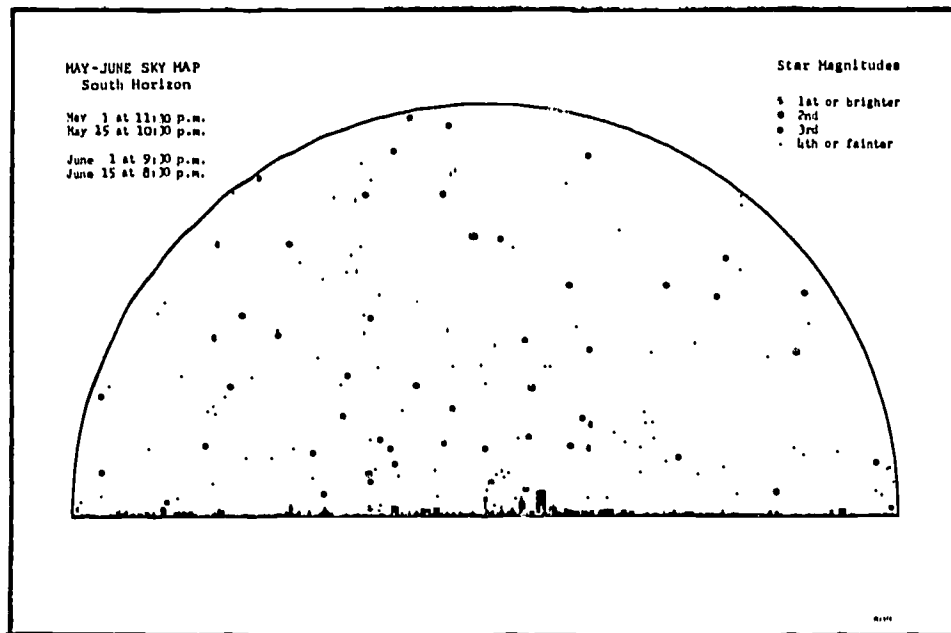

Tell the class you would like them to keep track of the planet's position over a period of a few months. Hand out the star maps, flashlights, and lap boards. Have the participants draw any constellations they know on the star maps. Then tell them to use the letter M with a circle around it to indicate the position of Mars ($\textcircled{\text{M}}$), a letter J with a circle around for the position of Jupiter ($\textcircled{\text{J}}$), and a letter S with a circle for the position of Saturn ($\textcircled{\text{S}}$). Make those letters very small. Advance annual motion another month. Bring the lights down and the stars and planets up. Tell the students to mark on their sky maps the new positions of the planets. After everyone has completed this task, ask the students to predict where they think the planets will be positioned the following month by lightly marking letters on their maps. Advance annual motion another month without bringing up the lights. Have everyone check their predictions and correct the positions of the planets, if necessary. Repeat this procedure several times. When Mars starts its retrograde loop, participants will be surprised. Ask them if they think Mars

will ever move east again. Continue predictions and plots until Mars had passed below the eastern horizon.

Bring the lights up slightly. Tell the participants to connect the positions of Mars to form a line with a loop. Through questioning and discussion, bring the class to the following conclusions:

1. The planets generally appear to move in the same direction from west to east.
2. The planets appear to move on nearly the same line.
3. The planets appear to move at different speeds. Mars is the fastest and Saturn is the slowest.
4. The small reverse motion (from east to west) is called "retrograde" motion.

Tell the participants that retrograde motion will be discussed later.

Introducing the Zodiacal Constellations (20-30 minutes)

Objective: Given a planetarium sky, red-filtered flashlight, pencils, an unmarked sky map, and a set of zodiacal constellation diagrams, participants will be able to find, in the planetarium sky, the constellations through which the planets move and draw each constellation on their sky maps.

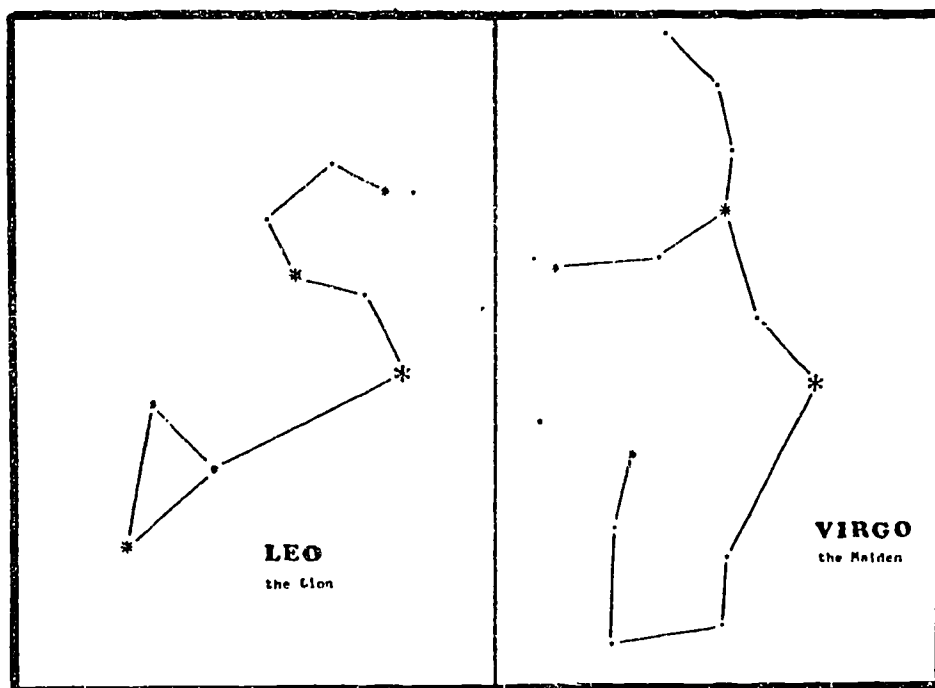

Tell the class that the ancient skywatchers kept track of the planets by noting which constellations the planets appeared to move through. Hand out the packet of zodiacal constellation diagrams. Bring down the lights and review the location of the line in the sky through which the planets appeared to move. Use your pointer for this. Start with the area of the sky where you first observed Mars. Show the participants (with your pointer) what this constellation's star pattern looks like. Ask if anyone can find a similar pattern in their constellation diagram packet. After the class identifies the constellation, have the participants trace the same pattern on their star charts (in a manner similar to that in Session 1). Project the picture of the creature over the star pattern and move on to the next constellation pattern. Work your way across the sky dealing with each constellation in the same way:

1. Trace the pattern with your pointer,
2. Have the participants identify the constellation using their constellation diagrams,
3. Have the participants trace the pattern on their star charts, and
4. Project the picture of the constellation figure in the appropriate place.

By the time you get to the fourth or fifth constellation, most of the participants recognize the constellations as those of the zodiac. Ask the participants what they know about the zodiacal constellations. Most participants respond that the zodiacal constellations are associated with astrological "sun signs". Explain to the participants that the constellations through which both the planets and the sun appear to move are given the name zodiacal constellations.

Ask the participants if they would like to see more zodiacal constellations. If the response is unfavorable, go on to the classroom portion of this session

If the response is favorable, bring the lights down and advance daily motion slowly. Tell the class what you are doing (by now they should relate the moving stars to the rotating earth). Point out the last zodiacal constellation you found and watch it move across the sky until it sets. The class is now looking at a completely different sky. Be sure to point out Mars.

Ask the class how they could determine where more of the zodiacal constellations would lie. One way would be to find the path of the planets. Accelerate annual motion so that Mars slowly moves across the sky. After Mars sweeps a line across the sky, point out each zodiacal constellation pattern and project each picture.

Building a Model of the Solar System (50-60 minutes)

Objective: The participants will be able to build a human model of the zodiacal constellations and the solar system to explain (a) why the planets appear to move in a line at different speeds through the zodiacal constellations, and (b) why the sun appears to move through the constellations of the zodiac (earth's revolution).

Before you start to construct the solar system model you must first tell the participants to imagine they are floating in space; the universe extends in all directions. There are stars below their feet, above their heads, and in all directions around them. The model the class constructs should utilize and be built on the observations made in the planetarium. A good starting point could be the band of zodiacal constellations that seem to circle the earth. Ask for volunteers to "play" the zodiacal constellations. People usually like to choose their "sign". After you have handed out the twelve Zodiac signs, help the Zodiac people arrange themselves in a circle using their birthdates as a guide. The circle should be at least 15' in diameter.

Have the participants decide whether the earth would be inside or outside the circle of constellations (the correct position for the earth is somewhere in the circle). Ask for someone to volunteer to "play" the earth. After he/she takes the "Earth" sign and moves to a place inside the Zodiac circle, ask the earth if he/she can demonstrate why the zodiacal constellations appear to rise in the east and set in the west to an earth bound observer. Give the earth person an "East" sign for his/her left and a "West" sign for his/her right hand. If the earth person rotates counterclockwise, the participants should see how the zodiacal constellations appear to move from east to west across the earth person's vision.

Now ask the class to decide where other constellations they are familiar with are located. Some will be below the zodiacal constellations, some will be above them. The signs with the names of these other constellations can be placed in their approximate locations, on the floor or held high by other participants.

If no one has thought of it by now, you can suggest that the class add a sun to their living model. Let the participants decide where they would like the sun person to stand. He/she should be in the middle of the zodiac



Building a Model of the Solar System

circle. This would be a good time to discuss the relative distances between the earth and the sun and the earth and the stars of the zodiacal constellations. Stress, of course, that the stars are not really part of the solar system.

With the sun now in the model, you can demonstrate, by having the earth rotate, how the sun rises and sets. You should also discuss which constellations would be visible to an observer perched on the end of the earth person's nose as the earth person rotates.

Add the planet Mars to the model now. Have the participants recall how Mars behaved as they observed it in the planetarium: to an observer on the earth, Mars generally appeared to move from west to east through the stars of the Zodiac. Therefore, you should instruct the Earth and Mars to walk so that they replicate what was observed in the planetarium sky. The earth travels around the sun in the same direction as Mars, but at a higher orbital velocity. Consequently, it periodically passes Mars, like a faster race car on the inside track. For most of the earth's orbit, Mars appears to move from west to east through the sky. However, just as the earth passes Mars, it appears to drift backwards, to the west in the sky, even though it is actually moving east (just as a slowly moving car appears to drift backwards with respect to the distant scenery when we pass it in a faster moving car). Tell the participants that they will be able to investigate this retrograde motion for themselves in a home activity. You can now add a Saturn and Jupiter somewhere beyond the orbit of Mars and discuss why they appeared to move so slowly in the planetarium.

After you have the sun, earth and at least three other planets, you should discuss how the solar system is approximately on a plane and how this demonstrates why all of planets appear near zodiacal constellations.

If the question has not come up by now, you can present it to the class: "Why is a person's astrologic sun sign determined by his birthdate?". The

answer to this question can easily be demonstrated if the participants understand the model as it is now constructed. Before you attempt any explanation, utilize the model to demonstrate any participant answers. If the participants do not come up with a suitable answer, you will have to explain. Start by picking another person to play the earth who has a birthday close to the date of the session. Ask this person where the earth would be positioned on their birthday. If s/he needs a hint, ask what constellations are visible during the evening around the time of their birthday (e.g., January: Orion, Taurus, Gemini). Then locate their "Sun Sign." It should be obvious that their astrological sun sign is not with the currently visible constellations, but lies somewhere behind the sun.

Explain to the participants that about 2000 years ago, when the astrological sun signs were first established, the sun appeared to be directly in front of your zodiacal constellation at the time of your birth. Since that time, however, the earth has shifted with respect to the stars due to a motion called "precession". So it is no longer true that the sun is directly in front of your zodiacal constellation at the time of your birth.

At this point, you may want to pick a person to represent a zodiacal constellation. Ask this person to reveal her/his birthdate (not age), and have the earth and sun position themselves for this date. What zodiacal constellations are visible on this date?... Repeat this procedure two or three times. Then have the earth person demonstrate revolution and discuss why constellations are seasonal.

If you have time, you may want to add an inner planet to the model and discuss why the planet appears only as an "evening star" or a "morning star" and why it would never be seen straight south at midnight.

Optional Activity: Tracking Mercury and Venus (10 minutes)

Objective: The participants will be able to observe that Mercury and Venus always appear near the sun as morning or evening "stars".

If time allows, you may want to take the class back into the planetarium and demonstrate the Sun's apparent motion through the zodiac, and have the participants observe that Mercury and Venus always appear near the Sun.

Home Activity (5 minutes)

Objective:

The participants will be able to observe and record the position and shape of the moon at sunset.

During the last few minutes of class, pass out the home activity sheets and briefly discuss the activities. Remind the participants to be on time next week for the trip to the observatory. Waiting for tardy people to arrive could throw the whole schedule off and shorten the time at the observatory.



Home Activity V

WHERE IS THE MOON?

For the next two weeks, observe and record the position and shape of the moon at sunset. Choose a spot near your home where you have a fairly clear view of the horizon from west to south to east. On a plain piece of paper, draw your horizon. Be sure to label E, S, and W. Your picture might be similar to the one shown below.

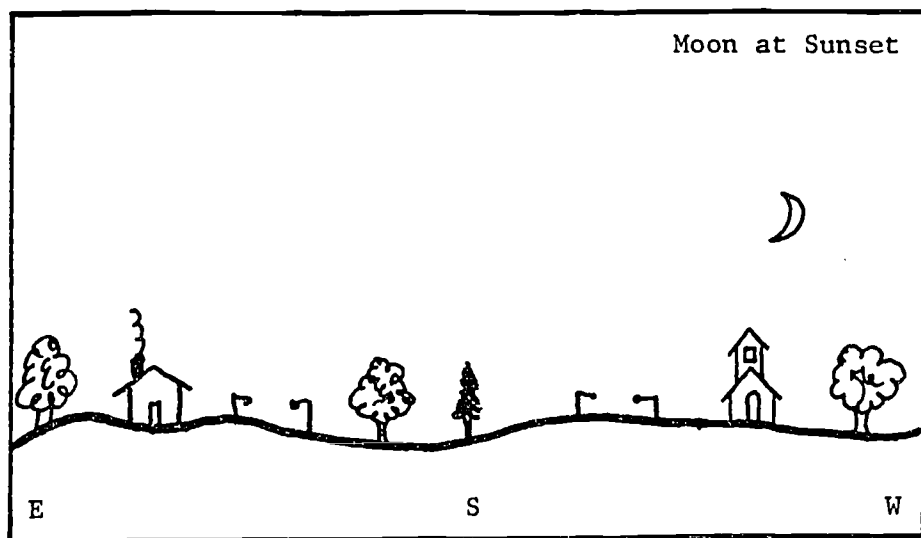

March 6
 25° above horizon
 30° from sun

At sunset on clear evenings, go to the same spot and observe the moon. Draw the shape and position of the moon on your horizon drawing. Write the date next to each drawing. If you have the time, you can use your hand (see "Spanning the Night Sky") to estimate (1) the altitude of the moon above the horizon and (2) the angle between the sun and the moon. Here are some questions to consider as you observe the moon.

1. Is the moon always in the same position in the sky at sunset? If not, has it moved higher in the sky, or lower in the sky? West or East?
2. Does the moon itself seem to have changed shape since you last saw it?
3. Can you begin to make guesses? Where will the moon be and what will it look like in
 - ...one day?
 - ...three days?
 - ...seven days?
 Check your guess.

SESSION 4

VISIT TO AN OBSERVATORY

OVERVIEW

During this session, participants visit a local observatory and discover astronomy from a professional's point of view. They discover the differences between an observatory and the planetarium, and observe celestial objects with a telescope. Time permitting, they also learn some of the work being conducted at the facility they visit. Through a homework activity, participants are introduced to the advantages larger telescopes have over a small homemade instrument, while also discovering the surprising number of objects that can be seen with a relatively small telescope.

MATERIALS

For each family:

1 Edmund Scientific 8x refractor telescope kit (#71,473)
or 10 kits (#P-71,474)

1 map of the current night skies showing the location
of a few deep sky objects

ADVANCE PREPARATION

A few days before this session, double check with the observatory operator(s) and the bus company to make sure all of the parties have the details correct. You should already have ordered and received the telescope kits from Edmund Scientific. Assemble the parts of the telescope into packages that you can easily distribute to the participants after you return from the observatory

It is a good idea to give the participants something to look at with their newly constructed telescope (besides the people across the street). The best way to accomplish this is to hand out star maps that show the positions of nebulas, star clusters, planets, and galaxies that are visible to low power

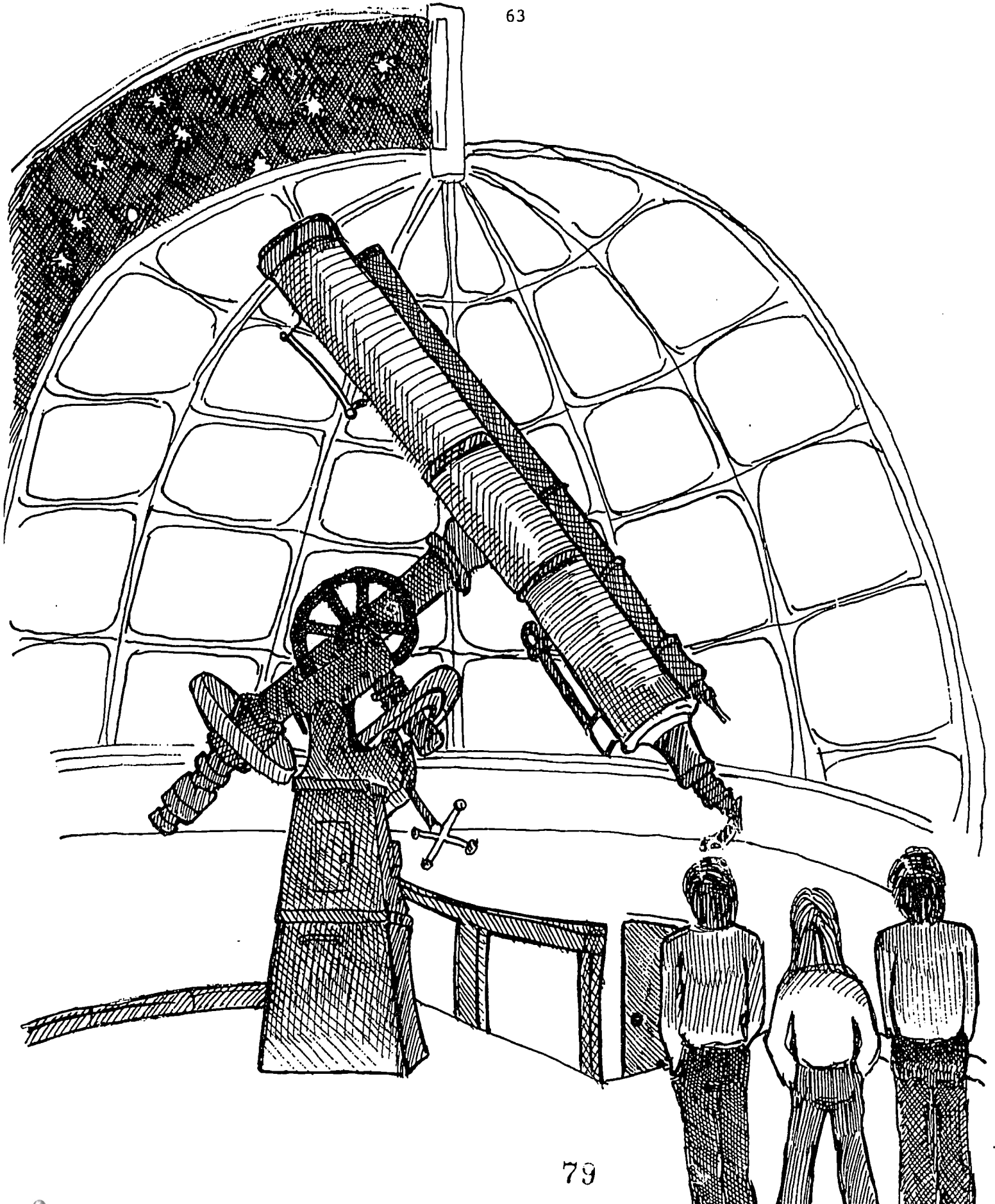

telescopes or binoculars. An example of an appropriate star map is the Abrams Planetarium Sky Calendar. This monthly guide to the night sky is written by Bob Victor and published by Abrams Planetarium of East Lansing, Michigan. The subscription fee is \$3.00 per year.

TEACHING SUGGESTIONS

The Observatory (50-100 minutes)

- Objectives:
1. Participants will be able to state the differences between an observatory and a planetarium.
 2. Participants will observe at least one object in the sky with a telescope.
 3. Participants will be able to describe some of the kinds of activities carried out at an observatory.

Most of the work for this session will be done by other people. Your job is to act as a coordinator. You will need to see that:

1. Everyone gets off the bus at both sites.
2. Everyone has a chance to look at the various objects in the telescope.
3. The observatory personnel have adequate opportunity to discuss their occupation. You can do this by asking questions that elicit responses of details you feel they overlooked.
4. Be sure the observatory personnel have some alternative activity in the event that the weather does not cooperate on the night of your visit, such as examples of work done, photography, operation of the telescope, lens grinding, etc.

Home Activity (15 minutes)

- Objectives:
1. Participants will learn to use a different type of star map to locate some celestial objects for observation.
 2. Using a small refractor-type telescope of their own making, participants will locate and observe at least one of the following objects: a double star, a star cluster, a planet, or the moon.
 3. Participants will be able to state at least one reason why astronomers prefer to use larger telescopes.

After you return from the observatory, discuss the home activity, "Where is the Moon?" Encourage participants to continue observing the moon for the next week.

* The time available for the activity will depend upon the time necessary to travel to the observatory.



Hand out the telescope kits. The instructions are given with each kit so there is little need to spend time doing this. Give each family a sky map and the "Deep Sky Records" sheets. Demonstrate how to use the map and point out features you know of that would be of interest. Also, tell the participants to look at terrestrial objects through their telescope. This will allow them to discover the images produced by the telescope are inverted.

You may want to suggest that the participants compare their telescopes to binoculars, if they have them. Their findings can be a point of discussion in the next session.

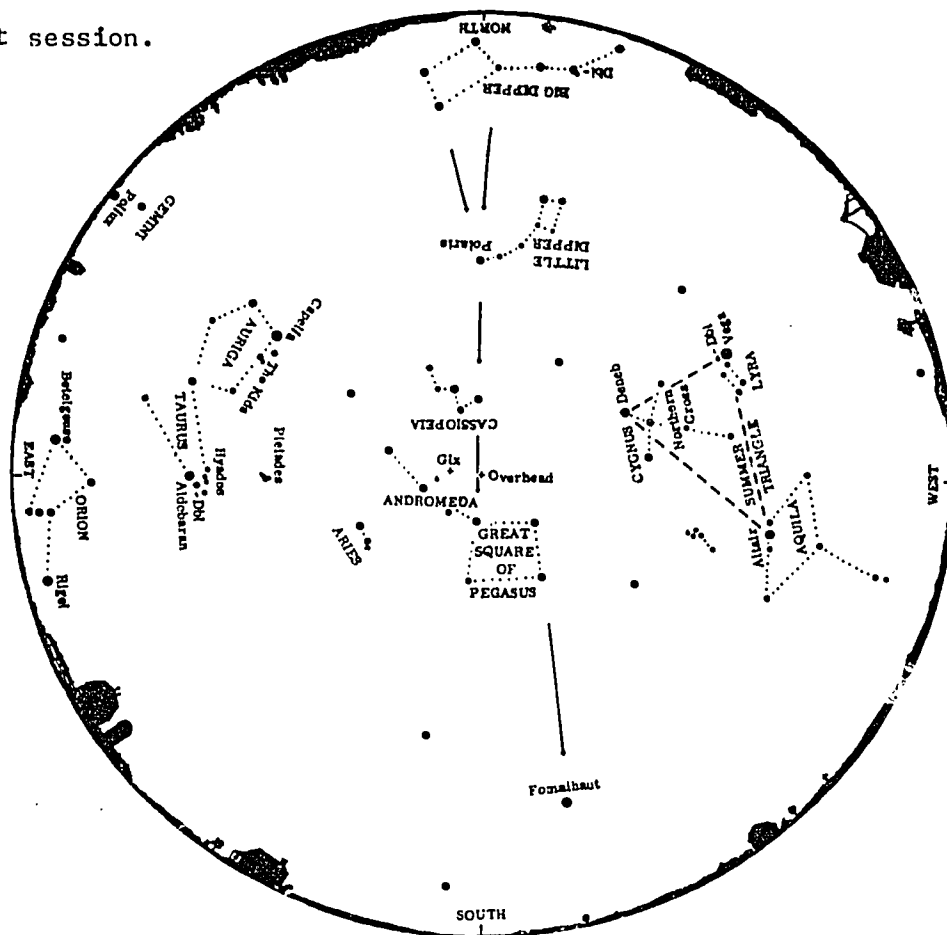

November Evening Skies

This chart is drawn for latitude 40° north, but should be useful to stargazers throughout the continental United States. It represents the sky at the following local standard times:

Late October	10 p.m.
Early November	9 p.m.
Late November	8 p.m.

This map is applicable one hour either side of the above times. A more detailed chart by George

Loeb appears monthly in the publication *Sky and Telescope*.

The planets are not plotted on this map. Check the *Sky Calendar* for planet visibilities. At chart time, nine objects of first magnitude or brighter are visible. In order of brightness they are: Vega, Capella, Rigel, Betelgeuse, Altair, Aldebaran, Pollux, Fomalhaut, and Deneb. Because of the low altitude of several of the bright stars, their relative brilliance will be diminished, accompanied by increased twinkling.

In addition to stars, other objects that should

be visible to the unaided eye are labeled on the map. The double star (DS) at the bend of the handle of the Big Dipper is detectable low in the north. Another double star is close to Aldebaran in the "face" of Taurus. More closely spaced is the double star near Vega in Lyra. The position of an external star system, called the Andromeda Galaxy after the constellation in which it appears, is also indicated (Glx). Try to observe these objects with unaided eye and binoculars. D. David Barsh, Abrams Planetarium, Michigan State University, East Lansing.

Example of Abram's Planetarium Sky Map

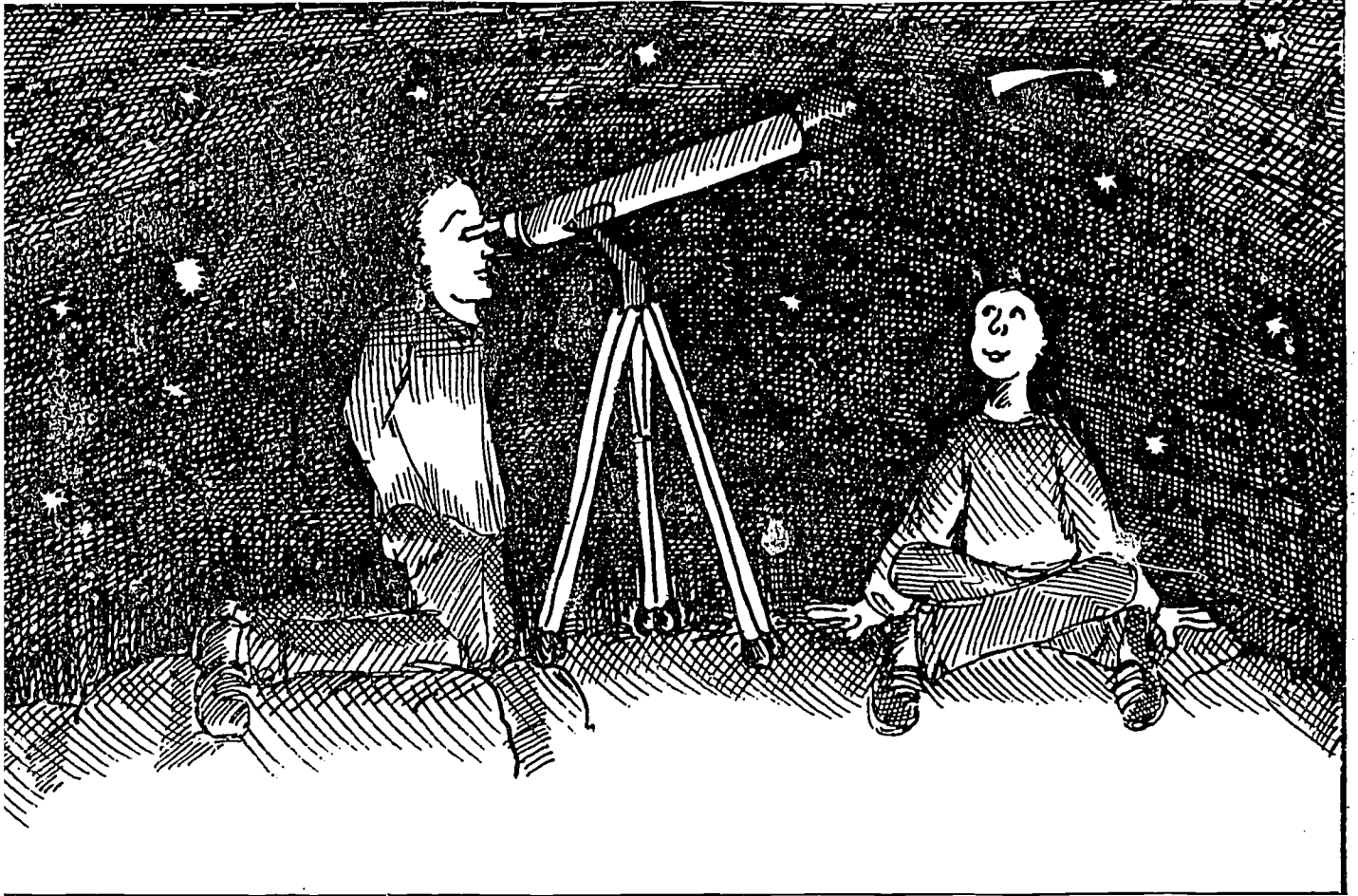



HOME ACTIVITY VI

MOON, PLANET, AND DEEP SKY RECORDS

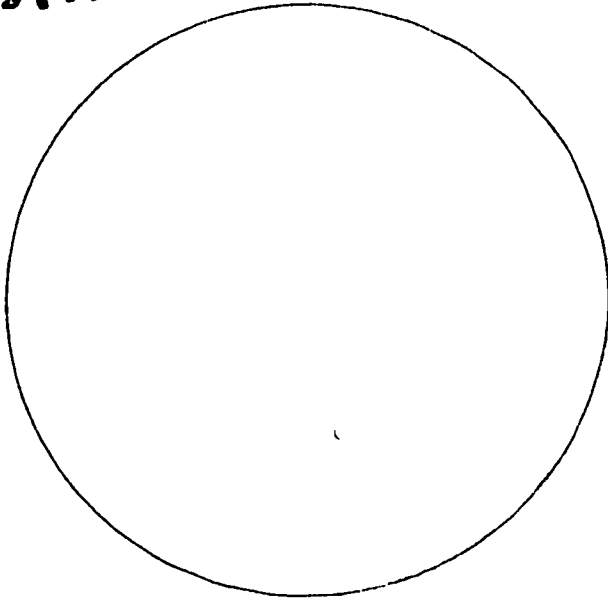

Date: _____

- Seeing: Excellent
 Good
 Moderate
 Fair
 Poor

Notes:

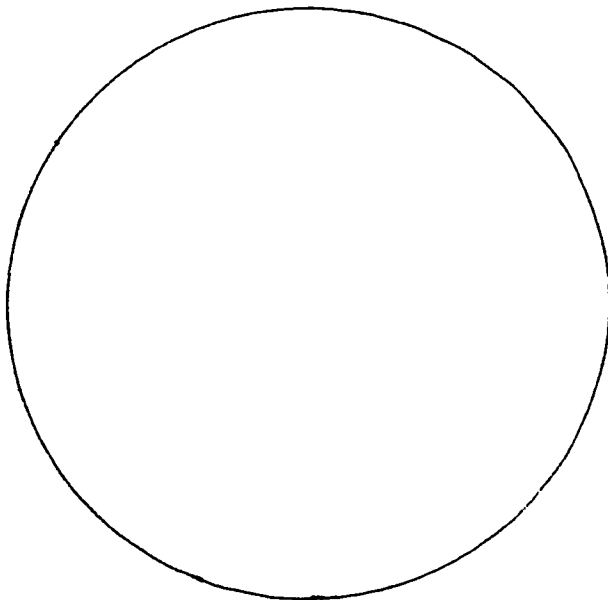

Date: _____

- Seeing: Excellent
 Good
 Moderate
 Fair
 Poor

Notes:

8.4

SESSION 5

WHERE IS THE MOON?

OVERVIEW

During this session, the participants observe and predict (over several consecutive days) the position and shape of the moon in the planetarium. The observations are first made at sunset (waxing moon), then at sunrise (waning moon). In the classroom, the participants use illuminated ping pong ball models of the moon to observe and record the phase of the moon when it is in different positions in its orbit around the earth.

MATERIALS

1 set of handouts

pencils

ping pong ball glued to golf tee for each family member

1 slide projector

ADVANCE PREPARATION

1. Horizon or Star Chart

In this session the class will observe the moon's position in the planetarium sky and record it on a chart. The chart can have either a star field or a horizon scene to match one along the dome's horizon line. If you have a panorama scene already in use, you may be able to use it for this session. This panorama scene must have features that participants can easily use as reference points. If you feel your panorama scene will serve this purpose, make a recording chart with the same scene along the bottom of the page and duplicate a copy for each family (see page 64 for an example).

If you do not have an adequate panorama scene, you will have to produce one. This can be done with one or two single slide projectors. In trial classes we used a simple line drawing horizon scene for two reasons: (1) it is very simple to produce and (2) it contains reference points easily recognized by the participants. To make this simple horizon scene, photograph with Kodalith film the sheet provided (see page 64), or a line drawing of your own. If you plan to use three projectors, photograph the scene in three parts. If you project the scene with more than one projector, it is not necessary to spend time in precise alignment. Slight misalignment is not noticeable or detracting with line drawing panoramas. Duplicate a copy of the horizon scene for each family.

If you decide to use the stars as reference points to locate the moon, then select a Southern sky map for the current season (like the one used in session one), and duplicate a copy for each family.

2. Lunar Phases Activity

For each participant, glue a ping pong ball onto a golf tee. This will give each participant a handle for revolving the ping-pong ball moon. Duplicate a copy of the "Lunar Phases" worksheets for each family.

Take the lens out of a slide projector or film strip projector. Set the projector in front of the classroom and point it towards the class. Arrange the chairs so each participant is in the light of the projector.

TEACHING SUGGESTIONS

Getting Started (10 minutes)

Ask the participants what they were able to discover and observe with their telescopes. Most participants find the small telescope somewhat frustrating to us. This leads to a discussion of why astronomers use large telescopes with equatorial mounts.

Tracking the Moon (35 minutes)

Objectives: Using the planetarium sky, red-filtered flashlights, pencils, and a horizon map of the southern sky, participants will be able to:

- (1) observe and predict the position and shape of the moon at sunset (or sunrise) on successive days,
- (2) conclude that the direction of the moon's motion appears to be from west to east,
- (3) conclude that the moon first appears to increase in size (waxing) to full moon, then appears to decrease in size (waning) to new moon.

Ask the participants what they have discovered by observing the moon. Most participants do not observe the moon for a long enough time to be able to explain what they observed. Explain to the participants that you are going to give them another chance to repeat their moon observations. They will observe the moon on successive nights at about the same time each night.

Hand out the lap boards, flashlights, pencils and recording sheets. Change the sky to blue, add the sun, moon, cardinal points, and horizon scene. Run daily motion slowly until the sun is on the evening horizon. As this occurs, discuss again with the class what is happening. Note that both the sun and the moon move from east to west as the earth rotates. It is important that the class differentiate between rotation and revolution.

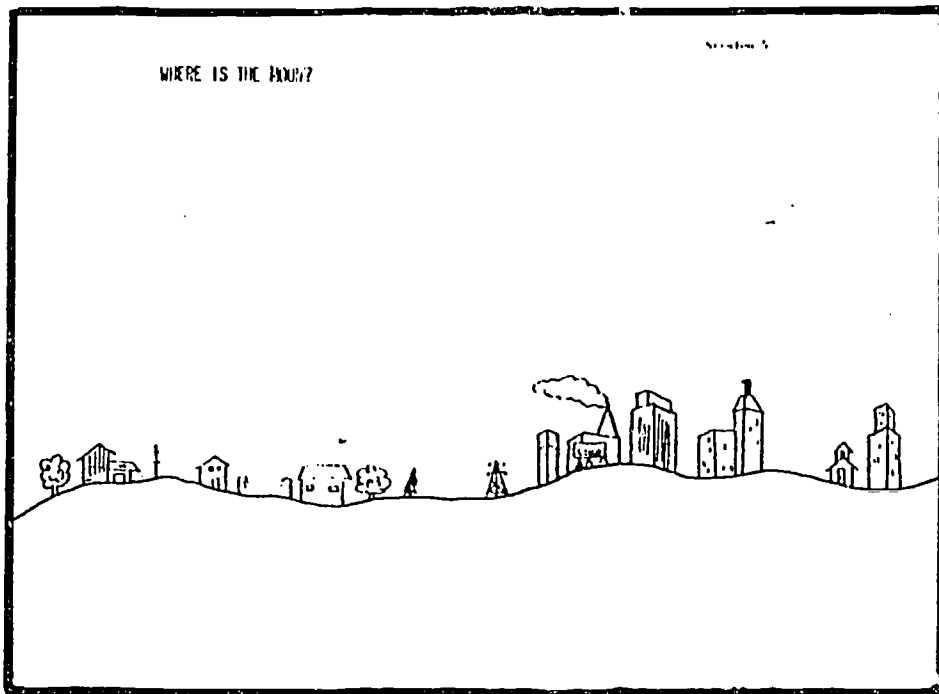

Once the daily motion has ceased, use your pointer to help them locate the moon above a landmark on the horizon. The participants are to then draw a similar moon on their papers. Their recorded moon should be of the same shape and in the same place above the horizon as the moon in the sky. Have the students write the date the moon was in that position.

Run daily motion again, being sure that your annual motion is noted in. Use a sunset special effect, if you have any. Add music if you like. Run daily motion through the night. Discuss anything they recognize. Run daily motion through sunrise with any special effects you want to include. Stop the sun when it is on the western horizon again.

Tell the participants to note the position of the moon and draw a second moon on their recordingsheet in the same place and shape as the observe in the sky. Have the participants write the date the moon was in that position. Repeat the daily motion 24 hour cycle, being sure to stop

the sun in the same place on the western horizon. Again, have the students draw the moon on their papers, with the correct date.

Bring the lights up slightly and discuss what they have observed.

Be sure to note that each time they observed and recorded the moon, the sun was in the same position. The students should note at least the following:

1. The moon's shape has changed from day to day.
2. The moon has changed position.
3. The direction of the moon's motion appears to be from east to west.

During the discussion, try to lead the group towards the reason for the moon's apparent motion. Now try to have the students predict where the moon would be on the next date. Have them mark an x on their papers where they think the moon will be. Run the daily motion through another 24 hour cycle. When the sun returns to the horizon, the class can confirm their prediction.

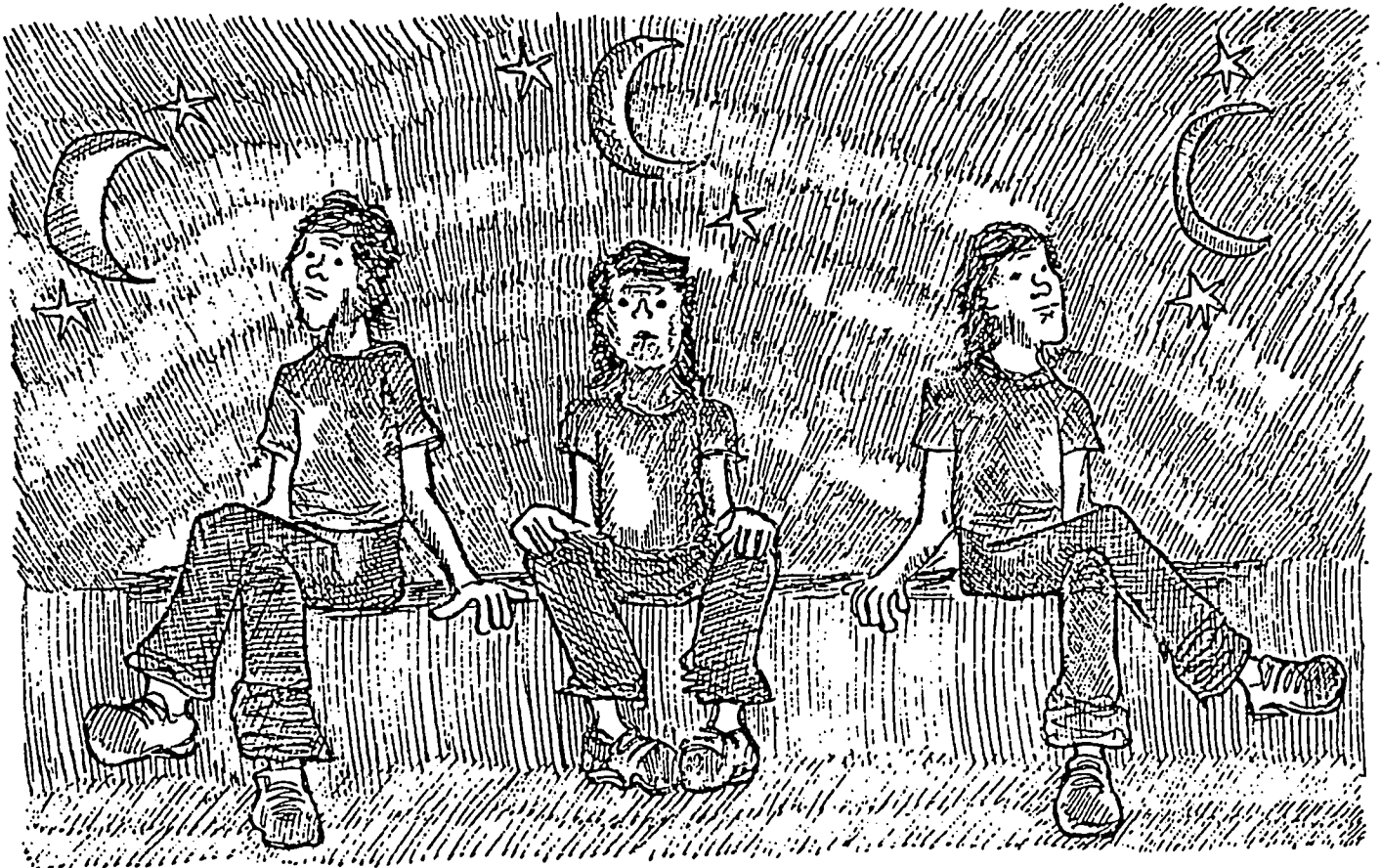

By this time the participants are well aware of how the moon changes from day to day. You can continue to show them how the moon will look on successive days. It is not necessary to take the time to go through daily motion. You can advance time day by day with annual motion.

By advancing annual motion approximately one day at a time, you will move the moon to the eastern horizon. In order to continue this motion and still retain the students perception of what is actually happening, tell the students that you will change the time of day from sunset to sunrise, and then do so.

After you reach sunrise position, run annual motion until the moon disappears. Points of discussion that should occur during these changes are:

1. Note how the moon appears to increase in size and then decrease in size.
2. Is the moon actually changing shape?
3. Differentiate between waxing moon and waning moon.
4. What is the position of the moon with respect to the sun during full moon and new moon?
5. How long does it take for the moon to orbit the earth?

The Lunar Phases (40 minutes)

Objectives: Using ping pong balls, a slide projector and observation sheets, the participants will be able to

- (1) draw the moon (with respect to the earth and sun) at eight different positions in its orbit around the earth,
- (2) observe and draw the shape (phase) of the moon as viewed from the earth at each of these eight positions, and
- (3) name the different phases of the moon.

Give each family a set of "Lunar Phases" sheets. Have the students look

through the sheets and notice the eight identical drawings. There is one drawing for each distinct phase. Explain that the drawings are not to scale. Ask, "Why is the earth half light and half dark?" (The light portion of the earth is illuminated by the sun; this is the day side. The dark portion is facing away from the sun; this is the night side.).

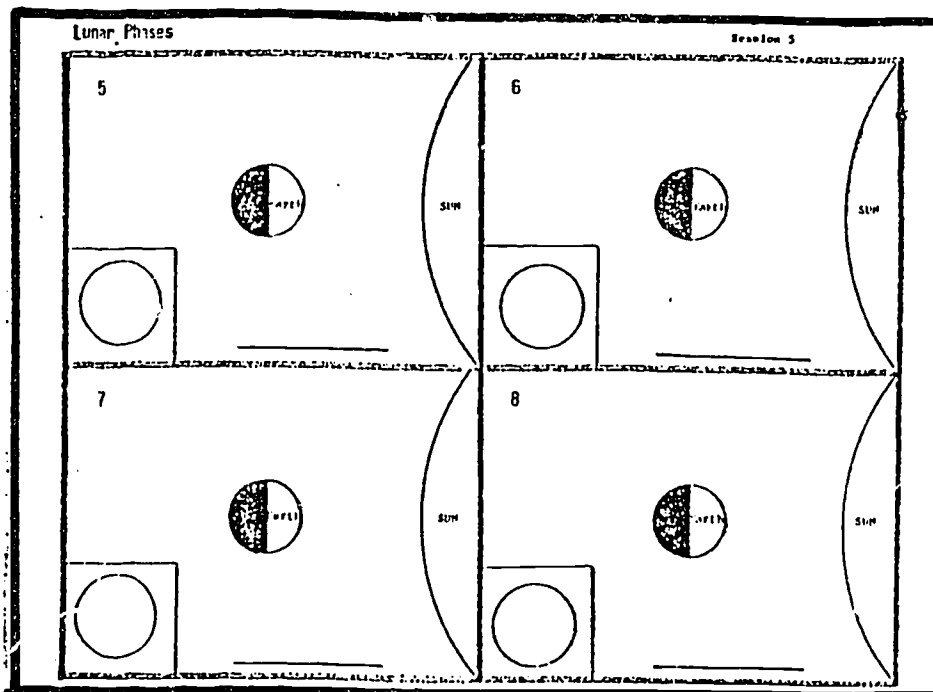
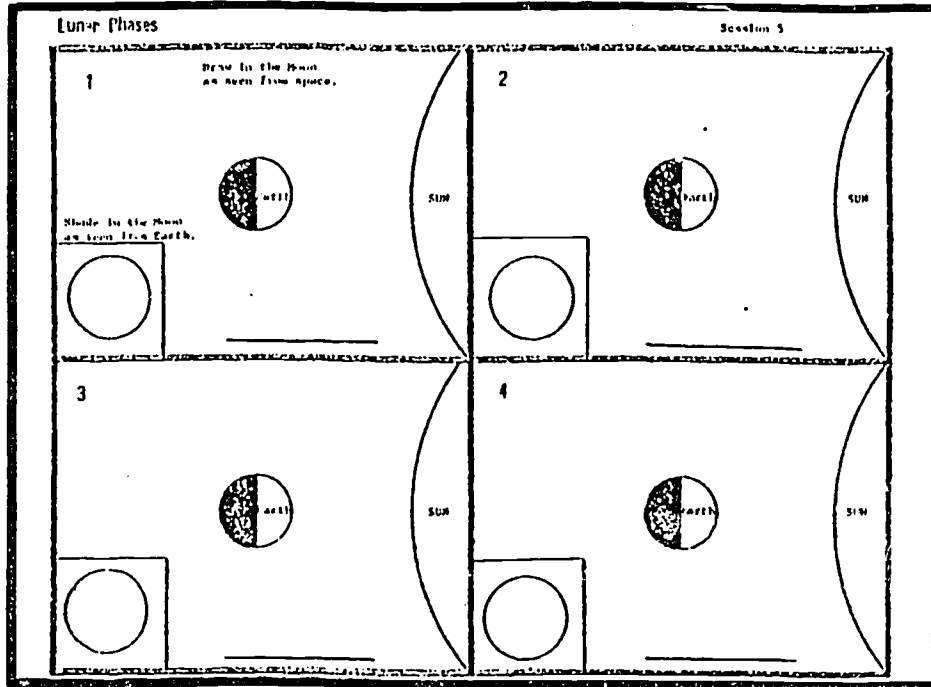

Give each participant one ping pong ball mounted on a golf tee. Tell the students to pretend their head is the earth, the ping pong ball is the moon, and the slide projector is the sun. Discuss the motion of the moon with respect to the earth; stress the word "revolve". Explain that perspective, the moon will revolve in a counter-clockwise direction as viewed from above (see the diagram below). Have the participants practice revolving the moon around the earth in this manner.

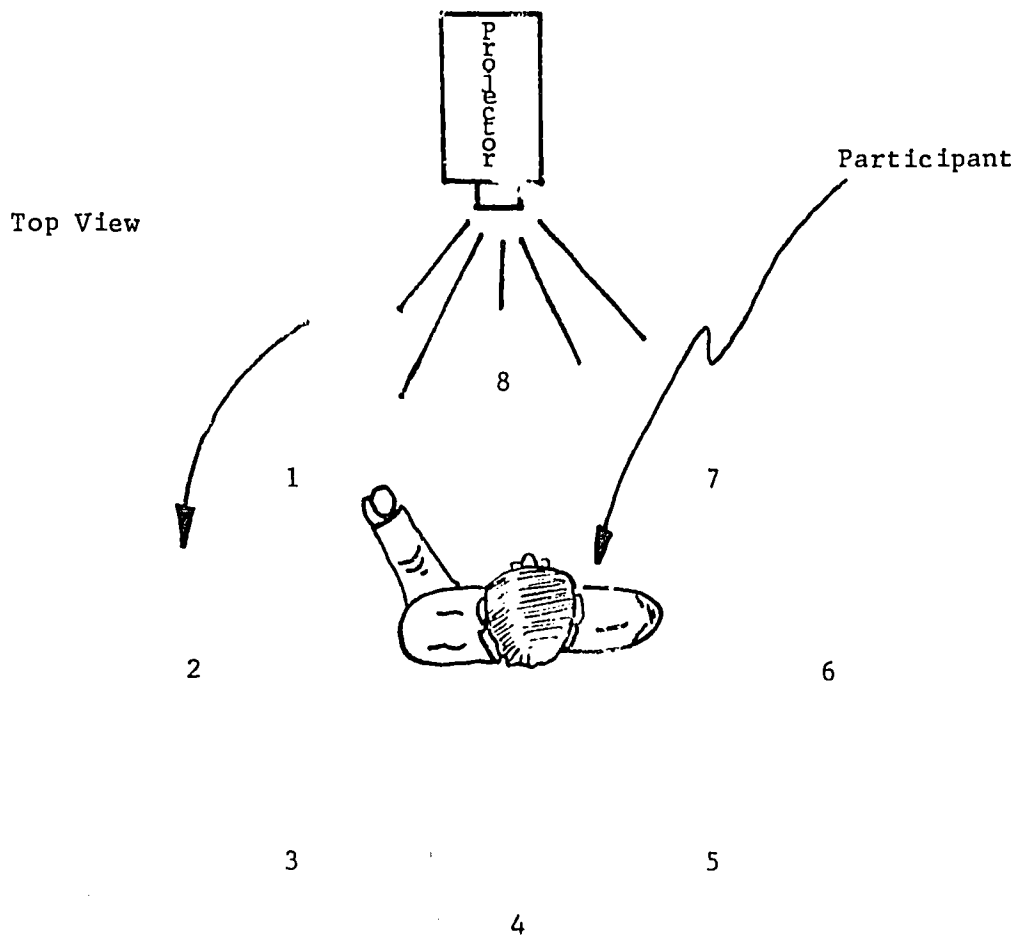

For the sake of convenience, the moon's 360° orbit is divided into eight numbered parts. The names of the phases for each number will be filled in later. Use your own ping pong ball and show the participants



how to hold the moon for each position (see diagram on page 68). Start with the number one position. After the participants hold their moons in the correct position, instruct them to draw the moon in the "as seen from space" section of diagram number one. (Ignore the "Moon as seen from Earth" portion of the diagram at this time). Ask the participants, "Do you think your diagrams should be half light and half dark like the earth diagram?". As the participants are drawing their diagrams, circulate around the class to see if they have drawn the moon correctly.

After everyone has drawn in the number 1 position of the moon, go to number 2. Show the participants how to hold the moon, have them hold their moons in the correct position and then draw in the moon in the proper place in diagram 2. Continue this procedure until all of the moons "as seen from space" are filled in.

When all of the "as seen from space" diagrams are filled in, the class is ready to discover what the moon looks like from earth for each of the eight positions. Turn off all lights and turn on the projector. Instruct the participants to hold their ping-pong balls in the correct position for diagram number one. They should see the entire ball dark except for a thin crescent of light along the right edge of the ball. Tell the participants to fill in the circular inset in diagram number 1 to match what they see. They should shade in the part of the circle to match the dark part of the ball, and leave white the part of the circle that matches the lighted part of the ball (see diagram at the top of the next page). Some families will inadvertently do the opposite (i.e., shade in the light part and leave the dark side blank). You will have to watch them closely to prevent this.



When all of the families have filled in diagram number one, instruct them to write the name of the phase "Waxing Crescent" on the line at the bottom of the diagram. Repeat this step with each of the remaining seven (7) phases. The names of the phases are listed below.

1. Waxing crescent
2. Waxing quarter (First quarter)
3. Waxing gibbous
4. Full moon
5. Waning gibbous
6. Waning quarter (Third quarter)
7. Waning crescent
8. New moon

After the students have filled in all of the diagrams, tell them to slowly revolve the moon around the earth a couple of times to see how the change in the moon's appearance is continuous. Explain to participants that astronomers have divided the entire cycle of the moon into two halves: "Waxing", which refers to the phases that show an increase in the lighted portion, and "Waning", which refers to the phases that show a decrease in the lighted portion.

Questions for Discussion (15-20 minutes)

If you have the time, you may want to discuss the following questions with the class. Before you begin, remind the class that the entire lunar phase cycle takes $29\frac{1}{2}$ days.

1. Approximately how long does it take for each phase? (3.7 days or $3\frac{11}{16}$ days. $3\frac{3}{4}$ is close enough).
2. About how long after a new moon would you expect to see a first quarter moon? (approximately $7\frac{1}{2}$ days).
3. About how long after a new moon would you expect to see the full moon? (approximately $14\frac{3}{4}$ days).
4. Compare the waxing crescent phase with the waning crescent phase. How are they different? (They appear to be opposite images.)
5. Compare the two quarter phases. How are they different? (same as #4).
6. Compare the two gibbous phases. How are they different? (same as #4).
7. If you were to see a quarter moon in the sky, how could you tell which quarter it was in?
8. By noticing which side and how much of the moon appears lighted, can you tell where the sun is? You can explain this using a couple of different phases.
9. If you were stationed on an exploration base on the surface of the moon, how long would you experience day-time? How long would you experience night-time? (Each would be $\frac{1}{2}$ of $29\frac{1}{2}$ days, or $14\frac{3}{4}$ earth days.)

10. When the participants were using ping pong balls to find the new moon, some of them probably got the impression that an eclipse should occur each time the sun, moon, and earth are in these relative positions. Why does an eclipse not occur every month? You may want to demonstrate and discuss eclipse of sun and eclipse of the moon.

In the last few minutes of class, pass out the bibliography of astronomy books and discuss briefly. You may want to recommend your favorite books.

WHERE IS THE MOON?

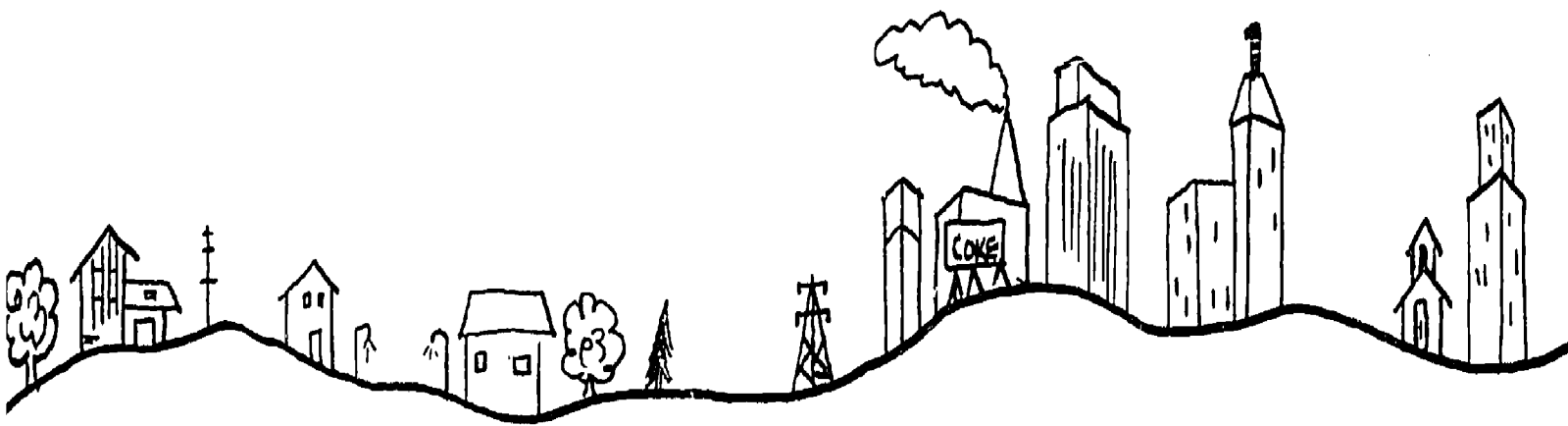

1

Draw in the Moon
as seen from space.



SUN

Shade in the Moon
as seen from Earth.

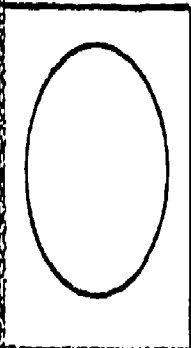

2



SUN

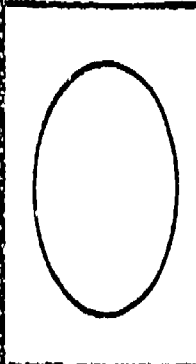

3



SUN

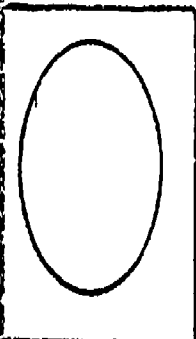

4



SUN

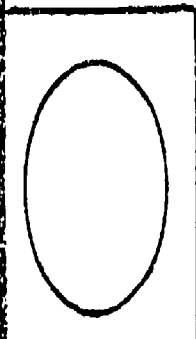

83

100

01

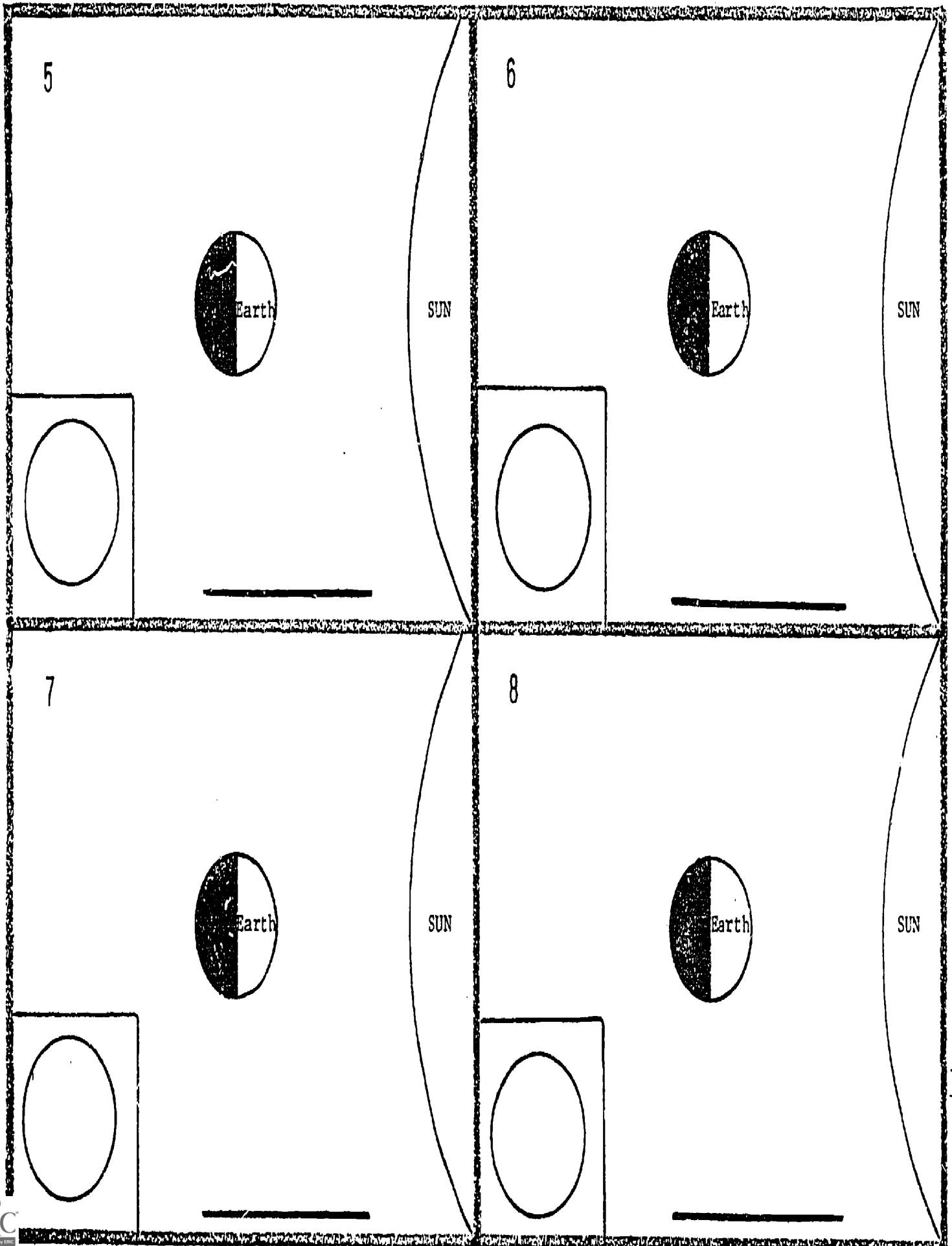

84

102

103

ASTRONOMY BOOKS FOR YOUNG ADULTS

I. The Sun:

The Mysterious Sun, by Nigel S. Hey. G.P. Putnam's Sons, New York. 1971.

The First Book of the Sun, by David C. Knight. Franklyn Watts, Inc., New York. 1968.

II. The Solar System:

Comets, Meteoroids, and Asteroids: Mavericks of the Solar System, by Franklyn M. Branley. Thomas Y. Crowell Co., New York. 1974.

Pieces of Another World: The Story of Moon Rocks, by Franklyn M. Branley. Thomas Y. Crowell Co., New York. 1972.

Comets, by David C. Knight. Franklyn Watts, Inc., New York. 1968.

The First Book of Mars, by David C. Knight. Franklyn Watts, Inc., New York. 1966.

Meteors and Meteorites: An Introduction to Meteoritics, by David C. Knight. Franklyn Watts, Inc., New York. 1969.

The Tiny Planets: Asteroids of Our Solar System, by David C. Knight. William Morrow and Co., New York. 1973.

Thirty-Two Moons: Natural Satellites of Our Solar System, by David C. Knight. William Morrow and Co., New York. 1974.

The Asteroids, by Alan E. Nourse. Franklyn Watts, Inc., New York. 1975.

The Giant Planets, by Alan E. Nourse. Franklyn Watts, Inc., New York. 1974.

Venus & Mercury, by Alan E. Nourse. Franklyn Watts, Inc., New York. 1972.

III. Field Guides:

The Beginner's Guide to the Skies: A Month-By-Month Handbook for Stargazers and Planet Watchers, by C.H. Cleminshaw. Thomas Y. Crowell Co., New York. 1977.

Constellations: A Concise Guide in Colour, by Josef Klepesta. Hamlyn Publishing Group Ltd., New York. 1977.

ASTRONOMY BOOKS FOR YOUNG ADULTS

North Star to Souther Cross, by Will Kyselka and Ray Lanterman. The University Press of Hawaii, Honolulu. 1976.

What's In the Names of Stars and Constellations, by Carolyn Croll. Coward, McCann & Geoghegan, Inc., New York. 1976.

Field Guide to the Stars and Planets, by Donald H. Menzel. Houghton Mifflin Co., Boston. 1964.

Color Star Atlas, by Patrick Moore. Crown Publishers, Inc., New York. 1973.

Astronomy With Binoculars, by James Muirden. Faber and Faber Ltd., London. 1976.

Field Book of the Skies, by William T. Olcott. G.P. Putnam's Sons, New York. 1954.

Guideposts to the Stars, by Leslie C. Peltier. McMillan Publishing Co., Inc., New York. 1972.

Whitney's Star Finder, by Chalres A. Whitney. Alfred A. Knopf, New York. 1975.

IV. Stars:

Alpha Centauri: The Nearest Star, by Isaac Asimov. Lothrop, Lee & Shepard Co., New York. 1976.

Black Holes, White Dwarfs, and Superstars, by Franklyn M. Branley. Thomas Y. Crowell Co., New York. 1976.

Eavesdropping on Space, by David C. Knight. William Morrow and Co., New York. 1975.

V. Spaceflight, UFO'S, and Life In Space:

Planets, Life, and LGM, by Ben Bova. Addison-Wesley Publishing Co., Reading, Mass. 1970.

Starflight and Other Improbabilities, by Ben Bova. The Westminster Press, Philadelphia. 1972.

The Cosmic Connection: An Extraterrestrial Perspective, by Carl Sagan. Dell Publishing Co., New York. 1975.

Other Worlds, by Carl Sagan.

ASTRONOMY BOOKS FOR YOUNG ADULTS

VI. General Astronomy:

The Amazing Universe, by Herbert Friedman. National Geographic Society, Washington. 1975.

U.S. Observatories: A Directory and Travel Guide, by H.T. Kirby-Smith. Van Nostrand Reinhold Co., New York. 1976.

1001 Questions Answered About Astronomy, by James S. Pickering. Dood, Mead & Co., New York. 1976.

The Stars & Serendipity, by Robert S. Richardson. Pantheon Books, New York. 1971.

APPENDIX A
Monthly Sky Maps

THE MONTHLY SKY MAPS

The heavens present the appearance of a dome over our heads. Mapping the stars, therefore, is like mapping the curved surface of the earth. It is impossible to chart, without distortion, such a surface on a flat map. Several methods of mapping exist which help to minimize the effect. The one used here, stereographic projection, has the advantage of preserving the shape of small areas such as those of the individual constellations. The chief disadvantage lies in the fact that constellations shown near the margins look larger than they really are.

The maps have been prepared for observers located at latitude 45° north; but should work fairly well for others located within 5 to 10 degrees of this. The maps have been carefully constructed from a number of astronomical texts and catalogs, with four separate characters to represent a range of star magnitudes. It is hoped that the symbols chosen will give users a feeling for the apparent brightnesses of stars so that constellation identification will be an easier task.

In keeping with the convention established for sky maps, the times given are for local standard time. Remember that daylight savings time is in effect from roughly May through October. If you are teaching this course during one of these months, be sure to add one hour to the times stated on the appropriate sky maps. In using the sky maps with a class, set the planetarium so that the value for right ascension given in the list below, appears at the observer's meridian:

<u>Monthly Sky Map:</u>	<u>Right Ascension:</u>
January-February	6 hours
March-April	10 hours
May-June	14 hours
July-August	18 hours
September-October	22 hours
November-December	2 hours

THE MONTHLY SKY MAPS

For each two month period throughout the year, two maps are provided—one shows the sky from west to east along the northern horizon and the other, a view from east to west along the southern horizon. In addition, a duplicate set of the same twelve maps is included on which the names of the visible constellations are shown together with lines connecting the members of each star grouping.

JANUARY-FEBRUARY SKY MAP

North Horizon

January 1 at 11:30 p.m.
January 15 at 10:30 p.m.

February 1 at 9:30 p.m.
February 15 at 8:30 p.m.

Star Magnitudes

- ⊙ 1st or brighter
- ⊙ 2nd
- ⊙ 3rd
- 4th or fainter

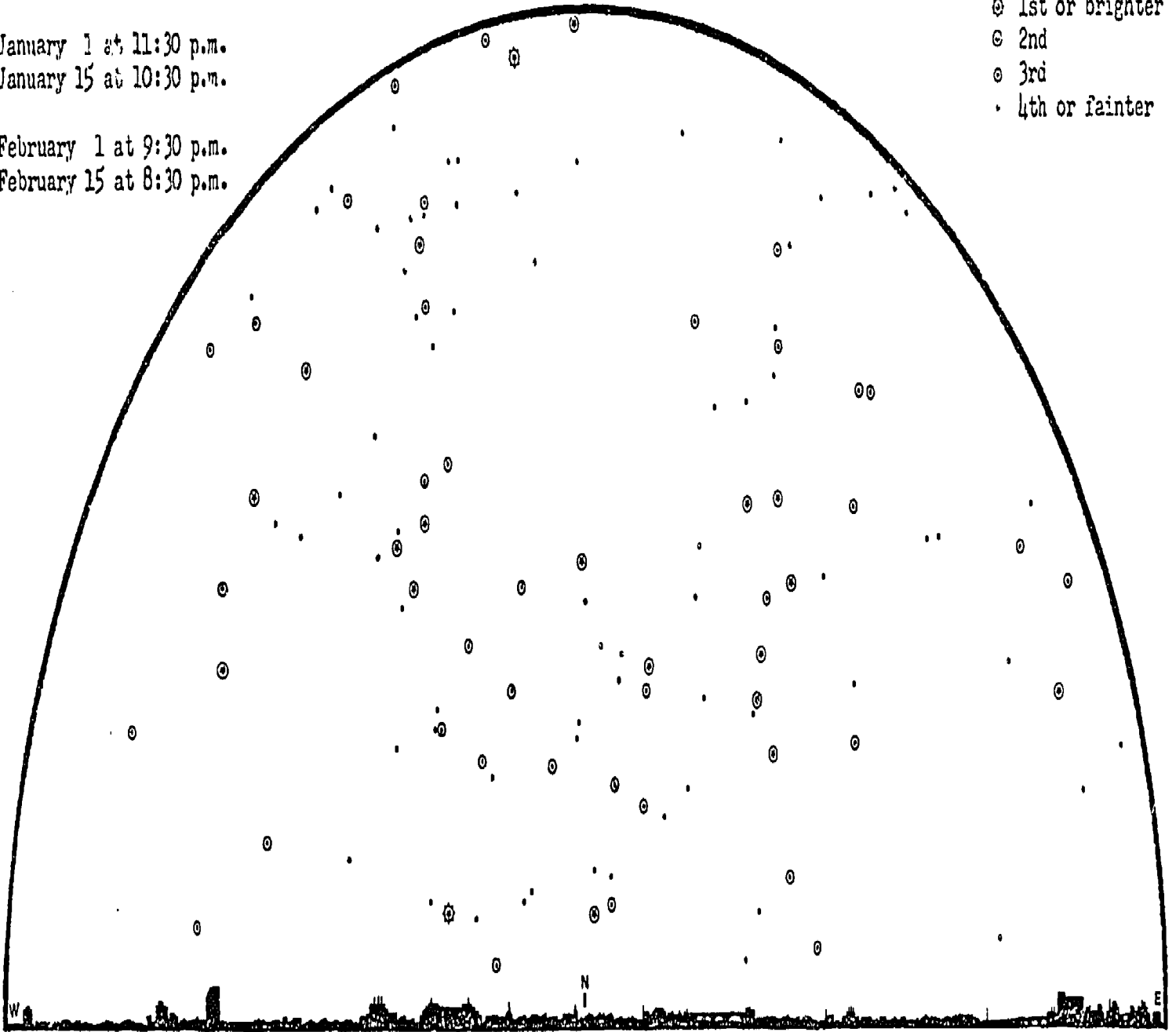

JANUARY-FEBRUARY SKY MAP

South Horizon

January 1 at 11:30 p.m.

January 15 at 10:30 p.m.

February 1 at 9:30 p.m.

February 15 at 8:30 p.m.

Star Magnitudes

⊙ 1st or brighter

⊙ 2nd

⊙ 3rd

· 4th or fainter

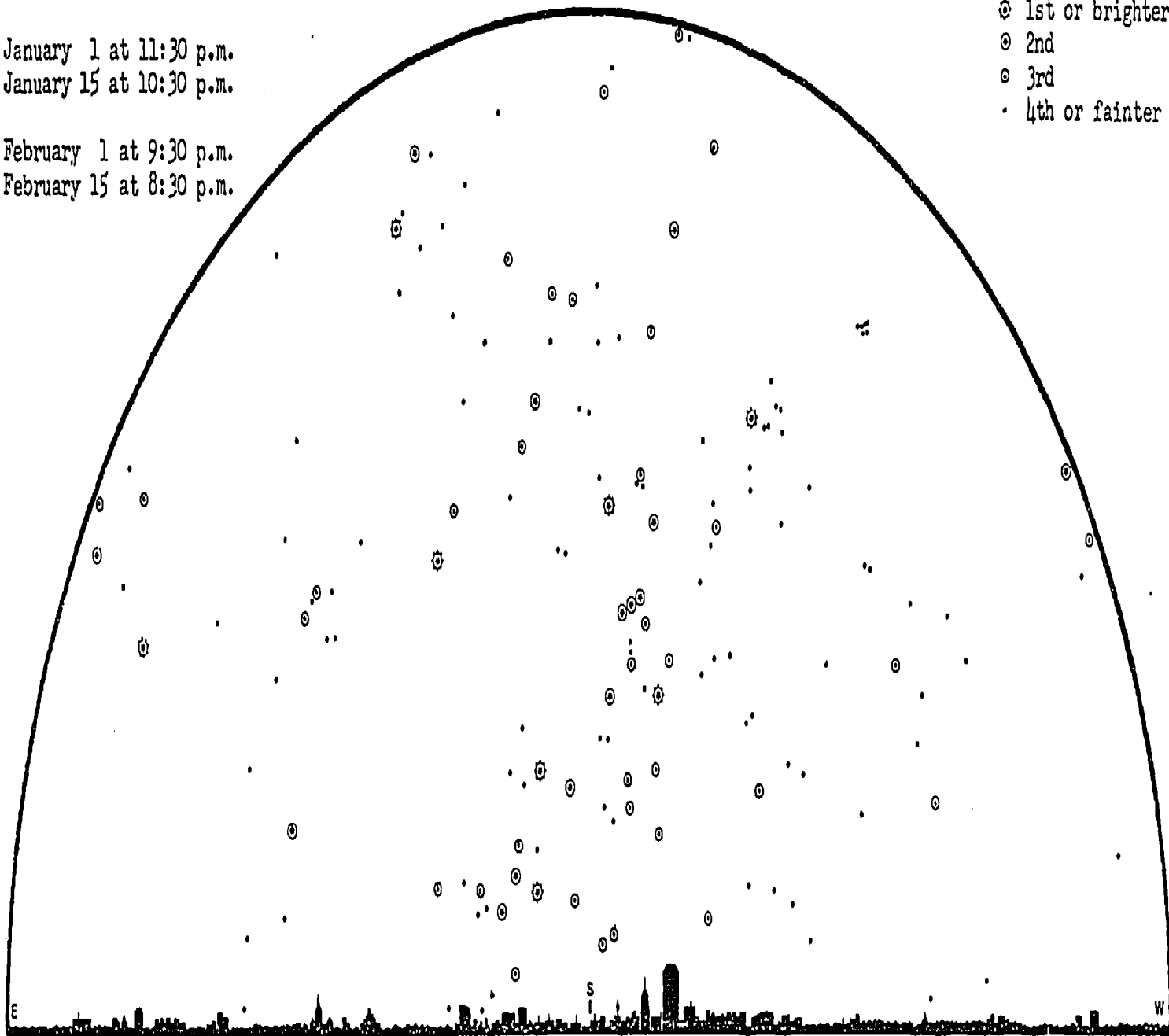

MARCH-APRIL SKY MAP
North Horizon

Star Magnitudes

March 1 at 11:30 p.m.
March 15 at 10:30 p.m.

April 1 at 9:30 p.m.
April 15 at 8:30 p.m.

- ⊙ 1st or brighter
- ⊙ 2nd
- ⊙ 3rd
- 4th or fainter

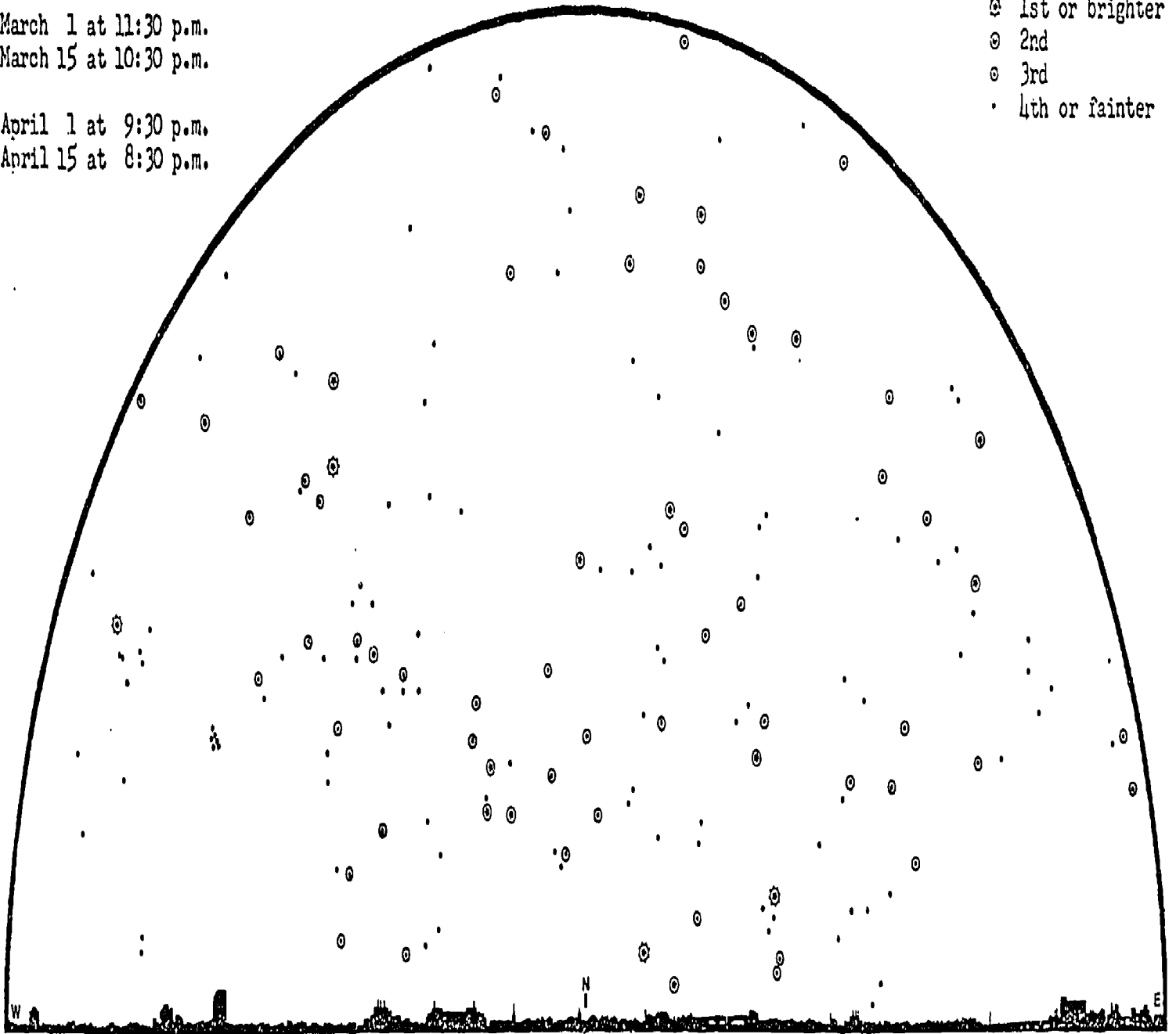

MARCH-APRIL SKY MAP
South Horizon

Star Magnitudes

March 1 at 11:30 p.m.
March 15 at 10:30 p.m.

April 1 at 9:30 p.m.
April 15 at 8:30 p.m.

- ⊙ 1st or brighter
- 2nd
- ◉ 3rd
- 4th or fainter

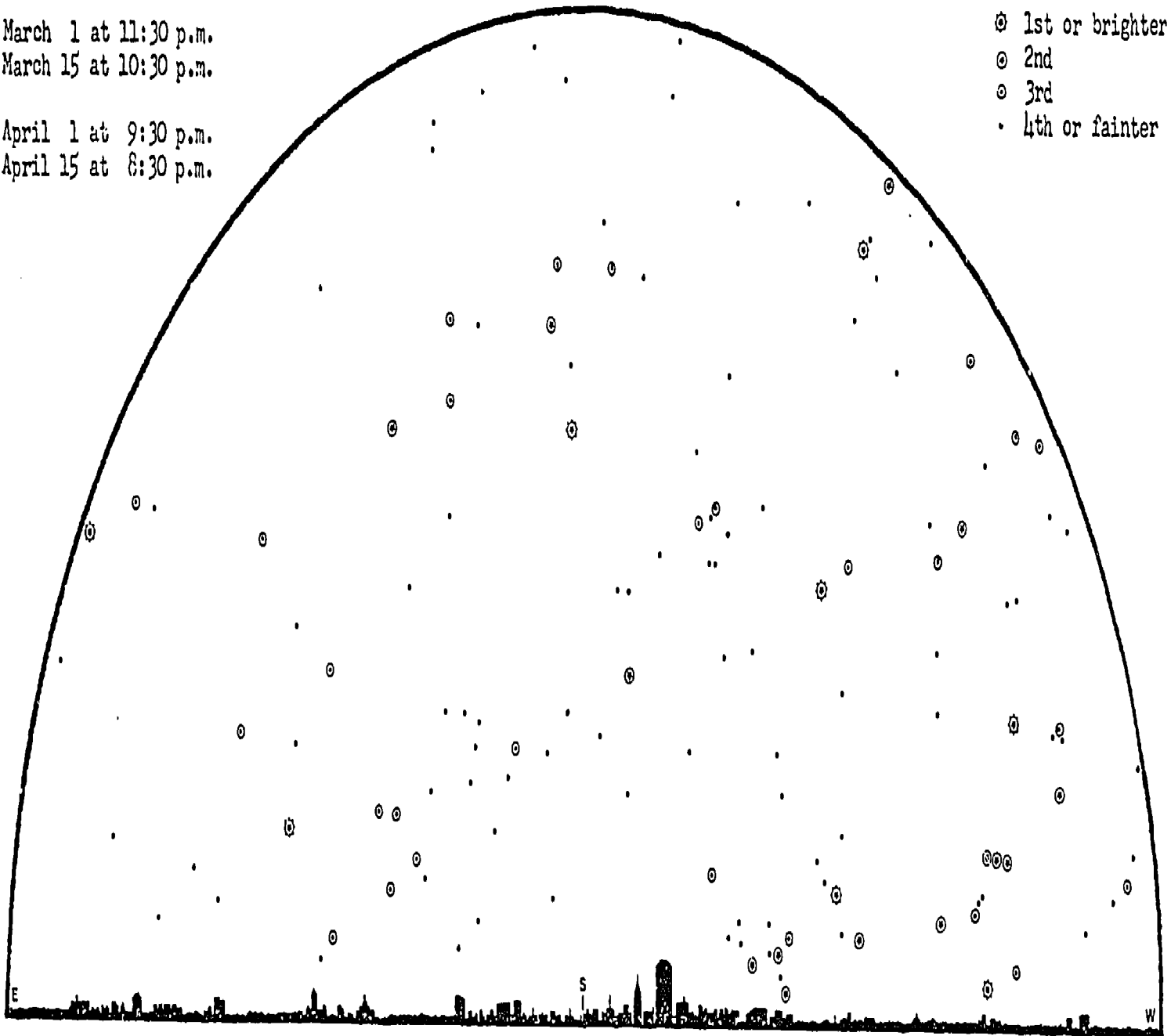

MAY-JUNE SKY MAP
North Horizon

Star Magnitudes

May 1 at 11:30 p.m.
May 15 at 10:30 p.m.

June 1 at 9:30 p.m.
June 15 at 8:30 p.m.

- ⊙ 1st or brighter
- ⊙ 2nd
- ⊙ 3rd
- 4th or fainter

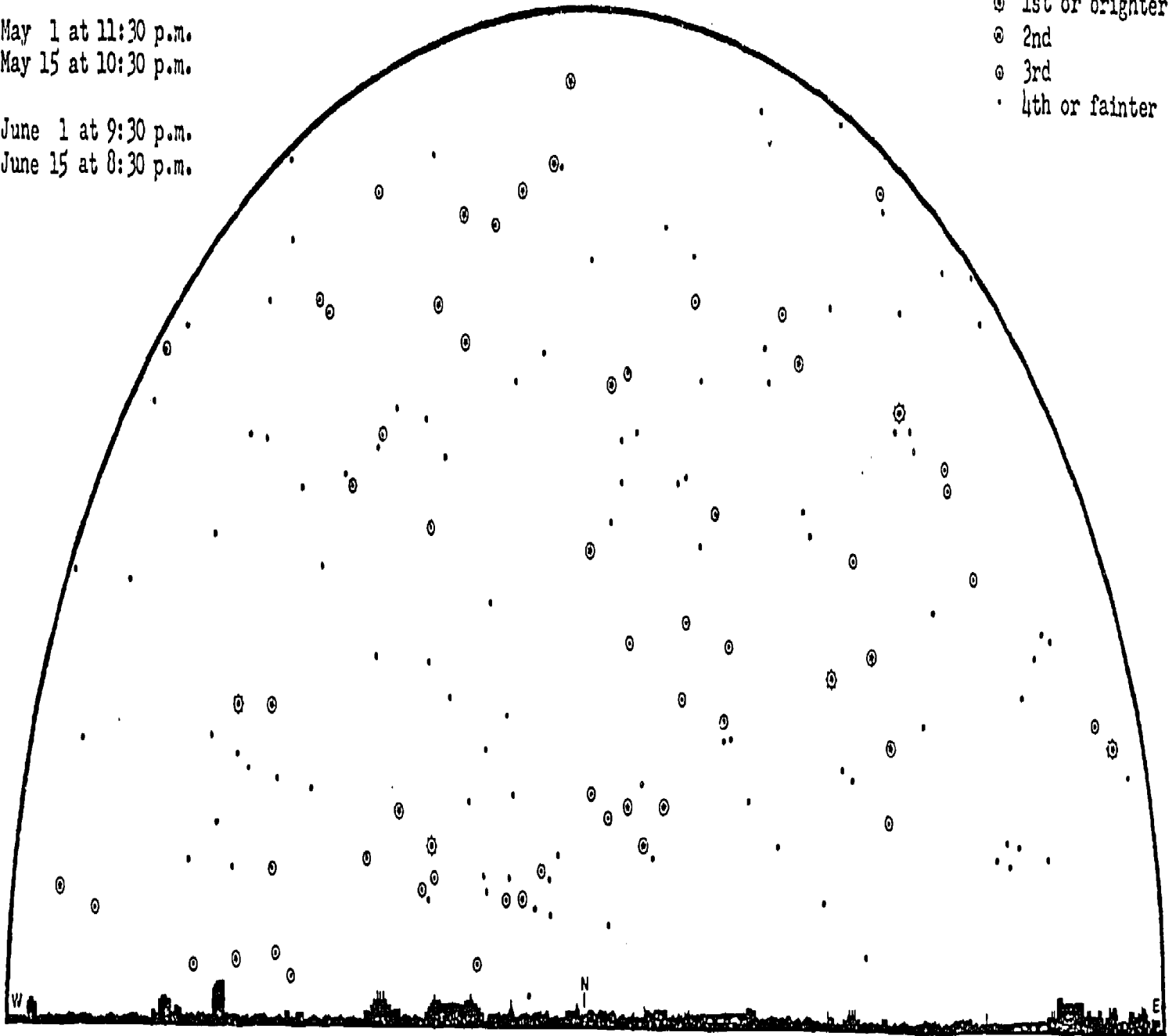

MAY-JUNE SKY MAP
South Horizon

Star Magnitudes

May 1 at 11:30 p.m.
May 15 at 10:30 p.m.
June 1 at 9:30 p.m.
June 15 at 8:30 p.m.

- ⊙ 1st or brighter
- ⊙ 2nd
- ⊙ 3rd
- 4th or fainter

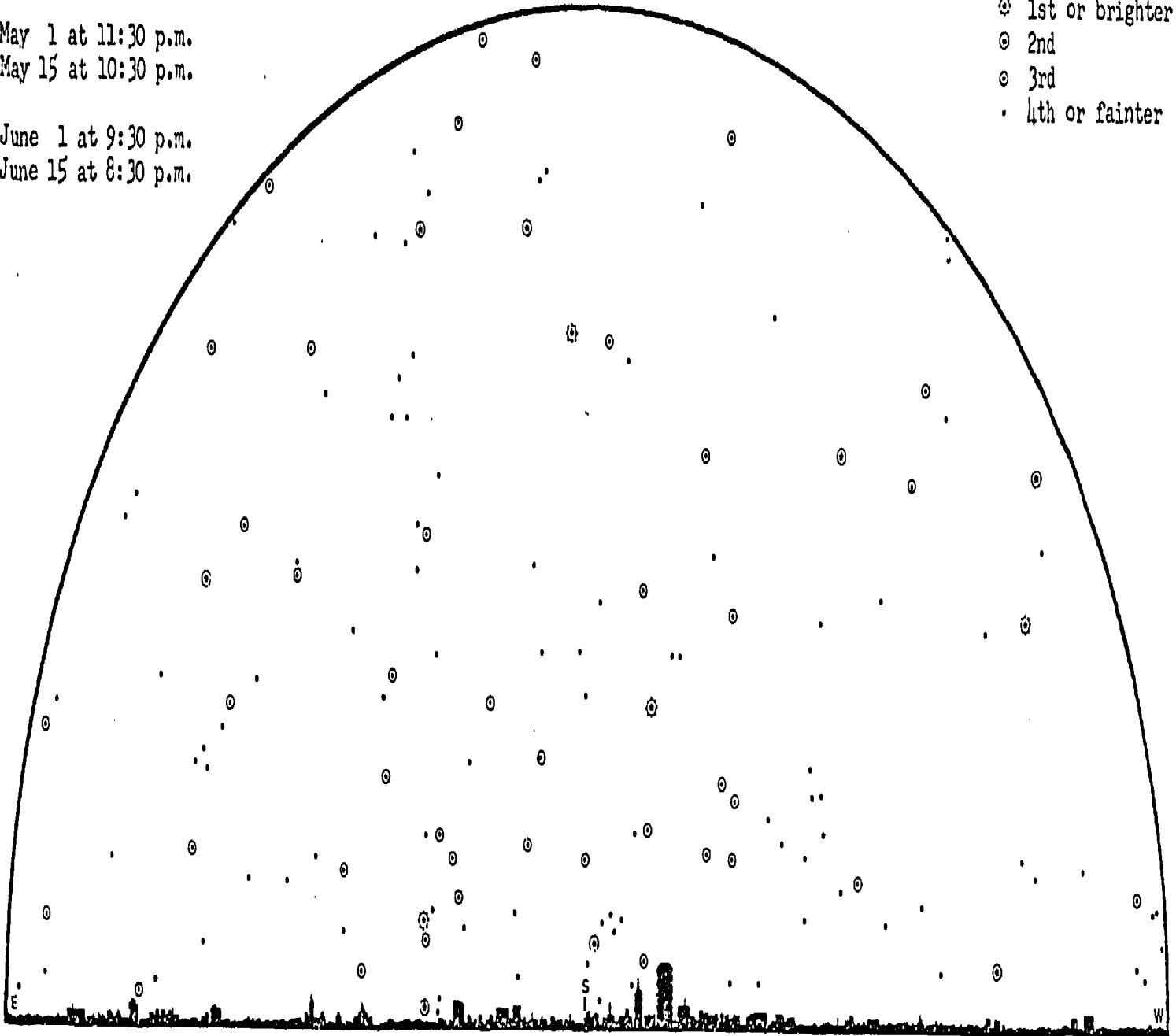

JULY-AUGUST SKY MAP
North Horizon

Star Magnitudes

July 1 at 11:30 p.m.
July 15 at 10:30 p.m.

August 1 at 9:30 p.m.
August 15 at 8:30 p.m.

⊙ 1st or brighter
⊙ 2nd
⊙ 3rd
• 4th or fainter

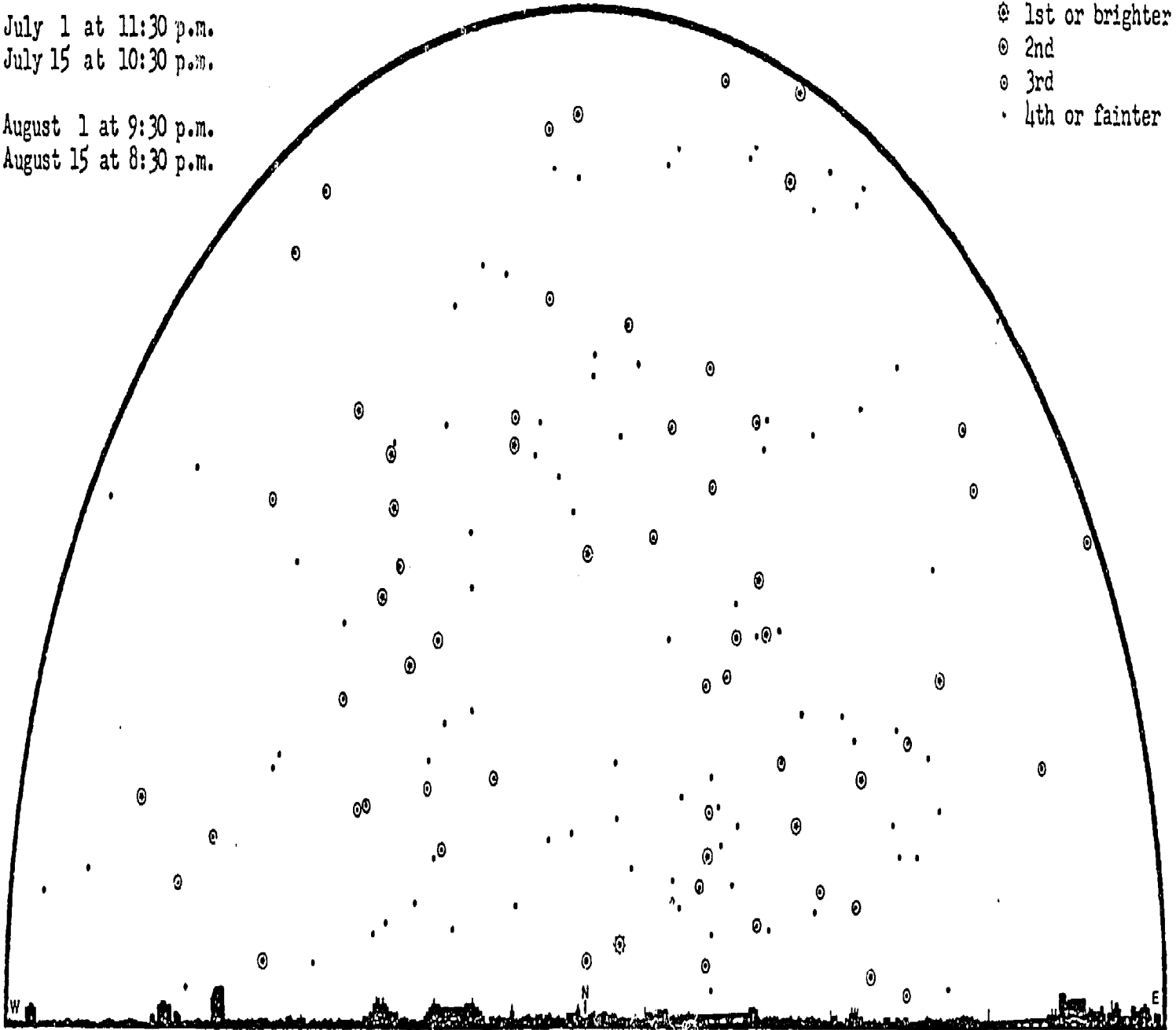

JULY-AUGUST SKY MAP

South Horizon

July 1 at 11:30 p.m.

July 15 at 10:30 p.m.

August 1 at 9:30 p.m.

August 15 at 8:30 p.m.

Star Magnitudes

⊙ 1st or brighter

⊙ 2nd

⊙ 3rd

• 4th or fainter

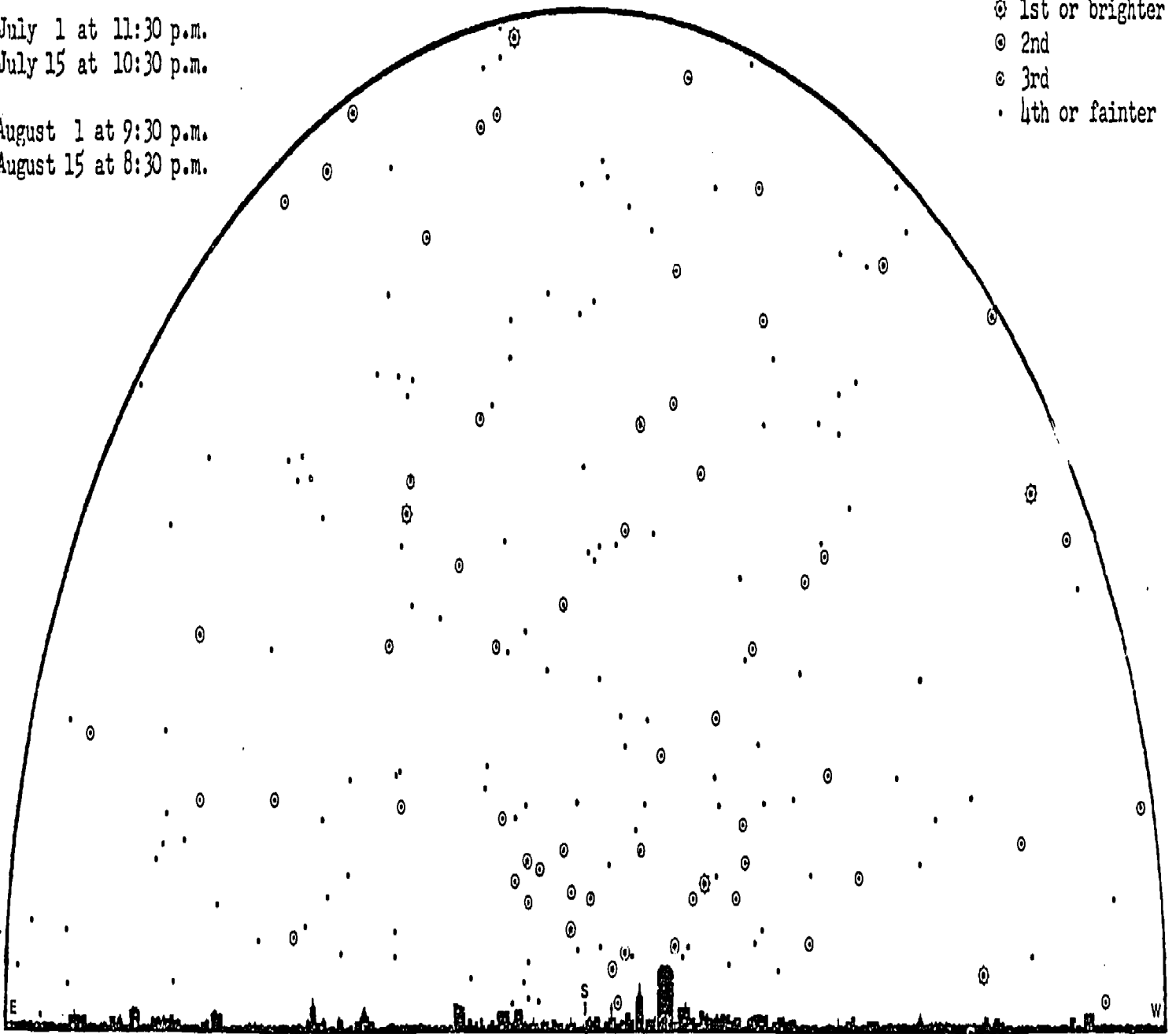

SEPTEMBER-OCTOBER SKY MAP

North Horizon

September 1 at 11:30 p.m.

September 15 at 10:30 p.m.

October 1 at 9:30 p.m.

October 15 at 8:30 p.m.

Star Magnitudes

⊙ 1st or brighter

○ 2nd

◉ 3rd

• 4th or fainter

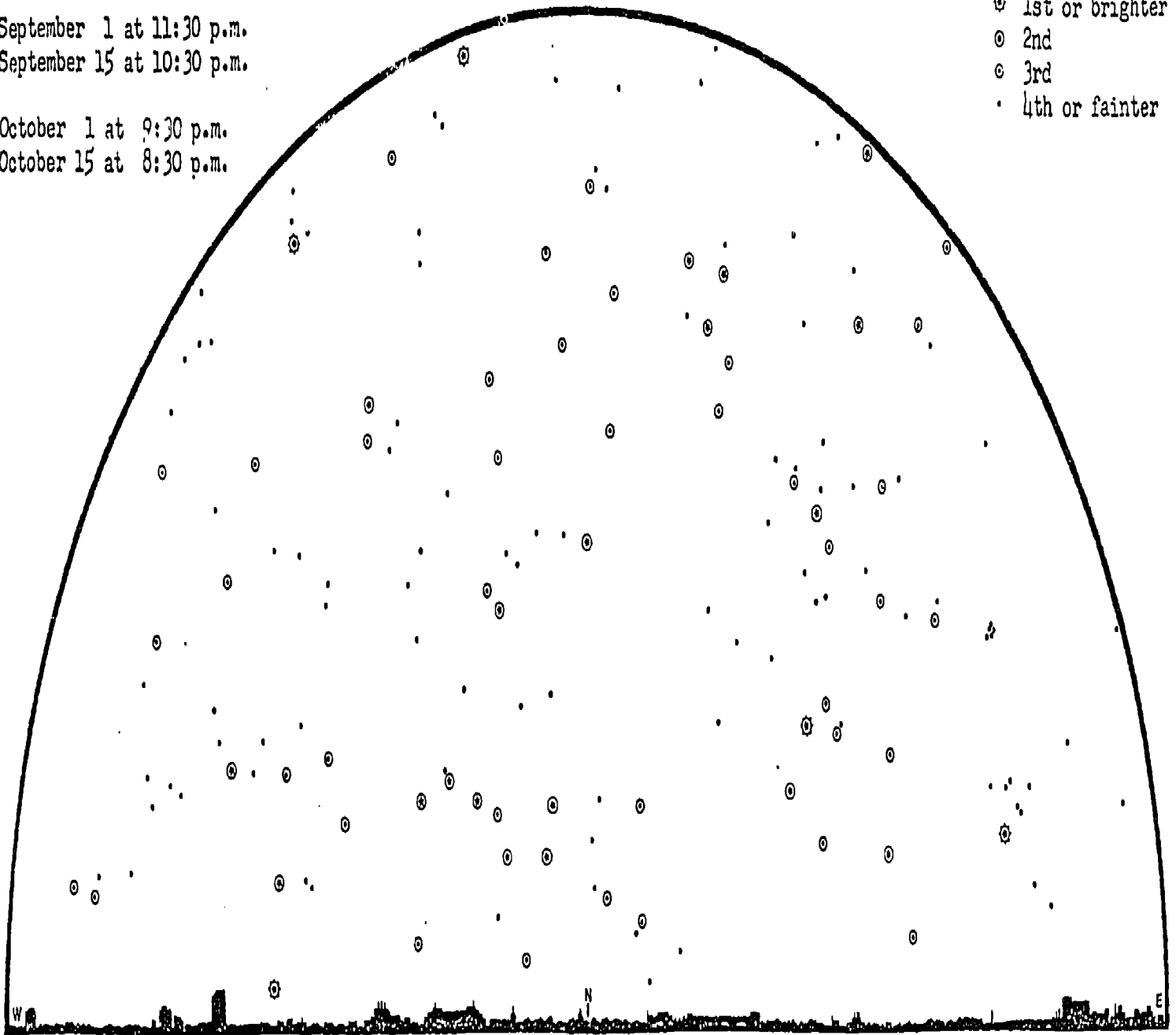

SEPTEMBER-OCTOBER SKY MAP

South Horizon

September 1 at 11:30 p.m.

September 15 at 10:30 p.m.

October 1 at 9:30 p.m.

October 15 at 8:30 p.m.

Star Magnitudes

⊙ 1st or brighter

⊙ 2nd

⊙ 3rd

· 4th or fainter

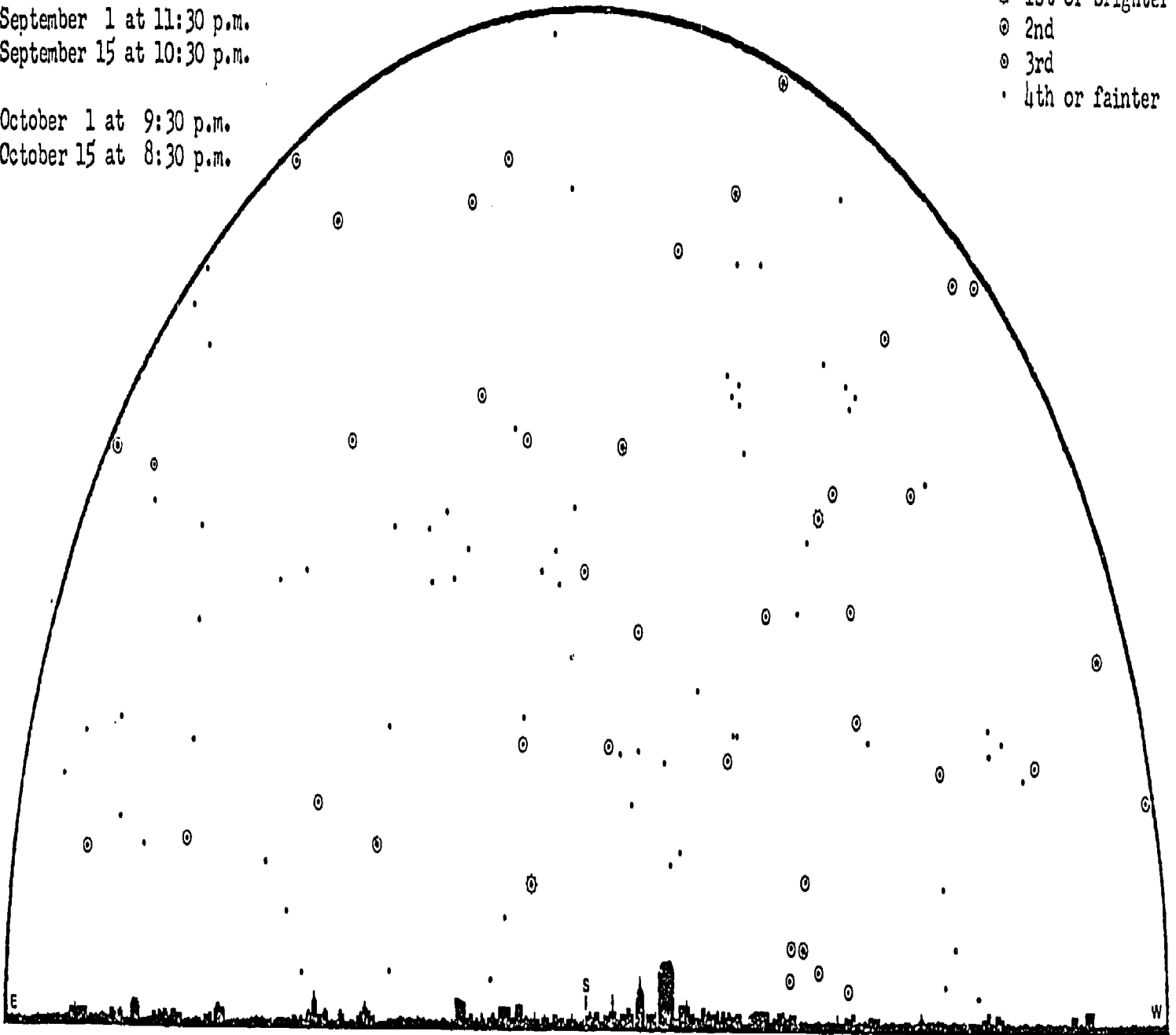

NOVEMBER-DECEMBER SKY MAP

North Horizon

Star Magnitudes

November 1 at 11:30 p.m.

November 15 at 10:30 p.m.

December 1 at 9:30 p.m.

December 15 at 8:30 p.m.

⊙ 1st or brighter

⊙ 2nd

⊙ 3rd

· 4th or fainter

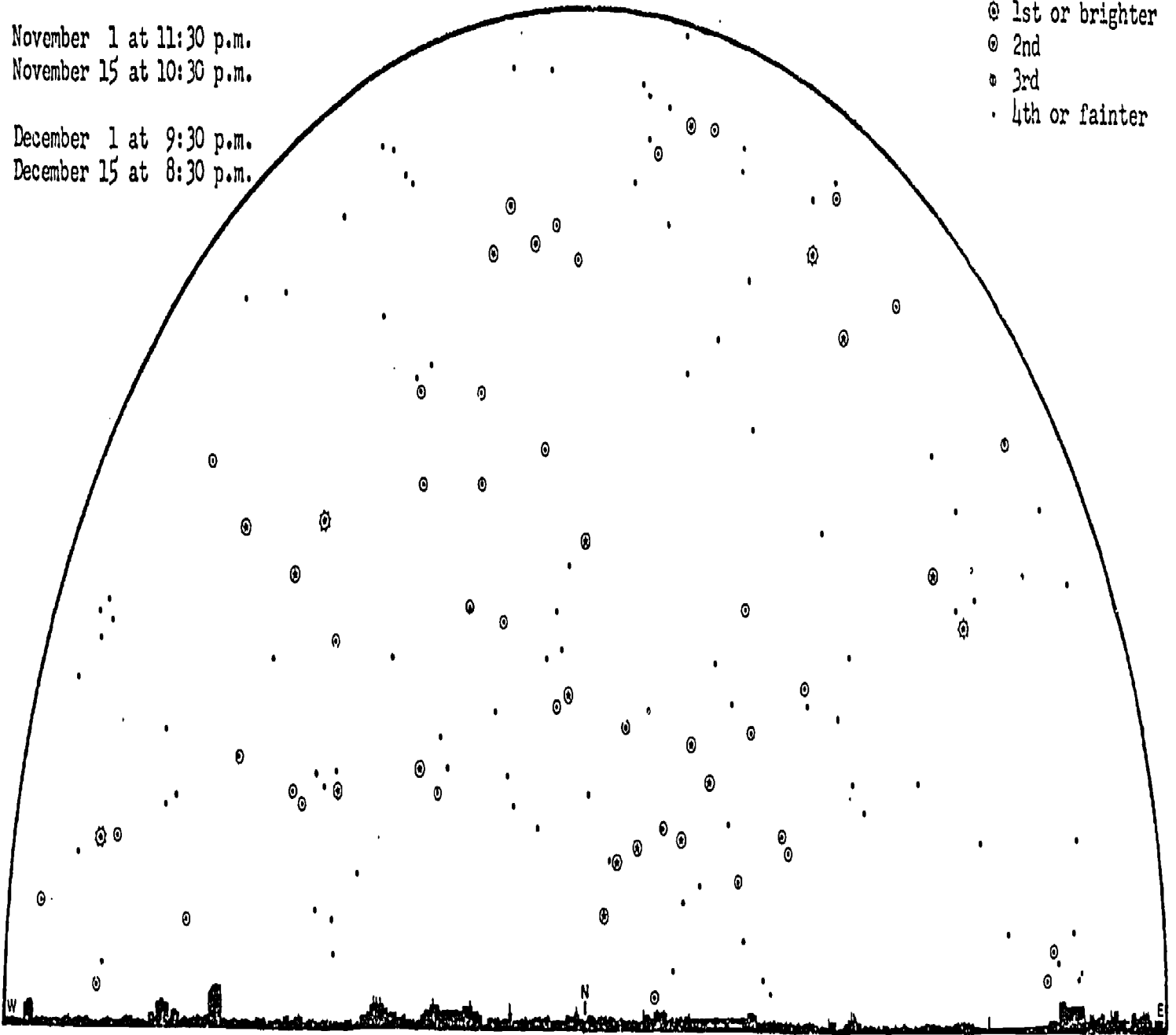

NOVEMBER-DECEMBER SKY MAP
 South Horizon

Star Magnitudes

November 1 at 11:30 p.m.
 November 15 at 10:30 p.m.

December 1 at 9:30 p.m.
 December 15 at 8:30 p.m.

- ⊙ 1st or brighter
- ⊙ 2nd
- ⊙ 3rd
- 4th or fainter

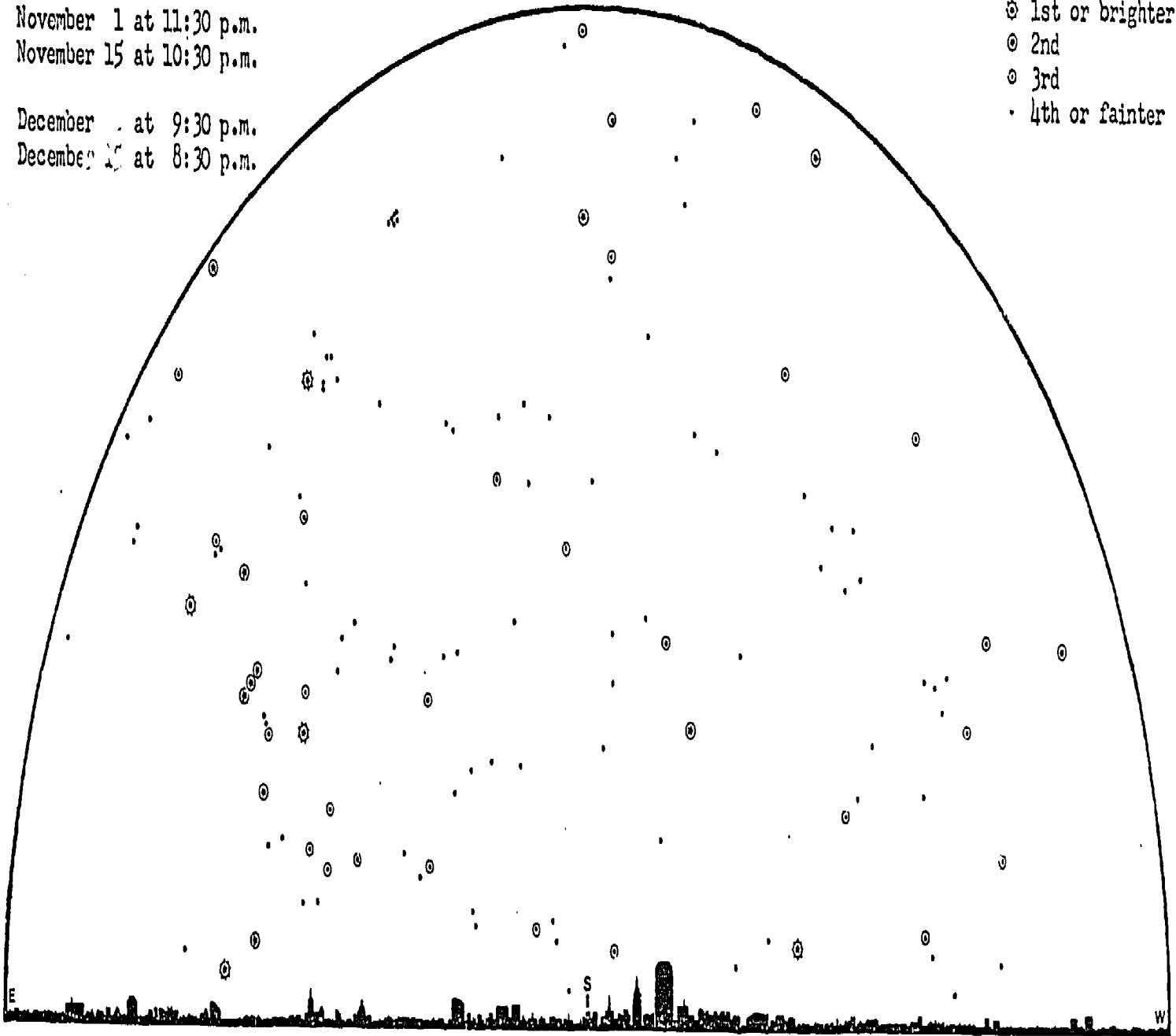

JANUARY-FEBRUARY SKY MAP

North Horizon

Star Magnitudes

January 1 at 11:30 p.m.

January 15 at 10:30 p.m.

February 1 at 9:30 p.m.

February 15 at 8:30 p.m.

- ⊙ 1st or brighter
- ⊙ 2nd
- ⊙ 3rd
- 4th or fainter

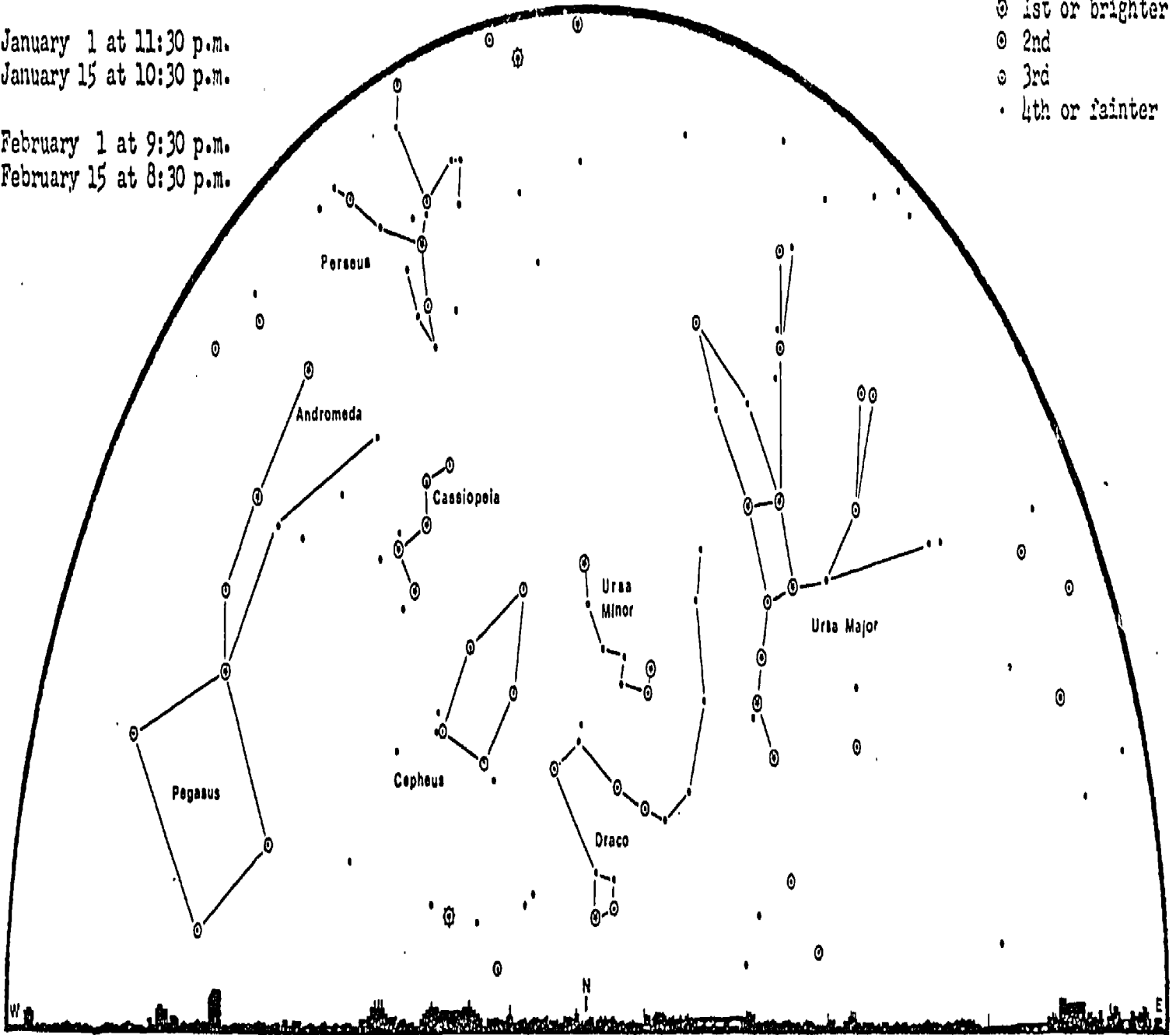

JANUARY-FEBRUARY SKY MAP

South Horizon

January 1 at 11:30 p.m.

January 15 at 10:30 p.m.

February 1 at 9:30 p.m.

February 15 at 8:30 p.m.

Star Magnitudes

- ⊙ 1st or brighter
- ⊙ 2nd
- ⊙ 3rd
- 4th or fainter

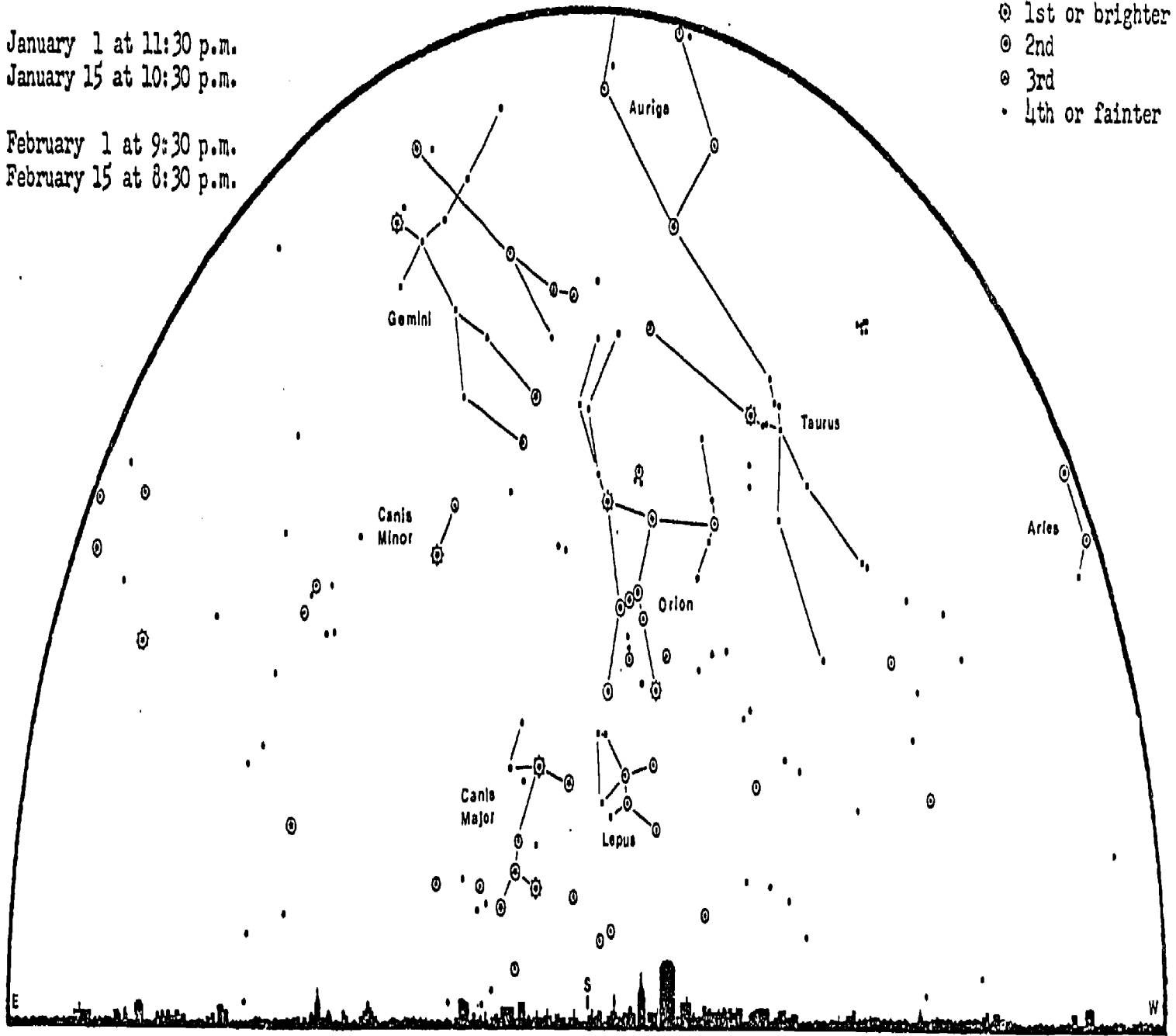

MARCH-APRIL SKY MAP
North Horizon

March 1 at 11:30 p.m.
March 15 at 10:30 p.m.

April 1 at 9:30 p.m.
April 15 at 8:30 p.m.

Star Magnitudes

- ⊙ 1st or brighter
- ⊙ 2nd
- ⊙ 3rd
- 4th or fainter

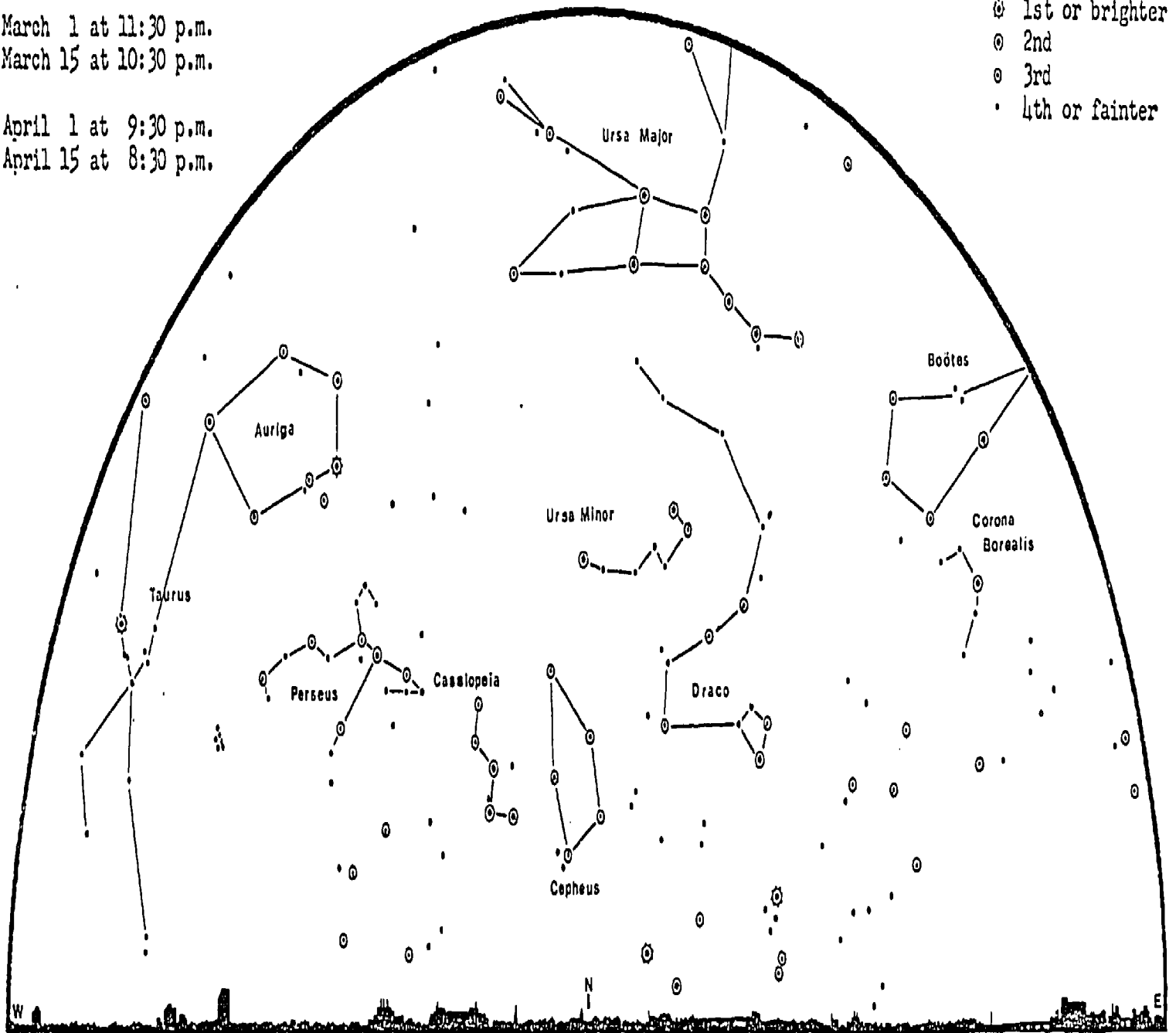

MARCH-APRIL SKY MAP

South Horizon

March 1 at 11:30 p.m.

March 15 at 10:30 p.m.

April 1 at 9:30 p.m.

April 15 at 8:30 p.m.

Star Magnitudes

⊙ 1st or brighter

⊙ 2nd

⊙ 3rd

• 4th or fainter

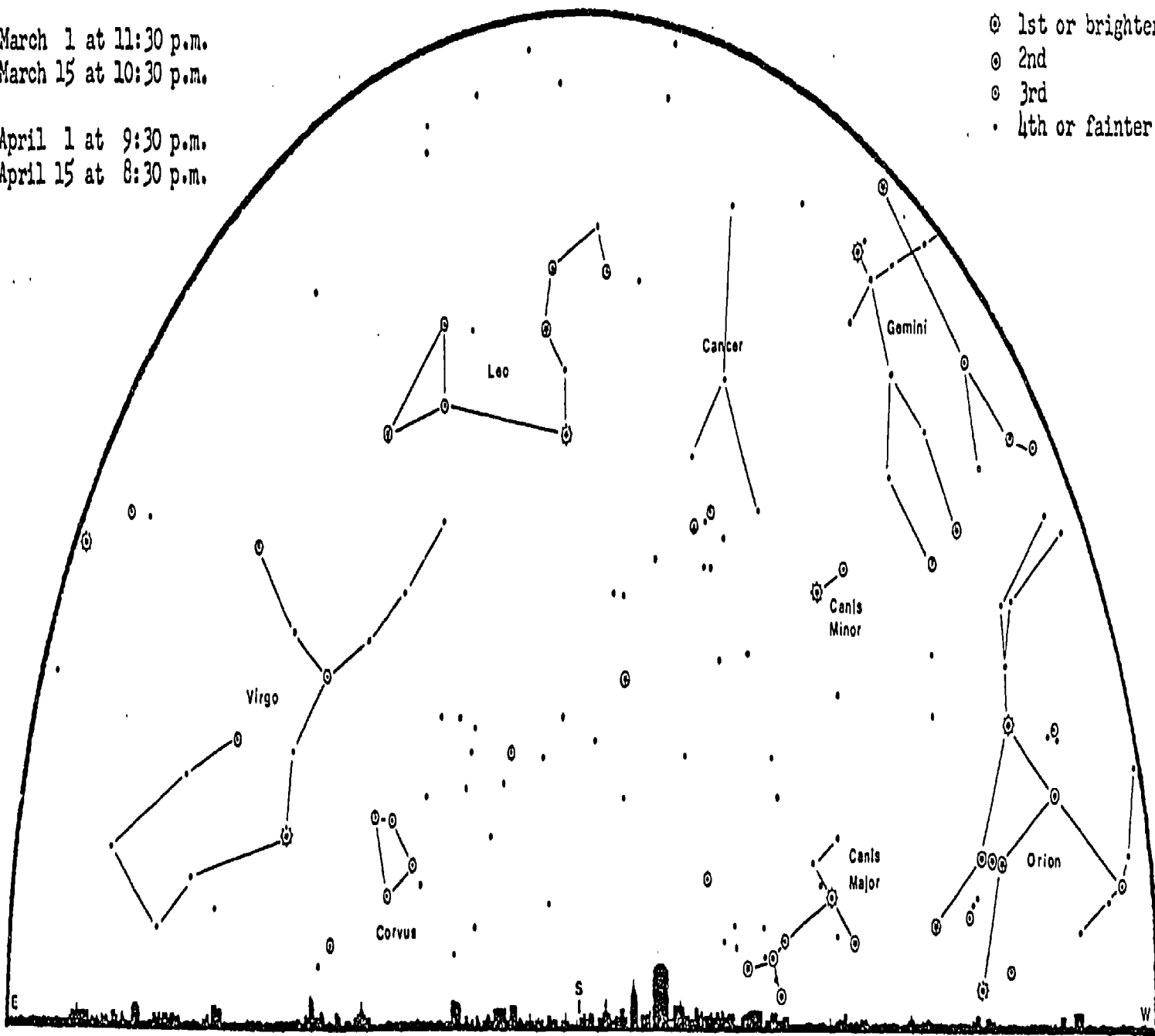

MAY-JUNE SKY MAP
North Horizon

Star Magnitudes

May 1 at 11:30 p.m.
May 15 at 10:30 p.m.

June 1 at 9:30 p.m.
June 15 at 8:30 p.m.

- ⊙ 1st or brighter
- ⊙ 2nd
- ⊙ 3rd
- 4th or fainter

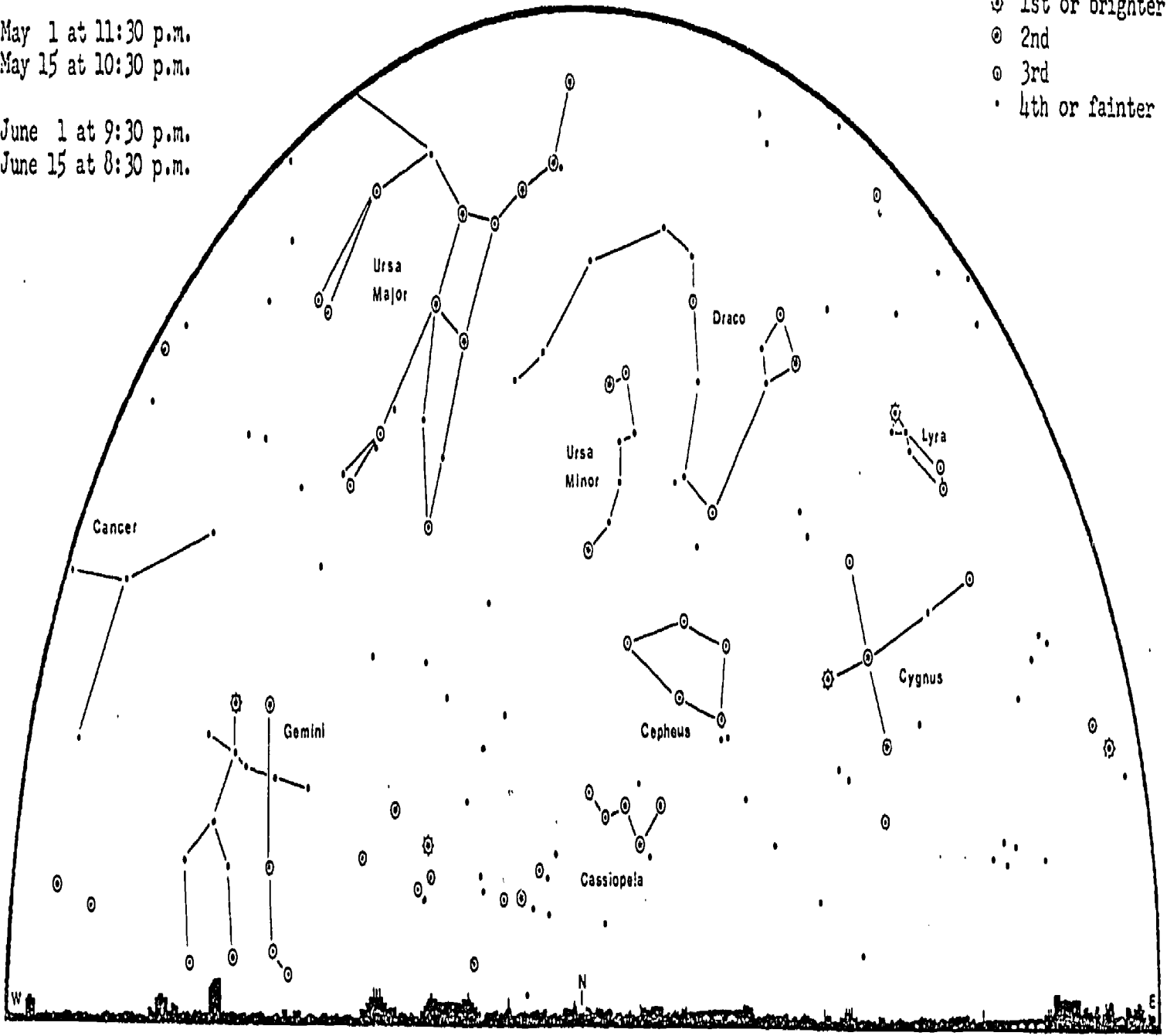

MAY-JUNE SKY MAP
South Horizon

Star Magnitudes

May 1 at 11:30 p.m.
May 15 at 10:30 p.m.

June 1 at 9:30 p.m.
June 15 at 8:30 p.m.

- ⊙ 1st or brighter
- ⊙ 2nd
- ⊙ 3rd
- 4th or fainter

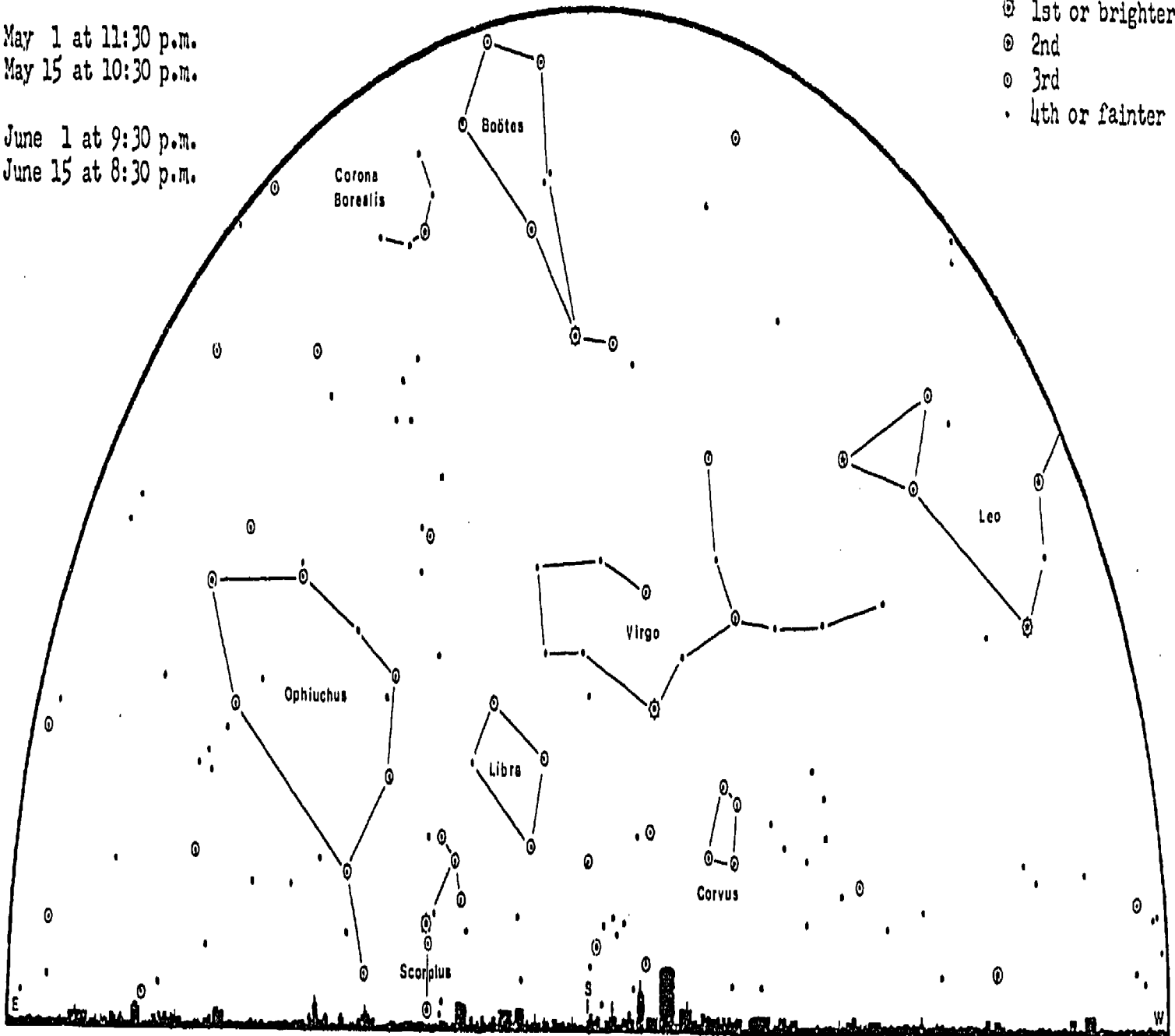

JULY-AUGUST SKY MAP
North Horizon

Star Magnitudes

July 1 at 11:30 p.m.
July 15 at 10:30 p.m.

August 1 at 9:30 p.m.
August 15 at 8:30 p.m.

⊙ 1st or brighter
⊙ 2nd
⊙ 3rd
· 4th or fainter

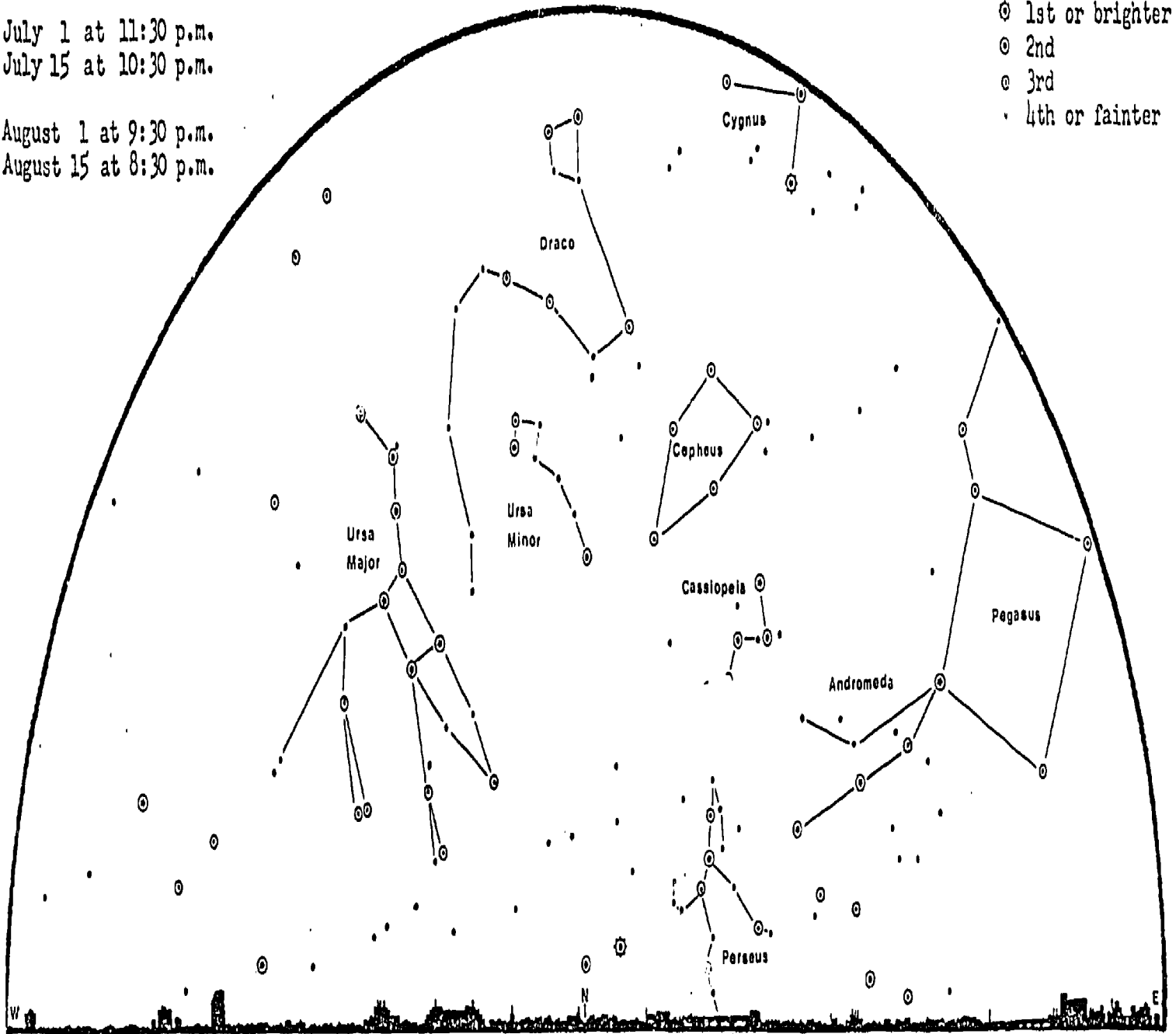

JULY-AUGUST SKY MAP
South Horizon

Star Magnitudes

July 1 at 11:30 p.m.
July 15 at 10:30 p.m.
August 1 at 9:30 p.m.
August 15 at 8:30 p.m.

- ⊙ 1st or brighter
- ⊙ 2nd
- ⊙ 3rd
- 4th or fainter

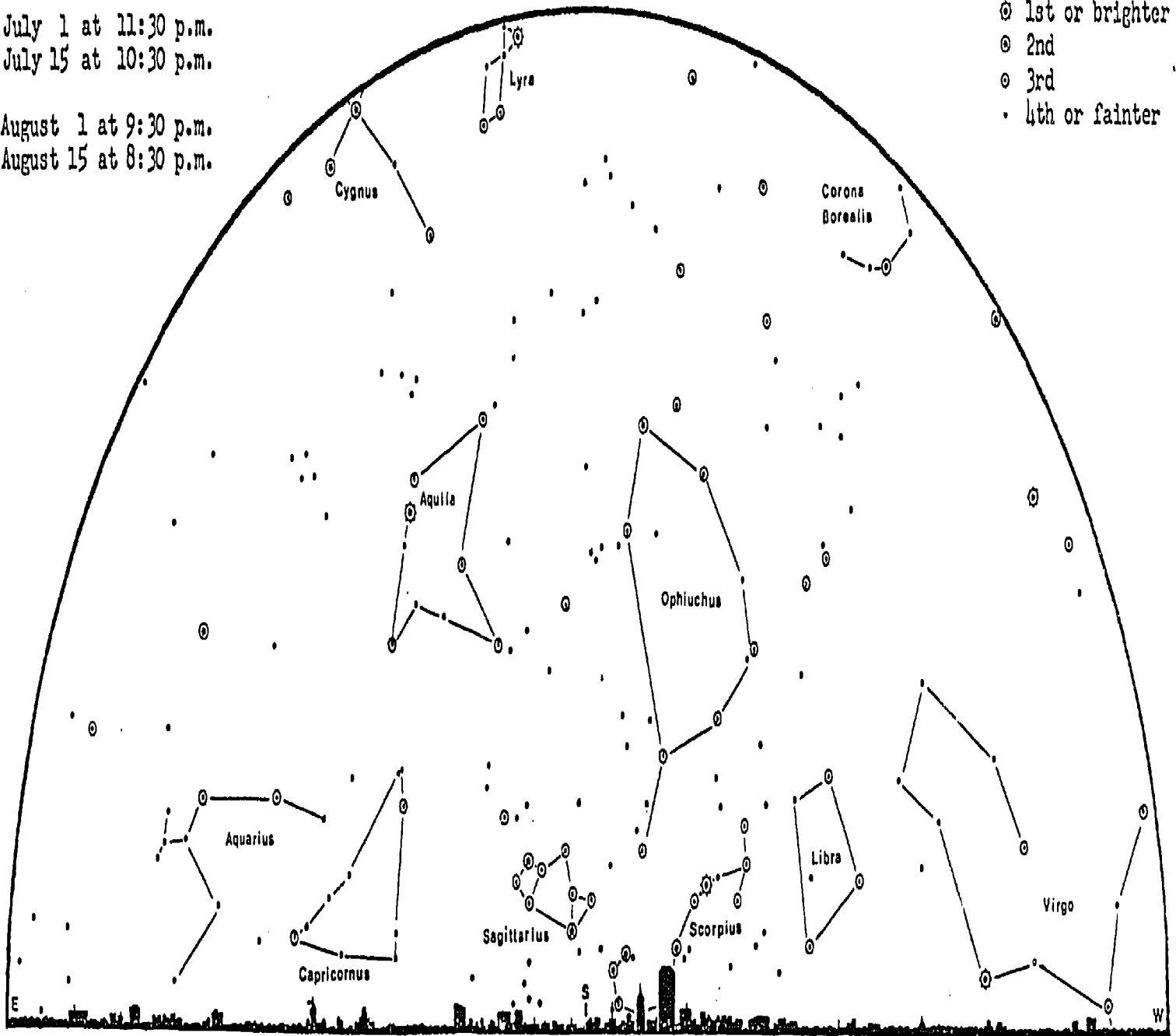

SEPTEMBER-OCTOBER SKY MAP

North Horizon

Star Magnitudes

September 1 at 11:30 p.m.

September 15 at 10:30 p.m.

October 1 at 9:30 p.m.

October 15 at 8:30 p.m.

⊕ 1st or brighter

⊙ 2nd

⊖ 3rd

· 4th or fainter

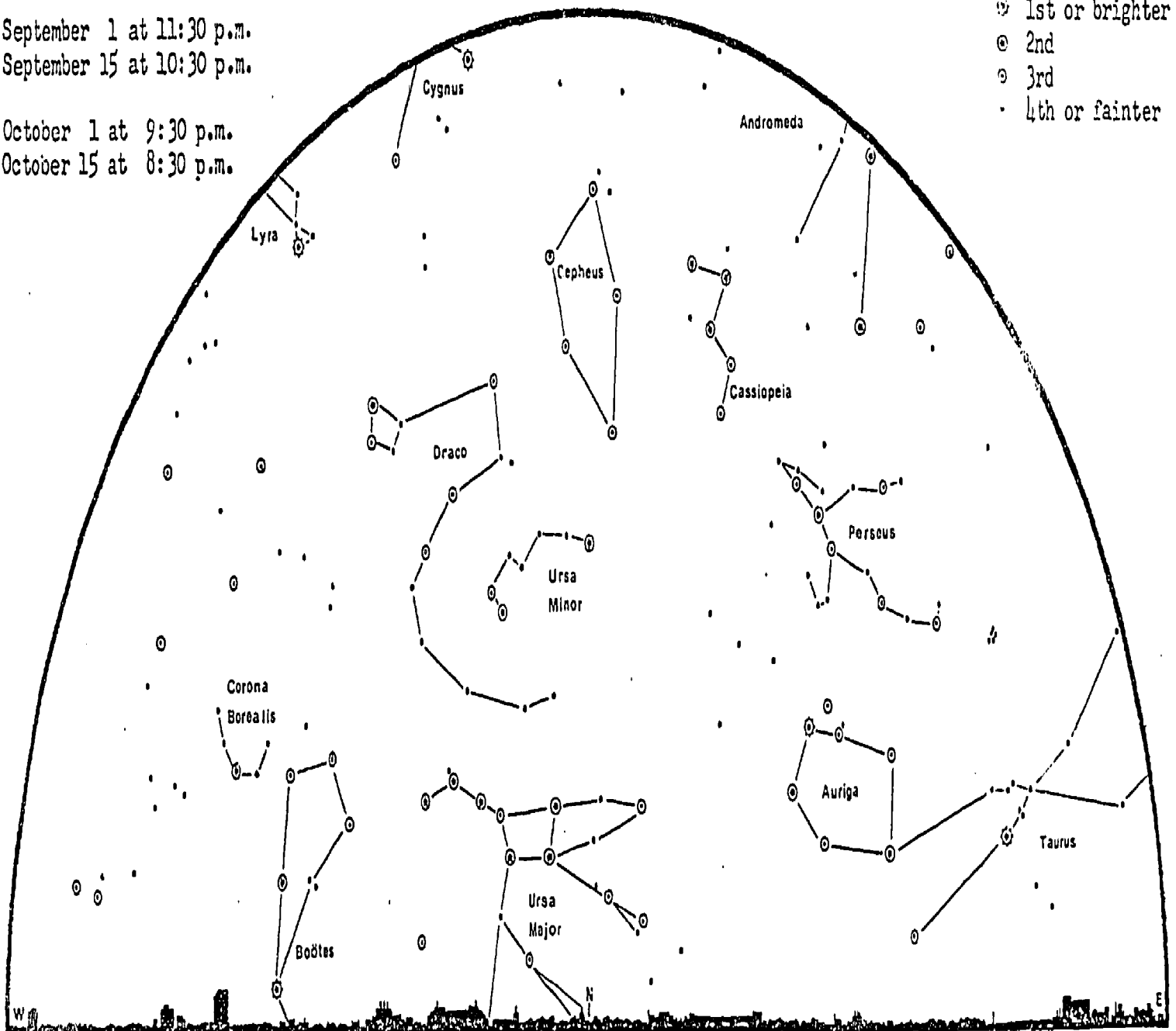

SEPTEMBER-OCTOBER SKY MAP
South Horizon

Star Magnitudes

September 1 at 11:30 p.m.
September 15 at 10:30 p.m.

October 1 at 9:30 p.m.
October 15 at 8:30 p.m.

- ⊙ 1st or brighter
- ⊙ 2nd
- ⊙ 3rd
- 4th or fainter

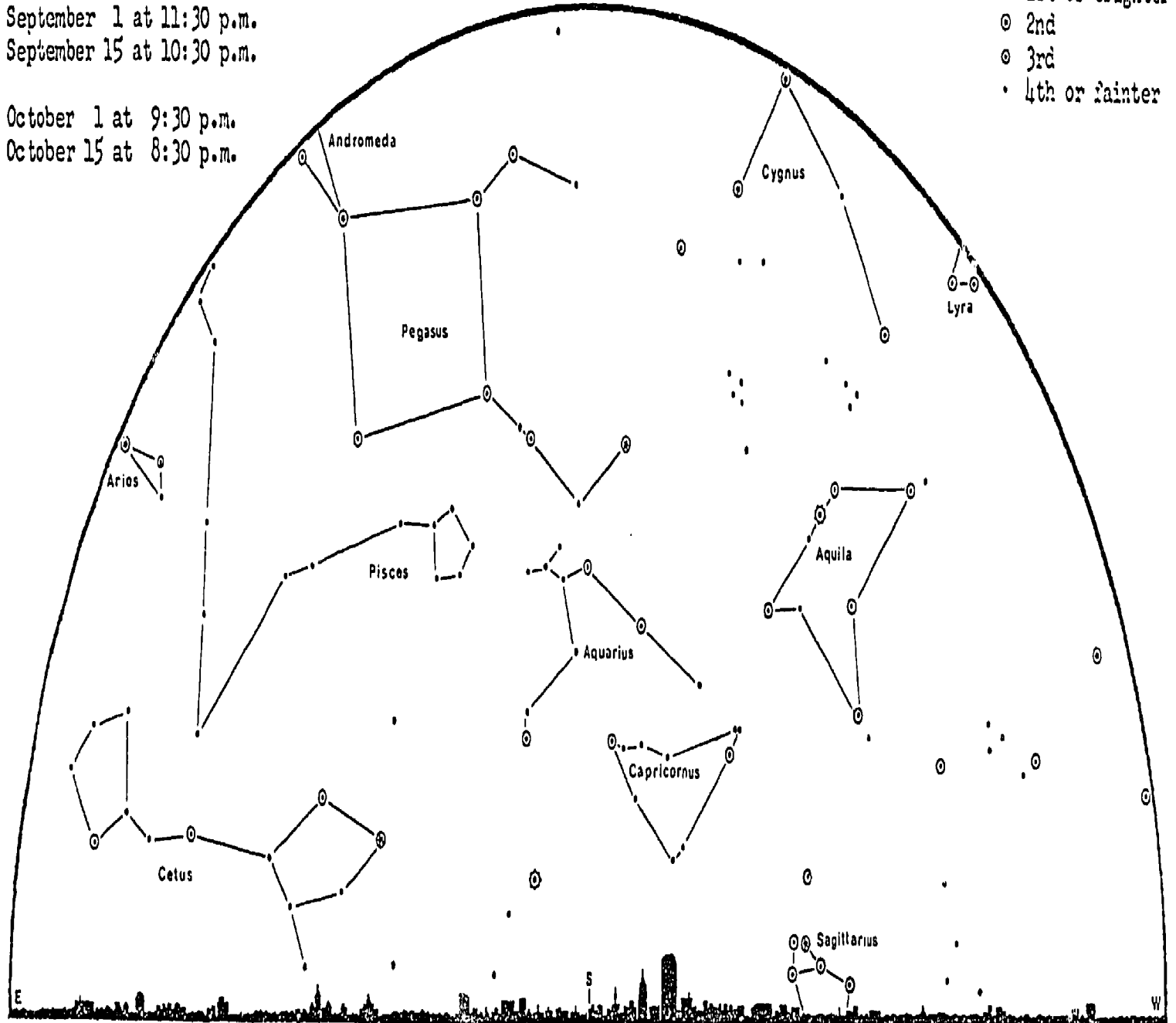

NOVEMBER-DECEMBER SKY MAP

North Horizon

November 1 at 11:30 p.m.

November 15 at 10:30 p.m.

December 1 at 9:30 p.m.

December 15 at 8:30 p.m.

Star Magnitudes

⊙ 1st or brighter

⊙ 2nd

⊙ 3rd

• 4th or fainter

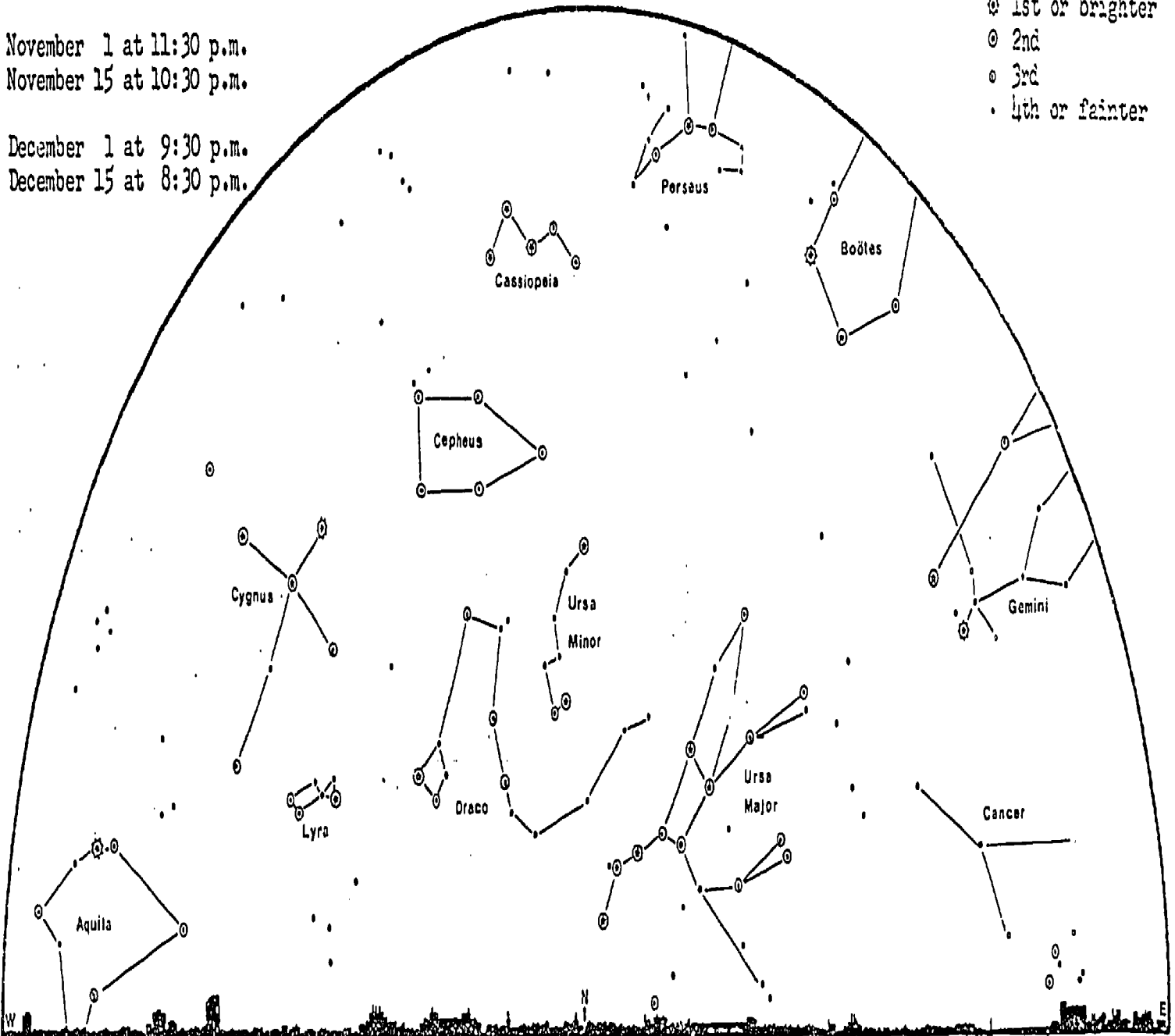

NOVEMBER-DECEMBER SKY MAP
 South Horizon

Star Magnitudes

November 1 at 11:30 p.m.
 November 15 at 10:30 p.m.

December 1 at 9:30 p.m.
 December 15 at 8:30 p.m.

- ⊙ 1st or brighter
- ⊙ 2nd
- ⊙ 3rd
- 4th or fainter

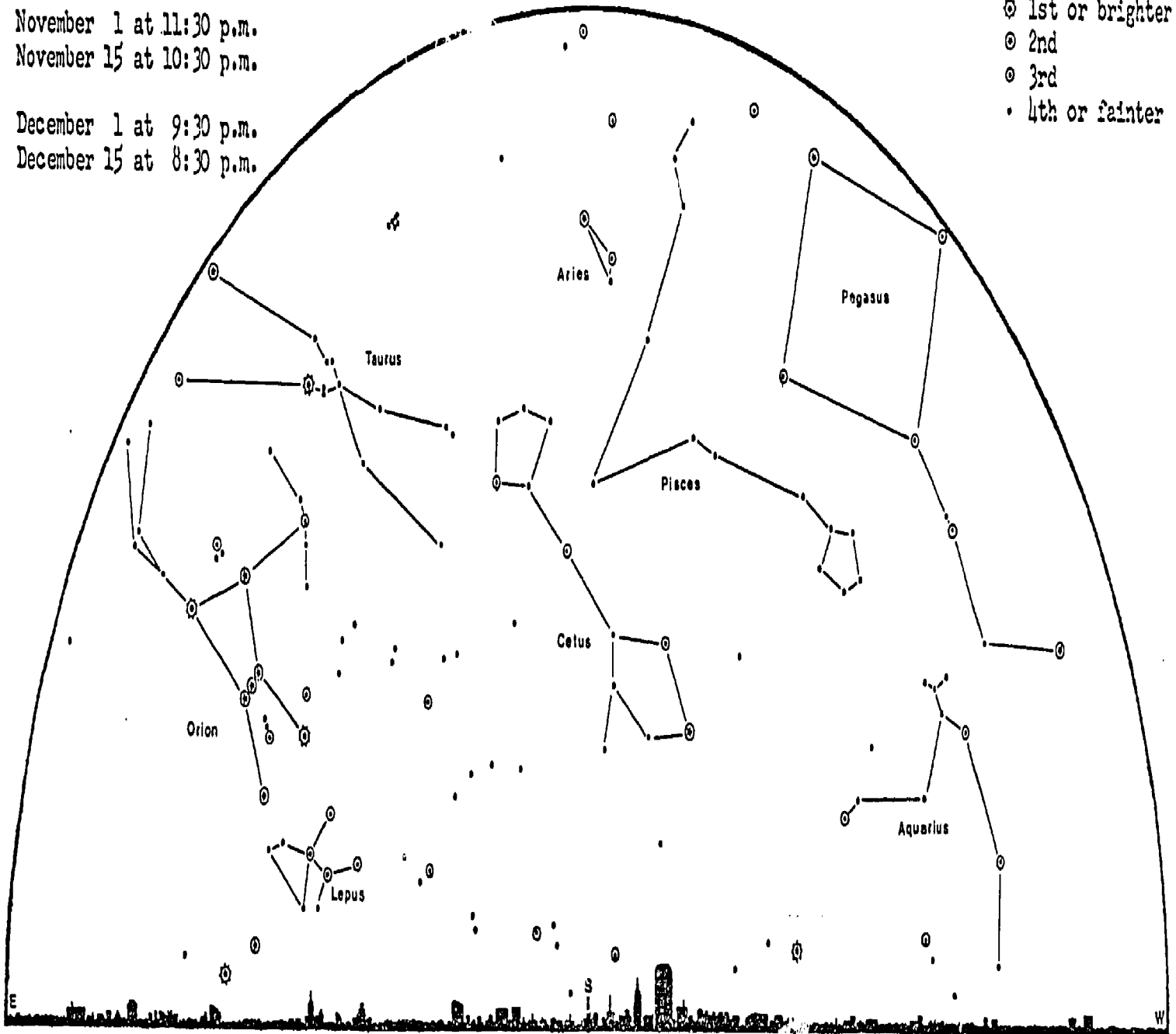

APPENDIX B
Constellation Diagrams

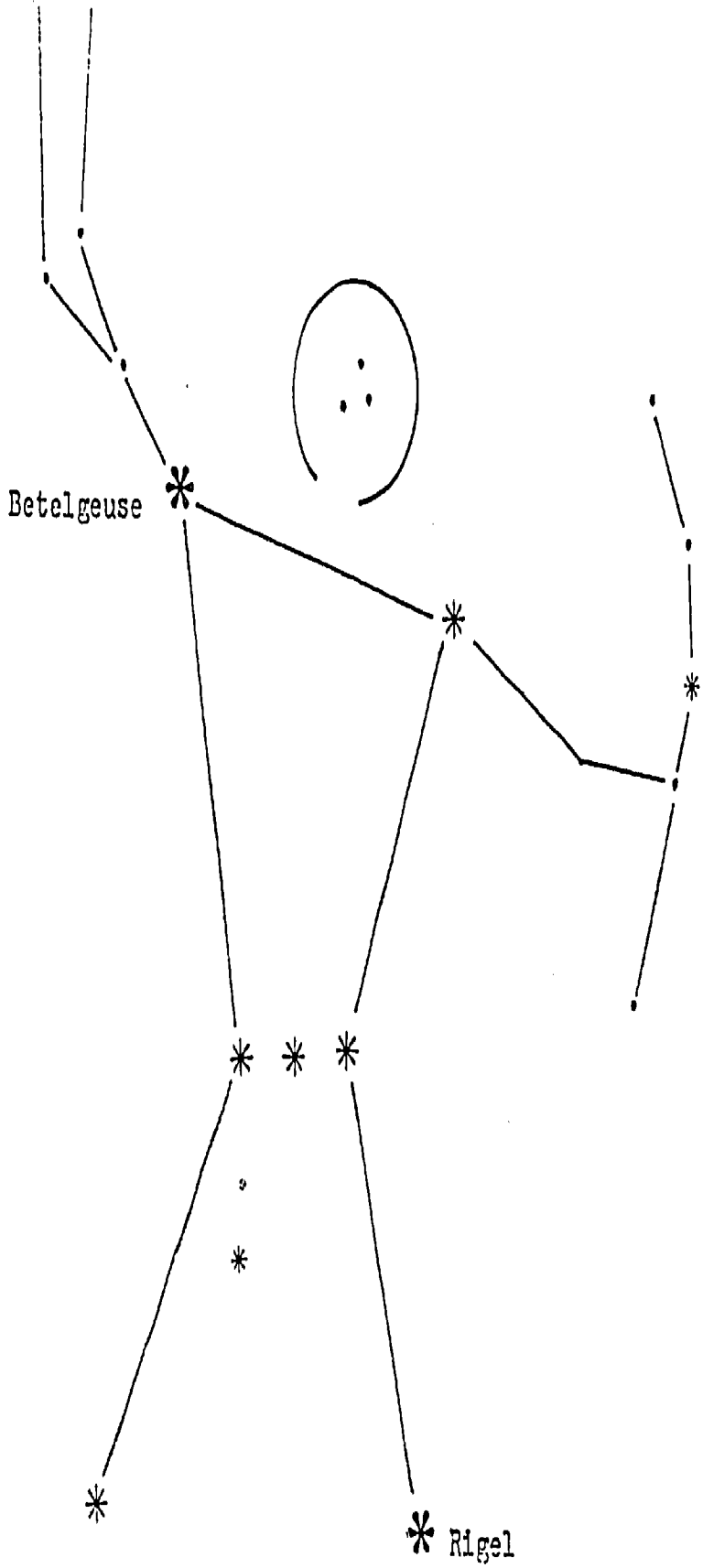

ORION
the Hunter

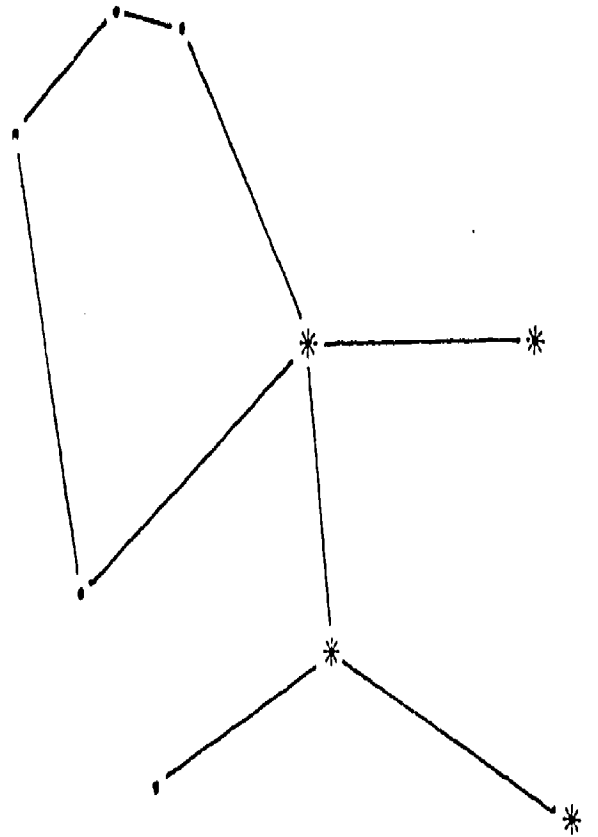

LEPUS
the Rabbit

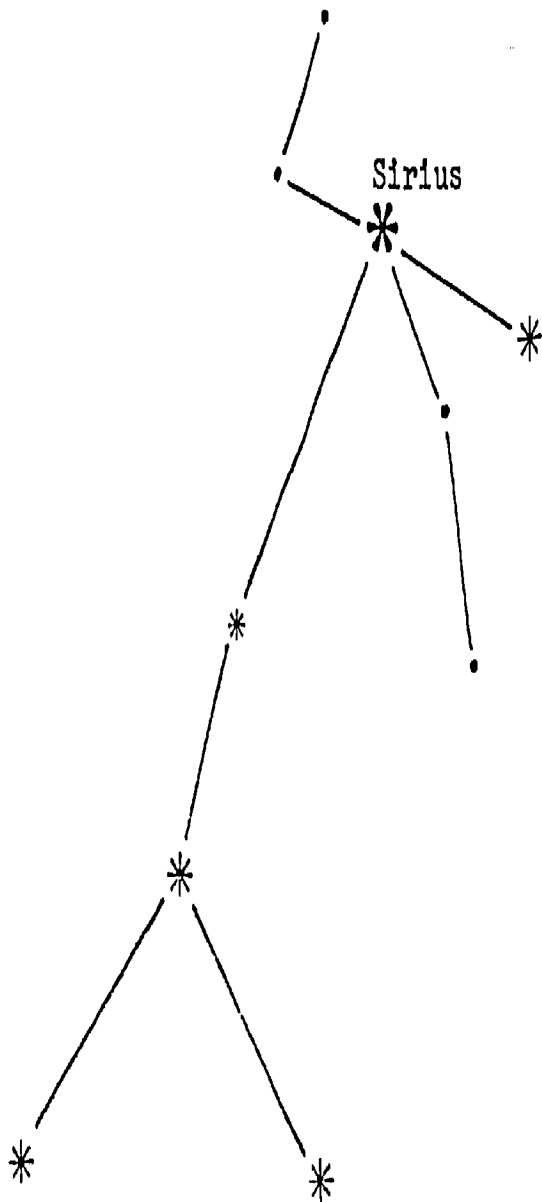

CANIS MAJOR

the Big Dog

CANIS MINOR

the Little Dog



*

TAURUS

the Bull

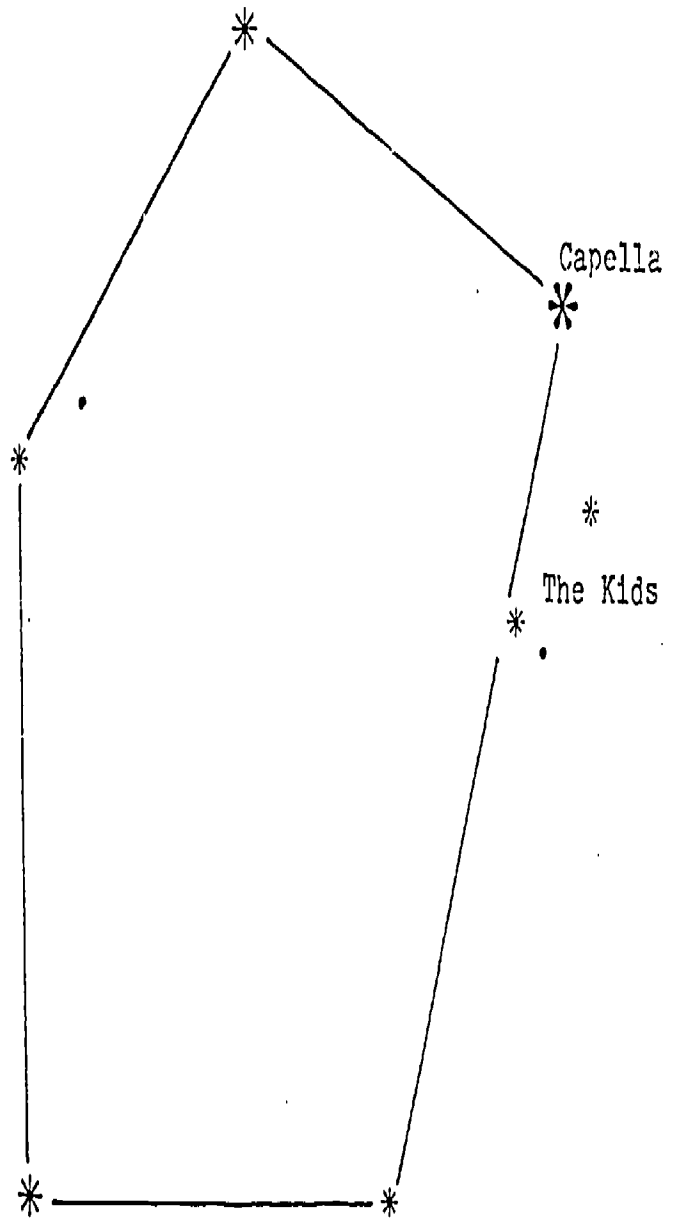
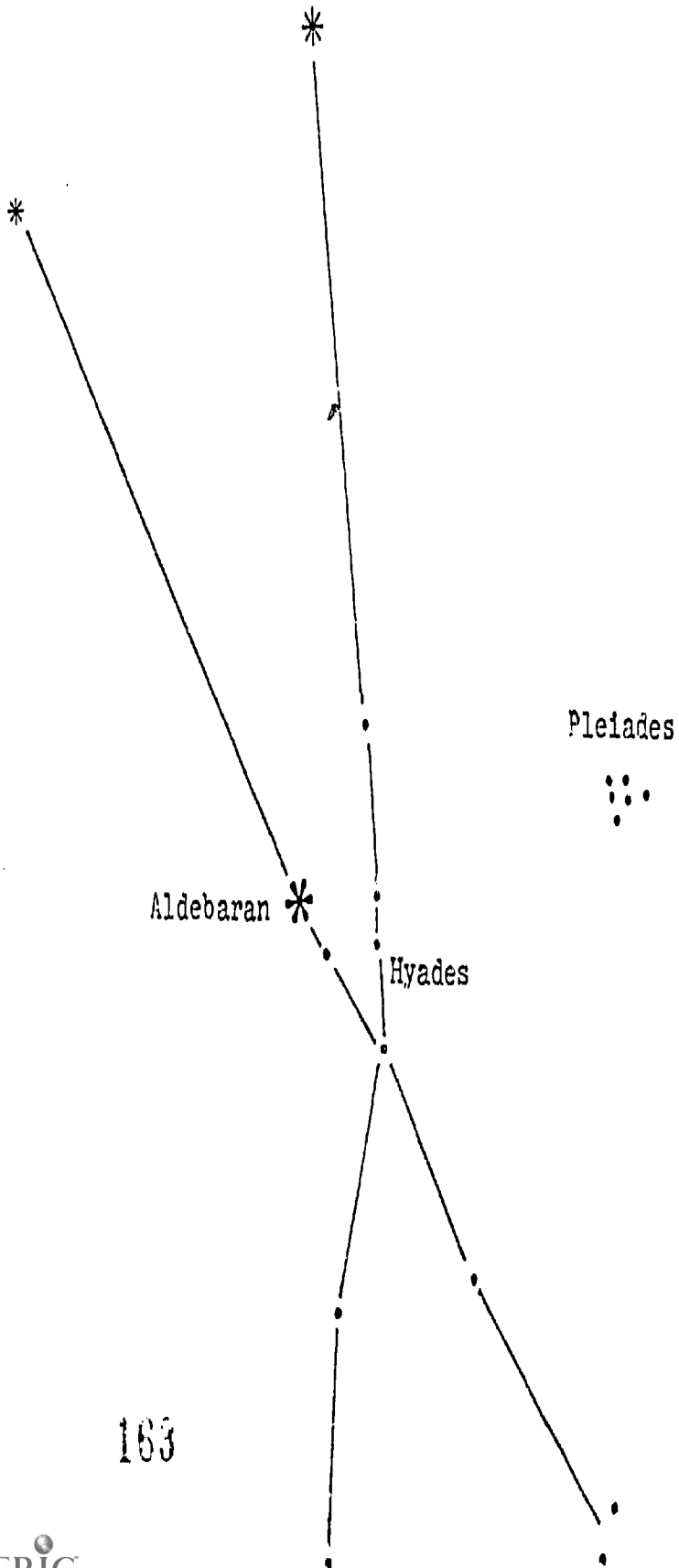

AURIGA

the Goatkeeper

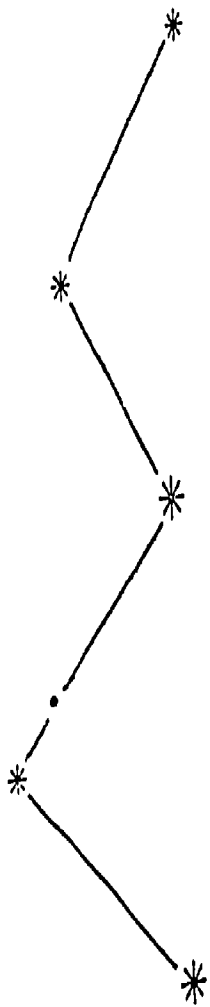

CASSIOPEIA

the Queen

165

CEPHEUS

the King

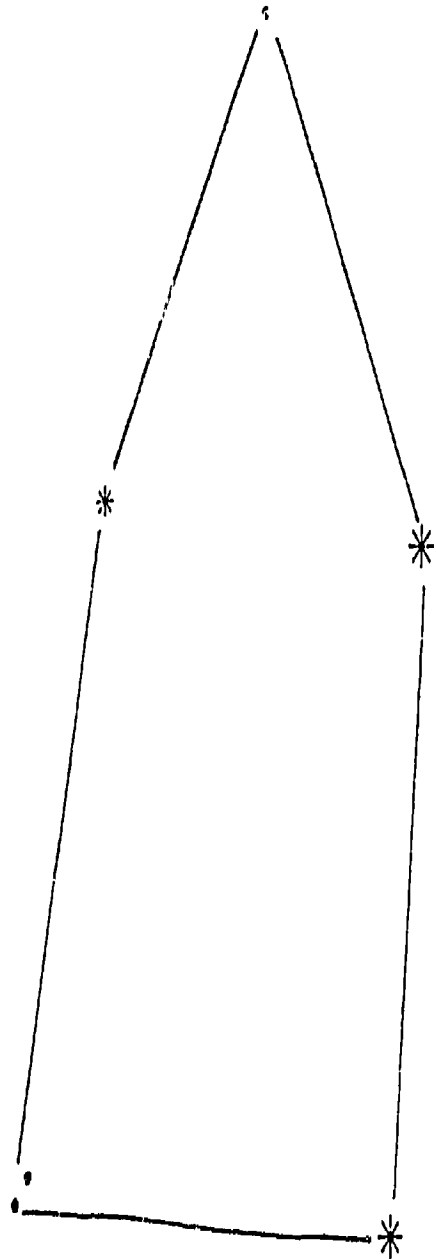

166

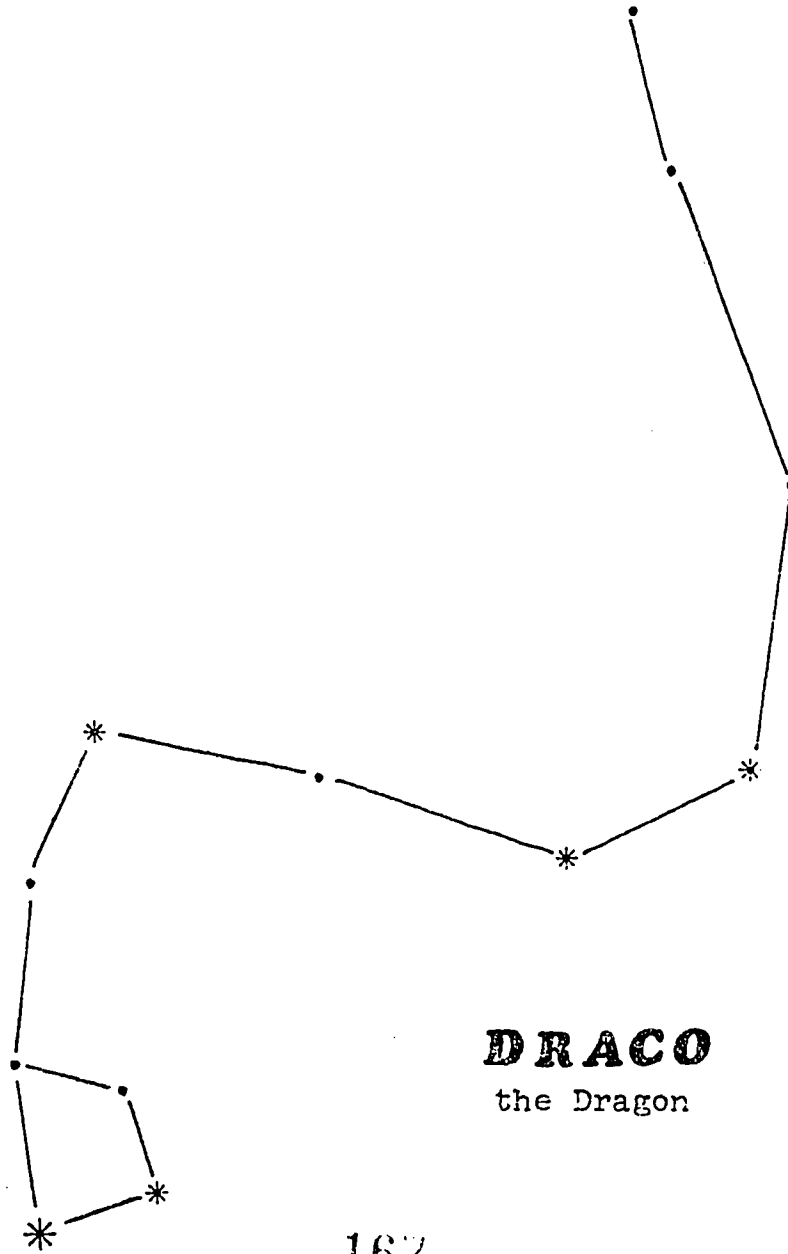

DRACO
the Dragon

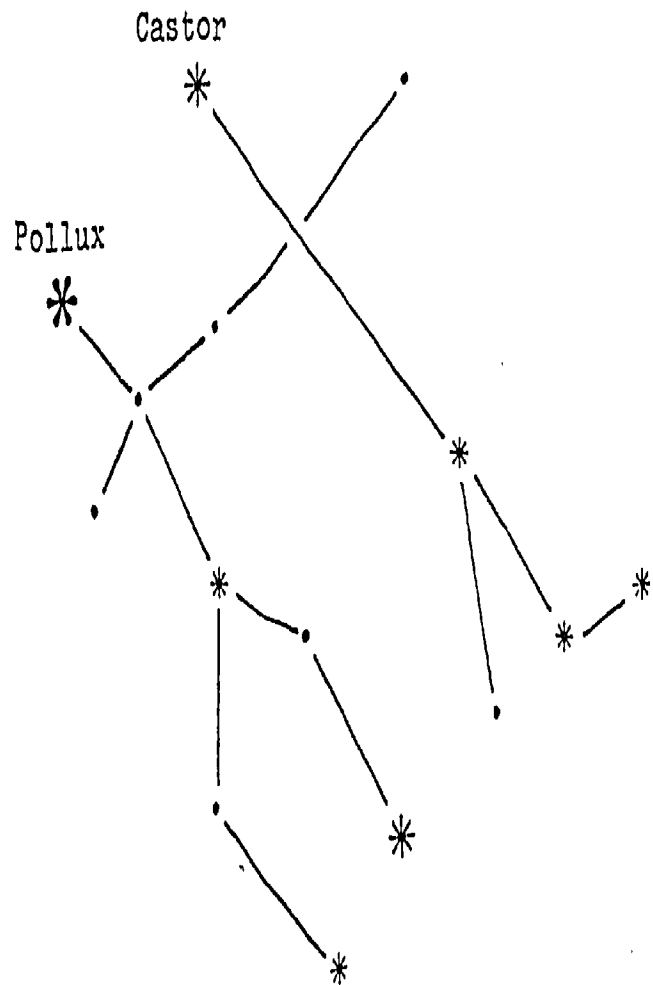
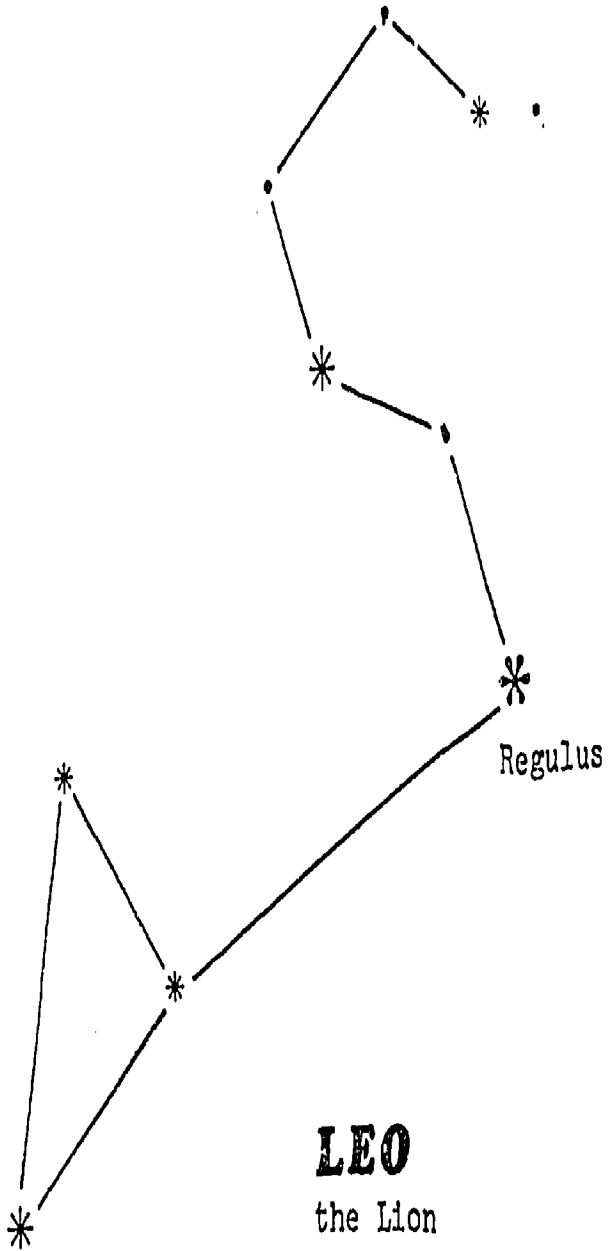

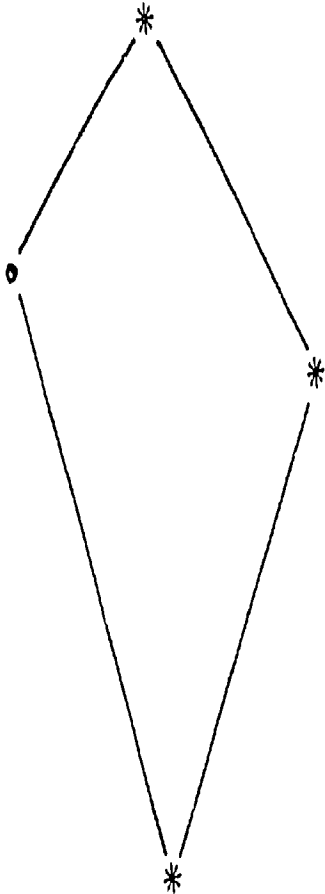

LIBRA

the Balance

170

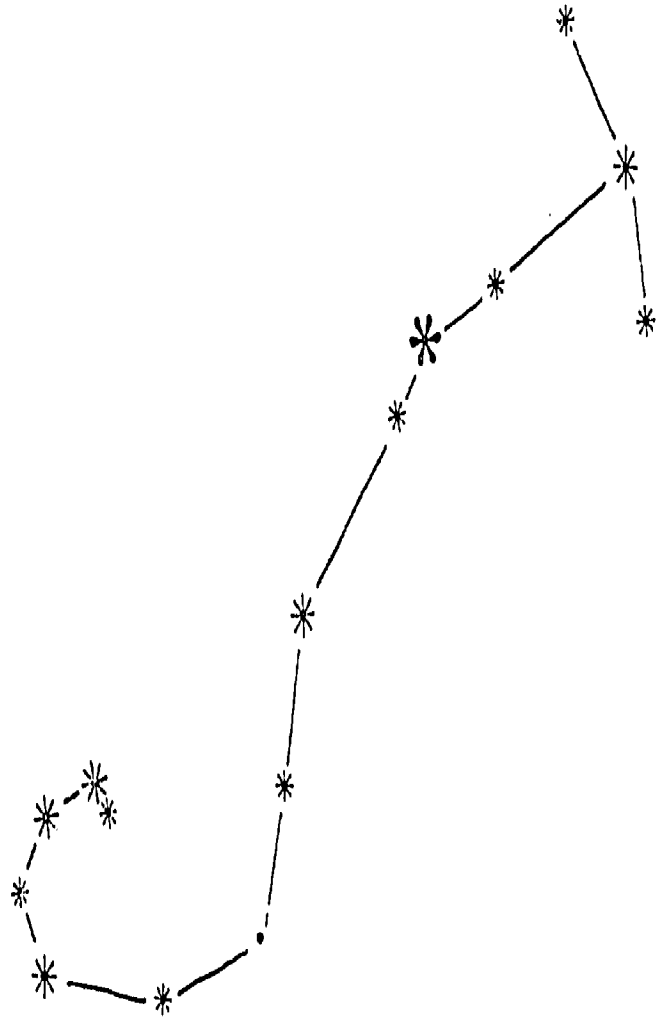

SCORPIUS

the Scorpion

171

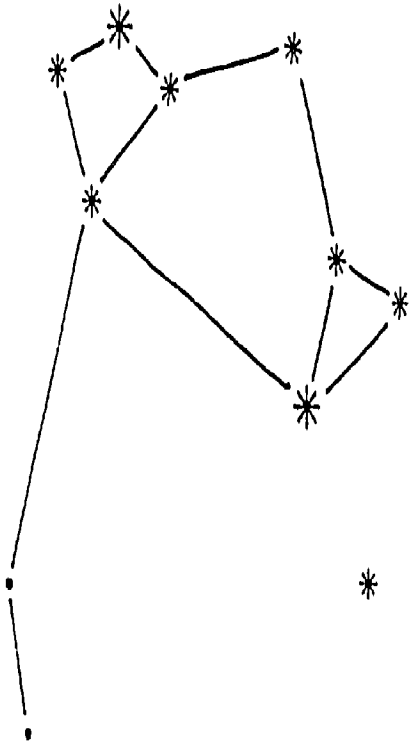

SAGITTARIUS

the Archer

172

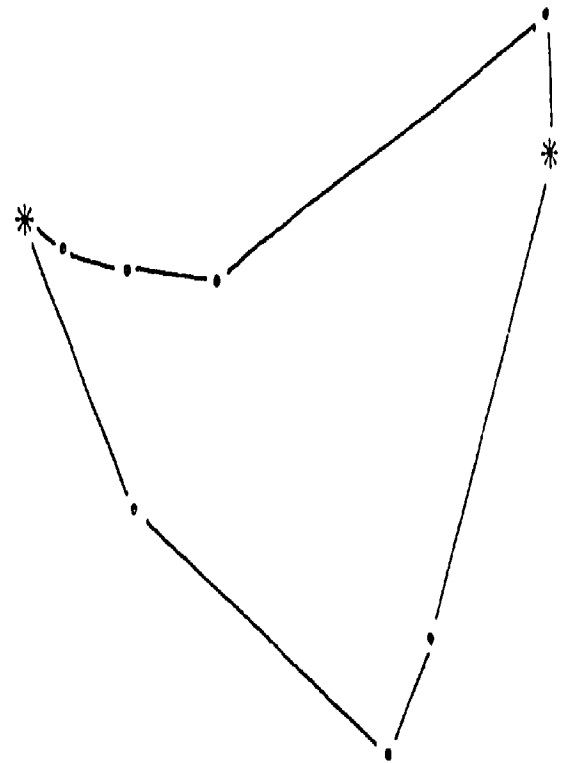

CAPRICORNUS

the Sea Goat

173

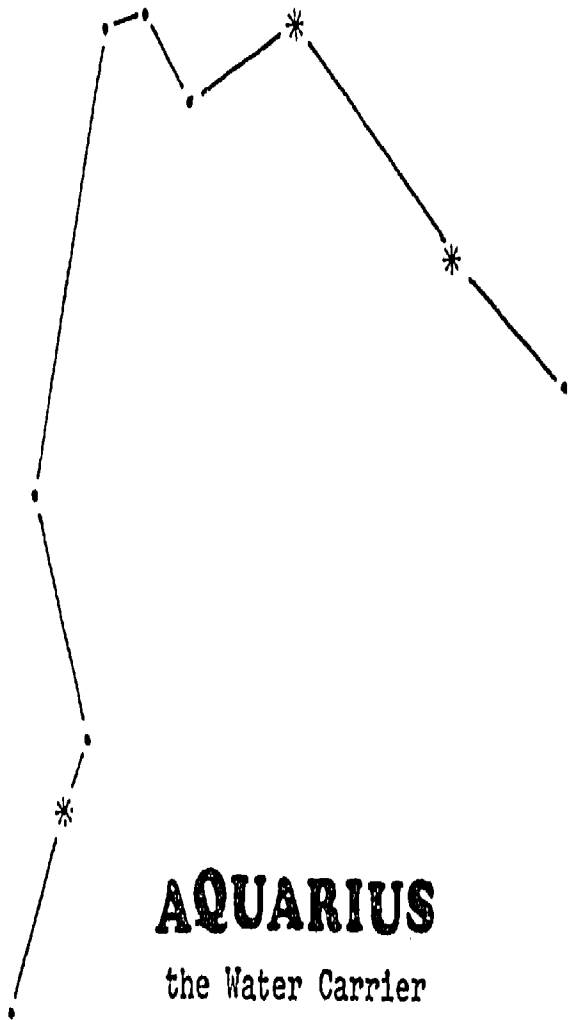

174

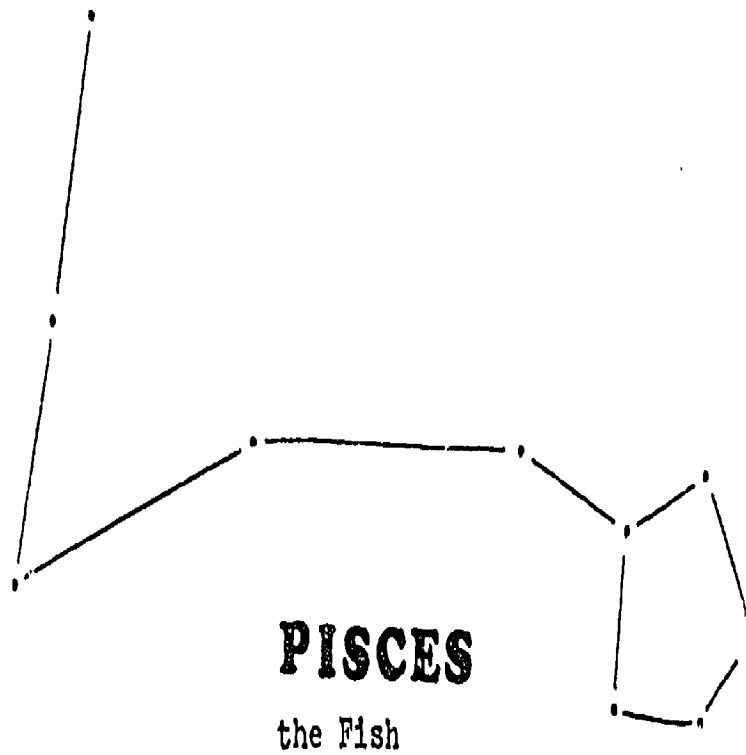

175

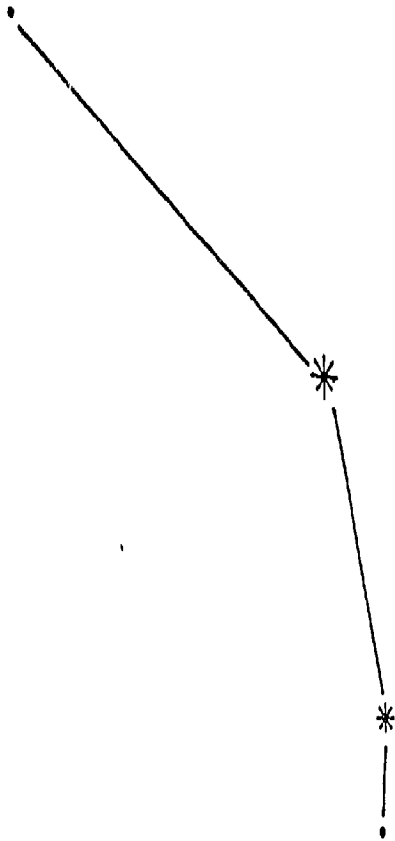

ARIES

the Ram

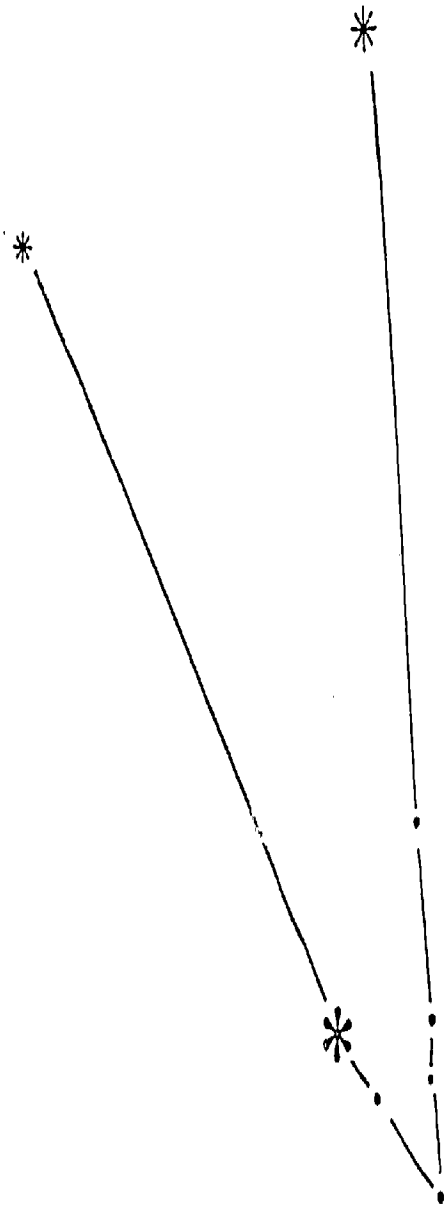

TAURUS

the Bull

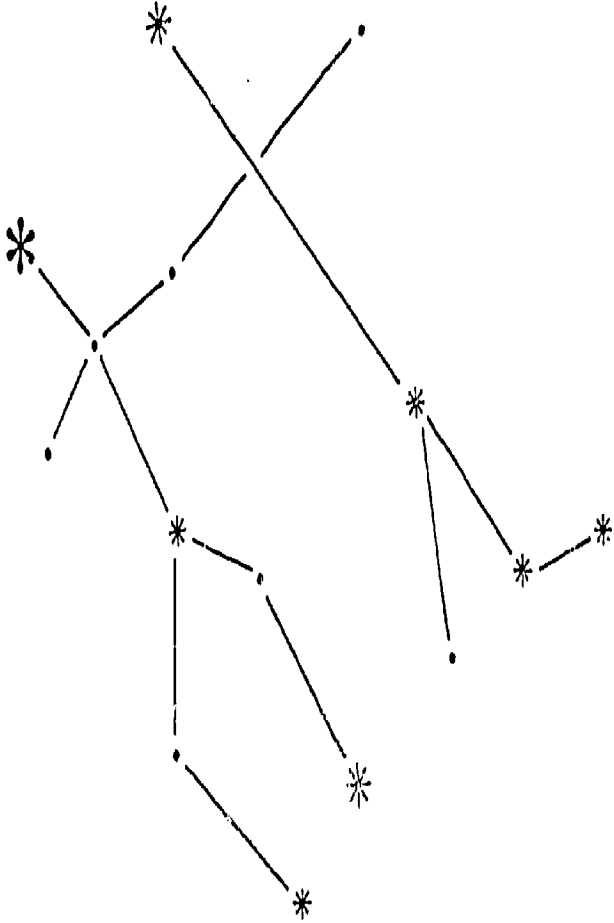

GEMINI

the Twins

178

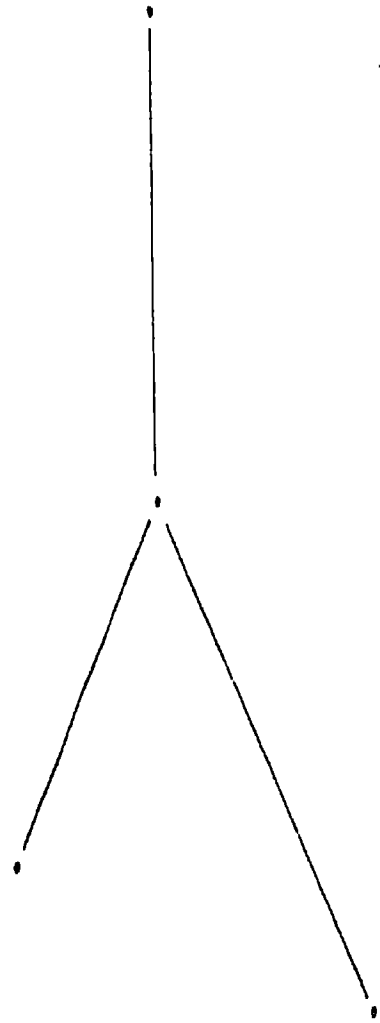

CANCER

the Crab

179

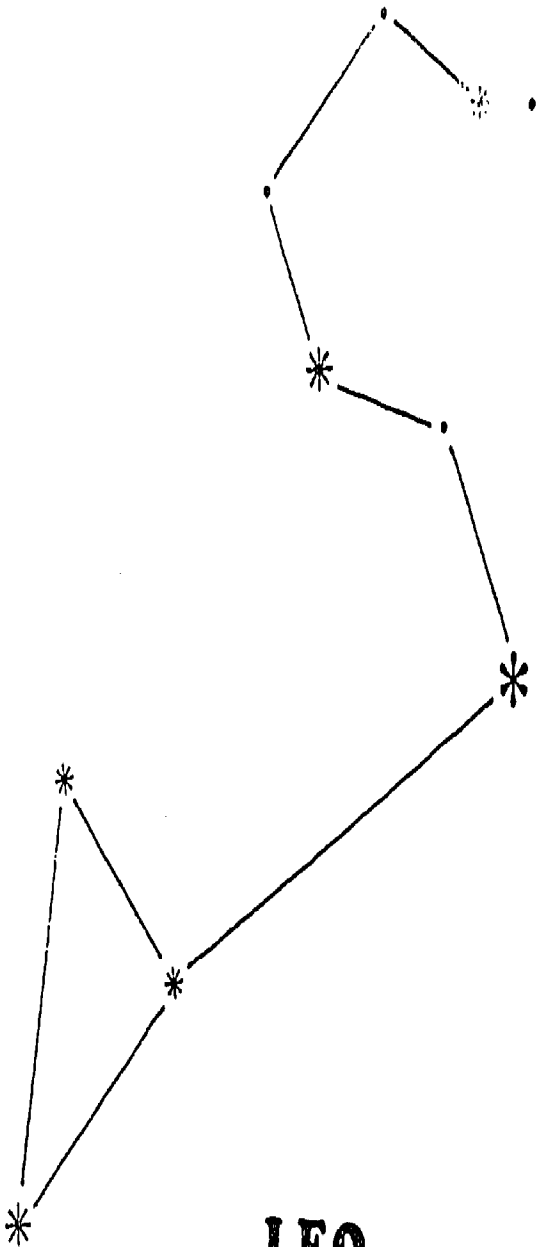

LEO

the Lion

180

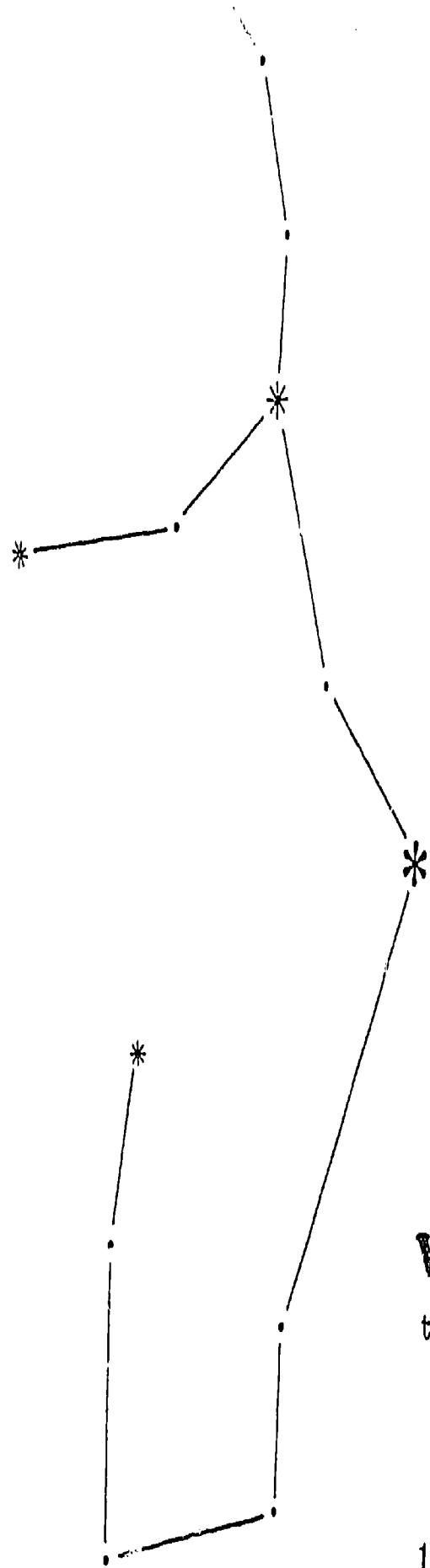

VIRGO

the Maiden

181

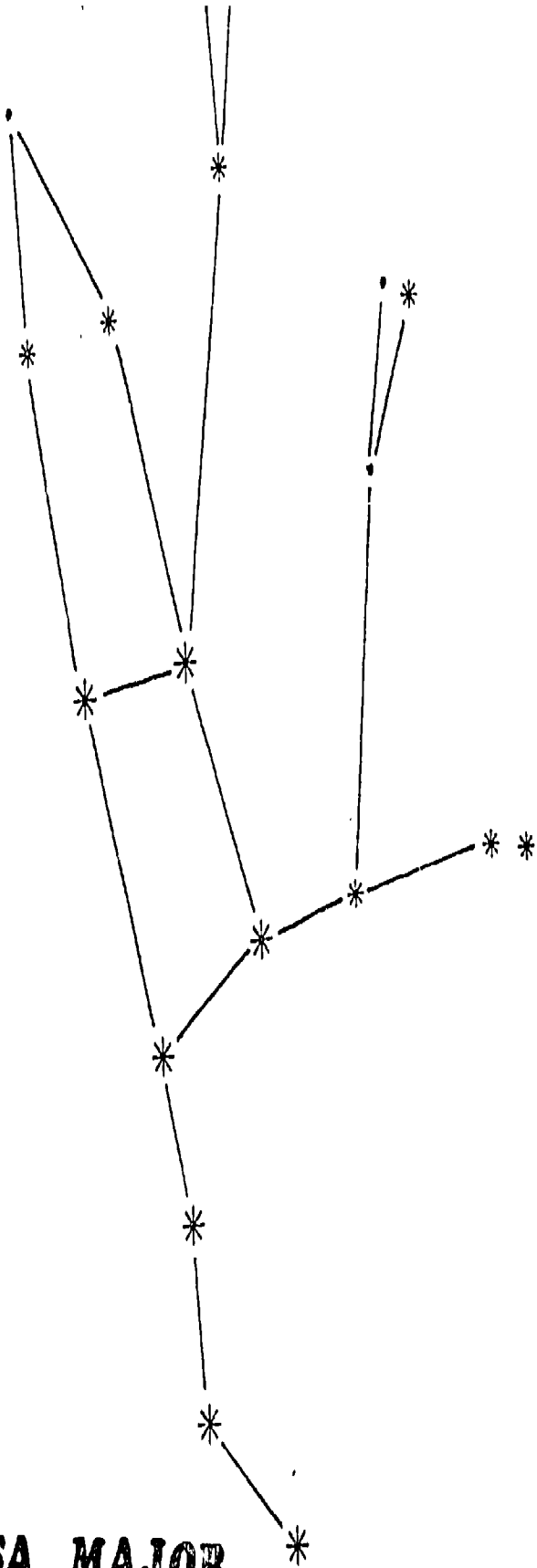

182

URSA MAJOR

the Big Bear

Polaris

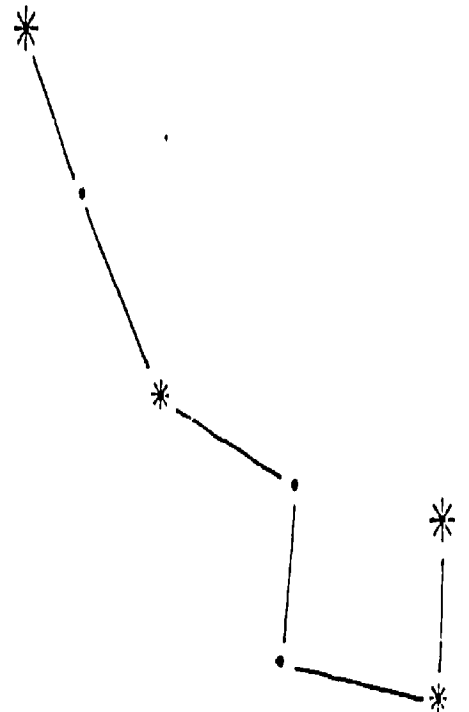

URSA MINOR

the Little Bear

183

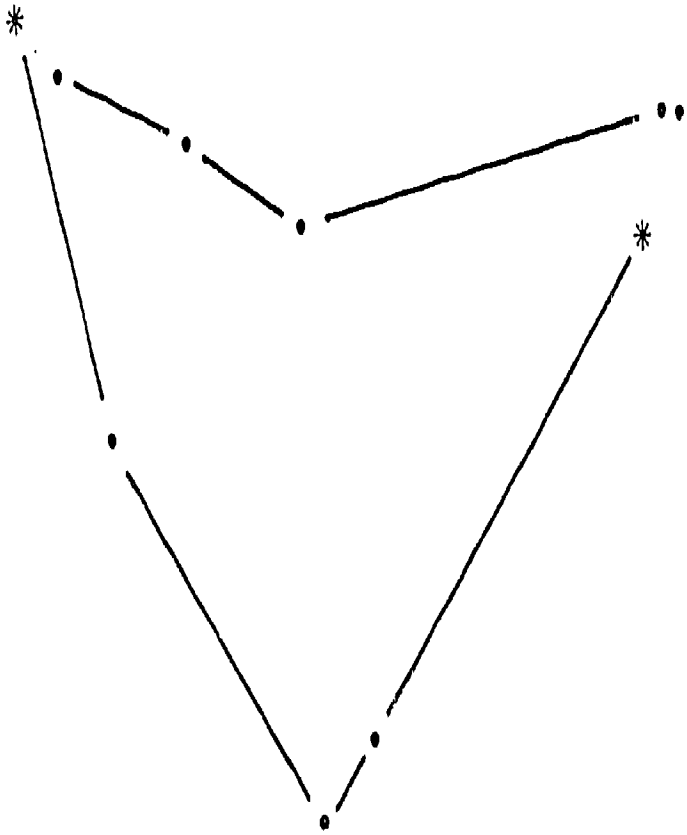

CAPRICORNUS

the Sea Goat

184

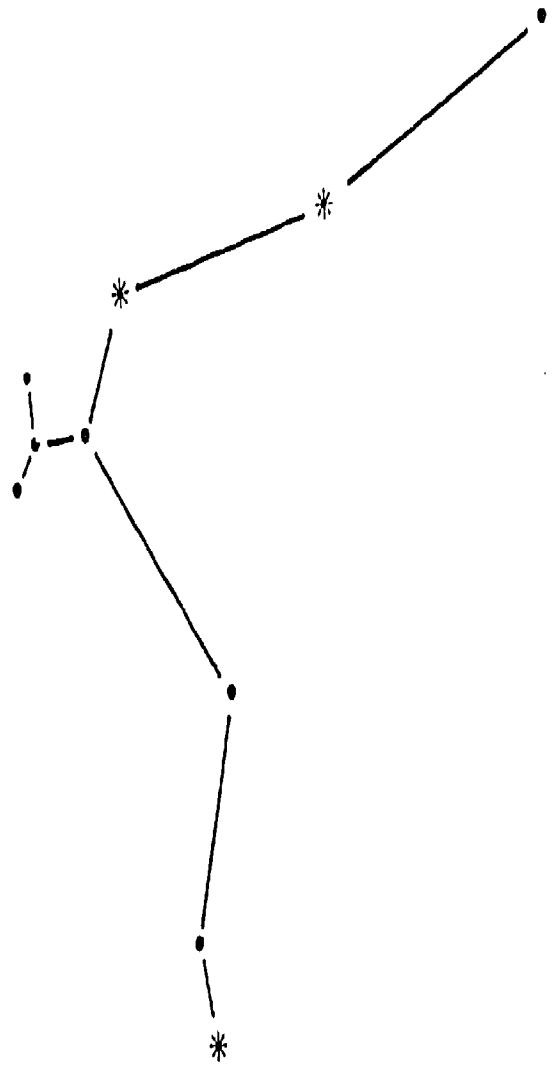

AQUARIUS

the Water Carrier

185

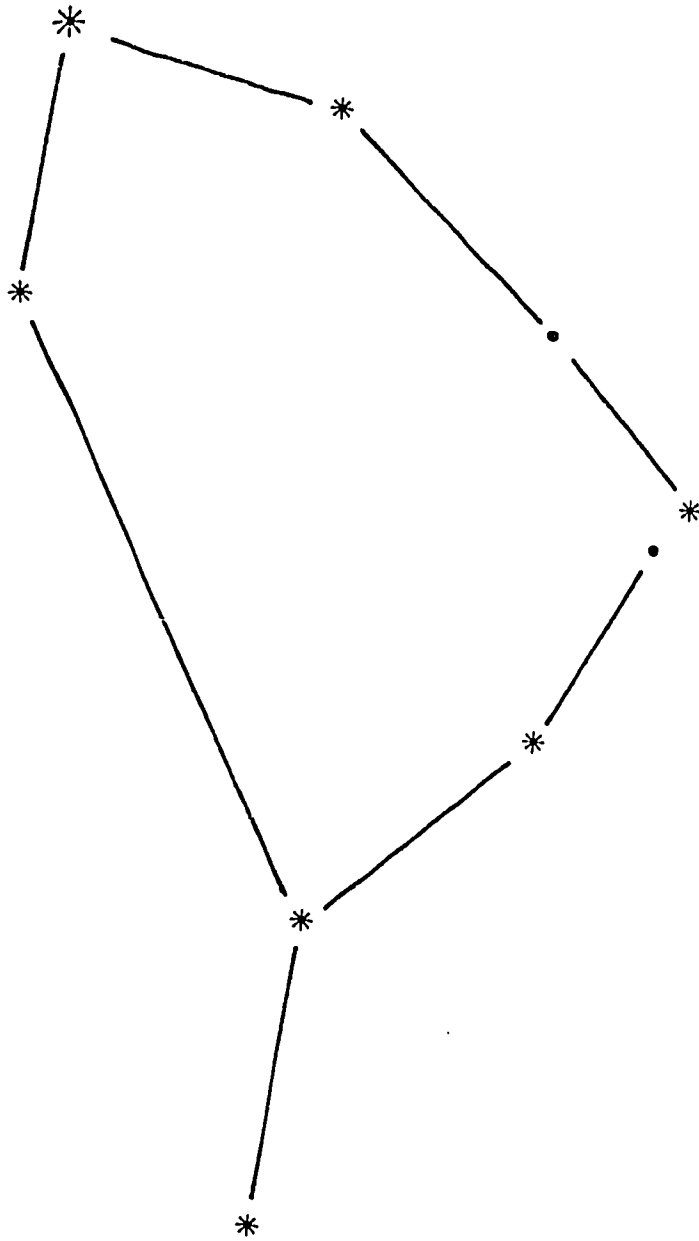

186

OPHIUCHUS
the Serpent Bearer

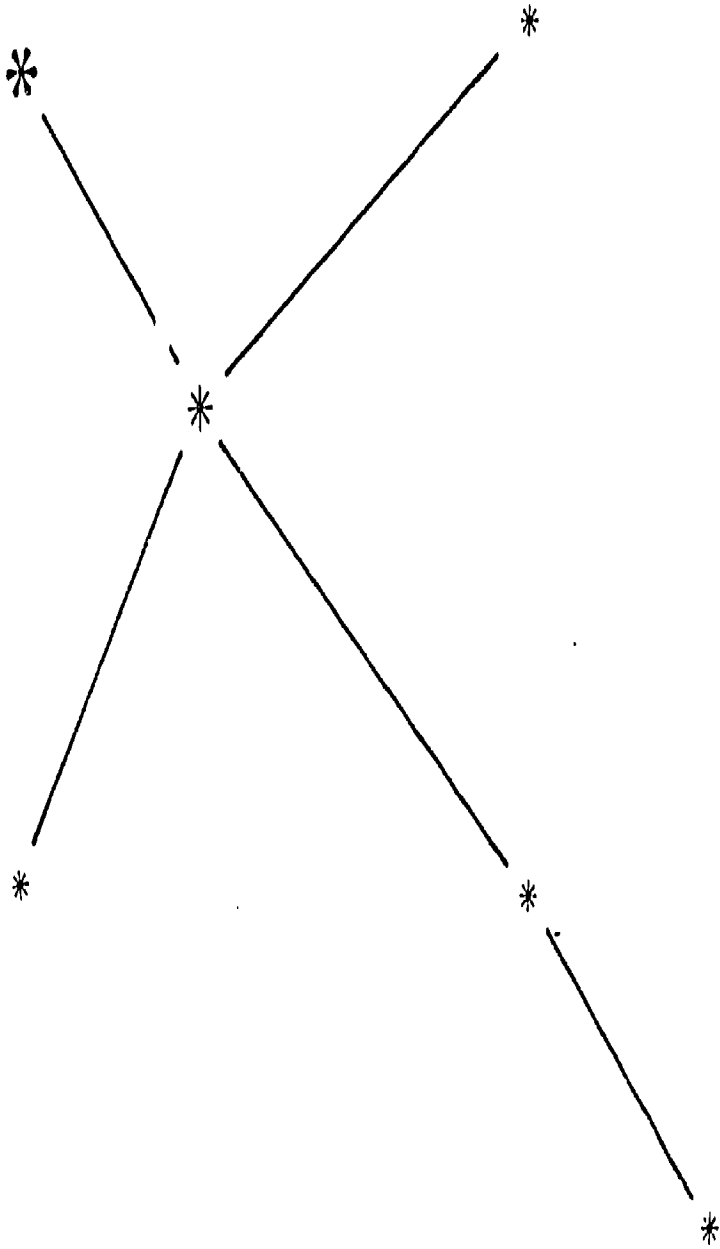

LYRA
the Harp

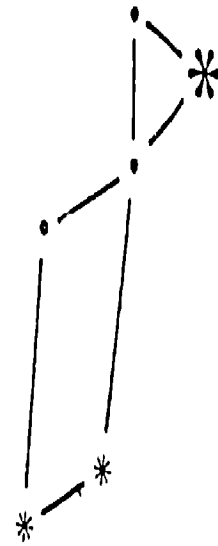

CYGNUS
the Swan

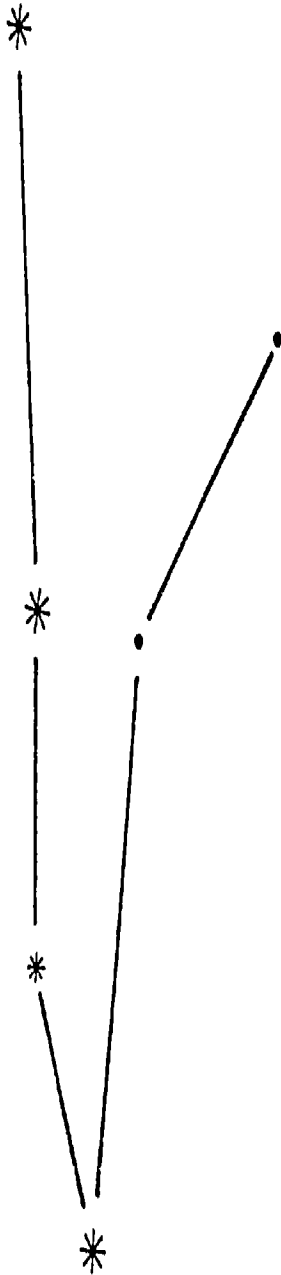

ANDROMEDA

the Princess

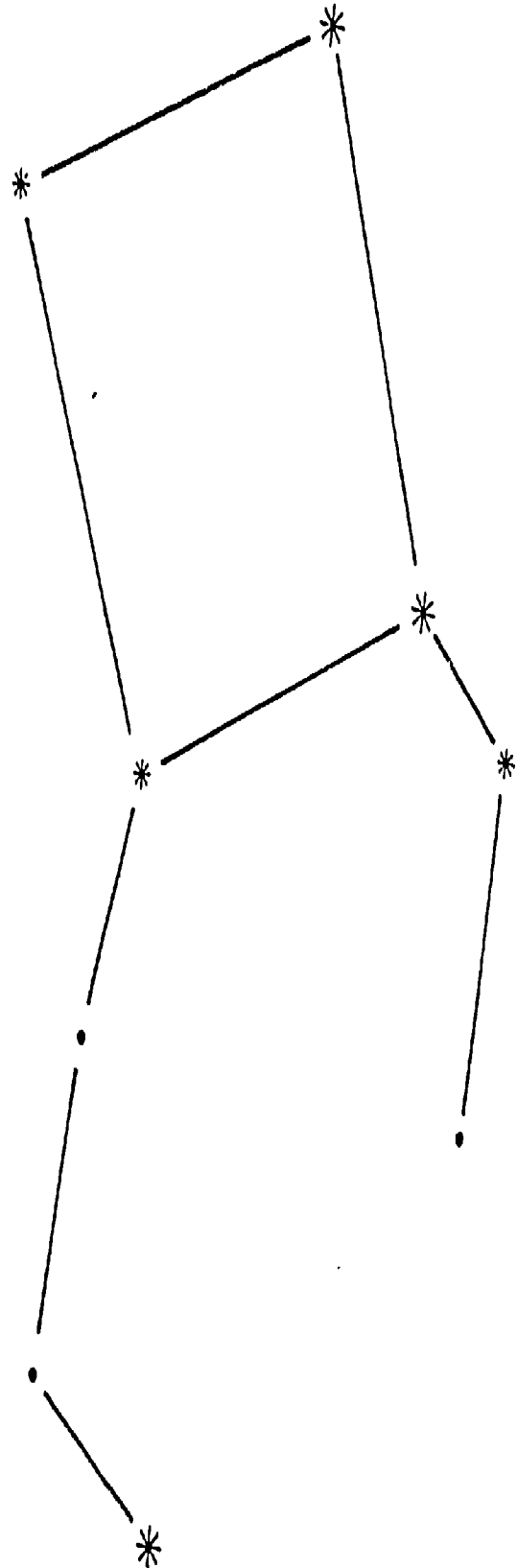

PEGASUS

the Winged Horse

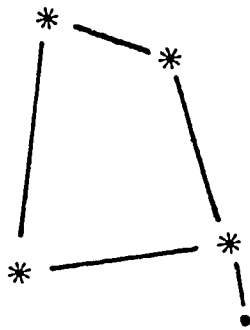

CORVUS
the Crow

191

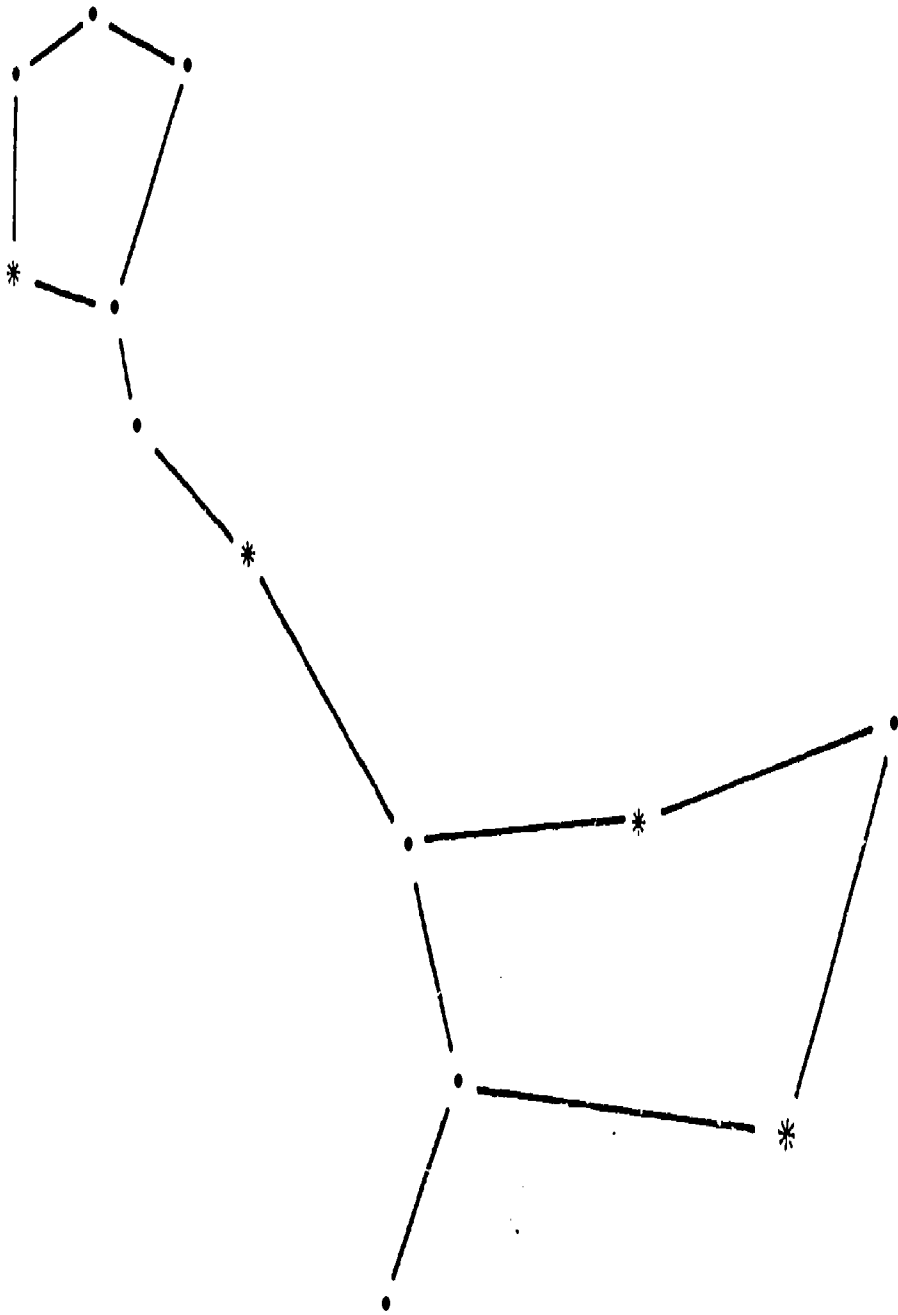

192

CETUS

the Sea Monster

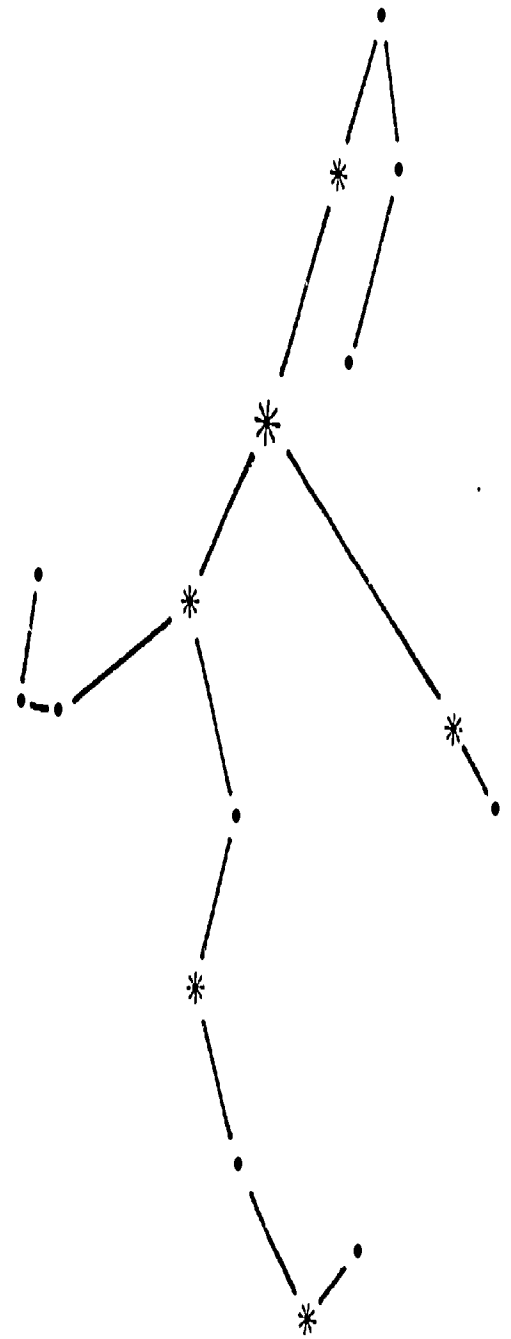

193

PERSEUS

the Hero

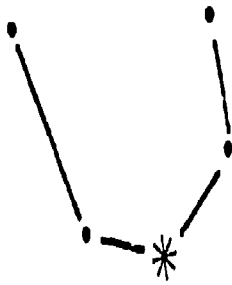

CORONA BOREALIS
the Northern Crown

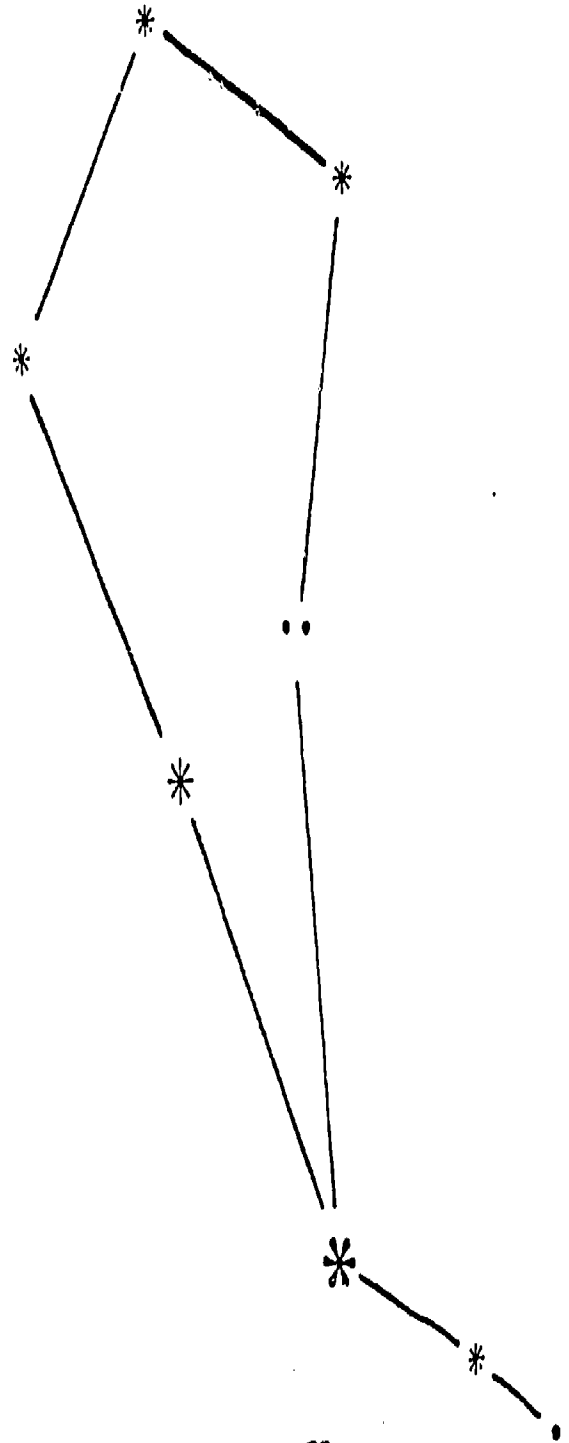

BOÖTES
the Bear Driver

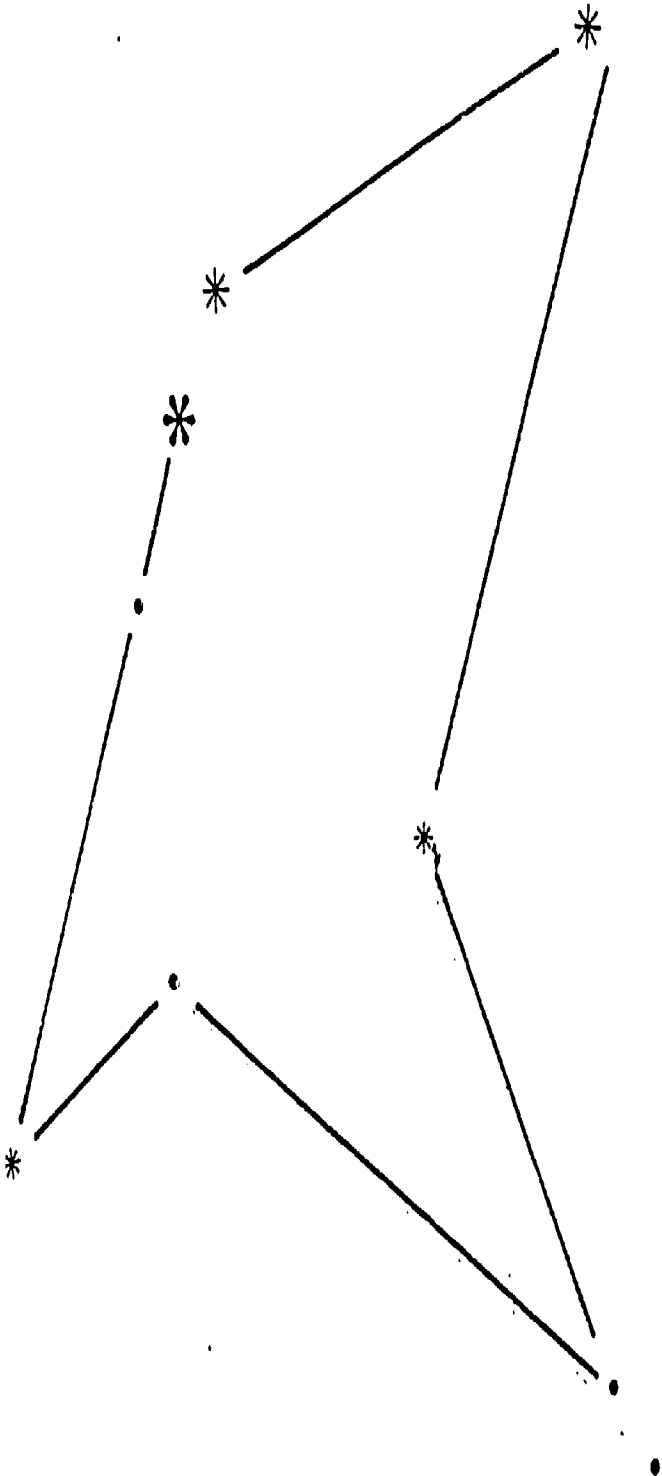

AQUILA

the Eagle

196

ARIES

the Ram

197

APPENDIX C

Planetarium Settings for Session 3

For Session 3, set your planetarium for one of the following dates. Mars, Jupiter, and Saturn will appear in the west. A 4-month advance in annual motion will retrograde Mars.

Date	Hours of Right Ascension of Meridian	South Horizon Star Chart
November 31, 1981	14	May - June
January 11, 1984	18	July - August